

## CHAPTER 3: DESCRIPTION OF OPERATIONS

### 3.1 INTRODUCTION

The previous chapter described the main part of the model, which calculates and stores the information on the age, size, number, and other characteristics of the trees on the block, throughout the transformation period. This chapter expands on the previous one, in describing each of the forest operations available to the user of the model. The operations included in the model are:

1. Forwarder extraction
2. Skidder extraction
3. Shortwood felling and pole length felling
4. Brashing
5. Pruning
6. Replanting

For each of these operations, the model assumes that the volume of any produce is distributed evenly across a group, i.e. the model does not work on an individual tree basis for the purposes of felling and extraction etc.. Each operation is contained in its own subroutine and these subroutines are detailed below.

### 3.2 FORWARDER EXTRACTION

The forwarding subroutines for both group management and clearfelling are based on Method One of the working methods described in the Appendix of the Output Guide (XXIIG13) for Kockums and Lokomo 10-tonne class forwarders (Forestry Commission, 1983), the Output Guide (XXIIG14) for the Valmet 10-tonne class forwarders (Forestry Commission, 1983b) and the Output Guide (XXIIG12) for the Mini Bruunett 578f 7-tonne forwarder (Forestry Commission, 1981).

Method 1: Move into the rack in reverse. Commence loading at the far end of the rack, moving out forwards. Subsequent loads will clear the rack of the product being extracted from the far end of the rack entrance. ~~Part~~ loads remaining at the rack entrance are topped up from the entrance of the next rack.

Figure 3.1 : Diagram of a Typical Forwarder

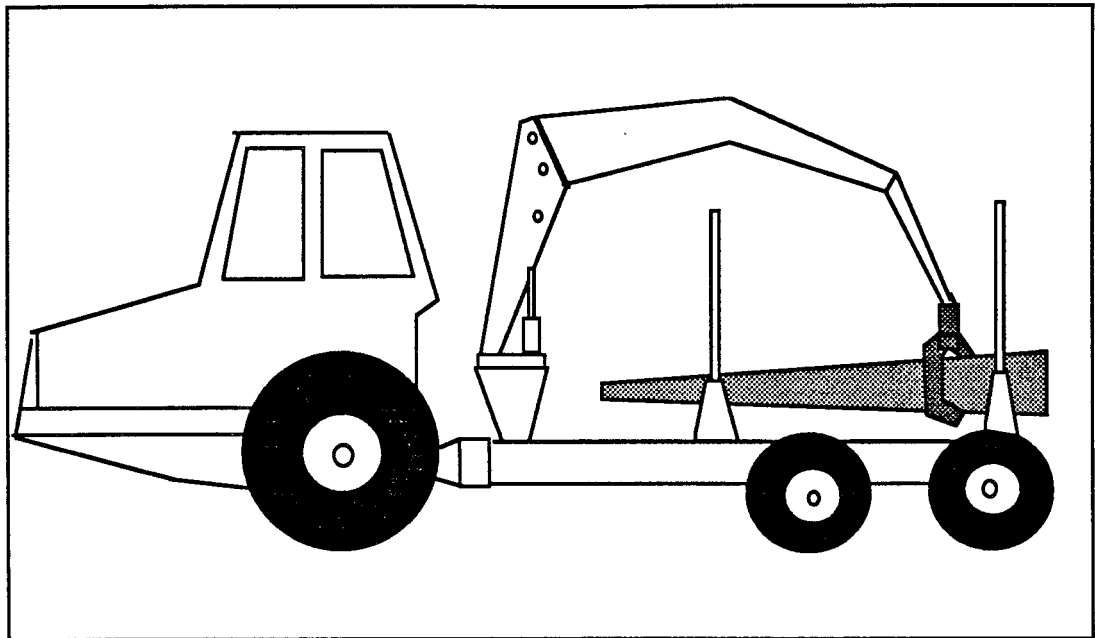

### 3.2.1 GROUP MANAGEMENT OPTION

Based on the principle of Block-of-the-year working, felling and thinning operations are assumed to be carried out at the same time.

In the model, the permanent extraction racks located between every other group are four metres wide. The Forestry Commission recommend that forwarder extraction racks should be 1.25 metres wide plus the forwarder width (Forestry Commission, 1985). As the widths of the 10-tonne forwarders range from 2.49m for the Valmet 872 to 2.70m for the Valmet 862 (Muhl and Allison, 1980), a four metre extraction rack is adequate.

The spacing between extraction racks within each group (referred to as "temporary extraction racks" to distinguish them from the permanent extraction racks) is variable, but the maximum spacing is 20-metres, again based on operating conditions specified in the Forestry Commission Output Guides. However, in this case the spacing is not dictated by dimensions of the forwarder, but by the type of crane fitted, because the rack spacing depends on the distance the crane can reach into the stand to pick up produce. The sequence of steps in the calculation of forwarder movement time are summarised in Figure 3.2 and those for forwarder terminal time in Figure 3.3.

**Figure 3.2: Sequence Of Steps for Calculation of Forwarder Movement Time**

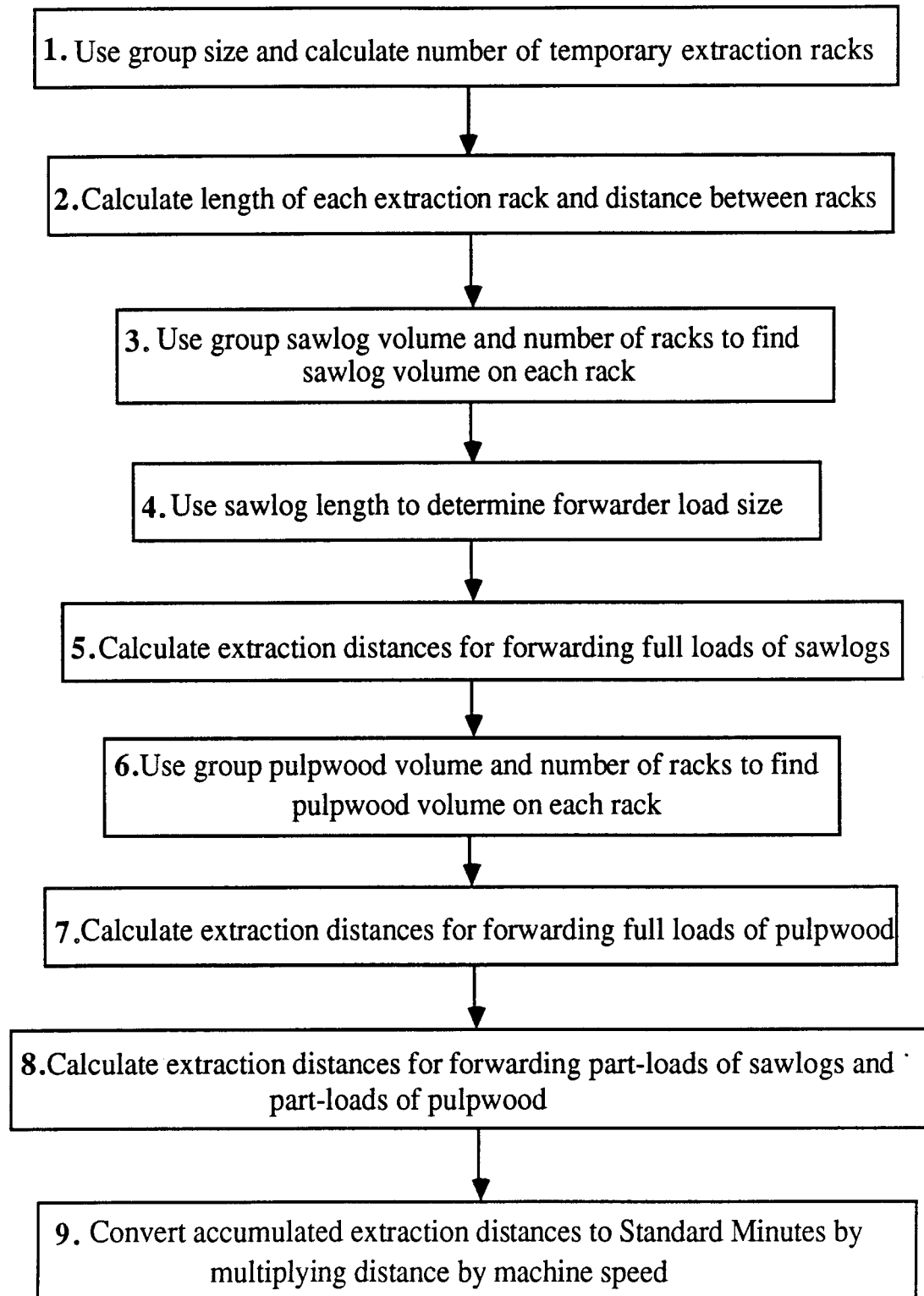

**Figure 3.3: Sequence of Steps for the Calculation of Forwarder Terminal Time**

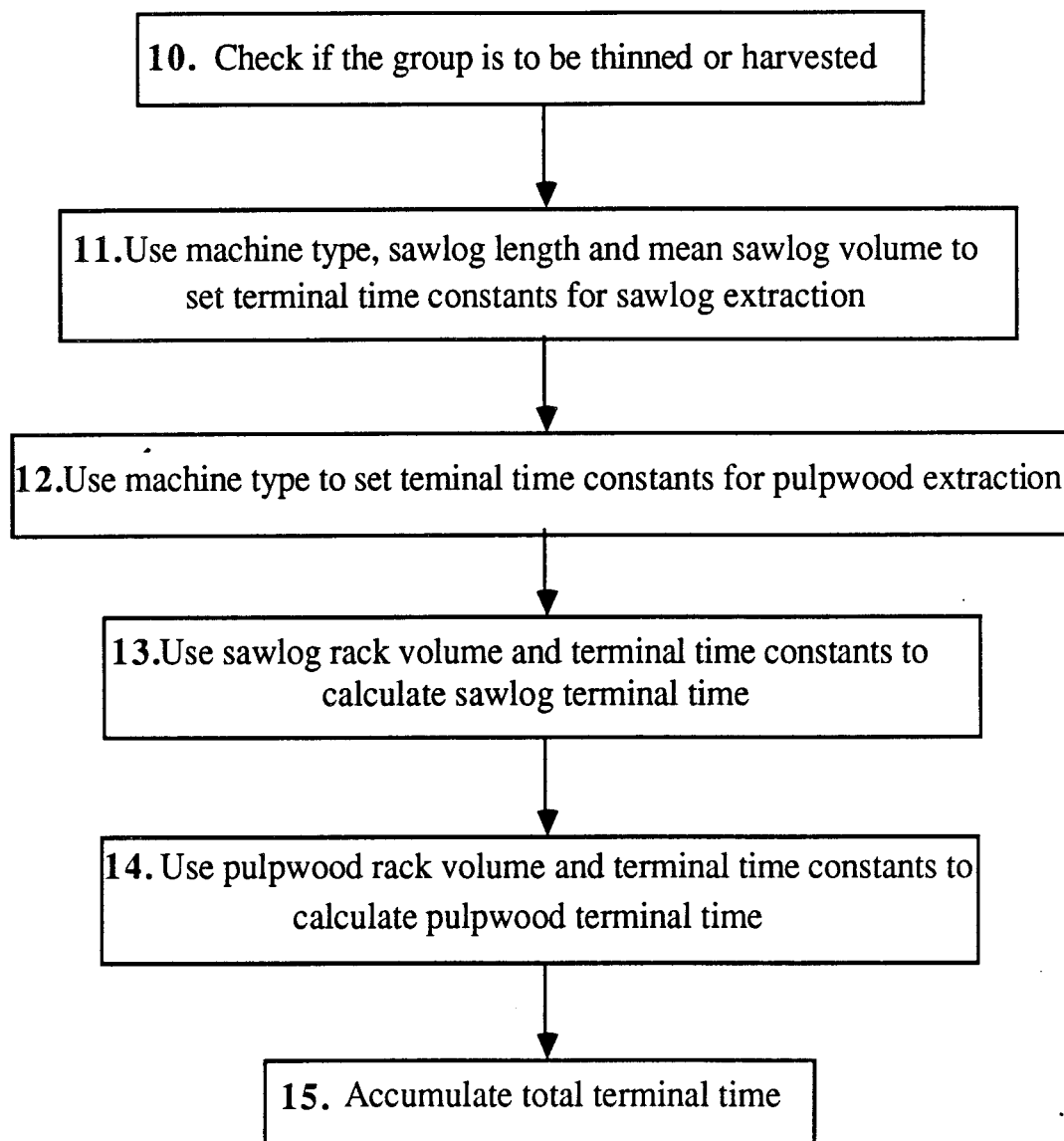

In addition to the subroutine outlined in figures 3.2 and 3.3, an alternative forwarding subroutine was developed where all produce is extracted as mixed loads of sawlogs and pulpwood (rather than pure loads of each), but I felt this method did not reflect the real world situation because sorting out the loads into sawlog piles and pulpwood piles at the unloading point is complicated and time consuming. It is also difficult to model because standard times are not available for such an unconventional working method.

The numbers in bold type in the following sections refer to the steps in the diagrams above (Figure 3.2 and 3.3).

The first step (**1**) in the subroutine is to calculate the number of temporary extraction racks within each group, based on the size of the group, as shown below.

Length of the edge of the group	Number of racks
0m- 20m	1
21m-40m	2
41m- 60m	3
61m- 80m	4
81m-100m	5
101m-120m	6

I have restricted the maximum number of temporary racks to six which in turn restricts the maximum group size to 1.44 ha. (120 metres x 120 metres = 1.44 ha.). This limit has been set arbitrarily to reduce the running time because during the extraction of part loads of sawlogs and pulpwood, each temporary extraction rack is treated as a new group and the array size increases to 1296 elements (36 x 36). Using the group size, the length of each extraction rack is then determined (**2**):

$$E_1 = \sqrt{G_{ha} \times 10000}$$

Where:

$E_1$  = extraction rack length

$G_{ha}$  = group size in hectares

The next step (3) in the subroutine is to use the array containing the sawlog volume in each group and divide it by the number of racks, in order to find the sawlog volume present on each rack. Then, by examining the specifications of the produce in each group ( details of which have been calculated and stored earlier in the program), load sizes for the different types of machine can be determined (4). In the case of the 10-tonne forwarders, if the average sawlog length is greater than 6.5 metres, the load capacity is reduced from 10 tonnes to 8 tonnes.

**Figure 3.4: Forwarder Extraction of Full Loads of Sawlogs**

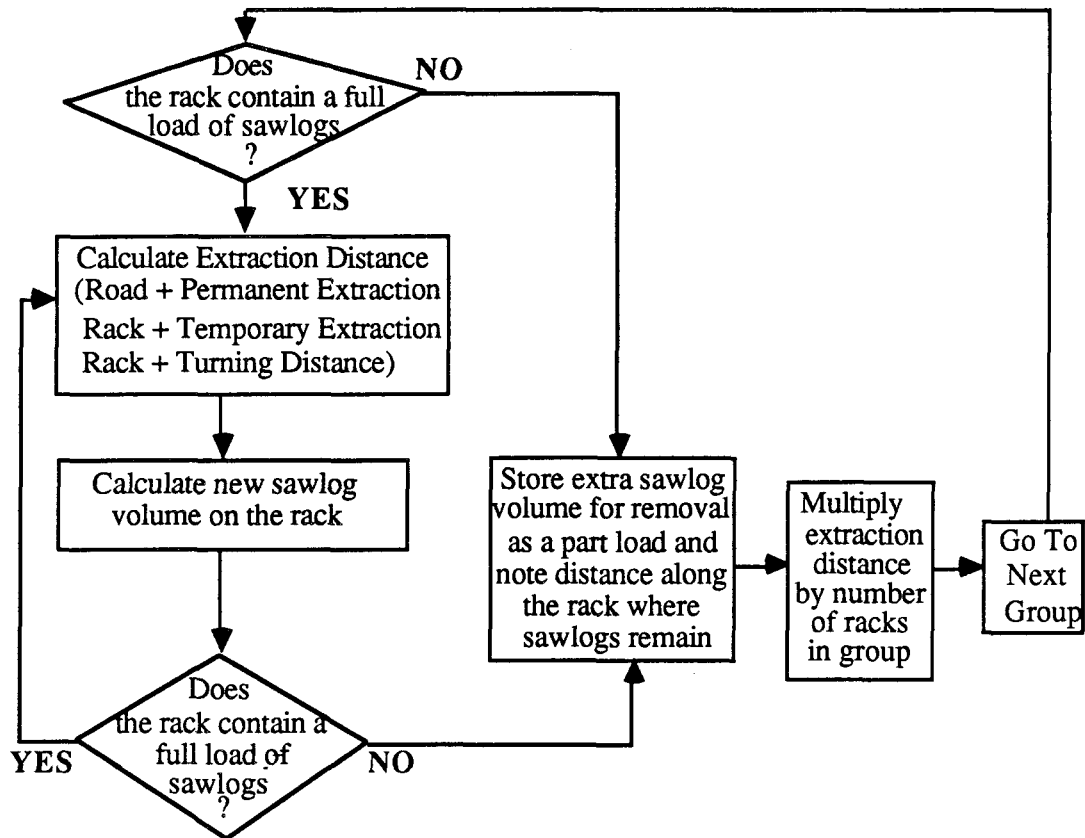

The sawlogs and pulpwood are assumed to be distributed evenly across the group with each temporary extraction rack in a group containing an equal volume of produce. Also, the subroutine assumes that all produce is unloaded at a central collection point on the road. Calculation of extraction distances proceeds as outlined in Figure 3.4 above, starting with the group in the top left corner of the block and extracting full loads of sawlogs (5).

The process is then repeated for full pulpwood loads (6 & 7). Once full loads have been removed from each temporary extraction rack, the remaining produce is also extracted as full loads of pure sawlogs or pure pulpwood, but the loads are collected from more than one temporary extraction rack (8) as outlined in Figure 3.5.

**Figure 3.5: Forwarder Extraction of Part Loads**

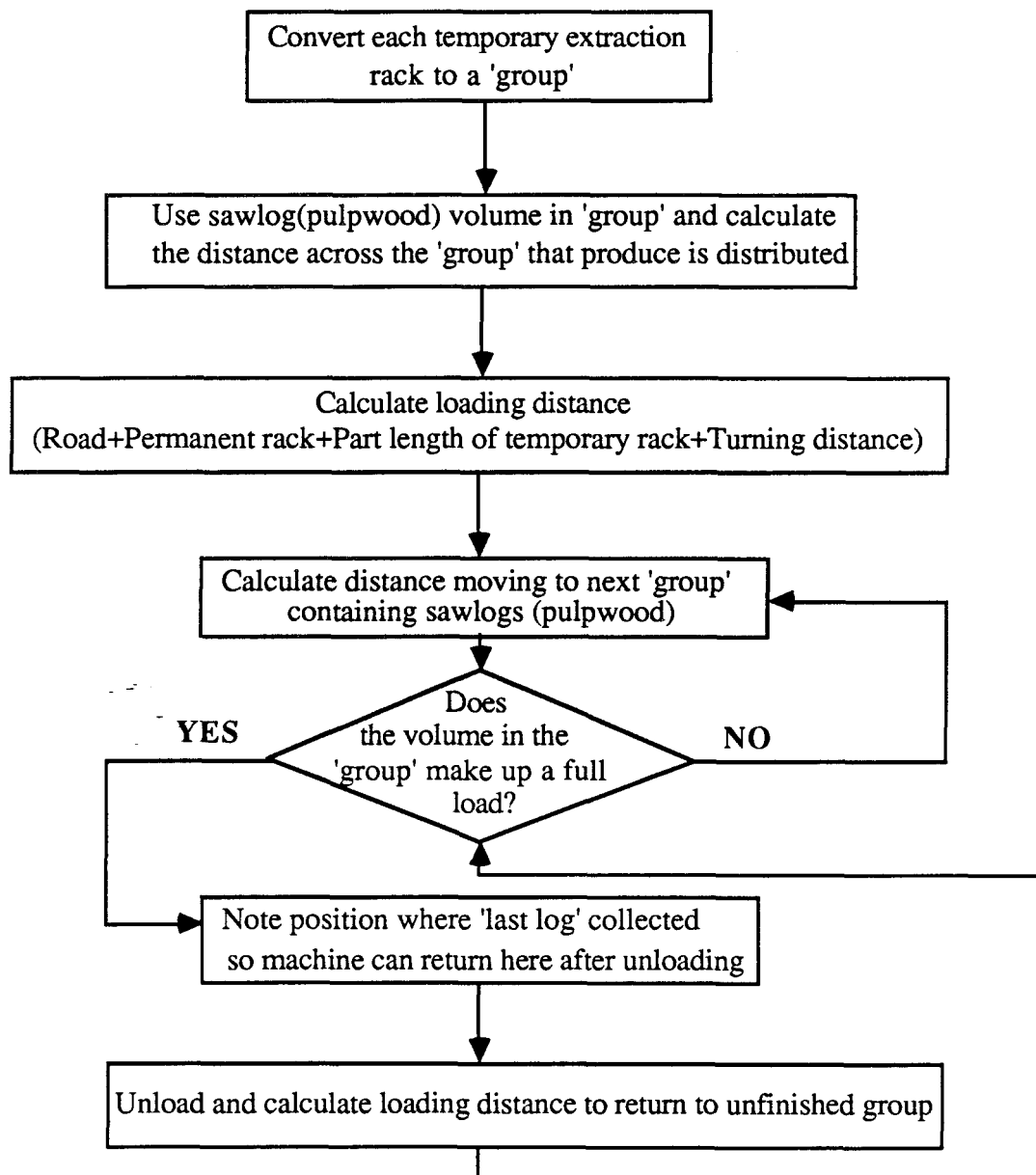

Extraction distances for each rack are accumulated for a whole group and then for the whole block and the total distance<sup>(m)</sup> is multiplied by the speed of the chosen machine to<sup>(mins./m)</sup> find total machine movement times. Machine speeds have been calculated from the Output Guides for each machine. As **total extraction times** over different mean extraction distances are given in these tables, it is possible to separate out **movement time** (time spent moving into and out of the wood) from **terminal time** (time spent loading and unloading the machine) to find machine speeds. These values were validated by comparison with results from Forestry Commission forwarder trials and manufacturers machine specifications.

Terminal times for sawlog extraction are determined by the load size, the mean sawlog volume, and whether the logs are being removed from a clearfelling or a thinning operation. Terminal times for thinnings are higher than those for clearfelling because more time is spent manoeuvring the crane around standing trees. Larger load sizes have higher terminal times because the terminal time includes the time taken in moving during the loading process.

Terminal times for pulpwood extraction are determined by the load size and whether the pulpwood is being removed from a clearfelling or a thinning operation for the reasons given above.

**Total extraction time** is calculated by adding the **terminal time** and the **movement time**. Machine costs and labour costs can be specified by the program user, or average Forestry Commission values can be chosen.

### 3.2.2 CLEARFELLING OPTION

Following the same pattern as the group felling option, the first step of the forwarding subroutine is calculation of the number, length, and spacing of the temporary extraction racks. Rack spacing is again restricted to a maximum of 20-metres, but in this case the temporary racks are perpendicular to the road rather than parallel (See Figure 3.6).

**Figure 3.6: Arrangement of Forwarding Racks for the group Felling Option and the Clearfelling Option**

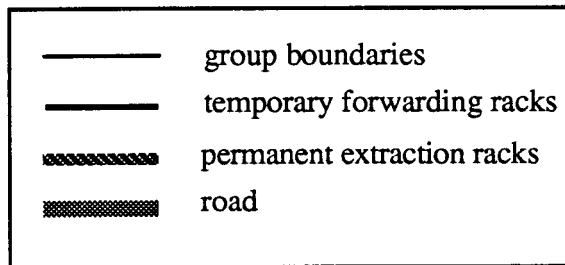
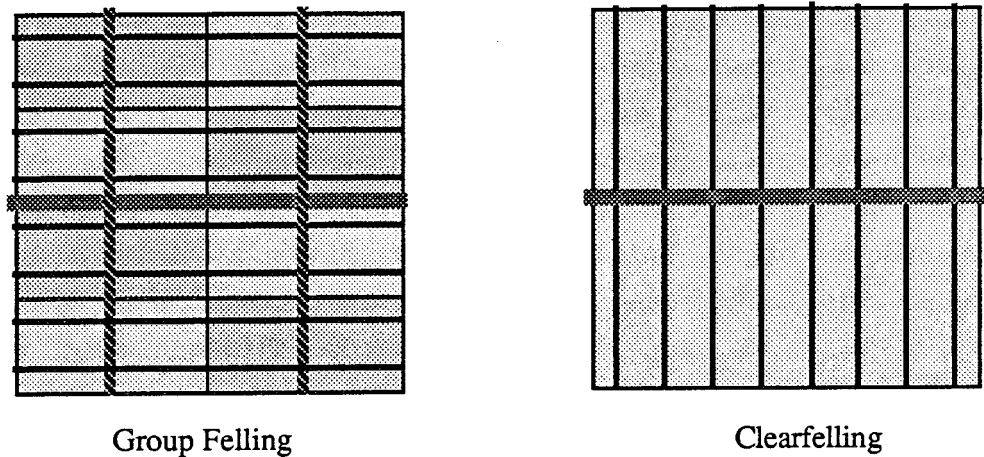

The produce is extracted as pure loads of sawlogs or pulpwood and the material is again assumed to be distributed evenly across the group, with each temporary extraction rack containing an equal volume of produce. Extraction begins at the top left hand corner of the block and any part-loads remaining at the entrance of the rack are extracted as pure loads of sawlogs or pulpwood, made up by visiting more than one rack. The calculations are carried out for a quarter of the block and the extraction distances multiplied by four to give a total value for the whole block. This can be done under the assumption of even distribution of produce. The extraction terminal times are handled in the same way as in the group felling option.

### 3.3 SKIDDER EXTRACTION

The skidding subroutines for both group management and clearfelling offer a choice from a range of skidder sizes: The Roadless Logmaster skidder (load size – 1.5 - 3.5 cubic metres), the Falstone skidder (load size – 1.0 - 5.0 cubic metres) and the Timberjack 200/300 skidders (load size – 3.0 - 6.0 cubic metres). The skidding method (outlined below) and the time data for the skidding operation were taken from the Provisional Standard Time Table (XXII/28) for the Roadless Logmaster (Forestry Commission, 1980), the Standard Time Table (XXII/25) for the Falstone skidder fitted with an Iglan 4-tonne double drum winch (Forestry Commission, 1979), and the Standard Time Table (XXII/26) for the Timberjack 200/300 series skidders (Forestry Commission, 1979).

Working Method:

1. Prepare unloading area.
2. Drive into wood, manoeuvre tractor and present butt plate to load.
3. Walk to rear of tractor, collect rope and chokers.
4. Take out rope and chokers and choke poles starting with the pole farthest away from the tractor.
5. Return to tractor, prepare to winch in, winch in lifting load as high as possible off the ground.
6. Drive out of wood to unloading area.
7. Unload. Stack poles as necessary.
8. Repeat above cycle.

Figure 3.7 : Diagram of a Typical Skidder

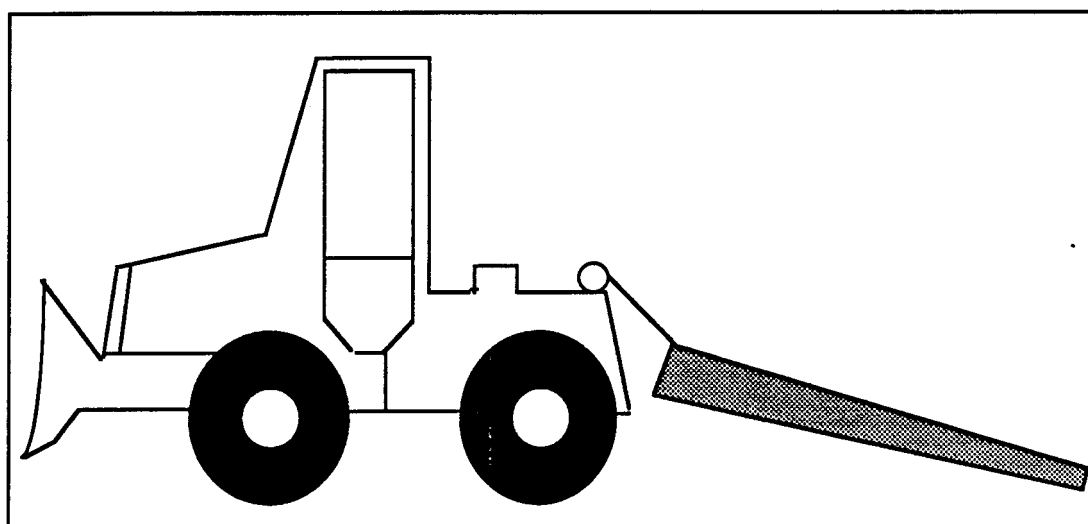

### 3.2.1 GROUP MANAGEMENT OPTION

The very nature of the skidding operation makes it difficult to extract timber from more than one area during a single skidding cycle. Once the poles are choked and winched in, the skidder can only then move forwards and cannot reverse into another group to collect more poles. Therefore, the model works on the assumption that the final load removed from each group during skidder extraction may be a part one.

The extraction racks for skidding also need to be 1.25 metres greater than the width of the skidder (Forestry Commission, 1985) and as the largest skidder included in the model, the Timberjack 360, is 2.65 metres wide at its widest point (anon, 1975), the 4-metre extraction racks used in the model are again adequate.

The skidding distances in the skidding cycle can be divided into three parts: road distance, ride distance, and wood distance. The actual harvest area is referred to as a setting and the average skidding distances (wood distances) for different sizes of settings (group sizes) must be calculated. Matthews (1942) in his classic book, developed an expression for average skidding distance using the distance to the centroid of a triangle. This definition did not, apparently, have a very sound mathematical base. The equation for average skidding distance used in the model was developed from the one presented by Peters (1978) for rectangular settings. The resulting equation, for a square setting, is shown below.

$$ASD = \frac{1}{6} [ (8 \times G_1) + (2 \times G_1 \times \ln (2.4142))] ]$$

where

**ASD** = Average skidding distance

**G<sub>1</sub>** = Length of the edge of the group

The three skidders are treated slightly differently within the skidding subroutine because data for the Falstone skidder are far more detailed than that for the other two skidders. Falstone skidding speeds are given for a variety of conditions such as road speed, ride speed, and wood speed, and each of these is further divided for the machine travelling loaded or unloaded. For the other two machines the loaded and unloaded speeds have been averaged to give a single value.

The sequence of steps in the skidding subroutine is summarized in Figure 3.8.

**Figure 3.8: Sequence of Steps in the Skidding Subroutine**

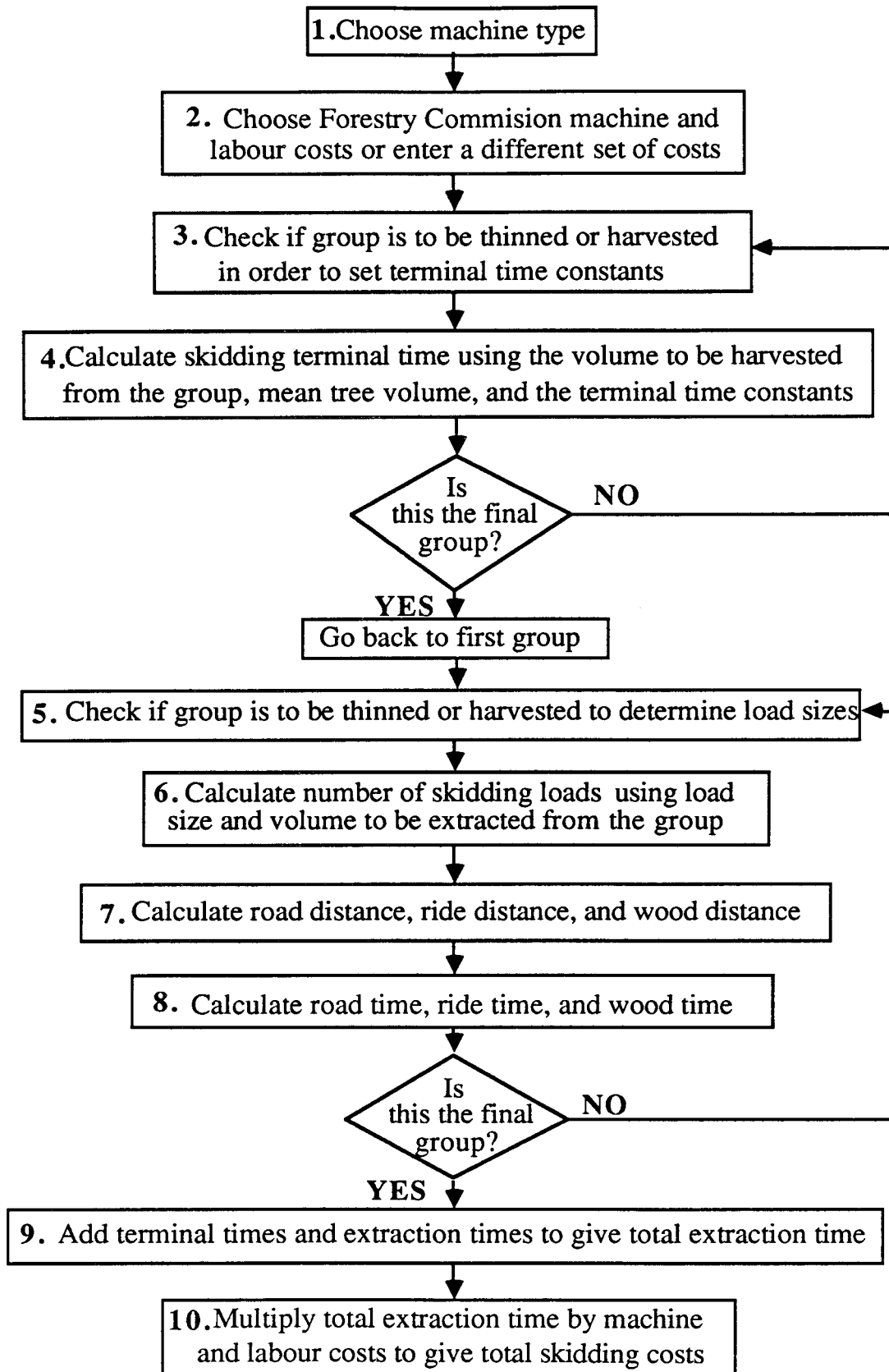

## 3.4 SHORTWOOD AND POLE-LENGTH FELLING AND THINNING

### 3.4.1 INTRODUCTION

Shortwood and pole-length operations are contained in two separate subroutines, but as the structure of each is essentially the same, they are described together.

Extra time may be needed for felling operations with a group management system, to allow the fellers to move between groups and locate new groups to be felled. This can easily be incorporated into the model and hence be quantified. However, a second factor leading to possible increases in felling time is the extra care needed when felling trees in small groups, in order to avoid damaging regeneration in the surrounding groups. This is less easy to incorporate into the model because data obtained from managers of uneven-aged forests in Britain are not consistent. Some managers argued that directional felling is simply part of the job of felling trees and, therefore, no additional costs are incurred. On the other hand, the felling tariffs for the Bavarian state forests allow an increase in felling time of up to ten percent to allow for delays in felling when working in areas with a lot of regeneration. This tallies well with the situation at Tavistock where the standard felling times are increased by ten percent for the final fellings. At Tavistock, the trees in the final fellings (mostly Douglas fir) are 34-36 metres tall and the group size is approximately 0.004 ha. It is difficult to imagine a more difficult felling situation than this, and I have, therefore, constructed a scale of percentage increases using this combination of tree height, group size and a 10% increase in felling time as the maximum point. The minimum point (0%) is the combination of tree height and group size where the trees can be felled into the group itself. This scale of increases is shown in Figure 3.9 below.

The points for the final fellings at Tavistock were plotted first and a curve fitted. The end points of the curves for the other tree heights were then plotted and joined by curves similar to that for Tavistock.

The final factor which leads to increased felling time for group working relates to the growth patterns of trees in groups. Extra snedding time is required for the edge trees of the groups because the higher light levels on the edges of the groups lead to production of thicker branches (See Appendix B).

Figure 3.9: Graph of Percentage Increases in Felling Time with Tree Height and Group Size

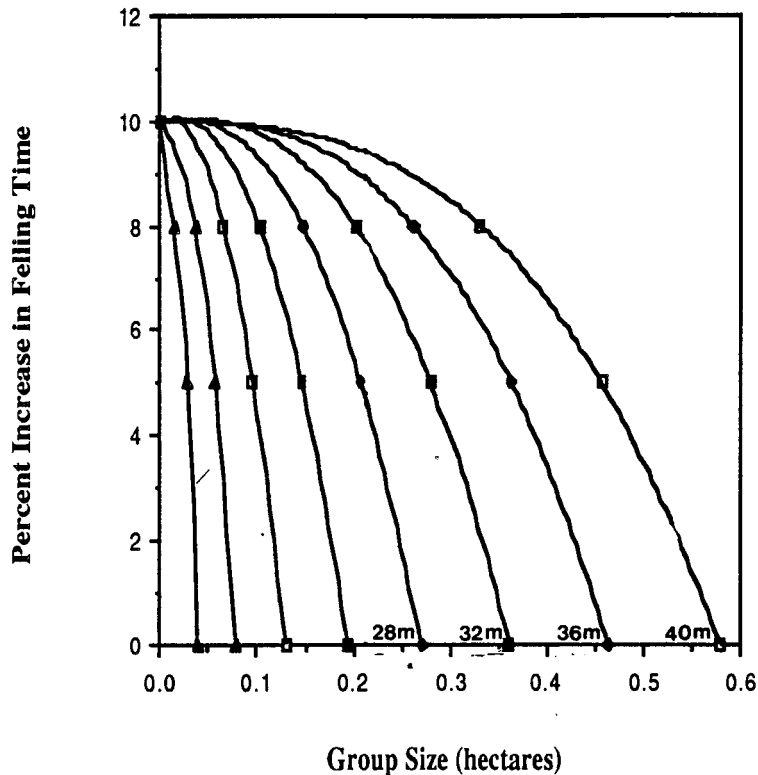

The first stages of the felling/thinning subroutines are summarized in Figure 3.10. **If** the group is being harvested, **as** opposed to thinned, a percentage increase is read from the table of increases which is accessed by tree height and group size. This correction is not applied to groups being thinned because the nature of the thinning operation requires directional felling and a time allowance for this is already incorporated into the Standard Time tables. The felling time per tree is calculated using equations derived from the Standard Time tables relating felling time to mean tree volume. If the trees have not been brashed, felling time is adjusted to take into account extra time needed to brash the lower portion of the tree before it can be felled. **During** the first felling period no extra time is added for snedding of edge trees because the edge trees of the groups being felled in the first felling period have grown up in an even-aged stand and are not, therefore, more coarsely branched. **In** subsequent felling periods the felling time per tree is adjusted to take coarse branching into consideration.

Figure 3.10: Flowchart for First Section of Felling/Thinning Subroutine

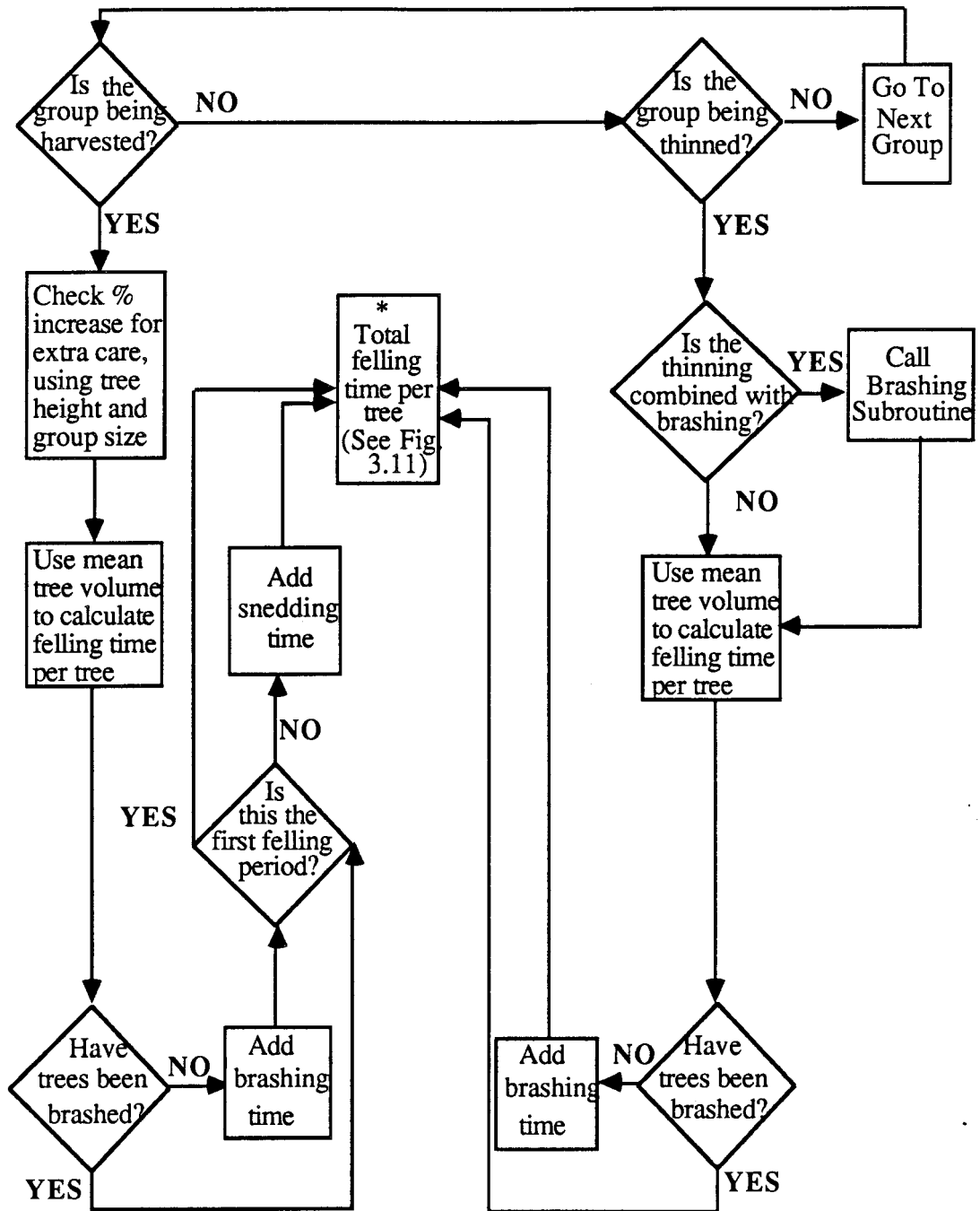

\* This value is the input for figure 3.11



Figure 3.11: Second Section of Flowchart for Felling/Thinning Subroutine

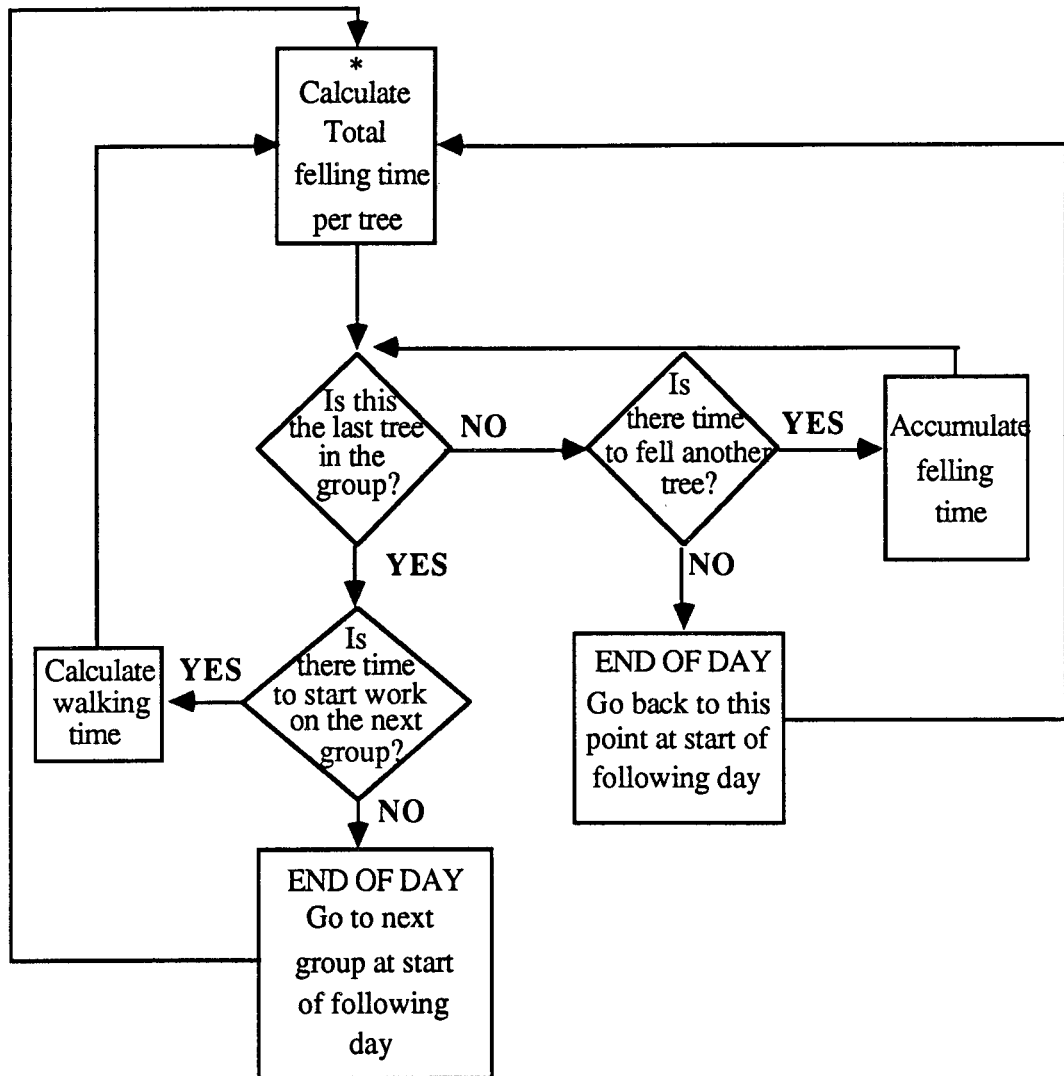

The organization of the whole felling/thinning operation is summarized in Figure 3.11 above. The number of trees in each group is calculated and the time for felling each tree is accumulated. As each tree is felled, the time left in the working day is checked to see if there is time to start felling another tree. When it comes to the end of the day, the number of days is incremented by one and the workers are assumed to return to this point at the start of the next day. Similarly, when all the trees in a group have been felled the time remaining in the day is checked to see if there is time to move to another group and begin felling. If there is not, the number of days is again incremented by one and felling begins in the next group at the start of the following day.

### 3.5 BRASHING

The brashing subroutine is based on the Output Guide XVI G1 for brashing spruces, the Output Guide XVI G3 for brashing Japanese larch and the Output Guide XVI G4 for brashing Douglas fir and Grand fir (Forestry Commission, 1978). The operation, if selected, is carried out at the age of first thinning and is combined with the thinning operation. The sequence of steps in the brashing subroutine are shown in Figure 3.12.

Figure 3.12: Sequence of steps in the Brashing Subroutine

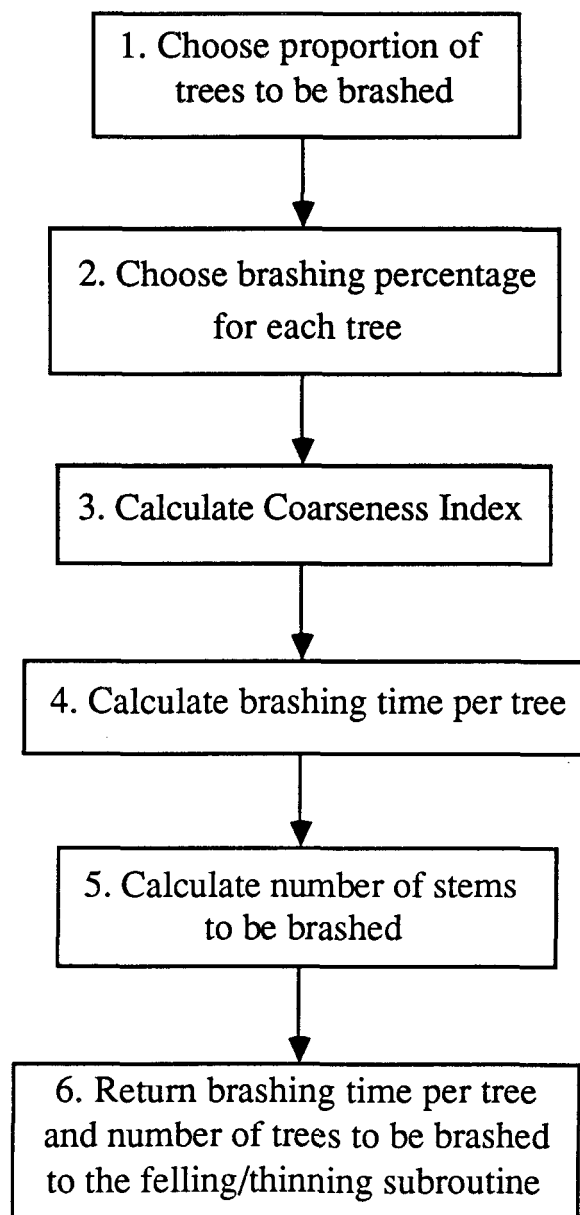

The user is given the choice of full or partial brashing for each group **(1)** with the partial brashing offered as one tree in four (25%) or one tree in three (33%). Each tree may be fully or partially brashed **(2)** with a choice for the proportion of brashing of 30%, 40%, **50%**, 60%, **70%**, and 100%.

For all three Output Guides, the coarseness of the trees is assessed in the same way **(3)**:

**Fine branched:** Under 13mm diameter, brittle and more than one branch removed with one stroke of the saw.

**Medium branched:** 13-25mm diameter, most branches removed with one stroke of the saw.

**Coarse branched:** Over 25mm diameter, tough, most branches require more than one stroke of the saw. Sometimes many internodal branches.

The trees in the group plantings at Glentress were categorized using the above criteria (See Appendix B) and in general, the outer half of the edge trees in each group was classified as coarsely branched and the inner portion of the edge trees, along with the trees within the group, was classified as finely branched. In order to calculate the Coarseness Index, the number of trees in each category is expressed as a percentage of the total number of trees in the group and a multiplying factor is applied to each percentage. The resulting values are then summed to give the Coarseness Index.

A Coarseness Index was calculated for each species over a range of group sizes (changing the group size alters the proportion of coarse-branched to fine-branched trees changes) and a regression of group size and Coarseness Index was carried out using Minitab. **As an** example, the resulting equation for Sitka spruce is shown below:

$$\text{COARSEIND} = 3.703 - 4.383 \times G_{\text{ha}} + 12.286 \times G_{\text{ha}}^2 - 8.592 \times G_{\text{ha}}^3$$

where

COARSEIND = Coarseness Index

$G_{\text{ha}}$  = Group size (hectares)

A regression of Coarseness Index and brashing time (for the range of intensities of brashing per tree) was then carried out, also using Minitab so that brashing time per tree may be obtained for any Coarseness Index **(4)**.

The number of stems to be brashed **(5)** is the product of the number of stems remaining after the first thinning and the proportion of trees to be brashed. These two values (brashing time per tree and number of trees to be brashed) are passed back to the felling/thinning subroutine where brashing time is incorporated into the thinning time, when a group reaches the age of first thinning.

### 3.6 PRUNING

Pruning operations are a feature of several uneven-aged forests in Britain, most notably Tavistock, where it is carried out regularly in order to obtain the high value Douglas fir which is the main management objective. The pruning subroutine was developed from the results of a work study experiment carried out at the University Experimental Area at Glentress. The pruning equipment was a long-handled pruning saw and a variety of species (Norway spruce, Sitka spruce, and Douglas fir) were included. Measurements were taken for the time to remove a single branch and the diameter of the branch was measured using Vernier Callipers. Also, the branch was placed in a height category (High=>3.5m, Medium=2.5 - 3.5m, Low=<2.5m) and a note was made of whether it was dead or alive. See Appendix C for pruning data.

The numbers in bold type in the following section refer to the diagram summarizing the pruning operation shown in Figure 3.13.

The first step in the pruning subroutine **(1)** establishes the characteristics of the branches being removed. The user is first asked to select medium branches (<30mm diameter) or coarse branches (>30mm diameter). The pruning height must then be chosen **(2)** from the following three categories:

- a) Up to 2.5m
- b) Up to 3.5m
- c) Over 3.5m.

As pruning time increases rapidly with increases in pruning height, the average number of whorls in each section of the stem must be entered (3). The stem sections correspond to the height categories (High, Medium, and Low) described for the pruning experiment. Once these three variables have been selected, the pruning time per stem is calculated (4). A fourth value is actually included in this calculation - the average number of branches per whorl. This has been fixed at 4 in the model, based on the average values from the pruning experiment. Pruning time per group (5) is then simply the product of the pruning time per stem and the number of stems requiring pruning, with an allowance for movement. The number of stems to be pruned is arrived at by assuming that only the trees adjacent to the extraction rack would necessarily require pruning.

Figure 3.13: Sequence of Steps in the Pruning Subroutine

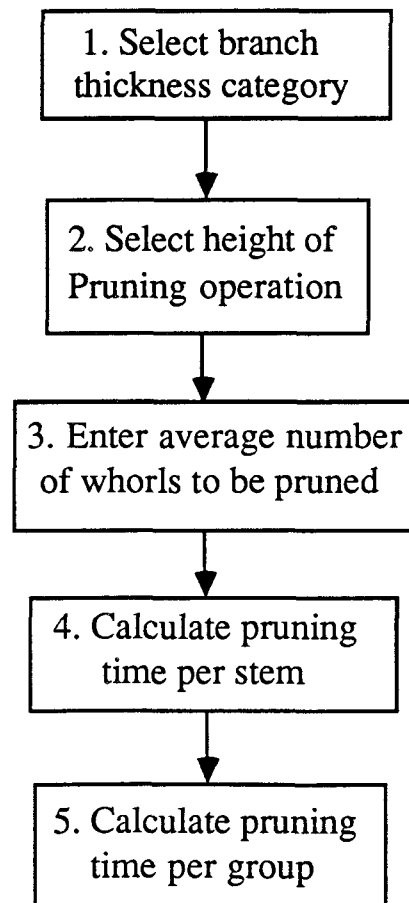

## 3.7 REPLANTING

### 3.7.1 INTRODUCTION

The replanting subroutine is based on the Standard Time table XIV (Forestry Commission, 1980) for replanting trees of any species. The working method is outlined below.

1. Collect trees from plant dump, cull as necessary and tease apart root systems before placing in planting bag.
2. Walk to row to be planted, set up sighting stick and choose first planting spot.
3. Separate the brash etc. and/or screef and make a vertical notch in the ground using the planting tool. Leave the tool in the notch.
4. Take the tree from planting bag and plant it in the notch; withdraw the planting tool, ensure the roots **are** well spread out and the shoot is upright and **firm** as required.
5. Walk to next planting spot and repeat operations 3 and 4. Continue planting until row is complete.
6. Move to next row and move sighting sticks as necessary.
7. Recommence planting.

The first section of the replanting subroutine (summarized in Figure 3.14) establishes the planting conditions on the site by eliciting information on the depth and age of any brash on the site. This information is then used to determine the planting time for an individual tree. The effect on planting times of chopping the brash on the site is included in the model but, unfortunately, the time taken to carry out the brash chopping operation is not included in the model because this is a relatively new operation in British forests and insufficient data were available. Other ground preparation techniques, such as ploughing, were not included because they are not a feasible option for small group working.

Various other assumptions are built into the replanting subroutine rather than being offered as choices for the user. The most important of these is the assumption of a 2.0 metre planting spacing, which was necessary because the yield tables which are applied to the groups when they are harvested are based on a **2.0** metre initial spacing. The second important assumption is that, as with the previous operations, the land is assumed to be flat or gently sloping. The results from the model only apply on slopes up to 30%, because planting times are fairly constant up to this point, then increase rapidly with increase in the slope.

Figure 3.14: Sequence of steps to determine planting time per plant

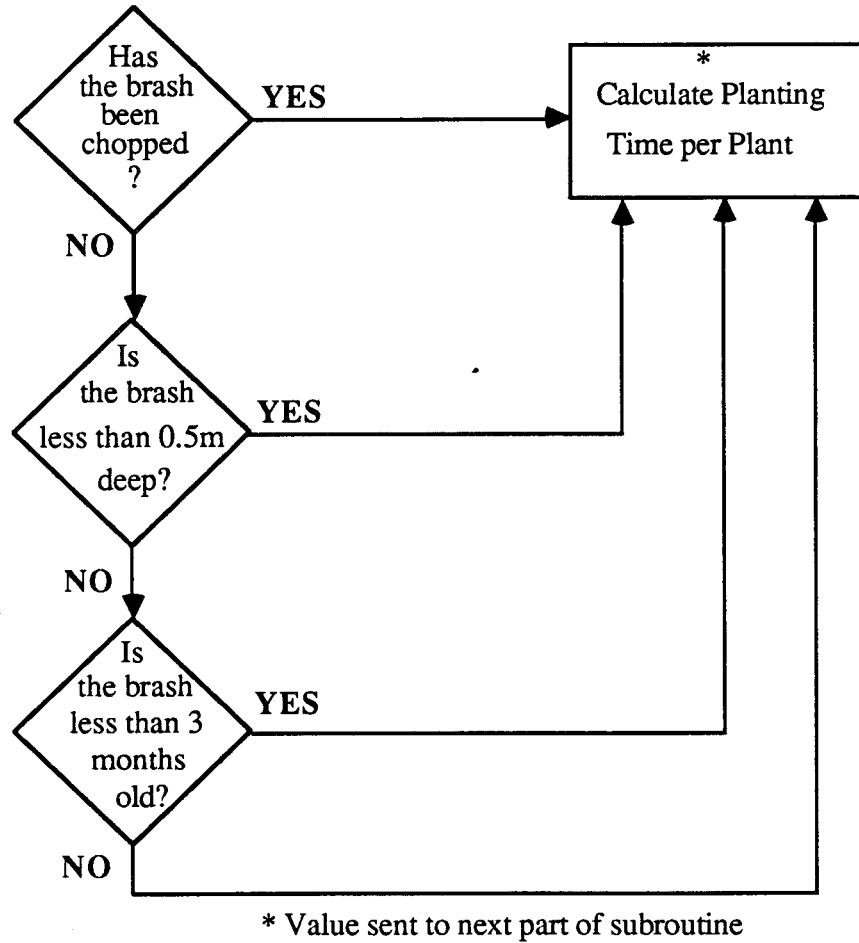
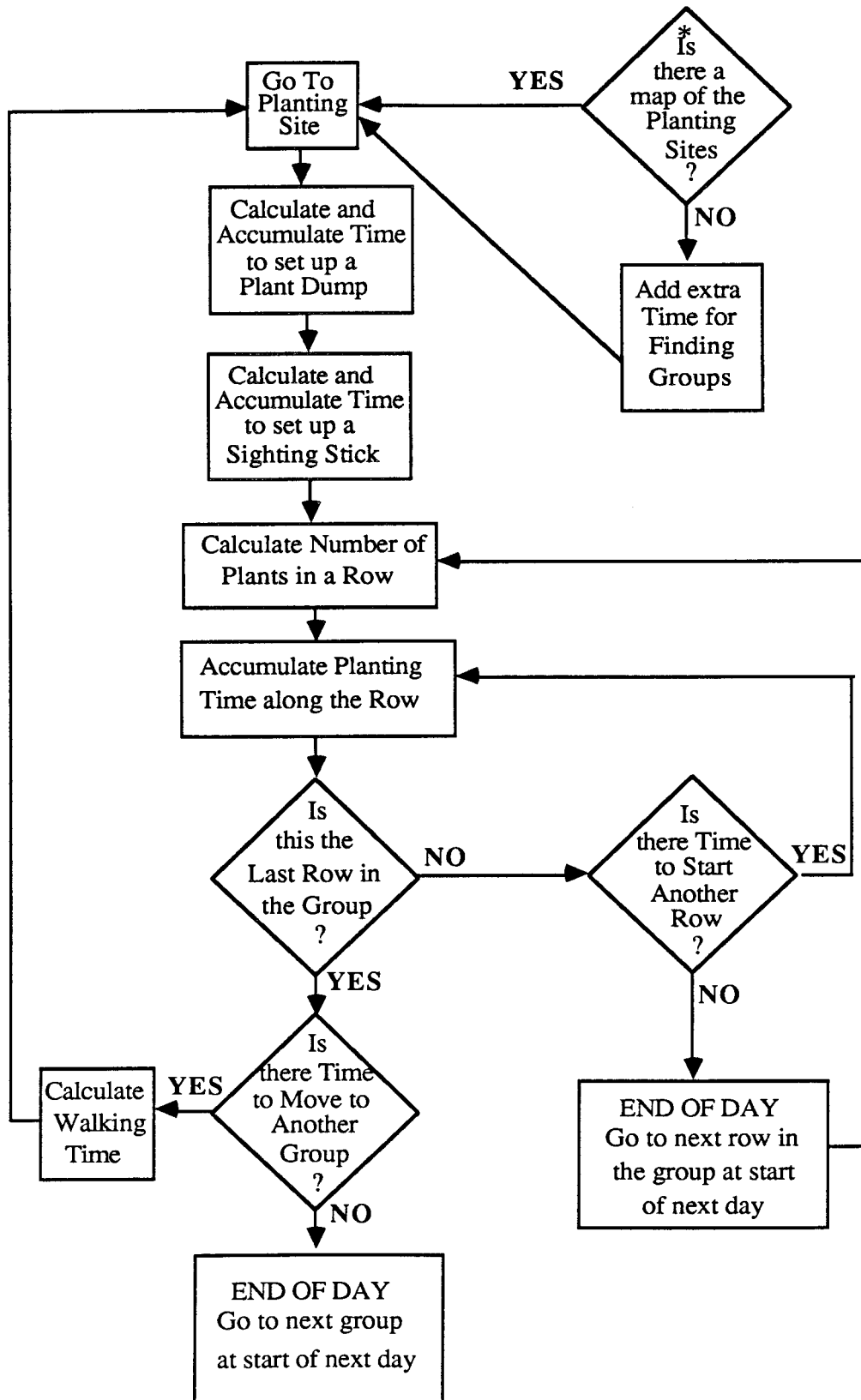

Figure 3.15: Sequence of operations in the replanting subroutine



The actual planting operation is summarized in Figure 3.15 above. Finding the planting sites is likely to be a problem with the group management system, particularly as the group size decreases and the number of groups increases. It may be that a simple map of the block, indicating which extraction racks contain planting sites, would be helpful and reduce unnecessary movement time. This mainly applies when the group sizes are so small that the harvested areas are not necessarily visible from the road, and is offered as an option in the model.

The first step in the planting operation is to set up plant dumps at the planting site, followed by the setting up of a sighting stick, to ensure straightness of the planting rows. The rest of the operation is then treated in a similar way to the felling and thinning operations. The number of plants to be planted in a row is calculated and the planting time is accumulated across the row. At the end of the row a check is made on the time remaining in the day and if there is sufficient time the next row is started. If there is not time to start another row, planting recommences at the next row at the **start** of the following day. This is repeated for each row until the last row in the group is completed. At this point another check is made on the time remaining in the day and if there is sufficient time, the first row in the next planting site (i.e. the next group) is started. If there is not time to start another group, planting begins in the next group at the start of the following day. This sequence is then repeated until all the groups have been replanted.