

Code of Practice
Safety of Loads
on Vehicles

THE LIBRARY
FIRE RESCUE STATION
BORING WOOD
HERTS.

No. 48490



Department of the Environment

HMSO 30p net

~~2~~ Code of Practice

~~HS 490~~
HS490

SAFETY OF LOADS ON VEHICLES

Department of the Environment

/

© Crown Copyright 1972

SBN 11 550261 0

FOREWORD BY THE MINISTER FOR TRANSPORT INDUSTRIES

People are too often killed and injured in accidents caused by badly secured loads falling off lorries. This Code provides very full guidance as to how loads should be secured and needless casualties avoided.

I hope that the Code, which has been drawn up after full consultation with the Road Transport Industry, will be widely used. The public are entitled to expect a very high standard of care. The industry will I have no doubt be anxious to safeguard its own good name.

A handwritten signature in black ink, appearing to read 'M. K. T.', located in the lower right quadrant of the page.

CONTENTS

GENERAL REQUIREMENTS		Page.
Section 1	Introduction	1
Section 2	Statutory Requirements	3
Section 3	The Safety Problem.....	5
Section 4	Basic Precautions	7
Section 5	Strength Requirements of Restraint Systems	11
Section 6	Load Securing Equipment	15

SPECIALISED REQUIREMENTS		
Section 7	Containers	17
Section 8	Pallets	29
Section 9	Engineering Plant	35
Section 10	General Freight	61
Section 11	Timber Loads	69
Section 12	Metal Loads	73
Section 13	Loose Bulk Loads	77

APPENDICES		
Appendix A	Regulations concerning 'Dangerous Goods' carried by road vehicles	79
Appendix B	Do's and Don'ts for drivers and others concerned with the loading of vehicles	80

ACKNOWLEDGEMENTS

The following organisations and departments collaborated in the production of this Code of Practice

National Freight Corporation

Road Haulage Association

Freight Transport Association

Road Transport Industry Training Board

Contractors Plant Association

Federation of Civil Engineering Contractors

Transport and General Workers Union

United Road Transport Union

Society of Motor Manufacturers and Traders

Home Office

Home Office (Police Inspectorate)

Ministry of Defence (Army)

Ministry of Defence (Air)

Military Vehicles and Engineering Establishment (Chobham)

Military Vehicles and Engineering Establishment (Christchurch)

Royal School of Military Engineering

Department of the Environment

SECTION 1. INTRODUCTION

1. The law requires that the weight, distribution, packing and adjustment of the load of a vehicle or trailer shall at all times be such that no danger is caused or is likely to be caused to any person in or on the vehicle or on a road. This requirement is contained in the Motor Vehicles (Construction and Use) Regulations 1969 the relevant extract of which is shown on page 3.

2. The object of the Code is to provide operators, drivers and loading staff with guidance as to the basic safety principles that must be followed generally, and as to some particular precautions that can be taken to ensure the safe carriage of several of the more common types of load. This Code provides a useful range of information based on recognised proven good practice in this field and has regard particularly to the increasingly higher performance capabilities of modern vehicles.

3. Because of the extreme variety of loads, vehicles and operating conditions it is not possible to cover all the circumstances likely to be encountered by operators so the contents of the Code must not be regarded as exhaustive or exclusive. Satisfactory securing methods not mentioned in this Code are no doubt in existence or will be developed in the future. It is essential, however, that their intrinsic safety be judged by the extent of compliance with the basic requirements described herein, which are applicable to all load restraint systems.

4. The adoption of some of the load restraint methods recommended in this Code may necessitate modifications to existing vehicles, eg the fitting of load anchor points. Accordingly their introduction may not be achievable in the immediate future. Until this has been done vehicle operators should ensure without delay that some alternative suitable means is available for securing properly the loads likely to be carried by their vehicles.

5. In addition to the safe loading methods described in this Code extra precautions are necessary when 'dangerous goods' eg toxic and corrosive chemicals and inflammable substances, are carried on road vehicles. A list of the main regulations and instructions

currently applicable to the carriage of these substances is given at Appendix A—others are in the course of preparation by the Home Office.

6. Inevitably, as a result of further experience and the continual development of load securing systems this Code of Practice will need to be periodically reviewed and amended. The first review is likely to be made two years from the date of publication and persons wishing to contribute to improving or adding to its contents should write to:

The Department of the Environment
Vehicle Engineering Division
St Christopher House
Southwark Street
LONDON SE1.

SECTION 2. STATUTORY REQUIREMENTS

**THE MOTOR VEHICLES (CONSTRUCTION AND USE) REGULATIONS 1969
REGULATION 76**

Maintenance and use of vehicle so as not to be a danger

1. A motor vehicle, every trailer drawn thereby and all parts and accessories of such vehicle and trailer shall at all times be in such condition, and the number of passengers carried by such vehicle or trailer, the manner in which any passengers are carried in or on such vehicle or trailer, and the weight, distribution, packing and adjustment of the load of such vehicle or trailer shall at all times be such that no danger is caused or is likely to be caused to any person in or on the vehicle or trailer or on a road:

Provided that in the case of a public service vehicle the provisions of this Regulation with regard to the number of passengers carried shall be deemed to be complied with if the number does not exceed that for the time being permitted by regulations made by the Minister of Transport with regard to the carrying capacity of public service vehicles.

2. The load carried by a motor vehicle or trailer shall at all times be so secured or be in such a position that danger is not likely to be caused to any person by reason of the load or any part thereof falling from the vehicle or by reason of any other movement of the load or any part thereof in relation to the vehicle.

3. No motor vehicle or trailer shall be used for any purpose for which it is so unsuitable as to cause or be likely to cause danger to any person in or on the vehicle or trailer or on a road.

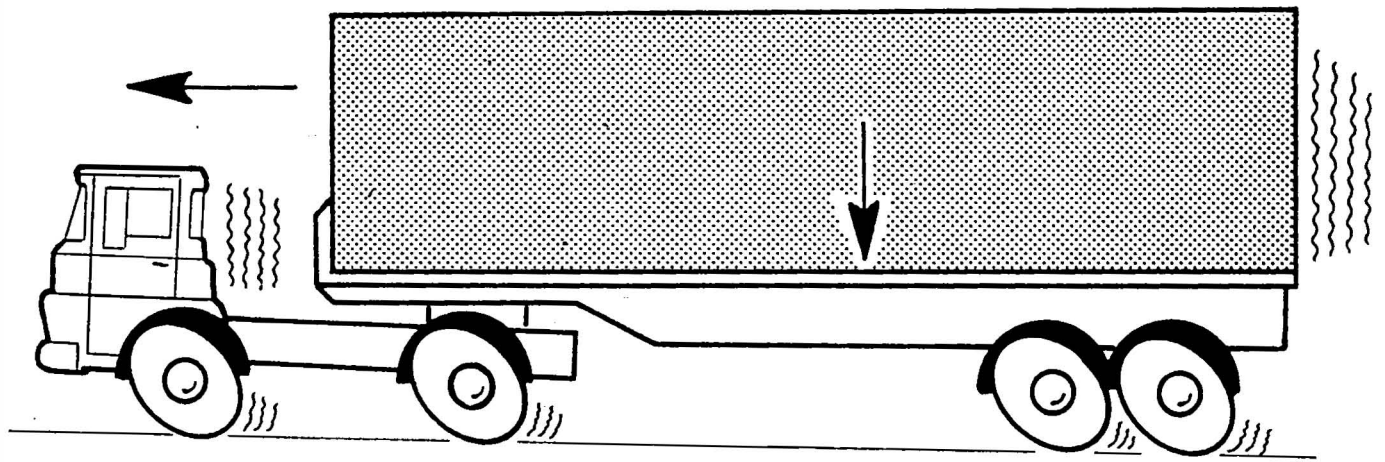

Figure 1

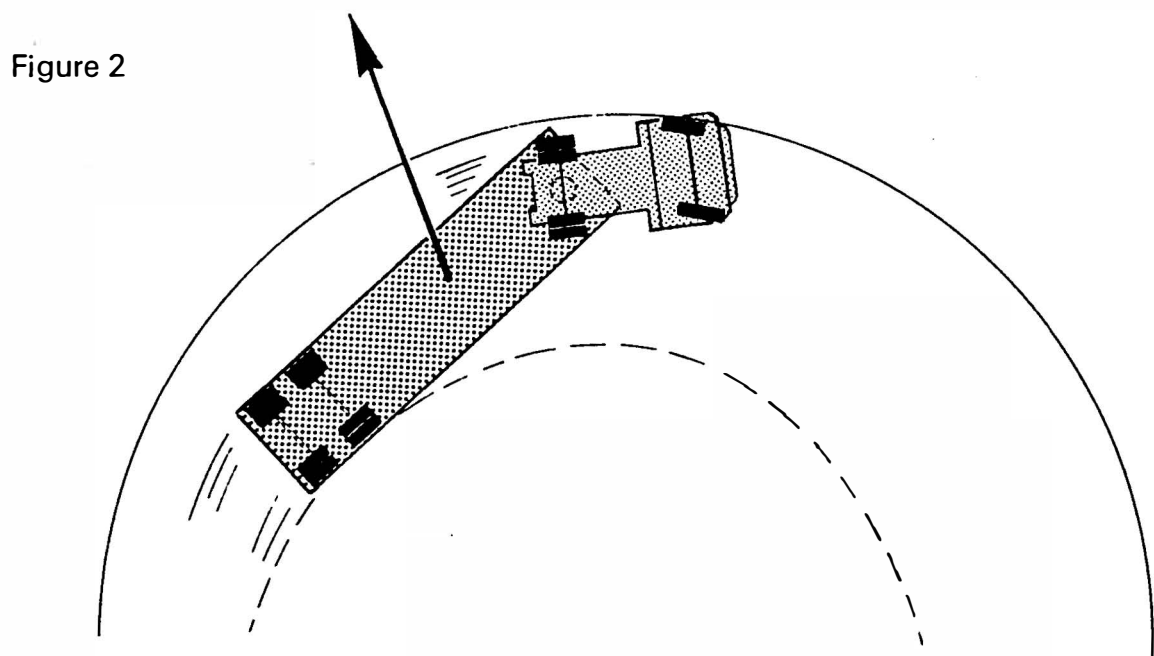

Figure 2

SECTION 3. THE SAFETY PROBLEM

- 1.** Any load carried on a vehicle must be sufficiently restrained to prevent movement under the forces which arise from the vehicle passing over road undulations, when it changes direction or when it is being braked or accelerated (see Figs 1 & 2).
- 2.** The forces involved in restraining the load in braking depend on the deceleration and the weight of the load. Thus, as braking efficiencies and vehicle payloads increase it becomes more important that load restraint should be adequate.
- 3.** The forces involved in restraining a load under braking are not dependent on the speed of the vehicle, and are the same at low speeds and high speeds, in both forward and reverse directions. If, however, a load does move at high speed it will have more energy, and hence will cause more damage.
- 4.** It requires much more force to stop a load which has started moving, than it does to prevent the movement in the first place. It is essential, therefore, that the vehicle is loaded and the load restrained in such a way that no part of the load can move in any direction relative to the vehicle.
- 5.** The total restraint required to accommodate the forces which arise will generally be obtained from a combination of the following:
 - a) Lashings secured to the vehicle chassis including crossbearers, outriggers etc,
 - b) Baulking arrangements including headboards, bulkheads, spigots, transverse beams, shoring bars etc,
 - c) Friction between the load and the vehicle platform
- 6.** A load carried on a vehicle without restraining devices will not be secure because the frictional restraint between the load and the platform of the vehicle will be less than the dynamic forces which tend to move the load. It follows, therefore, that it is necessary to provide additional restraint to prevent the load moving.

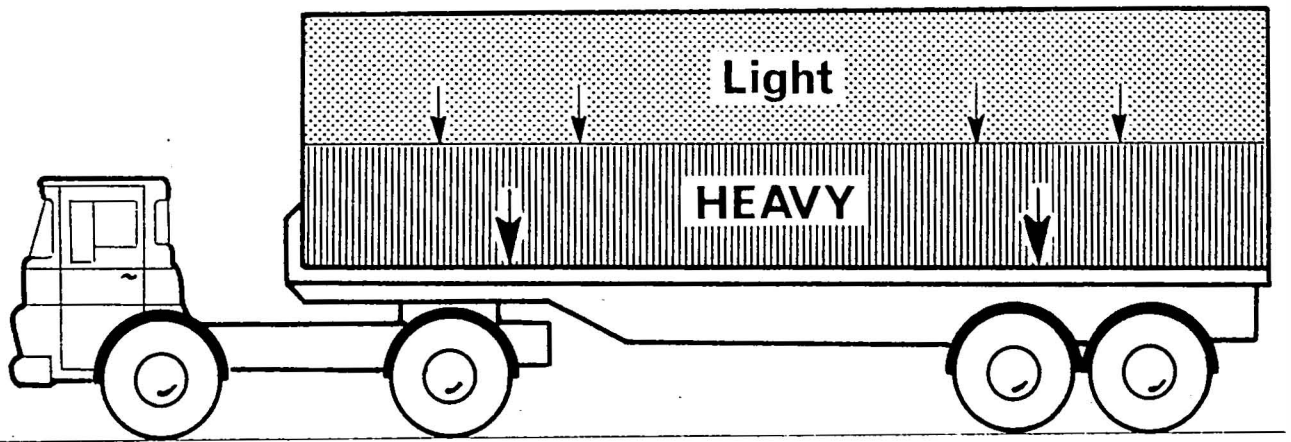

Figure 3

2008

SECTION 4. BASIC PRECAUTIONS

METHODS OF LOAD RESTRAINT

1. The basic concept of the load restraint systems outlined in this Code of Practice is that they should prevent movement of the load under the following conditions:

- forward deceleration of 1.0 'g'
- rearward deceleration of 0.5 'g'
- lateral acceleration of 0.5 'g'

[A deceleration of 1.0g requires that the means of restraint provided to resist the forward motion of the load must be capable of withstanding a force equal to the total weight of the load the vehicle is carrying].

Vertical acceleration may occur but this will be overcome if the above criteria are met.

2. In order that the restraining system is at all times fully effective, it is essential that certain basic requirements are met; these are outlined in the following sub-paragraphs a)-g).

a) In addition to meeting normal statutory requirements applicable to the construction and use of goods vehicles contained in the Motor Vehicles (Construction and Use) Regulations 1969, the vehicle's load space and the condition of the platform must be suitable for the type and size of load to be carried.

b) *Friction.* A slippery platform surface is always dangerous and the aim should be to obtain the maximum advantage from the frictional restraint by keeping both the base of the load and the platform surface as clean, dry and free from grease as possible. Also: (i) metal to metal contact should be avoided, (ii) the use of loose dunnage between the load and the platform should be avoided wherever possible. Where, however, dunnage must be used because of the shape of the load and the need to provide adequate support, this should be selected and secured so as to prevent movement during the journey. Desirably, timber dunnage should be of uniform thickness and maximum possible width. (The minimum width should, where practicable, be twice the thickness and a single layer is preferred to a double layer between the base

of the load and the body deck and also between layers of load, if any).

c) *Baulking*. The front of the load should be abutted against the headboard of the vehicle or an obstacle fitted transversely across the vehicle platform and firmly attached to the chassis frame. Blocks, wedges and scotches may be used to prevent individual items of a load from moving in any horizontal direction. Care must be taken to ensure that these are stout enough and are adequately secured to the vehicle platform.

d) *Load Anchorage Points*. The number of anchor points fitted and used and their strength should be based on the principles outlined in Section 5 of the Code. In the case of those existing vehicles, where the provision of such anchorage points is impracticable, adequate load restraint must be achieved by other available means including baulking. Anchor points which are secured to wooden members only may not be strong enough to provide the restraint required.

e) *Lashings*. The lashings or fastening devices, chains, cables, clamps, etc, should be in a sound condition and must be capable of transmitting all the forces likely to be induced in them. The following requirements should be met: (i) The lashing or fastening devices must be properly tensioned at all times, and checked en route, so as to avoid the load moving on the vehicle platform, and to keep it firmly abutted against the obstacle referred to in Paragraph 2c above. Over-tensioning of the fastening which might subject them to undue strain and weaken them should be avoided. (ii) The restraining system should be so arranged that the failure or slackening of a single component does not render the remainder of that system ineffective. (iii) It is important to ensure that lashings which provide forward restraint are as near to the horizontal as possible, and never at more than 60°, since the stress level rises sharply as the lashing approaches the vertical. (iv) Lashings must not contact any sharp edges on the vehicle or the load.

f) *Sheets*. Except in the case of very light bulk loads, conventional sheets (tarpaulins) should be regarded as providing no more than weather protection and the load must be independently restrained against movement. Purpose made load sheets embodying webbing straps are available, however, and are satisfactory up to their rated load capacity provided the straps are secured to body attachments of equivalent strength and preferably to anchorage points of the type described in Paragraph 2d above.

g) Ideally the securing system should be tamper proof and should be so arranged that it cannot be accidentally released by vibration or movement of the load while the vehicle is in motion.

3. All items of loose equipment, dunnage etc, must be securely restrained when not in use wherever they are placed.

LOAD DISTRIBUTION AND ARRANGEMENT ON VEHICLES

4. The first priority with any load is to keep within legal axle load requirements, and if the load can be placed against the headboard this should be done provided the vehicle's

handling is not impaired. If the load cannot be placed against the headboard, baulking must be used.

5. The load should be spread to keep the centre of gravity as low as possible. Where the load is stacked, larger and heavier items should be placed at the bottom (see Fig 3).

6. If possible the vehicle should be loaded to give an even weight distribution over its floor area.

7. In order to maintain lateral stability, the centre of gravity of the load should be on the centre line of the vehicle or as near to it as possible.

8. It is better for heavier items to be carried on the centre line of the vehicle than at the sides.

9. Heavy, solid items should where possible be placed in front of light, crushable ones.

10. A high load will seriously affect the stability of the vehicle, and may cause it to overturn when cornering. It is imperative, therefore, that this type of load should be carried on vehicles with a low platform whenever possible. The overall height of a loaded vehicle must be checked to ensure that it is less than that of any overhead obstruction likely to be encountered en route.

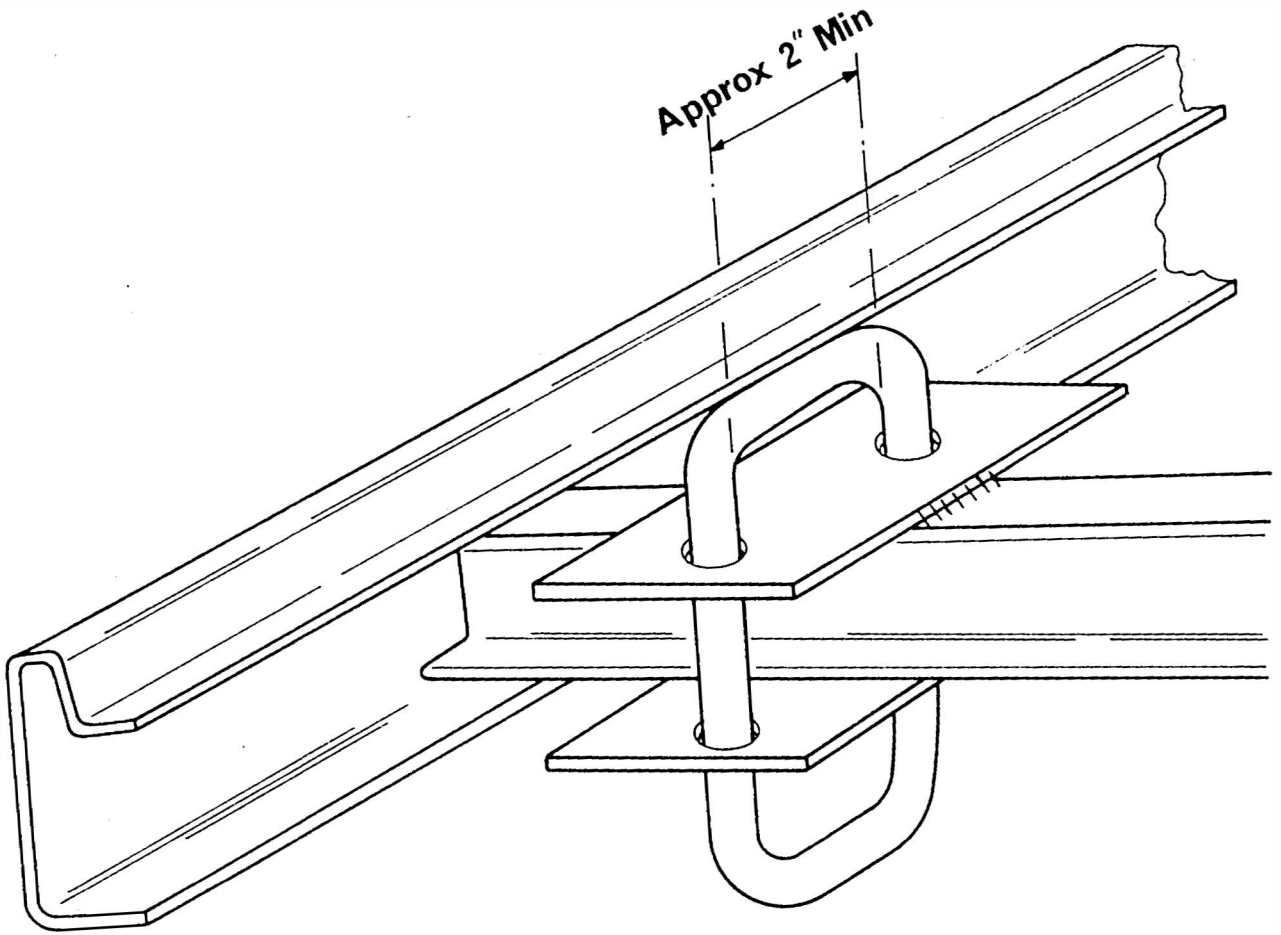

Figure 4

SECTION 5. STRENGTH REQUIREMENTS OF RESTRAINT SYSTEMS

1. In Section 4, it has been stated that the load restraint system must be capable of preventing movement of the load under the following conditions:

- a) forward deceleration of 1.0 'g' (emergency braking)
- b) rearward deceleration of 0.5 'g' (braking when reversing)
- c) sideways acceleration of 0.5 'g' (side forces produced when cornering).

FORCES INVOLVED

2. The forces resulting from these deceleration/acceleration factors, which must be safely contained by the load restraint system, are greatly increased if the load is allowed to move relative to the vehicle (ie the 'battering ram' effect) and the restraint system must be designed, constructed and used in such a way as to prevent this.

3. Because this ram effect increases rapidly with the increase in distance through which the load moves relative to the vehicle, it is hazardous to locate loads away from the headboard or other fixed abutment unless the means used for load restraint are adequate to prevent such movement under the conditions described in Paragraph 1 above. Failure of the load restraint system in these circumstances could result in the load developing sufficient impetus to demolish the headboard or other abutment with potentially serious consequences.

4. Provided movement of the load relative to the vehicle is prevented, the forces to be contained by the load restraint system are as follows:

- a) forward—equal to the payload (1.0 'g')
- b) rearward—equal to *half* the payload (0.5 'g')
- c) sideways—equal to *half* the payload (0.5 'g').

LOAD RESTRAINT

5. As indicated in Section 3, Paragraph 5, the forces involved in restraining a load from

movement will normally be provided by:

- a) Lashings secured to anchor points.
- b) Baulking arrangements, including headboards, bulkheads, spigots, transverse beams and shoring bars which are securely attached to the vehicle.
- c) Friction between the load and the vehicle platform.

In most circumstances it will be appropriate to obtain half the total restraint required from a) and the remaining half from b) or from b) and c).

ANCHOR POINTS

6. Traditional rope hooks and the method by which they are attached to the vehicle structure cannot be relied upon for the safe restraint of other than light loads. For this reason, platform vehicles in particular should be equipped with load anchorage points, so designed and integrated into the structure that the maximum forces likely to be imposed on them are transmitted to the main chassis frame of the vehicle.

7. Load anchorage points should be standardised at Safe Working Load (SWL) of 0.5 tons, 1.0 tons or 2.0 tons, as may be required to suit the type and payload capacity of the vehicle and the nature of the load to be carried. The SWL of each point should be clearly indicated on the vehicle and the design and construction must be such as to have a safety factor of twice the SWL, acting in any direction through which the lashing can be attached.

8. While no specific recommendations are made about the form of load anchorage points, save that they must satisfy the prescribed strength requirements and be suitable for use in combination with the type of load securing equipment to be employed (see Section 6), Fig 4 illustrates a suggested anchorage point of 2.0 tons load capacity. In the particular case of 0.5 tons capacity anchorage points, a hook form may in some cases be more convenient and is acceptable subject to the above conditions being met.

9. Sufficient load anchorage points should be provided in relation to platform length, with a minimum of *six* or such greater number as is necessary to ensure that the sum of the SWL of the anchorage points is not less than the maximum payload capacity of the vehicle. Thus a 3-ton payload vehicle would require at least six points of 0.5 tons SWL capacity. In the case of higher payloads, the number of anchorage points and their capacity will also depend on whether the vehicle is purpose-built for a particular type of traffic or is to be engaged in general haulage operations where the size and weight of individual items may vary considerably. Thus an operator of a 20-ton payload vehicle used exclusively for a particular commodity might need to choose between specifying 40×0.5 ton points, 20×1.0 ton points or 10×2.0 ton points, depending on the character of the load. On the other hand, the general haulier with a similar vehicle used for miscellaneous loads would in all probability need six or more 2.0 ton points plus enough 1.0 or 0.5 ton points to make up at least the required 20 tons of restraint. Here again the precise pattern

would depend upon his foreknowledge of the types of load to be carried.

10. The number of these anchorage points used on particular journeys will depend on the weight and dimensions of the load actually being carried and its location on the platform in relation to the headboard or other additional means of restraint.

11. When it is feasible to modify existing vehicles to include anchor points, their mounting must in no way weaken the chassis/body structure. In particular, no holes may be drilled in the top or lower flanges of the chassis sidemembers, and welding to the chassis without the approval of the original manufacturer is not recommended.

HEADBOARD

12. Headboards must be capable of withstanding a horizontal force uniformly distributed over the vertical area equal to half the rated payload capacity of the vehicle. The headboard should also meet the following requirements:—

a) Width should be at least equal to the width of the cab, and for preference should be equal to the width of the loading platform.

b) Height will depend on the kind of load the vehicle is designed to carry and must be sufficient to obstruct forward load movement during deceleration unless adequate load restraint is provided by other means, but should at all times be a minimum of 2ft. 6in.

c) When loads such as metal bars, beams, pipes, girders, sheet metal, etc, are liable to penetrate the cab of the vehicle in the event of failure of the securing devices, the headboard must be adequately reinforced.

d) When a trestle type headboard or bolster is fitted behind the driver's cab for the purpose of supporting long loads, the trestle or bolster must be capable of resisting the combined effect of two forces each equal to half the permissible payload acting forwards and downwards through the top of the trestle or bolster.

13. In the case of closed vans of 3 tons Gross Vehicle Weight (GVW) or more where the driver's cab is integral with the body, the transverse bulkhead behind the driver must be the full height of the load compartment and of sufficient width to afford adequate protection. Such bulkheads should be designed to resist a uniformly distributed horizontal force of $1/5$ of the payload or 1 ton whichever is the greater.

OVERTURNING

14. The height of the centre of gravity of a load is critical in helping to prevent vehicles overturning. It is therefore essential that this should be kept as low as possible at all times.

SECTION 6. LOAD SECURING EQUIPMENT

- 1.** The selection of the means for securing a load on a platform will depend to a large extent on the type and construction of the load to be carried. Clamps, special bolts, steel wire rope, chains, webbing straps, cordage and when used with van bodies, shoring bars, are all suitable devices. Cordage, however, whether made from natural or synthetic fibre should be used with care as its strength cannot readily be assessed and it can be seriously weakened by age, wear or incorrect use.
- 2.** Purpose-made clamps are suitable for loads eg containers where special lifting pockets, brackets or attachments are fitted to the loads. In most cases it will be necessary to reinforce the deck of the vehicle in the vicinity of the clamp position. The design of the clamp and reinforcement should be carried out in accordance with the recommendations of the vehicle manufacturer. Where clamps are used a minimum of four should be fitted and three of these must be strong enough to restrain the load if one clamp fails to function correctly.
- 3.** Steel wire rope made up into special strops or slings is suitable for securing a load when used in conjunction with other suitable devices eg shackles or thimbles. The strength of the steel wire rope will depend on the quality of the steel used, the number of strands, the number of wires in each strand, the diameter of the rope and the method of construction. The rope should be free from rust and there should be no broken wires or strands. Each length of wire rope used should have a safe working load compatible with the strength of the vehicle's anchorage points eg for 2 tons anchorage points a safe working load of 2 tons is required, and its diameter should not be less than $\frac{5}{16}$ ". This gives a safety factor of 2:1 approximately and whilst it is realised this is not in accordance with BS 302 (1968) it is considered satisfactory for load security. Other coupling equipment used with the rope must be of corresponding material quality and strength. Sharp bends will reduce the ropes effective strength.
- 4.** Chains are also suitable for lashing loads when used in a similar manner to steel wire rope. Three properties determine the strength of a chain: the length of its links, the quality of metal used and the thickness of the links. A chain with a given link diameter

and material will possess varying strengths depending upon the length of the link. The longer the link the weaker the chain—long links can be easily deformed if they are tensioned over a corner. The chain used should be compatible with the strength of the vehicle's anchorage points eg for 2 ton anchorage points a safe working load of 2 tons is required. This means that the diameter of the links should not be less than $\frac{3}{8}$ " (steel). It is considered this gives a safety factor adequate for load security purposes. The use of iron chain is not recommended.

5. Where hooks, shackles, rings are incorporated in the lashing system they should have a safe working load and safety factor compatible with that of the restraint system used. They should preferably comply with the following British Standards, where appropriate:

Steel Hooks	BS 2903 – 1970
Shackles	BS 825 – 1949
Rings	BS 781 – 1950

6. Purpose-made lashing harnesses and nets are also available for securing loads and containers. These are generally manufactured from synthetic fibre materials such as nylon or Terylene made up into a webbing. The harnesses may also consist of webbing straps with some form of snap hook at either end and a tensioning device. Care should be taken to ensure that the metal components of the harness do not become corroded or damaged, that the webbing is not cut and that all stitching is sound. These lashing devices should only be used for applications approved by the manufacturers.

7. Rope may be made up from synthetic or natural fibres such as nylon, hemp, manilla etc. It should however be borne in mind that rope made from natural fibre will stretch when dry allowing the load to move. When wet, it is liable to shrink with the risk of damaging the load and jamming the anchor points. The breaking strength of a new rope will depend upon the material used and its method of construction, the diameter of the finished rope and any manufacturing treatment to which it has been subjected. It is extremely difficult to assess the strength of used rope. Knots, sharp bends, water saturation will reduce the effective strength of a lashing and due allowance must be made for these factors when selecting a rope. When wet, rope should always be allowed to dry naturally before use. When purchasing, a good quality rope must always be specified.

8. In general, the method of securing any load must obviously be decided by the type of load. It is therefore strongly recommended that operators equip themselves with the correct type of securing equipment for the type of load carried, and where general cargoes are carried various types should be made available.

SECTION 7. CONTAINERS

1. The majority of containers in use are constructed to International (ISO) or British (BS) standards and are of the type shown in Fig 5. A feature of all ISO and BS containers is that they are equipped with specially designed corner castings which are provided for lifting purposes and as a means of securing the container while it is being transported.

2. There are also a number of containers in use which are not built to ISO or BS standards. Some of these containers may be fitted with corner castings or have lashing rings attached to their sides as shown in Fig 6 or they may be equipped with both types of fitting. Other containers may be secured by specially designed clamping systems.

3. Safe methods for the carriage of containers will therefore vary according to the type being transported and the securing attachments provided on the carrying vehicles.

4. As mentioned above ISO/BS containers are fitted with a casting at each corner and this enables them to be securely attached to the carrying vehicle by means of specially designed locking devices known as 'twist locks' (see Fig 7). A vehicle properly equipped for carrying containers has twist locks built into its structure at appropriate spacings to line up with the corner castings on the container(s) which it is designed to carry. Provided the twist locks are then fully engaged and properly locked the container may be regarded as being secure.

5. Containers equipped with corner castings should, except in unavoidable circumstances always be carried on vehicles fitted with twist locks. If the container is carried on a vehicle without twist locks the following precautions should be taken.

CONTAINERS CARRIED ON VEHICLES NOT EQUIPPED WITH TWIST LOCKS

6. As explained elsewhere in this Code a load carried on a vehicle without the use of restraining devices will not be secure because the frictional restraint between those parts of the load in contact with the platform of the vehicle will not always prevent it moving when the vehicle is braked or changes direction. It follows therefore that a container

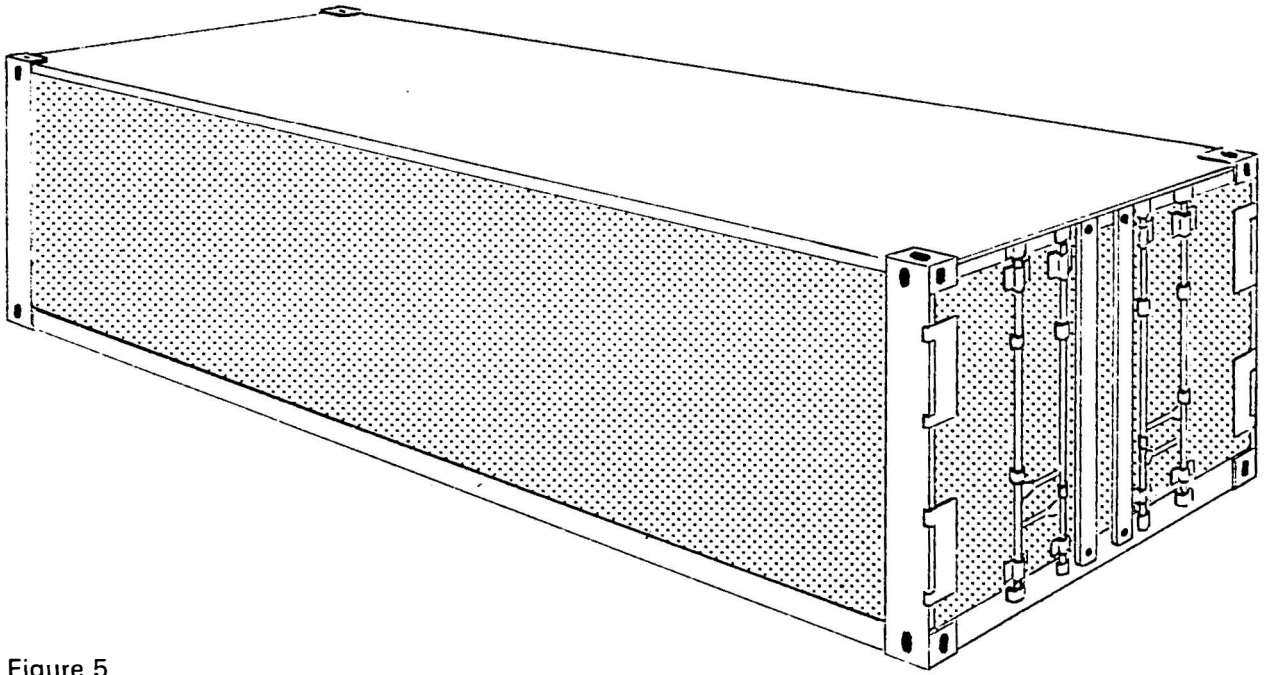

Figure 5

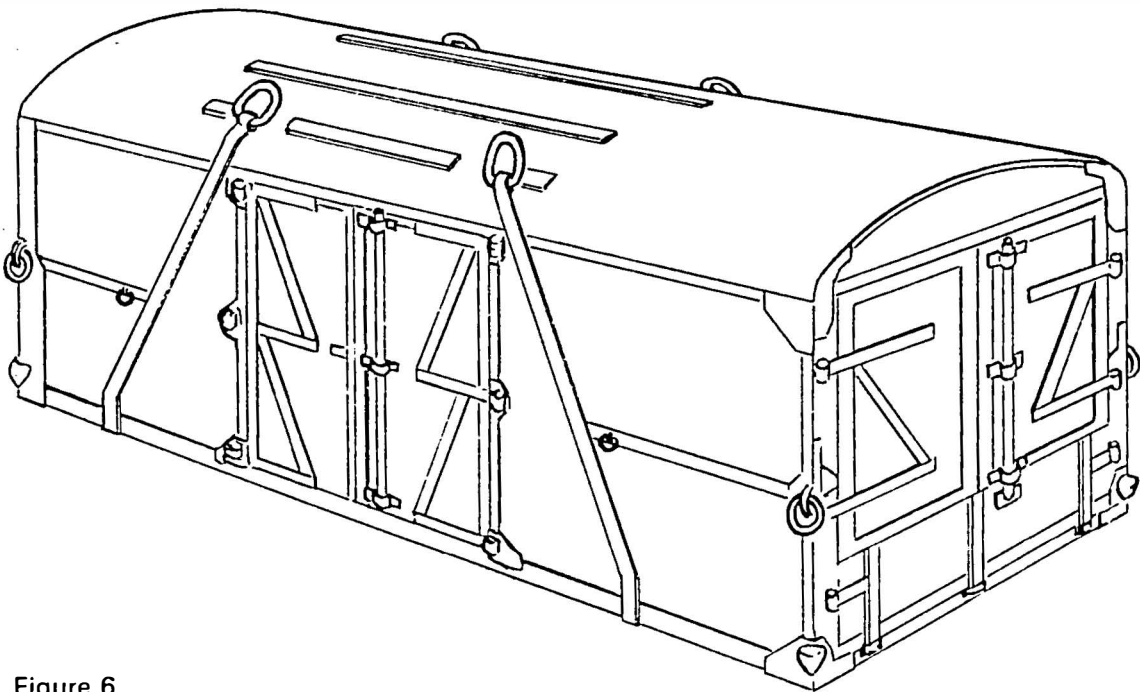

Figure 6

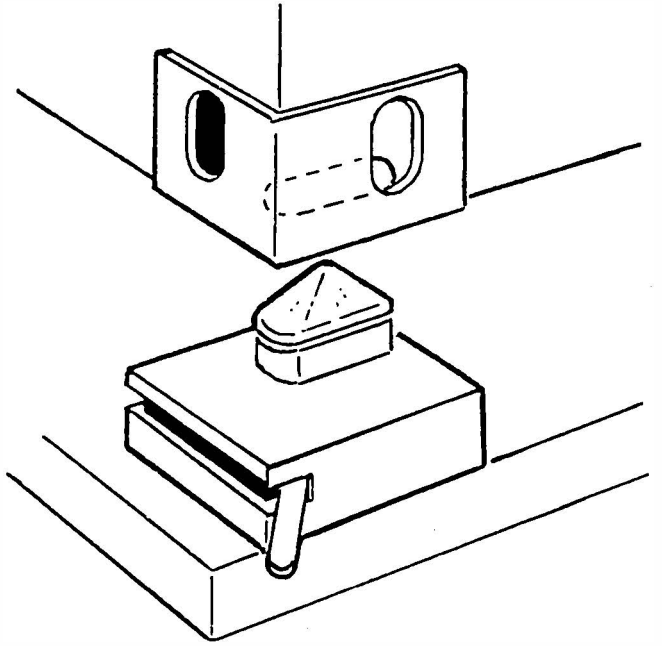
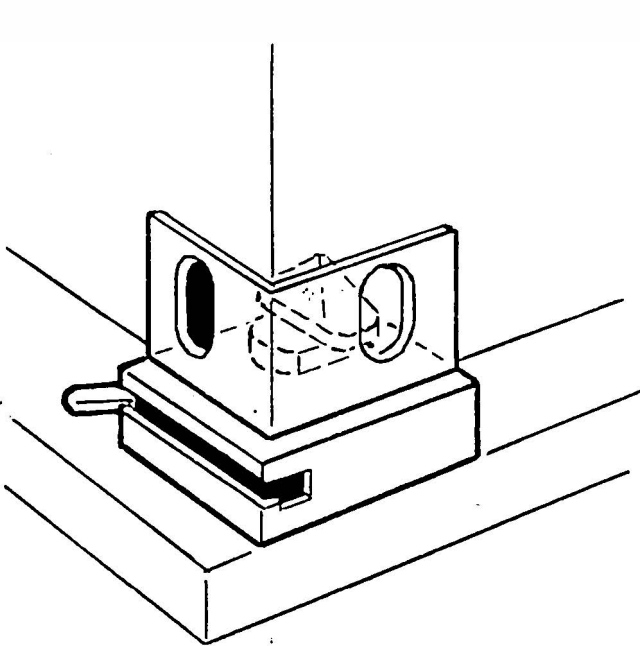
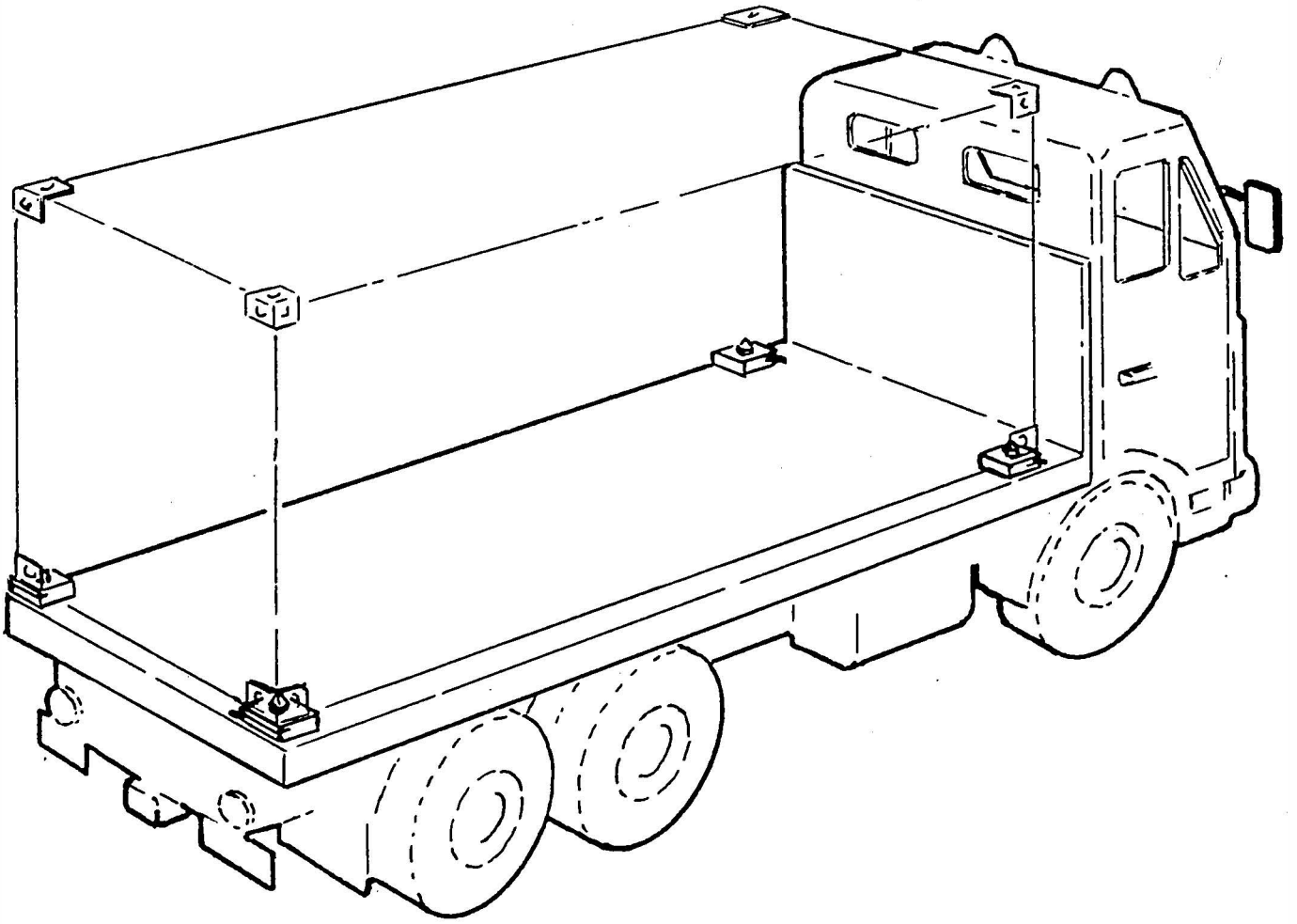

Figure 7

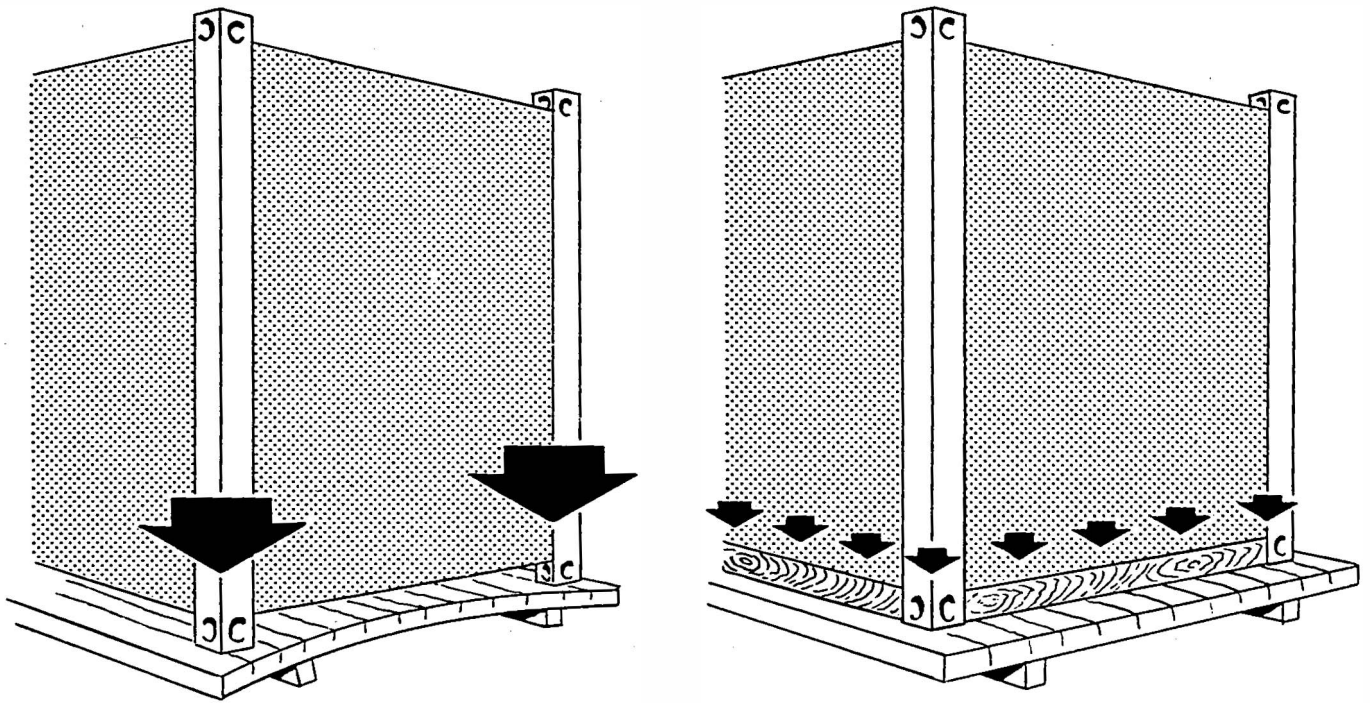
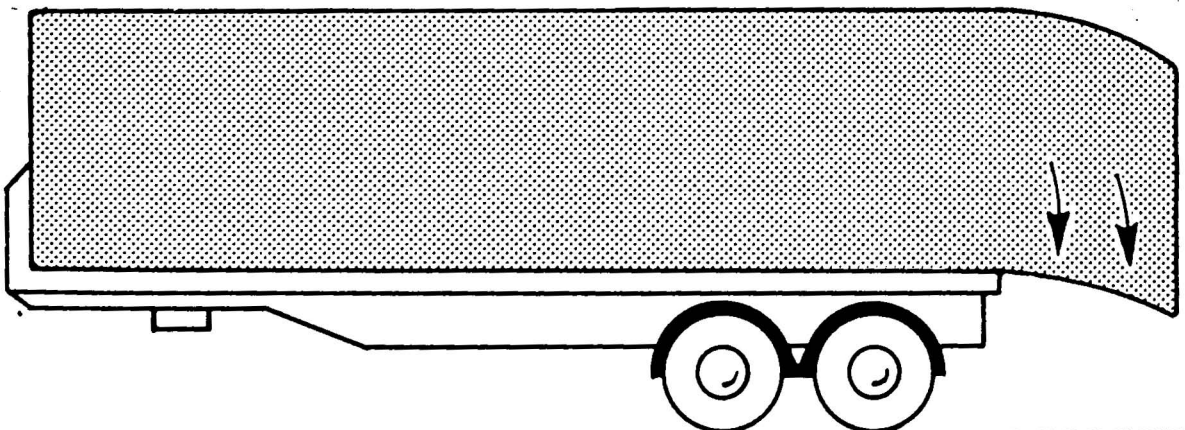

Figure 8

Figure 9



requires means of restraint to prevent it moving on the vehicle.

Loading arrangement on vehicle

7. The container should be located so that it is in contact with the headboard of the vehicle; alternatively where no headboard is fitted or where it is necessary to set back the container from the front of the vehicle in order to obtain the correct weight distribution then an equivalent restraint should be provided. This should be in the form of a baulking member sited transversely across the vehicle platform and securely attached to the chassis.

8. In order to obtain the maximum advantage from the frictional restraint it is necessary to avoid as far as possible the use of dunnage interposed between the container and vehicle platform. The container should therefore be accommodated within the side raves or carried on a vehicle without side raves. In those circumstances where the use of dunnage is unavoidable it is essential that the timber is of uniform thickness and of maximum possible width (the minimum width of the timber should be at least twice the thickness and not more than one layer should be used).

9. Containers built with corner castings which stand proud of the container base will require to be positioned on thin dunnage around their periphery to avoid excessive load concentration on the vehicle platform from the container corner castings (see Fig 8). The container should not project beyond the rear of or the sides of the vehicles loading platform, because permanent distortion may take place if part of its base is left unsupported; in addition the stability of the vehicle may also be affected (see Fig 9).

Securing points on the container

10. Lashing or securing devices used should only be attached to those fitments on the container intended to facilitate its lifting or mechanical handling when laden, ie lashing rings or corner castings. These fitments should be examined to ensure that they are in sound condition, and all the fitments on the container should be used to secure it to the vehicle platform.

Anchor points on vehicle

11. The number of anchor points used will be decided by:

- a) The need to position the container to achieve the correct load distribution.
- b) The extent with which other load restraint features are incorporated in the design of the vehicle.
- c) The load of the container to be carried.

However there should never be less than four anchor points used in any circumstance ie two per side.

12. It is essential that the loads transmitted by the securing devices shall be finally absorbed by the vehicle's chassis frame. Anchorages must therefore be fixed securely. Wood screws are quite unsuitable for this purpose. Each anchorage should be capable of

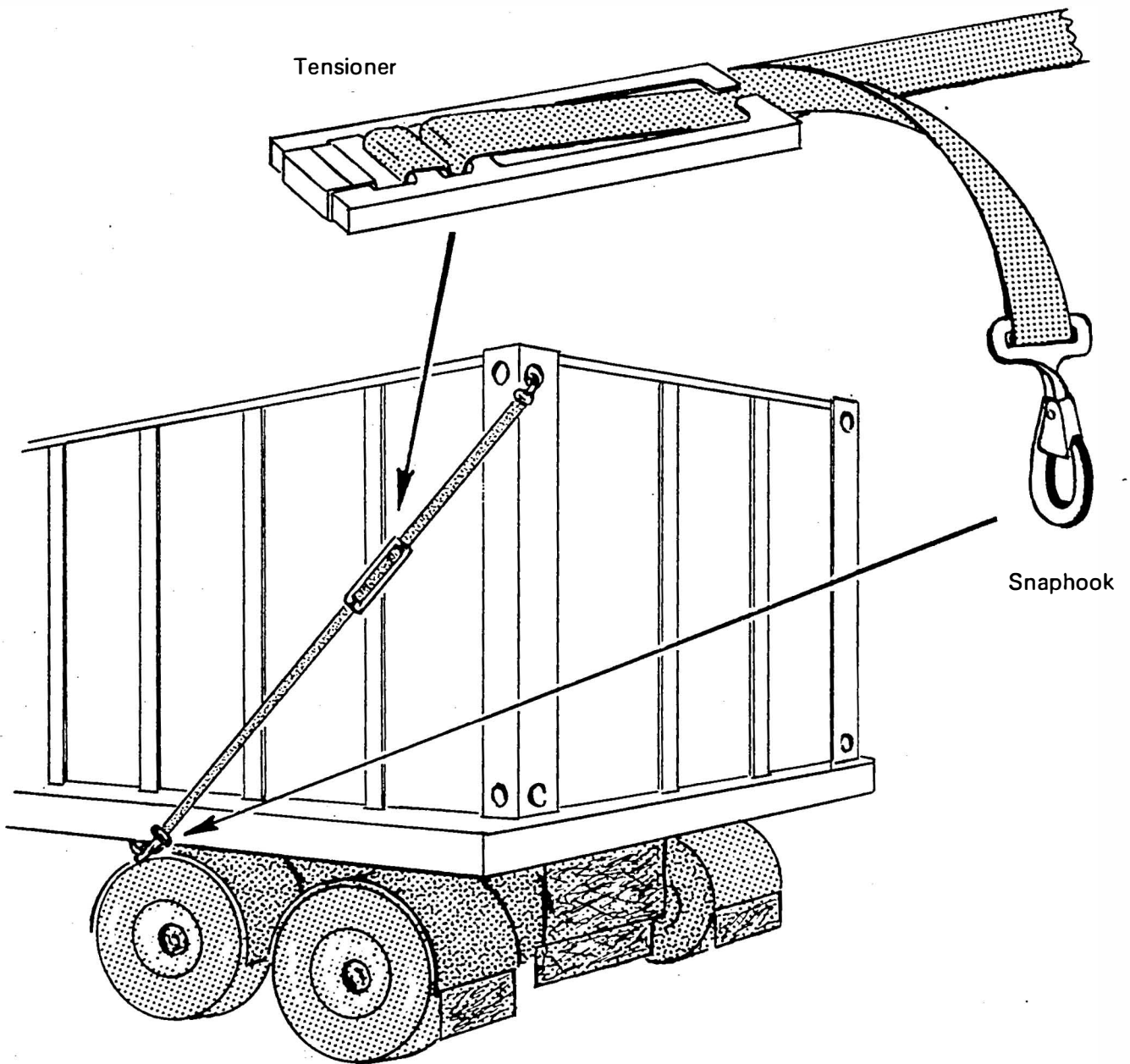

Figure 10

withstanding its rated capacity acting in the direction of the side members within an included angle of 10° to 60° to the horizontal. To achieve this it may be necessary to strengthen cross members by the use of stays or bracing secured to the vehicle's chassis. **Rope hooks are not strong enough for anchorages and must on no account be used for this purpose.**

Securing devices

13. The selection of the means for securing a container will depend to some extent on the type and construction of the container to be carried. Clamps, special bolts, steel wire rope, chains, and webbing straps are all suitable devices. The use of cordage, whether made from natural or synthetic fibre, is not recommended as its strength cannot readily be assessed and it can be seriously weakened by age, wear, or incorrect use.

14. Purpose-made clamps are suitable where special lifting pockets, brackets or attachments are fitted to the container. A minimum of four clamps should be used and three of these should be strong enough to restrain the container if the other clamp fails to function correctly. In most cases it will be necessary to reinforce the deck of the vehicle in the vicinity of the clamp position, ensuring the loads are transferred to the vehicle chassis. The design of the clamp and the reinforcement should be carried out in accordance with the recommendations of the vehicle or trailer manufacturers.

15. Steel wire rope, chains, and other associated equipment, eg shackles, thimbles and tensioners are suitable for securing a container. The required strength of these items will depend on the amount of restraint the lashings are required to provide bearing in mind any other load restraining features incorporated in the vehicle's construction. Selection and use of these devices should be based on the principles contained in the Sections 5 and 6 of this Code.

16. Chains and steel wire rope will normally be used with tensioners or turnbuckles. Care should be taken that these are adequately tightened and are checked once the vehicle has travelled a short distance. They should not however be over tensioned as this can cause the chain or rope to be overloaded and possibly fail.

17. Purpose-made lashing harnesses are also available for securing containers. These are generally made from nylon or Terylene made up into webbing. A typical application of a harness is shown in Fig 10. The selection of these devices should be based on the principles contained in the Section 6 of this Code. The lashing devices should only be used for applications and in the manner approved by the respective manufacturers.

18. It is important to ensure when using the lashing devices referred to in the previous paragraphs that the angle of the lashing does not exceed 60° from the horizontal, since the load on it increases sharply as it approaches the vertical position. The lashing has not lost any of its strength but it has come under a much greater stress.

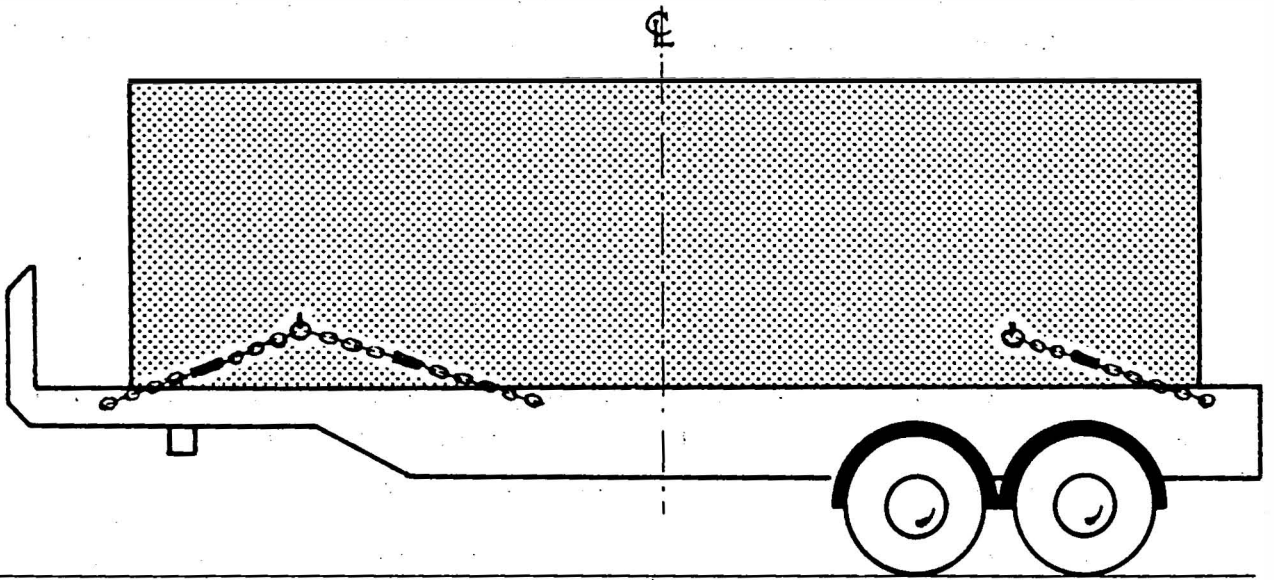

Figure 11

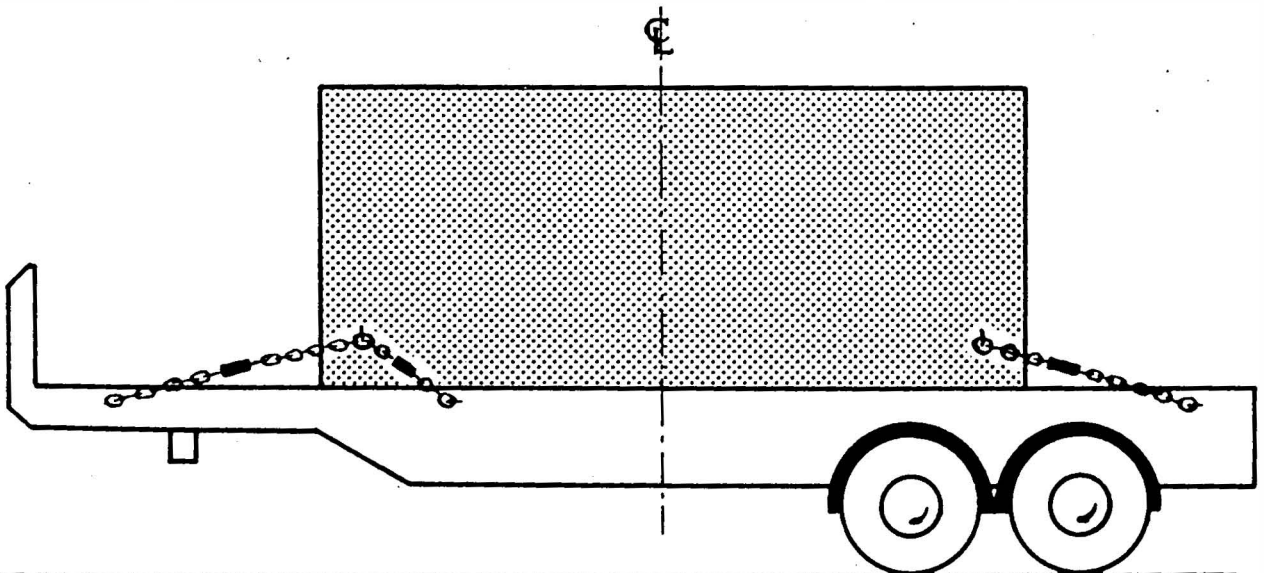

Figure 12

Suggested container tie-down schemes

19. Figs 11 and 12 illustrate a securing arrangement for a container fitted with lashing rings. The container is secured to the vehicle from the four lashing rings to six anchorage points on the vehicle in such a manner that two chains at each side provide forward restraint, and one rearward. It should be noted that the angle of the chains does not exceed 60° from the horizontal for the reasons given earlier.

20. Suitable tie-down schemes for containers fitted with corner castings only and carried on a vehicle not fitted with twist locks are shown at Figs 13 and 14. The following points should be noted:

- a) The container must be set firmly in contact with the vehicle headboard. possible because the container has to be set back from the headboard to comply with the load distribution requirements then an equivalent restraint must be provided.
- b) The container must be restrained by chains or similar securing devices from the top corner castings as shown. The bottom corner castings should not be used for this purpose.
- c) The chains or other securing devices must be properly tensioned.
- d) Since the corner castings on the container stand proud of its base thin dunnage must be used between the base and the vehicle platform.

LOADING ARRANGEMENT WITHIN CONTAINERS

21. Incorrect loading of a container may result in dangerous situations occurring when the container is handled or transported; in addition serious damage may be caused to the goods carried. In many instances the driver or vehicle operator will have no control over the packing of a container nor indeed be able to inspect its contents when he accepts it for movement. However the following basic principles should be followed whenever possible. If it is then apparent that the container has not been safety stowed then it should not be accepted.

22. If a container is unevenly loaded with its centre of gravity offset towards one side or one end then there is a risk of it tipping when lifted. When it is loaded on the vehicle there is a risk that the vehicle's axles will be incorrectly loaded and the stability of the vehicle adversely affected.

23. Inadequate stowing arrangements within the container may result in the load shifting, which again may cause a dangerous situation to occur.

24. The following general stowage rules which affect road safety should always be observed:

- a) Light goods should be stowed on the top of heavy goods (see Fig 3 on page 6).
- b) A container should be filled so that the weight of goods is evenly distributed over

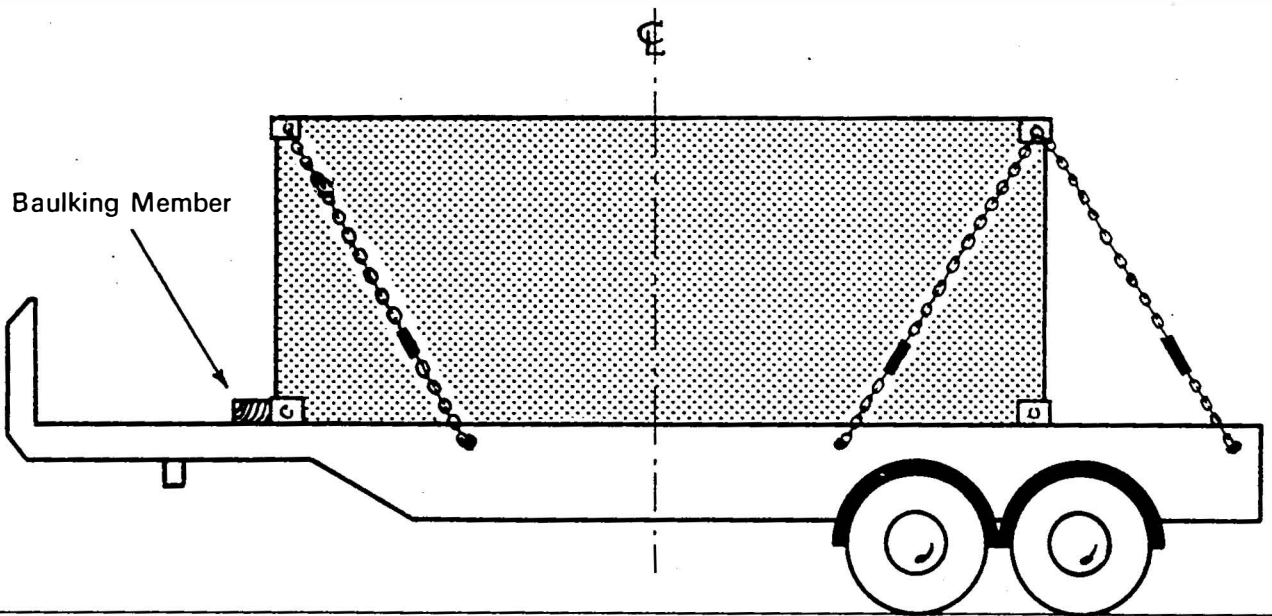
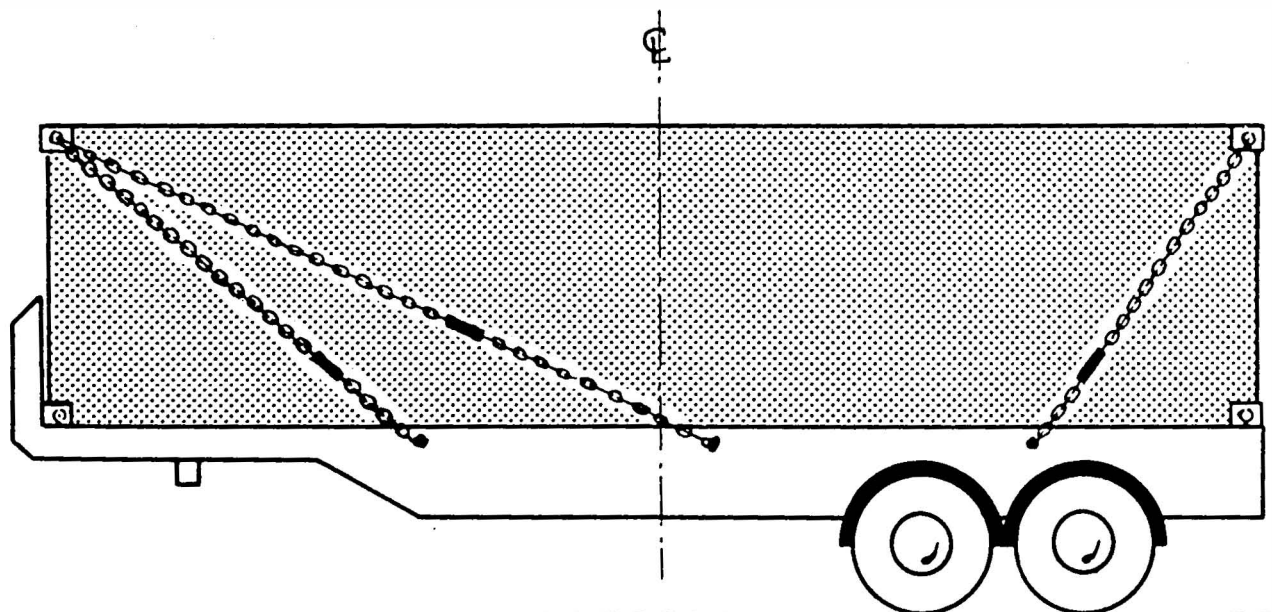

Figure 13

Figure 14



the floor area.

c) If the container is not fully stowed the goods already stowed should be strutted or otherwise restrained (see Fig 15).

d) If the container is fully loaded the internal securing arrangements must be suitable to restrain the full mass of the load.

Figure 15

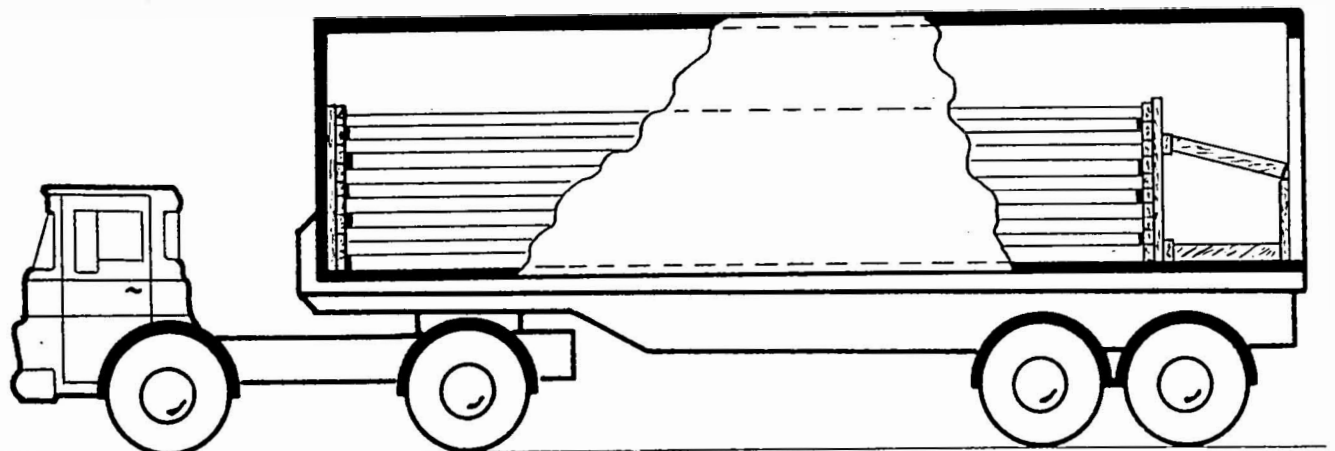

SECTION 8. PALLETS

1. Pallets represent a two-fold problem from the point of view of security of load. First there has to be considered the stability of the items stacked on the pallet and then follows the security of the pallet on the vehicle platform. In the case of small containers and cased machinery, usually only the second factor need be considered, and the load securing requirements for pallets equally apply.

2. There are two basic types of pallet; those which have a number of horizontal bottom members in contact with the vehicle platform, and those supported by corner legs and feet. Pallets themselves have a two-fold role, in that they enable individual articles to be handled mechanically and also enable goods of similar nature and size to be made up into unit loads. In both cases the effort generally required to handle and transport them is considerably reduced. Because of the wide variations in the weight and sizes of pallets, situations will arise when the full cargo space cannot be utilized, without either exceeding the permitted gross weight of the vehicle or its individual axle weights. This free cargo space will enable the pallets to move when they are subjected to the forces arising when the vehicle is in motion, either braking or cornering.

3. Before loading on any goods vehicle, it should be ascertained that the pallets themselves are of sufficient strength to withstand satisfactorily the load they carry and that they are in a good state of repair.

BASIC SAFETY PRINCIPLES

4. The frictional restraining force between the base of the pallet and the deck of the vehicle is related to the weight of the pallet and the nature of the two surfaces in contact. Surfaces with low frictional properties, eg wet greasy wooden platform, or where there is metal to metal contact, will give relatively low restraining forces. Even where there are surfaces with higher frictional properties in contact, it is possible for the pallets to be moved by the forces arising during normal braking and cornering manoeuvres. In order therefore to prevent this movement, additional means of restraining the pallets should be used.

Maximum
Payload
by weight

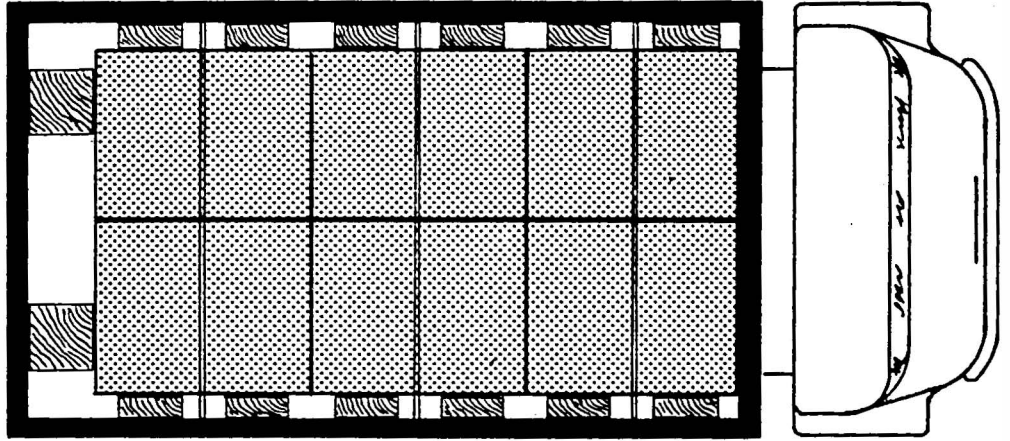

Figure 16a
6 Pallets

Vehicle fitted with side and tailboard

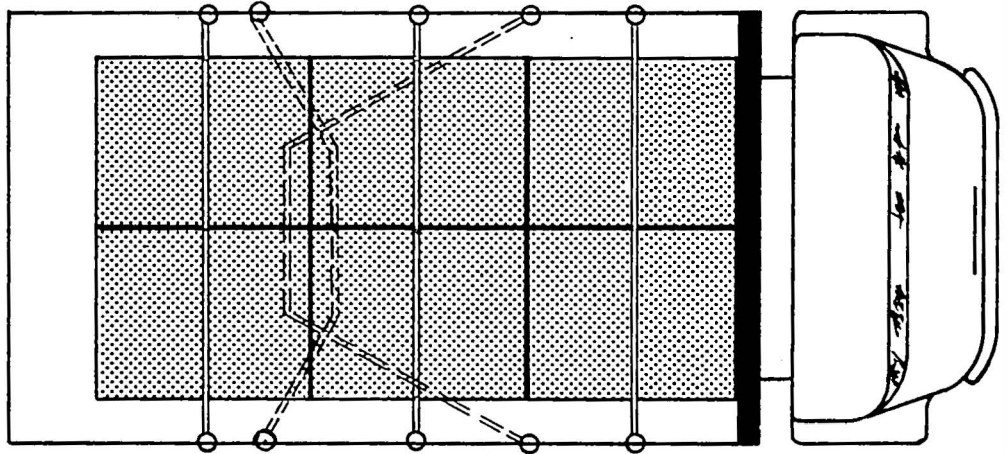

Figure 16b
6 Pallets

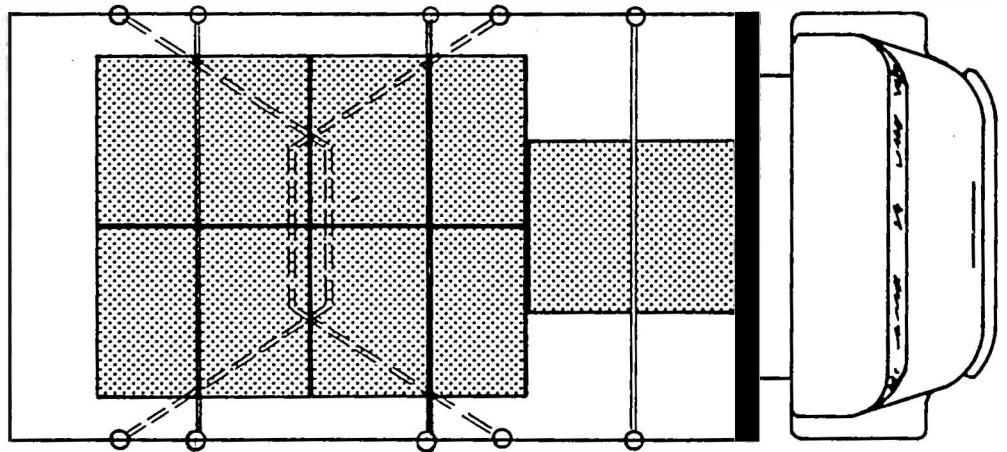





Figure 16c
5 Pallets

-  Anchor Points
-  Vertical Restraint
-  Horizontal Restraint
-  Chocks

5. Where pallets are carried in vehicles with van bodies or with fixed or drop sides, it will still be necessary to provide additional restraints for the pallets if there is space between them or between the pallets and the vehicle sides or headboard. This is necessary because, if there is space for the pallets to move when the vehicle is braked or is cornering, they could develop sufficient momentum to break through the side or headboard.

6. In order to utilise the full payload capacity of the vehicle, it may be feasible to stack palletised loads. This method of loading will introduce an additional risk of some of the upper layer of pallets falling from the vehicle if not adequately positioned and secured. Unless the upper pallet is supported by that underneath—independent of the load on it—the contents of the lower layer must be of sufficient structural strength to take pressure on its top without being distorted.

7. Since the restraining devices may of necessity envelope the load on the pallet, it follows that the individual items in the load must themselves be firmly secured to the pallet if they are not to be dislodged when the vehicle is in motion. Movement of the load on the pallet may lead to a failure of the restraint system attached to that pallet and those adjacent to it. Bagged items tend to settle under vibration to fill air spaces between the bags, thus loosening any strapping.

8. The following additional provisions apply to the movement of all types of palletised loads.

a) The arrangement of the pallets on the vehicle must be such that the maximum permitted gross vehicle weight and axle weights are not exceeded.

b) Wherever feasible pallets should be 'closed up' to the headboard and each other.

c) Unless the pallets are adequately constrained by the body, sideboards and headboards of the vehicle, additional means of restraining the horizontal and vertical movement of the pallets should be provided.

d) The pallets should be so positioned that the load is balanced across the vehicle.

e) Where the load space is not fully utilised and where weight distribution is a problem, pallets should be placed along the centre line of the vehicle.

f) When part of the load is removed from the vehicle care must be taken that the remaining pallets do not cause the vehicle's maximum axle weights to be exceeded or its lateral stability to be impaired.

g) Where pallets are stacked on open platform vehicles, restraining devices must be used to prevent movement of each layer of pallets carried. Tarpaulin sheets and covers are not adequate by themselves for this purpose.

RESTRAINT DEVICES AND MATERIALS

9. A variety of materials may be used for restraining pallet loads. These include chains, steel wire rope, rope, and specially designed nets, or webbing strapping made up into

Maximum
Payload
by weight

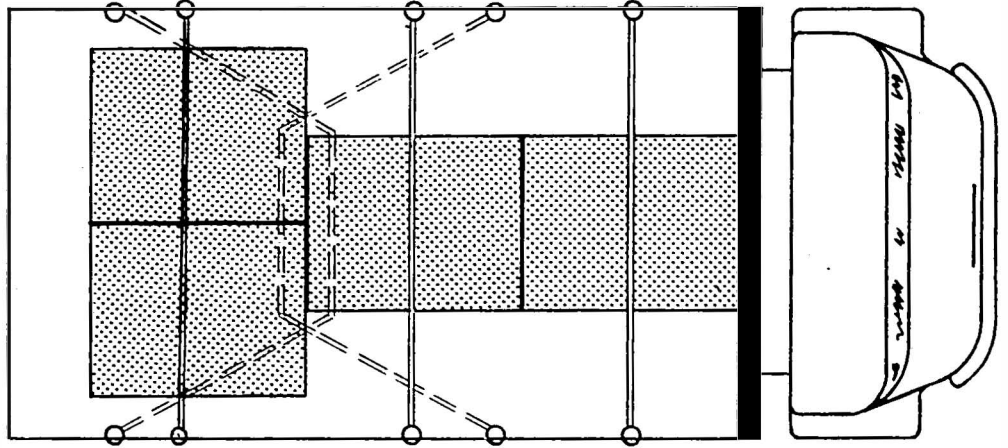

Figure 17a
4 Pallets

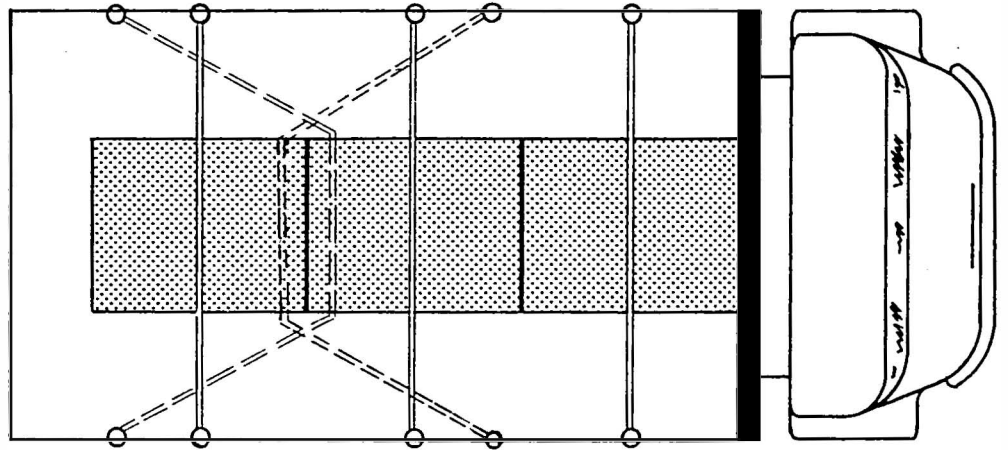

Figure 17b
3 Pallets

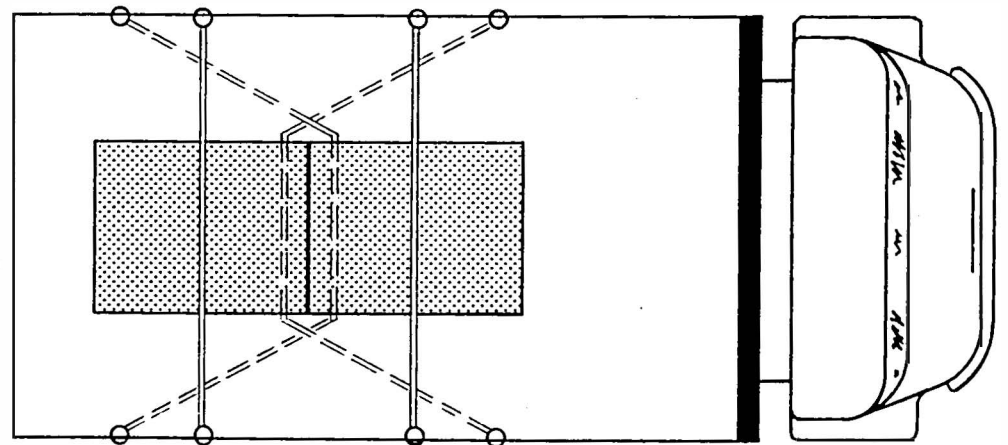
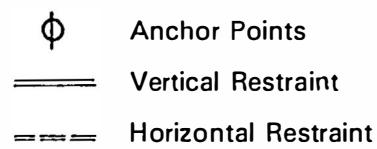

Figure 17c
2 Pallets



a harness or bands.

10. Although the metal restraining devices are stronger, they are less convenient to use and require to be used with end attachments such as shackles, thimbles, etc and unless the load is adequately protected, it will be damaged resulting in permanent distortion of the load and slackening of the restraint.

11. Where rope is used, knots must be correctly made and the lashing scheme so arranged that failure of one length of rope does not lead to failure of the entire lashing. It should be borne in mind that rope made of natural fibres will stretch when dry, allowing the load to move, and when wet it is liable to shrink, with the risk of damaging the load and jamming the securing points.

12. Commercial webbing and strapping is available which is designed specifically for lashing palletised loads to vehicles. These straps incorporate quick fastening/release hooks and tensioning devices, and may include an anti-chafing sleeve. The webbing is usually made of synthetic fibres and has the property of being slightly elastic in use which prevents the load from 'working' loose.

13. The following points should be considered when selecting webbing type restraint equipment for use with palletised loads.

a) In general construction, the assembly should be adjustable in length, incorporate a tensioner, have an overall length when reeved of approximately 18' and be provided with a hook and keeper at each end.

b) The hook and keeper, which should be made of steel, should be suitable for hooking on to $\frac{1}{2}$ " or $\frac{7}{8}$ " diameter rod, or rings of inside diameter $1\frac{1}{2}$ " if formed of $\frac{1}{2}$ " diameter rod, or 2" inside diameter if formed of $\frac{7}{8}$ " diameter rod. Rubbing plates should be provided if there is a risk of the webbing chafing where it passes through the hook and keeper. A keeper should be fitted to prevent accidental release of the hook.

c) The webbing should be at least of $1\frac{3}{4}$ " width, the stitching should be sound and webbing ends should be properly heat sealed.

d) The tensioner should be of a simple type preferably without loose parts. It should be capable of being readily operated by one man and be capable of taking up a minimum of 3" of slack webbing. It should include some means to prevent it releasing the tension when subjected to vibration from the motion of the vehicle.

LOADING ARRANGEMENTS

14. Pallets of Similar Weight. Light pallets may fill the load space of the vehicle before it is loaded to its maximum payload capacity. In these circumstances the pallets may be disposed uniformly over the vehicle's platform. If the vehicle has adequate sideboards and headboard and it is only carrying one layer of pallets, it may only be necessary to position chocks between the outer rows of pallets and the headboard, and the sides and tailboard of the vehicle to provide sufficient restraint. Loading diagrams which illustrate

arrangements for various pallets of equal weight are shown in Figs 16 and 17. The principles illustrated apply to all vehicles likely to be used for this purpose.

15. *Pallets of Differing Weights.* There will be occasions when vehicles are obliged to carry a number of pallets of widely differing weights. Because of these large variations, it is not practicable to show loading patterns for every possibility. However, certain principles should be observed and these are outlined as follows:

- a) The maximum permitted vehicle gross weight and axle weights must not be exceeded.
- b) The lateral stability of the vehicle must be maintained, ie pallets of near equivalent weight as possible should be loaded in pairs across the vehicle.
- c) If possible, it is better for the heavy pallets to be carried on the centre line of the vehicle than around the sides, but this will depend on the proportion of light and heavy pallets. In any event, as stated, the vehicle must be balanced laterally.
- d) Pallets should be closed up as far as possible. If this is not practicable suitable baulking between pallets should be provided.
- e) The pallets should preferably be positioned with their long sides along the length of the vehicle, as there is then more stability under braking forces.

RESTRAINING METHODS

16. The restraining method adopted will depend on the type and size of the vehicle, the position and number of anchor points and the size, weight and number of pallets in the load. However, the following principles should be followed for whatever scheme is chosen:

- a) Vertical and tipping motions should be prevented by a restraint placed across the top of the pallet load.
- b) Forward and rearward movement should be prevented by restraints passed through the base of the pallet wherever possible.
- c) The restraints whether across the load or through the pallet base should be so positioned to prevent sideways movement of the pallet.
- d) The pallet restraining device should not be attached to or passed under the strapping or binding used to secure the load to the pallet.
- e) Cross lashings must be such that each pallet of the top layer has at least one cross lashing. Any pallet which is above the general height of the load should have at least two cross lashings.

17. Chocks may be used in some cases to assist in restraining the load. If the sideboards, headboard or tailboard are sufficiently strong and the pallets occupy all the vehicle's platform space then chocks alone may be sufficient to restrain the load horizontally, but some vertical restraint may be necessary.

SECTION 9. ENGINEERING PLANT

1. This section is intended to provide guidance on the measures necessary for the safe movement of tracked and wheeled engineering plant by vehicles constructed to comply fully with the Motor Vehicles (Construction and Use) Regulations 1969, and thereby permitted unrestricted use of the roads. It does not deal with the carriage of motor cars, or caravans on specially designed transporters or the carriage of large machines on special purpose vehicles whose use on the road is restricted by current regulations. However, the general advice contained in this section is still applicable.

2. Heavy engineering plant is normally transported on purpose-built vehicles which are specifically designed to provide easy loading and unloading facilities and are adequately provided with means for securing the load when the vehicle is in motion. Lighter engineering plant may in some circumstances be carried on general purpose vehicles. However, in these cases the method of securing the load should be at least as secure as that obtaining with the purpose-built vehicles.

BASIC SAFETY PRINCIPLES

3. When a vehicle is carrying a load such as a wheeled or tracked vehicle, the load will be subjected to forces during the motion of the vehicle which will tend to cause it to move. These forces will arise when the carrying vehicle is braking, accelerating, cornering, or moving over an undulating or rough surface.

4. In addition to the movement of the complete load there is a risk in some instances that part of the equipment (eg booms, superstructure) may have freedom of movement and this can lead to dangerous situations arising when the vehicle is in motion and the load is subjected to the forces mentioned earlier.

5. When a wheeled or tracked vehicle is positioned on the carrying vehicle and not lashed down it is restrained from movement solely by its own rolling resistance and its brakes if applied. Further restraint may be provided by the frictional resistance between the deck of the vehicle and any part of the equipment being carried which has been

loaded so that it is in contact with the vehicle deck.

6. Additional restraints must be provided since even in normal driving situations the restraints outlined above are inadequate. These additional restraints should take the form of a lashing system and some arrangement whereby the load is prevented from moving either forward or to the rear by an obstacle (or obstacles) securely fixed to the vehicle which butt against the wheels or tracks or some other part of the equipment carried.

7. High loads may endanger overbridges and when these are carried the instructions contained in the pamphlet 'High Loads', available from the Department of the Environment or the Trade Associations must be followed. Since loads with a high centre of gravity will seriously affect the vehicle's stability such items of engineering plant should only be transported on vehicles with a low platform.

GENERAL SAFETY PRECAUTIONS

8. The following precautions should be taken when carrying engineering plant on a road vehicle.

9. The consignor of the plant in consultation with the hauliers should, if possible, ensure that the engineering plant is dismantled as far as is necessary to keep its overall dimensions within the length and width limits of the carrying vehicle. Where this is not possible then care should be taken that the conditions and restrictions contained in the Motor Vehicles (Construction and Use) Regulations 1969 and the Motor Vehicles (Authorisation of Special Types) General Order 1969 concerning the carriage of wide or long loads are complied with where applicable.

10. All moveable assemblies on the engineering plant such as jibs, buckets, booms, slewing superstructures and cabs etc., must be left in the position recommended for transportation by their manufacturers and must be secured to prevent movement relative to the main body of the machine.

11. The fuel tanks of petrol-engined machines being transported should only contain sufficient fuel for the machine to be manoeuvred if necessary under its own power during the loading and unloading operations.

12. The loaded machine should be inspected after the vehicle has been driven for a short distance in order to check that no movement has taken place and that restraining devices are still secure. Periodic inspections should be made during the course of the journey.

13. The adjustable restraining system should be so arranged that failure or slackening of one component does not lead to the failure or reduction in the effectiveness of the remainder. Restraints must not be passed round or fastened to items that are able to move relative to the base machine.

14. The brakes of the machine should be applied. In addition the machine unless fitted with an air clutch should be left in gear provided that it is impossible for the engine to be accidentally started in this condition. Bags, tool kits, or heavy objects should not be left loose in the operator's cab in such a way that they can move control levers, etc.

LOADING ARRANGEMENT ON THE VEHICLE

15. The positioning of the engineering plant and any of its detached assemblies must be so arranged that the legal axle weight limits are not exceeded and the safe-handling of the vehicle is not impaired. The clearance between the undersides of low-loading vehicles and the road surface should be checked before moving off. Where there is a danger of 'grounding'—for example, on an uneven railway crossing—the ground clearance must not be less than six inches.

16. The machine should be positioned on the carrying vehicle's platform so that forward movement is prevented either by part of the main body of the vehicle, eg swan neck step or headboard or by an attached transverse member securely attached through the platform to the vehicle's chassis frame.

17. All removed items from the superstructure or chassis of the machine such as buckets, grabs, blades, shovels and lifting appliances should be secured to the deck of the vehicle.

18. Wheeled and light tracked machines should be restrained so that the effect of bouncing caused by road shocks transmitted from the carrying vehicle and amplified by the machine's tyres or suspension units is minimised. Where possible the suspension unit of the machine should be locked and vertical movement limited by lashings or other means of restraint.

19. The full contact area of the equipment's tyres, tracks or rolls should rest on the platform or extensions to the platform of the carrying vehicle.

20. All the wheels or rolls of the machine should be prevented from rolling or sliding relative to the deck of the vehicle.

21. The machine should be restrained against forward, backward or sideways movement by adjustable restraining devices attached to anchor points on the vehicle.

22. The overall height of the loaded vehicle should be checked before it is driven on the road. Although correctly stowed the machine's overall height may have changed since last transported through changing positions of its components, eg repositioning of pivot pin positions. It is also possible that a different vehicle will have a different platform height.

23. With the engine turned off the pressure in a machine's hydraulic system should be relieved by moving all control levers through all positions when the machine is stowed. This operation should be done at least twice.

ANCHOR POINTS ON THE VEHICLE

24. The principles to be followed when deciding on the strength, number, and position of anchor points to be fitted to a vehicle are as described in Section 5 of this Code. The anchor points should be fixed securely to metal members of the chassis and should be capable of transmitting all the forces imposed on them to the main chassis frame of the vehicle.

25. Each anchor point should be capable of withstanding a force of at least 2 tons acting in any direction through which the lashing can be attached.

26. In deciding the number of anchor points to be used when devising a restraint system, the following factors should be considered:

- a) The need to position the machine to achieve the correct load distribution to meet the legal axle load requirements and to ensure that the vehicle's handling is not impaired.
- b) The extent to which other load restraint features are incorporated in the design of the vehicle.
- c) Whether the machine has wheels, tracks or rolls.
- d) The weight of the machine to be carried.

However, there should never be less than four anchor points used, ie two per side.

RESTRAINING DEVICES

27. Apart from specialised fixing devices, the selection of material for use in tie-down schemes for engineering plant will be limited to chains, steel wire rope and the associated tensioner and coupling devices. For lighter machines it may be possible to use specially made webbing harnesses, but these should only be used for applications approved by the manufacturer. The use of cordage, whether made from natural or synthetic fibre, is not recommended as its strength cannot be readily assessed and it can be seriously weakened by age, wear, or incorrect use.

28. The strength of the lashing should be compatible with the strength of the anchor points used and its selection and use should be based on the principles contained in Section 6 of this Code.

29. Where a transverse beam is used as a baulk it should be securely fixed so that all loads imposed on it are transmitted to the carrying vehicle's chassis frame. Where individual wheels, or rolls are chocked with blocks or scotches these must be robust enough to resist crushing and be securely attached to the vehicle's platform where possible.

30. The lashings or securing devices should only be attached to those parts of the engineering plant which are compatible in strength with the vehicle's anchorage points.

They should not be attached to any part of the machine where there is a risk that damage can be caused when the vehicle is in motion.

SUGGESTED TIE-DOWN SCHEMES

31. The tie-down schemes described in the following figures and related schedules are typical systems which might be adopted for the securing of the various types of engineering plant. Variations to any of these schemes would be acceptable provided all the basic safety precautions outlined earlier have been complied with.

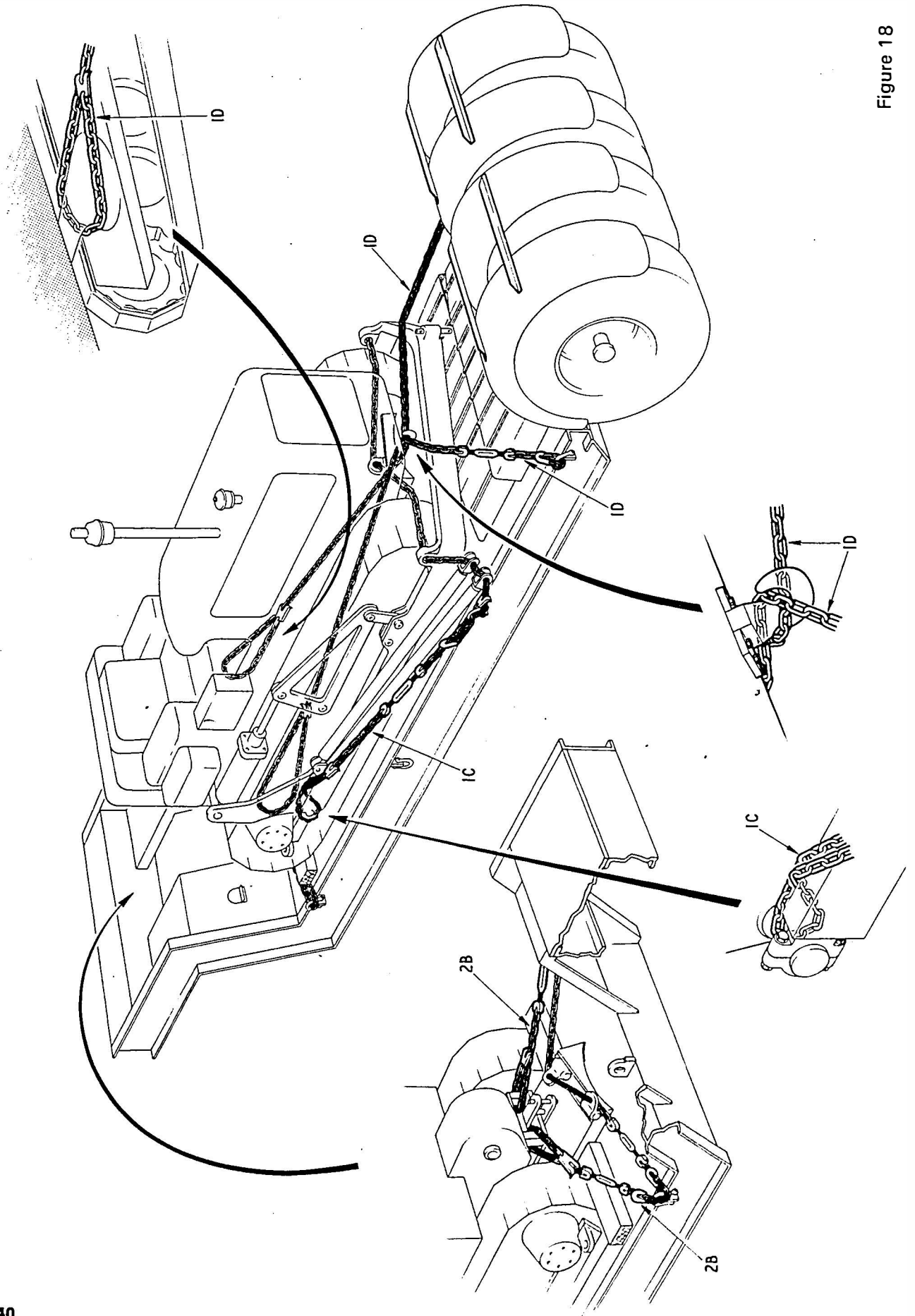

Figure 18

POSSIBLE HAZARD

PRECAUTION

1. Forward movement of machine

A. Remove dozer blade and place on trailer deck between dozer tracks.

B. Reverse dozer onto trailer and chock the tracks against trailer bulkhead.

C. Lashing chains from dozer blade U-frame trunnions to trailer side members.

D. Lashing chains from track roller frame brace to dozer front towing hook to trailer side members.

2. Rearward movement of machine

A. Tracks butted against chocks butted against trailer loading ramps.

B. Lashing chains from towing point to trailer side members.

3. Sideways movement of machine

A. Restraint provided by lashing chains used for forward and rearward movement.

4. Movement of ancillaries

A. Dozer blade stowed on deck. Lashing chains front and rear to trailer side members.

B. Dozer blade U-frame and dozer blade side arms. Lashing chains passing through the dozer blade side arms and through to dozer blade U-frame to trailer side members.

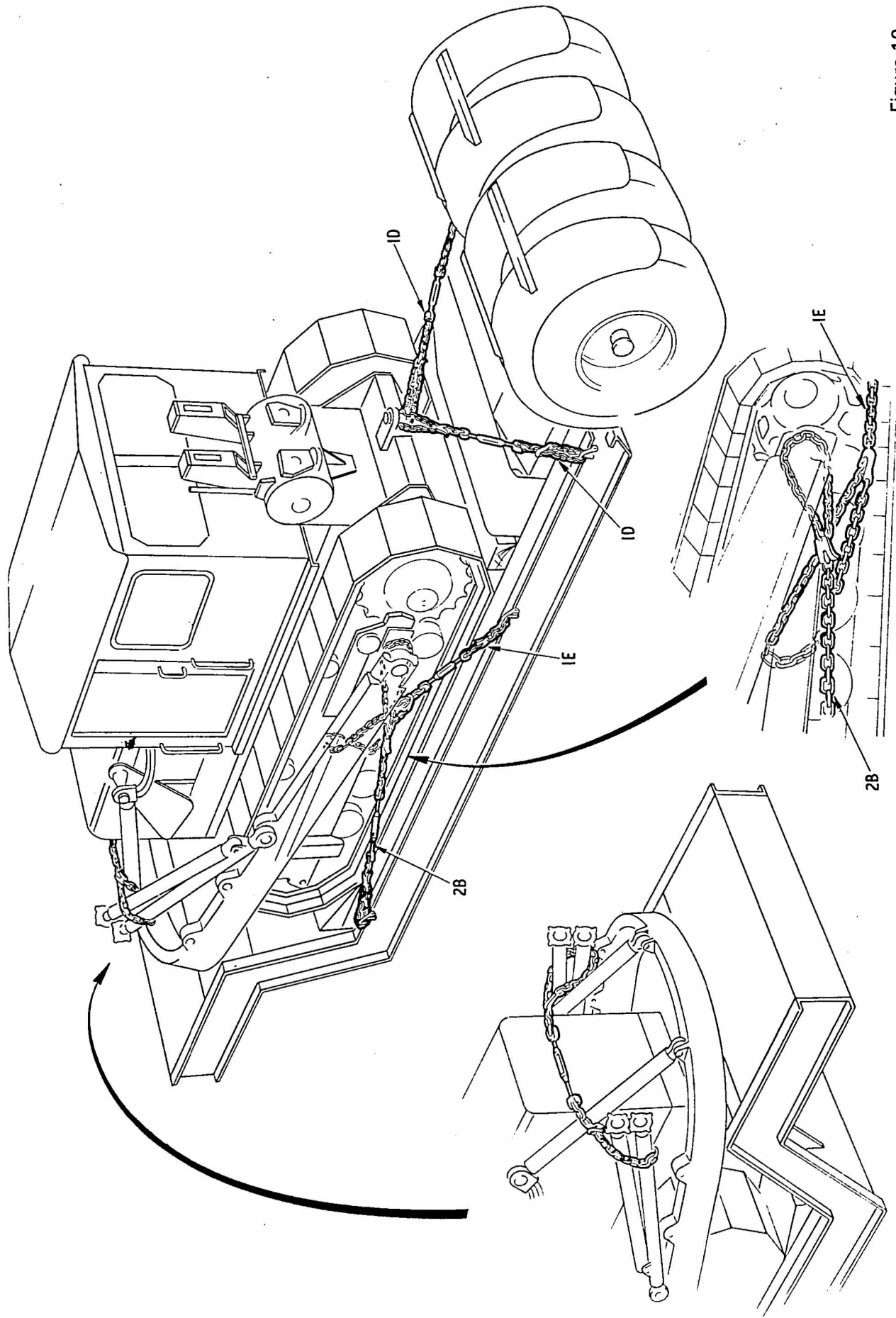

Figure 19

POSSIBLE HAZARD

PRECAUTION

1. Forward movement of machine

A. Dozer blade removed, placed on trailer deck between tracks.

B. Position dozer with U-frame resting on trailer swan neck.

C. Tracks butted against chocks against trailer bulkhead.

D. Lashing chains from towing hook to anchor points on trailer side members.

E. Lashing chains from track frame to anchor points on trailer side members.

2. Rearward movement of machine

A. Tracks butted against chocks against trailer loading ramps.

B. Lashing chains from U-frame trunnions to anchor points on trailer side members.

3. Sideways movement of machine

A. Restraint provided by restraints for forward and rearward movement.

4. Movement of ancillaries

A. Dozer blade side arms are lashed together across U-frame.

If necessary sleepers must be placed under dozer tracks to allow dozer to clear the blade, lying on the deck.

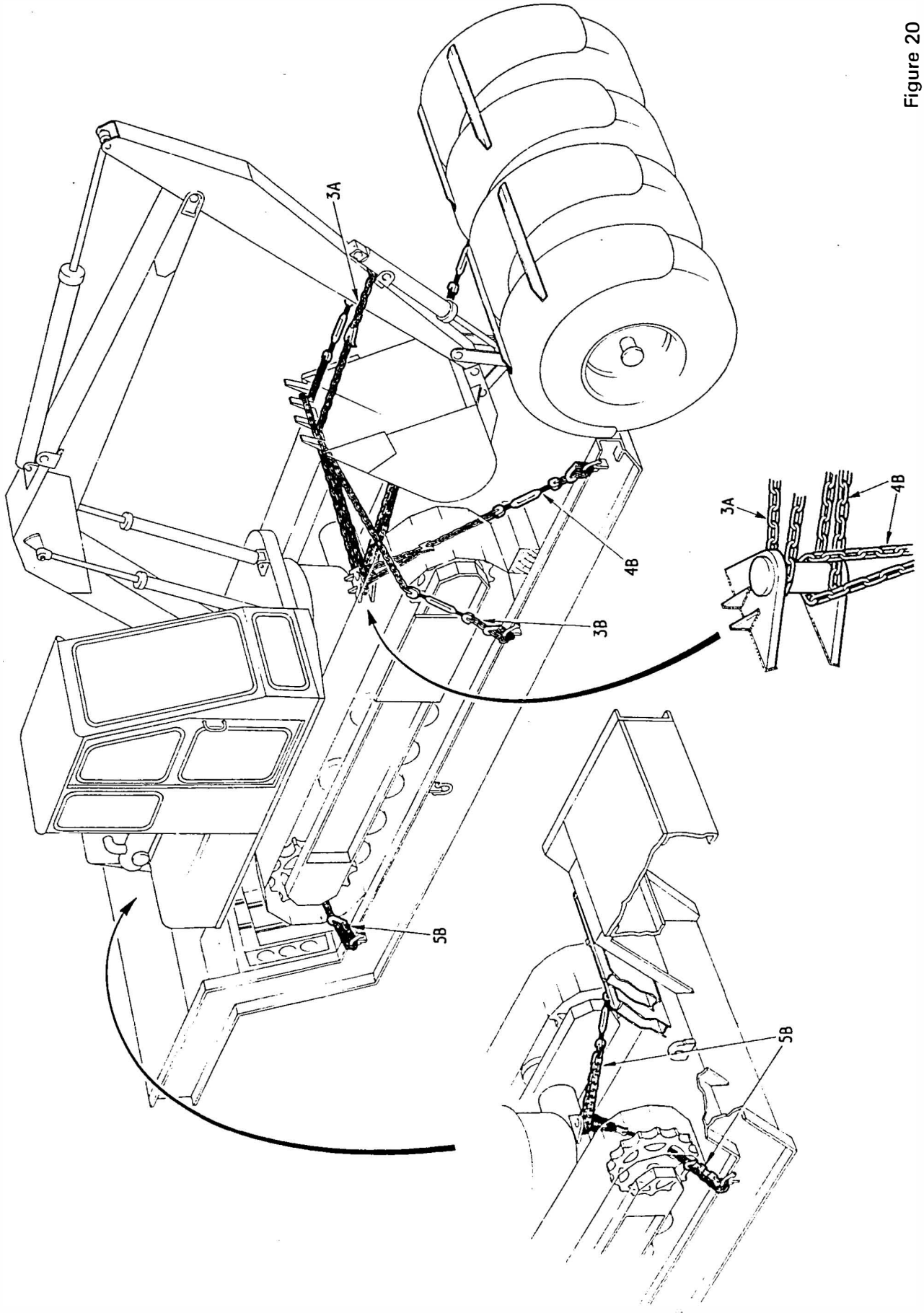

Figure 20

POSSIBLE HAZARD

1. Machine striking overhead obstructions
2. Movement of cab and superstructure relative to chassis of machine
3. Movement of dipper arm away from stowed position.
4. Forward movement of machine
5. Rearward movement of machine
6. Sideways movement of machine

PRECAUTION

- A. Stow equipment in position to give lowest overall height.
 - A. Relieve hydraulic pressure by operating all controls twice, with engine switched off.
 - B. Apply slew lock on slewing ring.
 - A. Lash lower end of dipper arm to machine chassis.
 - B. Lashing chain securing the bucket to anchor points on the trailer side members.
 - A. Tracks butted against loading ramps which are stowed vertically against the trailer bulkhead.
 - B. Lashing chains from excavator rear towing point or chassis cross member to anchor points on trailer side members.
 - A. Tracks butted against chocks.
 - B. Lashing chains from excavator front towing point or chassis cross member through the idler sprocket to anchor points on trailer side members.
 - A. Restraint provided by lashing chains used for forward and rearward movement.
- Do not wedge heavy objects between the bucket and the machine chassis.

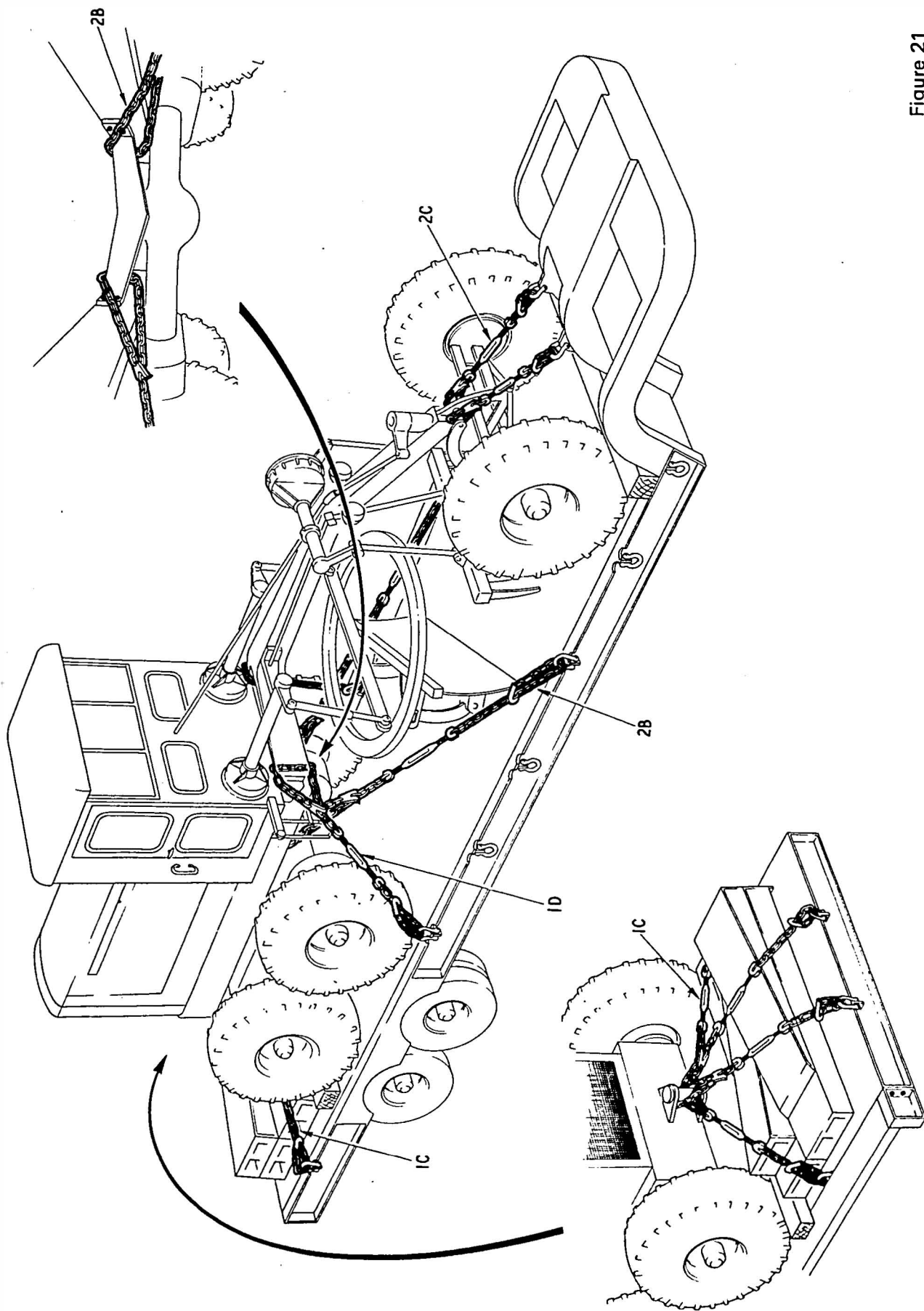

Figure 21

POSSIBLE HAZARD

1. Forward movement of machine

2. Rearward movement of machine

3. Vertical movement of machine

4. Sideways movement of machine

PRECAUTION

A. Blade and scarifier lowered to trailer deck.

B. Front wheels butted against chocks against trailer bulkhead.

C. Lashing chains from towing hook to anchor points on trailer side members.

D. Lashing chains from main frame to anchor points on trailer side members.

A. Rear wheels butted against chocks against trailer ramps which are held by chains from towing hook to anchor points on trailer end cross member.

B. Lashing chains from cross frame member to anchor points on trailer side members.

C. Lashing chains from front of main-frame to anchor points on the trailer bulkhead.

A. Restraint provided by lashing chains providing forward and rearward restraint.

A. Restraint provided by lashing chains used for other restraints.

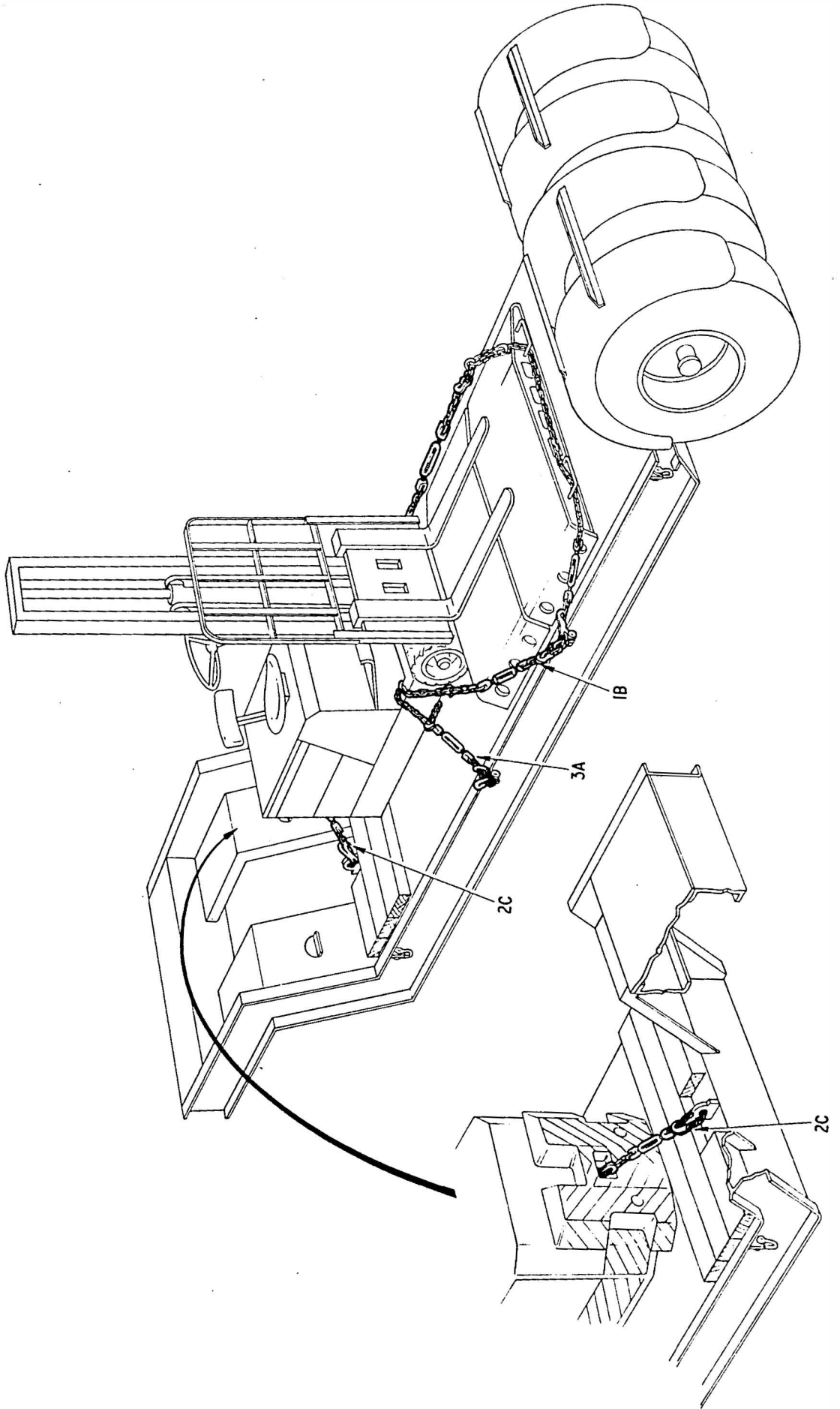

Figure 22

POSSIBLE HAZARD

1. Forward movement of machine

2. Rearward movement of machine

3. Sideways movement of machine

PRECAUTION

A. Rear wheels or counterweight of truck butted against chocks against trailer bulkhead.

B. Lashing chains from truck frame to anchor points on trailer side members.

A. Front wheels of truck butted against trailer ramps which are lashed to anchor points on trailer side members.

B. Forks lowered on to ramps and hydraulic pressure relieved by operation of controls twice, with engine switched off.

C. Lashing chain from truck towing point to anchor point in centre of trailer bed.

A. Lashing chains from truck frame to anchor points on trailer side members.

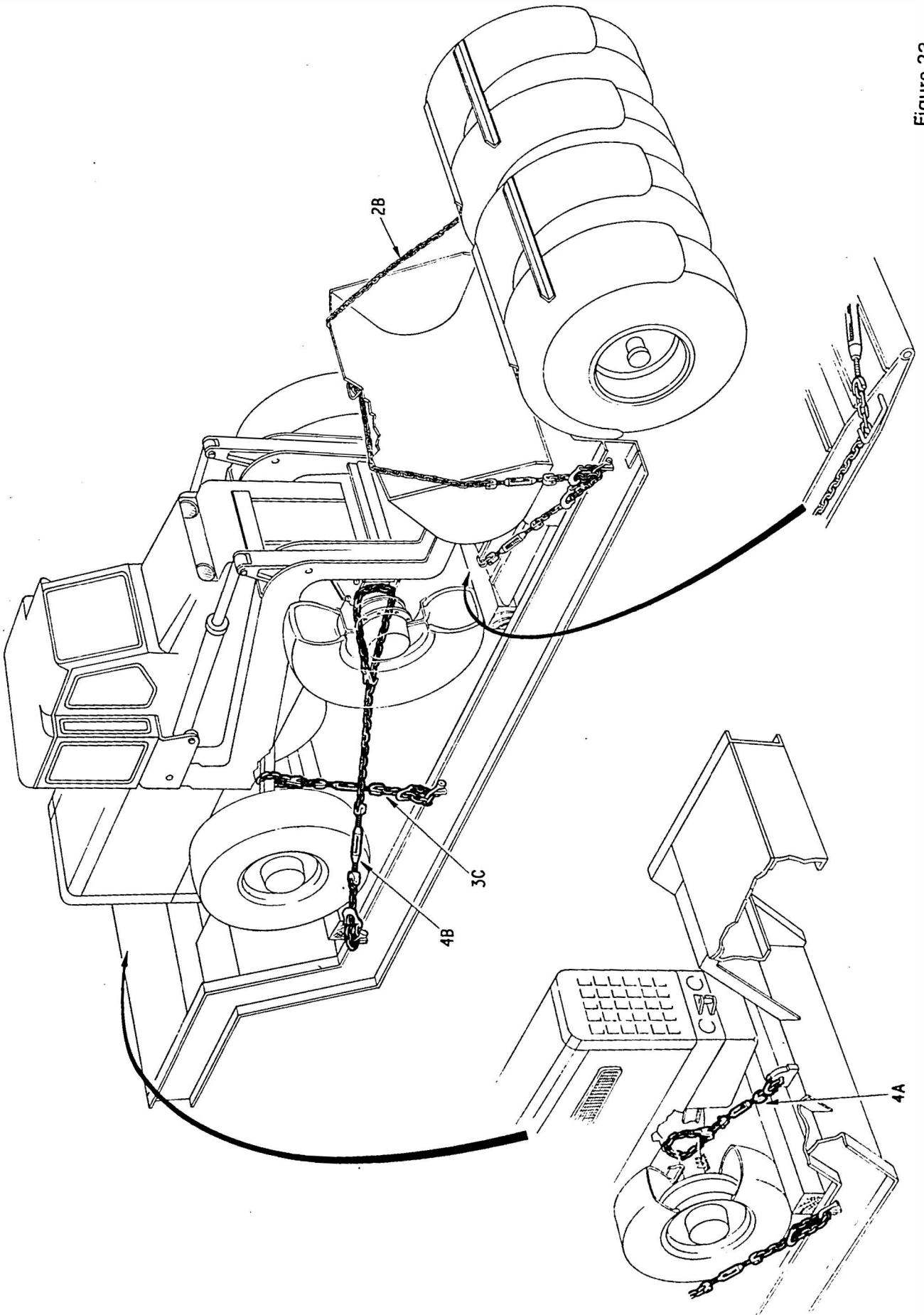

Figure 23

POSSIBLE HAZARD

1. Articulation of front part of machine relative to rear part
2. Movement of bucket assembly
3. Forward movement of machine
4. Rearward movement of machine
5. Sideways movement of machine

PRECAUTION

- A. Pivot locking bar bolted in position, in the case of pivot steer machines.
- A. Relieve hydraulic pressure in system by operating all controls twice, with the engine switched off.
- B. Lashing chains from bucket to anchor points on trailer side members.
- A. Machine reversed on to trailer.
- B. Rear wheels butted against chocks against trailer bulkhead.
- C. Lashing chains from rear axle or rear axle swivel support to anchor points on trailer side members.
- A. Lashing chain from rear axle to anchor point on centre of trailer deck.
- B. Lashing chains from front axle to anchor points on trailer side members.
- C. Front wheels butted against chocks against trailer ramps which are lashed to anchor points on trailer side members.
- A. Restraint provided by lashing chains used for forward and rear restraint.

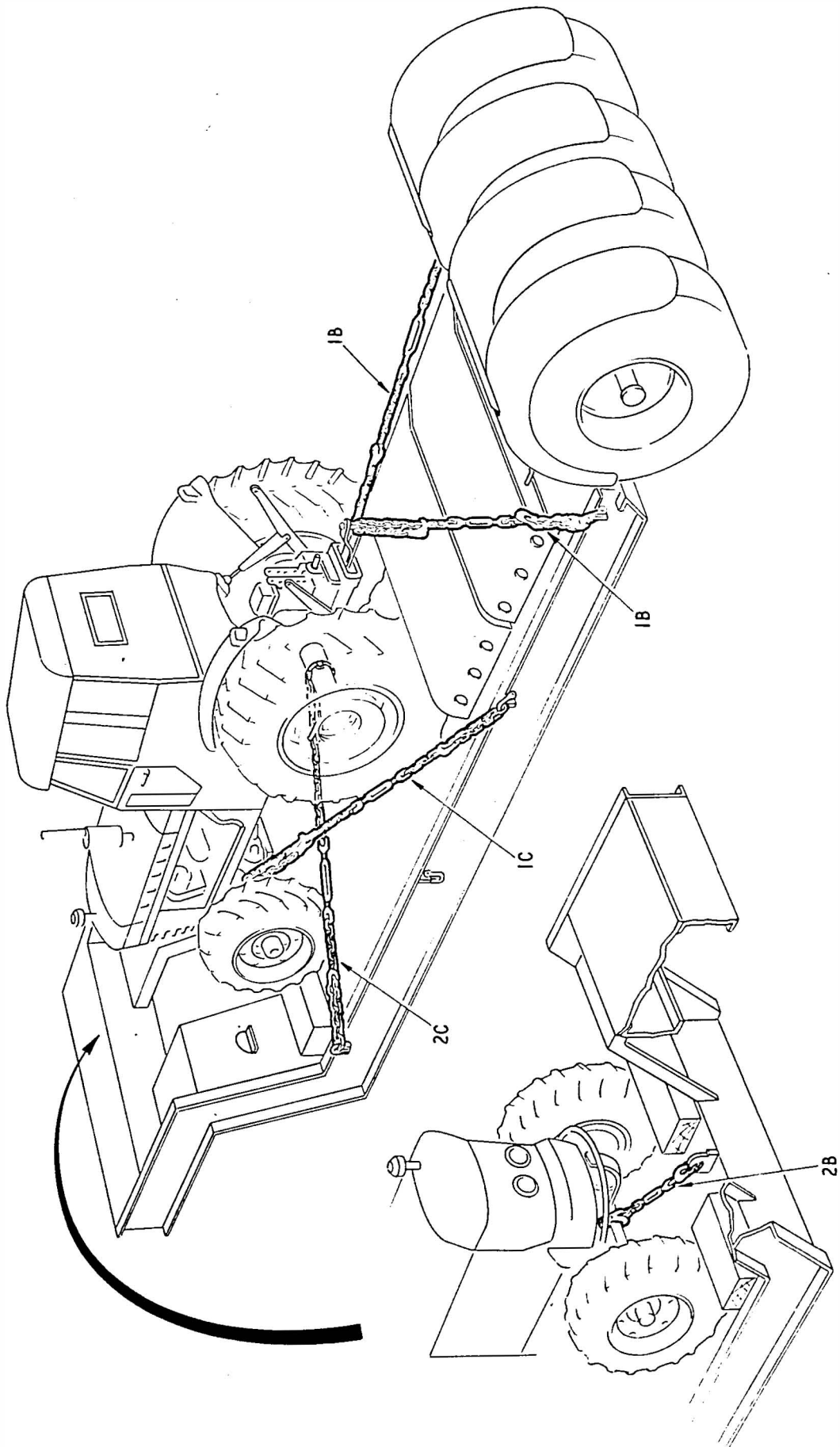

Figure 24

POSSIBLE HAZARD

1. Forward movement of machine

2. Rearward movement of machine

3. Sideways movement of machine

PRECAUTION

A. Front wheels butted against chocks against trailer bulkhead.

B. Lashing chains from rear towing hook to anchor points on trailer side members.

C. Lashing chains from front axle to anchor points on trailer side members.

A. Rear wheels butted against chocks against trailer loading ramps.

B. Lashing chain from front axle to anchor point on centre of trailer deck.

C. Lashing chains from rear axle to anchor points on trailer side members.

A. Restraint provided by lashing chains used for forward and rearward restraint.

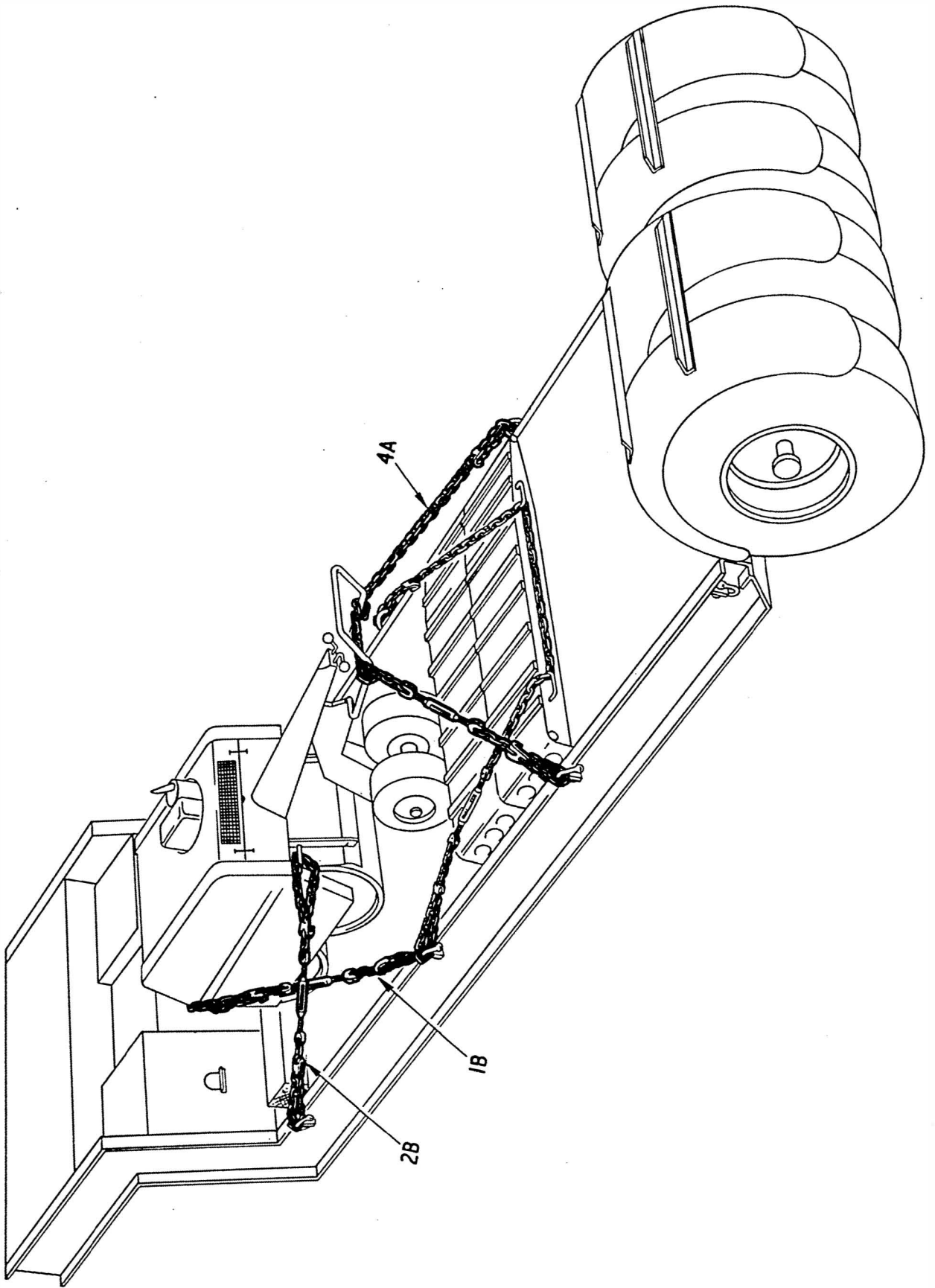

Pedestrian Roller

(See Figure 25)

POSSIBLE HAZARD

1. Forward movement of machine
2. Rearward movement of machine
3. Sideways movement of machine
4. Movement of body of roller relative to the roll

PRECAUTION

- A.** Roll butted against chock against trailer bulkhead.
 - B.** Lashing chains from machine body to anchor points on trailer side members.
- A.** Roll or rear wheels butted against chock against trailer ramps which are lashed to anchor points on trailer side members.
 - B.** Lashing chains from machine body to anchor points on trailer side members.
- A.** Restraint provided by restraints for forward and rearward movement.
- A.** Lashing chain from control arm to anchor points on trailer side members.

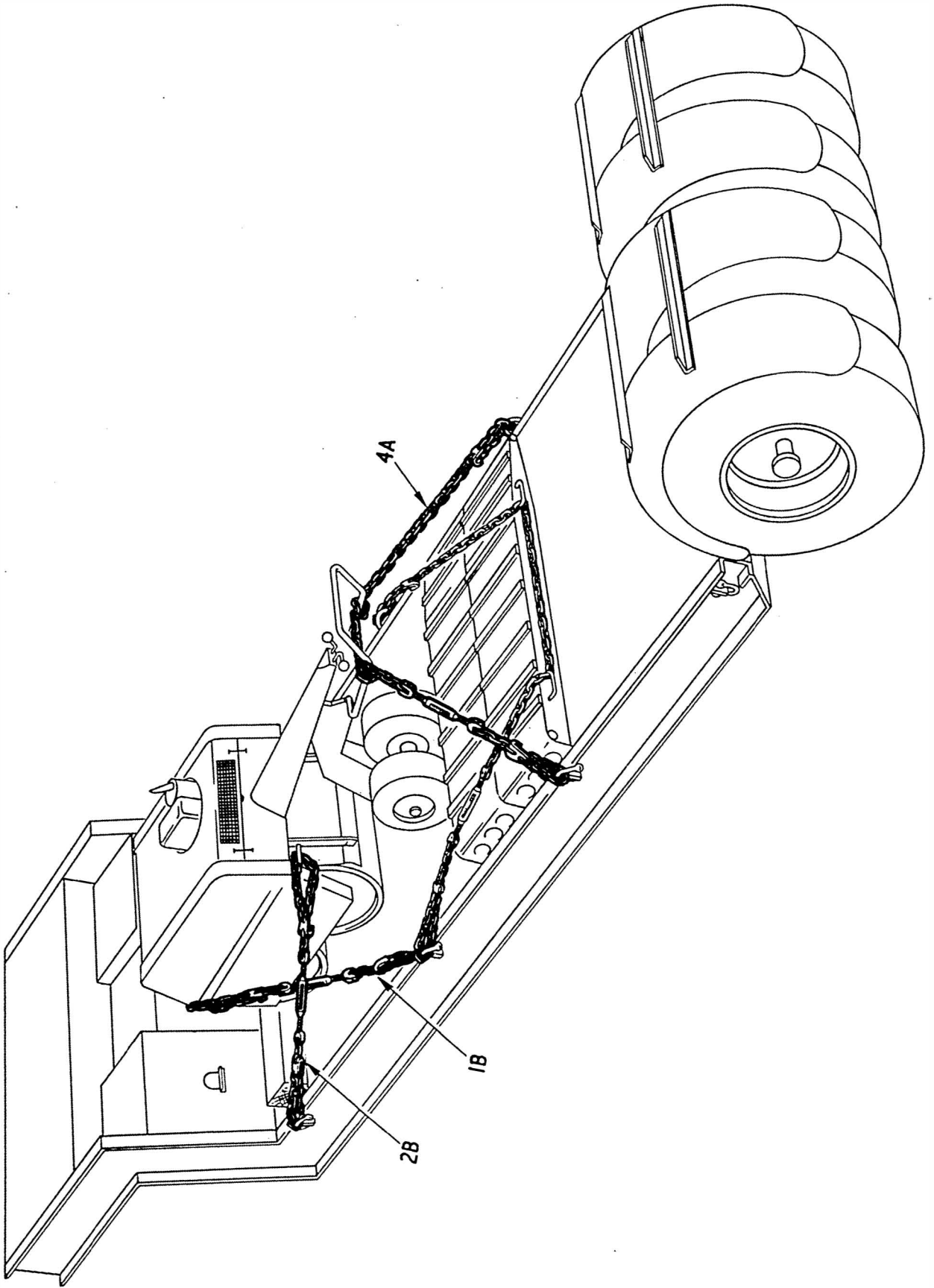

Pedestrian Roller

(See Figure 25)

POSSIBLE HAZARD

1. Forward movement of machine
2. Rearward movement of machine
3. Sideways movement of machine
4. Movement of body of roller relative to the roll

PRECAUTION

- A. Roll butted against chock against trailer bulkhead.
- B. Lashing chains from machine body to anchor points on trailer side members.
- A. Roll or rear wheels butted against chock against trailer ramps which are lashed to anchor points on trailer side members.
- B. Lashing chains from machine body to anchor points on trailer side members.
- A. Restraint provided by restraints for forward and rearward movement.
- A. Lashing chain from control arm to anchor points on trailer side members.

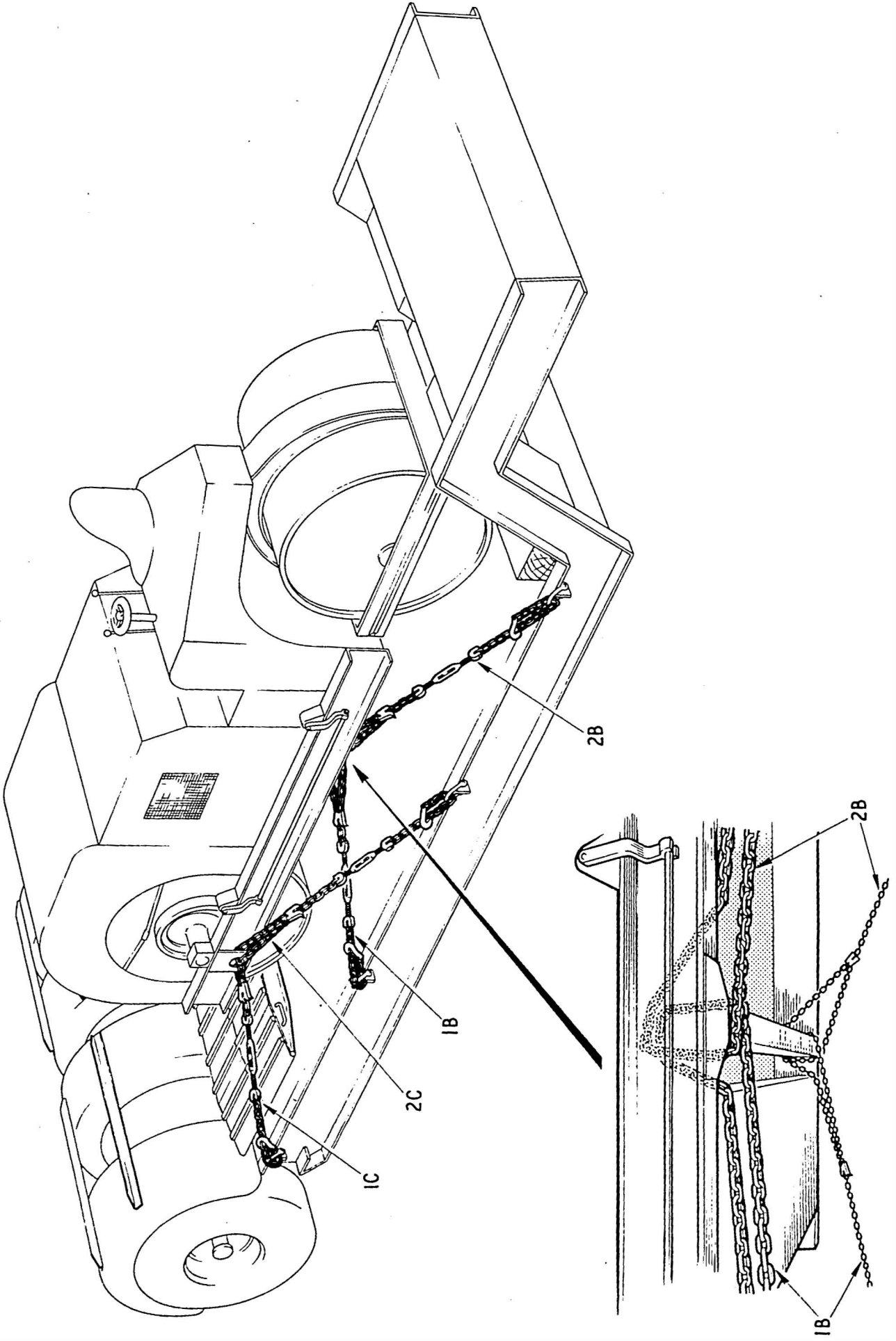

Figure 26

POSSIBLE HAZARD

1. Forward movement of machine

2. Rearward movement of machine

3. Sideways movement of machine

PRECAUTION

- A. Front roll butted against chocks against trailer bulkhead.
 - B. Lashing chains from frame cross member to anchor points on trailer side members.
 - C. Lashing chains from frame to anchor points on trailer side members.
-
- A. Rear roll butted against trailer ramps.
 - B. Lashing chains from frame cross member to anchor points on trailer side members.
 - C. Lashing chains from frame to anchor points on trailer side members.
-
- A. Restraint provided by lashing chains used for forward and rearward movement.

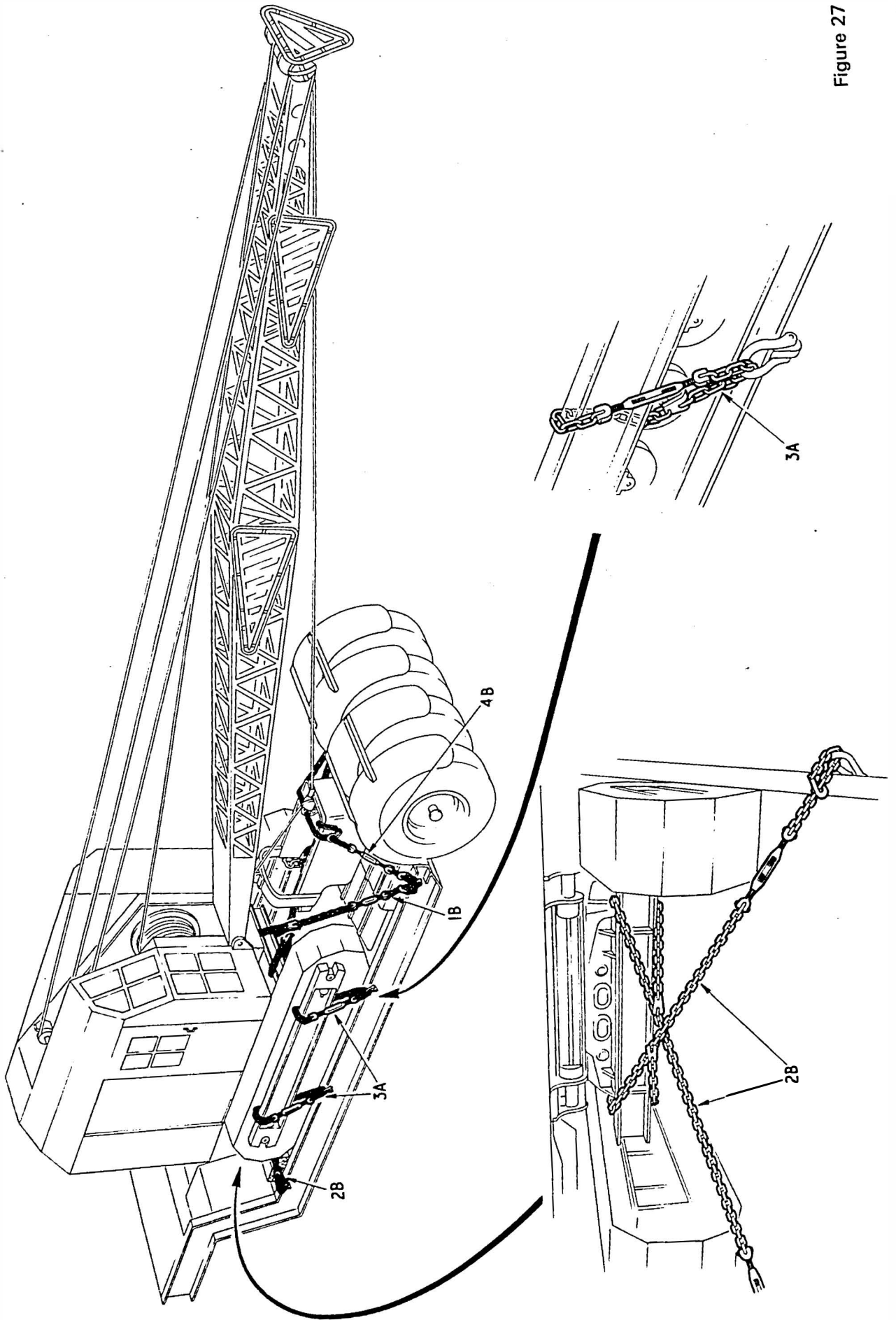

Figure 27

Roped Excavator (Tracked)

(See Figure 27)

POSSIBLE HAZARD

1. Forward movement of machine
2. Rearward movement of machine
3. Sideways movement of machine
4. Movement of ancillaries

PRECAUTION

- A.** Tracks butted against chocks against trailer bulkhead.
 - B.** Lashing chains from chassis rear cross member to anchor points on trailer side members.
- A.** Tracks butted against chocks against trailer loading ramps.
 - B.** Lashing chains from chassis front cross member to anchor points on trailer side members.
- A.** Lashing chains from track frame to anchor points on trailer side members.
- A.** Slew boom to rear and apply slew lock on slewing ring.
 - B.** Position bucket centrally on trailer ramps and lash to anchor points on trailer side members.
 - C.** Lower jib until it is just below the height of the excavator cab and engage locking pawl on hoist drum.

SECTION 10. GENERAL FREIGHT

1. The loading and securing of general freight loads on goods vehicles is rendered difficult by the wide diversity of shape, size and nature of this type of load. Vehicles equipped with headboards or sideboards, or van bodies, will provide some restraint to movement of the load. However, additional load restraining devices may still be required under the following conditions:

- a) If there is a risk that the load may break through the walls or sideboards of the vehicle.
- b) When the load is higher than the headboard or sideboards of the vehicle.
- c) If the load is liable to be damaged should it move during transit.

2. When general freight loads are carried on platform vehicles some form of load restraining device will always be required.

LOADING ARRANGEMENT ON VEHICLE

3. Two essential requirements must be satisfied when loading vehicles, namely the load must be so distributed that:

- a) the maximum permitted gross vehicle weight and axle weights are not exceeded.
- b) maximum stability is ensured when the vehicle is braked, or accelerated or changes direction.

4. For maximum stability, the items comprising the total load require to be evenly spread to achieve minimum height and to be so arranged as to form a unified whole so that no excessive stress is applied to whatever restraining devices are used. Where a part of the load is to be picked up or removed in the course of a journey, the effect on gross vehicle weight, individual axle weights and on the securing and stability of the load then being carried must not be overlooked. Although removal of part of the load will reduce the gross vehicle weight, it may so change the weight distribution as to cause individual axles to exceed their plated weight and this possibility must be borne in mind during the initial loading operation.

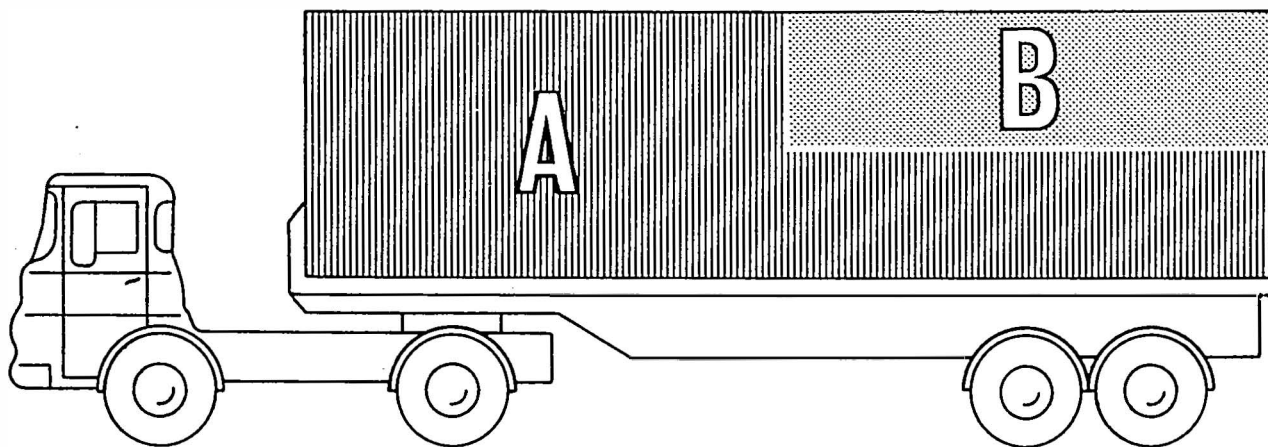

Figure 28

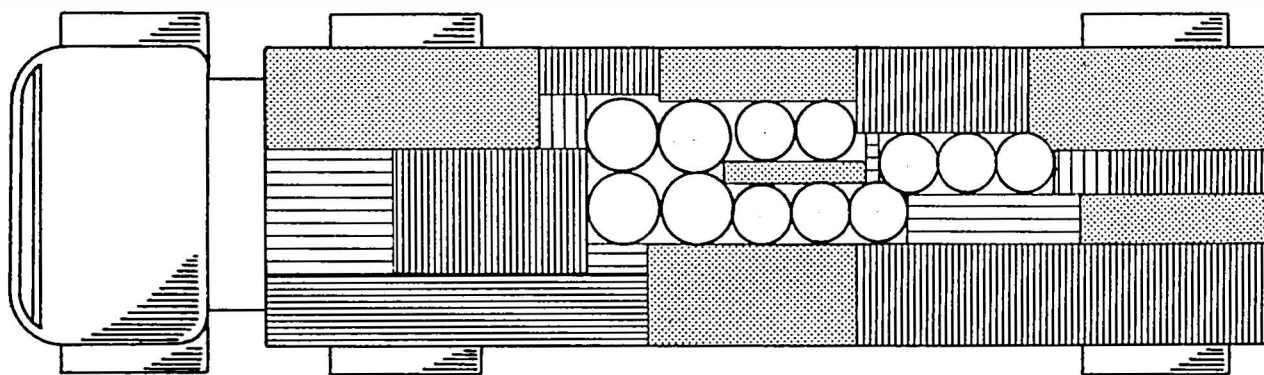

Figure 29

5. In addition to the general principles outlined above the following procedures should be followed whenever applicable:

- a) Where mixed loads involve heavy, solid articles and light, crushable boxes etc, the former should provide the base and forward part ('A' in Fig 28) and the light portions to be loaded on top and to the rear ('B' in Fig 28).
- b) Throughout the journey, at every stop, the load should be checked for security and the lashings tested. Weather conditions can effect the tension of ropes and this may lead to damage of the load or loss of security.
- c) Where mixed goods involve different sizes of container, small items should be central, with the larger items forming the outer walls of the load. Avoid as far as possible obstructions or projections beyond the vehicle sides (see Fig 29).
- d) Keep irregular shaped items for the upper part of the load where it is not possible to place them centrally within the load.
- e) The load must be packed tightly before applying restraint.

RESTRAINT DEVICES

6. A variety of materials may be used for restraining general freight loads. These include rope, steel wire rope and specially designed webbing strapping made up into a harness, or net. For the securing of loads inside van bodies and similar load containers, specially designed shoring poles used in conjunction with the appropriate securing fixtures on the vehicle deck and sides are suitable. Purpose built restraining devices should only be used for applications and in the manner approved by their respective manufacturers.

7. The selection and use of restraining devices should be based on the principles contained in Section 6 of this Code. However, there are some special points which need to be considered when dealing with general freight and these are outlined in the following paragraphs.

8. Sheets may be used subject to the conditions outlined in Section 4 of this Code. Where several sheets are required to cover one load they should be put on at the rear of the load first, (see Figs 30, 31, 32 and 33). This ensures the over-lapping portion of the sheets face rearwards so preventing wind, driving rain, snow and sleet, penetrating between them. The same principle must be applied to folds in the sheets at the front or on the sides of the vehicle—so that wind pressure will tend to close any gaps or folds in the sheet. After being sheeted and roped a vehicle should present a neat, compact and safe picture—not only when the vehicle is stationary but also on the move. The following points should always be checked:

- a) The lights, reflectors, number plates and rear markings etc, should not be obscured.
- b) All loose rope ends should be tied up.
- c) There should be no loose flaps or tears in the sheet liable to cause danger to other road users when the vehicle is moving (see Fig 34).

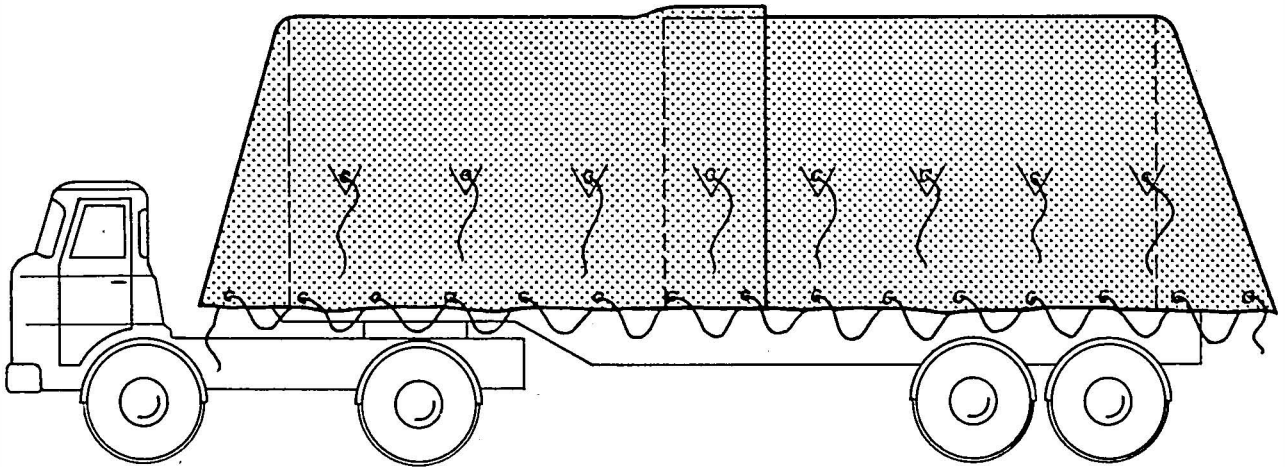

Figure 30

- a) Where more than one sheet is required to cover and protect the load the rearmost sheet is positioned first. This ensures that overlaps do not face forward allowing wind and rain etc. to get between sheets.
- b) Having positioned the sheets on the load ensuring that all parts are covered and that sheets are equal on each side, secure the front of the rear sheet followed by the rear of the front sheet. Do not overtighten or sheets will be drawn up to expose the load at the rear or at the front.

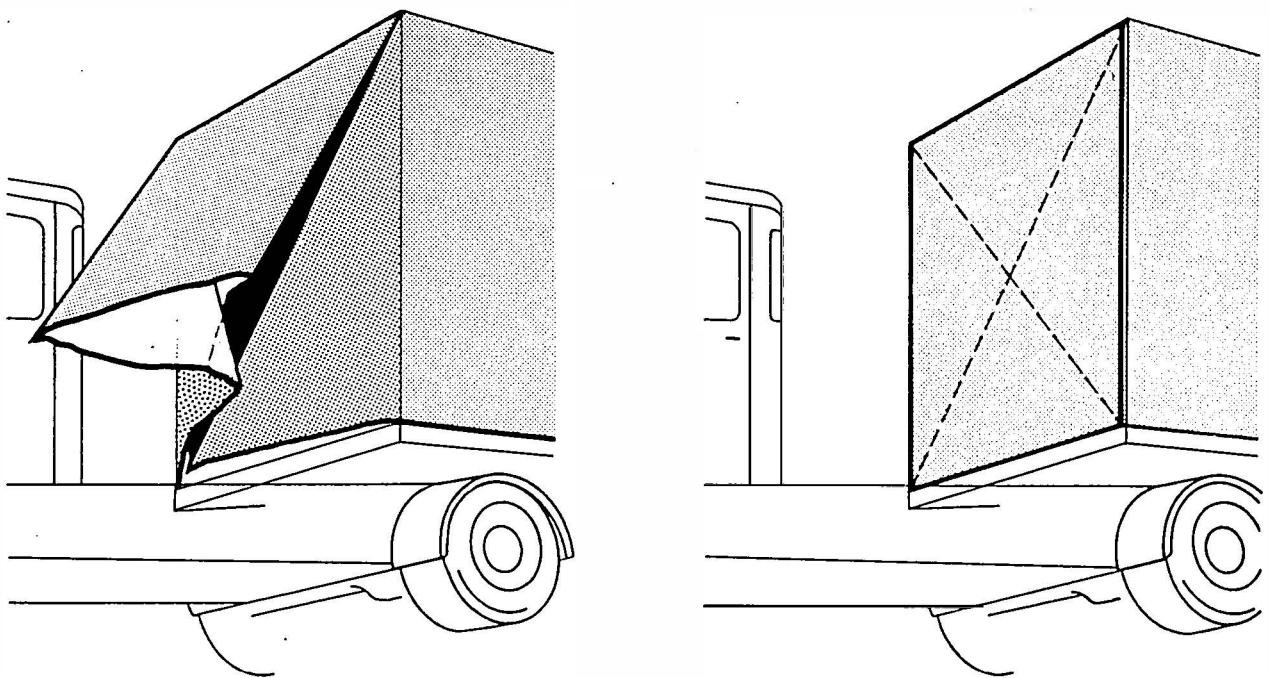

Figure 31

- c) The next stage is to secure the front of the sheet. This can be done in either of the following ways:
1. Step 1. Draw in surplus sheet from sides, cross over front and secure.
Step 2. Draw down over cross-overs the remaining surplus sheet to form a full width flat front flap.

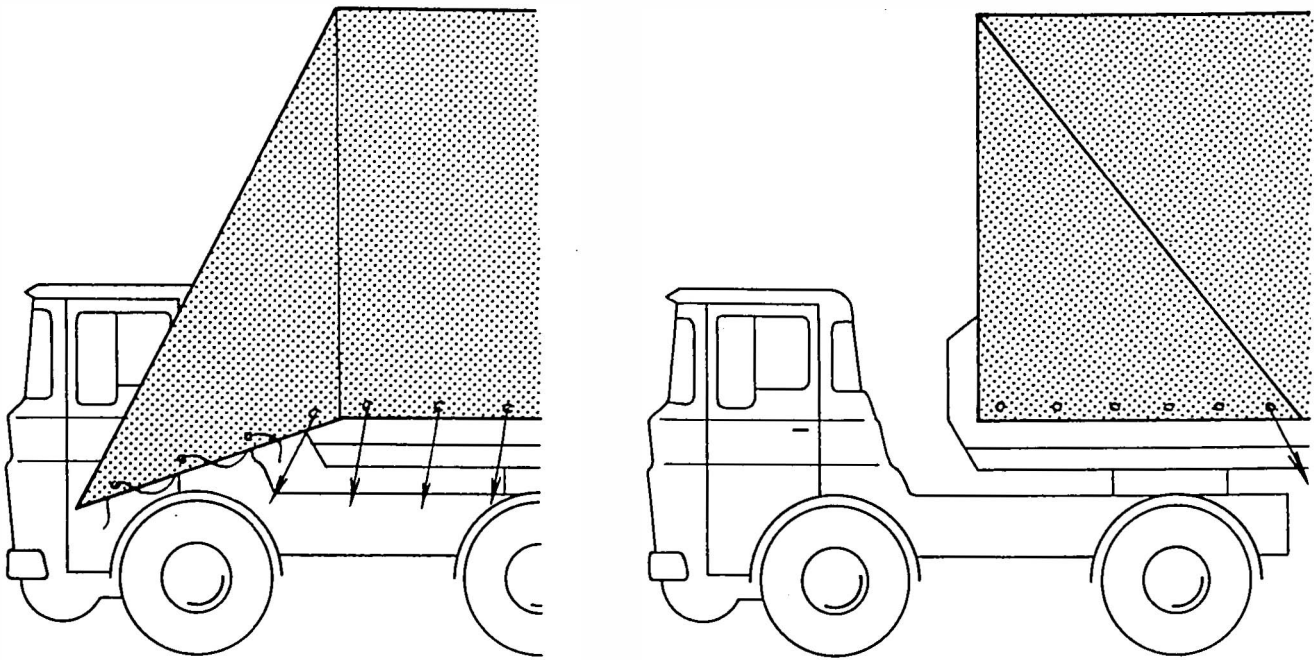

Figure 32

2. Step 1. Secure the bottom of front sheet along the entire width of headboard or trailer body.
- Step 2. Draw surplus sheet forward at front corner until sheet lies flat on load side. Secure side-sheet from front corner as shown above (left). Repeat on other side drawing sheet taut when tightening second side.
- Step 3. Fold back surplus corner sheet triangular shape and secure.

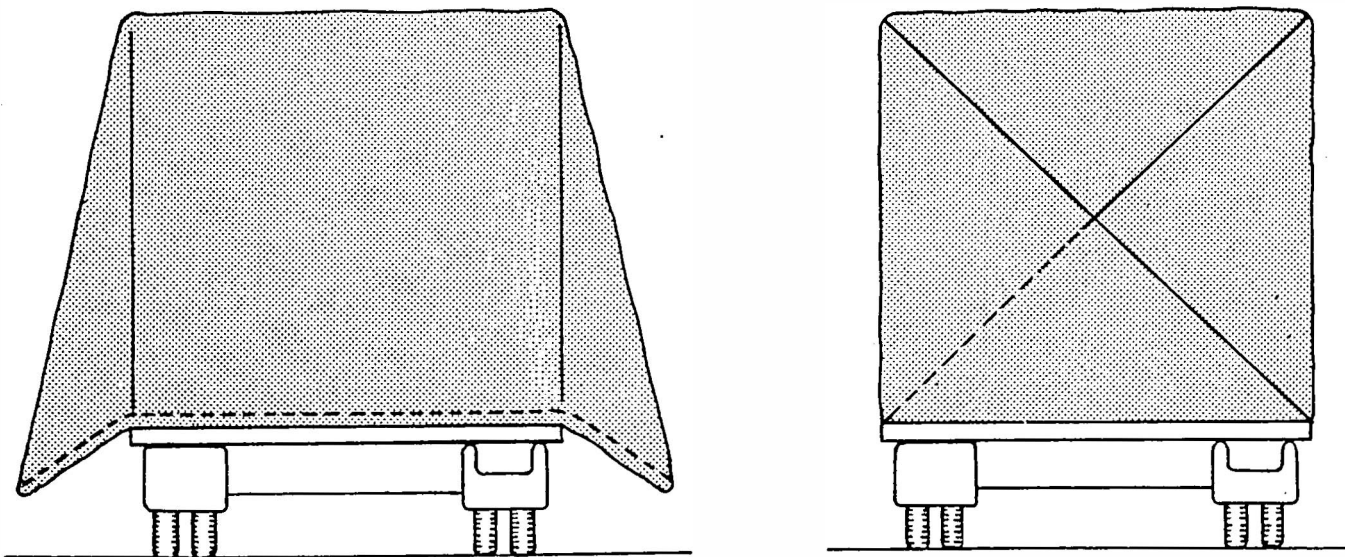

Figure 33

- d) Having secured front sheet, secure the sides of the rear sheet to the rear-most corners.
- e) Rear of the load should be sheeted and folded as illustrated above (right).

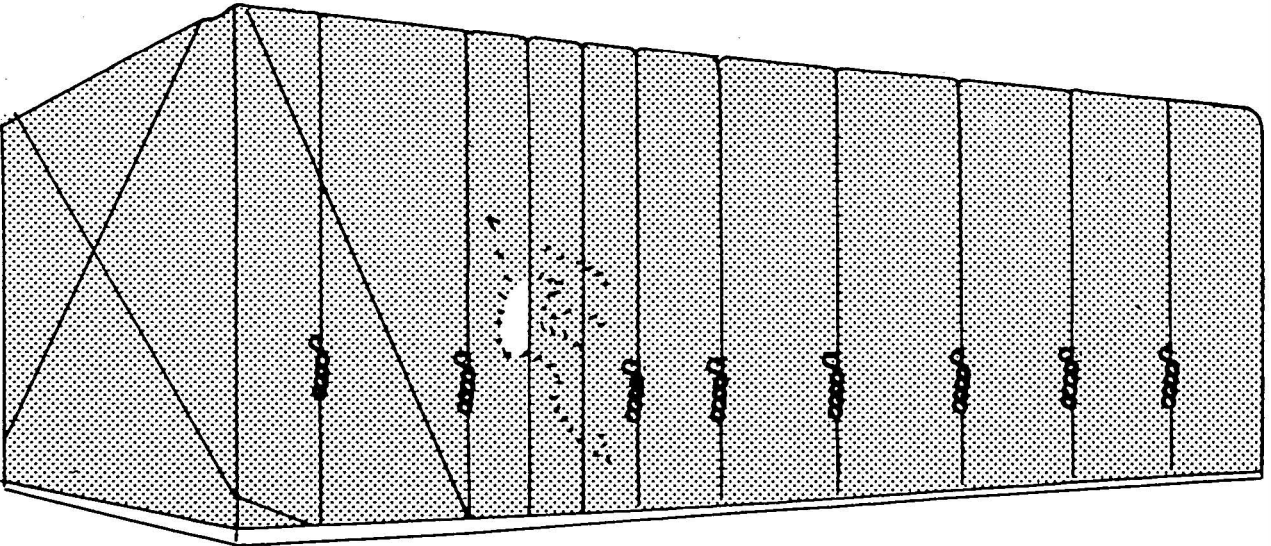
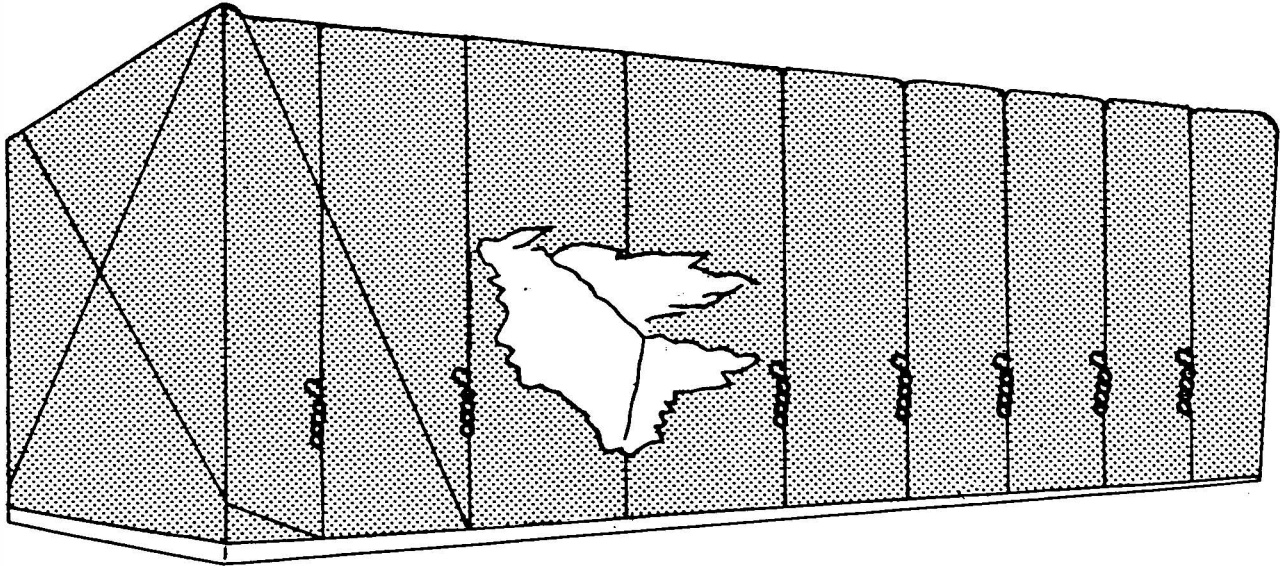

Figure 34
Do not leave tears where wind can cause further damage.

LOADING METHODS

9. In view of the wide diversity of general loads it is not possible to suggest loading methods for all the types of loads likely to be encountered. However the basic precautions outlined in Section 4 of this Code will always be applicable. Loading methods for certain general categories of loads are outlined in the following paragraphs.

10. *Rolls, Drums or Cylindrical Loads.* a) Rolls or cylindrical items should be placed with their axis across the vehicle in order that the rolling tendency will be to the front or rear. Use chocks and lashings liberally to secure them. Fig 35 illustrates a load consisting of paper or cardboard rolls. When the bottom layer of rolls has been positioned and secured on the platform and the first rolls of the second layer ('A' in Fig 35) loaded, the over-lashings are laid over 'A' and across the top of the remaining bottom layer rolls. No tension is applied to the lashings at this stage. The remaining rolls in the second layer are now loaded and at the conclusion the 'between-layers' lashings secured to the rear of the vehicle and 'top-over' lashings applied if required. 'Between-layers' lashings, as illustrated, may be omitted when metal or concrete pipes are carried, since the weight and abrasive nature of the load would excessively damage the lashings. Only the top lashings are retained but liberal use of chocks is essential. The use of fore and aft lashings between layers provides extra security on acceleration and braking whilst also providing some side-thrust resistance from lashings 'biting' into rolls. NB. these particular lashings may have to be omitted if the customer so dictates or if the 'biting' damages the load. The omission should be made good by extra top lashings and chocks. b) If the length of the cylinders is less than twice their diameter they should be placed on end unless instructions are given to the contrary by the consignor. If the length is greater than twice the diameter, but less than the width of the vehicle, they must be positioned so as to roll forwards. Each row must contact the one in front, and the front and rear ones must be chocked to prevent rolling backwards or forwards. c) If the drums, rolls, etc, are standing on end, lashings must be used to prevent lateral movement and further cross lashings must be applied. If on their sides, they should have at least one cross lashing for each item. If there is more than one layer the rearmost roll must be restrained by lashing or blocking against rearward motion.

11. *Boxes.* a) Boxes must be loaded so that they are prevented from moving in any direction. They must interlock if possible, and be loaded to a uniform height. Heavier boxes should be at the bottom of the load. For a load which is not sheeted there must be one lashing for each row of boxes across the vehicle. Any box which is above the general height of the load must have at least one cross lashing, and two if it weighs more than $\frac{1}{2}$ ton.

12. *Sacks.* a) When possible sacks should be laid on their sides, with alternate layers in opposite directions. In any event no more than two successive layers should be in the same direction. The load should be of uniform height when possible. b) There must be at least one cross lashing for each two sack lengths. Loads of sacks should be sheeted if

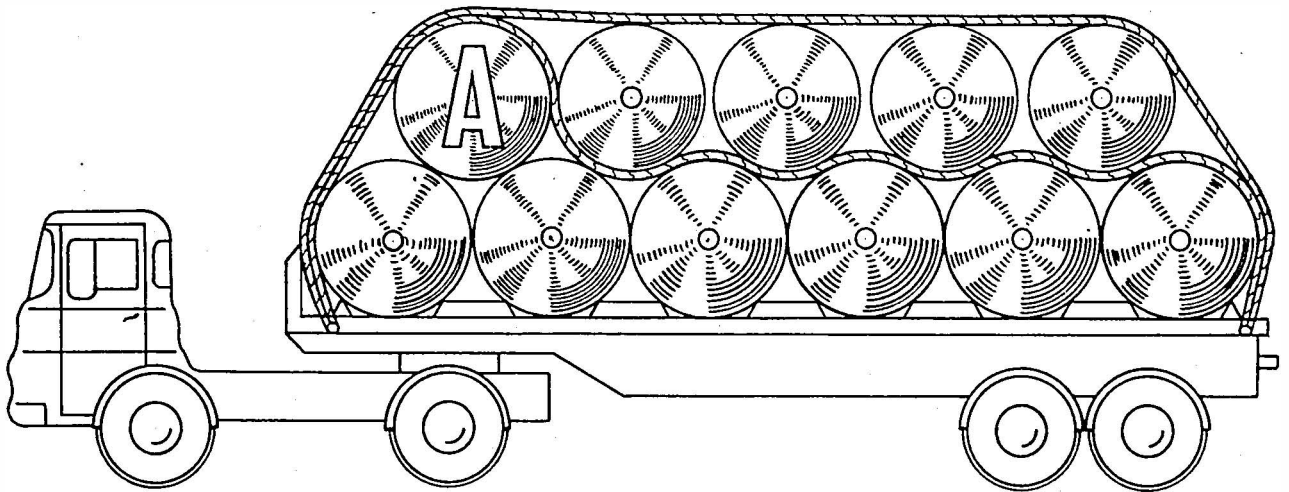

Figure 35

possible. c) With certain loads the use of tensioners may be desirable. This is particularly true of loads which tend to settle around the lashings. d) Empty sacks, which can fall from a vehicle when in motion can be extremely hazardous and these must therefore be securely restrained to the vehicle's platform.

13. Glass. a) This type of load would normally be carried on purpose built vehicles embodying specially designed glass clamps and supports. However, when sheet or plate glass is carried in crates or timber pallets load restraint precautions as for general freight apply.

14. Bricks. a) All retaining systems must restrain both the bulk mass of the load and individual bricks. These requirements can be met by load-surrounding sides, bulkhead and tailboard all of which satisfy requirements given in Section 5. The load height should not exceed the height of the surrounding body. Purpose-made nets may also be used for securing this type of load providing the strength of both these and the load securing points used is equal to the load being restrained. Sheeting should only be used subject to the conditions given in Section 4.

15. Mixed Loads. a) When a load is composed of different items each part of the load must be secured in a manner suitable to a load of its type. This applies mainly to cross lashings. The longitudinal lashings must be adequate for the total weight of the load, and separators must be used so that no part of the load can move forward independently.

SECTION 11. TIMBER LOADS

1. This section is intended to provide general guidance on the measures necessary for the safe carriage of timber, both bulk and sawn. Timber is a 'live' commodity; it is therefore essential to ensure that it is not loaded to a height likely to result in instability, and particular care must be taken to ensure that the load is correctly secured.

SAWN TIMBER

Loading arrangement and methods

2. The general principles of load distribution outlined in Section 4 should be adhered to. It is particularly important to ensure that, whenever practical the load is placed against the headboard. If this cannot be done, the load anchor points must provide all the restraint.

3. Bulk packaged timber is generally strapped or wired at each end; before loading the straps should be checked to ensure that they have not been damaged during transit or handling. If the straps are damaged, care must be taken to ensure the complete load is secure.

4. Loose timber is generally made up into standard setts, which should be kept to a uniform height. The uneven ends should where possible be at the rear of the vehicle and packed out to prevent whip. Generally the use of dunnage should be as outlined in Section 4 of this Code.

5. Light loads of timber, eg for retail deliveries, can be carried on sided vehicles where the height of the load does not exceed the height of the sides, thus avoiding the need for constant lashing and relashing of the load. Where the height of the load exceeds the height of sides, lashings must be used.

Restraining devices

6. In general the use of chain or webbing lashing rather than rope is recommended. The number of lashings required should be in accordance with the weight of the load and the number of anchor points used, see Section 5. At least one intermediate lashing should be

passed around the lower half of the load only. Care must be taken to ensure that restraining chains or webbing are placed at points where the load is rigid, ie where there are no uneven ends of timber, and that the load is protected from damage by toggles or load binders.

7. Lashings should be regularly checked at the start of a journey and they may need to be re-tightened several times during the course of the journey as the timber settles on the vehicle.

8. Any loose ends of timber at the rear of the vehicle should be secured with rope, pulling them downwards, to minimise whip.

9. Certain types of planed timber loads present a particular problem since the outside lifts tend to spread sideways, causing the load to belly outwards. To avoid this the vehicle should be fitted with side stanchions that reach the height of the load. It is essential that the stanchions are capable of resisting any outward movement of the load.

ROUND TIMBER

General load distribution and restraining devices

10. In general, the principles of load distribution outlined in Section 4 should be adhered to, and again it is important to ensure that, whenever possible, the load is placed against the headboard. Also, the use of chains or webbing is recommended and all lashings should be capable of being tightened by use of a toggle or load binder. These lashings should be attached to suitable anchor points and should be regularly checked after the start of a journey and re-tightened if necessary. The selection of the lashings and the use to which they are put should be based on the principles set out in Section 6.

Stacks on the longitudinal axis

11. Each outer log or piece of timber shall be supported by at least two uprights, and pieces shorter than the distance between two uprights should be placed in the interior of the load. The uprights should be fitted with top chains, so as to be capable of resisting the load's outward movement. Where a pile is supported by only two pairs of uprights, the ends of the outer logs should extend at least 12" beyond the uprights where practicable.

Logs should preferably be laid top to tail alternately so as to ensure an even balance of the load. Each pile should be lashed together and the lashing secured by a suitable device. Where necessary, staples may be used in conjunction with chains. A single chain stretched between uprights, even if well secured, is not enough. For barked roundwood at least two lashings are required.

WHOLE TREES

12. The carriage of whole trees is a highly specialised field of timber haulage and is generally accomplished using pole vehicles, or vehicles where the timber load is secured

to a trailing dolly at one end. Vehicles should be fitted with bolsters and stanchions of sufficient strength to restrain the load. Chains are necessary for securing the load and generally a minimum of 3 chains should be used, one of which should bind together any overhanging tails or the middle of an awkwardly shaped load. The chains should be capable of being tightened using a toggle or load binder.

Rows along the Vehicle

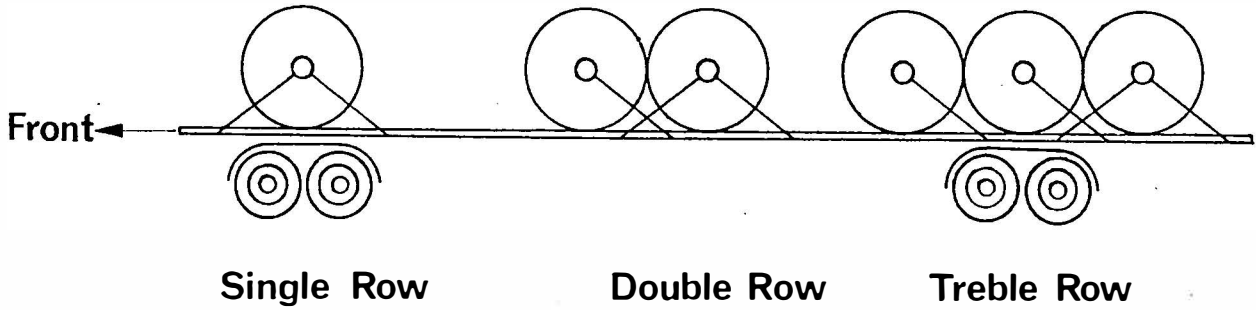

Rows along the vehicle

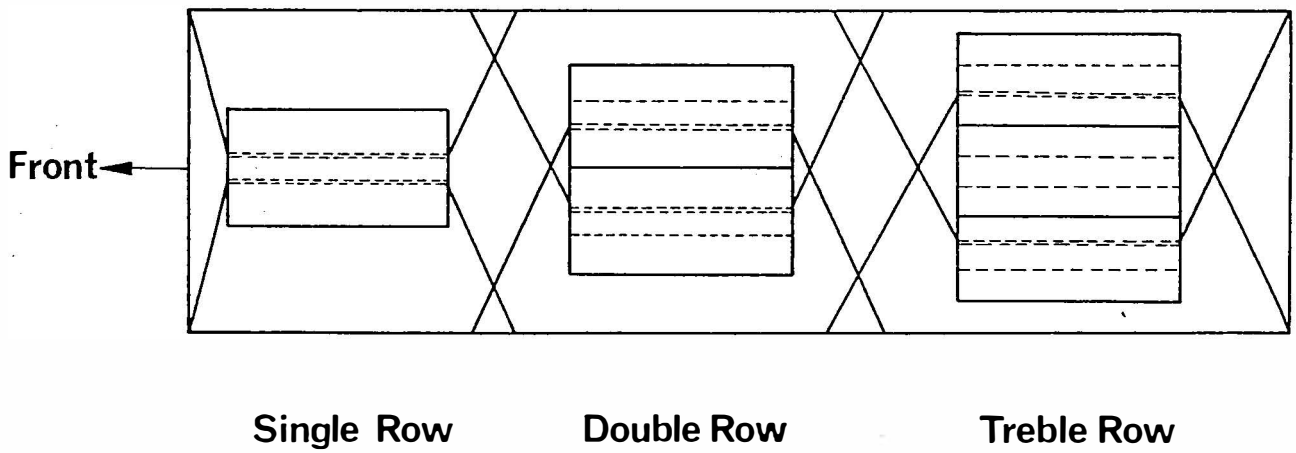

Coils with the eye vertical

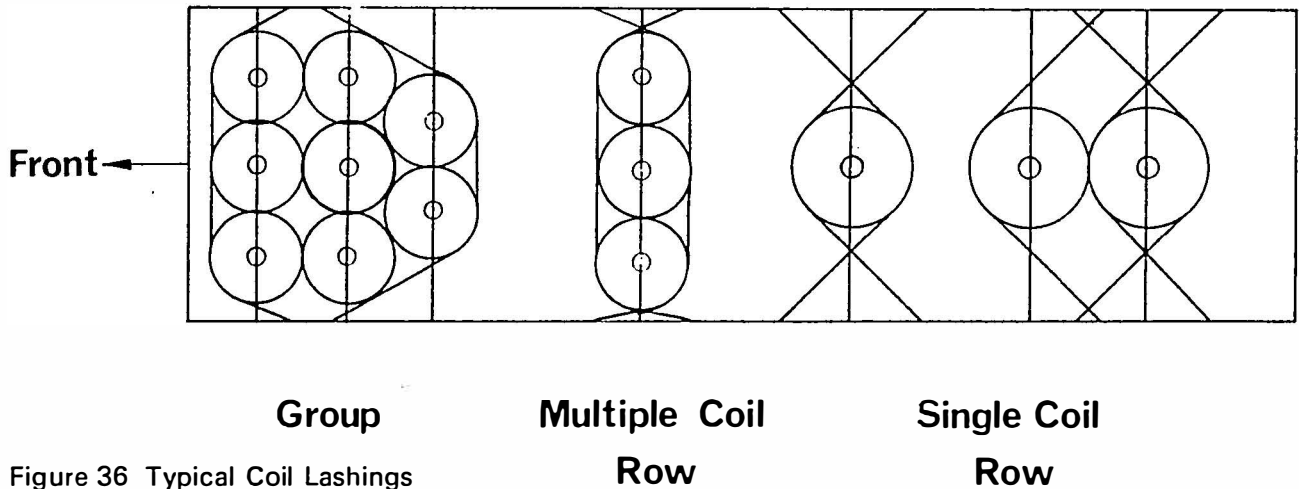

Figure 36 Typical Coil Lashings

SECTION 12. METAL LOADS

1. This section is intended to provide guidance on the measures necessary to ensure the safe carriage of metal loads. Although these can be of many forms, they can be divided into the following broad categories.

- a) Metal plate.
- b) Metal sheet in rolls (coils).
- c) Metal bars or billets.
- d) Structural steel and pipes.
- e) Large castings and fabricated units.
- f) Wire coils.
- g) Scrap metal.

2. Some types of light load eg small castings, can be carried on sided vehicles and no additional restraint will be required if the sides of the vehicle are higher than the load. In general, however, additional means of restraint will be necessary. Where loads are carried which could apply localised forces, headboard and sideboards should be reinforced.

3. Certain general principles apply to all metal loads, and these are outlined below.

LOADING ARRANGEMENT ON VEHICLE

4. The principles outlined in Section 4 will apply. In particular the load should, whenever possible, be placed against the headboard, and evenly spread to keep the centre of gravity as low as possible. The load should be packed and lashed in such a way that no part can move in any direction independently.

RESTRAINING DEVICES

5. In general chains and tensioners will be used to secure many types of metal load. The

selection of lashings should be based on the principles set out in Section 6. Where ropes or webbing are used, particular care should be taken to avoid contact with sharp edges.

FRICTION

6. The friction within metal loads will, in general, be low particularly if the metal is greased. It should therefore be disregarded when methods of restraint are being decided.

7. If the metal is strapped into units for ease of handling, the straps should be in good condition, and should be examined to ensure that they have not been damaged in transit or handling.

METAL PLATE

8. The load should, whenever possible be placed against the headboard or bulking, with short plates on top of the load and at the front so that they cannot slide forward. Smaller plates should be placed on top of large ones where practicable.

9. When the load consists of two or more lifts along the deck of the vehicle, the lifts must be placed in contact, or spacers must be used to prevent the rearmost lift(s) sliding into the other(s). No lift should be higher than the one in front where possible and each lift must be restrained in a manner which complies with the principles set out in Section 4.

10. Where the use of dunnage is unavoidable, it must comply with the conditions set out in Section 4. It must be positioned so as to prevent any whip in the load.

METAL SHEET IN ROLLS (COILS)

11. In the following paragraphs a coil face means the rounded outer surface, and the side is the flat surface presented by the edge of the metal strip. A coil refers either to a single coil or series of coils bound together side-to-side to form a cylindrical unit. A row of coils is one or more coils on a line across or along the platform, resting on their faces. All coils in a row must be of approximately equal diameter.

12. Coils should whenever possible be carried on purpose-built vehicles.

13. *Arrangements of Coils on the Platform.* Coils must not be loaded higher than one layer.

a) Where rows are lined across the platform, the coils must be in contact with the next row on the vehicle, and the front and rear rows must be blocked across the entire width of the platform. The blocking timber must be at least 4" x 4". No row should be wider than the one in front of it.

b) Where rows are lined along the platform, the rows must be in contact along the centre of the platform, and of equal length. They must be blocked against outward movement by timbers at least 4" x 4" along their entire length.

c) Where coils are on their sides, all coils in a line across the vehicle should where

possible be approximately equal height and contact the coils in front of them or an intermediate spacer. No line of coils across the vehicle may be wider than any group in front of it, and the front line must be blocked against forward movement.

14. *Lashing.* The lashings must comply with the principles outlined in Section 4. For this purpose each line of coils across the vehicle is considered separately, and must be lashed. If the load is placed with the eyes across the platform, the cross lashings may pass through the eye and be angled forward or rearward to provide the appropriate restraint. The lashing of the rearmost row must be angled forward to prevent spreading. If the coils are loaded on their faces, the lashings for each line must pass approximately over the centre of each coil (see Fig 36).

METAL BARS OR BILLETS

15. This type of load poses particular problems since one bar can easily penetrate a headboard if it is allowed to move. It is essential, therefore, that the vehicle is loaded in such a way that the complete load forms a unit, and no bar or bars can move out of the load.

16. *Arrangement of the Load on the Platform.* The load must be stable without lashing. If lower layers are lashed to prevent spreading, this must be done before the next layer is put in place, and lashings must not support the weight of the upper layers. If the bars are laid along the platform, where possible, no bundle or pile should be bigger than a bundle or pile in front of it, and piles must be in contact or baulked to prevent forward motion.

17. *Lashing.* Each pile must have sufficient cross lashing to comply with the conditions in Section 4. If it is possible to baulk against sideways movement this should be done. It may be necessary, if the load is not against the headboard, to provide baulking to the height of the load at the front to prevent forward movement.

STRUCTURAL STEEL AND PIPES

18. Many of the problems associated with metal bars also apply to structural steel and pipes, and, in particular, to maintaining the load as a solid unit.

19. *Arrangement of the Load on the Platform.* The load should, whenever possible, be placed against the headboard or baulking, which should extend to the full height of the load. It should be kept as low as possible, and smaller items placed on top. No layer should be bigger than the one beneath it.

20. *Lashing.* The selection and use of lashings should be based on the principles set out in Section 6. Whenever possible stanchions, either attached to the vehicle or to specially made bolsters should be used to provide lateral restraint. The stanchions should extend to the height of the load, and be fitted with top chains. If there are no stanchions baulking should be used to prevent lateral movement. It is essential that the load be restrained in

such a way that no single part of it is free to move in any direction independently of the rest. The use of dunnage should be avoided wherever possible, but if it is necessary then it should comply with the requirements of Section 4.

LARGE CASTINGS AND FABRICATED UNITS

21. This type of load is usually carried in a purpose-made cradle, which must be sufficiently strong to resist the forces which might be imposed on it.

22. It will often be impossible, for weight distribution reasons, to place this type of load against the headboard, so, if no baulking is provided, all the restraint will have to come from the lashings, and thus a correspondingly greater number will be necessary.

23. The lashings must be so arranged as to prevent the load toppling, as well as preventing movement relative to the vehicle. Thus, it will be necessary to lash over the top, or to points high on the load or cradle, even if baulking at deck level is used to provide the majority of the restraint.

WIRE COILS

24. Wire coils carried on purpose-designed vehicles according to the manufacturer's recommendation will be secure.

25. *Load Arrangement on Vehicle.* When coils are carried on flat platform vehicles, they will in general, be placed in rows along the platform. There will usually be three rows, and it is not recommended that coils should be placed on top of those on the deck. It will be necessary to place the front coils against a vertical obstacle, usually the headboard, to prevent them falling over. All coils behind them must be kept as nearly vertical as possible. The rows of coils along the deck must be in contact with each other.

26. *Lashing.* The coils must be baulked against sideways movement along the entire length of the load. The rearmost coils must also be baulked against rearward movement. The lashings must prevent the coils from rocking backwards and forwards under braking and acceleration. Thus, particular care must be taken to lash forwards from the rearmost coils. The lashings must comply with the requirements set out in Section 4.

SCRAP METAL

27. Scrap metal can be of many forms and may or may not come into one of the categories itemised above. If it does, then the loading and lashing arrangements must be as outlined in the appropriate section.

28. Scrap metal may be carried in sided vehicles, with no additional means of restraint. The conditions which must be met are outlined in Section 13. Care must be taken with loads of scrap to ensure that the load forms a complete unit, and all parts of it are secured to the standards of Section 4.

SECTION 13. LOOSE BULK LOADS

1. Loose bulk loads can be described generally as those having a nature which does not readily lend itself to any form of packaging or containerisation, eg, sand, ballast, aggregate, shingle, etc.
2. Clearly the loading and securing of such loads do not pose the many problems associated with general freight, but nevertheless they do have security problems peculiar to themselves.

BASIC SAFETY PRINCIPLES

3. Vehicle's gross weight and/or individual axle weights must never be exceeded.
4. Loose bulk loads which are liable to fall from the vehicle should at no time be higher than the sides of the body in which the load is being transported. If the load is heaped to its own natural 'angle of repose' this could result in load shedding due to the vehicle's movement.
5. As these loads normally rely upon the body for restraint against those conditions given in Section 5, it becomes extremely important to ensure all body-to-chassis attachment points eg 'U' bolts, hinge pins, hinge pin brackets etc, are always secure and that these and the body are in sound condition.
6. Loose bulk loads should be sheeted whenever there is a risk of load shedding due to wind action.
7. Bodywork should be kept in good condition so as to minimise the nuisance effect of leakage during transportation.
8. Body height extensions should only be used where conditions and type of load permit. In these circumstances their supports must be adequately fixed to the existing body. It is not considered adequate to rely upon the load within the parent body of the vehicle for support. Where necessary tie-chains should be used transversely at the top of body extensions to prevent sideways spread.

APPENDIX A REGULATIONS CONCERNING 'DANGEROUS GOODS' CARRIED BY ROAD VEHICLES

Order of Secretary of State (No 11) dated 20 September 1924, byelaws as to the conveyance of explosives on roads and in certain special cases—SRO 1924 No 1129.

The Conveyance of Explosives Byelaws 1951—S.I. 1951 No 869.

The Conveyance by Road of Military Explosives Regulations 1969—S.I. 1969 No 20.

Poisons Rules 1970—S.I. 1970 No 798.

The Carbon Disulphide (Conveyance by Road) Regulations 1957—S.I. 1958 No 313.

The Gas Cylinders (Conveyance) Regulations 1931—SRO 1931 No 679.

The Compressed Gas Cylinders (Fuel for Motor Vehicles) Conveyance Regulations 1940—SRO 1940 No 2009.

The Gas Cylinders (Conveyance) Regulations 1959—S.I. 1959 No 1919.

The Petroleum-Spirit (Conveyance by Road) Regulation 1957—S.I. 1957 No 191 and amending regulations S.I. 1966 No 1190.

The Inflammable Liquid (Conveyance by Road) Regulations 1971—S.I. 1971 No 1061.

The Corrosive Substances (Conveyance by Road) Regulations 1971—S.I. 1971 No 618.

The Radioactive Substances (Carriage by Road) Regulations 1970—S.I. 1970 No 1826.

Other regulations are in the course of preparation by the Home Office.

APPENDIX B THE SAFETY OF LOADS ON VEHICLES DO'S AND DON'TS FOR DRIVERS AND OTHERS CONCERNED WITH THE LOADING OF VEHICLES

SAFE LOADING

Your own life and the lives of others may depend upon the security of your load.

DO'S

1. Do make sure your vehicle's load space and the condition of its load platform are suitable for the type and size of the load.
2. Do make use of load anchorage points.
3. Do make sure you have enough lashings and that they are in good condition and strong enough to secure your load.
4. Do tighten up the lashings or other restraining devices.
5. Do make sure that the front of the load is abutted against the headboard, or other fixed restraint.
6. Do use wedges, scotches etc so that your load cannot move.
7. Do make sure that loose bulk loads cannot fall or be blown off your vehicle.

DON'TS

1. Don't overload your vehicle or its individual axles.
2. Don't load your vehicle too high.
3. Don't use rope hooks to restrain heavy loads.
4. Don't forget that the size, nature and position of your load will affect the handling of your vehicle.

5. Don't forget to check your load:
 - a) Before moving off.
 - b) After you have travelled a few miles.
 - c) If you remove or add items to your load during your journey.
6. Don't take risks.

FINALLY

Study the more detailed advice in the code of practice on the safety of loads on vehicles.

If you are in doubt at all about the safety of your load seek guidance from your employer or supervisor.

HER MAJESTY'S STATIONERY OFFICE

Government Bookshops

49 High Holborn, London WC1V 6HB

13a Castle Street, Edinburgh EH2 3AR

109 St Mary Street, Cardiff CF1 1JW

Brazennose Street, Manchester M60 8AS

50 Fairfax Street, Bristol BS1 3DE

258 Broad Street, Birmingham B1 2HE

80 Chichester Street, Belfast BT1 4JY

*Government publications are also available
through booksellers*