

AKAN STOOLS AND THEIR SOCIAL CONTEXT

by

A.K. Quarese

**Thesis submitted for the Degree of
Doctor of Philosophy at the
University of Edinburgh
August 1970.**

PREFACE

One of the fields of study that has unfortunately received little sustained interest and serious research in Ghana is that of the Visual arts and Society. This is unfortunate because in a country like modern Ghana, where a lot of social history and many aspects of the anthropology or sociology of the people lie dormant and documented in what I call voices of silence or plastic language -- the visual arts, material culture and symbolic anthropology. In this matter, I regard Captain R.S. Rattray as one of the greatest scholars who studied As^{ante} among other methods, that of observing and reaching their culture by way of their material culture. I have been indeed, greatly inspired by his works. Recently, Dr.A.A. Kyerematen has been studying As^{ante} regalia and his contributions promise to throw a lot of light on aspects of the topic.

My own interest in this field of study -- the visual arts and society -- was initially kindled by Prof. J.H. Nketia of the Institute of African Studies, University of Ghana, Legon, and I am very thankful to him.

This thesis, Akan Steels and their social context, is an attempt to study the aesthetics, the social and political significance of an object of art in the culture of the Akan of Ghana. The study centres round the sculpture and how ideas and institutions have developed in relation to and association with its use in society. The object is ubiquitous in the culture. It is present at the domestic level of society where it has attained importance in ceremonies relating to life crises in addition to its use as an

item of household furniture. It is, however, in politics and government that we come across the highest development of its use. We have the fact of a special kind of government which is referred to in the thesis as the Akan 'stool polity' -- a type of political organization of offices that has developed in relation to, and in association with, the use of a special object of art -- the stool in society; a stool complex -- the complex of material objects and personnel which support the stool office; the stool and ancestor reverence -- the use of the stool in ceremonies of reverence to the ancestors and also a means of political socialization of the people; stool symbology -- a complex of symbols in stools and their extensions as epitomes of communal values and usages in plastic proverbial language; and the stool in contemporary culture of Ghana.

This particular topic of my study was first suggested to me by Dr. Malcolm Ruel in 1967 when I was in the University of Edinburgh to begin a preliminary work on a similar project - the social framework of the arts of a people of Ghana. This study has been both exciting and exacting and I am very grateful to Dr. Ruel who suggested it to me.

The field work of this study was done extensively and intensively over a period of four and two years respectively in which the author continuously participated in the social life of stool carvers, officials of Akan and non-Akan chiefs and the life of selected village or town communities. He sat in the courts of Ghanaian chiefs of all ranks and not only observed but also participated in state ceremonies to the extent he was allowed to do.

The method of study, therefore, consisted primarily in participant observation, informal and formal discussions with ordinary citizens of the communities, carvers, chiefs and court officials.

The approach was inter-disciplinary -- art, history and sociology. Relevant available literature on the sculpture, the history and culture of the Akan with special reference to Asanté, Denkyira, Akim, Akuapim were read. Material on other Akans like the Fanti, the Wassi and Nzimas, and other non-Akans like the Gas and Adangmes were also examined for comparative studies. This was useful background work to the primary and secondary studies I had to undertake in the project.

First, pilot surveys were conducted in Ahwiaa, the accredited stool carving village of the king of Asanté, and Apsah, a village of Mampong Asanté. The purpose of the surveys was to test draft questionnaires on (a) the stool carver in Ghana and (b) how much alive the sculpture and its associations are in present day Akan society.

Four categories of questionnaires were administered. They were a) a general questionnaire - a physical count questionnaire to find out actual numbers of stools that exist in given communities and what ordinary people mainly knew about the functions of stools; (b) qualitative questionnaires to find out from specialists on aspects of stools, (black stools, priestly stools, etc.); (c) the aesthetics of the sculpture from carvers, stool symbology from stool artists, chiefs and the court officials of chiefs.

After the pilot surveys in which the questionnaires were open ended, precoded questionnaires were drawn for the actual field research.

Three undergraduate assistants namely Messrs Alex Agyeman, Appea (Legon) and K. Okyere (Cape Coast) helped in the administration of the first category of questionnaire. The author and his permanent research assistant supervised the administration of this physical count questionnaire in ten selected towns in the summer of 1968. The assistants had a fortnight's training since their work involved writing down answers there and then on provided forms as they interviewed respondents. Their work ended with the completion of the interviews, but Mr. Agyeman later helped in the final collation and in many other vital ways.

The other questionnaires were dealt with by the author and Mr. Kwabena Ameyaw now the Rev. Fr. Ameyaw Gyamfi of the Anglican Church, Ghana, who was then permanently attached to the ethnographic section of the Institute of African Studies, Legon. Histories, customs, ceremonies, the language of drums and art were recorded by the author assisted by this field auxiliary.

The author found that it would be more meaningful and easier to study and indeed more interesting to record aspects of the work by resorting to some documentation in photos. Photography was not only a useful research device but also a profitable recording method. Photography of stools and associated sculpture and art was undertaken. A number of these pictures have been used in illustrating the write up of the results of my research. In this, the inspiration was taken from Captain R.S. Rattray's

works on the Art and Religion of the Asanté and the Asanté in general.

There are ten chapters in all in the thesis, and they deal with the following sub-topics as indicated. I. An introduction, giving the background of the Akan and the study, II. The making of the stool, III. the stool as a symbol of office and the 'stool polity', IV. the stool complex, V. Akan stool symbology, VI. the stool and ancestral reverence, VII. Other common non-chiefly Akan asesedwa (stools), VIII. Akan stools in non-Akan lands, IX. Stools in contemporary Ghana and X. Recapitulation and observations.

The style of the write up is both in the ethnographic present and the past tense. Many of the recorded ceremonies are records of actual field observations although they are put in the present. In spite of the fact that the records referred to are mostly eye-witness accounts, references have been quoted where they have been observed before and recorded by previous investigators.

In the final chapter, an attempt has been made to assess the value of the facts to such studies relating to the culture of Ghanaian society as a whole.

At the end of the specific period of my study, I fully realized that I was only able to scratch the surface of an apparently rich mine of knowledge waiting to be exploited. The study of the arts and society of Ghana seems to have

considerable light to shed on the visual anthropology and aesthetics, history and sociology of the country. The author will in future be looking in more detail at aspects of this kind of study.

A. K. G.

TABLE OF CONTENTS

	<u>Page No.</u>
PREFACE	i
TABLE OF CONTENTS	vii
LIST OF TABLES	x
LIST OF FIGURES.....	xi
LIST OF PLATES.....	xii
LIST OF APPENDICES.....	xvi
ACKNOWLEDGEMENTS.....	xviii
SUMMARY	xxi

CHAPTER I - INTRODUCTION 1

The Akan of Ghana - Administrative Divisions. The major Akan groups - Akwamu-Akim-Denkyira-Asante - the asasgdwa (stool) in Akan culture - the Osgsg tree and the stool called after it - the gsasg and preservation of the stool - the idea of the stool - duties and privileges imposed by the stools as a political symbol - terminology and categories of stools (akonwa) in Akan culture - glossary of terms.

CHAPTER II - THE STOOL AND ITS MAKING 37

A typical Akan asasgdwa - general extent of the carving -table showing interview with carvers outside Ahwiaa and their idea of relationship with Ahwiaa as the origin of the art - Akanland as the home of the art, history of origin and growth of Ahwiaa - spreading the art of stool carving from Asante - the role of the Ahwiaahene as the Asante-hene's stool carver - relationship between the Ahwiaahene and the king's carver - political and social ranking in Ahwiaa - the stool carver of Ahwiaa - the Ahwiaa stool carver of today - the technical process of stool carving and terms of stool carving and the tools - evaluation of stool carving and its anonymity:Ahwiaa - replacement of stools.

CHAPTER III - THE STOOL AS A SYMBOL OF OFFICE	Page No.
	84

Akan political stools and their development -
 The Abakandwa of Denkyira stool polity pre 1700 -
 Akwamu - the Golden Stool of Asante as head of a
 polity - the coming of the Golden Stool - the Golden
 Stool of Asante as an unwritten constitution - the poli-
 tical position of Asante stools in relation to the
 Golden Stool - Creation of further stools offices -
 Mmamadwa - constitutional use of the stool - succession
 to a stool and the queen-mother - enstoolment of the
 Asantehene - other occasions in which the stool is in
 evidence - (a) destoolment; (b) the stool in battle,
 the Akan stool polity - a summary.

CHAPTER IV - THE STOOL COMPLEX AND ITS ASSOCIATED REGALIA..	122
--	------------

Definition - Akia Abuakwa - Stool Carriers - Stool
 Houses - Wirempefe - Kwadwofoe - Kyeremadefo, Asekwafo
 ne Mpintinkafe - Black stools - (a) How stools are
 blackened; (b) When stools are blackened - the
 late Asantehene Nana Sir Agyeman Prempeh II and his
 regalia at one of his last durbars at Kumasi - Descrip-
 tion of the Mamponghene of Asante in some stool regalia
 - pictorial examples and notes of some Akan stool regalia
 (in the stool complex).

CHAPTER V - SYMBOLISM IN STOOLS	178
--	------------

General Elements of Design.
 Common Symbolic Elements.
 Typology of Stools. Other Typologies.
 Clan Totems in Asgadwa
 Ranking of Stools and Their Designs.
 Symbolism of Metals and Stools.
 A further Note on the Social Uniqueness of the
 Golden Stool of Asante.
 The Art of the Golden Stool.
 Newer Asgadwa (Stools).
 Recognizability of Designs and Meanings.
 Symbolism in Stools Presented to some Heads of
 States in 1961 and 1962 and their Significance.
 Other Royal Stools also called Nnwa or Ndwa.

CHAPTER VI - AKAN 'STOOLS' AND ANCESTRAL REVERENCE 226

Ahenwa - Awukudae - Akwasidae, Odwira - The religious and political significance of the black stools in rituals, social and political drama in Odwira or Adae Keeseg.

CHAPTER VII - OTHER COMMON NON-CHIEFLY AKAN ASESEDWA..... 244

Children's stools - Nkrabea stool - Household and bridal stools given in ten selected towns - puberty and bridal stools - edudwandwa - Marimadwa - Priestly stools - other kinds of stools.

CHAPTER VIII - THE STOOL (ASESEDWA) IN NON-AKAN LANDS OF GHANA..... 256

Emergence of the asesedwa in Ga, Krobo, Shai and parts of Eweland - Ga (Accra) - Shai - Manya and Yile Krobo Northern and Southern Krobo - Ho and Kpandu (Eweland). The asesedwa and chiefship in these non-Akan lands - Stool festivals.

CHAPTER IX - THE STOOL IN CONTEMPORARY GHANA..... 273

Resilience of the Asesedwa in the Culture.
Description and Use of Presidential Stool in Parliament House.
The Mace.
Other Symbols in Parliament House - Accra.
Further Development and Use of Stool Symbology in Ghana.
Names of Miniature Stools - Donated to the Scottish National Museum, Edinburgh by Dr. A. MacPherson, 1948.
The Stool in Ghanaian Heraldic Shields.
Stool Symbolism and Christian Church Art.

CHAPTER X - RECAPITULATION AND OBSERVATIONS..... 285

APPENDICES 290

BIBLIOGRAPHY 329

.....

LIST OF TABLES

<u>Table No.</u>		<u>Page No.</u>
I	Table showing the Eight Principal Akan Clans, their Moities and Symbols and the Eight Principal Patrilineal Groups.....	6
II	Table showing interviews with carvers outside Ahwias and their relationship with Ahwias as origin of the art.....	39a.
III	Households and Bridal stools given in the ten towns of the Survey. Children's stools given in four of the ten towns.....	251a.

LIST OF FIGURES

<u>Figure No.</u>		<u>Page No.</u>
1.	Map of Administrative Divisions of Ghana	2
2.	The Climate of Ghana and Mean Rainfall in inches.....	3
3.	Map of Ghana - Vegetational Zones.....	4
3a.	Map of Ghana, 1629	11
3b.	Diagram of typical <u>asgsadwa</u>	38
4.	General elements of design. <u>Asgsadwa</u> - Female	178a
5.	General elements of design. <u>Asgsadwa</u> - Male	178b
6.	Diagram of the ivory piece referred to as Ashangwe Stool by Dr. Carl Reindorf.....	258a
7.	Some Diagrams of Traditional Akan Stools in Contemporary Ghana (2 pages).....	279b & c.

LIST OF PLATES

<u>PLATE NO</u>		<u>BEHIND PAGE</u>
Ch. II P1a	First Group.....	71
Ch. II P1b	Second Group.....	71
Ch. II P1c	Third Group.....	71
Ch. II P2a	Nnamadwa.....	71
Ch. II P2	Karikari and Apprentices/Osei Yaw.....	71
	Yaw Dwanena; Akwasi Osei.....	71
	Kwasi Nsiah; Kwame Sampene.....	71
	Kwasi Nsiah; Kwame Adomake.....	71
	Opanyin Karikari; Yaw Kyei.....	71
	Osei Kwame; Adomake.....	71
Ch.IV.P1A & B	Example of Stool Complex.....	123
Ch.IV. P2	Historical Paluquin from Mampong Asante.....	123
Ch.II. P3	A Set of War Drums.....	126
Ch.IV. P4A	A Short Horn - I.A.S. Museum.....	127
Ch.IV.,P4B	Seven Long Horns.....	127
Ch.IV. P5	Umbrella - <u>Ebi-te-ebi-so</u>	127
Ch.IV. P5A	<u>Asoafena</u>	127
Ch.IV.P5B	Umbrella and Tops, Principal State Linguists' Staff - <u>Esono a edi nne</u>	127
Ch.IV.P5C	Asoafena - Kumasi Cultural Centre....	127
Ch.IV. P6	Linguist Staff, Fans, Umbrella Tops and Stool Bells.....	127
Ch.IV. P7	Ceremonial Stools.....	130
Ch.IV. P8	Stool Carrier of Assin Apimanin..... carrying Ceremonial Stool.....	131
Ch.IV. P9	Portrait of a Stool Carrier of Asante-Mampong, c 100 years old.....	134
Ch.IV. P10A	Black Stool in the Royal Scottish Museum, Edinburgh.....	148

Ch. IV. P10B & C	Black Stools of Akwamu.....	148
Ch. IV. P11	Asante-Mamponghe in State Regalia..	164
Ch. IV. P12A(1)	<u>Adweneasa</u>	170
Ch. IV. P12A(11)	<u>Sika Futuru</u>	170
Ch. IV. P12A(111)	<u>Needa</u>	170
Ch. IV. P12B(1)	<u>Asankanea</u>	170
Ch. IV. P12B(11)	<u>Kyiritwie</u>	170
Ch. IV. P12C(1)	<u>Oyokoman</u>	171
Ch. IV. P12C(11)	<u>Okomfo Anokye</u>	171
Ch. IV. P12D(1)	<u>Akyempim</u>	171
Ch. IV. P12D(11)	<u>Sika fra mogya</u>	171
Ch. IV. P12E(1)	<u>Asisrapa ne nnomaa agorg</u>	172
Ch. IV. P12E(11)	<u>Fie buo ye buna</u>	172
Ch. IV. P12F (1)	<u>Kyiritwie</u>	172
Ch. IV. P12F(11)	<u>Abrewaben</u>	172
Ch. IV. P12G(1)	<u>Toku</u>	172
Ch. IV. P12G(11)	<u>Nyankonten</u>	172
Ch. IV. P12H	Battle Dress and Complex.....	173
Ch. IV. P12J	Kuntunkuri and Adinkra Cloths.....	173
Ch. IV. P12J	Other Items of Battle dress	
	Complex - Whisks and Caps.....	173
Ch. V. P1	<u>Duakoro</u>	178
Ch. V. P2.	<u>Afanu</u>	178
Ch. V. P3	<u>Anansa</u>	178
Ch. V. P4	<u>Nyaana</u>	178
Ch. V. P5	<u>Nyaanum</u>	178
Ch. V. P6	<u>Abebudwa</u> (nwa - pl.).....	178
Ch. V. P7	Ahwiaahene's Stools (A & B).....	180
Ch. V. P8	A Set of Stools from Koferidua.....	180
Ch. V. P9	Queenmother's Ceremonial Stool	
	Mampong-Asante.....	182
Ch. V. . 1.65.38(9a)	Stool of Akomadanhene - Nana Kofi Nti.	
	I.A.S. Museum. Legon - Accra.....	182
Ch. V. P10	<u>Apodwa</u>	182

<u>PLATE NO</u>	<u>BEHIND PAGE</u>
CH. V. P11	A Set of Proverbial Stools..... 182
Ch. V. P12(A & B)	<u>Nyansapo</u> 182
Ch. V. P13	<u>Nyamedua</u> 182
Ch. V. <u>R</u>	Rattray's Examples of Stools (1927)..... 182
Ch. V. P14	A Set of Stools - Four Types..... 189
Ch. V. P15	<u>Asempa Mmeremu</u> 189
Ch. V. P16	Metalled Stool 200
Ch. V. P17	Richly decorated <u>Nyansapo</u> with Repouse. 200
Ch. V. P18 A&B	'T' and 'X' shaped Metal Crosses..... 201
Ch. V. P. 19	A Set of Special Historical Stools..... 201
Ch. V. P 20	Nana Kofi Adinkra Stool enlarged..... 201
Ch. V. P21	The Ceremonial Golden Stool of (a) Asante (b) Ceremonial Silver Stool of <u>Mampong-Asante</u> 204
Ch. V. P22	Contemporary Stools in Traditional Idiom..... 209
Ch. V. P 23	<u>Baako-Nntena Stool</u> - Yugoslavian President.....216
Ch. V. P24	<u>Hye-wo-ho-nnhye</u> stool. Hungarian President.....217
Ch. V. P25	<u>Dwantire Stool</u> Polish President.....218
Ch. V. P26	<u>Adwoe</u> Stool Indonesian President.....219
Ch. V. P27	<u>Odofe Nnyera kwan</u> stool Russian President..... 220
Ch. V. P28	<u>Siare</u> Stool Czechoslovakian President..... 220
Ch. V. P29	<u>Odofe Nnyera kwan</u> stool..... 221 Queen of England.
Ch. V. P30	<u>Nkonsonkonsen</u> Stool Prince Charles of Britain..... 222
Ch. V. P. 31 A & B.	<u>Asipin</u> 223

Ch. V. P32	<u>Hwedom or Naama</u>223
Ch. V. P33	Chair of State belonging to the last Dutch governor of Gold Coast..... 224
Ch. V. P34	Chair of State of last governor of Togoland..... 224
Ch. VI. P1 (1 & 2)	White Stool Washing..... 228
Ch. VI. P 1(1 & 2)	More White Stools..... 228
Ch. VI. P2 (1 & 2)	Drama at an Akwasidae at Kumasi..... 241
Ch. VII. P1A	An <u>Nkrabea</u> stool..... 246 (Stool given as a result of divination) Cat. No. 1.67.58. I.A.S. Museum. Legon.
Ch. VII. P1 (1 & 2)	<u>Tekua Nta</u> (Double <u>Ntekua</u>)248 <u>Makai Hairdo</u>248
Ch. VII. P3(1)	Recipient of an <u>Eduwandwa</u> at Mankessim....249
Ch. VII P3(2)	<u>Eduwandwa</u> - <u>Nyaanan Maadwa</u> Type.....249
Ch. VII. P4	A White <u>Asasedwa</u> plastered with white clay.....252
Ch. VIII. P1	The Ceremonial Stool.....259
Ch. VIII. P2	Round Top Type.....260
Ch. IX. P. 1 & 2	Presidential Chairs in Parliament House, Accra - Ghana 275
Ch. IX. P.3	Speaker's Dais and Clerk's Table - Parliament House, Accra - Ghana..... 278
Ch. IX. P4A	Crest of Kumasi College of Technology, Kumasi - Ghana.....281
Ch. IX. P4B	Main Gate of the Kumasi University of Science and Technology, Kumasi.....281
Ch. IX. P5	Altar of Emmanuel Church, Labadi, Ghana.....283
Ch. IX. P6	Half moon State Umbrella283
Ch. IX. P7	Railings Replica of State Swords. The Symbol of Promise..... 283

LIST OF APPENDICES

<u>Appendix No.</u>		<u>Page No.</u>
1	Dynasty of Boa Asri Stool (Ahwisa)	290
2	The Artist - Carver	291
3	Summary of Requirements of the Golden Stool	294
4	Stool Occupant and Ownership of Private Property	296
5	Family Head Only -- Physical Count and Analysis	298
6	Involvement of the Stool in Social Life Regalism/Government and Politics	302
7	Black Stools	307
8	Examples of Lineages that possess Black Stools and the Design of the Principal Stool of the Village or town..	313
9	Motifs on top of Linguist Staff etc. ...	316
10	HORNS. Nine Special Horns of Juabeng Asante	319
11	Adinkra Designs (A Selected Sample).....	321
12	MEMORANDUM on the Relation between Christian and the State presented to Nana Agyemang Prempeh II, Asantehene, by representatives of the Christian Churches in Asante on the 16th October, 1942	326

BIBLIOGRAPHY

1	Books and Publications Quoted or Referred to in the Text	329
2	Books and Publications Consulted but not mentioned in the Text	333

ACKNOWLEDGEMENTS

This study was possible because of the help of many people and agencies. I have mentioned Dr. Malcolm Ruel with gratitude as the scholar who first suggested the topic of this thesis to me. Not only did he do this, but he was my official supervisor throughout my work and his interest in the work was marked in several ways. He was out in Ghana in the spring of 1969 while I was doing my field work to help and encourage me among other things. He took a major part in fashioning the framework and even the chapters of the thesis. Furthermore, he read my drafts painstakingly and wrote copious criticisms on them. His patience in supervision and direction has been mainly responsible for the merits in the present form of the thesis and I am very heavily indebted to him. I thank him most sincerely.

The nature of the study demanded considerable financial assistance. In the matter I am very grateful to Prof. J.H.Nketia of the Institute of African Studies, University of Ghana who made funds available to me for my field work. I had an almost exclusive use of a departmental car and this facilitated my movements. Upon the recommendation of my supervisor, Prof. Nketia provided me with an efficient camera with which I documented in pictures most of the objects of art I had to study. It was in fact, he who arranged for the grant of my leave of absence from my post at the university. I am very thankful to him for making the study possible at all.

At this point I should like to thank the vice chancellor, Prof. A.A. Kwabong of the University of Ghana for granting me the leave of absence and for being the final authority that sponsored my research.

I thank all my field informants some of whom had to be subjected to rather long and tiresome interviews. I also thank Mr. T. Paplampu, B.A. (Hons.), headmaster of A&A Secondary School, Ghana, who was in Edinburgh in the academic year 1969/70 for his encouragement and help in diverse ways; Dr. J. Aye Langley of the Centre of African Studies, University of Edinburgh for constantly drawing my attention to material in his field of political science relevant to my study, and for reading through parts of the thesis and making useful suggestions; Rev. Alan Cliff, M.A., Dip.Th; and my many well-wishers of his church - Methodist Central Hall Edinburgh - whose help and moral support sustained me during my most difficult days in Edinburgh; my colleague Richard Greenfield of the Institute of African Studies, Legon, for chasing after and sending to me vital pictures for my work which I had to leave in Ghana. Other people whose help cannot remain unacknowledged are my research assistant, now the Rev.Fr. Ameyaw Gyamfi of the Anglican Church, Ghana, who besides helping in my field recordings did most of the driving on my treks; and to each and all of the supporting research staff of the Institute who helped in the typing and other work in the preliminary processing^{of} my material. I also thank Mrs. Aileen Harper of the Department of English Studies (Foreign Students), University of Edinburgh for her part in the typing of this thesis.

Finally, I thank all the authors whose work I consulted or quoted. I have clearly indicated whom and what I have quoted in the thesis in appreciation of their invaluable contribution to my work.

While thanking all who helped to make this work possible, I should like to state that I am solely responsible for any demerits of this work.

A. K. Quarcoo.

DECLARATION

Except where otherwise indicated, the fieldwork and the write up has been done entirely by me.

A. K. Quarcoo.

AKAN STOOLS AND THEIR SOCIAL CONTEXT - A SUMMARY

This thesis is a study of aspects of the aesthetics, the social and political significance of a simple sculptural object in the culture of the Akan of Ghana.

As an introduction, an attempt is made to give a brief survey of the geographical spread and sub divisions of the Akans, the principles of their social organization and the special position of Asɔntɛ among this ethnic group, the emergence of Denkyira and other Akan states which had centralized political systems that preceded Asɔntɛ. The introduction mentions the general method by which the Akan institution of chiefship especially, and the art of carving the asesedwa type of stool - the central object of the study - associated with the institution spread to the neighbouring peoples.

Since Ahwiaa, a village of Ashanti, has for many years been the official stool carving village of most of the important Asɔntɛ chiefship stools, its history is studied with the view of tracing the history of this art. The stool artist, both past and present, is studied and the technical process of carving and finally the art and life in the village are examined. Denkyira is suggested as the known origin of the art in Ghana and stool carving is the chief occupation of the people of Ahwiaa.

Central to the thesis is the object of the stool in the political organization of the Akan. In Akan, stools acquired

a marked importance but this was very outstanding in Asanté. The asesedwa acquired special significance in relation to developed attributes of chiefship where chiefship is set within a complex of office holders each with specifically defined duties and rights. A special kind of organization emerged where there were hierarchies of stools and not persons culminating in an ultimate all inclusive constitutional symbol, which in Asanti has been the Golden Stool - the symbol of Asanté unity and continuity. There has been a clear distinction between the person and the office of a stool occupant and there are procedures of installation of a person to the office and demotion from the office. We have called the political organization which evolved in association with the use of stools where stools attached to kin-groups, the 'stool polity'. The success of stool polities helped a spread of the idiom and personnel which by the time of an Asanté King, Osei Kwadwo in 1764, as it has been rightly described, reached its peak of development in the creation of specialist stools. Among others there were stools which attached to kinship only. The symbol of stool was a focus for complex constitutional structure - the office of leader, the authority of bearer and the representative of the ancestors. The clear constitutional delimitation of office allowed for recognition of personal attributes of individuals given stool offices. By the consecration of personal stools to the memory of chiefs this is given concrete evidence.

Stool offices were progressively supported by a series of material objects which we call extensions of the central symbol of office - the stool. We have defined this as the 'stool com-

plex', and have given examples from Akropong-Akuapim, Kibi in Abuakwa and other Akan states. Included in our definition for stool complex are the various officers who attend various items in the stool complex, especially stool carriers, and other stool attendants.

So in the study of the stool and the political organisation, we have distinguished between the stool - the material object - the stool office, which is office attaching to stools of kin-groups or kinship only, and the stool complex which are actually a series of material objects and personnel associated with stool offices.

We also examine the symbolism in stools - the general significance of stools, and common and specific elements - for example, femaleness and maleness, proverbs and use of metals on stools. We observe that this section will be given more examination in depth in later studies since the subtlety of the subject and other factors did not make it possible for us to know all we wished to know.

In Chapter VI the main point we attempted to make is that, quite apart from the religious significance of black stools as documented in the literature on the Akan, there is the political aspect of this object and the rituals associated with it which have not been very much stressed. Ceremonies in which black stools and others are used in ritual are besides a means of giving reverence to the ancestors, means of political socialisation and inter-generational value transmission. Hence the

great drama of stool ceremonies.

Chapter VII is a report on non-chiefly stools and their uses whilst Chapter VIII examines the emergence and significance of the asgsdwa in some non-Akan lands of Ghana for comparative purposes. Most of these places actually learnt the art of chiefship and carving of the asgsdwa from one or another of the Akan states or adopted it through contact, friendship or acculturation.

Chapter IX is an examination of the stool in contemporary Ghana, especially the use of the object and idea of the stool and stool regalia in the country's parliament. The concluding Chapter X is a recapitulation and observations. We observe in conclusion that the cultural significance of the asgsdwa is resilient but the phenomenon of cultural revivalism is giving it further importance. The study seems to confirm the notion that the stool and its extensions and other objects of art may be potential sources for validating oral traditions which the Ghana Institute of African Studies is currently actively collecting. (Ashanti Project Progress Report 1963-1966, (1966). - Institute of African Studies Ghana). The subject of symbols will be given further study as complementary studies to this thesis.

A. K. Q.

AKAN STOOLS AND THEIR SOCIAL CONTEXT

INTRODUCTION

The Akan of Ghana

The present spread of the ethnic group called Akan in Ghana is approximately between latitude 5 and 8.5° North. Parts of the Eastern Region, the whole of the Central and Western Regions, Asante and Brong Ahafo areas of Ghana are Akan. See Map Chapter I Fig 1 Modern Administrative Divisions.

Within the Eastern Region live the Akyems of Kotoku and Abuakwa, Kwahus, Akuapems, and the Asante of New Juaben who came to this part of Ghana in about 1828 as a result of a quarrel and war with Nana Osei Akote (1825 - 1827). The central Region is mainly occupied by the Fanti Akan, while in the Western Region live the Wassa and the Nzima speaking Akan. Until 1957, all Brong Ahafo was part of the Asante Region and the Brongs speak both a dialect of Akan and Asante Twi.

Climatically, all Akan lands lie within the tropical rain forest. The densest forests lie in the extreme south-west and then move North eastwards from this region to Asante and Brong Ahafo. See Maps Chapter I Fig 2 (Climate) and Chapter I Fig. 3 (Vegetation).

The forests contain various deciduous hard and soft woods including the Funtamia species, the commercial cedars like Odum the oil producing palm tree (eleas guineensis) and the plant on which the economy of Ghana has depended for the past century,

ADMINISTRATIVE DIVISIONS



Chapter I. Fig. 1

THE CLIMATE OF GHANA

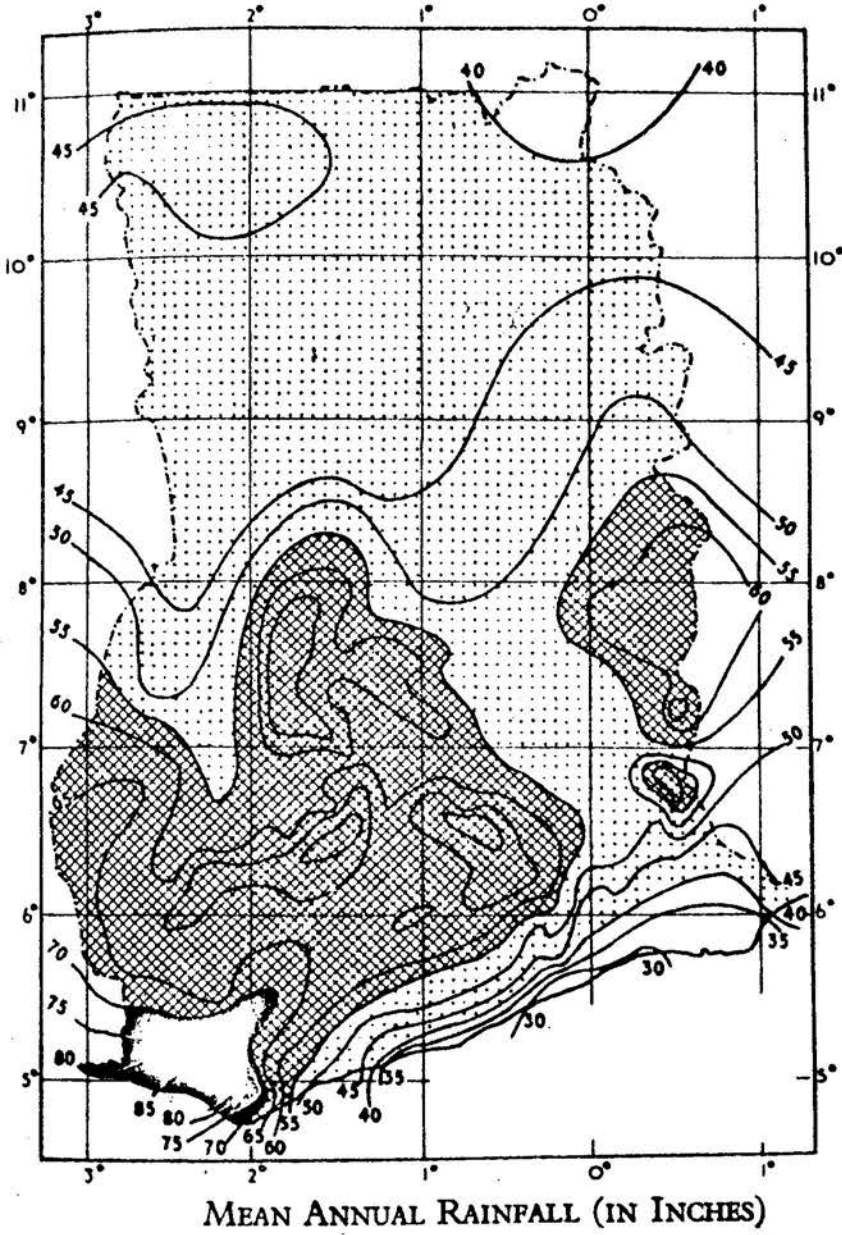

Chapter I Fig. 2.

THE PLANT LIFE OF GHANA

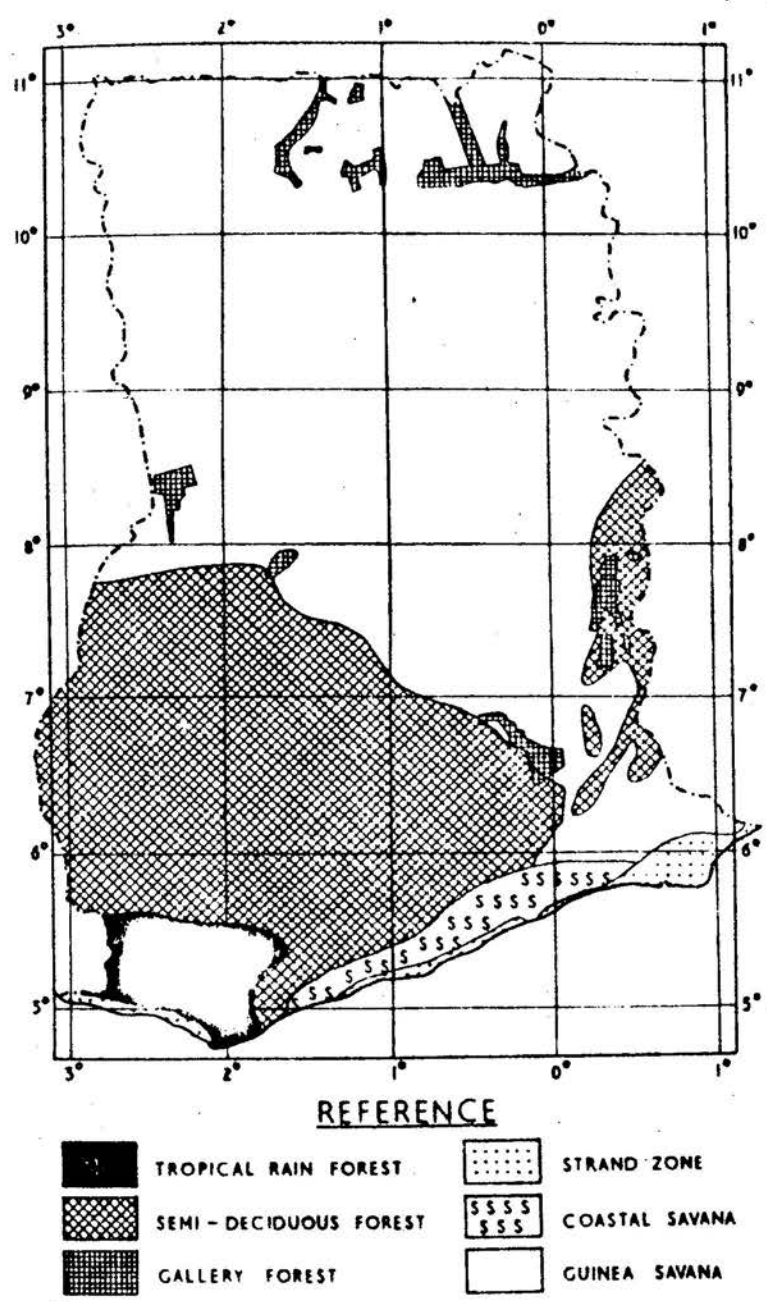

Chapter I. Fig. 3

cocoa (cacao theobroma.) In the belt most plant food items of Ghanaian diet are grown.

Linguistically the Akan have been placed in the Kwa group. A number of variations and dialects exist within this ethnic unit.

The Akan are divided into a number of matri-clans which spread all over Asante, Akuapem, Fanti, Akim and Wassa.

'Each genuine Akan group is divided into eight principal matrilineal and eight patrilineal clans: The former and their moities are Ekogna and Asokore, Oyoko (Anona in Fanti) and Dako, Asona and Dwum (or Dwamina), Asene and Asonten, Agona and Toa, Bretuo (Twidan in Fante) and Tena, Asakyiri and Amoakaade and Aquana and Abrade. The principal patrilineal groups are Bosommuru, Bosompra, Bosomtwe, Bosonnaram, Nketia, Poakwa Aram and Abankwaade. Not only do the same clans exist among all Akan groups wherever they are found, but what is more interesting is that members of the same clan consider themselves as brothers and sisters irrespective of where they hail from' (Boahen, 1966 p.4).

Each of the major matrilineal clans has a symbol. Hence the Oyoko clan which is the clan of the Premier ruling group in the historical Asante Union has the hawk (akqdeq) for their symbol. Other symbols are the parrot (akoo) for Agona; raven (kwakwaadabi) and red snake for Asona; buffalo (ekwo) for Ekogna; bat (ampan) for Asene; leopard (etwie) for Bretuo; eagle (kgre) for Asakyiri; and fire (ogya) for Aquana.¹

¹ BOAHEN, Adu A, 1963. The Akan of Ghana. Notes and Queries on History, No. 9. Also DANQUAH, J.B., 1928. Akan Laws and Customs, p. 47. London: George Routledge' Sons Ltd.

Table 1 Showing the Eight Principal Akan Clans, their Moities and Symbols and the Eight Principal Patrilineal Groups.

C L A N S

	EKOONA	OYOKO	ASONA	ASENE	AGONA	BREUTU	ASAKYIRI	ADUANA
(CLANS)								
(MOITIES)	ASOKOBE	DAKO	DWUM	ADONTEN	TOA	TENA	AMAKAADE	ABRADE
(SYMBOLS)	Bufallo	Hawk	Red Snake	Bat	Parrot	Leopard	Eagle	Fire

PATRILINEAL GROUPS

BOSOMMURU	BOSOMPEA	BOSOMTWIE	BOSOMNARAM	NKETIA	POAKWA	AFRAM	ABANKWADE
-----------	----------	-----------	------------	--------	--------	-------	-----------

Not much is known of ancient Akan history in spite of some attempts that have been made to show connection with, and influences on, Akan culture from distant lands in the Near East and North Africa. Tekyiman in Ghana is the place actively remembered everywhere we worked as the place where many Akans settled together for a time before dispersals occurred. However, allusions are often made in current oral traditions to Egypt and other lands as the original home of the ethnic group. The late Nana Attah Kwaku, Omanhene of Enchi, Nzima, gave an eloquent oral history in which he firmly underlined the validity of such claims. He traced their migration from Egypt across the Sahara. The major partings between the Akans, he said, occurred at Tekyiman.¹

¹ SIEBER ROY & QUARCOO A.M. 1967. Sefwi Wiawse and Enchi Oral Traditions. Institute of African Studies Legon Research Review. Vol. 3, No. 3, 1967.

For our purpose it is sufficient to note that the Akans have lived in their present geographical spot for the past three or more centuries and today this ethnic group is really an amalgam of people and institutions and among them are communities which are matrilineal or patrilineal or even of double descent.²

2

Generally descent is traced through the mother. It is believed that the physical continuity between one generation and another is maintained in the blood of the mother, and so a man is physically a product of his maternal kin. His jural rights and obligations are largely determined by his membership within the group. In spite of this general rule among some of the 'matrilineal Akan' specific offices, and even property may be inherited patrilineally. This happens because of the Akan theory that, man comes into being through the fusion of the mogya (blood) which comes from the mother and the ntoro (spirit) which is supplied by the male progenitor. A child's training is primarily the responsibility of his father. When a man dies, it is ideally, the son who should provide his coffin and part of his funeral expenses. He may inherit his working tools and moveable property. A son fights in the asafe (war company) of his father in war. This was why in the special political system of the Akan, the Kontɔ, stool (lit. ke = war, enti = because of) is often patrilineal; for it is the agyabosom (father's spirit) which must operate in such crises. Fortes' case study of Asante on Time and social structure throws a lot of light on the closeness and interaction of matrilineity and patrilineity in selected Asante towns.

Within the Akan are groups like the Guans who trace descent strictly from the paternal progenitor, but in such cases too, people still think of themselves as belonging to the mother's group in all things except the fact of specific descent identification.

The military organisations called Asafe among the Fanti are patrilineal organisations. Membership defines certain rights in land and inheritance of moveable property.

See also RATTRAY R.S., 1929. Ashanti Law and Constitution, p.9. 2nd Impression 1956, Oxford University Press, Amen House, London, E.C.4. RATTRAY R.S., 1927. Religion and Art in Ashanti p. 236. Oxford University Press.

It is worth mentioning Eva Meyerowitz, who contributed a lot to this aspect of the literature on Akan in her three essays on Akan: The Sacred Akan (1951), Akan Traditions of Origin (1952) and The Akan of Ghana: their Ancient Beliefs(1958). The Akan of Ghana: their Ancient Beliefs, begins with a summary of reconstructions of Akan migrations contained in the Akan Traditions of Origin. She gave an impressive account of reigns of kings and queens of the Bono Kingdom from 1295 - 1740 and attempted to draw analogies between Akan beliefs and custom in Libyan North Africa.

Assessing her contribution, Goody¹ rightly points out that it is difficult to accept her hypothesis wholesale for she obviously neglected the relevant fields of study such as linguistics, social anthropology and ethnography. The over-ambitious nature of her project too added to the deficiency of her work. Goody, however, continued his assessment of the work by saying that he did not imply by his overall criticism that:

'there has been no connexions between the present state of Ghana and the medieval kingdom of the same name, even with North Africa and the near East. There certainly has. But to interpret the Akan peoples in terms of a mass of wholesale migrations from one place to other is to disregard the three basic factors: (1) The Akan language is placed by all authorities among the Kwa languages, spoken over the greater part of the forest belt of West Africa. (2) That the culture of the Akan speaking peoples has never been regarded by observers as being 'non-Negro'. Indeed the religious institutions as described by Rattray and Busia have parallels among the inhabitants of other parts of

¹GOODY JACK. 1959. Ethnohistory on the Akan of Ghana. Africa, 1959, p. 67.

South of the Sahara. (3) That the physical characteristics are not noticeably different from other forest dwellers.'

This summary of Goody, like the general theme of Meyerowitz, implies that there has been a connection between the present state of Ghana and ancient Ghana, but this is yet to be conclusively proved. At a recent symposium of the Ghana historical association in Legon, Ghana,¹ the concensus of opinion was that the supposed link between ancient Ghana and modern Ghana could be accepted only for the meantime since a lot of research is needed to prove the alleged link. Danquah, of course, agreed with many aspects of Meyerowitz's contribution. He was principally responsible for the present name of the Republic of Ghana, for having accepted the thesis, he argued for the adoption of the new name Ghana very seriously before the national independence of the country in 1957².

What the stories of migrations would have given us, if they were authentic, would have been some reasons for the near homogeneity of the Akan culture as a whole. However, this ethnic group has lived at least for over three centuries in their present home and the history of their interaction in war, trade and other social situations give us sufficient data for most of the present cultural conditions in the community as a whole.

In matters of belief, the social institutions on the whole we

¹ See Notes on Symposium on the Akan in the occasional journal. Ghana Notes and Queries No.9 Dr. Adu Boahene's short paper is particularly interesting and pertinent to the subject of the Origins of the Akan people.

² cf. DANQUAH J.B., 1955. Akan claims to origin from Ghana. West African Review 26, 338, 339 Nov.&Dec., 1955; 1968-70. The culture of Akan Africa Vol. XXII No.4 Ward, E.W. A short history of the Gold Coast, 1948. pp. 39-45. Africa Affairs Oct. 1952 See Bibliography for other contributors on this topic. Notes and Queries quoted.

find a number of uniformities throughout. Beliefs in God, gods, ancestors and other spirits are identical or similar. Chiefship and all that is associated with it is not only common in all Akan but very similar or identical in even many non-Akan lands of Ghana. To a large extent, therefore, the Akan are culturally a unit, and the place and function of the stool as one of the principal sculptural objects in the community is very important.

The major Akan groups

As far as the history of the Akan in modern Ghana is concerned, the major groups have been the Asante, the Denkyira, the Akwamu, the Akim and the Fanti, and to a lesser extent the Nzima and Wassa groups. Their material culture and elements of their non-material culture have influenced all other people of present-day Ghana considerably over the years. Denkyira was the greatest northern Akan group prior to 1700, but Asante conquered and replaced her as the most powerful state.

Many of the social institutions and way of life of the Akan as a cultural whole were present before the fall of Denkyira but the literature on Asante suggests that, in certain important aspects, these were further elaborated or their significance heightened in Asante.

The report of a special seminar of Ghanaian historians recorded in the Ghana Notes and Queries No. 9 suggests that at the same time as the Denkyira were exerting themselves as the Northern Akan, Akwamu and Akim were doing the same in Southern Ghana and

extending the bounds of the culture. Fanti and the Western Akan, namely, Wassa and Nzima were the principal intermediaries between Denkyira, Asante and the coastal traders, both foreign and indigenous. This means that most parts of Ghana south of Asante were touched by Akan culture even at this time.

Very brief notes on some of these major Akans may be useful background to understanding the special place of the material artifact that came to be known as the asesedwa - the stool. The asesedwa was usually made from the Ocseodua funtunia afficana; and its social, political and ritual uses have influenced the culture of all Ghana.

AKWAMU

Akwamu reached the peak of her eminence in the 17th century and round about this time both the Akuapim and the Akwamu moved into the Guan communities of South East Ghana. Akwamu was powerful in her region and levied tribute from the Accra traders before they were allowed to pass through the hills. By 1681, the Akwamu empire extended along the Gold and Slave Coasts and incorporated Accra. A century later Accra recovered her independence after it had absorbed much of Akwamu culture. (Wilks 1957, 1959; also M.J.Field 1940).

When the Akuapim state was formalised about this time after the battle at Abotakyi, a village half a mile from present Mampong Akuapim, the foreign dominant Akims who came to help the Guans against the Akwamu lords, saw that their hosts already knew the use of the asesedwa in the institution of leadership. They, the new comers, knowing more about that particular statecraft, allocated specific places and titles to those who had the symbols of leadership.

Among non-Akan peoples it was not only Accra that was influenced. From the recent history of those Northern Krobo called the Manyaali we see that the Akwamu actually taught them the Akan statecraft including the use of the asesedwa.¹

AKIM

Akim was another southern Akan community which was fairly powerful during the 17th century. She was rich and challenged the power of Akwamu seriously. According to Danquah (1928, p. 2), Akim Abuakwa had dominions by 1660 which spread over the Densu river to Accra, with the Fanti as their western borderland and the Krobo and Adangme as the eastern limits of their kingdom. The Akim Abuakwa always tell the story of their successful encounter with Nana Osei Tutu of Asante to show how powerful they were at the time. When King Osei Tutu of Asante was crossing the River Pra to punish Akim for helping Denkyira against him about 1730, he was killed. The history as given by the Kyidomhene (chief of the rear guard), an old horn blower and court historian, and the State Secretary of Akim Abuakwa is confirmed by records in the Ghana Archives. The fall of Osei Tutu at the Pra river is the principal incident forming the substance of the great Asante

¹ Extracted from a certified copy of Basel Church notes by the courtesy of Nene Aketeku Akrobette, Paramount Chief of Yile Krobo. Other informants are Nene Adu of the Asu lineage Manya Krobo, Odumasi and Nana Kwafe Akoto, Paramount chief of Akwamu.

'forbidden word' Ntankese (the great oath). The Akia say they thus became the killers of the most formidable man of that age. This event added to the special merits of their king Kuntunkrunku as one who should have a memorial in the form of a black stool. Until this day, one of the titles of the Okyehene is the king who captures kings (that, is, the bravest of kings) Ohene a okyere ahene. The full title is Kwaabibire mu hene, Ohene a okyere ahene, Kwaa mu ade kase (King of the deep forest, the king that catches kings, the great thing - referring to the leopard of the forest).

Akia later received a section of the people from Juabeng Asante who came south about 1828. They gave land to the British colonial government at the time at a nominal price for the resettlement of these refugees.

DENKYIRA

We have mentioned that historically Denkyira preceded Asante as the greatest power definitely in the north. After falling in 1702, she made a number of attempts, the last in about 1730, to regain her lost position. (J.K. Kum, 1965. Also Ghana Notes and Queries No. 9. Wolfson Freda - 1958 - summaries of Bosman on Denkyira).

The history of stools, the present principal symbol of Akan chiefship, begins to take shape in Denkyira; for the history of the rise of the art in Asante as told in Akriva looks back to Denkyira as the home of one Bosari who popularised its carving in Asante. We are led to this conclusion by our analysis of

the oral tradition collected from Ahwiaa, Denkyira and also from the material referred to on Denkyira. The kings of Denkyira before the fall in 1702 used stools as symbols of their office. Nana Ntim Gyakari was captured and beheaded as he sat on asesedwa playing the game of Oware behind his forces (see Chapter V, Plate 19). Again, it is the first place in Ghana we hear of a stool descending from heaven and given by God to be the embodiment of the soul and being of a people¹. This stool is called the Abakandwa and it descended with a sword named Sasatia.

Denkyira's influence was mainly on other Akan states. Bosman² mentions the conquest of the state of Aowin by Denkyira and from these regions including Sefwi Wiawso, Denkyira got rich ores of gold. Elaboration of golden ornaments of chiefly symbols not excluding the asesedwa was very remarkable in Denkyira during her great days. New ornaments were made every season of the first fruit festival and at the purification ceremony called Odwira. During these festivals, the principal stools, as extensions of the one which fell from heaven, were ritually washed. In a historical praise song of the Abakandwa of Denkyira, Nana Boa Amponsem III expressed this in an interview at an Odwira festival in 1966 *

¹ Heaven is associated with God and great things in Akan. It is not without basis that Anokye decided that the Golden Stool of Ashanti which was to be the symbol of their continuity should fall from heaven. This will be discussed in more detail later.

² BO-SMAN, W., 1705, A New and Accurate Description of the Guinea. Translated from Dutch. London. See Freda Wolfson 1958. Pageant of Ghana. London. Oxford University Press. Reprint 1959.

Amponsem dwa a odi sika atopenada

Amponsem dwa a odi sika atopenada

Amponsem, Nana Amponsem, Amponsemdwa a onom sika toasen.

Amponsem stool that (eats) new gold

Amponsem stool that eats gold mass (gold mashed yam)

Amponsem, King Amponsem, son of Amponsem stool who smokes
the long golden pipe¹.

ASANTE

After successfully throwing off the yoke of Denkyira rule, Asante became the principal community in the spreading of Akan culture. This she did through imperialism, trade and other forms of social interactions with other peoples of Ghana. From a wide range of documentary sources we get an idea of the content and spread of this Asante imperialism. A brief but succinct summary is given by Wilks in his essay on Asante government. He outlines

¹ The meaning of 'Odi sika atopenada' takes its root from the great days of Denkyira. It was the king of Denkyira, Amponsem I who first had this appellation. Amponsem kesee a odi Sika atopenada. He was rich and had a lot of gold flowing in from his several dominions. Every morning slaves brought him gold from one or the other place. Gold was spread on his table as he dined. He used gold but once for every occasion. He had new ornaments all the time. It was only freshly mined gold that he used for his affairs. He was said to have refused to see on his dining table any gold which was a few days old. Every morning his table must be decorated with new gold. This gave him the great name of Amponsem who never uses (eats) old gold.

Amponsem never really ate gold. Indeed, what the appellation means is that he was very rich and, of course, got new ornaments made for him very frequently. At every Odwira, he must have completely new set of ornaments of gold.

An example of the golden pipe which Amponsem smoked was shown to me at the Odwira where I taped this interview.

the growth of the Asante power from the eighteenth century when Osei Tutu established control over lands immediately around Kumasi like Tafo. A new state evolved, and as he puts it, 'the segmentary social organisation of the newcomers, in matrilineages, was reflected in the segmentary character of the new state that came into being after the war of liberation with Denkyira.' (I. Wilks, 1967. 'Ashanti government' in West African Kingdoms of the Nineteenth century, pp. 207 - 209).

Although the other Akan communities we have mentioned did a lot in this field, it was Asante that widely spread the Akan art of statecraft, in which the asesgdwa became an object of very great importance. Osei Tutu, the chief who led the nucleus of the Asante union to victory over the Denkyira, and who is regarded by the Asante as the greatest king they have had, gave special place to the stool as a symbol of chiefship.¹

¹ Osei Tutu became the chief of Kumasi area sometime after his escape from Denkyira. Denkyira exercised her power over Kwaaman and the other Asantɛ 'states' which had segmentary political systems. These states had similar institutions, common language, and religion and were bound by ties of clanship. (Busia 1958, p.85). The tradition is that these states often came together to defend themselves against a common enemy. At this time, Denkyira was the common enemy. Ntim Gyakari in about 1700 or 1701 sent messengers to demand tribute from the Kwaaman chief and other states around the area. He asked that the chief should fill a big brass pan sent to him with gold dust. In addition he should send his most beloved wife and the finger of some of his clansmen back to him in Denkyira. Osei's Oyoke clansman, Juabeng was at the meeting which received this insulting news. He swore that the insult should be thrown back to Ntim. It was done by sending the messenger spitefully back to Denkyira. War broke out and in this war the united forces of the Asante defeated Denkyira and Ntim Gyakari was beheaded while sitting on an asesgdwa at the rear of his armies. (Baill Freestone, 1968) Osei Tutu, pp. 114-136. The brass pan, a replica of the stool on which Ntim Gyakari was sitting when he was beheaded and one other personal stool of the chief are at present in the National Cultural Centre, Kumasi.

Asante here, refers to the initial states whose armies fought Denkyira c.1702. The principal states were: Kumasi, Juabeng, Mampong, Kokofu, Nsuta, Bekwai. Except Mampong which is of the Bretue clan all are Oyoke. Also see BUSIA, 1958, p. 84.

With the help of his priest Anokye, a special stool was made to fall from heaven. That stool was more than a memorial to a past chief or chiefs. It came to serve and also helped to emphasize that element in the conception of the stool which made it a symbol of the collectivity. This stool was from that time to be the sacred shrine which should symbolize the unity of the *Asante* and it has had an immense power over the minds of the people. The stool was named the Sika dwa Kofi (The Golden Stool Kofi). Hence Busia says "The concept of the nation is mystical and derives from antiquity . The Golden Stool is a symbol of its unity and continuity". (Busia, 1958, p. 195). This particular idea is one of the greatest contributions of *Asante* to the culture of Ghana, for the coming of the Golden Stool ushered in what might be called, a new political theory or a monument of an unwritten constitution.

Further use was made of the object and idea of the stool in later bureaucratic, financial and political matters in *Asante* history. As they spread their influence, the political culture built around and in relation to the asesedwa stool was also spread. Nana Opoku Obedom 1731 - 1741 spread this culture to Dahomey after defeating Gyaman. The Dagomba with their *Kambosi* organisation and the military organisation of Salaga, Yendi and Gonja are believed to reveal *Asante* influence. Parts of Adangme-land and the Ewe across the Volta show clear indications that many aspects of their chiefship and the use of the stool in it, were borrowed from *Asante* or one or other of the Akan communities. (Basil Freestone, 1968, p. 155).

The asessedwa in Akan culture

The asessedwa is first and foremost one of the vehicles of thought and the concrete expression of aspects of Akan culture. It is an art because it is man-made and conveys meaning, a product of conscious effort and interest. Ostensibly, its first property is its utility but its dimension as art becomes very evident when aspects of the view that all art is utilitarian is taken.

In time, this art-cum-utilitarian object became domestically, politically and ritually important in the culture. Our knowledge at present does not make us able to establish a definite evolutionary order of the asessedwa but there are established categories into which set types fall. Thus, there are children's stools, male and female stools, with sub-divisions of these. Besides these, are leadership stools which may become ancestral black stools. Chiefly stools may be either gudwa (the original stool or stools) or bodwa (stools made later to mark specially created chiefly or other offices in a particular community or realm). Kyerematen gives a fair summary of the kinds and functions of stools in Akan culture. He writes:

'Among the settled peoples of the south, the acquisition of a stool was regarded as a prime necessity. The first gift to be made by a father to his child when the latter began to crawl was a stool. Crawling signifies that the child has come to stay. A young girl undergoing the rite to mark her attainment of puberty was placed on a stool, and it was customary for a husband to present his newly married wife with a stool to make sure of keeping her. It was on the stool that a deceased person was bathed before being laid in state. Because of this association between a person and his stool - there is a saying that there can be no secrets between a man and his stool - it was believed that his spirit inhabited the stool which he regularly used and this persisted even after his death.

Hence it was expected when vacating one's stool to tilt it on its side to prevent someone else's spirit or an evil spirit from occupying.

(Kyerematen, 1964, p.11)

A father gave a crawling child a stool at that stage ^{for it} was believed that the child was one that had come to live. By the stool, a child is welcomed into the family. Wa ba a, tra ase (If you have come, do stay).

Generally, Akan custom requires that a stranger who enters a house must be given something to sit on and plain cold water given him to drink before greetings are exchanged. Aggression or unfriendliness is being indicated one way or the other if a guest refused or is refused a seat as he enters a house. The kind of social interaction that follows any particular type of reception is thus determined by offering the stranger a seat and something to drink. The Akan say, that even if you will kill a person, let him first sit down. It is a basic courtesy to be observed. Even people under death sentences in the past were made to sit down before their final fates. Hence criminals were executed sitting not standing or hanging. This essential function of the stool as a household furniture made it one of the things that every self-respecting man procured. It was unconsciously an artifact which indicated warm heartedness and dignity.

A further reason given for offering a stranger or guest a stool before anything else is to make his kra (soul) which always journeys with him settle in him. No one is himself when his kra is not settled or at ease. Sometimes, it is believed,

the soul of a man could trail behind him as he moves from one place to the other. This is why he must settle to give his soul also the opportunity to settle back in him.

Every household has a number of stools reserved for the use of strangers as well as stools for individual members of it. A child or youth is regarded to be hurrying an adult to death by sitting on the adult's stool.

It is the very close intimacy existing between a man and his stool that gives rise to the general saying that a man's spirit lives in his stool, and so to avoid the danger of other spirits entering into an unoccupied stool, men usually tilted their stools against walls or columns or let the stools lie on their sides, when vacating them. There is a belief that conflict is inevitable between a spirit which may enter such an unoccupied stool and the spirit of the owner of the stool. Such conflicts are always fatal to the owner of the stool. It was, therefore, essential to avoid the situation in which such conflicts might occur.

Personal stools could, however, be inherited after the death of their owners. As families grew, one may assume that the personal stools of certain individuals became correspondingly important. The heads of the families possessed stools which passed down to posterity and the stools so inherited helped to preserve and present the presence of the departed elders.

The importance of such stools must be related to the importance of the matrilineal bond in Akan social organisation. The potential heirs of a man were descendants through his sisters' children and so the lineage as a group traced its descent in

a matrilineal line to a common ancestress. Succession to political offices normally went down the matrilineal line and the stools too were inherited for they were the most intimate things possessed by the dead. They are first acquired and all other things belonging to the deceased pass on to the inheritor.

Elders of lineages and clans are ranked in Akan. Elders of some importance lineages may form part of the councillors of a chief. Each office is often hereditary and the most important symbol of these offices are physical stools. The importance of the stool as an artifact may be supposed to have increased as it was inherited to keep fresh the presence of ancestors.

Head chiefs, of course, had stools which were kept in their remembrance when they died. As the number of personal stools of past heads in the community increased, the problem of picking on a stool which should get the most reverence occurred. From our interviews with chiefs and their elders in all the places in which we worked, we know that the stool of the first or the most illustrious is normally regarded as the stool of the collectivity. Sometimes, as it is in the case of Akropong Akuapim, a number of them may be regarded as together forming the stools of the collectivity. The other stools are then regarded as extensions of the one or those used in the installation of the chief to his office. As mentioned earlier on, the idea of a stool being a focus of values or the collectivity objectified in a visual aid was supremely formalized by the coming of the Golden stool of Asante.

With the institution of the black stools of Akan whereby the memories or histories of periods and people were recorded, the notion of continuity of a people was established but the Golden stool carried the importance of the stool a step further. No more did the first stool represent persons or history of any of the individual states that formed the Asante union but it represented the whole - all other stools subsumed in it. The idea was, we suggest, built on an existing philosophy and that it was exactly why all the stools were collected and destroyed so that history might begin with the great stool.

The Osese and the Akan stool called after it

Osese (*Puntumia africana*) mentioned in Nketia's Drumming in Akan Communities of Ghana is believed to be one of the trees especially endowed with good spirit. Together with the Kodia or or Tweneboa - *Entandophragma* species; the Nvamedua (*Alseodia gongensis*) they are supposed to have vindictive spirits when wantonly destroyed.¹ Other important trees also mentioned which rank with or lower than the Osese (*Puntumia africana*) include the palm tree (*Elaeis guineensis*), Odadee, (*Adansonia digitata*), Agyabosum (*Cantium alabriflorum*) Akakapempen (*Rauwolfia vomitoria*),

¹The spirit contained in the Osese is described as good because once the tree is properly approached and treated it is amenable to its use - carving. The spirit makes way for the human spirit which is to inhabit it when it is used as a stool. It is a safe refuge for the spirit of man. (Informants.. Kwasi Adai and Nana Ampofo and the court of Ahwiaahene of Ahwiaa, Nana Akuapemhene, Baamuhene of Kibi). The spirits of trees are also racked. Spirit of weeds are usually lower than the trees named above. Later, the idea of spirit of trees was explained to mean also the life or usefulness of a plant. Medicine man (Atakora of Tafe) showed me barks of trees and later some trees which were supposed to be very powerful. Their powerfulness were, in some cases, deeply buried in mysticism. See also RATTRAY, R.S. 1927, pp. 1 - 8.

Odan (*Piptadenia africana*), Odum, (*Chlorophora excelsa*) Wisa, Black pepper-guinea grain (*Aframomum melegueta*) Oves, (*Ancistrophyllum spacum* or *Calamus deeratus*). Onyina, silk cotton (*Ceiba pentandra*) Nkranku (*Butyrospermum parkii*) and Kora or Towa or Bentoa, (*Lagenaria vulgaris*). The special place of the Osese (*funtumia africana*) is in the sphere of carving whilst the exalted places of the others lie in the fields of medicine and religion.

In the institution of puberty rites for girls, marriage, showing thankfulness to the gods for safe and difficult deliveries of children by wives, final funeral baths and rites, the osese stool is very important as the artifact which can stay or bring or settle the spirit of those for whom or on whose behalf the stools are used.

The Osese Kofi, is so called because the tree is supposed to have appeared on a Friday during the creation of the earth. The Osese tree is further considered great because in spite of its exalted place among trees, it is used at all social levels in the culture. It is constantly in touch with man who has the spirit of God and therefore, according to Akan beliefs, he dies only when God is dead. This is expressed in the saying, Nyame bewu ansa na onipa awu or Nyame bewu na mewu (God dies before I die).

The Osese and reservation of the stool

Besides all its excellencies of being an exceedingly suitable wood for carving the stool and its spiritual nature, the

osese could be preserved fairly successfully in many ways.

On its own, the Osese stays good under all conditions. It is not particularly easily destroyed by insects. The white colour of the stool could always be maintained by washing it with water. Ceremonial chiefly stools of Akan are mostly kept white by periodic washing during specific times called adae, which will be examined later in this thesis.

Since the Akans thought it desirable to keep the most intimate things of past people who may be very important chiefs or leaders, the patase (the ceilings of buildings) assumed a special importance in the matter of preservation of stools. Ceilings ranked among the safest places where most valuable things were kept in Akan. Important stools were kept above the kitchen fires. This process helped to dry off all humidity and made the stool still resistant to insect attacks. When stools stayed long in such places they became smoked and turned black. This gives the black stool one of its names arunwa (apu - smoked, nwa - stool).

The idea of the stool

From the fact that stools were supposed to be or could be the physical temporary abodes of the spirits of their owners, we notice a development of the idea that the stool could be a physical memorial of the dead and later a useful means of identifying the presence and history of a past leader. We also see that it became a focus of national consciousness. The asesedwa at the political level attained the position where it was sometimes equated metaphorically to the office of chiefship. The stool is always,

however, separate from the person and office of the occupant and greater than both.

We have suggested that the chiefly stools developed from lineage stools, and that the political organization of the Akan is really organized around, in association with, or in relation to, the stools. The polity is therefore an organization of the offices of the personnel engaged in political administration of a given community. Not only did the offices entail political duties as such but they also included some religious and military duties in the case of higher chiefs - leaders whose lineage stools came to be regarded as the supreme stools. In the *Asante* case, all the other stools and stool offices culminate in the Golden Stool and the office of the *Asantehene*.

At every point the political segments show high regard for the physical stools - the visual aids of the offices of their incumbents. Historically, as our discussion of the coming of the Golden Stool will reveal, it was regarded as the thing for which Asante people should be prepared to die for to the last man. This was proved by the Yaa Asantewa War of 1900. So much is indeed heard about stools in Akan that it is important to find out exactly what people mean when they refer to them.

The term stool is used in a number of contexts in Akan and it is sometimes difficult to find out immediately to what it is meant to refer. There is the physical stool - akonwa; but the stool office is similarly referred to as akonwa. Hence people speak of Nana Mamponghe akonwa, when they mean the stool office

of the chief. Nkonwa suna (sons of the stools) means citizens generally or people who are of the royal lineage. There is also the stool which refers to the complex of stools, that is, their extensions and regalia and their organization as supporting material things to the stool office.

It is common to hear in Akan people saying they 'run to refuge in a chief's stool' medwane toa Nana akonwa, literally meaning, I run to the chief's stool. We are informed that in the past it meant exactly what it literally said. When one was able to get to any of the physical stools of a chief, one was able to escape from one's adversary who might be pursuing. That was then a wise thing to do when in danger. For in ancient times, no one would lay his hands on anyone in touch with any ancestral or even ceremonial or private stools of a chief.

Later, it was used figuratively. Running to a chief's stool meant running to his person, or more precisely, to his stool office from where justice and succour was expected as of right. Running to a chief's stool compels him to help bring justice to the one who runs to him. It is similar to the condition into which a chief is placed when the oaths - the forbidden words - are said by citizens, but different in the sense that, no oaths are involved here. Running to an akonwa is more of an appeal for justice than a coercion of the chief for justice.

In the course of history, there developed in the political situation the fact of what might be called a 'stool polity' as very clearly defined in the Asante case. It is an organisation

of offices which developed in relation to the use of the object of the stool as a symbol of chiefship.

Duties and privileges imposed by stool as a political symbol

As we shall consider in more detail, the office of a stool may be described as a 'corporation sole', having an identity and estate that continue irrespective of the particular occupants of the office at any one time. (Smith, M.G. 1956; after Maine 1866; p. 155, edition of 1905). By succession to the stool-office, the holder gains access to the benefits and duties successively held by his predecessors and he holds them as long as he continues to fulfil his office as was expected of him and to which he swore in his oath at his installation. As a chief, he has military, judicial and religious functions to the collective unity of all the lineages of group corporations within his territorial boundaries. These functions were very marked in the past.

Invariably, within the territorial boundaries of an Akan political community, there are lands belonging to lineages. These, together with acquired lands, and lands attached to the stool office may be referred to as stool lands. They are to be defended by the occupant of the premier stool; for land is one of the most important things bequeathed to the living by their ancestors. He may be ceremonially only regarded as 'custodian' of all the land by virtue of his association with the stool - the symbol of the continuity - This is an important point to note since in some cases, the ruling lineage may not even be a land owning group in the community. For example, initially, the ruling Aduana lineage of Akuapim state was a stranger lineage. There are other examples in non-Akan lands of Ghana too. The Kudragbe lineage of Ada (Adangme) at the confluence

of the river Volta and the sea claims to be the original owners of the land and not the ruling Adibue lineage. Land is usually owned collectively and therefore the geographical area of a state is made up of lands belonging to lineages. This is why the ruling monarch is only usually a ceremonial head and not literally the owner of the land.

Of course, Akan head chiefs have rights in the land and there are specific things which must go to them by virtue of their offices as head of the whole group. They are entitled to maintenance in every way since they are not allowed to work for themselves. Their whole time and life should be dedicated to the service of the states.

The stool is, therefore, ubiquitous in Akan culture. It is present at the domestic level as an object which has attained importance in making life crises and of course as an item of furniture. Generally, it is an art for documenting history, and it is a form of language or visual aid that has helped to perpetuate the moral values of the Akan. It is of course in the field of government that we see the highest development of the use and symbology of this cultural artifact.

Terminology and categories of stools (nkonwa) in Akan culture

As we have seen, there are a number of categories of 'stools' in Akan culture. All seats are called Nkonwa (Pl.) of adwa or akonwa (sing.) They may also be called simply, Nnwa. A child's stool may be called dufua, when it is only a block of wood, but mpeswadwa (penny stool) or more popularly paamadwa (two penny stool) when it has the special shape of an indigenous

child's stool. (Chapter II Plate I 1 - 11 and Chapter II Plate 3A.)

Maadwa is the blanket term for all women's stools; but there are stools for girls' puberty rites called bradwa or simply maadwa. Bridal stools asetrabodwa are given to women when they marry by their husbands, and anisendwa (bravery stool) are presented to women who are successfully delivered of their tenth children or three sets of twins in succession.

A general class of men's stools is called needwa or mmarimadwa. Within this class is the chiefly stool called ahendwa or ahonwa. The first big stool that a man may make for himself he usually called me mmarantedwa (the stool of my youth). It is really the stool by which he asserts himself as a man to be reckoned with in the family and in society. Mmanyindwa (stool for elders) may either be just any domestic stool for an old man in the family but also a stool of an ordinary family head.

All categories of the asesedwa were carved from the Osese wood which is white. Now other woods of rather a harder nature may be used; but the chiefly stools continue to be carved from the Osese. Chiefly stools (osese nwa) Pl. remain white during the lifetime of their owners. The ceremonial stool, that is, the special asesedwa, often a replica of the original stool of the first ancestor is also white. These white stools are called nkonwa or nkondwa fufuo of a chief or even an important family head may be ritually treated to be a memorial to him. In the process of consecration of the stool, it becomes black and then it is called akondwa or akonwa tumtum or apunwa (black stools or smoked stools) - the subject of a later chapter.

The apuwwa of the first ancestor is usually referred to as the gudwa. In any community, there may be one or more gudwa, since the community is usually made of a number of families or even chiefdoms. As we shall be seeing, Akan social organization involves a complex of stools which support what we have called the stool polity. New stools may be carved or drawn into the circle of existing stools for the purpose of increasing the efficiency of government or accommodating situations brought in by the accident of history. Such stools which were later 'created' to add to the original stools are bodwa. Bodwa may also be a stool specially created by a ruling leader for special people in the realm for specific reasons. In this category of Bodwa is the Akan chiefly stools - that are usually inherited patrilineally. Most of such stools are called ahenemmadwa or mmamadwa (stools for sons and grandsons of chiefs).

Nearly all the officers of the premier stool have their places because they are stool occupants (wo tete nkonwa so). Chief stool carriers, and chiefs of various supervisors of the king's palace and services have their official stools called asomwa.

The queen mother who in Akan is either the ruling chief's sister, cousin, or mother, is a very important official in Akan political system. She has a stool referred to as Obemmadwa (Queen's stool).

A lot of elaboration developed in the asesedwa in terms of design, chiefly offices, political post and insignia. Designs became indices to sex, posts, political manifestos of individual

chiefs, history, and proverbs.¹

Partly as a product of history and as a means of giving more dignity to the chiefly asesedwa, which should not, and at any rate, could not be easily carried about, other forms of seats had recognition as chiefly seats. These are also called nkonwa. They do not however, receive the reverence that is given to the asesedwa. They are more or less for purely utilitarian purposes. The particular name for the first of these stools is asipim (stands firm). It has four legs and a back rest. (Chapter V Plate 31) The modern asipim is believed to have developed from an older form which was made with cane plant (denire). Hwedom is a more elaborate form of the asipim and it is used often by the premier chiefs when they sit in state and in their courts. The hwedom, meaning look at the people or armies or enemy, is very high and it is on such a seat that the Golden Stool of Asanté is expected to rest.²

Following this general introduction, we shall look first at the actual processes by which stools are carved and brought into use and then consider their place in the social organization of the Akan and some non-Akan lands of Ghana.

¹ By the design of his personal stool a chief could make known the way he intended to carry out his task of government. So the late Asantehene, Nana Sir Agyeman Prempeh II had a personal design called Nyansapa - wisdom knot, which was meant to say that his rule would always be through the exercise of wisdom and persuasion and not force. See symbology of stools in thesis. *Chp V*.

² For further notes form and design see the above mentioned chapter V.

GLOSSARY OF TERMS

<u>Adwa</u>	Seat or stool .
<u>Osese</u>	The tree <u>funtumia</u> (Of Ghana).
<u>Osessedwa</u> or <u>asesedwa</u>	The stool made from the osese wood. Has the special typical form discussed under A typical Akan <u>asesedwa</u> or <u>osessedwa</u> . Chapter II.
<u>Dufua</u>	A piece or block of wood used as seat by children.
<u>Nnwa</u> (pl. of <u>adwa</u>)	<u>Adwa</u> - seat or stool.
<u>Mpesua dwa</u> or <u>Naamadwa</u> or <u>Ndaamadwa</u>	Penny stool or children's stool. Two penny stool - both terms are current.
<u>Bradwa</u>	Puberty rites stool .
<u>Maadwa</u>	Female stool - <u>asesedwa</u> used by females.
<u>Asetrabodwa</u>	Bridal stool .
<u>Anisendwa</u>	Bravery stools. Given to mothers of ten children or three sets of twins in succession.
<u>Mmarimadwa</u> or <u>meedwa</u>	Stool for males .
<u>Mmrantedwa</u>	A man's first stool or what is called the stool marking his youth. Sort of indication that he is one who fends himself.
<u>Mpanindwa</u>	Stool for the (old) elders.
<u>Abusuadwa</u>	Lineage stool.
<u>Aesenwa</u>	Another plural form of <u>asesedwa</u> .
<u>Nkonwa</u> (pl.) <u>Akonwa</u>	Blanket term for seats and stools.

Ahendwa or Ahenwa

pl. of Ahendwa - blanket term - chiefly stools.

Gudwa
or Fuduadwa

The special stool for the ruler of a people whose origin is buried in the dim past. The original stool or stools of a chiefdom.

Apundwa or Apunwa

Smoked or black stool for ancestral shrines.

Fodwa

Lit. (Eg = made, created dwa = stool)
Created stools - stools for other chiefs of a chiefdom.

Ahenmadwa

Stools for sons and grandsons inherited patrilineally.

Asomdwa

Service stools - stools of palace officials and those for posts created to serve the first chief or certain sub chiefs or a chiefdom.

Ohemaadwa

The queen mother's stool .

Asipin

The four-legged seat with a back rest .

Hwedon

A more elaborate form of the Asipin type of seat. It is usually a high chair which carries a lot of symbolism in its arm rests and especially the back rest. Hwedon may mean look at the enemy, armies, or look at the people or beat the enemy. All the translations are current in the literature.

Sika dwa Kofi

The Golden Stool Kofi, Kofi because it descended from heaven on a Friday. Kofi is the day name for every one born on Friday.

Abakandwa

Stool supposed to be beaded. It is the Denkyira equivalent of the Golden Stool of Ashanti.

A typical Akan asessedwa

The asessedwa was originally carved only from the tree called osese (*Funtumia* species) and this gave the object its technical name asessedwa, that is, a stool made from the osese tree. Among the reasons given for the choice of this particular tree are: its pliability, the symbolic significance of the whiteness of the wood, and its supposed accommodating nature for spiritual forces, which will be discussed later in this chapter.¹

A typical asessedwa has three parts. It has a top (animu), a middle section (annan) and base (wiabog). See Figure 5b.

The animu is slightly elliptical and concave. The surface of its top is very smooth and the concaveness helps to receive a man's seat and make sitting on it comfortable. On either side of the shorter sides of the animu could be holes and on the reverse sides of the animu near the holes are mpua; pua (sing.) knobs. The tokuro is a necessary feature of a finished asessedwa and it is either only ornamental in ordinary domestic asessedwa or also utilitarian in chiefly stools. It is through the holes that bells, effigies and other forms of war trophies which later became extensions of such stools were hung. The mpua are also decorative as well as useful. They provide pegs which can be held

¹ My principal informants - Ahwiaa, Kumasi, Kibi, Akropong.

DIAGRAM OF A TYPICAL ASESEDWA.

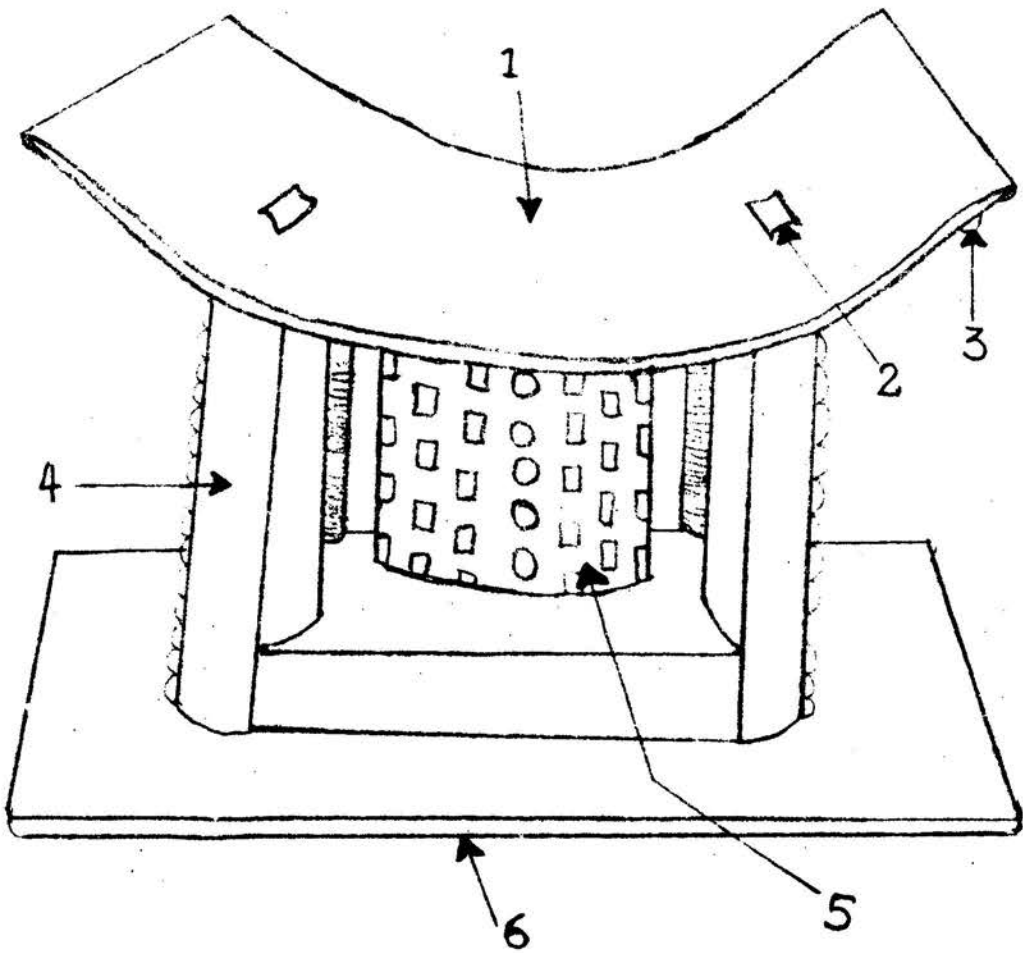

- | | |
|-----------------------|----------------|
| 1. ANIMU (Face-Seat). | 4. MFINIMFINI. |
| 2. TOKURO. | 5. SEKYEDUA. |
| 3. PUA. | 6. WIABOO. |

in lifting the stool. Engraved straight lines gbai, aban (sing.) may run along the edges of all the sides of the wiabog -base.

The middle section is very important because it usually carries different symbols and emblems which are discussed in Chapter V. It is also the section which determines the height of any particular stool.

The base of the stool is its wiabog. As a rule, it is rectangular, and the longer sides of the rectangle are parallel to the animu. Geometric and/or zoomorphic patterns may be made on both the long and short sides of the wiabog. While the geometric designs are both line patterns or decorations and proverbial, the zoomorphic figures, often appliqued, are always meant to be meaningful symbols.

General extent of the carving

The making of the type of stool we have just described is spread over all Southern, Western, Central, Eastern, Asante and Brong Ahafo regions, but it is in Ahwiaa in Asante, that we see the highest development in, and carving of, the asesedwa. This village is on the great North road through Mampong Asante, and only six miles from the Asante capital of Kumasi. Most of the work on the carver of asesedwa as an artist was necessarily done in this village but others were visited and interviewed in Enchi, Sefwi Wiawso, Axim in the West; Pepease Kwahu, Old Tafo Akim, Osino - Akim, Oyoko and Koforidua-New Juabeng, Mampong-Akuapim, Oda-Akim Kotoku, Dodowa, Doryuma, and Kordiabeh-Adangme, Ada-Adangme

Table II showing interviews with carvers outside Ahwiaa and their idea of relationship with Ahwiaa as origin of the art

	Number interviewed	Learnt-Divine Inspiration	Do not rule out Ahwiaa connection
Enchil	4	3	1
Sefwi Wiawso	2	2	1
Pepese (Kwahu)	5	3	2
Old Tafo (Akim)	3	2	1
Osino (Akim)	2	1	1
Oyoko (New Juabeng)	2	0	2
Koforidua (N. Juabeng)	6	0	4
Mampong (Akuapim)	5	1	1
Oda (Akim Kotoku)	3	2	1
Dodowa (Adangme)	2	1	1
Kodiabeh	3	1	2
Donyumu Ad.	1	0	1
Ho (Ewe)	4	2	1
Kpandu (Ewe)	5	3	3
Nudu (Akwamu)	1	0	1
Akwamufie (Akwamu)	3	2	1
Okponglo (Accra)	1	0	1
Mankessim (Fanti)	6	5	5
Axim (Nsima)	2	2	1
TOTALS	60	29	31

29 Interviewees claimed to have learnt the art from divine inspiration (meaning that they learnt from no one in particular).

31 Would not rule out the possible connection between their art and Ahwiaa — the carving village of Asante.

Okponglo near Legon, Accra-Ga, Akwamu and Nudu-Akwamu; all in the East; Mankessim in the Central region, Ho and Kpandu in the Volta region. Sixty carvers in all were interviewed in these places outside Ahwiaa in Asante, which is the most celebrated carving place in all Ghana.

The result of interviews with current chiefs and their elders in ten of the nineteen towns listed above testify that the art came directly or indirectly from Asante, (meaning Ahwiaa) but the other nine towns believe that Asante just happened to be the region in which there was pronounced specialisation in the carving of the asesedwa type of stool. The exact origin of the form is 'divine' or just 'unknown'. The carvers interviewed in these places had their own ideas and the table gives a picture of what they thought. Frequently carvers claimed that either they or their ancestors came by the art through divine inspiration. The general impression gathered was that they learnt to carve rather informally. Of our total sample of sixty carvers in the nineteen towns, 29 carvers thought they got to the art through divine inspiration or divinely inspired teachers. 31 did not rule out the possibility of a relationship between their art and that of Ahwiaa. 37 were part time carvers only. Kpandu and Ho carvers, interviewed between 1967 and 1969, traced their art to Nwakyee, their ancestral home, but Kpandu informants would not rule out the origin of the making of the stool as Akan.

Akanland as the home of the art

So far we find the origin of the asasgdwa as an art is more or less legendary in most carving areas but it is generally believed that it is Akan that popularized it. While some carvers proudly like to trace the source of the art to Asante and beyond to Denkyira and even to the supposed Akan 'homes' in the near East and Egypt, a few outside Asante prefer to claim distinctiveness and dissociate themselves from Asante or the Akan origin as the case may be. We find examples of willingness to associate with Asante in Adangmeland and parts of Eweland where some carvers said they got the art as war trophy from the Asante. The carvers of Adangmeland were specific about what they meant by that. After the war of Dodowa in about 1826, the Shais generally say, Tei Tsu, Akotia and Doryumu alias Opata who were active in the war against the Asante captured an Asante stool and a man offered to teach them how to carve stools as shrines for war gods. There is a family in Kordiabeh now which claims to have a stool believed to have been seized from a wing chief of the Asante armies during the war.¹

We notice a number of carvers in Akan lands outside Asante refusing to give Asante in particular or Denkyira for that matter, the credit of being the source of the art. Akwamu, Nzima and Akin

1

In 1967, a middle-aged woman of the family of one Ogun Akotia was suddenly seized with fear and depression. She walked miles on foot and behaved abnormally frequently. Then she travelled from the village where her grandfather whose father was the founder of the Ogun Akotia family to Kordiabeh, the town regarded as their ancestral home. She claimed that an Asante stool seized by her great grandfather was annoyed with all the family and has claimed her to be a priestess to it and 'feed' it; for it has been neglected for a long time, since successive generations have been Christian. This woman now lives with the stool in Kordiabeh and I interviewed her and saw the stool. She is called Dewi. The stool is an example of an asasgdwa supposed to have originated from Asante.

particularly tend to look outside Asante for the origin of the art.¹

History of origin and growth of Ahwiaa

Modern Ahwiaa whose population in 1960 was 965² is an amalgamation of the three villages of Ahwiaa proper, Ntaamu and Anyinam. This amalgamation was done in 1935. The houses in the village line the sides of parallel roads which run east to west. The origin of the inhabitants of each of the three groups of houses is marked on the houses by the letters AH, for Ahwiaa, NT for Ntaamu, and AN for Anyinam. The great North road through Mampong runs through the village such that three quarters of it lies to the east of the road. The ruling and dominant clan in this village is Asona and they trace their origin to Kokobiante, east of Dompase near Fomena. Nana Adabor Ababie II, the Ahwiaa-hera and his elders who were my principal informants, as far as the history is concerned, assign the people of Ahwiaa to the land of Boa Amponsem I when Denkyira was the most powerful forest state of Akanland. They were supposed to have originally left Kokobiante under a leader called Boa Asri. When they arrived in Asante from Denkyira, they became guests of Nana Aduopim of Aduabin. Aduabin was on the Esuasegya - Bekwai road, and fourteen

¹ Informants here were: the late Nana Attah Kwaku of Enchi 1967 (and elders), Nana Kwafu Akote of Akwamu Fie (and elders), Kyidomhene of Akim Abuakwa, and Nana Frimpong Manse, Paramount Chief of Akim Kotoku. This is generally understandable now as they think their histories as Akan peoples have been unduly shadowed by that of literature on Asante. Akim, Akwamu and Fanti were all established states at or before the Asante ascendancy and they claim that they knew the use of the asesedwa as a cultural artifact before the Asante empire.

² Ghana Census, 1960, Vol. II.

miles from Boaman. The chief Nana Aduopim was in the Adonten (advance guard) division of the Asantehene's army and their clan was Asene.

Nana Akwasi Adai, otherwise known as Adabor Ababie II, and his elders could not tell exactly under what circumstance Okomfo Anokye, the spiritual confidant of the Asantehene specially met Nana Boa Asri. However, they said the oral history handed down to them suggests that he first met him toying with wax; some of the chief's elders said, however, that he was toying with pitch of a plantain (*musa sapientum* var *paradisiiaca*). As he toyed, he produced an object with the form of the asosedwa as we have it today. Anokye was said to have been thrilled by it. He encouraged Boa Asri to make samples of his art wood, which Boa Asri made later on.¹ Boa Asri's people began to make this kind of seat which was widely used in the community. The example which Anokye saw Boa Asri make was, however, special, for nothing exactly like it had been seen in use for many years. Anokye, we were told, decided to capitalize on the stool and make it a very important object in the institution of leadership². Somehow, the making of the type of stool which Anokye encouraged the Ahwiasa leader to take seriously became a court art and Ahwiasa the village responsible for this art.

¹Informants: Nana Adabor Ababie II. Story cross-checked from Opanin Poku aged eighty plus. A retired carver of the royal Asena clan.

²Ibid. Principal recorder of history, Kwabena Ameyaw. Research Assistant. Ethnography and History. I.A.S. Legon, Ghana.

Nana Boa Asri, according to the oral tradition we collected from Ahwiaa stool elders, carved four shenwa (chiefs' stools) that is, chiefly stools which came to be regarded as original stools and some asomdwa (service) stools commissioned by the Asantehene around the time of the Asante invasion of Dermaa. Nana Boa Asri elected to stay in Sefwi in Ahafe area where there was a lot of game at the time, for when one Abiria Moro was defeated by the Asante, the land lying between the rivers Bia and Tano became a special game land of Nana Opoku Ware of Asante who was his master. Opoku Ware, however, requested that Boa Asri must live near him because of the importance of the art of his people and depend on the Asantehene when they were in need. In Asante rendering, the king used the word 'hungry' or 'need'. So he said 'Mo maetra aban me na se gkpa de me a wohwiaa me' (Come live near me and when you are hungry beg ~~for~~ or depend on me for your sustenance).

When Nana Boa Asri died, Nana Anyinam became the Odikre and he lived mainly during the reign of Nana Osei Kwadwo of Asante 1752 - 1781. There was, according to the literature, a marked growth at the time in Asante financial and political bureaucracy - a period referred to by Wilks as Kwadwoan Revolution (I. Wilks, 1967, p. 244). Agyabi Nti succeeded Anyinam and lived into the period of Nana Osei Kwame 1777 - 1801. The Atinia and Apagya principal stools were carved during this time. They were carved for posts which fell to sons and grandsons of the Asantehene (Ahenemadwa). One of these stools carved by him, or during his time, is inherited solely by the descendants of Brempona, wife of Osei Tutu and sister of Aseyaw Kotoko, an occupant of Maovere stool of

Denkyira ancestry¹. When the post called Apasamka of the Asante kingdom was created and made subordinate to the Apagyahene in the reign of Nana Opoku Fofie, the younger brother of Osei Kwame in 1797 - 1799, Agyabi Nti was made to carve a stool for it.

Nana Okyere Panin of Ahwiaa carved four chiefly stools in his time, during the reign of the Asantehene Bonsu Panin 1800-1824. The stools were Amanimako (Kumasi), Atene Akotene² (Office of the torch bearer), Adu Kwame stool for the son of Osei Bonsu Panin; Atene Akuanon for Sarkodie (a faithful servant of the principal stool)³. Nana Okyere Kuma the successor of Okyere Panin lived during the time of Nana Osei Yaw Akoto of Asante: 1824 - 1836 and this Ahwiaa chief was followed by Akwasi Yoyee.

Nana Akwasi Yoyee was not only an Odikre of Ahwiaa, but also a very competent carver in his own right. This is the man who is remembered by most of the carvers of modern Ahwiaa and even a lot of the old and retired carvers, as the father of the art. He is remembered as the chief who carved a lot of childrens' stools

¹ The oral traditions we collected suggest that the Asantehene had the right of Ayete (sorrorate) among the descendants of Ameyaw Kotoko. The family name of the line of Ameyaw was known as Apagu fie mu.

² Later, we were told that the Amanimako and Atene Akoten stools were actually made during or after the Kofi Adinkra of Gyaman war. The occupants of these stools have the task of guarding the Golden Stool with muskets.

³ Such a stool is reserved for recognition of faithful service of the group of nhenkwaa, (servants of the king or chief). Recorded history on tapes at Ahwiaa. Now in Archives of Institute of African Studies - Legon, Ghana.

called mpesudwa or naamadwa (penny or two penny type of stools) partly to teach his many children and his sisters' children the art of carving. These children used the stools of their practice as their personal stools in their homes. The surplus stools that were made got into the hands of other children in the village. During his time we were told, practically every child had his personal stool and blocks of wood for seats disappeared. Villages like Pankrono, Mamponenten, Botease and other further away from the main highways also bought their stools from Ahwiaa. This greatly revived the use of the stool as a children's seat.

Equally important did men and women's stools become, for Akwasi Yoyee not only carved Mmaadwa (female stools) for his wives but taught his learners to make them for sale. Meedwa (male stool) as a counterpart of the mmaadwa is believed to have also been made in great numbers for the market.

Carvers were encouraged to travel from Ahwiaa to other places in the country, since the type of stool that was being made in this village began to be popular elsewhere as a general cultural artifact. It is probably for these reasons that Akwasi Yoyee is the one remembered by most of present day carvers as the father of the art. (See example of this under 'The Stool Carver of Ahwiaa p.61 et. seq.)

Stool carving as an art and industry was fairly firmly established in Ahwiaa by the time Akwasi Yoyee died. His successor Nana Akuoko continued to encourage the art as his mother's brother did. According to our informants, Akuoko did

not live long. Ntibeng was enstooled Odikre after him and this man lived in the days of Nana Kwaku Duah, also known as King Prempeh I. Stools that were carved at this time in Ahwiaa were mostly domestic ones for there was not much creation of posts which required the making of new chiefly stools.¹ Nana Adabor Panin was the Odikre of Ahwiaa when King Prempeh I returned. This Odikre abdicated and the chiefship of the village fell on Nana Akwasi Acaae, who was the chief at the time of the investigation in 1966 - 1969².

Until this day, the chiefs of the village have continued to be the official carvers of all the stools for the Asantehene. Who were carving stools for the chiefdom of Asante before the great King Osei Tutu have, be design or accident, been forgotten.³

Within the Asante political organisation, Ahwiaa is now

1

My informants (the chief and his council at Ahwiaa) explained when I was anxious to know the chiefly stools carved during the reign of every Ahwiaa chief and I learnt that as there was no king after the 1896 sack by the British there was not much activity in the political sphere of the Asante union. So they could not remember stools that might have been carved.

2

This chief was very helpful during the investigations. He thinks not much attention is paid to him as the head of the village which makes stools for the Asante realm today. He was at Aburi in Southern Ghana and Kotoku in Akim when he was a young boy and again when he was in his youthful days. He carved at Aburi. He is now nearly ninety. See chief list of Ahwiaa since 1700. Appendix I.

3

It will be recalled that all the stools of the Asante chiefdom were collected and destroyed. See Kyerematen, 1969. The royal stools of Ashanti. Africa. January 1969. Vol. XXXIX No. 1.

in the Atipin group which forms part of the Ankobia division¹. This division transferred from the Adonten section to this new section during the time of the Asantehene Nana Osei Kwame.

Spreading the art of stool carving from Asante

History of Ahwiaa says that people went out of the town to other parts of Ghana to teach or earn money from carving. This was very marked during the reign of Akwasi Yoyce. The tradition of leaving Asante to teach carving or to earn money from the art elsewhere in Ghana has continued until recent times. The present chief of Ahwiaa and others like Nana Kofi Poku, who was one of our informants, were at Aburi in Akuapim during the early part of this century. The present carver who carved for the Asantehene on behalf of the Ahwiaa chief has also been in Akuapim and Akim.

One carver who is well remembered by the chiefdom of Akim Kotoku is one Prince Bempah. He was closely associated with the Kumasi Oyoko stool. His father lived as a great drum carver in Asante. Bempah was taught to carve by his father in accordance with the customary requirement of Asante - that a father should be responsible for the training of his son. By the age of twelve, Bempah was a proficient carver.

¹ Ankobia Anko-baabiera - Does not go anywhere. This group is one of those that are expected to move only when the supreme chief moves. They form part of his personal bodyguard. In the olden days, when there were constant wars, this division was a very important group. Heads of this group now form part of the King's advisory councils. My information from Akropong Akuapim (Chiefs and elders) is that it was not customary in the past for the Ankobiahene (the chief of the Ankobia division) to travel away from the supreme chief. He is one of the permanent companions to the chief.

On the invitation of the chief of Swedru, Bempah went to Akim Kotoku where he taught carving. He carved stools and a totem pole which is still in the court of the chief. Later, Nana Attafuah, the Omanhene of Akim Kotoku gave him large commissions.

When he returned to Asante, he lived principally in the village of Sasa to carve many items of the stool regalia for Nana Kwabena Safo the Anantahene of Kumasi. He also carved drums and totem poles for the chief of Adanse, Nana Kwabena Fori and he is remembered as having carved several things for the Ohene of Mampong. He took part in carving the articles Rattray commissioned for the Wembley Exhibition in 1924. (Rattray, 1927, p. 274).

He was one of the principal carvers to King Prempeh I on his return from the Seychelles Islands.

Meyerovits was able through the Asantehene, to get Oheneba Bempah to be an instructor in carving to some students of Achimota School. Oheneba Bempah is also remembered as having carved models round about 1937 for an exhibition in Glasgow, Scotland.

The history of this man though outstanding is not the only example of carvers who seriously disseminated the art of carving. According to our Ahwiaa informers, there are many such people who remain unnamed.

The role of the Ahwiaahene as the Asantehene's stool carver

The specific political relationship between the Ahwiaahene and Asantehene derives from the former's position as the official carver of the latter's stools. Although the Ahwiaahene is only an Odikro, or village chief, that is one of the lowest chiefs in the political organization of Asante, he has direct access to the person and stool house of the Asante King.

Although the Odikro is said to be the carver of the Asantehene's stools, he need not necessarily be the actual carver of any stool required by the king. It is his duty to arrange for any carver of any stool commissioned by the king; for he is not only the political head of the village but also the substantive head of the carvers. Where he does not carve the stool which is asked for by the king, he in concert with his elders should appoint a competent carver to do it. The most proficient in the village at any time is normally chosen.

The Odikro lit.-owner of the town - otherwise called the Ahwiaahene (chief of the Ahwiaa), however, continues under every circumstance to be executor of the rituals connected with the carving. From the beginning to the end of the carving, he must know what goes on until the final day when the stool leaves the village to go to the Asantehene.

When the Ahwiaahene received an order for carving from the Asantehene, he either goes to the Kumasi palace alone or with the carver chosen to do the carving for further instructions and specifications. Accompanied by the carver, he next selects the tree to be used. A day is then appointed when a number of

the carvers of the village go to the bush to hew down the tree. The Ahwiaahene goes to the bush with the cutting band and performs the rituals which are believed to make the tree amenable to carving. These rituals include a libation at the foot of the tree and sometimes an egg may be broken and rubbed into its bark.

Formerly, no part of the tree from which the Asantehene's stool is carved could be used for any other stools or anything else. This piece or pieces are wrapped in bark cloth called kwenkyen (bark cloth) or edowa kete (raffia palm mats) and conveyed into the private carving shed of the carver or one of the special carving booths for the royal stools under the supervision of the Ahwiaahene.

It is a special privilege and pleasure to those who take part in this preliminary work for preparing the wood for the king's stools and normally all who are eligible to participate in the exercise like to do so. There is, however, a sanction against those who may refuse to help in this communal work without any reasonable cause or prior permission from the Ahwiaahene. A fine of not less than (N\$4.07) is imposed today on such people and the money is put into a special fund from which participants are fed, or entertained. In the past, severer punishments were given.

Whoever is carving a stool for the Asantehene at any time enjoys a lot of favours, from the Asantehene to the Ahwiaahene. During all the period of his work, he is given his daily subsistence, money besides other gifts of tobacco or drinks, which he may consume after his work hours. Before he begins his work, he is put under

a ritual sanction through libation to observe some taboos relating to carving and especially that of carving the king's stools. The taboos include abstaining from sexual intercourse (this, it appears, is relaxed now but it was supposed to be one of the most serious taboos), avoiding quarrels during the period of carving, and very importantly, making sure that no woman in her menstrual period comes anywhere near the carving shed. The carver must, preferably, eat food cooked by himself, a man or a boy while carving a 'king's' stool. This type of invocation or sanction referred to above is supposed to invoke both negative and positive ritual consequences on the carver and the Ahwiaahene together and this act of invocation takes the form of libation on the carving tools. The king could after this come down to Ahwiasa to visit the carver at work. While he is with the carver, a kind of joking relationship may exist between them and the carver could even ask the king to reach him a tool, if a particular tool in demand at the time happens to lie near the king.

Relationship between the Ahwiaahene and the king's carver

Although the actual carving of a stool for an Asante King may be done by somebody other than the official head of the carvers who is the Odikro, the head of the village of Ahwiasa, the Odikro must be on cordial terms with whoever is carving for the 'king'. Any one carving for the Asantehene is, by tradition, expected to work together with the Odikro, for the understanding is that he, as a carver, carves first for the Odikro, who in turn presents the carving as if from himself - the head of the king's carvers - to

the Asante king.

It is the duty of the Odikro to see that such traditional requirements as the taboos that the carver must observe are strictly kept. Carvers of stools are generally required to observe such taboos as abstinence from sexual relations before carving. Drinking of alcoholic liquids and quarrelling at the carving booths are tabooed. Menstrual blood is especially fatal to chiefly stools.

It is necessary for the Ahwiaahene to be on such terms as to facilitate his supervision of the work of the carver. When the Ahwiaahene receives his annual customary gifts which include a piece of cloth, tobacco and sheep, from the Asantehene he may give such a carver some token of gratitude from these. He is constantly with him and gives him company, for no one else should be by a carver who is making a stool for the king.

The Ahwiaahene makes and regards the king's carver as a special councillor. This carver helps him in the organization of carving in the village.¹

¹ If, for example, a carver abuses any of the canons of their art or cheats or makes himself a nuisance in anything which relates to carving, this king's carver is called upon by the Ahwiaahene to help discipline him. If there should be any order for carving from or for any people, the Ahwiaahene arranges with this man for the execution of the order. At the time of my research in 1968, an American film company wanted something about carving for a film and Opanin Agyei, the king's carver was commissioned by the Ahwiaahene to find some competent young men to do it. The honorarium was shared among all the participants.

When a stool for the king is completed, the Ahwiaahene pours libation on the tools of the carver again to reverse the invocation effected on them at the beginning of the carving. Then he treats the stool ritually to commission it. He has a special horn called abentia - short horn - and with it he strikes the animi or the face of the stool, three consecutive times saying to it:

Woo gya yan ha, gne;

Baabi a yesen wo.

Woo gya yan ha akodi hene

We sunsum enye den, na nkwa ntra wo mi.

Wase nna faa

Deg gtra wo so enya nkwa

Na kora ne sunsum na gman no.

You are leaving us today

From where you have been made (carved)

You are leaving us to be a chief

Your spirit is expected to be sharp and you must be alive.

Bless him who sits upon you

Be a safe refuge (shrine to his soul) for the people.

After this, the stool is conveyed to the king, usually at night under the supervision of the Ahwiaahene, who may be accompanied by the carver.

In the past, all orders for stools for the chiefdoms of Asante were routed through the Asantehene. As time went on the head chiefs of the constituent regions usually called the abrempen (the great ones), could ask for stools directly from the

Ahwiaahene. More conventionally, the abrempon continued to place their orders through their head, the Asante king.

No pattern or symbol acknowledged as the monopoly of the Asantehene could be carved for any other chief or anybody. This rule is still strictly observed even in the contemporary situation when most of the once very special patterns seem to be used indiscriminately¹.

Political and social ranking in Ahwiaa

The head of the village of Ahwiaa is said to occupy the Boa Asri stool which was consecrated to his memory when he died. Under this stool are two stools that mark the positions of the Gyasehene, the chief of the palace and the Konti stool. The Konti stool is occupied by the next in command to the Ahwiaahene. Every section of the communities which came together to form the Ahwiaa village in 1935, have their heads and within these sections are family heads who are important only in local matters of Ahwiaa.

Apart from these political and lineage heads, the king's carver or carvers have special respect. They are important in the

¹ All carvers and retired carvers that were interviewed stoutly supported the idea that it has never been possible to make the pattern or design specifically set aside by the king for himself for anybody else. They, as carvers, are not prepared even now to make the exact symbols or patterns for any customer, no matter how such a customer will be prepared to pay for it. This is confirmed by further cross-checks done under the examination of The carver as an artist later on in this thesis. A customer may mention a pattern or symbol which he wants carved for him to a carver, who may agree to make the named pattern for him. What he carves, however, will have many subtle deviations from the king's stool of similar name.

Ahwiaahene's councils and in the organization of carving generally in the village.

Each carving booth in the village has a head and they are invited into a council of the chief which deals with the organization of carving in the village. One such head of a carving booth is Kofi Karikari. It was his group that demonstrated the stages of carving in this chapter.

The stool carver of Ahwiaa

Traditionally, male children were started on carving very early on in their lives. By six or seven some children were able to make some very simple stools. They were, indeed, expected to take very active interest in their fathers' daily carvings. They went to the carving sheds of their parents with the little tools fashioned for them and at the feet of fathers toyed with little blocks of wood. Mothers' brothers could give their sisters' children a set of junior carving tools at this time. Such gestures were always appreciated by the fathers of the children, who took up the challenge to interest the children in the art of carving.

Initially, only very soft types of wood were given to the little boys. As they moved from stage to stage on a sort of graded course they had the use of several types of blocks of wood which were often the left-overs of their fathers' carving woods. The movement from one grade to another depended on the intelligence, interest and dexterity of the apprentice. By the age of six or eight, most boys were able to carve not only their own stools but types

of the *naamaadwa*, (two penny stool) which they sold to outsiders. Many of their own earlier stools which they made were constantly replaced by them because they were made from very soft wood, and usually, their inability to hold the adse firmly and make only intended cuts in the wood, rendered the stools weak and prone to quick breaking.

Even at those early ages, the children accompany their fathers to the bush to cut and bring back home the carving wood for the stools. Children were allowed, when they were able to do so, to cut their own wood from the branches of the felled trees. As they grew, they helped in cutting and conveying home the actual carving wood which their fathers used.

The first actual symbol that children learnt to carve, after gaining proficiency at carving all types of children's toys and real stools was, paradoxically, the Asante Kotokodwa (Asante porcupine stool) which is the design of most supreme stools of Asante chiefship. There are, however, grades of the kotokodwa and the initial ones that learners make are simpler in details than those used as chiefly stools. Most kotokodwa are highly stylised and bear no resemblance whatsoever to the animal, porcupine. To reach the precise form of the kotokodwa takes carvers a long period of apprenticeship, and this is why learners are encouraged to begin with the simpler forms of it as early as possible. While continually returning to this design, learners have to move to other forms like the Dua koro (one central column or support) and Nyaanan (four legged support stools) all of which are discussed later in the thesis.

No real formal teaching was done except at later stages, when fathers tried to stamp their personality on the art of their children, although the idiom was and continued to be apparently conservative. As in the past, there is always room for personal style and trade mark.

The general pattern, therefore, of how the art is handed down from generation to generation has been from father to son. This may seem contrary to what might be expected, according to Opanin Opoku, who was one of our principal friends during the investigations. However, the pattern respects Asante moral code which stipulates that the responsibility to train a child and give him a good start falls to fathers and not mothers' brothers from whom the children inherit landed property. Some have reciprocal obligations. It is his father's spirit, ntore that activates him. This is very important to him if he should be manly. He fights on his father's side during any wars and provides a coffin for his interment.

During the period of training, the mother's brother of a boy kept finding out the progress of his sister's son. Where the boy proved unco-operative, this must be made known to the mother's brother. If the boy failed to reform, his mother's brother from whom the particular boy was most likely to inherit, might report the matter to other brothers of the mother. If it became necessary later, he was reported to the Ahwiaahene. Report to the Ahwiaahene in the last resort was necessary because it was regarded a big disgrace to the village, if a young man of the community was unable to carve. Besides, such young men were unlikely to be

able to help in the type of communal work constantly undertaken by young men for the Asantehene. They tended also to be drags on the society and were disrespected by the women. Women of Ahwiaa confirmed that in the past no women would condescend to marry men who could not carve. That, in itself, was a strong sanction the society had against those who would, otherwise, not learn to carve.

For about a century now, the teaching of carving to young ones has not been confined to fathers alone. More often, mothers' brothers took their sisters' sons out on their journeys out of Ahwiaa to establish cocoa farms. Many boys who were unable to learn to carve earlier on because of such movements, tended to be taught the art by their mothers' brothers. There are a number of carvers who said they even learnt to carve from their peers or kinsmen in one or other of the three carving booths in Ahwiaa today.

So training patterns have changed only slightly and the financial stability, which carving gave people in the past, continues to exist.¹ Now, carving appears to be mainly confined to three booths which are along the side of the trunk road through the village. These are attached to lineages in Ahwiaa. In any one booth may be mothers' brothers and fathers or brothers or other

¹ Opanin Opoku Sintin, Ampofo and Agyei told us this and proved it by examples; and our later general interviews with all the carvers in the booths on a particular day tended to confirm most of their information.

members of the extended family. Every one in the booth is a potential tutor to the younger people who come to the sheds. Even so, it is still the special responsibility of the father to take the greatest interest in his child.

Nowadays, the ideal conditions which made children learn from their fathers in particular are not often there. There is greater migration to farms outside Ahwiaa and seeking of jobs in the big towns of Ghana. Young people, therefore, now learn to carve from any of their relatives who are available. Those whose fathers or mothers' brothers or other relatives are not available to teach them could learn informally from people in the booths.

In the past, carvers were very traditional in their styles and continue to be so to a large extent today. People who want very traditional stools look to Ahwiaa carvers. At the same time, many of the newer forms of stool designs found in Ghana today originated from Ahwiaa. It is interesting to note how the village of Ahwiaa continues to be very traditional in style although there is, side by side with this, active experimentation on newer styles for an expanding tourist trade in stools and other items of Ghanaian sculpture.

It was an enviable thing to be able to carve well, for not only did the carvers enjoy a lot of prestige, but many of the retired carvers we met claimed to have had a good start, financially, through their earnings from carving.¹ His prestige was not

¹ In our analysis of the answers to the questionnaire on the modern carvers of Ahwiaa, (See later in this chapter) it will be seen that both some old and middle aged men have established cocoa farms with the initial monies they got from carving. A carver with only average skill could make at least (N\$735.00) about £300 easily per annum.

confined to Ahwiaa but the Ahwiaa carver was respected throughout all Asante.

In the Asante king's court, the carver had freedom of movement and the accredited carvers of the court from Ahwiaa could be within the precincts of the stool house without making themselves liable to punishment.

If ever there should arise a quarrel, or even a fight between a stool carver from Ahwiaa and a stool carrier of the king's court, it was the king's own duty, according to the demands of custom, to restore the broken sacredness. This he did by providing a live sheep which was slaughtered to restore the ritual sanctity of both of them. Like the king, no stool carrier or stool carver should be struck by human hands.

These privileges do not seem apparent now but the carvers of Ahwiaa are still regarded with special honour and their place in Asante, as the king's carvers, continues to be recognized and respected.

The Ahwiaa stool carver of today

Precisely one hundred and twelve carvers were examined at various times between 1967 and 1969. In September 1968, a test was conducted to examine the constancy of what now forms the bases of most of our observations on stool carving and the carver at Ahwiaa. 16 carvers who were found in the carving booths on a particular day were exhaustively interviewed and the results of that which confirm most of the basic facts we had are given. (See also analysed results of questionnaire on the 'Artist - Carver', Appendix 2). Questions on the following among others were asked.

Why do you carve? How did you train to carve? Who was your teacher? Who trained your teacher? What do you carve? Why do you carve those things? Others were: Would you continue to carve? How do you regard your carving in relation to the community? What do you express in your carving? How are you socially regarded? Have you any special privileges in the society? Are there any special taboos for your art? Do you observe them or have you to observe them today? What is the income you derive from carving, in a year, for example? Do you carve stools for chiefs? Who is the leader of your kind of art in this village? Other questions sought to find out the carver's knowledge about the history of his art and that of Ahwiaa, what are the traditional styles of stools, and how innovations come about and why the object of the stool continues to be demanded?

On being asked why they carved, more than 9 of the 16 interviewees answered that they carved because their fathers or mothers' brothers carved and taught them to carve. Six carved because they thought it was essential to continue the art of their ancestors. However, a strong economic motive was a very important element in their decisions to carve. All the 16 indicated unmistakably that the financial help that carving has always continued to give men of Ahwiaa constantly draw them to it. It is the first thing a citizen of Ahwiaa could do to earn money. At least, an annual income of about ₦735.00 (about £300 sterling) could be earned by an average but consistent carver. The prospects of this source of income continuing to be certain is enhanced by the fact

of cultural revivalism which has favourably affected the demand for stools, especially, for domestic purposes¹.

Fourteen trained informally to carve. Nine did their informal training at the feet of their fathers, whilst five did at the feet of their mothers' brothers. Two were taught either by a brother or no relative at all.

Ten would like to continue to carve but two added that they would always want to supplement their earning from carving with farming - the usual side line of all carvers. Only one would give up carving altogether if and when he got a salaried or wage-earning job elsewhere. Two were indifferent, but all were aware of the possibility of getting a good financial start from carving. A number of cases were mentioned by the interviewees where people had invested in economically viable projects beside cocoa farms.

The Ahwiaa carver is alive to the fact that he is in the line of carvers who have made Ahwiaa an important village and he is anxious to play his part as a good citizen. This came out clearly not only in the statistical evidence assembled on this material day but also throughout the interviews of various kinds and categories of people all the two years we worked on the project in the village.

As to what they express in their carving, fourteen out of the sixteen carvers, thought they constantly reflect the values, or

¹ By cultural revivalism I refer to, return to the bases of cultural patterns of behaviour as premises and foundations for change in culture and society.

what they called Ade a eye fe or Oro (What is beautiful of Culture). By what is beautiful, they refer to the form and the values enshrined in the forms they carve. They believe and say that the proverbs and symbology of their ancestors are the beautiful things they express in their carvings. They also think they remind people of the very elementary things which make living, as a people, possible; and also call the attention of their fellow men to the supreme values of 'doing to their neighbours what they wish to be done to themselves'. The stool, as will be discussed more fully in Chapter V, is believed to be first and foremost symbolic of goodwill, respect and awareness of the ancestors. Two said that they help to activate ideas based on or opposed to those of the culture. In a nutshell, they expressed the philosophy embedded in proverbs, language, politics, history and religion to some extent of the people.

Although the artist of Ahwiaa now attempts new designs for economic reasons, he says and notes that he has a better chance of making more economic gains if, paradoxically, he keeps within the traditional canons of style and form, in the essentials of his art¹.

New designs may be reached by accident or deliberately. Two men, one of whom is dead, have been particularly known as clever initiators of new designs. The living man is Kwaku Ahimfie

¹ They are unable to list very neatly what they mean by this, (also canons for art criticism) but when confronted with the object, they are explicit in their criticism. Compare with RATTRAY R.S. 1927, pp.274, 276 and his Mampong criticism of carved objects relating to chiefship.

aged about fifty-two. One very young boy recently carved a design through a technical error while he was carving a very traditional pattern. The Kotokodwaa (Kotoko stool) which he set out to make ended in a piece now called asempa (good news). (See symbolism in stools, Chapter V. Plate 7 & 19)

New names for new stools or new names for older patterns slightly modified do occur. An initiator of a new pattern may be the one who gives it a name. Naming of stools is also influenced by new ideas in the society, events of history, social pressures and change. Thus the silver cup stool which is a variation of an older form called the Nyamedua (God's tree) got that name when a renowned footballer was honoured as the football hene (the football chief) in Ghana in 1965. A variation of a lion symbol in the mfinifini (the central section) became popularly known as Obaake muu man (one man cannot or should not attempt to own or govern a country) in 1967. Both this stool and a kente design which was named after the wife of the first president of Ghana became known by this name.

The Ahwiasa carver still observes a number of taboos which relate to his carving. This time, however, about 15 carvers observe even the only one they all respect very much, as a matter of convention only. This respected taboo forbids carving on the great Fofie day in remembrance of the Friday on which the Golden Stool 'descended from heaven'. Twelve of the carvers have no objections to the observation of another taboo which requires no carving when there is a funeral and a corpse awaiting burial in the village.

Other interesting things about the carver are that 15 of the sample regard their art as historical and not essentially a religious sculpture. This reflects favourably on our diffuse interviews within the entire period of our investigations. They remember that the older carvers had privileges in Asante in general and in the Asantehene's court. I think that they engage in a very prestigious art and that they could be accepted in various and many places in Asante or Akan in general where others would be refused.

Each carver knows that it is his duty to maintain the traditional standards in carving the asesedwa. The morality governing the sale of stools is that bad stools must not be put on market for sale. The Ahwiaa carver's market includes all Ghana and the tourists who travel all the way to the village to buy stools and other items of Asante sculpture.

In the village of Ahwiaa we find an important Ghanaian art and its artist. This art which has attained a lot of prestige as a symbol of political leadership continues to be virile in the village and Ahwiaa is proud to be associated with it.

The technical process of stool carving

We notice that originally the Osese was the principal wood for carving the stool we have described, the Osesedwa or Asesedwa. Other famous trees like the Nyamodua (*Alstonia gongensis*) and Amsidua (*Funtumia Africana*) are known to have been used in the past. Various kinds of hard woods, like cedars of Africa, are now used. Osese, however, continues to be the most generally used wood for

very important leadership and chiefly stools, whilst species of the mahogany are the popular woods for big domestic stools.

The distinguished position and the 'powerful nature' of this tree makes it necessary for the tree to be cut down only after a number of rituals. Some of these rituals have been mentioned earlier on, but we saw a variation of the ceremony of propitiation which precedes the felling of an Osese in a forest about eleven miles from Ahwiaa. The hewers of the tree were altogether nine. They had with them a modern wood saw, axes and nine big adzes. At the foot of the tree, the carvers put an earthenware Asante dish with eleven eggs in it. There was another dish with mashed yam and three soaked eggs planted on its top. A big pot of palm wine stood at the base of the tree before we arrived there. With the help of the men, an old man who officiated, tied a piece of white calico half way round the tree. He drew the mashed yam close to the foot of the tree. A libation was poured by the old man to the spirits of the ancestors of the land on which the tree stood. They were mentioned in an act of reverence. From the same calabash used in the libation ceremony, palmwine was served to all of us. The company sat and relaxed for some time conversing generally about their work and the special qualities of the particular tree which they had found. It was actually one they bought from the owner of the land on which it stood.

After a time, the old man called the gathering to attention and requested that all of them should get ready for the task before them. A full bottle of schnapps gin was handed to him as he stood at the foot of the tree. Reverently, he bowed down and placed the

bottle at the foot of the tree holding it with both hands. He reached out for three of the raw eggs in the dish and threw them one after another at the tree, 'Oh Osese tree, take these eggs and eat them'. He took the gin and poured it all down in another act of libation saying:

Osese Kofi, Kofi Katakylie
 Ygbae a yeama no bane bi.
 We na wode hene na obi di bie.
 We na woye hene na wosi hene.
 Katakylie Kofi, Katakylie Kofi.
 Sese Kofi ee, yegebu wo ma wakodi wo hene,
 Enti yeebu wo a ma yen mpera,
 Na beema Kofi ee, emmubu nso;
 Bgega Kofi bgye wo nsa nom.
 Osese Kofi, Kofi Katakylie.

Osese Kofi, Kofi the great;
 We come to you not up to any mischief.
 No one can be chief except you first are.
 It is you who makes a chief.
 Great Kofi, Kofi the great.
 Hail Osese Kofi we come to cut you to go and
 be the chief you are,
 Therefore, spare us any injuries,
 And brave Kofi, do not break into pieces.
 Brave Kofi, come take this gin and drink.
 Osese Kofi, great Osese.

The men approached the tree and cut it down with the long wood saw.

The old man who did the propitiation explained that the acts used to be very important and necessary to ensure technical efficiency and maleability of the carving

wood.⁷

The carving of this important Akan artifact is done with comparatively very simple tools. Among these tools are various types of adzes, chisels, scraping knives, small piercing rods, and sand papering materials. The tools can be grouped into four: First the axes and adzes. Under this group are: asen sɔsɔ kɔsɛɔ (big adze), asen sɔsɔgwa (small adze), sɔsɔ atwanua (cutting adze), sɔsɔ dianim (lit. the leading adze -- strong and heavy adze used to begin a heavy carving) sɔsɔ payee (adze for splitting), sɔsɔ trɛ (broad edged adze) (Plate (P1A)). The second group consists of chisels or chise-like tools. They are: Bɔnye (cutting 'chisel') Payee kɔsɛɔ (big chisel), Payee ketewa (small chisel), bɔmɛe kɔsɛɔ and bɔmɛe ketewa (big and small chisels -- a kind), bɔwɛrɛ (finger-like chisel), fifiyɛ (very thin piercing tool), ahɔn (a tool like the fifiyɛ), dawuruwa (small edged chisel), pɛwɛ (chisel). The third group of tools are various kinds of knives; the blanket term for them is asekai (knives) sekannɔa (knife-like tools) pɛwɛ pasue (knife used as a carpenter's plane), nwayɛ (scraper plane) sekannɛa (small knives for putting in finishing touches). The last group of tools consist of miscellaneous sharp and tiny tools for putting in line and geometric designs. Nyankyerɛn (*Ficus asperifolia*) is used as sand-paper for sand papering and finished stool.

⁷ This ceremony was not specially mounted for me to see. I was anxious to see this if it still existed and so intimated that if any one should hear that somebody was going to do it, I would appreciate it, if I was told about it. Luckily, someone was casually talking to Opanin Ampefo, one of my informants, who now buys stools from the carvers in the village and retails them. He was telling him that he (the carver) would be able to give him some real asɛsɛdwa to buy because he is a member of a group who have bought an osɛsɛ which they were going to fell and share. Opanin Ampefo asked whether they were going to prepetiate the tree to which the carver answered, yes. This reached me through a messenger and I arranged to go and see it. Compare with RATTRAY, R.S., 1927, p. 1.

Terms of Stool Carving and Tools

Dua buo	Hewing down the tree
Dua no twitwa	Cutting the tree into pieces
Dua ho awaewae	Removing the bark of the tree and
<u>or</u>	
Dua ho titi	sometimes rough shaping
Nnufua (sing. dufua)	Rectangular blocks of wood ready for carving
Sese atwanua	Adze for cutting wood
Sese tre	Wide edged adze
Pace	Chisel
Pace ketewa	Small chisel
Imowere	Finger-like chisels
Fifiye	Chisels for boring small holes
Ahon	
Dawuruwa	
Bomee	Round edged chisels
Asekai	Knives
Nwarye	'Spokeshave'
Nyankyeren	A kind of rough faced leaf (<i>Ficus asperifolia</i>)
Akonwa anim so	'Digging' the face of a seat
Akonwa ho so	Digging out the sides of a seat
Akonwa so twitwa	Shaping the <u>anim</u> or face
Akonwa atiko sese	Shaping the sides of the top
Esini anim tene	Straightening the sides of the face
Akonwa atiko yiyde	Finishing touches of the sides and face.
Akonwa anim nwanee	Scraping the face of the stool with the plane or spokeshave

Diagram of some carving tools in PLATE CH. II, P1 A+B.

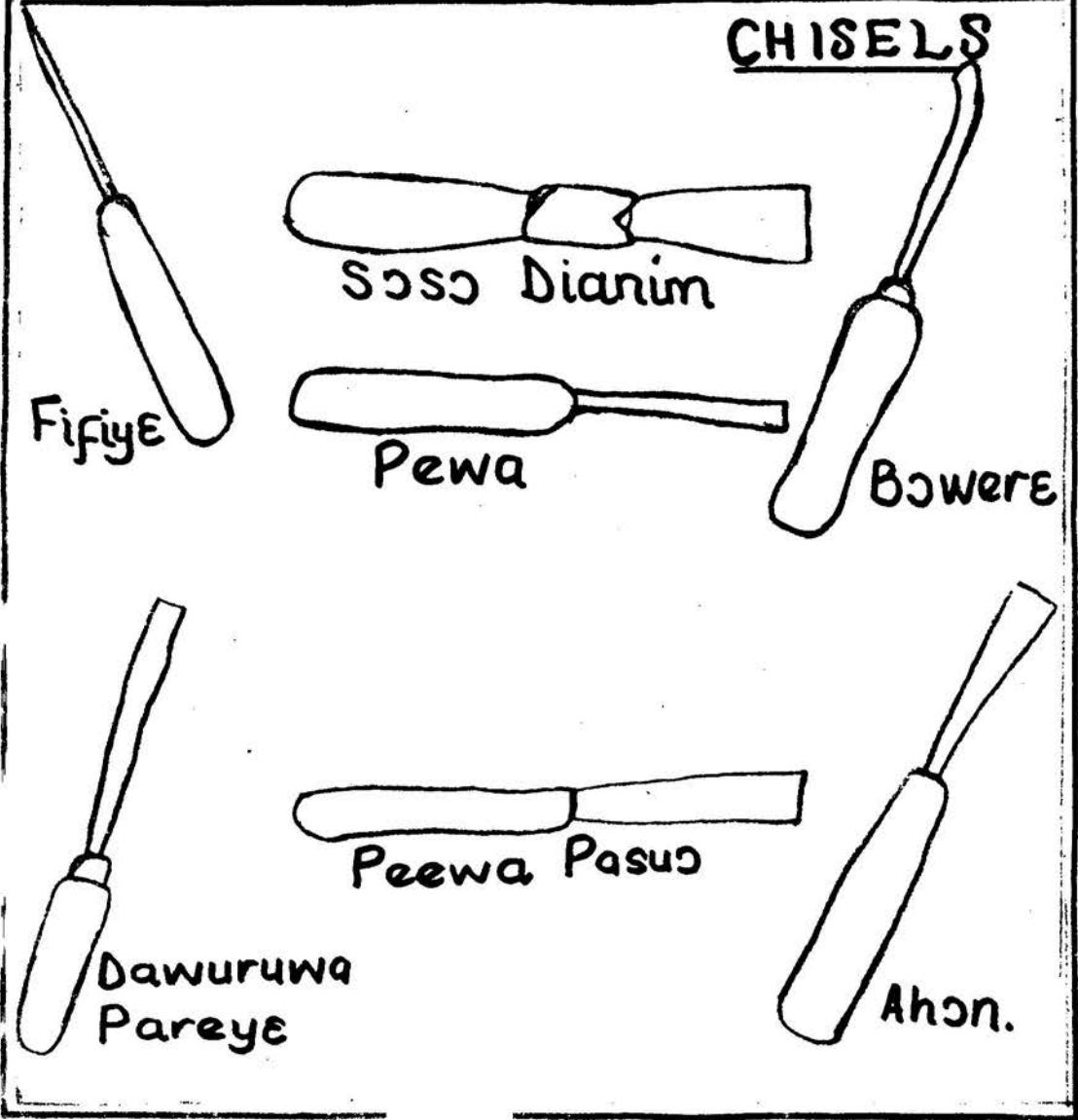
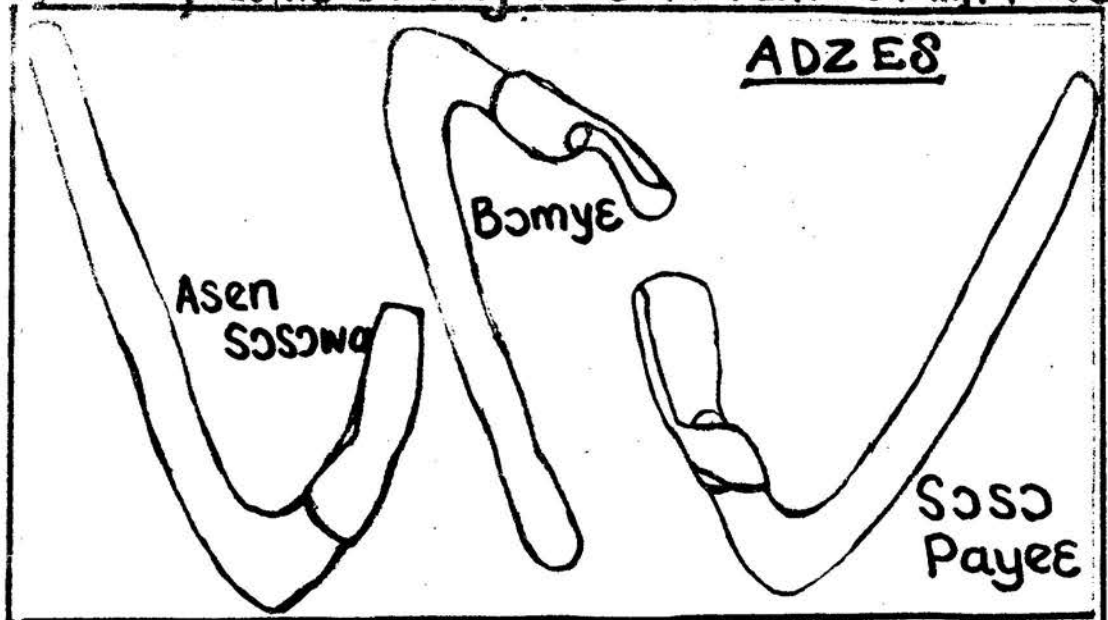

Adwini die	Working designs into the stool - lines and other designs.
Akonwa ho twie or twa	Sand papering the stool
Mpae yie	Pouring libation on the finished stool.

The axe was the traditional tool for felling down the tree and cutting it into suitable pieces. Yede abonua no kotwa dua no yeve atitimu. Usually the bark of the tree is removed in the forest and this is called Dua ho awaewae. Rough shaping may begin in the forest where distance from the wood to the carving sheds at home is considerable. This helps to reduce the weight of the blocks and also cuts down the work that would be done on them in the sheds.

When the required pieces are shaped as in 1 & 2, in Chapter II Plate 1 they are called nnufua (dufua, sing.). Children may sit on nnufua at home but adults sit on nnufua only on farms or in circumstances when they are in grief.¹

The shaping of the stool begins with the animu, when the sogkases is used to dig out the 'face'. A few strokes of the adze begin to show the 'future face or seat' of the stool. Chapter II Plate 1, 2 & 3 also Akonwa no so twitwa or animu so. Next, the sides are cut. Eso twitwa (cutting of the sides). This is done with some of the adzes (nagsa pl. sog). The sides are then marked and the adzes are used to scoop out the sides. The sog atwanua is frequently used in this exercise. It is therefore a very important tool in the carving. From this point, the chisels and the adzes are used as they are needed alternatively.

¹See numbers of the pictures on the pictures themselves - below.

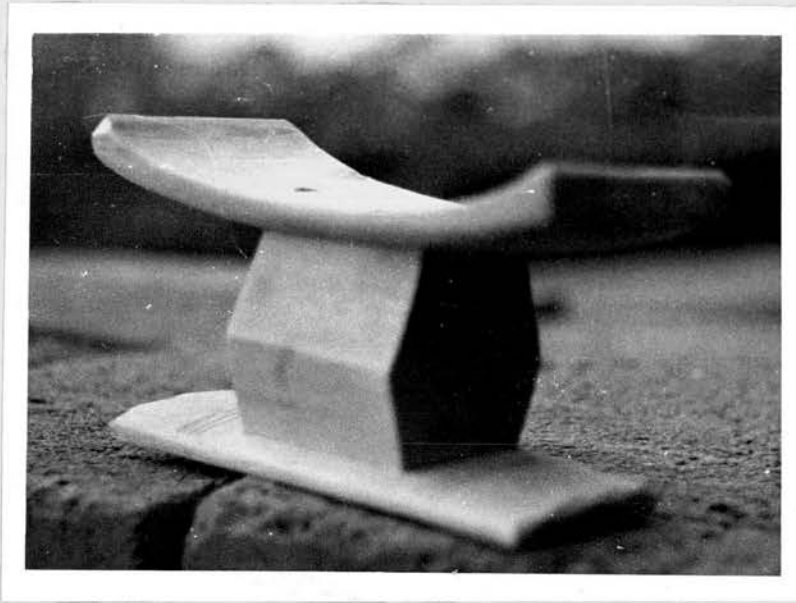

Full view

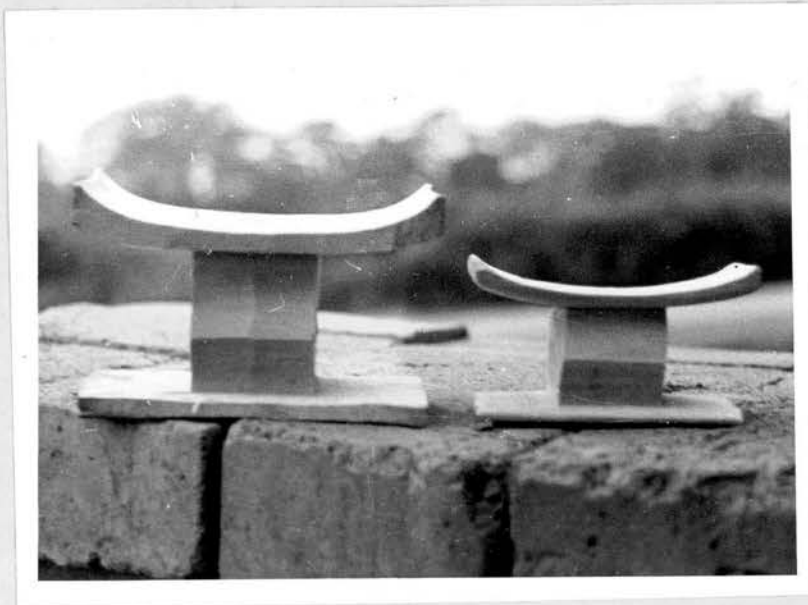

Side view

Diamond shaped nagamadwa (children's stool).

Chapter II PLATE IA



First group
Axes and
Adzes

1 Akuma (axe) 2 & 3 Sgsg (adze)

PLATE IB

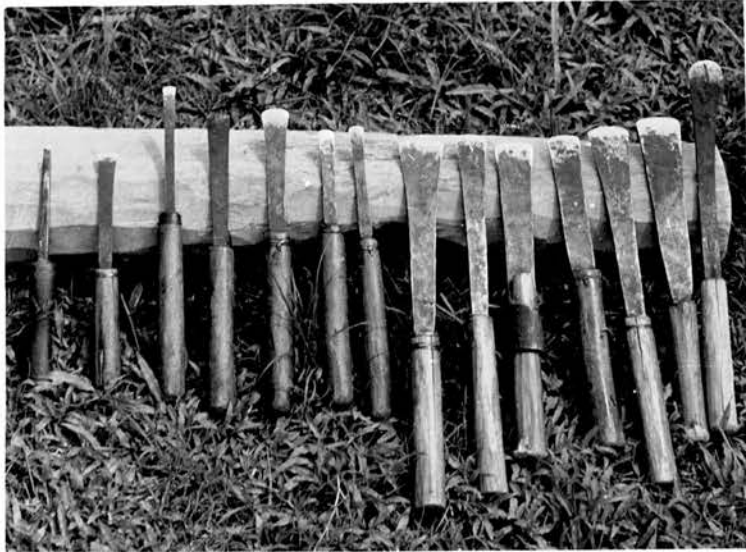

Second group
Chisels
AB.



Second group
(cont'd)

AC

Fifiye (Finger-nail-like chisels)

Bgwoye (Broad and round edged chisels)

Nnwaye - spokes shave - extreme left corner belongs to the group four. The instrument - on the extreme right is a modern carpentry tool not normally used in Ahwiaa. This picture was taken in Osino in Akim Abuakwa.



PLATE CHAPTER II, PIC



Third Group
Knives



Opanin Karikari and his 'apprentices'
hewing down a tree.



Osei Yaw. Opiɔ dɔdɔ. (Beginning to
cut the block of wood).

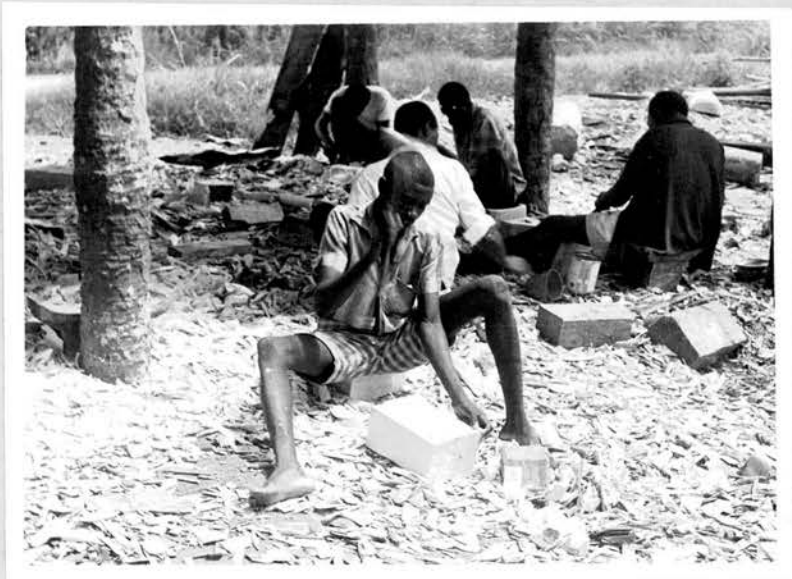

Yaw Dwamina. Otwitwa so, or Animu pie. (Cutting the top or piecing the face.) (Continuation of I)



Akwasi Seo. Animu pie (Completion of....)



Kwasi Nsia. Abain bo. (Shaping the middle)



Kwame Samponi. Otens esino anim. (Straightening the sides).



Kwasi Nsia. Oyivi atiko. (Shaping the back
of the head.)



Kwame Adomako. Ofeffa. (Shaping with a knife.)



Opanin Karikari. Owain animu. (Planing the surface)



Yaw Kyei. Qbg tokuro. (Piercing the hole)



Osei Kwame. Ode sekai yivi tokuro mu.
(Shaping the hole with a knife)



Adomako. Otwi ho. (Sand papering the stool).

A lot of care is taken in this section, for it is here that the main pattern of the stool is shown.

The wiabea (base) of the stool is next marked and carved to some extent. The carver turns again to the middle section called mfinifini and spends a lot of time on it.

In Plate II, No. 5, the carver straightens the sides of his 'children's' stool' - Otens esini anim. No. 6 is a continuation of No. 5 and this stage is technically called akonwa no atiko yiyie; that is 'the shaping of the back of the stool's head'.

The pase (chisels) and osohodoo (the various kinds of adzes) are used as they are required in deepening incisions and smoothing holes and bores in the process of carving. The mbowere (finger-like chisels) and asekai (knives) alternate in the carver's hands.

One important operation is the boring of a hole through the sekyedua (central support). The way this is done depends on the type of stool the carver is making. The hole through the sekyedua may be cylindrical or rectangular or modifications of these. It is the Bomee that is used in doing much of this boring of holes through this part of the stool.

Designs on the sekyedua are done with all types of tools including the ahon, dawuruwa and fifiyie. The way these designs are done depends on a number of things: the carver's own predilections, the specifications of the owner of the stool, or the message which the stool must bear.

The Nwaye, is a kind of spokeshave, and it is used in smoothening the animu and other surface of the stool. (Plate II, No.8). By applying a uniform pressure on the tool and moving it from one point to the other on the stool, a degree of smoothness is obtained which prepares the way for successful 'sand papering' with Nyankyeren leaves or these days with sandpaper.

The ntokuro (the holes) that appear on both sides of the animu are pierced with fifiye and asekain. The holes which are begun on the animu are continued on the reverse side of the stool with peewa or the ahon. The type of hole that is made is dictated by the grade of the stool.

The adwinidie (decoration in lines and motifs) requires specialised and patient hands. This stage of carving is usually undertaken by every experienced carvers. Young carvers do not often attempt this for, in addition to their carving skill, they must know the proverbs and other meaningful embellishments put on stools before they begin to carve them.

The stool is expected to obtain symmetry and balance even before the adwinidie stage. Those who attempt the adwinidie must also strive to reach a complete balance in the designs. Where zoomorphic or anthropomorphic designs are incised or embossed, they must respect certain canons and must be at or on the appropriate parts of the stool.

The stool is ready for its last operation and it is sand-papered, Akorwa ho twa. The dry rough leaves of a plant called nyankyeren were formerly used. Now ordinary sand paper is easier to get and it is almost replacing the leaves for this exercise.

Ordinary stools are ready for use after they have been sand papered, but in the case of chiefly stools, the Ahwiaahene effects the first commissioning of the stools as one of the leadership grade in ritual. With a short buffalo horn, he knocks the animu (face of the stool) and 'speaks' to it. He pours libation and the stool is considered safe to leave Ahwiasa. The following is an example of what the Ahwiaahene says in commissioning the stool:

Twa twa twa !

Twa twa twa!

Eng yewie wo sen,

Woye ahemwa a yaasen.

Yesen wo fri sese mi.

Yesen wo fri dua Kofi mi.

Wocka aka di hene.

Yebuu dua no a ammbu

Yebuu katakyie a aspara yen

Yesen a yenho seseese.

Asesedwa, wockodi hene.

Deg otra wo so ndi nim.

Deg yade ne si wo so nya nkwa

Deg otra wo so mfa obue mma wo.

Efiri se wo na wodi hene na obi di bie.

Akorwa yi wowe ase !

Akonwa yi wodi asem pa.
 Hyira dee otra wo so.
 Hyira woama a wodi won so.
 Akonwa kesee, mo Afi.

Amen Amen Amen !
 Amen Amen Amen !
 We have finished carving you today.
 You are a chiefly stool that has been carved.
 You were carved from the Sese tree.
 You have been carved from the tree Kofi.
 You leave to go to be chief.

The tree we fell for the purpose did not break.
 When we fell the great one it did not harm us.
 We were also free from hurt when we carved you.

O Ase stool you are going to be chief.
 He who sits on you should be brave.
 He who sits on you should have long life.
 He who sits on you should give you your due respect.
 Because it is you who makes the king.

You have an ear :
 You (this stool) are full of goodness.
 Bless him who sits on you -
 Bless the children upon whom you rule.
 Great stool, hail Kofi!

This done, the stool is conveyed to the king, usually at night, who, in turn, further commissions the stool by pouring libation on it and inviting the ancestors to bless those who will occupy it and make them successful chiefs. This ceremony often takes place in the palace in the presence of the king's elders. After this is done, the stool becomes one marking a place in a hierarchy of leadership in a place or in the realm.

Evaluation of stool carving and its anonymity: Ahwiaa

Our examination of kinds and aspects of symbology of the asesedwa will give us more insight into what an Akan carver or citizen would expect in every stool he sees. A stool is good or bad as it conforms to certain criteria. These criteria exist in the minds of stool carvers, priests, kings and even commoners. In other words, the criteria are matters of opinion widely shared, but fully comprehended by the guardians of philosophic thought. We noticed that the form of a stool, the context in which it is expected to be used, the degree of finish and its symmetry have been among the essentials which help a critic to determine the goodness or badness, the ugliness or beauty of a stool.

An asesedwa must have a typical form and the broad category into which it falls must be evident. That is, a stool must be unmistakably a children's stool, a male or female stool, or a stool meant to be used for one or the other kind of ritual.

The animu of the stool must be concave. The degree of concaveness is not standardized but usually it is slight and not very deep. The shorter sides of the animu must be seen to be looking or flying upwards as the carvers describe it. This face or animu of the stool which receives the seat of people who sit on it, needs to be smooth. The tokuro or ntokuro are essential features of the animu and on the reverse sides of upward flying sections, the nua (ɛnua pl.) must exist. No stool without the ntokuro

especially, but also the muug, at times, could be used as an ordinary seat. Such a stool may be for ritual acts in which evil may be said to have been removed or averted (susuyie)¹.

The kind of mfinifini (middle section) that is carved must be identifiable. There are known symbols which may be shown in this section. The lines and curves regarded as characteristic of the designs must be present, if any of the traditional symbols which we shall be examining, is carved. The mfinifini is to a large extent, the bearer of the bulk of proverbial and traditional features of the stool, and it is expected that a lot of care would be devoted to it. Usually, it is the source of wrong symmetry for the stool as a whole. Wrong symmetry expressed in Akan as 'Akonwa no akyinkyim' (the stool is crooked) is one, if not the most devastating criticism, that could be levelled at a piece of work.

The wiabog (base of the stool) must have no cracks in it so as to be able to stand the heavy wear and tear on it. On the wiabog one could expect both line and solid or motif designs. The incised lines called abain are often straight, but other zigzag designs are also normal. Zoomorphic figures tend to be embossed or carved on the face of the shorter sides of this section.

Straight sides of the stool must be absolutely so but the sharp edges of the stool must be slightly rounded and made

¹ The stool may be involved in a ritual at the end of which it may be thrown away at the outskirts of a town to drive away or avert a bad omen.

blunt. Curvatures and wrong sides of hole patterns should be smooth.

Chiefly stools have broader animu, higher mfinifini and more solid wiaboa, and the message they are meant to carry depends on the accuracy of their symbology.

There are, of course, various named stools in the culture and people know what to expect when they ask for specific stools by name. A customer could always reject an ordered stool, if the carver fails to make the right type of stool ordered.

Rattray realized this keen ability of evaluation among the Asante several years ago when he commissioned different types of carving for a show at the British Empire exhibition in Wembley in 1924. He reports that intelligent interest and keen critical examination were displayed by the Asantes who came to see the exhibits he was taking to the Wembley exhibition. Since there is a definite symbology for definite situations, a woman was quick to point out that the stool upon which a figure was seated was wrong. We are told that the carver was much twitted for this inaccuracy and eventually, the stool with correct design was carved for the female figure. That is, a mandwa, instead of the wrong one was carved to replace it.

All Akan stools have canons to which they are expected to conform; and these canons take their source from knowledge of the culture. Criticism of sculpture may be said to depend on recognisability and propriety of designs, motifs and their placements,

and not least, the degree of finesse.¹

A stool carver then seems to work within a framework of tight, traditional prescriptions, since all stools have specific categories into which they must fall and since all the categories have set requirements. To an extent, this is so, but artists have room within the idiom to express their personalities. During the later part of a carver's training, one of the things that their tutors do is to impart particular individual lineage skills on their trainees about to graduate. With practice, it is possible to tell apart the sculpture of different carvers in Ahwiaa.

These personal and distinctive marks are often very subtle and not readily distinguishable by an unpractised eye. It is nevertheless fairly easy for carvers and many people of Ahwiaa to tell almost instantaneously the maker of any particular stool.

Three examples may help to illustrate this point. Three carvers whose styles were closely studied over a period of time even had such points of convergence at times that obscured their differences. One Opanin Karikari and those who carve in the shed in which he is leader, tend to give their almost completed hard wood stools, a mosaic finish by making very gentle scoops by very light strokes of small adzes. Final sand-papering is done after this exercise. When the wood is polished it gives it a particular

¹ Recognisability of designs among carvers is further discussed in Chapter V - Symbolism in stools p. 178..

look, although not very different from others to a casual observer. Again, Karikari specialises in making nsononwa (elephant stools).

Kwabena Boame is the leader of another carving booth. He specialises in carving the traditional Kotoko:wana. This is supposed to be the most primeval of Akan stool designs. Kotoko is the Asante porcupine. There are two distinctive porcupine stools in the system of designs. Boame's specialization is the highly stylised porcupine stool. (See symbology of Akan stools, Chapter V). He is neat as far as the line designs are concerned. His circles and ovals are geometrically very accurate, although he has no literate formal education and does not use geometrical instruments. So accurate are his designs by Ahwiaa standards that he is one of the carvers who could be asked to carve some of the junior stools that the Asantehene may ask for from Ahwiaa.

Opanin Adjei, the principal carver of Asantehene's stools is the most complicated designer of the three. He has many line designs which the others do not often carve. Even stools which he makes for the market have usually many pointed nkyekyaa, if they are female stools; and very highly structured nkntan, if they are male stools.¹ He is one of the few carvers who is able to make some of the complicated designs seen in such stools shown under "Gifts to Heads of States" in Chapter V.

¹ This subject of individual styles needs a more patient study. Unfortunately, the bulk of the stools that are put on the market tend to be very similar. It is only when special orders are placed that the individualities become very apparent. This is so because most tourists are unable to tell the fine differences between the carving of different carvers. The significant thing, however, is that most of the carvers keep to very traditional forms but also make newer forms.

Replacement of stools

Children's stools are known to be constantly replaced. This happens because, normally, children's stools are made from very soft wood not necessarily from the normal wood used for carving stools. Children's stools are carved even from the wood of the silk cotton tree. Since the making of such stools needs only rudimentary skill, many of them could be obtained from very inexperienced carvers. The result is that such children's stools may initially look like good ones but deteriorate and become unusable in a very short time. Consequently, they need replacement after short periods of use. However, since they are traditionally cheap, people do not seem to be bothered by this.

Wear and tear on normally well-carved adult stools, however, do occur. We have seen even bridal stools supplemented or replaced. Other domestic stools may be replaced when this becomes necessary. We have retrieved some such stools for the ethnographic room of the Institute of African Studies, Ghana, from different parts of the country.

In the life time of a man, he may possess many stools as his household furniture. To these he may add new ones or replace damaged ones. Damage, for example, may occur when a stool falls on a hard surface from a great height. Slits may occur in places like the animi, parts of the sekyedua or the wiaboa where mending is impossible. Stools made by novices or not very skilled hands may have unintended and concealed cuts before they are handed over to buyers as finished products. Master carvers, of course, see to it as far as they are able, that no such stools are sold,

since it is one of the codes of ethics in stool marketing. In spite of these traditional rules there is occasionally the odd man out, who disregards the rules of the game. According to the Ahwiaahene, they are always sorry for such cases.

To combat this, people are normally, in Asante at least, careful about who made their personal stools and the wood used in carving them. Personal stools are, as a rule, expected to be durable to contain the owners' spirits when they are dead. More appropriately, they represent, or sort of prolong memory of them on their death.

Sometimes it becomes necessary to replace some personal stools of adults or even children deliberately because rituals are performed on their original ones and thrown away at the outskirts of the towns or into the sea to avert imminent disasters which would have otherwise fallen on the owners. We saw three such cases in Asanté, Kpandu, and Ningo. The geographical spread of the practice is remarkable and further investigation of how much more the practice is common should be interesting.

As a stool becomes important to a collectivity the care for it increases and the occasion for its replacement becomes rather rare. Such categories of stools begin to get people who are responsible for them and they are kept away, by custom, from harm. One of the class of such stools that are known to need replacement are bath stools of great chiefs. This becomes necessary if the chiefs reign for long periods; for the daily soaking of the bath stool with water from the baths of the chiefs tend to make the

stool an easy prey to certain types of insects. Sometimes the stools disintegrate from the softness that is occasioned by the soaking.

When a bath stool in use reaches a point where it is no longer serviceable - usually when it begins to show signs of disintegration, a new one is commissioned by the user (the chief) on the advice of the Adwarefoohene (chief of those responsible for the head chief's ablutions and toilet affairs). On receipt of the new one, the old one is either dried and burnt and the powder rubbed into the new one or the old one is left in the bath house until the death of the chief, when it is dried, burnt and the powder added to the soot with which his stool (the new bath stool or any other chosen for the purpose) is blackened.

Our informants at Ahwiaa and the old stool carrier at Mampong Asante, said replacement of stools in this way, however, is not a frequent phenomenon.

We notice in this study occasions when new stools are commissioned. These occur especially in the creation of new posts or giving of symbols meant to be landmarks of valour displayed by people or some special contribution of one sort or the other given by a member of the community.

CHAPTER III

THE STOOL AS A SYMBOL OF OFFICEAkan political stools and their development

The principal symbol of office in Akan chiefship is the stool we have called the asesedwa. Around and in relation to this symbol has developed a kind of political and bureaucratic organization in which a theory concerning incorporated offices is embodied.

In the introductory chapter we saw that this object of art has significance at all levels of Akan society and culture. We noted that a lot of sentiment became attached to the artifact at all levels. Personal stools were inherited with other property and they were regarded as the first and most important items of any property that was inherited. Some personal stools, of course, attained the status of *lineage* head stools, or *lineage* stools, or a kin-group stool, a clan stool or oman (town or national) stool. What is called a national stool could, actually, and is often, a *lineage* stool which, in time, and for specific known reasons, becomes accepted as the 'premier' stool in a large political community. Because it was believed that there was a special intimacy between a stool and its owner, it was also believed that a stool provided an abode for the spirit of the owner while alive, but especially when he was dead. So the continuing identity of an ancestor was thus focussed on his stool, and lineage stools provided focal points for the departed owner or owners. They served as reminders to the living of the whole 'crowd' of a people's ancestors. Any change in the circumstances of a group or its

leaders must in turn be reflected back on to those stools with which the group is identified.

A given Akan political community or Oman may grow in one of several ways. Families may multiply, clans may come together, other groups may be absorbed through conquest, marriage or political diplomacy. As large groups form in this way, a system of political organisation emerges around the object of leadership - the stool. It is this type of political organisation which developed around and in relation to the use of the asesedwa which we refer to as the 'Stool Polity'.

In trying to exemplify the position of the head stool in an Akan political organisation, W.E.G. Sekyi, in his essay on 'Comparison of English, Gold Coast, Akan and Fanti Laws relating to absolute rights of individuals', suggested how a large political community may form in 'concentric circles of people' around the founding ancestors and make definable corporate groups. He was, as it were, putting forth the thesis that government in Akan did grow around the stools of these mythical, legendary or real people whose stools were the visible manifestations of them.

Danquah gives a very concise account of the difference between stools in his Akan Laws and Customs (1928, p. 144). Here he was trying, like Sekyi, to show how one stool may attain premiership over others. He rightly points out that 'Family Stools' are the real things on that:

'There are no tribal stools as a fact, and there is no town stool in theory. Family stools are the real things.'

He continues to show how a *lineage* stool may upgrade itself or be upgraded by a political community that has resulted from a coming together of people. He writes:

'A family stool, by means of the influence, prowess and intelligence, or sagacity of its occupants can become a town-stool, a tribal stool, a provincial stool, and at last, the Paramount or National stool. Having attained this pinnacle of success by gradual evolution, the paramount stool comes to be looked upon as endowed with supernatural powers and consequently no power on earth should attempt to undo what the gods have brought to perfection. It becomes sacred to the nation or tribe. It becomes an object of worship. The spirit of their history the soul of their ancestry and tradition come to be enshrouded by and enshrined within it' (Danquah, 1928, *ibid.*).

As could be inferred, several stools from the grade of what is normally called personal stools exist and may graduate to lineage stool status. Others go up to the status of town or clan stools in any political community. Each stool comes to be assigned a place in the political organization which grows out of their use as symbols of office. If when a lineage stool comes to be regarded as a national stool, it is also regarded as one which embraces the spirits of all the dead and living in the community and its occupant links the dead with the living¹. Each lineage is a political unit (Busia, 1958, p.2). Elders of lineages are councillors to their lineage chief. Chiefs of lineages that make

¹The case of the Golden stool of Asante apparently does not fall into such a developmental process. We have a further note on the uniqueness of the Golden stool which explains how it is in a similar situation.

up an Akan state are also councillors to the chief of the lineage that has been accepted as the head lineage of all the others. An Akan state is, therefore, made up of tiers of lineages and as we mentioned in the introduction of this thesis, the lineages are ranked. The complex of rights and political interaction will be examined more explicitly. Meanwhile, we continue to summarize a few findings and some ethnographic material on the development of Akan communities.

Rattray (1929, p. 63) does not differ from Sekyi and Danquah in what he had to say about the growth of Asante political units.

He says:

Various family groups, in course of time, came under the head of one particular family, to whom, all the important matters, appeals are made. This process of amalgamation went on in independent localities, and in this manner, numerous Territorial Divisions grew up under different heads, independent and often rivals of each other. The lesser of these again tended to be merged into the greater, and, at the period when "Ashanti" history begins (Certainly he was thinking of the Asante under Osei Tutu) we find this people grouped into five or six great Divisions....

He further illustrated this by saying:

To use a metaphor upon which I shall enlarge in more detail, the family was like a circle. Later, lines of contact - at first weak and undefined - stretched from the centres of many such circles and emerged upon a point which was the centre of another, but greater, concentric circle, the house-father of which now came at least nominally to control the heads of all the lesser circles. These now assumed much the nature of satellites grouped around a greater body. This central body was itself ever expanding and throwing out greater and greater concentric circles, each ring embracing fresh systems until finally, the circumference of the greatest circle of all formed the boundary of a kingdom. Its centre remained the original family group -- now the royal house -- its head was still a house father, but now also a king - Ashantehene...

(Rattray, 1929, p. 63)

With regard to migrations that helped the formation of political groups around stools, Busia (1958, p. 4) has an illustration for us in his Wenchi material. He reports the tradition that shows that people think the Wenchi state or Division was built up by successive migrations among other things. He suggests that some aggregations of the Asante union state might have been formed in this way and points out that the explanation of the criss-cross pattern of kinship and clanship ties connecting widely separated lineages might be sought in this.

In Wenchi, he says, some villages were formed as a result of migrations and the leaders of those villages became subject to the Wenchihene (Wenchi chief) or rather the Wenchi stool. Wenchi's mpaninfo (elders) or Nsafohene (Captains) were themselves heads of different lineages, and had high sounding titles to designate them. This is about Wenchi in the 18th and 19th centuries.

Generally, the specific political places of lineages or clans within a unit, therefore, develop over a period of time. However, there are a few stools which appeared suddenly and have mystical, legendary or mythical stories to back them and their competences. Without exception, such stools tend to be those for dominant lineages within a defined political community. Their supposed extraordinary nature helps to build up or confirm the position of the ruling lineages.

The Abakandwa of Denkyira stool polity: Pre-1700

Although even the present oral history and the earliest records we have on Denkyira tell us little about the various

families which formed the political groups in the realm, references to Abankesiese where the Denkyira settled at a point in their history as an ethnic unit are numerous and definite.¹ At Abankesiese a woman by name Ayekraa is said to have been very powerful. She reigned as queen or rather leader of a dominant and powerful group of the Denkyira. She had three sons, namely: Anim, Ahi and Aha and these sons reigned in three divisions in the then Denkyira community. The personal stools became their symbols of leadership. Wars were frequent and leaders were necessarily military leaders. Anim, Ahi and Aha became some sort of military leaders and a military organization evolved around their symbols of leadership. These organizations became political organisations in peace time. In war the leaders advanced in such a way that two of the brothers flanked the sides of the third brother to form a special strategy which came to be called the Pesua formation. The following were the divisions of the right, centre and left wings of the militia. The right wing was known as Kyerefem, the advance guard was called Abuakwa Adonten, and the left wing was the Akumatire. These divisions were better known as Nifa (right, Adonten (Advance guard) and Benkum (left) wings in Akan military or political organisation after the fall of Denkyira. There were further divisions of the above. Hence the left wing had divisions called Osono - N - panto, Tamatu and Naase. The Akumatire literally the head of the axe, was a very important unit. However, Agona Adontendom

¹ BLAKE, J.W., Europeans in West Africa, 1460 - 1560, Vol. 1, p.56;
PAGE, J.D., Ghana: Historical Interpretation - Mandison, 1961;
KUMA, J.K., DENKYIRA, 1600 - 1697 (Unpublished M.A. Thesis 1965).

or Adonten was said to be the largest section and constituted the main body of the army in war. In this section were the Twafo (Scouts) Koronko or Koronti (the war leader) and the Adonten ankasa (the Adonten proper). In addition to these divisions developed the Gyase (the body guard of the king and the Kyidom (the rear guard) again of the most superior leader, here referred to as the king.

Two major descriptions of the Abakandwa have been given. First, this stool is described as a gold asesedwa with a V-shape design in the middle section. Later elaborations in gold brought complexity to its form. The other description of the Abakandwa by our informants at Denkyira present it as an asesedwa covered all over with beads. We suggest that these two descriptions are reconcilable; for beads and gold ornaments are part and parcel of the paraphernalia of Akan chiefs. Indeed, beads used to be more highly priced in many social situations than gold.

Abakandwa means literally the stool that was first to come - (aba = has come; kan = first; dwa = stool). Although not all who talked of it to us seem to refer to it as such, they all believe that it is the first of Akan stools that are believed to have 'come from heaven'. They say the Asante example took its source from Denkyira. Fage (1961) actually suggested once that the Abakandwa and the Sasatia could be examples for the Asante in the foundation of their kingdom, which as he said 'involved creating a common allegiance for the kings and people of allied states which would transcend the allegiance which each owed to his own

stool and those of his ancestors¹. The first kings of Denkyira inherited a powerfully organized army and the Abakandwa became a symbol of the very embodiment of the being and strength of the people.

This suggestion is very significant, for Anokye that spiritual confidant of King Osei Tutu of Asante, according to oral traditions in both Asante and Denkyira, lived with Okomfo Kyerekye at Denkyira before the war between Asante and Denkyira in 1700. Osei Tutu is believed to have known Anokye in Denkyira when he himself was a page at the court of Boa Ampensem I.

Akwamu

Two other Akan communities that have claimed that they had stools which came from heaven apart from Denkyira and Asante are Akwamu and Akim. According to a version of their oral traditions Akwamu had a Sika-Agua-Kofi (golden stool Kofi) together with two senior stools from time immemorial. One of the two stools was created by a man called Agyen Kokobo, and the second stool was created by a powerful queen mother when she broke away from Akwamu with one Ata Kuma to found the Dormaa state. The Sika-Agua-Kofi is otherwise called Amanpon (Great state). This Amanpon stool

¹When the Abakandwa came, it became the state stool and superceded all the stools of the various lineages. Akwamu and Asante are the other Akan states that claim they had stools falling from heaven. At a seminar on the Akan in Legon, some of the participants (like some of the informants we had in Asante Ahwiasa), suggested that the Abakandwa 'came' after the Asante example to copy the example that pulled Asante together and so the Denkyira tried the same device to pull Denkyira together, in the bid to retrieve the lost power of Denkyira. These remain conjectures; but it is not improbable, as suggested by Fage, that the Abakandwa came first, for Denkyira was a power prior to Asante.

features very prominently in the Akwamu Apafram, which is the Akwamu equivalent of the Ahafo Kaseg of other Akan states. (Kyere-maten, A.A., 1964, p. 16; also oral tradition from Akwamufie 1968).

So again, we see a pattern being stabilized, in which a stool is recognized as the principal stool of a community and this principal stool has subsidiary stools at different levels. The subsidiary stools in Akwamu also had specific political significance in the community and they have lower and lower levels of subsidiary stools which end in family stools - stools of the lowest level of corporations (Rattray, 1929) p. 62. As far as the literature is concerned, however, it is the Asante example of stool polity that was very defined and distinct in Akan history.

The Golden Stool of Asante as head of a Polity

The coming of the Golden Stool of Asante is one of the great political landmarks of Asante history. It began a new era of political history. After the destruction of the power of Denkyira by the Osa-Enti¹ forces under Osei Tutu, one Okomfo Anokye, the

¹BUSIA, K.A. (1958). The tradition is that the states came together only because of the war. Osa (war) Nti (because of..). This etymology was referred to by my informants in Mampong and Ahwiaa. Kyere-maten agrees that this meaning is valid. My Yankessim (Fanti) informants say Asante is 'Aso antsi' that is, stubborn (lit. Those whose ears hear not..) Kofi Adinkra's declaration that he had a golden stool is supposed to be the main reason for the war against him ending in his defeat and execution. See also, Rattray 1927, p. 131, Note 1 of p. 131. The Ahanta sa of Akim Abuakwa (fought by Opoku Ware who reigned after Osei Tutu) was also partly because the Akim, encouraged by the death of Osei Tutu while crossing the river Pra to do battle against them, claimed to have a Golden Stool. It is called Ahanta sa because, it is alleged that the Asante King went to the field of battle in golden sandals (meaning by it that the Akim forces were no problem at all). This oral tradition is proudly related in Asante and my informants in Ahwiaa and Juabeng did not hesitate to tell it.

spiritual friend of this king, worked out a device to give all Asante one unifying symbol of office in a mystic stool. This was called Sika-dwa-Kofi (the Golden stool Kofi). Anokye decreed after its coming that the like of it had never been and should never come again. Therefore, it should be an affront which would be punished by the Asante, if any community should at any time claim to have the like of it. Indeed, when Nana Kofi Adinkra of Gyaman claimed to have had a golden stool falling from heaven as did the Asante famous stool, he was attacked in 1880, and his head was cut off for his insolence. 1918

Before the coming of this unifying political symbol of Asante, the community, like other Akan speaking peoples of Ghana, were composed of a number of dispersed matri-clans or mmusua-kese (I. Wilks, 1967). The segments or states, called amantoo were bound principally only by similarity of their social organizations, religion, language and ties of clanship. The forces that came together to fight the Denkyira were those of Juabeng, Mampong, Nsuta, and Bekwai (Busia 1958, p. 85). Each chiefdom had its distinct stool polity - a political organization which centred on the continuing identity of the founders of groups ranged in their corporate relationships according to the stools that represent them. This is an important point to make when (Rattray (1929, p. 62) referred to the family as a corporation and that action and even thought were corporate affairs. Every lineage in the community is a level in the overall political organisation. So that Juabeng, Mampong, Nsuta and Bekwai that came to fight Denkyira were complete states with many political segments in each of them.

When they formed the Asante union, and Mampong became the second after the king of Kumasi, what really happened was an agreement whereby governments centered in various specific lineages were arranged in hierarchies with the particular lineages of Oyoko clan in Kumasi as head of the new machinery of unity and government. Mampong with their most superior lineage stool, the Bretuo clan silver stool and Juabeng with their Oyoko clan Akyam Nyame stool as well as the other states thus came to form another framework of political organisation or stool polity.

To begin with, each amantog had strong allegiance to their respective amantog stools which had come to be accepted as the primsa inter pares. of their units. One of the functions of the Golden Stool of Asante was precisely to break this extreme and exclusive allegiance to the stools of the units. The Asante Union government continued, however, to be a loose federation. Each segment had its own government through its lineage, village, and sub-division. Indeed, this is how the internal government of the divisions have continued to be. In the 19th century there were even periodic attempts to dismantle the union government by the rebellions of some of the members. (Busia 1958 p. 87 et seq.)

The coming of the Golden Stool of Asante

The coming of the Golden Stool is narrated with great dramatic effect. Amid deafening sounds of drums called Fontomfrom and the Mpintin, clanging of gongs, radiant female voices and humming deep male ones, the chanting of various musical types of the courts of the amantog chiefs, dancing and clouds of dust,

dark smokes from musketry, the Golden Stool descended onto the lap of the king - Osei Tutu - as he sat in state. All the principal stools of the constituent states of the union were collected together with their swords and buried in the bed of the Subin river at Bantama Kumasi. It is said only the Akyem Nyame stool of Juabeng was spared. Into the new stool - the Golden Stool - was rubbed a powder made from the nail parings and hair of all the abrempon or chiefs of the states (Kyerematen 1969, p. 3). In that way, their stools and their spirits were symbolically subsumed in the new object and symbol of political leadership.

This object of national Unity has been described by a number of people who have written on the Asante. (Rattray 1923, Preface and Chapter XXIII, 1927, p. 131; Busia, 1958, p. 74.). Kyerematen (1969), recently presented it as an asesedwa about one and half foot high with a two foot long animu, and one foot wide. The Golden Stool which comes out on ceremonial days in the Asante capital of Kumasi is liberally covered with gold. The animu has scalloped edges. The sekyedua is cylindrical and there are little square or slightly oblong holes on it. The wiaboo is elliptical. Through the ntokuro on the animu are hung bells and effigies of vanquished warriors of history.

The Golden Stool of Asante as an unwritten constitution

The Golden Stool of Asante enunciated a definite political theory but it did not create this theory. It of-course enlarged upon the idea of the stool in politics that had already developed in time in relation to the lineage asesedwa as a social and

political symbol in Akanland. The Golden stool was not to be regarded as a stool of a family in Asante but the stool of all Asante, although a specific family was to continue to supply occupants for it. It did not usher in an era of Republicanism, but a monarchical system of a kind in which the ruler and the ruled were subject to the law personified in the object of an overall Asante political stool. Specific social and political laws were enacted by its coming, and beside the minute definition of the military, judicial and administrative functions of the occupant, also social and criminal laws were promulgated (see Appendix 3). Above all, the stool was to be regarded as greater than all including the ruler and the ruled. It was to give an office with specific rights and benefits to be held by successive duly selected persons, of course, from a specific lineage group of the Oyoko clan of Kumasi. This office was to be the supreme headship of the new Asante nation. Whoever was elected to it from this particular Oyoko royal lineage in Kumasi was to be regarded as one who has inherited the social personality of the ancestors as an organic whole and not the ancestors of the particular Oyoko lineage alone. It is the special inclusive nature of this stool that makes it the 'soul' of the people. As the Asante say, it is the symbol of their solidarity, continuity and being. It is the document and witness to the terms on which the states came together to form a politically organized nation of Asante. The sovereignty that was forged was sovereignty of the people and that is why the people would die rather than let go this symbol of their being.

In his paper on the Comparison of the English, Gold Coast, Akan and Fanti laws relating to absolute rights, Sekyi argued that a stool (and this would apply very much to the Golden Stool of Asante) could compare with the Holy Crown of Hungary which was regarded by the peoples as a mark and symbol of the sovereignty - the symbol of their organic unity.

Specific places were assigned to constituent chiefs who represented these states. Their new stools were to be historical charters for these states forming the union. Subsequent chiefs of each state added stools to those that were carved after the historic destruction of the original supreme lineage stools, but each state, continues to have a stool which is regarded as their coronation stool.

The Golden stool was, however, to be used as the coronation stool of the Asantehene. This would enable him to reflect the national wholeness and make him the hub of the national political relationships. While they, as a people, could fight for the king, they would do so with all their might if the safety of the symbol of national being was threatened. The evidence of this is seen in the historical Yaa Asantewa war of 1900. When the Asante saw the pointlessness in continuing the war of 1896, they gave in and reluctantly, however, accepted the deportation of their King Prempeh I (Busia, 1958, p. 114.) In 1900, however, the Asante could not compromise when a British colonial governor asked for the stool - the 1900 war was led by a woman to show that the nation was prepared to fight to the last person to save it. Again, even under the British colonial government in the 20th

century, Asante asked for the trial of a former stool carrier of the Asantehene who together with others, stole some gold attached to the stool which had been secretly taken to the two villages of Wawase and Aboabogya in Asante¹. By this time the colonial power, ostensibly, had come to appreciate the sentiment that the Asantes attach to the Golden stool, and the trial of the malcontents demanded by the Asantes was allowed but under clearly stated conditions².

¹ Aboabogya and Wawase were the two places where the stool was kept. Part of the stool was kept in Aboabogya and part in Wawase. The actual stool is believed to have been kept in Wawase but most of the ornaments which were complementary to the stool went to Aboabogya. (Informants: A.C. Denteh and two eye witnesses of the incident in Wawase - still living). The Wawase bit of the stool was kept on top of a huge silk cotton tree (*Ceiba pentandra*). How it was done is yet to be explained. The tree is no longer standing but the spot where it stood is there to be seen. This spot is, however, not cordoned nor is it regarded a sacred spot marked by a shrine.

² The Asantes regard the crime as one punishable by death. On the evening when the matter was reported to the representative of the colonial power, all Asante was mourning and people put on the visual art for mourning - the kuntunkuni cloth. Mentioned and explained later under stool regalia. The chief commissioner stipulated that:

i. The enquiry was to be held not at Aprensac (sacred place in the palace) but in the open space behind the police barracks, where if necessary, police reinforcements could appear at a few minutes' notice.

ii. Government police were to be at the enquiry to maintain order and preserve peace.

iii. The accused attend under armed police escort.

iv. Witnesses should be summoned and any other further arrests were to be made through the Commissioner of Police.

v. The accused and witnesses were to be under police protection.

vi. The enquiry was to be conducted according to principles of British justice.

vii. At the conclusion of the enquiry a report was to be made to the chief Commissioner, who would consider the question of guilt and the nature of the punishment to be inflicted (Busia 1958, pp. 115-116.)

At the end of the trials, the chiefs forming the panel at the court under the presidency of the Mamponghe found the culprits guilty and some of them were sentenced to death. They included Seniagya, Kwadwo Danso, Yenkyira, Yoko, Kwadwo Poku and Asubonten. The death sentence was nullified by the colonial government but Seniagya and others were allowed to be deported¹ (Rattray, 1923, p. 288; Busia, 1958, p. 146.)

Political position of Asante stools in relation to the Golden stool

The Asante union was, to begin with, a military one, and each chief had a definite place in the ranks. The places they held were in essence a picture of repetitions of the political organizations in their individual states. There were the right, left, rear positions among others, we saw in the Denkyira government in its hey day, earlier on. In the Asante Union government, an obrempon (constituent state chief) became one or other wing chief of the Union government. Whilst internal government was left to them, power of death sentence for example, was the monopoly of the Asantehene. Every segment of the polity under the asantoo chiefs also had their competences and it was possible to appeal from a lower court to a higher one. The main function of the Union was in the past the execution of war. Busia writes: that:

¹ Seniagya was deported to Nigeria. He was allowed to come back after 1957 and died later in Ghana.

The union enabled adequate and effective measures for defence or attack to be taken. This was achieved by all the states combining their forces.....The union military organization was the same for a state. It consisted of an advance guard (twafe), a main body (adonten), and a rear-guard (kyidom) and two wings, left (benkum), and the right (nifa). In the national army each wing had two formations: right- and right-half (nifa-noase), left and left-half (benkum noase). Each state was assigned its place in the organization, and one of the chiefs of the more important states commanded the section. The positions of the major units were:

The Konti and Adonten clans of Kumasi-

The right half wing: Juabeng, Kokofu and Bekwai.

The right wing: Mampong, Adansi, Nkoranza, Offinso, Ejisu.

The left wing: Asumegya and Kumawu.

The rear guard: Kyidom of Kumasi, Ankaase, Domakwai.

The Asantehene, who was in command of the whole army after the usages of Asante warfare directed operations from behind (Busia, (1958 p. 90.)

Creation of further stools and offices

Akan stool polities are by nature dynamic. Lineages may develop by accretion or by addition through migrations or some other forms of internal development. Lineage heads increase and stool headships also increase. The heads augment the governmental machinery. It happened that in some Akan communities another dimension of offices in government emerged.

In the special example of Asante, stool offices and other special non stool offices developed besides the normal sources of leadership. As the political domains of Asante grew, elders in the amantoo could be asked to oversee the affairs of distant conquered lands. Such people also may have representatives thus adding other levels of offices not necessarily attached to lineage stools.

Whilst the civil and military organizations of the amantoo continued to be largely based on lineage, later military organization of Kumasi began to give way to other groupings not based on lineages as such but on military considerations. In place of lineages, there were military units or companies which were called fekue (party) composed of different clans. Their leaders were called nsafohene (Busia, 1958 p. 90).

This type of development was *most* pronounced in Asante although it appeared also in Akim and Akwasi. The Akim Safohene did not seem to be a parallel of the Asante safohene. Danquah (1928 p.38) gives the impression nsafohene in the Akim Abuakwa case referred to the heads of the constituent states. The important thing to note is that the Akan polity is dynamic and it also makes room for development of other agents of political action in addition to the regular lineage personnel who get their positions as a matter of descent and attachment to lineage stools.

The creation of stools and other offices in Asante is reported to have started even before the Asante union. Osei Tutu, according to the literature, met the post of Soaduhene and Tokohene of Juabeng in the system before he asked permission after a war with the people of Dormaa to establish military posts to help in the government and particularly defence of Kumasi. (Busia, 1958 p.91 et seq.) He is reported to have said that he thought it was necessary for him to create war captains who would protect Kumasi, when they (the amantoo chiefs) were away in their capitals, for he had then many captives in Kumasi. Amankwatia stool was the first to be given this new political significance after this declaration by Osei Tutu to his amantoo chiefs. He called the stool

'Oko enti'. That is, the stool was being accorded the political recognition to become a 'war stool'. The occupant was to be a war leader. Captives under their own captains were placed under this new Safohene. They included captives from Banda, Berekuu, Suatre and Dormaa. Other raised 'abusua mpanyinfo stools' by Osei Tutu were Kra Bosompra (Akyempem), Suduhene was changed to Akwamuhene and the company was enlarged. Asumen stool was raised to be Twafohene symbol (leader of the advance guard) Akrafo stool was instituted. Osei Tutu, therefore, is known to have 'created' or raised some lineage stools as Konti (right) Kyidom (rear), Akwamu (to immortalise the name of the place to which he fled after leaving the Denkyira court before 1700) and also Oyako companies, but in each company, there were people of different clans.

Traditional accounts, and of course (Busia 1958 and Wilks 1967) relate how later successors of Osei Tutu expanded this political machinery begun by him. By the time of Nana Osei Kwadwo a period Wilks called that of Kwadwoan revolution,

'the size and complexity of the Ashanti empire in its developed state posed problems of organization of a quite different order from those of the early kings. Government had to be developed in range, to embrace far distant from original settlements; in depth to control spheres of activity previously untouched by authority; and in efficiency beyond the abilities of non-professional administration such as the hereditary chiefs, mpanyinfo of the king, and his amanhene, upon whom, under, the early constitution, responsibility had developed' (Wilks, 1967, p. 211, et seq.)

Mnamadwa

One way in which the efficiency of government was enhanced in Asante was by developing an element in the administration which

was not necessarily attached to the traditional lineage matrilineal stool offices. Wilks (1967) refers to Bowdich's assessment of the situation as we saw - the departure from the normal stool office personnel in government. The exercise he reports entailed:

'the subversion by a systematic campaign of disgrace and banishment of the power of the Kumasi hereditary chiefs, and the transfer of the functions of government to a new class of officials controlled by the king and charged with the administration of the affairs of the empire, and instrumental in the achievement of the revolution was the Ankobea a newly created para-military body directly responsible to the King, and deployable at his will.' (I. Wilks, 1967).

Two most senior posts in this new force of political re-organization or change were the Ankobea stool and the Atipin (I.A.S. 2 and 9). The new posts, however, went mainly to descendants of previous kings, who have been known in Asante and many other Akan states as, the ahenemma (the sons of kings). In the Asante Union administration, the ahenemma were the sons and grandsons of the Golden Stool. The mmamma stools¹ were:

¹The Institute of African Studies has been collecting Asante stool histories as from 1965. The first hundred collected by 1967 from Kumasi show that more than one third (in this context) are mmammadwa. The records of Huydecoper, Bowdich, Hutchison, Dupuis, and others, show that almost all occupied were other than matrilineal stools. I. Wilks, 1967 p. 236.

Some other notable mmammadwa are:-

1. Ankobiahenecreated by Osei Kwadwo -IAS 2
2. Gyasehene.....created by Opoku Ware - IAS 15
3. Atene Akuopong.....created by Osei Asibe Bonsu Panyin-IAS 21
4. Boakye Yam.....created by Osei Kwadwo-IAS 23&27
5. Abrafoghene.....created by Opoku Ware -IAS 27
6. Sanahene.....created by Opoku Ware -IAS 41
7. Okyeame Gyebi Banahene...created by Osei Kwadwo-IAS 46
8. Ankaakade(Linquist stool) " " Osei Bonsu Panyin -IAS 75
9. Nsenie..... " " Oti Akenten -IAS 81 (both matrilineal and Patrilineal) in the Gyase division.

Seniagyaa a stool carrier descends from this line. Note his trial and banishment September, 1921. Allowed to return from Nigeria after 1960. Died two and a half years after return. The abbreviation I.A.S. refers to the source material on Asanti stool histories in their library in Legon.

vested in patri-centric residential groups, within each existed an accumulation of particular administrative skills, and the conditions necessary for their transmission from generation to generation. Rattray paid tribute to the 'remarkably efficient results' obtained from the generations of continuity in office, son learning from the succeeding father, and saw in the system the tendency 'to break down the rules governing matrilineal descent and to prepare the way for a patrilineal way of reckoning. In fact, however, the quasi-patrilineal pattern of succession to office appears to have been without effect upon the continued matrilineal inheritance, since only skills, and not capital tended to accumulate with the patri-group. The bureaucratic class therefore retained its distinctive official character, and showed few signs of transforming itself into an independent and propertied middle class'. (Wilks, 1966. Aspects of Bureaucratization in Ashanti. Journal of African History, Vol. VII, No.2.)

....For example, three commissioners of Asante lived in Accra in the Danish, Dutch and English sectors, when it was so divided by the European powers at the end of the eighteenth century.

The new dynamism in the growth of bureaucracy in Asante government made it possible for the mmammadwa (sons' stools) to function where kinship attached to stool rather than the stool being attached to a kin group. The kin group stools were occupied by specific lineages of the kin group and they were mainly matrilineal stools. In other words, the incumbents of the stools derived their right to office by virtue of their membership of the matrilineal lineages who were the stool occupants. The mmamma attached to kinship only and therefore the sons and grandsons of past chiefs could have the office designated by the stools created for them.

There are still very important mmamma offices in Asante traditional government. Many Akan states like Akim, Akwamu and Nsima have mmamma stools and so important are they that one may be led to think that they are evidence of a possible future turn to patrilineal inheritance in Akan society. For example, a mmamma

stool of Kibi, the Abontendomdwa gives the occupant a very responsible position, and the office of the incumbent is ranked with the status of a head of any of the constituent states of the oman (nation). He is the first minister of the government of the capital of the nation which is the totality of all the states in Akim Abuakwa.

Constitutional use of the stool

We recall that over time the Akan asgsadwa attained the position of the greatest political symbol of office which at the same time helped its distribution and further elaboration. At any given level of the political community, chiefs were elected and installed as leaders of the people and this installation of a chief involved the use of a stool in the formal rites. Over all Akanland, the chief is ritually 'placed' on the stool by lowering him three consecutive times towards the animu of the stool, making sure that no part of his body touches it (Danquah, 1928; Chapter 5, Busia, 1958 p. 13; informants - Mampong and Ahwiaa.)

When chiefs are installed they swear to their elders to uphold the values of the constitution of the communities and respect the elders of the stool. On behalf of the communities the elders also swear to him to give him their co-operation so long as he remained faithful to the oath of his office which he swears to his people.

Each lower level of lineage chief swears an oath of allegiance to his higher chief after he has been given the office of chiefship of his lineage. The installation of the Asantehene is an elaborate affair. Nana Adabour's eye witness account which

we got confirms many of the details of the records of the Institute of African Studies, Legon collected mainly by Agyeman Dua.

Succession to a stool and the Queen Mother

Any particular chief is chosen from a branch or a clan to which a stool in question is attached. Although there may be many separate kindred groups, all tracing their descent from a common ancestress, the line or lines from which a chief may be chosen are confined to one or a few branches; and in this matter of nomination of a chief in the chosen family, a very important person and post in Akan culture is the queen mother. (Rattray, p.29, p. 83, et. seq.) The queen mother is the official mother of the reigning monarch. In reality, she is often a sister of the chief or some female from his maternal kin group. Danquah describes her position as the most sacred in the realm of a political community. (Danquah, 1928 p. 27; Busia, 1958, p. 19.) She is not only expected to nominate a candidate for a particular stool for which she is the female head or mother, but she is, by Akan constitution, the principal private advisor of the monarch, and she may be sanctioned or removed from her exalted and responsible place, if she fails to exercise the traditional duties imposed on her. Her position is very institutionalized and symbolized in a special stool of her office. It is significant that the queen mother continues to be a very important person in Akan political organization. Besides all else, she symbolizes the general importance of, and respect for, women in Akan social affairs. When queen mothers fail in their duty to advise their 'social sons' well enough -- the chiefs they are required to

supervise -- they suffer grave consequences. This is why queen mothers Atta Birafe and Kobi were destooled, according to Busia, for not disciplining the chief under their 'care'.

When a chief is needed for a vacant stool, it is the queen mother of the ruling lineage who is approached to nominate a candidate. Although she nominates the candidate, it is the wishes of the elders of the community and the common man in the street represented by the nkwankwaa (young men's band) that finally prevail. If her first choice is unacceptable she is allowed to make a second and third choice. Where there are more than one ruling sectors in the lineage, the other sector may be given the chance to nominate one.

Probably, a discussion of the enstoolment of the greatest Akan chiefs known in history of the past centuries may be useful in giving insight into the process of incorporation of a chief.

Enstoolment of the Asantehene

The entrenchment of the Asantehene into his office is finalised by his enstoolment. Thereafter, he is described as a person 'sitting on the Golden stool'. The idiom Ote Sika-dwa no so - he sits on the Golden stool, means he 'hangs or floats' on the stool. This means he is supported by the stool and that he himself is lighter than the stool. The description of the actual use of the stool to be given will show that the king-elect never really sits on the stool. The stool is symbolically used to indicate that the king always has the moral support of the people and that the support is spiritual rather than physical. This does not rule out the physical support which he would need. Indeed, the idea of putting the stool behind him and yet not allowing him to sit

on it means that he has a powerful force which is even greater than physical power. Ye gyina n'akyi (we stand behind him).

When the Golden stool becomes vacant ^{through} the death, abdication or removal of the occupant from office, the queen mother of Akyias Ama stool is approached to nominate a candidate for it. She is by tradition required to discuss her candidate with elders of her own ruling lineage. She also has to confer with the queen mother of Kokofu, the head of the Gyase (the house-hold wing) for they are regarded as complementary lineages to the ruling Oyoke lineage of the Asante union. The Ankobia (home guard division) is also consulted in the initial stages, for the Ankobia supplies the right hand man of the kings. If a candidate who is proposed is acceptable, he is publicly nominated by an electoral body. All the senior linguists of the regional chiefs of Asante come to Kumasi for the purpose. They assemble at Pampaso, a meeting place in the royal palace, and there the installation begins.

Occasionally a deadlock in the nomination of the king-elect may occur. Provision is made for resolution of such situation. The Mamponghehe who is deputy king of Asante union and the traditional guardian of the Asante union affairs during inter-regnums, is expected to come down to Kumasi and help resolve it.

All shades of opinion must be considered in the matter of the choice of an Asantehene even more than is necessary in the case of other chiefs, for his office is an all inclusive one. He is chief of chiefs, the living representative of the ancestors considered as an organic whole. Here again the young men's association called the mmerante with their head the Nkwankwachehe,

whose office is not anyway a stool office, must be consulted in a way. They should know of the candidate and it is helpful to get their co-operation if further steps in the installation of the king could go on successfully.

While the queen mother of the Akyia Ama stool is the ritual mother of the king elect, the Adumakwaihene, the lineage chief of a lineage called the Adumakwai, is the ritual father of the king. It is he who has the sole right to unsheath a sword called the Bosomuru with which the king elect swears his oath of office. The sword is, however, not kept by him but by another lineage chief - the Adumakaasihene of Kumasi.

So there is a complex of stools and ^{the} holders of offices in the complex have specific duties to perform. Each holder of a lineage office which has responsibility in this exercise will have to do his or her duty to make the installation possible, and the ritual enstoolment essentially brings together the person of the king with the office he is to hold. In the royal family, the king elect has a profane status of eba (son), but as a king, he becomes Nana (grandfather).

Usually the enstoolment of an Asantehene begins on a chosen Monday, called Nkyidwuo in the Akan traditional calendar which has been explained by many of the principal people who have written on the Asante. The following account adds a few more details to the enstoolment of the kings of the Asante nation (Stool Histories. IAS, Legon No. 33).

When the new Asantehene arrives at Pampaso he greets nobody but walks majestically ahead to Pampasohene's house. The Pampasohene at this time takes no part in the ceremony, but his mother, the occupant of the Akylaa Ama stool, on this ceremonial occasion acts as the Asantehene's mother. Those privileged to be present at this juncture enter a special room where the new Asantehene is locked in and after the inside ceremony is completed the Mamponghene (Nifahene of Asante), acting on behalf of all the chiefs, instructs the Gyasehene, the Akyeamehene and Nseniehene of Kumasi to request the occupant of the Akylaa Ama stool to give them her son, the Asantehene elect, to go and occupy the Golden stool. She refuses three times, then consents and charges a fee of peredwan esea (£9.6.0). Then she puts down the Asantehene elect, whom she has been carrying on her back in the Kente cloth and puts on white shirting, signifying success achieved by her. The kente cloth she puts on at first signified the importance and dignity of her titular son whom she has been carrying on her back. Then he is taken to another room where the occupant of a stool whispers a secret word to him and then he comes out and stands with the Gyasehene while the Akyeamehene and the Nseniehene return to report to the Mamponghene and the chiefs assembled that the Asantehene elect has been given to them. (ibid.)

The Asantehene enters upon a situation where he has to maintain a proper balance between the ideas and interests of the Kumasi state and his Asante union. The king-elect is thus presented to the nation and those who have the responsibility of installing him into his office proceed to a stage of legitimizing of his authority as described in the following:

At this stage the Adwumakaasihene is sent for; but he excuses himself on each occasion when any one of the sword bearers is sent for him until the Busumuru sword is sent. He dresses in the Kente cloth presented to him and with all the state swords followed by the Busumuru sword in front of him, he at last arrived at Pampaso and compliments nobody but enters the Pampasohene's house. Akyeamehene then informs him that the Asantehene elect is about to occupy the Golden stool and it is the Adwumakaasihene's duty to come and draw the Busumuru Sword, the emblem of the Asantehene's authority and power, from its sheath for him to take the Oath. Here too the Adwumakaasihene declines twice, but on the third occasion consents and charges Peredwan Esea (£9.6.0.) and then draws the sword held by the Busumuruhene from its sheath and gives it to the Asantehene and places the Denkyekye (a kind of hat) on his head. He then puts on the white cloth instead of the Kente cloth he too was wearing to show his success at performing his important national duty. Otumfue Asante-

hene elect still in the Yard of Pampaschene's house, takes the customary oath there with the Busummuru sword, and then all the regalia except the Golden Stool are returned to him, after which the State drums begin to sound and women folk sing songs of praise. The Asantehene dances three times to the music of the Aperede drums and holding Apim-Asanta (a shield) in his left hand and the Busummuru Sword in his right hand respectively and leaves the house and steps outside (I.A.S. 33, p.6).

After the swearing of this oath, the Asantehene elect dances to the throbbing of Fontomfrom drums. He later sends a sword bearer to Mamponghene and the bearer of the Busummuru sword to the queen mother, the occupant of the Akyiaa Ama stool informing them of the completion of the ceremony at Pampaso, and inviting them to Dwabirem, the central meeting place in the palace. The king-elect soon appears at the Dwabirem in war dress to demonstrate his prowess as a war leader. This particular ceremony ends late in the evening.

At mid-night, with the exception of the Mamponghene, all the Amanhene and all the chiefs arrive at the Palace, in simple dress, without their seats and with only one Umbrella bearer each, who are turned out immediately the chiefs arrive. The Golden Stool is then carried by the Chief Stool Carrier, followed by his subordinate colleagues, and brought out and placed on Banwuma (Elephant skin) in the middle of Bampanase Court Yard in the midst of the Chiefs, while, the Queen mother of Asante, the Queen Mother of Kokofu and a few senior female royals of the Asantehene stand some yards on the left of the Juabenghene, the Gyokohene and Dake chiefs stand on the right hand side to watch the ceremony. Then the chief stool carrier sends the Gyasehene to inform the Asantehene elect that the Golden stool is ready at Bampanase.

Asantehene dressed in white Adinkra cloth lowered to his waist with the Afudue on, and the Busummuru sword in his left and the Mponpensue sword on his right, gold Kantan (Gold Necklace) and gold Awoso on his neck, Denkyemkye (crocodile skin hat on his head, and wearing the Mpaboakese (King sandals), with his Nhinkwaa (attendants), marches majestically to the Court Yard towards the Golden Stool and halts in front of it. Then he turns about and sends the Mponpensuehene holding the mponpensu Sword (which has been corrupted into mponpensue sword), to tell the Mamponghene in his house that he is ready for his coronation.

The Mamponghene wastes no time but proceeds with his Akyeamhene (Head linguist) and on arrival takes his stand with the Nifa Chiefs, the Adontehene of Asante and all the Adonten Chiefs, takes hold of the Asantehene's right hand. The Esamegyahene supported by all the Benkum chiefs join on his left. The Kronti and the Akwamu chiefs hold his right foot, the Gyase, Ankobia and Manwere chiefs hold his left foot; the Akyeampihene and all the kyidom chiefs (Rear guard of the Asantehene) hold his waist.

The Kokofuhene, at this time holding his cap gun, stands behind the Golden Stool on the right; Nsutahene, holding his cap gun also, stands on the left of the Golden stool, while the Chief stool carrier in white dress holds the Golden Stool standing. The Asantehene is then lifted up and the Mamponghene repeats, three times, the words 'we place you on the Golden Stool of Asante with our united blessings'; and each time he is placed upon it; then the Queen mother of Kokofu, and the women present sing songs of praise and the Asantehene is given to Asuamfuo (State palanquin carriers) who carry him in their palms, in charge of the Gyasehene, the Ankobeahene and Manwerehene, to a room called Me Ede, where he remains quietly till the next day, which is the Fobera (Tuesday). (I.A.S. 33).

According to the elders of the Oyoko lineage of Kumasi and the stool elders of Mampong, the Asantehene duly enstooled must give some stipulated traditional gifts and money. He sends rum and Ntaamu, about sixteen pounds, by a linguist to the Mamponghene. Then adorned in a white ceremonial cloth taken from the regalia, which we shall be discussing, he sits on a gilded stool to receive compliments and greetings of his subjects who come to see him.

Right from the beginning, he is expected to demonstrate the spirit of abundance, liberality and affluence. Palm wine and food is normally served to all who enter the palace and care for them.

His wing chiefs are free to leave Kumasi after the third day and he sits in state particularly on the third day to bid farewell to chiefs who leave.

By the final ceremony of installation of the King with the Golden stool, he seals his willingness to serve as king and his preparedness to uphold the constitution of Asante. His time and everything including his life becomes state property. He is judge and grand father for all Asante, and he is the supreme military leader of the Asante forces in time of war. Every male child is a potential member of the forces through his lineage head or chief, who are, as groups, auxiliaries in the Asante army.

By his enstoolment, the king reciprocally becomes entitled to the right to receive all he needs in life - food, clothing and means to maintain his chiefship. Hence such animal skins like that of the lion and the leopard, to a lesser extent, obtained from the geographical area over which his jurisdiction extends must be surrendered to him to augment his regalia.

So by his enstoolment rights are transmitted and he is incorporated into his stool office. The spirit of the ancestors is said to have been transmitted to him and he inherits the social personality of the ancestors as an organic whole through the immediate past king. He is Nana despite his age for his person is identified with his office through his ritual enstoolment.

This is what the late W.E.G. Sekyi, a Ghanaian lawyer and philosopher, tries to express in comparing the ceremony of enstoolment to the idea of apostolic succession. It may be argued that it is not an exact parallel but the essence of it may be granted as similar. It is the perpetual nature of the office and the fact that the power and the authority that the king receives was first typified in the first ancestor, whose place he takes.

In a paper read to a seminar on Ideology in the University of Edinburgh in February, 1970, Ayo Langley draws attention to what Sekyi writes on this:

I am of opinion that, according to the primitive idea, the new chief was believed to inherit not only the office, but also the personality of his predecessors. The chief is placed upon the stool which is the emblem of his office and in course of time he is identified with it, his spirit being believed to continue to dwell in it after his death, and so sacrifices are made at stated times to the stool and its imminent spirit. On installation (enstoolment) the spirit embodied in the stool enters into the new chief who thus continues the personality of his predecessor by a kind of apostolic succession. (W.E.G. Sekyi. Custom and Law in E. Africa - n.d.)

Unlike Danquah, Sekyi did not overstress the religious aspect of the stool. Danquah, of course, modified a lot of his views about the stool as a god in his time. It is a symbol of office. It helps to symbolize the perpetuity of rights and the legitimization of authority. Ohene nwa, oke na kuma (The king does not die, he goes to his village) is the idiom for announcing the death of a king. The person of the king may pass away but the spirit he inherits from the organic whole - the ancestors - is perpetual. His person, the stool, and the office he receives by his ritual instalment on the stool are different things, and these differences are made in different social circumstances. Hence, he could be stripped of his office and then his person is detached from the stool and his office.

By the same object of the stool, the king's authority and power is kept in check. The Akan stool, as we have suggested, embodies a political theory as well as constitutional norms. The king is

subject to the constitution which is embodied in the stool, and by the constitutional practice of destoolment he is removed when that becomes necessary.

Other occasion in which the stool is in evidence

a. Destoolment

Chiefs are expected to keep to their oath of office and they are removed from office when they are proved to have broken the pledges. This practice continues to be followed. There are many examples in Akan history. Even kings of the Asante union are known to have been destooled. Kings Kofi Karikari, 1874, and Osei Bonsu 1800, were destooled. According to Busia, (1958 pp. 21 - 22), Kofi Karikari did not give enough respect to his elders and removed at one time some gold from the Bantama mausoleum, while Osei Kwame clashed with some of the abrempon (constituent state chiefs) when he embarked on his centralizing policies. Busia lists other causes for destoolment and some chiefs who were removed from their offices. Chiefs Kwabena Aboagye of Asumegya, Kwabena Bruku and Kwasi Ten were destooled for drunkenness; Kwame Asomane of Bekwai for being a glutton (adidifurum); Kwame Asona for dealing in charms and noxious medicines, and Akwamoa Panyin of Juabeng for his abusive tongue, and for not following the advice of his elders. In Kokofu, Osei Yaw was destooled for being fond of disclosing the origin of his subjects (that is reproaching them with their slave ancestry) and Mensa Bonsu for his excessive cruelty.

Before a chief is destooled he must be impeached by his

elders, sub chiefs and he must be proved guilty. For obvious reasons sub-chiefs must be very sure of their grounds before bringing forward accusations against their head chief. Relationships get strained between the impeachers and the impeached and in the interest of future government restraint is to be exercised and rushing into such actions must be avoided.

According to tradition, if a chief is found guilty on the last day of his trial, the nkwankwaa (the common men's band) and their leader the Nkwankwaahene who is not a holder of a stool office, are allowed to approach the chief and remove his sandals from his feet to make the soles of his feet touch the ground. The stool on which he may be sitting may also be removed suddenly and his back may touch the ground. If this should happen, the chief formally ceases to be a chief, for the taboos, that his back or the soles of his feet should not touch the ground, are broken.

Subsequent to this, the coronation stool is brought into the yard of the stool house or room by the stool custodians and libation is poured to it to inform it of the destoolment of its current occupant. No one has recorded an eye witness^{account} of the physical action that is said to be part of the destoolment process but it is generally agreed by informants, that this was a recognized practice. Nana Ghartey of Winneba, for example, confirms that this was done and that he himself nearly suffered that in 1960 but Nana Kwame Fori of Akropong Akuapim, maintained the view that it is not a historical fact that this ever happened. In parts of Asante it is believed that physical action could

accompany destoolment although it has never been done to any Asantehene. In Kibi, it is still regarded as something that could happen and be perfectly legal. The young men (mmerante or nkwankwaa) form part of the asafo groups - the military companies from the three counties of the state. A few years ago the nkwankwaa of Akim Abuakwa were very powerful political pressure groups and tended to arrogate to themselves the absolute power to enstool and destool chiefs. (Danquah, 1928)

As we understand, the situation was that they should be instruments to the sub chiefs and the nsafo (plural of asafo) to which they belonged and they were not expected to act independently of them. Destoolment continues to be characterized by demonstrations in asafo songs, tongue lashing songs and frantic evert behaviour, but a stool comes into the destoolment process only as it is always brought out at a point, to be informed of what has happened through libation. The act of libation involves also a cleansing of the stool. This is usually done by the second in command to whichever chief is being destooled.

b. The stool in battle

Another occasion in which the stool as a symbol of a chief's office is in evidence is on the field of battle. Normally, the Golden Stool, for example, is never put on the ground, for this prohibition was one of the laws given by Okomfo Anokye. It was to rest every time on a coarse blanket called Nsaa. King Osei Tutu made for it a high kind of chair called hwedom mentioned in passing earlier on. (See plates and further notes Chapter V). The Golden stool, therefore, is expected to rest on this hwedom every time it is in the stool room or house.

The stool could be taken out to the field of battle.

Even there, it was expected to rest on the Nsaa and never on the ground. From the time the hwedom was made for it, Osei Tutu decreed that it should also be put on this kind of chair on the field of battle, to face the armies - ma wahwe dom no.

However, if the Asante forces were being forced back or defeated, then a challenge should be thrown to the ancestors by throwing the stool to the ground for them to come to the aid of the armies suffering the setback. The king should then jump or stand on the stool, which was a further challenge to the ancestors. At the same time, the act was regarded as a challenge to himself and his office and to the forces for allowing the ancestral stool to come into that state of degradation. They fought harder to show the ancestors that they, on their part, would hate to see the community and state which they (the ancestors) laboured for, and built, come into disgrace.

If after this, things seem still difficult, then the stool must be saved by retreating or escaping with it and never without it. It is for its inspiring value that it was often taken to war. King Osei Yaw Akote of Asante is remembered as one of the kings who took the Golden stool to war. This he did in about 1824 when in the war usually referred to as the Mankata Sa (the McCarthy war), Osei Yaw Akote was, according to Asante oral history, very agile in that war which he had to continue after the death of his uterine brother Nana Osei Bonsu, whom he had to succeed. He moved to the front with the Golden stool and that, it is believed, inspired the armies and urged them on to victory. His action is seen today by

some historians as being a device to guard his own interests. He, according to Kyerematen (January, 1969) took the stool to the front of the armies because his sister's son Kwaku Dua, the immediate heir to the Golden stool, was more popular. Kwaku Dua's popularity stemmed from his youthfulness as opposed to the aging person of Osei Yaw Akoto, for it must be remembered that all things being equal, youthfulness gave candidates for chiefship advantage over older contestants. By taking the stool to the front and to the field of battle, some people believe, he forestalled the eventuality of Kwaku Dua being made chief while he (Osei Akoto) was on the battle field. Without the stool, the office of the king could not be consummated.

Osei Yaw Akoto took the stool again to the Dodowa war of 1826. This was is sometimes referred to as the Akantamansu war. This marked the turning point of the Asante advances to the Southern part of Ghana, known before the Political Independence of Ghana in 1957, as the Colony of the Gold Coast. Nana Osei Yaw Akoto was severely wounded and virtually lost control over the Golden stool and it was rescued from an inevitable capture by the enemy forces, by the Chiefs of Juabeng Kwaku Boateng, Antwi and young Kwaku Dua.

Rather indiscreetly, Osei Akoto became antagonistic towards Juabeng, alleged to have kept part of the paraphernalia and wealth of the stool. Relationships became so strained that he made war on the Juabengs contrary to an injunction of Okomfo Anokye that there should never be war between Kwaman and Juabeng. Part of the Juabengs migrated south to the Akim and finally settled on land purchased for them by the then colonial government of the

Gold Coast. This land is the region designated New Juabeng with Koferidua as the chief town.

The Akan stool polity - a summary

We have been concerned mainly with the development of a kind of political organization of a group of Akan states among which are Akim Abuakwa, Akwamu, Denkyira and Asante. We notice political offices being organized around and in relation to stools which attached to kingroups.

In a given political community, like the Amantoe of Asante, the Asanteman (Asante kingdom), Akim and Akwamu examples, there are segmentary lineages which are corporate groups. Their leaders have stools - the principal symbols of their offices. The administrative structure of government derives from the combination of stools at different levels which represent those offices which are themselves the focus of lineage interests and corporate identity. That is, more inclusive corporations have tiers of lineage offices within them. So the Asanteman is an all inclusive union of big aggregate corporations. In the Asanteman, the elders of the lineages and the chiefs of villages, town and the constituent states come together to form the Asanteman government.

The system of government takes off from the family group with the fathers or grandfathers in the matrilineage as the ruling patriarchs and the spirit of the dead as the greatest sanction on behaviour. Each kingdom, in the Asante example, retained its identity and structure of government which were identical - each chief with his own mpanyinfe (elders) and abrempon (wing chiefs).

This form of government being one of concentric circles of political organisation with hierarchies of competences but all with one centre; or as Freestone (1968) puts it, a state or government comparable to a big square with a number of smaller squares. Each square led to the next higher in command, and all the lines from the most important squares led straight to the Asantehene or the apex king.

The pattern is one of Corporations Aggregate related to each other and represented in the Corporations sole which are the 'stools' which in combination form the structure (cf. M.G. Smith, 1956, p. 68).

CHAPTER IV

THE STOOL COMPLEX AND ITS ASSOCIATED REGALIADefinition

Functionally, the Akan stools and their associated insignia of royalty, help to legitimize and enhance a chief's authority, and also to inculcate political and social values among the peoples who have them. They are therefore important to the Akan political organization referred to as the stool polity. The Akan stool regalia includes carved stools, chairs, ceremonial state swords, linguist sticks or staffs, state umbrellas, palanquins and carrying chairs for junior chiefs and queens, drums, horns, bronze, silver and gold jewellery, treasure boxes, gold weights, and paraphernalia for other court officials. In addition to these, there are various art of leather work, animal skins regarded as prestigious among the regalia of senior chiefs. Central to any set of regalia of a political community is a chief's lineage stool which he inherits by the ceremony of enstoolment.

The nsasese is a carved object, the chief's office is a stool office as it derives from the incumbent's membership of a kin group. Later of course, we noted that the Akan stool polity developed in a way as to accommodate a limited number of offices attached to kinship only, and yet still a few that had no kinship attachments.

Specific offices in a polity are supported by specific regalia and servicing personnel and this we describe now as the Akan stool complex. We define the stool complex as the complex

of objects, personnel and traditions which support or are associated with any particular office in Akan political organization. Examples from a few Akan communities may help to elucidate this notion of stool complex. (See Plate Chpt.IV PIA%)

Akim Abuakwa

In the Akim Abuakwa indigenous government - in Southern Ghana, there are strata of chiefs and stools and the supporting regalia of these strata also show a corresponding stratification. The number of items in a set of regalia, their kind and elaboration, and stool personnel, range of stools and where they are kept, vary with the level of chiefs. The chief who has the most elaborate stool complex in Akim Abuakwa is the supreme chief officially referred to by people of Akim Abuakwa as the Okyehene (The King of Akim). Immediately below him are the amansin chiefs (chiefs of the constituent states that make up the Okyeman state (Akim nation)). The stools and regalia of the amansin chiefs are fewer and less elaborate than those of the Okyehene. As the status of a chief in the Okyeman stool polity decreases, so there is a decrease in the complexity of the material objects, personnel and traditions that support his office. The adikro (village chiefs) being the lowest category of chiefs in the state have the least number of stool paraphernalia and complex.

First, the Okyehene has, as his most supreme stool, an ancestral stool called the Okunsunkrunku or Kuntunkrunku. This stool is now regarded as the stool of the most illustrious past head of the ruling Aduana lineage of Kibi. King Kunsunkrunku reigned in Kokobiante - a former home of the people of Akim Abuakwa round

Example of Stool Complex.



1A



These pictures were taken with the kind permission of the chief Nana Kwame Fori and his elders at Akropong Akuapim, Eastern Region during an Ayukudae stool washing ceremony.

See Chapter VI for further details on Ayukudae.

STOOL COMPLEX - REGALIA

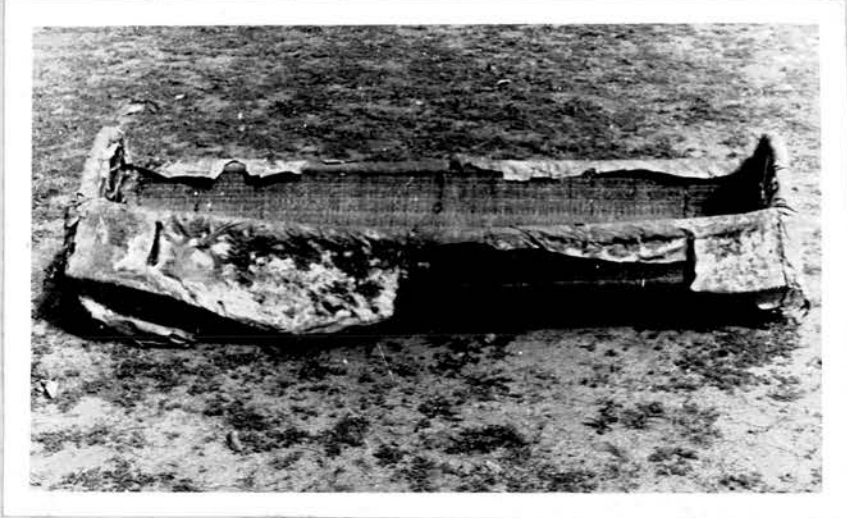

A historical palanquin from Mampong Asante.
Now in the Museum of the Institute of African
Studies, Legon.

about the fifteenth century. Successive incumbents of the Okunsunkrunku stool have added a number of stools to it and these added stools are extensions of the original stool. The original stool and the complementary stools are regarded as a whole although each is really a consecrated personal stool to a particular chief. They help to tell the history of the chiefs severally. Such stools are the kind we have mentioned earlier but whose nature and function will be examined presently. The black stools in the Okye-hens' complex are today eight in number and they have been chosen from the personal stools of about twenty three past heads of the Aduana ruling lineage of Akim Abuakwa state¹.

Representative of all the black stools is the state ceremonial stool which is a richly gilded asesedwa. It is this golden stool which is carried before the Okyehens on ceremonial occasions in the capital of the State. There is an additional gilded ceremonial stool which has for its mfinifini (central part of the stool) a naturalistic representation of the leopard sitting beneath a tree. No other chief can have this kind of stool in the state. When the Okyehens sits in state, he may actually sit on one of the ceremonial stools whilst, a high state chair called the hwedom stands behind him. Both the hwedom and the golden asesedwa are

¹ Informants: Head horn blower of the state and the Kyidomhens of Kibi. The Kyidom division is supposed to have reached the present site of Kibi before the ruling Ahana lineage.

placed on a leopard skin and they do not touch the earth directly.¹

The Okyehene is the first palanquin chief, that is, he has attached to his office, a number of state palanquins in which he is carried especially on ceremonial processions. His palanquin is always richly decorated with golden jewels and rich kente to indicate that he rules over land full of gold and riches. Some of his palanquins are to be carried by eight bearers, others are designed to be carried by four people (See Plate Chpt. IV P2). There is a particular one which is covered with leopard skin, again signifying the seniority of the chief and his position as the guardian of the rich forests of Akim. The premium put on leopard skin is both artistic and historical. The Okyehene is the 'king of the forest' because the armies of an Okyehene killed the greatest king of Asante history - king Osei Tutu. At the same time, the artistic identification of the leopard with the Okyeman stool is meant to show the strength and affluence of the state. All tenants on Akim Abuakwa land rent the land essentially from the head of the state - the leopard of the land, hence the Akim proverb, Asase wo etwie (the leopard owns the land) (cf. Basel Freestone, 1968, p. 131). Both leopard and lion skins form part of the Okyehene's regalia and are symbolic of his

¹ See Asipim and Hwedom chairs as chiefly stools in Chapter V.

greatness as the king of Akim Abuakwa¹.

The Okyehene has richly decorated golden head gears to match his many kente cloths. A golden crown, velvet or silk fillet with silver and gold embossments are regalia restricted to the office of the Okyehene in the state.

As he rides in his palanquin or sits in state, music is provided by various court musicians. His musical ensembles include membran^{no}ophones and aerophones. Atumpaa (talking drum), Bomaa (long drums), Mnebi ne nkawiri, (special drums used to summon people and to say proverbs), Mpintin (the drums that dictate the king's pace when walking or riding in a procession), Fontomfrom (a set of war drums) are among his membran^{no}ophones (See Plate Chpt.IV P3). His

¹Dr. M.J. Ruel makes an interesting contribution on the significance of lion and leopard skins as symbols of office. Lion and leopard skins are items of the stool regalia of only very important chiefs. Both leopard and lion skins are used by the Okyehene. They claim to be kings of the forest and the leopard symbolises this. Okyehene is king of the forest because his armies killed the greatest king of the Asante, Osei Tutu, as he was crossing the Pra to punish Akim for helping Denkyira in 1730 against Asante.

As Ruel rightly points out, 'the term skin itself may sometimes refer to the status of the ruler'. He suggests lion skins may be regarded as superior to leopard skins, and referred to Sutherland's note that lions are artistically often represented as standing upon stools which he correctly indicates represents the office of chiefship. Like the Akim Abuakwa leopard in their state crest, the animal is often seen beneath or behind the stool. This, he suggests, depicts a "power implicit within chiefship but not as it would seem, to be identified with it. The people of Abuakwa interpret the position of their leopard as showing the serene but powerful nature of the chief. He is a calm watchdog of the rich lands and forests. Dr. Malcolm Ruel - 1970. New Society No. 3 80, pp. 54-56; see also D.A. Sutherland, State emblems of the Gold Coast quoted in the article.

PLATE CHAPTER IV. P 3 A & B



A



B

aerophones include Muentia (pl.) Abentia (sing.) - short horns - menson or ntahera (seven long horns) Plate Ch.IV P4).

State swords attached to the office of the Okyehene are many and varied. Some of the swords are attached to specific ancestral stools. Two broad categories of the swords are the ako-fona (the war swords) and the asoafona (the swords for swearing oaths of office (Plate Chpt. IV P 5A).

Carried over the head of the Osanhene and the ceremonial stool in procession are various brightly coloured state umbrellas. One of the umbrellas has a double dome, one decked upon the other. It is called ebi te bi se (some one sits on another) - a sign of the supremacy of the Okyehene (See examples in Plate Ch.IV P.5) Among other items of the Okyehene's regalia are also various kinds of jewellery, beads, cloths, battle dresses, and linguist sticks. He has thirteen linguists who carry different linguist staffs with proverbial motifs on top of their sticks (See examples, Plate Ch.IV P6, and Appendix 8). Almost all officers of the Okyehene's court have special insignia to mark the offices and these they often display when the chief sits or rides in state.

Other personnel of the Okyehene are the Osamanyawa (chief councillor), Akveame (linguists with their linguist staffs), Nsafohene (captains), Nkom-asofofo ne won hene (stool carriers and their chief), Fotosanfoohene (state treasurer), Akrafohene (soul bearers or washers), asoamfo (palanquin bearers), tu-ntofo (gun bearers), Aackwafe Akveramadefo ne Mpintinkafoc (Mpintin drummers), Abrafo (executioners) and monafo (court jesters).

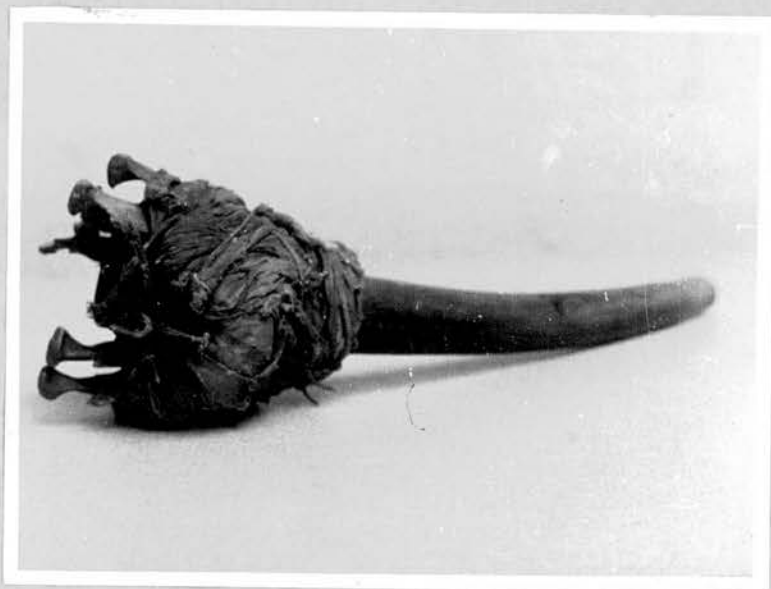

A

A jaw bone horn. I.A.S. Museum, Legon.



B

A Menson ensemble at a durbar at Dunkwan-on-Offin.



A

from National Museum, Kumasi.

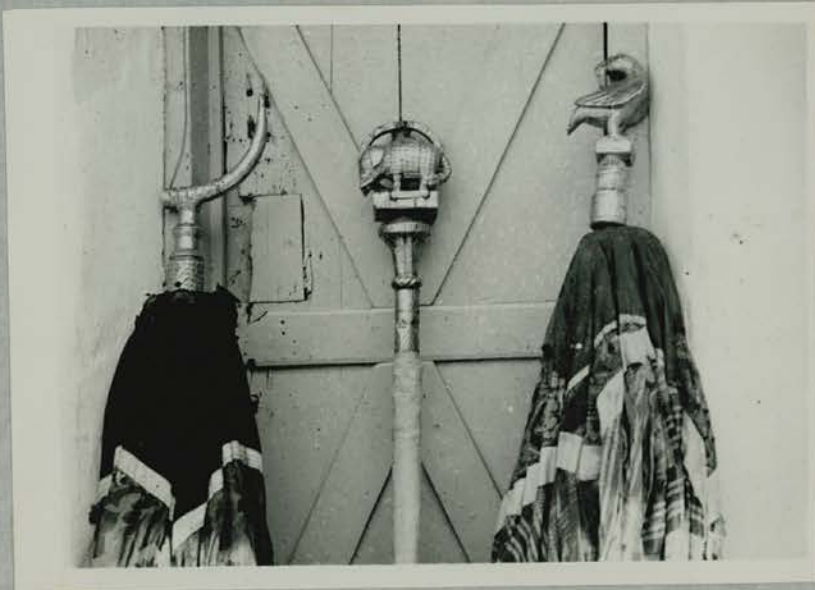

B

From Akropong-Akuapim.

PLATE CHAPTER IV. P 5(C)



PLATE CHAPTER IV. P 6

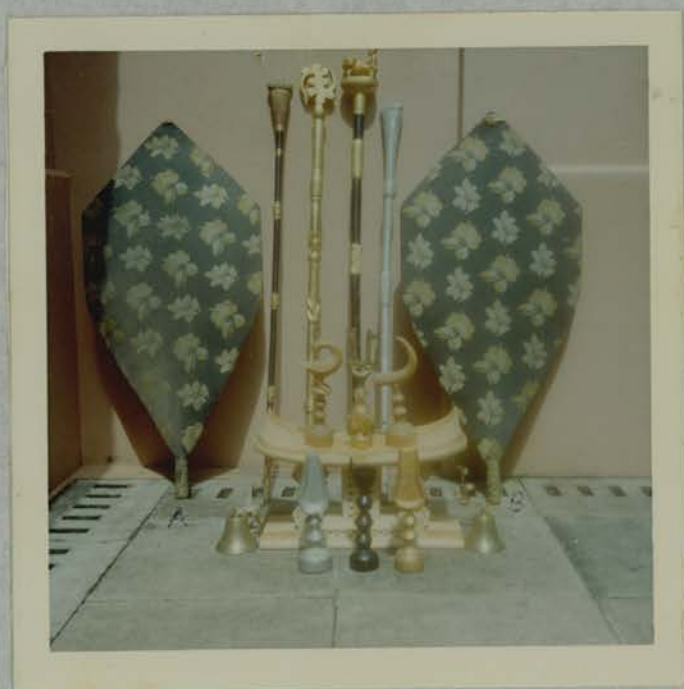

Immediately below the oman head are the heads of the constituent states which together make the oman. These chiefs are referred to as Apakainfoe (chiefs that are entitled to the use of palanquins). The Ohene, as each is called, is the sole head of an amansin or sub-division of his state (Native Administrative ordinance 1927). The chiefs in this category are five. Although only five chiefs are in this stratum and are regarded as next below the Omanhene's position, there are as many as thirteen chiefs who now could ride in palanquins. The five amansin chiefs are the Adontehene (advance guard), the Nifahene (right wing), Tarkwahene (Tarkwahene is in the right wing division), Benkumhene (left wing) and Gyasehene of Akim Abuakwa (Chief of the king's household). The stool complex of this level of chiefs are similar, but the Adontehene who is regarded as primus inter pares in this group and the most immediate chief after the Okvehene has a few items which his other colleagues could not use. The most outstanding of these is the Adonten fillet or coronet velvet head gear with four large pieces of gold across it. Like the Omanhene, he too has a few proverbial motifs either on his state umbrellas or on the tops of his linguist staffs which he monopolizes. The Nifahene could have only one gold centre piece and three silver mountings on his coronet. Danquah 1928 p. 31. The Benkumhene (left wing chief), Oseawuhene and the Gyasehene are entitled to similar head gears and all other stool regalia of chiefs in this category.

Below these chiefs are their own elders who have posts of right, left, Adonten officers - repetition of the pattern we see in the Oman (state) polity. In the Oman organization, Adikorofe

(chiefs of towns or villages) come next below the head chiefs. Their regalia do not include palanquins, although by an act of the Okyeman council reported by Danquah they were allowed to use seke chairs - a kind of regalia in which they could be carried (Danquah (1928) p. 35.) They, too, can have Mpintin drums, Anampan Pona (black linguist staff - not gilded ones) and carry an ox tail, not an elephant tail which could be carried only by superior chiefs. An Odikoro could also have a Twenesin (a short drum) and an abentia (short horn).

The stool of an odikoro could be raised to a higher status in Akim Abuakwa as in other Akan communities. This could happen when the odikoro has rendered an extraordinary patriotic service to the State, or many more tribal stools come to owe allegiance to him or if the elevation of the person or stool would be in the best interest of the State. It is upon the last provision in Abuakwa customary law, that Dr. J.B. Danquah was made a senior chief in the Adonten division in 1955¹. A head man without a stool

¹This action of the Okyehene was described as an abuse of power and was one of the causes for his destoolment. It was alleged that he created the office in the Adonten division without consultation with the Adonten division. He seemed to have done that to make it possible for the machinery of government to run since the Adontehene of that time refused to go to Kibi for council meetings. He was in the Convention Peoples' Party whilst the Oman and the Omanhene were against the policies of the C.P.P. See H.K. Akyeampong, Abuakwa Crisis, with foreword by J.B. Danquah, published by H. K. Akyeampong.

could apply to be given the status of an adikoro and permission to use the regalia of an adikoro. When such a stool is created it becomes the property of the lineage of the headman for whom it is created, and in time, becomes an ancestral stool.

In summary, whilst the stool complex of the Okyehehene, the highest chief in the realm of Akim Abuakwa is elaborate, the stool complex of his amansin chiefs are not as elaborate as his own. The lowest grade of chiefs, the adikoro are graded. Those nearer the sub chiefs have their village stool or stools, some asipim chair or chairs, and small state umbrellas, and seko (chairs for carrying them) are very few or absent. At the bottom are adikoro with single asipim chairs and no other regalia. So the degree of a stool complex provides an unmistakable index to the stratum of a chief and the level of his office in the polity.

Of special significance to the Akan stool polity, as a whole, are ceremonial stools, black stools, stool houses, stool carriers and the court minstrels. Other aspects of the importance and grandeur of chiefship are displayed during state festivals, as we shall see in the vast items of regalia and personnel of the Asantehene at a recent stool festival in Kumasi. Meanwhile, we examine the nature and some of the functions of some of the above items.

Ceremonial white stools are representative of the real ancestral stools which are never publicly displayed. Plate Chapter IV P7 shows the ceremonial stool of Mampong - Asante which was displayed at an Adae festival in September 1968.

PLATE CHAPTER IV. P.7 A & B



A cleaned silver ceremonial stool
of Mamponghene at an Akwasidae.



A silver ceremonial stool of Mamponghene
lying on a lion skin.

Other examples of ceremonial stools are illustrated in Chapters V and VIII, [Akropong Akuapim, Ho, in the Volta Region and the ceremonial Golden Stool of Ashanti]. Usually, ceremonial stools have bells hanging down from both sides of the asesedwa and through the ntokuro. A ceremonial stool is carried on shoulders such as to make the seat lean on the nape of the neck of the carrier. Since they are regarded as representing a collectivity of ancestral stools, they are accorded a lot of respect, reverence and ovation as they are borne before chiefs during ceremonial occasions. These stools and the black ancestral stools have special officers who carry them and these officers are called Nkonwasofofo (stool carriers). Plate Chapter IV P8, (A stool carrier of Assin Apimanim carrying a ceremonial stool).

Stool Carriers

The Nkonwasofofo (stool carriers) have a recognized head with the status of a chief. A chief's white ceremonial stools and chairs are carried by them. They are also the custodians of the black ancestral stools. Danquah writes about the importance of Nkonwasofofo in this way:

'Perhaps the highest post to which a young man in the State who is not eligible to linguistship, can aspire is the chieftaincy of stool carriers, called in the vernacular Nkonwasofofohene or, shortly Ahenwa (Throne). The emolument and privileges accompanying the post are very alluring. It is a lucrative post, honourable and peaceful.....'

The chief of the stool carriers at Kibi is not a member of the Kibi council, but in spite of that, he is looked upon as equal in dignity to the highest member in the council, except that he does not ride in a palanquin nor in a sedan-chair. He is master of the stool-house and caretaker of the stools and of the national calendar kept in the stool house. (Danquah, J.B., (1928)...pp. 43-45.)

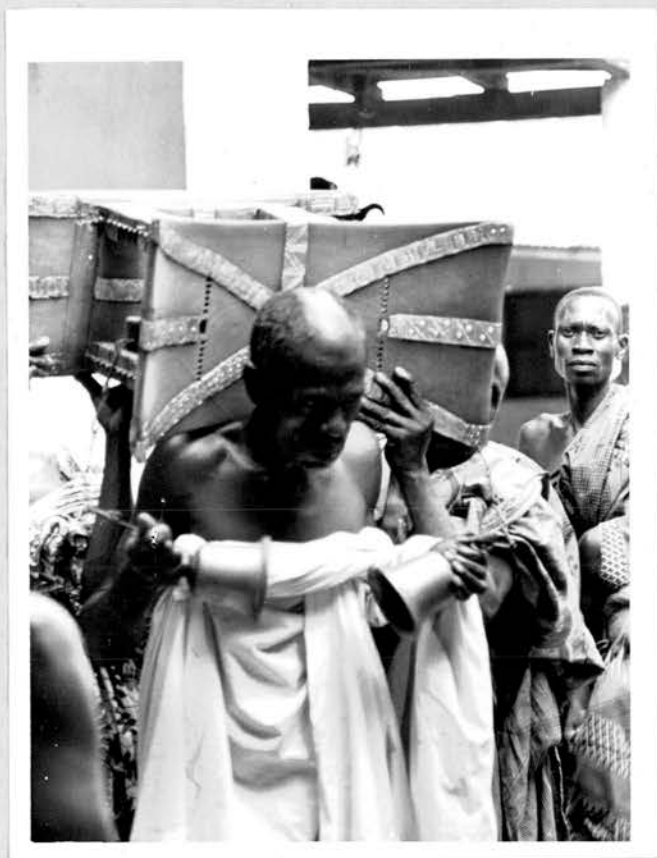

A stool carrier of Assin Apimanin carrying
a silver ceremonial stool.

Stool carriers are easily distinguishable especially on ceremonial days when their hair from the forehead to the back of the neck is freshly and cleanly cut. The width is about four inches large enough to receive the animu of the stool on the hairless part of the head with the uncut hair bordering on the left and right brows. (See Plate Chapter IV P8). Not only do they carry stools before the chiefs wherever they go but when the chiefs sit in state or public, they stand or sit behind them. Stool carriers are regarded as people filled with the presence and power of the ancestors. They therefore give strength to the chiefs they attend and inspire them. If a chief should temporarily vacate his seat, an attendant stool bearer tilts the stool to avoid its occupation by an evil spirit. They are expected to raise an alarm and order an attack on anyone who should do anything tantamount to an attack on the king or chief's stool.

Although Danquah speaks about the chief stool carrier in Akin Abuakwa, it is typical of all Akan lands to have such officers. The chief stool carrier has an ancestral black stool and his own stool room in which it is kept. This post has become hereditary in most Akan lands and it is inherited either matrilineally or patrilineally. Writing about who could become stool carriers in Akuapim, Akuffe rightly indicates that the keepers of the nkon-wafieso and its stools are the head stool bearer and his subordinates, and sons of the chief. (Akuffe (1945) p. 15). Meyerowitz records that the chief stool carrier's assistants are either his brothers or sons. (Meyerowitz, E.L. 1960 p. 128.) An example of a very important stool carrier in Akan whose post is a mmamadwa

office is the keeper of the Bampanase mausoleum in Asante. Unlike the Bantama mausoleum, sacred black stools are also kept here and their chief heads a number of the oman stool carriers (I.A.S. Stool histories No. 91). In the past the king of Asante went to the Bampanase-baama (Bampanase mausoleum) on the ceremonies called Aɔae (ceremonies relating to the reverence of the ancestors) to pour libation to the stools under the supervision and help of this official. Now it is the Baamuhene (chief of the mausoleum) who supervises a number of specialized priests to carry out the custom. As master of the stool house (room in which the ancestral black stools are kept) he is the caretaker of the stools of the past chiefs. He wields a lot of political power in the state. He helps chiefs when they go in to the house to pour libation and 'feed' the ancestors. The place of Nkonwasoafoo in Asante government was summarized in these words by Rattray:

Stool carriers - Nkonwasoafoo - are always in attendance on a chief. They carry his 'white stool' during life and attend to the blackened or 'smoked' stools of his ancestors. The three ^{head} stool carriers of the Asante king were in charge of the Golden Stool; they might not be killed whatever the offence they committed. In the time of Prempeh these men were Amo, Yao Dabanka, and Kobina Nyame. Any one striking one of these men would have been killed. Among other privileges they had the right to intercede for the life of any one sentenced to death. The youthful stool-carriers were in charge of the king's palm wine.... Women carriers carry Queen Mother's stool. Rattray (1927) ...p.129, note -

....Stool carriers are not so powerful now but traditionally no one strikes them. Their function today is essentially ceremonial but head stool carriers have still the responsibility of supervising the periodic libations poured to the stools and the 'feeding' of these stools. Stool carriers continue to be associated

with the stool house even though they retire when very old from active service. A hundred years old stool carrier of Mampong Asante¹ summed up his life and work like this:-

Great were those days when most of my life was at the court of the occupier of the silver stool of Asante. Those were good days when the chief had a lot of influence and of course we the stool carriers had a lot to be proud of for belonging to the class of court officials. As youth, we were 'above' our fellows and could do what others could not dare to do. As a matter of fact, we were sometimes reckless. We had fun but this fun never ran out of hand for although we were supposed to be immune to death, we were liable to a lot of sanctions exercised by our chief carrier, the chief, outside the stool room, and above all Odomankoma (God). So although we had a lot of privileges, we never thought of ourselves as above the law of the ancestors¹. (See portrait of the stool carrier, Plate Chapter IV P9.)

His active memory and disposition, he said, derived from the great fun and joy he obtained from his services at the court. The only thing he looks forward to is the ceremonial burial he is destined to have when he dies.

One of the greatest functions of stool carriers came out vividly when this old man cited a lot of history to prove the present chief's claim to the office of the Mampong silver stool. Stool carriers are an important part of the hard core of Akan court historians. They are instructed about all the stools they carry and they learn from the court minstrels too, who may be linked with the stool house. This aspect of the duties of stool carriers makes it essential that they should be mentally sharp and able to remember and recite facts given to them through their instruction.

¹Extract from records and interviews with stool carriers in Mampong Asante. 1969.



Portrait of a stool carrier of Asante
Mampong c.100 years old.

The post of carriers are normally held by men but women stool carriers exist and they carry the female stool of queen mothers. Men carriers also carry such stools in addition to those of kings and chiefs.

Like men stool carriers, women carriers also help in stool blackening. While it is men carriers who could seal the forehead of a chief with sacrificial blood during stool ceremonies, women carriers do this for the queens. Stool carriers also continue to take charge of palm wine of kings and queens which they use in entertaining the many people who go daily to pay their respects to them. The last but not the least of the functions of stool carriers is that they help to keep the national calendar, which tells when stool festivals are due.

Stool House /Nkonwafieso/

Stool carriers with their heads are custodians of the houses or rooms in which black stools and some state swords are kept. Such houses are usually attached to the official residences of head chiefs. Only special people are allowed into any stool house. Informants confirm the taboos of stool houses which may be found in the literature on Asante and other Akans. Stool houses are not open to strangers, the circumcised or the general public. Danquah adds to this list of prohibited persons, Christians ^{and} Mohammedans. Even those who are entitled to go there could be refused entrance when they are in European attire. (Danquah, 1928, p.44). Now, however, chiefs or attendants who are Christians or Mohammedans could go into the stool houses if they are traditionally entitled to

enter and they wish to do so. Other prohibited persons are women generally, but especially those in their menstrual period. Although they may not suffer the punishment of death as was the case in ancient Asante, both diffuse and specific negative social sanctions are so great that the taboo continues to be strictly observed.

Persons of the Royal lineage who are immediate heirs to the office of chiefship may not go into the stool house. So those who enter continue to be of a closed group. Attendants, the servants of the chief's household, mainly of the lineage of the Gyase stool, and linguists are allowed in the stool house.

On specified occasions like the Adae the stools in the stool house are ritually fed and the stool carriers help the chiefs to celebrate the ceremonies according to established procedures (see Chapter VI).

Normally, the arrangement of the stools in the stool houses reflects the order of precedence of stools. The arrangement may be such that the most important or ancient or illustrious lies at the remotest corner of the room from the entrance to the house, or in the centre of the stools. Meyerowitz's material on stool houses suggests that stools stood in a semi-circle on a platform usually along the eastern wall of the main rooms in stool houses. The stool of the founder of the dynasty was, and in many cases still is, placed in the middle. (Meyerowitz, 1960 .p. 127). Rattray's account also states that the stools he saw in Mampong were so arranged that the most important lay in the middle.

(Rattray, (1923)...pp.110-115.) In Kibi, Akim Abuakwa, the Kusunkrunku stool - the most ancient - lies at the remotest corner as seen in the picture of the eight foremost stools of Abuakwa, first shown in Kyerematen's Panoply of Ghana (1964...p. 19.) We are informed that the others displayed with the Okusunkrunku stool are the stools of Ofori Panyin (dated c.1733), Bakwante (dated c. 1742), Owusu Akyem, Kofi Asante (dated 1811), Dokua (dated c.1817), Amoako Atta (dated c. 1868) and Nana Sir Ofori Attah. Informants say that the eight stools are those that are specially regarded as the state stools and they have been chosen for their extraordinary history. This confirms Danquah's record of over thirty-one kings in 1928 who had their consecrated stools in the stool room.

In a recent article, Kyerematen gives us an idea of the arrangement of the black stools in the stool house of the past Oyoko clan chiefs of Kumasi, as shown below. (Kyerematen, A.A. Africa Vol. XXXIX, 1969).

6	7	8	9
Osei Yaw	Kwaku Dua I 1834	Kwaku Dua II 1888	Premph I
5	3	(1)	2
Osei Bonsu 1777	Osei Kwadwo c.1777	Osei Tutu	Opoku Ware 1750
10			4
Opoku Kwame			Agyeman Badu

In his presentation, the Osei Tutu Stool is in the middle of the lot. The arrangement follows largely the order of precedence of occupants of the Golden stool. However, another factor appears to have been considered which needs to be investigated. The kings listed under the numbers indicated show their Ntoro or the origin of their spirit forces.

- | | |
|----------------|---|
| 1, 3 and 5 | An Ntoro group called the <u>Adufudee</u> |
| 2, 4 and 6 | <u>Asafodee</u> |
| 7, 8, 9 and 11 | <u>Abodee</u> |

The Ntoro of the late Nana Sir Agyeman Premph II is given as Adufudee.

From the above examples and from our information, we suggest that black stools are always arranged in a pattern as to give pride of place to the most valued one. The others take their places in relation to the most important one.

Chiefs are instructed as to how they should comport themselves in the stool rooms. They enter it reverently with their sandals slipped off their feet. In the stool room, and before the ancestral stools, they are inferiors and must acknowledge this very clearly.

Wiremefo

The wiremefo consist of a group of court officials who stay in the background and who are most actively seen at work when a king or chief dies. As Rattray (1927) p. 178) puts it, the title of this group of men is rarely mentioned during the lifetime of a

chief or king. The membership of the wirempefe varies from division to division and from realm to realm. Everywhere, however, one common aspect is noted. A member of the lineage which supplies the ruler may not be one of the wirempefe (Rattray, *ibid.*)

On the death of a chief, the wirempefe constitute themselves into an armed body, rush on the stool house and either take away the black stools or make sure that they are very safe. This is a measure to guard against the possible attempt of members of the ruling lineage or ambitious queen mothers who may want to seize the stools and so become strong in pressing forward their own interests. Without the black stools or at least some particular ones, there can be no legal enstoolment of any chief. This 'force' ensures, to some degree, that proper elections and considered verdicts are reached before the next enstoolment is done. So that the wirempefe are functionally important in considered elections of successors. This is why we saw earlier on that an Asantehene, Nana Osei Yaw Akoto 1825, took the Golden Stool, regarded as the black stool of Nana Osei Tutu, to the Kantamansu war of 1826 to forestall the possibility of the installation of Kwaku Dua as king of Asante instead of himself (Kyerematen, 1969).

No wirempefe exist in the lower levels of the political hierarchy and in the higher levels where they exist, they always stay in the background in the political matters and administration. Indeed, they have no active political duties in the day to day affairs of government. Their main duty lies in the field of guarding the state's black stools from being seized by would-be 'usurpers' within the ruling houses or king makers.

Their function is more than military, for they are the last guardians of the 'soul and being' of the communities. In fact, they even guard against possible unauthorised interference with the stool by the chief or king himself. The wirewefe are, therefore, both feared and revered in Akan political organisation.

Kwadwomfoe (Court minstrels)

The Kwadwomfoe are headed by a chief who is very close to the paramount stool, or other ancestral stools and regalia. Stories are still told in Asante that the Golden stool could suddenly force its bearers to stop dead when it is being carried in a procession on ceremonial days. Such stories were also told to Rattray in early nineteen twenties. He records:

'I have heard it stated that at times when the Golden Stool was carried it would come to a halt and the men bearing it could not advance until the Kwadwomfoe, the minstrels come and sing before it. (Rattray, 1927, p. 129 Note 2.)

The kwadwomfoe are court officials specially trained from childhood in all history of the clan and chiefdom. Even now they still form an important group since, they too like the stool carriers, are an important source of history. They have a wider field of history to cover but their speciality is intimate history of titles of the court, appellations of the past rulers and origins of verbal art of the court. They chant the titles and deeds of the departed as they walk in the ceremonial crowds and they stand before or behind the chief as he sits in state. The recitals are very moving.

The musical form called Kwadwom is therefore essentially

a serious musical court art. They are recited rather than sung to chiefs to remind them of their grave responsibilities and to draw their attention to the achievements of their ancestors. They are used as means of challenging current occupants of ancestral stools to great deeds of valour. At the same time they are among the musical forms for expressing condolences to the chiefs and their people. On some occasions when Akans congregate for state functions, the ancestors are remembered, for they form part of the whole - the living the dead and the yet unborn. This is what necessitates the expression of condolences when the people meet to express their solidarity. Since in the past, wars were the principal things that took away many of the people's men of valour, what the court minstrels have to say are mostly things that are painful to remember. Kwadwom ka enibresem (lit. Kwadwom says things that make the eyes red.) For this reason, they are not sung frivolously. In fact, it is not at all meetings of the people that they are performed. Kwadwom is similar to the Akan dirges but different, because the contents refer specifically to history and principally to the apex or very senior chiefs.

Kwadwomfoe (the court minstrels) are as a rule, a men's group. However, very elderly women, especially those who serve or live in the ahemfie (the chief's palace) know some kwadwom, that is, music and content of what the Kwadwomfoe (court minstrels) recite. On solemn days like the adae (remembrance of dead chiefs and re-creation of the community) such women could sing some kwadwom as dirges.

Kwadwomfoe (court minstrels) also recite some verses that occur in stanzas of the awan (drum language of the twin drums called

atumpan). Both the kwadwomfoe and the abrafoe (executioners) have recitals that are of this musical form.

According to Nketia, the exact origin of Kwadwom is unknown, but the history of Denkyira indicates that kwadwom and kwadwomfoe existed in Denkyira even during the reign of one king Boaɔu Akafu, about 1650. King Boaɔu was succeeded by Boa Ampensem I who was in turn succeeded by Ntim Gyakari whom Osei Tutu fought to establish the freedom and kingdom of Asante. From the history of Denkyira we find that kwadwom is a very old Akan institution (Nketia 1952).

There are two kinds of the kwadwom. First, the sen-kwadwom. This is a type which is sung by all members of many of the kwadwomfoe at the same time. Second, the kwadwom, and this is sung in solo or as duets. Third, the nwentens (straight verse) and fourth the nwentia (short verse). The straight verse kwadwom has also sub divisions. They are nwentens a edi kan (the first straight verse), nwentens a eto so mmienu (the second straight verse) and one which is called asafodee (that for the asafos or war companies) Nketia, 1962 in I.A.S.No.01/A2.

The final characteristic of kwadwom is that, the language of it is highly proverbial and the sound of the music of the recitals is nasal. Oral tradition has it that in ancient times, parts of the noses of kwadwomfoe were sometimes cut to enable them to produce the desired nasal recitals.

No matter how a recital is done by a member of the kwadwomfoe band, it is binding on chiefs to be serious. Nothing should be

funny to them when the past of their ancestors are being played back to them. If anything, it should inspire them to great deeds. They may dance, and in the dance before the drummers and the public, show, in the language of symbolic dancing, their concern for those things being said and their acceptance of the challenge posed by the recitals .

Kyeremadefo, Asokwafo, Mpitinkafos

Closely allied to the Kwadwomfo (court minstrels) are the Kyeremadefo (drummers) and asokwafo (horn blowers). We have seen that the higher the status of chief the more complex the regalia he is likely to have. The number and variety of drums also increase or decrease with the status of a chief. Hence we saw that the paramount chief of Kibi has many drums whilst an Odikore in the realm may have one or even none at all. Some of the reasons for this is that, high chiefs have many more administrative, judicial and ritual functions which demand varied music, and the provision of varied music is essential in most of the situations relating to these functions. Nketia writes:

For maintaining the solidarity of the state, festivals may be instituted around major agricultural rites, the divinities recognized as state divinities, or around episodes from history and traditions of the people....In addition to festivals there are ceremonies and rites designed to give opportunities for expression of loyalty to the state and ancestors. There are ceremonies and rituals concerned with the installation of kings or the assumption of other political offices.... Due regard may also be given to the king as a person, to his movements which are heralded by music, to his need for relation and entertainment which may also be met through music and dance. Nketia, J.H., 1966 . Music in African Cultures. Published by Institute of African Studies. Legon, p.17.

The Kyeremadefe include the atumnan or twin drum players. These drummers are usually people who know the history of the state. The higher a chief the more complicated are the histories, of his office and state. The drummers play histories and urge occupants of stools to great deeds. Talking drums are used to say proverbs and reiterate items of the people's values to them on festive occasions. Indeed, there are drums for tribunals. They are used for summoning various councillors to court. There are drums for raising alarms and to call to quick communal action, like extinguishing a fire or going out to search for a missing person. There are drums for military or warrior organization like the asafo. Politically, in military and civil administration, religious and secular matters, drummers are essential in an Akan community. They are also important in bringing people together and this is an important aspect of their function.

The language of Akan talking drums is essentially tympanophonic. That is, the drums actually are made to imitate the tone patterns of verbalization of Akan words. Rattray observed that the sounds are always tympanophonic and not tympanosemantic Rattray (1923, edition 1969, Chapter XXII, pp.242-293). This is largely true, but some of the sounds that are emitted are not meaningful or translatable. They are therefore *forms more* of communication than words in communication and such renderings on the Akan talking drums could be regarded as tympanosemantic. Therefore, Akan drum language, which is in its own way a means of supporting particular chiefships, is both tympanophonic and tympanosemantic.

Like the Kyeremadefe, who are varied because they perform

on various drums, the asokwafo - the complex of horn blowers and other musical personnel not mentioned-form part of the court historians and servicing staff of a chiefship. They help in the provision of music used in the community life of a people - in recreation and action. They provide the art which fosters creativity, overt expression of joy, sorrow and other forms of social activities. The Akan say there can be no chiefship without court musicians, and the higher the status of the chief the more varied the musical personnel¹. This is why it will be noticed that chiefs of the grade of the Okyehene have more of these officers than those of the amansin chiefs. In a diminutive order the number of musicians decreases with the status of still lower chiefs. As we shall soon see the Asantehene who is the greatest chief in the Ghana has the greatest number of drums, horns, and musicians, and some of these have been briefly described in this thesis.

Black Stools

The Kwadwofo, the atumpan drummers and indeed other servants of a chief's court are inspired by the fact and presence of what we have called black stool².

Earlier we noted that every Akan citizen may possess an asesedwa and that it is white in colour, since the osese wood is white. Only a few people, however, have the right and honour to possess what is called a black stool. These honoured few include

¹ NKETIA, J.H. (1963) Drumming in Akan Communities of Ghana. pp. 119 - 151. Thomas Nelson & Sons. Edinburgh.

² See questionnaires Black stools, the stool in society and stool court in 10 towns. - Appendices 7 & 8.

elders of clans, the various chiefs, asafohenfo (captains) queen mothers, abrempon (the great chiefs of the Asante kingdom or nation) and the amanhene (paramount chiefs) whose positions were actually those of kings before the colonial era.

Not even all stools of the categories listed are blackened. Only chiefs or holders of stool offices who were faithful to their oaths of office from the day they swore them, to the day of their deaths, may have black stools. Chiefs who die bravely for their people may also have their stools blackened. Chiefs who die ignominiously have their stools excluded from the stool room. To the Akan, ignominious deaths include deaths through drowning, lunacy, epilepsy, dropsy and leprosy. If a chief unfortunately contracts any of the above diseases, he is immediately destooled. If, however, the chief should be cured of the disease, he is regarded as having won a battle and he may be given the honour of a black stool after his death.

The exclusions of certain stools from blackening is influenced by the Akan belief that a bad man's ghost is bound to be bad. They say: Dea onye no ovi koraa a nesaman onye. (The ghost of a bad man is bound to be bad when he is dead.) Chiefs who fail to live up to the expectations of their people may have their stools in a corner of the stool house or in separate rooms or they may be treated indifferently until no one is able to identify them any longer¹.

¹Informants. Ahwiaa dikore, also Kampong Asantɛ stool elders.

On rare occasions, a person may succeed to the office of a chief in spite of his shortcomings. This happens if no other eligible heir is available for the office. In such a case, his stool is not blackened. If he should change completely during the period of his office, his white stool could be blackened after his death. Instances are given of people who became good after their installation as chiefs but informants refuse to cite specific examples, since custom demands that no mention should be made of the former evil of a chief once his stool has qualified for blackening.

Sometimes the posterity of slaves survive to throw up very eminent and worthy persons who, in times of need, could be regarded as family heads. Such lineage heads could even be chiefs but in the past the stools of such persons were not normally blackened, although they were given the office of the ancestral stool and thereby were links in the perpetual succession.

The particular stool of a past chief that is blackened is his most intimate stool. He owns many stools during his reign as he even inherits some of the stools. Usually he has some special ones made specifically for him. If he is a head chief he may ask for a special design which he desires to have, or one initiated by him or modification of some of the traditional ones that exist in the culture.

One of the important stools of chiefs are their bath room stools. Bath room stools are very jealously guarded and they are in the care of special officers called the Agwarefochene (chief of the kings ablution men). If a chief should reign for a long period,

his bath room stool may be changed as it becomes old and disintegrated. The old stool may be buried or burnt and the ashes rubbed into the new ones made to replace the old ones. Informants say that sometimes the old ones may remain in the bath house until the deaths of the owners when they are buried with them. The current stool is then consecrated in the ritual of blackening.

The evidence we have suggests that it is the most intimate stool of a chief that is blackened after his death. This may be his bath stool or some other stool of the dead chief. However, many of our informants think it is the bath stool which is the popular one for the purpose of blackening. Sarpong gives, as reason for this predilection, the fact that it is believed that the daily bathing on it meant full penetration of the soul of the chief into the stool. If damaged or not available, any other on which he often sat, as for example, when at meals, could be used. (Sarpong, 1967, *Anthropos*, No. 62, No.1). Other views are those of Nketia and Meyerowitz. Nketia suggested that the stool that is blackened is the one on which the corpse of a chief or king is washed for the last time just before it is laid in state for his last public honour (Nketia, (1951), *ADAE*.) Meyerowitz reported that a special stool is always set aside during the lifetime of a chief and it is this stool that is blackened when he dies. (Meyerowitz, 1960 p. 189.) Generally, we noticed slight variations in the detail of the customs and usages relating to such objects of political eminence in different parts of Akan, but the main thing to note is that stools are blackened in one way or the other as memorials to chiefs. (See plates Ch.IV.10A-C).



A Black stool in the Royal Scottish Museum, Edinburgh. (Numbered 1906-517-1-) Labelled. Regalia of Kwame Intiakui of Sarwan, Elmina, Gold Coast. Chief deposed about 1902. Bought for £30. Installation stool of wood, curved seat on supports. The central one hollow and perforated. H.12", L.19" W.9". By the kind permission of the keeper of ethnography, Miss Dale Idiens. The stool is, from the look of it, a sort of black stool, indeed, but a number of details make its history rather unusual. The stool is aesthetically a female stool; and a regal female stool would be expected to have many finely carved nyekyan (spikes) seen on the outside of the columns or legs). See Chapter V . . . p 78 Symbolism in stools. The stool, however, is described as belonging to a chief of Sarwan in the Elmina area. A traditional male stool which is central to the Akan stool regalia is usually a male stool in design. Scallops replace the spikes in male stools and they are called Nuntan (see Chapter V. p. 7&8).

Another strange thing about its history is that it happened to be the stool of a deposed chief. Maybe, it was sold because the chief was deposed but this is an unlikely situation. Black stools are monuments raised to the memory of chiefs only, after their deaths. Stools as a rule are also never blackened for bad chiefs, that is chiefs who failed to honour their oaths of office. It is difficult to explain how a chief who was deposed could have had a black stool dedicated to his memory. Besides the stool in the plate is female in design. Although the stool was obtained from an Akan area -Fanti - it might well be that the mistake was made by the elders for our experience in the field shows that some people are ignorant about the

/cont'd/

differences and therefore propriety of stool designs. This may be the tentative explanation for part of the confused information we have here. Undisputably, however, the stool looks very much like a black steel. That it was an installation stool which belonged to a chief is not evident from the design of the stool.



BLACK STOOLS OF AKWAMU.

These are Akwamu stools believed to be original stools. Have been there since the time of the founder of Akwamu, Agyen Kokobe. In this plate is Anpon Kofi (left - the supreme stool). The female counterpart of that stool is, the middle stool. The queen mother's stool is that on the right and resting on a white stool. Picture obtained from the elders of the Akwamu paramount stool.

PLATE CHAPTER IV P 10 C

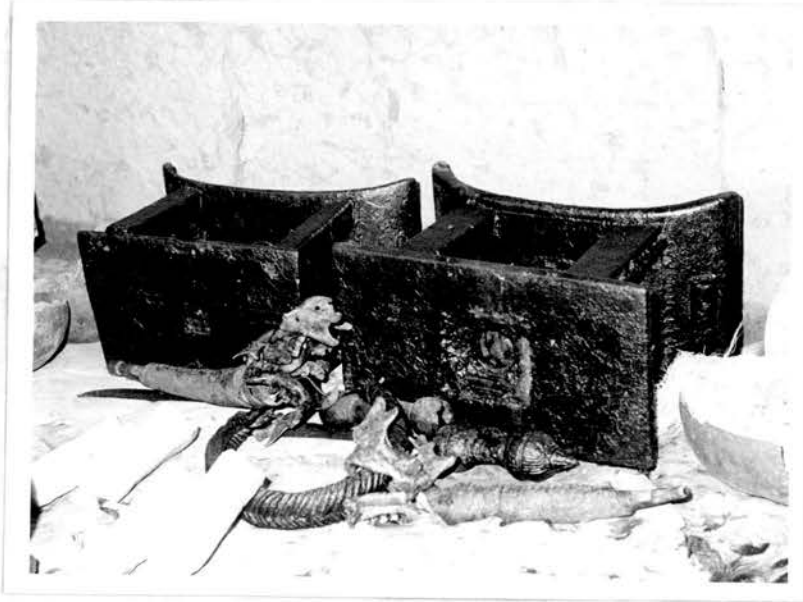

Twidan Lineage Black Stools — Akwamu.



Purifying the above stools.

a. How stools are blackened.

Several views are given but the process suggested by Rattray in his 'Ashanti' is given by many people in Asante as the traditional method of blackening stools. We may look at a few of them here.

A stool that qualifies for blackening is taken to the yard of the stool house where it is reverently placed on a flat surface or a skin of a sheep. Egg yolk is mixed with soot from a royal kitchen. The stool is then evenly coated with the mixture after libations have been poured to inform the ancestors of what is being done. The blackening that Rattray saw was a particular one in which a special stool was being blackened as a gift for Her Highness Princess Mary Viscountess Lascelles on the occasion of her wedding. It was a replica of the silver stool of the Ohemma of Mampong (Rattray, (1923) pp .298-299.) He gives a complementary statement on the matter of blackening of stools in 'Ashanti' which is a good example of what may be expected in most cases in Akan and non-Akan Ghana. His statement also refers to the time when stools are blackened, discussed more fully later.

'After the death of a wise ruler, if it be desired to perpetuate his or her memory the late owner's 'white' stool is 'smoked' or blackened by being smeared over with soot, mixed with egg yolk. It then becomes a black stool (spunna) and is deposited in the stool house, (akonnudan) and becomes a treasured heirloom (agyapadie) of that clan'. Rattray, 1923. p. 92.

He talks of 'smoked' stool and this is confirmed or rather explained further by Lanquah in his account about the blackening of a white stool of a chief. He gives the impression that the blackening is actually smoking of the stool and that it is so

treated to save it from quick decomposition¹.

Historically it was the practice in Akan to keep treasured things on ceilings - Pataaso. Some foods like corn are still preserved by smoking them on shelves over fire places. Treasured pots like those used for the great communal meals or those used for serving food to the ancestors in burial places or stool rooms were kept over fires in kitchen. When wooden artifacts are placed over kitchen fires, they tend to become hardened and immune to the attacks of many insects².

Danquah might well have meant by 'the stools are smoked' that they are coated with soot, which is solid smoke, for we learn from our informants, and of course the literature, that egg yolk and soot have a preservative influence on asesedwa stools.

Sarpong³ gives a good summary of other various views on the blackening of stools: he says that there are some people who would hold that the stools become black as a result of the sacrifices of blood that they get through time. One of the exponents of this theory was Busia, who wrote that the stool 'is black from the blood of sheep with which it has been besmeared at many ceremonies' (Busia, 1958: ...p.33.)

¹ Danquah, J.B. The Gold Coast Akan, p. 16
Example of Akan Black Stools, and Notes on them.
Plate Chapter IV. P10 A, B, & C.

² Quarcoo, A.K. The Remnants of Old Tafo Glories in Pottery.
I.A.S. Research Review. Vol. 3, No.2, 1967.

³ SARPONG, Rev.Dr. Anthropos 1967, No.62, vol.ii.

Another opinion held by some people is that the stool is black to accord with the symbolism of black for death in the culture. White is symbolic of happiness and rejoicing and therefore it would be improper to leave the stools of the dead in white. This point of view is widely supported by the Akan, and the evidence of the validity of this view, is supported by the usual colour of mourning cloths in Akan. They include principally the kuntunkunfi and adinkra cloths. The kuntunkunfi is named after a dye obtained from a tree named kuntunkunfi. This dye helps to give plain fabric of white cotton a russet brown of almost black colouration. Those who take part in the esoteric ceremonies in the stool room must wear this type of cloth. The adinkra was originally a stamped type of the kuntunkunfi. On the kuntunkunfi, special designs made out of dry calabash are stamped. Now there are all hues of the adinkra and the lighter colours may be used for occasions other than mournings depending on the kind of designs stamped into the cloth.¹

There are other views on the colour symbolism just discussed. Blackness is also symbolic of beauty. The famous Akuaba dolls of Asante must be black, if they are play dolls. White Akuaba dolls are often fertility dolls or dolls on which magic spells may be worked².

Sarpong mentions as the third opinion he observed, that the blackness 'makes it worthy of veneration and reverence it deserves'. A check upon these strengthens the reasons given for the black

¹ See Other regalia associated with stools and political symbols. seq.

² Quarcoo, A.K., I.A.S., Research Review, Vol. 3 no.2, 1967.

colour of the stool. Sarpong continues that the general authoritative temperament of the Asante and their respectful fear of the elders accord perfectly with this view - the view that the stool must be culturally one regarded as fearful, reverential or inspiring.

The fourth view he offers from his investigations is very much like that of Danquah. It is suggested that the stool is smoked to make it durable, but he adds that it is also done to make it beautiful to behold.

He attempted a synthesis of the opinions summarized above. Like him, we notice that black stools are first blackened before they are put in the stool houses, and that this blackening is done with egg yolk and soot. The jet blackness a stool attains when it is first made may increase or decrease in time. Sarpong's synthesis is that: '...firstly, in order that they (stools) may not be too repulsive to sight, secondly, that they may properly represent the dead and signify sorrow of the living at the death of their chiefs, thirdly, so as to produce the respectful demeanour with which those who appear before them must comport themselves, and lastly, to render the stools durable, since they must be perpetually present to receive the sacrifices and offerings of the people to their departed rulers'. (Sarpong, ibid.)

Although we find slight variations existing in the actual process of blackening ancestral stools from chiefdom to chiefdom in Ghana, the main point of interest to us is that, all who blacken stools as a means of making them consecrated or monuments to the

departed chiefs, do it with a mixture of soot and egg yolk. After treating them that way, they are set aside for the remembrance and veneration of those who owned them when they were alive. The stools therefore serve as charters or memorials in the history of a people. The restatement of the concept of ancestral worship in Akan presented in the chapter on stools and ancestor reverence suggests that this category of stools tell personal histories of past chiefs and eras more essentially than they provide shrines for worship of the dead. They are objects for political socialization but it must be added, that the human actions around them tend to be expressed in almost religious terms. This may be why black stools have always been reported upon as objects of worship.

b. When stools are blackened

It is regarded as culturally wrong to raise any sort of memorial to anybody at all while he lives. Some of the arguments given against this are that a beneficiary may change in character and cease to do that for which a memorial is raised to him. It is also believed that since memorials are essentially for the dead, in this context, the living must feel unwanted or always reminded of their death by memorials while they are alive.

In accordance with these customary beliefs and usages, therefore, a dead chief's stool could be blackened only after his final funeral celebrations which was usually not earlier than a whole year. The doteyie (lit. soul funeral) that is, first burial, is comparatively solemn. The Akyeampihene is the man who should be called to the bed side of a dying Asantehene. The king must

die while resting against the *bossem* of the Akyempimhene. This right and responsibility derives from an historical episode when an Akyempimhene

'Sabene embracing his falling father, King Obiri Yeboa 1633-1677) who had received a mortal wound on the battle-field at the hands of King Domaa Kusi, the ruler of the Domaa State in the Brong-Ahafe Region'. (Kyerematen, 1970 p.7.)

The corpse of the dead king is immediately laid on a mat in the manner that it would be later laid in state. The corpse receives the royal treatment it is given while alive. The nails are paired, the body is given royal bath. The news of the king's death is later given in to the nsafohene (chiefs) of Kumasi. The queen-mother sends delegations to the amanhene (chiefs of the constituent states) to inform them of the death. When they arrive they all renew their oath of allegiance to the corpse and declare that if the death were not 'natural one' (i.e. cause by violence in war attack by an adversary) they would have revenged bravely. Although traditionally, the supreme chief of Kokofo and his queen-mother are the first of the constituent chiefs and queen-mothers to be informed of the death, (because they are supposed to be blood relations of the ruling lineage members of the Asante King) it is the *Kamponghene* who first swears the oath of allegiance. He constitutionally takes charge of affairs relating to the funeral.

The body is later conveyed by the asokwafo (the drummers, horn-blowers etc. of the household) for burial in a mausoleum. Kyerematen says that there were seventy-seven of such mausoleums important for this first burial. In the mausoleum, the corpse

is laid in state again usually for one year to allow blood and water to dry out of the body. These mausoleums are referred to as asonee (place of drainage). After a year the skeleton of a chief so buried was removed to Bantama mausoleum, where the joints were braced with gold links and gold leaf and laid in state again. Nana Prempeh I, according to Kyerematen, built another mausoleum the current Asante mausoleum at Breaman after 1874. There the skeletons have a yearly visitation for inspection and reconditioning where necessary. It is usually during the time when the skeleton of a chief is being removed to its final resting place that the ohene ewie or second funeral is observed. Such funerals are expensive, and in a measure are mechanisms of social control since the kind of final funeral a chief got was in the past meant to be an index to his popularity and greatness. Future chiefs desiring such honours, which were believed to be good for the spirit of the departed, try to live according to the cultural norms and the demands of their oath of office.

The last funeral is also believed to be the last ceremony which helps to liberate the king's spirit and thereafter his spirit becomes closely identified with those of the past chiefs¹.

It is then normally after the second burial that a stool may be blackened for the memory of the chief or king, who in the estimation of the elders of the original stool of the state, ^{is} worthy

¹ cf. Robert Hertz Death and the right hand Trans. Rodney & Claudia Needham (1960) pp. 29-76.

of that honour.

A lot of bloodshed was supposed to accompany burials of chiefs especially those of Asante. Rattray's (1927) p. 105 gives a good idea of what exactly happened. It is pertinent that he discusses this question of supposed slaughters during funerals and says that even in the past when it was believed human sacrifices accompanied burials, there were never indiscriminate massacres. Rattray (1927) p. 106.

The Asantehene, Nana Otumfue Sir Agyeman Prempeh II and his regalia at one of his last durbars at Kumasi.

The Akan chief with the greatest stool complex is the Asantehene. He has the greatest complex of objects, personnel and traditions which are associated and support his office as king of Asante. The versions of all the items of the stool complex of the Asantehene are more elaborate than any complex of any of the abrempon chiefs (great wing chiefs). So the range of items of regalia which the Asantehene may have is wide as is suggested by the following insignia of his office that appeared in the procession of Nana Otumfue Sir Agyeman Prempeh II in Kumasi at an Akwasiadae (the great Aday festival). As the other chiefs waited at the Dwaberega (the nation's ceremonial grounds) he appeared preceded and followed by chiefs and specific regalia in this order. First the advance group, then the Golden Stool group, the Asantehene in palanquin and lastly, the rear band.

First the ADVANCE GROUP

- Prempeh Drum Leading the procession. A kind of drum which was seized from the Denkyira. Among the drums of the Juabenhene is the original (informant Juabenhene 1968).
- Nkofe A horn used formerly only by the Asantehene.
- Ntahera A set of seven long horns. Usual measurement is about three feet each. The above are found in the stool regalia of most paramount and senior chiefs in the state of Ghana.
- Sika Mbaboa Golden Sandals. There is always a spare pair of sandals for the king. This is to ensure that he gets a pair to wear if anything should happen to the pair he has on his feet; for the soles of his feet should not touch the ground. It is golden because that is the principal jewel of his status.
- Nsafoa Bunches of steel, silver and golden keys. Symbolic of his greatness. He has many 'doors'. The silver and golden keys symbolize his affluence, and power. He can open the door of 'silver and gold'.
- Nkototwaa Two large wallets with silver and golden padlocks. Symbolic of his affluence. Asante gold weights. In the past the king carried gold with him when he was out and gave those who needed it. He has obligations to fulfill as 'father' of the people and must always have money on him. The gold weights now symbolize affluence and liberality.
- Nseniefoc Court eriers, wearing gold decorated caps.. The eriers are orderlies among other things. Their gold caps signify the position of the Asantehene.
- Kete The principal drum of the Queen's court entertainment. Kete dance was a special dance at which the king could relax. It took place in one of the inner courts of the palace.
- Banwuma A broad piece of elephant skin which was to be a rest for the Golden Stool. Symbol of the supremacy of the king. (See note on skins in chiefship.)

- Hwedom (silver) A silver plated high 'Asipim' chair on which the Golden stool is to be placed, when exhibited in public like this occasion. The Hwedom stands on the Banwuma. (See Chapter V.)
- Asipintia
Asipim and
Kukwaboo See example (Chapter V) Chairs used in king's court. Present in courts of great chiefs.
- Naamu A kind of elaborate asipim with silver nails.
- Hwedom A golden hwedom i.e. a hwedom with golden decorations.
- Kodie Silver and gold plated eagle motif. The symbol of Asante's strength and prudence.
- Fotoaba Gold plated asesedwa. A ceremonial stool of the Asantehene. Symbolic of affluence.
- Nyansapoh Gold plated ceremonial asesedwa. The design is Nyansape (Wisdom knot). Accepted by Asante as the personal design of Otumfuo, Sir Nana Agyeman Prempeh II.
- Kotokodwaa Gold plated asesedwa. The Porcupine stool. The symbol is stylised. The principal design of the Asante court.

Gold plated chairs and stools have a pair of bells attached to them.

Then THE GOLDEN STOOL GROUP

The Golden stool carried under two well known state umbrellas: the Nsaakvineye (made of coarse camel hair blanket) and Nhwewhwekyiniye (having at its fringes small mirrors.) State umbrellas are special symbols of prestige attached to special stools. They have proverbial motifs, which specify the distinctions of the chiefs.

Proceeding the stool were:-

Taahyefoo Bearers of silver and tobacco pipes. Symbolic of the king's affluence.

Dwete kuduo

Silver bowl containing coins and other treasures for use in cases of emergency. This bowl is placed on the right hand side of the Asantehene when he sits in state.

A number of gilded swords. Principal among them the Gyegvetiri, Wosatiri, Abonus and Akuma symbolize the power of the king. Abonus and akuma (lit. the axe and the double axe, respectively). There are many kinds of swords, for swearing and swords as symbols of office. See plates for examples of some swords of the kings.

Right of the stool

Sika Akua - A golden drum.

Left of the Golden stool

Apen Asantan Golden shield, steel arrow and Sika Senkua - Golden concertinas.

Rear of the Golden stool

Aprede drum and Asankutwens with a number of chiefs guarding with guns.

Behind the Golden Stool. THE ASANTEHENE'S GROUP

Nkukuadwe, Moebi, Nkawiri and Twea drums.

The twea drum imitates the cry of the leopard. It is not beaten but the face of the drum is rubbed with the stick to produce a friction and the friction sounds like the cry of a leopard. cf. (Rattray, 1927 p. 113.)

Adumfoo and Abrafoo

Traditional executioners wearing on their heads leopard skin caps and around their necks bunches of silver and gold knives. The Adumfoo also carry bayonets while the Abrafoo carry steel swords. They symbolize the power of the Asantehene.

Kwantinponuta

Two drums. They are special drums that announce the coming of the Asantehene on the main roads - a sort of siren for the approach of the Asantehene.

Akyemfoo

Bearers of decorated shields. Such shields were used in the past for warfare. They are now used as symbols of royalty.

- Kokosesefoe Swithers of Ostrich feathers. Ostrich feathers are used to blow away flies that may come near the king.
- Ahoprafoo Elephant tail swithers. Elephant tail because the king is great. It is symbolic of his greatness.
- Nhenkoa - Court servants bearing:
- Afenatenten (Long sword)
- Nkatohono (sword named after shell of groundnuts)
- Nfenata (Twin swords or double edged swords)
- Pentoa (Named after a bottle -- looks like a bottle).

THE ASANTEHENE in PALANGUIN. Anakain

Over the head of the Asantehene are seven state umbrellas

- Boaman.. with a gold plated motif on top.
- Oyokoman made of silk Kente the 'Tartan' of the Oyoko clan. Has a proverbial motif. See the tartan Plate Chapter IV P.12).
- Akoko State umbrella with a gold plated motif depicting a hen with its chickens. Symbolic of the exalted position of the Asantehene as mother of all the other states within the realm.
- Nankaninakyi Gold plated snake. Symbolic of prudence and craftiness.
- Nyankonton Umbrella with velvet canopy in which there are the colours of the rainbow. Has a gold plated motif on top. Symbolising the encompassing nature of the stool and also the presence of God everywhere.
- Nfofofa Canopy of many colours - gold plated top.
- Prekese Colourful canopy. Special motif of a fruit. The fruit has a strong and unmistakable scent even from afar. Signifies the greatness of the King.

On the sides of the King's Apakain rest gold plated swords.

- Mponponsuo On the blade of this sword is a coiled snake and the sword is contained in a leopard skin sheath. The bearer of the mponponsuo wears a cap of eagle feathers called Ntakrakye. (Hat of feathers).
- Ahmehwebaa On the blade is cast the head of a defeated warrior. Symbolic of the superior strength of the king. Reminds state and king of the valour of the state and the distinguished military prowess of Asante. Plays back history and urges on the people to great deeds and distinction even in the present.
- Kraku On the blade is cast a shield. Same theme.
- Anem A bunch of the anem plantain. A kind of plantain with many fingers (*musa sapientum* var *paradisica*). Symbolic of affluence and benevolence of the king.
- Bema Cast on the blade a bunch of palm nuts. Symbolizes goodwill, benevolence and affluence.
- Basomuru Cast on blade - crown bird's head contained in Golden sheath. The bearer wears a replica of the Asantehene's denkyemkye (Crocodile cap). A cap for war.
- Bosompra Cast on blade a pot. Contained in a silver sheath. Symbolic of mercy and kindness.
- Nimsaakaakyi Cast on blade of a beast illustrating the proverb 'Had I known' is always too late. Warning or reminder to people to think ahead. Be careful about what they do. Also is symbolic of the power of the king.
- Akokobaatan Cast on blade 'Chicken and their mother' hen. (Significance as in the case of the umbrella motif explained).
- Otwee Cast on blade the antelope one of the emblems of the late Asantehene, Nana Sir Agyeman Prempeh II.

BEHIND THE ASANTEHENE

- Kwadwomfoo Court minstrels -- Are historians, poets, and special privileged people to tell the king things which are essential which ordinary people and even the chiefs could not tell him without peril to themselves. These relate to his behaviour and painful historical allusions.
- Drugyafoo Reed pipe blowers. Reed pipes orchestra of the king.
- Mentiahyenfoo Blowers of short horns. Most of these horns speak proverbial language or make specific historical allusions. See Appendix 10 (Nine special horns of the King of Juaben Asanté)
- Asokobenfoo Long horn blowers like the Ntehera type of horns.
- Tatwea Blowers of another type of regal horn.
- Mpintin drums The round drums of the king. They dictate the pace of the king. The set comprises, a long drum Gyaamadudu. Two or more of the gourd round drums Mpintin, Apentima Hour drum, donno and iron gongs. More drums have been added to this set, but the original are the named ones. See plate Chapter IV P 3B and notes.
- Fontomfom The long drums and the talking drums called Atumpan or Atumpani. See plate Ch. IV A & B and notes.
- Bente Drums in the group of the Fontomfom.
- Mprakyififoo White horse tail swithers. Usually done by daughters of the Asantehene. In this instance two daughters.
- Apimadaka Two boxes, one silver and the other gold nail decorations, carried by grand daughters of Asantehene. Supposed to contain valuables.
- Atutufoo Gun bearers in the body guard. Some carry gold and silver guns symbolic of the affluence and importance of him they are guarding.

The Mamwrehene and followers with their regalia -- The state guards -- The Ankobiahene and his followers and their regalia.

This catalogue is specifically that of the regalia in the Asantehene's procession at the adae kekie (great adae) to which we have referred, but it gives an idea of the range of such items that may be expected in the regalia of paramount or very senior chiefs in Ghana. In the pictorial examples and notes which will follow, further illustration of the types of stool regalia that are usually found in Ghana are given.

First, we describe an Akan chief - the chief of Mampong Ashanti - in some of the items of cloths and jewellery of the regalia of his office. This may give a picture of the nature of regalia that may be expected of a chief in his stratum of chiefs, then we shall look at the illustrated regalia of Akan chiefs in general.

Description of the Mampongene of Ashanti in some stool regalia

In reference to the regalia¹ of the Okyehene of Akim Abuakwa and those of his sub chiefs, we observed that the number and

¹Akan regalia have been documented in the literature but there is a lot yet to learn about other types both old and new. For example the origin and initial meaning of some in the art of the motifs and designs of, and, on various items, are lost. A lot of history is yet to be unearthed or validated by the art history of several items of many regalia in Ghana. Most of the art history itself has not been studied. The works on regalia which we can extract from the following are useful.

Rattray showed something of Akan regalia in the carvings he ordered for exhibition at Wembley in 1924, reproduced in photographs in Art and Religion in Ashanti. In the same book, his report on weaving and wood carving generally, tells us a lot about the art we may come across in Akan stool regalia. Antumbam's Symbolic objects used in adorning state regalia on pages 165-186 of his Ghana Heritage of culture is useful material on symbolism in some items of Akan stool regalia, and Kyerematen's Panoply of Ghana wholly devoted to regalia should be a useful reference on this subject.

type of regalia vary according to the social status of the different stools and the offices derived from them. Each time a chief sits in state, his regalia and attire is in accordance to specific rules. Hence in the following example, the Mamponghene is seen resplendent in a special adweneasa kente cloth and many gold ornaments in Mampong. He is a chief entitled to the regalia to be described but when he is in Kumasi, his jewellery would traditionally have to be predominantly in silver and not gold. This is so because by the customary usages of the Asante, the King of the Asante nation wears golden ornaments whilst the Mamponghene should wear silver adornments. The King of Asante has, however, right to put on ornaments of all kinds including those to which the wing chiefs, like the Mamponghene, are entitled.

In Plate Chapter IV¹ the Mamponghene of Asante regarded as next in rank after the Asantehene, is richly attired. It was on a private ceremonial day. On state ceremonial days he could be more richly decorated. He wears a rich adweneasa called Obaako mmu man¹; one man cannot run a nation or oman. Adweneasa is, as we shall see, a blanket term for a class of Kente designs. In the adweneasa we reach the most complicated of types that are made by the kente artist. This is why it is called the adweneasa, that is (my designs are exhausted). A better idiomatic

¹ It was originally called Fathia Fata Nkrumah (Fathia is worthy of Nkrumah) - a name meant to praise the first Republican head of the state of Ghana as a whole. Its name was changed to this present one after the military take-over on the 24th February, 1966. The background could be in other colours.



Mamponghe, Nana Atakora Amaniampong
in 'stool regalia'.

translation may be - the 'master of designs'. Adweneasa is made only by very skilful weavers. In this Kente, the whole weft and warp of the Kente appear in complicated weaves. This particular one is fairly new as far as the design or arrangement of the designs is concerned. The dark red, green, violet, and other colours feature against a prominently golden background, characteristic of the Sika futuru (The kente called sika-futuru ..gold dust). On his head he wears a head gear or fillet studded with gold plated motifs - the stars and moon. Both the moon and the stars are symbols of royalty and benevolence. On his neck is a gold pendant for a neck lace of gold, red, and green cord - the anyance. The asadee, another gold chain lies across his chest. Gold bangles and gold leaved bansare - talisman ornaments - decorate his right arm. The ubiquitous, priceless aggrey beads which unmistakably mark royalty, liberally decorate below his knees. In his left hand he holds a fly whisk made of horse tail and on his fingers he wears large gold finger rings. The ring symbolising the radiant sun or star is a mark of his royalty and his dependence on the source of the sun for his vitality and vigour as a king.

His legs are adorned with gold beads, talismans and precious traditional rock beads, whilst his feet rest in richly gilded mmaboa - sandals. Its size, besides its decoration, tells it apart from ordinary sandals which may be worn by anybody in the community.

The Kampong sits on the Kampong silver ceremonial stool and behind him stands the silver hwedom tea (slender hwedom)

on which the stool traditionally rests. Hung to the ceremonial stool on which he sits are the silver ceremonial bells of the Mampong stool.

As he sits, with a serious countenance on the stool and his feet resting on the richly decorated foot stool placed on a lion skin, he is, to the Akan, an unmistakable representative of the ancestors whose place they occupy today and who must not be let down.

Pictorial examples and Notes of some Akan stool regalia

It may be useful at this point to introduce notes on some pictorial examples of the regalia that may be expected in a stool complex in Akan.

State Umbrellas. Plate Chapter IV.P5 A & B

Only senior chiefs could have such colourful state umbrellas. These examples in the plate are in the National cultural centre at Kumasi. The National Cultural centre will be referred to in the following text as N.C.C.K. The umbrellas are turned upside down. At the tops are proverbial motifs and symbols. See Appendix 8 motifs of state umbrellas at an Akwasiadae at Denkyira in 1967. The Oyokoman Umbrella of the Asantehene has its canopy made of the Oyoko clan tartan. (See Plate Chapter IV Kente P.12A).

Two of the many colourful state umbrellas of the Akropong-hene of Akuapim. Left. Red and white with the Horn motif symbolic of strength and peace at the same time. Centre. The principal linguist staff of the state. The elephant symbol, the symbol of the state ceremonial stool is repeated in the linguist staff. Right. An umbrella bearing the motif San ko fa (Return and pick it up) That is, pick up the gems you have passed in the culture. Kinds mentioned in the Asantehene's procession apart from the Oyokoman. Boaman (red and black) Nyankonton - colours of the rainbow, symbolises greatness, inclusiveness and mercy of God. Mfofa - many colours, Prekese - has the prekese (fruit motif).

Further references

Kyerematen, 1964, ...pp. 89-90.

Rattray, 1927, Chapter XXVI, p.270, p.130.

Antumbam, 1963, pp. 165-194.

In front of the state umbrellas lies a palanquin.
(N.C.C.K)¹ Palanquins are owned only by superior chiefs.
Developed from traditional carrying baskets and
baskets for carrying corpses.

Kyerematen, 1964, p. 91.

Palanquin chiefs. Danquah, 1928, p. 12.

A number of state swords lie at one side of the
palanquin. See note to them under State swords,
Chapter IV, P5 A & C. Plates II & III.

State swords. Plate Chapter IV, P5 C.

The central sword with a white hilt is called Akrafena.
The bearers of this type of sword are the Soul washers.
Immediate left of it: Mansie Pramire (Bekwai state sword).
Symbolises power and patience. Second from Akrafena is
Prekese (Power and Omnipresence of God). Also signifies
influence of occupant of the stool. The ASantehene has
many state swords as mentioned. There are swords for all
occasions.

Further references.

Rattray, 1927. pp. 274-280. See also index of this book.

Kyerematen, (1964) Excellent documentation in pictures
pp. 33 - 42.

Specimens of swords lying flat on the ground. Plate Chapter
IV P5 C. (N .C.C.K)¹ Akrafena, Prekese, Mansie, Pramire.

Linguist staffs and some of the motifs mentioned in connection
with the ASantehene's procession.

¹National Cultural Centre Kumasi.

Plate Chapter IV P6

The linguist staffs (left to right) Pot with the head of an animal in it. A Proverb: Abos tiri anyera wo nkwan mu. (The head of an animal cannot be missed in a pot of soup. Symbolic of greatness.

The Gye Nyame motif (Only God is supreme) No one has power to make and unmake ultimately but God.

Proverb: Akaabi nim gyata, A man with his hand on a lion. Lit. Akaabi (Name for man - does not know what is a lion). Symbolic of patience that the chief must have. He must be prepared to forgive them who 'Know not what they do'. Proverb: Abubu mmaba, se ohwene na oko hwe mu, se oye e, obi nim. The wonder worm. (Whether it first made its abode before entering or what, no one knows.)

Signifies the mystery of things.

A & B are silk covered fans. Used in fanning kings or queen mothers.

In front of the staffs is the Nvansapo a special symbolic ceremonial stool of the late Asantehene. The three motifs standing on it are.

Left to right:

Sankofa. Same as the Akropong motif explained. Sankofa.

(Key) symbolizes power and goodwill.

Mmen (Horn) Same as Akropong motif explained.

Drums Plate Chapter IV. P3

They form an integral part of the stool complex. Drummers are very important people in Akan society and especially as people attached to the stools, of the state. Drum language contains history and 'law' of the communities. Rattray, 1923, gives example of how whole histories are told on drums - Drum language - Chapter XXII, pp. 242-293, (Mampong history).

The following are some of the drums mentioned in connection with the Asantehene's procession.

A & B Fontomfrom drums (N.C.C.K)

D & E The talking drums called Atumpan or Atumpani. The Ga and Adangnes of the South of Ghana call this set the obonu. In these non-Akan areas the drums still speak Akan. Fantomfrom is first and foremost a war dance.

Further references

Rattray, (1923) and (1927).
Historical allusion in drum language.

Especially the works on this music by Prof. J.H.Nketia.
Drumming in Akan communities. Published by Thomas Nelson, Edinburgh.

Mpintin Ensemble D Gyamadudu A & B Mpintin G Donno. A, B, C, D written on the drums.

(Hour drum)

Special drum which dictates the pace of the Asantehene in procession. The way it is beaten at any one time dictates whether the king should hurry or go slow.

Kete mentioned in the list is a favourite court dance. The ensemble includes Kete drums, durugya (reed flutes) and choral music. Songs include praise songs, and history.

Horns 1 Part of the musical instruments attached to stools. See Appendix D for a set of horns of the chief of the royal Gyake clan. Juabeng.

Plate Chapter IV, p12 A - H. Kente cloth and other apparel attached to stools.

Kente. The most priced cloths attached to stools are called Kente (nkente pl.). The king of Asante has a special village which is responsible for weaving his kente cloths and this village is called Bonwere. The history and exact origin of this kind of cloth is yet to be satisfactorily resolved. (Part of the art history under investigation by the author). Like some of the stools of an oman some kente tell history and are visual art for documenting a number of other things. For

example, there are specific cloths or patterns which may be regarded as the tartans of specific clans. The type of kente worn by a chief used to be a means whereby his status could be determined at sight. Although this is not very easy now, something is always special about any particular pattern or design worn by chiefs. This is specially so with the kente cloths of the Asantehene, and to a measure, all the abremnon chiefs of Ashanti.

Even among ordinary people, the type of kente that a person wears may help to determine his wealth, or at least the social stratum to which the wearer assigns or herself.

In the examples that follow, most of them were special kente which were to be worn only by the Asanté king or types marking eras or history.

Plate Chapter IV P 12 A1 Adweneasa, ii. Sika futuru, iii Mneeda.

- i. Adweneasa - lit. end of my skill or my designs are exhausted, or my ideas have come to an end (Rattray 1927, p. 237). It was one of the cloths presented to Princess Mary on the occasion of her wedding (ibid.) Various hues and designs of this kind of cloth are made. The main thing about them is that all the strips are complicated designs. It takes a longer time to make them than to make the ordinary kente and they are more costly than the ordinary ones.

Chapter IV. P 12A ii. Sika Futuru (gold dust). This is also full of difficult weaves. The background is always rich golden silk. It was formerly worn only by the Asantehene. Only rich people were able to afford the price. The average price is now not less than fifty-five pounds or more.

Chapter IV. P12Aiii. Mneeda. A type of the mneeda is the clan tartan of the Asona of Akan - the clan of the father of one of the kings of Asanté called Nana Osei Bonsu. Osei Bonsu created some mmamɔdwa (stools inherited patrilineally discussed).

i. Adwineasa



A

i. Sika Futuru

iii. Mneeda



B

ii. Kyiritwie.

i. Asankanee

Those he created were the three Ankobia stools of Anaminako, Atene Akoten and Atene Akuapen. (I.A.S. 42, 45, 21).

Osei Bonsu's father was called Owusu Ansa.

Tradition has it that the cloth is called emmaada (has never happened) to mark this because he was the first of that clan ever to be the father of an Asante king. Today, Emmaada is one of the very favourite patterns which people wear to celebrate special occasions.

Plate Ch.IV P 12 B (i) Asankanea or Nsenkane ii. Kyiritwie

i. Asankanea. It is a pattern called after a flower in Asante. The cloth was formerly worn only by the kings and queens of the Asante nation.

ii. Kyiritwie (One who subdues the leopard). The late Asantehene was also called Kyiritwie. This particular cloth was named after him.

Plate Ch. IV P 12 (C) i. Oyokoman ii. Okomfo Anokye

i. Oyokoman. Tartan of the Oyoko ruling clan of Kumasi and Juabeng Asante. It is one of the cloths now usually worn by the Asantehene on the great Adae (Stool festival). A variation of it is the type of cloth used for one of the great state umbrellas that covers the ceremonial Golden stool when it is out on state ceremonies.

ii. Okomfo Anokye. This cloth is named after the priest of Nana Osei Tutu, the founder of the Asante nation.

Plate Ch. P 12 (D) i. Akyempim ii. Sika frg mogya

i. Akyempim (Giver of thousands). This cloth is believed to have been worn first by Osei Tutu the first king of the Asante union after 1700. Tradition says that one of his sub chiefs gave it to him as a gift. The chief was Nana Owusu Afriyie. Another version of tradition suggests that the cloth was ordered by Osei Tutu to mark a great war in which his armies nearly were defeated. This cloth was first to be worn only by the Asante king.

ii. Sika frg mogya (Wealth attacks families)

When one is poor, he may be just taken for granted in many things but when he is affluent, people may take him more seriously. It is a cloth worn also by rich people.



C

1. Dyokoman

11. Okomfo Anokye

1. Akyempin



D

11. Sika fre mogya

Plate Ch. IV. P12 (E) i. Asisrane ne anomaa agoro.
 ii. Fie bue ye buna.

i. Asisrane is a kind of insect and anoma is a bird. The bird appears to be playing with the insects but ends in eating them. The cloth is proverbial. It urges honesty and decries pretence and hypocrisy.

ii. Fie bue ye buna. lit. (it is not easy to run a house.) A proverbial cloth saying that it is not easy to be a chief. Patience is essential. It reminds people to put premium on patience.

Plate Ch. IV P12(F) i. Kyiritwie. ii. Abrewaben.

i. Kyiritwie. Personal design of the late Asantehene.

ii. Abrewaben was a woman of a clan called Asenie who lived in the time of one of the Kings of Asante, called Kwabia Amanfi c. 1600. This cloth was worn by the chief of the Adonten (the advance guard of the Asante army in the past). See also Rattray 1927, p. 239.

Plate Ch. IV P12 (G) i. Toku. ii. Nyankonton.

Toku is the name of a queen who was overthrown by Nana Opoku Ware. This particular pattern was first used by that woman. Nana Opoku Ware later assigned it to the queen mother of the Oyoko clan of Kumasi. In the past it was worn only by the queen mother of Asante.

ii. Nyankoton (rainbow). The Sky God's arch. Was worn only by the permission of the king of Ashanti.

Further reference

Rattray, 1927 Chapter XXIV

Kuntunkuri or Kuntunkruni and Adinkra cloths

On state mourning or stool ceremonies in the stool room the king wears a dark brown dyed cloth called kuntunkruni. Kooben, wine or red coloured cloth is also used. So to the supreme state stool office are attached some of these cloths which form part of the stool regalia.

1. Asisrape ne nnoosa seere.



11. Fie buo ye buna.

1. Kyiritwie



11. Abrewaben.

11. Nvankonton



1. Toku

There are many kinds of Adinkra which are worn on different occasions apart from funerals. The Adinkra cloth is a traditional kind of cloth stamped with Adinkra motifs. See Appendix 11 for specimens of Adinkra motifs. Note that the arrangement of the design in any cloth is determined by many factors. Cloths that are worn by the supreme chiefs could not be worn by other chiefs or ordinary people. The cloth is now, however, one of the national cloths of Ghana (Asante Brong Ahafo and the South).

Further references

- Kyerematen, 1964.
 Antubam Kofi, 1963.
 Rattray, 1923.

Kunini Ntoma

Applied cloths worn by chiefs.

References ibid.

Battle dresses

On certain ceremonial occasions chiefs wear battle smocks if they have them. They were supposed to be bullet proof in the past. An Ashantehene elect displays his valour to his people before his enstoolment on the Golden Stool. See example of such dress. Plate Ch. IV P12 (H).

Other personal ornaments attached to stools.

They include beads, jewellery (neck chains in gold, silver, copper). Finger rings of various motifs. Pendants, fly whisks, head gears and crowns, caps and hats, head pieces (as in the North of Ghana).

See examples in Plate Ch.IV.P.12(J).

The Mamponghe in State

See notes.



Battle dress; Associated with Akrokeri
Adansi in Asante - paramount stool. Donated
to the Institute of African Studies, Legon - Ghana,
by Nana Owusu Sampa III, Akrokerihene.

PLATE CHAPTER IV. P12J

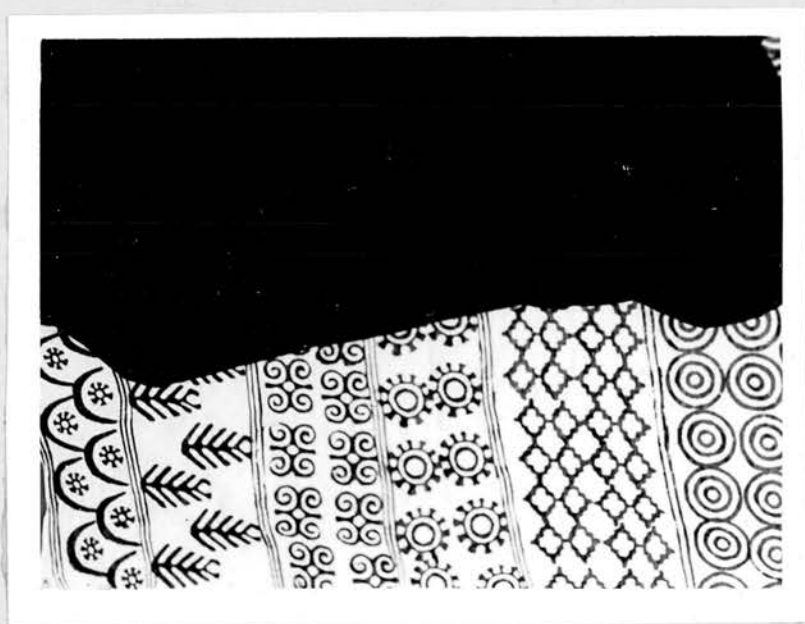

Kuntunkuni and Adinkra Cloths.



Caps and whisks which go with the battle dress.
I.A.S. Museum, Legon 1 & 2.

Other references for Regalia

Kyerematen, 1964.

Rattray, 1923, 1927.

Antubam Kofi, 1963.

Summary of General Characteristics of Akan Stools

In fine it may be said that stools are the most outstanding symbols of leadership in Akan. From the lowest social units, to large political communities, stools are recognized as symbols of authority. We have noted that every lineage has a head. Some of these lineage heads are not chiefs. Indeed, where a lineage head has a stool whose occupant is a chief, the group still has a head who is not a chief as such. The non-chiefly stools and lineage heads who occupy them form a pattern which is repeated in the strata of chiefly stools and their incumbents.

Each political group we notice is made up of corporations and each group owns a stool. The stool offices of these groups tend to be political officers in more inclusive corporations. Again the pattern of stools and stool offices is repeated at more and more inclusive aggregations. At each level is a complex of stools and offices, and in states, or certain cases, nations, there are vast numbers of political offices deriving from kingroup attachments, kinship relations or even offices created as extensions from the above. The stool complex ^{tends} to be greater and greater with the political importance of any particular chief.

Sometimes stools of ruling lineages of large communities, states or nations are presented as stools with mysterious origins,

as in the examples of the Abankandwa, the silver stool of Mampong Asante and the Golden Stool of Asante. Such stools are usually the highest stools of the collectivities and are regarded as the symbols even of the very being of the people.

As a general feature of stools of a political community we have noticed that they may start as single units, but in time complementary stools called black stools are added. These stools are consecrated stools of successive holders of the office of chief installed by means of the original stool or a lineage stool brought into being later, in some mysterious way.

Each complementary stool tells the history of the owner of the stool, but all of them together with the original stool are looked upon as an organic whole and referred to as Nananom (grandfathers) or Nananom nkonwa (the stools of the grandfathers). They are also regarded as the symbolic abode of the spirits of the ancestors and so representative of them. So while the whole tells the history of the community as a unit, each of the complementary stools tells the history of individual chiefs. All the stools 'subsumed' in the first of the stools, are the principal shrines of all the dead chiefs and, by extension, all the dead of the community; but each stool of the complex is also the shrine for the spirit of the chiefs who owned them.

The spirits of successive occupants of coronation stools are regarded as having merged together because by the process of enstoolment they are believed to have assumed the social personalities of those from whom they inherited the office. By this

same ceremony of enstoolment, the authority of a new incumbent is legitimized and checks are imposed on his actions. He is no longer for himself when enstooled. His time and everything that he is or has, becomes the property of the community for reciprocal rights and duties from his subjects. He remains, however, under the law with his subjects and not above the law. The kind of position or office given by any particular enstoolment defines the political competency of the enstooled. So head chiefs get their authority and stool buttressed by the offices and stools of sub chiefs - the stool complex reflecting various competences and inclusiveness. A holder of an office who over-steps the bounds of his competency in any way - word, deed, or display of regalia is disciplined by the checks and balances implicit in the structure of the stool polity.

For example, the various wing stools and chiefs of a paramount chief are the buttresses of the apex stool and office. At the same time they act as checks and balances in the social and political organization of the community. Hence the stools of Mampong, Juabeng, and the rest of the constituent states of Asante are the powers that build up the Asante nation, but they are at the same time the checks and balances in the Asante political structure. In turn, all the states have also chiefs and stools and personnel for making up their own complexes of checks and balances.

Many objects of leadership have grown around stools - the central symbols of leadership. These include the things we have called stool regalia. These are graded according to inclu-

siveness of a stool and its office to which the regalia are attached. The regalia of a sub-chief are different from that of a head chief, and that of a head chief from that of a paramount chief. That is, regalia are stratified and they are associated with hierarchies of stool offices.

Through the various levels of stools, the lineage stools, black stools, coronation stools, regalia, and stool ceremonies, political socialization is effected. The general and essential features of stools are that they are the means whereby the office of chiefships are legitimized, they provide continuity of stool offices and the perpetuity of the corporations aggregate, they have implicit in them the power and check upon the individual office holders. Finally, although characteristically the idiom of stools is single, it allows for a great variety of application; for as we note, stools help tell history of units but also individual histories. They are memorials but also living mechanisms of social control.

CHAPTER V

SYMBOLISM IN STOOLS

Further to the general point made about the all pervading nature of Akan stools and the brief descriptions of various symbols in a number of stools, we now consider the subject of symbolism -- the types of symbols that may be found in stools and the significance of such symbols. This will include an examination of something of the range of possible designs and typologies. Considering a similar subject, in 1927, Rattray observed that:

'In Ashanti a generation ago every stool in use had its own particular significance and its own special name which denoted sex, social status or clan of the owner.' (Rattray 1927 p. 271).

In addition to the various specific symbols which developed in the art of the asesedwa type of stool, there evolved other symbols and newer forms of seats, like the types of the asipim (four legged chair with a back rest) and the hwedom also a more elaborate, bigger and higher kind of asipim. These were mentioned earlier but we illustrate them with further notes at the end of this chapter.

General elements of design

Every asesedwa must have the three basic parts, namely, animu (top or surface) the mfinifini - (middle section) and the wiabog - (base) described earlier in chapter II. It was indicated that essential features of the asesedwa type of stool include ntokuro, (pl. of tokuro, hole) on either of the shorter ends of the animu. A stool without ntokuro is usually a child's stool or one set aside

PLATE CHAPTER V. P1



DUAKORO

PLATE CHAPTER V. P2



AFANU

PLATE CHAPTER V. P3



ANANSA

PLATE CHAPTER V. P4



NYAANAN

PLATE CHAPTER V. P5



NYAANUM

PLATE CHAPTER V. P6



ABEBUDWA (nwa) Plural.

GENERAL ELEMENTS OF DESIGN

ASESEDWA.

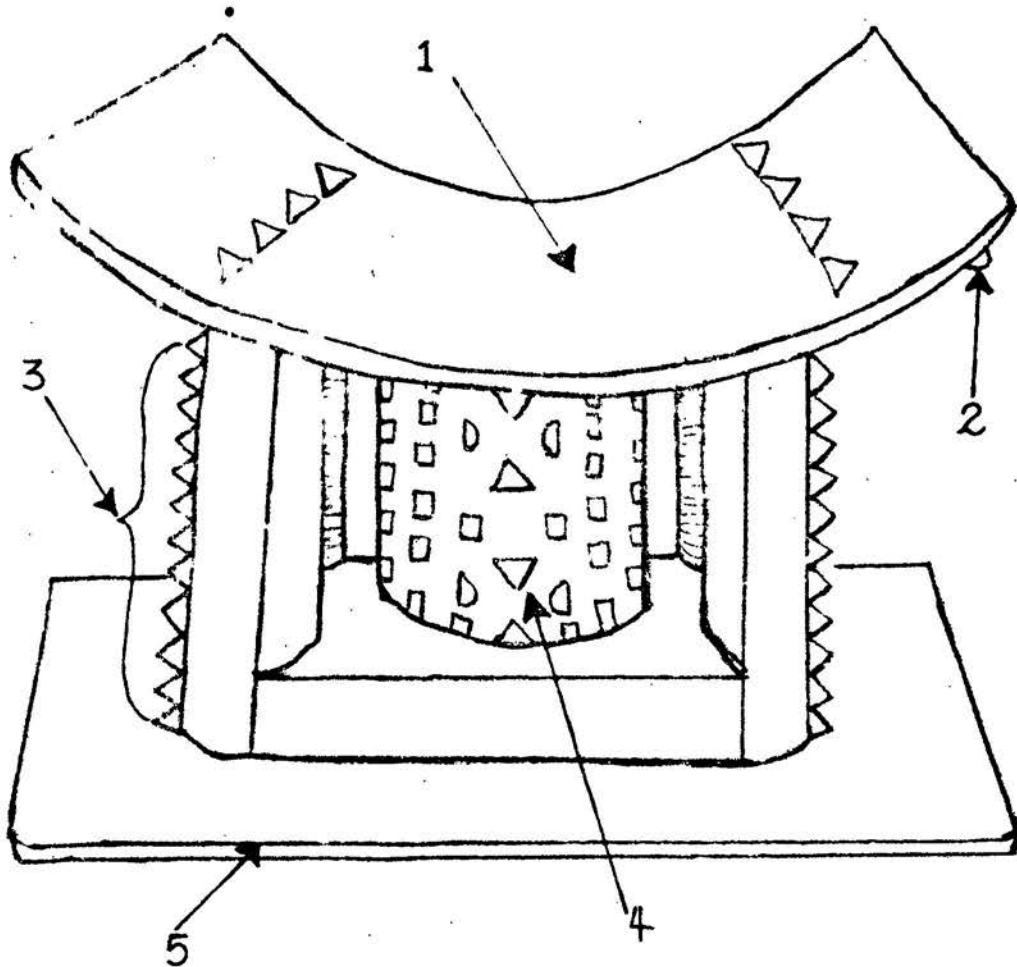

- | | | | |
|----|-----------|----|-----------|
| 1. | ANIMU. | 4. | SEKYEDUA. |
| 2. | PUIA. | 5. | WIABOO |
| 3. | NKYEKYAA. | | |

CH.V., FIG. 4. FEMALE

GENERAL ELEMENTS OF DESIGN
A SESEDWA.

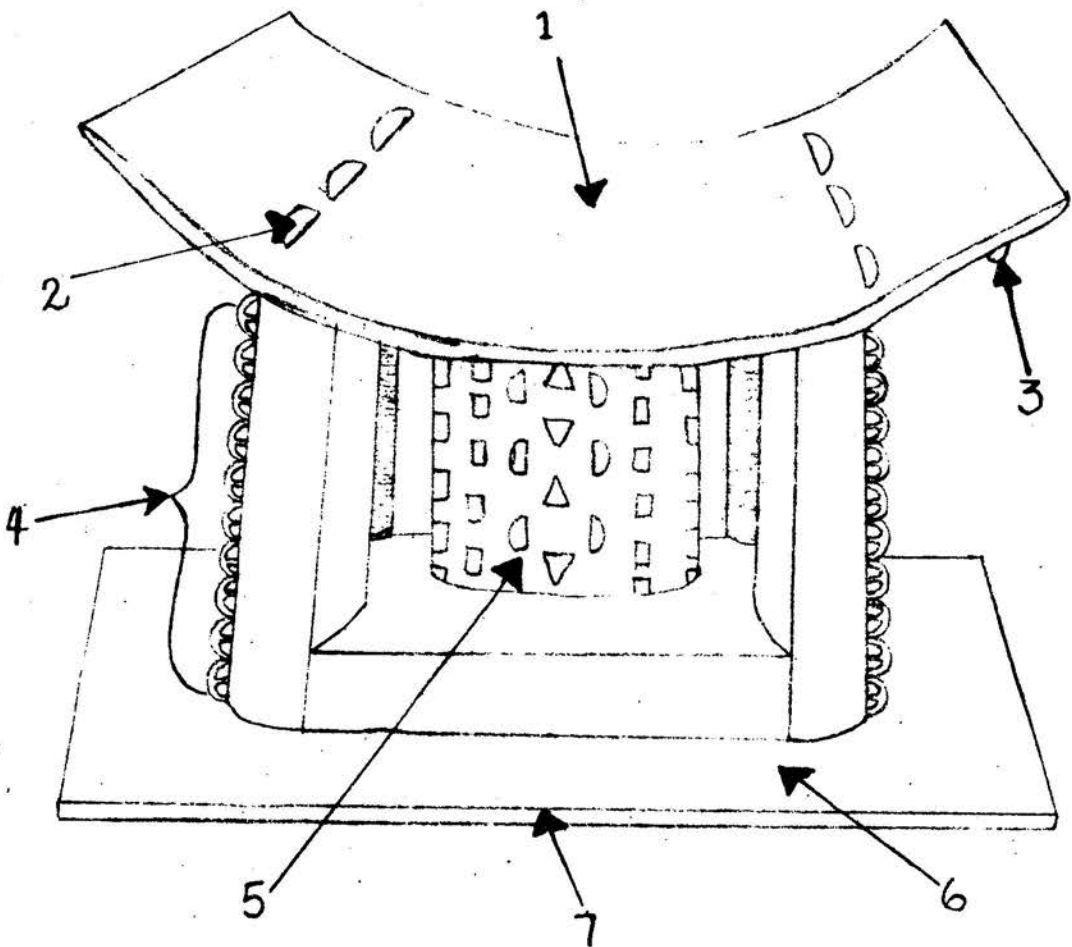

- 1. ANIMU.
- 2. TOKURO.
- 3. PUA.
- 4. NKUNTAN

- 5. SEKYEDUA
- 6. ABAIN
- 7. WIABOO

CH. V., FIG. 5.

MALE

to be used in rituals involving the averted of evil omen. Complementary to these general elements are others which lend themselves to classification by name, form or design. From analysis of the main forms that exist, it is possible to put all asgsedwa (stools) into six categories. These six groups are (i) duakoro (one central support) plate Ch. V. P.1, ii. afanu (two sided) with a sub group of this - anannu (two legged) plates Ch. V.P.2(a) and P.2 (b), iii. anansa (three legged) plate Ch. V.P.3, iv. nyaanan (four legged) Plate Ch.V. P.4, v. nyaanum (five legged - also called nyaanan by many people in Akan) plate Ch. V.P. 5 and vi. abebunwa (proverbial stools) see example in Plate Ch.V. P.6. Proverbial stools are however many and varied as will be seen later in this chapter.

Common Symbolic elements

- (a) Nkuntan and nkyekyaa - Principal male and female indicators respectively.

Apart from the above categories there are male and female distinctive signs which we designate as some of the common symbolic elements in stools. These sex determining signs are carved on the outer side of the columns in the middle section called mfinifini.

Nkuntan derives its name from the word kuntan meaning circular. Circular figures are regarded as having an embracing nature or element. Part of men's responsibility is traditionally to shield children and women. The Akan say "Mmaama ba gmaa ho bann" (men must encircle, that is, shield women). We find some consensus of opinion among the Akan that the crescent moon is essentially

male but there is also the belief that the moon is female whilst the sun is male. However, many of our informants support the view that the moon was originally regarded as male. It was suggested that the male distinguishing nkuntan take its form after that of the crescent moon. Hence stools, with nkuntan on them are meant for male users.

Regal male stools have elaborately structured nkuntan (scallops) whilst simple nkuntan are typical of ordinary male stools. In the examples in (Plate Ch.V.P.7) the scallops on stool of the chief of Ahwiaa, the carving village are delicately carved but those on the set of stools in (Plate Ch.V.P.8) the property of an ordinary man in Koforidua in the Eastern region of Ghana, are comparatively simple. The nkuntan on the Ahwiaahene's (chief of Ahwiaa) stools are called abubumabaa. Abubumabaa is incidentally the name of a kind of worm which encloses itself in a rather complicated 'casing' it constructs for itself.¹ The nkuntan has this name because of its design which is similar to the complicated casing. ~~The complicated casing.~~ The complicated nature makes it difficult to determine how the worm structures this casing. A proverb based on this is: Abubumabaa, se onweneq na gka hyaa mu o, sa gka hyaa mu na onweneq o, obi nnim. (No one knows whether the worm abubumabaa

¹ Rev. J.G. Christaller defines abubumabaa as a kind of worm caterpillar or moth. It is not any ordinary chrysalis. Chrysalis is Osa. It has not been possible to get the exact zoological name for this worm but the particular kind of casing it makes for itself is known. The abubumabaa design is represented on various kinds of stool regalia in gold and silver. Goldsmiths even now produce women's ear-rings and neck-laces named after abubumabaa casing.

AHWIAAHENE'S STOOLS

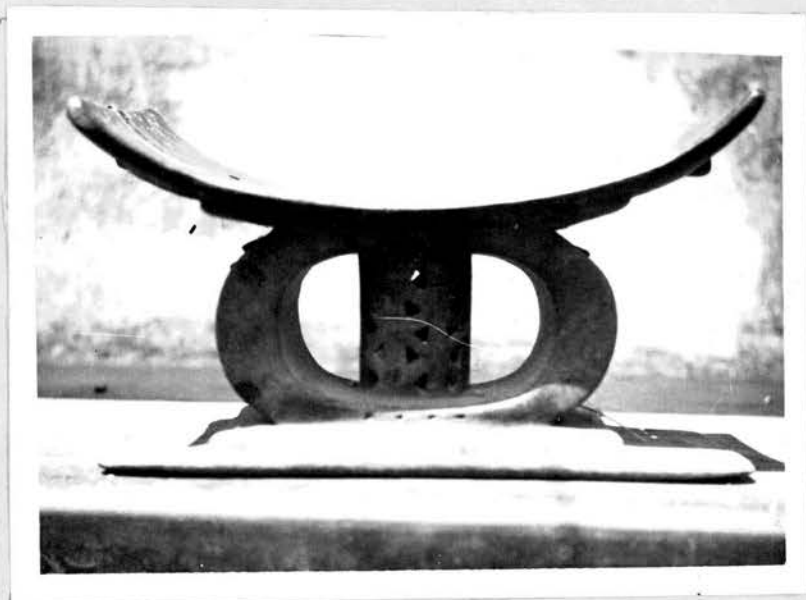

A



B



Set of stools from Koforidua.

(Note the simplicity of the Nkuntan on the stools).

builds its case before it enters it or enters it before building it around itself).

The outstandingly distinctive female symbol on stools is the nkyekyaa. Like the nkuntan, the nkyekyaa are carved on the outer side of columns. While the nkuntan are scallops the nkyekyaa are saw-like edged structures as in (Fig. 4). Kykyg is the name of a star which, according to the Akan, is always nearest the crescent moon. It is believed that this star is female and it puts high premium on marriage hence its constant closeness to the moon. Kykyg pa aware enti na gben bosome dabiara - lit. Kykyg likes her marriage so much that she is always by the moon, her consort. Reference to the example of kykyg is made when bridal speeches advising women are being made. Nkyekyaa designs on stools therefore are meant to remind women of the requirements for successful marriage which, traditionally, include devotedness and concern for the things affecting the life of their husbands. The word nkyekyaa therefore derives from kykyg, the star called Venus by some of our informants. This explains the regard given to nkyekyaa as being symbolic of femininity. Quite apart from this, nkyekyaa represent motherhood and children. Female stools with many nkyekyaa may be used by mothers, with many children. Hence a queenmother, who is the social mother of all women in a community and the king or chief himself, qualified for such a stool. Finely carved nkyekyaa has therefore come to be specially representative of royalty. Many stools with such nkyekyaa that we saw were indeed royal ones and if not strictly royal they were at least stools with considerable high status. Numerous and delicate nkyekyaa

could be carved only by very competent carvers. They are, as a matter of fact, undertaken by men who are as good as to quality as some of the Asante king's carvers. The spikes are carved with asekai (knives) and each unit of the spikes or saw-like design must be absolutely identical to any other in the total design. This means that there must be absolute symmetry which requires only very practised hands to attempt the exercise. The queenmother's ceremonial stool in Plate Ch.V.P.9 is an example of finely carved nkyekyaa. Contrast between that and the spikes on the stool in Plate Ch.V. I.65.38 brings out the difference vividly.

b. Proverbial Stools: Proverbial designs could also be regarded as one of the common symbolic elements in stools. The proverbs convey various meanings which are social, philosophic or historical. The following illustrations and notes are a few examples but as will be seen from other illustrations of stools in this thesis and from Rattray's documentation of stools, many Akan stools fall into this category. (Rattray, 1927. Chapter XXVI) The examples we select are Apodwa (sturdy limbs) Plate Ch.V.P.10, the set of stools in plate Ch.V.P.11, abaadaho (one does not starve when one has the means) top, owu ntwedeg (the ladder of death is to be climbed by every mortal) middle, Fotoaba (the seed of affluence) bottom and left, kotokodwaa (the unbeatable porcupine) bottom right, Nyansape (wisdom knot or reef knot) Plate Ch.V.P.12, and nyamedua (God's tree) Plate Ch. V. P.13.



Queenmother's Ceremonial Stool
Mampong-Asante.

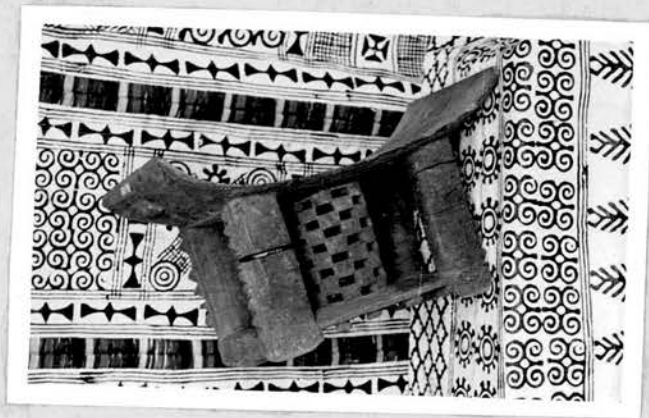

Stool of Akomadanhene, Nana Kofi Nti.
(I.A.S. Museum).



APODWA



A Set of Proverbial Stools.



A



B

NYANSAPQ

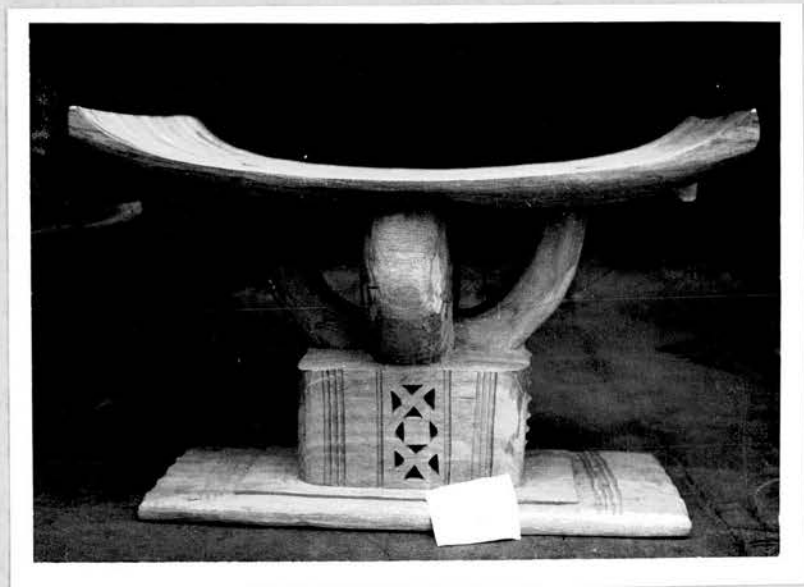

NYAMEDUA STOOL.

PLATE CHAPTER V. 'R'

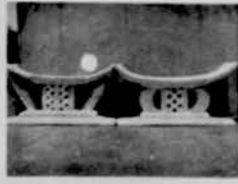

FIG. 158. 1. The Golden stool (model);
2. the Queen's stool (model)

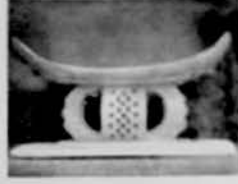

FIG. 159. Kanda stool

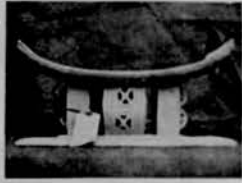

FIG. 160. Minon stool



FIG. 161. Andara Inakun stool



FIG. 162. Adenkyon stool



FIG. 163. Ose Jijou alibi stool

Rattray's
Examples of
Stools (1927).

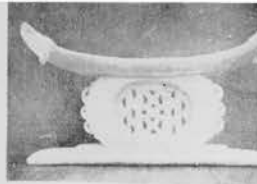

FIG. 164. Koutakumori uzema stool



FIG. 165. Koutakumori stool



FIG. 166. Sakya dai kyō stool



FIG. 167. Nanzan stool



FIG. 168. Nishi stool



FIG. 169. Mma stool

PLATE CHAPTER V. 'R'



FIG. 170. *Me fa ana* stool



FIG. 171. *Mmaroma* stool



FIG. 172. *Mmasemu* stool



FIG. 173. *Waiatu* stool



FIG. 174. *Ssane* stool

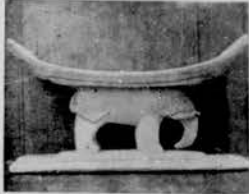

FIG. 175. *Eisan* stool



FIG. 176. *Oieho* stool

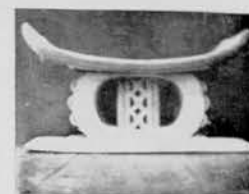

FIG. 177. *Koto* stool



FIG. 178. *Akyon* stool



FIG. 179. *Pantu* stool



FIG. 180. *Krado* stool

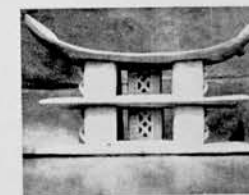

FIG. 181. *Ohi-to-obi-to* stool

(cont'd)

PLATE CHAPTER V. 'R'



FIG. 182. *Adinkira* stool



FIG. 183. *Damedame* stool



FIG. 184. *Mframadan* stool



FIG. 185. *Nkonta* stool



FIG. 186. *Animinkwa* stool



FIG. 187. *Brakantz* stool

(e) Metals used on stools have a specific significance, which is discussed under the heading of symbolism of metals later in this chapter.

Typology of Stools

In his documentation of Asante asesedwa kind of stools, Rattray illustrated thirty selected types, but he added a note at the end indicating that there were some others which he could not illustrate. The evidence today seems to bear out the fact that stool designs might have been indeed many. At various points in the cities and even some villages, stools of diverse designs and other carvings may be seen on display for sale. According to one of our principal carver informants at Ahwiaa, who happened to be one of the principal carvers for the late Asantehene, Nana Otumfuo Sir Agyeman Prempeh II, only about twenty of the present many stool designs could be regarded as basic. He, however, granted that some of the designs he does not include in his list may be fairly old. The author feels what Opanin Adjei meant exactly is that his list could not be faultlessly comprehensive. Although he felt apparently sure about accuracy of those in his list we noticed a margin of uncertainty about his number when afterwards we confronted him with some of the types mentioned by Rattray which he left out of his list. However, the point that was established was that many of the designs which, ^{do} by name of towns and chiefs like those presented in Fig. 7 and the list on page 279 of Chapter IX, are not all of the very ancient designs. They were developed later for various reasons including the fact that the colonial

central government recognized the stool as the people's traditional symbol of leadership. Since this remained an accepted idea after the Ghana National independence in 1957, the many newly created chiefships under the first republican government wished to have specific designs as their own. The fact of stool designs by name of towns and villages is, therefore, a new phenomenon in the art history of the stool in Ghana. A possibility is that some of the basic designs disappeared with the vanishing of many other visual arts of Asante and Akan during the later part of the 19th and most of the 20th century. We discovered that the ordinary man's acquaintance with the stool as an object of art was slight as a result of a number of factors including missionization and formal literary education.

It will be useful to present those types illustrated by Rattray and compare them with our informant's basic designs. The following are Rattray's designs by name as he presented them. Some of his descriptions are enlarged upon with comments but his spellings and most of the first part of his descriptions are retained.

Fig. 158. Sika 'gwa Kofi. 'Kofi, the Golden Stool.'

This form is still recognized as the Golden Stool by some carvers of Ahwiaa. We have compared this type and the form of the ceremonial Golden Stool as seen today. (See after p. 204 of thesis).

Fig. Ahema 'gwa. 'The Queen's stool;' that of Nyako Kusi Amoa, one of the early Queen Mothers of Ashanti.

Fig. 159. Kotoko 'gwa. Porcupine stool. This is one of the most highly rated stools. Many amanhene (paramount chiefs

have this as the design in their principal stools.)

Fig.160. Mnom 'gwa. 'The stool with two (instead of the usual four) side supports'; a sub-chief's stool.

Two column compares with stools we have called ananu (two legs) under stool typologies. It is correct that some junior chiefs have this design in their stools.

Fig.161. Atoduru kwadwom 'gwa. 'The keg of gunpowder stool.' It was a stool for captains and warriors of distinction.

Fig.162. Ademkyem 'gwa. 'The crocodile stool.' The crocodile may have a fish in its mouth. Such stools were principally for the shrines of some gods. (See Religion and Art in Ashanti figs 71-2, 1927). The Ademkyem 'gwa 'Crocodile stool' without a fish in its mouth may be mainly used today by sub-chiefs below the grade of wing chiefs of one locality e.g. Mampong Asanté. Rattray is, however, validated by many of our informants for 'priests' may also use this stool.

Fig.163. Qwg fore adgbg 'gwa. 'The snake climbs the palm-tree stool'; a stool used by ordinary persons of either sex. Although ordinary people of both sexes may use this stool as Rattray points out, it has become one of the favourite patterns for senior chiefly stools. The difference between ordinary stools and chiefly stools lies in the size, degree of finish and minute details most of which, we were told, are secrets carvers would not divulge.

Fig.164. Kontonkorowi mpemu 'gwa. 'The divided circular rainbow stool' (the rainbow sometimes seen round the sun), only used by the King of Asanté. There is a well-known proverb - Kontonkorowi gda amansan komu, 'The circular rainbow that encircles the neck of the nation.'

It is confirmed that this used to be one of reserved patterns for the Asantehene. In order to impress upon the people the necessity of public participation in political processes, this pattern was released from the monopoly. When exactly the release was effected is not remembered, (Ahwiaa informants.)

Fig. 165. Kontonkorowi 'gwa. 'The circular rainbow stool'; Note its similarity to the kotoko stool. See the central supports - sekyedwa usually kotokodwa is flanked with crescents that are not perfectly round. They are slightly elongated or oval. (See stools Plate Ch.V. p.14 'C').

- Fig. 166. Sakyi dua koro 'gwa. 'The stools with the single centre support'; used only by the priesthood. Informants were not agreed on this use of the stool. Very few agreed that it has ever been used solely by priests. Our research supports their view because all the priests we interviewed used other stools; like the Nyaanan and the denkyem stool. One common feature is that most of them were besmeared with white clay. Some had also little fragments of egg shells on them. This is a common stool in terms of numbers. Children's stools may be of this duakoro type, although other designs like the Nyaanan - (four legged stool) are also found among children's stools.
- Fig. 167. Nnanna 'gwa. 'The two penny stool', i.e. the poor man's stool. In olden days it cost one danna in gold dust. This is also called mpesugwa (penny stool). It is essentially a children's stool. Another popular children's stool is one with a single centre support discussed above. See Plate ~~Chapter II~~ P.1a in Chapter II.
- Fig. 168. Nsebe 'gwa. 'The amulet stool'; the decorative effects on the sides are supposed to be like the leather sebe amulets. This is not a common stool today. It was popular stool for captains (asafe henfe).
169. Kma 'gwa. Woman's stool; when a man marries he generally presents his wife with this stool. Correctly indicated as the type that may be presented as a bridal gift to a would be wife. It is generally the type of stool a woman may sit on. Note the female distinguishing sign - the akyekyaa.
- Fig. 170. Me fa asa 'gwa. 'My half is finished', half of my clan is dead; a woman's stool. We are informed that Mefa asa - is the name of a stool first carved for the chief of Ofinso. His stool, however, has only one column besides the central column. Although our chief informant says this stool may be found, we did not see an example of it during our investigation.
- Fig. 171. Mmarima 'gwa. 'The man's stool. The distinguishing sign about the stool is the nkuntan.
- Fig. 172. Mmaremu 'gwa. 'The cross stool'; only used by the King of Asanté or by a great amanhene (paramount chiefs) with the king's authority. Crossed stools are still not commonly found among ordinary stools.
- Fig. 173. Wasaw 'gwa. 'The Wasaw stool'; this stool was presented by the King of Asanté to the Chief of Wasaw. It might only be used by him, the King of Ashanti and the greater amanhene,

(paramount chiefs) with prior permission from the King. This story is confirmed in Ahwiaa and Asante generally and partly in Wasaw too.

- Fig. 174. Srane 'gwa. 'The moon stool'; used by men or women. There is a confusion here to be cleared. There is the tradition that the moon is male. Under many circumstances it has been known by many as being female. Those who say it is female say it derives its source of brightness from the sun which is male. The exponents of the idea that the moon is male say kygkyg that star which is always by it is the female and always gravitates towards the male moon because it cherishes 'marriage' above all other things.
- Fig. 175. Esono 'gwa. 'The elephant stool'; only used by the King of Asante. Some Ahwiaa carvers including Opanin Agyei whose category is presented next to Rattray's does not regard the elephant stool as one of the oldest designs. However, they say the king of Asante claimed the design when it appeared. The elephant stool has continued to be a popular design of stools for ordinary people. Again the difference between stools for chiefs and ordinary people lies in the degree of finish. The king's elephant stool has also more pronounced bulging sides and a more representational kind of tusks.
- Fig. 176. Oseba 'gwa. 'The leopard's stool'; only used by the King of Asante. This stool is still not very much used by ordinary people. In Asante at least, it still is regarded as a special stool for (ohene) the king. The Akim Abuakwa and Akim Kotoku definitely regard leopard stools as very senior stools. They have been used by the paramount chiefs.
- Fig. 177. Kotoku 'gwa. 'The porcupine stool'; the stool upon which sat members of the king's council, composed of the Asantehene, the amanhene, and the greater priests. As in Fig. 159. Elsewhere we indicate that the design - porcupine stool is the design of designs. Chiefs and councils of chiefs use more finely finished and bigger stools.
- Fig. 178. Akyem 'gwa. 'The Akyem stool'. The design of this stool is said to have been copied from a stool owned by the Chief of Akyem, Atafa, who was defeated by Bonsu the elder; It was used by chiefs and priests. This design is the Akim Kotoku equivalent of the Kotoku-dwa of Asante. (Note our spelling of 'stool' - dwa).
- Fig. 179. Pantu 'gwa. 'The big spirit (gin or rum) bottle stool.' The centre of the stool is not unlike a European decanter.

Came into being during the era when gin was used for negotiating for land and concessions. Informant Kyidomhene (Chief of the Rear Guard in Kibi).

Fig. 180. Krado 'gwa. 'The padlock stool'; used by Chiefs and also linguists (akyeame). Continues to be regarded as such.

Fig. 181. Obi-te-obi-so 'gwa. 'Someone-sits-on-top-of-someone else stool' is carved to represent one stool standing on top of another. Was very popular with paramount chiefs especially of Western and Central Akan Chiefs. See Kyerematen 1964. Example is Ahanta State stool in the Western region. Also the kudragbe division of Ada State - Coastal non-Akan State, Eastern Region.

Fig. 182. Adinkra 'gwa. 'The Adinkra stool'; the stool of the King of Gyaman.¹ Commonly known as Fotoaba, a stool for the affluent.

Fig. 183. Damedame 'gwa. 'The draught-board stool'.

Fig. 184. Kframadan 'gwa. 'The-house-of-the-winds stool; so called after the open lattice-work designs on some of the temples. See e.g. Frontpiece of Rattray's (1923) may be used by persons of either sex. Compare with Sankudwa in Plate Ch. V. P. 14.

Fig. 185. Nkonta 'gwa. 'Stool of head of king's stool-carriers'.

Fig. 186. Animinkwa 'gwa. 'Animinkwa's stool'; a chief of Wasaw.

Fig. 187. Brakante 'gwa. 'Brakante's stool'; a chief of Akyem. Compare with the new stool - the personal design of the late Asantehene, Otumfuo Sir Nana Agyeman Prempeh II. The Brakante stool appears to have been the first stool, according to some of our informants at Ahwiaa, which had a kind of reef knot - which appears in the arnan or legs of the Nyansapp.

¹ See Rattray 1923. p. 291.

Our informant, Opanin Agyei's examples of basic designs which include almost all of Rattray's are presented here. Opanin Agyei however, tended to group a number of stools under the basic categories we have outlined in the analysis of the basic forms of the asagdwā earlier. This is one of the reasons why his basic designs number fewer than Rattray's.¹

Opanin Agyei gave the following design types: i. Duakoro (one central support) R.Fig. 166, ii. Afanu (two sided) Ch.V. P.2(a) also R. Fig. 160, iii. ananu (two legged) Ch.V. P.2(b), iv. Naansa (three legged) Ch.V. P.3, v. Nyaanan (four legged) Ch.V.P.4, R.Figs. 167, 168, 169; vi. Nyaanan ne ne sekyedua (four legged with a central column or support) and Ch.V.P.5. In Rattray's list this last type is also called nyaanan. The other types are: vii. needwa (male stool) - any illustrated stool with nkuntan on it, viii. katqkdwaa (porcupine stool) R.Fig.177 also Ch. V. P.14 'C' of the set of four stools, ix. Kontonkrowi (rainbow stool) R.Fig. 164, 165, also Ch.P.14 'D' of the set of four stools. x. Nyamedua (God's tree) Plate Ch.V.P.13, xi. Ebi-te-bi-so (one sits on another) R.Fig. 181, xii. Owo-kafore-adoba (the snake climbs the raffia palm tree) R. Fig. 163

¹When Opanin Agyei started to categorize and name his stool designs he actually particularized 26 stools and not 20 as he previously said. We consider that there is the need to continue the search to find out the designs which might be called the truly first few original designs. Most of those named by Rattray and Opanin Agyei are however established as very authentic ones. For comparative purposes we put 'R' and the number of Rattray's illustrated stools before the names of those of Opanin Agyei which are the same or regarded as in the same class.

PLATE CHAPTER V. P14



A Set of Stools - Four Types.

PLATE CHAPTER V. P15



ASEMPA MMEREMU.

xii. Mmarimu (the cross stool) R.Fig. 172, xiv. Damedame (chequer board stool) R.Fig. 183, xv. Fotoaba (affluence stool called adinkradwa by Rattray) R.Fig. 182, xvi. Nnaamadwa (two penny stool) Ch. II P.1(A), a newer type Rattray's example of a naamadwa (two penny stool) is a small nyaanan (four legged stool) and this is also correct because quite apart from the stool type acknowledged as the naamadwa in Asante, rough and small editions of most stools may often be referred to as naamadwa (children's stool). The rest of design types in Opanin Agyei's list are:

xvii. Atoduro kwadwom (keg of gun powder stool) R.Fig. 161, xviii. esonodwa (elephant stool) R. Fig. 175, xix. pantudwa (gin bottle stool) R. Fig. 179, xx. kradodwa (padlock stool) R.Fig. 180, xxi. Qsebgdwa (leopard stool) R. Fig. 176, xxii. sankudwa (accordion stool) Plate Ch.V. P.14, xxiii. sranedwa (moon stool) R. Fig. 174, xxiv. Denkyamdwa (crocodile stool) R. Fig. 162, xxv. Brakantedwa (Brakante - a chief of Akyem stool) R. Fig. 187 and xxvi. Needwa (Male stool) and maadwa (female stool) are two special kinds which have been discussed.

Other Typologies

(a) Adinkra designs in stools: Under the subject of the Akan stool complex in Chapter IV we came across a kind of cloth called the Adinkra in Akan. Adinkra literally means saying goodbye. There are many patterns which can be stamped into an adinkra cloth. These patterns are mainly proverbial. The arrangement of a set of the patterns in cloth makes it regal or ordinary. In appendix 11

examples of these patterns are presented.¹

We observe that in the symbolism of stools, there are some instances of over lapping between known stool symbols and adinkra designs if not exactly in form at least in name. The first seven of the following twenty adinkra patterns are also found in stool designs. They are Biribi wa soro (there is something in heaven), Musu yi dea (that which is used to remove evil), Owu atwedeg (the ladder of death), Owa aforo adoba (the snake climbs the raffia palm tree), Mra krado (the seal of law), Damedame (chequer board and game of draughts), Futufurama koro (the one stomach, but two headed crocodile). (See the rest of the designs illustration and notes on pages 321-325).

The second set of designs do not occur frequently in stools but we are informed that their rarity may be taken as an index of the high regard in which they have been held. None-the-less, we found the first design, Gye Nyame, in this second set to have been almost absent in all the oldest stools we ever saw. Instead a naturalistic design or version of this abstract representation is known, which is a fist with only the pointer finger released carved on the side of an afanu type of stool (two sided) or even on the sekyedua (middle column). Hye-wo-ho-nhye (unburnable), Bi nka bi (no one

¹The exact origin of the adinkra patterns is yet to be determined. It has been suggested that the patterns were first used in Gyaman and Denkyira before they were ever used in Asante. Some informants say the patterns were part of the trophies the Asante took from Gyaman in addition to the head of Nana Kofi Adinkra. One thing that appears certain is that the patterns have been known among the Akan as far back as is remembered today.

SEVEN ADINKRA PATTERNS AS MFINIMFINI OF STOOLS.

(REF. P. 191)

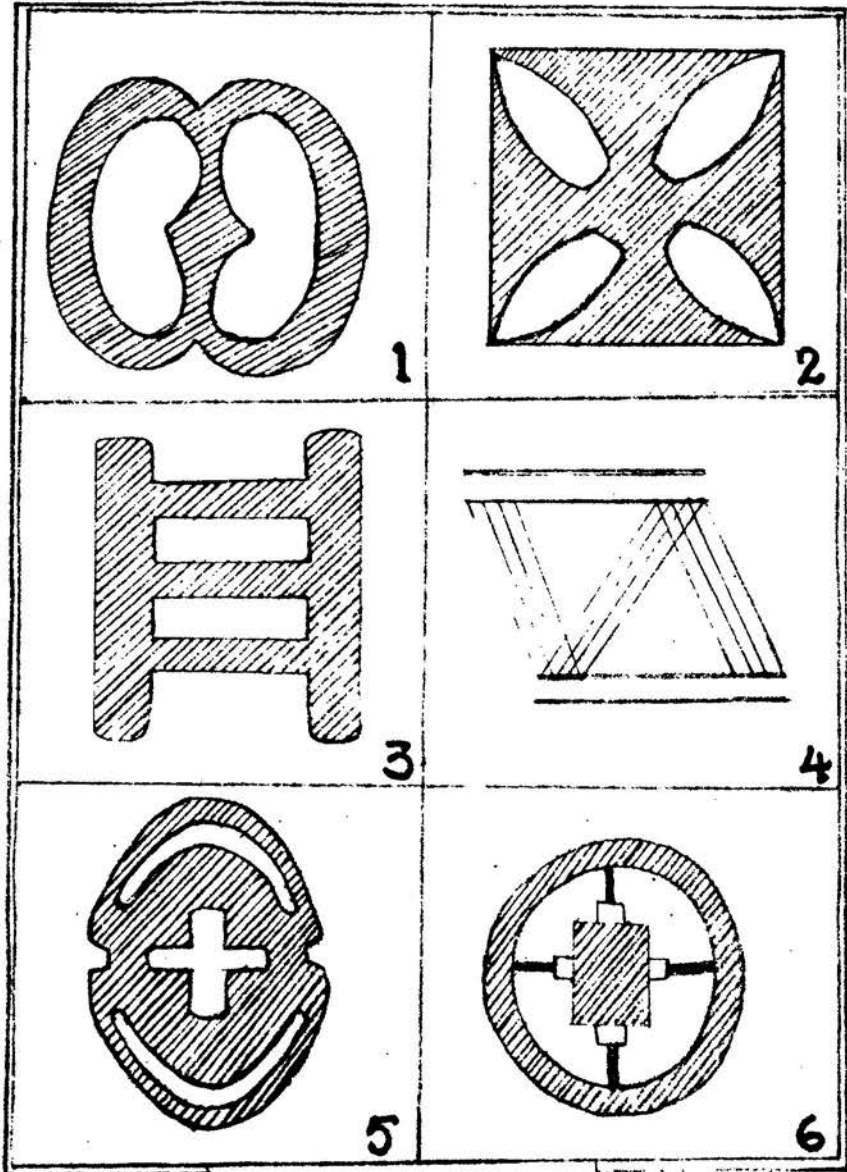

1. Biribi wɔ soro.

2. Musu yi deɛ.

3. Owu atwedɛ.

4. Owɔ aforo adoba.

5. Mra krado.

6. Damedane.

7. Futufuma koro.

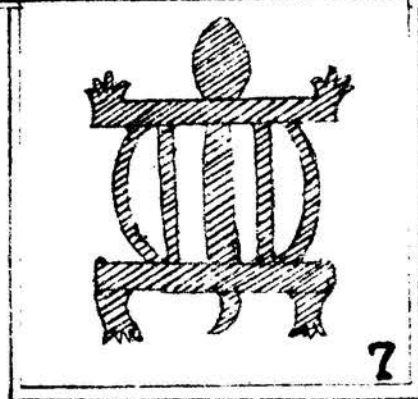

should harass his neighbour), Nyame Nwu na rawu (while God is alive I live), Ntesie (what I hear I keep), Bese saka (a bunch of cola nuts), Kodee mmowers (the talons of the eagle), Pempansie (uncrushable), Nkɔnsɔnkɔnsɔn (chain), Konti ne Akwamu (Konti and Akwamu names of chiefdoms subordinate to Asantehene) Found only in Kumasi), Nkyinkyim (zig-zag pattern) Toughness, Ese ne tekrama (the teeth and the tongue).

The following are brief notes on the adinkra designs in stools.

1. Biribi wɔ soro: Nyame'biribi wɔ soro na ma ɛmɛka mensa.
(God there is something in heaven. I pray let me reach it). This design is the mfinifini (central section) of the stool. The centre of the design becomes a sort of sekyɛdua (central column) in a stool. The symbol is one of hope and confidence in God's purposes. Equivalent to No. 3 in Adinkra designs Appendix 11).
2. Musuyideɛ: (that with which evil is removed). Carved either on the two sides of an afanu (two sided) stool or carved as the block design of the mfinifini (middle section). The design symbolises man's belief in the perpetual existence of the human race and the spirit of man. (No. 6 Appendix 11).
3. Ɔwɔ-foro-adɔbɔ: (snake climbs the raffia palm tree). Same as R. Fig. 163. It is a symbol of greatness. (Compare with other notes on this in the chapter) No.19 App. 11.
4. Owu Atwedɛ: (the ladder of death). The ladder may be incised on parts of the stool - often on the central piece. The ladder may also be carved to flank the central column. See Fig. cf. No. 42 of App. 11.
5. Era Krado: (it. the padlock of the law). The adinkra design bears some semblance to the stool design which goes by the name. See R. Fig. 180.
6. Dɔmedame: (chequer board and game of draughts). The adinkra design called by this name was seen only on one stool in Ahwiaa. The commonly known damedame stool is as presented in R. Fig. 183 Symbolises - craftiness & intelligence. (See No. 29 App. 11).

7. Futufruma koro: (the two headed but one stomach crocodile).
This design also popularly occurs among Asante Gold weights. The adinkra pattern is more stylised than the design in stools. However, the design could easily be identified as similar to the adinkra version of the proverb. Stresses the value of solidarity in spite of minor disagreements that may arise in a community. No. 18 App. 11.
8. Gye Nyame: (lit. Only God). Symbol of omnipotence and immortality of God with the capital 'G'. This particular adinkra design is now appearing in the mfinifini (middle) of asesedwa stools. The other pattern which is a naturalistic representation of a human fist with the pointer finger released and pointing upwards was incised on the face of afanu type of stools. See Plate 2 chapter V. The example of it enlarged and the stool modified to serve as a church altar. (No. 1 App. 11).
9. Hye-wo-ho-phye: (lit. unburnable). Symbol of magnanimity and political greatness. Carved in the mfinifini - (central section). A comparatively new design when treated this way in stools. The design was, however, well known during the early part of the 19th century in Asante. cf. (No. 4 App. 11).
10. Bi-nka-obi: (lit. No one touches another) justice. A symbol of Unity - like Futu-fruma-koro discussed urges avoidance of strife which is socially divisive. Used to be incised on the animu or wiabog of stools. Now almost extinct. Carvers told us of such stools but we never saw one with the centre styled as in this figure. (Fig.5 App.11).
11. Ntesie: (I remember or what I hear I ponder over or keep). Symbol of knowledge and wisdom. Appears in the middle section of a stool bearing the name. More usually it is incised on the animu of the stool. Rather a rare stool but not so rare on Hwgdon and akomkromfi chairs. (See Plates Ch.V P.31&32) cf. (No. 10 App. 11).
12. Bese saka: (a bunch of cola-nuts). Symbol of political eminence. Carved for the centre of a stool bearing this name. Though an old design its use in stools dates from the beginning of the twentieth century.
13. Kpdee mmowerę (the claws of the hawk)
Typically an Oyoko clan design. Symbol of strength. Has never been seen carved as mfinifini (centre) of an asesedwa ; but usually incised on the sides of the animu(face).

It is rare on even ordinary Oyoko clan stools.
(See No. 11 App. 11).

14. Pempamsie: (Sew up for the future). Symbol of steadfastness, strength and political greatness. Appears in newer stools but not so new on asipim chairs. (cf. No. 17. App.11).
15. Dwanimen: (ram's head). Symbol of humility, wisdom and vitality. Found on the back rests and other parts of hwgdom and akomkromfi chairs. Although carvers say they are old designs in asgsdwa stools the evidence is to the contrary. It is, however definitely a favourite design for royal chairs. See Plate. Ch.V P.32 Refer. No. 41 App.11.
16. Nkgnsonkgnson: (Chain). A symbol of unity. Could be used by ordinary people. It was supposed to have been initiated by a chief but the informants could not remember the particular chief (Abwias informants). (No. 52. App. 11). See also design of stool presented to Prince Charles (Plate Ch.V. P.30).
17. Konti ne Akwamu: (Konti and Akwamu). Design for the two sub-chiefdoms of Konti and Akwamu in the Kumasi asafo (group captains) initiated by King Osei Tutu - the first King of united Asante. Signifies toughness and having many parts to play. (No. 31 App. 11).
18. Nyame Nnwu na mawu: (God is immortal hence I am immortal). A symbol of the belief in the perpetual existence of the spirit of man. This was supposed to be one of the designs that appeared in some priestly stools but it could be used by all ordinary people. Stools with this design were very rare. The new cultural revivalism seems to be bringing it into vogue, but they are found mainly in tourist stools. This is because the use of asgsdwa stools in all ordinary homes nearly withered away in the last two decades. This is a point we may be making again in relation to tourist stools. Tourist stools are really not necessarily of poor or indigenous designs. They may be only modified but also revived types. (No. 7. App. 11).
19. Ese ne tekrgma: (teeth and the tongue). Although man's teeth and his tongue are very close, the occasions on which there is a 'clash' between/are rare, if at all. The symbol is one signifying friendliness, unity and dependence. Stools bearing this design could be used by male or female. (No. 16 App. 11).

then

20. Nyamedua: (God's tree) - the altar of the high God. There is a stool by the name Nyamedua - (God's tree) i.e. three forked tree or stick. The adinkra pattern is a stylised form of the design. Used by both male and female. (No. 2 App. 11).

(b) Clan totems in aseseɔdwa.

Another known class of designs worth mentioning is what may be called clan patterns. Under Chapter IX, the stool in contemporary Ghana, we refer to the modern shields of some Akan communities of Ghana in which some totems have been incorporated in rather complicated patterns. The combinations as seen are modern but the objects illustrated and the ideas are ancient. They are examples in which some gems of the heritage have been used in modern complex designs for crests or emblems. (See over-leaf p. 281)

It is necessary, however, to state that the aseɔɔ-dwa (the leopard stool) for the Akan clan called the Bretuo, and Gyatadwa (the lion stool) for the clan called Aguana, are said to be stools that have been known for the past two or three hundred years.

Lack of examples of clan stools with the known clan totems is outstanding and it appears the totems as such were not subject of stool designs in the past. This is why we suggest that most of these that are presented now are likely to be new. The following are examples which although not reproduced in their major stools are nevertheless identified with specific clans. Okɔdeɔ (hawk) is associated with the Oyoko clan, akoo (parrot) with the Agona, ɔwɔ (snake) or kwakwaadabi (raven) with the Asona, skwa (buffalo) with the Ekogona, ampain (bat) with the Asene, ɔɔwa (fire) with

the Akuana, and gsebg (leopard) with the Bretuo. These totems are also found incorporated in the diagrams on 'heraldic shields' of some of the former states of contemporary Ghana. See (Sutherland, D.A. 1954, P. 19).

In appendix 9 a table of lineages that possess black stools and the design of the principal stool village or town are given. Of the nine villages or towns in which we did a physical count and also a special study of stools in regalism and government, only three could or were willing to tell us the design in their supreme stool. Ahwerease, a village in Akuapem, gave their design as a naturalistic representation of the vulture, Aburi also a town in Akwapim said the mfinifini of their stool is a sculpture of two guns, two swords and a warrior, and a lineage in Oyoko village in New Juabeng said their design is a tortoise and a snail. Although all these are naturalistic, none agrees with the known totems of the clan of the ruling lineages. Ahwerease belongs to the Asona clan whose totem is the raven or snake, and the totems of Aburi and Oyoko are fire and the hawk respectively.¹

At this stage, therefore, it is not possible to attempt an accurate classification of stools by clan designs. It is, however, relevant to mention that further patient investigation is needful in this sphere. This is important since a great number of important black stools of Ghana are not available for public examination.

¹Refer also to modern heraldic emblems of Ghana in Sutherland, D.A. State emblems of the Gold Coast, 1954.

Ranking of stools and their designs.

Stool designs may be ranked in a number of ways - by the age group that may use stools, a particular design, the sex to which the stool belongs, the status of people or chiefs that may use a design, the metals that decorate a stool, its physical size and the style of a stool. These are all possible indices for classification.

(a) Age Group

Children's stools, discussed more fully in Chapter VII, are at the bottom of the ladder in classification. Children's stools are also graded. The mere block of wood dufua is the least among other children's stools. The diamond shaped duakoro as in plate (Plate Ch. II No. P1(a)) is the next in an ascending order. The highest type among them are the miniature nyaanan (four legged) ^{and} Nyaanum (five columns). According to Ahwiaa carvers, the size of stools is a serious factor in ranking them. All children's stools, which are also often small editions of adult stools, are called mpesuanwa or Maamadwa, meaning two-penny stools. They are so called originally because all children's stools did not cost more than two pence. See Chapter II. A proverb connected with mpesua is 'Wo pe mpesua tumpain a, wonya, na yede ma we damirifa a wonte,' (If you desire to have a talking drum which costs only a two-pennies, you will have it, but if condolences are played on it, they would not be audible to you). Mpesua adeg ya nkwadaa dea (Things whose worth are only a two penny pieces are for children).

(b) Sex: Stools can also be ranked by sex. Female stools are inferior to male stools although stools of queen-mothers are, as a rule, higher than ordinary men's stools. Stools of women who were regarded as having done deeds of bravery meriting recognition as associates of the 'secret society' of men, could use female stools but such stools have the same rank as men's stools. Often female stools of this category have, as we have mentioned, many nkygkyaa on the outside columns or annan of their stools.

As we found in the case of children's stools, the size of a stool here too may be an index to its status. Large stools are higher in status than small stools. Medium sized stools are the normal ones presented as ordinary bridal stools referred to in Chapter VII. Normal stools in this context are at least about one foot high and one foot six inches across the animu (seat).

(c) Antiquity of pattern

Another index for ranking stools may be by the antiquity of the design. It is significant that ordinary people who want stools carved for them today ask that they should be given old traditional ones, even though they themselves may not know which are the ancient designs. We actually witnessed such cases in Ahwiasa. We record an occasion when Opanin Agyei, a carver of Ahwiasa was asked by some customers to name some of the original designs to them so that they might pick upon some to be carved for them. He showed them a number of stools and gave them their names. Finally, they commissioned him to carve five sets of the

following for them: Kotokodwaa, Owo ko foro adobe, sranedwa, mnomdwa and adinkradwa.

There is a point, however, which must be noted about this matter of antiquity as an index of the rank of a stool. The classification is not progressive or lineal. Although apodwa is believed to be newer than mframadan for example, it has a higher status since it is regarded as the personal design of an Asante king. In the same way the nyansapɔ design of the late Otumfuo Nana Sir Agyeman Prempeh II is a very high stool in the estimation of Ahwiaa carvers and Asante. A variation of it may be carved for a customer but the exact copy of Nana Prempeh's Nyansapɔ stool would not be carved for anybody. This emanates from the respect for the stool and the people associated with it.

Ordinarily, the stool designs regarded by the Asante as the most ancient and original are first the kotokodwaa (the stylized porcupine stool), the female and male nyaanan (four legged), and the nyaanum (five legs and a central column). The denkyemdwa (the crocodile stool) and the kontonkrowi (rainbow stool) have high regard, being originally stools for priests and chiefs.

(d) Naturalistic and stylized designs

We present the stylised kotokodwaa (porcupine stool) as the stool regarded by many Asante Akans as the most ancient. This leads us to another way of ranking stools in Akan. We learn that except in a few cases the design of the principal stool of most Asante communities was the kotokodwaa or a stylised proverbial stool. Zoomorphic designs meant to be proverbial stools are, according to our Ahwiaa informants, higher in status than anthropo-

morphic ones. Indeed, anthropomorphic designs are rare and here their rarity is not incidental to their 'highness'. Anthropomorphic designs are, it appears, comparatively fairly recent.

Symbolism of metals on stools

We now examine the place and significance of metals on asesedwa stools.

On the stool in Plate Ch. V. P16 are metal blades or bands both on the animi and mfinimfini. This introduces us to the symbolism of metals on Akan stools. Gold, silver, brass, alloy or bronze may be used with reference to the status of the stool and the stool office of the occupant. Silver is generally the kind of metal chiefs who are entitled to ride in palanquins, referred to earlier in the thesis, may use to decorate their stools and other items of their regalia. Brass, alloy and bronze, in that order, are used by sub-chiefs and still lower chiefs to the sub-chiefs in the political system. The lowest rank of chiefs, namely the adikro (small village chiefs) do not normally use metals on their stools.

In Asante, it is, traditionally, only the Asantehene who should decorate his stool with gold leaf. The chief of Juabeng may use gold sparingly on his stool and other regalia since he is the Oyoke chief whose stool was spared from the mass destruction of Asante chiefly stools prior to the coming of the Golden Stool of Asante.

The example in Plate Ch.V. P17 shows a complicated gold



Metalled Stool. One of the stools removed to Britain from Kumasi about 1900. Recently returned to Ghana from the British Museum.



Richly decorated Nyansapa with Repouse.

decorated Nyansapɔ of the late Nana Otumfuo Sir Agyeman Prempeh II. There is central repousse decoration on the animu and to it are crosses of gold bands. The bands may be T-shaped or X-shaped. Plate Ch.V. 18 A & B show examples of the 'T' and 'X' shaped crosses. Both are tops of some stools recently returned from the British museum. On the corners of such gilded animu may be found smaller repousses.

In the set of five stools in Plate Ch.V. P.19 all but one are metalled stools. The top and middle stools have silver on them and they were among the stools that were taken to Britain after the British conquest of Asante. One of the bottom stools is a copy of the stool seized from Nana Kofi Adinkra in about 1800 and the other one which is gilded is a copy of the late Asantehene's Nyansapɔ (wisdom knot). See the Plate Ch.V. P.19. Plate Ch.V. P.20 is an enlarged copy of the Kofi Adinkra stool whilst Plate Ch. V.P.18 is an enlarged edition of the Ntim Gyakari Stool - in the middle in Plate Ch.V.P.19.

These silver stools may be compared with the Mamponghe stools in Chapter IV., Plate Ch.IV.P.7 A & B. The metals on the two top stools in Plate Ch.V.P.19 suggest that they belonged to an asafohene (captain of Kumasi) and a queen mother respectively.

The insistence on the restriction of gold in Asante to the Asantehene's stools is illustrated by Busia's report on an incident which happened in 1941. He reports that on the 26th of September, 1941 the Dormaa chief went to a confederacy

'T' & 'X' Shaped Metal Crosses

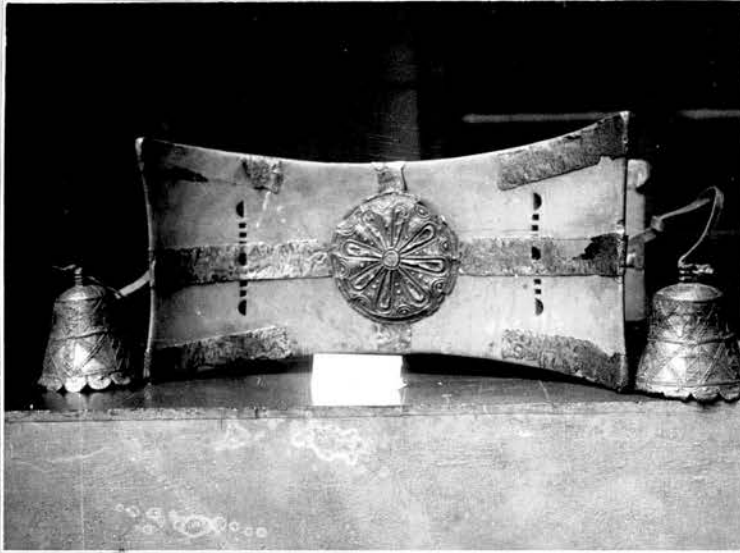

A

T-cross. A stool recently returned from the British Museum.

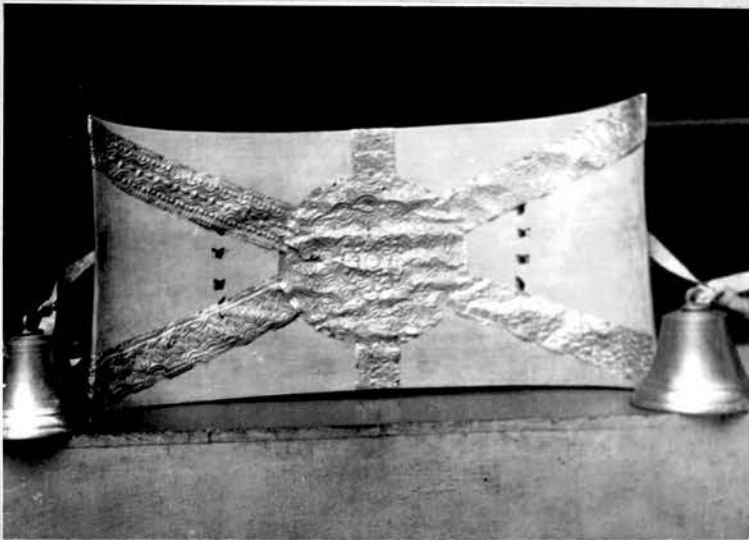

B

X-cross. A stool recently returned from the British Museum.

PLATE CHAPTER V. P19



A Set of special historical stools.

PLATE CHAPTER V. P20



Enlarged copy
of stool not
metalled.
(Bottom right).

NANA KOFI ADINKRA STOOL.

meeting at Kumasi with a gilded asipim chair. He had to apologize to the Asantehene through the chief of Kokofu. He thought the restriction excluded asipim chairs. It is reported that his apology was accepted but he had to pacify the 'King' with twelve live sheep. (Busia 1958, p. 96).

A further note on the Social Uniqueness of the Golden Stool of Asante.

Reference has been made to the Golden Stool of Asante as the highest stool in the kind of government we have called the Akan Stool polity. We have reiterated the tradition that this stool was supposed to have descended from heaven dramatically on a Friday. We recall that the Golden Stool came into being to be a symbol of united Asante after 1700 when separate Asante states came together initially for purposes of aggression, offence, and territorial expansion. Right from the beginning, we are told in the literature that Okomfo Anokye, the priest of Nana Osei Tutu, the first king of united Asante, declared that he shall be punished by death who dared to claim to have the like of the Golden stool. In connection with this we learnt that Nana Kofi Aqinkra fell a victim to the sword of Asante for his insolence in declaring in about 1800 that he had a golden stool.

Another thing we have discussed is, as we see it, the uniqueness of the Golden stool, as a 'political theory' in visual art. The point was made that this stool enunciated the theory but that theoretically the seeds of this were embedded in the political

system -- the Akan stool polity.

Indeed, lineage stools became national stools as we have indicated with references also to Rattray, Danquah, Busia and Kobina Sekyi. Further investigation and analysis support this assessment of Akan national stools. A difficulty that is raised in consideration of the Golden Stool, in the light of how national stools may attain their position, is the fact that the Golden Stool 'descended' from heaven to be a symbol of a created union. It is held that essentially what happened was a replacement of the stool of the Oyoko lineage, which lineage continued to supply the incumbents of the Golden Stool. The stool did not usher in a republican government. The monarchy continued and the monarch continued to be selected from the lineage of the King in whose time the Asante union was effected. Asante say "Osei nananom akonwa no ara ni-Sikagua Kofi no. Adwa no wa sika dwa no mu". (The ancestral stool of Nana Osei Tutu is the same as the Golden Stool. The stool is in the Golden Stool Kofi). We reiterate that oral tradition and the literature reveal that only the Golden stool of Juabeng Asante was spared the mass destruction of all the stools of those states that came together to form the union after the coming of the Golden Stool. Whether the 'lineage stool is in the Golden Stool' means that it has been incorporated into the Golden Stool by being rubbed into it or whether it was bodily incorporated has not been discovered. It is possible, according to some informants, that the former is more likely than the later.

What is important to note about this, however, is that instead of taking it for granted that a lineage stool, and in this case

a special lineage of the Oyoko clan, has become the stool of a collectivity -- a nation -- a specific stool was actually created other than the physical old lineage stool; because it was to be the stool -- the supreme political symbol -- of the head of the polity. It is essential, while appreciating the uniqueness of the Golden Stool of Asante, not to lose sight of the fact that there are lineage stools elsewhere in Akan that have come to be accepted as the national stools. Hence the lineage stool of an Aquana clan, for example, is the national stool of Akim Abuakwa. It was the overall social and political uniqueness, expressedly the special symbol of the unity, solidarity and very being of the united Asante, which put it in a class by itself. It will be remembered that the Asante nation was prepared to be annihilated rather than surrender the stool to Governor Hodgson on the 28th day of March, 1900. Even under the British, the Asante tried and condemned to death the desecrators of the Golden Stool which was hidden in Abeabogya, a village of Asante, to escape its capture. They were, we recall, saved by the intercession of the British authority under which they found themselves after the Yaa Asantewa war of 1900. The alternative to the deaths of malcontents was banishment from Asante and the Gold Coast.

The Art of the Golden Stool

This unique Golden stool of Asante continues to be regarded as the greatest known ascedwa (stool) of Asante in particular and Ghana generally. The stool has been artistically presented in different forms apart from the form now known and seen as the ceremonial Golden stool of Asante. Rattray illustrated



The Ceremonial Golden Stool of Asante.



The Stool
against
a Hwedem.

Ceremonial Silver Stool of Mampong-Asante

in his 'Art and Religion of Asante' as a duakora type with slanting columns which link the animu (seat) with the wiabog (base). The columns swing to the points on either sides of the upward turned bits of the animu (seat) where mpua (pl.) of pua (the knobs) are usually carved on other stools. Plate Ch.V. No. R. Fig. 158 (cf. Rattray 1927 opposite p. 272).

The ceremonial Golden stool as seen today is illustrated in Plate Ch. V, P.21. (Compare Kyerematen, 1964, p. 24). This is also a duakora type of stool with an unusually scalloped edges of the animu (seat). The sekyedua is cylindrical and the wiabog (base) is circular in form. It is the largest and most elaborately decorated stool with gold and other embellishments of all the Asante-hene's ceremonial stools. We note that many of the additions of art figures on the stool tell special historical events or express particular ideas.

Huge bells and other figures like effigies are the most striking things on the stool. The big bells are called donkgaeg (big bells) and they are made of alloy, brass and copper. Additional black bells on the stool are called adomiri (black bells), which we learnt, were added by Nana Osei Tutu Opoku Ware I, who succeeded Osei Tutu. Nana Opoku Ware added other art figures. The first of these were four golden bells one of which is an effigy of Ntini Gyakari of Denkyira. The second represents Ofoosu Apenten of Akim Kotoku defeated by Osei Tutu; the third represents one Abo Kwabena defeated by Opoku Ware I, himself. Eight other bells are said to have been added in 1824. Two foot cuffs, one of copper

and the other made of gold are hooked on to the central column. Like one of the golden bells, the foot cuffs remind Asante of Ntim Gyakari. They represent the cuffs on the feet of Ntim Gyakari when he was captured in 1702. On the stool are various gold and rock beads and the scalloped edges represent the chain which binds the nation into one. The scallops are, therefore, symbolic of strength, solidarity and unity. (Informants: carvers at Ahwiaa, secretary State Council, Kumasi and the Director of the National Cultural Centre, Kumasi.)

This is an obvious difference between Rattray's illustration, which is still recognized and called the Golden Stool by Ahwiaa carvers, and the ceremonial Golden Stool which appears periodically on the Adae (state ancestral ceremonies) discussed in Chapter VI.¹ The question of which is more authentic arises and the answer is not an easy one. It will be remembered that the Golden Stool had to be taken away from Kumasi to forestall its seizure by the Colonial power round about the time of the Yaa Asantewa war of 1900. (Reference Page 95 of thesis).

Informants are not sure about the answer but it might well be that a change in form might have occurred when the stool was desecrated. Although we do not regard the question of which form of the Golden stool must have been the original one, yet resolved² it appears its present form is accepted by Asante stool elders

¹ Adae ref. Chpt. VI of thesis.

² Golden stool ref. pg. 95 *seq.*

as the most authentic. However, the form of so called stool we present in chapter VIII, which Field called a head rest, is very much like one of the old designs of the Golden stool (Field, 1940).

The difficulty of resolving the problem is made more difficult by the fact that, according to our informants, the real Golden stool is not allowed ever to be seen by anybody other than the head of the Asante King's stool carriers and some members of the Gyase stool in the King's household. The Asante King, according to tradition, never sees the stool not even during his coronation, and never sits on it. Kyerematen and other informants at Ahwias and Kumasi seem to agree that the Golden stool is like the ceremonial stool now openly seen. It is still, however, believed that there is an inside piece of the coronation stool which is secret. We have yet to find out whether the stool supposed to have never been seen is incorporated in the ceremonial stool.¹

Newer asɛsɛdwa (stools)

In the second group of Opanin Agyei's categories of stools were those he regarded as not as old as these in his first group. Other carvers think some stools in his list like the kradodwa (padlock stool) R. Fig. 180, nsebedwa (talisman stool) R. Fig. 168, ɛsonodwa (elephant stool) R. Fig. 175, pantudwa (gin bottle stool) R. Fig. 179, and ɛvatadwa (lion stool) are old designs. There is,

¹ This problem is still under investigation. The older form is still quickly recognized at Ahwias as Sikadwa Kofi - The Golden stool Kofi.

however, a consensus that the most ancient of asesedwa designs are few and they include practically all in his first group. The kotokodwaa (porcupine stool), kontokrowi (rainbow stool), the nyaanan (four legged), maadwa (female stools) and naamadwa (children's stools), were specially mentioned by all the carvers interviewed.

In spite of this observation, there are designs which are definitely new in stools. In chapter IX, the asesedwa in contemporary Ghana, diagrams of a number of stools are designated as stools of chiefs of certain towns and villages. While it is correct that there are village, town or national stools, it is not equally correct that each village, town or nation has a design over which it holds monopoly, but, as we have indicated, the kotokodwaa appears to be the type used by many lineages which found themselves or became the ruling ones in some specific communities. As we explain in that chapter, the phenomenon of all villages, towns claiming the designs in the figure 7 as their own particular ones is new. (See Fig. 7 and pp.279a-c of chapter IX). The names of miniature sample stools whose catalogue numbers are given in a collection of Dr. McPherson now in the Royal Scottish Museum in Edinburgh, are in this category.¹ In that same chapter (IX), we present the use of stools in the heraldic emblems of a number of states in Ghana. These give a further idea about newer and

¹ His spelling of towns and villages are retained in the list we give.

additional concepts in the use of stools. The significant thing is that the stool became the accepted symbol of royalty, legitimized power or authority and unity. If we should pick upon one symbol to epitomize the culture of Ghana, it could appropriately be the asgedwa.

In the following Plate Ch.V.P.22 are thirty stools. Although the designs are basically new, some of them are, nonetheless, plastic representations of old proverbs or copies of adinkra patterns. A few of them are so severally named, but our chief informant at Ahwiaa advised that we call them by the categories into which they fall. Indeed, most of these stools are similar to known stools or Adinkra designs.

[Looking from left bottom to top.]

1. Anannu - (two legged). This form is, however, new.
2. Sranedwa - (moon stool) a kind of the exact shape of the old moon stool is as in stool No.4.
3. Anansa - (three legged).
4. Sranedwa - (moon stool).
5. Epa - (hand cuffs) the law is no respecter of persons - an adinkra design No. 28 App. 13.
6. Anansa - (Three legged).
7. Nkunindwa - (victory stool). Some stools in this style were found in Ejisu and Offinso in Asante. It is named Ejisuhene stool in the Fig. 7 of Chapter IX.
8. Epa mmienu - (two handcuffs) or Nkonsonkonson - chain (both adinkra patterns. Nkonsonkonson is a symbol of unity.
9. Srane - moon stool.
10. Vframadan - House of winds. Relatively old design - Also in Rattray's list R.Fig. 184.
11. Anannu - Two legged.
12. Donno - Hour drum (adinkra pattern).
13. Ode nka anumu - (Sweetness does not remain perpetual in in a man's mouth). Symbol warning against selfishness.

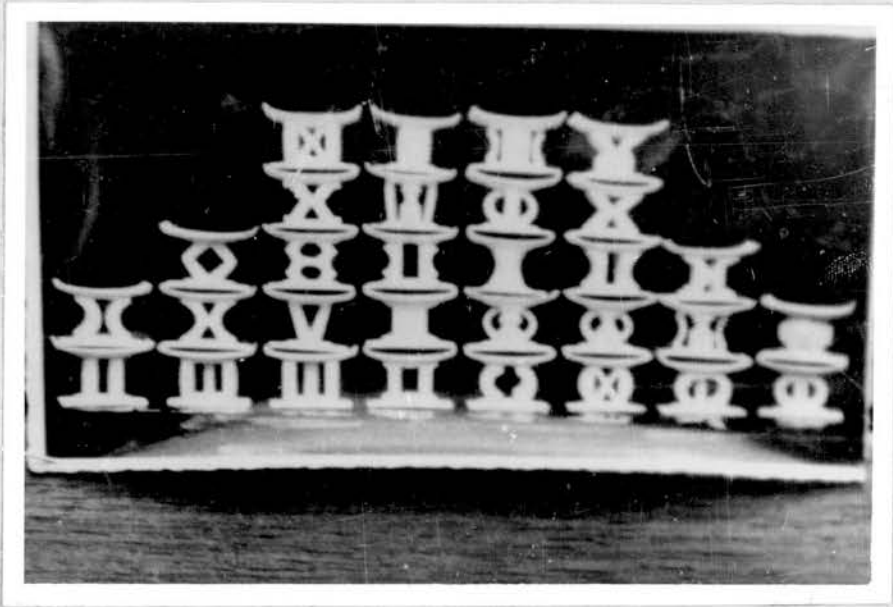

Contemporary Stools in Traditional idiom.

14. Donno (hour drum) sikadwa (Golden stool).
Chemaa adididwa (the queenmother's dining stool).
15. Duakoro - (one central support stool). It is a version of the duakoro otherwise called sakyadua koro or sekyeduakoro.
16. Kradodwa - (padlock stool). This is an old design but slightly modified. It is also an adinkra design - mra krado - lit. the lock of the law.
17. Penpamsie - (uncrushable) also an adinkra design.
18. Donno kaseg - (bit hour drum or Toa - a kind of drum).
19. Piribi wa sore - (there is something in the heavens). Also the adinkra design - symbol of hope and confidence in God.
20. Owo-foro-adoga - one of the older designs. See same design in Rattray's list and others documented in this chapter and elsewhere in the thesis.
21. Nyame nnwu na mawu - (God is immortal and so am I) or Enarimu (the crossed stool).
22. Penpamsie - same as 17.
23. Abaadaho - (there is a stick lying close by or A stick lies ready by). A new stool for the affluent.
24. S-rane - moon stool.
25. Dwagokuruwa - (the silver cup).
26. Kgotokodwa - (porcupine stool) an old design.
27. Dwagokuruwa - (silver cup) or Donno (Hour drum).
28. Aseda (thanks) a modification of the srane design.
29. Fotokodwa - porcupine stool. Old design.
30. Atuduru kwadwom - (keg of gun powder - a modification of the old design. Also called Fantomfrom (the fontomfrom drum).

We can examine the subject relating to recognizability of stools on a number of levels. First, the extent to which carvers know and recognize design and typologies; secondly, how much they know about the history and significance of the designs third how much the general public knows about stool designs, and the distinguishing features which help court officials and stool carriers to construct or remember histories associated with particular black stools.

We find the carvers of Ahwiaa, for example, know and recognize most designs by sight and by name. It was not only Opanin Agyei who was knowledgeable in the matter of stool designs when we examined this aspect of the problem of this thesis. All the carvers knew most of the basic stool types which we have presented or discussed. Only a few in Rattray's examples like Mnom stool, R.Fig. 160, Kontonkrowi (the second type R. Fig. 165) Fnanma stool, R.Fig. 167, Nsaba stool R.Fig. 168, Mefa asa R.Fig.170, Akyem stool R.Fig. 178, Nkonta stool R.Fig. 185, Animinkwa stool R. Fig. 186, and Brakante R.Fig. 187 were not readily identified by a number of the carvers. We realized that they knew of some designs which were not exactly like the named ones or the nearly identical ones but different in details. For example, Mmaa stool was called Nyaanan (four legged stool) the kontonkrowi was confused with Katokndwaa. Nsaba stool was not known at all and some of the older carvers called it a kind of apodwa (a stool symbolic of health) which was a historical stool carved for Nana Kofi Karikari of Asante. Mefa asa, R.Fig. 170, Akyem stool R.Fig.178,

Akonta stool R.Fig. 185, Animinkwa stool R.Fig. 186, and Brakante were not known, at least by the names. The name mmarima R.Fig.172, and adinkradwa were known but they were applied to other stools.

Mmarimu was applied to almost all crossed stools and adinkra to a special stool we presented in Plate Chapter V.P.20. The adinkra stool in Rattray is known as Fotoaba.

Fewer carvers still knew about the histories behind stools. One that almost everybody knew something about even though very slight in some cases, was the atuduro kwadwom R.Fig. 161, (the keg of gunpowder stool). It is remembered that the design was initiated to honour captains of war called akatskyie (the brave ones) or those whose singular contribution, especially in war, was recognized by the state or king.

The story of the coming and special place of Golden stool was generally known. We also found that the crocodile stool, (R.Fig. 162), was recognized to have been a stool found in shrines. Esono stool (elephant stool) we learnt, was regarded a great stool and was not used by ordinary people in the recent past, but who was exactly the first to hold monopoly over the design was not remembered. Many guessed rightly that the Pantu stool, (Gin bottle stool), might have been contrived during the early colonial era of Asante trade with the white settlers of the Gold Coast. Asante people give high place to this stool because gin came, and continues, to be one of the highly ranked drinks for pouring libation to ancestors.

Older carvers like Opanin Agyei, Opanin Opoku, a seventy year old informant, and especially the nearly ninety year old chief of Ahwiaa were those who could tell the histories of many of the stool designs. They grant that the sakyiduakoro (one central support) type of stool was known to have been used by priests but deny that it was solely a priestly stool as Rattray indicated. (See his illustration of stool - R. Fig. 166).

Kontokrowi stool R. Fig. 164, was held to be an old design of the Asante court meant to remind all the chiefs and people of Asante of the ~~supremacy~~ *supremacy* right of everyone, and the need for participation in political process of the nation. Mefa asa R. Fig. 170 was a design contrived by a chief of Offinso to mourn the death of several of his royals after a battle in which many of them fell. Wasaw stool was ordered and presented to a Wasaw chief by an Asantehene as a symbol of his friendship and investment of power in him. The Wasaw chief was then a helpful middleman in the trade with Europeans on the Western Coast of the Gold Coast. Ahwiaa carvers generally know that the design of Akyem stool R. Fig. 178, has Akyem origin but how exactly it came into Asante is unknown. Qseba stool R. Fig. 176, is believed to be a design for the ruling lineage of Mampong Asante whose clan is the Bretuo. However some other Asante chiefs of old used stools of that design. The kotoko stool could be rightly regarded as the design which holds pride of place in Asante history. The proud appellation of the Asante nation is 'Asante Kotoko, wokua apem a apem baba', (Asante porcupine, if you kill a thousand, a thousand will appear). This refers to their bravery, prowess and fearlessness in war.

We have already indicated that the older generations of Asante public know more about types of designs and their meanings than the younger generation. Recent cultural revivalism, however, has improved the situation but ordinary people's knowledge about the traditional designs is comparatively still small.

Since stool designs are widely known and recognised among carvers in Ahwiaa, however, they are able to carve for their customers the stools they name. If, however, there are further details that are desired, these are particularised. For example, a customer may ask for a female bridal stool. This additional information helps the carver to decide on the approximate size of the stool. A customer may yet desire that the stool should be bigger than the ordinary.

As to how much is known about ordinary and sacred stools by carriers, we record that the degree of knowledgeability is high especially in Asante and Akim. For example our stool carrier informants in Mampong Asante had no difficulty at all to identifying all the designs or diagrams that we examined with them. The old carriers were strikingly proficient. All were relatively old and it is difficult to guess what the situation is likely to be in a few year's time. We realised, however, that some few young people understudy them but they are unable to give full time to the study because of their commitment to school formal education.¹

¹ A situation arose recently when a chief sent a messenger down to Professor Nketia to give him a copy of his notes on drum language and appellations which he collected when he was doing his research in this field several years ago. His old drummer friend happened to be blind now and worn down by age and disease and no one knows even a fraction of what he knew.

Stool keepers, however, tell the histories of chiefs and eras more through association of ideas than reading of naturalistic or abstract symbols in the stools. Nevertheless, there are specific general elements like proverbs originating from particular chiefs or designs regarded as personal designs which help in the identification of the stools e.g. Refer to Nyansapɔ (Plate Ch.V.P.12 and Apodwa, Plate Ch.V.P.10).

It is worth remarking, anyway, that there are fine points about very senior kinds of stools besides their general design which we have not yet been able to get even from the greatest stool carvers of Asante. It is, at present, impossible to say whether or not chiefs of stool carvers know all these fine points since there is the traditional ban on divulging all that is known about such stools to people outside the stool carrying fraternity of any particular chiefdom. Whatever is the case, stool carriers appear to know a lot about the stools and the houses in which they serve and they continue to be an important source of stool histories.

Symbolism in stools presented to Heads of States in 1961 and 1962 and their significance.

In 1961, a number of stools, kentes, sandals and other regalia were presented to a number of heads of states visiting Ghana. Among them were Presidents: Josip Bros Tite of Yugoslavia, Istvan Bobi of Hungary, Wladyslaw Gomulka of Poland, President Soekarne of Indonesia, Breshnev of Union Socialist Soviet Russia, Anonin Novotny of Czechoslovakia, Her Majesty

Queen Elizabeth II of England and her son Prince Charles.

Most of the designing work on the gift stools was done by the late Kofi Antubam¹, one of the most eminent modern sculptors of Ghana, who carved mostly in the traditional style or idiom. Some of his most outstanding works in the city of Accra are in the Community Centre, the Ambassador and Continental hotels.

Kofi Antubam used in his designs for the gift stools a number of Ghanaian proverbial symbols, some of which appear on senior royal stools in Ghana. They include the skosan, a symbol of reincarnation, gdgfe awaamu symbolizing the warmth of Ghanaian traditional embrace, awebo fodwe symbolic of prosperity resulting from friendliness, and @baa-asobon symbolizing the keen sense of a woman's hearing in relation to her child. By extension, this also symbolizes keen sense of hearing of the leaders of states and justice. Plate Ch.V.P.23 shows the stool which was donated to President Josip Tito of Yugoslavia in 1961. The stool represents the soul of the society -- omankra. The total design of the stool is Baako-ntena (one does not live alone). That is, man is not created to live alone in isolation. He realizes himself and prospers when he shares his life and bears the burden of life in association with others. The entire stool is gilded. The seat of the stool has

¹ Some of Kofi Antubam's masterpieces in Accra may be seen in Parliament House, the Community Centre, and Continental Hotel. He was born on the 14th of April, 1922, educated in Achimota School and Goldsmith College. He died on the 4th of April, 1964 while he was at his post as Senior Art Master of Achimota School.

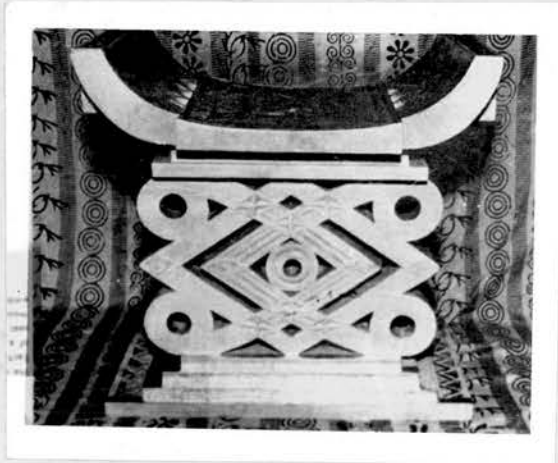

YUGOSLAVIA
President Josip Tito.

BAAKO-NTENA STOOL

The Stool - Adua. Oman-kraa (the soul of society.)
It is presented now to symbolize the warmth of Ghana's national welcome and the memories of it. This symbol is called Baako-ntena, which means One does not live alone. In other words, Man prospers best only when he bears the burden of life in association with others.

Antubam 1961.

(cont'd)

YUGOSLAVIA

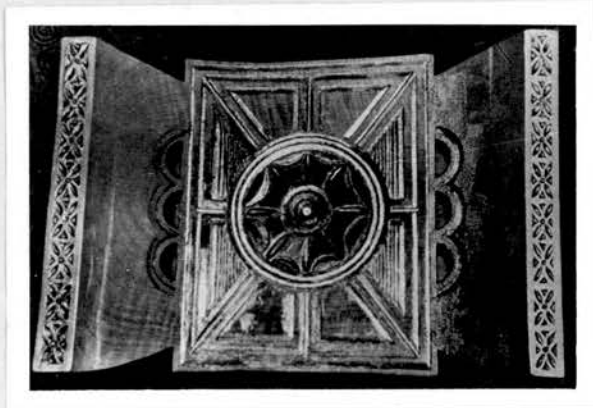

Top



Middle

Page

the traditional form but it is more concave and the ends turn upwards more sharply. They are bigger than any ordinary asasadwa. The half moon shape of the seat is meant to indicate the warmth of a good mother's embrace. At the same time, some informants liken it to the moon whose consort, the star kygkyg, is. In other words, the form represents to them the strength of a man and the ready or available care of a devoted man or good husband towards his wife.

It is, as we have seen, the central portion of a stool that normally bears the design and name of a stool. Hence, the middle design is called Baako-nntena and the name of the stool is also Baako-nntena (Man is not meant to live alone).

Looking at the stool from the top, the decoration seen in the centre of the seat is gdqfo awaamu. This also symbolises the warmth of sincerity of a sincere friend's embrace. On either side of this symbol are crescent moon shaped holes known as gbaa-asobgn (the holes in the ear of a woman). This refers to special holes pierced in most Ghanaian women's ears to hold their ear-rings. They symbolise the delicate sensibility of a woman's hearing. The significance of this lies in the fact that heads of communities have to hear the cry of their subjects. They are obliged to hear, feel and minister to their subjects even as women should pay attention to their infant children. On the surface of either end of the crescent-shaped, moon seat is a frieze of a Ghanaian motif called krapa (good soul), symbolising sanctity and good fortune.

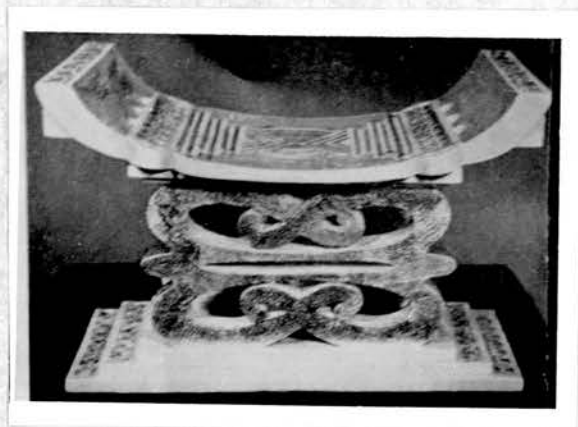

HUNGARY

President Istan Bobi

HYE-WO-HO-NNHYE STOOL.

The Stool

Agua, a stool in Ghanaian traditional life symbolizes Oman-kraa, the soul of society. It is presented now to symbolize the warmth of the bond of friendship between Hungary and Ghana. There are many Ghanaian traditional stool designs and this particular one is called Okye or Hye-wo-ho-nnhye, symbol of immortality. The stool which is covered with pure gold leaf, is made up of three main parts, namely, the seat, the central portion and the three-stepped base. The seat is Oseramfa, a crescent moon, symbolizing the warmth of a mother's embrace.

Antubam 1961.

HUNGARY



Top

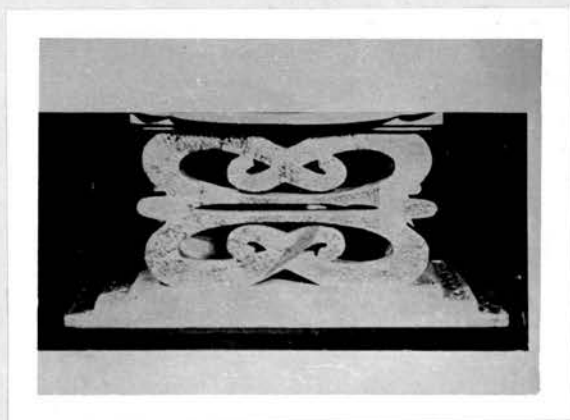

Middle



Side

He who sits on the 'throne' is expected to have good luck and this wish is expressed in plastic language as well as instructionalised gift and service giving during specified festival like the first fruit and adae (remembrance of the dead kings.) At this time, as we further explain in chapter VII, the chiefs receive expressions of goodwill in prayers, praise songs and utterances mostly in proverbial language. The kings, they say, deserve thanks and life - Ahene sg ayeyi ne nkwa. On both the legs and on the bottom slab of the base is a frieze of a motif called awa-ko-foro-adoba (the snake goes to climb a raffia palm tree.) This symbolises the exercise of prudence which is most essential for rulers.

The stool in plate Ch.V.P.24 was given to President Istvan Bobi of Hungary. The stool is called hve-wo-ho-nnhye (lit. burn you but without success). This is a symbol of immortality. The stool takes its name after the design in the central portion of the stool - hve-wo-ho-nnhye.

Viewed from the side, the two bottom slabs of the base bear on each one, a frieze of a motif called awa-ko-foro-adoba.

The seat is crescent moon shaped and bears a centre design known as Akosan - a symbol of reincarnation. It is at the same time a symbol of welcome. On either side of this design are crescent moon-shaped holes -- qbaa asobgn. On the surface of either end of the seat is a frieze of motif called nkotonoe - a symbol of life stream.

The stool in plate Ch.V.P.25 was a gift to President Wladyslaw Gumulka of Poland. Like the others the stool as a whole symbolises

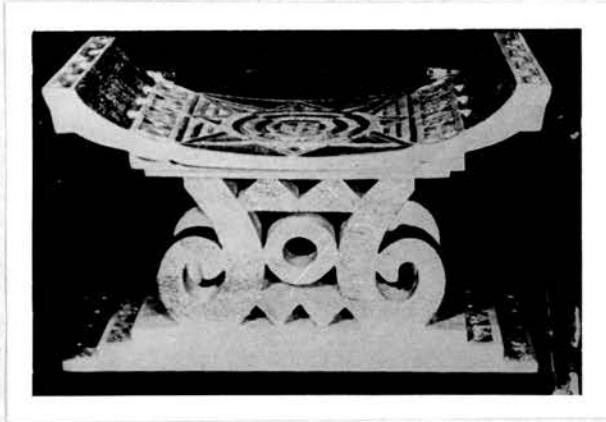

POLAND

President Wladyslaw Gumilka.

DWANTIRE STOOL

The Stool

Agua, symbolizes Oman-kraa, the soul of society. It is presented now to symbolize the warmth of the bond of friendship which exists between Poland and Ghana. This symbol is called Dwantire, symbol of guiltlessness. The stool is covered with pure gold leaf.

Antubam 1961

omankra - the soul of the society. It was presented to symbolize the warmth of friendship which existed between Poland and Ghana.

The name of the design in the central part of the stool is dwantire - (ram's head) and the stool takes its name after the design in this section. Kofi Antubam gives the meaning of the design as guiltlessness but it is also regarded as a symbol of wisdom and holding truth as a sacred thing.

The top of the seat bears, at the centre, a decoration called Abamban fodow - the symbol of great prosperity and glory. On either side of the symbol are three crescent-shaped holes called gbaa-asobon - which we have been described above. On the surface of either end of the seat is a frieze of a motif known as pkotoma - symbol of kind-heartedness.

The symbol in the central part of the stool in plate Ch.V. P. 26 Adwoe (peace), and the stool is called adwoedwa (the peace stool).

Looked at from the top, the central decoration it bears is Awebo-fodow which is a symbol of prosperity - resulting from friendly association. On either side of this symbol are three crescent moon shaped holes - gbaa-asobon which is explained above. We find on either end of the crescent moon-shaped seat a frieze of Ghanaian motif - krapa which symbolizes sanctity and good fortune.

On the side of the middle section is gwq-kg-foro-adobg (the snake goes to climb the raffia palm tree) the meaning of which symbolism has been given.

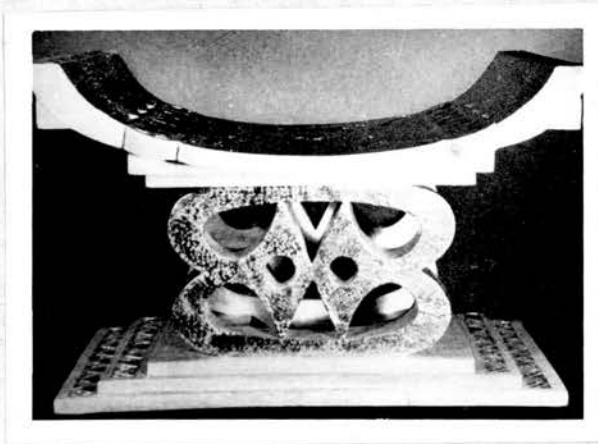

INDONESIA
President Soekarno

ADWOEDWA STOOL

The Stool

Agua, Oman-kraa, the soul of society. It is presented now to symbolize the warmth of Ghana's national welcome and the memories of it. There are many traditional stool designs and this particular one is called Adwoedwa, stool of peace. The stool is covered with pure gold leaf.

Antubam 1961 .

INDONESIA



Top



Middle

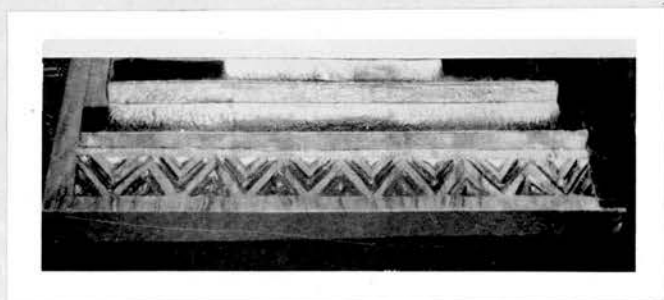

Base

The Bambasa (three stepped base) symbolises esom ne siare - meaning success as a result of readiness to bear one's fair share of the burden of life.

This particular stool described above was presented to President Soekarno of Indonesia.

In plate Ch.V.P.27 is a picture of another stool which was donated and this went to President L.G.Brezhnev of Union Socialist Soviet of Russia. The stool is called Qdofe nyera kwan (a friend does not miss his way). It is, according to Kofi Antubam, a symbol of welcome and friendliness.

The top symbol Fodobere is regarded as a symbol of righteousness and prosperity. On either side of the crescent moon-shaped holes are Qbaa-asobgn explained. On the surface of either end of the seat is the frieze nkyedene - a symbol of steadfastness.

Viewed from the side the two bottom slabs of the base each bears a frieze of motif called nkotosare - symbolizing the idea of falling only to give rise again to survival of suppressed good qualities and ideas (Antubam 1961).

The surface of the side handle of the seat bears a decoration based on the motif awg-ka-foro-adoba: (snake goes to climb raffia palm tree.)

Plate Ch.V.P.28 gives an idea of the kind of asgsadwa which was presented to another Eastern head of state - President Anonin Novotny of Czechoslovakia. The design of the central section siaredwa gives the stool its name. The top has a central decoration traditionally called kratene (good soul). On either



RUSSIA

President L.B.Brezhnev.

Qdfo nmyera kwan Stool.

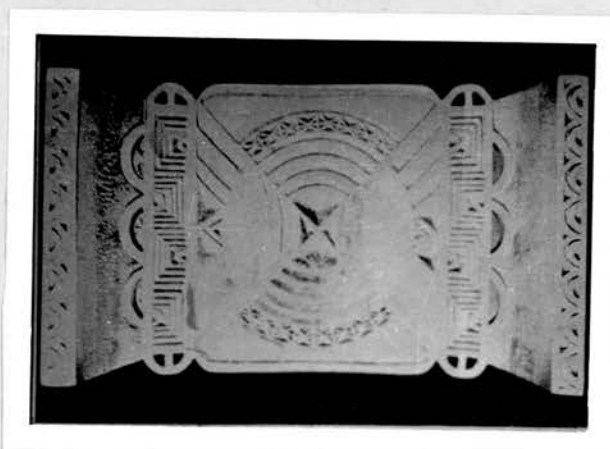

Top of Stool.

RUSSIA

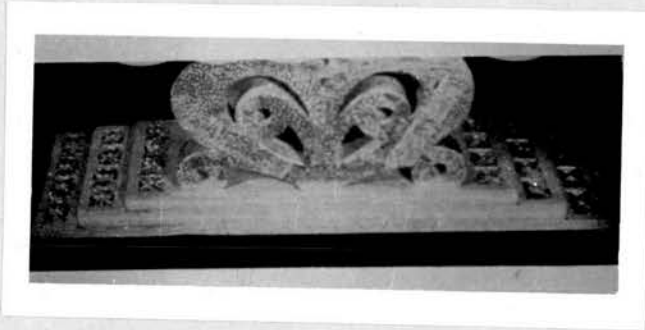

Middle of Stool.



Side view.

PLATE CHAPTER V. P28

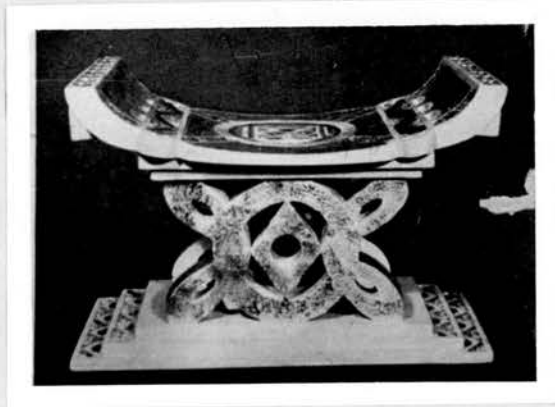

SIAREDWA.

CZECHOSLOVAKIA
President
Anonin Novotny.

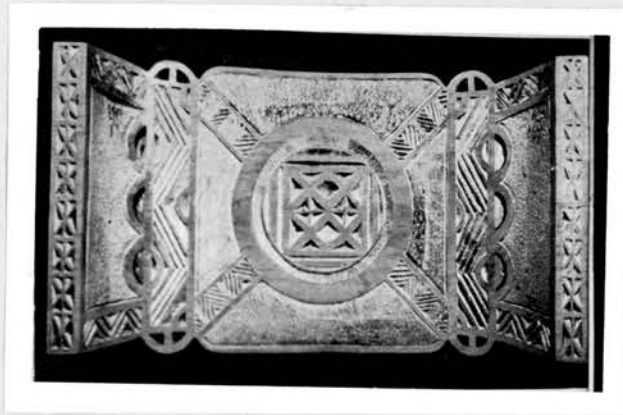

Top.

CZECHOSLOVAKIA.

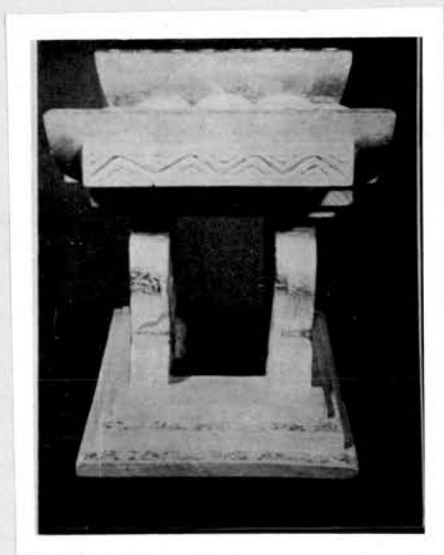

Side.

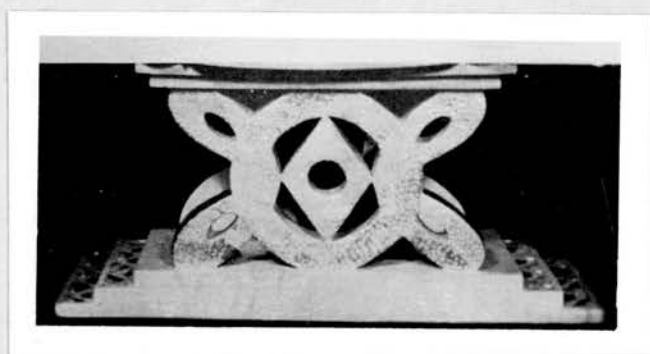

Middle.

side of this symbol are three crescent moon shaped holes - the gbaa-asobgn. On the surface of either end of the seat is a frieze of a motif called ndondowa - a symbol of benevolence.

The wiabog is three stepped and on the last two is a frieze of a motif called nkotosgre - symbolizing unsuppressability of a good man's soul. On the surface of the side handles of the seat bear the decoration of the motif gwq-kg-foro-adobg.

Siradedwa was meant to bring to the recipient a lot of good luck or at least, it was meant to remind the receiver of the stool that great things are expected to be accomplished by him through good luck.

Her Excellency, the Queen of Britain, Elizabeth II, received a stool with the same name and pattern as the Russian head. The difference lay in the size and other motifs on the seat. The stool was, therefore, the gdgfe nnyera kwan. The full title of Queen Elizabeth's stool was gdofe nnyera afikwan (a well wisher cannot miss his way home.) Plate Ch. V., P29.

The top of this stool bears a central decoration sgdeg mentenna - symbol of the ideal living together with others in happiness. Around this is a circle linking two triangles to form Ahokeram - symbol of the quickening power of life. Bordering this on either side is a band of zigzag motif gwq-kg-foro-adobg. Next to the bands are the three crescent moon-shaped seat a frieze of krapa mmusuyidie (a symbol of good fortune or God's blessing.) The base is also three stepped - and symbolises gsom ne siare meaning success as a result of readiness to bear



Her Majesty
Queen Elizabeth II.

QDQFO NNYERA KWAN.



Top.



Middle.

a fair share of life in one's society (Aantubam 1962).

At the same time as Queen Elizabeth was presented with the adgfo-nyera-kwan stool, her son, Prince Charles, the heir apparent to the throne was given another stool called nkgnsnkgnsn (chain). In plate Ch. V.P.30 is a picture of this particular stool. It is one of the adinkra patterns which is met in stool designs. His stool is meant to signify the chain of 'kinship' which will continue to link Ghana and Britain.

All the stools were richly gilded - gold being one of the most prized metals for decorating the stool of the most supreme king in Ghanaian history - and were given away together with other gifts like kentes, golden Ghanaian wrist and finger rings, sandals, and ear-rings, neck-laces for the wives of the presidents and for the queen of Britain. Ghanaian motifs were also carved on paper knives, recorder or radio chests or boxes which accompanied the gifts. In the gifts, therefore, were presented summaries of the culture and the sentiments of the donors towards the recipients and in each case, the stool was the centre of all the items of gifts.

Other royal stools also called nwa or ndwa.

In the description of the items of regalia that were displayed at one particular Adae (ceremony of honouring the ancestors) in chapter IV, a number of seats other than the asagdwa were mentioned. The list included the asipim, naamu, akonkromfi, and hwedom. Kyerematen has suggested that the original form of the

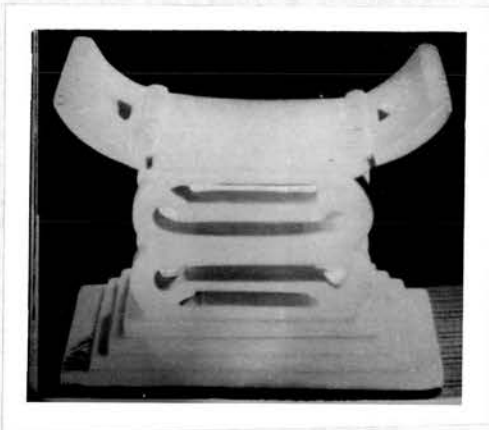

PRINCE CHARLES OF BRITAIN.

NKONSONKONSON STOOL.

asipim Plate Ch. V.P.31 1 & 2 derived from an indigenous cane chair called the apentennwa or akentennwa.¹ This kind of chair had a framework of wood or cane and the seat which was woven into chequers. He states that the cane seat was superseded by antelope hide which material was also used as membrane for drums and scabbard for some state swords. Instead of strings and cane, brass nails were used to keep the skin in place after it had been spread on the seat and back of the asipim chair. The new chair derived its name from the stableness of its equilibrium. Osa ho pia (it stands firm or stably.) Two kinds of brass nails are usually used on asipim chairs. They are the ankaahono (the covering of lemon) and mpeaboa which is so called because it has the form of one of the weights used for weighing gold dust in the past. (cf. Kyeremateng, 1964 p. 26.)

Other types of the asipim referred to by Kyerematen are asipintia (short asipim), asipim tenten (high asipim).

Naamu or akonkromfi chairs have indeed developed from the asipim as Kyerematen observes. He further describes them thus:

"Smaller round-headed nails in bands of several lines, and elaborate repousse metal work were used to adorn the main body of the chair. These were mostly in brass, but silver was used by those entitled to do so. In some cases the back of the chair had embossed circular patterns, like those found on the seat of

¹His spelling. Note that this spelling has also been given in the glossary at the end of Chapter 1.

ASIPIM & AKONKROMFI STOOLS.



A
Cultural Centre
Kumasi.

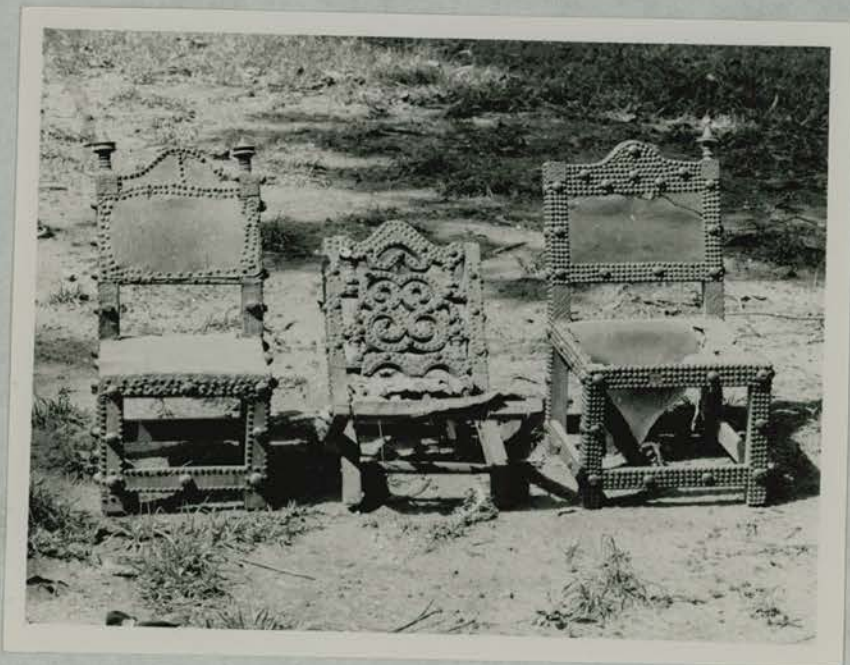

B
(I.A.S. MUSEUM)



I.A.S. MUSEUM.

NAAMU STOOL otherwise called HWEDOM.

ornamented stools, and triangles, sometimes enhanced by hachures or hatching". (Kyerematen, 1964).

In Plate Ch.V.P.32 is a naamu in the ethnographic room of the Institute of African Studies, University of Ghana. The back of the 49" tall stool is traditional proverbial design. Central to the design is the dwanimen or dwantire (ram's head) a symbol of wisdom, valor and devotedness to work. Most naamu have arm rests which may be straight or carved to look like knots. In each case the arm rests are also covered with brass or silver nails in meaningful patterns.

Hwedom or Hwedomtea chairs are chairs like the chair we have just described. We have indicated that whilst some of our informants translate hwedom to mean 'face the enemy' others think it means 'beat the enemy'. Others give the meaning as 'face the crowd or people'. Essentially, all the translations are valid. The hwedom has been usually the chair on which chiefs sat to hold arbitrations or when they were in state during functions. As they sat on the chair, they faced the crowd - their people. In war, a chief sat on a hwedom chair at the back of his combatting forces and looked towards the direction of the enemy. In battle however, it was often the stool of the nation which was rested on such a chair to act as a force emboldening the armies to victory. It is believed that the original function of the first hwedom was to serve as the 'seat' for the Golden stool since Okofo⁽¹⁾ Anokye decreed that it should never be placed on the ground under ordinary circumstances. Some of the chiefs, now called paramount chiefs among the Akan in Ghana, have



Chair of State belonging to the last Dutch Governor of Gold Coast. Handed over to the British Government in 1872. By the kind permission of the Keeper - Ethnography.

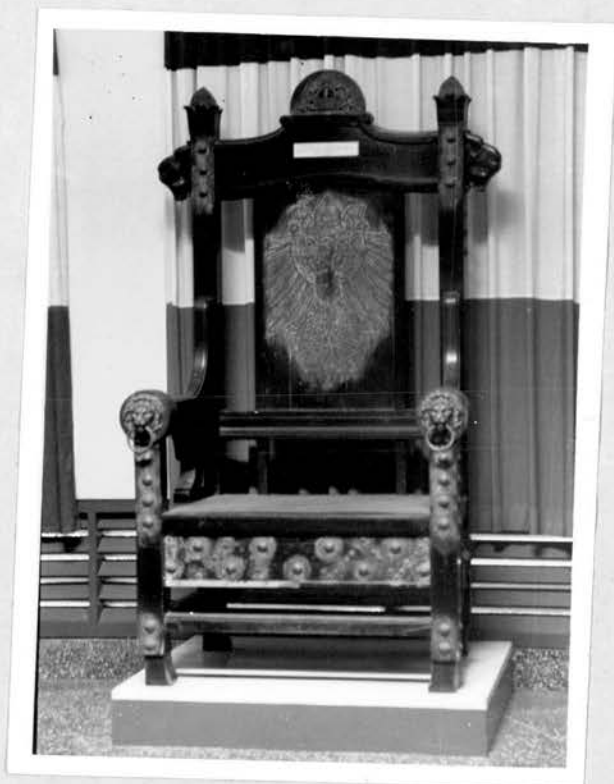

Chair of State of the last Governor of
Togoland taken over and placed in Christiansborg
Castle, Accra during the 1914 - 18 War. By the
kind permission of the keeper - Ethnography.

their coronation stools resting on hwedoms.

There is a significant similarity on the style of the hwedom chair and some of the state chairs used by the Dutch and Danish Governors of the Gold Coast. The examples in plates Ch. V.P.33 and Ch.V.P.34 are in the National Museum of Ghana, Accra. Suggestions have been made that the style of hwedom chair is actually a copy of the style of such foreign chairs.

The suggestion is reasonable although it is essential to seek more evidence on this to be able to make a conclusive declaration. The interesting thing about some of these high hwedoms is the intricate traditional motifs on them.

CHAPTER VI

AKAN 'STOOLS' AND ANCESTRAL REVERENCE

Ahemwa - the chiefly stool is that to which people's minds usually turn when akomwa (stool) is mentioned in Ghana because the object and idea of the chiefly stools have relegated all other asesedwa in the culture to the background. Ordinarily, it is the ceremonial stools, but especially, the black or ancestral stools that are given the greatest attention and reverence.

As we have seen, the Akan social system takes off from the lineage and the indigenous political organization is largely based on it. The various levels of chiefs derive their authority from the fact that they sit on or occupy specific lineage stools which have specific political eminence and represent discrete collectivities. That is, the stools symbolize the solidarity and being of the communities. They provide the shrines or foci for contact with the ancestors.

Each chief or person, who becomes entitled to a black stool after his death, adds a stool to the original ancestral stool of a community. In a sense, as we have noticed, such additions are complementary to, or form extensions of the original stool. In any one political community, therefore, there is a hierarchy black stools which support the political hierarchy of territorial and lineage offices.

It is believed that the black stools of any supreme chief in Akan symbolically contain all others and they help through the ceremonies in which they are involved, to re-act-

vate social and renew the well-being of communities.

Among the principal ceremonies involving the stools, are the Adae and the Odwira.

There are two Adaes. They are the Wednesday and the Sunday Adae, respectively called the Awukudae and the Akwasidae. On these days, the ancestors are remembered and given reverence in rituals.

Eminent ethnographers like Rattray and Busia - and indeed, almost all who discuss these ceremonies, do so under the topic of religion. Rattray indicated that the purport of the ceremonies is the propitiation of the spirits of the departed rulers of the clans. The names of the past rulers are mentioned and their deeds recalled. Then favours and mercy are solicited from them. Sentiments of reverence, awe and oneness with the departed section of chiefs and people are kept alive in the ceremonies. The following, from Busia, is a fair summary of the manifest content of the Adae and the Odwira.

'... At the Adae ceremonies the departed rulers are recalled, food and drinks offered to them, and their favours are solicited for the welfare of the tribe. An Adae occurs every twenty-one days, known alternatively as Kwasidae or (Adae Kese) and Wukudae. The former the Great Adae, falls on Sundays and the latter on Wednesdays, so that there are six weeks between one great Adae (Kwasidae or Adae Kese) and the succeeding Great Adae and six weeks between little Adae (Wukudae) and the next little Adae. So every third week, on the Adae day, whether it is a Great Adae or a little Adae, an Ashanti chief officiates before the ancestral stools and prays to his ancestors on behalf of the tribe, asking that the earth may be fruitful, that the tribe may prosper and increase in numbers. (Busia, African worlds, ed, Daryll Forde, p. 202).

The Awukudae

The Awukudae is everywhere in Akan regarded as the smaller Adae. The details of ceremonies that take place differ from place to place but the essentials, as regards the stool in ritual, are almost identical everywhere in Akan. The preceding day of the Wednesday is called Adana or Danaada - good day. On this day preparations for the celebrations and rituals of the next day are ostensibly made. Food, wine, water, fireweed, are all collected. Such preparations are also necessary for the ordinary citizens, for Adae days are compulsory holidays.

The state drums like the Atumpan, Fontomfrom, Mrebi and Nkawiri, Kete, Mpintin, Aperede, and others are assembled. The Asokwafo - court horners and musicians - gather to hold vigil for the next day.

The most important servants of the court on such occasions are the stool carriers and the Kwadwomfo (minstrels) mentioned earlier. The ceremonial white stools are normally washed on the Awukudae and in Mampong-Asante and Akropong Akuapim, we saw some 'white stool washing' - Plate Chapter VI.P.1, 1 & 2. The white stools were scrubbed with sand in scrubbing sponges. The sand was a special sand collected from the principal river of Akropong. As they washed the stools, they put the leaves of a plant called gumme across the gate of the yard. This signified that no one who was not qualified Shuid enter.

In addition to the washing of white stools, the black stools are, as a rule, visited and fed on the Awukudae day.

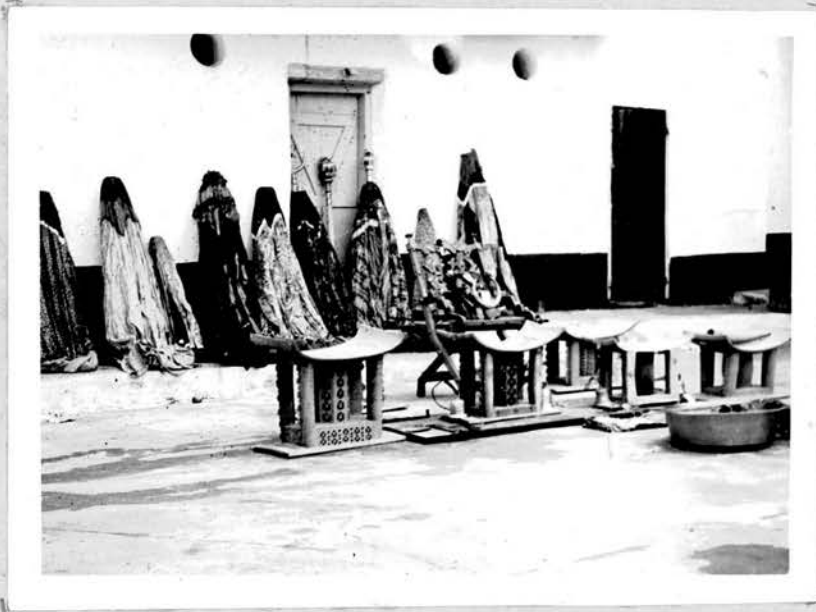

1

Regalia at a stool washing ceremony at Akropong.



2

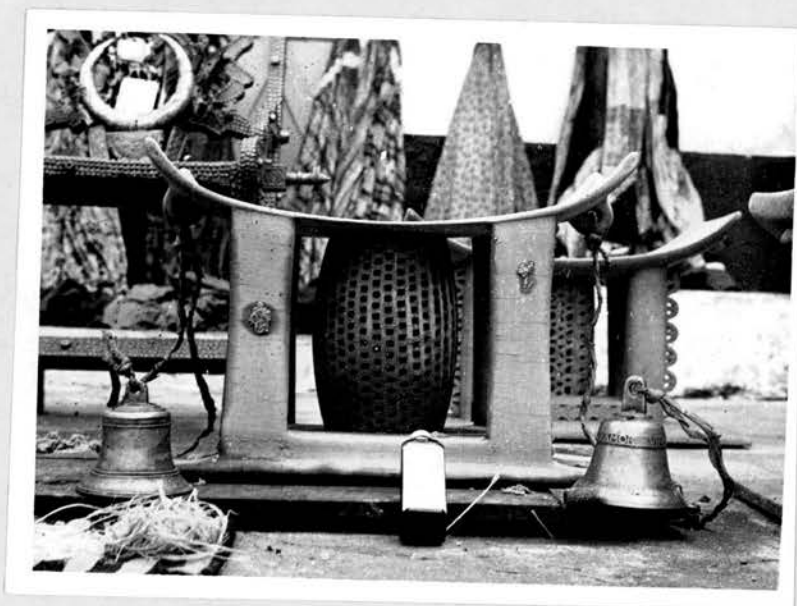

Some more stools of the paramount chief of Akropong Akuapim seen at an Awukudae. The symbol in the middle were described as Esono (elephant) or Odum (a kind of cedar)

The chief stool carrier opens the door for a group which consists of the chief, an okyeame or akyeame (linguist), an osen (a herald) stool bearers and carriers, and select members of the chief's council. The dress for the chief and his party is the mourning cloth called kuntunkuri. At the door the chief and his party slip off their sandals in reverence. Then they bow as they enter with their cloths lowered from their shoulders. The chief says 'Nananom nsamanfo, no-somfo ma no akye ool' (Good morning to you the spirits of my grandfathers, your servant greets you.) Then they stand before the covered stools. While their eyes are fixed on the stools, the head stool carrier uncovers them. He receives water from one of the stool carriers and pours it into a jar. In Kibi the jars are many. (Kyerematen illustrates them in the Panoply of Ghana, page 19.) The head stool carrier then walks back to the door of the stool house where he pours water from a jar to the ground saying: Nananom, mongye nsu nhoho monsa. (Grand fathers, take this water and wash your hands.)¹

At this point, mashed plantain or yam is brought into the room by a sodofo (male cook) of the chief. Receiving the bowl of mashed stuff, from the sodofo, the head of the stool carriers hands it over to the chief. In Mampong, the chief is given, to begin with, only a ladle full of the mashed plantain

¹Informants, Kibi and Mampong Asante. See also Rattray Ashanti 1923. Chapter V.

or yam, and he reverently goes from stool to stool, beginning from the oldest stool saying

'Nananom, me nananom nsamanfo, nna ya Awukudae,
Mommegye eto nni, na moma kuro yi nye yiye, na mo mma
mmaa nwo mma, na nnipa a awa kuro yi mu nyinaa nya sika!

The spirits of my grandfathers, today is a Wednesday Ada. Come, receive and eat this mashed stuff. I pray that you prosper this town. Let women be fertile and let them give birth to children. I pray, let affluence be the lot of all who live in this place.

As he speaks, the herald punctuates his sentence by the cry, Tie! Tie! Tie! (Hear! Hear! Hear!) The rest of the mashed yam or plantain is sprinkled on the floor of the stool house and outside it for the remembrance of the spirits of the dead and past stool carriers.

This is followed by the offering of a sheep to the stools. The sheep is held by the fore and hind legs and the chief again reverently offers it to the stools to the ancestors. He slits open its throat with a short knife, called kuroto. A few drops of the blood are allowed to drop on the floor of the house. The rest of the blood is received in a wooden bowl (kurowa) and the carcass of the sheep is carried out of the stool house to the sodofo (cooks). With the blood collected in the kurowa, the stool carriers smear the animu (face) and atiko (edges) of the stools using their hands as brushes. We are told that the omentum mentioned in Rattray's account of the Awukudae. (Rattray, (1923) p. 97) are still put on the sekyedua of each stool. The sheep is cut up, threaded (sina) on small skewers (mfofo) and roasted over hot coals of fire. Then they are returned to the

stool room. On each of the stools, some roasted meat on skewers is placed by the chief. As he goes from stool to stool, he reverently says Wonam ni, wosomfoo sre wo, gye na we. (This is your meat, please accept it and eat) [Compare with Rattray (1923) p. 97.]

In effect, both cooked and raw meat is offered, since the head and pieces of the sacrificed ram are also laid before the stools even before the roasted meat is ready.

The final libation with rum follows. While in Kibi and Mampong it is the chief or the head of the stool carriers who may pour this libation, an okyeame (linguist) could do this in some other Akan communities like Akropong and Winneba. The chief again goes to the stools one after another dropping some rum on each stool beginning from the oldest to the newest.

The chief's party retires and the rest of the meat is eaten by the servants of the court comprising, the stool carriers, horn-players, drummers, and others. The remaining hours till dusk are spent in gift giving, drink parties and reflection.

In parts of Akan, as Sarpong observes, the chief himself does not take part in the stool ceremonies in the stool room. He may sit in the open yard of his palace where stool bearers are said to convey the stools. We did not come upon any of such practices in our research, but the chief of Winneba, in Affutu Ghana, told us that he does not take part in the stool room festivals.

Awukudae are not usually followed by state durbars - these

gatherings where the chief sits in state to receive homage from his subjects. Our information and experience is that there could be some minor state functions. Sarpong (1967) actually records that occasionally, some Awukudae in Asante are rounded off by the chiefs sitting in state and receiving homage from the people of the village or town. At such moments, the Kwadwomfoo who will be mentioned again in the Sunday Adae, remind the chief of the attributes of each of the very illustrious chiefs of blessed memory. They are sad but challenging moments.

Akwasidae

Everywhere in Akan, the Akwasidae is more elaborate than the Awukudae. The Akwasidae has a public side of the celebrations which tend even to overshadow the other events of the occasion. The esoteric rites in the stool room are very similar to those of the Awukudae. Mausoleums are visited, where they exist. The period of Akwasidae is particularly a time for renewing solidarities and it is not unusual for people to go back to their own 'tribal areas' for this occasion. In Kibi, the ninth Akwasidae is called the Odwira or Odwera. Odwira involves purification of the stools and the whole state. The last Odwira in Kumasi, described by Bowdich (See Rattray, 1927, ch. XII) was in 1896. A number of chiefdoms in Asante, however, continue to celebrate the Odwira. Busia describes a Wenchi Odwira which is, of course, not very different from an Akwasidae. (Busia, 1958, pp. 27 - 35).

A Saturday is the adana or danaada, in the case of an Akwasidae. An Akwasidae we saw at Mampong in Asante in 1967 is

typical of the Akan Akwasi. Early in the morning, pots of water were carried towards the palace. The grounds of the palace were 'cooled'. Water was overturned onto the ceremonial grounds in front of the palace to symbolize the tranquility and peace that should necessarily be in the hearts of all who came to the grand public meeting of the Adae.

The akyerema drummers of the talking drums heralded in the day with proverbial and set themes saying:

Akokg sgre bon angpa hemahemahema The cock is up early and crows early, early, early.

Obonanopa hemahema hemahema It crows early, early early.

They went on to tell people the business of the day and reminded them of the thanks they owed to God and the earth He created to give them sustenance.

Esoro tre tre tre tre!	The heavens are great (wide)
Asase tre tre tre tre !	The earth is wide wide wide.
Yekukuru ako, yekukuru aba.	We lift it away and lift back we trudge along)
Tetetete, tetetete!	From time immemorial
Kwaadwaa Tweadeampong Nyame,	The dependable God
Otweadeampong Nyame se	The dependable God
Okyere mo asem bi a momma yenni so;	Bids us go by His word
Na yepe fufue a yeanya.	in order to grow old (get good luck)
Tetetete, tetetete!	From time immemorial
Kwakwaa Tweadeampong Nyame,	Great great dependable God
Oboo Nyame akuruntq.	The creator God, who is the rock to man

Onyame makye, Okesee.

Good morning to you God,
the great.

Akoko bon anpa

The cock crows early at dawn

Akoko tua bon anpa

The cock crows at dawn

Akoko tua bon nhemahemama

The cock crows early at dawn.

Meresua monna menhu

I am learning, let me know.

(Text: J.H. Nketia. I.A.S.No.01/44. Translated by author.)

Asase damirifua!

Earth condolences

Asase damirifua!

Earth condolences

Asase boe mfuturu kyerebiampam

Earth and dust (kyere bi ampam)

Ntikumakuma na ekum adakwabie

Ntikuma killed(adakwabie)

Asase mete ase mesom wo

While I live, I depend on you

Asase merebewu a mesom wo

When I die I depend on you

Asase a odi enu

The earth that keeps dead bodies

Asase Amponyinamoa

The earth (Amponyinamoa)

Amponyinamoa akuronto

Dependable (Amponyinamoa)

Asase makye o, makye Okese

Good morning earth, good morning
great ones.

Akoko bon anpa hemahema

The cock crows early at dawn

Meresua monna menhu

I am learning, let me know

Meresua monna menhu

I am learning, let me know

(J.H.N. IAS No. 40. See also Busia 1958, p.41).

Except for brief periods when the drummers are entertained to drinks, they continued to tell the history and remind people of the values of the community.

In the yard of the palace the ceremonial white stools were washed and lime juice was squeezed into the stools. These stools were dried for the afternoon ceremonies. (See Ch.VI¹ & 2).

In the dark Kuntunkuri the royal mausoleum was visited later in the day and there the chief paid his final respects to the stools. There was a grand public meeting after this. Mamponghe sat in state and received his chiefs. It was his first Akwasiadae and he made a public statement of what his policies were going to be.

Odwira

In Akuapim, Akwamu, and Akim, the Odwira is a general cleansing ceremony. In Kumasi today, one of the Akwasiadae is essentially the Odwira. In Kibi all the stools are cleansed at the sacred river Birim. In Asante the Golden stool is, on the general cleansing Akwasiadae, placed on a Hwedon chair while other stools are held in their respective places by stool carriers in front of it during the ritual stool washing at the river. With sunne leaves, the king sprinkled sacred water from a brass pan upon the Golden stool saying:

Ahenwa Kofi, mebe wo asuo, ama wo ano aba nam nam.
 Ama mene obiara hyia a, wato.
 Se mene Denkyira hyia a, wama na twa ne ti.
 Akyem hyia wama matwa ne ti.
 Domaa hyia wama ne twa ne ti.
 Tekyiman hyia wama matwa ne ti.
 Gyaman hyia wama matwa ne ti.
 Afi ano ahya.
 Yesre wo nkwa.
 Oman nye yiye
 Mmaa awofe nwo mma.
 Msofoe nkum nam
 Yen a edie sika, yensa sika ntu, na menya bi nni - hene.

Rattray, 1927, p. 138.

The stool Kofi, I cleanse you, to render you keen
 and fierce
 To make you help me over-run those I meet in war.
 Even as I cut the head of 'Denkyira'
 So let me be victorious always
 If I meet Akyem let me cut off his head (Let me be
 victorious
 If I meet Dormaa, let me be victorious (cut off his
 head)
 When I meet Gyaman, let me cut off his head
 The year has 'finished a round'. We pray for
 health and life
 We pray for prosperity for the nation
 Let women bear children
 Let hunters get good game
 Grant that winners of gold get rich finds
 That I may get gold to support my kingship.

The religious and political significance of the black stools in rituals

The rituals of the black stools are rich in symbolic significance. The stools are addressed as if they are living things. It is believed that the spirits of the dead being spirit, are more able to intervene for the living but they are not regarded as gods in their own right. The asamanfo (the dead) are in a class of their own and as we have stressed, are, as it were, human beings lifted to a higher plane - one to which all men eventually go. It is, indeed, the political aspects of the ceremonies that form the substance of the festivities which are couched in many instances in religious terms. In these festivities there is a recapitulation of social values and the overt behaviour remind people of their history and their being as members of the community.

The ancestors, as spirits of persons once alive, stand in closer relationship to Nyame (God) and mediate to the living the underlying and ultimate values of Akan society.

When people behave badly, they alienate themselves from the ancestors and make themselves easy prey to malevolence; for Onyame mape bone (God abhors evil).

Three points emerge here. First, that ancestral stools represent general values - traditions, ancestral blessings, history and sanctions of the society. Secondly, the stools particularize these values for certain communities and offices - showing how people in the past upheld and manifested them. Thirdly, they provide means of social control - ways of enforcing norms of behaviour for office bearers (that is stool holders) and community members (that is stool subjects).

Stools represent general tribal or national values because they turn people's minds to the valued traditions, religious beliefs, the place of the ancestors in the life of the community, the king's or chief's position as living representative of the ancestors and the need for solidarity.

Foremost under the respect for values is that of the over-riding supremacy of God. For example, although the ceremonial stool of the Asantehene is carried under seven big and outstanding state umbrellas, the ancestral stools which it represents are approached with absolute reverence by the king in a relationship of servant and master; but the king is under Nyame ne ne mra (God and His Law). Hence the verses in the war and praise songs Onyame ne panyin (God is the elder) and Onyame ne hene nakwa di nehene. (God is the king and the king - that is the chief - is made king for God.)

Following this value of respect for the tradition of belief in God, Obi nkyere abofra ana akwadaa Nyame (No one even points or shows a child God), is the respect for authority, age and wisdom. It is claimed that belief in God is endemic in the society. By the ancestral stools and the chiefs who respect these stools, attention of community members is drawn to the value and need of respect to the authority of the chief. The chief is Nana, grandfather. As we have seen, he is called Nana because he is by virtue of his position and in spite of his own age, the oldest in the community. In the same way as the king being the first grandfather in the community, is respected, so lineage members are requested to respect their lineage heads, and young people their elder fellows. This does not mean that literally age is synonymous with wisdom in Akan culture. It signifies, however, that all things being equal, age may be a criterion for wisdom.

Another general respect for values that stools represent is the need for solidarity and interpersonal peace. All must come to the stool festival of the Adae to forgive and forget and reassert the oneness of the community. In this, the idea that all men are under God's grace - nnipa nyinas wo Onyame adom ase - and that discrimination is bad is re-asserted by the presence of the stools in ritual and processions.

The stools also represent the blessings that the ancestors are to the living. The ancestors are regarded as spirit, and being spirit they intercede for the living, for God is very great and does, at times, give some of his powers to other agents

to administer. Therefore, the ancestors help to get the blessing of fertility and fecundity, and general prosperity for people and the nation. At the same time, the presence of the stools remind people of the tribal expectations and punishments that are likely to follow negligence of these duties.

As state ceremonial stools are carried during festivals, the appellations of daasebre (cannot be tired of giving thanks⁴), daasenya (privilege to thank), are shouted at them and also to the chiefs in their palanquins or in state. In praise songs and other forms of verbalization, the value of the need to be thankful is upheld being sharply engendered by the confrontation with the stools as representatives of the ancestors.

Finally, as a general value, pride of belonging to the community is re-activated. Asante kotoko, okum apem a, apem beba. (The Asante porcupine, if you kill a thousand, a thousand will come.) This refers to the greatness of the Asante people and their bravery. In Akim, the expression of their uniqueness is expressed in their praise song and appellation - Kwabremu or Kwae bibrimu hene, ohene a okyere ahene. (King of the forest, the king and people who overcome the king of kings.) So national pride is renewed.

The second point we mentioned with the religious and political significance is that the stools and the ceremonies particularize these values for certain communities and offices and they stress the ways in which those who preceded them upheld and manifested these values. In song and recitals by the people

and by the kwadwofo (court minstrels) we recall, chiefs are told of their ancestors, their successes and their particular excellences, and how they helped to preserve the nation which they passed on to posterity. We have mentioned that through this medium, a challenge is thrown which occupants of stools have to accept as custodians of the traditions of the ancestors. Through the idiom of music and dance at stool festivals, stool subjects remind themselves of their duties and re-affirm their support to the chief or chiefs. Usually, at every other third Odwira in states like Kibi and Akropong, at the Adae Kesse in Kumasi; there is actual renewal of oaths. Chiefs renew their oath of allegiance to the supreme chief and the supreme chief also renews his oath to the chiefs and the people.

The last of the three things we said the presence of ancestral stools do is that they thus provide means of social control, that is, means of enforcing norms of behaviour for all. Having particularized values for communities and offices, the stools remain as the symbols of positive and negative sanctions for the communities. To stool occupants the presence of particular stools in the stool rooms and the exclusion of others from them remind them of their responsibilities to the people. The fate that awaits their memory is brought home to them again and again as they enter the stool rooms. In the same way, the presence of various kinds of proverbial motifs that appear on ceremonial days have specific messages they carry across to the communities. Summarizing how they affect the minds of people, we were referred to a number of Akan philosophic maxims in

various places. In Kibi we were told, the symbols remind people of what they should do 'for if one does not know what is death one could imagine it by looking at sleep' - Se wonnim owu a hwe nna. In Mampong ASante, we were told, 'A wise man is spoken to in proverbs and not plain words' - Onyansafo, yebu no be na yennka no asem. Indeed, it could be said that the whole point of the ceremonies is political socialisation and social control.

Social and Political drama in Odwira or Aday Kesse

Much has been written about the sacred and spiritual aspects of stool festivals like the Odwira or Aday Kesse and not so much about the political or social aspects on which we report. The ceremonies surrounding stools during the Aday are not all sacred, but also profane. They are, in a nutshell, multi-functional. They are enactments of the dead, recreation of society and re-dedication of king and people to life. These things are done in drama and with religious fervour. So that the mourning for the dead, the hopeful rejoicing for days ahead, and the feeling of newness, the renewal of cordial and social relationships, the prayers for the most valued things in life and society - fertility, prosperity and peace - are effected dramatically and in colourful symbolism.

We have referred to various kinds of items of art objects that a superior Ghanaian chief may possess giving as a specific example, the artifacts which appeared at an Akwasidae durbar of the late Nana Otumfuo Sir Agyeman Prempeh II in Chapter IV.

Drama at an Akwasidae at Kumasi



1

People dancing and making merry.
Chiefs are carried in palanquins.



2

Ceremonial processions at Akwasidae
in Kumasi.

The notes on each item of the stool complex clearly indicate that very few, if any at all, are per se religious artifacts. Among the artifacts were prestige, status and political items like various kinds of drums, golden sandals, keys, various chairs and stools, umbrellas, horns and cloths which also were indices of stratification within the ranks of the chiefs. Each item and the songs, actions and overt reverential behaviour surrounding it is a complex drama speaking specific language which, among other things is preponderantly political.

Failure to recognize the political and other facets of rites and usages in general in Akan by many of the early missionaries and Christian converts, for example, led to a number of unnecessary social conflicts between them and the chiefs as political authorities. While some of the chiefs were unable to isolate the apparently religious aspects of their performances from their purely political roles, most of the converts of various religious persuasions saw themselves as contravening the dictates of their consciences built up by their beliefs. (See Appendix II Memorandum on the relation between Christians and the state presented to the late Nana Otumfuo Agyeman Prempeh II by the representatives of the Christian Churches in Asante, on the 16th of October, 1942).

We summarise our observation on the political and social function of stool ceremonies like the Adae Kesse and the Odwira in the content of the following, presented by Kyerematen in the 1952 brochure for the Kumasi Adae Kesse¹, where he wrote:

¹ See example of the Akwasidae durbar and drama in Plates Ch. IV P2 1 & 2.

'It may now be asked: why this pomp and pageantry, this wild festivity and mystical libations? The answer is to be found in the message which Okomfo Anokye about three hundred years ago gave to a similar assembly at Dwabirem in the reign of Nana Osei Tutu, Asantehene. After calling down from the heavens, as tradition goes, the Golden Stool he told the assembly, at which were present the Asantehene, Amanhene, chiefs and people of Asante, that the occupant of the Stool was to be the Father and Supreme Ruler of all within the nation. Thus starting from the time of Nana Osei Tutu, a day in the year is set apart when the Asantehene gathers around him his chiefs and people. As father, he extends hospitality and bestows gifts on his children and as Supreme ruler of the land he receives the demonstrations of his people's loyalty. The Asante, like other Akan peoples believing as they do so strongly in the continued existence of their ancestors in the spiritual world and of the latter's unflinching interest in the affairs of their descendants, remember the ancestors on such an occasion, and thus the offering of the libations to them and the purification of the stools. Adae Kesse means the Great Adae. The qualifying suffix is used to distinguish the annual Adae from similar Adae festivals (the Akwasidae and Awukudae) which are held at intervals of every forty three days observed by the Amanhene and other chiefs in their respective States and villages.....

It may be that the spontaneous release of fraternal emotions overt expressions of loyalty to a common authority have great lessons to teach our generation.'

Kyerematen, 1952.

CHAPTER VII

OTHER COMMON NON-CHIEFLY AKAN ASESEDWA

We return to other kinds of ordinary stools in Akan culture before we consider this type of artifact in non-Akan lands of Ghana. We mentioned earlier on that there are such kinds of stools as children's stools, female and bridal stools, men's stools, priestly and other stools used in a number of contexts. We examine some of these more closely in this chapter.

Children's stools

The naamadwa (two-penny stool) was mentioned in Chapter II. As we saw, it is technically the simplest to make. In Chapter II we said that such stools were given to symbolize the warm welcome that awaited children in the families into which they enter. The naming ceremony of a child establishes it as a member of the family and the gift of a stool to it later is supposed to be a confirmation of this fact.

Since Akan etiquette requires that children should sit on children's stools and not on the stools of their parents or more elderly people, they are expected to take particular care of their own stools. The beginnings of care for private property and responsibility are informally taught through this.

Children's stools are usually low and small. They may be seven to eleven inches long and four to six inches high. The animu (face) may be six inches wide. The measurements may be

increased according to the specifications of the father who orders it. The design, as a rule, is a special type of the duakoro stool discussed in Chapter V. In the picture, (Plate Chapter V P.1) a kind of this duakoro is shown. The central column is diamond shaped. The symbolism is said to mean that a child must have 'corners', by which it could be supported. It is not a straight, cylindrical or four cornered column, for the child is not able to support himself in life. It is dependent on its parents and later his extended family relations. Besides, it must be different from the duakoro stools of adults. Although this is the type of stool that a child may traditionally have, more specialized forms as seen in men's or women's stools were given even to children. In houses on their village farms we have seen simple blocks of wood - dufua with or without handles which could be legitimate children's stools (Plate Chapter II P.1, Nos. 1 & 2).

Any of the above children's stools, but not the dufua, could be given after rituals have been performed over it, to a child of parents who have been suffering successive child deaths. Such special stools, like dolls used for similar purposes almost everywhere in Ghana, are called donkor, that is, slave. A child who owns a donkor stool is not normally given any of the family names to which it would have been entitled. It is given 'ugly' ones like donkor (slave), summa (refuse or dumping ground). Among some of the littoral Akan and specially among the Ga and the Ewe, the gift of this stool may be supplemented by giving the owner some 'special' facial marks also called the

donkor. They usually consist of four sets of three strokes to form a sort of broad arrow incised on either side of the eyes and mouth. It is explained that the disfigurement made the children unwanted by the spirits that constantly snatched them as they were born.

Another kind of children's stool is the nkrabeadwa (the stool of destined fate). Such stools are given on advice received from divination, and are meant to be concrete representations of given prophecies. One such stool is about 5 $\frac{1}{5}$ " high asesedwa, Cat. I.67.58 and is in the ethnographic room of the Institute of African Studies, University of Ghana. It was collected from Akomadan in Asante, near Techiman. It was given to one Kwasi Boaten, on the advice of a diviner, who predicted that Kwasi Boaten, then a toddler, was destined to be a carver of great skill. It turned out that the recipient of the stool, indeed, became a carver at fourteen. (See Plate Chapter VII, P.4A).

The importance of traditional children's stools, as essential artifacts to be given by fathers, is today on the decline. This is part of more general cultural changes. About 35 only of the 167 fathers interviewed in Mankessim (Fante) in 1968 had given their children the traditional children's asesedwa. The overall picture of the situation in our sample seems to be the same. In the table of Children and Bridal stools given in ten towns the following figures were obtained.

Oyoko (New Juabeng) 50 (27.93%) of 179 fathers had given



An Nkrabea Stool.

(Stool given as a result of Divination.)
Cat. 1.67.58. I.A.S. Legon, Ghana.

their children asesedwa. In Mamfe (Akuapem) 17(11.11%) of 153 parents had offered their children this stool. In Aburi (Akuapem) only 15 of the 65 fathers we interviewed, that is 23.07% had done so.

Divination stools were even less to come by in the sample. Its almost absolute absence in Akuapem may be a result of Christian missionization which definitely denounced such stools and artifacts. The history of missionization of Ghana shows how a lot of art objects have had to be destroyed when their owners were converted to Christianity. In other places like Wassai in the Western region of Ghana, we noticed that such artifacts like divination stools and dolls are 'private' things and are hardly displayed.

However, we have made this discovery about the situation of children's stools in Akan and Ghana as a whole. Instead of the traditional asesedwa some other 'seats' are given. One of these is a cheap Odum or any packing case stool made by modern carpenters. It is a rough and ready type of seat. Erroneously, this type of seat is called mmamadwa by some people even in Apeash, Kyekyewere, and Kumasi in Asante, where it would be expected they would keep the name for the traditional children's stools mostly produced in Ahwiaa. The practice of giving seats to children, therefore, has not actually died. It is all over Southern Ghana regarded as desirable even if it is not done as would normally be expected.

Puberty and bridal stools

Just as traditional custom requires that an Akan should name his child, ideally a week after its birth, and give it a stool when it begins to crawl, so custom demands that a look should be taken at the growing child during some of its life crises. In the case of girls, their attainment of puberty is marked by a ceremony called the bragro. The central action of the ceremony is the 'sitting' of an 'initiate' on a maadwa at the door step of her home to receive gifts. This special honour and the giving of gifts are meant to be part of the positive sanctions attendant on reaching physical maturity. Gifts that are received range from eggs, foodstuffs to clothes, beads and gold ornaments. Sitting on a traditional maadwa symbolises her graduation into womanhood.¹

A girl is expected to marry soon after this public announcement of her womanhood. In marriage she is expected to get her own maadwa which affirms her status as wife and head of her own house. Ceremonies around the stool are less grandiose at this stage than at the period of 'graduation' into womanhood. In Fantiland, however, the nhvehye (the decoration) which is done to a girl who is engaged is very spectacular. Her hair is specially done in the ntekua or Oduku style and in

¹This custom is still popular in Asante. See the description of it by Rattray, 1927, p.67. Also see Chapter VII of this same book. It is almost absent in Akuapim where missionization labelled it as heathenish or pagan in the early part of the 19th century.

PLATE CHAPTER VII. P 1. & 2.



1
Tekua ata
(Double tekua)
Decoration for girls
at puberty in Fanti.
Elderly people may
have this hairdo
during festive occasions.



2
Makai hairdo
seen at an Adee
ceremony at Kumasi.

it are studded gold ornaments.¹ In the ntekua hair-do, all the hair is swept together to form a dome on the top of the head. The hair is made jet black, smooth and shiny by plastering it with soot mixed in grease-like oils. A girl who gets this type of decoration qualifies for the gift of a maadwa from her would-be husband. (See Oduku hair-do Plate Chapter VII P.1).

The implication is that not all kinds of marriages involve the gift of a maadwa for marriage is essentially a union between two families and not between two individuals. Some of our informants thought the maadwa was given only after a period of trial in marriage. It was necessary to be sure of the intention of the woman to stay, before a maadwa was given. However, most people said that the maadwa was given at the beginning of the marriage and we are inclined to believe that this was generally the case. The confusion appears to have arisen in the minds of people because another kind of stool was given to wives after they have delivered of their tenth children. It is called the edudwandwa.

Like the bridal stool, the edudwandwa is often an ordinary maadwa, but in some Akan and non-Akan lands, like Adangme and Nzima, the central column could be proverbial, stylised or elaborate motifs. In Plate Chapter VII P3(1), recipient of an edudwandwa at Mankessim sits on her stool. It is an ordinary Nyaanan maadwa stool. It does not have the characteristically

¹ See Plate Chapter VII, P 1 & 2 (1) Double Ntekua. There is a hair-do in which the whole dome is one. (2) Makai Hair-do. May be done by the mother of girl decorated in (1) or a woman at an Adae festival - The state durbar - part of it).

PLATE CHAPTER VII. P3 (1 & 2)



A Recipient of an Adudwandwa



Adudwandwa - Nyaanan-Mmaadwa.

distinguishing nkyekyaa female design on the 'legs', and it looks more like a kind of naamma dwa. [Plate Chapter VIIP3 (21) of. Rattray, 1927, p.272, fig. 167].

The outstanding distinguishing design of maadwa is, of course, the nkyekyaa. There are, however, four-legged maadwa without the nkyekyaa. The central support may be incorporated depending on the status of the man or the husband or brother of the woman. Hence, queen mothers may have more elaborate designs and may even use male stools.

Like the children's stools, the giving of the bridal stools decreased with the coming of Christianity and other changes consequent upon westernization. The figures on Table 2 obtained from the ten towns in which we did physical count of stools indicate this trend of change. Only the actual figures for children's stools given in four of the towns were obtained. There was to be a recount of children's stools in the other towns because there was a mistake in how the questioning on that particular item was done. This could not be done but the intimate participation on the affairs of the town helped to give us the trend of the change in those towns also, and they were not different from those whose figures we got.

To many Christians for example, associations with the stools in chiefship and other customs like bragore - the celebration of the first menstrual flow of girls are heathenish. They, therefore, regard all forms of stool giving as sacrilegious. Instead of bridal stools in particular, people resorted to the giving of bridal gold rings. Church officials were to marry

according to Christian wedding procedures which exclude the giving of stools. Taking after most people in the educated section of the population, the ordinary citizens no longer took the giving of bridal stools seriously, ~~to~~ them, the act was a thing of the past besides being 'primitive'.

The idea of giving stools as part of the marriage presentations is one of the things that is being revived with the national re-awakening, and we have witnessed a dozen or more weddings in the Christian church around Accra between 1967 and 1968 in which bridal stools were given. Among the rural population, some men accuse women vice versa for the disappearance of the custom. Opanin Ampefo and a number of our Ahwiaa friends attribute the disappearance to the unstableness of women of today. There is no point, they hold, in giving bridal stools to women who are not likely to stay anyway. They even said some women frankly do not want it. Other women we met, informally in conversation, shifted the 'fault' on to men and said, there was nothing they could do about it. If men would not give them bridal stools they could not force them. There was indifference towards whether it was given or not but recent trends, observed in the first half of 1969, tend to suggest that people, especially the literate, are turning back to it as one of the things to be given at marriage.

Mmarimadwa

Unlike women, men are normally neither presented with stools nor are stools used in any particular life crisis apart from washing their dead bodies as they sit on stools. If a

Table III: Households and Bridal Stools given in the ten towns of the Survey. Children's Stools given in four of the ten towns.

	No. of house-holds.	No. which had Bridal Stools given	% of Number of Bridal Stools	Children's Stools Given			
				Tradition Type	Modern Type any other seats		
				No	%	No.	%
Kyelgewere	36	9	25	-	-	-	-
Apash	61	10	16.42	-	-	-	-
Oyoko (N.J.)	179	27	15.78	48	26.81	15	8.37
Tafo (Akin Abakwa)	230	44	19.13	-	-	-	-
Ahwerese (Akurpin)	60	7	18.33	-	-	-	-
Hanfè (Akurpin)	153	6	3.92	16	10.45	1	-
Aburi (Akurpin)	65	18	26.67	15	23.07	-	-
Oda (Akin Kotoku)	43	3	6.97	-	-	-	-
Kankassin (Panti)	167	24	14.37	35	20.95	28	16.76
Pepase Kwahu	144	18	12.50	-	-	-	-

man has no stool of his own when he dies, a stool may be borrowed from his paternal family. In all Adangme, Ga and Ewe, a corpse is necessarily laid in state in its paternal home and house. Most adult men have their own stools anyway; not because one is needed at their deaths, but because it is normal in Ghana society for all self-respecting people to possess their own stools.

Although in the main, men order their own stools, individuals could be presented with stools to mark some special distinction that they have won in the society. Rulers of states could give some mpanimfog special stools. Such stools are different from the stools of office that may be created in time in any political realm.

Priestly Stools

Akomfedwa (priestly stools) may be ordinary asgsadwa which are often male in design. Priestly stools which are female in design, are, however, also present in Akan and other parts of the country excluding Ghana north of Asante and Brong Ahafo. In addition to such ordinary designs for priestly stools, fierce animals may be the subject of the mfinifini (middle section) or anan (legs) of official stools of priests. Naturalistic or stylized representation of the crocodile or the leopard-creatures of valour - are known among priestly stools in Ghana, (cf. Plate Chapter V. R. Figs 162, 176). A priestly stool may also have little bells and iron cuffs on its 'legs' or columns. Blood stains, but more often, white clay, egg shells or speckles of chewed cola nut may be found on such stools. See special Stool in Ch. VII P.4.



A white asesedwa plastered with white clay. Royal Scottish Museum, Edinburgh. Labelled: Oath stool of wood coated with white lime curved seat on five supports. H. $10\frac{1}{2}$ " , L. 14" ; W. 7". By the kind permission of the keeper of ethnography - Miss Dale Idiens. It is very likely that this stool was a priestly stool because of the thick layer of white clay and speckles of egg shell on it.

Priestly stools may belong to one or other of the following groups. They may be stools of medicine men or women attached or unattached to stool offices and so the chiefs who occupy the offices at any particular times, or they may be priests specially trained or specially picked up by specific spirits or deities to become their mediums. All these categories of priests exist in many parts of Ghana.

Priests, in the category of medicine men, do not usually have special priestly stools but may use their personal stools which serve as their private as well as official stools. No one else sits on them; for the stools are in a special class and so regarded as possessing special powers or properties. Priests who were suddenly 'seized' by deities normally have stools of the type we have described above. In a school of priestesses at the Akonode shrine at Larteh in Akuapim Ghana, most of the initiates have their own stools which are either ordinary or special as we have described depending upon their year in training. The minimum period of their training is three years and those who are towards the end of their training qualify for the use of white clayed stools.

Some priestly stools are believed to have mystical origins. Hence the stool of Okomfo Anokye of Asante fame was supposed to have suddenly appeared. The chief of Ahwiasa in 1967/69 during the period of this study, however, suggested that from the less known oral traditions of stool carving of Ahwiasa, Okomfo Anokye's stool was likely to have been among the first carved

by Nana Boasri of Ahwiaa history.

Two priests called Bonsam and Ladde interviewed in Kurasi Asiantɛ in 1967 at an Akrasidae festival claimed that they were suddenly seized by their respective spirits and the stools they use are their personal stools which they used before their possession by the spirits. The only additions made are iron cuffs put round one leg of each of their four-legged male asesedwa. Most priests and priestesses in Akan are usually of the type that suddenly appear and not those who train to become priests, and no evidence of inherited stools was obtained among the matrilineal Akan. However, among the Guan Akan, who are patrilineal, certain stools in the shrines of Akonode in Larteh are supposed to have been handed down from one priest to another. The Akonode deity has several priests and they use stools permanently attached to the shrine. Those who are chosen to be priests from the lineages that are attached to the deity, train at the shrine and they inherit the stools at the shrine. After graduation at the shrines, Akonode priests use special stools consecrated for them at the shrines.

Among the Ga, and the Adangnes a number of priesthoods were hereditary as in the case of the Opata lineage of Shai. Others were priests suddenly chosen by the national gods to be leaders of the communities as was in the case of Labadi Accra. In the former case, the stool of office was hereditary and attached to the priestly family. In the latter, the stool and other paraphernalia were attached to the Lakra or (La

deity) shrine.¹ Those who become the priests of the deities, inherit the stool and use it as their seat. In other cases as recorded by Field² they are used as seats for the deities in special rooms in the shrines and washed during ceremonies they call broi ahedzui (broom washing).

Other kinds of stools

Further divisions of stools are provided by the names that they bear. They serve as patterns for carvers. Reference has been made to designs in Chapter V classified by one of our very proficient Ahwiaa carvers and the most ancient in Akan. In that same Chapter we record, however, that many more designs have been added in the past. Rattray, who first recorded a study of this subject in some detail, indicated that he could document only some and not all of the designs that existed in the culture even at the period he was working on them. Change in general and change in political and social situations, have brought about considerable additions to the types and patterns some of which we discussed in symbolism in stools in the fifth chapter of this thesis.

¹Quarcoo, A.K., 1967. The Lakpa (La deity), Research Review. Institute of African Studies, Vol. 3, No. 1

²Field, M.J., 1940. Social Organization of the Ga People. pp. 12, 15-24.

CHAPTER VIII

THE STOOL (ASESEDWA) IN NON-AKAN LANDS OF GHANA

We have noted that in the North of Ghana, kinds of animal skins, ranging from the domestic sheep to that of wild animals like the lion replace the asesedwa as seats and objects of regal significance. Instead of the chiefly asesedwa which has wide spread use in Asante and other lands south of Asante, skins have attained a special importance in the institution of chiefship in Northern and Upper Ghana. 'Enskinning' of a chosen chief elect completes his installation and legitimization of his authority, (Kyerematen, 1964 Chapter 2).

In the South of Ghana, the cultural influence of the Akan - the largest single ethnic and linguistic unit in Ghana - has been great and their asesedwa is used by many non-Akans. Akwamu and Asante are the two main Akan peoples whose impact have been most remarkable. The Ga, Adangme, the Manya or Northern Krobo, and the Ewes learnt the use and the carving of this sculpture, principally, from them. Contrary views on this were expressed by some informants but the available evidence indicates that these communities have not been without the Akan influence in carving.

Emergence of the asesedwa in Ga, Krobo and Shai and part of Eweland.

Ga (Accra)

The Ga today includes communities of Ga Mashi or Accra proper; Osu (Christiansborg), La or Labone, Teshi, Nungua and Tema.

These communities were welded together into one unit by the exigencies of war in the past. The union seems to have been effected finally for the war in which they had to fight against the Asante on the side of the Fanti round about 1840.¹ There are 'pockets' of people within the Ga Mashi (Accra proper) division whose social organization is different, but on the whole, most of them had a segmentary and theocratic social and religious organization.² Otobluhum of Accra, and 'Ashinte' of Osu claim to have come from Akwamu and Asante Juaben respectively. As a result of the close contact with the Akan from the time of Asante conquest of Denkyira, principally through trade, there was acculturation resulting in certain material and social institutions of Akan being adopted, by accident or by design or necessity.

Among the things that were adopted was the asesedwa stools with the social institutions that have developed around them. The most outstanding institution adopted is that of chiefship.³ It started as an object of 'war medicine' for them during their wars against Asante. The Ga were the allies of Fanti. This accords with the information we get in Ga Mashi where they maintain that the asesedwa appeared suddenly in the culture. Within the same group, however, others claim

¹ Field, M.J., Social Organization of the Ga people, p. 156

² Ibid.

³ Ibid., p. 73. See also Reindorf Carl, History of the Gold Coast and Ashante.

that the object, particularly the asesedwa type of stool, was known in the culture even before the Ga settled in their present home in Ghana. It is, however, certain that the asesedwa as an object or symbol of leadership developed in time and after the adoption of the institution of chiefship from their Akan neighbours.

Rev. Carl Reindorf was one of the first to write about a stool among the Ga before the Akan influence. He referred to a stool which the Ga had prior to the death of one of their leaders called Okaikwei in 1660.¹ Field has, however, suggested that the object to which Reindorf referred in his history could not be an asesedwa. Quoting from him, she said the Ga arrived from the East (the La mantse names Nigeria, and this is widely held by many Gas) under the leadership of two powerful priests. According to Field, no stool was involved in the leadership but one family possessed a small sacred relic in the shape of an ivory pillow or head rest carved out of one piece of ivory and 'small enough to hide in a man's armpit'.² Field continues to say that:

'The Gold Coast people do not know the use of head rests, and so strikingly similar is the shape of the ivory pillow to that of an Ashanti stool that the relic became known as a 'stool' and after its departure, the attributes of a stool were quite erroneously associated with it.'
(Field, (1940) p.145.)

¹ Reindorf, Carl Rev., ibid.

² Field, M.J., 1940, Ibid., p. 145. (See Ch.VIII Fig.6 Overleaf).

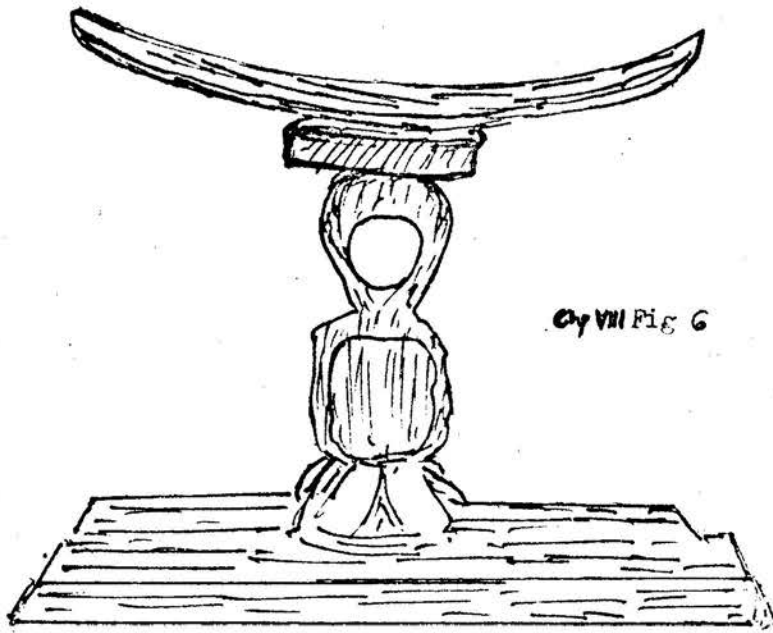

Diagram of the 'stool' referred to by M.J. Field
'pillow for the neck' . It is a kind of artifact
Dr. Carl Reindorf referred to as the Ivory stool
of Ashangao. (Field , 1940,140-145)

She further proves her case by her account of investigations she carried on in Aneko and to the village of Glidzi. In this village the descendants of Foli Bebe continue to hold the supposed stool as a family relic. This account is interesting, but our immediate interest centres around the form of the 'stool' or more properly designated, head rest.

It is significant to remark that it is not unusual to have smaller 'real stools' or ancestral stools apart from the ceremonial stool. The ceremonial stools that are displayed are essentially only replicas of the smaller real or original stools. It is claimed, for example, that the Golden Stool of Asante that is seen at the great Asante durbars is representative of that stool, which was supposed to have fallen from heaven.¹ In the same way, Togbe Apedo Asor paramount chief of the Ho traditional area and his elders claim that the little stool tied to the bigger, clay-smeared ceremonial stool is a replica of their real stool the people of Ho brought from Nwatse.²

¹ Informants in Ahwiaa and Kumasi. This seems to be the rule all over Akan. Even the Asantehene is not expected to see it during his installation. It is supposed to be shrouded in a lot of other things. The suggestion that the inside of the stool is wood is proved by the Seniagya case when he and others were charged for scraping the Gold off the stool and selling it. Horton R. Kalabari Sculpture, p. 13, last para. remarks a similar thing. He says a smaller sculpture often may be the real ritual object and the large one which may only be a fake of the original.

² Informant. The Ho chief and his elders. The ceremonial stool Cht.VIII Plate P1. There is a smaller replica of the real stool.

PLATE CHAPTER VIII P1

The ceremonial stool of the Paramount Chief of Ho
in Eweland, Trans Volta Region - Ghana.

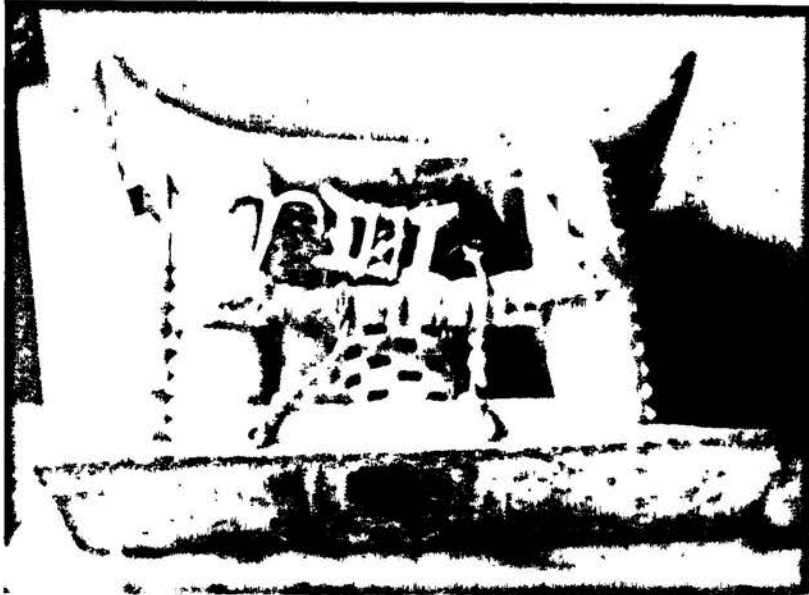

Note the small stool attached to the middle column of the main one. It is a replica of the stool of the founder of the state. The bar wrapped with mystic materials touches the two outside annan (legs). The hooks, one on each 'leg' ward off the danger from lightning. The bells are rung as the chief approaches. They are rung in commemoration of the ancestors. The ceremonial stool is always coated with krabo (white clay); when it is to be used, a fresh coating of krabo is given to the stool and libation is poured on it with gin.

As we have seen, such white clay beamed stool might well be regarded as a priestly stool in Akanland. In Ho, however, it is the principal ceremonial stool of the most supreme chief of the area. In Adangme and other Ewe areas which were theocratic, such stools may be found. This strengthens the argument that such stools might well have been priestly stools in the past.

This is not to say that there were no seats or any other forms of stools in places like Ga or Ewe areas before the historic appearance of the asasadwa stools as war medicines and later as objects of regal importance. There is a tradition for a round top type of stool; (See Plate Chapter VIII P2.) This kind of stool is still used as priestly stool in Adangme-land and Eweland as rests or stands for various kinds of paraphernalia relating to certain deities, and during such ceremonies which the Gas, for example, call broom washing, some of these old types of stools may be seen.¹

At all levels of Ga social organization, the asasadwa is very much used. Field² has several pictures of the use of the stool at home, in shrines and recreation. People are attached to special personal stools and they like to use them, as far as it is possible. Ga children do not sit on the stools of older people because, besides anything else, it is regarded to be disrespectful.

¹ I saw such a stool covered with medicines in Prampram festival in 1967.

² Field M.J. 1940, Social Organisation of the Ga People
1937 & 1961, Religion and Medicine of the Ga People.

PLATE CHAPTER VIII. P2

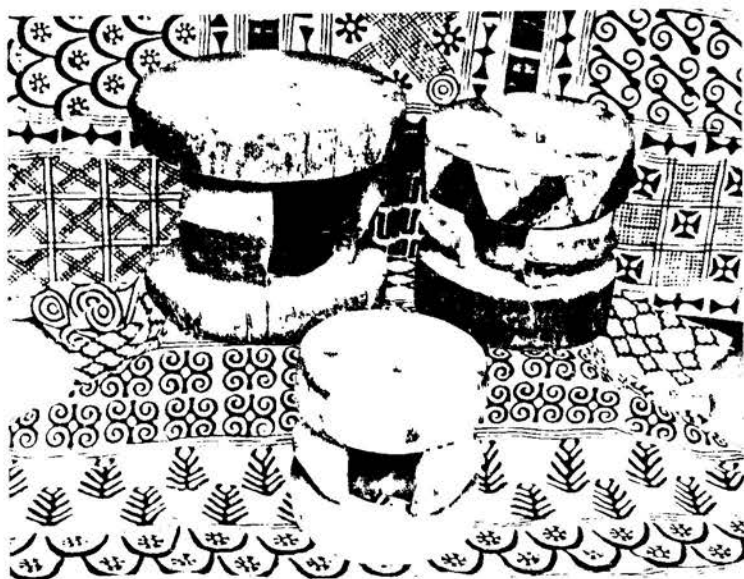

Round Top Type of Stool.

Women continue to have their own stools for women should not sit on men's stools. Only women who graduate into the society of men could sit on men's stools. Old women who have passed their menopause are also free to sit on men's stools, if offered to them.

Heads of quarters may have special stools that symbolize their leadership. In Ga Mashi, there are seven divisions and they all claim to have specific leadership stools.

In Teshi, there is, according to the chief and his elders, only one stool which was consecrated about 1600. It came into being on a Thursday and it is called Nii Sei Kwao. That is, Grand father Stool Thursday child. Apart from the supreme stool, only the deputy to the supreme chief, the Mankralo, has a black stool, and his stool is called Aku, that is, stool born on Wednesday. There are five quarters and each has been given a definite place in the political set up of the town. They also have some symbols of office, mainly of a ritual nature. Leeshi quarter has the Dzasetse (the Gyase chief), Gubla the Atofotse (rear guard) Krobo, the Mankralo, Agbawe the Skitele (leader of the armies) and Kli has, as its leader, the Ayiku priest.

What we see about the Ga use of the stool is that an attempt has been made to copy all the social uses of the stool as they exist in Akan but not with absolute minuteness and success. We shall be seeing later in this chapter the role the stool plays in ancestral reverence and ceremonies.

Shai

The appearance of the stool in Shailand dates around 1826 after the Kantamansu war which halted, once and for all, the Asante advances to South on raids and political expansion. 1726 has also been named as the date the stool appeared in Shai. Exponents of this later date say that Akwamu over-ran the country then, and nearly annihilated the community.¹ The second date is more realistic since the story of Akwamu conquest has little confirmation either from oral tradition or from documents. The most authentic history of the Shai people dates from 1892², when they were ordered to quit the hills in the neighbourhood of modern Tema for their alleged participation in certain customs, which included objectionable sacrifices. It was after the Kantamansu war that Shai had open contacts with Asante. One of the stories about how the asesedwa type of stool was known is given by the family head - a man now living in the vicinity of Dodowah. The present, proficient carver learnt to carve from an Asante man who was captured after the Kantamansu war. Paradoxically, there are carvers in this region who neither know of this story nor

¹ Informant. Nene Lanimo Opata II Mantse of Shai recorded by the author. See unpublished thesis. Processes of social control among the Shai. 1965. Institute of African Studies, Legon. Also Enoch Asu Adangme historical and proverbial songs. Gold Coast Review 1925-1927.

² Crowther's memorandum Secretary of Native affairs in the Gold Coast, 1915.

accept that they got the art of stool carving from anywhere outside their Adangus culture. The consensus of opinion, however, leans towards the belief that the art was introduced into the culture by contact with the Akan through trade and war.

In this culture too, we find the asesedwa being used at all levels of the social structure. Bridal stools are specially cherished. In the dipe (coming of age ceremonies of girls) the stool is used at the end of the ceremonies when there are festivities and gift giving. Initiates may sit on such stools to receive their gifts, although other stools or even chairs could be used.

The round top stools, mentioned in connection with the Ga, are used to a great extent here but it seems that the asesedwa is given special pride of place at homes, and in the political context. The premium that was put on the asesedwa type of stool resulted from the recognition of this artifact as the first symbol of office by the colonial administration of the then Gold Coast (Ghana). Shai has had a long, drawn-out controversy about who is paramount in the political administration. One contestant entered the controversy because he was donated a stool by Akrepong Akiapimand with its possession he had something to show for his claim. On the 4th of May, 1898, the leader of a section or quarter, chief Okra Amponsa was 'begging' the colonial administration to restore his seat that

was seized from him.¹ So the right to rule was recognized by the colonial government, when a claimant had a stool which was also accepted as a national stool. In addition to the fact that the stool and the institution of chiefship was learnt or borrowed from the Akan, it received further support from its recognition by the colonial government.

Manya and Yilo Krobo. Northern and Southern Krobo

Whilst Manya Krobo actually learnt to carve the asesedwa after acquiring the institution of chiefship from Akwamu, the Yilo or Southern Krobo claim to have had the knowledge of carving from Denkyira. According to the oral tradition given by Nene Aketeku Akrobbeto, the paramount chief of Yilo and some of his court historians, the ruling *lineages* of the Yilo are strangers. They arrived in Kroboland under the leadership of one Antwi. His great wealth and influence helped to draw people to himself. Antwi's family is said to have brought with them a stool. Until now, the Yilo have only three black stools for the past paramount chiefs. Yilo has other stools which are *lineage* stools but they serve as wing chiefs' stools. The following stool offices are important:

¹ QUARCOO, A.K. 1965. Processes of Social Control among the Shai (Dangme). Unpublished thesis, pp. 12-20. Also Appendix E of same thesis. Institute of African Studies. University of Ghana, Legon.

Se Tatse

Rear

Atofo Tatse

Immediate back

Muom

Head chief

Hiom

Left

Konor

Right

Hekpe Tatse

Advance

Again, we see a repetition of some of the main political and military positions noticed in Akan stool systems.

Ho and Kpandu (Eweland)

Carvers of the asesedwa type of stool of both Ho and Kpandu live mostly in the outlying villages. Very few of those we met knew any history or the origin of the art of stool carving. Historically, both communities think of Nwatse in Togoland as their original home. They left this home independent of each other at different times to escape the cruelties of a ruler they name as Agokoli. Each community claims there was already in Nwatse, before they left, this object -- the asesedwa. The seat was used for all purposes, but it was also a symbol of office of the great leaders. They brought with them some stools which, they said, were replicas of some of the stools they had in Nwatse community.

The man who led the people of Ho from their Nwatse home to their present site was, Apedo Asor I. Heviakpe tribe moved too, and settled in Ho area. Bankoe, Hliha and Heve joined the Heviakpe. As they settled, their lineage stools gained recognition as symbols of political leadership. Five stool offices of great eminence in the Ho realm are the Apedo Asor stool, the Megbe, Miame, Dusime and Ngg, and they stand in the following relationship to the Apedo Asor stool:

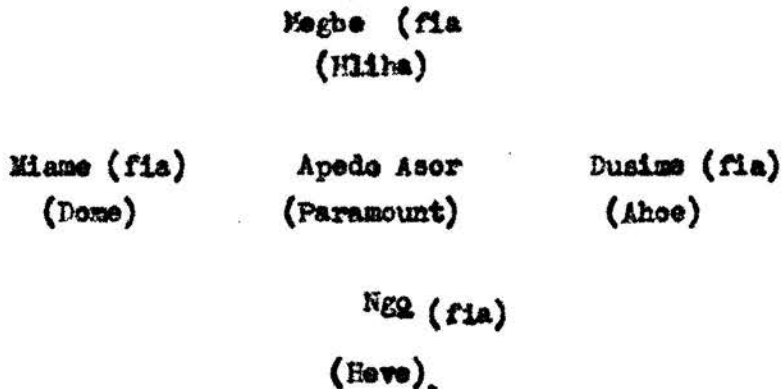

The most important item in the stool complex associated with the stool office of Apedo Asor is the state sword called Brangbe. The special sword used for swearing the oath of allegiance is the Atankayi. Others are the drums common in Akan courts, and other ornaments forming part of the regalia of the stool. The paramount stool has no palanquin to it. It is the chief Apedo Asor's deputy, the chief of the advance guard, who owns a palanquin. It was explained that this was purposeful. Normally, the most senior chiefs ride in palanquins in Akan. By denying the paramount chief this regalia, he was saved from evil people who would naturally think that the

supreme chief should be the one in palanquin.

In Kpandu, the *lineage* stool of Togbe Dagadu is the one that has attained the position of first among the others. Another important *lineage* stool which is now state stools is the Abendza. It is next in importance to the Dagadu stool. The stool office of the Abendza is the advance guard stool of the community; the Loko stool now the Nukusimefia stool of Kpandu, that is, the right wing stool. The fourth important family stool is the Asimedu stool.

The asessedwa and chiefship in these non-Akan lands

We notice that, the most spectacular use of the asessedwa in these non-Akan lands we mentioned, is its use as a symbol of leadership. Here, more than in Akan, it is still regarded as a vital force or god by a number of our informants. It will be remembered that in Accra, the asessedwa came to them as war medicine. All the chiefly stool offices, we have mentioned, have complexes of other material objects and regalia. They include state swords, drums, head gears, and palanquins, in some cases. The Akan Atupan and Fontomfrom drums, called Obonu by the Ga and all Adangmes, continue 'to speak Akan' after all these years of their adoption.

Without exception, the stools regarded as the political symbols of leadership in these lands are never seen but there are ceremonial representations of them. Plate Ch.VIII P1 shows the ceremonial stool of the ruler Apedo Asor of the Asogli state of Eweland. It is the principal stool of the state. This

stool is regarded as representing the state in its entirety and enshrines its soul. It is 'medicine'-charm-against evil and other spirits which would want to work evil against the state. Tied to the Sekyedua of the stool is a replica of Asor stool brought from Nwatse. The ceremonial stool, by contagious magic, draws its power from this smaller stool.

Ceremonial stools of these lands tend to be as elaborate or even more so in these lands. The stool of Picee Pediator, a senior sub-chief of Ada is two-tiered, like his state umbrella. It is comparable to the two-tier ceremonial stool of the ruler of Ahanta state in Ghana, (Kyerematen, 1964, p. 17).

Significantly, while Asante stools remain traditional, stools, in Southern Ghana and many non-Akan lands tend to be elaborate or complex in design, especially in the central section. A number of my informants in Ahwiasa referred to this tendency as asuatra (over learning or over perfection). They think it is an attempt to be over smart. The carvers miss the real point of the symbolism. This, of course, is a point of view. Definitely, the Asante know more about stylisation in this matter and they are able to say very much in very simple designs. Another point is that as far as the chiefly stools are concerned, we get the impression - and this will have to be investigated more thoroughly - that the main stool of a stool office in a state is often of the kotokodwa type.

Among the complicated designs seen in non-Akan lands of Ghana are: Gyata akyere abafog (a lion catches the hunter) that is, killing the killer; Owu atwede (the ladder of death); Meda asase makyere owam (I lie on the ground but have caught the crafty bird).

The paramount chief of Shai had an impressive array of these stools and which decorated his court where he held arbitrations. The stools helped to give the dignity one would expect in a chief's court. In Asante and in other Akan lands, even the architecture and the several apartments in the palace, unmistakably, present a regal atmosphere.

Stool festivals.

There are a number of stool festivals in all these lands. In Kpandu there are two festivals in which stools are involved. There are the Adae,¹ which are like the Akan Adae we have discussed. The other festival is the Dainbekaka in which the paramount stool Dagadu and the other original stools, now sub stools to the Dagadu stool are washed. The Dainbekaka is a ceremony in which the people of Kpandu commemorate their coming to Kpandu and the marvellous crossing of the river Volta. They tell a story of a wonderful root-like substance which lined the whole length of the river for them to use as a bridge. This bridge disappeared after they had crossed the river. Every three years, the stools, according to our informants, are carried to the river and washed to commemorate that great event.

¹ Similar in every way to the Akan Adae, Chapter VI.

It is also the time for a three-yearly special fruit festival always celebrated with great enthusiasm.

In Shai (Dangme) and Ga, stool washing ceremonies form part of their first fruit festivals. What is known as ritual broom washing festivals in Ga also involve the washing of stools. Singularly absent in Adangme stool festivals and those of some Ga stool ceremonies is the absence of blood. The Adangme say: Wake muo pewe no - we do not use blood in doing things.

In stool washing festivals in Asere Ga Yelleyeli (Asere yam eating festival) the stools are washed. (See Field 1940, pp. 178-180). When the stool room is opened amid hooting and drumming, the spirits of the dead are called. Libation is poured and the stools are informed of the meeting of the select company in and around the stool room. The Ga and Adangme had special stool priests. At the stool washing ceremonies they take the stools one by one and place them in a brass pan containing sea water. Special women called seiheyeyi (women of the stool or stool servants) then wash the stools and rub lemon juice into them. They are then given a coating of sweet scented ground leaves. Finally, the stool priest sets them in their places again. In the Asere case being described, it is still held that there are only six physical stools which include the stool of Okaikwei and Ayi Frimpong. The arrangement below represents how the stools are arranged in the stool room of the Asere of Accra.

Nii Boi

Teiko Ansa

Akrama

Ayite

Akotia

Okaikwei

Unlike the Akan stools, the ancestral stools of the Asere are not black but white. In the stool room the chief is made to carry a white ram to offer to the spirit of the stools. This he does after he has bathed with the water used in cleansing the stools. He carries the ram and swings it three times down towards the stools saying 'O my fathers, today is your day. I held my ram to give you. Come and take your offering.' After this he pours rum on the stools saying as before, 'Your servant, your child, holds rum to give you that you may bless him and your people.'

The ram is killed and in Asere in particular, some of the blood is allowed to drip on each stool. The rest of the blood, is made to run into a tsese (wooden bowl) and sprinkled everywhere in the house. Washed yam is next put on each of the stools. Money may also be put on the stools.

The rest of the day is spent in merry making and feasting. Most of the drumming and singing is in Akan but there are some Ga songs too. The reason for the Akan songs is that, accompanying the first stool when it was procured, were Fanti songs. Singing of Akan songs helps to remind people of that fact.

Common features, dissimilarities of usage.

Like the case in Akan lands, there are domestic stools for ordinary use but the most outstanding use of the stool

is now in chiefship and leadership. Children's stools, bridal stools and especially stools for priests abound in these cultures. Here too women who get special promotion into secret societies or to men's statuses in the groups may be given special stools to mark them.¹

So the asesedwa is used in many contexts here as in Akan lands. The artifact is an object with which the spirit of even ordinary people and also those of chiefs could be identified. In some of these non-Akan lands, the stools do not have to be necessarily blackened after the deaths of such owners, whereas in Akan society they would qualify for this honour of stool consecration.

In these cultures, the asesedwa is also a symbol of respect, honour, and in some cases, shrines of 'gods'. Above all, the idea that a lineage or state stool is a symbol of the collectivity has grown and is firmly accepted.

¹ There are women in such exclusive men's societies as in the Tegble group of Adangme. Documented by the author in Processes of Social Control among the Dangme Shai. 1965 - Unpublished M.A. Thesis quoted, Chapter II, 1.

CHAPTER IX

THE STOOL IN CONTEMPORARY GHANAResilience of the asessedwa in the Culture

We see in the culture of Ghana today, a definite resilience in the object and idea of the asessedwa. It may be said that the artifact belongs to the overall culture of the country, for there is, at least, a national culture in the making.

There is currently, a revival of interest in the asessedwa type of stool and all it symbolizes at all levels of the social structure, consequent partly, upon the phenomenon of cultural re-awakening in Ghana, partly because it is a known object and idea from which the unknown new styles of government are being forged or inculcated. The use of this type of artifact, as a symbol of respect and of political leadership, is made more manifest to a wider circle of people in the country by its use in Parliament House in Accra.

The realization of the importance of the political institutions that have developed from the use of such a sculpture as the adwa, has not, of course, been a sudden affair. For example, the guiding principle of the 'elitist' political association as the Aborigines' Rights Protection Society of history, seems to have been this one passion to recognise and build upon indigenous institutions and W.E.G. Sekyi, is known to have devoted a lot of attention to stool institutions and championed their cause.

Speaking to the Aborigines' Rights Protection Society at one banquet of the association during the governorship of Sir Hugh Clifford, in the Gold Coast, (Ghana) the Rev. S.G. Gibson, then principal of the Mfantshipia, (Ghana's first secondary school) commended the society for their aim.

He said:

It is a grand thing that a people recognize that it has a heritage of ancestral rights when it feels the past is not a nameless, shameful shadow, and realizes that its fore-fathers have in the long, long years evolved a system of customs and usages which are trustworthy, practical and expedient in economy and polity of the present.

(Alicoe. Thomas. 1951, p.64)

All through the history of Ghana there has been a steady effort to keep alive the institution of chiefship, which we have argued developed in relationship to and the use of the artifact - the stool. It has been constantly felt that the institution should provide a foundation for the inevitable political institutions that may be seen in Ghana in time. However, no generation of the educated population has failed to indicate that the institution presented by the Golden Stool of Asante, upon which many Ghanaian 'stool constitutions' appear to have been built, made room for some change. This is why although a single idiom, it made it possible for display of personal attributes and ingenuity, of successive occupants.

There has always, therefore, been a clear recognition of the principle that a system built upon traditions of the stool and its institutions may help the survival of the superstructure.

Hence, there is even today an experiment in the use of the symbol and symbolism attached to this known object in the house of the supreme legislative body of modern Ghana.

Description and use of Presidential Stools in Parliament House

We now describe the stools, sword and linguist staff or mace in Parliament House and their use in The Assembly. The presidential stool. (Chapter Plate IX P1 (1 & 2) is a combination of two of the forms of regal seats the Hwedom or asipintea (long asipia) and the asasadwa. The asasadwa part is ebi-te-bi-so. The bottom section on which the wiabog of the top section stands, is a kind of Nyamedua stool.

The top section is a Kotokodwa stool with one central support sekyedua which in this case is said to symbolize the unity of the country and strength of the nation. On the sides of the mfinifini are the Nkuntan which we have noticed as the most essential symbol of maleness in a stool.

Raised on the top of the stool - the kotokodwa is a hwedom type of chair to give the stool a back rest. On either side of the stool are broad, soft and leather covered arm rests.

Every part of the stool bears symbolic designs. The Nasoma (the guiding star) is conspicuously embossed over the top of the back rest.

On the second chair Plate Chapter IX P1 (2) can be noted concentric designs. The coat of arms made up of the black star and the two eagles is depicted on the chair. The eagles signify

PLATE CHAPTER IX P1 & 2

Presidential Chairs in Parliament House

Ghana - Accra.



1



2

the strength and calculating nature of the president. The concentric circles make the traditional symbol called adinkrahene (king of the patterns) which here depicts royalty and sovereignty. In the inner-most circle is a cross, called Krapa (good soul).

Other symbols on the chairs are the Prekese, Qwg-aforo-adobe (the snake climbs the raffia palm tree). Nkonkyema, characteristic of the akuaba doll to symbolize beauty - beauty or adroitness to exist in everything and move in the house. Dwantire (ram's head) here to signify continuity of the sovereignty of the state. Nkonsonkonso (chair) signifies cordial relationships which exist among members in the house and Nkyinkyia (zigzag pattern) which is symbolic of selfless service and sturdiness. Ntesie or Matemasie is to remind parliamentarians that the exercise of prudence is required of them.

Both presidential chairs are gilded. The coat of arms on the presidential stool and the speaker's chair are in Sese wood.

Originally, there was only one presidential stool. Later, the stool became a sort of ceremonial artifact - a coronation stool and the simpler stool and more like the hwedom chair plate Chapter IX P4(2) was carved to be the presidential stool for ordinary use. This accords with the traditional function of simpler court stools, namely, the asipim and akonkronfi, which were more frequently used in the palaces of chiefs.

Attached to the presidential stool as part of its complex are the state ceremonial sword and the mace. The sword is the

symbol of presidential authority. It is an afena-nta -- double-edged sword made in solid gold. In addition to being a symbol of presidential authority, it is the traditional symbol of inter-state peace. On the obverse of the blade, are three symbols. Fawoho (Take yourself) is a symbol of freedom. Bi-nka-bi (no one harasses another). We learn it is a symbol of justice. There is also adehye-brobe (royal pineapple) to indicate continuity in Ghana's sovereignty. On the reverse of the blade occur two symbols Nyametumi (the might of God) consisting of a square, a circle and a triangle. This signifies the presence and power of God in the realm. The Adehye-brobe occurs again here. A heraldic star is placed astride the top of the blade to accentuate the fact that the two edges belong to the same sword. This again is meant to emphasize the unity of the nation.

The Mace

The mace is the symbol of the authority of parliament and it is fashioned in silver and gold. It has for its head, a heraldic bird - the eagle. The mace rests perpendicularly and not horizontally as do many maces in the world. It is, according to the clerk of assembly in 1963 the only known mace that rests that way. The position of rest is like that of a linguist stick of Akan culture.

The following Mfinifini (pl.) on traditional asesedwa(pl.) appear on the shaft of the mace. Kontenkrowi (rainbow), Nyamedua (God's tree), Kudu-pono (lasting personality), Mnaadwa - to signify the presence and effect of women in the

society, and Kuntankuntan. On the shaft of the mace are embossed Hwedua (critical examination), Gye Nyame (only God has the ultimate power), or Hye-wo ho-ahye.

Other symbols in Parliament House - Accra.

The whole chamber of Parliament House has symbols which are extension of the chiefly stool regalia and symbology. Right from the main door to the Bar of the house, the Clerk of parliament's table and up the ceilings are symbols. We are informed that they are meant to 'speak' the language of constitutionalism as known and understood in Ghanaian culture and this means an interpretation of the new constitutionalism in the symbolic idiom of the culture.

Further development and use of stool symbology in modern Ghana.

We have discussed symbolism in Akan stools in Chapter V and here, we examine further ways by which designs multiply in modern Ghana. There are designs of the central portion (mfinifini) that are completely new ones, but others are modifications of pattern regarded as old and very traditional. The modern trend of presenting more and more plastic forms of known proverbs or traditional philosophical ideas is demonstrated in Parliament house of Ghana. Elsewhere one cannot escape evidence of the increased use of proverbial designs in stools and other visual art.

We gather through our informants and observation that there is definitely an increased interest in the aesthetics of the stool. Most visitors to the country who get an interest in the stool and its political significance often



Speaker's dais and clerk's table.
Parliament House, Ghana.

demand to know which designs belong to which chiefs. To meet this need, a number of court clerks and other officials of chiefs have been briefed to name certain patterns as the state patterns. It has, therefore, been possible for some interested artists or collectors to assemble and present designs supposed to belong to specific Asante chiefs. In actual fact, the designs as presented by such people are not the designs of the first or most illustrious stools of the villages, town or chiefdoms at all.¹ We have remarked that the design of the original ancestral stools are the Dua koro or Kotokodwaa type.²

Historically, however, chiefs are known to have chosen designs for their personal stools, some of which qualified for consecration. There is, therefore, a wide variety of designs even among traditional black stools in Ghana. Stools that are labelled Mampong, Juabeng and so on, as in the line drawings of Emerico Samassa Mayer - inset Fig. 7 are often, at best, variations of the principal stools of the named places. The same remark applies to Dr. MacPherson's collections.³

¹Principal informant in this, Opanin Adjei, Ahwiasa. When I asked him to help identify a number of line drawings of stools I presented to him. His information was crossed checked in Akim, Agantse, Akwamu and Akuapim royal houses.

²Ibid.

³Emerico Samassa Mayer, owns a curio shop in Accra and has business interests. Dr. MacPherson's collection are in the Scottish National Museum, Edinburgh. Access to them was by the kind permission of Miss Dale Idiens, Assistant curator. (Ethnography).

Names of miniature model stools - donated to the Scottish National Museum, Edinburgh by Dr. A. MacPherson, 1948.

Classified as follows:

1948.183	Akekaasie Ashanti	1948.199	Dadesebahene
1948.175	The King's Stool	1948.200	Deneyesie
1948.176	The Queen's Stool	1948.201	Domenasie
1948.177	Adansie (Ashanti)	1948.202	Ejisu
1948.178	Adontihene Ashanti	1948.203	Jamasie
1948.179	Adumhene Ashanti	1948.204	Juaso
1948.180	Afiguasie	1948.205	Jubemi
1948.181	Ajonah Ashanti	1948.206	Kaneyesie
1948.182	Ahenkuro Ashanti	1948.207	Kokofu
1948.183	Akekaasie	1948.208	Kontasie
1948.184	Akobiyahene	1948.209	Kukuom
1948.185	Akolopong Ashanti	1948.210	Kumawao
1948.186	Akyenpenhano Ashanti	1948.211	Kwansa
1948.187	Atiapinehene	1948.212	Kyidom
1948.188	Amateihene	1948.213	Mampong
1948.189	Apagyahene	1948.214	Nkawe
1948.190	Asafe Ashanti	1948.215	Ntowasie
1948.191	Asaaman Ashanti	1948.216	Offinsu
1948.192	Aokore	1948.217	Saaman
1948.193	Asomwiya	1948.218	Sunyani
1948.194	Asutai	1948.219	Tafue
1948.195	Bantima	1948.220	Takyiman
1948.196	Bechem	1948.221	Wenchi
1948.197	Bekwai	1948.222	Womu
1948.198	Belekumo(?)	1948.223	Yonko

Figure 7

TRADITIONAL AKAN STOOLS

G H A N A











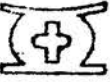



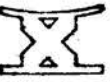
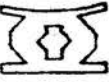
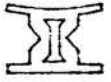



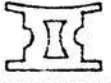
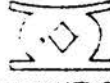

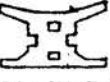



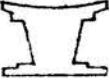
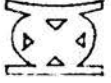

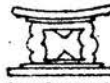

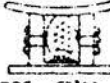















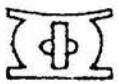
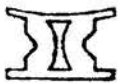
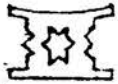





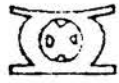

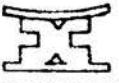
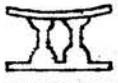
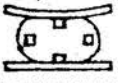
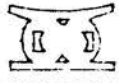
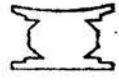





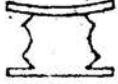

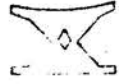
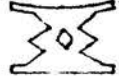



 JWABENHENE STOOL	 EJISUHENE STOOL	 OFFINUHENE STOOL	 NKROOGAHENE STOOL	 BOMPATAHENE STOOL
 TAFOMENE STOOL	 VENCHIHENE STOOL	 BEREKUNHENE STOOL	 JWASUHENE STOOL	 SUNYANIHENE STOOL
 AKYEMPNEHENE STOOL	 ADONTINEHENE STOOL	 DADESUBAHENE STOOL	 ADUMHENE STOOL	 ANUOBIAHENE STOOL
 AMPONGIHENE STOOL	 ASAMANHENE STOOL	 AHENKROHENE STOOL	 JEMASEHENE STOOL	 AGYAMANHENE STOOL
 KWAKUOHENE STOOL	 KHEDOMHENE STOOL	 AGOOGHENE STOOL	 AKYEMKROMHENE STOOL	 ADINKIRA STOOL KING OF SHAMAN
 OSFO POFORO ASOFO GYA THE SHAME CLIMBS THE PALM TREE STOOL	 SAKUI DWAKORO GYA SINGLE CENTRE SUPPORT STOOL	 NHANRA GYA TWO FEET STOOL FOR MAN STOOL	 NSEBE GYA AMULET STOOL	 NANA GYA WOMAN STOOL PRESENT TO WIFE
 NKONTA GYA STOOL OF HEAD LONG CARRIAGE STOOL	 SRANE GYA MOON STOOL	 ESONO GYA ELEPHANT STOOL	 OSEBO GYA LEOPARD STOOL	 KOTOKO GYA ROCK STOOL
 BRANLANTE GYA CHIEF OF AYEVA	 WONTOKRO MPONO GYA SIXED CIRCULAR RAINBOW STOOL THE KING OF AYEVA	 ANINWA GYA CHIEF OF YAKO	 NANA GYA WOMAN STOOL PRESENT FOR WIFE OF A KING	 AKWANTEHENE KING STOOL
 SANKPA GYA GO BACK TO WIFE STOOL	 NYANAN GYA WOMAN STOOL	 ANIMA GYA GREEN MOTHER STOOL	 GREEN MOTHER STOOL	 SIKA GYA KOFI THE GOLDEN STOOL

Figure 7

 MAMPONHENE STOOL	 BEMAHENE STOOL	 NDUTAHENE STOOL	 VAMPENHENE STOOL	 KOKOPIHENE OVA
 TECHENHENE STOOL	 ASAFHENE STOOL	 MUMADUHENE STOOL	 ADANSHENE STOOL	 AONAHENE STOOL
 KONTANSHENE STOOL	 BECHENHENE STOOL	 EFFIGIASHENE STOOL	 ASORKOREHENE STOOL	 OYOMHENE STOOL
 ATIPENHENE STOOL	 APAGYAHENE STOOL	 ANANTAHENE STOOL	 ANTOASEHENE STOOL	 NKWATAHENE STOOL
 AONINGYAHENE STOOL	 DANYAHENE STOOL	 ANKASEHENE STOOL	 ODUMASHENE STOOL	 KANNASEHENE STOOL
 KONTONHOBOR OVA CIRCULAR RAIN BOD STOOL	 KOTOKO OVA PARAMOUNT CHIEF STOOL	 MNON OVA SUB CHIEF STOOL	 ETUDURHODUM OVA HEE OF GUNPOWDER STOOL	 ADENKEM OVA CROSBIE STOOL
 WE RA ASA OVA DEATH STOOL	 MMARDA OVA MAN STOOL	 MMAREMU OVA CROSS STOOL	 DAMEDAME OVA DRAUGHT BOARD OVA	 MMARAMAM OVA HOUSE OF THE POOR STOOL
 ETUMYAN OVA THE TALKING DRUM STOOL	 ALUYEM OVA ALUYEM STOOL	 PANTU OVA BIG SPIRIT (GWA OR RUMU) BOTTLE STOOL	 WABO OVA PADLOCK STOOL	 OM-TI-OM-BO OVA SOMEONE SITS ON TOP OF SOMEONE ELSE STOOL

Between the years of 1959 and 1966, the number of patterns for 'state stools' increased phenomenally. It was a period when as a political strategy, the national government of Ghana helped to create many chiefdoms. Many stools, with rather very elaborately designed mfinifini, were made for these newly created chiefs. Many of such chiefs had their positions reverted or abrogated after the military takeover in 1966.

Another factor that has brought about an increase in patterns is the multiplication of tourist type of stools. Investigations reveal that the spectacular interest of tourists in the sculpture has been given fillip by ^{the} symbolic use of it in Parliament House in Accra.

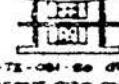
In addition to the stool as a symbol in the crest of a division of the Ghana army, another creature of wisdom, power and diplomacy in Ghanaian folklore is incorporated. The Ananse (the ordinary spider and also the Tarantula) is the distinguishing symbol of the 81st and 82nd divisions. The symbol was given to them during their battles in Myohaung about twenty five years ago, to signify their calmness and bravery. The stool in the symbology of the crest, takes its source from that in the Ghana Coat of arms representing power and authority of the head of state of Ghana, and so these divisions are units to which soldiers are proud to belong.

The power represented in the crest of the University of Science and Technology, Kumasi is of a different kind. It is power derivable from learning and wisdom. Wisdom today, ^{it} is

emphasised in the crest, is enhanced by technology and science. This notion is also concretely represented in an architectural form of the main gate to the campus of the university. It is actually part of a flyover bridge built by the civil engineering section of the university. The symbol at the gate stands to welcome all who enter -- the symbol of respect, wisdom and power. Odo, nindeg ne tumi (Respect, wisdom and power.) Plate Chapter IX P4.

The Stool in Ghanaian Heraldic Shields

By the end of the 19th century, many tribal units later called states in Ghana had adopted definite state emblems. Mr. Magnus Sampson who had been secretary to The Council of chiefs of Southern Ghana for several years wrote the following in 1953 in his forward to a book compiled by Mr. Sutherland, a retiring Administrative Officer of the then Gold Coast.

'The origin of state emblems is lost in antiquity as no historical record is available. But it can be safely assumed that they were adopted to distinguish the tribes in their incessant internecine wars. In time, they became national emblems influencing the actions of the people on festive and other ceremonial occasions.' (Sutherland 1954, p.2).

.....Indeed the origin of many of the emblems as presented in the book, are difficult to find. That they were adopted to distinguish the tribes from one another in their internecine wars' as Magnus Sampson wrote has, however, not generally been supported by our field investigations. It is correct that the colonial government recognized most of these emblems and that the states had even flags in which the emblems appeared; but they

Six examples of the state emblems/shields

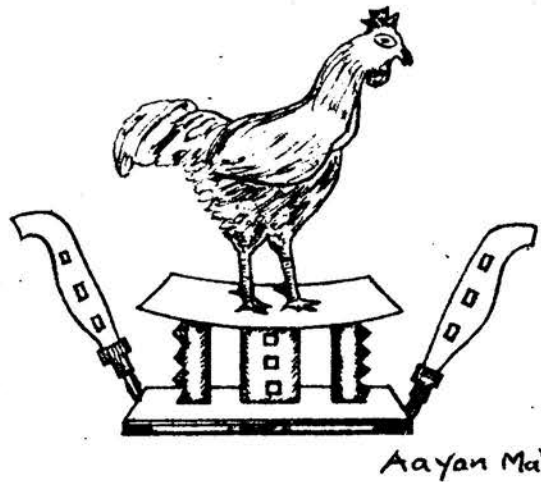
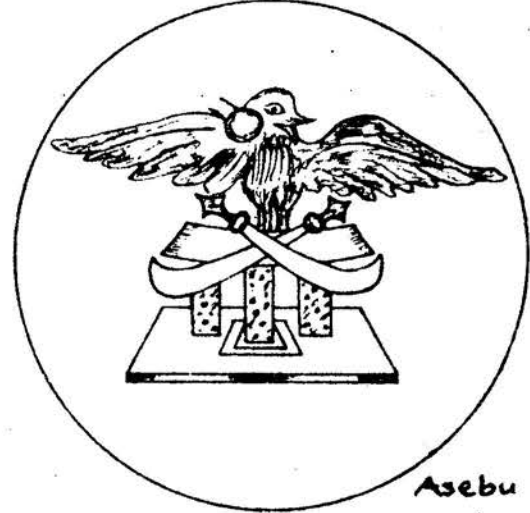
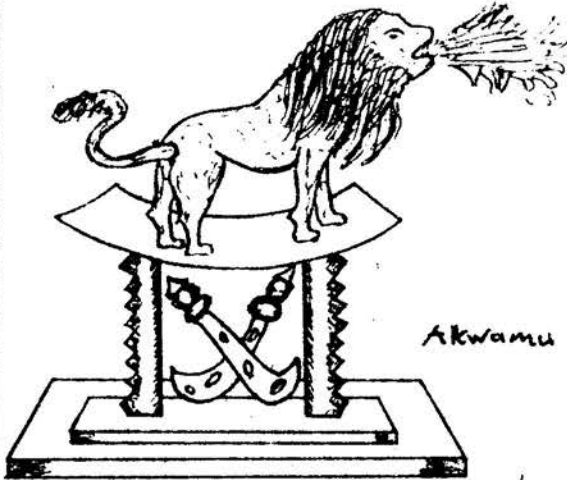
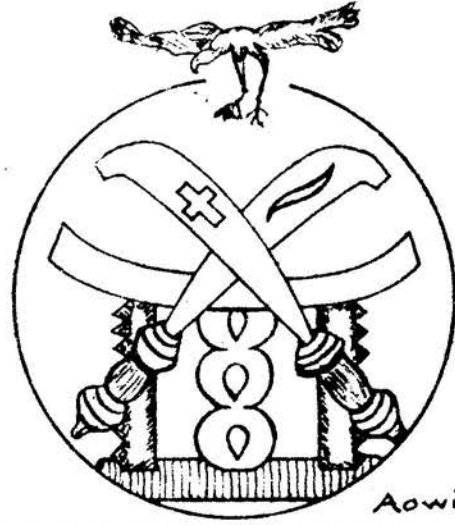
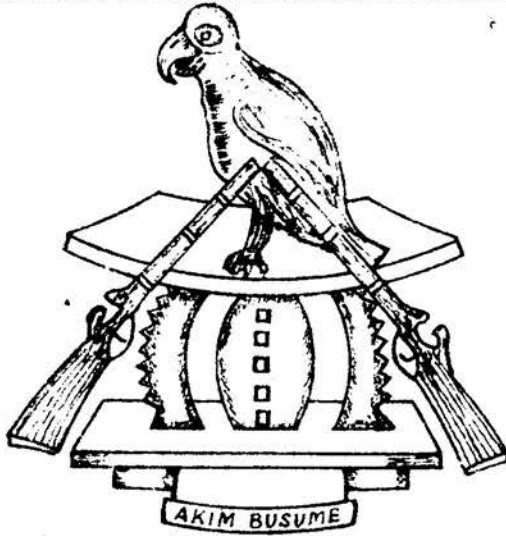

As illustrated by Mr. Among Kotei.



Crest of Kumasi
College of
Technology.
Note the stool.



Main gate of
Kumasi Univer-
sity of Science
and
Technology

were distinctive signs for administrative purposes more than anything else as far as the colonial power was concerned. Never-the-less, they were meaningful emblems to the people; for most of them included the Akan asasadwa type of stool which had been adopted by most states of Asante and south of this 'nation' as the symbol of unity and soul of their peoples.

Mr. Anon Kotsei, the main artist, who helped in the sketching of the emblems and compilation of the book, inclines to this later view that these emblems were not necessarily adopted for identification because of wars. They were and have been the emblems of the 'states or tribal units.

The main point of interest is that, as a later development of the use of stools in political life of peoples of Ghana, adopted emblems, had central to the designs, ^{the} asasadwa (the stool). This further confirms the point which we have made in chapter V that the stools is the one symbol which may be rightly regarded as the plastic representations of the culture of a large section ^{of} modern Ghana.

Stool symbolism and Christian church art

Another field into which Ghanaian stool symbolism is making a successful debut is the Christian liturgical arts of Ghana. The idea in this exercise we learn is to help bring about a more effective medium of evangelization by teaching from the known to unknown. Again, it is held, that the use of the symbolism, will make the people feel that the message is not a foreign one being imposed on them. In a paper in the Research Review of

the Institute of African Studies, Vol. 4, No. 3 of 1968, entitled 'A debut of Ghanaian traditional art into Liturgical art of the Christian church of Ghana; the writer examined the role that the visual art is playing in the church.

The principal church building that formed the basis of the study is the Immanuel church - the Methodist church at Labadi, Accra. The church has, for its altar, a replica of a large stool. (See Plate Chapter IX P5). On the Sakyedua and annan are both the male and female distinctive signs, the nkuntan and nkyekyaa to indicate that God is a mother-father God. This accords with a traditional belief of the Ga people who often call God Ataa-Naa Nyame. (Father-mother God.) On the Sakyedua of the altar is engraved the greatest traditional symbol for God - The Gye Nyame Sign. Over the altar is a half moon state umbrella which is an important artifact of a stool regalia. This is meant to help remind the congregation of the majesty of God. (Plate Chapter IX. P6).

The promise of God to His people is signified and inculcated by the railings in front of the altar which cut it off from the rest of the church. These railings are formed with copies of the traditional state sword with which a chief swears the oath of office and service to his people on his installation. (Plate Chapter IX. P7).

In modern Ghana, therefore, the asasedwa continues to be an artifact of multi-functional significance. It is a utilitarian artifact and an important symbol at the lowest level of the social

PLATE CHAPTER IX. P 5.

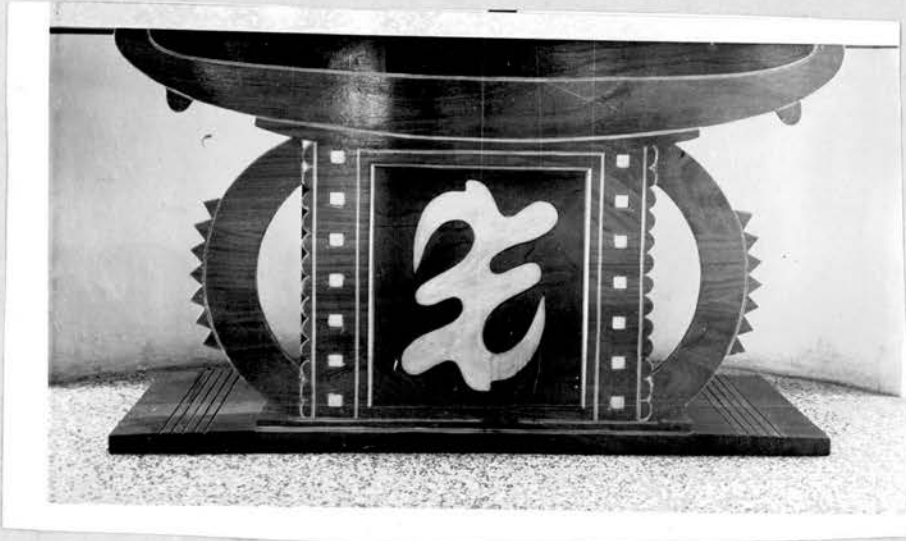

Altar of Emmanuel Church, Labadi, Ghana.



Half moon state umbrella over the altar.



Railings - replicas of state swords. The symbol of promise. Here - God's promise to man.

unit, among the lineages, and also in villages, schools, church
and state.

CHAPTER X

RECAPITULATION AND OBSERVATIONS

In this study of Akan stools, an attempt has been made to examine the aesthetics, history and sociology of the asgsadwa in particular. The significance of this object of art at all levels of Akan social structure and social processes gives it a special uniqueness. The central idea of this chapter, is our observation that, the asgsadwa might well be regarded the summary of Akan culture.

From being an ordinary domestic seat sentiments developed around it. Specific stools came to be classified as stools for children, women, men, lineage heads, village or town heads, and 'states'. Therefore lineage, village or state stools actually evolved. Even in the case of the historic Golden stool of Asante, it really came to replace a lineage stool which, through the accident of history, was given new, wider, and all inclusive powers.

The significance of stools in chiefship grew also from the practice of regarding personal stools as the first things of any legacy. Once a stool is handed over to an inheritor, the rest of the legacy is regarded as having been automatically inherited by him.

In course of history, the idea of stools being objects for legitimising authority got itself established. Stools became symbols of respect and authority. Lineage stools which became

politically significant gave their incumbents political power and privileges for reciprocal responsibilities and duties towards those upon whom the stools had jurisdiction. It is this development in stools which makes the stool as a symbol of office an important facet of this study. We high light the governmental process as a special kind of democratic political organisation and call it the Akan stool polity.

The study of who carve stools and where they are carved led to the study of the history and processes of carving in Ahwiaa - the renowned stool carving village in Asante.

Tracing the development of chiefly stools from Denkyira before 1700, we looked at the era of the Asante Union and power, when king Osei Tutu heightened the importance of the object and idea of the asgsdwa. The object, and especially the chiefly use of it, reached its highest development in Asante government of the later eighteenth and nineteenth centuries. From the Asante kingdom the use of the stool as a symbol of leadership and chiefship and that of the being of a people spread both northwards and southwards of Ghana. However, Akwamu and Akim, in their own right, helped the development and spread of the idiom.

The object became central to all other objects of leadership known in the culture, making what we have called the stool polity and stool complex, definite and important features of Akan social organisation.

We suggest that the Golden stool of Asante was a 'political theory' and was essentially the 'unwritten' constitution of the

people. We regard the black stools which are, in effect, monuments to deceased chiefs as essentially historical charters. Basing our conclusion on the entire field work on ancestral stools, we have suggested that ancestral stools are not regarded as deities by the Akan of Ghana. Instead they are principally objects of social history, reverence and ceremony.

Although the subject of symbolism of stools is examined, there are a number of details and facts which need further intensive investigation and study. For example, there are many abstract symbols on stools and items in stool complexes yet to be investigated. Most of these were, in the past, meaningful symbols and a discovery of as many as possible might throw more light on the subject as a whole.

The comparative study of stools in non-Akan lands has revealed the wide extent of the idiom in the country.

Finally, our examination of the asasadwa in contemporary Ghana reveals a noticeable resilience of the object and idea of it in the country's traditionalism and change. It is believed, for example, that the use of this symbol of office together with other associated regalia may enhance modern national political socialization. Hence the concept and use of stools and items of stool complex in Ghana's National Parliament House. A clerk of The National Parliament explained that it was the view of the governments of both and first and second republics of the country that such symbolism may help to present the new styles of government to the ordinary people. For it is believed that the seeds of the envisaged modern democratic government are there

in the system of government we have called the stool polity.

For our purpose, the significant things at the moment are first, that the stool and other associated objects of leadership constitute the major part of the decoration of parliament house. Secondly, the decorations are not for their own sake but, in the true spirit of Ghanaian art, are meant to reflect specific political process and culture.

One of the lessons supposed to be taught by the decorations is that of abhorrence of discrimination as enunciated by the Golden stool. - Obi nkyere obi ase. - No one unearths the antecedents of another. This is a call to national unity and the avoidance of tribal divisions.

It became evident from the study of Akan asagadwa and stool complexes that they help to validate or invalidate some oral traditions. A later more intensive study of the art history of specific stool complexes and art objects, in general, would be complementary to the present work. Akan leadership symbols in Museums outside the country and those in the British Museum especially are worth studying. In addition to these, a comprehensive study in the near future, of the court art of Akwamu, Akim and Akropong is very likely to add to the knowledge on this subject. We, therefore, propose to do it or encourage our people to do it.

These observations are made in the recognition of the fact that there is a lot yet to be known about this topic of the thesis. The Akans say: Esono, yennwa no dakoro. (It is impossible to cut an elephant to pieces in a day). Paradoxically, this same idea

of the need for patience in understanding stools in social context is expressed by another proverb—B_oaseto na yehia se y_gdedwa at_gtea na y'ahu ne krona. (Patience is what is needed in the dissection of an ant if its heart is to be seen).

The very ubiquitous nature of this artifact and symbol in the culture of Ghana, the complexity of other artifacts in chiefship to which the stool has become central, and the multitude of ideas and symbols that have developed on and around the stool make it a vast subject for study. The author reckons and regards this thesis as only a modest contribution to the study of art and society in Akan and other parts of Ghana through a sculpture—the as_ggdwa not excluding its associated art.

APPENDIX 1Dynasty of Boa Asri Stool (Ahwiaa)

1. Boa Asri
2. Anyinam
3. Asan Genne
4. Agyeben Nti
5. Okyere Panin
6. Okyere Kuma
7. Kwasi Yoyee
8. Akioku
9. Nti Beng
10. Adabe
11. Gyamfi Kwame
12. Kwasi Adee alias Ababe Abadie

The Dominant clan claims affinity with that of Ejisu, Offinse in Asante and Kyebi in Akim Abuakwa.

APPENDIX 2

1. Why do you carve ? Father was carver, 6. Uncle was carver, 2. Brother was carver, Chose to be, 2. Family legacy, 6. Must continue ancestral craft , Legacy & ancestral craft but also for money, money first, other reasons subsidiary, Don't know (DK) Don't apply (DA)
2. How do you train? Formal instruction 1, Informal 14, Boarded out to other craftsman, not relative, Studied at feet of no relative 1, D.K. or D.A.
3. Who was your teacher? Mother's brother, 5. Father, 9. Brother, 1, Other relative - No relative 1.
4. Who taught your teacher? Uncle 5, Father 9, Brother 1, No relative, 1.
5. How did your teacher train? Mother's brother taught him 7, Father 6, Grandfather 1, no relative 2.
6. Type of story given as origin of stool or other carving? Mythical, Legendary, Historical 15, Religious 1.
7. Is special place given to carvers? Yes 9, No 4, Indifferent 2. DK 1.
8. Who is head of the carvers? Ahwiahene 6, Emerged leader 2. DK 7.
9. Do you find carving worthwhile? Yes, 10, Yes with supplementary work 2, Want salaried job, 1. Indifferent 1, DA 1.
10. What things do you carve? Stools 13, Dolls 1, Ladies 1, Anything ordered 1.
11. What did your tutor carve? Stools 10, Dolls 2, Stools and dolls 3, Miscellaneous 1.
12. Would you continue to carve? Yes, principally because of financial benefits 6, Yes, it is prestigious 2, Family obligation 6, Yes, enjoys it besides all else 2.

13. Do you regard carving important to the community?
Yes, honour to village 16.
14. What do you express in your carving? (a) Concepts of traditional beauty 7. (b) Ideas treasured in the culture 7, a & b but personal ideas too 2.
15. How do your ideas play on those of the society?
(a) Correct 3, (b) Correct & encourage status quo 9. (c) Correct & perpetuate values 4.
16. How are you regarded by people?
As creator of ideas 3, Interpreter 2
DK 11.
17. Are you an ordinary carver? Yes 13, No. 3.
18. What are your special privileges?
Respected in the village 1, Could rise to status of Asantehene's carver 1, Accepted where others are disallowed in Kumasi palace 9. Others 2, DK. 2, DA. 1.
19. What taboos relate to carving?
Abstinence from sex before carving 1, No anger - No carving on Fofie when corpse in village 13. H.K. 1 when carver has a hidden sin 1.
20. Do you observe the taboos? Yes, 12. No, only the Dabone days 4.
21. Do you observe merely out of convention?
Yes, 12. No, something real exists in taboos 3, Indifferent 1.
22. Would you be a commercial or amateur carver?
Professional 13, Amateur 3.

23. What, therefore, do carvers express in carving?
Philosophy or proverbs, language,
history, politics 16.
24. For whom do you carve? General public 12, Also Asantehene 8.
25. How do people become royal carvers?
By age 2, Experience 1, Birth right 3,
Proficiency 3, Election 2. DK. 5.
26. Do you help in preliminaries - carving Asantehene's stools?
Yes, 12, Not qualified 4.
27. How are styles initiated? Study traditional ones and
add to them, 7. As prescribed by customer, 9.
28. Status of royal stool carvers? Have right to stool houses 1,
Special gifts from chief 5, Special gifts
from Asantehene 3, D.K. 7.
29. How the Ahwiaahene is chosen and installed? Hereditary
stool, 7. Chosen from Asona ruling
clan of Ahwias and installed on Boasri
stool, 9.
30. Has Ahwiaahene a black stool? Yes, 16.
31. Who was first to carve in Ahwias? Akwasi Yoyee 12. Some
one else, 2. D.K. 2.

APPENDIX 3Summary of Requirements of the Golden StoolPreamble

No one should make the like of the Golden stool in or outside the Asante nation that has been created. (Note that this item in the theory of Asante political ideology has remained respected) Busia records the apology which had to be rendered by Dormaahene to the Asantehene for bringing to a council meeting a gilded asipim.— 26th September 1941.

Social and political laws 'given' by the Golden stool
(after Kyerematen)

- i. It should be sacriligious for any person within or without Ashanti to make another Golden stool or to decorate a stool or any other kind of seat with gold. Any such stool should be seized. (The war against Kofi Adinkra in 1818.)
- ii. Thursday should be regarded as a holy day. No war should be begun on Thursday.
- iii. Only the king has power of life and death. Hence man's slaughter or murder were challenges of his authority and punishable by death.
- iv. In dealing with his subjects the king must observe strict impartiality.
- v. False prophecy, when proved was punishable by fine or death. If fined, the guilty person must be retired from the 'priesthood'.
- vi. Certain types of wood and certain articles of utility must not be used as firewood.
- vii. Farm crops which serve as boundaries must not be uprooted.
- viii. A girl becoming pregnant before the public proclamation of her nubility, and the man responsible, should be banished and allowed to return only after the birth of the child and after

purification rites have been undergone. The child should be surrendered to the king or other appropriate chief, for training as one of the nsurankwaa - court officials responsible for medicines.

ix. It should be capital punishment to put in Kumasi a building of wattle and not to reinforce it with turf, so that it falls.

Kyerematen refers to this as the decalogue of the Golden stool.

See Africa. Vol. XXXIX. No. 1, January 1969.

APPENDIX 4Stool occupant and ownership of private property

The custom, as it was and which was rectified in 1942 at a Confederacy Council meeting of ASanté, is this:

A chief should not own private property, for as they put it, he and the stool are one. He is to be cared for from what traditionally belonged to the stool.

His private property, if he has any at the time he is chosen to become chief, reverts to his family or he may dispose of them. This applies specially to farm-lands and any family property in his possession.

The only way in which the stool could be said to owe money to the occupant is only when he, as leader, with the consent of his elders, according to Busia, negotiates a loan on behalf of the stool and becomes the principal debtor.

Where with the consent of the elders a chief engages in a business, the gains accruing from the business is gained for the stool and in this case, any loss becomes debt for the stool.

The chief could not stand surety for anybody without the consent of his elders. If by any unauthorized action he incurs a debt that may be sufficient grounds for his destoolment.

A chief should not be a debtor after his enstoolment. Before his enstoolment, his debts, if he has any at the time of

his election may be settled for him, if the people want him in spite of his debts.

The most important point that is made here is the absolute necessity that a chief must be free of debts and that he cannot have private property.

See rectification of this custom.

Minutes of Council meeting, 1947. Gistin Busik 1958, p.201 - 204.

APPENDIX 5Family Head only - Physical Count and Analysis

Town/or Village

House Number

-
1. Number of households
 2. Number of wife or wives in each household.
 3. Family head/or heads.
 4. Number of children.
 5. Number of children's stools(?)
 6. Design of the stools (?)
 7. Number of 'marriage' or bridal stools (?)
 8. When was each given?
 1. At marriage
 2. Before marriage
 3. With the bride prestations.
 9. Why was it given?
 1. Symbol of welcome
 2. Symbol of 'office'
 3. Symbol of authority as registered wife.
 10. What is the pattern of the stool ?
 11. Is it proverbial ?
 12. What is the proverb?
 13. Why the particular pattern?
 14. When did this pattern become the pattern of your family prestations to new wives?
 15. Do men regard it a necessary artifact to be given?
 16. Do women consider it a necessary artifact to receive?

17. Why is it so?
- 17a. Is the stool to the wife a symbol of office?
18. Is it still regarded necessary?
- 18a. Does the type of stool given suggest the type of life expected from the new wife?
19. Is failure to observe this custom indicative of something going wrong?
20. What is going wrong if so?
21. How many female stools are in this house?
22. How many male stools are in this house?
23. How many are part of the ordinary furniture?
- 23a. Number belonging to men?
- 23b. Number belonging to women?
24. How many are special?
25. To whom do the special ones belong?
26. Are any of the stools 'oman' stools?
27. Number of the stools or 'Oman' stool status.
28. Are they 'female' stools or 'patrilineal' stools?
29. Is any a Gu-dwa (divine existence)?
30. Is it Bo-dwa (created by chief etc.)?
If (30) year of coming into being and how?
31. If (30) year of creation.
32. If (30) name of creator.
33. Which stool or stools will you hardly part with?
34. Why will you part with it?

55. Why do you blacken them?
56. Have you terra cotta (kuruwa or Nkua) heads that go with these stools?
57. Why do you make them?
58. Who makes them?
59. Are they still being made?
60. Do you consider them important?
61. Are there some special rites to any of the stools here?
62. What are the rites?
63. Who performs them?
64. Are there any special music types associated with any stool here?
65. Are there any special dances associated with any of the stools here?
66. Any special artifacts associated with any of the stools here?
67. How did they become part of the stool 'regalia'?
68. How would you like the disappearance of the stool and the things associated with it?

APPENDIX 6Involvement of the Stool in Social Life
Regalism/Government and Politics

Name of Town or Village

Informant

-
1. The ruling clan?
 2. How did it become the ruling clan?
 3. Immigration story, legend or history?
 4. Ruling houses?
 5. Lineage heads of ruling houses (?)
 6. Abrono (wards in the town or village)
 7. How did the wards or abrono come about?
 8. Which families are associated with the abrono you name?
 9. Are these families the only occupants of the wards or are they joined by others?
 10. Enumerate the types of persons mixed with the family groups?
 11. The Abusua
Find out which relatives own lands in common, pay funeral expenses together, share marriage fees, have a common head, ofiepanyin.
 12. Find out the duties of the ofiepanyin. Do all, for example, Asenie clansmen in the village have a common ofiepanyin and occupy a stretch of farming lands?
 13. Are they exogamous?
 14. Is the ofiepanyin the same as the abusuapanyin?
 15. What are the differences between them, if they are not the same?

16. Political organisation

Does the village have an odikro, that is, a chief whose ancestors under e.g. the (Mamponghe)er a divisional chief, are said to be 'Owners' of the land or who occupy blackened stools?

17. Or does the village have a headman?
What stools have they?

18. Enquire into the distinction, if any difference between an Odikro who is chief and an odikro who is a headman and state type of stools they have.

19. Which family occupies the village stool?

20. Enquire into the historical circumstances in which they came to occupy it?

21. Who are the traditional chief-makers?

22. Describe the processes of enstoolment and destoolment?

23. Enquire into the historical circumstances in which offices, accrued to particular families?

24. Are these offices hereditary or appointive? If appointive by whom is the appointment made?

25. Name their offices and the part that they are supposed to play in the enstoolment, installation and destoolment of the Odikro?

26. Enumerate the councillors of state and their particular offices, e.g. Akwamu, Kronti, etc., and name the families or villages with which they are associated.

27. Describe the part that all chiefs/councillors are expected to play in the enstoolment/destoolment of a chief?

28. Make lists of all past and present Odikrofo and Afiepanyin or Abusuapanyin.

Akonwa too

Service of agricultural nature to the Chief (Stool)

Entitlement to special game or parts of

Entitlement to game - wild animals hunted.

29. Political position of the chief in Ashanti set up.Other regalia associated with the stool:-

a. <u>Horns</u>	Vital	Sound	History
Name	Statistics		
b. <u>Drums</u>	Vital	Sound	History
Name	Statistics		
c. <u>Swords</u>	Vital	Sound	History
	Statistics		
d. <u>Others</u>	Vital	Sound	History
	Statistics		

II

1. What type of sitting artifact is expected in a chief's house?
2. What is the design of stools to be expected?
3. Clan of Odikro, head, Ohene.
4. What type of stools are used by his councillors?
5. Why do they use that particular type?
6. What type is used by the chief himself?
7. Why that particular design?
8. How did he come by it?
9. How did he acquire it?
 - (a) Military right?
 - (b) Predilection?
 - (c) Imposed by position ?
 - (d) Chief giving the right to it?
10. Can a family stool become the Oman stool?
11. Military duties
Did the village, town, constitute a single military unit?
12. What units within the state served as the e.g. (Twafo, Adonten)?
Enumerate all.
13. What symbols distinction has (any particular division) your division? (e.g. Sandals, umbrellas or any other special military recognition). Any verbal art -- abodin or proverb or praise song?
14. Judicial
What judicial duties fell to chiefs?
15. What judicial duties fall to chiefs now?
16. What is the principal concept chiefs follow (reconciliation, retribution, allotment of punishment, etc)?

17. How much judicial function do chiefs play now?
18. Do chiefs receive any 'thanks' for their judicial duties today from ?
 - (a) Government?
 - (b) The people?

Ceremonial

19. How is the chief regarded in matters of ceremonial now?
20. Are chiefs satisfied with the position?
21. Land
What is the position of the chief in relation to land?
22. Is land the link between the living and the dead in anyway?
23. Why is libation poured on the ground for the ancestors?
24. Why is it foul to put the stool on the bare ground?
25. Why is the chief destooled when the sole of his foot touches the ground?
26. Why is he destooled when his hinds touch the ground?
27. What are chiefs' privileges in land?
28. Whence the chief's political right to levy taxes?

Service to the Stool

Fara work .

Liability to levies for specific purposes .

Ahensa .

Ayitoe .

Asekantoe .

Apeatoo .

Musutoo .

APPENDIX 7Black Stools

- 5 Sex of respondent Male (1); Female (2) .
- 8 How did each come to have the black stools?
- They are the ruling houses .
 Their lineage is the land-owing group/clan .
 They were given the power to do so - their stool being a Gudwa .
 One of the first lineages of town/village .
Ohema stool .
 One of the organized chiefly lineage/houses .
 D.K.
 One of the Bodwa lineage/houses .
- 9 Status of owners of black stools?
- All chiefs .
 Not necessarily .
 D.K.
- 10 Which stools are blackened?
- Personal stool (used most) .
 Official stool (made at installation) .
 Bath stool .
 Dining stool .
 New stool unused .
 D.K.
- 11 Why are stools blackened?
- To preserve to get a record of the chief and his/her history.
 A "monument" of the chief .
 Provision of an abode for the ancestral spirit of the chief .
 Provision of abode for all the ancestral spirits .

- An altar of the ancestors.
- A god to be worshipped .
- An artifact through which ancestors are worshipped .
- D. K.
- 12 When the state black stools are many, which are/is regarded as the state stool?
- The founder of the stool or ruling clan .
- The most illustrious chief.
- The bravest .
- Other specify .
- D.K.
- 13 What taboos relate to the stools?
- Code 0 - 8 order of importance .
- Specify (Those relating to the occupant) .
1. Circumcision
2. Menstruation
3. Deformity
4. Others
(Specify)
- D.K.
14. The black stool is:
- A fetish .
- A shrine .
- Home of ancestral spirit .
- D.K.
- Artifact which gives history and symbol which inspires .
- 15 How does the spirit of a man become the spirit of the village/nation?
- By adoption .
- Spirit merges into the pool of all the departed so becomes spirit of the people .
- Spirit of the ruling head represents all the spirits - link between the living and the dead.
- D.K.

- 16 What feelings are encouraged by black stools?
Inspire great deeds .
Brings back vividly the "personality" of the departed - so mixed feelings are aroused .
Inspires awe and reverence .
- 17 Why is the stool supposed to be magical?
Because the people set it apart in their minds as very reverential and inspire great deeds -
Because spirit of the dead dwells in it .
Because it is a god .
D.K.
- 18 Does the stool of a bad chief have any significance apart from its historical importance?
Yes
Yes. Acts as a social sanction.
No.
D.K.
- 19 The word "som" means in 'Yesom yen nananom' :-
Worship them as gods .
Give them their due service, honour and reverence .
D.K.
- 20 What do we get out of our "som"
Get 'spiritual' satisfaction \ "Psychological" satisfaction
But believe they intercede for us .
Hence we commune with God via them .
Give us opportunity to worship them as gods.
D.K.
- 21 What is crystalised by the black stool?
The imperishable spirit .
The perishable Mogva .
The spirit (sonsom) \
D.K.

- 22 Is the "sonsom" male or female?
- Male
Female
D.K.
- 23 Is the stool a repository of soul or spirit of the ancestors?
- Yes
No
D.K.
- 24 What other artifact is regarded as being able to represent or remind people of, or contain the spirit of the ancestors?
- Bosomfena
Other regalia
Special shrines in the palace, and elsewhere specially set aside
D.K.
- 25 How are the black stools in the state arranged hierarchically?
- Akan order of precedence
Akan order of precedence with occasional changes by particular chiefs.
D.K.
- 26 How are the black stools of the head chiefs palace hierarchically arranged?
- According to order of period of rule
As (1) but regard for the most illustrious etc., rank first in the minds of the custodians and the stools and people
D.K.
- 27 Which type is that of your state?
- Traditional Mmaa dwa
Traditional Mnema dwa
Traditional Mmaa and mnema dwa
Modern Mmaa dwa)
Modern Mnema dwa)
Modern Mmaa and Mnema dwa
D. K.

- 28 What is the design
in your stool?
- Traditional (specify) .
Modern and Traditional.
Modern (specify) .
Traditional (many designs specify).
D.K.
- 29 How did the group come
by the particular design?
- Chosen by a chief .
Suggested by the headchief .
Chosen by chief, only approved by
the head chief .
Special historical incident suggested
what the design must be .
Family totem or crest .
D.K.
- 30 How is the asafohene
stool created?
- Result of a valour displayed .
There are original asafo's but new
ones come when occasion arises .
Others - specify .
D.K.
- 31 Are Asafo stools male
or female stools?
- Male .
Female .
Could be either.
D.K.
- 32 Are all military stools
black stools?
- Yes .
No .
D.K.

- 33 Are military titles which are (products of stools) inheritable and by whom?
- It all depends.
- Yes by sons or others - other than nephews .
- Yes by nephews .
- No .
- D.K.
- 34 What are the rules of inheritance relating to the principal stools?
- Matrilineal mostly.
- Matrilineal.
- Patrilineal.
- Patrilineal mostly.
- D.K.
- 35 So to your mind what is the purpose of the stool on the whole?
- A symbol of chiefship and all it stands for in Akan society.
- A sacred object only.
- A regalia and sacred artifact.
- A visual link between the dead and the living .
- D.K.
- A symbol of love and chiefship and (4) .

APPENDIX 8Examples of Lineages that possess black stools and the design of the principal stool of the village or town.

Town or Village	Lineages with black stools	Taboos that relate to the black stools	Stool in festival (purpose)	Designs of the supreme stool
ABURI	Aduana, Abra- de, Asona, Agona, Oyoko, Baretuo, Asekyiri, Asene.	Circumseision, menstrual blood, six- fingered per- son, leprosy, palm-wine, kenkey, sugar- cane, mourning cloth & epi- lepsy.	Ancestors are remem- bered and honoured.	Two guns, two swords, two keys and a warrior.
ANWEREAKS	Asakyiri	Circumseision, menstrual blood, leprosy, six- fingered per- son, mourning cloth.	Spiritual communion with the ancestors	Effigy of the vulture in the <u>mfinifini</u> .
MAMFE	Asona, Aduana, Agona.	The goat, fowl, menstrual blood, lep- rosy, mour- ning cloth, six-fingered person.	Period of annual symbolic feasting with the ancestors	(Could not be ascer- tained)
MAN - KESSIM	Asona, Annona, Aberade, Twidan, Nwonna	Menstrual blood, widow, sexual intercourse previous night, palm wine, lep- rous person, six-fingered person, one- eyed person and physically deformed.	Occasion for re- membering the an- cestors.	Not known by informants, rather un- willing to disclose.

Town or Village	Lineages with black stools	Taboos that relate to the black stools	Stool in festival (purpose)	Design of the supreme stool
	Agona, Tca, Asona, Oyeko, Asene, Aduana, Bretuo.	Circumcision, menstrual blood, leprosy, maimed or deformed person, mourning cloth, six-fingered person, and 'kyame-bire' a kind of skin disease. No entering of stool room after sexual intercourse	Spiritual communion with the dead.	Could not specify
OYOKO	Oyeko Aduana, Bretuo, Asona, Koona and Agona.	Menstrual blood. Should not enter stool room if has ever had anything to do sexually with a woman who has copulated before with a circumcised man.	Could not tell.	Tortoise and the snail. Symbolic of peace loving people.
	Bretuo, Akuona, Aduana, Asene Agona, Amoakada.	Six-fingered person. Deformed, circumcised, leprosy, menstrual blood.	Stool, the focal point for remembering ancestors who are thought to be able to mediate between the living and the dead.	Could not be ascertained.

Town or Village	Lineages with black stools	Taboos that relate to the black stools	Stool in festival (purpose)	Design of the supreme stool
OLD TAFO	Adiana, Bretuo, Asene & Ekoona.	Circumcision, menstrual blood, leprosy.	Period for cleansing the stool.	Could not be ascertained.

1 From the tabulated evidence here, menstrual blood, circumcision, leprosy, deformity appear to be the most common taboos to all the stools.

2 Clan names are meant to be names of lineages.

APPENDIX 9Motifs on tops of Linguist Staff etc.DenkyiraA young man attempting to swallow a small bird is restrained by a chief.

'Anoma sua a, ye mpatu nwe ne ne ntakra, yetutu ne ho ansa.'

No matter how small a bird may be, it should not be eaten with the feathers.

Gently does it, that's the motto.

A man trying laboriously to scrape the bark of a tree into a receptacle.

'Obaako were aduru a egu.'

If one person attempts to scrape the bark of a tree for medicine the scrapings fall to the earth.

Many hands make work light. (Co-operation and effort of everyone in the community is essential).

Three people seated together with their heads together.

'Etire ne etire hyia, ntoto mma.'

Round table conference dispel misunderstanding. Appeal for unity and mutual understanding.

A 'have-not' looking on hopelessly as the 'have' enjoys his plenty.

'Dee adee wo no na edie, na gnyg nea gkpm d& no.'

It is he who has the right to a thing who enjoys it and not just anyone who thinks he should have it or wants it.

Warning against covetousness. Also counselling hard work.

A man holding a box of matches and standing before a lantern.

(The man could hold a flaming torch -- the Older version of the motif).

'Dee ekura gyaten onkanea na ohunu dee ooko.'

The light bearer sees where he goes.

Symbol of Abuakwa twafohene (chief of the scouts). He knows whither to go in war.

Also means: Follow good counsel and help him that is chosen to lead. i.e. the chief. No sabotage.

A hen looking at the beak of a cockerel.

'Akoko bedee nnim adekyee, nanso ohwe no onini ano.'

Learn to live well from the example of the past good ones.
OR Propriety is a vital canon of life.

The head of an animal in a 'soup pot'.

'Aboa tiri nyera nkwan mu.'

The head of an animal cannot be lost in a pot. A giant cannot be mistaken for a dwarf although he mixes with them.

Humility counselled. One does not lose his high position by stooping to help.

A nest, a weaver bird and an eagle.

'Akyem anwene ne birebuo, na akoropon agye afiri ne nsga.'

The weaver bird has made its nest and the mighty eagle has seized it.

Paradoxically, might is not always right.

A man seated, with his right hand covering up one eye and his left pointing to the ear.

'Wani aanhu a waso nso sante?'

If your eye is closed, is your ear also stopped?

You do not want to stand aloof in everything. Do not be ignorant.

Two spiders sitting on their web and two men on either side of the web.

'Obi nkyenkyere nyansa nko Kwaku Ananse kurom.'

No one ties up wisdom to convey to the domain of Kwaku Ananse.

One does not carry coal to Newcastle.

Warning also against intrigues. The wise in the state will see through the craftiness of those who think they can pull wool over the eyes of the 'state'.

A pineapple with suckers.

'Abrgba ase ntu.'

Grace will never run dry.

Akropong Akuapia

Bird with the neck turned right to its back.

'San kg fa.'

Pick it up from behind.

Make good your mistakes or Pick up the good things of your ancestors. Learn from them.

An elephant and a palm tree.

'Kwakwaduan, Esone a odi mmg' (The state emblem)

The elephant is mighty, the palm tree is steadfast and does not fall easily. It is also a very useful plant. Its uses number ninety-nine. (Counted and documented rather roughly by a Basel Missionary. Manuscript missing).

However, the palm tree has indeed many uses. It is used for many types of food, oils, building huts, roofing huts, palm wine extracted etc.

Hence the Akuapia state is manifested as a great one, steadfast and dependable.

The buffalo horn.

'Mmen.'

Signifying strength and constancy.

APPENDIX 10

Horns. Nine special horns of Juaben Asante

1. Oboduan. 2ft. 4ins. It is specially blown to invite people to state events, e.g. death of Ohene, Royal princes and persons of importance, out-break of fire, etc.
2. Krachi Denteh Awisi captured from Subri of Basa by Nana Kofi Akrasi. Basa was beheaded and his horn was given to Okyeame Asare. Nana Akrasi ordered that the horn be blown to invoke the spirit of a god this man brought with him. It was called Krachi Denteh. Hence the horn sounds 'Krachi Denteh-Awisia'.
3. Asante Kotokɔ Wobɔkae me. Nana Akuamoah Panin succeeded Nana Kofi Akrasi. Through his pride and unwholesome practice of unearthing the antecedents of people in the community he was dethroned. Nana Fetua succeeded him. Nana Fetua proved a bad king selling parts of the stool lands and properties to some other chiefs. He was therefore dethroned and Akuamoah was recalled. He caused the horn blowers of this set to horn the epigram, Asante Kotokɔ, wobɔ kae me. (Asante Kotokɔ, you will remember me.)
4. Nana Kwasi Boateng, also called Juaben Boateng, the son of Nana Juaben Serwaa, who was supposed to have recaptured the Golden Stool from enemy hands at the battle of Kantamansu war and brought it back to Asante was afterwards charged to have taken for himself some Gold attached to the Stool worth about a thousand pounds sterling. Boateng denied having taken this gold. He was very sorry for the ungrateful reward given to him and caused the horn to be fashioned to commemorate this. Akani Mane Ante ei (Had I known, but now!)
5. Mate! Mate! is another horn which has to do with the same incident above. Nana Juaben Boateng was being pressed to surrender the gold which he denied he had taken. His mother caused this horn to be blown to warn his son to answer Mate, Mate and nothing else. (I have heard, I have heard).
6. We Ahantan! We Ahutu! During the trials, Boateng conceived an idea and fashioned a horn to blow to 'insult' the Asantehene - we ahutu! We Ahantan! (Lit. you are too proud.)
7. Amofu-Adufa or Mawo Awopa! Horn of Nana Asafu-Adjei Juabenhene in praise of his marriage to Nana Akua Sapomaa in which Nana Afrakoma Panin, Akua Boatemaa and Akua Mansah were born. As

a result he was made to occupy the paramount stool and so he got this horn to blow (I have given a lucky birth). i.e. I have had lucky children.

8. Ntamera otherwise called Mmen-Nson. Seven long horns about three feet each captured from Ntiamoah-Amankoa of Abuorse. In the Asanteh-Jaman war Nana Akuamoa Panin crossed the river Nimpere and climbed the Kamsampere hill to ward off attack of the Jamans. This Nimpere mafore Kasamperebuor (lit. I have crossed river Nimpere and climbed Kasampere Hill) commemorates the incident.

9. Akroben. Nana Kofi Akraasi walked on thorns and fought the Subiri of Basa and captured him and caused a horn to blow Akraasi Ayie, Akraasi Ayie. (lit. Akraasi on thorns).











































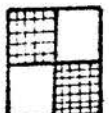









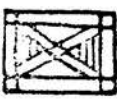







Note: Ayie is a plant with thorns around the stem.

Information by the Juabenghene.

Recorded by the State secretary.

APPENDIX 11Adinkra Designs (A selected sample)

1. Gye Nyame - lit. Only God. Symbol of Omnipotence and immortality of God.
2. Nyame dua - God's tree - altar of the high God.
3. Biribi wo soro - Nyame biribi wo soro na ma emmeka me nsa. God! there is something in heaven, I pray that you let me reach it. Symbol of hope and confidence in God and His purpose.
4. Hye wo ho nhye - That which cannot be burned. Symbol of magnanimity and greatness.
5. Bi nka bi - One does not touch one, or bite not one another. Symbol of Unity. Advice to avoid strife.
6. Musu yi die - that with which evil is removed. Symbol of the belief in perpetual existence of man.
7. Nyame nna na ma wu - God does not die and therefore I cannot die. Symbol of the belief in perpetual existence of man.
8. Akoma - the heart. Symbol of goodwill and patience.
9. Nsroma - the star (child of the heavens) Symbol of belief of man's sonship of God. Dependence on God and giving Him whatever glory man has.
10. Osrane ne nsroma - The moon and the stars. Symbol of faithfulness and benevolence.
11. Kodae anowero - The talons of the eagle. Symbol of strength. (Oyoko clan symbol)
12. Aban - Double fence. Fenced homes - double security. Safety.

1		13		25		37		49	
2		14		26		38		50	
3		15		27		39		51	
4		16		28		40		52	
5		17		29		41		53	
6		18		30		42		54	
7		19		31		43		55	
8		20		32		44		56	
9		21		33		45		57	
10		22		34		46		58	
11		23		35		47		59	
12		24		36		48		60	

13. *Mkyin kyin* - Toughness, having many roles to play.
14. *Akoko nan tia neba
a, enkum no* - The hen may tread upon its chickens
it does not kill them by this. Symbol
of mercy and protectiveness.
15. *Ako ben* - War horn. Symbolises readiness to be
called to arms.
16. *Ese ne tekrema* - the teeth and the tongue. Symbol of
friendliness, unity and dependence.
17. *Penpansie* - That which will not crush. Symbol of
steadfastness, strength and greatness.
18. *Funtunfunafu
denkyem funafu wo
afurubom nse worldidi
a na woko* - Two crocodiles that have one stomach.
In spite of this, they quarrel when
they are eating. Symbol reminding
people that they are one and need not
strive unholy.
19. *Owe fere adobe* - The snake climbs the raffia palm tree.
Doing the impossible. Greatness.
20. *Ntesie, matomasie* - What I have heard I keep.
Symbol of wisdom and knowledge.
21. *Kuntinkantan* - Greatness at the same time, bloated or
inflated. Symbol warning against boast-
fulness. May be worn to speak to
juniors who try to do things above
themselves.
22. *Adinkrahens* - King of the adinkra patterns. Symbol
of greatness.
23. *Another version of 22*
24. *Mra krado* - lit. The padlock of the law.
Seal of the law.

25. Akoma ntoase - lit. the joined heart. Symbol of agreement or a charter to be observed by a people or parties.
26. Sankofa - lit. return and take it. Learn from the past. Turn and pick the good things in culture.
27. Akofena - the fighting sword. Crossed state swords the symbol of authority.
28. Epa - hard cuffs. The law is no respecter of persons.
29. Damedame - Game of Drafts. Craftiness and intelligence.
30. Sunsum - soul. Symbol of purity and spirituality.
31. Konti ne Akwama - The asafo created by Osei Tutu. Konti and the Akwama bands or asafo or fekuo.
32. Anibere nso gya - Anger or covetousness does not light fire. Symbol of defiance.
33. Mframadan - The house of winds. House reinforced to face all odds. Symbol of fortitude and readiness for all eventualities.
34. Aya - fern. Symbol of ability to endure. Hardiness and defiance.
35. Tabon - paddle. A sure helmsman.
36. Krado mra - as 24.
37. Ohene aniwa - The eyes of the king. (The king has many eyes. Nothing is hid from him.)
38. Fihankra - A kind of architecture very much desired in Akan. Kind of forms desired. Rooms or walls on four or more sides with a wuadrangle in the centre. Symbol of security, brotherliness and solidarity.

39. Sankofa as in 26 - One can always begin again. Symbol of hope.
40. Wawa aba - The seeds of the 'wawa' tree - hardiness.
41. Dwanimen - the horns of a ram. Humility, and strength.
42. Owu atwedee - The ladder of death. Remember death. Live well.
43. Kramo bone amma
yenhu kramo pa - The bad mohammedan makes it difficult for the good one to be recognized. Symbol of warning against hypocrisy.
44. Nsaa. Nea onnin nsaa
na eto na go - A kind of coarse blanket on which the stools of great lie. He who does not know the 'nsaa' that buys the fake of it. The sign of stool carriers. Has come to mean ability to discern, knowledgeable.
45. Afen as in 18.
46. Fofae - The seeds of a plant. Symbol to warn against jealousy.
47. Nkyima - Crossing patterns made on the cloth before stampings are done.
48. Pa gya - lit. Strike fire. Symbol of gunners, bravery.
49. Apunnum - five tufts. A hair design.
50. Nsirewa - Cowries. Symbol of affluence.
51. Sepow - execution knife.
52. Nkonsonkonson - chain. Symbol of unity.

53. Aban - two storied house. Greatness. Used to be monopoly of kings.
54. Gyawu atiko - the back of the head of Gyawu. Commemorates the escape of Gyawu who was a sub-chief of Bantama.
55. Ohen tuo - the king's gun. Greatness. Defender of goodness or the king.
56. Dua fe - the wooden comb. Representative of femininity female consideration, patience.
57. Dene ntoaso - the double hour drum. Symbol of persistence and greatness.
58. Bese saka - a bunch of kola nuts. Symbol of greatness.
59. Nkruma kesee - the big ekro. Symbol of greatness.
60. Kwatakye atiko - special hair style of stool carriers.

APPENDIX 12

MEMORANDUM on the relation between Christians and the state presented to Nana Agyaman Prempeh II, Ashantiene, by representatives of the Christian Churches in Ashanti on the 16th October, 1942.

1. In the first place we wish to take this opportunity of placing on record our regret that so often in the past there has been a cleavage between Christians and non-Christians in this country, and our resolve to do all in our power to bring these two sections within the community together.

2. We must, however, state our conviction that in so far as some elements of the cleavage are due to difference of belief, the purpose of reconciliation cannot be furthered by a discussion which unduly minimizes these differences. We are forced to recognize that in some of its aspects Ancient Ashanti Religion asks an allegiance to certain spiritual powers which worshippers of the God and Father our Lord Jesus Christ cannot give.

3. Even so we recognize that in the past there has been unnecessary cleavage and we cannot hold individual Christians blameless for this. They have not always been ready to distinguish those claims of Native Customary Law which had for them 'fetish' association and those which had not. They have therefore at times broken unnecessarily with Native Customary Laws and have not fulfilled their rightful allegiance to their chiefs.

4. On the other hand, we feel that Native Customary Law has not been widened to acknowledge the religious freedom which is implicit in British Law. In consequence there has been no general recognition of any procedure alternative to that laid down by Native Customary Law as possible for Christians in those matters which they regard as vital to conscience. These two together, misunderstanding on the part of certain Christians on the one hand, and on the other, failure to make adequate recognition of good conscience in matters touching on belief, have led chiefs not unnaturally to question the loyalty of the Christian community.

5. In order that this sense of division may be broken down we on our part pledge ourselves to impress ever more fully on the members of our Churches their duty to the state.

6. On the part of the chiefs we would ask that they accept as a fact the existence of Christians as members of their State and lay down ways by which they can show their allegiance to their chiefs without at the same time offending their Christian conscience (e.g. if a chief orders community work, say on roads, to take place on a Sunday as being the most suitable to the majority of his subjects, he might at the same time state that Christians may do their share

of the work on the preceding Saturday. This taking of initiative by the chief in remembering those of his subjects who are Christians would, we believe, go a long way towards relieving the strained feeling at present existing in such matters.)

7. We believe that the Christian community is large enough for the State to be the loser if Christians are cut off from a share in the country's political life. If no place exists in the Native customary Law for those who do not believe in 'fetish' has not the time come in view of many changing circumstances for the adaptation of Native customary Law in order that it may include in its provisions all loyal citizens? (e.g. if a new way of renewing allegiance to a chief is being considered on hygienic grounds, is it not more vital to the well-being of the state that new ways be considered which will not do violence to conscience of many subjects?)

8. We therefore take this opportunity of suggesting to the Confederacy Council through the Ashanti ~~hene~~ that consultation may take place before any future codification of what has been up to the present Customary Law. Such codification seems to us to be foreshadowed in this discussion by the Confederacy council of a document like that of the late captain Warrington. By such consultation procedure in those points in which the Christian has difficulty, e.g. oaths, may be settled before codification rather than appeal afterwards. Every such appeal puts the Christians and non-Christians on the defensive and increases the feeling of separation between them.

9. Against this background we look at the position of Christians in relation to the observance of Thursday. We recognize that this is an observance closely linked with ancient beliefs of the Ashanti people - beliefs which, however, are not to our mind wholly compatible with the Christian belief in God. Our members, if they observe the day, cannot do so for ancient Ashanti reason. The question arises should they be asked to observe the day out of respect for the beliefs of others in the community? We feel that we cannot ask this of our members, in that to refrain from work on Thursday would be to them a confession of the faith in Asase Yaa and her relation to harvest and famine and therefore a denial of the Fatherhood and providential care of God. A like difficulty of conscience holds in a relation to other special days and observances which have a similar significance to Asase Yaa. If, however, the chief reason behind the observances is not so much the association with Asase Yaa as a desire for some communal act to express the unity of the nation, we would ask whether there is not an other act of allegiance in which the Christians could take part; an act which would not place the working life of farmers under the disadvantage of refraining from work on two days in the week.

We believe that a sympathetic understanding of the Christian position with regard to this day resulting in a dispensation from the present law could be the first step towards the new cooperation between Christians and the State which we earnestly desire to see. If at the same time some definite communal undertaking were suggested to the Christians by which they could show in concrete form their sense of unity with the whole nation we believe that the chiefs would be assured of the loyalty of the Christians to themselves and the state.

With the best interests of the Ashanti nation in mind we submit this statement of our position for the consideration of the Otumfuo and the Confederacy Council.

O.M. Renner (English Church Mission)
 F.E. Akuban (Methodist Church)
 T-A Beetham (Methodist Church)
 H. Henking (Presbyterian Church)
 E.M. Asiedu (Presbyterian Church)
 E. Paulissen (Roman Catholic Mission)
 Isaac Sackey (AME Zion Mission)

Books and Publications quoted or referred to in the text.

- AKUFFU, B.S. 1945 Ahenfie Agesua. Studies in Akan Customs and institutions. Vol. 1. Exeter.
- AKYEMAMPONG, H.K., Akyem Abuakwa Crisis. The author, Box 368, Accra.
- ALICOE, Thomas, 1951. The evolution of Gold Coast Chiefship. The Sheffield Telegraph and star Ltd. Kemsley House, Sheffield.
- ANTUBAM, Kofi Ghana Heritage of Culture. Koeler & Amelang, Leipzig.
- ANTUBAM, Kofi, 1961. A Brochure on the symbolic significance of Ghana's state gift to:
- (a) President Sukarno (Indonesia)
 - (b) President and Madame Gomulka (Poland)
 - (c) President and Madame Bobi (Hungary)
 - (d) President and Madame Bros (Yugoslavia)
 - (e) President and Madame Brezhnev (USSR)
 - (f) President and Madame Novotny (Czechoslovakia)
 - (g) Queen Elizabeth and Prince Philip, Duke of Edinburgh (Great Britain).
- BASEL - Church Notes by courtesy of Nene Akrobetto, Paramount chief of Yilo Krobo, Ghana.
- BLAKE, J.W. 1960. European in West Africa, 1460-1560. Vol. 1, p.56.
- BOAHEN, Adu, A. 1966. The Origin of the Akan. Ghana Notes and Queries, No. 9 November, 1966. pp. 3-10.
- BOATENG, Mary, 1958. The Stool Carving industry of Ahwiaa. Dissertation - Institute of Education, University College of Ghana 1957/58. Unpublished.
- BONSU, Osei, 1938. Wood Carving by the Wood Carver of Ashantehene. In the Teachers Journal. Gold Coast. Vol. 10, No.3 1938, pp 269 - 270.
- BOSSMAN, W. 1705. A new and accurate description of the Guinea. Translated from Dutch. London 1705. See Freda Wolf's on 1958 Pageant of Ghana. London Oxford University Press, Reprint 1959.
- BOWDICH, Thomas E., 1819. A mission from Cape Coast to Ashantee with statistical account of the kingdom and geographical notices of other parts of the interior of Africa. pp. viii and 512. London: John Murray.
- BUSIA, K.A., 1958. The position of the Chief in Modern Political System in Ashanti, International African Institute, Oxford University Press.

- BUSIA, K.A. 1954. The Ashanti. African worlds. 1954. ed. Daryll Forde, pp. 190-209.
- CHRISTALLER, J.G. Rev. 1881, Dictionary of Asante and Fante Language. Basel Missionary Society, Basel.
- DANQUAH, J.B. 1928. Akan Laws and Customs and the Abuakwa Constitution. London, Routledge & Kegan Paul.
- DANQUAH, J.B. The Culture of the Akan Africa Vol. XXII. No. 4
- DUA AGYEMAN, 1964. Ashanti Stool Histories. Source Material in the Library of the Institute of African Studies. Legon. Ghana. In progress.
- PAGE, J.D. 1961. Ghana Historical Interpretation. Madison University of Wisconsin Press, 1959, 1961.
- FREESTONE, Basil, 1968. Osei Tutu, (The Leopard owns the land) London: Dennis Dobson. The Garden City Press. Letchworth, Hertfordshire.
- FIELD, M.J. 1940. Social organization of the Ga people. Crown Agents for the Colonies. 4 Milbank London, S.W.1
- FIELD, M.J., 1939. Religion and Medicine of the Ga people. Reprint 1961, Oxford University Press. Amen House, London E.C.4.
- GHANA census, 1960. Volume 11 Government Printing Department, Accra. Ghana.
- GOODY, J.R. 1959. Ethnohistory on the Akan. Africa, 1959 P.67
- HERT, Robert 1960. Death and the right hand. Transl. by Rodney and Claudia Needham. University of Aberdeen Press.
- KUMA, J.K. 1965. Denkyira 1600-1617 Unpublished M.A. Thesis. I.A.S. Legon also Ghana Notes and Queries No. 9. Ghana.
- KYEREMATEN, A.A.Y. 1960. A brochure for an Akase Kaseg. Published by author, Kumasi.
- KYEREMATEN, A.A.Y. ¹⁹⁶⁴ Panoply of Ghana. Longman Green & Co. Ltd. 48 Grosvenor Street, London W.1. Printed by Jarrold & Sons. Ltd. Norwich.
- KYEREMATEN, A.A.Y. 1970. Kingship and Ceremony in Ashanti. Printed by the U.S.T. Press, Kumasi.
- KYEREMATEN, A.A.Y. 1969: The Royal Stools of Ashanti. Africa. Vol. XXIX. No. 1.

- MALRAUX, Andre 1954. (ed.). The Voices of Silence.
Transl. Stuart Gilbert. Secker and Warburg
London, 1954.
- MAYER, Emerico Samassan, 1967. Diagrams of Akan Stools. Ghana Museum.
Ghana.
- MEYEROWITZ, E.L. 1952. Akan Traditions of Origin. London Faber and
Faber.
- MEYEROWITZ, E.L. 1958. The Akan of Ghana: their ancient beliefs.
Faber and Faber. London.
- NKETIA, J.H., 1963. Drumming in Akan communities of Ghana.
Thomas Nelson and Sons. Ltd. Edinburgh.
- NKETIA, J.H., 1966. Music in African Cultures. (A review of the
meaning and significance of traditional African music.)
I.A.S. Legon.
- NKETIA, J.H., 1966. Ayan. Vol. 1. Poetry of Atumpan Drums of the
Asantehene. Institute of African Studies, Legon.
- NKETIA, J.H., Kwadwo. IAS.01/A.2, Institute of African Studies, Legon.
- QUARCOO, Alfred K., 1965. Processes of Social Control among the
Dangme (Shai). Unpublished M.A. Thesis, Univ. of
Ghana, Legon.
- QUARCOO, Alfred K. 1966. The phenomenon of ancestor Cult.
Institute of African Studies Research Review,
Legon. Vol. 3 No.1. 1966.
- QUARCOO, Alfred K., The Lakpa - (La deity) Institute of African
Studies Research Review Vol.3 No.1
- QUARCOO, Alfred K., The ancestors in Ghanaian Religious and
Social behaviour. Institute of African Studies
Research Review, Legon. Vol.3 No.2, 1967.
- QUARCOO, Alfred K., A debut of Ghanaian traditional art into the
liturgical art of the Christian church of Ghana.
Institute of African Studies Research Review
Vol. 4 No.3 of 1968.
- RATTRAY, R.S., 1923. Ashanti. Oxford University Press, 2nd
impression, 1955.

- RATTRAY, R. S. 1927. Religion and Art in Ashanti.
Oxford Clarendon Press.
- RATTRAY, R.S. 1929. Ashanti Law and Constitution.
Oxford, Clarendon Press.
- REINDORF, Carl. Rev.1895. A history of the Gold Coast and Ashanti.
Basel Mission Book Depot, Kumasi, pp. 357.
- RUEL, M.J.,1970. Lions, Leopards and Rulers. New Society.
Merrit Hatcher Ltd. Published by I.P.C. Magazines Ltd.
128 Long Acre London, W.C.2. pp. 54-56.
- SARPONG, P.K., 1967. The sacred stools of Ashanti.
Anthropos Herausgeber Anthropos Institut.
5205 St. Augustin, Deutschland.
- SEKYE, W.E.G., 'Comparison of English Gold Coast Akan relating to
Absolute rights of individuals' (nd) Archives
Cape Coast, Ghana.
- SIEBER, Roy, 1962. Masks as agents of Social control. African
Studies Bulletin. African Studies Association,
New York, 27. N.Y.
- SMITH, M.G., 1956. Segmentary Lineage Systems Journal of Royal
Anthrop. Inst. LXXVI (1956) part 2. pp.54-55,67.
- SMITH, M.G., Structural approach to comparative politics in
Varieties of Political theory (ed) David Easton.
- SUTHERLAND, D.A.,¹⁹⁵⁴ State emblems of the Gold Coast.
Government Printing Department, Accra.
- WARD, W.K., 1942. A short history of the Gold Coast.
pp. 39-45 London, Allen and Unwin.
- WACHSMANN, K.P., and PLESS Margaret Tribal Arts of Uganda,
New York.
- WILKS, Ivor, 1964. The Growth of Akuapim State. The Historian
in Tropical Africa. (ed.) by Jan Vansina, Raymond
Maundy, L.V. Thomas. London, 1964.
- WILKS, Ivor, 1967. Ashanti Government for West African kingdoms
of the 19th century. ed. by D. Forde and Kaberry.
International African Institute. Oxford University
Press, 1967.

Books and Publication consulted but not mentioned in the text.

- ADU, A.L., 1949. The Role of chiefs in Akan Social Structure - An essay. pp. 18. Accra Government Printing Department.
- AGYEMAN, E.A. 1966. A note on the foundation of the Gyaman Kingdom. Ghana Notes and Queries. No. 9. Nov. 1966, pp.36-39.
- AKESSON, S.K., 1960. The secret of Akom, African Affairs 49
19th July, 1950, pp. 237-46. October, 325-33.
- AKROFI, C.A. Twi Emebusem (Twi Proverbs) London.
- ANTUBAM, Kofi, 1957. The Arts of Ghana in United Asia. No. 9,
Vol. 1, 1957, pp. 61-70.
- APTER, David E. (ed.) Ideology and Discontent. Essay Ideology as
a cultural system by Clifford Geertz. The Free Press
of Glencoe. Collier-MacMillan, London.
- ARCHIDIOCESAN Committee 1958. Libation - A report of Archdiocesan
Committee appointed to study African Customs.
Cape Coast, Ghana.
- ARENSBERG, Conrad Kaynadier, 1959. Irish Countryman. Gloucester,
Mass.
- AZU, Enoch, 1925. Aqangme historical and proverbial songs.
Gold Coast Review, 1925/1927.
- ASHANTI Confederacy: Council Minutes: June, 6th - 17th, 1935;
4th, 5th and 9th August, 1955; 11th, 21st March, 1946
and others.
- BALMER, W.T., 1926. A history of Akan peoples of the Gold Coast
pp. 208. Atlantis Press.
- BOAHEN, Adu, 1964. The decline of Ashanti. Ghana. Radio and
T.V. Times, Vol. 5. No.16. June 12, pp. 10-13.
- BOAHEN, Adu, 1964. The rise and Growth of the Ashanti Empire.
Ghana Radio and T.V. Times. Vol. 5 No.15, June 5,
1964. pp. 2, 5 & 7.
- BASCOM, William, 1962. African Arts and Social Control. African
Studies Bulletin. African Studies Association. N.Y.27.
- BREFFIT, G.W., 1960. Ashanti's living legends: the history of the
sacred stool of Ashanti. In West African Review.
November, 1960. pp. 40-43.

- BREFFIT, G.F., 1960. The Golden Stool of Ashanti. Gazette of John Lewis partnership. 6th August, 1960 pp. 649-653.
- BRINKWORTH, Ian., 1960. The Wallace collection. West African Review. March, 1960. pp. 26-30.
- BROKENSHA, D., 1962. Kinship residence in a Guan Town. Proceedings of the Nigerian Inst. of Soc. & Econ. Research.
- BROKENSHA, D., 1962. Akuspin Studies. Universitas. Vol. V, No. 1 4 - 7. January, 1962. University of Ghana.
- BROKENSHA, D., 1966. Social Change in Larteh. Oxford Clarendon Press.
- BUTLER, William Sir. Akimfoo: The history of a failure (a journey in Fanti Akim and Ashanti) London. Sampson Low.
- CANHAM, Peter, 1947. Ashanti Case History. Africa 17. 1 Jan., 1947. pp. 35-40.
- CLARIDGE, Walton W., 1964. A history of the Gold Coast and Ashanti. New Introduction by W.E. Ward. 2nd ed., Frank Cass. 2 Vols.
- CLARK, E., 1930. Sociological significance of ancestor worship in Ashanti. Africa 3. 4, 1930, pp. 431-71.
- COLKMAN, James, S., 1962. African Arts and Political Science. African Studies Bulletin. African Studies Association, New York 17. N.Y.
- CORY, H., 1936. An East African Native Treatment for psychological disorder, Journal of Roy Anthropol. Inst. Vol. 66, 1936. p. 209.
- GROWTHER, 1915. Memorandum on Shai Dangme political history. Secretary of Native Affairs in the Gold Coast. Government Printing Department, Accra.
- CRUICKSHANK, Brodie, 1853. 18 years on the Gold Coast of Africa including account of Native tribes and their intercourse with Europeans. 2 vols. London:
- CURTIN, Phillip, 1962. African Art and African History. African Studies Bulletin. African Studies Association, N.Y. 27, N.Y.
- DAAKU, K.Y., 1966. Pre-Ashanti States. Ghana Notes and Queries No. 9 pp. 1 - 13.

- DANQUAH, J.B., 1952. The Culture of the Akan Review of Meyerowitz's Sacred State of Akan. Africa 22, 4th Oct., 1952. pp. 360-366.
- DOUGLAS, Mary, The Lele of Kasai. African Worlds ed. by Daryll Forde. pp. 1 - 26. London: Oxford University Press.
- DUPUIS, Joseph. ed., 1966. Journal of residence in Ashanti ed. with Notes by W.K. Ward. 2nd ed. London: Frank Cass., 1966.
- FIELD, M.J., 1948. Akim Abualwa - an oman of the Gold Coast p. 221. London Crown Agents for the Government of the Gold Coast.
- FORTES, Mayer, 1950. Kinship and Marriage among the Ashanti, in African Systems of Kinship and marriage. ed. A.R.Radcliffe. Brown and Daryll Forde, pp. 252-284.
- FRIMPONG, Kwame, 1945. The final obsequies of the late Nana Sir Ofori Aŋtahn K.B.E. Abuakwaahene. Africa 15, April, 1945 pp. 80-86.
- FULLER, Sir Francis C., 1921. A vanished Dynasty Ashanti XII, 242 J. Murray.
- GERRTZ, Clifford, Ideology as a cultural system in Ideology and Discontent, ed. by David Apter. Free Press, Glencoe, Collier, MacMillan London.
- GHANA University. I.A.S. 1967. Ashanti Court Records 1963-67. In progress.
- GORDON, J., 1954. Some oral traditions of Denkyira. Trans.G.C and T. Hist. Soc. 1,3, 1954. pp. 83-95.
- HAMMOND, Peter, 1942 (reprinted 1965). Cultural Anthropology. Selected Readings. p. 283. N.Y. 1965.
- HERSKOVITS, Melville, J., 1948. Man and his works - The Science of Cultural anthropology. N.Y. Knoff.
- HILL, Polly 1956. Companies and Cocoa growing in Akim Abuakwa. Universitas. Ghana 2,4 December, 1956. pp. 103-111.
- HOLTSBAUM, Fr. P., 1925. Sefwi and its peoples. Gold Coast Review. 1 June/December, 1925. 76-94.

- HORTON, Robin, 1963. Kalabari Sculpture. Published by Department of Antiquities, Federal Republic of Nigeria.
- JOHNSON, J.C. de Graft, 1926. Significance of some Akan titles. Gold Coast Review. Vol. 2 No.2. July-December, 1926. pp. 208-223.
- JOHNSON, J.C. de Graft, 1926. Akan Land Tenure. Trans. G.C. Hist. Soc. 1,4, 1955. pp. 99-103.
- JOHNSON, Martin. Art and Scientific Thought. Faber and Faber, 24 Russell Square, London.
- LYSTAD, Robert, A. 1958. The Ashanti - a proud people. New Brunswick. N.J. Rutgers, University Press, New Jersey.
- MANOUKIAN, Maudeline, 1950. Akan and Ga-Adangme Peoples. International African Institute Ethnographic Survey of Africa, Part 1.
- MAUNY, Raymond, 1954. The question of Ghana. Africa. 24, 3. July, 1954, pp. 200-213.
- MESSENGER, John, C. 1963. Anang Are, drama and Social control. p. 29. African Studies Bulletin. African Studies Association Inc.
- MEYEROWITZ, Eva L. 1951. Concepts of the Soul among the Akan of Gold Coast. Africa. 21 January, 1951, 24-31.
- MEYEROWITZ, Eva L. 1955. Art and Anthropology among the Akan. West Africa. 22 October, 1955, p. 987.
- MEYEROWITZ, Eva L. 1957. The Akan and Ghana. Man 57. 99. June, 1957, pp. 83-88.
- MEYEROWITZ, Eva L. 1960. The Divine kingship in Ghana and ancient Egypt.
- MEYEROWITZ, Eva L. 1962. At the court of an African king. London, Faber and Faber.
- WAHN, Milton, C. 1956. The Artist as creator - An essay on human freedom. Baltimore. The John Hopkins Press.

- NKANSI-DWAME, 1958. Adae Kesse - Ghanaian, No.3, Sept., 1958, p. 21.
- NKETIA, J.H., 1957. Funeral Dirges of the Akan people. p 296 Achimota. University College Gold Coast. Department of Sociology.
- NKETIA, J.H., 1959. African gods and Music. Universitas Vol.IV, No.1. pp. 3 - 7.
- NKETIA, J.H., 1965. Music, Dance and Drama. Published - Ministry of Information, Accra. Ghana.
- NKETIA, J.H., 1962. Folk Songs in Ghana. London Oxford University Press.
- NKETIA, J.H., 1966. Aowa. IAS/OL/A.1. Words only. Institute of African Studies, Legon.
- PLASS, Margaret, 1967. African Miniatures. The Goldweights of Ashanti. Percy Lund Humphries Co.Ltd. 12 Bedford Square, London, W.C.1.
- NORRIS, A.W., 1926. Notes on Ashanti heraldry. Gold Coast Review. Vol. 2, No.2. July - December, 1926. pp. 235-8.
- OZANE, Paul, 1963. The archaeological contribution to Asante abakosem. Legon. Department of Archaeology, University of Ghana. Draft paper.
- PARKER, De Witt, H., 1926. The Analysis of Art. Yale University Press. London, Humphrey Milford. Oxford University Press.
- PARKINSON, John. 1911. A note on the social organization of the people of Western Gold Coast. Kan 11,12, 1911. pp. 2 - 3.
- PARRINDER, Geoffrey, 1956. Divine kingship in West Africa. Numen. Vol. III, fasc. 2. pp. 111-121.
- PEACOCK, James, 1968. Rites of Modernization - Symbolic and social aspects of Indonesian Proletarian Drama. University Press, Chicago & London.
- PHILLIPS, March, L. 1912. The Works of Man. Printed in Great Britain. R. & R. Clark Ltd., Edinburgh.

- PONOFSKY, Erwing, 1940. Meaning of the Humanities. New York
Whitlessy House, London.
- READ, Sir Herbert. The Meaning of Art. Faber and Faber, Ltd.,
25 Russell Square, London.
- RATTRAY, R.S., 1916. Ashanti Proverbs
(Primitive ethnics of a savage people.)
The Clarendon Press.
- RATTRAY, R.S., 1926. Ashanti Folk Tales. London: Oxford University
Press.
- ROBIN, Arnold, 1969 (& Roy Sieber). Sculpture of Black Africa.
Los Angeles. Los Angeles County Museum.
- SARBAH, J.M., 1897. Fanti Customary Laws. A brief introduction
to principles of the Native laws and customs of the Fanti
and Akan Districts of the Gold Coast with report on some
cases thereon decided in the Law Courts. Frank Cass & Co.,
Ltd., 1963. London.
- SHAW, J.V.W., 1925. A brief note on the Constitution and Customs
of Akim Abuakwa. Gold Coast Review. No. 1 Vol. 1, June -
December, 1925. pp. 53-55.
- SIEBER, Roy, 1969. Sculpture in Black Africa, Los Angeles,
County Museum of Art.
- SMITH, Edwin W., 1945. Religious beliefs of the Akan. Africa.
15 Jan., 1945. pp. 23 - 29.
- SMITH, M.G. 1956. The Hausa system of social status. Africa.
Vol. XXIX, 1959, p.248.
- TORDOFF, W.I., 1961. The Political history of Ashanti, 1888 - 1935.
2 vols. University of London, Ph.D. Thesis, 1961.
- STILES, Raymond, S., (ed). The Arts of Man. N.Y., Whitlessy House,
London. McGraw Hill Book Company, Inc. Section in the
Meaning of the Humanities by Erwing Ponofsky.
- WACHSMAN, K.P., Musical Instruments in the Ki-Ganda. Tradition and
their place in East African Scene. Paper read at symposium
on Music & History at the Royal Anthropological Institute,
London.
- WILKS, Ivor, 1966. Aspects of bureaucratisation in Ashanti.
Journal of African History vii 2, 1966, pp. 215-232.