

John's copy
N13.7/469

UNIVERSITY OF EDINBURGH
SCHOOL OF ENGINEERING SCIENCE
(MECHANICAL ENGINEERING)

WAVE ENERGY REPORT
ON
THE ELECTRICAL ASPECTS OF THE
EDINBURGH UNIVERSITY WAVE ENERGY DEVICE

NOVEMBER, 1979

SCOTTISH OFFSHORE PARTNERSHIP
CHARING CROSS TOWER
GLASGOW
G2 4PP

N13.7/469

UNIVERSITY OF EDINBURGH
SCHOOL OF ENGINEERING SCIENCE
(MECHANICAL ENGINEERING)

WAVE ENERGY REPORT
ON
THE ELECTRICAL ASPECTS OF THE
EDINBURGH UNIVERSITY WAVE ENERGY DEVICE

NOVEMBER, 1979

SCOTTISH OFFSHORE PARTNERSHIP
CHARING CROSS TOWER
GLASGOW
G2 4PP

CONTENTS

	<u>Page</u>
SECTION 1 - TERMS OF REFERENCE AND INTRODUCTION	1
SECTION 2 - THE REFERENCE DESIGN FOR THE EDINBURGH WAVE ENERGY DEVICE	4
2.1 - Structural arrangement	4
2.2 - Geographical arrangement	4
2.3 - Hydraulic drive unit	5
2.4 - Electrical ratings	6
TABLE 1	7
SECTION 3 - DESIGN PRINCIPLES	8
3.1 - Design philosophy	8
3.2 - Access and maintenance	9
3.3 - Reliability	10
SECTION 4 - POWER GENERATION	13
4.1 - Synchronous generators	13
4.1.1 - Rating	13
4.1.2 - Excitation system	13
4.1.3 - Generator construction	14
4.2 - Generator control equipment	15
4.2.1 - Starting equipment	15
4.2.2 - Speed control	15
4.2.3 - Generator switching	16
4.2.4 - Electronic control equipment	16
4.3 - Spine cable arrangements	16
4.3.1 - Duck to spine connections	16
4.3.2 - Connections along the spine	16

	<u>Page</u>
SECTION 5 - SEA TO SHORE TRANSMISSION	18
5.1 - Submarine cables	18
5.2 - The optimum sea to shore transmission system	20
5.3 - Arrangement of the reference electrical design	23
5.4 - Cable reliability and security	23
5.5 - Cable charging current	25
5.6 - Cable circuit reactance	26
5.7 - Summary of cable specification	27
TABLE 2	28
SECTION 6 - TRANSMISSION TO THE MAINLAND	29
6.1 - Transmission route (see Plate 9)	
TABLE 3	30
6.2 - 132kV overhead lines	31
6.3 - 132/400kV transforming station	31
6.4 - Overhead lines	32
6.5 - 400kV submarine cable circuits	34
6.6 - Shunt compensation	35
6.7 - Series compensation	35
6.8 - 400kV receiving station	36
6.9 - Spare capacity	36
SECTION 7 - COST ESTIMATES	37
7.1 - Scheme Costs	37
7.2 - The basis of costs	37
7.3 - A.C. generation and transmission costs	38

	<u>Page</u>
TABLE 4	39
TABLE 5	40
SECTION 8 - OBSERVATIONS AND SUMMARY	41
SECTION 9 - FUTURE WORK	46
SECTION 10 - CONCLUSIONS	48
APPENDIX A	
APPENDIX B	

SECTION 1

TERMS OF REFERENCE AND INTRODUCTION

In our offer of services there were no formalised Terms of Reference given, although the object of our participation was:-

"To assist the ETSU Wave Power Programme by providing consultant services to Edinburgh University, the latter acting under an Agreement with the Secretary of State for Energy".

By mutual agreement with ETSU and the Edinburgh Wave Power Team, the objectives of our investigations were:-

- a. To examine theoretical electrical concepts.
- b. To determine whether a.c. or d.c. electrical transmission is appropriate.
- c. To determine the specification of electrical generation equipment.
- d. To minimise the cost of generation and transmission plant.
- e. To make recommendations on transmission lines and cables.
- f. To produce an overall scheme for generation and transmission of electrical power, including an estimate of the cost thereof.

The concept of installing generators, switchgear, transformers and cables out in the most exposed area of our coast line may be regarded as adventurous and perhaps this is the reason why SCOPA have been asked to work with the Edinburgh University Wave Energy Team on this project. We are proud that we are accepted as part of the team because it is refreshing to work with people anxious to overcome problems and reluctant to give up a promising concept when faced with apparent difficulty. At the same time we have come to respect the tenacious search for practical solutions to problems which is one of the main characteristics of the members of the team.

It is with a sense of some surprise that we have found ourselves able to present a scheme for the generation and transmission of electrical energy from the Edinburgh 'Salter Duck' devices to the Scottish grid system which uses conventional ideas albeit in a manner not hitherto associated with the Wave Power Project.

Of course there are a number of problems with the 'Duck' scheme, and, on our conventional assessment, it is relatively expensive; but we now believe it is possible, and promising.

Certain problems common to wave power devices were identified during the investigations described in this report. We feel that this report would be incomplete without describing such problems, and accordingly have included these in the last Section (9) of this report.

This report is confined to the technical and cost aspects of generating electrical power at sea on board the ducks, and delivering this power to the Scottish Transmission Grid System.

The optimisation of hydraulic drives within the ducks, and the design of coupling arrangements between ducks is still

proceeding. Arrangement of the electrical system has had to proceed on the basis of a specified duck design, which has a specific output.

For reasons explained in the text of our report we consider the term "Wave Energy device" more appropriate than "Wave Power device". Henceforth the term "Energy" is used in preference to the term "Power" to describe the device.

SECTION 2
THE REFERENCE DESIGN
FOR THE EDINBURGH WAVE ENERGY DEVICE

This section describes the structural and mechanical arrangement along with the geographical location of the reference duck design. The reference electrical design is based upon the information contained in this section.

2.1 - Structural arrangement (Plate 1)

The agreed reference design for the duck is a 24 metre long duck which oscillates on a spine 9.8 metres in diameter.

The spine, about which the ducks oscillate, is broken up into sections 61 metres in length, and each length of spine supports two ducks. Each section of spine is coupled to the next by a 'Hookes' joint together with hydraulic rams which control the mutual compliance.

The hydraulic design of the duck string is such that the effective length for power generation is equal to the distance between centres which is 30 m. A power module is contained in the "beak" of each duck.

2.2 - Geographical arrangement (Plate 2)

The reference design for the transmission system is based on a string of 1000 ducks located 10 km from the west coast of South Uist, and follows the 35 m sea depth contour.

Recent measurements on the available wave energy at South Uist indicate that higher energy levels occur 30 - 40 km offshore. It is therefore necessary to assess the technical

performance and cost of a wave energy scheme located 40 km offshore, as an alternative to the reference design.

2.3 - Hydraulic drive unit (Plate 3)

A unique feature of the Edinburgh wave energy device is the use of gyros which precess and produce torque from the oscillating motion of the floating duck.

In addition to converting wave motion into torque, the gyros are used to store and provide energy by allowing their speed to vary. Fast acting hydraulic actuators, associated with the hydraulic motors used for the gyro drives, enable rapid storage or extraction of energy from the spinning gyros.

The sent out mean electrical power over the whole year has been taken as approximately 14.0 kW/metre of duck length. This figure (ie 14.0 kW/metre) is based on a mean wave power level of 20 kW/metre of duck length. 75 kW/metre sent out electrical power was selected as the nominal maximum electrical output power level; this being a reasonable limit which would not appreciably reduce the annual energy output of the duck. A torque limit equivalent to 375 kW/metre allows the extraction of energy from waves possessing high power levels. Rapid absorption and slow release of energy extracted from the waves is possible due to the action of the energy store incorporated in hydraulic drive unit thus giving a high efficiency of energy conversion using a small electrical generator designed for constant shaft torque.

Sufficient energy is stored in all the gyros to supply 1 MW for 1 hr per duck by allowing the gyro speed to fall from 2000 rpm to 400 rpm.

Efficiency of the hydraulic drive unit is determined by fixed and variable losses. Special measures, such as running the gyros in a reduced atmosphere, are necessary to reduce the

standing, or fixed losses. Variable losses are load dependent, and the design is such that high efficiency is obtained around the mean power output.

2.4 - Electrical ratings

A nominal power rating of 2 GW was chosen for the scheme for the purpose of establishing the cost of the electrical generation and transmission equipment. Of much more importance is the associated mean annual power level of around 425 MW over the year, since the revenue to pay for a wave energy scheme must come from the sale of kW hrs of electrical energy.

The reference design employs one electrical generator on each duck rated at 2.25 MW (ie 30 metres at 75 kW/metre electrical power). Considerable economies can be achieved in the cost/kW of generating plant by an increase in machine size. The decision to base the reference design on a generator in each duck was influenced by the difficulties which are assumed to exist by installing common hydraulic oil circuits for a number of ducks.

A summary of the main parameters for the reference design is given in Table 1.

TABLE 1

SPECIFICATION FOR "SALTER DUCK" WAVE ENERGY SCHEME (REFERENCE DESIGN)

Dimensions of Structures

Spine Diameter (metres).....	9.8
Minimum Access Diameter at Joint (metres)	2
Duck diameter (metres).....	10
Distance between Duck Centres (metres).....	30
Duck length (metres).....	24
No of Ducks.....	1000

Geographical Location at South Uist

Approximate Distance from Shore (Km).....	10
Approximate Distance to point of Interconnection with Scottish Grid System (Km).....	250

Hydraulic Drive Unit* (All power ratings are quoted as KW/metre of duck length)

Speed of Generator Drive (r.p.m.).....	1500
Number of Gyros per Duck	4
Energy Stored in each Gyro at 2000 r.p.m.(Joules) ..	1.05×10^9
Recoverable Energy per Duck 400 -2000 rpm (MW hrs)..	1.0
Mean Annual input power to Gyros (KW/metre)*	20
Approximate Mean Annual sent out Electrical Power (KW/metre)*.....	14
Maximum Sent out Electrical Power (KW/metre)*.....	75

Scheme Electrical Ratings

Nominal Scheme Peak Sent out Electrical Power at Shore line(MW).....	2000
Approximate Mean Annual Sent out Electrical Power from 1000 ducks(MW).....	425
Availability factor for generation (° per annum) ...	90%
System Frequency (Hz)	50

Duck Electrical Ratings

Duck Generator Rating (MVA).....	2.81
Nominal Duck Generator Power output.....	2.25
Power factor (lagging).....	0.8
Power factor (leading).....	0.8

SECTION 3

DESIGN PRINCIPLES

Wave energy devices will, in general, be located in remote areas where a stormy climate prevails. Certain design principles need to be discussed as a basis for a detailed specification of the electrical generation and transmission plant.

3.1 - Design philosophy

Power generated by wave power devices is dependent on weather conditions. Periods of calm weather may occur at any time during the year, and so all of the potential output of wave power generation must be duplicated by land based generation.

The primary function of a wave energy scheme will most probably be the conservation of fossil fuel. For most of the year the power level at which the wave power generation and transmission plants operate will be less than 50 per cent and during this period a plant outage will not cause undue loss of annual energy (kW hrs). Even the loss of the whole of the wave energy transmission system could be accepted for a day or two on economic grounds; there is, however, a limit to the transient disturbance which may be reasonably imposed on the mainland grid system. In our view sudden loss of 1000 MW will probably be acceptable to the grid bearing in mind the additional conventional generation which will be installed.

On these grounds we have selected a firm transmission capacity of 1000 MW for the transmission system to ensure that very little loss of revenue occurs due to a transmission plant outage. The transmission system will be non-firm in the transmission range of 1000 to 2000 MW, thus limiting the disturbance

to the Scottish grid system to 1000 MW power reduction should a sudden failure occur. Spare transmission plant is not justified except where the outage of the plant is prolonged due to difficulties in repair.

Spare capacity for transformers and cables can be justified, since these items of plant would take several months to repair if they failed. Overhead lines can be repaired in a matter of a day or so, and therefore spare line capacity would not be justified.

A feature of design for equipment in inaccessible locations would be the provision of extensive monitoring systems. Such monitoring systems would forewarn control room staff of an impending breakdown and avoid the need for human intervention.

3.2 - Access and maintenance

The installation of equipment in floating structures at sea obviously requires careful consideration as regards access and maintenance.

Since wave power devices will, of necessity, be installed in areas which are subject to a high frequency of storms, there may only be a small part of the year during which repair and maintenance can be carried out. It is essential therefore, that the methods of construction adopted should enable such maintenance and repair work to be carried out easily and quickly, or alternatively on shore.

We understand that means will be developed to enable ducks to be uncoupled from the string and towed into harbour for maintenance and repair. The generator cabling will be affected by this requirement as electrical connections will have to be broken and reconnected at sea.

A modular form of construction will enable whole modules to be replaced, rather than attempting extensive maintenance and repair activities on the floating structures.

3.3 - Reliability

Breakdown of electrical plant is due to direct electrical failure; or as a result of mechanical damage.

Electrical equipment is usually designed to internationally agreed standards which give an acceptable level of reliability under normal operating conditions.

Failure rates predicted by the use of statistics for plant operating at normal stresses and conditions may produce an over-pessimistic estimate for the failure rate of equipment designed to specifications which are more exacting than IEC requirements.

There are ways of improving the reliability of electrical equipment by reducing the electrical stresses within the equipment under normal operating conditions; and by providing additional mechanical protection. If either, or both, methods are used to improve the integrity of electrical equipment then a significant increase in reliability can be expected.

The most obvious way of improving reliability is to use the minimum number of components and to eliminate those components which are known to require constant maintenance.

Inevitably there is a tendency to apply past experience on the performance and security of equipment, to proposed designs which appear to be similar. The application of failure rates of submarine cables is one example where pessimism can too easily prevail by ignoring the differences between existing cable systems and future systems. In this case, the vast majority of existing submarine cable systems have inadequate mechanical protection. Technical literature is full of information on improvements obtained by applying mechanical protection to cables on the seabed. Averaging the performance of all existing cable systems cannot indicate the probable performance of an adequately mechanically protected submarine cable system.

Fault rates quoted on the basis of experience can therefore be viewed with some reserve.

Equipments which possess moving parts, eg switchgear, should be eliminated as far as possible, and, if absolutely necessary, a careful selection made to employ only types of equipment that are noted for low maintenance requirements.

Consideration of some of the difficulties involved in engineering a wave energy scheme led us to adopt certain design principles.

1. The length of underwater cable route should be kept to a minimum, because of cost, maintenance and fault location.
2. Submarine cable system reliability is primarily affected by the installation and mechanical protection, and not by operating voltage. Careful route survey can avoid the installation of cables in hazardous areas.
3. The adoption of parallel paths for sea to shore transmission can be used to reduce the effect of a cable fault on the overall transmission capability.
4. The amount of underwater equipment should be reduced to a minimum on the grounds of access, maintenance and reliability.
5. No maintenance on the seabed should be attempted since this would be difficult and personnel with the necessary diving and electrical skills may not always be available.
6. The use of a substation in the spine improves access and would enable rapid maintenance using surface vessels.

7. The reliability of certain critical components may be increased by operating at low electrical stresses, and providing mechanical protection. These components can be developed outside the normal commercial restraints of competitive cost.
8. The minimum amount of plant should be used at sea. Switchgear should not be used unless it is essential, or is of a type possessing high availability.
9. Plant that is employed at sea should be specially designed to have low maintenance requirements and be subjected to a rigorous quality assurance programme during manufacture.

These design principles influence the nature of the electrical systems which we propose for generation and transmission.

SECTION 4
POWER GENERATION

The duck design used in our studies differs very considerably from the design in previous studies, insofar as it now incorporates a large energy store. The energy stored is sufficient to give a constant output torque from the hydraulic power unit. It is this unique feature which supports the choice of an a.c. transmission system and synchronous generator.

Each duck will have a 4.7 m diameter sealed equipment container or 'power module' which extends over the whole width of the duck. Four gyros and all the mechanical and electrical equipment for power generation and control will be housed in the power module. A block diagram of the electrical equipment in the power module is shown on Plate 4. In concept, a 'generator unit' includes the synchronous generator, duck to spine connections, and cabling along the spine.

4.1 - Synchronous generators

4.1.1 - Rating. Each generator will have a rating of 2.25 MW 0.8 pf at 3.3 kV; 1000 ducks are considered as equivalent to a nominal rating of 2000 MW for the complete scheme. The rated voltage of 3.3 kV is high enough to avoid the need for large heavy current connecting cables, and low enough to give an economic design for generator stator insulation. The generators should have a leading power factor rating of 0.8 (reactive power absorption), since it may be necessary to supply appreciable cable charging currents under some system operating conditions.

4.1.2 - Excitation system. The generators are fitted with brushless excitation systems (a.c. exciters) which will require the minimum amount of maintenance.

4.1.3 - Generator construction. The hydraulic drive unit operates in a vacuum chamber with a reduced atmosphere to reduce the windage losses of the gyros and prevent deterioration of the hydraulic oil. Two alternative arrangements for mounting the generator are possible.

- a. The generator can be mounted within a vacuum chamber which contains the gyros.
- b. The generator can be mounted outside the vacuum chamber; in which case a rotating seal round the drive shaft of the generator is required.

Vacuum is a double enemy of electrical machines. It prevents convection cooling of the rotor and stator and significantly reduces the dielectric strength of the air insulation within the machine. Corona may occur in conventional machine designs even at the low voltage of 3.3 kV.

The breakdown voltage and corona inception voltage of the environment of the generator are dependent on the product of its relative density (p - relative to 1 mm Hg at 20°C) and electrode separation (d - in cms).

For instance, to achieve a breakdown voltage of greater than 4.67 kVp, (3.3 kV rms voltage), the product 'pd' needs to be at least 0.11. With very low spacing, say 0.1 cm, the air pressure would need to be above normal atmospheric pressure; and, conversely a considerable spacing of 16 cm would be necessary for the low pressure of, typically a few mm of Hg (the proposed pressure within the gyro chamber). Consequently even with a lower generator operating voltage than proposed, of say 1.5 to 2.0 kV the increase in the pressure might well need to be more than that which would be acceptable for the satisfactory performance of the gyros.

An alternative to air would be hydrogen gas, because of its much lower density. Hydrogen, however, has about half the electric strength of air so that the product (pd) would have

to be at least 0.26 to achieve the same minimum breakdown voltage. In other words the absolute pressure of hydrogen would need to be even higher than that of air (ie about 70 mm Hg).

Direct cooling of both rotor and stator windings would be required for alternative a. Cooling of auxiliary equipment associated with the generator, eg diode rectifiers, would also require careful consideration.

Alternative arrangement b., for the generator mounting would remove the generator from the environment of the gyros and totally enclose it with air at a normal pressure. For this purpose dynamic seals would be necessary to maintain the differential pressure; further study is needed to determine the type and performance of such seals. Adoption of such an arrangement would obviate the need for direct liquid cooling of the generator.

Comparing the two proposals for the generator mounting arrangements; alternative b., allows for the use of a conventional machine, while alternative a., results in an unconventional machine without the complication of rotating seals. At the time of writing, no judgement can yet be made as to which arrangement is superior until more information on the reliability and maintenance of seals is obtained.

4.2 - Generator control equipment (Plate 4)

4.2.1 - Starting equipment. From time to time it may be necessary to run up the gyros from standstill: this situation can occur under 'black start' conditions when no other power source is available in the duck. A hydraulic 'pony' pump driven by an induction motor can be fed from the 3.3 kV a.c. duck busbar. If a 50 kW motor was employed it could run all four gyros in turn from rest to 2000 rpm in 20 hours.

4.2.2 - Speed control. Hydraulic speed governing equipment will be essential as the generators are synchronous. The nature of the control required during generating periods is

essentially load control within the confines of the Scottish grid system frequency. Outside the limits of the national grid system frequency, frequency control will be required.

4.2.3 - Generator switching. Each machine will be controlled by a circuit breaker. Vacuum or SF₆ circuit breakers at most require attention at 10 year intervals and have a target life of 25 years. Each circuit breaker will be provided with conventional protective circuits and auto synchronising facilities of high integrity.

4.2.4 - Electronic control equipment. Monitoring and telemetry circuits will be used to control all the equipment in the power module. It is essential that high integrity supplies are available for the electronic control system, so that control may be maintained, even in the event of a complete power failure within the power module.

4.3 - Spine cable arrangements

4.3.1 - Duck to spine connections. Flexible main cables and control cables will be required from the 'beak' mounted equipment cylinders in the oscillating ducks to the stationary spine. Cables which can withstand 10^8 flexures will be required.

A likely solution appears to be the use of flat multi-conductor cables, with special insulation suitable for 3.3 kV a.c. operation. Whilst there is some development work required to make such cables available, the problems appear likely to be resolved and can be verified by tests.

4.3.2 - Connections along the spine. The specially flexible cables from the duck will be connected to cables possessing normal flexibility running inside the spine. Since the spine consists of separate lengths, 61 metres long, the cables will be subjected to flexing at each joint. Flexure at

the joints is restricted by hydraulic rams to a 12° angle; the cable will not be flexed severely at the joints.

A scheme of electrically unique ducks was envisaged initially and the costs included in this report are based upon LV cables from each duck accumulating in number towards a power collection point. Appendix B discusses an alternative arrangement using a standardised generator cabling arrangement which would allow all ducks to be fully interchangeable.

The cable from each duck is terminated in a 3.3 kV power fuse, which is connected to the 3.3 kV primary winding of a generator or 'grouping' transformer. The use of fuses avoids the unnecessary use of switchgear, which would otherwise have to be maintained.

If a fault develops in either the spine cables or the 'duck to spine' cable, then it will be cleared automatically by 3.3 kV power fuses. Fuse blowing characteristics will co-ordinate to allow the generator circuit breakers to operate and clear generator faults, without the fuse blowing.

The permanent loss of any one generator represents only 0.1 per cent power loss since there are 1000 generators in the reference scheme. It is, however, worth noting that hydro-dynamic studies indicate that if one generator or one duck in a string ceases to function, the output of adjacent ducks will increase; thereby compensating in part for the loss of output from the faulty duck.

SECTION 5

SEA TO SHORE TRANSMISSION

In the consultants second report (issued August 1978) a d.c. transmission scheme was adopted as the basis of costing wave energy schemes including the Salter Duck (SEA) device.

Since the unique energy storage capacity of the Edinburgh device now enables the use of synchronous a.c. generators; an a.c. transmission scheme can be considered as an alternative to a d.c. transmission scheme. In our opinion the additional cost of rectification and inversion would not be justified for the transmission distance of about 250 km. Objective (b) of our terms of reference (ie whether a.c. or d.c. transmission is appropriate) is, therefore, resolved by factors outside the field of electrical design concepts. Accordingly we have not attempted to design a d.c. transmission scheme similar to that used in the consultants second report.

5.1 - Submarine cables

The submarine cable route to land may be divided into two separate sections. The section connecting the floating wave energy device to the seabed requires a flexible cable connection, while that from the seabed to the shore does not.

Flexible cable lengths are relatively short, since the wave energy device will never be stationed in water depths greater than about 100 metres. Development of flexible cables for this special purpose need not be constrained by economic considerations normally applied to cable manufacture. For instance, much lower electrical stresses than would be commercially acceptable could be employed in design for the insulation.

A "low stress" cable would inherently be less susceptible to insulation breakdown mechanisms which occur in "high stress" commercial cables. Ideally, the flexible cable should also be able to operate satisfactorily with moist insulation, thereby not relying on the complete integrity of the cable sheath to keep the insulation dry. Flexible cables would need mechanical support, preferably from a suitable structure.

Cable requirements from seabed to shore are for "high" electrical stress cables, which can transfer the maximum power at minimum cost. These cables would form sea to shore "busbars" and, needing less flexibility, could have large cross sectional areas. Seabed to shore cables, however, would need mechanical protection to prevent damage due to abrasion against rocks.

A cable joint is required between the two sections of submarine cable, where the relatively inflexible "seabed to shore cable" is jointed to the flexible "seabed to surface" cable.

It is desirable to joint several flexible HV submarine cables on to the end of the seabed to shore cable because:-

- a. The flexible cables will have a reduced cross sectional area thereby increasing their flexibility and hence their suitability for seabed to surface connections.
- b. A multiple take-off from the duck string at HV reduces the need for long lengths of LV cables running parallel to the shore.

The transmission from sea to shore will therefore consist of power collection on the surface at 3.3 kV; transformation to some higher voltage; and an HV submarine cable system to the shore.

A summary of the items of transmission plant required is:-

1. A 3.3 kV cable from each duck feeding a 3.3 kV "group" busbar through a fuse.
2. A grouping transformer which collects power from several incoming 3.3 kV cables and transforms from 3.3 kV to a higher transmission voltage.
3. A flexible high voltage submarine cable from each group transformer to the seabed.
4. A cable multi-joint box on the seabed joining the flexible cables from the surface to the main HV seabed to shore cable.
5. A main seabed to shore HV submarine cable.
6. Cable terminations on the shore for the incoming HV submarine cables.

5.2 - The optimum sea to shore transmission system

Collection of power at sea parallel to the shore is at low voltage, while transmission of power from sea to shore is at high voltage. In effect, power collection and transmission circuits form a number of "T" shaped cable circuits.

If power "take offs" from sea to shore occur at frequent intervals then the cost of LV power collection cables parallel to the shore will predominate.

The number of parallel sea to shore circuits is primarily determined on grounds of minimum cost, so it is timely to introduce a discussion on cost at this point in our report. It is shown later, however, that an increase in the number of parallel sea to shore circuits (perhaps required for security reasons) only marginally increases the overall cost of the sea to shore transmission scheme.

Notes on the derivation of costs used for cost analysis may be found in Appendix B. There are, however, one or two points of special interest that should be mentioned.

We selected 132 kV as being a suitable transmission voltage from sea to shore for the purpose of cost studies. As discussed in the Section 4.1, 3.3 kV has been selected for the generation and power collection system.

The installed cost per metre of HV submarine cable, including laying and mechanical protection is not significantly affected by operating voltage; since laying and mechanical protection costs are a high proportion of the total installed cost. Variation of the sea to shore transmission voltage either side of 132 kV (ie 110 kV - 161 kV), or the cable size will not significantly affect any costing exercise.

A sea to shore route length of 15 km has been selected for study purposes. A distance of 15 km will include horizontal and vertical deviations of the laid cable to a string of ducks located 10 km from the shoreline of South Uist.

Although 15 km sea to shore transmission route is considered for the reference design there is no reason why the a.c. transmission scheme proposed should not be extended to 60 km. A case study for 60 km of sea to shore a.c. transmission by cable is included in Appendix A.

All costing studies are for the transmission of 2000 MW from sea to shore. Costing studies showing the variation of total transmission cost with the number "n" of sea to shore 132 kV transmission circuits have been made. (See Plate 5). Each sea to shore transmission circuit will carry 2000/n MW.

The grouping of generators to each of the grouping transformers is another possible variation in the configuration of the sea to shore transmission system. Each sea to shore transmission circuit includes several flexible 132 kV cable

circuits which connect the grouping transformers in the duck string to the seabed. The costing studies for sea to shore transmission costs have been repeated for three different take-off configurations.

Plate 5 shows the variation of total transmission cost for 2000 MW with the number (n) of 132 kV sea to shore transmission circuits. Configuration A is for two grouping transformers for each 132 kV sea to shore transmission circuit. The price per metre of 132 kV 3 phase submarine cable circuits was assumed to be £120/metre. Three curves are given for 3.3 kV 3 core cable prices of £6, 12 and 24 per metre, respectively. Figs (B) and (C) show the effect on total transmission cost of increasing the number of grouping transformers in each 132 kV sea to shore circuit to 3 and 4 respectively.

The costing exercise is repeated in Plate 6, but this time a cable price of £240/metre of 132 kV submarine 3 phase cable circuit has been assumed.

The results of costing studies shown in Plates 5 and 6 reveal:-

- a. The cost of 3.3 kV LV cabling is a significant proportion of the overall transmission cost.
- b. Doubling the price of 3 phase 132 kV cable circuit from £120/metre to £240/metre increases the overall transmission cost, but not proportionately to the increase in the 132 kV cable price.

Five 132 kV sea to shore transmission circuits have been chosen on the basis that the limiting current for 132 kV single core cables is about 2000 amps (2000 mm^2). The output of the 2000 MW scheme would only reduce by 20 per cent for a permanent cable failure.

The reference electrical design chosen is based on a 132 kV cable circuit price of £240/metre and 3.3 kV cable price of £24/metre. The price of 3.3 kV cables includes racking, plug connections and multicore cables for control.

With the cable prices used in the study there is no significant economic advantages in increasing the number of flexible cable connections and grouping transformers to beyond three.

5.3 - Arrangement of the reference electrical design

The reference electrical design shown in Plate 7 consists of 5 parallel 132 kV sea to shore cable circuits each rated at 450 MVA. Each sea to shore cable circuit connects to 3 separate flexible cables which, in turn, connect to grouping transformers at the surface. Each grouping transformer collects power from 67 or 68 ducks.

Grouping transformers (see Plate 8) are rated at 150 MVA and have two 3.3 kV primary windings each fed by 34 ducks. A double primary winding is necessary to keep the current rating of each winding to a reasonable level. A single 132 kV secondary HV winding feeds the outgoing 132 kV flexible cable.

5.4 - Cable reliability and security

The majority of faults in submarine cable circuits are mechanical in origin, rather than the direct result of electrical failure.

Constant movement of the cable on the seabed caused by tidal currents may cause abrasion and fracture of the cable sheath with the subsequent penetration of moisture into the cable insulation. A solution usually adopted is the use of pressurised cable systems which are capable of keeping moisture out of the cable insulation for small fractures.

Severe cable damage may result from the movement of large rocks on the seabed, unsupported cable lengths resting over rock ledges, or ship's anchors. Pressurised cable systems cannot keep the cable insulation dry for severe damage to the cable. Cables which are constructed using solid insulation (eg EPR and XPLE) would be less susceptible to the ingress of water following severe damage, than cables insulated with impregnated paper.

A first requirement for submarine cable installation is an exhaustive survey of the seabed. It is essential to avoid laying the cable in hazardous areas where abrasion of the cable might occur. We can only avail ourselves of such expertise as exists in the North of Scotland Hydro Board, and the Marine Institute at Dunstaffanage. Preliminary surveys indicate that the seabed is rocky and mechanical protection for cables may well be necessary.

Mechanical protection of the cable can take many forms. A cable may be protected by concrete, either laid in slabs over the cable, or in the form of bags of slow setting mix tied to the cable itself. Another form of mechanical protection could be a spiral protection wound over the cable as it is laid. Application of such protection measures, as appropriate, will increase the reliability of any submarine cable considerably.

There is, however, much that can be done to reduce the possibility of all three phases of the cable circuit being severely damaged by ships anchors and fishing trawls. If the phase spacing is 200 - 500 metres then the risk of severe damage to two phases simultaneously is much reduced.

A fourth (spare) single core cable has been installed on certain cable installations which are mentioned in technical literature, to enable a three phase cable circuit to be operated in spite of the loss of one phase. The spare phase, however, would have to be automatically switched and kept energised to avoid deterioration of the cable.

We feel that the complication of switching and energising the spare phase would not be worthwhile since at least four other parallel sea to shore transmission circuits will also exist. If it is felt that additional security of sea to shore cable circuits is required then more sea circuits could be provided, reducing the permanent outage to less than 20 per cent of the nominal generation capacity of 2000 MW.

We envisage the 132 kV multi-way connection being made in the fashion of existing metal clad SF6 switchgear. In this case there would be a single phase metalclad SF6 busbar with the appropriate number of solid cable entries. Gas leakage rates of less than 1 per cent p.a. can be guaranteed now and together with further marine protection the present day techniques will provide a secure arrangement. The techniques of lowering and securing the connector on the seabed and for raising it for repairs require study.

5.6 - Cable charging current

The charging current of cables can be compensated by the provision of shunt reactors. Shunt reactive compensation, however, does not reduce the heating of the cable due to the flow of cable charging current. Where charging currents are drawn by a cable system the cable must be compensated at intermediate points along its length, to avoid overloading the cable at its end connections due to the flow of charging current. Installation of intermediate compensation for submarine power cables poses difficult, but not insuperable, technical problems.

Submarine cables using XLPE insulation have been used in several parts of the world. The most significant electrical parameter of XLPE cables is that the charging current is only 1/3 that of the equivalent paper insulated oil impregnated paper cable. This significant change in electrical parameters greatly increases the length of uncompensated a.c. cable that can be employed for power transmission.

The distance limit imposed by charging current alone for a 3 phase 132 kV XLPE cable circuit rated at 450 MVA is around 100 km (see Appendix A). Reactance of the cable circuit becomes more of a limiting factor than the cable charging current, due to the much reduced charging current of XLPE cable.

Sea to shore transmission distances of up to 60 km will be satisfactory for the reference electrical design proposed. Beyond 60 km the additional circuit reactance introduced, or sheath heating may cause power transfer to be limited; and these aspects would need to be examined in greater detail.

5.6 - Cable circuit reactance

Cables in excess of 400 mm² csa (as required for the reference design) are usually of single core construction at 132 kV due to the bulk of the cables. Reactance of cable circuits may be reduced by laying single core cables in trefoil formation, but this may not be acceptable for submarine applications because:-

- a. Severe mechanical damage could result in the loss of all three phases.
- b. Cables may chafe and damage each other if subjected to tidal currents.

Magnetic fields caused by current flow in the cable core, cause voltages to be induced in the cable sheath. When the cable sheaths are solidly bonded the flow of currents in the sheath cause power losses. Power losses in the cable sheath result in a reduction of the current carrying capacity of the cable. For this reason cables laid on land have their sheaths "cross bonded", which eliminates the current flow in the cable sheath with a subsequent increase in the current carrying capacity of the cable.

Obviously, cross bonding cannot be applied to submarine cables, as a complex system of sheath connections could not be installed under the sea. The only feasible solution is the solid bonding of cable sheaths; but in spite of increased cable losses, it has benefits as well as disadvantages.

The flow of currents in the sheath and armouring has an important influence in reducing the three phase circuit reactance of 3 - single core cables which are separated by large phase distances.

A single core a.c. submarine cable may be likened to an air cored transformer with a single turn primary (the core) and a shorted circuited secondary turn (the sheath and armouring). The flow of current in the cable armouring reduces the cable reactance. Losses in the armouring are reduced by ensuring that short circuited "secondary turn" has a low resistance. For these reasons, low resistance aluminium alloy armouring would be required for the submarine cables connecting seabed to shore.

5.7 - Summary of cable specification

Bearing in mind the previous discussion, we have adopted the following cable Specification given in Table 2 for study purposes for the seabed to shore 132 kV cables.

TABLE 2

No cores	single core/copper
Armouring	non-magnetic (aluminium alloy)
Insulation type	XLPE/Pressurised
System voltage	132 kV
Rating per phase	2000 amps
Cross-section area	2000 mm ²
Reactance/km at 50 Hz	0.11 ohms/km
AC resistance 85°C	0.12 ohms/km
Charging current per 3 phase	1.6 MVAR/km
Sea bed thermal resistivity	0.3°C/m/W
Land thermal resistivity	1.05°C/m/W

SECTION 6
TRANSMISSION TO THE MAINLAND

This section is concerned with the collection of the power from the 132 kV submarine cables, then by land on South Uist, through to the delivery of the power at Craigroyston, near to Cruachan.

The injection of 2000 MW power into the Scottish grid system will inevitably require some reinforcement of the grid system. Reinforcement of the Scottish grid system is outside the scope of our report and we assume that the point of inter-connection will be reinforced.

Cruachan and the surrounding area is suitable for the development of pumped storage schemes and one at Craigroyston is under consideration. If such schemes are developed, a 400 kV grid system connecting the Cruachan area with the major load centre at Glasgow will have to be constructed. Furthermore, the nature of a pumped storage scheme is that facilities exist for the generation of reactive power, and the storage of large amounts of energy. Accordingly, we consider the Cruachan area to be suitable for the termination of incoming transmission lines from a wave energy scheme.

The technical particulars of the components of this system are shown in Table 3.

6.1 - Transmission route (see Plate 9)

The incoming 132 kV submarine cables on the west coast of South Uist will feed single circuit 132 kV overhead lines which terminate in a 132/400 kV transforming station. A short length of 400 kV overhead line will then run from the 132/400 kV transforming station to a 400 kV cable termination.

TABLE 3

Parameters of Electrical Transmission Plant Selected
for the Reference Electrical Design

O/H AC TRANSMISSION LINES

- A1 (Route: 110 km
- (Arrangement: Single Circuit 400kV ...
- A2 (Conductors: Twin Aluminium Alloy 35mm^o/D per phase
- A3 (Each Conductor 0.65 sq.in Copper Equivalent
- A4 (INSULATION LEVEL: 400 kV
- (Current Ratings: Cold: 2500 amps
- (per circuit 65°C. Normal: 2200 amps
- (Operating Temperature) Hot: 2000 amps

ROUTE: 20 km

- A5 (As for lines A1 - A4
- A6 (except 500kV Insulation for
- (Salt spray conditions

ROUTE: 10 km

- A7 (Arrangement: Single Circuit 132kV
- A8 (Conductors: Twin Aluminium Alloy 35mm^o/D per phase
- A9 (Each Conductor 0.65 sq. ins Copper Equivalent
- A10(Insulation Level: 275 kV*
- All(* For salt spray conditions

SUBMARINE AC CABLES

- (Route: 30km
- B1 (Arrangement: 3 single Cores / Circuit + spare phase
- (Type: 400kV XLPE Insulated
- (Current Rating: 1600 amps / Circuit
- B2 (Charging MVAR: 180 MVAR/Circuit
- B3 (Route: 15km (10 km Nominal)
- B4 (Arrangement: 3 Single Cores/Circuit
- (Type: 132kV XLPE Insulated
- B5 (Current Rating: 2000 amps / Circuit
- B6 (Charging MVAR: 25 MVAR / Circuit
- B7 (

TRANSFORMERS

- T1 (Voltage: 400/132/66kV
- (Group: Star/Star/Delta
- T2 (Rating: 670MVA Single Phase Banks
- T3 (Reactance: 12%
- T4 (Taps On 132kV: -10% + 5% ON LOAD
- T5 (Voltage: 132/3.3/3.3
- T6 (Group: Star/Delta/Delta
- T7 (Rating: 150MVA
- T8 (Reactance: 12%
- T9 (Taps On 132kV: +10% - 5% OFF Load

SHUNT REACTORS

- R1 (Voltage: 132kV
- R2 (Rating: 150 MVAR
- R3 (

SERIES CAPACITOR

- C1 (Insulation: 400kV
- (OHMS/PHASE: 20 (60% Series Line Reactance Compensation)
- (Current Rating: 3400 amps
- (Normal Operating Voltage: 68kV rms
- (GAP Setting: 140 kVp
- (Total 3 Phase MVAR Rating: 615 MVAR

Submarine cable circuits will run under the Little Minch for a distance of 30 km, to the Isle of Skye. A 400 kV overhead line will then run across the Isle of Skye, across the Kyle Rhea on overhead towers, and on to a substation at Fort Augustus.

We have not carried out a field survey of any of the line routes, but on the basis of local knowledge of the area, have selected a west coast route to Craighroyston. The route follows the railway line past Loch Rannoch to Dalmally, and thence to Craighroyston.

6.2 - 132 kV overhead lines

From where the 132 kV submarine cables land on the west coast of South Uist, overhead line connections will be required to transport the energy to a 132/400 kV transforming station. These overhead lines will be subjected to excessive salt pollution and will therefore require extended creepage distance on the insulation. One method of providing this extended creepage distance is to construct the line as a 275 kV insulated line. Each overhead line would be of single circuit construction and terminate at the switching station; in this way the overall reliability of these connections will be at least as high as normal 132 kV construction.

6.3 - 132/400 kV transforming station

In the system diagram shown on Plate 10 it can be seen that a $1\frac{1}{2}$ circuit breaker substation has been proposed for the 132 kV connections of South Uist. This will provide security against loss of power due to a busbar fault and enable circuit breakers to be maintained without the outage of the main equipment.

Four of the 'diameters' of this switching station will contain an incoming line and a transformer connection, the fifth

having an incoming line and a reactor. This connection arrangement minimises the loss of power in the event of a fault on the centre switch of the 1½ breaker arrangement. The other two shunt reactors would be connected to a sixth 'diameter'.

To enable the use of conventional 132 kV switchgear, four 132 kV transformer circuit breakers of 3150 amp normal current rating will be necessary. This requirement, together with the foreseen need to restrict transport weight of transformers to South Uist, leads us to suggest that there should be four 400/132 kV transformers, connected into pairs. Their capacity would be 670 MVA, enabling three out of the four transformers to take the full 2000 MW throughout. Further, these transformers would most probably have to be single phase units.

The tertiary windings associated with these transformers could be wound 33 kV and jointly would be capable of providing a local firm load capacity of several hundred MW.

The 400 kV side of these transformers would feed into a standard 400 kV four switch mesh enabling any or all of the transformers to be connected to either or both of the outgoing overhead lines.

6.4 - Overhead lines

Two transmission circuits each capable of delivering 1000 MW to the Cruachan area fulfil the security criteria of 1000 MW firm and 2000 MW non-firm. (see Section 3.1).

The route length between the Isle of Skye and the Cruachan area would be about 240 km, using a line route following the contour of the valleys, and the railway line to Rannoch.

Line routing and construction will be mainly determined by environmental considerations. The area concerned is a tourist area and every attempt would have to be made to avoid unsightly transmission towers and lines.

The visual impact of the transmission towers could be reduced by using the minimum number of line conductors and minimum tower height.

A wave power project may take say, ten years to construct and commission. In the early stages only a limited amount of power will be available for transmission. If economic considerations only were involved, then the phased construction of two separate single circuits would be favoured to delay the capital expenditure for the second circuit.

Without having inspected the proposed line route, it is difficult to give a firm recommendation on line construction. It may well be that several types of tower construction, both single and double circuit may have to be used to reduce the visual impact of the transmission lines.

Where minimum height is the main consideration two single circuits would be preferable. If wayleave is of primary importance double circuit towers would be favoured. Special double circuit towers, a top arm carrying two conductors and a bottom arm carrying four conductors could be used to reduce tower height.

A suitable conductor arrangement would be twin aluminium alloy conductors 35 mm diameter. The conductor arrangement would meet the minimum radio interference level acceptable to the CEGB, and reduce the amount of tower structure required to support the lightweight conductors. The circuit rating of each circuit would be 2500 amps under winter conditions, which corresponds to a thermal limit of 1300 MVA.

Electrical security against lightning is increased by the use of two separate single circuits. Lightning is likely to cause an outage of both circuits occasionally if double circuit construction is used.

In desolate locations the mechanical integrity of the transmission circuits is important. Wind and ice loading on

conductors will be severe. Although double circuit construction can be designed satisfactorily, the phased construction of the second circuit would involve live stringing, and increase the overall cost.

Our view is that the use of two separate single circuit lines should be used wherever this is possible. The justification is primarily on economic grounds that only one circuit be needed for the first five years of a wave energy project. Secondly, the mechanical and electrical integrity of two separate single circuits is marginally better than for double circuit construction.

6.5 - 400 kV submarine cable circuits

A submarine crossing is necessary between the Isle of Skye and South Uist at a voltage level of 400 kV.

Two circuits each consisting of three single core cables would be required. The circuit rating of each circuit would be 1600 amps. To enable a faulty cable to be repaired, which could take months to complete, without restricting the system throughout to 50 per cent for more than one day, spare cable would be laid. Isolators would be provided at each of the cable termination stations to enable the faulty cable to be isolated and the spare cable selected.

The choice lies between cables insulated with oil impregnated cables or XLPE insulated cables. The principle difference in the electrical properties of XLPE and oil impregnated cables lies in the magnitude of charging current. XLPE cables only require one third of the charging current required by oil impregnated paper cables as we have stated in Section 5.6. For a distance of 30 km the charging current required by an oil filled cable will not limit the power transfer capability of the cable, but more reactive compensation equipment will be required. Oil impregnated paper cables would be satisfactory for a 30 km submarine crossing.

Although XLPE cables above 230 kV are not yet in commercial service throughout the world it is expected that cables up to 400 kV will be available by 1985. Rapid advances in the manufacturing processes used for XLPE cables are improving the reliability of XLPE cables. Trial installations of 380 kV cable now exist.

If a submarine cable suffers minor damage then a pressurising system can prevent the ingress of water into the insulation. For major damage, however, the ingress of water cannot be prevented. Under these circumstances XLPE cable is less liable to permanent damage than an oil filled cable, since water cannot penetrate the insulation easily.

On balance, our recommendation would be a 400 kV XLPE cable if these are available when the project is constructed. Reactive compensation is therefore based on the charging current required by XLPE cable. Reactive compensation of the cable charging current is achieved by three switched reactors situated at the South Uist end of the cable circuit.

6.6 - Shunt compensation

The charging current of the 400 kV cable circuits between Skye and South Uist are compensated by 3 x 150 MVAR reactors at South Uist switched at the 132 kV busbar. The cables are of relatively low impedance and compensation at one end only is sufficient. Reactors can be switched out during heavy load conditions on the transmission circuit to improve power factor.

6.7 - Series compensation

Due to the comparatively long lengths, and therefore high inductive reactance of the 400 kV overhead lines there would be an excessive change in phase angle which would reduce the power transfer capability unless means were used to compensate for this line reactance. The scheme includes series

capacitors to provide compensation equal to 60 per cent of the line reactance. An intermediate switching station at Fort Augustus is provided to increase 400 kV transmission circuit security in the event of an overhead line fault. A $1\frac{1}{2}$ circuit breaker switching station has been included for this purpose. The series compensation will be switched between the busbars of this station and the switching arrangement will enable the compensation to be removed at will.

6.8 - 400 kV receiving station

The overhead lines will terminate at the 400 kV switching station which it is proposed will be built adjacent to the pumped storage scheme at Craigroyston. The reactive compensation for the load at this end of the system can either be provided by the generators or by additional reactive compensators. Whichever is chosen, a sum of £8 million has been included to cover the cost.

6.9 - Spare capacity

Plate 11 shows the spare capacity available for items of plant incorporated in the scheme. No spare line capacity is included since a line fault may be repaired in a day or so. Spare capacity is required for items of plant that will take a considerable time to repair such as transformers and cables.

SECTION 7

COST ESTIMATES

7.1 - Scheme costs

The scheme costed in this section is the reference electrical design, as described in the previous sections of this report, namely 1000 ducks supplying energy to the Scottish grid system on the mainland.

Costs include all spare capacity installed to cover loss of plant contingencies. The scheme is nominally rated at 2000 MW covering generation offshore on the west coast of South Uist and transmission to Craigroyston.

7.2 - The basis of costs

Wherever possible we have used FOB (free on board) prices of equipment, based on actual costs tendered on projects we have engineered within the past five years. These costs have been adjusted to September 1979 costs in accordance with the cost increase trends, based on BEAMA material and labour cost indices for switchgear and transformers.

Synchronous machine costs include all the auxiliary equipment, main switchgear, AVR and control equipment. Costs have been based on information supplied by a leading British manufacturer, and spot checks from tender prices have confirmed their validity.

An allowance of 40 per cent of the FOB prices has been included to cover CIF (carriage, insurance and freight) and erection charges on all costs except the cable costs for which installation costs are conventionally included. For equipment

manufactured and installed in the same country, an allowance of 25 per cent on FOB prices for CIF and erection would be more appropriate than 40 per cent. A generous allowance of 40 per cent is included to offset the probable higher cost of erection due to the remote location of the South Uist site.

Cost trend curves for variation of plant rating are included in Appendix B.

7.3 - A.C. generation and transmission costs

A summary of the transmission and generation costs are given in Table 4. The total scheme cost for the reference electrical design is £266 million. The figure of £266 M assumes that all the equipment is installed in the first year. A more realistic installation would be 100 ducks each year over a 10 year period. At an interest rate of 10 per cent pa the present value of the scheme on this basis would be reduced from £266 M to £203 M. It will be seen from the cost evaluation shown in Table 5 that the phasing of the equipment to facilitate the installation of 100 ducks per annum is effectively installing a 132 kV submarine cable circuit and connections to the 132/400 kV South Uist substation every 2 years and installing the second 400 kV circuit in the fifth year. To assist in showing the effect of the interest rate on the proposed phasing of the work, Table 5 includes the phased costs at 8 per cent, 10 per cent and 12 per cent interest.

TABLE 4

AC SCHEME COSTS

	£M
1. 2000MW of synchronous generators comprising 1000 - 2.6MW gens. incl. aux. equipment, controls, protection and switchgear	71
2. Transmission from ducks to S Uist comprising 5 - 132kV cable circuits, transformers 3.3kV cabling, controls and protection	45
3. Collection and transmission across S Uist comprising 132kV collecting O/H lines, 132kV 1½ CB switching station, 4 - 670 MVA groups of 1Ø transformers 3 - 150 MVAR reactors, 400kV 4 switch mesh 2 - 400kV single circuits O/H lines.	22
4. 2 - submarine cables 400kV circuits plus 1 spare cable and selecting switchgear 30 km route length	25
5. Cable termination station on skye 4 switch	2.5
6. O/H lines to Comer	47.5
7. Fort Augustus Switchgear Station and Series Capacitors	9
8. Terminal Switchgear at Comer and increase in m/c MVAR capacity	<u>8</u>
TOTAL	£230m
Engineering Charges 5%	<u>11.5</u>
	241.5
Contingencies 10%	<u>24.5</u>
GRAND TOTAL	<u>£266 M</u>

TABLE 4 ITEM NO	YEAR										TOTAL
	1	2	3	4	5	6	7	8	9	10	£M
1	7.1	7.1	7.1	7.1	7.1	7.1	7.1	7.1	7.1	7.1	71
2	9	-	9	-	9	-	9	-	9	-	45
3	11	-	-	-	11	-	-	-	-	-	22
4	12.5	-	-	-	12.5	-	-	-	-	-	25
5	2.5										2.5
6	24	-	-	-	24	-	-	-	-	-	48
7	2	-	-	-	7	-	-	-	-	-	9
8	4	-	-	-	4	-	-	-	-	-	8
	72.1	7.1	16.1	7.1	74.6	7.1	16.1	7.1	16.1	7.1	230
incl. eng. and cont.	83.3	8.2	18.6	8.2	86.2	8.2	18.6	8.2	18.6	8.2	266
8% PV factor	1	0.926	0.857	0.794	0.735	0.68	0.63	0.583	0.54	0.50	
8% PV cost	83.3	7.6	15.9	6.5	63.4	5.6	11.7	4.8	10	4.1	212.9
10% PV factor	1	0.909	0.826	0.751	0.683	0.62	0.565	0.513	0.466	0.42	
10% PV cost	83.3	8.1	15.4	6.2	58.9	4.6	10.5	4.2	8.7	3.4	203.3
12% PV factor	1	0.892	0.797	0.712	0.636	0.568	0.507	0.453	0.404	0.361	
12% PV cost	83.3	7.3	14.8	5.8	54.8	4.7	9.4	3.7	7.5	3.0	194.3

TABLE 5

SECTION 8

OBSERVATIONS AND SUMMARY

In this section we offer our observations and give our answers to the objectives (a - f) defined in our terms of reference in Section 1.

The title of this report is 'Wave Energy Report'. The title is significant since it underlines that the power is not of primary importance. Power is of premium value when it can be scheduled on a firm basis to meet load demands. Power output from natural power sources such as tide, wind or waves rarely, if ever, coincide with power demands created by human living patterns and industrial activities. The storage of energy in both the short, medium and long term, and the utilisation of energy to supply the load demand over 24 hour periods, is a matter of some complexity. Any wave energy scheme must be supported from the sale of electrical energy (ie kW hours) to consumers which is generated at random power levels.

One of the fundamental design parameters of wave energy schemes is the ratio of peak power to mean power. Increasing peak power capability yields a diminishing return of energy. The design of the duck and the electrical system proceed in parallel, so that a firm decision had to be reached to enable electrical design work to proceed. The power rating for the scheme was fixed at 2000 MW peak and about 425 MW mean electrical power for the reference electrical design, and this represented the best compromise that could be made at the time.

The transmission of energy does not require a firm transmission system. Complete loss of transmission capability would result in a large power loss but little loss of energy, providing repairs to the transmission system can be effected

quickly. The cost of a secure transmission system is not therefore justified. The loss of 2000 MW peak power input into the Scottish grid system would however, produce an unacceptable disturbance to the grid system. Our opinion is that, by 1985, the generation connected to the National grid system will be so reinforced that the sudden loss of 1000 MW of generation would be acceptable. If the transmission system is designed to deliver 1000 MW firm power and deliver power on a non-firm basis between 1000 and 2000 MW, then the maximum power loss will be limited to 1000 MW.

Some component parts required for the implementation of wave energy schemes may not be commercially available at the present time. It would be unrealistic to use present technology as a basis for a scheme that could not be constructed before 1985 at the earliest. Critical components which must operate satisfactorily may be developed outside the constraints of commercial competition. For instance, flexible cables of special design for seabed to surface connections will be required. Another area is the use of electronics for control and monitoring purposes, which will both be reliable in themselves, and improve the reliability of equipment with which they are associated.

Large spinning gyros provide unique energy storage facilities in the Edinburgh wave energy device. The size of the energy store enables 1 MW per hour of energy to be stored in each duck. The energy converter enables high peak power levels to be extracted from waves, and converted into a steady mean power level. A constant torque drive can be provided suitable for driving a.c. synchronous generators.

The question of whether a.c. or d.c. transmission is appropriate had next to be resolved. The attraction of a.c. transmission is that, over short to medium distances, it is cheaper than d.c. transmission, due to the high cost of d.c. transmission terminal equipment. Furthermore, a.c. transmission is very flexible as it can be integrated into existing power supply systems for the supply of local loads. Our conclusion is

that, since synchronous a.c. generators can be employed, the use of a.c. transmission offers advantages both in cost and flexibility.

Early studies on generation indicated that generation costs could be considerably reduced by using large electrical generators. It was felt, however, by the Edinburgh team that the problems of paralleling hydraulic oil supplies outweighed the advantages to be gained by the use of large generators. A unit duck design each with its own 2.25 MW generator was accordingly selected. Each generator could be mounted either in the gyro chamber under vacuum, or in a separate compartment at normal air pressure.

The problems of operating an a.c. generator in the low pressure environment of the gyro chamber have been examined. Problems of cooling and electrical insulation are formidable, but not insuperable. No corresponding investigation into rotating seals, necessary to isolate the vacuum in the gyro chamber from air pressure, have been made. A firm recommendation on whether the a.c. generator should be contained in the gyro vacuum chamber or mounted externally in air cannot be given as we do not yet have sufficient information to assess the reliability of rotating seals.

Power collection parallel to the shore may best be achieved by the use of 3.3 kV cables. A lower voltage would increase the cost of cables required and a higher voltage would increase the cost of electrical generators.

The number of parallel sea to shore transmission circuits is primarily determined by consideration of cost. A near optimum arrangement is five parallel 132 kV sea to shore cable circuits. The estimated total sea to shore transmission cost is £42.5 M which includes all transformers, cables and mechanical protection. If greater security is required, then an increase in the number of 132 kV sea to shore cable circuits only marginally increases the overall transmission cost. The

cost of additional 132 kV cable circuits is offset by the reduction in the 3.3 kV cables required.

Discussion of generation at sea, and of sea to shore transmission must inevitably introduce the questions of reliability, access and maintenance. Reliability may be improved by eliminating all unnecessary switchgear and other plant requiring maintenance. The equipment that is employed should be designed and selected to have low maintenance requirements. Furthermore, electronic monitoring devices can be employed to increase the reliability, and reduce the need for direct access to equipment. On these grounds we feel it unrealistic to judge the maintenance and access requirements to generation plant on conventional land based equipment.

Recent developments in XLPE insulated cables will extend both voltage and current ratings. The use of XLPE insulated cables is desirable on two counts. Firstly, the charging current is only about one third of the equivalent paper insulated cable, thereby increasing the permissible transmission distances. Secondly, XLPE insulation will inherently absorb less water than oil impregnated paper cable following severe mechanical damage.

The use of failure rates to assess the fault incidence for submarine cables for wave energy devices can be misleading. The majority of cable faults are not due to direct electrical failure, but as a result of mechanical damage. Many of the existing cables possess inadequate mechanical protection, and have not been laid using modern techniques. If existing statistics are employed to assess cable failure rates, an over pessimistic estimate will result. An increase in the number of parallel sea to shore cables above five, may initially increase the security of power transmission, but too many parallel cables might result in a loss in overall reliability of the transmission system.

We have selected the point of connection with the Scottish transmission grid system to be at Craigroyston. The

reasons for this are that a substantial pumped storage scheme is likely to be located at Craigroyston, and the 400 kV grid system will have to be extended between Craigroyston and Glasgow.

The injection of power from a wave energy scheme into a transmission system connected to a pumped storage scheme has two principle advantages. Firstly, the a.c. machines used for the pumped storage scheme can provide reactive power, and secondly any additional power above that needed by the system load may be used for pumping.

The transmission system voltage between South Uist and Craigroyston could be selected at 400 kV or higher in view of the distance and peak power transfer capacity of 2000 MW. Power transmission at 400 kV is limited by reactive voltage drop on the overhead lines. Our finding is that the lines may be run near to their thermal capability by providing series compensation for the line reactance. This solution avoids the use of a higher voltage than 400 kV, and enables standard 400 kV equipment to be used. Two parallel 400 kV overhead lines satisfy the criteria for 1000 MW firm 2000 MW non-firm power transmission.

The overall cost for the electrical generation (excluding primemovers) and transmission of 2000 MW power from South Uist to Craigroyston for the reference electrical design is £266 M. This cost takes no account of staging which, if the construction spanned ten years, would give a present value of around £215 M. The cost of a scheme located 40 km offshore from South Uist (60 km route distance) would be £320 M.

There is much more that could be written about the electrical aspects of wave energy generation and transmission and these topics are outlined in Section 9. For the purpose of this report, however, we have confined ourselves to answering as clearly and concisely as we can the questions agreed in our terms of reference with the Edinburgh team.

SECTION 9

FUTURE WORK

The most significant aspect of our studies is without doubt the introduction of an a.c. generating and transmission scheme rather than the d.c. scheme previously considered. The a.c. scheme has been possible only because of the large store of energy inherent in the flywheels of the gyros and the fast acting hydraulic drives to the generators.

Energy storage both at sea and on the mainland could have an influence on the application of wave energy schemes. The integration of wave energy devices with land based power plant, and the operational requirements, will need further study.

Improvements to the a.c. scheme which would result in a lowering of the cost are only possible or probable where the scheme is unconventional. This is to say, to the generators and to the sea to shore transmission part of the scheme. Such improvements are only probable by increasing the size of equipment because of the attendant decrease in cost, which is clear from all the pricing information we have included in this report.

Whilst the scheme presented in this report is based on gyros and generators fitted to each duck, it would be worthwhile to assess the possibility of obtaining larger hydraulic motors driving larger generators. To achieve this, flexible high pressure hydraulic pipes may be necessary. Their availability should be investigated, if not for this scheme, as a general investigation as their use may be applicable to other devices.

Further investigation into the practical design of high voltage submarine cables and their mechanical protection is vital to any further consideration of wave power and is necessary.

Greater attention to XLPE type cables than has hitherto been paid is advisable, because of their particular advantages in an a.c. scheme.

The elimination, total or as far as possible, of any maintenance of equipment at sea requires investigation, as the benefits which would accrue are potentially high.

The ideas which have already been developed by the team have had important influences on the potential harnessing of wave power for commercial use. The possibility of new ideas of far reaching consequence should not be overlooked. At this stage, it would appear to be useful to allow new ideas to be generated in parallel with applied research into the development of equipment to facilitate the application of the present ideas.

Finally, the question of the advantages of a wave energy scheme operating in conjunction with conventional generation and pumped storage schemes could well be worth the more detailed investigation not covered in this report.

SECTION 10

CONCLUSIONS

The first and most important conclusion we draw from the work we have carried out on the electrical aspects of the Edinburgh University Team Device is:-

1. It is an important contribution to future means of obtaining energy without depletion of natural resources, which can be put into commercial service in a decade of years with the continuing drive and enthusiasm of the team, if facilities for this are provided.

Further, we conclude that:-

2. At a capital cost of some £250 M, a 2000 MW maximum (425 MW mean) array of generating modules associated with an a.c. transmission scheme to deliver this power to Craigroyston can be provided.

These conclusions are based upon other supporting conclusions which include:-

3. An a.c. transmission scheme is feasible in view of the energy store provided by the gyros and the fast response of the hydraulic driving motors.
4. Research and development of high voltage submarine cables and in particular cables with enhanced flexibility is needed but will in our view result in the provision of satisfactory cable installations.
5. Research and development of generators capable of running in vacuum conditions is required. Alternatively into maintenance free rotating seals.

We are also of the opinion, although this is not a conclusion, that the work of the team should be supported at least for a further year, allowing the free ranging thinking and study to continue before pressure to produce a working design places restriction on this productive process.

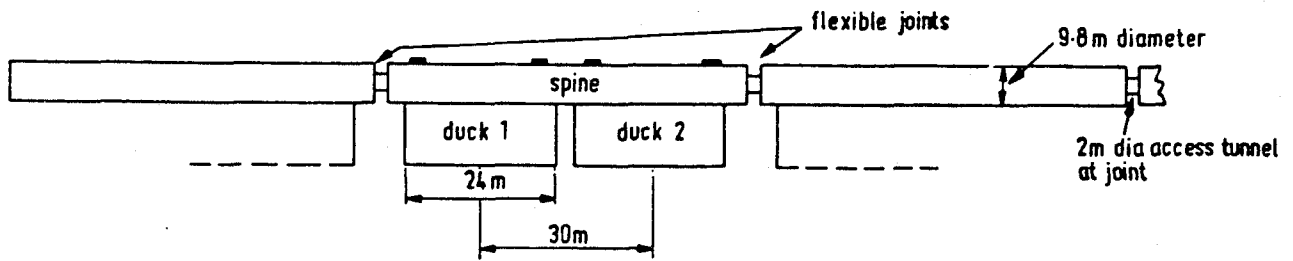

Plan

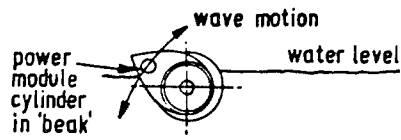

Typical Cross Section
of Duck

ARRANGEMENT OF 'DUCK' STRING

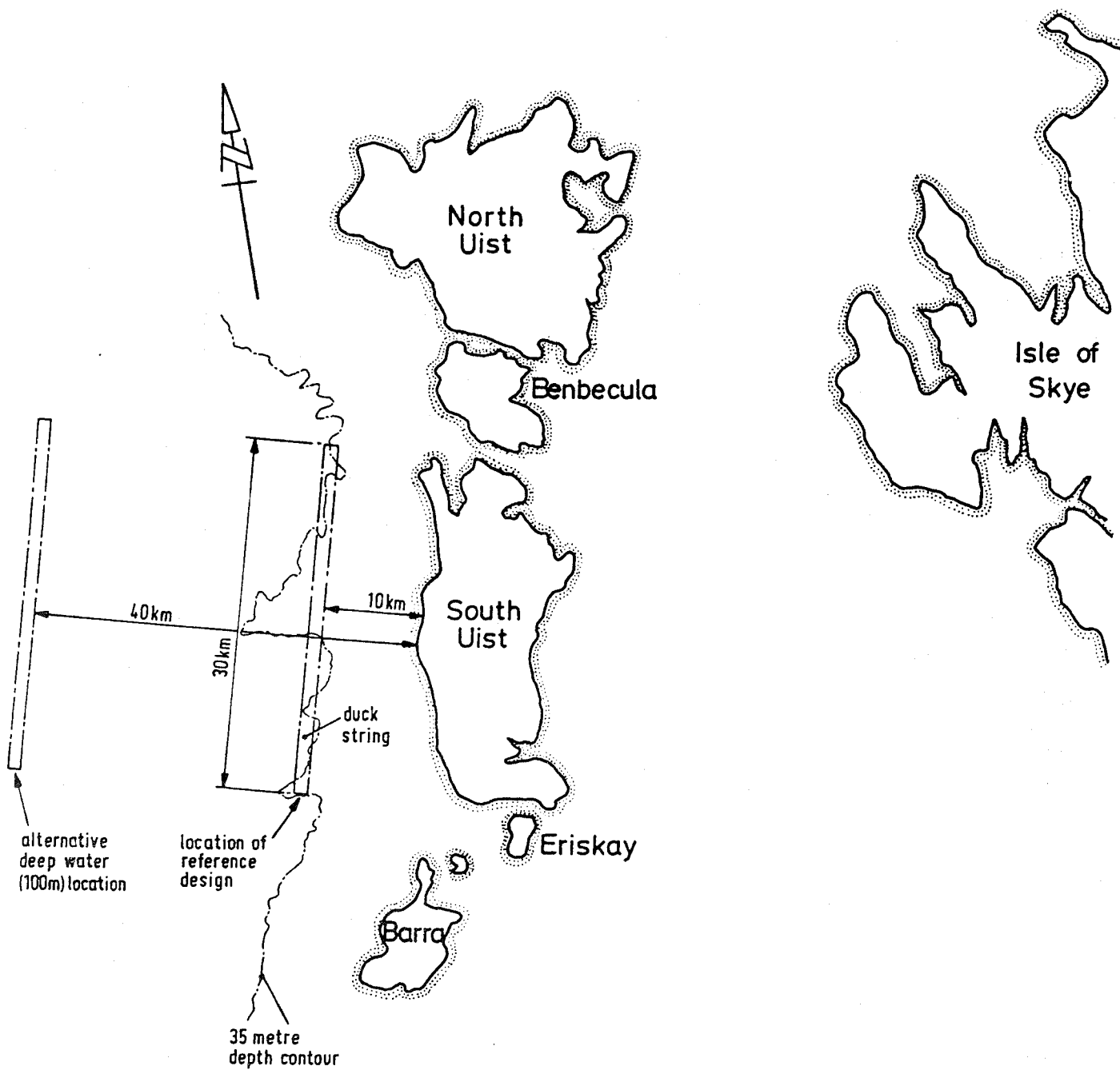

**LOCATION OF 'DUCK'
WAVE ENERGY DEVICE**

REF: ADMIRALTY CHART 2635

25. 11. 77

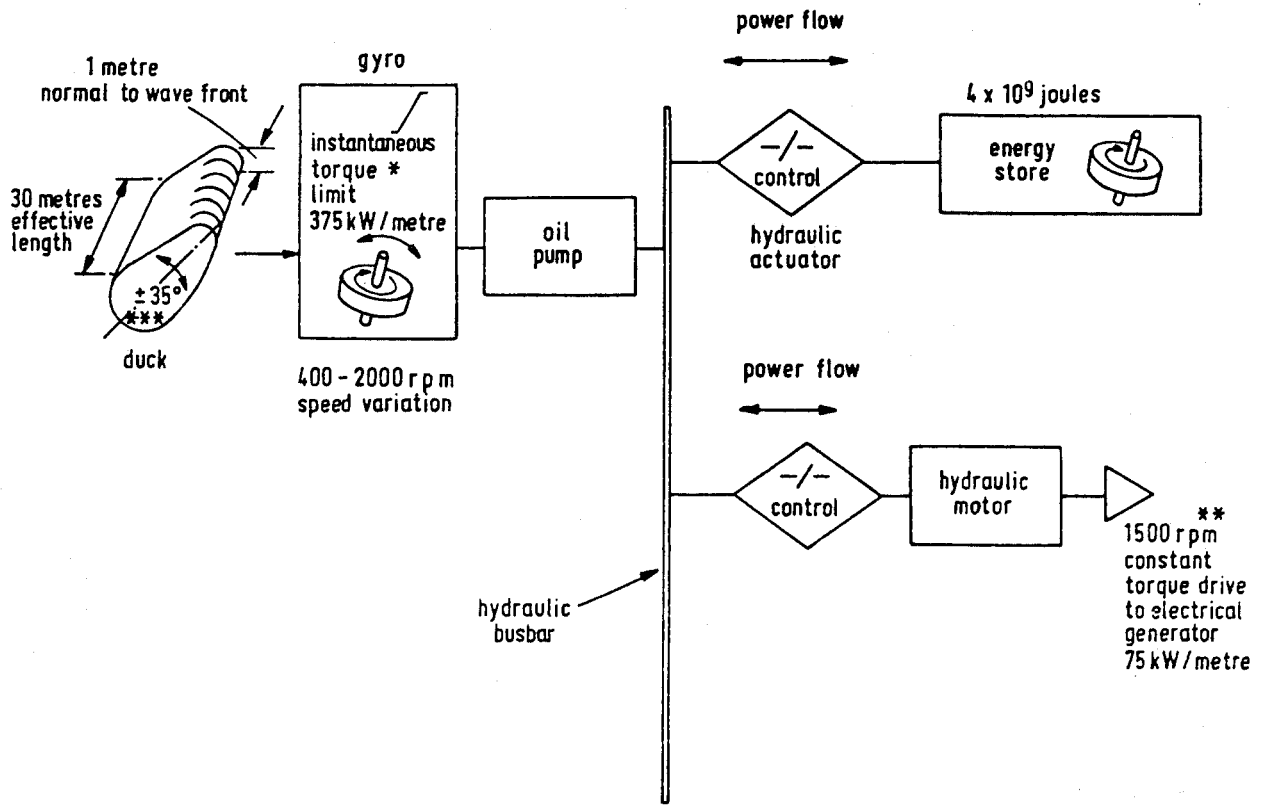

- * peak instantaneous output = 11.25 MW
- ** peak output = 2.25 MW
- *** normal angle of oscillation for maximum output

SCHEMATIC DIAGRAM OF
ENERGY STORAGE ARRANGEMENTS
FOR HYDRAULIC DRIVE UNIT

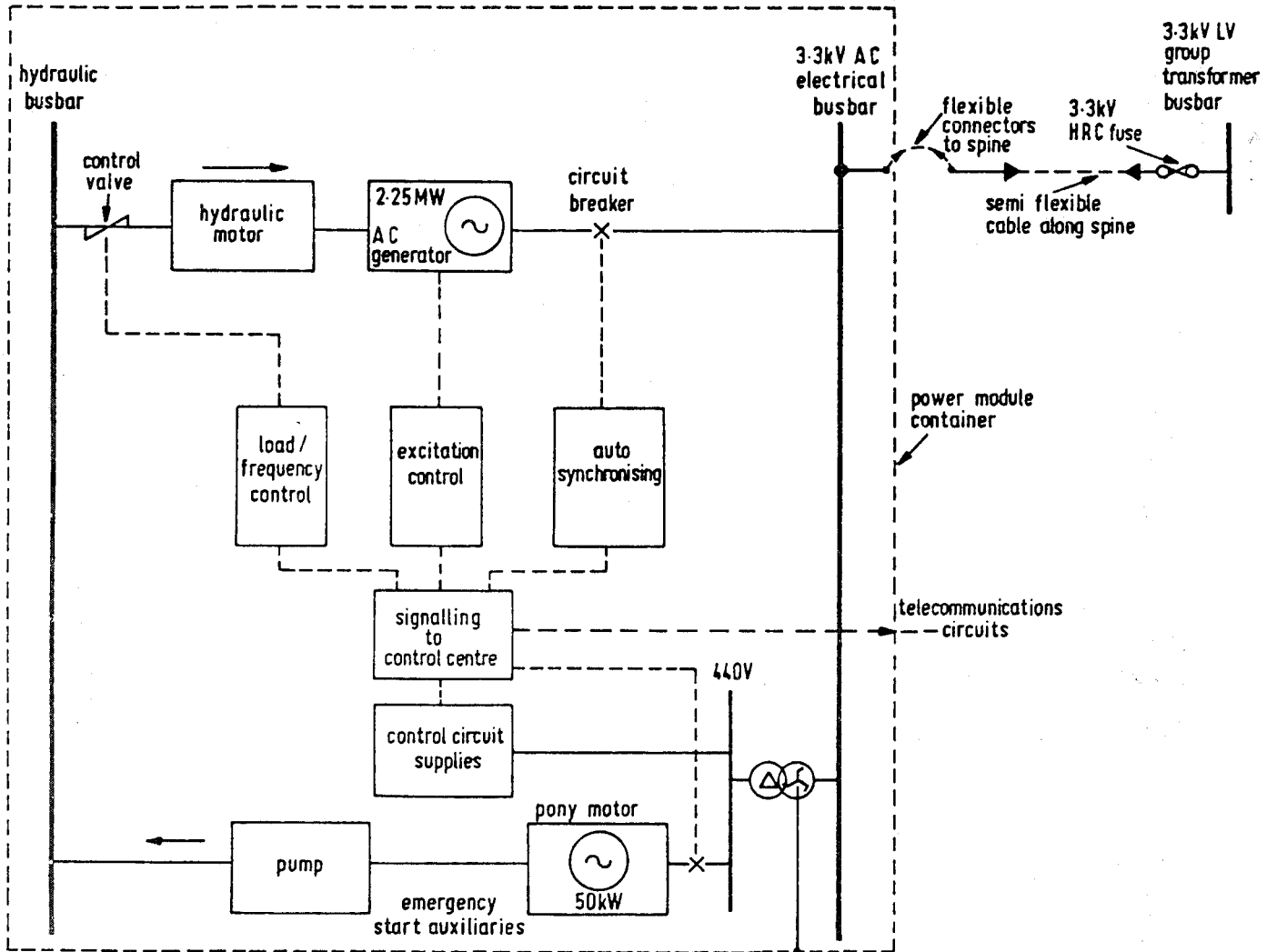

ELECTRICAL EQUIPMENT
MOUNTED IN POWER MODULE

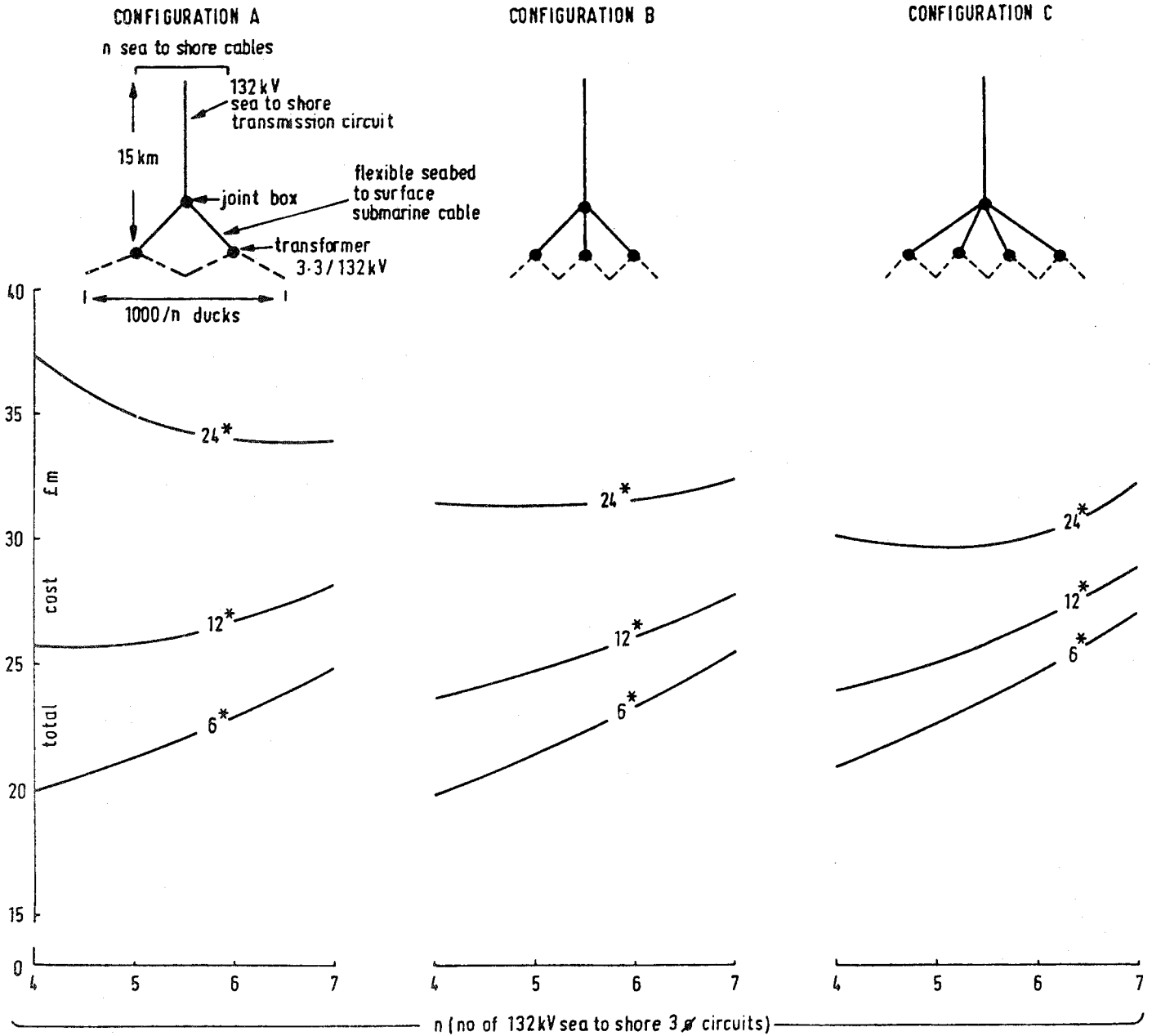

cost of 132kV cable = £120 /m per 3 ϕ circuit
 * cost of 3-3kV 3 core cable = £6, 12 and 24 /m
 cost of transformers - see appendix B

Note:
 1) all costs are for 2000MW sea to shore transmission
 2) costs include 3-3kV cables 132 kV cables and transformers

SEA TO SHORE TRANSMISSION COST
 (132kV 3 ϕ CIRCUIT AT £120 /METRE)

CONFIGURATION A
n sea to shore cables

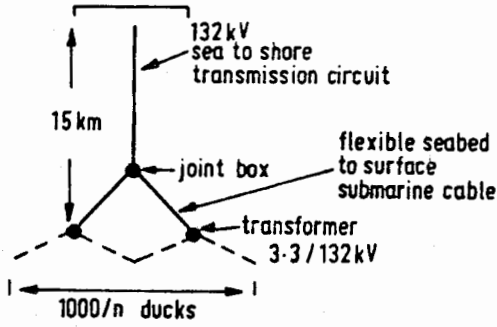

CONFIGURATION B

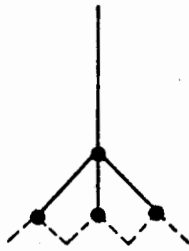

CONFIGURATION C

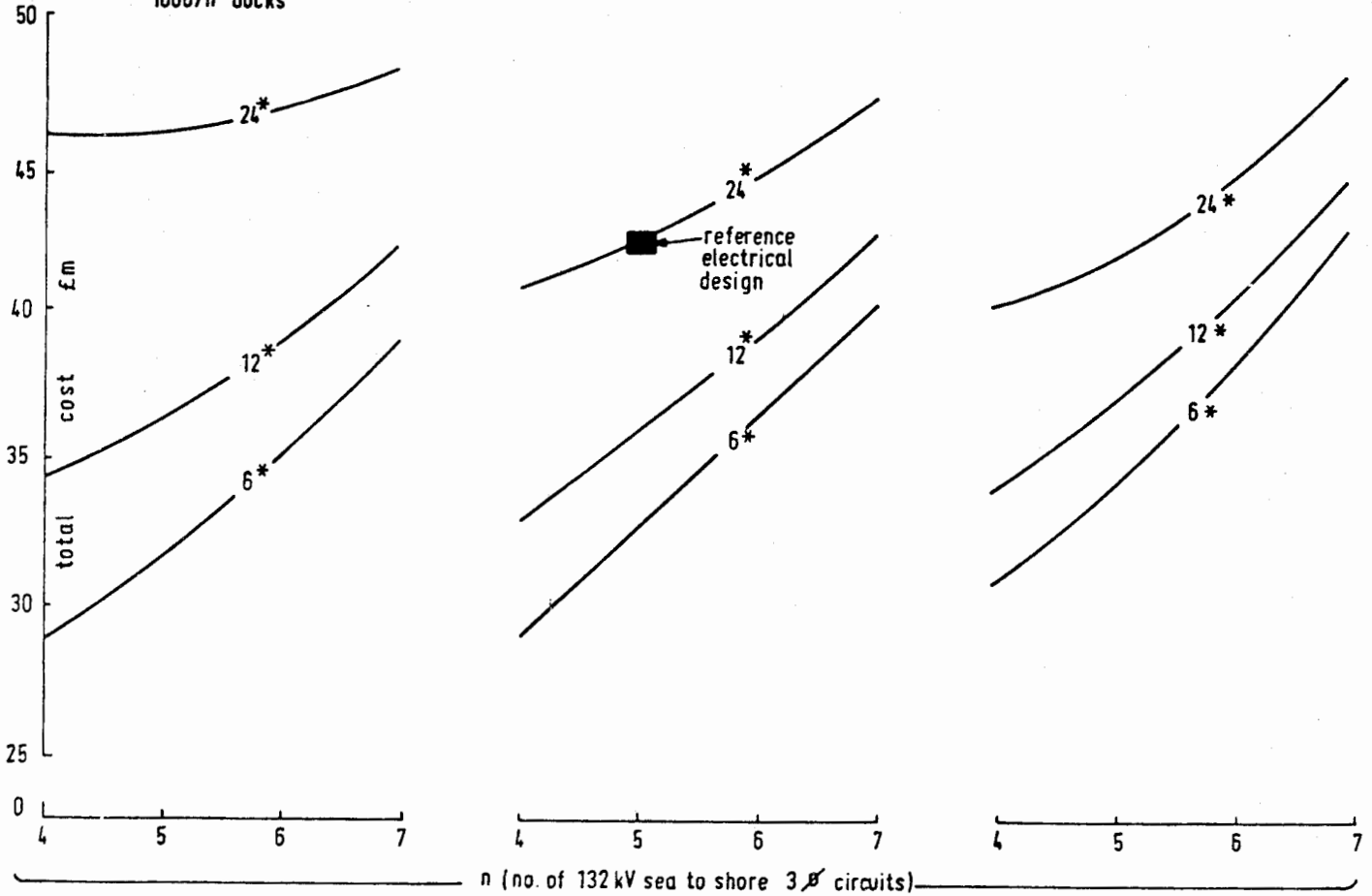
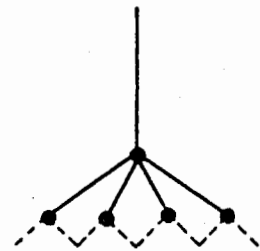

cost of 132 kV cable = £240 / m per 3 ϕ circuit
* cost of 3-3kV 3 core cable = £6, 12 and 24 / m
cost of transformers - see appendix B

Note :

- 1) all costs are for 2000 MW sea to shore transmission
- 2) costs include 3-3kV cables, 132 kV cables and transformers

SEA TO SHORE TRANSMISSION COST
(132 kV 3 ϕ CIRCUIT AT £240/METRE)

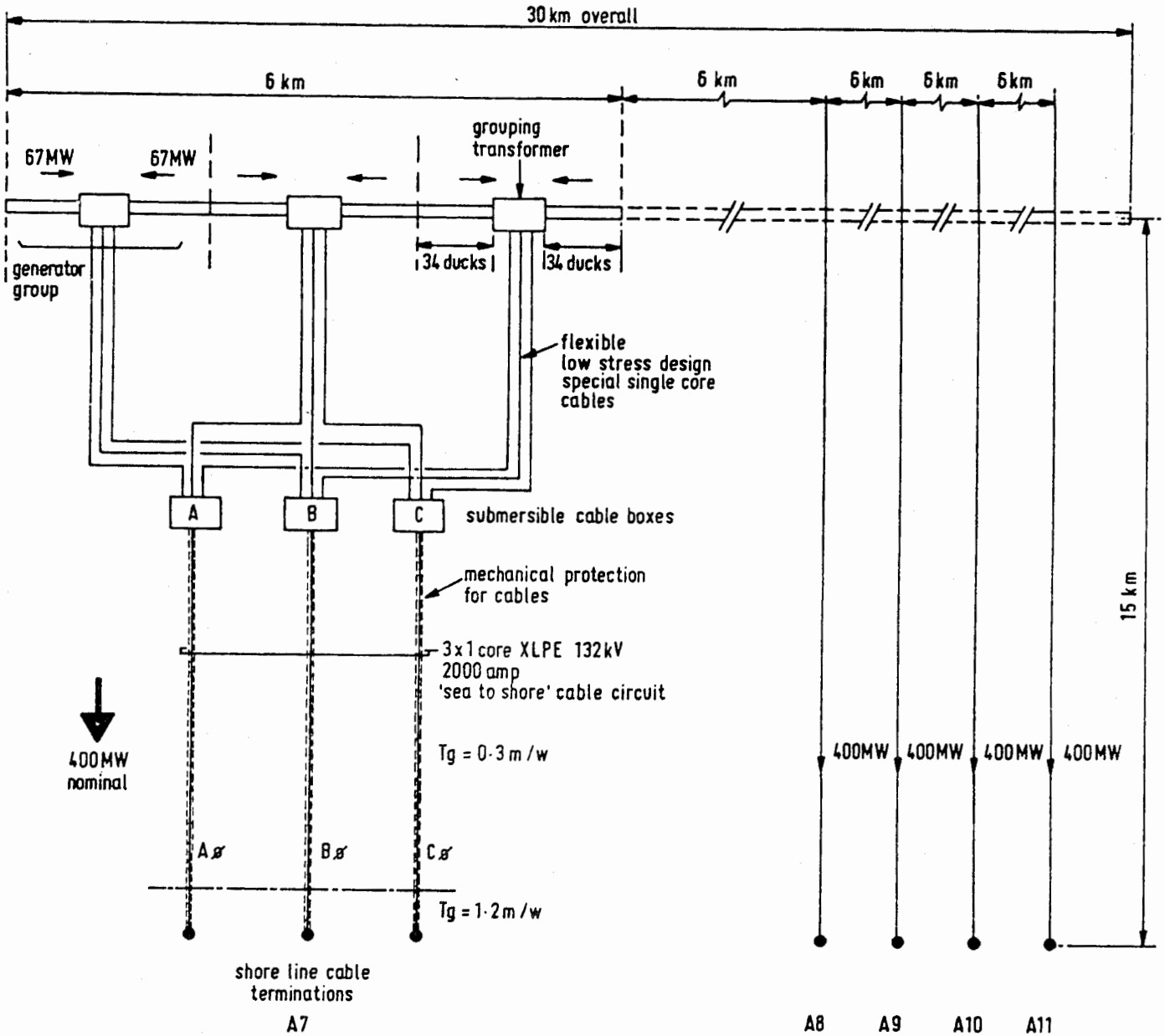

GENERAL ARRANGEMENT OF
SEA TO SHORE TRANSMISSION CIRCUITS
FOR REFERENCE ELECTRICAL DESIGN

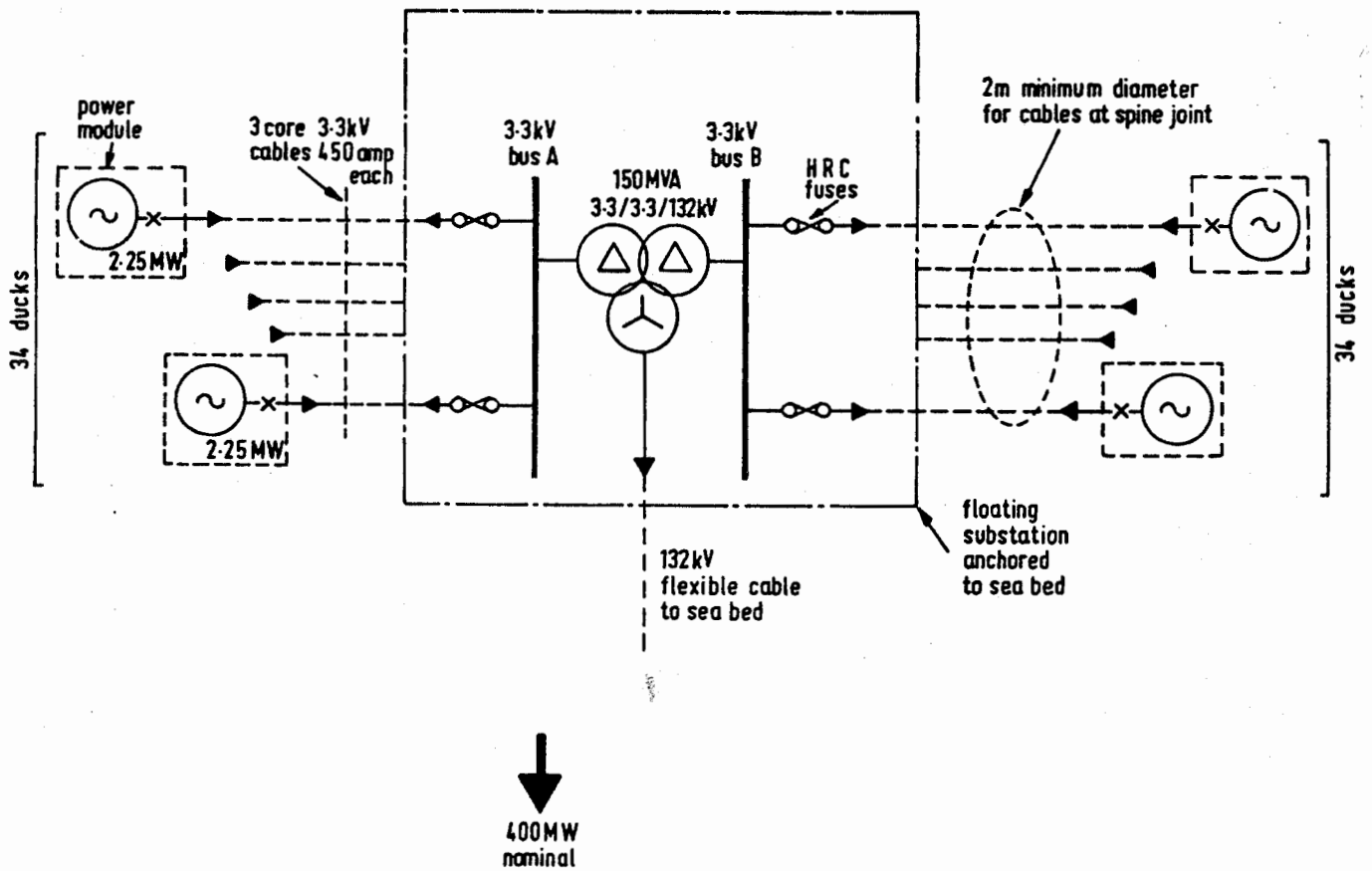

ARRANGEMENTS FOR POWER COLLECTION
FROM GENERATING GROUP

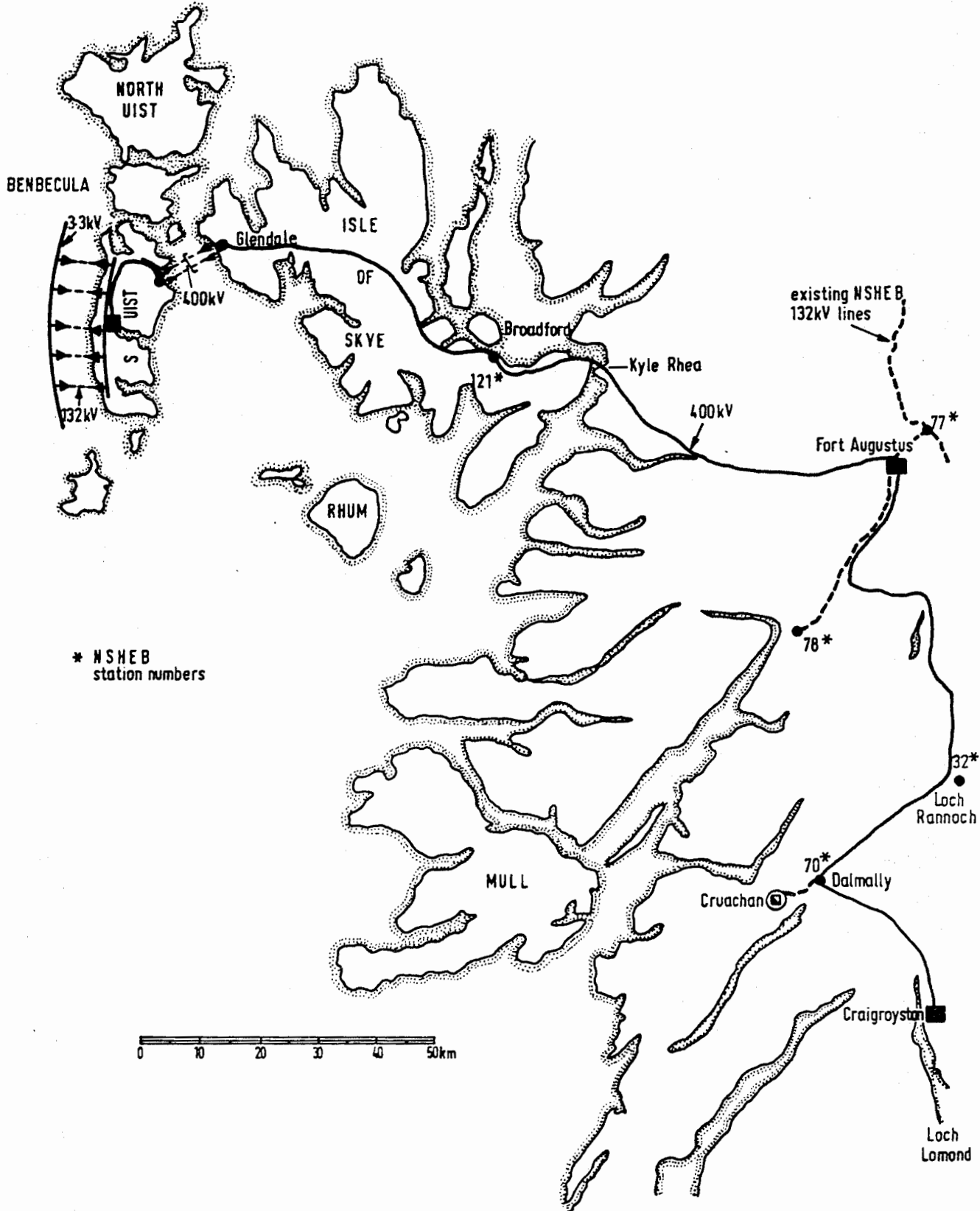

PRELIMINARY OVERLAND TRANSMISSION ROUTE FOR AC TRANSMISSION

**GENERAL ARRANGEMENT OF
 ELECTRICAL GENERATION AND
 TRANSMISSION CIRCUITS**

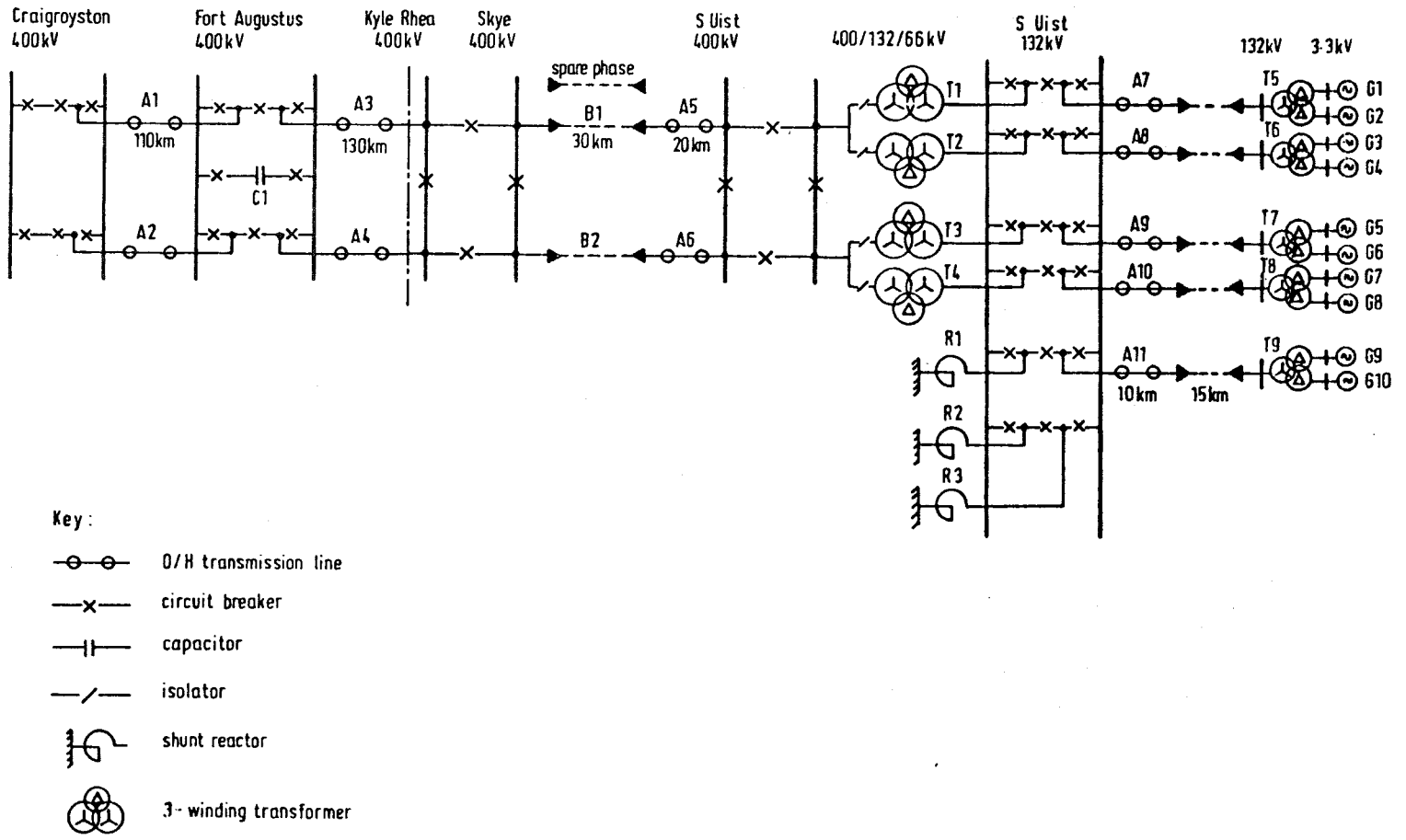

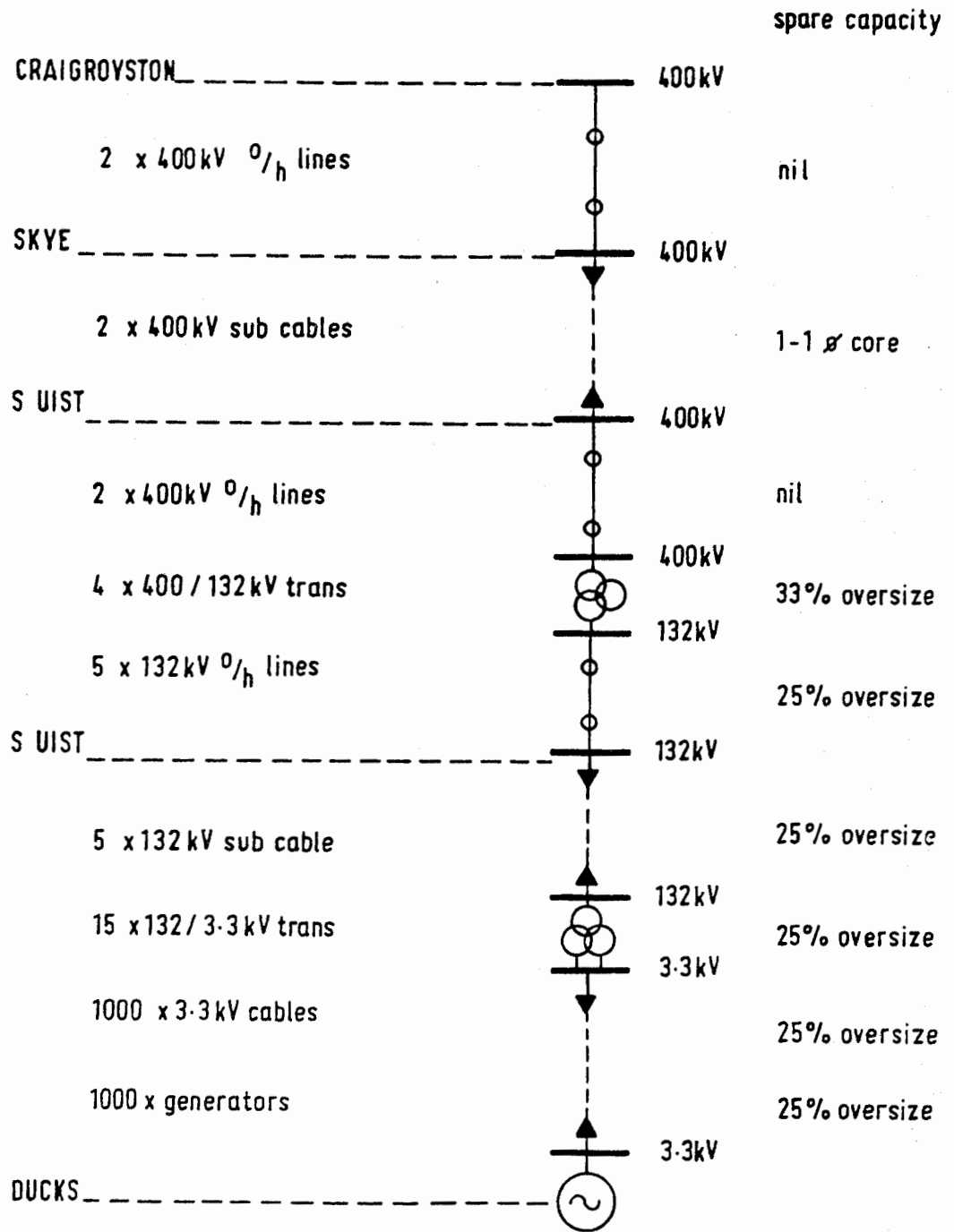

SPARE CAPACITY FOR INSTALLED PLANT
FOR REFERENCE ELECTRICAL DESIGN

APPENDIX A
SYSTEM STUDIES

Power limits for 400 kV overhead transmission lines

Power limits for the 400 kV transmission lines are determined by the constraint that the 400 kV system voltage should be controlled within +5 per cent. The constraint is met with 1.05 per unit sending end voltage and 0.95 pu voltage at the receiving end at times of peak power (see Plate 12e).

Plate 12 shows the voltage drop characteristics for two parallel 400 kV a.c. transmission circuits each 240 km in length. The lines are compensated with series capacitors to varying degrees.

Plate 12 (Fig (a)) shows the power limit is 1000 MW, 300 MVAR (0.95 pf lag), for uncompensated lines. The power limit is increased to 2000 MW, 600 MVAR (0.95 pf lag) by introducing 60 per cent series compensation for the line reactance (Fig (d)). The power limit may be raised to 2800 MW by compensating the receiving end load to unity power factor should this be required.

The proposed configuration for overhead lines is therefore well able to supply 2000 MW to the Scottish grid system. The overhead lines are also capable of supplying up to 600 MVAR of reactive power, within the constraints of controlling the 400 kV system voltage to +5 per cent. This ability to supply reactive power will reduce the amount of reactive power compensation required at the receiving end of the line circuits.

Power limits for 132 kV XLPE cable. Plate 13 shows a cable circuit rated at 450 MVA, 132 kV, 100 km long. Fig (a)

shows cable energisation from one end. The voltage rise at the far end is only 5 per cent, which is satisfactory, and no reactive compensation is necessary provided that the generators are capable of supplying the 166 MVARs required to charge the cable.

Fig (b) shows that the cable link is able to supply a load of 400 MW at unity pf with a more or less flat voltage profile along the cable. When supplying a load of 400 MW, with for example, 100 MVAR (0.95 pf lag) a voltage drop of almost 10 per cent occurs across the cable (Plate 12c); indicating that the power factor of the load must be tightly controlled.

The study is interesting in three respects:-

- a. It shows that a.c. transmission over 100 km of HV XLPE insulated cable is feasible at 132 kV. The charging current of the equivalent paper insulated cable would exceed the full load current rating of the cable circuit.
- b. The limitation of cable circuit length is now due to impedance drop and load angle across the cable link and heat losses in the armour for single core cable circuits. Circuit reactance in the cable circuit could not be reduced further, but special low reactance transformers at the ends of a long cable link could be used to reduce the overall system reactance.
- c. The operating voltage of the cable could be increased to 161 kV, which would decrease the effective circuit reactance, but at the expense of a slight increase in charging current.

The conclusion we reach is that a.c. transmission from sea to shore up to 100 km is feasible, using the same design concepts which are satisfactory for 15 - 20 km. It would, however, require fresh examination to optimise the sea to shore transmission voltage for distances in excess of 40 km.

System studies. A comprehensive set of load flow and stability studies are not warranted since only the feasibility of the proposed scheme needs to be proved and we have no reservations about stability. Plate 14 shows the system impedances used for the study of some selected conditions.

For the purposes of transient studies the following were represented.

- i. Induction motor auxiliary drives.
- ii. A.C. exciters on the generators.
- iii. Fast acting governing system (0.5 sec time constant).
- iv. Generator tripping should this be required to stabilise the system following a system fault.

For study purposes only, the power drawn by auxiliary induction motor drives is assumed to be 100 MW for each 920 MW block of generation. It should be stressed that this artificially high auxiliary load does not represent actual auxiliary loads. The large auxiliary loads which are an exaggeration of practical conditions are represented so that the recovery of auxiliary drives after a system fault may be clearly illustrated.

System energisation (Plate 15) - 15 km sea-shore. The system is energised from the Craigroyston end of the line, with the series capacitor shorted out. Sufficient compensation is provided by the 3 x 150 MVar shunt reactors connected at South Uist 132 kV busbar to obtain a flat voltage profile. If one of the reactors is out of service this would be no problem since one line could be energised at a time.

Once the 132 kV busbar on the wave power device is energised supplies are available for starting pumps and auxiliaries and main generators.

Synchronisation would be performed at sea on the wave power device, using remote control and automatic synchronising equipment.

Maximum system load (Plate 16) - 15 km sea-shore.

Only one system load condition was considered, this being maximum load with 1900 MW and 400 MVARs being injected into the National 400 kV grid system.

The voltage drop 'end to end' of the 400 kV system is 9 per cent and it is assumed that the Cruachan busbar would be at 0.95 pu under full load conditions. The voltage of the Craigroyston busbar could be raised if more reactive power were supplied from local generating plant, or from compensation at Craigroyston.

Maximum system load (Plate 17) - 60 km sea-shore. The maximum system load case is repeated for a nominal 60 km sea to shore cable link. The increase in system load angle is small compared with the 15 km sea to shore case.

Fault on a 400 kV cable circuit (Plate 18). Plate A5 shows the transient performance of the system for a three phase fault of the 400 kV submarine cable between South Uist and Skye, cleared after 80 m sec by switching out the cable.

The change in overall circuit impedance is small when one cable circuit is switched out. Consequently, it is not necessary to trip any generation to stabilise the system. The remaining cable circuit could carry the overload for a few seconds while power levels were reduced by control commands.

The inertia of the generators was assumed to be 1.5 MJ/MVA and proved to be adequate to retain stability if the fault was cleared in 80 m sec, which is a typical fault clearance time.

The final graph (Fig (c)) shows that the induction motors feeding auxiliary supplies recover after the cable fault.

Fault on 400 kV Fort Augustus - Skye line (Plate 19).

The most severe fault is a fault on the longest 400 kV transmission line section followed by an outage of the line section. In order to stabilise the system it was necessary to shed 920 MW of generation, leaving 1380 MW of generation connected.

The system is shown to be stable for this 'worst fault' condition.

Conclusions on system studies. Consideration of the two main transmission circuits associated with the wave power scheme show that:-

- a. The use of 60 per cent series compensation enables a 240 km double circuit 400 kV overhead line to transfer 2000 MW to the National grid system.
- b. The overhead 400 kV line is also able to deliver 600 MVars to the load, which will reduce the requirement for reactive power compensation at the receiving end.
- c. It is feasible to transfer for 400 MW through 100 km of XLPE insulated 132 kV cable circuit. The transmission limit is imposed by series reactive drop and armour heating rather than shunt charging current.
- d. The worst fault on the system is an overhead line 3 phase fault on the Fort Augustus - Skye section followed by an outage. Three phase faults are extremely infrequent.

The system is stable for a machine inertia of $H = 1.5$ MJ sec/MVA providing that:

- i. The Fort Augustus - Skye 400 kV line is cleared within 80 m sec.

- ii. The power transfer is immediately reduced to 60 per cent by tripping two of the incoming 132 kV feeders at South Uist. The load reduction will have only a small disturbing effect on the National grid system.

- e. A fault on one of the two 400 kV cable circuits does not change the overall system impedance significantly when the faulty circuit is cleared. An immediate reduction of the generation level is not necessary to stabilise the system, and a slow reduction by control action would be sufficient to remove overloads.

POWER TRANSMISSION LIMITS FOR 240 km DOUBLE CIRCUIT 400kV O/H LINE WITH SERIES COMPENSATION.

(a)
Uncompensated
0.95 pf Lag. Load

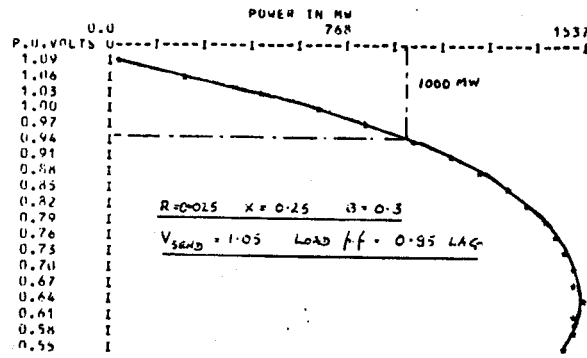

(b)
20% Compensation
0.95 pf Lag. Load

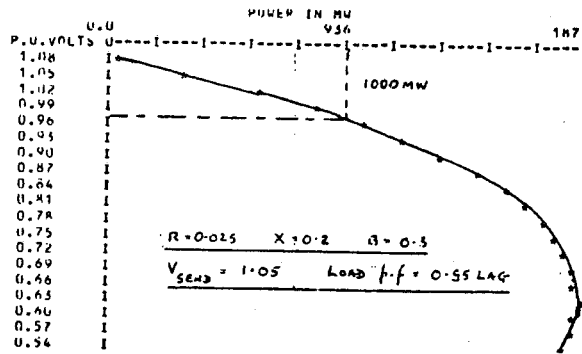

(c)
40% Compensation
0.95 pf Lag. Load

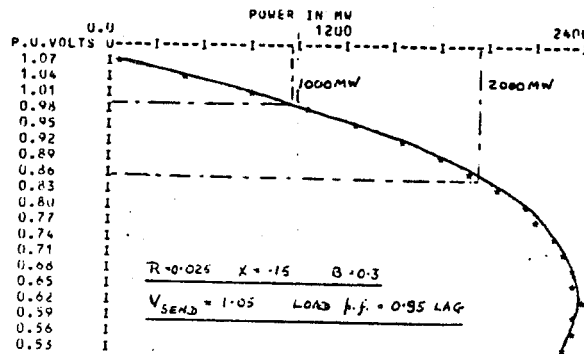

(d)
60% Compensation
0.95 pf Lag. Load

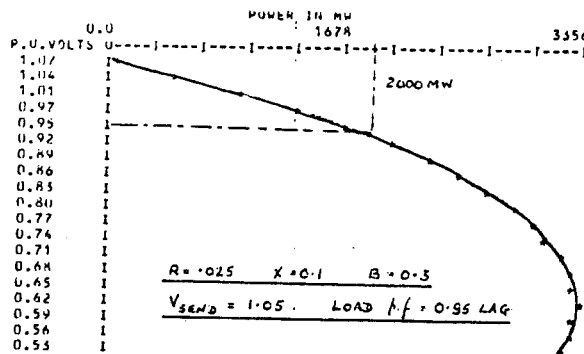

(e)
60% Compensation
Unity pf Load

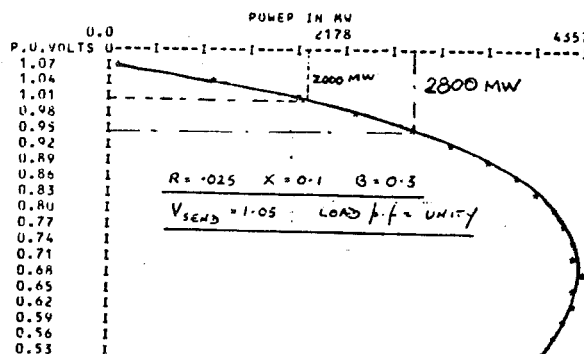

1000 MVA BASE

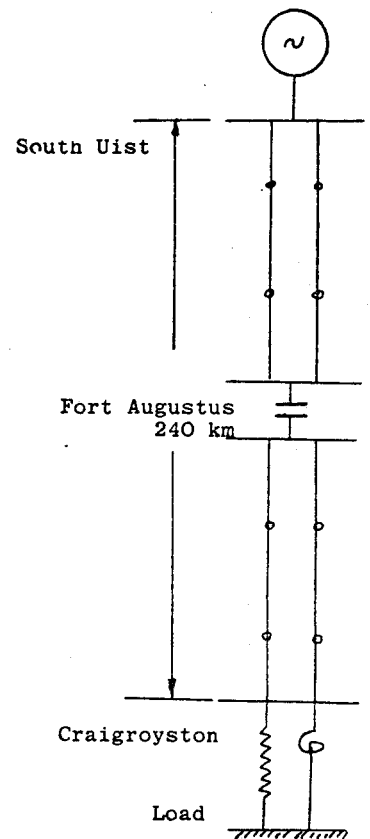

XLPE CABLE PARAMETERS ON 450MVA BASE

$R = .012/km \quad X = .11\Omega/km \quad B = 1.6 \text{ MVAR/km}$

POWER TRANSMISSION
THROUGH 100km 132kV
XLPE INSULATED CABLE

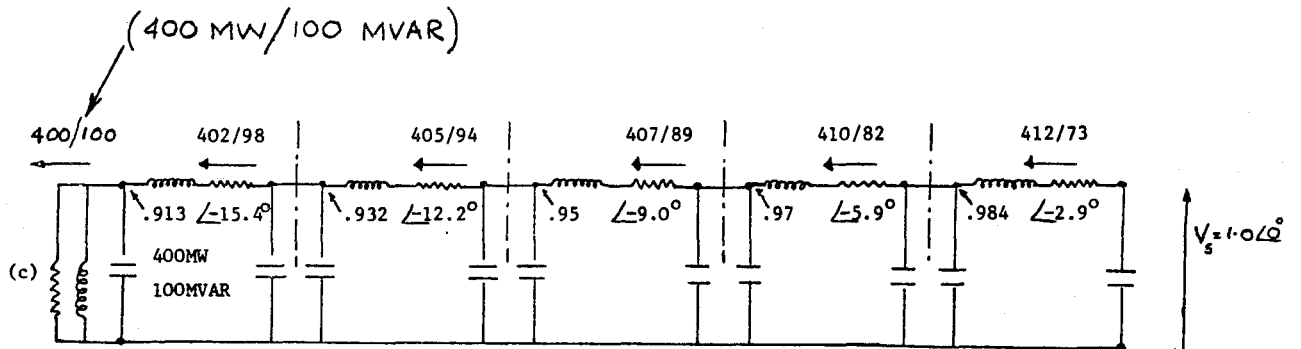
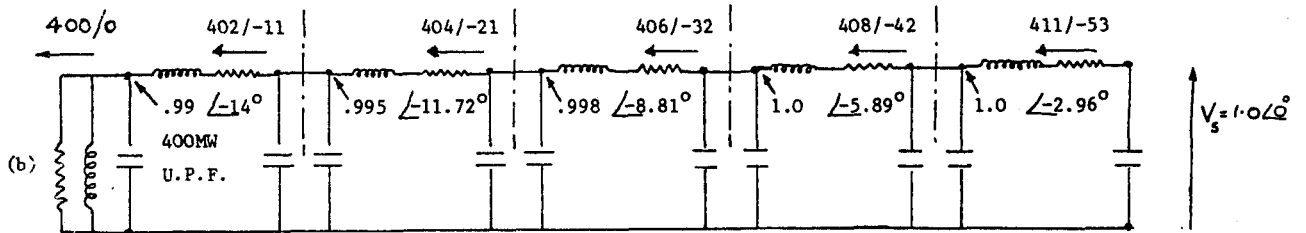
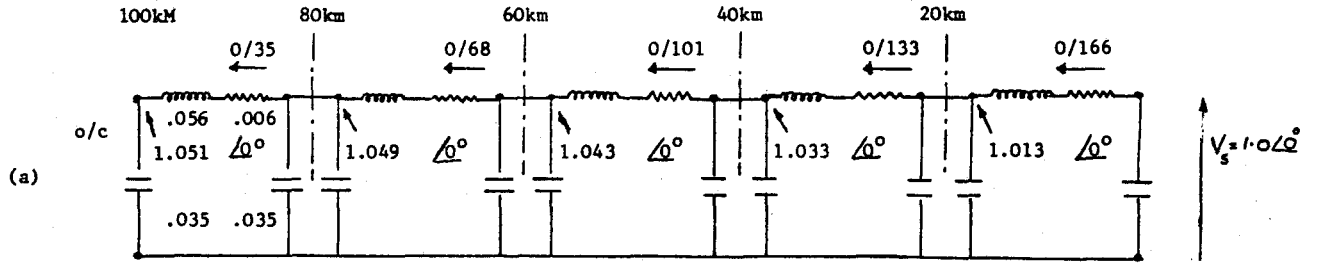

CRAIGROYSTON
400

FORT AUGUSTUS
400A 400B

KYLERHEA
400

S.U.I.S.T
400A

S.U.I.S.T
400B

S.U.I.S.T
132

S.U.I.S.T
132V

DUCK
132A

DUCK
3.5A

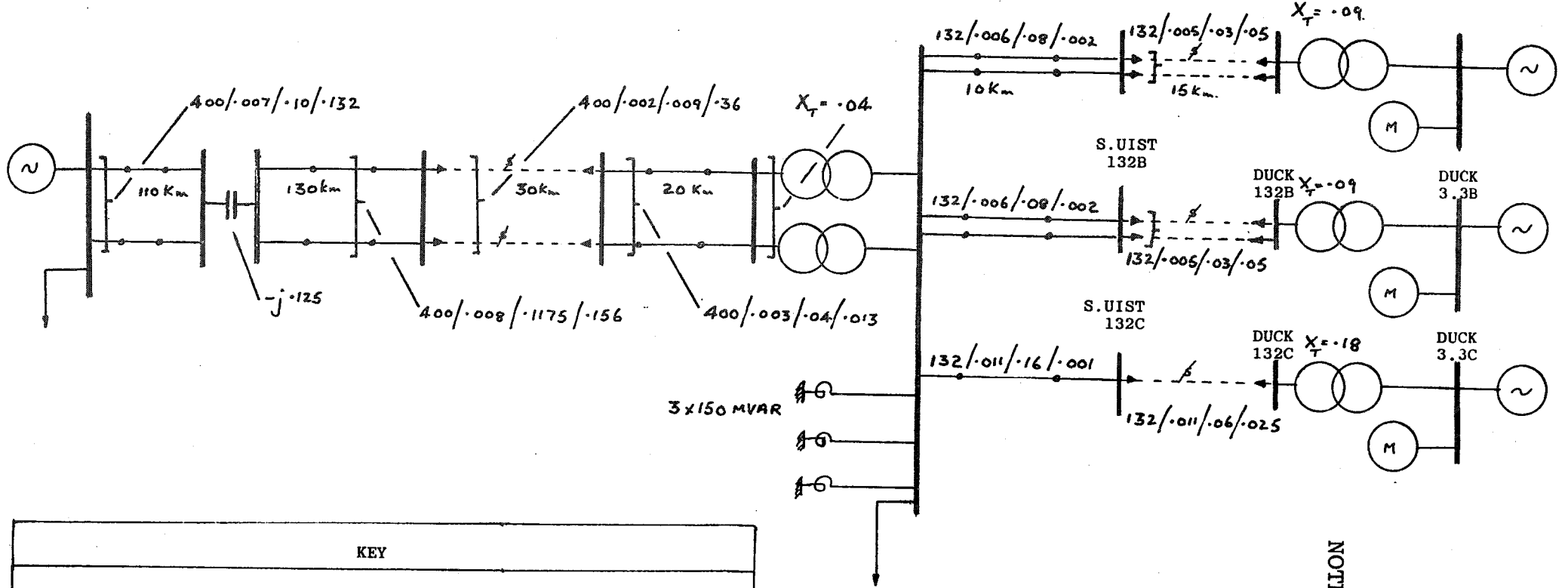

KEY

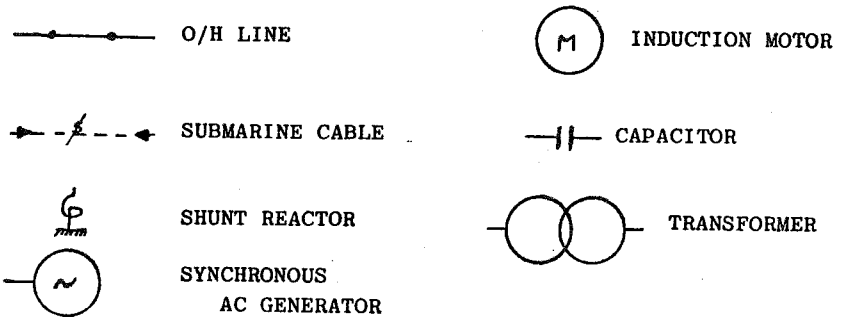

400/.01/.1/.02 VOLTAGE/R/X/B
 100/50 REAL/REACTIVE POWER
 (MW) (MVAR)

NOTE: All impedances
 on 1000 MVA Base

IMPEDANCE DIAGRAM
 FOR SYSTEM STUDIES

CRAIGROYSTON
400

FORT AUGUSTUS
400A 400B

KYLERHEA
400

S.U.IST
400A

S.U.IST
400B

S.U.IST
132

S.U.IST
132V

DUCK
132A

DUCK
3.3A

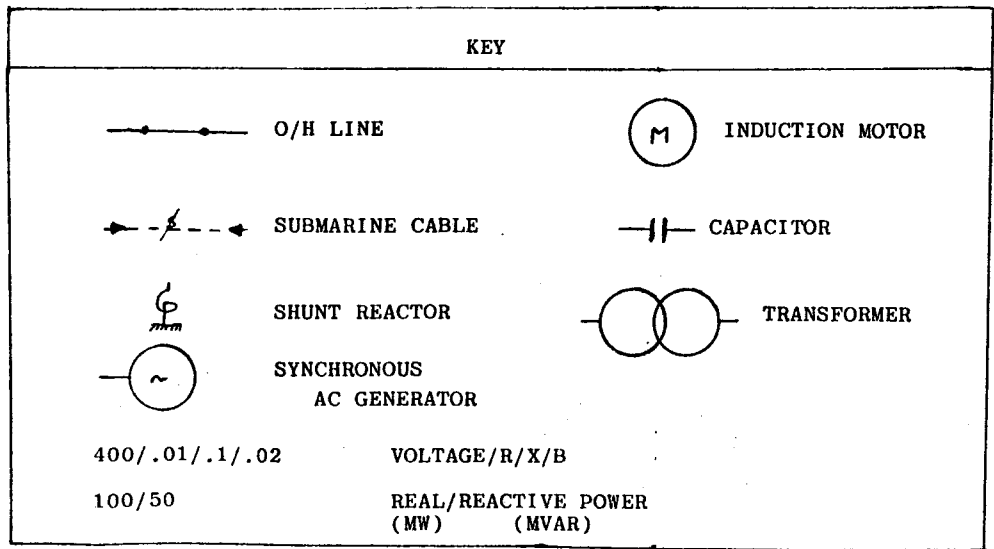
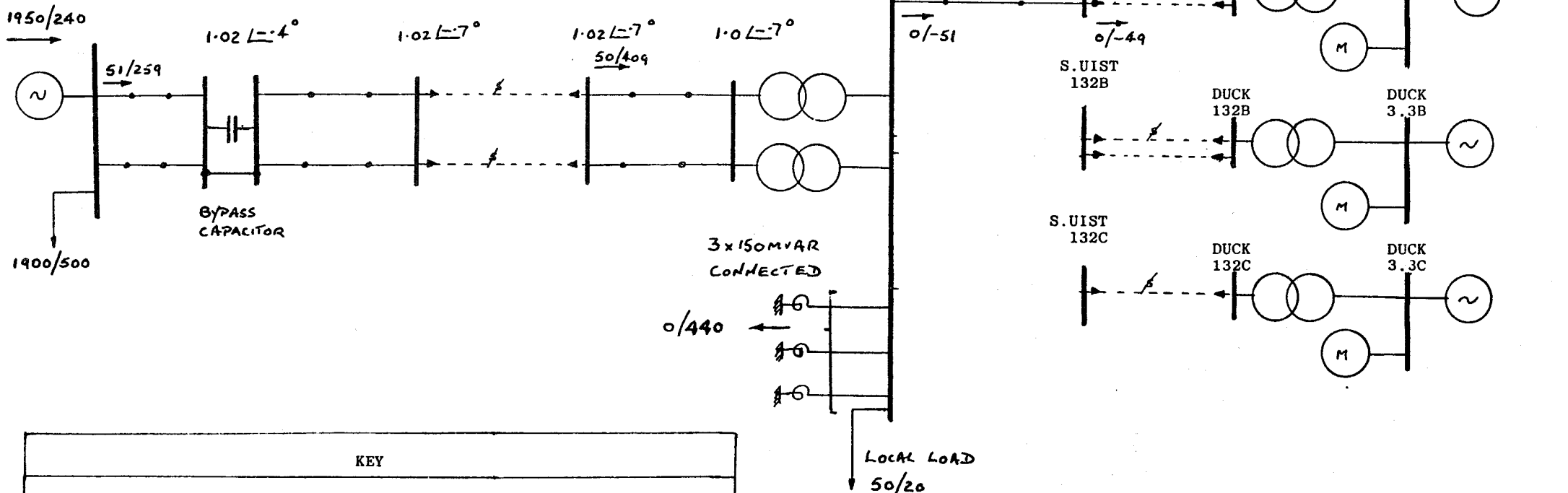

3x150MVAR
CONNECTED
0/440

Local Load
50/20

SYNCHRONISING C.B.

SYSTEM ENERGISATION
CRAIGROYSTON TO S.U.IST

NOTES:
100/50 P(MW)/Q(MVAR)
1 / 50 MODULUS/ANGLE

CRAIGROYSTON
400

FORT AUGUSTUS
400A 400B

KYLERHEA
400

S.UIST
400A

S.UIST
400B

S.UIST
132
0.98 / 20.2°

S.UIST
132A
1.0 / 23.9°

DUCK
132A
1.02 / 25.1°

DUCK
3.3A
1.0 / 29.5°

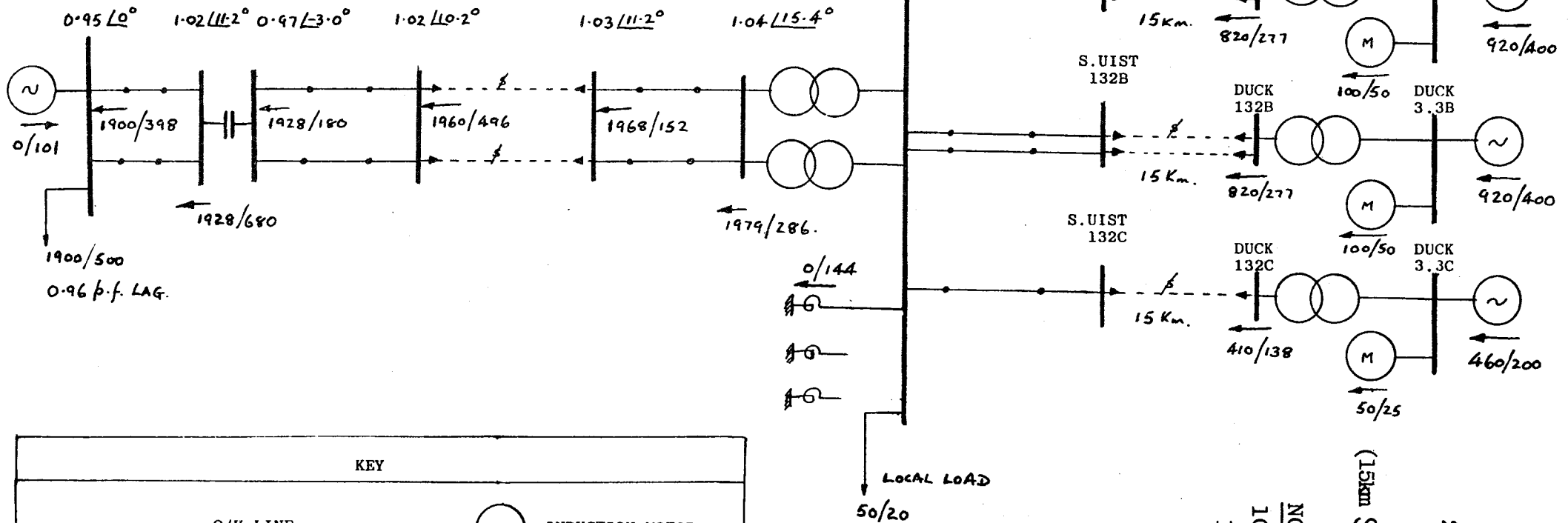

KEY

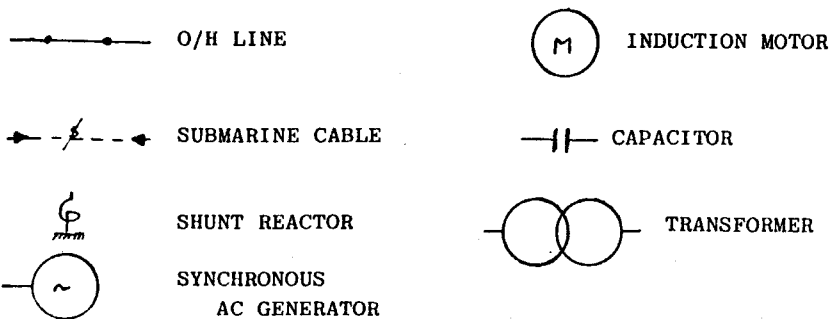

400/.01/.1/.02

VOLTAGE/R/X/B

100/50

REAL/REACTIVE POWER
(MW) (MVAR)

NOTES:
100/50 P (MW)/Q (MVAR)
1/5° MODULUS/ANGLE

(15km SEA TO SHORE TRANSMISSION)

2000MW NOMINAL OUTPUT
PREFault LOAD FLOW

CRAIGROYSTON
400

FORT AUGUSTUS
400A 400B

KYLERHEA
400

S.U.I.S.T
400A

S.U.I.S.T
400B

S.U.I.S.T
132
0.97 / 20.2°

S.U.I.S.T
132A
0.99 / 24.1°

DUCK
132A
1.03 / 29.3°

DUCK
3.3A
1.0 / 33.6°

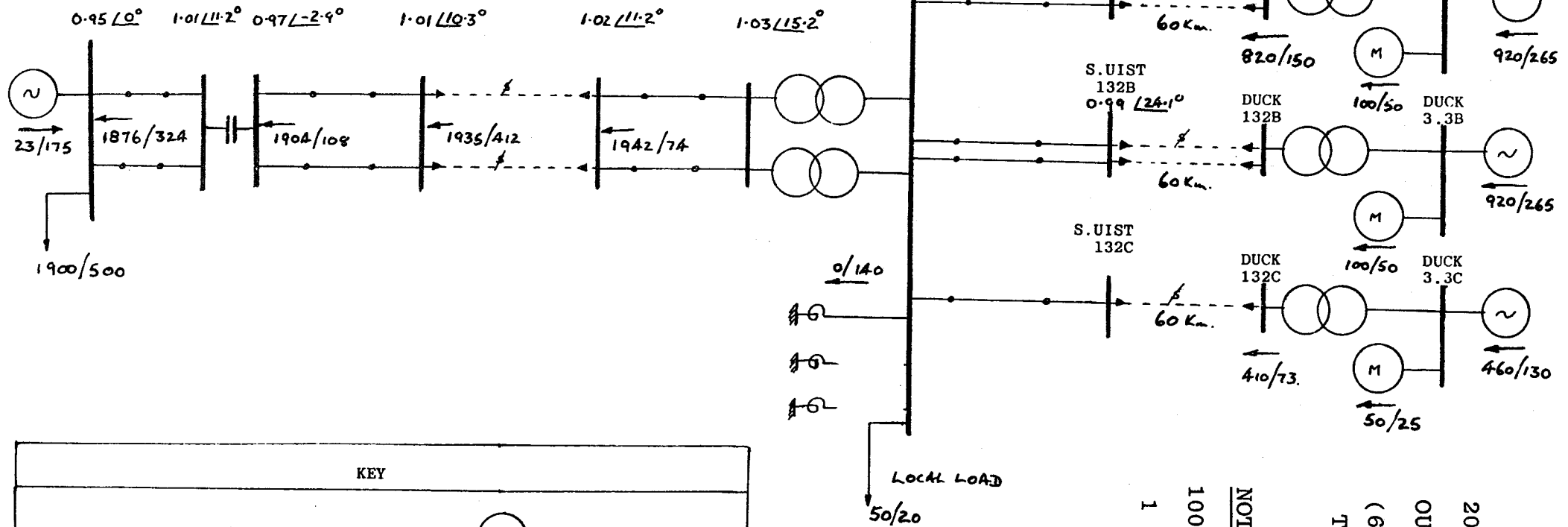

KEY

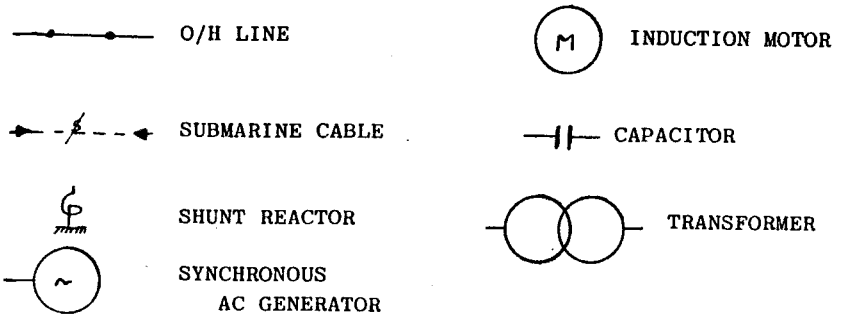

400/.01/.1/.02 VOLTAGE/R/X/B

100/50 REAL/REACTIVE POWER (MW) (MVAR)

NOTES:

100/50 P(MW)/Q(MVAR)

1 / 5° MODULUS/ANGLE

2000 MW NOMINAL OUTPUT (60km Sea to shore Transmission).

TRANSIENT STABILITY OF
SYSTEM FOR 3 Ø FAULT
ON SKYE - SOUTH UIST
SUBMARINE CABLE.

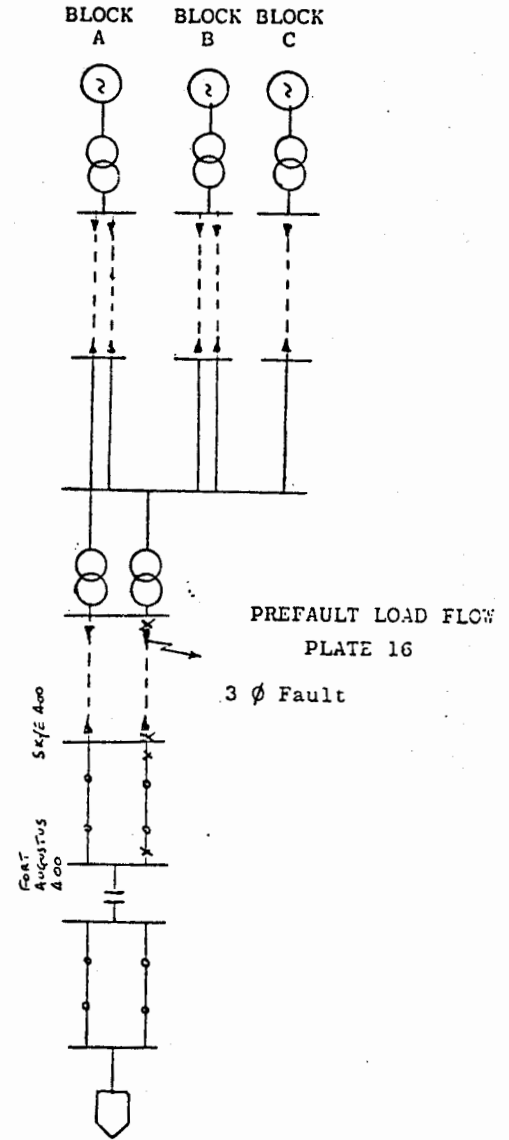
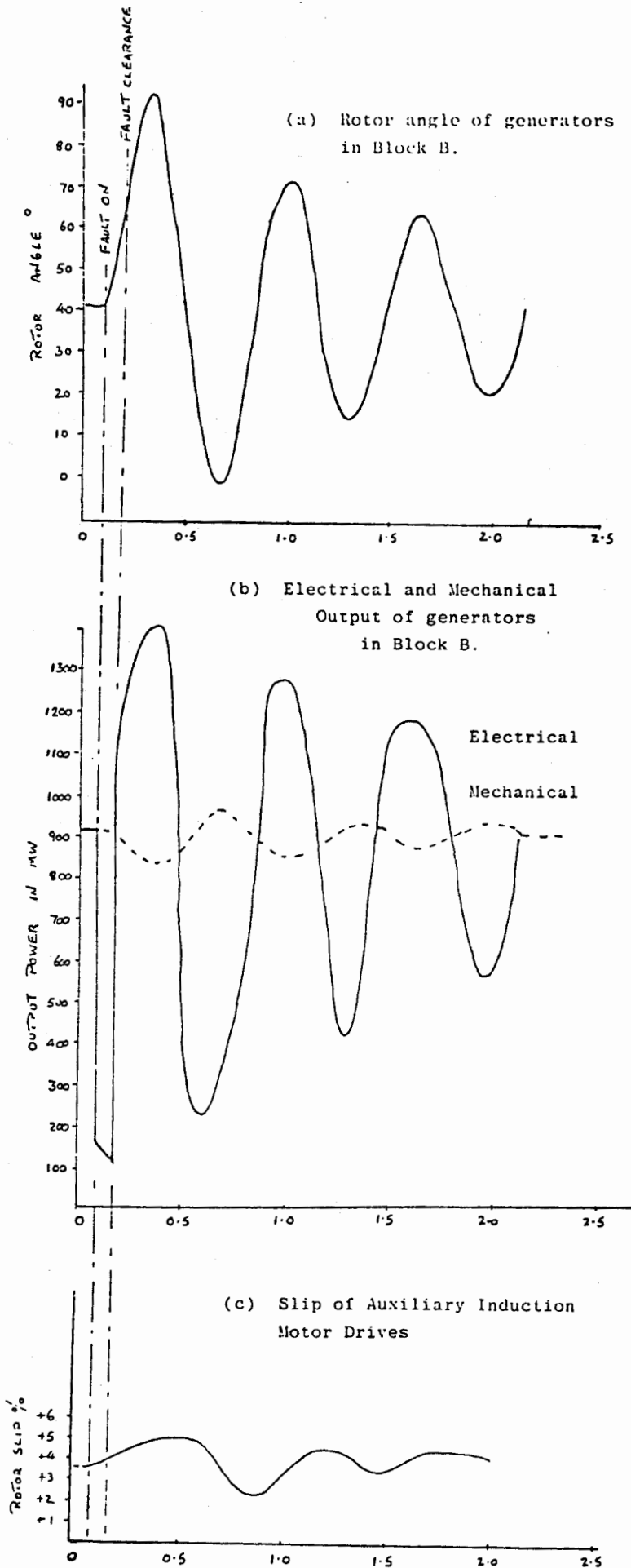

Timing Sequence
 0 - Start Study
 0.1 sec. 3 Ø Fault on South Uist -
 Skye Submarine Cable.
 0.18 sec. Clear Fault Trip on
 Skye - S. Uist Submarine
 Cable

TRANSIENT STABILITY OF SYSTEM FOR 3 ϕ FAULT ON SKYE AND FORT AUGUSTUS LINE.

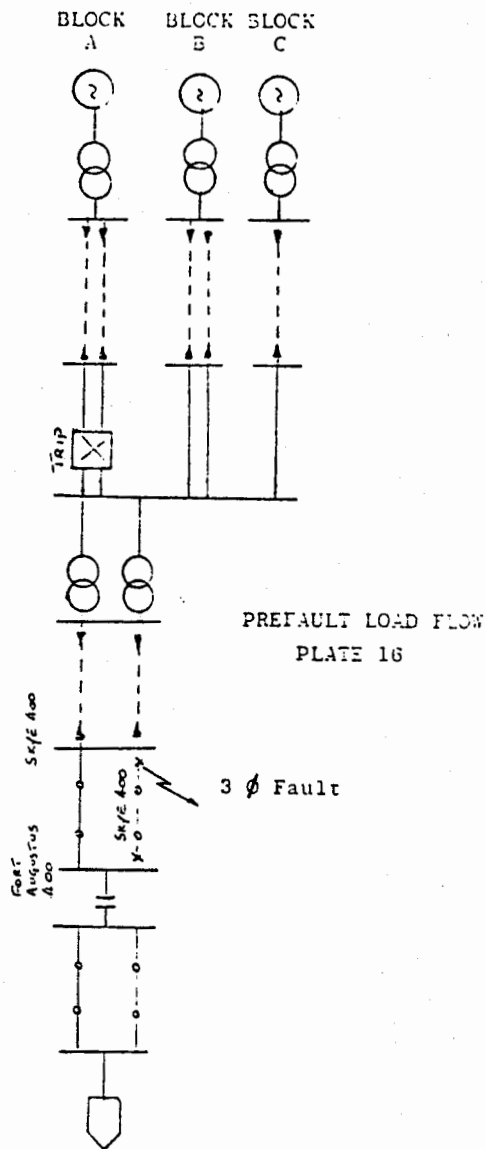
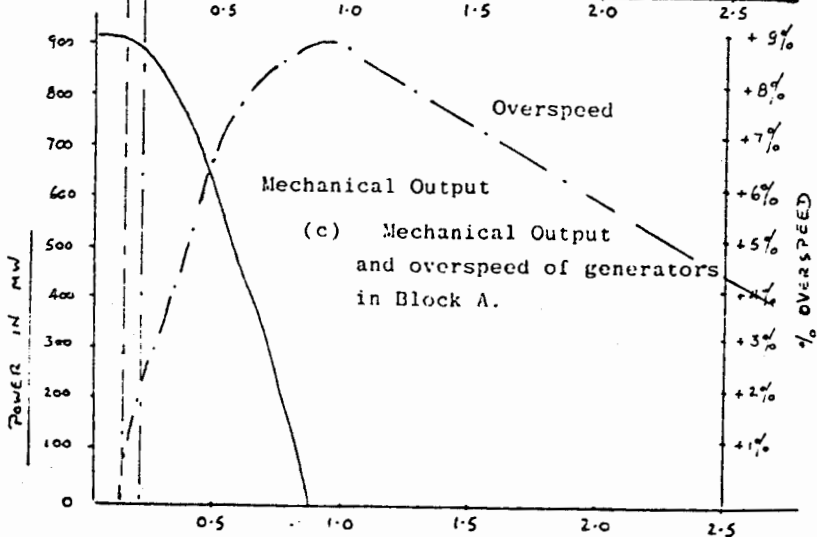
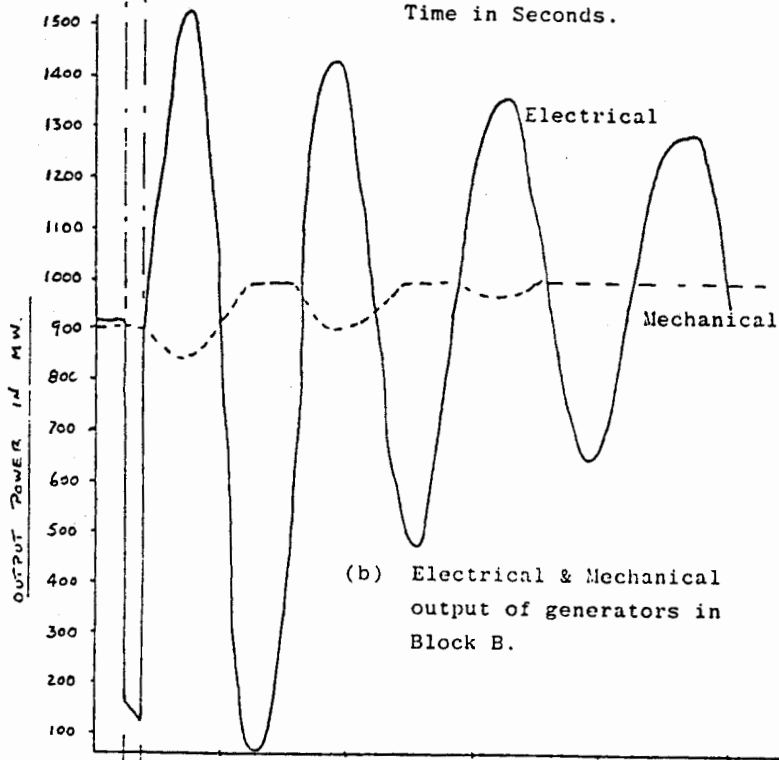
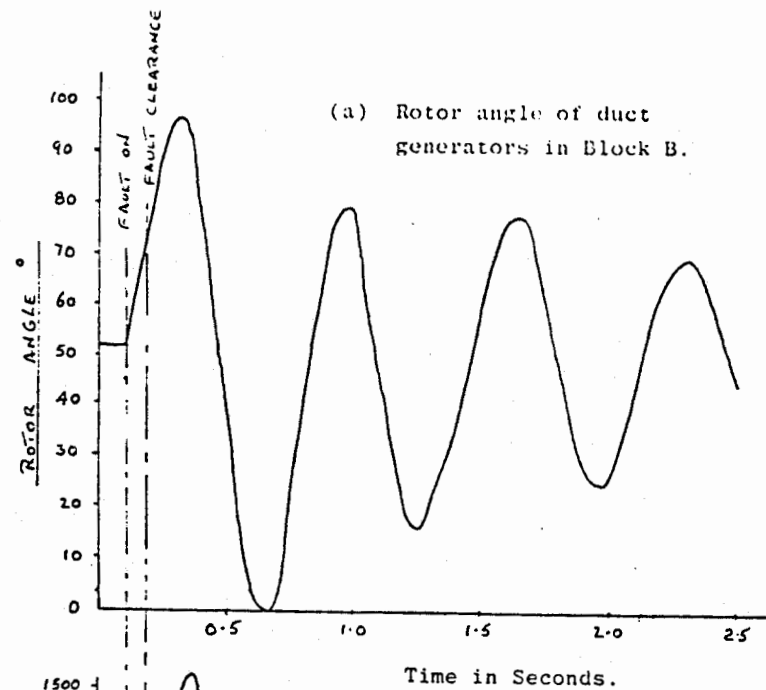

APPENDIX B

ADDITIONAL INFORMATION ON COSTS

This Appendix covers the cost trends in electrical plant, and supports our costing exercises given in the main body of our report. All costs are based on September 1979 prices.

Synchronous generator prices

Plate 20 covers the cost trend for synchronous electrical generators in the range 1 MW to 10.00 MW. The 2.25 MW reference design used for costing purposes is £30/kW in Table 4.

Example

Cost of 2 x 2.25 MW generators = £2 x 30 x 2.25 x 10³ = £135 K
Cost of 1 x 4.5 MW generator = £30 x .65 x 4.5 x 10³ = £87.75 K

The above example illustrates the cost reduction that can be achieved by using a single 4.5 MW generator instead of two 2.25 MW generators.

3.3 kV cable costs

Plate 21 shows the cost assumptions made for costing the reference electrical design.

In our report we have described an arrangement of 132 kV cables together with a tapering arrangement of 3.3 kV cables. This was chosen only to freeze the design for the purpose of writing the report.

Further study of the team has indicated the advantages of having the ducks of a standard design and to provide facilities to enable a pair of ducks to be removed and a replacement

pair of ducks connected in to a string. For this a plug arrangement between pairs of ducks would be required. The 3.3 kV cabling would consist of a cable for each pair of ducks throughout. Hence the 34 duck arrangement described in the report would require 34 cables in each duck.

The additional cost of these cables has been assessed and alternative combinations of 132 kV cables, transformer and 33 kV cables costed. The curve in Plate 22 indicates the optimum combination would be five 132 kV/3.3 kV transformer platforms per main 132 kV cable, with 20 ducks in series. The cost of the main 132 kV cables was not included in this study as it is a constant.

As the spine extends through two ducks, each pair of ducks would share a three phase group of 1000 mm^2 single core cables, requiring ten groups of each cable throughout the spine. The transformers would be rated 90 MVA with twin 45 MVA secondaries.

Submarine cable costs

Submarine cable costs have been difficult to obtain. Such costs as have been available have been adjusted on the basis of changing copper prices and labour costs.

Transformer costs

Plates 23 and 24 show the cost/kVA trends for auto and double wound transformers respectively.

Shunt reactor costs

Plate 25 shows the cost per kVA trend for shunt reactors.

COST TREND FOR
SYNCHRONOUS GENERATORS

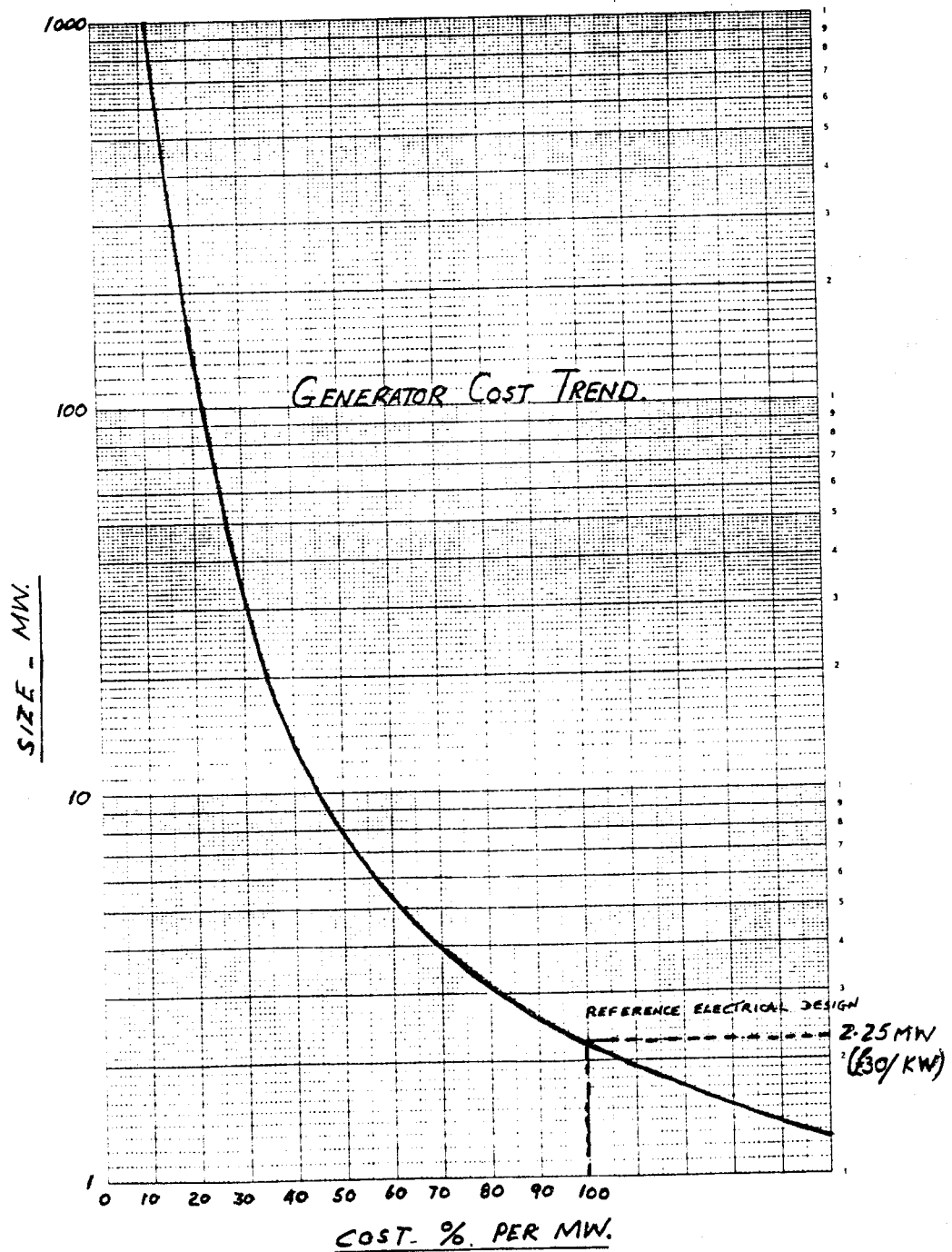

CALCULATION OF LENGTH
OF 33KV CABLES

(Taper Arrangement for
Reference Electrical
Design)

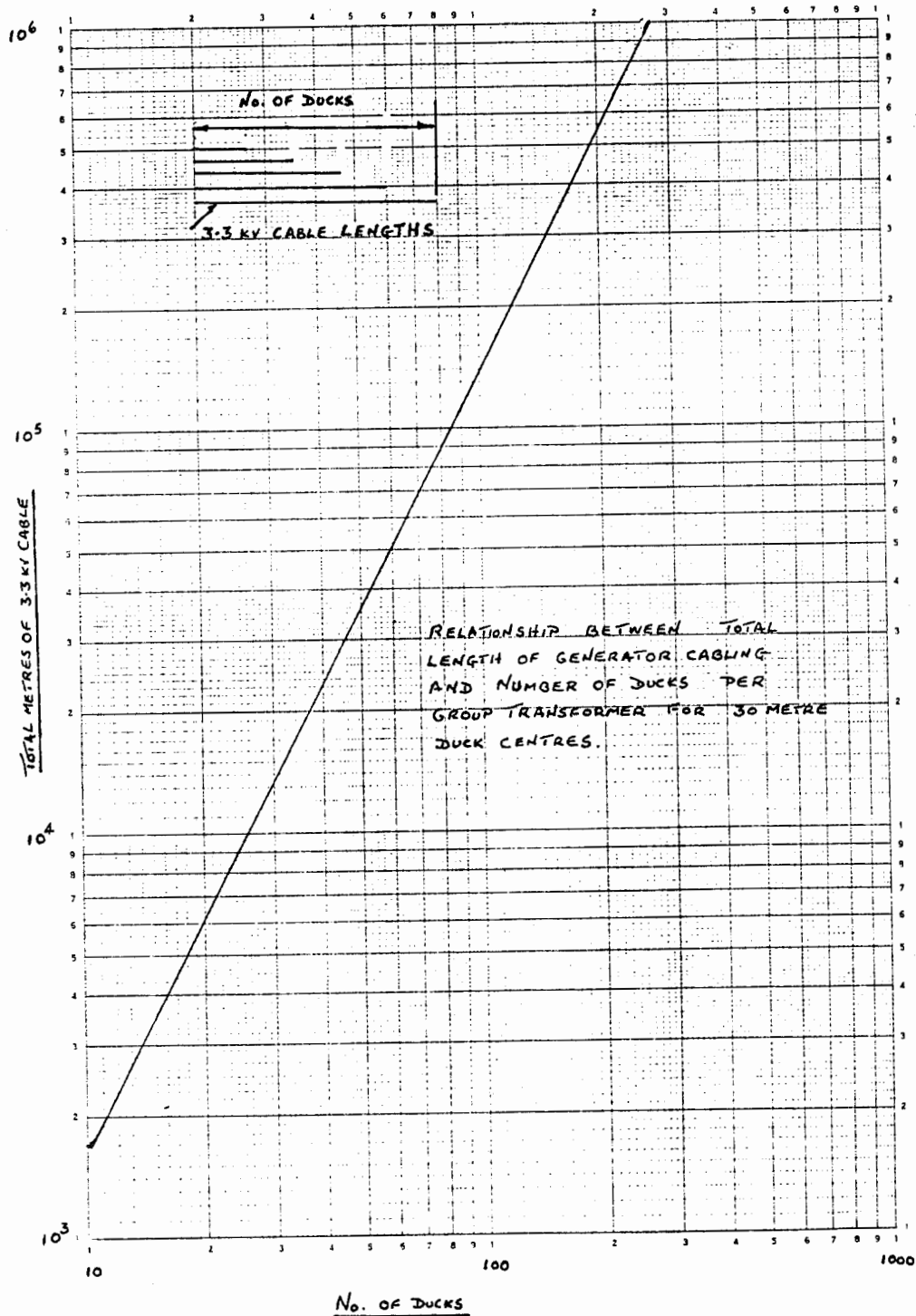

OPTIMISATION OF DUCK
STRING LENGTH FOR
UNIFORM CABLE ARRANGEMENT

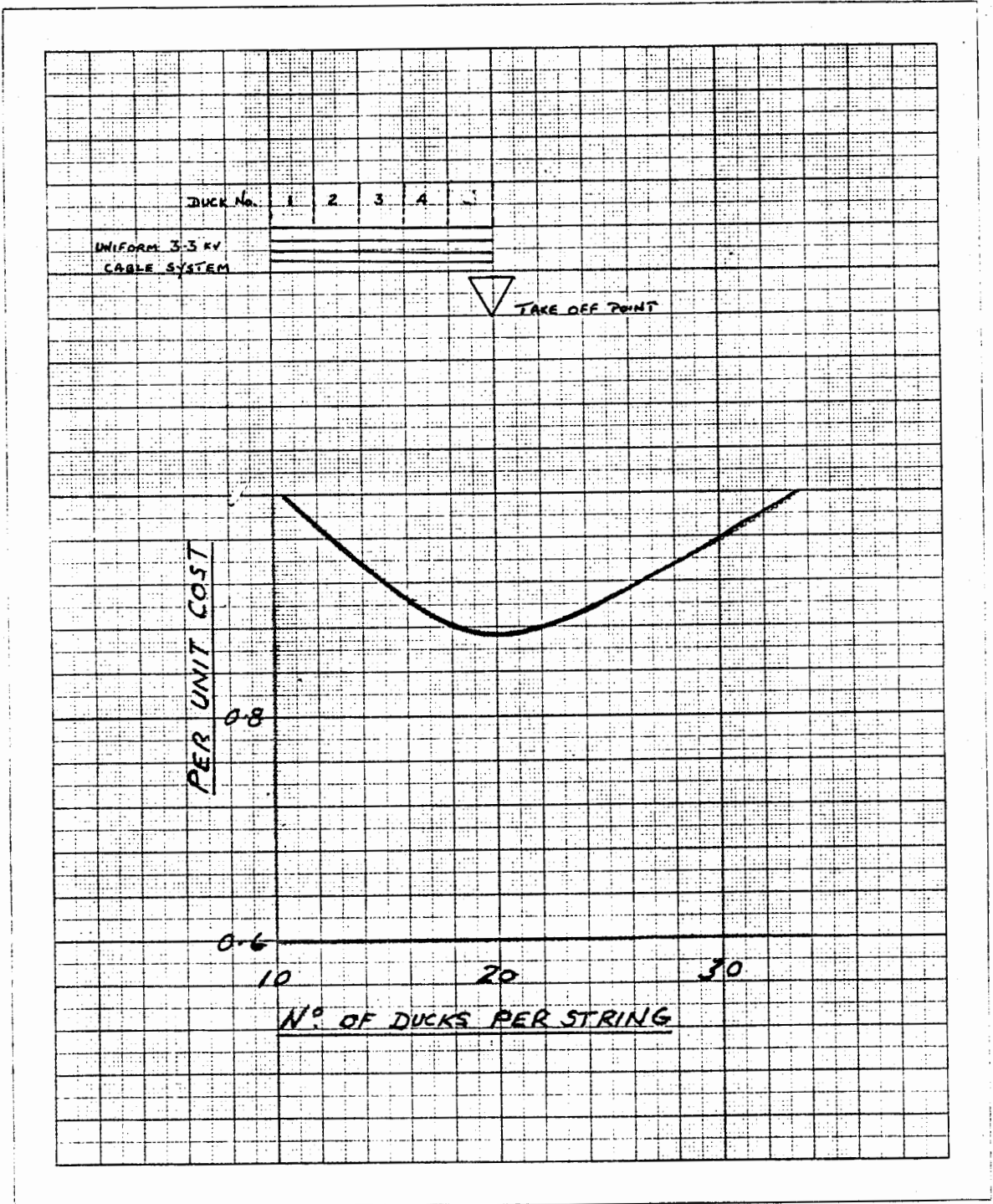

COST TRENDS FOR
AUTO-TRANSFORMERS

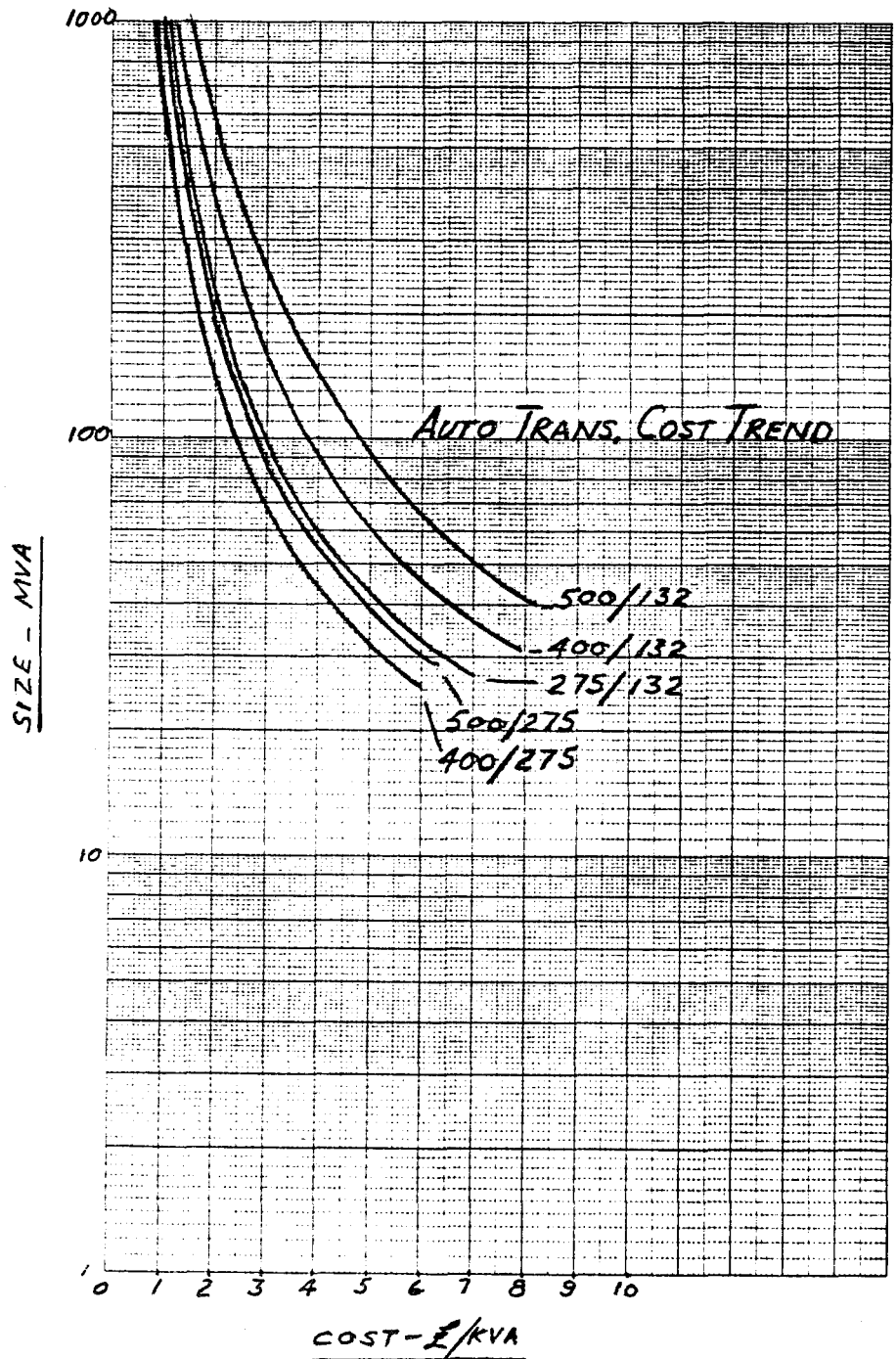

COST TRENDS FOR
DOUBLE WOUND
TRANSFORMERS

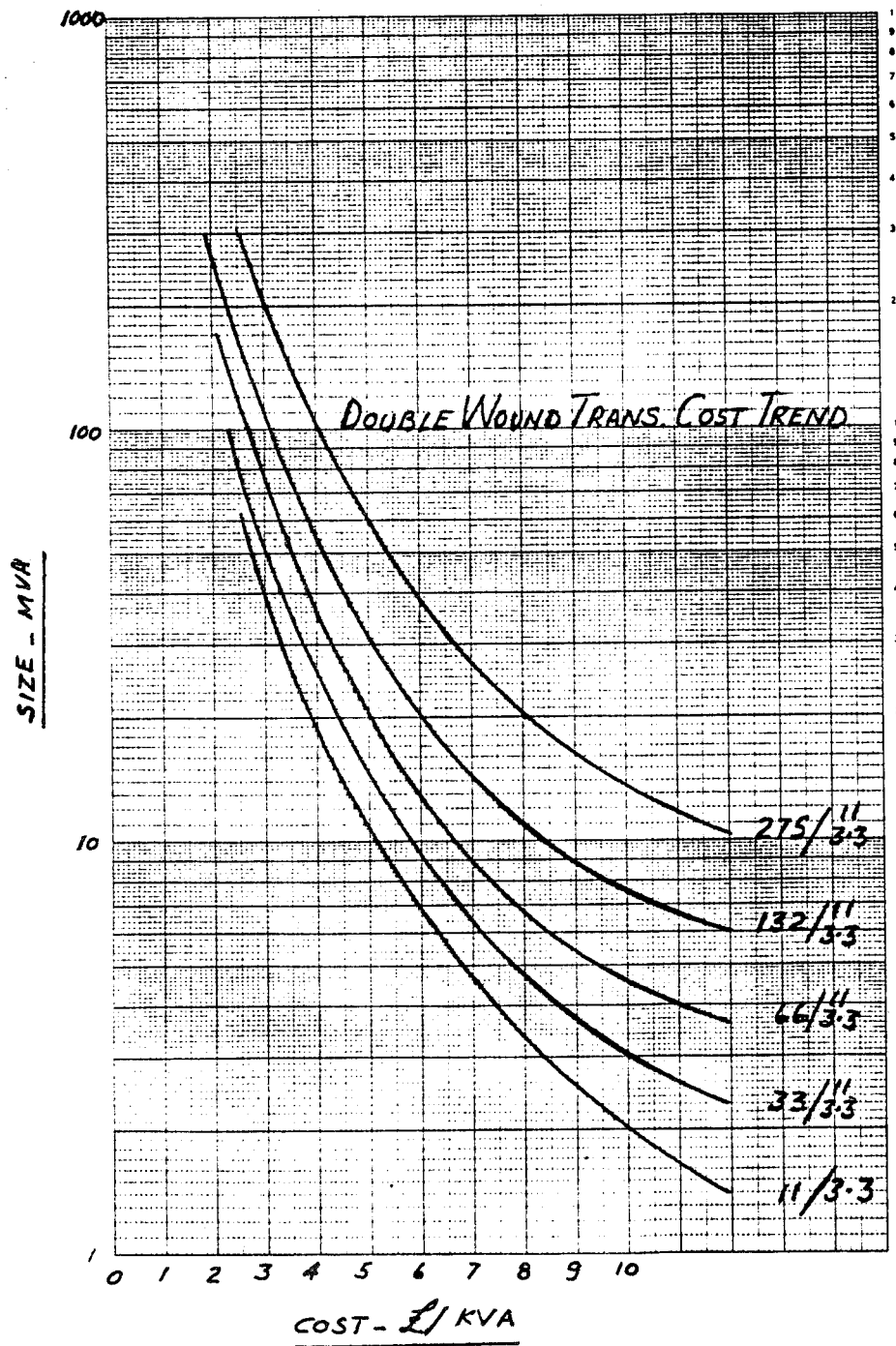

COST TRENDS FOR SHUNT REACTORS

