

6/

A GRAMMATICAL DESCRIPTION OF MELANAU

Iain F.C.S. Clayre

Presented for the Degree of Doctor of Philosophy
of the University of Edinburgh.

1972



CONTENTS

Acknowledgements	page 3
Abstract of Thesis	5
Maps	7
<u>Chapter 1. INTRODUCTION</u>	9
1.1 The Melanau People and their Way of Life*	10
1.2 Previous work on the Language	21
1.3 Aims of the present Study	23
1.4 The Corpus of Data	25
1.5 The Linguistic Description	28
<u>Chapter 2. PHONOLOGY</u>	30
2.0 Introduction	31
2.1 Statement of Phonemes	36
2.2 Description of the Phonemes	39
2.3 Distribution of Phonemes	53
2.4 Dialect variation	62
2.5 Intonation	65
2.6 Practical Orthography	80
<u>Chapter 3. MORPHOLOGY</u>	88
3.0 Introduction	94
3.1 Morphological Processes	94
3.2 Morpho-phonemics	97
3.3 Morphology of Word Classes	102
<u>Chapter 4. SYNTAX</u>	225
4.0 Introduction	235
4.1 The Grammatical Hierarchy	236
4.2 The Phrase level	238
4.3 The Clause level	300
4.4 The Sentence level	391
4.5 Levels higher than the Sentence	419
4.6 Analysed text fragment	431

* A more detailed table of contents appears at the beginning of each Chapter in the text.

<u>Chapter 5. STYLE</u>	437
5.0 Introduction	438
5.1 Narrative style	438
5.2 Didactic style	447
5.3 Conversational style	450
5.4 Ritual Poetic style	452
5.5 Individual style	456
<u>Chapter 6. SEMANTICS</u>	459
6.0 Introduction	460
6.1 Likou	460
6.2 Colour	466
6.3 Living Things	470
<u>Appendices</u>	
(1) Symbols and Abbreviations	477
(2) Dialect Survey	482
(3) Bibliography	503

Acknowledgements

A study of this nature cannot be undertaken without the goodwill and co-operation of a large number of people and organisations. It is not possible, other than in a general way, to render to all the thanks that is their due. Among those whose assistance has been vital to that contribution which this thesis may make to the sum of knowledge of the Bornean languages - and even in sum, it is lamentably little - I wish to acknowledge my gratitude to:

The Summer Institute of Linguistics, who gave me that early training in linguistic skills and curiosity which enabled me to feel at home in the Bornean jungles;

Dr R.E.Asher and many colleagues of the Department of Linguistics at the University of Edinburgh, for agreeing to guide a mere engineer through the intricacies of describing something as non-mechanical as a natural language;

Dr H Stephen Morris of the Department of Anthropology of the London School of Economics, who engaged me in the work in the first place and encouraged me in it thereafter;

The Social Sciences Research Council, who funded the phase of overseas field study and a certain amount of the subsequent stages of collating and writing up the material there gathered;

The Curator and Staff of the Sarawak Museum in Kuching, for their constant graciousness in bridging the formidable gap between my ignorance and the wealth of the Melanau heritage;

The Ministers and Deacons of the Roman Catholic Missions in Sibü, Mukah and Dalat, for their friendly co-operation and frequent hospitality; and especially Fr. Julij of Dalat, who placed at my disposal the resources of his home, his workshop, his library and his memory, without which not one half of my own work could have been accomplished in the time allotted;

The Melanau people of all walks of life, in Government service in Sibü or in their farms, their boats and their homes in Matu, Mukah, Bintulu and many places in between and beyond, who were continually kind and helpful to a stranger and pilgrim

in their land and their language; and most especially to the folk of Dalat and its neighbours of Tanam, 'Ud, Kekan, Kut and Medong, who patiently taught me to speak, regaled me with stories, enlightened me as to customs and answered my endless (and often, it must have seemed, obscure) questions over the period of some fifteen months that I spent as a guest among them. It would verge on the invidious to mention one and not another; yet I am bound to make acknowledgement of the special debt I owe to the a-nyat Ignatius Kelumai of Tanam, 'Uncle'¹ Munan of Dalat and the recently deceased Ta'iah of Kekan, whose patronage made me respectable, and to Arip Dina, Barnabas Semait, Hilary Supin and Paul Muris, all teachers, whose patient persistence made me understand.

For all of these people living in remote places, I trust that the outcome of this work in which we have co-operated will be to their benefit in the communication of ideas and the retention of much of the treasure of their past in a more accurate degree, now that a writing system is available which represents with considerable faithfulness the way that they all speak in their homes.

Finally, I must pay tribute to my wife, whose superior scholarship drove me into the enterprise, and whose devoted mothercraft through the long separations of study abroad and the strictures of study at home made that enterprise possible of completion.

Edinburgh.

August 1972

1. It is a pleasant custom of the Melanau to refer to an aged man held in affectionate respect as 'Uncle'. Thus the Chief Minister of Sarawak Haji Abdul Rahman Yakub, himself a Melanau, addressed 'Uncle' Win of Tanam when conferring on him the rank and title of Temonggong at the end of the 1971 Regatta, the first time any Melanau has received this dignity.

ABSTRACT OF THESIS

"A GRAMMATICAL DESCRIPTION OF MELANAU"

The thesis presents a description of the Dalat dialect of the Melanau language which, amplified by reference to the other known dialects, serves as representative of the language as a whole. The description is given in six chapters and a short appendix.

Chapter 1 is introductory to the thesis, giving (with the aid of sketch maps) a general picture of the Melanau way of life and the geographical setting of their habitat, an outline of their history, numerical distribution, social organisation and customs. Previous work on the language is reviewed and the methods of eliciting and processing the data on which the analysis is based are described.

Chapter 2 treats on the Phonology of Melanau, reviewing such previous attempts as there have been to write it down. A Phonemic analysis is given to justify a practical orthography for all the known dialects, which is used in the description.

Chapter 3 deals with the Morphology from the level of morpheme itself to the formation of words. Four classes of words are distinguished, Nominals, Verbals, Adverbials and the remainder called Particles. Each class is described in separate detail; particular attention is paid to the Verbs, in which separate classes of Uninflected verbs and two distinct classes of Inflected verbs are described. These verbs are formed on stems by quite different systems of affixation, referred to mnemonically as the MNP and the UIE paradigms after their principal morpheme forms.

Chapter 4 treats on Syntax in a Tagmemic framework, working upwards through an ordered hierarchy from the Phrase level to the Discourse. Nominal, Verbal and Adverbial Phrases are set out as the main constituent tagmeme fillers for Clauses. Most interesting are the range of Transitive Clauses in which either the grammatical Subject, Object, Indirect Object or the Verb may be brought into Focus; the choice typifies that clause

construction. Sentences, Paragraphs and Discourse are analysed to show their distinctive structures, and a text fragment is set out at all levels in the description.

Chapter 5 is concerned with a description of Style, in which Narrative, Didactic, Poetic and Conversational are shown to have certain distinctive characteristics.

Chapter 6 goes at no great depth into three limited areas of Semantic enquiry that were relevant to the Anthropological studies for which the enquiry was commissioned.

Appendices contain:

- (1) A glossary of symbols and abbreviations used in the text.
- (2) Word lists from 11 of the 20 and more dialect samples taken during the field-study phase, and comparative text in five of them.
- (3) A Bibliography of relevant literature.

THE MELANAU REGION OF COASTAL SARAWAK

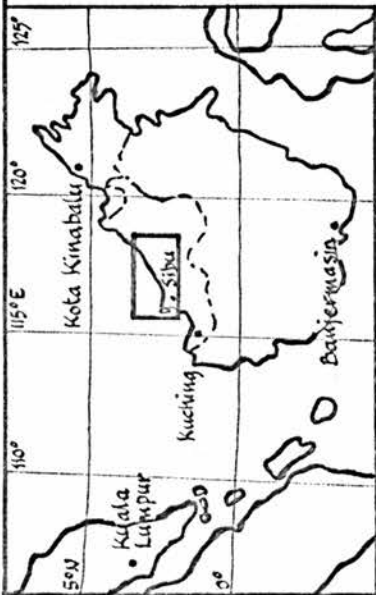
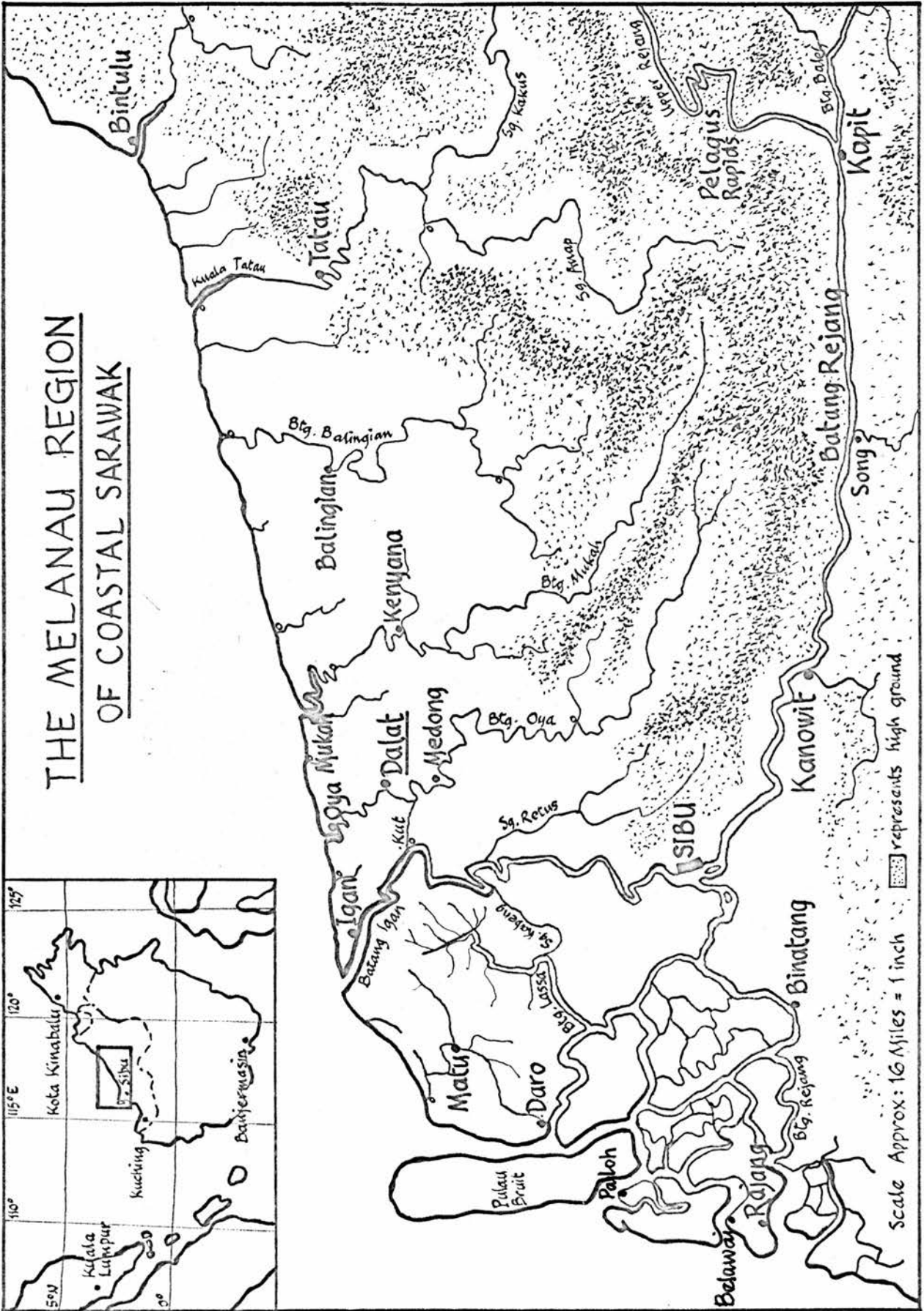

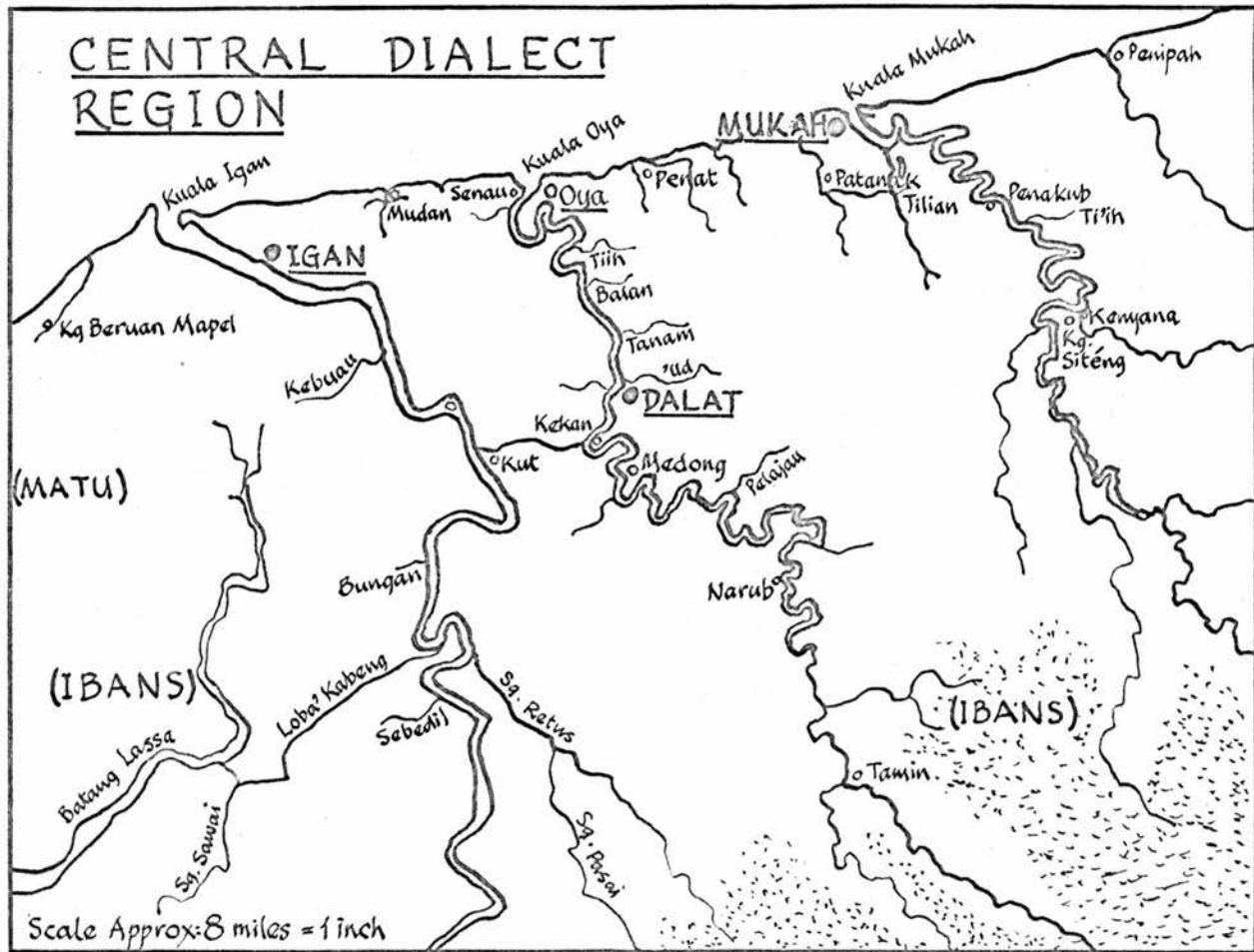

MAP 3

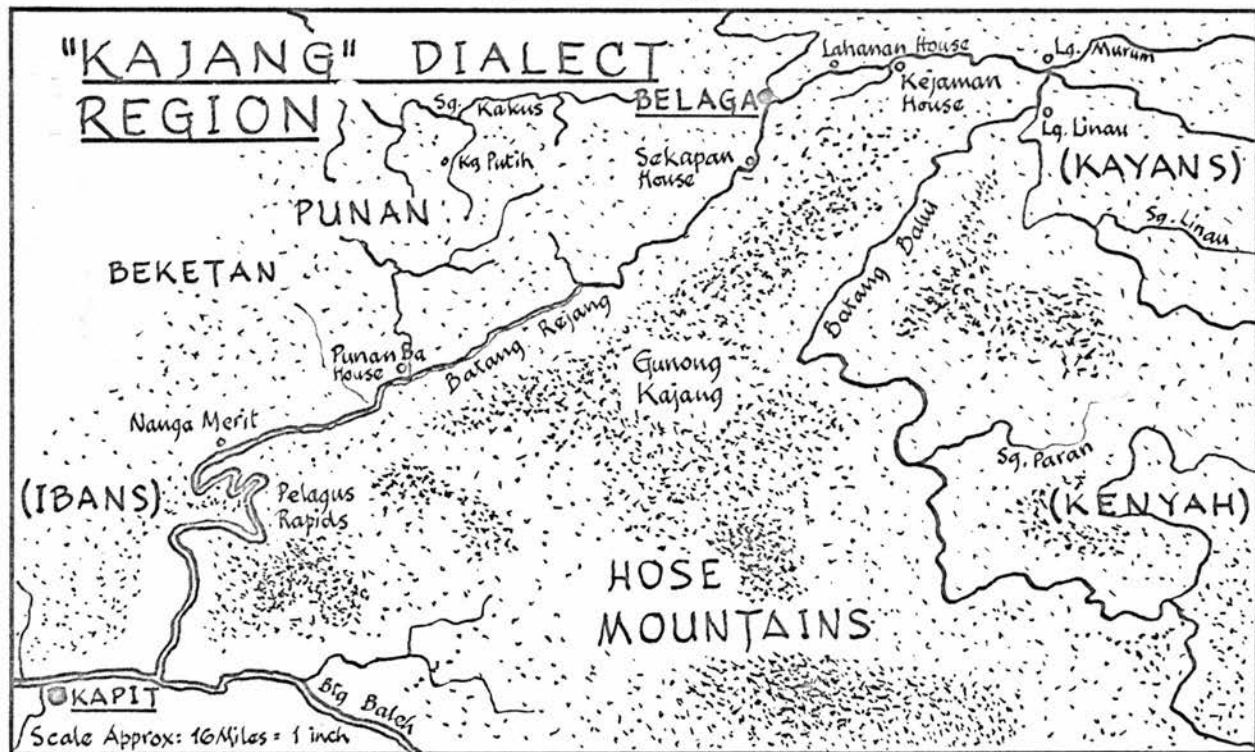

Chapter 1. INTRODUCTION

1.1 The Melanau People and their Way of Life	page 10
.11 Geography and History	11
.12 Numerical Distribution	14
.13 Social Organisation	15
.14 Customs and Beliefs	17
.15 The Melanau Language	19
1.2 Previous work on the Language	21
1.3 Aims of the present Study	23
1.4 The Corpus of Data	25
1.5 The Linguistic Description	28

"Among the four large islands of Indonesia, it is Borneo which has been least studied from a linguistic point of view. ... Data consists mainly of incidental remarks of explorers and travellers."

- Cense and Uhlenbeck 1958.3

1.1 The Melanau People and their Way of Life¹

Although the name MILANO appears on maps of the East Indies from the late 16th Century onwards, little of any scholarly note has been published about the people until quite recently. Fortunately many of the men in Rajah Brooke's Civil Service were keen observers of all that went on around them, deeply interested in the customs, beliefs and speech of the peoples whose territory they administered. Some of their observations found their way into the Sarawak Gazette², the June issue for 1876 containing an account by William Crocker of 'the most numerous and widely ranged tribe in Borneo', who turn out to be The Milanoes.³

Mr Barnes, an early Curator of the Sarawak Museum, Buck, Newington and Aikman who served as District Officers in various Melanau stations, and George Jamuh the Iban dresser in the

1. Much of this material appears in Clayre 1971(b), and is given far more adequate treatment in Morris 1973 (forthcoming)

2. A semi-official Government monthly publication in which, among more political matters, appear notes on a wide variety of Sarawak's peoples and wild life, long before the Museum was founded. This practice has recently been revived. A list of relevant articles is grouped at the end of the Bibliography.

3. The most usual of the various spellings of Melanau until the mid 1930s, as explained in Clayre 1971(a)

hospital at Mukah all contributed fragments of knowledge at one time and another. The definitive study however, at the present time, is H.S.Morris' 1953 Report to the Colonial Office¹ on the Sago industry of Sarawak, which has always been based on the Melanau region. While the scope of this report is mainly restricted to the Oya River, and in particular to the village of Medong some considerable distance from the coast, much the same general pattern of social organisation and day-to-day activity may be observed throughout all the traditional Melanau communities.

1.11 Geography and History.

The principal Melanau region stretches from Rajang and Belawai in the Rejang Delta as its South Western extremity (Map 1) to Bintulu in the North East, along a strip of low-lying coastal land varying from ten to fifty miles in depth inland. In the South West this comprises flat islands and sago swamps criss-crossed by waterways, bordering on the Iban land further from the sea. The lower tidal reaches of all the big rivers (the likou from which the Melanau derive their own name for themselves) are Melanau territory, much of it peat-swamp forest with clearings for sago farms and a few rice plantation attempts. This riverine settlement stretches along the banks of the Igan, Oya, Mukah, Balingian, Tatau and Bintulu Rivers, with many smaller ones such as Mudan and Patanak in between. Further inland, all of these give way to Iban settlers whose head-hunting raids contributed to the Melanau custom of making

1. Morris 1953 at Appendix 3

their old longhouses a prodigious height above the swampy ground¹. The communities on these rivers, producing the bulk of Sarawak's raw sago (and therefore at one time some 3/4 of the total world supply) were vital to the economy of the country, and the siege of Mukah² was critical to the establishment of Sarawak as a viable state in its own right in the mid 19th Century.

The villages and more modern towns at the river mouths long subsisted on their fishing industry, and as trading depots in a country where all major communication was, until very recent times, by water³. These villages were, by virtue of their commanding position, under the control of Malay pengirans responsible (in greater or less degree) to the Sultan of Brunei on whose account they farmed the tax-potential of the upriver

1. Remaining in use until the recent war, one of the last of these to be occupied now stands in ruins at Medong. The floor-beams pass through the main uprights (diei langit 'sky pillar') above the roof-tops of the present village. In style of layout and construction it bears unmistakable resemblance to the great Sekapan long-house below Belaga (Map 3)

2. Sarawak Gazette for 1921, 1922.

3. This has always been the accepted notion; virtually all travel is still by boat between Dalat and anywhere in the outside world. Yet this has overlooked the importance of overland routes that link the headwaters of the great rivers, thoroughly as this has been understood in the more remote inland regions. It is by such paths that a great deal of traffic continues between the upper Rejang above Pelagus Rapids and the Tatau and Bintulu basins. On foot along these tracks, Morris and I were able to trace the link that undoubtedly exists between the Kajang peoples and the coastal Likou ('The Kajang Kingdom' in Clayre 1971(a)).

communities as far as they dared penetrate. Many of the better known stories collected in the region, legends of Tugau and Jilag and other Melanau heroes, have as their theme the constant struggles of these subjugated peoples for safety from Iban war parties on the one side and independence from Malay taxation on the other.

One large group under Tugau settled further inland in the Pasai branch of the Retus River, while Kampong Nangka at Sibul claims descent from the Tanjong people of Kanowit on the mid Rejang¹. These same settlements are held in Kajang tradition to be the furthestmost seaward of the colonies established by their great war-leader, also known as Tugau.

Melanaus are perforce experienced boatmen, both on their rivers and out at sea, so that it is not surprising to find Melanau communities on many of the rivers further North East than Bintulu, rivers such as the Suai, Niah and Miri. Local tradition claims the Land Dayaks to be descended from Melanau who fled a supernatural disaster at Oya, making landfall at Tanjong Datu in the South West². The capital Kuching has a considerable Melanau community (who have recently given the country a Chief Minister), and their expertise as loggers has taken Melanaus as far away as Banjarmasin in the Very South of Indonesian Borneo, Kalimantan.

1. See the résumé of the story Naga Deluh at 5.12(b)

2. Despite many interesting arguments in the story, Land Dayak social organisation is so very far from Melanau (cf: Geddes 1954) that any close connection between the tribes must be extremely unlikely on cultural grounds.

It will be evident from the maps that Dalat, situated near the end of the Sungai Kut, the umbilicus that links much of Melanau country with Sibu and greater Sarawak, is approximately the geometric centre of the central dialect region. All manner of dialects are to be heard in its busy bazaar, and it was therefore chosen as the base for the learning and collecting phases of the present study.

1.12 Numerical Distribution

It is not easy to assess accurately the size of the Melanau population, on two accounts.

(i) No-one has really decided who the term Melanau ought to include, as a glance at the lists in Ray (1913) and Druce (1949) will make evident. The dialect survey undertaken as part of the present study (Appendix 2) certainly provides no ground for excluding the inland Tatau and Kajang peoples, whose dialects are no further from present day Bintulu speech than Bintulu is from, say, Mukah. Lahanan in particular, though not for various reasons included in the dialect sample given, is remarkably close to that of the Siténg families, still spoken by only the elders of the households living near the small upriver bazaar at Kenyana on the Mukah river. They claim affinity with each other, affirming the traditional link between coastal Melanau and inland Kajang of the upper Rejang (Map 3).

(ii) No-one has managed to prevent the name 'Malay' being put down in census returns against many Melanau (as well as other indigenous tribespeople) who have become Muslims. This is in accord with the practice throughout Sarawak (and perhaps else-

where) of referring to conversion to Islam as masuk Melayu, 'to enter the Malay (community)'. This makes it impossible to base accurate estimates on these figures; and there are no others available to correct the confusion.

In the 1970 census, of the 18 563 residents of all ages and races of the five administrative sub-districts of the Dalat district on the Oya River, approximately 10 000, it would seem, are Melanau of one religious persuasion or another. Of these, about one half speak the Dalat dialect as their first language; the remaining half approximate in greater or less degree to the inland dialect of Medong (which may historically be more primitive, along with the speech of Sungai 'Ud) or the coastal dialect of Oya, as their territorial position dictates.

This would make 50 000 a not unreasonable estimate for the Coastal Likou, of whom perhaps two thirds are now Muslim, the remaining third part approximately evenly divided between the Roman Catholic religion and the old pagan traditions of likou Likou (cf: 6.1). If the Tanjong and Kajang peoples are to be included, the total will be nearer 60 000; other fringe groups may add a few thousands more, but there is no verification of any upper figure.

1.13 Social Organisation

Melanau society is highly stratified into several basa¹ (Malay bangsa 'type, family') with dipen 'slaves' as the lowest grade and an aristocracy at the highest which measures its rank

1. This is one of the most obvious differences between Melanau and Land Dayak society referred to at fn.2 on p.13 above.

in pikul¹; to be ulan pikul 'nine hundredweight' is a mark of considerable position in society. While slaves no longer exist (at least in law) the people of Patanak near Mukah (Map 2) still regard themselves as socially inferior to the residents of nearby Kampong Tilian to whom they used to be in servitude, and often claim not to know the stories and traditions which were, by right of rank, the property of their erstwhile overlords². Among the upper ranks there is a certain mobility made possible by a pragmatic recognition of the power of acquired wealth. There is also a social élite known as a-nyat 'big people' or 'men of substance' who actually discuss and to a large extent control the affairs of the community. Membership of this coterie is not guaranteed to an aristocrat, although social position and wealth tend to make a person eligible by virtue of potential influence by other means. Greatly prized in this informal assembly is one who ta'ou kerapek 'has the gift of speech'; such men (and women) are in demand as go-betweens in the protracted negotiations necessary to secure advantageous terms for a good marriage, and as arbiters in such disputes as are not brought before the tua kampong, the village headman. This position of local justice of the peace and voice of central government on the one hand and local opinion on the other is filled by a man

1. The pikul is a measure of weight, 100 kati each of about $1\frac{1}{3}$ lbs, and here refers to the accumulation of brass-ware such as old Brunei cannon, jars and gongs which formed the berian or 'bridal tokens' at an aristocratic wedding. The terms are still applied to conventionalised gifts forming part of the elaborate contemporary ceremonial, the jar replacing the traditional slave being known as 'dipen' to this day.

2. This explains the introduction to story cited at 4.51.11(a)

popularly elected who can wield an influence quite outwith the bounds of his often humble rank on the aristocratic scale.

Education, largely the advantage of the younger generations who are only just beginning to approach the status which makes them acceptable in the discussion of affairs, is having quite a considerable effect on this status quo.

1.14 Customs and Beliefs

Much of the old tradition is disappearing in the wake of Progress¹; education, Christian and Muslim missionary activity and the economic demands of a progressively materialistic society make much of the old beliefs unacceptable. In the more remote communities such as Medong and Sungai 'Ud, however, the tide of new ideas sweeps in less dramatically and the old ways linger longer².

The visible world is peopled by spirits as well as men and animals, tou who are always malevolent and ipu' who may be no more than whimsical³. Lesser inhabitants of likou tou 'the land

1. Typical of this erosion is Jali' of Medong who, since his conversion to Islam, now either denies all knowledge of pagan stories recorded at his dictation twenty years ago, or recasts them with particular, and often predictable, slants reflecting his new ideals and allegiances.

2. As in so many places where conformity outruns conviction, help for the sick (to cite but one area of divergence between profession and practice) is first sought from traditional cures employing the bayuh and the belum (Morris 1967.199ff), then from the Dresser at the Government clinic, and lastly from the Priest when it is perhaps too late to make other service of much use.

3. Both these are counted with apah 'body', see 3.31.11.221

(or, it may be, the river, see 6.1) of the spirits' are such goblin-like beings as kulum and the amou of dead humans. The well-ordered man¹ holds his position in the social and spiritual order in a nice balance, having recourse to the services of a-bayuh 'shamans' and the tukeng belum who carve sickness-images² to aid him in its maintenance or restoration.

Dreams and augury, particularly regarding the flight and calls of birds, play a considerable part in the communication between these somewhat matched realms; accounts of trafficings between them provide a large portion of the narrative, didactic and poetic textual material on which this study is based. One particular form these dreams often take is the explanation by some ghostly figure (usually aged with an un-Melanau beard, or young and beautiful) of the deeper significance underlying some remarkable event. The result of this revelation is almost always the addition to the already considerable repertoire of some new palei, a prohibition against eating some particular food or carrying out a very necessary part of daily life in a particular (often the simplest) way, as eg: 5.14 and 5.2

There are ways round many of these taboos³; yet the fact

-
1. cf: 'the good man' central to Schärer's thesis (1963)
 2. Made of soft sago-pith carved expertly into representations of over a hundred tou responsible for causing - and therefore to be cajoled into removing - all manner of ills.
 3. The husband of a pregnant woman, for instance, may not tie a knot. But in a world without nails, life cannot proceed without knots in rotan strip used for all manner of fastenings. So the crafty will tie their knot with one surplus twist, and escape the strictures of the palei by obviously untying it in full view.

remains that considerable economic and other straitness results from their observance even to this day. Neither conversion to Islam or to the Roman faith is of itself a release from the pressures of such prohibitions.

The likou matai 'land of the dead' influences the ritual culture in many detailed ways too numerous to mention here. Of linguistic import, however, is a canon of verbal literature in epic ballad form known as the mu'éh Rajang (5.41) and its derivative lesser laments, and the set-pieces of poetry used as invocation to the spirits at many ceremonies. In the payun¹ ritual, the bayuh is overcome with speech in a variety of different languages, some recognisable and some totally unknown, not unlike the glossalalia phenomena associated with some forms of Christian religious experience. Unfortunately it was not possible to record any of this without offence, so no account is taken of it in the analysis.

1.15 The Melanau Language

The confusion about numbers (1.12 above) is closely tied to a vexed question of what constitutes the Melanau language². Voegelin (1965.17) lists 'Milano' languages much as Ray had done fifty years earlier³; he could hardly do otherwise, for little has appeared in the interval to challenge that listing. The classificatory index I.1.4 is no more than geographical, placing the group in the Austronesian Family, Indo-Pacific

1. cf: Barnes 1966

2. Cense and Uhlenbeck 1958.18

3. Ray 1913, see chapter 2.0 below

Location, much as Dempwolff (1938). And while one is tempted to wonder, in view of the links between Melanau and the Kajangs of more central Borneo, what connection there may be with the 50 000 'Kadjangs' of the Celebes or with the Rejangs of nearby Sumatra¹, data is not available to make an informed comment.

Structurally, the Melanau language (or languages) shows similarities with Malay on the one hand and Philippine languages (possibly traced through Murut as an intermediate step²) on the other. Typical word order of favoured clause-types is similar to Malay, there is no sharp distinction between predicative and attributive verbs and, with the exception of Quantity terms, attributes follow their respective Heads in both nominal and verbal syntagms. In clause level structures, there are three basic word orders in syntagms unmarked for emphatic style; the grammatical Subject, Object (direct or indirect) or the Verb may come first in the string, depending on the Focal valence of the clause. While this notion of Focus is pursued in the light of studies in the Philippine languages (and the Philippine-like languages of North Borneo) it does not of itself align Melanau more with that region than with Malaya. It is suggested in passing that the grammar of Malay and Bahasa Indonesia would profit from a re-examination in similar terms.

What is peculiar to Melanau (among Malay-like languages of Central and Southern Borneo) is the verb morphology (3.32), in which it is shown that a large number of verb stems inflect

1. Voegelin and Voegelin 1965.17,7 respectively

2. B.M.Clayre 1967, 1972 cf: 4.201,202 below

not with the prefixes which attach to the greater moiety of verbs, but by ablaut of the first vowel. This is more akin to Murut and the Dusunic languages of Sabah than to Malay, a group of languages whose affinity to the Philippines is beyond serious question¹.

Clearly the synchronic patterns of Melanau lexicon and syntax represent a stage of diachronic flux and probable fusion, but just what are the proto-sources cannot at present be said with any certainty.

Alongside the spoken languages grouped together under the title 'Melanau', there is some rudimentary form of written Melanau (rudimentary in that there is no recognised spelling convention, which rather defeats the inter-personal uses of writing and has certainly inhibited the growth of a written literature, cf:2.0 and 2.6 below) and at least one workable deaf - and - dumb language used by a middle-aged man and his helper in Tanam (Map 2). While the problem of the orthography receives considerable attention in this thesis, it was not possible to make a detailed study of the other very interesting language form.

1.2 Previous work on the Language

As far as is known, no previous attempt has been made to provide any kind of analytical description of any dialect of Melanau, despite Crocker's generous acclaim of the people (1.1 above) and Leach's recommendation for a thorough study (1958. 44) of all Sarawak's languages. In Appendix 3 are listed a

1. B.M.Clayre 1967 and Prentice 1965

number of short articles which, in the course of descriptions of lore and custom, mention a few Melanau words - the 'incidental remarks' of the quotation at the head of this chapter - in each author's notional spelling. Such fragmentary material is of little use for serious study.

The vignettes of life described by Jamuh and others have been mentioned earlier; Morris' account of Melanau living and dying does not set out to deal formally with language, in direct consequence of which fact the present study was commissioned by Morris himself. Other accounts of Melanau stories (such as Jamuh 1965) are all in English translation, with no vernacular base text accompanying this gloss. Only Brodie (1955) troubles to give the actual form of a Melanau fragment, but this is in a somewhat elliptical verse form, which cannot serve as indicative of the regular grammar.

The only two serious works on the language to be published are Mulder and Lawrence's Vocabulary of Mukah Milano (sic) and Aikman's little word - and - phrase - book of the Matu dialect composed (one must imagine from the tone of many of the examples of helpful phrases) for the use of visiting European dignitaries. Both of these are criticised in some detail in Chapter 2; neither goes beyond the listing of words and sometimes somewhat dubious phrases relying heavily on Malay syntax. Although the carefully detailed work of Mulder and Lawrence closes with a paradigmatic display of some of the more common verbs (in only three of their four forms), there is no attempt to group them into inflection classes of any kind.

Never published - or, indeed, completed - is a remarkable dictionary largely of Dalat words but interspersed with many extraneous forms, originally compiled by one of the Catholic missionaries, Fr Mak, on odd scraps of paper during his internment in Kuching prisoner-of-war camp during the Japanese occupation of Borneo (known throughout Sarawak as masa Jipun or some recognisable equivalent, 'the Japanese time'). This has been carefully typed out by his parish clerk Munan¹ (a Mukah Melanau living in Dalat) as far as it goes - and further, for Munan has made numerous additions and given valuable glosses to many of Mak's entries - and was of great value at all stages of this study. Every entry has now been checked for spelling and for current usage in the Dalat dialect area, and its full contents are in the process of being rationalised with the rest of the material gathered for this thesis. A trial portion of some 2 500 words has been put through a computerised sorting programme for an alphabetical dictionary; the larger set of data awaits preparation for the programme², and will be published in due course.

1.3 Aims of the present Study

During his many years of association with the Melanau, Morris has collected a corpus of poetry, folk-lore and other verbal literature whose value as a lode of rich anthropological ore would be greatly enhanced by a detailed description of the

1. Referred to hereafter as Mak and Munan, and undated.
2. The programme was provided by Dr Colin Day of University College, London, and successfully modified by Mr W. Watson of the Edinburgh Regional Computing Centre, to both of whom I am indebted for their frequent assistance in technical matters.

language in which this material is recorded. This was the main practical aim of the study at its inception, to enable this data to be understood more plainly than had been heretofore possible.

A number of secondary aims inevitably develop out of such a simple plan. The Melanau are not forward among the literate peoples of Sarawak, for reasons that have been mentioned before. It is hoped that a good orthography will assist them in taking their proper place among their neighbours as composers of contemporary literature¹. If this orthography were able in any way to unite the fragmented dialectal position, so much the better.

A survey of the languages popularly known as Melanau was then properly suggested, partly for the purpose outlined above, partly to ascertain just what are the true bounds of Melanau, more or less as envisaged by Leach (1948, see above). This survey was extended inland to the sub-tribes of the Kajang group, to test the persistent rumour that a Melanau could make out the conversation on the veranda of the Sekapan long-houses²; a summary of the findings is given at Appendix 2.

Specific areas of semantic and cultural obscurity were from time to time delineated by Morris, requiring detailed enquiry as the work proceeded. This has resulted in the collection

-
1. The value of a good phonemic orthography can hardly be over-emphasised for the encouragement of new readers and writers. The nomadic Penan (of whom Rodney Needham has written) often amaze their more sophisticated neighbours by their skill in both, since they have been equipped with a New Testament in a good script designed by translators of the Borneo Evangelical Mission who have lived among them in their jungle homes.
 2. 'The Melanaus' in past editions of Peoples of Sarawak.

of an even more voluminous corpus of oral texts on matters of antiquity and present-day interest, much of which remains to be arranged in a systematic way for publication, although some surface skimmings have appeared in the Sarawak Gazette (Clayre 1971(a) and 1972(a)).

Arising directly out of this collection¹, as it became apparent that few of the younger generations of Melanau were conversant with much of the traditional knowledge of their forebears, has come a desire - in fact a promise - to compile a book of Melanau stories in the various main vernaculars in which they were recorded, so that coming generations will not be denied the opportunity to read "in their own tongue where-with they were born" the tales of glory and of delight that were the fare of their ancestors through the long tropical evenings before the advent of more modern synthetic entertainments. This last aim has been forced by the demands of this thesis to take a lowlier place in temporal priorities than its importance warrants.

1.4 The Corpus of Data

All possible contact with the language was sought in an attempt to become rapidly familiar with its many facets and styles. Enquiry in the early stages was through the medium of Malay, which is everywhere understood with more or less adequacy. Sometimes English was used with those who had been

1. In this I was greatly helped by Edward Assim Bul of Kekan, who accompanied me on many of my earlier expeditions to houses where I was a stranger, and elicited stories on my behalf.

educated in that medium in schools, colleges and occasionally in University. It did not prove possible to secure the services of a suitable full-time informant for long periods, so that the language - learning process became perforce a far more natural and informal interaction with a great variety of people of all ages and both sexes, both in their homes and farms, at work in their boats and gardens, in the markets and at the many social functions to which they generously invited me.

It would be pleasant to be able to make a virtue out of each necessity; yet there are drawbacks to such a procedure as that outlined above. While the learner is forced to come to grips with a broad swathe of the language performance upon which the description of competence will eventually rest, the corpus at no point represents all the phonological and grammatical norms of any one speaker. While care is taken in all texts to label them for speaker, age, location and other such factors as may determine to some extent the variables in question, it is still not always easy to establish from such a wide corpus of fragments the definitive set of oppositions that make up a particular person's competence within the langue¹, less easy to pontificate about what expressions are basic and which are parasitic or ideolectal.

In compensation for this lack of methodological precision, the data collected has been used to form the basis of a corpus of Melanau folk-lore in the Sarawak Museum's archives. This is

1. In de Saussure's well known opposition of langue and parole.

recorded onto 5 inch diameter Tape spools at $3\frac{3}{4}$ i.p.s, using a Sony TC-800B tape recorder¹ and 'Double-play' tape. Most of the contents of these tapes has been transcribed into the orthography described in the thesis, and given both a word-for-word gloss and an amplified colloquial English meaning in collaboration with a great number of part-time Melanau helpers while the actual situational contexts were still vividly recalled. A selection of the better texts were then transferred to Cassette tapes on a matching TC-80 portable recorder for checking and further reference on return to the U.K. A broad cross-section of speech-types, styles and dialects is thus represented in both collections, with transcriptions and translations.

Rather less than half of this corpus, mainly that from the Dalat area, has since been typed onto machine punch cards, with much corroborating paradigmatic and amplifying language samples elicited by direct questioning. This data has been processed on the IBM 360/50 machine at the Edinburgh Regional Computing Centre using a Concordance programme² and a Dictionary sorting routine. This method of collating data from a number of sources to a large extent obviated the need for a bulky card-filing system such as that recommended by Nida (1963.195ff) and others. It has also provided the basis for that Dictionary project to

1. This machine of my own was not always available to Assim Bul, who had on occasions to use alternative equipment of a less satisfactory specification supplied by the Museum.

2. 'Concorda', the programme offered by the ERCC, was modified for Melanau by Mr Watson, but did not always function well with the great volume of data supplied.

which reference has been made already, although much work is still required on this aspect of the total programme.

In order to produce a description that would be as far as possible representative of the Melanau language as a whole, and yet describe adequately the dialect of a locality (and so avoid the pitfall of describing something actually occurring nowhere) Dalat dialect was chosen as the core of the study. From this pu'un or trunk spreads the lawei, a foliage in the form of that material gathered from other sources mentioned at several points throughout the description. For this reason not only the lexis of other dialects but also the basic grammatical forms (such as favourite clause types in various focal transformations) were investigated. Texts were gathered in twenty localities for comparative (and, later, illustrative) purposes, a sampling of which is given at Appendix 2.

1.5 The Language Description

In order to satisfy the aims set out at 1.3 above, a phonemic analysis of the Dalat dialect is presented in Chapter 2 with annotations relevant to the other major dialect regions. This provides the theoretical ground for the practical orthography devised for the whole Melanau language complex, which is used throughout the remainder of the description.

The Morphology of Melanau is not overtly complex, and Chapter 3 follows the general lines of description suggested by Nida¹. Particular attention is devoted to the inflection of verbs, which fall into three major categories called for

1. No great differences appear between Nida 1963 and earlier versions of this standard work.

simplicity the Uninflected verbs, MNP and UIE verbs (after the typical affixes pertinent to each paradigm).

The bulk of the thesis is then directed towards a study of the Syntax, described in Chapter 4. This progresses upwards level by level through an ordered grammatical hierarchy from Phrase to Discourse level, within a Tagmemic framework. Of special interest also the range of Transitive Clauses in which is manifested the grammatical device of Focus (1.15 above), seen to be basic to Melanau syntax at this level and above. This approach is developed out of previous work in the Philippines (4.201) largely by members of the Summer Institute of Linguistics.

Chapters 5 and 6 are short, touching in no great depth on matters of Style and Semantics. It is clear that a far more detailed investigation of the latter would be profitable when a suitable framework for the study is available. A text fragment is then analysed at all levels according to the terms of the description to that point.

Finally, in Appendices, are given a gloss to each of the symbols and abbreviations used in the text of the description, samples of dialect word lists and comparative texts recording a common myth, and a bibliography of relevant literature.

Chapter 2. PHONOLOGY

2.0 <u>Introduction</u>	31
2.1 <u>Statement of Phonemes</u>	36
2.11 The Vowels	37
2.12 The Consonants	37
2.13 The Suprasegmentals	39
2.2 <u>Description of the Phonemes</u>	39
2.21 The vowels V	39
.211 Allophonic variation	40
.212 Vowoid glides	44
2.22 The consonants C	44
.221 Stops	45
.222 Fricatives	46
.223 Liquids	48
.224 Semivowels	49
.225 Nasals	49
2.23 Suprasegmentals	50
.231 Stress	51
.232 Pitch	51
.233 Juncture	52
2.3 <u>Distribution of Phonemes</u>	53
2.31 Syllable structure	53
2.32 Word structure	55
2.33 Vowel sequences	56
2.34 Consonant sequences	57
2.35 Metathesis and Stammer	59
2.4 <u>Dialect Variation</u>	62
2.41 Northern dialects	62
2.42 Southern dialects	64
2.43 Other Central dialects	65
2.5 <u>Intonation</u>	65
2.51 Declarative	67
2.52 Interrogative	72
2.53 Exclamatory	77
2.54 Inventory of Contours	79
2.6 <u>Practical Orthography</u>	80

2.0 Introduction

Melanau is still very largely a spoken rather than a written language¹. Those who have the temerity to write at all do so with a gay disregard for systematic spelling, and have considerable difficulty in reading back a text of their own compiling². Such conventions as are incidentally observed are more relevant to the writing of Malay, Dutch or English than to Melanau itself, the legacy of a number of gifted amateur linguists whose primary responsibility was the administration of local Government or Missions.

An article in the Sarawak Museum Journal of 1949 contained a plea for a single system of spelling³. There is little doubt that a standardised system would greatly assist the Melanau, who have a rich cultural heritage enshrined in spoken tradition, to take their place among the literate peoples of Sarawak.

Previous attempts at recording spoken Melanau have all been hampered by inadequate phonological theory and method. The value of Ray's careful comparative study of the languages of Borneo is seriously undermined by its method of data-collection. Local Government officers⁴, often with a good speaking ability

1. The greater part of this description has appeared in the Sarawak Museum Journal XVIII (1970) pp330-352

2. The weekly news broadcast over Radio Sarawak is a case in point; everyone, unfortunately, blames the Melanau news-reader instead of the script from which he reads.

3. Archer 1949

4. Ray makes no secret of this (1913.3-6 and 51), but no later work (including Cense and Uhlenbeck 1958) has paid sufficient attention to the fact in basing conclusions on the data.

in the languages they recorded, but with no sophistication as phoneticians, wrote as best they could the local vernacular words corresponding to those on Ray's comparative list. Quite apart from the variability of real-world reference of a lexeme which this introduces, it removes virtually all possibility of any kind of standardisation of spelling. This in turn reduces seriously the value of the resulting lists as data for serious comparative study; real similarities are obscured, and equally important differences fail to stand out.

Of all the contributing deficiencies evident in these long lists, the most confusing is the allocation of thoroughly English values to the five vowel characters a, e, i, o and u. All subsequent attempts to commit Melanau to writing have suffered from this initial setback, a reliance on a basic five vowel system. It carries over into the painstaking work of the Mulders¹, quite the most valuable of all the works available, and thence into several writings derived from it. All, with the exception of Aikman (1947) treat the [ə^u] sound of, say, English 'go' as a simple vowel isolate, instead of recognising it as a member of the well-defined diphthong set ai, oi, au &c: so obscuring one of the systematic regularities of all Melanau dialects.

The Mulders' otherwise excellent Vocabulary suffers also from an undue dependence on Malay. Finding in Melanau a word [ikan] meaning 'fish', they recognised it as cognate with the Malay ikan and accordingly spelled it identically. As it turns

1. Mulder and Lawrence 1930

out, this was quite correct. But finding then a word [ʌdət̚] meaning 'customary law, tradition', they recognised it as the equivalent of Malay adat, and spelled it similarly. The fact that the second vocoid is not the same as the [æ] of Malay did not escape Mulder's careful ear, but he would appear to have fallen into the common mistake of regarding Melanau as a dialect of Malay, a corruption or adaption of the superior language; the second vowel was therefore called a 'shortened a', and written â, giving adât as the final form. In this way a series of 'short vowels' are added to the basic five. Similarly, the geminated vowels described in detail at 2.33 are not recognised as precise equivalents to a sequence of two unequal vowels, but called 'long vowels'; this series adds a further five to the list, yielding a total of fifteen vowels in the written convention of the Mulders.

The genius of the Melanau language itself is thus obscured in a pseudo dependence on Malay and English. Place names, of all the truly local landmarks to phonology (as to geography), are spelled as the recently arrived English and Malay languages dictated, so that [igən] is written Igan, [dʌləd] becomes Dalat, [tʰʔt̚] is reduced to a mere Teh, and the language is colonised along with the land.¹

1. This gives rise to a joke in such communities as Igan village where the Muslims aspire to a Malay-like pronunciation. The word perkilat 'shining like lightning' (Malay) is taken into Melanau applied to the gleaming ceremonial cloth of special sarongs worn at weddings, becoming in the process first [pɛkilət̚] and then by the metathesis described at .351 below, [pɛlikət̚]. But this also means 'sticky', fitting the tight shiny trousers sported by many of the young men of the place; Muslims say [pɛlikət̚] instead, but more traditional Melanaus make no difference; hence laughter.

Of Aikman's little phrase-book, the only published record of the Matu dialect, two things need to be said in addition to the general comments on inadequate vowel representation. Its great contribution is in attributing the sound value [ɔ] to the letter o (which sometimes appears word-final in his lists written ö), an insight which could have (and should have) saved much subsequent confusion. However, while Aikman states "an apostrophe at the end of a word indicates a glottal check or stop", he is actually very casual about recording it either word medial or final. Since numbers of minimal pairs differ in only this one phoneme, a certain accuracy is sacrificed in an area where it can be ill afforded.

The 'Coast Liko Adat' published by the Sarawak Government¹ follows Aikman's lead in a whole-hearted manner, dispensing altogether with any written representation of the glottal stop consonant. In their zeal for economies, the compilers of this document also neglected all the Mulders' diacritic marks for apparent vowel length which, however tiresome they were to write and however far short of ideal representation of the phonetic material, did serve to distinguish many otherwise similar words from each other. The result is unfortunate. Reading the 'Adat' becomes, even for an educated Melanau, largely a matter of memory and inspired guesswork.

None of the many articles on Melanau (or Milano) topics that have appeared in the Sarawak Museum Journal or the Gazette,

1. A codification of Melanau customary law on marriage and such matters, mentioned but not inspected by Cense and Uhlenbeck (1958,20)

illuminating though they have been in matters of custom and¹ culture, have cast any light on the structure of the language. The resultant confusion is reflected in the first essay by the Borneo Literature Bureau to add a Melanau author to their list of indigenous writers in the vernaculars. 'Bato Ikan' is dogged by the chaotic spelling that is the inevitable outcome of un-systematic adventures into writing without analysis or, at the least, codification of some convention. buya and boia appear in the same paragraph, elsewhere by a happy chance appearing as buya', 'on account of'. The singular pronoun 'you' is on the same line both kaau and ka'au, while the structurally similar [tA[?]e^u] is disguised as tao.

Of the quantity of booklets of prayers and catechisms produced by the Roman Catholic Missions at Dalat and Mukah, the same general remarks may be made. The word list compiled by Fr Mak and Munan is invaluable as a much amplified version of Mulder and Lawrence's list, but very untrustworthy as a guide to pronunciation. Many minimal pairs are compounded by poor spelling into the same written form, making its revision and publication both pressing tasks.

While a practical orthography as one of the goals of the present study has to take a high place in priority, the Phonemic method of analysis adopted widely by members of the Summer² Institute of Linguistics is an obvious choice for the theoretical

1. As for instance the mu'éh chants described (under the heading muah) in Morris 1953, and the writings of George Jamuh at Mukah mentioned in Cense and Uhlenbeck's Survey (1958) and listed in Appendix 3.

2. Pike 1947

background to the following description of the sound system of the Melanau dialects.

A brief statement of both Segmental and Suprasegmental phonemes is given at section 2.1, amplified by a Descriptive Statement at 2.2. Syllables and the formation of phonological Words is covered at 2.3, while 2.4 presents a brief outline of the more regular divergences of the outlying dialect norms from the patterns of the central core. 2.5 contains a short description of some of the more regularly recurrent Intonation Contours, and at 2.6 the Practical Orthography in which the remainder of vernacular examples in the Description appear is justified. It has been found in practical use to be adequate for all the dialects of Melanau encountered, as well as the Dalat dialect on which the Grammatical Description is largely founded.

2.1 Statement of Phonemes

The phonological system of Dalat Melanau operates with an inventory of 27 segmental phonemes, of which 6 are vocalic contrasts of the syllable nucleus, and 21 are consonantal contrasts of the onset and coda. Within this broad classification, groups of phonemes have widely differing ranges of distribution in phonological syllables and words.

At the level of the phonological word, a suprasegmental phone of primary stress falls predictably on the final syllable and is therefore not emically relevant to the system. At higher levels within the Grammatical Hierarchy, contrastive stress on certain syllables combined with recognisable patterns of pitch

and juncture phonemes contribute to the total information content on an utterance.

2.11 The Vowel Phonemes V contrast between Front, Central and Back tongue positions, between Close and Open jaw approximation. As a set, the Central vowels are placed lower on the chart because their realisations are produced with a more open jaw than Front and Back vowels.

		<u>Tongue position</u>		
		Front	Central	Back
<u>Jaw</u>	Close	/i/	/e/	/u/
<u>Jaw</u>	Open	/ɛ/	/a/	/ɔ/

According to their distributional privileges, the vowels fall into three distinct sets; Primary Vowels, occurring in all word positions, /i/, /a/, /u/; Secondary vowel, in any closed syllable but not open syllables, /e/; Tertiary vowels occurring only in final stressed syllables with consonant coda, /ɛ/, /ɔ/.

2.12 The Consonant Phonemes C contrast between Labial, Alveolar, Palatal,¹ Velar and Glottal regions of articulation. A contrast of Voicing : Non-voicing pertains to Stops and Fricative consonants; the Vibrants, Lateral, Semivowels and Nasal consonants are all voiced.

1. Etically there is an observable difference between palatal and alveo-palatal articulation, but this is extra-systemic. The same is true between etic fricatives and affricates.

<u>Mode of</u> <u>Articulation</u>	<u>Region of Articulation</u>				
	Labial	Alveolar	Palatal	Velar	Glottal
Stops (Voiceless)	/p/	/t/		/k/	/ʔ/
(Voiced)	/b/	/d/		/g/	
Fricatives (Vless)		/s/	/ç/		/h/
(Vcd.)	(v)	(z)	/ʃ/		/H/
Vibrants		/r/		/R/	
Lateral		/l/			
Semivowels	/w/		/y/		
Nasals	/m/	/n/	/ɲ/	/ŋ/	

Distribution of the palatal consonants is limited to word initial and medial position, except for the semivowel. The set of systemic Fricatives includes consonants whose etic realization is an affricate, but are distinguished from the Stops by their component of friction. In the idiolect of many individuals /s/, /ç/, /h/ and /H/ are all allophones of one another, allowing of considerable simplification of the systemic oppositions. There is no doubt that the system is under pressure from outside influences such as the National Language, which has already caused the separation of /s/ and /ç/ for most adult speakers in Dalat.

Two additional phonemes, /v/ and /z/, are required to maintain the oppositions of the Northern dialects, and other modifications to the pattern described here are discussed at 2.4 below, and in Appendix 2.

2.13 The Suprasegmental Phonemes operate at levels above that of the phonological word. Three phonemes are recognised, all having range rather than point values. Normally modulated speech patterns may be described with the following:

Stress / ' / primary, / " / secondary
 Pitch / 0 / lowest - / 3 / highest, / 4 / emphatic stress
 Juncture / - / hyphen, / / inter-word, / # / comma pause.

2.2 Description of the Phonemes

.21 The Vowels V represent the set of central oral resonant vocoid contrasts within the syllable nucleus. A number of general statements may be made concerning the etic variants of the emic vowel norms:

- (1) In final open syllables, vocoids are predictably lengthened, and approach most closely to the phonetic value of the chosen vowel symbol.
- (2) In final syllables closed by the glottal stop consonant, Close vocoids are slightly lengthened with a non-contrastive off-glide towards an unstressed [ə]
- (3) Final syllables of phonological words are marked by predictable stress placement. It is this phonetic syllable that the maximum number of emic vowel contrasts occur.
- (4) A degree of vocoid harmony tends to affect the vocoid nuclear to the penultimate syllable, which assimilates towards the general positional value of the stressed vocoid in the final syllable. This tendency is most marked when the vocoids are separated by labial or glottal stops whose articulation involves no tongue movement.

- (5) All vocoids are voiced, and produced with egressive lung air.

2.211 Allophonic Variation

/i/ [ɪ] lowered and retracted Close Front Unrounded vocoid, occurs between contoids except as noted below:

[tæŋtɪ] /təŋih/ 'weep', [bedɪl] /bedil/ 'cannon'

[tɪp] /tip/ 'thirsty', [sɪʔɪ^u] /siʔiw/ 'before'

[ɪ^a] as above, lengthened with off-glide towards [ə], in final stressed syllable with glottal stop coda:

[pɔɪɪ^aʔ] /puliʔ/ 'go away', [sɪɪ^aʔ] /siʔ/ 'snail'

[mæpɪ^aʔ] /mapiʔ/ 'preserve in sago'

[i] Close Front Unrounded vocoid, occurs elsewhere:

[ɪlɪʔ] /ilaʔ/ 'look at', [sɪlɪʔ] /siah/ 'salt'

[luɪn] /luin/ 'they', [tuli:] /tuli/ 'bone'

The phoneme /i/ occurs before voiced velar /g/, as in

/Ribig/ 'pinch', but not before voiced /ŋ/ or voiceless /k/.

/ɛ/ [ɛ] half-close Central Unrounded vocoid, following labial and glottal contoids before final unstressed semi-vocalic closing glide coda:

[bɛⁱ] /bɛy/ 'be, have', [nɛⁱʔ] /nɛy/ 'stomach'

[ɛ] half-open Front Unrounded vocoid, occurs in other final closed syllables carrying word stress¹:

[biɛʔ] /biɛh/ 'body', [tæŋsɛʔ] /təŋsh/ 'burn incense'

[mæpɛʔ] /mapɛʔ/ 'lame', [pæsɛr] /pasɛr/ 'sand grains'

[kɛɪɪɛŋ] /kɛɪɪɛŋ/ 'wooden burial monument'

The Front Vowels as a set contrast in the final syllable of

1. The only recorded occurrence of [ɛ] in final open syllable is the female name [ulɛ:] /ulɛ/. In modern loan words, [ɛ] may be in non-contrastive fluctuation with [i] to produce a more typically Melanau phonetic form, eg: [ɛndʒɪn] [idʒɪn] /iʃin/ 'engine'.

minimal pairs /taŋsh/'burn incense' and /taŋih/'weep'
 /mapɛʔ/'lame' and /mapiʔ/'preserve in sago'

/ə/[ʌ] half-open Central Unrounded vocoid, occurs before final
 velar contoids:

[sʌk]/sək/'grass' [mɛdʌg]/mɛdɛg/'touch'

[atʌŋ]/atɛŋ/'really'

[^əi] on-glide from unstressed [ə] to Close Front Unrounded
 vocoid carrying word stress, in final syllables with
 glottal stop coda:

[s^əiʔ]/sɛʔ/'red, ripe' [tɔl^əiʔ]/tulɛʔ/'push away'

[ʃ] syllabic length (with some degree of stress) on voice-
 less Alveolar grooved fricative, following [s] before
 voiceless stops, following [p] before [s]:

[ʃkɛn]/sɛkɛn/'arms akimbo' [pʃa^ua:]/pɛsawa/'married'

[ɛ] half-close Central Unrounded vocoid, occurs elsewhere:

[lɛŋɛn]/lɛŋɛn/'arm' [pʌsɛr]/pʌsɛr/'bazaar'

[sɛluⁱ]/sɛluy/'gently' [tɛkɛdʌŋ]/tɛkɛdɛŋ/'stand up'

The phoneme /ə/ does not occur in open syllables.

The half-open and half-close Unrounded vowels contrast in
 the final syllable of minimal pairs /pʌsɛr/ 'grains of sand'
 and /pʌsɛr/ 'bazaar', /kʌbɛŋ/ 'goat' and /kʌbɛŋ/ '(river in
 between Igan and Lassa)'

/a/[æ] Open Front Unrounded vocoid, fluctuates with [ʌ] in
 unstressed non-final syllables, only in part predict-
 able by the tongue and jaw positions of the following
 stressed vocoid:

[tʌŋtɪ] /taŋih/'weep' [tʌma:] /tama/'father'

[ægeⁱ][ʌgeⁱ] /agɛy/'yet, still'

[a] Open Central Unrounded vocoid in final stressed syllables, except before glottal stop coda:
 [pəla:] [pla:]¹ /pəla/ 'paddle' [baⁱ] /bay/ 'loincloth'
 [ləŋan] /ləŋan/ 'voice' [mɪkaŋ] /mikaŋ/ 'unfurl'

[ʌ] half-open Central Unrounded vocoid, occurs elsewhere:
 [ʌba:] [aba:] /aba/ 'rivermouth' [bʌlʌʌ] /balah/ 'Iban'
 [təkædʌŋ] /təkadəŋ/ 'stagnant water'
 [məmʌdʌʔ] /məmadaʔ/ 'give command, order'

The Central vowels contrast in the final stressed syllable of minimal pairs /ləŋan/ 'voice' and /ləŋən/ 'arm'
 /mədag/ 'make landfall' and /mədæg/ 'touch'

They also contrast in unstressed syllables, as in the minimal pairs /təkədəŋ/ 'stand up' and /təkadəŋ/ 'stagnant water', /səluy/ 'gently' and /saluy/ 'canoe', /bəlah/ 'split' and /balah/ 'Iban'.
 cf: also /dəpa/ 'fathom' and /dipa/ 'snake' contrasting close vowels.

The Open Unrounded vowels contrast in the final stressed syllable of the minimal pairs /sey/ 'flesh, pith' and /say/ 'who?', /pəbich/ 'having a body' and /pəbiah/ 'run'.

/u/ [o] lowered and advanced Close Back Rounded vocoid, occurs between contoids except as noted below:

[ʌnom] /anum/ 'water' [dɔg] /dug/ 'flood-tide'
 [bɔʔəŋ] /buʔəŋ/ 'war canoe' [ʔod] /ʔud/ 'headwaters'
 [baⁱoŋ] [baⁱoŋ] /bayuh/ 'spirit medium, shaman'

[o^ə] as above, lengthened with off-glide onto [ə], in final stresses syllable with glottal stop coda:

[ʌso^əʔ] /asuʔ/ 'plank' [geto^əʔ] /getuʔ/ 'completed'
 [təmo^əʔ] /təmuʔ/ 'bathe'

1. cf: the alternative forms with [pʂa^ua] /pəsawa/ 'married' above.

[u] Close Back Rounded vocoid, occurs elsewhere:

[u^udu:] /udu/ 'nose' [bua^u] /buaw/ 'run away, flee'

[su:] /su/ 'morning' [dʒuo^ə?] /juu?/ 'juice, sap'

The phoneme /u/ occurs before voiced velar /g/, but not before voiced /ŋ/ or voiceless /k/.

/ɔ/[ɒ] Open Back Rounded vocoid, occurs before final glottal stop coda in stressed syllables:

[petɔ?] /petɔ?/ 'fruit basket' [inɔ?] /inɔ?/ 'bundle'

[tʌdʒɔ?] /taʃɔ?/ 'edible shoot'

[ɔ] half-open Back Rounded vocoid, occurs elsewhere in final stressed syllables with contoid coda¹:

[ʔɔk] /ʔok/ 'owl' [gadɔŋ] /gadɔŋ/ 'green'

[susɔʔ] /susɔʔ/ 'fritter' [stɔŋɔ] [stɔŋɔʔ] [stɔŋɔ:] /siŋɔR/ 'cold'

Occurrence of the phoneme /ɔ/ is highly restricted, in many environments appearing to be in complementary distribution with /u/. Before final aspiration, both [ɒ] and [ɔ] are in fluctuation without contrast (the former being the emic norm in the dialect of neighbouring Mukah and favoured in Igan).

1. The only recorded occurrence of [ɔ] in final open syllable without trace of velar or uvular friction is the male name [idʒɔ:] /iʃɔ/. There is, however, some fluctuation in the etic forms of such words as /siŋɔR/ 'cold', as between [stɔŋɔ:], [stɔŋɔ] and [stɔŋɔʔ]. Because of the evident similarity of distribution pattern of the Front and Back vowel pairs, the occurrence of etic [ɔ:] is interpreted as having final consonant closure /ɔR/, except in proper names. These differ in a number of minor ways from the emic patterns established for lexical items, and are left alone with a near phonetic transcription. It is interesting to note that in each of the names cited above, opposite 'corners' of the vowel chart begin and end the word.

There are few minimal pairs depending on the Close : Open contrast of the Back vowels, as eg: / ʃuʃu? / 'wait a while' and / ʃuʃo? / 'go against the current'. There are, however, numerous examples of contrast in analogous environment before a final glottal stop, as / binu? / 'killed' and / ino? / 'a bundle', / ʃau? / 'far' and / gaʊ? / 'bully'.

2.212 Vocoid Glides onto Close unstressed Front Unrounded and Back Rounded vocoids are analysed as Consonantal semivowels.

Two pairs of contrasts with final Vowels are important:

(1a) /-i/ : /-ey/, eg: [tuli:] /tuli/ 'bone' : [toleⁱ] /tulsey/ 'resin'

b) /-u/ : /-ew/, eg: [su:] /su/ 'morning' : [se^u] /sew/ 'grandchild'

(2a) /-ui/ : /-uy/, eg: [lui:] /lui/ 'lui tree' : [sæluⁱ] /saluy/ 'canoe'

b) /-au/ : /-aw/, eg: [petau:] /petau/ 'howl' : [tata^u] /tataw/ 'riddle'

There is a system of six of these diphthongs, whose slight asymmetry arises from the phonetic ambivalence of the glide interpreted /ey/; three front closing glides, and three back closing glides:

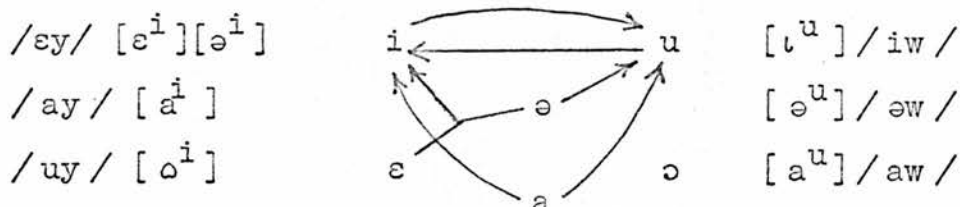

2.22 The Consonants C form both onset and coda to the great bulk of phonemic syllables. In normally modulated speech, the stops are unreleased in word-final position¹. The examples given below are chosen to highlight the contrast between pairs of phonemes which are usually treated as being suspect segments (Pike 1947.70)

1. In slow deliberate speech the stops may be released quite distinctly, facilitating the distinction of final /k/ from /ʔ/.

2.221 Stop Consonants

/p/ [f] voiceless labio-dental fricative, fluctuates with [p] in word final position in ideolect of some speakers¹:

[pətɪp][pətɪf]/pətɪp/'be thirsty'

[p] voiceless bilabial stop, occurs word initial, medial and final:

[pəʔəʔ]/pəʔəʔ/'remain' [təpɪɿ]/təpɪh/'filter'

[tap]/tap/'palm (of hand), sole (of foot)'

/b/ [b] voiced bilabial stop, occurs word initial, medial and final:

[bəʔəʔ]/bəʔəʔ/'seed' [təbɪɿ]/təbɪh/'spit betel

[tab]/tab/'window opening' juice at'

/t/ [t̚] voiceless dental stop, occurs word final only:

[sopot̚]/suput/'shoot with a blowpipe'

[paot̚]/paut/'long time' [uot̚]/uut/'current in river'

[t] voiceless alveolar stop, occurs word initial and medial: [tʌʔə^u]/təʔəw/'know' [patak]/patek/'wooden nail'

/d/ [d] voiced alveolar stop, occurs word initial, medial and final:

[laod]/laud/'spirit-boat' [uod]/uud/'ridgepole, shinbone'

[dʌʔə^u]/dəʔəw/'good' [padak]/padək/'prawn'

/k/ [k] voiceless velar stop, occurs word initial, medial and final:

[kɪʔɪɿ]/kiʔih/'to here' [mekan]/mekan/'fetch water'

[madak]/madək/'sniff' [kokaⁱ]/kukay/'scratch in soil'

1. Final [f] and [p] are allophones in many dialects of Malay.

/ʃ/[dʒ] voiced alveo-palatal grooved affricate,

occurs word initial and medial only:

[dʒʌʔitʃ]/ʃaʔit/'sew' [baɔʒa:] /baʃa/'lizard (var:)'

The phonemes /č/ and /t/ contrast, eg: word medial /kučij/ 'Kuching' and /kutit/'(an omen bird)'; /ʃ/ and /d/ contrast, eg: /ʃaʔan/'well' and /daʔan/'branch', /muʃun/'mouth' and /udun/'(fish variety, taboo to many Melanau)'

/h/[ɥ] voiceless lowered and retracted close front unrounded vocoid, occurs word final following [t]:

[kæɔɥtɥ]/kaʃih/'finished' [mæɥtɥ]/mačih/'matches'

[ɛ] voiceless half-open front unrounded vocoid, occurs word final following [e]:

[mæpeɛ]/mapɛh/'rough-hewn' [toteɛ]/tuteh/'sever'

[ə] voiceless half-close central unrounded vocoid, occurs word final following [ə]:

[dʒəə]/ʃɛh/'one'

[ʌ] voiceless half-open central unrounded vocoid, occurs word final following [ʌ]:

[dʒʌʌ]/ʃah/'bake' [duʌʌ]/duah/'two'

[o] voiceless lowered and advanced close back rounded vocoid, occurs word final following [o]:

[lokoɔ]/lukuh/'hungry' [ʌkoɔ][ʌyoɔ]/aRuh/'pathway'

[] of infrequent occurrence word initial and medial, freely fluctuating with voiceless counterpart to proximate vocoid:

[ʌrɛp][ʌʌrɛp]/harɛp/'rely on'

[pa:la:][pʌʌala:]/pahala/'nutmeg'

2.224 Semivowels

/w/ [ʷ] voiced labio-velar semivowel, occurs word initial, medial and final:

[ʷʌb]/wab/'up the coast' [bʌʷaʷ]/baway/'ascend'
 [sʷʔʷ]/siʔiw/'before' [kʌʷaʷ]/kaʷaw/'you (single)'
 [dʌʷəʷ]/daʷəw/'good'

/y/ [j] voiced palatal semivowel, occurs word initial, medial and final:

[jəʷj]/yoy/'yes' [pəʷʷan]/puyan/'hearth'
 [bʌʷəʷj]/baʷəy/'rotting' [bʌʷaʷj]/baʷay/'descend'
 [səʷsʷj]/susuy/'recount, tell'

The contrast between final vowel and semivowel following similar vowels has already been highlighted at .212 above; etically this contrast is manifested by the placement of predictable word stress on the final syllable nucleus, a different position if the word ends in a consonantal semivowel or a true vowel.

2.225 Nasal Consonants

/m/ [m] voiced bilabial nasal, occurs word initial, medial and final:

[mʌgəm]/magəm/'grasp' [tʌmʌʷʷ]/tamaʷ/'father'
 [mɛgəm]/megəm/'invite'

2. In the idelect of many of the more Malayanised Melanau, /r/ and /R/ are totally fused having [ɾ] as a non-contrastive allophone in all word positions, much as in Sarawak Malay. In the Southern dialects, [ɾ] is the etic norm, [ʀ] in the Northern, while nearby Mukah has /h/ word medial in cognate words such as /mahaw/'woman' (cf:/məRəw/), /gəhut/'scratch' (cf:/gaRut/).

/n/ [n] voiced alveolar nasal, occurs word initial, medial and final:

[nʌgəm]/nagəm/'grasped' [tʌnʌʔ]/tanaʔ/'earth, land'
[məkən]/məkən/'fetch drinking water'

/ŋ/ [ŋ] voiced palatal nasal, occurs word initial and medial only:

[ŋʌgəm]/ŋagəm/'hand, fist' [ŋʌdɪn]/ŋadin/'become'
[lɛŋəd]/lɛŋəd/'drowned' [pʌŋɪn]/paŋin/'flock, herd'

/ŋ/ [ŋ] voiced velar nasal, occurs word initial, medial and final:

[ŋʌdan]/ŋadan/'name' [lɪŋɪd]/liŋid/'tilt over'
[tæŋɪtɪ]/təŋih/'weep' [pɛlɪkʌŋ]/pelikaŋ/'lie down'

In addition to the contrasts exemplified above, /n/ and /ŋ/ contrast medially in the minimal pair

/munuʔ/'kill' and /muŋuʔ/'sit down'

2.23 Suprasegmental Phonemes are predictable at the level of the phonological word. Spoken in isolation, a word has primary stress on the final syllable nucleus, accompanied by a rise in pitch which falls off from a peak to approximately the starting datum level. Polysyllabic words have a secondary stress, accompanied by a less marked pitch change, on the penultimate syllable nucleus. Words are bounded on either side by word-juncture pause, which is modified to hyphen pause between the component elements of a reduplicated form, a compound or a reflexive nominal.

In syntagms at the clause level and above, pitch changes form recognisable intonation patterns, described at 2.5 below.

2.231 Stress

/1/ primary stress, a toneme of loudness of the syllable nucleus, occurs on final syllable of stressed words in syntagms, and of words spoken in isolation:

[ba'u:] / bau / 'Bau (town)' cf: [ba^u] / baw / 'up, above'

[sa'i:] / sai / 'what a pity!' cf: [saⁱ] / say / 'who?'

/"/ secondary stress, a toneme of loudness of the syllable nucleus, occurs on penultimate syllable of polysyllabic words in isolation, and in syntagms as marked in 2.5:

[te["]kə'daŋ] / tekədəŋ / 'stand up'¹

At levels above that of the word, the final syllable of a stressed word in a phonological phrase is invariably accompanied by a rise or fall in pitch; there is considerable mapping of phonological phrases onto grammatical phrases, as eg: [ud["]ΛΛ kəʒi 'in #] / udah kəʒi in , / 'after that,'

2.232 Pitch

/0/ datum pitch, a toneme of musical register of the syllable nucleus, on which words spoken in isolation generally begin and end.

/1/, /2/, /3/ successively higher pitch tones, of relevance at levels of the grammar above that of the phonological word.

/4/ emphatic high pitch toneme, occurs in company of primary clause stress in phonological stress groups marked for

1. This general rule is perturbed when the penultimate vowel is /a/, before a final /ə/. Then both the last two syllables have approximately equal stress, at level /"/, eg:

[te["]kæ["]dəŋ] / tekədəŋ / 'stagnant water'



Pauses of length greater than the comma, contrastive at hierarchical levels of the clause and above, are treated as made up of multi-comma pause indicating a greater degree of closure of the grammatical unit (Longacre 1964.125). (There is one notable exception, the juncture between questions requiring information and their answer, described in 2.52.31)

2.3 Distribution of Phonemes

Distribution of segmental phonemes is described at two levels, that of the syllable and the phonological word.

2.31 Syllable Structure is limited to four productive patterns, V, VC, CV, CVC which are described in detail.

.311 V. While very few words have V as their total structure, syllables of a single vowel occur as an open syllable in conjunction with other syllables in polysyllabic words. Only the primary vowels (2.11 above) occur in this word position, initial or final in a phonological word.¹
 /i/, /i.ni/'look for', /i.du/'darling', /lu.i/'lui wood'
 /a/, /a.at/'copra press', /a.ma/'land crab', /nu.a/'we two'
 /u/, /u.nu/'purple', /u.ya/'caulking', /ba.u/'Bau town'

1. / . / represents a syllable boundary within the phonemic word. No sophisticated mechanical or electronic gear was used in the field-work, so that the intersyllabic breaks are not always marked by recorded phonetic data such as break in the voicing continuum &c: Appeal is therefore made to the most favoured word patterns for establishing the most likely cuts, CVC favoured before CV, then VC and finally V.

2.312 VC. Word initial, these syllables are limited to those with a nuclear primary vowel, as eg:

/i/, /in/ 'that' /in.an/ 'yonder' ¹

/a/, /an/ 'which?'

/u/, /uy/ 'greeting cry'

Word medial, the other three vowels may form VC syllables manifesting the selection restrictions noted at 2.11. (This shows that these restrictions operate at the level of the phonological word rather than the syllable.)

/i/, /lu.in/ 'they' /mi.ib/ 'push along'

/ɛ/, /ta.ɛh/ 'ironwood' /ki.ɛh/ 'mosquito'

/ə/, /si.əl/ 'worthless' /bu.ən/ 'retribution'

/a/, /su.at/ 'fall over' /da.at/ 'sea'

/u/, /mi.ud/ 'drag along' /ka.ul/ 'annual ceremony'

/ɔ/, /ti.ɔŋ/ 'mynah bird' /ga.ɔʔ/ 'bully'

.313 CV. Word initial, all those formed with primary vowels are illustrated in the words above. Tertiary vowels are restricted to final syllables at all times, but the secondary vowel /ə/ forms open syllables word initial, followed by another syllable to give closure:

/ə/, /bə.nuh/ 'coconut' /pə.sey/ 'fishingline' ²

1. The ranked order of likelihood of syllable breaks can be upset by structural dependence, as in this example. Elsewhere, such as /a.mut/ 'root' and /a.mun/ 'if', there is some corroboration in finding /mun/ as a frequent variant to /amun/.

2. This break is favoured because of the word-level restrictions on /s/ and /p/; it would appear that Melanau words are structured from back to front, the stressed end taking precedence.

2.314 CVC. This is the most productive syllable pattern, as may be seen from the exemplification of single words with this structure. (There is no restriction of the vowels occurring in such monosyllabic words.)

/i /,	/bin/'basket'	/tip/'thirsty'
/ɛ /,	/beh/'after'	/pek/'mud'
/ə /,	/ʃəd/'strength'	/dən/'visible, seen'
/a /,	/bap/'squirrel'	/pak/'ledge, shelf'
/u /,	/bun/'smell, scent'	/sug/'knot'
/ɔ /,	/bɔ?/'hair'	/pɔR/'harvest'

2.32 Word Structure manifests many different patterns. Monosyllables of structure V, VC, CV, CVC have all been given in examples above.

.321 Disyllables are found with the following patterns:

V.VC	/a.at/'copra press'	/u.ɔŋ/'rapids'
V.CV	/u.du/'nose, snout'	/a.di/'arrow, dart'
V.CVC	/a.nə?/'child'	/u.rɛh/'dust, rubbish'
CV.VC	/tu.ah/'we two (inc)'	/di.əm/'dwell'
CV.CV	/bi.ti/'star'	/Rə.bu/'edible shoots'
CV.CVC	/pa.sad/'stop'	/pu.sɛŋ/'turn round'
CVC.CV	/mə.s.ti/'must'	/kər.ʃa/'work'
CVC.CVC	/pəR.ŋət/'horsefly'	/kər.pək/'gossip, talk' ¹

1. Alternative etic forms of this word are found, both [kəɾəpək] and [kəɾapək] being recorded, suggesting a possible emic form /kəɾapək/. But the syllable level rules that disallow CC (see 2.34 below) need not apply to syllable junctions at the level of the phonological word; /kəɾpək/ is also admissible because of the built-in vocalic quality of voiced continuants.

2.322 Polysyllables of an order higher than two tend to have very simple CV patterns, such as manifested in:

CV.CV.CV /bə.na.wi/ 'door'¹ /tə.Ru.su/ 'conical ladle'

CV.CV.VC /kə.Ru.in/ 'putty' /pə.sa.ug/ 'paddle fast'

CV.CV.CVC /pə.li.kəŋ/ 'lie down' /tə.ŋa.ʔup/ 'rainbow'

CV.CV.CV.V /kə.lə.pa.i/ 'wing'²

CV.CV.CV.VC /kə.la.su.uʔ/ 'grub' /mə.Rə.da.aʔ/ 'startled'

CV.CV.CV.CVC /bə.lə.ti.kaʔ/ 'mud-skipper (lung fish?)'

/sə.nə.RA.bəw/ 'welcomed ceremoniously'

The longest words are most often formed by affixation of a polysyllabic stem. No word with more than four syllables has been recorded in any of the recognised dialects of Melanau.

2.33 Vowel Sequences

The vowel sequences word final which contrast with sequence of vowel + semivowel have been noted at .212 above. Restricted to the last two syllables, there is also the productive word pattern CV.VC, of which several examples have been cited in .321 and .322 above. The vowel V_1 in this sequence is limited to the primary vowel set; all the vowels may occur as V_2 , with the exception that the sequence */Ca.əC/ does not appear to occur, perhaps because of etic confusion with /Ca.aC/.

1. The etic form of this word is [bə.na.wi:] , with marked nasalisation on the final vowel which presumably represents vestigial [ŋ] consonant coda (see fn 2. below). Only two other words with this feature were recorded, the name [mɔʔi:] /muhi/ and a verb [mɔʔi:] /maʔi/ 'to covet'

2. The Medong and 'Ud dialects (Map 2) have [kələpa¹an] /kələpayaŋ/ as the cognate, Mukah has /kələpayəŋ/ and Igan /kələpayə/ ; it is possible that there should be a /y/ between the final two vowels although such a sequence is permissible as eg: /nu.a/ 'we two (exc)'

The complete paradigm of VV sequences in disyllabic words represents, therefore, all the combinations occurring. It will be seen that a gemination of the primary vowels forms a leading diagonal of the display:

/liid/ 'side-by-side'	/kain/ 'cloth'	/duin/ 'they two'
/kich/ 'mosquito'	/mach/ 'skinny'	/push/ 'fed up'
/diəm/ 'dwell'	*/-aə-/	/buən/ 'retribution'
/biaʔ/ 'leaky'	/maap/ 'lost'	/buaw/ 'run away'
/miud/ 'drag along'	/paut/ 'long time'	/guun/ 'forest'
/tionʒ/ 'mynah bird'	/gaoʔ/ 'bully'	/uonʒ/ 'rapids'

In each word, the final vocoid is stressed. This rule holds even for words cognate with Malay, in which the stress is differently distributed in the word, as eg: [ka 'in] /kain/ 'cloth', cf: ['ka in] (Malay)¹.

2.34 Consonant Sequences

It is a general rule of Melanau of the Central dialect group² that two consonants may not abut without a vowel in between. This is clearly demonstrated in the bulk of examples cited, with the possible exception of syllable junctions of which one consonant is a voiced vibrant. The dominant CVC-type patterning is invoked to interpret the anomalous etic forms [ʃpoʔ], [pʃa^ua:] as /səput/ 'blowpipe', /pəsawa/ 'married' &c.: There is good evidence to support this analysis;

1. The colloquial Malay expression bukan main 'no joking!' is sometimes heard with typical Melanau adaption, final /a/ changed to /ə/ and the typical Melanau stress placement [boken ma'tn].

2. The Northern group has somewhat different restrictions (2.41).

if the related forms [supoŋ]/suput/ 'shoot' and [sɪpoŋ]/siput/ 'shot with a blowpipe' are compared with the paradigm of any other UIE verb¹ such as that of /l-pəŋ/ 'snap', i.e.:

[lopaŋ]/lupəŋ/, [lɪpaŋ]/lipəŋ/, [ləpaŋ]/ləpəŋ/

the justification for the inserted etic /ə/ is evident. Also the related forms [məpa^ua:] /məpawa/ 'give in marriage' and [səna^ua:] /sənawa/ 'given in marriage' are compared with the paradigm of any other causative MNP verb, such as that of /liid/ 'side-by-side', i.e.:

[məliid] /məliid/, [nəliid] /nəliid/, [pəliid] /pəliid/

the patterned dependency of /pəsawa/ is transparently obvious.

However, at word-medial junctions between syllables, it has been noted that while the bulk of consonant sequences have an etic (and emic) vocoid between them, voiced continuant vibrant consonants such as /r/ and /R/ appear to have sufficient vocalic quality about them to obviate the need of this vowel, transition between consonants being sufficiently open without it. The same would appear to be true of CC sequences of which one member is the voiceless continuant /s/. The following transition rule may therefore be formalised:

C_1C_2 is a permitted sequence only at syllable boundaries, internal to a phonological word, when C_1 is /r/, /R/ or /s/.

2.341 Over-correction

Melanau and Malay are known to differ in respect of the above rule. For reasons outlined in the Introduction, there are various pressures on some parts of the community to

1. UIE and MNP paradigms are explained fully at 3.32.2 below.

approximate to Malay pronunciation in their speech. Many of these speakers will re-insert into words the C_2 missing in the Melanau cognate, as eg: [tʌmbʌk], [ɔ̃æntɔŋ], [bʌŋsa:] etc:

This process is carried to the point of over-correction by the more determined, who often refer to Labuan Island as [pula^u læmboan], to 'enemies' as [monsɔŋ] /musuh/¹, 'secure' as [təntap] /tətəp/ and 'arrangements' as [æntoran] /aturan/. Many other examples of this artificial kind of speech appear at random points in the data, almost always correlating with a strong Muslim tradition in the area where they were heard.

2.35 Metathesis and Stammer²

Two interesting etic phenomena are noticed operating in the first two syllables of a considerable number of words, of which not more than a passing account can be given (although the metathesis in particular is evoked on occasions to explain at least tentatively the form of some derived words). The first is a metathesis of the syllable onsets, the other an apparent doubling of the first syllable of a shorter form to make a longer one, usually as an alternative form of the word.

1. It is possible that /munsuh/ is actually the correct form of the neighbouring Iban language, and not a Malay corruption at all. But sometimes specifically Malay words are imported where a traditional Melanau form already exists, and even these may have the extra C_2 slipped in, eg: [maŋka:] /maka/ 'and so...' (cf: the frequent jadi at 4.52.12). This is not an unusual form of speech change in areas where some other language carries more prestige than the local speech; Burling (1970.110) describes a very similar situation in an Indian village.

2. Archer 1949 refers to "the well known Melanau stammer".

2.351 Metathesis is optional on many lexical items, but usually one form or other appears to emerge as the norm. The name of the Melanau themselves (passing over for the moment the many attempts at spelling this form of the name¹) is only the more usual of two forms, [ləmʌnʌ^u] and [məlʌnʌ^u], both of which are heard in everyday speech in the villages.

Other words such as sekuan 'a net-makers shuttle' have two forms [səkoʌn]/səkuan/ and [kətʃoʌn]/kəčuan/, of which that represented in the orthography above is chosen somewhat arbitrarily as the form first encountered. jereki is similarly chosen between [dʒərəki:] /jərəki/ and [rəɟəki:] /rəjəki/ 'livelihood'

Sometimes it appears that a typical Melanau word is derived by a process involving metathesis from a readily recognisable cognate with a wider distribution in Malaya and Sarawak (and, it must be supposed, Indonesia in general). This is no more than informal conjecture, but the following is suggested as a possible route by which the Melanau word [ɤʌbu:] /Rabu/ 'model boat, made to carry the spirits away down to the sea' has come into being.

- (1) Malay barong 'booth, stall' is applied in Sarawak to the trading boats, generally plied by Malay traders in the past, which travel the lower reaches of the rivers between coastal bazaars (mostly Malay, see Introduction 1.11) and the river-side villages of the Melanau.

1. Clayre 1971(a).55 reviews some of these. The Sarawak Gazette of May 1929 carried a notice to the effect that Lemanau was now a possible examination subject for cadets in the Sarawak Civil Service.

(2) Sarawak Malay has [ɣ] realising /r/ in many Malay words, hence barong → [bɔɣoŋ]

(3) Central Melanau dialects harden [ɣ] to [ɤ] in many cognate words (see Appendix 2), hence

[bɔɣoŋ] → [bɔɤoŋ]

(4) Metathesis of the first two consonant syllable onsets,

[bɔɤoŋ] → [ɤɔboŋ], the form often heard in Medong, 'Ud, and related dialects (cf: fn2. p56)

(5) Dalat dialect has final open /-u/ where others have the full velar nasal ending /-oŋ/, hence in Dalat

[ɤɔboŋ] → [ɤɔbu:] , 'boat which carries cargo from the village to the sea'

An obligatory metathesis of the first two consonants of many MNP verb forms is described in the sections dealing with their morphology, 3.32.31.21.100 and .22.100, accounting in some measure for the allophonic variations of the me- and ne- prefixes. This gives rise to such forms as:

[kəmɪloŋ] /kəmɪlut / ← /mə-/ + /kilut/, 'cause to hang down'

[səna^ua:] /sənawa / ← /nə-/ + /sawa /, 'given in marriage'

2.352 Stammer is optional on many lexical items. The longer form is regarded as a modification of the shorter, since it invariably has the neutral vocoid [ə] for its syllable nucleus without regard to the first vocoid in the (assumed) stem.

eg: [bɔɔʒa:] [bəbɔɔʒa:] /baʒa / 'small black lizard'

[sɪŋeŋ] [səsɪŋeŋ] /siŋet / 'wasp'

[tətɪn] [tətətɪn] /tatin / 'dragonfly'¹

1. Although the examples are drawn from the lexical field of small creatures, "stammer" is not confined to this area of the vocabulary (although there may well be some semantic link with

No analysis of the stammer is offered at this stage. It is further noted that many of the UIE verbs have the same consonant onset to the first and second of their syllables, eg: /dudut / 'pull up', /juʃa? / 'slash (grass)', /kukut / 'dig' /luləw / 'wait for', /susud / 'follow', /tuteŋ / 'drink' /RuRaw / 'pass by' and many more; and in fn1 to 3.32.32.22 it is shown that many of these "rhyming" verbs have an archaic imperative form based on the second half only of the present-day stem, eg: /sudən / 'follow (me)!'. One can only observe at this stage that Melanau affords many examples of euphony of one kind and another which require much more detailed study at some later date.

2.4 Dialect Variation

As illustrative of the more general variations noted along the almost unbroken chain of gradually changing village dialect norms throughout the Melanau region, the Northern group will be exemplified by Bintulu differences from Dalat, and the South West extreme by the dialect of Matu.

2.41 Northern dialects do not manifest the separating between /h/ and /H/ recorded in Dalat, and both /r/ and /R/ are the observed sharp darting movement of many of them). Indeed, it is a field less subject to reduplication than in Malay (if stammer is a form of reduplication, as Gonda 1948 suggests for Indonesian). cf: Malay laba-laba 'spider' with [bəlagi:] /bəlagi/ in Melanau, and also layang-layang 'swiftlet' with [kələpisan] /kələpisan/ which, though polysyllabic, is not strictly reduplicated in any of its syllables. Others, eg: 'leech' [sələmatak] [ləmatak] /ləmatak/ do not even repeat the consonant of the first syllable, but merely extend the length of the form.

fused into a single phoneme /r/ whose etic form is, in fact, [ʀ]. From the comparatively limited data, it appears that the Open Front vowel is of very limited use, and it is quite possible that all its functional load may be apportioned out between /a/, /ə/ and /i/. In addition to the Dalat list of phonemes, /v/ and /z/ are required to maintain all the emic contrasts in the available data. Thus eg:

[æβə ^u]	/avəw/ 'ashes'	cf: /abəw/ in Dalat dialect
[βat̚]	/vat/ 'heavy'	/baat/ " "
[kʌzə ^u]	/kazəw/ 'wood, tree'	/kayəw/ " "
[bʌza:]	/baza/ 'crocodile'	/baya/ " "
[ʀiɛ ⁱ]	/riɛy/ 'pillar'	/diɛy/ " "

In addition, final /-s/ is tolerated, as eg:

[βas]	/vas/ 'rice grain'	cf: /bərəh/ in Dalat dialect
[ɕʌʔəs]	/ʃa'əs/ 'bad'	cf: /ʃa'ət/ " "

and a number of sequences of nasal and homorganic stop, as eg:

[məmbʌk]	/məmbək/ 'hit'	cf: /mubal/
----------	----------------	-------------

Lastly, Bintulu speech is characterised by a series of pre-glottalised stops, of which ʔk, ʔb, ʔd have been recorded. It is not quite clear whether they are in systemic contrast with single stops, since there is some degree of ideolectal variation of speech involved,

both [ʔkʌban] and [kʌban] 'forest' cf: /guun/ in Dalat dialect

[ɕʌbʌʔ] and [ɕʌʔbət̚] 'short' cf: /dadit/ being heard.

But [ʔda^u]/ʔdaw/ 'day' and [ʔbɔʔ]/ʔbuʔ/ 'below' were always recorded with a preglottalised stop, so that for the time being limited CC clusters in syllables must be recognised.

2.42 Southern Dialects do not separate /s/ and /ʃ/, /h/ and /H/, /r/ and /R/. In each case, the former remains the emic norm, realised by [s], [ʃ], and [h] respectively.

eg: [bətʃs]	/bətis/ 'leg'	cf: /bətih/ in Dalat
[tɛluʌs]	/tɛluʌs/ 'maiden'	" /tɛluʃh/
[pɛyas]	/pɛras/ 'remain'	" /pɛRɛh/
[muɣɛ ⁱ]	/muɣɛy/ 'dry out'	" /muɣɛy/
[ɪnʌʌ]	/inah/ 'mother'	" /tina/

While CC clusters are tolerated in many Proper names, and VV clusters in contiguous syllables remote from the final, (also in names only, and those largely of Malay origin) they do not occur in lexical items, as eg:

[tɔkɛʃ] /tuket/ 'stick, staff' cf: /tukat/ in Dalat,
tongkat in Malay.

The Open Back vowel /ɔ/ carries a greater work load than in the Dalat dialect, occurring in many words where Dalat has /u/, and in final open syllable where all central dialects have the diphthong /-əw/.

eg: [tɛɔⁱ] /tɛɔy/ 'egg' cf: /tɛluʃh/ Dalat, /tɛluɣ/ Igan
 [æbɔ:] /abɔ/ 'ashes' " /abəw/ "
 [tɔ: mɛɔ:] /tɔ-mɛɔ/ 'woman' /a-mɛRəw/

It appears that the Open Front vowel may not be systemic to the Southern dialects either, much of its functional load in the Central dialects being shared between /a/ and /i/¹.

1. It would be surprising if this turned out to be the case, since Malay (which Matsu speech resembles more closely than most other dialects of Melanau) has both /ɛ/ and /ə/ in its phonemic system, a source of constant difficulty to successive spelling reforms (Asmah haji Omar 1971).

2.43 Other Central Dialects from Dalat differ slightly in a number of systemic ways, some of which (at Medong, 'Ud and Mukah) have been already mentioned. The sequence /-əʔ/, at least with its slightly unusual phonetic value, appears to be limited to Dalat and its surrounding villages only. Both Medong upriver, and 'Ud on the side-stream at Dalat bazaar, have final /-ak/ in cognate words such as [sak]/sak/ 'red' (cf: /səʔ/ in Dalat) and Mukah has /sek/.

Another characteristic difference involves many of those words in Dalat ending in final open /-i/ and /-u/. The /-i/ ending in Dalat corresponds regularly to /-aŋ/ in Medong and 'Ud, /-eŋ/ in Mukah and /-ɛ/ in Igan; the /-u/ ending in Dalat corresponds to /-ɔŋ/ ending at Medong and 'Ud.

The equivalence of /R/ in Dalat and /h/ in Mukah has already been noted, and is seen also in the lists at Appendix 2 and the discussion accompanying them.

2.5 Intonation

By Intonation is meant that complex inter-relation of Stress (apparent loudness of the sound), Pitch (musical register of sound, both at discrete level and gliding) and Juncture (degree of pause between adjacent sounds) which gives a recognisable tune to an utterance. That tune will hereafter be referred to as the Intonation Contour (I.C.) carried by a group of words, the Base¹.

1. The term 'Sentence Base' applied to the words of an utterance associated with a given I.C. is from Cook 1969.34. It has no further relevance to Grammar, and is restricted to the context of Intonation.

Contrasting tunes are characteristically associated with utterances of different types, conveying information about the Illocutionary force of the words (Austin 1955). Sometimes only the I.C. (apart from context, both linguistic and extra-linguistic, whose power of resolution in cases of potential ambiguity should never be under-estimated) serves to distinguish a question, for instance, from a statement with an identical Base.

In the following discussion, Intonation is described as it is observed mostly at the Sentence level of the grammatical hierarchy¹. Complex sentences are found to have complex I.C. made up of a number of recognisably distinct sectional contours, notably those appropriate to Introductory, Non-final and Sentence Final clauses. At levels above the Sentence, some speakers have a very pronounced I.C. accompanying Narrative Final, often a summation of the moral point of the story (4.51.3)

Within the Central dialect group which forms the main focus of this study, the exact shape of each I.C. described below is not found to remain uniform in all its details. Variations are noted between the speech of very old men and younger men, and between men and women. Differences of intonation serve to link large dialect communities, and at the same time to distinguish in more subtle ways the minor groupings within these dialects, as for instance Igan River dwellers from those of the Oya, alud 'riverside' Dalat dwellers from those inland (dayeh) on one or another of the side streams such as Sungai 'Ud; upriver (aju) dwellers of Medong from those at the river-mouth, downriver

1. (see following page)

(ga' kala aba'). Skilled raconteurs tend to employ a wider range of variations of pitch and stress than more pedestrian speakers. The present description is therefore limited to those Intonation Contours found to recur with considerable regularity and type-similarity in the speech of two men², both in their early thirties at the time of the study, who are taken as representative of the Dalat speech community as a whole. Markedly wide divergences from these norms are noted at various points in the text of the description.

Three main divisions are drawn within the total inventory of I.C. on sentence Bases, which correlate with Declarative sentences (particularly in Narrative and Didactic material), Interrogative and Exclamatory utterances.

2.51 Declarative Intonation

Four distinct sectional contours are found to contribute to the total I.C. on a Narrative sentence Base. These accompany Introductory clauses (and phrases), Non-final clauses, Echo Addition clauses and Final clauses. In the short Declarative clauses which form many Simple sentences (4.4 introduction) the Final I.C. alone operates over the whole sentence.

1. cf: Lyons 1968.180 "It is probably the case that in all languages the sentence is the unit at which there is the greatest congruence of levels, particularly between the phonological and grammatical levels of description."

2. Arip Dina, a schoolmaster of Dalat, and Ramli Bandung, a wood-cutter of Kekan, both of whom told many stories for recording in the first part of the field programme. (Ramli in particular is possibly the most gifted raconteur in the Dalat area at the time of writing, with a wide vocabulary and great fund of legends.)

2.51.1 Introductory I.C.11 characteristically contains two units of stress, a secondary stress (") on the last syllable of the first semantically contributive word¹, and a primary stress (') on the last syllable of the last such word in the tone group. Such syllables as may precede the first stress are on a low level of register pitch, labelled 1 (2.232 above) which may, however, creep upwards a little towards the level of the stressed syllable they precede. The secondary stress is accompanied by a pitch rise to 2. Thereafter there is a general downdrift until 1 is reached again immediately prior to the syllable carrying primary stress, which is marked by loudness and a drop in level to 0, gliding up to 1 again². The clause (or phrase) is followed by Comma pause (#), thus:

I.C.11 1 .. 1 "2 2 .. 1 '0-1 #

eg:

/ud"ah kəʃi 'in/ #

after like that 'After that, ...'

-
1. By "semantically contributive word" is meant a word which adds lexical information to the sentence, rather than euphonic balance or rounded style. Excluded by this restraint are such introductory connector words as /ʃadi/ 'and so it came about that .. , well now,' the limitation particle /kawa?/, and the clause-final adverbial tags /saw/ 'by the sound of it', /ʃi/ 'by the look of it' and /tan/ 'in manner' (among others) which echo a contributive word earlier in the utterance (3.31.11.21)
 2. These pitch levels are all relative within an utterance section, varying absolutely from speaker to speaker and even from one part of the utterance to another. Only in chanting is the same musical pitch maintained with any degree of strictness, as in any other language (including 'tone' languages).

 #

/jadi "bey ta?un in ka'wa? /

and-so is year that also

'So it came about that year also, that ...'

2.51.2 Non-final I.C.12 characteristically contains a single unit of stress (') on the last semantically contributive word; in longer clauses there may be an earlier secondary stress (") on the final syllable of some word, as noted in the earlier portion of I.C.11. Pitch on unstressed syllables is more or less constant at level 1, jumping to 2 or 3 on the stressed syllables. Semantically empty syllables following the last stress are at level 1. The clause is followed by Comma pause (#) which provides closure to the tone group, thus¹:

I.C.12 1 .. ("2) .. 1 '3 (1) #

 #

eg: ... / lalu nin mu"pɔR / ...

and-then he A+pluck, '... then he picked (some),'

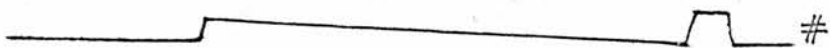
 #

... / sɛrta pi"ni ʒi bua? wa? sɛ? -'sɛ? ʒi /

with S+seek sight fruit rel. red-red appearance

'looking for fruit that appeared to be ripe,'

2.51.3 Echo Addition I.C.13 is a muted form of the I.C. on the preceding clause which is echoed (cf: 4.32.224), often a Base carrying I.C.12. The end of I.C.13 glides down in a manner characteristic of Final I.C.14 (described below), but the range of pitch is not so great. Thus I.C.13 cannot be clearly

1. The affixes A+ &c: in the gloss refer to the morphemic representation of the clause Focus (see Appendix 1) and are fully defined at 4.31.12.203 in the Focal Matrix display.

described without reference to the preceding I.C., and will be exemplified only, from recorded material¹:

(1) ... / sama mə'dut duin agey 'ʔih, sama mə'dut duin /
 alike afraid they-two yet this alike afraid they-two
 'they were both equally terrified, equally terrified.'

(2) /ud'ah kəʃi 'in, petə'mu nin gaʔ də'ŋən,
 after like that S+meet he at otter

petə'mu nin gaʔ də'ŋən. /
 S+meet he at otter

'After that he came across an otter, came across an otter.'

2.51.4 Final I.C.14 characteristically contains two units of stress, a secondary stress (") on the last syllable of the Head word² of the first phrase, and a primary stress (') on the last syllable of the last semantically contributive word. Syllables preceding the first stress are on level 1, and the secondary stress is accompanied by a pitch jump to 3. After that the pitch drifts downwards until 1 is reached again just prior to the syllable carrying the primary stress, which is at level 3, gliding down to 1 or even 0. Semantically empty syllables following this are on the lowest level 0. The final syllable is followed by Full-stop pause (##) thus:

1. The first example is from the speech of Ta'iah, an aristocratic old lady who has, sadly, died since this study was begun.
2. 'Head word' is used in the sense commonly understood in grammatical description, further exemplified at 4.21-.23 dealing with the Phrase level of the grammatical hierarchy at which it is most relevant.

I.C.14 1 .. 1 "3 .. 2 .. 1 '3-0 (0) ##

eg: .. / duah "ʔih peʃaneʔ bey ʃataʔ kəbun la'ʔey. /
 two this S+brother have one garden orchard
 '..these two brothers had an orchard - plot.'

.. / baʔ məmi"liʔ mana ʃi buaʔ waʔ ŋaʔ baʔ 'səʔ ʃi. /
 int. A+choose which fruit rel. past int. red sight
 '..to choose which fruit looked already almost ripe.'

Final I.C.14 is the minimum I.C. for a complete utterance or a complete Simple sentence in Narrative.

eg: / "ʔih lah kedaw 'təw. /
 this emph. place spirit
 'This is where the goblins are!'

2.51.5 Women's speech

Many women, especially the older ones, have characteristic intonation patterns somewhat different from many of the examples above. The main difference is a longer drawn-out glide between levels of pitch¹, as shown below:

/saw "nin gaʔ apah mə'Rəw ʔih,
 sound he at cl. female this

apah "lay mənaʔ sa'luy, mənaʔ bu'ʔəŋ. /
 cl. male A+make canoe A+make war-canoes

'He told the girl that the menfolk were making boats, war canoes.'

1. Ta'iah's speech, exemplified here, is very similar to that of many older men and women in the Dalat area, and to the generally observed contours of tone in the Igan speech-community as a whole.

2.51.6 Narrative Final

Some raconteurs exaggerate the I.C.14 to give, in effect, a final flourish to the end of a story, thus¹:

I.C.14* 1 .. 1 '3 .. 2 .. 1 '0 ###

eg: /luin dəbey bey bera["]ni lah kə'man./
 they not be brave emph. A+eat
 'They would never dare to eat (it)!'

2.52 Interrogative Intonation

Four types of Question (see 4.41.131) distinguished on grammatical grounds yield five distinct Intonation Contours.

2.52.1 Yes-No Questions, requiring simple Affirmation or Negation, are associated with I.C.21

There are two sub-types of this Question,

(1) those conforming to a simple short formula which may (or may not) employ the Existential Copula verb /bey/ 'be, there is'. Characteristically these carry one unit of stress (') on the final syllable of the last word, which is on pitch level 3 falling to 2. (Preceding syllables start at level 1 and may mount to 2 approaching the stressed syllable.) Thus:

I.C.21(1) 1 .. ("2) '3-2 ##

eg: /bey ap'ah/
 be body
 'Is there anyone in?'

(Answer: /bey/)
 be
 'Yes.'

1. This is the ending of a story by Kamarudin of Kampong Brunei, accounting for the palei against eating a small black fish known as ikan udun; the excited interjection /bəmigu-migu/ quoted at 2.232 above rises to pitch level 4. (cf: also 5.21)

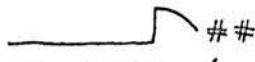
 ##
 /na? tu'teŋ/
 past A+drink
 'Have you had a drink?'

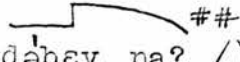
 ##
 (Answer: /dɔbɛy na? /)
 not past
 'Not yet'

(2) those optionally employing the query words /an/ initially and (or) /kah/ finally. Characteristically the contour is similar to that of (1) above, but extended at the level of pitch level 2; the final /kah/ is on pitch level 1, thus:

I.C.21(2) 1 .. ("2)... 2 '3-2 (1)

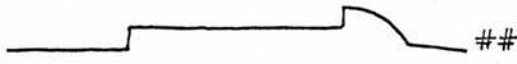
eg:  ##
 /wa? "sɛ? ?ih kə'nah kah/
 rel. red this able query
 'Will this red one do?'

 ##
 (/kenah /)
 able
 'Yes.'

 ##
 / (an) anɛ? " ?ih anɛ? ka' ?aw /
 (query) child this child you
 'Is this your boy?'

 ##
 (/ i? /)
 yes
 'Yes.'

It will be seen that the contours of (1) and (2) vary only in incidental detail, largely dictated by the length of the utterance. They are therefore conflated into one Intonation Contour,

I.C.21 1 .. ("2 .. 2) '3-2 (1) ##

2.52.2 Tag Questions I.C.22 are of two sub-types, those with /kah/ already described at .1 above (which have Declarative clause structure until the introduction of the query word), and those framed as a Declarative clause with Non-final I.C. 12 followed by a pause, and then the Sentential Tag /ɔ/ 'no?' on a rising glide. Thus:

I.C.22 I.C.12 # 0-2 ##

eg: / "ŋa? law ba'sa? , ɔ / (Answer: / ŋa? /)
 past day wet, no? past
 'The day has turned to rain, hasn't it?' 'Yes.'

/ tɛ'lew abɛy ma'lɛm , ɔ / (/ i? , tɛ'lew /)
 three evening night, no? yes, three
 'For three nights, isn't that correct?' 'Yes, three.'

2.52.3 Questions requiring Information I.C.23

There are two sub-types of these questions, those employing the range of interrogative pronouns or adverbs, and those beginning with the Echo Interrogative formula typified by the adverbial /kɛtan an tan ... / 'what is the manner of ...?'¹

.31 General Information questions characteristically contain one unit of stress (') on the final syllable of the interrogative word itself, which occurs at or near the start of the question string. Longer questions may have a secondary stress (") on a later syllable. Pitch is at level 1 before the primary stress, which is accompanied by a rise to 3, falling to 2. The remainder of the utterance has a downward drift of pitch towards 0, which is interrupted by a sudden rise (or fall) of pitch at the syllable carrying the secondary stress².

-
1. This formula actually has NECl structure, cf: 4.31.11.11
 2. The choice between rise and fall appears to be a function of the status of the stressed word in terms of New and Given information; if New, it is likely to rise, if Given the pitch is more likely to fall. A more precise formulation of this statement is not possible until further work has been done on this theme.

I.C.23 (1 .. 1) '3-2 .. 1 .. ("0) .. ##

eg:(1)  ##
 /ba? ka 'an ka?aw /
 int. to-which? you
 'Where are you going?'

(2)  ##
 /'say ŋadan ka?aw /
 who? name you 'What is your name?'¹

(3)  ##
 /buya? 'new ka?aw memili? usid "in /
 cause what? you A+choose knife that
 'Why did you select that knife?'

2.52.32 Echo formula Information questions are a subset of the general Information questions, in which a first stress falls on /an/ 'which?', the query word of the formula. The pitch register of these questions is consistently higher than .31 above, so that syllables preceding the first stress are likely to be at level 2 rather than 1. The stress itself is likely to rise to 4, followed by a downdrift to the stress on a later lexical item (not a function word) involved in the query. If this word introduces a new topic into

1. Emphasis of some item in the question may perturb the I.C.; the personal pronoun, for example, may be stressed:

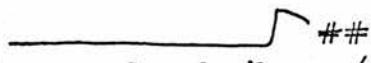
 ##
 /say ŋadan ka 'an ka?aw /
 who? name you 'What is your name, then?' A systematic description of intonation under all conditions of stylistic and emphatic choice is beyond the scope of the present study.

the discourse, it will take the primary stress and will rise; if it represents a known topic, it takes secondary stress and is accompanied by a drop in pitch:

I.C.23* 2 2 '4-3 .. 2 .. "1-0 ##

eg: / kəʃi 'an ʃi "bap /
 sight which? sight squirrel
 'What does a squirrel look like?'

I.C.231 2 2 "3-2 .. 1 '4-2.##

eg: / ch, ketan "an tan gaya ka?aw ti'ked /
 hey, manner which? manner way you climb
 'Hey! How did you manage to climb up there?'

2.52.4 Rhetorical Questions I.C.25

These begin with the Interrogative Locative Static Adverb /gaan/ 'where?'. The last syllable of /gaan/ carries secondary stress ("), at pitch level 3, while the preceding syllable is at 2. Thereafter there is a general downward drift of pitch to the final stressed syllable on level 1 or 0,

1. The full-stop pause indicated by ## occurs after questions in direct person-to-person speech, but not always in reported speech in a narrative. Ramli in particular, and many older men, join the reported reply to the final word of the question or to the quotative phrase NP321.6 (see 4.21.321.6) /saw təlabaw pin / 'he asked', without even normal inter-word juncture between. It appears that this is an archaic narrative tactic (or perhaps it is only used by the best story-tellers) used to relate the words of a reply to their initiating enquiry, in the same sort of way as the anaphoric reference particle /uncy/ keeps track of the 'dramatis personae' in an ongoing narrative (4.41.4)

depending on the length of the utterance.

I.C.24 2 "3 .. 2 .. '1/'0 ##

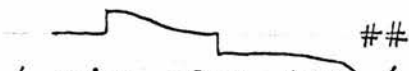
eg:  ##
 / ga'an udey tan /
 where again manner
 'What's to be done, then?'

 ##
 / ga'an naseŋ ba? dəbey ge'li? /
 where heart int. not revolted
 'How can one help being revolted?'

2.53 Exclamatory Intonation

Three types of exclamatory utterance are distinguished, Imperatives, Expostulations and Assent.

.53.1 Imperative I.C.31 characteristically has one primary stress (') on the final syllable of the Focal Verb¹ which occurs as the first item in the utterance string, at pitch level 3; the preceding syllable (if there is one) is on 1. A general downdrift in pitch follows, to level 0 if the utterance is long enough.

I.C.31 (1) '3 2 .. 1 (.. 0) ##

eg:  ##
 / ma'kat ka'aw /
 V+lift you 'Get up!'

1. Verb Focus is described fully at 4.31.12.203 and includes, as well as Imperatives, short narrative sentences with an I.C. very like that described above, eg: '3-2 1-0 ##

 ##
 / 'tug nin /
 V+kick he 'So he kicked it!'

##

/i'gi? ka?aw pəla in /
 V+get you paddle that
 'Get hold of that paddle !'

2.53.2 Expostulation I.C.31 follows the same general pattern as Imperative intonation. Characteristically very short and sharp utterances of not more than two words, the I.C. does not differ sufficiently to warrant a separate Contour.

I.C.31* 1 .. '3-0 ##

##

eg:(1) /a'teŋ /
 true
 'That's right !'

##

(2) / ta'ʔəw /
 know
 'I don't know !'

##

(3) / dəbey kə'nah /
 not able 'No you cannot !' or 'I can't !'

.53.3 Assent

Two Assent words are associated with distinct Contours, corresponding to their position relative to other words in the utterance. /iʔ/, while often occurring as a total reply (4.42.32) may be followed by other words of amplified assent or explanation (as eg: 2.52.2 p74); /yɔy/ is always a total utterance, and therefore approximates to Narrative Final I.C. (the minimum utterance contour).

I.C.33 1-3-2 #
 #
 / iʔ /
 yes
 'Yes, ...'

I.C.33* 1-0 \ ## (cf:I.C.14*)
 ##
 / yɔy /
 yes
 'Yes !'

2.53.4 Onomatopoeic Intonation

A great variety of colourful intonation patterns are employed by skilled raconteurs to bring life to their narrative, reduplicated forms being a favourite Base for this verbal virtuosity. It is not possible to do more than suggest the range of intonation contours found.

eg: I.C.41 2'0-1 2"3-4 # 2'0-1 2"3-4 #

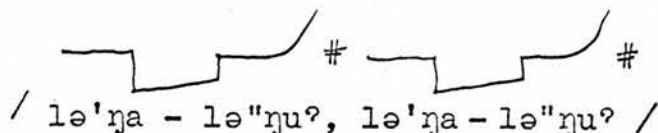

/ lə'ŋa - lə'ŋu? , lə'ŋa - lə'ŋu? /

'walk with a pleasing wiggle of the hips'

I.C.42 0'1-0 0'1-0 #

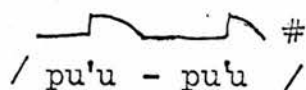

/ pu'u - pu'u /

'go along with a swishing sound'

I.C.42* 0 1'2-0 0"1-0 #

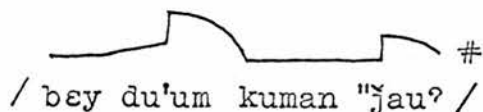

/ bəy du'um kuman "jau? /

be buzz from far 'There was a buzzing far away'

2.54 Inventory of Intonation Contours encountered includes:

- I.C.11 Declarative Intonation, Introductory.
 - .12 Declarative " , Non-final
 - .13 Declarative " , Echo Addition
 - .14 Declarative " , Final
- I.C.21 Interrogative " , Yes-No Questions
 - .22 Interrogative " , Tag Questions
 - .23 Interrogative " , Information
 - .231 " " , New Topic
 - .24 Rhetorical Questions
- I.C.3 Exclamatory Intonation
 - .31 Imperative and Expostulation
 - .33 Assent
- I.C.4 Onomatopoeic Contours

2.6 Practical Orthography

An orthography for a vernacular language in Malaysia is necessarily something of a compromise between systematised representation of the sounds of the various regional dialects of that language and the current form of writing in use in the National Language . At the same time, one cannot ignore the tradition of writing that has arisen out of the painstaking efforts of Missionaries and Government Officers¹; effort which, although founded on an insufficient understanding of phonemic principles, has served as a medium of some sort of written communication for a generation and more. There are therefore two somewhat alien traditions to be conciliated in any reasonable attempt to provide the Melanau with an acceptable writing convention, of which they stand in great need.

In addition to these considerations, the divergence of the dialect norms has to be taken into account. With respect to a future National literature, the place of Melanau among the other more recently literate languages of Sarawak and greater Borneo has to be born in mind.

.61 The vowels have to receive the first attention. There are six vowels in the Dalat phonemic system and, while it may be that only five are required in some of the other dialects, a Melanau orthography must have six vowel characters to avoid the pitfalls into which earlier writing ~~attempts~~ have fallen. The allocation of traditional symbols is valuable as far as possible; and there is basically no difficulty in linking orthographic a with /a/, i with /i/, u with /u/ and, if

1. In particular Mulder and Lawrence 1930 and Aikman 1947

Aikman's insight is recognised (p34) o with /o/. The two remaining vowels in the system, however, are in competition for the remaining traditional vowel symbol e, and another character has to be found suitable for the loser.¹

Two courses are open in practical terms; either to adopt the traditional Malay ě for /o/ and reserve e for /e/ or, as has been done in many of the languages of Indonesia under Dutch influence, adopt é for /e/, leaving e free for /o/.

Despite the pressures to conform to Bahasa Kebangsaan, the latter course has been adopted on the ground of statistical frequency of occurrence of /o/ as against /e/, approximately three to one in the lexicon compiled parallel with this study and as much as seven to one in any page of connected text. It seems more reasonable to mark the less frequent phoneme with a diacritic; less confusion is likely to arise if it is left off, and less work is involved in putting it on. This solution has the further advantage of compatibility with several of the more recently written languages of Sarawak receiving attention from the Borneo Literature Bureau, and with current Indonesian convention.²

1. Ejaan Bersama Malaysia-Indonesia, a standardised unified spelling system for Malay and Bahasa Indonesia, is the seventh in a series of proposals this century, listed in Asmah 1971.85. Malaysia comes into Fishman's Group C, "characterised by a conflicting or competing multiplicity of Great Traditions" (1969.120)

2. The Soewandi System is the present standard spelling of Bahasa Indonesia (B.I.), in which the diphthong /ay/ and the vowel cluster /ai/ are written identically, as is proposed in a later stage of this chapter.

The six vowel symbols used throughout the remainder of the description in the representation of the vernacular are:

	Front	Central	Back
Close	<u>i</u>	<u>e</u>	<u>u</u>
Open	<u>é</u>	<u>a</u>	<u>o</u>

2.62 The consonants present few problems, with the exception of /ʔ/, /R/ and /H/. There is no acceptable monograph for /ŋ/ and /ɲ/; nor does it seem necessary to introduce one, since no written tradition in the region differs from the widely accepted norm of ng and ny¹. Since Melanau lacks [ʃ] in its etic system, there is no call for the digraph sh, and therefore the customary ch to represent /ç/ is abandoned in favour of a single letter c to balance its voiced counterpart j.

/ʔ/ is frequently represented by a raised apostrophe mark ' (where it is represented at all), but this is unfortunate. Such a small sign tends to get lost; it does not look like a real letter of the alphabet, yet /ʔ/ functions as a stop consonant with a work-load equal to any other. The confusion that arises in written Iban, where Scott's suggestion² of q has not proved acceptable to entrenched traditional opinion and where even ' has not been used instead, is enormous.

-
1. Indonesian nj is not very different in appearance from ny. Some of the more recent proposals at unification of Malay and B.I. include c instead of the digraph ch, a welcome move.
 2. In Scott 1956, a traditional spelling without any glottal stop written (given alongside his own phonemic pronunciation guide) as the main dictionary entry obscures many distinctions proper to the spoken language. This deficiency in written Iban has been noted in Cense and Uhlenbeck 1958.11 and elsewhere.

Melanau also abounds with minimal pairs whose resolution depends on the glottal stop only, many of them likely to occur in similar contexts, as for example:

/bah aba sunjay ʔud/ 'at the mouth of the River 'Ud'

/bah abaʔ sunjay ʔud/ 'downriver from the River 'Ud'

The tradition, however, favours ʔ (in theory if not in practice, since most Melanaus who write at all leave it out altogether, or scatter a few along the line of script as an after-thought, seeds of goodwill in a furrow of words): ʔ is therefore adopted to represent the glottal stop consonant in the orthography of this description, and suggested for use in written Melanau in a broader context.

/R/ presents something more of a problem. It was hoped to devise an alphabet that could be used equally by all the Melanau dialects. But, as pointed out above (2.4) only the central dialects distinguish etic [r] from [R] and [ɣ], which, in the other regions, are the realisations of /r/. The choice in the end is a little arbitrary. r is retained to represent /r/, and x is introduced for /R/. This will give a uniformity to the written language only if r is used for [R] and [ɣ] in the Northern and Southern dialects respectively despite the closeness of their etic realisations of /r/ to that of Dalat x. It would appear to be a very likely occurrence, since x is unfamiliar to most readers of Malay and the previous Melanau scripts.

/H/ occurs in the emic system of the Dalat area only. It has not escaped the notice of some of the more observant

local literates that some distinction in the written form is as important as that of the spoken language, and on occasions one finds ih written (as eg: ratu^h for /ratu^h/'hundred'). For new readers, this obscures the pronunciation rule which places word stress on the final vowel; the convention proposed is to write a digraph yh instead, since y is already needed to represent an unstressed Close Front Vowoid [i̯].

The following consonants therefore serve to maintain all the systematic oppositions of the spoken dialects of Melanau encountered in the survey described at Appendix 2:

Seven stops:	<u>p</u>	<u>t</u>	<u>k</u>	<u>'</u>	<u>b</u>	<u>d</u>	<u>g</u>
Seven fricatives	<u>s</u>	<u>c</u>	<u>j</u>	<u>h</u>	<u>yh</u>	<u>v</u>	<u>z</u>
Three liquids	<u>r</u>	<u>x</u>	<u>l</u>				
Two semivowels	<u>w</u>	<u>y</u>					
Four nasals	<u>m</u>	<u>n</u>	<u>ny</u>	<u>ng</u>			

2.63 Final vocoid glides are under pressure from the tradition current in Malay spelling (and B.I.) in which /ay/ is written ai, and final /aw/ as au. To change this would lead to some considerable difficulty with words in common use in both Malay and Melanau, such as sungai (sometimes written sungei) 'stream' and pulau 'island' which feature in place names. A compromise is indicated; the six vocoid glides (2.212 above) are written by a vowel sequence where they terminate a word, the consonant symbol being retained word initial and medial. Moreover, since there is no systemic contrast between [e̯ⁱ] and [e̯ⁱ], the simpler ei is adopted to represent /e̯y/.

Considerable confusion arises at present from the use of o to represent both the sound [ɔ] and the diphthong [ə^u], which have been shown to be separate phonemically. Despite the theoretical "correctness" of ew for the diphthong, it approaches more nearly to the present practice to write it ou, and this is adopted throughout. Such a conciliatory gesture has the further advantage that isolation of the Matu (and other Southern dialect) norm of final /ɔ/, spelled o, is not so obvious.

The six glides are therefore written:

<u>iu</u>	for	/iw/	<u>ei</u>	for	/ey/
<u>ou</u>	"	/ew/	<u>ui</u>	"	/uy/
<u>au</u>	"	/aw/	<u>ai</u>	"	/ay/ word final.

(ui is simply modified to oi for the Igan and Matu area dialect differences, to conform to their spoken language.)

This convention raises the problem of how to formally distinguish the true final vowel sequences. In traditional Malay spelling, final /ai/ is written ai, which would be acceptable were it not that Melanau has also final /aw/ which, written au, would be confusing in cursive script. In the description, the true vowel sequences are distinguished by a raised bar, ai and au. In practice, it is felt, these bars will not be written; but the words with final open vowel sequence are few, and no great confusion is likely to arise in consequence. Contemporary Bahasa Indonesia, as has been noted, employs this simplification formally and Malay informally, without much difficulty resulting.

2.64 Hyphen signs are another discrepancy between current Malay and B.I. writing conventions. Melanau has a phonological hyphen between elements of compound nominals, as described at 3.31.12 below; the most important from the viewpoint of a clear orthography is that linking a nominal Head and the reflexive particle debei.

In the spoken language there is considerable difference made between the phrasing of (n-debei VP) - a reflexive nominal in construction with a verbal phrase - and the negative predication (NP debei-V). If this distinction is lost in the orthography, it introduces an unacceptable sort of ambiguity into a text. Such a passage as:

lakau 'ih, Dul debei jigem¹

occasion this, Dul * * with (them)

is ambiguous between 'This time, Dul himself accompanied them' and 'This time Dul did not go with them', a radical ambiguity resolved in speech by the placement of the hyphen juncture phoneme / - /.

The hyphen is therefore seen as a necessary distinguishing character in the inventory of the written language to separate negative debei from reflexive -debei, which attaches to the last word of the nominal expression much like the English possessive 's (4.21.314), eg:

ane' raja likou in-debei

child ruler river that-self

'the ruler of that country's daughter herself'

1. This confusing clause is extracted from Abeng bin Mega 1969, the only Melanau text so far published by the Borneo Literature Bureau. The construction is further described at 4.31.11.2219

In the description of the grammar, elements in a compound may be joined by a hyphen to demonstrate their close phonological juncture and syntactical dependence, but it is not expected that hyphens will be employed much in written Melanau for normal purposes. One possible further use is in the many nominalisations such as a-lai 'one who is male, a man' and a-puma 'one who farms, a farmer', but this introduces a nice theoretical argument. Whether, in the latter example, puma 'having a farm, working as a farmer' is more closely linked syntactically or semantically to the preceding a 'one who' or to the following qualifying noun such as padai 'rice' in the very common syntagm a puma padai 'one who farms rice, a padi farmer', it is not easy to say, since it is argued at 3.32.31 .23.206 below that the p- prefix is enclitic to the phrase uma padai 'a rice farm' rather than to uma only. But this is of little consequence to the everyday use of the written script.

It may be added that such texts as have been written in this alphabet¹ have proved acceptable to most Melanaus, and are read with considerably greater ease than anything in the existing scripts. Some of the differences between this system and the spelling of the National Language are disappearing as better orthographies for Malay are being proposed and adopted. It is hoped that Melanaus using this writing system will master orthographic competence rapidly in their own native language, and make the transition to the National Language more readily with this acquired skill.

1. Extracts from traditional stories and folk-lore are often included in Clayre 1971(a) and (1972(a) for trial purposes.

Chapter 3. MORPHOLOGY

3.0 <u>Introduction</u>	94
3.1 <u>Morphological Processes</u>	94
3.11 Affixation	94
3.12 Compounding	95
3.13 Reduplication	96
.131 Repetition	96
.132 Reformation	96
3.2 <u>Morpho-phonemics</u>	97
3.21 Changes on Affixation	97
.211 the MNP affix paradigm	97
.212 the UIE affix paradigm	97
.213 the <u>ke-</u> affix producing abstract nouns	98
.214 the <u>de-</u> affix producing state verbs	98
.215 the <u>-ai</u> affix producing dynamic adverbs	98
.216 the <u>je-</u> enclitic form of <u>jeh</u> 'one'	99
3.22 Changes on Compounding	99
.221 <u>ga'</u> + deictic particles	99
.222 <u>kv-</u> + deictic particles	99
.223 <u>wa'</u> + deictic particles	100
.224 <u>béh</u> + deictic particles	100
.225 <u>leu</u> + deictic particle	100
.226 <u>buya'</u> + enclitic <u>nou</u>	100
.227 Neg: + Copula verb	101
.228 Speech formulae	101
3.23 Changes on Reduplication	101
3.3 <u>Morphology of Word Classes</u>	102
3.30 Word Classes	102
3.31 <u>Nominal Morphology</u>	104
3.31.1 <u>Nouns</u>	105
3.31.11 <u>Noun roots</u>	105
3.31.11.1 Proper nouns np	105
.11.11 Animate np	106
.11.12 Inanimate np	106
3.31.11.2 Common nouns nc	107
.11.21 Abstract nc	107
.11.22 Concrete nc	108

3.31.11.221 Animate common nouns nc	108
.2211 Human animate nouns nc	108
.2212 Non-human animate nc	108
3.31.11.222 Inanimate inc	109
.2221 Mass inc	109
.2222 Countable nc	110
.2223 Unit nu	112
3.31.12 Compound nouns	113
.121 General compounds	113
.122 Reflexive compounds	115
.123 Indefinite compounds	115
3.31.13 Derived nouns	116
3.31.14 Reduplicated nouns	116
3.31.2 <u>Nominalisations nom</u>	117
3.31.21 Personal nominalisations	117
.211 Singular	117
.212 Plural	117
.213 Indefinite	118
3.31.22 Non-personal nominalisations	118
.221 Definite	118
.222 Indefinite	119
3.31.3 <u>Pronouns pn</u>	119
3.31.31 Personal pronouns	120
3.31.31.1 Particular personal pronouns	120
.11 Singular	120
.12 Plural	120
.13 Vocative	121
.14 Possessive	122
3.31.31.2 General personal pronouns	122
.21 Singular	122
.22 Plural	123
3.31.31.3 Interrogative personal pronouns	123
3.31.31.4 Reduplication of personal pronouns	124
.41 Total repetition	124
.42 Partial reformation	124

3.31.32 Non-personal pronouns	125
3.31.32.1 Particular non-personal pronouns	125
3.31.32.2 General non-personal pronouns	125
.21 Relative clauses	125
.22 Pronominal reference	126
.23 Deictic pronouns	126
.24 Quantity pronouns	127
3.31.32.3 Interrogative non-personal pronouns	127
3.31.32.4 Reduplication of non-personal pronouns	128
.41 Total repetition	128
.42 Partial reformation	128
3.32 <u>Verbal Morphology</u>	129
3.32.1 <u>Uninflected verbs</u>	132
3.32.11 <u>Verb roots v</u>	132
3.32.11.1 Process verbs vp	132
.11 Static process, occupation	132
.12 Dynamic process, motion	132
3.32.11.2 State verbs vs	132
.21 Quality	133
.22 Manner	133
3.32.11.3 Ambivalent verbs	133
3.32.11.4 Copula verbs vco	133
3.32.11.5 Sentential Complement verbs	134
.51 the verb <u>ta'ou</u> 'know'	136
3.32.12 <u>Derived verbs</u>	138
3.32.12.1 Process verbs vp	138
.11 Noun base	139
.12 Adverb base	139
3.32.12.2 State verbs vs	139
.21 Noun base	139
.22 Numeral base	139
.23 Adverb base	139
3.32.12.3 Ambivalent verbs	140
3.32.2 <u>Inflected verbs</u>	140
3.32.21 <u>Intransitive vi</u>	140

3.32.21.1 Process verbs vp	140
.11 MNP paradigm	140
.12 UIE paradigm	140
3.32.21.2 State verbs vs	140
.21 MNP paradigm	140
.22 UIE paradigm	140
3.32.21.3 Ambivalent verbs	141
.31 MNP paradigm	141
.32 UIE paradigm	141
3.32.21.4 Sentential Complement verbs	141
3.32.22 <u>Transitive</u> vt	142
3.32.22.1 Active verbs va	142
.11 MNP paradigm	142
.12 UIE paradigm	143
3.32.22.2 Causative verbs vc	143
.21 MNP paradigm	143
.22 UIE paradigm	144
3.32.22.3 Ambivalent verbs	145
.31 MNP paradigm	145
.32 UIE paradigm	145
3.32.22.4 Sentential Object verbs	145
3.32.3 <u>Verb Inflection</u>	146
3.32.31 the MNP paradigm	146
3.32.31.1 the Zero affix \emptyset -	147
.11 Verb Focus Dynamic	147
.12 Object Focus Static	148
3.32.31.2 the <u>me-</u> / <u>ne-</u> / <u>pe-</u> affix system	148
.21 <u>me-</u> affixation	149
.22 <u>ne-</u> affixation	165
.23 <u>pe-</u> affixation	170
3.32.31.3 Summary of affix meanings	164, 169, 187
3.32.31.4 Remaining problems	188
3.32.32 the UIE paradigm	189
3.32.32.1 the Bound stem	190
.11 the case $C_1 = \text{III}$	190
.12 the case $C_1 = C_2$	190
.13 the case $C_3 = \emptyset$	190
.14 the case $C_1 V_1 = \emptyset$	190

3.32.32.2 the <u>-u-</u> / <u>-i-</u> / <u>-e-</u> affix system	191
.21 <u>-u-</u> affixation	192
.22 <u>-i-</u> affixation	193
.23 <u>-e-</u> affixation	195
3.32.4 Verb Compounding	198
.41 Verb + verb	198
.42 Verb + noun	199
3.32.5 Verb Reduplication	200
3.32.51 Repetition of stem	200
.511 Processes	200
.512 States	200
3.32.52 Reformation of stem	200
.521 First part of stem	200
.522 Final part of stem	201
.523 Formation of adverbs	201
3.33 <u>Adverbial Morphology</u>	202
3.33.1 <u>Deictic adverbials</u>	202
3.33.11 Temporal deixis	203
.11.1 The Basic Time Scale	203
.11.2 Proximate Time Scale	203
.11.3 Remote Time Scale	204
.11.4 Relator Time Scale	205
.11.5 Day, Month and Year scales	206
.11.6 Clause-initial adverbials	206
3.33.12 Locational deixis	207
.12.1 The Basic Space Frame	207
.12.2 Positional system	209
.12.3 Motion system	210
.12.4 Sea-coast re-orientation	211
3.33.2 <u>Descriptive Adverbials</u>	212
3.33.21 Degree adverbs	212
3.33.22 Manner adverbials	213
3.33.23 Sentential adverbs	215
3.34 <u>Particle Morphology</u>	216
3.34.1 <u>Full words</u>	216

3.34.11 Numerals nm	216
.111 Cardinal numbers	216
.112 Ordinal numbers	217
.113 Range numbers	217
3.34.12 Quantifiers qu	217
3.34.13 Connectors c	218
.131 Sentence connectors	218
.132 Clause connectors	218
.133 Phrase connectors	219
.134 Word connectors	219
3.34.14 Prepositions pr	219
.141 Simple prepositions	219
.142 Compound prepositions	220
.143 Reduplication of prepositions	220
3.34.15 Tense-aspect words	220
3.34.16 Negation words	220
3.34.17 Deictic words	221
3.34.18 Emphatic words	221
3.34.19 Exclamation words	221
3.34.2 <u>Enclitic particles</u>	222
3.34.21 Nominalising particles	222
3.34.22 Query particles	222
3.34.23 Reflexive particle	222
3.34.24 Anaphoric reference particle	222
3.34.3 <u>Bound particles (Affixes)</u>	223
3.34.31 Class-maintaining affixes	223
.311 Nominal affixes	223
.312 Verbal affixes	223
3.34.32 Class-changing affixes	223
.321 Nominal affixes	223
.322 Verbal affixes	223

Chapter 3MORPHOLOGY

"The 'simple' morphologies of languages like Javanese ... and Malay, which have at their disposal only a handful of formal elements ... may be quite complicated ... and consist of many categories forming several quite distinct subsystems, without making use of a rich variety of formally different processes." (E.M.Uhlenbeck 1962.431)

3.0 Introduction

Melanau words are mostly stable free forms manifesting a very limited degree of inflection. Three morphological processes are found to operate on word roots, Affixation, Compounding and Reduplication; these are described at 3.1. The morpho-phonemic changes which then take place are described at 3.2, and the detailed application of these processes is exemplified at 3.3 where the word classes are discussed.

It will be observed that the very limited number of formal elements employed in the morphology of Melanau leads to quite a complicated substructure underlying the simple surface organisation of the Affixation process.

3.1 Morphological Processes

3.11 Affixation of stems involves a remarkably small number of affix forms, even by comparison with Malay and the related Iban language of Sarawak. In this respect Melanau is nearer to Kayan and other inland languages of central Borneo¹. This gives rise

1. Malay affixation systems are well publicised. Iban has been described most recently in Asmah haji Omar 1969, and Kayan in an unpublished manuscript by Cubit and in Southwell's comprehensive Kayan Dictionary (as yet still unpublished).

to a complexity of homophonous affixes which may convey quite different meanings, even when attached to stems of the same class. Once such homophones are recognised, the morphemes isolated convey much the same meaning whatever stem class they are attached to.

The affixes are listed at 3.34.3 below, and represent three types of affixation:

- (1) Prefixes, eg: me- 'AFDyn verbal affix' MNP paradigm
- (2) Infixes, eg: -e- 'Static verbal affix' UIE paradigm
- (3) Suffixes, eg: -ai 'Dynamic adverb affix' deictic adverbial

The process of Affixation involves a number of morphologically and phonologically conditioned allomorphs, which are described in detail in that section of 3.32.3 dealing with each verbal inflection paradigm. The very limited nominal affixation follows the same pattern of allomorphic variation.

3.12 Compounding is a process operating on all classes of word roots, the resulting construct manifesting either co-ordinate or subordinate relation between its constituent elements. The following combinations of root classes are found:

First word	Second word			
	noun	verb	adverb	particle
noun	<u>ane' sawa</u> family	<u>tipou ayeng</u> ancestor	<u>bah bau</u> on top of	<u>ketan in</u> like that
verb	<u>maa' buut</u> breathless	<u>tujuh ta'ou</u> inform	<u>puluh ba'ai</u> descend (rope)	
adverb			<u>wab la'an</u> east - west	<u>ajau 'ih</u> now
particle	<u>ga' jawai</u> in front of			<u>in lah</u> that's why

Some of these compounds are more closely coupled phonologically than others, and these undergo a morphophonemic change which is among those described at 3.2 below.

3.13 Reduplication is of two basic types, Repetition of the entire root, and Reformation of part of one of the repeated roots. The process operates on roots of all classes, and the resulting semantic correlates are broadly in line with those outlined by Key¹.

.131 Repetition involves the total repetition of the root without any morphological change, and is exemplified with roots from the classes of:

Nominals,	<u>rayet rayet</u>	'commoners'	(pluralisation)
Verbals,	<u>da'ou da'ou</u>	'very good'	(intensification)
Adverbials,	<u>gaan gaan</u>	'anywhere at all'	(generalisation)
Particles,	<u>bukan bukan</u>	'it is by no means the case'	(intensification)

.132 Reformation involves only one of the repeated roots, usually the latter end of the first form. This sub-type of reformation is apparently restricted to Verbal and Adverbial roots, as exemplified in:

Verbals,	<u>tepa - tepuyh</u>	'puff away (at cigarette)	(continuation)
Adverbials,	<u>jela - jelau</u>	'day by day'	(repetition)

Occasionally it is the second root which is affected, eg:

Particle,	<u>unou - nou</u>	'anything at all'	(generalisation)
-----------	-------------------	-------------------	------------------

1. Key 1965 contains some observations on the Malay studies of Gonda (1948(a) and (b)) and Javanese material from the same sources, suggesting semantic values of the process.

The morpho-phonemic changes in roots affected by reduplication are very regular, and are described at 3.23 below

Reduplication of colour terms can involve either type of root doubling, repetition or reformation, and always implies a generalisation rather than an intensification (fc: 6.32)

eg: sa' - sa' 'red - ish'
 bira - biru' 'blue - ish'

3.2 Morpho-phonemics

A very limited amount of morpho-phonemic change occurs in the limited morphological processes of Melanau.

3.21 Changes on Affixation

.211 The MNP affix paradigm is fully described at 3.32.31.2; each section .100 introductory to the description of the affixation of the verbs for Focus sets out the various allomorphs of the basic me-, ne-, and pe- affixes. This allomorphy may involve loss of the affix vowel before a stem-initial vowel, replacement of many stem-initial consonants by a homorganic nasal, and metathesis of the affix elements to form an equivalent infix¹.

.212 The UIE affix paradigm is completely stable, with the exception of the verb 'to eat' (the only verb showing quite irregular inflection; there may, of course, be others not encountered in the study).² In AFDynamic form, this verb

1. This is a metathesis seen as operating on the prefix itself. More typical of the metathesis patterns, which all involve consonants, would be the alternative statement that the prefix consonant and the stem-initial consonant change place after the affixation process.

2. mena' 'to make' also presents some problems (3.32.32.14)

does not have the expected -u- as the first vowel, but is keman 'to eat', formally distinct from kuman 'from'¹. In its OFDyn form the expected -i- vowel is present, but the form of the stem is irregular, kinah 'eaten by'; the Static form is also irregular, lacking the expected -e- vowel, kanen 'eating, eaten'.

.213 The ke- affix producing abstract nouns has only two forms which manifest the basic phonological conditioning of all the prefixes in the Melanau language:

k- before stem-initial vowels, eg: kayeng 'breadth'²
ke- elsewhere, eg: keteben 'depth'

.214 The de- affix producing state verbs has also two forms, parallel to those of other CV- affixes:

d- before stem-initial vowels, eg: diba 'short, low'
de- elsewhere, eg: debau 'tall, high'

.215 The -ai form of the Dynamic adverb morpheme³ involves no true morpho-phonemic alternation, but rather a morphographic rule included here for convenience of description. Justified in the text of 2.63, the effect is that:

Final orthographic -u and -i of suffixed stems
 → -w- and -y- in the resulting complex word.

eg: bau + -ai → bawai 'upwards (dynamic), ascend'

1. In Northern dialects the words 'from' and 'eat' are homophonous, similar to Kayan and other inland languages.
2. Some speakers use ayeng for both 'broad' and 'breadth'.
3. Although {kV-∞-ai} is a bound Compound component (cf: ga' at 3.33.12.3) the formation of the compound follows the basic affixation patterns, and is therefore described here.

.216 The je- enclitic form of jeh 'one' patterns exactly like the bound affixes,

j- before stem-initial vowels, eg: jumit 'a little'

je- elsewhere, eg: jelau 'one day'

3.22 Changes on Compounding all involve some reduction of one of the component roots of the compound. This is most often the first component, which is reduced to a single syllable and in the process loses its consonantal coda. The normal stress its vowel would have carried as a free word is also lost, and the vowel itself assimilates to the vocalic quality of the resultant final stressed vowel.

.221 ga' + deictic particles behave typically in this way, establishing (for the purposes of description) the pattern observed on other such compounds.

ga' + 'ih → gi'ih 'at here' (cf: ga'ih 'make a trail')

ga' + in → giin 'at there'

ga' + an → gaan 'at where?'

.222 kV- + deictic particles behave similarly¹.

kV- + 'ih → ki'ih 'to here, come here'

kV- + in → kiin 'to there, go there'

kV- + an → kaan 'to where?'

Before polysyllabic stems, the compound component {kV-} has the form ke-~k- similar to the nominal affix described at .213 above:

1. It is this pattern regularity which suggests postulation of a morpheme {kV-} similar to {ga'}, not unlike the Malay clitic ka 'to a place' (Winstedt 1952.81)

kV- + inan → kinan¹ 'to yonder, thither'

kV- + aju' → kaju' 'to upriver, go upriver'

(kV- + dayeh → kedayeh 'to inland, go away from the River'
in the Matu dialect; Dalat has no polysyllables in the
set of static deictic adverbs prefixed by kV- → dynamic.)

3.223 wa' + deictic particles join with loss of the consonant
coda of the first component, but no predictable vowel change.

wa' + 'ih → wa'ih 'this thing'

wa' + in → win² 'that thing, it'

.224 béh + deictic particle follows the same general pattern
in the only compound which results in a single phonological
word (which is therefore written also as one word)

béh + in → biin 'after that, afterwards'

.225 lou + deictic particle reduces to a single disyllabic
word, of which two allomorphic forms are in regular use.

lou + in → luin or liin, in free fluctuation without
apparent contrast.

.226 buya' + enclitic nou similarly reduces to a disyllable:

buya' + nou → binou '(causal) why?'

While the first -i- vowel is typical of this reduction-and-
assimilation process, it must be assumed that it represents an
entire syllable -uy- from the original buya'.

-
1. The CV rules of word formation (2.32) disallow *kiinan (cf: kiin) since a sequence of two vowels may occur only at the end of a word.
 2. The derivation of win may be otherwise; wa'ih has a freely fluctuating allomorph u'ih parallel to unou 'what thing?' (3.31.32.3), so that win may perhaps represent /uin/ with the first of the two vowels less heavily stressed. There is no parallel *uan.

3.227 Negative + Copula undergo a similar reduction to form a single disyllabic word of typical vocalic form:

debei + bei → dibei 'is not, there is not, nothing'

The -i- vowel in the first syllable is presumed to be a reduction of the total vocalic content of the original debei, perhaps via some intermediate stage *deibei which (2.32) would be unstable.

.228 Speech formulae (cf: 4.21.321.6) undergo a reduction to a disyllable in normal informal speech of many in the Dalat speech-community (and almost all the speech styles of some).

sau kou → sekou [ʃkə^u] 'I said, I'd say'

sau ka'au → (seka'au) → sekau [ʃka^u] 'You said, you'd say'

sau nyin → senyin¹ [ʃnɪn] 'He said, he'd say'

3.23 Changes on Reduplication

In almost all cases where Reduplication is not realised by total repetition of the full form of the root, the first of the components is reduced to a disyllable ending with open -a, as in the illustration of Colour terms at .132 above. Even where the first form does not reduce to a disyllable, the -a ending is typical of the process, eg:

pesepa - sepun 'be all heaped up, in a heap'

tegesa - gesa' 'by degrees, cautiously'

There are, however, roots which undergo no such change, eg:

peribu - ribu 'in their thousands' (cf: 3.33.223)

1. senyin [ʃnɪn] is marginally distinct from senin [ʃniɪn] 'some while ago' (3.33.11.41), also a product of compounding; but their different lexical value is reinforced by likely context difference.

This can be explained by according to the resultant form an internal structure pe-(ribu ribu), the affix being enclitic to the Repeated (and therefore not Reformed) word ribu, nu, 'a thousand'. There is no doubt that some affixes are enclitic in their process of attachment to a stem, as eg: 3.32.31.21.207 below¹, but no explanation can at present be offered for why some forms are Repeated and others Reformed.

Occasionally reduplication has the further process of reduction to a single disyllabic word effected after the prior doubling, so that the repeated form undergoes a process very like those described at 3.223-227 above.

eg: luui - luui → lua - luui → lului 'slow of speech'

both the reduced forms being heard in the Dalat speech-community.

3.3 Morphology of Word Classes

"... as far as word-classes are concerned, problem-less or or 'regular' hypotheses about little known languages are always very suspicious!" (D.Crystal 1967.67 fn)

3.30 Word Classes

Melanau words manifest considerable mobility among the Word Classes of traditional grammar. laju, to take an instance, may occupy the Head position in an endocentric Nominal Phrase and will then be classed as a noun 'speed'. Substitution in

1. It is at points like this that an analysis confined to the surface structure is somewhat inadequate; the formal statement of algorithmic process rules in sequential order, however, can hardly be done until much more is known of the language.

the typically adjectival position attributive to a nominal Head in another NP requires its reclassification as a State verb, confirmed by its Head position in the Predicate tagmeme of salui in laju angai 'that canoe is very fast'. It may also occupy attributive position within an endocentric Verbal Phrase, as pepela laju 'paddle quickly', which requires its reclassification as an Adverbial. Thus while each occurrence of the word in construction with other words is classifiable by the familiar methods of substitutability in Distribution classes (Fries 1952.74, Robins 1964.224, Lyons 1968.318 et al.) according to its function, the root laju itself is too mobile to be allocated without cross-classification to any one class alone.

This problem of cross-classification is by no means restricted to Melanau, but does appear to be a prevalent feature of many Malayo-Polynesian languages and has received considerable attention on this account (eg: Teeuw 1962, Buse 1965). Longacre (1964.102) regards roots in Malayo-Polynesian languages as "building blocks entering indifferently into the structure of various contrasting types of (syntagmemes)".

Nevertheless, it would appear that in Melanau many useful generalisations can be made by recognising Distribution Classes within which many roots are highly mobile, the first of the typical positions outlined by Bazell (1958.7). It is not a tidy system of taxonomy; there is no good reason why a natural language should be tidy.

Accordingly, four hyperclasses are recognised on the grounds of distribution privileges of their members in Phrases, Clauses and Sentences. Three of these are open classes, whose membership can be no more than exemplified and whose patterns of derivation and affixation conform in all important respects to the examples cited. These are the classes of Nominals, Verbals and Adverbials. The remainder of full words, enclitic and bound forms are grouped together in a fourth hyperclass of Particles, subdivided functionally into many small closed sets of forms.

The Nominal class is described at 3.31, Verbals at 3.32, Adverbials at 3.33 and Particles at 3.34

3.31 Nominal Morphology

Within the broad distributional class Nominal, three sets of forms are distinguished according to more delicate distributional criteria and internal structure; these are Nouns, Nominalisations and Pronouns. Nouns are further subdivided into Noun roots *n*, which are uninflected free forms, Compound nouns and Derived nouns. Pronouns *pn* are subdivided into Personal and Non-personal pronouns. Nominalisations *nom* follow the division of the pronouns. Thus:

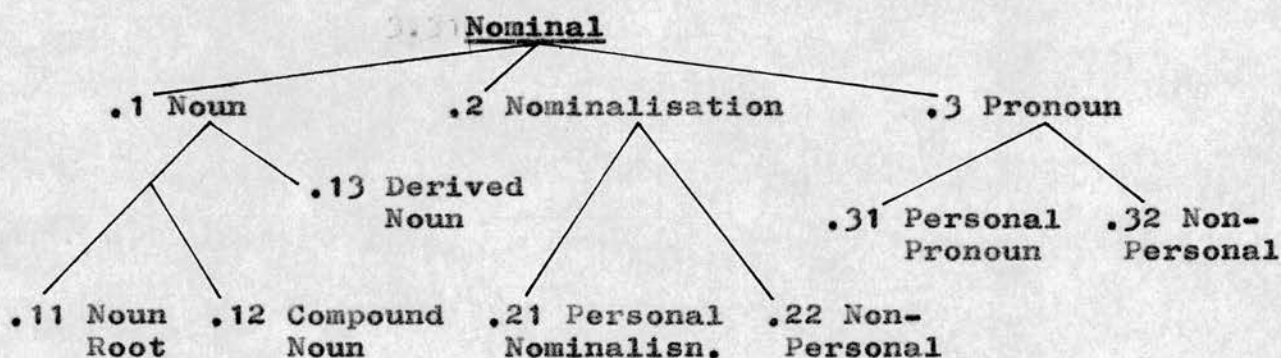

3.31.1 Nouns form one of the two major open word classes, typically filling the Head position in NP of all kinds. Three sub-types are distinguished on grounds of internal structure (or lack thereof):

- (1) Noun roots, uninflected free forms which may take both preposed and postposed modification. Nouns are unmarked for number, case or gender¹.

eg: amut 'root' daat 'sea' kuyad 'monkey'
ngadan 'name' sawa 'spouse' xa'ib 'sago bark'

- (2) Compound nouns, having a degree of phonological and syntactic cohesion closer than that of a phrase.

eg: a-lai 'man' tipou ayeng 'ancestor'
Dul-debei 'Dul himself'

- (3) Derived nouns, all of which are abstract nouns formed from stems of noun or verb class by affixation with the bound form ke- (or its allomorph k-).

eg: keteben 'depth' kesau 'kind of sound, sound'

3.31.11 Noun roots are further subcategorised according to their degree of identification into Proper nouns np and Common nouns nc.

- .11.1 Proper nouns np are distinguished from nc by being completely identified (cf:4.21.1). They fill Head place in Minimal NP1, and cannot be quantified or qualified in the phrase (other than by the emphatic identifier).

1. The noun-classifier system described at .2222 below is not regarded as a manifestation of the category of gender (despite the traditional analysis of Swahili and similar languages) on account of the common association of gender with sex (Lyons 1968 .283); there is no such correlation in Melanau syntax.

np are further subcategorised as animate or inanimate according to their collocation with process verbs, and the pronoun by which they are represented in anaphoric reference (cf: 3.31.32.22).

3.31.11.11 Animate np may be represented by any of the personal pronouns akou 'I' &c: listed exhaustively at 3.31.13, and may enter into construction with such verbs as makau 'walk', keman 'eat', pikér 'think', kaju 'go upriver' &c: Semantically, animate np are all human, eg: Tugau 'Tugau' Matali 'Mohammed Ali' and are all represented in the orthography with an initial capital letter.

In fables, which form a considerable part of the corpus of data, non-human animate nouns may be effectively re-categorised, permitting the predication of human actions and emotions, and the lack of their normal appropriate superordinate category term (cf: NP321.2).

eg: "Singed Kekaput" sau Tejali
remember Cuckoo sound Hornbill
'"Think of Mr Cuckoo", said the Hornbill.'

3.31.11.12 Inanimate np are semantically restricted to names of places, and are represented in pronominal reference by the static deictic adverb inan 'there, yonder'. All predications about inanimate np are static, not dynamic.

eg: Sibau jau' angai
Sibu far very 'Sibu is a long way away'

These np are also represented orthographically with an initial capital letter.

3.31.11.2 Common nouns nc are distinguished from np by being incompletely specified, denoting classes of items which may be further individualised and described (most typically in the ways described at 4.21.3ff). Common nc are further subcategorised as Abstract or Concrete.

3.31.11.21 Abstract nc may not be quantified or represented by pronominal reference. Such predications as may be made about them are Equative (cf: 4.31.11.1).

- eg: (1) ngai nyin 'ih ngai¹
 size he this size
 'he is as big as this'
- (2) ayeng salui in pat kaki
 width canoe that four foot
 'that canoe is four feet wide'

The total inventory of abstract nc includes:

- (1) a subset drawn from the inventory of verbs vq,
 such as: ayeng 'large, breadth'
 baat 'heavy, weight'
 lalou 'long, length'

- (2) a subset whose distribution includes the "tag"
 clause endings shown at .21(1) above, such as:

<u>gai</u>	'distance'	<u>ngai</u>	'size'
<u>dakai</u>	'quantity'	<u>nyam</u>	'taste'
<u>ji</u>	'appearance'	<u>tan</u>	'feeling, manner'
<u>sau</u>	'sound'	<u>umor</u>	'age'

1. The break in the line under the vernacular material is to indicate a syntactic division relevant to the discussion. In this case it marks the division of the two major components of the Equational Clause, Subject NP and Complement NP. The convention is employed only where it contributes to the clarity of the descriptive text.

3.31.11.22 Concrete nc constitute the remainder of nc, and are further subcategorised as animate or inanimate according to the classifier used for counting and for pronominal reference, and the subset of verbs with which they may be in construction.

.221 Animate nc are counted in NP32 with one of the classifiers apah 'body' or lawéh 'person', may enter into construction with process verbs (both transitive and intransitive) such as illustrated at 3.31.11.11, and may be Subject in Focus of Causative clauses (see 3.32.31.23.209). In selective relative clause construction, all animate nouns are represented by apah, but elsewhere may be further subcategorised as human or non-human.

.2211 Human animate nc are distinguished from non-human nc by the classifier lawéh in the NuP of which they are the referent, as

jelawéh ane' umit
one - cl child small 'one child'

This subset of nc includes such nouns as:

jane' 'sibling' bayuh 'shaman' raja 'ruler'
sakai 'friend' tua 'aunt' tipou 'grandfather'

.2212 Non-human animate nc are counted with apah, as
eg: duah apah payau
two cl deer 'two deer'.

Semantically, these nouns represent the great body of animate beings about which process and transitive predications can be made. The subset includes many of

the superordinate nouns which require further specification (cf: NP321.2), as eg:

ikan 'fish' mano 'bird' tou 'spirit'

and also creatures which occur without the cover-term attached, as eg:

asou 'dog' baya 'crocodile' payau 'deer'

3.31.11.222 Inanimate nc comprise the most voluminous set of nc, and are subcategorised into a large number of subsets according to the classifier with which they are quantified. One primary division is into Mass and Count nouns, which are respectively measured and enumerated.

.2221 Mass nc are quantified with a number of terms of length, area, volume and weight (or sometimes the price for a quantity) such as pasou 'eight-gallon measure', kati 'kati weight (about 1¹/₃ lbs)', ika 'acre' and the like, some indigenous and some not.

This subset of nc includes such nouns as:

guun 'forest' nyu 'oil' sei 'wet sago pith'

thus: jexuked bulu'

one-node bamboo 'one node-length of bamboo'

telou pasou sei

three measure sago-pith

'(some) twenty four gallons of wet sago pith'

There is considerable cross-classification possible at this point in the taxonomy, since nc which are proper members of this set may often also be enumerated. An example is padek 'prawn', which belongs in the semantic class ikan (cf: 6.31) and the enumeration class .2212

counted with apah, yet may also be measured by mass,
 as eg: pat tenuyh padek
 four string prawn 'four strings of prawns'¹.

3.31.11.2222 Countable nc comprise the remainder of nc, and further subcategorised according to their enumeration classes² as those which are counted:

- (1) with ata', a "sink" class in which are grouped a variety of objects of less specific shape (or other defining form) than others³, along with objects of a general compactness more precisely enumerated with some other classifier. Many of these nc are hollow, and more or less compact, round or roughly cubic rather than elongated or flattened.

eg: agen 'fish trap (variety) kuden 'cooking pot'
bup 'book' kubou 'house'

-
1. tunuyh is a typical UIE verb (3.32.32.2) 'to string together' descriptive of the way prawns and small fish are collected into bunches by a string or grass through the gills. tenuyh is the regular form of the associated nominal, as well as the Stative.
 2. It is not possible to give a complete list of these terms, if the system is as developed as others in the Far East (cf: Hla Pé 1965), but the general outlines of the system will be clear from this partial description.
 3. It is not unusual to have such a "sink" class within which many semantically disparate items may be enumerated for convenience at a less-than-precise level of delicacy (Burling 1965.252). Many nouns found enumerated with ata' occur elsewhere with a particular classifier; fruits, for instance, are usually counted with 'ou in speech between Melanaus, while the general-purpose ata' is sufficiently precise for trade in the Chinese bazaar in the town of Dalat.

- (2) with awa 'river', elongated objects or even geographical features; the list includes:
likou 'River' salui 'canoe' tukat 'stick'
- (3) with bah 'side', objects which naturally occur in handed pairs, including:
kelepaī 'wing' nyagem 'hand' tebi 'river-bank'
- (4) with belah 'split', material in thin sheets for constructing surfaces, articles of clothing, &c:
bai 'loincloth' bajou 'shirt' kajang 'thatching'
- (5) with bexéh 'seed', small compact objects such as:
beréh 'rice grain' manék 'bead'
- (6) with be 'blade', implements with a flattened part, paddle-shaped or bladed weapons, including:
besei 'spear-head' pela 'paddle' usid 'knife'
- (7) with lepér 'sheet', materials that come in flat sheet form capable of being spread out, such as:
kertih 'paper' surat 'letter, newspaper'
- (8) with usah 'trunk', timber in some relatively natural or undressed form, still basically a whole tree, as:
bati 'log' kayou 'tree' tengen 'tree-trunk'
- (9) with 'ou, small compact objects larger than those counted with bexéh and smaller or more rounded than those counted with ata, such as:
batou 'stone' bua 'fruit' teluh 'egg'
- (10) with macem 'kind, sort'; not a well-defined group, since almost any one of which there may be variety may be counted with macem, yet specifically such as:
tenga'up 'rainbow' perintah 'government'

- (3) Restricted nu, that subset of nu which appear to have their range of enumerable nc restricted to only one item, eg:

betu 'fleck', occurs only with buda' anum (or, it may be, with other closely related nouns not encountered in the study)

'foam on the water, scum, flotsam'

kap 'flat piece', occurs only with asu 'plank'

utéh 'skein', occurs only with benang 'thread'.

3.31.12 Compound nouns have distribution identical to that of Noun roots, but the internal structure of a two-place Modification Phrase with close phonological juncture (represented by the hyphen) between the component elements (cf: 2.23.3). Specifically excluded from this set of nominals, therefore, are the Specified Categorical NP321.2 which have full inter-word juncture between elements, and the Fixed-Order Co-ordinate NP21, which do not manifest a Head:Attribute internal structure.

3.31 .121 General Compounds may be exemplified by:

a-jemelai¹ 'person-bachelor, young man'

a-mexou 'person-woman, woman'

1. The status of words like jemelai, mexou is distributionally ambivalent between nominal (as example (2) below) and verbal vq, as suggested by the gloss to each compound. They appear in the clause-level Complement tagmeme with only the auxiliary VP, as eg: lian in, Tugau nga' jemelai

time that, Tugau past bachelor

'by then, Tugau was already of marriagable age'

but in that the vco is optional in Equation Clauses, jemelai is syntactically ambiguous between the nominal complement of NEC1,

(continued at foot of p114)

<u>a-sawa</u>	'person-spouse, spouse'
<u>ane' - sou</u>	'child-grandchild, grandchild'
<u>ayeng-buka'</u>	'large-width, width'
<u>sala'-pikér</u>	'* ¹ * -thought, thoughts'
<u>tipou-ayeng</u>	'ancestor-great, forefather'
<u>ti-kedau</u> ²	'the very place'
<u>tuju-layan</u>	'heading-side, direction'

It is characteristic of Melanau compound nouns that

- (1) their internal cohesion takes precedence over other qualifying modifiers in the ordering of post-Head attributes, as is seen in the bracketing given to the NP22

and verbal predicate with tense-aspect nga' 'past'. As in many such ambiguities, there appears to be no clear way of resolving it finally, and it is semantically irrelevant (cf: Lyons 1968.363). The same is true of lai 'male (human)' which is also 'man' in its own right, or (cf: 3.31.21.1) as a personal nominalisation a-lai. 1. sala' is a recognisable Melanau word, 'wrong', with the ambivalent distribution common to many Melanau roots, as eg:

"Sala! Ka'au pemudei."

wrong! you S+lie "'Wrong! You're lying.'"

nyin debei ta'ou sala' nyin

he not know wrong he 'he did not recognise his error'

In this expression, however, it appears to have no connection with error, although no informant was able to give the isolated constituent any other gloss. The expression is equivalent to tan pikér 'manner of thought' or indeed to pikér alone, suggesting (as 3.32.4) that the compound may in fact be verbal.

2. ti on its own has the gloss 'water's edge' (cf: tang 'forest' in the Rejang dialect) either of the river or the sea. As a compound, there is no obvious reference to this specific location, but to any specific spot as an intensification of kedau 'place'

(((tipou-ayeng)_n kamei)_{NP322} Jilag)_{NP22}
 ancestor we(exc) Jilag
 'Our forefather Jilag'

and (2) often one, and sometimes both, of the components may occur alone, substitutable semantically as well as syntactically for the entire compound, as eg:

(((Tegiok)_{np} jigem (sawa nyin)_{NP322})_{NP23} tawi)_{IC1}.
 Tegiok with wife he flee
 'Tegiok and his wife fled'

in which sawa 'wife' is seen as nominal, not adjectival vq.

Two other compound patterns are noted, the Reflexive compound and the Indefinite compound, described below.

3.31.122 Reflexive compound is formed with the enclitic particle -debei 'self' (3.34.23 cf: 2.64). As shown at 4.21.314, this may attach to entire phrases as well as to a single noun or pronoun; the listener relies on the close phonological coupling of the compound to distinguish it from the homophonous negative free particle debei 'not'.

eg: Besiong-debei 'Besiong himself'
luin-debei 'they themselves'

3.31.123 Indefinite compound is formed with the indefinite adverb mana 'however' and one of the abstract nc listed at 3.31.11.21 above.

eg: mana ji 'whatever might appear'
mana sau 'whatever might be heard'
mana tan 'whatever might be felt'
mana ngai 'whatever the size might be'

3.31.13 Derived nouns are formed by affixing roots of all word classes with the prefix ke- (and, presumably, \sim k-)¹ to form a set of abstract nouns, such as:

(1) ke- + abstract noun, eg:

+ ji 'sight' → keji 'appearance'

+ sau 'sound' → kesau 'sound'

(2) ke- + adjectival verb vq, eg:

+ teben 'deep' → keteben 'depth'

+ debau 'tall' → kedebau 'height'

(3) ke- + adverb, eg:

+ paut 'for a long time' → kepaut 'duration'

(4) ke- + quantifier, eg:

+ dakai 'in number' → kedakai 'number'

3.31.14 Reduplication of nouns always involves Repetition of the complete form (3.131) and represents an optional overt pluralisation (as distinct from the semantic shift implicit in reduplication of verbal forms, 3.32.5). Although Melanau roots are not marked morphologically for number, reduplication makes explicit the implied plurality of such expressions as benatang ki 'other animal(s)'. As a device, reduplication of nominal forms appears to be a somewhat idiolectal speech-style of some speakers, more noticeably those with Islamic (and hence Malay-language) affinities.

1. No further simplicity is brought to the description by isolating numerous homophonous affixes {ke₁-}, {ke₂-} &c: as is required within the verbal affix system. In the data collected there are no derived nouns formed on stems with an initial vowel, but this is presumably accidental rather than systematic.

eg: benatang benatang 'animals'
pengawel pengawel 'guards'
uxang uxang 'servants, subjects, crew members'

Sometimes an element of indefiniteness is added by the reduplication process, as eg:

bareng bareng 'whatever it is that ...'
macem macem 'different kinds, of any sort'

3.31.2 Nominalisations nom

Nominalisations are of two types, personal and non-personal, distinguished by the choice of nominalising particle used as enclitic prefix to the stem.

3.31.21 Personal nominalisations are formed with adjectival verbs vq as stem, affixed transitive or intransitive verb stems, or even an entire phrase or clause; either a 'person, the one who ...' or lou 'general pluraliser' is the prefix.

.211 Singular nominalisations are prefixed with a, eg:

a nyat 'one who is great, a grown-up, person of means'
a puma 'one who farms, a farmer'
a ki 'one other, someone else (or others)'
a memeket 'one who uses a peket fishing-net'
a Likou 'person of the River/Country, a Melanau'
a likou Uya 'person from the Oya River'
a sega 'one who is close, close relative'

.212 Overtly plural nominalisations are prefixed by lou, eg:

lou dipen 'those who are slaves, the slaves'
lou mexou 'the women (of the house)'

lou aba 'those from down-river, coastal folk'
lou pekaxi 'those who go fishing, fisher-folk'
lou rayet rayet 'the common people, retainers'
lou in 'those people' (also reduced to luin 'they')

3.31.213 Indefinite nominalisations are formed with the indefinite adverb mana 'however' and the personal nominalising particle a, prefixed to a word, phrase or clause such as those at .211 above; eg:

mana a kenah 'whoever was able to ...'

This is semantically equivalent to the reduplicated pronominal form sai sai 'whoever' (cf: 3.31.31.41.1)

3.31.22 Non-personal nominalisations¹ are formed with all kinds of verbal stems and clausal constructions, nominalised by enclitic wa'; they are not marked for number, and are definite or indefinite.

.221 Definite non-personal nominalisations are such as:

wa' asek 'what is worn, clothing'

wa' ja'et 'what is bad, wickedness'

wa' li' 'what is played, a game'

wa' (ba') kanen² 'what is (to be) eaten, food'

wa' ba' sabi' 'what is to be asked, a request'

wa' penalei a bayuh 'what is forbidden by the shaman'

1. Nominalisations with wa' may in fact be personal in referent, as those with a may be plural. There are degrees of grammaticality within the control of the speaker, as cf: the use of lawéh and apah described at .2211, ata' and other cl. at .2222 above.

2. Both of these forms are found, and also simply ba' kanen 'to be eaten' with nominal distribution meaning also 'food'.

A particular use of this nominalisation formula is the construction with ngadan 'name, named'. The verbal gloss is assumed to be appropriate rather than a nominal, the whole syntagm manifesting OFStat clause structure with \emptyset form of the Agent tagmeme indicating indefinite or general agency (3.32.31.22.202 cf: 4.32.26). For example:

wa' ngadan mano' 'what is called a bird'

wa' ngadan payau 'what is called a deer' &c:

These idiomatic relative clauses appear to be semantically equivalent to lou mano', lou payau &c: (cf: 3.31.31.22), with the gloss 'all kinds of birds'(or deer)', equivalent to the paraphrase 'all that goes by the name of bird'.

An apparently anomalous construction wa' + n, such as eg: wa' saban 'ih 'what curse this' is treated as a reduction of the wa' ngadan formula (no attempt being made to trace an algorithm for the process) which therefore carries the gloss 'this, which is called saban'¹.

3.31.222 Indefinite nominalisations are formed with the indefinite adverb mana 'however' prefaced to the normal nominalisation construct, eg:

mana wa' pexéh ga' likou 'whatever remained in the village'

3.31.3 Pronouns pn

Pronouns fall into two subsets, Personal and Non-personal pronouns. Both of these are further subdivided into Particular

1. Saban is the generic name of a number of malevolent curses attached to various aspects of Melanau life, exemplified in 'Saban Kuyad' in Clayre 1971(a)

and General pronouns, and manifest the distinction Singular and Plural not found on Melanau nouns.

3.31.31 Personal pronouns are particular or general.

3.31.31.1 Particular personal pronouns are not marked for case or gender, except that the 1st person singular has two forms corresponding to the clause-level dichotomy Focal : Non-focal which is described at 4.31.12.203¹.

.11 <u>Singular</u> :	1st pers. (focal)	<u>akou</u>	'I'
	(non - focal)	<u>kou</u>	'I'
	2nd pers.	<u>ka'au</u>	'you'
	3rd pers.	<u>nyin</u>	'he, she, it'
.12 <u>Plural</u> :	1st pers. dual		
	(including hearer)	<u>tuah</u>	'you and I'
	(excluding hearer)	<u>nua</u>	'we two, not you'
	1st pers. general		
	(including hearer)	<u>telou</u>	'you all and I'
	(excluding hearer)	<u>kamei</u>	'we all, not you'
	2nd pers. dual	<u>kedua</u>	'you two'
	2nd pers. general	<u>kelou</u>	'you all'
	3rd pers. dual	<u>duin</u>	'they both'
	3rd pers. general	<u>luin</u> / <u>liin</u>	'they'

1. It is suggested here that the dichotomous pair akou : kou may represent all that remains of a once fully distinguished list of focal and non-focal forms such as are found in Philippine and Dusunic languages today. In formal speech, especially among the more Islamic Melanau, self-derogative terms such as dipen 'slave' are used instead of akou 'I', much as hamba in Malay (Winstedt 1952.66) or urang in Sundanese (Wessing 1972).

These pronouns may be conveniently arranged to show the semantic contrasts involved:¹

	Speaker included	Speaker excluded
Hearer included		<u>ka'au</u> (single)
	<u>tuah</u> (dual)	<u>kedua</u> (dual)
	<u>telou</u> (plural)	<u>kelou</u> (plural)
Hearer excluded	<u>akou</u> (single)	<u>nyin</u> (single)
	<u>nua</u> (dual)	<u>duin</u> (dual)
	<u>kamei</u> (plural)	<u>luin</u> (plural)

from which morphological components may be extracted if it is desired to continue the fragmentation process further.

3.31.31.13 Vocatives are not case-marked as the pronouns are, being all potentially 3rd person in general use, and used in 2nd person as vocatives according to the style typical of the language region² instead of ka'au 'you'; eg:

tuen 'you' (usually reserved for Europeans)

haji 'you who have made the haj to Mecca'

tawkei 'you the Chinese shopkeeper' (towkay)

Sometimes a relation-term is used in address, as eg:

ma'it 'brother-in-law, sister-in-law'

tua' 'aunty'

1. These contrasts appear to be typical of a number of languages of S.E.Asia, cf: Palaung pronouns in Burling 1970.16

2. The convention of avoidance of direct 2nd person in servile address is not limited to S.E.Asia, as evidence the form of shopkeeper's speech "What would madam like to be shown?" &c:

Sometimes a diminutive form is used as the vocative:

<u>ka'</u>	'sister'
<u>ma'</u>	'mother'
<u>pa'</u> ¹	'father'
<u>idu</u>	'darling' (used only with children)

3.31.31.14 Possession is denoted by placement of the personal pronoun following the possessed nominal in the typically Malay Item and Possessor Nominal Modification Phrase NP322 illustrated at 4.21.322.1

3.31.31.2 General personal pronouns are singular or plural.

- .21 Singular: a 'person, the one who' (non-selective)
apah 'body, the one who' (selective)

The use of a in forming nominalisations has been described, in which it is seen that a can act as a Head for attachment of deictics and attributives to a non-selective impersonal (but human) 'one'. Occurring freely as a minimal NP, a has the added connotative meaning 'someone else', as in the typical

in hal a
 that affair someone 'that is someone else's worry!'

Similarly, apah has the general meaning 'someone' or 'anyone' (as well as its literal gloss 'body'), as

bei apah?
 be body? 'Is anybody at home?'

1. The choice of vocative sobriquet rather than the name is in part at least culturally determined, since it is palei 'forbidden, taboo' to many people to use the name of a parent openly.

In relative clause construction, a is in contrast with apah in denoting non-selective as against selective pronominal reference. Thus:

(1) Jilag, a diem ga' tugi' sungai 'Ud

Jilag cl. dwell at mouth stream 'Ud

'Jilag, who lived at the mouth of the River 'Ud'

(2) ane' Tegiok apah buya' beragen in

child Tegiok pcl. suffer violence that

'the one of Tegiok's children who was violently treated'

With a single adjectival vq, apah forms a selective nominalisation without any immediately preceding nominal referent, as eg:

apah umit

pers. small 'the younger one'

3.31.31.22 Plural: lou 'those who' (non-selective)

The use of lou has already been described, in which it is seen to be capable of functioning as a general plural Head for deictics and attributives (3.31.212).

3.31.31.3 Interrogative personal pronoun, unmarked for number, is sai 'who?', thus:

sai munu' tina tama kou?

who? A+kill mother father I

'who killed my parents?'

sai is also used (reduplicated) in construction of indeterminate nominalisations (3.31.213) and in enquiring about a name:

sai ngadan ka'au 'what is your name?' (cf:2.52.31)

sai a kenah mubat nyin ba' kawin jigem ...

who? pers able A+cure her int. wed with

'whoever is able to cure her will be married to ...'

3.31.31.4 Reduplication of personal pronouns may be total or partial.

3.31.31.41. Total reduplication is with interrogative sai and with the enumerated form japah 'one person'.

.41.1 of sai, gives the open general pronoun sai-sai

'whoever it may be' or 'anyone at all', as eg:

ka' a sai - sai medeg tengen balek in

pro. pers who-who A+touch trunk banana that

'No-one at all is to touch the banana tree!'

.41.2 of japah, gives the serial connotation 'one after another, one by one' as eg:

a lakei in pesusui ga' luin japah - japah¹

pers. old that S+speak to them one-by-one

'The old man spoke to them each in turn'

3.31.31.42 Partial reduplication is with japah only, giving the serial connotation 'from one to another', as:

belabei pila' ji jawai luin apah - japah²

butterfly S+look-at face them one-to-one

'the butterfly looked from one face to another'

1. This total form is written out, although the actual etic form may follow the general rules of duplication to give japa-japah, as explained at 3.13. In either case it is minimally distinct from the example following.

2. This partial form is a particular of the adverbial pattern of nominal reduplication described at 3.31.11.2223 above.

3.31.32 Non-personal pronouns are particular or general.

3.31.32.1 Particular non-personal pronouns are co-extensive with the set of 3rd person pronouns listed at 3.31.31.1, with addition of a specifically non-human singular win 'it'

3.31.32.2 General non-personal pronouns are co-extensive with the set of classifiers cl. already cited in subcategorisation of noun roots n (3.31.11.222). Although many of these differ distributionally from the nominal homoseme in that they form a suppletion set with wa' in selective (as against non-selective) relative clause construction, they have a nominal gloss in NP and the general gloss cl. in other syntagms. In pronominal reference, they may form a complete quantified NP without the overt referent (cf: .22 below). The set includes:

apah, ata', awa', bah, belah, bexéh, be', kap, lepér,
macem, usah, 'ou

and the inventory of quantity terms denoting length, area, volume, weight and time already exemplified above.

.21 Relative clauses are selective or non-selective, exactly as exemplified for personal pronouns; eg:

(1) kapek wa' belei kou dagen kedai (non-selective)
axe rel. R+buy I in shop
'the axe, which I got in the shop'

(2) kapek be' belei kou dagen kedai (selective rel.)
axe cl. R+buy I in shop
'that one of my axes which I got in the shop'

(3) kelidéng usah bah aju' kenedau tou (selective)
monument cl. side upriver P+place spirit
'the upstream monument is haunted'
(and by implication there is another, which is not)

3.31.32.22 Pronominal reference with a numeral is made with the classifier alone, without repetition or the noun Head, as eg: ka'au bei duah be' kapek; juh kou jebe'
 you have two cl. axe; V+give I one-cl.
 You've got two axes; give me one of them'

.23 Deictic pronouns are of a somewhat uncertain status lexically, in that their distributional privileges are not typical of any of the major word classes. The set comprises: 'ih 'this'
in 'that'
an 'which?'

and perhaps also the locative pronoun inan 'yonder'.

'ih and in have as their principal distributional context the final place in many nominal expressions where they provide a degree of closure to the NP (4.21.31). Both are coupled with wa' to form compounds:

wa'ih 'this thing'
win 'that thing, it'

indicating that they are adjectival rather than nominal in status, requiring a Head word to be attached to.

However, in many instances 'ih and in occur as free pronouns, manifesting Subject tagmeme in clauses such as the Equational clauses EC1. below:

- (1) 'ih tayan
 this sago-making-platform
 'This is the sago-making platform'
- (2) in hal a (quoted at .21 above)
 'That is someone else's worry'

Both of these examples suggest full nominal status.

Moreover, it is noted at 3.33.12.2 below that all three members of the set form the stem for affixation of class-changing particles gV- and kV- to produce compounds with an apparent covert RAP structure, indicating that they have nominal status.

All are therefore listed here among the non-personal pronouns. But since their distribution is not typical of the Pronoun subset of Nominals, this is interpreted as a pronominal function of words belonging to the hyperclass of Particles.

3.31.32.24 Quantity pronouns. It is shown at 4.21.64 that the quantity phrase QuP may have pronominal distribution, without any overt nominal Head to the syntagm (as also the selective relative clause examples at .21 above)

3.31.32.3 Interrogative non-personal pronoun, unmarked for number, is formed by nominalising the enclitic interrogative nou 'what?', to give unou 'what thing?', as eg:

unou wa' tutup pesei kou?

what rel. A+bite tackle I

'What is biting on my fishing-line?'

unou sebab ka'au kemasau luin?

what reason thou A+make-trouble they

'What is your reason for disturbing them?'

(Other compounds with nou are described at 3.34.22 below)

The enclitic particle an 'which?' also functions as a non-personal pronoun, in the set of stylised Manner questions described at 4.31.234, as eg:

ketan an gaya ba' munu' Berantai?

manner which? int. A+kill Berantai

'How is Berantai to be killed?'

in which one of the many ways in which the English passive construction (chosen to avoid specifying an Agent) is not matched by the Object Focus construction in Melanau (cf: 4.31.12.23.121). The Agent here is simply not specified in an Actor Focus clause, and that is sufficient generality (cf: also 4.32.26).

More general indefiniteness is conveyed in
akou debei ta'ou siau apah an tetep meneng
 I not know cock cl. which? sure A+win
 'I have no idea which fighting-cock will win'

3.31.32.4 Reduplication of non-personal pronouns is similar to that of personal pronouns, and may be total or partial.

.41 Total repetition occurs with the enumerated single pronominal forms, as already exemplified at 3.31.31.41.2 above, and also with macem 'sort, kind' to give macem - macem 'of any kind at all, of many sorts' as eg:

macem - macem lah sau rudéng luin
 of-many-sorts ! sound discuss they
 'all sorts of things they discussed together'

.42 Partial reformation, other than with enumerated single pronouns, occurs with unou 'what thing?', giving unou - nou 'anything at all', as eg:

dibei anum, dibei unou - nou¹
 not-be water not-be anything-at-all
 'there was no water, there was nothing!'
dibei jed ba' unou - nou agei
 not-be strength int. anything yet
 '(she) had no more strength to do anything any more'

1. Sometimes the etic form is the enclitic only, nou - nou.

3.32 Verbal Morphology

On grounds of formal composition, Verbs *v* occurring in speech contexts may be divided into two hyperclasses, Uninflected and Inflected verbs. This dichotomy itself is insufficient to capture all the useful generalities about Melanau verbs, and further formal distinctions are made between verbs formed on verbal stems by class-maintaining affixes and those verbs which are derived from nominal or adverbial roots by class-changing affixes. Within the class of Inflected verbs, affixation patterns are similar whether the stem class is verbal, adverbial or nominal, so that homophonous affix systems are described having different syntactic valence and semantic correlates.

Inflected verbs are Transitive *vt* or Intransitive *vi*. According to their inflection paradigm, they are distinguished as MNP verbs (taking the me- / ne- / pe- affix system) or UIE verbs (taking the ablaut set of infixes -u- / -i- / -e-). These two affix systems are parallel in operation, the first of each set indicating Actor Focus of a clause nucleus in a dynamic situation and so on, as detailed in each relevant section below. Further distributional criteria require the recognition of two subsets of verbs from each paradigm class, Active verbs *va* and Causative verbs *vc*. (While this distinction is quite clear for a large number of verb forms, there is a sizeable remainder which might equally well be allocated to either of these well-founded subsets.)

Uninflected verbs are Intransitive¹ *vi*. Distributional

1. With the possible exception of such verbs as sapai 'reach' which also functions as a dynamic preposition in Direction and

criteria require the recognition of two subsets of vi, Process verbs vp and State verbs vs. As noted above, a residue of verb forms (termed Ambivalent verbs) might equally well be put in one class as in the other - or, perhaps, in both.

The broad groupings of verb forms described above are all illustrated in Table 32.0 below. In the table,

- + marks those forms in which a verb is exemplified by its ne- (i.e. Object Focus, or passive) form, as occurring in Object Focus clauses.
- * marks verbs included for comparison only, discussed elsewhere in terms of Dynamically marked deictic adverbs (3.33.12.3)
- The dotted line from the heading UIE to Active and Causative subheadings indicates that the distinction is not always as clear for these verbs as it is for MNP equivalent forms.
- ∴ A series of dots under a column indicates that the list is no more than an exemplification of a much larger set.

Ambivalent verbs are exemplified between the main columns.

1 (continued from overleaf)

Limitation Relator-Axis phrases (4.23.22); buya' 'suffer' which functions as a clause-level relator in similar constructions (4.31.11.2213); also a few other verbal forms whose status is, at best, ambivalent such as bei 'have, possess' homophonous (and perhaps also homosemic) with bei 'be, exist', the existential copula verb.

3.32.1 Uninflected verbs are either uninflected Verb roots or uninflected Derived verbs.

3.32.11 Verb roots may be Process verbs vp or State verbs vs.

3.32.11.1 Process verbs are those which characteristically occur as predicates in Process Intransitive clauses pIC1. They are potentially modified within the Verb Phrase by verbal adjuncts of Manner (4.23.11.22), and in the clause string by phrase-level expressions of Time and Place, Cause, Direction &c: (4.23.22)

.11 Static process (Occupation) is exemplified by:

pikér 'think, ponder' tetawa 'laugh'

as eg: nyin pikér deréh angai
 he think determined very
 'He pondered very deeply'

.12 Dynamic process (Motion) is exemplified by:

makau 'walk' balék 'return'

as eg: nyin makau laju angai
 he walk quick very
 'He walks (or walked) very fast'

Semantically there is often a correlation with Activity, and Agency of the subject of the clause.

3.32.11.2 State verbs are those which characteristically occur as modifiers within NP, and as State predicates (or state Complements) in Intransitive clauses sIC1. with or without a Copula verb. They are themselves potentially modified by adverbial adjuncts of degree add. (4.23.11.21) and, according to their typical distribution, may be subclassed

as Quality or Manner state verbs:

3.32.11.21 Quality vq are exemplified by:

bilem 'be black' tu'uh 'be dry'

as eg: salui in bilem lalu
canoe that black quite
'That canoe is black all over'

.22 Manner vm are exemplified by:

laju 'fast' deréh 'determined'

as eg: salui bilem in laju angai
canoe black that fast very
'That black canoe is very fast'

Semantically there is often a correlation with adjectival quality or adverbial manner, Non-agency of the subject of the clause.

3.32.11.3 Ambivalent verbs are those which, functioning as a clause-level predicate nucleus, may have either Static or Inchoative aspect.¹ They are exemplified by:

tudui 'be asleep, fall asleep' matai 'be dead, die'

(cf: the inflected verb typified by pebunga 'have flowers, burst into flower' exemplified at 3.32.31.23.202)

as eg: debei paut béh in akou tudui udei
not long-time after that I sleep again
'Not long afterwards I fell asleep again'

3.32.11.4 Copula verbs vco are a particular subset of the uninflected verbs, with a somewhat complex syntax (4.22.13)

1. The inchoative aspect referred to here is semantic aspect, as implied in the gloss 'fall asleep'. Grammatical aspect, as one of the categories of the verb, is described at 4.22.111.

They form the Predicate of Sentence Introducer formulae (4.32.122), and the optionally overt connection between the substantives and (or) adverbials in Equational and Adverbial clauses (4.31.11.1-2). Two copula verbs are found in Melanau:

bei 'be, exist'¹ nyadin 'become'²

- as eg: (1) bei jelau, Jilag ba'ai kubou
 be one-day Jilag go-down house
 'One day, Jilag came out of his house ...'
- (2) asu' 'ih ba' (nyadin) pela
 plank this int.(become)paddle
 'This plank is for a paddle'
 or 'This plank is intended to become a paddle'
- (3) lebu' nyin (bei) alud
 house he (be) towards-river
 'His house is by the riverside'

3.32.11.5 Sentential Complement verbs are those verbs from the inventory of Uninflected Intransitive vs occurring in a clause as the first of two verbs "associated in a manner more intimate than the sort of conjoining found in juxtaposed sentences" (Longacre 1970.813); but excluding the vp verbs of motion. Of these vs, the subset (1):

-
1. It happens in many languages that there is considerable semantic overlap between 'to be' and 'to have' (Lyons 1968.388) In Melanau the verbs are homophonous; in some sentences it is far from clear whether existence or ownership is implied, since bei has none of the transitive affixes, and Melanau nouns have no case marking.
2. nyadin, nyadi or the completely Malay jadi often occur alone as a sentence-level connector in discourse, equivalent to Malay maka which, though glossed 'and so ...' (as eg: 3.34.131) "does not need translating" (Winstedt 1952.119)

<u>cuba'</u> / <u>suba'</u>	'try'
<u>inget</u>	'remember'
<u>kenah</u> / <u>kena'an</u> ¹	'be able, manage'
<u>mesti</u>	'must'
<u>pawah</u>	'long, desire, yearn'
<u>sagup</u> / <u>berani</u>	'be brave, dare'
<u>tukeng</u>	'be clever'

must all have the same subject as their sentential complement; that is, they can only take a Subject sentence complement, much like the traditional modal verbs. Thus:

Tugau sagup ba' kawin jigem ane' raja
 Tugau be-brave int. marry with child ruler
 'Tugau dared to marry the king's daughter'

Other verbs form another subset (2), as:

<u>lu'</u>	'wish, agree'
<u>setuju</u>	'agree, be of one mind'
<u>suka</u>	'enjoy'
<u>ta'ou</u>	'know'

can take Subject and also Object sentence complements, although there is sometimes a shift of meaning greater than the simple change of referent.

eg: raja kamei debei lu' ka'au puli'
 ruler we(exc) not wish you go-away
 'Our ruler does not wish you to leave'

cf: pededug jigem moto, salui kou lu' rusek
 Re+S+bang with launch, canoe I will broken
 'My canoe will be damaged, banging against that launch'

1. While there is a general polarisation of kenah as 'be able' and kena'an as 'get, catch', they also occur in exactly the reversed roles. Only with the gloss 'catch', however, can kenah occur in Object Focus dynamic form kenenah 'caught (by ...)'

in which collocation with the state vs rusek 'be damaged' and an inanimate subject combine to give lu' the modal sense of necessary outcome of a process.

3.32.11.51 The verb ta'ou 'know' requires special attention because of an irregular pattern of affixation which it exemplifies, and its dual status as a main and a modal verb.

.511 Affixation. ta'ou is an uninflected state verb¹, occurring in such overtly Intransitive constructions as: (1) akou ta'ou pasel hal in

I know concerning matter that 'I know that' in which the relator pasel 'concerning' makes the axis hal 'matter' oblique (4.31.11.2215). Moreover, (1) may be understood as a paraphrase of such a sentence as:

(2) akou ta'ou nyin nga' labi'

I know he past come 'I know he has arrived' an Object sentence Complement, compared with the Subject sentence Complement manifested in, say:

(3) akou ta'ou tuun

I know swim 'I know how to swim'

The difficulty of analysis arises because of the form keneta'ou which, occurring in sentences like:

(4) tuba in debei nga' keneta'ou tenawan

tuba that not past *+know mankind

'The tuba-root was not yet known by man'²

1. Lyons (1968.324) points out that verbs like 'to know' are in fact Intransitive, although it is not clear whether Process or State. In the Dusun language of North Borneo, okilo 'know' has the -o- infix typical of Stative (i.e. not Active) verbs.

2. That is, as a poison for fishing. (cf: 3.32.31.21.207 below)

whence keneta'ou appears to be some sort of Object Focus form of ta'ou 'know', glossed perhaps 'be known by ...'

Yet such a form would be anomalous, *tena'ou being the regular expected OFDyn form of such a verb (cf: tubu', tenubu' at 3.32.31.22.206). It is therefore assumed that in some diachronically relevant way, the following derivation process has taken place.

1. me- + ta'ou 'know' → *meta'ou 'make known'
2. *meta'ou assimilates to Malay form (mengetahui)
→ mengeta'ou 'make known'
3. mengeta'ou ← me- + *keta'ou, by analogy with other verb forms with k- initial stems.
4. ne- + *keta'ou → keneta'ou (3.32.31.22.100) in a completely regular way.

If this is correct, a better gloss is 'be made known to...'
and the nominal following is in semantic Dative rather than Agentive case.

Such an analysis suggests a parallel derivation of the two anomalous forms noted at 3.32.31.22.202 below, and a parallel understanding of their constructions with nouns.

- (1) kenasusou 'be born', followed by a Locative rather than an Agentive expression; from mesusou 'give birth' (the regular linking of me- + susou 'female breast' → menyusou 'suckle') via an intermediate stage mengasusou
- (2) kengadan / nengadan 'be named' followed by the name (Associative case?). Both of these forms may be remnants of an earlier *kenengadan 'be given the name ...', which has been diachronically reduced in two similar ways.

3.32.11.512 Modal construction. The 'acquired skill' component of the semantic content of ta'ou in Subject sentence complement construction noted at .511(3) above appears to be lacking in its use in such sentences as:

keman si'et, a likou debei ta'ou geli'
 A+eat grub Melanau not know revolted
 'Melanau can never have too many sago-grubs to eat !'
 (they always want more)

in which geli' is a state verb, and the syntagm ta'ou geli' 'experience revulsion'¹ is the sentient equivalent of the inanimate lu' rusek 'experience damage'².

In Object Focus construction, only lu' and kenah appear to be able to act as modals to a main verb:

bati in debei kenah benatun luin
 log that not be-able P+lift they
 'The log was too much for them to lift'
 or 'They were unable to lift up the log'

3.32.12 Derived Verbs may be Process or State verbs.

3.32.12.1 Process verbs vp may be derived from noun roots by a productive process of affixation with {me₁-} or {pe₁-}. A small number of specialised monosyllabic sense nouns are verbalised by the rare process of suffixation with {-en}. The semantic feature [+dynamic] is added to deictic locative adverbs by the appropriate allomorph of the particle {kV-∞-ai}.

1. cf: the Greek idiom idein thanaton 'see death'

2. cf: the English idiom 'come to harm'

3.32.12.11 Derived from noun roots:

eg: me- + pesei 'fishing tackle' → memesei 'go out
fishing with hook and line tackle'

pe- + salui 'canoe' → pesalui 'go by canoe'

ted 'the moment before' + -en → teden
'make preparation for'

sau 'sound' + -en → sawen 'make a noise'

.12 Derived from deictic adverbs:

eg: kV- + aju 'upriver' → kaju 'go upriver'

bau 'up' + -ai → bawai 'go up, ascend'

3.32.12.2 State verbs vs may be derived from noun roots and from Numeral units by a productive process of affixation with {pe₁-}, or a less productive process with {me₀-}. Some, but not all, of the deictic adverbs may be affixed with {de-} to yield adjectival vq.

.21 Derived from noun roots:

eg: pe- + jane 'sibling' → pejane 'be siblings'

me- + jed 'strength' → mejed 'be strong'

.22 Derived from numeral units:

eg: pe- + pulu 'units of ten' → pepulu 'in tens'
(cf: English 'in their dozens')

pe- + beléh 'units between ten and twenty'

→ pebeléh 'in teens'

.23 Derived from deictic adverbs:

eg: de- + bau 'up' → debau 'be tall, tall'

de- + iba 'down' → diba 'be short in height'

and presumably, de- + *adit → dadit 'be short in length'

although no free form *adit now occurs in Dalat dialect.

3.32.12.3 Ambivalent verbs are derived from noun roots. Drawn from the inventory of vp and vs, they depend on some further specification from the context to indicate whether the Inchoative aspect of the State is to be understood, yielding a Process (cf: 3.32.31.23.202).

eg: pe- + ane' 'child' → pane' 'have a child, give birth'

3.32.2 Inflected verbs

Inflected verbs are either Intransitive vi or Transitive vt.

3.32.21 Intransitive verbs vi may be Process or State, exactly like the uninflected verbs vi.

3.32.21.1 Process verbs vp are inflected according to their stem class, following either the MNP or the UIE paradigm.

.11 MNP paradigm, the pe- form being typically intransitive, as eg: pepela 'paddle along'
puluh 'lower oneself down (a rope)'
 but also: makat 'rise up'

.12 UIE paradigm, the -e- form being typical¹.

eg: benu' 'killing' selud 'combing the hair'

3.32.21.2 State verbs vs are inflected according to their stem class, following either the MNP or the UIE paradigm.

.21 MNP paradigm, the pe- form being typical.

eg: pelim 'hidden' pexéh 'remaining'

1. It is typical of these UIE verbs that the -e- form is also the associated nominal, eg: benu' 'slaughter', selud 'a comb', seput 'a blowpipe'.

3.32.21.22 UIE paradigm, the -e- form being typical.

eg: lenyed 'submerged' xemai 'crushed, powdered'

3.32.21.3 Ambivalent verbs are characteristically the set of reflexive verbs, in which it is unclear whether the form is Process or State.

.31 MNP paradigm, the pe- form being typical.

eg: paman 'drift with the current, be adrift'

puei 'dry out in the sun, be parched'

.32 UIE paradigm, of which the -e- form is typical.

eg: kexid 'shaving, shaved'

sekel 'choking, strangled'

thus: lou musuh in pesekel

gpl enemy that Re+S+choke

'The enemies are strangling one-another'

a musuh in matai sekel talei

pers enemy that die R+choke rope¹

'That enemy is dead, strangled with a rope'

(It may prove after further investigation that all UIE verbs are ambivalent, from the lack of a fourth verbal form to distinguish SFStat from OFStat, see further comments at 3.31.22.22 below.)

3.32.21.4 Sentential Complement verbs are those Intransitive verbs, affixed for Subject Focus with the pe- prefix (cf: 3.32.31.23) but taking an apparent Object in semi-transitive clauses (4.31.12.21.19). They may also occur in

1. Lacking the fourth form, some UIE verbs are given the R+ gloss by analogy with the overtly OFStat parallel MNP verbal construction, which would here be just the verb root (hence R).

Object Focus with ne- affixation (3.32.31.22). It is a characteristic of this set that the apparent Object may be a Subject sentence complement or an Object sentence complement, as 3.32.11.5 subset (2).

eg: becerita 'recount, tell a story'
beguna 'be of use, make use of'
pepikér 'think, think that ...'
pesusui 'talk, tell, say that ...'

thus: Besiong pikér nyin debei kenah pigi' tumek in
 Besiong think he not able S+get spear-head that
 'Besiong thought he would never get the spear-head.'
Jilag penikér nyin a wakil singen
 Jilag P+think he pers deputy only
 'He thought of Jilag as no more than his deputy'

3.32.22 Transitive Verbs vt.

Transitive verbs may be Active va or Causative vc.

3.32.22.1 Active verbs va are those verbs which maintain as Agent in transitive Dynamic clause construction¹ the Subject of intransitive or Static clauses. Verbs va are inflected according to their stem class, following either the MNP or the UIE paradigm.

.11 MNP paradigm. Subject of the pe- form (or uninflected vp) → Agent of the me- form in AFDynamic clause transform, and of the ne- form in OFDyn clause. Verbs va of this subset may be derived from noun roots, or may be inflected verb stems.

1. The two interacting systems employing the oppositions Transitive : Intransitive and Dynamic : Static are more fully described at 4.31.12.21 below.

3.32.22.11) Noun roots:

eg: mulin 'steer with rudder' nulin 'steered'
kemi'it 'fan into flames' keni'it 'fanned'
(cf: ulin 'a rudder' ki'it 'a fan')

.112 Verb stems:

eg: mayam 'tame, break in' nayam 'tamed'
melei 'purchase' benelei 'bought'

3.32.22.12 UIE paradigm. Subject of the -e- form verb → Agent of the -u- transform in AFDyn clause construction, and of the -i- transform in OFDyn. Verbs va of this subset may be derived from Noun roots, or be inflected verb stems.

.121 Noun roots:

eg: suput 'shoot with a blowpipe' siput 'shot'
guga 'greet, welcome' giga 'welcomed'
(cf: seput 'a blowpipe' gega 'a greeting')

.122 Verb stems:

eg: tuteng 'drink' titeng 'drunk (by ..)'
xuxau 'pass by' xixau 'passed'

3.32.22.2 Causative verbs vc are those verbs which have as Object in transitive Dynamic clause construction the noun which is Subject of the intransitive or Static clause. Verbs vc are inflected according to their stem class, following either the MNP or the UIE paradigm.

.21 MNP paradigm. Subject of the pe- form (or uninflected vs) → Object of the me- transform in AFDyn clause

construction, and of the OFDyn transformation with a ne- form verb. Verbs vc of this subset may be derived from Noun roots, or may be inflected verbs or adverbs.

3.32.22 .211 Noun roots:

eg: mino 'parcel up' nino 'parcelled up'
menyawa 'marry off' senawa 'given in marriage'
 (cf: ino 'a bundle' sawa 'a spouse')

.212 Verb stems:

eg: kemilut 'hang up' kenilut 'hung up'
mebetul 'put right' benetul 'corrected'
 (cf: pekilut 'hanging' betul 'correct')

.213 Adverbs roots:

eg: kemekel 'leave in place' kenekel 'left there'
 (cf: kekel 'still')

3.32.22.22 UIE paradigm. Because the UIE paradigm lacks a fourth verb form equivalent to the unaffixed stem of MNP verbs (\emptyset affixation), there is no morphological distinction between Subject Focus Static and Object Focus Static forms, merely one Static form with -e-. This clouds the formal distinction of transformation potentials which allows vc to be clearly defined in the MNP paradigm. UIE verbs are therefore tentatively assigned to va and vc subsets on the grounds of their actual occurrence in texts, vc being those which are found in specifically adjectival construction with an -e- form, as eg: bati lenyed 'a sunken log' (cf: lunyed

'to submerge (something), to drown (someone)'

eg: subit 'tear' sibit 'torn (by...)' sebit 'torn'
lupeng 'snap' lipeng 'snapped (by)' lepeng 'broken'

3.32.22.3 Ambivalent verbs are those in which there is no change in the form of the verb in transitive or intransitive construction, or where the intransitive form is ambivalent between Process and State¹.

.31 MNP paradigm.

eg: mikax 'unfurl, unroll'
miga 'wake up, awaken'

.32 UIE paradigm.

eg: kuxid 'shave' sukel 'choke, strangle'
 (Subject to the general rider that all UIE verbs may prove to be ambivalent after further research)

3.32.22.4 Sentential Object verbs are those transitive verbs va which take a full or truncated sentence as their Direct Object². (In this, they parallel the distribution of those intransitive verbs which may take Subject or Object sentence complements) These verbs occur in Agent Focus clauses with me- affixation, and in Object Focus with ne- .

1. See further at 3.32.21.3 Ambivalent verbs

2. Following Palmer's suggestions for the English verb (1965. 150ff), Longacre (1970.804) treats these included syntagmemes as "merged sentences" without the status of Clause or Complement. Their parallelism as a set with the intransitive verbs is the main reason for treating them as Verbs with Sentential Object, where the form of the Object is $O_S = O + (\underline{ba}')$ + V, as eg: Jilag megam (luin ba' kukut giin)₀ 'Jilag invited them to dig just there.'

eg: demu'a 'pray' kemudin 'forbid'
megam 'invite' memada' 'command'
menyabi' 'request' metox 'allow'

thus:

- (1) Tugau memada' urang nyin pepela lega-legah
 Tugau_F A+order slave he S+paddle fast-fast
 'Tugau made his men paddle as fast as they could'
- (2) Likou Tanam kenudin nyin ba' pekaxi bah aba'
 folk_F Tanam P+forbid he int. S+fish side downriver
 'He forbade the Tanam people to fish downriver'

In construction with 1st person pronouns as Subject, these verbs form the nucleus of Performative Sentences PS1 (cf: 4.41.12). (The subscript_F is explained at fn1 on p.147)

3.32.3 Verb Inflection

Of the four distinct processes of verb affixation which have been described in the foregoing sections, the highly restricted -en suffixation will receive no further attention. Affixation of deictic Locatives is a form of Derivation, and is dealt with in more detail at 3.32.12.23 above.

Two productive processes remain, the Inflection paradigms of MNP verbs and UIE verbs respectively.

3.32.31 The MNP paradigm.

Verbs inflected according to this paradigm form the most numerous subset of Melanau inflected verbs. They have the general structural formula at the word level:

$$V = \text{Affix} : \begin{bmatrix} \emptyset- \\ \underline{me}- \\ \underline{ne}- \\ \underline{pe}- \end{bmatrix} + \text{Stem} : \begin{bmatrix} \text{noun} \\ \text{verb} \\ \text{adverb} \end{bmatrix}$$

(where the : separates place and filler, in tagmemic notation)

3.32.31.1 The Zero affix \emptyset -

For reasons of structural uniformity, the unaffixed stem is treated as carrying a Zero affix \emptyset -. This form of the MNP verb has two syntactic distributions; string initial position (Focal item in clauses unmarked for emphasis) of Verb Focus Dynamic clauses, and in the first non-focal position (that a Predicate may occupy) in the Object Focus Static transform string.

3.32.31.11 Verb Focus Dynamic clauses are of two kinds, the Imperative and the Narrative¹.

.111 Imperative (and related Hortative) clauses:

eg: atu' (ka'au) teluh in
 V+pick-up_Fyou egg that
 'Pick up that egg!'

.112 Narrative:

eg: atu' nyin ga' teluh in
 V+pick-up_Fhe at egg that
 'So he picked up the egg.'

1. The various kinds of Verb Focus clause are described in detail at 4.31.12.2, where the Focal distinctions receive due attention. The system of affixes attached to verb stems in the GLOSS is also explained there, being largely mnemonic: A+ = Actor (or Agent) Focus Dynamic clause structure, with appropriate verbal affix in the vernacular, O+ = Object Focus Dynamic, V+ = Verb Focus Dyn; S+ = Subject Focus Static, R+ = Object Focus Static, the form of the verb identical to the analogous noun root. Subscript _F is attached to the lexical item in Focus.

The distinction between Dynamic and Static clauses, which is tacitly accepted throughout the verbal morphology, is explicitly formalised in the syntax of transitive clauses, 4.31.12.21.

3.32.31.12 Object Focus Static clauses, in which the verb is attributive as opposed to its predicative role in OFDyn clauses, have a verb with \emptyset affixation as nucleus. The Zero-affix signals a state of completed action.

eg: teluh atu' nyin nga' madam nga'
 egg_F R+pick-up he past S+rot past
 'The egg he picked up was already addled'

3.32.31.2 the me- / ne- / pe- affix system on MNP stems.

The apparently simple pattern of me- / ne- / pe- affixation disguises a complex set of homophonous morphemes¹ labelled on identification as eg: {me₃-}. Each morpheme in the set has the same inventory of allomorphic homophones, which are not distinguished by indices, as seen for example at 3.32.31.21.100 below.

It appears at present that the system comprised of the affixes {me₂- : ne₂- : pe₁- / pe₂-} functions to mark the oppositions, in terms of clause organisation,

Active	: Passive	: Middle
AFDyn	OFDyn	SFStat

while {me₃- : ne₃- : pe₁- / pe₃-} mark oppositions of

Causative	: Passive	: Stative	within the clause nucleus.
AFDyn	OFDyn	SFStat	

1. This is due in no small measure to the metathesis of the consonantal onsets to the first two syllables of polysyllabic words which, it has been shown at 2.35 above, is characteristic of much (but not all) Melanau long-word morphology. It is, then, arguable that at some level of analysis the form kemilut 'hang up' should be handled as *mekilut before this morpho-phonemic process has operated; such an intermediate level is not set up in this description, but is implied in the gloss 'A+hang-up'.

There is a residue of affixes not accounted for in these basic oppositions, Second Order affixes of Continuative aspect and Reciprocity which are discussed at an appropriate point in the text. (as eg: 3.32.31.23.211,212)

3.32.31.21 me- Affixation

A general breakdown of verbs with initial m- is given at Table 32.1 and discussed in the following sections of text 3.32.31.21.100-218.

Beacuse the affixed stems are drawn from the inventory of nouns, transitive verb stems and, in some cases, intransitive verb stems and even adverbs, a multiplicity of examples is cited to give some idea of the diversity of forms which manifest a particular affixation process.

3.32.31.21.100 Allomorphs of the me- affix

- m- Affixed to polysyllabic stems with initial vowel,
eg: mubat, mapun;
- menge- Affixed to the monosyllabic stem nyat 'grown up'
mengenyat (possibly to balance those below)
- meng- Affixed to some polysyllabic stems with initial
vowel, eg: mengasou, mengupat;
- meN- (where N is a replacive nasal homorganic with
the initial consonant of the stem) Affixed to
polysyllabic stems with initial voiceless con-
sonants p, t, s
eg: memereng, menuba, menyadai;

- meN- / -em- (in apparently free fluctuation, depending on the idiolect of the speaker) Affixed to polysyllabic stems with initial velars k, g
eg: mengilut / kemilut, mengaup / gemaup;
- meN- ∞ me- Affixed to polysyllabic stems with initial b, as eg: memada', memujo',
mebatu', mebetul;
- me- / -em- (in apparently free fluctuation) Affixed to some polysyllabic stems with initial j,
eg: mejaja / jemaja, mejeji / jemeji;
- me- Affixed to all monosyllabic stems, and to polysyllabic stems with initial liquid or nasal, eg: mesen, metug; merata,
meliid, mematuh, menyadin;
- em- Elsewhere,
eg: demipih, kemulit, gemeleng, jemala.

3.32.31.21.200 Breakdown of affix homophony

Verbs with an initial m- (or recognisable -em- infix) are found to fall into a number of coherent and more-or-less homogeneous groups, allowing of several general "meanings" to be associated with the four homophonous me- prefixes discussed below. These four are mutually distinguished on composite grounds of Syntactic Function of the affixed form, Combinatorial Valence, and Meaning, corresponding to the triple of Form, Distribution and Meaning which define a tagmene (Cook 1969.20) and hence must hold over allotagmes within a tagmeme.

The me- form
of verbs

TABLE 32.1

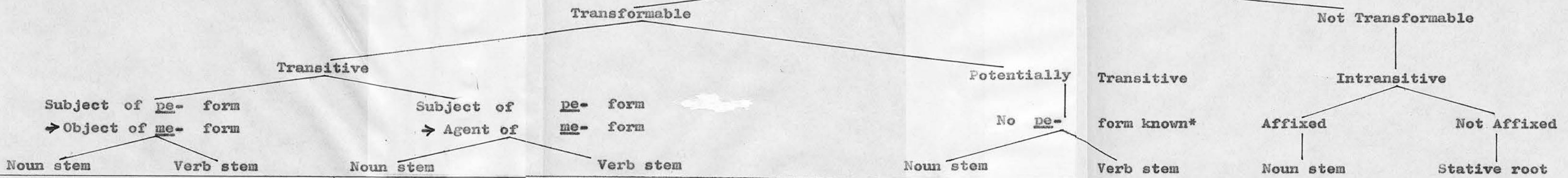

Transformable		Potentially		Not Transformable			
Transitive		No <u>pe-</u>		Transitive			
Subject of <u>pe-</u> form → Object of <u>me-</u> form	Subject of <u>me-</u> form → Agent of	Noun stem	Verb stem	form known*	Intransitive		
Noun stem	Noun stem	Noun stem	Verb stem	Noun stem	Affixed		
Verb stem	Verb stem	MNP stem	UIE stem	Verb stem	Not Affixed		
					Stative root		
<u>mebin</u> carry on back	<u>demadah</u> warm by fire	<u>generaji</u> saw up, use saw		<u>demepa</u> sound depth in fathoms	<u>madam</u> rot, go rotten	<u>jema'et</u> collect edible fern tips	<u>mama'</u> be dirty
<u>melap</u> arrange in layers	<u>gemeleng</u> roll along	<u>kemi'it</u> fan into flames	<u>gemaup</u> blow, puff at	<u>mubah</u> split	<u>makat</u> rise up, lift	<u>masi'</u> show mercy	<u>mapé'</u> be lame
<u>mesen</u> dam up	<u>kemilut</u> hang up	<u>memeritah</u> govern	<u>jemaja</u> sell (for others)	<u>mubut</u> bore hole in	<u>miga'</u> wake up	<u>mejed</u> be strong	<u>maxet</u> constricting
<u>menunang</u> promise in marriage	<u>kemekel</u> leave in place	<u>menibah</u> call, instruct	<u>kemudin</u> forbid, prohibit	<u>munu'</u> put to death	<u>mikax</u> unfurl, unroll	<u>melaméh</u> collect edible caterpillars	<u>medut</u> be afraid
<u>menyawa</u> give in marriage	<u>madam</u> allow to rot	<u>meraja</u> rule over, govern	<u>matu'</u> pick up in the fingers	<u>mupox</u> pluck, reap	<u>mengupat</u> swell up, make large and round	<u>memeng</u> intone, make incantation	<u>mexih</u> be angry
<u>mino'</u> bundle up	<u>meba</u> open (a door)	.	<u>mebatu'</u> assist	<u>muput</u> spit out	<u>mengenyat</u> grow in size, enlarge	<u>mitul</u> be filthy	.
.	<u>mebetul</u> put right	.	<u>megam</u> invite	.	.	<u>menatau</u> ask riddles	.
.	<u>meliid</u> arrange side-by-side	.	<u>melei</u> purchase	<u>menyikep</u> fish for prawns with a sieve	.	<u>mu'éh</u> mourn, lament	.
<u>kemulit</u> remove skin, peel	<u>melim</u> conceal	<u>miud</u> drag overland	<u>mulin</u> steer with a rudder-paddle
<u>meneluh</u> castrate	<u>mexéh</u> leave behind
.	<u>menyapai</u> bring about
.	<u>muei</u> put out to dry
.
.	← <u>Causative</u> →	← <u>Active</u> →
.	•by inflection	Basically transitive
.	<u>meleka'</u> undress (other)
.

← Externally related Internally related →
Dynamic Static

*Assumed not to exist, but
see fn. at 3.32.31.21.209

3.32.31.21.201 Zero meaning, a fortuitous m- initial as far as contemporary Melanau is concerned. The verbs in this group fall into the broad class of Intransitive vp or vs, for which the me- form is not typical.

eg: <u>maléh</u>	'be lazy'	<u>manah</u>	'be happy'
<u>mapé'</u>	'be lame'	<u>maxet</u>	'be tight'
<u>medut</u>	'be afraid'	<u>megou</u>	'on fire'
<u>melep</u>	'pass from view'	<u>memo'</u>	'be rotten (fruit)'
<u>mexih</u>	'be angry'	<u>mitul</u>	'be filthy'

Verbs within this group, Group 1, cannot be divided into Immediate Constituents in any meaningful way (however possible that may be for recognisable cognates in related languages) and are regarded as Unaffixed verb roots vi (vp or vs).

3.32.31.21.202 Possession of a quality, the abstract noun root which forms the stem for affixation. These are all Intransitive, have no transform potential, and take a non-agentive Subject (Fillmore 1967.25, Lyons 1968. 357). They occur in Subject Focus clauses.

eg: <u>mamo'</u> / <u>mengamo'</u>	'go crazy, run amok' (<u>amo'</u>)
<u>masi'</u>	'be merciful, show mercy' (<u>asi'</u>)
<u>mejed</u>	'be strong, have strength' (<u>jed</u>)
<u>mengakel</u>	'deceitful, practice deceit' (<u>akel</u>)
<u>mengipin</u>	'be crazy, lapse into madness' (<u>kipin</u>)

Verbs in Group 2 may be paraphrased by a formula such as: mejed = bei jed 'have strength'

In construction with another nominal, the semantic recipient is syntactically an Indirect Object in an oblique case (the Referent of the Focal discussion)

eg: a raja masi' ga' lou rayet nyin
 pers ruler S+pity at ppl subject he

'The ruler is merciful towards his subjects'

There is no Active : Passive or Active : Causative distinction possible with these verbs, which are semantically and syntactically parallel to those of Groups 2-7 discussed in pe- affixation below. They are therefore regarded as being in 'Middle Voice' (in the sense of Lyons 1968.373), and as a set they manifest {me₀-} affixation.

3.32.31.21.203 Reflexive process or action, formally intransitive.

The stem is either an Uninflected intransitive State verb vs or one of a small class of Ergative verb roots (Lyons 1968.351ff, cf: 4.31.12.18).

eg: mengupat 'swell up' (cf: upat 'swollen')
mengenyat 'grow large' (cf: nyat 'grown up')
madam 'rot (of carcass)'
melawa' 'grow mildew' makat 'get up'
miga' 'wake up' mikax 'unfurl'

Verbs in Group 3 may occur in transitive clauses with a Direct Object, without morphological change, as

eg: buki babui in madam

corpse pig that rot

'That dead pig is rotting' (or 'is rotten')

cf: likou Penan madam sei babui si'iu, béh in keninah¹
 tribe Penan_F A+rot meat pig before after that P+eat

'The Penan "hang" pig-meat before they eat it.'

1. The reason for the shift from Agent Focus to Object Focus in the serial clause is discussed in section 4.32.25 as a rule of compound sentence construction.

The reflexive nature of these constructions, self-interest in the action (Lyons 1968.373), is taken as typical for expression of Middle voice. Group 3 therefore also manifest {me₀-} affixation.¹

3.32.31.21.20⁴ Active, collect the noun which forms the stem.

Formally intransitive, the covert Object of transitive action is the verb stem itself, which is one of a set of naturally occurring edible substances.

eg: gemexawat 'collect tuberous roots' (gexawat)
jema'et 'collect leaf-tips' (ja'et)
melaméh 'collect caterpillars' (lelaméh)
menyi'et 'collect sago-grubs' (si'et)

Verbs in Group 4 may be paraphrased by some such formula as: gemexawat = pinyi gexawat² 'search for tubers'

There are no transforms of these verbs into other forms. The Subject of each verb is semantically an Agent in formally intransitive construction. This is distinguished as {me₁-} affixation.

1. An alternative treatment of these verbs would be to regard them as a subset of Causatives with deleted Object (= 'self'). The case is argued at 4.31.12.18. Because of their internal structure me- + vs, the first two appear also in the list of Causative verbs vc, Group 14 below.

2. In practice this is most unlikely to be heard, because of a palei 'taboo' forbidding the name of gexawat to be mentioned at the time of the search. The actual formula would probably be: da'ou telou pinyi akah 'let us go looking for vines', lest the tubers hear and hide under stones and roots. This is a cultural rather than a linguistic probability, and does not alter the fact that the form gemexawat exists, with the meaning assigned.

3.32.31.21.205 Active, perform the noun which forms the stem.

These stems are drawn from a restricted set of names of activities which exist only in the performing¹. Formally intransitive, they have an implied Object, much as verbs in the groups above.

eg: mematuh 'bark, make sound of barking' (matuh)
memeng 'call down curse, cast a spell' (meng)
menangih 'weep, make sound of weeping' (tangih)
menatau 'quiz, ask riddles' (uba' tatau)
menerjun 'leap down, take a leap' (terjun)
menyuket 'sing a ritual chant' (suket)
mui 'call out customary cry' ("Ui!")
mu'éh 'keen over dead, intone lament' (u'éh)

Verbs in Group 5 may also occur in transitive clauses and are cross-classified in Group 10 below. When in intransitive construction, they have obvious affinities with Groups 4-7, and are regarded as manifesting {me₁-} affixation.

3.32.31.21 .206 Active, bring into being the noun which forms the stem, which is drawn from a set of nouns naming artefacts. Like .204 above, these verbs have a covert Object of transitivity, despite the formal intransitive constructions in which Group 6 occur. Subjects are semantically Agentive.

eg: makit 'make a raft' menalei 'make rope'
menatau 'make riddles' menulih 'compose writing'

1. These verbs are, in an active sense, parallel to the set of performative verbs forming the nucleus of sentences PS, which are discussed at 4.41.12.

menyayur 'prepare vegetables'

menyurat 'write a letter'

Verbs of Group 6 may all be paraphrased by some such

formula as menalei = mena' talei 'make rope'

The similarity with Group 5 is obvious, and these

are also seen to manifest {me₁-} affixation.

3.32.31.21.207 Active, use the noun which forms the stem. The stem nouns are drawn from a set of names of tools or instruments (which may be animate or inanimate); the verbs are formally intransitive, as Groups 1-6.

eg: kemetem 'use a plane' (ketem)
gemereji 'use a saw' (gereji)
memesei 'fish with hook and line' (pesei)
memugu' 'set a trap made of sago-stump' (ugu')
mengabai 'fish with a large-mesh net' (abai)
mengasou 'hunt with dogs' (asou)
menuba 'fish with poison-root' (tuba)
menyadai 'ambush pigs at river-crossing' (sadai)
menuju 'take a direction' (tuju)¹

1. Appeal is made at .211 below to the notion of pseudo-transitivity, when the syntactic forms of a language force on its speakers an apparent way of thinking (Lyons 1968.351) which is counter to a semantic analysis of the linguistic material. Such a mismatch is evident in the apparently transitive construction: menuju mata lau matai 'go in a Westerly direction'. I.C. analysis shows, however, that the me- prefix is enclitic to the entire nominal phrase which forms the stem, me-(tuju ((mata lau) matai)), NP323.3 'the direction of the setting (dying) sun'. The entire verbal syntagm is therefore equivalent to the dynamic deictic adverbials such as kaju' 'go upriver' (aju'), which are discussed in detail at 3.33.12.3

Verbs in Group 7 may be paraphrased by some such formula as: mengabai = peba' abai 'use an abai net' and by clear parallel with Groups 4-6 above are seen to manifest {me₁-} affixation.

3.32.31.21.208 Active, make the noun which forms the stem from the material specified as Direct Object; there is a clear relation with the verbs in Group 6.

eg: menalei (akah) 'make a rope (of vines)'

makit (bati) 'make a raft (of logs)'

menikem (rigit) 'make a wager (with dollars)'

Verbs in Group 8 may all be transformed from the AFDyn form cited above to the passive form nuclear to OFDyn clauses, and to the root ("zero affix") form in OFStat clause construction, as

eg: akah tenalei nyin sapai cukup lalou

vine_F P+rope he until enough long (OFDynamic)

'He plaited vines into a rope until it was long enough'

akah talei nyin sapai tana' iba'

vine_F R+rope he reach ground below (OFStatic)

'The vines which he had plaited into a rope reached down to the ground'¹

In both of these clauses, the Agent is the same as the Subject would be in the intransitive construction diagnostic of Group 6 above. Although there is no

1. The NP323.3 akah talei nyin could also be interpreted as NP321.3 'the vines in his rope', regarding talei as nc. This is always possible with the root form of MNP verbs, making for several structural ambiguities discussed in the text (eg: 4.32.223)

recorded pe- prefix form to these verbs¹, the clear structural parallel within the set of Groups 8-12 is such that Group 8 must manifest {me₂-} affixation.

These Groups 8-12 are all of transitive verbs, occurring as the nuclei of Agent Focus Dynamic clauses. The Agent of a transitive Dynamic clause is the same nominal as the Subject of a related Static clause in which the verb is in Middle Voice.

3.32.31.21.209 Active, measure the Direct Object in units of the stem. Stems of this group are drawn from a small set of nu, mensuration units of length, area and volume (but not, as far as is known, of weight).
eg: mika (padang) 'measure (field) in acres' (ika)
demepa (anum) 'sound (the water) in fathoms' (depa)
Verbs of Group 9 are found in OFDyn clauses more typically than in the Active form cited here. No pe- form is found in the textual or elicited material. Group 9 manifests {me₂-} affixation.

3.32.31.21.210 Active, act on the Direct Object with the noun forming the stem. These verbs are largely, but not exclusively, those of Group 7 in transitive syntagms.

1. A. Teeuw (1962.411) discusses the implications of such lacunae in a corpus of material, debating whether they are fortuitous or systematic. Since pe- forms are absent throughout the entire set of verbs comprising Groups 8-11 (even though regular for verbs of Group 12) and irrelevant to Group 13, it is assumed that the omission is systematic for this subset of stems of Basically Transitive verbs. (Lyons 1968.386).

eg: gema'ih (kayou) 'carve trail-mark (on a tree)'
jemaxet (payau) 'set a snare for (a deer)'
kemetem (asu) 'plane smooth (a plank)'
mejil (a-ja'et) 'put (a criminal) in jail'
mubat (a-pedih) 'treat (a sick person)'
matep (sei) 'pick up (meat) in tongs'

The pattern of affixation is already clear from the clause examples cited previously. OFDyn and OFStat transforms are regular, maintaining the same Agent throughout. Group 10 manifest {me₂-} affixation.

3.32.31.21.211 Active, extend intransitive verb to an Object of transitivity (or pseudo-transitivity, in the sense discussed in Robins 1964, 266, Lyons 1968.351, 363). The stems themselves are regular intransitive vp.

eg: jemaga (ane') 'guard (a child)'
menangih (a-matai) 'weep over (a dead person)'
menetawa (a-lakei) 'mock (an older person)'
menyeruru' (a) 'play a joke on (someone)'

Verbs in Group 11 have no corresponding pe- form, but OFDyn clauses with a ne- form are regular, having the same Agent as is Subject of the intransitive verb in its constructions.

eg: ane' apah maap tenangih a tina
 child_F cl. be-lost P+weep mother (OFDynamic)
 'The mother wept over her lost child'
 or 'The lost child was mourned by its mother'

Verbs in Group 11 manifest {me₂-} affixation.

3.32.31.21.212 Active, transitive; the typical group for this form of affixation. Stems are transitive verb roots vt,

Active *va* (in distinction to Causative *vc*); the clause Subjects are semantically Agentive.

eg: demipih 'store up' gemuguh 'shake, sieve'
jemaja 'sell'¹ masek 'put on (clothes)'
matu 'pick up' megam 'invite'
melei 'purchase' mena'ah 'listen to'
meninou 'set fire to' mibet 'throw away'

Verbs in Group 12 are cited in Active form, as in AFDyn clauses; all have corresponding SFStat (Middle Voice), OFDyn (Passive), OFStat (Adjectival) and VFDyn (Narrative and Imperative) forms. With Group 10 they form the largest and definitive set of verbs which manifest {me₂-} affixation

3.32.31.21.213 Active, special case. There is some overlap in the AFDyn form between the two large Form classes of MNP and UIE transitive verbs. A subset of UIE verbs carries initial m- before the regular -u- in AFDyn of stems with an initial labial stop consonant p or b; other forms are regular for the UIE paradigm, as described at 3.32.31.11 below. This is regarded as a form of redundant double affixation, with no synchronic significance and carrying no semantic load, (therefore not treated as Second Order affixation).

eg: mubah 'split' mubed 'tie up'
mubal 'beat' mubex 'cast (a fishing net)'
mubut 'bore a hole' munu 'kill'
mupex 'knock' mupox 'harvest, reap'

1. jemaja appears to have the added connotative meaning of selling an article on behalf of someone else, thus distinguishing it from the self-interested Middle verb pejaja 'to sell'.

The initial m- is the normal allomorph of all me- prefixes occurring before a vowel stem (see .100 above). Group 13 manifests redundant {me₂-} affixation.

* . * * * * * .*

Groups 14-18 are all transitive, occurring in Agent Focus in Dynamic clauses. The Object of the me- affixed verb is the Subject of the intransitive or Middle Voice related verb (see syntax of Causative verbs at 4.31.12.2), which is diagnostic of the set of Causative constructions.

3.32.31.21.214 Causative, bring about the State denoted by the uninflected intransitive vi forming the stem.

eg: gemetu 'complete' kemekel 'leave in place'
madam 'leave to rot' mebetul 'put right'
menagep 'strengthen' menigah 'straighten'
menudui 'put to sleep' merata 'level off'
menyadin 'bring about, put into effect'

There is no corresponding pe- affixed form of the verbs in Group 14, which manifest {me₃-} affixation.

3.32.31.21.215 Causative, bring into being a Process or State

denoted by the pe- form of a verb stem. Agents of these verbs are all animate (see 3.32.31.23.209).

eg: gemeleng 'roll along' kemilut 'hang up'¹
meba 'open (a door)' medag 'bring onto land'
meliid 'put side-by-side' muei 'dry out'
memuséng 'turn round and round'
mexéh 'leave behind' muluh 'lower down'

1. kemilut appears to have the added connotative meaning that the article kenilut will then hang down, as a length of cord put over a peg, or a loin-cloth worn about the waist.

Verbs in Group 15 are parallel in their transform potential to Groups 14, 16, and with them are seen to manifest {me₃-} affixation

3.32.31.21.216 Causative, bring about a Process or State

denoted by the pe- form of the related verb vi formed on a nominal stem.

eg: mebin 'carry on the back'
melap 'arrange in layers'
menunang 'arrange engagement of'
mesen 'dam up'
mesusou 'give birth to, lactate'
menyawa 'give in marriage, marry off'
mino 'parcel up, do up in a bundle'

Verbs of Group 16 have a transformation paradigm like that already exemplified for other Causative verbs vc, and manifest {me₃-} affixation.

3.32.31.21.217 Causative, bring about a Negative State, the

reverse of that denoted by the pe- form related vs, which is always formed on a noun root as stem.

eg: kemulit 'remove the skin (kulit), peel'
meneluh 'remove the "eggs" (teluh), castrate'

Verbs in Group 17 occur more frequently (a comparative term, since they are not of frequent occurrence any way) in Object Focus clauses, and must be presumed to be idiomatic.

Group 17 manifests {me₃-} affixation, idiomatically.

3.32.31.21.218 Causative, bring about a State denoted by the
-e- form of the inflected UIE verb forming the stem.
 eg: meleka' 'undress (someone else)'

This is the only recorded form of Second Order affixation in AFDyn construction, and must be distinguished from that at .213 above as {me₄-} affixation.¹

The inflection of l-ka' 'undress (oneself)' is regular within the UIE system (3.32.32.2 below) so that the form leka' occurs in SFStatic clauses such as: ane' in leka' bajou

child that S+undo coat

'That child has its blouse undone'

Secondary affixation is required when an outside Agent performs the action to produce the state leka',

thus: a mexou meleka' bajou ane'

woman_F A+undress coat child

'The woman undresses her child'

in which me- is enclitic to the State VP..2 (4.22.122) leka' bajou 'undone at the blouse', much as discussed in the fn. to 3.32.31.21.207 above.

1. In conditions of dialect fusion, a redundant form of double affixation is found which, apparently similar to that described here, adds no further semantic component to the message. The Northern dialects of Melanau do not all have the full inventory of UIE verbs, making fuller use of MNP paradigm affixation. In the Ulu Tatau (Map 1) I have heard a Dalat born school-teacher cite the following paradigm of the (Central Melanau) verb s-but 'bite': menyubut, senibut, pesebut, sebut in which both the UIE vowel ablaut and the corresponding MNP affixes for the same voice and focus are applied together in a redundant, not an additive, way.

3.32.31.3 Meanings assigned to Affixes may then be summarised as follows:

- First Order {me₀-} Middle Voice, Subject Focus. It implies Possession of quality, or Reflexive action of a verb stem.
- {me₁-} Active Intransitive, Subject Focus; implying Collection of noun stem, Performance of noun stem, Creation of noun stem, and Use of noun stem.
- {me₂-} Active Transitive, Agent Focus; implying Making noun stem, Measuring in units of noun stem, Using noun stem; Extension to second n of intransitive verb stem, and transitivity of transitive vt stem.
- {me₃-} Causative Transitive, Agent Focus; implying States related to noun stems, and States related to verb stems vp and vs.
- Second Order {me₄-} Causative Transitive, Agent Focus; implying State of inflected UIE verb stem.

3.32.31.22 ne- affixation.

A general breakdown of verbs with initial n- is given in Table 32.2, and discussed in the following sections 3.32.31.22.100-206

3.32.31.22.100 Allomorphs

n- Affixed to stems with initial vowel,

eg: nakat, nigi', nubah

ne- Affixed to other monosyllabic stems, and to polysyllabic stems with initial liquid or nasal consonant,

eg: nebam, negap, nesen, netum, nexéh;

neraja, neliid, nenyadin

-en- Elsewhere,

eg: benada', kenulit, penaxut,

senerebou, tenangih

3.32.31.22.200 Breakdown of affix homophony

Verbs with an initial n- (or recognisable -en- infix) are found to fall into a number of coherent and more-or-less homogeneous groups, parallel to those already discussed for the me- prefixes above. For this reason the exemplification is reduced to a minimum, and Indices attached to the various ne- affix forms will be kept in correspondence with those already allocated to the {me-} morphemes.

TABLE 32.2

The ne- form of verbs

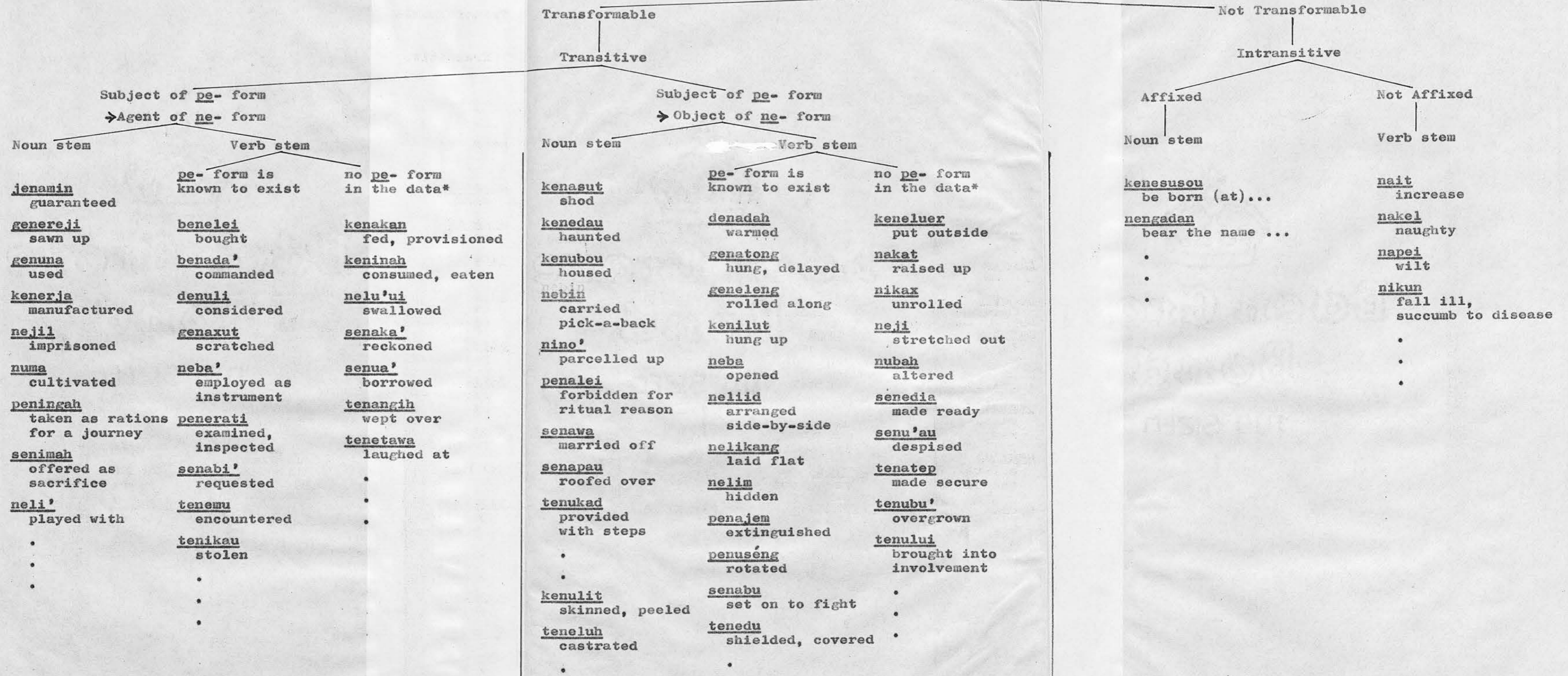

Subject of pe- form
→ Agent of ne- form

Noun stem	Verb stem	no <u>pe-</u> form in the data*
<u>jenamin</u> guaranteed	<u>pe-</u> form is known to exist	
<u>genereji</u> sawn up	<u>benelei</u> bought	<u>kenakan</u> fed, provisioned
<u>genuna</u> used	<u>benada'</u> commanded	<u>keninah</u> consumed, eaten
<u>kenerja</u> manufactured	<u>denuli</u> considered	<u>nelu'ui</u> swallowed
<u>nejil</u> imprisoned	<u>genaxut</u> scratched	<u>senaka'</u> reckoned
<u>numa</u> cultivated	<u>neba'</u> employed as instrument	<u>senua'</u> borrowed
<u>peningah</u> taken as rations for a journey	<u>penerati</u> examined, inspected	<u>tenangih</u> wept over
<u>senimah</u> offered as sacrifice	<u>senabi'</u> requested	<u>tenetawa</u> laughed at
<u>neli'</u> played with	<u>tenemu</u> encountered	.
.	<u>tenikau</u> stolen	.
.	.	.
.	.	.

Subject of pe- form
→ Object of ne- form

Noun stem	Verb stem	no <u>pe-</u> form in the data*
<u>kenasut</u> shod	<u>pe-</u> form is known to exist	
<u>kenedau</u> haunted	<u>denadah</u> warmed	<u>keneluer</u> put outside
<u>kenubou</u> housed	<u>genatong</u> hung, delayed	<u>nakat</u> raised up
<u>nebin</u> carried pick-a-back	<u>geneleng</u> rolled along	<u>nikax</u> unrolled
<u>nino'</u> parcelled up	<u>kenilut</u> hung up	<u>neji</u> stretched out
<u>penalei</u> forbidden for ritual reason	<u>neba</u> opened	<u>nubah</u> altered
<u>senawa</u> married off	<u>neliid</u> arranged side-by-side	<u>senedia</u> made ready
<u>senapau</u> roofed over	<u>nelikang</u> laid flat	<u>senu'au</u> despised
<u>tenukad</u> provided with steps	<u>nelim</u> hidden	<u>tenatep</u> made secure
.	<u>penajem</u> extinguished	<u>tenubu'</u> overgrown
.	<u>penuséng</u> rotated	<u>tenului</u> brought into involvement
<u>kenulit</u> skinned, peeled	<u>senabu</u> set on to fight	.
<u>teneluh</u> castrated	<u>tenedu</u> shielded, covered	.
.	.	.
.	.	.

Affixed

Noun stem	Verb stem
<u>kenesusou</u> be born (at)...	<u>nait</u> increase
<u>nengadan</u> bear the name ...	<u>nakel</u> naughty
.	<u>napei</u> wilt
.	<u>nikun</u> fall ill, succumb to disease
.	.
.	.

*Assumed not to exist, but see fn. to 3.32.31.21.209



3.32.31.22.201 Zero meaning, a fortuitous n- initial as far as contemporary Melanau is concerned, the verbs of Group 1 do not appear in Object Focus construction for which ne- type affixation is the norm.

eg: nait 'increase' (cf: Malay naik 'ascend')
nakel 'naughty' (cf: Malay nakel 'naughty')
napei 'shrivel away'
nikun 'succumb to disease'

While the last word nikun occurs in construction with a noun¹ pedih 'sickness', as nikun pedih 'fall ill', suggesting an OFDynamic clause (4.31.12.21.12), two facts militate against this interpretation. (1) There

(1) There are no corresponding forms *mikun, *pikun, or *ikun; (2) With much the same frequency, there is the parallel form nikun udei 'succumb again' VP..4, in which there is no suggestion of Agency attributable to udei or, indeed, any nominal at all. It is therefore appropriate to analyse nikun pedih as manifesting VP..2 structure, similar to ja'an pedih 'recover from illness' (see 3.32.42 below and 4.22.122)

3.32.31.22.202 Intransitive verb vs., in which there is a noun root recognisable; but the noun following is not in any sense Agentive.

eg: kenesusou 'be born (at)' (cf: susou 'breast')
nengadan
kengadan 'be named'... (cf: ngadan 'name')

1. There is rarely much certainty in classifying pedih as a noun except when it is in unambiguous NP construction, as eg: NP321.1 pedih babui 'pig fever = epilepsy' (cf: 4.21.321)

The first word is commonly followed by an Adverbial expression of time or place, while the latter (in either form) is followed by the name itself. It is shown at 3.32.11.51 that the final form of each has a diachronically interesting Causative affixation, but synchronically there is no possible verbal form of further (or less) inflection.

These verbs manifest {ne₀-} affixation.

3.32.31.22.203 It is noted that Groups 2-7 of the me- verbs are all intransitive, and therefore have no corresponding Object Focus form. There is therefore no ne- with index 1.

3.32.31.22.204 Passive of transitive action in OFDynamic clause construction. This section may be subdivided into groups exactly parallel to Groups 8-12 of the me- form verbs, yielding form classes as outlined in the Table at 3.32.31.2 introductory to this discussion. Verbs in parallel Groups 8-12 manifest {ne₂-} affixation.

3.32.31.22.205 Passive, Caused state in OFDynamic clause construction. This section may be subdivided into groups parallel to Groups 13-17 of the me- form verbs, so yielding form classes outlined in the introductory table. These are therefore Groups 13-17, which all manifest {ne₃-} affixation.

3.32.31.22.206 Passive, accomplished state occurring (in the material on which this study is based) only in the ne- form. Stems carrying this affix are nouns n or uninflected verbs vi.

eg: kenedau (tu) 'haunted (by ghosts)' (kedau 'place')
penesaka 'given as inheritance' (pesaka 'wealth')
tenubu' (nap) 'overgrown (with scales)' (nap 'scales')
tenukad 'with steps cut in' (tukad 'rung')

By clear parallel with Groups 14 and 16 of the me- verb morphology, these are regarded as manifesting {ne₃-} affixation.

3.32.31.22.207 Passive, Caused state denoted by the -e- form of an inflected UIE stem¹ which is itself a State verb, eg: neleka' 'undressed (by someone else)'
'caused to have (clothes) undone'

By clear parallel with Group 18 of the me- verbs, this is distinguished as {ne₄-} affixation.

3.32.31.3 Affix summary: the meanings assigned to the homophonous ne- form prefixes are:

First Order	{ <u>ne</u> ₀ -}	Intransitive verb (state)
	{ <u>ne</u> ₂ -}	Passive of transitive action, further subdivided parallel to { <u>me</u> ₂ -} above
	{ <u>ne</u> ₃ -}	Passive, Caused state, subdivided as the parallel { <u>me</u> ₃ -} was subdivided
Second Order	{ <u>ne</u> ₄ -}	Passive, Caused state of a UIE verb.

1. keninah 'eaten' might also be included here, having redundant double passive affixation -en- and the following -i-, much like the verbs described at fn. to 3.32.31.21.218 above.

3.32.31.23 pe- affixation.

A general breakdown of verbs with initial p- is given at Table 32.3, and discussed in the following sections 3.32.31.23.100-213.

3.32.31.23.100 Allomorphs

p- Affixed to stems with initial vowel,

eg: pasad, piib, puluh, puei

pe- Elsewhere,

eg: pedadah, pejuu', pemudei, pexuked

3.32.31.23.200 Breakdown of the pe- affix homophony

" ... the complex interrelationships which exist between the 'middle', the reflexive, the passive and various kinds of intransitive and pseudo-intransitive constructions in particular languages."

(J.Lyons 1968.375)

Verbs with an initial p- are found to fall into a number of coherent and more-or-less homogeneous groups, allowing several "meanings" to be associated with the five homophonous pe- prefixes which are isolated below.

The pe- form of verbs.

TABLE 32.3

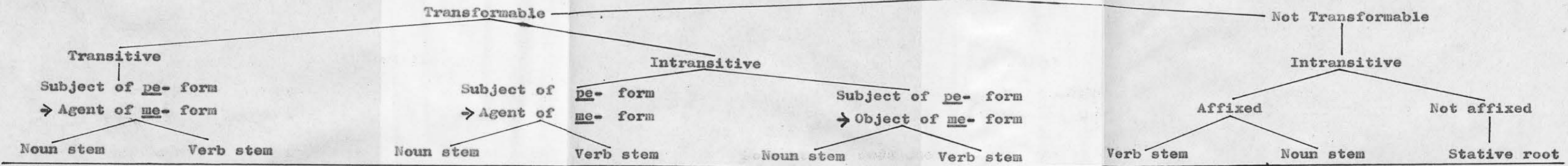

pasek
be clothed

pebelait
be armed

pekaxi
go fishing

pe*li*'
play

pe*pa*gut
be rasping

puma
be farming

.

.

.

payam
tame, rear, pet

pe*ba*'
use, by using

pe*ja*ja
sell (on ones own behalf)

pe*ng*an
accompany

pe*pe*rai
scatter, sow

pe*ta*'ah
hear, overhear

pe*gi*'
fetch

pe*la*'
look at, seeing

pe*se*'
cook (for self)

pe*ny*i
search for

.

.

.

pe*ba*m
take steps, by stepping

pe*ku*asa
have power

pe*pu*gu'
go trapping, by trapping

pe*ba*t
be curing

pe*ba*'
speak

pe*ta*'
vomit

.

.

.

pe*ma*n
drift on current

pe*de*g
touching

pe*ga*'ih
leave a trail behind one

pe*li*m
hide oneself

pe*ng*an
accompany (willingly)

pe*nd*ud
dragging over-land, porterage

pe*ue*i
dry out, sunbathe

pe*lu*h
lower oneself down (a rope)

.

.

.

pe*be*d
knotted together

pe*ku*lit
having skin on

pe*pa*lei
observing taboo, in 'retreat'

pe*sa*wa
married

pe*te*luh
having testes

pe*tu*ng
betrothed

.

.

.

pe*ki*lut
hanging down

pe*li*id
side-by-side

pe*li*iu
back-to-front

pe*li*m
concealed

pe*pu*se*ng*
rotating

pe*sa*bit
caught up

pe*sa*ng
paddle fast

pe*xe*h
remain

pe*ue*i
dry out

.

.

.

pe*be*nu'
killing each-other

pe*bu*kut
box one-another

pe*de*dug
bumping into each-other

pe*mu*i
kissing

pe*sa*bu
cock-fighting

pe*sa*ki'
copulate

.

.

.

pe*ne*'
have children, give birth

pe*bu*lu'
have feathers, grow body-hair

pe*bu*nga
have flowers burst into flower

pe*da*a'
covered in blood

pe*ja*ne'
be siblings

pe*pu*lu'
in tens

pe*ru*ku'
smoke cigarette

pe*sa*kai
be friendly

pe*si*nek
be sweaty

pe*te*luh
whole male

.

.

.

← Basically Dynamic Active by inflection

Basically Static Causative by inflection →

← Potentially Active (and reciprocal)

Essentially Stative (but can be inchoative) →

3.32.31.23.201 Zero meaning, a fortuitous p- initial as far as contemporary Melanau is concerned, although the verb forms belong in the broad class of intransitive vi.

eg: <u>padem</u>	'be dark, darkness'
<u>pedih</u>	'be sick, a sickness'
<u>penu'</u>	'be full'
<u>pebiah</u>	'be running, run'
<u>pedaat</u>	'be on land, go on foot'
<u>pegagau</u>	'be on all fours, crawl'

Verbs of Group 1 have no transform potential to the corresponding me- or ne- forms manifested by true inflected MNP verbs.

While the last three appear to have Immediate Constituents if split after the pe-, the pseudo-stem is not related to the present meaning in Melanau. pe- + daat, for example, would appear to be classable with Group 4 below, with the meaning 'make use of the sea, go by sea' (daat); which it does not mean. It may be recognised as the cognate form of Malay bedarat 'make use of the land (darat), go on foot'¹, but that is irrelevant to the synchronic study of Melanau. No meaning is attached to this initial p-.

1. The same cognate is clearly recognisable in contemporary Java Sundanese, badarat 'go on foot' (Robins 1965.438), and doubtless occurs in other related languages throughout the Indonesian archipelago. A similar equivalence by loss of intervocalic /r/ (in all probability via [ɣ] in Sarawak Malay → [h] in some Melanau dialects → ∅) is shown in the pairs daa' 'blood' (Malay darah) and baat 'heavy' (Malay berat), as shown in Appendix 2. It is quite possible that some similar derivation process may reveal the reason for the mismatch between the form pegagau 'crawling'

3.32.31,23.202 Inherent State, intransitive (or pseudo-intransitive, as Lyons 1968.364, 375), denoting possession of the noun which forms the stem.

eg: pane' 'have a child (ane'), give birth'
pebua' 'have fruit (bua'), come into fruit'
pebulu' 'have feathers (bulu'), sprout hair'
pedaa' 'have blood (daa'), covered in blood'
penupei 'have a dream (nupei), be dreaming'
pesawa 'have a spouse (sawa), be married'
pesinek 'produce sweat (sinek), be sweaty'

Verbs in Group 2 are found to indicate both the State of possession and the inchoative aspect of becoming in that state, without morphological change; only semantically does the Subject have the added feature [+Agentive] (Fillmore 1967.25, Lyons 1968.357).

eg: a mexou pane' jelawéh singen
 woman S+child one-cl. only
 'The woman has just the one child'

cf: a mexou pane' adep
 woman S+child alone
 'The woman gave birth unattended'

Verbs of this group may be paraphrased by some such formula as pebulu' = bei bulu'¹ 'have feathers, have body hair'. Group 2 verbs manifest {pe₁-} affixation.

(continued) and the homophonous (but not homosemic) stem gagau 'busy' (cf: Malay gagau 'fumble, in a dither') which may be expanded gemagau 'interrupt', genagau 'interrupted'.

1. Later diachronic study may reveal that the {pe₁-} prefix is a reduction of bei 'be, have'; but the present study makes no claim to such sophistication.

3.32.31.23.203 Bodily function, often accidental (see group 10 also). Heterogeneous as a stem class, all are in some sense Process verbs rather than State.

eg: pebeg 'to kneel, kneeling'
peden 'to see, noticing that ...'
pekijat 'to wink'
pejuu' 'to ooze (some secretion)'
pesinek 'to sweat, be sweaty'
peta'ah 'to hear, overhear, hearing that ...'
pila' 'to see, look at, seeing that ...'
puba' 'to speak, speaking'
puta' 'to vomit, retching'

Verbs of Group 3 are heterogeneous as to transform potential; such as have full or partial transformation paradigms tend to have also a shift in meaning outwith that imparted by the grammatical transform. eg: den 'visible' contrasts with nila' 'seen' in having the semantic feature [-volitional] : [+volitional]. The same contrast, however, distinguishes the two transitive forms peta'ah 'hear' and mena'ah 'listen to', while OFDyn tena'ah is neutral between the two. pila' and puta' have no corresponding forms *mila' or *muta'¹, while muba' and its transform nuba' have the distinct connotation of detrimental speech or 'blame' quite lacking from puba' 'speak'.

1. By normal correspondence rules, the Malay verb munta 'to vomit' would appear in contemporary Melanau as *muta', which is not found in the corpus. The initial p- is therefore seen as significant in the classification of Melanau affixes, placing 'vomit' among those p- initial verbs concerned with bodily functions.

While there is some obvious overlap with Groups 2 and 11, the essential self-interest of the verbs in Group 3 is a characteristic feature of 'middle voice' of classical grammars, (Lyons 1968.373), under which cover term are subsumed all forms manifesting {pe₁-} affixation.

3.32.31.23.20⁴ Contingent Process or State, intransitive (or pseudo-intransitive) denoting possession or use of the noun forming the stem.

eg: pepela 'have a paddle, to paddle along'
pesalui 'have a canoe, go by canoe'
peseput 'armed with a blowpipe'
peruku 'smoke a cigarette'

Verbs in Group 4 have not the inchoative sense of those in Group 2 above, and the possession is not the outcome of an internal or natural process. There is no transform potential to other MNP forms.¹

While the latter two forms cited lack the clear feature [+dynamic] that characterises the closely parallel set of verbs in Group 7 at 3.32.31.21.207 above (suput 'shoot with a blowpipe' is the dynamic form of seput 'a blowpipe', see 3.32.32.23 UIE verbs) it is not clear how pesalui 'use a canoe' is less dynamic than, say, mengabai 'use an abai net'; thus the pe- prefix instead of an expected me- prefix has no obvious semantic correlate. Nevertheless, by clear parallel with the {me₁-} affixation, Group 4 is seen to manifest {pe₁-} affixation.

1. But cf: pepela as it occurs in Group 5 also.

3.32.31.23.205 Reflexive action, process or state, intransitive (or pseudo-intransitive); the Subject of the Action is animate, of the Process or State may be animate or inanimate.

eg: paman 'drift with the current, floating'
pasad 'stop'
pelim 'hide, hidden from view'
pepela 'paddle (oneself in a canoe)'
pexéh 'remain behind'
pixat 'stretch (one's arms, wings)'
puei 'dry out, lie in the sun drying'
puluh 'lower oneself (down a rope)'
pelikang 'lie down, laid out on the ground'
petikau 'steal (oneself) away unnoticed'
petili 'reveal oneself, be visible'

Verbs of Group 5 all contain an element of semantic application of the action or process to "self", and are therefore labelled pseudo-intransitive and grouped with other verbs in 'middle voice'. They could be included equally well in Group 8 for their feature of Continuity, or Group 9 as formally Intransitive. They are the most cross-classifiable group of verbs, and it is eventually somewhat arbitrary to assign them to any one group rather than another¹.

Dynamic transformations of clauses containing the verbs of Group 5 maintain the Subject of the pe- form

1. Crystal (1967.46ff) finds that, while some of the nouns of English have sufficiently clear features to allow mutually distinct sub-classes to be established, a considerable number may equally well be classed with several of these subsets.

as Agent of the me- and ne- form verbs. It is also possible to construct Active sentences semantically equivalent to the Middle sentences by overtly specifying the reflexive nature of the direct Object.

eg: a lai puluh ba'ai kuman lawei kayou

man S+lower go-down from foliage tree
'the man lowered himself down from the branches of the tree.'

cf: a lai muluh nyin-debei ba'ai kuman lawei kayou

man A+lower he-self go-down from foliage tree
'the man lowered himself down from the branches of the tree.'

It is further noticed that verbs in Group 5 retain their pe- prefix in the Imperative mood, implying a Process rather than State base meaning.

eg: "pexéh ka'au!"

S+remain you 'Please stay where you are'

(a polite formula used by a guest taking leave of his host, see 4.42.35)

These verbs are regarded as Inherently Transitive (or Basically Transitive, as Lyons 1968.386) with a deleted object¹ "self" in the pe- form syntagm; as a group, they manifest {pe₁-} affixation.

3.32.31.23.206 Transitive (or pseudo-transitive) Process or State
with animate Subject.

eg: pasek (bajou) 'have on (a shirt, blouse)'

1. The term "deleted" is borrowed from the vocabulary of T.G. description to distinguish the recoverable nature of the implied "self" from the general nature of unspecified objects (or subjects) seen in expressions such as lian ba' meninou 'the burning-off season, the time for burning-off (farmland)' - see 4.21.323.2

<u>patu'</u> (<u>si'</u>)	'be a collector (of shells)'
<u>peba'</u> (<u>ketem</u>)	'use (a plane), with (a plane)'
<u>pe'</u> (<u>dam</u>)	'be playing (draughts)'
<u>pila'</u> (<u>ji ...</u>)	'look at (the appearance of ...)'
<u>puma</u> (<u>balau</u>)	'be a farmer (of sago-palm)'
<u>pebelait</u> (<u>senapang</u>)	'be armed (with a shot-gun)'

All the verbs in Group 6 with the exception of peba' 'use' may be seen as pseudo-transitive only, since the pe- prefix is really enclitic to the NP including the apparent object (cf: discussion of menuju at 3.32.31.21.207); thus p-(uma balau)_{NP321.2} 'have (or use) a sago "garden"' or even as an occupation, 'be a sago-palm planter'. As such, all these verbs might be classed with Group 4.

The status of peba' is itself anomalous, since by distribution it may be grouped with the class of Prepositions (cf: 4.32.221), thus:

- (1) akou menedu siau peba' da'un balau
 I_F A+cover fowl S+use leaf sago-palm
 'I shield the hens (from the sun) with sago fronds'
- (2) akou menedu siau jigem da'un balau
 I_F A+cover fowl with leaf sago-palm
 which has an identical gloss.¹ As a set, however, the verbs of Group 6 manifest {pe₁-} affixation.

1. This correspondence between some verbs and prepositions in the related Bahasa Indonesia has been noted by Becker and Arms (1969.7), and receives further attention at 4.32.221 where it is noted inter alia that (1) but not (2) above may be switched to a transformation with da'un as direct object. A similar ambivalence is found in directional adverbs (4.31.12.143)

3.32.31.23.207 Transitive action of possible self-interest, in

Agent Focussed clauses.

eg: pejaja 'sell (on one's own account)'
payam 'keep as a pet'
pengan 'accompany (willingly)'
pigi 'fetch (from more remote to proximate)'
pinyi 'seek, look for'
pise 'cook (food) for oneself'
peba 'use'

While all the verbs in Group 7 except pinyi and peba have regular me- and ne- form in transformations, in which the Agent is the same as with the pe- verb, in each case there is a distinct shift in connotative meaning, as evidenced in the glosses of:

jemaja 'sell (for someone else)'
mayam 'train, make a pet of ...'
mengan 'force to accompany'
migi 'carry'
mise 'cook (food) for someone else'

It is possible that mayam and mengan might be accounted for under the Causative label (cf: 3.32.31.21.214), except for the fact that the pe- Subject is maintained as the me- Subject, which is counter to the first diagnostic feature of Causative construction. Also the glosses of pigi and migi are counter to the general correspondence of active and causative pairs.

The first and last examples in the list, however, are clearly marked in their compositional features for self-interest of pe- form (as against external relation of the me- form), suggesting 'middle voice' and therefore {pe₁-} affixation.

3.32.31.23.208 Simple intransitive process or action with an animate Subject (which may also be Agentive).

eg: pebam 'take a step (bam), move one step'
peduli 'take thought, be concerned'
pekana 'give voice (non-human), cluck &c:'
pega'ih 'blaze a trail, leave tracks'
piud 'dragging (overland), portage'
pupo' 'engaged in washing (clothes)'

Verbs in Group 8 may all be used in an Adverbial sense¹ in expanded clauses,

eg: Jilag pedaat dagen guun bau pega'ih
 Jilag go-on-foot in forest up S+leave-tracks
 'Jilag walked through the deep forest, leaving a trail behind him as he went.'

As a group, these verbs have regular transformational potential, maintaining the Subject of the pe- form as Agent of the me- and ne- form verbs in transitive construction.

eg: semua ane' debei ta'ou tuun mebam apui in
 all child not know swim A+step fire that
 'all the children who could not swim stepped (back and forth) across the fire.'
ba'ai kubou, kamei kenana penga'ed
 go-down house we(exc) P+cluck lizard
 'as we left the house, a lizard clucked at us'

1. While a sequence of two (or more) intransitive verbs may be analysed as a reduction of two (or more) clauses, it often also manifests a General : Specific relation similar to that of the Noun + Noun constructions as kayou péh 'tree manggeris' (NP321.2), typical of VP..2 (cf:4.22.122) so that pedaat pega'ih is equivalent to pedaat seneng 'walked freely' or wab la'an piud 'went to and fro (between major rivers) dragging (his canoe)'. This is specially a feature of verbs of motion, as 4.31.12.143 below.

Verbs in Group 8 (with the possible exception of peduli 'care', which can also be classed with Group 3) are the most typical of the Active verbs (cf: Causative) in intransitive construction; they are Basically Transitive (fn. to 3.32.31.21.208 above), manifesting as a group {pe₂-} affixation.

3.32.31.23.209 Contingent State (which may incidentally involve motion or other semantic process), intransitive, with non-agentive Subject.

eg: paman 'drifting on the current'
pasad 'stationary'
peba 'standing open (as a door, window)'
pekilut 'hanging down (as a tail)'
peleid 'standing side-by-side (as books)'
pesawa 'married'
pesug 'joined end-to-end'
pexéh 'remaining'
puei 'drying out'
peliliu 'turning round to face the other way'
'turned round to face the other way'
pepuséng 'turning round and round'

Verbs in Group 9 all manifest a Completed aspect in their semantic component, the last four also having Continuative features as an ongoing process. The last two in particular (and perhaps others, as eg: pesawa) may also occur in Ergative construction of self-initiated action (4.31.12.21.18, cf: verbs like 'open' and 'move' in English, Lyons 1968.350ff), as well as processes brought about by an external Agent. Considering peliliu, for example, cited above with

typically ergative and causative glosses, one may

gloss: salui in peliliu

canoe that S+turn-round

'the canoe swung round' (as with the tide)

or 'the canoe was facing backwards' (as the way
it was found by an observer, who may attribute
this to external agency, or may not)

While it is a moot point whether an unspecified
inanimate agent is presupposed in such a sentence,
an agent is always made overt in constructions where
a process rather than a state is specifically to be
understood; as, for instance, with ba 'open'¹.

eg: (1) benawi in peba

door that S+open

'the door is standing open'

(2) benawi in peba buya' pangai

door that S+open on-account-of wind

'the door was opened by the wind'

In transformations involving the me- and ne- dynamic
forms of the verb, Group 9 verbs require an agent with
the semantic feature [+animate], and then the Subject
of the pe- verb becomes the Object of transitivity.
This criterion is definitive of the system of affix-
ation of Inherently Stative verbs, Causative by

1. I am indebted to Mohammed Baidjuri and Yusof Awang Salleh, two
Melanaus students in Britain, for bringing to my attention these
details of inanimate agency and their non-volitional connotation.
Inche Baidjuri's comment is particularly revealing; "One might
also say benawi neba pangai 'the door was opened by the wind' as
if pangai were a person, but benawi peba is not satisfactory for
the process of the door opening on its own." cf: 4.31.12.121.

Inflection (see 3.32.31.21.214 and Lyons 1968.384).
Verbs of Group 9 are distributionally equivalent to both Uninflected State verbs *vs*, and to the inflected -e- form of UIE verbs.

cf: (3) padai puei buya' selau

rice S+dry on-account-of sunshine

'the rice is drying because of the sun's heat'

(4) padai tu'uh buya' selau

rice be-dry on-account-of sunshine

'the rice is dry because of the sun's heat'

(The is no lexically suitable UIE verb for this sense, but the exemplification of .210 below shows the -e- equivalence of the state caused in (4) above)

Consider also the pairs of related forms below:

(5) segaut 'be in a hurry' (uninflected *vs*)

menyegaut (ane') 'hurry up (a child)' (AFDyn)

(6) lepeng 'snapped' (inflected UIE, SFStat)

lupeng 'snap, bend to break-point' (AFDyn)

(7) pesawa 'be married, have a wife' (SFStat)

menyawa (X) jigem (Y) 'marry X to Y, cause X and Y to be married' (AFDyn)

There is clearly considerable possibility of cross-classification of membership of this group with some groups manifesting {pe₁-} affixation, while several clearly have a reciprocal relation built into them. Group 9 is classed as manifesting {pe₃-} affixation.

3.32.31.23.210 Accidental process or state in which there is a clear feature [-volitional] in the componential analysis of at least the connotative meaning (as in

Nida 1968.108ff).

eg: peden 'see, notice (without really looking)'
peta'ah 'hear, overhear (rather than listen)'
pesabit 'chance to get caught up, catch'
peliliu 'chance to swing round'

The first two examples have already been discussed in Group 3 (bodily function) and the second two are also in Group 9. They are drawn together here because of their common non-volitional content, a very real part of their total "meaning" as explained by some informants. It might be appropriate to allocate a further pe- prefix to this feature; compare, however, the following pair of sentences:

- (1) bajou in pesabit ga' pakou
 shirt that S+hang at nail
 'the shirt is hanging on a nail'
 or 'the shirt got caught (and so torn) on a nail'
- (2) bajou in sebit buya' pakou¹
 shirt that S+tear on-account-of nail
 'the shirt got torn on a nail'

Because of the parallelism of the pe- prefix and the -e- infix of the corresponding UIE stem, it would appear that Melanau does not mark the non-volitional semantic feature in the surface grammar beyond the use of Stative voice, the meaning regularly associated with the {pe₃-} prefix.

There is also distributional correspondence between

1. sebit is the Static form of s-bit 'tear', indifferent formally for Subject or Object Focus, with a regular UIE paradigm such as that described in detail at 3.32.32.2.

the Causal and Locational prepositions noted in .209 above, suggesting that Groups 9 and 10 are very closely linked. For these reasons, Group 10 verbs are tentatively regarded as manifesting {pe₃-} affixation.

3.32.31.23.211 Continuous or Habitual action or state (which may amount to the sense of occupation or profession); transitive or intransitive verbs in Subject Focus.

eg: <u>pasek</u> (<u>bajou</u>)	'have (a shirt) on'
<u>patu'</u> (<u>si'</u>)	'collect (sea shells)'
<u>payam</u> (<u>siau</u>)	'rear (hens), be a (chicken) breeder'
<u>puma</u> (<u>padai</u>)	'farm (rice), be a (rice) farmer'
<u>petinou</u> (<u>uma</u>)	'be engaged in burning-off (farm-land)'
	or 'accidentally set fire to (farm)'
<u>pemusuh</u>	'be in continual enmity with,' 'be enemies'
<u>pekubou</u>	'be housed (not merely sheltered)'
<u>pelikou</u>	'be settled, have made one's home'
<u>petili</u>	'go on flying' (<u>tili</u>)
<u>pelepeng</u>	'remain bent after being snapped'
<u>pelelou</u>	'just hanging about, go on waiting'

Group 11 is not homogeneous in regard to stem class or potential transitivity; many of its members have appeared also in the other groups of verbs, notably Groups 2 and 6.

However, the last three cited are pe- applied to intransitive verb stems, of which the last two are already inflected (cf: fn to .210 for UIE paradigm). Continuative aspect appears therefore to be denoted by Second Order affixation, distinguished as {pe₄-}.

3.32.31.23.212 Reciprocal action, process or state, formally intransitive. Verbs of Group 12 all take plural Subjects which are semantically also recipients of the transitive action &c:

eg: pesawa 'married to each-other'
pejane 'be siblings of each-other'
pemusuh 'be enemies of each-other'
pemui 'be kissing, kiss one-another'
pedudug 'bang into one-another, collide'
pesusud 'follow on one behind the other'
pededug 'banging into one-another, jostling'
pebenu 'killing one another, mutual slaughter'
pebegu 'crowded together noisily'
pesug 'joined to each-other end-to-end'
petuxut - tuxut 'following each-others' example'

There is considerable cross-classification possible among the verbs of Group 12. In any given occurrence of, say, pesawa, it is not always clear from the text which of several pe- affixes is to be understood; it makes little semantic difference between Group 9 and Group 2. However, with a plural subject, at least two possibilities are open: duin pesawa is syntactically open to translation 'those two married people' and 'those two married to each-other' (see Relation 1 Idiom NP323.21 at 4.21.323.21), and the fact that the latter is usually understood appears to be a matter of idiomatic regularity rather than syntax.

Similarly, it is unclear whether pesug manifests {pe₃-} (Caused State) affixation or that under present discussion, since it is evident that two units cannot

be joined to each-other without also being in a joined state (although, as with pesawa, the converse is not always true).

It is further noted that the Dynamic : Static distinction denoted by the choice of vowel in the V_1 position of the UIE stem d-dug 'bang' is carried into the complete word prefixed again by pe-, giving the nice distinction between the glosses 'collide' and 'bumping together' (as boats moored together at a wharf bump, with no implication of direction or reference to primary agency). Reciprocity is seen as a Second Order prefix, and Group 12 verbs manifest {pe₅-} affixation.¹

3.32.31.3 In summary, the meanings assigned to the various pe- homophones are:

First Order {pe₁-} Middle Voice, variously further implying Inherent State, Bodily Function and Possession or use of noun stems; Bodily function, Reflexive action, self-interest and pseudo-transitivity affixed to verb stems.

{pe₂-} Intransitive

{pe₃-} Stative (Causative by Inflection), Accidental process with inanimate agency.

1. In MNP affixation, this must fuse with the First Order affix, since there are no examples of additive affixes of the same set; note pemui 'kiss one-another', but not *pememui or *pepemui.

Second Order {pe₄-} Continuative aspect

{pe₅-} Reciprocal.

* * * * *

3.32.31.4 Remaining problems

It will be evident that some of the distinctions still unclear at the present stage of analysis of Melanau may be resolved when much more study has been applied to the language in various detailed areas. This will have to include the interrelationships between Melanau and the many surrounding languages which enter into mutual borrowing from each other; most particularly Sarawak Malay, about which very little has been published, and Bahasa Indonesia.¹

One explanation of an otherwise puzzling form has already been shown (in .201 above) to lie in its relation (by a so-far unspecified derivation process) to the Malay cognate; others have had a tentative process outlined (3.32.11.511). Further, it appears that Malay (or some proto-Malay) prefixes may be recognised in a somewhat altered form in contemporary Melanau cognates, even when the roots are not identical.

cf: Malay ladang 'farm'; saya berladang padi 'I am a rice-farmer.'

Melanau una 'farm': akou puma padai 'I am a rice-farmer'

Melanau in the Dalat and Igan dialects in particular has (retains?) /be/ as a morphologically conditioned allomorph of {pe₁-} in some few words such as beguna 'be of use' (guna), bedalou / pedalou 'quarrel'. But beyond observations of this sort, further work of a comparative and diachronic nature is

1. Uhlenbeck (1962.432) notes five different meanings associated with final -i / -ni following initial nasalisation in Javanese.

beyond the scope of the present enquiry.¹

3.32.32 The UIE paradigm

All UIE verbs are Basically Transitive, and make up a numerous subset of Melanau Inflected verbs.² There is no free Root form corresponding to the unaffixed stem of the MNP verb paradigm, so that the distinction of Focus as between Subject and Object Focus is lost in Static verbs. This reduced paradigm of verb forms, not matched by a reduction in the syntactic relations the verbs may contract, leads to some minor variance of dialectal usage among speakers even in the Central dialect grouping whose speech provides the central core of this study. It also obscures the clear distinction between Active and Causative verbs, which must then be made largely on the ground of analogy with MNP forms and on the actual textual occurrence of a given verb form in a definable role clearly denoting an Action or a Causation.

1. It is noted en passant that Iban (Sea Dayak, Asmah haji Omar 1969) and Kayan (Cubit and Clayre 1966), among other languages of Borneo for which no Grammars are available, both have a multiplicity of meanings assigned to their be- and pe- affixes respectively, among which are State, Accidental, Possession and Reciprocity. In Sundanese (Robina 1965, 438-9) one of the three functions of the pi- prefix is almost equivalent to that manifested by Group 2 above, while the two meanings assigned to ba- correspond closely to Groups 4 and 12. Similar correspondences are found in other Bornean languages, and may be expected in many others within the wide Malay language family.

2. Northern dialects differ somewhat in this regard, as has been noted at 3.32.31.21.218 for the Tatau dialect.

3.32.32.1 The bound stem

All UIE verbs have the general structural word-form

$$V = C_1 \begin{bmatrix} \underline{u} \\ \underline{i} \\ \underline{e} \end{bmatrix} C_2 V C_3 \quad . \text{ Ablaut of the first vowel gives} \\ \text{the distinguishing name to the}$$

verb paradigm; the stem is therefore bound, of the form C-CVC.

.11 the case $C_1 = \underline{m}$ (replacive of p or b)

These verbs form a small subset of UIE verbs already listed at 3.32.31.21.213. The remaining forms of their inflection paradigm are regular, eg: munu', binu', benu' 'kill', and need no further exemplification.

.12 the case $C_1 = C_2$

These verbs form a large subset of UIE verbs, many of which have an archaic form of the contemporary norm with -e-; a few remain in current use. The form of these words is $C_2 V C_3 \underline{en}$, as eg: tengen 'drinking' (cf: teteng) Others in the set are j-ja 'slash', k-kut 'dig', s-sud 'follow' and x-xau 'pass by'¹.

.13 the case $C_3 = \emptyset$

There are not many verbs in this subset, and all end with the open vowel -a.

eg: $C_1 = C_2$ g-ga 'greet'

$C_1 \neq C_2$ t-pa 'stab, bite (as snake)'

.14 the case $C_1 V_1 = \emptyset$ in Stative form

Some UIE verbs have a deficient paradigm, lacking any -e- form at all. The suppletive form is always a

1. Final orthographic u represents consonantal /w/, as at 2.63 above.

monosyllable, the second half of the fuller form, (of which it may perhaps represent the historically earlier form, as discussed at 3.32.32.23.1 below).

eg: bed 'tied, a knot' (cf: mubed 'to tie')
juh 'given, give !' (cf: tujuh 'to give')
na' 'made, make !' (cf: mena' 'to make')¹

3.32.32.2 the -u- / -i- / -e- affixation system

While the form of the affixes to UIE verbs differs markedly from that on MNP verbs (and, as far as is known, from other verb affix systems in Sarawak, being more akin to those described for the Sabah languages²) there is a close overall correspondence between the "meanings" which may be assigned to each corresponding member in the two sets. In parallel with the MNP affix paradigm, the two sets of oppositions are therefore labelled:

	{	-u ₂ -	:	-i ₂ -	:	-e ₁ - / -e ₂ -	}	
		Active	:	Passive	:	Middle		
		AFDyn		OFDyn		SFStat		
and	{	-u ₃ -	:	-i ₃ -	:	-e ₁ - / -e ₃ -	}	respectively.
		Causative	:	Passive	:	Stative		
		AFDyn		OFDyn		SFStat (and OFStat ?)		

1. The verb mena' 'do, make' is encountered with two inflectional paradigms; mena', nená', na', which is regular for an MNP verb but lacks Stative (Middle) form *pena', and more often heard in Dalat the set mena', nina', na', which is almost regular for the set .14 above, with a mutation of the expected form *nuna'

2. D.Prentice 1965 and B.M.Clayre 1967

3.32.32.21 -u- affixation

.211 Since all UIE verbs are basically Transitive roots, there is no *{-u₀-} affix corresponding to the {me₀-} morpheme isolated at 3.32.31.21.202, nor is there a *{-u₁-} corresponding to {me₁-} isolated at .204-7 of the same section.

.212 Active, use noun which forms the stem, AFDynamic in transitive process clauses.¹

eg: sulud 'comb (the hair)' (cf: selud 'a comb')
suput 'shoot with blowpipe' (seput)

by comparison with .21.210 of the MNP paradigm, verbs of Group 2 manifest {-u₂-} affixation.

.213 Active, form noun which is also the stem, AFDyn in transitive process clauses.

eg: mubed 'tie up, tie a knot' (bed)
tupad 'advise, give advice' (tepad)

by comparison with .21.208 of the MNP paradigm, verbs of Group 3 manifest {-u₂-} affixation.

.214 Active transitive, the Subject of the -e- form

→ Agent of the -u- form verb in AFDyn construction.

eg: lului 'mimic' cf: lelui 'mimicing'
tukud 'worry' cf: tekud 'concern, concerned'
xuxau 'pass by' cf: xexau 'in passing'²

by comparison with .21.212 of the MNP paradigm, verbs of Group 4, the most typical of all UIE verbs, are seen to manifest {-u₂-} affixation.

1. The -e- form of UIE verbs appears to be analogous to the stem.
 2. xawen is more often heard than xexau, cf: the discussion on the archaic form of some statives at 3.32.32.31 below.

3.32.32.215 Causative, bring about State of the -e- form. The Subject of the -e- form → Object of the -u- form verb in AFDyn construction (subject to the general rider on Causative UIE verbs at 3.32.22.22 above).

eg: lupeng 'snap' cf: lepeng 'broken'
mubah 'split open' cf: bebah 'split'
susam 'rip to shreds' cf: sesam 'in tatters'
xumai 'break into bits' cf: xemai 'crushed'

by comparison with .21.215 of the MNP paradigm, verbs in Group 5 manifest $\{-u_3-\}$ affixation.

3.32.32.22 -i- affixation

.221 Occurs in Verb Focus Dynamic clauses (cf: Zero affix of MNP paradigm at 3.32.31.11)

.2211 Imperative:

eg: kikor 'stir!' (the gruel)
lilou 'wait!' (for me)¹

.2212 Narrative:

eg: sisud, sisud, sisud nyin
follow_F follow_F follow_F he
'on and on he followed ...'

There is no -u- equivalent to this -i- affix, (which corresponds to the \emptyset - affix of MNP system) which is therefore distinguished as $\{-i_1-\}$ affixation.

.222 Passive of transitive action in OFDynamic clauses.

The Subject of the -e- form → Agent of the -i- form.

eg: didat 'beaten out in a forge, hammered'
didut 'pulled out, pulled up by the roots'

1. luen si'iu is also regularly used, 'wait a bit first'; [luen] is the current spoken form of archaic /ləwən/, see .23.31 below.

kixid 'shaved clean of bristles'

lilou 'awaited'

pipex 'beaten'

sisud 'followed'²

thus: bo' ane' in silud nyin peba' selud ba'ou
 hair_F child that P+comb she S+use comb new
 'She combed the child's hair with a new comb'

In comparison with .32.22.203 of the MNP paradigm,
 verbs of Group 2 manifest {-i₂-} affixation.

3.32.32.223 Passive, Caused state in OFDyn₂mic clauses; the

Subject of the -e- form verb → Object of the -i-

form, eg: bibah 'split'

kikuyh 'erased'

lipeng 'snapped'

linyed 'submerged, drowned'

sibit 'torn'

thus: kayou bibah nyin ba' apui belanga

wood_F P+split he int. fire bakehouse

'He is splitting wood for the bakehouse oven'

In comparison with .32.22.204 of the MNP paradigm,
 verbs in Group 3 manifest {-i₃-} affixation.

1. One old man in Tanam (Map 1) is on record with the spontaneous encouragement to a child going through unfamiliar forest:

"Debei ibuh, ka'au suden kou"

not-matter you_F P+follow I 'Don't worry, I'm right behind.'

This is most interesting as (1) an instance of the cultural use of Object Focus (child as centre of attention) not matched by an English Passive, and (2) as the only instance of -en marking OF in a Melanau clause; but such a suffix is a common morphemic mark of 'non-past Object Focus' portmanteau in Lun Bawang, (Sarawak Murut) described briefly in B.Clayre 1970.204

3.32.32.23 -e- affixation

.231 Noun root as stem, associated with Active verb *va*.

eg: bed 'knot'
selud 'comb'
seput 'blowpipe'
tepad 'advice'

and of uncertain status, whether nominal or verbal:

benu 'slaughter'
dedat 'forge'

as: apui dedat 'the fire of the forge'
 or 'the fire for forging'

It is assumed that all of these do not represent a verbal affixation; as an integral part of the noun root, the e is not a morpheme, and is therefore not assigned a distinguishing index.

.232 Nominalisation of a verb (cf: the classical Gerund)

associated with an action, as occurs always in the Cause construction following buya' (4.31.11.2213).

eg: (1) Ameran matai buya' ubat bisa angai
 Ameran die on-account-of medicine powerful very
 'Ameran was killed by a very powerful poison'

(2) Berantai matai buya' tebek Damag
 Berantai die on-account-of R+stab Damag
 'Berantai was killed by Damag's dagger-thrust'

Because of the substitutability of the two NP coming after buya', the -e- form is seen as structurally the equivalent of the noun roots of .231 above, but in this case morphemically marked. This is labelled {-e₁-} affixation.

3.32.32.233 Simple static, intransitive form of Active verb va, also used as stative adjunct.

eg: dedug 'banging, bumping'
kexid 'shaving'
lelou 'waiting about the place'
sekel 'choking'
teteng 'drinking'
xexau 'passing by'

thus: lou Balah jigem a Likou peseped
 gpl Iban with Melanau Re+S+slash
 'The Ibans and the Melanaus used to hack away
 at each other'

In comparison with .31.23.208 of the MNP paradigm, verbs in Group 3 are labelled as manifesting $\{-e_2-\}$ affixation.

.2311 The archaic form ending -en

This is cited by informants as an imperative form, pexen 'beat!', suden 'follow!' &c: But the Dalat dialect imperative appears to be in a state of diachronic change; many older people use the -e- form of verbs as the Imperative rather than the -i- form now in more widespread use. It is one of the problems arising out of a three-term set used as situationally equivalent to a four-term MNP system; there is bound to be some overlap of forms. As an Imperative, on the other hand, the short forms listed at .14 above are then equivalent to the archaic -en forms; and the short forms are both imperative and stative in their function.

Still in use as Statives are the two forms tengen (anum tengen 'drinking water') and xawen (makau xawen 'just passing by, walking about aimlessly'), which suggests a possible earlier overlap of Stative and Imperative forms of the UIE verb; this overlap does in fact occur in the speech of older folk, and in the more conservative dialect of Sungai 'Ud. It is possible that the Passive -en cited at fn to .222 above, linking Passive and Stative, is the link to the present overlap of Passive and Imperative forms of the verb.

3.32.32.23⁴ Contingent State (which may be accidental, as if it were caused by an inanimate Agent); intransitive and SFStatic clauses, in which the Subject is semantically non-agentive.

eg: bebah 'split'
kekuyh 'erased, invisible, illegible'
leka' 'undone (of clothing)'
lenyed 'submerged'
sebit 'torn'
sepuh 'tough, tempered (of iron)'
xemai 'crushed, in tiny pieces'

Within the reservations of the general rider on UIE Causative verbs, by comparison with .31.23.209 of the MNP paradigm, verbs of Group 4 are tentatively given the index of $\{-e_3-\}$ affixation.

3.32.32.23⁵ It is evident that the two systems of affixation differ in accidental detail, but in essence cover the

same (or very nearly the same) syntactic ground. There is no obvious division of the Lexicon between the two groups in anything but a random way; some notions have near synonyms drawn from each paradigm, as: anum tapu 'flood-water, a flood'

anum lenyed 'submerging water = flood'

The basic oppositions in the verbal system are those of Focal Valency combined with an intersecting axis of Dynamic or Static clause Status. The opposition Active : Causative is assumed to be a major axis of both verb moieties, although it is not so clearly evident in the UIE paradigm.

3.32.4 Verb Compounding

Two distinct forms of verb compounding are found, the difference between them being the class of the second member of the compound.

3.32.41 Verb + Verb compounds are distinguished from verbs in serial construction by (1) their close phonological coupling, appropriate to hyphen pause (although it is not in practice marked by an orthographical hyphen), and (2) by their fixed order, regardless of the semantic or logical propriety of this order.

eg: ba'ai bawai
go-down go-up 'go up and down'

kidei kinan
come-here go-there 'go hither and thither'

jangai udai
go-inland approach-river 'go to and fro'

paai udai

go-across-river approach-river 'criss-cross the river'
'tack to and fro'

sala' pikér

?wrong think 'have a bright idea' (cf. fn.1 p114)

tujuh ta'ou

give know 'tell, inform'

3.32.42 Verb + Noun compounds are distinguished from ordinary transitive constructions in that the verbs are from the class of vi (either Process or State) and would not in ordinary use have an Object of Transitivity; they are not marked for clause Focus, as is typical of transitives. The noun is therefore seen as a Complement in attributive function¹.

eg: ayeng lengan

large voice 'big as to the voice, boastful'

ba'ai kubou

go-down house 'come down out of doors, leave home'

se'ap beba'

noisy mouth 'noisy as to the mouth, chatterbox'

There are other compounds complying with this general pattern which appear to have no possibility of individual occurrence without the qualifying noun, as

eg: maa' buut 'be short of breath' (buut)

sui' naseng 'be sad at heart' (naseng)

1. It is probably within this framework that one ought to consider the anomalous pe- constructions discussed at 3.32.31.23. 206 above, such as pebelait senapang 'be armed with a shot-gun'. They all fit the structural pattern of VP..2 (4.22.122).

3.32.5 Verb Reduplication

As shown at 3.13, reduplication of verbs is divided into two subtypes, according to whether the complete verb stem is Repeated, or whether there is Reformation of part of the stem.

3.32.51 Repetition of stem has a different denotation for the transitive and Process intransitives on the one hand, and State intransitives on the other.

.511 Process, whether transitive or intransitive, is made continuous or repetitive by repetition of the stem.

eg: lian nyin juja' juja' juja' sek in
 time she A+cut A+cut A+cut grass that
 'while she went on cutting the grass'
sisud sisud sisud nyin lau malem
 V+follow he day night
 'on and on he followed by night and day'

.512 States, by contrast, are intensified by repetition of the entire stem.

eg: da'ou da'ou 'very good indeed, as good as gold'
nyat nyat 'as big as could be'
penu' penu' 'full right up to the brim'
sega' sega' 'as close as possible'

3.32.52 Reformation of part of the stem usually involves the the first half of the reduplicated form in a reduction to a stylised disyllable; only on comparatively rare occasions is the latter half of the final word modified.

.521 Reformation of the first half of the final word is parallel to that already outlined at 3.132 above; the stem is shortened (where necessary) to a disyllable

ending in final open -a. The most usual meaning denoted by the reduplicated form is an intensification of the basic stem meaning, which may be vp or vs.

eg: kapa - kapan 'be very thick'
juna - juno 'jostle in an uncouth manner'
leta - letep 'feel lonely'
leta - letatu 'be left out of things'
pada - padem 'be quite dark, pitch dark'
sela - selui 'go slowly and cautiously'
tepa - tepuyh 'puff away (on a cigarette)'

Clearly onomatopoeic are such reduplicated forms as

tenga - tengut 'eat noisily, with a smacking of lips'
di'a - di'ut 'grunt, as a pig truffling in earth'

3.32.522 Reformation of the last part of the final word is less widely used as a reduplication device, and often appears to be somewhat onomatopoeic¹.

eg: bereti - reti 'stop now and then'
ta'uh - 'uh 'gasp in pain'
tengaduh - ngaduh 'weep in self-pity, sob'

A different form of final part reformation is limited (in the corpus) to a single word, a form also found in contemporary Malay,

tulong - menulong 'mutual aid, help one-another'

.523 Formation of Adverbs from verb stems is very often achieved by reduplication as at .521, although on occasion

1. These forms are from the stories of Ramli Bandung, whose narrative style is comparatively rich in reduplication (and also in Malay borrowing). It is a style highly thought of by others in the community who employ it less themselves.

it may involve the entire stem in repetition.

eg: dika - diket 'in an excited way'

supa - supé 'unexpectedly, suddenly'

sela - selui 'with great care'

tudip - tudip 'still alive, in a live state'

thus: kuyad nigi' tudip - tudip mapun likou

monkey P+take alive-alive A+approach home¹

'The monkey was taken home still alive'

3.33 Adverbial Morphology

Within the broad distributional class of Adverbials, many roots are recognisable as drawn from the inventory of nouns *nc* (as eg: malem 'night, by night') and verbs *vp* and *vs* (as segaut 'make haste, hurriedly'). Noun roots appear most frequently as adverbial expressions of Time and Place, verb roots as Manner adverbials. The fourth subset of adverbials, Degree adverbs, appear to be mainly Adverb roots.

A description falls most easily into two major groupings, the Deictic adverbials and the Descriptive adverbials, within each of which are to be found adverb roots, compounds, derived adverbs and reduplicated forms.

3.33.1 Deictic adverbials *adic.* provide the spatio-temporal setting of an utterance (or stretch of recorded text), with particular reference to some overt or covert datum. Melanau deictic adverbials divide clearly into those belonging to a

1. 'home' is one of the many glosses given for likou, a word at the pivotal point of much Melanau thought and language (3.33.121 and some further explanatory comment at 6.1)

Temporal and those belonging to a Spatial deictic system.

3.33.11 Temporal Deixis has as its basic framework a system of oppositions broadly defined by the glosses 'before' and 'after', with 'now' as the datum. This is the Basic Time Scale, from which the Proximate, Remote and Day, Month and Year Scales are derived.

3.33.11.1 The Basic Time Scale has three terms which may be seen as dividing the time continuum into three zones:

si'iu		ajau		mudei
'before'		'at present'		'later'

These terms on their own are sufficient to provide the essential temporal reference in minimal utterances, as

eg: (1) ka'au si'iu

you before 'You (go) first'

(2) ka' ajau

pro. present 'Not now!'

(3) akou mudei

I later 'I will (come) later'

3.33.11.11 Reduplication of these basic terms is a form of intensification of the word's temporal significance, as described at 3.13.

eg: ajau ajau 'right now, do it now!'

muda - mudei 'later on, much later, in due course'

3.33.11.2 The Proximate time scale represents a secondary degree of temporal distinction. The oppositions lack a single word for the present time datum, having the adverbial phrase ajau 'ih 'this present moment, now' at

the centre of the scale. Distance from the Present is less than that generally understood by the Basic terms which, however, must be seen as superordinates including the terms of the Proximate scale as hyponyms.

japan ¹	ajau 'ih	na'ah
recently	presently	not long after

Of these terms, japan precedes the verb, while the others usually follow it.

eg: nyin japan labi'

he recently come

'He has just arrived'

akou labi' na'ah

I come later

'I'll be along in a little while'

3.33.11.21 Reduplication is manifested in the term japa-japan 'only just, just this minute past', whose distribution is the same as that of japan alone.

3.33.11.3 Remote time scale has only two terms which, although they may qualify nouns and NP, do not have adjectival (ie. vs, or more particularly vq) distribution; they are therefore classified as Adverb roots, representing the polar values of the intermediate time scales.

sabei		sunih
'ago'		'to come'

thus: duah ratuyh ta'un sakei

two hundred year ago

'Two hundred years ago'

1. While baru' 'newly' (cf: Malay baharu 'new') sometimes occurs as an apparent synonym for japan, its more usual distribution is as described at .11.5 below.

sou sikou sou silou sunih

great-grandchildren¹ to-come 'succeeding generations'

silih 'one unit more remote' is a comparative term entering into construction with this set, never occurring on its own but giving a further degree of remoteness in either temporal direction to both sabei and sunih. (sih is often heard as an apparent synonym for sabei, or it may be for sabei sunih, but it is regarded by many as a culturally inferior choice, a shortening bordering on slang.)

While these terms represent polar extremes of the time scale, they do not necessarily indicate a very remote time in absolute terms, as evidenced in the adverbial phrase lau sabei 'yesterday' manifesting ØAP.T structure, which is described at 4.23.222.

3.33.11.31 Reduplication and Compounding are both encountered in this temporal field,

eg: sabei sabei 'long, long ago'

sabei sih 'long ago'

silih sunih 'the next one after sunih'

3.33.11.4 Relator time scale manifests a further set of oppositions, but the terms belong properly to the set of Time relating Prepositions, manifesting Relator tagmeme in RAP structures (4.23.22). There is, however, partial overlap

1. sou sikou sou silou is a highly idiomatic expression by no means confined to Melanau (see fn. to 4.51.33) meaning literally 'grandchildren of the elbow and of the fingernail'; it refers in an expansive way to all future generations, to one's progeny, in the frequently occurring context of prohibitions binding them.

with the set of discrete adverbs, as

eg: si'iu Brooke labi'

before Brooke come 'before the arrival of Brooke'

3.33.11.41 Compounding has resulted in at least two words in common use, distributionally within the set of terms described at .11.2 above, but manifesting an internal structure proper to this group (cf: 3.224)

eg: seniin 'a while ago', presumably a reduction of the phrase si'iu in unei;

biin 'afterwards', certainly from béh in, to which it is normally expanded in more careful speech;

these follow the general principles set out in 3.22.

3.33.11.5 Day, Month and Year scales also exist, with the AP

ajau 'ih 'now' giving place as the central datum to the relevant expression lau 'ih 'today'

bulan 'ih 'this month'

ta'un 'ih 'this year' as the case may be.

All these terms are phrasal in structure, and are described at 4.23.2221 in the chapter on Syntax.

3.33.11.6 Clause-initial Adverbials include single roots,

compounds and some reduplicated forms.

eg: baru' 'only then, not until then'

si'iu sabei 'long ago'

mula mula 'at first, first of all'

paut paut 'for a long time'

ujong ujong 'eventually, in the end'

The distinction between specifically Deictic adverbs and general Temporal adverbs without a definite point of Datum reference is not always clear. Near the borderline are

such words as selalu 'always'
selama - lama 'for ever'
kada - kadeng 'rarely'

3.33.12 Locational Deixis has as its basic conceptual framework a three-dimensional system of orthogonal axes, one vertical and two horizontal which, while mutually at right-angles, are applied to a point in space much like tangents on a mathematical curve, rather than the axes against which it is plotted; in absolute terms, they may point in different directions at different times and places.

The horizontal axes have likou 'the Main River' as their covert datum¹. Secondary systems are of two orders; an extension of the space-frame to include terms of nautical or sea-side reference, and a Proximate system with 'self' as the covert datum.

3.33.12.1 The Basic Space Frame has vertical and horizontal axes systematically at right-angles to each other, each with two polar terms². This yields six orthogonal directions, one

1. While inspection of the terms and oppositions might suggest that a further component [⁺land] might be extracted to sort out the last three terms from the middle two, the derived system of Motion terms shows that this is not a true distinction. Also, aju 'upriver' is equally well applied to a place on land as on the surface of the water; dayeh 'away from the River' may be on land 'inland' or on a tributary stream. These details are given fuller treatment in Chapter 6, and in Clayre 1972(b).

2. The rectangular, boxlike system in no way precludes application of its terms to directions oblique to the axes, to general directions not strictly perpendicular to each other. Melanau is still a human language, not a mathematical formularisation.

of which is extended to give a seven-term Riverine system:

static adic.

- RIVER	Vertical	<u>bau</u> 'up'	<u>iba</u> ' 'down'
		<u>aju</u> ' 'upriver'	<u>aba</u> ' 'downriver'
+ RIVER	Horizontal	<u>dayeh</u> 'inland from river'	<u>alud</u> 'riverwards'
			<u>ipah</u> 'across river'

3.33.12.11 These terms and their derivatives may be illustrated to advantage in a diagram, for they relate very closely to the sort of country in which the Melanau dwell.¹

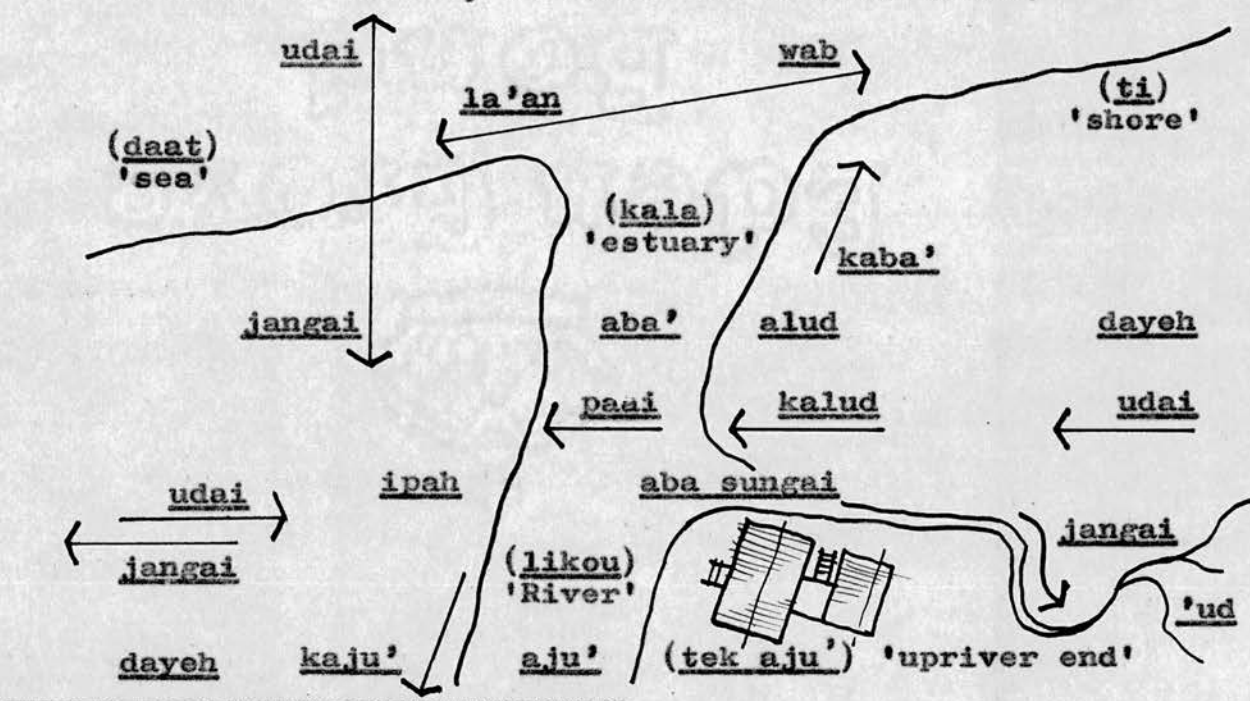

1. Similar systems are described by Cook in the Narak language of New Guinea (with suitable variations for the more mountainous terrain, Cook 1967) and by the Henrys in Kuyukon (D. and K. Henry 1969); from personal communication with Dr. Sunil Nath of the Malaysian Health Department, I learn that the Bengali languages of the Ganges delta maintain very similar sets of oppositions.

3.33.12.2 Positional system for denoting a position

in space rather than a direction along which that position is located, employs the seven terms of static deictic adverbial reference without morphemic change. Discrimination of a particular location along the appropriate axis is by the use of descriptive phrases of distance, or by reference to known spatial objects such as villages, river mouths &c:

eg: aju' sega' ijin balau

upriver near mill sago-palm 'up by the sago factory'

In addition, there is a set of "situationally bound adverbs of place" (Lyons 1968.278) which are compounds by reduction of the preposition ga' 'at' and terms from the set of deictic pronouns 'ih 'this', in 'that' and an 'which?' listed above (3.31.32.23, cf:3.221). This process yields the Proximate system (as distinct from the Riverine system already described) with 'self' as the covert datum: gaan 'at where?',
gi'ih 'at here',
giin 'at there',
and inan 'at yonder' forms an extension of the third term, introducing the distinction of 'there (proximate)' from 'there (remote)'.

A secondary set of anthropomorphic terms is described among the Adverbial phrases (4.23.221) having compound prepositions not yet reduced to single words, such as ga' dawek 'beside'. These all function as Relator in RAP syntagms (which may, in some instances, have void Axis tagmeme).

3.33.12.21 Reduplication of positional terms is exemplified by the nominal expression a giin - giin 'people living about

there', a generalisation rather than a reinforcement of the deictic power of giin (cf: sai - sai 'whoever' at 3.31.31.41)

3.33.12.3 Motion system composed of Dynamic adic. is derived from the Riverine Directional system by compounding with the morpheme $\{(kV-\sim k-)\infty -ai\}$, yielding the set of oppositions: dynamic adic.

- RIVER	Vertical	<u>bawai</u> 'ascend'	<u>ba'ai</u> 'descend'
		<u>kaju'</u> 'go upriver'	<u>kaba'</u> 'go downriver'
+ RIVER	Horizontal	<u>jangai</u> 'go inland'	<u>kalud / udai</u> 'go riverwards'
			<u>paai</u> 'cross river'

In this system, the double entry for 'go riverwards' produced by compounding the stem alud 'riverwards' with each of the allomorphs¹ (with minor modification) is exploited to make the further distinction shown on the diagram appended to .12.1 above, udai 'approach the river from far away, from dayeh' and kalud 'approach the river from close to, from alud' (as it might be, from the steps of the house), analogous to the added discrimination possible with giin and inan at .12.2 above.

A set of Proximate terms is derived from the deictic pronouns in a process parallel to that which yielded the Location terms, compounding with the allophonically variable morpheme $\{kV-\}$ (cf: 3.222) to produce a set of Motion terms parallel

1. The dialect of nearby Igan is unique in having a term with redundant double affixation, kejangai 'go inland from River'.

to the positionals: kaan 'to where?'
ki'ih 'to here'
kiin 'to there (proximate)'
kinan 'to there (remote)'

and kidei 'to here' appears as an apparent synonym of ki'ih, although no stem *idei or Locational *gidei occur in the data¹.

3.33.12.31 Reduplication of these terms is a productive process yielding both true repetitions of the base term, such as

kaan-kaan 'to anywhere at all'

and such balanced, fixed-order compounds as

kaju' kaba' 'upriver and downriver'²

jangai udai 'go to and fro' (cf: 3.32.41)

3.33.12.4 Sea-coast re-orientation of some of the terms listed in .12.2 and .12.3 above occurs in the dialects of the coastal villages such as Oya, Mudan, Igan and the like³ (Map 1); these sea-coast terms, of primary application to travel out to sea rather than up the rivers, are also in the everyday vocabulary of the upriver dwellers, who make use of them for their own particular purposes. It thus becomes necessary to hold clear throughout a discourse what primary reference point is datum for the deictic terms employed at each stage, the River likou or the sea-shore ti.

1. There is also no word *ka' to balance ga' in Melanau of Dalat.

2. This compound is also used to refer to an alignment parallel to the river; a longhouse, or a boat drawn up for mending.

3. There are also some differences as to which words take a ke- affix, and which the -ai suffix (see Appendix 2), as eg: ju'ai 'go upriver' in Mukah dialect, kipah 'cross river' in Igan.

The re-orientation of the axis jangai - udai to a new direction parallel to the Main River -ie: 'inland - out to sea' is shown on the diagram on p.208; this is its normal referent in coastal speech, and is taken over in Dalat in accounts of sea travel. The axis parallel to the coast is renamed, the terms wab and la'an referring to both Direction and Motion 'up the Coast' (-ie: in the general direction of Brunei) and 'down the Coast' (-ie: towards Kuching in the South West) respectively. wab-la'an is then to 'travel to and fro' in a direction approximately parallel to the coast. (This shift of meaning is further detailed at 6.11, with the circumstances in which it is employed upriver and inland.)

3.33.2 Descriptive Adverbials fall into two groups according to their position in the string of the Verbal Phrase (4.22.12), and to the word class from which they are typically drawn.

3.33.21 Degree adverbs add. are almost all adverb roots which occur immediately after the Head verb in the VP, typically manifesting Degree tagmeme in ViP. The inventory of add.

includes:	<u>agei</u>	'yet more'	<u>alu'</u>	'more'
	<u>angai</u>	'very'	<u>ateng</u>	'really'
	<u>axuyh</u>	'completely'	<u>jumit</u>	'slightly'
	<u>lalu</u>	'totally'	<u>lauyh</u>	'utterly'
	<u>min</u>	'all'	<u>kajih</u>	'completely'
	<u>sapah</u>	'extremely'	<u>singen</u>	'only'

.211 Pre-verbal Degree tagmeme is manifested by the add. makin 'increasingly', followed by the Head vs.
eg: makin ayeng ji 'looking bigger than ever'

3.33.212 Derived adverbs add. appear to be limited to the one word jumit ← je- 'one' + umit 'small'

.213 Reduplication produces some add. from add. roots, the general meaning being a reinforcement of the original, as eg: leba - lebih 'more and more, much more'

3.33.22 Manner Adverbials adm. are largely, but not exclusively, drawn from the inventory of vs, occurring in attributive relation to a Head verb, typically in ViP manifesting the Manner₂ tagmeme (4.22.123). The set includes:

adverb roots, eg: maler 'continually, all the time'

paut 'for a long time'

sapeng 'gradually'

teruyh 'right through, all the way'

verb roots, eg: deréh 'hard, heavy' (or 'heavily' of rain)

laju 'quickly'

segaut 'hurriedly'

seneng 'in comfort'

.221 Derived adverbs adm. are formed from many noun stems by affixing with je- 'one', without the classifier word required in an enumerated NP (4.21.321.5).

eg: jebebex 'one-net-throwing, in a moment'

jelakau 'one-occasion, once'

jekatil 'one-bed, in one bed together'

iekapong 'one village, from the same village'

.222 Compound adverbs adm. are formed with the root mana 'however?' and a restricted list of adverbs of place, time and quantity, and with the copula verb. The word mana itself may occur singly in the compound, or it may

be reduplicated.

eg: mana kedau 'in whatever place, wherever'

mana lian 'at whatever time, whenever'

mana bei 'in whatever way possible'

mana mana lian 'at simply any time at all'

mana mana dakai 'as much as possible'

The same word mana forms compounds of an indeterminate status, which may be nominal or may be adverbial, with some of the special abstract nouns described at 3.31.12, as eg: mana sau 'whatever is heard', or
'however it sounded'

mana ngai 'of whatever size', or
'however big it might be'

3.33.223 Reduplication is a productive process for deriving Manner adverbs from noun and verb roots; some of the resulting forms convey the sense of serial action, and others of simple repetitiveness.

eg:(1) from noun roots

apah - japh 'from one to the other'

japh - japh 'one after the other'

jelau - jelau 'day by day, day after day'

lau lau lau 'all day long'

susun - susun 'layer upon layer'

and, including se- as an allomorph of je- 'one':

seputun - seputun 'first at one end, then the other'

(2) from verb roots

leba - lebih 'more and more, increasingly'

lega - legah 'quickly, quick as you can'

taxa - taxéh 'with a circular movement'

and tegesa - gesa 'cautiously, by degrees'

The list is doubtless as long as the ingenuity of the more gifted raconteurs care to make it by exploitation of the processes of repetition and reformation.

(3) from affixed noun roots (cf: 9.32.31.23.20⁴) vp:

<u>pesepa - sepun</u>	'all heaped up, in a heap'
<u>peribu - ribu</u>	'in their thousands'
<u>peta'un - ta'un</u>	'year in year out, for years on end'

3.33.23 Sentential Adverbs ads. other than those of specifically Temporal denotation already mentioned at .11.6 above, include an apparently small set of single forms, reduplications and compounds which serve as the speaker's comment on the truth-value of the content of the following clause.

eg: <u>ateng ateng</u> (<u>lah</u>)	'indeed, it's the truth'
<u>buka - bukan</u>	'by no means can it be that ...'
<u>kali</u> '	'perhaps' ¹
<u>makin</u>	'the more ...'
<u>malum</u>	'it is reported that ..., so they say'
<u>mimeng</u>	'of course, naturally'
<u>saji / taji</u> (<u>lah</u>)	'to be sure, ...' ²

(The last form, saji (or taji) sometimes appears after the Subject of the clause, immediately preceding the VP; in this case, its domain is the clause nucleus, and not a sentence composed of more than one such clause.

eg: <u>a likou Mudan saji debel lu' ba' kaya</u>
inhabitants Mudan sure not will int. rich
'to be sure, the people of Mudan will never be rich'

-
1. Malay barangkali and pseudo-Malay mengkali' also occur in some of the oral texts; neither obeys Melanau syllable rules.
 2. It is possible that saji represents a fusion of sah ji 'it seems certain'; but that leaves taji without explanation.

In this position, saji has two near-synonyms, tetap 'fixed' and tetu 'certain'.)

Beyond these few words, there are Adverbial Phrases having a similar distribution and function, described at 4.23.42.

3.34 Particle Morphology

The hyperclass of Particles subsumes the many small sets of words which are presumed to be closed sets of words, enclitic and bound particles not assigned to one or other of the three open classes. The membership is listed as exhaustively as the data of a first survey of the language will allow.

3.34.1 Full words, cited as independent verbal units:

3.34.11 Numerals form a decimal system of cardinal numbers; there is also a set of ordinals.

.34.111 Cardinal numbers are from the numerals nm.

<u>satu</u>	'one'	(for counting only)
<u>jeh</u> ~ <u>je-</u> ~ <u>ji-</u>	'one'	(enumeration)
<u>duah</u>	'two'	<u>telou</u> 'three'
<u>pat</u>	'four'	<u>limah</u> 'five'
<u>nem</u>	'six'	<u>tuju</u> 'seven'
<u>ayan</u>	'eight'	<u>ulan</u> 'nine'
<u>pelu'en</u>	'ten'	<u>jebeléh</u> 'eleven'
<u>jeratuyh</u>	'a hundred'	<u>jeribu</u> 'a thousand'

There are higher terms of decimal units in infrequent use, identical with Malay higher numerals.

.1111 Compounding of numerals to form higher terms in each decimal range is described in 4.21.62, the Numeral Phrase.

.1112 Reduplication of numerals is always in construction with the static verbal prefix pe-, and the resulting

form is typically adverbial in distribution.

eg: peribu - ribu 'in their thousands'

3.34.112 Ordinal numbers are attributive words with adjectival distribution. Only two discrete terms are found, others manifesting compound structure:

batui 'the first'

kejian 'the last'

.1121 Compound ordinals are formed with the locational (or dative) preposition ga' + a numeral.

eg: ga' duah 'the second' ga' telou 'the third'

3.34.113 Range numbers have the structure of state verb *vs* with the static prefix pe- (3.32.32.23), and are typically adverbial in distribution.

eg: pebeléh 'in teens = in the range 11 - 19 approximately'
(the expression is not precise, rather like English 'dozens')

3.34.12 Quantifiers qu. are a set of plural quantity range words analogous to the set of numerals (.11 above) manifesting pre-Head Quantity tagmeme in QuP of Modified NP (4.21.61).

dida' / ida' 'many, much'

semuah 'all'

ga' 'some'

tiep - tiep 'each, every'

saparuh 'some, a part'

tugan (lawéh)¹ 'a good many'
(always of people only)

The range numbers pepulu' &c: (.113 above) may occur in the QuP also.

It is shown at 4.21.64 that some of these terms have also pronominal distribution. As pronouns, jumit 'a bit' is added to the list of *qu* from the inventory of *add.* (3.33.21), and maséng - maséng 'each one, every one' appears to be a situationally conditioned allomorph of tiep - tiep.

1. (see p.218)

The accuracy particle angaren 'approximately' is always followed by a numeral (4.21.62), and is synonymous with the phrase kurang lebih 'more or less'² and the reduplicated form tia' - tia' ('reckon - reckon') 'reckoned to be ...'

3.34.13 Connecting words c. function at several levels of the grammatical hierarchy.

3.34.131 Sentence connectors appear to be random variations on the dynamic copula verb nyadin 'become',
eg: nyadin 'and so it came about that ...'
jadi 'and so ...'

(nyadi and jadin are also heard)

These words occupy sentence initial position, providing serial connection in a paragraph or higher unit of composition.

3.34.132 Clause connectors link clauses in co-ordinate and in subordinate relation.

.1321 Co-ordinate connection tagmeme is manifested by:

- (1) Associative: jigem 'and' serta 'and also'
- (2) Alternative: atau 'or' tapi 'but'
- (3) Serial: lalu 'and then'
- (4) Completive: kawa' 'moreover'

.1322 Subordinate connection tagmeme is manifested by:

- (1) Condition: amun 'if' asel 'if only'

1. (from p.217) *tugan 'a good number' never occurs without its 'human' cl. lawéh, and never occurs with any other cl. In that case, tugan lawéh must be regarded as a compound with the same distribution as any other (qu. + cl.)QuP

2. Both these terms appear to be strictly Melanau pronunciations of the Malay cognates kurang lebih 'more or less' and anggaran 'estimation' (Winstedt 1952.12)

(kalau 'if' in Malay, is also heard)

(2) Circumstance: ni 'although' nuli 'except that...'

(walaupun 'although' Malay is heard)

(3) Reason: kerna 'because' sebeb 'because'

(4) Purpose: migi 'in order that'

samu 'on order that not, lest'

(supaya Malay 'in order that' is heard)

(5) Limitation: sapai 'until'

3.34.133 Phrase connection tagmeme is filled with c from the same set as clause-level connectors above:

jigem 'and, with', serta 'at the same time', atau 'or'

3.34.134 Word connectors are the same as phrase connectors.

3.34.14 Prepositions pr. manifest the Relator tagmeme in RAP constructions, signalling a number of semantic case-relations.

.141 Simple prepositions

Associative: jigem 'with'

Benefactive: gim 'for, on behalf of'

Cause: buya 'on account of, caused by'

Circumstance: pasel 'concerning'

Direction: kuman 'from' sapai 'as far as'¹

Location: dagen 'in' ga 'at'

luer 'outside' patéh 'between'

sega 'near'

Manner: alah 'as, like'

(saperti 'just like' Malay is also heard)

Temporal: lian 'when' béh 'after'

masa 'while' ubi 'when'

(bila 'when' Malay is also heard)

(pada 'at the time' " " ")

1. The AFDyn verb form mapun 'approach' functions as the usual opposite to kuman, discussed at 4.31.11.2214.

3.34.142 Compound prepositions are formed by compounding roots from a number of different classes:

- .1421 cl. + ad. bah bau 'side up = on top of'
bah iba 'side down = beneath'
- .1422 pr. + nc. ga' jawai 'at face = in front of'
ga' dawek 'at side = beside'
ga' buta 'at back = behind'
- .1423 pr. + pr. ga' luer 'at out = outside'
ga' patéh)
dagen patéh) 'at / in between'
- .1424 pr. + nm. dagen duah 'in two = in the middle of'
- .1425 pr. + vp. sapai labi 'until arrive = as far as'

3.34.143 Reduplication is not a productive process in the preposition class, limited (in the data) to the one form exemplified at 4.23.2211

ga' dawek dawek dawek 'all the way round, on all sides'

3.34.15 Tense-aspect particles occur in the Verb Phrase:

- agei 'present continuous'
ba' 'future intentive'
nga' 'past completive'
udei 'repetitive (tense neutral)'

3.34.16 Negation tagmeme in VP is manifested by:

debei 'not'

In sentence initial position, bukan 'it is not the case that' appears to be the situationally bound allomorph.

.161 Compound negatives occur in pre-Head position of VP,

- eg: debei mudah 'never'
debei nga' 'not yet'

debei bei 'not be = there is not'¹

3.34.162 Reduplication of the negative is limited to the total repetition or partial reformation of the Sentential negative.

bukan bukan / buka - bukan 'It is by no means so that ...'

3.34.17 Deictic particles manifest Identifier tagmeme in NP,

in 'that, the' 'ih 'this' inan 'that over there'

.171 Compound forms made with these deictics include:

in lah 'that is why'²

in erti 'which means ...'

3.34.18 Emphatic words

Positive: lah '!'

Query: kah '?', o 'sentence-tag "no?"'

Prohibitive: ka' 'do not'

Balance: pun 'even' pu'un 'even'

Additive: kawa' 'also'

Positional: tara 'the very spot' (ti is similar)

3.34.19 Exclamatory words are presumably many and varied; those occurring with some considerable regularity in a number of texts and spoken contexts are:

Agreement: yoi, i' 'yes'³

Dissent: debei 'no' debéh 'certainly not!'

ta'ou 'I do not know!'⁴

1. This is usually reduced to dibei (3.227) which in many of the Southern dialects appears as the cognate mibei 'there is not'
2. The common idiomatic expression in lah ka'au 'that's just what you would do!' is taken to be a reduction of in alah ka'au.
3. yoi (2.212) is the only word recorded in Dalat with glide /cy/.
4. ta'ou 'know' is the only verb stem to occur in this highly idiomatic usage denoting emphatic negation of its basic meaning.

Greeting: ui 'hoy!' hai 'hail'
 Grief: duh, aduh 'Oh dear!'
 Vexation: cis 'tcha!'

3.34.2 Enclitic particles

3.34.21 Nominalising particles (see 3.31.2)

.211 Personal: a- 'the one who'

eg: a-puma 'one who farms, a farmer'

.212 Non-personal: wa' 'that which' (glossed rel.)

eg: wa' asek 'what is put on, clothing'

3.34.22 Query particle

an 'which?' (4.31.21) nou 'what?' (3.31.32.3)

eg: siau apah an

cock cl. which? 'which fighting cock?'

.221 Compound queries are formed with the enclitic particle

nou 'what?' and the 'intent' ba' or 'cause' buya', to

yield the equivalent of the two English 'why?' queries:

ba' nou 'intend what, why?'

buya' nou 'caused by what, why?' (cf: 3.226)

3.34.23 Reflexive particle

-debei 'self'

(This is shown at 4.21.314 to be enclitic to a whole NP,

not just to a single word. There is thus a possibility

of misconstructions of meaning of a phrase such as

tama kou-debei, as between 'my own father' (not my

step-father, or father-in-law), and 'my father himself')

3.34.24 Anaphoric reference particle

unei 'previously mentioned', glossed ref. (see 4.41.4)

3.34.3 Bound particles (Affixes)

As already noted, there are very few forms which each carry a considerable work load.

3.34.31 Class-maintaining affixes

- .311 Nominal affixes, affixed to a noun stem, are limited to the single form

ke- ~ k- + abstract nc → 'abstract nc' (3.31.13)

eg: kesau 'sound'

- .312 Verbal affixes, affixed to a verb stem of the MNP or UIE paradigm as appropriate, are limited throughout to the following forms (whose detailed allomorphy and homophony is described at 3.32.31.21.100, .22.100 and .23.100, compared with 3.32.32.2)

me- -u- 'Actor Focus Dynamic'

ne- -i- 'Object Focus Dynamic'

pe- -e- 'Subject Focus Static'

∅- -i- 'Verb Focus Dynamic'

∅- -e- 'Object Focus Static'

3.34.32 Class-changing affixes

- .321 Nominal affixes, affixed to state verb vs stems:

ke- ~ k- + vs → 'related abstract nc' (3.31.13)

eg: keteben 'depth'

- .322 Verbal affixes form verbs from noun roots and adverb roots, with different affix forms.

- .3221 Affixed to noun roots, the affix forms are the same as those attached to MNP and UIE verbs (3.31.31.21.3)

eg: me- + talei 'rope' → menalei 'make rope'

-u- + seput 'blowpipe' → suput 'shoot at'

3.34.3222 Affixed to adverb roots (as stems), there are two:

(1) de- ~ d- + ad. → 'related vs.' (3.32.12.23)

eg: debau 'be tall'

(2) kV- ∞ -ai + adic. → 'related dynamic adverb'

eg: kaju' 'go upriver' (3.32.12.3)

udai 'approach River, go out to sea'

Chapter 4. SYNTAX

4.0 <u>Introduction</u>	235
4.1 <u>The Grammatical Hierarchy</u>	236
4.2 <u>The Phrase level</u>	238
4.21 <u>The Nominal Phrase</u>	239
4.21.1 Minimal NP1	239
4.21.2 <u>Co-ordinate NP2</u>	240
.21 Fixed order NP21	240
.22 Appositive NP22	240
.23 Associative NP23	241
.24 Alternative NP24	242
.25 Neutral NP25	243
4.21.3 <u>Modification NP3</u>	243
4.21.30 Unidentified NP30	243
4.21.31 Identification NP31	243
.311 Exclusive Identity NP311	243
.312 Inclusive Identity NP312	244
.313 General Identity NP313	244
.314 Reflexive Identity NP314	245
4.21.32 Qualification NP32	245
4.21.321 Specification NP321	248
.321.1 By Naming NP321.1	248
.321.2 Categorical NP321.2	248
.321.3 By Location NP321.3	249
.321.4 By Purpose NP321.4	250
.321.5 By Enumeration NP321.5	251
.321.6 Speech Formula NP321.6	252
4.21.322 Possession NP322	253
.322.1 By Proper noun NP322.1	253
.322.2 By Common noun NP322.2	253
4.21.323 Description NP323	254
.323.1 Nominal description NP323.1	254
.323.2 Verbal description NP323.2	255
.21 Relation Idiom NP323.21	255
.323.3 Clausal description NP323.3	256
.323.4 Adverbial description NP323.4	257

4.21.4	<u>Expansions of Nominal Phrases</u>	257
4.21.41	Minimal NP1	257
4.21.42	Co-ordinate NP2	257
.421	Fixed-order NP21	257
.422	Appositive NP22	257
.423	Associative NP23	258
.424	Alternative NP24	259
.425	Neutral NP25	259
4.21.43	Modification NP3	259
.431	Identification NP31	260
.432	Qualification NP32	260
4.21.5	<u>Ambivalence of I.C. cutting for analysis</u>	262
4.21.6	<u>Pre-Head Modification of NP</u>	264
4.21.61	Quantity phrase QuP	264
4.21.62	Number phrase NuP	264
4.21.63	Complex Numeral phrase NnP	265
.631	Head-Modifier	265
.632	Co-ordinate associative	266
.633	Co-ordinate alternative	266
.634	Fractional numbers	267
4.21.7	<u>Post-Head Modification of NP</u>	268
4.22	<u>The Verbal Phrase</u>	269
4.22.1	<u>The Simple VP1</u>	269
4.22.11	Pre-Head Modification	270
.111	Aspect ₁ tagmeme VP.1	270
.112	Modal tagmeme VP.2	272
.113	Negative tagmeme VP.3	273
.114	Combination of tagmemes	273
4.22.12	Post-Head Modification	274
.121	Degree tagmeme VP..1	274
.122	Manner ₁ tagmeme VP..2	275
.123	Manner ₂ tagmeme VP..3	275
.124	Aspect ₂ tagmeme VP..4	276
.125	Sense tagmeme VP..5	276
.126	Combination of tagmemes	277
4.22.127	Emphatic particle <u>lah</u>	277

4.22.13 The Copula phrase VcoP	277
.130 Minimal VcoP	278
.131 Aspectual ₁ VcoP.1	278
.132 Modal VcoP.2	278
.133 Negative VcoP.3	278
.134 Degree VcoP..1	279
.135 Aspect ₂ VcoP..4	279
.136 Combination of tagmemes	279
4.22.137 The copula as an Emphatic	279
4.22.14 The Intransitive phrase ViP	281
.141 Process phrase pViP	281
.142 State phrase sViP	282
.143 Verb Focus in the ViP ViP	282
4.22.15 The Transitive phrase VtP	283
.151 Active phrase aVtP	283
.152 Causative phrase cVtP	283
.153 Ditransitive phrase dVtP	283
.154 Actor Focus in the VtP	283
.155 Object Focus	284
.156 Verb Focus	284
4.22.2 <u>Compound Verb phrase VP2</u>	285
4.22.21 Intransitive co-ordinate ViP2	285
.211 Fixed-order co-ordinate ViP21	285
.212 Associative co-ordinate ViP22	286
.213 Alternative co-ordinate ViP23	287
4.22.22 Transitive co-ordinate VtP2	287
.221 Fixed-order	287
.222 Associative co-ordinate VtP22	287
.223 Alternative co-ordinate VtP23	287
.224 Ditransitive co-ordinate dVtP2	288
4.22.23 Reduplication of the verb phrase	288
4.22.3 <u>Complex Verb phrase VP3</u>	289
4.22.31 Manner adverbial VP31	289
4.22.32 Sentential Complement string VP32	289
4.22.33 Motion string VP33	290

4.23 <u>The Adverbial Phrase</u>	290
4.23.1 <u>Endocentric Adverbial phrases</u>	291
4.23.11 Simple phrases AP1	291
4.23.11.1 Deictic AP1.1	291
.11 Temporal AP1.1T	292
.12 Static Locational AP1.1L	292
.13 Dynamic Locational AP1.1D	292
4.23.11.2 Descriptive AP1.2	293
.21 Degree AP1.2deg.	293
.22 Manner AP1.2man.	293
4.23.12 Compound phrases AP2	293
4.23.12.1 Deictic AP2.1	293
4.23.12.2 Descriptive AP2.2	293
4.23.13 Complex phrases AP3	294
4.23.2 <u>Exocentric Adverbial phrases</u>	294
4.23.21 Verbal phrases as AP	294
4.23.22 Relator-Axis phrases RAP	294
.221 Compound prepositions	295
.222 RAP with Void relator \emptyset AP	296
.223 Phrases with Void axis R \emptyset P	298
4.23.3 <u>Reduced clauses RC1. as AP</u>	298
4.23.4 <u>Sentence-initial Adverbial phrases</u>	299
4.23.41 Temporal initial AP.T	299
.411 Unmarked AP.T	299
.412 Anaphoric AP.Ta	299
4.23.42 Sentence initial AP.S	299
4.3 <u>The Clause level</u>	300
4.30 Introduction	300
4.31 Independent Clauses	302
4.31.1 Declarative clauses DeCl.	302
4.31.11 <u>Non-centred clauses</u>	303
4.31.11.1 Equational clause ECl.	303
.11 Nominal NECl.	303
.12 Adverbial AEC1.	304
.13 Quotative QEC1.	305

4.31.11.2 Adverbial AC1.	306
4.31.11.21 Deictic DAC1.	307
4.31.11.22 Prepositional PAC1.	307
.2211 Associative PAC1.A	307
.2212 Benefactive PAC1.B	308
.2213 Causative PAC1.C	308
.2214 Directional PAC1.D	308
.2215 Circumstantial PAC1.K	309
.2216 Locational PAC1.L	309
.2217 Limitation PAC1.Lm	309
.2218 Temporal PAC1.T	310
.2219 Void axis clauses PØC1.	310
.2220 Other Adverbials	310
4.31.11.3 Stylistic Permutation	311
4.31.12 <u>Centred clauses</u>	311
4.31.12.1 <u>Intransitive IC1.</u>	313
4.31.12.11 Existential EIC1.	313
4.31.12.12 Process pIC1.	314
.121 <u>buya'</u> in Process clauses	318
4.31.12.13 State sIC1.	319
.131 Simple	320
.132 Comparative	320
.133 Superlative	321
.134 Simile Comparison formula	322
4.31.12.14 The Verb string	323
.141 Sentential complement string	323
.142 Modal string	324
.143 Motion string	325
4.31.12.2 <u>Transitive TC1.</u>	327
.200 Focus in Transitive clauses	327
.201 Focus in Philippine languages	328
.202 Focus in Bornean languages	332
.203 Focus in Melanau	334
4.31.12.21 <u>Monotransitive clauses MTC1.</u>	337
4.31.12.21.1 <u>The MNP paradigm</u>	338
.11 Actor Focus Dynamic	338

4.31.12.21.12	Object Focus Dynamic	339
.13	Verb Focus Dynamic	341
.14	Subject Focus Static	342
.15	Object Focus Static	343
.16	Verb Focus Static	344
.17	Roots underlying Causative constructions	345
.18	Ergative constructions	347
.19	Semi-transitive constructions	348
4.31.12.21.2	<u>The UIE paradigm</u>	349
.21	AFDynamic	349
.22	OFDynamic	350
.23	VFDynamic	350
.24	SFStatic	350
.25	Ambivalent constructions	351
4.31.12.21.3	The Clause Margin	352
4.31.12.22	<u>Ditransitive clauses DTC1.</u>	353
4.31.12.22.1	Referent Focus	354
.11	Beneficiary Focus	355
.12	Direction Focus	355
.13	Locational Focus	356
.14	The Static : Dynamic contrast	356
4.31.2	<u>Interrogative clauses QC1.</u>	357
4.31.21	Nominal Query NQC1.	358
.211	Equational NQC1.E	358
.212	Adverbial NQC1.A	359
.213	Intransitive NQC1.In	359
.214	Transitive NQC1.Tr	359
4.31.22	Verbal Query VQC1.	360
.221	Copula VQC1.Co	360
.222	Sentential Complement VQC1.S	361
.223	Tag queries VQC1.Tg	361
4.31.23	Adverbial Query AQC1.	362
.231	Causative AQC1.C	362
.232	Directional AQC1.D	362
.233	Locational AQC1.L	363
.234	Manner AQC1.M	363
.235	Purpose AQC1.P	364
.236	Quantity AQC1.Q	364
.237	Temporal AQC1.T	364

4.31.24 Rhetorical Query RhQC1.	365
.241 Specific	365
.242 Generalised	365
4.31.3 <u>Imperative clauses ImC1.</u>	366
4.31.31 Positive Imperatives ImC1.Po	366
4.31.32 Negative Imperatives ImC1.Ng	367
.321 Definite prohibitions	367
.322 Indefinite prohibitions	368
4.31.33 Cajoling Imperatives	368
4.31.34 Hortatives ImC1.H	368
.341 Positive Hortatives	368
.342 Negative Hortatives	369
4.31.4 Co-ordinate clauses	369
4.32 <u>The Dependent Clause</u>	369
4.32.1 <u>Full Dependent clauses DC1.</u>	370
4.32.11 Sentence-level Connector clauses SDC1.	370
.111 Conditional SDC1.Con	370
.112 Circumstantial SDC1.Cir	371
.113 Reason SDC1.R	372
.114 Positive Purpose SDC1.Po	374
.115 Negative Purpose SDC1.Ng	375
.116 Limitation SDC1.Lm	375
.117 Addition SDC1.Ad	376
4.32.12 Sentence-level Relator clauses SDC1.	376
.121 Temporal SDC1.T	376
.122 Introducer SDC1.∅	377
4.32.13 Clause-level Relator clauses CDC1.	378
.131 Locational CDC1.L	378
.132 Temporal CDC1.T	378
4.32.14 Reduplication of clauses	378
4.32.2 <u>Reduced Dependent clauses RC1.</u>	380
4.32.21 Relator-Axis clauses RAC1.T	380
.211 Void relator tagmeme RAC1.∅	381
4.32.22 Reduced clauses without relator RC1.	382
.221 Instrument RC1.I	382
.222 Purpose RC1.P	383

4.32.223	Structural ambiguity of Purpose clauses		384
4.32.224	Clause additions		386
4.32.23	Sentential Complements		387
4.23.24	Idiomatic Negative IdCl.Ng		388
4.32.25	Dependent Serial clause RC1.S		389
4.32.26	Generalisation clause RC1.G		390
4.4	<u>The Sentence level</u>		391
4.41	<u>Major Sentence types S1</u>		392
4.41.1	<u>Simple Sentences S11</u>		392
4.41.11	Statements SS11		393
4.41.12	Performatives PS11		393
	.121 Commands		393
	.122 Invitations		393
	.123 Petitions		394
4.41.13	Questions QS11		394
	.131 Question types		394
4.41.14	Commands CS11		395
4.41.15	Exhortations ES11		395
4.41.16	Combinations of sentence types		395
4.41.2	<u>Compound Sentences S12</u>		396
4.41.21	Statements SS12		396
	.211 Associative		396
	.212 Alternative		397
	.213 Serial		397
	.2131 Focus shift in serial clauses		397
4.41.22	Performatives PS12		400
4.41.23	Questions QS12		400
4.41.24	Commands CS12		401
4.41.25	Exhortations ES12		401
4.41.3	<u>Complex Sentences S13</u>		401
4.41.31	Statements SS13		402
	.311 Condition SS13.Con		402
	.312 Circumstance SS13.Cir		402
	.313 Reason SS13.R		403
	.314 Positive Purpose SS13.Po		404
	.315 Negative Purpose SS13.Ng		404
	.316 Limitation SS13.Lm		404
4.41.317	Combinations of Dependent clauses		404

4.41.32	Performatives	PS13	407
4.41.33	Questions	QS13	407
4.41.34	Commands	CS13	408
4.41.35	Value	VS13	409
	.351	Statements	409
	.352	Hortatory formula	HS13
			410
4.41.4	Anaphoric Reference		411
4.42	<u>Minor Sentence types</u>	S2	413
4.42.1	Expostulations	XS2	413
4.42.2	Elliptical sentences	RS2	413
	.21	Title ellipsis	RS21
			414
	.22	Sequence ellipsis	RS22
			414
	.23	Response ellipsis	RS23
			414
4.42.3	Ready-made utterances	US2	416
	.31	The colon	US21
			416
	.32	Story endings	US22
			417
	.33	Colloquialisms	US23
			417
	.34	Riddle formulae	US24
			418
	.35	Greetings	US25
			418
4.5	<u>Levels Higher than the Sentence</u>		419
4.51	<u>Paragraph level</u>		419
4.51.1	Introduction		419
	.11	Narrative introduction	420
			420
	.12	Didactic introduction	420
			421
	.13	Ritual Poetic introduction	421
			422
4.51.2	Text		422
	.21	Narrative text	422
			422
	.22	Didactic text	422
			423
	.23	Ritual Poetic text	423
			423
4.51.3	Conclusion		423
	.31	Narrative conclusion	423
			424
	.32	Didactic conclusion	424
			425
	.33	Ritual Poetic conclusion	425
			425
4.51.4	Conversation		425

4.52 <u>Discourse level</u>	425
4.52.1 Narrative structure	426
4.52.2 Didactic structure	428
4.52.3 Ritual Poetic structure	428
4.52.4 Conversation structure	429
4.6 <u>Analysed text fragment</u>	431
4.61 The text	431
4.62 Macro-analysis	431
4.63 Detailed analysis	433

4.0 Introduction

The Tagmemic method of grammatical description has been developed by Pike (1954 - 1960), Pickett (1956), Longacre (1964) and others in the field of research into the lesser-known languages of the world. It is thus an obvious choice of model for a first description of a relatively unknown language, such as this Melanau grammar. Furthermore, Tagmemics provides a homogeneous continuation from the Phonemic analysis of the sound-system and the Morphemic description of words in the earlier chapters.

While matrices as a display heuristic are now an integral part of the tagmemic method (Pike 1962, 1963 and current work as yet unpublished), the device is not exploited in this description beyond a limited application to the Focal structure of the Melanau clause. Similarly, no space is devoted to the detailed exponence techniques by which Longacre (1964.24ff) and Cook (1969.151ff) seek to match the generative potential of Transformational Grammars¹.

Clause structure, particularly that of Transitive clauses, is examined in terms of the clause Focus, following the pioneer work on Philippine language structure by McKaughan (1958, 1962) and others. This approach proves to be better suited to the structure of Melanau clauses than the traditional dichotomy of Active and Passive voice of the verb², being particularly apt

1. Shortened, especially in footnotes, to T.G.

2. Or trichotomy, if Middle be included. These terms are in fact used, with explanation, because of their familiar connotations; the shortcomings of relying solely on these notions are made clear.

when clauses are combined into more complex syntagmemes. The distinction between Dynamic and Static clause nuclei is shown to be equally fundamental to this level of the grammar.

4.1 The Grammatical Hierarchy

From the combination of morphemes into words (where the levels of morpheme and grammatical word do not already map in an identity relation) in Cp.3, the syntax is described in terms of a hierarchy of levels each of which provides the main constituents of syntagms at the level above. Thus the typical combinatorial relations within the hierarchy are that:

Words are combined to form Phrases,

Phrases are combined to form Clauses, while

Clauses, singly or in combination, form Sentences, the basic unit of composition of many utterances. In many speech situations there is an equally formal combination of

Sentences to form Paragraphs, and

Paragraphs to form Discourse, the highest level in the hierarchy. The structure of each of these underlined level-specific grammatical units is the burden of the syntactical description within the Grammar.

Each level of the hierarchy represents a class of syntagmemes, constructs of tagmemes arranged in strings¹. The tagmeme, an essentially bipartite correlation of grammatical-function position (slot in some tagmemic literature) with a class of mutually substitutable items which may fill that position, is fundamental to all tagmemic analysis (Longacre 1965.65).

1. This arrangement in strings does not imply a strict serial "left-to-right" temporal ordering of all the constituents (Lyons 1968.76).

While lower levels in the hierarchy typically provide the main tagmeme filler class of the level immediately above, atypical filling is recognised in the processes of level-skipping (eg: clause slot filled by a single word), layering (eg: clause slot filled by a clause) and loop-back (eg: clause filling a constituent position in a phrase; that is, phrase slot filled by a clause). The notion of total accountability¹ of all the data at every level is not seen as a requisite of the model of description.

At the Phrase level, Nominal, Verbal and Adverbial phrases are described. At the Clause level, Equational clauses, Intransitive and Transitive clauses are described, having both Independent and Dependent status with respect to their occurrence in the next level of description. Major Sentences of varying degrees of complexity have the speech-function of Statements, Performatives², Questions and Commands; other utterances are often categorised as Minor Sentences.

At the level of the Paragraph, Narrative, Didactic and Ritual Poetic Discourse are all shown to have typical form. Conversation is also examined in the description of the four Discourse structures at the highest level of Syntax.

A short fragment from a recorded text³ is analysed at all levels described from Morpheme to Discourse, to demonstrate the coherence of the analytical and descriptive processes.

1. Halliday (1966.113-115 passim) discusses total accountability.

2. Austin 1955, see 4.41.12

3. Except where specifically noted as elicited material, all exemplification is drawn from actual recorded texts.

4.2 The Phrase Level

The Phrase is a class of syntagmemes of a hierarchical level above that of the Word, the level of its main constituent tagmemes, and below that of the Clause, in which it functions as the main tagmeme filler.

Phrases are endocentric or exocentric. Endocentric phrases have either a single Head position with various nuclear and non-nuclear Modifier positions in subordinate relation (Modification Phrases), or multiple Heads of equal status (Co-ordinate Phrases). Exocentric phrases are typically Relator-Axis constructions of which the Axis has not the internal structure of a clause (cf: Longacre 1964.75), or phrases of endocentric construction whose distribution in syntagmemes of a higher order is not the same as that of the nuclear constituents (Lyons 1968.232).

These basic Phrase types may be illustrated by an array of phrases having nominal Head tagmeme:

Modification Phrases:	H:nc Mod:vq	
	<u>salui ba'ou</u>	
	canoe new	'a new canoe'
Co-ordinate Phrases:	H:nc C:c H:nc	
	<u>salui atau akit</u>	
	canoe or raft	'a canoe or a raft'
Relator-Axis Phrases:	Rel:pr Ax:nc	
	<u>dagen salui</u>	
	in canoe	'in a canoe'
Adverbial Phrases:	H:nu H:nu	(= Co-ord NP)
	<u>lau malam</u>	
	day night	'by day and night'

In that Phrases typically fill Clause-level tagmeme slots, they are grouped together for description according to their

clause-level functions, as Nominal Phrases NP, Verbal Phrases VP, and Adverbial Phrases AP. Within this major distributional classification, further functional and distributional differences distinguish Pre-Head Modification phrases (Quantity Phrase, Verbal Auxiliaries) and Post-Head Modification phrases (Adjectival phrases, Adverbial phrases). Where it is appropriate, further distinction is made according to the internal structure of these phrases, by the class of Head and Modifier position fillers.

4.21 The Nominal Phrase

The Nominal Phrase NP typically fills Subject and Object positions in clause-level syntagmemes, and the Axis position in Relator-Axis Phrases. Endocentric NP described are the Minimal NP, Co-ordinate NP and Modification NP; Exocentric NP are indistinguishable from the Nominalisations described at 3.31.2

4.21.1 Minimal Nominal Phrase NP1 is fully identified, having the bipartite nuclear structure of an obligatory Head position filled by a Proper noun¹ np or a Pronoun pn, followed by an optional Identifier position filled by a deictic particle. (A subsequent Anaphoric Reference position filled by the reference particle unei 'ref.' is not included within the NP structure itself, for reasons given at 4.41.4).

Thus: NP1 = +H:np / pn ⁺Id:deic

eg: H:np
Tugau 'Tugau'

1. Brøndal (1928.20) insists that proper nouns are the most truly nominal expressions in a language. (cf: Lyons 1968.337)

H:pn +Id:deic

akou 'ih

I this 'I' (emphatic)

H:pn +Id:deic (+An:ref)

luin in unei

they that ref. 'they (previously mentioned)'

4.21.2 Co-ordinate Nominal Phrase NP2 has four allotagmas, distinguished by the presence or absence of Connector tagmeme, the connector used (if there is one), and by the semantic relation of the co-ordinate status Heads to each other if connector is absent from the (surface)¹ string.

4.21.21 Fixed Order NP21 have connector obligatorily absent between the nominal Heads, which always appear in the same linear order regardless of the semantic propriety of that serial ordering.

eg: H:nc +H:nc

(1) tina tama

mother father 'parents'

(2) ane' sawa

child spouse 'dependent family'

H:NP H:NP

(3) sou sikou sou silou

grandchild elbow grandchild fingernail 'future generations'
or 'descendants in perpetuity'

4.21.22 Appositive NP22 have the bipartite nuclear structure of an Item position It: filled by an NP, and an Appositive position Ap: filled by a Minimal NP1, a Categorical Specification NP321.2, or some higher level syntagm with NP status at

1. The notion of 'surface structure' (as opposed to deep structure) is borrowed from the vocabulary of T.G. in which it is sufficiently well understood to require no further explanation.

this point (cf:4.62). The tagmemes are typically separated by comma pause, and their order is variable.

eg:(1) It:NP322 +Ap:np
benatou nyin, Besiong¹
 son-in-law he Besiong 'Besiong, his son-in-law'

(2) Ap:NP1 +It:NP321.3
Jilag 'ih, raja likou Uya'
 Jilag this ruler River Oya
 'This fellow Jilag, ruler of the Oya River'

4.21.23 Associative NP23 have an overt connector jigem 'with'² between the Heads, or comma pause, or neither. An optional Limitation tagmeme manifested by the completive particle kawa 'also' may close the phrase, typically if the final nominal is less well defined than the foregoing one(s).

eg:(1) H:nc +C:c +H:nc
pangai jigem duduh
 wind with thunder 'wind and thunder'

(2) H:nc +C:c +H:NP32 +Lim:kawa
asou jigem benatang ki' kawa
 dog with animal other also 'dogs and other animals'

1. This structure can also have the distributional status of an Equational Clause NEC1.(4.31.11.1), depending entirely on its function in some higher level of the hierarchy such as Paragraph or Discourse. It is treated here as NP22 on the tacit assumption that it is extracted from a clause-level syntagme. As NP22 it could be a complete Minor Sentence, eg: RS23 in answer to the question "Who is that?". (4.42.23)

2. Occasionally the Predicate connector serta 'and at the same time' is used between Nominals, as for instance in the NP23 a jemelai serta teluéh 'young men and maidens'; and jigem may occur between co-ordinate Verbals (4.22.212) despite the overall polarisation of meanings assigned here.

(3) H:nc +H:nc
udu, jawai nyin
 nose face he 'his face and nose'

(4) H:nc +H:nc
bei padang sayur bunga¹
 be field vegetable flower
 'there was a garden of vegetables and flowers'

A very common NP23 without overt connector is the association of an unspecified plural quantity of some nc with the Interrogative non-human Pronoun nou 'what?', to yield a vague plural generality.

eg: lou kupéh lou nou
 gpl prawn gpl what?
 'such things as prawns and so on'

4.21.24 Alternative NP24 are of two types, according to their construction with atau 'or', or with kah 'perhaps'.

.241 Alternative NP241 is the more usual, and can occur in declarative or interrogative clauses of a firm or of a tentative nature.

eg:(1) H:nc +C:c +H:nc²
babui atau lelaméh
 pig or caterpillar 'pig(s) or caterpillar(s)'

(2) H:NP321.4 +C:c +H:NP323.3
beluba' sekaut atau beluba' salui saug
 race power-boat or race canoe R+paddle-fast
 'race for speed-boats or for paddled racing-canoes'

1. Because the reverse order would mean distinctly 'The flowers (that grow on) vegetable plants', it is possible that this may prove to be a fixed-order expression NP21.

2. Where there are more than two Associative or Alternative Heads, all except the last two are usually separated by comma pause only, (see eg: 4.21.21, 423 and .424)

4.21.242 Alternative NP242 occur in queries or statements of alternatives which cannot be verified with much certainty.

eg: H:nc +q. +H:nc +q.
keluer dipa kah, alou kah
 come-out snake perhaps lizard perhaps
 'either a snake or a lizard will come out'
 or 'out came a snake, or perhaps it was a lizard'

4.21.25 Neutral co-ordinate NP25 has the bipartite structure

bai' N₁ bai' N₂ 'as well N₁ as N₂'¹

which may be associative or alternative according to the context in which it occurs dictates.

eg: bai' ipu' pega', bai' ipu' tana'
 as well sprite shoots as sprite earth
 'Sprites who live on the mangrove mud-flats just as much as those who inhabit the dry ground above'

4.21.3 Modification Nominal Phrase NP3 has two major allotagmas distinguished by the potential of Quantification tagmeme in pre-Head position, and by the semantic relation of the Head and Modifier to each other.

4.21.30 Nominal phrases capable of expansion, but having no actual modification or identification of the Head, are classed as Unidentified NP30.

4.21.31 Identification NP31 has two minor allotagmas, the Exclusive Identity and the Inclusive Identity Phrase. Neither can take further modification with a pre-Head QuP, but both may have optional final Id:, which closes the phrase string.

.311 Exclusive Identity NP311 has bipartite nuclear

1. bai' is presumably cognate at this point with Malay baik 'well' (a similar expression existing also in colloquial Malay) and is sometimes heard as [baɪ̯t̚].

structure, a Head position filled by a noun nc, followed by an Identifier, a Proper noun np.

- eg:(1) pengiren Matali
 princeling Mat Ali 'the princeling Muhammed Ali'
- (2) sungai Kabeng in
 stream Kabeng that 'the River Kabeng'

4.21.312 Inclusive Identity NP312 has bipartite nuclear

structure, a Head position filled by a personal pronominal or the general plural indefinite quantifier lou, followed by an Identifier, a Proper noun np.¹

- eg:(1) nua Arip
 we-2 Arip 'Arip and I'
- (2) lou Besiong
 gp1 Besiong 'Besiong and his companions'

A non-contrastive allotagma of the Identifier is a common noun of relationship (chiefly found in texts of Igan speech)

- eg:(3) nyin sawa
 (s)he spouse 'him, the husband'
 or 'her, the wife'

.313 General Identity NP313 has bipartite nuclear structure, a Head position filled by a noun nc followed by an Identifier position filled by one of the deictic pronouns 'ih 'this' or in 'that'.

- eg:(1) kubou 'ih
 house this 'this house'
- (2) salui in
 canoe that 'that canoe, the canoe'

1. (lou + np) is distinguished from (lou + nc) by its different semantic content 'np and his companions' as against generality of plural quantity (cf: Quantity Phrase at 4.21.26)

A non-contrastive allotagma of this Identifier is the choice of the Adverbial deictic inan 'yonder' in place of 'ih or in , adding the further distinction 'that one over there' (cf:3.33.12.2)

eg:(3) salui inan
canoe yonder 'that canoe over there'

4.21.314 Reflexive Identity NP314 has bipartite nuclear structure, a Head position filled by a proper noun np, a pronoun pn or a noun phrase with an animate [+human] noun as Head, followed by an obligatory Reflexive slot filled by the enclitic particle -debei 'self'.

- eg:(1) Tugau - debei
Tugau self 'Tugau himself'
- (2) nyin - debei
(s)he self 'himself, herself'
- (3) ane' raja likou in - debei
child ruler country that self
'the king of that country's daughter herself'

4.21.32 Qualification NP32 represents the most typical subset of Modification Phrases, displaying the greatest variety of internal structure. NP32 are distinguished from NP31 by

- (i) the potential occurrence of an optional Quantity tagmeme in pre-Head position,
- (ii) the potential occurrence of a number of optional Modifier tagmemes in post-Head position, and
- (iii) the lack of built-in Identity which characterises NP31.

Unless further identified by a deictic, the NP32 defines a class of syntagmemes which conforms to its description, not a unique item of reference.

Because of the generality of NP32, a very large number of subsets might be recognised subject to a law of diminishing returns, according to the presence or absence of particular tagmemes which appear to be optional in the maximal string; for no two linguistic units have exactly the same distribution (Lyons 1968.232). Three major allotagmas are described, mutually distinguished according to the semantic relation that obtains between the Head and the immediate post-Head Modifier¹.

Nominal Phrases NP32 have a general common nuclear structure, an optional pre-Head Quantity position filled by a Quantity Phrase QuP, an obligatory Head position filled by a noun or pronoun, an obligatory immediate post-Head position which in effect defines the subset of NP32 to which the Phrase type is assigned, and an optional Identifier position filled by a deictic particle, which closes the phrase string.²

Various non-nuclear positions between the defining post-Head Modifier and the final Identifier may be filled with a wide variety of expressions of quality such as size, colour and so on, and of location in time and space; subject to the general distribution rule that:

Fillers of a higher level of the grammatical hierarchy follow those of a lower level in the phrase string.

1. At such places, the line dividing syntax from semantics is ill defined. In English, the various relations between N_1 and N_2 in a phrase " N_1 of N_2 " may be handled by the semantics of the word 'of' (Nida and Taber 1968.40). Melanau has no intervening word like 'of', and the semantic distinctions are discussed as a matter of the construction N_1N_2 , a syntactic device of serial ordering.

2. (see p.247)

This means that embedded clauses follow embedded phrases, which themselves follow single words.

In the great bulk of narrative material collected, usually no more than two or three post-Head modification tagmemes occur in any NP¹. The order of occurrence is not absolutely invariant, appearing to be that which entails the least chance of confusion as to the referent of a particular attribute; it is in general the order in which the major Modifiers are set out in the following description, which is Specification, then Possession and Description.

2. (from p.246) Such apparent counter-examples as:

H:nc Poss:pn Id:deic Mod:RAP(Rel:pr Ax:NP22)

layan kamei 'ih kuman tipou ayeng kamei Jilag

direction we(exc) this from ancestor we(exc) Jilag

'our line of descent from our ancestor Jilag' do not upset the general statement that 'ih (or in) usually close the NP. It has been shown (4.21.32.313 above) that 'ih is an optional demonstrative which may be attached by way of emphasis to any pn, itself fully identified already without an identifier.

1. Informants can be persuaded to construct longer NP strings, but these tend to have closure with 'ih or in after two or three Modifier positions have been filled; remaining attributives are framed as a dependent clause or phrase, as eg:

bup ayeng se' 'ih (wa') senarong peba' belulang maal

book big red this (which) P+cover S+use leather expensive

'this large red book with expensive leather binding'

It is worth noting that the English equivalent sentence, by the inclusion of the adjective 'expensive' to qualify 'leather', can no longer be constructed as a simple serial of attributes, as *'this large red expensive leather covered book', without making the referent of 'expensive' ambiguous between the leather and the book. The relative clause resolves the ambiguity.

4.21.321 Specification NP321 has the Head position filled by a noun which has superordinate status over a range of hyponyms. The immediate post-Head position is filled by a Specifier, which may be nominal or verbal. Many subtypes of this construction may be found, but the following appear to have more particular significance:

.321.1 By naming, NP321.1 The Head is a common noun *nc*, and the Specifier is a nominal associated with the Head much as in the NP311 described above. All these phrases may be expanded with nengadan 'named' between Head and Modifier, to yield an instance of NP323.3

eg:(1) palei payau

taboo deer 'prohibition against eating deer-meat'

(2) pekan kubou

curse house 'curse associated with dismantling a house without certain ceremonials'

(3) pera'un nyu' géh

fever kerosene 'dysentry'

.321.2 Categorial, NP321.2 The Head is a Categorial term used in the classification of the observed world (cf: 6.31) The Specifier is a hyponymous term narrowing the range of the Categorial, which is not often used in speech without being preceded by its cover-term¹. All these phrases may

1. This close-knit Head-Attribute relation is marginally distinct from Compound nouns (3.31.12), in that there appears to be more open phonological juncture between the members of NP321.2. The difference is not great, and no essential modification is made to the overall description if the two syntagms are conflated into one single type, either Compound or NP321.2

be expanded with macem 'kind, sort' between Head and post-Head Modifier, yielding a more complex NP321.2.

eg: kayou taéh

wood belian 'ironwood tree'

mano' kenyiu

bird hawk 'hawk'

ikan panit

fish shark 'shark'

xebu bulu'

shoot bamboo 'edible bamboc-shoots'

Also included within this subtype, but not expandable with macem for obvious reasons, are:

layan bulai

direction left 'left, to the left'

layan ta'ou

direction know 'right, to the right'

4.21.321.3 By Location of origin or present position, NP321.3

The Head is a common noun nc, the Specifier is either a proper noun np denoting place of origin, or a common nc denoting location. All may be expanded with kuman 'from' between the Head and the Modifier.

eg: jalu' Kina

plate China 'a plate from China'

sigup Java

tobacco Java 'Javanese tobacco'

ikan daat

fish sea 'fish from the open sea'

ipu' talun

sprite jungle 'sprite(s) from the jungle'

There appears to be some marginal difference between the

Head-Specifier relation above and that in the examples below, but not enough to justify a separate sub-type; it is not appropriate to insert kuman between the phrase constituents, unless the N_1 has been removed from its natural location specified by N_2 .

eg: tuli asar

bone rib-cage 'rib'

nyu' benyuh

oil coconut 'coconut oil'

kulit kayou

skin wood 'bark'

betih ulou

leg head 'fore-leg (of animal)'

4.21.321.4 By Purpose, NP321.4 Two distinct sub-types are found in which the Specifier position is filled by a noun or by a verb root. All may be expanded by insertion of the future tense-aspect particle ba' 'intend to, intended for' between the Head and the Modifier.

.41 Nominal specifier

eg: balau upan

sago-palm bait 'sago-palm for use as bait'

tanki nyu'

tank oil 'fuel tank'¹

.42 Verbal specifier

eg: kedau tudui

place sleep 'sleeping quarters'

1. The word tanki does not conform to the well-defined patterns of Melanau word-formation (see 2.34), but is now in common use along with other loans from Chinese, English and Malay as well as from neighbouring Bornean languages (cf: fn to 2.341, p.59)

anum tengen

water S+drink

'drinking water'

Included in this subset of NP321.4 are phrases with Specifier position filled by a Generalisation Reduced Clause (4.32.26) containing not a verb root but an inflected verb without the nominals required to make the inflection grammatically relevant¹.

eg: lian ba' meninou

time int. A+burn-off

'the season for burning-off (farm land)'

4.21.321.5 By Enumeration, NP321.5 has two subtypes, according to whether the post-Head Modifier is a cardinal numeral nm or an ordinal number, which has the structure of an RAP with nm manifesting Axis tagmeme (making ordinal enumeration equivalent to NP323.4).

.51 Cardinal specifiereg: pukul duah

strike two

'two o'clock'

lau telou

day three

'Wednesday'

bagian pat

part four

'The Fourth Division'

ta'un jeribu tuju' ratuyh nem beléh

year one-thousand seven hundred six-teen

'the year 1716'

1. The inflected verb meninou is transitive and marked morphemically for Actor Focus in a Dynamic clause, but the construction lacks both Actor and Object of transitivity. This is explained (4.32.26) in terms of generalised (because unspecified) action, 'the time of year when people in general burn-off their farms'

4.21.321.52 Ordinal specifier

eg: lakau ga' duah
 occasion at two 'the second time'
 or 'on the second occasion'

.321.6 The Speech Formula, NP321.6 is a special form of the general Head-Specifier syntagm, in which the Head position is filled only by the superordinate nc sau 'sound'; the post-Head Specifier position is filled with one of the inventory of nc denoting a particular speech-act, such as dengah 'news report', jawab 'answer', telabau 'enquiry', uba 'speech', uli 'response' &c:

eg: sau dengah
 sound news 'what was reported'

sau titah
 sound command 'what is commanded'

sau uli
 sound response 'what was said in reply'¹

cf: sau sesu
 sound snore 'the sound of snoring'

1. This analysis underlies the treatment of reported speech as an Equational Clause (4.31.11.13); sau being always nominal, the phrase sau uba' nyin 'he said' (clausal in English) manifests a progressive Head-Modifier attributive construction:

((sau uba')_{NP321.6} nyin)_{NP322.1} 'the sound of his speech'

But the etic form [ʃpʌn], analysed /saw pin/ at 3.227, may equally well represent /suy pin/, OFStat 'said by him', and sui uba' is then VP..2 (vs+N) analogous to sui' naseng 'sad at heart', sui 'say' being one of the 'short UIE roots' like juh, which may be expanded to susui, sisui regularly.

Whatever the correct interpretation of [ʃpʌn] is, sau belongs to the set of sense nouns which, having also adverbial distribution (4.22.125) are never unambiguously verbal; so the analysis rests.

4.21.322 Possession NP322 has the Head position filled by a Nominal, followed by a Possessor position filled by a proper noun np or pronoun np, or by a common noun nc. Different degrees of specification are signalled by this variable filler, since Melanau nouns are not formally marked for number and may therefore denote an item or a class of items; Head + np/pn approaches a fully identified NP more closely than Head + nc. All may be paraphrased by the formula Mod:n +bei 'possess' + H:nc, yielding a semantically related clause.

.322.1 Proper noun or pronoun NP322.1

eg: <u>tumek Tugau</u>	
spear-head Tugau	'Tugau's spear-head'
<u>kubou peritah</u>	
house government	'the Government Office' or 'a government-owned house'
<u>salui kamei</u>	
canoe we(exc)	'our canoe'

.322.2 Common noun NP322.2 is only marginally distinct from NP321.3(b), if indeed the difference is real at all¹.

eg: <u>kulit anum</u>	
skin water	'the surface of the water'
<u>tap nyagem</u>	
sole hand	'the palm of the hand'

1. While kulit anum appears to delimit a part of the water, the surface not the depth, and kulit kayou to specify a kind of skin, tree-skin rather than human skin (the semantic difference meant above), it is quite possible to switch the mental images and read the difference backwards; kulit kayou is the surface of the wood &c.: So there may be no real difference in fact.

ane' siau
child fowl 'chick, young hen'

4.21.323 Description NP323 is the most typical subset of all Qualification phrases, as they are the most typical of all Modification phrases. NP323 display the greatest variety of internal structure; the Head position is filled by a nominal and the immediate post-Head position by one of the many descriptive expressions of size, colour, age, material of construction, texture, weight and so on. Subject to the generalisations already made about the co-occurrence of multiple Modifiers and the ranked ordering in a string, these may occur in any order and any combination¹. The modifying tagma (or syntagm) may be nominal, verbal or adverbial.

.323.1 Nominal description NP323.1 has the Descriptive position filled by a common noun *nc*, which most typically denotes material of construction or constitution .

eg: gunong méh
mountain gold 'a mountain of gold'

tumek besei
spear-head iron 'an iron spear-head'

sua kayou
spoon wood 'wooden spoon'

1. There is some evidence to suggest that colour terms, if not included in a relative State clause such as wa' se' ji 'which be red in appearance', occur closer to the Head word than other types of attributive. This is a statistical observation only, and the analysis is not yet conclusive on such a nicety.

4.21.323.2 Verbal description NP323.2 has the Descriptive slot filled by a State verb vs, of which the most typical is the Quality verb vq (the adjective).

eg: kubou ayeng
 house be-big 'large house'
nasip ja'et
 luck be-bad 'ill fortune'

It is not clear at the present stage of investigation whether Stative forms of Transitive verbs in Object Focus, which are shown at 4.31.12.21.15 to be attributive in function, should be handled in this category or with the embedded clause structures described below. At present, where the vs is a single non-predicative verb only, it is allocated to this construction pattern, even though the phrase may be shown to be derivable in some way from a full clause structure (Longacre 1964.75)

eg: cerita na'-na'
 story R+make R+make 'a made-up story'
tukat lepeng
 staff S+break 'broken walking-stick'

.323.21 Relation Idiom NP323.21 is a special form of NP323 in which the Head position is filled by a pronoun pn, and the Descriptive position by a State verb of Relationship, typically formed by pe- +noun affixation.

eg: duin pane'
 they-2 S+child 'those two in a child-birth relation'
 ie. 'mother and child'
 which is synonymous with duin petina, 'those two in a motherhood relation = mother and child'

4.21.323.3 Clausal description NP323.3 has the Descriptive slot filled by a clause-level syntagma, with or without an overt Relator; in non-selective subordination, the relator is wa' 'rel. which', while selective subordination is denoted by the choice of the appropriate Classifier ci, as eg:

apah 'body, which [+animate]' (cf: 3.31.32.21)

eg: da'un wa' nanyam luin (non-selective)

leaf which P+plait they

'leaves they had plaited together'

gunn na' nyin uma

forest R+make he farm

'forest he had made into a farm'

siau apah belei kou ga' pasar (selective)

fowl which R+buy I at bazaar

'chicken which I bought in the bazaar' (not the other)'

siau igi' nyin bawai

fowl R+take he go-up

'the fighting-cock he had brought up into the house'

The nominalisations described at 3.31.2 may be seen as a special case of this NP323 subtype, in which wa' 'which, what' or a 'the one who' acts as pronominal Head, the rest of the nominalisation being an attributive predication;

thus: wa' debei da'ou

what not be-good 'something terrible'

a puma padai

pers S+farm rice-grain 'a rice-farmer'

Such nominalisations may have further attributive modification, while maintaining their distributional status as Phrase-level constructs operating at the word level, nom.

eg: a puma padai apah lakei angai (selective)
 rice-farmer who old very
 'the oldest of the rice-farmers'

4.21.323.4 Adverbial description NP323.4 has the Descriptive position filled by an Adverbial expression; a deictic adverb adic.(3.33.1), an adverbial phrase AP (4.23) which may be RAP in form.

eg: lau sunih
 day in-future 'tomorrow'
a-dana sabei
 old-folk ago 'people who lived long ago'
kebun sega' kubou
 garden near house 'the garden near the house'

4.21.4 Expansions of Nominal Phrases. In the description of NP so far the examples given are of minimal forms of phrases, to demonstrate their essential structure. Typical expansions below illustrate the fuller syntagms found in actual textual material.

4.21.41 Minimal NP1 cannot be expanded. It enters into phrase-level constructions with other NP to form NP of greater complexity, as for example those shown at 4.21.22 above.

4.21.42 Co-ordinate NP2 may have a theoretically unlimited number of Heads in co-ordinate relationship, although more than three are rarely found in the data collected.

.421 Fixed-order NP21 appear to be limited to two Heads only, with no possibility of further expansion.

.422 Appositive NP22 are found with up to three Heads, which themselves may be quite complex.

eg: Tejali, raja tergagah, raja ayeng lengan

Hornbill ruler famous ruler large voice

'The Hornbill, a famous king, a loud-mouthed ruler'

The longest NP22 found in the texts has for the filler of Appositive position the expanded Associative NP23 given at 4.21.423 below, and occurs in the sentence:

dagen kebun in bei buah', buah' padok ... la'ei ki'

in garden that be fruit jackfruit ... orchard other

'In that garden were fruit trees, jackfruit

It is shown at 4.6 that an entire Quotative Equational clause may realise the Appositive tagmeme.

4.21.423 Associative NP23 occur with up to four Heads, of which only the last two are joined by the overt connector (in this case serta rather than jigem, cf: fn.2 p241), the preceding pairs being linked with phonological comma pause. In such long strings, it is common to have the enclitic particle kawa' 'also' at some indeterminate position near the end of the string.

eg: bua' padok, buah' dian, buah' rambutan ...

jackfruit durian rambutan

... serta dida' kawa' la'ei la'ei ki'

and many also orchard orchard other

'jackfruit, durian, rambutans and many other kinds of fruit tree as well'

(The enclitic kawa' is treated as NP23 closure, transposed to its position in the string relative to its normal one for some stylistic reason as yet imperfectly understood. It is not yet possible to account for all those variables which are at the voluntary control of the speaker.)

4.21.424 Alternative NP24 are usually restricted to a simple alternative between co-ordinate Heads, but may be extended very much as the NP23 cited above. The longest to appear in the corpus of data is: (describing prizes at a regatta) bajou, radiū, sigup, bebalei atau mana-mana ji lah shirt radio tobacco doll or whatever sight emph. 'shirts, radios, tobacco, dolls or any other kind of thing for that matter'

(Such strings are unusual, and call for the enclitic lah '!' to emphasise the all embracing scope of mana-mana ji and provide some kind of eventual closure to the list.)

If the alternative connector atau occurs more than once in the string, its last occurrence is often accompanied by the enclitic particle pun¹.

eg: duum pangai atau duum kuyad kah ...
buzz wind or buzz monkey perhaps

... atau pun duum benatang benatang ki'
or (else) buzz animal animal other

'a buzzing noise caused by the wind, or maybe it was monkeys or some other kind of animal'

.425 Neutral NP25 occur in the data available only as nuclear NP with no expansion. It is not known whether this is a fortuitous lacuna, or systematic (cf: fn at 3.32.31.21 .209) hole in the pattern.

4.21.43 Modification NP3 have different potential for expansion according to the subset of which they are a member.

1. The enclitic pun is identical to the Malay pun, which "is not to be glossed" (Winstedt 1952.146). Occurring also as pu'un, it appears to function as a euphonic balance word, not unlike the 'even' of colloquial English (cf: 3.34)

4.21.431 Identification NP31 are completely identified, and therefore incapable of taking further expansion¹.

4.21.432 Qualification NP32 have the general structural formula:

$$NP32 = \dagger Qu +H \dagger Spec \dagger Poss \dagger Des^n \dagger Loc \dagger Tem \dagger Id$$

(where the superscript ⁿ indicates potential recursiveness at this Descriptive position, limited in practice to two or rarely three realisations of the tagmeme²) The inventory of possible expansions of such a formula is clearly very large indeed³, and only a small representative selection

1. The apparent counter-example sungai Kabeng inan 'the River Kabeng yonder' does not upset this general restraint, since it has been shown (4.21.313) that inan is a member of the set of deictics which provide closure to any NP. In this example, it is not a Locative pronoun but manifests the optional Identifier tagmeme inherent in even an Identified NP1 or NP31.

2. As noted in the fn to 4.21.32 at p247, informants can make a verbal joke of constructions expanded beyond the normal point of practical usefulness in conversation. In the Dalat school, a long series of embedded clauses on the lines of "The House that Jack Built" was recorded, which ran:

Mista 'ih mengajer ane' apah mubal asou wa' melibek ngau
Teacher this A+teach child who A+hit dog which A+chase cat

wa' diem ga' kubou na' Ajun
which dwell at house R+make Ajun

'This teacher teaches the child who hit the dog which chases the cat which lives in the house built by Ajun'. Plainly this can be expanded to any length as the game of memory goes on.

3. Longacre (1964.27) computes the total number of readings and permutations of similar formulae as running into hundreds, which would grossly overload the present description of phrase structure.

can be given below, abstracted from oral texts.

- eg: (1) Qu:nu +cl.+H:nc +Id:deic
duah bah nyagem 'ih
 two side hand this 'these two hands'
- (2) Qu:nu + cl. +H:nc +Spec:nc +Id:deic
pat usah bua' dian in
 four trunk fruit durian that 'those four durian trees'
- (3) Qu:qu +H:nc +Pos:pn
tugan lawéh tipou ayeng kamei¹
 a-good-number ancestor we(exc) 'a good many of our
 ancestors'
- (4) H:nc +Spec:np +Pos:np +Id:deic
salui bu'eng Tugau 'ih
 canoe war-boat Tugau this 'this war-canoe of Tugau's'
- (5) H:nc +Spec:nc +Pos:NP32 +Loc:RAP.L
ijin balau likou Kina dagen bateng ayer Uya'
 mill sago-palm Chinese in major-river Oya
 'the Chinese sago-mill on the Oya River'
- (6) H:nc :Spec:nc +Des:RIC1.
bua' balek wa' papid duah ata'
 fruit banana rel. S+twin two cl. 'a twin-bodied banana'
- (7) Qu:qu +add. +H:nc +Des:RIC1.
ida' angai bua' wa' se' ji
 much very fruit rel. red sight 'a lot of ripe-looking
 fruit'
- (8) H:nc +Des:col +Des:RTCl.
kain kunéng wa' tenukar nyadin méh
 cloth yellow rel. P+change become gold
 'yellow cloth which was changed into gold'

1. The inclusion of ayeng 'great' between the Head nc and the Possessor nc is one of the reasons for treating tipou ayeng as a compound noun rather than a phrase-level construct (3.31.12).

- (9) Qu:nm +H:nc +Loc:RAP,L(NP322)
sekutum bunga dagen kebun raja
 one-bud flower in garden ruler
 'a young flower in the king's garden'¹
- (10) H:nc +Des:col +Loc:RAP(NP323.3)
babui puti' dagen panyin tuun paai likou Igen in
 pig white in group swim go-cross River Igan that
 'a white pig among those swimming across the River Igan'
- (11) Qu:NmP +H:nu +Tem:RAC1.
kira-kira duah telou ratuyh ta'un si'iu Brooke labi'
 reckoned two three hundred year before Brooke come
 'some two or three hundred years before the coming of
 Raja James Brooke'

4.21.5 Ambivalence of I.C. cutting for analysis

Example (10) above, while containing at least one embedded clause, is analysed as having overall phrase structure, largely on account of the gloss worked out with the informant. The NP32 is the Object Complement of the Middle verb peden 'see', in the clause Besiong peden babui puti' ... likou Igen in.

S Pm Obj.Comp

Analysed as a NP, example (10) has the following IC structure:

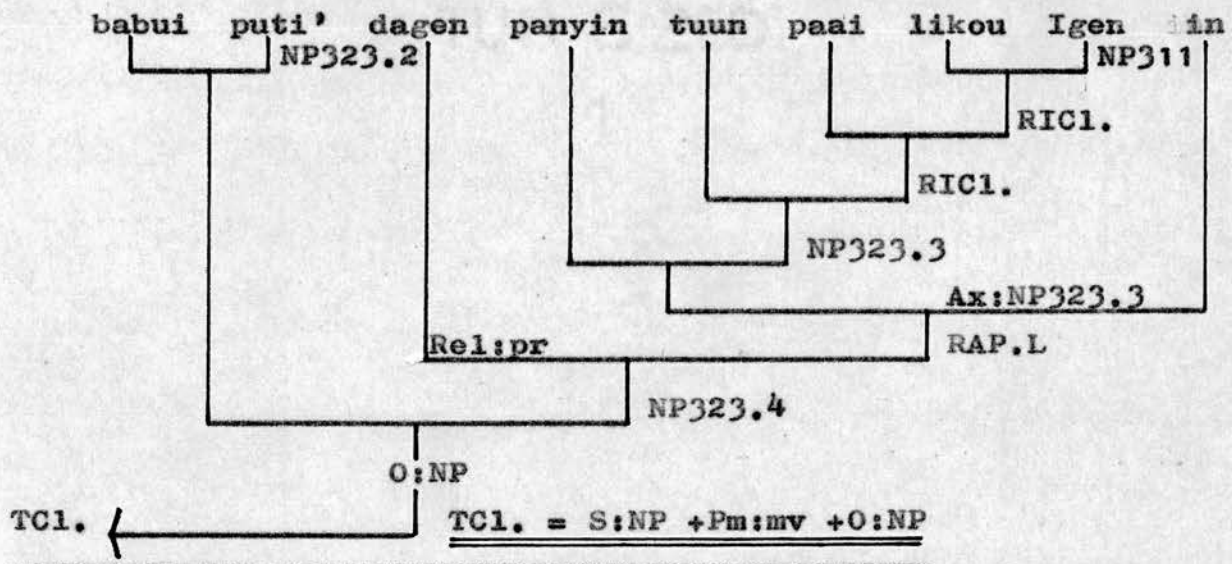

1. See 5.31 for further examples of courtly speech used in the preliminaries to a well-arranged marriage.

In this analysis, tuun paai likou Igen is treated as a Dependent Clause lacking the optional non-selective subordinating pronoun wa' (see 3.31.32.21 above, and neglecting the fact that the referent of in is in fact open to doubt as between likou Igen and panyin, the analysis given), embedded in the NP323.3 panyin tuun ... Igen in.

However, this analysis hinges on the placement of the first Immediate Constituent cuts at clause-level, which were made (in this instance) only after the gloss was given, when the meaning of the story was being worked out with the informant¹. And so dagen, the Relator of the RAP dagen panyin ... in, receives the Locative gloss 'in' or 'among'. But dagen may also be Relator in a Temporal RAP, receiving the gloss 'while' or 'during'; had this possible interpretation been assigned, the IC cutting would be importantly different, to give the clause-level structure:

Besiong peden babui puti' dagen panyin ... likou Igen in
 S Pm O.Comp T.Margin

having the following pattern of Immediate Constituents:

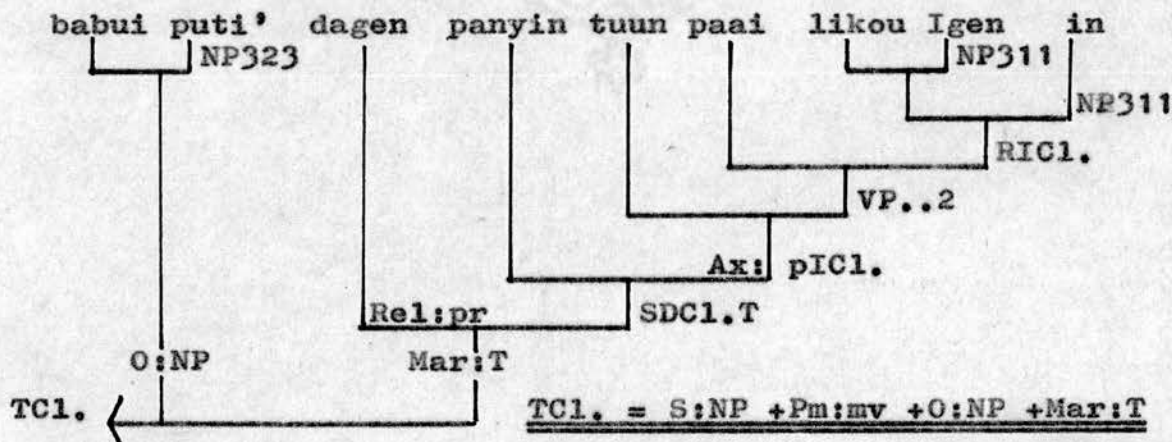

1. This on-the-spot translation and partial analysis is seen as a vital part of the field-work that cannot be put off until a more convenient time without attendant disaster.

At the present state of analytical knowledge of Melanau, it is not at all obvious how the correct choice of cutting point is to be made without reference to the general meaning of the story; the linguistic context is vitally important. Even then in a case like that exemplified, a reasonable argument might be made for either pattern, each of which yields a grammatical structure and a semantically satisfying end result.

4.21.6 Pre-Head Modification of the NP is by the Quantity tagmeme Qu:, which may be discontinuous. There are two allotagmas of Qu: in complementary distribution.

4.21.61 Quantity Phrase QuP, which may consist of

- (1) a single word from the inventory of quantifiers qu, listed at 3.34.12, occurring in pre-Head position,

eg: dida 'many, much'
ga 'some'
semuah 'all'

- (2) a single word post-Head,

eg: jumit 'few, (a little)'
min 'all, (all over)'
singen 'only'

- (3) a compound of which the first word never occurs freely without the second,

eg: bisu dakai 'as many as possible'
tugan lawéh 'a goodly number (of people)'

- (4) or the general plural quantifier gpl.

lou 'those ... , such things as ...'

4.21.62 Number Phrase NuP, which has bipartite nuclear Head-Modifier structure the reverse of those so far described; an obligatory Unit position filled by a unit of mensuration nu

or a classifier cl. preceded by an obligatory Number position filled by a simple or complex numeral nm. Optional non-nuclear Modifier position delimits the degree of accuracy of the number, and a discontinuous post-Head Limitation position terminates the NuP. Thus:

NuP = \pm Mod:acc +Nm:nm +U:nu ... \pm Lim: $\left[\begin{array}{l} \text{lebih} \\ \text{kawa} \\ \text{singen} \end{array} \right]^1$

The constitution of the string is subject to the following situational rule: When the Head noun of the phrase to which the NuP is attributive is itself an nu, then the Unit position is Void.

eg: +Nm:nm +U:nu

ayan ta'un

eight year 'eight years'

(2) +Mod:acc +Nm:nm +U:cl +H:nc +Lim

angaren tuju' ata' teluh singen

about seven cl. egg only 'only seven eggs or so'

(3) +Nm:nm +U:nu +Lim

nem bulan lebih

six month more 'six months and more'

4.21.63 Complex Numeral Phrase NmP is a microcosm of all the Nominal Phrase structures, having internal Head-Modifier and Co-ordinate constructions.

.63.1 Head-Modifier relationship obtains between higher decimal units and the number of them being counted; there is an obligatory Head position filled by a decimal unit nu, preceded by an obligatory Modifier position filled by a simple numeral.

1. The choice is apparently limited to these three terms only.

eg: +Mod:nm +H:nu

telou ratuyh

three hundred

'three hundred'

ulan beléh

nine teen

'nineteen'¹

4.21.63.2 Co-ordinate Associative relationship obtains between complex Head-Mod. numerals and simple numerals in the formation of complex numerals, subject to the common decimal rule of sequential ordering that:

Higher decimal units, and multiples thereof, appear in the string before lower units and multiples.

eg: Nm:nm +Nm:nm

telou ratuyh ulan

three hundred nine

'three hundred and nine'

jeratuyh ulan pulu'

one-hundred ninety

'a hundred and ninety'

.63.3 Co-ordinate Alternative relationship obtains between numerals of any decimal level and complexity connected by the Alternative connector atau 'or', and between numerals of the same decimal level and complexity without overt connector.

eg: duah pulu' atau duah pulu' limah

twenty

or

twenty five

'twenty or twenty five'

telou pat bulan

three four moon

'three of four months'

1. pelu'en 'ten' is an exception to this ordering. Although it bears obvious family resemblance to pulu' 'units of ten', the lack of any other occurrence of a morpheme *{'en} 'one', and the neutralisation of the first vowel to /ə/, lead to its treatment as a simple numeral. Close-coupled jeratuyh '100' &c: are also treated as compounds, not phrases.

It appears to be a limitation of this Alternative construction that, unless the atau is replaced by comma pause, the numerals in alternation must be next in series to each other. Thus *telou limah bulan 'three (or) five months' would appear to be inadmissible.

4.21.63.4 Fractional numbers do not occur very much in the everyday speech of most people, although the specialised languages of artisans and tradesmen undoubtedly employ greater numerical sophistication. The only fraction in common use is the imprecise 'half' division tengah.

.41 Compounds with tengah include:

<u>setengah</u> ¹	'a half, some of'
<u>tengah-duah</u>	'in between' (cf: <u>ga' patéh</u>)
<u>tengah-jalan</u>	'half-way, on the way'
<u>tengah-lau</u>	'mid-day'

.42 Additive fractions have two forms, depending on whether the term tengah or its compound form setengah is employed. (No clear choice-initiating criterion is yet apparent.)

(1) with tengah preceding the numeral:

<u>tengah duah bulan</u>	
half two moon	'a month and a half'

(2) with setengah following the numeral:

<u>pukul duah setengah</u>	
strike two a-half	'half past two o'clock'

1. Cognate with Malay satengah 'a half'

4.21.64 Pronominal QuP

The Quantity Phrase may have the distribution of a pronominal phrase in syntagmemes (or sequences of syntagmemes, such as occur in connected discourse) in which its referent is specific.

eg: (1) jeratuyh lawéh a lai atau pun dida' alu'
 one-hundred cl. man or (else) many more
 'a hundred men or even more'

(2) bei bua' dagen, labi' telou ata'
 be fruit in come three cl.¹
 'there are as many as three fruit inside'

(3) sabi' ga'
 V+ask some 'Give me some!'

and also examples at 3.31.32.22 and at 4.62a.

4.21.7 Post-Head Modification of the NP is typified in the expansions exemplified for the Qualification NP32 at 4.21.432 above.

The Post-Head Modifier positions are seen to be filled by three basic syntagm types:

- (1) Nominal Phrases NP of types described above;
- (2) Adjectival expressions having the structure of State Verb Phrases sViP described at 4.22.143 below, or embedded clauses as described at 4.32.2;
- (3) Adverbial expressions of Temporal and Locational denotation, having the structure of embedded clauses, endocentric Adverbial Phrases AP or exocentric RAP described at 4.23.22 below.

1. It will be noted that ata', used pronominally here, is the usual classifier for enumerating fruit bua' of any kind.

4.22 The Verbal Phrase

The Verbal Phrase VP typically fills Predicate position in centred clause-level syntagmemes, and Copula position in non-centred clauses. Endocentric VP described are the Copula VcoP, Intransitive ViP (which may be Process pViP or State sViP) and Transitive VtP (which may be Active aVtP, Causative cVtP or Ditransitive dVtP). These VP may be Simple, Compound or Complex, depending on the pattern of nuclear positions in the phrase. Exocentric VP having the structure typical of VP, but not being predicative in distribution, are typically fillers of Manner Adverbial positions in Complex VP and Clause strings.

4.22.1 Simple VP1 consist of a single nuclear Head position filled by a verb whose class determines the type of VP, with an optional nuclear pre-Head and peripheral post-Head set of modification positions.

Pre-Head tagmemes manifest Negation, Modal and Tense-aspect categories of the Verb, while post-Head positions manifest Modifiers of Degree, Manner expressions closely bound to the Head¹, and secondary Aspect. An Emphatic tagmeme may follow the VP immediately, but is not included within it.

According to the Head word, three basic types of VP are to be distinguished, exemplified each with a tense-aspect particle.

eg: (1) VcoP ba' nyadin
 intent become ' ... to become ...'

1. It is not as clear as one might hope which of these tagmemes should be regarded as included within the VP and which are in the domain of the extended clause string. In general, the more close-bound are regarded as internal (cf: compounds at 3.32.4).

- (2) ViP agei tudui
 cont. sleep ' ... still asleep'
- (3) VtP nga' mebatun
 past A+lift ' ... had lifted ...'

4.22.11 Pre-Head Modification tagmemes are nuclear, being common to all VP types (with the exception of the obligation restrictions in VcoP noted at .13 below) and manifest, in order of proximity to the Head verb, Tense-aspect (hereafter called Aspect₁) Mode and Negation¹. A general formula for VP with nuclear pre-Head tagmemes is therefore:

$$VP_1 = \dagger Neg. \dagger Mode \dagger Asp_1 +H:v$$

(In the description which follows, all VP are understood to be Simple VP unless it is stated to be otherwise; the index 1 is therefore omitted immediately after the symbols VP unless it is being compared with Compound or Complex VP.

The first decimal point represents pre-Head position index, the second decimal represents post-Head positions)

4.22.111 Aspect₁ tagmeme is in inner position immediately proximate to the Head verb. Fillers are from the range of tense-aspect particles ba' 'future intent'
agei 'present continuative'²
nga' 'past completive'

1. This is the reverse of the order of occurrence in the phrase string. Post-Head modifiers have the same order of occurrence in the string and proximity to the Head verb.

2. agei also appears in a number of idiomatic expressions not analysed into constituents, such as nou agei 'and at once ...' It is possible that, in dependent Purpose clauses, ka' 'negative future intent, lest' should be included in this set (4.62)

- eg:(1) akou ba' pesawa (VP.1)
 I int. S+spouse
 'I propose to get married'
- (2) Besiong agei jemelai
 Besiong cont. bachelor
 'Besiong was still a bachelor'
- (3) nyin nga' nyadin benatou Tugau
 he past become son-in-law Tugau
 'he has / had become Tugau's son-in-law'¹

The Aspect₁ position may recur in proximate position relative to the Head verb, although this recurrence is apparently limited to agei or nga' in first place, and ba' in second place.

- eg:(4) akou agei ba' belelang
 I cont. int. gain-experience
 'I still want to gain experience of the world'
- (5) bua' wa' nga' ba' se' ji
 fruit rel. past int. red appearance
 'fruit looking as if it was almost ripe already'

4.22.1111 Pre-verb Degree tagmeme is an allotagma of Aspect₁ in mutually exclusive distribution, and is manifested by the add. makin 'increasingly' before vs.

- eg:(1) duum in makin sega'
 buzz that increasingly be-close
 'the buzzing got closer and closer'

1. Melanau does not make all the tense distinctions of European grammars, but the context generally affords sufficient further background information to allow the proper translational gloss to be adduced. In any vernacular example, the gloss given is usually that appropriate for the larger portion of text from which it was abstracted. (The same is true of gender distinction).

- (2) sei balau 'ih lu' mena' ane' unit makin ayeng
 flesh sago this will A+make child increasingly big
 'The pith of this sago-palm will make children grow'

This form of pre-Head modification is exploited in the set-formula phrase makin ad. makin vs. 'the more ... the more ...'¹, which very often precedes the Subject NP.

- eg:(3) makin jelau makin susah kamei 'ih lian in unei
 more one-day more troubled we this time that ref.
 'Day by day things got more difficult for us in those days (I have been telling you about)'

The order of ad. and vs appears to be flexible without any corresponding change in meaning of the expression.

- eg:(4) teluh in makin ayeng makin jelau
 egg that more be-big more one-day
 'the egg grew bigger and bigger each day'

4.22.112 Modal tagmeme is in intermediate position between the Aspect₁ and Negative tagmemes, and is manifested by one of the Verbs taking Sentential Complement exemplified above at 3.32.11.5. Modal tagmeme is exemplified, added to Copula, Intransitive and Transitive VP₁, yielding VP.2

- eg:(1) mesti ba' beiepaxi' (VP.2)
 must int. be wedding-gift
 'There has to be a gift (at this point in the ceremony)'
- (2) lou tou in debei kenah tawi
 gpl goblin that not be-able run-away
 'the goblins were not able to get away'

1. The same general form is exploited also at clause-level, with the second makin optionally covert.

eg: makin luin peta'ah kesau in unei, tamah luin kayou 'the more they heard that, the more they piled up the wood', in which it may be regarded as a Circumstantial subordinator of the first clause.

(3) bedua nyin lu' titam baya mudei

soul he will P+seize crocodile later

'his soul will be siezed by a crocodile in due course'

4.22.113 Negative tagmeme is in initial place in the phrase string, and is manifested by the word debei 'not'¹, as in .112(2) above (which may also, therefore, be a realisation of VP.3). Alone in a clause containing VtP, it may be seen in eg: a likou debei kemacau ikan udun (VP.3)

Melanaus not A+trouble fish Udun

'Melanaus do not bother the Udun fish'

4.22.114 Combinations of pre-Head tagmemes are also exemplified in the foregoing material. With Negative tagmeme realised in the VP, there is far greater incidence of occurrence of the Degree tagmeme in post-Head position. It may occur close-coupled to the Modal verb in pre-Head position, as seen with lalu 'completely' (or, with Neg. '...at all').

eg:(1) a likou debei kenah lalu ba' keman payau (VP.123.1)

Melanaus not be-able at-all int. A+eat deer

'Melanaus may not in any circumstances eat venison'

When they occur together, debei and agei change position; other Aspect₁ particles retain their usual position.

eg:(2) ka'au agei debei ta'ou

you cont. not know 'you still do not know'

1. In speech, as yet the only widespread form of Melanau, Neg. debei is distinguished from enclitic -debei 'self' by a greater degree of phonological pause between the end of the Subject NP and the beginning of the VP (cf:2.333 and 2.65).

debei is a phrase and clause-level tagmeme, distinct distributionally from Sentential negative bukan 'it is not the case that'

4.22.12 Post-Head Modification is largely confined to ViP, in which there is no nominal expression to interrupt the string following the verb. In VtP, these tagmemes occur most often in VP nuclear to Object Focus clauses, with a passive verb.

The most frequent order of occurrence of post-Head tagmemes (which is not as invariant as pre-Head slots) is Degree next to the Head verb, Manner and secondary Aspect. An enclitic nominal Sense tagmeme provides a measure of positive closure to VP not unlike that of the deictic identifiers in the NP (cf: 4.21.32). A generalised formula for VP with post-Head tagmemes is: VP = +H:v ... ⁺Deg. ⁺(⁺Man₁ ⁺Man₂) ⁺Asp₂ ⁺Sense

The hiatus after the Head verb position represents possible disjuncture caused by the Agent of a passive verb; the realisation of Manner₁ and Manner₂ is mutually exclusive and optional (except in the case of Compound verbs). In particular, the syntagms H:v +Man₁ and H:v +Man₂ represent interesting phrase structures, and receive distinguishing indices.

4.22.121 Degree tagmeme is manifested in VP..1 by one of the set of Degree adverbs add. (3.33.21) proximate to the Head verb (or Agent NP), of which angai 'very', lalu 'completely' and singen 'only' are the most usual.

eg:(1) a tama nyin manah angai (VP..1)

father he joyful very
'his father was overjoyed'

(2) kanan in lenyed lalu

jar that S+sunk completely
'the jar was completely submerged'

(3) bareng wa' tubu' singen

thing rel. S+grow only
'what grows up all on its own'

4.22.122 Manner₁ tagmeme is manifested in VP..2 having the nominal modification structure (+V +N), where N is filled by an nc excluding the set of sense nouns (3.11.21) which fill the Sense tagmeme position at the end of the string. (Some of the Compound verbs at 3.32.42 have this structure).

- eg: (1) sui' naseng (VP..2)
sad emotion 'sad at heart'
- (2) se'ap beba'
noisy mouth 'be garrulous'
- (3) matai beragen
die violence 'die a violent death'
- (4) titah nupei
R+tell dream 'informed in a dream'

.1221 A non-contrastive allotagma of this Manner₁ position filler is a numeral in place of the nominal.

- eg: papid duah (VP..2*)
be-twin two 'twinned'

4.22.123 Manner₂ tagmeme is manifested in VP..3 having the verbal modification structure (+V +V), whose status is in fact somewhat ambivalent between Simple Verb Phrase VP1 with Manner modification and Complex VP3 (4.22.3 below).

- eg: (1) ja'an pedih (VP..3)
well ill 'recover from being ill'
- (2) miga' tudui
awake sleep 'awake from sleep'

But a simplistic interpretation of sequential 'process V₁ then V₂' is ruled out by the further example

- (3) sinu' tudui (VP..3)
snore sleep 'snore in one's sleep'

4.22.124 Aspect₂ tagmeme is manifested in VP..4 by one of the set of post-Head aspectual particles agei 'continuative, still' nga 'completive, already' udei 'repetitive, again'.

- eg:(1) lemah angai agei¹ (VP..14)
tired very still 'still very tired'
- (2) debei den agei (VP.3.4)
not be-seen still 'not seen any more'
- (3) tili bau nga' (VP..4)
fly up already 'already flown upwards'
- (4) labi' jangai udei
come go-inland again 'return to the shore'²

4.22.125 Sense tagmeme is enclitic to all VP, and is manifested by one of the set of abstract sense nouns described at 3.11.21. In practice, except where there is a previous occurrence of the noun to call for the 'echo', the set commonly occurring as VP closure particles is limited to ji 'appearance' sau 'sound' tan 'feeling, manner'

- eg:(1) maal angai ji
expensive very appearance
'very expensive, by the look of it'
- (2) duum bei jau' sau
buzz be far sound
'the buzzing sounded as if it was a long way off'
- (3) da'ou kawa' tan
good also feeling
'feeling well enough'³

1. kekel 'still' sometimes occurs in Aspect₁ and Aspect₂ position as an alternative to agei, as likou Mudan kekel debei ramai 'the settlement of Mudan is still not very well populated'

2. (4) is drawn from a sea-side story, hence the gloss (3.33.12.4)

3. (see p.277)

4.22.126 Combinations of these tagmemes are possible within the range delimited by the formula, although more than two places are not usually filled in practice. The most usual of these to be realised are Degree with secondary Aspect or Sense.

eg: (1) +Degree, example .125(1) above

(2) langet min udei (VP.1.4)
 itchy all again 'itchy all over once more'

4.22.127 Emphatic particle lah is appropriately mentioned at this point, since it is usually enclitic to the VP although not strictly tied to any position in the clause string (as is seen in many of the longer examples in later sections of the clause-level description).

eg: padou lah luin lau malem

S+travel ! they day night

'On and on they travelled, by night and day'

4.22.13 The Copula phrase VcoP has structure as defined in the general formula for VP, with significant restriction of post-Head modification to Degree and Aspect₂ tagmemes only.

A further difference from the other VP is that the Head position, while nuclear to the phrase, is optional if Aspect₁ position is realised. The formula has therefore to be restated:

$$VcoP = \dagger Neg. \dagger Mode + (\dagger Asp_1 \dagger H:vco) \dagger Deg. \dagger Asp_2$$

3. (from p.276) This idiomatic use of kawa 'also' as a limiter of degree, giving the sense '...enough, fairly ...', is similar to the use of Malay juga 'also' in expressions such as boleh juga 'able to manage, more-or-less' (cf: Winstedt 1952.80)

4.22.130 Minimal VcoP consists of Head only, bei 'be' or nyadin 'become', with no modification.

eg:(1) saji ateng, luin bei tenawan (VcoP1)
 sure real they be human
 'sure enough, they were real people'

(2) ka'au nyadin raja
 you become ruler 'You become (our) king!'

4.22.131 Aspectual modification, to VcoP.1 consists of tense-aspect particle, with or without an overt Head vco.

eg:(1) méh 'ih ba' piou nua
 gold this int. funeral-gift we-2(exc:)
 'this gold is to be our funeral gift'

(2) examples .111(1 and 2) above

4.22.132 Modal modification, VcoP.2 consists of a modal verb followed by a Head vco. (In that the modal verbs appear to be closely linked with future aspect, VcoP.2 does not occur in texts without aspectual marking ba' 'intent').

eg: kamei mesti ba' nyadin babui
 we(exc) must int. become pig 'We have to become pigs'

4.22.133 Negative modification, VcoP.3 consists of a negative particle followed by the Head vco.

eg:(1) debei bei anum
 not be water 'There is no water'

(2) debei nyadin likou lalu agei
 not become likou at-all still
 'never become one of us again'¹

1. This sense of likou is not covered in chapter 6. It appears to be an extension of the uses described there, occurring in a story of a spirit-medium who went into a trance from which she could not be brought back to normal sanity. (Account by Ta'iah of Kekan)

4.22.134 Degree modification, VcoP..1 consists of the Head vco followed by degree tagmeme.

eg: wa' tadu' kou nyadin angai
 rel. R+plant I become very
 'what I planted comes up nicely'

4.22.135 Aspect₂ modification, VcoP..4 does not occur without some form of pre-Head modification as well, and may have a Complement interrupting the string.

eg:(1) uled ga' da'un debei bei agei
 grub at leaf not be still (VcoP.3.4)
 'there were no more grubs on the leaves'

(2) Tugau nga' jemelai nga' (VcoP.1.4)
 Tugau past bachelor past
 'Tugau was already grown to marriageable age'

4.22.136 Combinations of these tagmemes are illustrated in the examples .133(2) and .135 above.¹ Example .133(2) therefore is a realisation not only of VcoP.3, but further of VcoP.3.14.

4.22.137 The Copula Phrase as an Emphatic appears to have two semantic correlations; it can emphasise the following predication, and it can also have the further connotation that there exist other related entities about which the predication does not obtain. The first, essentially emphatic use of bei occurs when the optional copula is realised in non-centred C1.

1. Where it becomes helpful to refer to a specific type of VP, whether VcoP or any other, in which more than one modification tagmeme is realised, those occurring in the string are indexed in numerical order regardless of their actual string order. The pre-Head tagmemes are thus referenced eg: VP.12, even though Modal actually precedes tense-aspect; both decimal points are used to index pre- and post-Head modification together.

(cf:4.31.11); the first and the second use of bei occur in centred clauses and in Existential sentences.

4.22.1371 bei in non-centred clauses is always optional, and hence is always emphatic when it occurs.

eg:(1) in Equational clause:

ikan 'ih bei ikan penipu ga' tenawan
 fish this be fish S+deceive at human
 'this fish is very clever at deceiving people'

(2) in Adverbial clause:

bau katil bei jelawéh ane' mexou
 on bed be one-cl. child female
 'on the bed, there was a girl ...'

.1372 bei in centred clauses may be emphatic or selective.

eg:(1) emphatic bei

ubat 'ih bei mena' tenawan matai
 medicine this be A+make human die
 'this poison is a real killer!'

(2) selective bei

debei paut béh in luin bei buau tungan lawéh,
 not long-time after that they be flee a-good-number
bei kawa' kekel menaan
 be also still A+endure
 'Not long afterwards, a good number managed to get away, while others remained standing fast!'

.1373 bei in Sentence initial position may be emphatic or selective, the latter use apparently restricted to its occurrence immediately before a verb nuclear to the main clause of the sentence.

eg:(1) emphatic bei

bei lah babui labi' ba' merusek kebun in
 be ! pig come int. A+damage garden that
 'there came the pig, intent on damaging the garden'

(2) selective bei

bei bebali' nyadin babui, ...
 be S+change become pig
 'there were some who changed into pigs, ...'

4.22.14 The Intransitive Phrase ViP has structure defined by the general formulae for VP, with either a Process verb vp or a State verb vs as its Head. These fillers of the Head position formally distinguish Intransitive Process Phrase pViP and Intransitive State Phrase sViP from each other; both manifest a considerable variety of pre-Head and post-Head modification patterns.

The pre-Head tagmemes are nuclear to all VP, and the cited forms below follow the general lines already exemplified for the VcoP, delineating patterns observed in textual material.

4.22.141 Process phrase, pViP is exemplified by expansions of the nuclear phrase for the vp makau 'walk'.

eg:(1) a lakei makau peba' tukat¹ (pViP1)
 pers old walk S+use staff
 'an old man walks with a stick'

(2) ane' 'ih ta'ou makau singen (pViP.2.1)
 child this know walk only
 'this child can only walk (as yet)'

1. peba' tukat 'making use of a walking-stick' manifests clause-level Instrument tagmeme, and is so excluded from the domain of the VP proper.

- (3) a pedih in debei nga' makau udei (pViP.13.4)
 pers ill that not past walk again
 'that patient has never walked again'

4.22.142 State phrase, sViP is exemplified by expansions of the nuclear phrase for the vs pedih 'be ill'.

eg:(1) ka'au lu' pedih maned kah (sViP.2.3)
 you will be-ill have-crimp perhaps
 'you will suffer, it may be cramps'

(2) kamei pedih sapah angai (sViP..1)
 we(exc) be-ill indeed much
 'we were very ill indeed'

(3) and with pedih itself in attributive position:

lalu akou ja'an pedih na'ei in (sViP..2)
 then I be-well be-ill stomach that
 'then I recovered from my stomach complaint'

4.22.143 Verb Focus ViP precludes any pre-Head tagmeme, the Head verb itself occupying first position in the string¹.

eg:(1) makau kou (Narrative VFocus)
 walk_F I 'So off I walked'
 or 'It's time I went'

(2) ki'ih alu'² (Imperative VFocus)
 to-here more 'Come a bit closer!'

1. Although this is true for Positive Imperatives, Negative Imp. (or Prohibition) clauses have the prohibitive particle itself in the initial Focal position (cf: 4.31.32)

eg: ka' ka'au tudui udei
 pro. you sleep again 'Don't you dare go to sleep again!'
 (cf: also fn to 4.22.111 above)

2. The use of the dynamic deictic adverbs as Imperative forms is a further justification for treating them as full verbs vp.

4.22.15 The Transitive phrase, VtP has a nuclear structure as defined for the VP with pre-Head modification tagmemes, but is restricted in post-Head modification, the two Manner tagmemes being obligatorily unrealised.

VtP have either an active verb *va* or a causative verb *vc* as nuclear Head, these fillers defining the Active Transitive phrase *aVtP* and the Causative Transitive phrase *cVtP* respectively. The Ditransitive phrase has a ditransitive verb.

.151 Active phrase aVtP has an Active transitive verb as its nuclear Head, and may be Actor, Object or Verb Focus.

.152 Causative phrase cVtP has a Causative transitive verb as its nuclear Head, and may be Actor, Object or Verb Focus.

.153 Ditransitive phrase dVtP has a Ditransitive verb as its nuclear Head, and may be Actor, Object, Referent or Verb Focus.

As well as the Focal valenciés of the Head verbs, the parameter of clause Status affects the form of the Head verb (4.31.12.203ff), but has no further effect on the phrase as a whole. As noted in the formula for post-Head modification, there are significant differences in the actual string form for different Focal valenciés of the Head *vt*. These are exemplified below by expansions of the *aVtP* with batun 'raise' as its nuclear Head root. No significant differences exist between the overall form of the *VtP* with a Causative verb as nucleus; basically ditransitive verbs have a nuclear Referent tagmeme (4.31.12.22) which may, on occasion, be void, outwith VP.

.154 Actor Focus aVtP may have at least the Aspect₂ tagmeme between the verb and the Object tagmeme.

- eg: (1) tenawan ta'ou mebatun udei kelidéng in (aVtP.2.4)
 human_F know A+raise-up again monument that
 'People were able to raise the monument up again'
- (2) ka' kelou mebatun kelidéng in ?(aVtP.1) ?
 pro you_F A+raise-up monument that
 'Do not raise the monument up again!'¹

4.22.155 Object Focus aVtP have the Agent tagmeme in proximate position to the Head vt, so making the VP discontinuous if there are post-Head modification positions realised in the string.²

- eg: kelidéng in debei kenah ba' benatun luin udei (aVtP.123.4)
 monument_F that not able int. P+raise they again
 'the monument was too much for them to lift up again'

.156 Verb Focus aVtP are severely restricted as to the occurrence of any nuclear or non-nuclear elements other than the Head vt itself. No modified VP occurs in the data in Narrative VFDyn, and Imperative VFDyn all lack overt 2nd person addressee tagmeme so that it is not known whether the string would be discontinuous or not.

- eg: batun udei kelidéng in (aVtP..4)
 raise_F again monument that
 'Raise the monument up again!'

1. Transitive Prohibitions have the nuclear VP marked for Focus appropriate to the clause comprising the content of the negative Imperative (cf: 4.31.31.21); hence the query on the mod. index.

2. It becomes somewhat arbitrary at this point to decide which of the post-Head positions are to be considered as part of the VP expansion, and which are part of the clause string per se. As they occur in Transitive clauses, those Adverbials recognised as part of Intransitive VP are considered integral with the VtP; all others are clause-level tagmemes external to the VP.

4.22.2 Compound Verb Phrases VP2 have more than one Head verb in co-ordinate relation, and may have optional modification tagmemes in pre-Head and post-Head positions like other VP.

While it is a requirement of orthodox tagmemics that a clause shall have one and only one predicate tagmeme (Elson and Pickett 1962.64) there exist numerous cases of a clause in which two verbs are conjoined by jigem 'with' or serta 'and also, at much the same time' on the one hand, and atau 'or' on the other, into a single compound predication with respect to the Subject and other nuclear tagmemes in the clause. It seems to be introducing too much structure to analyse all of these as sequences of clauses with co-referential Subject (and often Object and attributes as well), although it is clearly needful to formulate some diagnostic criteria by which compound verb phrases and serial clauses may be differentiated.

4.22.21 Intransitive co-ordinate ViP2 are recognised if the two (or more) Head verbs are of the same kind, both vp or both vs, evidently describing related aspects of the same process or state and having the same Subject referent. They must not be separated by any word other than the conjoining particle (with the rider that c may be covert in some compounds, such as the fixed-order compounds described below at .211).

.211 Fixed Order co-ordinate ViP21 have no overt connector, and always occur in the same order (cf: 3.32.41). They are largely co-extensive with the set of compound verbs.

eg: kidei kinan

go-here go-there

'go hither and thither'

tubit batun

dip-down raise-up

'swoop down and up again'

'rise and fall (in flight)'

4.22.212 Associative co-ordinate ViP22 have two or more Head verbs usually joined by jigem 'with' or serta 'and', and may also be closed by the enclitic kawa' 'also' manifesting Limitation tagmeme. Much the same restrictions are applied to the practical length of the string as restrained the NP co-ordination described at 4.21.23.

eg: (1) sungai in nyadin ayeng jigem teben

stream that become large and deep

'the stream became broad and deep'

(2) luin na'ah teriak serta begu lalu

they later shout and clamour completely

'then they shouted and cried out all together'

(3) Jilag pepela piud wab

Jilag S+paddle S+drag (go-)up-the-coast

'Jilag paddled and dragged (his canoe) eastwards'

By the criteria of .21 above, the following clause is to be analysed as having not one compound VP, but a Simple VP with a Compound exocentric VP as Manner Adverbial:

(4) nasi' in paman serta menanggih jigem papa'

rice that S+float and A+weep with S+cry-out

'the rice floated down on the current, weeping

and calling out as it went'

Since the predication paman is clearly describing a different part of the whole occurrence than the compound VP menanggih jigem papa'¹, they being the voluntary activity

¹ Although marked with me- affixation, menanggih is Intransitive (3.32.31.21.205) Subject Focus, as is papa'; both are therefore "of the same kind", despite appearances to the contrary.

of the rice, rather than its involuntary state of drifting.

4.22.213 Alternative co-ordinate ViP23 have multiple Heads vi conjoined by atau 'or', and may have an optional atau in string initial position as extra Alternate particle.

eg:(1) dibei a pekebun atau pelikou ga' gi'ih
not-be pers S+garden or S+home at here

'no-one has their home or garden here'

(2) siau ka'au lu' atau ba' tawi atau matai
fowl you will or int. flee or die

'your fighting-cock will either run for its life,
or die(where it stands)'

4.22.22 Transitive co-ordinate VtP2 are less common by virtue of the Object tagmeme which follows transitive verbs in most transitive clauses. There are, however, cases where two verbs in co-ordinate relation have the same Subject and also the same Object referent, each overt in the clause string only once. Such verbs are recognised as forming co-ordinate VtP when they are in the same Focus, being by this combination of criteria clearly compatible with analysis as a single phrase.

.221*Fixed Order VtP do not appear to be formed.

.222 Associative co-ordinate VtP22 may be in Actor Focus or Object Focus, as long as both Head verbs are of equal valency, and the same Dynamic or Static status.

eg:(1) Actor Focus Dynamic:

kamei menolong luin ba' mengenyat jigem mengupat luin
we(exc)_P A+help them int. A+grow-up and A+swell-up them

'we help them, making them big and fat'

.223 Alternative co-ordinate VtP23 have the same range of variables as Associative VtP2,

eg:(2) Object Focus Dynamic:

dipa in pun bibal atau siped nyin
 snake that * P+hit or P+slash he
 'either he hit the snake or he slashed at it'

4.22.224 Ditransitive co-ordinate dVtP2 are not of frequent occurrence, but appear to follow the general rules which have been delineated for co-ordinate mono-transitive vt. A single example will suffice, of Alternative dVtP23 in Object Focus Dynamic construction with covert Agent.¹

eg: tukat 'ih mesti ba' tjuh atau peniti ga' Jilag
 staff this must int. P+give or P+send at Jilag
 'this staff (of governmental authority) must be given direct to Jilag, or sent to him'

4.22.23 Reduplication of the Verb Phrase

The Reduplication process is applied to phrases just as to words, always being manifested by a total Repetition of the entire phrase without reformation of any part. The semantic correlate of the process may be repetition of the predication, or merely a stylistic addition of words to the clause without new lexical information.²

eg:(1) selemawa' in pixat jebah, pixat jebah, lalu ...
 fruit-bat that S+stretch one-side X2 then
 'the fruit-bat stretched himself, first to one side then the other, and then ...'

-
1. An elicited clause structure.
 2. While skilled raconteurs employ Reduplication as a stylistic sophistication in their narrative (4.32.224), others appear to repeat themselves unconsciously as a way of recapitulating their thoughts; this is especially true in stories recorded from the more elderly, which is perhaps none too surprising.

Sometimes it is even a reduplicated form stylistically repeated within the VP,

eg:(2) sapa-sapeng duin mexa-mexat mexa-mexat lisi daat
 gradually they-2 A+come-into-view X2 edge sea
 'very gradually, the sea-shore came more and more
 clearly into their view'

4.22.3 Complex Verb Phrases VP3 are limited to those ViP already described as VP..3 (see .123 above), Subject-sentence complements, and the Motion string described at 4.31.12.143 in which the second verb is clearly not an independent new clause-level predication, but attributive to the Head verb.

4.22.31 Manner Adverbial complex VP31 are already described, and may be briefly exemplified by:

diem seneng
 dwell be-easy 'live at one's ease'

4.22.32 Sentence Complement string VP32 follow the general pattern of Manner Adverbial phrases for verbs taking Subject sentence complements. The reduced clause RC1, forming the Complement has no overt Subject, it being co-referential with that of the Head verb so that the two verbs are juxtaposed in the phrase string.

At the phrase-level, the RC1. forms an Adverbial adjunct to the Head verb, as in

eg: S:NP321.5 +Pi:sViP32
semuah a likou tukeng mena' salui
 all Melanaus be-clever A+make canoe
 'all Melanaus are clever at making boats'

4.22.33 Motion String complex VP33 follows the pattern of the Nominal phrases NP321.2 (in which the first noun, a superordinate *nc*, is Head, its more precise denotation being the burden of the second term). In VP33 the Head verb is always a rather general *vp* of motion, made more specific by the second.

Although the second verb is frequently directional, there are often other clause-level terms filling Direction tagmeme position in the expanded clause string having more typical RAP structure (4.31.11.2214).

- eg: (1) tiked bawai
 climb go-up 'climb up(wards)'
- (2) puluh ba'ai
 S+lower go-down 'lower oneself down(wards)'
- (3) jalan piud¹
 travel S+drag 'get along by dragging (a canoe)'

4.23 The Adverbial Phrase

The Adverbial Phrase AP typically fills clause-level tagmeme positions attributive to the clause Predication. AP manifest a wide variety of clause tagmemes; within the cover-term Referent (R), nuclear to ditransitive clauses, Adverbial Phrases contain Indirect Object NP "labelled" by prepositions for Associative (A), Beneficiary (B) and Dative (D) semantic case². Clause margin tagmemes of Cause (C), Circumstance (K),

1. By virtue of the fluidity of Melanau roots between classes, jalan piud can also be glossed 'a way for dragging, portage'

2. Fillmore 1967.16 calls the case-marking system of prepositions a syntactic "labelling" of the nominal phrases.

Direction (D)¹, Instrument (I)², Location (L), Manner (M) and Time setting (T) all have Adverbial fillers. As well as deictic Adverbial Phrases, sentence-initial AP.S contain the speaker's assertion as to the truth-value of the following clause-content (cf: 3.33.23).

Endocentric AP, even if containing only one word, are all potentially expandable by a degree ad. into a phrase which is strictly complex, having two members of the same class in a relation of subordination. These are, however, analysed as Simple AP, distinguished formally from Compound AP and Complex AP (analogous to complex NP and VP syntagms).

Exocentric AP are of two types, distinguished by their internal composition; VP having Adverbial distribution, and RAP with NP manifesting Axis tagmeme (not limited to simple NP).

4.23.1 Endocentric Adverbial phrases are composed of one Head adverb ad. optionally followed by one or more ad. in subordinate relation.

4.23.11 Simple phrases AP1 may have a Deictic or Descriptive adverb as their nuclear Head filler.

4.23.11.1 Deictic AP1.1 are Temporal or Locational. If Locational, they may be Static or Dynamic, corresponding to the Location: Direction distinction of clause-level tagmemes.

-
1. Direction and Dative semantic case manifest the same prepositions in Relator position, and appear to maintain a similar relation between the nominals; both are assigned the D index.
 2. Instrument tagmeme may be realised by an AP syntagm, or by a Reduced clause (3.32.31.23.206 cf: 4.32.221)

4.23.11.11 Temporal Deictic AP1.1T consists of a single temporal deictic adverb adic. in nuclear Head position, optionally followed by another like adic. or an adverb of degree add. (3.33.11.1-3)

- eg:(1) na'ah 'later'
 (2) si'iu sabei
 before ago 'long ago'
 (3) mudei angai
 after very 'last of all'

.11.12 Static Locational Deictic AP1.1L consists of a single positional deictic adverb adic. in nuclear Head position, optionally followed by another like adic. or adverb of degree add. (3.33.12.1-2)

- eg:(1) alud 'by the river'
 (2) ipah inan
 across-river yonder 'over there on the far side
 of the river'
 (3) aju' angai
 upriver very 'right upriver'

.11.13 Dynamic Locational Deictic AP1.1D consists, apparently, of a single adic. from the list at 3.33.12.3 only, with no potential for modification¹.

- eg:(1) kaju' 'in an upriver direction, go upriver'
 (2) jangai 'in an inland direction, go inland (from
 the riverside or from out at sea)'

These AP typically modify the Motion verbs (4.31.12.143).

1. While it is accepted that a tagmemic Phrase must potentially have structure of more than one word (Pike 1960.5a) it seem best to handle AP1.1D in a way similar to its functional counterparts, which have regular phrase structure.

4.23.11.2 Descriptive AP1,2 are degree or manner, filling post-Head modification positions in Verb Phrases.

.11.21 Degree AP1,2deg. consist of one of the degree add. listed at 3.33.21, optionally followed by another add.

eg:(1) junit singen
a-little only 'only slightly'

(2) angai lalu
very completely 'absolutely'

.11.22 Manner AP1,2man. consist of one of the manner adm. exemplified at 3.33.22, optionally followed by an add.

eg:(1) segaut angai
hasty very 'in great haste'

(2) jelakau singen
one-time only 'just this once'

4.23.12 Compound Phrases AP2 show the same subdivisions as Simple AP, but appear to have some further limitations.

4.23.12.1 Deictic AP2,1 have more than one adic. in co-ordinate relation as multiple Head filler, and are exemplified by the fixed-order Dynamic locatives.

eg: AP2.1D kidei kinan
'hither and thither'¹

4.23.12.2 Descriptive AP2,2 have more than one adm. in co-ordinate relation as multiple Head filler.

eg: AP2.2man. seneng jigem aman
'at ease and in peace'

1. It is not clear whether overtly Associative and Alternative co-ordinate AP2 may be formed; none occur in the texts used as the corpus for this study, although related RAP type manifest both, eg: kuman daat serta kuman aju 'from out at sea and from upriver as well'

4.23.13 Complex Phrases AP3 are those consisting of more than one AP of differing types within the same expression, such as Sentence-initial Time phrases.

eg: AP3.T paut paut ketan in (= AP1.2man. + ØAP.M)
 long-time manner that
 'after a long time like that'

4.23.2 Exocentric Adverbial phrases are divided according to their structure; they may be VP with atypical distribution, or overtly RAP.

4.23.21 Verbal phrases as AP are not accorded any other index, being fully exemplified in the Manner Adverbials AP1.2man., and in the Motion String (4.22.32 above).

4.23.22 Relator - Axis phrases RAP manifest clause-level tagmemes in all types of clauses, and are the most typical of all Adverbial constructs. They have a common structure: a nuclear Relator position filled by a preposition pr. which indicates the semantic case of the following nuclear tagmeme, the Axis position filled by a nominal phrase NP (or, in the Direction RAP, by a deictic).

The prepositions may be simple (eg: dagen 'in') or complex (eg: bah bau 'on'); the NP may be simple, compound or complex, and the deictic may be static or pronominal.

The semantic case labels listed in the introduction 4.23 are each exemplified in the simple RAP below; further examples are cited where complications of interpretation arise.

eg:(1) RAP.A jigem sawa nyin 'with his wife'

(2) RAP.B gim sai? 'who for?'

- (3) RAP.C buya' selau 'on account of the sunshine'
 (4) RAP.D kuman alud 'from near the river'
ga' nyin 'to him'
 (5) RAP.I jigem tapih 'with a filter'
 (6) RAP.K pasel hal in 'about that matter'
 (7) RAP.L dagen anum 'in the water'
 (8) RAP.Lm sapai Balan 'as far as kampong Balan'
 (9) RAP.M jigem segera 'with haste'¹
 (10) RAP.T béh telou lau 'after three days'

4.23.221 Compound prepositions such as bah bau 'on top of' cause little or no confusion; there is no possibility of construing a meaning with the constituents of the RAP in a different I.C. arrangement. But the anthropomorphic set of terms ga' jawai 'at face, in front of' (cf: 3.33.12.2)
ga' buta 'at back, behind'
ga' dawek 'at side, beside'

are all open to at least two interpretations in RAP structure in which the axis may be able to include the body term as a part of its well-formed NP. Consider the clause:

ji lah, tumek Tugau ga' dawek nyin

sight ! spear-head Tugau at side he 'there was Tugau's spear...'

The Locative phrase may have two patterns of I.C. cutting, as

- (1) (ga' (dawek nyin)_{NP322})_{RAP.L}
 at side he '(sticking) in his side'
 (2) ((ga' dawek)_{pr} nyin)_{RAP.L}
 at side he 'beside him'

1. Manner RAP with jigem has an axis ambivalent between noun and verb class, so that this is structurally ambiguous, RAP or RC1. (cf: 4.32.2). jigem in Instrumental above is an allotagma for the SFStatic verb peba' 'using', (see 3.32.31.29.206).

Such a passage may be disambiguated by further verbal detail, as eg:

... peliket ga' dawek nyin 'sticking into his side', or
 ... bau sulih ga' dawek nyin 'on the floor at his side';
 otherwise the speaker leaves his hearer to rely on the larger context to provide clues for the correct interpretation. (In the story from which this was extracted, it was quite clear that the spear was protruding from the side of someone who had been speared when a pig, and was now changed into a human being.)

4.23.221 Reduplication of compound prepositions yields a form with a closely related meaning, as shown in:

Besiong kemaréh nyu' ga' dawek dawek dawek tumek in
 Besiong A+smear oil at side side side spear-head that
 'Besiong smeared oil all round the spear-head'

4.23.222 RAP with Void Relator, ØAP occurs often as alternative to a full RAP syntagm, particularly in the Temporal, Direction and Manner clause margin positions.

.2221 Temporal ØAP.T, typified by the general lian in 'time that' have identical distribution with overt RAP such as:

pada masa lian in
 at while time that 'at that time'

and include many terms of the Day, Month and Year Scales (cf: 3.33.11.5).

eg: bulan 'ih 'this month, during this month'
ta'un ba'ou 'new year, in the coming year'

and also more delicately defined times, such as:

badi' 'dawn, in the early morning'

awel su 'early morning, in the morning'
bah abei 'the evening, in the evening'
lau' malem 'at the dead of night'

Having the same surface structure are the temporal phrases with the RAP in attributive position to a given time span. These may be short,

eg: lau sabei 'day ago, yesterday'
lau sunih 'day to come, tomorrow'

or may include a Number phrase NuP (4.21.62)

eg: duah telou lau b'eh in
two three day after that 'two or three days later'
pat ratuyh ta'un sabei
four hundred year ago 'four hundred years ago'

4.23.2222 Direction ØAP.D, typified by the general layan in

'direction that' have a distribution identical with overt RAP such as kuman Sibau 'from Sibau', as evidenced in the equivalence of the clauses:

- (1) nyin puli' kuman kerja nyin
he S+return from work he
'He goes (or comes) home from his work'
- (2) nyin puli' kerja
'he goes (or comes) home from work'¹

.2223 Manner ØAP.M, typified by the general ketan in 'way that' have a common structure; one of the derived abstract nc (3.33.13) followed by a determiner, a deictic particle 'ih or in. There is an optional 'echo' of the basic

1. It may be that, lacking the possessive nyin, this syntagm represents VP..3 in which kerja is verbal 'from working'. But the parallel puli' permissi 'return from leave' appears to justify the recognition of ØAP.D, regardless of the interpretation of kerja as verbal or nominal.

abstract stem after the determiner.

- eg: keji in (ji) 'like that in appearance'
kesau in (sau) 'sounding like that'
kegai 'ih (gai) 'as far as this, just this far'

Where they occur in such expressions as exemplified at 4.23.41.2 below, the choice of ji, sau or tan does not correlate rigourously with a visual, auditory or felt phenomenon; the terms are virtually interchangeable.

(cf: 4.31.12.132)

The interrogative form of these \emptyset AP.M is basic to the Manner Adverbial Interrogative clause: AQCl.M (4.31.234),

- eg: ketan an (tan) 'in what manner, how?'

4.23.2224 Reduplication of these expressions has the immediate denotation of repetition of an action, the connotative meaning being uncertainty or generalisation.

- eg: tan 'ih tan 'ih 'in some way or other'

Most of the RAP described above are included in the examples of Adverbial Clauses AC1. described at 4.31.11.2 below.

4.23.223 Phrases with Void Axis, R \emptyset P are only possible in a context allowing recovery of missing information, as illustrated at 4.31.11.2219 below.

4.23.3 Reduced Clauses RC1. as AP equivalent usually manifest the Instrumental tagmeme rather than RAP.I (.23.22(5) above), as described also at 4.32.221 below.

- eg: peba' tapih

S+use filter 'making use of a filter, with a filter'¹

1. As argued in the text, there is considerable value in treating peba' here as Relator to a nominal Axis, just as in other RAP.

4.23.4 Sentence-initial Adverb Phrases are of two types, and provide the temporal setting for the following stretch of discourse or assert the speaker's feelings about its truth.

4.23.41 Temporal initial AP.T have the same distribution as the Existential clause EIC1, which introduces a sentence or paragraph, bei jelau 'one day, once upon a time' &c: They are divided into two sub-types on the diagnostic grounds of the occurrence or absence of the anaphoric reference particle.

.41.1 Unmarked initial AP.T are of the types AP3.T, RAP.T and \emptyset AP.T described at .23.13 and .23.22 above.

.41.2 Anaphoric initial AP.Ta are marked by the presence of unei 'anaphoric reference' enclitic to the NP manifesting the Axis tagmeme.

eg: sudah nga' ketan in unei

past past like-that ref. 'After that, ...'

AP.Ta cannot initiate a Discourse, but may come at the beginning of any stretch (particularly of Narrative and of Didactic text) subsequent to the first (4.414 and 4.51).

4.23.42 Sentence-initial AP.S are phrases including one or more of the truth-value adverbs exemplified at 3.33.23 expanded to a phrase (often of idiomatic force, not directly adducable from the normal gloss given to the constituent words).

eg: ateng kawa' tan 'that's just what happened'

tigah ateng 'true enough'

bulih jadi 'most likely'¹

saji lah 'for certain'

majih tan kerja 'all that happens in that case is ...'

1. An adaption of the Malay expression boleh jadi 'can do', the words both having lexical equivalents in Melanau cf: kenah 'can'.

4.3 The Clause Level

4.30 Introduction. The Clause is a class of syntagmemes of a hierarchical order above that of the Phrase, the level of its main constituent tagmemes, and below that of the Sentence, in which it functions as the main tagmeme filler (Longacre 1964.35).

Clauses are subclassified according to their distribution in Sentences as Independent or Dependent. Independent clauses form the nucleus of Simple sentences, and are taken as basic to the clause-level analysis presented in this study. They may also be conjoined to form co-ordinate Compound sentences. Dependent clauses do not form Simple sentences, but are subordinated at a variety of levels in the grammar, at the Sentence level to form Complex sentences, or embedded in a matrix structure at clause or phrase level. Structurally, Dependent clauses may be Full clauses identical to Independent clauses, or Reduced clauses.

Independent clauses are further subclassified according to the type of sentence in which they fill the nuclear position, as Declarative (DeCl.), Interrogative (QCl.) or Imperative (ImCl.)¹. Within this framework, they are further subcategorised according to their internal structure as Non-centred or Centred clauses.

Non-centred clauses are Equational or Adverbial, and have no

1. Although there is a recognisable relation between any Interrogative (or Imperative) clause and a possible Declarative clause in which "some major element of meaning appears to be held constant" (Harris 1957.290), no attempt is made in this description to establish a set of Kernel sentences (Chomsky 1957.80) for Melanau, beyond the simple patterns listed at 4.31.1 below, nor to derive algorithmic transformational rules describing these relations between clauses marked (or unmarked) for various moods.

verbal predicate other than an optional (but nuclear) copula signifying emphasis of the non-verbal predication, or embodying aspectual features auxiliary to any verbal phrase. The semantic dichotomy of the clause content into Topic and Comment is seen to be appropriate to non-centred clauses.

Centred clauses are Intransitive or Transitive. Intransitive clauses are further subcategorised according to the class of verb forming the nuclear predicate, as Existential, State or Process. Transitive clauses are Dynamic or Static, Mono-transitive or Ditransitive.

The grammatical dichotomy Focal : Non-focal is more revealing than one of Topic : Comment¹ in the description of Centred clauses. Intransitive clauses have little range of Focus, but in Transitive (and especially in Ditransitive) clauses the range of Focus can include any of the substantives in the clause and also the predicate. The domain of Focus is restricted to the clause nucleus; substantives in marginal positions cannot be In Focus, or brought into Focus by transformations of one clause.

Mono-transitive Dynamic clauses, the most typical of the transitives, have a transformational paradigm in which the semantic Agent, Object or Process may be brought into the focal position in the clause string. Static clauses may be Subject or Object focussed. Ditransitive clauses have a further transform

1. Forster (1964.26-48) maintains the Topic : Comment dichotomy throughout her analysis of Dibabawon clauses. Although this and related studies in the Philippine languages appear crucial to a clear understanding of the operation of Focus in clause structure, the terms Topic and Comment are so traditionally associated with

potential by which an Indirect Object of the Agent Focus clause (such as semantic Beneficiary, Location or Instrument) may be brought into Focus.

Dependent clauses are subcategorised according to their internal structure as Full or Reduced clauses. Reduced clauses lack at least one tagmeme nuclear to Full clauses, and occur embedded in a matrix structure with or without an overt Relator particle. They may be Transitive or Intransitive, Dynamic or Static. They occur embedded in other syntagmemes, and also as the main (or sole) constituent of many Minor sentences such as Responses to questions, Additions, Corrections and the like.

4.31 The Independent Clause

Independent clauses are those clause-level syntagmemes with a single nuclear predicate functioning, or capable of functioning, as the nucleus of complete sentences.

4.31.1 Declarative clauses DeCl. are unmarked for mood (Lyons 1968.307), and are taken as basic to the description of the Clause level of Melanau grammar. They are Non-centred or Centred, and conform to the general clause patterns of the display:

Simple Clauses:

- | | |
|-----------------|-----------------------------------|
| 1. NP (VcoP) NP | <u>a puma in (bei) tama kou</u> |
| | farmer that (is) father my |
| 2. NP (VcoP) AP | <u>a puma in (bei) dagen guun</u> |
| | farmer that (is) in forest |

the distinction between Given and New information (Halliday 1967. 200) as to prove less helpful in this description of clause-level organisation of the linguistic material, since that is not always the semantic distinction correlated with Focus in Melanau.

3. NP ViP a puma in pedih
farmer that is-sick
4. NP VtP NP a puma in mupox padai
farmer that reaps rice
5. NP VtP NP AP a puma in tujuh padai ga' kou
farmer that gives rice to me

Complex clauses:

6. NP VP Sentence a puma in memada' kou ba' puli'
farmer that orders me to go-away

4.31.11 Non-centred clauses have no obligatory nuclear verbal predicate. The optional Copula VP may contain tense-aspect particles related to the non-verbal Complement, which is Nominal or Adverbial. This choice of Complement tagmeme filler distinguishes between Equational and Adverbial Non-centred clauses.

4.31.11.1 Equational clauses EC1. have a common tripartite nuclear structure; an obligatory Subject position filled by an NP (the Topic) and an obligatory Complement position (the Comment) whose filler distinguishes between the three emic subtypes of EC1. The Topic and Comment may be linked by an optional Copula VcoP.

.11.12 Nominal NEC1. have a second NP filling the Complement tagmeme position. Apart from the optional VcoP, non-nuclear Adverbial positions in the clause may have Temporal or Locational fillers. The NP may have internal structure of a word, a phrase or a looped-back clause (Longacre 1964.75).
NEC1. = †Mar:AP +S:NP †VcoP +Comp:NP

- eg: (1) S:NP313 +Comp:NP321.2
mano' in mano' tejali
 bird that bird hornbill
 'that is a hornbill'
- (2) S:NP313 +VcoP.1 +Comp:NP323.2
jali' 'ih ba' kedau tudui
 mat this int. place sleep
 'this mat is for sleeping on'
- (3) S:NP313 +Comp:NP323.3
sau in sau duum ta'ah kou jelau sabei
 sound that sound buzz R+hear I a-day ago
 'that is the buzzing sound I heard yesterday'
- (4) Mar:RAP.L +S:NP322.2 +VcoP +Comp:NP321.5
ga' gi'ih keteben anum bei jedepa
 at at-here depth water be one-fathom
 'the water is six feet deep here'
- (5) Mar:RAP.D +S:NP323.2 +Comp:RIC1.
kuman ane' unit wa' suka kou payam siau
 from child small rel. R+like I S+tame fowl
 'ever since a child I have enjoyed keeping hens'

4.31.11.12 Adverbial AEC1. equate a Nominal and an Adverbial

expression. The distinction between this and non-equational Adverbial clauses AC1 (4.31.11.2) is not easily defined grammatically, but the semantic distinction between a definition (AEC1.) and a descriptive statement (AC1.) appears to be well-founded. Order of elements is not rigid.

AEC1. = †Mar:AP +A:AP †VcoP +Comp:NP

- eg: (1) A:∅AP.T +Comp:NP323.2
ajau 'ih lian ba' meninou
 now time int. A+burn-off
 'now is the time to burn-off (farmland)'
 or 'it is now the burning-off season'

- (2) Mar:AP1.1T +A:AP1.1L +Comp:NP323.1
si'iu sabei aju' (bei) kedau kala
 before ago upriver (be) place estuary
 'long ago, the river-mouth was where upriver is now'
- (3) Comp:NP322.1 +A:ØAP.D (=NP323.3)
tuju luin mata lau matai
 direction they eye day die
 'Westwards was the way they went'

4.31.11.13 Quotative QEC1. equate a Speech formula NP321.6

with its Complement, the quoted speech. The Quoted complement may be direct or indirect speech, and may be discontinuous¹.

QEC1. = [†]Mar:AP +QF:NP321.6 +Comp:Sentence(s)

.131 Direct continuous:

- eg:(1) "Unou pela ka'au ki'ih?" sau telabau raja
 what? visit you to-here sound question ruler
 "Why have you come?" asked the king'
- (2) sau susui ane' apah umit, "Ketan 'ih tan"
 sound speak child cl. small manner this manner
 "Like this," said the younger boy'

.132 Direct discontinuous:

- eg:(3) "Ka' ka'au jangai alu'," sau uba' nasi',
 pro. you go-inland more sound speech rice
"pasad gai 'ih singen ka'au"
 S+stop distance this only you
 "Don't go upstream any further," said the rice,
 "this is far enough for you"

1. The VcoP may prove to be obligatorily absent from QEC1. If this is a systematic restriction on its occurrence, some minor rephrasing of the general statements will be required.

4.31.11.133 Indirect continuous:

eg:(4) nyin ba' juja' sek, sau susui nyin ga' a sawa
 he int. A+slash grass sound speak he at wife
 'he told his wife he was going to cut the grass'

.134 Indirect discontinuous:

eg:(5) baxu liin kekel, sau cerita, nga' nyadin batou
 boat they still sound story past become stone
 'their boat is still there, it is said, turned
 to stone'

Non-distinctive allotagmas of the Quotation Formula

(i) have the quote noun sui 'speech' in place of sau in
 the NP321.6:

eg:(6) "Budei ka'au!" sui nyin
 V+lie you speech he
 "You're lying!" he said'

(7) aba' kedau 'ud a dana sabei, sui dengah
 downriver place source long-ago speech news
 'long ago, down by the sea was where the river
 had its source, so they say'

(ii) lack the Head word sau from the NP321.6 altogether:

eg:(8) uba' nyin, nyin kenesusou ga' kapong Ti'ih
 word he he be-born at village Ti'ih
 'he says he was born at Kampong Teh'

4.31.11.2 Adverbial clauses AC1. have a common tripartite

nuclear structure; an obligatory Subject position filled by
 a Nominal phrase, an optional Copula VcoP, and an obligatory
 Adverbial Complement position. The filler of this position
 distinguishes between two emic subtypes of the AC1., the
 Deictic and the Prepositional clause. AC1. differ from EC1.
 in that the Adverbial complement is a predication descriptive

of the Subject, not equated with it¹.

4.31.11.21 Deictic DAC1. have the Adverbial position filled by either a single deictic adverb adic. or an expanded deictic phrase AP1.1.

DAC1. = ±Mar:AP +S:NP ±VcoP +Comp:AP1.1

eg:(1) S:NP322 +VcoP.1 +Comp:adic.

a tama nyin agei dayeh
father he still away-from-river
'his father was still inland'

(2) Comp:adic. +VcoP +S:NP +Mar:RAP.L

alud bei sapau bau tebi
towards-river be roof up river-bank
'by the riverside a shed stands on the bank'

(3) S:NP313 +Comp:AP1.1

kelideng in aju' agei
monument that upriver yet
'the monument is further upriver'

4.31.11.22 Prepositional PAC1. have the Adverbial position filled by one of the Adverbial expressions described at 4.23 above. Typical Relator-Axis phrases RAP are exemplified manifesting the Complement tagmeme of PAC1.A-T. The serial order of the main constituent tagmemes may be reversed for stylistic reasons without affecting the meaning.

.2211 Associative PAC1.A

eg: S:NP321.5 +VcoP +Comp:RAP.A

pat apah asou bei jigem nyin
four cl. dog be with he
'there were four dogs with him'

1. (cf:4.31.11.12 above) Clauses with an obligatory Existential verb bei in the string initial position represent Existential Cl. in Verb Focus, and do not belong to this subset of Non-centred clauses (see also 4.31.12.11 below).

4.31.11.2212 Benefactive PAC1.B

eg: S:NP313 +VcoP +Comp:RAP.B

ubat 'ih ba' gim ka'au

medicine this int. for you

'this medicine is for you'

.2213 Causative PAC1.C

eg: S:NP313 +Comp:RAP.C

pedih 'ih buya' pekan kubou

sick this on-account-of curse house

'this illness is brought on by (disregarding)
a building-taboo'.2214 Directional PAC1.D are distinguished from Locational

by (i) their collocation with Process rather than State verbs (including the Dynamic Copula nyadin 'become'), and (ii) the Dynamic component of fillers such as sapai 'reach, until' and kuman 'from' in the Relator position, which are distributionally equivalent to such morphemically marked verbs as mapun 'A+approach'¹.

eg: (1) S:NP313 +Comp:RAP.D

duum in kuman bati dana inan

buzz that from log old yonder

'the buzzing comes from that old log over there'

(2) S:NP323.3 +VcoP +Comp:RAP.D/L²wa' debei da'ou bei nyadin ga' kamei

what not be-good be happen at we(exc)

'something terrible happens to us'

1. Becker and Arms (1969.7) have noted the same dynamic component of some prepositions in Indonesian and English. The Direction AP is thus somewhat anomalous; it may be handled as an embedded clause or as a phrase with a verbal Relator, as discussed at 4.31.12.143.
2. The status of ga' 'at, to' is also unclear, between static and dynamic, so that this RAP may be Locational or Directional.

4.31.11.2215 Circumstantial PAC1.K

eg: S:NP313 +Comp:RAP.K

cerita 'ih pasel wa' ngadan pugai

story this about rel. name love-potion

'this story is about a love-potion'

.2216 Locational PAC1.L have the greatest diversity of filler for the Relator position.

eg:(1) S:NP322 +Comp:RAP.L

tumek Tugau in ga' dawek katilspear-head Tugau that at side¹ bed

'Tugau's spear-head was there beside the bed'

(2) S:NP313 +VcoP +Comp:RAP.L

ane' in agei sega' tengen balak

child that yet near trunk banana

'the child was still near the clump of bananas'

(3) S:NP321 +VcoP +Comp:RAP.L

ikan udun debei bei dagen daat

fish Udun not be in sea

'Udun fish do not live in the open sea'

(4) Comp:RAP.L +S:NP321.5

bah iba' lapau in pat apah babui

side down hut that four cl. pig

'beneath the hut there were four pigs'

.2217 Limitation PAC1.Lm

eg: S:NP313 +Comp:RAP.Lm

adan 'ih sapai ijin Pou Lai²

course this until mill Pou Lai

'the course is as far as Pou Lai's mill'

-
1. The ambiguity of compound prepositions like ga' dawek is discussed in detail at 4.23.221 above, and in Clayre 1972(b).
 2. labi 'come, arrive' sometimes occurs as an alternative to sapai 'arrive, until' (cf:4.21.64(2)).

4.31.11.2218 Temporal PAC1.T also have a considerable variety of fillers for the Relator tagmeme position.

eg:(1) S:NP321.4 +Comp:RAP.T

ramai beluba' si'iu bulan ayeng

festival race before moon big

'the Regatta will be before the full moon'

(2) Comp:RAP.T +S:NP1

béh telou lau, Kaul

after three day Festival

'three days later comes the annual Cleansing of the Village Boundaries'

.2219 Void Axis clauses PØC1. Non-contrastive allotagmas

of the Complement tagmeme occur in which the Axis is lacking from the surface string, but is recoverable from the linguistic context. This is shown in several places in the text to be a requirement of covert (or "deleted" in T.G. terminology appropriate to "surface" structures) occurrence of a linguistic item, as opposed to simple absence of a tagmeme from the formulation.

eg:(1) lian a mexou tabui ba' mekan anum,...

time woman set-out int. A+fetch water

... lou lai bei jigem

gpl male be with Ø

'when women went to fetch drinking water, men went with (them)'

(2) keji 'ih ji palei in, biéh nyin langet min buya'

sight this sight taboo that body he itchy all on-
accout-of Ø

'this is what that taboo is like, his body gets itchy all over on account of (it)'

.2220 Other Adverbials such as Instrumental and Purpose manifest clause structures RC1. Clause-level Manner

(as opposed to VP included Manner) does not occur in Non-centred clauses¹.

4.31.11.3 Stylistic Permutations

With non-centred clauses polarised into Topic and Comment, there is little possibility of permutation of clause elements. 4.31.11.12(3) and .11.21(2) above are examples of transposition of the Comment to the front of the clause, but this involves no morphemic change in any of the elements of the clause-nucleus, nor in semantically relevant syntactic ordering (as eg: N_1 possessed by N_2). These permutations are therefore seen to be basically stylistic rather than grammatical, a means of highlighting one or other of the polar components.

4.31.12 Centred Clauses are Intransitive or Transitive, according to whether one and only one, or more than one nuclear Nominal expression at the phrase-level is in construction with a Verbal predicate.

It is shown in the discussion of Focus in Transitive clauses that the Focal position in the clause string unmarked for Emphasis is the initial position in the nucleus. In Intransitive clauses, this allows either the Subject or the Predicate to be in Focus, a degree of flexibility more grammatically determined than the Emphasis permutation possible in non-centred clauses.

1. This does not mean that they do not occur as non-centred clauses. The Purposive Equation clause has been described at 4.31.11.11(2), in which ba' is treated as tense-aspect particle in a VcoP (without overt Head vco) rather than recognise a homophonous preposition ba' 'for'. This latter scheme would, however, be quite workable, and not greatly different in effect on the overall description.

The only morphemic distinction marked in the grammar of Intransitive clauses is that 1st person singular pronoun akou 'I' may occur only in Focal (ie. grammatical subject) position; elsewhere the form kou 'me, my; I (not in Focus)' occurs¹. And since Focus is a property of the clause nucleus, non-nuclear permutations do not represent a shift of clause focus. Thus:

(1) akou makau bau alun

I_F walk up path 'I (in focus) walk along the path'
is a Subject Focus clause, the unmarked form of the clause in narrative and normal for the introduction of New information into a Given setting.

(2) bau alun akou makau

up path I_F walk 'Along the path I (in focus) went'
is still a Subject Focus clause, marked for Emphasis of the Location Adverbial Phrase by stylistic permutation of a non-nuclear tagmeme and the entire clause nucleus.

(3) makau lah akou bau alun

walk emph. I_F up path 'Walk along the path, I did'
is still in Subject Focus, marked for Emphasis of the predicate by a stylistic permutation of the two nuclear elements of the clause, and by presence of the emphatic particle lah.

(4) makau kou bau alun

walk_F I up path 'Off I went (focal) along the path'
is a Verb Focus clause, involving grammatical permutation of Subject and Predicate, both nuclear elements of the clause, and morphemic change of the subject pronoun from akou to kou.

These four examples outline the limits of Focal change in Intransitive clauses. All other examples will assume one of these

1. The personal pronouns are described exhaustively at 3.31.31.1

two focal possibilities, by analogy of concatenatory form. No further appeal will be made to the implications of the shift of Focus in Intransitive clauses until the section dealing with serialisation of clauses in structures of higher level (4.41.2131 below), except the affixation on the gloss of verbs.

4.31.12.1 Intransitive clauses IC1. are further subcategorised according to the class of Verb filling the Head position of their obligatory nuclear verbal predicate. Three types are recognised, Existential, Process and State IC1.

4.31.12.11 Existential clause EIC1. has a bipartite nuclear structure; an obligatory Statement position filled by a VcoP with the existential copula verb bei 'be' as its overt Head, followed by an obligatory Complement position filled by a NP or clause. Existential clauses may be positive or negative.

EIC1. = +Sta:VcoP +Comp: $\left[\begin{array}{l} \text{NP} \\ \text{Cl.} \end{array} \right]$

eg:(1) Positive, +Cl.

bei a ga' matai beragen
be pers some die violence

'there are those who meet a violent death'

(2) Negative, +Cl.

dibei¹ jelavéh pun kena'an mubat nyin
not-be one-person even manage A+cure he(r)

'there was not a single person able to cure her'

(3) Positive, +NP22

bei a bayuh likou Mukah, a mexou
be shaman River Mukah woman

'there was a spirit-medium from Mukah, a woman'

1. The common reduction of debei bei 'not be, there is not' to dibei (and the corresponding word in related dialects) is given in the Morphology at 3.227 above.

(4) Negative, +NP323.1

debei bei nyam anum dagen daat agei

not be taste water in sea yet

'there was no longer any taste of sea-water'

(In which it is seen that the NP Complement may make the VcoP manifesting Statement tagmeme discontinuous, coming between the vco Head bei and agei manifesting Aspect₂ tagmeme of VP..4)

Existential clauses may occur as the sole constituent of Existential Sentences, but the forms of Negative and Interrogative Existential sentences differ from the Affirmative statement, and are described at the Sentence level 4.41.11

4.31.12.12 Process clause pIC1. has bipartite nuclear structure, an obligatory Subject position filled by a NP, and an obligatory verbal Predicate position filled by a pViP with Intransitive Process verb vp as its Head. Non-nuclear tagmeme positions in the clause, capable of being permuted in order independently of the parameter of Clause Focus, constitute the optional Margin, and are typically filled by RAP-type Adverbial syntagms.

pIC1. = +S:NP +Pi:pViP [†]Mar:RAPⁿ(A,B,C,D,I,K,L,Lm,M,T)

in which the Adverbial phrases manifesting Margin tagmeme are represented by their initial letter, and capable of co-occurring in multiple manifestation of the tagmeme; no theoretical value can yet be assigned to the index n.

Using a simple substitution frame such as:

S:NP1 +Pi:pViP +Mar:RAP

nyin makau

he walk

it is possible to demonstrate each of these marginal expansions singly using simple prepositional RAP such as those in the ACI, described at 4.23.22 and 4.31.11.22 above.

There seems little reason why any number of marginal RA phrases should not be strung together¹ to make a clause of transparent simplicity but cumbersome length. In practice, not more than two or three generally occur together in a single clause of the recorded data. Even so, the possible permutations of combinations of two or three are very numerous², and below are given those which occurred in a medium length story of some 180 clauses of all types³. Locative and Temporal margins are by far the most common, followed by Associative, Direction and Cause, depending somewhat on the content of the narrative.

- (1) +S +Pi
jane' apah umit tabui
 brother cl. small set-out
 'the younger brother set out'
- (2) +S +Pi +Mar:A
nyin kerapek jigem jane' apah ayeng
 he converse with brother cl. big
 'he talked with his elder brother'

-
1. nyin makau jigem kou bau axuh kuman alud bah awal béh kakok siau . .
 he walk with me on path from riverside early after cock-crow
 is by no means complex, and is evidently further extensible. It is simply not found in texts, except as a joke.
2. Longacre 1964.26ff
3. 'The Brothers at Sungai Lebu', favourite folk-tale, as recounted by Arip Dina of Dalat, and analysed at 4.52.1

- (3) +S +Pi +Mar:L
lou tou in sexaat ga' bua' padok in
 gpl spirit that pounce at fruit jackfruit that
 'the goblins pounced on the jackfruit'
- (4) +S +Pi +Mar:D
a lai in pepela kaju'
 man that S+paddle go-upriver
 'the man paddled upriver'
- (5) +S +Pi +Mar:T
nyin tabui kira-kira pukul nem jam telou
 he set-out reckon strike six hour we(inc)
 'he set out about six o'clock (by our time)'
- (6) +S +Mar:T +Pi
nyin in, bah abei mudei, tabui lah
 he that evening after set-out !
 'so he set off the very next evening'
- (7) +Mar:T +S +Pi
udah in, lou tou in puli'
 after that gpl spirit that go-away
 'after that, the goblins went away'
- (8) +Mar:T +S +Pi +Mar:D
nou agei lou tou in tiked bawai
 at-once gpl spirit that climb go-up
 'at once the goblins climbed up'
- (9) +Pi +S
nga' pegegex aked nyin
 past S+tremble joint he
 'already his knees were knocking'
- (10) +Pi +S +Mar:T
tabui lah nyin bah abei, angaren pukul pat
 set-out ! he evening reckon strike four
 'off he went, about four o'clock in the afternoon'

- (11) +Pi +S +Mar:L
labi' nyin ga' ati kedau la'ei
 come he at very-place orchard
 'he arrived at the spot where his fruit-trees were'
- (12) +Pi +S +Mar:D
susui nyin ga' lou a kapong
 tell he at gpl pers village
 'he reported to the villagers'
- (13) +Pi¹ +Mar:L +S
pedaa' min ga' jawai, luin in
 S+blood all at face they that
 'they were bleeding all over their faces'
- (14) +Pi +S +Mar:D +Mar:L
tiked nyin bawai ga' bua' padok in
 climb he go-up at fruit jackfruit that
 'he climbed up the jackfruit (tree)'
- (15) +Pi +S +Mar:M +Mar:D
puli' nyin lega-legah ba'ai
 go-away he quickly go-down
 'quickly he escaped down (the tree)'
- (16) +Pi +S +Mar:C
pieg lalu biéh nyin min buya' lou tou in
 S+shiver much body he all on-account-of gpl spirit that
 'he was trembling all over because of the goblins'

The permutations of Subject and Predicate only represent shift of Focus in the clause nucleus; in disconnected clauses the progression of focus of the narrative cannot be followed in any revealing way (but cf: 4.41.2131). Mobility of the non-nuclear Marginal elements represents stylistic permutation, or (as eg: (7) and (8) above) the necessary construction for

1. pedaa' is ambivalent between Process and sState (3.32.31.23.202) so that (13) might really be a State IC1, glossed 'they were covered in blood...'; little difference is made to the analysis either way.

continuity of the serial clauses.

4.31.12.121 buya' in Process clauses. By the criterion of substitutability, the set of clauses 4.31.11.2211-2218 show that buya' has clear prepositional distribution; it belongs, then, to the distribution class of prepositions (3. 34 141). Indeed, in some clauses it may be replaced with a typical preposition without much change in the overall meaning. Compare:

(1) padai in puei buya' selau
 rice that S+dry on-account-of sunshine
 'the rice is drying in the sun'

(2) padai in puei dagen selau
 rice that S+dry in sunshine
 'the rice is drying in the sun' ; the equivalence of the two prepositions is immediately evident, although a slight shift in semantic content is discernable.

At 3.32.31.23.209 and 210, buya' is shown to indicate a process rather than a state denoted by the pe- prefixed verb nuclear to the clause; or at least a state brought about by a related process, rather than an ontological state existing in its own right.

At 4.31.11.2219 buya' is exemplified as a pro-phrase, standing alone for a RAP with void Axis tagmeme.

Elsewhere, however, buya' appears to have a distribution very much closer to that of Transitive verbs; yet it lacks the morphemic affixation characteristic of VtP in clauses marked for one Focal valency or another (3.32.2). In this regard it is much closer to the verb ta'ou 'know'

(cf: 3.32.11.51) which may take an Object complement; it might then have the gloss 'suffer from'.

eg:(1) paut-paut béh in, luin buya' kasau lanun
 long-time after that they suffer-from trouble pirate
 'much later, they were troubled by pirates'

(which is semantically equivalent to the Object Focus Transitive clause ...luin kenasau lanun); and

(2) cerita 'ih pasel ane' buya' saban pekilih
 story this about child suffer-from curse S+twist
 'this is an account of a child suffering from the
 curse which makes it twist and writhe (like a snake)'¹

In this ambivalent behaviour (cf: Longacre's observations at 3.30) buya' is not unlike the dynamic preposition sapai 'until' (4.31.11.2217) which can also behave as a verb 'to arrive at'; and indeed the fully affixed MNP verb mapun 'A+ approach ...', which has distribution parallel to kuman 'from' (4.31.12.143). In general, buya' is treated as a Causative preposition, and its related sense as a verb 'suffer from' seen as a derived meaning, since it lacks Transitive form.

4.31.12.13 State clause sICl. can be simple, comparative or a special formula for Simile Comparison. The basic structure of the State Intransitive clause is similar to that of Process Intransitive clauses, except that a vs rather than a vp is the Head of the nuclear sViP, and the range of Adverbial non-nuclear clause adjuncts is more restricted.²

sICl. = +S:NP +Pi:sViP †Mar:RAP^H(A,C,M,L,Lm,T)

1. saban pekilih is a particular form of imitative magic, more fully described in Clayre 1971(a) 'Saban Kuyad'.

2. see p320.

4.31.12.131 Simple State clauses, like Process clauses, tend to have a practical limit of two or three on the index n, limiting the number of RAP that actually occur in recorded textual material in any one clause. It is a characteristic of the Temporal margin in State clauses that the filler is often durative time rather than a point in time.

eg: +S:NP1 +Pi:sViP.1 +Mar:T

nyin in nga' pedih duah telou lau nga'

(s)he that past sick two three day past

'she had been ill for two or three days already'

4.31.12.132 Comparative state clauses are essentially of two minor sub-types, the equal comparison and the disparate.

.1321 Equal comparative clauses have the formula

NP₁ (Vcop) sama $\left[\begin{array}{c} \text{kawa'} \\ \text{alah} \end{array} \right]^1$ jigem NP₂

'... is just the same as ...'

eg: anum 'ih sama kawa' jigem anum guun

water this same also with water forest

'this water is just like forest-water'

.1322 Disparate comparative clauses have the formula of

2. (from p319) It may be that the frequent ambivalence of State and Process verbs, together with the fact that the restriction of adjuncts is in the non-nuclear clause Margin, so reduces the distinction that the Rule of Two Differences (Longacre 1964.18) is not satisfied. It would not affect the presentation of the description greatly if all the Intransitive clauses were merged into one type; for the present it seems better to keep them apart on account of the several well-founded distinctions noted at many points in the text.

1. It is often unclear whether the speaker says alah 'as' or lah 'emphatic'; either is acceptable in most contexts.

the Simple clause, with the restriction that sViP may optionally be expanded with a degree adverb add, to yield sViP..1; the Margin filler has kuman 'from' as its Relator¹, which is nuclear to this construction.

eg:(1) S:NP313 +Pi:sViP..1 +Mar:RAP.D

a mexou in jernih alu' kuman semua a kapong
 woman that pretty more from all pers village
 'she was the prettiest girl in all the village'

(2) S:NP313 +Pi:sViP32 +Mar:RAP.D

a lakei in tukang mebasa kuran kuman a ki'
 old-man that clever A+read Koran from pers other
 'that old man is better than other people at
 reading from the Koran'

4.31.12.133 Superlative state clauses have an idiomatic formula which might equally well be assigned to non-centred clause Adverbial category (4.31.11.22), but is grouped here with the other comparatives for semantic tidiness.

The clause has a tripartite nuclear structure, a Subject position filled by any NP, a Verbal Predicate sapai 'reach'² and a metaphorical Locative complement, an abstract noun (3.31.11.21) with the structure ke- +vs. The string order appears to be inflexible.

1. One interesting exception occurs in the texts, presumably a productive alternative form of the Comparison clause; eg: da'un sepa' umit buya' tap nyagem 'the lime-leaf is smaller than the palm of your hand'; in which the component 'suffer' appears uppermost in the semantic content of buya' (cf: 4.33.11.2216 and the discussion at 4.31.12.121 above), 'suffer by comparison ...'

2. In an alternative analysis, sapai may be seen as a regular Directional preposition 'until'; sapai ke-... would then be RAP, patterning as the missing Manner *PAC1.M (see 4.31.11.2220) or as PAC1.Lm.

- eg: (1) kamei sapai kelukuh
 we(exc) reach hunger
 'we are as hungry as can be'
- (2) ane' raja in sapai kepedih
 child ruler that reach sickness
 'the king's daughter is near death's door'
- (3) ukum Jipun sapai kekeréh
 rule Japan reach severity
 'the Japanese rule was terribly strict'

A non-contrastive allotagma of the predication is based on the adverbial intensity modifier sapah 'extremely', in the normal Included Adverb syntagm pedih sapah angai (AP1.2deg)
 sick extremely very

- eg: ane' raja in sapai kesapah pedih
 child ruler that reach extremity sick
 'the king's daughter is as sick as can be'

4.31.12.13⁴ Simile Comparison is by a special formula:

$$+S:NP_1 \quad \pm P:VP + \text{sama alah} \quad \begin{matrix} \pm \\ \text{ji} \\ \text{tan} \\ \text{sau} \end{matrix} \quad +\text{Comp}:NP_2 \dots$$

in which the choice $\pm(\text{ji} / \text{tan} / \text{sau})$ is to some degree irrelevant, but partly conditioned by the semantic content of the VP. The VP may be a Copula, in which case the Simile is an Identity Simile (the most usual form), or any other kind of VP whose semantic content is to be compared with the predication about NP_2 , which may be followed by VP_2 &c:

- eg: (1) S:NP1 +Comp:NP323.3
kelou 'ih sama alah tan kuyad tujuh belacen¹
 you-all this same as manner monkey P+give pickles
 'you're just like a monkey who has been given pickles'
 (ie. at a loss as to what to do next)

1. The Complement here is a Ditransitive clause in Beneficiary Focus, see 4.31.12.22.11 below, with covert (not specified) Agent.

(2) S:NP1 +P:pViP.3.1 +Comp:NP323.3

Tegiok debei sigah lalu, sama alah 'ok pireng ageng

Tegiok not make-sound at-all same as owl P+throw ember
'Tegiok made no answer, like an owl which has had a
glowing stick thrown at it'

(ie. frightened out of his wits)

4.31.12.14 The Verb String is a syntagm in which an Intransitive verb is followed by one or more verbs in adjunctive relation, but without any obligatory overt subordinating relator. Three emically diverse forms of this pattern are noted, the Sentential Complement, the Modal and the Motion verb string.

.141 Sentential Complement string.

Verbs taking sentential complements have been described in the Morphology at 3.32.11.5, both Subject and Object sentence complements appearing in the examples of the verb ta'ou 'know', which may be seen as typifying the overall pattern of complementation.

The significant syntactic fact which emerges is that when the complement is a Subject sentence, having the same semantic subject as the first verb, that second reference to the subject may be covert (or "deleted"). This allows the verbs to be strung together as proximate elements in the resultant string.¹

At this point the fragmentation of neat word sets is made apparent. ta'ou 'know', which patterns elsewhere very much like lu' 'wish', has a different meaning when followed by overt and covert subject having the identical referent, a difference conveyed by the glosses 'know that' and 'know how to' respectively.

1. Asmah (1969:5.13.14.4) describes a similar concatenation of verbs in Iban, a neighbouring language of Sarawak.

4.31.12.142 Modal string

It is seen that the subset of verbs which can take only Subject sentence complements overlaps, but is not co-extensive with, the set of modal verbs traditionally recognised for, say, English¹. On the one hand, it includes such verbs as cuba 'try' and sagup 'dare', which are not modal in the formal sense that mesti 'must' or kenah 'able' is. The sentences²

- (1) Tugau mesti ba' kawin jigem ane' raja
 Tugau must int. marry with child ruler
 'Tugau had to marry the king's daughter' and
- (2) ane' raja mesti ba' kawin jigem Tugau
 child ruler must int. marry with Tugau
 'the king's daughter had to marry Tugau'

are clearly semantically very close, perhaps even identical, in a way that does not depend merely on the reciprocity of the marriage relationship; for

- (3) Tugau debei sagup ba' kawin jigem ane' raja
 'Tugau did not dare to marry the king's daughter' and
- (4) ane' raja debei sagup ba' kawin jigem Tugau
 'the king's daughter did not dare to marry Tugau'

do not have the same meaning, although apparently related by an identical syntactic permutation. The difference must then lie in the relation between mesti and its following verb on the one hand, and sagup and what follows

1. As eg: Boyd and Thorne 1969, although it must be admitted that all of these verbs in some sense "reflect the attitude of the speaker to the factual status of (what follows)" (Lyons 1968.307)

2. All of the related sentences except the first represent a set of elicited statements designed to illustrate the point.

on the other hand, lu' 'wish' and ta'ou 'know', which can both take Object sentence complements, form the most clearly modal constructions of all, in which the subject of the modal verb is not the agent of the following process. In this, they behave like kenah 'be able', as shown in the exemplification of 3.32.11.512; but kenah can take only Subject sentence complements.

It appears impossible at present, therefore, to separate out a well-defined set of modal roots as such, while remaining quite feasible to define a Modal String by a mixture of syntactic and semantic criteria:

A close coupling of two verbs allowing of no more than the tense-aspect particle between, in which the essential predication of the clause is contained in the second verb.

4.31.12.143 Motion String

It is typical of the Intransitive verbs of Motion in Melanau that they often occur in strings, in which the second (and sometimes third or more) verb has not the status of clause Predicate. It would be cumbersome to treat each of these subsequent verbs as a minimal embedded clause; more important, it would deny Melanau roots that very flexibility of distribution which appears to be part of the genius of the language.

Appeal is therefore made to analogy with the variety of semantic relationships conveyed by the $(N_1 N_2)$ phrase structure described at 4.21.321. In the verbal analogy, since a clause may have only one predicate, the V_2 &c: in the Motion string are interpreted as Dynamic Adverbials, essentially attributive to the main predication, filling several of the Adverbial

Margin positions in the clause. (Tacit acceptance of this analysis has already allowed the exemplification given for the Process clauses at 4.31.12.12). Specific examples of this syntagm are, eg:

(1) S +P +D +Lm

Jilag pepela kaju' sapai Kekan

Jilag S+paddle go-upriver reach Kekan

'Jilag paddled upriver as far as Kekan'

in which the single dynamic adverb kaju' 'go-upriver' is seen to be syntactically equivalent to the dynamic RAP sapai Kekan 'as far as Kekan' (cf: 3.33.12.3)

(2) S +P +I

likou Balah in kaba' pesalui

tribe Iban that go-downriver S+canoe

'the Iban(s) went downriver in a canoe'

(3) S +P +M

luin kenah wab la'an piud

they be-able go-east-and-west S+drag

'they were able to travel between the main rivers'¹

by dragging (their boats)'

Once the Dynamic status of Adverbial fillers of some of the Margin positions is established, it seems only reasonable to recognise as equivalent the two directionally opposite clauses:

(4) nyin tabui mapun guun

he set-off A+approach forest 'he went to the forest', and

(5) nyin labi' kuman guun

he come from forest 'he came from the forest'

1. The significance of wab la'an applied to travel not out at sea is explained at 3.33.12.4 and 6.11

although (3) has a morphemically marked Transitive verb as the Relator, while (4) has a dynamic preposition kuman. Both overt verbal and overt prepositional constructions fill the same distributional slot in the Motion string; the common feature is that the Relator in Directional RAP must be dynamic. At the clause level, it is irrelevant that one filler has clause structure and the other phrase structure; both fill the Direction Margin tagmeme. mapun may thus be handled as a dynamic preposition, much like sapai and kuman.

- 4.31.12.2 Transitive clauses TC1. are Mono-transitive or Ditransitive. Monotransitive clauses are described first, and the range of Focal possibilities in the clause is displayed. Once the basic form of the Focus matrix is assembled, its extension to bring the additional substantives of Ditransitive clauses into Focus is described in terms of the extant patterns.

4.31.12.200 Focus in Transitive clauses

The grammatical device of Focus as a clause-level feature of the language structure of the Philippines has been extensively described during the past fifteen years, largely in Tagmemic descriptions originating from the Summer Institute of Linguistics. Much more recently, a pilot study of a number of Bornean languages¹ from a similar stand-point has shown that the clause in all those studied appears to be organised with one particular nominal "in focus", although the realisation of this Focal structure

1. B.M.Clayre 1970

in the surface grammar is progressively less complex as geographical distance from the Philippines increases.

Melanau was not included in that study, but shows sufficient similarity with some that were to justify carrying the investigation one language further.

It seems likely that an approach to clause structure which has proved so illuminating in the study of one branch of Malayo-Polynesian languages will be more revealing of the true genius of Melanau than a conceptual framework derived from essentially European grammar. For this reason, while terms such as Active, Passive and Middle voice are retained for their explanatory usefulness (especially in the gloss given to each vernacular passage), the clause structure is examined along intersecting axes of Focus (with a range of semantic Subject, Agent, Object and Process, and including Referent in ditransitive clauses) and Status (Dynamic or Static). Comparison of the grammatical role assigned in Dynamic clauses to the semantically constant Subject nominal of a related Static clause introduces a further distinction, that between Active and Causative predications (cf: 3.32.22.1 and .2).

4.31.12.201 Focus in Philippine languages

Bloomfield recognised that Ilocano had "... a syntax which differs strikingly from that of Indo-European languages"¹.

1. Bloomfield 1942.193 Although Bloomfield was at pains to dispense with familiar European grammatical categories, he did not make clear the relation between pre-nominal particles and semantic role in the way that the study of Focus has done. (The greater part of this chapter is published as Clayre 1972(c)).

Tagalog, typical of the other main branch of Philippine languages¹, poses similar problems to a western translator; Waterman discusses these in relation to the Biblical passage "In those days I will pour out my Spirit on all flesh"². One of the three nominals of the main clause, I, Spirit or flesh, must be selected as the principal topic of the prophecy before the sentence can be construed in a Philippine language, and the original Hebrew gives no more clue than English as to which of the three is correct.

In the literature on Focus, which effectively begins with the work of Dean and Abrams in Bilaan³ and the Healeys in Agta⁴, the name Focus is given to "what-we-are-talking -about"⁵ in the clause. 'Subject' is not a suitable name, for there is general recognition that the operation of Focus is to link the nuclear verb with one of the nominals in the clause, which may be the grammatical Subject, Object or Indirect Object. Typically, a portmanteau morpheme containing "something like tense" is affixed to the verb signifying which of the nominals is in primary link with the predication, which is then termed "in focus"; the other nominals have their semantic relation to the verbal process indicated by case-marking particles. It is usual to have pronouns divided into two moieties, Focal and Non-focal pronoun sets, the

1. Voegelin 1965.227 quotes Conklin and McKaughan in favour of this bipolar grouping of the Philippine languages.

2. Waterman 1960.162

3. Dean 1958 and Abrams 1961

4. A.Healey 1958 and P.Healey 1960

5. Forster 1964, in which Hockett's dichotomy of Topic and Comment is most extensively explored in its application to the structure of the Dibabawon clause.

latter at least being subdivided into Actor and Non-actor sets.

The selection of pronouns and the focal link between one nominal and the verb may be demonstrated in a Bilaan clause containing Actor and Goal nominals (both pronouns) and a transitive verb in Goal-focus. This verb-goal link is indicated by an n- prefix to the verb; -m is an enclitic pronoun from the non-focal set appropriate to the semantic role of Actor, and ale is a pronoun from the focal set. The semantic role of the Actor is shown in the verbal affix, which links the verb and a Goal.

n-ebe-m ale

G.F-bring-you them_F

'You bring them (about whom we are talking)'

By contrast, a Maranao clause from McKaughan (1962) shows the operation of the case-marking particles o and sa on non-focal items, the "topic" marker so being neutral for case. The verb affix -an signifies the primary association of the verb to be with the Referent (a generalised oblique case including I.O. of many kinds), and the clause is in Beneficiary Focus.

<u>sombali'an</u>	<u>o</u>	<u>mama'</u>	<u>so</u>	<u>maior</u>	<u>sa</u>	<u>karabao</u>
slaughter		man		mayor		buffalo
-Ref.Focus						

source	topic	involved
of	of	object
action	clause	of process

'it is for the benefit of the Mayor that the man kills the buffalo'

In his discussion of this case-marking system, Fillmore suggests that the "true" case carried by maior in some deeper level of the grammar has been deleted in the surface structure as part of the topicalisation process¹. If so, then it may be observed

1. Fillmore 1967.55ff. The illustrative material is also discussed by McKaughan in his earlier study of Maranao (McKaughan 1958).

that the deleted information is totally recoverable from the verbal affix -an (as it was in the Bilaan clause quoted above) since this affix signals the semantic relation of the topic nominal to the verb.

The essential linking function of the Focus device is emphasised by Pike in his development of matrix displays for Dean's material¹, and the range of focal possibilities within the transformational paradigm of any given verb is used by Kerr to classify the verbs of Manobo² very much as Fillmore suggests with his Case-frames for English verbs³. Kerr also draws attention to the skew that is often apparent between the semantic role and the syntactic form of a nominal in a clause, a Direct Object being marked in some instances as an Indirect Object (Referent).

Dean, Pike and Forster devote considerable care to a formal treatment of Emphasis, deriving transformational rules for the procedures by which non-focal items may be brought into the focal position in the clause string when, for some reason, Focus and Emphasis do not converge on the same nominal.

Because Focus links the verb and one of the nominals, none of these writers considers the verb itself as a potential Focal item. The Philippine literature has no Verb-Focus clauses.

Against this background, work on Focus in Bornean languages is seen to be to some extent derivative, and yet to reveal features not yet described in the Philippine literature.

1. Pike 1963.216-230

2. Kerr 1965.20

3. Fillmore 1967.27

4.31.12.202 Focus in Bornean Languages.

Only two writers to date have attempted to deal with the concept of Focus in the languages of Borneo. Prentice, in his studies of North Borneo Murut¹, analyses clauses within a framework of five contrastive focal cases: Actor, Beneficiary, Patient, Instrument and Associative (along with intersecting axes of aspect mode and so on not germane to the present discussion). B.Clayre interprets the focal structure of this language somewhat differently², recognising only three forms of verb stem inflection. (Instrument focus is handled analogously to its clear manifestation in Dusun³, where it is marked not on the verb but on nominals in equational clauses, never occurring as an overtly verbal syntagm.)

Both writers recognise the critical distinction between Dynamic and Static clauses. Dusun and Tagal both have contrastive sets of focal and non-focal pronouns which, in Dusun at least, are ranked in the order in which they must occur in a clause string, 1st person taking precedence over 2nd person over 3rd person. With word-order to some degree fixed, the feature [+Actor] distinguishing pronoun sets is critical to an understanding of the sentence.

In her work comparing Bornean languages, B.Clayre traces the gradual relaxation of the complexity of the focal affix system the further removed geographically in a roughly southerly direction the languages are from the Philippines. Sarawak Murut

1. Prentice 1965. North Borneo Murut is also known as Tagal, to distinguish it from Sarawak Murut (Lun Dayeh or Lun Bawang).

2. B.M.Clayre 1970.201

3. B.M.Clayre 1967

manifests only three focal possibilities formally differentiated from each other, Actor, Object and Instrument¹. Topicalisation or prominence of the Beneficiary of an action requires a special permutation of word-order, a device which assumes increasing importance as the affix system declines. Case-marking particles are preposed to personal pronouns only, and there are only three sets of pronouns altogether.

In Penan, the Dynamic : Static contrast is no longer in evidence in the clause structure, and the Object Focus is restricted to actions marked for completed aspect. Kayan, a language spoken very widely in central Borneo, has only two pronoun sets; verbal affixes are rare, and the Object Focus is marked by a free particle en initial in the clause string. (This is reminiscent of the -Vn or nV- affix types marking Object Focus in many Malayo-Polynesian languages, found also in the MNP verb paradigm of Melanau).

Sekapan, Punan Ba and other inland languages related to the coastal Melanau² have two pronoun sets, and word order has assumed completely the case-marking function for other nominals. A typical pair of related sentences from Sekapan, transforms of each other in much the same way as an Active and Passive pair of traditional Malay and of European grammars, show this affixation in operation (and demonstrate, in passing, the close resemblance of this up-

1. Actor and Object only are isolated in the 1970 text; later research at the 1972 Summer Institute of Linguistics with a Lun Dayeh informant Simeun Lalung has added Instrument Focus to the inventory (in at least the Indonesian dialects of the language).
 2. I. Clayre 1971(a) and 1972(a) include 'The Kajang Kingdom' and 'Punan Ba, Melanau link with the Ulu Rejang' in which a number of relations between these upriver peoples and the Melanau are shown to be as well founded in fact as in tradition.

river language to coastal Melanau examples elsewhere in the text). The first nominal in the string is "in focus", the grammatical subject of the clause.

Actor Focus: (Focal)pn + m- Verb stem + Object

akau makup parai

I_F A+scoop-up rice

'I scoop up rice-grain'

Object Focus: Object + n- Verb stem (non-focal)pn

parai nakup - kau¹

rice_F P+scoop-up I

'the rice was scooped up by me'

or 'I scoop up the rice (we are talking about)'

Other languages included in the survey go beyond the chain of relationships interesting to the present discussion, the Focal mechanism becoming less and less dominant in the organisation of the clause. Sekapan and Melanau are sufficiently close for the description of Focus in Melanau to go forward from here.

4.31.12.203 Focus in Melanau

The formal distinction between Focal and Non-focal 1st person singular pronoun has already been mentioned at 3.32.31.1 and 4.31.12 above. In clauses unmarked for Emphasis, akou occurs always in the initial position in the clause string which, it has been shown, appears to assume the status of Focal position in many Sarawak languages that lack the complex affixation system typical of Philippine languages: akou is found to occur as the grammatical subject of Intransitive verbs, and as the subject of Transitive verbs having either an me- or a pe- prefix (3.32.31.2)

1. kau is treated as an enclitic, as in Philippine languages. In Melanau the cognate kou is regarded as a free form.

or the equivalent -u- or -e- infix appropriate to the UIE verb paradigm of inflection. kou occurs in all other positions in the clause string. A very similar distribution of mutually exclusive allomorphs led Abrams to regard the actual occurrence (or the potential substitutability) of the 1st person singular Focal pronoun as definitive of Focal position in a clause.¹

With this initial assumption, Actor Focussed Dynamic clauses are recognised in Melanau by the combination of (1) actual (or potential) occurrence of akou in the initial position in the clause string, and (2) an me-² (or -u-) affix to the verb stem. Further inspection of the transform paradigm of these clauses provides the grounds for distinguishing between Active and Causative clauses in Actor (or Agent) focus. Object Focus Dynamic clauses have an ne- prefix (or the equivalent -i- infix) to the verb in both Active and Causative construction. In Static clauses, Subject Focus static clauses have a pe- prefix (or -e- ablaut infix vowel) to the verb, and Object Focus static have no affix to the stem (paralleled by analogous -e- vowel in the UIE verb, indistinguishable from Subject Focus Static; see 3.32.22.22).

Dynamic clauses are also found without any affix on MNP stems (or with the -i- form of UIE verbs) in the Focal position of the clause, in construction with non-focal kou as grammatical Subject and the semantic Direct Object, where there is one, in oblique case. By clear analogy with the established pattern whereby the Focal nominal takes the clause initial position, these are seen

1. Abrams 1961.395

2. Or the allomorphic equivalent forms described at .100 of each section of the verb affix morphology 3.32.31.21 &c:

to manifest Verb Focus. These V.F.Dynamic clauses occurring in Narrative text have a structure very similar to Imperatives.

The Focal matrix for any Transitive verb vt is shown below. (akou) represents the potential occurrence of this form of the pronoun, defining Focal position in the string. The verbal affixes are given for MNP verbs and for UIE verbs, and under them is the gloss used throughout this description for affixed verbs.

Clause Status	Dynamic	Static
Clause Focus: Subject } Actor } Agent }	(<u>akou</u>) <u>me-</u> " <u>-u-</u> AFDyn A+	(<u>akou</u>) <u>pe-</u> " <u>-e-</u> SFStat S+
Object	(<u>akou</u>) <u>ne-</u> " <u>-i-</u> OFDyn P+	(<u>akou</u>) $\emptyset-$ " <u>-e-</u> OFStat R+
Verb	$\emptyset-$ (<u>kou</u>) <u>-i-</u> " VFDyn V+	VFStat

It will be noted that there is no entry for the box formed by intersecting axes Verb Focus and Static Status, although it would be filled by Intransitive verbs (4.31.12 at p312) in Verb Focus; the presumed form of such an entry is discussed at .21.16 below. In that Intransitive verbs occur in sentences of the same general form as those containing pe- (or -e-) marked verbs (many of which are in fact Intransitive), it is suggested that a single

matrix may be constructed to include Intransitive uninflected verbs as well, with all uninflected verbs entered in the Static side of the matrix¹ despite the evident semantic dynamism of the Process verbs vp tuun 'swim', pebiah 'run' &c:

Beyond the limited choice of pronouns, Melanau clause structure manifests no morphemic case-marking on nominals beyond the general observation that a preposition before a nominal puts it into some oblique syntactic case or other (3.31.1). The affixes on MNP verbs have a number of non-contrastive allomorphic variants.

The domain of Focus is the clause nucleus. Permutation of nuclear elements of the clause attended by morphemic change represents a change of Focus in the clause organisation. (Many intransitive clauses have to have focus interpreted by analogy with transitive clauses having similar word order, if the Subject nominal is not 1st person pronoun.) Permutations within the nucleus not attended by morphemic change, and permutations of non-nuclear elements in the clause Margin, are stylistic rather than grammatical, and are discussed briefly at 5.15. Serial construction of clauses at the level of the Sentence and above determines many choices of Focal valency, and is discussed at 4.32.25.

4.31.12.21 Mono-transitive clauses MTCl. have a tripartite nuclear structure; an obligatory First Nominal position filled by a NP whose semantic case depends implicitly on the Focal valency of the clause, an obligatory Predicate position filled by a Transitive VP, and an optional Second Nominal position whose grammatical case (however marked) is one of the distinguishing criteria of the three Focal valencies outlined above.

1. Much as Pike 1963.219-220.

The ordering of nuclear elements in the clause string is the other distinguishing criterion of Focal valency. Non-nuclear clause Margin positions may be distributed before and after the nucleus (and even, to some extent, intermingled with the nuclear elements) without affecting the valency or status of the clause, much as already illustrated for Intransitive clauses (4.32.12.12).

4.31.12.21.1 The MNP paradigm verbs occur as nucleus in Actor, Object and Verb Focus clauses, which may be Dynamic or Static (in which case, Actor Focus is replaced by Subject Focus, there being no predicated action). According to the semantic role of their grammatical subject, these clauses are seen to be Active or else Causative.

4.31.12.21.11 Actor Focus Dynamic clauses have the common nuclear formula: +A:NP_F +Pt:VtP †O:NP

The First Nominal is the semantic Actor and grammatical subject in Focus. The Second Nominal position, which may be covert in various circumstances discussed later, is the semantic Object (or Goal) as well as the grammatical object. Active and Causative clauses are distinguished by having va or vc as Head of the transitive verb phrase VtP.

.111 Active AFDyn have va as Head of aVtP.

eg: S:NP1 +Pt:aVtP +O:NP30 +Mar:RAP.D
akou matu' teluh kuman pu' in
 I_F A+pick-up egg from nest that
 'I pick up an egg from the nest'

.112 Causative AFDyn have vc as Head of cVtP.

eg: S:NP1 +Pt:cVtP +O:NP313 +Mar:RAP.L
Arip menyabit tapou 'ih ga' pakou
 Arip_F A+hang-up hat this at nail
 'Arip hangs (hung &c:) this hat on a nail'

4.31.12.21.12 Object Focus Dynamic clauses have the common

nuclear formula: +O:NP_F +Pt:VtP †A:NP

The First Nominal is the semantic Object and grammatical subject in Focus. The Second Nominal position, which may be covert in various circumstances, is the semantic Actor (or Agent), and the transitive verb filler of VtP nucleus is a passive verb form. The examples given represent Passive transforms of the examples in Actor Focus above, (and may be compared with the Sekapan exemplification to .12.202 above to see how close are Sekapan and Melanau in this detail).

.121 Active OFDyn transformation, with va nucleus:

teluh natu' kou kuman pu' in

egg_F P+pick-up I from nest that

'the egg(s) was picked out of the nest by me'

(or 'I pick up an egg from the nest', since the Object Focus construction is not used always where a Passive would be in English grammar).

.122 Causative OFDyn transformation, with vc nucleus:

tapou 'ih senabit Arip ga' pakou

hat_F this P+hang-up Arip at nail

'this hat was hung on a nail by Arip'

(or 'Arip hangs (hung &c:) this hat on a nail')

.123 Covert Agent tagmeme may occur in either of these

clauses, where it is not required to specify the agent (cf: RC1.G at 4.32.26). This is not the same as specifying no agent, which is signalled by the use of the Static form of the verb as the clause nucleus (see .21.15 below, and 3.32.31.23.209 above).

- eg:(1) tapou 'ih senabit a ga' pakou
 hat_F this P+hang-up person at nail
 'Someone hung this hat on a nail'
- (2) tapou 'ih senabit ga' pakou
 hat_F this P+hang-up at nail
 'This hat was hung on a nail'

4.31.12.21.124 Roots underlying OFDyn construction may be drawn from the inventory of any of the word classes¹.

eg:(1) from tubu' 'grow' vp.

biéh nyin tenubu' nap
 body_F (s)he P+grow scale
 'her body was overgrown with fish-scales'

(2) from kedau 'place' nc.

kelidéng bah aju' kenedau tou
 monument_F side upriver P+place spirit
 'the upstream monument is haunted by ghosts'

(3) from kekel 'still' adm.

padek sikep nyin kenekel iba'
 prawn_F R+sieve he P+still down
 'the prawns he had caught¹ were left down below'

1. It is characteristic of verb forms that greater diversity of root class is manifested in OFDyn than in AFDyn (although the AF equivalents can then be elicited from informants). In OFStat, the verb form is identical with the related nominal root (as eg: sikep in the fn. 2 below), which gives rise to several problems of structural ambiguity such as that discussed at 4.32.223 below.

2. sikep 'sieve' as OFStatic verb here is typical of the fluidity of Melanau roots (cf: 3.32.31.21.207 and .210), here related to the AFDyn form menyikep 'catch (prawns) in a sikep' - a broad dished sieve woven of semat fibre from the sago-palm frond, in which the shallow brackish water near the river-bank is panned for prawns, often at night by the aid of a lamp which illuminates the eyes of the quarry sheltering under the bank.

4.31.12.21.13 Verb Focus Dynamic Narrative clauses have the common nuclear formula: +Pt:VtP_F +A:NP †(ga' +O:NP)

The predicate itself occupies the Focal position in the clause string. Immediately following is the Actor, and the semantic Direct Object appears as Indirect Object in Locative (or Dative) case in the RAP following that.¹

- .131 Active VFDyn transformation lacks the Marginal elements of the other clauses. This is typical of Verb Focus clauses, which occur in rapid narrative passages concentrating on the nuclear action with a minimum of verbal "furniture" (Cook 1969.69).

atu' kou ga' teluh

V+pick-up_F I at egg

'I picked up the egg ...'

- .132 Causative VFDyn is similar in structure.

sabit Arip ga' tapou ...

V+hang-up Arip at hat

'Arip hung up the hat ...'

- .133 Short Narrative VFDyn is a minimal two-word VF clause, which occurs in narrative in which a fully dimensioned clause is considered to be stylistically cumbersome.² The linguistic context is required, to allow a full semantic "reading" of the cryptic syntactic form.

1. cf: Kerr's observations (1965.20) on Manobo clauses where the semantic case and the syntactic form are skewed.

2. This short narrative form is related to its fuller semantic reading at 5.5 below.

eg: +Pt:VtP_F +A:pn

tug nyin
V+kick_F he 'So he kicked (it)'

4.31.12.21.13⁴ Verb Focus in Declarative clauses, with its related manifestation in Imperative clauses, has not been recognised by previous writers on the languages of Borneo or of the Philippines¹, yet it seems to be the natural parallel of the other Focal valencies of the clause nucleus.

4.31.12.21.14 Subject Focus Static clauses differ as to the optional presence or obligatory absence of a Second Nominal tagmeme, which distinguishes between Active and Causative verb nuclei of the clause.

.141 Active SFStat clauses have the nuclear formula:

+S:NP_F +Pt:aVtP †O:NP

in which the grammatical subject is the semantic Subject in Focus. The transitive predicate VP has a Middle Voice verb form with pe- affixation, and the optional Object nominal is in some sense attributive to the VP (cf: 3.32.31.23.206)

eg: akou patu' teluh mano'
I_F S+pick-up egg bird
'I collect birds' eggs'
or 'I am a birds' egg collector'

1. In common with many Bornean languages, Dusun (of Sabah) does not mark tense on verbs once the temporal aspects of a passage are clear (B. Clayre 1967.122), but uses a "timeless" form of the verb identical to the Imperative. It is possible that some sort of neutralisation, rather than an independent Focal valency, may be manifested in what are here termed VF clauses; yet for the present, they seem well-defined in terms of the description given.

The example answers the question "What do you collect?" rather than "What do you do to birds' eggs?", and typifies the Static use of Active verbs in apparently transitive constructions¹, which may be semantically no more transitive than verbs with no separate Object tagmeme in their clause string, such as melaméh 'collect edible caterpillars (lelaméh)', are intransitive (see discussion at 3.32.31.21.204).

4.31.12.21.142 Causative SFStat clauses have the nuclear formula:

+S:NP_F +Pi:ViP

in which the Subject position is filled by that NP which becomes the Direct Object of the related AFDyn and OFDyn transform clauses. The Predicate position is filled by an intransitive VP which may have as its Head an inflected verb with the pe- affixation typical of States or involuntary Processes, or an uninflected verb vi (3.32.11 and .21).

eg: tapou 'ih pesabit ga' pakou

hat_F this S+hang-up at nail

'this hat is hanging on a nail'

(or 'this hat is (accidentally) caught on a nail'²)

4.31.12.21.15 Object Focus Static clauses have a nuclear formula identical in form to that of OFDyn clauses, but the tagmeme fillers are likely to differ somewhat in that OFStat clauses typically occur in attributive clauses within NP323.3; the nuclear verb is an unaffixed stem. Thus the Object tagmeme

1. In intransitive construction, pe- verbs of Active stems often occur as adverbial adjuncts to a main verb (4.31.12.143)

2. The accidental overtones of pe- affixation are noted at 3.32.31.23.209; this does not appear to be relevant to all such forms.

may be realised by a NP or by the Relator pronoun wa' (or the appropriate pronominal classifier cl. for selective relative clause construction, 3.31.32.21) followed by RC1. syntagm.

4.31.12.21.151 Active OFStat embedded in SFStat clause:

S:(O:NP_F +Pt:aVtP +A:NP1)_{NP323.3} +Pi:ViP..1
teluh atu' kou 'ih baat angai tan
 egg_F R+pick-up I this heavy very feeling
 'this egg I picked up feels very heavy'

.152 Causative OFStat embedded in OFDyn clause:

O:(O:NP_F +Pt:cVtP +A:NP1 +Mar:L) +Pt:aVtP +A:NP
tapou sabit kou ga' pakou inan tenikau ane'
 hat_F R+hang-up I at nail yonder P+steal child
 'the hat I hung on the nail over there has been
 stolen by a child'

.153 Selective relative clauses in OFStat may be exemplified sufficiently by:

S:(O:NP_F+cl. +Pt:aVtP +A:NP1 +Mar:L) +Pi:ViP.1.4
parang be' belei kou ga' passer nga' nyel nga'
 machete cl. R+buy I at bazaar past be-blunt past
 'the jungle-knife I bought at the bazaar is already
 blunt' (but the others are not).

4.31.12.21.16 Verb Focus Static clauses do not occur in the data, as far as can be ascertained. Causative stems are State vs such as betul 'be correct', tigah 'be straight', or Process vp such as tudui 'sleep'. Active verb roots are also used in a simple adjectival function in NP323.2, as eg: ane' ixou 'an adopted child', in which the agent is unspecified¹. If

1. see p345.

the transitive root ixou may occur as an intransitive state vq (an adjective) in such a phrase, there seems no good reason why there should not be such VFStat clauses as:

*atu' seneng teluh in
pick-up_F easy egg that
'that egg was easy to add to the collection'

But there are not. For the present, the omission is deemed to be systematic rather than fortuitous², and the VFStat box is left void in the matrix for transitive verbs.

4.31.12.21.17 Roots underlying Causative constructions.

The multiplicity of homophonous verb prefixes (see 3.32.31.21.100 &c:) is justified on the grounds that similar verb forms are constructed by affixation of identical bound morphemes to stems of disparate root class. Despite the fluidity of roots, the surface similarity of the following sentence sets should not disguise the well-founded distinction between the hyperclasses of roots.

Sentences (a), (b) and (c) in each set bear the same grammatical relation to each other throughout.

- 1(a) akou menyabit tapou ga' pakou
'I hang the hat up on a nail'
- (b) tapou senabit kou ga' pakou
'the hat has been hung on a nail by me'

1. It might be argued that, since there must be an agent to such a clause, ane' ixou is a realisation of NP323.3 with deleted (or covert) Agent. The question is one of delicacy, and by no means critical to the description offered.

2. This problem in gathered material forming a corpus for analysis is discussed at some length in Teeuw 1962.411, and has been noted in fn to 3.32.31.21.209 above.

(c) tapou pesabit ga' pakou

'the hat is hanging on a nail'

(which last sentence may be thought of as underlying all three sentences, in a transformational sense).

2(a) akou menyawa Supin ga' ka'au

'I marry Supin to you'

(b) Supin senawa kou ga' ka'au

'Supin was married to you by me'

(c) Supin pesawa ga' ka'au¹

'Supin is married to you'

Despite the evident surface similarity between the Dynamic causative clauses 1(a) and 2(a), 1(b) and 2(b), arising out of the similarity between the Static clauses 1(c) and 2(c), nuclear to sentences 1 is the verb root sabit 'hang up', while at the heart of sentences 2 is the noun root sawa 'a spouse'. Although roots are often mobile between root classes, the distinction between what may be termed "essentially verbal" and "essentially nominal" roots is seen to be well-founded by comparing in turn the following pair of sentences, also directly related to 1 and 2 respectively.

1(d) sabit ka'au tapou 'ih'Hang up this hat!' - a well-formed Imperative VFDyn clause with overt 2nd person addressee ka'au 'you';2(d) sawa ka'au Supin 'ih'your husband is Supin here' - a well-formed Equational clause NEC1., of which the Subject tagmeme is manifested by the NP322 sawa ka'au 'your spouse'.

1. The essentially reflexive nature of the marriage relation is reflected in the alternative use of jigem 'with', Associative c in place of ga' cited here for its obvious parallel with 1(c).

4.31.12.21.18 Ergative constructions are formed with that subset of MNP verbs exemplified at 3.32.32.21.203, in which no formal distinction is made between the verb affixation in overtly transitive and apparently intransitive clauses.

eg:1(a) akou miga' ga' pukul pat badi'

I_F S+wake at strike four dawn

'I wake up at four in the morning'

(b) a sakai miga' kou ga' pukul pat badi'

friend_F A+wake I at strike four dawn

'I am woken by a friend at four in the morning'

2(a) buki babui in madam

corpse_F pig that S+rot

'that dead pig is going / has gone rotten'

(b) likou Penan madam sei babui si'iu, béh in kinah

tribe_F Penan A+rot flesh pig before after that P+eat

'the Penan "hang" pig-meat first, then eat it'

The list of verbs entering into this ambivalent relation with nominals is not long, and is restricted to those with me- affixation (or allomorphic variant). Example (b) can not be seen as a simple causative construction, because the verb root in each case is also affixed at (a); forms niga' 'woken up' in OFDyn, and wa' adam 'carrion' (nominalisation using OFStat form) do occur, to show that the m- initial is not fortuitous (cf: 3.32.31.21.201). In this specific way, the me- affixed form of the verb occurring in both SF and AF clauses, the Ergatives differ from the semi-transitive verb constructions below. (Corresponding pe- affixed ergatives are described at 3.32.31.23.209 above).

4.31.12.21.19 Semi-transitive constructions occur always in SFStatic clauses, apparently intransitive, but denoting real-world situations of transitive activity reflexive on the actor. The verbs carry pe- affixation (3.32.32.23.205).

- eg: (a) mayéh in puluh ba'ai kuman lawei kayou
 ape_F that S+lower go-down from foliage tree
 'the orang-utang lowered itself down from the branches of a tree'
- (b) sawa mayéh puluh ba'ai kuman lawei kayou
 spouse_F ape S+lower go-down from foliage tree
 'the orang-utang's wife lowered herself down from the branches of a tree'
- (c) mayéh in muluh sawa nyin ba'ai kuman lawei kayou
 ape_F that A+lower spouse he go-down from foliage tree
 'the orang-utang lowered his wife down from among the branches of a tree'

As stated in the discussion of the morphology of the pe- form verbs exemplified here, it is not clear whether (a) and (b) represent a reflexive transitive construction with deleted Object 'self', or a regular intransitive construction of which (c) is the related transitive (3.32.31.21.211). These clauses with a nuclear Group 5 pe-verb are tentatively labelled Semi-transitive.

The formal transitivity of the me- affixed verb as against the pe- form (intransitive) is demonstrated by the following triple:

- (a) mano' tejali pegep ga' lawei kayou
 bird_F hornbill S+perch at foliage tree
 'a Hornbill was sitting in the treetop'

- (b) mano' tejali megep lawei kayou
 bird_F hornbill A+perch foliage tree
 'a Hornbill was occupying the treetop'
- (c) lawei kayou negep mano' tejali
 foliage_F tree P+perch bird hornbill
 'the treetop had a Hornbill sitting in it'¹

4.31.12.2 The UIE paradigm

UIE verbs manifest the same range of Focal valency in Dynamic clauses as MNP verbs, but are limited to a single form in Static clauses. While this limitation obscures the clear distinction between Active and Causative verbs to some degree, there are verbs which appear to be unequivocally one or the other sufficient to define the subsets. It is their fuller membership which is open to question.

4.31.12.21.21 Actor Focus Dynamic clauses have the same nuclear formula as that for MNP verbs, the differences in inflection being a secondary accident of the grammar.

.211 Active AFDyn are exemplified by:

S:NP1_F+Pt:aVtP +O:NP3O +Mar:T

akou lulou a sakai bah awal

I_F A+wait friend side early

'I wait for (my) friend in the morning'

.212 Causative AFDyn are exemplified by:

S:NP1_F +Pt:cVtP +O:NP323.3

Jilag lupeng tukat piti pengiren

Jilag_F A+snap staff R+send prince

'Jilag broke the staff-of-office sent by the prince'

1. (c) is structurally parallel to .21.124(b); but the verb gep 'perch' is neutral as to the connotation of 'haunting' associated with kenedau, which always co-occurs with some unpleasant occupant such as tou 'spirit' or gergasi 'giant'.

4.31.12.21.22 Object Focus Dynamic clauses have the same nuclear formula as that shown for MNP verbs.

.221 Active OFDyn are exemplified by:

O:NP30_F +Pt:aVtP +A:NP1 +Mar:T

a sakai lilou kou bah awal

friend_F P+wait I side early

'I wait for (my) friend in the morning'

.222 Causative OFDyn are exemplified by:

O:NP323.3_F +Pt:cVtP +A:NP1

tukat piti pengiven lipeng Jilag

staff_F R+send prince P+snap Jilag

'Jilag broke the staff-of-office sent by the prince'

4.31.12.21.23 Verb Focus Dynamic clauses have the same nuclear formula as shown for MNP verbs.

.231 Active VFDyn are exemplified by:

Pt:aVtP_F +S:NP1 +ga' +O:NP30

lilou, lilou kou ga' a sakai

V+wait V+wait_F I at friend

'I waited and waited for (my) friend'

.232 Causative VFDyn are exemplified by:

Pt:cVtP_F +A:NP1 +ga' +O:NP30

lipeng nyin ga' tukat, lalu ...¹

V+snap_F he at staff then

'he snapped the staff in two, and ...'

4.31.12.21.24 Subject Focus Static clauses demonstrate the critical difference between va and vc in the choice of

1. VF clauses in narrative characteristically occur in serials of clauses describing vigorous action of some kind (cf: .21.131 above)

subject nominal.

4.31.12.21.241 Active SFStat are exemplified by:

S:NP1_F +Pi:pViP..1 +Mar:L

akou lelou¹ singen bah iba'

I_F S+wait only side down

'I was just hanging about down below'

.242 Causative SFStat are exemplified by:

S:NP323.3_F +Pi:sViP

tukat piti pengiren lepeng

staff_F R+send prince S+break

'the staff-of-office sent by the prince is broken'

4.31.12.21.25 Ambivalent constructions, unclear between SFStat

and OFStat (and therefore between Active and Causative) do occur, because Passive verbs may be used without overt Agent following (cf: .21.123 above). A case in point is the verb stem k-kut 'dig', which seems intuitively to be Active not Causative; a piece of ground has to be dug, and is only then in a dug state. The "accidental" connotation of many of the Causative SFStat verbs noted at 3.32.31.23.209 can hardly apply to digging and being dug.

Therefore, despite the occurrence in texts of expressions such as sungai kekut 'dug-out stream, the Kut Canal' (Map 2) apparently parallel to .242 above (ie. SFStatic and therefore potentially Causative in Dynamic clauses), kukut is listed as *va*, an Active verb. It seems nonsense to do

1. The redundantly static form pelelou is often used here with the same apparent meaning. (With plural subject, the pe- prefix would denote secondary affixation for reciprocal waiting, for each other. cf: 3.32.31.23.212)

otherwise. The adjectival use of kekut 'dug' is then parallel to that of the MNP va syntagm ane' ixou 'adopted child' cited at .21.17 above, an OFStat construction with covert Agent either "deleted" but recoverable, or simply not specified. Thus:

... nengadan Sungai Kekut,
 P+name stream R+dig (not S+dig)

sebeb saxap 'ih kikut luin teruyh
 because watershed this P+dig they through
 '... named the Kut Canal, for this watershed was dug
 through (from one River to the other) by those folk'

4.31.12.21.3 The Clause Margin

For the sake of clarity, very few marginal tagmemes have been shown in the examples above, the description being largely restricted to the clause nucleus. In transitive clauses there appear to be no more restraints on the occurrence of such peripheral adverbial elements, characteristically in the form of Relator-Axis Phrases, than in the intransitive clauses of earlier description. There is, however, a difference possible in the status of some of the elements as between nuclear or non-nuclear; for the subset of Transitive verbs commonly recognised as Ditransitives, one of the RAP is part of the clause nucleus, being involved (with consequent morphemic change) in transformations of Focal valency. These are described in the following section.

Defined in this way, some of the Melanau ditransitive verbs are outwith the set widely recognised under this title; verbs such as 'send', 'give', 'offer', 'lend' occur in Melanau, but

in the same set, having a nominal in construction which can shift from an Indirect Object to the Focal position, are verbs like gep 'perch' illustrated at .21.20 above. In those examples the Locational RAP ga' lawei kayou of the SF clause (a) became Object in Focus of the process clause (c). This is an example of Locational Focus, a special form of the general Referent Focus similar to that described in Philippine languages (see 4.31.12.201 above). It is noted that no new form of Focal structure is evolved to cover this clause organisation; the existing Object Focus forms, which appear to deal primarily with the Direct Objects of transitivity in Transitive clauses, are exploited to bring the Referent into Focal position. Every Focal arrangement of the language has to be handled in the terms of the 3X2 Focal matrix set up for monotransitive verbs.

4.31.12.22 Ditransitive clauses DTCl. have a four-part nuclear structure; an obligatory First Nominal position filled by a NP whose semantic case depends on the Focal valency of the clause, an obligatory Predicate position filled by a ditransitive NP dVtP, an obligatory Second Nominal position filled by a NP and an optional Third Nominal position which will be termed the Referent in conformity with established practice.

DTCl. = +S:NP_F +Pd:dVtP +O:NP †R:NP / RAP

In Actor and Object Focus clauses, the Referent is in oblique case, the Nominal of the RAP Axis labelled for case with an appropriate preposition manifesting Relator tagmeme. This preposition (indexed B,D,&c: as previously explained) defines the potential Focus when the Referent is shifted by

transformation to Focal position (as the Locational Focus at .21.3 above).

The verbs which fill Head position of dVtP may be either essentially ditransitive (as eg: tujuh 'give') or only accidentally ditransitive on account of the particular construction in which they appear, (as eg: belel 'buy').

Since MNP verbs and UIE verbs have been shown to cover essentially the same distributional ground, no further distinction will be made between them. The exemplification draws on both paradigms as may be most appropriate at any point in the description.

4.31.12.22.1 Referent Focus is demonstrated in sets of three clauses, each set being transforms of one another in which the Focus of the clause is shifted from one nominal to another. (Verb Focus is still possible in these clauses, but incidental to the present exposition of the mechanics of Referent Focus.)

The range of Referent Focus appears to be limited to Benefactive, Dative (a special case of Direction, and on that account accorded the same index D) and Locative NP. Instrument, typically a member of the Referent set in the literature, has been shown to be an embedded clause construct¹, so that the operation of Instrument Focus involves a different order of transformation, at the Sentence level.

1. Unless Instrumental case on a NP is labelled by the Associative Relator jigem 'with' (3.32.31.23.206), in which case it cannot be made Focal. To conform to the established terminology, it is best to restrict the name Referent to NP as Axis of RAP syntagms.

4.31.12.22.11 Beneficiary Focus is exemplified by the optionally ditransitive MNP verb belel 'buy'.

(a) S:NP1_F +Pt:aVtP +O:NP313 +R:RAP.B

akou melel ubai 'ih gim a pedih

I_F A+buy medicine this for pers sick

'I buy this medicine for someone who is ill'

(b) O:NP313_F +Pt:aVtP +A:NP1 +R:RAP.B

ubat 'ih benelei kou gim a pedih

medicine_F this P+buy I for pers sick

'I buy this medicine for someone who is ill'

(c) R:NP323.2_F +Pt:aVtP +A:NP1 +O:NP313

a pedih benelei kou ubat 'ih

person_F ill P+buy I medicine this

'it is for a sick person that I buy this medicine'

(the gloss being given in this form for direct comparison with the McKaughan example cited at .12.201 above)

4.31.12.22.12 Direction Focus (which includes Dative NP) is

exemplified by the essentially ditransitive MNP verb

piti 'send'. The AFDyn form of the clause is taken as

basic to the set. Structurally, the clauses are identical

to those analysed above, except that the Predicate tag-

meme is marked Pd:dVtP to indicate the essential Third

Nominal required by the "case-frame" of this verb.¹

(a) S:NP30_F +Pd:dVtP +O:NP313 +R:RAP.D

tama memiti surat in ga' kou

father_F A+send letter that to I

'that letter was sent to me by (my)² father'

1. Fillmore's term "case-frame" has been mentioned at .12.201 above.

2. Unless otherwise specified, tama is taken as referring to the speaker's own father (who may not, in many Melanau households, be mentioned by name.)

- (b) surat in peniti tama ga' kou
 letter_F that P+send father to I
 'that letter was sent to me by (my) father'
- (c) akou peniti tama surat in
 I_F P+send father letter that
 'I was sent that letter by (my) father'

4.31.12.22.13 Locational Focus is exemplified by the essentially ditransitive MNP verb u'em 'soak'.

- (a) S:NP1_F +Pd:dVtP +O:NP313 +R:RAP.L
akou mu'em batou 'ih dagen anum
 I_F A+soak stone this in water
 'I soak these stones in water'
- (b) batou 'ih nu'em kou dagen anum
 stone_F this P+soak I in water
 'I soak these stones in water'
- (c) ... anum u'em kou batou 'ih
 water_F R+soak I stone this
 '... water in which I have soaked these stones'

(In the last example, the text from which the clause was extracted¹ made use of OFStatic rather than OFDynamic construction at this point.)

4.31.12.22.14 The Static : Dynamic contrast in Referent Focus is maintained just as in Direct Object Focus. Consider the following Directional RAP, nuclear to the clause; its transformations highlight the dichotomy.

- (a) S:NP1_F +Pt:VtP +O:NP30 +R:RAP.D
akou ba' mena' uma kuman guun 'ih
 I_F int. A+make farm from forest this
 'I propose to make a farm out of this forest'

1. An account of magical healing by Mang of Kekan (Map 2).

(b) R:NP313_F +Pt:VtP +A:NP1 +O:NP30

guun 'ih ba' nina' kou uma

forest_F this int. P+make I farm

'I will make this forest into a farm'

(c) Static transform of (b), which uses OFDyn verb form:

guun 'ih ba' na' kou uma

forest_F this int. R+make I farm

'this forest will be a farm of my making'

The last example speaks of the forest as in a state of being made, or of having been made, rather than as in a process of becoming made, which is predicated by the OFStat verb root na' in (c) rather than the Dynamic form nina' in (b). There is also, as has been noted earlier, a feeling of proximate time reference about (b) that is lacking in (c); but not all informants were agreed on this subjective judgement.

4.31.2 Interrogative clauses QC1.

Interrogative clauses are those which, having the structure distinctive of Interrogative clauses and potentially carrying one of the Interrogative Intonation Contours IC.21-25¹, form the nucleus of Question Sentences².

-
1. Intonation Contours are sentence-level tagmemes, and not a part of clause structure as such.
 2. According to the response they evoke, these are distinguished variously at 4.41.131 below. Not all Question sentences are structured as Interrogative clauses; Tag questions in particular are a subset of those with Declarative clause structure and Question I.C. when realised as an Utterance (cf: 4.4)

Interrogative clauses differ from Declarative clauses in one or more of the following ways:

- (1) Inversion of Subject and Predicate tagmeme positions in the clause string, bringing the Predicate into clause-Focus (ie. string-initial) position.
- (2) Presence of the Query particle kah immediately following a verbal Predicate.
- (3) Presence of Interrogative pronouns sai 'who?', unou 'what?' or the adjectival and adverbial syntagms formed by compounding with nou and an. Particular forms of this distinctive criterion are the Echo Adverbial formula typified by ketan an tan 'what sort of way?, how?', and the 'why?' compound forms ba'nou and buya'nou (3.226)
- (4) Presence of special Rhetorical Adverbs in the initial slot in the clause string.

Criteria (1) and (2) typify Questions requiring Affirmation or Negation; (3) typifies Questions requiring Information; (4) and gaan from the set of compounds at (3) typify Rhetorical Questions.

4.31.21 Nominal Query clauses NQC1. may be non-centred or centred. Non-centred clauses are Equational or Adverbial (cf: 4.31.11), centred clauses may be Intransitive or Transitive, the nominal in Focus being Subject or Object (cf: 4.31.12)

4.31.211 Equational clauses NQC1.E have in the Focal position a noun nc followed by the interrogative particle an 'which?', or a personal or non-personal pronoun only. The Complement tagmeme of the Equational clause is manifested by a NP.

- eg:(1) sai ngadan ka'au
 who? name you 'What is your name?'
- (2) unou pela ka'au
 what? S+visit you¹ 'Why have you come?'
- (3) bup an bup ka'au
 book which? book you 'Which is your book?'
- (4) wa' nou kah 'ih
 rel. what? ? this 'What is this?'

4.31.212 Adverbial clauses NQCl.A contain one of the above pn as Axis of a Relator-Axis phrase, which may be exemplified by Associate and Benefactive RAP:

- eg:(1) sai jigem ka'au
 who? with you 'Who is with you?'
- (2) gim sai ubat in
 for who? medicine that 'Who is that medicine for?'

4.31.213 Intransitive clauses NQCl.In typically have the main structure of an Intransitive Declarative clause, with an interrogative pronoun in Subject position.

- eg:(1) sai labi' jigem ane' 'ih
 who? come with child this
 'Who came with this child?'
- (2) wa' nou labu' kuman bah bau
 rel. what? fall from side up
 'What was it that fell from up there?'

4.31.214 Transitive clauses NQCl.Tr are similarly structured, and may be in Subject (or Actor) or Object Focus.

1. pela here, homophonous with the noun root pela 'a paddle', is presumed to be an expansion of the stem *ela 'visit', since the expanded forms mela, nela 'to visit' are found (as against the set memela, pepela &c: 'to paddle'). Since all usual travel is by small dugout canoe, there may be some diachronic connection not relevant to the present description of the clause structure.

eg: (1) sai munu' tina tama kou (AFDyn)
 who? A+kill mother father I
 'Who killed my parents?'

(2) unou ba' sabi' ka'au (OFStat)
 what? int. R+ask you
 'What is your request?'

4.31.22 Verbal Query clauses VQCl. have the common formula:

VQCl. = +P:VP †kah +S:NP +Comp †Mar

Two subtypes are recognised, depending on whether the VP filling the Predicate slot has as its Head a copula verb *vco* or one of the set of verbs taking Sentential Complement discussed at 3.32.11.5.

4.31.221 Copula VQCl.Co are typical of those Verbal QCl. which require affirmation or negation only, and may be exemplified

by: (1) bei kah luin sala' ga' ka'au
 be ? they wrong to you
 'Have they done you any harm?'

(2) debei kah ka'au perasa mia'
 not ? you S+feeling shame
 'Do you feel no shame?'

Identical in distribution is the allotagma having the query particle an 'which?' in place of the copula bei.

(3) an anum teben
 which? water be-deep
 'Is the water deep?'

(4) an 'ih bap kah
 which? this squirrel ?
 'Is this a squirrel?'

4.31.222 Sentential Complement VQCl.S typically evoke as reply the verb in Focal position as affirmation, or debei + verb as negation.

- eg: (1) kenah (kah) kou pigi' pedeng 'ih (+I.C.21)
 be-able ? I S+take sword this
 'Can I take this sword?'
- (2) lu' kah ka'au alah sau bada' kou
 wish ? you as sound command I
 'Do you agree to do as I say?'
- (3) sagup kah kelou ba' menolong kou
 brave ? you(pl) int. A+help I
 'Do you dare to help me?'

4.31.223 Tag queries VQCl.Tg typically evoke a direct positive or negative reply, and are of three kinds; those using a final kah enclitic to a declarative clause, those using enclitic debei 'not' after a declarative clause, and those using the sentence-level tag o which, with its Intonation Contour, is described at 2.52.2¹. Some question sentences have a nuclear clause combining more than one of these features.

- eg: (1) wa' se' 'ih kenah kah
 rel. red this able ?
 'Will this red one do?'
- (2) ka'au nga' tuteng kah debei
 you past A+drink ? not
 'Have you finished your drink or not?'
- (3) nyin tudui ateng debei
 he sleep really not
 'Is he really asleep or not?'

1. Tag (4) nga' malem, o 'It's already night-time, isn't it?' is strictly a sentence-level structure, included here for the purpose of comparison with clause-level queries only.

4.31.23 Adverbial Query clauses AQCl. may be non-centred or centred (cf: AC1. at 4.31.11.2), and cover the range denoted by indices C,D,L,M,P, and T¹. There are also Quantity queries which, properly belonging among the enumerative terms, are gathered here for simplicity of description.

4.31.231 Causative AQCl.C manifest the compound buya' nou 'on account of what?', the Causative 'why?' in initial position in the string.

eg:(1) buya' nou ka'au menangih
 why? you S+sweep 'Why are you crying?'

(2) buya' nou ka'au memili' usid in
 why? you A+choose knife that
 'What made you choose that knife?'

4.31.232 Directional AQCl.D fall into two non-contrastive sets, those with the query word as Head of the Query phrase in the clause string (1,3), and those where it follows the verb (2,4). As noted at 4.31.11.2214, Directional adverbs are Dynamic, and overlap with Intransitive verbs of Motion in their distributional privileges.

eg:(1) ba' kaan ka'au ji
 int. to-where? you appearance
 'Where do you think you're going?'

(2) tabui kaan ka'au
 seg-off to-where? you
 'Where are you off to?'

1. Benefactive query gim sai ...? derives its status as a query from the nominal sai 'who?', not from any adverb, and is therefore excluded from the range discussed, along with several others from the range of semantic cases listed elsewhere.

- (3) kuman an nyin labi'
 from which? he come 'Where does he come from?'
- (4) labi' kuman an ka'au sabei
 come from which? you ago
 'Where were you before you came here?'

4.31.233 Locational AQCl.L manifest the Static adverb compound gaan, with or without the redundant Locational preposition ga' 'at', in the initial position in the string.

- eg:(1) ga' gaan kedau Jilag sabei
 at at-where? place Jilag ago
 'Where is it that Jilag used to live?'
- (2) gaan kah wa' tujun 'ih
 at-where? ? rel. R+show this
 'Where is this thing (you) are showing (me)?'

4.31.234 Manner AQCl.M manifest the Echo formula adverbial phrases \emptyset AP.M constructed on the set of abstract nouns ji 'appearance', nyam 'taste', sau 'sound' and tan 'feeling, manner' with the query particle an 'which?'.
 manner' with the query particle an 'which?'.

- eg:(1) keji an ji _bap
 what appearance? squirrel
 'What does a squirrel look like?'
- (2) kenyam an nyam _kenyuma
 what taste? garret-worm
 'What do garret-worms taste like?'
- (3) kesau an sau _tou ta'ah ka'au
 what sound? spirit R+hear you
 'What did the ghosts you heard sound like?'
- (4) ketan an tan _ka'au ba' tiked
 what manner? you int. S+climb
 'How does one manage to get up there?'

4.31.235 Purpose AQCl.P manifest the compound ba' nou 'intend what?', the Purposive 'why?' in initial position.

eg:(1) ba' nou baya debei menyamex pelano'

why? crocodile not A+size mouse-deer

'Why does the crocodile not sieze the mouse-deer?'

(2) an allotagma of this Query formula, presumably of direct Malay ancestry by translation of apa sebab

'what reason?', is:

uncu sebab kereja in

what? reason work that

'What are (you) doing that for?'

4.31.236 Quantity AQCl.Q are of several kinds, including at least one Echo formula.

eg:(1) kedakai rega bajou 'ih

how-much? price blouse this

'What is the cost of this blouse?'

(2) kuba dakai keteben gi'ih

how-much? depth at-here

'How deep is it just here?'

(3) dakai kepaut nga' lobu' Jilag neretuh

how-long-time past house Jilag P+dismantle

'How long ago was Jilag's house pulled down?'

(4) kegai an gai adan beluba'¹

what distance? finishing-point race

'How long is the course?'

4.31.237 Temporal AQCl.T are of two kinds, according to the Temporal adverb used, either specific or general.

1. This echo-formula would appear to fill the slot in the set of Adverbials not realised by the Limitation tagmeme with sapai 'until' which is manifested in Declaratives as at 4.31.11.2217.

eg:(1) paya ka'au labi'

when? you come

'When did you arrive?'

or 'When will you arrive?'

(2) kala' ka'au kaju' mapun Pelajau

ever? you go-upriver A+approach Pelajau

'Have you ever been up to Pelajau?'

4.31.24 Rhetorical Query clauses RhQC1. are of two types; those manifesting the specific Rhetorical adverbs in string initial position, and those with the generalised formula gaan ba' ...

4.31.241 Specific RhQC1. are exemplified by:

sina' lah ji ka'au na'ah

of-what-use appearance you later

'What possible use do you think you could be!'

.242 Generalised RhQC1. are identical in form to the AQCl.L described at 4.31.233(2) above, lacking only the query particle kah¹.

eg:(1) gaan naseng debei ba' geli'

"how?" heart not int. revolted

'How could one avoid being revolted?'

(2) gaan tan ba' bei teluh tara keji 'ih

"how?" int. be egg place like-this-in-appearance

'How ever could there be eggs in a place like this!'

1. It is therefore possible that a more rigorous analysis would omit these clauses from the Rhetorical set, and treat them at the sentence-level only, like Tag Questions. It is certainly true that some Rhetorical Questions lack clause structure, such as the idiomatic gaan udei tan 'What's to be done, then?' not derivable from the meaning of the constituent words; these are handled at the sentence level as Minor Sentences of one type or another (see 4.42.3).

4.31.3 Imperative clauses ImCl. are marked for Imperative mood by obligatory Verb Focus with the Direct Object (if there is one) occurring in direct case (ie. not oblique, cf: .31.12.21.13 above). They function as the nucleus of Command Sentences and of some Exhortations¹, the division of function corresponding to a difference in structure and defining two subsets of Imperative clauses, true Imperatives and Hortatives.

Imperatives are positive or negative, always vocative.

4.31.31 Positive Imperatives ImCl.Po have the structure of Intransitive or Transitive centred clauses in Verb Focus, with obligatory 2nd person vocative Subject tagmeme filler optionally realised in the string. A minimal imperative clause may thus consist of a single uninflected verb root,

eg: buau! 'run away! be off with you!'

kidei! 'to-here = come here!'

saug! 'paddle quickly! quick as you can!'

Or the clause may manifest fuller structure,

eg:(1) apun lah ka'au!

V+approach_F ! you 'You may approach!' ²

(2) kidei bup in

to-here_F book that 'Give me that book' ³

1. These differ from Hortatory Formula Sentences (4.41.34)

2. 'You may approach', a polite formula with the connotative meaning of a direct Imperative, seems the best way of rendering apun lah ka'au which, despite its imperative form, has not the direct brusqueness of 'Come here!'

3. An idiomatic use of kidei, usually non-agentive or at least self-initiated motion. Another cryptic imperative of uncertain derivation is sabi' ga' 'ask some', which has the sense of 'give me some' (as in the story of The Brothers at Sungai Lebu').

- (3) juh win ga' kou
 V+give_F it to I 'Give it to me!'
- (4) kikut kelou ga' gi'ih
 V+dig_F you(pl) at at=here' 'You all dig here!'
- (5) bier lah kou pepela kaba'
 allow_F ! I S+paddle go-downriver
 'Let me paddle downriver!'

4.31.32 Negative Imperatives ImCl.Ng or Prohibitions have the prohibitive particle ka' 'do not' in initial position in the clause string, followed by a Declarative clause which may be definite or indefinite in its application according to the choice of vocative Subject nominal. ka' may be followed immediately be an intensifying adverb add.

4.31.321 Definite Prohibitions have obligatory 2nd person pn as Addressee tagmeme filler, which is optionally realised in the (surface) string.

- eg:(1) ka' pila' dagen katil
 pro. S+look in bed-curtain
 'Don't peep into the bed-space!'
- (2) ka' singen kedua lijah
 pro. only you-two be-amazed
 'You must not be surprised'
- (3) ka' lauyh ka'au jangai
 pro. at-all you go-inland
 'Whatever you do, don't leave the riverside'

It is noted at 4.22.151 that Transitive prohibitions have the verb nuclear to the main clause marked for focus, which may be Actor or Object.

eg:(4) Actor Focus, with the obligatory addressee tagmeme covert in the string:

ka' sekali keman wa' ngadan payau

pro. at-all A+eat rel. name deer

'Do not in any circumstances eat any kind of deer!'

4.31.322 Indefinite prohibitions have the indefinite nominal pn

a in Addressee position, with the gloss 'someone'; it may be made more indefinite by adding sai-sai, 'anyone at all'

eg:(1) tengen balek 'ih, ka' lalu tenaban a (OFDynamic)

trunk banana this pro. at-all P+grasp person

'No-one is to touch this banana stem!'

(2) ka' a sai - sai medeg tengen balek 'ih

'No-one at all is to touch this banana stem!'

4.31.33 Cajoling Imperatives are a proper subset of ImCl., having regular Imperative construction with cuba' 'try' followed by a Sentential Complement.

eg:(1) cuba' ka'au udai

try_F you go-out-to-sea

'You just have a try at going out to sea'

(2) cuba' perati lou ki'

try_F S+inspect ppl other

'Why not have a look at other people?'

4.31.34 Hortatives ImCl.H all have obligatory overt 1st person dual or plural inclusive Addressee which, in the corpus, are all pronominal. Hortatives are positive or negative.

4.31.341 Positive Hortatives are structured as Intransitive or Transitive clauses in Verb Focus:

eg:(1) tabui tuah ba' migi' méh

set-off_F we-2(inc) int. A+fetch gold

'Let us go and fetch some gold'

(2) mexawat lah telou¹

V+get-tubers_F emph. we(inc)

'Let us go and collect edible tubers (mexawat)'

1. see p369

(3) xéh telou singen winV+leave_F we(inc) only it

'We had better leave it alone'

4.31.342 Negative Hortatives have structure similar to that of Definite Prohibitions, except that the pronoun manifesting Addressee tagmeme is 1st person dual or plural inclusive.

eg: ka' telou mupox padai lau 'ih

pro. we(inc) A+reap rice day this

'Let us not reap the rice-harvest today'

4.31.4 Co-ordinate clauses

Clauses joined in co-ordinate relation form compound Sentences, described at 4.41.2 below.

4.32 The Dependent Clause

Dependent clauses are those clause-level syntagmemes with a single nuclear Predicate which do not function (actually or potentially) as the nucleus of Simple sentences. They are of two basic structural types, Full Clauses and Reduced Clauses. Full clauses have Relator-Axis structure, the Axis being identical to an Independent clause. Reduced clauses lack an overt Subject tagmeme, thus being unable to function in Simple sentences. Structurally they are of two subtypes, those having an overt Relator and those without.

At the Sentence level of distribution, Relator-Axis clauses with a Connector filling Relator position (eg: amun 'if') form

1. (from p368) mexawat appears to be a reduction of gemexawat (cf: 3.32.31.21.204); it is not clear why the AFDyn form rather than the stem alone representing VFDyn should be used.

Dependent clauses in Complex sentences. Relator-Axis clauses with Adverbial Relator (eg: lian 'when') fill marginal positions of Temporal and Locational setting of the following narrative clauses. Reduced clauses manifest serial clause construction in which pronoun deletion laws operate.

At the Clause level of distribution, Adverbial relator-axis clauses fill Temporal and Locational positions in Simple clause margins. Reduced clauses without an overt Relator fill Instrument and Purpose positions in Complex clauses. They also manifest the Reduplication process at clause-level.

At the Phrase level of distribution, Reduced clauses form adjectival adjuncts to Modification phrases NP323.3, and adverbial adjuncts to Verb phrases such as the Motion string 4.31.12.143.

4.32.1 Full Dependent clauses DC1. are relator-axis syntagmemes with a sentence-level connector or an adverbial relator.

4.32.11 Sentence-level connector clauses SDC1. have a range of connectors such as amun 'if', asel 'if only', ni (pun) 'even though', migi 'in order that' &c: as Relators, and may be sufficiently exemplified by the following:

4.32.111 Conditional SDC1.Con having amun 'if', asel 'if only' subordinating the following clause at the Sentence level.

eg: (1) amun ka'au lu', akou ba' pila' kayou si'iu
 if you agree I int. S+see wood before
 'If you are agreeable, I will look at the tree first'

(2) bada' nyin puli' udei, asel kamei bei jereki singen
 V+tell he S+return again if-only we have livelihood only
 'Bid him return, just so long as we have some way of staying alive.'

4.32.1111 Contrary to Fact Condition is a proper subtype of the Condition clause, beginning with amun 'if', but also containing the further diagnostic element setigel, to which no precise gloss can be given apart from its sense in the whole condition phrase of which it is a part, amun debei setigel +NP 'were it not for ...'

eg: amun debei setigel ikan udun 'ih
were-it-not-for fish Udun this

a tipou ayeng kamei mesti ba' matai min
pers ancestor we(exc) must int. die all
'Had it not been for the Udun fish, our ancestors
would certainly have all died'

4.31.112 Circumstantial SDC1, Cir have ni' (or ni' pun) 'although' or nuli' 'except',¹ or nya dakai 'with the exception',² subordinating the following clause at Sentence level.

eg: (1) ni' da'un sepa' umit buya' tap nyagem,
though leaf lime small suffer sole hand

nyin beguna angai
he S+use very

'Although the lime leaf is smaller than the palm of
your hand, it is very useful indeed'

1. nuli' is unique among the connectors in signalling the exact opposite when the clause it preposes is first in the sentence. Then the 'contrary to fact' exception is changed to a simple cause relation 'because', as evidenced in:

nuli' nyin a tama kou singen, akou debei medut gareng nyin

'Only because he is my father do I not fear his anger'. Several sentence pairs in elicited data attest this contrast of meaning with serial order of the clauses in the sentence.

2. nya lah appears to be a non-contrastive variation; sometimes the Malay form cuma is used by Moslem Melanaus. nya itself is vs, with the meaning 'finished, all gone', so the expression is idiomatic

- (2)
- ni' pun nyin teniman unei,

although he P+praise ref.

debei kenah nyin saber agei

not be-able he patient yet

'Although he was praised (as we have heard) he could hold his patience no longer'

- (3)
- akou kenah makau si'iu,

I be-able walk before

nuli' nyin in a tua-kapong kamei

except he that head-man we(exc)

'I would be able to walk in front, were it not that he is our village head-man'

- (4)
- lou sakai nga' matai min,

gpl friend past die all

nya dakai ka'au pexéh singen

except-that you S+remain only

'All our friends are dead; you are the only one left'

- (5) (cf: 4.22.1111 fn) As far as surface structure is concerned, another Circumstantial subordinator is the pre-Verb degree adverb makin 'increasingly'. In initial position in the first of two clauses, it has the force of subordinating that clause with the circumstantial gloss 'the more ...'

eg: makin peta'ah kesau in, apah lai in gareng

the-more S+hear like-that cl. male that angry

'The more the husband heard of that kind of talk, the angrier he became'

4.32.113 Reason SDCl.R have sebeb 'because' as relator, subordinating the following clause at Sentence level.

eg: (1) nyin debei den lalu, sebab a ki' dibeidagen lebu'
 he not be-seen at-all because other not-be in house
 'He was not noticed, because there was no-one else in the house'

- (2) telou tabui juluh jigem seneng naseng,
 we(inc) set-out hunt with easy heart
sebeb telou harep ga' baya'
 because we(inc) trust at omen

'We can set out on the day's hunting with a high heart,
 because we trust the omens'

4.32.1131 Explanatory clauses are reinforced by in lah 'that is why' prefaced to the Main clause. This may take over the functional load of sebeb altogether, which then does not appear as Relator. Although this gives the preposed clause the appearance of a subordinated syntagmeme, it is still semantically the Main clause and is so treated in this description.

eg: (1) sebeb ka'au tulah,
 because you lacking-in-respect¹
in lah ka'au nga' buya' wa' ja'et 'ih
 that-is-why you past suffer rel. evil this
 'Because you have failed to accept hospitality,
 that is why this harm has befallen you'

(2) kelou ba' tabui jau'
 you(pl) int. set-off far
in lah kelou pepingah nyu' kou 'ih
 that-is-why you(pl) S+provision oil I this
 'You are setting out on a long journey, that is
 why you must take along this oil of mine with you'

.1132 Cause clauses SDC1.Rc. Although Cause is generally manifested in RAP constructions with buya' 'on account of'

1. The concept of tulah, lack of courtesy on the part of a guest, is one of the strong social pressures guiding Melanau etiquette. A story from the Punan Ba of the Ulu Tatau (Map 3) pivoting on the same tradition is recorded in Clayre 1972(a) 23-25.

as the Relator¹, sentence-level clausal constructs occur with buya' as a subordinating particle. These sometimes mark the Dependent clause subordinated to an in lah Main clause (.1131 above).

eg:(1) sapai lian 'ih kayou in sudai kedau nyin pesader
 until time this tree that lean place he S+recline
buya' apah nyin nyat angai
 cause body he large very

'To this day that tree leans over where he (Tugau)
 leant against it, so large was his body'

(2) buya' kamei debei lu' negam nyin,
 cause we(exc) not wish P+invite he

in lah nyin ba' munu' kamei
 reason he int. A+kill we(exc)

'Because we would not be pressed into his service,
 that is why he means to kill us'

4.32.114 Positive Purpose SDC1.Po have migi' 'in order that'² as Relator, subordinating the following clause at sentence level.

eg:(1) akou menadu' bexéh 'ih

I A+plant seed this

migi' bei bua' ba' kanen mudei lau

so-that be fruit int. P+eat after day

'I plant these seeds (now) so that there shall be
 fruit to eat another day'³

-
1. buya' constructs treated as RAP, with a MNP root (or -e- UIE verb) may in fact represent OFStatic clauses. Thus buya' kasau lanun may in fact be RC1. 'because they were attacked by pirates', a typical Dependent clause construction (cf:4.31.12.121 p319)
 2. migi' is presumably the same word as the MNP verb 'to fetch'. Some speakers use pigi' 'get for myself' instead at this point.
 3. This is likely to be 'be' rather than 'have' bei because the rules of pronominalisation of serial clauses (4.32.25 below) would require akou to be made overt, if possession were meant, in initial position in the second clause.

- (2) siau in nelim kawa', migi' debei den a melabi'
 fowl that P+hide also so-that not seen pers A+come
 'the fighting-cock is kept hidden so that it will
 not be seen by the visitors'

4.32.115 Negative Purpose SDC1.Ng have ka' 'Neg.Imperative'¹ as
 relator, or samu' 'lest', subordinating the following
 clause at the sentence level.

- eg:(1) kamei peba' pang ba' mesen sungai 'ih
 we(exc) S+use net int. A+dam stream this
ka' ikan puli' mapun likou udei
 pro. fish return A+approach River again
 'We use this seine-net to block off the stream so that
 the fish shall not get back into the main river'

- (2) nyin mia' angai, medut samu' siau nyin kalah
 he be-shy very afraid lest fowl he be-beaten
 'He is very upset, worried in case his fighting-cock
 should be defeated'

4.31.116 Limitation SDC1.Lm have sapai 'until' as relator, sub-
 ordinating the following clause at sentence level.

- eg:(1) nyin debei tudui lalu sapai labi' lau na'ah
 he not sleep at-all until come day later
 'he did not sleep a wink until daybreak'

- (2) luin cuba' jelakau udei, jelakau udei,
 they try one-time again one-time again
sapai udu jawai luin mesax, pedaa min
 until nose face they grazed S+blood all
 'time and again they tried, until their noses and
 faces were all scratched and covered in blood'

1. Various allotagmas may occur according to individual style; an
 alternative to ka' alone has migi'...ka'... 'so that ...should not'
 very much like the example (2) of .114 above. It appears that some
 considerable degree of choice is open to the speaker at this point.

- eg: (1) duah ratuyh ta'un si'iu Brooke labi',
two hundred year before Brooke come
'Two hundred years before the arrival of James Brooke'
- (2) dagen luin berudéng kesau in,
in they S+discuss like-that-in-sound
'while they were discussing together like that'
- (3) ubi lian babui in nga' labi' setengah likcu,
when time pig that past come one-half River
'when the pigs were half-way across the river'

4.32.122 Introducer clause SDC1.∅ . There are some Dependent clauses which, while translated with a temporal relator in English, lack any such word in the Melanau. These are then analysed as Circumstance clauses with Void relator tagmeme SDC1.∅, manifesting clause structure RAC1.∅ (4.32.211).

- eg: nila' nyin ji belebi labi',
P+see he appearance butterfly come
'when he saw that the butterfly had arrived, ...'

Others have Existential clause structure, with bei 'be, there is / was' in initial position in the string, followed by a nominal expression which may have a temporal adverb adic. in construction.

- eg: (1) bei jelau,
be one-day 'Once upon a time, ...'
- (2) bei ta'un in kawa',
be year that also 'So it was that, that year also..'
- (3) bei pat lau béh in,
be four day after that 'Four days later, it happened
that'

4.32.13 Clause-level Relator clauses CDC1. have Adverbial fillers of the Relator position, forming relator-axis syntagmemes filling clause-margin tagmeme positions.

4.32.131 Locational clauses CDC1.L are typified (and may prove to be uniquely represented) by kedau 'place, where' as the filler of Relator tagmeme position. This is often preposed by the particle tara (or ti), apparently reinforcing the exactness of the location, as conveyed in the gloss 'the very spot where ...'

eg:(1) sungai in tunyek kedau nyin wab la'an
stream that muddy place he go-east go-west
'the stream became muddy where he kept going to and
fro from one big river to the other'

(2) duin xuxau ga' kayou ti kedau nyin in pelim
they-2 pass at wood very-place he that S+hide
'then two of them passed by the tree just where
he was hiding'

4.32.132 Temporal clauses CDC1.T are typified by lian 'time, when'¹ in relator position, which may be replaced by a range of more specific temporal adverbs.

eg:(1) Dul agei tudui lian lou Berantai labi'
Dul cont. sleep when gpl Berantai come
'Dul was still sleeping when Berantai and his
companions arrived'

(2) béh duin peruku', ulou nvin bida-bidem
after they-2 S+smoke head he become-dizzy
'after they had had a smoke, his head began to spin'

1. All temporal nouns (such as malem 'night, at night') overlap distributionally with adverbs. lian 'time, season' and lian 'when' are therefore treated as two occurrences of the same word, rather than as homophones. The same is presumably true of locationals.

- (3) dagen luin in keman inut, labi' beletika'
 in they that A+eat jelly come mud-skipper¹
 'while they were eating sago-jelly, some mud-skipper
 arrived on the scene'
- (4) kepaut luin diem ga' giin, apah luin petamah
 duration they dwell at there body they S+increase
 'as long as they stayed there their numbers increased'
- (5) masa duin pesawa 'ih diem giin, luin puma balau
 while they-2 S+spouse this dwell there they S+farm
 'while those two married people sago-palm
 lived in that place, they had a sago farm'
- (6) nga' kajih kereja nyin², nyin pun keluer
 past finished work he he then go-out
 'when his work was over, he went away'
- (7) si'iu nyin tili, nyin puba' "...."
 before he fly he S+speak "...."
 'before flying away, he said "...."'
- (8) ubi nyin sader udei, den nyin paman dagen likou
 when he concious again seen he S+float in River
 'when he regained conciousness, there he was afloat
 on his own river'

4.32.14 Reduplication of clauses

The Reduplication process is applied at the clause level as well as at the word level and phrase level (cf: 4.22.23). When the clause which forms the repetition has full clause structure, it may represent a Serial co-ordinate clause lacking overt Connector tagmeme (4.31.43) or any of the other stylistic

-
1. beletika' are provisionally identified at 6.32
 2. This temporal clause may, of course, be no more than a non-grammatical permutation of the pICl. kereja nyin nga' kajih 'his work was finished', but at the sentence level it is introductory.

reduplications described elsewhere in the text.

eg: lima depa jelakau nyin terjun,

five fathom one-time he plunge

lima depa jelakau nyin terjun, lalu ...

five fathom one-time he plunge then ...

'he swooped down a full five fathoms at each plunge,
and again another five, then ...'

Reduplication of the VP alone represents at clause level RC1. structure of a Dependent clause with no overt subordinator or co-ordinator. It seems best to treat them all as special forms of Dependent RC1. in subordinate relation to the main predication, since they cannot occur without it. Examples are cited at 4.31.43, and the clauses described at .32.22⁴ below.

4.32.2 Reduced Dependent clauses RC1. lack any overt Subject tagmeme, and are further subdivided according to the presence or absence of an overt adverbial relator. They fill clause-level margin positions.

4.32.21 Relator-axis clauses RAC1.T are the only such syntagms appearing in the data¹. The typical relator lian 'when' may be replaced by more specific temporal adverbs, just as in the SDC1.T described above.

eg: (1) mujun nyin pesapek puti² min

mouth he S+mottle white all

béh keman ikan in wa³ palei

after A+eat fish that rel. taboo

'he was all mottled white about the mouth after
eating the forbidden fish'

1. It seems likely that the absence of Locational clauses parallel to the Temporal clauses RAC1.T is a systematic rather than chance

- (2) nga' kena'an sei, jadi kamei ma'ui ba' sagu'
 past get wet-sago then we(exc) A+bake int. sago-pearls
 'having got the wet sago-pith filtrate, we bake it
 into sago-pearl biscuits'
- (3) kelou mesti pekaréh peba' nyu' 'ih si'iu tudui
 you(pl) must S+rub S+use oil this before sleep
 'You must anoint yourselves with this oil before
 you go to sleep'

4.32.211 Special case with Void relator position RAC1,∅. As with

the sentence-level temporal adjuncts, there are clause-level margin tagmeme fillers with reduced clause structure that lack an overt relator. Semantically they may have temporal or circumstantial reference (cf: SDC1,∅ at .32.122 above).

- eg:(1) peden nyin memereng bua' padok jau' jau', luin ...
 S+see he A+throw jackfruit far far they
 'seeing him throw the jackfruit far away, they ...'

(continued) omission, from the vary nature of the two types of deixis. Spatial reference takes points in space for datum, in particular 'self' and in Melanau (and other languages spoken in deltas, as observed in Clayre 1972(b) and briefly at 6.11) the main river likou. This type of reference lends itself to phrase structures of the preposition and noun type, dealing with more-or-less fixed referents. Temporal events, on the other hand, are the substance of temporal reference, with events in time as the datum. Events characteristically involve process, and process leads to clause-type structures with a nucleus of a verb denoting that process.

Against such a relativist argument, it may be observed that a language such as English which is capable of naming events and processes as if they were objects in the real world (eg; baptism, the coronation) can also use clause-type structures for locative reference: 'On your right as you go down the hall', 'As thou goest up to the Mount of Olives'. All that can be said with any finality is that the data lacks the parallel *RAC1.L

- (2) nisu' tou keman bua' padok jau' dagen sek inan,
 P+abandon spirit A+eat jackfruit far in grass yonder
nyin pun segaut ba'ai ...
 he then hasten go-down

'being left to himself by the goblins, who were eating the jackfruit in the grass over there, he made haste to come down (from the tree)...'

4.32.22 Reduced clauses with no Relator RC1. but with type-specific verb nucleus, fill Instrumental and Purpose tagmeme positions in complex clauses.

4.32.221 Instrument clause RC1,I has no relator; rather, the verb peba' 'S+use' in Subject Focus static form functions as Relator tagmeme filler, followed by a nominal Axis in the form of the Object of the verb, semantic Instrument of the main predication.

The clausal status of Instrument margin is seen in its potential for transformation to become the matrix clause, which may be in any of the focal valencies described at 4.31.12.21 above.

eg:(a) luin tabui peba' salui ayeng

they_F set-off S+use canoe large
 'they set off in a large canoe'

(b) luin peba' salui ayeng ba' tabui

they_F S+use canoe large int. set-off
 'they used a large canoe to get away'

(c) salui ayeng neba' luin ba' tabui

canoe_F large P+use they int. set-off
 'they used a large canoe to get away'

(d) ba' kelou salui ayeng ba' tabui

V+use_F you canoe large int. set-off
 'Use the big canoe for getting away!'

While the Instrumental construction is clausal, from the standpoint of the matrix clause peba' in (a) above has the same distribution as a preposition dagen 'in'. Elsewhere, as shown at 3.32.31.23.206, the proposition jigem 'with' may be substituted for peba' without much alteration in the overall meaning. It is therefore convenient to treat the untransformed string (a), which is typical of Melanau Instrumental construction, as a clause with one nuclear verb tabui 'set off', Instrumental case being marked on the nominal phrase salui ayeng 'large canoe' by a pseudo-preposition peba' 'with the use of, by means of'.

This would then make Instrumental case a clear parallel to the other cases listed at 4.31.11.22 above, as suggested at .2220 in the text of that section. It is thus also very similar to the adjunctive use of motion verbs in the Motion string described at 4.31.12.143.

4.32.222 Purpose clause RCl.P has no relator; rather, the verbal auxiliary aspect particle ba' 'future intent' has the simultaneous functions of Relator of the reduced clause following, and of Aspect, tagmeme filler in the VP nuclear to that clause.

- eg: (1) a lai in segaut ba'ai ba' tawi
 man that hasten go-down int. flee
 'the man hurried down (the tree) in order to flee'
- (2) apan umit 'ih tabui ba' tiked bua' padok
 cl. small this set-off int. climb jackfruit
 'the younger (brother) set out to climb the
 jackfruit tree'

It is not unusual to have two successively embedded Purpose Dependent clauses RC1.P in a complex clause¹.

eg: (3) nyin pelikang ba' tudui, ba' lilu' wa' sakit in
 he S+lie-down int. sleep int. forget rel difficult that
 'he lay down to sleep, hoping to forget his difficulties'

(4) tou in sexaat ba' matu' bua' padok in,
 spirit that jostle int A+pick-up jackfruit that
ba' keman wa' nga' se' ji
 int. A+eat rel. past red appearance
 'the goblins jostled one another to get at the jack-
 fruit, to eat whatever looked ripe'

4.32.223 Structural ambiguity in Purpose clauses arises from constructions of ba' + Root, where it is not clear whether this root is verbal or nominal. Typical of such ambiguous passages is the purpose clause in:

(1) béh in baru' akou menadu' balau ba' guna kou mudei
 after that new I_F A+plant sago-palm int. USE I later

While it is simple to give a gloss which conveys the general meaning, "Only then do I plant out sago-palm for use later on", it is not clear whether the Purpose clause is a serial clause in a complex sentence, or an embedded clause attributive to NP323.3 Head balau at the clause level.

1. Two embedded clauses appears to be the upper limit of common usage, but greater degrees of layering are possible (cf: nominal phrase relativisation 4.21.432, and related verbal phrase rules) and easily constructed as a kind of joke. eg: (akou memada' (ka'au (ba' menyuba' (ba' menyinged (ba' menolong (ba' melei salui in)))))))
 'I want you to try to remember to help to buy that canoe' - a complex sentential complement of the sort described at .32.23 above.

Even when a decision is made (if it can be made) on this point, the internal structure of the clause is open to two interpretations. guna can be nominal, 'a use, usefulness'; or it can be verbal, an MNP stem taking normal affixation¹, so that the form guna may represent 'R+use', the gloss to OFStatic construction. These two interpretations would lead to slightly different glosses, 1 "for my subsequent use" or 2 "to be used by me later on". There is little semantic difference between the two, but a structural difference exists which one would like to resolve. 1 could take a range of Modification fillers after the nominal Head guna, such as ba' guna ayeng mudei 'for an important use later on', or ba' guna maal mudei 'for a valuable use in the future'. 2 on the other hand could be transformed into OFDynamic, to become ba' genuna kou mudei 'to be used by me later'.

A similar clause occurring in another context may help to resolve the ambiguity, salui 'ih ba' ba' kou-debei .

canoe this int. USE I-self

Here also, ba' (and USE) represents either a noun root or the related verb root, so that while "This canoe is for my own exclusive use" could be reached from either analysis, a verbal structure is considered most likely on the following grounds. salui 'ih nga' ba' kou-debei

canoe this past USE I+self 'No-one but me has

used this canoe' was elicited as Completed Aspect transform, and there is no precedent for recognising (nga' + noun root) as a well-formed Melanau syntagm found in the data. The ba'

1. With exception of its less usual be- alternative to pe- affix form, noted at 3.32.31.4

form of the clause is therefore also taken to be verbal; and by analogy, the guna clause at (1) is probably verbal as well. No more than such a tentative solution can be offered at present.

4.32.22⁴ Clause additions not having the structure of an Independent clause are sometimes tacked onto a main clause without the function of describing a serial action. This partial repetition may be seen as a stylistic refinement, reinforcing the predication for dramatic effect, or it may be a formal recapitulation, or merely an addition of more words for padding or for gaining thinking-time (5.11).

Serial repetitions are described at .32.1⁴ above, such as

mano' set in tutau japah, tutau japah ...

sun-bird the A+call one-cl A+call one-cl

'the sunbird called first one person, then another ...'

Emphatic repetitions are similar in form, but their content does not suggest a serial interpretation.

eg: lalu lulin tawi mapun guun, tawi mapun guun

then they flee to forest flee to forest

'then they fled to the forest, fled to the forest!'

Such repetitions are characteristically on a lower pitch register than the main predication (cf: Echo I.C, 2.51.3).

Other additions may be interpolations of any kind, giving the VP nuclear to the clause overall structure of an Appositive phrase (cf: NP22), such as that in:

lalu lulin mapun guun, pebiah mapun guun

then they approach forest S+run approach forest

'then they got to the forest, ran to the forest'

in which there is an amplification of the original predicate rather than a serial addition of independent information.

4.32.23 Sentential Complements have been described for both Intransitive verbs (3.32.11.5 and .21.4) and Transitive verbs (3.32.22.4). All these represent forms of DC1.P; those with no overt subject (Subject complements) have covert subject co-referential with that of the matrix clause, and manifest RC1.P structure, while those with overt subject co-extant with the Direct object of the main verb manifest Full clause structure (Object complements)¹.

The desiderative (and potentially performative) verbs sabi 'request', du'a 'pray', kudin 'forbid' &c: may have as their complement a special formula to which the verb root bada 'tell, command' is nuclear, a formula closely equivalent to the gloss 'Let there be ...'. This demand complement may be positive or negative.

eg: (1) kamei menyabi' ga' ka'au bada' bei ba' kanen
 we(exc) A+ask at you command be int. R+eat
 'We implore you, let there be something to eat'

(2) akou demu'a, ka' bada' bei anum;
 I_F A+pray pro. command be water
ikan wa' kenah dagen guun pun ka' bada' bei
 fish rel. R+get in forest * pro. command be
 'I pray, let there be no water; nor let there be such fish as are caught in the forest (streams)'

1. An alternative analysis of Sentential Complements may be developed from the Ditransitive clause structure exemplified at 4.31.12.22. A typical AFDyn clause with Full clause complement

(a) Tugau menitah Besiong ba' pekaxi

Tugau_F A+tell Besiong int. go-fishing 'Tugau told Besiong to go fishing' may be a realisation of DTCl. structure

S:NP1_F +Pd:dVtP +R:NP1 +O:RC1.

in which Besiong is semantically Dative, the syntactic relator ga' being for some reason covert. ba' pekaxi is then a verbal Object of the transitive verb menitah, what Besiong was told to do.

(continued p387a)

(footnote continued from p387)

Two observations appear to support this suggested analysis.

(1) The somewhat parallel verb melabau 'enquire' (cf: telabau 'a question', menelabau 'ask in marriage, court') appears in construction with an overtly oblique Dative pronoun, very much like the example (1) on p386, and a request content as object:

(b) akou melabau ga' ka'au, likou nou ngadan likou 'ih?

I_F A+enquire at you country what? name country this

'I ask you, what is the name of this country' (or 'River')

In the Speech clauses 4.31.11.131, a quoted content is an acceptable Object construct; it is, however, always a full clause structure (or a Minor Sentence type, which is equivalent in distribution).

(2) A transformation of (a) occurs later in the same text, in what may be seen as Dative Focus (cf: 4.31.12.22.12):

(c) nyin in tenitah Tugau ba' pekaxi

he_F that P+tell Tugau int. go-fishing 'He was told by Tugau to go fishing', in what may be seen as the Reported Speech form

of (d) "Tabui ka'au ba' pekaxi" sau titah Tugau ga' nyin

set-off you int.go-fishing sound tell Tugau at he

"Off you go fishing!" Tugau told him.

Such an analysis has the advantage of accounting for the division of the Sentence Complement clause into discontinuous parts nyin and ba' pekaxi, but introduces the complication of verbal objects which are not full clauses, a contingency not covered in the formulation of Indirect Speech at 4.31.11.133.

It must be admitted that this is one of the areas where a concentration on the surface strings to the exclusion of underlying structures does not provide the most revealing analysis. The tidiest solution is to suppose that (c) represents a fuller underlying form in which the indirect quote was nyin ba' pekaxi (cf: ka'au ba' pekaxi in (d)) 'he int. go-fishing', from which the second occurrence of nyin has been deleted. This raises the new question of recoverability of deleted information, who the deleted nyin actually refers to (cf: .32.25 below). No final solution can be offered at present, beyond these tentative suggestions.

4.32.24 Idiomatic Negative clause IdCl.Ng is a special idiomatic adaption of the Prohibition clause ImCl.Ng (4.31.31.2), having the distribution of a Dependent clause in Complex sentences whose burden is the description of a negative state. The Dependent IdCl.Ng intensifies this negation, in much the same way as the gloss 'Let alone X, there was not even Y'. Three non-contrastive allotagmas of the Prohibition formula are found, ka' 'pro.', ka' agei 'pro. yet', and ka' ngadan 'pro. name'¹.

eg: (1) ka' ba' kena'an méh, ba' kanen pun dibe²
 pro. int. get gold int. R+eat even not-be
 'let alone getting hold of gold, there was not even anything to eat'

(2) ka' agei a-nyat, ane' umit pun labu' debei benasa
 pro. yet grown-up child even fall not disaster
 'let alone grown-ups, even children falling off came to no harm'

(3) ikan udun dibe² dagen likou, aba' pun dibe²,
 fish Udun not-be in rivers down-river even not-be
ka' ngadan ba' dagen daat
 pro. name int. in open-sea

'Udun-fish do not live in the big rivers that run down to the sea, nor in the estuaries, let alone there being any in the open sea itself'

1. ngadan 'name' appears in many places to have the idiomatic sense 'all kinds of' or 'all that might go by the name of' (cf: 3.31.22 p119), and it may well be this secondary meaning that is implied in the idiomatic expression ka' ngadan, 'no such thing' or something of the sort. (cf: also ka' lalu at 4.31.32 above).
 2. This particular form of the idiom is from a story in the Igan dialect, in which the actual wording is identical to that cited except in having mah for méh, and mibe² for dibe², the equivalent words being substituted for consistency of exposition.

4.32.25 Dependent Serial clauses RC1.S are described as to their distribution at 4.41.2131, being properly a part of Sentence structure. Even though they are not embedded in a matrix clause like RC1.P, they also lack an overt subject. The covert subject is co-referential with the last nuclear nominal in the clause to which they are appended, not with the subject of that clause unless it was an intransitive clause with only one nuclear NP.

eg:(1) a sawa nyin matu' teluh in nigi' nyin puli'
 wife he A+pick-up egg that P+take (s)he go-away
 'his wife picked up the egg and took it home'

(2) a lai in memereng bua' padok in jau' jau'
 man that A+throw jackfruit that far far
lalu labu' dagen sek inan
 then fall into grass yonder
 'the man threw the jackfruit as far away as he could
 and it fell in the grass over there'

This rule of co-reference of covert subject in serial clauses is fundamental to an understanding of the syntax of Complex sentences, for it governs "deletion" of pronouns in the string and, from the hearer (or, one hopes in due course, reader) end of a speech-situation, recovery of the covert information needed to allow a full semantic "reading" of the message.

In Melanau syntax it is the fruit in (2) that fell into the grass, not the man (as a literal interpretation of the word-by-word gloss would lead one to expect). If the man had fallen, an obligatory overt subject would be needed in the serial clause, which would then have Full clause structure:

lalu nyin labu' dagen sek inan 'then he fell into the grass over there'; precisely as the English needs the overt object pronoun

in the free translation beneath the gloss.

4.32.26 Generalisation clause RCl.G has either a 'person' manifesting Subject tagmeme (in which case it has Full clause structure), or may have void Subject tagmeme. Transitive clauses may also have void (ie. generalised) Object tagmeme (cf: 4.31.12.21.123 above); ditransitives may lack an essential NP.

- eg:(1) Intransitive: da'ou tetawa
 be-good laugh
 'It is good to laugh'
- (2) Semitransitive¹: ta'ou bei sei bah iba'
 know be flesh side down
 'It is known that there is flesh
 (ie. gexawat tubers) underground'
- (3) Transitive: lian ba' meninou
 time int. A+burn-off
 'the burning-off season'
- (4) Ditransitive: piti tama'
 R+send father
 'sent by (my) father'
- piti ga' kou
 R+send at I
 'sent to me'

In each such case, the missing information is not recoverable from the linguistic context; it must be assumed to be null and therefore unspecified altogether.

1. It may well be that the second half of example 4.32.131.(8) represents this impersonal construction, lalu den X 'then it was seen that X'. den is used as an adjective in this way, 'visible', and debei den is equivalent to 'invisible', both of which require a semantic Agent (or Experiencer, in Longacre's recently developed terminology, as yet unpublished outside S.I.L. mimeograph).

4 The Sentence Level

The Sentence is a class of syntagmemes of a hierarchical level above that of the Clause, the level of its main constituent tagmemes, and below that of the Paragraph and Discourse¹.

(Longacre 1964.125)

The most basic subdivision of sentences introduces the traditional distinction between Major sentences, which have internal structure of at least one Independent clause, and Minor sentences which do not. Within this broad classification are grouped those Simple sentences with a nucleus of one and only one clause, the Compound sentences with more than one clause in co-ordinate relationship, and Complex sentences with one or more Dependent clauses in subordinate relationship to a Main clause.

According to their function in Discourse, narrative or other speech-events, Major sentences are subcategorised as Statements, Performatives², Questions, Commands and Exhortations. Principal attention in the description is given to Statements, to which other sentence types are semantically and grammatically related.

1. Even sentences show some patterned dependency (Longacre 1964. 127) in their relation to one another in higher-level syntagmemes, and are therefore not "the largest unit of grammatical description" (Lyons 1968.172).

2. Austin (1955) draws attention to those utterances which do what we say when we utter them, as eg: "I name this ship Queen Elizabeth", a performance which is enacted rather than described in the saying of the words. Not all Austin's Performative types appear in the data on which this description is based, but there are enough to show that it is required to recognise them as a distinct category of sentence-type in the spoken language (still the only widespread form of Melanau).

Minor sentences lack the complete structure of an Independent clause. Typically they manifest such features as reduction of the clause nucleus, ellipsis and exostulation. It is not possible to give more than an outline account of this portion of the language, but three types of Minor sentences are recognised: Exostulations, Ready-made utterances¹ and Elliptical sentences.

While the hierarchy set up for this description has higher levels than the sentence (described at 4.5 below), it is a fact that many utterances are composed of a single sentence². Such sentences then manifest Base tagmeme, and are accompanied by a characteristic Intonation Contour from the inventory of I.C. at 2.5. Major and Minor sentences are associated with similar I.C. in similar linguistic contexts.

4.41 Major Sentence types S1

The types of sentence distinguished by their function are most easily described with reference to Simple sentences, and then examined in Compound and Complex sentences.

4.41.1 Simple Sentences S11 have manifesting their Nucleus tagmeme clauses of the types described in detail at 4.31.1-3. Optional Introducer Margin position may be filled with the Sentence Adverbial expressions described at 4.23.4

1. "les locutions toutes faites, auxquelles l'usage interdit de rien changer." (de Saussure Cours 172)

2. Many, says Harris (1951.14) are not. However, his "incomplete sentences" are subsumed under the heading Minor Sentence types in this description, so that his objection is not particularly relevant to that part of the analysis dependent on the linking of Sentence forms and Intonation Contours to form Utterances.

4.41.11 Statements SS11 have a nuclear Independent clause and optional margin. (For ease of reference, material drawn from previous detailed exposition is given its section heading reference number, so that lower-level structure may be taken as already analysed and transparent.)

eg:(1) DTC1. (4.31.12.22.11(3))

a pedih benelei kou ubat 'ih

'I have bought this medicine for the patient'

(2) +Mar:ads. +NEC1. (4.31.11.11(1))

mimeng lah, mano' in mano' tejali

'Of course, that is a hornbill'

4.41.12 Performatives PS11 are those sentences comprised of clauses with a 1st person subject¹ and a nuclear verb from the set taking Object sentence complements (3.32.22.4), in which the Complement tagmeme is realised as a full clause structure. Each such verb has a slightly different purport ranging from Supplication to Command (cf: 4.32.23); three examples will be sufficient to illustrate the sentence type, which is associated with Declarative intonation I.C.1

.121 Commands are typified by the verb titah 'instruct'

eg: akou menitah ka'au ba' kaba' mapun Uya'

I_F A+instruct you int. go-downriver A+approach Oya

'I instruct you to go (come) downriver to Oya'

.122 Invitations are typified by gam 'invite'

eg: kamei megam kelou ba' tutui beluba' 'ih

we(exc) A+invite you(pl) int. A+join-in race this

'We invite you to join in this race'

1. The status of Object Focus transformations "You are bidden to .." is ambivalent between Performative and Statement, as in English.

4.41.123 Petitions are typified by the verb du'a 'pray'

eg: (4.32.23(2)) +I.C.11,12

akou demu'a, ka' bada' bei anum ...

'I pray, let there be no water ...'

4.41.13 Questions QS11 have Nucleus tagmeme manifested by an Interrogative clause QCl. (4.31.2)

eg: +Mar:ads. +AQCl. (4.31.231(1)) +I.C.23

eh, buya' nou ka'au menangih?

'Oh dear, what are you crying for?'

4.41.131 Four functional Question types are recognised at the Sentence level, each correlating with a distinct clause type and a distinct Intonation contour when occurring as Base tagmeme in an Utterance.

.1311 Questions requiring Affirmation or Negation are all Verb-query questions; usually answered by the verb in question or Affirmation particle i', or by the Negation particle debei (debéh for emphatic negative). The question has VQCl. manifesting Base tagmeme (4.31.22) with either the initial query particle an 'is it so?' or the final particle kah '?', and Interrogative Intonation.

QS111 = VQCl. + I.C.21

.1312 Tag questions require simple affirmation or negation, and are based on a Declarative clause DeCl. with non-final clause Intonation, followed by the sentence-level Tag o on a rising tone.

QS112 = DeCl. +Tg: o +I.C.22

4.41.1313 Questions requiring Information are Nominal, based on NQC1. (4.31.21), or Adverbial based on AQC1. (4.31.23). The answer is typically more fully structured than those answering QS111 and 112, though not necessarily manifesting Independent clause structure.

QS113 = NQC1. / AQC1. + I.C.23

.1314 Rhetorical questions are based on Rhetorical query clauses RhQC1. (4.31.24), and may manifest a normal range of choices at points in the clause structure, or the fully determined arrangement of Ready-made Utterances (4.42.2). They evoke no direct answer, although some form of riposte or apology is not an unusual sequel.

QS114 = RhQC1. + I.C.24

4.41.14 Commands CS11 have Nucleus tagmeme manifested by an Imperative clause ImCl. having 2nd person Addressee as the grammatical subject; they are positive (.Po) or negative (.Ng)
eg: ImCl.Ng (4.31.31.21(3)) + I.C.31

ka' lauyh ka'au jangai

'Whatever you do, don't go inland'

4.41.15 Exhortations ES11 have Nucleus tagmeme manifested by an Imperative clause ImCl.H with 1st person plural Addressee as grammatical subject.

eg: ImCl.H (4.31.32.1(1)) + I.C.31

tabuituah ba' pigi' méh

'Let us go and fetch some gold'

4.41.16 Combinations of these types within the Simple sentence occur in the Quote formula QEC1., in which, for instance, the

Command of .14 above is quoted, becoming the Quote Complement
 as: Comp:(+Mar:APS +ImCl.N) +QF:NP321.6 +I.C.11,14

"Ateng kawa', ka' lauyh ka'au jangai", sau uba' nyin
 'I mean it; whatever you do, don't go inland', he said'
 Similarly, Performatives can include a sentence of some other
 type while remaining a Simple sentence, as eg: sentence (b)
 in the extended footnote on p387,

S:NP1_F +Pt:aVtP +R:RAP.L/D +Comp:NECl.
akou melabau ga' ka'au, likou nou ngadan likou 'ih
 'I ask you, what is the name of this country?'

4.41.2 Compound sentences S12

Compound sentences are found with the same basic types
 as Simple sentences, but compound construction.

4.41.21 Statements SS12

Independent clauses may be conjoined in co-ordinate
 relationship to form co-ordinate Compound sentences, the
 connection being effected by a co-ordinate connector c (3.34.
 1221) or by comma pause, much as described for co-ordinate
 phrases (4.21.42).

4.41.211 Associative connection is by connectors jigem 'with'
 and serta 'and (at approximately the same time)'

eg: a tama Tugau bei a kuman Retuyh,
 father Tugau be pers from Retus
serta a tina nyin a mexou kuman Manyug 'ih
 and mother he woman from Manyug this

'Tugau's father was from the Retus river, and his mother
 was a local woman from Manyug here'

4.41.212 Alternative connection is by the connectors atau 'or' and tapi 'but',

eg: a sawa nyin keréh angai ba' pila' batou sakti in
 spouse he anxious very int. S+see stone magic that
tapi Dul debei lu' lalu
 but Dul not wish at-all

'His wife was ever so anxious to look at the magic stone, but Dul would not allow it at all'

4.41.213 Serial connection is by connector lalu 'and then',

eg: (1) nou agei, naseng nyin manah angai,
 at-once heart he be-glad very
lalu nyin pu'un puli' mapun kubou
 then he begin S+go-away A+approach house
 'He was then filled with joy, and set off home'

(2) igi' nyin ga' parang, titéh nyin ga' talei salui
 V+get he at jungle-knife V+cut he at rope canoe
lalu pesaug nyin kaju' segaut angai¹
 then S+paddle-fast he go-upriver hasty very
 'He grabbed a jungle-knife, slashed the canoe-rope and paddled off upriver for all he was worth'

.2131 Focus shift in Serial clauses

Compound clauses contain Dependent Serial clauses RC1.S as well as Independent clauses, RC1.S being the favoured type of serial clause when one (or more) of the nominals in the clause is co-referential with a nominal in the foregoing clause.

Typically, new information is introduced into a narrative in a Subject (or Actor) Focus clause. Focus being a category of the clause nucleus, its range is limited to Subject

1. This series of Action clauses is typical of the Verb Focus in narrative.

or Verb in an Intransitive clause. Therefore in whatever focus the first Cl₁ is, SF is the automatic focal choice for the next clause, the Subject of Cl₁ being the last nuclear nominal preceding Cl₂ (4.32.25).

If the subject of Cl₂ is co-referential with the subject of Cl₁, it is typically covert; Cl₂ has void Subject tagmeme. The verb nuclear to Cl₂, however, will be marked for Subject Focus; "deleted" information is thus recoverable.

If both clauses are in Verb Focus (as 4.41.213(2) above), then both subjects are obligatorily overt.

If the second clause is Transitive, but the subject is co-referential with the subject of Cl₁, Subject tagmeme will be void but the verb will be marked for Actor Focus on a covert subject, as eg: luin manah angai serta mebatun kelidéng in

they_F rejoice very and A+raise-up monument that

'They were delighted and erected the monument'

If both clauses are Transitive, the first will typically be in Actor Focus (introducing a new situation) and its object is then the last nuclear nominal of Cl₁. Should Cl₂ contain this substantive in its denotata, the serial clause Cl₂ is automatically focussed on this semantic Object¹, which is typically covert as co-referential grammatical subject of the clause. This is the construction configuration exemplified in both sentences cited at 4.32.25 above.

1. A similar rule is formulated very clearly for Bahasa Indonesia by Junus (1967.21), so that he is able to affirm categorically, confronted with two sentences in series but not manifesting this construction (which he refers to as Active and Passive, rather than in terms of Focus), "they do not belong to a discourse as two immediate sentences".

When the serial clause Cl_2 lacks an overt Subject tagmeme, its form is typical of RC_1 ; it is a Dependent clause, although in co-ordinate relationship with the foregoing clause Cl_1 , rather than in subordinate relationship.¹

The subject of the serial clause Cl_2 (semantic Object of the continuing process²) is optionally made overt; when this option is realised, the overt subject typically follows the Agent in the Object Focussed configuration of Cl_2 .

eg: sau uba' luin, "Da'ou telou mibet win",
 say they good we(inc) A+throw-away it
lalu nibet luin lasong in dagen likou
 then P+throw they mortar that in river

'"Oh, let us throw it away!" they said, and they pitched the rice-pounding mortar out into the river'

(in which win is co-referential pronoun 'it' for lasong 'rice-pounding mortar' in the second clause)

This overt mention of the Object is obligatory if there is yet another serial clause to follow in the same sentence; otherwise the cross-referencing of substantives is not clear. The following clauses are Cl_2 and Cl_3 of a Complex/Compound sentence:

... nesi' luin dagen kanan lah nyin,
 P+put they in jar emph. (s)he
lalu naman luin kaba' mapun Igan
 then P+float they go-downriver to Igan
 '... she was stuffed into a jar, and they floated her off on the current down to Igan'

1. It is shown at 4.41.312 below that the same deletion rules apply to Circumstance clauses of the sentence Introductory margin even though they precede the Main clause.

2. Junus' rules (1967.25) include Indirect Objects; it is not yet clear how these operate in Melanau ditransitive clauses.

(in which the serial connection between Cl₂ and Cl₃ has pronoun deletion in accord with the general rule).

4.41.22 Performative compounds PS12

Clauses containing nuclear desiderative verbs (3.32.22.4) may be conjoined like other DeCl. , as exemplified by the verbs bada' 'command' and kudin 'forbid'. The first clause typically carries non-final intonation I.C.12; the second is cast in Object Focus, and has I.C.14 final contour.

eg: TC1.(AFDyn) +c +TC1.(OFDyn)

akou memada' kelou puli' teruyh kaju',

I_F A+order you(pl) go-away straight go-upriver

serta kelou kenudin ba' pekaxi agei ga' kala aba'

and you(pl) P+forbid int fishing yet at estuary down-river

'I order you to return upstream at once, and forbid you to fish down at the estuary any more'

4.41.23 Questions QS12

Compound questions are not common in the data; each query tends to be framed in a separate question sentence. A few do occur, however, and the construction is clearly permissible.

eg: VQCl. +c +ICl.

bei kah luin sala' ga' ka'au,

be ? they wrong at you

atau kou pun sala' ga' kelou

or I even wrong at you(pl)

'Have they done you any harm, man, or have I wronged any of you?'

These sentences do not manifest any of the restraints on the reference of pronouns, such as are found to apply to the conjoining of other sentence types below.

4.41.24 Command compounds CS12

To be conjoined in co-ordinate relationship, two (or more) commands must have the same 2nd person referent as the common addressee, even though the realisation of the tagmeme is optional in both clauses.

eg: ImCl. +c +ImCl.

igi' ka'au nyu' 'ih jigem karéh ga' badan biéh
 V+take you oil this with V+anoint at body body
 'Take this oil and rub it on your body!'

4.41.25 Exhortations ES12

To be conjoined in co-ordinate relationship, two (or more) exhortations must have the same 1st person plural referent as the common addressee, which is obligatorily overt in the first of the clauses. (In the data, this conjoining is found only with exhortations of ImCl.H type)

eg: ImCl.H +c +RCl.

pepingah telou wa' lebih lalu tabui ba' juluh
 S+rati on we(inc) rel more then set-off int. A+forage
 'Let us take what remains along as our food, and go off
 for a day's hunting in the forest'

4.41.3 Complex Sentences S13

Complex sentences have two nuclear tagmemes, a Main Clause tagmeme Mn: filled by an Independent clause, and a Subordinate Clause tagmeme Sub: filled by one or more Dependent clauses. The semantic relation of these dependent clauses to the Main clause is described at 4.32.111-26, and is signalled by the choice of sentence-level subordinator. Main and Subordinate

clauses are not restricted to the same type; Declarative Circumstance DC1, for instance, is often subordinated to an Interrogative IC1, or an Imperative ImC1, as Main clause.

The main headings in the following description refer to the type of the Main clause, while the various sub-headings define the dependency relationship manifested by the subordinate clause.

4.41.31 Statements SS13 are basic to the description.

4.41.311 Condition SS13.Con has Condition clause SDC1.Con manifesting Sub: tagmeme, exemplified at 4.32.111(1) with the complex structure

Sub:SDC1.Con +Mn:TC1.

4.41.312 Circumstance SS13.Cir has Circumstance clause SDC1.Cir manifesting Sub: tagmeme, exemplified variously at 4.32.112 (1)-(5). Typical structures are those of sentences

(1) Sub:SDC1.Cir +Mn:IC1.

(3) Mn:IC1 +Sub:SDC1.Cir

although these do not represent the full range of possibility.

.3121 Void relator Circumstance clauses introduce many Main clauses in connected narrative. A typical SDC1.∅ of this type is exemplified at 4.31.1121.

Sometimes these clauses manifest RC1. structure, often in Object focus lacking an overt grammatical subject (cf: serial clauses described at 4.41.213 above).

eg: sentence (2) at 4.32.211 (p382), which manifests the structure Sub:RC1.∅ +Mn:IC1.

In such cases, the grammatical subject of the dependent clause is co-referential with the overt subject of the Main

clause. The conditions permitting "deletion" of the subject from the string of a following serial clause are therefore seen to obtain also over a preposed dependent clause.

- 4.41.3122 Discontinuous clauses are formed when the Circumstance dependent clause interrupts the Main clause, as in the following example (in which the hiatus represents the real position of the Sub: clause in the final string).

Mn:TC1.(Pt:vt +S:NP1 ... +Mar:RAP.L +O:NP323.1)

+Sub:SDC1.Ø(Pi:vi +Mar:RAP.L)

nila' luin labi' ga' kebun la'ei in,

P+see they come at garden fruit-tree that

ga' tengen padok in ketep daa' singen agei

at trunk jackfruit the drop blood only cont.

'Arriving at the orchard, they saw nothing but a few drops of blood on the trunk of the jackfruit tree'

- .3123 Temporal circumstance is manifested by the presence of SDC1.T in Sub: position, as exemplified by 4.32.131 (1) - (8), of which a typical structure is that of sentence (7) Sub:SDC1.T +Mn:QEC1.

- .3124 Idiomatic Negative clauses IdCl.Ng fill Sub:Cir. position in examples 4.32.24 (1) and (2).

- 4.41.313 Reason SS13.R has Reason clause SDC1.R manifesting Sub: tagmeme, exemplified at 4.32.113 (1) and (2) with structures typified by

Mn:IC1. +Sub:SDC1.R

- .3131 Explanatory reason has no obligatory overt relator to the dependent clause, but in lah introduces the Main

clause, as exemplified at 4.32.1131(1) and (2) with structures typified by

Sub:SDC1.R / IC1. +Mn:(in lah +TC1.)

4.41.3132 Causative reason has buya' in relator position in the dependent clause manifesting Sub: tagmeme, as exemplified at 4.32.1132(1) and (2) with structures typified by

Sub:SDC1.Rc +Mn:(⁺in lah +TC1.)

4.41.314 Positive Purpose SS13.Po has Purpose clause SDC1.Po manifesting Sub: tagmeme, as exemplified at 4.32.114(1) and (2) with structures typified by

Mn:TC1. +Sub:SDC1.Po

4.41.315 Negative Purpose SS13.Ng has Purpose clause SDC1.Ng manifesting Sub: tagmeme, as exemplified at 4.32.115(1) and (2) with structures typified by

Mn:TC1. +Sub:SDC1.Ng

4.41.316 Limitation SS13.Lm has Limitation clause SDC1.Lm manifesting Sub: tagmeme, as exemplified at 4.32.116(1) and (2) with structures typified by

Mn:IC1. +Sub:SDC1.Lm

4.41.317 Combinations of Dependent clauses in Complex sentences of a higher order of complexity are not uncommon in connected narrative. There appear to be no systematic restraints on the combination of both co-ordinate and subordinate additions to a Main clause, other than the pronominalisation requirements noted at various places in the text. Five examples will be sufficient to give an idea of the scope of such combinations

of subordinate clauses.

4.41.3171 Multiple Circumstance dependency:

Sub:(SDCl.Ø₁ +SDCl.Ø₂) +Mn:(pICl. +RC1.₁ +RC1.₂)

den luin a tiked,

seen they pers climb

peden a 'ih memereng bua' padok jau' jau',

S+see pers this A+throw jackfruit far far

lou tou in sexaat ba' matu' bua' in,

gpl spirit that swarm int A+pick fruit that

ba' keman bua' in

int. A+eat fruit that

'Having noticed the climber, and that he had thrown the jackfruit as far away as he could, the goblins all surged forward in an effort to pick it up and eat it'

.3172 Circumstance and Limitation dependency:

Sub₁:SDCl.Cir +Mn:TC1. +Sub₂:SDCl.Lm

makin luin peta'ah kesau in unei,

the-more they S+hear sound that ref.

tamah luin ga' kayou

V+add they (at) wood

sapai kedau lou pengamou in kajih megou

until place gpl hobgoblin that finish aflame

'The more they heard of the sound, the more wood they added until the hiding-place of the hobgoblins was utterly burned up'

.3173 Limitation interrupted by Circumstance dependency:

Mn:sICl. +Sub:(SDCl.Lm +SDCl.Ø)

biéh nyin langet min

body he be-itchy all

sapai genaxut nyin labi' pali' lalu

until P+scratch he come wound all-over

'His body itched all over until, by his scratching, it was a mass of open wounds'

(in which case both the dependent clauses have the same covert subject biéh nyin 'his body').

4.41.3174 Multiple Reason dependency:

Mn:pIC1. +Sub:(SDC1.R₁ +SDC1.R₂)

Radin in makin jelau makin susah,

Radin that more a-day more be-troubled

sebeb dibei a ba' midex ane' nyin

because be-not pers int. A+care-for child he

kerna nyin debei kenah menaan gareng nyin

because he not be-able A+firm anger he

'Day after day things got more difficult for Radin

because, since he could not control his temper,

no-one could be found to care for his baby'

(in which the two reason clauses are successively embedded one in the other).

.3175 Reason and Limitation dependency:

Mn:TC1. +Sub:(SDC1.R +SDC1.Lm)¹

debei kenah nyin nyunya' bulu agei

not be-able (s)he A+chew sago cont.

sebeb nyin dibei nyipen,

because (s)he not-have tooth

sapai jed nyin pun dibei lalu

until strength (s)he even not-be at-all

'Having no teeth left she was unable to chew the baked sago-biscuits, until her strength was quite gone'

1. There might be some case for making the Limitation dependency in some sense the primary one, the Reason having the main verb as its domain of semantic relevance while Limitation operates over the content of the whole sentence; ie:

((Mn:TC1. +Sub:SDC1.R) +SDC1.Lm)

4.41.32 Performatives PS13

The range of dependencies so far exemplified may occur with Performative Main clauses, for example:

.321 Reason dependency:

Mn:TC1. +SDC1.R

akou menyabi' ga' ka'au demu'a bada' bei ba' kanen

I_F A+ask at you A+pray command be int R+eat

sebeb kamei 'ih sapai kelukuh

because we(exc) this limit-of-hunger

'I beg you to pray that there may be food, for we are perishing from hunger'

.322 Negative Purpose dependency:

Mn:TC1. +SDC1.Ng

akou menegah kelou ba' pekaxi bah aba' gi'ih

I_F A+forbid you(pl) int. fishing side downriver at-here

samu' dibeil lalu ba' kena'an kamei 'ih na'ah

lest not-be at-all int R+catch we(exc) this later

'I forbid you to come downriver here fishing, lest there be nothing left for us to catch'

4.41.33 Questions QS13

Condition, Circumstance and Reason dependencies are of frequent occurrence subordinated to Main QC1. in Complex sentences. The Sentential-tag question is itself a complex syntagme.

.331 Condition dependency:

Sub:SDC1.Con +Mn:VQC1.

amun salui buat telou pulu' lawéh, kenah nyin meneng kah

if canoe R+load thirty person able it win ?

'With thirty people aboard, can this canoe win?'

4.41.332 Circumstance dependency:

as well as the more regular examples of SDC1.Cir, the idiomatic question type below manifests Circumstance Sub:

Sub:SDC1.Cir +Mn:NQC1.

agei sedeng ji akou nibet luin,

cont. while sight I_F P+throw-out they

sina' lah ji ka'au na'ah?

how-then sight you later

'Seeing that they have disposed of me, how do you imagine things will go with you?'

.333 Reason dependency:

Sub:SDC1.R +Mn:VQC1.

sebeb a tama ka'au nga' matai nga',

because father you past die past

an lu' kah ka'au labi' diem ga' gi'ih?

? wish ? you come dwell at at-here

'Now that your father has died, would you like to come and live here?'

.334 Sentential-tag dependency:

Mn:DeC1. +Tg: o (cf:4.31.223 above)

ka'au ba' mebatun kelidéng udei, o?

you int. A+raise-up monument again, no?

'You mean to erect the monument again, don't you?'

4.41.34 Commands CS13

All the dependencies exemplified are subordinated to ImC1. Main clauses in Complex Command sentences. Two examples will suffice to indicate the pattern.

.341 Condition dependency:

Mn:ImC1.Po +Sub:SDC1.Con (cf:4.32.111(2) at p370)

4.41.342 Negative Purpose dependency:

Mn:ImCl.Ng +Sub:SDCl.Ng (cf:4.32.115)

ka' peli' ga' dawek a juja' sek

pro. S+play at side pers A+slash grass

samu' ka'au pali' seped na'ah

lest you S+wound R+hack later

'Don't play around a person cutting grass, in case
you get hurt on one of his cutting-strokes'

4.41.35 Value VS13

As noted at 4.23.42 and 4.31.12.11, there are sentences of an essentially bipartite structure having an Introductory statement followed by an Independent clause. The form of the Introduction distinguishes the two main sub-types of this sentence type, the Statement and the Exhortation.

4.41.351 Statements have Introducer tagmeme manifested by the Existential copula verb bei 'be', a sentential negative, or some clause declaring the speaker's evaluation of the content of the following message.

.3511 Existential statements have Assertion or Negation by way on Introduction, as for example the Existential clauses EICl. cited at 4.31.12.11(1) and (2) on p313.

.3512 Truth-value statements have a truth assertion manifesting Introducer tagmeme:

eg:(1) Int:VcoP +Mn:TCl.(SFStat)

bei lah akou peta'ah a ngadan ka'aube emph. I_F S+hear pers name you

'It's a fact, I have heard of someone of your name'

(2) Int:pICl. +Mn:NECl. (NP313 +Nom)

debei lah akou ba' pibudei,

not emph. I_F int. S+lie

istana in wa' na' kou-debei

palace_F that rel. R+make I+self

'I'm not telling you a lie, that palace is
all my own work!'

Alternatively, they may have Introducer tagmeme manifested
by an Adverbial phrase AP.S (4.23.42)

eg:(3) Int:AP.S +Mn:DeCl.

bukan-bukan ji

not not appearance (= it-is-not-right)

ane' a miskin ba' kenah kawin jigem ane' raja

child pers poor int. able marry with child ruler

'It is not seemly for the child of a pauper to
marry the king's daughter'

4.41.352 Hortatory Formula HS13 differs from Imperative ImCl.

with 1st person included pronominal subjects, in that it
has the essential bipartite structure of VS13. It differs
from non-centred clauses in having a nuclear verb in each
of its two constituent parts, and no flexibility of order.

The Introducer tagmeme, which is first in the string,
is manifested by the state verb da'ou 'be good', and may
be regarded as Comment on the Topic which follows, the Main
clause of the Hortatory sentence HS13. This clause has an
obligatory 1st person included plural pronominal subject.

HS13 = da'ou +Mn:DeCl.

eg:(1) Semantically identical to the example cited at

4.31.341(1) on p368

da'ou tuah pigi' méh ba' piou tipou

good we-2 S+get gold int. funeral-gift ancestor
'Let us go and fetch some gold, as a funeral-gift
for our benefactor'¹

(2) da'ou telou puli' jangai

good we(inc) go-away go-inland

'Let us return to the shore'(from out at sea)²

4.41.4 Anaphoric Reference

The anaphoric reference particle unei (glossed 'ref.' as at 3.34.24) is enclitic to many NP (cf: 4.21.1) but is also found attached to VP and clause fragments such as that cited at 4.32.112(2). In such circumstances, the fragment is usually preceded by (s)udah nga' ... 'after the occurrence of ...', or some similar past tense-aspect expression linking the following narrative to what has been expressly mentioned before.

This anaphoric reference is an integral part of Narrative style (5.11) and links passages as blocks of speech; but unei refers in fact to the previously uttered words themselves, not to a referent in the real world. Consider:

(1) ... labi' kuman Retuyh.

come from (the) Retus.

Jelawéh a kuman Retuyh in unei a wakil Tugau, ...

one-man from Retus that ref. deputy Tugau

'... came from the Retus river. Now a man from there was Tugau's right-hand man, ...'

1. tipou has primary meaning 'grandfather', and thus is extended to ancestors in general; here it is used as a term of respect for the one who had provided them (goblins) food for so long.

2. This excerpt is from a sea-story, hence the gloss (6.11 below).

It may happen, according to the correlation that often exists between serial ordered parts of narrative and relative temporal order of the events described, gratuitously this anaphoric ref. is also temporal back-reference. But that is the outcome of a particular (if widespread) style of Discourse structure, not a part of the meaning of unei.

eg:(2) "Juju' singen akou labi'", sau uba' nyin. ...
a-moment only I come sound speech he

(Here follow several lines of recorded text; then:)

... wa' jaji nyin unei juju' angai ba' labi'
rel. promise he ref. a-moment very int. come

'"I shall be along in a minute", he said ...

... his promise to be along very soon'

In some instances, however, it is manifestly obvious that the reference is to the words previously spoken in the story, with no other temporal significance in the real world implied by unei, as a further excerpt from the story of the Goblins and the Gold makes clear:

(3) "Da'ou tuah tabui ba' pigi' méh ...", sau uba' duin.
'"Let us go and fetch some gold ...", they said.'

Udah nga' pigi' méh in unei,
after past S+fetch gold that ref.

duin makat ba' pigi' méh in.
they-2 S+rise int. S+fetch gold that

'After saying which, they set out to get the gold'

4.42 Minor Sentence types S2

Three types of Minor sentence are distinguished by their function and form, Expostulations, Elliptical sentences and Ready-made Utterances.

4.42.1 Expostulations XS2 are mostly single words or reduplications, some of the more usual of which are described at 3.34.19¹.

While ejaculations such as éh, mm, cis, ui, yoi and so on clearly have no grammatical structure, and may be supposed not to represent any fuller structure either, it is not so evident that such as agei 'still!', alu 'more!', nyaxi 'not enough!', ta'ou 'I don't know!' and other expressions of this sort may be treated in such isolation. Rather, they appear to represent a drastic trimming down of fuller clausal syntagms, reduced to a single nuclear word; as such, they shade off imperceptibly into the other types of Minor Sentence, RS2 and US2.

These Minor sentences are typically associated with intonation contour I.C.3

4.42.2 Elliptical sentences RS2 often bear much the same relation to full sentences as Reduced clauses RC1. bear to full clauses. In much the same way, also, they rely on the linguistic context to supply the fuller information needed for a properly structured sentence. They are distinguished by the speaker's role into two subsets, Sequence ellipsis and Response ellipsis. This dichotomy

1. The onomatopoeic ejaculations of English such as 'bang', 'splash' are mostly incorporated into verb forms in Melanau, eg: kakok 'crow' puu 'go along with a swishing noise', along with a great many other highly suggestive reduplications (cf: 2.53.4)

on functional grounds is matched by considerable structural difference also, and usually distinct intonational patterns appropriate to an ongoing narrative or an interjection.

4.42.21 Title ellipsis RS21 is not part of normal conversation.

Many spoken texts (and such as have been written) have a title, which usually lacks full Independent clause form.

eg:(1) NP321.3 batou ikan
stone fish

'The stones that were found in a Fish'

(2) RAP.K pasel kaul a-likou
about ceremony Melanau¹

'Concerning the annual Melanau
Village Cleansing Ceremony'

4.42.22 Sequence ellipsis RS22 is the form in which a speaker often frames afterthoughts, additions and corrections to his narrative; sometimes this may have the structure of a reduplicated word, phrase or clause (4.32.14), and sometimes of a clause addition RC1. (4.32.224).

eg: ... ngadan nyin ... sai .. éh, Dina, i', Dina; ...
name he who? er Dina yes Dina

'... called, what's his name? -er- Dina, yes, that's it ...'

4.42.23 Response ellipsis RS23 is the form usually taken by replies to questions, and interpolations into someone else's narrative.

.231 Replies are often as little as a word, more often RC1. depending on the linguistic context for fuller reading, and

1. This important ceremony, the pivot of the Melanau year, is described in Morris 1953 and Clayre 1971(a)1-2

typical of what Lyons (1968.175) calls 'context dependent' utterances.

eg:(1) in reply to: sai ngadan ka'au?

'what is your name?'

the response: Dul 'Dul'

which may be expanded, either actually or mentally, from the linguistic context to the full clause

ngadan kou Dul (NEC1.)

'My name is Dul'

(2) in reply to: lu' ka'au labi' kawa'?

'Do you want to come too?'

the response: i' 'Yes'

which cannot be expanded in any way other than a repetition of the queried predication.

(3) in reply to: kuman an ka'au?

'Where are you from?'

the response: kuman Medu 'from Medong'

and so on.

4.42.232 Interpolations and interjections into the speech of another are often elliptical in form¹.

eg: ... erti nyin, bei a matai beragen -

'... It means, someone dies a violent death -'

New voice: mano' kenyiu? (on rising intonation)

'(You mean) the hawk?' or 'the hawk (says that)?'

- i', baya' kenyiu, sama alah mano' 'ok

'Yes, the omen of the hawk, just like the owl'

1. This parsimony, it may be supposed, is because no more need be said, rather than out of a courteous desire to limit the interruption to a minimum.

4.42.3 Ready-made Utterances US2 occur in great profusion, including many idiomatic forms found in the texts which do not yield to an analysis as endocentric constructions. No more than an outline can be given of what is, in many ways, the flowering of the language on the trellis of its syntax.

4.42.31 The Colon syntagmeme US21 has bipartite structure of two clauses separated by comma pause and obligatory void connector tagmeme; the first is in much the same relationship to the second clause as Condition or Circumstance SDC1. is to a Main clause in a Complex sentence. The clauses comprising a Colon are generally RC1., and the form is apparently restricted in function to the framing of pithy sayings of a semi-proverbial nature.

- eg: (1) bida - bida pemupok, labi' kawa'
 gradually S+go-slow come also
 'gently does it, but we'll get there in the end'
 (cf: the longest way round may be the shortest way home)
- (2) medut ga' amou, tatah ga' tou
 afraid at ghost happen at spirit
 'run from a ghost and you meet an evil spirit'
 (cf: out of the frying pan into the fire)
- (3) silud layan ta'ou, pane' mexou
 V+comb side right S+child girl
silud layan bulai, pane' lai
 V+comb side left S+child boy
 'comb your hair on the right to bear a girl,
 comb it on the left to bear a boy'

Many similar aphorisms are framed in Colon form which bears more or less resemblance to full clause structure. In some

extreme cases, the RC1. structure may be reduced to no more than the nuclear verbs:

eg: (4) tapu', tuun

flood swim 'If there's a flood, then we must swim'

(cf: where there's a will there's a way)

4.42.311 Colon structure is manifested by a number of fixed

formulae such as kajih ..., kajih ... 'finished ..., finished..'

whose meaning is not immediately obvious from a literal gloss (cf: Colloquialisms, cat .33 below)

eg: kajih kinah, kajih nibet wa' dida'

finished P+eat finished P+throw-out rel. much

'much was eaten, but even more was thrown away'

4.42.32 Story endings US22 are more or less stylised in the form of Equational Adverbial clauses AEC1.

eg: gai in gai singen

distance that distance only 'That's all there is'

sapai 'ih wa' keneta'ou kou

until this rel. P+known I 'That's all I know'

4.42.33 Colloquialisms US23 must be very many in number, and quite impossible to isolate with any claim to finality at present. The following are among the more frequently recurrent:

bei apah (+I.C.21)

be body? 'Is anybody there?'

debei ibuh (which never exists in the positive)

not * 'It doesn't matter'

gaan tan udei

where? manner again 'It cannot be helped'

sapai tan ka'au

until manner you 'What a way to behave!'

4.42.34 Riddle formulae US24

Riddles are always prefaced by one of two set phrases; if the answer is a natural object (such as a flower), the set preface is: bunga' tadu' Allah Taala
'a flower planted by God'

If the answer is an artefact (such as a chair), the preface takes the form: ane' raja Kina
'child of the Chinese emperor'

4.42.35 Greetings are to some extent situationally dictated, yet fall into two highly stylised subtypes; those requiring a mere repetition of the initial greeting as response, and others.

4.42.351 Echo greetings US251 are semantically void, being always in the form of a comment whose truth is transparently obvious to both participants. The reply confirms the observation.

eg: (Passer-by, to a man working on a canoe hull)

mena' salui ka'au 'You're making a canoe'

(answer): i', mena' salui 'Yes, making a canoe'

4.42.352 Other greetings US252 differ as between meeting and parting pleasantries.

.3521 Meeting most often involves an enquiry about one's destination, or where one has come from, and receives a short factual answer.

eg: ba' kaan ka'au?

'Where are you going?'

mapun pasar

'To the market'

.3522 Parting takes one of two forms, a comment on one's own departure and/or a polite request to the host to remain where he is; both are in Verb Focus.

eg: mupok kou

'I'll make my way slowly'

pexéh ka'au / kelou

'(Please) stay where you are'

4.5 Levels higher than the Sentence

The bulk of the material on which this description is based is narrated text of one kind or another, in which a number of sentences are grouped together into coherent units, a number of which comprise a whole discourse. There is sufficient regularity about the intermediate higher level to recognise it as a level of the hierarchy, the Paragraph¹; the largest groupings of all are termed Discourse, for which no distribution is mapped.

Four types of Discourse are described, each with its own characteristic and defining forms. These are Narrative, Didactic, Ritual Poetic and Conversational Discourse.

4.51 The Paragraph Level.

Sentences are grouped together by semantic unity of content and by formal grammatical and phonological features into sub-terminal units called Paragraphs. These features are to some extent dependent on the Discourse type, and are therefore not as well defined as the diagnostic features of lower levels of the hierarchy. All these types, however, manifest three common structural divisions, Introduction, Text and Conclusion, which provide the basis for subclassification of the Paragraph level.

4.51.1 Introduction paragraph Par1 provides information about the subject matter of the Narrative (ND), Didactic (DD) and Poetic (PD) Discourse, usually also giving it a Temporal and Spatial setting. SDC1.Ø are typical fillers of the initial position in the string of Par1.

1.1 Narrative introduction Par1 is exemplified by:

1. The analogous syntagmeme in Ritual Poetic style is the Verse, (cf:4.52.3).

4.51.11 Narrative introduction NPar1 is exemplified by:

- (1) SS11 = AP1.1T +sIC1. (4.31.12.141)

si'iu sabei,

before ago

tenawan ga' Patanak debei ta'ou kubatan ba' matai

humans at Patanak not know what-way int. die

'In the olden days, the people of Patanak had no idea of the proper way of dying'

- (2) SS13.Cir = SDC1.T (4.32.121) +TC1.(OFDyn)

kurang lebih limah pulu' ta'un si'iu Brooke labi' Sarawek,

less more fifty year before Brooke come Sarawak

bateng Uya' peneritah Pengiren Matali'

River Oya P+govern prince Mat Ali

'Some fifty years before Brooke arrived at Kuching, the Oya River was governed by Prince Muhammed Ali'

- (3) SS11 = SDC1.Ø (4.32.122) +EIC1.

bei satu masa sabei,

be one while ago

bei duah lawéh a pejane' diem sega' likou Kekan

be two persons S+brother dwell near village Kekan

'Once upon a time, there were two brothers who lived near the village of Kekan'

4.41.12 Didactic introduction DPar1 is exemplified by:

- (1) SS11 = EIC1.

'ih tayan

this sago-trampling platform

'This is a sago-trampling platform'

- (2) RS21 = RAP.K

pasel wa' ngadan puni'

about rel. name courtesy-punishment

'Concerning the punishment that comes to those who neglect the rules of hospitality'

(3) SDC1.Con

amun bei a matai beragen,

if be pers die violence

'If someone should die a violent death, ...'

It is seen that the Introduction is not always in a unit of the same level of the hierarchy, varying in the examples cited from a full sentence (of a single Independent clause) to a sentence fragment, the Condition margin for a fuller Main clause forming part of the Text. As a set, DPar1 are succinct, less discursive than NPar1.

4.51.13 Ritual Poetic introduction PPar1 is exemplified by:

(1) PS12 = \emptyset AP.T. + (RC1₁ + RC1₂)

jadi lau 'ih kamei ba' menyabi' batu',

"now" day this we(exc) int. A+ask-for help

ba' menyabi' batu' ba' merara likou kamei

int. A+ask-for help int. A+care-for village we

'Now, today we ask for help, for help in caring for our village'

(2) CS12 = ImCl. +2xVP.31¹ +2xNP321.3

keman ipu'; keman ramai, keman ucai,

V+eat sprite V+eat crowd V+eat together

ipu' guun, ipu' talun

sprite forest sprite jungle

'Come and eat, you sprites;

Eat with the crowd, eat in festive mood,

Sprites of the tall trees, and of the tanglewood'

Intonation I.C.11 is typically associated with the first phrase or clause introductory to a longer text.

1: keman, the AFDyn form of the highly irregular verb 'to eat' is often used as an Imperative in place of the expected kinah, the corresponding OFDYN which, in other UIE verbs, is identical in form to the VFDynamic Imperative. keman telou at .51.23 below is clearly a functional Hortative, despite the form of the verb.

4.51.2 Text paragraphs Par2 provide the content of the text, and vary somewhat according to the Discourse type. They are characterised in Narrative by a shift in serial time with a link to the foregoing paragraph provided by anaphoric reference (4.41.4); in Didactic and Poetic passages there is a shift in subject and, in verse, often an accompanying change in the rhyming pattern.

4.51.21 Narrative text NPar2 is exemplified by the following clauses, selected from the beginning of relevant paragraphs:

(1) SS11 = AP3.T + EIC1.

debei paut béh in, bei a ngadan Berantai labi'

not long-time after that be pers name Berantai come

'Not long after that, a man called Berantai arrived'

(2) SS11 = SDC1.∅ + TC1.(SFStat)

bei jelau, Merun peta'ah tangih kuman kanan gusi in

be one-day Merun S+hear weep from jar (type) that

'Now one day, Merun heard a sound of crying coming

from inside the "gusi" jar'

(3) SDC1.T + ref.

sudah nga' salui in getu' unei

after past canoe that completed ref.

'When the canoe had been completed, as we have heard, ...'

4.51.22 Didactic text DPar2 is exemplified by the following clauses, selected from the beginning of relevant paragraphs:

(1) SS11 = SIC1.

kaul bekadep jigem beluba'

ceremony be-different with racing

'The annual Cleansing Ceremony and the Regatta are quite different occasions'

(2) Sub:SDC1.Cir

amun bei a matai binu'

if be person die P+kill

'If (on the other hand) someone gets killed, ...'

4.51.23 Ritual Poetic text is exemplified by the following verse beginning (which follows on from that cited at .51.11(1) above):

ES12 = ImC1.H +2xImC1.Ng + 2xVS13(RC1.G)

keman telou; ka' gawek, ka' menyipek,

V+eat we(inc) pro. bully pro. A+push

da'ou gega, da'ou tetawa

good greet good laugh

'Now let us all eat;

Don't be awkward, don't jostle your way,

For it's good to greet friends, to be merry and gay'

4.51.3 Conclusion paragraphs Par3 usually contain some sort of summing-up of the text, frequently including an in lah¹ main clause near the end, and US22 after the actual narration has finished.

4.51.31 Narrative conclusion NPar3, often accompanied by I.C.14 (or .14*) is exemplified by the following:

(1) RAP.T +sIC1. +SDC1.R (cf: 4.51.11(1) above)

béh in, luin semua ta'ou kubatan ba' matai,

after that they all know what-way int. die

sebeb luin nga' mena' kuyad alah buki tenawan

because they past A+make monkey as corpse human

'After that they all knew the right way of dying, for they had treated a monkey just like a dead person'

1. cf. Explanatory clause 4.32.1131 above.

- (2) ØAP.T +sIC1. +SDC1.Po +US22 (cf: 4.51.11(2) above)

lian 'ih, Sungai Kut nga' ayeng jigem teben
 time this stream Kut past large with deep
migi' kenah nasok rayet ba' wab la'an.

so-that able P+enter commoner int. travel-to-
Gai in gai singen. and-fro.
 distance that distance only
 'Nowadays the Sungai Kut is broad and deep enough to let
 anyone who wants to travel to and fro between the main
 River systems. That's all.'

- (3) part. +sIC1.(NP22 +sViP.1) (cf: 4.51.11(3) above)

in lah ji lou tou ga' Sungai Lebu',
 that's-how gpl spirit at stream house
lou pengamou in, nga' kajih.

gpl hobgoblin that past be-finished
 'That's how the ghosts at Sungai Lebu' (or hobgoblins,
 as they were really) were wiped out.'

4.51.32 Didactic conclusion DPar3 is similarly spoken with
 I.C.14 (example (2) having the exaggerated I.C.14*).

- (1) RAP.T + sIC1.

béh in, kaul pun nya
 after that ceremony * be-over
 'After that, the Annual Cleansing ceremony is over'

- (2) US22 (NP22)

in singen lou wa' bei kenata'ou kou,
 that only gpl rel. be P+known I
ji gaya kamei a-Melanau mena' sei
 sight way we(exc) Melanaus A+make wet-sago
 'That's all there is to it, then, the way we Melanaus
 make wet sago filtrate.'

4.51.33 Ritual Poetic conclusion PPar3 is not marked by the same formal sequences, but contains a summary in another poetic form.

eg: TC1.(AFDyn) +RAP.D (cf: 4.51.23 above)

kamei agei manyabi' murah jereki

we(exc) cont. A+ask-for easy livelihood

kuman sou sikou labi' sou silou junih

from gr.child elbow come gr.ch. nail future¹

'So we implore you to grant us the means of living at ease; not for ourselves only, but for our great grandchildren and their grandchildren after them.'

4.51.4 Conversation passing to and from between two or more speakers has somewhat different formal breaks and, in the more intimate circumstances of many such speech-acts, the grammatical form are often elliptical. A description is given at 4.52.4.

4.52 The Discourse Level

The Discourse is the highest level of the hierarchy, representing a complete speech-situation. More than one participant may be involved -eg. partner in conversation or interlocutor in some narrative who asks questions or prompts (4.42.222). The total Discourse is bounded at either end by silence.

1. H.S.Morris informs me that there is an exactly equivalent way of reckoning future generations in Anglo-Saxon, and that its use correlates with a particular form of bilateral kinship terms in the societies where it occurs. The apparent allusion to an anthropomorphic set of measurements is also interesting; it may have to do with measure terms such as ila 'one arm's reach' and jebikul 'two arms' span in circumference', or to a superceded counting system akin to the body-term counting common among many of the New Guinea tribes.

While the four types of Discourse noted at .51 above are recognised as mutually distinct, any discourse may contain more than one type embedded within its characteristic type. Narrative, for instance, may contain a Didactic portion; instructions given during a dream are frequently style-breaks of this kind. Conversation may contain Narrative portions as a speaker recounts events, or may be included within Narrative. The introduction to Ritual Poetry is seen to include prose (4.51.13(1) above).

The individual speech-styles of different participants clearly have a considerable effect on the structure of a discourse, but each type is illustrated below to give some indication of this level of the Grammar.

4.52.1 Narrative structure is exemplified by the story A pejane' ga' sungai Lebu' 'The brothers at Sungai Lebu'', extracts from which have appeared in each of the paragraph type illustrations¹.

4.52.11 Intruduction:paragraph (1) cited at .51.11(3) above.

4.52.12 Text:paragraphs (2)-(13), beginning as follows:

(2) jadi bei ta'un in kawa', padok pebua' dida' angai
'Well, it happened that that year the jackfruit were very plentiful indeed'

(3) kurang lebih duah pulu' ata' nga' nibet nyin ba'ai, bua' in, peta'ah nyin duum kuman jau'
'When he had thrown down some twenty of the fruit, he heard a buzzing sound in the distance'

1. This form of the popular story was narrated by Arip Dina of Dalat, recorded as Text 42 and on Tape 2/R280-R557 in the Sarawak Museum collection of Melanau folklore. Other versions of the story are by Ta'iah of Medong (7 R521-R715) and Ramli Bandung of Kekan (8 R195 - R495). The story contains several examples of the rhyming speech and special vocabulary attributed to tou 'spirits'.

- (4) jadi, jajah tou in unei melabau ga' nyin, ...
'Then one of the goblins asked him, ...'
- (5) - a didactic interpolation, explaining the rhyming speech of the goblins, which uses special words -
in erti, dagen uba' a likou, ...
'which means, in our Melanau language, ...'
- (6) dagen masa in lah, a tiked 'ih unei memereng bua' padok in jau' jau'
'All this time, the man up in the tree was throwing jackfruit as far away as he could'
- (7) jadi nyin nga' labi' kubou, susui nyin ga' jane' apah ayeng in, ...
'Now when he got home, he told his elder brother ...'
- (8) jadi cerita in pun tena'ah lou a kapong, ...
'Well, the sorry tale was heard by all the villagers'
- (9) jadi keji in, tou pila' ga' lawei bau, bei tenawan bau
'Well then, one of the goblins looked up into the branches of the tree, and there was a man!'
- (10) labi' lou tou bau in unei, lalu sibat ...
'When the goblins got up there, they bit him ...'
- (11) jadi jane' nyin jajah ga' likou in unei ...
'Then the brother who was still in the village ...'
- (12) udah in luin pinyi, pinyi
'After that they searched here and there'
- (13) jadi kayou wa' tu'uh in unei, wa' neba' luin ba' meninou, ...
'Then the dry wood which they had got together for making a fire, ...'

4.52.13 Conclusion: paragraph (14) cited at 4.51.31(3) above.

4.52.2 Didactic structure is exemplified by the explanatory text Ba' mibet lawa' 'How to get rid of bad luck', extracts from which have been cited in the illustrations of paragraph types¹.

4.52.21 Introduction: paragraphs (1) and (2), representing the spoken title (RS21) ba' mibet lawa' and didactic introduction cited at 4.51.12(3) above.

4.52.22 Text: paragraphs (3) and (4), beginning as follows:

(3) amun a peduli

'If proper care is taken, ...'

(4) given at 4.51.22(2) above.

4.52.23 Conclusion: paragraph (5) below:

(5) semuah u'ih ba' mibet lawa', ka' luin buya' senei²

'All this is to get rid of the bad luck, so that they will not become senile before their time'

4.52.3 Ritual Poetic structure is exemplified by the Kaul incantation Keman ipu' 'Come, ye spirits', extracts of which have appeared in the description of paragraph types³.

4.52.31 Intruduction: paragraphs (1) and (2), which begin as follows:

(1) mekat luat kelou Rirang Penyibex⁴

'Get up from your rest, Rirang and Penyiber'

-
1. Recounted by Kelumai of Tanam, as Text 45 (not recorded on tape).
 2. senei describes a state in early life in which the hair goes to grey and the teeth fall, as in senility; it is always attributed to some supernatural agency, as a punishment for infringement of taboo.
 3. Chanted by Ma'ou of Medong, Tape 3 R496-R731 of the Museum set.
 4. Penyibex is now said to be 'the wife of Rirang', who is called on to accompany him in his nurturing of the riverine community, the likou. The name bears a marked resemblance to the Malay title Penghibor 'the Comforter' given by Christian missionaries to the

(continued on p429)

(2) 'ih ji telou 'ih ba' menibah kelou in, ...

'This is what we are calling on you to do, ...'

4.52.32 Text: verses (3) - (8), beginning as follows:

(3) nyin kuasa, nyin bernama

'He is power(ful?), he is famous'

(4) jadi menyabi' batu';

ipu' kuman guun, ipu' kuman talun, ...

'Well then, we ask for your aid,
Sprites of the jungles and of the forest glade'

(5) mekat luat kelou si'iu,

pedun beripun sama-sama telou 'ih;

'Wake yourselves from out of sleep
And gather here our tryst to keep'

(6) mana ipu' lakei, ipu' sabei, ...

'All kinds of sprites, the old and sage
And those from every bygone age'

(7) mibet wa' ja'et, mibet wa' langet, ...

'(Come) to throw out inner sin
And what irritates the skin'

(8) 'ih singen dakai wa' bei sabi';

jekan lati', jekan tugi',

'This, then, is the sum of all our asking;
Fish at the river-mouths, on mud-banks basking'

4.52.33 Conclusion: verse (9), cited at 4.51.33 above.

4.52.4 Conversation structure is naturally very fluid, varying almost infinitely with the situation. There are, however, some commonly observed formulae, as outlined below, which impart a recognisable structure to conversation.

(continued) third person of the Trinity. Much of the Kaul chant, and much more Melanau magic, makes use of Malay rather than uba' likou, cf: verse (3), in which both the attributes of pronominal nyin 'he' are Malay words for which Melanau has equivalents, mejed 'powerful' and timan 'famous'.

4.52.41 Prelude: exchange (1) is typical in a situation of a visitor arriving at the outside of a house, wishing to converse with the occupants.

(1) Person from outside:

ui ! bei apah ? +I.C.21 (cf:4.42.33)
'Hey, is there anyone at home?'

Reply from indoors:

bei ! bawai lah¹
'Yes, come on up'

4.52.42 Introduction: exchange (2), a formality regularly observed whether the meeting is chance or designed.

(2) Host: kuman an ka'au ? (cf: 4.42.3521)
'Where have you come from?'

Visitor: kuman Medu aju'
'From Medong, upriver'

4.52.43 Text: exchanges (3) onwards, until the time comes to draw the visit to an end.

4.52.44 Conclusion: final exchange (n)

(n) Visitor: mupok kou, pexéh ka'au (cf: 4.42.3522)
'I'll be on my way, don't move'

Host: labi' udei na'ah;
'Come again some time'
(jaga' ga' jayu, telasui angai tan win !)
'Watch your step going down to the jetty, it's terribly slippery'

1. Houses are traditionally built on stilts above the soft peaty soil of the Melanaus' habitat, hence the use of bawai and ba'ai for 'enter' and 'leave'. Because of the riverside situation of most Melanau houses (see sketch plan at 3.33.12.11 p208), jangai 'go inland from the river' is a situationally bound synonym for bawai or progress inwards after entering, udai for ba'ai.

4.6 Analysed Text Fragment

The second half of Text 45, Ba' mibet lawa', is given below, with a colloquial translation. The analysis of each paragraph is presented first in outline, and then in detail from Sentence to Morpheme level of the Grammar as set forth in this description.

4.61 The text.

The Introduction has already been cited at 4.51.12(3).

(4) A dana sabei, amun bei a matai binu', mesti tiep-tiep lawéh ba' mupex atau tupa jigem besei buki a matai binu' in, migi' luin ka' buya' senei.

(5) 'Ih lah sebab nyin, sau dengah, a mexou dagen kapong mupex ulou a matai binu' wa' kenilut. Semuah u'ih ba' mibet lawa', ka' luin buya' senei.

(4) In the olden days, if someone got killed, everybody had to beat or spear the corpse of the dead man, so that they themselves should not be afflicted by senility before they were really old.

(5) That is the reason for the tradition that the women of the village would beat the head of a murdered man when it was hung up. All this was in order to get rid of the bad luck (attendant on violent death), so that they should not become senile while still young.

4.62 Macro-analysis

The sentences in these two paragraphs have the following major components:

(4) Introduction + Text.

Introduction: NP323.4

a dana sabei,

Text: SS13.Con.Ng : Sub₁:SDC1.con amun bei a matai ...

Mn: SS11 mesti tiep-tiep

Sub₂:SDC1.Ng migi' luin ka'

4.63 Detailed analysis

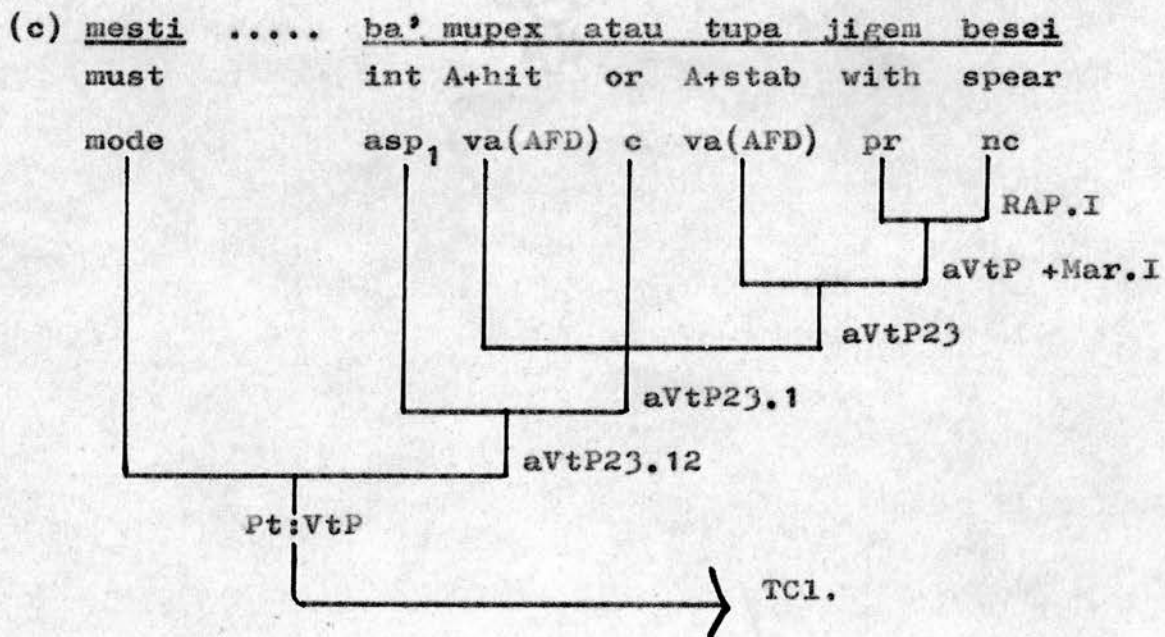
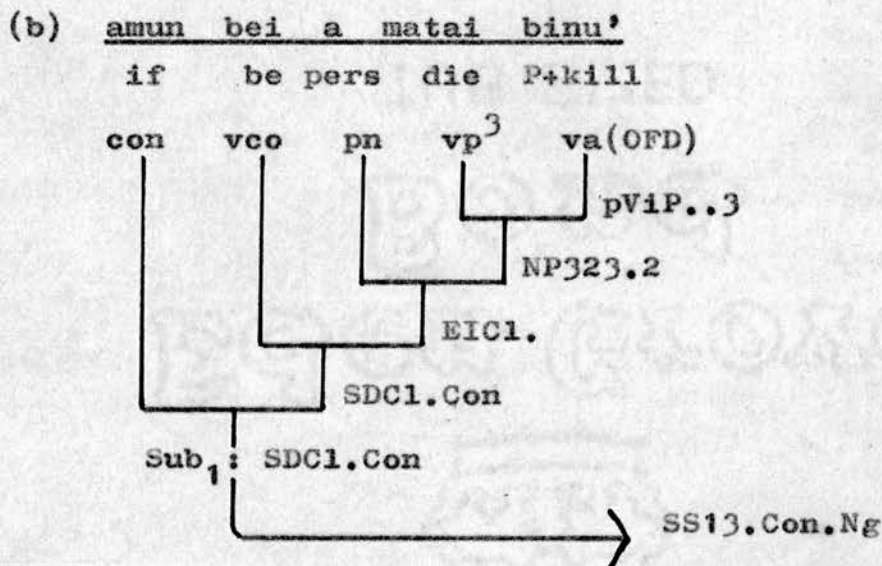
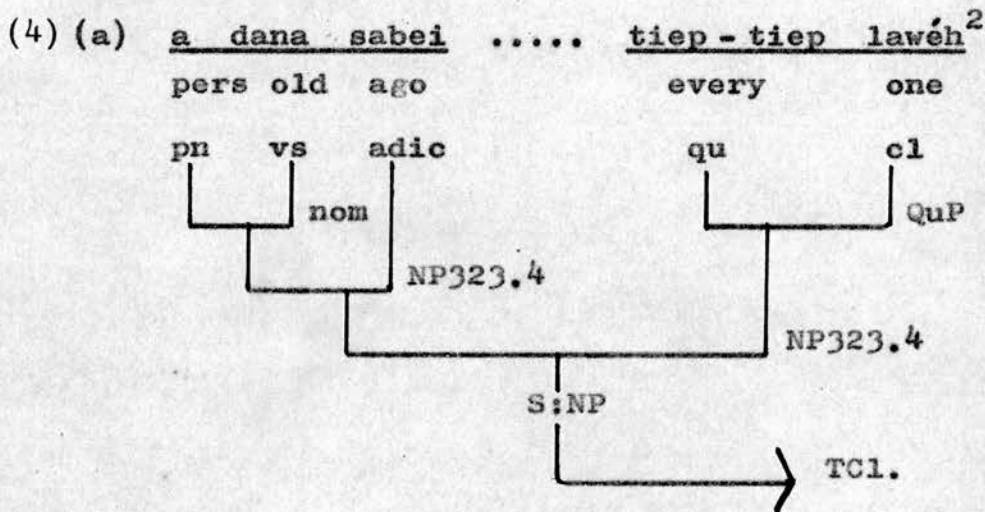

(d) buki a matai binu' in
corpse pers die P+kill that

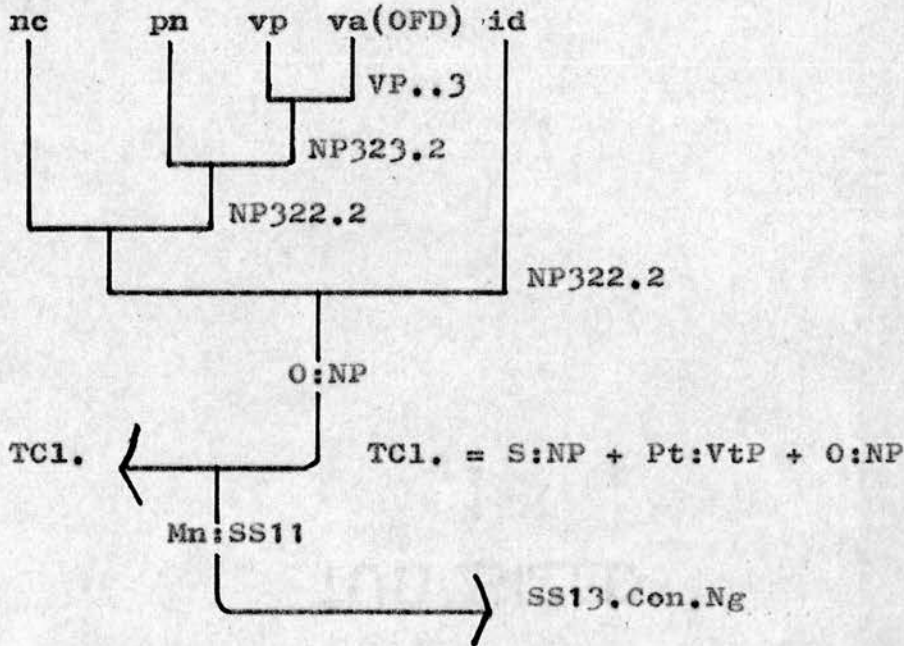

(e) migi' luin ka' buya' senei.
so-that they pro suffer be-senile-while-young

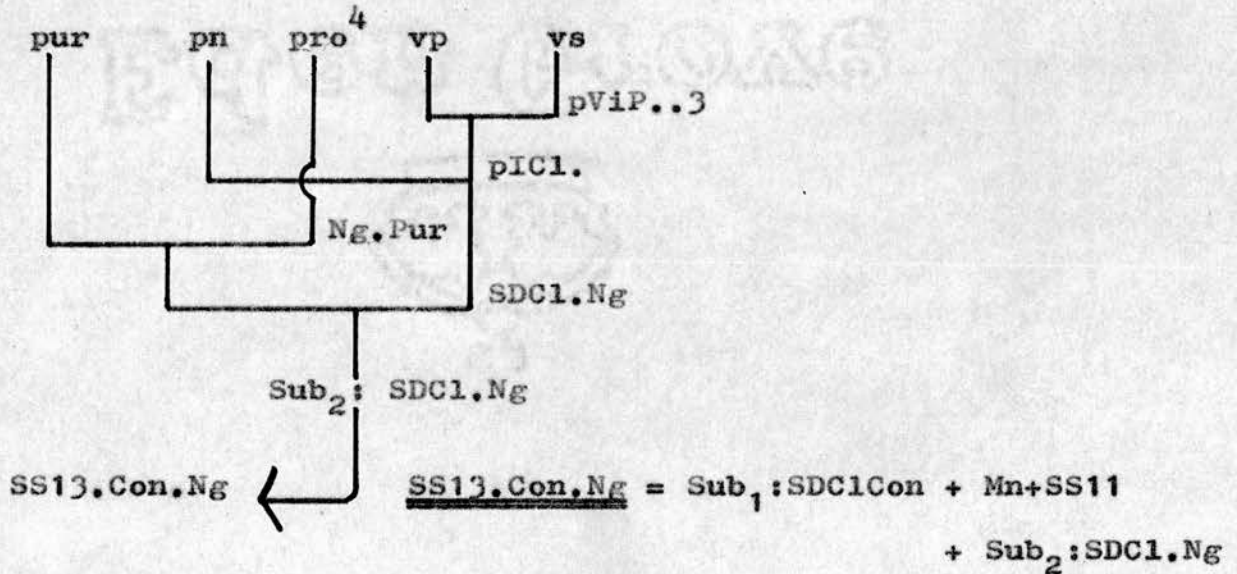

(5) (f) 'ih lah sebab nyin

this ! reason it

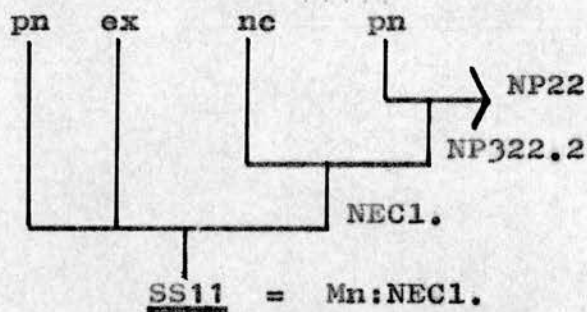
sau dengah

sound news

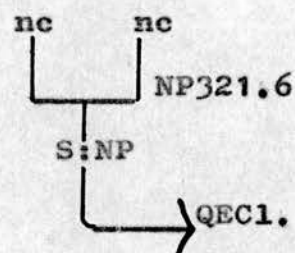
(g) a-mexou dagen kapong mupex

woman in village A+hit

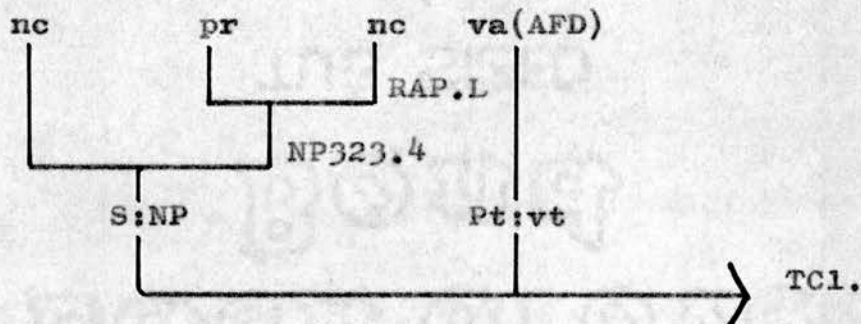
(h) ulou a matai binu' wa' kenilut

head pers die P+kill rel P+hang

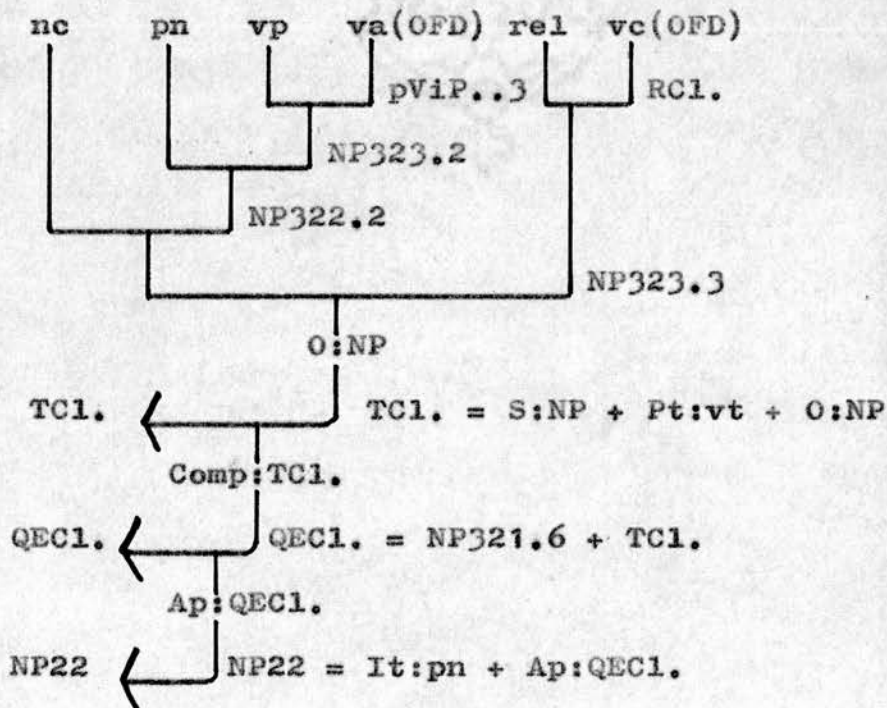

Chapter 5. STYLE

5.0 <u>Introduction</u>	438
5.1 <u>Narrative style</u>	438
5.11 Recapitulation	438
5.12 Extensibility	440
5.13 Natural explanations	444
5.14 Cultural explanations	444
5.15 Stylistic permutation of Word Order	445
5.2 <u>Didactic style</u>	447
5.21 Palei	447
5.22 Baya'	448
5.23 Social occasions	449
5.3 <u>Conversation style</u>	450
5.31 Courtly speech	451
5.32 Uba' tatau	451
5.4 <u>Ritual Poetic style</u>	452
5.41 Mu'éh Matai	452
5.42 Keman Selamet	454
5.5 <u>Individual style</u>	456

5.0 Introduction

Four formally distinct styles were distinguished in the outline description of Paragraph and Discourse levels of the grammatical hierarchy in Chapter 4; Narrative, Didactic, Ritual Poetic and Conversation. The structural skeleton inevitably imposes a certain shape onto each Discourse type, yet each of these four may be profitably examined from quite another viewpoint also concentrating not so much on the formal composition as on the richly varied content of a passage.

In the following description, for reasons of logical continuity the order of exposition is slightly different from what has gone before; Conversation will be described before Poetic style, following on from Narrative and Didactic passages.

5.1 Narrative style

The Introduction which characterises Narratives has been described at 4.51.11. It sets the stage, as it were, for the following story, very much as Longacre's dramatic analogy for clause structure suggests (1964.35). Time, place and characters are introduced in a fairly full way¹, and the action may then proceed in a formally ordered way.

5.11 Recapitulation. The language being as yet very little committed to writing, Melanau stories are handed on by rote

1. The full beginning of stories is noticeable in contrast with the very sparse introduction typical of story-telling in the more remote highland regions of Sarawak, as illustrated (Clayre 1970(a) 324) by the beginning of the Sa'ban epic of the flood, one of the common Origins stories: weh lún weh lanak, si' lei si' súel

two pers. two sibling one male one female

'There were once a brother and sister'

in common with the more formal Oral Tradition of the Melanau people. This makes it important to have ways of keeping check of the story as it proceeds, so that no important details are omitted. The literary device employed is one of extensive back reference to the preceding narrative (described at 4.41.4) which can give a passage the overlapping structure of a shingle roof. Each sentence may be composed of two halves, one recapitulating the previous sentence and the other moving the narrative forward one step. This step in turn becomes the content of the next reach backward, so that a high degree of redundancy is built into the narrative, as exemplified by the following fragment (from which the illustration of the anaphoric reference particle unei was drawn in Chapter 4)¹.

"Bagimana tuah!" sau uba' nyin sawa, "Da'ou tuah migi' lungun."
Ba' migi' lungun mah, duin in. Udah 'migi' lungun mah' in unei,
mekat duin ba' tabui migi' lungun mah ba' sawa' a 'ih unei, ba'
sawa' buké. Udah nga' tabui duin in unei, mibei den agei, mekat
a 'ih, Besiong mekat. ...

"What on earth are we thinking about!" said the wife, "We ought to fetch a coffin." They proposed to get a coffin made of gold. Having decided on that, the two of them set off to fetch a gold coffin to put this chap in, the body that was lying there. But when the two of them had gone, when they were quite out of sight, this fellow Besiong got to his feet. ...'

This degree of back-reference is by no means unusual, and may serve not only the memory of the speaker but also the listeners

1. Text 92 of the collection, recorded on Museum tape 6 G1165 - G1190. The story is in the Igan dialect, which accounts for the spelling of mah (méh) 'gold' and buké (buki) 'corpse' (cf: 2.43). The context suggests that the coffin is made of gold rather than full of gold, but both options are possible (cf: 4.21.323.1), and exploited in the fuller story "Kinah Kulum" (Clayre 1972a 67-69).

who will retell the story later. (It also helps to spin out a long tropical evening. It is hard to find any other point in the repetition of such stylised phrases as erti nyin, sau uba' nyin 'it means, as he said it' which are often distributed through a long passage without any explanation being offered to justify the erti nyin 'it means'.)

5.12 Extensibility. Many of these epic narratives appear to be almost infinitely extensible, their length being tailored to the situation in which they are told. Two popular stories are here summarised to show the kind of stock situations that, elaborated and minimally altered, may recur as often as required to fill out the essential narrative to any desired length. The Kekaput epic¹ and the very different Naga Deluh will serve for this purpose.

In the Kekaput story, the plot is simple. Kekaput and Tejali (the great Crested Hornbill of Sarawak folklore) are engaged in a quarrel as to which of them is really the greatest of the birds, who should therefore be King. Kekaput is worsted in argument and berated by all the other birds for his noisy chatter (se'ap beba') so he flies off in a sulk to an island puşed anum 'the navel of

1. T.Harrisson (1968.186ff) notes a very similar tale among the Iban of Sarawak and the Ngaju of Southern Kalimantan, each with its own particular twist. Whether this results from Inheritance from a common ancestry or Diffusion from one culture to another (Tolkein 1964.24) cannot be said with any certainty.

Kekaput cannot be identified immediately from Smythies 1960, but may well be the brown Quaker Babbler (Lord Medway, private communication) or the Indian Cuckoo Cuculus Micropterus which the Ibans call Kuang Kapong (Harrisson 1964.538). This latter name could well be shortened by the Melanau to Kekaput; it is known to rural Malays as Raja Burong, 'King of the Birds', which would appear to fit the story well at several points.

the waters'. There he prays for vengeance; and at home the rains fail, the trees do not come into new leaf or flower, there are no caterpillars or grubs for the birds to eat. Chaos. He must at all costs be persuaded to come back. One bird after another is summoned to the Tejali's presence, entrusted with the diplomatic responsibility of bringing Kekaput back, asel ba' bei rejeki singen ga' telou, 'just so long as we may have some way of staying alive'. One after another fails in the task, providing the skilled raconteur endless opportunity to indulge in playful descriptions of their boastful beginnings and feeble failures. Udah keji in, titah nyin ga' Set, set basa lalou mujun, "Ka'au udai, Set! Laju lah ka'au!" "Ja'an kawa'", sau uli mano' set in, "Kerna bei pakat kalau udai. Debei ibuh singen wa' ki' ba' juh ga' kou na'ah, asel bei tujuh madu singen." Nou agei, Set kinan inan keji in kawa', tubit batun singen palih nyin in ... Ubi nyin melep ji iba', palih nyin ketan in unei, nila' nyin ji Panit iba'. Pikér nyin, "Saji lah, kalau labi' iba' jelakau udei, generaji Panit; unou jadi lah ga' sawa kou na'ah?" Nou agei, balék nyin puli' ...

'After that, he called for the Sunbird, the sunbird with the long beak. "You must go out to sea, Sunbird, for you fly so fast." "Right-ho!" answered the sunbird, "For there is honour to the one who makes the journey. It is not necessary to give me any reward afterwards as long as there is some honey for me." At once the Sunbird set off yonder, climbing and dipping in his energetic way of flying. ... When he was quite out of sight from the ground on account of his flying so hard, he looked down and saw Shark there below. "For sure," he thought, "If I dip down just once more, I shall be sawn in half by that shark. Then what will become of my poor wife?" At once he turned back and started home ...'

Eventually the wee butterfly belebi makes the trip successfully, and persuades Kekaput to accompany him home. On the way, as many adventures are fitted in as the occasion demands, but one detail is important. There has to be an accident, to account for the Kekaput's odd limping way of waddling about on the ground when taking evasive action (one of the characteristics linking it with the Babbler family). In one of the two accounts, a marlin ikan ibul snaps at his foot as he is resting on some flotsam in the water, waiting for belebi to catch up¹.

By and by they arrive home and with due ceremony Kekaput is made King. He begins his well-known song, welcomed now instead of shunned by the other birds. The trees burst into new leaf, the flowers and fruits abound, caterpillars appear and the rains begin 'as if a bung were knocked out of the heavens'. And "that is why men always pay honour to the Kekaput when they hear him sing in the forest ..."

The tale of Naga Deluh 'The water-serpent of Deluh' is very different. It is one of the many tales of a person who turned into a creature which serve to establish the unity of the Melanau cosmos². In this story, a girl from Kanowit³ finds an egg afloat

1. In another account, Kekaput does not return but gives detailed instructions for finding his appointed successor who, still in his egg, is waiting in the one unblighted tree in the forest. During the rescue of this substitute his leg is broken while the egg is being opened... Mr Harrisson records other variations in Iban lore.

2. cf: Morris' footnote in Kaboy and Moore 1967.22

3. Kanowit, half-way up the Rejang river between the Pelagus rapids and the Delta (map 1) features in many Melanau stories concerned with their origins. The Tanjong dialect spoken in parts of the town is certainly related fairly closely to uba' likou, the Melanau of the coasts (though more closely to the Kampong Nangka dialect of Sibul).

on a clump of hyacinths at the river's edge and, against the emotional advice of her family, cooks it and eats it. Gradually (just how gradually is up to the story-teller) she turns into a water-serpent like the spirit who appears to her in a dream to explain what is going on. The people of Kanowit, warned in another vision of what they must do, make a huge raft and, with gongs and shouts and much scattering of saffron rice, set off with the Naga on a long voyage downriver to find the ideal spot to put her off into the river.

Their adventures on the way again vary according to the whim of the story teller, provided that he includes somewhere the important encounter with the stranger from Engkalili¹, himself a Tanjong Melanau who has long been exiled among the Iban of that Delta area; he takes charge of the situation and, in due time, leaves them and founds the Melanau settlement at Kampong Nangka, the present day Sibul, second city in Sarawak (and mostly occupied by Chinese businessmen). The girl is eventually dispatched to her watery home at Deluh off the mouth of the Retus River², where to this day there is a great whirlpool that must be treated with considerable respect by travellers in their small boats.

Lalu lou nyen pepela puli' jigem lou saneng lou nou ien, ...

'They then all paddled home with their gongs and whatnot, ...'

1. Engkalili is an Iban settlement in the Rejang delta.
 2. Retus is the traditional home of Tugau, the most famous of all Melanau heroes, who also sprang from an egg discovered by his foster-parents in an unlikely spot (cf: 4.31.242(2) example). His "real" mother was, according to some accounts, Raja Likou Yang, the ruler of the Underworld, always symbolised in Ngaju tradition as a great water-serpent (Schärer 1963.14). The story is by Yusup of Igan, Tape 5 R475 - R1325 of the Museum collection.

5.13 Natural Explanations. Both stories, and some hundreds more, contain an element of explanation for some natural curiosity; the Kekaput's odd walk, the whirlpool at Deluh. Why the dog, of all the animals, came to live with Man; why crocodiles, which are as big as humans and have four legs for walking on, prefer to live in the water like fish; how people learned that the inside of the sago-palm was good for eating, and that the tuba root produced a juice which poisons fish in the river. Many of these "Why-so" stories have their cultural counterparts in many other parts of the world; one has only to think of Kipling on the one hand and, closer to Melanau country, the Ngaju mythology so carefully recorded in Schärer 1963. While some occur with only minor variations among many Bornean tribes, some are of considerable value as determiners of cultural boundaries; one in this category is the Rice Myth cited in four dialects at Part 2 of Appendix 2, which serves to unite the Melanau and other sub-tribes having it in their repertoire and to delimit them from the Ibans, Kayans and Kenya who do not.

5.14 Cultural Explanations. Some of these stories contain a crisis as one of the stock situations, it may be an attack by an Iban war-party perhaps, or lack of drinking water on a sea-voyage. The sequel in each case is intervention by some creature - a fish, a turtle, a deer - and by this intervention (tipeng) the threatening disaster is averted. Then follows a dream in which the hero is shown the significance of the event, and its inevitable outcome; from then onwards the rescued man and his descendants in perpetuity, sou sikou sou silou, are forbidden (penalei) to molest the creature, or to eat it. The catalogue

of ills that will come on the person who neglects the palei is pretty well standard. Aside from a few minor ailments such as turning white round the mouth or getting cramps for weeks on end (cf: fn to 2.51.6), they always end up with the men peted lai dying violent deaths, and the women dying in child-birth.

Often such a story is linked up with a particularly rare piece of local treasure, an ancient plate or jar, or some odd shaped stones, which afterwards become objects of veneration on a par with the relics at mediaeval shrines in Europe¹. Some quite remarkable cures are claimed to have resulted from suitable ablution with water or oil stored in these jars².

A great number of anecdotes accompany these stories, linking otherwise inexplicable occurrences in the community with some infringement of one of the palei. A whole case-book of imitative magic is built up in the mind of the attentive listener.

5.15 Stylistic Permutation of Word Order. The permutation of nuclear elements in the clause string has been shown (4.31.12.203) to be a Focal device if there is a corresponding morphemic change in some of the elements involved, and an Emphatic change of order in all other cases. Thus Emphasis is seen as a stylistic gloss superposed on a clause formally structured for a given Focus.

The most usual permutation to come under this heading involves the shift of the verb to the front of the string in a clause not marked for Verb Focus. This is described (4.31.11.3) for Intransitive clauses, with or without the emphatic particle lah; more interesting is the same permutation in an Object Focussed clause,

1. Kaboy and Moore 1967 contains several such accounts, eg: 19-22.
2. "Magic Oil" and "Saban Kuyad" in Clayre 1971a 42,166.

in which the verb comes first and the Direct Object is permuted to a position following the Agent.

eg: (1) lalu nibet luin lasong in dagen likou
then P+throw they mortar that in river

'Then they pitched the rice-pounding mortar out into the river'

(2) nexut nyin tumek in kuman dawek ane' raja
P+extract he spear that from side child ruler

'He pulled the barbed spear-head out from the princess' side'

In their contexts, (1) follows immediately from a discussion by the people of Mudan as to what they ought to do with the old, cracked rice-mortar lasong; it may therefore be seen as an application of the general principle of serial clauses (4.32.25), with a strict application of the 'last nominal' rule even when that is represented in the foregoing clause by no more than the very general pronoun win 'it' as part of a quoted complement (4.41.2131)

(2), on the other hand, is separated from the last mention of the spear-head by a considerable stretch of narrative, in which the young hero Besiong gets rid of all the courtiers and goes in alone to the bed-chamber of the wounded princess ane' raja. The Object Focus arrangement of the clause cannot be accounted for in the same formal way as that of (1). All that can be said is that the spear-head tumek is still the focal point of the story; with it Besiong wounded the pig that turned into the beautiful princess who is to be his bride, without it he cannot return to face the mighty Tugau who lent it to him, his real father-in-law whom he is quitting for this bewitching girl. It is the object which unites the world of Faërie¹ with that ordained for mortals,

1. Tolkein 1964.16 passim

and as such it is the Narrative Focus which, in such circumstances, appears able to over-ride the well-formulated rules of clause-level focal organisation.

This is not, perhaps, a very satisfying explanation, relying as it does on para-linguistic elements of the Discourse rather than on the analysable hardware of formal clause elements. It may well be that much of Discourse analysis must remain formally unsatisfying just as long as only the hardware qualifies for serious consideration as the proper material of study.

A further parameter, equally difficult to treat in any very formal way, is that of Individual style. In the story from which (2) is taken, there are more examples of this permuted structure than in most other texts. The narrator of the Sekapan Rice-myth (Appendix 2.2) is seen to favour the same device at many points in his narrative where there is no 'last nominal' to follow on from. However much it may depend on the individual taste of the speaker, the permutation from unmarked OPDynamic word-order to this style is clearly tolerated in the grammar, and must be accounted for in a formal way in some more detailed treatment at a later stage of the study of Melanau along with other Bornean languages.

5.2 Didactic Style

The palei legends verge onto the ground of didactic oratory, for it is important that they should be properly observed if lawa' (4.61) is to be averted, puni' (4.51.12(2)) avoided.

5.21 Palei. There are many wrong ways and generally one right way of doing almost anything in the private or communal life of the Melanau. One may not eat out of a pot lid or off the end of a

wooden ladle, lest one's best efforts be covered over by shame and one's friends keep their distance (as with a bargepole). One may not give a child the delicious flesh of aam the anteater or tenga'ou the soft-shelled river turtle, lest it curl up or shrink into a corner when rebuked. There are palei about building houses and there are palei about dismantling them¹, containing long and involved explanations of the custom of hammering a nail into the base of an upright support and of covering its top with a red, a white and a black cloth before adding the cross-beam. Each of these must be known in detail so that it may be observed in detail, and the formulae are learned from the old and wise.

5.22 Baya' are another rich lode of didactic lore, the rules of augury whereby the flight or calls of birds is studied (by the cognoscenti) for its predictive power before any important event. It becomes immensely important to distinguish silam pu'un from semuah kana ki', a single call from one's right-hand side from all other bird sounds. Each chirrup has a different message, but the most common ingredient in them is ka' menyurong 'Go no further!' Mano' 'ok the owl tells of death in the family, mano' kutit warns of general disaster to loggers or hunters; even the humble house-lizard penga'ed (the chichak) warns a traveller of impending peril if it "sneezes" in front of him as he leaves the house and proceeds heedless of the message from the spirits.

The accounts of these beliefs are crammed full of detail, and he is a clever man who can make his way through the twistings and turnings of 'two chirrups on the right followed by one on the left'

1. Some of these are described in "The House at Ipu' Corner" in Clayre 1971(a) 199-201. I am indebted to Vincent Kiri of Medong for his help in collecting much data on this topic.

without losing his sense of direction altogether. But then, the Melanau are adept at direction finding in the contorted waterways of their delta habitat.

5.23 Social Occasions. The Melanau belong to that central belt of Bornean tribes whose society is strictly stratified into ranks or basa.¹ Social occasions provide ample opportunity for the reinforcement of these differentials by the strict observance of an established code of practice. Ta'iah² from Kekan is one expert in aristocratic procedure to whom others refer for points of detail, and her account of the procedure to be followed in a correct betrothal and wedding is typical of the genre of didactic oral literature. It maintains its strict procedural pattern by using the overlapping style of much Narrative, underlining by its back-reference the correctness of doing everything decently and in order.

...Jadi sukup sapai ga' labi' tipuh seta'un, kedua berudéng ba' pekerja, mengawin ane' kedua in jigem a bei ane' buya' telabau ka'au. Sudah nga' betul jigem pekat, betul jigem rudéng kedua, 'ih bulan ba' kawin. Sudah nga' kawin, tunang 'ih teruyh petunang, nyadin "penyekab". Ka'au tujuh jebe' pedeng pamur ...

'...Well now, when the agreed period of one year is up, the two of you must take counsel how to arrange to work it all out, how to set forward the marriage of your child with the person whose child you have requested in marriage. When your discussion has

-
1. Or bangsa, the full Malay cognate often used in this context.
 2. The account of betrothal procedure is recorded on Museum tape 8 G003 - G192 as Text 78 in the collection. I wish to express my gratitude here to Ta'iah for all her encouragement during the year I spent on the Oya river; her recent death is a sad loss to the community there.

been settled to your satisfaction, in accord with your own thoughts on the matter, this is the month for the wedding. After the wedding, this fiancée is still only affianced; then comes the "penyekab"¹. You hand over one damascened sword ...'

Betrothals and weddings are also occasions for pukih², a style of astringent wit much prized among cultured Melanau. The talk favours the use of simile³ and all kinds of esoteric effloration to the ordinary styles of speech. There are jars known as dipen 'slave', because they now replace the slave who was once included in the dowry of any self-respecting groom. There are brass canons called lapong 'the volcano (Krakatoa)', though it is seventy years since that eruption startled far-off Sarawak and longer still since these ornate firearms made their puny imitation of its fury. Imperceptibly, once the rigid formalities have been attended to, language lapses into more relaxed forms.

5.3 Conversation Style

The ornate ceremonial of these occasions calls for ornate speech, and several different styles are appropriate to different occasions, all somewhat formalised above the level of day-to-day conversation on mundane matters such as were described sketchily at 4.52.4 above.

1: "penyekab" is not a Melanau word, and appears to derive from a Malay root *sekab which cannot be identified. It is token that the doors are now open, the young couple may consort together as man and wife without further restraint.

2. cf: Clayre 1972(a) 3-6

3. The Simile Formula is described at 4.31.12.134

5.31 Courtly Speech. The proper procedure of menelabau 'seeking a betrothal' is conducted in an indirect manner by go-betweenes, wakil who represent the interest of at least one of the parties to the agreement. It is considered appropriate to make use of a pretty metaphor rather than outright businesslike talk.

...Jadi sau uli a tina Tugau, "Bei kawa' lakau kou 'ih. Ane' kou Tugau bei peden sekutum bunga dagen kebun Raja. Akou 'ih benada' ane' kou ba' mapun ka'au, sebab ane' kou in unei suka ateng ba' mupox bunga in." A raja in paut menyenunu singen. Béh in sau nyin, "Akou debei lah kenah ba' jemawap dagen segera, ..."¹

'Then Tugau's mother answered, "There is indeed a reason for my coming. My son Tugau has noticed a flower-bud in the Raja's garden. I am bidden by my son to approach you like this, for my son is very anxious to pluck that flower." The ruler sat a long time deep in thought. Then he said, "I cannot give you an answer outright, ..."

The story continues with a series of proving tests set by the ruler, to try the mettle of the young man to whom he will give his daughter in marriage, much after the style of many mythologies the world over.

5.32 Uba' Tatau belong to another occasion calling for protracted conversation of a semi-ritual nature, the funeral wake. This was traditionally a three-night vigil kept in the house of the dead person. Young men and unmarried girls (lou jemelai jigem teluéh) formed two teams and, aided by their elders, asked uba' tatau or riddles of each other through the small hours. The introduction

1. Recounted by Arip Dina of Dalat, from the collection made by H.S.Morris and Tuton Kaboy in Medong on the Oya about 1964.

formula for these has been given (US24, as 4.42.34) and a typical riddle (perhaps predictable in the circumstances) is:

"Ane' Raja Kina: A mena' debei peba',
A peba' debei peden;
Wa' nou lah in?" "Lungun"

'Child of the Chinese Emperor (ie. an artefact)
 He who makes it doesn't use it,
 He who uses it doesn't see it;
 What is this thing?' 'A coffin'

The other stylised language form from the funeral wake is the dirge u'éh, which takes the description into the realm of Ritual Poetry. Both these artistic forms are now almost defunct.

5.4 Ritual Poetic Style

Two kinds are described, the u'éh lament and the keman selamat invocation (which has already been touched on in the outline of Kaul poetry given at 4.51.13 above).

5.41 Mu'éh Matai. To lament the dead is one of the duties of the relicts, and professional wailers are still to be found among the Melanau¹. In Sungai 'Ud, a tradition-honouring settlement off the main stream of modern affairs in the 'Ud side-river at Dalat (Map 2), the retired Headman Sinu' still remembers huge sections of the great Mu'éh Rejang which is at once a lament, a folk epic and a genealogical record². It contains much Melanau

1. cf: Newington 1961.106 "I remember how these ladies sat astride the coffin which had been dug up, and rent the heavens with their moaning, weeping and screaming and scrabbling at the coffin-lid with their nails until their fingers were raw and they had to be carried away to recover..."

2. Some communities entrust these records to an official whose business it is to remember them. Even when he is way past accurate memory, he is paraded out on special occasions to go through his

lore, but in an archaic language now little understood even by those who claim to recall the words accurately. It sets the pattern for all lesser private u'éh, laments for an individual.

These, then, conform to type. The dead man's qualities are lauded, he is told how much he is missed by those left behind in penury and distress, and finally given directions for the passage of his soul (if that is how we ought to understand the word bedua which, by its composition of: *peduah 'to be two, to have a double', appears to mean very much the same as the German Doppelgänger, a notion found in Malay magic also) to the likou matai 'the land (or river) of the dead'. There he will be at peace, and not be tempted to wander back to disturb the courageous struggling-on of those so cruelly left behind.³

"... Giin lah kedau ka'au diem.

Ka' bedua ka'au muau, in lah kedau ka'au.

Tipou ka'au, Lai, nisu' ka'au, paut ka'au bei nga' nu'éh.

Nisu' lah ka'au kubou 'ih,

In lah kedau tama' ka'au susah naseng,

Ida' kenang manyit sau, kubou nisu', tabui ka'au. ..."

(2 continued) ritual recitation, until so fatigued that some younger understudy may take over without offence being given to honoured age. Such a remembrancer was Aké Bu'au of the Kejaman house Rumah Lasah included in the survey trip referred to in Appendix 2 (see Map 3); we were much obliged to his companion Aké Inya, a sprightly supporter of the official record-keeper, for a coherent account of the old man's chant when he had stopped.

3. This represents a modern Melanau rendering on the ancient version, collected at 'Ud by Morris and Kaboy in 1963. The lament is for a young man Lai, who died in his twenties before two of his older generations, a most improper occurrence.

'... There is the place where you now dwell.

Let not your soul be distressed; seek consolation,
For that is now indeed your rest, your habitation.

Lai, your grandfather and grandmother are left forlorn
While you are mourned; by day and night they mourn.

Desolate is your home, empty. Without his son
Your father's heart is heavy, torn between
His many memories, so sharp and keen,

And the house seems abandoned now that you are gone.'

5.42 Keman Selamat, the ritual meal of friendship, is an integral part of Melanau community life, as indeed it is of almost all the tribes-people of Borneo. It is initiated by an incantation to the spirits, much after the style of the great Kaul chant outlined at 4.52.3, but smaller, as private u'éh are smaller than the great Mu'éh Rejang. One recorded at Kut contains only two verses¹.

Keman ipu', Keman ramai, keman usai,
keman xia, keman sama.
Wa' lakei, wa' lumei,
tutun mapun serta semuah.
Wa' umit, wa' utit,
wa' ipah, wa' dayeh,
Wa' aju', wa' aba',
tutun rata, tutun segera.

Keman telou. Menyabi' umor, menyabi' selamat
apah biéh kamei agei,
Menyabi' jereki murah
Kuman sou sikou na'ah
labi' sou silou junih.

1. Recited by Uchang Tong of Kampong Kut at the Kaul December 1970

'Come spirits and eat!

Crowd into our hall, there's plenty for all;
 Be you aged or elfin, don't wait for a call
 From your river or jungle. There's no-one too small,
 From upstream and downstream, come one and come all.

Come now to our treat!

We ask for long life, we ask for good health,
 For peace from all strife, and easy-won wealth.
 For our grandchildren's children we make this request;
 May all who shall follow them also be blessed.'

The free translation attempts to convey some of the way in which rhymes are sought not only for their euphony, but also for their semantic balance¹. ramai is a crowd gathered together for a festive occasion, usai (or ucai) speaks of moving together in accord with a single purpose; ipah is simply the far side of the river, dayeh the reverse direction (3.33.12.1), back away from the river into the trees. And so on. In the longer versions a great play is made on parts of the riverside and house where the sprites ipu' might be found lurking, from which it is wise to invite them in to the festivity lest they feel snubbed and so malicious. Sometimes one is tempted to suspect that the rhyming names are so close to being synonyms that they are no more than metric padding. (In one incantation over some magic oil, the a bayuh actually resorts to da-da-da where the proper words elude his memory, but the meter must be preserved.) A skilled performer can go on for upwards of ten minutes, improvising these rhymes round a formalised core as he scatters the yellow rice on the assembled people and their votive offerings.

1. One is reminded of similar Hebrew parallelism such as that of Psalm 24.7 "Lift up your heads, oh ye gates,

And be ye lifted up, ye everlasting doors..."

Euphony is clearly one of the requirements of this style, and the last two reduplicated forms of 3.32.521 are from such an invocation intended to obtain, among other things, plentiful game in the forests surrounding the village of Medong (Map 1) by the intervention of these ipu' in the villagers' interest.

5.5 Individual style.

All these observations provide no more than an account of the framework upon which one who ta'ou kerapek, who is skilled in speech and has a way with words, can build up his own style and reputation as an individual to be reckoned with at gatherings of a jovial or an altercations kind.

In the whole district surrounding Dalat there is probably no match now in straight story-telling for the young logger Ramli Bandung of Kekan who, though he mixes Malay (and even the content of films he has seen) into his traditional tales, yet has control of a vocabulary far beyond that of most of his contemporaries. His stories are specially rich in metaphor; from mubex jala 'to cast a fishing-net' comes the nominal bebex 'a casting', and hence jebebex 'the moment between casting the net and its striking the water' which corresponds to 'in the twinkling of an eye'. Ramli uses many more reduplicated forms than others, to the delight of his audiences. He also employs the short narrative Verb Focus clauses (4.31.12.21.133), reducing the fully-identified (but cumbersome) clause:

lalu temaru in metug dalid kayou péh in unei (AFDyn)

'then the rhinoceros kicked the buttress-root of the manggeris tree (that we have been talking about)'

to: tug nyin 'so he kicked it!', relying on the context of his

story to fill in the missing detail.

This parsimony of words can, however, be balanced by a rounded simile, for he is not naturally an economist in such matters as descriptive detail.

juu' mata nyin sama alah manék labu' kuman talei lah tan
'her tears fell like pearls from a broken necklace'

Nor is Ramli out of touch with the ancient culture from which his tradition descends; his tales are full of old words and allusions to bygone customs which he has to explain to many of his better educated young listeners. From one of his accounts of the exploits of Jilag¹ we get reference to an outmoded way of telling the time of day:

Debei nga' lasu' bati, luin labi' bah inan utu ga'ih Jilag.
(Lasu' bati, sau uba' telou lian 'ih kalau ba' kira alah tan
pukul ayan. 'Ih sebab awel su, buya' selau, bati in lasu',
jadi den nyin pemun ...) Udah keji in, lalu ...

'Not yet "Heat on the landing-stage", they arrived at the far end of the trail Jilag had blazed. ("Heat on the landing-stage" we call nowadays about eight o'clock. This is because in the early morning sunshine the landing-stage warms up and, as it gets hotter, you can see it steaming...) Well now, after that, ...'

and many other details of Melanau life otherwise inaccessible to most modern educated or urban Melanau.

This expertise as a raconteur does not confer on him the status needed for the gathering of a-nyat (cf: 1.13) but it is to be hoped that he will attract a wider forum of attention than the strictly local situation in which he is known at present. For

1. Recorded as Tape 3 R875 - 4 G325 in the Museum collection of Melanau folk-lore.

many lament the passing of Sakul¹ as the end of an era of Melanau verbal excellence which, with the advent of modern communications in the National language and outside entertainment on radio and films, Melanau story receives as a death-blow. It would be an enormous loss to the cultural heritage on an emergent Nation if that were to happen; there is a living dynamism about the folklore in the mother-tongues that survives long after a common language has spread over the whole people. The search to recover what is once lightly swept away is an arduous (and un-necessary) labour.

1. Sakul, tua kampong of Medong, was the best known of Melanau raconteurs of recent times. He died about 1968.

Chapter 6.SEMANTICS

6.0 <u>Introduction</u>	460
6.1 <u>Likou</u>	460
6.11 Off the likou	464
6.2 <u>Colour</u>	466
6.21 Primary Colour terms	466
6.22 Secondary terms	467
6.3 <u>Living Things</u>	469
6.31 Regular categories	470
6.32 Problem creatures	472
6.33 Metaphor	475

6.0 Introduction

The detailed study of Melanau semantics must await a less crowded occasion than a grammatical description of the language as a whole. Three areas only will receive attention here, since they seem to be of particular importance; the meaning of likou in the Melanau scheme of things, the colour system and the categorisation of living creatures.

6.1 Likou

The notion of likou 'the Main River' (called batang in the Malayan tradition adopted in the naming of geographical features on all available maps, as eg: Batang Rejang, Batang Kayan) has been shown to be pivotal to all Melanau directions (3.33.12.1) and, one suspects, to much of their orientation to the world about them. Into likou flow tributary sungai, which rise at a source 'ud in the high (or, in much Melanau country, minimally higher) ground saxap separating one river system from another. Small creeks li'i do not contribute to the water flow, though irrigation ditches parit channel much land water off the sago gardens and plantations into the likou. On occasions these may be dammed up, nesen, ka' anum puli' mapun likou 'so that the water shall not get away to the main river'. The natural current uut is employed to float the rafts of logs or sago baulks pegged together into a semblance of the original palm, felled inland and dragged or rolled to the bank of likou, down to the mills for processing. Here they are dragged up onto dry land to be stripped of their bark (sago bark xatai is an excellent fuel when dry, and provides a basic matting material for constructing pathways, wharves and the great sago drying floors)

and then treated in appropriate ways. While men handle the logs of timber, dragging the sago baulks about and stripping them is women's work, hence:

a mexou medag jetek balau bawai kuman dagen likou

'women drag a baulk of sago-palm up onto dry land from the river'

Such a sentence would be unacceptable in the context of a mill situated on a side-stream or creek, like that belonging to 'tua kampong' Ijo of Dalat dunguyh (that part on the inside of the big bend below the bazaar; takex is the outside of bends on the likou); the water there is anum sungai or anum li'i, and there would be no reference to likou in the directional reference of medag 'to drag onto dry land'.

The primary reference of likou, then, is the Main River that drains to the sea at a kala (see diagram at 3.33.12); it stretches from a region aju 'upriver' to aba 'downriver'. In this context, likou forms a set of oppositions with sungai 'tributary stream' kala 'estuary' and daat 'open sea'.

Since Melanau villages are built along the river-banks (and to a lesser degree on tributaries, such as Kapong Sungai 'Ud at Dalat and Kapong Jebungan on the Mukah) likou Daled becomes a suitable term for 'the habitation at Dalat' as well as for the portion of the River that flows past the congregation of houses and jetties there. likou now takes the added meaning of 'that part of the country which is inhabited', in opposition to 'that part of the river-banks in between habitations' kenuou (very much like the Hebrew 'wilderness'), which is a tangle of undergrowth unsuitable at present for farming or building on.

It is only a step from here to likou as the village itself, so that a traveller labi' likou 'comes home' to where his home is, his permanent dwelling rather than any lepau or farm hut he may maintain in the sago gardens. In this portion of its total meaning, likou is a stem for verb affixation (3.32.31.23.211); melikou means something very close to 'colonise', and pelikou the stative equivalent form may be glossed 'to be a permanent resident at, to have a home' in opposition to such less permanent accommodation in which one might be pelepau¹. This contrast is made explicit in a story of the progressive development of one of the more distant Melanau colonies, at Tanjong Datu,²:

... Paut paut luin nga' pelepau giin, luin pun berasa ja'an tan, luin mupo' mena' kubou ateng serta pelikou ga' giin. ...

'When they had been in camp there for a long time, they felt secure and so by degrees they made proper dwelling-houses and settled down there for good.'

Not only are the Main Rivers themselves designated likou Uya', likou Mukah and so on, but the people who live there are also the likou Mukah or whatever it may be, 'the inhabitants of Mukah'. So a sentence such as:

sabei si'iu, likou Mudan ramai ateng
ago before LIKOU Mudan be-crowded true

is ambiguous between readings 'Long ago, Mudan was a populous place'

1. pelepau can also be in opposition to pekubou 'having/being in a proper house', which is very close to the meaning of pelikou.
2. Text 21, lines 14,15 in the Sarawak Museum collection; dictated by Austen Druce of Kampong Nangka, Sibu, a man of consequence in Melanau affairs. Tanjong Dato is on the Indonesian border of the 1st Division of Sarawak, 100 miles to the South West, and still boasts a hill called Gunong Melanau.

and 'Long ago, the people of Mudan were a great crowd'. In the event it makes little difference.

A-likou 'the River people' is the Melanau's own name for themselves¹. The extension of likou beyond the confines of the river itself to include the inhabited land round the village - in which case likou is in opposition to such terms guun 'the forest' and talun 'the tanglewood, jungle', oppositions which are exploited in the keman selamat extensions (cf: 5.42) - and thence to the residents in it, allows the understanding of likou Sarawak as

- (1) The Sarawak River
- (2) Kuching, the capital (on that river)
- (3) The Country called Sarawak

and (4) The people of Sarawak .

likou Malaysia is thus the Nation, Malaysia.

But within the Nation, as a microcosm of its many divisions contributing to a remarkable varied unity, the Melanau tribe has three large religious communities, each with distinctive customs that make them recognisably distinct social groups. There are the Muslims a-selem (often called Malays regardless of their true tribal affinity, a source of continual perplexity to census-board officials and ethnographers), a-sebiang 'those who pray' the Christians (in the Melanau area almost exclusively Roman Catholic) and lastly, at the inner core, a-likou likou, the Melanau *crème de la crème*, those who still adhere to their old religions system, an

1. In this naming, the Melanau must be seen as very like the Murut and Kelabit peoples of much further North (and inland), who call themselves lun dayeh 'the inland people' and lun bawang 'the hill people'. The name Land Dayak would appear to be of similar origin; Mr Druce claims it to be so in the story cited above, line 24.

animistic tradition of alternately cringing before the tou and ipu', spirits and sprites which invest every aspect of life with spiritual significance and nyawa¹, and shamelessly manipulating their goodwill for one's own ends (as seen in the invocations cited at 5.42 and elsewhere).

6.11 Off the likou. Once a traveller departs from the likou, by a tributary sungai, by land or by sea, he is no longer aligned with the axis aju' - aba' which, following every twist and turn of the River, provides a constantly tangential direction upriver and downriver from which all other directions take their bearings. At sea (3.33.12.4) the principal axes are alud - dayeh (or udai - jangai) and wab - la'an, with reference to the winds (pangai daat 'wind from the sea' and pangai selatan 'off-shore wind') and to the sun (mata lau musit 'sunrise' and mata lau matai 'sunset') as auxiliaries. On land, the flow of small streams is examined so that the direction to the likou may be determined; these are sometimes not visible, and then the detritus piled against one side of a tree bole will show from which direction the last flood waters receded. Lichens and other tell-tale signs known to woodsmen the world over are studied as supplementary direction aids and indicators.

In the estuary kala, or in the swamps of the delta, there are often small streams interconnecting bigger ones. Some, like the Kut canal (Map 2) actually link two rivers having the status of likou, in this case the Oya and the Igan. A traveller paddling

1. H.S.Morris (1953 and forthcoming) associates nyawa with the Malay notion of semangat 'life force', after Skeat. Opinions differ as to what possesses nyawa and what (if anything) does not.

into the Sungai Kut from the Oya end at Kekan is therefore at systematic rightangles to the main directional axis of the River, and so is unequivocally pepela jangai, 'paddling away from the likou inland'. But so is another man entering the Kut from the other end at Kut village on the Igan, six miles away to the West. As long as they confine their movements to the region of the houses and fruit gardens that congregate near either end of the waterway, there is no confusion. In the mid-reaches, however, they have opportunity of colliding head-on while, as far as the language is concerned, both are going in the same direction.

The problem is resolved (again, only as far as the language is concerned; actual collisions are not infrequent and, with the advent of high-powered engines, sometimes fatal) in the region of the Sumatran settlement of Kut Tengah half-way, by resorting to the sea-going terminology wab 'up the coast' indicating the Oya direction, and la'an 'down the coast' towards the Igan River. wab - la'an thus refers to travel between the two main rivers (and, presumably, other river pairs), as has been noted in several illustrative excerpts (see eg: 4.51.31(2)). All the time, however, to travel inland by a li'i or on foot to visit a sago-garden, an orchard (like the one in the story of 'The Brothers at Sungai Lebu') or to go hunting on the sea-ward side of the canal is without question to kaba', while on the inland side one must kaju' away from the stream. The Basic Space Frame (3.33.12.1) obtains wherever possible, and always with reference to the likou as its datum even when it is not quite clear which likou is meant.

6.2 Colour

Another specialised area investigated was that of colour terminology¹. The result shows that there is a set of terms which may with some justification be called the Primary colour terms, names for colours without any further modification or qualification. Just colours. After these come two different secondary sets of colour terms, both derivative; one cites a primary colour and adds post-Head modification (cf: 4.21.32), the other consists of descriptive and metaphorical names for colours. All together form a substitution set of colour terms (represented by col. in the syntactic description), belonging to the verbclass ovs, which may be used adjectivally or predicatively in clauses.

6.21 Primary Colour Terms are as defined above (without reference to the hues often called 'primary colours' for one reason or another; they are not, however, greatly different from them).

These words are found to be in common use among men and women of all ages, and there was considerable consensus of opinion as to which of the panels on the colour chart represented the 'best' example of each colour.

<u>bilem</u>	'black'	(cf: Malay <u>hitam</u>)
<u>puti</u>	'white'	(" " <u>puteh</u>)
<u>se</u>	'red' (<u>sak</u> in 'Ud, Medong)	(" " <u>merah</u>)
<u>biru</u>	'blue'	(" " <u>biru</u>)
<u>kunéng</u>	'yellow'	(" " <u>kuning</u>)
<u>gadong</u>	'green'	(" " <u>hijau / gadong</u>)

1. At the request of Dr R. Wales of the University of Edinburgh Department of Behavioural Psychology. A standard chart such as that in Berlin and Kay 1969 was used, and a method of enquiry similar to that described for both naming the colours and for choosing the 'best' representative of each.

Beyond these colours, two more are found in regular use, but with far less convincing placement of 'the best sample' on the standard chart; both are closely related to Malay names.

kaléh 'pink - mauve' (cf: Malay kalas)
ungu 'purple' (" " ungu)

kaléh was usually associated with the floating hyacinth sapaxo' (also known as bunga Lawrence); but since this flower varies a lot between lilac and mauve (neither term very specific in the usage of most English-speaking people) it is not easy to identify the colour formally. kaléh is that kind of colour; se' is not.

6.22 Secondary terms supplement the primary system. The primary colours (all of which were accorded norms well down on the 'dark' intensity scale) may be qualified by muda' 'pale' and tu'a 'dark' exactly as in Malay colour terminology¹.

eg: (1) se' muda' 'pale red = (various shades of) pink'

The qualification may also be descriptive, such as that which distinguishes the pale green shades of blue as

(2) biru' laut 'sea blue = pale turquoise'.

Again, it will be noticed, the qualifying word is Malay, not daat 'the sea' as in regular Melanau speech. The difference between an English understanding of marine blue and this 'sea blue' is most likely accounted for by the shallow coastal water with which many Melanaus are acquainted. Not all venture far from home in open boats as Jilag and his companions used to do.

All primary terms may be qualified by reduplication (3.132) of the reformation type, which adds an '-ish' component to the basic

1. cf: Malay muda 'young, pale of colour', tua 'old, dark of colour' as in merah tua 'dark brown, deep red' (as dried blood)

colour term: kuna - kunéng 'yellowish'
bila - bilem 'very dark, blackish'

so that peaty water, such as the swamp-spring water collected (by women, cf: 4.31.11.2219(1)) for drinking, is described as (3) wa' se' se' ji, bila - bilem 'that which is a deep dark red'¹

A further stage removed again from the simple colour names is cukulet 'deep brown', used more by the younger folk. Beyond this again are other metaphorical terms, all appearing to be of fairly direct Malay origin.

eg: (4) pecah telur 'break eggs' - a pale ochre

(5) utek udang 'prawns' brains' - deep pink to orange.

It is not at all obvious why these terms are preserved in Malay, with no more alteration than the customary shift of vowel quality (2.0 on the "short a"). A similar predilection for Malay words is a characteristic of much Melanau magic muttering.²

Many women were able to name other shades of colour, often with recourse to flowers or the sky or some other external referent to aid their description. It is not possible at present to say how widely used are these last terms, beyond noting that only the three cited above evoked an immediate response from all the women asked to locate them on the chart.

1. Critical to the whole point of the ikan udun story, to which passing reference has been made at 6.317 below, this brackish water is always meant in the use of the verb mekan 'fetch water'

2. This fact is noted in Clayre 1972(a)5 and 51; it is a fact that all up the lower reaches of Sarawak's rivers, Malay medicine-sellers practice a sort of rough magic in the bazaars, and perhaps this is the origin of the Melanau's interest in these terms which have then been adopted as more efficacious than their own meng.

6.3 Living Things

One of the objects of the study of Melanau dialects¹ was to discover the categorial divisions of the Natural World maintained in the language and thus, it was hoped, to gain an insight into the world-view of Melanau thought. One avenue of exploration was the systematic oppositions worked into Ritual Poetry, especially into the great Kaul incantations (4.51.13, 5.42 &c:). Thus where, in order to gain a rhyme with a semantic parallel in it, the officiating "priest" calls on ... tou guun, tou talun,

tou kayou, tou padou, ..., one sees beyond the barest lexical meaning of the words chosen, to a fuller reading of the balance of ideas locked into the rather trite rhyming, and finds neatly balanced oppositions of thought:

'spirits of the tall forest (not yet felled for farming),
 spirits of the tanglewood (overgrowing old cultivation),
 spirits of the tall trees (which must be felled to make farms),
 spirits of the weeds (which must be thereafter cleared away while the farm is in use) ...'

As an introduction to artistic thought this is productive, but of limited usefulness for the purpose of studying the world categories as planned.

A less poetic but more direct way of enquiry was to ask the people quite simply into what basa or 'family group' they would place any recognised species of creature, flower or plant. When

1. On behalf of the Department of Anthropology of the London School of Economics and Political Science, in whose interest (see Introduction) the study was undertaken. One of Dr Morris' main interests is the way in which cultures cope with boundaries both "real" and "imagined", and the ritual protection needed when crossing them.

a sufficient inventory of these categorial terms was built up, it was then most interesting to ask children of a school¹ to name as many members of each basa as they could and, if there were any substantial disagreement over any, to find out the distinctive criteria that were at issue in the discussion.

6.31 Regular Categories. It has been noted at 4.21.321.2 that many natural objects (whether 'living' or not in Western ideas) are specified in the grammar at two levels; the complex name has a categorial superordinate (peted) term with post-Head specific naming, giving NP321.2 structure. Typical of these names for class items are the names of the larger flora, such as:

.311 Trees: kayou jita' 'wood balsa, balsawood tree'
kayou nuno' 'parasite fig tree'²
kayou péh 'manggeris tree'

.312 Fruits: bua' dian 'fruit durian, durian'
bua' balek 'bananas'³
bua' pisang 'pineapple'

.313 Tubers: ubei badong 'tuber shop-boat, tapioca'
ubei bukou 'yam'

(but not, however, gexawat 'vine-potato' which, of a kind with the others, is not classed as ubei group)

1. The upper class of St Bernards preparatory school, Dalat, were the collective informants in this test, by the kind co-operation of Fr Julij the supervisor and Mr Arip Dina the headmaster.

2. Many, but by no means all, the trees have been identified by reference to Anderson 1964.18-25. Most flowers and fruits remain unidentified in scientific terminology. The nuno' features in an apt (if unkind) metaphor sua' nuno' 'borrowing like a parasite-fig tree', applied to the relatives who cluster round anyone who acquires advancement or financial success and 'bleed him dry'.

3. Also used as a sobriquet for the anatomical heart.

6.314 Edible sprouts are of several subclasses exemplified by:

xebu bulu' 'bamboo shoots' from a corm
tajo' balau 'sago sprouts' from the bole
ja'et sepaxo' 'new hyacinth-leaf tips'
pakou nyexam 'nyexam-fern tips'

.315 Edible fungus: kulat belabau 'rat fungus', a small white growth (like rat-ears) growing on trees.

kulat tana' 'earth fungus, mushrooms'

.....

and so on. None of these, however, proved as interesting as the peted (or basa) into which living creatures were classified.

These are as a set counted with apah (3.31.11.2212), and among them are:

.316 Birds: mano' tejali 'bird hornbill, the crested hornbill
mano' set 'the sunbird (family)' (cf: 5.12)
mano' tepasi' 'kingfishers'
mano' kenyiu 'hawks (various)',¹

...some of which have been given a plural gloss because they are themselves superordinate terms, within which classification greater degrees of identification are possible.

.317 Fishes: ikan butel 'the puffer-fish'
ikan ibul 'the marlin'
ikan tekili' 'fresh-water eel'
ikan udun ' ? , a small black fresh-water fish palei to many Melanau',²

... in which no overt classification is made distinguishing ikan likou, ikan sungai or even ikan guun (if, like tekili' and udun they inhabit inland water) from sea fish, ikan daat.

1. Used also as name for the kites which Melanau children fly.⁵⁰

2. The ikan udun story cited in part at 4.32.24 (and fully at Clayre 1970a 348-9) turns on the fact that ikan udun only live in anum guun 'forest (ie. inland) water' which may then be drunk.

- 6.318 Snails: si' baben 'snail brooch, large garden snail'
si' tirem 'barnacles'
si' tu'ai 'edible clam'
- .319 Snakes: dipa ulah 'snake cobra, cobra'¹
dipa depu 'the short python' -(one of the creatures
of fun in Melanau animal stories)
dipa penganen 'reticulated python'

There are also other categories, but these will serve to outline the concept of categories, and point up a few of the more interesting problems that result from an enquiry of this nature, a pursuit to which few local people appear to direct their mind in the normal course of events.

6.32 Problem creatures begin to appear when one enquires into the criteria by which these many beasts are assigned to one class rather than to another. With many there is no difficulty. It is obvious to everyone that ikan panit is a shark fish; it looks like a fish and it behaves like a fish - except in its tiresome penchant for eating people, which is exactly counter to the way in which fish are usually recognised, as is shown below. Not quite so fish-like is ikan paai (or ikan paf) the manta ray, whose tough upper skin is used by coastal carpenters for sandpaper; yet it swims in the sea, and ikan it is.

Possibly because of its appearance which, while hard as any other crustacean, is yet very like a small paai, is the king crab ikan belakih; this is also categorised by its name as a fish. But

1. It is interesting to note the small shifts in meaning across related language and dialect boundaries. ular is Malay 'snake' of all varieties (cf: ulah the specific for 'cobra'), while in the Tanjong dialect (cf: fn at 5.12 on p442) the superordinate term is penganen, here specific for 'python'.

the humble mud-skipper¹, for all it lives in the sea (much of the time) and has fins (on which it appears also to shuffle along quite well on land or logs) and a tail like fishes, is simply beletika'; it is not eaten, they say, and 'fish' are edible. Some, it is true, like ikan kex (a kind of small conger-eel), are liable to do considerable damage to the eater; others such as ikan belusu' are so like humans with their long eyelashes and odd moaning sound that they are palei, complete (like all self-respecting palei) with a story of how someone's ancestor turned into an ikan belusu' and gave strict instructions to his future descendants sou sikou sou silou ka' lauyh keman ikan belusu'.² But they are potential food, and this turns out to be a required component in the analysis of ikan.

The river turtles tenga'ou and belabei, penyu' the great sea turtle and di'a the tortoise family all have hard backs and legs that can be withdrawn (cf: 5.21), yet they have no common class-name.³ Equally out on their own are the crabs, buyou, ama and a good few others; padek the prawn of the brackish water where sea and river meet is the end of a line of development of several distinctly named creatures such as utud 'immature prawn', and si'et the sago-grub, eaten as a great delicacy, bears no name-relationship to its several morphological relations in the biological world, sebalun in its cocoon and buyun later on. The less said about kenyuma, the (edible) garret worm, the better.

1. Regarded by Dillon Ripley (1965.96) as one of the least known of marine creatures in scientific terms, beletika' figure in a cautionary tale about the danger of mocking harmless (boundary ?) creatures, described at Clayre 1972(a)3-6

2. Tape 6 R1287 - R1423 of the Museum collection, in Mudan dialect.

3. belabei''s long snout and excellent eating flesh earn it the pet name of babui likou, the river pig.

Some other creatures are themselves superordinates (or else the name is fed to the enquirer as a last resort). baya is the crocodile, and also cited as a cover-term for all the larger creatures of its general appearance that lay eggs, such as alou 'monitor lizard', bebaja and bekaxu 'tree lizards (variously)'; even the little chichak penga'ed may be classed among the baya. This is perhaps connected with a well-established tradition that when a crocodile lays its eggs, it does so on a small island (in a lake which serves as a nursery for the hatchlings) and lays them all in a great heap. The egg on top of the pile is the only one to become a true baya; successive layers hatch into alou, dipa (snakes) and eventually beruang a bear. For this last idea to make any sort of sense, it is necessary to look first at some more of the regular categories and their attendant problems.

All the insects that bite and sting may be referred to loosely as kiéh 'mosquito', while singet (or sesinget, 2.352) the wasp covers in a general way both the larger stingers (such as swi the hornet and sadi' the mudwasp, and also biters as vicious as tetela' the 'painted lady' horsefly, and its larger relative pexngat which can raise a large ulcer on the limb it bites.

Bats and flying squirrels pose a problem. It is readily granted that selemawa' the great fruit-bat and nenawai and other smaller varieties living in trees and caves all have ears and fur, quite unlike any other flying things. Moreover they lack a bird's beak, having a face like ground-based animals; nor do they lay eggs. It is admitted that tetah and kekamen, two varieties of flying squirrel, cannot really fly but only melayang, glide from one tree to a lower one. None the less, these are all mano' this-and-that, birds.

Any other animals which cannot be classed with one of the several categories described (or those carefully left nameless so far, which are less easily delineated) are negatively defined as benatang, 'animals'; they have no superordinate term attached to their specific name. Such are payau the various deer, bap the red squirrel and asou the dog, among very many more. beruang the honey-bear is benatang, despite his oval origin.

6.33 Metaphor or at least mythology is the means by which beruang is included along with lizards and what-not lou alou lou nou in among the fry of the crocodile's nursery.

It is commonly held that the soul bedua of a social offender, especially one guilty of tulah (4.32.1131) will be senaang baya, 'seduced by the crocodile'. This is the way by which the spirit realm gets the offender into titsr punitive power. If by some devious cunning the guilty person manages to escape the crocodile, he is handed over (as it were) to the power of the bear, and is thereafter senaang beruang¹. The bear and the crocodile are thus related in a spiritual amity which must, perforce, have a natural concomitant affinity in the seen world.

Not so easy to understand is the reasoning (if reasoning is correctly supposed to be at the back of the extremities of folk taxonomies) by which mano' dengen, mano' mesala and mano' munin find themselves in this category of birds. For munin turns out to

1. It is reported that quite recently a pair of bears were heard prowling about under a house at Igan right on the sea-side, a most unusual occurrence attributed to their role as punitive agents. Everyone waited (in vain, as it happens) for disaster to strike the house they visited, certain that their purpose was ba' menyaang bedua a 'to steal away someone's soul' as puni, 'decreed fate'.

be the destructive little mongoose, terror of chickens and many other small creatures (including birds); mesala is not known by any scientific name yet, but has a long tail, fur and four legs like a dog, yet swims much of the time; dengen is the crab-eating otter (or something so like an otter that the name will do).

The clue to at least a reasonable explanation for this odd categorisation comes in the story quoted at 4.32.24(1) and 5.11. When Besiong finds his fish-traps empty, before giving vent to the interesting Idiomatic Negative, he exclaims "kinah kulum", 'eaten by goblins'; kinah kulum atau kinah mano', the narrator goes on, are common Melanau expressions in Igan, and the latter we recognise as 'eaten by the birds'.

kulum are well-known spirit-beings. There is a sizeable oral literature concerning their ways, and how to escape from their clutches¹. The other culprit, then, is the mano' family, the birds. But in fact, everybody knows that the most likely robbers of fish traps (after kulum, that is) are munin, mesala or dengen, who are themselves sometimes trapped in specially baited bubou. And hence, perhaps, they come to be classed among the more regular mano' which, furred or feathered according to their kind, fly.²

It is most unusual, one would imagine, for a semantic label to be metaphorically attached in this way on a mythological string. There comes a point in the description of a natural language at which componential analysis and all the formal techniques have to bow out and yield the day to usage.

1. Described in outline in 'Kinah Kulum', Clayre 1972(a)67-69

2. It is tempting to wonder how the Melanau would classify the emu or ostrich, which are so far beyond their ken as not to enter into their scheme of taxonomy. The domestic hen siau tina and the fighting cock siau lalong are not usually prefaced mano', so there is precedent.

Appendix 1 List of Symbols and AbbreviationsChapter 2. Phonology

I.P.A. symbols are as described in IPA 1949

[xy]	phonetic transcription of a vernacular word
/xy/	phonemic transcription of a vernacular word
<u>xy</u>	orthographic representation of vernacular
V	any vowel
C	any consonant
'	syllable carrying primary stress
"	syllable carrying secondary stress
#	phonological pause
'az'	colloquial English gloss to the vernacular
I.C.	Intonation Contour typical of utterance type

Chapter 3. Morphology

X ~ Y	X and Y are phonologically conditioned variants
X ∞ Y	X and Y are morphologically conditioned variants
X- + Y	X is a bound morpheme, prefixed to Y
Y+ -X	X is a bound morpheme, suffixed to Y
-X- + Y	X is a bound morpheme, infix into Y
X → Y	X becomes Y (by a defined or undefined process)
X = Y	X is the same as Y
X ≠ Y	X is not the same as Y
X / Y	X or Y is selected at this point in the structure
$\left[\begin{array}{c} X \\ Y \\ \vdots \end{array} \right]$	one of the set of enclosed variables is selected
∅	Zero form in a set of alternatives
*X	X is a reconstructed or hypothetical form
{ <u>X</u> }	orthographic representation of morpheme norm X
(XY) _{NP32}	the syntagm enclosed within brackets manifests structure of Noun Phrase type 32; &c:
{ <u>xy</u> ₂ }	one of a set of homophonous morphemes distinguished by the subscript numeral
X : Y	X and Y form a set of mutually exclusive oppositions
+	(i) Concatenation (ii) Positive value of a binary variable
-	(i) Hyphen between reduplicated or other bound forms (ii) Negative value of a binary variable

[Z]	a semantic feature
X _F	X is the grammatical Focus of a clause
AFDyn	Actor Focus Dynamic clause structure, marked on the gloss A+; &c:

Chapter 4. Syntax

Morphemes and words are represented by lower-case symbols:

acc.	an accuracy word in a Quantity Phrase
ad.	an adverb
add.	adverb of degree
adic.	deictic adverb
adm.	adverb of manner
ads.	sentential adverb
c.	a connector
cl.	a noun classifier, numeral coefficient
col.	a colour term
cont.	continuative tense-aspect
deic.	a deictic pronoun, an identifier
ex.	an exclamatory particle
gpl.	general plural pronoun
int.	future intent tense-aspect
n.	any noun
nc.	a common noun
ng.	negative particle
nm.	a numeral
nom.	a nominalisation
np.	a proper noun
nu.	a unit noun
pn.	a pronoun
pr.	any preposition
pro.	prohibitive particle
pur.	purpose particle
q.	question particle
qu.	quantity term
ref.	anaphoric reference particle
rel.	relative pronoun
v.	any verb
va.	active verb
vc.	causative verb

vco.	copula verb
vd.	ditransitive verb
vi.	intransitive verb
vm.	manner intransitive verb
vp.	process intransitive verb
vq.	quality intransitive verb, adjective
vs.	state intransitive verb
vt.	transitive verb

Phrases and higher levels are represented by upper-case symbols:

Phrase-level

Ap:	Appositive tagmeme in Item-Appositive syntagm
Asp:	Aspect tagmeme in Verb Phrase
Ax:	Axis tagmeme in Relator-Axis syntagm
AP	Adverbial Phrase, further specified as eg:
AP.S	Sentential AP
AP.T	Temporal AP
AP.Ta	Anaphoric reference AP, &c:
C:c	Connector tagmeme, manifested by connector c.
Deg:	Degree tagmeme in Verb Phrase
Des:	Descriptor tagmeme in Nominal Phrase
H:	Head tagmeme in Head-Modifier syntagm
Id:	Identifier tagmeme closing Nominal Phrase
It:	Item tagmeme in Item-Appositive syntagm
Lim:	Limiter tagmeme in Quantity Phrase
Loc:	Locative tagmeme in Verb Phrase
Man:	Manner tagmeme in Verb Phrase
Mod:	Modifier tagmeme in Head-Modifier syntagm
Mode:	Mode tagmeme in Verb Phrase
Neg:	Negation tagmeme in Verb Phrase
NP	Nominal Phrase
NmP	Number Phrase
NuP	Numeral Phrase
Poss:	Possessor tagmeme in Item-Possessor syntagm
Qu:	Quantity tagmeme in Quantity Phrase
QuP	Quantity Phrase
Rel:	Relator tagmeme in Relator-Axis syntagm
RAP	Relator-Axis Adverbial Phrase, further specified eg:
RAP.C	Cause Adverbial Phrase
RAP.K	Circumstance Adverbial Phrase, &c:

ØAP	RAP with Void Relator tagmeme
Sense:	Sense tagmeme in Verb Phrase
Spec:	Specifier tagmeme in Head-Specifier syntagm
Tem:	Temporal tagmeme in Verb Phrase
U:	Unit tagmeme in Quantity Phrase
VP	Verb Phrase, further specified eg:
VcoP	Copula Phrase
ViP	Intransitive Verb Phrase
pViP	Process Intransitive Verb Phrase
VtP	Transitive Verb Phrase
dVtP	Ditransitive Verb Phrase

Clause-level

An:	Anaphoric reference tagmeme
.A	Associative semantic case marker
.B	Benefactive semantic case marker
.C	Causative semantic case marker
.D	Directional semantic case marker
.I	Instrumental semantic case marker
.K	Circumstantial semantic case marker
.L	Locative semantic case marker
.Lm	Limitation semantic case marker
.M	Manner semantic case marker
.P	Purposive semantic case marker
.T	Temporal semantic case marker
Cl.	any Clause, further specified eg:
ACl.	Adverbial Clause
DCl.	Full Dependent Clause
DeCl.	Declarative Clause
DTCl.	Ditransitive Clause
ECl.	Equational Clause
ICl.	Intransitive Clause
IdCl.	Idiomatic Clause
ImCl.	Imperative Clause
MTCl.	Monotransitive Clause
NECl.	Nominal Equational Clause
PACl.	Prepositional Adverbial Clause
pICl.	Process Intransitive Clause
QCl.	Interrogative Clause
RCl.	Reduced Dependent Clause

RAC1. Relator-Axis Clause
RhQC1. Rhetorical Question Clause, &c:
Comp: Complement tagmeme in Intransitive syntagm
Mar: Margin tagmeme in expanded Clause
P: Predicate tagmeme, further specified eg:
Pi: Intransitive Predicate
Pd: Ditransitive Predicate
Pm: Semitransitive Predicate, middle voice, &c:
O: Object tagmeme
R: Referent tagmeme in Ditransitive Clause
S: Subject tagmeme
Tg: Tag tagmeme in Tag Question

Sentence-level

Int: Introducer tagmeme
Mn: Main Clause tagmeme
Sub: Subordinate Clause tagmeme
S any Sentence, further specified eg:
CS Command Sentence
ES Existential Sentence
HS Exhortation in Hortatory formula
PS Performative Sentence
QS Question
RS Reduced Elliptical Sentence
SS Statement
VS Value Statement
US Ready-made Utterance
XS Exclamatory Utterance
SDC1. Dependent Clauses, further specified eg:
SDC1.Con Condition Dependency
SDC1.R Reason Dependency, &c:

Appendix 2 Dialect Survey

1. Word Lists

In order to ascertain how representative of the whole spread of the Melanau language complex the Dalat dialect is, a survey was undertaken throughout the acknowledged Melanau region and beyond its borders. Lexicon, basic grammatical patterns and folk-lore texts were elicited in the following places:

Rajang (in the extreme South West, Map 1)

Daro

Matu

Kuala Matu and Kampong Beruan (Map 2)

Igan

Kut

Kampong Nangka, Sibu

Tanjong, Kanowit

Kuala Oya

Tanam

Dalat (3 different areas in the township)

Kampong Sungai 'Ud, Dalat

Medong

Kampong Tilian, Mukah

Siténg houses of Kenyana, Mukah River

(Balingian lists are only partial)

Tatau

Bintulu (in the extreme North East, Map 1)

Ulu Tatau, Punan Ba of Rumah Kaséng, Sungai Kakus

Punan Ba of Rumah Kupak, Upper Rejang River (Map 3)

Sekapan of Rumah Pusou, Belaga district

Lahanan of Rumah Jok Seting, Belaga district

Kejaman of Rumah Lasah, Belaga district

and for comparison

Kayan of Long Linau, Balui River above Belaga

Kayan of Baram River (by L.Cubit of Borneo Evangelical Mission)

Traditional stories in Mukah, Balingian and Bintulu dialects were recorded by students of Three Rivers School, Mukah. It was most interesting to compare a phonemic transcription of each of these with the author's own written draft; one student from the Balingian dialect group in particular noted the preglottalised stops as different from others, writing an h after them. (cf. 2.41)

A 250-word list was evolved during the survey, based on a conflation of Swadesh and Gudschinsky lists compiled by Samarin (1967.220). However valuable it may be to philologists to have the same set of words sampled from all over the world, there are a number of practical drawbacks to this. An obvious area of difficulty is that part of the lexicon which is geographically determined; less easy to predict are culturally determined gaps in one language which correspond to lexical items one finds on the favoured word lists. There is also the problem that, with the same starting list in English (or other bridge language) a field-worker may elicit near synonyms rather than true cognates such as the various words for 'leg' and 'hand' which follow. Even more important, as the survey progresses the linguist is progressively aware of areas of close overlap and areas of marked contrast which become more important to the comparative work in the region. Lexical contrasts and phonological contrasts claim his attention, and these may crop up in parts of the lexicon of little interest to the world at large. (The gradual change from r to x to h that happens to show in 'woman' is fortunately in a word of world-wide importance; the further disappearance of even the h evidenced in words for 'post' would not be caught in the net of Swadesh listing alone.) To investigate all these

a private list must be developed which bears only family resemblance to its parents.

To save overloading an Appendix, only a 70-word sample is abstracted from 11 of the dialects, representative of the wide spread of Melanau along the coast and inland. These are then compared with Malay and two of the related Kajang dialects of the upper Rejang. (Current work involves further checking with Dempwolff's Proto-Austronesian, in an effort to place Melanau more definitely among the world's languages.)

The spelling of dialects remote from Dalat, Oya, Medong and Mukah is semi-phonemic only. It makes use of the orthography described at 2.6 but, in as much as these dialects were studied less, some symbols are nearer to their etic value than may turn out when their system is better understood. The o letter in Matu and Punan Ba, and the frequent use of x in other dialects are examples of this representation; the latter is normal in Sarawak Malay (as well as some dialects of Peninsula Malay) as the etic norm for /r/, and may well be so in Matu and Bintulu.

Peninsula Malay is given in the glosses to the lists, but a more revealing comparison might well be with Sarawak Malay which differs in a number of ways from the Standard. Thus the Malay word sampah 'rubbish' bears little comparison to Melanau uréh, but Sarawak Malay uras immediately shows up the regular éh : as contrast of many cognates.

Other noteworthy contrasts include:

2. Blood dara' / daxa' / daha' / xa' / da'
 8. Fish jan / ikan / jekan / jin / njen
 21. Star bitang / biti / betu'en

36. Alive tudip / mudip / murip

45. Heavy berat / bexat / baat / bahat / vat

as well as those mentioned at 2.4

All the coastal Likou Melanau belong to that broad group of Bornean languages which differ collectively from Malay in eg:

<u>mano'</u>	(with variations)	for 'bird'	(cf: <u>manuk</u>	in Kayan)
<u>lau</u>		'day'	(" <u>dau</u>	")
<u>asou</u>		'dog'	(" <u>aso'</u>	")
<u>ngadan</u>		'name'	(" <u>aran</u>	")
<u>ayeng</u>		'big'	(" <u>aya'</u>	")
<u>anum</u>		'water'	(" <u>danum</u>	in Kenya)

and it is interesting to note miléh 'to descend' in the Matu dialect as well as in Tatau, cf: ngiléh in Kayan.

Another contrast to be noted is the slight shift of meaning in a word as it diffuses through related languages. Cases in point are Mukah lubéng 'in', which is the phonological equivalent of Dalat lubi, Medong and Malay lobang, all of which are glossed 'a hole'; and sakai used in Bintulu as the preposition 'with', occurring in many of Sarawak's languages with the gloss 'visitor' (cf: rumah sakai 'guest-house') or 'friend'.

While it is not proposed yet to describe formal comparative rules in phonology, consider the informal account of relations between the various words for 'woman' (of perhaps 'female') in the lists, taking as starting point Proto Austronesian¹ */daRah/ 'maiden' (cf: dara Malay):

(i) */daRah/ → dera (Tatau), de'ra (Sekapan), by loss of feature LOW on first, unstressed vowel (and other related changes)

(ii) */daRah/ → *daxu by a process as yet undefined; then by the Metathesis to which Melanau is prone (2.35)

*daxu → *xadu → xe'du (Bintulu)

- (iii) cf: the close correspondence tudip / mudip 'alive' above,
 *daxu → *maxu → mexou (Dalat), mahau (Mukah)
- (iv) cf: opui / apui 'fire' above,
 *daxu → *axu → oro (Punan Ba)
- (v) finally, *daxu → *dahu → duh (Kayan)

It is clear that there is much scope for further work in the direction suggested by Leach (1948.44) which can go on from the termination of the present study.

English	Tanjong	Rejang	Matu	Igan	Dalat	'Ud	Mukah	Tatau	Bintulu	Punan Ba	Sekapan	Malay
35. Afraid	bu'ut	mamou	medut	medut	medut	medut	mengéng	mama	mau	bu'ut	bu'ut	takut
36. Alive	mudip	mudip	mudip	tudip	tudip	tudi'	tudip	murip	murip	merip	murip	hidup
37. Bad	jé'é'	ja'et	ja'et	ja'et	ja'et	ja'et	ja'et	jati	ja'es	jetei	ja'at	jahat
38. Big	ayu'	ayeng	ayeng	ayeng	ayeng	ayeng	ayeng	ayeng	azeng	ayo	ada'	besar
39. Black	bilem	bilem	bilem	bilem	bilem	bilem	bilem	metem	mitem	menyurom	useng	hitam
40. Cold ¹	dadem	dadem	dadem	singox	singox	singox	singuh	melarem	mexaxem	belarom	darem	sejo'
41. Dead	kebéh	kebes	matai	matai	matai	matai	matai	meso'	mesu'	mokovo ⁴	getu'	mati
42. Dirty	mama'	tigé'	tigi'	mama'	mama'	mama'	mama'	tekara'	jemi'	luo'	lu'	kotor
43. Dry	bahang	muang	muang	tu'uh	tu'uh	tu'uh	wéng	merahan	kaxéng	mo'u	mejelen	kering
44. Good	jia'	da'ou	dao	da'ou	da'ou	dia'	dia'	ja'	zéyan	dia'	dia'	bagus
45. Heavy	berat	bexat	bexat	bat	baat	baat	baat	bahat	vat	movat	baat	berat
46. Hot	lasu'	lasu'	lasu'	lasu'	lasu'	lasu'	lasu'	berengah	pedi'	belou'	belu'	panas
47. Many	buna'	ida'	ida'	dida'	dida'	dida'	ida'	buna'	mine'	owat	buna'	banyak
48. New	ubah	jakin	ubas	ba'ou	ba'ou	ba'ou	ba'ou	bahou	vau	uva	ba'ou	baru
49. Old ²	lakei	lakei	lakei	lakei	lakei	lakei	lakei	sepeng	sepeng	token	ada'	tua
50. Red	sak	sak	sak	sé'	se'	sak	sék	rahéng	mila	mengan		merah
51. Short	kadi'	dadé'	dadit	dadit	dadit	dadit	adék	mami'	ji'bet	kivu'	karu'	pendek
52. Small	isit	umé'	imit	umit	umit	umit	umit	sisi'	disi'	isut	ju'	kecil
53. Come	labé'	labi'	labi'	labi'	labi'	labi'	tapa'	sungen	jukat	lomu'	lucan	datang
54. Drink	nyirut	tuteng	tuteng	tuteng	tuteng	tuteng	tuteng	du'	suba'	du'	du'en	minum
55. Eat	kemu'	keman	keman	kuman	keman	keman	keman	kuman	penya'	koman	keman	makan
56. Give	pubé'	bi'	bi'	tujo'	tujuh	tujuh	juah	moho'	muju'	mekan	makan	memberi
57. Hear	kinam	tu'ing	tu'éng	peta'ah	peta'ah	peta'ah	ta'ah	mengenah	kexnga	ngeléngo	ndarah	dengar
58. See	nyipu'	duding	déng	pila'	pila'	pila'	goei	megui	pilau	maré	mirap	melihat
59. Sit	kudu'	kudu'	mungu'	mungu'	mungu'	mungu'	kudok	menungo'	kudu'	murung	ungau'	duduk
60. Sleep	melut	tudui	tudoi	tudui	tudui	tudui	tudoi	melut	megen	meturui	medyut	tidor
61. Stand	kedeng	tekedeng	tigex ³	tekedeng	tekedeng	tekedeng	pekadeng	tekereng	mexiei ³	mekéring	jut	bediri
62. Swim	pelangui	tuxun	tuxun	tuhun	tuun	tuun	pesengan	pelangui	pexingoi	pelangui	belangui	bernang
63. Talk	tekunan	puba'	puba'	puba'	puba'	puba'	tegoh	matah	mela'ei	kela'ék	mara'	chakap
64. Walk	pelakau	sibal	pelakau	makau	makau	makau	makau	melakau	melakau	mekayo	belakau	berjalan
65. Ascend	kegau	kamuh	kamau	kebau	bawai	bawai	bawai	bawai	'bawai	jaka'	bagwai	naik
66. Descend	kiba'	kiba'	miléh	kiba'	ba'ai	ba'ai	ba'ai	miléh	'bu'ai	muo	va'ai	turun
67. To-river	kawix	kawir	kawix	kawix	udai	udai	udai	durai	duxai	jelalom	paai	menyeberang
68. From-river		kedayeh	kedayeh	kejangai	jangai	jangai	jangai	jangai	jangai	depa	lemai	
69. Go downriver		kaba'	kaba'	kaba'	kaba'	kaba'	seba'ai	ba'ai	va'ai	deva'	sa'ou	menghilir
70. Go upriver		kaju'	kaju'	kaju'	kaju'	kaju'	ju'ai	ju'ai	ju'ai	devou'	ja'ai	mudek

1. This appears to be the difference between being cold and feeling cold.

2. the word elicited is for an old man.

3. Both these words relate to the idea 'straight up'.

4. This would appear to mean 'buried'; getu' is 'finished'.

Appendix 2 The Melanau Rice Myth, in different dialects

2. English translation of Dalat dialect version

Once upon a time there was a man fishing with rod and line by the riverside. All day he caught nothing, and he returned home empty-handed. Next day he tried again, but still he caught nothing. On the third day, as he was fishing from the same bend in the river, at last he hooked something. He pulled in his line but it would not come up, so he dived into the water to see what was snagging it. He was amazed to see his hook stuck in the roof of a longhouse.

Straight away he entered the house, which was very fine to look at. There were many people in it, and they asked him, "Where are you from?" "I dived into the river to see what was biting my hook," answered the fisherman. "That is how I came across this longhouse under the water."

Then one man spoke up. "I," he said, "an King of the Under-World. If you wish to stay here with our people, that will be quite alright." The fisherman consented, and the ruler ordered food to be brought in for him. He was surprised to be given cooked rice, for he had never seen it before. At first he thought it was just grubs, but when he had eaten it he found that he was completely satisfied.

He stayed a long time with the King of the Under-World, and joined the common people in their rice farming. When the rice was ripe he also went out to help them harvest it, and when the harvest was in he said to the ruler, "I have been here a long time with your people. I ought to go home again, for there is no-one to provide for my children."

"Indeed you may go home," said the ruler. "But we will give you only husked rice for your provisions; you are not to take seed rice. Tomorrow you must spread out rice to dry, and I will tell the women to pound it so that I can provide you with rice for your journey home."

Next day, while he was drying the rice, the fisherman put some of it under the foreskin of his penis, and no-one saw him hide it there. Then when the rice was ready husked, the ruler

gave the fisherman a little of it; and then he took his leave. But before he set out, the ruler had his person and possessions searched, in case perhaps he was making off with some of the seed rice. After being inspected, the man went his way. When he had walked for a long time, suddenly he saw his fishing-line again and, following it upwards, arrived at his own house.

There he recounted to his family all that had happened, and how he had come back from the long-house of the King of the Under-World. Then he showed them how to eat rice. After that he took out the rice-grain which was hidden under his foreskin, and planted it.

When the seedlings grew up, the ruler noticed it spreading out in the earth, and he was very angry. He had the path to the Under-World stopped up, so that we can no longer go there these days. And that was the very beginning of the rice which we have to this very day.

* * * * *

The texts which follow are ordered:

- 1 Dalat dialect, by Ignatius Kelumai
- 2 Rajang dialect, by Taijudin bin Suhaili
- 3 Matu dialect, by Julaihi
- 4 Bintulu dialect, by Drahman bin Alim

They all follow closely the same story, with only minor variations on incidental points of detail. The Bintulu account in particular adds a final "Why-so" twist, which is quite in character with many such tales in Borneo.

Lastly, for comparison, is one of the Kajang languages, 5 Sekapan dialect, by Tugue' Pusou.

This covers much the same ground, although the style and the detail vary more than the Coastal versions. It is typical of the accounts of the Origin of Rice as Food collected in the Kejaman house Rumah Lasah and the Punan Ba house Rumah Kupak. Together with similarity in kinship terminology and land tenure tradition, Morris accepts this as positive evidence of a common culture such as might result from common ancestry (cf: 'The Kajang Kingdom' and 'The Punan Ba' in Clayre 1971a).

Melanau Rice Myth 1 - Dalat dialect

Jelawéh a lai pekaxi memesei. Nyin pun debei kena'an
 One-cl. man fishing use-line. He even not catch
 sapai abei, lalu teruyh nyin puli' kubou. Lau mudei, nyin
 until evening, then straight he return home. Day after, he
 pun tabui udei, tapi japha pun debei kenah. Kepaut
 even set-out again, but one-cl. even not get. Duration
 telou lau nyin memesei ga' telok sungai, béh in bei
 three day he use-line at bend-of stream, after that is
 lah ipit nyin. Nyin pun mexut pesei nyin, tapi debei
 ! hooked-by-him. He then pull-in line his, but not
 labi' bawai. In lah nyin sused ba'ai, ba' pila' wa'
 come go-up. And-so he dived go-down, to look-at what
 meliket pesei nyin. Nyin pun iran angai peden dega'
 make-stick line his. He then amazed very seeing that
 pesei nyin peliket ga' sapau lebu'.
 line his sticking at roof long-house.

Nyin segera jaka' dagen kubou in, wa' da'ou angai ji.
 He at-once enter into house that, which good very to-see.

Ida' angai apah dagen kubou in, lalu luin menelabau:
 many very person in house that, and they question:

"Labi' kuman an ka'au?" Jawab a memesei in: "Akou sused
 Come from where you? Answer fisherman that: I dived-to-see

dagen sungai unou wa' tutup pesei kou. In lah akou ta'ou
 into stream what which bite line my. That's-how I know

bei lebu' dagen anum."
 be long-house in water.

Béh in, jelawéh puba' ga' a memesei: "Akou 'ih Raja
 After that, one-cl. speak to fisherman: I this King of

Yang, serta amun ka'au suka ba' diem jigem basa kamei,
 Underworld, and if you like to dwell with tribe our,

kenah kawa'." A memesei in sagup. Raja in kemakan nyin
 able also. Fisherman that brave. Ruler that feed him

béh in. Nyin pun iran angai lian nyin kenakan nasi'.
 then. He then amazed very when he was-fed cooked-rice.

Si'iu in, debei lah nyin peden win. Si'iu pikér nyin
 Before that, not ! he see it. At-first think he

nasi' in wa' ngadan uled. Den nyin béh keman nasi',
 rice that what is-called grub. Seen by-him after eat cooked-rice

nyin pun besuh angai.
 he even replete very.

Nyin diem paut jigem Raja Yang lalu tutui rayet
 He dwell long-time with King Underworld and join-in people

Raja in puma padai. Ubi lian padai nga' se', nyin pun
 ruler the farm rice When time rice was ripe he then
 tutui jigem luin pepox kawa'. Béh in, pox nga' kajih,
 join-in with them harvest also After that harvest was finished
 nyin pun puba' ga' Raja: "Akou nga' paut jigem basa
 he then spoke to ruler I have long-time with tribe
 kelou; patut lah akou ba' puli' likou agei. Debei bei
 your proper ! I will return home now There-is-not
 a ba' kemakan ane' ane' kou."
 one to feed children my

"Ka'au kenah puli'" sau Raja, "tapi kamei ba' tujuh
 You able return sound ruler but we will give
 beréh singen ba' pingah ka'au, bukan padai ba' igi'
 husked-rice only for rations your not seed-rice to be-taken
 ka'au. Lau sunih ka'au mikax padai ba' uei, lalu akou
 by-you Tomorrow you spread-out rice to be-dried and I
 ba' memada' lou mexou tutug win migi' akou kenah tujuh
 will tell the women to-pound it so-that I can give
 beréh ba' pingah ka'au puli'."
 husked-rice for rations your return

Lau mudei, ubi lian nyin muei padai in unei,
 Day next while he dry-out rice that ref.

a memesei pun tujuh padai iba' selekeb nyin, lalu dibe
 fisherman even give=put rice under foreskin his and is-not
 sai sai peden nyin melim win. Béh in, beréh pun nga'
 anyone notice him hide it After that husked-rice already
 genuguh, Raja pun tujuh jumit ga' a memesei in; nyin
 be-husked ruler then give a-little to fisherman that he
 pun pesusui: "Pexa' kelou!" Si'iu nyin tabui, ga'an
 even said Remain you = Goodbye Before he set-off goods
 jigem apah nyin peneresa' Raja; nyin medut kali' bei
 and body his inspected-by ruler he fear perhaps happen
 nyin menikau padai jumit. Béh peneresa' nyin, a memesei
 he steal seed-rice a-little After inspected-by him fisherman
 pun makau lah. Nga' paut nyin makau, jigem supu' angai
 then walk-off ! After long-time he walk suddenly very
 nyin peden telih pesei nyin. Nyin susud win bawai lalu
 he notice line-fishing his He follow it go-up and
 labi' ga' lebu' nyin - debei.
 arrive at long-house his-own

Nyin becerita ga' sawa ane' nyin pasel nyin labi' kuman
 He tell-story to family his about he arrive from
 lebu' Raja Yang, lalu menujun ba' kaman nasi'.
 house King of Underworld then demonstrate to eat cooked-rice

Béh in, nyin mepit padai wa' nelim iba' selekeb, lalu
 After that he take-out seed-rice which hidden under foreskin and
 tenadu'.
 it-was-planted

Wa' tadu' pun nga' tubu', Raja pun peden ji
 What planted then was grow-up ruler then see appearance
 mekax dagen tana', lalu nyin mexih angai. Lalu nesen
 unfurl in earth then he be-angry very Then stopped-up
 axuh mapun Likou Yang. In lah sebab kamei debei sepet
 path to Underworld That's-why reason we not priveleged
 mapun Likou Yang in unei sapai lian 'ih. In lah asel
 approach Underworld the ref. until time this That !origin
 padai wa' bei ga' telou ajau 'ih.
 seed-rice which is at us present this

Melanau Rice Myth 2 - Rajang dialect

Nu'en jelau, japha tenawan melah mesei. Melai udah
 Once-upon-a-time one-cl. person set-out to-fish Long-time past
 idun mesei mei bei kena'an apa' apa', tapi bas idun
 ne be-fishing not be catch anything but after that
 nu'en tan ngan utung pesei. Idun jemeru' telih ipesei,
 there-be feeling with end line He pull-in line of tackle
 tapi pesei idun deket. Lu' mei lu', idun pun tawang
 but tackle that be-stuck Like-it-or-not he then leaped
 tugun kalah, ba' duding yah nou sala'. Idun lijah
 into river to look-at what wrong He surprised
 ateng duding pesei idun deket ngan sapau lebu' lalou
 truly to-see tackle his stuck with roof longhouse
 wang anum.
 in water

Lebu' idun da'ou gaya'. Idun pun masuk kewang. Lou
 House that good appearance He then enter go-in The
 tenawan wang lebu' idun maneng duding idun, lalu menaba'
 people in house that happy to-see him and questioned
 kuman an idun labi'. "Kou mesei ngan sungai amau,"
 from where he came I fishing at stream above
 ulang idun, "Kou labi' kiba' 'ih ba' duding yah nou
 answer he I come go-down here to look-at what
 sala' ngan pesei kou." Tenawan pun migi' idun petemung
 wrong with tackle my People then take him to-meet
 ngan raja lebu', lalu idun puba' ngan idun: "Kou lah
 with ruler house then he speak with him I indeed

Raja dunia iba'. Kawan kenah kedap wang lebu' 'ih
 King world below Friend=you may stay in house this
 kah kawan suka." Idun pun mada' lou mexou wang lebu'
 if friend like He then order the women in house
 idun menyedia kun; kun pun didax ngan jawai tenawan idun.
 that to-prepare food food then was-put in-front-of person that

Bila idun duding kun, belinan kuman sagu' yah kikun
 When he look-at food different from sago which eaten-by
 lou idun wang dunia amau. Tia' idun ulat, idun mei lu'
 them in world above Reckon he grubs he not wish
 keman. "Kun idun da'ou ba' kun," lou idun pasuh ngan
 eat Food that good to be-eaten they tell with
 idun, "Idun lah ngadan nasi'. Nyadin idun keman jumi',
 him It indeed called cooked-rice So he ate a-little
 kun idun da'ou ga' nyam. Na'ei idun pun besur.
 food that good to the-taste Belly his even replete

Melai ga' idun kedap teng tat dulei dunia; nu'en ga'
 Long-time he dwell at place below world sometimes
 idun menulong tenawan pupox padai wang umah. Tenawan
 he help harvesters seed-rice in farms People
 teng dulei pun suka tenulong idun wang maca-macam kerja;
 at under even like be-helped-by him in all-kinds-of work
 tapi idun benawi' bila ba' muxai padai wang lasu',
 but he prevented when intend dry seed-rice in sunshine
 sebab lou idun mamou ja'ei idun menikau padai ba' penatun
 because they afraid lest he steal seed-rice to be-planted
 idun teng tat lou idun bah amau.
 him at place them up-above

Bila idun ba' muli', raja mada' lou mexou tupah padai
 When he intend return ruler tell the women to-pound rice
 ba' pingah idun muli'; tapi idun mei kenah bibi' padai.
 for provisions his return but he not able to-be-given rice
 Bila mei bei tenawan duding idun, idun menikau padai
 When not be anyone look-at him he steal seed-rice
 jumi'. Padai yah tenikau¹ idun nina' idun wang kulit
 a-bit Seed-rice that stolen-by him put-by him inside skin
 butu'. Bila nina' idun teng dulei, mei bei tenawan
 penis When put-by him at under not be anyone
 kenah ba' pinyang.
 able to search

Nyadin jalan 'ih idun kena'an padai jumi'. Nasuh idun
 And-so way this he obtain seed-rice a-bit Told-by him

1. The narrator had tikau idun in his draft notes, but read it out as tenikau idun; this is the difference between OFStat and OFDyn, exactly as in Dalat dialect (cf 4.31.12.203)

ngan kelurega idun pasel pengalaman melah-pelah idun
 with family his about adventures come-and-go he
 melah kemelai idun melah. Padai idun pun penatun idun
 travel so-long he travel Seed-rice that then planted-by him
 ngan umah. Padai pun bebua' ida'. Bibi' idun ngan
 in farm Rice then bear-fruit much Given-by him to
 tenawan ki' jumi' japh. Mei melai bas idun, tiep tiep
 people other a-bit each Not long-time after that every
 apah tenawan matun padai, serta betijam keman beras.
 body people plant seed-rice with learn to-eat husked-rice
 Tapi raja dunia iba' maxah, bila idun duding akai
 But ruler world below angry when he look-at roots
 tubu' iba' tana', sebab idun ta'ou idun udah buya'
 grow below earth because he know he had suffered
 akel tenawan in. Nyadin idun mei mada' tenawan melawet
 cunning person ref: And-so he not tell people to-visit
 tugun tat lou idun agi'.
 into place their any-more

Melanau Rice Myth 3 - Matu dialect

Jemen ubeng idun sabei, nuan lah japha to lai memesei
 There-was time long-ago there-was! one-cl. man go-fishing
 wang sungai. Katah udah idun memesei, mei ga' kena'an
 in stream While past he be-fishing nothing catch
 pa' nyama'. Sunei agi' nuan ga' tan ngan utong pesei
 at-all At-last there-was feeling at end tackle
 idun, banus jenixi' idun kebau; ti' deket wai pesei
 that and-so pulled-up-by him go-up but stuck rottan tackle
 idun ni'in. Nyadin tawang lah idun tegun wang sungai,
 his ref: And-so leap-down! he to in stream
 ba' dudéng wa' nou baten hal teng pesei idun.
 to look-at what matter trouble at tackle his

Ai! Kexenyi idun dudéng baten gaya pesei idun ni'in
 Well! Amazed he to-see way-in-which tackle his ref:
 deket teng padong lebu' lalou. Sawa' lebu' lalou 'ih
 stuck at gable-end house long Remain house long this
 bah iba' anum agi'; labu' lalou 'ih ni'in da'ou baten.
 beneath water still house long this ref: good appearance
 Masok lah idun tegun wang. Tenawan iba' ixen dudéng
 Enter! he to inside People below amazed to-see

idun, banus menelabau: "Labi' kuman an mou?" Ulang idun,
 him and-then enquire Come from there you? Answer he

"Kou memesei wang sungai bah bau inan ni'in. Uli'
 I go-fishing in stream up-above yonder ref: Since

pesei kou deket, nyadin tawang lah kou tegun wang
 tackle my caught and-so leap-down ! I into in

sungai ba' dudéng wa' nou baten hal teng pesei kou."
 stream to look-at whatever wrong with tackle my

To iba' anum idun pun banus migi' idun tegun apah
 Those below water that then take him to the-one

menguasa wang lebu' idun. Apah menguasa idun pun puba':
 have-power in house that The-ruler that then spoke

"Kou lah Ipu' wang dunia bah iba' 'ih. Mou kenah ga'
 I indeed Spirit in world beneath this You may also

tutui besawa' teng lebu' 'ih asel mou lu' ma'."
 join-in be-dwelling at house this is you wish only

Bas idun, ipu' wa' menguasa gidun banus masuh mana
 After that spirit who ruled at-there then told whoever

pun to mexou wang lebu' idun menyedia ba' kun.
 women in house that to-prepare food(=to-be-eaten)

To lai idun banus nidang. To idun mula-mula mei lu' ba'
 Man that then be-served He at-first not wish to

keman uli' ba' kun idun tujuh lou idun ni'in mei samah
 eat because food that given-by them ref: not same

dengah sagu' wa' kikun idun wang dunia bah bau. Singed
 with sago which eaten-by him in world up-above Think

idun, uled; nyadin mei lu' lah idun ba' keman. "Wa' 'ih
 he grubs and-so not wish ! he to eat This

lah da'ou ba' kun. 'Ih lah ngadan bexas padai," uba'
 indeed good to be-eaten This! is-called husked rice speech

to iba' anum idun ngan idun. Nyadin nada' kikun idun
 they below water that with him And-so tried eaten-by him

jumit; uli' da'ou nyam banus kinah idun gen besuh ateng.
 a-bit since good taste then eaten-by him until full truly

Katah ga' udah to lai idun tutui teng lebu' lalou
 Time some past man that join-in at longhouse

bah iba' anum idun ni'in menulong to menyali' sexeta
 below water that ref: helping them to-gather and

mupox umah padai. Mana baten kerja wa' nuan tenulong
 harvest farm rice Whatever kind work which there-be helped-by

idun ni'in, tituh lou idun ma'. Kida' lou idun mei lu'
 him ref: let-by them only Except they not wish

to lai idun menulong muxei padai, medut ji'i to lai idun
 man that assist to-dry seed-rice fear lest man that

menikau padai ba' benih idun teng dunia bah bau na'ah.
steal seed-rice for seed his at world above later

Sebeb to bah bau mei ngah ta'ou wa' nou baxeng idun.
Because they above not yet know what (is) thing that

Sunei agi', lian idun ba' muli' tegun ted, ipu' gidun
Later-on time he intend return to home spirit there

masuk to mexou gidun mena' nasi' ba' pingah idun muli'
tell women at-there to-make cooked-rice for rations his return

kebau. Tapi lou idun mei lu' tujuh padai benih. Nyadin
to-up But they not wish to-give rice seeds And-so

ubeng to gidun mei bei dudéng ti' teknikau idun jimit
when folk there not be watching but stolen-by him a-little

padai benih, nina' lah an idun teng utong bah iba'
rice seed put-by ! place that at end underneath

kulit butu', sebeb singed idun teng 'ih mei bei to
skin penis because think he place this not be person

ta'ou.

know

Sebeb basa idun lah idun keban kena'an benih padai
Because manner that ! he managed to-get seed-of rice

wa' igi' muli' tegun ted. Labi' lebu' ngan ted bau,
which taken return to home Arrive house at home above

banus idun pitér semuah baten gaya hal wa' pelah idun
then he recount all that-had-happened what journey he

teng ted¹ bah iba' anum ni'in. Bas idun lou idun pun
at country beneath water ref: After that they even

mengada' mematun benih padai wa' kenah idun ni'in.
attempt to-plant seed-of rice which got-by him ref:

Padai idun pun tubu' dengah da'ou sexeta dida' bua'.
Rice that then grow with good and plenty fruit

Padai idun pun benagi lou idun jimit japha wang ted,
Rice that then divided-by them a-little each in village

banus tenijou idun sekali baten gaya-gaya mematun,
then taught-by him together the-way-of planting

gaya-gaya ba' mena' nyadin ba' kun.
the-way- to make become for eating

Ipu' wa' menguasai ted bah iba' anum idun ni'in, mei
Spirit which ruled country beneath water that ref: "no-

tekebix, legit ateng teng to lai idun, ubeng idun seba'an
fooling" angry truly with man that when he noticed

xamut padai dida' tubu' wang tana'. Sedex lah udah idun
roots rice many growing in earth Realise ! after that

buya' akel to lai idun ni'in. Nyadin bas semeja' idun
because-of cunning-of man that ref: And-so after-that-onwards

lah Ipu' wa' menguasai bah iba' anum idun mei memenex
 ! Spirit which ruled beneath water that not allow
 manusia melah tegun wang ted bah iba' agi',
 mankind visit to in country beneath any-more.

1. ted is given various glosses, River, village, country &c: just exactly parallel to likou in Dalat dialect.

Melanau Rice Myth 4 - Bintulu dialect

Mukou ji'eng 'dau, ji'eng manai sepeng menyilem njin.
 Once-upon-a-time one-cl. man adult go-fishing fish

Penga' meli' nyam isa menyilem inah u'ah, aukou kinah
 Past long-time it he be-fishing there ref: nothing at-all

me'dep. Tapi 'a meli' tegi' inah isa gi' mivéng silem
 bite But not long from then he will lift-up line

nya, kirem nya vat, 'a kala' nivéng. Isa menyuba' kinah
 his feel-to-him heavy not able be-raised He try again

mivéng, 'a kinah kala'. Isa pun patud temai sungai inah
 raise not at-all able He then jump-down into stream that

ga' pilau anou nah beta' silem nya inah telei. Isa
 will see what ! cause tackle his that caught He

lalu tekejit peka'a silem nya telei bele'bau buvong uma'
 then surprised to-see tackle his caught in-top-of roof-of house

bebat belemai 'ba'.
 long inside water

Uma' inah zé'ian lalu. Isa lalu pasek temai uma'
 House that good extremely He then enter into house

inah. Ulun mai uma' inah ka'a isa, lalu selou pun
 that Folk in house that notice him then they even

kisiu isa tegi' mbah isa jukat. "Akou menyilem mai
 ask him from where he arrive I was-fishing in

sungai ya'," li'a nya, "Akou 'bu'ai ya' gi' pilau anou
 stream this speech his I go-down here to look-at what

nah be'dem silem kou telei."
 ! makes tackle my caught

Selou lalu maza' isa mapun raja uma' inah, sai cerita
 They then lead him towards ruler house that who speak

sakai isa: "Akou lah raja mai negeri mai 'ba' ya'.
 with him I indeed ruler in country in water this

Ikau kala' kinah menda' sakai melou mun ikau mesat."
 You may moreover remain with us if you desire

Raja inah pun menyua' selou va'i xe'du dinah menyedia'
 Ruler that then command them the-women at-there to-prepare
 anou gi' ninya'. Selou lalu bexika-xikah be'dem anou
 what to-be-eaten= food They then busy-themselves making what
 ninya'. Penga' semua anou ninya' inah masak, lalu
 eaten After all food that ready then
 degidang sakai manai inah. Kitam nya anou ninya' inah
 served with man that Reckon he food that
 lain tegi' sei, anou selalu ninya' selou mai dunia
 different from wet-sago which always eaten-by them in world
 'bau. Pikér nya inah u'ah telu uled. Isa 'a mesat gi'
 above Think he that ref: eggs grub He not desire to
 penya'.¹ "Anou ninya' inah zé' nyam ninya'," li'a selou
 eat Food that good taste eaten speech they
 va'i 'ba', "Inah lah anou nivai sixa nasi'." Lalu isa
 folk water That ! what called-by people cooked-rice So he
 pun menyuba' penya' anou ninya' inah, anou nivai nasi'
 even attempt to-eat food that what was-called rice
 u'ah; kiram nya zé' nyam. Isa pun penya' sapaí isa vesu'.
 ref: reckon he good taste He then eat until be replete

Meli' kinah isa pun menda' sakai selou inah mai 'ba'.
 Long-time yet he even remain with them that in water

Isa menulong selou menggut bexa mai njab. Selou selalu
 He assist them to-harvest rice in farms They always
 kinah pezu isa menulong selou, tapi' selou 'a pezu isa
 still allow his to-help them but they not allow him
 me'dau bexa kexna selou mau isa mengakel selou, megí'
 dry-out rice because they fear he deceive them take
 jimi' bexa gi' neja isa mai dunia 'bau ya', dembah
 a-little rice to be-planted-by him in world above this where
 sixa 'a ta'ou meja.
 folk not know to-plant

Mai isa gi' muli' apun uma' nya, raja menyua' selou
 During he will return to house his ruler command them
 va'i xe'du tupa bexa gi' valun isa muli'. Tapi' selou
 the-women to-pound rice for provision his return But they
 'a muju' bexa sakai isa; selou muju' vas.
 not give seed-rice to him they give husked-rice

Ja'dai isa pun menyekau jimi' bexa inah bila selou 'a
 And-so he even stole a-little rice that when they not
 pilau isa. Isa lalu melim bexa inah belemai kulit butu',
 watch him He then hide rice that inside skin penis
 dembah selou 'a ka'a lalu 'a pilau.
 at-where they not see and not look

1. The p- prefix to the verb presumably indicates self-interest of the action, as in Middle Verbs of Dalat dialect (4.32.31.23)

Ja'dai inah lah gaya nya gi' bekala' benih bexa gi'
 And-so that ! the-way-of-it to obtain seed rice to
 negi' isa muli'. Isa lalu serita sakai selou va'i mai
 be-taken-by him home He then recounted with them folk in
 uma' nya pasel lakau nya, sapai isa menda' sakai raja
 house his about journey his until he dwell with ruler
 'ba'. Isa pun lalu menyuba' peja bexa inah mai njab
 water He then attempt planting rice that in farm
 nya. Bexa anou neja nya inah ja'dai lalu. Isa pun
 his Rice what planted-by him that get-on-well He then
 muju' selou va'i kapong inah jimi' jusa,
 give them folk-of village that a-bit each

'A meli' selou pun sama mukou njab bexa, lalu ta'ou
 Not long-time they even all possess farm rice then know
 penya' nasi'. Tapi' raja 'ba' membeng bila isa ka'a
 to-eat cooked-rice But ruler waters furious when he notice
 amut bexa te'dai 'bu'ai tana', sebab isa ta'ou isa
 roots rice spread go-down earth because he realise he
 penga' dengakel¹ manusia. Ja'dai isa lalu 'a pezu sai -
 past deceived-by mankind And-so he then not allow any-
 sai mapun negeri 'ba' nya alum. Inah lah bila telou
 one approach kingdom water his again That's-why when we
 kam, telou ta'ou² mesu' bila telou 'a kala' pexingui.
 capsized we know=will die when we not able to-swim

1. This would appear to be a somewhat Malayanised form of the typical Melanau passive (OPDyn form) of verbs, connected with the active form mengakel. Others in Bihulu dialect are quite regular, cf: mivéng / nivéng 'raise up' in first paragraph.

2. For this sentient modal verb, cf: 3.32.11.512)

Sekapan Rice Myth - Rumah Pusou, Belaga.

Jadé' pu'un namei, sagwi ayu' Lajée' inei, ta'an mei'
 Now beginning we people in Rejang this know to-make
 tana', ta'an mula parai, tou'-tou' turun menurun kamei
 farms know to-plant rice handed-down-from-ancestors our
 bétou. Jalau ja dedyai mesei ayu' Ba' Mesua inan, ayu'
 before One-day a man fished at mouth-of Mesua yonder, in
 lérue Ba' Mesua naju'. Jeman namei uya mei' budée'
 pool Mouth-of Mesua upriver. Before we not-yet make move-house

sa'ou, mesei ayu' anan, lalu pesei nya kalen. Kalen
 go-downriver fished in here then line his caught Caught
 pesei inan, tei isa meneleng. Teneleng nya pesei inan,
 tackle that went he to-inspect Inspected-by him line that
 neka' nya, bu'ut isa sa'it kayou, ku nya. Nérap nya
 freed-by him afraid he caught wood said he Seen-by him
 levou' linou. Nah! Neka' nya pesei inan, kelulun nya
 house people Well! Loosed-by him line that rolled-up he
 nah, lalu nya tei ungau' jan linou inan ayu' levou'
 ! wait he went sit with people those in house
 inan. Ungau' isa la', legwa' luku' sipa'; nou'an nya
 that Sit he just get-out cigarette sirih there he
 peruku', nnu'an nya pesipa'; isa de'ra inan mei' kun.
 smoked there he chewed betel-nut the-women there make food

Nemei' nemei' deh kun nya, sia' kun inan, narau deh.
 Fully made-by them food the ready food that scooped-by them
 Beh narau deh kun inan, ja'ei deh isa keman. Jadé',
 After served-by them food that call they him to-eat Then
 ku nya, isa uya meja' keman. "Ulet isa!" ku nya, "Ulet,
 say he he not wish to-eat Grubs it sau he Grubs,
 'u!" "Uya inei ulet. Inei la' kun tah linou murib;
 ugh! Not this grubs This only food we-people live-on
 kinan la'!" lé'in de'ra manau; buya' sira irei baliu¹
 eat only! speech woman there because they ref: tribe
 ipa' kiva'. Jadé' baliu inei ipa' kebau. Beh isa keman,
 from below Then person this from above After he eat
 beh lan ikut lé'in deh, mi kun irei nekun nya.
 after true follow speech their sweet food ref: eaten-by him
 Tupu isa keman la', paa isa la', ungau' jendah isa,
 Finished he eat only go-out he just sit with her
 isa mara' isa mulei' la', mulei' baliu inei. Nérap nya
 she tell him to-leave just to-leave village this Seen-by him
 sira meka' parai ayu' padée' levou' direi, nakup nya
 them dry rice in platform of house that ref: taken-up-by him
 mesei' alem sud ikée' nya, tebokou ayu' juman bai nya.
 shove into pocket clothes his tied in front-of loin-cloth
 Tei sira irei, nanap deh meh. "Ih! Kupah masem aken
 Go person this, caught-by them also "Oh, by-what-means able
 kau manap ud inei la'?" kinan lé'in nya. Beh isa, isa
 I keep-hold stuff this just? thus speech his After that he
 mesei' parai inan ayu' lekid butou' nya; pikin sira
 put seed-rice that into foreskin penis his think they
 manap, sira mia' ngelewat butou' nya. "Eh! Nau téau nya,
 catch they shy to-inspect penis his Oh! Not-matter

1. baliu here has all the meanings of likou (Dalat), ted (Matu)

bukan isa kura-kura," kinan lé'in linou ada' la', "Mei'
not he very-important thus speech people old only make
ané'k nya la'." Kinan isa levan deh la'.
child his only Thus he trick them just

Nah. Mulei' isa, bagwai lusam levou' nya. Jia' isa,
Well! Leave he go-up as-far-as house his Well-as-able
mirie' la'. Dirie' dirie' dirie' nya; nah, sé'e' dirie'
cut-grass only Cut, cut, cut-by him then, dry cutting
inan, tenutue nya. Tupu tutue inan, tenguan nya la'.
that burned-by him Finished burning his dibbed-by him just
Tenugan, nupan nupan nupan nya, parai irei la' nupan
Dibbed sown sown sown-by him rice ref: just sown-by
nya. Kenyam nya la', kenyam nya. Ada' makin ada', tira'
him Guarded-by him just guarded-by him Older-and-older until
parai irei bagwa'. Dirie' nya meh ba'ou badyei, pekatan
rice ref: have-fruit Cut-by him also new again increase
parai irei makin buna' makin buna' makin buna', parai
rice ref: get more get more get more rice
irei, makin pat-lima ratus guni' la'. Nah anan isa
ref: get four-or-five hundred sacks just After that it
cukup bagi linou semua-mua, tou' mula turun-menurun
sufficient for people all from beginning ancestors
namei, murip ayu' Lajée' ani. Isa kamei ta'an mei'
our living in Rejang here That we know to-make
tana' la', semua ud pula parai nula namei la', parai
farms only all stuff plant rice planted-by us just rice
tou' inan.
from that

Deng inan juran kau.
Until that story my

It is at once evident that, while there is considerable diverg-
ence in the vocabulary of Bintulu dialect and even more markedly
in Sekapan, the grammatical form of sentences is very similar.
In particular the same rules of focus in serial clauses apply.

There is also a very marked overlapping structure discernable
in this last story, each new bit of the story recapitulating a
part of the previous clause (cf: 5.11). A more detailed analysis
must wait until a direct study of the Kajang languages, Punan Ba
Sekapan, Lahanan and Kejaman has been undertaken.

Appendix 3 Bibliography of works cited

(The following abbreviations are used in the Bibliography:

- AnthL Anthropological Linguistics, Indiana University, USA.
JL Journal of Linguistics, London and New York.
Lg Language, Baltimore, USA.
SG Sarawak Gazette, Kuching, Sarawak.
SIL Summer Institute of Linguistics
SMJ Sarawak Museum Journal, Kuching, Sarawak
SOAS School of Oriental and African Studies, University of London.)

- Abeng bin Mega 1969 Bato Ikan (sic) Borneo Literature Bureau, Kuching, Sarawak.
- Abrams N. 1961 'Word Classes in Bilaan' Lingua 10 (391-401)
- Aikman R.G. 1947 A Vocabulary of Matu Melanau Government Printing Office, Kuching, Sarawak.
- Anderson J.A.R. 1964 Field Check List of Trees of Peat Swamp Forests of Sarawak Sarawak Forestry Department, Kuching, Sarawak.
- Archer J.D. 1949 'Melanau as it is Spoken' SMJ I (New Series)
- Austen Druce 1949 'A Melanau comment on the above' SMJ I
- Asmah haji Omar 1969 The Iban Language of Sarawak: A Grammatical Description Unpublished thesis No:695 SOAS.
 1971 'Standard Language and the Standardisation of Malay' AnthL 13.2 (75-89)
- Austin J.L. 1955 How to do things with Words William James Lectures, Harvard University.
- Barnes G.T. 1966 'A Melanau Curing Ceremony payun at Mukah' SMJ XIV.28 (87-90)
- Bazell C.E. 1958 Linguistic Typology SOAS London
- Becker A. and Arms . 1969 'Prepositions as Predicates' Papers from the 5th Regional Meeting, Chicago Linguistic Society (1-11) Chicago.
- Berlin B. and Kay P. 1969 Basic Colour Terms University of California Press.
- Bloomfield L. 1942 'Outline of Ilocano Syntax' Lg 18.3 (193-200)

- Brøndal V. 1928 Les Parties de Discours Copenhagen.
- Buck W.S. 1933 'Notes on Oya Milanos' SMJ IV.2 (157-174)
- Burling R. 1965 'How to Choose a Burmese Numeral Classifier' in Context and Meaning in Cultural Anthropology Melford Spiro ed. New York.
- 1970 Man's Many Voices Holt, Rinehart and Winston New York.
- Buse J.E. 1965 'Problems of Morphology and Classification, illustrated from Rarotongan' Lingua 15 (32-47)
- Catholic Mission, Sarawak 1953 Melanau Catechism and Prayers Dalat (imprimatur Kuching) Sarawak.
- 1969 Wa' pesaia eklesia katolika jagem adat Kristian (sic) A Catechism of Christian Doctrine in Melanau, Mukah, Sarawak.
- Cense A.A. and Uhlenbeck E.M. 1958 Critical Survey of Studies on the Languages of Borneo Nijhoff, The Hague.
- Chomsky N. 1957 Syntactic Structures Mouton, The Hague
- Clayre B.M. 1967 'Two Favourite clause types in use in Dusun' Sabah Society Journal 3.3 Jesselton, Sabah.
- 1970 'Focus: A Preliminary Survey of Some Languages of Eastern Malaysia' SMJ XVIII.35 (193-219)
- Clayre B.M. and Cubit L. 1966 'An Outline Kayan Grammar' in Southwell H. unpublished Kayan Dictionary in preparation, Miri, Sarawak.
- Clayre I.F.C.S. 1970(a) 'The Sa'bans Revisited: a sequel to Bolang and Harrisson 1949' SMJ XVIII.35 (318-329)
- 1970(b) 'The Spelling of Melanau' SMJ XVIII.35 (330-352)
- 1971(a) 'The Malanau Kaul at Medong' SG 1355
- 'Magic Oil among the Melanau' SG 1357
- 'A Milano is a Melanau by any other name' SG 1358
- 'Co-operation, the Essence of Community Living' SG 1359
- 'A Melanau Regatta' SG 1360
- 'Imitative Magic among the Melanau' SG 1361
- 'The Kajang Kingdom' SG 1362
- 'Milne the Melanau' SG 1363
- 'Saban Kuyad - Pregnancy Taboos' SG 1364

- 'The House at Ipu' Corner - Building Taboos' SG 1366
- 1971(b) 'The Melanaus' in The Peoples of Sarawak
(revised edition) Borneo Literature Bureau, Kuching.
- 1972(a) 'Pukih - the Melanau sense of Fun' SG 1367
'Punan Ba, Melanau link with the Ulu Rejang'
SG 1368
'The Coffin that came to Life' SG 1369
'Kinah Kulum - Two Melanau Ghost Stories'
SG 1370
- 1972(b) 'Notes on Spatial Deixis in Melanau' AnthL
(in press)
- 1972(c) 'Focus and Emphasis in Melanau' Lingua 30/31
(in press)
- Cook A. 1967 'A Preliminary Statement of Narak Spatial Diexis'
(sic) AnthL 9.6 (1-29)
- Cook W.A. 1969 Introduction to Tagmemic Analysis Holt, Rinehart
and Winston, New York.
- Crocker W.M. 1876 'A Short Account of the Milanaes of Sarawak'
SG (June)
- Crystal D. 1967 'Word Classes in English' Lingua 17^s (24-36)
- Dean J. 1958 'Some Principal Grammatical Relations of Bilaan'
Oceanic Linguistic Monographs 3, Canberra, Australia.
- Dempwolff O. 1938 Vergleichende Lautlehre des Austronesischen
Wortschatzes, Dietrich Reimer, Hamburg (3 Volumes)
(English translation of parts, with annotated studies
by Cecilio Lopes, SIL Manila, Philippines.
- Elson B. and Pickett V. 1962 An Introduction to Morphology and
Syntax, SIL Santa Ana, California.
- Fillmore C.J. 1967 'The Case for Case' in Universals in
Linguistic Theory Bach & Harms eds. (1-88)
- Fishmore J. 1969 'National Language and Languages of Wider
Communication in the Developing Nations' AnthL 11.4
(111-135)
- Forster J. 1964 'Dual Structure of Didabawon Verbal Clauses'
Oceanic Linguistics 3 (26-48)
- Fries C.C. 1962 The Structure of English Harcourt Brace, New
York.

- Geddes W.R. 1954 The Land Dayaks of Sarawak, Colonial Research Studies no:14, London.
- Gonda J. 1948 'The Comparative Method in Indonesian' Lingua I (86-103)
- Halliday M.A.K. 1966 'The Concept of Rank: a Reply' JL 3.1 (110-118)
1967-8 'Notes on Transitivity and Theme' JL 3.1 - 4.2 (37-81, 199-244, 179-216)
- Harris Z. 1951 Methods in Structural Linguistics University of California Press.
1957 'Co-occurrence and Transformation in Linguistic Structure' Lg 33 (283-340)
- Healey A. 1958 'Notes on Yogad' Unpublished MS in SIL Manila.
- Healey P.M. 1960 An Agta Grammar Manila.
- Henry D. and Henry K. 1969 'Kuyukon Locationals' AnthL 11.4 (136-142)
- Hla Pé 1965 'A Re-examination of Burmese Classifiers' Lingua 15 (163-185)
- Hockett C. 1958 A Course in Modern Linguistics Macmillan, New York.
- International Phonetic Association 1949 The Principles of the International Phonetic Association, University College London.
- Jamuh G. 1950 'Katuong: a Melanau Rite' SMJ V.2 (229-232)
1951 'Some Melanau Pastimes' SMJ V.3 (446-456)
1958 'Coastal Melanau Taboos' SMJ VIII.12 (710-731)
1959 'Melanau Healing' SMJ IX.13 (186-194)
1965 'A Melanau Population Destroyed by Poisonous Smoke' SMJ XII.25 (230-234)
1969 (May) 'Jerunei and their significance' SG (May)
- Junus U. 1967 'Syntactical Structure Analysis of Written Indonesian' Linguistics 32 (15-38)
- Kaboy T. and Moore E. 1967 'Ceramics and their Use among the Coastal Melanau' SMJ XV.30 (10-29)
- Kerr H.B. 1965 'The Case-marking and Classifying function of Cotabatu Manobo affixes' Oceanic Linguistics 4.1 (15-47)

- Key H. 1965 'Some Semantic functions of Reduplication in Various Languages' AnthL 7.3 (88-102)
- Leach E.R. 1948 Social Research in Sarawak: a report on the possibilities of a Social Economic Survey of Sarawak, presented to the Colonial Social Science Research Council, H.M.Stationery Office, London.
- Longacre R. 1964 Grammar Discovery Procedures Mouton, The Hague.
 1965 'Some Fundamental Insights of Tagmemics' Lg 41 (65-76)
 1970 'Sentence Structure as a Statement Calculus' Lg 36.4 (783-815)
- Lyons J. 1968 Introduction to Theoretical Linguistics Cambridge University Press, London.
- Mak (Fr.) and Munan English - Melanau, Melanau - English Dictionary Unpublished MS, Catholic Mission Dalat, Sarawak.
- McKaughan H. 1958 The Inflection and Syntax of Manobo Verbs Institute of National Language, Manila
 1962 'Overt Relation Markers in Maranao' Lg 38 (47-51)
- Mooney P. 1959 'The Keliding at Sungai Ud'(sic) SG (May)
- Morris H.S. 1953 Report on a Melanau Sago-growing Community in Sarawak H.M.Stationery Office, London
 1967 'Shamanism among the Oya Melanau' in Social Organisation, M.Freedman ed. Frank and Cass, London.
- Morrison W.G. 1949 'Melanau Customs' SG (June)
- Mulder (Fr.) B. and Lawrence A.E. 1930 'A Vocabulary of Mukah Milano' SMJ IV.12 (87-130)
- Newington P.C. 1961 'Melanau Memories' SMJ X.17 (103-107)
- Nida E.A. 1963 Morphology: the Descriptive Analysis of Words (3rd edition) University of Michigan Press, Ann Arbor.
- Nida E.A. and Taber C. 1968 Theory and Practice of Translation pre-publication mimeograph, Bible Societies, Manila.
- Palmer F. 1965 A Linguistic Study of the English Verb Longmans, London.
- Pickett V. 1956 An Introduction to the Study of Grammatical Structure SIL Glendale, California.

- Pike K.L. 1947 Phonemics: a Technique for Reducing Languages to Writing University of Michigan Press, Ann Arbor.
- 1954-1960 Language in Relation to a Unified Theory of the Structure of Human Behaviour (3 Volumes) SIL Glendale, California.
- 1962 'Dimensions of Grammatical Analysis' Lg 38 (221-244)
- 1963 'A Syntactic Paradigm' Lg 39.2 (216-230)
- Prentice D.J. 1965 'Form and Function in Sabah Murut' Oceanic Linguistics 4 (127-156)
- Ray S. 1913 'The Languages of Borneo' SMJ I.4 (1-112)
- Ripley D. 1965 The Land and Wild-Life of Tropical Asia Time - Life, London.
- Robins R.H. 1964 General Linguistics: An Introductory Survey Longmans, London.
- 1965 'Some Typological Observations on Sundanese Morphology' Lingua 15 (435-450)
- Samarin W.J. 1967 Field Linguistics Holt, Rinehart and Winston, New York.
- Sarawak Government 1941 Coast Liko Adat (sic) Government Printing Office, Kuching. (Three versions: Mukah and Oya dialects, and English translation)
- de Saussure F. 1955 Cours de Linguistique Générale 5th end. Payot, Paris.
- Schärer H. 1963 Ngadjoe Religion (R.Needham translation from original Dutch) Nijhoff, The Hague.
- Scott N.C. 1956 A Dictionary of Sea Dayak SOAS London.
- Skeat W.W. 1900 Malay Magic Macmillan, London.
- Smythies B.E. 1960 Birds of Borneo Oliver and Boyd, Edinburgh.
- Teeuw A. 1962 'Some Problems in the Study of Word Classes in Bahasa Indonesia' Lingua 11 (409-421)
- Uhlenbeck E.M. 1962 'Limitations of Morphological Processes: some Preliminary Remarks' Lingua 11 (426-432)
- Voegelin C. and Voegelin F. 1965 'Languages of the World: Indo-Pacific Fascicle Four' AnthL 7.2
- Waterman H. 1960 'Problems of Translation into Philippine Dialects' The Bible Translator 11 (162-172)
- Wessing R. 1972 'Levels of Language in Sundanese' unpublished manuscript in preparation for Man, University of Illinois.

Winstedt R.O. 1952 Malay - English Dictionary Kelly and Walsh
Singapore.

* * * * *

The Sarawak Gazette also includes a number of relevant but unsigned articles on the customs, beliefs and folklore of the Melanau, notably:

1907 (May) Jiluan and the Pig-girl: a fable¹

1921 (series) Sherip Mashor at Mukah

1922 (series) Pengiran Matusin of the Mukah

1928 (April) Fishing 'barongs' at Mukah

The Life and Death of Fr, Bernard Mulder

1929 (May) Review of Melanau Stations

Lemanau accepted language for the S.G.O.
Examination

1931 (Feb) An Old Milano Story: 'Two Eggs at Mengkilo'

1948 (May) Tugau, paramount chief of the Melanaus

1949 (May) Melanau Customs at Mukah and Balingian

1969 (May) A list of Melanau Omen Birds

1969 (Nov) A Melanau Fishing Calendar

1. This story is told in many slightly different forms, and is nowadays generally attributed to Besiong, son-in-law of Tugau; another cultural hero added to the stock of the Soup which continually boils in the Pot of Myth (Tolkein 1964.30). The device of man-beast change is very widespread in Melanau myth, and also beast-jar (see Kaboy and Moore 1967 above).