

**PALACES OF CRYSTAL, SANCTUARIES OF LIGHT: WINDOWS, JEWELS AND GLASS IN
MEDIEVAL ISLAMIC ARCHITECTURE.**

Finbarr Barry Flood

Volume III:
Colour Illustrations and Figures

Doctor of Philosophy
University of Edinburgh
1993



LIST OF COLOUR ILLUSTRATIONS.

1. Painted alabaster window, Qubbat al-Sinānī, Jihāna.
2. Detail of alabaster window, Sana'a'.
3. Window glass, Khirbat al-Mīnya and Montfort.
4. Painted window glass, Khirbat al-Mafjar.
5. Painted window glass, Khirbat al-Mafjar.
6. Painted window glass, Khirbat al-Mafjar.
7. Painted window glass, Khirbat al-Mafjar.
8. *Qamariyyat* fragments, Qaṣr al-Hallābāt.
9. Reverse of *qamariyyat* fragments, Qaṣr al-Hallābāt.
10. Palace of Theodoric, Sant Apollinare Nuovo, Ravenna.
11. Painted *claustra* fragments, Fustat.
12. *Qamariyya* fragment, Palace B, Raqqa (National Museum, Damascus).
13. Painted window glass, East and West palaces, Raqqa.
14. Painted window glass, East and West palaces, Raqqa.
15. Painted window glass, East and West palaces, Raqqa.
16. *Qamariyya* fragment, East and West palaces, Raqqa.
17. *Qamariyyat* fragments, East and West palaces, Raqqa.
18. *Qamariyyat* fragments, East and West palaces, Raqqa.
19. Window glass, Samarra (British Museum).
20. Window glass, Samarra (British Museum).
21. Window glass, Samarra (British Museum).
22. Window glass, Samarra (British Museum).
23. Reverse of a *qamariyya*, al-Azhar Mosque, Cairo.
24. Window glass, Qaṣr al-Banat, Raqqa.
25. Window glass, Qaṣr al-Banat, Raqqa.
26. Window glass, Qaṣr al-Banat, Raqqa.

27. *Qamariyyat* fragments, Raqqa.
28. Fragment of a blind *qamariyya*, Qasr al-Banat, Raqqa.
29. Windows in the western wall of the Madrasa al-Shamīyya, Damascus.
30. *Qamariyyat* in the western wall of the Madrasa al-Shamīyya, Damascus.
31. *Qibla* wall, Jāmi' al-Hanābīlā, Damascus.
32. *Qamariyya* in the *qibla* of the Jāmi' al-Hanābīlā, Damascus.
33. *Qamariyya* in the eastern wall of the Jāmi' al-Hanābīlā, Damascus.
34. *Qamariyya* in the Maridāniyā Madrasa, Damascus (after Sauvaget, Les Mosquées III, fig. 75)
35. Modern *qamariyya*, mausoleum of Ṣalīḥ Najm al-Dīn al-Ayyūb, Cairo.
36. Painted glass, Rayy (National Museum, Stockholm).
37. Stucco and glass decoration, Mausoleum of Aḥmād ibn Sulaymān al-Rifā'ī, Cairo.
38. Detail of decoration, *qibla* wall of the Mausoleum of Aḥmād ibn Sulaymān al-Rifā'ī.
39. *Qibla* wall, Great Mosque of Qairawān.
- 39a. *Shamsiyya* above the *mihrab*, Great Mosque of Qairawān (after Marçais, Coupoles, fig. 8).
40. *Qibla* wall, Bu 'Ināniya Madrasa, Fez.
41. Exterior of a *shamsiyya*, Bu 'Ināniya Madrasa, Fez.
42. Window glass and lead tracery, Alhambra Palace, Granada (Museo de Arte Hispanomusulmán, Granada).
43. Tiled dado, Hall of the Ambassadors, Alhambra (after Sordo and Nestares, Tramas Geométricas, p. 45).
44. Mausoleum of Sultan Qalā'ūn, Cairo.
45. *Qamariyyat*, mausoleum of Sultan Qalā'ūn, Cairo.
46. *Qamariyyat*, mausoleum of Sultan Qalā'ūn, Cairo.
47. Window between pendentives, mausoleum of al-Ashraf Khalīl, Cairo.
48. Window between pendentives, mausoleum of al-Ashraf-Khalīl, Cairo.
49. Mausoleum of Zayn al-Dīn Yūsuf, Cairo.
50. *Qamariyya* above the *mihrab*, *madrasa* of al-Nāṣir Muḥammad, Cairo.
51. Mamluk and Ottoman *qamariyyat*, Museum of Islamic Art, Cairo.

52. *Qamariyyat*, mausoleum of Sanjar al-Gāwli, Cairo.
53. *Qamariyya*, mausoleum of Sanjar al-Gāwli, Cairo.
54. *Qamariyyat*, mausoleum of Baybars al-Jāshankīr, Cairo.
55. *Qamariyyat*, mausoleum of Baybars al-Jāshankīr, Cairo.
56. *Qamariyyat*, Qaṣr Bashtāk, Cairo.
57. *Qamariyya*, Qaṣr Bashtāk, Cairo.
58. *Qamariyya* in the *qibla* wall, Māridānī Mosque, Cairo.
59. *Qamariyyat* fragments, Museum of Islamic Art, Cairo.
60. Dome in front of the *mihrab*, Māridānī Mosque, Cairo.
61. Circular *qamariyya*, Māridānī Mosque, Cairo.
62. Part of a *qamariyya* from the Māridānī Mosque, Museum of Islamic Art, Cairo.
63. *Qamariyyat* in the zone of transition, mausoleum of Aṣlām al-Silāhdār, Cairo.
64. Circular *qamariyya* above the *mihrab*, mausoleum of Aṣlām al-Silāhdār, Cairo.
65. *Qamariyya* in the *qibla* wall, mausoleum of Aṣlām al-Silāhdār, Cairo.
66. Detail of a *qamariyya* in the *qibla* wall, mausoleum of Aṣlām al-Silāhdār, Cairo.
67. *Qibla* wall, *madrassa* of Amir Mithqāl, Cairo.
68. *Qamariyya* in the *qibla* wall, *madrassa* of Amir Mithqāl, Cairo.
69. *Qamariyya* in the *qibla iwan*, *madrassa-khanqah* of Barqūq, Cairo.
70. Detail of the *qamariyya* shown in ill. 69.
71. *Qamariyya* in the *qibla iwan*, *madrassa-khanqah* of Barqūq, Cairo.
72. Detail of the *qamariyya* shown in ill. 71.
73. *Qamariyya* in the *qibla iwan*, *madrassa-khanqah* of Barqūq, Cairo.
74. Circular *qamariyya* above the *mihrab*, mausoleum in the *madrassa-khanqah* of Barqūq, Cairo.
75. *Qamariyya* in the *qibla* wall, *madrassa* of Ināl al-Yūsufī, Cairo.
76. *Qamariyya* in the *qibla* wall, *madrassa* of Ināl al-Yūsufī, Cairo.
77. *Qamariyyat* in the north-western *iwan*, *madrassa* of Ināl al-Yūsufī, Cairo.
78. Detail of the *qamariyyat* shown in ill. 77.

79. *Qamariyya* above the *mihrab*, *madrasa* of Īnāl al-Yūsufī, Cairo.
80. Detail of a *qamariyya* in the north-western wall of the mausoleum, *madrasa* of Īnāl al-Yūsufī.
81. *Qamariyya*, mausoleum of Yashbak, Damascus.
82. *Qamariyya* in the the north-eastern *iwan*, *madrasa* of Jamāl al-Dīn Yūsuf al-Ustādār, Cairo.
83. *Qibla* wall, Tayrōzi Mosque, Damascus.
84. *Qamariyya* above the *mihrab*, Tayrōzi Mosque, Damascus.
85. *Qamariyya* in the *qibla* wall, Tayrōzi Mosque, Damascus.
86. *Qamariyya* in the *qibla* wall, Tayrōzi Mosque, Damascus.
87. *Qamariyya* above the *mihrab*, Jāmi' al-Hanābilā, Damascus.
88. *Qamariyya* in the eastern wall, Jāmi' al-Hanābilā, Damascus.
89. *Qamariyya* above the *mihrab*, *Madrasa al-Shamīyya*, Damascus.
90. Type II *qamariyya*, *madrasa* of Abū Bakr ibn Muzhir, Cairo.
91. Type II *qamariyya*, *madrasa* of Abū Bakr ibn Muzhir, Cairo.
92. Type III *qamariyya*, *madrasa* of Abū Bakr ibn Muzhir, Cairo.
93. *Qamariyya*, mosque of al-Mu'ayyad, Cairo.
94. Detail of the *qamariyya* shown in ill. 93.
95. *Qibla* wall, mosque of Qajmās al-Ishāqī, Cairo.
96. Circular *qamariyya* above the *mihrab*, mosque of Qajmās al-Ishāqī, Cairo.
97. North-eastern wall, mosque of Qajmās al-Ishāqī, Cairo.
98. Type I *qamariyya*, mosque of Qajmās al-Ishāqī, Cairo.
99. Type I *qamariyya*, mosque of Qajmās al-Ishāqī, Cairo.
100. Type II *qamariyya*, mosque of Qajmās al-Ishāqī, Cairo.
101. Type III *qamariyya*, mosque of Qajmās al-Ishāqī, Cairo.
102. Type IV *qamariyya*, mosque of Qajmās al-Ishāqī, Cairo.
103. Type V *qamariyya*, mosque of Qajmās al-Ishāqī, Cairo.
104. *Qamariyya* in the south-western wall, mausoleum of Qāyṭbāy, Cairo.
105. *Qamariyya* from the mosque of Qajmās al-Ishāqī, Museum of Islamic Art, Cairo.

106. Tenth/sixteenth-century Mamluk carpet, Textile Museum, Washington DC (after Atil, Renaissance, No. 127).
107. Tenth/sixteenth-century Mamluk carpet (after Sotheby's, Islamic Works of Art, No. 38).
108. Illuminated Qur'an, Iraq or Persia, 485/1092 (after Lings, Quranic Art, pl. 16).
109. Humay at the Court of Humayūn, Diwān of Khwājū Kirmānī, Baghdad 799/1396 (after Gray, Persian Painting from Miniatures, pl. 4).
110. Type I window, Gulistan of Sā'di, Herat 831/1427, fol. 16v (Chester Beatty Library, Dublin).
111. Type I window, Gulistan of Sā'di, Herat 831/1427, fol. 36 (Chester Beatty Library, Dublin).
112. Bahram Gur in the Hall of the Seven Images, Anthology of Iskandar Sultan, Shiraz 813/1410 (after Gray, Persian Painting, p. 75).
113. Detail from The Fire Ordeal of Siyavush, Shāhnāma, probably Shiraz 800/1397-8 (after Hillenbrand, Imperial Images, No. 124).
114. Tahmina's visit to Rustam, Shāhnāma, Herat c. 844/1440 (after Pope, SPA, pl. 875).
115. Scandal in a Mosque, Diwān of Hafiz, Shiraz c. 942/1535 (after Welch, Royal Persian Manuscripts, pl. 16).
116. Why is that Sufi in the *hammam* ?, Haft Awrang, Mashhad 964-73/1556-65 (after Welch, Royal Persian Manuscripts, pl. 38).
117. Detail of a window from the Darb-i Imām, Isfahan (after Orazi, Wooden Gratings, pl. 3).
118. Detail of a window in the Mosaver al-Mulk House, Isfahan (after Cantacuzino and Browne, Isfahan, pl. 16).
119. *Qibla* wall, Süleymaniye Mosque, Istanbul.
120. Windows above the *mihrab*, Süleymaniye, Istanbul.
121. Window in the *qibla* wall, Süleymaniye, Istanbul.
122. The guild of cooks, Surnāme-i Humayūn (after Ministry of Culture, Ottoman Empire, pl. 42).
123. Windows in the Harem of Topkapi.
124. Windows in the Harem of Topkapi.
125. The guild of harness-makers, Surnāme-i Humayūn (after Ministry of Culture, Ottoman Empire, pl. 56).
126. Portrait of Selim II (after Welch and Welch, Arts of the Book, No. 6).
127. The guild of glaziers, Surnāme-i Humayūn (Topkapi Palace Library, H.1344.1 folios 410b-402a).
128. *Qamariyya* in the *qibla* wall, Mosque of al-Ṣafīḥ Talā'ī, Cairo.

129. Detail of the *qamariyya* shown in ill. 128.
130. Mirador de la Daraxa, Alhambra Palace, Granada.
131. Detail of the ceiling visible in ill. 130.
132. Muhammad sees the *Sidrat al-Muntaha*, *Mir'āj Nāma*, Herat ninth/fifteenth century (after Séguy, *Miraculous Journey*, pl. 31).
133. Detail of the mosaics in the western *riwaq*, Great Mosque of Damascus.
134. Heavenly Jerusalem, San Vitale, Ravenna.
135. Fragments of a glass pavement, Palace B, Raqqa (National Museum, Damascus).
136. Wooden ceiling, Hall of the Ambassadors, Alhambra (after Rodriguez, *El Techo*, pl. XXV).
137. The 'zodiac clock' of al-Jazarī (after al-Hassan, *al-Jāmi` Bain al-'Ilm*, pl. 4).
138. "Cup of Khusrau", Bibliothèque Nationale, Paris (photograph A. Shalem).
139. Qur'an frontispiece found in Sana'a' (after von Bothmer, *Architekturbilder*, fig. 1).
140. *Mihrab* in the Mosque at Bīdakhavīd (photograph B. O'Kane).
141. *Mihrab* in the shrine at Tulan Pusht (photograph B. O'Kane).
142. *Mihrab* in the shrine of Qadam Gah, Bīdakhavīd (photograph B. O'Kane).
143. Illuminated dome and minarets, Aṣwān.
144. Making an 'aqd - tracing the design (photograph M. Mutahir).
145. Making an 'aqd - cutting the design (photograph M. Mutahir).
146. Making an 'aqd - the finished design (photograph M. Mutahir).
147. Making an 'aqd - preparing the glass (photograph M. Mutahir).
148. Making an 'aqd - laying the second layer of plaster (photograph M. Mutahir).
149. *Qamariyyat* and *mashrabiyyat*, Coptic Museum, Cairo.

FIGURES.

1. Windows depicted on a stele at Axum (after Krencker, Nordabessinien Denkmäler, figs. 47-8).
2. Design carved on an alabaster window, Masġid al-`Abbās, Ḥaulan (after Finster, Masġid al-`Abbās, fig. 61).
3. Design on an alabaster window, mosque of al-`Abbās, Ḥaulan (after Finster, Masġid al-`Abbās, fig. 60).
4. Reconstruction drawing of the Ka`ba after the description of Ibn `Abd Rabbih (after Jairazbhoy, Shrines, fig. 11b).
5. Reconstruction drawing of the Ka`ba after the description of Nasir-i Khusrau (after Jairazbhoy, Shrines, fig. IV).
6. Antique basalt window-grilles in the facade of the Turbat Aidekin, Damascus (after Herzfeld, Studies III, figs. 84-5).
7. *Qamariyyat* fragments from Qaṣr al-Ḥayr al-Sharqī (scale 1:1).
8. Painted window-glass from Khirbat al-Mafjar (after Brosch, Glass windows, fig. 3).
9. *Qamariyyat* fragments from Qaṣr al-Hallābāt (scale 1:1).
10. *Qamariyyat* fragments from Qaṣr al-Hallābāt (scale 1:1).
11. Stages in the manufacture of a *qamariyya*.
12. Section through a modern Yemeni stucco and glass window (after Bonnenfant, Artisans, fig. 4).
13. Stages in the manufacture of stucco and glass windows from Umm Qais (drawings, F. Gor Andersen).
14. *Qamariyyat* fragments from the `Abbasid palaces at Raqqa (scale 2:3).
15. *Qamariyyat* fragments from the `Abbasid palaces at Raqqa (scale 2:3).
16. Examples of painting on colourless window-glass, `Abbasid palaces at Raqqa (scale 1:1).
17. Examples of painting on blue window-glass, `Abbasid palaces at Raqqa (scale 1:1).
18. Examples of painting on purple window-glass, `Abbasid palaces at Raqqa (scale 1;1).
19. Examples of painting on dark green window-glass, `Abbasid palaces at Raqqa (scale 1:1).
20. Examples of painting on yellow window-glass, `Abbasid palaces at Raqqa (scale 1:1).
21. Designs from two lustre-painted glass vessels found at Raqqa (R 49-50, National Museum, Damascus).
22. Hypothetical reconstruction of a *qamariyya* from the West Palace, Raqqa. (scale 1:5, stucco tracery shaded).
23. Stucco roundel from Kish (after SPA, fig. 193a).

24. *Qamariyyat* fragments from Samarra, scale 2:3 (after Lamm, Das Glas, figs. 72-6).
25. Painted window-glass from Samarra, scale 1:1 (after Lamm, Das Glas, figs. 58-60).
26. Stucco tracery, Deir Abū Makar, Wadi Natrun (after Evelyn-White, Monasteries, fig. 7).
27. Stucco tracery, Deir al-Sūryānī, Wadi Natrun (visible in Evelyn-White, Monasteries, pl. LXX)
28. *Qamariyyat* fragments from Qaṣr al-Banat, Raqqa (scale 2:3).
29. Partial reconstruction of *qamariyyat* fragments from Qaṣr al-Banat, Raqqa (scale 2:3).
30. Pieces of cut window-glass, Qaṣr al-Banat, Raqqa (scale 2:3).
31. Border motif from a *qamariyya* formerly in the Jaharkasiyya Madrasa, Damascus (after Sauvaget, Monuments I, p. 43).
32. Reconstruction of a stained glass window from Atlit (after Johns, Excavations, fig. 8).
33. Windows above the *mihrab*, Great Mosque of Qairawān (after Golvin, Mihrab, fig. 13.).
34. *Shamsiyya* in the Bu 'Ināniya Madrasa, Fez (after Dannerbeck, Representations, pl. 11).
35. Cut pieces of colourless (transparent) and white (opaque) window-glass in the collection of the Museo de Arte Hispanomusulmán, Granada (scale 3:4).
36. Cut pieces of blue glass, Museo de Arte Hispanomusulmán, Granada (scale 3:4).
37. Lead tracery and pieces of amber, ultramarine and bottle green glass, Museo de Arte Hispanomusulmán, Granada (scale 3:4).
38. Window said to be from the Alhambra (after Day, Windows, fig. 3).
39. Three Mamluk windows featuring vase motifs:
 - (a) *Madrasa* of al-Nāṣir Muhammad, Cairo.
 - (b) Mosque of al-Ṣalīḥ Talā'ī, Cairo.
 - (c) Museum of Islamic Art, Cairo (Inventory No. 4282).
40. Circular *qamariyyat* of the Ayyubid and Bahri Mamluk periods:
 - (a) Maridāniyyā Madrasa, Damascus.
 - (b) Mausoleum of al-Ashraf Khalīl, Cairo.
 - (c) Qaṣr Bashtāk, Cairo.
 - (d) Māridānī mosque, Cairo.
 - (e) Mausoleum of Aṣlām al-Silāḥdār, Cairo.
41. Bahri Mamluk *qamariyyat*:
 - (a) Qaṣr Bashtāk, Cairo.
 - (b) *Madrasa* of Amir Mithqāl, Cairo.
42. Bahri Mamluk *qamariyyat*:
 - (a) Māridānī Mosque, Cairo.
 - (b) Mausoleum of Aṣlām al-Silāḥdār, Cairo.

43. Bahri and Burjī Mamluk *qamariyyat*:
 (a) *Madrasa* of Ilgay al-Yūsufī, Cairo.
 (b) & (c) *Madrasa-khanqah* of Barqūq, Cairo.
44. Circular *qamariyyat* of the Burjī Mamluk period:
 (a) Mausoleum adjoining the *khanqah-madrasa* of Barqūq, Cairo.
 (b) *Madrasa* of Ināl al-Yūsufī, Cairo; *qibla iwan*.
 (c) *Madrasa* of Ināl al-Yūsufī, mausoleum.
 (d) Mosque of Gānī Bek, Cairo.
 (e) Mosque of Qajmās al-Ishāqī, Cairo.
45. Star medallion, Khatūnīyya *Madrasa*, Jerusalem (after Burgoyne, Mamluk Jerusalem, fig. 31.121).
46. Design on a mirror from Aleppo dated 720/1320 (after Aga-Oglu, Prachtspiegel, fig. 1).
47. Burji Mamluk *qamariyyat*:
 (a) *Madrasa* of Ināl al-Yūsufī, Cairo.
 (b) *Madrasa* of Jamāl al-Dīn Maḥmūd al-Ustādār, Cairo.
 (c) *Madrasa* of Jamāl al-Dīn Yūsuf al-Ustādār, Cairo.
48. Window in the mosque of Gānī Bek, Cairo.
49. *Qamariyyat* in the *madrasa* of Abū Bakr ibn Muzhir, Cairo:
 (a) Type II
 (b) Type III
50. *Qamariyyat* in the mosque of Qajmās al-Ishāqī, Cairo:
 (a) Type I.
 (b) Type II.
 (c) Type III.
 (d) Type IV.
51. *Qamariyyat* in the mosque of Qajmās al-Ishāqī, Cairo:
 (a) Type V *qamariyya*, mosque of Qajmās al-Ishāqī, Cairo.
 (b) Detail of type I *qamariyya*, mosque of Qajmās al-Ishāqī.
 (c) Detail of a *qamariyya* in the mosque of al-Mu'ayyad, Cairo.
52. Detail of a *qamariyya* in the Turbat al-Tāynābīyya, Damascus.
53. a-c: *Qamariyyat* in the Yalbughā Mosque, Damascus.
54. Mamluk *qamariyyat* in Damascus (yellow glass shaded).
 (a) Jāmi' al-Tayrouzi, above the *mihrab*.
 (b) Jāmi' al-Tayrouzi, in the *qibla* wall.
 (c) Jāmi' al-Hanābilā, above the *mihrab*.
55. Windows in Persian miniatures type I, sources:
 (a) Humay at the court of Humayūn, Diwān of Khwājū Kirmānī, Baghdad 799/1396 (Gray, Persian Painting from miniatures, pl. 4).

- (b) Giv brings Gurgan before Kay Khusrau, *Shāhnāma*, Gilan 899/1493-4 (Lowry and Nemazee, *A Jeweler's Eye*, No. 17).
- (c) The King of the East before two ladies, *Khavar Nāma*, ? Shiraz 881/1477 (Hillenbrand, *Imperial Images*, No. 101).
- (d) Nauruz and Gul, Berlin Baysunghur Manuscript, Shiraz, 823/1420 (Enderlein, *Miniaturen*, No. 32).
- (e) Iskandar in a magic garden, *Khamsa* of Nizāmī, Tabriz 945-9/1539-43 (Robinson, *Persian Miniature Paintings*, No. 39).
- (f) *Gulistan* of Sā'adi, Herat 831/1427, fol. 36 (from ill. 111).
56. Windows in Persian miniatures type II, sources:
- (a) Bahram Gur introduced to the Hall of Seven Images, *Khamsa*, Shiraz 813/1410 (Gray, *Persian Painting*, p. 75).
57. Windows in Persian miniatures type III, sources:
- (a) Humay at the court of Humayūn, *Diwān* of Khwājū Kirmānī (Gray, *Persian Painting from Miniatures*, pl. 4).
- (b) Tahmīna's visit to Rustam, *Shāhnāma*, Herat c. 844/1440 (*SPA*, pl. 875).
58. Windows in Persian miniatures type IV, sources:
- (a) Tahmīna's visit to Rustam, *Shāhnāma*, Herat c. 810/1440 (*SPA*, pl. 875).
59. Windows in Persian miniatures type V, sources:
- (a) Bahram Gur introduced to the Hall of the Seven Images, *Khamsa*, Shiraz 813/1410 (Gray, *Persian Painting*, p. 75).
60. Windows in Persian miniatures type VI, sources:
- (a) Scandal in a mosque, *Diwān* of Hafiz, Shiraz c. 942/1535 (Welch, *Royal Persian Miniatures*, No. 16).
- (b) The Assassination of Khusrau Parviz, *Shāhnāma*, Tabriz c. 942/1535 (Dannerbeck, *Representations*, pl.16).
- (c) Bahram Gur in the black pavilion, *Khamsa* of Nizāmī, Shiraz, early tenth/sixteenth century (Guest, *Shiraz Painting*, pl. 13).
61. Windows in Persian miniatures type VII, sources:
- (a) Shirīn giving an audience to Khusrau, *Khusrau-u Shirīn*, Shiraz 955/1548 (after Guest, *Shiraz Painting*, pl. 7).

- (b) Why is that *sufi* in the *hammam* ?, *Haft Awrang*, Mashhad 964-73/1556-65 (after Welch, Royal Persian Manuscripts, pl. 38).
62. Windows in Persian miniatures type VIII, sources:
 (a) The wedding feast of Khusrau and Shirin, *Khusrau-u Shirin*, Tabriz c. 937/1530 (Robinson, Persian Paintings in the John Rylands Library, No. 553).
63. Windows in Persian miniatures type IX, sources:
 (a) Zulaikha and her companions, *Yusuf-u Zulaikha*, Shiraz 954/1547 (Guest, Shiraz Painting, pl. 35b).
 (b) Zulaikha and her companions, *Yusuf-u Zulaikha*, Shiraz c. 954/1547 (Guest, Shiraz Painting, pl. 35a).
64. Window from the Yesil Turbe, Bursa (after Arseven, Arts Decoratifs, fig. 467).
65. Window from the Yeni Çami, Istanbul (after a photograph in Arseven, Arts Decoratifs, fig. 461).
66. Windows in the Beyazit Pasha Mosque, Amasya (after Gabriel, *Monuments* II, fig. 13).67.
- 67 Domes of the Amūniyya *hammam*, Damascus, late sixth/twelfth century (after Sauvaget & Écochard, Bains, fig. XXXV).
68. Dome of the Mukhfiya *hammam*, Fez, eighth/fourteenth century (after Terrasse, *Trois bains*, fig. 7).
69. Lamp motif painted on the interior of Kharraqān I (after Daneshvari, Medieval Tomb Towers, fig. 28).
70. Lamp hanging in the doorway of a shrine, detail from the fifth-century mosaics on the triumphal arch, S. Maria Maggiore, Rome (after Cecchelli, Mosaici, pl. LXII).
71. Lamp images on Egyptian tombstones:
 (a) On an Egyptian tombstone dated 576/1181 (after Wiet, Stèles, No. 6738, pl. XLI).
 (b) On an Egyptian tombstone dated 684/1285 (after Wiet, Stèles, No. 13079, pl. LII).
72. Detail of a carving on the facade of the Friday Mosque at Eski Malatya (after Baer, *Eski Malatya*, fig. 2b).
73. *Mihrab* plaque from the Madrasa al-Budayriyya, Cairo 759/1357 (after Atil, Renaissance, No. 111).
74. Carved plaque in the *mihrab* of the Great Mosque of Tunis (after Lézine, Architecture, fig. 32).
75. The world map of al-Birūnī (after Nasr, *Cosmographie*, fig. 3).
76. Medallion above the windows of the Takritiyya Madrasa, Damascus (after Herzfeld, *Damascus: Studies* III, fig. 82).
77. Medallion on a lintel at 'Ujah (after Butler, Ancient Architecture, ill. 71).
78. Stucco panel on the rear wall of the *mihrab*, Great Mosque of Taza (after Terrasse, Taza, pl. LV).

COLOUR ILLUSTRATIONS



1. Painted alabaster window, Qubbat al-Sinānī, Jihāna.



2. Detail of alabaster window, Sana'a'.



3. Window glass, Khirbat al-Minya and Montfort (Israel Museum, Jerusalem).

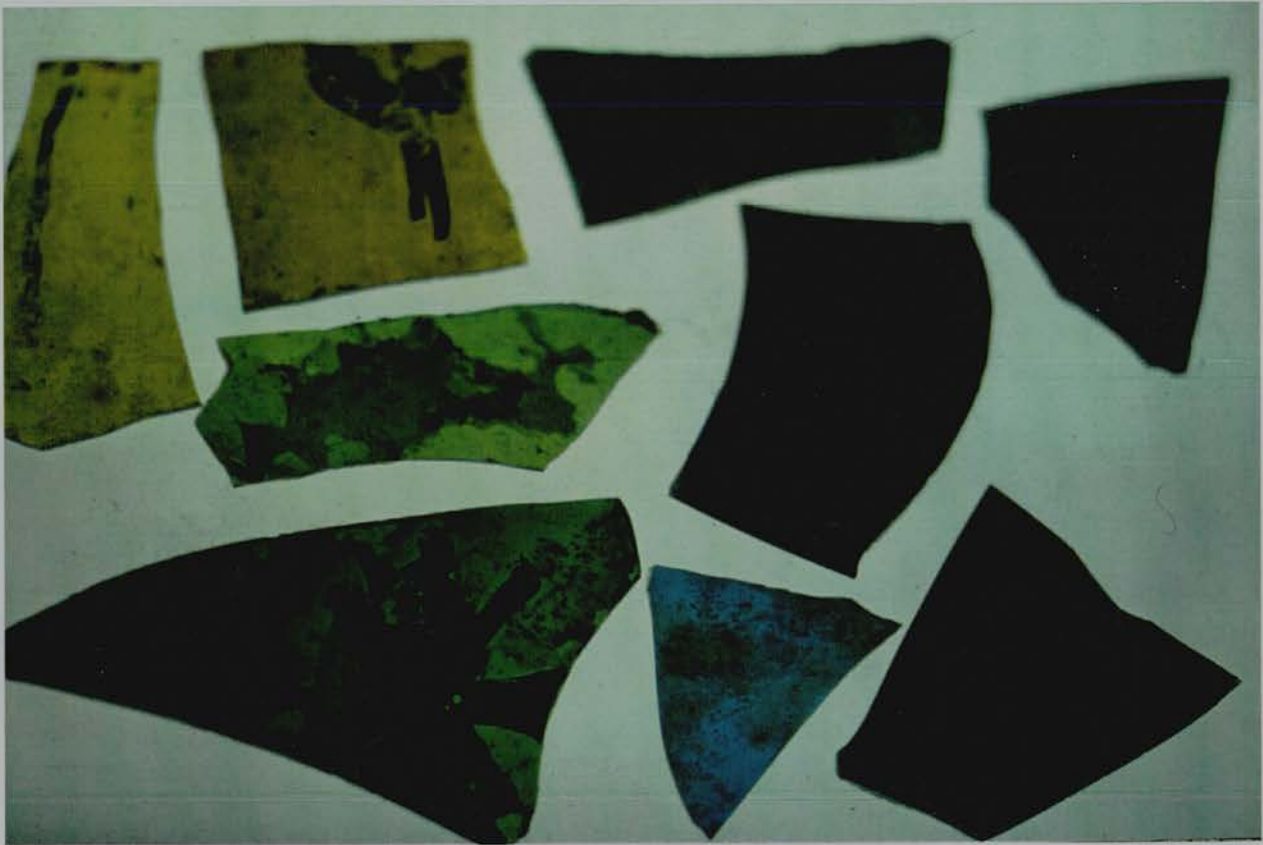

4. Painted window glass, Khirbat al-Mafjar (Israel Museum, Jerusalem).



5. Painted window glass, Khirbat al-Mafjar (Israel Museum, Jerusalem).



6. Painted window glass, Khirbat al-Mafjar (Israel Museum, Jerusalem).

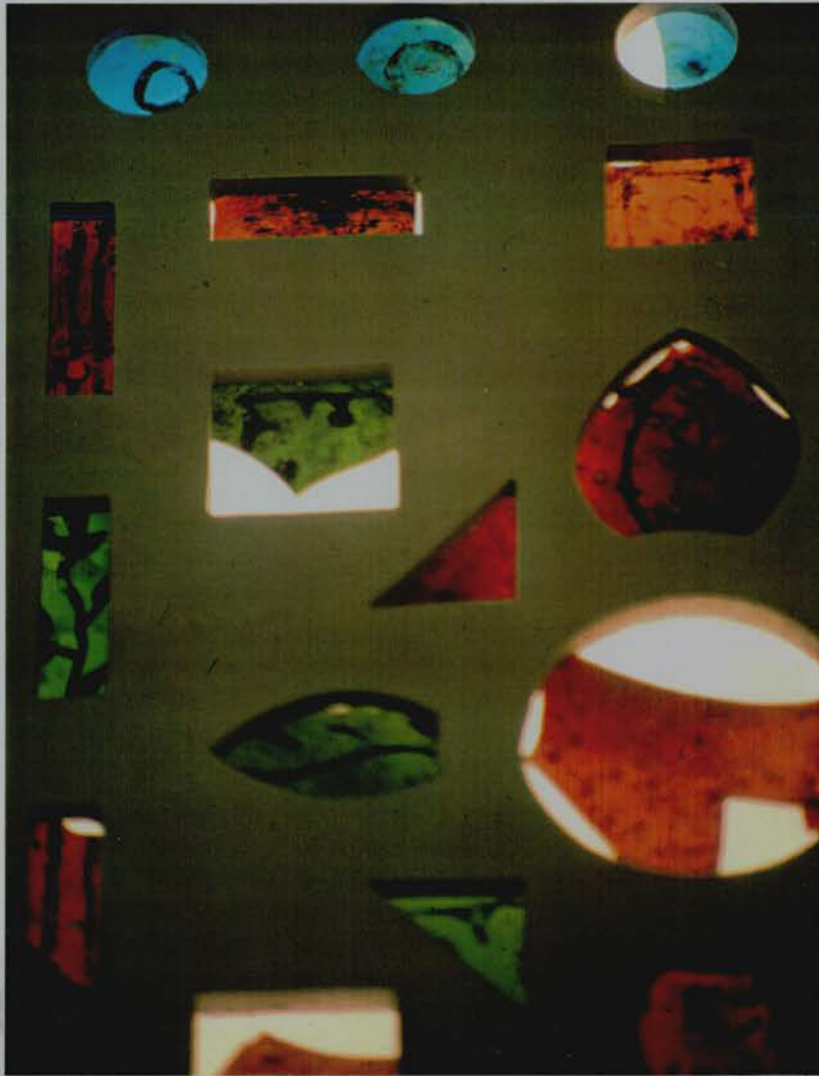

7. Painted window glass, Khirbat al-Mafjar (Israel Museum, Jerusalem).



8. *Qamariyyat* fragments, Qaṣr al-Hallābāt.



9. Reverse of *qamariyyat* fragments, Qaṣr al-Hallābāt.

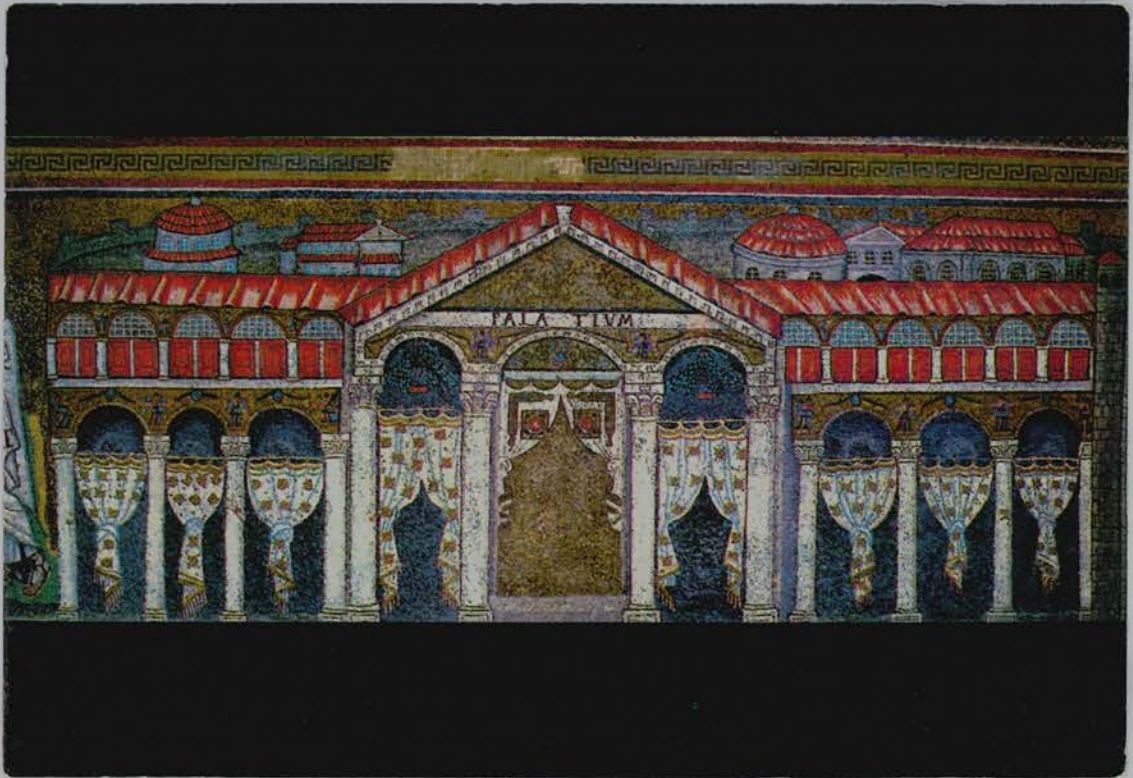

10. Palace of Theodoric, Sant Apollinare Nuovo, Ravenna.



11. Painted *claustra* fragments, Fustat (photograph G. Scanlon)..



12. *Qamariyya* fragment, Palace B, Raqqa (National Museum, Damascus).



13. Painted window glass, East and West palaces, Raqqa.



14. Painted window glass, East and West palaces, Raqqa.



15. Painted window glass, East and West palaces, Raqqa.



16. *Qamariyya* fragment West palace, Raqqa.



17. *Qamariyyat* fragments, East and West palaces, Raqqa.



18. *Qamariyyat* fragments, East and West palaces, Raqqa.

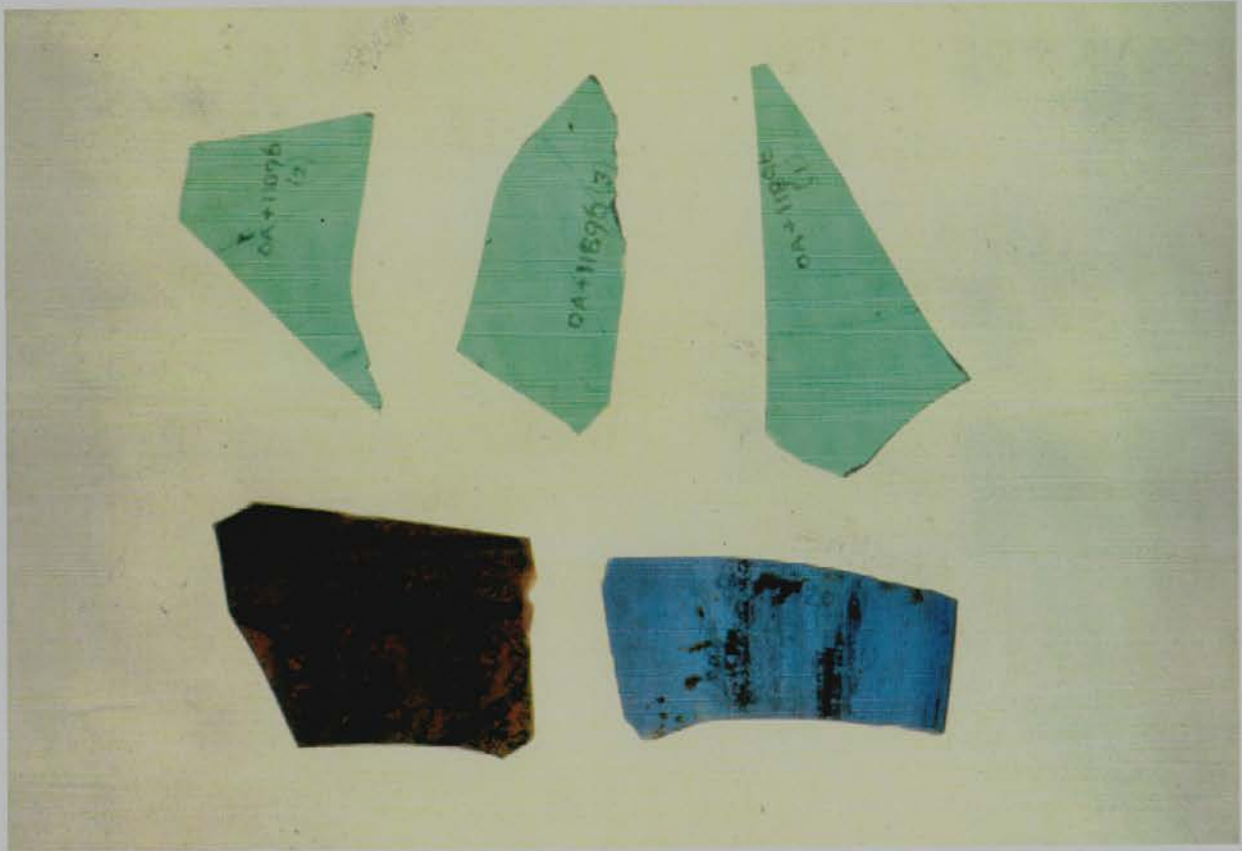

19. Window glass, Samarra (British Museum).

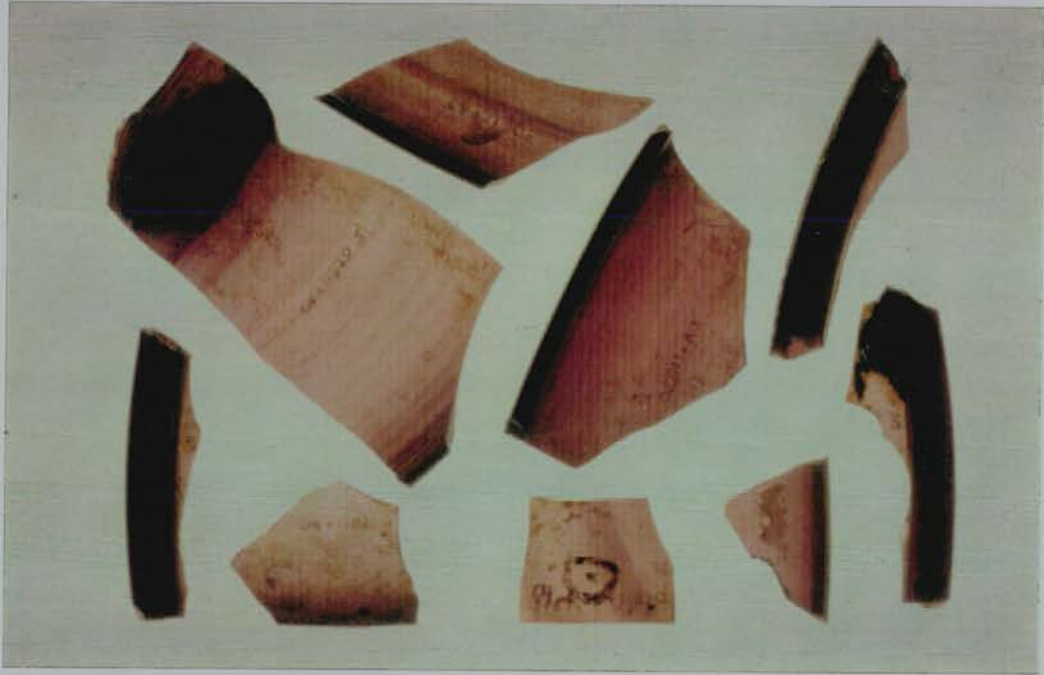

20. Window glass, Samarra.

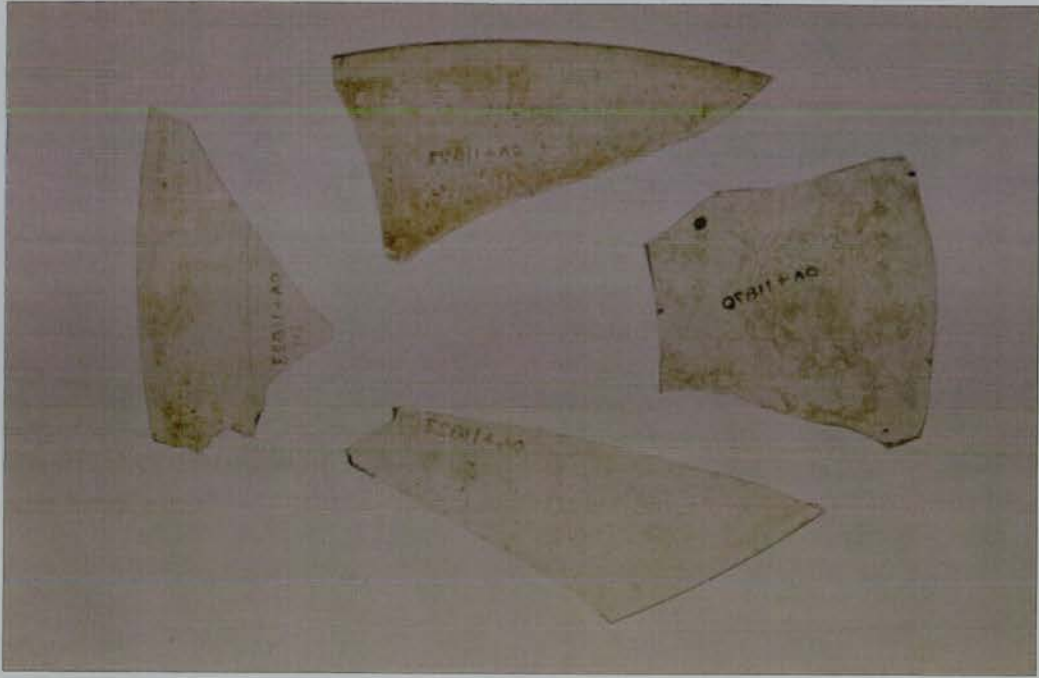

21. Window glass, Samarra.



22. Window glass, Samarra.



23. Reverse of a *qamariyya*, al-Azhar Mosque, Cairo.



24. Window glass, Qasr al-Banat, Raqqa.

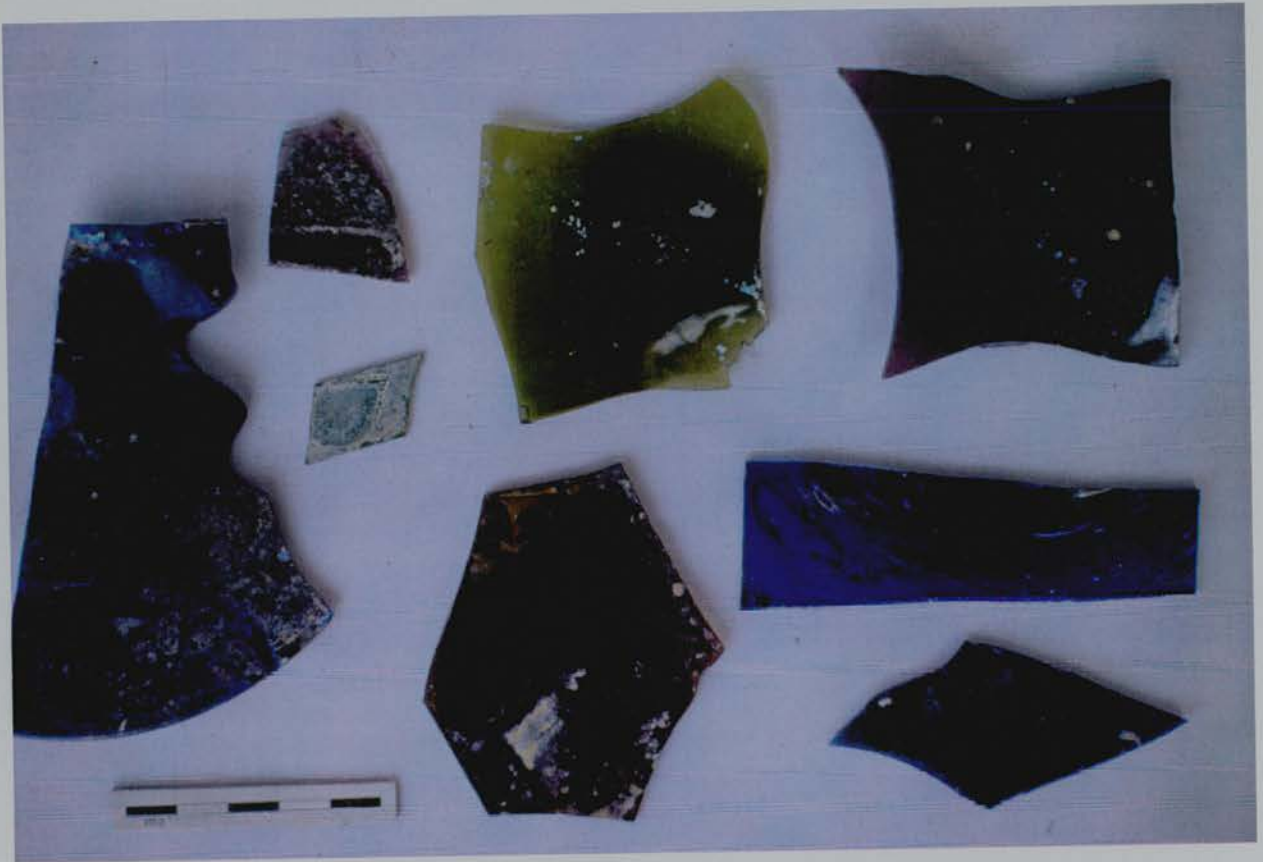

25. Window glass, Qasr al-Banat, Raqqa.



26. Window glass, Qasr al-Banat, Raqqa.



27. *Qamariyyat* fragments, Qasr al-Banat, Raqqa (photograph A. 'Abd al-Ghafour).



28. Fragment of a blind *qamariyya*, Qasr al-Banat, Raqqapp.



29. Windows in the western wall of the Madrasa al-Shamiyya, Damascus.

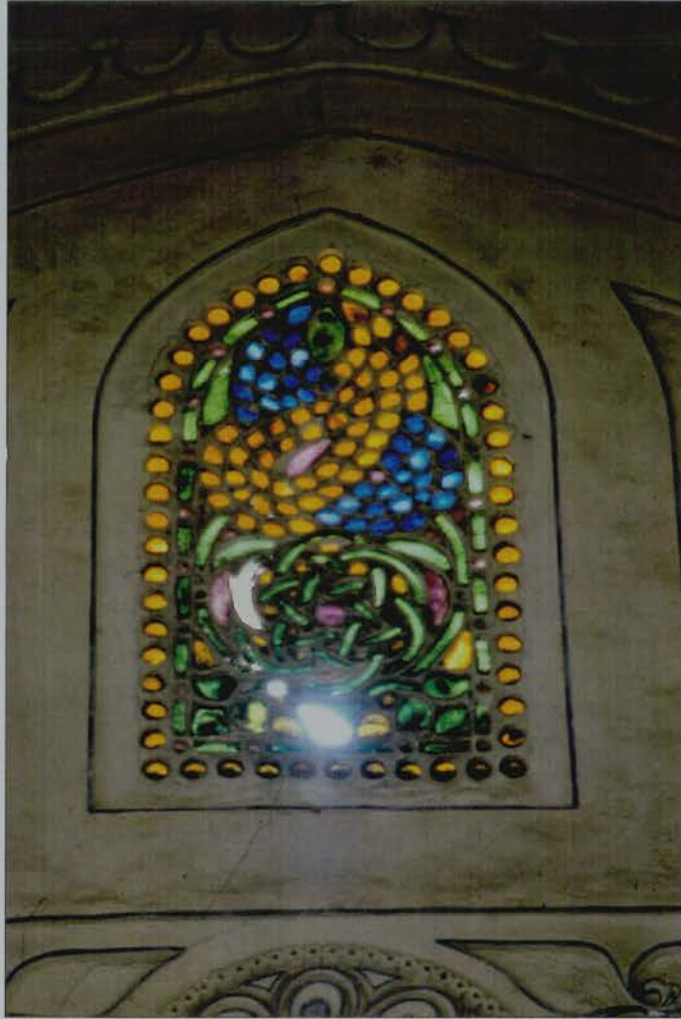

30. *Qamariyya* in the western wall of the Madrasa al-Shamīyya, Damascus.



31. *Qibla* wall, Jāmi' al-Hanābilā, Damascus.

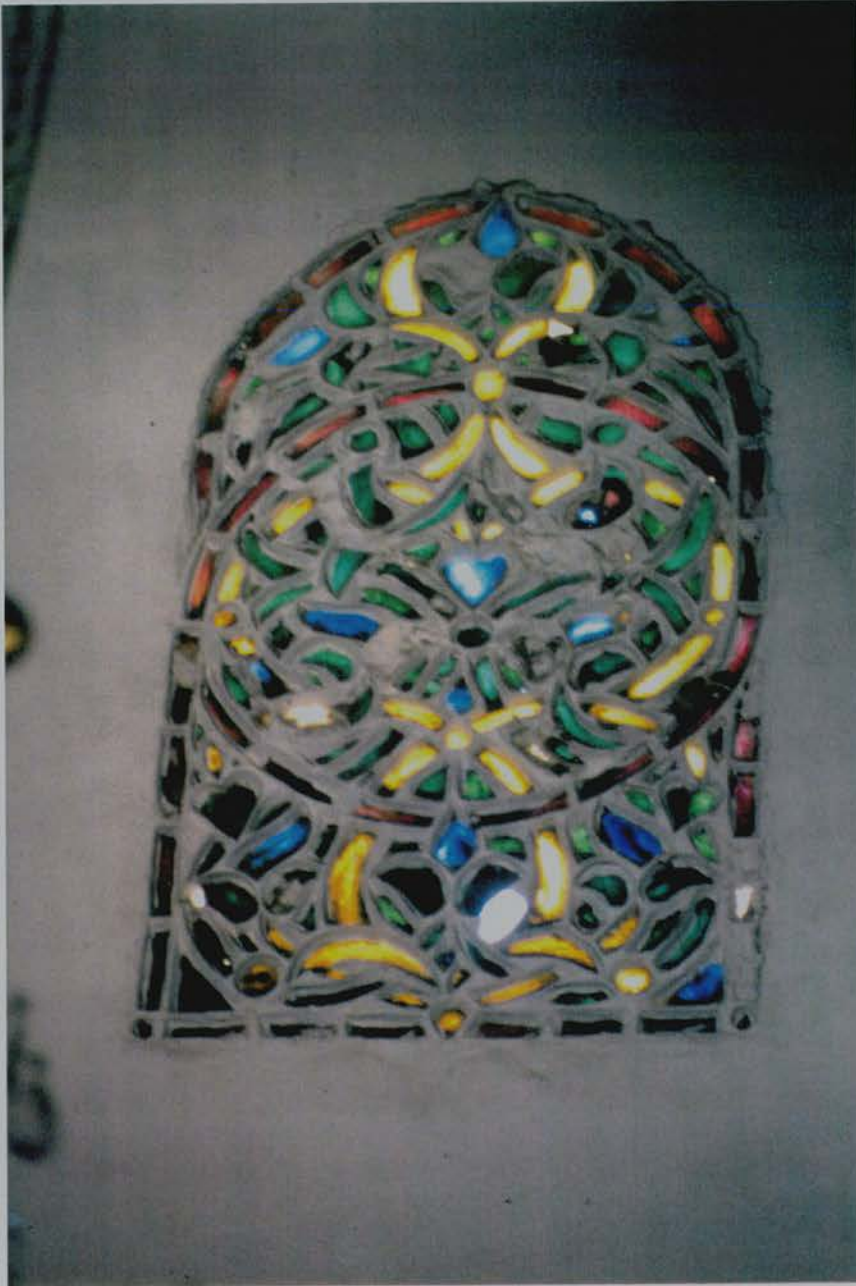

32. *Qamariyya* in the *qibla* wall of the Jāmi' al-Hanābīlā, Damascus.

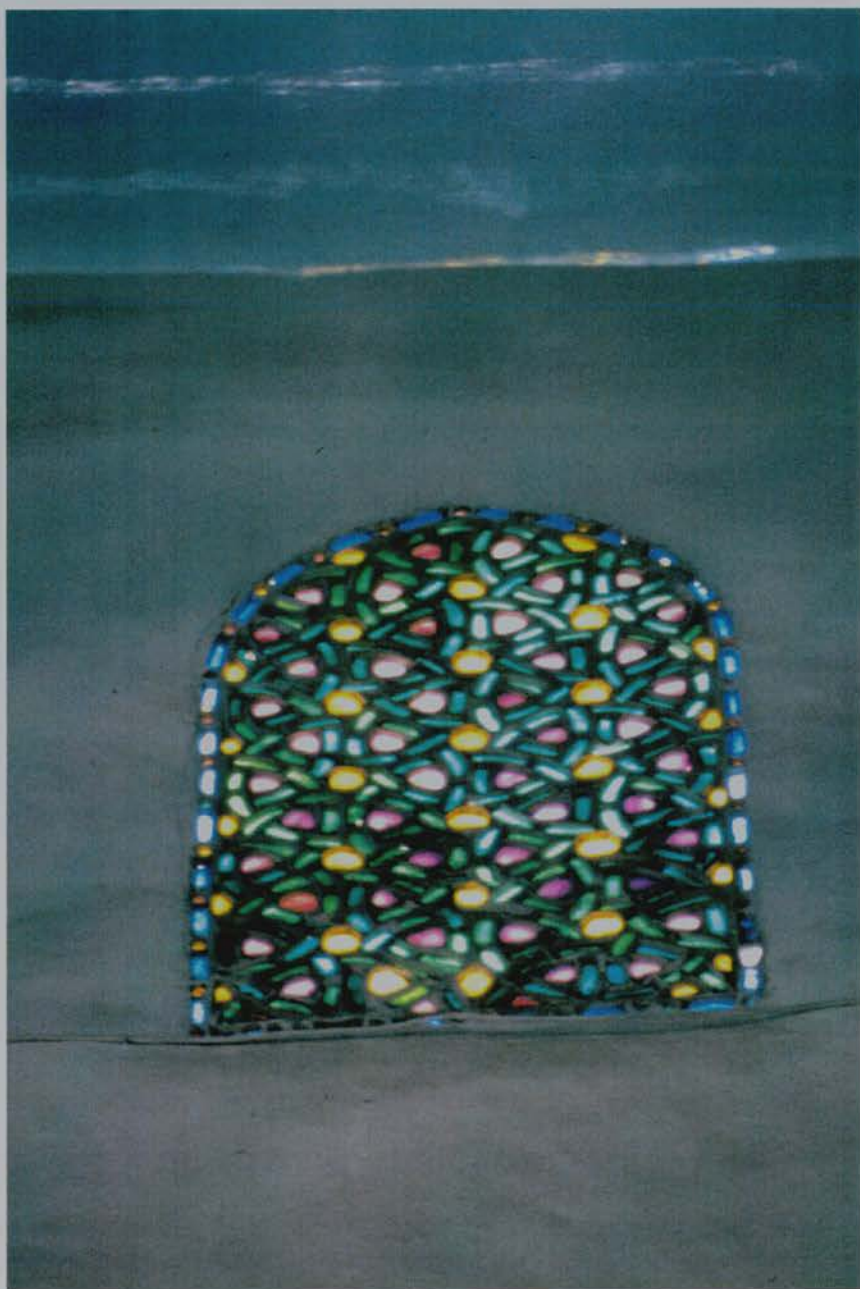

33. *Qamariyya* in the eastern wall of the *Jāmi' al-Hanābilā*, Damascus.



34. *Qamariyya* in the Maridāniya Madrasa, Damascus (after Sauvaget, Les Mosquées III, fig. 75)



35. Modern *qamariyya*, Mausoleum of Ṣalīḥ Najm al-Dīn al-Ayyūb, Cairo.



36. Painted glass, Rayy (National Museum, Stockholm).



37. Stucco and glass decoration, Mausoleum of Ahmad ibn Sulaymān al-Rifāʾī, Cairo.



38. Detail of decoration, *qibla* wall of the Mausoleum of Ahmad ibn Sulayman al-Rifāʾī.



39. *Qibla* wall, Great Mosque of Qairawān.

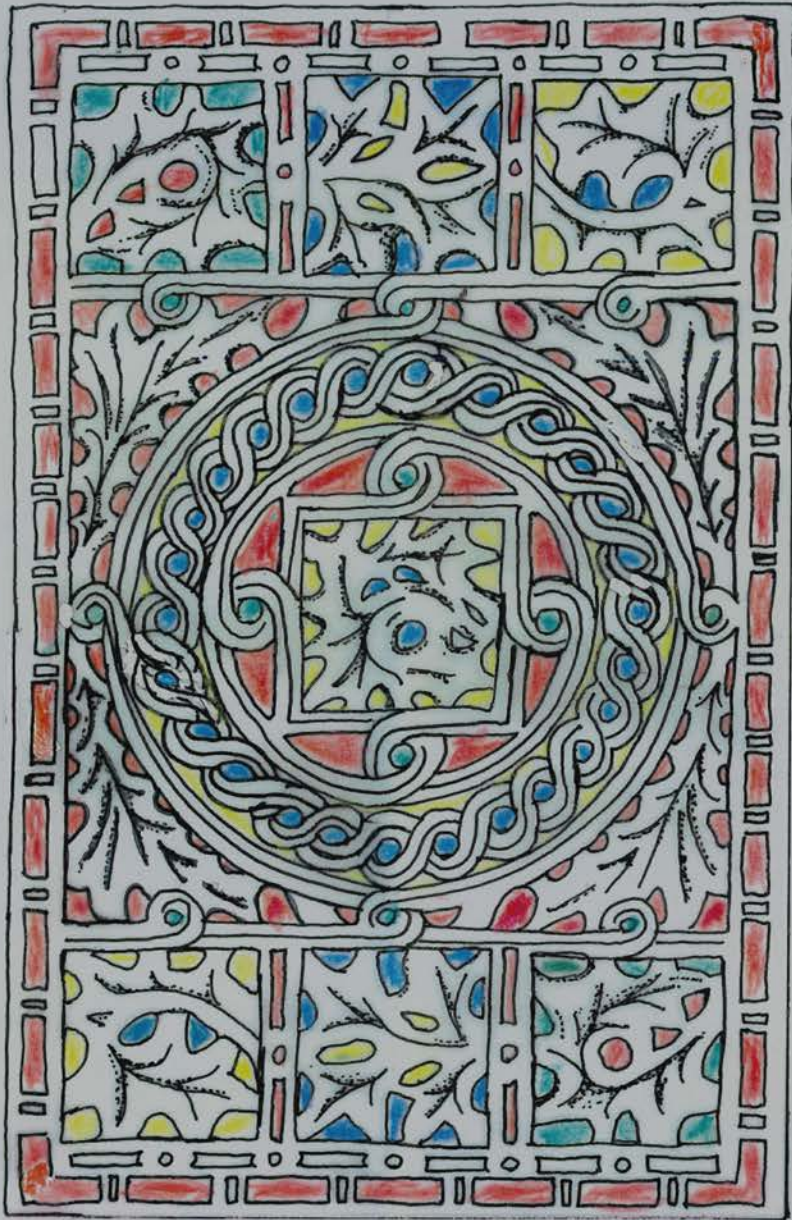

39a. *Shamsiyya* above the *mihrab*, Great Mosque of Qairawān (after Marçais, *Coupoles*, fig. 8).



40. *Qibla* wall, Bu 'Ināniya Madrasa, Fez.

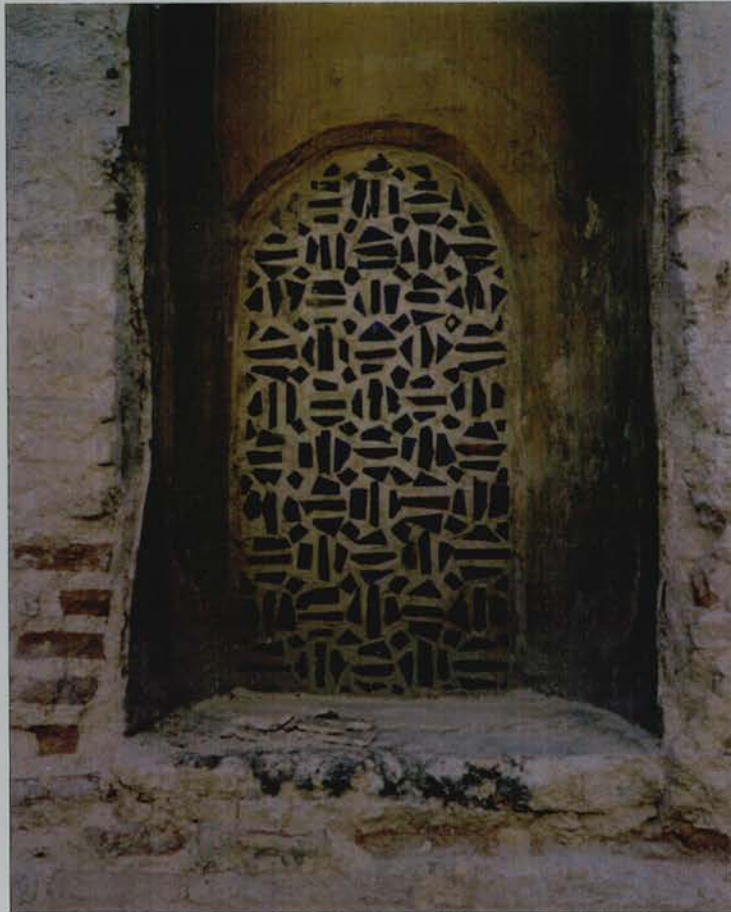

41. Exterior of *shamsiyya* , Bu 'Ināniya Madrasa, Fez.



42. Window glass and lead tracery, Alhambra (Museo Nacional de Arte Hispano-Musulmán, Granada).

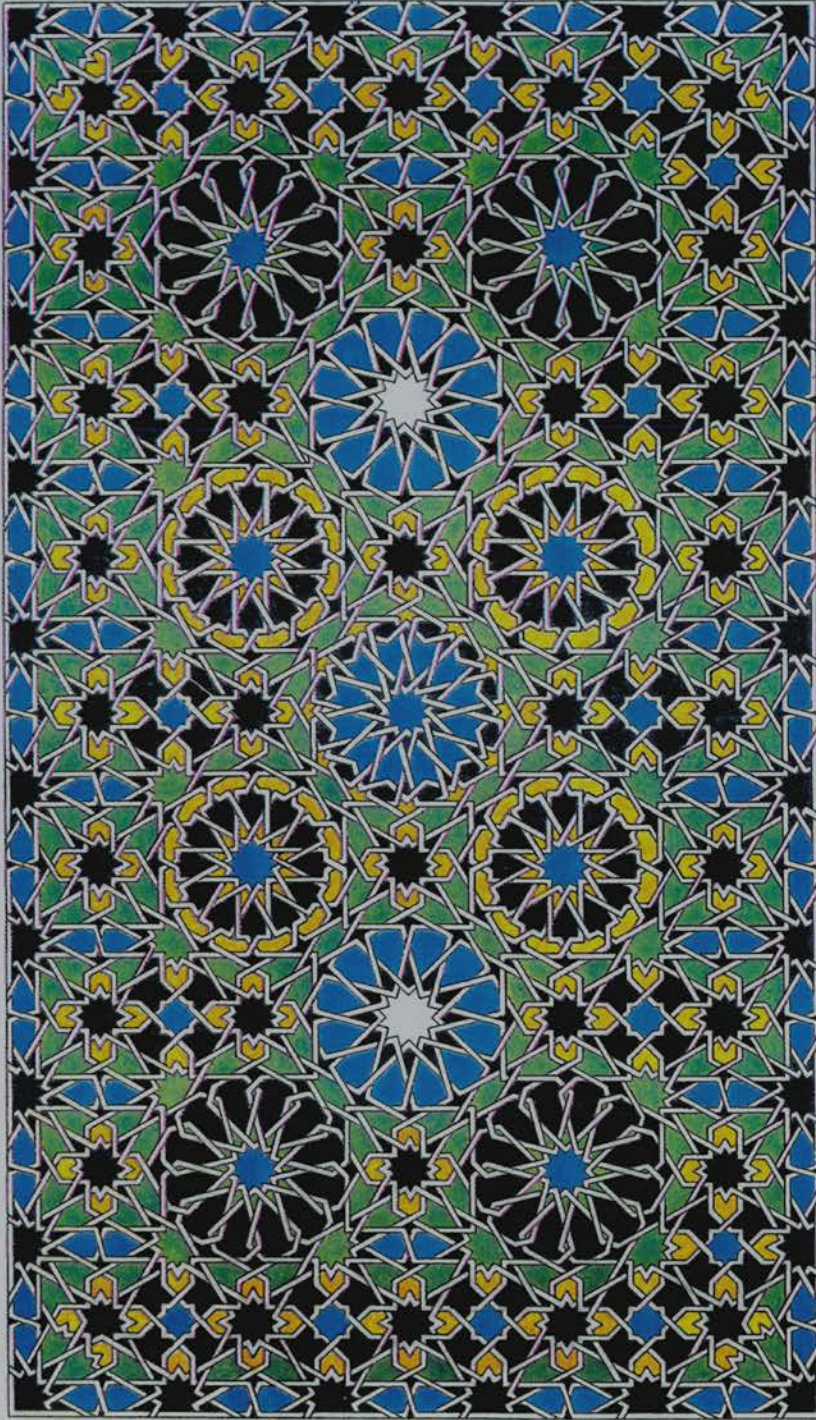

43. Tiled dado, Hall of the Ambassadors, Alhambra (after Sordo and Nestares, *Tramas Geométricas*, p. 45).



44. Mausoleum of Sultan Qalā'ūn, Cairo.



45. *Qamariyyat*, Mausoleum of Sultan Qalā'ūn, Cairo.



46. *Qamariyyat*, Mausoleum of Sultan Qalā'ūn, Cairo.

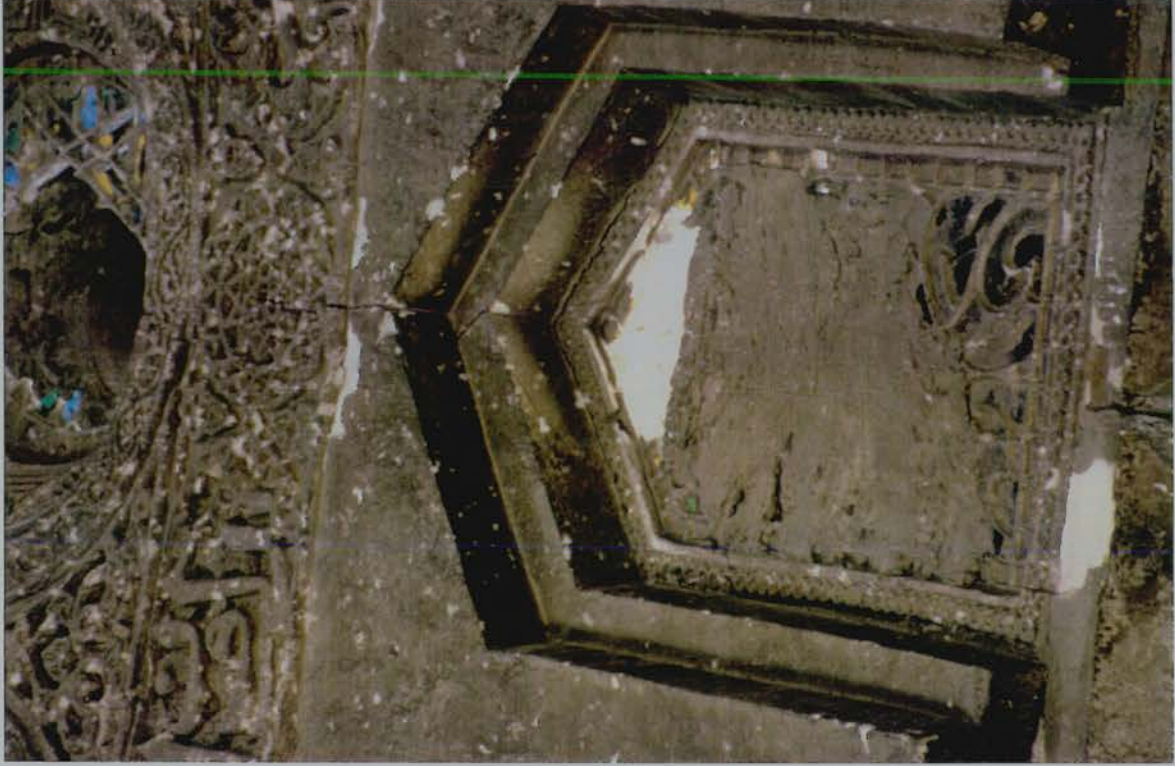

48. Window between pendentives, mausoleum of al-Ashraf-Khalīl, Cairo.

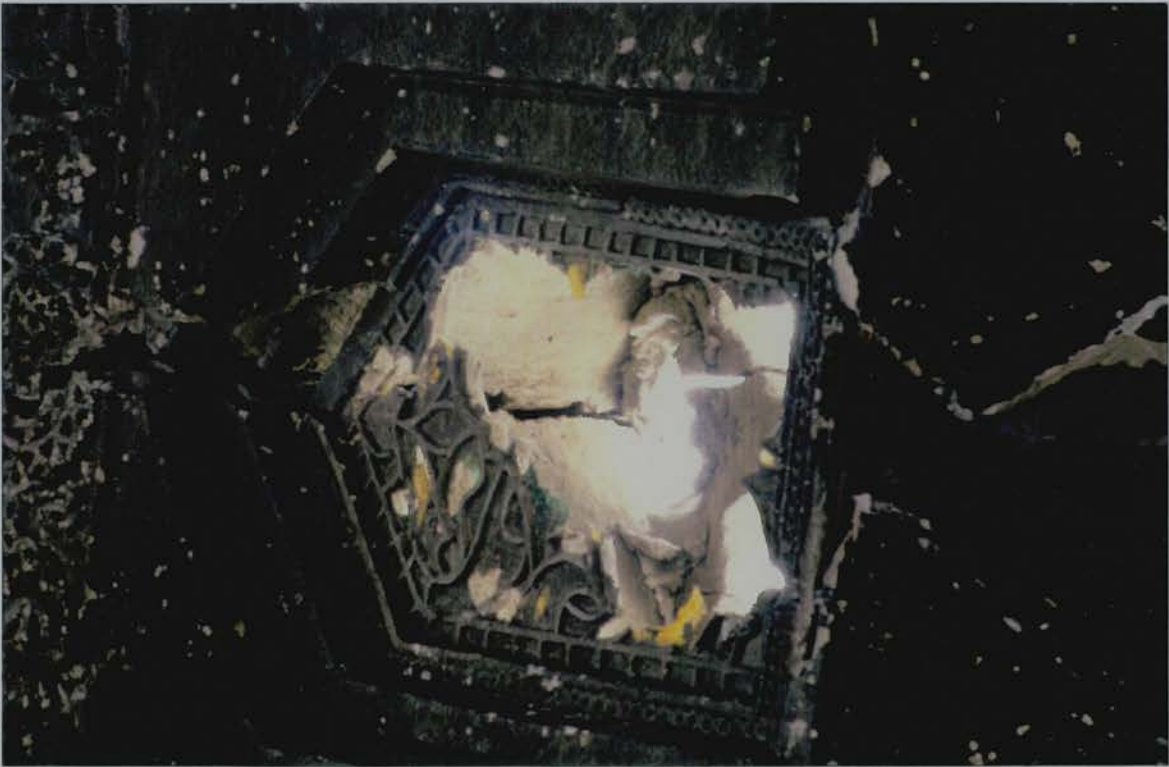

47. Window between pendentives, mausoleum of al-Ashraf Khalīl, Cairo.



49. Mausoleum of Zayn al-Dīn Yūsuf, Cairo.



50. *Qamariyya* above the *mihrab*, Madrasa of al-Naṣīr Muḥammad, Cairo.



51. Mamluk and Ottoman *qamariyyat*, Museum of Islamic Art, Cairo.



52. *Qamariyyat*, Mausoleum of Sanjar al-Gāwli, Cairo.



53. *Qamariyya*, Mausoleum of Sanjar al-Gāwli, Cairo.



54. *Qamariyyat*, Mausoleum of Baybars al-Jāshankīr, Cairo.



55. *Qamariyyat*, Mausoleum of Baybars al-Jāshankīr, Cairo.



56. *Qamariyyat*, Qaṣr Baṣṭāk, Cairo.

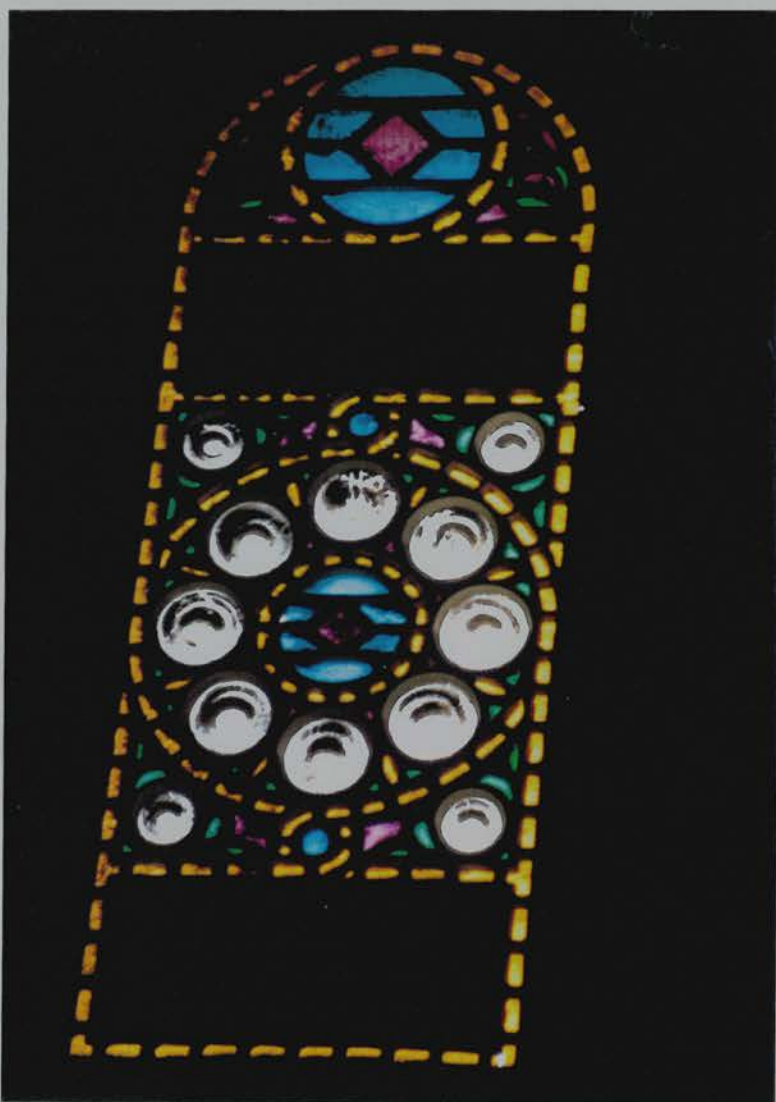

57. *Qamariyya*, Qaṣr Baṣṭāk, Cairo.



58. *Qamariyya* in the *qibla* wall, Māridānī Mosque, Cairo.



59. *Qamariyyat* fragments, Museum of Islamic Art, Cairo.

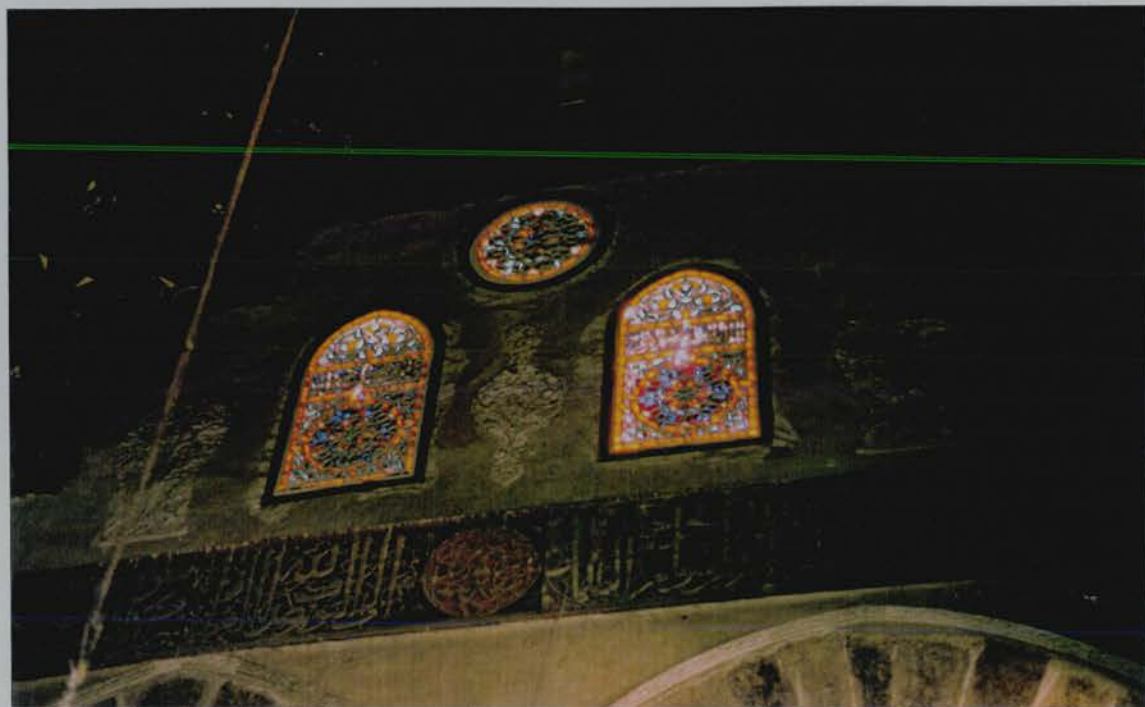

60. Dome in front of the *mihrab*, Māridānī Mosque, Cairo.



61. Circular *qamariyya*, Māridānī Mosque, Cairo.



62. Part of a *qamariyya* from the Māridānī Mosque, Museum of Islamic Art, Cairo.



63. *Qamariyyat* in the zone of transition, Mausoleum of Aslām al-Silāhdār, Cairo.



64. Circular *qamariyya* above the *mihrab*, Mausoleum of Aslām al-Silāhdār, Cairo.

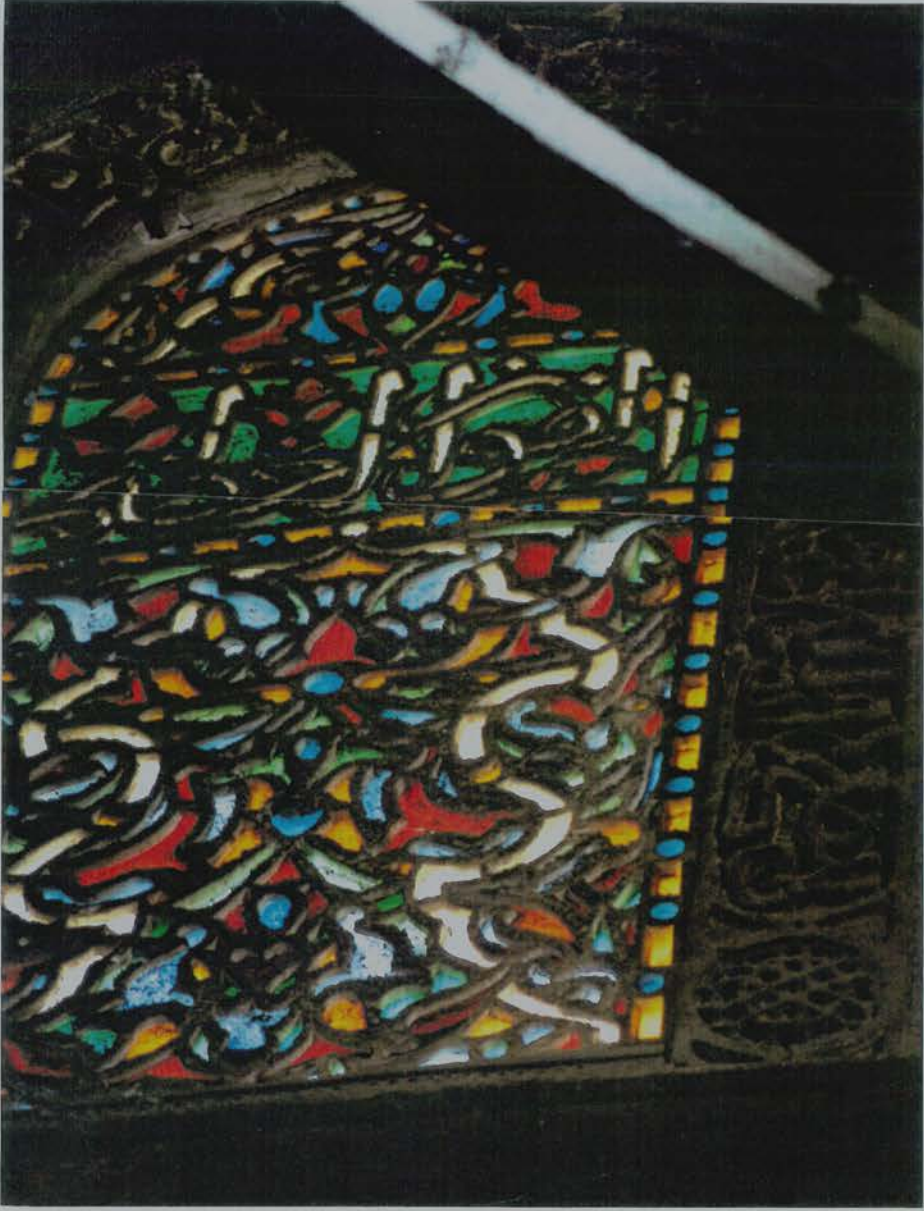

65. *Qamariyya* in the *qibla* wall, Mausoleum of Aṣlām al-Silāhdār, Cairo.

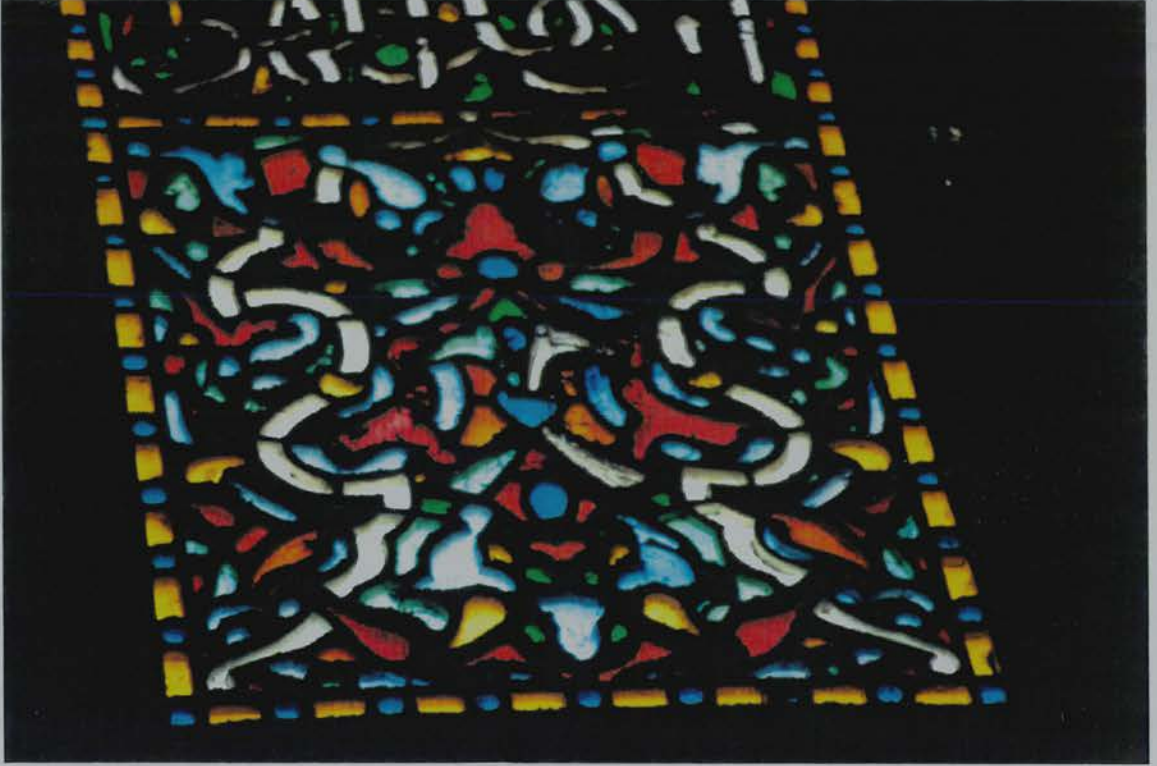

66. Detail of a *qamariyya* in the *qibla* wall, Mausoleum of Aṣlām al-Silāḥdār, Cairo.



68. *Qamariyya* in the *qibla* wall, Madrasa of Amir Mithqāl, Cairo.

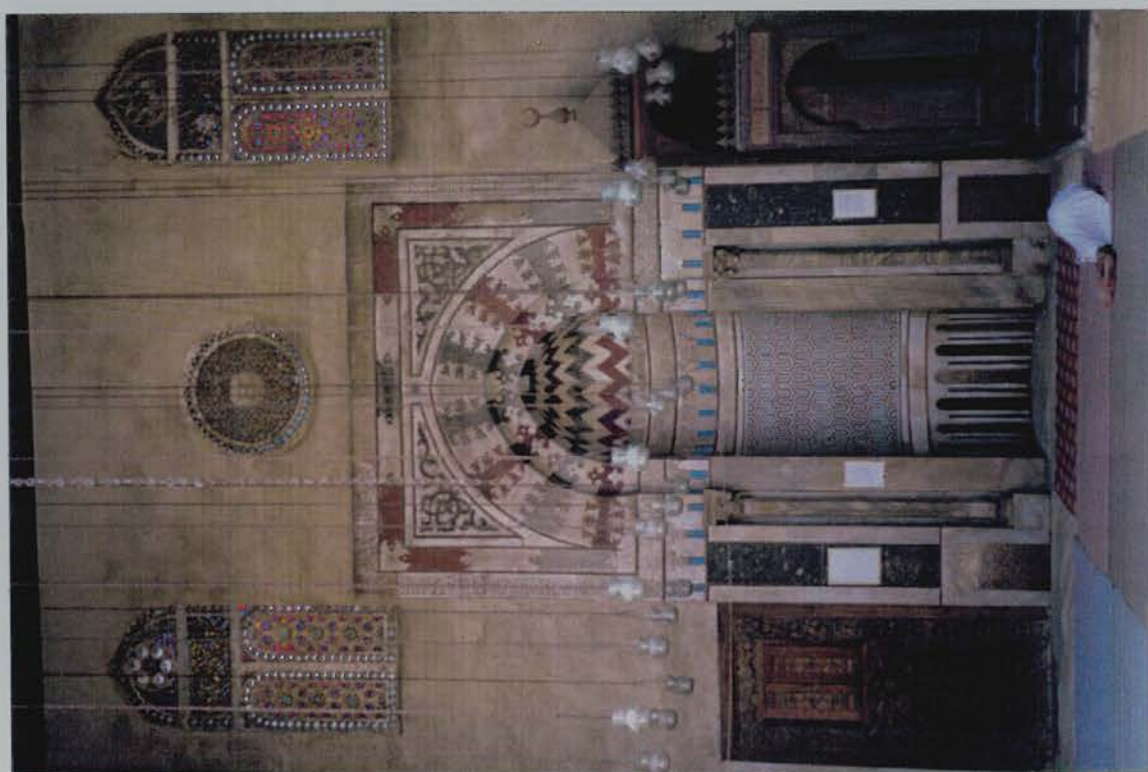

67. *Qibla* wall, Madrasa of Amir Mithqāl, Cairo.



69. *Qamariyya* in the *qibla iwan*, Madrasa-Khanqah of Barqūq, Cairo.



70. Detail of the *qamariyya* shown in ill. 69.



71. *Qamariyya* in the *qibla iwan*, Madrasa-Khanqah of Barqūq, Cairo.

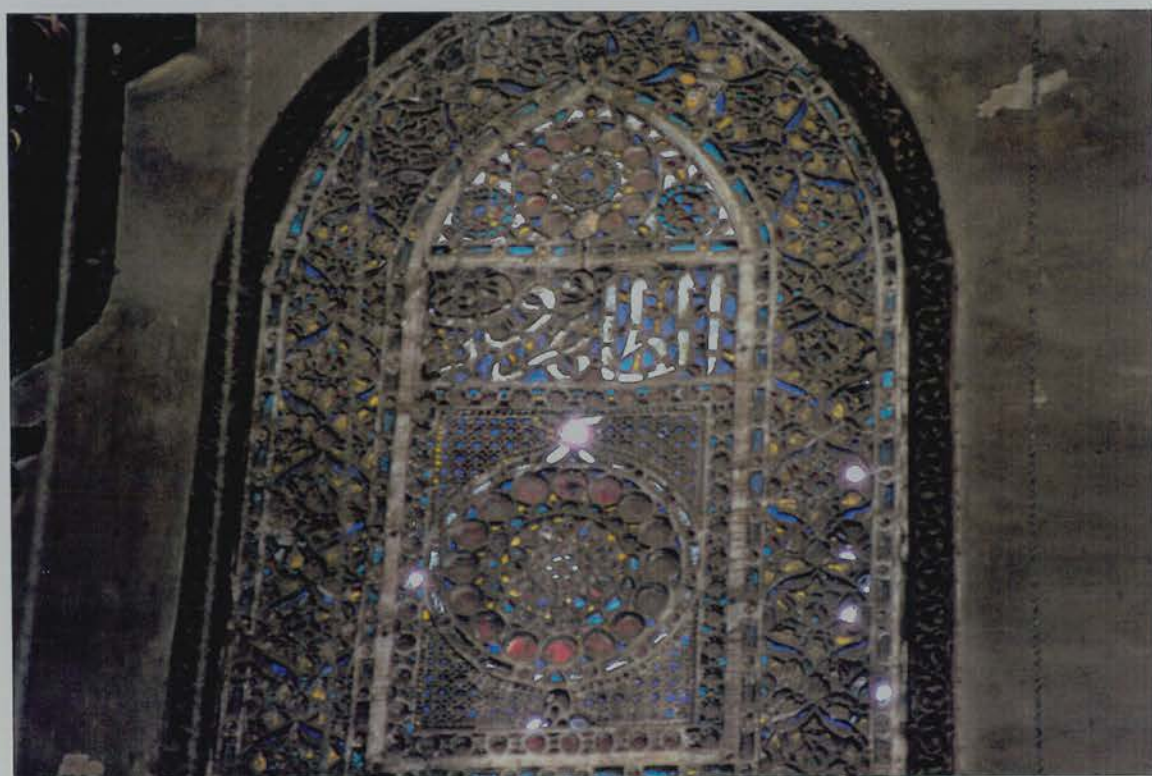

72. Detail of the *qamariyya* shown in ill. 71.



73. *Qamariyya* in the *qibla iwan*, Madrasa-Khanqah of Barqūq, Cairo.



74. Circular *qamariyya* above the *mihrab*, mausoleum in the Madrasa-Khanqah of Barqūq, Cairo.

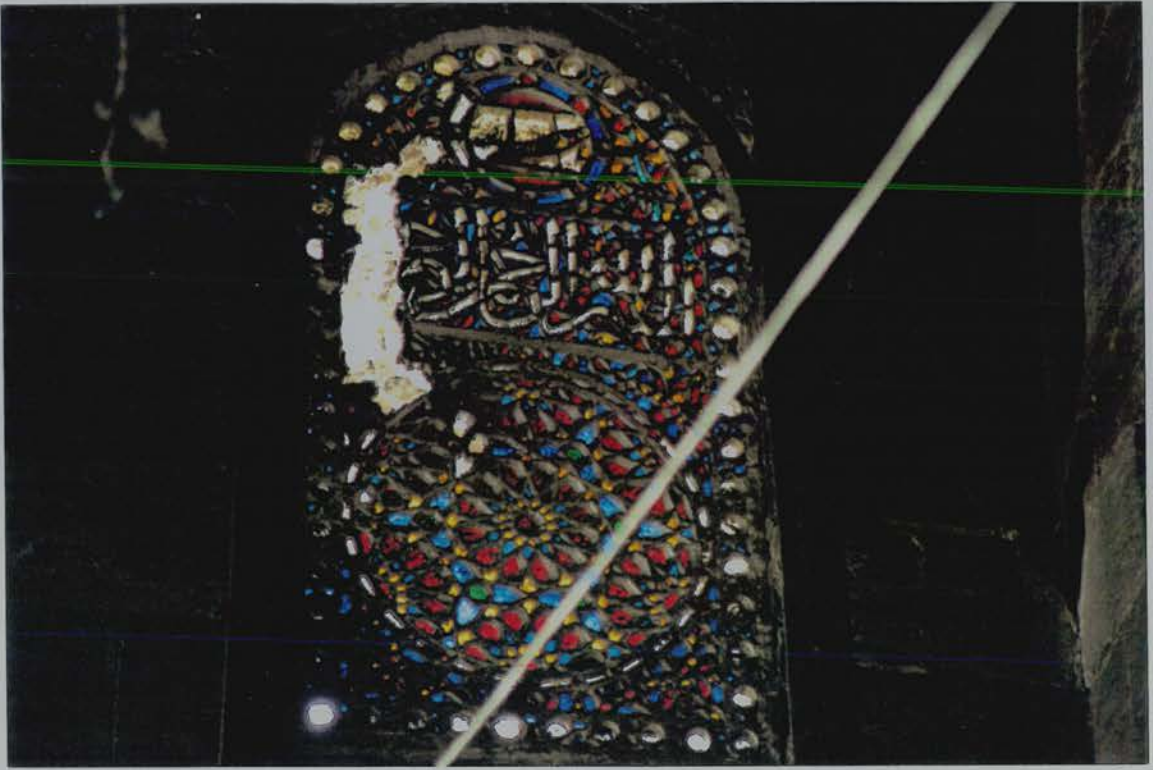

75. *Qamariyya* in the *qibla* wall, Madrasa of Īnāl al-Yūsufī, Cairo.

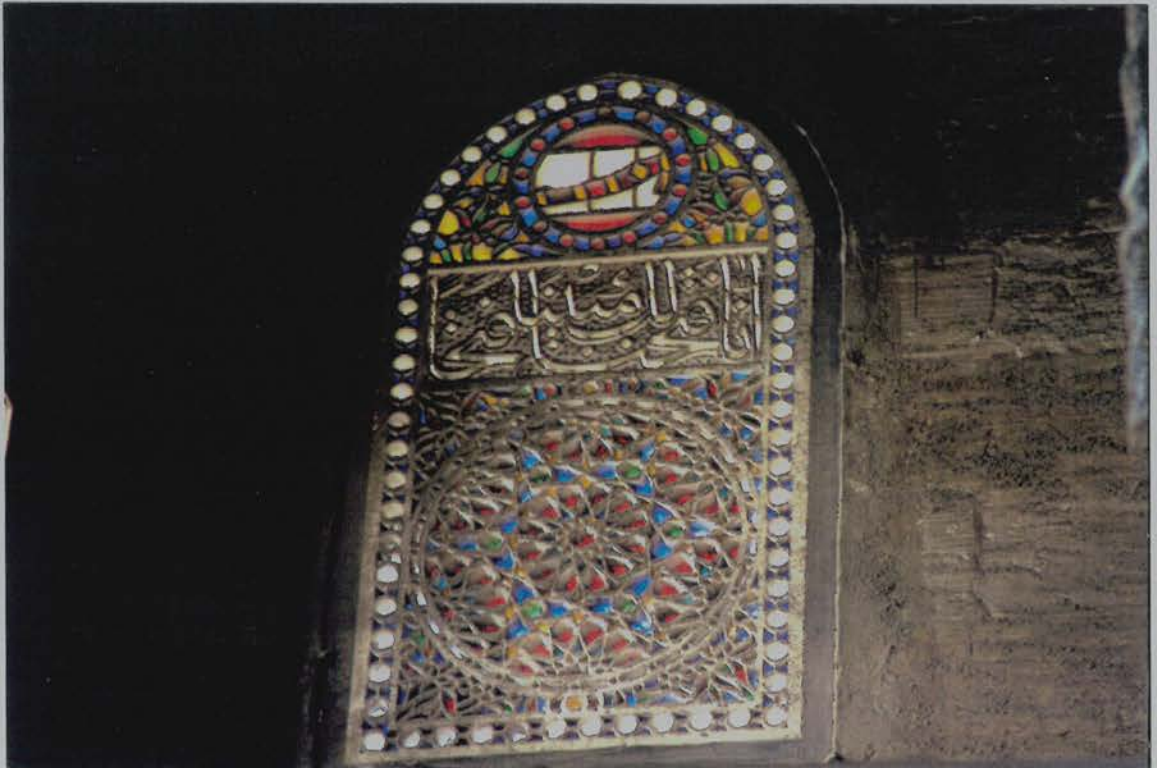

76. *Qamariyya* in the *qibla* wall, Madrasa of Īnāl al-Yūsufī, Cairo.

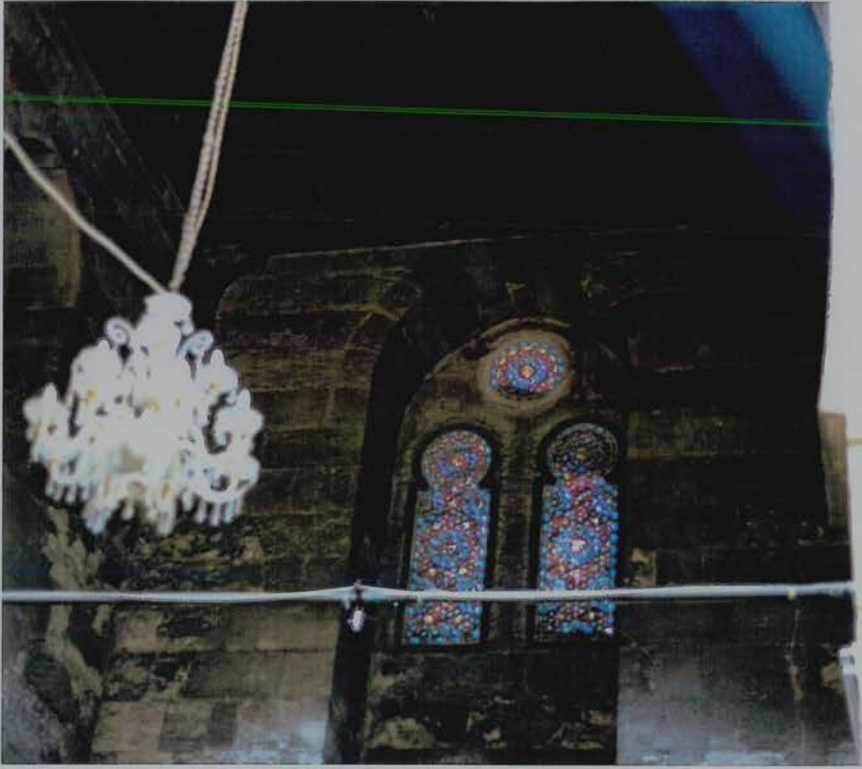

77. *Qamariyyat* in the north-western *iwan*, Madrasa of *Īnāl al-Yūsufī*, Cairo.

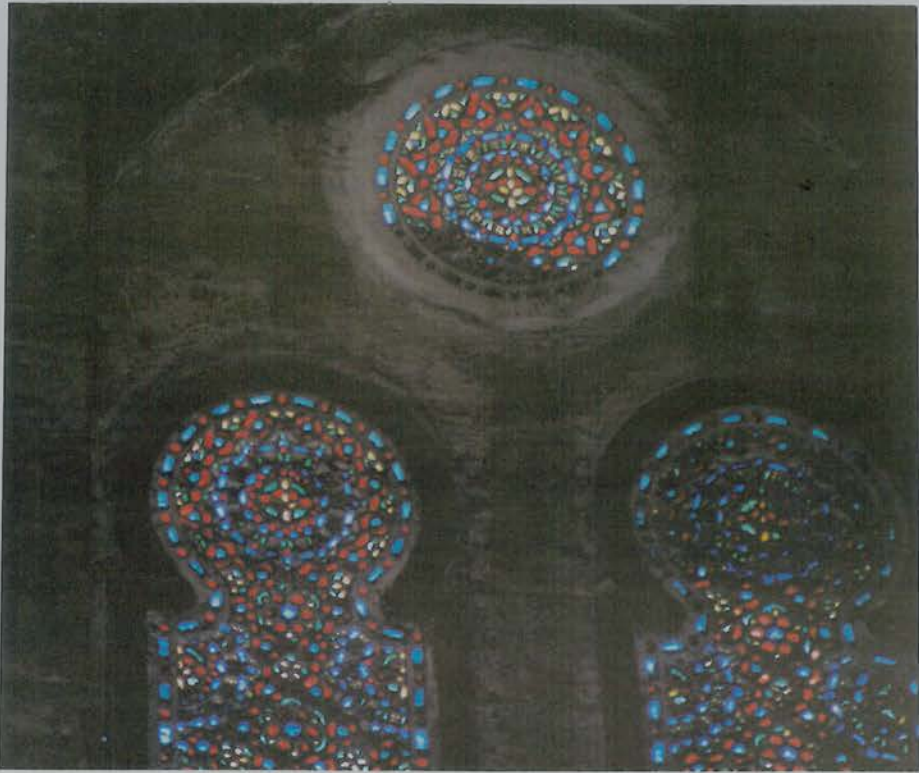

78. Detail of the *qamariyyat* shown in ill. 77.



79. *Qamariyya* above the *mihrab*, *madrasa* of *Īnāl al-Yūsufī*, Cairo.



80. Detail of a *qamariyya* in the north-western wall of the mausoleum, *madrasa* of *Īnāl al-Yūsufī*.



81. *Qamariyya*, Mausoleum of Yashbak, Damascus.



82. *Qamariyya* in the the north-eastern *iwan*, Madrasa of Jamāl al-Dīn Yūsuf al-Ustādār, Cairo.



83. *Qibla* wall, Tayrouzi Mosque, Damascus.

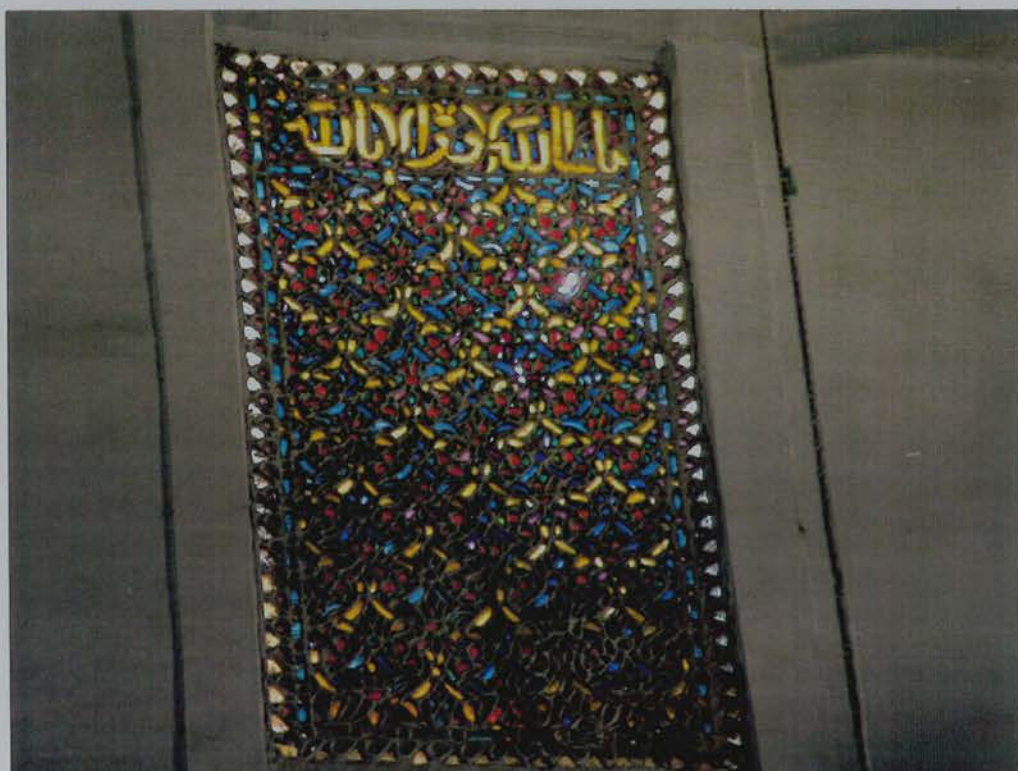

84. *Qamariyya* above the *mihrab*, Tayrouzi Mosque, Damascus.



86. *Qamariyya* in the *qibla* wall, Tayrouzi Mosque, Damascus.



85. *Qamariyya* in the *qibla* wall, Tayrouzi Mosque, Damascus.

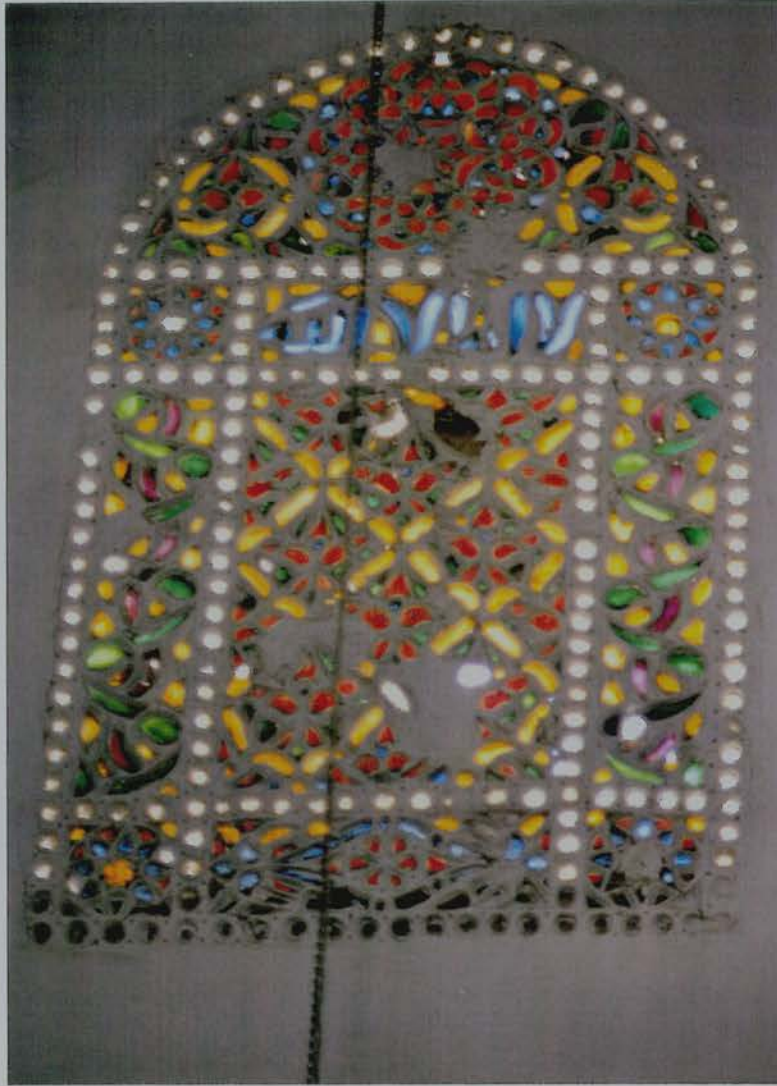

87. *Qamariyya* above the *mihrab*, Jāmi' al-Hanābīlā, Damascus.



88. *Qamariyya* in the eastern wall, Jāmi' al-Hanābīlā, Damascus.



89. *Qamariyya* above the *mihrab*, Madrasa al-Shamīyya, Damascus.

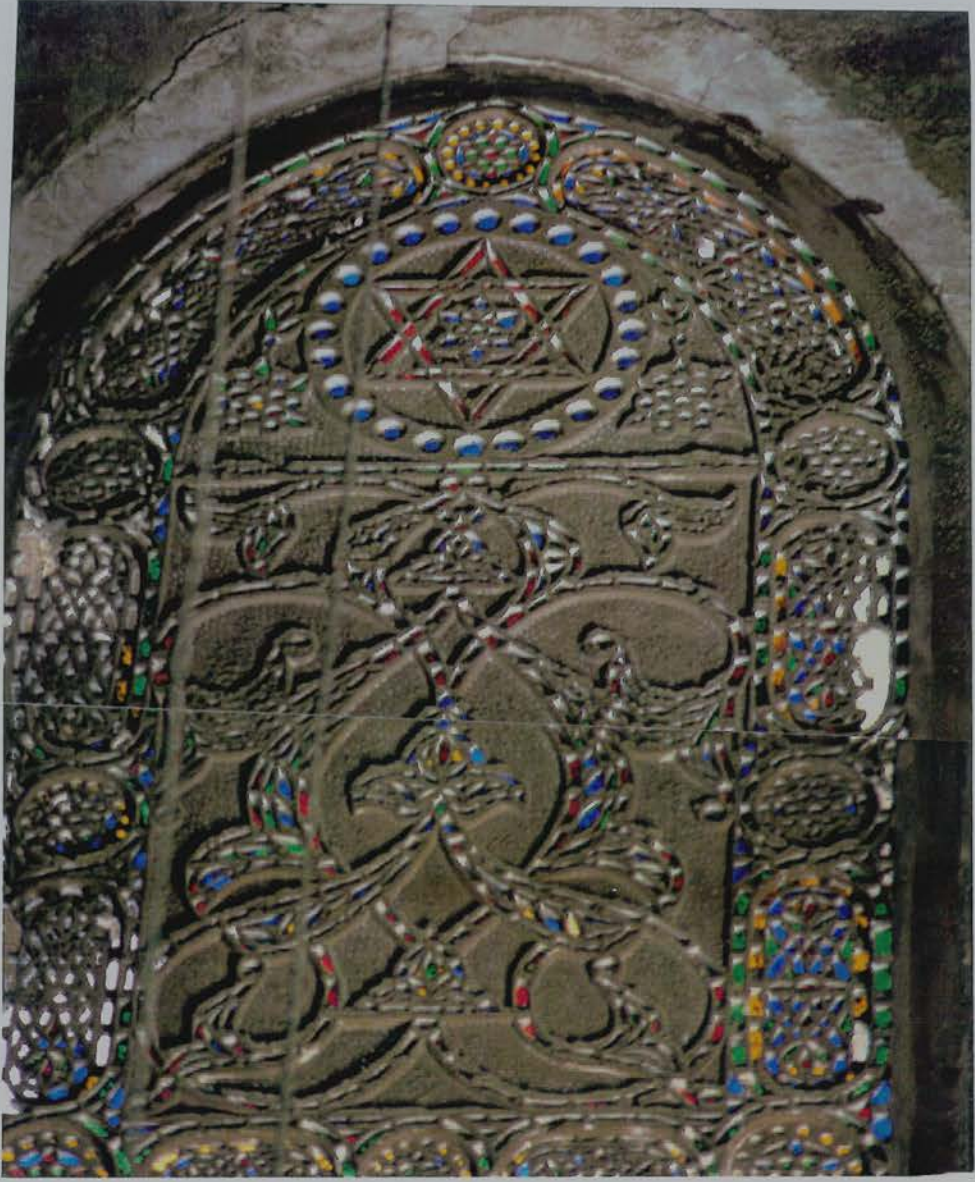

90. Type II *qamariyya*, Madrasa of Abū Bakr ibn Muzhir, Cairo.



91. Type II *qamariyya*, Madrasa of Abū Bakr ibn Muzhir, Cairo.



92. Type III *qamariyya*, Madrasa of Abū Bakr ibn Muzhir.



93. *Qamariyya*, Mosque of al-Mu'ayyad, Cairo.



94. Detail of the *qamariyya* shown in ill. 93.

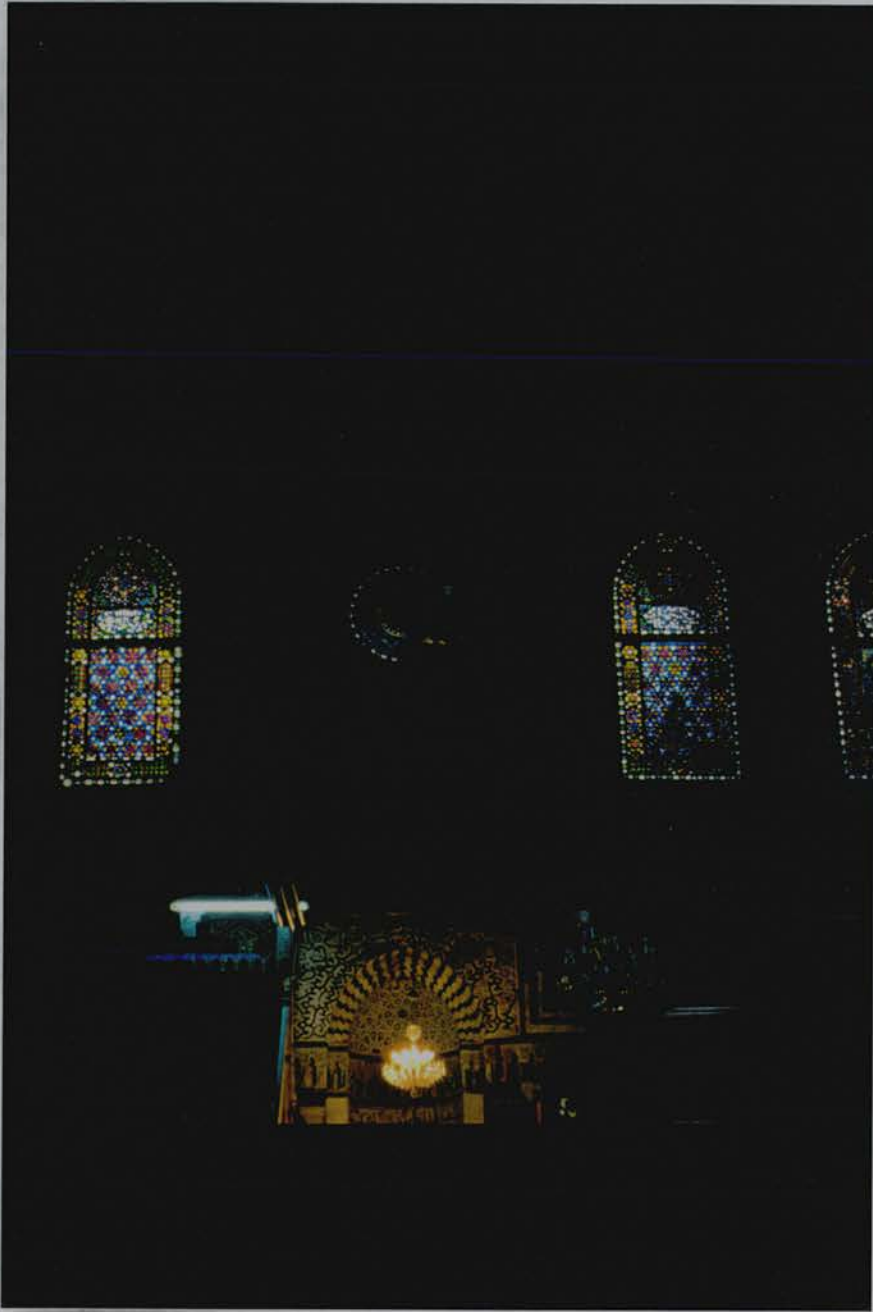

95. *Qibla* wall, Mosque of Qajmās al-Ishāqī, Cairo.



96. Circular *qamariyya* above the *mihrab*, Mosque of Qajmās al-Ishāqī, Cairo.



97. North-eastern wall, Mosque of Qajmās al-Ishāqī, Cairo.

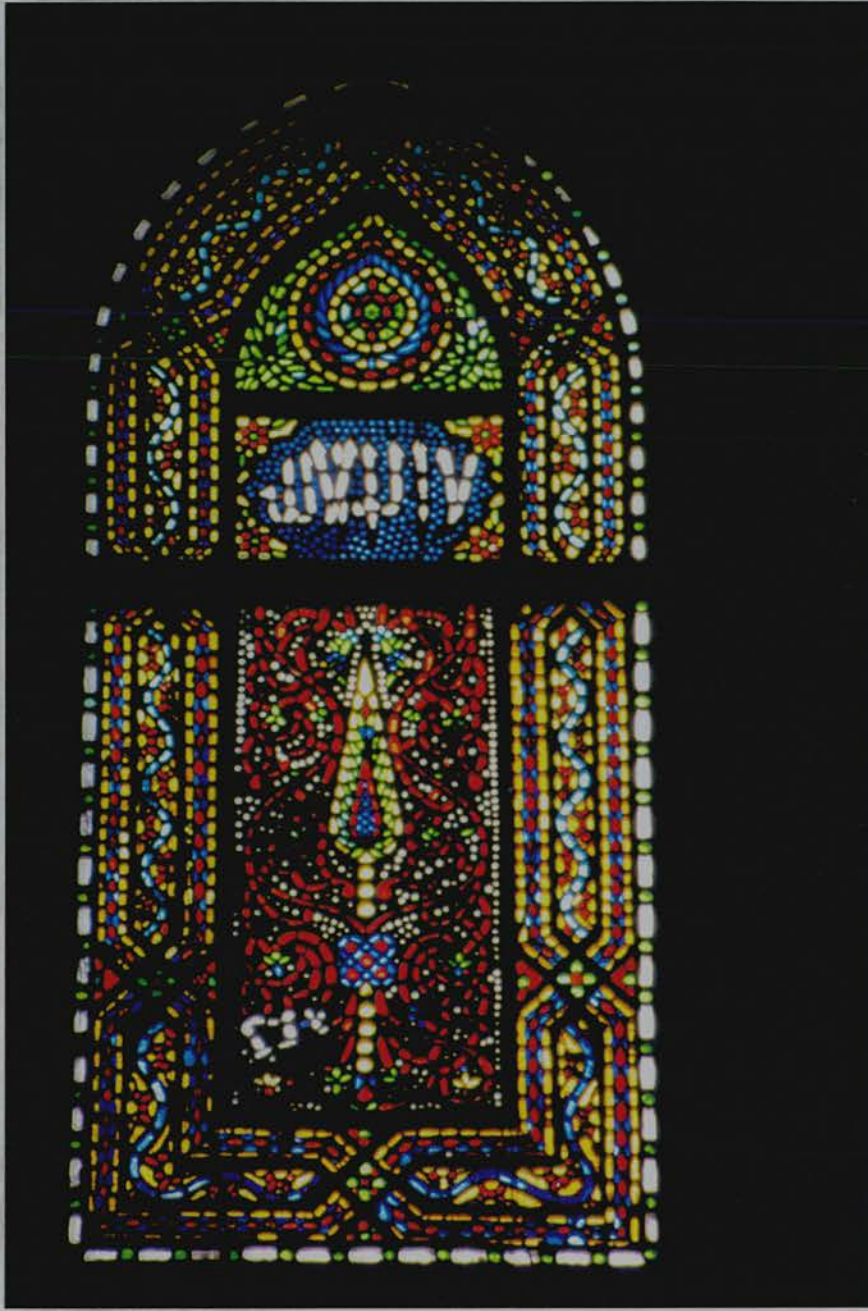

98. Type I *qamariyya*, Mosque of Qajmās al-Ishāqī, Cairo.



99. Type I *qamariyya*, Mosque of Qajmās al-Ishāqī, Cairo.



100. Type II *qamariyya*, Mosque of Qajmās al-Ishāqī, Cairo.

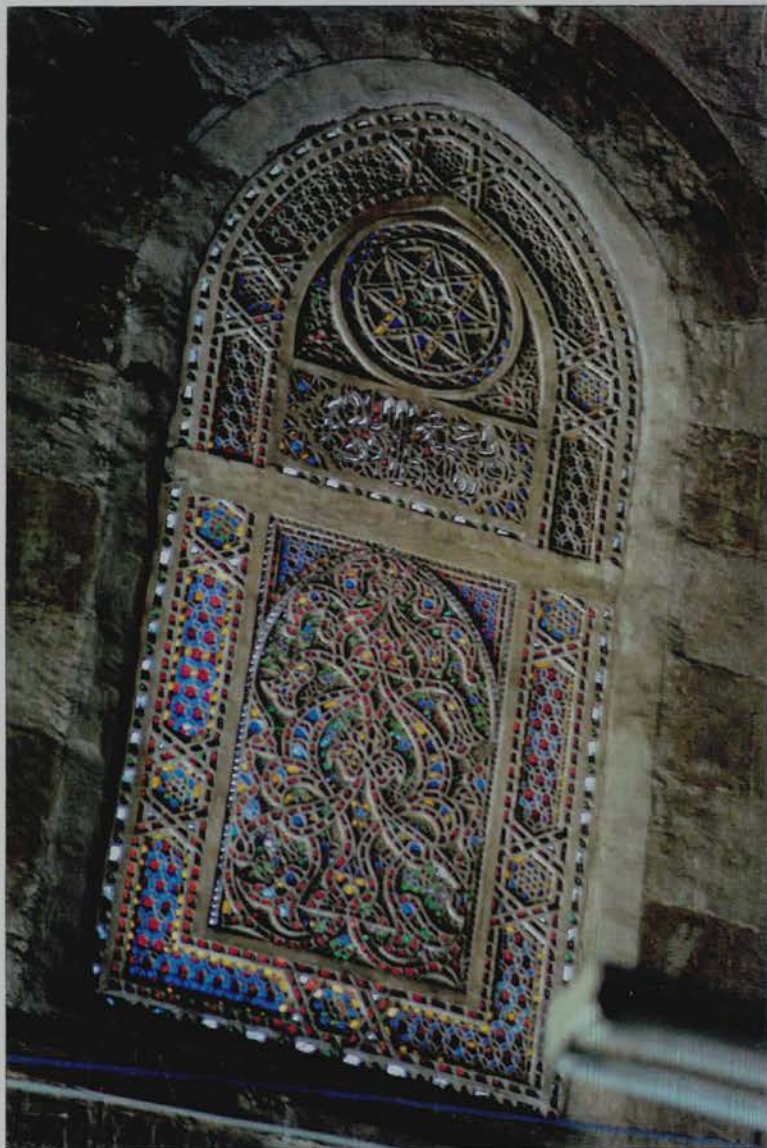

101. Type III *qamariyya*, Mosque of Qajmās al-Ishāqī, Cairo.

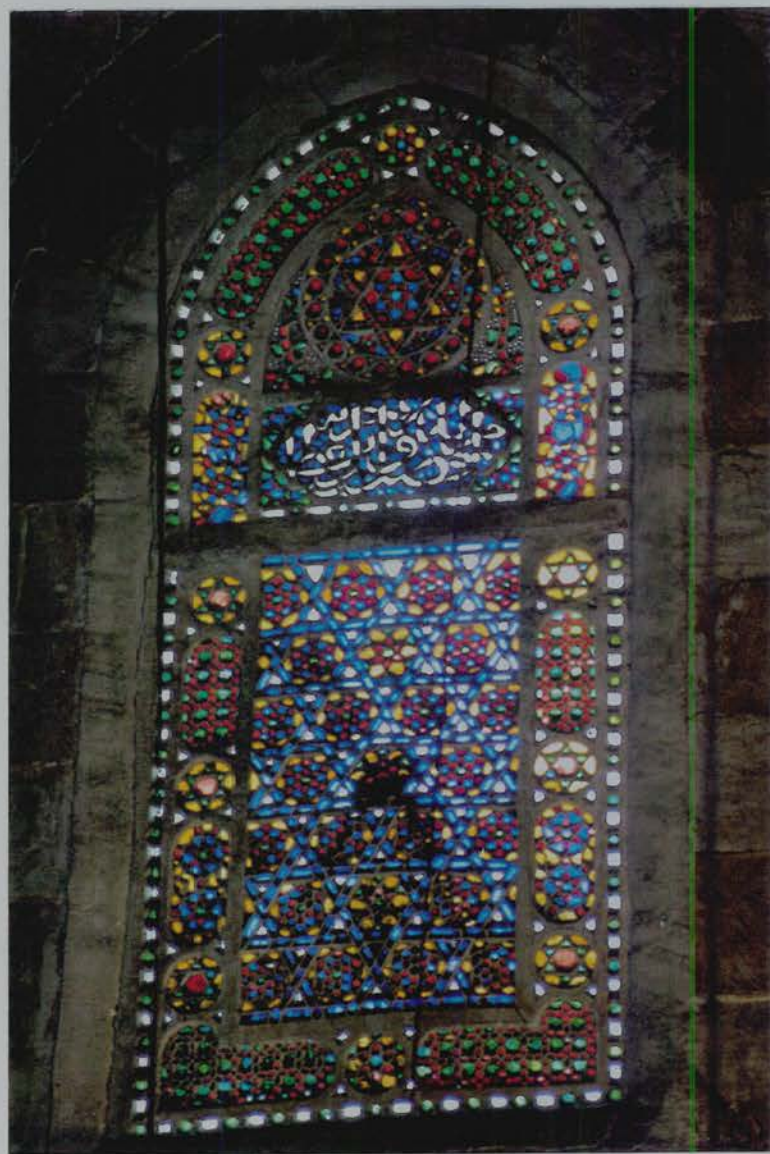

102. Type IV *qamariyya*, Mosque of Qajmās al-Ishāqī, Cairo.

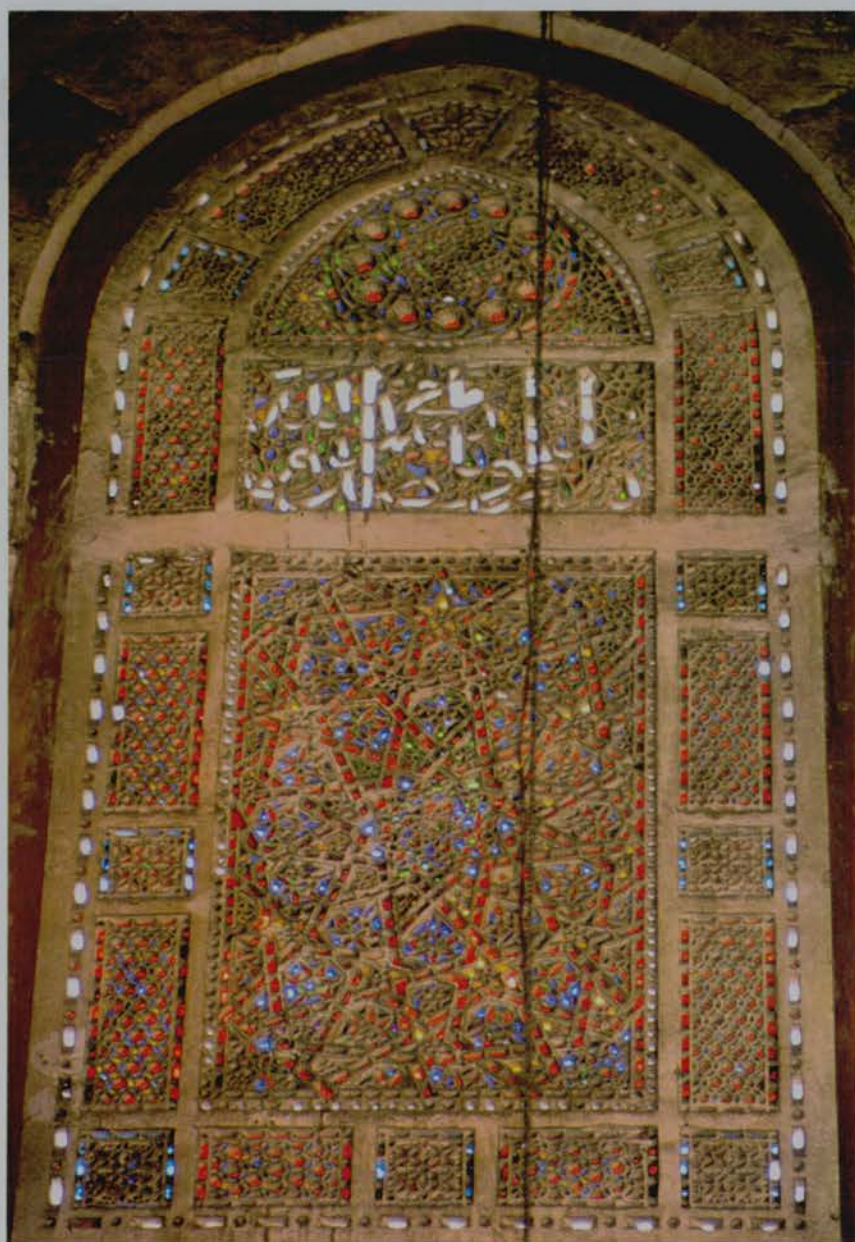

103. Type V *qamariyya*, Mosque of Qajmās al-Ishāqī, Cairo



104. *Qamariyya* in the south-western wall, Mausoleum of Qāyṭbāy, Cairo.

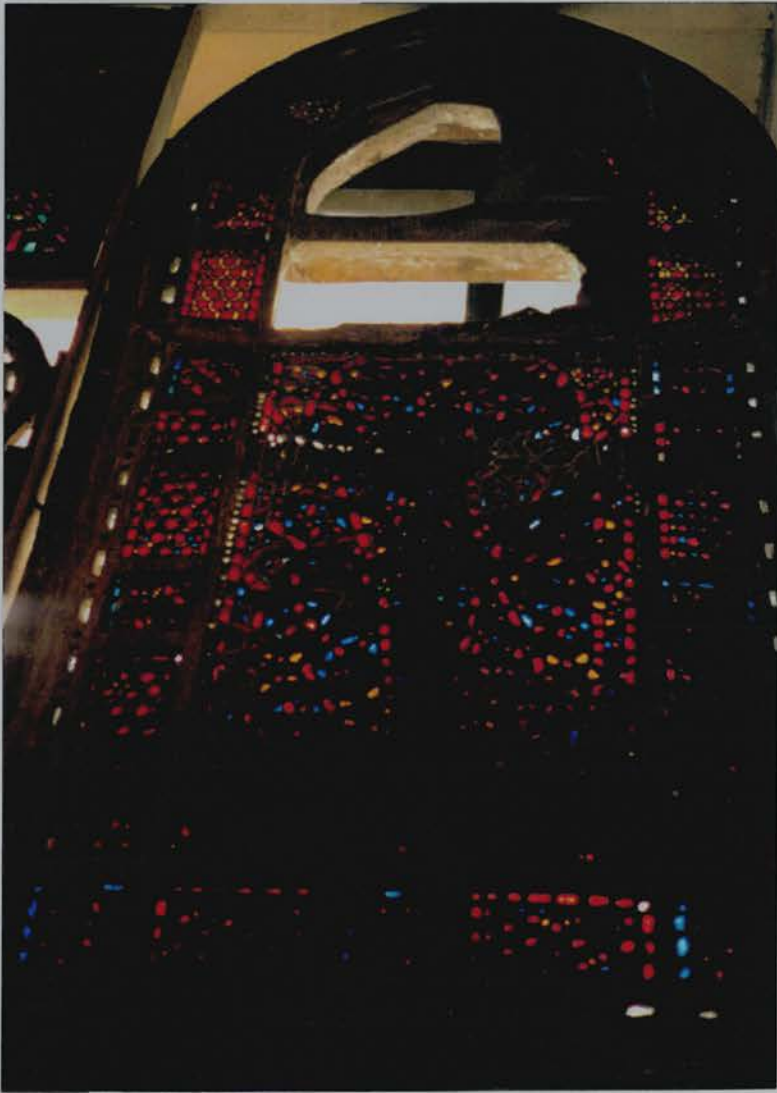

105. *Qamariyya* from the Mosque of Qajmās al-Ishāqī, Museum of Islamic Art, Cairo.



106. Tenth/sixteenth-century Mamluk carpet, Textile Museum, Washington DC (after Atil, Renaissance, No. 127).

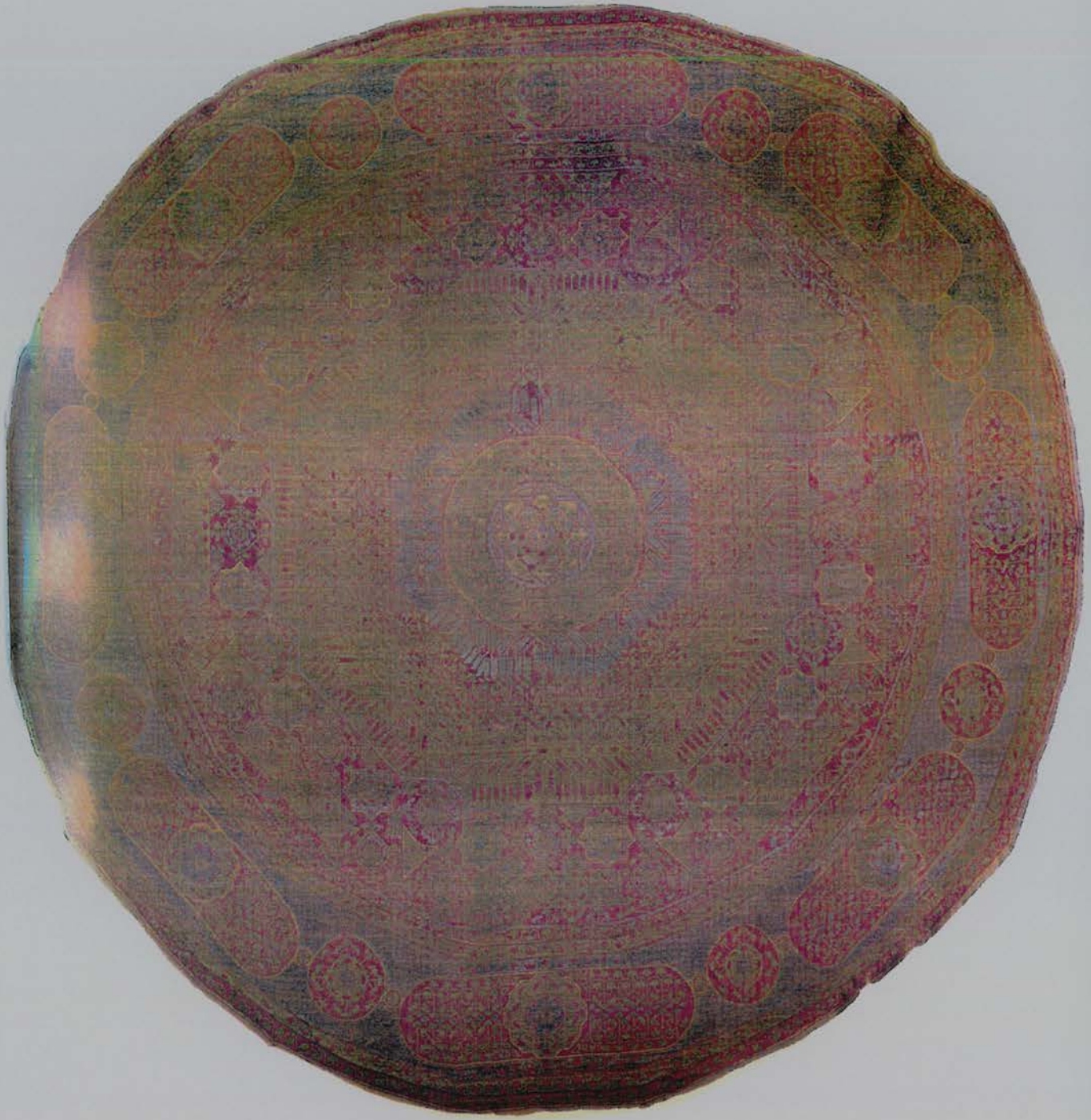

107. Tenth/sixteenth-century Mamluk carpet (after Sotheby's, Islamic Works of Art, No. 38).



108. Illuminated Qur'an, Iraq or Persia, 485/1092 (after Lings, *Qur'anic Art*, pl. 16).



109. Humay at the court of Humayūn, *Diwān* of Khwājū Kirmānī, Baghdad 799/1396 (after Gray, *Persian Painting from Miniatures*, pl. 4).



110. Type I window, *Gulistan* of Sā'di, Herat 831/1427
(Chester Beatty Library, Dublin).



111. Type I window, *Gulistan* of Sā'di, Herat 831/1427
(Chester Beatty Library, Dublin).

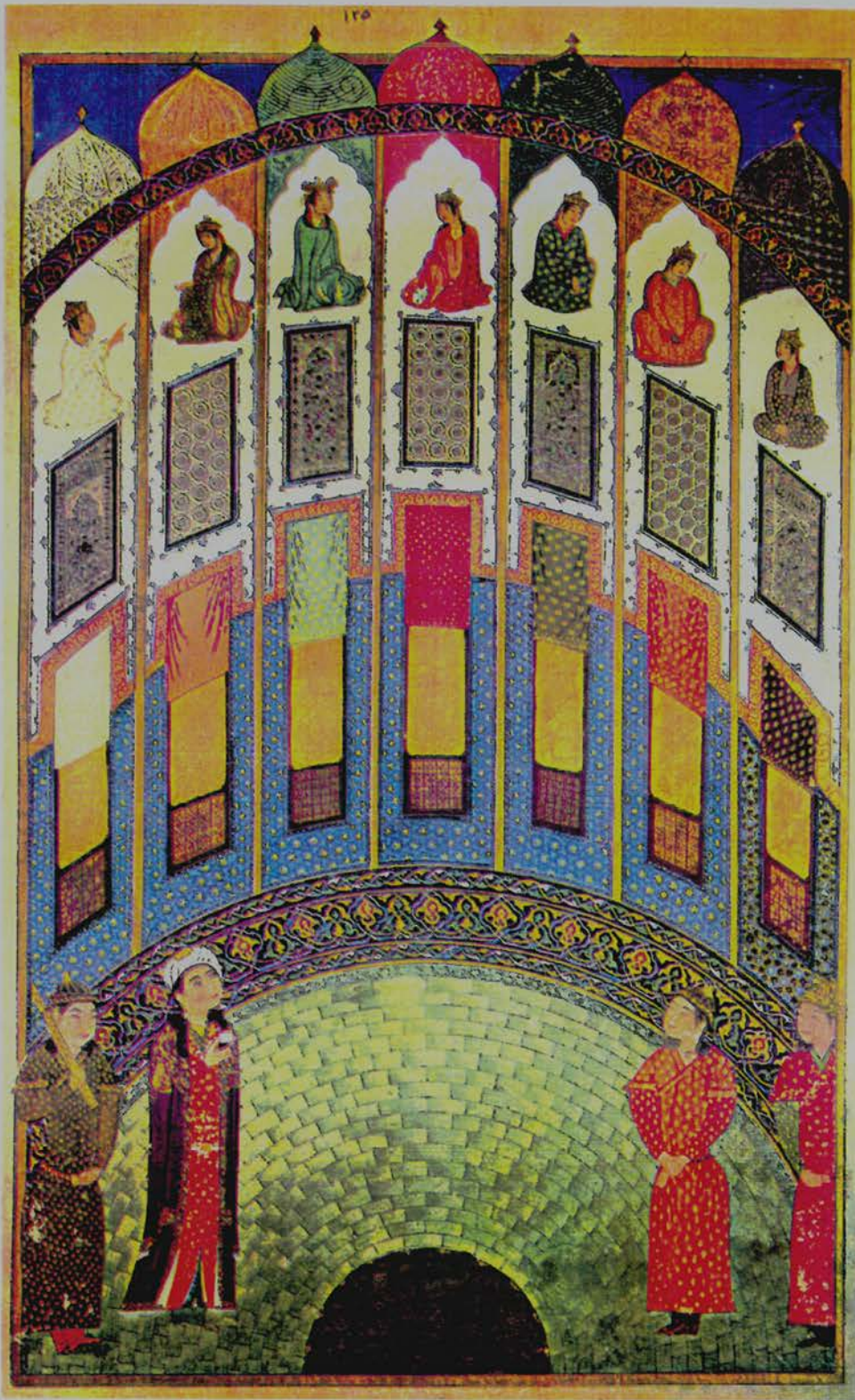

112. Bahram Gūr in the Hall of the Seven Images, *Anthology of Iskandar Sultan*, Shiraz 813/1410 (after Gray, *Persian Painting*, p. 75).

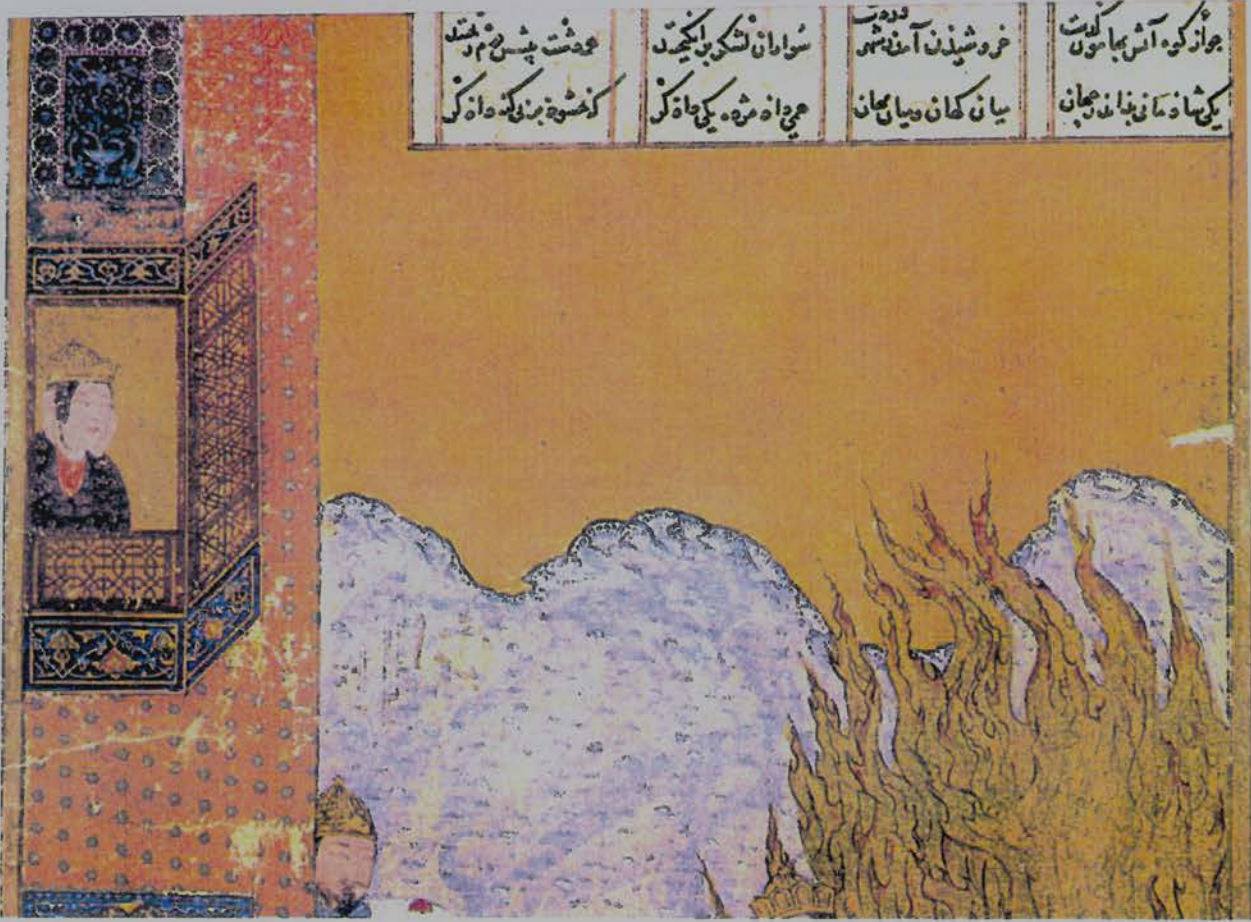

113. Detail from The Fire Ordeal of Siyavush, *Shāhnāma*, probably Shiraz 800/1397-8 (after Hillenbrand, *Imperial Images*, No. 124).



114. Tahnmina's visit to Rostam, *Shāhnāma*, Herat c. 844/1440 (after Pope, SPA, pl. 875).

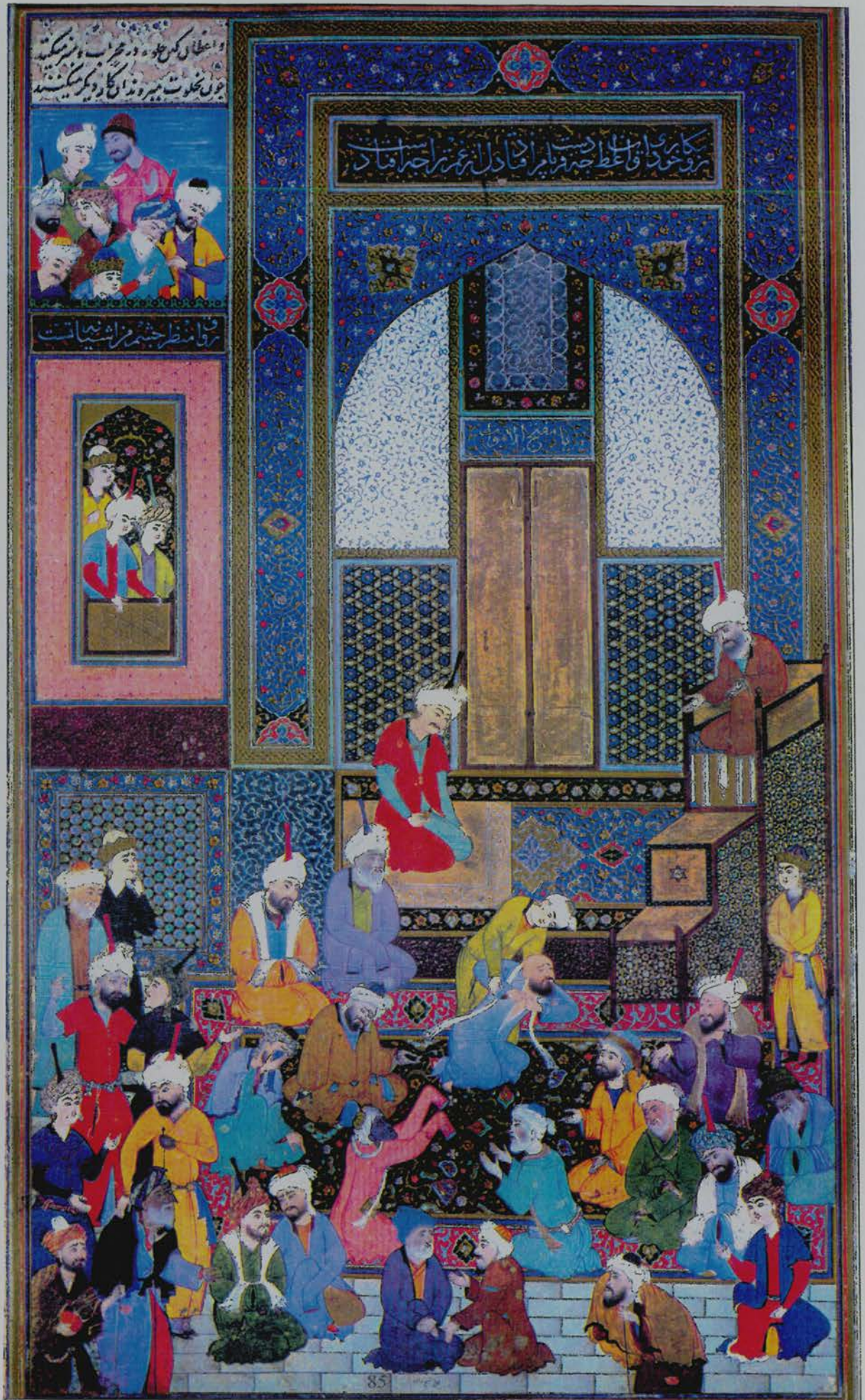

115. Scandal in a Mosque, *Diwān* of Hafiz, Shiraz c. 942/1535 (after Welch, *Royal Persian Manuscripts*, pl. 16).



116. Why is that Sūfī in the *hammām* ?, *Haft Awrang*, Mashhad 964-73/1556-65 (after Welch, *Royal Persian Manuscripts*, pl. 38).

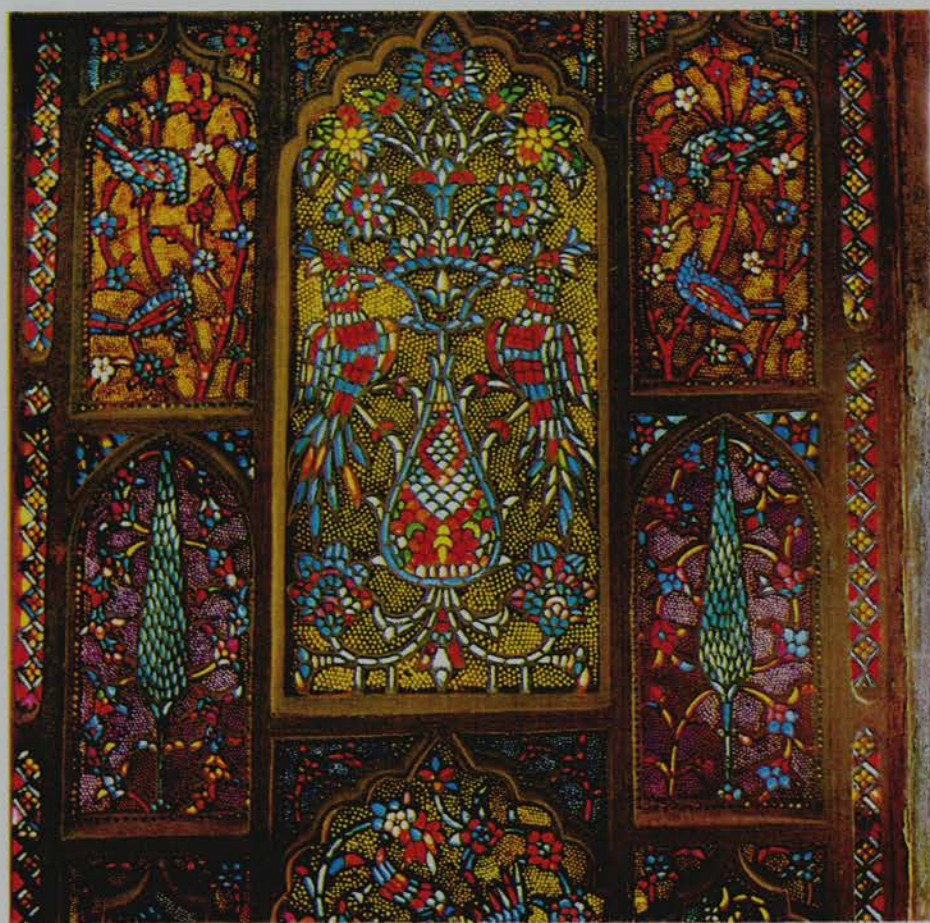

117. Detail of a window from the Darb-i Imām, Isfahan (after Orazi, Wooden Gratings, pl. 3).

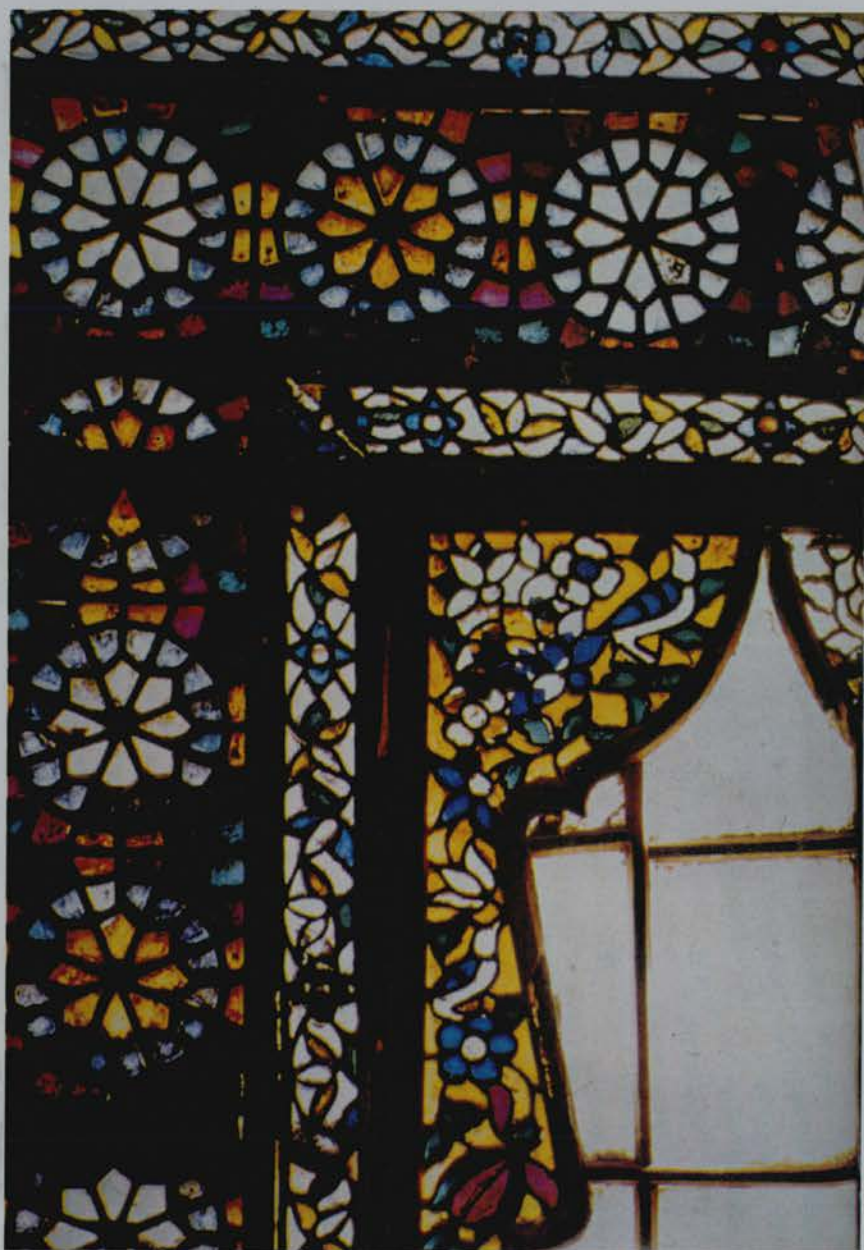

118. Detail of a window from the Mosaver al-Mulk House, Isfahan (after Cantacuzino & Browne, Isfahan, pl. 16).



119. *Qibla* wall, Süleymaniye Mosque, Istanbul.



120. Windows above the *mihrab*, Süleymaniye, Istanbul.

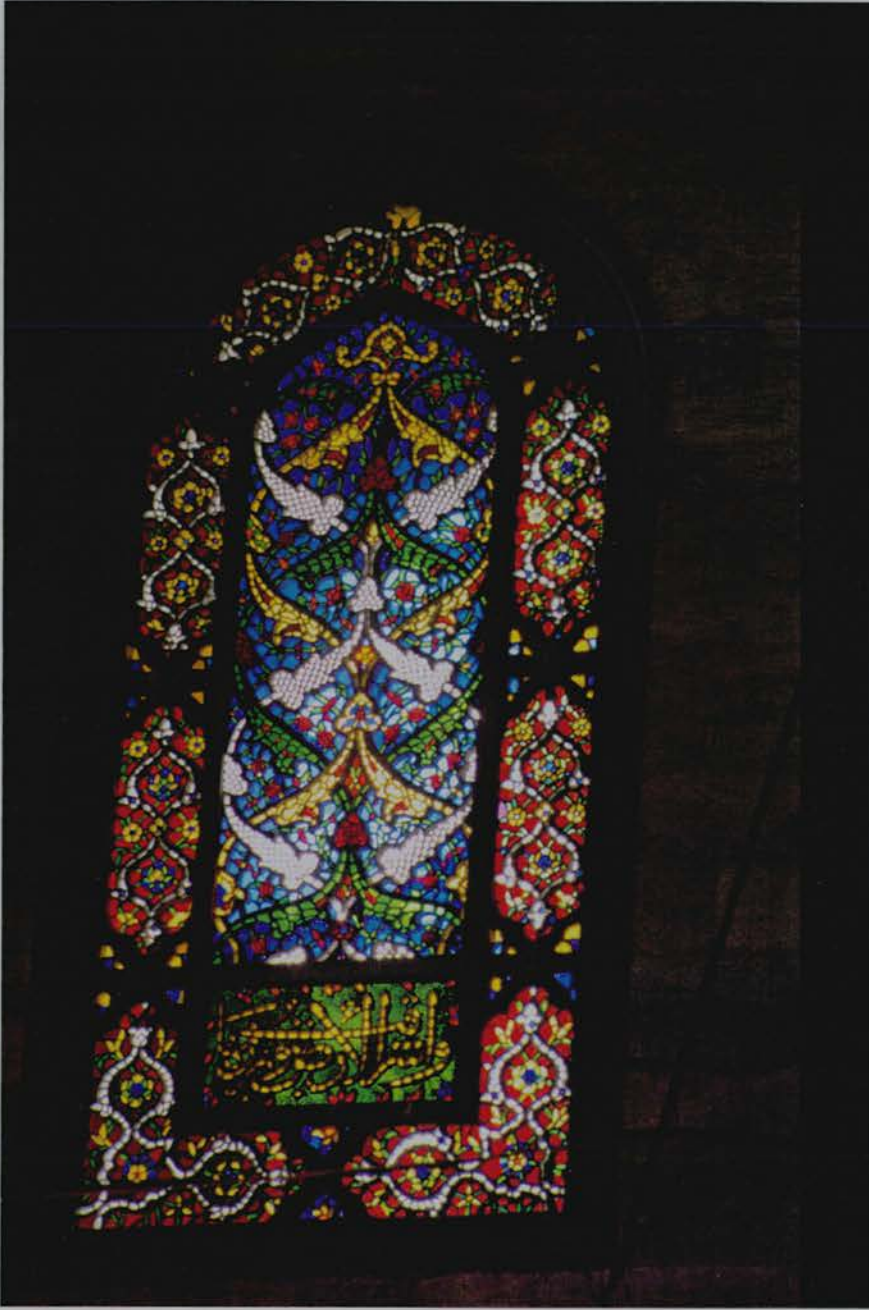

121. Window in the *qibla* wall, Süleymaniye, Istanbul.

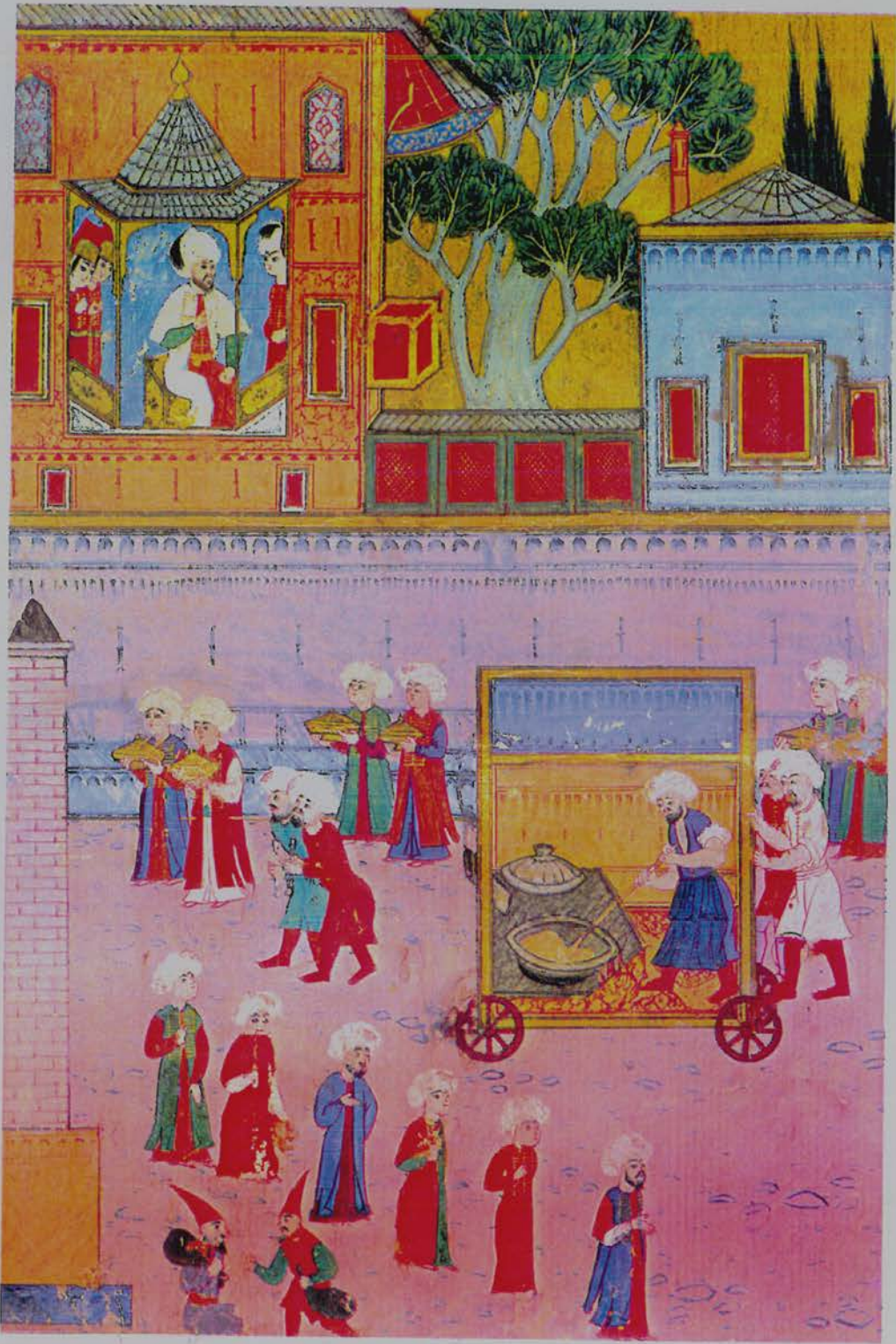

122. The guild of cooks, *Surnāmē-i Humayūn* (after Ministry of Culture, *Ottoman Empire*, pl. 42).



123. Windows in the Harem of Topkapi.

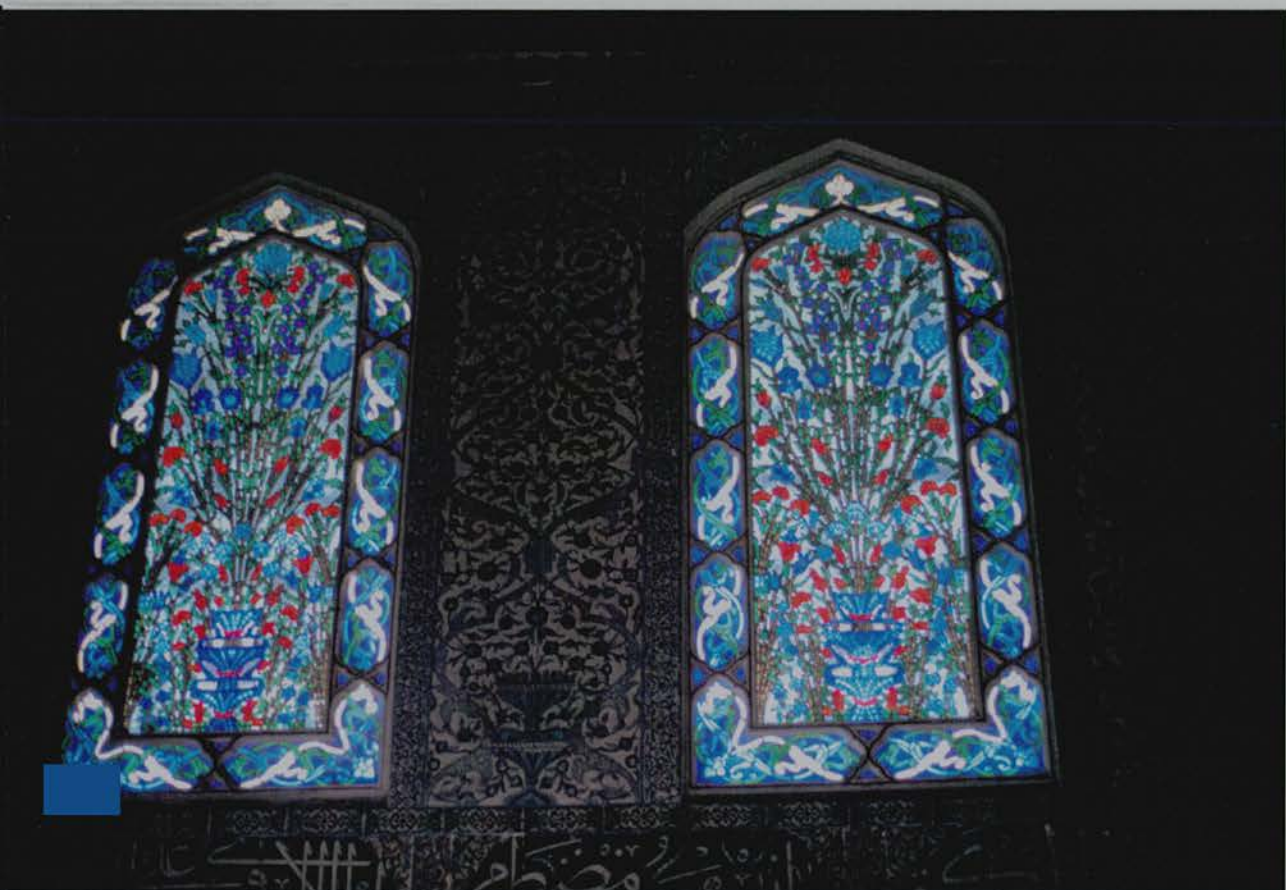

124. Windows in the Harem of Topkapi Palace, Istanbul.

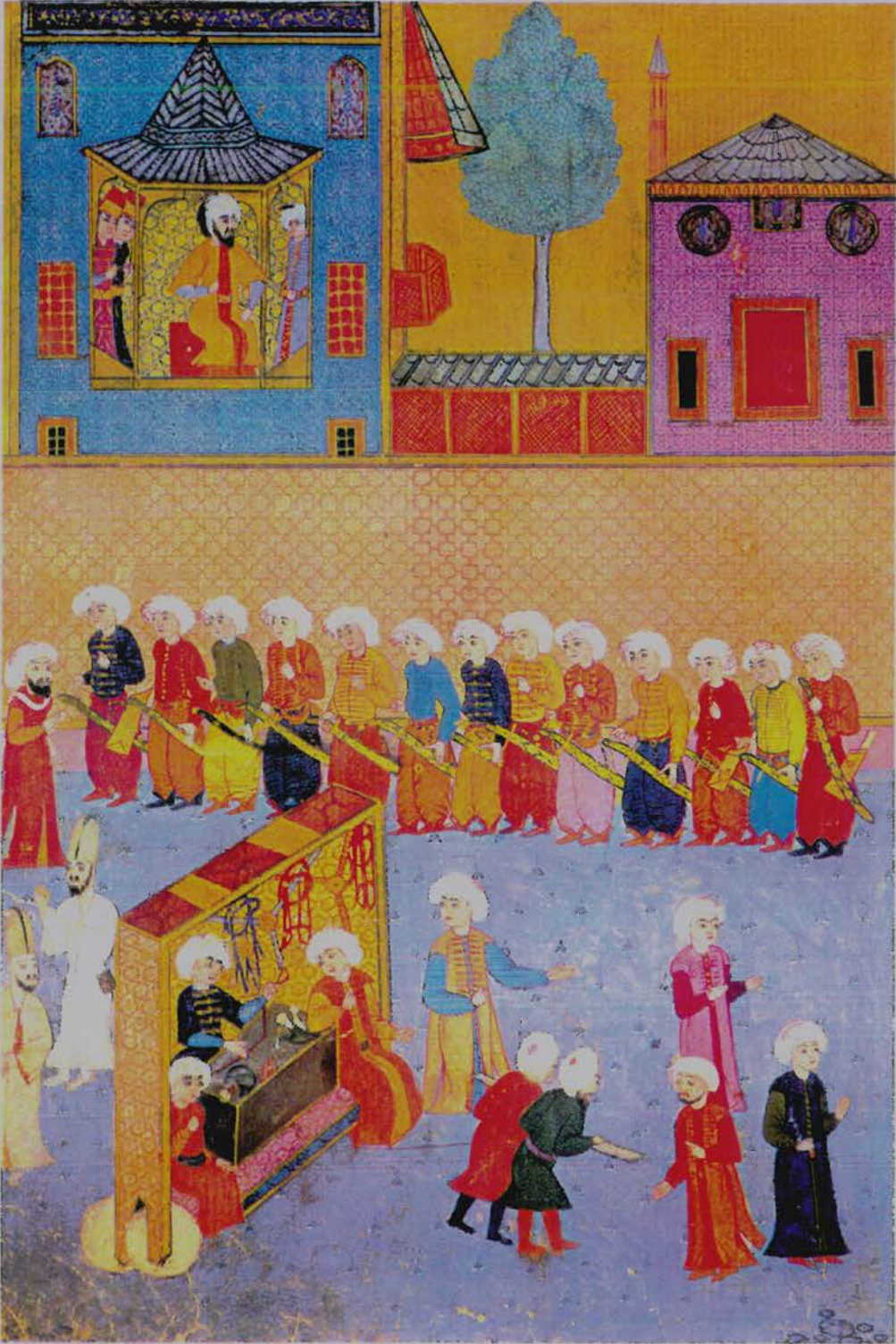

125. The guild of harness-makers, *Surnāmē-i Humayūn* (after Ministry of Culture, *Ottoman Empire*, pl. 56).



126. Portrait of Selim II (after Welch and Welch, *Arts of the Book*, No. 6).

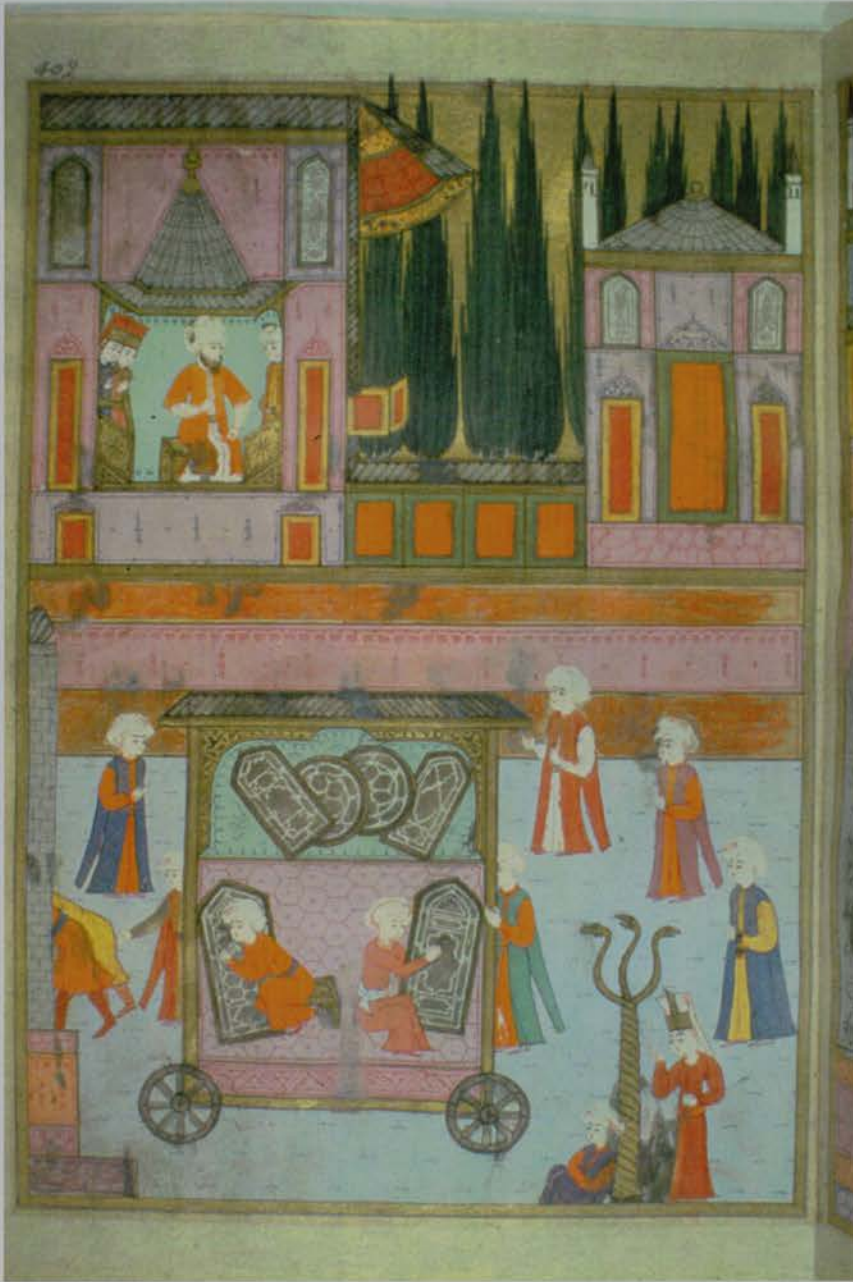

127. The guild of glaziers, *Surnāmē-i Humayūn* (Topkapi Palace Library, H.1344.1 folios 401b-402a).



128. *Qamariyya* in the *qibla* wall, Mosque of al-Ṣalḥī Talāḥī, Cairo.

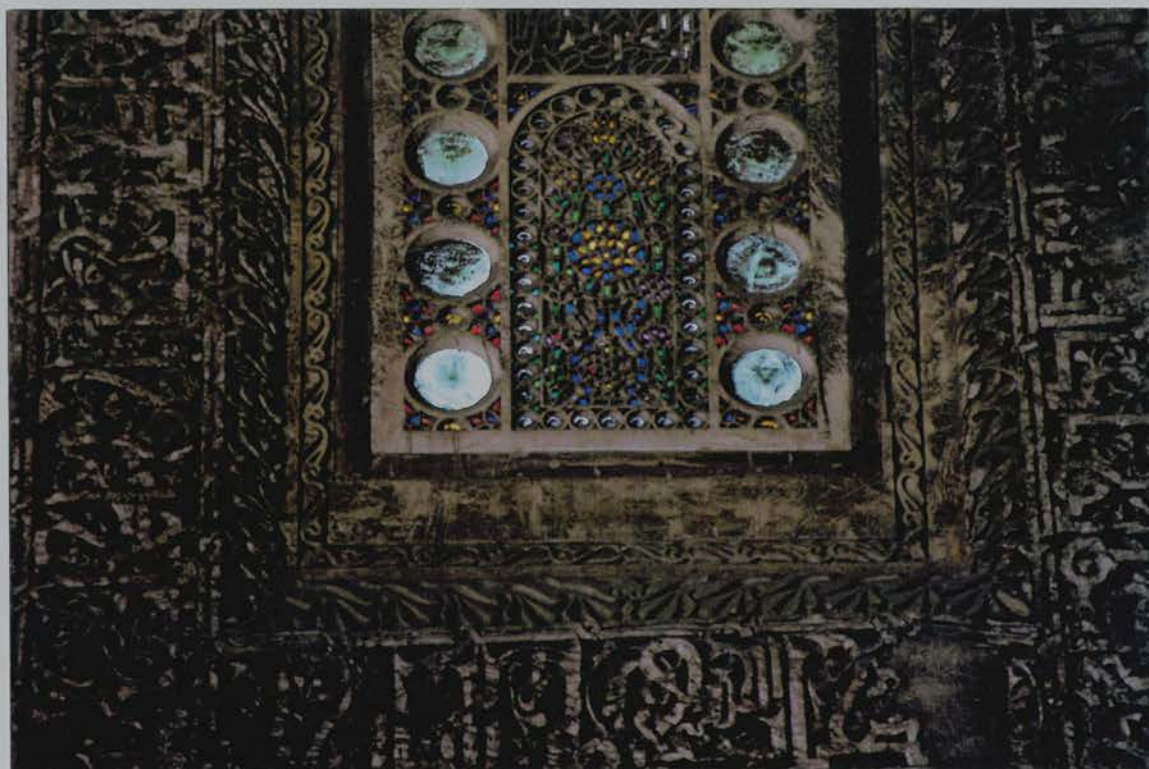

129. Detail of the *qamariyya* shown in ill. 128.

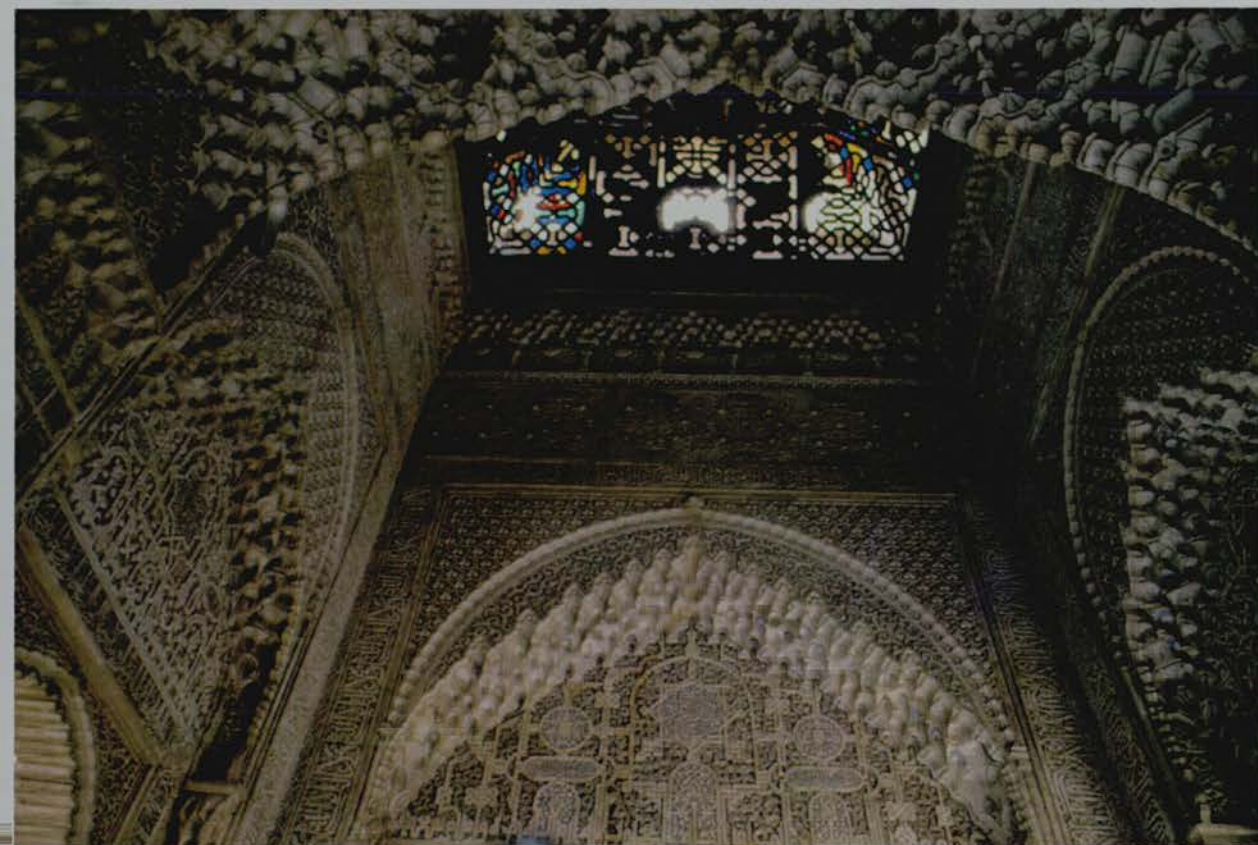

130. Mirador de la Daraxa, Alhambra Palace, Granada.



131. Detail of the ceiling visible in ill. 130.



132. Muhammad sees the *Sidrat al-Muntaha*, *Mir'aj Nāma*, Herat ninth/fifteenth century (after Séguy, *Miraculous Journey*, pl. 31).



133. Detail of the mosaics in the western *riwaq*, Great Mosque of Damascus.

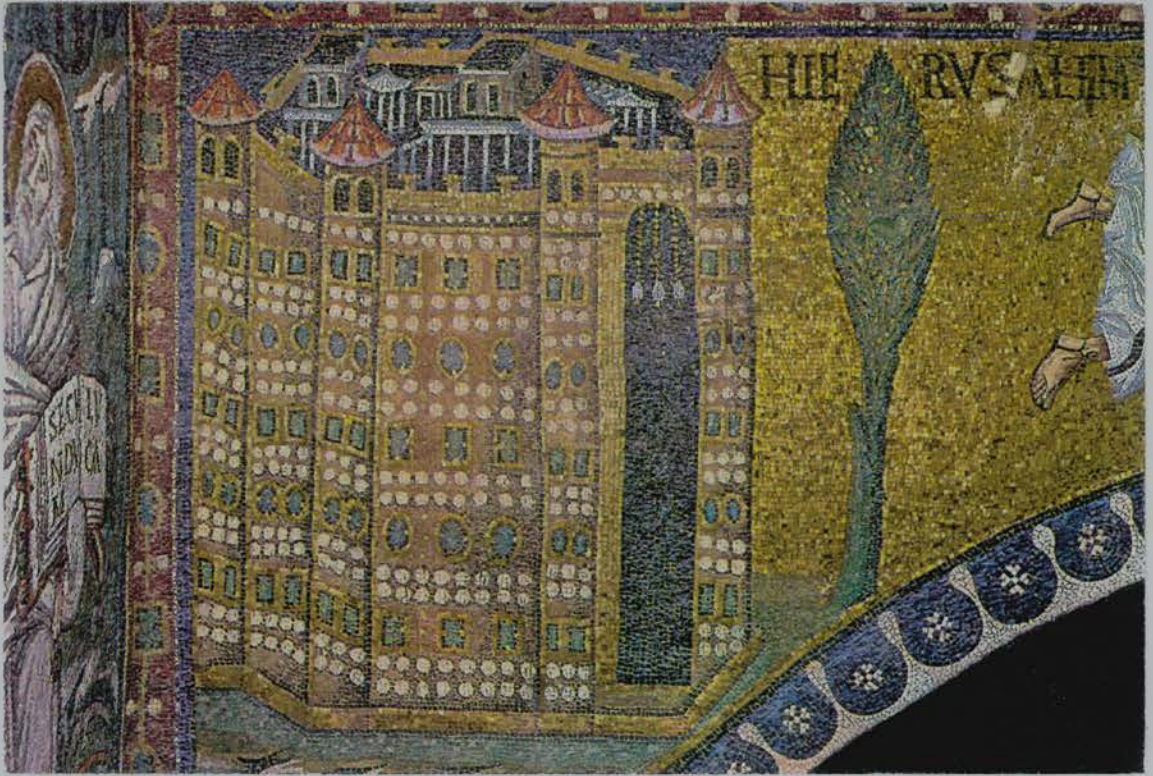

134. Heavenly Jerusalem, San Vitale, Ravenna.



135. Fragments of a glass pavement, Palace B, Raqqa (National Museum, Damascus).

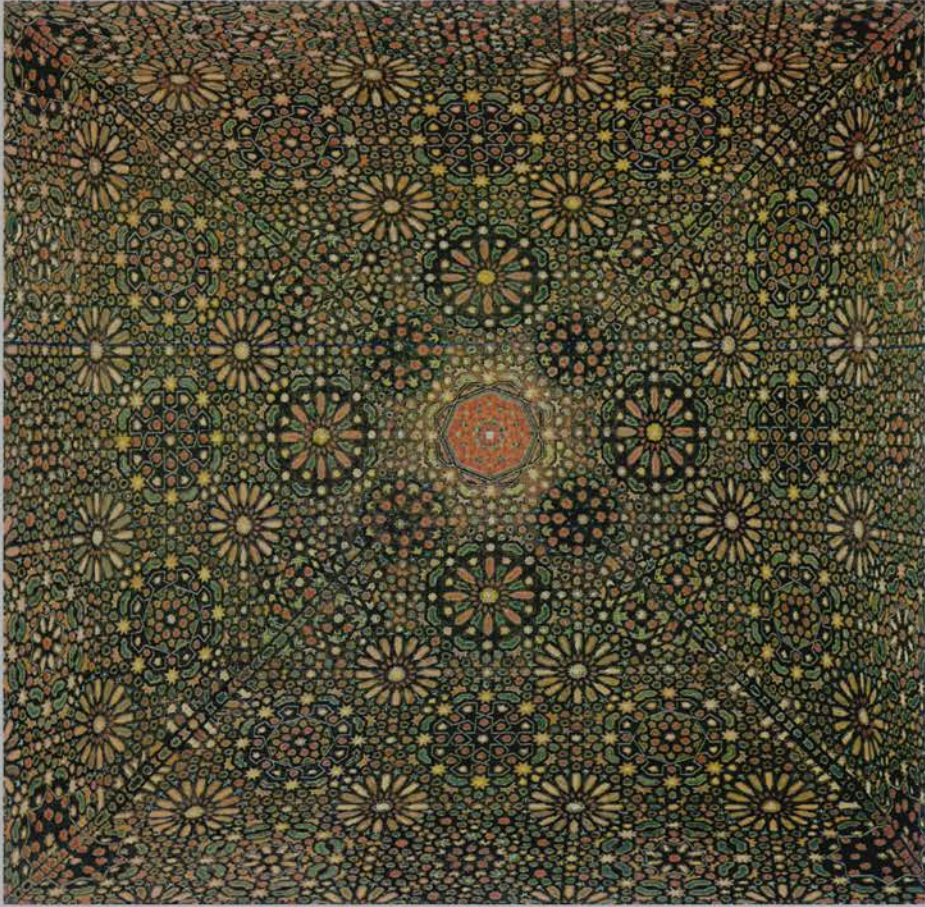

136. Wooden ceiling, Hall of the Ambassadors, Alhambra (after Rodriguez, El Techo, pl. XXV).



137. The 'zodiac clock' of al-Jazari (after al-Hassan, *al-Jāmi' Bain al-'Ilm*, pl. 4).



138. "Cup of Khusrau", Bibliothèque Nationale, Paris (photograph A. Shalem).



139. Qur'an frontispiece found in Sana'a' (after von Bothmer, *Architekturbilder*, fig. 1).

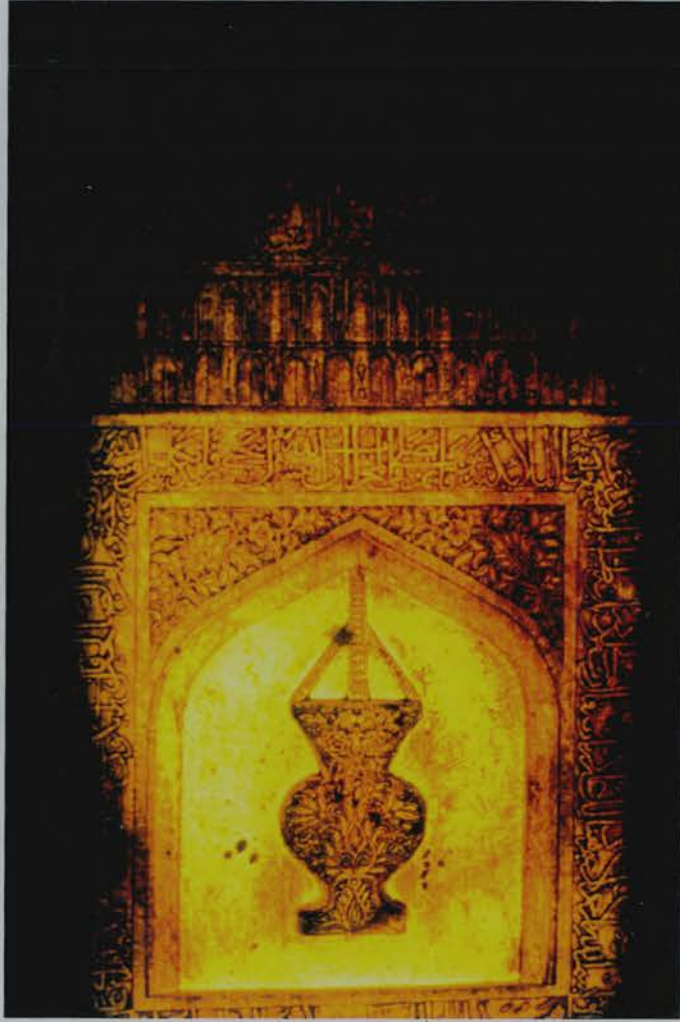

140. *Mihrab* in the Mosque at Bīdakhavīd (photograph B. O'Kane).



141. *Mihrab* in the shrine at Tulan Pusht
(photograph B. O'Kane).

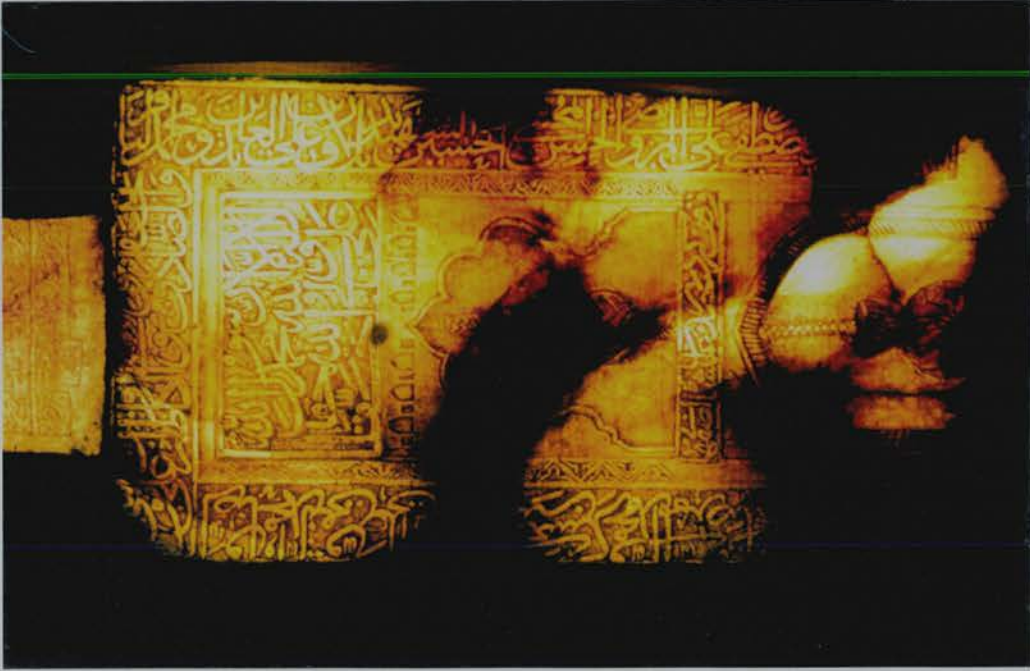

142. *Mihrab* in the shrine of Qadam Gah, Bidakhavīd
(photograph B. O'Kane).



143. Illuminated dome and minarets, Aswan.



144. Making an '*aqd* - tracing the design (photograph M. Mutahir).



145. Making an 'aqd - cutting the design (photograph M. Mutahir).



146. Making an 'aqd - the finished design (photograph M. Mutahir).



147. Making an 'aqd - preparing the glass (photograph M. Mutahir).



148. Making an 'aqd - laying the second layer of plaster (photograph M. Mutahir).

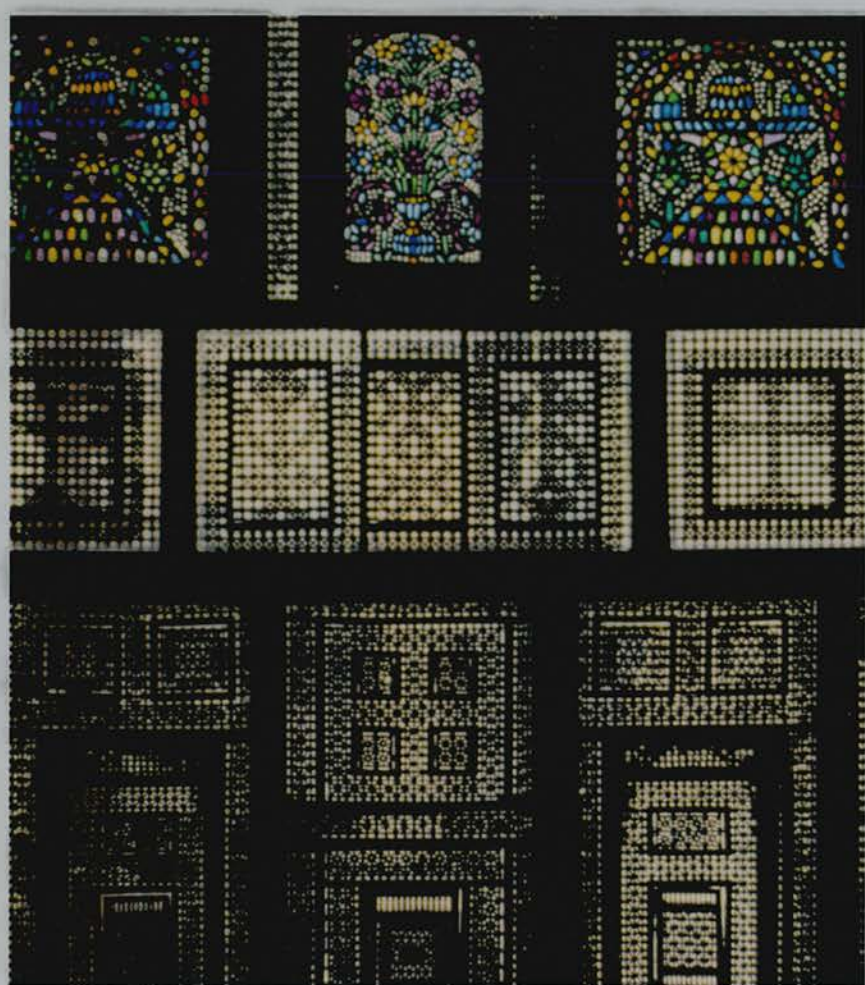

149. *Qamariyyat* and *mashrabiyyat*, Coptic Museum, Cairo.

FIGURES

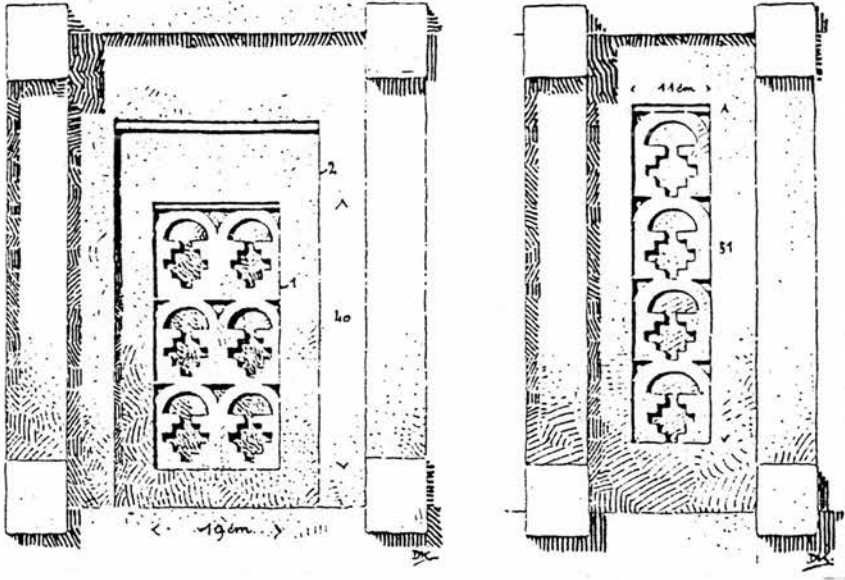

1. Windows depicted on a stele at Axum (after Krencker, *Nordabessinien Denkmäler*, figs. 47-8).

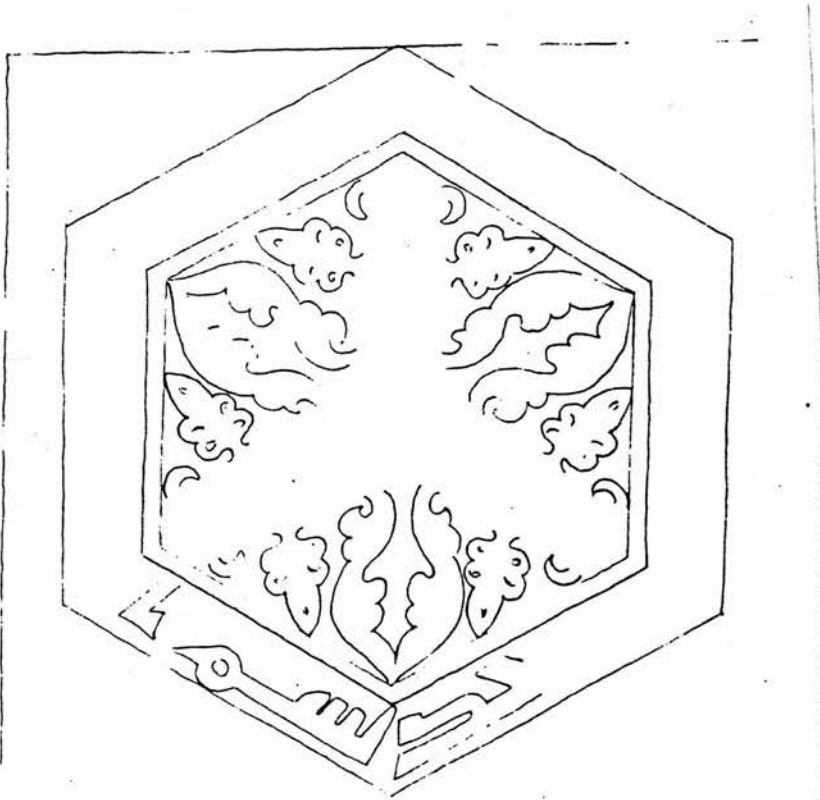

2. Design carved on an alabaster window, Masjid al-'Abbās, Haulān (after Finster, *Masjid al-'Abbās*, fig. 61).

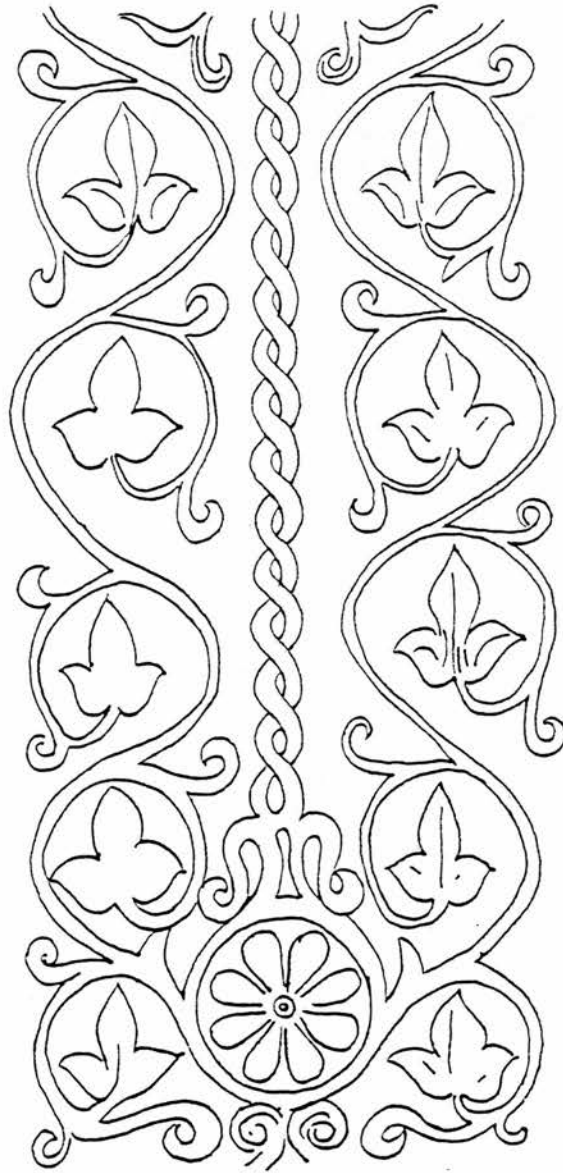

3. Design on an alabaster window, mosque of al-' Abbās,
Ḥaulān (after Finster, *Masǧid al-' Abbās*, fig. 60).

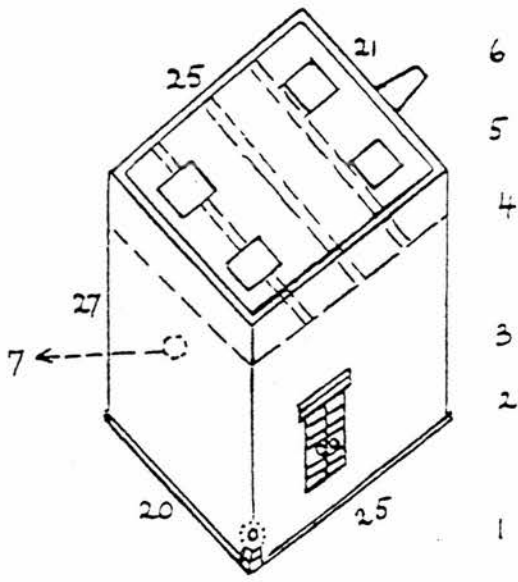

4. Reconstruction drawing of the Ka'ba after the description of Ibn 'Abd Rabbih (after Jairazbhoy, Shrines, fig. 11b).

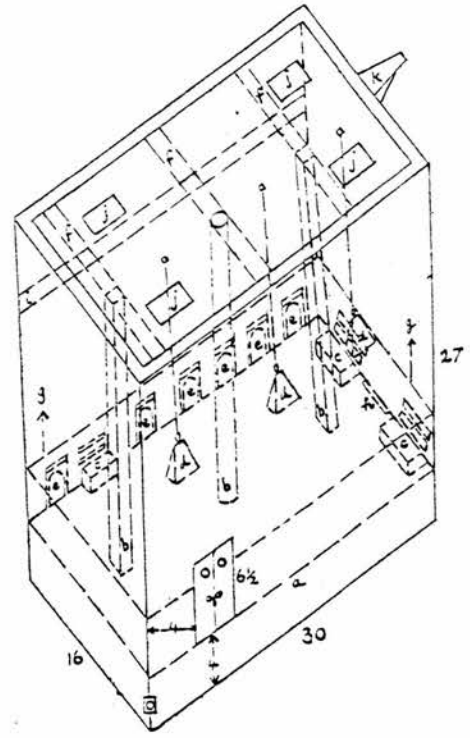

5. Reconstruction drawing of the Ka'ba (after Jairazbhoy, Shrines, fig. IV).

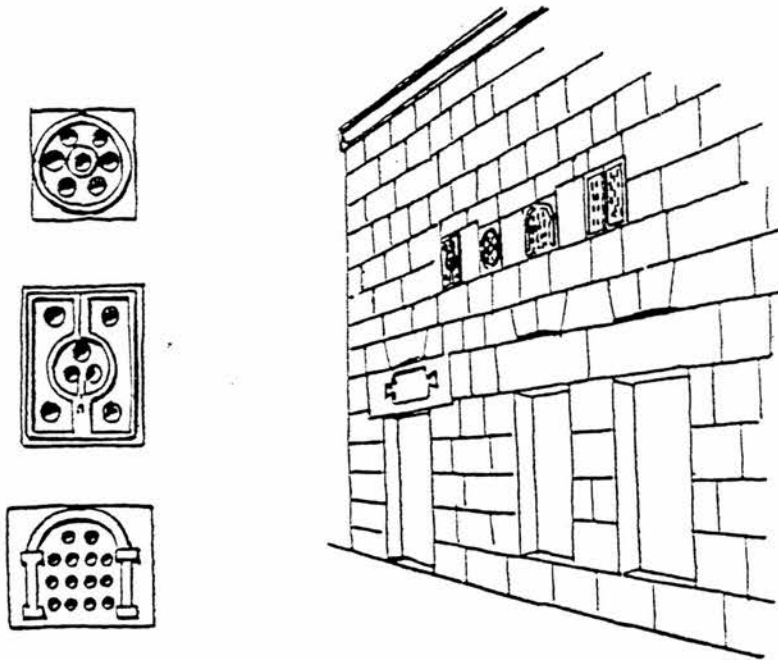

6. Antique basalt window-grilles in the facade of the Turbat Aidekin, Damascus (after Herzfeld, Studies III, figs. 84-5).

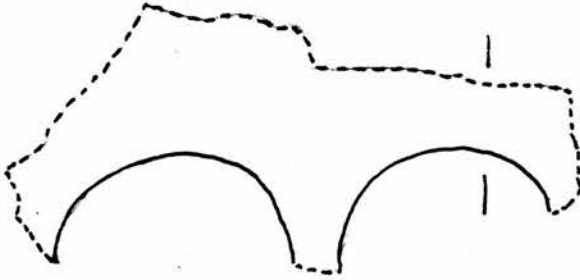
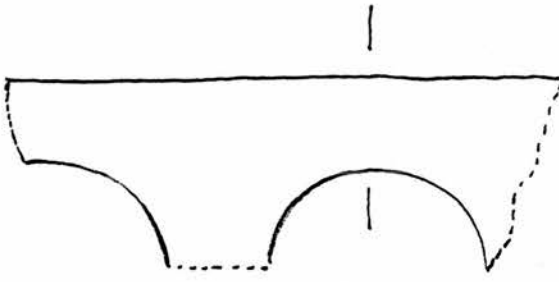

7. *Qamariyyat* fragments from Qasr al-Ḥayr al-Sharqī (scale 1:1).

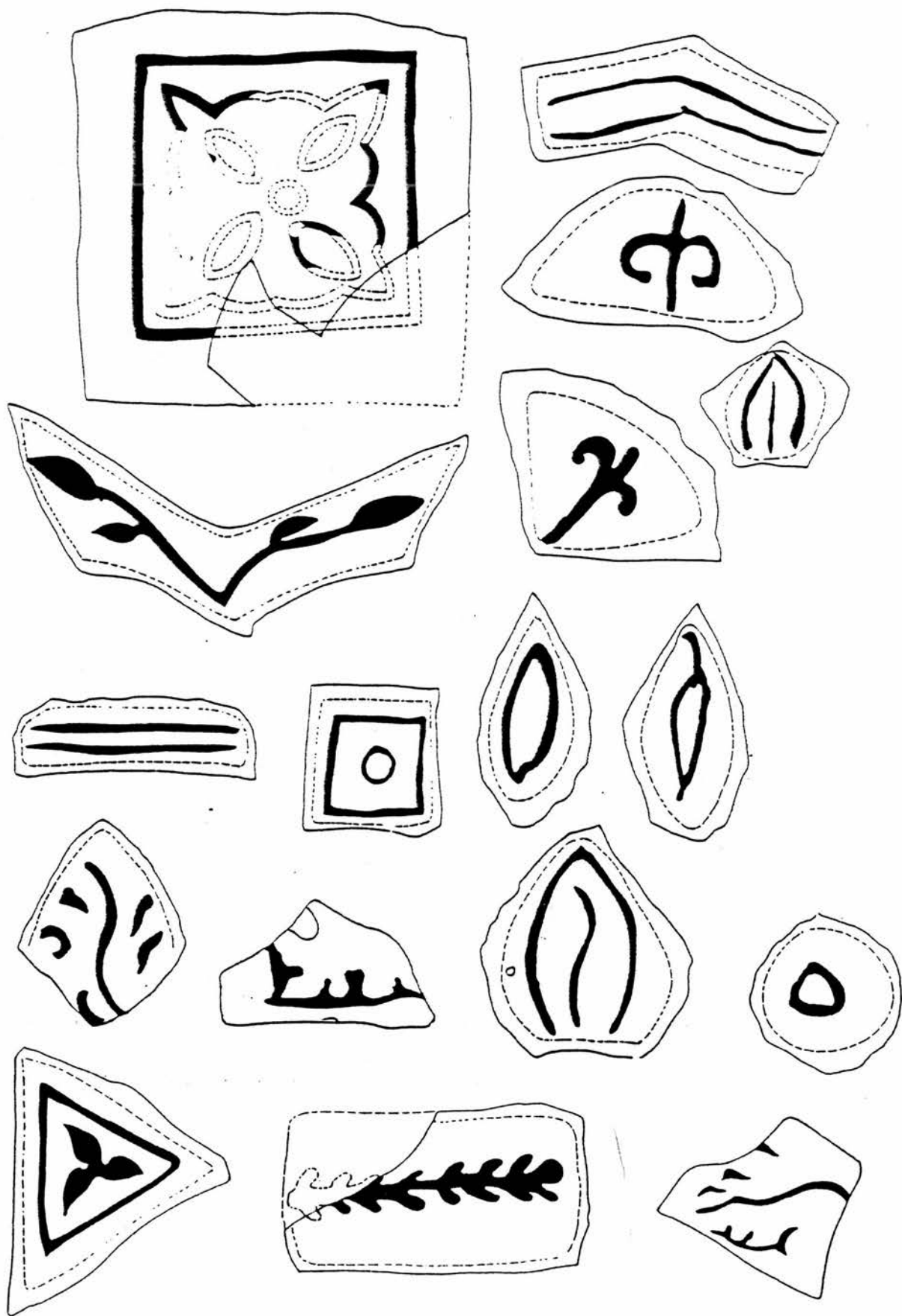

8. Painted window-glass from Khirbat al-Mafjar (after Brosch, Glass windows, fig. 3).

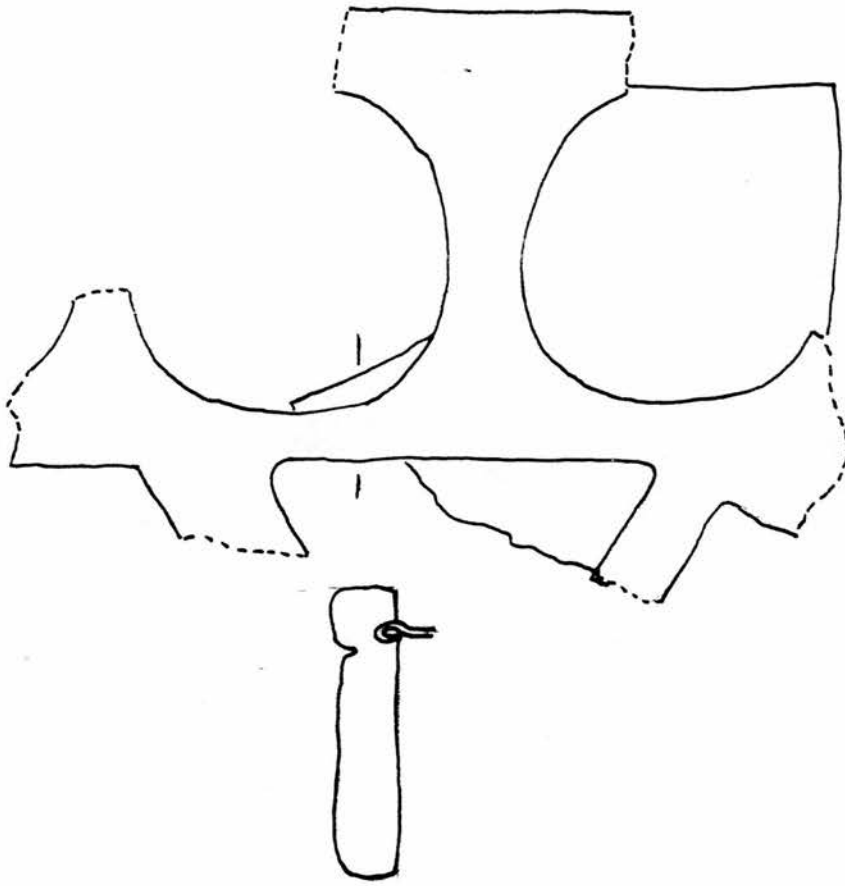

9. *Qamariyyat* fragments from Qasr al-Hallābāt (scale 1:1).

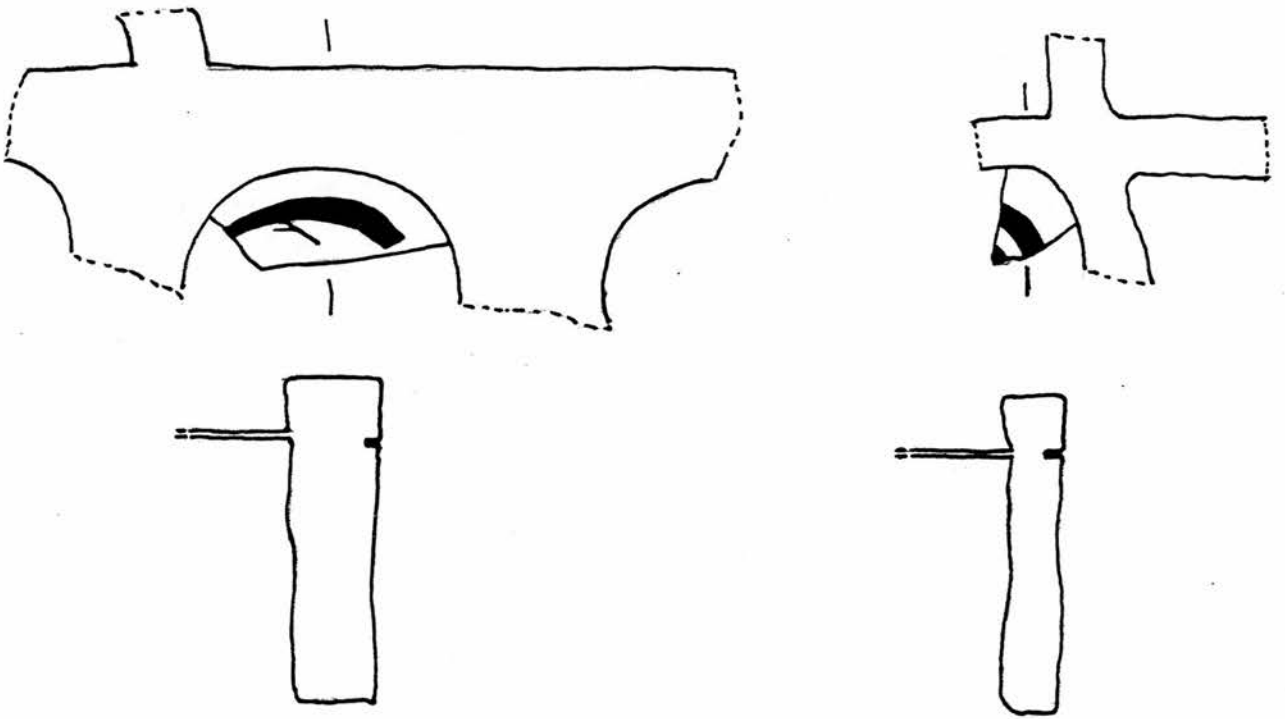

10. *Qamariyyat* fragments from Qasr al-Hallābāt (scale 1:1).

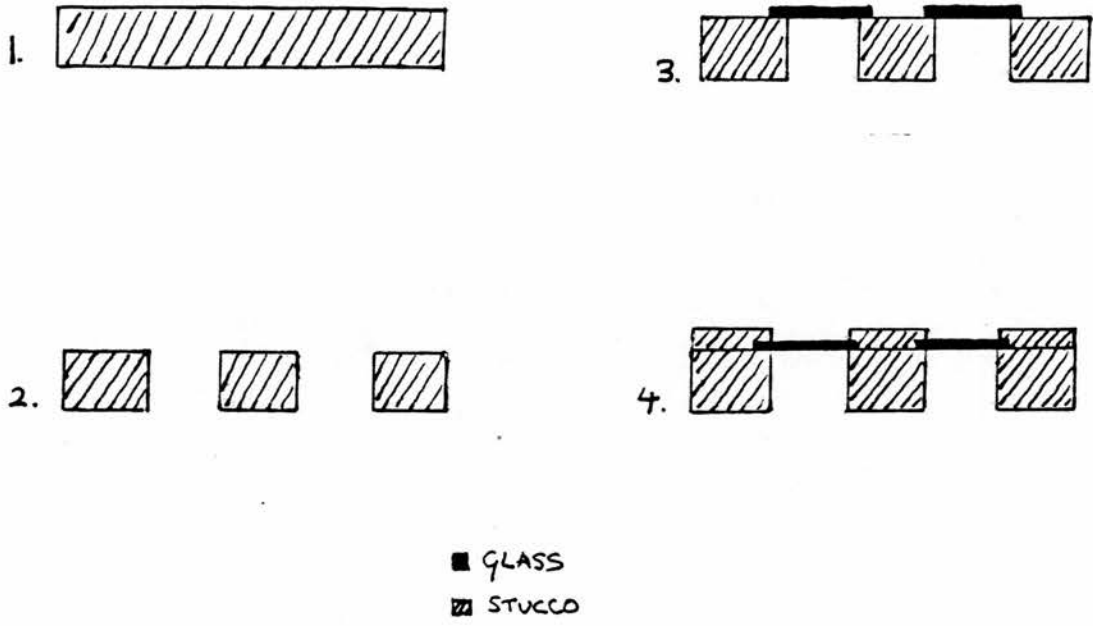

11. Stages in the manufacture of a *qamariyya*.

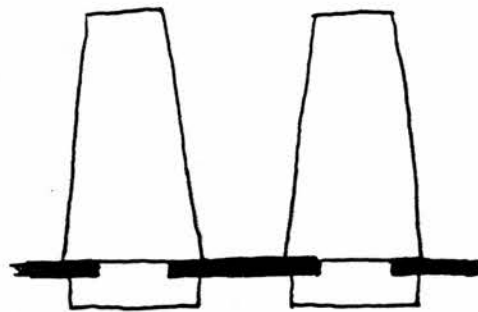

12. Section through a modern Yemeni stucco and glass window (after Bonnenfant, *Artisans*, fig. 4).

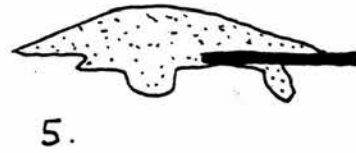
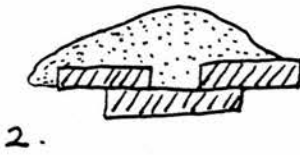
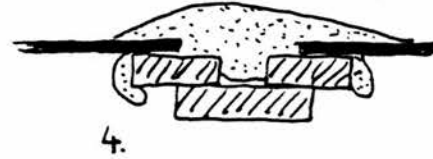
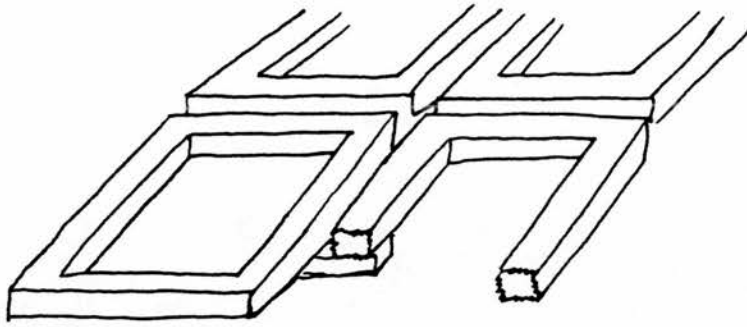

■ GLASS
 ▨ STUCCO
 ▩ WOOD

13. Stages in the manufacture of stucco and glass windows from Umm Qais (drawings, F. Gor Andersen).

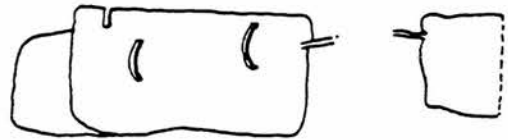
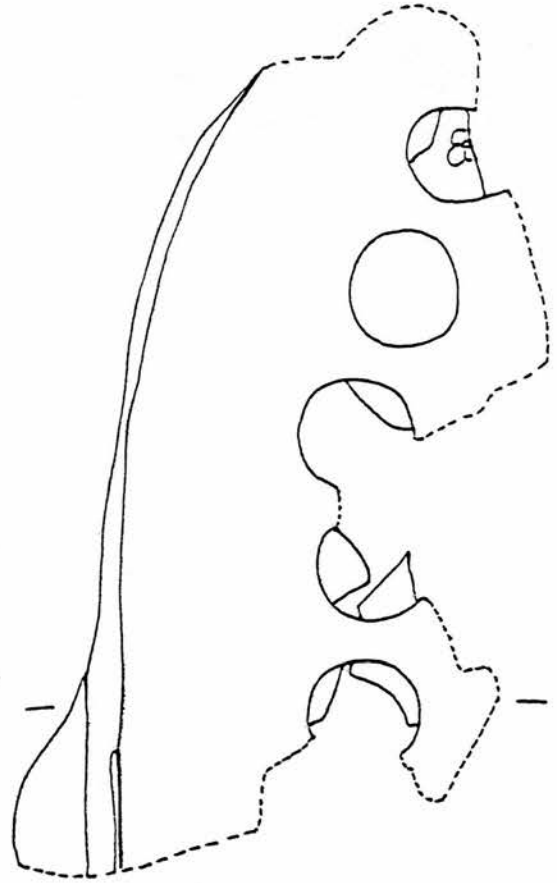
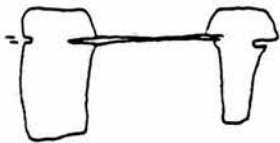
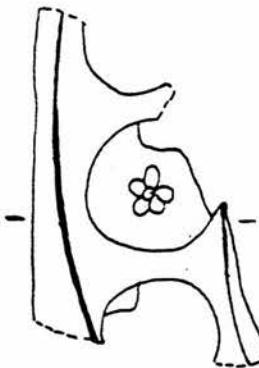
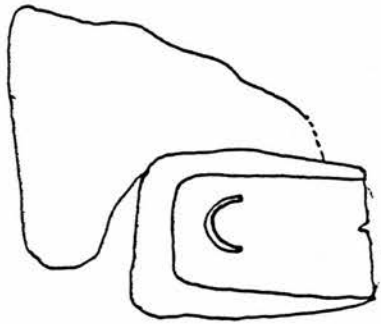
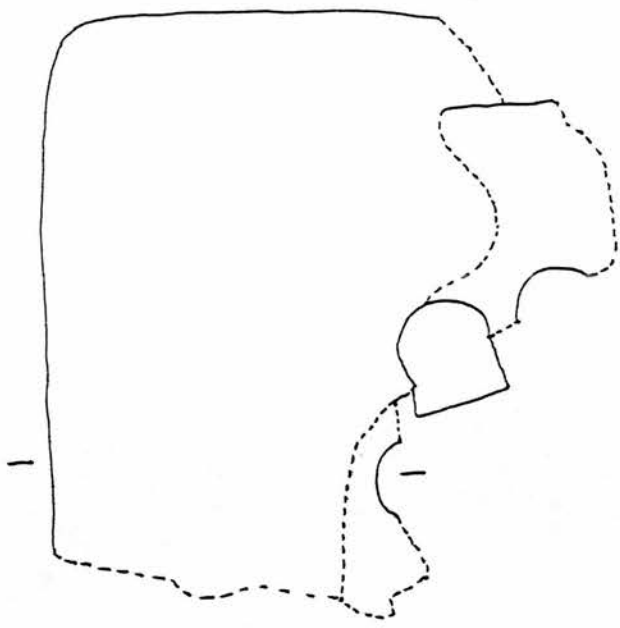

14. *Qamariyyat* fragments from the 'Abbasid palaces at Raqqa (scale 2:3).

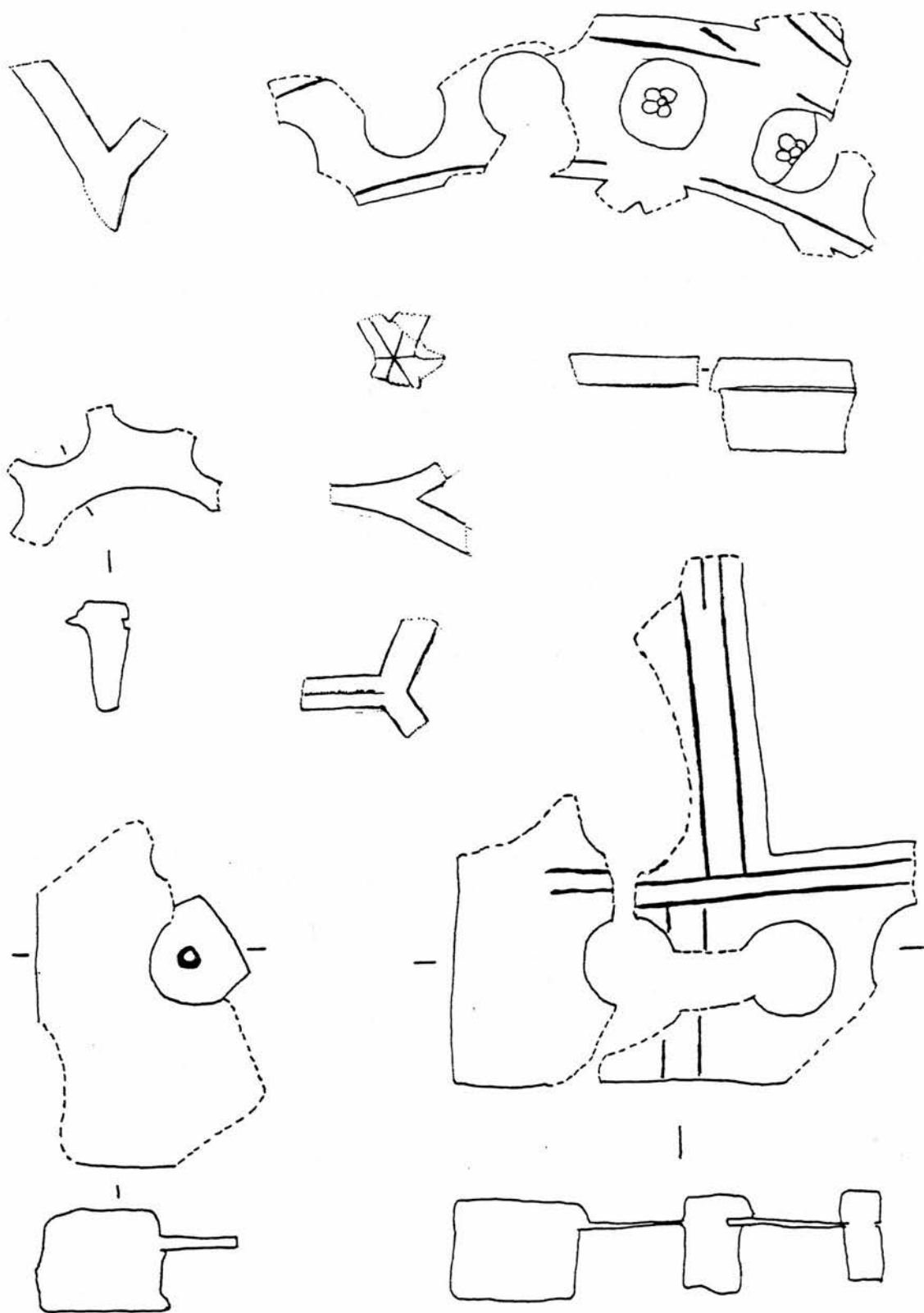

15. *Qamariyyat* fragments from the 'Abbasid palaces at Raqqa (scale 2:3).

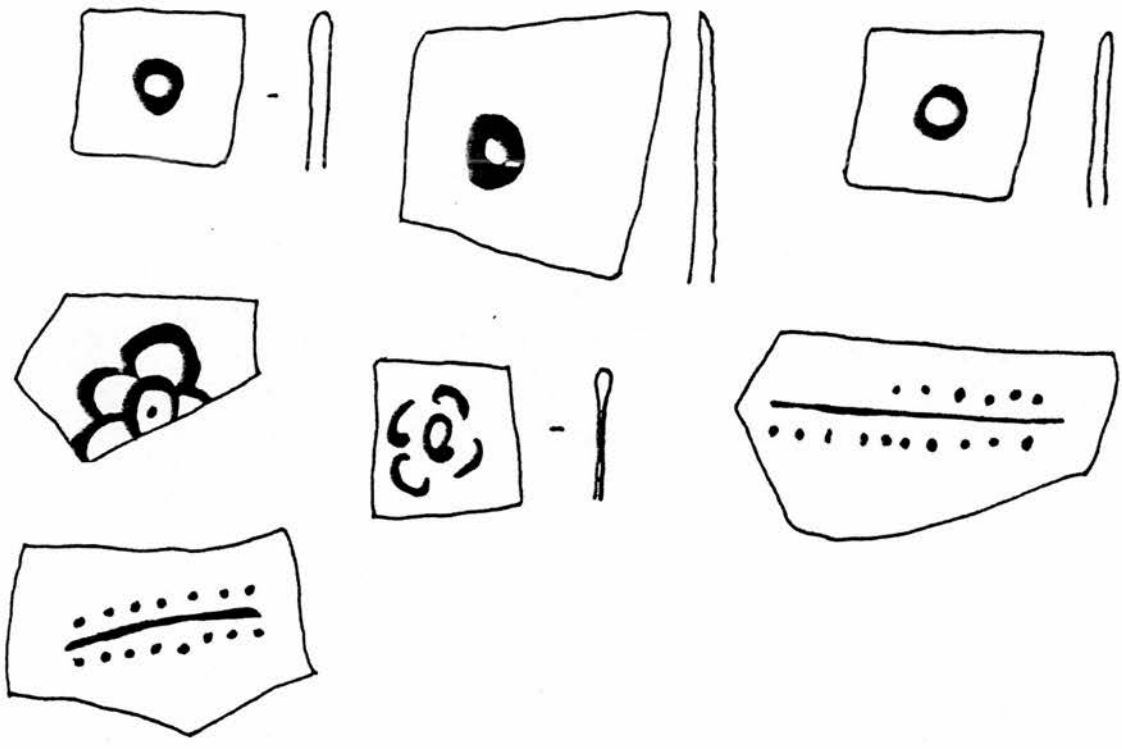

16. Examples of painting on colourless glass, 'Abbasid palaces at Raqqa. (scale 1:1).

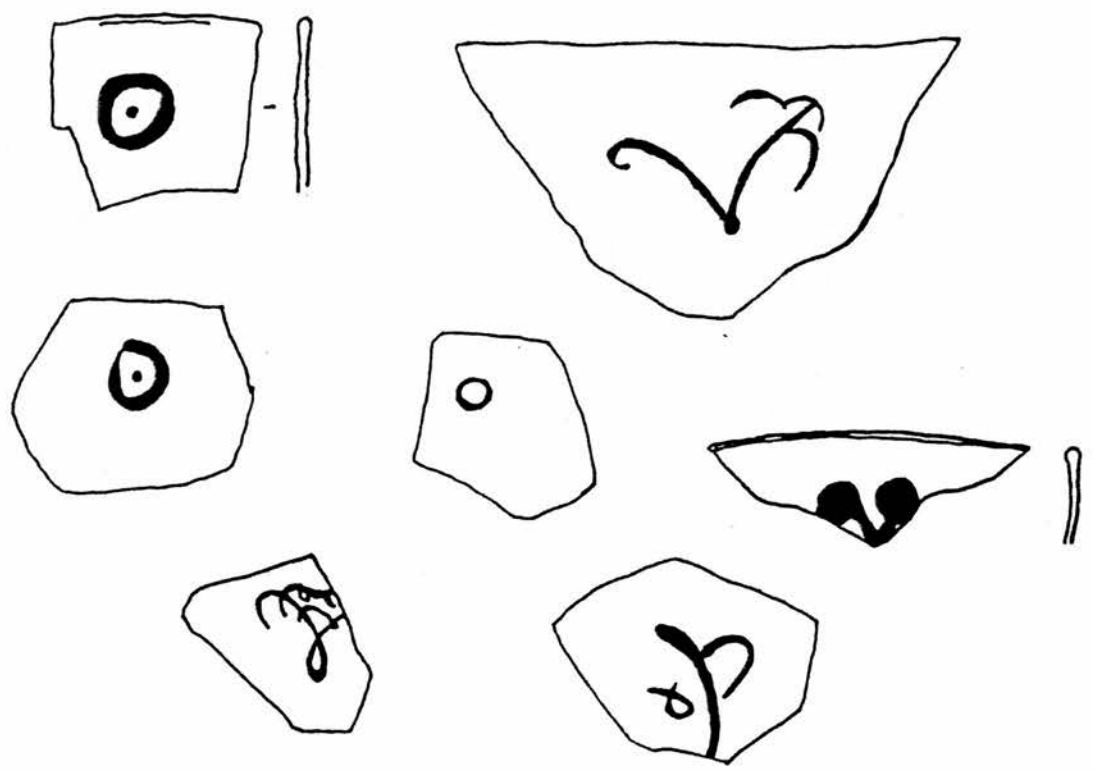

17. Examples of painting on blue glass, 'Abbasid palaces at Raqqa (scale 1:1).

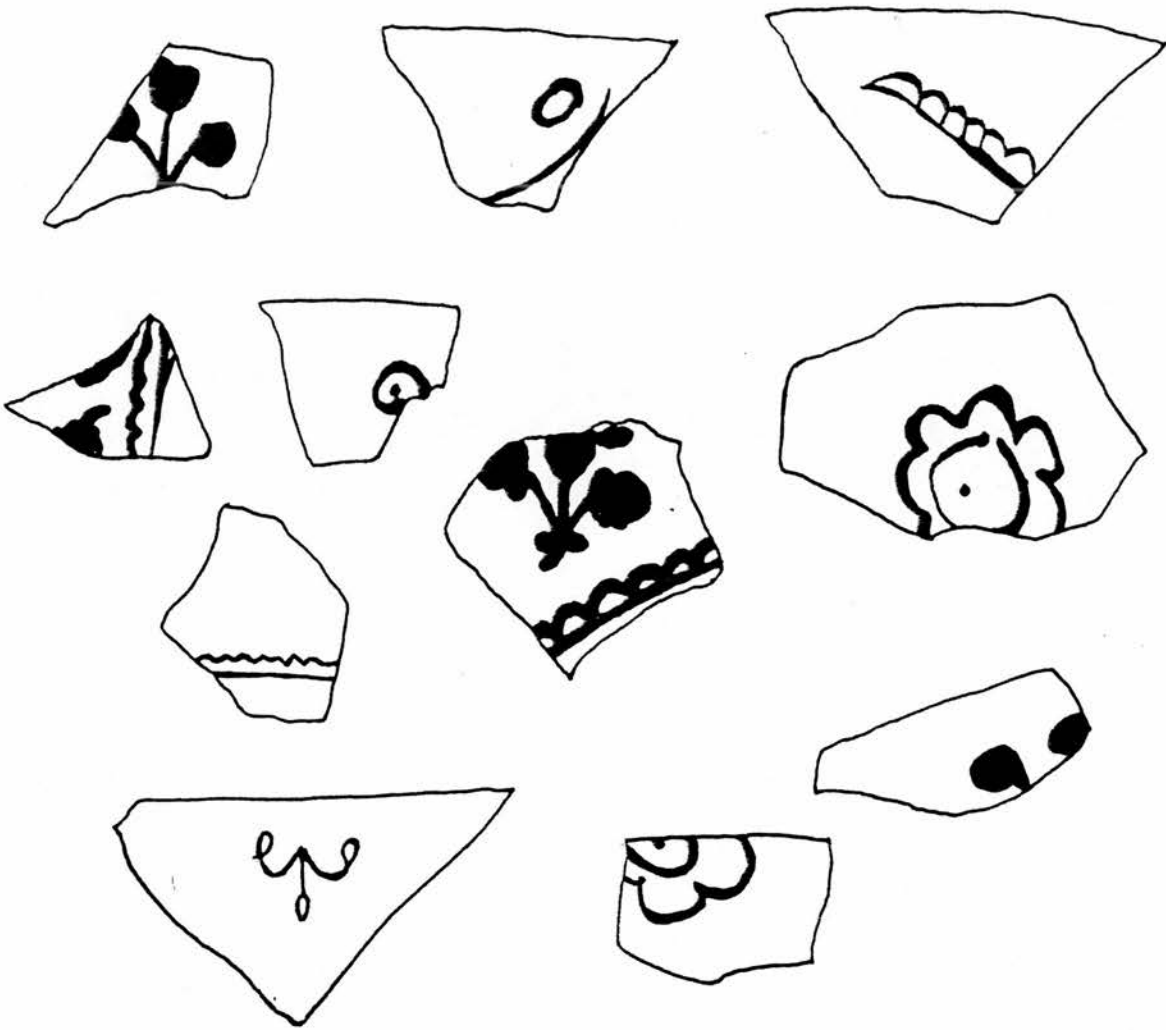

18. Examples of painting on purple glass, 'Abbasid palaces at Raqqa (scale 1:1).

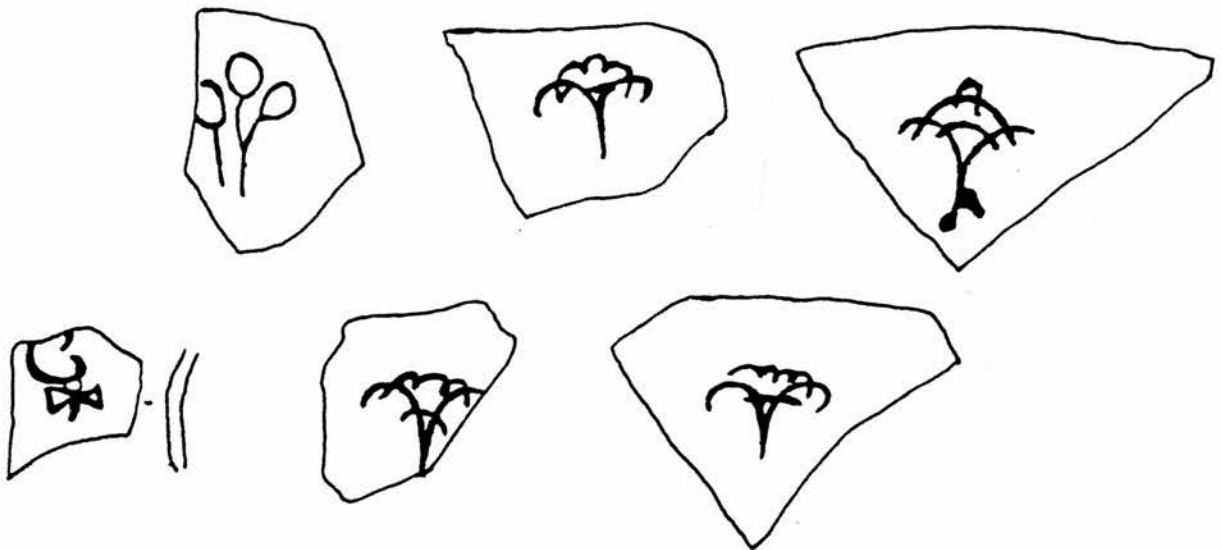

19. Examples of painting on dark green glass, 'Abbasid palaces at Raqqa (scale 1:1).



20. Examples of painting on yellow glass, 'Abbasid palaces at Raqqa (scale 1;1).

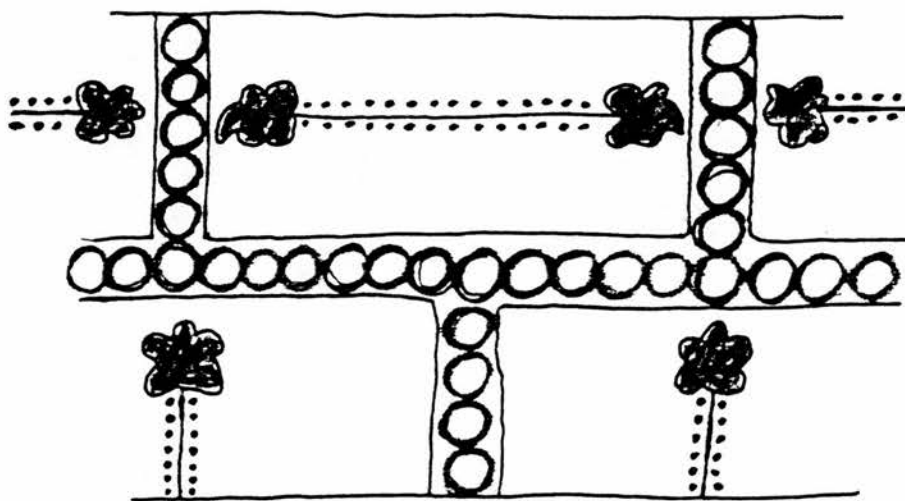
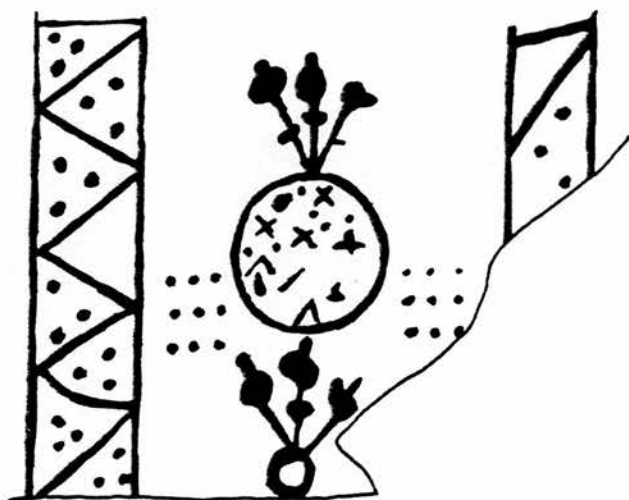

21. Designs from two lustre-painted glass vessels found at Raqqa (R 49-50, National Museum, Damascus).

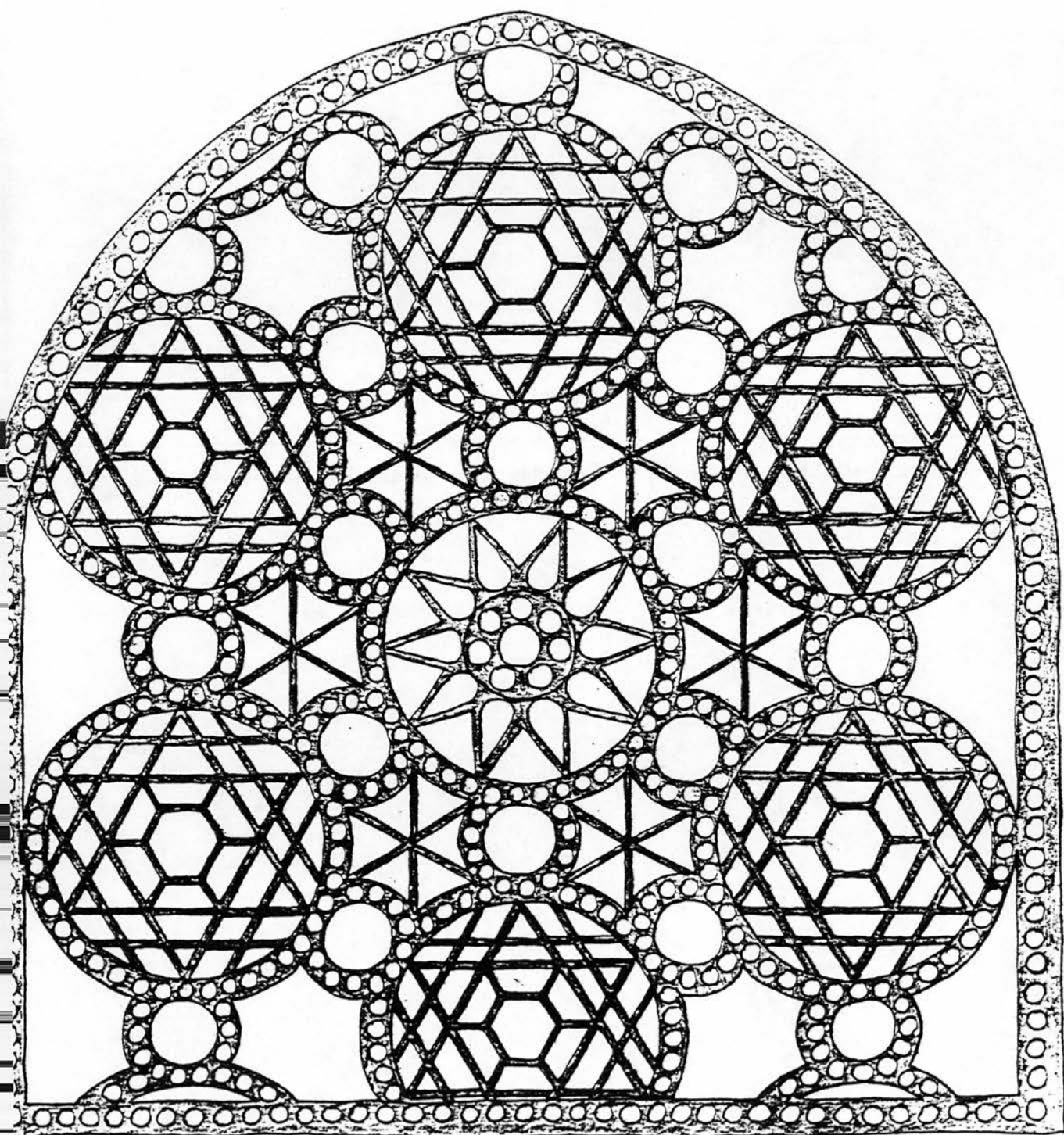

22. Hypothetical reconstruction of a *qamariyya* from the West Palace, Raqqa
(scale 1:5, stucco tracery shaded).

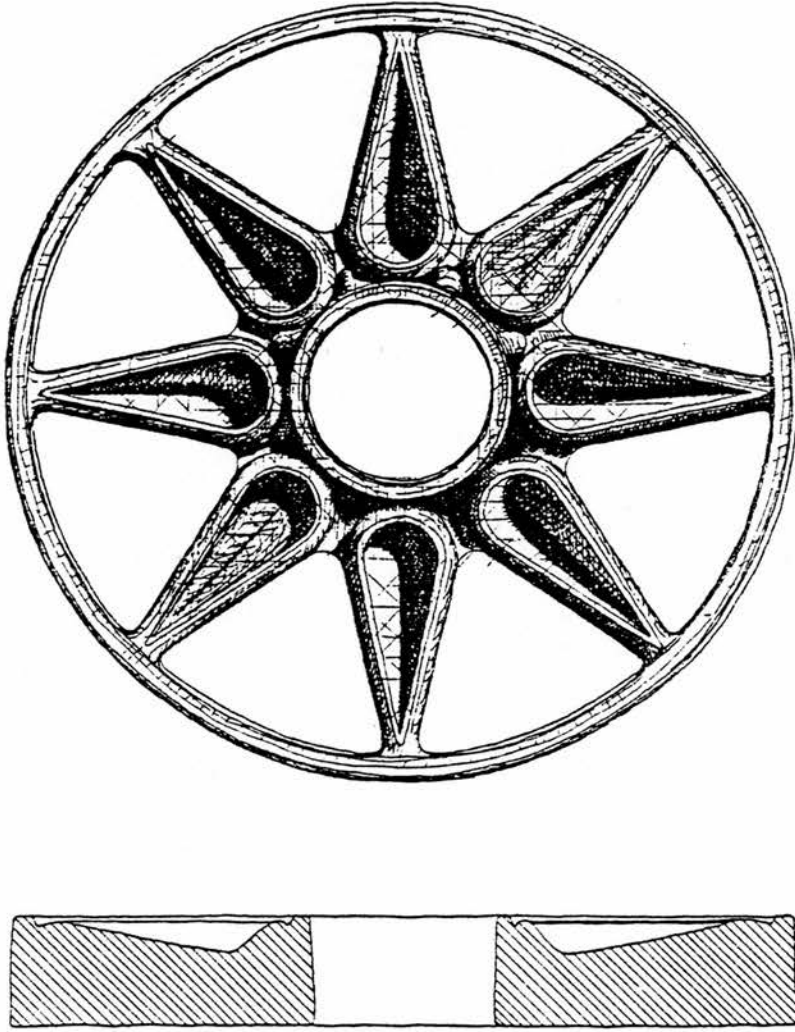

23. Stucco roundel from Kish (after SPA, fig. 193a).

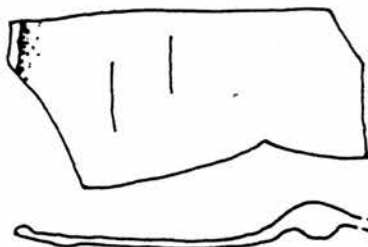
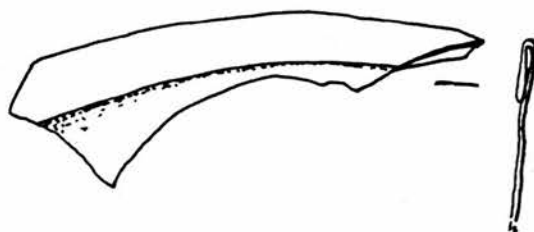
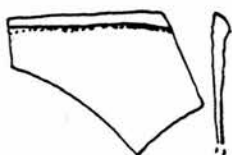
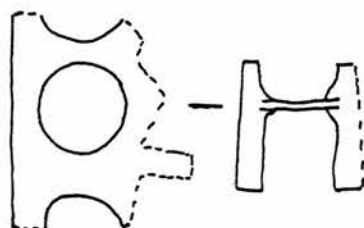
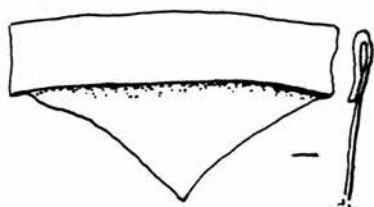
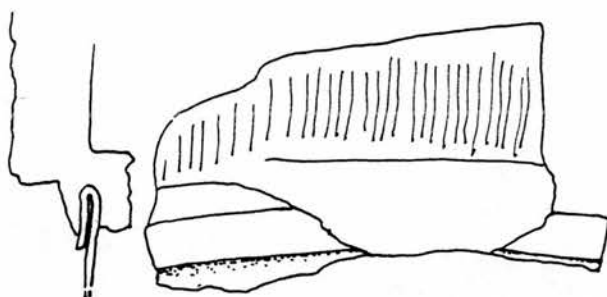

24. *Qamariyyat* fragments from Samarra, scale 2:3 (after Lamm, *Das Glas*, figs. 72-6).

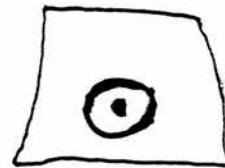
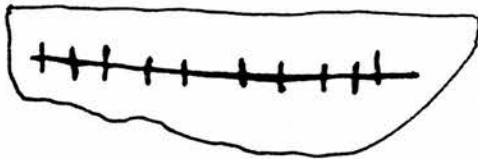
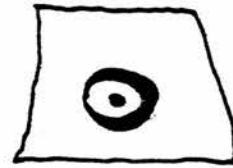
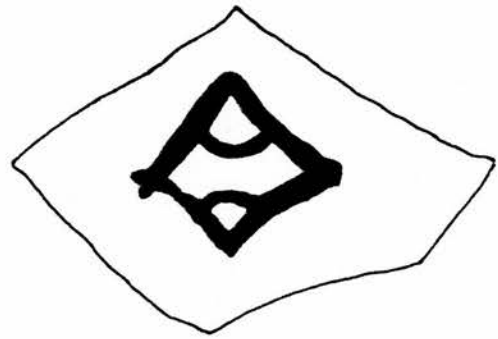
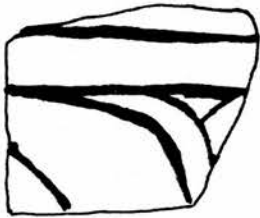
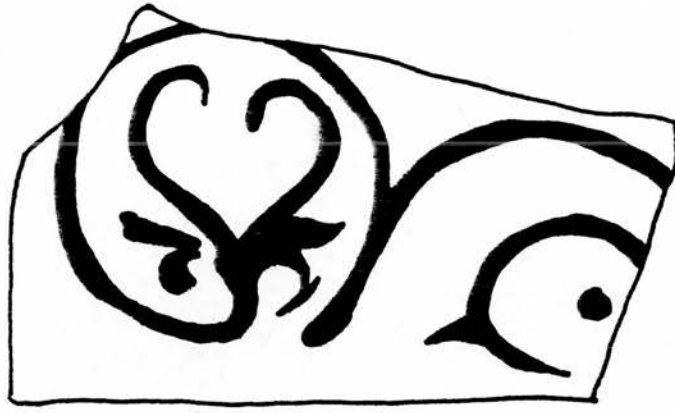

25. Painted window-glass from Samarra, scale 1:1 (after Lamm, *Das Glas*, figs. 58-60).

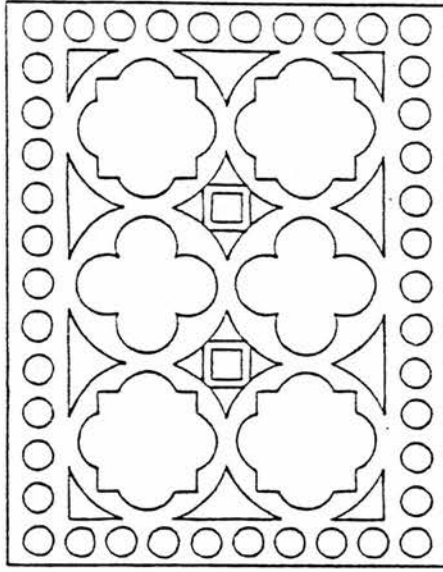

26. Stucco tracery, Deir Abū Makar, Wadi Natrun (after Evelyn-White, *Monasteries*, fig. fig. 7).

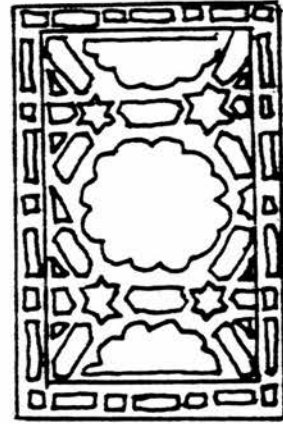
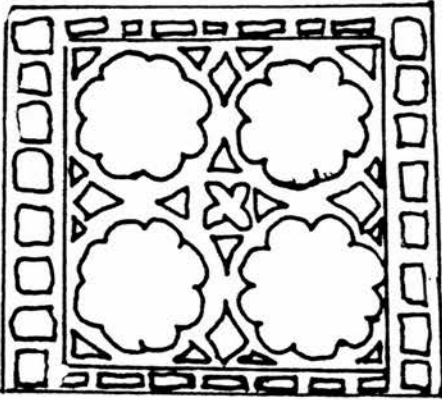

27. Stucco tracery, Deir al-Sūryānī, Wadi Natrun (after windows visible in Evelyn-White, *Monasteries*, pl. LXX)

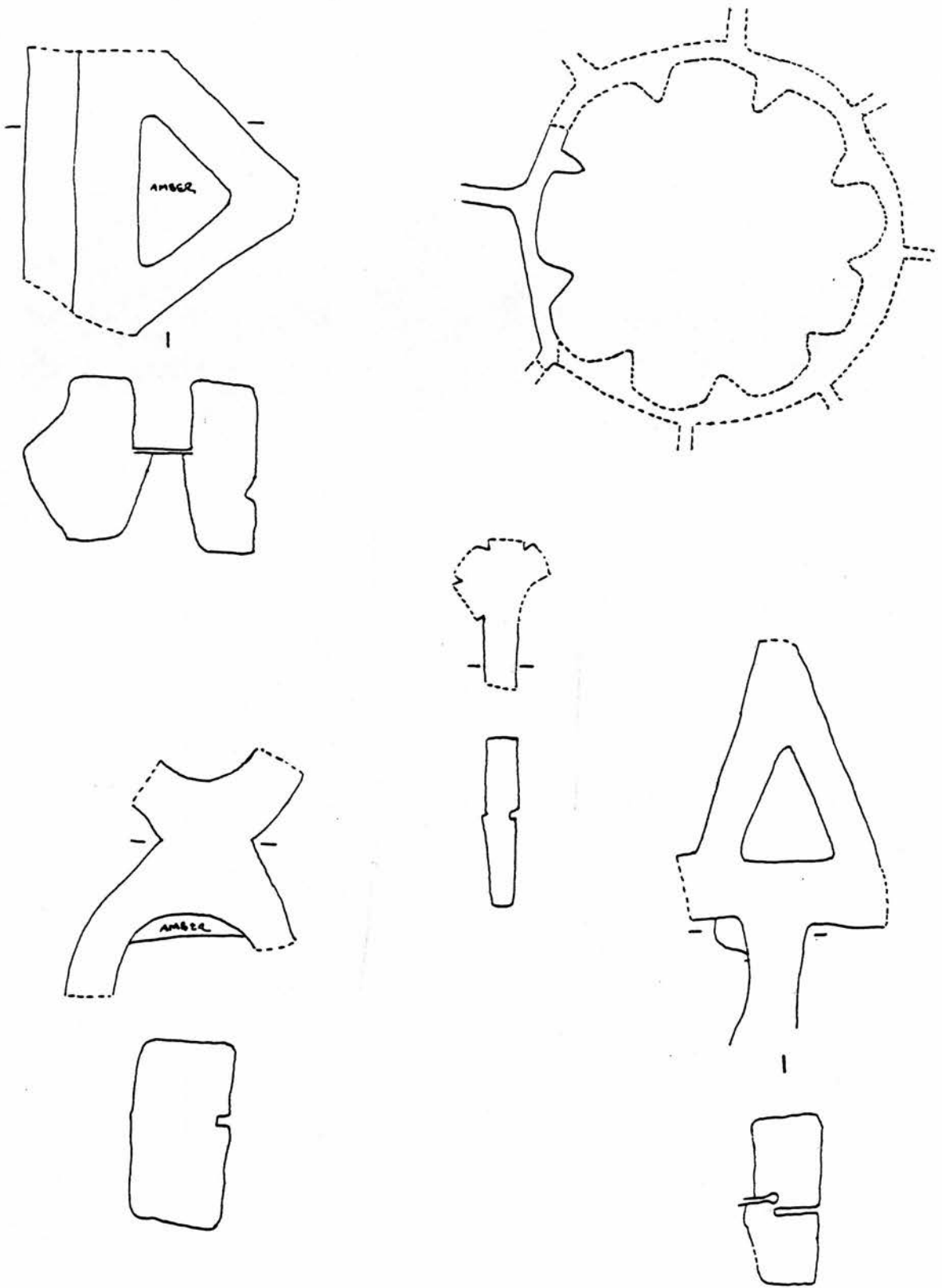

28. *Qamariyyat* fragments from Qasr al-Banat, Raqqā (scale 2:3).

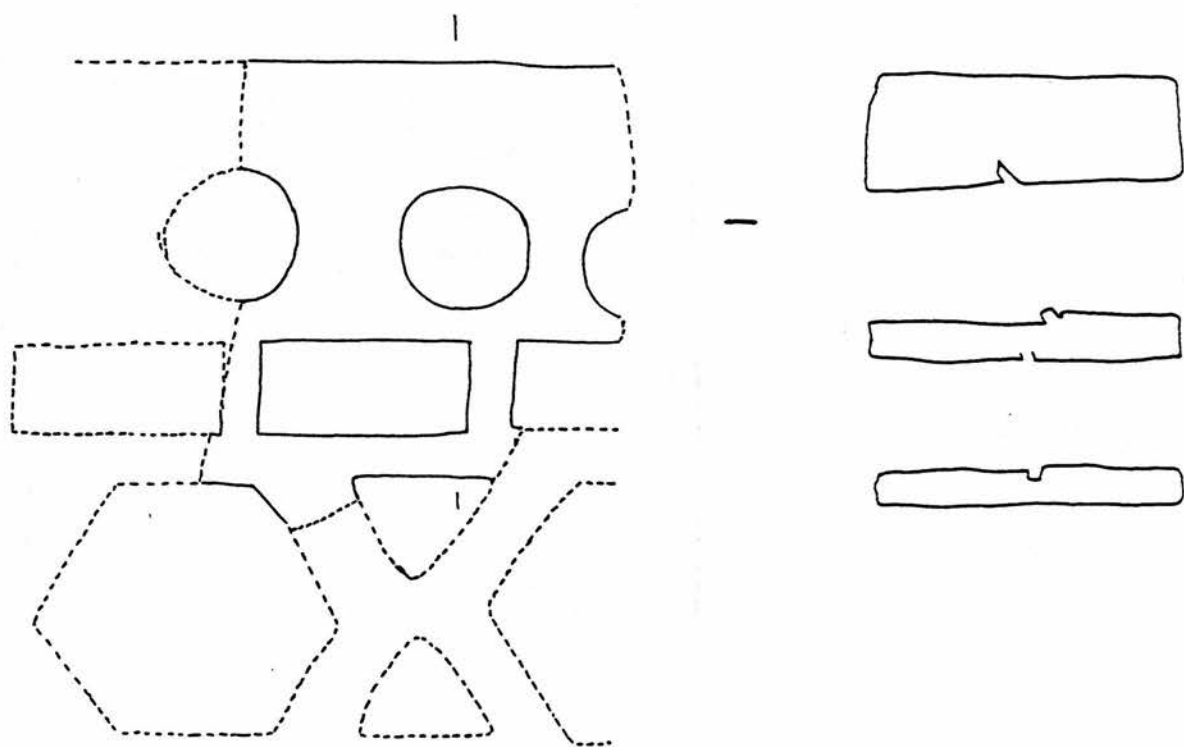
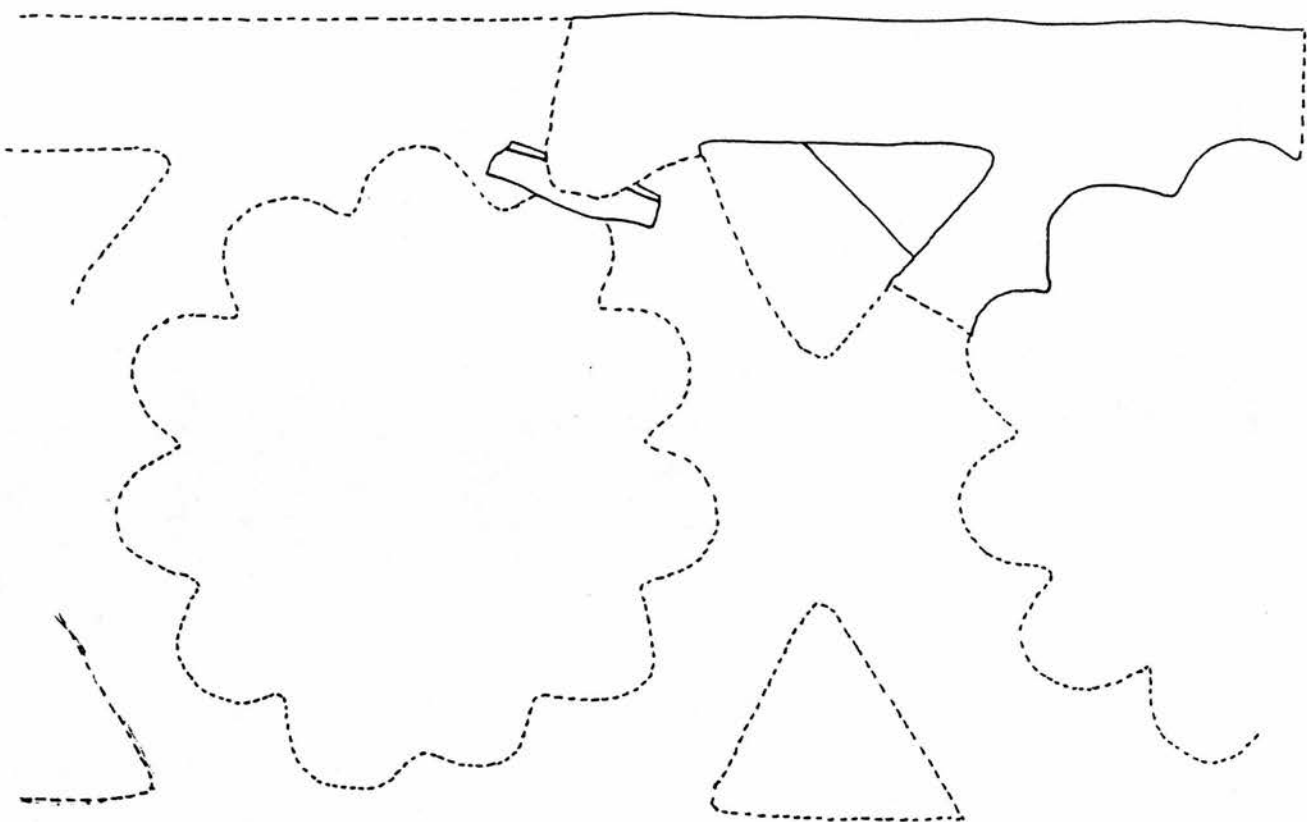

29. Partial reconstruction of *qamariyyat* fragments from Qasr al-Banat, Raqqa (scale 2:3).

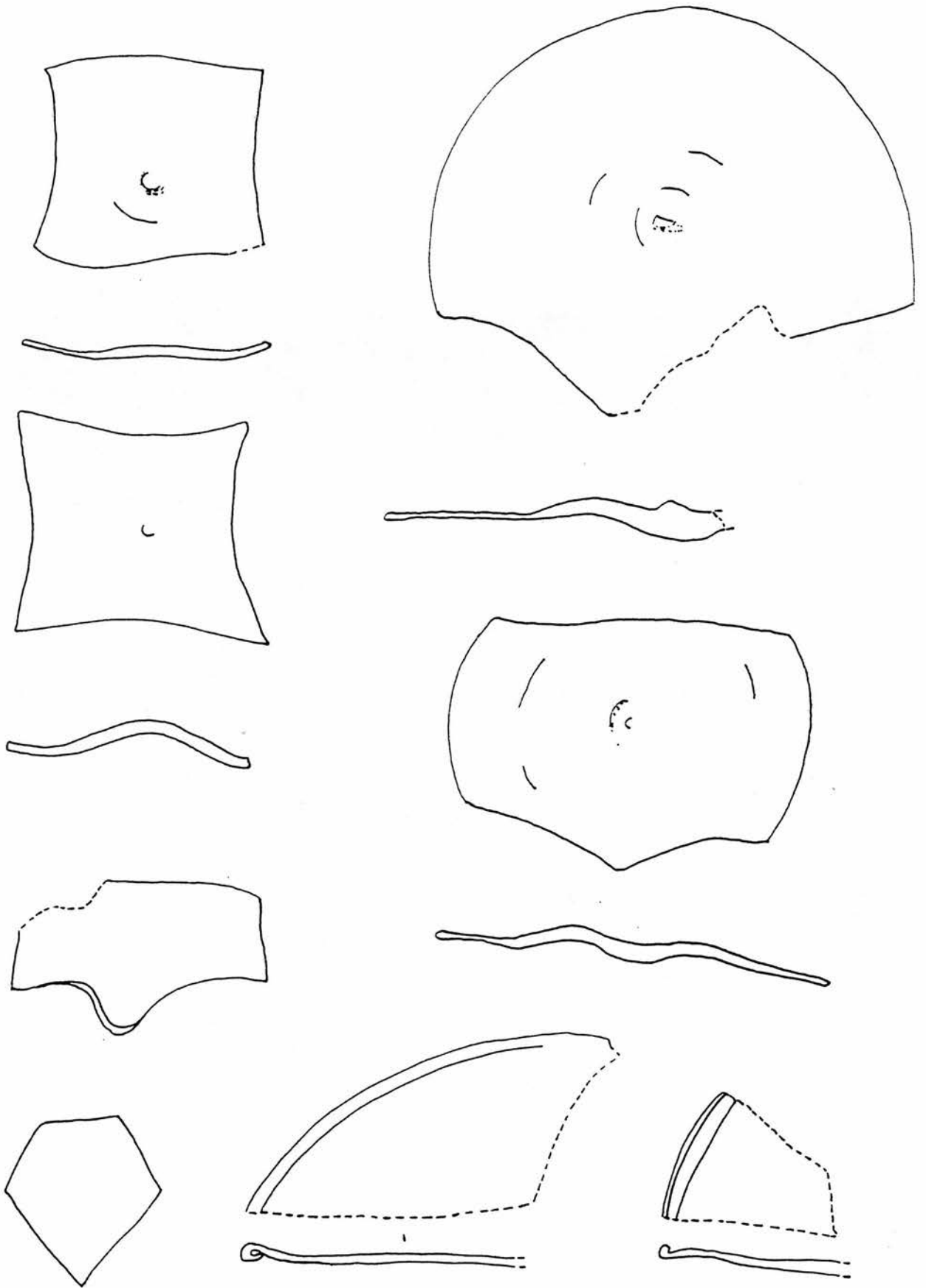

30. Pieces of cut window-glass, Qasr al-Banat, Raqqa (scale 2:3).

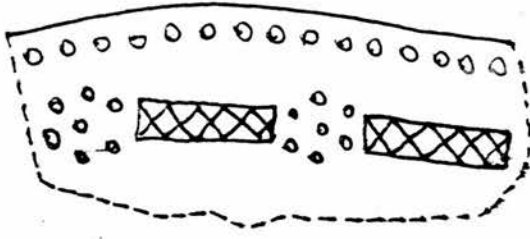

31. Border motif from a *qamariyya* formerly in the Jaharkasiyya Madrasa, Damascus (after Sauvaget, *Monuments* I, p. 43).

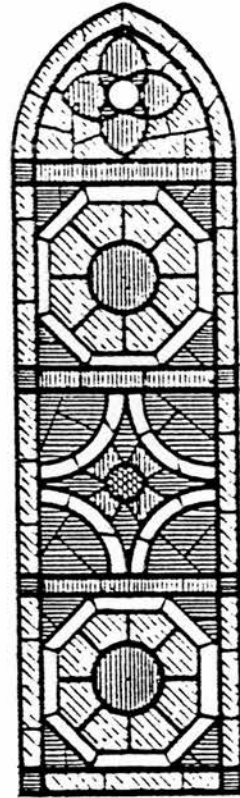

32. Reconstruction of a stained glass window from Atlit (after Johns, *Excavations*, fig. 8).

PLAIN WHITE.
 GREENISH WHITE.
 PURPLISH RED.
 BLUE.
 BROWNISH YELLOW.

10 5 0 10 20 30
 CM. GMS

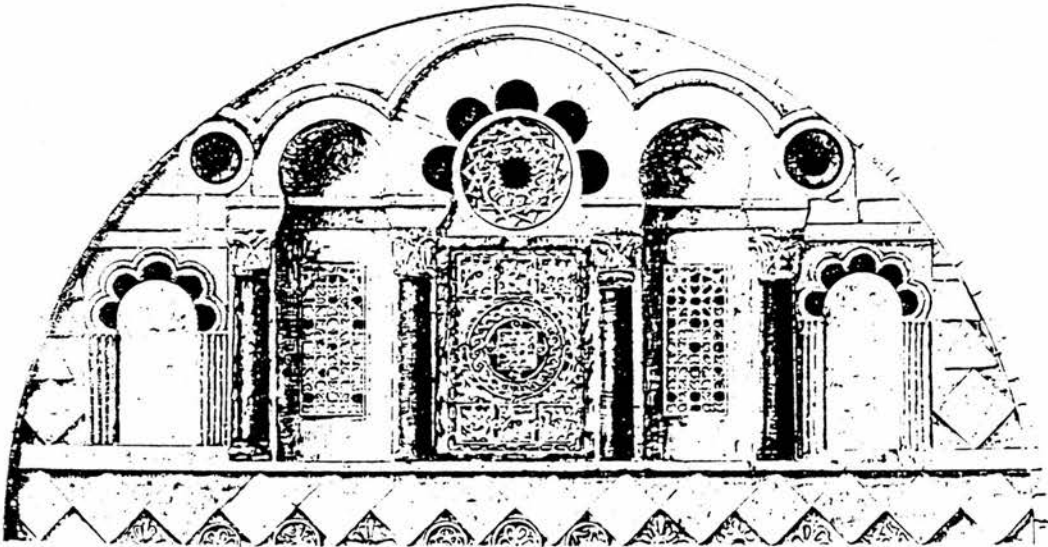

33. Windows above the *mihrab*, Great Mosque of Qairawān (after Golvin, *Mihrab*, fig. 13).

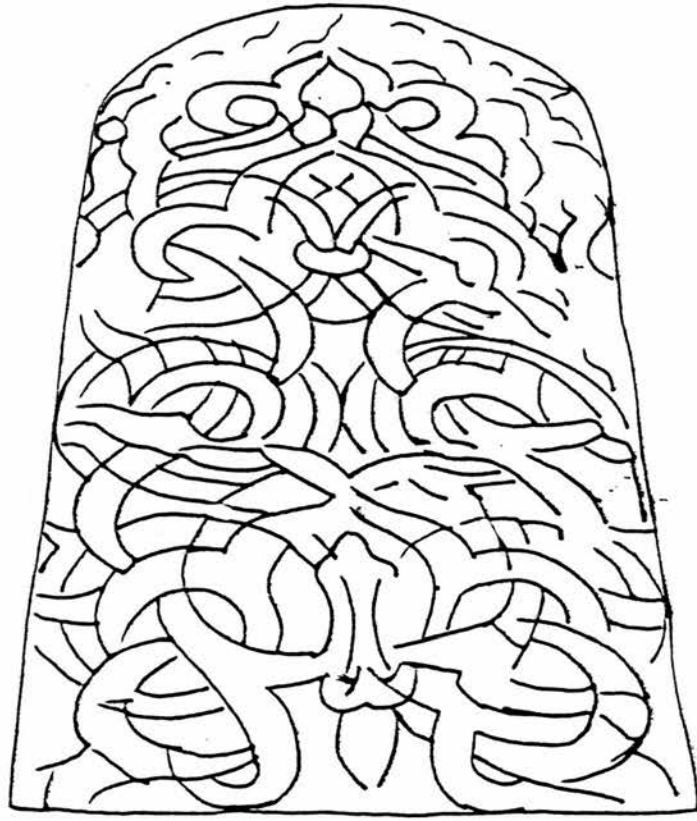

34. *Shamsiyya* in the Bu 'Ināniya Madrasa, Fez (after Dannerbeck, Representations, pl. 11).

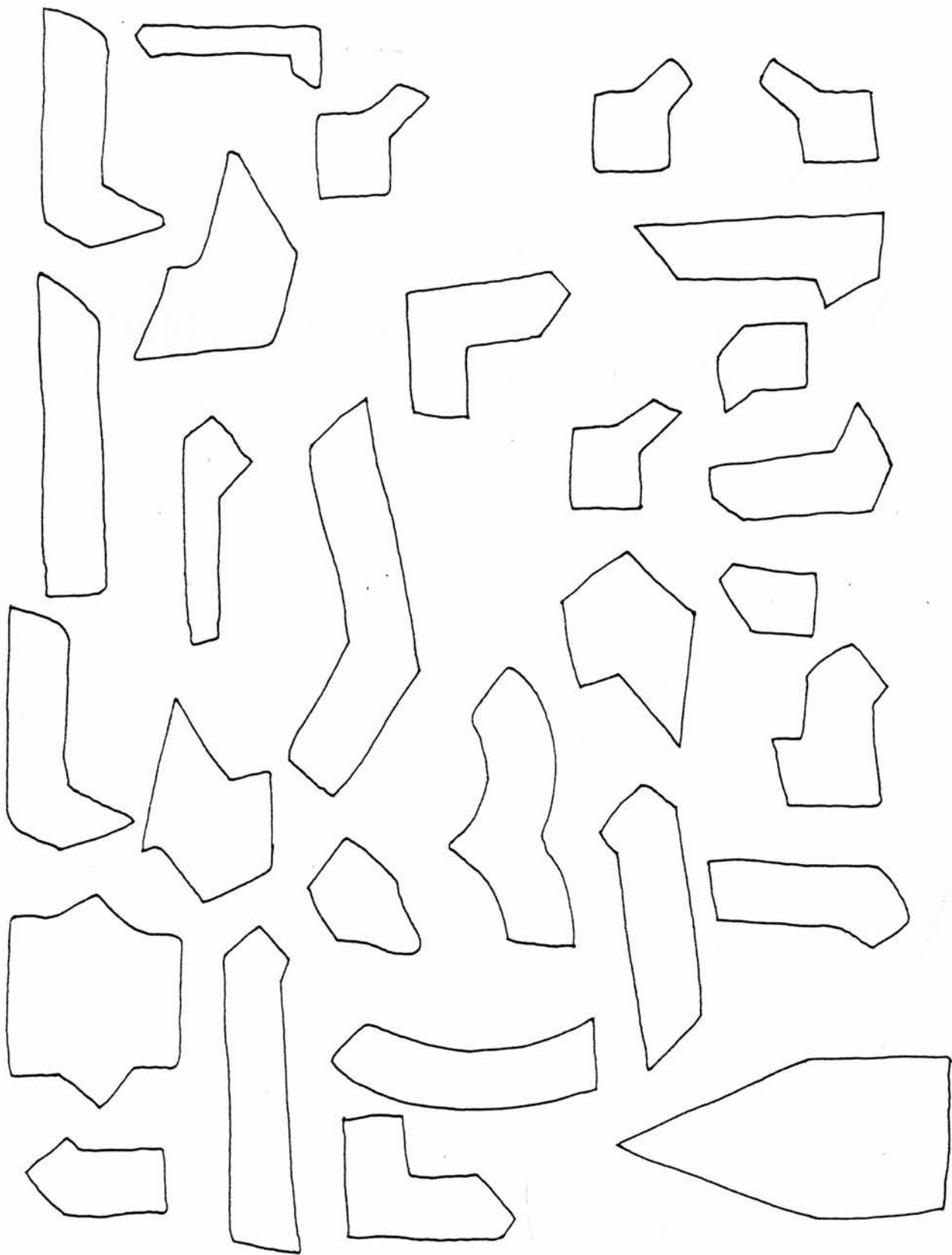

35. Cut pieces of colourless (transparent) and white (opaque) window-glass in the collection of the Museo de Arte Hispanomusulmán, Granada (scale 3:4).

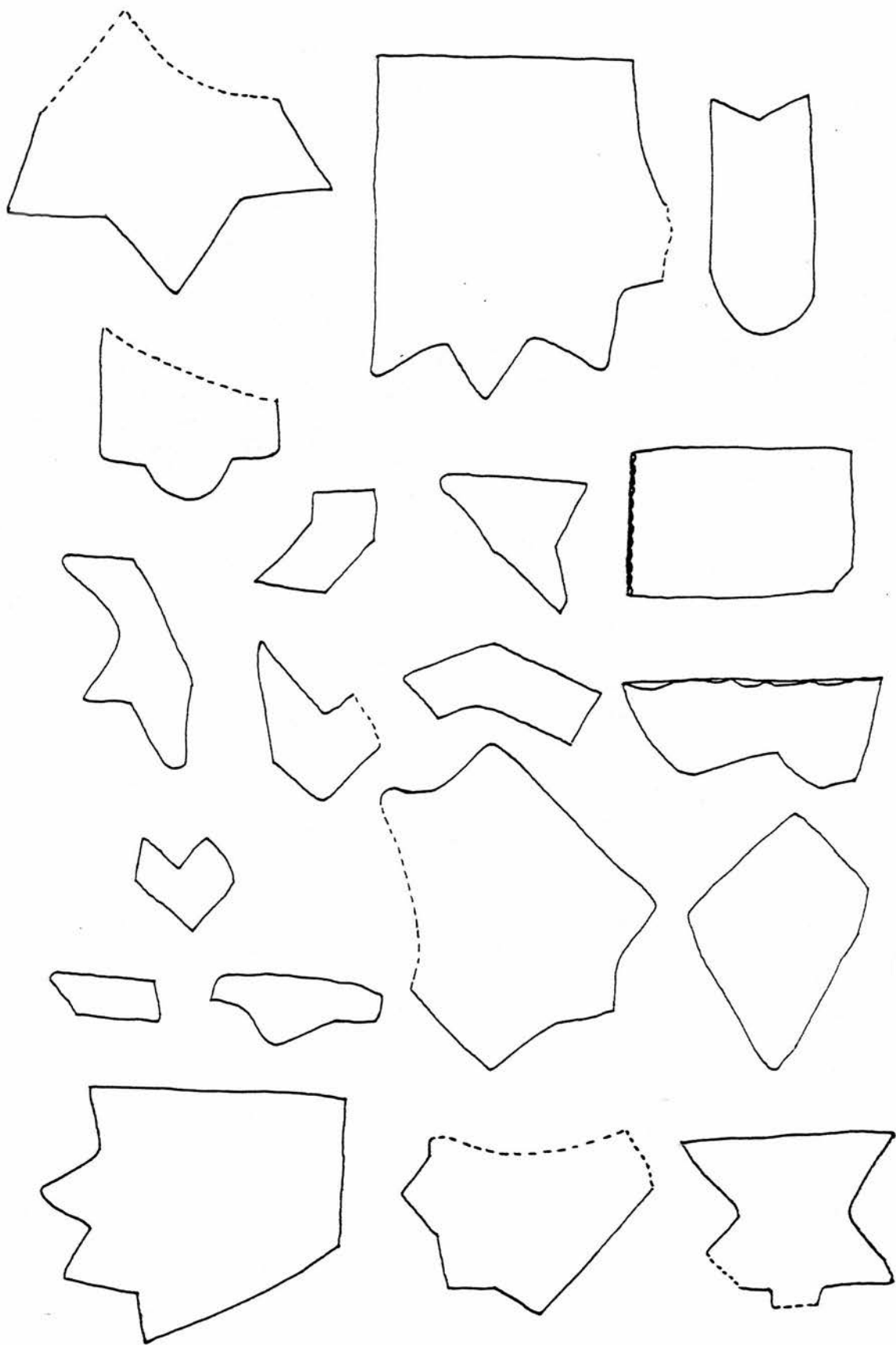

36. Cut pieces of blue glass, Museo de Arte Hispanomusulmán, Granada (scale 3:4).

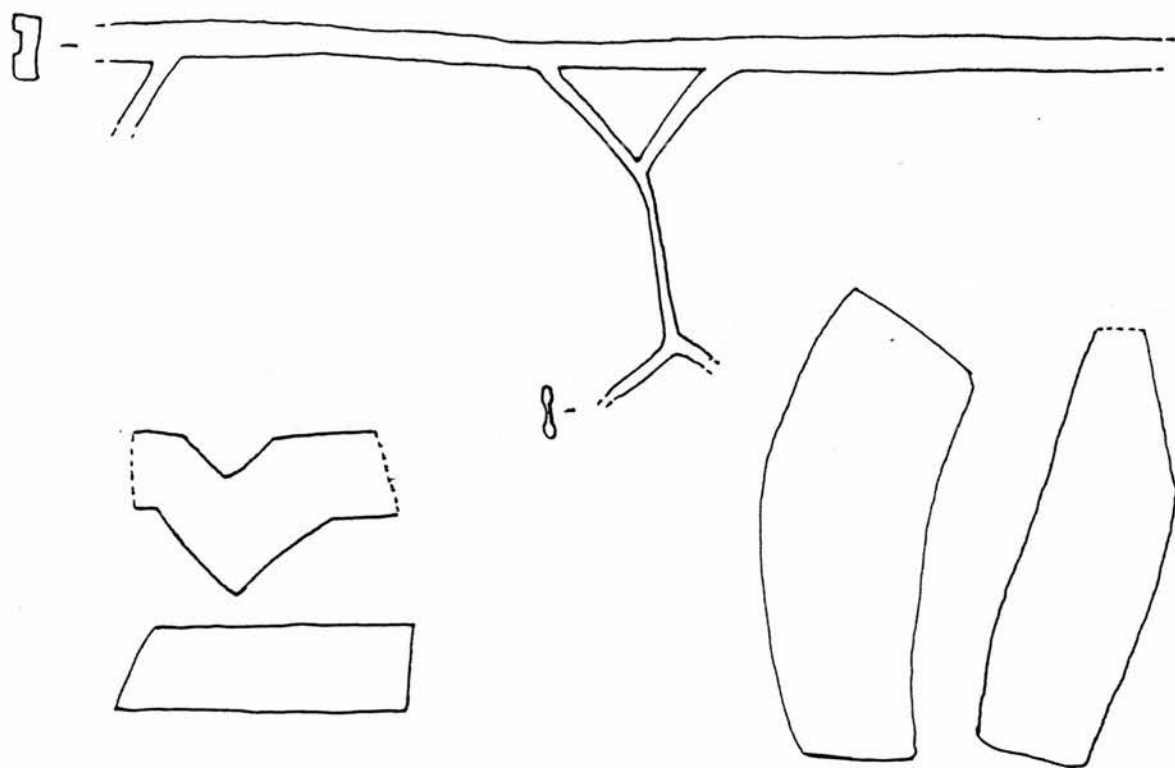

37. Lead tracery and pieces of amber, ultramarine and bottle green glass, Museo Hispanomusulmán, Granada (scale 3:4).



38. Window said to be from the Alhambra (after Day, Windows, fig. 3).

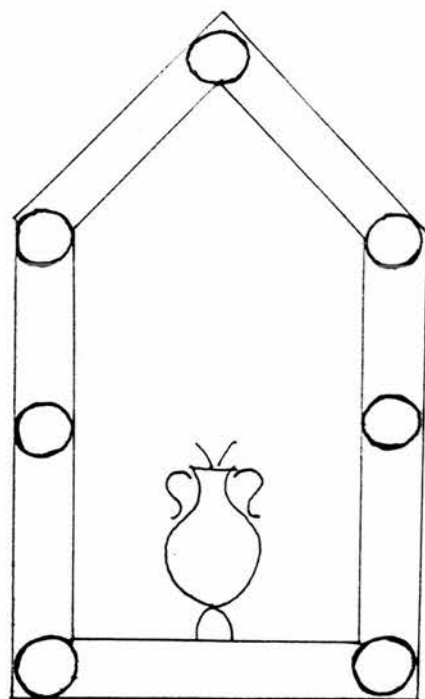

(c) Museum of Islamic Art, Cairo (Inventory No. 4282).

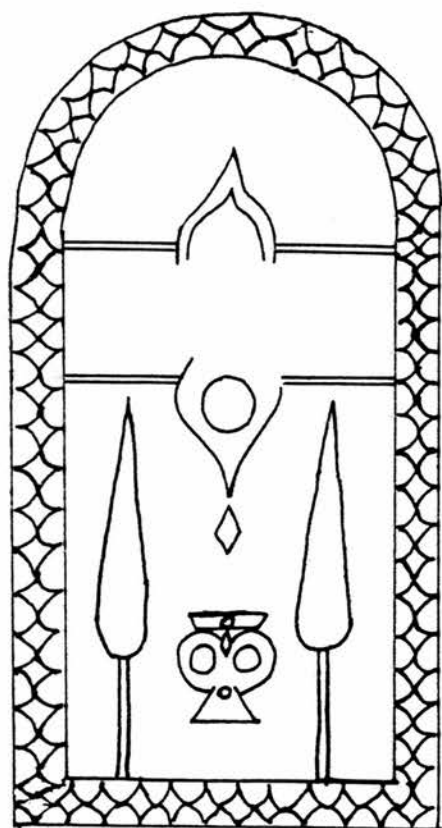

(a) Madrasa of al-Nāṣir Muḥammad, Cairo.

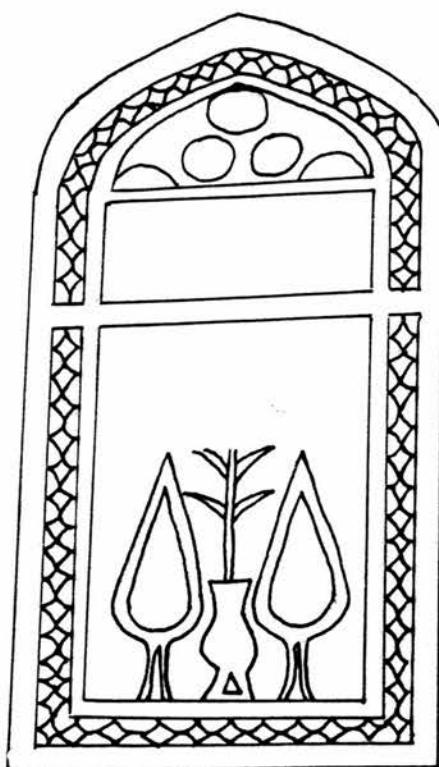

(b) Mosque of al-Ṣalīḥ Talā'ī, Cairo.

39. Three Mamluk windows featuring vase motifs.

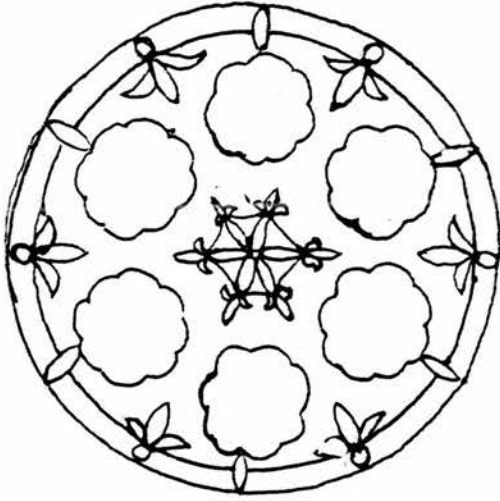

(a) Maridāniyyā Madrasa, Damascus.

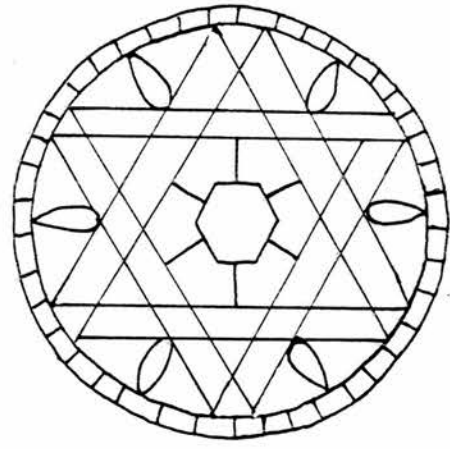

(b) Mausoleum of al-Ashraf Khaḥlī, Cairo.

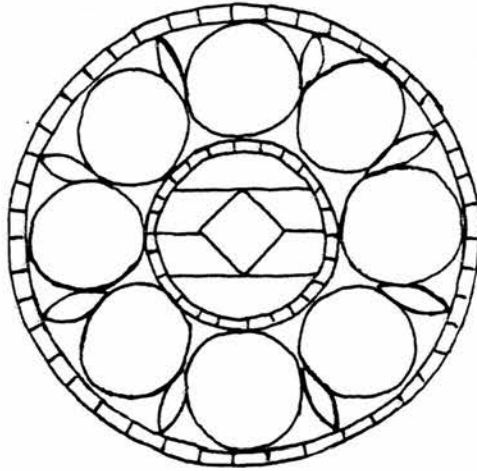

(c) Qasr Bashtāk, Cairo.

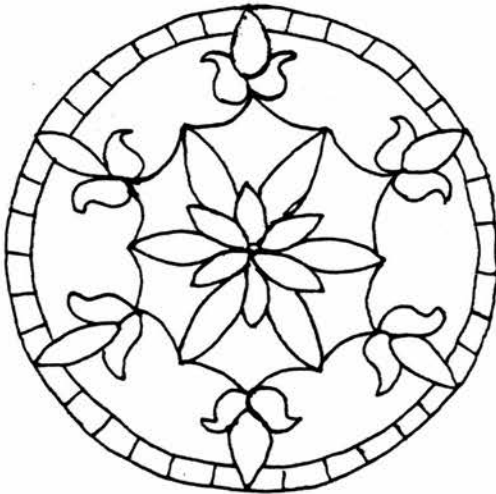

(d) Māridānī mosque, Cairo.

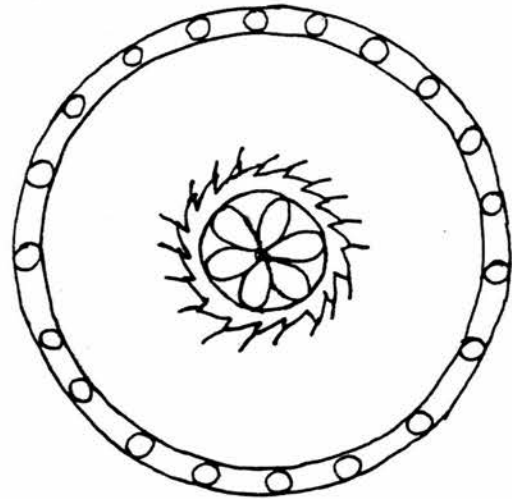

(e) Mausoleum of Aḥlām al-Silāhdār, Cairo.

40. Circular *qamariyyat* of the Ayyubid and Bahri Mamluk periods:

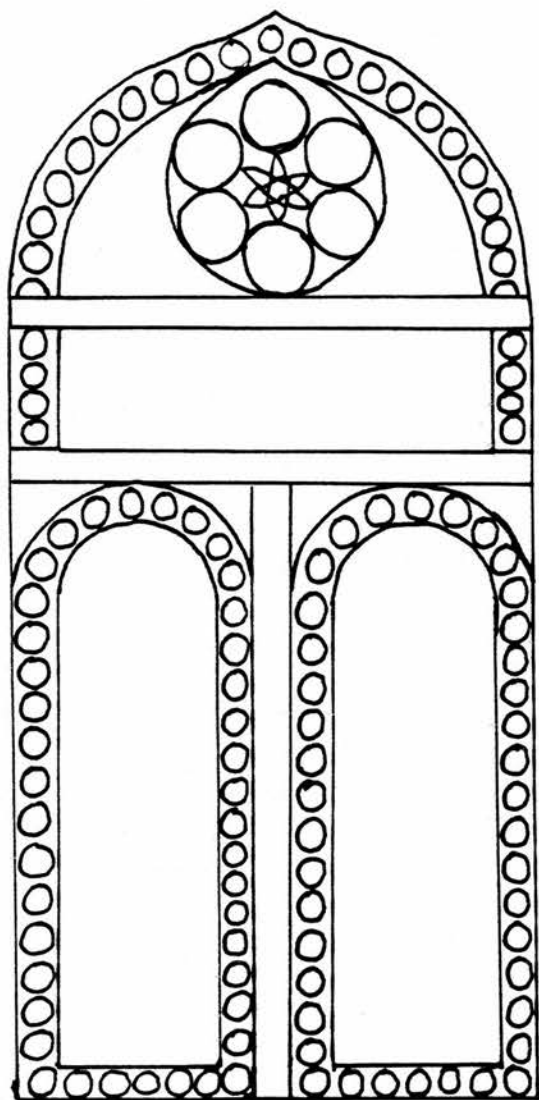

(b) *Madrasa of Amir Mithqāl, Cairo.*

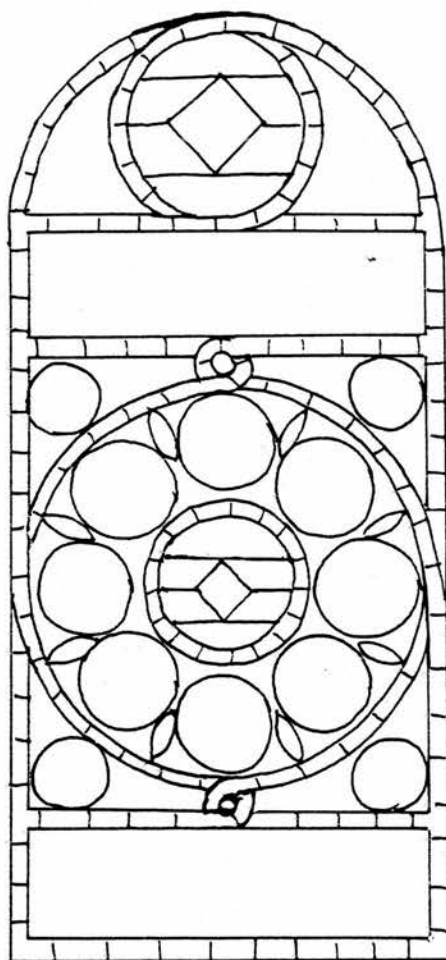

(a) *Qasr Bashtāk, Cairo.*

41. *Baḥri Mamluk qamariyyat.*

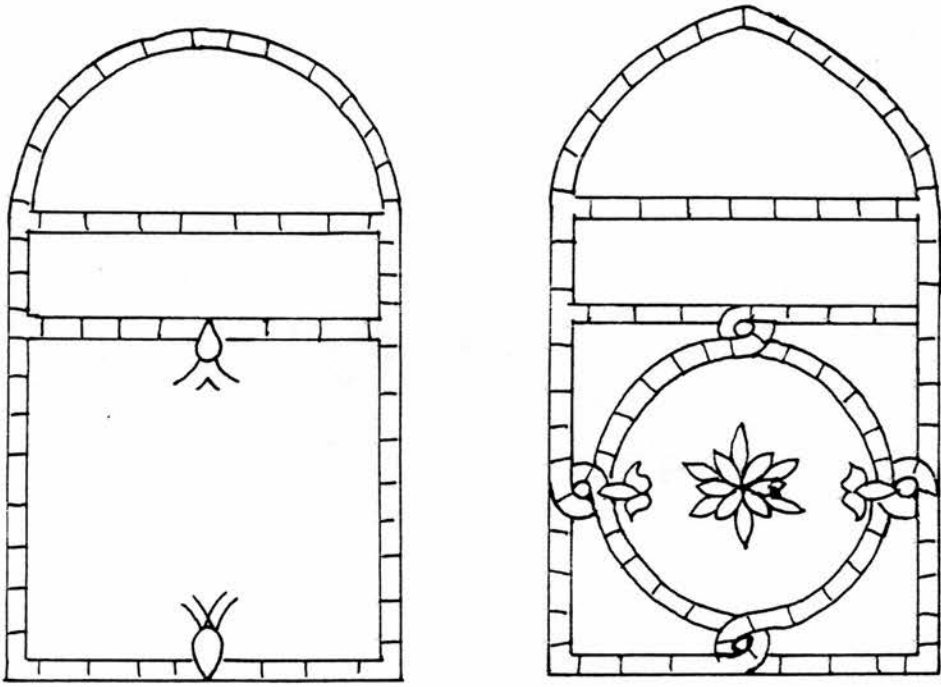

(a) Māridānī Mosque, Cairo.

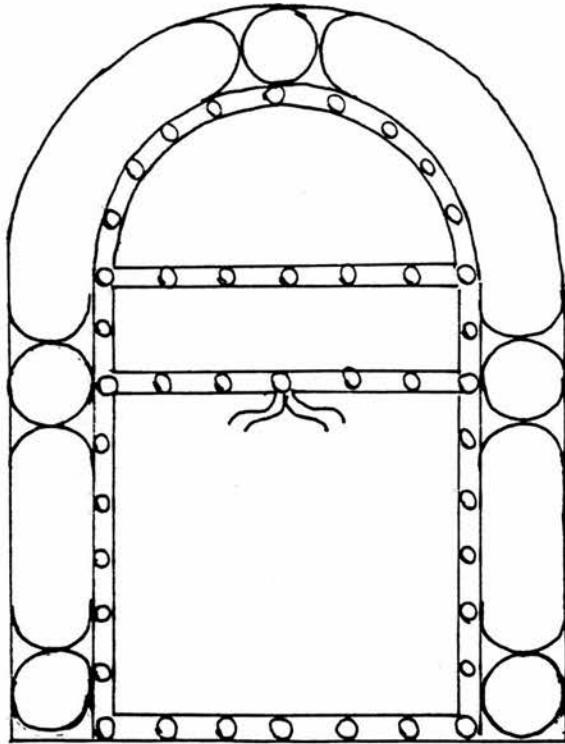

(b) Mausoleum of Aṣlām al-Silāhdār, Cairo.

42. Bahri Mamluk *qamariyyat*.

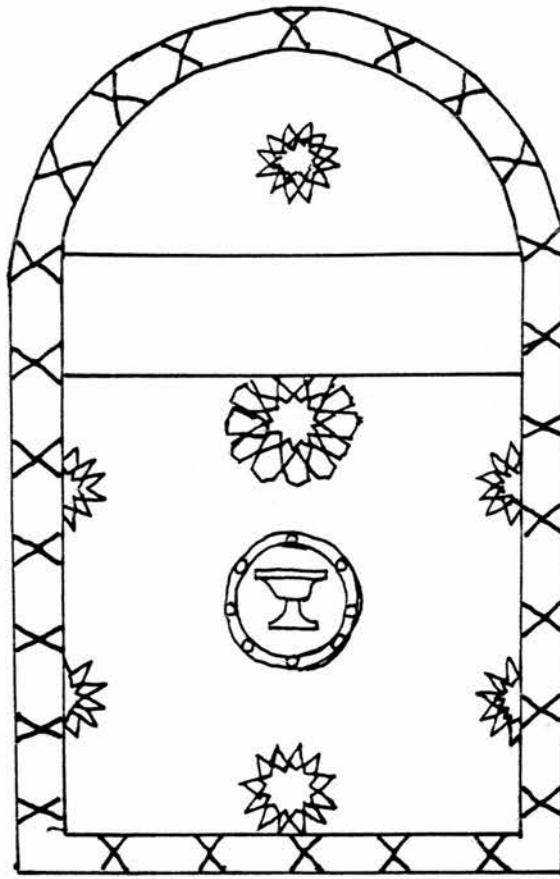

(a) *Madrasa* of Ilgay al-Yūsufī. Cairo.

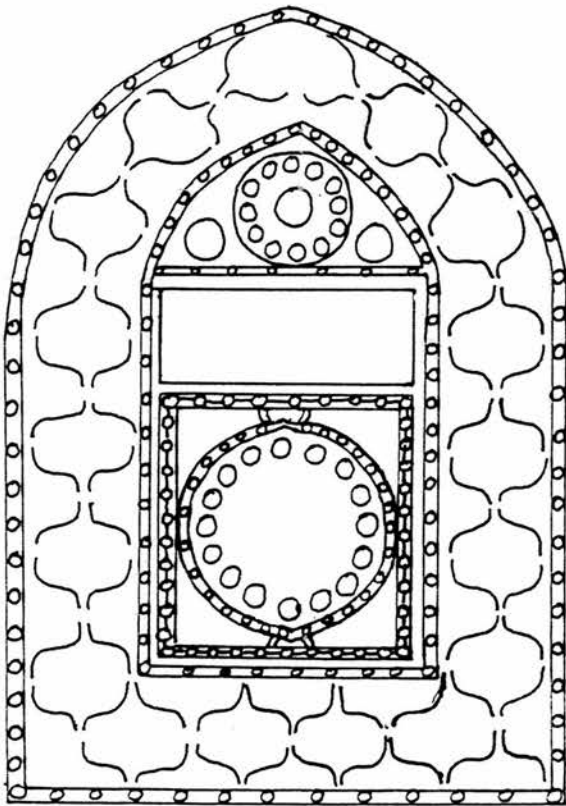

Madrasa-khanqah of Barqūq, Cairo.

(b)

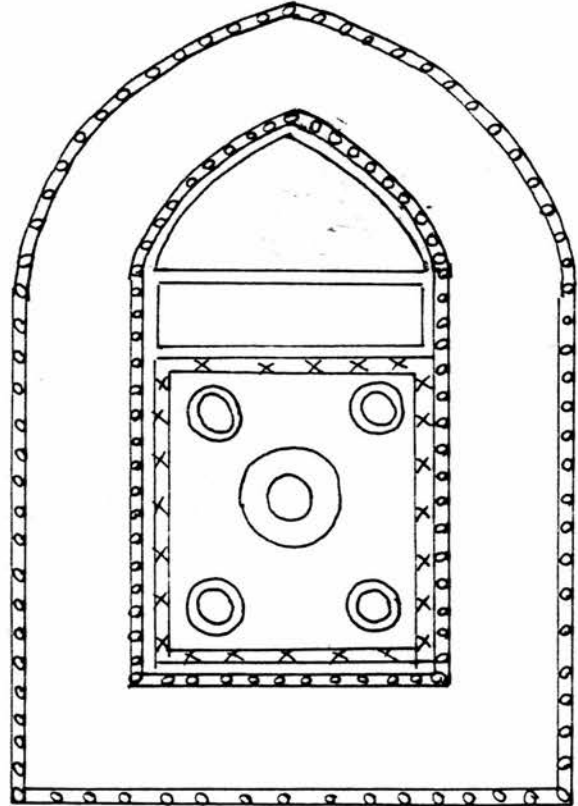

(c)

43. Bahri and Burjī Mamluk *qamarīyyat*.



(a) *khanqah-madrasa* of Barquq, Cairo.

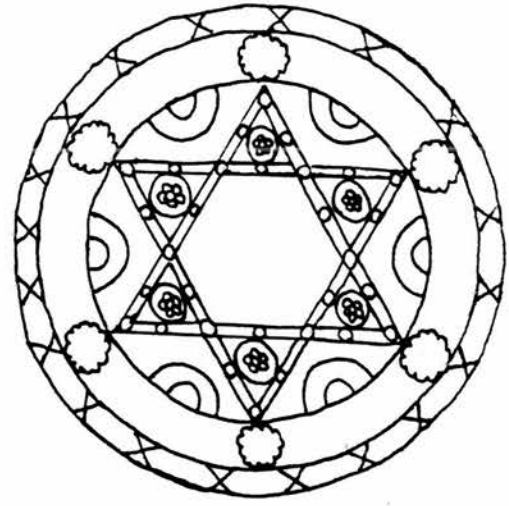

(b) *Madrasa* of Inal al-Yusufi, Cairo: *qibla iwan*.

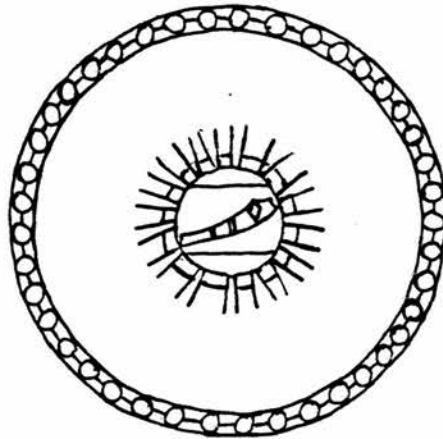

(c) *Madrasa* of Inal al-Yusufi, mausoleum.

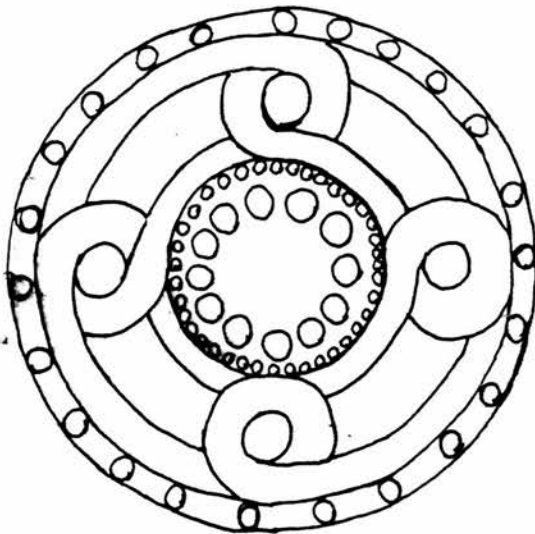
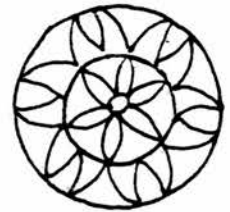

(e) *Mosque* of Qajmas al-Ishaqi, Cairo.

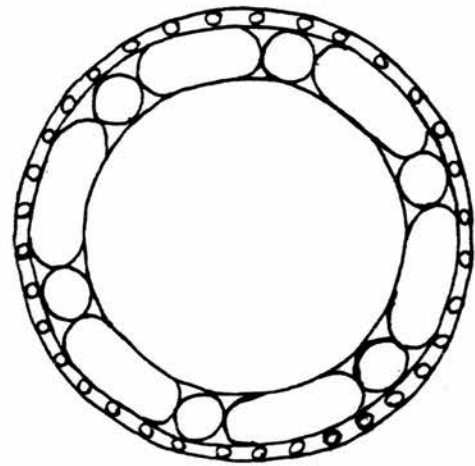

(d) *Mosque* of Ganj Bek, Cairo.

44. Circular *qamariyyat* of the Burji Mamluk period.

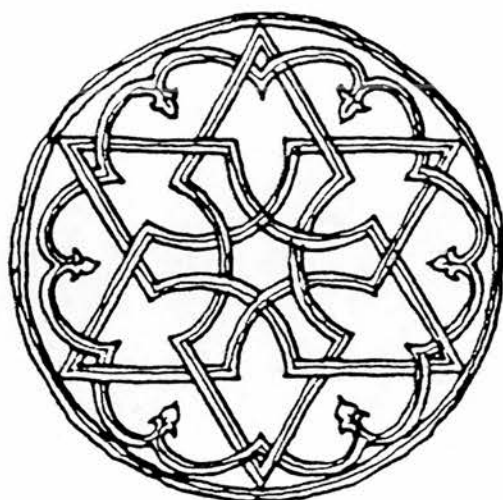

45. Star medallion, Khatūniyya Madrasa, Jerusalem (after Burgoyne, Mamluk Jerusalem, fig. 31.121).

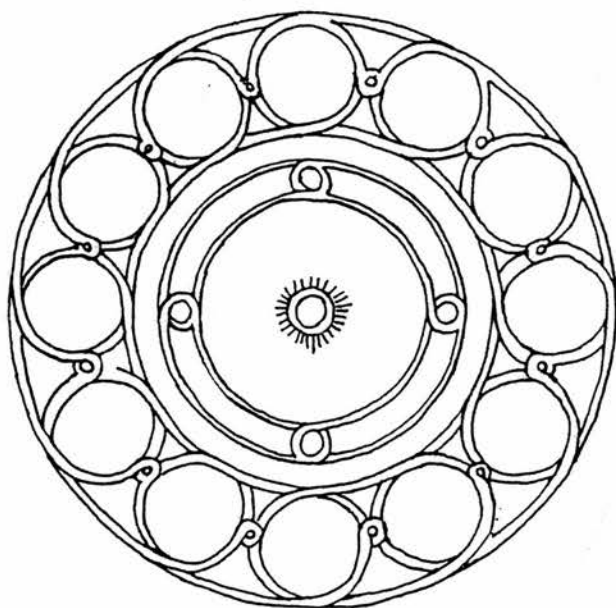

46. Design on a mirror from Aleppo dated 720/1320 (after Aga-Oglu, Prachtspiegel, fig. 1).

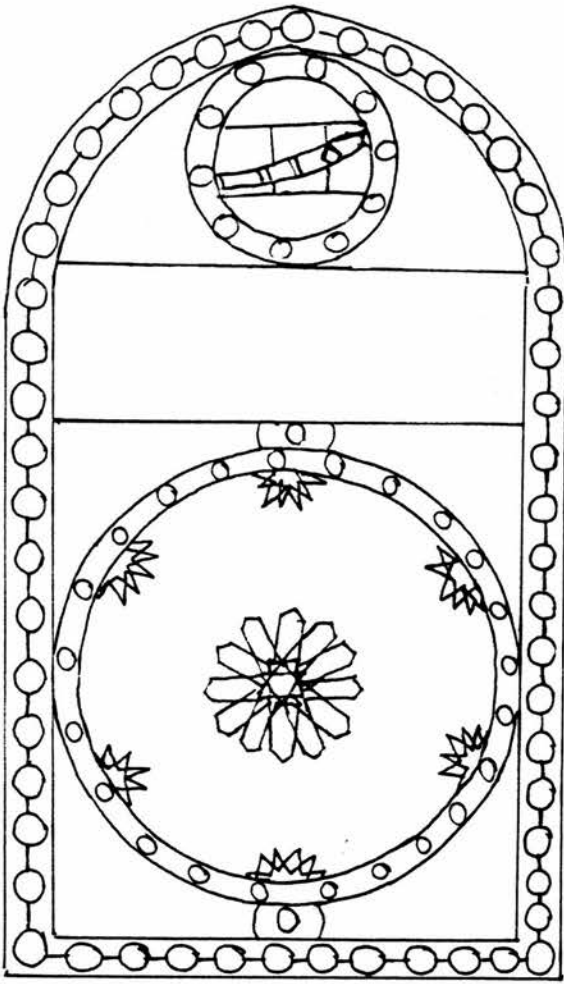

(a) *Madrasa of Īnāl al-Yūsufī, Cairo.*

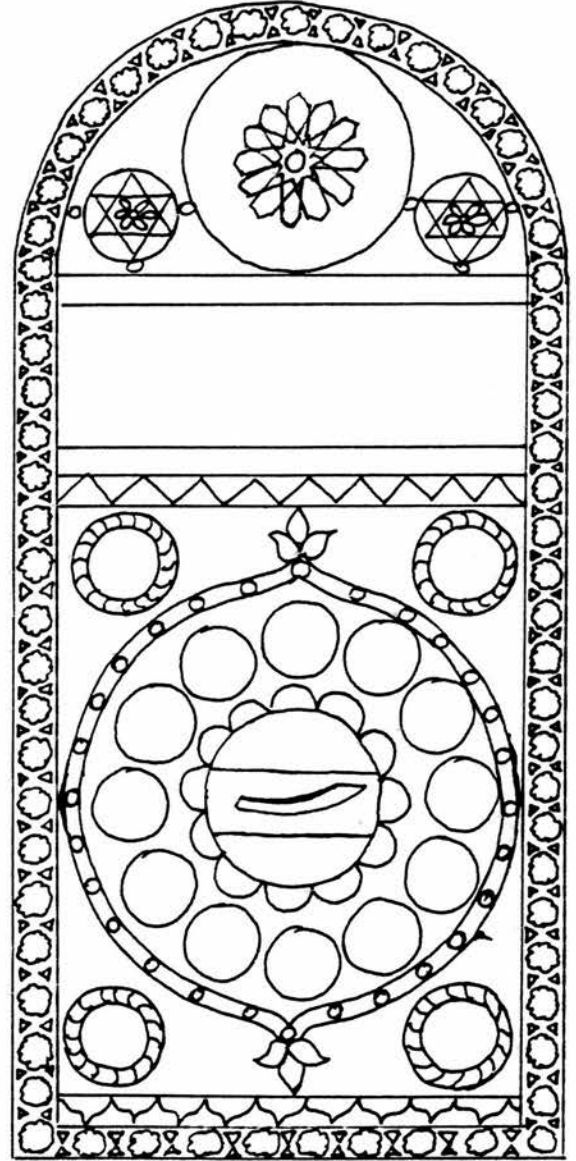

(c) *Madrasa of Jamāl al-Dīn Yusuf al-Ustādār, Cairo.*

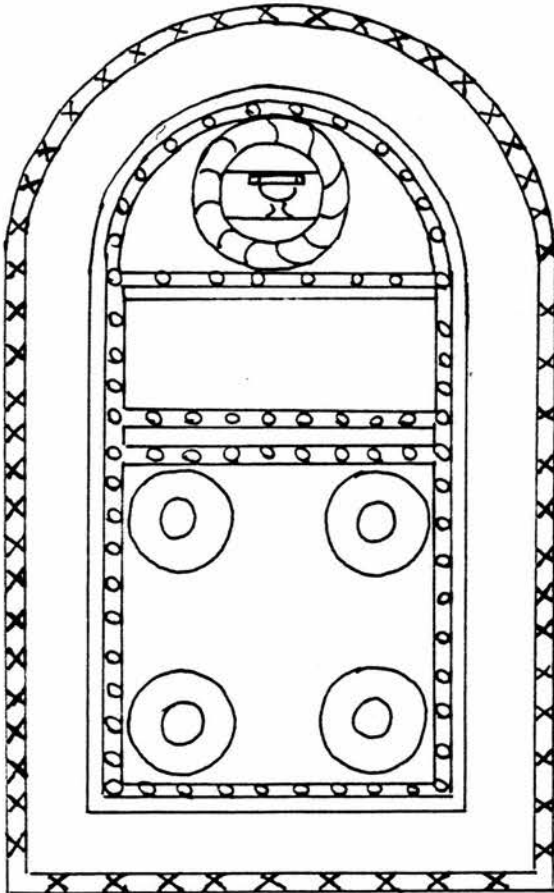

(b) *Madrasa of Jamāl al-Dīn Maḥmūd al-Ustādār, Cairo.*

47. Burjī Mamluk *qamariyyat*.

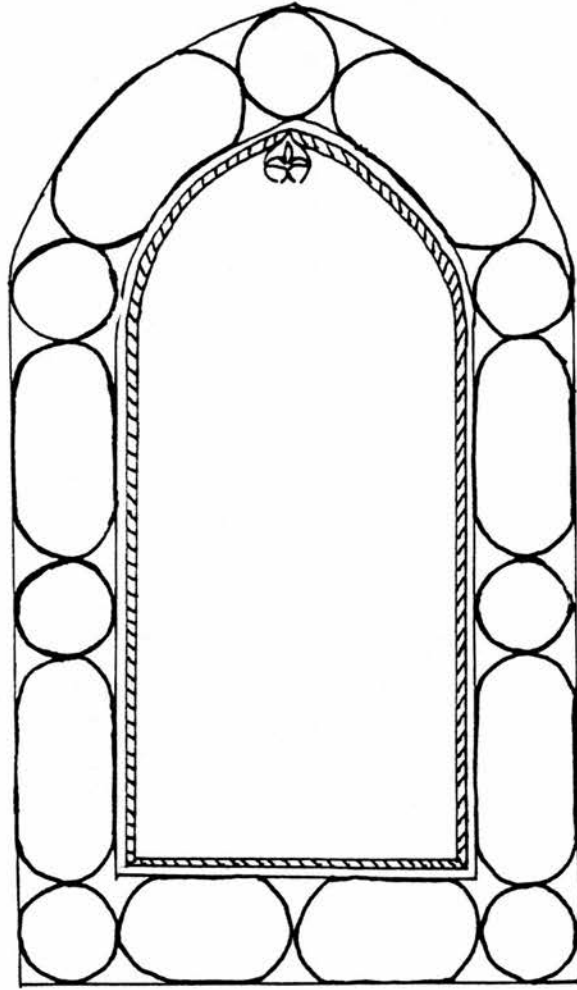

48. Window in the mosque of Gānī Bek, Cairo.

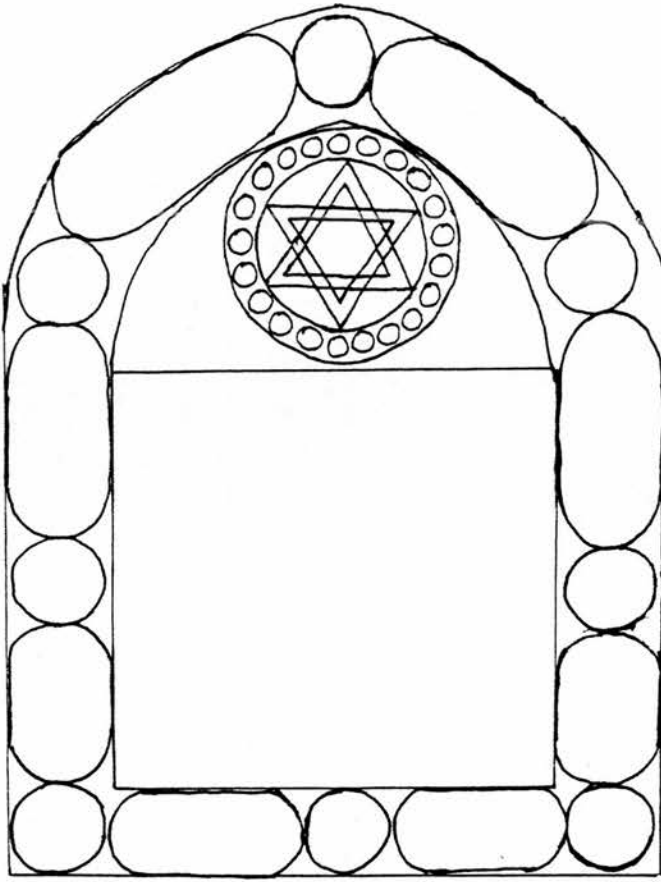

(a) Type II

49. *Qamariyyat* in the *madrasa* of Abū Bakr ibn Muzhir, Cairo:

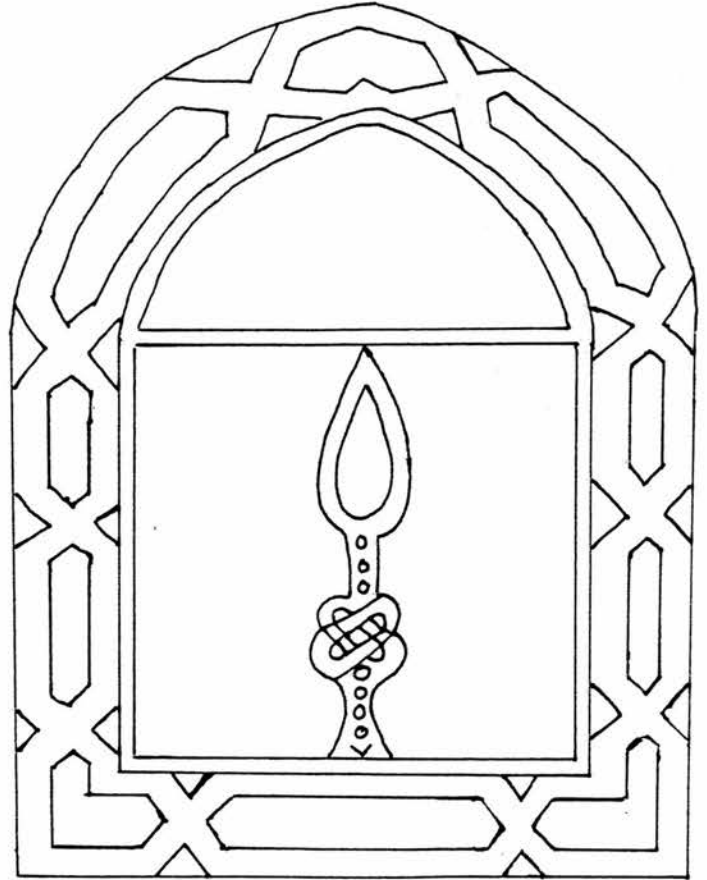

(b) Type III

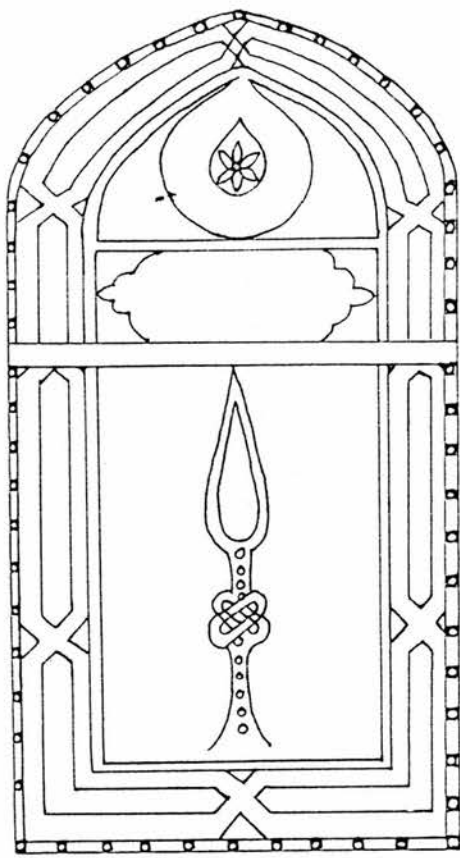

(a) Type I.

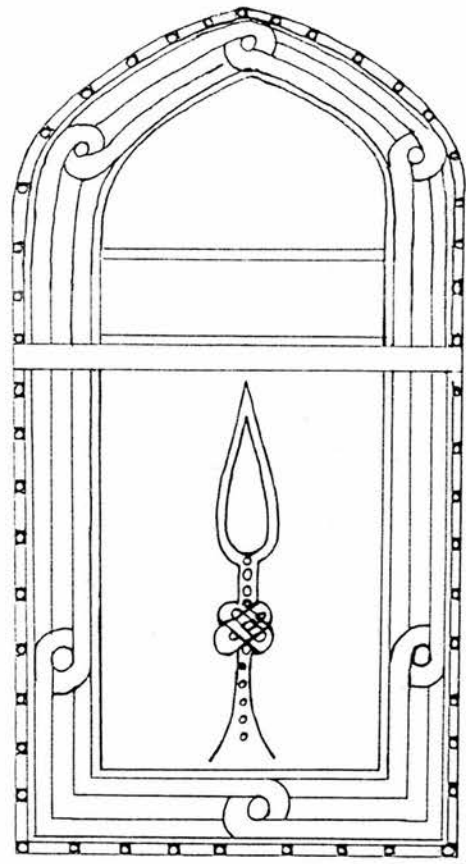

(b) Type II.

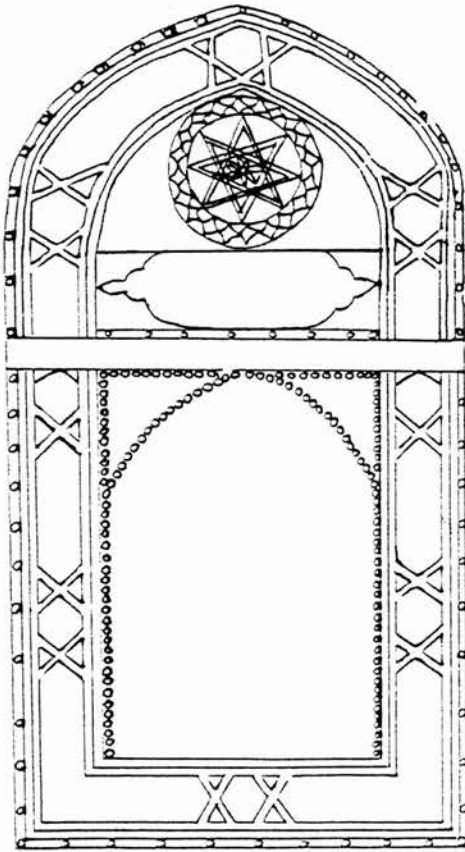

(c) Type III.

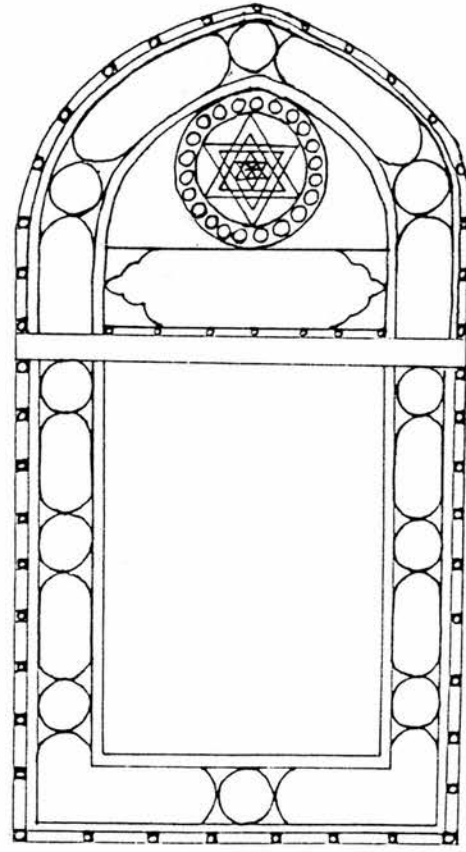

(d) Type IV.

50. *Qamariyyat* in the mosque of Qajmās al-Ishāqī, Cairo.

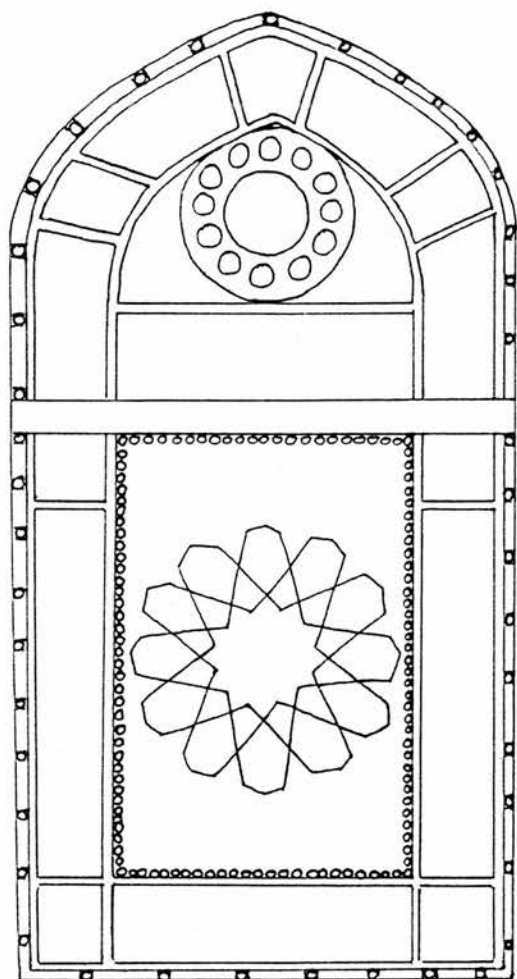

(a) Type V *qamariyya*, mosque of Qajmās al-Ishāqī, Cairo.



(b) Detail of type I *qamariyya*



(c) Detail of a *qamariyya* in the mosque of al-Mu'ayyad

51. *Qamariyyat* in the mosque of Qajmās al-Ishāqī, Cairo:

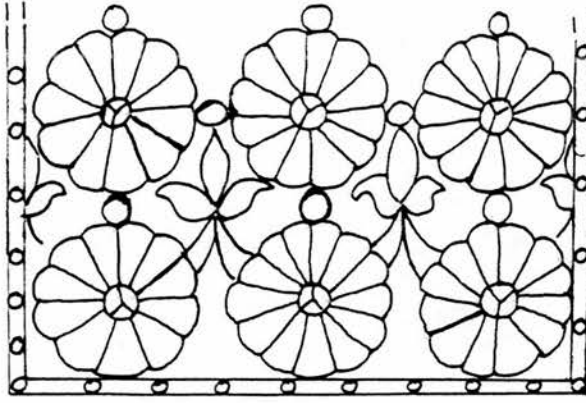

52. Detail of a *qamariyya* in the Turbat al-Tāynābiyya, Damascus.

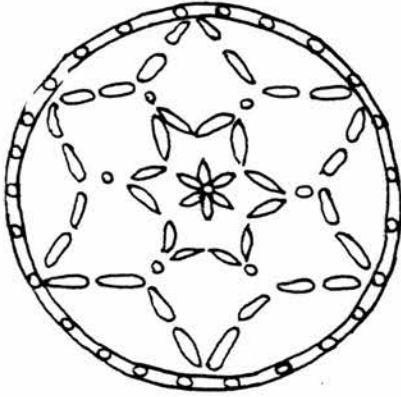

(a)

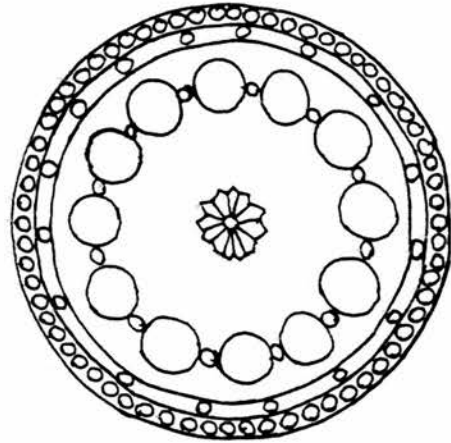

(b)

(c)

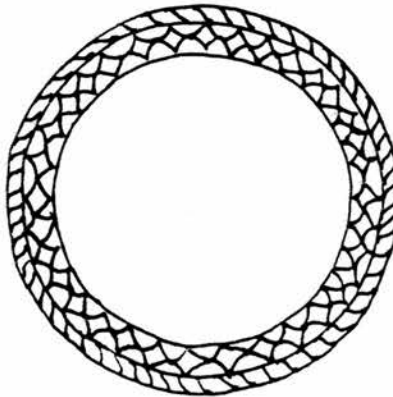

53. a-c: *Qamariyyat* in the Yalbughā Mosque, Damascus.

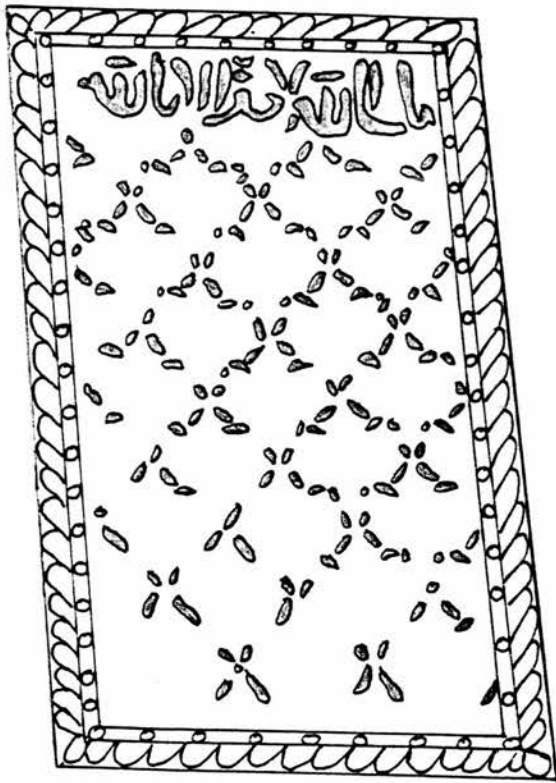

(a) Jāmi' al-Tayrouzi, above the *mihrab*.

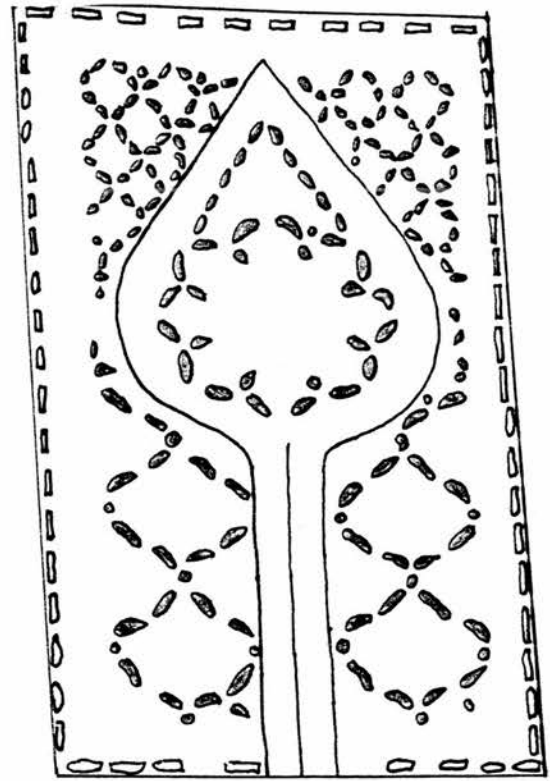

(b) Jāmi' al-Tayrouzi, in the *qibla* wall.

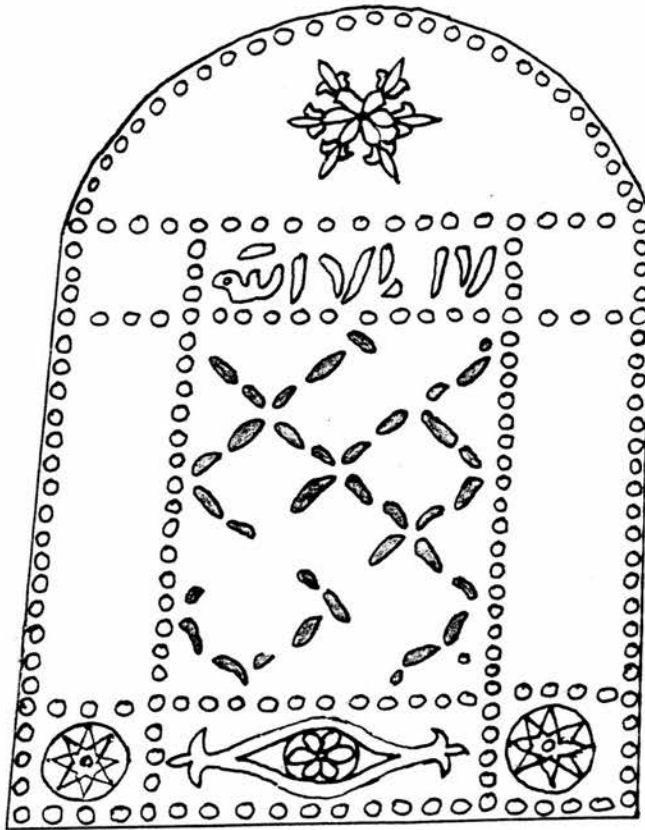

(c) Jāmi' al-Hanābilā, above the *mihrab*.

54. Mamluk *qamariyyat* in Damascus (yellow glass shaded).

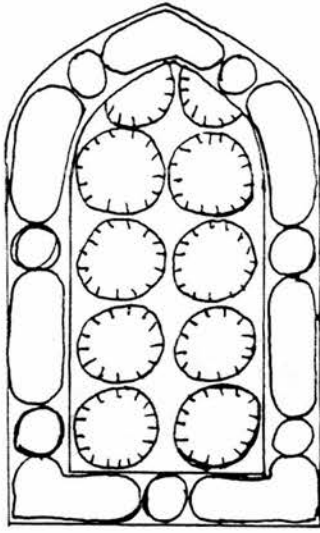

(a)

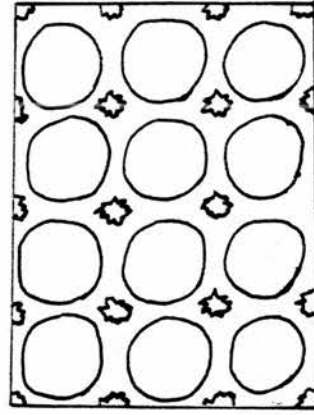

(b)

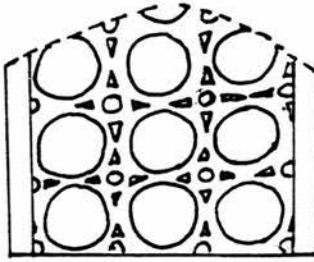

(c)

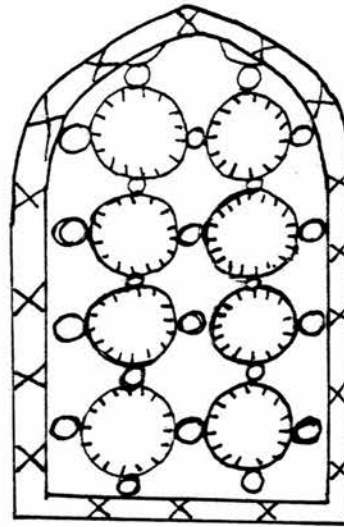

(d)

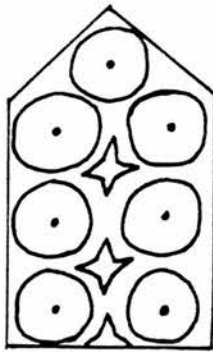

(e)

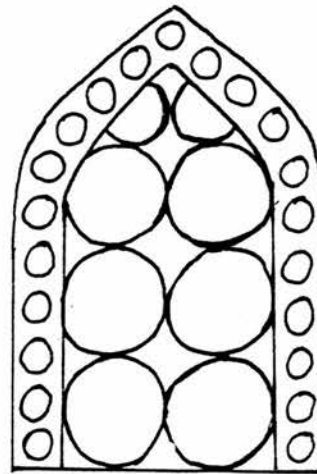

(f)

55. Windows in Persian miniatures type I.

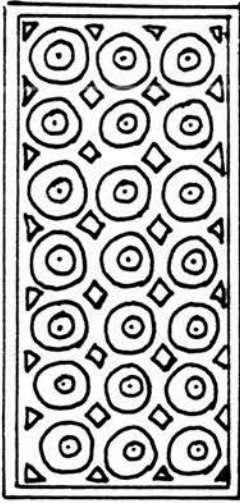

56. Windows in Persian miniatures type II.

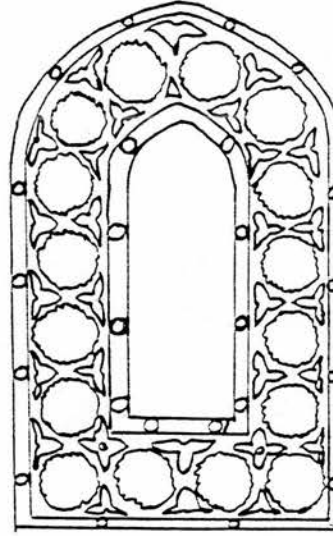

58. Windows in Persian miniatures type IV.

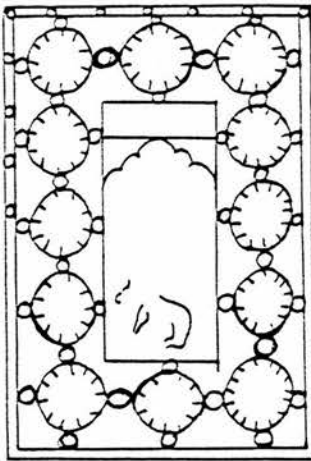

(a)

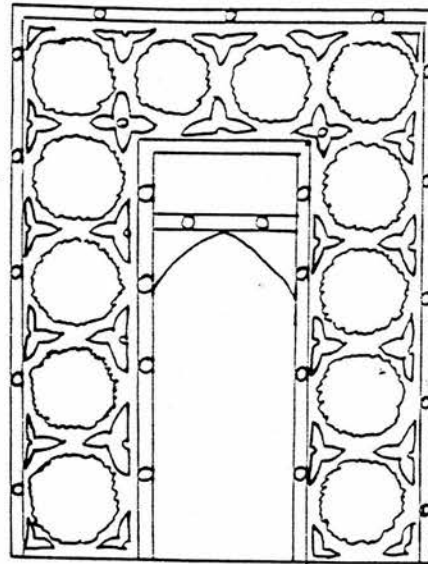

(b)

57. Windows in Persian miniatures type III.

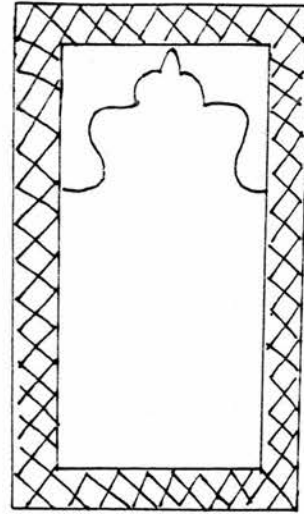
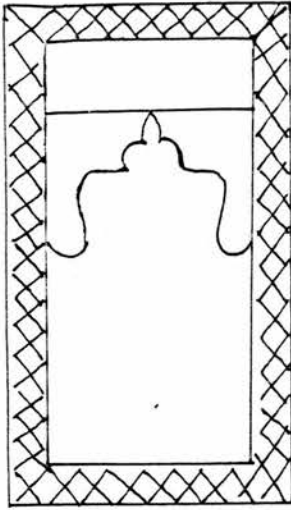

59. Windows in Persian miniatures type V.

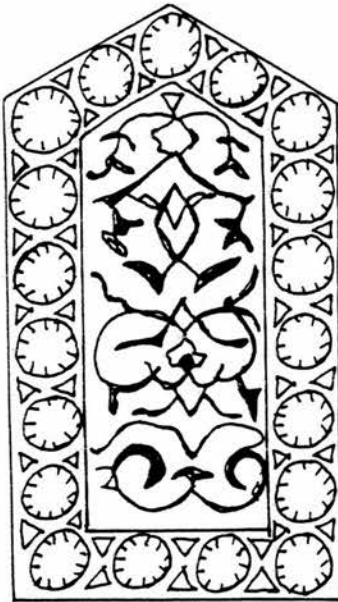

(a)

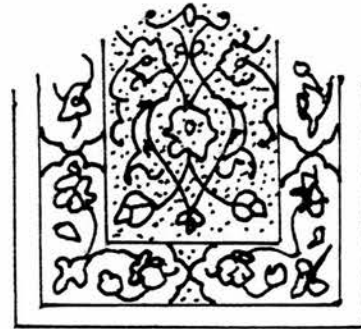

(b)

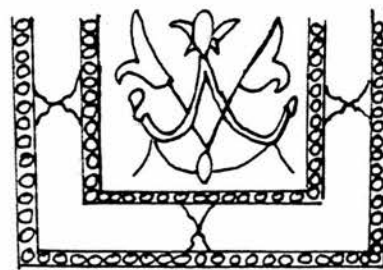

(c)

60. Windows in Persian miniatures type VI.

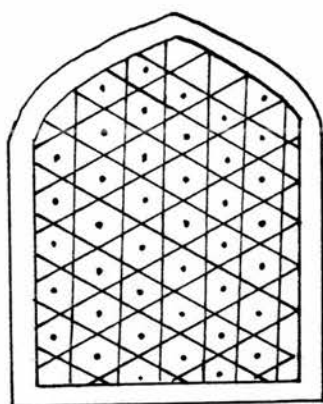

(a)

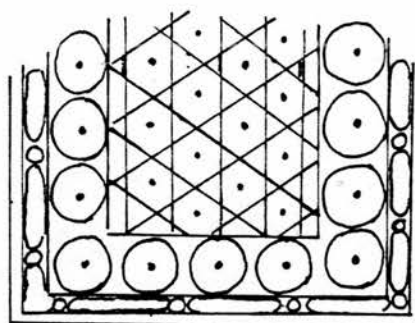

(b)

61. Windows in Persian miniatures type VII.

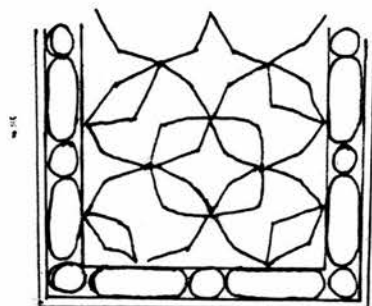

62. Windows in Persian miniatures type VIII.

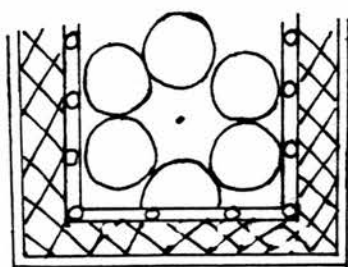

(a)

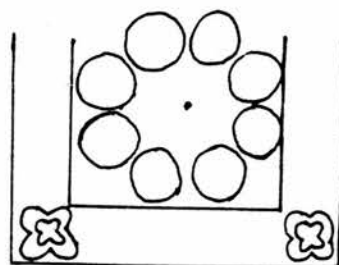

(b)

63. Windows in Persian miniatures type IX.

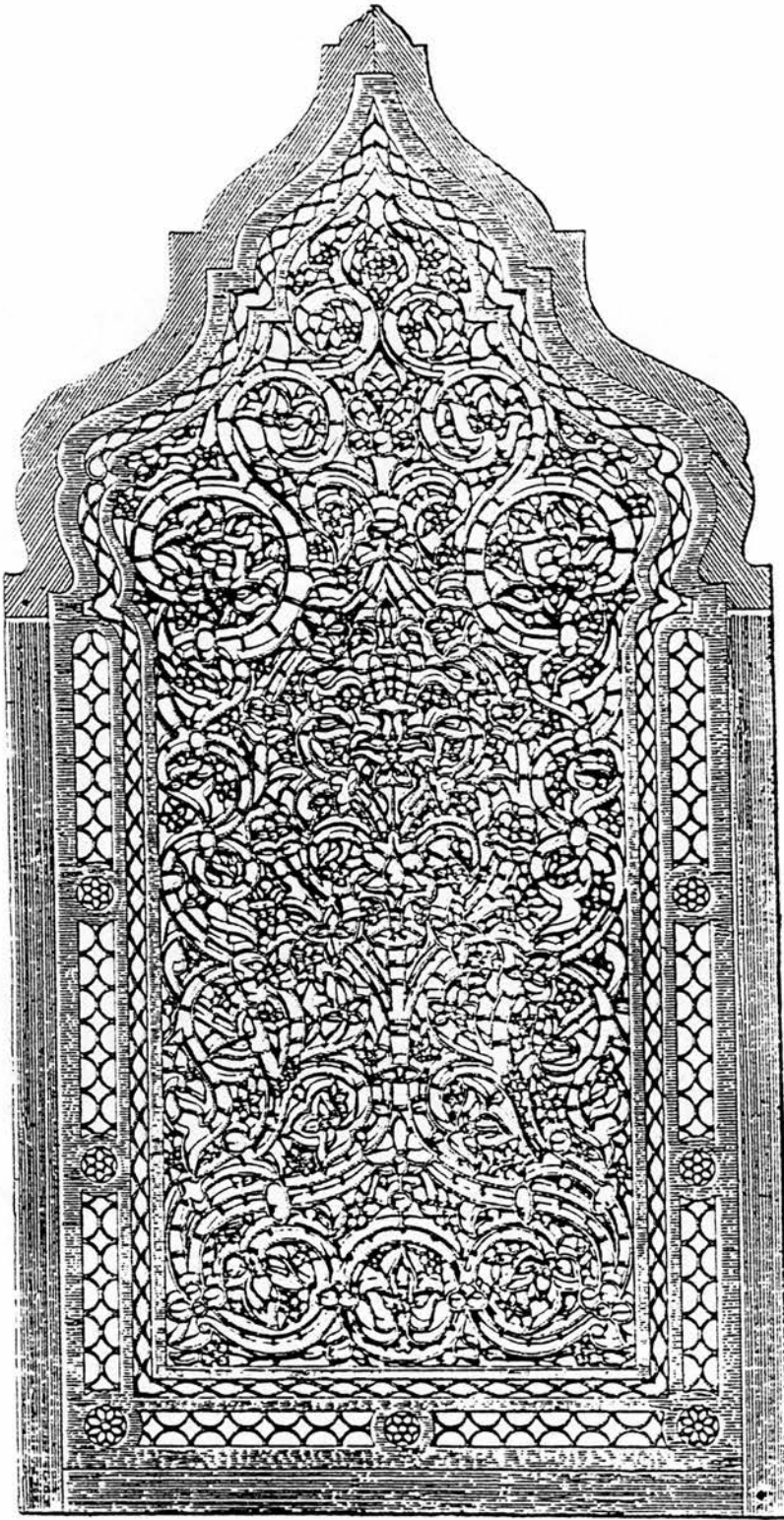

64. Window from the Yesil Turbe, Bursa (after Arseven, *Arts Decoratifs*, fig. 467).

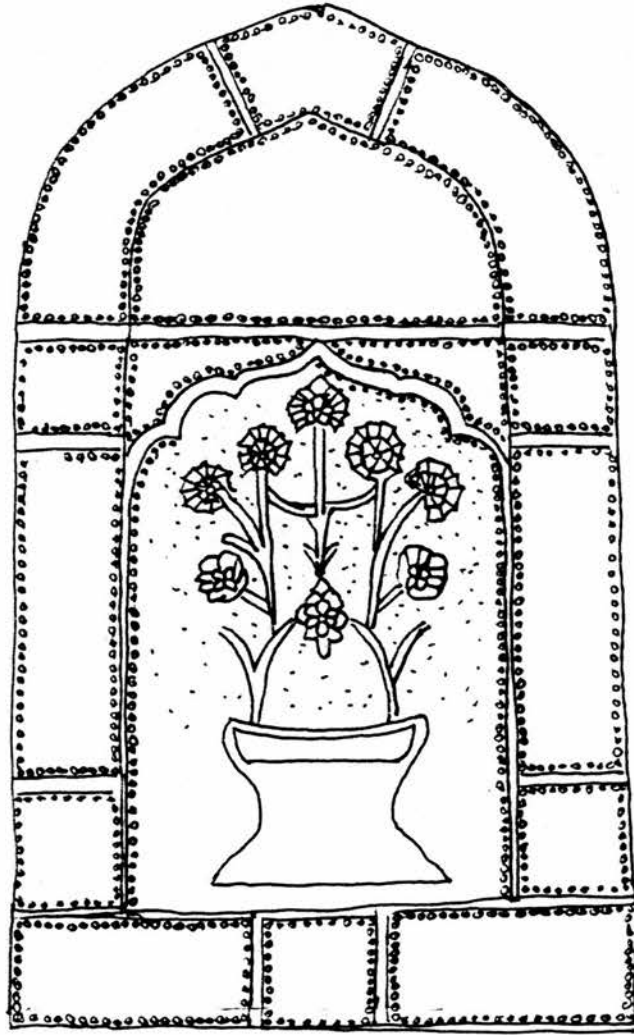

65. Window from the Yeni Cami, Istanbul (after a photograph in Arseven, *Arts Decoratifs*, fig. 461).

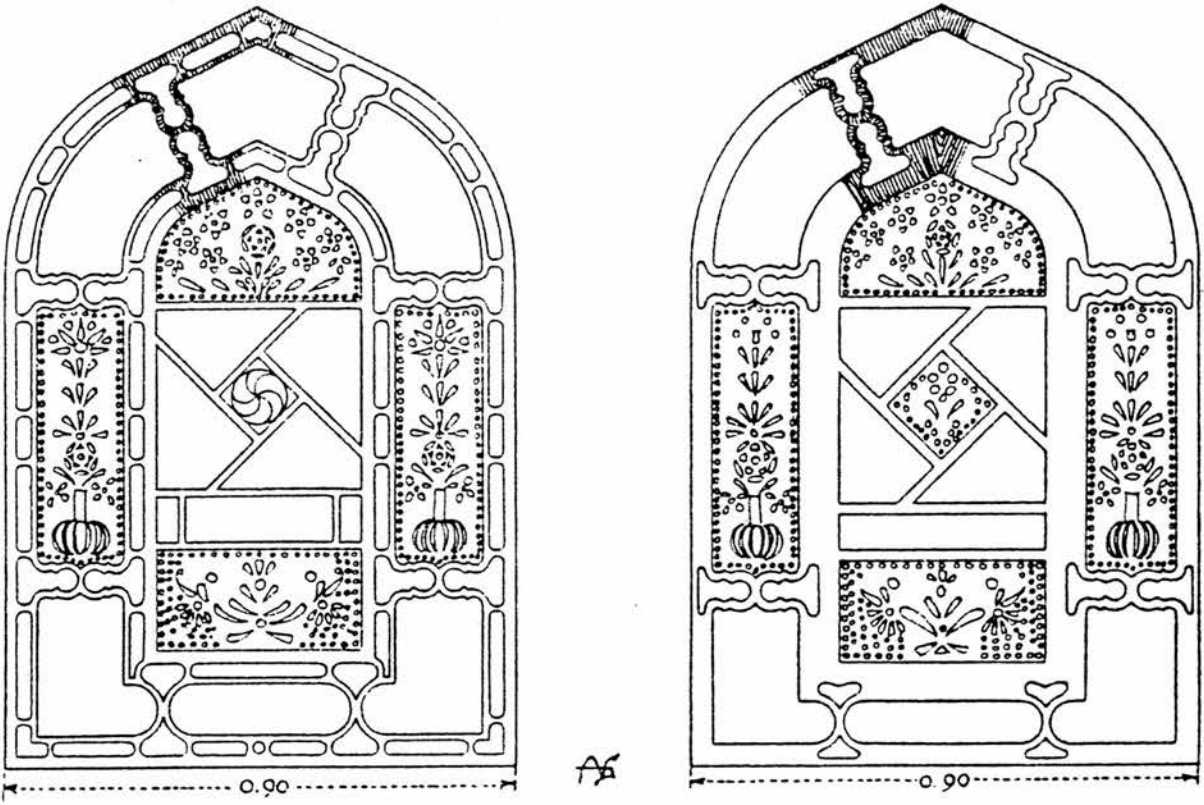

66. Windows in the Beyazit Pasha Mosque, Amasya (after Gabriel, *Monuments II*, fig. 13).67.

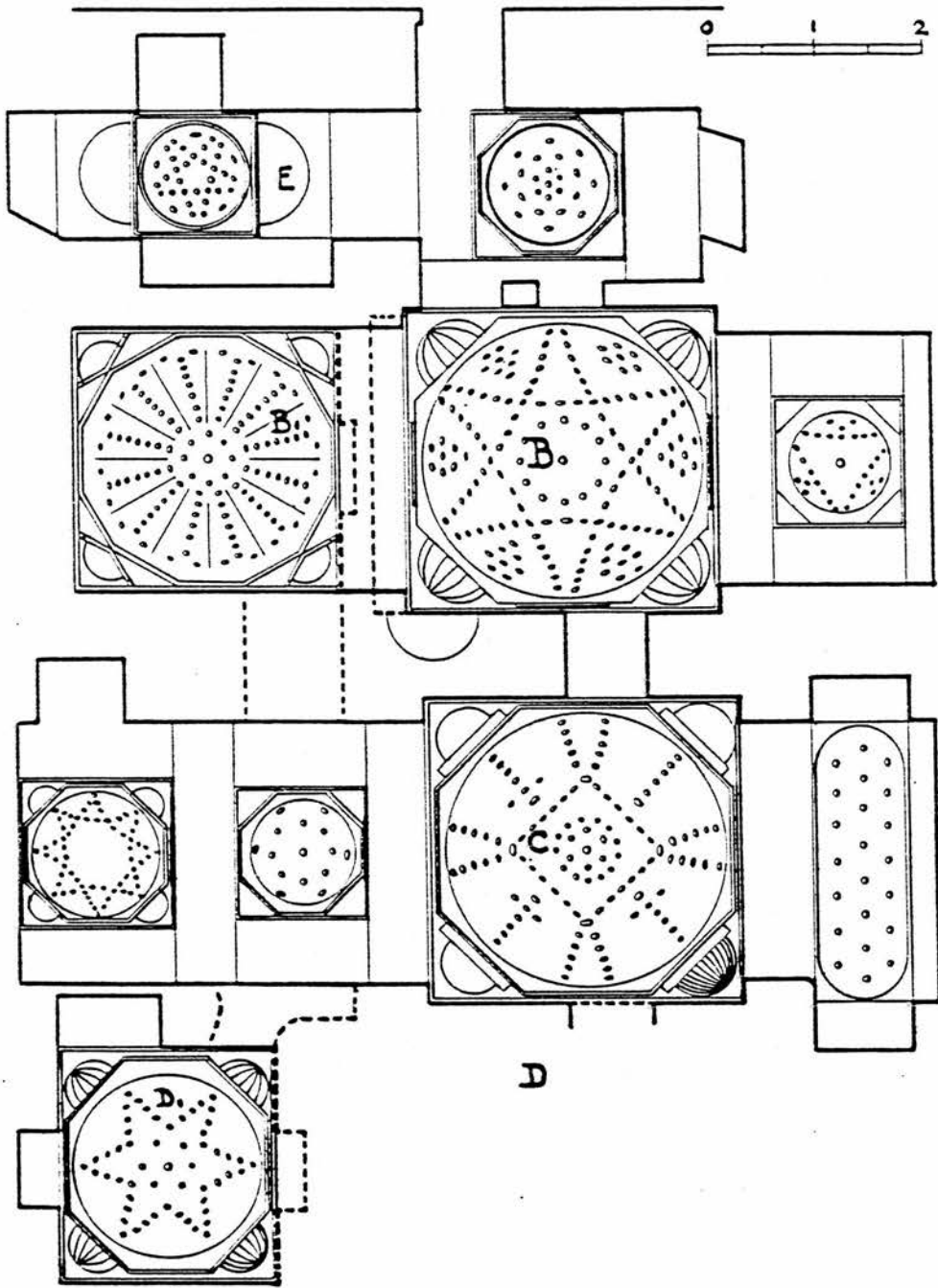

67 Domes of the Amūniyya *hammam*, Damascus, late sixth/twelfth century
 (after Sauvaget & Écochard, *Bains*, fig. XXXV).

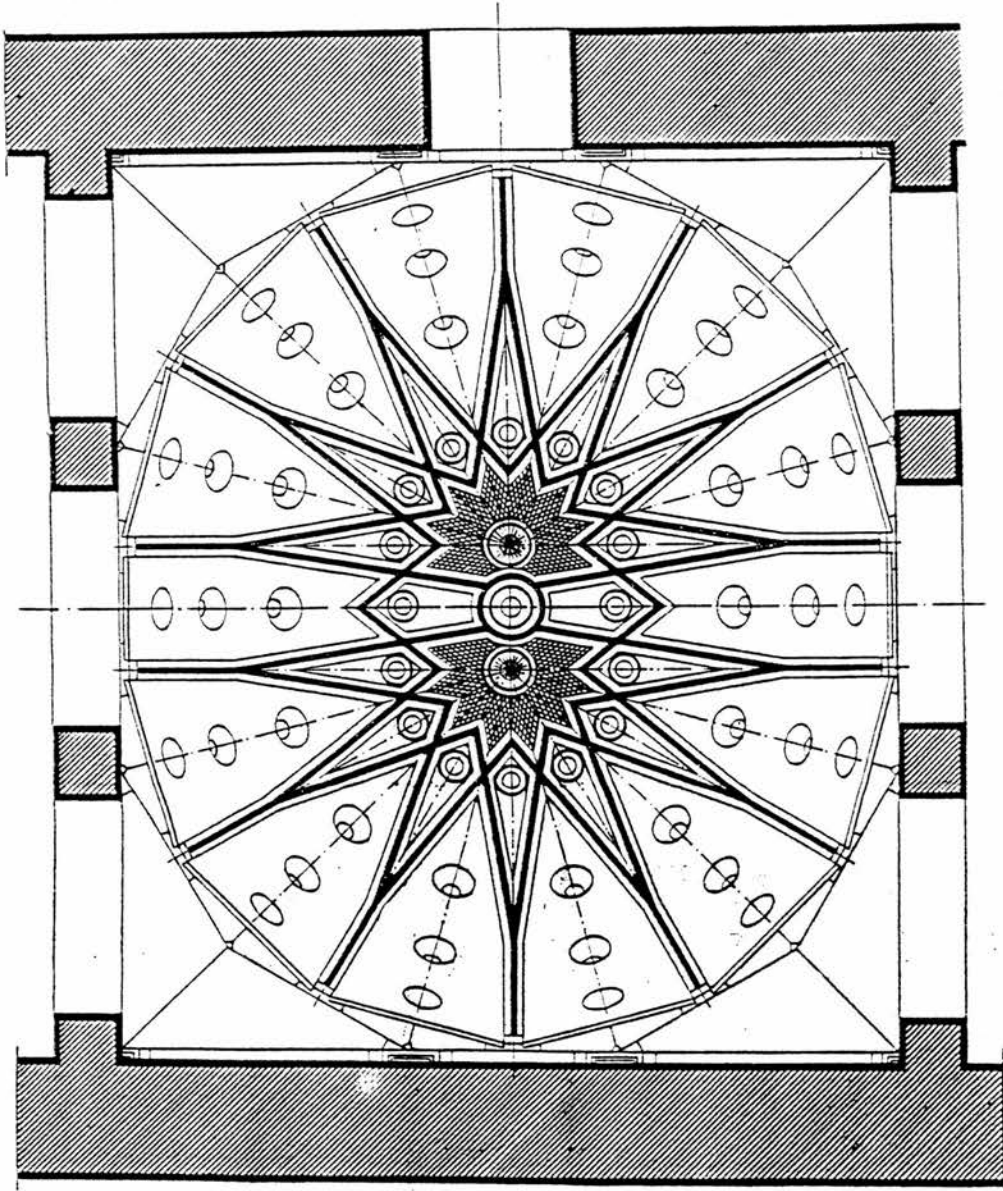

68. Dome of the Mukhfiya *hammam*. Fez, eighth/fourteenth century
(after Terrasse, *Trois bains*, fig. 7).

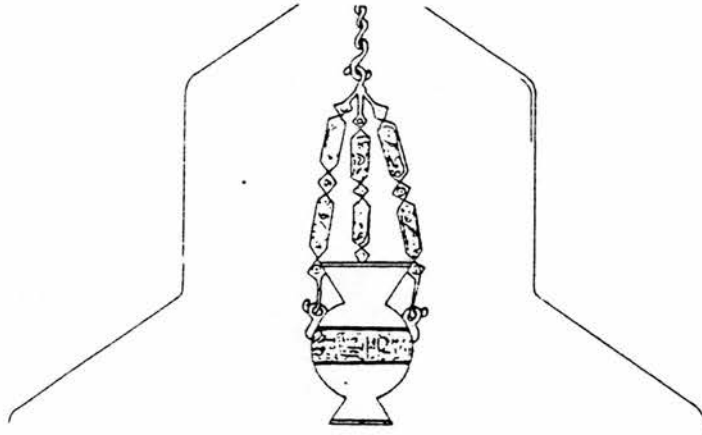

69. Lamp motif painted on the interior of Kharraqān I (after Daneshvari, Medieval Tomb Towers, fig. 28).

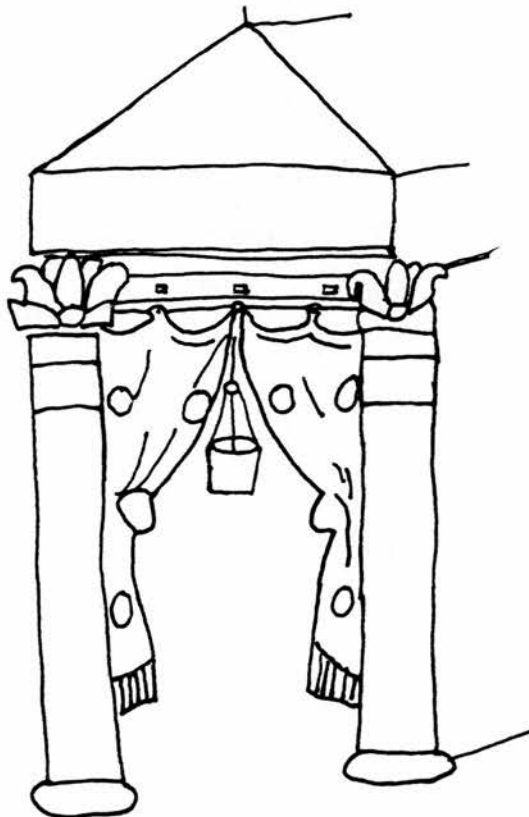

70. Lamp hanging in the doorway of a shrine, detail from the fifth-century mosaics S. Maria Maggiore, Rome (after Cecchelli, Mosaici, pl. LXII).

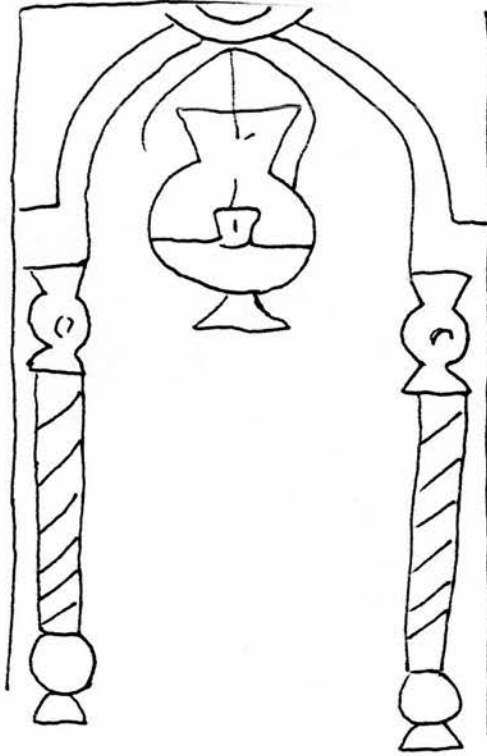

(a) On a tombstone dated 576/1181 (after Wiet, Stèles, No. 6738, pl. XL1).

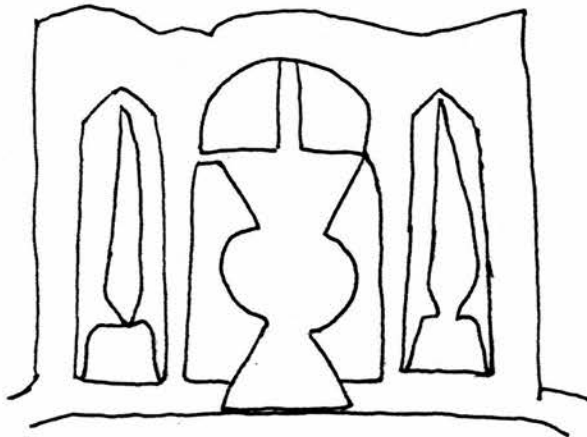

(b) On a tombstone dated 684/1285 (after Wiet, Stèles, No. 13079, pl. LII).

71. Lamp images on Egyptian tombstones.

72. Detail of a carving on the facade of the Friday Mosque at Eski Malataya (after Baer, *Eski Malataya*, fig. 2b).

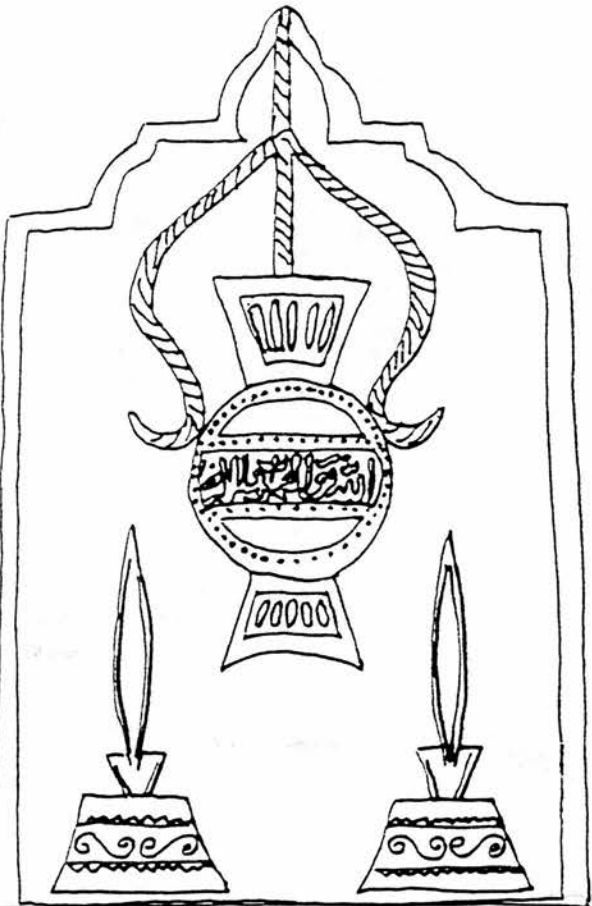
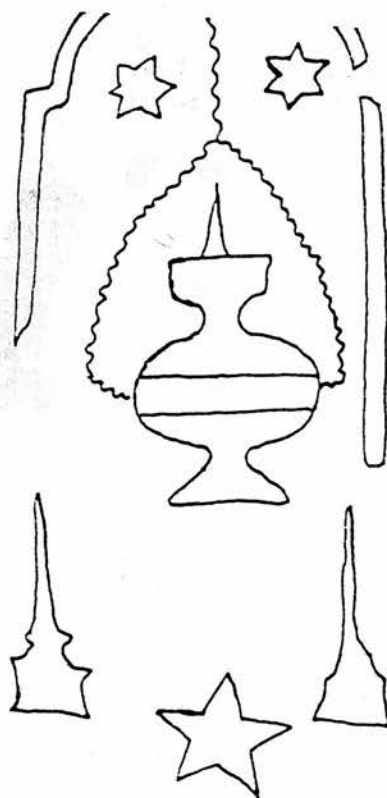

73. *Mihrab* plaque from the Madrasa al-Budayriyya, Cairo 759/1357 (after Atil, *Renaissance*, No. 111).

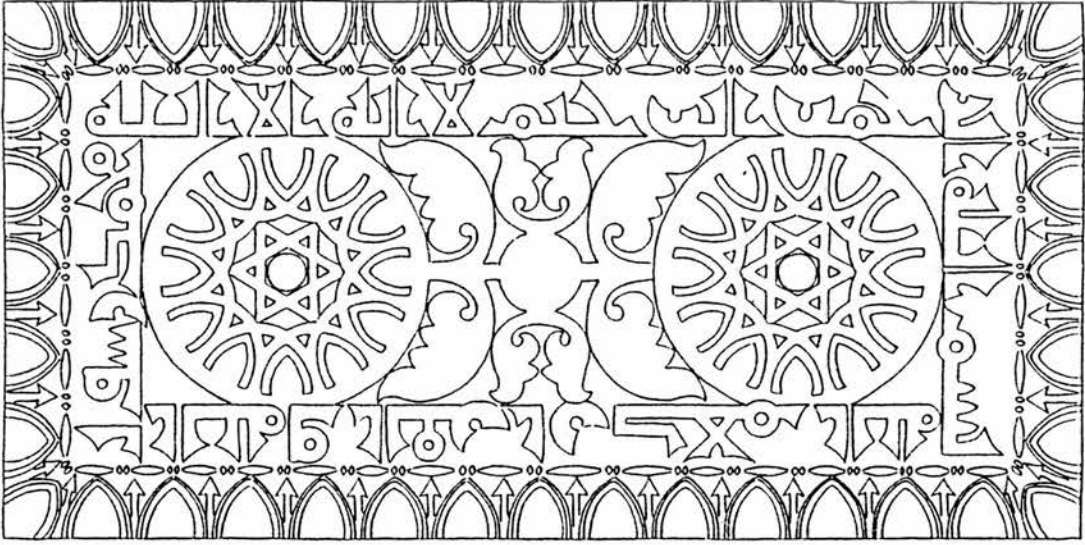

74. Carved plaque in the *mihrab* of the Great Mosque of Tunis (after Lézine, *Architecture*, fig. 32).

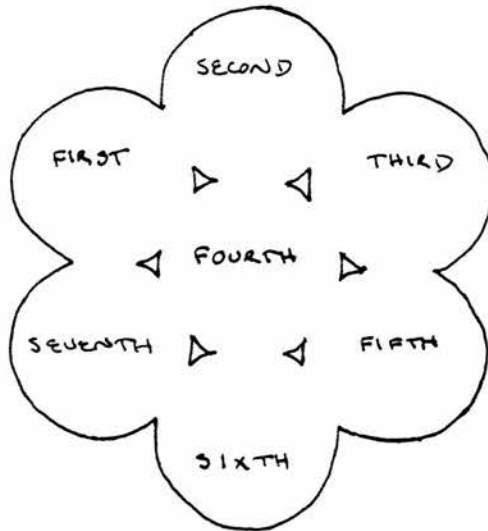

75. The world map of al-Birūnī (after Nasr, *Cosmographie*, fig. 3).

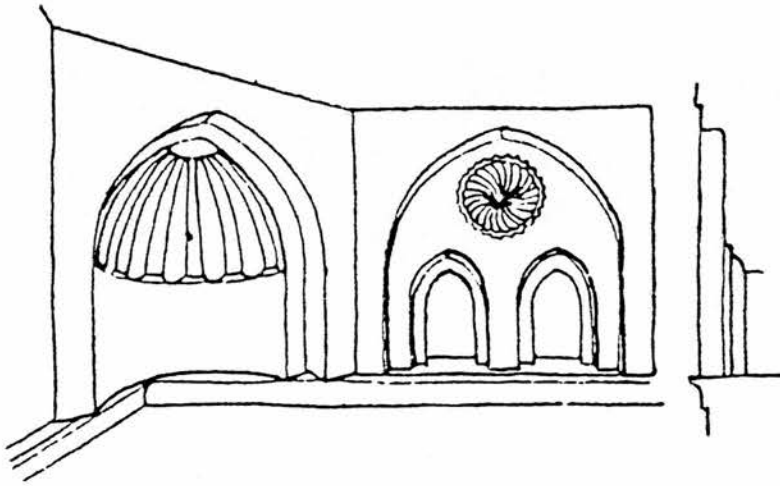

76. Medallion above the windows of the Takritūya Madrasa, Damascus
(after Herzfeld, *Damascus: Studies III*, fig. 82).

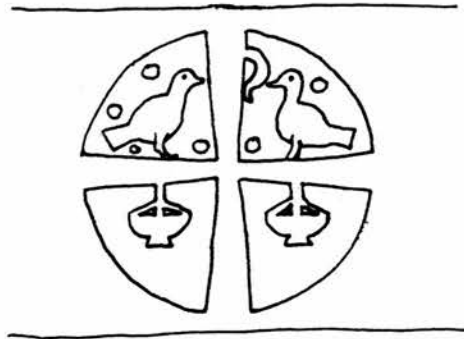

77. Medallion on a lintel at Ujah (after Butler, *Ancient Architecture*, ill. 71).

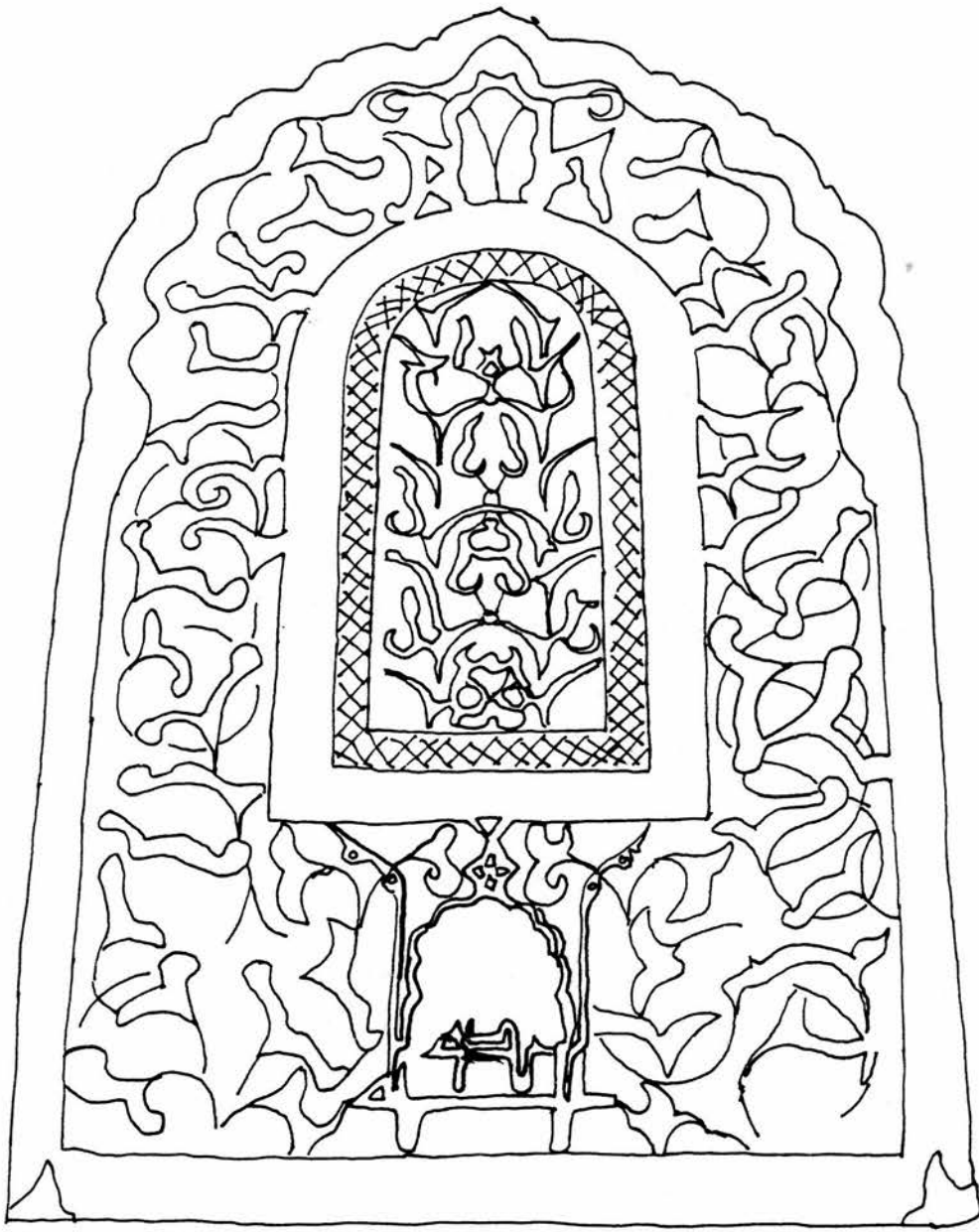

78. Stucco panel on the rear wall of the *mihrab*, Great Mosque of Taza (after Terrasse, *Taza*, pl. LV).