

TIME BUDGET STUDIES IN STALLED HORSES

THOMAS SYME OGILVIE-GRAHAM

DOCTOR OF VETERINARY MEDICINE AND SURGERY

THE UNIVERSITY OF EDINBURGH

1994



DECLARATION

I hereby declare that the thesis submitted by me for the degree of Doctor of Veterinary Medicine and Surgery of the University of Edinburgh embodies the results of my own work and that it has been composed by myself.

All the work undertaken is my own with the exception of (a) assistance in scanning video cassettes by Joanne Pilkington, Louise Campbell and Sara Hammon; (b) assistance in technical processing of data by Sara Hammon.

The thesis has not been submitted in candidature for any other degree, diploma or professional qualification.

THOMAS S OGILVIE-GRAHAM

17 MAY 1994

ABSTRACT

This study was designed to record the behaviour of stabled horses from the Household Cavalry over an extended period. Eighty horses were observed using infra-red time-lapse video for between 48 and 72 hours each, over 2 years, under similar management conditions, and in total 5,424 hours of data was collected. All the horses were kept in stalls at either Hyde Park or Windsor barracks and continued with their normal duties throughout observation periods.

The horses were found to spend 36.3% (8.7 hours per 24-hour period) of their time feeding and 1.01% (0.2 hours per 24-hour period) drinking. The horses were alert in their stables for 7.5% (1.8 hours per 24-hour period) of their time, non-alert for 63.03% (15.1 hours per 24-hour period), resting for 10.89% (2.6 hours per 24-hour period) and sleeping for 2.33% (0.6 hours per 24-hour period). The horses stood for 57.92% (13.9 hours per 24-hour period) of their time in stalls, with 18.67% (4.5 hours per 24-hour period) of the time leg-resting and 6.17% (1.5 hours per 24-hour period) lying.

The horses were exercised for 4.92% (1.2 hours per 24-hour period) of the 24-hour period and spent 2.54% (0.6 hours per 24-hour period) of their time moving within the stalls. They interacted for 2.04% (0.5 hours per

24-hour period) of their time and spent 2.12% (0.5 hours per 24-hour period) of their time in abnormal behaviour (0.69% or 0.17 hours per 24-hour period being spent in stereotypic behaviour - this was seen in only ten horses). The times spent in different behavioural categories are not necessarily mutually exclusive.

Analyses of variance showed no significant differences (i.e. $p > 0.05$) in behaviour resulting from factors such as age, time spent in barracks, type of horse or height. Welch 't' test showed that sleeping was affected by gender ($p = 0.0089$), with females spending considerably more time sleeping than males.

The percentage time spent eating was less than for feral horses or stabled horses fed hay ad libitum, but was comparable with other studies on stabled or enclosed horses on a restricted hay diet. The horses spent less time resting, and more time alert, than free-ranging horses, possibly owing to the different sensory stimulation associated with their environment. This may also be a factor in producing the low level of abnormal activity recorded and the relatively low time spent sleeping.

Time spent in interaction was low but the close proximity of the horses and regular human contact may compensate for any possible ill-effects of reduced social contact. The level of abnormal behaviour was low compared with

other restricted-hay fed stabled horse studies. This may be due to the management routines, high sensory stimulation levels, type of horse and the almost "communal" living associated with stalls and cavalry routines.

The time-budgets of these horses is compared to that found in other studies and the implications for welfare discussed.

ACKNOWLEDGEMENTS

I should like to thank Dr Debbie Marsden for her constant support, enthusiasm and expert advice - without her help, this project would not have been possible. I am also grateful to Dr Derek Cuddeford for his overall supervision and energetic encouragement.

I must also thank Brigadier A H Parker Bowles OBE, Director Royal Army Veterinary Corps, and Lieutenant Colonel H P D Massey RHG/D, Commanding Officer of the Household Cavalry Mounted Regiment, for their permission in allowing me to carry out this project.

LIST OF CONTENTS

PAGE

ACKNOWLEDGEMENTS

1. INTRODUCTION

- 1.1. PROJECT AIMS 1
- 1.2. SUITABILITY OF HOUSEHOLD CAVALRY HORSES 2

2. LITERATURE REVIEW

- 2.1. BEHAVIOUR AS A MEANS OF ASSESSING WELFARE IN HORSES 6
 - 2.1.1. Background 6
 - 2.1.2. Homeostasis 7
 - 2.1.3. Importance of behavioural signs 7
 - 2.1.4. Methods used in behavioural studies designed to assess welfare 11
 - 2.1.5. Particular importance of time budgets 12
- 2.2. SUMMARY AND COMPARISON OF FERAL AND PRZEWALSKI HORSE TIME BUDGETS
 - 2.2.1. Background 13
 - 2.2.2. Ingestive behaviour 13
 - 2.2.3. Standing and resting behaviours 19
 - 2.2.4. Eliminative behaviour 22
 - 2.2.5. Comfort behaviour 24
 - 2.2.6. Locomotion 25
 - 2.2.7. Social behaviour 27
- 2.3. SUMMARY AND COMPARISON OF DOMESTIC HORSE TIME BUDGETS
 - 2.3.1. Background 33
 - 2.3.2. Ingestive behaviour 33

	PAGE
2.3.3. Standing and resting behaviours	36
2.3.4. Eliminative behaviour	41
2.3.5. Comfort behaviour	42
2.3.6. Locomotion	43
2.3.7. Abnormal behaviour	43
2.4. FACTORS AFFECTING TIME BUDGET DIFFERENCES BETWEEN FERAL AND DOMESTIC HORSES	
2.4.1. Introduction	45
2.4.2. Ingestive or oral behaviour	45
A. Time spent feeding	
B. Abnormal oral activity	
C. Type of horse	
2.4.3. Sleep and resting behaviours	57
A. Stable environment	
B. Familiarity with surroundings	
C. Conditions of confinement	
D. Sensory deprivation	
E. Type of horse	
F. Diet	
2.4.4. Eliminative behaviour	61
2.4.5. Comfort behaviour	62
2.4.6. Movement anomalies	63
A. Paddock size	
B. Temperament	
C. Exercise	
D. Restriction	

	PAGE
2.4.7. Social behaviour	66
A. Type of horse	
B. Isolation	
C. Confinement	
D. Gender	
2.5. VALUE OF TIME BUDGETS IN ASSESSING WELFARE	
2.5.1. Definitions and assessment of welfare	73
2.5.2. Value of abnormal behaviour in assessing welfare	75
2.5.3. Use of time budgets in assessing welfare	81
3. <u>MATERIALS AND METHODS</u>	
3.1. MATERIALS	84
3.2. METHODS	94
4. <u>RESULTS</u>	
4.1. TIME SPENT IN MAJOR BEHAVIOURAL CATEGORIES	98
4.2. THE EFFECT OF VARIOUS FACTORS ON MAJOR BEHAVIOURAL CATEGORIES	101
5. <u>DISCUSSION</u>	
5.1. TIME SPENT IN MAJOR BEHAVIOURAL CATEGORIES	115
A. Ingestive behaviour	
B. Levels of alertness and posture	
C. Locomotion	
D. Interactions	
E. Abnormal behaviour	
5.2. THE EFFECT OF VARIOUS FACTORS ON MAJOR BEHAVIOURAL CATEGORIES	147

	PAGE
A. The effect of age	
B. The effect of time spent in barracks	
C. The effect of horse type (light or heavy)	
D. The effect of gender	
E. The effect of height	
5.3. SUMMARY OF CONCLUSIONS	156
5.4. IMPLICATIONS FOR WELFARE	
5.4.1. Welfare and "Stress"	162
5.4.2. Relevance of results to welfare	163
5.4.3. The way forward	169
<u>REFERENCES</u>	174
<u>APPENDICES</u>	189

FIGURES, TABLES AND CHARTS

	<u>PAGE</u>
<u>FIGURES</u>	
2.1. Some Behavioural Symptoms	10
2.2. Proportion of time spent in sleep, wakefulness and different postures	40
2.3. Time budgets of horses under different management regimes	48
2.4. The effect of dietary level of protein on time spent feeding and on occurrence of abnormal behaviour	50
2.5. 24-hour time budgets for horses fed ad libitum (Pasture & Feral)	51
2.6. 24-hour time budgets for horses fed ad libitum ((Pasture & Stalls Hay)	52
2.7. 24-hour time budgets for horses fed to maintenance (Stalls Hay & Stalls Concentrate)	53
2.8. The relationship between time spent feeding and the time spent performing abnormal behaviour	54
2.9. Equine behavioural problems and their possible causes	77
7 The layout and dimensions of the lines of stalls at the Knightsbridge Barracks	88

TABLES

2.1. Summary of most commonly measured behaviours	14
2.2. Time Budget for Camargue Horses	20
2.3. Population characteristics and social patterns of 4 feral horse populations	29
2.4. Time budgets of stabled horses and ponies	34
2.5. Proportion of time spent in sleep and wakefulness	39
4.1. Time spent in the major behavioural categories	98

CHARTS

- 5.1. Total 24-hour period of time resting for Household Cavalry Horses

BAR CHARTS

4.2 (a) Time spent eating	101
4.2 (b) Time spent in oral movement (including abnormal oral movement)	102
4.2 (c) Time spent alert	103
4.2 (d) Time spent non-alert	104
4.2 (e) Time spent resting	105
4.2 (f) Time spent sleeping	106
4.2 (g) Time spent standing	107
4.2 (h) Time spent lying	108
4.2 (i) Time spent leg-resting	109
4.2 (j) Time spent in leg movement	110
4.2 (k) Time spent in stereotypic behaviour	111
4.2 (l) Time spent in interaction	112

PHOTOGRAPHS

	PAGE
1. Horses on parade at Buckingham Palace.	5
2. The Household Cavalry Mounted Regiment at Hyde Park Barracks.	5
3. Household Cavalry horses in Hyde Park.	85
4. "Heavy" type of horse.	85
5. "Light" type of horse.	86
6. Drum horse (Clydesdale).	86
7. Stalls.	89
8. Inspection of morning stable routine.	89
9. Horses being led out to go on the "Queen's Life Guard".	91
10. Remount in training.	91
11. View similar to that recorded by the video camera.	95
12. A horse cribbing on its waterbowl.	173
13. The Queen's Life Guard preparing to leave Barracks.	173

CHAPTER 1

INTRODUCTION

1.1 PROJECT AIMS

The horse is essentially a herd animal which relies on the herd's collective ability to detect and then outrun predators. Evidence such as the success of feral populations in surviving, and even thriving, in harsh environments suggests that domestication has not greatly affected its instincts and innate behaviour patterns.

Whilst detailed studies, often involving time budgets, have been undertaken on feral horses or horses at pasture (*Equus caballus*) and on the non-domesticated Przewalski horse, few studies have been attempted on stabled horses. These studies on stabled horses were seldom sufficiently detailed (for instance, not involving large numbers of horses, under similar management conditions, over an extended period) to allow accurate comparisons with the feral horse studies. Since, as observed by Ellis (1990), freedom of behaviour and movement are likely to be severely restricted in captivity, and since the opportunity to graze continuously will probably be denied, one might expect that stabled horses would restructure their activity time budgets in association with the degree of physical restriction and social isolation experienced.

It is proposed, therefore, that a long-term time budget study of large group of stabled horses would prove useful for comparison purposes with time budget studies already conducted in free ranging or wild horses and ponies in order to examine in detail any differences between stalled horses and their feral conspecifics. Such comparisons would aid in the assessment of the welfare of stalled horses and might assist in making practical recommendations for changes in housing and management practices

(Marsden, 1993a). Changes in behaviour have often been suggested as indicative of impaired welfare or "stress" in horses (e.g. Kiley-Worthington, 1987; Fraser, 1992; Mal et al., 1991)

A housed environment may represent, at one end of the range, an "ideal" system where the time budgets differ little from the free ranging counterparts and little or no anomalous behaviour is seen or, at the other end of the range (possibly despite the provision of adequate feed, shelter, and treatment of disease or illness), a system in which the animals appear directly stressed by their environment, and reflect this in markedly altered time budgets and in new or abnormal behaviour. The most common finding might be expected to be somewhere on the scale between these two extremes. One might also expect that good stable management and design could compensate, to some degree, for possible gaps in the stabled horse's time budget, which might otherwise have represented potential welfare impairment.

The aim of this study is to compile time budgets for a large group of stalled horses under constant management. Factors including various characteristics of the horses such as age, sex, breed, type and time they have spent under these management conditions, which might be expected to affect the time budgets, will be examined and, by making comparisons with feral studies, an evaluation of the welfare of the horses will be attempted. The relevance of comparisons with feral horse studies as well as the value and limitations of stabled horse studies in assessing welfare will be discussed.

1.2 SUITABILITY OF HOUSEHOLD CAVALRY HORSES

For reasons of finance (horses are expensive to buy, feed and look after) as well as emotion ("companion" animal status) stabled horses are not ideally

suited for experimental investigation. Moreover, even within one large stable such as a racing yard, there is usually enormous variation in management (e.g. where a conscientious lad may groom 2 or 3 horses more carefully than another within the same yard), type of horse (e.g. 2 year olds alongside aged brood mares), training (e.g. some horses will race and travel much more than others), and feeding regimes. The varying requirements of owners and economic necessities also tend to curtail detailed observations over extended periods. Some stables or yard owners may perceive a study of this nature as a threat, since they may hold entrenched opinions on stable management and horse welfare.

The Household Cavalry Mounted Regiment provides an environment at Hyde Park Barracks and Windsor where a large number of horses, on a rigidly-maintained and almost identical routine, can be studied. As the Regimental Veterinary Officer, I have control over any alterations in management such as feeding, exercise, grooming and transport. I also have the advantage of being able to ensure, by issuing of orders if necessary, that the study is carried out over whatever period is desired. As opposed to reporting to numerous owners, I am only required to account for my actions to the Commanding Officer.

The vast majority of the horses (in total, approximately 270) live in stalls within the 6 Troop lines at Hyde Park Barracks or within the 2-3 Troop lines at Windsor. They are groomed, exercised, mucked out, fed and ridden by the soldiers which are available within that Troop at any particular time. In this way, although Troops have favourite horses, individual variation in management is minimalised and military routine supersedes all other considerations. This routine has developed over centuries and the strenuous efforts made not to deviate from it reflect the necessity of maintaining continuity within an Armed Service as well as the importance

attached to tradition in the care of items of military equipment such as the horse.

The Household Cavalry horses provide a very well controlled population ideally suited to a study where variation in routine between the horses would severely undermine the overall significance of the results. The military horse was probably first used as a draught animal (the Assyrians used them with devastating effect against the Egyptians in c.2000 BC and the Egyptians then used them in chariots thereafter). They were later used as cavalry (Xenophon, a Greek cavalry officer, discussed their merits and uses at length in the 5th Century BC). The horse has had a vital role in warfare, and hence in the development of civilisation. For instance, the inspired use of cavalry by William the Conqueror probably won him the day at Hastings in 1066, whilst the improved veterinary services of the British Army (who had learned, at hard cost, many lessons in the modern military use of horses during the Boer Wars) enabled nearly twice as many wounded horses to be returned to the Battle Front as the German Army during the Great War - this must have been a major factor affecting the outcome of a war of attrition such as this. Even in 1939, the German Army still retained nearly 6 million horses. Photograph 1 illustrates the high profile accorded to military horses within modern Britain - the mounted band of the Household Cavalry Mounted Regiment is in the foreground, with the draught horses of the King's Troop Royal Horse Artillery in the middle distance and the "Windsor Greys" pulling the State Coach are flanked by Foot Guard officers of the Household Division. The Household Cavalry Mounted Regiment is shown being inspected on parade at Hyde Park Barracks in Photograph 2.

Photograph 1. Horses on parade at Buckingham Palace.



Photograph 2. The Household Cavalry Mounted Regiment at Hyde Park Barracks.



CHAPTER 2

LITERATURE REVIEW

2.1. BEHAVIOUR AS A MEANS OF ASSESSING WELFARE IN HORSES.

2.1.1. BACKGROUND

There are various different approaches to the study of behaviour, ranging from physiological, which Manning (1979) describes as concentrating on the study of mechanisms, with a view to explaining behaviour as functionings of the nervous system; and experimental psychological (concentrating on learning in particular); to the ethological approach, pioneered by Konrad Lorenz and Niko Tinbergen (centred on studying a wide range of animals under near natural conditions).

One of the major aims of ethology is to investigate the way behaviour fits animals for survival (Tinbergen, 1951). Fraser and Broom (1990) note that there have been recent advances in the precision of behaviour description and the understanding of behavioural patterns in relation to physiological as well as evolutionary processes. Modern techniques in ethology and in experimental psychology mean that there is now an extensive knowledge of sensory analysis, motor control, hormonal effects, motivation, body maintenance behaviour, reproductive behaviour and social structure.

These techniques have been applied to horses as well as to farm animals in order to examine the way in which environment and management affect behaviour. Applied ethology relates this study of behaviour and environment with the disciplines of animal science, veterinary medicine and

animal husbandry with a view to improving husbandry, housing, health, productivity and welfare of the animal studied.

2.1.2. HOMEOSTASIS

The establishment of homeostasis through feeding and related behaviour is a major factor in the adaptation of an animal to its environment.

Maintenance behaviour is varied and complex. Fraser (1992) suggested that maintenance is the essence of homeostasis and that the main objective of management should be to facilitate the self-maintenance of the animals. Horses are still perfectly capable of surviving and reproducing successfully, in an appropriate environment, without the intervention of stable managers, as shown by many different groups of feral horses. This illustrates that their innate behavioural resources are still capable of expression after centuries of domestication (Keiper, 1985; Rubenstein, 1981; Rifa, 1985).

Kiley-Worthington (1987) stated that time budgets in captive horses which are similar to feral horse time budgets indicate good welfare. Marsden (1993 a) broadly supports this point of view but also points out that certain changes in domesticated horse time budgets may represent appropriate adaptations.

2.1.3. IMPORTANCE OF BEHAVIOURAL SIGNS

Various activities or changes in behaviour can be manifestations of ill-health. Altered behaviour may frequently be the first indication of illness (Fraser & Broom 1990). Veterinary surgeons regularly deal with clinical cases that are symptomatically behaviour-based. In fact, animal behaviour and veterinary diagnosis have long been closely associated and there are many references to the behaviour of sick animals in Ancient Greek literature.

Several common diseases are primarily diagnosed on behavioural grounds. Examples include; deficiency diseases such as aphosphorosis, metabolic diseases such as hypomagnesaemia and hypocalcaemia, and infectious conditions such as encephalitis.

Altered behaviour is also one of the principal signs of "stress" in horses (Fraser, 1992), and many aspects of environment are thought to cause "stress". The changes in behaviour imposed by intensive housing and management of farm animals often gives rise to concern for their welfare (e.g. in calves, Saville & Webster, 1981; in sheep, Marsden & Wood-Gush, 1986; in pigs, Appleby & Lawrence, 1987) and similar concern has also been expressed for horses (Kiley-Worthington, 1987; Fraser, 1992). Mal et al., (1991) showed that environment and management methods affected physiology and behaviour, and suggested that some of these changes indicated an alteration in the physiological state and thus the welfare of the animal.

Animals under "stress" may develop abnormal forms of behaviour (Fraser, 1992). Consistent with this observation is the finding that as well as diminished maintenance behaviour, young pigs showing the lowest level of playing and the highest level of abnormal activity have significantly elevated cortisol levels (Schmidt, 1982).

Waring (1983) states that a behavioural symptom, which may be physiological or psychological in origin, can be used as a signal that the horse requires medical or other special care. A change in behaviour is often determined by comparing observed patterns to traits shown previously by the individual or by most horses of the same type (e.g. sex, age and breed).

Changes in behavioural expressions or posture, decreased ability to orientate or move normally, apparent loss in perception, poor maintenance activities, altered social interactions, and excessive agonistic behaviour are all examples of such behavioural symptoms (Figure 2.1). Waring (1983) emphasises that, in some cases, only a shift in intensity, frequency of occurrence, or rhythmicity is symptomatic whereas, at other times, entirely new behaviours occur.

Hence, a thorough knowledge of behavioural traits, within groups as well as individual animals, would appear useful in the identification of animals with a reduced state of health and, in particular, those animals failing to cope with a domesticated environment where welfare is at risk. A detailed study of many animals' behavioural patterns within a domesticated environment, such as this study is intended to provide, may assist in assessing the degree to which that environment affects welfare.

FIGURE 2.1

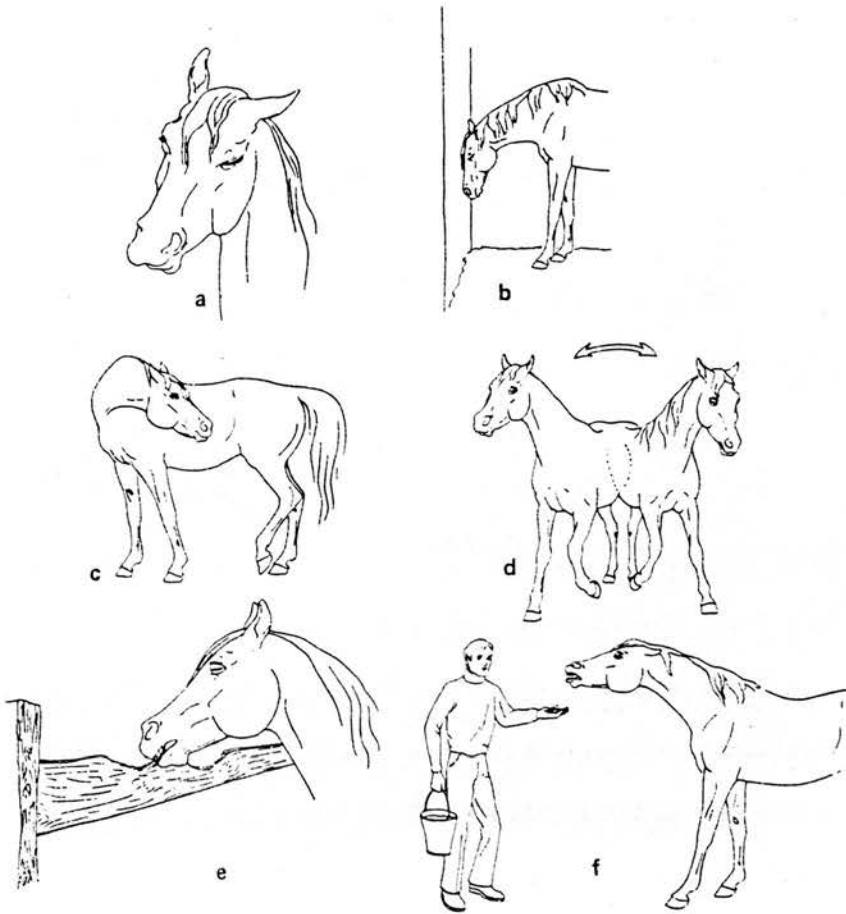

Some Behavioural Symptoms:

- a Change in facial expression (damage to left facial nerve).
- b Change in posture or orientation (head press against wall).
- c Sign of discomfort (looking at abdomen).
- d Stereotyped movement (weaving).
- e Pica (wood chewing).
- f Change in temperament or social behaviour (abnormal aggression).

Modified from Waring 1983.

2.1.4. METHODS USED IN BEHAVIOURAL STUDIES DESIGNED TO ASSESS WELFARE

The biological approach to behaviour advocated by Tinbergen (1951) is usually called ethology (Thorpe, 1979). A key feature of ethology is the belief that animals must be studied in natural conditions if useful questions about their behaviour are to be asked and answered. Such a study, according to Huntingford (1984), should, therefore, start with a period of unobtrusive but precise and careful observation; some ethologists believe that many questions about behaviour can be answered without experimental interference. Any experiments which may eventually be performed should be kept simple and, wherever possible, carried out in the field.

Huntingford (1984) noted that the early ethologists were impressed by the fact that behaviour lends itself to description in discrete terms and that a given species tends to show a characteristic repertoire of behaviour patterns. The aim of such early ethological investigation was to produce inventories of such actions (ethograms) for a range of animal species. There is a belief that ethograms (which are simply detailed descriptive lists) of animals "in the wild" may be considered representative of their normal, or even complete, behavioural repertoire (Arnold & Grassia, 1982). However, by putting animals into "new" or "different" environments, one may expect to see some "new" or "different" behavioural patterns, which do not necessarily reflect diminished welfare, although time budget studies combined with further experimentation may be required to assess the implications of these changes for welfare (Marsden, 1993 a). It is also likely that any detailed behavioural study will add to our knowledge of the repertoire and organisation of that animal's behaviour so no ethogram is ever complete (Fraser & Broom, 1990).

2.1.5. PARTICULAR IMPORTANCE OF TIME BUDGETS

Animals in the wild divide their time between activities which allow them to satisfy their basic requirements for food, movement, social interaction and rest. The list of time spent in each activity is called a "time budget". The time budget of a population is determined both by the characteristics of the species to which it belongs, and by the characteristics of its environment and may be further constrained by the forms of social organisation that a population can adopt (Duncan, 1980; Kiley-Worthington, 1985). Time budgets provide a precise, numerical description.

There are limited data available on the (24-hour) time budgets of horses as well as other large herbivores on which to base intra-and inter-species comparisons - presumably a consequence of the logistic difficulties involved in following and observing such animals at night (Duncan, 1980).

Comparisons between studies are difficult due to the variety of methods used in observation and in defining the particular behavioural patterns.

However, comparisons must be attempted in order to find common baselines against which to measure or evaluate the time budgets of horses in this study.

2.2. SUMMARY AND COMPARISON OF FERAL AND PRZEWALSKI HORSE TIME BUDGETS

2.2.1. BACKGROUND

Table 2.1 summarises time-budget literature of the most commonly measured behaviours in both Przewalski and feral horses. Przewalski horses, although kept in zoos or on restricted pastures only, will be included in this section on the grounds that all current populations have been line bred from individuals caught in the wild and that these represent immediate ancestors of modern domestic horses.

These horses' freedom of movement may vary from groups restricted within zoo enclosures to horses confined within well defined geographical boundaries such as on islands; to horses within more loosely defined parameters of range, as in the Camargue; to horses in vast territories such as Western Alberta. The time budgets of these horses may also be expected to vary considerably and most studies have concentrated on a few broad behavioural categories, which are discussed below. Behaviour is divided into the following sections for discussion; ingestive behaviour; standing; stand-resting; sleep; lying (laterally and sternally); eliminative behaviour; comfort behaviour; locomotion; social behaviour.

2.2.2. INGESTIVE BEHAVIOUR

As shown in Table 2.1, most feral and Przewalski horses spend 55-75% of their time feeding. However, the Przewalski horses in the study at Front Royal spent only 46% of their time feeding (Boyd *et al.*, 1988). The Front Royal horses were kept on a large grassy pasture but received approximately 3 kg complete cubed feed each per day. It is presumed that

TABLE 2.1

Summary of most commonly measured behaviours

Source	Season ¹	Time of		Time spent 3 (%)		Stand	Stand awake	Stand rest	Self-groom	Locomotion
		Day 1	Day 2	Feed	Drink					
Domestic horses:										
Sweeting <i>et al.</i> , (1985)	-	D	D	70	2	18	11	7	1	3*
Crowell-Davis (19483)	Sp, Su	D	D	70	-	-	-	-	-	-
Houpt <i>et al.</i> , (1986)	Su	N	N	62	-	28	-	-	-	4*
Suft <i>et al.</i> , (19485)	-	24	24	-	2	-	-	-	-	-
Duncan (1980)	Su	24	24	57	-	28	10	18	-	10
Kownacki <i>et al.</i> , (1978)	Yr	24	24	70	-	23	-	-	-	4
Feral horses:										
Salter and Hutson (1979)	Yr	D	D	75	-	-	-	-	-	-
Rita (1985)	Yr	D	D	75	0.3	-	-	-	2	8**
Keiper and Keenan (1980)	Su	N	N	-	0.1	-	-	-	-	-
Kaseda (1983)	Yr	24	24	74	-	-	-	-	-	-
Przewalski horses:										
Skiff (1982)	Su	D	D	63	-	-	-	-	-	-
Popolow (1984)	Su	D	D	55	0.7	25	-	-	2	13
Griffiths (1985)	Su	D	D	65	-	22	-	-	-	7
Griffiths (1985)	Su	N	N	36	-	51	-	-	-	2
Boyd <i>et al.</i> , (1988)	Su	24	24	46	0.5	37	21+	16+	2	7

¹ Spring (Sp); Summer (Su); Year-round (Yr)

² Day (D); Night (N); 24-h observations (24)

³ Where a range was given, the median is presented.

* Walking only; ** Walking and trotting only.

+ Figures from 1985 study.

Adapted from Boyd *et al.*, (1988)

the horses received enough of their energy requirement in concentrated form so as to enable them to reduce their total foraging time.

Feral horses generally spend a great deal of time feeding (Table 2.1). The horses at Front Royal were found to spend the least time feeding between 0800 and 1200 hrs and the most at night. The study was conducted during the summer and the assumption made was that the cooler temperatures encouraged greater feeding activity. This probably accounts for the increased activity at night and some of the decreased activity in the late morning, though the fact that the concentrate feed was fed in the morning and presumably, as a reasonable energy source, produced a degree of satiety should have some significance.

Although the Front Royal horses were primarily mares in late lactation, and all reportedly in good condition, none was pregnant. Pregnant mares, with higher energy requirements, would have been present in all of the feral horse groups and most of the domestic horse groups referred to in Table 2.1. Another factor in producing the relatively low percentage of 46%, as time spent eating, is the number of juvenile horses present, which generally spend less time eating than adults owing presumably to their obtaining much of their nutritional requirements rapidly, in the form of milk (Tyler, 1969; Duncan, 1980). The presence of stallions could be another factor - stallions tend to be more active and alert and possibly as a consequence, to spend less time feeding than mares (Duncan, 1980). Duncan also notes however, that the quantity of food eaten by males was apparently very much in excess of their metabolic requirements, even allowing for them being more active, so that a considerable amount of their summertime energy intake was probably stored as reserves for the winter.

Prior to the Front Royal study, the only results to be analysed by time of day were from the study on Assateague Island ponies (Keiper and Keenan,

1980; Keiper et al, 1980). This study showed that during the summer the ponies grazed 54.6% of the nocturnal period, with greatest activity early in the evening and again at dawn. Assateague Island is primarily flat salt marsh with a strong seasonal climate (hot and humid summers). The ponies do not receive any supplementation to their natural diet. The high proportion of nocturnal grazing found in this study may be due to the hot days being a disincentive to feed.

Daytime studies by Salter (1978) and Tyler (1969) noted both that peak grazing activity occurred at dawn and early evening and that around 75% of the daylight hours in the winter were spent foraging by adult ponies. Salter's study showed that feral foals in western Alberta, in contrast to the adults, spent only 41% of their time foraging - this is similar to the findings of Tyler (1969) and those of Duncan (1980). As with the Front Royal and Assateague Island ponies, Tyler (1969) found that the proportion of time spent grazing decreased and the proportion of time spent resting increased throughout the summer as the days became hotter and the ponies sought shade. In June when flies became a major problem in addition to the heat, this pattern was even more apparent.

Whilst the proportion of time spent grazing during the day is apparently reduced in the summer relative to the proportion of time spent grazing at night, owing possibly to the requirement of avoiding thermal stress and flies, the overall grazing time also appears reduced in the summer as shown by Rubenstein (1981) in the Shackleford Island ponies. Kaseda (1983) and Rubenstein (1981) also both observed decreased daytime feeding in summer but not winter. Kownacki *et al.*, (1978) found that horses on a forested reserve in Poland varied very little in total time spent foraging (24 hour samples) between early summer, fall and winter. The practice of giving supplementary hay during the winter to these horses might explain this result as the hay would alleviate the effects of poorer quality grazing. Table

2.1 shows that studies carried out throughout the year generally find higher percentage time spent feeding than those carried out in the summer alone. Direct comparison of results from these studies is complicated owing to the variation in factors such as many studies being day- or night-time only, the types and metabolic states of the horses differing and environmental conditions being diverse. However, the general pattern may be explained where nutrient requirements are ^{greater} in winter when a higher metabolic rate must be supported in order to maintain thermal homeostasis. Not only would this require additional nutrition but the poorer quality, and possible scarcity, of vegetation might necessitate more time spent foraging.

Salter and Hudson (1979) noted that feral horses in Alberta spent 75% of the daylight hours grazing while Duncan (1980) recorded a figure of between 59-63% of the 24 hour period spent grazing by Camargue horses. The lower percentage for the Camargue horses may be explained by a possible increase in grazing time during the winter in the year-round study in Alberta (forage is scarcer hence more steps between bites of food); as the Camargue study was carried out during the summer, the daylight period is longer, and heat combined with biting insects ^{could constitute} a major problem so that horses seek out shade rather than graze; most importantly, the higher quality forage in the Camargue study would meet the energy demands of the horses more readily (although readily available good quality forage may also result in greater selectivity by the horses).

It has been estimated that the higher quality, and increased availability of forage (as well as increased biting insect numbers) produces an average reduction in grazing time of 15 minutes for every extra hour of sunlight in the spring (Tyler, 1968). Duncan (1980) and Tyler (1972) both found that time spent eating increases in winter when forage is scarce (and of low quality), and decreases in summer when food is abundant.

Drinking frequency varies according to thirst and accessibility of water source. According to Waring (1983), drinking can occur at almost any time during the day or night. Free-roaming horses with reduced access to water sources may drink once each day (Feist, 1971) or even only once every other day (Pellegrini, 1971). In extreme heat, herds may stay close to water and drink more often. Przewalski horses have been recorded as drinking as infrequently as every two or three days (Bannikov, 1961). This may be an adaptation in their behaviour to the harshness and lack of drinking sites of their arid native environment. Boyd *et al.*, (1988) observed that Przewalski horses at Front Royal spent 0.5% (which represents 7.2 minutes in a 24-hour period) of their time drinking. Both Boyd *et al.*, (1988) and Crowell-Davis *et al.*, (1985) noted that the fewest drinking bouts occurred early in the morning and that there was an increase in drinking bouts in direct proportion to increasing temperatures (normally around mid-day). The water content of available feedstuffs may also affect drinking behaviour. The dew on the grass may have reduced the need for drinking at Front Royal just as a succulent feedstuff might.

The frequency of nursing and total time spent nursing decreases with age. During summer daylight periods, Feist (1971) observed foals of feral horses nursed nearly twice each hour, whereas the yearlings that were nursing did so only 50 percent as often. Tyler (1969) recorded a more marked decrease in nursing frequency with age in New Forest ponies. Whilst nursing can occur at any time, Schoen *et al.*, (1976) noted mid-morning and early evening peaks. Boyd *et al.*, (1988), however, observed that Front Royal Przewalski mares and foals spent 1% of their time nursing and recorded no variations throughout the day - this discrepancy may result from Boyd *et al.*, employing a more accurate recording technique (fifteen-minute focal-animal samples) or it could be due to breed differences. The findings of Boyd *et al.*, (1988) are similar to the findings with Przewalski horses at Prague Zoo (Bubenik, 1961). Even the possibly more accurate figure for

nursing time found by Boyd et al., (1988) is likely to be an underestimate since 1% represents only 14.4 minutes per 24-hour period. It would, presumably, be difficult if not impossible to consume sufficient milk during those few minutes.

2.2.3. STANDING AND RESTING BEHAVIOURS

Various definitions of standing and resting have been used. For instance, "standing" may include stand-resting behaviour, whilst "resting" may include lying and sleeping - the variety of terms used in different studies can sometimes make direct comparisons difficult. As in other higher mammals, horses have four states of alertness, which can be recognised by characteristic patterns of cortical electrical activity and associated motor patterns: wakefulness, drowsiness, slow-wave sleep and paradoxical (or Rapid Eye Movement, REM) sleep (Ruckebusch, Barbey and Guillemot, 1970). Drowsiness can be considered as a transition between alert wakefulness and slow-wave sleep. Slow-wave sleep is the initial and more frequent form of sleep and whilst occurring in recumbency, can occur when standing owing to the unique stay apparatus of the hind limbs in horses. Paradoxical sleep is a very deep sleep which occurs either in lateral equine recumbency or in sternal recumbency with the muzzle touching the ground, according to Ruckebusch (1972), so that the head is supported during the atonia which accompanies that phase Ruckebusch et al., (1970) originally stated that paradoxical sleep could only occur in the position of lateral recumbency. It would seem that paradoxical sleep does not require complete lack of muscle tone and can be seen during situations of very low muscle tone.

Duncan (1980) points out in his study of Camargue horses that it was not possible to determine precisely the time spent in the four different states of alertness shown in Table 2.2. (owing to the impracticalities of fitting

TABLE 2.2

Time Budget for Camargue Horses

(All units are percentages of time spent)

	Standing resting	Standing Alert	Recurr- bent	Lying flat	Trotting	Galloping	Rolling	Walking	Eating
Spring to Autumn 1976									
Adult mares, foal at foot	20	6.8	4	0.6	0.4	0.4	0.05	9	58.5
Young mares and all yearling	15	7.2	7	2.7	0.6	0.2	0.1	9.4 57.5	
2-3 year old colts	14	10.1	8	1.5	0.4	0.35	0.17	8.5 57.4	
Adult stallions	16	11.1	5	1.9	0.5	0.4	0.26	10	55.1
New foals (taken from a different study on same group)	8	131	8	15	1.8	1.8	?	18	13

Adapted from Duncan (1980)

automatic recording devices). However, since horses have preferred postures for these states (Dallaire, 1974), it was possible to divide "resting" into three postures i.e. standing, stand-resting (but with head below level of withers, fully relaxed, weight distributed on 3 legs only) and sternal/lateral recumbency (the preferred postures of drowsiness, slow-wave sleep and paradoxical sleep respectively, Dallaire 1974).

Horses usually rest several times in every 24 hour period and can sleep during any of these periods (Dallaire, 1974). Tyler (1969) observed that New Forest foals rested 50% of their time, during the daytime observational periods, until 3 months old and that the pattern of resting shifted from most occurring during recumbency to most occurring during standing, the most common posture when resting at about 5 months old. The change continues with age and Duncan (1980) found that Camargue adult females spent 25-50% more time stand-resting than yearlings who correspondingly spent more time lying. Since stand-resting is the most common posture for dozing and lying is the most common posture for sleeping (Dallaire, 1974), this study also strongly suggests that young feral horses spend more time sleeping than older ones. Time spent standing alert was similar to adult females and significantly lower than for adult males - this may be a result of adult males having to spend more time guarding their mares against predators or potential competitors. However, Duncan (1980) also noted that adult males spent more time lying than females, possibly indicating a higher requirement for paradoxical sleep, although it may also be a reflection of them being, for example, more tired after being more active overall.

Boyd *et al.*, (1988) recorded that the Front Royal Przewalski horses spent 34% of their time standing (24 hour period). Most standing occurred in the daylight hours, although it is unclear how long the daylight period was in comparison with the night-time period, and this would vary considerably over a season, so that the significance of this finding is somewhat uncertain.

This is similar with Tyler's (1972) findings that New Forest ponies spent the majority of the time between 0900 and 1400 hours resting during the summer, when temperatures were higher and total daytime grazing time was less.

Boyd *et al.*, (1988) found that the Front Royal horses spent 2% of their time lying laterally and 4% lying sternally. Reasonably similar percentages for time spent lying sternally (1.8-4.6%) and laterally (0.05-2.4%) were found in Asturcon ponies (Rifa, 1985). Rather less time was spent overall in lying down by Polish primitive mares (3.6%) in a study by Kowanacki *et al.*, (1978) - this may be explained by the exclusion of juveniles from this figure. The relatively young age of the Front Royal horses (all under 4 years age) may also give a figure that is seemingly high - the absence of old horses could be important. It may be that old horses sleep less or, perhaps owing to orthopaedic conditions such as hind limb arthritis, they may choose to lie down less frequently. The percentage time spent in recumbency was greatest from 0000 hrs to 0400 hrs at Front Royal, which was also found to be the case on Assateague Island (Keiper and Keenan, 1980) and at Prague Zoo (Bubenik, 1961).

2.2.4. ELIMINATIVE BEHAVIOUR

Urination and defecation are normally considered to be primarily physiological processes but have some voluntary control and may be associated with specific behaviour patterns linked to social behaviour. For instance, when one horse eliminates, other horses in a herd, especially stallions, may then be stimulated to eliminate and whilst in oestrus, mares may urinate frequently, providing a small quantity of urine each time. Stallions will "mark" boundaries of their home range by defecation and cover other stallion droppings with their own.

Tyler (1969) noted that foals urinated more frequently than adult mares, during daylight hours, until one year old when the rate then stabilised at a rate similar to adult mares. The predominantly liquid-based diet of foals is probably the main reason for their increased frequency of urination. The adult mares in this study urinated every 3.8 hours on average in summer and every 4.5 hours on average in winter (daylight hours only). Kowanacki *et al.*, (1978) found mares urinated every 3.2 hours on average per 24 hours (average figure taken over the whole year) - stallions and foals were found to urinate every 1.9 hours. The slightly lower rate of urination in Kowanacki's study for adult mares may result from differences in intake of drink or differences in the ambient temperature between the two environments as well as other factors such as the water content of the forage and amount of exercise and sweating undertaken by the respective herds. The Przewalski horses at Front Royal (Boyd *et al.*, 1988) urinated at the even more frequent rate of every 3 hours on average, but this figure included the stallions and foals. The high frequency of the stallions could be explained by a behavioural difference between the sexes. Increased stallion marking of excrement in the Kowanacki study, perhaps owing to a heightened perceived threat of challenge by other stallions, could result if there was increased stallion numbers or increased competition for territory and mares. It could also, in part, be a factor of more overt dominance behaviour in stallions of that genotype (primitive Polish horses) although there is no evidence to support this directly. The absence of night time recordings in Tyler's work might also affect the comparison.

Boyd *et al.*, (1988) suggested that a peak in the defecation rate between 0800 and 1200 hours coincided with concentrate feeding and hence resulted from the "gastrocolic" reflex, but it is not clear physiologically what he means by this. It may be that the excitement and increased activity associated with a palatable feedstuff could lead to increased defecation. The other peak between 1600 and 2000 hours was noted to be 16-20 hours

after the peak of feeding behaviour - the significance of this is not known, but is probably associated with the overall gut transit times in these horses on a particular feeding regime.

The frequency of defecation can vary between sexes, age groups, and apparently with diet (Waring, 1983). Tyler (1969) found that New Forest ponies defecated on average every 2.2 hours in summer and every 2.4 hours in winter. These recordings were daylight hours only and this period is obviously reduced in the winter. Kowanacki et al., (1978) observed a quite uniform frequency of defecation frequency during a 24 hour period; mares averaging 6.5 times, stallions 12.8 times and foals 10.3 times. Unfortunately, no information is available on the quantities of faeces produced and body weights of the individuals - this would have yielded information on whether increased frequency of defaecation was principally resultant from increased forage intake to meet higher metabolic requirements or whether it was a function of stallion/^{social}behaviour.

2.2.5 COMFORT BEHAVIOUR

Comfort behaviour comprises a range of behaviours which include sucking (in foals), scratching, rubbing, rolling, licking, shaking, nibbling, twitching, tail switching as well as mutual grooming. Season may greatly influence the occurrence of many of these behaviours (Waring, 1983).

Feist and McCullough (1976) observed that mutual grooming lasted from a few seconds up to 10 minutes, but for 90% of the occasions, it lasted less than 3 minutes. Those areas of the horse which were difficult to reach during self-grooming are apparently favoured. Grooming at a preferred site (front of shoulder) produced a significant reduction in heart rate in one study (Feh & de Mazieres, 1994). Some individual horses never indulge in mutual grooming (Wells & Goldschmidt-Rothschild, 1979). Tyler (1969) noted that

mutual grooming occurred between a variety of individuals of both sexes and that subservient animals often initiated the behaviour whilst dominant individuals always ended it. However, Watt (1993) found that grooming was usually initiated and ended by dominant horses.

Time budget information is particularly scarce for comfort behaviour (and perhaps this is because studies do not appear to have rated it important enough for inclusion). Boyd *et al.*, (1988) noted that Front Royal Przewalski horses spent 2% of their time self-grooming. Keiper and Keenan (1980) recorded a percentage of only 0.5% with Assateague Island ponies but this was at night during the summer when the horses were spending much of their time foraging.

The figure for mutual grooming obtained at Front Royal (Boyd *et al.*, 1988) was also 2% but was variable, with peaks of activity. These peaks, as also found by Kowanacki *et al.*, (1978) and Keiper and Keenan (1940), occur at times of the day when the horses are standing resting near one another, thus creating the opportunities for mutual grooming to take place.

Alternatively, social facilitation may occur, which is not unexpected in a primarily social activity.

2.2.6. LOCOMOTION

The findings of Duncan (1980) are summarised in Table 2.2. Adult stallions are apparently much more active (more time spent walking, trotting and galloping) and alert than mares. They, therefore, spend less time resting, although more time is actually spent lying which may indicate a greater requirement for paradoxical sleep, than mares. Juvenile horses are also quite active and alert, young mares were much more active than old mares. The adult mares in this study had foals at foot, which may have limited their desire to move. Another factor could have been the necessity of these

mares to concentrate on eating, to meet the increased energy demands during pregnancy and lactation.

The activity of feral horses is greatly influenced by the environment. It may be assumed that foul weather will force them to seek shelter; poor grazing should illicit more active foraging behaviour; reproductive urges which inspire young stallions to seek mares may force them to travel considerable distances, or older ones to spend more time shepherding and driving their harems; predators, or perceived predators, might be expected to increase overall alertness and movement. However, horses do restrict their movements to specific home ranges as well as to a limited distance away from social companions. They may also defend areas around themselves and their social unit (Waring, 1983). Horses are remarkably adaptable depending on their environment - in one study horses foraged in one area and regularly travelled as much as 16 kilometres to obtain water (Feist and McCullough, 1976).

As can be seen from Table 2.1, many studies do not register locomotion, whilst some record walking or walking/trotting only. It would appear, judging from the Table 2.1, that locomotion is reduced at night - this is in keeping with both the Boyd et al., (1988) findings, wherein 2% of the 7% time spent in locomotion was at night, and the Keiper & Keenan (1980) study which also found Assateague Island ponies to be less active at night. Both groups of horses were found to be feeding or recumbent for most of the night.

In Table 2.1 the domestic horses spend up to 10% of their time in locomotion, and as shown in Table 2.2., the adult Camargue horses also spend around 10% of their time moving. There may be some inverse correlation between time spent feeding and time spent moving. One could envisage more time being spent moving where forage is scarce. However, a large range of other environmental factors such as access to water and

avoidance of flies in summer may also be involved. For instance, the low figure of 4% for Kowanacki *et al.*, (1978) might be explained by low activity resulting from a desire to seek shelter or conserve energy in harsh Polish winters. It could also result from a lack of incentive to forage in winter owing to hay supplementation. The figures for the Przewalski horses are probably of limited value for direct comparison with feral or free-ranging horses as they are largely kept in zoos or paddocks, usually fed supplements and, as in the Boyd *et al.*, (1980) study, are frequently rather artificial groups of young animals. It may also be, however, the Przewalski horses are rather more active despite the confines of their surroundings, owing to inherent characteristics of alertness or aggression (which could lead to more movement by agonistic behaviour).

2.2.7. SOCIAL BEHAVIOUR

According to Rubenstein (1981), the social organisation of mainland feral horses is similar to that of the Asiatic wild horse, except for the lack of seasonal migrations, in that they tend to live in small permanent groups composed of females, their offspring, juveniles and a dominant stallion. Houpt (1982) observed that stallions are not always dominant in such groups. Adult males not possessing harems live either alone or in permanent bachelor groups. A social group, or band, usually contains less than ten individuals and four is the most common (Waring, 1983).

Table 2.3 shows that horse groups vary in size and behaviour according to the type of land they are on. In the dry, open mountains (Marlboro country) small bands of horses have huge, overlapping ranges and a few mares drift from group to group; in this harsh country infant and old-age mortality is high. In the vertical desert of the Grand Canyon the ranges do not overlap so much and the bands remain separate, each probably in its own side-canyon. But on the wetter islands the ranges are much smaller (more food and

water). On the relatively lush Shackleford Bank the population is so high that on one end of the island the stallions, with large harems, defend their territories - not entirely successfully, since their mares do stray.

Table 2.3**Population Characteristics and social patterns of 4 feral horse populations**

<i>Location</i>	<i>Pryor Mts (Montana) Open Mountain (US)</i>	<i>Grand Canyon (Arizona)</i>	<i>Sable Island (East Coast)</i>	<i>Shackleford (East Coast)</i>
<i>Conditions</i>	<i>Fairly dry (1970)</i>	<i>Steep desert (1974)</i>	<i>Sandy, flat (1970)</i>	<i>Sandy & marshy (1974)</i>
<i>Total number</i>	225	78	240	104
<i>Density per sq km</i>	2	0.2	6.3	11
<i>Age structure</i>				
<i>Adults</i>	58%	?	64%	61%
<i>Youngsters</i>	28%	-	21%	21%
<i>foals</i>	13%	-	15%	19%
<i>Group range</i>	25 sq km	20 sq km	under 7 sq km	6 sq km
<i>Defended territories</i>	no	no	no	yes: 3 sq km
<i>Average adults in group</i>				
<i>Harems</i>	5.0	4.5	6.0	12.3
<i>Bachelor groups</i>	1.8	?	2.0	2.6
<i>Solitary males</i>	few	few	few	few
<i>Temporary banding into big herds</i>	no	no	yes	yes
<i>band stability: mare changes per year</i>	7.6%	none	?	10.8%

Adapted from Rubenstein (1981)

On the East Coast islands, as in the marshy Camargue, bands may group together in large herds when resting (up to 80 in the Camargue) especially in summer. Camargue horses have been shown to be bitten by horseflies less often when they are in large groups than when they are in small groups (Wells and Goldschmidt - Rothchild, 1979). The fact that horses group in marshy places in the summer but not in the winter or in dry country also supports the theory that they do so as a protection against these bloodsucking flies (Duncan, 1980). Although most adult stallions will not let other adult stallions near their mares, they may tolerate such closeness if it means suffering less discomfort from flies.

The fact that horses are social suggests that this characteristic may increase survival. The main theory to explain the advantage of grouping to equids is suggested as predator defence (Kiley-Worthington 1987). (There are also the advantages of mutual grooming, the removal of ectoparasites (Hart et al., 1992) and protection from flies.) The food of horses is widely distributed and available to all and, therefore, there is neither an advantage nor disadvantage to feeding by being social. A group with several "look-outs" may be more likely to see a predator than an individual. Being in a group also means that there is less chance of an individual becoming the prey than when alone. This advantage to each individuals' survival may have caused horses to evolve as social animals.

Many studies have been carried out on the social organisation of both free-ranging and captive horses. In particular, studies (such as Boyd 1988; Keiper and Receveur 1992) have looked at the Przewalski horse, which is believed to be extinct in the wild, in an effort to preserve the captive population and to reintroduce it to a free-living existence.

A band of horses is held together through affiliative interactions between the members (Waring, 1983) and there is generally a linear dominance hierarchy (Waring, 1983; Keiper and Receveur, 1992) which is formed through aggressive interactions. However large herds may have more complex triangular relationships (Haupt et al., 1978; Wood-Gush and Galbraith, 1987). Animals that live in groups show aggression which leads to the establishment of an hierarchy (Haupt, 1992). Once the hierarchy has been established, less aggression is required to establish dominance and threats alone maintain the hierarchy. Animals at the top of a hierarchy may have priority if resources such as food and shelter are scarce. In equid hierarchies, the stallion may occasionally be dominant over his harem due to the age differential, although the highest ranking mare usually acts as a matriarch and leads the band, for example to a new feeding site. Haupt

(1991) and Boyd (1991) found that the dominance hierarchies in Przewalski horses were remarkably stable over periods of years.

In feral and wild populations of horses there are bachelor males who are unable to obtain a harem and form less stable groups (Waring 1983). The social structure of a bachelor group of captive Przewalski horses was studied by Tilsen et al., (1988) in order to find a solution to the problem of how best to keep surplus males. These males do not have harems because of the fact that one stallion usually has several mares in his harem. Tilsen et al., (1988) also suggested that males gain the necessary experience required to obtain and maintain a harem through associating with other males. Thus, these bachelor groups are very important in establishing the social structure. Tilsen et al., (1988) found that the horses rapidly formed a linear hierarchy after being introduced to one another, and Houpt et al., (1978) found that the individual temperament of each horse determined its rank in the harem situation more than other factors such as age or size.

Social facilitation (where behaviour of one animal influences another (Sweeting et al., 1985)) often occurs in herd animals, particularly when feeding. Sweeting et al., (1985) found that horses would eat for a longer time if they were in visual contact with another horse. Houpt and Houpt (1992) also found that horses living on their own spent less time eating and more time moving around. Tyler (1972) found that social facilitation occurred when resting, leading to increased overall resting being observed in the group. When one horse moved off to graze it was often observed that others followed and all the horses then began to graze as a group.

Boyd (1988) found that gender affected the number of aggressive interactions which were largely unaffected by reproductive status, although this did affect time spent feeding, moving and playing. Aggression was apparently more pronounced when the horses were standing near one

another while resting in the midday heat. Overall, the horses averaged 1.5 aggressive interactions per horse per hour. The Bronx Przewalski horses averaged 0.6-2.0 aggressive interactions per horse per hour (Popolow, 1984). Assateague Island ponies were found to have 0.2-0.7 aggressive interactions per horse per hour (Houpt & Keiper, 1982), while Highland ponies exhibited 1.9 aggressive interactions per horse per hour (Clutton-Brock et al., 1976).

The distance outwith which horses will tolerate others (and, therefore, display little aggression) varies with the situation but is commonly thought to be one or two metres (Waring, 1983). Most animals display no more aggression than the situation requires. Thus, threats are far more common than violent acts. Berger (1977), for example, found only 24% of the 1162 intra-band aggressive acts he recorded around a water hole involved anything more than a threat or mild push. This is backed-up by the study, in semi-reserves (or particularly large enclosures) carried out by Keiper & Receveur (1992) on Przewalski horses, which showed that the most common aggressive interactions were lower intensity, lower cost displacements. However, this study showed much higher overall aggression rates than in the studies cited earlier, such as that reported by Boyd (1988). This higher rate may have resulted from greater competition for concentrates which were provided regularly, as well as from the inability of the horses to leave the group, unlike Assateague Island ponies (Keiper et al., 1980). The Assateague ponies have the freedom to leave one band and move to another, possibly leading to reduced tension between band-mates and lower rates of aggression.

Boyd (1988) also recorded in his Front Royal time budgets that the Przewalski horses vocalised an average of 0.7 times per hour. The distribution of vocalisations was even over the course of a 24 hour period, but the nature of these vocalisations was not recorded.

2.3. SUMMARY AND COMPARISON OF DOMESTIC HORSE TIME BUDGETS

2.3.1. BACKGROUND

The behavioural patterns of domestic horses have received little attention (Sweeting *et al.*, 1985). However, Francis-Smith *et al.*, (1982), Houpt (1991) and Crowell-Davis *et al.*, (1985) studied grazing behaviour of pastured horses. Waters (1992) studied total time budgets of horses in stables and stalls and Ralston *et al.*, (1979) investigated the feeding behaviour of stabled ponies. The first study which reported a broad range of behaviour in stalled horses was that of Willard *et al.*; (1977), in which the horses were kept in metabolism cages. Despite domestic horses representing the majority of horses and despite many of these living in stalls, Caanitz *et al.*, (1990) claimed that their study might have been the first conducted on stalled horses during the day. The main findings from various time budget studies on stabled (or at least closely confined) horses and ponies are summarised in Table 2.4.

2.3.2. INGESTIVE BEHAVIOUR

Studies of stabled ponies^{by} Sweeting *et al.*, (1985), Marsden (1993b), Houpt (1991) and Kiley-Worthington (1990), found that under conditions in which hay was available ad libitum, as opposed to restricted hay combined with concentrates, the percentage time spent eating (50-76%) was very similar to that observed in feral and free-ranging horses and domesticated horses on pasture.

Meeting the energy demand in both horses at pasture and in stables, would appear to be the most important factor affecting their feeding patterns.

TABLE 2.4

Time budgets of stabled horses and ponies

Time/Equid	Environment	Diet	Percentage of Time				Reference	
			Feeding	Standing	Moving	Drinking		Lying
Day/Horse	Metabolism cage	Limited Hay	50	45	0	1	4	Willard et al., (1977)
		Concentrates	32	62	0	1	5	Willard et al., (1977)
Day/Pony	Box stall	Ad lib. hay	76	19	3	2	1	Sweeting et al., (1985)
Day/Horse	Small pen	Limited hay & grain	43	27	6	-	0	Houpt and Houpt (1988)
Night/Pony	Box stall	Limited hay & grain	15	17	1	-	13	Houpt et al., (1986)
Night/Horse	Box stall	Limited hay & grain	27	67	0.3	-	6	Shaw et al., (1988)
24 hr/ Pony	Pen	Ad lib. grain	17	-	-	2	-	Laut et al., (1985)
24 hr/Pony	Pen	Ad lib. pellets	31	-	-	-	-	Ralston et al., (1979)
Day/Horse	Small pen		68	18	12	1.5	0	Boyd (1988)
Day/Przewalski	Large pen		44	45	8.5	1.5	0	Boyd (1988)

Doreau et al., (1981) and Ralston et al., (1979) both considered that glucose and/or insulin signal satiety in horses. In addition, volatile fatty acid levels absorbed from the caecum may also influence intake. The results of a study by Houpt (1982) indicated that horses eat for energy, not for volume of intake, so that a horse can maintain its liveweight by changing its voluntary intake from, for example, eating large amounts of low energy roughage to eating a small amount of energy-dense grain.

The energy requirements of an individual would appear to be of paramount importance in controlling grazing or eating time, and this is reflected in the fact that lactating mares graze more than barren or pregnant mares presumably on account of the greater energy demands of milk production (Waring 1983). Houpt (1982) noted that feeding behaviour may not only occur in response to a fall in the level of some nutrient in the brain or blood (although satiety and cessation of feeding would presumably result from increased glucose or insulin levels, as discussed above), but also that it may be an innate behaviour pattern with an ultradian rhythm of 60 minutes during the day and 2 to 3 hours at night. Ralston (1984) points out that the effects of glucose, cellulose and volatile fatty acids are post-absorptive and that the initial signal for satiety, as found in sham-fed horses, is some form of oropharyngeal metering. The study by Marsden et al., (1994) suggested that time spent feeding was important and also that neural feedback from biting, chewing or swallowing was probably involved. Rhythmic patterns of eating in a herbivore would serve to reduce fluctuations in energy stores. Other physiological mechanisms would only come into play at times of nutritional stress.

"Horses eat when other horses eat and eat more if they can see another horse eating" according to Sweeting et al., 1985. Social facilitation (as noted by Sweeting et al., 1985) is important when creep feeding a foal and when encouraging an anorexic horse to eat. Environmental disruptions

such as storms or intrusions can temporarily cause horses to stop feeding (Waring, 1983).

Horses appear to prefer eating from the floor and from shallow buckets or mangers. As 360 degree vision, and vigilance, cannot be maintained when the animal puts its head in a trough or bucket, both head lifting and pushing hay from the trough are probably residual anti-predator behaviours (Sweeting *et al.*, 1985). Waring (1983) suggests that a problem with captive horses is to prevent ingestion of parasite eggs whilst still encouraging feed intake and this is a major reason given by handlers for feeding from buckets, troughs or mangers.

Drinking behaviour, (Table 2.1) occurs in stabled horses with ad lib. access to water throughout the 24 hour period much as it does with feral horses.

Feral horses may have restricted access which may reduce the time spent drinking, as in the Feist (1971) study.

2.3.3. STANDING AND RESTING BEHAVIOURS

Sleep in the adult horse, according to Houpt (1980) occurs in cycles of about 5 minutes slow-wave sleep (SWS), followed by 5 minutes PS, then another 5 minutes SWS. Dallaire (1986) recorded these cycles, of which five to seven occur per night, as lasting 30 to 40 minutes rather than about 15 minutes. However, he included some drowsiness within these phases. Houpt (1986) states that the horse is usually awake for up to about 45 minutes and then goes through another sleep cycle. Horses do not appear to enter PS directly from SWS (there is a partial awakening according to EEG recordings) presumably as a protective mechanism to avoid going into the deepest sleep without considering the security of the environment (Dallaire, 1986).

The Total Sleep Time (TST) averages 3 to 5 hours per day - that is 15 per cent of the total time budget of adult confined horses (Houpt, 1986). The TST and the PS/TST ratio are determined by the age of the animal. Whilst there is no direct study of this, Boy and Duncan (1979) observed Camargue foals lying laterally 15 per cent of the time after birth and only 2 per cent after weaning. Owing to the close relationship between lateral recumbency and PS (Dallaire, 1974), this change probably relates to a decrease in PS time. (Whilst SWS may occur standing, if the subject is well adapted to its environment, it will take the recumbent position. Paradoxical sleep nearly always occurs in lateral recumbency (Dallaire, 1986)).

For stabled horses, sleep is mainly nocturnal. There is also a tendency, according to Dallaire (1986) to sleep between 12pm and 2pm, but this does not necessarily occur regularly under stable conditions (presumably the level of activity around the stall affects this and the presence of an observer may also influence it unless automatic recording devices or videos are used).

In stabled horses, Steinhart (1937) found 11.5% of each 24-hour period was spent in either lateral (4.0%) or sternal (7.5%) recumbency. The stabled horses observed by Ruckebusch (1972) were recumbent 8.2% of the average 24-hour period; he also noted that in daylight the horse is awake 88.8% of this period. Even at night his horses were awake 71.4% of the time.

Ruckebusch (1972) further examined sleep patterns using electrocorticography and concurrent electromyography (techniques which would be impractical in feral horses as noted by Duncan (1980)). He found that stabled horses sleep in slow-wave for 2 hours and sleep paradoxically (REM) for 47 minutes (in nine periods, each 5 minutes long) - both types of sleep occurred at night only.

The figures given above may be assumed to be considerably more accurate than those obtainable by observation alone (although very few animals were used and very unusual conditions were imposed). It can be seen that Dallaire's (1974) assumption, which is applied to most feral horse time budget studies, that standing, resting and sternal/lateral recumbency are the preferred postures of drowsiness, slow-wave sleep and paradoxical sleep respectively, are only a rather loose guide. For instance, the 8.2% (or 1 hr 59 mins) recumbency occurred only at night, whereas paradoxical sleep occupied only 1 hour of this period and slow-wave sleep a further 2 hours. However, Ruckebusch does not differentiate between different postures when standing or between sternal and lateral recumbency. Drowsiness was recorded as an intermediary state between alert wakefulness and slow-wave sleep - it is unfortunate that more precise correlation with observed postures was not made. Since both drowsiness and slow-wave sleep have different depths, this would have yielded more information correlating posture with type and depth of particular sleep patterns. This information could have been compared with detailed time budget studies such as those by Nomura *et al.*, (1980) which showed stabled horses lying for only 30-60 minutes per 24 hours and apparently sleeping most often whilst standing in a "drowsy condition".

A summary of Ruckebusch's (1972) findings are shown in Table 2.5 and Figure 2.2. It should be noted that this study involved only 3 horses of the same sex while the study by Nomura *et al.*, (1980) involved only 2 horses. The use of such low numbers of horses in stabled horse studies results from the expense, labour, space and other difficulties in controlling management factors in housed horses. Although more detailed observation and recording may be possible compared with feral horse studies, the low numbers generally involved must affect the statistical significance of results.

TABLE 2.5

Proportion of Time Spent in Sleep and Wakefulness*

	<i>10 hr Night Period</i>	<i>24 hr Period</i>
Wakefulness		
Alert wakefulness	5 hr 14 min (52.4%)	19 hr 13 min (80.8%)
Drowsiness	1 hr 54 min (19.0%)	1 hr 55 min (8.0%)
Sleep		
Slow-wave sleep	2 hr 5 min (20.8%)	2 hr 5 min (8.7%)
Paradoxical sleep	47 min (7.8%)	47 min (3.3%)
Posture		
Standing	8 hr 1 min (80.5%)	22 hr 1 min (91.8%)
Recumbent	1 hr 59 min (19.9%)	1 hr 59 min (8.2%)
Mean duration and no. of periods		
Drowsiness	3 min 56 sec (2)	3 min 29 sec (33)
Paradoxical sleep	5 min 13 sec (9)	5 min 13 sec (9)

* Average values for three stallions housed in stalls.

Data from Ruckebusch (1972)

FIGURE 2.2

Proportion of Time Spent in Sleep, Wakefulness and Different Postures

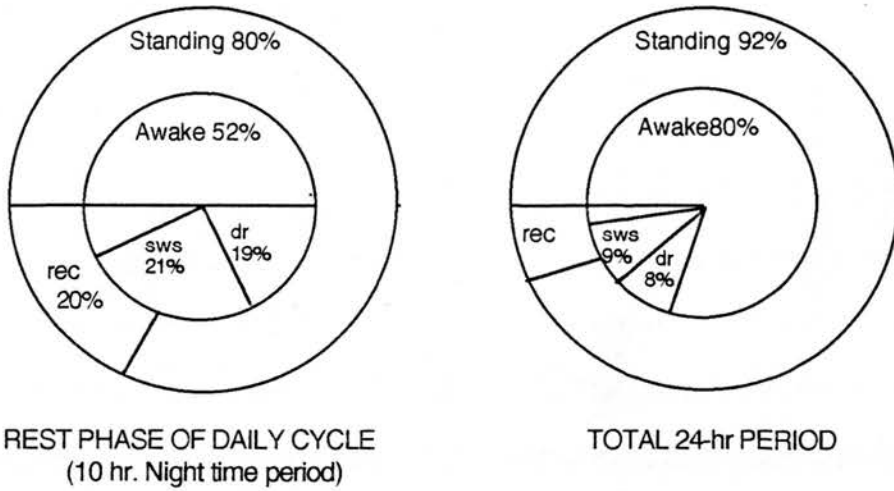

Average sleep and wakefulness pattern of three stallions monitored electroencephalographically while in stalls. Outer circle shows postures, and the inner circle represents the relative duration of sleep and wakeful states. Paradoxical sleep is shown in black; dr = drowsiness; sws = slow-wave sleep; rec = recumbent.

Adapted from Ruckebusch (1972)

The percentage of time which horses spend standing has been found to vary markedly from study to study. Much of the variation may be due to the various criteria used for defining standing. However, Sweeting *et al.*, (1985) found that housed ponies given ad libitum access to hay spent less of their time standing (19%) than ponies managed similarly but fed restricted amounts of hay (23%). The study by Willard *et al.*, (1977) in metabolism cages also found that feeding concentrates rather than limited hay increased the time spent standing from 45% to 62%.

Whilst some deductions may be made as regards possible effects of time spent eating on time spent standing, little information is available on the effects of other factors which may influence standing time, such as suitability of substrate (it may be presumed that a well-bedded down and dry stall would encourage more lying down); the type of horse (older horses, as stated in the last section may be less inclined to lie down on clinical grounds); feelings of security (a long term stabled horse with docile neighbours and sympathetic or not excessively disturbing/intrusive management may respond less to events and continue to lie for longer periods). Many other factors (eg. genotype, sex, space, proximity of other horses) should also be considered, as will be discussed further in the next chapter.

2.3.4. ELIMINATIVE BEHAVIOUR

The amount of elimination per day, as faeces and urine, reflecting the intake of food and drink as well as factors such as ambient temperature is obviously easier to measure stabled horses (especially in metabolism cages). Stabled adult horses apparently defecate 6-12 times per day depending on the nature of the feedstuff eaten. This is similar to feral horses (Fraser, 1992). The time of feeding may also be expected to influence the time of faecal output in domesticated horses.

It may be presumed that the lack of social units in stabled horses reduces the 'knock-on' effect apparently recorded in feral horses, where the sight of one horse defecating may induce others to do so. Grooms report, however, that putting down new bedding often encourages urination. Mares in oestrus are still observed to "wink" and may urinate more frequently in this condition. Stallions are regularly reported to defecate in the same corner of their stables quite possibly as a form of marking behaviour. From the evolutionary point of view, marking behaviour in non-territorial equids is postulated to be a vestigial behaviour pattern inherited from territorial ancestors (Klingel, 1972).

2.3.5. COMFORT BEHAVIOUR

The limitations imposed by stabling inevitably reduce, and in some cases can completely eliminate, behavioural activities such as sucking, scratching, rubbing, licking rolling and shaking as well as ritual interactions such as allogrooming. However, actions such as avoiding the effects of storms, heat and pests may not be necessary for stabled horses.

Stabled horses can rub and scratch themselves, although rugs and lack of suitable rubbing surfaces may inhibit this; they may lick themselves (those areas which they can reach may be restricted by the length of their headropes and by rugs); space may not permit rolling and shaking; stalls permit limited contact and loose-housing may permit full contact. In the latter case, social aspects as well as the comfort aspects of some behavioural patterns such as mutual grooming may be enhanced. It is interesting to note in the study by Watt (1993) that, in a loose housed system, mutual grooming is most often initiated by the more dominant individuals, suggesting that it is an activity desired and sought out by horses. Once again, the time budget

information for this, as in many other areas of behaviour, is minimal for stabled horses.

2.3. 6. LOCOMOTION

The ability to move may be severely reduced by the physical restrictions of the stable's walls and the use of tether ropes. Exercise outside the stable is largely dependent on the rider's choice. Locomotion within stalls is generally low and is rarely measured (Waters, 1992).

The abnormal behaviours of weaving, pacing or stall-walking which are displayed by horses in some stabled environments may markedly alter the time budgets in those affected individuals. Abnormal locomotory behaviour will be discussed later.

2.3.7. ABNORMAL BEHAVIOUR

Limited forage, living in a constricted area and limited social contact, none of which would be applicable to feral horses, may produce large apparent gaps in the stabled horse's time budget. The lack of opportunity to forage, move and socialise could be major factors in the development of abnormal types of behaviour in stabled horses and, therefore, have important welfare implications. "Abnormal behaviour" generally encompasses any behavioural patterns not seen in feral or free-ranging horses, although some types of behaviour such as hay-dipping may be adaptations within a stabled environment (Marsden, 1993a).

Stereotypies are the most common form of abnormal behaviour seen and have been defined as "unvarying, repetitive behaviour patterns that have no obvious goal or function" (Odberg, 1978). They seem to be restricted to captive animals, mentally ill or handicapped humans, and subjects given

stimulant drugs such as amphetamines. So-called "stable vices" include some other activities, in addition to stereotypies, such as excessive aggression, biting, rug-chewing, kicking and ingestion of bedding (Kiley-Worthington and Woodgush, 1987; Prince, 1986). All of these abnormal behaviours are thought to be signs of an inadequate environment or improper care. More specifically, Schilder (1986) hypothesised that environmental stimulation may be inadequate in stabled horses so that, for example, the opportunity to grab something edible with the mouth, which is a normal part of the feeding repertoire, may be reduced, and abnormal oral activity, such as cribbing, may develop as the only means of providing the necessary neural feedback to reduce frustration caused by the lack of "normal" amounts of feeding activity.

The study by Borroni and Canali (1993) is of particular interest as it attempted to evaluate the presence and frequency of abnormal behaviours in 1125 Thoroughbreds distributed in 20 locations. The prevalence of behavioural problems was 5.9%, which is rather lower than the findings of some other authors, which found a frequency of stereotypic behaviour ranging from 7% to 15% (Vecchiotti and Galanti, 1986; Luescher et al. 1991). However, it is difficult to compare the data of different studies because some authors took into consideration only the stereotypies while others did not explain the breeds of the affected animals. As with studies by Houpt (1987) and Ralston (1982), crib-biting and windsucking were found to be the most frequent oral problems (while stall-walking and weaving were the most common locomotory problems). Both the studies by Borroni and Canali (1993) and by Vecchiotti and Galanti (1986) found that about two and one-half percent of Thoroughbreds crib. This may be a reflection of a predisposition within this breed type or may be due to the common intensive management factors associated with stabling Thoroughbreds (Kiley-Worthington, 1987). Any environment in which stereotypic behaviour occurs is indicative of impaired welfare (Duncan et al., 1993).

2.4. FACTORS AFFECTING TIME BUDGET DIFFERENCES BETWEEN FERAL AND DOMESTIC HORSES

2.4.1. INTRODUCTION

All phenotypes are derived from the interaction of an organism's genetic potential with its environment. Phenotypes include physiology, morphology, biochemistry and so on as well as behaviour. Even when behavioural phenotypes, such as temperament, differ with regard to the interaction between experience and genotype, some contribution from each factor takes place in each instance (Lorenz, 1965). The genetic nature of behaviour is like a template and the full expression of a behavioural trait may only be expressed with precise stimulation, such as appropriate environment (Klingel, 1969).

The domestic horse, *Equus caballus*, is one of several living equid species. Other members of the family equidae are the Przewalski horse (*Equus Przewalskii*), the African ass (*Equus asinus*), the Asian ass (*Equus hermionus*) and the zebras (*Equus grevyi*, *Equus burchelli*, *Equus zebra*) (Waring, 1983). Mating between Przewalski horses and domestic horses produces fertile offspring, revealing just how similar physiologically the two species are, although Przewalski horses have 2 extra chromosomes. No major qualitative differences between the behaviour of Przewalski horse or that of domestic or feral horses have been identified with the exception of tameness (Haupt and Fraser, 1988).

2.4.2. INGESTIVE OR ORAL BEHAVIOUR

A. TIME SPENT FEEDING

As pointed out in the previous section, the time budgets of stabled ponies under conditions where hay was available ad libitum are very similar (57-60% time spent eating) to those observed in feral and free-ranging horses.

Not only are the overall percentages time spent eating similar but the feeding patterns are closely related (Dorean, 1978). Confined horses will eat 10 to 12 hours a day in bouts lasting 30 to 180 minutes. Horses have not been observed to fast voluntarily for more than 3 to 4 hours. The diurnal distribution of intensive eating in the early morning, late afternoon and evening is again the rule (Dorean, 1978). However, horses have their longest meal immediately after food is supplied, even if fed ad libitum, and this could influence the reduced feeding rate at night if meals are provided at, for instance 0800 hours and 1800 hours (as in the study by Ruckebusch et al., 1976) so that the reduction is not a true difference between night and day.

Horses eat high-calorie low-bulk food such as oats and horse cubes faster than high-fibre foods such as hay (Ruckebusch et al., 1976), taking 65 minutes to eat 1 kg hay but only 15 minutes to eat 1 kg of oats. The faster uptake is achieved by a faster rate of chewing with less displacement of the lower jaw (Ruckebusch et al., 1976). As a consequence, if horses are required for work, it may be advantageous to reduce their daily feeding time by supplying a proportion of concentrate food in their diets. However, many stabled horses do not receive a great deal of exercise and may consume their entire rations in less than 5 hours of total feeding time. Although nutrient intakes of concentrated rations may be adequate, the motivation toprehend and chew may not be satisfied, contributing to vices such as cribbing and wood chewing (Ralston, 1986).

Sweeting et al., (1985) observed that stabled ponies fed on a limited amount of hay spent 57% of their time feeding. An additional 8% of their time was spent eating bedding or faeces. It has been suggested that when hay is not available, stabled ponies may spend time eating non-food items (Waring, 1983). Ralston (1986) states that if there are no obvious dietary causes of coprophagia, the level of exercise and social stimulation that an animal is

receiving should also be investigated. Coprophagia may, therefore, result from lack of time spent feeding.

Chewing of non-food objects has been found to be low in incidence when stabled horses are fed ad libitum rations. Willard et al (1977) showed that the provision of roughage reduces wood-chewing, coprophagy and food-searching activity.

Figure 2.3 illustrates some of the points made above. The time budgets for group housed horses and Camargue horses (B and A of Figure respectively) are almost identical. The horses in part C however, spend less time eating and engaged in 'other' activities (presumably social behaviour principally) and much more time standing. The horses in part D spend only 15% of their time eating with a vast increase in standing (and a slight increase in lying). It is unfortunate, that 2 factors were altered for part D (restricted fibre was introduced and social contact limited) so that one is uncertain how much of the major change in the time budget results from the roughage limitation and how much results from social deprivation. It is also unfortunate that abnormal behaviour was not recorded as one might presume that stable vices would develop, probably as a direct result of the vacuum created by denying the horses the opportunity to feed for long periods (Ralston, 1982; Kiley-Worthington, 1983).

The time spent eating pellets (Ralston et al., 1979) is intermediate between the time spent eating grain (Laut et al., 1985) and the time spent eating hay (Sweeting et al., 1985) when the diet was available ad libitum. Houpt et al., (1986) found that stabled pre-partum ponies, when provided with a limited hay diet, spent much less time feeding than similar ponies kept at pasture (15% as opposed to 55%). This study was quite detailed with the behaviour of each mare being recorded every 30 minutes from 1800 hours to 0600 hours. 26 pastured ponies and 19 stabled ponies were studied, which

FIGURE 2.3

Time Budgets of Horses under different management regimes.

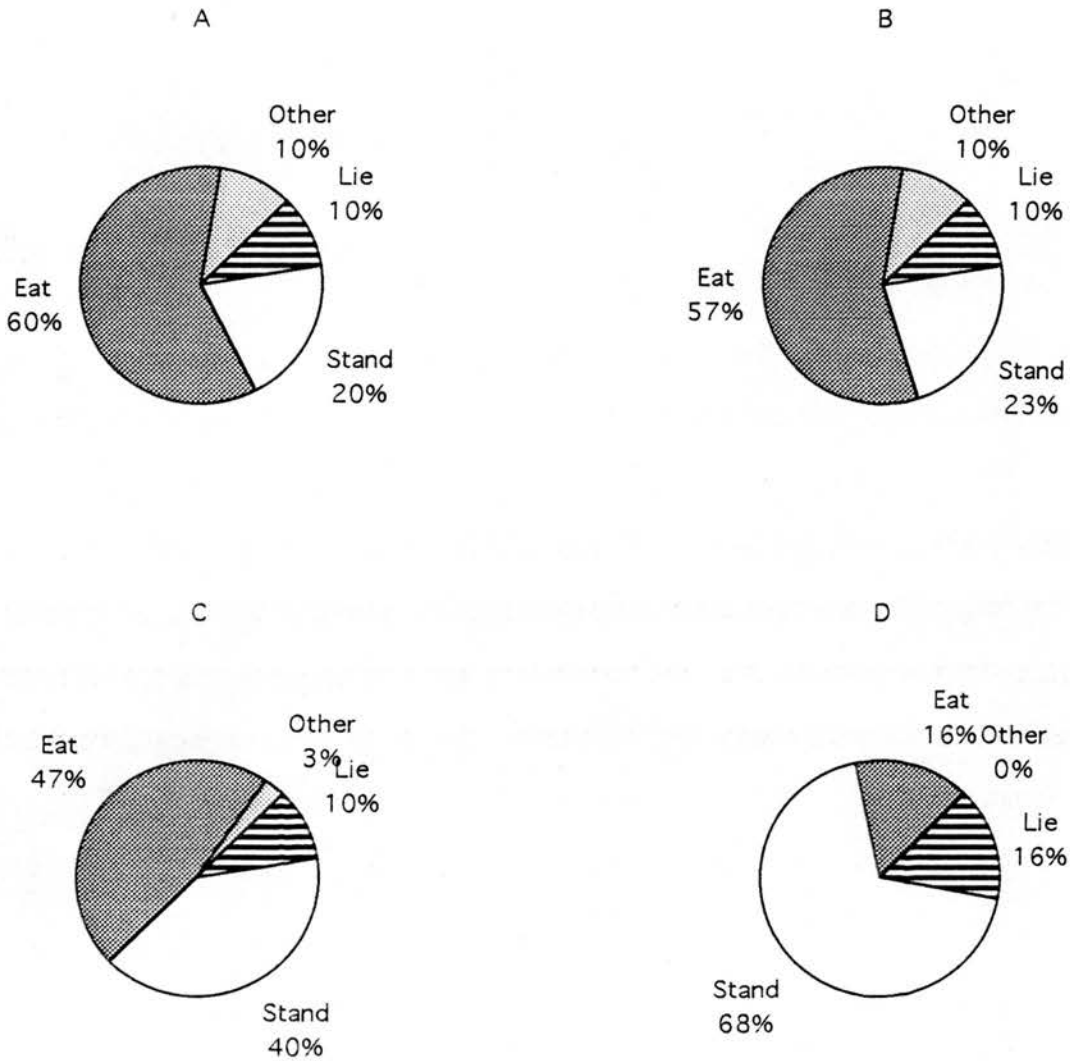

- A The average time budgets for Camargue horses throughout the year. (After Duncan 1980)
- B Time budgets for a group of eight horses in a yard with *ad libitum* hay and straw.
- C The time budgets for three horses in individual stables fed *ad libitum* hay and straw and able to see and touch each other.
- D Time budgets for horses in stables where they cannot touch each other and only see each other over stable doors; they were fed restricted fibre (about 3 kg/day, horses of 5.2 - 16hh).

(Kiley-Worthington, 1987)

yielded statistically significant results. The study strongly recommended feeding hay ad libitum with a view to reducing considerably the incidence of stable vices.

Some recent work has been carried out at Edinburgh University which corroborates, reaffirms and more clearly defines many of the findings mentioned above.

Marsden et al., (1993a) and Marsden et al., (1994a) found that the most important management factor affecting time spent in abnormal behaviour is the lack of time spent feeding (eg. less than 15 hours per day). Figure 2.4 shows that the level of dietary protein is not a significant factor affecting the abnormal behaviour performed.

Figures 2.5, 2.6 and 2.7, show the slight effects only, on abnormal behaviour, between feral and domestic horses at pasture or between horses at pasture and horses in stalls fed ad libitum. The findings shown in Figure 2.7, illustrate a considerable increase in abnormal behaviour when stalled horses are fed concentrates, as opposed to hay, for maintenance. The percentage time spent in abnormal behaviour varies inversely with the percentage time spent feeding (Fig 2.8). Therefore, Marsden (1993b) showed that provided the time spent feeding is considerable, it is not necessary to feed high fibre or even ad libitum in order to reduce time spent in abnormal behaviour. Increasing feeding time without feeding considerable amounts of fibre is not straightforward, but would be important in horses required to do fast or strenuous work such as racehorses or eventers. One means of increasing feeding time, which reportedly reduces the incidence of stereotypies is to reduce the availability of feed, for instance by the use of haynets with smaller holes (Kiley-Worthington and Woodgush, 1987).

FIGURE 2.4

THE EFFECT OF DIETARY LEVEL OF PROTEIN ON TIME SPENT FEEDING
AND ON OCCURRENCE OF ABNORMAL BEHAVIOUR

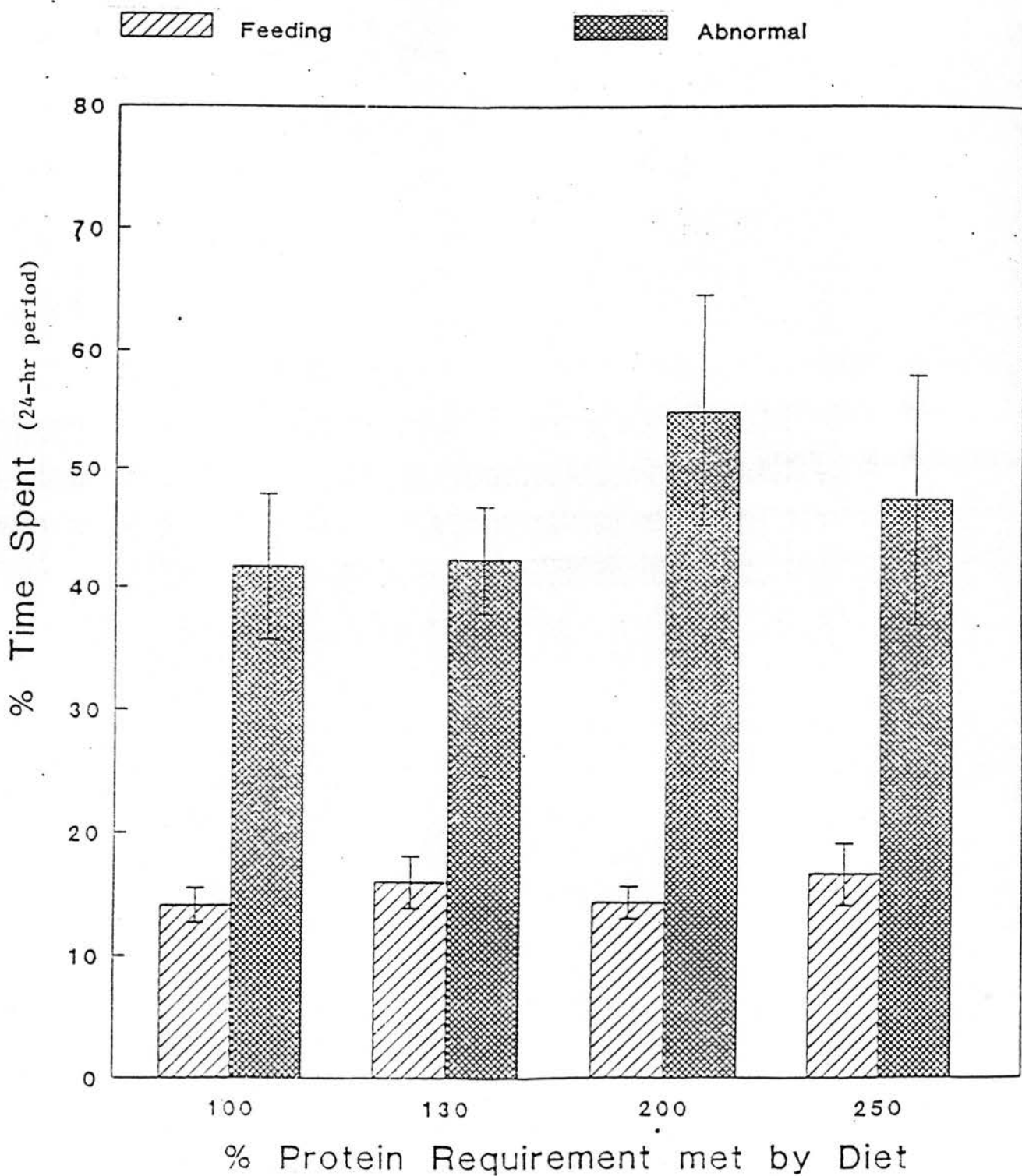

Adapted from Marsden (1993b)

FIGURE 2.5

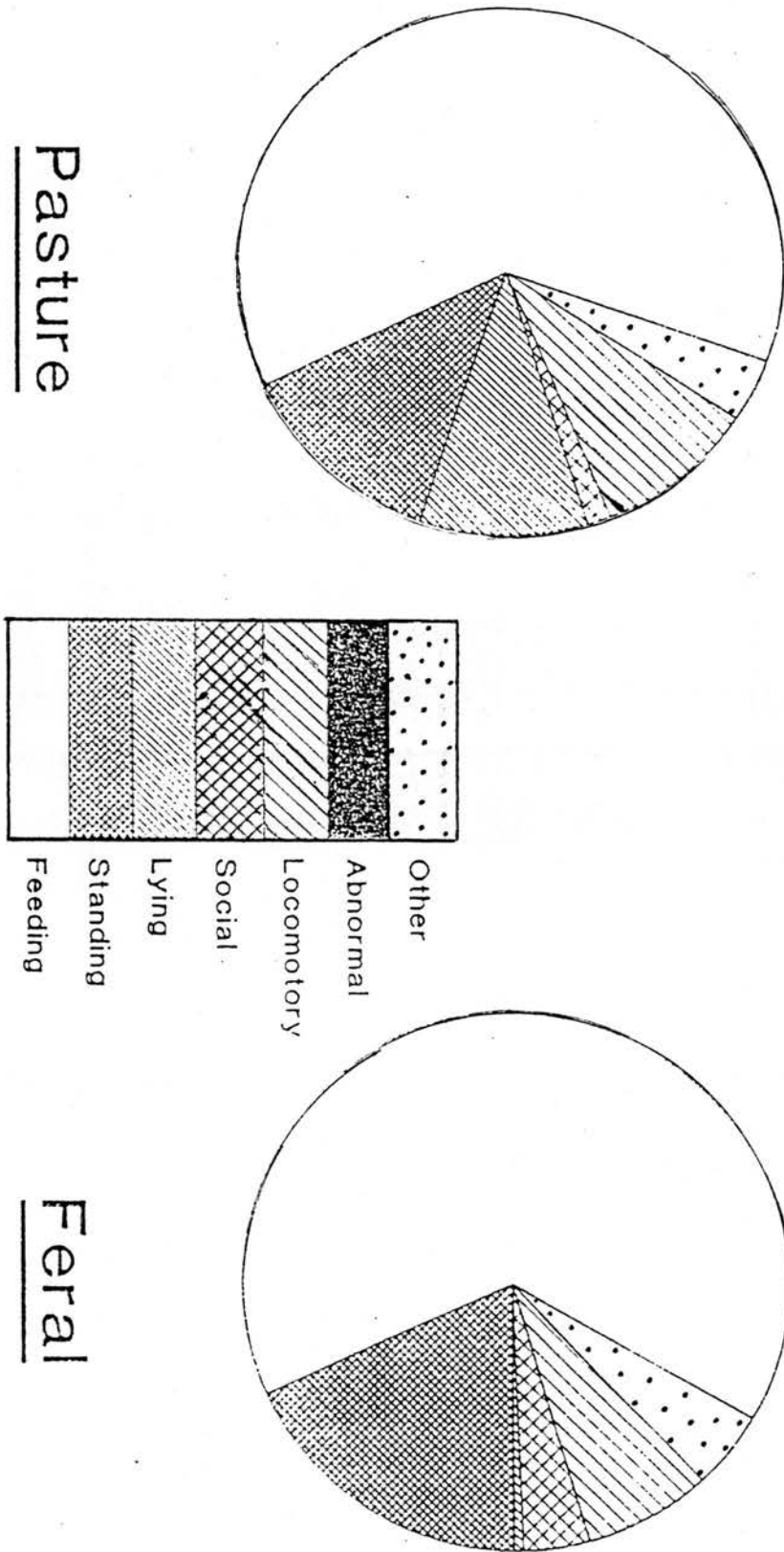

24-HOUR TIME BUDGETS FOR HORSES FED AD LIBITUM



Adapted from Marsden (1993b)

FIGURE 2.6

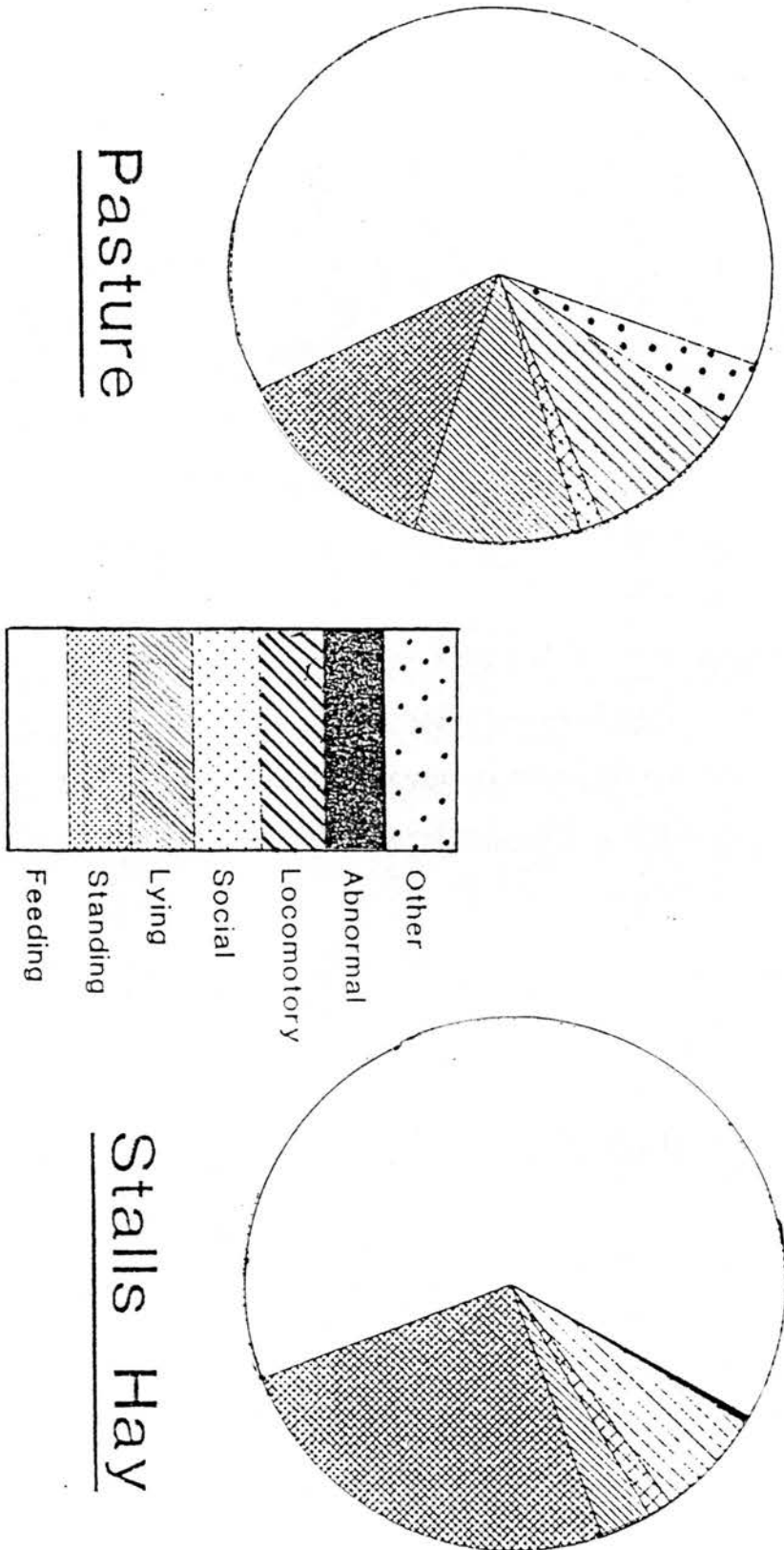

Adapted from Marsden (1993b)

24-HOUR TIME BUDGETS FOR HORSES FED TO MAINTENANCE

FIGURE 2.7

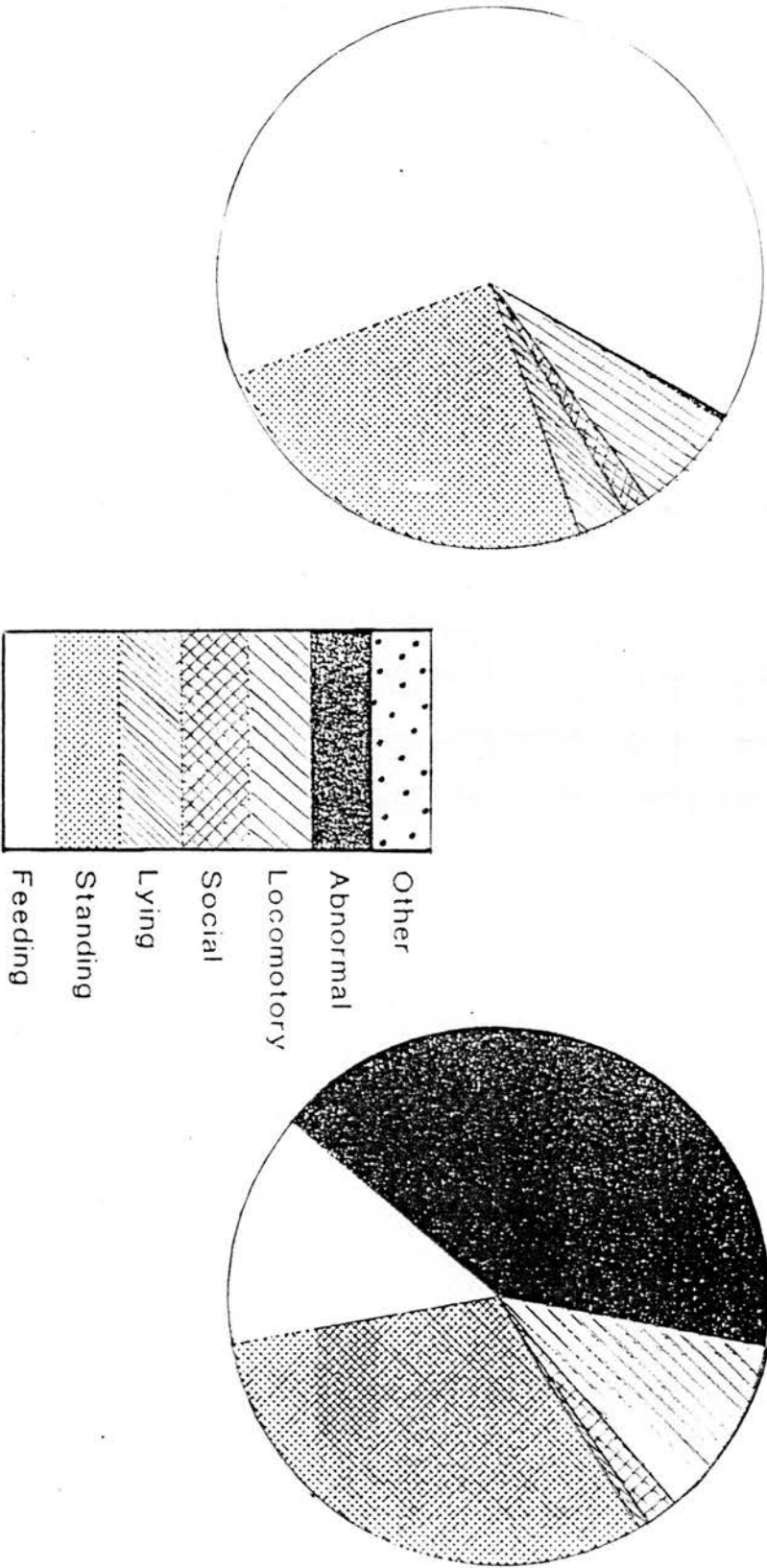

Adapted from Marsden (1993b)

FIGURE 2.8

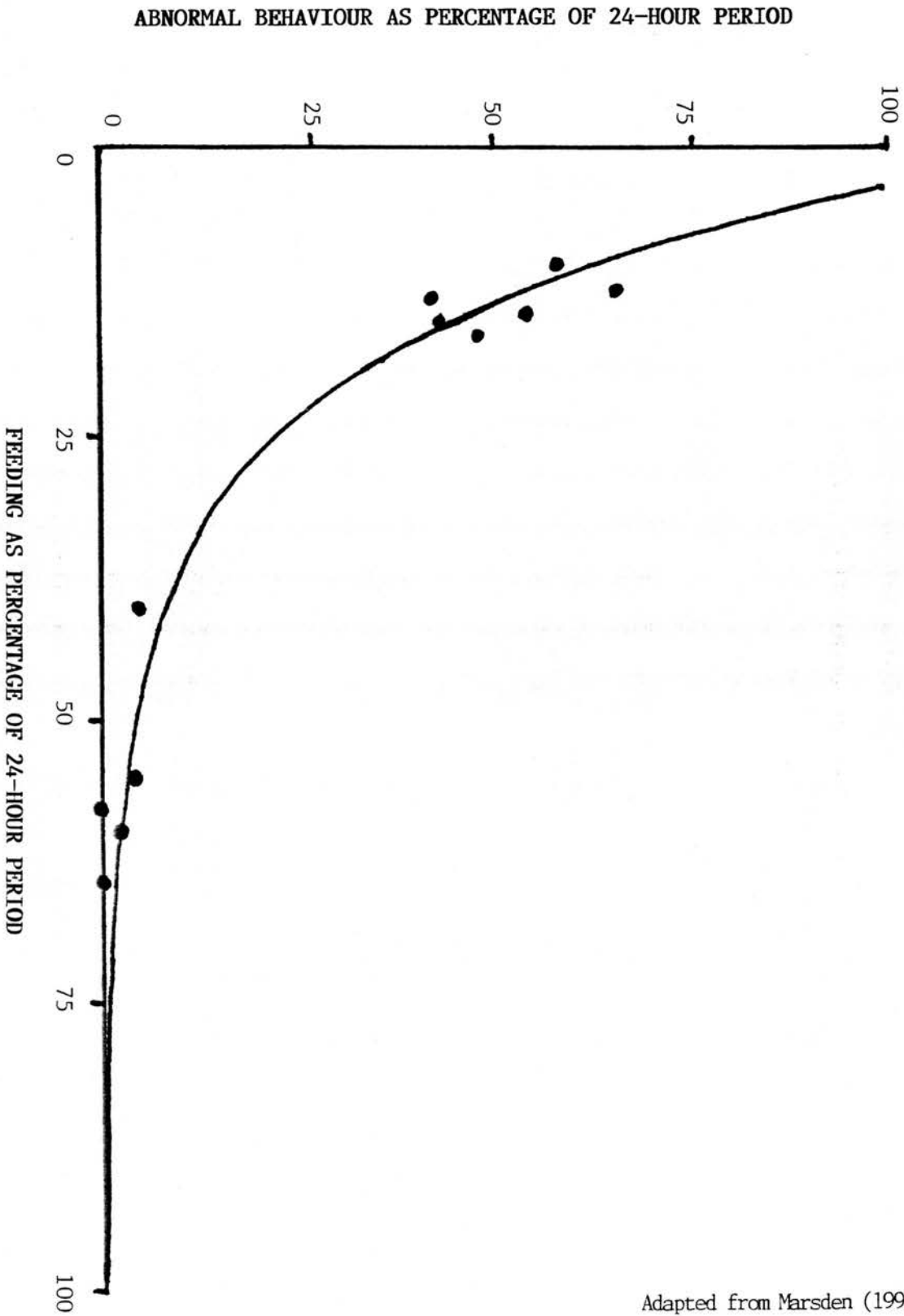

Adapted from Marsden (1993 b)

B. ABNORMAL ORAL ACTIVITY

Kusunose (1992) suggests that crib-biting may be caused not only by boredom but also by frustration of ingestive behaviour which may be particularly associated with denying access to palatable feeds. The diurnal pattern of cribbing in three horses, whose cribbing was habitual and persistent, was observed in stalls for 24 hours using video recorders. The frequency of cribbing varied throughout the day, with three major cribbing periods in early morning, evening and midnight. There was a strong association between the frequency of cribbing and feeding. Before and after delivery of a meal of roughage, the level of cribbing frequency was low, and around the concentrated meal delivery, the frequency of cribbing increased. Similar results were obtained in a study on Household Cavalry horses by Pilkington *et al.* (1994). These studies confirmed the association of concentrated, palatable feeds with cribbing and the existence of a diurnal pattern makes the point that boredom is apparently not a factor involved in cribbing. It would be valuable to repeat this study with ad lib hay in order to assess cribbing behaviour without any restrictions on opportunity to perform feeding behaviour.

Imitation learning has been suggested as a cause of stereotypies, Fraser (1992) states that young idle animals standing in company with confirmed crib-biters may imitate the condition. Houpt (1991) states it is often suggested that horses learn to crib by observing other horses cribbing and that young horses may be more likely to learn the habit from an adult than are other adults (learning to crib may be associated with other aspects of development). Imitation has, however, never been proven and the environment that causes one horse to crib is likely to be the cause of other horses in the same environment also doing it. Owen (1992) states that although it has been widely reported in the lay literature that horses acquire stereotypies from watching other horses, this has not been the experience

of those investigating such cases scientifically, (Baker and Kear-Colwell, 1974; Brain, 1981).

Borroni and Canali, (1993) almost always found wood-chewing to be coupled with other behavioural problems in Thoroughbreds. Wood-chewing is associated with insufficient roughage in the diet and it is believed to be aggravated by close confinement (Sanbraus, 1985). Crib-wetting, where the tongue is repeatedly drawn across some part of the stall, is also supposedly associated with close confinement (Fraser and Broom, 1990). According to Fraser (1992), coprophagia in adult horses is typically a problem of confinement, insufficient exercise or inadequate roughage in the diet. Polydipsia may be associated with "boredom", when water is available ad libitum within a stall, but the habit can reportedly be controlled and eliminated by an increase in regular exercise (Falk, 1969). Trichophagia (ingestion of hair) is possibly associated, at least in Przewalski horses, with a lack of roughage in the diet (Fraser, 1992). Eating bedding can develop in stabled horses (Fraser and Broom, 1990) and is probably most frequently associated with high concentrate, restricted hay diets.

C. TYPE OF HORSE

The next few paragraphs will concentrate on the importance of the type of horse on the percentage time spent performing oral-ingestive abnormal behaviours. Kiley-Worthington (1983) considered the question of whether performance of stereotypies is related to temperament. Thus, animals often considered particularly reactive and sensitive have a lower threshold for their performance and are more likely to develop them. More stereotypies are reported in "warm-blooded" Thoroughbreds and Arabs than in cobs and heavier horses, although this may well be due to "warm-blooded" horses being kept in conditions (such as restricted environments, high concentrate diets, and only short exercise periods) likely to give rise to stereotypies.

Vecchiotti and Galanti (1986) suggested a genetic predisposition for some abnormal behaviours such as crib-biting, stall walking and weaving. However, their limited data did not allow them to ascertain inheritance patterns. Hosoda (1950) suggested a recessive gene might be responsible, at least as a predisposing factor. Vecchiotti and Galanti (1986) considered that a polygenic inheritance mechanism was involved, with the genes involved perhaps not producing the stable vice directly, but possibly making the horse less able to cope with stabled environments, and thus more likely to pick up the vice.

Some of the eating disorders and oral-ingestive anomalies observed in man and in domesticated species may stem directly from the tendency of some genotypes to react adversely when exposed to environments with diets markedly different from the "evolutionary norm" for the species (Owen, 1992). This would be an area worth studying in horses along with a further investigation of a genetic predisposition to behavioural problems.

2.4.3. SLEEP AND RESTING BEHAVIOURS

Sleep patterns may be affected by factors such as type of confinement, age, social grouping, feeding programmes, absence of stimuli, tameness, type of equid, time of day or night and weather, according to Belling (1990). No satisfactory explanation for the necessity of sleep has been defined but sleep cycles are probably involved in learning and memory consolidation - in particular, paradoxical sleep (PS) is regarded as important in this respect (Dallaire, 1986).

Since horses tend to lie down at about the same time each day (Belling, 1990), concern should be shown by the owner if it is found lying down at other times. This may result from a veterinary problem such as colic, severe lameness, severe metabolic disorder or from exhaustion. The only specific

pathological condition which has been recorded is narcolepsy, which is associated with the rapid onset of PS-like signs (Dallaire, 1986).

A. STABLE ENVIRONMENT

Drowsiness occupies a significant amount of time both in individuals kept in stables and at pasture (Dallaire, 1980). It accounts for 8 per cent of resting time indoors and 13 to 14 per cent outdoors. The decrease in SWS and PS, and hence time spent in sternal and lateral recumbency, at pasture, may be related to survival or predation factors (Dallaire and Ruckebusch, 1974), since drowsiness represents a light sleep or perhaps a very reduced wakefulness state. At pasture, horses only lie down for SWS and PS and never when drowsy (Dallaire, 1986). The stabled horse may feel more secure in its stall, once it is familiar with it, but the difference may also be linked to the lack of necessity to forage (Belling, 1990). Ruckebusch (1975) has suggested that sleep in horses kept in stables is in excess of the normal level as measured in free-ranging individuals. In an experiment on the effect of partial sensory deprivation in ponies, it was shown that SWS increased during the deprivation period, and PS immediately after the perceptual deprivation. This effect may be associated with some stabled environments (Dallaire and Ruckebusch, 1974). However, these data are difficult to interpret in regard to practical management. Nevertheless the study draws attention to the importance of the physical surroundings of the horse.

B. FAMILIARITY WITH SURROUNDINGS

One may also make a comparison with the study of Houpt (1980) and, as one practical conclusion, assume that horses prevented from lying down (by being tied too short, or by being constantly disturbed, for instance) will not rest properly and will suffer from sleep deprivation. Houpt (1980) also points out that sleep deprivation may precipitate abnormal behaviour patterns.

The most significant difference in the time budgets of free-living horses (Duncan, 1980; Keiper, 1981; Boyd et al 1988) and stalled ones (Sweeting et al, 1985) in time spent stand-resting. Stalled horses seem to spend less time stand-resting perhaps because they rest more when lying down. Although horses may sleep when standing, they will lie down to rest when they feel confident about their environment (Dallaire, 1980). Therefore, stalled horses may feel safer in their environment.

Since horses will lie down only in a familiar environment and sleep may be retarded for between 2 to several days on movement to new surroundings, including being put outdoors (Dallaire, 1974). This habituation may be socially facilitated, in that if one horse lies down, others will follow this lead (Ruckebusch, 1972). The importance of sentries who remain standing whilst others lie has not been fully investigated (Belling, 1990).

C. CONDITIONS OF CONFINEMENT

Glade (1984) studied six "weanling" thoroughbreds in different conditions of confinement. The study found that overcrowding led to decreased frequency of recumbency and much less time actually spent in recumbency. However, individually housed foals spent more time recumbent, probably reflecting the predictable contrast between the relatively quiet and protected box stall arrangement and the exposure to increased distractions and potential interactions with other foals when grouped. However, individually kept foals in big pens spent less time recumbent than in smaller stalls (approximating to time spent by foals grouped in a large pen), presumably since their neighbours were more linearly separated and, therefore, lacked the social facilitation which encourages recumbency (Haupt, 1980). These findings are important in that they emphasise the potential risk of sleep deprivation which may occur by maintaining / in an environment which is either overcrowded or isolated and which prevents sufficient time spent in lateral recumbency. It is interesting to note that a herd of horses may

behave as though it is in an intangible enclosure (as observed by Gates 1979), and may restrict itself to the territory with which it is most familiar.

D. SENSORY DEPRIVATION

Whilst sensory deprivation may cause increased sleep (Dallaire and Ruckebusch, 1974), as well as presumably being associated with abnormal behaviour during the periods awake according to Fraser (1992), factors within the stabled environment such as overcrowding and isolation, as mentioned in the preceding paragraph (Gates, 1984) may cause sleep deprivation, which in turn may also be associated with abnormal behaviour (Houpt, 1980). Noise or other disturbances are also likely to cause sleep deprivation (Houpt, 1980; Dallaire and Ruckebusch 1974). Transport may cause sleep deprivation. This may be an important factor in "transport stress" (Belling, 1990).

E. TYPE OF HORSE

The type of animal is important, with donkeys apparently spending more time in recumbency than horses, with about 31% of their time spent in recumbency, and less than 5% of that in lateral recumbency (Ruckebusch, 1963). It is unclear what conditions these donkeys were kept under. It would be beneficial if there were more studies similar to Glade's (1984) using horses and ponies, in groups of at least 6 (for statistical significance), other than yearling thoroughbreds. Such studies would help establish differences in sleep patterns between types of horses.

F. DIET

Diet may influence sleep. Dallaire and Ruckebusch (1974) found that changing the diet from hay to oats in ponies, increased the total rest time (both SWS and PS) and this was mainly associated with increased sternal recumbency. After 3 or 4 days, the values tended to return to their original values. Fasting also affects sleep time. During the first two days of fasting,

SWS and PS increased by 20 and 17 per cent, respectively. These effects may result from the reduction in visceral information to the brain so that reticular substance is less active and sleep is increased. Moreover, less time (or, in the case of fasting, no time) is spent choosing and ingesting food, so that total sensory input is greatly decreased. It is unfortunate that further work has not concentrated on these effects and that this study lost some of its significance by compiling data from only 3 ponies.

2.4.4. ELIMINATIVE BEHAVIOUR

Whilst diet is a major factor in determining the frequency of elimination, variations in patterns of this behaviour may be associated with reproductive status (for instance, marking by stallions, winking by oestrous mares and investigation of mare's urine by stallions to detect signs of oestrus), much of which is referred to in the previous two sections, no great change is expected in the time budget for eliminative behaviour as a result of domestication, or as a result of type (except for increased frequencies of urination with mares in oestrus and in younger animals).

However, Francis-Smith (1979) noticed that increased competition for hay resulted in pastured horses ceasing to visit rough areas to excrete and excreting randomly, soiling the hay and lawns with excrement. In the same study, mares also excreted at random when grazing with sheep and cattle. One might expect alterations in foraging behaviour to result (for instance, avoidance of contaminated hay or more intensive grazing owing to real or perceived competition) but this aspect of behavioural change has not been measured in sufficient detail. It should also be noted that young foals do not discriminate between lawns and roughs (Odberg and Francis-Smith, 1976) and free-ranging horses urinate and defecate indiscriminately on their home ranges, with the exception of specific marking behaviour (Feist, 1971; Tyler, 1972).

A well recognised indication of stress and nervousness in some species is an increased frequency of excretory activity (Archer, 1973). This has been studied extensively in rodents, with open-field tests on defaecation rates (Fox, 1968). McCann *et al.* (1988) found no differences in defaecation or urination rates between nervous and normal yearlings. It is arguable that the study's evaluation of the factors which might indicate "nervousness" in equids was not sufficiently precise to differentiate the two types, but marked differences were also found between the two groups of nervous and normal yearlings in other behaviours which were measured. It is probable that a more "nervous" temperament does, in fact, have no bearing on eliminative behaviour in the horse. However, the instantaneous behaviour samples were made only every 5 minutes. More continuous data collection methods may be required to determine differences for the brief and infrequent elimination behaviours.

2.4.5. COMFORT BEHAVIOUR

The confines of a stable may be expected to cause some frustration, or perhaps change, in behaviour when, for instance, a clipped horse has too few rugs or is denied grooming partners. Comfort-seeking behaviour may be accommodated by factors such as stable design or sufficient clothing to prevent thermal stress and grooming by stable staff to compensate, possibly, for the absence of allogrooming. This area, and in particular the effects on time budgets of comfort deprivation, has been insufficiently studied. It may be that some of the effects of social isolation discussed in other sections relate to comfort deprivation also.

The extensive and detailed study by Keiper (1988) at Munich Zoo with Przewalski horses is interesting. Although mutual grooming is commonly used to appease higher-ranked animals, more grooming bouts were seen

between related animals. In particular, mutual grooming was considered useful in reducing weaning conflicts between mares and foals and in forming female coalitions that defend against predators or aggression by the herd stallion. One may, therefore, postulate that both young and adult animals benefit, not necessarily in terms of establishing dominance, and that the absence of mutual grooming could be stressful in stabled environments, particularly when the animal is not fully habituated to its surroundings. In these circumstances, the close proximity of other horses may not sufficiently compensate for the lack of grooming behaviour.

Direct evidence of the physiological consequences of grooming at particular sites is provided in the study of Camargue horses by Feh and de Mazieres (1994). Thirty-eight grooming sequences in 18 animals were first video recorded and the preferred site at the base of the neck identified. Grooming was then imitated by scratching the base of the neck in 8 hand-tame adults and 8 foals. Heart rate was reduced by 11.4 per cent on average in the adults and 13.5 per cent on average in the foals. This calming effect probably explains why grooming is commonly associated with conditions of mild social tension (hence increased stallion-mare grooming in the breeding season.) The authors suggest that the stimulation of the base of the neck site may stimulate neural ganglia which are part of the

parasympathetic autonomic nervous system - this area is commonly used by veterinary surgeons and other horse handlers to calm horses. It is interesting that humans can elicit the same "tension reducing" effect as another horse would do - attentive and well directed grooming by a human handler in a stabled environment may, therefore, compensate in this respect for the absence of physical contact with another horse, possibly owing to the direct physiological effects of such stimulation.

2.4.6. MOVEMENT ANOMALIES

Sweeting *et al.*, (1985) found that walking occupied 2.9% of the 24 hour time budgets of stabled ponies. This is considerably less than, for example, the 9% observed in Camargue horses by Duncan (1980). However, it is not surprising given that ponies were limited by the confines of their boxes and were within a few paces of food and water at all times.

A. Paddock Size

In a study by Borroni and Canali (1993), paddock size apparently affected the incidence of behavioural problems. Locomotory problems, such as weaving and pacing, showed a higher frequency ($P < 0.003$) in small or medium sized paddocks (1000 sqm and 1.5 hectare). Whilst cribbing and windsucking were the most important abnormal behaviours and accounted for 43.3% of the 647 total of recorded cases of horses showing abnormal behaviour in this study, stall-walking and weaving accounted for the next highest percentages at 22.3% and 19.4% respectively. This is a good indication of reduced paddock size being associated with an increase in abnormal behaviour, at least in young Thoroughbreds, which was the only type of horse observed in this study.

B. Temperament

McCann *et al.* (1988) examined behavioural tendencies for horses separated by temperament tendencies into two levels of excitability, using 32 Quarter horse yearlings. They recorded "normal" yearlings spending 9.6% of the observational periods walking or trotting and 0.4% of the time cantering or galloping. The "nervous" yearlings spent approximately half as long lying down in the observational periods, the same time standing and, at 11.7% for walking or trotting and 3.4% for cantering or galloping, significantly more time moving around compared with the "normal" yearlings. Thus, the "nervous" individuals showed a trend to higher overall motor activity relative to the "normal" horses.

Kiley-Worthington (1983) also considered the question of whether performance of stereotypies was related to temperament. She considered "reactive" animals to have a lower threshold for the performance of stereotypies and were, therefore, more likely to develop them. She claimed that more stereotypies are seen in "warm-blooded" Thoroughbreds and Arabs rather than Cobs and heavier horses. Warm-blooded horses are more likely to be kept restricted in the types of environment likely to give rise to stereotypies. This is clearly an area that requires further study in order to establish the relative importance of degree of confinement (and other contributory environmental factors) vis a vis reactivity of the horses being observed.

C. EXERCISE

Caanitz *et al.* (1990) found that exercise produced no significant difference between the locomotory behaviours of stabled Standardbred horses on exercise and non-exercise days. It would be interesting to repeat this study with more prolonged periods of exercise denial, possibly with varying energy-content diets, and with different, possibly more "reactive", types of horses such as Thoroughbreds. It would also be useful to look at the effects of exercise on the performance of abnormal behaviours, under similar conditions. The effect of hard exercise on horses such as young Thoroughbreds, who might then be tired, less active in the stable and, therefore, possibly less likely to perform abnormal behaviour, could yield results which might have a bearing on their management (for instance, if abnormal behaviour developed only with no exercise in these types, they could be given light work rather than stand idle on "rest days").

D. RESTRICTION

Several stereotypies of horses are thought to originate from behaviour related to locomotion, when movement has been restricted by stabling or enclosures (Kiley-Worthington; 1977, 1990; Waring, 1983; Sambras and

Radtkig, 1989). The results of such studies suggest that horses are more likely to develop abnormal behaviour in response to increased physical restriction; the individuals at greatest risk are those which show above average motor activity, or "reactivity" levels (McCann *et al.*, 1988). Houpt (1981) states that, weaving occurs most commonly in riding horses which have been stabled for long periods in doing no work.

Depriving horses of the opportunity to graze, as well as social deprivation are important in the development of movement anomalies (Boyd, 1991). Boyd, (1991), points out that solitary captive Przewalski horses are prone to pacing, but also that the provision of ad lib hay reduces the time spent in pacing. The relative importance of restricted movement per se on the incidence of abnormal behaviour should be made the focus of further study. The effects of confinement, in comparison to the effects of restricted feeding, would appear slight when one considers the minimal levels of abnormal behaviour shown by stabled horses fed ad lib roughage (Figure 3) compared to those fed a concentrate diet (Figure 4).

Moreover, the detailed study by Sambraus and Radtkig (1989) suggested that the vacuum created by restricting grazing behaviour (or reducing roughage available) was the primary cause of the initiation of food-searching behaviour such as pawing or box-walking. It may be that weaving originates in the same way, or is simply a response to increased frustration and arousal (Marsden, 1993 b).

2.4.7. SOCIAL BEHAVIOUR

A. TYPE OF HORSE

Minor differences in behaviour between types of equid have been noted, e.g. Klimov (1988) observed that Przewalski horses do not stand nose to tail in mutual defence against flies as some domestic horses do. Although the time-budgets of Przewalski and domestic horses are similar (Boyd, 1991),

there do appear to be some minor quantitative differences in some behaviour patterns. Feh (1988) notes that the aggression rate is higher in Przewalski horses. It is certainly likely that domestic horses have been selected for non-aggression, as well as appearance, so that newly introduced horses could be pastured together, as well as reducing the danger to their handlers. The introduction of Przewalski horses to each other always carries a risk because of the aggression they show to unfamiliar horses (Kolter and Zimmermann, 1988).

Feist and McCullough (1976) noticed that some individuals show threatening behaviour when others come within 1.5m of them. Waring (1983) noted that individual distances within which agonistic responses were elicited appear to vary with the sex, age, social status, environmental context, and mood of the horses. He also noted that the common form of submission is to move away, but this may not always be possible in confined spaces.

There is evidence to show that the likelihood of developing abnormal behaviour patterns varies between individuals. In a study of equine reactivity by McCann *et al.* (1988), horses of different excitability levels exhibited different behaviour patterns. This knowledge may be important in identifying optimal husbandry practices for different horse types (e.g. choleric, melancholic, sanguine and phlegmatic). A propensity to perform abnormal behaviour may be under genetic control; an animal which shows pronounced sensitivity to some aspect of its husbandry may pass on this tendency to develop a stereotyped behaviour pattern or stable vice to its offspring (Williams, 1981). The influence of hereditary has already been discussed. In addition to the oral-ingestive and locomotory forms of abnormal behaviour, Fraser (1992) lists the abnormal reactive behaviours as including mobile aggression, mobile alarm (bolting), threatening, biting, kicking, shying, balking and tonic immobility.

Borroni and Canali (1992) showed that, 37% of Thoroughbred yearlings showed the same behavioural problem as their mothers. However, it was impossible to say whether these problems were learned, inherited, due to aspects of the environment or resulted from management practices which did not satisfy the behavioural needs of the horses. The findings confirmed those of Houpt (1987), in that, once developed, some abnormal behaviour went on even if the horses are kept in large paddocks. Cribbing is one example and this underlines the importance of prevention of these problems.

B. ISOLATION

Kiley Worthington (1987) stated that the two important factors controlling time-budgeting of stabled horses were (a) the availability of sufficient roughage if they were to allow them to spend the majority of their time eating as they would under feral or pasture conditions, and (b) the availability of social contact. Unfortunately, as discussed earlier, her study did not investigate the relative importance of these factors to each other. In addition, her published work lacks experimental detail and appropriate statistical information which makes interpretation and comparison with other studies difficult.

Mal et al. (1991) carried out a study on the behavioural responses of mares specifically to short-term confinement and social isolation. The study was detailed, involving 36 mares, blocked by age and temperament score. The temperament score ranged from one to nine and was based on factors such as ease of catching and reactions to unexpected stimuli or handling. The scoring was not detailed and was open to different interpretations. This is unfortunate as it somewhat devalues the overall findings. Another factor which could affect the results is the discrepancy in stall sizes for the confined and completely isolated individuals - the authors claim this should

not be significant because isolation tends to affect a social animal like the horse more severely than confinement in small pens (Kilgour and Dalton, 1984). However, this last statement represented the aim of their study (i.e. the relative importance of confinement and isolation) and, by altering more than one condition (reducing the stall size as well as isolating certain horses), the test results are again devalued. A final point concerning the experimental design is that the horses were placed on treatment for only 48 hours and were then observed in situ for only 1 hour. It is somewhat doubtful whether the full range of discrepancies in behaviour patterns could be observed in only 1 hour between the 3 experimental groups (pastured, confined and isolated horses). The study was strictly an investigation of short-term confinement and, as pointed out by the authors, further research is needed on the habituation of horses to chronic confinement and isolation.

Houpt and Houpt (1992), who observed 10 adult mares over a 2 week period, noted that isolated mares were up to three times more active but spent 10% less time eating than those that could make visual, auditory and physical contact with other horses. Mal et al., (1991) found that isolated mares (compared with mares in groups) and, to a lesser extent, confined mares (compared with mares at pasture) showed increased motivation to perform more activities and to travel further during a 15 minute open-field test. They also found that isolated mares exhibited more feeding bouts and spent more time feeding in situ than other mares. The increase in the feeding behaviour in the Mal et al. study was probably attributable to "nervous" horses not having finished their morning feed by the time that observations were made. "Calm" isolated mares, which had already consumed their morning feed, exhibited few feeding bouts and spent less time feeding. The authors commented that the calmer mares may not have perceived their environment to be enough of a stressor to disrupt their feeding habits.

The reduction in feeding time observed by Houpt and Houpt (1992) is probably more similar to expectations owing to the increased activity of the isolated horses and the lack of social facilitation to feed (Tyler, 1972). The Houpt and Houpt study showed that, when allowed to control their own environment, horses spent the majority of their time (88 to 95%) outside a stall and half of their time in contact with other horses. The horses also showed a preference for an environment with some light.

Work carried out in Edinburgh (Marsden *et al.*, 1994b; Waters, 1992) concluded that social isolation is extremely stressful for horses and that this contributed to the increase in abnormal behaviour shown by horses when separated by poles compared to when they were loose-housed in the same area. As well as increased abnormal behaviour, the isolated horses showed physiological changes such as decreased red and white blood corpuscle counts, decreased packed cell volume, decreased mean cell volume and reduced mean cell haemoglobin. Some of these changes may be associated with haemodynamics due to inactivity while other changes, such as reduced white corpuscle counts, may indicate stress-induced immunosuppression. Work is continuing to elucidate the minimum spacing at which aggression and abnormal behaviour develop, and thus produce practical recommendations as to optimal stocking density for horses. Loose housing may not be possible for many stabled horses (an owner's fear of a valuable horse being kicked and other management factors such as cost of alterations may preclude its use) and separate studies may be required on stalled horses where feelings of security derived from the presence of protective walls or grilles may compensate for the supposed deleterious effects of increased proximity to neighbours.

An interesting study by Jezierski (1993) on 8 Anglo-Arab horses concluded that social isolation in horses is a stressful situation because it caused an increase in heart rate. This increase was recorded over only 30 minutes, as

other horses (stable-mates) were led away, out of the stable where the individual was being observed. This study was, therefore, strictly short-term. However two more useful observations were made - the level of emotional reaction during social isolation depended on the number of neighbours left, and in horses which are more used to staying alone, the effects of social isolation on heart rate were less pronounced.

C. CONFINEMENT

The effect of confinement, and in particular, enclosure size on behaviour patterns has been studied in Przewalski horses. Typical findings, such as those reported by Hogan *et al.*, (1988) were that more time was spent pacing and milling in smaller enclosures, less time was spent feeding and aggression increased. Provision of hay increased the time spent feeding in the smaller enclosure. The authors recommended that larger sized enclosures and preferably *ad lib* hay were necessary to minimise aggressive interactions.

The study by Kolter and Zimmermann (1988) recommended that apart from enlarging the enclosure for the Przewalski horses at Cologne Zoo, the enclosure should be made more complex and that more feeding sites should be established. The recommendations would help to reduce "boredom" as well as to provide areas for less dominant individuals to escape to and thereby reduce aggressive interactions at feeding times. Most of the observations were non-quantitative, and those that were, were only taken for 4 hours daily. There was considerable disturbance by visitors and the study concentrated on social interactions. Nevertheless, the animals were monitored regularly over a nine year period and the recommendations were based on sound practical experience. It is a reasonable assumption that whatever methods work to reduce aggressive interactions in Przewalski horses will also work in domestic horses, owing to their behavioural and physiological similarity. The main observed difference

in behaviour is that free-ranging Przewalski horses average about twice the number of aggressive acts per hour as feral *Equus caballus* (Keiper and Receveur, 1992). Feh (1988) was the first to point out the increased aggression of Przewalski's.

Conditions of confinement are frequently more stringent for Thoroughbreds because there is a desire to minimise risk to a valuable animal by not allowing it to be loose-housed or put to pasture. Low resistance to inclement temperate climate compared to that of Przewalski or native breeds limits the time of year and length of time that Thoroughbreds can be kept outdoors. More "reactive" temperaments may increase activity and thus contribute to the risks of injury (either to themselves in flight or possibly during agonistic exchanges), although this has not been proved. The novelty or lack of experience outdoors may also increase the risk of horses, which spend most of their time stabled, injuring themselves when turned out onto pasture. The traditional desire to "do the best" for such valuable sources of enjoyment entails placing them in self-contained looseboxes. Following a survey of training yards in the South West of England, Jones *et al.*, (1987) concluded that the design and construction of stables for racehorses have changed little over the past century; and that modern designs have evolved through empiricism rather than from any scientific assessment of a horse's behavioural needs.

D. GENDER

A study on Przewalski horses by Boyd (1988), used fifteen-minute focal-animal samples to determine time budgets. Males were found to be more active than females; they moved more and spent less time foraging or socialising than females. Females mutually groomed more than males; perhaps because they had kin in the herd, whereas males did not. Solitary males, perhaps as a result of isolation - induced "stress", paced more, and exhibited more transitions, than harem males.

2.5. VALUE OF TIME BUDGETS IN ASSESSING WELFARE

2.5.1. DEFINITIONS AND ASSESSMENT OF WELFARE

Good animal welfare has been defined as being a state of complete mental and physical health in which the animal is in harmony with its environment (Hughes, 1976). This definition is a theoretical aim and it is much more difficult to define good animal welfare from a practical point of view. Hurnik *et al.*, (1985) defined good welfare as "a state or condition of physical and psychological harmony between the organism and its surroundings". There are obviously exceptions to both these definitions such as apparently normal animals with subclinical disease; animals may show some symptoms of stress because of participation in a rewarding activity such as sex; healthy, and possibly physiologically normal animals may perform stereotyped movements (Lawrence and Rushen, 1993).

The Brambell Committee (Command Paper 2836, 1965) was ahead of its time in referring to the "feelings of animals", and pronounced welfare to be a wide term that embraces both the physical and mental well-being of the animal. Duncan and Dawkins (1983) also concluded that "welfare" could not be given a precise scientific definition. They thought that a broad working definition would be one that included the ideas of: (i) the animal in physical and mental health; (ii) the animal in harmony with its environment; (iii) the animal being able to adapt to its environment without suffering; (iv) some account being taken of the animal's feelings. Similarly, they thought that a loose working definition of "suffering" would be "a wide range of unpleasant emotional states".

The attempts to find a more precise definition of welfare continue and opinions vary as to which aspect of animal welfare is the most fundamental. Duncan (1990) states that welfare is primarily concerned with "wants" not

"needs". An example of this, given by Lawrence and Rushen (1993), is that regardless of whether or not pigs need straw bedding to maintain thermal equilibrium, if they want straw and are unable to obtain it then their welfare will be compromised. If physical conditions prevent expression of a behaviour (eg. foraging in straw bedding), the activated drive will be thwarted and, according to classical ethological theory, in these conditions, displacement activities, ambiguous movements and other apparently inappropriate and compulsive actions occur (all of which could presumably be recorded in the time budget). If this is how motivation works, performance of such abnormal behaviour by domestic animals is a sign that an activated drive is thwarted and that the animal concerned is frustrated and probably suffering (Huntingford, 1984).

In addition to the view of animal welfare which emphasises emotional suffering, the other major view emphasises biological functioning. Lawrence and Rushen (1993) point out the close integration of behaviour, physiology and immunology. Huntingford (1984) states that the physiological bases of pain and stress are complex, variable and incompletely understood; in addition, since in the short term stress is an adaptive response, the fact that an animal shows these physiological symptoms may simply mean that its body's defence mechanisms are in good working order. Thus the presence of some or all of the physiological symptoms designated as the stress syndrome does not necessarily mean that an animal is suffering. Moreover, the techniques for detecting these changes are frequently intrusive, expensive and impractical when large numbers of animals are concerned or when, owing to the absence of information on stabled horses, detailed comparisons are required with their feral counterparts. Hence, the search for behavioural indices of suffering (such as may be recorded in time budgets) remains overridingly important, whilst we should, at the same time, continue to investigate the relationships between overt behaviour and the

endocrine symptoms of stress (as well as other physiological parameters such as heart rate), particularly in relation to chronic stressors.

Fraser and Broom (1990) mention that the effects on the individual must be considered when assessing welfare. It may be that for some species, the welfare of most individuals in captivity will be poor, however much people try to improve them. For other species, however, the welfare of most individuals in captivity may be good. For every species, detailed study of the behaviour (i.e. 24 hour time budgets over extended periods), as well as possibly the physiology, of individuals may help reveal whether or not their welfare is poor.

Fraser and Broom (1990) also state that if an animal is challenged by environmental conditions but its regulatory systems, with their behavioural and physiological components, allow it to cope, then "adaptation" is said to occur. When regulatory systems are operating but are not coping with environmental conditions then the word "stress" should be used. The ultimate measure of whether or not an individual is coping is whether there is a reduction in fitness. "Stress" has been defined as "an environmental effect on an individual which over-taxes its control systems and reduces its fitness" (Fraser and Broom, 1990).

2.5.2 VALUE OF ABNORMAL BEHAVIOUR IN ASSESSING WELFARE

Abnormal behaviour is defined as ^{an activity} not present in the feral horse's ethogram, although some changes may be adaptive (Marsden, 1993a). Abnormal behaviour is supposedly frequently associated with frustration, distress, pain, or grief, as the affected animal may function basically normally in all other physical respects - however, some forms of abnormal behaviour may acquire clinical sequelae in due course, as noted by such authors as Kiley-Worthington (1983); Waring (1983); Fraser (1984). Various

abnormal behaviours were referred to as "stable vices" in horses and there are estimated to be around 56 of them in farm livestock (Fraser, 1984). Included in the list of abnormal behaviours are stereotyped behaviour patterns such as weaving, pawing, wind-sucking and cribbing. "Stable vices" in horses are summarised in Figure 2.9.

Fraser (1984) states that certain behavioural manifestations in animals, including stereotypies, are unequivocal evidence of suffering through being outward expressions of a mental state. (Fraser also suggests that passively depressed behaviour and agitated behaviour certainly do reflect states of suffering.). He pronounces that such behaviours must be considered to provide reliable indices of confinement stress from aversive, restrictive management, either in the past or at the present time. Husbandry which produces such abnormal behaviour in a common population should be examined critically.

The evidence would support the view that stereotypies (which would, of course be recorded in a detailed time budget) may be used as indices of unsatisfactory environments (Duncan *et al.*, 1993). With regard to other behavioural indices, such as displacement activities, redirected activities and apathy, Wood-Gush (1982) states that their significance may be uncertain.

Mason (1991) suggests that stereotypies can only be considered abnormal in the maladaptive sense if costs of their performance outweigh any benefits. This reflects the view of Odberg (1978) who considered stereotypies to be devices for adaptation to an inadequate environment, with the term "unusual" better describing these behaviours than "useless" or "purposeless". Mason concluded that acquisition of stereotypies probably indicates an unsatisfactory environment, but stresses that without knowing the consequences of the performance, it cannot be inferred that this is

FIGURE 2.9 Equine behavioural problems and their possible causes. (Waring, 1983)

BEHAVIOURAL SYMPTOM	DYSFUNCTION AND TRAUMA	NUTRITION, ALLERGY AND TOXINS	PARASITES AND INFECTIONS	HANDLING AND MANAGEMENT
Social Abnormalities				
Solitary tendencies	Pending parturition	Locoweed poisoning	-	Abnormal early social development
Loss of foal mother bond	Convulsive syndrome foals	-	-	-
Seeks only human social contact	-	-	-	Social imprinting on humans
Docility	Pituitary tumor (Pars intermedia)	-	-	-
Change in personality or temperament (eg. hyperexcitability, lethargy)	Hypoglycemia, Cryptorchidism	Vitamin D deficiency	Listeriosis, Rabies	Drug overdose
Irritability	-	-	-	-
Aggressiveness	-	-	Rabies, Lice	Boredom, Poor handling, Sexual frustration
Viciousness	Pathologic Nympomania	-	Rabies	-
Increased libido	Cryptorchidism	-	-	-
Prolonged estrus	Irritation of clitoris by foreign body, Cystic ovary, Neuroendocrine disorder	-	-	-
Prolonged anoestrus	Infantilism, Ovarian malfunction,	Undernourishment	-	Poor nutrition
Impotence	-	Undernourishment	-	Adversive experiences during breeding. Frequent ejaculations.

FIGURE 2.9 contd: Equine behavioural problems and their possible causes. (Waring, 1983)

BEHAVIOURAL SYMPTOM	DYSFUNCTION AND TRAUMA	NUTRITION, ALLERGY AND TOXINS	PARASITES AND INFECTIONS	HANDLING AND MANAGEMENT
Abnormal Behaviour (Vices)				
Refusal to work	Liver dysfunction	-	-	Abnormal early social development
Difficulty to bridle	Dental abnormality	-	Spinous ear tick	-
Stall walking	-	-	-	Nervousness/excess energy
Weaving	-	-	-	Procaine HCl overdose Nervousness/excess energy
Cribbing/windsucking	Dental abnormality	-	-	Boredom, Poor social development
Pica (eg. wood, dirt)	-	Nutritional deficiencies	Parasite infection	Boredom
Coprophagia	-	Need for roughage	-	-
Fence chewing	Dental abnormality	Need for roughage	-	Boredom/restless energy
Digging	-	-	-	Nervousness/excess energy
Masturbation	-	-	-	Excess sexual energy
Charging/savaging	Hormone imbalance (eg. cystic ovaries)	-	-	Poor handling, Anxiety
Striking	-	-	-	Agonistic response to handling
Kicking	-	-	-	"
Rearing	-	-	-	"
Bucking	-	-	-	"
Boiling	-	-	-	"
Jibbing	Vision impairment	-	-	Fear response
Shying	Vision impairment	-	-	Agonistic response to handling

necessarily the case. She also proposed that even if stereotypies ameliorate a sub-optimal environment and are short-term coping mechanisms, it is not possible to state definitely whether they reward the animal since it is not known if they are associated with long-term benefit.

Dodman *et al.*, (1987) suggested that oral-related stereotypies could be induced by increased endorphin levels. Evidence supporting this hypothesis came from Cronin *et al.*, (1985), who worked with pigs that performed stereotypies. They found that naloxone (a narcotic antagonist) specifically interferes with stereotypies and, therefore, it is assumed that the performance and maintenance of the stereotypies depends on endorphin release. The endorphins may be implicated in the developmental stages of stereotypies, since older (i.e. longer established) stereotypies seem to be less sensitive to naloxone treatment. Thus, in the course of the development of these behaviours, they may become less dependent on the original mechanisms (which may also hold true for drug addictive behaviours).

Numerous attempts have been made to prevent stereotypies being performed in individuals rather than concentrating on identifying, and possibly then eliminating, the factors which seem to promote these behavioural patterns (Schilder, 1992). These attempts include anti-weaving grilles (which may lead to the horse weaving within its stable); inhibiting access to suitable surfaces for cribbing (the horse may learn to wind-suck without needing to crib); surgical section of the ^{sternothyroid} ~~sternohyoid~~ muscles, or their nerve supply, associated with neck-arching on cribbing (success is variable, from 0 to 70% according to Owen, 1982); various straps or muzzles have been used for cribbing. These techniques do not attack the cause of the stereotypy and, even if one type of stereotypy is prevented, another type could develop. One may speculate that prevention by these means is directly opposed to the promotion of an individual's welfare. If the

performance of stereotypy is not allowed, then no self-comfort may be obtained in those animals presumably struggling to cope with an inadequate environment.

Much more could be written concerning stereotypies. Whilst firm conclusions about the feelings of animals performing stereotypies, and their effect on physiology, cannot yet be made, Duncan *et al.* (1993) firmly recommend that appropriate steps should be taken to prevent their occurrence in the name of animal welfare. The points which they make to support this recommendation are listed in the conclusions of their paper and are reproduced below:

- 1 for some stereotypies, there is evidence that the animals have been through a period involving negative feelings such as aversion;
- 2 some forms of stereotypy appear symptomatic of a psychopathology;
- 3 there is some evidence from the underlying physiology that some stereotyping animals are stressed;
- 4 animals performing stereotypies may have negative feelings associated with boredom (or reduced active control). (This statement appears somewhat ambiguous);
- 5 stereotypies are not simple coping responses;
- 6 the lack of evidence of a relationship between most stereotypies and reduced welfare reflects a lack of research rather than negative findings;
- 7 enough is known about the eliciting environmental conditions to prevent the occurrence of some stereotypies;

The authors conclude that for these reasons, suitable provision for species-typical behaviour will in many cases largely eradicate performance of stereotypies.

2.5.3 USE OF TIME BUDGETS IN ASSESSING WELFARE

The value of time budgets in highlighting the differences in behaviour patterns between feral horses and horses under different management has been discussed in the previous sections. It is apparent that domestication produces major time budget alterations which have been associated with factors such as "boredom" or, more importantly, frustration which is largely due to a considerable reduction in feeding time and the lack of opportunity to feed. Other changes include frustration or thwarting of behaviour patterns (eg. resulting from restrictions on ability to forage); stress (eg. increased heart rates on isolation); lack of motivation (eg. sensory deprivation in stable environment could reduce incentive to move or attempts to socialise); increased agonistic behaviour (eg. competition at feeding sites); the development of so-called stable vices as new, and abnormal, types of behaviour. Time budgets can be used to assess the welfare of animals between the two extremes of an animal obviously in pain, frightened, or diseased and a healthy animal growing, reproducing and behaving "normally" in a "natural" environment (Lawrence and Rushen, 1993; Marsden, 1993a).

Ewbank (1973) divided behavioural changes into three types, with a view to assisting the field worker in trying to evaluate their significance. Type One change represented abnormal behaviour with pathological change and obvious economic loss. Type Two represented abnormal behaviour with no pathological change or economic loss. Type Three represented quantitative and qualitative changes in patterns and amounts of activity. The significance of Types Two and Three, as detected by means such as time budgets, may be difficult to judge, but comparisons with the ethograms of feral horses should help in this respect (Marsden, 1993a). Ewbank (1973) states there may be an optimal degree of stimulation to be aimed for and that extreme extensive systems (e.g. mountain sheep in winter) may be as

"stressful" as over-intensive systems. He also mentions that physiological and biological findings may be useful in identifying "stress" in addition to observing the behavioural changes.

Any recognition of good welfare should be carried out at various times during the animals' daily routine and should be combined with the use of indicators of poor welfare because an individual's welfare might be good at one time during its life, in given conditions, but poor at other times. It is, for example, possible that, if observations were made only in the afternoon, more behavioural abnormalities might be seen as the plasma corticosteroid levels are falling. It would appear that if a particular stressful stimulus is not met by a corticosteroid response, an abnormal behavioural response may occur (Haupt, 1980). Circadian patterns in plasma cortisol and corticosterone have been noted in horses by Hoffsis *et al.*, (1970); Bottoms *et al.* (1972); Zolovick *et al.*, (1966), and should, therefore, be taken into consideration.

Fraser (1992) goes so far as to state that the behavioural characteristics of self-maintenance are increasingly being recognised as indicative - and probably definitive - of the range of needs in horse welfare. In addition to providing food, water and shelter, the horse must be allowed to indulge in a number of classes of specific activities which are associated with self-maintenance and self-determination. In other words, time budgets which identify a full range of self-maintenance activities in a domesticated horse, and presumably in the absence of any signs of abnormal behaviour, should indicate an acceptable standard of welfare for that individual (over the time that the recordings are taken). Fraser (1992) concludes that any welfare assessment in horses is dependent on behavioural evidence. It is probable that this evidence may be most readily available, in the form most suitable for comparison, by detailed time budget studies, especially when any possible observer influence is eliminated by the use of video recorders.

Whilst recording of abnormal behaviour, in particular stereotypes, greatly assists in identifying suboptimal husbandry, all other time budget changes (from those recorded in feral horses) must be carefully assessed. By careful comparison with feral horse studies, and by taking into account the particular environment, this study was intended to help in identifying those changes associated with satisfactory adaptation and those which might be associated with impaired welfare.

Some changes in time budgets, such as hay-dipping, may be regarded as positive adaptations to environmental change - with hay-dipping, the horses are providing themselves with a more succulent feed. This would not necessarily be regarded as indicative of reduced welfare, whereas frustration of feeding behaviour might significantly increase alertness, oral, leg and head movements as well as heart rate and these changes could indicate reduced welfare in the particular environment that produced them (Marsden, 1993a). Some working towards "goals" may, however, be less frustrating than the "boredom" associated with having everything provided. Ewbank (1973) referred to the possibility that there is an optimal degree of stimulation which should be aimed for and, outside of which, in either direction, animals may show increasing signs of "stress".

CHAPTER 3

MATERIALS AND METHODS

3.1. MATERIALS

A. ANIMALS

All subjects were horses (*Equus caballus*) of the Household Cavalry Mounted Regiment (Photograph 3). Each horse could be identified by the name plate in their stall as well as by numbers branded on their hoofs. More detailed records (Army Forms B270) are also available and contain complete training and veterinary records, as well as full descriptions for every horse.

Eighty horses were used in this study. The horses were of mixed sex, ranging in age from four to 23 years' old and were of heights between 15.3 hh and 17.1 hh. The length of time they had been in the Regiment ranged from three to 173 months (Appendix A contains these details in full for each horse). The horses were divided into either heavy or light types as shown in Photographs 4 (inclining towards draught conformation) and 5 (inclining more towards Thoroughbred conformation) respectively. Unusual types (such as in Photograph 6) were not included.

B. STABLING

All the subjects were kept in stalls, either at Hyde Park Barracks, London, or Windsor Barracks, Berkshire.

Photograph 3. Household Cavalry horses in Hyde Park.



Photograph 4. "Heavy" type of horse.



Photograph 5. "Light" type of horse.



Photograph 6. Drum horse (Clydesdale).



The stalls are virtually identical at both sites and conformed to the layout shown at Figure 7. At Hyde Park Barracks the stables containing the Life Guards Squadron horses are on ground level (which is also the case with all the horses at Windsor) whilst the Blues and Royals Squadron horses live a floor higher, directly above. Within the Life Guards and also the Blues and Royals Squadrons, there are 3 Troops, each occupying a different line of stalls. Thus, each of the 6 Troops at Hyde Park Barracks and a further 2 (under normal circumstances) at Windsor would occupy the self-contained area shown in Figure 7.

The horses are tethered to the wall by a rope from the headcollar to a ring on the front bar of the stall. They face the wall, where a manger, automatic waterbowl (constant level) and hay rack (the latter is no longer used as hay nets or floor feeding of hay is now required) are located. There is enough freedom of movement to allow them, for example, to lie down or touch other horses through the metal grilles on the stall sides without being able to leave the stalls or turn themselves around. These stalls are shown in Photograph 7. As noted in Appendix B, the stalls are not bedded down during the afternoon. The floor is bluestone tiles with a graded slope of 1 cm per 1 m.

Figure 7: The Layout and dimensions of the lines of stalls at the Knightsbridge Barracks

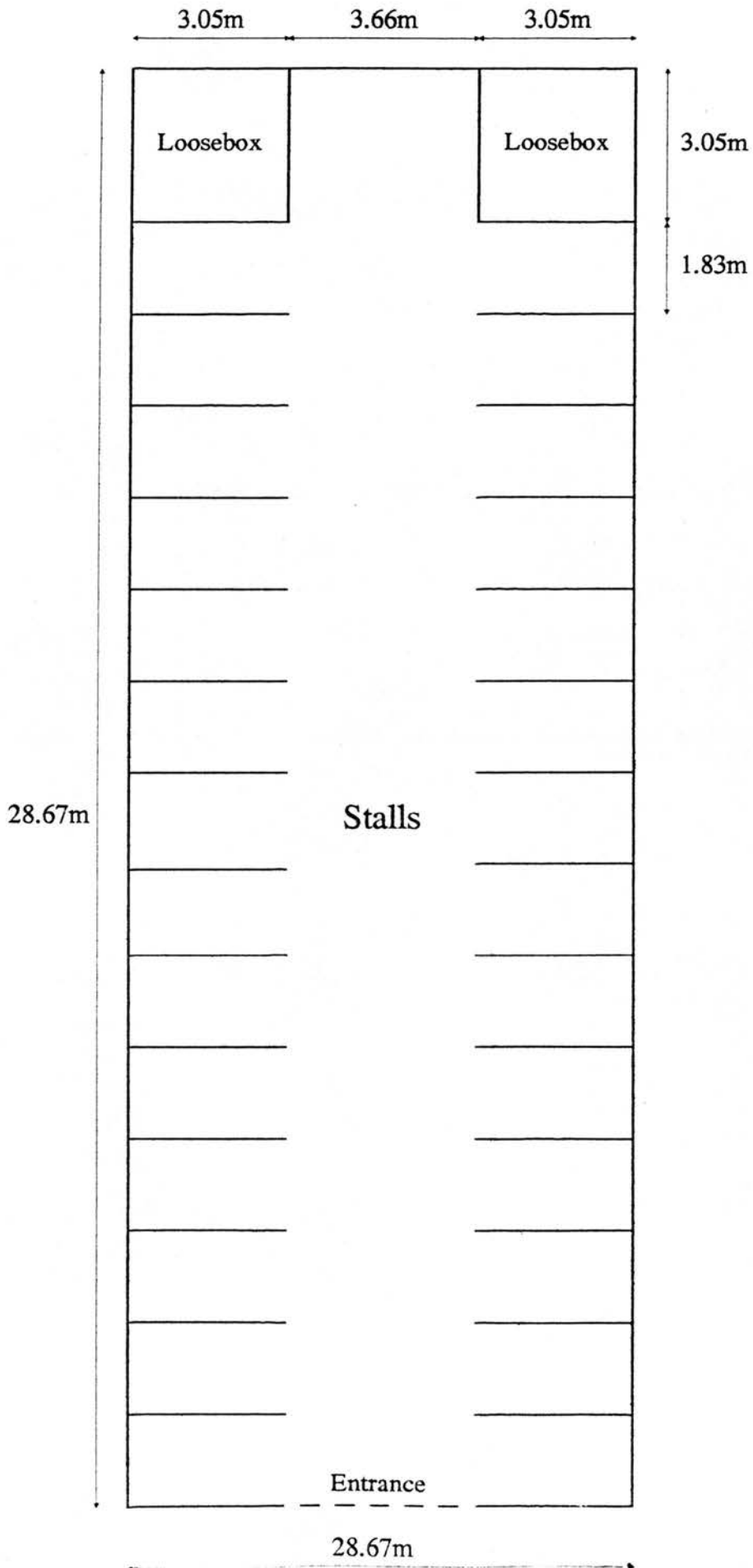

Photograph 7. Stalls.



Photograph 8. Inspection of morning stable routine.



C. MANAGEMENT

All the horses have a similar rigid routine (see Appendix B) with regular inspections to ensure that standards are maintained (Photograph 8). The morning feed times differed depending on the exercise regime, which could be as follows:

1) Horses going on the "Queens Life Guard" were exercised from 0630-0700 hrs (25 minutes trotting, 5 minutes walking as ridden exercise without saddles), then fed the normal morning feed (which is described later in this section) on return, before leaving the barracks at 1030 hrs to be ridden at a walk so as to arrive at Horse Guards by 1100 hrs (Photograph 9). They remained there overnight and returned to the barracks in time for the lunchtime feed at 1220 hrs. Only four horses actually went on guard and all were stalled in the same conditions as at Hyde Park Barracks. The four horses on guard alternated, each pair having two hours standing on guard and two hours in the stalls from 1200 until 1600 hrs. Altogether over this 24 hour period, each horse would have been ridden at a trot for 25 minutes, ridden at a walk for 35 minutes and, if selected for guard duty, 2 hours standing with a rider on its back.

2) Most of the rest of the horses went out on the "Watering Order", which consists of 25 minutes trotting and 25 minutes walking with a rider near to

Photograph 9. Horses being led out to go on the "Queen's Life Guard".



Photograph 10. Remount in training.



the barracks, between 0700-0800 hrs. Horses were fed the normal morning feed on return at 0815 hrs.

3) The remaining horses, newly arrived at the barracks and referred to as "Remounts", went out for approximately one and a half hours exercise, including schooling (Photograph 10). These horses received up to 45 minutes trotting, 30 minutes walking and 15 minutes cantering with a rider. They received their morning feed (which contained 1 kg more "cavalry mix" than the normal feed) after exercise at 0815 hrs.

4) At Windsor, horses were fed between 0600 and 0700 hrs (receiving 1 kg more "cavalry mix" than normal) and were exercised at varying times throughout the morning for up to one and a half hours. These horses were mainly riding school horses, used by new recruits in order to learn to ride. On average, they would receive up to 45 minutes trotting, 30 minutes walking and 15 minutes cantering with a rider.

Horses were not exercised on Sundays at either Hyde Park Barracks or Windsor and only one feed was given on this day, at 1600 hrs - the only exceptions were horses going on the Queens Life Guard. Horses were given a morning (0815 hrs usually), lunchtime (1220 hrs) and evening (1620 hrs) feed, with hay also being given as shown in Appendix C. A trumpet was sounded immediately prior to the morning, lunchtime and evening feeds. Each feed

generally consisted of 1 kg of alfalfa (16% crude protein), $\frac{1}{2}$ kg of chaff and 1 kg of "cavalry mix" (12% crude protein, 11.5 MJ/kgDM). Each horse received approximately 7 kg of hay daily.

Bedding was straw and stalls were cleaned out regularly, as is shown in the daily routine (Appendix B) and water was constantly available from automatic drinkers. At both sites horses were accustomed to soldiers passing through, and working in the stables throughout the day and also at night, when nightguards checked on the horses regularly.

The rigid, busy routine during the day and the similar conditions for all the horses involved in this study produced a large study group with minimal management differences between the individual horses. Soldiers are not assigned to look after or ride particular horses and no special treatment is given to any horse unless it is being used for competitions or under veterinary treatment (and, in both these cases, it would not have been included in the study).

3.2. METHODS

Each of the eighty horses used in this study was filmed between April 1992 and October 1993 using a time-lapse video recorder; 72 hours observation fitted onto a three hour video cassette. A small (9 inch) black and white television monitor was used to check the angle and focusing of the camera as well as the placement of the date-time-group (DTG) in the recorded picture. Two horses were filmed simultaneously and care was taken that the horses on either side were in view, so that detail of any interactions could be recorded. The video camera was attached to a girder above the opposite stalls (a distance of 4 m between the camera and the horses being filmed) and positioned to give a view similar to that in Photograph 11. An infra-red lamp was left on continuously over the study period to enable filming to occur during darkness without affecting the horses' behaviour. As far as is known, the visual range of horses is similar to humans (Waring, 1983) so it may, therefore, be assumed that infra-red light would not be detectable by the horses. More details of the equipment and its usage are given in Appendix F.

It was hoped to be able to obtain a full 72 hour record for each horse, but this was not always possible due to technical difficulties. However, a 72 hours record was obtained for sixty-six horses and a 48 hour record for another fourteen horses. In total, 5424 hours of

Photograph 11. View similar to that recorded by the video camera.



video recordings was gathered. Behavioural data was obtained from the video recordings by using 10-minute scan samples (as described by Altman 1974) and recorded onto raw data sheets, using the ethogram given in Appendix D. The following abbreviations were used on the raw data sheets:

E - Eating	NE - Not Eating
S - Standing	LS - Lie Sternally
LR - Leg Resting	LL - Lie Laterally
A - Alert	R - Resting
NA - Non-Alert	SL - Sleeping
HN - Hay-net	HD - Hay Dunking
HF - Hay from the Floor	CF - Concentrates
ST - Straw	H - Horse
I - Interactions	P - Person
AG - Agonistic	AF - Affiliative

The behaviour categories shown in Appendix D include descriptions of the overall "State" of the animal (e.g. eating concentrates, leg-resting, non-alert); normal behaviours such as interacting, comfort behaviour, vocalising, investigative, reacting to an event, urinating and defecating are noted under the heading "Other Norm."; abnormal behaviour is noted under the headings "Feet" (containing activity primarily involving the feet such as pacing, pawing, or threatening to kick), "Head" (e.g. head shaking), and "Oral" (e.g. biting or chewing). The section headed "Environment" was used to give an indication of what the behaviour was directed towards (e.g. another horse or person in the case of social interaction).

The scoring system used to measure alterness is shown in Appendix E. The data from the raw data sheets was summarised onto score sheets. The amount of time spent in major behavioural categories was calculated from these, for each horse.

CHAPTER 4

RESULTS

4.1. TIME SPENT IN MAJOR BEHAVIOURAL CATEGORIES

The mean number of scans, and hence percentage of total time spent in each major behavioural category, was calculated and a summary of the results, inclusive of standard errors, is shown in Table 4.1. These categories are not mutually exclusive except within the divisions a, b and c of Table 4.1.

The horses spent 36.3% (8.7 hours per 24-hour period) of their time feeding and 1.01% (0.2 hours per 24-hour period) drinking.

Of the four recorded states of alertness, the horses spent 7.5% (1.8 hours per 24-hour period) of their time in stables alert. If one includes time spent in exercise as being in the alert state, the total figure is 12.42% (3 hours per 24-hour period). The non-alert state accounted for 63.03% (15.1 hours per 24-hour period) of their time. Resting and sleeping were recorded separately and accounted for 10.89% (2.6 hours per 24-hour period) and 2.33% (0.6 hours per 24-hour period) respectively of the time spent.

The horses stood for 57.92% of their time in stables (13.9 hours per 24-hour period) and leg resting accounted for 18.67% (4.5 hours per 24-hour period) of their time.

Table 4.1

TIME SPENT IN THE MAJOR BEHAVIOURAL CATEGORIES

ACTIVITY	MEAN NO. OF SCANS	STANDARD ERROR	TIME SPENT AS PERCENT OF AVERAGE 24- HOUR PERIOD
(A) Alert	32.42	3.06	7.50 (1.8 hrs)
Non-Alert	272.30	6.36	63.03 (15.1 hrs)
Resting	47.05	3.30	10.89 (2.6 hrs)
Sleeping	10.08	1.21	2.33 (0.6 hrs)
(B) Standing	250.22	5.99	57.92 (13.9 hrs)
Leg Resting	80.66	3.73	18.67 (4.5 hrs)
Lying Laterally	4.45	0.85	1.04 (0.25 hrs)
Lying Sternally	22.15	1.48	5.13 (1.2 hrs)
Total Lying	26.64	1.82	6.17 (1.5 hrs)
(C) Eating	156.82	4.09	36.30 (8.7 hrs)
Drinking	4.35	0.29	1.01 (0.2 hrs)
(D) Total Abnormal	9.17	2.00	2.12 (0.5 hrs)
Abnormal (Non- stereotypic)	6.20	0.20	1.44 (0.35 hrs)
Stereotypic	2.98	1.15	0.69 (0.17 hrs)
(E) Interaction	8.81	0.65	2.04 (0.5 hrs)
Exercise	21.25	1.74	4.92 (1.2 hrs)
Other	45.15	1.23	10.45 (2.5 hrs)

Total time spent lying was 6.17% (1.5 hours per 24-hour period), which is divisible into 1.04% (0.25 hours per 24-hour period) lying laterally and 5.13% (1.2 hours per 24-hour period) lying sternally.

The horses were exercised for 4.92% (1.2 hours per 24-hour period) of their time. They also spent 2.54% (0.6 hours per 24-hour period) of their time moving within the stalls. They interacted with other horses for 2.04% of their time (0.5 hours per 24-hour period).

The total time spent in abnormal activity was 2.12% (0.5 hours per 24-hour period). Stereotypic behaviour accounted for 0.69% (0.17 hours per 24-hour period) of this and non-stereotypic abnormal behaviour for 1.44% (0.35 hours per 24-hour period) of the horses' time.

4.2. THE EFFECT OF VARIOUS FACTORS ON MAJOR BEHAVIOURAL CATEGORIES

Analyses of variance ("INSTAT", Graph Pad Software, San Diego) were carried out on the mean number of scans for each horse in order to determine whether age, time spent in barracks, type of horse (i.e. heavy or light), gender and height had any effect on time budgets. Kruskal-Wallis ANOVA (Mann-Whitney U tests and Welch t tests) were used for data that did not fit the assumptions of the one-way ANOVA tests. All tests were two-tailed. For each behavioural category represented in Figures 4.2 (a-1), the appropriate KW statistic (and p value) is given where Kruskal-Wallis tests were carried out, and the appropriate F value (and p value) where ANOVA was carried out.

A. AGE

Animals were divided into four groups according to age (0-6, 7-10, 11-15, and more than 15 years' old) for analysis. None of the behavioural categories shown in Tables 4.2(a)-(1) was significantly (i.e. $p > 0.05$) affected by age.

B. TIME SPENT IN BARRACKS

Animals were divided into four groups, according to time spent in barracks, for analysis. None of the behavioural categories shown in Tables 4.2(a)-(1) was significantly (i.e. $p > 0.05$) affected by time spent in barracks.

C. HORSE TYPE (LIGHT OR HEAVY)

Horses were divided into two groups according to whether they were classified as "light" (i.e. inclining towards Thoroughbred conformation) or "heavy" (i.e. inclining towards Irish Draught conformation).

Time Spent Eating Household Cavalry Horses

Bar Chart 4.2 (a)

KW = 8.778 (p = 0.7895)

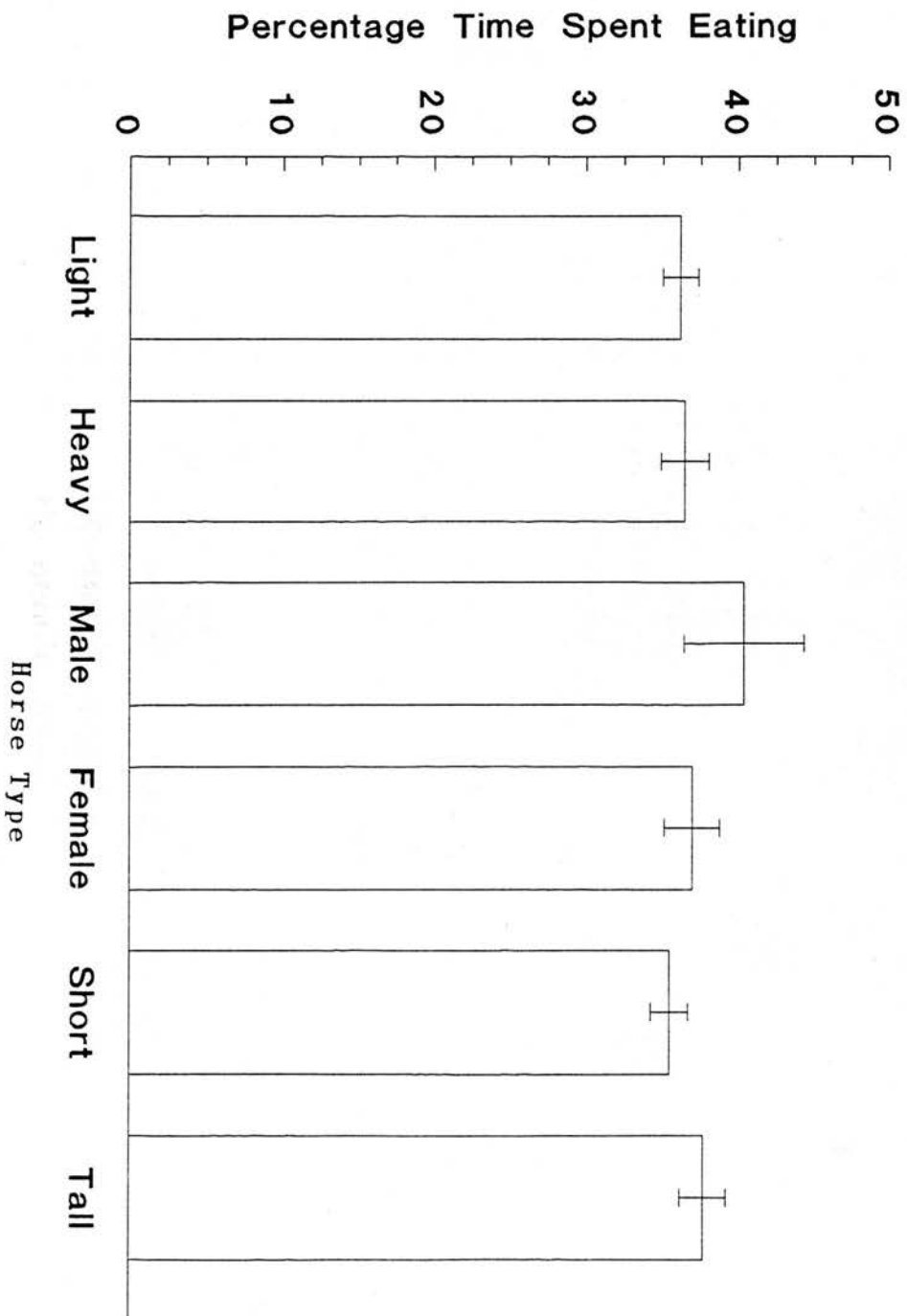

Bar Chart 4.2 (b)

Time Spent In Oral Movement
(including abnormal oral movement) $F = 0.2449$ ($p = 0.9970$)
Household Cavalry Horses

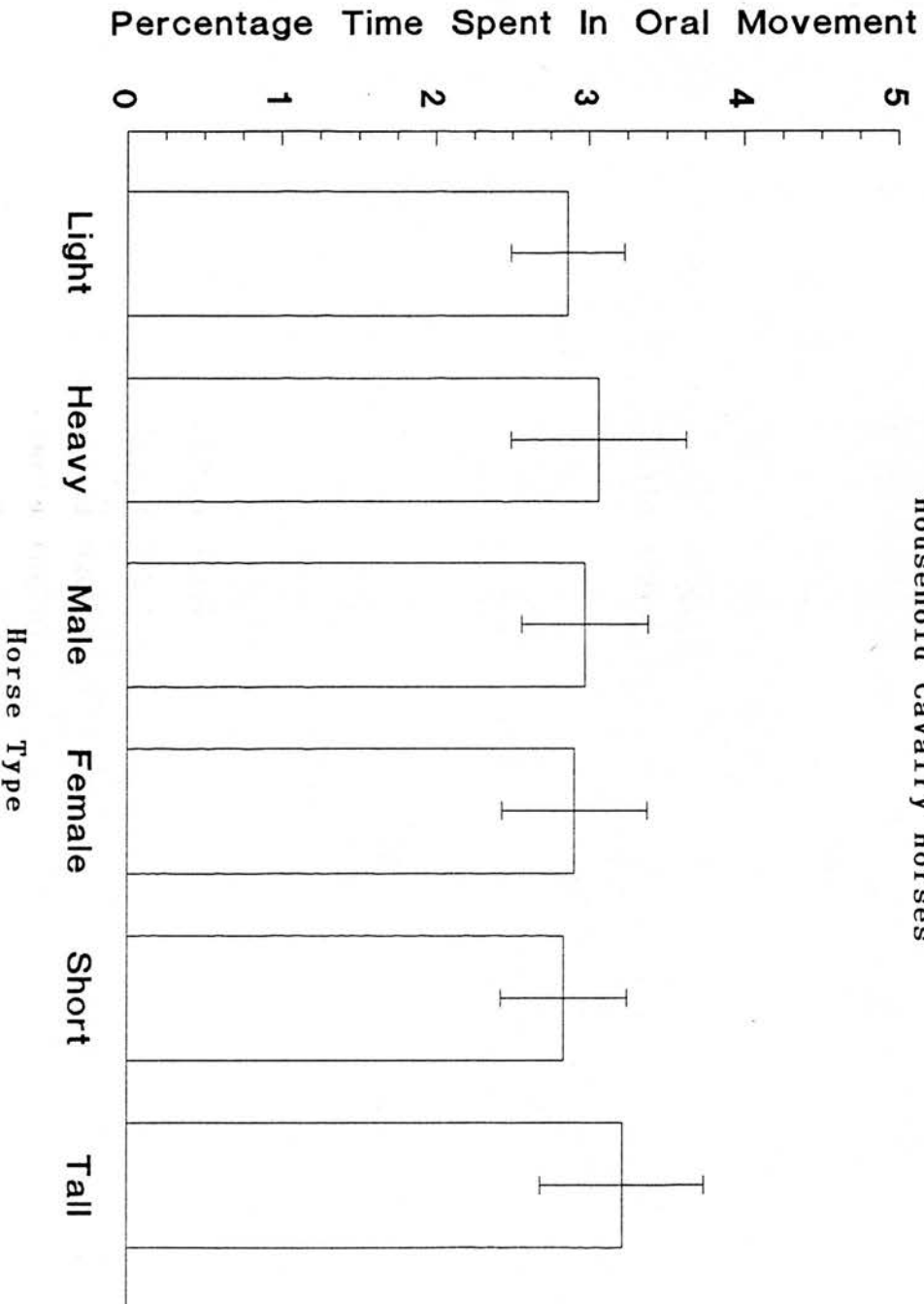

Time Spent Alert
Household Cavalry Horses

KW = 3.556 (p = 0.9951)

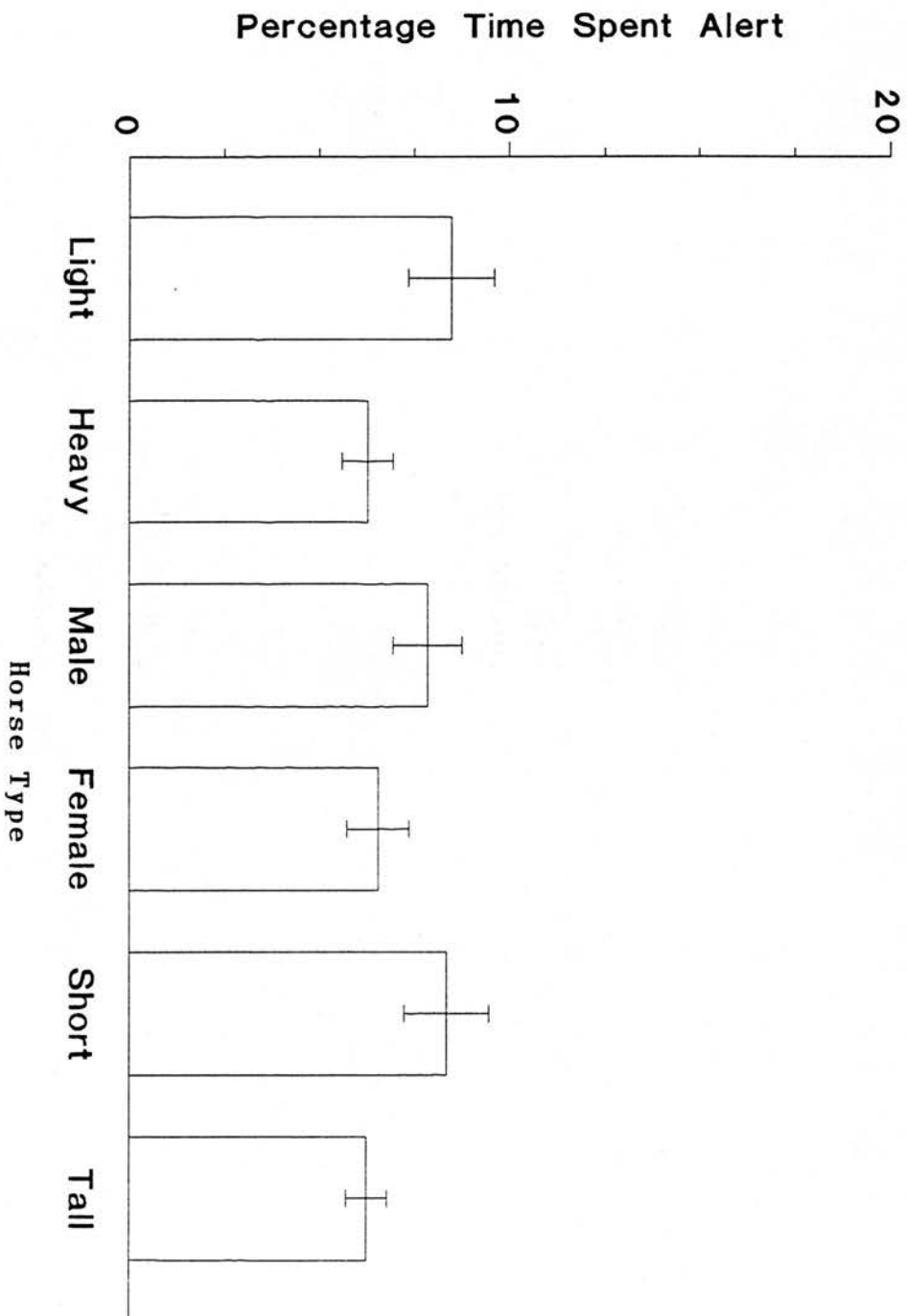

Time Spent Non-Alert Household Cavalry Horses

F = 0.7396 (p = 0.7240)

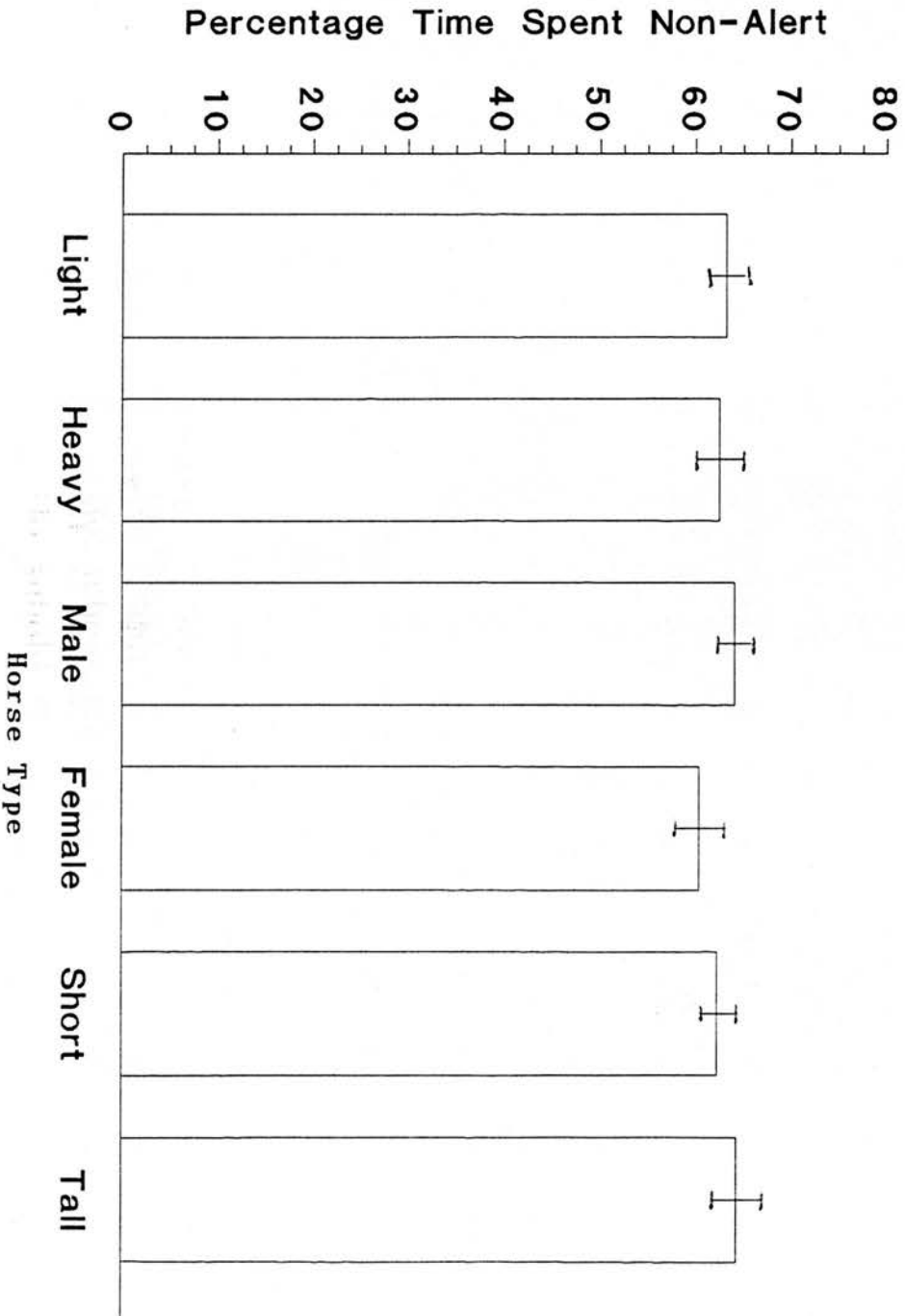

Bar Chart 4.2 (e)

Time Spent Resting
Household Cavalry Horses

KW = 19.461 (p = 0.1095)

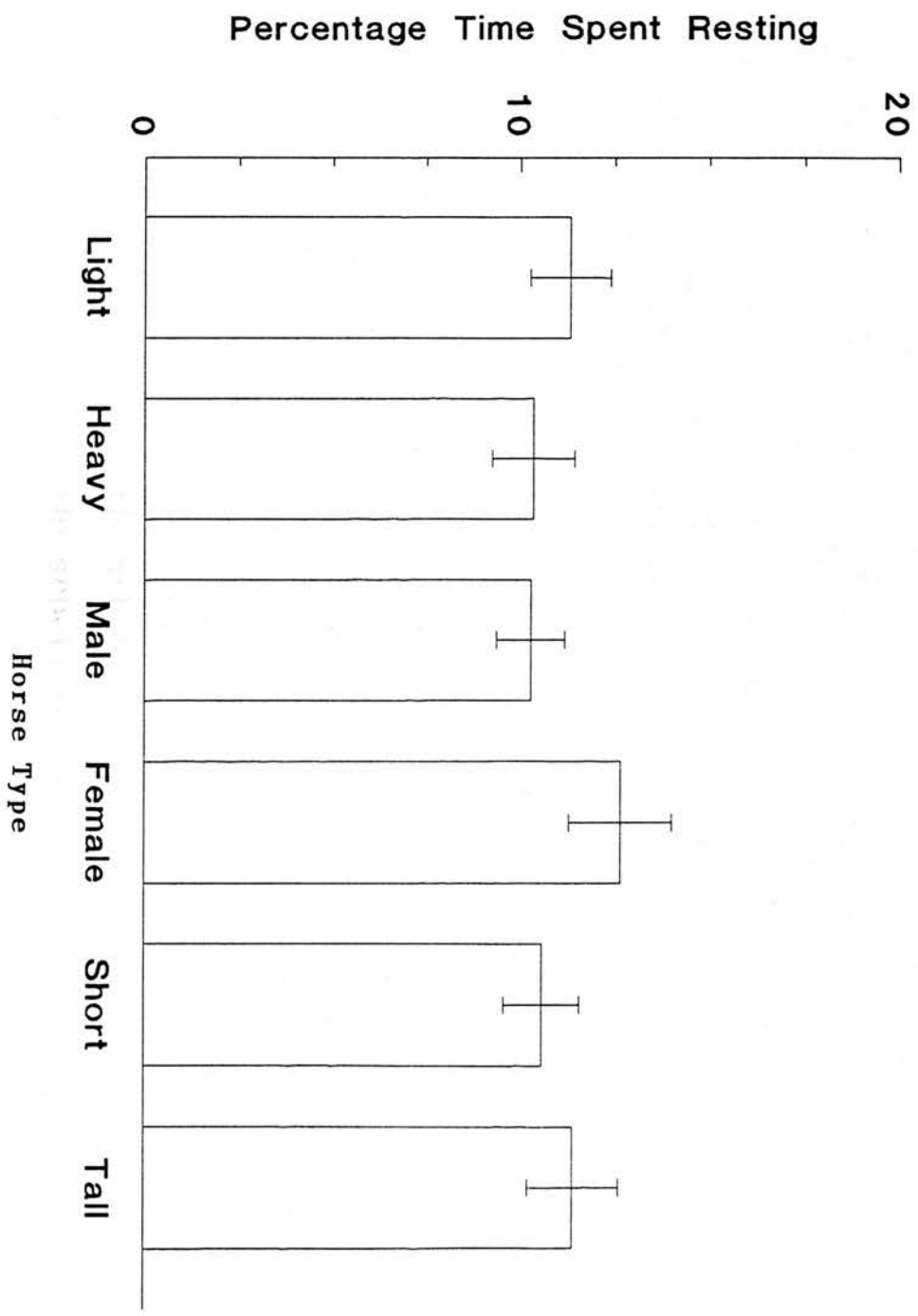

Bar Chart 4.2 (F)

Time Spent Sleeping
Household Cavalry Horses

$t = 2.685$, $df = 78$, $p = 0.0089$

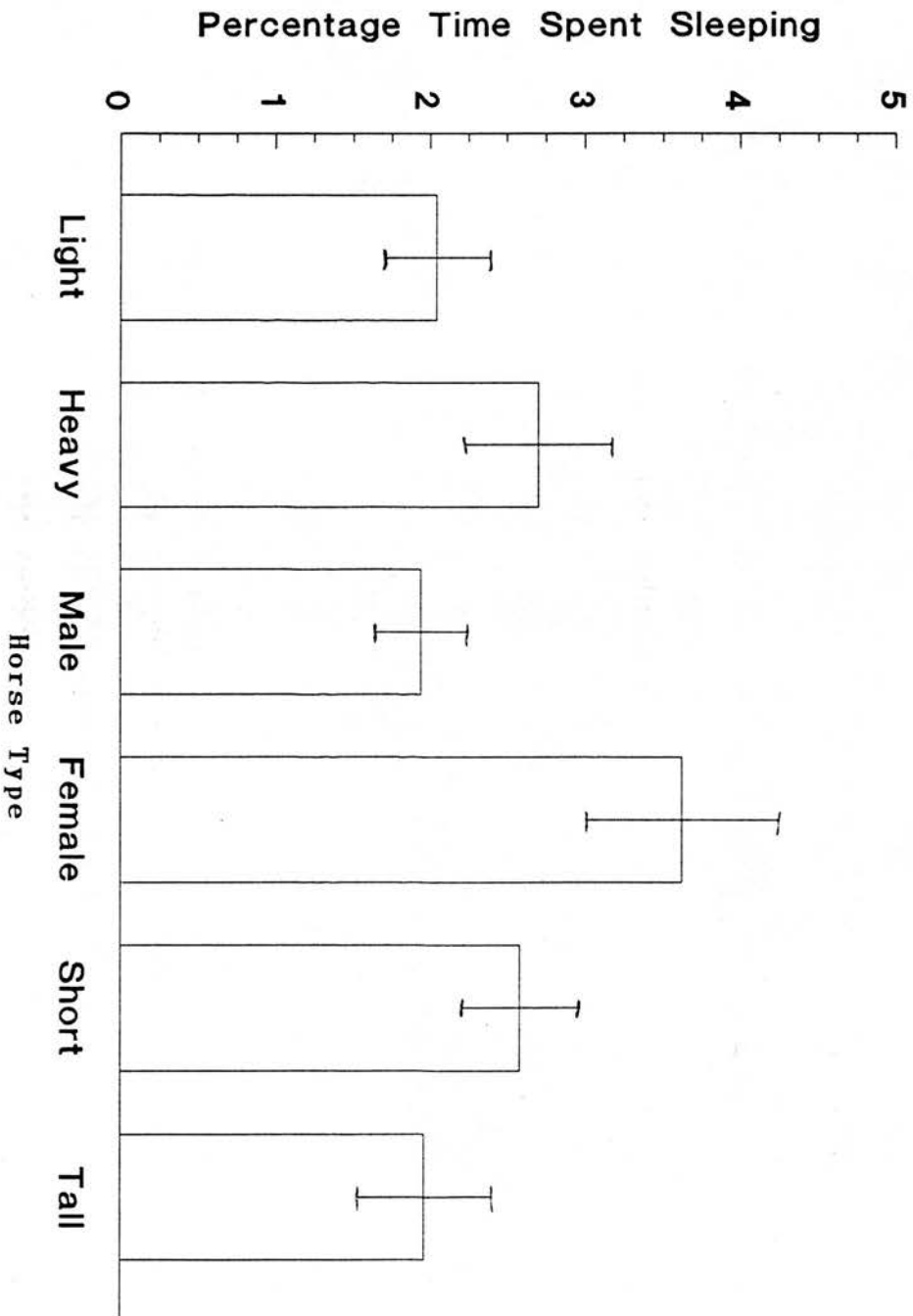

Bar Chart 4.2 (g)

Time Spent Standing Household Cavalry Horses

KW = 14.364 (p = 0.3487)

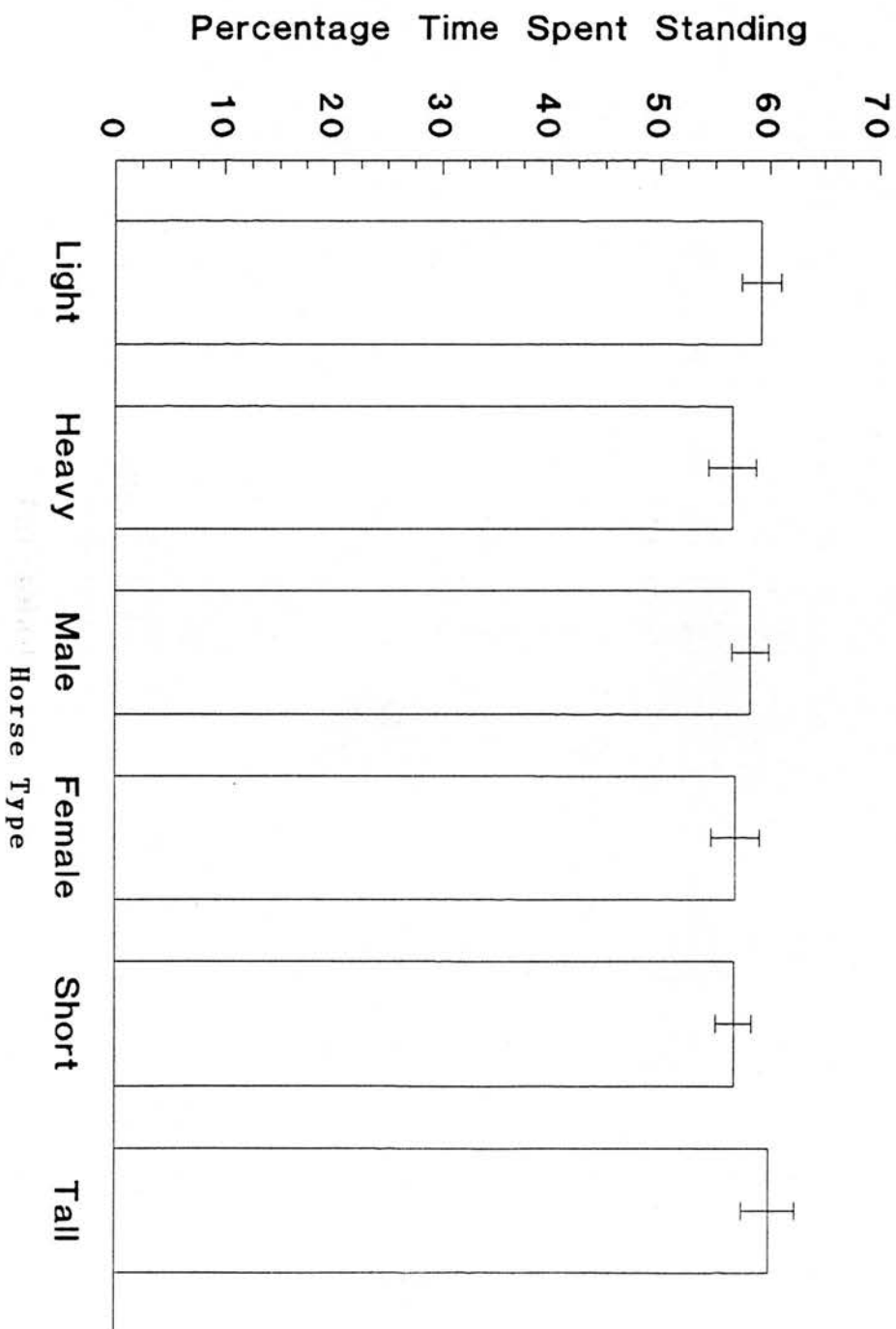

Bar Chart 4.2 (h)

Time Spent Lying
Household Cavalry Horses $F = 1.489$ ($p = 0.1183$)

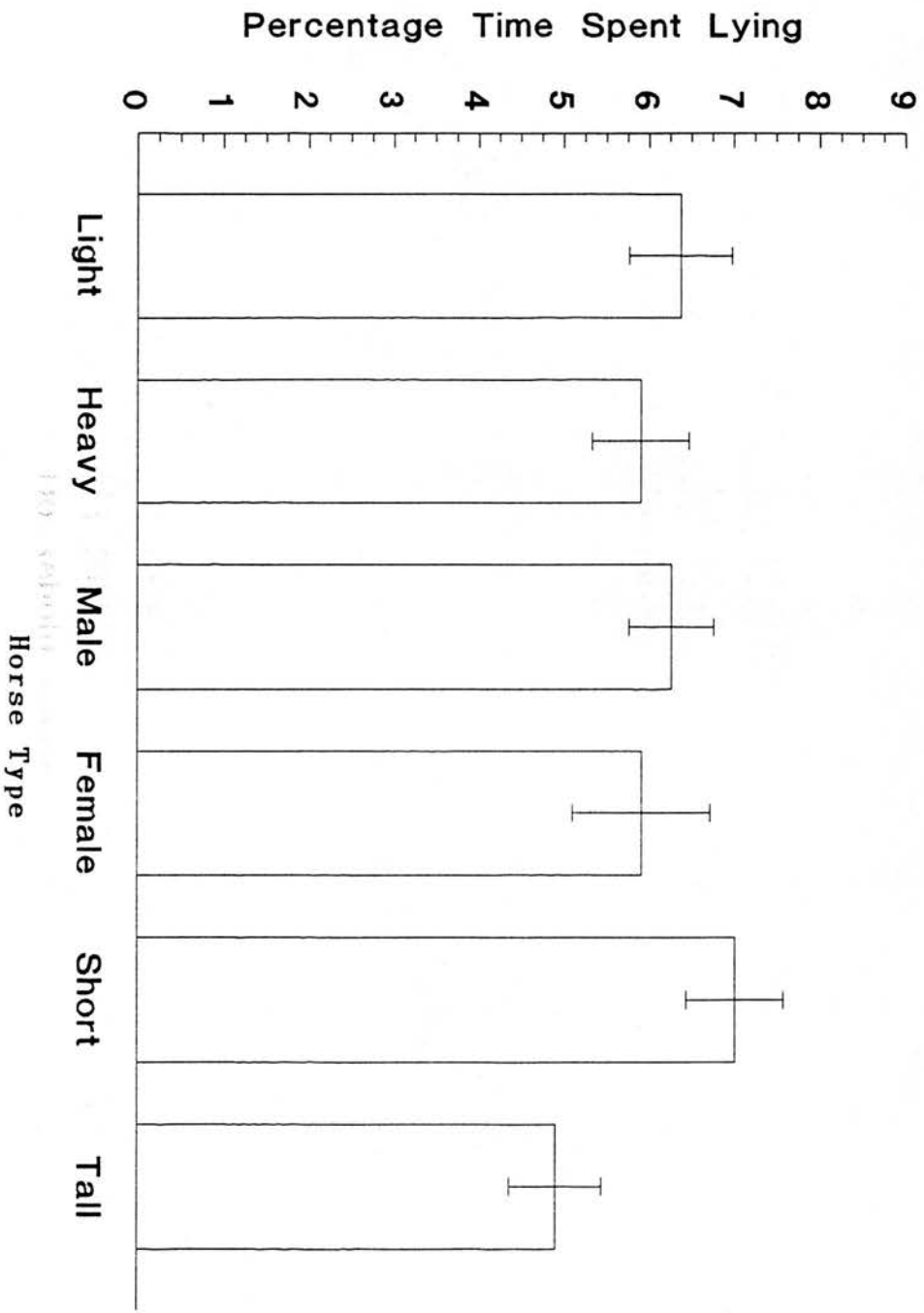

Bar Chart 4.2 (i)

Time Spent Leg-Resting Household Cavalry Horses

F = 1.342 (p = 0.1859)

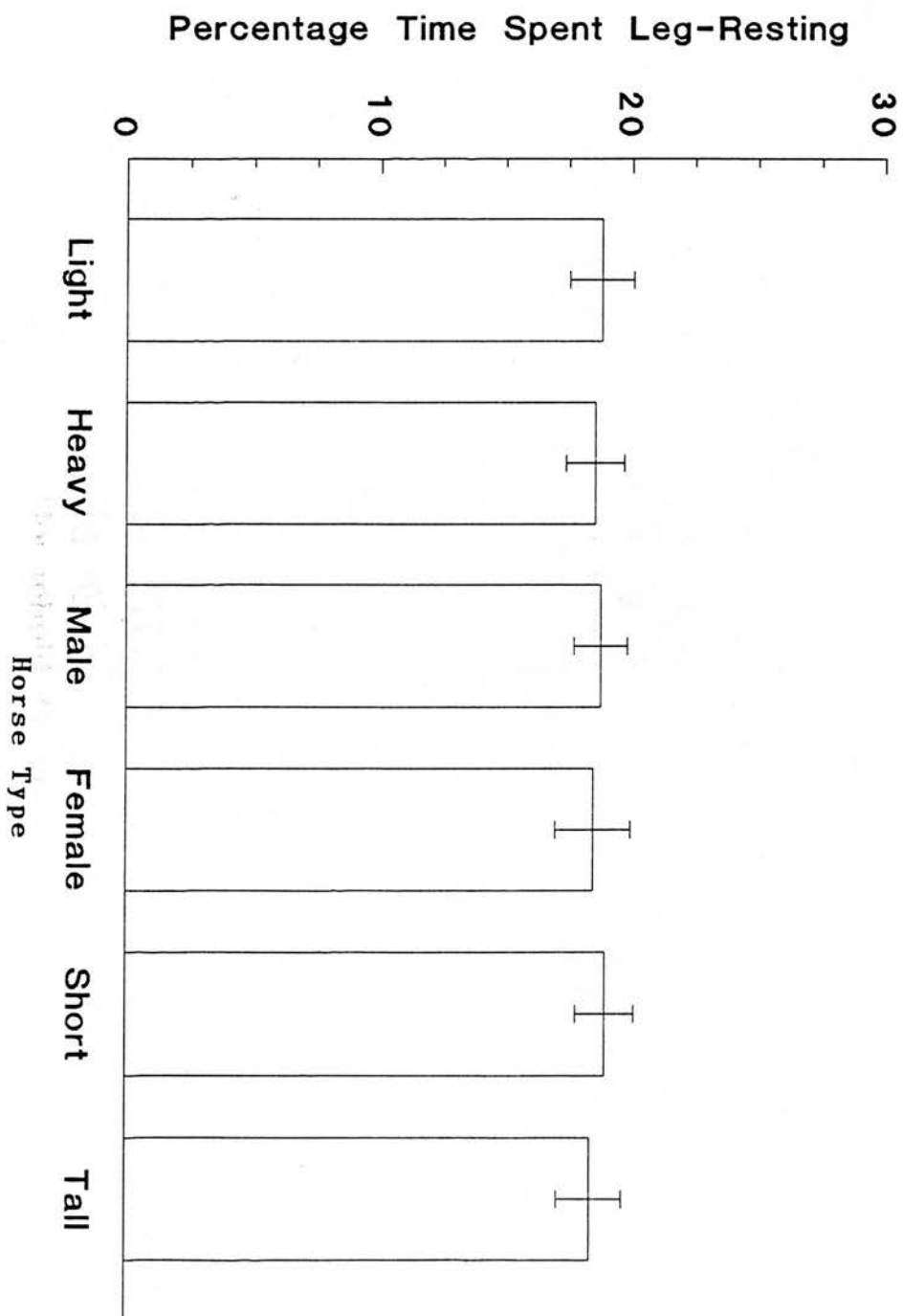

Time Spent In Leg Movement

(including abnormal leg movements)
Household Cavalry Horses

KW = 11.237 (p = 0.5910)

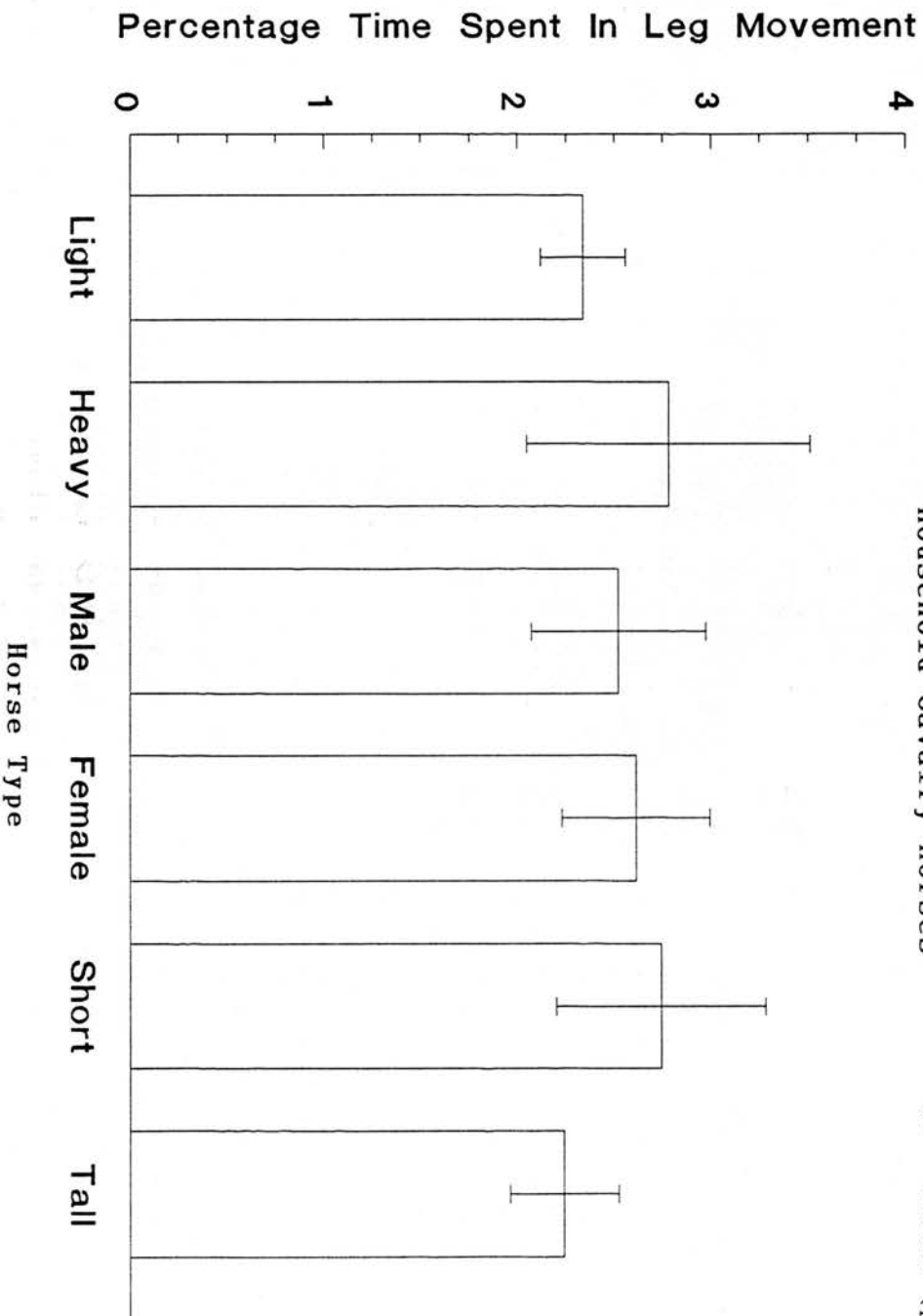

Bar Chart 4.2 (k)

Time Spent In Stereotypic Behaviour

Household Cavalry Horses

KW = 8.622 (p = 0.4729)

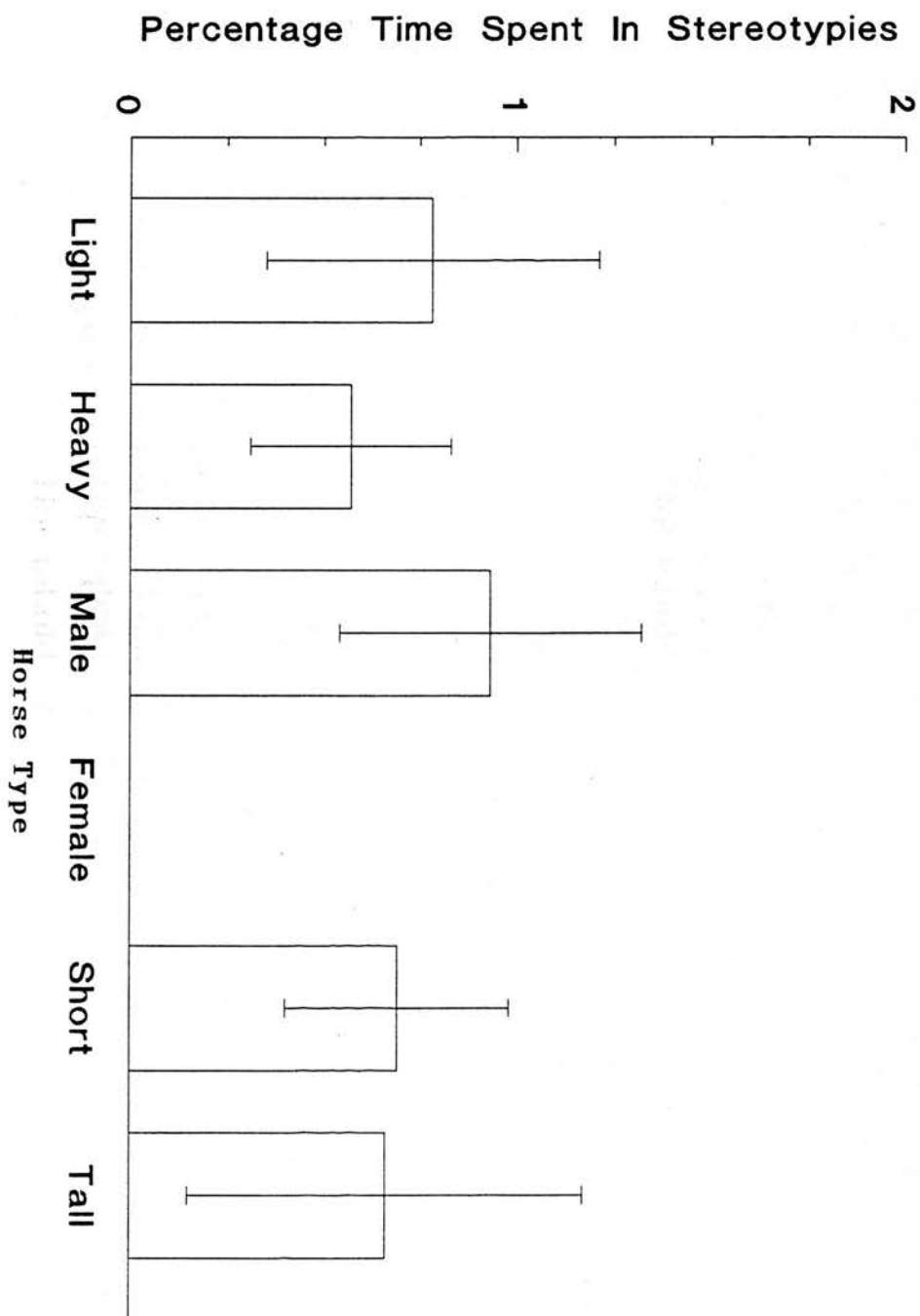

Bar Chart 4.2 (1)

Time Spent In Interaction

Household Cavalry Horses

F = 0.4398 (p = 0.9546)

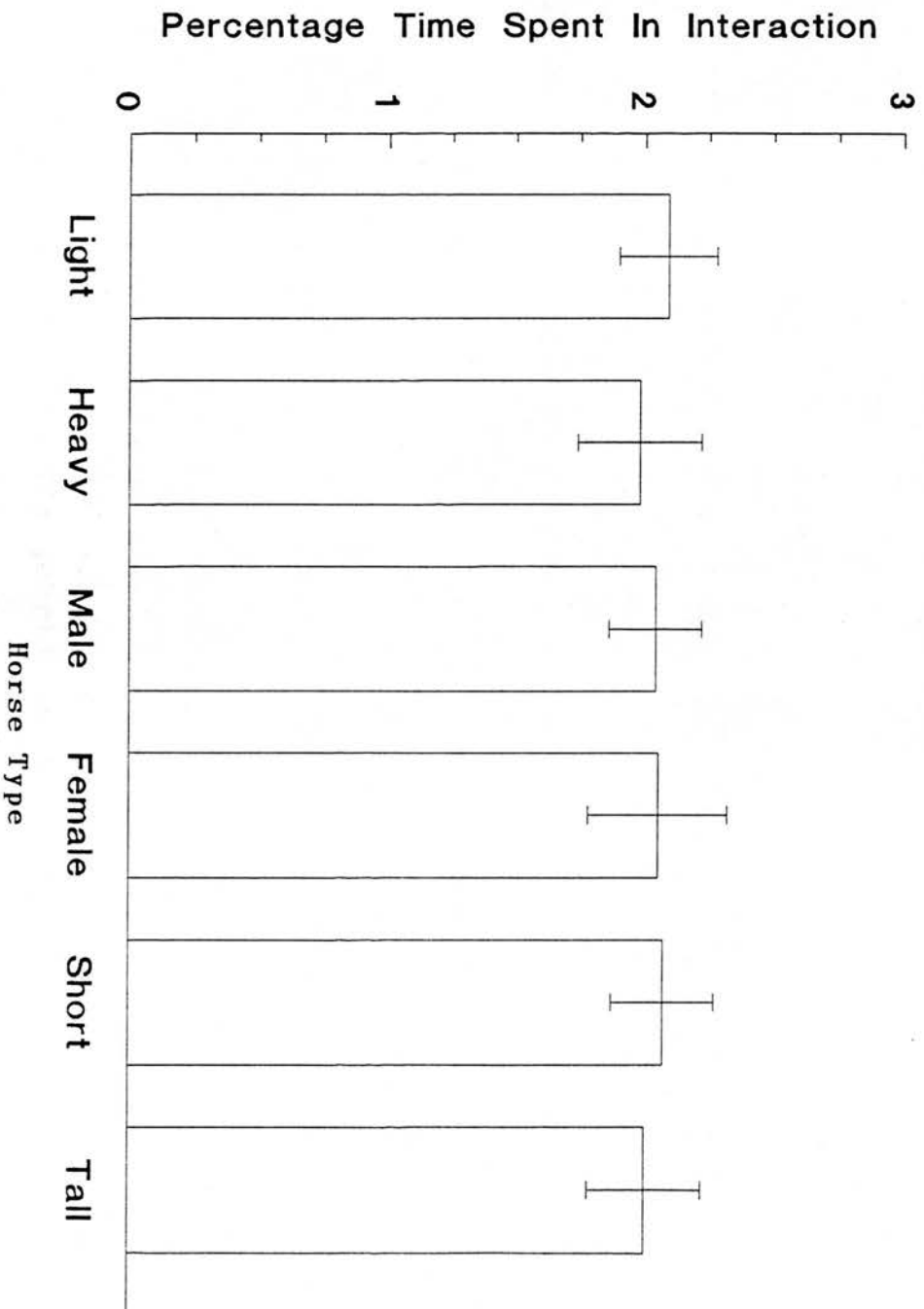

As shown in Bar Charts 4.2 (a)-(1), none of the behavioural categories was significantly (i.e. $p > 0.05$) affected by horse type.

D. GENDER

Animals were divided into 2 groups according to gender (either mare or gelding i.e. castrated male). While the time spent in most behavioural categories (eating, oral movement, being alert, being non-alert, resting, standing, lying, leg-resting, leg movement, showing stereotypic behaviour and interacting) was not significantly (i.e. $p > 0.05$) affected by the animal's gender.

Welch 't' test showed that the time spent sleeping was significantly affected by gender ($p = 0.0089$). Bar Chart 4.2 (f) illustrates the difference in time spent sleeping between the genders. Females spent on average 3.7% of their time sleeping compared with 2% in males.

E. HEIGHT

Horses were divided into 2 categories for analysis ("Short" i.e. less than 16.1 hands high and "Tall" i.e. over 16.1 hands high). The time spent in the behavioural categories shown in Bar Charts 4.2 (a)-(1) was not significantly (i.e. $p > 0.05$) affected by height.

CHAPTER 5

DISCUSSION

5.1. TIME SPENT IN MAJOR BEHAVIOURAL CATEGORIES

A. INGESTIVE BEHAVIOUR

The Household Cavalry horses spent on average 36.3% of their time feeding. In addition to eating concentrates and hay, some straw bedding was eaten. Although it was difficult to tell, from video observations, whether a horse was eating hay or straw, it was assumed that it generally took no longer than two hours to ingest the hay.

The figure of 36.3% is considerably less than the time spent eating by feral horses or domestic horses at pasture, as shown in Table 2.1. The average amount of time that feral horses appear to spend feeding is 75%. Willard et al., (1977) observed that stabled horses on a concentrate diet spent less time eating, and more time standing, than horses fed hay only. Sweeting et al., (1985), Houpt (1991) and Kiley-Worthington (1990) all observed that hay available ad libitum resulted in similar times spent eating to those of feral horses.

The Household Cavalry horses had restricted access to food and, owing to a large proportion of their diet consisting of grain, they tended to eat their ration

more quickly than if they were fed hay only or were at pasture (Laut et al., 1985; Sweeting et al., 1985; Ruckebusch et al., 1976). Adult feral horses need relatively high energy intakes in order to maintain body condition without protection against the weather as well as, in the case of mares, supporting pregnancy and lactation and, in the case of stallions, supporting reproductive activity. The energy content of feral horses' diets is much lower than the concentrate-based Household Cavalry diet, and one would expect feral horses to spend considerably more time eating so as to meet their energy requirements.

Stalled horses are not subject to seasonal variation in the quality of their feed, unlike feral horses who must further increase their time spent feeding in the winter to compensate for poorer quality forage (as well as for possibly reduced availability of forage and increased energy requirements for thermal homeostasis) (Ralston, 1986). The energy content of grass can fall from 12.0 to 9.5 MJ/kg DM and the digestible crude protein from 185 to 100 g/kg DM in winter (Pilliner, 1992). If forage is particularly sparse or of poor quality, up to 80% of a 24-hour period may be devoted to grazing (Rubenstein, 1981). No seasonal variation in time spent feeding is, therefore, expected in stalled horses, and none was found with the Household Cavalry horses.

The amount of feed given to Household Cavalry horses was principally related to their exercise requirements. For the horses studied, the average time spent on exercise was 4.92%, which is about half the time spent by adult Camargue horses, as shown in Table 2.2. However, the energy requirements of Household Cavalry horses for exercise (or work) were probably greater since they had the burden of carrying riders, and the overall energy requirements were probably similar although considerable variation would be expected.

The Household Cavalry horses, weighing an average of 600 kg, might be expected to require 79 MJ DE per day for maintenance and as much as 40 MJ DE per day for the work they undertake (according to the tables designed by Pilliner, 1992). Camargue horses, weighing an average of 400 kg, will require approximately 48 MJ DE per day for maintenance and possibly only another 10 MJ DE per day for exercise (although this figure is only approximate as Pilliner, 1992, does not detail energy requirements for unriden work). The Camargue horses may, of course, have additional energy requirements depending on factors such as pregnancy and lactation, as well as harsh climatic conditions during the winter. It is estimated that "exposed" horses, averaging 400 kg in weight, require between 22% (mild winter) to 44% extra feed above maintenance to maintain weight between mid October and mid April - smaller horses need proportionately more extra feed in the winter as their heat loss is greater

than for larger horses (Aberdeen Association for the Prevention of Cruelty to Animals, 1991).

The amount of time spent feeding by Household Cavalry horses is similar to the figures recorded by Houpt and Houpt (1992), and Ralston et al. (1979). The horses in the studies by Houpt and Houpt were in stalls and those in the study by Ralston et al. were in small pens. In both these studies the horses had restricted access to concentrates and hay. In the study by Sweeting et al. (1985), shown in Table 2.1, the stalled horses were on a restricted concentrate diet but spent up to 70% of the observed periods (day-time only) eating. These animals were provided with mixed-grass hay ad libitum, which allowed them to eat for a greater percentage of their time.

The Przewalski horses in the study by Boyd et al. (1988) fed for only 46% of their time, despite being on pasture. These horses were provided with concentrates, even during the summer when the study was conducted. In addition, juveniles in the study herd may have lowered the overall percentage (juveniles have been found to feed for less time than adults, Duncan (1980)). The quality and availability of grass in the summer may have been a factor in reducing the overall time spent foraging and excessive heat or flies may have forced the horses to reduce their grazing time and seek shelter.

The Household Cavalry horses are mares and geldings only. The lack of opportunity to perform reproductive behaviour, other than oestrous displays by the mares, may affect the relevance of comparison of time budgets with feral horses. For example, lactation requires a considerable energy intake and feral mares seemingly respond by spending a greater length of time grazing (Powell and Jackson, 1992).

In conclusion, the 36.3% time spent feeding by Household Cavalry horses is similar to the percentage found in other studies on confined horses fed concentrates and restricted hay. The figure is much lower than for feral horses principally owing to the restrictions on quantity of forage available, as well as the high energy content, and overall high quality of the ration provided. Although the energy requirements of the Household Cavalry horses are relatively high (owing to their work load being moderately high), they are largely unaffected by seasonal variations in weather and quality of forage, or by factors such as pregnancy and lactation.

The Household Cavalry horses spent 1.01% of their time drinking. This figure is greater than those shown for feral horses in Table 2.1, although these figures were not produced from 24-hour observation periods. Feist (1971) noted that free-roaming horses with limited access to water may drink only once a day and Pellegrini (1971) stated that drinking only every other day had been observed, although overall time spent was not calculated.

Sweeting et al. (1985) recorded horses in stalls spending 2% of their time drinking. However, his observations were daytime only. It is possible that the Household Cavalry horses also derived water from the hay which is routinely soaked prior to feeding, in order to reduce the risks associated with dust inhalation. Some horses were observed to soak the hay further by dipping mouthfuls into their water bowls prior to ingestion. Therefore, the horses probably took in more water than the figure of 1.01% time spent drinking might suggest.

B. LEVELS OF ALERTNESS AND POSTURE

Of the four recorded states of alertness, the Household Cavalry horses spent, on average, 63.03% of their time non-alert, 10.89% resting, 2.33% sleeping and 7.50% alert (if the 4.92% time spent exercising is included, the total time alert was 12.42%).

The horses spent 57.92% of their time standing, 18.67% leg resting, 5.13% lying sternally and 1.04% lying laterally. These findings are shown, along with alertness state, in Chart 5.1.

Alertness state and posture are discussed under one heading since, in the absence of electrocorticography and concurrent electromyography, as used by Ruckebusch (1972), they both provide information on resting and

Chart 5.1

**TOTAL 24-HOUR PERIOD OF TIME RESTING FOR
HOUSEHOLD CAVALRY HORSES**

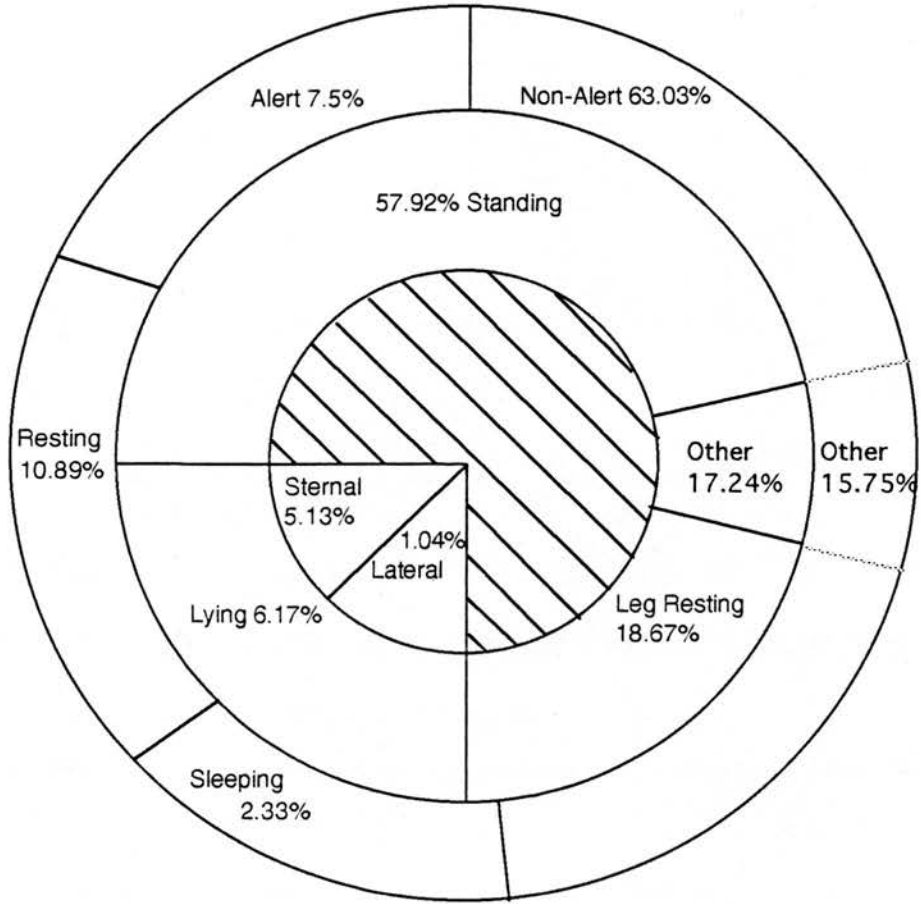

Note:

"Other" category includes absence from stall, locomotion within the stall (2.54%) and transitions from one posture to another. It also includes 4.92% time spent exercising, which may be added to the time spent alert (7.5%) in the stall to give a total time alert of 12.42%

sleeping behaviour. Assumptions based on the preferred posture for paradoxical sleep (PS) being lateral recumbency different states (Dallaire, 1974) and on other observations (such as position of head, expression and lack of movement) must be made in order to assess the alertness state. However, the variety of terminology used in the literature to describe alertness states complicates the comparison of findings.

Resting

The term "stand-resting" as opposed to the term "stand-awake" (both of which are used in Tables 2.1 and 2.2), is understood to correlate with the "resting" category in Chart 5.1 rather than the "leg-resting" category. The "leg-resting" category may include horses which, although non-alert, may not show all the signs of drowsiness, such as head being down, eyes partly closed and lower lip relaxed, associated with "resting".

Duncan (1980) recorded adult Camargue horses "stand-resting" for, on average, 18% of a 24-hour period. This study took place in the summer when it was possible, owing to an abundance of good quality grazing and the need to shelter from the sun and biting insects, that the horses spent more time resting. Sweeting *et al.* (1985) found that horses in stalls spent only 7% of their time "stand-resting" but this study was of little value, for comparative purposes, in this case as it involved

only daytime observations. Boyd et al. (1988) recorded the Przewalski horses kept in small enclosures spent 16% of their time "stand-resting". This study was also conducted in the summer.

The Household Cavalry horses, therefore, spent less time resting (10.89%) than either the free-ranging Camargue horses or the Przewalski horses kept in enclosures. Whilst the Camargue and Przewalski horse studies may have been influenced by the summer climate, it would nevertheless appear that the stalled horses in Knightsbridge and Windsor rested considerably less than free-ranging horses or horses in enclosures. However, in addition to the climate, the type of horse could be a factor in this comparison. The type of horse is known to affect time spent in recumbency (Ruckebusch, 1963), which may reflect time spent in paradoxical sleep (Dallaire, 1974), and so resting may also be influenced in this way. The relatively calm type of horse required by the Household Cavalry to stand on guard duty and not be disturbed by London traffic may spend less time resting than some other types. One might, however, expect "calm" horses to be less aroused by environmental stimuli and to spend more time resting as a consequence.

Diet was unlikely to be a factor in producing the relatively low time spent resting percentage. Diet has only been shown to produce short-term (i.e. 3 to 4 days)

effects on sleep (Dallaire and Ruckebusch, 1974). The lower time spent eating (36.30%) for Household Cavalry horses compared with feral horses (average 75%) might be expected to produce a "gap" in the horses' time budget which could be filled by more time resting. This does not appear to have occurred. It is possible that the sensory stimulation associated with the busy daily routine shown in Appendix B reduced the resting time. This could also account for the relatively high figure of 7.5% or, inclusive of time spent on exercise, 12.42% time spent alert, in comparison with other studies.

Alertness

The horses in the Sweeting et al. (1985) daytime study spent only 2.1% of their time in a state of alertness. One might expect this figure to be reduced in a 24-hour study owing to the reduced sensory stimulation at night. These horses were used solely for experimentation and were kept largely undisturbed. Free-living Camargue horses (Duncan, 1980) spent 7.5% of their time alert. This is similar to the figure for Household Cavalry horses but lower than the overall figure of 12.42% when exercise was included. The activity surrounding these horses may account for this result since, unlike the Camargue horses, the Household Cavalry horses might be expected to be less alert overall since they do not have the same need to be alert in order to detect predators, potential

rivals, possible mates and those other factors associated with living in a free-ranging herd.

However, it is also possible that the low figure for time spent resting and relatively high figure for time spent alert could be interpreted as signs that the horses have not adapted to their environment and are, as a result, unwilling to relax. Hammon (1991) stated that one of the effects of chronic frustration was to increase alertness. If this were the case, one might also have expected the horses to spend less time sleeping or less time recumbent (Dallaire, 1974). Horses will reportedly only lie down when they are confident about their environment (Belling, 1990). Horses would also be expected to show an increase in abnormal behaviour if they suffer from sleep deprivation (Haupt, 1980).

In fact, the level of stereotypic behaviour (2.5% of the horses showed stereotypies as 2 horses cribbed out of the total of 80 studied) appears low compared with the findings of authors such as Borroni and Canali (1993), at 5.9% total, and Vecchiotti and Galanti (1986), and Luescher et al. (1991) at between 7 to 15%. It is possible that abnormal behaviour associated with sleep deprivation may only occur in the short-term (for instance, only for 48 hours or so following a period of transport) and that long term they tend to adapt (Dallaire, 1986). There was no evidence from the current study that abnormal behaviour was increased by a relatively low time spent resting,

and the relatively low time spent sleeping also seems not to have greatly influenced abnormal behaviour.

Sleeping

The time spent sleeping was 2.33% (or 0.56 hours per 24-hour period). The time spent in recumbency was 6.17% (5.13% sternally and 1.04% laterally). These results are particularly interesting as they differ quite markedly from the findings of Dallaire (1974; 1986). Dallaire (1974) described standing, resting (or "stand-resting") and sternal/lateral recumbency as being the preferred postures of drowsiness, slow-wave sleep and paradoxical sleep respectively. This correlation would appear to be of little value for this study since, if these postures were an accurate indication of stages of sleep, then paradoxical sleep might have been expected to occupy 6.17% of the Household Cavalry horses' time. Slow-wave sleep would be represented by the resting category, without any periods lying down, and drowsiness would correlate most closely with the 18.67% leg-resting period. Even allowing for any possible limitations on detecting fine details, such as half-closed eyes or drooping lower lips when the horse's head was facing away from the camera, which might be associated with video observations, the categorisation of sleeping and resting in this study should be more accurate than by observing posture alone. However, it was assumed that lateral recumbency did represent paradoxical sleep and the horse's face could

not be seen in this position.

In field studies, observation of fine details is much more difficult to achieve and postural observations alone often have to suffice.

Contrary to the findings of Dallaire (1974), the paradoxical sleep element of the Household Cavalry horses can only have been between 1.04% (lying laterally) and 2.33% (total sleep time). Ruckebusch et al., (1970) stated that paradoxical sleep only occurred in lateral recumbency. If this was so, then Household Cavalry horses spent 1.04% of their time in paradoxical sleep and the remaining sleep time (1.79%) in slow-wave sleep. The 10.89% resting category would still represent drowsiness. It is possible, owing to the limitations of observation alone (i.e. in the absence of monitoring/recording devices) that some overlap of sleeping into the resting category occurred, and possibly also some overlap of resting (or drowsiness) into the leg-resting category for the Household Cavalry horses.

Boyd et al., (1988) found that Przewalski horses, in enclosures with concentrate supplementation, spent a similar amount of time recumbent when compared with the Household Cavalry horses. However, these horses included juveniles who were recorded as spending considerably more time recumbent than adults (Duncan, 1980). Camargue adult horses spent, on average, 4.5% of their time

recumbent (Duncan, 1980). Kowanacki et al., found that adult Polish primitive mares spent 3.6% of their time recumbent. It would appear, therefore, that Household Cavalry horses spend more of their time recumbent than adult free-ranging horses or Przewalski horses kept in an enclosure. If only a small part of the time spent in recumbency was for the purpose of paradoxical sleep (1.04% lying laterally) then the remaining time was probably an indication that the Household Cavalry horses felt secure and could relax more fully in this particular stalled environment. Dallaire (1980) stated that horses will lie down to rest when they feel confident about their environment. Lack of necessity to forage, owing to the horses receiving much of their energy requirements in a relatively short period as concentrates, could also affect time spent in recumbency (Belling, 1990). It is also possible that the work which the horses did on hard ground encouraged them to lie down, in order to rest their legs, even when they had no desire to sleep.

Feral horses might be expected to stand more as protection against predators, although one might also have expected the Household Cavalry horses to spend more time resting and less time alert - that this was not found suggests that their increased alertness was probably a consequence of the raised activity levels around them, rather than indicative of unease or frustration.

Ruckebusch (1972) recorded stabled horses spending one

hour in paradoxical sleep, on average, and two hours in slow-wave sleep per 24-hour period. This was considerably more than the 0.6 hours (2.33%) time spent in total sleeping by Household Cavalry horses, of which 1.04%, or 0.25 hours (time lying laterally), may represent paradoxical sleep. Ruckebusch (1972) did not differentiate between postures during these phases and so any other form of comparison was not possible. Nomura et al., (1980), however, recorded stabled horses spending only 2-4% of their time lying and sleeping most when standing. The study by Ruckebusch (1972) studied only 3 stallions, which were selected for having apparently prolonged and relatively unvarying sleeping patterns, while Nomura et al., (1980) studied only 2 stallions. Duncan (1980) noted that stallions appeared to spend more time sleeping than mares. The use of so few animals of the same sex and type, under experimental conditions, may detract from overall significance of their results. Nevertheless, the reduced time apparently spent in paradoxical and slow-wave sleep, without any marked increase in abnormal behaviour which might be associated with sleep deprivation (Haupt, 1980), could be another indication, along with long periods spent alert and reduced time resting, that the horses were stimulated by their environment without suffering from any obvious detrimental effects, particularly since sensory deprivation has been shown to increase sleeping time (Dallaire and Ruckebusch, 1974).

One may conclude that the high alertness states in Household Cavalry horses, although probably responsible for reducing the resting and sleeping times, was not indicative of chronic frustration, and hence the high degree of alertness did not represent impaired welfare.

Standing

Standing accounted for 57.92% of the horses' time at Knightsbridge and Windsor, and, if the time spent leg-resting was included, the total time standing was 76.59% or 18.4 hours. This percentage (76.59%) is slightly more than the time spent standing in the studies by Houpt et al., (1986), which recorded 71%, and by Shaw et al., (1988), which recorded 67%. In both these studies the horses were kept in stalls, but observations were made only at night. According to Ruckebusch (1972), horses are recumbent mostly at night and paradoxical sleep only occurs at night with adult horses. The horses in Ruckebusch's study, the results of which are summarised in Table 2.5, were only recumbent at night. The time spent standing at night would, therefore, be expected to be lower than for a 24-hour period.

No information is available on type of bedding, size of stalls, period that the horses had spent in the particular stables, and other environmental factors which may affect lying down in many of the studies on stabled

horses. It may be that the Household Cavalry horses were the only horses studied which did not have their stalls bedded down during the day (from 0800 - 1500 hours there was only a day litter which the horses could not lie on, as shown in Appendix B). This would obviously have forced them to spend more time standing. It could also be that the bedding was generally drier or more comfortable in other studies, encouraging more recumbency and correspondingly less time spent in the intermediate leg-resting stage. The size of stalls may have discouraged relatively large horses from lying down, or at least inhibited lying laterally for fear of becoming cast. However, the overall time in recumbency was comparable with other stabled horse studies (Ruckebusch, 1972).

Diet would appear to have a significant influence on time spent standing. Sweeting et al., (1985) found that the time spent standing increased from 19% to 23% when the diet was changed from ad libitum hay to restricted hay. The overall remarkably low percentage time spent standing (19% or 23%) could have resulted from environmental factors such as the stalls being particularly large or well bedded down, or it could relate to the type of pony used. Willard et al., (1977) found that feeding concentrates rather than limited hay increased the time spent standing, in metabolism cages, from 45% to 62%.

It would seem that the time spent standing by Household Cavalry horses was influenced by their concentrate and restricted hay diet as well as lack of bedding during the day and other possible factors such as stall size, type of horse and environmental stimulus. Lack of day bedding was possibly the most important factor.

C. LOCOMOTION

The horses were exercised for 4.92% of their time and moved of their own volition within their stalls for 2.54% of their time (total of 7.46% spent in movement). This is similar to the percentage recorded (7%) by Boyd et al., (1988) in their study of Przewalski horses kept in enclosures. It is rather less than the figure recorded (10%) for adult Camargue horses by Duncan (1980), but considerably more than the 4% recorded by Kowanacki et al., (1978) on Polish primitive mares. The Polish primitive mares were studied in the winter and fed hay so they were possibly lacking incentive to leave the sheltered areas near their feeding sites. The Camargue horses were studied in the summer and received no supplementation. Their overall movement may have been reduced by their need to forage and to seek shelter from flies and heat during the day. In every case, the environment would appear critical in affecting the time spent moving.

The Household Cavalry horses had no choice in the time spent exercising and the 2.54% time spent moving in the stalls must have been largely dictated by the confines of the stall and restrictions of tethering. The low percentage of abnormal behaviour (2.12%), including stable "vices" or stereotypic activities related to locomotion, compared with other stabled environments (e.g. Borroni and Canali, 1993), is a possible indication that the decrease in amount of time spent moving compared with free-ranging horses such as those in the Camargue is insufficient to cause weaving or other locomotory disorders (Haupt, 1986). Although the percentage time spent in movement was less than for Camargue horses, the extra effort involved in carrying a rider probably required more energy overall to be expended in movement. The effects of exercise on long-term locomotory behaviour have not been investigated. Caanitz et al., (1991), who found that exercise had little significant effect, looked only at short-term associations.

In summary, the time spent in movement by Household Cavalry horses was largely dictated by the exercise they were given and the limitations imposed by the stalls. The time spent in movement appeared less variable than for feral horses and this may be because factors such as flies, heat and cold had little influence in the Barracks. The overall energy expended in movement may have been similar to that expended by some feral horses

(Duncan, 1980). In view of the lack of abnormal locomotory behaviour, one may conclude that the restrictions imposed on movement, under these circumstances, did not significantly affect the horses' welfare.

D. SOCIAL BEHAVIOUR

The horses in this study were recorded as spending 2.04% of their time interacting with other horses. Social interaction has seldom been recorded in studies of free-ranging and confined horses and self-grooming is usually the only form of comfort behaviour noted, as can be seen in Tables 2.1 and 2.2. This makes comparisons with other studies difficult.

Grooming

Interactions such as mutual grooming, which is a form of comfort behaviour, are prevented by the design of the stalls, which have wire meshes extending from the wall to halfway down the length of the stall. The horses could, however, touch each other's muzzles and react to visual, auditory and olfactory stimuli originating from the horses on either side of them. The tether rope prevented the horses from moving back in their stalls and touching each other behind the wire mesh.

It may be that the physical element of interactions, especially mutual grooming, may not be a particularly significant factor in ensuring horses' well-being or it is possible that there are factors such as grooming by handlers which compensate. Feist and McCullough (1976) found that 90% of mutual grooming sessions in free-ranging animals lasted less than 3 minutes, whilst Wells and Goldschmidt-Rothschild (1979) noted that some free-ranging horses never indulged in it. The importance of mutual grooming in establishing dominance hierarchies is also uncertain since Tyler (1969) found that subservient animals often initiated it whereas Watt (1993) found that dominant animals usually did so. Boyd *et al.*, (1988) recorded that only 2% of the Przewalski horses' time was spent mutually grooming in enclosures.

The horses are groomed for up to 20 minutes during the period from 1045 hours to 1200 hours, as well as a further 10 minutes being spent adjusting their rugs, picking their feet out or tacking them up, each day. This is shown in Appendix B. Horse-to-horse physical contact is very limited (although some direct contact is possible when they are ridden out of Barracks en masse), so that human contact is the only means of grooming other than self-grooming, which is restricted by tethers in any case. Feh and de Mazieres (1994) record that grooming at a preferred site (front of shoulder) results in significant heart rate reductions. The low level of

abnormal behaviour (2.12% total) may be an indication that the low level of interaction between horses, at least in part resulting from the restrictions of the stall and its limitations on physical contact, did not significantly affect the horses' welfare. The lack of abnormal behaviour may be a guide, in this instance, that the horse's basic needs were not being denied but may not serve to indicate, perhaps at a more sensitive level, that all their preferences were being met. Houpt and Houpt (1992) found that horses given free choice would spend between 88 and 95% of their time outside of stalls and half of their time in contact with other horses.

In my opinion, the lack of physical contact between Household Cavalry horses was sufficiently compensated for by human contact and the close proximity of other horses at all times. This is reflected in the low levels of abnormal behaviour.

Interactions

The low level of aggressive interactions may represent a reasonable degree of perceived security by the horses in their stalls. The free-ranging horses studied by Feist and McCullough (1976) would frequently show threatening behaviour if other horses within the herd came within a distance of 1.5 metres. The horses at

Knightsbridge and Windsor were regularly changed between stalls (although not between different Troops) but the low level of overall interaction would suggest that this change of neighbouring horses, or the enforced close proximity of other horses, did not result in increased agonistic behaviour.

The constant routine, with all horses being fed individually and receiving attention from the soldiers at the same time, combined with the protection from unpleasant interactions which the stall walls and wire mesh provide, could presumably have contributed to the perceived security felt by the horses, as well as reducing attention-seeking behaviour and competition for feed. This would be in keeping with the findings of Waring (1983) who noted that environmental context was important in affecting agonistic responses and a stalled environment may encourage lying.

Isolation

Social isolation has been observed to affect horses' behaviour quite markedly. Houpt and Houpt (1992) recorded that horses with no other horses present were three times more active and spent 10% less time eating than those that could make visual, auditory and physical contact with other horses. Marsden (1993 a) noted that horses kept in loose boxes showed more abnormal behaviour than those kept in stalls or loose-housing systems. The

percentages for time spent in an alert state, time spent moving, time spent eating and time spent in abnormal behaviour by the Household Cavalry horses do not suggest that their partial physical isolation (in so far as contact is limited) had any significant effect on the horses' behaviour.

Other than loose housing, it would be difficult to design an indoor environment where the horses were in closer visual, auditory, olfactory and, to a limited degree, physical contact with other horses. Each horse can see up to 30 other horses at any time. This should reduce any feelings of isolation.

Confinement

The effects of confinement, as well as social isolation, were studied by Mal et al., (1991). The study concentrated on short-term confinement and the confinement stalls were, at 4.2m x 6.0m, what would be described in the U.K. as loose boxes. From this study, it appeared that confined mares exhibited more standing and activity bouts than mares at pasture. That standing should be interpreted to represent increased activity in confined mares is contentious. No increase in locomotion was noted and abnormal behaviour was not recorded. The relatively high percentage time spent alert could be an indication, according to the findings of Mal et al., (1991), that the horses are affected by confinement in

stalls, and that their well-being is compromised (Dellmeier, 1989). However, the increased alertness levels are considerably less than those found by Mal et al., (1991). Borroni and Canali (1993) noted that decreasing paddock size affected behaviour by increasing locomotory problems such as weaving and pacing. This effect may be relatively short-term and it is possible that Household Cavalry horses have overcome these problems by adapting to their environment.

The lack of locomotory abnormal behaviour or other increase in locomotion suggests that the Household Cavalry horses were coping with their confinement and their increased alertness levels were probably unrelated to the restrictions imposed by stalls. It is suggested that confinement, in the absence of isolation and in the context of the Barracks environment, has little effect on their welfare.

E. ABNORMAL BEHAVIOUR

The total time spent in abnormal behaviour by Household Cavalry horses was 2.12% and the time spent in stereotypic behaviour was 0.69% (limited to 2 horses who cribbed). The non-stereotypic behaviour patterns recorded included most of the categories listed in Appendix D under the headings "Feet" (e.g. stamping, kicking and pawing), "Head" (e.g. head shaking and tossing) and "Oral" (e.g. biting, nudging and chewing).

"Boredom"

Abnormal behaviour has been referred to and discussed several times in the preceding subsections of this chapter. Marsden (1993 b) stated that the most important cause of abnormal behaviour is lack of time spent feeding (e.g. less than 15 hours per day). She also found that spatial restriction had a relatively marginal effect compared with lack of time spent eating. The Household Cavalry horses spent less than 9 hours per day eating and this may, therefore, have been a major contributory factor in the appearance of abnormal behaviour patterns. However, the level of abnormal behaviour was low compared with the findings of other studies in stabled horses such as Borroni and Canali (1993), Vecchiotti and Galanti (1986) and Luescher et al., (1991).

The relatively low level of abnormal behaviour has already been explained, in part, by the suggestion that the regular and busy stable routine with considerable sensory stimulation may compensate for the "gap" in the time-budget which would be filled by eating in free-ranging horses, or horses fed hay ad libitum. Kiley-Worthington and Wood-Gush (1987) suggest that insufficient environmental stimuli may be a significant cause of stereotypic behaviour. The difference in the stabled horse's time-budget from that of its feral conspecific, without any strong suggestion of impaired welfare (such as greatly increased levels of abnormal behaviour),

highlights one difficulty in the use of time-budgets in the assessment of animal welfare. Marsden (1993 a) points out that positive adaptations to environmental change should be recognised by attention to the detail of quantitative changes (such as increased alertness states or increased horse-to-human interaction). She states that experimentation to reproduce or eliminate qualitative changes is also useful in realising the full potential of time-budget analysis in the assessment of welfare.

"Frustration"

Marsden (1993 a) also found that frustration of feeding behaviour (and, to a lesser extent, frustration of movement) was the main cause of abnormal behaviour rather than boredom. Pilkington et al., (1994) noted that weaving was primarily associated with periods of high activity or disturbance, rather than periods where boredom could have been a causal factor, in those horses which exhibited this form of abnormal behaviour. Although the sensory stimulation of their environment may compensate for lack of time spent feeding, it is possible that the strict management routine, with all horses being fed simultaneously at the same time of day and exercised daily at the same time, may, therefore, be of considerable importance also in reducing the level of abnormal activity.

In support of this conclusion, Kusunose (1992) suggested that crib-biting was caused not so much by boredom as by frustration of ingestive behaviour associated with denial of access to palatable feeds. Kusunose (1992) and Pilkington et al., (1994) found that the three major cribbing periods in the diurnal pattern of the horses studied co-occurred with concentrate meal deliveries. The study by Pilkington et al., (1994) was carried out on Household Cavalry horses. This study found that weaving was not associated with feeding-related activity. These findings emphasise the association between frustration of access to a palatable feed and the occurrence of cribbing. Sato et al., (1994) found that inconclusive tongue-playing in tethered Japanese Black cattle also emerged in the diurnal pattern, at a significantly higher level, during the periods associated with feeding behaviour. Dodman (1987) suggested that eating may stimulate the release of endorphins which, in turn, triggers dopamine release and enhances cribbing and windsucking behaviour.

Confinement

In addition to stable routine and sensory stimulation compensating for the time-budget gap produced by a restricted-hay diet, any possible effect of confinement in producing abnormal behaviour (Marsden 1993 a) may be reduced by the regular exercise imposed on the horses - a factor which may not be included in experimental

surroundings (e.g. Mal et al., (1991)). The study by Caanitz et al., (1991) which found that exercise had no significant effect on locomotory behaviour in stabled horses, was strictly short-term and probably has little relevance to this study. Any locomotory anomalies which developed in Household Cavalry horses would probably be associated with chronic effects of confinement and would possibly develop over relatively long periods (as opposed to a day-to-day basis) since these horses have all been in Barracks for, at least, several months and, in many cases, several years (as shown in Appendix A). Houpt (1981) noted that weaving occurred mainly in stabled horses which had done no work for long periods.

Type of Horse

The type of horse kept at Knightsbridge and Windsor may have been another factor in the low total of time spent in abnormal behaviour. Whilst the size, type (varying between Thoroughbred and Irish Draught), age and time spent in Barracks appeared not to have affected the behaviour patterns, including abnormal behaviour of the horses in this study (as discussed in Section 5.2), it is possible that the horses were all relatively calm. McCann et al., (1988) noted that "nervous" yearlings would lie down less and move around more than yearlings which they classed as "normal". Unfortunately, the study by McCann et al., (1988) did not record abnormal behaviour. However, Kiley-Worthington (1983) considered

"reactive" horses to have a lower threshold for the performance of stereotypies and were, therefore, more likely to develop them. The Household Cavalry horses have undergone some preselection for "normal" or "non-reactive" temperaments in so far as they are required to behave reasonably well on parade and be manageable by relatively junior soldiers in stables. Horses which do not accept Regimental tack, fail to behave on parade or are considered dangerous may be rejected by the Regiment.

Although many of the Household Cavalry horses are Thoroughbred in type, they are probably not pure bred. Vecchiotti and Galanti (1986) and Hosoda (1950) suggested a genetic predisposition might exist for some stereotypies. The hybrid genotype of most of the horses studied may have a dilution effect and may account, in part, for the considerably lower time spent in abnormal behaviour than, for example, the Thoroughbreds studied by Vecchiotti and Galanti (1986) or Borroni and Canali (1993).

Relevance of Abnormal Behaviour in Assessing Welfare

It is possible that some of the horses displaying stereotypies may have developed these stereotypies prior to arriving in the Regiment. Cronin (1985) noted that animals may become "addicted" to the endorphin release associated with the performance of stereotypies. This

may cause the stereotypic behaviour to persist even after the inadequacies of a particular environment have been eliminated. Houpt (1987) stated that some abnormal behaviour, such as cribbing, went on even if horses were moved out of stables into large paddocks, although this may not be a long term effect. This emphasizes the importance of preventing stereotypies from starting, at least from the point of view of reducing their performance.

It is worth mentioning that whilst stereotypies may be used as indices of an unsatisfactory environment, at least as regards the individual animals performing them (Duncan et al., 1993), the significance of other abnormal behaviour patterns in indicating impaired welfare is not entirely clear (Wood-Gush, 1982). It is possible, therefore, that some of the abnormal behaviour recorded in the Household Cavalry horses was not directly caused by an inadequate environment and its relevance to welfare may be difficult to interpret.

Conclusions on Abnormal Behaviour

Lack of time spent feeding was probably a major cause of the abnormal behaviour recorded in Household Cavalry horses. The level of abnormal behaviour was, however, low compared with other studies on stabled horses and this would appear to be a consequence of the considerable sensory stimulus, which may also have produced the high

alertness states. Frustration of feeding and movement behaviour was probably a less important factor in producing the abnormal behaviour since the management routine was rigid, especially as regards feeding all the horses simultaneously. Experimentation would be useful, but possibly difficult to arrange, in assessing the effects of lack of time spent feeding and frustration of feeding behaviour independently with a view to assessing their relative importance.

Confinement, in the absence of isolation, is apparently not an important cause of abnormal behaviour. Regular exercise was almost certainly more significant than the high levels of sensory stimulation or regular management routine in reducing any "stress" associated with confinement.

Household Cavalry horses, in common with most stabled horses although to varying degrees, are selected for relatively calm temperaments. This could be significant, as could their hybrid genotypes, in reducing possible predispositions to performing stereotypies.

5.2. THE EFFECT OF VARIOUS FACTORS ON MAJOR BEHAVIOURAL CATEGORIES

A. THE EFFECT OF AGE

Age appeared to have no significant effect on the horses' behaviour. Other studies have found that juvenile horses behave differently - for instance, Tyler (1969) and Duncan (1980) noted that juvenile horses spent less time eating and more time recumbent than adults. Duncan (1980) note that young mares are much more active than adult mares (although these may have been inhibited by having foals at foot) whereas adult stallions are more active even than 2-3 year old colts (these findings are summarised in Table 2.2).

The youngest horse in this study was 4 years' old. Therefore, there were no juveniles which might be expected to behave differently, although horses may not be regarded as fully mature until they are 8 years old. All the young horses studied had been broken-in at least 3 months prior to being recorded on video and were performing similar work to the others. Since they behaved similarly to the other horses, it would appear that 3 months is a sufficiently long period for them to adapt to their environment. It would be interesting, as part of a subsidiary study, to record the behaviour of horses which had newly arrived with a view to assessing the effects of a new environment, new horse and human contacts, training, diet and management on behaviour.

The oldest horses, with the exception of one 23 year old, were all under 20 years old. All the older horses have to be judged fit for parade and any that can no longer cope with the work are retired. One might expect, therefore, that, in the absence of any very old horses or horses with severe, chronic veterinary problems (such as arthritis in the hip joints which might discourage lying down), the older horses would behave much as the others did. The similar levels of abnormal behaviour in the older horses compared with younger horses is interesting as it may illustrate either a long-term failure to adapt to the environment or the extreme persistence of conditions such as cribbing, from a previous inadequate environment (Haupt, 1987).

B. THE EFFECT OF TIME SPENT IN BARRACKS

As with age, this factor had no significant effect. No new arrivals were studied so this lack of difference between groups is more an indication that behaviour does not appear to change long term within this environment. This finding suggests that, providing the environment itself does not change and presumably after a period of acclimatisation (3 months in this case), stabled horses will continue behaving in much the same way. If a horse behaves abnormally, therefore, during the period from 3-6 months after its arrival in stables, it would appear

probable that it will not adapt further and will continue to behave in this way unless the environment or management is greatly altered.

C. THE EFFECT OF HORSE TYPE (LIGHT OR HEAVY)

Whether a horse's conformation was more Thoroughbred or more Irish Draught in type had no significant effect on its behaviour. "Warm-blooded" horses, with conformation similar to Thoroughbreds, are reportedly more likely to perform stereotypies (Kiley-Worthington, 1983). This study would suggest that under conditions of similar (and presumably adequate) management, conformation has no apparent effect. It may be that the high incidence of abnormal behaviour reported by Borroni and Canali (1993) and Vecchiotti and Galanti (1986) in Thoroughbreds is genetically predisposed and this may only be of significance in pure Thoroughbreds. It may also be that the conditions of management in which these Thoroughbreds were kept, and the fact that many of them were under 4 years' old, were the principal predisposing factors to performing abnormal behaviour. Houpt (1991) noted that imitation of a stereotypy such as cribbing probably only occurs (although this has never been proven according to Owen, 1992) in young horses.

Rather than grouping the horses according to type, differences in behaviour (such as activity and abnormal behaviour) might have been found if the horses had been grouped according to temperament. McCann et al., (1988) classed horses according to their "level of emotionality" i.e. "normal" or "nervous". This classification would have involved a degree of testing (e.g. for factors such as heart and respiratory rates under circumstances such as isolation or handling) which would have been outwith the scope of this study, in that it would interfere with the normal routine of the horses. Classification according to temperament is also more subjective (although McCann et al., (1988) achieved acceptable results) than classification according to more readily discernible attributes such as size and shape. Although breeding records were not available for the horses, conformation is a universally acceptable indication of type, especially when the horses originate almost exclusively from a few farms in Ireland and are sold as a blend of Irish Draught and Thoroughbred.

D. THE EFFECT OF GENDER

Whilst none of the other recorded behavioural categories appeared to be affected by gender, there was a significant reduction in the amount of time spent sleeping in geldings (on average, mares spent 3.7% and geldings 2% of their time sleeping).

The findings of Duncan (1980), which are summarised in Table 2.2, suggest that adult stallions are more active and alert. The study also shows that they spend more time lying. These results may indicate a reduced requirement for slow-wave sleep (as more time is spent being active when non-recumbent) and an increased requirement for paradoxical sleep (for which horses must be recumbent, according to Dallaire, 1986). The adult mares in this study had foals at foot, which may have reduced their overall activity whilst reducing their time spent in recumbency owing to the requirements of suckling and maintaining contact with their foals.

Sex differences in behaviour patterns between geldings and mares may be expected in some areas of behaviour where they have been recorded between stallions and mares. Line et al., (1985) noted that 20-30% of geldings could be expected to display stallion-like sexual interest in mares and aggression towards horses and that about 5% could be expected to be aggressive towards people in a stallion-like manner. The percentages were considered to be the normal prevalence of stallion-like behaviour in geldings. Watt (1993) noted that geldings initiated more aggressive interactions, affiliated more and showed chasing behaviour more than mares. Geldings were often recorded as showing interest in mares who were in oestrus.

Whilst comparisons with recorded differences in behaviour between stallions and mares may be relevant, there is a lack of information on differences between both stallions and mares, as well as between geldings and mares, in stabled horses. The reduced time spent sleeping, compared with mares, in the Household Cavalry horses does not appear to be a consequence of residual stallion-like increased alertness levels (as recorded by Duncan (1980) since neither this, nor any factor other than sleeping time, was significantly different). In the absence of any other detailed information on gender differences in stabled horses' time budgets, the significant difference in sleeping time would appear to be directly related to gender. This finding would also appear to contrast with the possible increased time spent by stallions in paradoxical sleep observed by Duncan (1980), although these stallions may have spent less time in SWS sleep owing to their increased alertness. If sleep is influenced by testosterone levels, then this could explain why mares (with greater testosterone levels than geldings) slept more than geldings.

The absence of changes in other behaviour patterns, especially abnormal behaviour, suggests that the difference in sleeping time is not associated with mares feeling more secure, or adapting more successfully, within the Barrack environment. It may be that the mares, in the absence of any reproductive activity other than oestrus, compensate within the stabled environment by

sleeping more. It is possible that the geldings have retained stallion-like characteristics in such a diluted form that alertness levels are no longer raised but the time spent maintaining a greater degree of awareness (i.e. not asleep) is retained. It is also unproven, but possible, that hormone levels may in some manner affect neurotransmitters associated with sleep.

One major implication of this finding is that it highlights a limitation in the work on sleeping patterns undertaken by Ruckebusch (1972) and Nomura (1980). In addition to using small numbers of horses under artificial, experimental conditions, the relevance of these studies' findings is further limited in that only stallions were used. The sex differences found in the Household Cavalry horses in sleeping behaviour between mares and geldings might be more pronounced between mares and stallions. The sleeping patterns of stabled stallions may be markedly different from stabled mares. The work of Ruckebusch (1972), which is summarised in Table 2.5 and Figure 2.2, is the most detailed, and probably the most quoted, time budget for sleep and wakefulness in stabled horses. The Household Cavalry study's findings indicate, not only as a result of the apparent sex difference, but also the marked differences in total times spent resting and sleeping between Household Cavalry horses and the horses studied by Ruckebusch (1972), that this area requires further research.

E. THE EFFECT OF HEIGHT

There was no significant effect on the behavioural categories studied caused by the horses being either over or under 16.1 hands high. Since horse type also appeared to have no effect, and since the heavier horses (Irish Draught type) tended to be taller than the lighter horses (Thoroughbred conformation), this result might be expected. A positive correlation did not exist between these two parameters in all horses, e.g. some were light and tall, others heavy and short. It is possible that particularly tall horses might have found lying down difficult owing to the restriction of the stalls' width or that, with a possibly greater body weight, they might have spent more time eating. However, within the limits of these characteristics in the horses studied, no significant differences between tall and short horses were found.

It would appear that these stalls do not inhibit resting behaviour in tall horses, a factor which is often used to dispute their use on welfare grounds. The lack of difference in abnormal behaviour, in particular, strongly suggests that the tall horses do not react adversely more than smaller horses to the degree of confinement imposed by stalls. It is possible that if the tall horses' behaviour was compared with much smaller horses or horses in looseboxes, under similar management conditions, some differences might be observed. However,

the stalls in Barracks may simply be adequate for all heights of horses studied.

The lack of difference in time spent eating between tall and short horses could result solely from the restricted-hay diet, which limits the opportunities to feed. If the horses were fed hay ad libitum, preferably in the absence, or similar quantities per horse, of concentrate feed, then a difference might be apparent. However, there is nothing in the results of this study to indicate any such effect. It is possible that shorter, or at least smaller, horses may have slightly increased metabolic rates than taller horses and hence increased energy requirements for their body weight. This factor might reduce the difference in time spent eating but its importance is unlikely to be considerable, especially when the differences in height are relatively slight, and will be outweighed by the overall generally greater body weight of taller horses, which might be considered to require more energy overall.

5.3. SUMMARY OF CONCLUSIONS

Household Cavalry horses, in common with other horses studied on restricted hay and concentrate diets, spent much less time eating than feral horses. Although the Household Cavalry horses would ingest their energy requirements for maintenance and exercise, in concentrate form, much more quickly than feral horses could on pasture, especially in winter, it is suggested that the lack of access to hay ad libitum is the principal reason for lack of time spent feeding. This suggestion is substantiated by the findings of Sweeting et al., (1985) who noted that stalled horses fed concentrates and hay ad libitum spent up to 70% of the observed periods (day-time only) eating.

The horses in this study spent less time resting than free-ranging horses or horses in enclosures. Although climate and type of horse could have affected the comparisons with the free-ranging or enclosed horses (Duncan, 1980; Boyd et al., 1988), the reduction in resting time is probably associated with the increase in alertness states. The increased alertness was probably not indicative of chronic frustration (Hammon, 1991), since the horses would lie down more than free-ranging or enclosed horses and show little abnormal behaviour, but was most likely to be a consequence of the high degree

of sensory stimulation in their environment. In the same way, the low time spent sleeping could result from the high activity levels in their environment. This is less certain to be the case, however, as the studies used for comparison involved very few horses of the same gender (stallions), under experimental conditions (Ruckebusch, 1972; Nomura et al., 1980) and it is believed that the horses in these studies probably slept more than normal for a mixed gender population of stalled horses (Duncan, 1980, noted that stallions appeared to sleep more than mares).

The time spent standing appeared only slightly greater than in other stalled horse studies (Haupt et al., 1986; Shaw et al., 1988). This increase may result from the increased activity in the Barracks environment but since the overall time spent in recumbency, which occurs mainly at night, is quite high at 6.17%, it probably results mainly from the lack of bedding during most of the day.

The time spent in movement was determined almost entirely by the restrictions of the stalls and the amount of exercise that the horses are given. The overall time spent in movement may have been less than that recorded in some feral horse studies (e.g. Duncan, 1980) but the overall energy expended may be greater as the Household Cavalry horses have to carry riders. In the absence of much "vice" related to locomotion (compared with

studies such as Borroni and Canali, 1993), it would appear that either the time spent moving or the energy expended in movement, within the Barracks environment, is sufficient to meet the horses' needs. The relative importance of time spent moving to energy expended in movement could be investigated by experimentation (e.g. looking for an increase in locomotory abnormal behaviour in horses which are exercised for similar periods but not ridden).

Time spent in mutual grooming may be of less importance to horses' welfare than previously thought (e.g. Wells and Goldschmidt-Rothschild, 1979; Boyd et al., 1988) and it is suggested that the grooming received by the soldiers in their daily routine (Appendix B) may have compensated the horses for the lack of opportunity to groom each other in the stalls. Feh and de Mazieres (1994) note that grooming by humans at a preferred site can reduce heart rates significantly in horses. The low level of abnormal behaviour would once again support the proposal that welfare is not severely impaired in this case by lack of horse-to-horse physical contact.

The low level of aggressive interactions is principally attributed to the constant stable routine reducing attention-seeking behaviour and the stalls eliminating competition for feed. To a lesser extent, although the horses are moved between stalls, the horses are well

accustomed to the stalls and presumably feel secure in them, which may reduce the overall agonistic behaviour.

The very low levels of abnormal behaviour, especially that relating to locomotion, suggests that the confinement of the stalls, in the absence of isolation (other than physical separation), has little effect on the horses' welfare in Barracks.

The low level of abnormal behaviour compared with other studies in stabled horses (e.g. Borroni and Canali, 1993; Vecchiotti and Galanti, 1986; Luescher et al., 1991) may be due to the regular, busy stable routine which provides sensory stimulus and reduces the frustration associated with factors such as lack of exercise and delays in feeding concentrates. Frustration due to the lack of opportunity to spend time feeding was probably the most significant cause of the abnormal behaviour observed (Marsden, 1993 b). The type of horse selected for the Household Cavalry is, to a lesser extent, important in that the "nervous" horses described by McCann et al., (1988) are probably selected against. "Nervous" horses may be less suitable for the type of work required and these may be more prone to showing abnormal behaviour than "normal" horses. Further investigation could group horses according to temperament in order to determine its effect on abnormal behaviour. The lack of pure Thoroughbreds could also have reduced the level of

abnormal behaviour - a genetic predisposition may exist for some stereotypies (Vecchiotti and Galanti, 1986; Hosoda, 1950).

All the horses in this study had had at least 3 months to adapt to the environment and were at least 4 years old. There were no significant differences in behaviour between age groups or between horses which had spent different periods of time in barracks. This suggests that behaviour does not alter significantly unless during the initial 3 months in Barracks, providing the environment itself remains constant. The persistence of abnormal behaviour in older horses emphasizes the long-term nature of problems such as cribbing, as discussed by Houpt (1987).

Height and horse type (light or heavy) had no significant effect on the major behavioural categories studied. Since the more Thoroughbred type of horse did not show more abnormal behaviour than the rest, it would appear that the higher levels of abnormal behaviour reported in Thoroughbreds (e.g. Borroni and Canali, 1993; Vecchiotti and Galanti, 1986) are more likely to be a consequence of unsatisfactory management, and possibly immaturity in many of the horses studied, rather than genetic predisposition. Stall size would appear adequate in that heavy or tall horses did not lie down, move less or show more abnormal behaviour than others.

Gender appeared important in that geldings spent significantly less time sleeping than mares. This would correlate with the findings of Duncan (1980) which suggested that while stallions may spend less time than mares in slow-wave sleep, they spend more time in paradoxical sleep providing one assumes that circulating testosterone levels influence sleep. In the absence of any other behavioural differences, such as the increased alertness levels observed in stallions by Duncan (1980), the difference was probably directly related to gender rather than residual stallion-like behaviour which can occur in geldings (e.g. Line et al., 1985; Watt, 1993). This gender difference highlights a limitation in making comparisons on sleeping patterns with the studies of Ruckebusch (1972) and Nomura (1980), who both used only stallions.

5.4. IMPLICATIONS FOR WELFARE

5.4.1. "WELFARE" AND "STRESS"

"Welfare" has been defined in many ways, as discussed in Section 2.6. The term is wide, embracing both the physical and mental well-being of animals according to the Brambell Committee (Command Paper 2836, 1965), but lacking a precise scientific definition according to Duncan and Dawkins (1983). Whilst it is arguable that the term "welfare" is over-used (Broom and Johnson, 1993), it is apparent that detailed study at an individual animal's level, whether based on behavioural observation alone or combined with physiological investigation, will give meaning to the term.

"Stress" is another term which Broom and Johnson (1993) argue is now too vague and that it requires redefinition and quantification. Broom and Johnson (1993) are principally concerned with the biological measurement of stress, which may only be possible by the measurement of indicators, such as plasma or salivary cortisol. The Brambell Committee (Command Paper 2836, 1965) suggested that perhaps the first and possibly even the only sign of stress shown by animals kept under intensive husbandry might be an alteration in behaviour. Ewbank (1974) highlighted the significance of the various changes in behaviour which seem to occur under certain husbandry systems and pointed out that the field worker must attempt

to evaluate these changes. He also emphasised the importance of quantitative and qualitative changes in normal behaviour patterns detectable only by systematic observation (such as time-lapse video recording), in addition to the importance of abnormal behaviour. The importance of studying individual animals is re-emphasised by Fraser and Broom (1990) in their definition of "stress" as "an environmental effect on an individual which over-taxes its control systems and reduces its fitness".

5.4.2. RELEVANCE OF RESULTS TO WELFARE

Detailed time budget studies would seem to be a suitable means of accurately recording behaviour, at an individual animal level, with a view to quantifying behavioural changes. The change of behaviour observed then requires interpretation in order to assess whether an animal is suffering from "stress" and is subject to impaired welfare or not. Interpretation is sometimes complicated in that the identification of behavioural change requires comparisons with the possibly more "normal" behaviour of free-ranging or feral animals. Studies on such animals are unlikely to be as detailed as those which can be made on confined animals (owing to impracticalities of both using recording devices and constantly observing unconfined animals), although greater numbers of animals are often involved (housing of horses for experimental purposes is labour intensive and costly).

Different methods of categorising behavioural patterns further complicates comparisons.

Whilst abnormal behaviour appears to be directly associated with confinement and is relatively straightforward to record, the quantitative and qualitative changes in normal behaviour patterns, referred to by Ewbank (1974), may be more difficult to detect. Differences from "normal" free-ranging budgets are not necessarily indicative of impaired welfare, as positive adaptations to behavioural change occur. These changes need to be regarded within the context of the environment and interpretations can then be made. For instance, hay-dipping was found to be a positive adaptation to environmental change in that the horses are providing themselves with a more succulent feed. The activity is eliminated by providing soaked hay. Such behaviour is not considered stereotypic or in itself indicative of reduced welfare (Marsden, 1993 a).

The total time spent in abnormal behaviour was low for the Household Cavalry horses compared with other stabled horse studies (e.g. Vecchiotti and Galanti, 1986, and Borroni and Canali, 1993) despite their spending less than half the time eating as free-ranging horses. This finding suggests that the lack of time spent eating is not a major cause of abnormal behaviour in

Household Cavalry horses. In contrast, Cuddeford et al., (1993) found lack of time feeding to be the most important cause of abnormal behaviour. However, the results also suggested a high degree of sensory stimulation for the Household Cavalry horses, with considerable time spent in an alert state and comparatively little time spent resting. Marsden (1993 a) suggested that many of the abnormal behaviours observed in housed horses are primarily due to feed-related frustration, which may be associated with an increase in alertness, rather than boredom associated with lack of time feeding, and that these can be considered indicative of reduced welfare. This view is shared by others such as Duncan et al., (1993). The routine of feeding, which is rigidly adhered to along with other management factors (as shown in Appendix B) may reduce frustration associated with feeding whilst the sensory complexity of the environment may compensate for any boredom associated with reduced feeding times. Thus, the results may be interpreted to indicate, in this case, that any increase in abnormal behaviour associated with restricted-hay feeding is relatively minor, and that welfare is not severely impaired, owing to a constant stable routine and varied environment. This situation is representative of the "band of normality" described by Ewbank (1973) wherein the animals under this particular set of circumstances are neither "overstressed" nor "understressed" but have readily and successfully adapted to their environment.

At the level of the individual animal, those horses showing abnormal behaviour may be performing a stereotypy which has persisted from a previous inadequate environment or have failed to adapt to the present one. In the latter case, these animals would presumably benefit from specific environmental changes which might eliminate or reduce their abnormal behaviour. For instance, they might be given hay ad libitum. Even a few animals showing abnormal behaviour may indicate a degree of unsatisfactory management which, although not sufficiently severe to cause widespread abnormal behaviour (as most animals can adapt to it), would improve the overall welfare of the animals if it was removed. It may not be practical, in many cases, to make changes in the environment for possibly quite minor improvements in welfare (e.g. removing all stalls and loose-housing in order to increase their physical contact).

The low level of abnormal behaviour, including locomotory disorders such as weaving and pacing which might be associated with confinement (Haupt, 1986), suggests that the restriction on movement imposed by the stalls is not greatly affecting the welfare of the Household Cavalry horses. As with lack of time feeding, the reduced time spent moving compared with free-ranging horse studies might have suggested that welfare would be diminished. Kiley-Worthington (1983) and Fraser (1984) postulated that restriction was the most important cause of stereotypic behaviour.

It would appear that the confines of the stall did not affect the horses' ability to lie down (even among the taller, heavier or older horses), as well as having little apparent effect on the development of stereotypies.

It is possible that many locomotory abnormal behaviours may be associated with isolation more than physical restriction. Cuddeford et al., (1993) reported that horses kept in loose boxes show more abnormal behaviour than those kept in stalls or loose-housed systems.

Marsden (1993 b) concluded that dietary factors are considerably more important than physical restriction in the development of abnormal behaviour in horses.

The results of this study support these findings and suggest that restrictions on movement within the stall would not appear to affect significantly the horses' welfare. The lack of social isolation would appear beneficial, although the time spent in interaction between horses seems low. It is possible that grooming and other attention by handlers compensates for the restrictions on physical contact with other horses (Feh and de Mazieres, 1994), whilst the lay-out of the stalls, as shown in Figure 7, does not inhibit visual, auditory or olfactory communication. Environmental stimulus, as well as the work associated with being ridden, may also compensate for the relative lack of time spent in locomotion. Waring (1983) observed that varied environmental experiences, companionship and a regular programme of exercise would reduce the occurrence of abnormal behaviour patterns.

The similarity in behaviour between the different groups studied, with the exception of the gender difference in time spent sleeping, suggests that there was little variation in behaviour patterns between the various groups studied. It is important that these findings are not understood to signify that if the behaviour patterns for a group of horses do not indicate that the horses are failing to cope (and are, therefore, not suffering from the results of "stress"), then the welfare for all the individuals within the group can be judged satisfactory. Although the total time spent in total abnormal behaviour in this study is low, these are not behavioural patterns recorded in feral horses and some horses are, therefore, apparently not fully adapted to this particular stabled environment. These animals may not have stood out in the groups which were chosen (such as height, age, gender), which emphasises the importance of studying individual animals. It may also be that the rejection of horses which do not behave reasonably well in stables and on parade has created a relatively homogenous group of horses with many temperamental characteristics in common. A large group of horses selected partly for temperamental characteristics is not necessarily unusual in that few stables can tolerate particularly unmanageable individuals. However, the assessment of what constitutes "unmanageable" behaviour may vary considerably.

If the groups had been selected on the grounds of temperament, after individual assessment, as in the study by McCann et al., (1988), some significant differences in behaviour might have been noted between the "normal" and "nervous" horses. As discussed earlier, this pre-selection would not have been in keeping with the non-interference nature of this study. An approach based on individual assessment of the horses' temperament would be valuable as part of a future study. Fraser and Broom (1990) emphasised that the effects of "stress" should be examined in individuals.

In a future study, it might also be possible to study which horses might be considered more likely to suffer from the effects of stress, such as new arrivals, competition horses or horses on the Musical Ride which travel a great deal. At the same time, some experimentation to reproduce or eliminate qualitative changes, in addition to studying the quantitative changes, would render the time-budget analysis more useful in the assessment of welfare (Marsden, 1993 a).

5.4.3. THE WAY FORWARD

Concern for the mental well-being of domestic animals is as much a part of ensuring that their welfare is acceptable as factors such as treatment and prevention of injury or disease and eliminating cruelty. Whilst

this concern is growing within both the general public and the equine industry, many modern equine environments remain inadequate in meeting the needs of the horses living in them (Jones et al., 1987; Ellis, 1990; Kiley-Worthington, 1990).

Jones et al., (1987) noted that most modern racehorse stables showed clear deficiencies in size, design and construction and that 19th Century stables, and possibly husbandry techniques also, were better suited to horses' needs. Ellis (1990) considered pre-war stables to be better designed and stated that individually stabled horses were most at risk in developing stable vices. The apparently good standard of welfare of the Household Cavalry horses may be largely a result of tradition in that horses are kept in conditions of stabling and management which have changed little in the last hundred years.

The results of the time-budget study of Household Cavalry horses showed a low level of abnormal behaviour, many aspects of behaviour similar to feral or free-ranging horses and other aspects of behaviour, such as increased alertness levels, which might be interpreted as indicating a high level of environmental stimulus. The environmental stimulus, lack of isolation, regular exercise and stable routine are all important factors in producing a stable environment which has an acceptable standard of welfare.

Providing the environmental context is always considered, the results of this study should represent a detailed picture of stabled environment, which represents an acceptable standard of welfare, for direct comparison with other stabled horse time-budgets. There remains considerable scope within the Household Cavalry horses to study groups on different routines (e.g. competition horses or long term sick) as well as making controlled alterations in management or routine with a view to studying the effects on behaviour. Experimentation of this nature, combined with detailed time-budget studies, could prove invaluable in identifying specific causal factors of abnormal behaviour. These factors could then possibly be eliminated and welfare improved. Houpt et al., (1986) stated that the consideration of time-budgets in horses should result in more humane management.

When the level of welfare in the Household Cavalry has been described as "acceptable" in this section, it is understood that any level of abnormal behaviour may be regarded by some as being unacceptable. Whilst only a few horses may appear, through their behavioural responses, not to be coping with the environment, the point is reiterated that time-budget studies must be used to assess, and then monitor the effects of remedial action, at the level of the individual horse. As far as an individual horse is concerned (as shown in Photograph 12), the absence of abnormal behaviour in

other horses does not improve his particular welfare if he has failed to adapt or has developed a stereotyped behaviour pattern as an adaptive coping response.

There is a definite requirement for more time-budget studies, not only within the Army, but throughout the horse industry. The environment of the Household Cavalry horses might suit the Household Cavalry type of horse and enable it to perform its duties, at no detriment to its welfare (Photograph 13), but such an environment might not suit other types of horses in other types of work. It is improbable that one optimal design of stable environment would serve the needs of all horses required to do all kinds of work. Time budget studies could yield valuable information on the effects of different horse management practices in different surroundings.

Comparisons could be made, and the effect of altering management practices recorded, so that the implications for welfare could be assessed with a view to encouraging improved standards of husbandry.

An ideal state of welfare (if ever clearly defined) may never be achieved, within a stabled environment, but constantly seeking to manage horses more humanely should be a fundamental aim for everyone working with them. The use of time-budget studies in interpreting behavioural changes is of potentially major importance in realising this aim.

Photograph 12. A horse cribbing on its waterbowl.

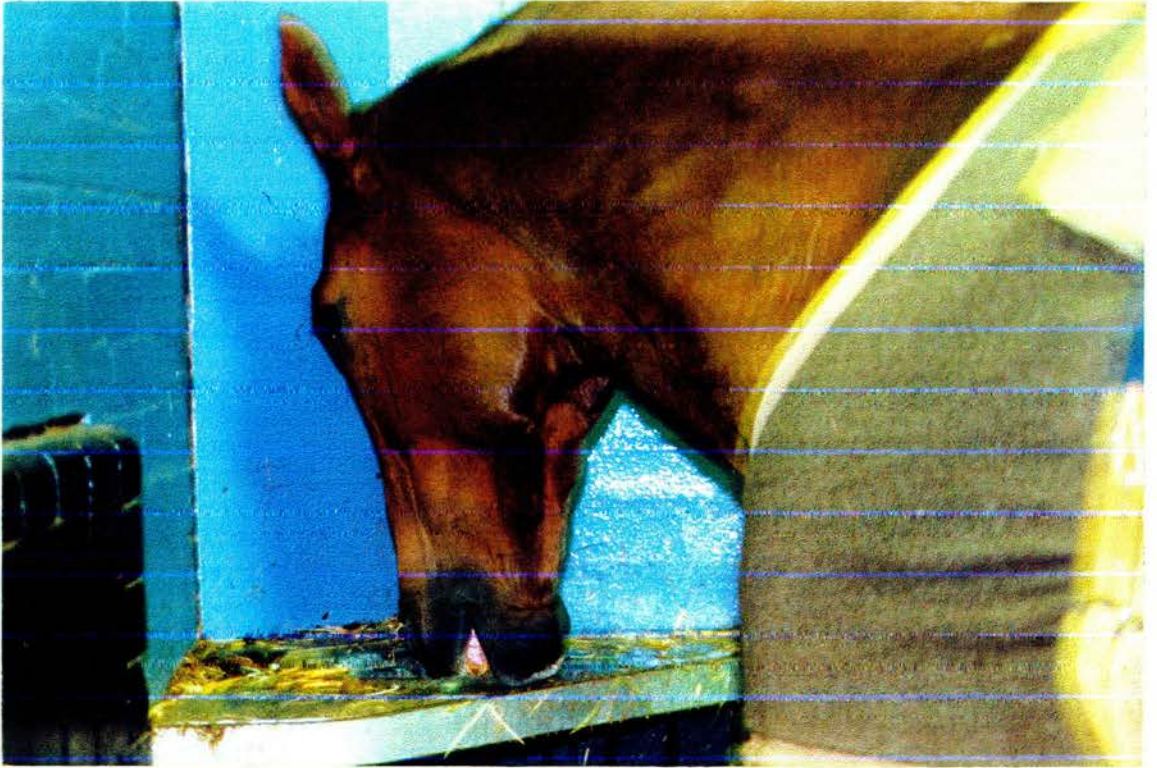

Photograph 13. The Queen's Life Guard preparing to leave Barracks.



REFERENCES

- ABERDEEN ASSOCIATION FOR THE PREVENTION OF CRUELTY TO ANIMALS (1991) The horse in winter-shelter and feeding. Scottish Agricultural College, Centre for Rural Building.
- ALTMAN, J. (1974) Observational Study of Behaviour: Sampling Methods. *Behaviour*, 49: 227-267.
- APPLEBY, M.C., LAWRENCE, A.B. (1987) Food restriction as a cause of stereotyped behaviour in tethered gilts. *Animal Production*, 45: 103-110.
- ARCHER, R.W. (1973) Tests for emotionality in rats and mice: a review. *Animal Behaviour*, 21: 205-235.
- ARNOLD, G.W., (1984) Comparison of the time budgets and circadian patterns of maintenance activities in sheep, cattle and horses grouped together. *Applied Animal Behaviour Science*, 13, 19-30.
- ARNOLD, G.W., DUDZINSKI, M.L. (1978) *Ethology of Free-Ranging Domestic Animals*, Elsevier, Amsterdam.
- ARNOLD, G.W., GRASSIA, A. (1982) Ethogram of agonistic behaviour for Thoroughbred horses. *Applied Animal Ethology*, 8, 5-25.
- BAKER, G.J., KEAR-COLWELL, J. (1974) Cited in OWEN, R.R. (1982), Crib-biting and windsucking - that equine enigma. *The Veterinary Annual*, 22: 259-167.
- BANNIKOV, A.G. (1961) Special natural conditions of the biotope of the Przewalski wild horse and some biological features of this species. [in Russian] *Equus* 1: 13-21.
- BELLING T.H. (1990) Sleep Patterns in the Horse *Equine Practice* 12, no 8: 22-27.
- BERGER, J. (1977) Organisational systems and dominance in feral horses in the Grand Canyon. *Behavioural Ecology and Sociobiology*, 2, 131-146.
- BORRONI, A., CANALI, E. (1993) *Behavioural Problems in Thoroughbred Applied Ethology*, Berlin 1993.
- BOTTOMS, G.D., RAUSCH, F.D. and AKINS, E.L. (1972)

- Circadian Variation in Plasmic Cortisol and Corticosterone in Pigs and Mares. *American Journal of Veterinary Research*, 33, no. 4: 785-790
- BOY, V., DUNCAN, P. (1979) Time-budget of Camargue horses. I Developmental Changes in the Time-budget of foals. *Behaviour*, 71(3-4): 188-202.
- BOYD, L.E. (1991) The Behaviour of Przewalski Horses and its Importance to their Management. *Applied Animal Behaviour Science*, 29: 301-318.
- BOYD, L.E. (1991) The behaviour of Przewalski's horses and its importance to their management. *Applied Animal Behavioural Science*, 29: 301-318.
- BOYD, L.E., CARBONARO, D.A., HOUPPT, K.A. (1988) The 24 Hour Time Budget of Przewalski Horses. *Applied Animal Behavioural Science*, 21 (1988) 5-17.
- BRIAN, J.R. (1981) Cited in OWEN, R.R. (1982), Crib-biting and windsucking - that equine enigma. *The Veterinary Annual*, 22: 159-167.
- BROOM, D.M., and JOHNSON, K.G. (1993). *Stress and Animal Welfare*. Chapman and Hall, London.
- BUEENIK, A.B. (1961) Vierundzwanzigtunden - Rhythmus des Przewalski-Pferdes (*Equus przewalskii* Pol. 1881) während der Laktation und beginnender Brunst. *Equus*, 1: 122-140.
- CAANITZ, H., O'LEARY, L., HOUPPT, K., PETERSSON, K., HINTZ, H. (1990) Effect of exercise on equine behaviour. *Applied Animal Behaviour Science*, 31, 1-12.
- CAMPBELL, L. (1993) BSc Zoology Thesis. *Studies in Stalled Horses*. University of Edinburgh.
- CLUTTON-BROCK, T.H., GREENWOOD, P.J., POWELL, R.P. (1976) Ranks and relationships in Highland Ponies and Highland cows. *Z Tierpsychol.*, 41: 202-216.

- Command Paper 2836 (1965)
 Report of the Technical Committee to Enquire into the Welfare of Animals kept under Intensive Husbandry Systems. HMSO, London.
- CRONIN, E.M., WIEPKEMA, P.R., VAN REE, J.M. (1985)
 Endogenous opioids are involved in abnormal stereotypies of tethered sows. *Neuropeptides*, 6: 527-530.
- CROWELL-DAVIS, S.L., HOUP, K.A., CARNEVALE, J. (1985)
 Feeding and drinking behaviour of mares and foals with free access to pasture and water. *Journal of Animal Science*, 60: 883-889.
- CUDDEFORD, D., IMLAH, P., MARSDEN, D. (1993)
 Equine Welfare Project: A study of Abnormal Behaviour in the Horse. Report to Home of Rest for Horses, 1992-1993. Royal (Dick) School of Veterinary Studies, University of Edinburgh.
- DALLAIRE, A. (1974)
 Recherches sur l'alternance des états de veille et de sommeil chez les équidés - Mémoire de Maîtrise en Sciences Vétérinaires, Ecole Nationale Vétérinaire de Toulouse, France.
- DALLAIRE, A. (1986)
 Rest Behaviour. *Veterinary Clinician of North America Equine Practice*, 2: 591-607.
- DALLAIRE, A., RUCKEBUSCH, Y. (1974)
 Sleep and Wakefulness in the Housed Pony under different Dietary Conditions. *Canadian Journal of Comparative Medicine* 38: 65-71.
- DALLAIRE, A., RUCKEBUSCH, Y. (1974)
 Sleep patterns in the pony with observations on partial perceptual deprivation. *Physiology of Behaviour*, 12: 789-796.
- DALLAIRE, D. (1980).
 Rest behaviour. *Veterinary Clinician of North America*, 2(3): 591-607.
- DELLMEIER, G.R. (1989)
 Motivation in relation to the welfare of enclosed livestock. *Applied Animal Behaviour Science*, 22: 129-138
- DODMAN, N.H., SHUSTER, L., COURT, M., DIXON, R. (1987)
 Investigation into the use of narcotic

antagonists in the treatment of a stereotypic behaviour pattern (crib-biting) in the horse. American Journal of Veterinary Research, 48:311-319

DOREAU, M. (1978)

Compartement alimentaire du cheval a L'ecurie. Ann. Zootech., 27: 291-302.

DOREAU, M., MARTIN-ROSSET, W., BARLET, J.P. (1981)

Variations at Cours de la Journée des Teneurs en Certains Constituants Plasmatiques Chez la Jument Pouliniere. Reprod. Nutr. Develop. 21 (1): 1-17.

DUNCAN, P. (1980)

Time budgets of Camargue horses. 2. Adults and Weaned Sub-adults. Behaviour, 72: 27-49.

DUNCAN, I.J.H., RUSHEN, J., LAWRENCE, A.B. (1993)

Conclusions and Implications for Animal Welfare, in Stereotypic Animal Behaviour - Fundamentals and Applications to Animal Welfare (eds, LAWRENCE, A.B., RUSHEN, J.). CAB International, Oxon.

ELLARD, M.E., CROWELL-DAVIS, S.L. (1989)

Evaluating equine dominance in draft mares. Applied Animal Behaviour Science, 24, 55-75.

ELLIS, R. (1990)

Welfare Problems of the Horse. In Practice: 234-238.

EWBANK, R. (1973)

Use and Abuse of the Term "Stress" in Husbandry and Welfare. The Veterinary Record, June 30th 1973: 709-710

EWBANK, R. (1974).

Clinical Signs of Stress in Farm Animals - Changes in Behaviour. British Veterinary Journal, 130, 85: 90-91

FALK, J.L. (1969)

Conditions producing psychogenic polydipsia in animals. Annals of the New York Academy of Science, 157, 569-89.

FEH, C. (1988)

Social behaviour and relationships of Przewalski horses in dutch semi-reserves. Applied Animal Behaviour Science, 21: 71-87.

- FEH, C., DE MAZIERES, J. (1994) Grooming at a preferred site reduces heart rate in horses. *Animal Behaviour*, Vol 46, no 6: 1191-1194.
- FEIST, J.D. (1971) Behaviour of feral horses in the Pryor Mountain Wild Horse Range. Ph.D. Thesis, University of Michigan, Ann Arbor. 130 p.
- FEIST, J.D., McCULLOUGH, D.R., (1976) Behaviour patterns and communication in feral horses. *Z. Tierpsychol*, 41: 337-371.
- FOX, R.V. (1968) (ed.) *Abnormal Behavior in Animals*. Saunders, Philadelphia, PA.
- FRANCIS-SMITH, K. (1979) Studies on the feeding and social behaviour of domestic horses. Ph. D. Thesis, University of Edinburgh.
- FRANCIS-SMITH, K., CARSON, R.G., WOOD-GUSH, D.G.M. (1982) A grazing recorder for horses - its design and use. *Applied Animal Ethology*, 8, 413-24.
- FRASER, A.F. (1984) The Behaviour of Suffering in Animals. *Applied Animal Behaviour Science*, 13: 1-6.
- FRASER, A.F. (1992) "The Behaviour of the Horse". CAB International, Wallingford, Oxon.
- FRASER, A.F., BROOM, D.M. (1990) "Farm Animal Behaviour and Welfare", 3rd ed. Balliere Tindall, London
- GATES, S. (1979) A study of the Home Ranges of the Free Ranging Exmoor Ponies. *Mammal Review*, 9: 3-18.
- GLADE, M.J. (1984) Social sleeping behaviour in young horses. *Equine Practice*, 6(5).
- HAMMON, S. (1991) Frustration Behaviour in the Horse - BSc Thesis. Department of Agriculture, University of Edinburgh.
- HART, B.L., HART, L.A., MOORING, J.S., OLUBAYO, R. (1992) Biological Basis of Grooming Behaviour in

- Antelope. *Animal Behaviour*, 44: 615-631.
- HEIRD, J.C., LOKEY, C.E., COGAN, D.C. (1986)
 Repeatability and comparison of two maze tests to measure learning ability in horses. *Applied Animal Behaviour Science*, 16, 103-19.
- HOFFIS, G.F., MUROICK, P.W., THARP, V.L. and AULT, K. (1970)
 Plasma Concentrations of Cortisol and Corticosterone in the Normal Horse. *American Journal of Veterinary Research*, 31, no. 8: 1379-1387
- HOGAN, E.S., HOUPPT, K.A., SWEENEY, K. (1988)
 The Effect of Enclosure Size on Social Interactions and Daily Activity Patterns of the Captive Asiatic Wild Horse (*Equus przewalskii*), *Applied Animal Behaviour Science*, 21: 147-168
- HOSODA, T. (1950)
 Cited in Galizzi Vecchiotti, G., Galanti, R., (1986), Evidence of heredity of cribbing, weaving and stall-walking in Thoroughbred horses. *Livestock Production Science*, 14: 91-95.
- HOUPPT K.A., LAW, K., MARTINISI, V. (1978)
 Dominance Hierarchies in domestic horses. *Applied Animal Ethology*, 4, 273-83.
- HOUPPT, K.A. (1980)
 Equine Biorythms. *Equine Practice*, 2(no.3): 8-12
- HOUPPT, K.A. (1980)
 The Characteristics of Equine Sleep. *Equine Practice*, 2(4): 8-17.
- HOUPPT, K.A. (1981)
 Equine behaviour problems in relation to humane management. *International Journal on the Study of Animal Problems*, 2: 329-332.
- HOUPPT, K.A. (1982)
 Voluntary Control of Feeding in Horses. *Equine Practice*, 7: 17-20.
- HOUPPT, K.A. (1987)
 Equine behaviour problems in relation to human care. *Anthrozoos* 1: 184-159
- HOUPPT, K.A. (1991)
 Domestic Animal Behaviour for Veterinarians and Animal Scientists. 2nd ed., Iowa State University Press.

- HOUPT, K.A. and KEIPER, R. (1982) The position of the stallion in the equine dominance hierarchy of feral and domestic ponies. *Journal Animal Science*, 54: 945-950.
- HOUPT, K.A., FRASER, A.F. (1988) Editorial, Przewalski Horses. *Applied Animal Behaviour Science*, 21: 1-3.
- HOUPT, K.A., HOUPT, T.R. (1992) Social and Illumination Preferences of Mares. *Equine Practice* 14 (6): 11-16.
- HOUPT, K.A., O'CONNELL, M.F., HOUPT, T.A., CARBONARD, D.A. (1986) Night-time Behaviour of Stabled and Pastured Peri-Parturient Ponies. *Applied Animal Behavioural Science* 15: 103-111.
- HUGES, B.O. (1976) Behaviour as an index of welfare. *Proceedings of the Fifth European Poultry Conference, Malta*, pp 1005-1018.
- HUNTINGFORD, F. (1984) *The Study of Animal Behaviour*. Chapman and Hall, London and New York
- HUNTINGFORD, F.A. (1984) "The Study of Animal Behaviour". Chapman and Hall, New York.
- HURNIK, J.F., WEBSTER, A.B., SIEGEL, P.B. (1985) *Dictionary of Farm Animal Behaviour*. University of Guelph, Guelph.
- JEZIERSKI, T. (1992) Effects of social isolation on heart rate in horses. *Proceedings of the (1993) 3rd Joint Meeting of the International Congress on Applied Ethology, Berlin*.
- JONES, R.D., MCGREEVY, P.D., ROBERTSON, A., CLARK, A.F., WATHES, C.M. (1987) Survey of the Designs of Racehorse stables in the South West of England. *Equine Veterinary Journal*, 19 (5): 454-457.
- KASEDA, Y. (1983) Seasonal changes in time spent grazing and resting of misaki horses. *Japanese Journal Zootechnological Science*, 54: 464-469.
- KEIPER, R., RECEVEUR, H. (1992) Social interactions of free-ranging Przewalski horses in semi-reserves in the Netherlands. *Applied Animal Behaviour Science*, 33: 303-318.

- KEIPER, R., RECEVEUR, H. (1992).
Social interactions of free-ranging Przewalski horses in semi-reserves in the Netherlands. *Applied Animal Behaviour Science*, 33: 303-318.
- KEIPER, R.R. (1981) *Equine Behaviour. Equine Practice* 3(4): 6-10.
- KEIPER, R.R. (1985) "The Assateague Ponies". Tidewater Press, Centerville, M.D.
- KEIPER, R.R. (1988) Social interactions of the Przewalski Horse (*Equus przewalskii* Poliakov, 1881) Herd at the Munich Zoo. *Applied Animal Behaviour Science*, 21:89-97
- KEIPER, R.R., KEENAN, M.A., (1980) Nocturnal activity patterns of feral ponies. *Journal Mammalia*, 61 (1).
- KEIPER, R.R., MOSS, M.B., ZERVANOS, S.M.M. (1980) Daily and seasonal patterns of feral ponies on Assateague Island. *Conference on Scientific Research in National Parks*, 2 (8): 369-381.
- KILEY-WORTHINGTON, M. (1977) *Behavioural problems of farm animals*. Oriel Press, London.
- KILEY-WORTHINGTON, M. (1983) Stereotypes in Horses. *Equine Practice* 5(1): 34-40.
- KILEY-WORTHINGTON, M. (1985) Time-budgets and social interactions in horses: the effect of different environments. *Applied Animal Behaviour Science*, 13, 181-2
- KILEY-WORTHINGTON, M. (1987) The behaviour of horses in relation to management and training. J.A. Allen, London.
- KILEY-WORTHINGTON, M. (1990) The Behaviour of Horses in relation to Management and Training - towards Ethologically Sound Environments. *Equine Veterinary Science*, 10 (1): 62-71.
- KILEY-WORTHINGTON, M., WOOD, GUSH, D.G.M. (1987) Stereotypic behaviour in Stabled Horses. *Equine Veterinary Science*, 6 (1):49-54
- KILGOUR, R., DALTON, C. (1984) *Livestock behaviour: a Practical Guide*.

Granada, London pp 125-150.

- KLIMOV, V.V. (1988) Spatial-ethological organisation of the herd of Przewalski (*Equus przewalskii*) in Askania-Nova. *Applied Animal Behaviour Science*, 21: 99-115.
- KLINGEL H. (1969) Reproduction in the plains zebra, *Equus burchelli boehmi*: behaviour and ecological factors. *Journal of Reproduction and Fertility (Supplement)* 6, 339-345.
- KLINGEL, H. (1972) Social behaviour of African Equidae. *Zoology of Africa*, 7: 175-185.
- KOLTER, L., ZIMMERMANN, W. (1988) Social behaviour of the Przewalski horses (*Equus przewalskii*) in the Cologne Zoo and its consequences for management and housing. *Applied Animal Behaviour Science*, 21: 117-145.
- KOWANACKI, M.E., SASIMOWSKI, M., BUDZYNSKI, T., JEZIERSKI, M., KAPRON, M., JELEN, B., JAWORSKA, M., DZIEDZIC, R., SEWERYN, A., SOLMKA, Z. (1978) Observations of the 24 hour rhythm of natural behaviour of Polish primitive horses bred for conservation of genetic resources in a forest reserve. *Genetica Polonica*, 19: 61-77.
- KUSUNOSE, R. (1992) Diurnal Pattern of Cribbing in Stabled Horses. *Japanese Journal of Equine Science* 3(2): 173-176.
- LAUT, J.E., HOUPPT, K.A., HINTZ, H.F., HOUPPT, T.R. (1985) The Effects of Caloric Dilution on Meal Patterns and Food Intake of Ponies. *Physiology of Behaviour*, 35: 549-554.
- LAWRENCE, A.B., RUSHEN, J. (editors) (1993) *Stereotypic Animal Behaviour - Fundamentals and Applications to Welfare*. CAB International, Oxon.
- LINE, S.W., HART, B.L., SANDERS, L. (1985) Effect of preubertal versus postpubertal castration on sexual and aggressive behaviour in male horses. *Journal of American Veterinary Medicine*, 186, 3:249-251
- LORENZ, K. (1965) *Evolution and Modification of Behaviour*. University of Chicago Press, Chicago.

- LUESCHER, A.V., McKEOWN, D.B., HALIP, J. (1991)
 Reviewing the causes of obsessive-compulsive disorders in horses. *Veterinary Medicine*, 527-530.
- MAL, M.E., FRIEND, T.H., LAY, D.C., VOGELSGANG, S.G., JENKINS, D.C. (1991)
 Behavioural responses of mares to short-term confinement and social isolation. *Applied Animal Behaviour Science*, 31: 13-24.
- MANNING A. (1979)
 "An Introduction to Animal Behaviour", 3rd Ed., Contemporary Biology; William Clowes & Sons Ltd., London
- MARSDEN, M.D., WOOD-GUSH, D.G.M. (1986)
 A note on the behaviour of individually penned sheep regarding their use for research purposes. *Animal Production*, 42; 157-159.
- MARSDEN, M.D. (1993)a
 Are Changes in Time-budgeting indicative of changes in Welfare? *Animal Production*, 56, part 3.
- MARSDEN, M.D. (1993)b
 Proceedings 8th International Livestock Symposium, University of Warwick. "Feeding Practices on the Behaviour and Welfare of the Horse", pp 314-318.
- MARSDEN, M.D., CUDDEFORD, D., HAMMON, S. (1994)
 Effect of Dietary Protein on Abnormal Behaviour in the Horse. *Applied Animal Behaviour Science* (in press).
- MARSDEN, M.D., CUDDEFORD, D. and WATT, F.N. (1994)
 Study on effects of isolation on abnormal behaviour in stabled horses (in preparation). Royal (Dick) School of Veterinary Studies, University of Edinburgh.
- MASON, G. (1991)
 Stereotypies - a critical review. *Animal Behaviour*, 41; 6: pp 1015-1039.
- McCANN, J.S., HEIRD, J.C., BELL, R.W., LUTHERER, L.O. (1988)
 Normal and more highly reactive horses. Heart rate, respiration rate and behavioural observations. *Applied Animal Behaviour Science*, 19, 201-14.
- McDONNELL, S.M., DIEHL, N.K. (1990)
 Computer-assisted recording of live and videotaped horse behaviour: reliability studies. *Applied Animal Behaviour Science*, 27; 1-7.

- NOMURA, KAZUO, RYO KUSUNOSE, MIKIHICO TOKURIKI, SHIN-ICHI NOMURA (1980). Japanese Journal Zootechnology Science, 51(ii): 786-795.
- ODBERG, F.O. (1978) Abnormal behaviours: (Stereotypes) in Proceedings of the 1st world congress on ethology applied to zootechnics, 475-480. Ed. Garsi, Madrid.
- ODBERG, F.O. FRANCIS-SMITH, K. (1976) A study on the eliminative and grazing behaviour - the use of the field by captive horses Equine Veterinary Journal, 8, 147-9.
- OWEN, J.B. (1992) Feed preference - learned or pre-ordained? Biologist, 39, no 1: 7-10.
- OWEN, R.R. (1982) Crib-biting and Windsucking - that equine enigma. The Veterinary Annual, 22: 159-167.
- PELLEGRINI, S. (1971) Home range, territoriality, and movement patterns of wild horses in the Warsuk Range of Western Nevada. Thesis, University of Nevada, Reno. 39p.
- PILKINGTON, J., MARSDEN, M.D., OGILVIE-GRAHAM, T.S. (1994) A Study of Stereotypic Behaviour by Time-budgets. In preparation, University of Edinburgh.
- PILLINER (1992) Horse Nutrition and Feeding. Blackwell Scientific Publications, Oxford.
- POLLOCK, J (1980) Behavioural ecology and body changes in New Forest ponies. Scientific Publications 6, 1-98. RSPCA, Horsham, England.
- POPOLOW, C. (1984) Time budgets of Equus przewalskii at the Bronx Zoo. Unpublished work, Cornell University, Ithaca, NY.
- POWELL, D.G. and JACKSON S.G. (1992) The Health of the Horse 1st ed., Bath Press
- PRINCE, D. (1986) Stable Vices in McBane, S. (Ed.), Behaviour Problems in Horses. David & Charles, London.
- RALSTON S.L. (1986) Veterinary Clinics of North America: Equine Practice, 2, no 3, December 1986.
- RALSTON, S.L. (1982) Common Behavioural Problems of Horses. The Compendium of Continuing Education for

the Practising Veterinarian, 4: 152-159.

- RALSTON, S.L. (1984) Controls of feeding in horses. *Journal Animal Science*, 59: 1354-1361.
- RALSTON, S.L., van den BROEK, G., BAILE, C.A. (1979) Feed Intake Patterns and Associated Blood Glucose, Free Fatty Acid and Insulin changes in Ponies. *Journal Animal Science*, 49: 838-845.
- RIFA, H. (1985) "Activity patterns of feral Asturion ponies during the breeding season". Poster, 19th International Ethological Conference. Toulouse, France.
- RUBENSTEIN, D.I. (1981) "Behavioural ecology of island feral horses". *Equine Veterinary Journal*, 13, 27-34.
- RUCKEBUSCH, Y. (1963) Cited in Belling, T.H. (1990). Sleep Patterns in the Horse. *Equine Practice*, 12, no 8: 22-27.
- RUCKEBUSCH, Y. (1972) The relevance of drowsiness in the circadian cycle of farm animals. *Animal Behaviour*, 20: 637-643.
- RUCKEBUSCH, Y. (1972) The relevance of drowsiness in the circadian cycle of farm animals. *Animal Behaviour*, 20: 637-643.
- RUCKEBUSCH, Y. (1975) The hypnogram as an index of adaptation of farm animals to changes in their environment. *Applied Animal Ethology*, 2: 3-18.
- RUCKEBUSCH, Y., BARBEY, P., GUILLEMOT, P. (1970) Les etats de sommeil chez le cheval. C.r. Seances Soc. Biol. 164, p.658-665.
- RUCKEBUSCH, Y., VIGROUX, P., CANDAU, M. (1976) Analyse du comportement alimentaire chez les equides. C.R. Journee d'Etude CEREOPA,

Paris pp 69-72.

- SALTER, R.E. (1978) Ecology of feral horses in western Alberta. Thesis, University of Alberta, Edmonton. p.233
- SALTER, R.E., HUDSON, R.J. (1979) Social Organisation of Feral Horses in Western Canada Applied Animal Ethology 8: 208-223
- SAMBRAUS, H.H. (1985) Mouth-based anomalous syndromes. In: Fraser, A.F. (ed), Ethology of Farm Animals, World Animal Science, A5, Elsevier, Amsterdam, pp. 381-411.
- SAMBRAUS, H.H., RADTKIG, K. (1989). Study with respect to the "weaving" of horses. Dtsch. Tiergerztl Wochenschr., 96 (5): 243-255.
- SATO, S.NAGAMINE, R. and KUBO, T. (1994) Tongue-playing in tethered Japanese Black cattle : diurnal patterns, analysis of variance and behaviour sequences. Applied Animal Behaviour Science, 39: 39-47
- SAVILE, C., WEBSTER, J. (1981) Basic necessities for ensuring the welfare of veal calves in various housing systems. Applied Animal Ethology, 7: 382-383.
- SCHILDER, M.B.H. (1986) Vices in Stabled Horses with Special Reference to Crib-biting. Applied Animal Behaviour Science, 15: 89-90.
- SCHILDER, M.E.H., POST, J. (1992) Crib-biting in experienced horses: its relation to events in the stable. In press.
- SCHMIDT, M. (1982) Abnormal oral behaviour in pigs. "Disturbed Behaviour in Farm Animals", ed. W Bessei, Hohenheimer Arbeiten, 121, 115-132. Stuttgart: Eugen Ulmer.
- SCHOEN, A.M.S., BANKS, E.M., CURTIS, S.E. (1976) Behaviour of young Shetland and Welsh ponies (*Equus caballus*). Biology of Behaviour, 1: 199-216.
- SHAW, E.G., HOUPPT, K.A. and HOLMES, D.F. (1988) Temperature and Behaviour of Mares during the last two weeks of Pregnancy. Equine Veterinary Journal 20(3): 199-202

- STEINHART, P. (1937) Der Schaf des Pferdes. Z Veterinaark. 49: 145-157, 193-232.
- SWEETING, M.P., HOUPPT, C.E., HOUPPT, K.A. (1985) Social Facilitation of Feeding and Time Budgets in Stabled Ponies. Journal Animal Science 60 (2): 369-374.
- THORPE, W.H. (1979) "The Origins and Rise of Ethology". Heinemann, London.
- TILSEN, R.L., SWEENEY, K.A., BINCZIK, G.A., REINDL, N. (1988) Buddies and Bullies: Social Structure of a Bachelor Group of Przewalski Horses. Applied Animal Behaviour Science, 21: 169-185.
- TINBERGEN, N. (1951) "The Study of Instinct". Oxford University Press, London
- TYLER, S.J. (1969) The behaviour and social organisation of the New Forest ponies. MSc Dissertation, University of Cambridge, Cambridge. 188 p.
- TYLER, S.J. (1972) The behaviour and social organisation of the New Forest Ponies. Animal Behaviour Monographs, part 5: 85-186.
- VECCHIOTTI, G. and GALANTI, R. (1986) Evidence of heredity of cribbing, weaving and stall-walking in Thoroughbred horses. Livestock Production Science, 14: 91-95.
- WARING, G.H. (1983) Horse Behaviour - the behavioural traits and adaptations of domestic and wild horses, including ponies. Noyes Publications, New Jersey, USA.
- WATERS, A.J. (1992) The Impact of the Domestic Environment upon Equine Behaviour and Welfare. MSc Dissertation, University of Wales.
- WATT, F.N. (1993) The Social Behaviour at Pasture of the Domestic Horses (Equus Caballus). Zoology Honours Project, University of Edinburgh.
- WELLS, S.M. and von GOLDSCHMIDT-ROTHCHILD, B. (1979) Social behaviour and relationships in a herd of Camargue ponies. Z. Tierpsychol, 49: 363-380.
- WILARD, J.G., WILLARD, J.C., WOLFRAM, S.A., BAKER, J.P. (1977) Effect of Diet on Caecal pH and Feeding Behaviour of Horses. Journal Animal Science, 45: 87-93.

APPENDIX A

HORSE DETAILS

HORSE	SEX	HEIGHT (hands)	AGE (yrs)	TIME IN BARRACKS (months)	NO. OF HOURS RECORDED ON VIDEO
Baronsay	G	16.1	11	53	72
Bogar	G	16.2	23	70	48
Fathom	G	16.1	19	102	48
Ferdinand	G	16.2	19	148	72
Flamingo	G	16.0	19	151	72
Foxhunter	G	16.0	18	173	72
Gladstone	G	16.1	18	140	48
Hero	G	15.2	16	135	72
Hopeful	M	16.2	16	144	72
Hyperion	G	16.1	18	133	48
Imperial	G	16.3	15	139	72
India	G	16 1/2	16	156	72
Inniskillin	G	16.3	16	119	72
Invader	G	16.0	16	119	72
Jasper	G	16.1	15	128	72
Jerusalem	G	16.2	14	128	72
Jericho	M	16.3	15	110	72
Jorrocks	G	16.1	14	119	72
Jumbo	G	16.3	18	105	72
Kermit	G	16.2	14	114	72
Kingfisher	G	16.2	14	107	72
Kinsman	G	16.2	13	107	72
Knibbler	G	16.0 1/2	11	54	72
Langtry	M	16.1	13	97	72
Lawrence	G	15.3	13	83	72
Leyland	G	15.3	13	92	72
Londonderry	G	16.0	14	82	72
Lord Louis	G	16.3	18	48	72
Lucinda	M	16.2	13	92	72
Lucy	M	16.2	12	96	72
Lusitania	M	16.2	14	82	48
Macbeth	G	16.2	13	81	72
Manderin	G	16.12	11	55	72
Marksman	G	16.0	13	79	72
Matilda	M	16.0 1/2	13	81	72
Moonstone	M	16.0	12	69	72
Naomi	M	16.1	10	57	72
Narvic	G	16.1	11	69	72
Natasha	M	16.2	9	69	72
Nightingale	M	16.0	9	65	48
Nizefella	G	16.1	10	58	72
Nordic	G	16.2 1/2	9	62	48
Norton	G	17.0	12	68	72
Nula	M	15.3 1/2	10	69	48
Oak	G	16.1	10	52	72
October	G	16.2 1/2	9	55	72
Olympus	G	16.1	9	47	72
Oman	G	16.0	11	50	72
Ondine	M	16.1	9	57	72
Opal	M	16.0 1/2	12	60	48
Opera	M	16.3	9	51	72

Organza	M	16.1 1/2	9	57	72
Ormond	G	16.2	9	60	72
Othello	G	16.2	9	49	72
Owl	G	16.0 1/2	9	57	72
Owston	G	15.3 1/2	9	60	72
Phantom	M	16.2	10	44	72
Ponchards	G	16.2	10	44	72
Quartz	G	16.1	9	29	72
Quatra Bras	G	16.1	9	32	48
Quattro	G	16.0	9	32	72
Queensland	G	16.0	8	22	72
Quetta	G	16.2	9	32	48
Raffles	G	17.1	8	7	72
Ramilies	G	16.1	6	17	72
Ratty	G	16.0	6	8	72
Rebecca	M	16.0 1/2	6	17	72
Remus	G	16.0 1/2	9	17	72
Renegade	G	16.1	8	8	72
Rochester	G	17.1	10	8	72
Royalist	G	16.1	6	17	72
Rumbold	G	16.0	9	17	72
Scorpion	M	16.0	5	3	72
Sebastian	G	16.2	4	3	72
Sennelager	G	16.2 1/2	4	3	48
Singapore	M	16.0	7	3	48
Somerset	G	15.3 1/2	5	3	72
Smarja	M	16.3	5	8	48
Sultan	G	16.2	4	3	72
Syria	G	16.1 1/2	4	8	72

CATEGORIES:

In the results;

SHORT refers to horses that are 16.1.1\2 hands high (hh) or less

TALL refers to horses that are 16.2 h h and above

G refers to geldings

M refers to mares

TYPE refers to whether the horses are of LIGHT build such as Thoroughbreds, or HEAVY build, such as Draught horses.

TIME IN BARRACKS is split into four categories for analysis;

a) 0-30 months

b) 31-60 months

c) 61-90 months

d) 91 months and upwards

AGE of horses is also split into four categories;

i) 0-6 years

ii) 7-10 years

iii) 11-15 years

iv) 16 years and over

Appendix B: The Daily Routine At Knightbridge Barracks

b. DAILY ROUTINE

The following is a the Daily Routine based on a typical day at H Cav MR.

Time/Event	Csoll 1st & 2nd	NCOs	PGS	Troopers
0620 Revellie Stables	<ol style="list-style-type: none"> 1. Open Office 2. Check all Horses for injures and ensure they have 'eaten up'. 3. Check Exercise Detail 	<ol style="list-style-type: none"> 1. Help Coll 2. Help Muck out 3. Check horses going on RWO. 4. Adjust rugs if needed. 	N/A	<ol style="list-style-type: none"> 1. Those on RWO: Quarter Down and tack up 2. Those not on RWO: Muck out.
0700 RWO	<ol style="list-style-type: none"> 1. Check feeds with PSG. 2. Ride. 	<ol style="list-style-type: none"> 1. Ride or go to Breakfast 	<ol style="list-style-type: none"> 1. Arrive. Make out feeds 2. Feed horses not going on exercise. Lay out other feeds behind stalls 3. Sweep Through 4. Breakfast 	<ol style="list-style-type: none"> 1. Finish mucking out. Throw down. 2. Go to Breakfast
0800 - 0845	<ol style="list-style-type: none"> 1. Return from riding 	<ol style="list-style-type: none"> 1. One NCO to turn horsed in from exercise. Note any injures Ensure horses are fed and sadderly correctly put away. 	<ol style="list-style-type: none"> 1. Clean out feed tins 	<ol style="list-style-type: none"> 1. Breakfast and room cleaning.

Appendix B: Cont.....

Time/Event	Csoll 1st & 2nd	NCOs	Troopers	PSG
0900 - 1000	<ol style="list-style-type: none"> 1. Make out Grooming detail. 2. Checks over QLG horses and kits 	<ol style="list-style-type: none"> 1. Do admin jobs as detailed 2. Exchanges 3. Start Trimming manes and tails 	<ol style="list-style-type: none"> 1. Clean feed room. Get forage 2. Put down: dry litter 	<ol style="list-style-type: none"> 1. Clean out cleaning Room 2. Clean brown kits and civy kits. 3. Help QLG 4. Start Grooming
1000 - 1030	NAAFI BREAK	NAAFI BREAK	NAAFI BREAK	NAAFI BREAK
1045 -Sqn 1200 Grooming Prade	<ol style="list-style-type: none"> 1. Go round horses in detail with Tp Ldr 2. Fill in Sick Book 	<ol style="list-style-type: none"> 1. Trim manes and tails and supervise grooming feeds 	<ol style="list-style-type: none"> 1. Make out lunch time 	<ol style="list-style-type: none"> 1. Groom, Groom, Groom
1200	<ol style="list-style-type: none"> 1. Attend Pharmacy and notes remedial treatment 2. Inspect horses 	<ol style="list-style-type: none"> 1. Prepare stable for feed away 2. Check horses 	<ol style="list-style-type: none"> 2. Go to lunch 	<ol style="list-style-type: none"> 2. Prepare stables for feedaway 3. Lay out feeds
1220.	FEED AWAY	FEED AWAY	LUNCH	FEED AWAY
1230 Midday Break	Lunch	Lunch	Stand In	Lunch
1345 - Sqn Disposal 1520	<ol style="list-style-type: none"> 1. One Coh does afternoon stables 	<ol style="list-style-type: none"> 1. Admin jobs 2. 1/2 NCOs afternoon stables 	<ol style="list-style-type: none"> 1. Prepare evening feed away. Bed down and make out feeds 	<ol style="list-style-type: none"> 1. QLG knocked off to clean kit 2. Minimum numbers of Tprs kept for afternoon stables
1620	AFTERNOON FEED AWAY	AFTERNOON FEEDAWAY	AFTERNOON FEED AWAY	AFTERNOON FEED AWAY
1800 Last Twos				

Show Up Stables
to Ord Officer

Appendix C: Hay Feeding Times

		Time Hay Is Given At			
Lifeguards	Troop				
	1	1000	1400	1600	1800
	2	1000	1400	1600	1800
	3	1000	1400	-	1800
Blues and Royals	Troop				
	1	-	1200	1600	1800
	2	1000	1200	1600	1800
	3	1000	1200	1600	1800

Appendix D contd.

The raw data sheet is designed to allow normal behaviours or "states" (e.g. NE LR A represents not eating, leg resting, alert) to be recorded in the first half of the columns and abnormal activities, with reference to type (e.g. "chewing" directed at "stall top"), in the second half. Each sheet relates to a period of one hour (e.g. 0100-0200 hrs) and the day which this hour relates to is shown on the left hand margin. In most cases, 72 hours were recorded so all rows relating to days 1, 2 and 3 would be filled in but some horses were filmed for only 48 hours so only days 1 and 2 would be filled in.

The abbreviations used as column titles are shown on p96. Interpretation of which behavioural pattern an individual horse was performing at the moment of the scan sample was simplified by being able to view the tape before and after the sample time. Although not so important in interpreting posture, this capability to view the horse moving was important in identifying actions.

The raw data sheet was devised and tested in other studies, such as Waters (1992), and was found useful in allowing the maximum amount of data to be noted quickly and in a form that could then be used to extract total numbers of behaviour patterns recorded during the time

period covered by the raw data sheet (shown as T1, T2, T3 and T4 on the raw data sheet). These totals could then be collated and transcribed onto score sheets, to allow ease of addition of the time spent in each specialised behavioural category (TT). These (TT) could then be added together selectively, to provide overall record of time spent in each of various simpler behavioural categories, e.g. such as eating, or resting, or lying. These final simpler combined totals were those used for subsequent computer analysis by the statistical package INSTAT (Graphpad Software, San Diego, USA).

The observation and subsequent interpretation of behaviour patterns by noting them on the raw data sheets or ethograms could be open to observer variation. This variation was minimised by real time studies being compared with recorded studies of the same horses during the same period. The observers were then instructed on which pattern should be noted where discrepancies appeared in the two sets of results.

Scoring systems such as shown in Appendix E were devised and found useful in earlier studies (e.g. Marsden 1993 a, 1993 b). Although arbitrary, a system such as this ensures reasonably consistent interpretation of alertness state. There are, of course, limitations to what can be observed owing to the position of the camera. For instance, on occasions, the horse's head may not be visible. Fortunately, these occasions are rare and one

may view the video tape before and after the scan sample time with a view to making a considered judgement as to what the horse's expression is likely to be. Photograph 11 does not give a good impression of what can be observed as one cannot tell what the horse was doing immediately before or after the photograph was taken and the photograph has little of the resolution or clarity of a 24" television screen. The limitations of using an automatic recording device are thought to be outweighed by the benefits of there being no observer-induced disturbance (Fraser and Broom, 1990), video cassette tapes providing a permanent record and the infra-red lighting providing excellent night-time detail.

Appendix E: Scoring System For Alertness

SCORING SYSTEM FOR ALERTNESS LEVELS

HEAD	EARS	EYES	ALERTNESS SCORE	TOTALS
up	pricked	open	alert	6 alert 1 non alert 2 resting 0 sleeping
		1/2 closed	alert	
		closed	alert	
	both flat	open	non alert	
		1/2 closed	resting	
		closed	resting	
level	pricked	open	alert	3 alert 4 non alert 2 resting 0 sleeping
		1/2 closed	non alert	
		closed	non alert	
	both flat	open	non alert	
		1/2 closed	resting	
		closed	resting	
down	pricked	open	alert	2 alert 4 non alert 2 resting 1 sleeping
		1/2 closed	non alert	
		closed	resting	
	both flat	open	alert	
		1/2 closed	resting	
		closed	sleeping	
moving	open	alert		
	1/2 closed	non alert		
	closed	non alert		

Appendix F: Equipment Details

The video equipment was set up as shown in the video setting/adjustment guide included in this Appendix.

The camera was moved daily and attached to a girder opposite the horses being filmed, as described on p94, so that a picture similar to Photograph 11 was obtained on the television monitor. If the focussing and angle of the camera appeared correct on the monitor, recording onto a standard video cassette (180 minute) was then initiated. No horse was filmed for more than 24 hours at any one time so a particular video cassette was replaced every 24 hours when the camera was moved and only used again when one or both of the horses already recorded on it was being filmed again.

The time lapse video cassette recorder was set so that 72 hours could be recorded onto a 180 minute cassette. This is achieved by automatic slowing of the tape movements, the recorder taking and storing a picture less often, at only 4 frames per second. This gives a picture which if played back at "real time" speed appears a little jerky, rather like early movie film, but which if played back at the same speed as that which it was recorded, gives a clear and easy to observe picture.

Full details of this equipment are included in this Appendix along with copies of the instruction manuals for the camera and picture monitor.

The infra-red lamp used was a Deward 300W, model number D885, using a 1000 nm IR filter. It was left on constantly so that whenever there was insufficient daylight and the powerful strip lights in the stables had been switched off, the camera would automatically adjust its aperture size - using the auto-iris facility - and recording would not be interrupted. The infra-red lamp was positioned beside the camera, pointing in the same direction and held by a powerful metal bracket so as to be quite securely attached to the girder. In this position, at least 3m away from the bedding below, it was considered not to present a fire hazard.

Once the recording was complete, the tape could be placed in an ordinary VHS cassette recorder and rewound. It was then possible to play or fast forward the tape, using a large television set and pausing at ten minute intervals in the recording. The ten minute intervals could be judged precisely by using the Date Time Group (DTG) shown on the screen (the DTG would have been set when the recording was first made). Scan samples could then be made as described by Altman (1974).

The behaviour of the horse at the scan sample was noted onto the ethogram shown in Appendix D. The use of the ethogram and its limitations are also described in Appendix D.

The data extracted from the ethograms was then used, as summaries of totals, summarised onto the score sheets as already described, before final totals were entered into the computer package INSTAT (Graphpad Software, San Diego, USA) for analysis.

Appendix F contd.

VIDEO SETTING/ADJUSTMENT GUIDE

1. SELECT TWO HORSES. MAKE SURE THAT A HORSE IS EITHER SIDE OF CHOSEN TWO HORSES.
2. CHECK ALL FITTINGS ON VIDEO ARE IN ORDER (E.G. NO LOOSE LEADS).
3. THE PICTURE MUST BE FOCUSED CLEARLY ON THE HAY RACK BARS (IMMEDIATELY IN FRONT OF THE HEADS OF THE HORSES BEING FILMED).
4. VIDEO TO BE ON THE 72HR MODE.
5. SWITCH ON THE RECORDER BY PRESSING THE RECORD BUTTON.
6. CHECK THAT THE DATE IS CLEARLY IN VIEW ON THE SCREEN. IF NOT ADJUST BY USING THE VERTICAL-HORIZONTAL BUTTON.
7. DATE AND TIME MUST BE CLEAR. USE THE SCREEN BRIGHTNESS CONTROL
8. SET DATE AND TIME.
9. + OR - SETTING TO CORRECT TIME. SHOULD ONLY BE NEEDED IF POWER CUT.

10. THE MONITOR SHOULD VIEW THE FOLLOWING:

22.12.92 1400 72 (EXAMPLE)

11. PROGRAMME CLOCK. PRESS TO START.

12. THEN MAKE SURE A RECORD IS TAKEN AT THE TIME OF
CHANGE OVER OF HORSES, WHICH IS DAILY BETWEEN THE
FOLLOWING TIMES:

11.50 HRS AND 12.20

13. THE FOLLOWING DETAILS MUST BE NOTED ON THE TAPE:

- A. NAME OF HORSES (2)
- B. TEMPERATURE (LOWEST AND HIGHEST)
- C. TIME
- D. DATE.

INSTRUCTIONS

Keigami

TVR-625

TIME LAPSE VIDEO CASSETTE RECORDER

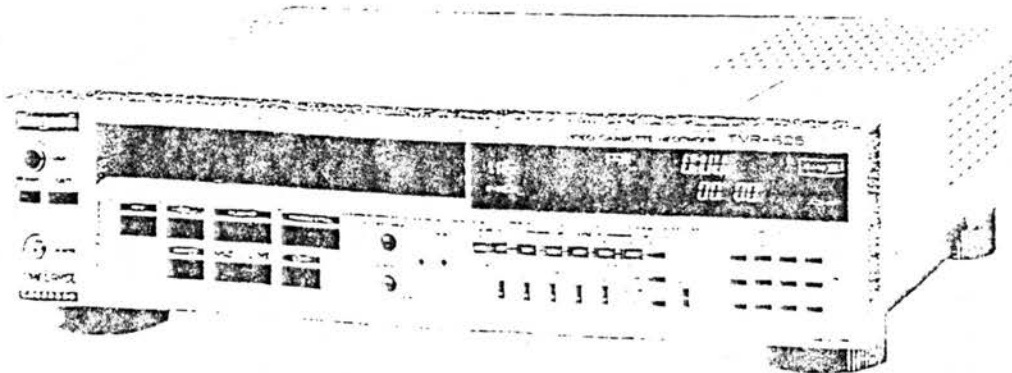

**Warning Notice
FOR YOUR SAFETY (Australia)**

1. Insert this plug only into effectively earthed three-pin power outlet.
2. If any doubt exists regarding the earthing, consult a qualified electrician.
3. Extension cord, if used, must be three-core correctly wired.

**IMPORTANT (In the United Kingdom)
Mains Supply (AC 240 V~)
WARNING — THIS APPARATUS
MUST BE EARTHED**

The wires in this mains lead are coloured in accordance with the following code;

GREEN-and-YELLOW: EARTH
BLUE: NEUTRAL
BROWN: LIVE

As the colours of the wires in the mains lead of this apparatus may not correspond with the coloured markings identifying the terminals in your plug, proceed as follows. The wire which is coloured GREEN-AND-YELLOW must be connected to the terminal in the plug which is marked with the letter E or by the safety earth symbol \equiv or coloured GREEN or GREEN-AND-YELLOW. The wire which is coloured BLUE must be connected to the terminal which is marked with the letter N or which is coloured BLACK. The wire which is coloured BROWN must be connected to the terminal which is marked with the letter L or coloured RED.

POWER SYSTEM

Connection to the mains supply

This set operates on 220 to 240V~,50/60 Hz.

This unit is produced to comply with Directives 76/889/EEC, 82/499/EEC and 87/308/EEC.

WARNING:

TO PREVENT FIRE OR SHOCK HAZARD, DO NOT EXPOSE THIS APPLIANCE TO RAIN OR MOISTURE.

CAUTION

To prevent electric shock, do not open the cabinet. No user serviceable parts inside. Refer servicing to qualified service personnel.

Note:The rating plate and the safety caution are on the rear of the unit.

CONTENTS

Precautions	2
Features	3
Controls and Connectors	4
Connections	7
Loading and Unloading a Video Cassette	9
Recording	9
Playback	10
Special-Effects Playback	10
Text-Function Memory	11

Clock Adjustment	12
Program Timer Setting	12
On-Screen Display	14
Instant Timer Recording	15
Time/Date Generator	15
Series Recording	16
Alarm Recording	17
In Case of Difficulty	17
Specifications	18

PRECAUTIONS

Handling and storage

- Avoid using the recorder under the following conditions:
 - extremely hot, cold or humid places.
 - dusty places,
 - near appliances generating strong magnetic fields,
 - places subject to vibrations, and
 - poorly ventilated places.
- Be careful of moisture condensation. Avoid using the recorder immediately after moving from a cold place to a warm place. The water vapor in warm air will condense on the still-cold video head drum and tape guides and may cause damage to the tape and the recorder.
- Handle the recorder carefully.
 - Do not block the ventilation openings.
 - Do not place anything heavy on the recorder.
 - Do not place anything which might spill and cause trouble on the top cover of the recorder.
 - Use in horizontal (flat) position only.
- In case of transportation.
 - Avoid violent shocks to the recorder during packing and transportation.
 - Before packing, be sure to remove the cassette from the recorder.

Video cassettes

- Video cassettes are equipped with a safety tab to prevent accidental erasure. When the tab is removed, recording cannot be performed.

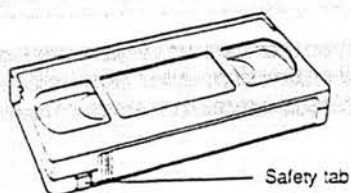

- Avoid exposing the cassette to direct sunlight. Keep them away from heaters.
- Avoid extreme humidity, violent vibrations or shocks, strong magnetic fields (near a motor, broadcasting antenna, wireless transmitter, transformer or magnet) and dusty places.
- Place the cassettes in cassette cases and position vertically.
- Do not use longer tapes than the E-180 Video Cassette with the TVR-625.

Moisture condensation

- If you pour a cold liquid into a glass, water vapor in the air will condense on the surface of the glass. This is called moisture condensation.
- Moisture condensation on the head drum, one of the most crucial parts of the video recorder, will cause damage to the tape.
- Moisture in the air will condense on the recorder when you move it from a cold place to a warm place, or under extremely humid conditions.

Operation

- When a cassette is loaded, the power is switched on and, if the safety tab has been removed, playback begins automatically.
- The cassette can be unloaded even when the power is off. Pressing the EJECT button turns the power on and, after ejection of the cassette, shuts it off automatically in this case.
- As long as the TIMER button is engaged with the TIMER indicator lit, the POWER and EJECT buttons have no effect and unloading of a cassette is not possible. If a cassette has not yet been inserted, simply insert a cassette: the power will be switched on to load the cassette properly and, after completion of automatic loading, the Timer Recording Standby mode will be engaged with power off.
- The batteries installed in the top panel must be replaced once a year.

Installing the batteries

1. Slide the battery compartment cover on the rear of the unit in the direction of the arrow (▶).

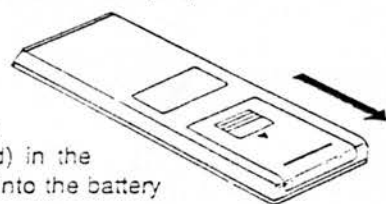

2. Insert 2 "AA"-size batteries (provided) in the correct directions into the battery compartment.
3. Replace the cover.

AVAILABLE RECORDING OPTIONS ACCORDING TO THE SETTING OF THE REC MODE BUTTON

REC MODE switch setting	Recording time					Recording interval	Audio recording	Playback interval
	E-30	E-60	E-90	E-120	E-180			
VHS/SP	30 min	1 hour	1 h 30 min	2 hours	3 hours	—	Yes	—
VHS/LP	1 hour	2 hours	3 hours	4 hours	6 hours	—		—
TL 24	4 h 30 min	9 hours	12 hours	18 hours	24 hours	0.16 sec	No	0.32 sec
TL 72	12 hours	24 hours	36 hours	54 hours	72 hours	0.48 sec		0.96 sec
TL 120	20 hours	40 hours	60 hours	90 hours	120 hours	0.8 sec		1.6 sec
TL 240	40 hours	80 hours	120 hours	180 hours	240 hours	1.6 sec		3.2 sec
TL 480	80 hours	160 hours	240 hours	360 hours	480 hours	3.2 sec		6.4 sec
TL 960	160 hours	320 hours	480 hours	720 hours	960 hours	6.4 sec		12.8 sec

FEATURES

RECORDING FUNCTIONS

MAXIMUM RECORDING TIME OF 960* HOURS

In the time-lapse mode, recording times of 24, 72, 120, 240, 480 and 960 hours can be selected with an E-180 cassette. Recording times of 3 hours and 6 hours are possible in the SP (Standard Play) and LP (Long Play) modes. This choice allows a recording time suitable for any purpose to be selected, whether you're out for a few minutes or several days at a time.

* Factory set to 480-hour mode.

Set DIP switch 7 on the rear panel to OFF.

ALARM RECORDING FUNCTION

When an alarm signal is input, the TVR-625 automatically switches from the time-lapse mode to the SP or LP mode to record the incident in greater detail, so that it can be seen clearly in playback. The alarm recording time is selectable between 15 sec. 180 sec, to the tape end, and while alarm pulses are being input, using a DIP switch on the rear panel.

TIMER RECORDING FUNCTION

The TVR-625 incorporates a 14-day/8-event timer that can be set to record for a predetermined time each day, each weekday (either Monday thru Friday or Monday thru Saturday) or each week.

The 8-event feature allows greater versatility in setting.

CANCEL PROGRAM

Timer recording can be cancelled for specific days; up to 14 days within one year can be specified.

CAMERA SWITCHING FUNCTION

The TVR-625 is designed for use with a sequential switcher and has a camera select signal output, so that camera switching is synchronized with the time-lapse recording intervals for continuous coverage.

TIME/DATE GENERATOR

The date (year, month, day), time (hour, minute, second) and recording mode when the recording was made can be superimposed on the screen.

The position of the display at the bottom right of the screen can be moved for improved visibility.

VIDEO MODE SELECTION

The TVR-625 incorporates a Colour/Auto B & W video mode select switch.

The horizontal resolution is more than 300 lines (B/W mode).

PLAYBACK FUNCTIONS

① SHUTTLE SEARCH

High-speed search in the forward and reverse directions is possible at 9x normal speed for recordings made in the SP, LP and time-lapse modes. 2x/-1x search is also possible for all recordings.

② STILL FRAME ADVANCE AND TL MODE PLAYBACK

These playback functions allow you to check any scene slowly and carefully.

⑩ ALARM SEARCH FUNCTION

A VISS (VHS Index Search System) code is recorded on the control track at the start of alarm recordings; these can be retrieved at high-speed even in the FF/REW mode to review any suspicious activities that triggered an alarm. Thanks to this function, the customers can trace the point of alarm recordings using the consumer model VHS deck which has a VISS capability at his home.

SAFETY FUNCTIONS

① POWER FAILURE AUTO RESET

If there is a power failure during recording, when the power is restored, recording restarts in the same mode as before the power outage, automatically.

⑦ NEWLY DEVELOPED HEAD CLEANING MECHANISM

For perfect picture, the heads are cleaned every time the tape is loaded and unloaded and at regular intervals in time-lapse modes.

⑧ REPEAT FUNCTION

When the tape has been fully recorded, it is rewound and recording restarts from the beginning, to ensure that nothing is missed. A similar function makes playback more convenient.

① KEY LOCK FUNCTION

By operating the lock key, the function buttons are disabled and mistakes in operation are prevented. The green LED on the front panel will light in key lock mode.

⑤ 5000-HOUR HOUR METER

This helps schedule maintenance.

⑥ TIME/DATE BACKUP

Even if there is a power failure, the time and date are backed up for about 1 year and do not need to be reset.

⑦ TAPE-END BUZZER (Three minutes)

When the tape is about to finish, this warns the operator.

⑩ ALARM/POWER LOSS MEMORY

The last alarm and power loss start time (YEAR/MONTH/DAY) will be memorized and indicated in the on-screen display.

⑨ WIRED REMOTE CONTROL CAPABILITY

⑫ SERIES RECORDING IN/OUT CONNECTORS

CONTROLS AND CONNECTORS

FRONT PANEL

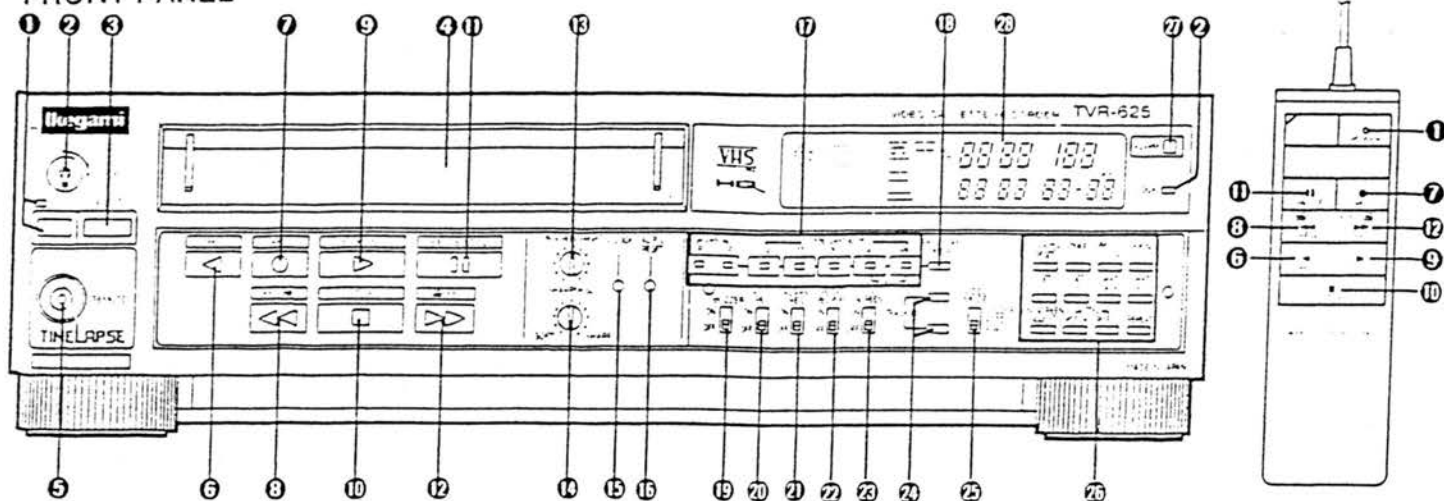

1 POWER button with LED indicator

Press to turn power on. The indicator will light. Loading a cassette also turns the power on.

2 Key Lock with LED indicator

To lock: Insert the provided key into this key hole and turn it clockwise. The LOCK indicator will light and all buttons and switches except the following will be locked:

Front panel: Buzzer switch, Auto Rec switch, Repeat switch, On-Screen switch, and Video Mode switch.

Rear panel: DIP switch in the compartment, and V-Pulse switch.

To unlock: Insert the provided key into the key hole and turn it counterclockwise. The LOCK indicator will turn off and all the locked buttons and switches will be released.

3 EJECT button

Press to eject the cassette. This button can be pressed in any mode except the Timer mode. The cassette indicator on the FDP (fluorescent display panel) will flash while a cassette is being unloaded and then go out upon completion of unloading.

4 Cassette loading slot

Insert a VHS cassette. The door will close and an indicator showing that a cassette has been loaded will appear on the FDP.

5 REMOTE control terminal (RCA)

The provided remote control unit can be connected to this terminal.

6 REV button

Press in the Play, Still or Search mode to play back a tape backwards.

7 REC button

Press once to start recording; press again for instant timer recording. Each time it is pressed subsequently adds 30 minutes to the recording time, to a maximum of 9 hours. (See pages 9 and 15.) To start recording with the remote control unit, press the REC and PLAY buttons simultaneously. (The REC button of the remote control cannot be used for instant timer recording.)

8 Rewind (REW) button

Press to rewind the tape in the cassette. While the tape is being rewound, the REW indicator on the FDP will light. This button can be pressed in any mode except Record, Eject or Timer. To release the Rewind mode, press the STOP or FF button, depending on which mode you want next. Pressing this button in the Play or Still mode enables high-speed playback at about 9 times normal in the reverse direction. During search, the REW indicator on the FDP will remain lit.

When the ALARM REC switch 21 on the front panel is set ON, and this button is pressed in the Play or Stop mode, the tape enters the alarm search mode in the reverse direction. If the PLAY button is pressed within 2 seconds after pressing the REW button, the tape will be rewound to its start and playback will start automatically. (During rewind, the PLAY indicator on the FDP will blink.)

9 PLAY/X2 button

Press once to play a tape; press again for double-speed playback. To return to normal playback, press again. Also press this button to cancel the Pause/Still and Search modes. (See pages 10 and 11.)

10 STOP button

To stop the tape. When the STOP button is pressed, the tape is unloaded and the Stop mode is engaged.

11 PAUSE/STILL button

Press to temporarily stop the tape to avoid recording unwanted material or to view a still picture. The picture advances every time this button is pressed.

12 Fast Forward (FF) button

Press to fast forward the tape in the cassette. While the tape is being fast forwarded, the FF indicator on the FDP will light. This button can be pressed in any mode except Record, Eject or Timer. To release the Fast Forward mode, press the PLAY, STOP or REW button, depending on the mode you want next. Pressing this button in the Play or Still mode enables high-speed playback at about 9 times normal, in the forward direction.

When the ALARM REC switch 20 on the front panel is set ON, and this button is pressed in the Play mode, the tape enters the alarm search mode in the forward direction.

13 ON SCREEN BRIGHT control

When time and date characters are superimposed on the picture, their brightness can be adjusted with this control by using a screwdriver. Turn clockwise for brighter characters and counterclockwise for darker characters.

14 SHARPNESS control

Turn to adjust the video output signal delivered from the VIDEO OUT connector on the rear panel for a sharper or softer picture. Turn clockwise for a sharper picture and counterclockwise for a softer picture. Effective only for the playback picture.

15 V-Lock control

In the Still mode, turn this to eliminate shaking of the picture.

16 ALPL RESET button

Pressing this resets the Alarm and Power lock counter.

REC mode indicators

These indicate the recording time and playback time (when using an E-180 cassette) selected with the REC/PLAY MODE button ⑩.

SP: SP mode
LP: LP mode
24: 24H mode
72: 72H mode
120: 120H mode
240: 240H mode
480: 480H mode
240: (960H mode)
480: (960H mode)

} VHS modes

} Time Lapse modes
(Note: The on-screen indication for the 960H mode is 480H.)

REC/PLAY MODE select button

Select the tape speed in recording or playback

VHS SP : for the VHS SP mode.

VHS LP : for the VHS LP mode.

TL : for time lapse mode 24: for 24-hour mode
72: for 72-hour mode
120: for 120-hour mode
240: for 240-hour mode
480: for 480-hour mode
960: for 960-hour mode

BUZZER ON/OFF switch

ON: The buzzer beeps 3 minutes before the tape reaches its end.

OFF: No buzzer operation. Also, set to OFF to stop the beeping buzzer.

Note: If the VTR is used for surveillance, this switch should be set to ON.

AUTO REC switch

ON: Recording restarts automatically when power is restored after a power failure. Also use this position when recording with an external timer.

Note: Effective with cassettes with safety tab in place.

OFF: If the AUTO REC function is not required, be sure to set the switch to OFF, otherwise recordings could be erased by accident.

ALARM REC switch

ON: To switch to the 3-hour (VHS/SP) recording mode or 6-hour (VHS/LP) recording mode when an alarm signal is input in time lapse recording mode. The recording mode can be set to continue for 15 sec, 3 min, to the tape end, or while alarm pulses are being input. If the FF or REW button is pressed in the Play or Stop mode, the tape enters the alarm search mode.

(The tape then enters the playback mode from the alarm cue point.)

OFF: To continue recording in the same mode with no alarm recording operation.

REPEAT REC/PLAY switch

ON: When the end of the tape is reached in recording, the tape is rewound and recording restarts automatically from the start. When the end of the tape is reached in playback, the tape is rewound and playback restarts automatically.

OFF: No repeat operation.

ON SCREEN ON/OFF switch

ON: Time/date information is added together with the input signal and is superimposed on the monitor screen.

OFF: No information is recorded or superimposed.

TRACKING (←) buttons

If the picture can be seen during playback, double-speed playback and slow search, use these buttons to minimize

their effect. Tracking is reset to normal when both buttons are pressed together, a cassette is ejected, or the power plug is disconnected.

⑫ VIDEO MODE select switch

Select one of the three positions according to the input signal during recording or the output signal during playback.

COLOUR: Set to this position when the input or playback video signal is a colour signal.

AUTO: The circuit is automatically switched between colour and black/white, allowing optimum recording and playback. When this position is used with black/white signals, a higher picture resolution can be obtained. Normally set this switch at this position.

B/W: Set to this position when the input or playback signal is a monochrome signal. Higher picture resolution will be obtained.

⑬ TIMER/TDG buttons

● COUNTER RESET button: Press to reset the counter on the FDP to "00 00".

● TIMER button: Press to engage the TIMER standby mode after you have preset the time for unattended recording.

● PROGRAM/CLOCK button: Press to change the display to the timer set mode.

● CANCEL button: Press this button at any time during timer programming to clear the program, or use to engage the cancel program mode.

● SET (+/-) button: Press these to adjust the displayed data when setting the clock and programming the timer.

● SHIFT (NEXT/BACK) buttons: Press these to change displayed figure when setting the clock and programming the timer.

● ON SCREEN SELECT button

Selects the on-screen display mode between the following three.

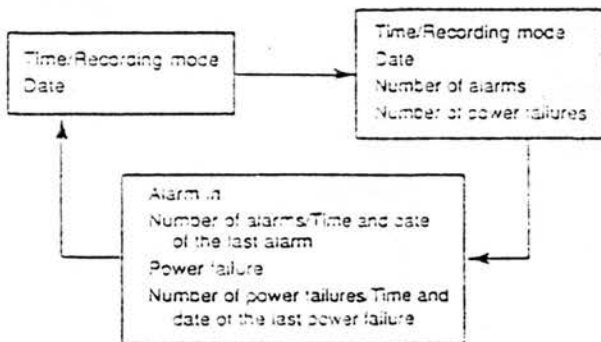

● TDG Position V/H buttons

Use to shift the position of the superimposed time and date characters in the vertical and horizontal directions. (See page 16.)

H: Horizontal direction

V: Vertical direction

● REPEAT button

Press to repeat programmed timer data weekly.

⑭ ALARM indicator

Light when an alarm recording starts.

23 Fluorescent display panel (FDP)

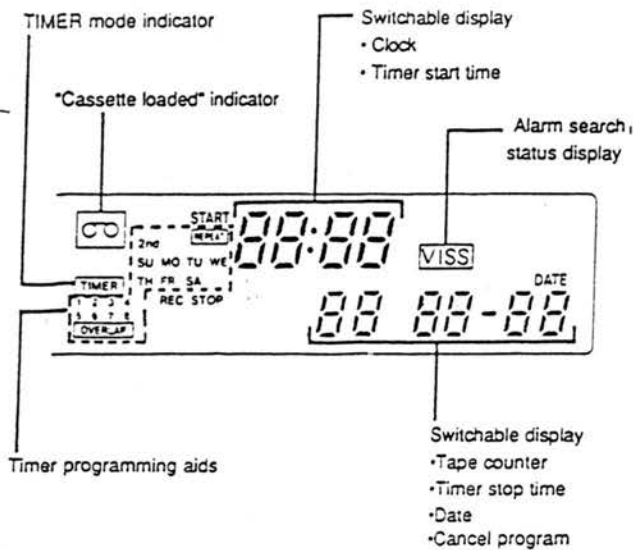

TOP PANEL

- 24 HOUR METER (5,000 hours)**
- 25 Battery Holder**
For the batteries backing up the time/date generator.
Note: The batteries must be replaced once a year.

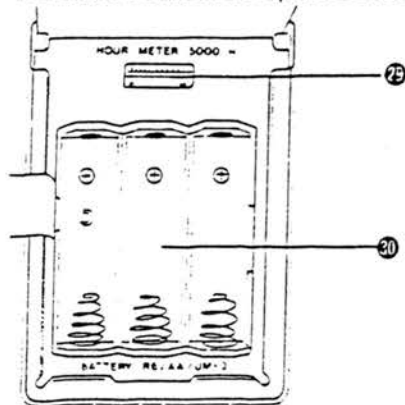

REAR PANEL

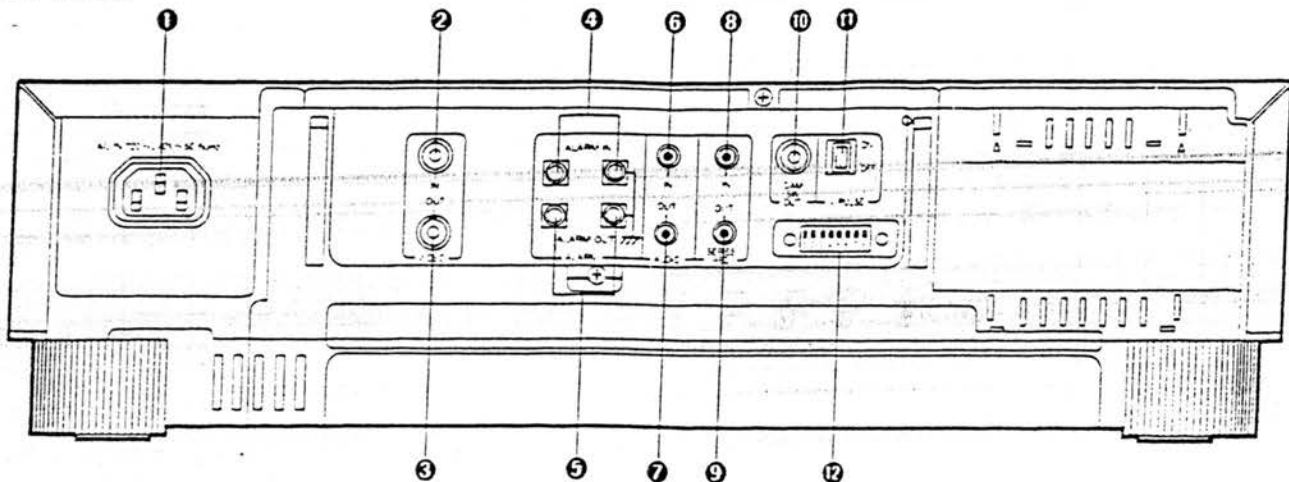

- 1 AC input socket (AC IN 220V-240V)**
Connect to a 220V-240V AC, 50/60 Hz power outlet.
- 2 VIDEO IN connector**
Input connector for composite video signal.
- 3 VIDEO OUT connector**
Output connector for composite video signal.
- 4 ALARM INPUT terminal with GND**
Accepts alarm signals; minimum pulse width is more than 20 msec.
The terminal uses an input-grounding type contact.
- 5 ALARM OUTPUT terminal with GND**
Outputs alarm signal.
- 6 AUDIO IN connector**
Input connector for audio signal.
- 7 AUDIO OUT connector**
Output connector for audio signal.
- 8 SERIES REC IN terminal**
Accepts a signal for series recording. With this input, the TVR-625 is automatically changed from the Stop mode to the Record mode. Connect this terminal to the SERIES REC OUT terminal of the preceding video recorder.
- 9 SERIES REC OUT terminal**
Delivers a signal at the end of the tape so that a second time-lapse video recorder can operate for recording in series. Connect this terminal to the SERIES REC IN terminal of the subsequent video recorder.
- 10 CAMERA SW OUT connector**
Delivers a command signal for camera switching to a camera sequential switcher.

Note:

Low active pulse, width: 5 m sec.

- 11 V.PULSE switch**
Usually set to OFF. When signals are supplied by non-interlaced cameras, set to ON for reducing vertical dancing of the playback picture on the monitor.
- 12 DIP switch**
Remove the cover with a screwdriver.
 - 1.2.3. ALARM REC select switches
 - 1. REC MODE select switches
 - ON: SP mode
 - OFF: LP mode
 - 2.3. REC TIME select switches

REC TIME	Alarm period	15 sec.	3 min.	Tape End
SW 2	ON	OFF	CN	OFF
SW 3	CN	CN	OFF	OFF

- 6. AUTO REWIND mode select switch**
 - OFF: No AUTO REWIND operation
 - CN: AUTO REWIND mode
- 7. 480H/960H time-lapse recording mode select switch**
 - ON: 480H

CONNECTIONS

Connection to a camera with a built-in SSG

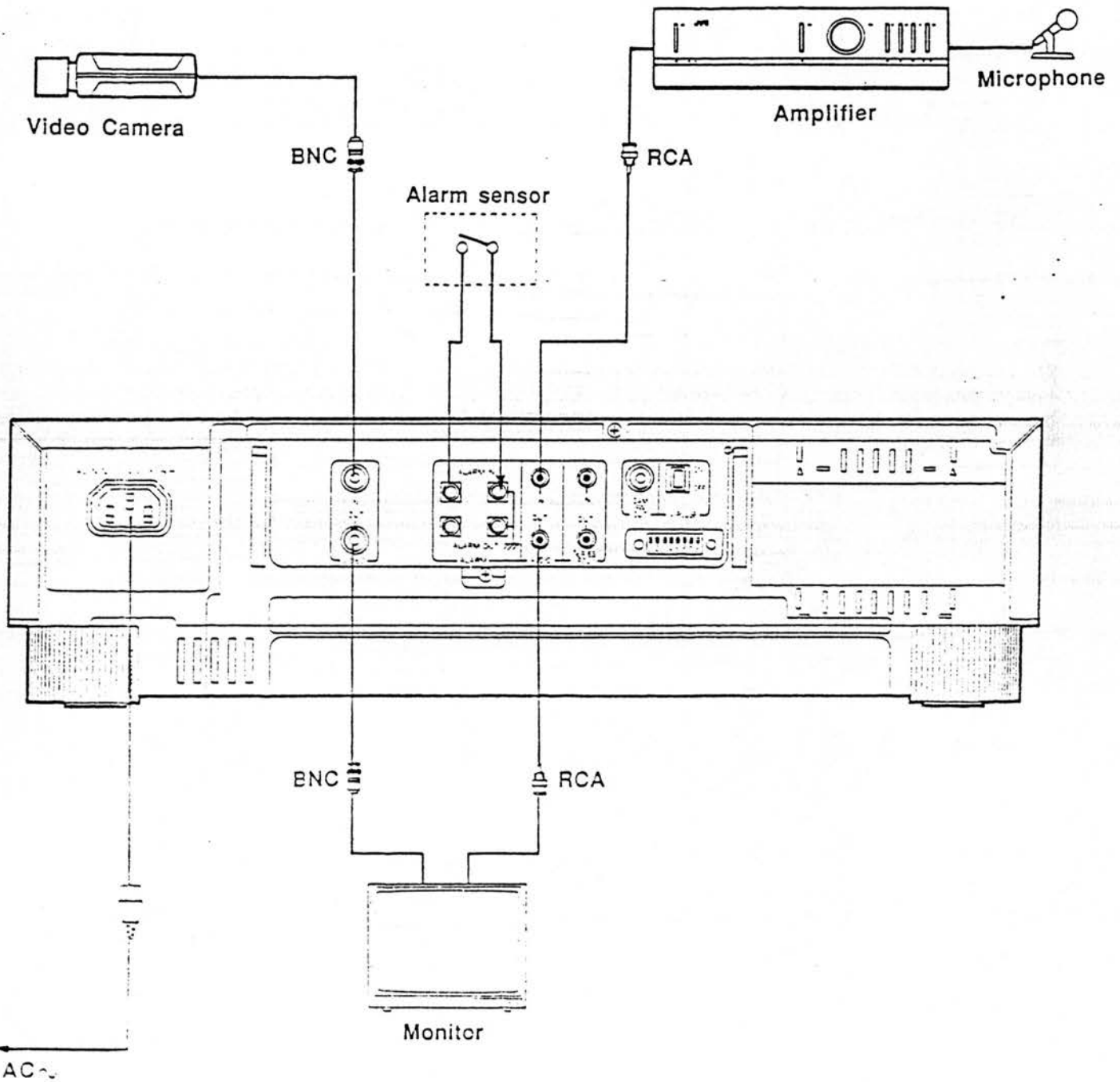

Connect the rear panel VIDEO OUT and AUDIO OUT connectors to a monitor.
Connect the video output of the camera to the VIDEO IN connector.
If an audio input is required, connect a microphone to the AUDIO IN connector via an optional amplifier.

- (4) If an alarm sensor is to be used, connect across the ALARM INPUT terminal and GND.
- (5) After completing connection, connect the power supply cord.

II Connection to several cameras using a sequential switcher

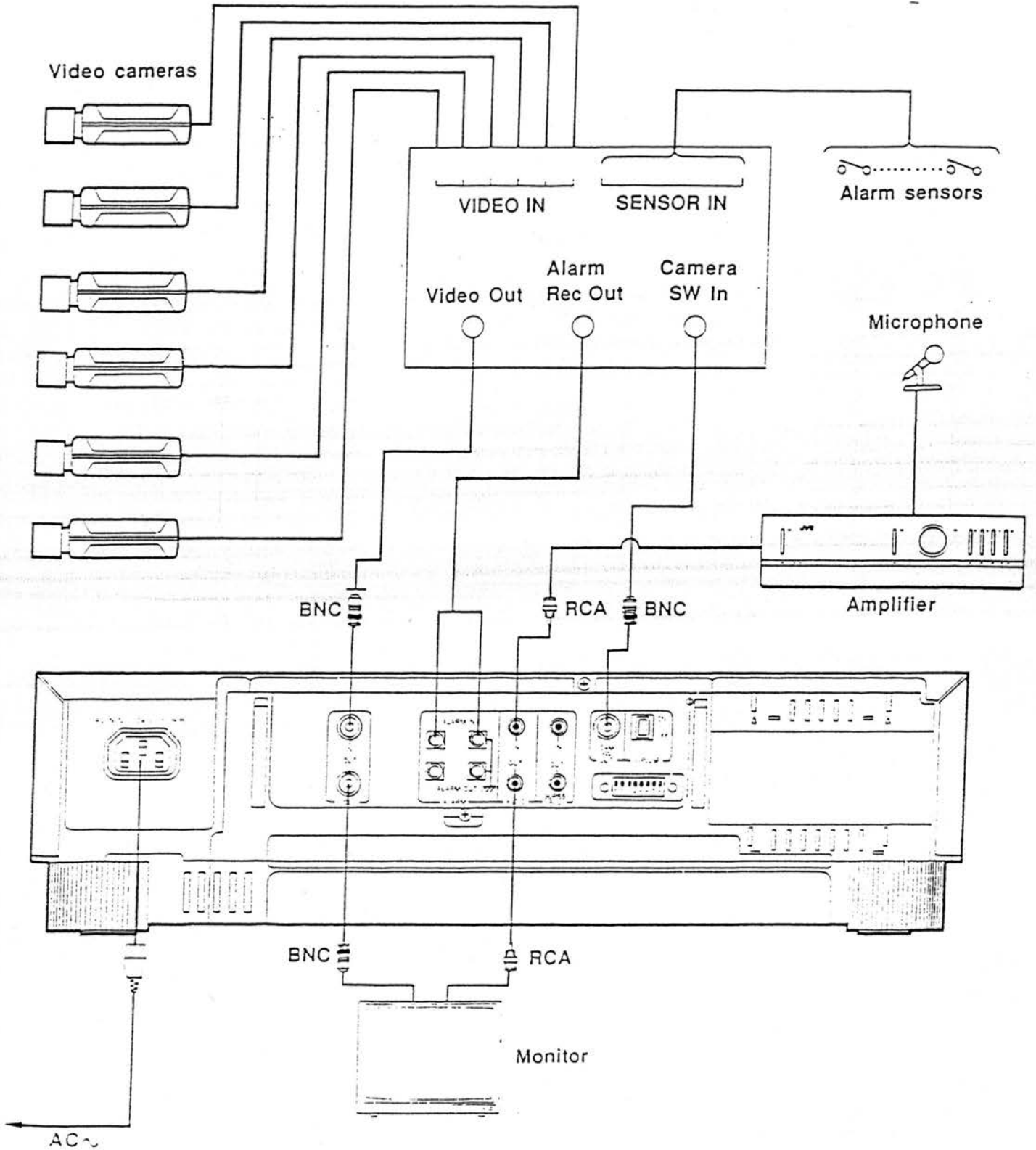

- (1) Connect the video cameras and alarm sensor to the sequential switcher.
- (2) Connect switcher's video output, alarm signal output and camera switching signal input to the corresponding terminals of the recorder.

- (3) Connect a monitor to the VIDEO OUT and AUDIO OUT connectors.
- (4) After completing connection, connect the power supply cord.

LOADING AND UNLOADING A VIDEO CASSETTE

Loading

Insert a cassette as illustrated with its labelled side facing you. With a cassette inserted, the  mark to indicate "cassette inserted" appears on the display panel.

Unloading

Press the EJECT button . The cassette will be ejected.

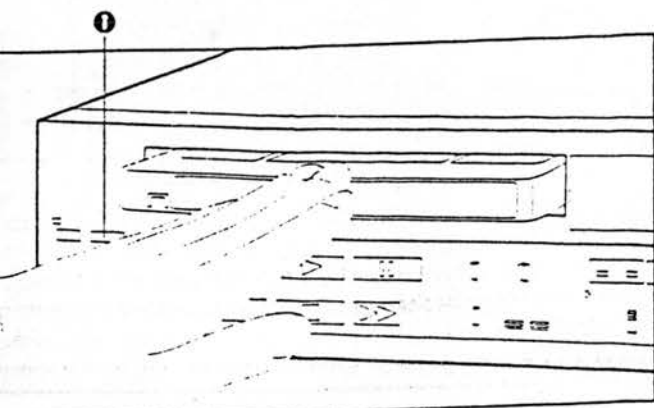

Authorized loading system

The cassette can be loaded even when the power has not been turned on. Inserting a cassette into the loading slot turns the power on automatically.

- The cassette can be unloaded even when the power has been turned off. If a cassette is inside, pressing the EJECT button turns the power on automatically and, after ejection of the cassette, shuts it off automatically.
- Inserting a cassette, with its safety tab removed, turns the recorder on and playback of the cassette begins automatically.

Notes:

- Be sure to insert the cassette firmly into the slot; otherwise, it will be automatically rejected.
- The automatic loading mechanism will operate only when the cassette is inserted correctly.

Caution

- If unloading of a cassette is not possible, check to see whether the TIMER indicator is lit. If so, press the TIMER button so the TIMER indicator extinguishes.
- Do not attempt to pull out the cassette once automatic loading has started.

WARNING

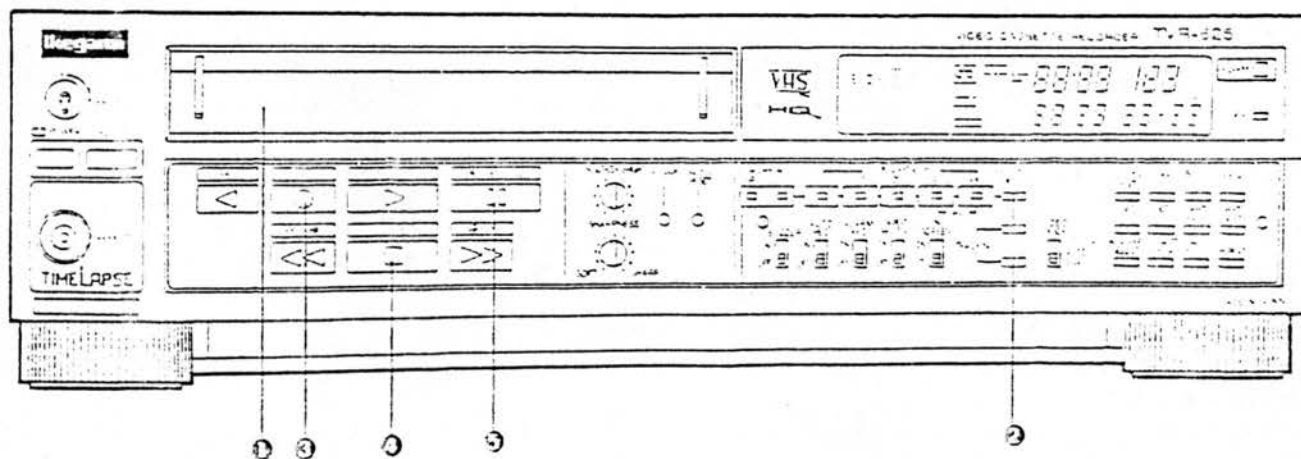

- Do not insert fingers or any foreign object beyond the door flap of the cassette loading slot, as this could lead to injury or damage to the mechanism. Show special caution with children.

RECORDING



Insert a video cassette into the cassette loading slot. Set the RECORD MODE button as required. Press the REC button to ON. The record mode will be engaged and the REC indicator on the FCP will light. Press the STOP button to stop recording.

RECORD-PAUSE

- Press the PAUSE button  to stop recording temporarily.
- Press the PLAY button  to restart recording.

Note: If left in the Pause mode for more than about 5-10 minutes, the VTR will enter the Still mode.

- While in the Pause mode, a Record-Pause bar appears at the bottom of the screen and indicates the elapsed time up to 5 minutes 25 seconds by reducing its size.

PLAYBACK

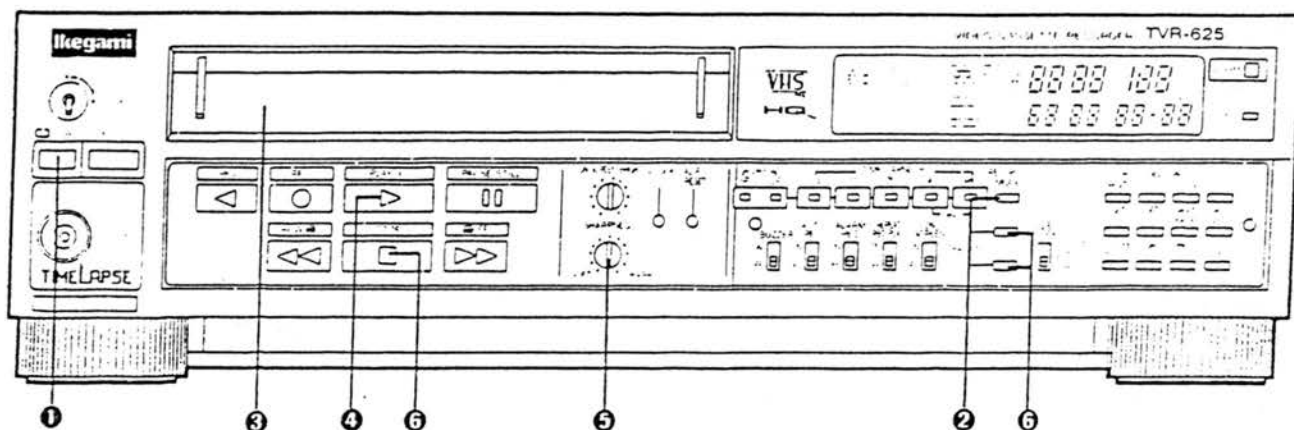

- ❶ Press the POWER button on.
- ❷ Set the REC/PLAY MODE button as required.
- ❸ Insert a pre-recorded cassette into the cassette loading slot.
 - When the cassette loaded has no safety tab, playback starts automatically.

Note:

- Noise bars may appear on the screen if you play back a tape which was recorded using another VTR. In such cases, adjust the TRACKING controls ❺. Press one of the buttons

- ❹ Press the PLAY/X2 button. The tape will start running and the playback picture will appear on the monitor screen.
- ❺ Adjust the picture as required with the SHARPNESS control.
- ❻ Press the STOP button to stop playback.

to correct the picture referring to the monitor. After playback, tracking may be reset manually by pressing both buttons simultaneously. It is reset automatically when the tape is ejected or the power cord pulled out.

SPECIAL-EFFECTS PLAYBACK

When the REW or FF button is pressed in the Stop mode, normal rewind or fast forward takes place. When these buttons are pressed in the Play, or Still mode, the tape runs at about 9 times normal speed in the corresponding direction. The buttons can be locked and the indicator lights.

You can follow the speeded-up picture on the monitor screen.

- For briefer scanning, keep the REW or FF button pressed for more than 2 seconds; when you release the button, the Search mode will be cancelled.

When the ALARM REC switch on the front panel is set to ON, pressing FF while in the Play or Still mode for less than 2 seconds initiates alarm search in the forward direction and pressing REW for less than 2 seconds initiates alarm search in the reverse direction. When the tape reaches the start of an alarm recording, it enters the playback mode automatically. During alarm search, the "VISS" mark on the FDP will light.

Note:

- If the FF or REW button is pressed in the Stop mode, the tape stops at the start of an alarm recording.

- Press the PAUSE/STILL button in the Play mode, the tape will stop and a still picture will be obtained.
- To advance the still picture, press again.
- To return to the normal Play mode, press the PLAY.X2 button.

Note:

- When the STILL mode continues for longer than about 5 minutes, the STOP mode will be entered automatically.
- Turn the V-LOCK control to eliminate shaking of the picture.

press the REV button in the PLAY mode; the tape will be played back in reverse at normal speed.

- To cancel reverse playback, press the PLAY, STOP, STILL or SEARCH button.

press the PLAY/X2 button in the Play mode; double-speed playback will be engaged.

- To resume normal playback, press the same button again.

NEXT-FUNCTION MEMORY

Memory Play function

If you want to watch the tape from its beginning after rewinding, press the REW button and then PLAY within 2 seconds. Playback will start automatically at the beginning of the tape.

While the tape is being rewound, the PLAY indicator is blinking. To cancel the Memory Play mode and go to another mode, press the corresponding button (STOP, PLAY, FF, REW, EJECT, Power OFF).

Memory Eject/Power-Off/Timer Standby

If you are going to eject the cassette, turn the power off or engage the Timer Standby mode after rewinding the tape, you don't have to wait for completion of rewind to press the corresponding button.

- To eject the cassette after rewind, press REW and then EJECT within 2 seconds. (To cancel the Memory Eject mode, press STOP, PLAY, FF or REW.)
- To turn the power off after rewind, press REW and then POWER within 2 seconds. (To cancel the Memory Power-off mode, press POWER.)
- To engage the Timer Standby mode after rewind, press REW and then TIMER within 2 seconds. (To cancel the Memory Timer Standby mode, press TIMER or Power.)

Memory Play

REW/FF



PLAY/X2



Blinking

→ Play mode

Memory Eject

REW



EJECT



Blinking

→ Cassette ejected

Memory Power-off

REW



POWER



Blinking

→ Power off

Memory Timer Standby

REW



TIMER



Lights

→ Timer standby mode

within 2 seconds

CLOCK ADJUSTMENT

Plug the recorder into an AC outlet. "SU" and "0:00" will flash on the FDP.

- If left for longer than one minute, this mode is cancelled.
1. Press the PRG/CLK button ① to enter the clock adjust mode.
 2. Press the SET(+/-) button ② to enter the hours.
 - If one digit is to be input, press "SHIFT NEXT", then the digit.

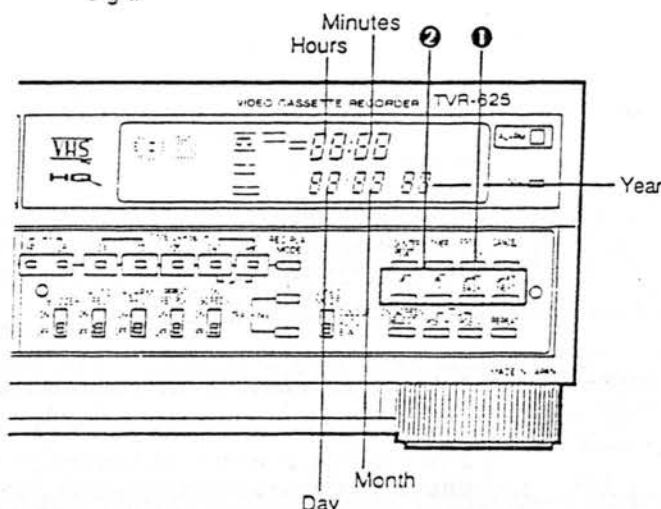

3. Press the "SHIFT NEXT" button, then the minutes will flash, then press SET(+/-) button ② to enter the minutes.

4. Press the "SHIFT NEXT" button, then the day will flash. Press the SET (+/-) button ② to enter the day.
5. Press the "SHIFT NEXT" button, then the month will flash. Press the SET (+/-) button to enter the month.
6. Press the "SHIFT NEXT" button, then the year will flash. Press the SET (+/-) button to enter the year (last two digits).
7. Timekeeping will start when the PRG/CLK button is pressed.

Notes:

- The correct day of the week will be displayed automatically.
- If you want to alter the setting of only one entry, the flashing digits can be changed by pressing the "NEXT" and "BACK" buttons.
- The seconds will be reset to "00" by pressing the SHIFT (NEXT/BACK) or SET (+/-) button in the Clock Adjust mode.
- When re-adjusting the time, pressing the PRG/CLK button repeatedly changes the display mode in the following sequence:

Timer mode → Clock Adjustment mode → Clock mode

Power failure indicator

The entire clock display may be reset to SU 0:00 and start to flash. This is not a malfunctioning of the clock, but it indicates that the batteries are discharged. Re-adjusting the time with replaced batteries restores the normal condition of the clock display.

PROGRAM TIMER SETTING

To program the timer, the clock must have been set correctly.

1. Turn on the power and press the PRG/CLK button ① to set to the Program Timer Set mode.
 - Program number "1" will blink.
 - To advance to programs 2 to 8, press the "SET +" button the required number of times. After program 8 the display will return to the clock mode.
2. Verify the program to be set by pressing the SHIFT NEXT button.
 - "SU" will blink.

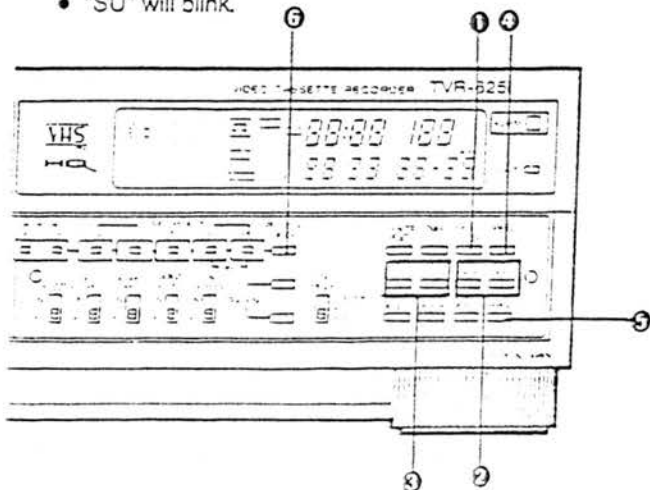

3. Then set the desired data by selecting the item to be set (day, starting time, and stop time) with SET (+/-) buttons ② and verify the data for each time with the SHIFT (NEXT/BACK) buttons ③.

The data is also displayed on the monitor screen.

- To see the on-screen data, supply a composite video signal to the video input connector.
 - To cancel the program, press the CANCEL button ④.
 - To repeat this program weekly, press the REPEAT button ④.
4. To select the recording mode, set the REC/PLAY MODE select button ⑤ on the front panel.
 5. After one program has been set, to move to the next program, press the SHIFT NEXT button ③.
 6. When data has been set, press the PRG/CLK button again.

Notes:

- The tens place will also change accordingly when the units place is advanced or reversed by pressing the SET (+/-) button.
- When the SHIFT NEXT button is pressed after the starting time has been set, the same time is displayed for the stop time.

Variety of day setting possibilities

No.	Setting	Setting method	Indication FDP
1	One day of the 1st week (week after week)	SET (+ REPEAT)	
2	One day of the 2nd week (week after week)	SET (+REPEAT)	
3	Daily recording from Sunday through Saturday (week after week)	SET (+ REPEAT)	
4	Daily recording from Monday through Saturday (week after week)	SET (+ REPEAT)	
5	Daily recording from Monday through Friday (week after week)	SET (+ REPEAT)	

As the SET (+) button is pressed, the indication progresses in sequence from No. 1 to No. 5 of the above settings and then returns to No. 1.

Note:

The 1st week or 2nd week do not refer to weeks on the calendar; the 1st week refers to the seven-day period from the present day and the 2nd week, to the following seven-day period. These two weeks are counted from the time of setting.

Error indication

When the TIMER button is pressed with a cassette loaded and the timer correctly programmed, the TIMER indicator on the display will light with the corresponding preset program number(s) also lighting and the power is turned off.

When you have preset several programs at a time, confirm that all the preset program numbers light together with the TIMER indicator when the TIMER button is pressed. The program whose number does not light has not been correctly preset. Recheck the programmed data. If two or more programs have overlapping times, the OVER LAP indicator on the FDP will blink rapidly after the TIMER button has been pressed. If no change is made in the programmed data, later programs will begin only after earlier programs are completed.

If all programs have been wrongly preset, the TIMER indicator will blink for about 10 seconds when the TIMER button is pressed, and then the Timer Standby mode will be cancelled.

If the TIMER button is pressed when a cassette is not loaded, the TIMER indicator will continue blinking.

If the TIMER button is pressed when a cassette whose safety tab has been removed is loaded, the "tape loaded" and TIMER indicators will blink and the cassette will be ejected.

As long as the TIMER button is engaged with the TIMER indicator lit, unloading of a cassette is not possible.

When the TIMER button is pressed before all programming is completed, the timer will set the program number to 0 and turns off after 10 seconds. Recheck the programmed data.

- REPEAT indication is available by pressing the REPEAT button at any time in the setting procedure.

Timer operation

- Tape loading starts 20 seconds before the preset start time and the recording start signal is triggered 2 seconds before the preset time so that recording starts exactly at the preset time.
- During timer recording, the number of the program that is presently operating will be blinking.
- If the end of the tape is reached during timer recording, the Auto Rewind mode is engaged and, after rewind to the tape beginning, recording will re-start if the REPEAT REWIND switch is set to ON. (If the REPEAT REWIND switch is set to OFF, the cassette will be ejected.) If the preset time expires during rewind, the power is switched off.
- When the tape is ejected at the tape end during timer recording, replace the cassette and press the REC button; timer recording will continue.
- If a power failure should occur, not only time-keeping stops, but also all the preset data will be cancelled. (A blinking SU 0:00 indicates this after power has been reappplied.) In such case, first correct the time indication and then re-enter the programming data.

Checking the programmed data

- To do this, press the recorder's PRG/CLK button while in the Timer Standby mode. The FDP will show programmed data for 5 seconds for each program number by automatic switching. You can also check each program by advancing program numbers manually with the SET (+) button. (If left for more than 30 seconds, this display will be cancelled.) If re-programming is required, disengage the Timer Standby mode and use the regular programming method.

ON-SCREEN DISPLAY

1. Normal display mode

Each time the front panel ON SCREEN SELECT button is pressed, the on-screen display changes in the following way:

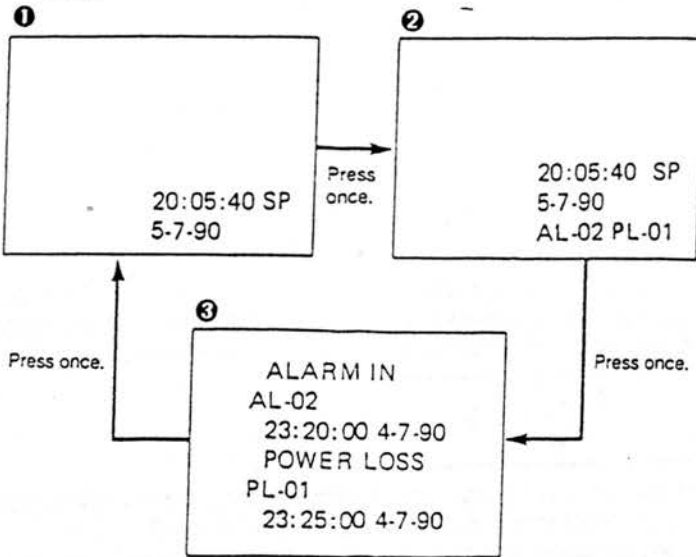

- ❶ Time/Date generator data to be recorded (hours, minutes, seconds, recording mode, day, month, year)
- ❷ Number of alarm inputs and power failures, in addition to ❶.
- ❸ Under ALARM IN, the number of alarm inputs, and the time/date when the last alarm recording occurred are displayed. Also, under POWER LOSS, the number of power failures and the time/date when the last power failure occurred.
Up to 99 can be displayed for both alarm inputs and power failures.

- Press the AL/PL RESET button to clear the numbers.

2. Cancel Program mode

After setting the timer for daily or weekly recording, up to 14 days in a year can be cancelled so that timer recording will not be executed on those days. For instance, 14 consecutive days or 14 Sundays can be omitted from timer recording.

Procedure:

- ❶ Press the CANCEL button ❶ for longer than 5 seconds and then press the PRG/CLK button ❷ within 5 seconds. Then the following on-screen display will appear with day digits blinking.

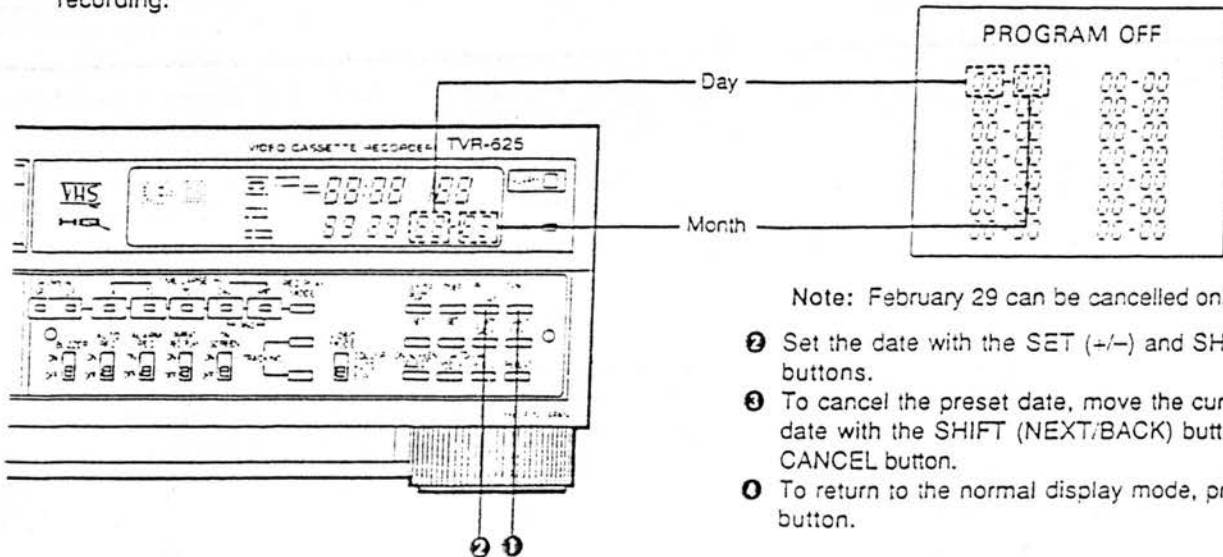

Note: February 29 can be cancelled only in leap years.

- ❷ Set the date with the SET (+/-) and SHIFT (NEXT/BACK) buttons.
- ❸ To cancel the preset date, move the cursor to the relevant date with the SHIFT (NEXT/BACK) buttons and press the CANCEL button.
- ❹ To return to the normal display mode, press the PRG/CLK button.

INSTANT TIMER RECORDING

After you start recording, the recorder can be set to stop automatically after a certain period of time.

Press REC button while recording (or twice if in the Stop mode). The following indication will appear on the display, to show that the recorder is recording in the Instant Timer Recording mode and power will switch off after 30 minutes.

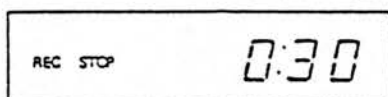

Each time the REC button is pressed, recording time increases 30 minutes to a maximum of 9 hours. If the REC button is pressed again, the Normal Recording mode will be entered.

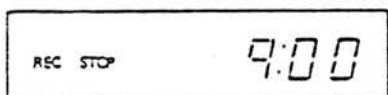

For a more precise time setting, use the SET +/- and SHIFT EXT/BACK buttons to set to the exact time required.

After "0:30" has appeared, press to set to the exact time required.

Press REC button so that the digits stop blinking.

Notes:

- Time setting in this mode is possible up to a maximum of 9 hours 59 minutes if the SHIFT (NEXT/BACK) and SET (+/-) buttons are used.
- While recording is in progress, the displayed time counts down; when 0:00 is reached, the Record mode is released after 10 seconds and the power is switched off.
- If you want to stop recording after having started recording in the Instant Timer Recording mode, press the STOP button.
- If instant timer recording is engaged while the unit is in the Pause mode, the timer will count down normally, but recording will not begin until the PLAY button is pressed.
- When the Instant Timer Record-Pause mode continues for longer than about 5 minutes, the mode is released and the power is switched off.

TIME/DATE GENERATOR

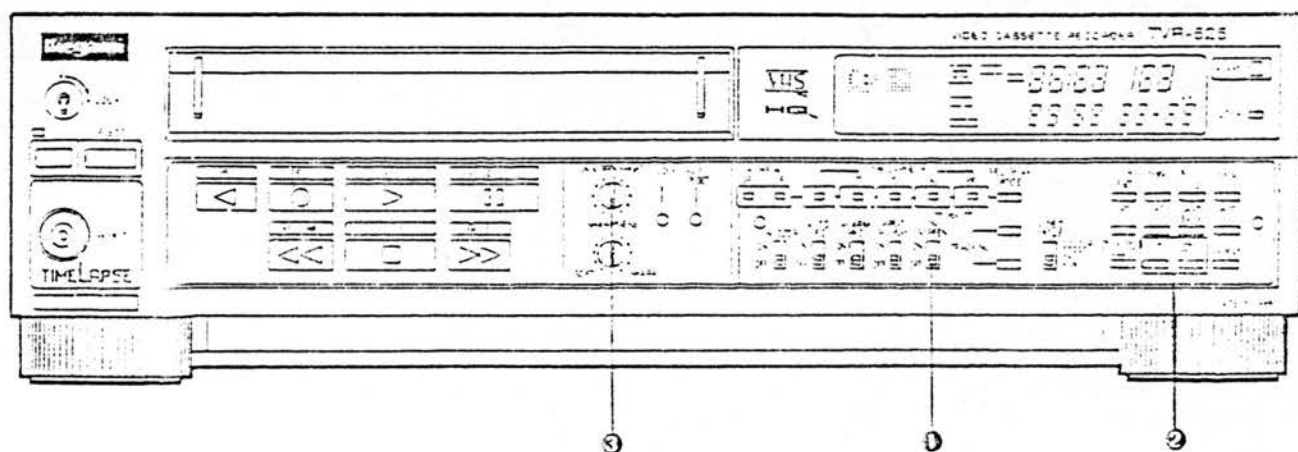

The built-in time/date generator allows the time and date to be superimposed on the video image and recorded.

Set the Clock Time accurately as described on Page 12.

Set the ON SCREEN BRIGHT switch to ON.

Move the cursor to the appropriate position on the screen with the TDG (Time/Date Generator) and "V" Position buttons. The cursor can be moved to the left or right in 13 steps by pressing the "H" button. The cursor can be moved up the screen in 13 steps by pressing the "V" button.

When the cursor is at the left or top of the screen, the next time the button is pressed, it will move to the right or bottom of the screen.

- 1 The brightness of the time/date display can be adjusted using the ON SCREEN BRIGHT control. Turn clockwise for a brighter display and counterclockwise for a darker display.

SERIES RECORDING

Series recording refers to successive recording with more than one recorder, allowing unattended recording for an extended time.

1. Load cassettes in the required number of recorders and locate the starting position for each tape.

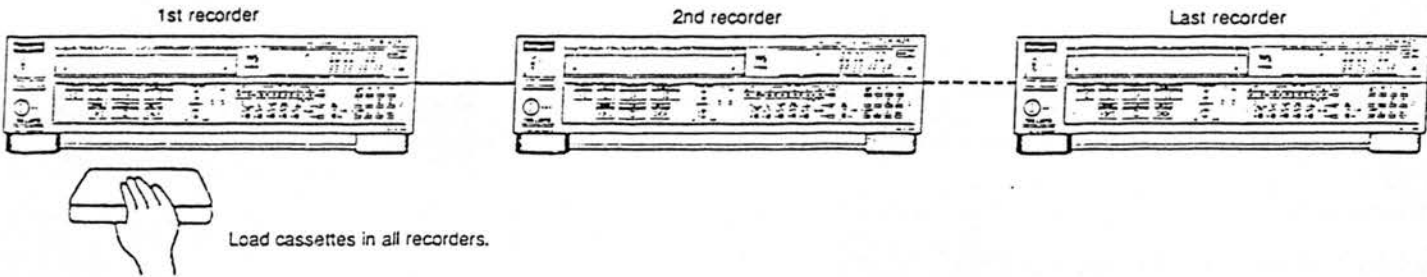

2. Start recording with the first recorder.
When the tape in the first recorder comes to an end, the second recorder starts recording automatically. Likewise, recording continues to the end of the tape of the last recorder.

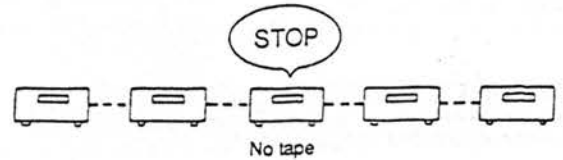

Note:

- If a cassette is not loaded in one of the recorders, series recording stops there.

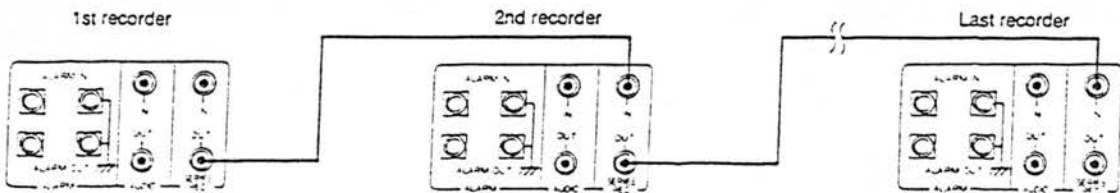

- Connect the SERIES REC OUT terminal 9 of the 1st recorder to the SERIES REC IN terminal 8 of the 2nd recorder. Connect the SERIES REC OUT terminal of the 2nd recorder to the SERIES REC IN terminal of the 3rd recorder, and so on.

ALARM RECORDING

When an unusual incident is observed in the scene being recorded in the Time Lapse mode and an alarm is given, the

Recording mode changes automatically to a faster speed for more detailed coverage of the incident.

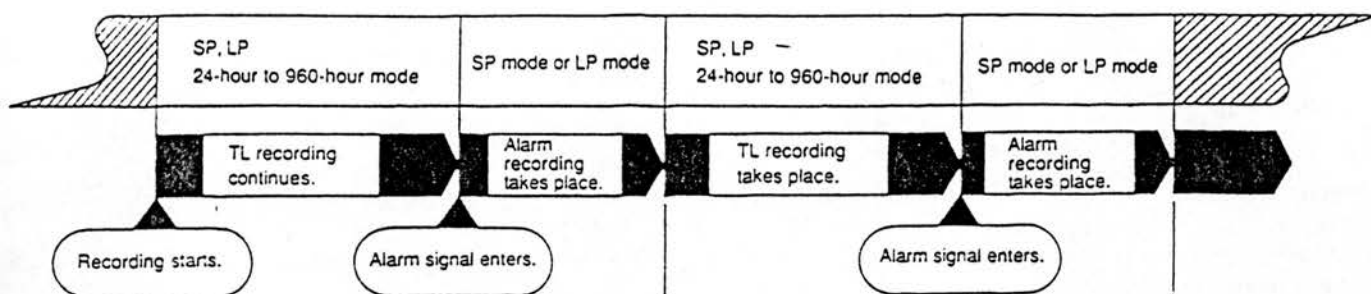

An alarm sensor can be connected across the ALARM INPUT and GND terminals.

Set the REC/PLAY MODE button to TL 24, 72, 120, 240, 480, or 960.

Set the ALARM REC switch to ON.

IN CASE OF DIFFICULTY

Symptom	Cause	Remedy
No power is applied to the recorder.	• Power cord is unplugged.	• Plug in the power cord.
Tape control buttons do not function.	• TIMER switch is set to ON.	• Release the key lock and set the TIMER switch to OFF.
Playback picture does not appear while tape is running.	• Monitor is not connected correctly.	• Check the connections.
Noise bars are visible during playback.	• TRACKING control is not correctly adjusted.	• Turn the TRACKING control slowly in either direction to move the noise bars off the screen.
Playback picture is blurred or interrupted.	• Video heads may be dirty.	• Head cleaning is necessary. Consult your nearest JVC dealer.
No audio is available during playback.	• No audio signal is recorded during TL recording.	• Check the mode in which the tape was recorded.
Recording is not possible.	• Safety tab is removed from the cassette.	• Change the cassette to one with safety tab in place.
Timer recording is not possible.	• TIMER indicator is off. • The time/date generator is not correctly preset.	• Press the TIMER switch set to ON. • First set the clock time correctly, then program the timer.

SPECIFICATIONS

GENERAL

Recording system : Luminance — FM
 : Chroma — Down-converted

Signal system : PAL/CCIR, 625 lines

Tape speed : 23.39 mm/s (VHS SP)
 : 11.70 mm/s (VHS LP)

Record/Play time : 3, 6, 24, 72, 120, 240, 480
 and 960 hours
 (with E-180 video cassette)

Operating temperature : 5°C to 40°C

Operating humidity : 35 % to 80 %

Storage temperature : -20°C to 60°C

Power requirement : 220 -240 V AC, 50/60 Hz

Power consumption : 30 watts

Dimensions : 435(W) x 124(H) x 370(D) mm

VIDEO

Input : 0.5 to 2.0 Vp-p, 75 ohms,
 unbalanced, BNC

Output : 1.0 Vp-p, 75 ohms, unbalanced,
 BNC

Horizontal resolution : Colour-240 lines (VHS SP)
 B/W-300 lines (VHS SP)

S/N ratio : More than 43 dB (VHS SP)

AUDIO

Number of tracks : 1

Input : -8 dBs, RCA

Output : -6 dBs, RCA

S/N ratio - : 40 dB (at 3% distortion)

TIME/DATE GENERATOR

Display : Day, month, year, hours, minutes,
 seconds, Recording mode

Character size : 16H

Power backup : Approx. one year

ALARM

Alarm input : Ground input

Alarm output : Alarm input through-out

Camera switching output : Negative pulse output (approx. 5 ms)
 BNC

SERIES RECORDING

Series input : Ground input, RCA

Series output : Series input through-out, RCA

Accessories : "R6" batteries x 5
 Remote control unit x 1
 Switch cover x 1
 Lock key x 2

Ikegami

INSTRUCTION MANUAL

MODEL ICD-42E Type F

B/W CCD CAMERA

OUTDOOR USE WARNING

**WARNING—TO PREVENT FIRE OR ELECTRIC SHOCK, DO NOT
EXPOSE THIS APPLIANCE TO RAIN OR MOISTURE.**

CONTENTS

1. General	2
2. Features	2
3. Standard Configuration	2
4. Precaution to be Taken When Handling The ICD-42E	2
5. Names and Functions of Each Part	3
6. Connection	5
7. Operation	6
8. Internal Unit Adjustments	7
9. Specifications	10
10. Block Diagram	11
11. External Appearance	12

1. GENERAL

The ICD-42E video camera is a B/W CCD camera containing an FT-CCD with approx. 420,000 picture elements and offers high resolution and sensitivity. It features no gemetric distortion, no sticking, longer life, and it also incorporates LSI and SMT technologies for resistance to vibration and shock.

With the internal line lock function (for AC type) and the external Genlock function adopted for synchronization, the ICD-42E is suitable for surveillance system which includes two or more cameras.

A compact version, the ICD-42E DC 12 V type, is also available.

2. FEATURES

- (1) Incorporates LSI and SMT technologies for compactness.
- (2) Sticking-free design gives longer life.
- (3) Unaffected by electrical or magnetic field.
- (4) Superior resistance to vibration and shock.
- (5) High horizontal resolution with 520 TV lines.
- (6) Sensitivity is about 20 times as high as the IT-CCD camera (compared with our products).
- (7) High sensitivity to near infrared rays (approx. 800 nm).
- (8) The Genlock (external sync function provided.)
- (9) Flange back adjustment mechanism provided.
- (10) The KNEE circuit is provided to improve the reproducibility of the highlighted portion.

3. STANDARD CONFIGURATION

- (1) Video camera (ICD-42E: AC type or DC type) 1 unit
- (2) Accessories
 - Connector plug for Auto Iris Lens (R05-PB3M) 1 pce.
 - Connector plug for DC input (HR10A-7P-4S-01) 1 pce.
(DC type only)
- (3) Instruction Manual 1 vol.

4. PRECAUTION TO BE TAKEN WHEN HANDLING THE ICD-42E.

- (1) Do not open the camera case unless necessarily. It may cause a trouble to the internal precision components.
The internal components, consult qualified service personnel.
- (2) Do not install this camera where it may get splashed with water or in the damp environment.
The ambient temperature should be within the range from -5°C to $+40^{\circ}\text{C}$.
- (3) The power source voltage should be within the specified range.
 - DC type:
12-volts DC rating: + 11 V DC to 13 V DC
 - AC230V type:
230-volts AC rating: 230 V AC $\pm 15\%$
 - AC24V type:
24-volts AC rating: 24V AC $\pm 10\%$
- (4) Make sure the power source is turned off before trying to install the camera or connect wiring. Use caution not to drop the camera or give strong shock to it.
- (5) Do not touch the CCD face plate.
- (6) The camera has sensitivity to infrared rays, but the image under the visible rays is not in the same focus as under the infrared rays. Set the camera focus according to your purpose.

5. NAMES AND FUNCTIONS OF EACH PART

● DC type

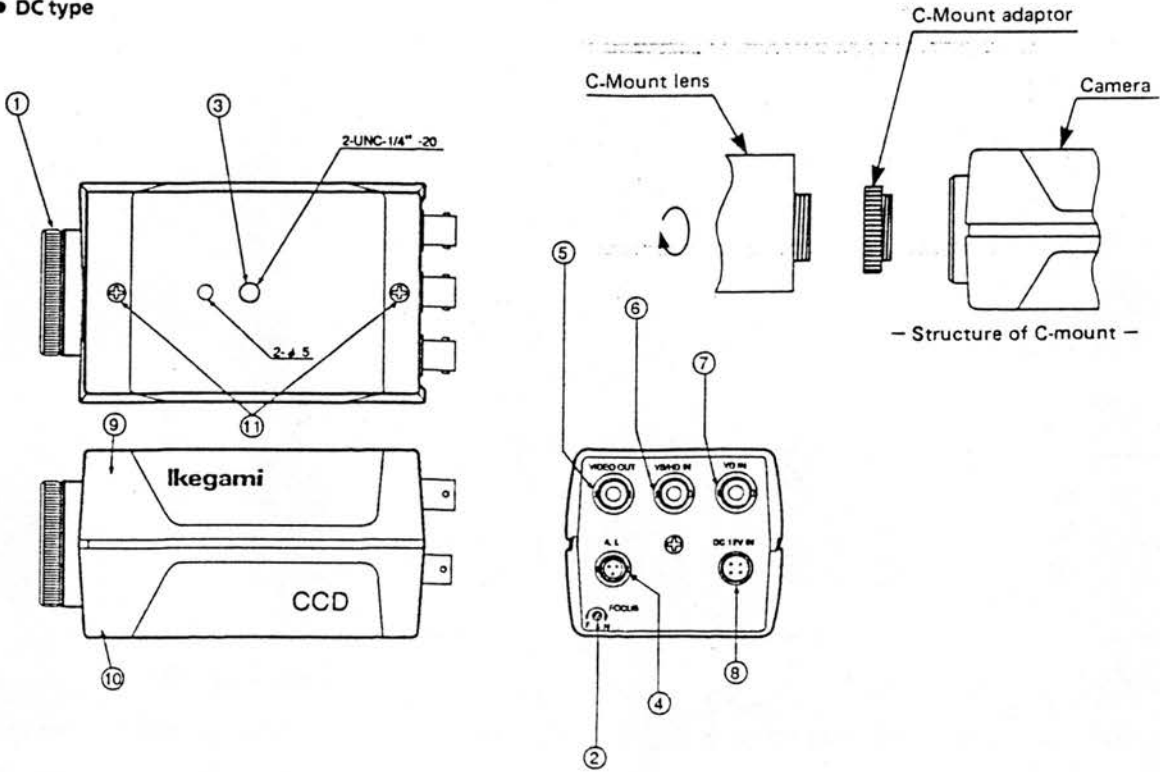

● AC230V type

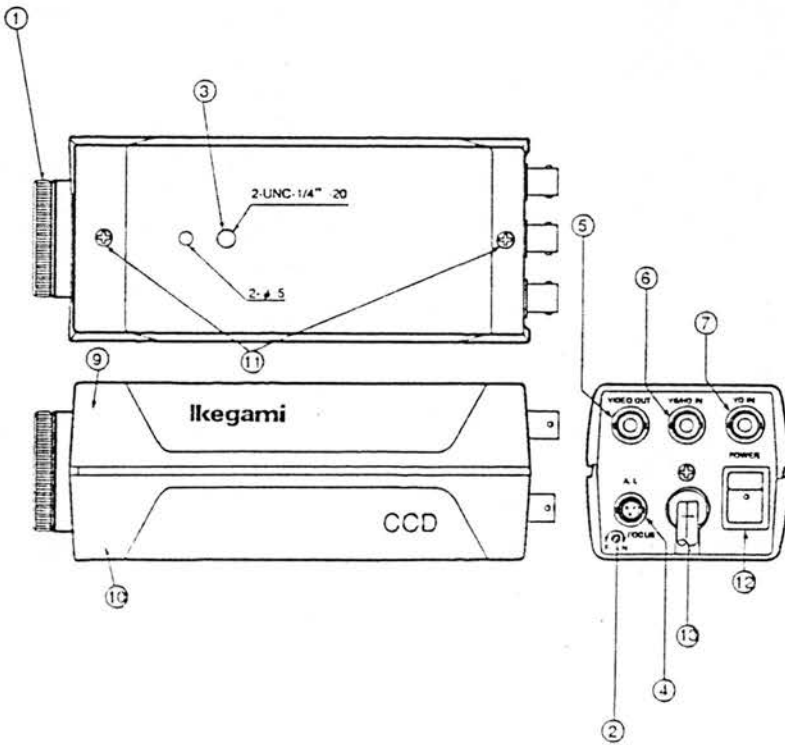

◀ AC24V type

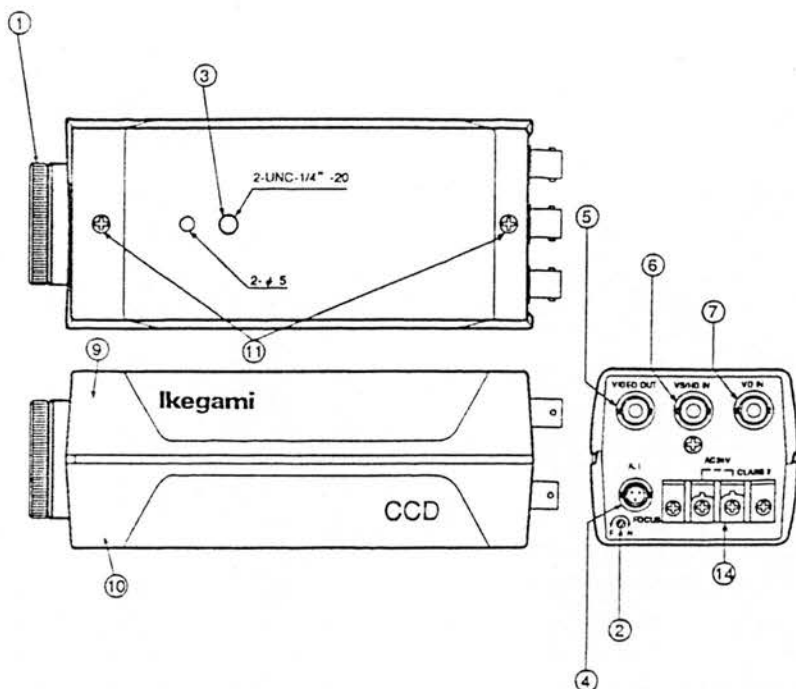

- ① Lens mount (C-mount)
The part to install a lens. C-mount lens is applicable.
 - ② Flange-back adjuster
By turning this adjuster, the distance from the lens fitting face up to the CCD image forming face (flange-back) can be adjusted. Make adjustment according to the lens used. (See page .)
 - ③ Camera mount
Screw holes to mount the camera body to a tripod, holder, bracket, and the like.
The holes are on the top and at the bottom of the camera.
 - ④ Auto Iris lens connector
This connector is for the +9 volts and video-signal output necessary to operate the auto iris lens. Connect the auto iris lens using the enclosed special connector.
 - ⑤ VIDEO Output connector
From this connector the video-signal is provided.
 - ⑥ VS/HD Input connector
When the camera is genlocked, the signal is received from this connector. In case genlock with a composite signal the VS or composite sync is received from this connector only. To genlock the camera with separate HD/VD signal, input the HD signal to this connector.
 - ⑦ VD Input connector
In case genlock with separate HD/VD signals. The VD signal is received from this connector.
 - ⑧ DC power source input connector
It is DC + 12-volts power source input connector. Input 12-volts DC (11V~13V) with the enclosed connector.
 - ⑨ Upper case
 - ⑩ Lower case
 - ⑪ Case fixing screws (Two pcs. each on the top and at the bottom)
 - ⑫ Power switch
On/Off switch for 230-volts AC power source
 - ⑬ Power cord
Power input cord for 230-volts AC. Input 230 volts $\pm 15\%$ AC.
 - ⑭ 24-volts AC power source input connector (2-pin terminal board)
Input 24 volts $\pm 10\%$ AC.
- * When using the CS mount lens, be sure to remove the C mount adapter.

6. CONNECTION

6-1 Connection of Auto Iris Lens

Use the auto iris lens control connector plug enclosed, with the camera for this purpose.

— Wiring of connector cables —

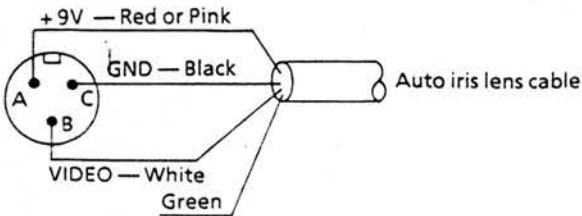

This cable should not be in touch with anything.

* The connector is R05-PB3M. The above sketch is viewed from the connection side.

After installing the lens to the camera's C mount securely, connect the connector to the AI connector at the rear of the camera.

6-2 Connection of Power Source

(1) Connection of DC input connector

Use the DC input connector enclosed, with the camera for this purpose.

Connector: HR10A-7P-4S(01)

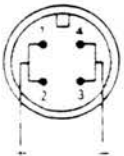

DC12V INPUT

* The pin arrangement is viewed from the connection side.

After connection is completed, connect to the 12-volts DC IN connector at the rear of the camera.

The ICD-42DC does not have a power switch, so the power source is turned on and off with the switch of the power source which provides 12 volts DC.

(2) Connection of 230-volts AC input cord

5. Insert the power cord plug to a 230-volts AC outlet.

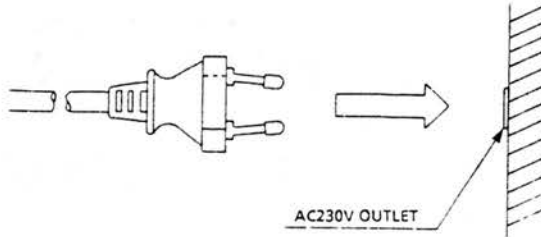

(3) Connection of 24-volts AC input connector

Connect the 24-volts AC line to the 2P-terminal board at the rear of the camera.

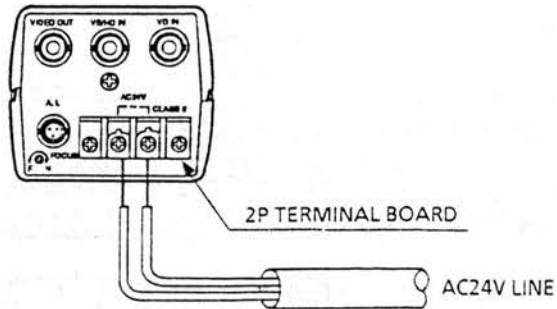

6-3 VIDEO OUT, GENLOCK IN

- (1) Connect the VIDEO OUT to monitor's VIDEO IN.

Use a commercial BNC coaxial connector.

- (2) GENLOCK IN

(a) To genlock the camera with the composite signal, connect the line to the camera's VS/HD IN.

(b) To genlock the camera with the separate signal HD/VD signals, connect the HD line to the VS/HD IN and the VD line to the VD IN. As connectors, use the BNC connectors in either case.

7. OPERATION

7-1 Power ON

- (1) Either the DC type or AC24V type does not have a power switch. Both models are put in operation by supplying 12 volts DC or 24 volts AC, respectively.
- (2) The AC230V type is put in operation by first inserting the power cord to the outlet and turning on the power switch.

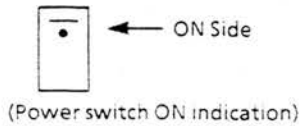

7-2 Video Level Adjustment

The video level can be adjusted by changing the iris of lens.

The auto iris lens has two adjusters, LEVEL and ALC.

Adjust the iris in the following manner:

- (1) Turn the ALC adjuster to the 'average' side to the full.
- (2) Bring up a scene whose ratio of brightness to darkness (white to black) is even on the screen. Adjust the video level for 0.7Vp-p with the level adjuster of the lens. Remember that too dark a scene is not appropriate for this adjustment.
- (3) Bring up a real scene on the screen and adjust the brightness of the scene properly with the ALC adjuster. When the bright portion of the scene is greater, the screen does not almost change even if the ALC adjuster is turned.

7-3 FOCUS adjustment

When the focus cannot be focused with the focus ring of the lens, adjust the optical focus of the camera. However, if the camera is to be focused on a object at a distance shorter than the MOD of the lens, use a separate close-up ring, etc.

— Adjustment of Optical Focus —

After lens mounting, adjustment of the flange-back (distance between the lens mounting face and the image forming face) is required in some cases.

When the image is not focused clearly by the focus ring of the lens, make adjustment with the flange-back adjuster shown in the figure below.

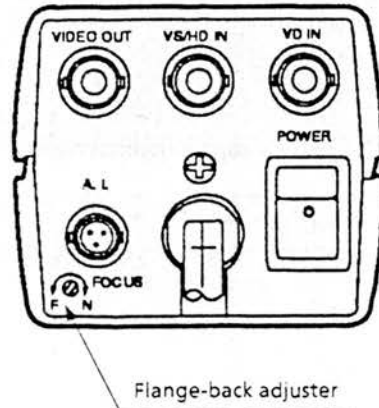

8. INTERNAL UNIT ADJUSTMENTS

Do not move internal adjusters unless necessary. Use insulated screw drivers such as ceramic ones for volume adjustment. Do not use conductive screw drivers which may cause danger of shorting the circuit.

8-1 Moving away the cases

Remove each two screws on top and bottom side to move away the cases.

8-2 Adjuster Position

(Do not move adjusters marked*.)

(1) VIDEO Board

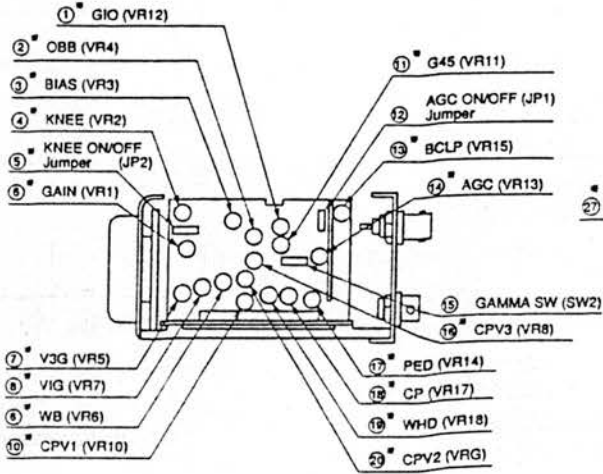

(3) SG/Timing Board (with extension board)

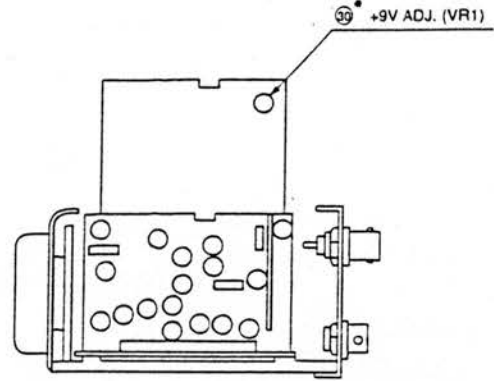

(4) GENLOCK Board (with extension board)

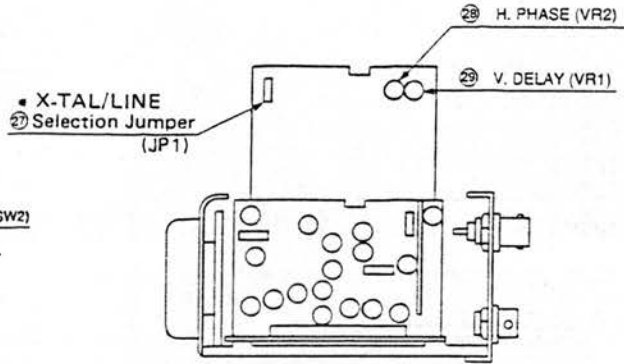

(5) POWER Board (with extension board)

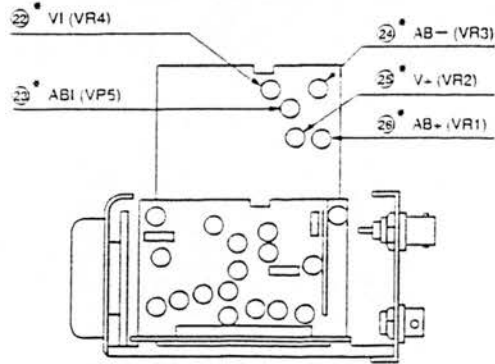

(2) SG/Timing Board (top view)

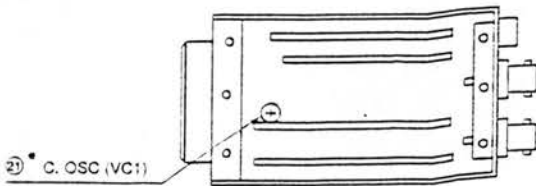

(6) POWER Board (for AC type only)

(Adjustable from outside)

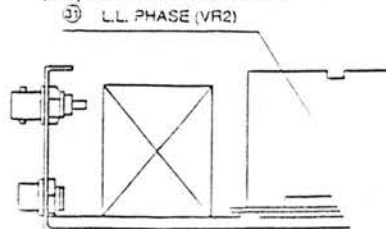

8-3 Internal Operation and Adjustment Procedure

(1) Video board

⑤ KNEE ON/OFF Jumper (JP2)

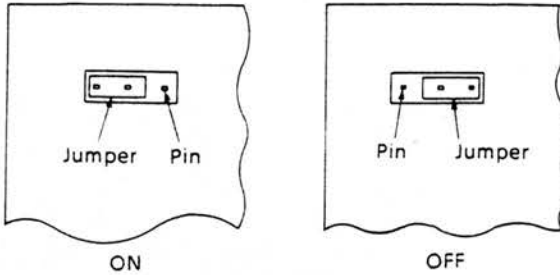

The jumper is used to switch on and off the KNEE. Disconnect and reconnect the jumper in the other position.

When the jumper is on, the reproducibility of the highlighted portion can be improved. This also helps correct the backlight effect when the auto iris lens is used.

⑦ Pedestal (VR14)

The pedestal adjusts the black level in video-out signal. Picture a test chart and adjust the black level for 0.1 Vp-p under standard illumination conditions.

This adjustment is usually not necessary, but is needed when the gamma switch has been operated.

⑬ GAMMA switch (SW2)

This switch selects between gamma levels 1.0 and 0.45.

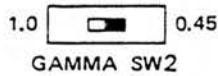

Whenever the gamma level is switched over, be sure to adjust the pedestal because its reference voltage changes.

⑫ AGC ON/OFF Jumper (JP1)

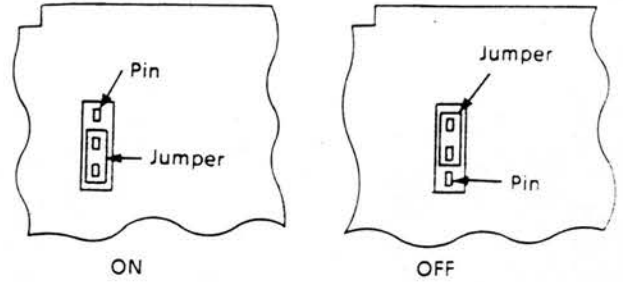

AGC is turned ON and OFF by changing the jumper position.

(2) Genlock board

⑳ H. Phase (VR2)

It is used to adjust the H. phase when the camera has been genlocked.

Since the phase alignment position for the composite genlock input signal is different from that for the separate HD/VD input signal, it is necessary to make adjustment.

The camera is factory adjusted for composite signal use. When it is to be genlocked by the separate HD/VD signal, phase adjustment is needed. This knob is also used to adjust the signal delay arising with the cable in the case of the composite signal input.

The adjustment procedure is as follows:

- (a) Genlock by composite signal
Align the H. sync. leading edge of the input signal with the H. sync. leading edge of the video out signal.
- (b) Genlock by separate HD/VD signal
Align the leading edge of the input HD signal with the H. blanking leading edge of the video out signal.

㉑ V. Delay (VR1)

It is used to adjust the V. phase when the camera has been genlocked by the separate HD/VD signal.

When the camera is genlocked by the composite signal, the V. delay is not used. If necessary, align the leading edge of the input VD signal with the V. blanking leading edge of the video out signal.

This knob has something with the field index pulse (VRS). If the signals were out of synchronization (when HD/VD is inputted), adjust synchronization with this knob.

(3) Power board (for AC type only)

㉒ L.L. Phase (VR2)

When the camera has been line-locked, this knob should adjust the phase of the video out signal (V. sync. rise) within the range of $\pm 90^\circ$ against to the input AC line zero cross point.

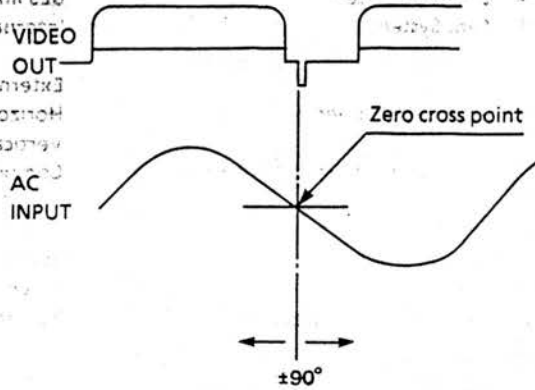

9. SPECIFICATIONS

(1) Image Pickup Device	1/2 Inch Type, Frame-transfer System CCD	
(2) Picture Elements	Horizontal	699
	Vertical	576 (288 × 2)
(3) Image Size	6.4 mm(H) × 4.8 mm(V)	
(4) Scanning System	625 lines/50 Hz, 2:1 interlace	
(5) Sync System	Internal sync.; Line-Lock (AC type)	
	Crystal-Lock (DC type)	
	External sync.; Genlock	
(6) Scanning Frequency	Horizontal	15.625 kHz
	Vertical	50 Hz
(7) Genlock Input Signal	Composite signal; VS or VBS	1.0 Vp-p ± 6 dB
	BBS	0.45 Vp-p ± 0.1 Vp-p
	C. SYNC	4.0 Vp-p ± 2 Vp-p
	Separate signal; HD/VD	4.0 Vp-p ± 2 Vp-p
	(In any case, the sync. signal polarity is negative.)	
(8) Genlock Input Impedance	75 ohms	
(9) Video Output	1.0 Vp-p, VS composite	
(10) Video Output Load Impedance	75 ohms	
(11) Resolution	Horizontal	520 TV lines
	Vertical	400 TV lines
(12) S/N Ratio	46 dB (p-p/rms) or better	
(13) Illumination (Light source of color temperature 2850°K)		
	Faceplate	* Scene
Standard illumination:	0.25 Lux (0.023 fc)	2.5 Lux (0.23 fc)
Minimum illumination:	0.01 Lux (0.001 fc)	0.1 Lux (0.01 fc)
(γ = 0.45, AGC ON, W/O IR cut filter)		
* Measurement conditions of scene illumination: Lens F 1.4, 89% reflectance object		
(14) AGC	Provided, ON-OFF Switching	
(15) GAMMA	0.45 or 1.0 Switching	
(16) Peak White Clipper	Provided	
(17) Auto iris function	Normally equipped with video signal and +9V output connector.	
(18) Power Source	AC type	AC230V ± 15%, 50 Hz
	DC type	DC12V ± 1%
(19) Power Consumption	AC type	8W
	DC type	4W
(20) Ambient Temperature	- 10°C ~ + 45°C	
(21) Lens Mount	C mount	
(22) I/O Connector	Video output;	BNC
	DC INPUT;	HR10A-7R-4P (01) (DC type only)
	Genlock input;	BNC × 2
	Auto iris;	R05-R3F
(23) Dimensions	AC type	70(W) × 60(H) × 160(D) mm
	DC type	70(W) × 60(H) × 110(D) mm
(24) Weight	AC type	1.2 kg approx.
	DC type	650 g approx.
■ Accessories		
● Auto iris lens connector plug; R05-PB3M	1 pce.	
● DC input connector plug (DC type only); HR10A-7P-4S(01)	1 pce.	
● Instruction Manual	1 vol.	

10. BLOCK DIAGRAM

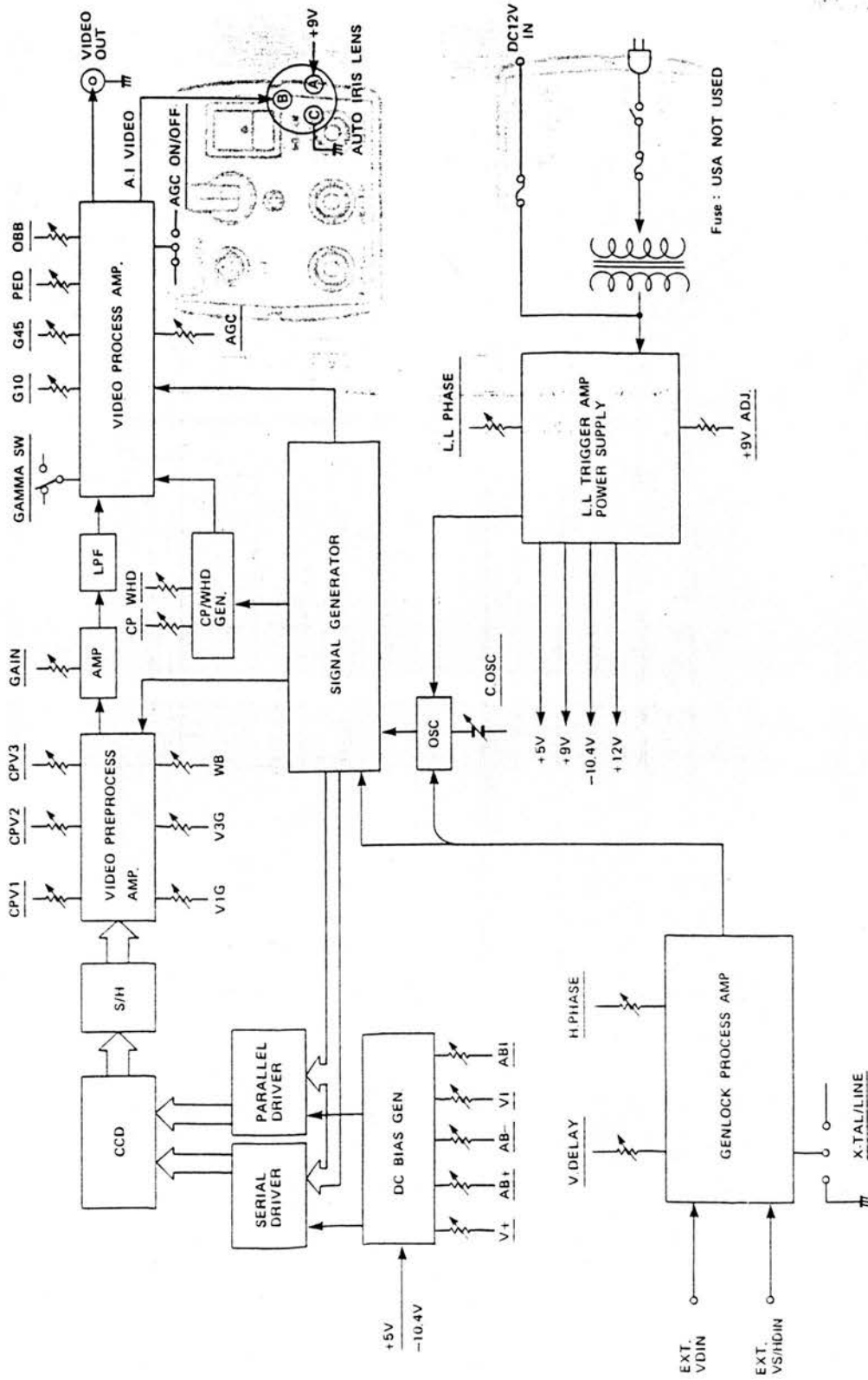

11. EXTERNAL APPEARANCE

(1) AC230V type

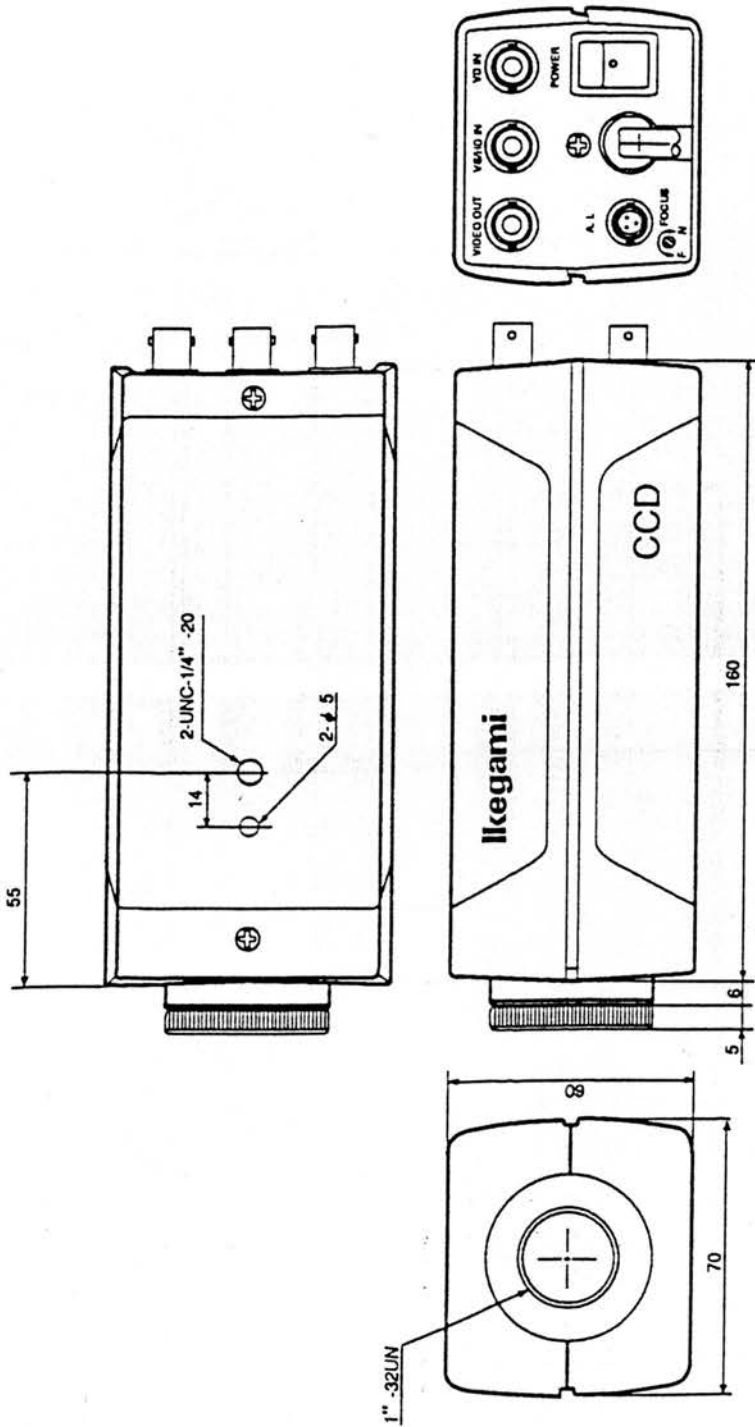

(2) AC24V type

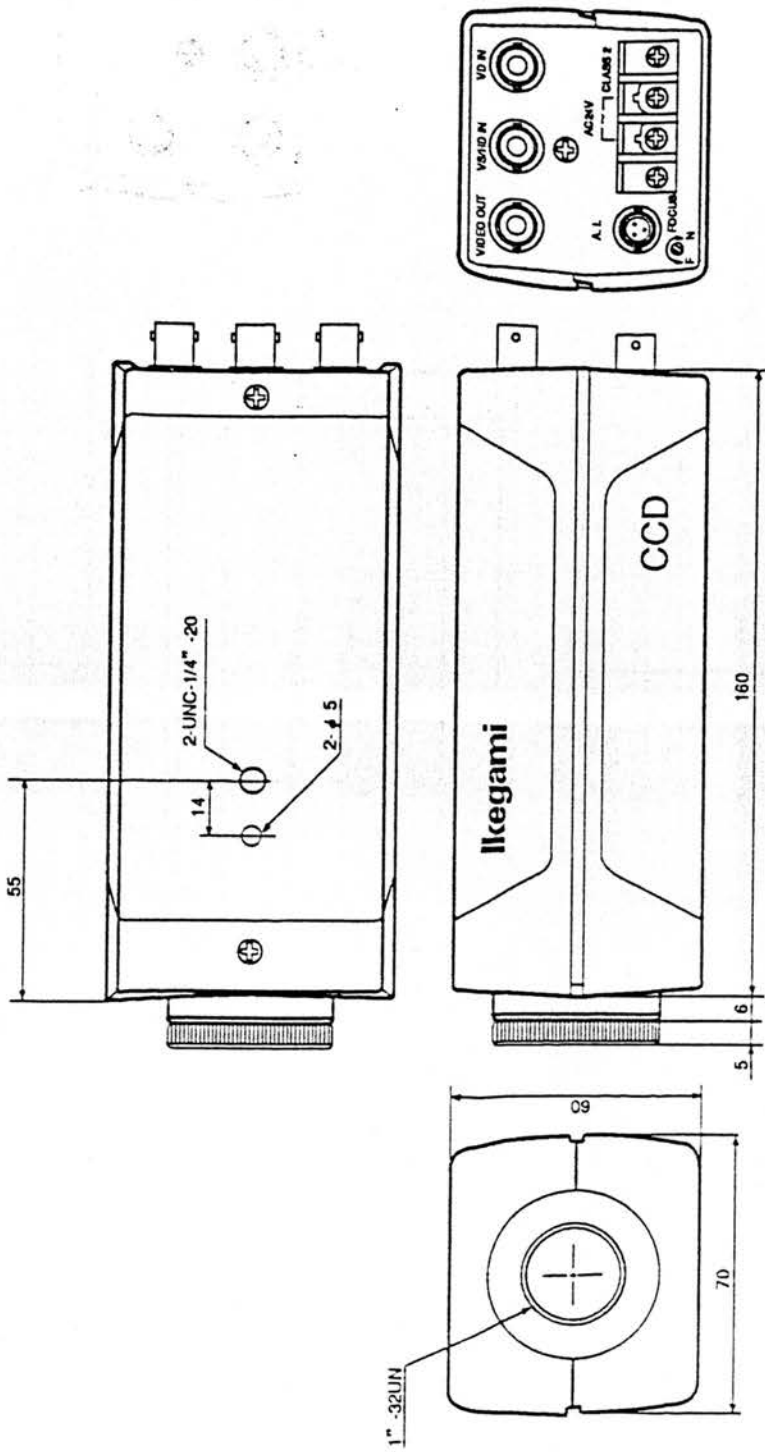

(3) DC12V type

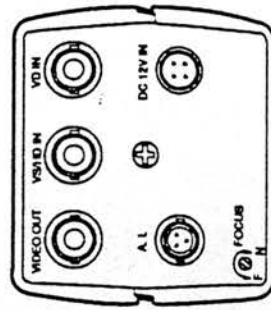
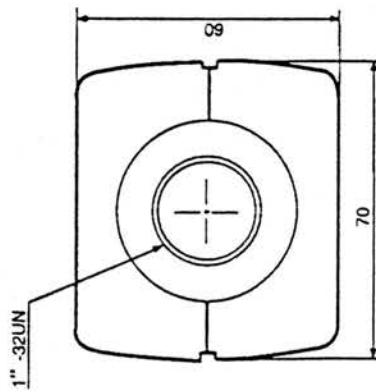
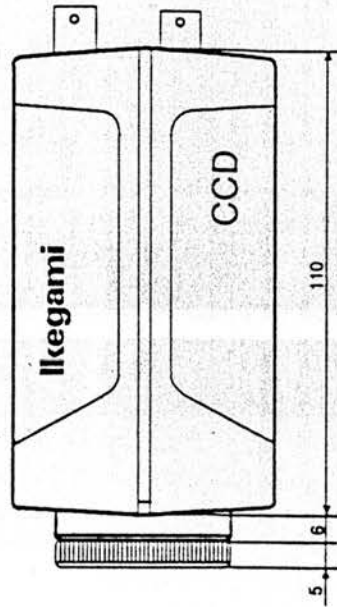
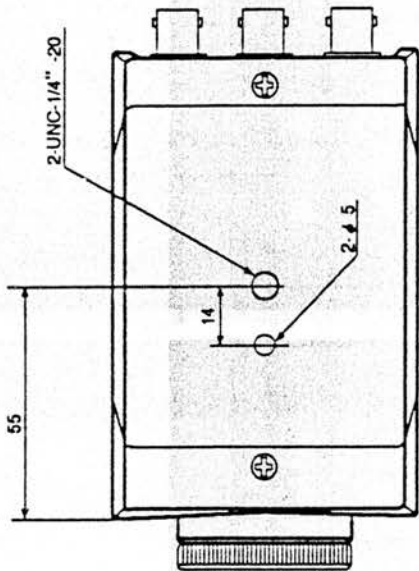

Ikegami Tsushinki Co., Ltd.

5-6-16 Ikegami, Ohta-ku, Tokyo, Japan
TEL. 03-3754-2121/TLX. 2486738 IKETSU J

■ Ikegami Electronics (U.S.A.), Inc.

37 Brook Avenue, Maywood, New Jersey 07607, U.S.A.
Phone: (201) 368-9171, Telex: ITCNY 422065

■ Ikegami Electronics (Europe) GmbH

Ikegami Strasse 1, 4040 Neuss 1, F.R. Germany
TEL. 02101-123-0/TLX. 2627-2101365 = IKE

■ Ikegami Electronics (Europe) GmbH U.K. Branch

Kestrel Court, Pound Road, Chertsey, Surrey KT16 8ER, England
TEL. 01-546-7772 & 0932-568966/TLX. 897005 ITC G

031

PRINTED IN JAPAN

Ikegami

INSTRUCTION MANUAL

MODEL: PM-930A/931

9-INCH B/W PICTURE MONITOR

OUTDOOR USE WARNING

WARNING – TO PREVENT FIRE OR ELECTRIC SHOCK, DO NOT EXPOSE THIS APPLIANCE TO RAIN OR MOISTURE.

CONTENTS

• IMPORTANT SAFEGUARDS	2
• SAFETY PRECAUTIONS	4
• FEATURES	4
• NAMES OF PARTS AND THEIR FUNCTIONS	5
• CONNECTION EXAMPLES	6
• SPECIFICATIONS	7
• WHAT TO CHECK WITH ON-SCREEN TROUBLES	7
• AFTER-SALES SERVICE	7
• GENERAL APPEARANCE AND DIMENSIONS	8

This device complies with Part 15 of the FCC Rules. Operation is subject to the following two conditions:(1) this device may not cause harmful interference, and (2) this device must accept any Interference received, including, Interference that may cause undesired operation.

CAUTION:
ANY CHANGES OR MODIFICATIONS
NOT EXPRESSLY APPROVED BY THE
PART RESPONSIBLE FOR COMPLIANCE
COULD VOID THE USERS AUTHORITY
TO OPERATE THE EQUIPMENT.

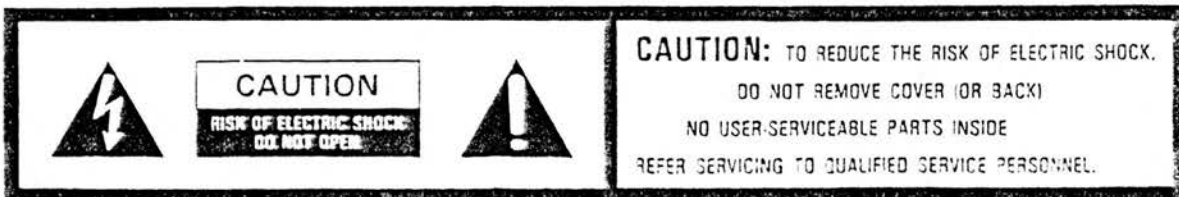

The lightning flash with arrowhead symbol, within an equilateral triangle, is intended to alert the user to the presence of uninsulated "dangerous voltage" within the product's enclosure that may be of sufficient magnitude to constitute a risk of electric shock to persons.



The exclamation point within an equilateral triangle is intended to alert the user to the presence of important operating and maintenance (servicing) instructions in the literature accompanying the appliance.

IMPORTANT SAFEGUARDS

- Read all of these instructions.
- Save these instructions for later use.
- Unplug this television monitor from the wall outlet before cleaning. Do not use liquid cleaners or aerosol cleaners. Use a damp cloth for cleaning.
- Do not use attachment not recommended as they may cause hazards.
- Do not use this television monitor near water—for example, near a bathtub, washbowl, kitchen sink, or laundry tub, in a wet basement, or near a swimming pool, etc.
- Do not place this television monitor on an unstable cart, stand, or table. The television monitor may fall, causing serious injury to a child or adult, and serious damage to the appliance. Use only with a cart or stand recommended, or sold with the television monitor. Wall or shelf mounting should follow the manufacturer's instructions, and should use a mounting kit approved.
- Slots and openings in the cabinet and the back or bottom are provided for ventilation, and to ensure reliable operation of the television monitor and to protect it from overheating, these openings must not be blocked or covered. The openings should never be blocked by placing the television monitor on a bed, sofa, rug, or other similar surface. This television monitor should never be placed near or over a radiator or heat register. This television monitor should not be placed in a built-in installation such as a bookcase unless proper ventilation is provided.
- This television monitor should be operated only from the type of power source indicated on the marking label. If you are not sure of the type of power supplied to your home, consult your television dealer or local power company. For television monitor designed to operate from battery power, refer to this operating instructions.
- This television is equipped with a grounding alternating-current line plug (a plug having one blade wider than the other) or with a 3-wire grounding type plug (a plug having a third grounding pin). This plug will fit into the power outlet only one way. This is a safety feature.

If you are unable to insert the plug fully into the outlet, try reversing the plug. If the plug should still fail to fit, contact your electrician to replace your obsolete outlet. Do not defeat the safety purpose of the polarized plug.

- Do not allow anything to rest on the power cord. Do not locate this television monitor where the cord will be abused by persons walking on it.
- Follow all warnings and instructions marked on the television monitor.
- For added protection for this television monitor during a lightning storm, or when it is left unattended and unused for long periods of time, unplug it from the wall outlet. This will prevent damaged to the receiver due to lightning and powerline surges.
- Do not overload wall outlets and extension cords as this can result in fire or electric shock.
- Never push objects of any kind into this television monitor through cabinet slots as they may touch dangerous voltage points or short out parts that could result in a fire or electric shock. Never spill liquid of any kind on the television monitor.
- Do not attempt to service this television monitor yourself as opening or removing covers may expose you to dangerous voltage or other hazards. Refer all servicing to qualified service personnel.
- Unplug this television monitor from the wall outlet and refer servicing to qualified service personnel under the following conditions.
 - a. When the power cord or plug is damaged or frayed.
 - b. If liquid has been spilled into the television monitor.
 - c. If the television monitor has been exposed to rain or water.
 - d. If the television monitor does not operate normally by following the operating instructions. Adjust only those controls that are covered by the operating instructions as improper adjustment of other controls may result in damage and will often require extensive work by a qualified technician to restore the television monitor to normal operation.

- e. If the television monitor has been dropped or the cabinet has been damaged.
- f. When the television receivers exhibits a distinct change in performance-this indicates a need for service.
- When replacement parts are required, be sure the service technician has used replacement parts specified by the manufacturer that have the same characteristics as the original part. Unauthorized substitutions may result in fire, electric shock, or other hazards.
- Upon completion of any service or repairs to this television monitor, ask the service technician to perform routine safety checks to determine that the television is in safe operating condition.
- Anappliance and cart with the below symbol, that is specified in UL standard UL-1410, should be moved with care. Quick stops, excessive force, and uneven surfaces may cause the appliance and cart combination to overturn.



Congratulations on having one of the top-of-the-line picture monitors.

Before use, read carefully this instruction manual to keep your unit in full swing. Save this manual in a safe place for future reference.

SAFETY PRECAUTIONS

- **Supply power**

Use the monitor on the specified supply voltage $\pm 10\%$.

- **Power cord**

Do not bend the power cord forcibly, nor leave anything heavy on the cord. Damaged power cord may invite fire hazard or electric shock. Be sure to hold the plug to unplug the power cord.

- **Magnetic field**

Keep the monitor away from any magnetism-provoking object.

Magnetism might cause colour distortion or unstable on-screen image.

- **Moisture, dust and vibrations**

Do not use the monitor in a dusty, moist or vibration-prone place. Such a place may get the unit in trouble.

- **No contact with the monitor inside**

Never open the monitor. There remains a high voltage inside, resulting in electric shock. Contact a qualified service engineer if the unit needs servicing.

- **Ventilation**

The cover is provided with an air vent to prevent the inside from getting too hot. Place the monitor with the air vent being not blocked--at least 10 cm away from walls.

- **CRT cares**

Position the monitor so that the screen be not exposed to direct sunlight and other strong light. When moving the monitor to another place, be careful not to give it an impact, especially against the screen.

FEATURES

- The highly reliable design, with abundant use of IC and silicon transistors, promises to reduce failures to the minimum. The stable circuits always assure high-quality pictures without requiring adjustment for power supply voltage or temperature variation.
- The CRT is 9-inch thick-neck 90° deflection type for clearer pictures.
- The system provides for use of several monitors connected in parallel.

- The equipment body has a metal cabinet providing ample strength and safety.
- High picture quality is further enhanced by the wider frequency response of the video AMP and superior linearity of the deflection system, and by other features.
- Safety standard, such as CRT X-RAY radiation, has fully been considered to meet the safety requirements of the equipment.

NAMES OF PARTS AND THEIR FUNCTIONS

• Front panel

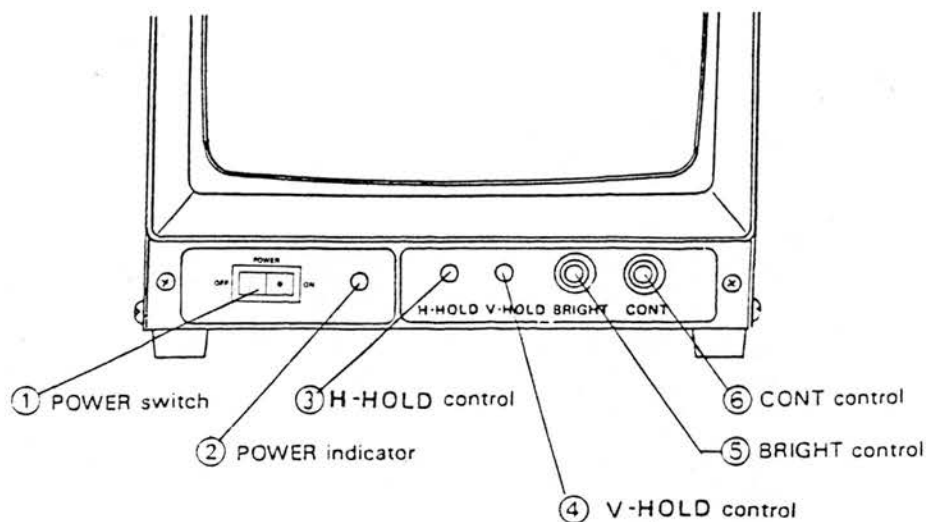

- | | |
|--|---|
| <p>① POWER switch
Press down the key to turn on the power.</p> <p>② POWER indicator
Lights up when the POWER switch is turned on. Indicates that the monitor is on.</p> <p>③ H-HOLD control
Adjusts the horizontal frequency.</p> | <p>④ V-HOLD control
Adjust the vertical frequency.</p> <p>⑤ BRIGHT control
Adjusts the brightness on the screen.</p> <p>⑥ CONT control
Adjusts the contrast on the screen.</p> |
|--|---|

• Rear panel

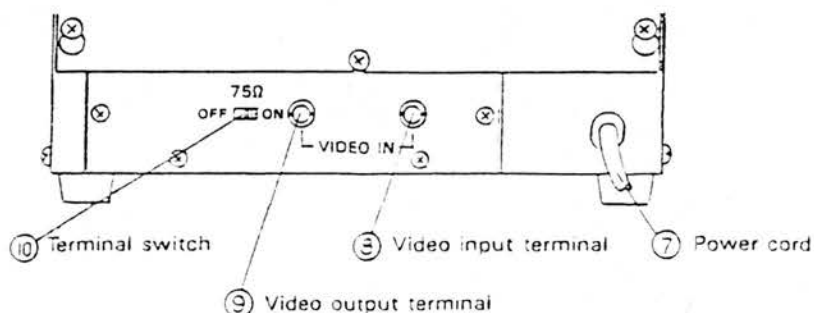

- | | |
|--|--|
| <p>⑦ Power cord
To be connected to an ac power supply.</p> <p>⑧ Video input terminal
Used to take in the composite video signal being transmitted from a video camera and VTR.</p> | <p>⑨ Video output terminal
Used to give out the composite video signal coming through the VIDEO IN terminal. For bridge connection, connect this terminal to the video input terminal of a VTR or other monitor.</p> <p>⑩ Terminal switch (75Ω ON-OFF)
To be set at the ON position when only the VIDEO IN terminal is used and there is no connection with the VIDEO OUT terminal. To be at the OFF position in order to use both the VIDEO IN and VIDEO OUT terminals.</p> |
|--|--|

CONNECTION EXAMPLES

- Standard connection

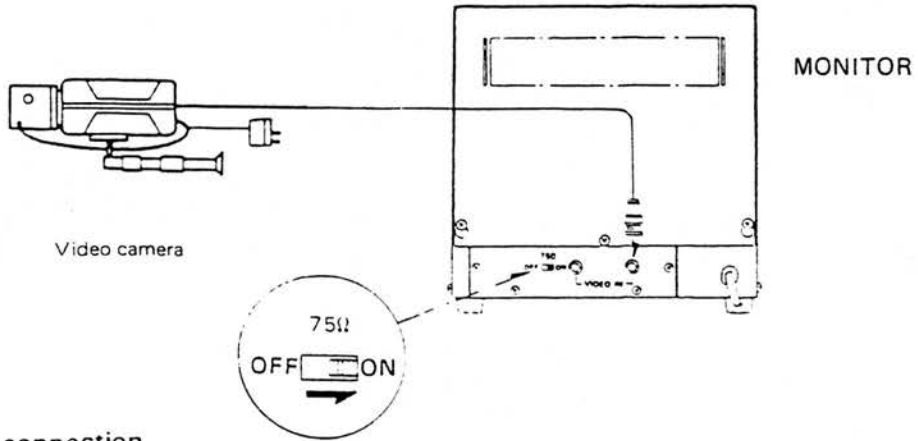

- Bridge connection

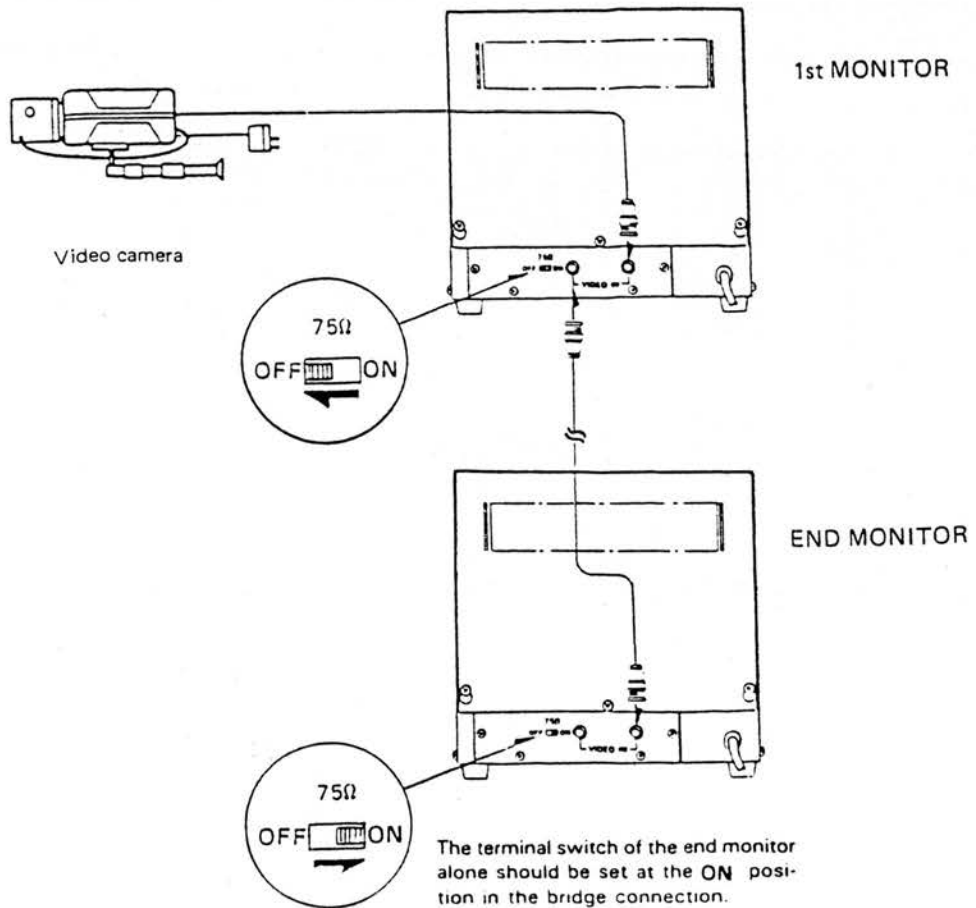

SPECIFICATIONS

• PICTURE TUBE	9" diagonal Implosion protected Type 230AXB4(L) or equivalent
• POWER REQUIREMENT	PM-930A : 120 V / 60 Hz \pm 10% PM-931 : 220 ~ 240 V / 50 Hz \pm 10%
• POWER CONSUMPTION	Less than 25 W
• VIDEO INPUT LEVEL VS	1.0 Vp-p
• VIDEO INPUT IMPEDANCE	75 Ω or high (switchable)
• VIDEO OUTPUT LEVEL	30 Vp-p
• VIDEO AMP GAIN	More than 33 dB
• VIDEO FREQUENCY RESPONSE	60 Hz ~ 8 MHz \pm 3 dB
• SIGNAL-TO-NOISE RATIO	55 dB or better (except sync noise)
• HORIZONTAL RESOLUTION	700 lines or better at center
• SCANNING RATES	PM-930A : 15.75 KHz / 60 Hz PM-931 : 15.625 KHz / 50 Hz
• LINEARITY	2 % or less (refer to ballchart)
• ENVIRONMENTAL TEMPERATURE	-10 ~ 40 $^{\circ}$ C
• WEIGHT	4.9 Kg approximately

HOW TO CHECK WITH ON-SCREEN TROUBLES

If there is something wrong on the screen, take the following steps yourself before asking for servicing.

- 1. Too dim picture or poor contrast**
 - Adjust the CONT and BRIGHT controls on the front panel.
 - When two or more monitors are in bridge connection, make sure the terminal switch on the rear panel of the end monitor alone is at the 75 Ω position.
 - See if it is too bright at and around the monitor.
- 2. Ghosts in the picture**
 - Make sure the terminal switch on the rear panel is at the 75 Ω position.
- 3. Distorted picture**
 - Check to see if the BRIGHT control on the front panel is too far clockwise.
 - Make sure the terminal switch on the rear panel is at the 75 Ω position.
- 4. No picture or abnormal picture**
 - Check to see if the CONT and BRIGHT controls on the front panel are too far counter-clockwise.
 - Be sure that the connection cord to the monitor is connected.
 - See if the POWER indicator on the front panel is on.
- 5. Unstable picture**
 - Look into the next, upstairs and downstairs rooms to see if there is a powerful transformer, electro-magnet, large-capacity cable and so on.
 - Recheck that the specified power is supplied to the monitor.
 - Look around the monitor to see if there is a device that generates magnetic field.

AFTER-SALES SERVICE

If you suspect that the monitor gets in trouble, turn off the POWER switch and unplug the power cord. Contact your dealer for advice or servicing. Never use the monitor in trouble, nor attempt to repair it yourself.

GENERAL APPEARANCE AND DIMENSIONS

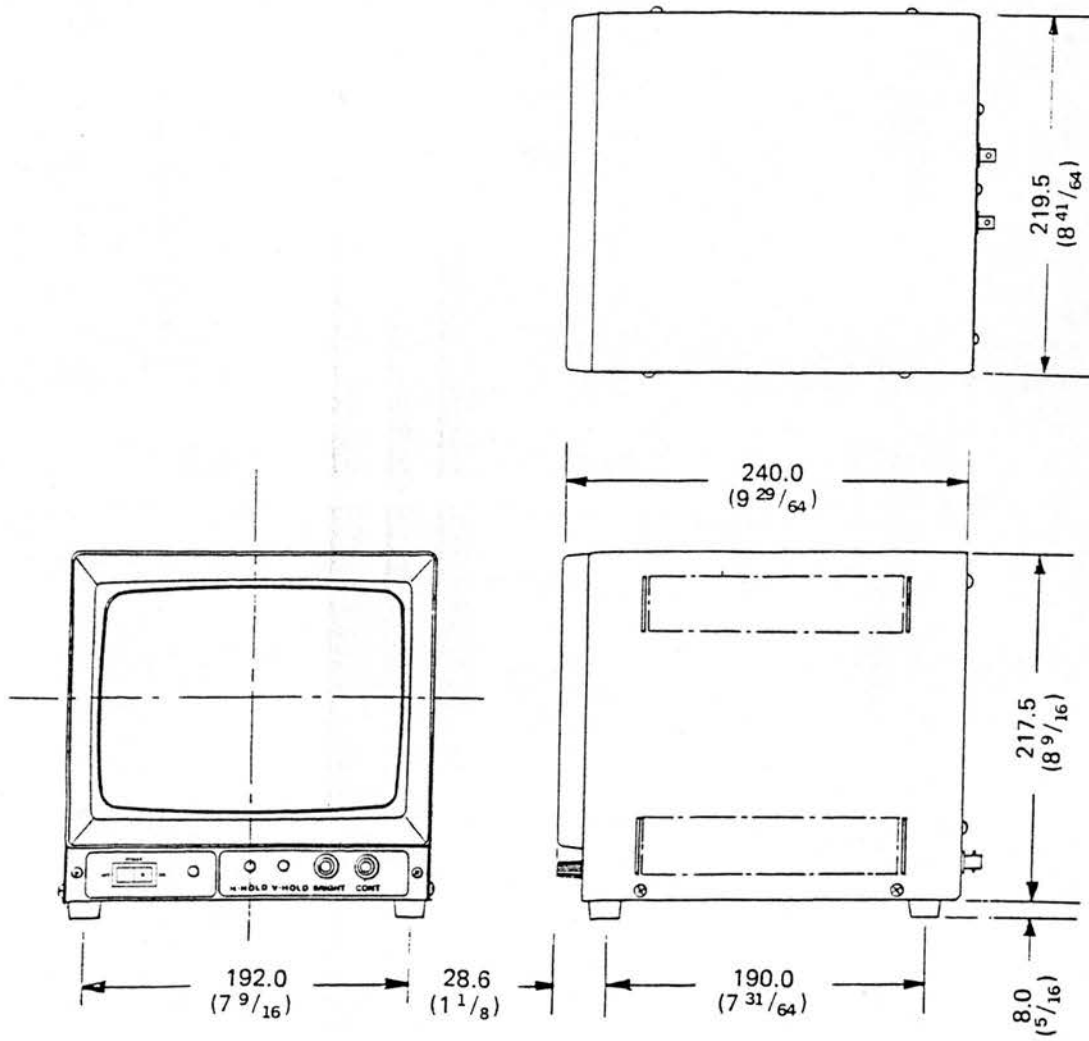

UNIT: mm (Inch)

Ikegami Tsushinki Co., Ltd.

5-6-16 Ikegami, Ohta-ku, Tokyo, Japan
TEL. 03-754-2121/TLX. 2466738 IKETSU J

■ Ikegami Electronics (U.S.A.), Inc.

37 Brook Avenue, Maywood, New Jersey 07607, U.S.A.
Phone: (201) 368-9171, Telex: ITCNY 422065

■ Ikegami Electronics (Europe) GmbH

Ikegami Strasse 1, 4040 Neuss 1, F.R. Germany
TEL. 02101-123-0/TLX. 8517960 ITC D

■ Ikegami Electronics (Europe) GmbH U.K. Branch

Kestrel Court, Pound Road, Chertsey, Surrey KT16 8ER, England
TEL. 01546-7772 & 0932-568966/TLX. 897005 ITC G

PRINTED IN JAPAN