

The Scottish Highland Dancing Tradition

by

Catriona Mairi Scott

**Thesis submitted in fulfilment of the requirements for the Degree of
Doctor of Philosophy (PhD)**

Department of Celtic and Scottish Studies

The University of Edinburgh

September 2005

Statement of Authorship

I hereby declare that I am the composer of this thesis and the work is entirely my own.

For the Chisholm Troupe

Abstract

The primary objective of this thesis is to investigate the development of and changes within the practice of Scottish competitive solo Highland dancing. Although this activity has been inherited through strong oral and military traditions, and is currently practised by over fifty thousand people world-wide, this theoretical and empirical work is the first in-depth study of its kind in the field. The focus of research is the extent to which the impact of regulation on a previously unregulated tradition has contributed to the usurping of creativity by technicality.

Five dances have formed the principal competitive repertoire since the nineteenth century. Their beginnings and early accounts are traced through oral, visual and literary sources, using an historical approach.

Two dominant organisational bodies were established around 1950 and letters, minutes and other unpublished material pertaining to the circumstances surrounding their formation are interrogated. Interviews with dancers, teachers, judges and examiners offer insights into the construction of this governance, and the impact of its policing of the dancing community, from practitioners' perspectives.

A written ethnography of a contemporary Highland dancing championship reveals procedures at such an event. This is illustrated by a video ethnography. Interviews with contemporary dancers and teachers form a narrative in which attitudes towards the management of a living tradition are foregrounded. Personal testimonies of competitions yield qualitative data in

which there are three dominant themes: aesthetic judgements, dancers' musicality, and dancing as sport. Matters of gender and identity also emerge.

The analysis shows that the content and conduct of competitions has not altered much in the last half century. However, there are significant differences between pre-regulated and post-regulated positions, gestures and steps. Extensive comparisons are made between components using Labanotation. Such standardisation is indicative of a climate of control which has led to a continual narrowing of style and an emphasis on technique. The thesis proposes that this pioneering study leads the way for future investigation into the Scottish Highland dancing tradition.

Acknowledgements

I am especially indebted to my Specialist Supervisor, Professor Helen Thomas (University of London), who, undauntedly, took on the task of overseeing this resubmission and without whose mentorship this would not have been possible. My thanks also go to Dr Margaret A. Mackay (University of Edinburgh) for her inimitable dedication and genuineness. Special thanks are also due to Mrs Joan Henderson, my initial supervisor and mentor, whose passion for and commitment to the research, performance and promotion of dance continues to inspire me.

I am also particularly grateful to Mrs Jean Johnson-Jones (University of Guilford), who checked and computerised the Labanotation with patience and humour, and to Ian MacKenzie and Stewart Smith (University of Edinburgh) for their technical support when recording and editing the accompanying video ethnography.

My heartfelt thanks also go to the dancers, teachers, examiners and spectators who formed the body of my informants, as their experiences, observations and opinions are the essence of this work. I am also indebted to the work of the Scottish Traditions of Dance Trust and am obliged to them for free access to their archive.

Lastly, thank you to my faithful friends, particularly Helen; Pastors Scott and Loretta; my lovely husband - 'a man of authority'; and my loving family 'whae haily thole me mair than they maun'. The successful completion of this thesis is a testimony to their love and unerring support.

Contents

Title Page	i
Statement of Authorship	ii
Dedication	iii
Abstract	iv
Acknowledgements.....	vi
Contents	vii
List of Figures and Plates	xii
<u>Chapter One: Introduction</u>	1
<u>Chapter Two: Methodology</u>	12
<u>2:I The Field</u>	
<u>2:I:i Highland Dancing Culture</u>	12
'culturally codified movement' (Buckland 1999: 6)	
<u>2:I:ii The Scope</u>	19
'The dancer... the dance' (Yeats ed. Flaneran 1984: 217)	
<u>2:I:iii Past Research in the Scottish Context</u>	22
'I think I see the dance begun' (Laing 1846: 110)	
<u>2:I:iv Main Themes</u>	34
'what it does... how it does it' (Merriam 1964: 209)	
<u>2:II Theory and Methods</u>	
<u>2:II:i Historical Approach</u>	40
'The researcher and the researched' (Buckland 1999: 4)	
<u>2:II:ii Ethnological Approach</u>	42
'text-making' (Cowan 1990: 6)	

2:II:iii	<u>Access to the Field</u>	49
	'from outside to inside' (Sklar 2000: 71)	
2:II:iv	<u>The Ethnography</u>	58
	'The... expression of the human spirit' (Duncan 1928: 56)	
2:II:v	<u>Movement Notation</u>	62
	'an artifact' (Van Zile 1985/1986: 42)	
 <u>Chapter Three: The Dance Histories</u>		71
3:i	<u>The Highlanders' History</u>	71
	'Handy with their feet' (Topham 1776: 345)	
3:ii	<u>The Highland Fling</u>	76
	'A Lowlan' fling' (C., R.H. 1928: 20)	
3:iii	<u>The Sword Dance</u>	99
	'Manly play with weapons' (Jaide 1936: 1)	
3:iv	<u>The Seann Triubhas</u>	126
	'As Heelan's a peat' (C., R.H. 1928: 19)	
3:v	<u>Strathspeys and Reels</u>	139
	'Life and mettle in their heels' (Burns ed. Barke 1990: 205)	
3:vi	<u>The Reel of Tulloch</u>	151
	'Far-famed foursome' (PDANZ 1927: n.p.)	
 <u>Chapter Four: Rule-Making</u>		168
 <u>4:I The Early Competitions</u>		
4:I:i	<u>The Competitions</u>	168
4:I:ii	<u>Regional Style and Individual Variation</u>	175

4:I:iii	<u>Adopted Styles</u>	180
4:I:iv	<u>Judging and Judgements</u>	186
<u>4:II The Formation of the Scottish Official Board of Highland Dancing</u>		
4:II:i	<u>Consequences of Management</u>	191
4:II:ii	<u>Regulation of a Technique</u>	196
4:II:iii	<u>The Mission Statement</u>	201
4:II:iv	<u>The Implications</u>	206
<u>4:III The Formation of the Scottish Official Highland Dancing Association</u>		
4:III:i	<u>'The Pirates'</u>	210
4:III:ii	<u>The Rebels</u>	216
4:III:iii	<u>The New Zealand Academy of... National Dance</u>	218
4:III:iv	<u>The Royal Scottish Country Dance Society</u>	223
<u>4:IV Evolution versus Regulation</u>		
4:IV:i	<u>The Inevitability of Regulation</u>	226
4:IV:ii	<u>The Process of Implementation</u>	230
4:IV:iii	<u>The Consequences</u>	235
4:IV:iv	<u>The Verdict</u>	240
<u>Chapter Five: Dance Structure</u>		244
<u>5:I The Tradition Bearers</u>		
5:I:i	<u>The Teachers</u>	244
5:I:ii	<u>The Dancers</u>	248
5:I:iii	<u>Judging and Examination</u>	252
5:I:iv	<u>The Textbook of the SOBHD</u>	255

<u>5:II Basic Key for Highland Dancing</u>	
<u>5:II:i General Notes and Terminology</u>	260
<u>5:II:ii Head and Arm Positions</u>	268
<u>5:II:iii Foot Positions</u>	278
<u>5:II:iv Eight Basic Movements</u>	298
<u>5:III The Dances</u>	
<u>5:III:i The Highland Fling</u>	305
<u>5:III:ii The Sword Dance</u>	320
<u>5:III:iii The Seann Triubhas</u>	333
<u>5:III:iv The Strathspey and Reel of Tulloch</u>	341
<u>5:IV Music and Musicality</u>	
<u>5:IV:i The Highland Fling</u>	347
<u>5:IV:ii The Sword Dance</u>	353
<u>5:IV:iii The Seann Triubhas</u>	358
<u>5:IV:iv The Strathspey and Reel of Tulloch</u>	362
<u>Chapter Six: The Ethnography and Ethnographic Themes</u>	366
<u>6:I Textual and Visual Ethnographies</u>	
<u>6:I:i The Event</u>	366
'Will you... join the dance?' (Carroll ed. Gray 1971: 79-80)	
<u>6:I:ii A Textual Ethnography</u>	370
'Explain it in words' (Thomas & Barnie 1990: 51)	
<u>6:I:iii A Visual Ethnography</u>	379
'lived dance experience' (Foley 2001: 3)	

<u>6:II Main Themes</u>	
<u>6:II:i Aesthetic Judgements</u>	381
'Intentions and expectations' (Sheppard 1987: 94)	
<u>6:II:ii Narrowing of Style</u>	387
'The crack dancer' (C., R.H. 1928: 11)	
<u>6:II:iii Musicality</u>	390
'what it does... how it does it' (Merriam 1964: 209)	
<u>6:II:iv Sport</u>	395
'An athletic step and feet like... ferryboat[s]' (Morrison 2000: 42)	
<u>6:II:v Gender Themes</u>	405
'If you can walk, you can dance' (Olaf 2002: n.p.)	
<u>6:II:vi Scottishness</u>	408
'Manifestations of the Scottish spirit' (McLaren 1956: 57)	
<u>Chapter Seven: The Future</u>	412
<u>7:i Conclusion on Methodology</u>	412
'Rigour, reflexivity... revelation' (Buckland 1999: 7)	
<u>7:ii Conclusions on Regulation</u>	420
'the spontaneous and the enforced' (Sparshott 1995: 41)	
Appendices	427
Bibliography	467

Length of Thesis: 100,000 words

List of Figures

1. Classification Table of Highland Dancing	16
2. The Spheres of the Organisational Bodies	17
3. The Tullochs of Scotland	159
4. The Stabilisation Process	232
5. Floorplan of Main Hall, Meadowbank Stadium, Edinburgh 26/02.05	371

List of Plates

1. A Highland Fling (North 1881)	63
2. The Sword Dance (North 1881)	65
3. A Highland Fling by David Allan	80
4. Frontispiece from <i>A Companion to the Ballroom</i> (Wilson 1816)	81
5. Scotch Reel (detail) from <i>A Companion to the Ballroom</i> (Wilson 1816) ..	81
6. Engraving of a Theatrical Highland Dancer, 1846	84
7. Highland Dancing at Crathes Castle	86
8. Stag from <i>Wild Sports of the Highlands</i> (St. John 1948)	86
9. Gillie Callum by Eachunn (<i>The Celtic Monthly</i> 1912: IX, 92)	120
10. The Gillies' Ball (detail) by Egron Lundgren	123

Chapter One: Introduction

This thesis investigates the contemporary practice of competitive Highland dancing in Scotland. This solo dance-form has a long history and disputed origins, some of which purport to be more than five thousand years old. As the name suggests, Highland dancing is thought to have originated in the North of Scotland, the first dancers being Highland clansmen. Many of the tales surrounding the origins of this activity relate to clan warfare, celebration, traditional beliefs, and tests of strength, fitness, daring or skill.

This thesis identifies both specialised and popular opinions concerning competitive Highland dancing, with the aim of analysing the current state and future survival of the tradition, approximately fifty years after the introduction of regulation. Key research questions are 'What factors led to such regulation?', 'What was the repertoire of steps and styles that were collected and selected and with whose expertise was this process done?', 'How were the new rules initially enforced and what was the reaction of the dancing community?', 'How does it continue to be managed?', 'How does contemporary Highland dancing style compare to either pre-regulated dancing or to the textbook standard?', and 'Will such stylised movements "give... no birth to future movements"?' (Copeland, R & Cohen, M 1983: 263).

Due to an absence of documentation or research relating to the origins of Highland dancing, historic early accounts of the five main dances which make up the basic current competition repertoire are

chronicled. The development of these dances prior to the twentieth century is recorded using primarily written sources. The evolution of the tradition throughout the early decades of the twentieth century is told through informants' living memories. Oral testimony from interview data also reveals details of the process of regulation by the Scottish Official Board of Highland Dancing (SOBHD) and the Scottish Official Highland Dancing Association (SOHDA) around 1950. Up-to-date fieldwork and interviews with contemporary dancers, complemented by Labanotation¹ and a film ethnography, provide a snapshot of competitive Highland dancing at the turn of the twenty-first century, for future study and analysis.

The five dances which make up the basic current competition and examination repertoire are The Highland Fling, The Sword Dance, The Seann Triubhas, The Strathspey and The Reel (or The Reel of Tulloch). The supposed origins of these have been passed through oral and military traditions. There is general agreement that Highland dancing was a male activity until the Second World War, when, for want of young men, the competitive dancing was assumed by female dancers to ensure its continuance. It has remained a female dominated activity ever since.

At this turning point in the history of competitive Highland dancing there was increasing dispute amongst dancers, parents, teachers, judges and organisers, concerning matters of adjudication and regulation. This was largely concerning local variations in style which,

¹ The American method (as opposed to the European favoured Kinetography Laban) is used due to the expertise of Jean Johnson-Jones who oversaw the final notations.

partly due to improved transport systems, were appearing on stages outside their locale. This variety in steps and sequences, and the differences between judges' preferences, was the catalyst for another significant change in the tradition: the introduction of authority. As a direct result of these concerns, the tradition became regulated in terms of organisation, operation and standardisation.

However, the establishment of government did not happen easily. Practitioners were divided in ideology and therefore various organisations were founded in the years leading up to 1950. The largest predominant administrative body then, and the largest one today, in terms of membership numbers and competitions operating under its auspices, is the SOBHD. At its inception, the SOBHD took an elite group of dancers (specialists, who were themselves 'popular' as world champions or teachers of champions) and agreed with them the acceptable steps and styles, rather than forming an administrative approach towards the systematic collection of tradition. A grievance held by practitioners both within and outwith the SOBHD was that the collection of methods, on which its current teaching is based, was not representative of all areas of Scotland. The Scottish Official Highland Dancing Association (SOHDA), although smaller, also controls and sanctions its own teachers, adjudicators, competitions and examinations. Its claims to authenticity are contested, by the SOBHD, to this day.

Highland dancing has been mainly a competitive activity, both historically and contemporarily. It remains popular in its native land,

and, in the last fifty years, it has experienced a growth of global interest. It is estimated that there are over ten thousand practising competitive Highland dancers in the world, a quarter of whom are based in the United Kingdom (SOBHD *Annual Report* 2003; 2004). Most of these operate under the SOBHD, whereas approximately four hundred are members of the SOHDA (SOHDA Website 2004). Membership of each organisation is exclusive of the other, with competitors limited to individual competitions sanctioned by their operator (Appendix 13). It is estimated that there are twice the number of non-competitive dancers as competitive ones in Scotland, some of whom may not be registered with any body.

Two elements which make the Scottish Highland dancing tradition distinct, besides its associated geographical roots, are the familial and military social systems through which it has passed. Presently, it is more difficult to define due to the spread of 'Highland' dancing activity outside the Highlands. In order to narrow a field that would otherwise span the globe, the parameters of this research were limited to the Scottish context. The research and data collection took place in environments where Highland dancing is taught, performed or remembered. There is a focus on competitive arenas, rather than non-competitive or examination contexts.

The duration of the research period was similarly limited to three years but my experience as both a teacher and performer of Scottish dance has provided me with invaluable access to the field. It could be argued that this knowledge and experience provides a firm

'embodied' basis for understanding the form. I have been aware, however, of the perspectives which insider status may provide and the need for self-evaluation. I have therefore endeavoured to be self-reflective throughout.

Chapter Two introduces my methodology. A combination of both historical and ethnological approaches forms the theoretical framework for the thesis. I consider this research to be ethnographic in nature since it provides detailed constructions of dance histories and descriptive, analytical and comparative approaches to the development of both the dance form and culture. The research is done in order 'to discover the cultural knowledge people are using to organize [sic] their behaviour and interpret their experience' (Spradley 1980: 31) and the product is therefore ethnography (Hanna 1979: 6). The second chapter also introduces main themes which emerge from the data. These range from matters of aesthetic judgement, dancers' musicality and dancing as sport, to themes of gender and identity.

The research uses historical methods of research to chronicle the supposed origins of the dances and their first introduction to any sort of competition. There has been a collection of evidence pertaining to the dances' origins and factors contributing to style. This initial collection work is collated to form Chapter Three, where these sources are brought together for the first time.

A substantive account of the geographically and non-geographically defined dance culture as it evolved and as it has survived in Scotland to this day is given in Chapters Three and Four.

Chapter Three is also concerned with the myths surrounding the dance activity, which was, at one point, 'saturated' with them (Oyorley in Thomas 1995: 196). An history of this kind of Highlanders' dancing and dances is constructed through tales and testimonies as well as through written sources.

Chapter Four offers a snapshot of attitudes towards the SOBHD and the SOHDA when standardisation was being introduced around 1950. These are taken mainly from interviews with past dancers, teachers, examiners, adjudicators and members of the organisations. Informants, speaking retrospectively, tell of the variations which were to be found within the steps and styles and these are recorded in as much depth as is available. The primary inquiry, here, is to establish the authenticity of the dancing collected prior to 1950. It may have been similar to an older style of dancing, recorded prior to the twentieth century but if what was collected was a 1930s style favoured by the specialists and champions on the SOBHD Technical Committee, then this was recorded and promoted as a pure style, rather than a popular one.

Through interviews with informants who remember dancing before the Second World War, some of the attitudes towards the activity and its roots are recorded. The events, discussions and dialogues leading up to the formation of the two main organisational bodies are chronicled through previously unpublished material such as minutes of meetings and personal letters.

Chapter Four is also concerned with the conduct of these early competitions, in particular the importance of regional styles, individual variation and dancers' attitudes towards 'adopting' styles in order to suit judges' preferences. This is grounded in an analysis of the influences which have affected the development of the dancing, in particular aspects of transmission and performance. Themes of judging arise before and after regulation. A body of evidence is therefore constructed, and this traverses both dancing history and the social context in which dances are currently performed.

The formation of the SOBHD, and the subsequent matters of management, regulation of technique, the process of implementation and the implications of such imposed authority are addressed. The attitudes of members of the SOBHD and the SOHDA are foregrounded. Comparisons are made with the examples of the New Zealand Academy of National Dancing (NZAND) and the Royal Scottish Country Dance Society (RSCDS).

While Chapters Three and Four explain much of the general social background against which the dances were set, Chapter Five provides a record of some of the specific dances and steps that were collected. The teachers, dancers, judges and the SOBHD are held up as bearers of the tradition, and each group's teaching methods, old and new, are considered. The SOBHD textbook is also considered to be a tradition-bearer, in this respect, and its impact on the dancing world, from 1950 onwards, has been shown through informant data and movement analysis.

Labanotation is employed in Chapter Five, to record the dances in the forms in which they survive today. A comprehensive key for Highland dancing is recorded for the first time. This includes general notes and terminology of dance structure, a full notation of head, arm and foot positions, as well as some basic movements. A working index of the steps and styles has been compiled to form a record of the current repertoire of the SOBHD, and to illustrate significant matters of contention between the different schools of thought. The material is at the same time factual and interpretative in order to strike the balance between objectivity and subjectivity. Themes of musicality naturally emerge, as these notations are based on various written instructions and practical observations from the field.

Without the extensive use of film recordings and Labanotation one would run the risk of shallow investigation which only skims the surface of the data collected, perpetuating myths or even creating new ones. The requirements of this investigation are such that a means of notation as versatile as Labanotation is essential for accurate representation and comparison. It provides an accurate account of movement witnessed, and is a means of fully understanding the nature of the movement, even after the event. It also serves as a reference for use by choreologists and readers in the future. The use of this method highlights descriptions of fieldwork material which would have otherwise been dense and circumlocuted. I therefore employ Labanotation in order to expose the intricate components of past and

present Highland dancing technique: this has produced the first extensive analysis of its kind in this subject.

Chapter Six includes a written ethnography of a one-off Highland dancing championship. This is incipient in the field, where there have been few dance ethnographies describing the activity, and even fewer scholarly analyses of the culture in which it takes place. Quantitative interviews with a sample of the society of Highland dancers enable me to present more qualitative data relating to the dance activity itself and to its growth and development than has hitherto been attempted. This textual account is complemented by an edited and annotated DVD recording which accompanies this thesis. The main themes drawn out for analysis in Chapter Six, in keeping with those arising in Chapters Four and Five, are aesthetic judgements, a narrowing in style, musicality, sport, gender and Scottish identity.

Above all, I study 'the producers as well as the product' (Keali'inohomoku 1972: 400-1). The informants chosen form a geographical and social cross-section. This diverse group of contributors ranges from early twenty-first century enthusiasts to those who are able to remember Scotland's earliest regulated competitions at the beginning of the twentieth century. Informants were encouraged to speak naturally about their opinions, and thereby an understanding of both the shared elements and the inconsistencies within the accounts are clear.

The written ethnography in Chapter Six confirms the themes which previous interview data collection yielded and this informs the

analysis. These recordings are used to triangulate both my observations and analyses. Much of the material collected is not seen here, but it has nevertheless informed thought and analysis. Sound recordings, interview transcripts, video footage, photographs, and other material is housed in the School of Scottish Studies Archives at the University of Edinburgh. References are made to, and quotes are taken from, these transcripts and videos.

It is hoped that the consequences of this research will be far-reaching, in that the data will form a lasting record of the Highland dancing culture as it has developed and survived throughout centuries of its history. The aggregation of archival sources and original documentation which is cited herein, augmented by the 'truths' of informant data, forms a body of practitioner viewpoints through which future readers and researchers can explore the dancing of previous generations to the early twenty-first century.

In the following chapter, the reader is introduced to some main themes of theory and methodology which require clarification before they can be fully utilised and applied with regards to this thesis. In the first part, the dancing culture, and specifically the historic rôle of Highland dancing as part of Scotland's cultural heritage, is outlined. This is done in order to situate what is known as a traditional activity both in history and in the current climate of competitive dancing. This sets the foundations for analysis of culturally codified movement in later chapters. The scope of the research and its parameters are set so that the limitations of the cultural context are properly established.

Since this is largely a path-clearing exercise, the past research in the Scottish context is examined for its relevance, and the lack of academic attention to this subject is exposed. The main themes emerging from the data are also introduced, so that threads of recognition may be woven throughout the subsequent text.

The second part of Chapter Two introduces the specific theory and methods employed throughout the investigation. These combine an historical approach with an ethnological and ethnographical approach. Matters of access to the field are highlighted and themes of reflexivity and critical reflection are foregrounded. I also give a full explanation of the significant advantages of using Labanotation for the presentation of the results.

Chapter Two: Methodology

2:1 The Field

2:1:i Highland Dancing Culture

'Culturally codified movement' (Buckland 1999: 6)

The status of Scotland's solo dancing is not unlike that of her language, in that deviations from the standard are by no means wrong. Rather, the differences that evolve often portray much about the original employment of the dance in different areas of the country. The evolution of Highland dancing has also given rise to diverse opinions as to the correct method of execution. There are also many myths surrounding the dance activity which was, at one point, 'saturated' with them (Oyortey in Thomas 1995: 196). This is one element that makes the Scottish Highland dancing tradition distinct, besides its associated geographical (i.e. Highland), familial and military social systems. Presently however, it is more difficult to define due to the spread of 'Highland' dancing activity outside the Highlands.

While the dances may be the primary unit (as shown in Chapters Three and Five), they are not abstract, but treated and understood in relation to the larger subject of dance culture (as shown in Chapters Four and Six). It is therefore necessary to address the apparent contradiction in the concept of culture, since it is at the same time both static and dynamic, preserving the tradition and having an in-built mechanism for change. Georgiana Gore uses the term 'culture' to mean an indicator of 'the products of human social

activity... as contextually constructed' (Gore 1999: 210). Culture then, in this case, is 'a process and not an absolute' (Williams 1958: 125). Whilst attempting to construct a detailed record of the activity at the beginning of the twenty-first century I have also been conscious of the need to gather memories and experiences from those who represent past periods. One of the key elements to any tradition's survival must be that core capacity to change along with the culture in accordance with the dance culture's perceptions and practices of acceptable social behaviour. The paradoxical nature of culture is that it has an element of predictability for those people who share it, and use it as a basis for organising their lives, but, at the same time, it undergoes constant change in order to ensure its survival.

My definition of dance is that it is 'composed, from the dancer's perspective, of purposeful, intentionally rhythmical, and culturally patterned sequences of... body movements... the motion having inherent and aesthetic value' (Hannah 1979: 56) and, at the same time, is a 'situated embodied aesthetic practice' (Thomas 2003: 1). These characteristics are pertinent to this investigation, particularly since this is 'a socially constructed system of knowledge' (Kaepler 1999: 22) in which there are distinct tiers within the dance culture and of achievement and recognition. In the words of dance anthropologist Joann Keali'inohomoku:

Dance is a transient mode of expression, performed in a given form and style by the human body moving in space. Dance occurs through purposefully selected and controlled rhythmic movements; the resulting phenomenon is recognised as dance both by the performer and the

observing members of a given group (Keali'inohomoku in Copeland & Cohen 1983: 541).

This idea of recognition is shown to be of paramount importance in the world of the Highland dancer through the analysis of a Highland dancing event in Chapter Six and through accompanying video footage.

The SOBHD and the SOHDA independently recognise, regulate and reward their members' activities in competitive and non-competitive spheres, according to their constitutions. Rewards may be in the form of adjudication, prizes, awards or, as is shown in Chapter Six, in simply belonging. These groups, and therefore the 'informed' informants whom I interviewed, are either founders or inheritors of groups of dancing people which

emerged and stabilized [sic] itself in what would otherwise be a flux of cultural influence, since wherever there are people, there is peoples' [sic] culture, but that it is now grounded not in the tradition of cultural phenomenon but in the subsequently imposed tradition of the practice and performance of this tradition (Sparshott 1995: 26).

In Chapter Four, I propose that it was not the distinguishing features of dance styles which brought these organisations into being, but the attraction of becoming part of the group and being identified with it by association.

The research is located within a cultural analytic approach which fits with a definition of culture as 'the embodied spirit of a People [sic]' (Williams 1958: 34). Highland dancing is therefore part of 'the culture' of Scotland, even if not performed by all Scots. It is a recognisable symbol, based in history and it

has been, and continues to be, cultivated and refined through practice in wider society. The identity of the dance manifestation, once it has passed through the refining process of a culture, speaks integrally of that culture through its form, performance situation, social significance and style. The evolution of the geographically and non-geographically defined dance culture, and its survival to this day, is chronicled in Chapters Three and Four. If this broad definition of culture is 'everything which the members of a social group... have in common - everything which they share and which contributes to and generates their sense of 'we-ness'.' (Thomas 1993: 3) then there are different cultural levels (or sub-cultures) within the 'social' grouping of Highland dancers. This is fully explored in Chapters Four and Six.

If dance is 'inherently social' (Ward in Thomas 1995: 16), then in the case of Highland dancing, the sociability is not necessarily in the actual execution of dancing, but in the teaching, transmission, learning and competing. Using Hannah's 'Dance Classification Considerations' (Hannah 1979: 55), the table below shows that Highland dancing activity can be split into three main divisions (see Figure 1: Classification Table of Highland Dancing). The areas of 'Competitive' and 'Non-competitive' dancing are terms recognised by the organisational bodies, and are investigated in Chapters Four, Five and Six. The 'Creative' Highland dancing category is of my own devising, and accounts for the possible inventive or organic growth in the tradition, which emerges as a theme in Chapters Four and Six.

Figure 1: Classification Table of Highland Dancing

		<u>'Dance Classification Considerations'</u>		
		<u>(Hannah 1979: 55)</u>		
		'Aspects of Participation'	'Genetic Classification'	'Consciousness' (related to participation practice)
<u>Highland Dancing Activity</u>	Non-Competitive	'Social dance' (interaction is primary)	'Borrowed voluntarily' (from 'traditional' repertoire)	'attaining goals... maintaining cultural patterns'
	Competitive	'Skill Acquisition' (by means of individual or class instruction or 'training')	'Imposed' (structure, steps and style prescribed by authoritative group)	'maintaining cultural patterns... physical preparation... fitness'
	Creative	'Theatrical performance' (of one or more dancers for an audience)	'Independently invented... Elaborated creation'	'concern with explanation... Adaptation... initiating and applying with change'

The shared remit of the SOBHD and the SOHDA can be shown as subcultures, as illustrated below (see Figure 2: The Spheres of the Organisational Bodies). The figure illustrates the global spheres of influences of the SOBHD and the SOHDA. Although the technique of competitive and non-competitive dancing may be similar (although this is not necessarily the case), the platforms, regulation and practitioners are divided. Similarly, the

SOBHD and the SOHDA do not overlap, but competitive and non-competitive dancing is part of the commission for both organisations².

Figure 2: The Spheres of the Organisational Bodies

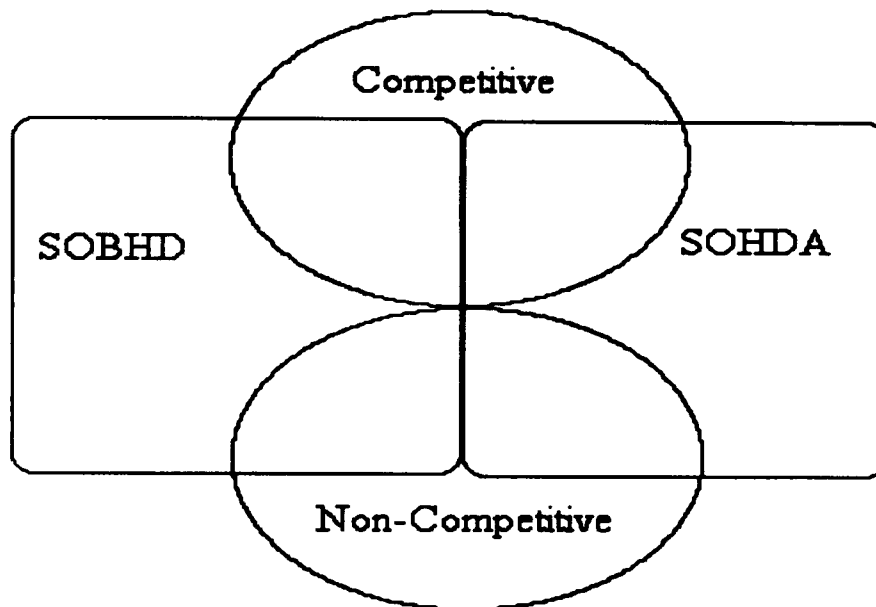

This shows the common root is the practice of a 'cultured' activity, but that the organisations are, at the same time, separate and comparative in their parallel remits. There is also some of their activity which does not fall into either the non-competitive or competitive category (such as administration and publication). If it is true that a narrowing of the style has taken place through the process of judging and competition, then the following questions arise: What did the style look like in the past and what were the regional variations? These questions are tackled in Chapters Four and Five. The long-term effects of such regulation, and the impact of tradition-bearers on post-regulated dancing, are brought out of the data in Chapter Four.

² Chapter Four refers to other organisational bodies which do similar jobs around the world.

The extent to which Highland dancing has become a defining part of practitioners' cultural identity is shown in Chapter Six where themes of belonging and nationalism also emerge. The extent of the SOBHD's influence in regulating and policing the dance activity, are exposed in Chapter Four. The resultant expression or suppression of the dancing, when compared to an older, pre-regulated style, is a recurrent theme through Chapters Four, Five and Six.

In Chapter Five, a thorough study of the dances in the forms in which they survive today is made and a working index of the steps and styles compiled. Labanotation has been employed to form this working key of the positions and steps of the current (SOBHD) repertoire, and the significant differences between schools of thought.

In the process of a relatively short period of study, the field has not changed significantly. However, a full analysis of the state of the tradition's stability with regards to expectation, innovation and vision for the future is addressed in Chapter Seven. In the following section of this chapter, the scope of the field is established and the parameters for the investigation are set, so that the boundaries are clearly marked for analysis and comparison.

2:I:ii The Scope

'The dancer... the dance' (Yeats ed. Flaneran 1984: 217)

In the context of this investigation into Highland dancing, the cultural aspects of transmission and absorption are of particular interest. The following five points show the sociomorphological aspects which appear throughout this investigation:

1. Structure and formal organisation of Highland dancing culture;
2. Accepted standard conduct within that group;
3. Teaching and transmission of the Highland dancing tradition;
4. Regulation of, and conformity to, rules, competition and examination;
5. Areas of growth and decline within the culture.

Each of these areas of structure has been thoroughly investigated and put into the context of a Highland dancing culture that is not necessarily geographically restricted. Instead, the research has been carried out within an organised group of people associated for a specific purpose on account of a common interest: it is a learned (dancing) society. The society that my informants represent is therefore one that is unified by a cultural influence or interest, rather than an inherited custom or local activity. The parameters of this study are that it is mainly the Scottish exponent of Highland dancing that is highlighted.

A system of human organisation, such as a Highland dancing society,

inevitably generates distinctive cultural patterns and institutions in order to provide protection, security, continuity, and identity for its members. This is shown to be the case for the Highland dancing community, in the variety of associations, competitions and rules that are discussed throughout Chapter Four.

The remit of my research was not only to investigate the shared skills, opinions and attitudes within the Highland dancing community, but also to identify specific factors outside the norm. The shared aspects of the tradition are contextualised and exceptions to expected rules of behaviour are recognised. In this respect, such a cohesive body of work accounts for many different viewpoints since, as no two physical bodies are identical, each individual's awareness of culture and experience of dance manifestations is unique. The advantage of this approach is that the informants' experiences, expressed in the words and memories which are recorded, are the main source of information as to how the Highland dancing culture operates. There are a number of recurring patterns and themes which emerge from the individual respondents which have been quoted and contextualised to demonstrate the social character of the field.

The research and data collection took place in environments where Highland dancing was taught, performed or remembered. Within each of these contexts, there were many variables, such as the nature of the manifestation (e.g. in a competitive or non-competitive arena). In this investigation, where the social factors are of primary importance, the process of gathering material in a social field is pertinent. More quantitative, and qualitative, data relating to the

dance activity itself and to its growth and development was collected than has hitherto been attempted.

The duration of the research period was limited to three years but my experience as both a teacher and performer of Scottish dance has provided me with invaluable insights and an interest in the field that goes beyond the realms of academic necessity. As a Scottish dancer and teacher, a prior knowledge of Highland dancing allowed me access to the unofficial yet close-knit culture of Highland dancers. Research was done through rigorous enquiry and involvement in practice and it was as a result of such epistemological privilege that insider knowledge was accessed.

The main advantage of an experience of the culture, and indeed an upbringing within the dancing culture, is that I am aware of the areas which have not been previously questioned with regards to the tradition's organisation and practice. These previously unanswered questions were the starting point for an investigation into the different rules of execution and into those who generate and enforce the rules. A critique of the inevitable subconscious presuppositions about the nature of the dance styles, steps and situations appears later in this chapter.

In the following section, a brief summary of past research in the Scottish context is made in order that the foundations are laid for the historical research of Chapters Three and Four and for the analytical work in Chapter Five.

2:I:iii Past Research in the Scottish Context

'I think I see the dance begun' (Laing 1846: 110)

In order to closely examine community members and groups, and to analyse the dance culture and organised society, a summary of previous research in this context must be established. This is done either to form a firm foundation on which to build, or re-establish points of reference for investigation into 'diversity of form, experience and practice in social life' (Nadel-Klein 1997: 95). However, as far as research goes within the field of Scottish solo dance, there are barely enough coherent ethnographic threads to weave a garment of identity, let alone a colourful and vibrant tartan that would better represent the nature of the culture.

It is perhaps due to the diverse nature of Scottish communities and regional constructs that there can be found no discourse suitable for the study of the country as a whole. The communality between various ethnographies and ethnographers of Scotland seems to be 'a concern with identity and boundary-making in the context of marginality and marginalisation' (Nadel-Klein 1997: 97). In the many regional incarnations of Scottish fieldwork, the emphasis seems to be on the importance of personal employment of disciplines in accordance with relative practices.

Fenton (1985) further explores and exemplifies the different methods of approach undertaken by scholars, members of local societies, museum workers, archaeologists, antiquarians and institutions, all of whom study their own

localities and therefore have their own localised and regionalised processes for researching and writing about Scotland. He emphasises the importance of a holistic as well as a specific approach, whereby long-term submersion in the culture can complement its detailed study and analysis. While Fenton (1985: 43) seeks to establish those elusive 'boundaries' between regional ethnology, sociology, social anthropology and history, he also summarises a 'broad conceptual framework' that comprises a multiplicity of approaches. In this respect, his work and methodological overviews have proved invaluable to me, as a number of techniques have been employed within the broad classification of ethnochoreology.

The twentieth century saw numerous attempts to rectify the lack of any extensive records of Highland dancing. Although some attempt was made to undertake research or comment, the most significant works are regrettably modest when compared to the extent of solo dancing activity in Scotland. However, George Douglas Taylor's *Some Traditional Scottish Dances*, and D.G. McLennan's *Traditional Scottish Dances*, published in 1929 and 1950 respectively, became 'the two recognised authorities on traditional Highland dancing' (Cameron Correspondence 1981, in Witta 1982). Through close association, their study of Francis Peacock's *Sketches Relative to the History or Theory but more especially the Practice of Dancing* allowed them to carefully piece together 'the early Highland steps we see in the dances today' (Peacock 1805).

The year 1964 saw the first full volume of fieldwork research to be

published by husband and wife team, Tom and Joan Flett: *Traditional Dancing in Scotland*. This was not only a landmark in terms of the history of Scottish dance, but also in the broader sphere of world-wide dance research, largely because of the detailed accounts of the fieldwork. The Fletts set forth the vision for this book in the Preface, stating that it is 'an attempt... to give a picture of social dancing in Scotland before the First World War' (Flett & Flett 1964: vii). From the outset, the authors claim not to have written a 'complete history of social dancing in Scotland' but rather a comprehensive collection of fieldwork observations (Flett & Flett 1964: vii). The fieldwork which was carried out by the Fletts was, although extensive, not done under the auspices of academic research, but rather it grew out of a passion for investigating early dance history and for mining the precious knowledge which was deep in the living memory of their informants.

It was the Fletts' natural curiosity to learn about dances and dance customs that became a deep-rooted passion for recording and, in turn, preserving their findings. Both academics and non-academics alike find their work informative reading, due to the meticulous way in which the interviews were conducted, field notes were recorded and information carefully extracted.

It seems that the Fletts were primarily interested in the dances and the dance context, rather than in the individual dancer. The first four chapters explain much of the general social background against which the dances were set, and Chapter Five provides a record of some of the specific dances and steps that were collected. The Fletts' field notes and records reflect their interest in

the dance itself as a unit of investigation. Even though the dance cannot be separated from the dancer (and the researchers make ample mention of both their gratitude and respect for their informants and of the credit due to them) the focus of this work and subsequent volumes of work is on the dance and dance event. This is valuable ethnographic fieldwork, in that the authors believed that 'anything less than complete descriptions would be of no real value as a record' (Flett & Flett 1964: vii). However, they did not offer any analysis of their collection.

While it can be appreciated that only a limited amount of information can ever be included in a one-volume dance history, this does not mean that incomplete steps are of no importance (or that the researchers did not transcribe such fragments in their field notes). One can appreciate that, while a fragmentary reference often has no firm performance context, and can therefore be misapplied or over-analysed, it can often also provide a vital link to understanding dance-structure. A lesser known or antiquated phrase found within a particular dialect would not be excluded from a study of language, even if only to illustrate lexical change. This has been the case within this investigation, since those less common movements are, at times, of particular interest.

The Fletts' fieldwork spans memories from the mid 1800s to just before the First World War, since it is a record of living memory which was 'collected personally from informants... who have themselves either taken part in... or witnessed [the dances]' (Flett & Flett 1964: viii) in the mid twentieth century.

The Fletts and their collaborator, Dr Frank Rhodes, may have collected this first-hand knowledge, but it is stated in the preface that the writers were the facilitators and that it was the informants who were 'the authors' (Flett & Flett 1964: viii).

After Professor Flett's death in 1976, the publication of a second volume of work was intended to give the historical background to step-dancing in Scotland and to give instructions for the many reasonably complete dances collected which would have been representative of the full range of styles within the Scottish solo dance tradition (Flett & Flett 1996). Joan Flett clearly states in her preface to *Traditional Step-Dancing in Scotland* that the impetus for researching and subsequently publishing Scots dance fomented by her and her husband's 'increasing scepticism about the stylised modern form of country and Highland dancing' (Flett & Flett 1996: viii). She recognised the great value of her husband's work, claiming that he was 'the only person to collect intensively all over Scotland' and that his findings were 'of the greatest importance in painting a picture of the social life in Scotland and recording the details of one of the greatest pleasures of her people' (Flett & Flett 1996: vii). This is certainly true as no other such extensive study has been made, or documented, by either an individual or an academic institution.

The Fletts' research therefore had a great bearing on my own. Although their aims, the collection and the presentation of their results is considerably different from mine, I am indebted to their trove of work. Despite the impressive range of material amassed from both literary and oral sources,

however, there is no attempt within the Fletts' work to compare or analyse the different versions of the dances. Joan Flett introduces the book by saying that she recognises how important it is 'to record the dances as collected so that others may analyse them if they wish' (Flett & Flett 1996: viii). However, her emphasis is less on the academic exegesis of the dances, and more on a practical level, as she also states with a marked enthusiasm 'I am now publishing these here for others to discover and enjoy' (Flett & Flett 1996: viii). Her emphasis on enjoyment would certainly imply that the presentation of dance was, in its rightful place in culture, a verb rather than a noun. As one of those 'others', my own research encompasses both theory and deconstruction but also with a view to practical application.

The depth of the Fletts' knowledge makes their work an invaluable source of information and a firm starting-point for my own research. After a lifetime of reading, collecting, absorbing, publishing and practising their findings, they have given back to the field a wealth of information. Their work might be considered the first extensive research into the Scottish dance tradition.

During the intervening time, another pivotal work was published. The year 1972 saw the first edition of George S. Emmerson's masterful tome *A Social History of Scottish Dance: Ane Celestial Receptioun*. His twenty-two detailed chapters, almost forty plates and extensive comments present 'a synthesis of the cultural and social history of Scotland with dance at its centre' (Emmerson 1972: 1). This research collates the scarce and scattered evidence of

the origins and development of Scottish dance. The work traces Scottish dance from the earliest times to the 1970s. He considers The Highland Fling, The Sword Dance, The Seann Triubhas, The Highland Reel and The Reel of Tulloch to be 'a class apart from the usual run of folk dances, highly cultured and disciplined' (Emmerson 1972: 2) and therefore worthy of special attention as high art, rather than popular cultural forms. He also explores the unity of dance and drama and dramatic meaning within the dances through written accounts, pictorial images, historical facts and history.

This thesis has been greatly influenced by such methods of research but also complements these findings with the personal accounts collected in detailed fieldwork similar to that of the Fletts. The emphasis on detailed analysis within this investigation, whilst narrower in its scope than the research of either Emmerson or the Fletts, benefits immeasurably from their work.

The School of Scottish Studies Sound Archive also includes sources on dance. Of these, recordings of dance bands, dancing masters, Highland Games, community dances, competitive dance and dance music have been the most useful. A number of videos held by the Archives have also been of interest. There has not, however, been any significant ethnological research into the field of solo Highland dancing in Scotland, within the School of Scottish Studies or the Department of Celtic and Scottish Studies at The University of Edinburgh, nor, indeed, at any other similar institution.

There are, however, three theses which are worth mentioning. First is Gillan Anderson's Stirling University MA thesis *Highland Dance in Education*

since 1945 (Anderson 1989), in which the author attempts to explain 'the absence of Highland dance from the curriculum of primary and secondary schools in Scotland' giving a brief history of Highland dance and in particular, citing the influence of the military in Scotland (Anderson 1989: n.p.). This work is neither a significant contribution in terms of quantitative or qualitative data or in terms of analysis. However, due to the lack of material relating to this area of enquiry and a desire to collect existing research for future analysis, it has been included briefly. Some mention is made of Highland Games as the main arena for the performance of Highland dance. The events leading to the formation of The Scottish Official Board of Highland Dancing (SOBHD) are also recounted and the operation of the Board in standardising content and teaching qualifications, and prescribing rules and regulations for competitions is explained.

The author's background as a physical education specialist and teacher in the military tradition, and the restrictions of an MA thesis means that her contribution, although important, is limited. Although there is some evidence of first-hand research, the contributors are few and from similar backgrounds, such as fellow instructors at the Queen Victoria (Military) School, Dunblane. While these methods may be apt for a study on 'dance in [physical] education', I would like to consider my thesis as being concerned with the customary significance and social relevance of Highland dancing manifestations. Anderson's thesis can therefore be considered a springboard for such a study.

Secondly, Catriona Macaffer's Royal Scottish Academy of Music and

Drama (RSAMD) BA dissertation *The Scottish Reel from a Social to a Competitive Dance and its Influence on Solo Dancing* (Macaffer 2002) is the most recent offering in the field of Scottish Highland dancing. Her thorough investigation into the Reel form as it 'evolved' and as it is preserved within the current Highland dancing repertoire offers a remarkable insight into the strength of form and in particular, the relevance of the associated music. Her experience as a piper enabled her to draw on a technical understanding of the structure of the music which acts as a framework for movement.

However, as with Anderson's thesis, the fieldwork undertaken was limited, citing, in fact, only two sources of interviews. In addition to this, an exposition of only ten thousand words is somewhat limited and leaves little room for alternative interpretation. Macaffer does, however, have some novel theories which are of particular interest referring to the origins of individual dances and the inter-relationship between a solo and social tradition. These are referred to in detail in Chapter Three of this thesis.

Lastly, Kim Witta's Queen's University (Belfast) MA thesis *Dance Research: Highland Dance Tradition and Style: A Comparison of the Scottish Official Board of Highland Dancing and the New Zealand Academy of National Dancing* (Witta 1982) is a piece of work which I have considered, like those by Anderson and Macaffer, because of the dearth of research in the field. It is by far the most thorough and also the most controversial piece of work to be produced on Highland dancing in recent years. His presentation of 'Stabilisation or Standardisation: The Control of Scottish Highland Dancing by the Scottish

Official Board' and 'An Alternative Conception of the Stabilisation of Highland Dancing by the New Zealand Academy of National Dancing' (Witta 1982: 3) is provocative, being a direct comparison of two governing bodies.

The tradition is foremost in his thinking, as each 'style' is uncovered (Witta 1982: 3) in its 'broad socio-cultural perspective' (Witta 1982: 57). The respective approaches to stabilisation are defined, as are the variations in the technique, execution and, most importantly, interpretation of Highland dancing. His results are drawn largely from written sources (especially those published by the two organisations), history books, rule books and theory examinations. There is an absence of interview material, although there is evidence of correspondence between the author and some informants from both Scotland and New Zealand.

The most significant factor in Witta's thesis, with regards to my own, is that he employed Kinetography Laban as a method of comparison. This is the technique favoured by European researchers, and is from the same root as the American preferred Labanotation, which is my method of choice. Witta has attempted to make direct comparison using hand-written notation. However, it is not easily legible and lacks full explanation of the actual diagrams. It is partly for this reason that I chose to expand and explain my computerised Labanotation with annotations.

There have been other works published on Highland dancing, particularly to set out rules of technique and style, and these are referred to in Chapter Five. However, I found that the aforementioned works have been the

most significant contributions to research into the Scottish Highland dancing tradition despite the limitations outlined above. Of all that has been written on this subject to date, Witta's thesis is the most relevant to my own with regards to the employment of a comparative method, the Fletts' work is by far the most extensive ethnographic (if not analytical) research and Emmerson's sets the standard for comprehensive presentation of other sources. The reader is referred throughout to these works, where appropriate, in order to avoid duplication of information.

Both the Scottish Official Board of Highland Dancing (SOBHD) and the Scottish Official Highland Dancing Association (SOHDA) have some records but these are now mostly in the form of articles and web-site information. Where possible, I have referred to sources advised by both groups but have not had access to any archival material as such, nor indeed have I been able to trace certain documents. The Royal Scottish Country Dance Society (RSCDS) also has an extensive archive, but, as I found to be the case with other collections of dance in Scotland, little research has been done or analysis offered regarding the dances' cultural background.

The Bobby Watson Collection at the University of Aberdeen forms an extensive record of dance in the twentieth century and this I found fully accessible. Watson's vitality not only as a dancer and teacher but also as a choreographer and storyteller is well documented. The material is a new acquisition and was only recently catalogued in the year 2000. I have drawn on this resource but its depth can yet still be plumbed with regards to his

association with both regulating bodies.

The Scottish Traditions of Dance Trust (STDT) is the only national organisation that exists for 'researching, conserving, fostering and promoting *all* of Scotland's dance traditions' (Newsletter, June 2000). The archive is growing steadily, thanks to the full-time researchers' and members' contributions, but there is little or no analysis or academically guided questioning of that material.

The main themes which emerged from my fieldwork data were ones which had not been discerned in any of these previous works. This is most likely due to the quantity of fieldwork from such a broad range of informants. The thoughts of my interviewees, despite their differences in age and experience, seemed to gravitate their thoughts to similar themes of rules and regulation as well as authenticity in style and the dominance of the SOBHD. Themes of enjoyment, expression, innovation and sport also arose, as did comments on the future stability and development of the tradition. Theories and opinions which were voiced in interviews in the field are recorded in Chapters Four, Five and Six of this thesis. These voices are, effectively, being 'heard' for the first time. The following section introduces these themes in more depth.

2:I:iv Main Themes

'what it does... how it does it' (Merriam 1964: 209)

The themes which arose through the data collection fall into two main categories. These were matters of practicality and identity. This is not to say that the two ideas are not connected, but they were certainly recurring in the attitudes of dancers, teachers, judges and organisers alike. The predominant practical themes are those of fairness in judging, especially with regard to matters of aesthetics, and the organisation and policing of transmission and competition. The perceived move towards physicality and technicality at the expense of musicality and enjoyment also emerges as a concern among informants, as does the lack of male dancers. The theme of identity emerges through discussions on the practice of dance and dancing under the auspices of an over-arching dance organisation. Cultural bonds are identified in practice, in competition, in the association of dancers as tradition-bearers, and in the notion of representing Scottishness.

It can be argued that the 'ownership' and practice of Highland dances has become part of the ideology of the nation (Hobsbawm & Ranger 1983: 13). Many of their origins have been preserved in popular memory, even if their use has changed significantly. One of the most fundamental themes arising from the data collected in this investigation was the nature of belonging to one of a small social group of dancers, a wider family of associated practitioners, and a nation of Scots.

The idea that everyone 'has' a nationality implies ownership of whatever constitutes that individual character (Anderson 1991: 5) and indeed '...dance rather obviously involves the corporeally [sic] being in the world that dance most deeply signifies' (Sparshott 1995: 95). However, 'in these days of multiculturalism and a greater mobility... a national identity is becoming more and more outdated and problematic' (Kearney 2005: n.p.). Highland dancing, according to the data, seems to signify 'Scottishness', since it is a unique dance-form, with regards to its combination of a solo form and style, which originated from Scotland and its people. It is therefore presumed that, in some way, Highland dancing has a cultural identity of its own, even if it does not seem to have the close associations with the wider culture that it once had on a national scale.

I use the term 'traditional' to mean 'the transference of cultural knowledge over a period of time' (Nilsson 2004: 1). One aspect is that this transference always brings about change, i.e., all 'living' cultural manifestations, as for example dance, are a continual mixture of old and new, of the invariable and the changeable. It is now a tradition, in that it is handed over and delivered (Williams 1976: 268) in its own right. It has been essential that I neither aim to construct my own ideas of what constitutes folk identity, nor mythologise dancing as it has survived, hoping that something so modern turns into folklore, since 'A tradition can be perceived to be older than the immediate past; hence the endorsement of tradition always implies a rejection of that immediate past in the interests of something uncontaminated, original' (Brocken 2003: 43).

Highland dancing is undoubtedly context-rich (Hall 1976) and yet this thesis tackles the question 'can still be removed, separated from its context' (Grau 29/11/04). In this respect, regulation is scrutinised, to speculate whether or not the dance-form has the same 'meaning' for the dancer, in a competitive and non-competitive sphere. The narrative value of the origins of the dances is therefore emphasised (in Chapter Three), the process of rule-makers rule-making is set out (in Chapter Four), the resultant style is shown (in Chapter Five) and regulated dancing in the field is shown, in context (in Chapter Six).

Inevitably, the themes of taste and personal preference, on the parts of dancers, teachers, judges and spectators alike, are recurrent within the collected data. However, it is important to identify a brief definition of 'Aesthetic Judgement' in order to understand the key information in a group of meanings which would combine to make 'social or cultural interpretation' (Williams 1976: 28). For the purposes of this investigation, I consider aesthetics to be 'a discourse of the body... as the Greek *aisthesis* would suggest, to the whole region of human perception and sensation, in contrast to the more rarified domain of conceptual thought' (Eagleton 1990: 13). When Hannah talks about 'aesthetic value' (Hannah 1979: 19) she qualifies this;

Aesthetic refers to notions of appropriateness and competency held by the dancer's reference groups which act as a frame for reference for self-evaluation and attitude formation to guide the dancer's actions ...aesthetic expressions [and, in this case, judgements] are often part of a culture's inventory of signs and demarcate and convey social groupings (Hannah 1979: 83).

There is not necessarily a relation between favourable assessment of a thing and enjoyment of that thing. But, in the case of aesthetic appraisal and aesthetic enjoyment, there is a connection between assessing something favourably and enjoying it. Judging Highland dancing is not, then, merely an aesthetic appraisal, but is based on rules, methods, examples and dictated steps. If judges could use their own interpretation, they would then surely be 'appraisers'.

The judgements made on the part of the examiner, judge, spectator, and sometimes, importantly, fellow dancers, are therefore part of the make-up of the social dynamics of encouragement and control. Essentially, with regards to identity formation, one question arises: 'who, or what controls and defines the identity of individuals, social ground, nations and cultures' (Marcus 1998: 58). This dynamic force is also evident in the policing or marshalling of the rules and regulations pertaining to the activity.

The notion of Highland dancing being a sport and not simply a leisure activity is a subject discussed widely among dancers and definitions of 'sport' and 'art' are complex and contested (Thomas 1997: 97). Highland dancing is recognised by Sport Scotland, primarily for purposes of funding, just as ballroom dancing is recognised by The International Dance Sport Federation (Thomas 1997: 109). The technical control and stamina required of dancers is unquestionable, but the approach taken by dancers differs, with regards to their aims and overall self-perception. This is exposed particularly in the fieldwork data arising from the research conducted for the ethnography of Highland dancing competition in Chapter Six.

Another debate among dancers, and one that emerged in the analysis of the fieldwork was that of 'musicality', that is, musical-ness on the part of the dancer. In order to narrow the field, I have had to treat music and dance almost as separate entities, which means that I will not consider music in depth as much as I would like. This restraint will hopefully pave the way for future study and I have done so (as dancer and musician) with due respect to the symbiosis of these elements and the unnatural divorce imposed by these academic restrictions.

Lastly, a noticeable absence: male dancers. There are few boys who take to local lessons, and fewer who take to the (public) competition stage. Highland dancing is, in the twenty-first century, an overwhelmingly female activity. This is not a lone phenomenon, as is clear in the Irish step-dancing tradition which, like Scottish Highland dancing, was once a male-dominated activity and is now 'too 'sissyish' for boys' (Foley 2001: 41, 36). The trend seems to pervade all aspects of dance in the twentieth century as partly explained below:

Up until the nineteenth century in Europe, prejudices against the male dancer did not exist. By the end of the twentieth century these have developed and changed in response to a variety of social and historical factors... one might feel distaste at macho displays of male energy on the dance stage - what are they trying to prove...? Or one might feel that male dancers are generally a disappointment - they just don't look very masculine (Burt 1995: 10).

One major factor of such a swing in popularity is that, following the Second World War, the male generation of dancers declined to such an extent that

female dancers were taking up the activity, partly to keep the tradition going. The effects of this are still felt today, and Chapter Six highlights practitioners' opinions on the dearth of male activity in the Highland dancing scene, as well as offering their ideas for the future of male participation.

The theory behind the mode of research chosen, and the methods used to collect the material which yielded these results, are revealed in the next section.

2:II Theory and Methods

2:II:i Historical Approach

'The researcher and the researched' (Buckland 1999: 4)

It was necessary to put my questionings and findings into an historical context, mainly because the tradition investigated has an origin pre-dating any informants' experience. Although contextual and historical information is required to locate and understand the dance as product, behaviour, and concept, comparative analyses are also required 'for the understanding of societies and their institutions' (Hammond 1971: 468). An examination of the dance itself is also pertinent in order to highlight not only its key structural elements, but also our understanding of the workings of the dance culture and underlying cultural concepts. For these reasons, dance positions and gestures have been recorded using dance-notation, so that the comparative aspects of dance dialects can be shown clearly. These have been matched with the attitudes of societies that have hosted, fostered and furthered this living tradition.

Primary historical sources such as written texts, poems, novels, diaries and dance notebooks and secondary sources, such as books of instruction, articles, academic and non-academic research and dance fieldwork are consulted. Artists have also depicted Scottish dancers and dance contexts through the centuries and their valuable sources of interpretative material have also been included. This was done in order to gain a full and relevant knowledge of the history of Highland dancing and Scottish folk dance in

general.

I have attended to historical records, and have, ultimately, drawn on older sources which have not been consulted before. Evidence, however, was scarce and therefore multiple personal narratives and perspectives were both valid and valuable (Berg 1999). Interviews which were conducted through both observational and participatory ethnology in the field were complemented by extensive field recordings. These are substantiated, where possible, through material sources, some of which can be found in the appendices, because personal testimony cannot be relied on as being anything other than individual (and, at times, speculative) truths.

Dance practitioners in Scotland have few resources for investigating the social and historical roots of their activity. The lack of documented research in this field is felt keenly. The sources which do exist are often fragmentary and scattered and rigour was therefore employed with regards to the scholarly approach, supported by evidence not always available in archival sources. This work will at least consolidate what archival evidence there is available as an historical foundation used in order to develop my own ethnography.

The following section demonstrates that there is, in the global field of traditional dancing, an abundance of dance ethnography and ethnographies, but no scholarly work, to date, on this specific area of Highland dancing.

2:II:ii Ethnological Approach

'text-making' (Cowan 1990: 6)

In this project the detail extracted from the dance movement constitutes the basis for an ethnological approach, whereby the whole has also been contextualised in order to understand the specific dances and dance components, using the inductive method: from specific to general. This type of study can be most comfortably termed 'ethnochoreology' as its methods have been based on ethnology, particularly with regards to the emphasis on origins and distinctive characteristics of the dance culture, and choreology (literally, the study of dancing). However, this model has not been constructed in isolation from other elements of either movement and music research, nor from the classical concept of folkloristics in which folk dance is embedded.

Alexander Fenton discusses the problematic nature of methodological definition, stating that an absolute definition is an elusive goal (Fenton 1985) due to the lively and dynamic nature of a subject which is a living (and therefore evolving) tradition. As the disciplines of choreology, ethnology, sociology and history are adjacent and complementary, mine was a methodology that drew from each of them.

Culture is therefore a theoretically valid field of research because within it ethnography is both a process and a product. It is also a shared phenomenon which is learnt, either directly or indirectly, within the confines of a group. As a result, it is important to assess and re-assess the complex rôles of

the observer and the observed within this research, since the participant observer will have an effect on the information collected and the interpretation of the data. This awareness ensured that the viewpoint taken was constant, in order to analyse interviews and evidence of fieldwork properly. When exercised with rigour, reflexivity has permitted the revelation of power relationships, values and ethics in field relations, and these are all things that must be constantly questioned and monitored. Reflections on the revelations of such a standpoint are made in the final chapter.

In addition to this were the moral, political and intellectual conflicts for the researcher with access to alternative cultural views, which underlie the 'paradigms of the authors' training, influences... from other disciplines... [and] the particulars of their field sites...' which affect 'the individual inflections and innovations of... research' (Buckland 1999: 2). Buckland explains succinctly the problems associated with researching one's own culture in her introduction to *Dance in the Field*: '...uncertainties surrounding [research] are thrown into sharper relief by undertaking fieldwork in one's own country; what then, or who constructs the field and when, if ever, is fieldwork begun or concluded?' (Buckland 1999: 8).

Specific insider knowledge has been ethnographic in nature due to an original interest in the specific steps and styles of the dances, which led to a broader contextualisation of the dancers themselves. In order to highlight contemporary practitioners' attitudes towards the history and supposed history of the dances they perform, ethnographic methods, such as unstructured and

semi-structured interviews, correspondence and film recordings produced extensive visual and verbal 'texts'. The underlying philosophies of the contemporary societal system of the competitive dancing world therefore inform an analysis of concepts of the current form. This material is at the same time a qualitative collection of attitudes and verbal 'histories' but also a quantitative collection of the current state of a movement system at the turn of the twenty-first century.

My investigation has not been strictly that of the lone participant-observer. Although alone, and participant in some of the teaching and transmission, and an observer, both as researcher and dancer, I did not have the same experiences as those treading the competition boards or indeed those who were taught within a different branch of the tradition. Long-term immersion in this culture, as a child and adolescent, meant that, in returning to certain areas and attitudes which are part of that broad field, I was not as much of an outsider as I might have been had there been no first-hand experience of Highland dancing. It is therefore imperative that a summary of previous research is made, thereby highlighting some of the strategies that have been employed in this field.

A selection of verbal ethnographies of dancing practice, particularly competitions, has therefore been collected and, from this perspective 'dance is explored as a system of movements, a system of meanings, and a system of rules which include use...' (Hannah 1979: 7). This bridges the gap between text (i.e. movement) and context (i.e. sociocultural setting) (Hannah 1979: 84). The extracts which have been chosen represent a small sample of the total

fieldwork but, with regards to matters of competition, old and new, they provide an overview of the data collected. Whether or not these contributions are true to fact, oral evidence about Highland dancing traditions adds to the emic value of the research. However, by using an ethnographic approach, the material herein is first-hand and the informants are quoted throughout and form the narration to the accompanying illustrative film.

Ethnography is also

[a] genre in which the description... exists side by side with the personal confession, the myth, and the well-worn fireside tale. It attempts to lead the reader to believe that the myth or the personal confession has a definite relation to the way the [society] works (Thornton 1988: 288).

This strategy is informed by recent textual theories in literary criticism that challenge the authority of one ethnographic writer in a text that is actually 'composed by many voices' (Marcus 1998: 36). One of the cultural concerns of this thesis is to enable the voices of the researched to be heard.

Primary sources, such as interviews with competitive and non-competitive dancers, teachers, judges, examiners and audiences, have been drawn on extensively for personal accounts of experiences and opinions. These testimonies served as the rich mortar with which the building blocks of written sources, and the cornerstone of theory, were cemented. This systematic investigation establishes facts about both the past and contemporary development of Scottish Highland dancing.

One of the crucial parts of this recording process was the notation of the dance, which can be found in Chapter Five. A Labanotation key of step variations and styles has been created in order to form a lasting record of the dance positions, gestures and movements within the Scottish Highland dancing tradition, and, in this respect, the notated text is the ethnography.

While it was important to 'freeze a dance for analytical purposes' (Van Zile 1999: 90), my main concern in using notation was to show the progression of dances, which are not static by nature, and, although I notate individual positions, the pairing of this with videos shows movement in real time and space - because dance is not essentially a speeded up collection of minute elements (just like a film is somehow greater than the sum of its individual still frames), but it is a vital and creative process. Dance is not text so much as action and practice (Hughes-Freeland 1999: 112) and 'a culture can never be reduced to its artifacts [sic] while it is still being lived' (Williams 1958: 323). In the same way, it cannot be freeze-dried into notation as a method of progress (notation is surely stagnant). The practice is therefore paramount.

Original informative material consists of numerous representational films which I made, not merely as an observer, but as a participant in the operations of data collection. This visual collection also helped me make the transformation from a word-and-sentence-based to image-and-sequence-based narrative (MacDougall 1995).

Other methods of recording information took a variety of forms: semi-structured questionnaires, unstructured or 'ethnographic' interviews (Brewer

1994), note-taking, field-notes, preliminary movement notation, film recording of performances and contexts (and interview research) and minidisk recordings of interviews and group discussions in which the interviewees talk about dancing and dance-events. In this way, I represented

the context, the understanding, the set of assumptions and reactions that fills out the processual nature of the event, providing a wholeness that, strictly speaking, cannot be located in or projected from the decontextualized [sic] text alone (Foley, J.M. 1995: 208).

These are quoted extensively throughout and I have provided catalogue numbers with each quote (see Thornton 1988: 287), which refers to accessions in the visual/sound collections of the School of Scottish Studies Archives at The University of Edinburgh. A full list of transcripts can be found in the Bibliography, under 'Primary Sources'.

From my own observation and participation and through the eyes of performers and audiences, I looked for patterns of movement and social action and the meanings of these for both dancer and spectator. Dance is meaningful not just to those dancing, but also to those observing dance (whether in a social or performance context), observers attribute meaning to what they see and indeed can be viewed making the dances that appear before their eyes - that is, they are not simply passive observers. Therefore, I interviewed not only competitors and judges, but also audiences of dancers and non-dancers. The video recordings have therefore been used for primary analysis, such as for information relating to the clarifying of movement motifs and sequences and to

find out about mistakes. In this way, movements or whole performances are evaluated.

The ethnographic field is an embodied field which touches on a range of related themes, such as the personal, social and ethical, which can be used to explore 'the relationship between fieldwork, the body and the nature of embodiment' (Coffey 1999: 68). In dance research the embodied character of the field becomes heightened through the situated embodied practice of dance. The following section explains matters of gaining access to the field and the process of ethnographic research in the competition arena and the socio-cultural arena.

2:II:iii Access to the Field

'from outside to inside' (Sklar 2000: 71)

The present-day microcosm of Scottish solo dancers is exclusive to its members who are recognised, regulated and rewarded according to established rules of conduct. As a Scottish dancer and teacher, a prior knowledge of Highland dancing allowed me access to this unofficial, yet close-knit, culture of Highland dancers. However there is an extent to which my own 'belonging' has influenced my results. As a non-competitive dancer in a primarily competitive arena, personal experiences have been not so much of inclusion but of exclusion. As with Simmel's 'The Stranger' (1950), I experienced 'nearness and remoteness' at the same time (Simmel 1950: 402).

One example of this was when, at a United Kingdom Alliance (UKA) event in central Fife, I participated in a dance lecture in which the teacher did not demonstrate movements, but recited, verbally, the positions and gestures as they appeared in the SOBHD textbook (1993). In my slowness to understand the mode of transmission, I was made to feel particularly uncomfortable by non-participating teachers and dancers, who looked on whilst seeming to pass comment with disapproval. The other dancers, who knew the phrases as if by rote, continued with ease. I later discovered that I was the only non-competitive dancer in attendance.

My personal experience was therefore limited, since I was conditioned according to my teacher's training, methods and preferences with regard to

platforms and performances, and so I employed continual vigilance with respect to reflexivity. My point of view was emic, as the analysis of the culture has been a life-long process of both a 'conscious and sub-conscious nature' (Garbarino 1977: 82). Although I am Scottish and have been brought up to know aspects of Highland dancing, my rôle was no longer that of a dancer, but of a researcher, and I was aware that 'the cognizance [sic] of the community being investigated is seldom the same as that of the newcomer from the outside' (Ronström 1999: 135).

The main advantage of having such closely linked experience of the culture in question is the foreknowledge of certain technical aspects of the dances that would otherwise have to be learnt in order to be understood. Having a working vocabulary as a starting point enabled me to put my own experience into context and adapt my terminology or understanding of terms accordingly. Although at times this might have proved problematic since the terminology has gone through constant change and re-employment, it was, for the most part, an advantage. Having a working vocabulary as a starting point enabled me to put my own experience into context and adapt my terminology or understanding of terms accordingly. As a participant observer, I increased my understanding of the structured movement, indigenous classifications, movement motifs and how pieces are put together as well as an observation of surface manifestations and behaviour.

Through the process of this investigation, my aim has been to cultivate as indigenous a viewpoint as possible in order to build an understanding of the

'conceptualisation of movement systems through the society's own eyes' (Buckland 1999: 5), whilst maintaining a reflective distance. As a participant observer, my aim was to become totally competent in the culture and therefore accepted into the dance culture. Therefore, in order to establish a more active place in the dance culture, I availed myself of opportunities to dance in demonstrations, dance days, and other performances as a participant observer. Whilst bearing in mind that an insider's view does not guarantee objectivity, due to any individual's cultural inheritance, I composed a commentary of both insiders' and outsiders' views.

The discrepancies between emic and etic perspectives are fitted in to the conceptual framework of meanings associated with the dance and the participants' conceptual and physical understandings of it, in Chapters Four and Six. In this way, I represented both the movement from the point of view of the dancer who was dancing and from the point of view of informed spectators (i.e. other dancers, teachers, mothers and judges). In order to explore the feelings of the participants and the more removed onlookers, I asked the performers and spectators alike 'what they thought they [the dancers] were doing' (Farnell 1999: 146). In this way, I was able to observe the content of the competitive dancing, while asking questions about movement contexts. My participation led to a developed questioning of underlying systems and intentions which had not been informed by the culture in which I was steeped as a child, but as a result of enquiry in the field.

Even as I danced before this investigation, my interests were changing:

I had moved from being a 'complete participant' (Hammersley & Atkinson 1995: 104) as a child, to an 'observing participant' (Horton-Fraleigh 1999: 264) as an adult. As I developed from practical interests to research interests, my rôle also changed from 'participant as observer' (Hammersley & Atkinson 1995: 104) to complete observer, especially at specialist and competitive events. Surprisingly, I also became observer as participant, particularly at dance days and workshops where, in order to be accepted as a researcher or dancer, I had to participate in the event. This seemed to alleviate suspicions that I had 'head' knowledge but was not using it practically. Although I had tried to distance myself, I was constantly choosing (or having chosen for me) the appropriate rôle (normally that of a dancer). Overall, I did not only move 'from outside to inside' (Sklar 2000: 71) but from inside to outside to inside, continually crossing the observation border, as the situation dictated.

My acceptance in the community of Highland dancing was a gradual process. This was not least due to the fact that I was perhaps the first researcher in the field. I was the first to ask questions about the origins, authenticity, regulation and the future of the dances, and one who did not fit into any existing category or have any recognisable status in the Highland dancing society.

I can liken my experience to that of Helen Thomas and Nicola Miller as described in their exposition of the social and political world of ballroom dancing in *Dance in the City* (1997):

we found that ballroom dancing, like a number of sports, is a highly competitive 'closed' world in which everyone seems to know everyone else, or, at least, everyone else who matters. There were occasions when some individuals, particularly professionals (teachers), were wary of being taped, despite guarantees of anonymity, in case their 'voices' would be recognised, and perhaps they would be seen to be treading on someone else's toes (the invisible [at least to us], yet ever-present, hierarchy (Thomas & Miller in Thomas 1997: 92).

This hierarchy was, indeed, an over-arching power, namely of the members of the Executive Committee of the SOBHD. These are the people who oversee the making and implementation of rules; the co-ordination of events; communication and collaboration with outside bodies; the amendment of guidelines for teaching and competing; and the authorisation of new editions of the textbook (SOBHD 1955; 1962; 1968; 1975; 1984; 1993).

When members of the committee did agree to be interviewed, it seemed that they revered the regulating body as greater than the sum of its parts. Little information was therefore offered on any subject which would be seen to be political or that would upset the status quo. There always seemed to be a glass ceiling, a level beyond which my questioning was not allowed. In general, the information given in interview was normally that which was already available in print, with the exception of personal opinions. There were three main areas where information gathered from informants was generally scant or unsubstantiated: the origin of the dances, the dates of the foundation of the SOBHD and the SOHDA and the circumstances surrounding their formation. Such imprecise information emerged due to a lack of knowledge or authoritative evidence on the part of the informants.

Although I did not have an academic predecessor who might have acted

as a contact, or 'gatekeeper' (Brown 1998: 13), by allowing me access to 'their people' (Grau 1999: 168), I did have two key contacts. The first, Charlie Mill, born in 1940, was Chair of the SOHDA Technical Committee and a long-standing member of the Association as a judge and teacher. He died in 2003. His contributions were extensive and detailed in both 'fact' and observation as he illustrated key events (involving both the Association and the Board in the late 1940s and early 1950s). Mill seemed to be one of the 'outs' who had lost power but are 'in-the-know' (Dean in Dolby 1967). The other informant with whom I had a great deal of contact throughout the lifespan of this thesis was Billy Forsyth. He is currently an examiner, co-ordinator of the Edinburgh Military Tattoo dancers and the master of ceremonies for the 'World Championships' at Cowal. I knew him initially in his capacity as Chairman, and later as President of the SOBHD.

These men had much in common although they were essentially on opposing sides of Highland dancing ideology (as illustrated in Chapter Four). As world champions who had competed in the 1950s and 1960s, both had extensive television and choreography experience. They had also 'extend[ed] their prestige and status into the social sphere, becoming leaders of... groups' (Giurchescu 1999: 48). They were also, interestingly, amateur dance historians (SA2003.036; SA2003.037; SA2003.038) who therefore had an interest in my findings, and therefore naturally directed my questioning. They acted as gatekeepers, as they provided information through interviews and correspondence, contacting colleagues for my inquiries, recommending me as a researcher and, at the same time, protecting certain subjects from exposure by:

imposing their personal scale of values on the rest of the community and guiding the researcher's contacts with new informants... filter[ing] information through their own representation, correct[ing] other informants, arrang[ing]... situations (Giurchescu 1999: 48).

These gatekeepers therefore had certain control over key sources and avenues of opportunity, since both had, at their disposal, contact with and influence in the respective committees of officials, and the power to recommend or reject my enquiries. They exercised this control during important phases of my acceptance into the dance culture and they seemed to consider themselves to have all the relevant experiences to constitute a thorough and balanced data collection.

Following an initial extensive interview with Mill (SA2003.037; SA2003.038; VA2003.007), letters were exchanged, and the informant was helpful in providing his own articles and excerpts of personal research. However, it seemed that there was a pervading attitude that I had met with the (designated) expert and that there was no (assumed) need to question others, as other attempts to interview key members of his Association proved unfruitful.

At a first meeting with Forsyth in Edinburgh, he was similarly helpful (UI2000.002)³. He spoke plainly about older, alternative steps no longer danced, demonstrating movements in quick succession. This discussion was not recorded, as it was after the main (group) exchange. Three months later,

³ This meeting was organised with Morag Fothergill, a student at Queen Margaret College, Edinburgh on placement at Adult Learning Project Scots Music Group. The group consisted of competitive and non-competitive dancers, teachers and judges who discussed the rôle of Highland dancing as a social activity (UI2004.05).

at the time of the first extensive interview, Forsyth denied all knowledge of such a demonstration having taken place (SA2003.036; VA2003.006). Although, like Mill, he offered help by email and telephone, the information gleaned was mostly that which was already available for research, in dancing books or manuals. In the same way as Mill had represented the official stance of the SOHDA, as its unofficial spokesperson, Forsyth was my first and last official contact with the SOBHD.

Although Forsyth was not forceful in his recommendations or direction, there was certainly some 'body-blocking' as I tried to delve further into the organisation of the SOBHD, as no access was allowed by either him or the SOBHD secretary to other members of the Executive Committee. Having been 'taken up' by such a sponsor (Hammersley & Atkinson 1995: 75), I found it difficult to achieve independence from him, as I needed not only access to his organisation but also his favour, with regards to attendance at events.

It was over a year after the original meeting that a significant breakthrough came with Forsyth. He volunteered a Hi-8 video recording of a discussion with Sheila McKay (seventh generation of dancing teacher and trainer of world champions until her death in 2001). In this, he and McKay debate pertinent topics leading to the foundation of the Board and the steps chosen by the appointed technical committee of 1950. Following this, my faithfulness as a fellow member of the Board of the Scottish Traditions of Dance Trust and my services as a teacher, choreographer and performer, meant that I eventually was able to set up a third meeting at which Forsyth offered me

copies of documentation relating to the formation of his organisation. Having mentioned this resource in 2000, he eventually offered me freedom of his personal archive of SOBHD documentation, in 2003. He was not simply a spokesperson for the Board, but, by having original letters and personal bequests from ex-dancers, he *was* the Board, as I came to realise.

My consistency had earned respect and trust. There had been a move, in the case of Forsyth, from an 'Obstructive' to a 'Facilitative Relationship' (Hammersley & Atkinson 1995: 74). This access was made possible through developing trust. It was by means of this trust that I was able to make an ethnography of an important championship event in the calendar of the SOBHD competitive dancers. The making of the ethnography and the actual data collection by means of semi-structured interviews, observation and film, are discussed in the following section.

2:II:iv The Ethnography

'The... expression of the human spirit' (Duncan 1928: 56)

Interviews with informants who remembered dancing in the first half of the twentieth century, and who had insights into the process of regulation in the 1950s did not, generally, take place at specific events. This meant that they were unhurried and private. The information they yielded revealed much about *what* Highland dancers dance. This material informs Chapters Three, Four and Five. However, following the assumption that the dances themselves are 'bound not only in its structure but also in the motives [sic] used' (Martin & Pesovár 1961: 21), these interviews were precursors to in-depth fieldwork at Highland dancing competitions. How the dancers dance, and why do they dance in the way they do are shown in practice in Chapters Five and Six.

The main event, from which I produce an ethnography of a competitive Highland dancing championship, took place in February 2005. The preliminary fieldwork was perhaps most valuable not in the resultant data, but in providing me with a status as a dance researcher, collector and converser. This ensured me access to places and, importantly, people who had, in the past, been unhelpful. The dance-event (Keali'inohomoku 1974) being temporarily and spatially bounded meant that my questioning was largely sanctioned through my gatekeepers. Informants naturally felt comfortable sharing their thoughts and experiences to an 'insider' who had been commended by a member of the Executive Committee, and therefore effectively endorsed by their organisation.

Verbally analysing the social and cultural meanings of an event which is primarily an embodied practice, and one which is conceptually set apart from the activities of everyday life, is fraught with difficulties. This is partly because 'The endless techniques of the body, practically mastered and mutely enacted, are rarely the objects of verbal elaboration' (Cowan 1990: 24). I have therefore aimed to draw my construct as near to dancers' reality as possible, by eliciting information and comments from the participants and their personal commentaries.

While dance is an embodied form of knowledge, there are difficulties in explaining what one is doing if one is not equipped with appropriate (culturally specific) terminology, since 'just because I dance it, doesn't necessarily mean I understand it and, just because I may understand it doesn't mean I can necessarily articulate it' (Bacon 29/01/2005). Similarly, dance researchers in other fields have found that 'few are able to provide verbal accounts of their engagement in music or dance... [due to] a lack of specialized [sic], technical and analytical language... [but] rather they do it.' (Ronström in Buckland 1999: 135-6). Highland dancing, however, has a highly codified language system for explaining step content and execution. This prevalent and commonly used terminology is set out by the textbooks used by students and teachers (SOBHD 1993; SOHDA 1994). I found that dancers often had the challenge of *not* using this language in order to articulate execution. However, when describing experience they had no trouble expressing analytical, emotional or self-reflective elements.

If the argument that the meaning of dance can only be grasped fully through dance (Hannah 1979: 24; Sparshott 1995: 80) and that 'the only method of describing a work of art, which... is entirely adequate for the purpose of aesthetic appraisal... is to say 'It goes like this' (Strawson 1974: 185 in McFee 1992: 254), then my experience as a participant observer also informed my thinking, questioning and subsequent analysis.

A visual recording of this event accompanies the thesis, and is referred to throughout Chapter Six. It is a combination of primary data and illustrative material. There have been no dramatic effects added, although there has been substantial editing in order to give the viewer an idea not only of the key elements of the day, but also the progression of the sequence of events⁴. Dances have not been cut, and, where appropriate, some are shown twice, with and without commentary. It has been the aim to show parts of the day in relative time.

It has been said that 'If dancers, or monkeys, are to be photographed, hours of observation have to be spent discovering their travel paths, habits and routines' (Prost 1975: 339). I did not have to familiarise myself in this way, as I was an insider to the extent that I had witnessed many Highland Games, I knew the stage, warm-up areas, seating, judges and announcers' positions, and the situation of other key areas and groups. I have tried, where possible, to film sequences containing material before and after the gestures or movements so that they are embedded in a sequence of greater length. In sequence, I also

⁴ The full-length fieldwork recordings can be accessed at The School of Scottish Studies Archives at The University of Edinburgh.

include representative images of dancers and commentaries from informants of varying ages and experiences.

However, the practice of Highland dancing and preparation for such an event is ongoing. This is why such extensive preliminary fieldwork was needed to contextualise a one-off event. The technical structure of the dances is therefore notated in Chapter Five. It is recorded by means of both written notation and Labanotation, which serves to give a multi-dimensional depiction which is also illustrated by the visual recording. The advantages of choosing such a method of written notation is discussed in the following section.

2:II:v Movement Notation

'an artifact' (Van Zile 1985/1986: 42)

It is difficult to recreate accurately, and almost impossible to notate, a dance manifestation, since, just as no two bodies are alike, a dance is unique on every occasion on which it is performed. The uses and functions of the dance are major influencing factors in its manifestation and these are exposed through the contrasting views of informants in Chapters Three and Four. The evidence within the style of movement employed is shown in Chapter Five. While appreciating that functions are often covert and that functional contributions to the dancing 'culture' are not constant, an interdisciplinary approach to recording results has been developed.

An appropriate movement analysis is of paramount importance for dance research, since human movement is the texture of dance. Indeed, I was at once ethnologist and ethnographer as I produced ethnography as qualitative data. Just as the vocabulary of dance has meanings that are coded and decoded for transmission, understanding and interpretation, so too does dance analysis. The analysis therefore had to be both morphological and structural. The former (that is the observation and classification of patterns of combination, derivation and change) has been borrowed from musicology. The latter explores the meanings and rules of movement logic embodied within the deeper structure of the dance idiom.

The traditional ethnographic methods of recording cultural practices or

events are film and audio recording of informants. The material in Chapter Six confirms themes which emerged in earlier interview data. The interviews which took place prior to the event informed the process of constructing the ethnography itself, as they often triangulated my observations in the field. In order to strike the balance between objectivity and subjectivity, the material is at the same time factual and interpretative. I chose to use video recordings during fieldwork, supplemented by cassettes, minidisks and transcripts, and annotated Labanotation for the presentation of dance structure for these reasons.

Plate 1: A Highland Fling (North 1881)

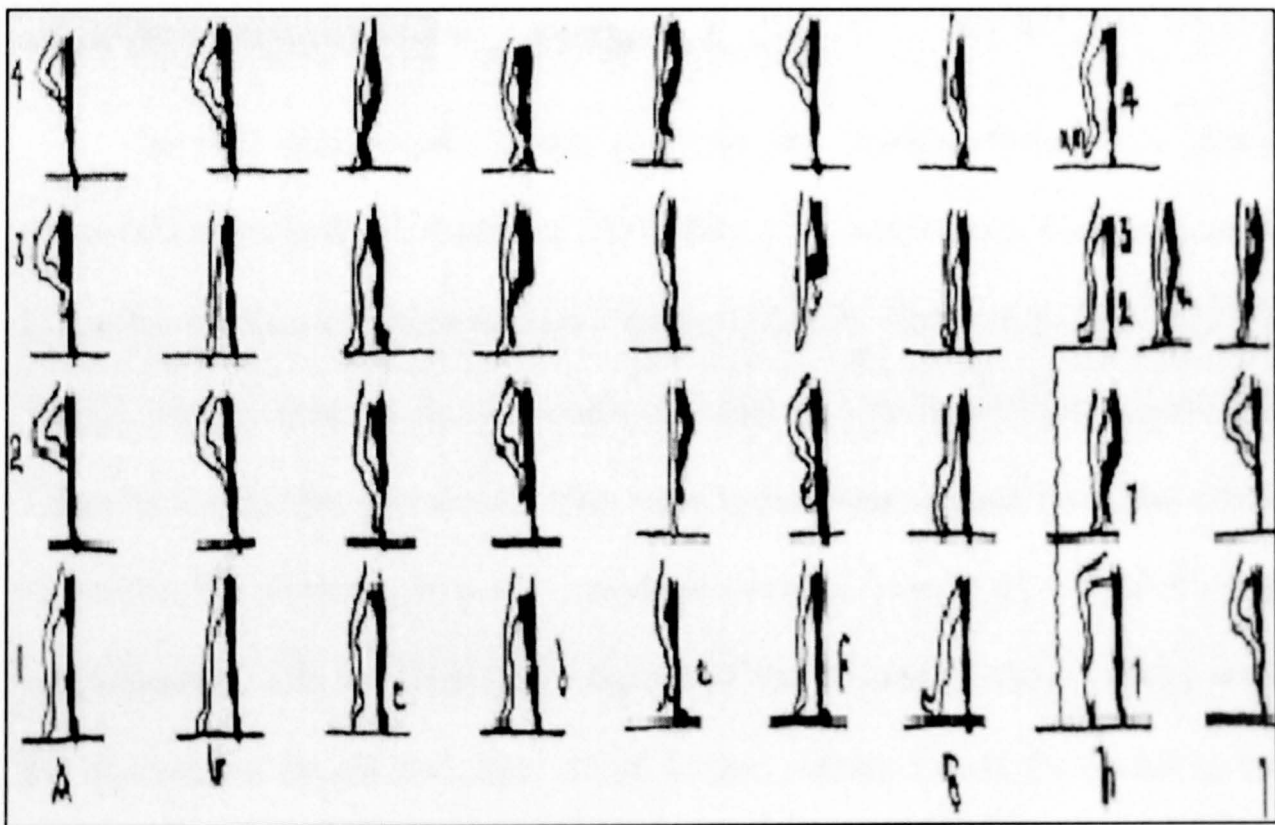

For the purposes of this investigation, I endeavoured to employ a method that is similar to standard musical notation for ease of understanding. However, since dance exists in space as well as time, problems of accuracy were fundamental. I therefore looked to the earliest notation of Scottish

Highland dancing to see if this objective had been met. A nineteenth century illustration of a Highland Fling (see Plate 1: A Highland Fling (North 1881)) is recognisable as a predecessor of the steps which are in the current repertoire.

In the above notation by North, the movements are read from bottom to top and the steps from left to right, which suits the four-beat step structure, but gives no indication of the intricacies of timing. The music and tempo would have been indicated separately. The third dimension is not easily indicated either, and only the positions are described, ignoring the movement, transfer of weight and flow. However, despite the differences in steps (and perhaps style, judging by the rough, approximate and heavy-handed drawings) the essence of a solo dance with minimal travel is apparent.

In the same book, North provides his readers (who were likely expatriate Scots living in London) with a four-fold multi-dimensional approach to the Sword Dance, which is shown below (Plate 2: The Sword Dance (North 1881)). This sixteen-bar musical stave is written in a circle with annotated code letters to depict the movements that were to be done at each bar. The circle represents the direction of travel round the sword as seen from the air. This is supplemented with two individual figures of the swords (without music) with the instructions for the two steps which follow, written across the blades in the direction of execution. This, again, is from an aerial perspective. The feet are also shown in detailed drawings of footwork across the blades and 'Plans' are also given of the floor, demonstrating the close positions of the feet. This is supplemented by extensive written explanation. Although this integrated

method is extensive in detail, it is not entirely comprehensible. Neither can it be read at a glance, nor can it be followed and executed without some contortion of either the page or the body. The three-dimensional approach is undoubtedly helpful, but despite meticulous detail, annotations have been added to provide necessary clarification.

Plate 2: The Sword Dance (North 1881)

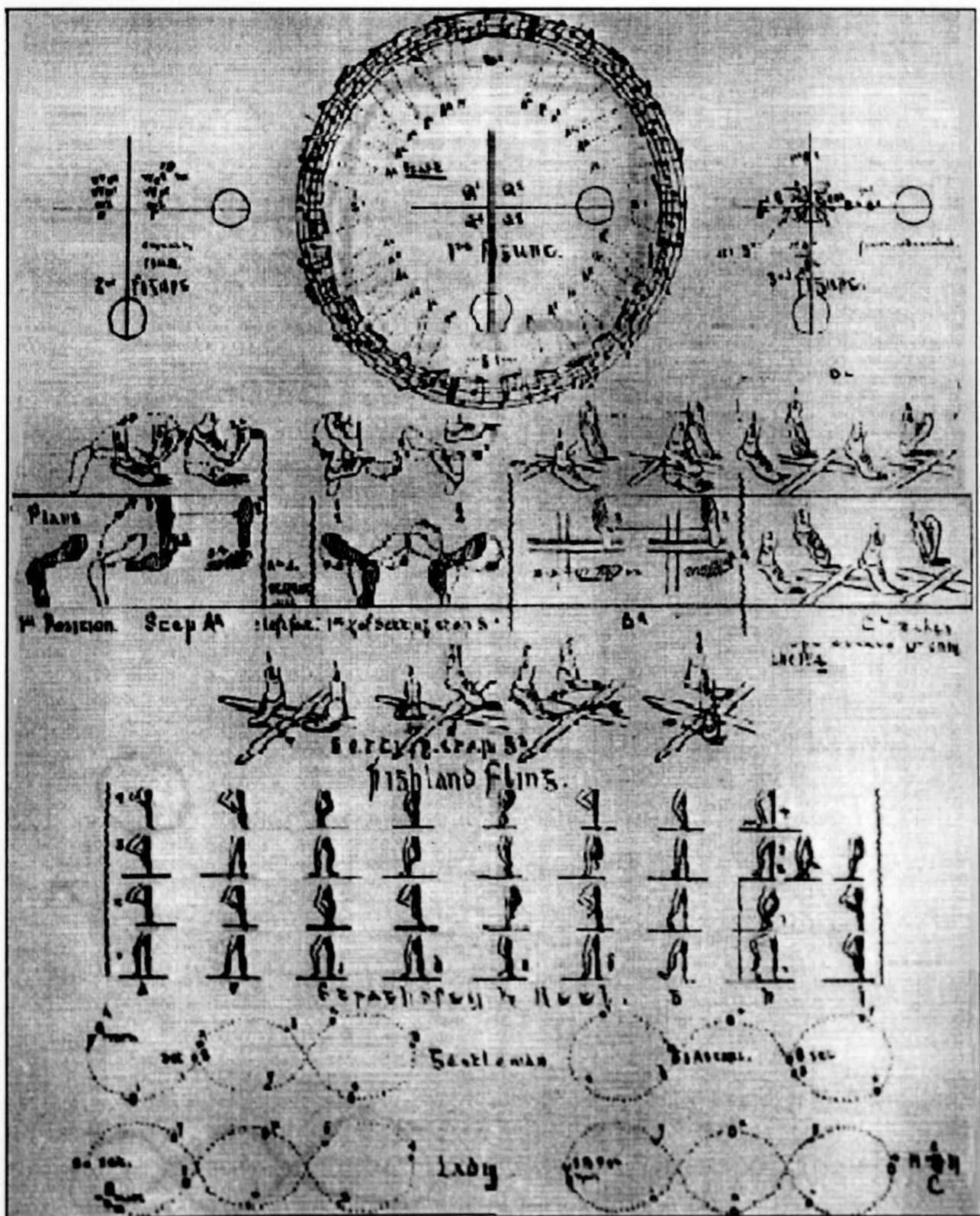

The complexities of notating movement based on spatial, anatomical and dynamic principles (as well as those of the character and build of the dancer) evidently proved to be insurmountable as far as the next seventy years of Highland dance notation was concerned. Despite the publication of written rules, the visual element was missing from printed instructions. The method of instruction employed by the SOBHD since the 1950s has shown little improvement. Individual drawings or photographs show all the positions, movements and steps. These depictions are, in fact, only a modern development of the stick-figure system. The limitations of this two-dimensional method are overcome to a certain degree by the inclusion of elaborate written explanation. A full explanation of the SOBHD textbook and other current tutors is found in Chapter Five.

The language used in the textbook (SOBHD 1993) is, in itself, a comprehensive endeavour, but has some disadvantages. Firstly, it is highly complicated, especially for the beginner and, unlike music notation, it cannot be read in real (musical) time. The words give no suggestion of interpretation and they may be taken to the letter, in the case of competitive or lone dancers striving for accuracy. The accompanying music is mentioned but not notated and this misleading separation of the movement and music results in a loss of artistic interpretation and general musicality as part of the learning process.

Billy Forsyth, President of the SOBHD, addresses some of these shortcomings in his foreword to *Highland Dancing: The Textbook of the Scottish Official Board of Highland Dancing*. He concedes that:

To transfer the poetry of music and movement into pages of text is a most difficult task. To try to describe in precise mathematical terms and plain English the smooth free-flowing movement of dance steps is almost impossible (SOBHD 1993: n.p.).

Over the years, refinements of language have helped to reduce this problem but this does not allow for the problems of misinterpretation. However, it is stated that 'a textbook still cannot replace a good instructor whose aim must be to guide students through the mechanics of movement to the feeling behind it, and this textbook should therefore be used as a guide and reference volume' (SOBHD 1993: n.p.). This leaves the onus on the student to find interpretation and 'feeling' from the style of the teacher.

The method I chose to employ in this investigation had to meet my requirements of *accuracy*, *legibility* and *longevity*:

1. *Accuracy* in the recording of complicated movements;
2. *Legibility* and consistency in presentation;
3. *Current, up to date and longevenous*, allowing for continual innovations in movement, theory and notation;

This pointed to a method of notation that:

- 1:i Records space and time, as the body is capable of simultaneous actions;
- 1:ii Favours the notation and extraction of full steps and component parts;
- 2:i Can be used for comparative analysis to show variations in steps and style;
- 2:ii Can be personalised, developed or annotated;

- 2:iii Can form a working glossary;
- 3:i Is currently in use and has long-term potential to be employed;
- 3:ii Will be understood by readers, dancers and theorists.

Hungarian-born dance and movement theorist Rudolf Laban (1879-1958) developed a full system of notation using proportional lengths of movement units along a central line in order to represent accurate time values, each shaped as a 'universal direction sign' (Laban 1956) to represent particular steps. This allows the graphic description of space and time relationships in the instantaneousness of one sign. Labanotation is therefore arguably 'the dominant mode of inscription' (Buckland 1999: 6). Certainly, with regards to the criteria of *accuracy*, *legibility* and *longevity*, set for this investigation, Laban's mode ranks highly:

- 1.i The basic principles are 'time' and 'flow' which make it a good method of notation for dances that rely on weight transfer (rather than weight use).
- 1:ii It is comparable to music notation in its universality and application and 'provides for movement a level of accuracy and flexibility which music notation has yet to achieve' (Hutchinson 1974: 5).
- 1:iii One can develop and incorporate new additions to the existing set of symbols with care.
- 2:i 'Through Labanotation we can actually sit down and compare or analyse different styles of dance. Even the complicated techniques and studies take up little space and are easy to reconstruct intellectually through the notated patterns. There is no longer any need to wade through pages of verbal descriptions, which eventually become unintelligible' (Hutchinson 1974: xii).
- 2:ii As technology develops, the mathematical system can be easily adapted to the computer for ease of composition and recording. There are two types of packages specific to Laban's methods:

Laban Writer and Calaban, both of which are efficient if limited to the existing components and technique.

- 2:iii As most forms of dance notation favour one form of dance, Laban's system is a tool of dance literacy which provides a greater insight into the nature of universal movement.
- 3:i 'Laban... based his system on thorough observation and a search for existing fundamentals, rather than on imposing conventional, contrived and short sighted solutions' (Knust 1963: 14).
- 3:ii It can be applied to all forms of movement, not just dance, and is applicable to all societies.

The process of culture and cultural development, that is, the practical application and implications of Highland dancing (and variations within the tradition) is, in this thesis, thoroughly scrutinised and therefore extensively analysed. In my view, the component parts have been best compared through the employment of Labanotation. By allowing the notation of the smallest indivisible units (or kinetic elements) which constitute minor units, Labanotation has enabled the morphological analysis of the recurring motifs, variants or developments in the dance. This also helped with the production of a key of the movements and styles which was a necessary first step to analysis. It is this medium, of analysis coupled with the process of fieldwork interviews, observation and background reading, which has allowed me to view the Highland dancing culture as a whole.

A study of this detail has been awaited with anticipation and enthusiasm by dancers and ethnologists alike since, until recent years, the climate for dance research in Scotland has not been one of nurture or growth. However, the lack of existing inquiry into this subject does not seem to reflect

a lack of interest. It is hoped that this study of Highland dancing will enhance the status of dance heritage in Scotland while, at the same time, providing a significant contribution in terms of international movement theory.

The following chapter traces the beginnings, or supposed beginnings, and development of the five main competitive dances in Scottish culture. This is a starting point for future studies of the form, as the accounts herein are the first extensive collection of tales and sources which pertain to these dances. As a result of a combination of historical and ethnographic methods, this chapter fills in gaps in knowledge for the dance researcher in Scotland, and paves the way for more in-depth analyses of the form.

In the following chapter, a body of evidence has been constructed which traverses both dancing history and the social context in which the dances were performed. This paves the way for subsequent chapters which provide an exposition of the contemporary Highland dancing microcosm in order that some indication might be given as to how the tradition might be shaped in the future.

Chapter Three: The Dance Histories

3:i The Highlanders' History

'Handy with their feet' (Topham 1776: 345)

In order to outline the histories of The Highland Fling, The Sword Dance, The Seann Triubhas, The Strathspey and The Reel of Tulloch there must be a recognition of the people who originally danced them and the culture in which they danced. These five dances are the most commonly competed in twenty-first century competitive Highland dancing. However, this repertoire is not new either in the composition of the individual dances, or in their combined association, as the five have appeared together, on the competition stage, since the late eighteenth century. This chapter not only asserts the histories and oral tales surrounding the dances, but also aims to go some way towards depicting the first dancers and those who carried, developed and taught the tradition.

Something of the character of a nation or people may be learned from the nature of their native dances. Notably, vigour in an unusual degree is conspicuous in those of the people of Scotland. There is no want of energy or vitality in present day Highland dancing, and this animation has been consistently evident in Scottish dance through the ages. Whilst there is no doubt that such dancing remains an energetic expression, the impetus is not necessarily ancient, as this dance tradition is no longer exclusive to the Scot, or indeed, Scotland.

In his preface to *The Scottish National Dances*, the author, known only as R.H.C., describes the distinctive character of the 'perfervid' Scot as one who

Throws his whole soul, his most strenuous effort, into his dancing, as he does (or did) into his work, his religion, and his fighting... [As the] paradigm of vigour... [he] would have danced 'till we be like to fa' and 'till piper lads be wae and weary,' as these are descriptions of Scottish rural dancing as persons still living have actually seen it, and perhaps have actually taken part in it (C., H.R. 1928: 1).

However, evidence concerning origins and early development of this 'aggressively... Scottish' (C., H.R. 1928: 11) dance is, according to the immediate past Technical Convenor of the SOHDA, 'scarce and scattered' (Mill 1999: 1). This dearth of reliable sources has contributed to the mystery and 'dark obscurity' (SOBHD 1993: n.p.) which surrounds the genesis of a dance form whose history is steeped in, if not plagued by, contending traditions and varying accounts. However, it is the oral tradition concerning the dances which is the primary source of information leading to the unfolding of the stories once contained within the dances.

There are few written records of Highland dancing in Scotland before the eighteenth century, probably due to practical and exemplary transmission, rather than a non-oral textbook transmission. The earliest written records date back to the fifteenth century (Witta 1982: 6) but no historical evidence informs us of the nature of those early dances, which are recorded by name only. However, we can be sure that, as the country is rich in folk song and music, it has a wealth of dance.

The dancing which is now known as 'Highland' falls into the category of solo dancing (with the exception of Strathspeys and Reels). In these dances, little attention is paid to the pattern on the floor but importance is placed upon precise execution of intricate footwork. This is by no means a recent focus, as, just as the finishing schools in late sixteenth century France taught deportment and social skills, the fashionable nobility soon came to consider dance as an essential part of a cultured education. European royalty would travel to far countries to be educated or to marry and, as they took with them their own fashions, arts and even musicians, the courts became increasingly cosmopolitan. Mary, Queen of Scots, who danced 'most excellently... gracefully and becomingly, for by the quiet and gentle motion of her limbs, she could express any harmony of the strings' (PV1999.007) brought Scottish dances to France. With reciprocity, the French Renaissance court dances came to Scotland, emerging in her courts and, in turn, her folk dances.

As French fashions became popular in the sixteenth and seventeenth centuries, the basic character of courtly dancing was French. This influence which grew to such an extent that, in 1661, under the auspices of Louis XVI of France, teachers of dancing from all parts of the world assembled in Paris to form the Académie Royale de Dance and to 'formalise... the technique of dance as never before' (Emmerson 1972: 65). They defined the five basic foot positions that were to influence greatly the future development of dancing on the continent. It is not surprising then, that this date is pivotal in the formation of technique in Highland dance.

The nation of 'proud, gallant, warlike' (McLaren 1956: 10) Scots nurtured this influence. Not least affected were the common dances which were described by David Anderson in his late nineteenth century *Universal Ballroom and Solo Dance Guide* as being 'of a very great antiquity although... originally practised by the ancients without any regard for method' (Anderson 1900: 183). This inevitably led to a process of adoption, personalisation and, eventually, ownership of an elaborated and cultured dance style that retained the term 'Highland'. Highland dancing as it was practised before the mid seventeenth century had been distilled through the cultivating influence of ballet technique.

This process of restraint and, to some degree, coalescence resulted not only in the loss or refinement of certain components, but also in what Emmerson calls an 'infiltration' (Emmerson 1972: 151) of a purer form. He argues that 'the cultured foot and leg movements which characterise what is called Highland dancing, distinguish... it in *refinement* and *elaboration* from other dances of the British jig or hornpipe tradition to which it belongs' [italics mine] (Emmerson 1972: 151). This 'refinement' implies a 'purification' of an 'impure' or defective form (*Oxford Dictionary* 1995). Whether or not these developments were elaboration (or simply a clarification of the organic form), the legacy of the cultured foot positions is that they still form the basis of teaching and transmitting the components of Highland dancing today. Emmerson fails to explain how this influence might have passed by the latter two traditions, but he does establish an important dichotomy: the corpus of Scottish Highland dancing has been influenced by European fashion and yet purports, by the very nature of its name, to be typically 'Highland'.

In 1912, an article by Mr Norman Hay Forbes appeared in *The Celtic Monthly* in which 'the Sword Dance, the Reel... the Strathspey, and the Highland Fling' are considered to be 'exclusively Highland' (*The Celtic Monthly* 1912: XX, 209). These are four out of the five dances that form the mainstay of the current Scottish Highland dancing repertoire, the fifth being The Seann Triubhas. Of these five dances, three of them have Gaelic names – Gillie Callum, Rìghil a' Thulaichean, and Seann Triubhas; and the other two are 'Highland', i.e. The Highland Fling and The Highland Reel. The names of the dances therefore place their origins in the North of Scotland. However, the constitution of the current competition dances throws descriptions of the ancients' unrefined dancing into sharp relief, as the emphasis is not so much on the character of the performer, as on the execution of the performance.

Each dance has a different history (and, in most cases, histories) of conception and influence. In order to understand the dances in as accurate an historical and social locale as possible, the remainder of this chapter examines the oral accounts of their origins and employment. This has been done with the following two principles in mind: '*Tradition... is a living thing open to a wide range of new influences which, once incorporated into regular practice, become themselves traditional*' (Purser 1994: 3) and '*Trowth, whither it is trowth o source, style or subjeck, is multi-facetet*' [*italics mine*] (Chisholm 1999: 40).

3:ii The Highland Fling

'A Lowlan' fling' (C., H.R. 1928: 20)

Even those with little knowledge of Scottish dance traditions are familiar with the phrase 'The Highland Fling'. An account of this dance illustrates the difficulties in source evaluation, there being visual, oral or written descriptions. The word 'fling' has often been applied to dance in the Scots tongue. In its earliest occurrences in connection with dancing, 'flinging' was an 'energetic dance' or 'kicking' movement (English 1991: 1). The word seems to have meant a kick or some similar violent movement in the same sense as to 'fling up one's heels or to fling out one's arms' (Emmerson 1972: 181). The implication that a fling was something that required energy and some degree of abandon underlies there being numerous mentions in works of Scottish writers from about 1500. Sir David Lindsay's description of 1528 whereby 'Sumtyme, in dancing, feiralie I flang' (Hamer 1931: n.p.) portrays a liberating activity whereby 'he took a spring and danced a fling' (Hogg 1819: 81).

The term 'Highland Fling' was certainly a step or 'movement in dancing' rather than the name of just one dance (Flett & Flett 1964: 29). However, from the late 1700s, material shows that the term 'Highland Fling' refers to both the name of a solo dance and the name of a particular step used in The Highland Reel. Indeed, in many of the early references one cannot be certain which meaning was intended. One can say, however, that the quintessential component of broad 'flinging' action is evident nowadays in both the solo

Highland Fling and setting steps of The Strathspey. This is likely evidence that the Fletts were noting not two different definitions but one term as used in both a solo and a group context.

One must assume that the term 'fling' was a broad term, which included a number of steps or 'species of movement... [identified by] much exertion of the limbs' (*An Etymological Dictionary of the Scottish Language* 1808: 202) which were defined by their character rather than their composition. One must deduce then, that a fling was a dance or dance movement of a vigorous nature, defined by the characteristic movement of the legs. This categorical description is given in the 1910 *Encyclopaedia Britannica*: 'The name comes simply from the *kick* which is characteristic of the step: the Highlander will dance on each leg in turn while *flinging* the other one in front of and behind him' [italics mine] (*Encyclopaedia Britannica* 1910: 251).

The earliest reference to a specifically 'Highland' fling comes in 1794 (Flett & Flett 1996: 29) and from this date onwards references to it are increasingly common. In the same year, it appears in the title of the tune 'The Marquis of Huntly's Highland Fling' composed by Thomas Jenkins, a teacher of Scottish dancing in London, contained in a collection of 'New' Scottish music (Jenkins 1794). There is no indication in the book as to the nature of such a fling. The Fletts assert that 'his choice of title for the tune does imply the existence at that time of some dance or dance step bearing that name' (Flett & Flett 1996: 30). However, this analysis is likely to have been influenced by the Fletts' previous knowledge of such a dance being in the current repertoire. Joan Flett concedes in a subsequent unpublished article that 'It is possible that

Jenkins himself arranged the dance as we know of no evidence that it originated in the Highlands' (Flett 2000: 2).

The Hon. E. Forbes-Sempill (later Sir Ewan Forbes of Craigevar) brought to light a notebook headed *Frederick Hill's book of Quadrilles and Country Dances, 22nd March, 1841* in which are recorded two 'sets' of the 'Marquis of Huntly's Highland Fling'. According to Sheila McKay, born in 1902, the seventh generation of dancing teachers in her family, this was 'the *really old* dancing... that was all lost, definitely lost' (VD114b). She claims that 'The Huntly Fling... was danced in 1745' by her great-grandfather⁵ and that, although there are similarities to the solo dance which is danced today to the tune of the same name (SA2003.037; SC2003.003), they were different dances.

According to McKay, the two dances had 'lots, lots of differences [as] the steps were executed in *a different way*... entirely different... Maybe some of the movements are the same, (your toe-heel and your hop), but done in *a different way now*' (VD114b). Ex-world champion and examiner Janet Gardner confirms that the Marquis of Huntly's Highland Fling was composed of 'Basically Highland Fling steps ... you always had extensions and *you had toe-heels* ... your basic work, but *a different way* of doing it' (SA2003.034).

The connection between the two dances is still evidenced in the name of an individual step, 'the Huntly' (SA2003.037), within The Highland Fling. Although not widely danced in competition or even recognised by the SOBHD, 'the Huntly' is now being resurrected by the SOHDA who call it a 'lesser-known'

⁵ The relation and the date do not correspond.

step (SOHDA Dance Sheet 1). Charlie Mill, born in 1940, recalled learning this, and other old steps, from his dancing teacher: 'the steps she was teaching me, I would say, were what her mother taught her twenty/thirty years before and it was... names [of steps] in The Fling like, The Huntly, The Puzzler...' (SA2003.037). He also claimed that steps he saw performed in New Zealand (with the New Zealand Academy of National Dance) had been passed down and had survived in a recognisable form: 'The steps that they did... they were all there with little variations...' (SA2003.037).

If a 'Highland Fling' was composed for the Marquis of Huntly, it could refer to a caper or similar 'flinging' in which the springing was somehow typically 'Highland' in a nature similar to the 'energy' of English's definition (English 1999: 1). Indeed, in *The Scottish Gael*, James Logan mentions 'the style called the Marquis of Huntly's' (Logan 1831: II, 314) implying that the named dance was one of a genre, rather than a unique composition. In the Hill manuscript, the same version is included with two other arrangements of 'flings' (Hill 1841).

David Allan's illustration from 1796 shows 'A Highland Fling' to be a group activity, and one that seems to have no prescribed steps (See Plate 3: A Highland Fling by David Allan). The male dancers, particularly, seem to be flinging one leg around the other which supports and is poised on the ball, ready to spring or hop.

Plate 3: A Highland Fling by David Allan



In the same way, in the following plates (Plate 4: Frontispiece from *A Companion to the Ballroom* (Wilson 1816) and Plate 5: Scotch Reel from *A Companion to the Ballroom* (Wilson 1816)) each dancer's weight is placed on the supporting leg, as the other leg is placed either in front or behind. All of the male dancers depicted have their arms raised, most likely for balance, resulting in every limb seemingly flung out from the body with little regard to space or restriction. The connotation is one of high and violent movement in the same sense as the 'flinging' of a horse (*An Etymological Dictionary of the Scottish Language* 1808). Social historian R.N. Goss gives these actions 'characterised by the kicking of the free foot into the air' the term "'home" flings' (Goss 1993: 73).

Plate 4: Frontispiece from *A Companion to the Ballroom* (Wilson 1816)



Plate 5: Scotch Reel (detail) from *A Companion to the Ballroom* (Wilson 1816)



In the above illustrations, the ladies have a more graceful demeanour than the men, as they too balance on one leg, but with the other not so much 'flung' but kept close to the ground for balance. The impetus for that wild

exertion seems to be driven by the male in each case. The female partners, holding their skirts, resting hand on hip and with altogether lower elevation seem to be party to the male's flinging of the limbs, and, one assumes, could have been flung by him. Whatever the protocol, the character shown by the males in each of these illustrations is reminiscent of the earlier literary descriptions of the sixteenth, seventeenth and eighteenth centuries. Prior to the early 1800s there is no known reference to The Highland Fling as a specific solo dance and there is still a degree of ambiguity with the use of the term in that period. The twenty-first century reader must therefore take care not to impose his own impression of a solo dance onto a reference that may in fact pertain to a reel movement or, indeed, a style of execution.

However, it has been suggested that at the beginning of the 1800s, the words 'Highland Fling' were so often associated with reels that they were considered to be synonymous. The Fletts suggest that the initial 'flinging' or 'shedding' step of the solo dance as it is known today, was most likely a form of movement that evolved from the reel tradition:

This step, consisting entirely of *fling* movements, is common to all our collected versions... as the first step... In view of this we are tempted to suggest that this was the original... *fling* step, referred to so frequently in the reel (Flett & Flett 1996: 112).

However, the term, although common throughout the history of Scotland's solo and social dancing, seems to be so broad that it is a general, rather than a specific term.

The first source in which the reference is clearly to 'a solo step-dance' occurs in Mozart Allen's early nineteenth century *Ballroom Companion* (Allen 1824). MacTaggart's *Gallovidian Encyclopaedia* considered the 'Hielan Fling' to be 'A rustic dance' (MacTaggart 1824: 263) which was common all over Scotland (Flett & Flett 1996: 31). However, at that time there was still some degree of freedom as to what was described as a fling, as the pre-existing Scots adjective was still in use (*Dictionary of the Scots Language* 1877).

In her *Memoirs of a Highland Lady*, Elizabeth Grant mentions that at Kinrara on Speyside c.1804, she learnt, among other steps, 'the single and double fling...' (Grant 1898: 34). There is no other source from that time that would elaborate on what these might have been, but Grant does later describe her father's dancing in 1813 as 'peculiar'. His performance was something of particular note for its creativity and interpretation, as he had 'a very quiet body and very busy feet [which] shuffled away in double quick time steps of his own composition, boasting of little variety, sometimes ending in a turn-about which he imagined was the fling' (Grant 1898: 34).

The following engraving (Plate 6: Engraving of a Theatrical Highland Dancer, 1846) shows another 'imagined' fling that was not so much a personal performance as a public one. The feathered bonnet, tartan bodice and thistle-rich scenery are indicators of supposed Scottishness. It might be surmised that such a 'Highland' fling was either an impression of, or tribute to, something descriptive of the Highlands or most likely the Highlanders of Scotland. The movement depicted can therefore be interpreted as typical either in its actual performance or in its allusions. As in Allen's depiction, the dancer, although

more refined, is using opposite arms and feet 'to balance fair in ilka quarter'
(Burns ed. Barke 1990: 550).

Plate 6: Engraving of a Theatrical Highland Dancer, 1846



Towards the end of the nineteenth century, and certainly by the beginning of the twentieth century, the term 'fling' refers to a specific solo dance performed to a Strathspey tune. There was no mistaking the difference between the uses of various fling movements. This is made clear in the instructions in an edition of *The Celtic Monthly* from 1912 which state expressly that 'the Highland Fling... must never be confounded with the skips and sprawls of the so-called Highland Schottische or Fling in the society ball-

room' (*The Celtic Monthly* 1912: XX, 209). It is clear that by this time in the vocabulary of Scottish dance, The Highland Fling was established as a solo dance and that the use of the verb 'to fling' was on the decline. It was to be usurped by what proved to be the most distinct, most revered and most imitated aspect of Scottish dance for the next one hundred years.

The Highland Fling is in good company amongst the solo dances of Scotland with regards to the mystery surrounding its inception and its nomination for 'the very first Highland Dance' (Lowe 1976: n.p.). The Southern California Highland Dance Association (SCHDA), in an over-exuberant claim of antiquity, promotes an unsubstantiated and uncorroborated theory that the dance dates back to the time of the Roman occupation of ancient Caledonia. There are, however, two principal recurring legends concerning the origins of The Highland Fling. The first is that the dance was inspired by 'the sight of a stag curvetting in the distance' (SOHDA 1994: 23) and the second is that it was a dance of joy performed at the end of a victorious battle (SOHDA 1994: 23).

The first and most prolific theory seems to be supported both by strong belief within the oral tradition and by the actual content of the dance and the description therein. It is generally agreed that the dancer depicts the stag: 'it's the stag they're imitating' (SC2003.003). The movements of the feet are commonly thought to suggest 'surefootedness' (VB056) or 'lightfootedness' of the animal on the hills (Mill 1999: 2; 1997: 10). The dancer's steps may also be mimicking 'the antics of a love-struck stag' (SA2003.034) or 'the stag's love play' (Mill 1999: 2; 1997: 10). The grouped fingers and raised arms of the dancer are said to represent 'the antlers' (SA2003.034; SA2003.035; Mill 1999:

2; 1997: 10). The following two illustrations (Plate 7: Highland Dancing at Crathes Castle and Plate 8: Stag from *Wild Sports of the Highlands* (St. John 1948) illustrate the similarity between the poise of the stag and the dancer, as the antlers and shanks are reflected in the flinging movement.

Plate 7: Highland Dancing
at Crathes Castle



Plate 8: Stag from *Wild Sports of the Highlands* (St. John 1948)



This theory has survived in essence, but in no great detail. One of the few elaborate accounts is given by G.B. Lowe, who, in his 'Random Thoughts on Highland Music and Dancing', claims that the story originated in the Forest of Mar, when one day:

Alastair McDuff... was sitting by the River Dee initiating his grandson, Malcolm, into the mystery of the bagpipe chanter. The sound of the chanter was broken by a rustle close at hand, and from the thicket there sprang a stag, lithe and ruddy, with antlers strong. With a swish and a watery splash it leapt over the stones of the river bed, and disappeared into the forest on the other side. 'Ye couldna dae that' cried the old piper to his grandson, and the young lad replied 'I could', and suiting the action to his words, he danced... as the stag had done, his arms and hands above his head, in imitation of the stag. Winter came, and by the glow of the log fire, the old man played his pipes, and the young lad recaptured the movement of the stag. So well did the boy dance that when there was a gathering of his clan he was called upon to do this stag dance to the music of the pipes, and the dance became known as 'The Fling'. This dance passed down from one generation to another through the ages, and is the dance we know today as the Highland Fling (Lowe 1976: n.p.).

This is by far the most detailed account, and gives weight to the supposed origins of the dance. However, the details of the place, names and the conversation would surely have been remembered, at least in part, by another source. There is no such corroboration, however, and although reference to the stag is common when explaining the arm movements the specifics given in this account cannot be relied upon any more than any other.

The SOHDA's official stance on the 'history and origins' of The Highland Fling is that it 'emanated [sic]... around the late eighteenth century' having been 'derived from an old shepherd who was sitting on the side of a hill... witnessing a stag pirouetting a short distance away...[he] asked the youngster if he could attempt to imitate the noble animal...' (SOHDA Website 2003). This tale evidently shares its roots with Lowe's account and may derive from it. There is still a notable absence of specific detail.

Janet Gardner gave a similar account: 'Legend has it that a shepherd teaching his son the pipes noticed a stag on the hilltop. The boy raised his arms

in the air like antlers and danced to his Father's amusement' (SA2003.034). Her account also accords with an article by an amateur dance historian (Shand 2000). Billy Forsyth, current President of the SOBHD, provides a similar account of the dance's history:

The Fling story [that] has always been the one that made most sense to me [was] ...The guy and his son watching the stag on the skyline and watching the stag jumping up and down. And him [the father] asking his son to try and describe this in dance and [the son] doing the same thing [as the stag]. When you go through the movements of a Highland Fling, you can see the similarities and the obvious one [is] ...the stag's head and antlers and the fingers (SA2003.036).

However, he admits that he has read Lowe's theories, and so his information is not necessarily from a different source. Interestingly, however, he does comment that

If you go to different parts of the country, certainly back in the earlier days, you had found dancers that never did that [hand and finger position]. They always did it as a closed... So they still had the same shape but it didn't describe the stag the way I would have described it with the antlers up (SA2003.036).

This could be indicative of two things: that the myth was not perpetuated in those areas and the element of imitation within the dance disappeared or that it was never known and therefore the dance had other origins.

It has also been suggested that 'when the male dancer raises his arms above his head and leaps up and down, he is enacting the movements of an ancient stag - a... link with the Druids for whom the stag was a symbol of

manhood' (Campbell & Martine 1973: 6)⁶. Deer legends are common throughout Celtic Britain, and it was recorded that in Perthshire, an image was uncovered which depicted a spirit wearing what appears to be a deer's head with a full rack of antlers as a headdress (MacLachlan 1998: 81). The image of 'the spirit of the wild or forest' (MacLachlan 1998: 80) depicts the arms as raised up at the sides and the feet are turned out and in the 'round-the-leg' or 'shedding' movement (SOHDA 1994: 42). The position is unmistakably like that of even the most modern interpretation of The Highland Fling and one cannot therefore depart from the image of the raised arms and 'flinging' legs as the most archetypal description of the stag.

This theory of evolution, although attractive, cannot be proven to be the inspiration for the dance. While the dance must have originated somehow, there is no means by which one can prove that it was an organic tribute to the stag or that it was created by one person. However, the perpetuation of the stag theory makes it the forerunner in the quest for authentic explanation.

The second principal theory is that a fling was 'stepped' by a 'mountain man' upon his targe, the round metal or hide covered shield (Milligan & McLennan 1950: 10) or that of a vanquished foe (SOHDA 1994: 23). One can understand the quick footwork and dexterity of the dancer when you realise that most targes carried a pinpoint sharp spike of steel projecting some five to six inches from its centre. A false or careless step could be more than painful. This fact is conveniently forgotten or omitted by other sources perhaps for reasons of

⁶ Campbell & Martine also suggest that there were links to 'manhood' within the reel as 'Two men setting to and turning one another... represent two stags battling for the attention of a doe' (Campbell & Martine 1973: 6).

incredibility. It is more likely that the spike was pushed into the ground thus providing the dancer with a firm platform.

Milligan and McLennan call The Highland Fling a 'warriors' dance and one which was 'accurately done on so small a spot the intricate stepping... [being] supremely difficult' (Milligan & McLennan 1950: 10). The general belief that there was a connection between the origins of Highland dancing and 'warriors' (SA2003.034) is still held, without substantiation, by many dancers and teachers. Certainly the idea of The Highland Fling as a victory dance would account for the main characteristics of the dance which it is generally agreed is performed on the spot or with minimum travel (*The Celtic Monthly* 1912: XX, 209; Taylor 1929: 21; McLennan 1972: 11-12; SOBHD 1993: 31; SOHDA 1994: 23; Mill 1997: 10; SOBHD Website 2003).

On the subject of this theory, Emmerson writes, 'This reasoning may well be nonsense, like most of these tales, but it seems to highlight a characteristic of the dance' (Emmerson 1972: 183). D.G. McLennan's notion that the dance was only performed on one spot after the 1890s is unlikely to be true. To 'dance in one place... [and] not to move' (SA2003.035) is still considered the most important, and certainly the most distinct, element of a Highland Fling. The idea that a fixed dancer was a good dancer has been perpetuated and is still maintained by the Scottish adjudicating bodies, judges and teachers. The idea that dancers should be able to dance a Fling on a bonnet, or the equivalent circumference is still found in accounts today, such as that of 1930s dancer Marie Livingstone, who remembered how she was taught:

When you did The Highland Fling, you were supposed to do it on a Balmoral.. [bonnet] ...when we were on stage or anything [we] fix[ed] on something away beyond people... that were watching you, and that helped you stand... in the one place (SA2003.035).

Similarly, Forsyth recalled the instruction he received from renowned champion Willie Cuthbertson:

He... says 'What you go and do, is you go back and you draw yourself a circle... and you danced on that spot or at least within that area... People would give you a *reason* for doing things. It wasn't just a case of 'in that first position all the time', there was a reason. It was a dance that's got to be danced within that spot. It's got to be danced within that area (VD114b).

It is interesting to note that Lowe, in his tale of Malcolm McDuff's first fling, says that the boy danced 'from rock to rock' (Lowe 1976: n.p.), thereby balancing and placing a supporting leg on each rock, while dancing. However the Fletts report that in the early 1900s J. Scott Skinner (a professional dancer and son of a fiddler and dancing master who achieved fame as a fiddler and composer) was supposed to have been responsible for perpetuating the myth of dancing on a Balmoral 'rather as a joke' (Flett & Flett 1996: 110).

A similar reference is made by R.H.C. in his short play, 'An Ameteur Dancin' Maister', in which the Maister says 'ye maun stan' yer grun' like a sodger... a gweed dancer wad dance... on a peat. Ye wad need a sod...' (C., H.R. 1928; 18-19). Interestingly, Dr Frank Rhodes, in 'Step-Dancing in Cape Breton Island, Nova Scotia', his appendix to *Traditional Step-Dancing in Scotland*, recorded that 'solo... setting steps [were] ... performed on top of a block' (Flett & Flett 1996: 191). However, the dance is unlikely to have *evolved*

from feats of dancing on bonnets, peats, sods or blocks, but is more likely to have inspired these tales of good practice which have perhaps survived due to an assumed antiquity. This has been found to be a recurring theme in the transmission of The Highland Fling for the past hundred years. Records show that, at the turn of the twentieth century, one dancing master would not tolerate a wandering dancer but, 'having spat on the ground, would command his young pupil to 'dance on that and dinna move aff it!' (Lockhart 1986: 73). It is this hopping on one foot while the other is moved to predetermined positions that Goss terms 'setting or capering' (Goss 1993: 73).

Both the stag and targe theories do fit with the belief that Highlanders formerly developed their most characteristic dances for the purposes of strengthening the legs of young warriors (VB056). Emmerson, who provides different versions of The Highland Fling for 'ladies' and 'gentlemen', states that 'The execution of the Highland Fling is all very much a matter of style based not only upon attitudes to male and female but also upon the decidedly differing physiques and sexual rôles' (Emmerson 1972: 184). As a certain strength of limb was required for the characteristic high elevation of The Highland Fling, a more fitting adaptation for ladies was danced. This required a lower elevation not least for reasons of decency.

In the previous illustration (Plate 6: Engraving of a Theatrical Highland Dancer, 1846) the skirts are shown to be below the knee and the feet are barely off the ground. This is certainly in keeping with David Allan's portrayal of female dancers (see Plate 3: A Highland Fling by David Allan). Such a graceful interpretation was perhaps indicative of a shift in emphasis from a

representation of the proud and strong stag to a slender and graceful doe. The style of the dance and nature of the narrative must therefore also have changed accordingly, although the nature of these changes is left to conjecture.

In whichever circumstance The Highland Fling was danced, it was undoubtedly a solo activity but was reliant on audience appreciation of its display of characteristic dynamism. Whether it was Elizabeth Grant's father, keen to compose his own fling at a Harvest Home, the lads keen to perform at the country balls, or the warriors flinging with triumph on the shield of their foe, the encouragement and marvel of the spectators has always been crucial to the inspiration of the dancer.

However, there remains one other theory: that The Highland Fling owes its origins to the Strathspey music of the eighteenth century. In the late 1920s this theory was raised by R.H.C, and does not seem to be tackled again until Emmerson in the 1970s, only to be quashed by Joan Flett in the 1990s. Piper and dancer Catriona Macaffer's dissertation gives a twenty-first century musicologist's view (Macaffer 2002). The Strathspey connection lacks the mysterious attractiveness of the aforementioned Highland folktales.

R.H.C. offers the explanation that the root of inspiration for The Highland Fling was 'dancers keeping time to the Strathspey tunes played on the bagpipes or the fiddle' (C., H.R. 1928: 11). This is backed up by a contemporary account found in an article for the *Encyclopaedia Britannica* which states that 'The Highland fling was originally a step performed to the music of the Strathspey, though it was soon transformed into a dance by itself (*Encyclopaedia Britannica* 1910: 251).

Emmerson refers to the conception of The Highland Fling as 'an arbitrary collection of reel steps' (Emmerson 1972: 183), which would certainly bridge the gap in our understanding of the social 'fling' (*Dictionary of the Scots Language* 1877) and the solo species of dance that has survived. If this theory is based in truth, there is no such contradiction in terms, but rather a development from a social to a solo dance. The first written record of Strathspey tunes was in the mid 1700s under the title 'Strathspey Reels' (Skinner 1890) and the first published accounts of associated dance steps are found in collections such as Mozart Allen's *Universal Guide to Ballroom* of 1824 and David Anderson's *Ballroom Companion* of 1894. Emmerson goes on to say:

Whatever the precise details, we are clearly dealing with a class of reel setting step associated with the Highlands; in all probability the reel in Strathspey style. In any case, we may reasonably conclude that the use of the term 'Highland Fling' often meant what we have called Highland 'capers'... This interpretation is reinforced by Lord James Murray in a letter to his mother in 1814: 'A guest... was very anxious to see the Highland Fling and accordingly I got... some others to figure in a Reel (Emmerson 1972: 182).

It is unclear whether or not he meant that it was a component of individual Strathspeys and Reels as danced by more than one dancer, but if this was the case, this description would be alone in its prescriptive implication. It is also possible that such flinging was danced to both Strathspey and Reel rhythms, but this is not substantiated by any contemporary sources. It is more likely, as Emmerson concludes, that the fling was to be found as a reel setting step within a Strathspey: 'it seems inevitable that dancers would develop

enchaînments of reel steps... as solo dances... with arbitrary arrangements without names' (Emmerson 1972: 182-3). This implies that the individual would adopt his own sequence of steps. These arrangements would be varied in content but similar in character, as they were 'flung'. The Highland Fling, notably without a Gaelic name (unlike The Sword Dance, The Seann Triubhas or The Reel) was therefore just an arrangement of steps and warranted no distinguishing title.

It would have been an inevitable part of dance evolution for dancers to combine reel steps as individual solo dances. Goss implies in *The New Companion to Scottish Culture* that it was as a result of such origins that 'The number and combination of fling steps is almost infinite' (Goss 1993: 73). Such measures would certainly have been influenced by the particular rhythms of the Strathspey. The complementary nature of the strong, steady music is paralleled by the repeated and symmetrical movements that are evident in historical accounts of The Highland Fling.

As a footnote to their theories on the origins of The Highland Fling, Flett and Flett write

We can only speculate that it is a compilation of some of the steps used in the Strathspey portion of the Reel. It may have evolved so that the solo dancers could display their skills at the dancing masters' "finishing balls" other than in the Reel which required a number of dancers (Flett & Flett 1996: 32).

There are reports of such spectacles at balls in the nineteenth century when, at an interval in the general dancing, a dancer would 'entertain the

company with an exhibition dance, very often the Highland Fling' while young lads in every parish assiduously practised the steps, and were ambitious to shine as performers' (C., R.H. 1928: 11). The dance was performed for exhibition as the dancers are keen to 'astonish the lads an' the lasses' as they 'cut a dash at the... ball' (C., R.H. 1928: 18).

The emphasis of the performance would most likely have been an entertaining portrayal of the great stag or the victorious warrior, rather than the execution of certain technical movements. And these roots seem even more plausible since the modern Highland Fling is indeed performed to a Strathspey tune. However, due to a lack of written or even anecdotal evidence, the Fletts just as quickly nullify this statement by prefacing it with slightly scathing realism: 'It [The Highland Fling] may equally well have been composed by a dancing teacher in the Lowlands or even in London' (Flett & Flett 1996: 32).

Macaffer offers an optimistic approach to the matter, asserting that 'The fancy steps used in the reels... developed into competition show dances' (Macaffer 2002 23) and 'the teaching of the Highland Fling and the Reel went hand in hand' (Macaffer 2002: 13). However, she does not limit the influence of the reel to The Highland Fling, but believes that 'the Highland dances evolved from the old Scotch reels, step by step, dance by dance and year by year', citing the dances as The Highland Fling, The Sword Dance and The Seann Triubhas (Macaffer 2002: 23). She also asserts that a solo dance comprising of setting steps, alternated with a travelling reel figure 'would have been... in Scotland before Highland dancing competitions were introduced' (Macaffer 2002: 11).

'Considered as an excuse', writes R.H.C., 'the Highland Fling has great qualities, conducting as it does to elasticity of step and grace of carriage. It also has the advantage that it can be practised alone, whereas the reels require a company of four at least' (C., R.H. 1928: 12). Rhodes makes a similar connection between the two dance traditions:

In... the solo dances, including the Fling, the various setting steps alternated with a travelling figure called a 'Reel'. In this the dancer danced round in a circle clockwise during the first half of the music... The older form was for each setting step to be danced only one way; it was not repeated starting with the other foot as is usual in the Highland and Hebridean dances... The dancing round the block of wood in the competition which Hugh McKenzie recalled was probably just the Reel part of the solo dances (Flett & Flett 1996: 191).

However the sparse anecdotal evidence and absence of historical documentation offers little proof.

The SOBHD recognises that the Highland Fling is 'a combination of a number of basic steps' (SOBHD 1993: 31), its guidelines referring to the component parts of movement, rather than the composition of the dance as an amalgam of reel steps. Dance researcher Mats Melin shares the opinion that the solo dances of today 'originally evolved from reel' (Macaffer 2002: 11) and Macaffer too believes in the shared roots of the Fling and the Reel:

Nowadays, there are no reel steps that are identical to those of the Highland Fling. This is mainly due to the different time signatures and tempos of both dances. However, in the past there was a time when both dances shared the Strathspey rhythm (Macaffer 2002: 12)⁷.

⁷ Strathspey time signatures are in 'Common' or 4/4 timing, whereas a Reel time signature is 'Half-Common' time, which gives the player the impression that the Reel tune is double the speed of the preceding Strathspey tune, although the actual tempo may not change.

She speculates that The Highland Fling derived most, if not all, of its steps from The Highland Reel, evolving as a compilation of setting steps. Joan Flett puts a date to this theory: 'Until the early 1800s the Highland Fling was simply one step used in the Reels. The solo dance was probably an arrangement of various Reel setting steps' (Flett 2000: 4).

Such development could have had two primary purposes. Firstly, the talented and most expert dancers would have had an opportunity to display their skills and strength in a solo manner. Secondly, the dance would have been a vehicle for teaching, learning and perhaps inadvertently preserving a collection of setting steps for use in reels. These theories cannot be substantiated by any evidence other than the presence of reeling and setting (or travelling and flinging) which still characterises Scotch reels.

The Highland Fling as it survives today was not always called by this name. The Gillis family from Gillisdale, South West Margaree, Cape Breton, remembered a dance executed by Mr John Gillis's grandfather (from Morar) who had been taught dancing as a child in Cape Breton Island by an itinerant tailor from Scotland, Donald Beaton: 'the fling' (Flett 1957; UI2001.004). This term has been passed down the family from the mid-1800s as has the knowledge that it refers to a 'Highland Fling' whose name has been shortened due to its familiarity. This does not prove, that the 'flings' of the middle ages were something of specific composition, but it does signify the trend to use the term 'The Fling' to mean one dance: 'The Highland Fling' (SOBHD 1993: 31; SOHDA 1994: 23).

3:iii The Sword Dance

'Manly play with weapons' (Jaide 1936: 1)

McGuire, in *Scotland's Dances*, describes what he believes to be the current perception among Scots of the origins of their national Sword Dance: 'a hairy war-like Highlander, arms raised aloft, emitting wild guttural sounds, as he leaps over and around the naked blades of claymores!' (McGuire 1994: 9). Similarly, Thurston observes that 'the very words "sword dance" conjour up the image of a kilted warrior dancing over naked blades' (Thurston 1954: 6). Although the Gillie Callum is a dance which is particular to Scotland, the style, and perhaps its roots are not.

Stephen D. Corrsin's survey of the history of European styles of linked sword dancing opens with the following statement:

One of the most far-reaching and dramatic styles of folk dance performance throughout Europe during the past six centuries has been sword dancing... Cultures throughout the world have developed fencing, mock combat, or Pyrrhic sword dances... The oldest records date back to the late Middle Ages, to the fifteenth and perhaps the fourteenth centuries (Corrsin 1997: 1).

Indeed, wherever there have been swords, one can assume that antics with swords were not limited to the battlefield: 'The common proverb teacheth us to say, "'Tis hazardous with sharp-edged tools to play"' (Gibson 1880: 117). However, despite man's natural fascination with such drama, Corrsin also argues that swordplay and sword dancing are by no means

ancient, timeless myster[ies]... deriving from the magical rituals of primitive humanity, insusceptible to historical study. It [sword dancing] is a relatively modern phenomenon, widely distributed from the mid-fifteenth century on, and popular in different eras in many parts of western, northern and central Europe and Britain (Corrsin 1997: n.p.).

There have been many references to early sword dancing across Europe since the 1300s. Most are a linked style of Pyrrhic, often called 'hilt and point' or 'chain' dances, with drawn swords. Scotland's solo sword dance is a different and rare form whereby the dancer avoids coming into contact with the swords. We are offered some indication of Belgian and Dutch dancers who, in the 16th Century, 'danced *over* [or through] the swords' (Corrsin 1997: 21-22). However, there is little record of similar dancing in existence in Scotland, or in the rest of the British Isles before the mid 1700s. An Elizabethan play cites the 'sword dance', and the diaries of two members of a single Lancashire gentry family mention dances in 1638 and 1712, but these are the only published references to sword-dancing in Britain from the sixteenth to the early eighteenth century (Hutton 1994).

Corrsin clarifies the relative dearth of reliable sources that have been found to record sword-dancing in the British Isles prior to 1750:

a sizeable amount of evidence on other British dancing has been preserved... on celebrations, calendar customs, and so on... [but] If there is almost none on sword-dancing, then the most reasonable assumption is that there was little to preserve (Corrsin 1997: 85).

The first detailed account of a Highland sword dance so far discovered comes from the celebrations in Edinburgh for King James VI of Scotland and

the Danish princess Anna after their marriage in 1590. The records show expenses which were 'debursit upone the suord dance and hieland dances' which included 'hattis of flouris,' 'bellis,' 'belis & buccrum,' and 'hei land menis claithis' (Mill, A.J. 1924: 200-201). According to the inventory, one can assume that there were seventeen Highland dancers and twelve sword dancers. The description is not unlike that of the Morris dancers of that time who produced rhythms from the bells attached to their costumes (*Encyclopaedia Britannica* 1910: 250). However there is no mention in the records of the style of the dances other than it being a group activity and, since they were in costume, it is likely that the performers were from somewhere other than the Highlands, or they were attaining to be something of antiquity.

An account is given by MacIan, in *The Highlanders at Home*:

The Highlanders have... the Sword Dance. The original name of the tune was 'Mac an 'orsair' which, with the mode of dancing... has disappeared... As danced by old men, in the course of the dance they took up swords and made certain flourishes as if fighting. It was also called 'An baiteal' and performed by 13 persons at Perth in 1633 before King Charles (Dalyell 1849: 104).

Similarly, a report from 1845 describes

Thirteen of our brethern of this our calling of Glovers, with green caps... strings... ribbons, white shoes, with bells about their legs, schering rapers in their hands, and all other abulyiment, danced our sword dance with many difficult knots and alla fallajessa, five being under and five [sic] (Dalyell 1849: 104).

However it is clear that, although the dance was 'our sword dance', that was common to Scotland at the time, it was a hilt-and-point dance rather than a crossed-swords step dance. Dalyell admits that

There is little intelligible matter to the moderns in this description. The dance itself may have adopted different characters in different times and places... [and] the dance of the nineteenth century has shown [but] very faint resemblance to that of the seventeenth (Dalyell 1849: 104).

'The Ancient Caledonians', wrote James Logan in *The Scottish Gael*, 'had a sort of Pyrrhic dance over swords, which is not yet entirely unknown but the Gillie-Callum, which generally terminates a ball, is supposed to have but a faint resemblance to the ancient sword dance' (Logan 1831: II, 302). As he gives no source for this statement it is suggested by Witta that Logan was

likely to be referring to Tacitus in *Agricola Germania* (A.D. 100) in which the author describes European tribesmen dancing amidst swords and spears that are levelled at them. These tribesmen were not Celts, they were Germans. The Caledonians may well have had such a dance, but no one ever reported seeing it (Witta 1982: 89).

This is confirmed by Fittis, who describes the Germanic manifestation to be a 'public diversion' not unlike that found in Scotland:

[The] young men who, by frequent exercise, had attained to great perfection in that pastime... dance among the points of swords and spears with most wonderful agility, and even with the most elegant and graceful motions. They do not perform this dance for hire, but for the entertainment of the spectators, esteeming their applause a sufficient reward (Fittis 1891: 182).

Milligan and McLennan confirm that hilt-and-point sword dances were 'fairly common' in Scotland, being recorded as early as the beginning of the 17th century and explain that a group of sword dances may have had a resurgence in popularity in the form of the Lochaber and the Argyll Broadswords. These, being danced by four men, are described as beginning with 'swaggering movements' (Milligan & McLennan 1950: 10), the swords raised horizontally above the dancers' heads, then laid on the ground and stepped over.

This over-the-crossed-swords type of dance seems to have had no relationship to the hilt-and-point tradition as evidenced in *The Sword Dance of Papa Stour* (Johnson 1926: 8). G.B. Lowe of Angus, whose dancing spanned most of the twentieth century, conjectures about the historic link between Pyrrhic dances of Scotland and the present-day Gillie Callum:

It is thought that the sword dance was originally performed by a dancer in the centre of a circle of eight other pyrrhic dancers who introduced swords into their dance. The sword dance is Celtic in origin, but the Scandinavians also had an ancient sword dance and probably some of its steps have come to us through the Shetlands, which were long under Viking domination. One of the ancient Scottish sword dances features the Seven Champions of Christendom who, each with a drawn sword, danced a short solo... Such sword dances were quite popular in Scotland 400 years ago (Lowe 1976: n.p.).

The earliest reference to a solo 'Sword Dance' also had a dramatic function as part of a playbill for Drury Lane Theatre on New Year's Eve, 1733. 'A New Scotch Sword Dance by Baker in a Highland Character' (Emmerson 1972: 190) was probably a dance similar to that recorded by *The Celtic*

Monthly of 1900 which described it as 'generally performed by one person over two naked swords laid across each other on the floor' (*The Celtic Monthly* 1912: IX, 92). Indeed the Scottish sword dancers of old do not seem to have indulged in intricate choreography so much as mastery.

Dalyell described 'A sort of tragi-comic savage dance, called the Dirk Dance... exhibited as of native origin, for the first time, at [a]... competition [in]... 1841' in his *Musical Memoires of Scotland* (Dalyell 1849: 105). However he also adds that 'Whether it has been transmitted from earlier times or is merely of modern - very recent contrivance, as some assert - may be questioned' (Dalyell 1849: 105). MacIan records that 'The Highlanders have a dirk dance, now almost forgotten' (MacIan 1848: n.p.) which he notably fails to record or describe, and Fittis similarly tells of a Pyrrhic and 'dirk dance' known to the old Gaels, but which dropped out of fashion, and which nobody can now describe (Fittis 1891: 182). With the oral tradition as his source, Fittis asserts that 'The existing *Gilli-callum* which arose... bears... only a faint resemblance to the original sword-dance of the Highlanders of Scotland' (Fittis 1891: 182).

Emmerson offers a connection between the Scottish solo sword dance and the ritualistic dances of antiquity. He suggests that there was a 'central episode in a unique version of the... sword dance with, perhaps each of the performers taking turns in the dance over the swords' (Emmerson 1972: 191-192), even though the Gillie Callum within recent memory follows a Pyrrhic tradition. He draws on Douglas Kennedy's account of the Lochaber Broadwords seen in the Highlands in 1879 which is similar in spirit, if not form, to the solo dance: 'The dance began slowly to pipe music, and grew faster

and faster, the dancers avoiding the rig of swords and never touching the swords on the ground' (Kennedy 1949: n.p.). However, Thurston says of this that 'it would be tempting to see in the dance a transition between the modern over-the-crossed swords type and a far older type were it not for the date, 1879' (Thurston 1954: 70). The solo sword dance was recognisable in its present form by the early nineteenth century.

Dalyell also tells us that the Scottish solo sword dance, known as the Gillie Callum, was 'said to be common in the Highlands' prior to the first recorded public exhibition by a competing piper, John McKay, at a Highland Society piping and dancing competition in Edinburgh in 1832 (Dalyell 1849: 105). It would appear given the frequency of references to a solo sword dance after that date, that it was not long before then that the dance as we know it today came into existence. Dalyell comments that 'So great a novelty could not fail of attracting much notice and receiving much applause' (Dalyell 1849: 105).

Lowe records that D.G. McLennan and his brother Willie, who figured in the Highland Games prize lists of the early twentieth century, danced a dirk dance that was ancient in origin. Brandishing dirks and targes, they performed a mock fight which was alternated with 'step dancing'⁸ which, it can be assumed, was a portion requiring skilled footwork. The dance was handed

⁸ This term has been applied to different forms of Scottish dance through the centuries. The common factor within the styles which have been associated with this term is that there is an emphasis on the *steps* of the feet (Flett & Flett 1996, 1). Lynn McLaren, SOBHD judge and teacher, recalled the term being used in the early 20th century: 'Some people called the Highland dancing 'step dancing' but I've always known it as "Highland dancing"' (STDT Recording 06/10/98).

down to the McLennans by their two great-uncles, who, by 1850, were among the very few who knew the dance and its mime and steps (Lowe 1976: n.p.)⁹.

In 1881, North, in *The Book of the Club of True Highlanders* describes a dance of similar roots, which he calls a 'Gillie Calluin' [sic]:

There appears to have been three methods of performing this dance: first the grand dance used on solemn occasions; the second would be a trial of skill and agility, and the third would be an exhibition by one person, like the modern style (North 1881: 40).

He describes the first as

similar to that... favourite of the Northern Goths and Swedes, wherein they exercise their youth; first, with their swords sheathed and erect in their hands, they dance in a triple round, then with their swords drawn, held erect; afterwards extending them from hand to hand, they lay hold of each other's hilt and point... *pipes and songs* direct the first measure, which at first is slow, but increasing after, becomes a very quick one towards the conclusion (North 1881: 40).

The only link one can make between this description and the solo sword dance of today is the pipe and song accompaniment. Otherwise, the description is more akin to one of the display dances performed for James VI or for Charles in 1633. The second, being a test of 'skill and agility', is depicted as being just that, with no additional explanation from the author. However, in keeping with written descriptions of the solo dance from this point in the late nineteenth century onwards, the third employment of a sword dance 'in the modern style'

⁹ 'The Dirk Dance' as taught by D.C.Mather, a Scottish dancing master who emigrated to Canada in 1899, is recorded by the Fletts (Flett & Flett 1996, 178-184).

is the first written record of the dance which remains in the repertoire of the solo dancer today (North 1881: 40).

It is interesting to note that the descriptions here are not an exhaustive account of the repertoire of steps for a sword dance at that time, but North has selected 'the set which is undoubtedly the best' (North 1881: 40). This implies that the steps provided are complementary, well-balanced and varied, forming a well-rounded performance and giving the student a firm grasp of its style in which any additional steps should be executed.

These are the first accounts of the roots of what survives in Scotland as a solo dance. At what time and in what form a sword dance found its way to Scotland, or evolved here, can only be a matter of conjecture. The records mentioned would suggest that, in its present form, it is probably no more than two to three hundred years old. It is clearly possible that forms of dancing with swords may have been common to other warlike nations, but that there somehow emerged a distinctly Scottish form. The only apparent similarities between the Gillie Callum and the group sword dances of Europe (and perhaps those of the ancient Scottish Highlanders) is a degree of skill and mastery. For want of written records of any detail, oral testimonies must be relied upon to indicate the nature and spirit of the dance. Certainly, in all of the oral accounts which circulate surrounding the origins and employment of the Gillie Callum, one thing is agreed upon: it is a highly athletic male celebratory dance of triumph or joy.

An English rhyme has been preserved as a spoken or sung introduction to a sword dance performance:

Yet we t'increase your honour's pleasures shall,
Adding more triumph to this carnival,
Forget the Muses' Hill, those nymphs, those dames,
And practice with our swords th' Olympic games (Gibson 1880: 117).

It was not the Olympic Games, but the nevertheless equally auspicious Highland Games that were, according to tradition, the means by which the old kings and chiefs of Scotland chose their men at arms. A Highlander's speed of foot was 'ever proverbial and Highland dancing was one of the various ways men were tested for strength, stamina and accuracy' (North 1881: 40)¹⁰. This idea is perpetuated in modern references to the dancing associated with the games as dating 'back to the days of clan rivalries... [which] originated from the practice of clan members meeting regularly to test their physical prowess in preparation for battle' (Hannah 20/07/2003: 16). Emmerson comments that this intra-clan competitiveness was due to 'Scottish Highland society [in which] male dancing proficiency was every bit as much esteemed as male athletic prowess' (Emmerson 1972: 155). He also notes the suggestion that the Highlanders had formerly developed their most characteristic dances for the purposes of strengthening the legs of warriors. In a society of mountaineers, the active use of the legs in dancing would surely have been natural and inevitable and Witta therefore suggests that it was the Highlander's second nature to dance (Witta 1982: 163).

The character of the present-day Scottish solo Sword Dance, in which the dancer crosses two swords (or his sword and scabbard) on the ground and

¹⁰ Other methods of training were, according to Fittis, a Highland Foot-Race, Gael-ruith (which included a hurdle, leap and step) and Mountain Running (Fittis 1891: 183).

performs steps over them and in the angles formed by them, would certainly allow the performer to demonstrate the same skills. However it is now rare for the dance to be performed by men outside the military. It also seems believable that this could have been the case due to the continued relationship between the Highland Games and dancing as a platform for competition. In the same way as the clan chiefs would choose the best men for their retinue, the Scottish regiments used to use solo Highland dancing to encourage the development of stamina and agility, but this has become less common. Although the tradition still survives in some regiments it exists for tradition's sake rather than for any reasons of training (Clement 1994).

There is much speculation regarding the possible war-like origins of the solo Sword Dance. It is interesting to note that there is an unsubstantiated theory that the Gillie Callum, as we know it, is actually composed of specific steps which would have been tailored for training in combat. This is particularly evident in the diagonal motions, whereby the front or 'working' leg is, more often than not, diagonally opposite to the supporting leg. This movement would have best ensured that the soldier would have kept his balance when crossing rough terrain, especially in the dark. The elevation of both arms would have acted as a balance and, should only one arm be raised, it would have been opposite to that of the front or 'working' foot, for reasons of equilibrium. These are certainly clear descriptions of elements consistent within the instructions for the Gillie Callum from its earliest technical descriptions in the late 1800s to the present. Perhaps it was this employment that Dalyell had in mind when he commented that, prior to 1849, there were elements of The

Sword Dance that were 'originally ceremonial... connected with some usages of antiquity now become obsolete' (Dalyell 1849: 104).

The warrior then must have excelled in agility and strength, if he was indeed dancing the first Gillie Callum over sharp swords or The Highland Fling over a spiked shield. However, one source makes a whimsical claim for greater antiquity. Hugh McRae of Skeabost begins his 'Biblical' story (notably in Gaelic rather than Hebrew) 'It was at the time when Noah was in the Ark...' (SA 1953/165/8 and 177/1). The story involves Noah's son Calum, who ventured out of the Ark to find dry land after the flood:

He could see that the waters were going down and down, so that more of the rock or knoll he was standing on was appearing... He was so pleased that he shouted to his father, 'This is dry land!' and he got two bits of wood that the waters had left on top of this knoll and laid them crosswise and began to dance. This was the first dance that ever was danced. And as he was prancing from point to point of those sticks, and Noah was so delighted that he cried out: 'Mo ghillie Calum!' [Calum's my boy!] said he. And that was the beginning... how that dance got its name. And one way or another, whether there is any truth in the story or not, one thing is certain: Noah spoke Gaelic anyway (SA1953/165/8 and 177/1).

Two of the most important elements of Highland culture i.e. religion and tradition, are the main themes of this tale. But whether they were matched in order to preserve or inspire interest in the Bible or in the dance, it is impossible to know. According to the tale, the Gillie Callum was not only first among the Highland dances, but also, by implication, the first dance ever¹¹. The laying claim to the religious origins of The Sword Dance is echoed in the

¹¹ The SOHDA also believes that this dance is 'the oldest of dances' (SOHDA Website 2003; Dance Sheet 2), a claim that is contested but is neither proven nor disproven.

assertion that Gaelic was the first, and God's own, language. Perhaps the message is best understood if one accounts for a third, and perhaps most distinct element of Highland culture: humour.

There is still a degree of wonder that surrounds The Sword Dance today, as it is still common for real swords to be used for performance. Perhaps this is why it is seen as signifying great antiquity, conjuring up a rugged Highlander with high elevation and precise footwork, dancing among the sharp points of two swords laid crosswise on the ground. The intricacies of such a feat are described in *The Celtic Monthly*: 'The person who dances moves nimbly around the swords, dextrously placing his feet by a particular step at intervals between the blades' (*The Celtic Monthly* 1912: IX, 92).

Similarly, Thurston calls The Highland Fling and The Sword Dance 'the Highland dances' (as opposed to reels which are a distinct form of dance) in his preface to *Scotland's Dances*, explaining that 'the Highland dances, by contrast, are mostly display dances, requiring a technique approaching that of the ballet' (Thurston 1954: 6). The description reveals the elements of showmanship, fitness, agility and precision which are evident in this, a solo dance, rather than in reels and strathspeys which are social and therefore inclusive by nature, being less demanding of one's fitness or skill.

However, the connection between The Sword Dance and the Highland clans does not stop there. It is a belief almost universally acknowledged that a sword dance of sorts would have been performed before a battle, and if the dancer completed the dance without touching or displacing the swords with his feet, it was considered to be a sign of a favourable outcome (Thurston 1954:

72). Although there is no historical basis for this, nor any visual evidence, it is not outside the realms of probability that clansmen, prior to battle, would have aimed to complete the dance 'without touching or dislodging the swords with his feet' so that 'the omens were auspicious' (Mill 1999: 2). The myth is even perpetuated by the BBC, whose documentary on the SOBHD 1995 World Championships begins 'Long, long ago before battle, clan warriors danced over their weapons. According to legend, they would be victorious provided no dancers kicked the swords' (VB056). Mary McHarg elaborates on the same legend and considers 'the origin of the Swords [dance] ...a battle dance [in which] ...if they touched the swords it was *a bad omen*' (SX2003.035). This explanation seems plausible, as 'the chief art of today's exponents consists in the dexterity with which the dancer escapes touching one or more of the crossed swords' (SOHDA Website 2003).

The legend, or at least the importance of its message of skill and confidence, is perhaps given more historical credence when North, in *The Book of the Club of True Highlanders* provides us with the first reference to a similar rule within competition. Citing Dalyell as his source, he states that 'Touching the swords was a mark of failure... In competing, as soon as the dancer touches, he should salute in acknowledgement, and then retire from the contest' (North 1881: 40). Such emphasis on precision and proper conduct certainly harks back to these supposed beginnings, and disqualification from the competition echoes respect for the impending death of the ancestral dancers.

An interesting comment appears in Dalyell's records of an event in 1844, when The Sword Dance had only been danced for just over a decade at

Highland Games. He recorded that some of the finalists avoided quick steps in the dance, treating them with caution due to an 'apprehension of touching the swords, which impaired the affect [sic] of the performance' (Dalyell 1849: 105). This emphasises the showmanship that was involved in the performance of the dance, and the consideration for the enjoyment of the spectators.

The same practice remains today, that a dancer is automatically disqualified from the dance should he or she come into contact with the swords (Mill 1999: 2). R.H.C describes the competitor as 'laying himself out' to the mercy of the audience or judges, rather than to opponents or superstition, as he gives 'a display of grace and agility... to show how neatly he can place his pointed toes in the angles of the crossed swords without touching them' (C., R.H. 1928: 8). This explanation of the dance's antiquity seems plausible then, as the chief art of today's exponents consists in the dexterity with which the dancer escapes touching the crossed swords.

There is still a certain amount of superstition associated with dancing The Sword Dance today. A related theory is that it was originally a dance of victory rather than forewarning: 'A warrior... seizing the sword of his defeated opponent placed it on the ground. Then, placing his own sword vertically on top of it to make four equal squares, danced a dance of victory over them' (Rankine 1977: 7-8). This theory is also suggested by R.H.C. (C., R.H. 1928: 8) and is accepted by Forsyth, who considers the dance to be a representation of 'placing your sword over that of your vanquished opponent and dancing a celebration over it' (SA2003.036).

Gardner gives an example of when this might have been the practice: 'The Sword Dance... was done by a warrior returning from battle... the warriors coming back from Bannockburn put their weapons down on the ground and danced over them. There were a few cut feet at the time!' (SA2003.034). This is a tale of the origins of one of Scotland's most distinct dances and one of her best-known battles. The association of two such prominent aspects of Scottish history and culture would imply that memory has perhaps grafted them together, somewhat conveniently, perpetuating the fame of each. This is not to say that it is not true, but the lack of supporting evidence would imply so.

Christina Morrison, a dancer of the 1930s, also suggests the idea of The Sword Dance as a victory dance. However, her theory is that it took place after a duel, probably because it involved only two swords, (rather than the weaponry of a whole army):

When they [clansmen] had a duel... the victor would cross his sword with the vanquished and do a dance... it is a possibility... Maybe when the people from Lochaber who had a battle, they all did theirs, and when the people in Argyll had a battle, they did it their way (SC2003.003).

The suggestion that there were specific dances of victory for each area of Scotland illustrates the geographical extent of sword dancing. However, the humorous image of numerous versions of a victory dance implies that, whether or not the root of sword dancing was on the battlefields of old, the association stresses a playful aspect, outwith the context of real conflict.

It is claimed that Scottish King Malcolm III (better known as Calum a' chinn mhòir or Malcolm Canmore), defeated one of MacBeth's chiefs at a battle near Dunsinane in 1054, (*The Celtic Monthly* 1912: IX, 92; McLennan 1952: 12). The Celtic Prince is said to have danced the very first solo Scottish sword dance, as the exultant hero of mortal combat (Mill 1999: 2). This historic connection between the dance and Malcolm Canmore is still foremost in the minds of some competitors, as Willie Shand explains:

This [dance] dates back to the aftermath of a duel in 1054, between one of MacBeth's chiefs and King Malcolm Canmore. Having put paid to his rival, Malcolm took both swords and laid them in a cross on the ground to dance triumphantly between the blades (Shand 2000: n.p.).

It could be, in the case of Malcolm Canmore, that he was the first to dance over the swords in a battle context. However, it is more likely that the tradition of sword-dancing was already in existence, within the ranks, but was immortalised by the King.

Mill suggests that his victory dance led to a new superstitious awakening of the troops who, from then on, danced before the battle to ensure victory (Mill 1999: 2). The truth is that, since there are no firm dates which refer to the employment of either the superstitious pre-battle dancing or the exultant post-battle celebration, one can only conjecture.

Mill also suggests that there was Christian symbolism within the dance, as the swords would form 'the sign of the Cross' (Mill 1999: 2). McLennan also suggests this when Malcolm Canmore 'took his [defeated] opponent's sword

and crossed it with his own on the ground, symbolising the sign of the cross, and danced over them in *exultation*' [italics mine] (McLennan 1952: 12).

Similarly MacLachlan describes the formation of the swords in more detail:

The sword of the victor is held in the right hand and the sword of the vanquished is held in the left hand. A St. George's Cross... [is] formed on the ground by placing the left hand sword down first in a horizontal manner and then placing the right hand sword perpendicularly over the left hand sword. The blades only are divided, the hilts not being included in the measuring (MacLachlan 1998: 83).

The method of intersecting the swords survives to this day (SOBHD 1993: 34) but symbolic association seems to have disappeared. The links to early Christianity seem dubious. The theme of the dance may have been the triumph of good over evil but that is not to say that it formed part of a religious enactment.

However the idea of the dance having originated from or being representative of exultant victory after battle has survived. North was the first to suggest this theory: 'it is very plausible that the victor placed the two swords on the ground and danced round them in *exultation* of his victory (North 1881: 40). Similarly, tales of '*exaltation* [sic] over... [the] fallen enemy' (Mill 1999: 2), '*exultation*' (SCHDA Website 2003) and '*ecstasy*' (SOHDA Website 2003) are still told in dance histories [italics mine].

Christina Morrison in *Yesterday's Child* calls the dance 'The Gillie Callum Sword Dance' (Morrison 2000: 3). However, when and why the dance became known by the Gaelic name Gillie Callum - the 'lad Calum', or the servant of Calum - is not clear. It is said to have derived its name from a pre-

existing tune of the same name: 'called Gilli-callum from the accompanying tune' (Fittis 1891: n.p.; SOHDA 1994: n.p.; SA2003.034). R.H.C. has theories on the root of the name of the dance having developed into some sort of vocal accompaniment:

The name is usually spelled Ghillie Callum. Other forms of the name are Killie Callum and Killum Kallum. On Deeside in the 'fifties of last century [1850s] a rhyme was often hummed to the tune of Ghile Calum - Keelie Kallie, Keelie Kallie/ Keelie Kallie ower a tree - which, if meant for Ghile Callum, shows a very wide divergence from the Gaelic (C., R.H. 1928: 7).

Dalyell uses the closest spelling to this 'divergence' which is 'Ghille Challaim' (Dalyell 1849: 104) and variants are still used, such as 'Ghillie Caluim' (Aboyne Highland Games Programme 07/08/1999).

This Gillie Calum, was simply a boy or 'the lad' Calum. This could have been anyone - the crack dancer, perhaps, but easily associated with Malcolm Canmore, as Callum is the Gaelic form of Malcolm. Unlike the other two Gaelic names of Scottish dances however, the dance The Gillie Callum seems to bear no essential relation in form or feature to the song with which it is commonly associated. One reason for this might be that the dance was already in existence when it was matched with the tune for reasons of rhythmical suitability, rather than the subject of the song. R.H.C considers this possible:

It [the name of the dance] neither describes nor explains. It is merely stuck on; though at one time there may have been a reason why it was stuck on. It may, indeed, be the name of the tune to which the dance is performed (C., R.H. 1928: 7).

It has been suggested that St. Columba or 'Columcille' became known as 'Gillie Calum' (MacLachlan 1998: 83) and brought the tune of the same name from Ireland to Scotland. This tune may have been Claid-heamh [sic] Cuthullin (North 1881; I, 2), 'a song in which the hero's exploits are recited, to stimulate a Keltic youth to deeds of valour, a most appropriate theme for pipe and voice as an accompaniment to the sword dance' (North 1881: 40). However, such a song no longer being in existence, or recorded in any form, would lead one to believe that it was a precursor to the song 'Gille-Callum' port-a-beuil [mouth-music].

The nature of the dance seems to have originated from a weaponry display or ritual, and, more generally, in association with a battle. If the dance was originally accompanied by a song recounting warlike deeds and heroic exploits it would surely have roused warriors to excellence in arms. This song could easily have been adapted and transmitted as one involving Malcolm Canmore's famed victory. The dance would not necessarily be one that was different but rather a developed one that had changed in employment. Certainly the tune fits the dance perfectly in tempo.

The rhythms of the Gillie Callum, as they were first recorded in the *Drummond Castle Manuscript of Highland Dance Music* (1734), were those of a Strathspey, danced at about the time of a march, with an accent peculiar to the dance; and the quick time with which the dance ends off is the same as that of The Highland Fling and The Strathspey Reel. This class of music is not known to have existed prior to the beginning of the eighteenth century (C., R.H. 1928: 6). One must assume, then, that it was danced to any tune of appropriate

rhythm, since the earliest published version of the tune 'Gillie Callum' does not appear until Bremner's *Second Collection of Scots Reels* (Bremner 1768). There is no dispute that the Gillie Callum is the most widely known and the best suited of all pipe tunes to accompany the dance of the same name. In fact, by the end of the nineteenth century, the dance was synonymous with the name of the tune and it is recorded as the 'Gille Cullum da' pheigin' (two-penny), which refers directly to the puirt-a-beul (Campbell 1895: 352).

According to K.N MacDonal, Gillie Callum was originally a song dating back to the eleventh century, having been composed to ridicule the tax collector (Thurston 1954: 60). This theory would certainly fit with the words of the song, assuming that the tax had been imposed by, or was 'collected' by, the Callum of the lyrics. This Callum was no doubt famous (or infamous) in his own right for there to have been a song about him. The song's survival is testimony to the fact that it was either politically astute or socially entertaining. It may simply also be the case that, having started off as a simple nonsense rhyme, it became so closely associated with the solo sword dance, that it was propagated as the name of the dance.

MacLachlan claims that, the words making little sense in their present form, actually hark back to an older form (see Plate 9: The Gillie Calum):

In the reign of Malcom... Ceann Mhor... a repetitious little ditty was sung to the tune 'Gille Calum'... a coin called the 'Bonn-A-Sia is mentioned. Because this coin is connected with Malcolm 3rd's reign, conclusions have been made that the dance belongs to this period. To substantiate this argument, Gille Calum has been translated 'Malcolm's servant' (MacLachlan 1998: 83).

However this supposes the existence of the tune, known as 'Gille Callum', before the reign of Malcolm Canmore. Her suggestion that 'the *Bonn-A-Sia Da Pheighinn* tax theme was a parody on the original words which actually referred to the 'Feinn', warlike heroes of Celtic lore' (MacLachlan 1998: 83) seems unlikely, since it is unsubstantiated by any other source.

Plate 9: Gillie Calum by Eachunn (*The Celtic Monthly* 1912: IX, 92)

KEY A. *Lively with marked time.*

Fine

s, s. -: t. s. | d : l. f. | s, s. -: t. s. | r : t. s. | l, f. -: f., r | d : l. f. | s, s. -: t., r | d. l. : r |

D.C.

s, s. -: t., r | f : l. f. | s, s. -: t., r | s., l. : s. r. | f., s : f. r | d, t. -: l. f. | s, s. -: t., r | d. l. : r |

Gillie-Calum dà pheighinn,
Gillie-Calum dà pheighinn,
Dà pheighinn, dà pheighinn,
Gillie-Calum bonn-a-sia.

Gillie-Callum, twa pennies (a bodle)
Gillie-Callum, twa pennies,
Twa pennies, twa pennies,
Gillie-Callum, ae bawbee.

Gheibhinn leannan gun dad idir,
Gheibhinn leannan gun dad idir,
Gun dad idir, Gun dad idir,
'S rogha 's tagha air bonn-a-sia.

I can get a lass for naething, (sweetheart)
I can get a lass for naething,
Lass for naething, lass for naething,
My pick and wale for ae bawbee.

Gheibhinn bean air dà pheighinn,
Gheibhinn bean air dà pheighinn,
Dà pheighinn, dà pheighinn,
'S té nach phiach air bonn-a-sia.

I can get a wife for tuppence,
I can get a wife for tuppence,
Wife for tuppence, wife for tuppence,
A useless ane for ae bawbee.

The same writer also suggests that there might have been a connection between 'Gilycolum', who was the son of Somerled and grandson of Gille Bridge, both Chieftains of Argyll and the Isles, who were killed at the battle of Renfrew in 1164 when they rose up against the Normanising policy of King Malcolm IV. Similarly, it may be that 'Gille' refers to the Gaelic prefix meaning 'servant' or 'boy' (MacLachlan 1998: 84). However, while there were many 'Gillies' (boys), Malcolm Canmore certainly would seem to be the most prominent. This is not to say that the song necessarily relates directly to him or that the dance stems from this in turn, but only that the nature of the connection between the character, song and dance will be subject to speculation.

The monarch had indeed provoked the displeasure of the Highlanders by removing the Court of the Scots from Dunstaffnage Castle, its ancient seat in Argyllshire, to establish it at Dunfermline and furthermore by marrying the Hungarian/Saxon princess, Margaret, which led to the change of the court language from Gaelic to English. He also introduced a very small coin, the bodle, or two Scots pennies, equal in value to a third of a halfpenny. These decisions may have won Canmore the title of 'a young boy called Callum' or 'a silly boy called Callum' (SC2003.003). Morrison remembers the words she was taught to that *Puirt-a-beuil*: 'The one [tune] to the Swords is called 'Gillie Callum' and it's a Gaelic song, 'Gillie Callum da pheignn, da pheignn Gillie Callum bonn a sia'. It's a sort of a nonsense rhyme' (SC2003.004). The *bon-a-sia* or 'coin of six' was the sixth part of a shilling Scots, which had been added to the coinage. It was 'so small as to be contemptible in the eyes of his Highland subjects' (*The Celtic Monthly* 1912: IX, 92). In the above plate the terms *penny*

and *tuppence* or *bawbee* are used in the text for want of a better literal translation and they give no idea of the actual value of the Scottish money.

The version of the Gaelic given by Thurston half a century later, is much the same, with a translation in English, rather than Scots, and an inversion of the second and third verses (Thurston 1954: 62-63). Morrison recollects the theme of another verse in which 'he took home a bowl of meal... and something about the mice in it...' (SC2003.003). This is not found in any other source, but the nature of the oral tradition would have allowed singers to have composed and developed verses as the subject or situation demanded.

Perhaps the greatest example of a Highlander's exuberant performance skills is embodied in this excerpt from the poem 'MacAllister Dances Before the King':

...The lovely ladies of the Court,
With pearls and jewels bedecked,
All blushed and trembled as I bowed
To them with great respect.

Slowly at first, with hands on hips,
I danced with ease and grace;
Then raised my hands above my head,
And swifter grew my pace.

At last no human eye could see
My steps so light and quick,
And from the floor great clouds of dust
Came rising fast and thick... (Author Unknown).

The energetic descriptions may have been inspired by actual events (as depicted in Plate 10: The Gillies' Ball by Egron Lundgren) as they powerfully entrance the reader as the energy and spectacle of the accelerating dance is

portrayed. Although there is no direct reference to the Gillie Callum in this tale, it is generally assumed that, due to the increase in speed as the dance progresses and the feat of dexterity, he was dancing a sword dance.

Plate 10: The Gillies' Ball (detail) by Egron Lundgren



The Celtic Monthly gives a similarly vigorous description of a dancer performing the Gillie Callum: 'at first by a single step but as he proceeds the movement becomes rapid and complicated' (*The Celtic Monthly* 1912: IX, 92).

North also writes a powerful, poetic description:

To the inspiring notes of the bagpipe he approaches the cross-swords, not timidly as is the wont of many dancers, but with an unaffected familiarity. When the pipes have almost flooded the room with romantic sounds, and warmed and cheered the company, the same influence seems to have a greater spell upon the dancer. Having bounded between the weapons as safely as ever roebuck cleared the forest path, he plies his limbs swiftly and unerringly, while toe and heel keep magic pace

with the music. The whirl and the swing are now in rapid succession, but the four quarters of the claymores have been dipped by the feet of the dancer with mathematical precision and accuracy (North 1881: 40).

In his 'Early Recollections' Charlie Mill also portrays the call of the pipes as one which would have inspired soldiers to dance, and fight, fearlessly:

I can truly verify why it was, that in times of hostility, the common soldier attacked the enemy with a more determined attitude when 'accompanied' by the stirring melody of the pipes. All uncertainties and restraints are eradicated, and a determined longing for action on [the] battlefield is foremost in the mind when the music drives you forward (Mill 1999: 2).

It is this same drive which seems to have propelled the Gille Callum - surely the most impressive of all exhibition dances.

In the above descriptions, the dance gains momentum. This is certainly a likely source for there being two speeds within the dance as it is performed today (SOBHD 1993: 34). Today, the dance consists of normally not more than five or six steps although it is usually limited to three or four steps within competitions. The first two or three steps are danced to the tempo of twenty-nine bars per minute, and the last step (or, at times, the last two steps, if a longer dance is being performed) is played at thirty-six bars per minute (SOBHD 1993: 34). The dancers indicate the change with a single clap of the hands and the tempo change takes place immediately as a new section of music is played, rather than gradually, as it may have been in the past.

Thurston laments the fact that the folktales and legends surrounding the dances are sometimes quoted 'as though they were part of the history of the

dances' (Thurston 1954: 72). Yet these theories, of the origins and past employment of the dances, which are shown in the fieldwork interviews conducted for this thesis, appear to heighten a desire among performers to invest the same spirit and gusto into the dances. Also, at the same time, the telling of these tales seems to act as a bond between and among the dancers. This sense of belonging is more fully explored in Chapter Six.

3:iv The Seann Triubhas

'As Heelan's a peat' (C., R.H. 1928: 19)

Following the Rising of the Clans in 1745, and the crushing defeat of Prince Charles Edward Stuart at Culloden on April 16th, 1746, by the Duke of Cumberland, the Government determined to suppress all Jacobite influences. The Act of Proscription, aimed at eliminating Highland culture was passed in 1746. The Act, which sought to curb national spirit and characteristics of the Highlands, forbade 'much... of Highland tradition' (Milligan & McLennan 1950: 10).

The oath which all persons were required to swear determined that the Highlander should not 'use any tartan, plaid or any part of the Highland garb', the consequences of rebellion being severe:

May I be cursed in my undertakings, family, and property - may I never see my wife and children, father, mother, and relations - may I be killed in battle as a coward, and lie without Christian burial, in a strange land, far from the graves of my forefathers and kindred (McKay 1884: 311).

A number of sources agree that 'The Seann Triubhas... can be traced back to the late eighteenth century' and that 'it refers to the time when the Highland dress was banned in Scotland... (VA2003.004; VA2003.005; VA2003.006; SX2003.035).

The exact date of the origin of the dance is not clear from either written accounts or oral sources. Neither is it clear if it was composed relatively quickly or if it evolved over a period of time. Lowe believes that 'it is certain

that the Shean Trews [Seann Triubhas] was invented immediately after the '45 ' (Lowe 1976: n.p.) when the kilt was outlawed, (C., R.H.1928: 10). As Milligan and McLennan note, the 'trews' (Mill 1999: 2) which were thrust perforce upon the Highlanders were worn in the eighteenth century by chiefs and 'might have been considered an honourable article of dress, but the clansmen despised them' (Milligan & McLennan 1950: 10-11).

Although it has never been established as fact, it is generally agreed that The Seann Triubhas carries us 'back to the time when trews were common' (*The Celtic Monthly* 1912: IX, 92), having been devised as a sign of contempt and derision against the English Government (SOHDA Dance Sheet 3). The dance resulted 'because of the proscription of the dances and the kilt and everything else' (VA2003.002) and was named 'in derision of the trews' (Milligan & McLennan 1950: 10-11).

One of the most common interpretations of this dance title is given by the Southern California Highland Dancing Association who believe that 'The Seann Triubhas, in English... translates to "old trousers"' (SCHAD Website 2003). This is confirmed by Milligan and McLennan, neither of whom were Gaelic speakers, as 'The Old Trews' (Milligan & McLennan 1950: 11). In Scots, the equivalent would be 'old' or 'aged' britches or 'trews' (*Gaelic - English Dictionary* 1973).

However this was not found to be the belief of Gaelic speaker Morrison, who translates 'Seann Triubhais' as 'Those Trousers' (Morrison 2000: 47; VA2003.002; SC2003.003). The close oral resemblance of 'Seann Triubhas' to 'such triubhas' or 'sic triubhas' seems to close the gap between the two

languages and would imply that this is the most fitting translation. '*Those trousers*' is much stronger than '*old trousers*' and seems more fitting with the historical context of the introduction (rather than *re*-introduction, as is implied by the latter adjective) of trousers to Highland society. Morrison's translation certainly demonstrates distain for the disliked trews.

Gardner also suggests that 'Seann Triubhas' is 'Gaelic for 'torn trousers' (VA2003.004), a theory that is also recorded by the SOHDA (SOHDA Website 2003). This depicts 'the disgust at the wearing of the trews' (SOHDA Dance Sheet 3). The essence of the meaning of the dance is therefore the same, no matter which translation is preferred. Interestingly, however, the dance is most commonly known not in English or Scots, but by its Gaelic name or by an anglicised pronunciation and phonetic spelling: 'shean' (Lowe 1976: n.p.), 'shan' (Flett & Flett 1996: 1), or 'shawn' trews (SCHAD Website 2003). Any of the above interpretations is possible linguistically and plausible within the culture. However, it is the Gaelic name of the dance, rather than the translation that is now inextricably linked with the garb central to its narrative, that which is scornfully designated as Seann Triubhas.

Elizabeth Grant also refers to the 'Highland walloch', seen in the year 1813, which appears to have been a messy and unrefined movement (Grant 1898: 147). Lockhart also describes 'walloping' postures, with reference to a sprawling style (Lockhart 1986: 73). While it is impossible to know whether these movements represented restriction (of the trews) or freedom (of the kilt) or, indeed, both in part, the spirited nature of the manifestation is foremost in the accounts.

The possible interpretations of the dance narrative are subject to much debate. Morrison writes, in her unpublished memoirs; 'the steps are meant to represent the advantages of the kilt, particularly in the whirling and birling steps. I remember we used to do a sort of pirouette step but I don't think it is done now' (Morrison Personal Correspondence 10/03/2000). She also explains the significance of this sort of step, since she believes it was specifically designed to be danced in a kilt:

[a] sort of silent pirouette... [goes] round in slow motion... It's a sort of slow motion and you come right round. Your arms are up and you're pirouetting, just... with your feet crossed. You just do a... slow pirouette... this was a slow one... And very slowly... [demonstrates]... And that's what made me think you couldn't do that properly with trousers, because... the kilt sort of coming in a fan-like way round the back of the person.... Never saw any of the boys in trows, our boys. I don't remember seeing them in trows doing the Seann Trows (VA2003.002).

These pirouette steps (VA2003.002) or 'pivot-turns' are still danced, albeit often as part of an alternative step (SOBHD 1993: 45). These, along with the travelling steps (SOBHD 1993: 42) in the current repertoire, would demonstrate the fullness and flare of the kilt. The grace of limbs and body is characteristic within exponents of the dance today and this would certainly fit with the theory that 'This dance is supposed to represent how much more *graceful* and free the kilt is as opposed to the hated "Trows" which the Highlanders were forced to wear' (Morrison 2000: 47).

However Morrison also suggests a 'shaking-off' movement within 'a clearing step' which she was taught to dance. She describes it as 'a sort of a

step... not actually against the apron, but you're doing that [gestures, brushing hands downwards, in front of kilt] as if you're trying to get the trews off...' (VA2003.002). The step demonstrated by Morrison and remembered by Alison Diack (UI2000.003) is similar to the sweeping outward movements of the present-day first [step, 'Brushing'] (SOBHD 1993: 41) and which is supposed 'to represent the dancer's resentment to wearing trews by trying to kick them off' (Thurston 1954: 74; Macaffer 2002: 14) with the addition of hand-movements to represent the smoothing of the kilt apron.

The more prevalent theory is that the action for getting rid of the trews was a 'shake' of the leg, a movement which is central to the current second [step, 'Side Travel'] (SOBHD 1993: 42). Billy Forsyth believes that the original dancers of The Seann Triubhas were 'trying to *shake off* these trousers that they had to wear' (VA2003.006). This belief is also held by Janet Gardner who describes the dancer as 'throwing [the leg]... trying to shake off the trousers... shaking off the trousers with The Seann Triubhas (VA2003.004). Milligan and McLennan give a spirited description of the meaning underlying the dance: 'various flicks of the fingers and quick turns of the wrists indicate derision and abhorrence of the tight, confining things and longing for the *freedom* if the kilt' (Milligan & McLennan 1950: 10-11).

The modern-day Seann Triubhas is by nature much more refined and smooth than is found in any of the descriptions of impassioned Highlanders. Whether the dance originally pertained to the abhorrence of the tight fitting trews or the freedom of the kilt (or both), the brushes, shakes and leaps typify and distinguish the dance from any other in the current Highland repertoire.

The narrative nature of all of these theories is still evident (albeit to a much lesser degree) within the steps and, therefore, so is the scope of interpretation for the dancer.

The 'freedom versus restriction' theories on the origins of The Seann Triubhas might be contradictory by nature but for the following theory of the presence of both elements within the dance:

The Seann Triubhas was performed in trews, which were so unpopular throughout the Highlands that *many of the movements and steps in this most elegant dance illustrate the dancers' disapproval at having to wear 'trousers' instead of their beloved kilt and his subsequent attempts to kick them off. The quick steps are a display of pleasure in their abolition some years later* [italics mine] (SOHDA Website 2003).

Mary McHarg provides a similar interpretation: 'You get the steps where they're throwing off the trousers, the trews, and getting freedom... and they were back to the kilt' (SX2003.035). The SOHDA also suggests that 'the slow tempo... is said to depict the disgust at the wearing of the trews, and the quick steps are a display of pleasure at their abolition' (SOHDA Dance Sheet 3). This interpretation of the quick-time is, according to Thurston, representative of 'the joyous delight at again being free to wear the kilt' or, according to Witta, 'the joy at being able to wear tartan 'whether it be trews or kilt' (Witta 1982: 95).

These theories of mourning and celebration are perhaps the most believable of all the theories, since the dance is split into two distinct time signatures. The triumphal nature of the narrative would certainly have been in keeping with the Highlander's success in getting rid of restrictions. Mill alone suggests that the quick steps might have been added on (Mill 1999: 2).

Similarly, researcher and dancer G.B. Lowe writes 'the slow steps are mourning for the kilt after the '45 [1745 Jacobite uprising] when Highland dancing and music was banned, and the quick steps are joyous because later the ban was lifted' (Lowe 1976: n.p.). He suggests that the last step (quick time) should be 'genuine Shean Triubhas steps and not steps borrowed from the Highland Fling' in order to represent 'the wish of the Scots to throw off the yoke of the English forever' (Lowe 1976: n.p.).

R.H.C. claims that this ending is even more dramatic, as the dancer reveals 'his true character of a Highlander in disguise' (C., R.H.1928: 10). Although this is not substantiated by any other source, it is a logical and perhaps more entertaining interpretation of the celebratory nature of the quick steps which is implied in other accounts as the Scot, 'kicking off his hated lowland britches... shows his joy of again being able to return to his traditional Highland dress (SCHAD Website 2003).

It was not until the year 1772 that the Act of Proscription, so galling to the Highlanders, was repealed, and the ban on the kilt lifted 'when tartan material became a fashion rage in London' (SCHAD Website 2003). The SOHDA suggests that The Seann Triubhas was not a dance which evolved as a result of oppression but 'a dance of celebration developed in response to the Proscription Repeal which restored to the Scots the right to wear their kilts and play the bagpipes once more' (SOHDA Dance Sheet 3; VA2003.002).

However Livingstone believes that the dance was supposed to be performed in trews, which would counteract the claim that it was a kilted-repeal dance: 'they were supposed to just wear trousers to it, to dance, then... I

don't know if that's true or not, but that's what they said' (VA2003.005). Morrison similarly notes that 'When the proscription was repealed, I think that the Highlanders were so fed up, they didn't go back to the kilt... so why should they wear trews, when they're extolling the virtues of wearing a kilt?' (VA2003.002). The younger generation had, by force of habit, become reconciled to the change, while the older generation could hardly be expected to resume the costume after three decades of proscription. The celebratory nature of the dance was, then, probably that of a spiritual freedom, rather than a physical one.

R.H.C prescribes that, for an authentic performance of the dance 'trews is the appropriate dress' (C., R.H. 1928: 10) although he does admit that The Seann Triubhas is occasionally danced in kilted attire. The hodden grey trews and knee breeches were typically the dress of a Lowlander: '...the dancer is (or should be) neatly attired in tight fitting trews of tweed or tartan cloth, with suitable tunic, stockings, and bonnet (C., R.H.1928: 11). McLennan also writes 'the costume now worn is either the usual Highland dress or Tartan Trews, with tartan doublet, hose and bonnet' (McLennan 1952: 22).

One of the earliest records of the dance is in Logan's *The Scottish Gael*, who writes in 1831 that it should be danced 'with much *grace*' (Logan 1831: 314). This would not seem entirely in keeping with a dance of defiance and rebellion. Mill comments that the dance ought to be rather more mournful than scathing as the dancer 'apparently represents the... mourning for the kilt' (Mill 1999: 2) and a sorrow for 'the disgrace of their cherished costume' (*The Celtic Monthly* 1912: 313). R.H.C also comments on the nature of a dance in which:

the dancer seems to aim at *gracefulness* rather than vigour (though vigour may also be displayed); as if the Highlander, whom he represents, were seeking to conform to the polish and refinement of the Lowlands, or to win the favour of some Lowland lass. (C., R.H. 1928: 10)

This is not a comment on the dance's beginnings, but rather seems to be a simile created by the author to describe the nature of the refinement. The mode of dancing in the slow section would certainly be more akin to the Lowland style of dancing, not least because of the restriction of trows.

A letter dated 22nd May 1884 to *The Celtic Monthly* from the Secretary of the Celtic Society of Dunfermline rejects the assertion that the dance represents the 'contempt' in which the breeches were held (*The Celtic Monthly* 1912: 312). He argues the trows, being an article of Highland dress of much older date than 1745, had their legitimate place for centuries and were of equal antiquity to the kilt. He asserts that the dance steps 'are universally admitted among both amateur and professional dancers to be at once *graceful* and easy... with the greatest éclât' and that contrary suggestion was 'disparaging... [towards] our ancient Celtic treasure' (*The Celtic Monthly* 1912: XX, 444).

While the rejection of the kilt theory may be in keeping with the Scots defiant, daring, rougher 'flinging' approach, it does not fit so well with the grace of the dance and its balletic, perhaps cultivated, influence. McLennan offers a possible solution to this dichotomy, by referring to characteristic 'old-time arm movements and... *graceful* action' (McLennan 1952: 22).

These features may therefore imply a link with an older dance form: 'The old dance, called "Scottish Measure", was the only one the Highlanders

would condescend to dance in this much-disliked garb; and it thus became known as the Seann Triubhas' (McLennan 1952: 22). Witta claims that the confusion as to whether the trows or the kilt should be the right garb for the dance 'further lends support to the notion that The Seann Triubhas is a very old dance which has now evolved to a very different technique and has acquired a new meaning or spirit from the time of the Act of Proscription' (Witta 1982: 95).

Further support for the ancient history of the dance is to be found in both of the tunes recorded for this dance. 'Shan Truish Willichan' first appeared as 'Seann Triubhas Willighan' in Bremner's *Second Collection of Scots Reels or Country Dances* (1768) and 'Whistle O'er the Lave O't' (Bremner 1768: n.p.), the title of which is the same as a seventeenth century song. Some other early references to The Seann Triubhas indicate that it is a step rather than a dance, for example in *National Dances of Scotland* (McKenzie 1910: 31), where a reel setting step is called The Seann Truihbas step and Grant in *Memoirs of a Highland Lady* (Grant 1898: 182) where Grant refers to the 'Shean Trows' ambiguously.

Linda Rankine also offers an explanation:

Highland Dancing... still includes intricate footwork and a great deal of leaping and jumping but not in such an urgent fashion. It is now done with much more control and is more "polished" rather than the original gay abandoned style... It is known... that... the top class Highland Dancers today have also undergone a great deal of ballet training and certainly Highland Dancing teachers of any standing use ballet technique as part of their training methods. This is not entirely a new approach for it has been said that William McLennan, in the late 19th century was responsible for introducing a balletic influence to Highland

Dancing. He was a Highland Dancer of considerable renown and studied ballet with Cecchetti and Barratti and apparently carried this training over to his Highland Dancing. However, ballet has become an obviously greater influence in the past fifty years. The most obvious result of this is that the style has become more refined (Rankine 1977: 19-21).

Similarly, Lowe writes that

A hard day's Highland dancing at the games would be considered by a ballet dancer to be heavy work indeed... According to Anton Dolin, star of the Diaghileff Ballet and many other ballet companies, there are three kinds of dancing that have to be taught from the foundation, and from the dancer's earliest years. They are Russian dancing, Spanish dancing, and Scottish Highland dancing, and probably the most difficult of the three is Highland dancing (Lowe 1976: n.p.).

Balletic arm movements are characteristic of the dance as it is performed today, and it could well have originated as a mournful dance, with a more highly cultivated style. While it is highly unlikely that the original inspiration for the dance could have come from a French tradition, since the subject of (or the inspiration for) the dance was Highland in nature, The Seann Triubhas has been subject to interpretation and, inevitably, alteration.

The obvious comparison to the older circular reels can be seen for instance in the early forms of The Seann Triubhas, where dancers would perform steps in a clockwise circle for the first part of the dance and anti-clockwise for the second. Today the dance is performed in an anti-clockwise circle for the second half of the first step (Thurston 1954: 74; SOBHD 1993: 41 and Macaffer 2002: 14).

The only names so far associated with these claims are the McLennan brothers. D.G. McLennan claimed to have been instrumental in the evolution of The Seann Triubhas as, being intimately acquainted with the history of the dance, he supposedly developed and first danced the circular movements. In essence, he claimed to have theatricised it:

The shovel step, now the first step of the dance, is only about seventy years old, and the pas de bourée, now the second step, was originally the first step. D.G. McLennan, the famous dancing teacher of Edinburgh, saw a performance of La Sylphide either in London or Paris, and he liked the shovel step in this ballet so much that when he got back to Scotland, he introduced the step into the Shean trews [sic] (Lowe 1976: n.p.).

Forsyth acknowledges the creative input that is attributed to the McLennans but emphasises that he has 'no fact for this' and that he can't identify 'any particular point' in the dance's history which might back up the claim (VA2003.006).

However, it was suggested to him that

many years ago... it was D. G. McLennan that came up with the first step of the Shawn Trews (the *current* first step of the Shawn Trews). The original second step was the first step until he introduced a sweeping movement in a circle to start the dance off. So, it's always very difficult to say what is the truth and what is just... a good story (VA2003.006).

D.G. McLennan himself claimed that 'The first circle step has nothing to do with the idea of kicking off the trews... it is new to the dance, and was composed by myself many years ago (McLennan 1950: 23).

It is generally agreed, then, that The Seann Triubhas is a man's miming solo dance (Milligan & McLennan 1950: 10) which was danced by Highlanders and for Highlanders. Despite the actual meanings or origins of the dance, which could have stemmed from a spirit of rejection, defiance, or lamentation, 'the dance itself must have been a favourite and the teaching of it went on' (Milligan & McLennan 1950: 10). However, there is little narrative element remaining in the dance which leaves us only with conjecture. The spirit of the eighteenth century Highlanders' Seann Triubhas is clearly now open to interpretation.

3:v Strathspeys and Reels

'Life and mettle in their heels' (Burns ed. Barke 1990: 205)

In 1585 the first, if rather obscure, mention of the dance-term 'reel' occurs in the *Oxford English Dictionary*. A description of a Reel is found in the 'News From Scotland' of 1591 where it is recorded that 'Agnes Thompson... confessed that... she was accompanied by... two hundreth... [and] they took hands on the land, and daunced this reill or short dance, singing all with one voice' (Thurston 1954: 20). This 'reill' seems to be identified as some sort of chain dance which was accompanied by song. This seems to be an early form of circular reel which was known to be in use at this time.

By the sixteenth century, dancing from the country had become fashionable at the court of Elizabeth I, the new style of comparative simplicity and naturalness counter-balancing the more stately and formal dances (PV1999.007). Inevitably, however, it became formalised, as it rapidly spread through the upper classes. Country dancing became known by the structure in which 'dancers formed two parallel lines and each couple progressed down their set in turn' (Milligan & McLennan 1950: 14; Flett 2000: 1). However the social dancing lived on 'in the countryside and, no doubt, [was] gathering elegance from French and Court fashions' (Milligan & McLennan 1950: 14).

Having been popularised by John Playford who, in 1651, published the first extensive dance collection (PV1999.007), these social dances had spread to the Lowlands and more accessible parts of the Highlands by the end of the eighteenth century. In the remote parts of the country, however, the spread was

much less rapid and it was not until about 1880 that the country dances were accepted everywhere in Scotland. This was helped in no small way by itinerant dancing masters who also began to compose in this country style.

Inevitably, circular reels were adapted to suit new venues, accommodating the available space¹² and the available number of participants. Gavin Douglas's *Aeneid* describes a reel as a dance 'where three dance together' (Douglas 1874: 40). Records of a Reel of Three from 1776 (Macaffer 2002: 5) show that it consisted of steps danced on the spot alternated with a travelling progression in the form of a figure eight (which is illustrated in Chapter Five). Although it has been recorded that there were many variations of this dance, the components of setting steps combined with a travelling figure were consistently present in all versions (Flett & Flett 1964: 140).

Reels had therefore developed into the distinct and recognisable reeling and setting form we know today by the late eighteenth century. Reels became so popular in Scotland that the Fletts have recorded them being danced in some form or another in virtually every district in Scotland (Flett & Flett 1964: 2). Reels of Four particularly, seem to have been at the height of their fashion in the eighteenth century. This form also appears to have close associations with the Circular Reel, either as a direct descendant or as an extended development of the Reel of Three (Macaffer 2002: 6). Macaffer explains that there were countless versions of the basic dance form and that

¹² It has been suggested that the circle may have originated from the venue of the black house, where dancers were restricted to performing around a fireplace in the centre of the room (Macaffer 2002: 3).

Hybrid versions of... their origins depending on how the teacher interpreted the dance and also depending on the region from which the reel appeared, each district eager to have a hand in developing their own unique style and dance (Macaffer 2002: 2).

The first serious attempt to write down reel steps was in 1805 by dancing master Francis Peacock, who recorded steps used by students at Aberdeen University. Perhaps this dearth of recorded material is due to the broad appeal of the style: 'The reel is... popular among all classes from the herd-boy to the nobleman...' (Thurston 1954: 6), its continuing popularity: 'Reels... need no particular description' (*The Celtic Monthly* 1912: IX, 92) and its inevitable transmission: 'so well known as to need no description' (*Caledonia* 1895: 23).

However, the distinction between the various forms of social dance is no longer made in the twenty-first century. Until one hundred years ago reels, country dances, square dances and circle dances were clearly differentiated. Milligan and McLennan write that 'Strathspeys and Reels are accepted as Country Dances when used in the ballroom' but their editor's note adds that this is a contemporary classification¹³. Reels and Country Dances therefore constituted the major part of the dance programme at the balls and social gatherings of Scotland for two centuries prior to the Great War. The popularity of these dances was 'a proof of their sustainability to the genius and temperament of the people' (C., R.H. 1928: 1). This same 'genius and temperament' is described in the *Caledonia Magazine* of 1895 which tells of

¹³ The Royal Scottish Country Dance Society which purports, by its name, to concern itself with dances of the *country* tradition, actually emphasises the publication and promotion of a broad range of *social* dances, rather than a specific mode of figure or set dancing.

'the Reel of the Highlands... danced with that life and spirit peculiar to each nation or province to which these dances belong' (*Caledonia Magazine* 1895: 351).

The matter of the locality of the origins of the dances is put in more general terms in Captain Gronow's *Recollections and Anecdotes* which recall that, in the Scottish-owned Almack's Assembly Rooms of early eighteenth century London, the popular dances were Scotch reels and old English country dances (Gronow 1864). The term 'Scotch Reel' is used freely amongst scholars to refer to any of the old social reels, such as Circular Reels, Foursome Reels and The Reel of Tulloch.

Reels have always been considered inextricably Scottish and Joan Flett writes 'Of the various forms of dance only the Reels are truly indigenous to Scotland' (Flett 2000: 1). Casciani makes the same assertion that The Reel is 'one truly Scottish dance [in which] dancers began all at the same time and formed a kind of chain' (Casciani 1994: 22). It is generally agreed, then, that The Reel was a dance form in its own right, stemming from the chain and circular dance traditions, at least as far back as the early eighteenth century, and, from the extent of its popularity, one can assume that it was rooted firmly in the Scottish tradition before then. The vigour, brilliance and neatness of the steps also seems to have impressed observers, as recorded by Ramsay of Ochertyre in the eighteenth century who writes that, in Scotland: Both sexes [are] passionately fond of dancing which consists chiefly in reels and other figures. The style was more remarkable for the spirit and agility of the performers than for its elegance and grace (Quoted in Thurston 1954: 21).

The reel therefore inspired an abundance of eighteenth century wit. An amusing picture of the popularity of the reels in an Edinburgh ballroom in the early eighteenth century is given by Major Topham, an English visitor to the capital:

The dances of this country are entirely devoid of *grace*... the general dance here is the Reel which requires that particular sort of step to dance properly, of which none but the people of the country can have any idea... the Scotch ladies... will sit totally unmoved at the most sprightly airs of an English Country Dance but the moment one of these [Reel] tunes is played, which is liquid laudanum to my spirits, up they start, animated with new life, and you would imagine they had received an electrical shock or been bit by a tarantula.... Here I have seen four gentlemen perform one of these reels seemingly with the same pleasure... as they would have done had they the most sprightly girl for a partner... and they give you the idea that they could with equal glee cast off round a joint stool or set to a cupboard (Topham 1776: 262).

The same spirit of abandonment and humour is evident in Barclay Dunn's description of 1818 which observes 'There are no dancers in the world more expressive of inward hilarity than the Scotch when performing their own reels (PV1999.007). A most fitting summary of the popularity of the reel form is given by Joan English who writes, in her 1986 lecture for Stirling University:

Since the eighteenth century the Scots have been famous for their reels, not only because of their unique form, but also because of the brilliant way in which they were danced. Foreigners wrote of the agility and vivacity of the dancers. They wrote of the quickness and precision and lightness and added that the women, as well as the men, were fine dancers. Versions of these reels became popular in other countries, and dancing masters travelled to Scotland to learn steps (PV1999.007).

Meanwhile, the Highland Reel was growing more popular in the Lowlands. This was also known as the Scotch Reel, Foursome Reel, Common Reel or The Strathspey Reel. The identity of these Reels was marked by two couples who began to dance at the same time instead of taking turns as in the country dances (Casciani 1994).

Although a foursome dance was and is not peculiar to Scotland and similar formations are danced generally throughout Great Britain and Ireland, and the rest of the world¹⁴, the following components make it distinct:

The Highland Reel is a combination of these two measures; first, the comparatively slow and grandiose measure several times over, then the quick time or reel proper, also repeated several times. The tunes are divided into two equal portions - reeling time and dancing time (C., R.H. 1928: 13).

The Highland Reel is now known as the quick time which 'usually follows the Strathspey, with the music changing to a Reel time without any break between the dances' (SOHDA 1994: 24) rather than a dance in its own right, or an inclusive term for both portions of the dance. The Strathspey would therefore, by such a definition, be termed a reel, since the travelling and setting portions defined the old-style dance. This is confirmed as being a reasonable definition as the Strathspey is 'closely related to the reel' (*Encyclopaedia Britannica* 1910: XI, 251), most likely being a measure of old and 'a slower and more grandiose

¹⁴ It has been claimed that the Highland Reel resembles an ancient dance of the North American Indians (*The Celtic Monthly* 1912: XX, 209), that it is 'of northern origin... a Norwegian folk dance' (*Encyclopaedia Britannica* 1910: XI, 250) and that 'As regards time and figure [is] share[d]... with Denmark' (C., R.H. 1928: 4). Although there is no substantiation for these claims, foursomes are inevitably part of other national repertoires.

modification of the reel' (C., R.H. 1928: 13) since it had the same component parts as the reels of old: travelling and setting steps.

The two different sections of the Highland Reel which would have been danced at different tempos are, from the late nineteenth century to the early twentieth century, shown to be inseparable. *The Celtic Monthly* reports that 'Highlanders excel in those steps and figures called Reels and Strathspeys, which they perform with vivacity, *grace* and agility... They are a class of dance... for which Highlanders have ever been noted' (*The Celtic Monthly* 1912: IX, 91). The same magazine, by 1912, uses the terms as proper nouns: 'The Strathspey and The Reel are the most popular of the Highland Dances' (*The Celtic Monthly* 1912: XX, 209). How the dances within the Highland repertoire today became distinct from a more general group of dances which were danced to the melodies bearing the same rhythm-names, is not clear. However it is logical to assume that Strathspey may perhaps have been its birthplace (*The Celtic Monthly* 1912: XX, 209; McLennan & Milligan 1950: 11).

It may be that the district of Strathspey, which gave birth to the lively Strathspey music, was also the birthplace of the dance so intimately associated with the music. If this be so, the dance is not very ancient, not more than two or three centuries, but it is indigenous to the soil from which it [literally] sprung, and is peculiarly... Scottish (C., R.H. 1928: 11).

This peculiarity is also celebrated by Lowe who claims that while solo dances have been influenced by other traditions, 'the Strathspey or Reel ...[bears] no

similarity... The Scots dance is a highly sophisticated performance' (Lowe 1976: n.p.).

The dancing in the Strathspey portion was described as '...spirited yet refined' (Witta 1982: 73) and 'sprightly' (Casciani 1994: 12). Poetess Mrs Grant of Laggan, attributes the same spirit to the dancing in the region:

The nymph that went to trace the source of Tay,
Or lead the sprightly dance by rapid Spey,
With conscious triumph smiles aside to see
This faint affection of the rural glee;
Short pleasure languid imitation feels,
While polish'd courtiers pant in native reels (Campbell 1895: 353).

Similarly, the river figures in the following analysis:

Strathspey gets its name from the valley (*Strath*) of the river Spey, one of the swiftest flowing in Scotland. It is... in four-four time as opposed to the reel's two-four time... and though its music is slower, its performance calls for a good deal of energy since the dance is full of rapid movements¹⁵ (*Encyclopaedia Britannica* 1910: 251).

Furthermore, Emmerson puts further meaning to the name of the dance:

The singularly cultured style of dancing prevailing in Strathspey which naturally came to be identified with that region and named after it. Perhaps it is not going too far to suggest that to Lowlanders the terms 'Strathspey' and 'Highland', as they applied to dance were synonymous. There seems every suggestion that this was so (Emmerson 1972: 182).

¹⁵ See footnote 7.

The Strathspey tempo seems to have been used for 'twosome' dances as well as foursomes and, of course the solo Highland Fling (*The Celtic Monthly* 1912: XX, 209). The components of the foursome described below seem to be the most common in the history of The Strathspey and Reel, it being danced by both sexes and being split by means of eight bar portions:

Now-a-days it is a 'foursome' usually two ladies and two gentlemen taking part. It is divided into two sections, the first or 'reel' consisting of eight bars and the second or 'setting' step of eight bars. The ladies standing on the right lead off the dance after the introductory bowing to partners (*The Celtic Monthly* 1912: XX, 209).

Casciani explains the floor-pattern: 'The dancers stood face to face and when reeling described a figure of eight' (Casciani 1994: 12). This clearly shows that the reeling was the crossing and weaving movement and the defining component after which the dance was named. This distinct formation is 'perhaps the most beautiful that can be exhibited... and the figure of eight is maintained in both the slow and quick portions of the Highland Reel (C., R.H. 1928: 13).

The method by which the dancers would have crossed the floor is epitomised in the *Collins English Dictionary* description of a Strathspey: 'a dance with *gliding* steps' [italics mine] (*Collins English Dictionary* 1994). By implication, the smooth movement of the travelling steps is, in essence, the defining motif. Ex-World Champion of the early twentieth century Bobby Watson is known to have taught a gliding Strathspey travelling step. Alison Diack recalled his teaching:

Instead of just stepping ... in the travelling step... you sort of almost glided the toe a bit, before you transferred your weight on to it... Your toe almost glided along the floor just a *little* before you transferred the working foot, before you transferred your weight on to it. I don't think I've seen anybody, I haven't seen anybody else doing it that way... I remember him always complementing me on that and saying that that's how the Strathspey *should* be done, but I haven't seen many others doing it that way. He also made a big thing of the fact that it's supposed to be a gliding movement (SA2003.040).

Flett and Flett did not find this style among traditional dancers (Flett & Flett 1957: 161) and they regarded the RSCDS's teaching of a 'polished gliding step' (Flett & Flett 1957: 161) to be somewhat incongruous, as it would require 'soft heelless shoes in order that it may be performed properly, yet the country folk from whom Strathspey dances were obtained wore ordinary shoes, while even in the 19th Century ballroom patent leather shoes were worn' (Flett & Flett 1957: 161). Witta suggests that the 'Strathspey gliding step' (Witta 1982: 74) would also have been seen in the Quadrille figure and that the technique of Highland Dancing had been 'refined... in accord with other influential and respected dances of the period' (Witta 1982: 74). This would account for there being two schools of thought regarding the smoothness of the action. Milligan and McLennan put the movement in the context of The Strathspey and Reel as a whole: 'It is now done in a gliding manner to a moderate, smooth rhythm after which the lively Reel tempo and Reel steps come as an exciting change - for a Reel always follows a Strathspey' (Milligan & McLennan 1950: 11).

The foot-movements used in The Strathspey travelling step have not always been as cultured as they are in today's competitions (SOHDA 1994: 40) but Billy Forsyth suggests their origins:

That movement just fitted into the dance and it seemed natural that this was just going round the ramparts of the castle, because that's what the Strathspey movement was supposed to be doing. And if you did it in the dance, it made you feel 'oh, that makes sense' (SA2003.036).

Should there be some basis to the 'ramparts' theory, it is surprising that it is not mentioned by any other source, or that the name of the step, movement or dance does not relate to a castle, ramparts, or soldiers. It is perhaps more likely that this was one interpretation of the step, an expressive means of dance narrative, rather than an accurate account of the step.

Unlike the travelling figure which was 'usually the same throughout the dance' (Thurston 1954: 1; Flett & Flett 1964: 1), the setting steps were 'as varied as the dancers please[d]' (Thurston 1954: 1; Flett & Flett 1964: 1) in keeping with the developments of the dance form. These could have been Fling steps (*The Celtic Monthly* 1912: XX, 209; C., R.H. 1928: 13), since they too were danced to a Strathspey rhythm. The steps of the Highland Fling were also used 'for setting in appropriate places in couple and set dances' (Goss 1993: 73) and the practice is still common today in some social dances, whereby a suitable Fling-style step is commonly inserted as a solo setting step, particularly into an Eightsome Reel. This is most likely why *The Celtic Monthly* describes the dance as 'Not unlike the Highland Fling in time and measure' (*The Celtic Monthly* 1912: XX, 209).

It would be logical to assume that, as steps were created specifically for The Strathspey, they would become increasingly complicated due to showmanship and natural competition. This does not seem to have been the case, as they are, largely, 'a simpler and easier class of steps called Strathspey

steps' (C., R.H. 1928: 13). However, perhaps the best fitting and most tailored steps survived, as is evidenced in today's repertoire (SOBHD 1993: 49), and as remembered by Morrison who recalls 'special steps' (SC2003.003).

There was a time when the Highland dances and social dances seem to have had a closer link. Eighteenth century poet Caroline Baroness Nairne, in her poem 'Country Meeting', asks for a customary dance to end a ball, (unusually not the Gillie Callum), as the showpiece of the evening: 'Afore we end, strike up the Spring/ O'Thulican and Heilan fling' (Nairne in Greffin 1872: 169). It is also not known what connection there might have been between these dances (Lockhart 1986: 43). It would appear that the Highland Fling was in some way associated to The Reel at that particular time (MacLachlan 1988: 82). A 'fling', however, often relating to a style, rather than a specific dance, was more likely simply to refer to a typically 'Heiland' dance which was characterised by a flinging movement.

This 'Thulican', (also known phonetically as 'Hullachan' or the anglicised name 'Hoolichan') or 'The Reel of Tulloch' is now generally accepted as the part which 'usually follows the Strathspey as an alternative to the Highland Reel' (SOHDA 1994: 41).

3:vi The Reel of Tulloch

'Far-famed foursome' (PDANZ 1927: n.p.)

The Piping and Dancing Association of New Zealand (PDANZ) 'Competition Rules, By-Laws and Other Regulations' state that The Reel of Tulloch and a tune of the same name were 'composed by one John MacGregor, about the year 1600' (PDANZ 1927: n.p.). The Reel of Tulloch is danced by a party, or by parties of four, and nowadays is danced after The Strathspey, or The Strathspey and Reel (SOBHD 1993: 54; SOHDA 1994: 40). The tune of The Reel and Reel of Tulloch is quicker than The Strathspey portion. In The Reel of Tulloch, a series of setting to partners takes place as follows: the couple 'set' for four bars, then, each grasping each other by the rear part of the arm with the right hand, turn to the left in two bars, then change hands, dancing two bars in the reverse way [two] meet in the centre and set as before, the partners resting, and thus alternating to the end.

Eleanor Sillar describes how, as a debutante at the age of eighteen, she went to her first Hunt Ball in Edinburgh's Assembly Rooms at the turn of the twentieth century:

I note with awe the rapt expression on my partner's face. His eyes gaze into space, then on once more; the Strathspey, the Reel of Tulloch. Wider the yells, our feet seem on springs. Then a long last enthusiastic chord, and the band sinks back and mops its brow. Loud clappings come from the serried ranks on the raised seats. Breathless, reluctant, a trifle dishevelled, from delirious heights we drop down again to the quiet levels of civilised behaviour (Sillar 1961: n.p.).

Alexander Smith's *A Summer in Skye* provides readers with a vibrant portrait the dance in the mid 1800s:

Away went the dancers, man and maid facing each other, the girl's feet twinkling beneath her petticoat, not like two mice, but rather like a dozen; her kilted partner pounding the flag-floor unmercifully; then man and maid changed step, and followed each other through loops and chains; then they faced each other again, the man whooping, the girl's hair coming down with her exertions; then suddenly the fiddle changed time, and with a cry the dancers rushed at each other, each pair getting linked arm in arm, and away the whole floor dashed into the whirlwind of the reel of Hoolichan (Smith 1865: 107, 9).

There are differences of opinion among writers on Scottish dance as to how and whether The Reel of Tulloch should follow The Strathspey or The Highland Reel. MacNeilage gives no details in *How to dance the Eightsome Reel* (MacNeilage 1900), but McKenzie gives The Strathspey followed by The Reel of Tulloch 'for the ballroom', and the 'outdoor' version consisting of The Reel of Tulloch alone (McKenzie 1910: 20). By the time Taylor published *Some Traditional Scottish Dances* in 1929, the substitution of The Reel of Tulloch in the foursome reel was so general that he reminds his reader that

The Reel of Tulloch is, strictly speaking, a separate dance, and hence, if it be intended that it should follow a foursome reel, this fact should be stated, otherwise it is an incorrect procedure to break into a Reel of Tulloch after a foursome reel (Taylor 1929: 68).

By the 1950s McLennan and Thurston call this the ballroom version (McLennan 1950: 38; Thurston 1954: 54).

The New Zealand Academy of Highland and National Dance (NZAND) have maintained, however, that The Reel of Tulloch was originally a Reel to be danced on its own, and that a combination of Strathspey and Reel of Tulloch is performed for display purposes only (NZAND n.d.). Emmerson suggests that the reason for the change in employment is due to 'elaborate reel combinations, particularly in the late nineteenth century ballroom [which] affected not only the quality of the execution but the original separate dance' (Emmerson 1972: 178). Similarly, R.H.C. explains that the characteristic movements of Hoolachan (i.e. the reeling, the setting and the swinging) are such as would come naturally to what he calls 'a primitive people', or, rather, 'unskilled' dancers. He reasons that 'it may only be comparatively recently that the dance attained the classic and ordered form in which we know it (C., R.H. 1928: 3-4). He gives a spirited description of the dance:

In Hoolachan proper reeling is dispensed with, and the enraptured dancers devote themselves entirely to setting and swinging. And hot work they make of it. They do it with all their might. The person who would dance the Hoolachan to purpose must be neither lame nor lazy. A native of one of the softer nations would very likely regard Hoolachan as tremendously hard work. He would see neither fun nor pleasure in it. But to the hardy Scot, reared in the bracing climate, and on the halesome parritch of Scotland, the dance is (or was) a delight, a congenial means of letting off his superfluous energy (C., R.H. 1928: 5).

According to Flett and Flett, and Thurston, the definition of a true Reel is one that consists of 'setting steps danced on the spot... alternated with a travelling figure' (Thurston 1954: 1; Flett & Flett 1964: 1). In true evolutionary

form, it has been said that the Eightsome Reel, of quite recent date, is 'an amplified and elaborate Hoolachan' (C., R.H. 1928: 5).

Macaffer suggests that The Reel of Tulloch was originally a society dance and that it was developed and made popular at grand occasions (Macaffer 2002: 9). However she offers no historical or ethnographic evidence for such a claim. The Fletts do however point out that The Reel of Tulloch was developed at the Breadalbane Balls (Flett & Flett 1964: 134). Emmerson confirms this development, as he describes the different forms of the dance: 'A number of versions of the Reel of Tulloch gained currency, and of course, there was a natural tendency to combine different foursome reels in a sequence dictated by the Master of Ceremonies or by the Musician' (Emmerson 1972: 177).

The first written record of the dance is a notice in the *Caledonian Mercury*, from 27th March, 1819 when four office bearers of the Edinburgh Society of Highlanders danced it in order to open the Society's ball (Thurston 1954: 35; Emmerson 1972: 177). The Reel of Tulloch is recorded by the Fletts as having been performed at the Edinburgh piping and dancing competitions of 1829, 1832, 1838 and 1844 (Flett & Flett 1964: 134).

The most common theory as to the origins of The Reel of Tulloch is that it was devised by a group of parishioners in a village of the same name. Macaffer claims that the reel steps were formalised and 'danced in a square formation' as a 'further variant of the Scotch Reel' (Macaffer 2002: 9). Some have put a place and date to the story: '[it] originated... at the small village of Tulloch, near Ballater, in Aberdeenshire, in 1781' (SOHDA 1994: 41) and '[This] area... is wholly responsible for conceiving... *The Reel of Tullich*' [sic]

(Mill 1997: 11). It is generally agreed that parishioners were waiting either inside or outside their local church. These were either 'well-wishers waiting for the minister to arrive' at the church for a wedding (SCHDA Website 2003; SOHDA Website 2003) or the congregation who awaited the arrival of the minister 'on a... Sunday morning' (Mill 1994: 36; Mill 1997: 11).

It is also believed that 'the basis of the footwork, style and execution of the dance was devised' (Mill 1997: 11) as a direct result of the cold weather conditions, and that 'the chilly group danced as a means of keeping warm' (SCHDA Website 2003; SOHDA Website 2003; SOHDA Dance Sheet 4). The parishioners, engaging in 'some light exercise to keep warm... started to stamp their feet and clap their hands' which then developed into 'swinging each other by the arm and dancing reel steps' (Macaffer 2002: 9). The rousing and energetic Reel of Tulloch evolved or was devised by the congregation who, 'became tired of waiting and, in an effort to keep the circulation going, they blew in their fists and started to stamp their feet' (Mill 1994: 36) while 'standing in the aisles [then] started to dance reel steps and swing each other by the arms' (Mill 1999: n.p.).

In today's version, very little of the character and spirit of that day has been lost. The myth remains unproven but, interestingly, in the year 1589 we are provided with an early use of the word 'reel' with reference to dance in the report of the great winter storms of that year (Chambers 1859: I, 214). This tale also surely explains Norman MacLeod's call to players:

Make the old barn shake with laughter,
Beat its flooring like a drum,
Batter it with 'Tullochgorum'
Till the storm without is done [dumb] (*Caledonia* 1895: 356).

A fuller description is given by Mill:

Some of the younger and bolder lads were giving lassies a twirl by the arms and a fiddler struck up a lively reel, when it was decided that the company deserved a dram on such a bitterly cold day. A keg of whisky was brought from the nearby inn and soon it had its usual effects, the feet and heads were lighter, the fiddler was the better of the drams and had soon improvised the Reel of Tulloch! Soon a merry dance was in full swing with spirits getting higher and higher, a local worthie climbed the pulpit and gave a 'sermon', while others took the rôles of elders and sang ballads. Just as the merriment was at its height the minister appeared and condemned his flock for such a sacrilegious act and declared 'doom and destruction' on all who had taken part! And now the famous Reel of Tulloch is known world-wide and is danced at Highland Games near and far (Mill 1994: 36-37).

However this is the only tale in which there is any mention of the minister in a negative light, even though it is generally agreed that it was due to his being late that the parishioners began to dance: 'It would seem the minister had been rather reluctant to leave his warm fireside' (Mill 1994: 36). Mill's use of conditional language prefigures the statement and thereby implies that it may be an embellishment. Similarly, it is difficult to believe that a congregation would have entertained such an act of irreverence and rebellion.

A later article by the same author appears in the Ballater Highland Games Programme from 1997, in which he asserts that Highland dancing history was made 'Just along the Road':

Thinking that no one would turn up for the service on such a biting-cold morning, the minister took his time in making his way to the kirk. What he didn't visualise was that several of his flock had in fact turned up and were standing in the freezing temperatures awaiting his arrival. Time passed - no sign of the minister! So in order to keep warm the congregation started to dance with each other and swing their partners by the arms. A fiddle was produced and the dancing intensified as dancers took it in turns to perform solo steps while the others stood aside and clapped - again in order to keep their hands warm!. With the help of a few drams which had somehow been acquired the church took on a party mood, and by the time the minister arrived a full-scale ceilidh was taking place, a sight which he instantly suspended with fierce words for 'enjoying' oneself on the Sabbath! But the foundations for the dance had been laid and over the years it was honed and polished to the perfection the visitor can see on today's platform. Watch the four dancers as they weave in and out in a tightly-knit pattern, dance, setting steps in the centre while their companions stand watching, and see them take each others arms and swing round and round exactly what the congregation did all those years ago in the church just down the road... this Mecca for all Highland Dancers... the old ruins of the church, just along the road (Mill 1997: 11).

It is interesting to note that, even though the dance programme includes this theory as part of a dance history article, the competition entries for that day are consistently for 'The Reel of Tulloch' rather than the local spelling 'Tullich' (Mill 1997: 18). This shows that, whether there is any truth to the assertion that the origins of the dance are local to the competition, the impact of such a theory has not affected the mindset of the dance organisers or the dancers themselves. Surely if even the dancing competition most local to the supposed place of origin cannot be sure of these claims, then neither can anybody in the wider dancing world.

The assertion that the Tulloch of the dance's origins is the village east of Ballater, is made in the article 'Dancing History - Just along the Road' in the 1997 Ballater Highland Games Programme, in the SOHDA's *The ABC of*

Highland Dancing and Games Directory and in the SOHDA's website article on 'Dance History' (SOHDA Website 2003). It is important to note that Mill, author of the programme article and co-author of the SOHDA's *The ABC of Highland Dancing and Games Directory* is also a key member of the Association as archivist and dance-historian. Although he admits that these are 'stories repeated from hand-down tales all claiming to be the rightful Tulloch!' (Mill 1994: 37), these accounts must therefore be considered as being from possibly just one source, rather than from various corroboratory sources.

The honour of being the birthplace of the famous reel has been claimed for several places. However R.H.C. claims that 'it is probable... that the dance is of greater antiquity than is implied in the claim of any of these places' (C., R.H. 1928: 3). The following lines, written by a Deeside poet, are the only source which link kirkyard, dance, reel and place. It relates to the kirkyard of Tullich, on the outskirts of Ballater:

For blythe and merry we'll be a'
As lang as we hae breath to draw,
And dance till we be like to fa'
The Reel of Tullochgorm (Skinner in Greig 1923: VI, 395).

Perhaps the author meant Tullich, but was diverted by the requirements of rhyme into confusing the issue.

There are no proofs then, which pinpoint in which Tulloch, if any, this dance might have arisen. There are many Tullochs in Scotland, with variations in spellings. The following figure shows the sites of some Tullochs (and its variant spellings), which are scattered over the North and West of Scotland.

Some of these localities are shown in the figure below (Figure 6: The Tullochs of Scotland):

Figure 3: The Tullochs of Scotland

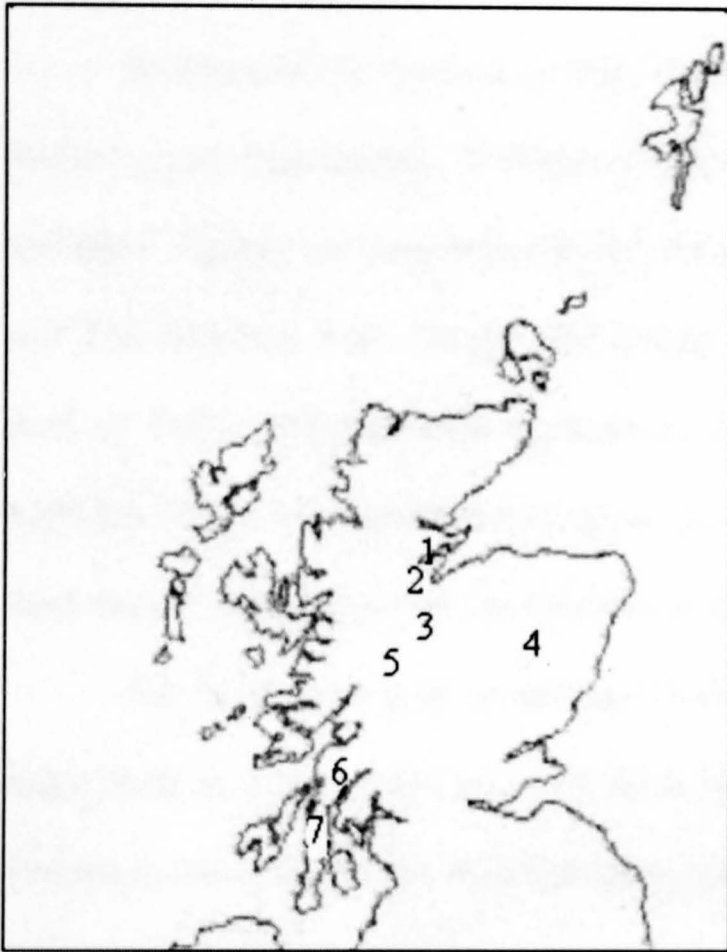

1. **Tulloch Castle** - a fine mansion one mile north of Dingwall.
2. **Tulloch** - a village one mile north of Bonar Bridge.
3. **Tullich** - a hamlet ten miles West of Tomatin.
4. **Tullich Burn** - stream two miles south of Ballater.
5. **Tullich Station** - outside Fort William.
6. **Tulloch** - two miles West of Balquidder.
7. **Tullochgorm** - a village six miles northeast of Lochgilphead.

If the rousing and energetic Reel of Tulloch or Hullachan was first danced by a congregation as they were standing in the aisles, this would perhaps account for the slimness of the reeling figure of eight form and the

symmetry of the setting and turning. 'With their compact travelling figures and well-contrasted periods of vigorous stepping, reels were ideally suited to the restricted dancing spaces available (Macaffer 2002: 2). Reels were therefore particularly popular within crofting regions where most dancing took place in the kitchens of croft houses.

Milligan and McLennan describe the portions of the dance: 'the Reel of Tulloch [has] eight figures' (Milligan & McLennan 1950: 9). One must assume that these 'figures' are the same portions of eight bars as were in The Strathspey and The Highland Reel. Should The Strathspey, The Highland Reel and The Reel of Tulloch be danced in succession, the repetition of the pattern of an eight bar refrain is maintained throughout the music of The Strathspey and The Reel timing, and also within the structure of the dances themselves.

The 'Hullachan grip' would have been well suited to such a restricted space such as a kirk. Once reserved for women, or possibly for a man and a woman in the swing where they link arms, each would put his or her free hand 'behind their backs to grasp the other's hand' (Thurston 1954: 54). This method by which dancers would turn one another has now become obsolete (Thurston 1954: 54). However the firmness of the grip remains in the present form, and it should not be forgotten that such a 'cleek' as Burns described (Burns ed. Barke 1990: 206), is also the word used for the propelling instrument when driving a gird, it being 'hooked' onto the gird (Chisholm Correspondence 2005). This dynamic and powerful image describes the firm grasp and inter-dependence which exists between dancers turning one another in the midst of a Reel of Tulloch.

Burns' 'Tam o' Shanter' describes a dance in which 'They reel'd, they set, they cross'd, they cleekit' (Burns ed. Barke 1990: 206). The 'setting' is most likely the addressing of the opposite dancer (without travel), the 'reeling' the travelling movement which was the common denominator within Scotch reels; the 'crossing' which described the figure of eight patterns; and the 'cleeking' was the linking of arms (Chisholm Correspondence 24/05/2000). These four components constitute what is known today as The Reel of Tulloch.

The association of witchcraft with the dance is not a novel idea:

So bewitching were the rhythms and figures of the reel that superstitious Scots detected in it the hand of the devil, who was said to turn up in person, in human form, or disguised as an animal. But despite church disfavour - which certainly repressed the spread of fashionable social dances - the reel never faltered in popularity (*Encyclopaedia Britannica* 1910: 250).

This is not a surprising connection in a society full of folk tales, songs and superstition warning about a darker spiritual world. The 1591 reference to the 'reill' danced by witches at Hallowe'en strengthens the association between this certain dance and the heady, unrelenting swirl of twisting movements notably mark out a floor pattern that is the universal sign for infinity (this pattern is shown in section 5:III:iv). Emmerson suggests that the 'affinity of the reel, as a figure, to Celtic scroll designs' (Emmerson 1972: 157) suggests an ancient form for the Highland Reel, as a form or motif which has been maintained within the convention of social dancing to this day. It is interesting to note that the PDANZ *Competition Rules, By-Laws and other Regulations* of 1927 refer to The Highland Reel as symbolising 'its own... motif' (PDANZ 1927: n.p.).

Tulloch is the Scots form of the Gaelic *tulach*, a hillock, and the *Rìghil a' Thulaichean* or *Ruidhle Thulachain* signifies the reel of the hillock. The full name of Hoolachan is *Rìghil a' Thulaichean*, but usually only the last word *thulaichean* is used (which is the genitive plural of *tulach*) and is pronounced 'hoolachan'. The name seems to imply that the reel was, or might be, danced on hillocks, or beside or among hillocks, where perhaps fairies were reputed to dance, and where human dancers presented a fairylike appearance.

R.H.C. asserts that 'the Hoolachan form of the reel is peculiar to Scotland' (C., R.H. 1928: 4). In the eighteenth century the influence of foreign dances and dance-styles was prevalent in Scotland and was bound to threaten the native form. Lady Nairne warns in her 'Country Meeting' of the infiltration of non-indigenous traditions:

But ne'er ye fash, gang thro' the reel,
The country-dance, ye dance sae weel,
An' ne'er let waltz or dull quadrille
Spoil our Country Meeting (Lockhart 1986: 17).

Burns, in his 'Tam o' Shanter', also portrays the indigenous dances as being those of most spirit: 'Nae Cottillion brent new frae France, but Hornpipes, jigs, strathspeys and reels put life and mettle in their heels (Burns ed. Barke 1990: 205). However, there was one significant foreign element which was and is to be found throughout the Scottish dance tradition and particularly in The Reel of Tulloch particularly: the *Pas de Basque*.

How the ballet step called Pas de Basque - which incidentally is an authentic Basque step used in the March des Mascarades by traditional Basque dancers - found a place in the Reel, as in more Scottish dancing, is an intriguing question. The answer seems to be: through French dancing masters. If so, it could only have been through its ballet connection, and that not before the mid-eighteenth century. What, then, was the Reel step previous to its introduction? Is there perhaps a truly traditional Reel step still to be found in unsophisticated places? French dances, fashionable in ballrooms, influences our native dances as they did in nearly every European country (Milligan & McLennan 1950: 11).

Emmerson explains that

[t]he ballet technique evident ... in the Reel in its allegro and Strathspey form has apparently come from European source. The obvious connection is with France, although the spirit is more Italian [there being] strong resemblance between the Galliard, with its variety of capers, alternating with travel, and the Scotch Reel (Emmerson 1972: 151).

It is likely that the balletic influence has become even more marked as dancing masters, trained in the principles of the French Academy, exerted their influence. The influence of Ballet was such that 'from their natural habitat, the high dances of the Highlands found their way into the studios of the city dancing masters' (Emmerson 1972: 156):

The great Scottish dance of the eighteenth century... was the Highland Reel, belonging to a tradition of highly cultivated virtuosity of footwork which places it on a technical plane far above normal folk dance and even above the 'cultivated' Country Dance (Emmerson 1972: 153).

The introduction of balletic elements which were utilised and modified by dancing masters and itinerant dancing masters brought about refinements in the traditional Highland dances. It is also likely that teachers and practitioners

of the day influenced the style of The Strathspey and Reel travelling steps which are 'the glory of the Scottish Reels [and] are wonderful in their variety, some are performed on the spot, while others involve some lateral travel' (Emmerson 1972: 170). There is no doubt that the virtuosity and theatricality of stage interludes would have left their mark on the Highland Reel.

The custom of 'clacking' fingers by the men when the women are dancing in the middle of the reel formation is mentioned by Anderson (Anderson 1900: 120) and McLennan (McLennan 1950: 39) but appears to have died out. McLennan relates an interesting story with regard to this custom and in particular with its association with the Fandango of Northern Spain:

A feature I noted in my youth in the dancing of Reels in certain parts of the Highlands - was the snapping and 'knacking' of fingers by excessively enthusiastic dancers, almost wild-like, especially in the Reel o' Tulloch when two men dance to each other. This I observed in Western districts of Inverness and Ross-shire. In late years when visiting Spain, the idea occurred to me that this finger-snapping greatly resembled similar snapping of fingers done by the people dancing the Fandango, especially in Northern Spain. To account for any possible or probable connection, I recollected the historical fact that in 1719, the King of Spain sent 300 men to fight for the Old Pretender, and although these troops were defeated in fights at Loch Duich and Glen Shiel and taken prisoners, it was generally believed that many of them did not find a way to return to Spain, but remained in the districts, and in this way, in peaceful times, they might quite conceivably have been dancing their own dances with their usual finger-snapping... which again may have been picked up by the local people (McLennan 1950: 39).

Similarly, Livingstone notes 'that Spanish dance... Fandango, where they clip their hands' (SA2003.035) may be connected in some way with the Highland tradition of finger-snapping. This theory is made all the more probable by the Spanish having no instruments to accompany their indigenous dances, so the

performance of their dances may well have relied heavily on the rhythms provided by their snapping.

The continental influence was not limited to Scotland's dances, but also the music. The eighteenth century poet Robert Fergusson warns against the influences of a classical style of violin playing that was becoming popular in Scotland:

Fiddlers, your pins i temper fix,
And roset well your fiddle-sticks,
But banish vile Italian tricks
 From out you quorum
Nor fortés with pianos mix,
 Gie's Tullochgorum...

For naught can cheer the heart sae weel
As can a canty Highland reel,
It even vivifies the reel
 To skip and dance:
Lifeless is he wha canna feel
 It's influence (Fergusson ed. Manson 1974: 122).

Not only does the poet give us 'Tullochgorum' as the name of the fiddle tune, but also it is specified as a 'Highland' reel.

The tune now known as Tullochgorum is commonly attributed to composer, fiddler and dancing master J. Scott Skinner (Lockhart 1985: 17). However, the 'Tullochgorum' is not to be confused with the dance currently known as the 'Tulloch Gorm': 'a solo Hebridean dance of 6 steps in 4/4 Strathspey tempo... sometimes called the Reel of Tulloch Gorm and... an earlier form of the Highland Fling' (SOHDA 1994: 55). The title refers to the

tune, although it cannot be ascertained whether it was one which accompanied a dance of the same name.

There is one further interesting reference to the 'Tullochgorum', sometimes erroneously called 'Reel of Tullochgorm' as being 'the earliest form of Highland Fling' (McLennan 1950: 21). No date is given for this dance but it seems to have appeared sometime after the Act of Proscription. It is not clear as to whether or not the author meant the comparison to be between the solo dance that is presently known as The Highland Fling, or simply a 'fling' that was somehow Highland in nature. Whatever the connection between the two, The Reel has, almost without exception, been referred to and recorded as a group dance, rather than a solo one. Scott Skinner's lines on the Tullochgorm certainly relate to a Tullochgorm which 'we... dance'. It is likely that the actual reference relates to the name of the tune, but nevertheless, it is a tune closely associated with an energetic and social dance.

Lastly (after the reeling and setting), we have the Reel proper, world-famed, brisk, and lively dance, and allied to it is the 'chief of Highland dances' (*The Celtic Monthly* 1912: XX, 209). A similar name is associated with the melody and Smith notes that the 'Ruidhle Thulachain, or the better known Reel of Tulloch... The air of that name is of great antiquity, and is called in the Highlands Righ nam Puirt or the king of tunes' (Smith 1865: 65). Why this should be the case remains a mystery as neither of these references is substantiated. However, perhaps it is the case that the first syllable of the Gaelic for Reel (Righil) is pronounced the same as the word for King (Righ). This is a

tenuous link and the popularity of the dance resulting in its being crowned in such a way will probably have to be consigned to the annals of history.

Like the Gillie Callum, this dance seems to be inseparable from the tune of the same name (Allan MacDonald transcript in Macaffer 2002: n.p.). In most parts of Scotland this dance is still performed to the tune 'The Reel of Tulloch' (Flett & Flett 1964: 148) or Tulloch Gorum (Logan, *Complete Collection of Highland Bagpipe Music* Tutor no.4). There have even been some instances where the dance could not be performed because 'The Reel of Tulloch' was not played (Flett & Flett 1965: 41).

Whether or not there is any truth in the antiquity of The Reel of Tulloch, its supposed origins in Aberdeenshire, or it being a natural development of The Highland Reel, the dance certainly seems to have spawned narratives concerning its pre-eminence as one of the oldest Reels, certainly the oldest one distinct in both name and form. It is true that 'Many of these stories are borne of legend and often the basics of these tales are somehow mystically and obscurely woven into the shape and contour of each dance' (Mill 1994: 36).

The following chapter depicts the state of the Highland dances in the early part of the twentieth century and the events leading up to the late 1940s and early 1950s when matters of adjudication were debated. The history of early competition, and matters regional variations are foregrounded. Developments in the area of competition are contextualised in the light of the changes which have taken place in teaching techniques and with the introduction of overall regulation.

Chapter Four: Rule-Making

4:I The Early Competitions

4:I:i The Competitions

The situation and nature of the Highland Games have evolved since they began and they have long provided an arena for fostering the art of Highland dancing. From the supposed origins of solo Highland dancing in the battlefields of clan warfare to the local competitive events of the twenty-first century, these events remain part of Scotland's living heritage. Although it has been commonly assumed that the Games in their present form were initiated by Queen Victoria (Flett & Flett 1956: 345), the events as we know them today were established in the late eighteenth century by the Highland Society of London. These took the form of a social gathering with a few days of festivities, the various competitions forming part of the entertainment as a product of all things popularly and typically Scottish.

The Highland Society of London was responsible for instituting the first bagpipe competition at the annual Falkirk Tryst of 1781 (Flett & Flett 1956: 346). As the name of the body suggests one would be led to believe that it was not an organically Scottish celebration, although it is thought to be the case that the society comprised Highlanders based in London. It was, however, the first of many similar events, significantly those organised by the Highland Society of Edinburgh in 1784, as 'an imitation of that in London' (Emmerson 1972:

242). It is possible that this London group of enthusiasts, who ran southern showcases of all things Highland, transported the increasingly popular event to Scotland, not just in name, but also in content concerning that which was supposedly Highland. These events were perhaps not so much local festivals as showcases of Scottishness and the 'wild' sports of the Highlands (St.John 1948: n.p.). There is little information surviving about the actual event.

The Falkirk Tryst, which originated as an annual cattle market, spanned three days. The cultural injection by the Highland Society of London was in response to 'a cultural concern about the loss of their traditional way of life' (Witta 1982: 96). However, this concern was felt by those expatriates and enthusiasts who, living in London, were removed from the oral tradition. Such a shared spirit of cultural exchange was found in smaller and more remote communities, and the instigation might therefore have been considered affected or artificial. There are no records which indicate the reaction of the Scots to what was perhaps an unnatural elevation of organic activity onto a new platform.

It was common around this time for dancing to be included in the proceedings but merely as a diversion for the audience, occurring as part of an interlude of entertainment, rather than as a competition or event in its own right (Flett & Flett 1956: 345). However, in 1783, 'several of the pipers afforded no small entertainment by giving a specimen of their agility... [and] spirit in Highland dancing' (Dalyell 1849: 103), a practice which was repeated by the pipers the following year and, eventually, in 1787, by dancers who were not

pipers¹⁶ (Flett & Flett 1956: 346). *The Scots Magazine* of that year reported that the company had been 'entertained... with Highland Dancing between the different parts of the competition (*Scots Magazine* 1781: 360) and Dalyell comments on the nature of what was originally a Piobairachd competition:

The tedium of the competition... is much relieved by the intermixture of that kind of dancing particular to the Highlanders. But whatever be its merits... it is distinguished less by grace than agility; for can anything blunt our sympathies more than beholding two brawny sons of Terpsichore leading up each other in measured time and pace; or the vehemence of greater numbers intermixing to sprightly music (Dalyell 1849: 103).

The relationship between Scottish piping and solo dancing is one which has tangled roots, the two traditions having been so inextricably linked that their close association can be traced back as far as the historical records for either tradition allow. This was, more often than not, because the military pipers were also trained as dancers, normally by the Pipe-Major who had to be proficient in both Country and Highland dance instruction¹⁷.

In 1795 Highland dancing competitions were instituted as part of Edinburgh competitions (*Scots Magazine* 1795: LVIII, 476) and the competitors were not necessarily also competing pipers. According to Joan Flett's research, the first games 'in approximate form to the modern Highland Games' were at St. Fillans, organised by the Strathfillan Society in 1819 (Flett

¹⁶ By 1795, money prizes were being offered for the dancing, although not as large as those for the long-established piping competitions (Flett & Flett 1956: 347).

¹⁷ Low ranking soldiers were trained in solo dancing which developed their fitness and stamina which was required for training in combat (SC2003.003). The social dances were the occupation of Officers, by which means they learnt the etiquette of conducting themselves in polite company (Henderson Correspondence 1999).

2000: 1). One assumes that this likeness to modern competitive dancing was the clear distinction that it was primarily for competitive purposes, rather than for display or entertainment. This event embraced some ancient athletic contests as well as the traditional piping (and some dancing). Adult and juvenile competitions were held in Highland Reels and the 'Ancient Scotch Sword Dance' took place. Unfortunately these came to an end in the 1840s just as the dances were establishing a firm root in the annual proceedings.

Little is known about the dances performed at early competitions. The first mention of a specific dance is in 1788 when Highland Reels were performed by the pipers. These continued to be danced until at least 1797 (*Scots Magazine* 1795: 476). Reels (presumably threesomes and foursomes) have been recorded in early nineteenth century Scotland as the most popular, or perhaps sometimes the only dance (Flett & Flett 1956: 347; Macaffer 2002: 19).

The next dance of which we have a record is a Strathspey two-some, which was danced by two couples at a time. Rankine writes: 'It is reasonable to assume that this was the forerunner of today's Strathspey which always precedes a Highland Reel and almost always precedes a Reel of Tulloch' (Rankine 1977: 13). It is recorded that from around 1816 other dances were introduced and that tests for the dancers were held a day or two before the public meeting (Flett 2000: 4). It is recorded that The Reel of Tulloch and the Sword Dance were introduced to major competitions in 1829 and 1832 respectively (Macaffer 2002: 19). In 1841 and 1844 prizes were also awarded for a solo 'Strathspey Dance' which appears to have been the Highland Fling (Flett 2000: 5; Macaffer 2002: 19). Emmerson observed that 'When one

considers the central position accorded the Highland Fling among Highland dancers today, it is remarkable that it was not introduced to dance competitions until around 1840' (Emmerson 1972: 183) by which time, it had become part of competition proceedings, having been commonly part of social proceedings much earlier.

There is evidence from a letter written by Allan Cameron McKay of Strontian to the organisers of an Edinburgh competition in 1834 which suggests that non-Highlanders did not have sufficient knowledge or skill to play for Highland dancing:

A.C. McKay took the liberty... to suggest... [that] the reel of Tulloch... [and] the sword dance hornpipe [should be] played to [sic] by his native music - Edinburgh musicians may play well enough for Quadrilles and Micolanzas. But they are certainly insufficient to play Gillie Callum. Highland Laddie and Highland Fling - with - over the Hills and Far Away - are in his humble opinion worth the viewing (Dalyell 1849: 93-102)¹⁸.

This is a valuable record of the dances considered, albeit by one vocal enthusiast, to be enjoyable both to the dancer and the spectator. Six years later, the Northern Meeting, held in Inverness, introduced Highland dancing to their competitions, by which time the Seann Triubhas also seems to have been included in such events (Macaffer 2002: 19).

¹⁸ The use of the term 'hornpipe' is most likely a generic term for a step dance, rather than an indication of the style of accompanying music (Emmerson 1972: 246).

Emmerson, writing in the early 1970s, lamented that 'some of the old gatherings, even in the heart of Strathspey... have been discontinued, but the Braemar, Oban and Glenfinnan gatherings are happily still with us and loyal to their old traditions' (Emmerson 1972: 249). Braemar Highland Games is one of the best known still in existence today, having begun in 1832 (Flett & Flett 1956: 345). The programme from 1848 consisted of 'reels and [the] Gillie Callum' (Queen Victoria 1861: n.p.). By 1853, the dancing competition included The Highland Fling, The Reel of Tulloch and The Seann Triubhas.

These dances, in name at least, comprise the competitive repertoire. Livingstone remembers these dances being performed in the early twentieth century: 'A Reel, a Foursome Reel... but not so much Foursome Reel, it was more just The Fling and The Swords and The Seann Triubhas' (SA2003.035). The only interruption to this established norm seems to have come with the First and Second World Wars, before which the only competitors were male. This changed as male competitors became scarce and females began to compete in their place:

I suppose the people just danced pre-war, they didn't have the money or maybe... It must have been after the war it changed... There was no dancing at the Northern Meeting, just piping competitions... Some Games... had a separate competition for the boys (SA2003.035).

However, female competitors were not commonplace for another fifty years.

The records of which dances appeared at the early competitions, and who danced them, are sparse. It is known, however, that by the twentieth century, the five main Highland dances, (as introduced in the previous chapter)

were commonplace and that by the 1920s it was becoming more common for girls to appear on the platform. Continually improving public transport systems also meant that by the 1930s dancers were not limited to local events but travelled to participate in others which were larger, often in cities, where titles were more hotly contested and the prizes more prestigious. This meant that the pool of cultural exchange was increasing, as dancers travelled increasingly further from their homes in order to compete. This inevitably meant that their dancing, like their dialects, would differ and, in some cases, be very distinct.

4:I:ii Regional Style and Individual Variation

Morrison, who competed in Highland Games of the 1920s and 1930s, recalls that 'People did different steps' (SC2003.003). This controversial freedom of interpretation is remembered by other competitors from the early twentieth century. Ex-world championship winner, Janet Gardner, reminisces about her experience of competition at this time:

When we danced, it was a case of, you went up and done your own thing. It didn't matter if you were doing different steps from somebody next to you... Competitively, it was the steps of the dance... You went up and done your own thing... Once I got up there, I'd say 'I'll change it, I'll do another step (SA2003.034).

Similarly, Sheila McKay explains the manipulation of component parts:

It was executed in a different way. Like, ye ken how you do yer shedding and your double shake-n-rock? [gestures] Well, you would [be] dae'in shedding than you would come onto *this* - entirely different foot, right? [gestures] And then you would come from that and maybe do a backstep on the back o't... The movements are the same, let's say, but they've been put in a different way (VD114b).

In the same way, Livingstone recalls some of the variations between the dancers: 'Some of them were very sort of... floppy... Some of them had different ways of holding their... hands up... And some of them had ways of turning' (SA2003.035).

Moreover, to the observant dancer, these differences went beyond the arrangements of steps. Within the style of the dance, influences common to

certain geographical areas could be determined, as there were 'different styles, different places' (VD114b). Gardner recalls that she was known by the other competitors as 'the wee Fifer' (SA2003.034) and Billy Forsyth recollected:

There was a lot of moving around... And because you did that, you came up against a lot of individuals from different parts of the country. So you did get a feel for the differences but at that sort of age of five to ten it wasn't something that you tried to analyse... there certainly were differences between the areas... And there were differences in the way dancers did things... You felt it at the time, that they didn't dance exactly the same as you did (SA2003.036).

Mill was also aware of differences in execution:

Basically you could tell the district... you could tell like, for example, if the... dancer was from, say Aberdeen, the Fling turned, they turned with the arm up, in second. Whereas Dundee dancers held the arms akimbo... There was a little variation you could see in the steps, but not so much the steps, I would say more in the deportment, the selling of... the dance rather than the actual steps... If anything maybe the West Coast dancers danced... slightly... more in tempo. On the East Coast here, I think it should have been the other way round because most of the dance bands and that at that time came from the East Coast. Whereas there was hardly any dance bands... But I would say the West Coast dancers were slightly better tempo wise than we were on the East Coast (VA2003.007).

Gardner recalls a similar issue of tempo. She claims that dancers from the Aberdeen area were 'softer... nice dancers' but slightly more erratic, as one movement was 'sort of even, and then maybe catch up [with the next]'. She claims that it was her fellow Fifers who were 'on the solid beat' (SA2003.034), rather than the West Coast dancers, as suggested by Mill.

Gardner also describes in more detail a style of dancing from the North of Scotland, which had 'a different beat in the music' (SA2003.034):

I would go up to the Games... Aboyne, Ballater, Aberdeen, Old Meldrum all in that area. You just done the same steps as everybody else, but they were softer dancers, they were... They were softer, more flowing, you know. It was softer, more balletic... It would be so, as I would say 'technical', even up in the North (SA2003.034).

Forsyth also mentioned an older competitor, Willie Smith, who, although from Markinch, Fife, had traits of this Northern style:

He was a softer (by a long way, a softer) dancer. And more perhaps akin to what I would recognise as an Aberdeenshire style of dancing - a softer style of dancer, without the energy that you would expect from people on the West Coast (SA2003.036).

Forsyth explained that, in common with Aberdonians, the Fifers 'tend[ed] to have a bit of a softer style to it... and you kept getting the feeling that within Fife there wasn't the same emphasis on getting off the ground' (SA2003.036; VD114b). This lack of vigour is also mentioned by Gardner, who reckoned that Aberdonians 'didn't seem to put so much into their dancing' (SA2003.034). In contrast, the 'energy' ascribed to West Coast dancers by Forsyth would certainly account for Mill's impression of strict tempo¹⁹.

McKay [SM] and Forsyth [BF] compared, in conversation, their experiences of different dancing styles within competition:

¹⁹ Further illustrations of different interpretations of steps and characteristics are shown in Chapter Five.

BF: One of the things I remember from way way back, when I was quite young... a girl... from Wick... dancing in Edinburgh and danced the Fling. To me, it looked like a St. Andrews cross because the leg was out there and the arm was out there [gestures opposite limbs diagonally stretched]. There was no shape tae it at all.

SM: We've always had our arms there [Gestures third position SOBHD 1996,14:28]... You had to have your thumb and that [middle finger] joined... And none of this open hands, now. You'd be like a boxer [gestures First Foot Position, SOBHD 1993,13,25]... The very Northern dancers... that's how they used to dance their Fling.

BF: Very wide.

SM: Yes, very wide. But their fingers were still right, but they were out like this [gestures opposite limbs diagonally stretched] and they never held their arms on the waist, it was always...

BF: Always below, on the hip bone (VD114b).

One of the recurring regional features which was recognised by both Livingstone and Morrison was 'The Aberdeen Beat' (Morrison 2000: 3; SA2003.035; SC2003.003):

Bobby Watson was another dancer whom we admired but I never liked the way he and some other Aberdonian dancers thumped the back foot on the boards when doing the pas-de-bas... it seemed to be a localised habit. However, I notice that my granddaughter Mairi, who was being taught Highland Dancing in Skye, uses the 'beat' and, although I don't approve, I told her to continue using it as that is what her teacher obviously wants (Morrison 2000: 3).

Livingstone cited the example of Aberdeen dancers using the same step in the Gillie Callum: 'We didn't thump like that... They thumped a lot, especially at the sword dance. You know, when they would go over the sword, they would

thump' (SA2003.035). Forsyth asserted that it was stylistically similar to the firmness of the West Coast style of dancing with which he was familiar. However his training from ex-world champion Cuthbertson (whose school was based in Glasgow) did not emphasise the noise of the beat, but rather the practical reasons for having a firm placing of the rear foot:

It was something that was always emphasised to me. It wasn't the sound, it was the movement. And this was always the distinction that was made. You could get many dancers who did a one and two - and they really hit the ground and you *heard* it. That wasn't the reason for doing it. The reason is to get the movement in and get that [working foot] extension out. And the beat *itself* was there, but it wasn't an emphasised *sound*; it was an emphasised movement, more than anything (SA2003.036).

The informants gave little indication of why the dancers had different styles. They generally agreed that there were no major physical or economic reasons, but that the variations in this specific form of cultural expression were as a result of social and geographic differences. It seems that these differences were evident to dancers and that they were tolerated as part of the rich cultural tapestry of Scotland. It has not been recorded that there were any incidents of prejudice or exclusion at this stage due to differences in style and discrimination does not seem to have been an issue between the dancers themselves. However the judges inevitably had their own style and therefore their own preferred mode of execution. Fair competition therefore did concern the dancers.

4:I:iii Adopted Styles

The differences of style sometimes worked in the dancers' favour. Competition judges were, prior to 1950, subject to no system of vetting, neither did they require any specific qualification other than appointment by the local Games or Highland dancing organisers. They tended to be local to the area and would inevitably have been trained in their appropriate regional styles. Livingstone, who was trained in the military tradition, recalls the advantages of such variation in the judges' experience:

If you went to the Games and the adjudicator was an ex-army man, Bingo! You had a good chance of getting 1st, or 2nd, or 3rd... The year I won the Fairburn Challenge Trophy, the man that was judging was an army man, MacLean was his name [Alasdair MacLean of Pennycross]... and he liked army dancing... So that was all right because he was an army man, so you were all right there (SA2003.035).

Morrison's memories are similar, as she was also taught dancing by a Pipe-major: 'when Brigadier Alasdair MacLean of Pennycross was judging, he usually gave us a prize' (Morrison 2000: 4).

The teachers' preferences were also often apparent (SA2003.035) as Gardner notes: 'Dundee dancers, not so good on the Highland, but good in Jigs and Hornpipes... North dancers – basic... Fife and the West of Scotland, they were the stronger dancers at that time' (SA2003.034). In the same way, Livingstone recollected particular dancing schools whose dancers were easily identifiable:

You just got to know, you would say 'Oh well, she was taught by Alice Bain, she was taught by so-and-so... she was taught by Chrissie Gray' you just got to know them, because you were with them so much, I suppose... Alice Bain... her dancers... flopped about an awful lot... Some of them, when I was younger, they danced, flapping their feet around the support foot... Now, Chrissie Gray's dancers... I think they were inclined to do an awful lot of head movements (SA2003.035).

Forsyth gave an account of his winning the World Championships throughout the 1950s, a result that was partly due to years of re-training in style. He moved from a local teacher in Bridge of Allan, Stirlingshire, to Glasgow-based Willie Cuthbertson, World-Champion of the 1930s and 1940s:

He gave me what was very much and what would have been described as a Cuthbertson style of dancing. And whilst again it tended to be tied into the Glasgow area, it can't possibly have been purely Glasgow, because there were a number of people that had gone from Glasgow tae other areas that were teaching. So it must have been something that was done elsewhere. But it was very much more an aerial style of dancing... The way I was taught by Willie was very much in the air, was very much his own style and that of his brother, Bobby, and the 'Cuthbertson style' (as it was known) was very much a very masculine - using aerial cutting and very much getting off the ground, using the strength that a man would have (SA2003.036).

This strength and elevation seems to exemplify West Coast style, as observed by Mill, Forsyth and Gardner. McKay added that she could tell the difference even between the two Cuthbertson brothers, and likewise, which pupils were taught by each:

I could tell which were Bobby's pupils and which was Willie's, anybody at that time could... Oh well, there were just certain things that they dae different... lots of things, lots of wee things that the ordinary people watching would never see, but people that studied dancing knew about (VD114b).

These differences in style were perhaps all the more noticeable, since the brothers trained world championship winners. Those dancers on the prize winners' platforms who were trained up by past champions would have inevitably had a strong commonality of style.

Forsyth adds that 'If you take even Bobby and Willie Cuthbertson, the style of Highland dancing that they did was completely different to the style that Jimmie McKenzie did' (VD114b). Sheila McKay accounted for the differences between the dancers being due to regional background, notably, in the case of McKenzie who had 'the Aberdeen style' (VD114b).

It is generally agreed, among those who were the leading lights of competitive Highland dancing, between the late 1930s and 1950s, that there was some degree of composition within the dances appearing on the competition platforms. Forsyth claimed that 'the accusation was always that... it didn't matter which teacher you went to at that time, they all produced [composed] steps' (VD114b). Mill also confessed that:

Deep down I think they did [choreograph] because every so often when you were watching them or admiring them, when I was a wee boy in the Juveniles, you used to think... 'I've never seen that before' and 'oh look what he did there'. There was always wee tricky bits that they put in (VA2003.007).

The thrill of unpredictable competition is evident in Mill's following description of a competition which was highly charged:

Because they were characters!... In those days you went to the Games and as well as competing for a prize which was the object of the games,

they were competing against themselves and we used to love going to these Games week in and week out and saying 'I wonder what Watson's going to do this week, will he do this step or will he do that, and I wonder if McKenzie will do this and what have you. And you could see they were fighting against one other. Not just... Watson/McKenzie, there was Jackie Grant, Andy Sullivan, and [others] (VA2003.007).

It was these exponents of the tradition who were, in the words of Forsyth, 'the more outrageous ones that you tended to notice' (SA2003.036). They were highly motivated to create and recreate steps in order to keep the competitors, spectators and judges on their toes.

The following account from Forsyth shows the adaptability that a successful competitive dancer would have to master:

When I was... a juvenile and travelling around the country, there was a *need*... to dance in the style of the *way* they danced in that particular local area. And the simple reason for that was if you didn't they decided you weren't dancing the way *they* liked to dance so you didn't get into the prize list. And it became very much a case of horses for courses. If you went up the West Coast (up by Fort William up to Mallaig) then there were certain steps and certain orders that you did up there that you wouldn't even think of doing if you were in Fife (because they had a different idea of what dancing should be like). So you adapted to what was required in the local area and that was purely and simply because if you didn't than you were nowhere within the prize list (SA2003.036).

It was at such Games which took place across Scotland pre-1950 that dancers would often incorporate the steps introduced by successful competitors, as well as the local variations which commonly appeared on the boards as a matter of course. Dancers would therefore become adept at assuming different styles and sometimes even steps in order to win competitions, as Gardner explained:

Most of the judges going round the Games were ex-dancers, and you knew what that judge liked. You could be on a soft-approach or middle-approach or the ballet-approach... You changed your style for that day... But this is how they did it. I admit I did it myself... 'Oh he likes good, wide highcuts' or 'She likes the soft approach'... a lot of them did. If you danced too soft... We played the game, of course we did, and it paid off. It's like everything else... if you can't beat them, you've got to join them (SA2003.034).

Similarly, McKay commonly featured in the prize lists of the 1940s:

When I was taught... I had dances for Aberdeen, I had dances for Edinburgh, I had dances for Stirling, I had dancing for Glasgow and dancing for Fife. Now, if Aul Gruan was judging someplace in the Dundee area, I would do his steps if my Mother knew what he liked. If I came into Fife here, I would do what 'Old Warmsley' liked (VD114b).

Competition seems to have had a great influence on the growth and change of the styles which were used, in that the desire to win dictated to a certain extent how the dancer chose to dance, both in style and in content. There seems to have been an exchange of information between dancers, of a non-verbal nature, whereby the dancers observed, practiced and subsequently performed steps and styles from areas of the country other than their own.

Successful placing in the competitions was therefore closely reliant not just on the dancer's skill but also on the competition experience and guidance of their teacher. Forsyth was one who regularly gave a canny performance, having been trained and informed by Cuthbertson:

My original forays up into the West Highlands in particular were very much on the back of stories that I got from ...Willie Cuthbertson. And one of the things that he said was that if you go up there and you dance

up there, it's a different style of dancing. And if you don't adapt to it then you're gonnae have to do or rethink why you're going... But it was something that you had to do. 'Cause it was as simple as that... So I got a lot of the background to where he danced and when he danced and *how* he danced and who the other people were at the time. (SA2003.036) The advantage I had was that Willie Cuthbertson had been there. So he could guide me and he could tell me (VD114b).

Dancers therefore became skilled at imitating successful competitors, accomplished at adopting a regional style as their own and practiced at dancing new techniques.

4:I:iv Judging and Judgements

A different style of execution could work against the dancer, however, should it not be to the judges' liking. This variety was nothing new, as until the mid twentieth century, the individual dancer was able to set his own sequence of steps and timing just as dancing masters had similarly established their own standards in the two previous centuries. Despite the publication of Peacock's technical descriptions of dance as performed in the Highlands (Peacock 1805)²⁰, there was no national consensus with regard to a standard mode of performance. The dances found in competitions and in dance schools varied significantly in all parts of Scotland. This inevitably led to debate and discussion as to the 'correctness' of the dancing appearing on the competitive platform, and the diversity of performances.

Similarly, there also seems to have been a legacy of debate regarding the fairness and quality of judging competitive pipers. The ground-breaking Falkirk Tryst lost many pipers after the competition of 1783, when, much dissatisfied following decisions made by the judges, they went to Edinburgh to find other patronage and, to their minds, a more favourable result (Flett & Flett 1956: 346). This seems to imply that the personal preferences of the judges were obstructing what the majority of the pipers considered to be a fair result.

Lowe gives a résumé of what he considers to be a good Highland dancing judge:

²⁰ Peacock taught in the Aberdeen area from 1745-1805.

A dancing judge has a difficult job, and must be knowledgeable about the Highland dance. It is almost impossible to be a judge, if at one time one has not been a dancer, but there are some quite good judges who might be described as 'frustrated dancers'. They have studied the art of Highland dancing, know how it should be done, yet cannot themselves dance. I always think that a dancer has more confidence in the judge who dances himself and knows every step and every variation of the dance he is judging. After all, if you want an operation carried through successfully, you would not send for a blacksmith. You would call for a surgeon (Lowe 1976: n.p.).

Livingstone confirmed that there was a possibility that there could have been a judge with little or no experience of actually performing Highland dancing:

If you went to the Games and it was somebody that didn't do dancing, which was quite often - they were pipers, but they weren't dancers - they were there to judge the piping, and they just took on the dancing (SA2003.035).

However, Gardner recalled that the judges were, by the 1950s, chiefly 'ex-dancers, mostly dancers, people who had danced' and that the number of military judges were on the decrease, there being 'some pipe-majors... but not very many' (SA2003.034).

The Highland Regiments had a strong tradition of dance, as Morrison recalls:

Before one could become a Pipe-Major or a Pipe-Sergeant... You had to learn Highland Dancing as well. So my Father [Pipe Major Malcolm Chisholm] would have been taught Highland Dancing. He was taught by John MacDonald, the famous Pipe-Major John MacDonald, but also by... Robert Meldrum, he was from down Aberdeen way. He was one of my Father's tutors. So my Father would have been taught dancing by one of those (SC2003.003).

This style of dancing is described by Livingstone as 'precise, very neat' (SA2003.035). Whether or not the judges at these competitions had experience as dancers, the piping tradition certainly shares competitive antecedents with the dancing tradition, and they also share a competitive ethos, which is manifest in the number of competitions for piping and dancing which still exist in the twenty-first century.

These differences between areas, schools and traditions yielded some interesting results: 'When on the games circuit the prize list would depend on who was judging and which system they approved' (Morrison 2000: 4). Livingstone recalls one judge who didn't favour her style: 'There was one I remember... well, if you went to the Games and he was judging, you could say goodbye. He didn't like army dancing' (SA2003.035) and Morrison gives a similar account:

It was Angus MacPherson of Invershin... he seemed to have different ideas. And he hardly ever gave us a prize. He couldn't have approved of our dancing. And I have a feeling that is because perhaps we were more to the military style... He very rarely gave a prize to any of our family as I think he and Dad had different ideas about dancing and piping (Morrison 2000: 4; SC2003.003).

Many of the innovations which periodically appeared on the Highland dancing platforms were generally accepted by dancers all over Scotland, as is the nature of a living tradition. Dancers would produce, as a means of expression, their own interpretation of the dance, based on the foundations of existing traditional and contemporary technique, which was then introduced to competition. Had this practice not been popular in the eyes of aspiring dancers, and encouraged

by the teacher, one assumes it would not have been such a large problem as it was perceived to be by competitors and judges alike.

Forsyth notes another unregulated area within Highland dancing, as prior to 1950 there were no rules defining the term 'amateur', which also led to dispute. There being no rules to give a clear definition of the status of the amateur dancer, the term 'amateur', in most instances, was 'merely farcical' (SOBHD 1955: ix-x). On the topic of dancers entering more than one age group, Forsyth admits that participants 'were all fiddling things' (VD114b).

Similar problems arising from a lack of clarity regarding the status of dancers and varying standards of organisation of competitions is mentioned by Pipe-Major G. Douglas Taylor in a letter dated 10th August 1950:

I have also been told by competitors, who should have been the prize winners, they sometimes want to compete and judge the same event... [also] a rule might be made as to number of dancers on Board at once, I have had six, at White City, impossible for Judges [sic], and unfair to Dancers [sic] (Appendix 8).

Gardner recalled that, without regulation, a broad range of ages would compete together:

In these days... when we danced, we either had to dance 'under-twelve'... [or] 'under-sixteens' and the next group was the adults. Nowadays you can get a group for every year of a child's age. You get nines, tens, elevens, all the way up. Well, they're dancing with children their own age. I mean, when I was four and a half I was dancing with eleven year olds (SA2003.034).

Fair judging was therefore high on the agenda of any competitive dancer. Not only did the dancers vary their steps and style in order to suit the known stylistic preferences of local judges, but there were also often issues of fairness within categories. Variation in the standards of adjudication and administration at competitions and Highland Games was also a matter of concern. These concerns inevitably led to great dissatisfaction and continual complaints (Flett 2000: 5).

4:II The Formation of the Scottish Official Board of Highland Dancing

4:II:i Consequences of Management

The confusion arising from matters of consistency in regulation was a major concern of the Scottish Dance Teachers' Alliance, which had been formed in 1924 by professional dancers of Scottish descent²¹. The SDTA made the initial move 'towards bringing this unsatisfactory state of affairs to an end, by advocating the establishment of a representative board of control for Highland dancing' (SOBHD 1955: ix). This took the form of a conference which was held in Edinburgh on 2nd April 1925, the primary aim of which was to preserve the traditional style, the main thrust of the discussion being that innovation and variation was incorrect (McLennan 1952).

The breakdown of authority in Highland dancing which led to the 1925 conference may have been a direct result of the death of William McLennan, who was universally recognised as the foremost exponent of his time. He might be considered the link connecting rival exponents of the tradition as his style was followed by well-known dancers, across Scotland, such as John MacNeill of Edinburgh, John McKenzie of Glasgow and J.A. Pirie of Aberdeen²².

²¹ The Society was formed 'in protest' that Scottish dancers were not fairly represented by the Imperial Society in London. It included members from Ballroom, Ballet, Scottish Country and Highland traditions (SOBHD Correspondence 2005).

²² These dancers went on to become teachers and then produced their own champions, the most prestigious of which were probably James Lumsden (J.L.) McKenzie and Bobby Watson who dominated the competitive dancing world of the mid 1900s.

The guidelines of execution and style of Highland dancing which were adopted as a standard by the conference were primarily formulated by D.G. McLennan, who was then representing the dancing of his late brother (McLennan 1952: 11-12; Appendix 7).

It would appear that the Edinburgh Conference of 1925 did not have the impact on stabilisation that had been expected. The meeting had not established an administrative body which could have functioned to regulate the activity, but only put forward suggested 'Rules' as a 'Guide for Judges, Competitors and Teachers' (McLennan 1952: 11). Matters of control therefore continued to be debated until, in 1949, there was a move made to establish a new body which would be 'representative of all associations or individuals interested in the art of Highland Dancing' (Appendix 2).

The Minutes of the Scottish Dance Teachers' Alliance Highland Branch meeting held on 28th August of that year state that 'there was a good attendance of members' including a guest from South Africa (Appendix 1). The matter of the effect of a 'new Highland Assoc. [sic]' was discussed. However the content of the contributions made in the several statements given by the members was not disclosed, as the secretary notes that 'some [being] farcical, some serious... it would not serve any useful purpose to disclose [them]' (Appendix 1). It is known, however, that the proposal for Highland Medal tests 'caused quite a sensation' when it came to be known that, should they be sanctioned by the 'parent body', there would be 'almost 200 applications without delay'²³

²³ These tests were to be in the same vein as those subscribed to by Ballroom dancers under the government of the Official Board of Ballroom Dancing.

(Appendix 1). The implications of such a move were the need for an established syllabus as well as standards of execution.

However, the radical re-shaping of the Highland dancing tradition did not stop there, by any means. At that meeting, there was proposed the formation of a 'Highland Official Board' (Appendix 1). A somewhat prophetic statement was recorded as being given by a Miss Lindsay who said that she thought 'a little difficulty would occur at the beginning, but that the time would come when the Official Board of Highland Dancing would be looked upon as the governing body' (Appendix 1). It is recorded that there was no dissention, but that the following recommendation was made: 'the S.D.T.A. [should] get in touch with all Associations interested in Highland Dancing with a view to forming an Official Board of Highland Dancing' (Appendix 1)²⁴.

Following the meeting an invitation, dated 22nd November 1949, was sent from the Honorary Secretary of the Scottish Dance Teachers' Alliance to delegates of associations, individual addressees, and 'any such responsible association or individual' with an interest in Highland dancing (Appendix 2). The proposed meeting on the 15th January the following year was, in essence, to discuss the proposed functions of the 'board of control'. These were set out as follows:

²⁴ The organisations contacted were as follows: 'British Association [of] Teachers of Dancing, National Association [of] Teachers of Dancing, Imperial Society [of] Teachers of Dancing, UKA [United Kingdom Alliance of Professional Teachers of Dancing], Scottish Highland Association' and 'N.B.R.A' [National Ballroom Association]. (N.B. the last was added to the minutes by hand). '[An] objection was taken to one of the Associations mentioned, but after a lively discussion, it was agreed to ask all associations' (Appendix 1).

To standardise the technique of Highland dancing.

1. To formulate rules governing the status of Amateur and Professional dancers;
2. To formulate laws governing all types of competitions;
3. To control the granting of championships;
4. To ensure that only those that are competent are allowed to act as judges at any championship or recognised competition;
5. To deal with any important matter relevant to the art of Highland Dancing (Appendix 2).

In response to the proposals, and in advance of the meeting, J.L. McKenzie, a member of the Scottish Dance Teachers' Alliance wrote to Captain Davidson, an independent delegate, on the 12th January 1950: 'I hope there will be a good attendance and that something will transpire... I don't think however it should be under the jurisdiction of any particular society, but a combination of all' (Appendix 3). In his postscript, he expresses that, in his position as a dancer and active competitor, the establishment of such a board of control would make it 'very difficult' for him, perhaps with regards to certain inevitable restrictions of conduct. However he also concedes that, for the sake of 'the art of Highland Dancing and the competitions... [dancing] should be of a high standard' (Appendix 3). This implies that there was no such consistent standard, and that the establishment of a ruling body might offer a solution.

In the corresponding letter from Captain Davidson to J.L. McKenzie²⁵, Davidson reports that Highland dancing judge Lieut. Col. A.G.L. MacLean had contacted him, assuring him that as long as the attempt to form a board of

²⁵ The letters are both dated 12th January 1950 but neither seems to be a direct response to the other. It can be assumed therefore that they were written concurrently on similar issues.

control was inspired by McKenzie, he would be willing to attend the meeting, being reluctant to support 'anyone else trying to run it' (Appendix 4).

At this time the 'Control Board' had not yet been authorised or formed and was only in 'interim stage' (Appendix 7). However, according to the minutes distributed at a subsequent continuation of the meeting on 15th January 1950²⁶, this date was recorded as being the 'inaugural meeting of the Scottish Official Board of Highland Dancing' (Appendix 5).

²⁶ The meeting was adjourned and continued on 16th April 1950 (Appendix 6).

4:II:ii Regulation of Technique

Following these developments, a correspondence took place between Davidson, then an Honorary Member of the newly formed SOBHD, and G. Douglas Taylor, President of the Scottish Piping Society of London. In his letter dated 25th July 1950, Davidson expresses a concern with the qualifications of J.L. McKenzie and D.G. McLennan as members of a technical committee, since 'neither of these gentlemen have had experience of the Argyll or Lochaber Broadswords since... both dances are to a great extent confined to the Army' (Appendix 7). This was simply an example of the inherent problem of one man's limited experience and perhaps implies the need for a broad range of board members and, accordingly, experiential qualifications. However, neither gentleman's discretion being called into question, McLennan was proposed for membership of the Technical Committee by Davidson (Appendix 7).

In his reply to Davidson, written on the 10th August 1950, Taylor responded to the inaugural meeting which had taken place earlier that year, explaining that he found the 'agenda, and... discussion... interesting reading' (Appendix 8). He echoed the concerns which Davidson had expressed, venturing to suggest that piping societies should perhaps be 'co-opted', without voting privileges, in an effort to broaden the range of the body's experience and also in acknowledgement of the close relationship between pipers and dancers (Appendix 8).

The first meeting of the new Technical Committee was held on the 8th October 1950, at which the newly appointed President of the Board, Harry Fairley, addressed the company, clearly defining the purpose of the meeting as

not to endeavour to impress any particular style of Highland Dancing on the rest of the world... not to standardise Highland Dancing, but to stabilise it, so that Caledonian Societies and Highland Societies all over the world would have a technique that would remain constant for a considerable number of years (Appendix 9).

Similarly, MacLean, who was elected Chairman of the Technical Committee, assured the members that 'he would like to emphasise what Mr. Harry Fairley had said regarding the meeting being impartial and not desiring to push any one particular style of Highland Dancing' (Appendix 9).

However, despite the care that seems to have been taken to establish a fair and representative group of individuals and associations, in order to form a well-balanced governing body, the accusation was still made that members of the council were not representative of Scotland's dancers or their experiences. The composition of the first Technical Committee seems to be a focus for this culture of blame. McKay claimed that:

Everybody that was sitting on that Board didna ken these old steps... None of them knew the old dances... Nobody knew it... there was nobody from Fife went to that first thing... they had a lot of good folk, but there was nobody fae Fife... The *really old* dancing... that was all lost, definitely lost (VD114b).

Similarly, Gardner explains the inevitable restrictions of such a select sample of dancers and potential rule-makers:

The Official Board only had to go on by... all the people who joined at the time were taught with... There was nobody came in and said 'We have to do *this* step'... they just gathered them all together, formed a few committees... you have your Executive Committee, you have your Examiners Committee (SA2003.034).

However Forsyth, aware of the accusations, is certain that the Board was, in its essence, representative, as indicated in the following two assertions:

It was always claimed at the time (and for a number of years, I would say probably the first ten years of its existence) that it didn't truly represent the competitive dancers. It was always said that it was a Board that had been formed by people who did dance examinations and not competitive dancing... The truth of the matter is that... it was one of the very well-known competitive dancers who suggested it, right at the very beginning - that was Jimmy McKenzie from Aberdeen... So whilst that claim had always been made... it was never really justified (SA2003.036)... When the Board's technical committee first started... they took all those different ways... If you go back... to the early days of the technical committee of the Board, we're back into the early '50s here... What they *apparently* did was try to get a basic dance and to use the different versions that had been done in different parts of the country as *alternative* versions of different steps (VD114b).

In the same way, Lynn McLaren, judge, teacher and a member of the SOBHD since the 1950s, is confident that the Technical Committee was assiduous in its collecting and promotion of technique:

There was [sic] lots of different teachers... Jack Muir was one of them, he was the Chairman of the Scottish Official Board at that time and Jessie Stewart was on of them and Cissy Tucker and... there was all the older Highland dancing teachers all got together and worked things out as to how the technique would be (STDT 06/10/1998).

Cameron, of New Zealand, painted a stark picture of those who considered themselves to be authorities within the field of Highland dancing. He seems to have valued something other than first-hand experience of the tradition: the ability to interpret, imitate and innovate. In a letter dated 23rd November 1980 he remembers the words of D.G. McLennan: 'as [he] used to say to me "they must feel the dance flow through the body, and know the foundation of the steps they dance" ' (Cameron Correspondence 1980, in Witta 1982). McLennan and Taylor had 'a Ballet background' which, in Cameron's opinion, equipped them fully for the task of 'research[ing] the movements used in Highland Dancing' (Cameron Correspondence 1981, in Witta 1982). Cameron's views were evidently borne out of a faithful following of one of the self-acclaimed experts of the day:

Not only should you know the history and tradition and changes in a dance; but it is an added advantage to be able to dance the changes when demonstrating. Old Mr D.G. McLennan and I spent many hours on this (Cameron Correspondence 1982, in Witta 1982).

However this degree of balletic, and therefore international advancement, within such a technical committee is perhaps the refinement about which some were sceptical:

It has been dominated, overwhelmingly, by people of the city and not by Highlanders and so it's generally called Highland dancing, strictly speaking, the way that it's done now is not the dance of Highland people and has not been for some time (VB057).

Morrison similarly claims that 'Times have changed in the Highland Dancing scene and most rules are now made by non-Highlanders, with the result that some dances are almost unrecognisable (Morrison 2000: 3).

The Board set out the reasons for the need of a regulating body in their first handbook, *Highland Dancing: The Textbook of the Scottish Official Board of Highland Dancing*:

...certain brilliant exponents of the art have, from time to time, introduced new ideas and variations of their own. These new ideas were adopted only by the pupils and followers of those who invented them, and there has developed a chaotic situation, in which our traditional dances are danced differently in different parts of our country. Dancers competing at various games throughout Scotland have had to vary their style and alter their steps according to the district in which they were competing, or according to the known stylistic preferences of the judges before whom they were appearing... ambassadors for this branch of our national culture... have been in a quandary as to whose description of the Highland dances, and whose version of the technique, they should adopt (SOBHD 1955: ix-x).

4:II:iii The Mission Statement

The following aims and objectives were then the principal reasons for the establishment of the organisation:

1. *To establish a standard 'version... of traditional technique'* and 'stabilise the technique', thereby relieving competition organisers of a 'constant thorn in the flesh' [italics mine] (SOBHD 1955: ix).
2. *To become a 'generally recognised authority* to which... legitimate grievance against the organisers of, or the judges at, any particular Games could appeal' against 'bad or biased judging' [italics mine] (SOBHD 1955: ix).
3. *To be 'A representative board of control'* by whom 'generally applicable rules governing the conduct of championships or other competitions' and 'laws and regulations concerning every aspect of the art' would be made [italics mine] (SOBHD 1955: ix; SOBHD 1993: n.p.).

It is interesting to note that there is no mention of regulation of a tradition which was performed for enjoyment outside the sphere (see Figure 2: The Spheres of the Organisational Bodies). This is most likely because there were no such politics or sensitivities within the more disparate and perhaps less vocal non-competitive teachers of Scotland²⁷.

The minutes of a Board meeting held in 1954, immediately prior to the publication of the first textbook, records the allusion made by the then Chairman, Harry Fairley, to the organisation as a 'powerful international force'. The seeds of a global vision had already been laid down by Fairley in 1950,

²⁷ Interestingly, fifty years after the establishment of the SOBHD, there is still no mention of the existence of such a group in the Board's manual, which, it claims, is the 'definitive textbook of our traditional Scottish art' (SOBHD 1993: n.p.).

with an expanding policy to stabilise Highland dancing for the Caledonian societies all over the world, as distinct from the initial ideal of stability for Highland dancing in Scotland, expressed a year earlier by the Scottish Dance Teachers' Alliance.

Those who introduced Highland dancing overseas introduced the technique in which they were originally instructed, and there grew different techniques of dancing in various parts of the world. This meant that no two versions of Scottish dance technique resembled one another precisely. The Board, however, planned to be a body of such authority, so that matters of regional and, indeed, continental interpretation could be managed:

They [dancers] look, naturally, to their mother country for guidance... if they wish further advice or clarification of any point on which they are in doubt, they need only communicate their difficulty to the Board, which will be very happy to render them every assistance in its power (SOBHD 1955: x).

Witta maintains that, 'as a result of the administrative and technical methods employed' the Board has '*standardised* dancing, rather than *stabilise* it' and that the textbook is a medium which is 'a powerful agent for the attempted control of Highland Dancing in those countries where there has grown up a tradition of dancing in the Highland [organic] manner' (Witta 1982: 16). However the Board make no secret that offering a standard to be applied worldwide in the practice of Scottish Highland dancing was precisely the remit of the organisation:

No longer is it possible to label a competitor as Australian, South African, Canadian or American because of the steps used or differences in technical approach. Indeed... an international community of Scottish Dancers [are] working for and with one another towards even higher standards of excellence (SOBHD 1993: n.p.).

Joan Flett comments on the effect these developments have had on the tradition globally, as she claims that the establishment of the Board led to

the complete standardisation of dances and technique, not only in Scotland but throughout the world. Whilst one can understand the reasons for this action it is to be regretted that many older solo dances died out because of this emphasis on just a few dances at the Games. In addition local variations in steps and techniques completely disappeared (Flett 2000: n.p.).

In defence of these decisions, the minutes of the first Technical Committee Meeting of the Board, held in 1949, record Lieutenant-Colonel Alasdair MacLean commenting that the object of the Board was 'not to put the clock back to 1880' but 'to stabilise [Highland] dancing with a traditional background' (SOBHD 1949).

Witta also comments on the Board's apparent forgetfulness regarding their initial concern for historical research, by claiming that they 'failed to capitalise on the knowledge and the approach to the technique of their art evidence by... early masters of Highland Dancing' (Witta 1982: 48). It is indeed a pity that the Board should have resigned themselves to abandoning their historical research of Highland dancing, as noted in the introduction to the current textbook which states the primary aims of the organisation as the provision of 'authoritative, practical and comprehensive instructions governing

that art in all its aspects' (SOBHD 1993: n.p.)²⁸. By providing an 'authoritative' account, the Board essentially prescribes the form for its members world wide.

The Board's priorities lie in 'the *correct* method of performing [Scotland's] ...traditional dance' with the assumption that it is the 'one generally recognised *authority*' [italics mine] (SOBHD 1993: n.p.). The organisation therefore has a great deal of responsibility for encouraging healthy attitudes towards the status and profile of their art and not least the research of it. However, all that is offered in the way of explanation is a footnote acknowledging the need for 'academic investigations' but the Board's lack of action would give little credit to their concern in this area.

The Board's priority, however, was not to act as a research body, but primarily to establish a standard to which dancers could aspire and which could be used as a benchmark for adjudication. Billy Forsyth explains:

They [dancers] were used to having a syllabus for teaching and for examinations, medal-tests and such like... four or five different systems. If you go around Scotland, you've got any number of different ways of dancing, because of the natural evolution of the dancing in those particular areas. Surely, if we're going to have some form of competition... And I think the examining bodies... realised that, if you're going to have examinations in a competition of purely a standard to quality of some kind, then you need something to base it on. And if you don't have something to base it on - who's making the decisions and why? My argument for the competition is that if you have a standard that you work to, then it's fairly easy to make a decision. If you leave it up to the individual to decide what may or may not be innovative or traditional or pleasing to the eye, then it's very difficult to make a rational decision, because then you're not comparing eggs with eggs (SA2003.036).

²⁸ The most significant predecessor to the SOBHD's textbook was McLennan's *Guide to Teachers, Dances & Judges* written in 1925 (McLennan 1925) and subsequently published in *Highland and Traditional Scottish Dances* (McLennan 1952).

Although wary of these initial decisions to regulate so strictly, Gardner also gave a similarly practical response:

The uniformity [was easier to judge], you know, that's all it is. In a way, it's good nowadays because the children who are competing, they are very, very technical, which they have to be, 'cause competitive dancing is very technical... And if you don't do what the Jones's are doing, you're as well not doing it at all (SA2003.034).

Similarly, in the words of Ben Matthews: 'If you are going to be competing and people are going to be taking it seriously (the way they do), then, yeah, it's got to have something standardised, because otherwise it will just be capricious' (SA2003.033b).

4:II:iv The Implications

The standards of exams and competitions being of utmost concern to most of the new members meant that the Board was closely scrutinised:

In those days before the Board you got lots of bad Highland dancers, what really made the difference was the Scottish Official Board for Highland Dancing and then to compete for the Scottish Official Board competitions the teacher must be a member of an association so, of course, it meant the teachers have a better knowledge now, so that the Scottish Official Board has made all the difference to Highland dancing. The steps are set now in the Official Board book so more people do them correctly now, partly because they are members of the associations, but the Board book was a big help to people and of course made the difference to the overseas dancers. Long ago we saw bad dancing... we would think, that'll be overseas, or English and it usually was. Nowadays you know them because they are such lovely dancers (STDT Interview 06/10/1998).

However the implication of such stringent rules was another matter, as Taylor suggested in a letter to Davidson in the same year as the Board was formed:

Will you be able to enforce your authority as to rules and bye laws, a difficulty will always arise re. pupils choosing teachers, very often, in the early stages at least the cheapest is usually chosen, irrespective of ability (Appendix 8).

Forsyth admits that, in the early years of the Board, 'it had no real influence on the outdoor Games' (VD114b) and that

Certainly it was the dance *teachers* who were still competing at the time (and their pupils) who took longest to be persuaded that there was a need for this... And it came about I would say, in the '60s. I would say

it took ten years for the Board to establish itself and be accepted on a wider basis than purely the original dance teachers (SA2003.036).

However it seems to have been to some extent the fear of exclusion which prompted teachers and competitors to submit to the jurisdiction of the Board.

Sheila McKay, in conversation with Billy Forsyth, explained her situation:

That was the thing, we taught by your standards, right?.. I done it, I mean, I wasna wanting our folk to fall behind... By that time, it was, I would think, well, when I went down to the Games, my Mother had... good lugs, and she started to use the expressions that other folk were daein, which was entirely foreign to her, because it wisna what she used (VD114b).

Gardner's story is something similar:

I joined basically... to suit my children. I mean I wasn't 100% [convinced] myself. I went and took my 'teachers' and my 'examiners' [exam] and everything else... I took them all, just so that my class would benefit (SA2003.034).

However during this period of change, there were also some experiences which seem to have involved much more friction, such as that of Mary McHarg, who was a teacher and judge at the time:

Oh, I stopped judging when the Board took over because I was determined... because I had been well taught and I knew my work. And I wasnae going to have anybody telling me what to do. So I just carried on. Mind, they tried to get me cornered and shoot me down, but I'm a tough nut you know, to get at... Well, I was penalised [in competition]. I can speak from experience. But it still didnae get me down. I kept going. But you see some of the judging jobs that I had they took from me (SX2003.035).

However, like McKay, she eventually succumbed to the pressure of exclusion:

Well we as teachers had to forget a lot of the stuff that we had because of this, because what I did was I registered my children... But you see I registered my children because [otherwise] they wouldn't have got competing (SX2003.035).

Perhaps the worst case of dogmatism with regards to the implementation of those new SOBHD rules was at Thornton Games in the mid 1950s, which is remembered well by Billy Forsyth [BF] and Sheila McKay [SM]:

BF: Of all the places, you've only got to go along the road there to Thornton Games. Because that's my one abiding memory of the two Meldrum brothers being chased off the field.

SM: I was on the other side at that time [SOHDA] And I can remember McGuire... and Auld Gourdie... I tell you, he was a stickler and he says '*No! It's the Board here!... If they don't get off the field, we'll have the police in here. They are not dancing here!*' ...there was about five folk went off that day (VD114b).

The influence the Board has presently, whether as a result of the original vision or not, is indisputably great. One might go so far as to argue that the Board have what Hardy in *Understanding Organisations* (Hardy 1976: 114) calls 'power of superior force', based on an authority concept derived from office. The Board's concept of control seems to be one of rigid command or rigid restraint and thus the process does not involve another important element of control, that is the idea of adjustment. Any change or growth in the practice of Highland dancing must therefore be initiated (or at least sanctioned) by the

Board committee, which is a relatively small group of only a few individuals whose deep understanding and knowledge of the tradition can not possibly be representative of 'all dancers everywhere' (SOHDA Website 2003).

4:III The Formation of the Scottish Official Highland Dancing Association

4:III:i 'The Pirates'

The inauguration of the Board was undeniably a response to the increasing dissatisfaction among practitioners but it did satisfy, to some extent, the growing need for a reliable channel of authority on Highland dancing. However, the very nature of the enterprise has attracted some counter-claims of seniority with regards to authority within the Highland dancing world.

Contradictory claims are made by the Scottish Official Highland Dancing Association:

Founded in 1947 by prominent dancers and teachers of that time, the SOHDA was formed to encourage the art of Highland Dancing by promoting competitions, examinations, seminars and holding meetings to discuss with parents, teachers and dancers their views and history of our Highland and National dances and their music (SOHDA 1994: 48).

Mill notes the official stance of the Association:

It was actually Bobby Cuthbertson who started it in 1947... [He] organised it... what was it called then? The Highland Dancing Association... After a while it changed... to the... Highland Dancing Specialist Association. It's now the Scottish Official Highland Dancing Association now, SOHDA... It started out basically as a group of teachers, dancers, or prominent dancers of that age... In 1947... the other organisation before they started... I was only seven years old at that time, but... I believe there was... there is a constitution now when I got changes made to the SOHDA (VA2003.007).

The story is somewhat similar to that of the establishment of the Board and the perceived problems raised by the founding group are certainly not in question. However no documentary evidence is extant to back any such assertions of this group being the first of the two main Scottish regulating bodies. And this race for claiming seniority would perhaps not be so contentious except that it was the self-styled and non-regulated dances (and therefore self-styled and non-regulated dancers) that were the crux of the matter.

It seems that there was, and perhaps still is, a degree to which each body wanted to be the overseer of the tradition. Bobby Cuthbertson was one such individual who, unimpressed with the Board, felt he could do better himself:

Some [dancers] such as Bobby Cuthbertson, who set their own standards, wanted to be regulated as an authority on Highland Dancing... without the build up of background. I term them imitation dancers (Cameron Correspondence 1981, in Witta 1982).

As one of the innovative champions of his generation, Cuthbertson's desire was to encourage more interpretation and less restriction. This attitude towards standardisation is very much evident in the letters written at the time. His stance was against the Board and what he saw as unnecessary sanctions. Davidson wrote to Taylor regarding Cuthbertson's concerns and his unease at the situation:

Cuthbertson was invited to attend right from the very start but in his characteristic manner has chosen to ignore all letters and invitations without even the courtesy of a reply. In spite of this his name was

permitted to go forward for the Technical Committee! I personally think that everyone who is interested to get an opportunity of having his or her say and the more divergent the individual opinions in the first instance the better, providing they are all prepared to work towards a common goal. Unfortunately not all members are of the same opinion as I am [in] this matter and they don't like others who don't agree with them on various points and as far as Cuthbertson is concerned I am well aware that there are several who would walk right out if he came in. He has not exactly gained a reputation for popularity in Scotland but no doubt you are well aware of this and there is no need for me to enlarge on what is undoubtedly a rather unpleasant subject. However I met him recently in Edinburgh (he has taken up residence in Portobello) and I left him in no doubts regarding what I thought of his attitude in ignoring the Board's invitations and invited him to come and state his case which he said he would do. It might clear the air a little and I think it is worth trying but unfortunately I feel that there will be so much on both side[s] which remains unsaid that progress is likely to be small (Appendix 7).

There seems to have been some threat of counter-action by Cuthbertson, in response to the formation of the Board, which would infer that the Association did not actually come into being until this came about. In *A Companion to Scottish Culture*, Goss writes 'Highland Dancing... was not regulated or standardised until the formation of the Scottish Official Board of Highland Dancing 1953' (Goss 1993: 73). This date is perhaps a more accurate record of the official establishment of the Association, for want of any earlier documentation. This is not to say that it was not in existence prior to the Board, but simply that the Board seems to have had better management.

Notably, the 'Specialists' were not invited to the meeting in 1949, nor do they seem to have been present at the Stirling meeting in January the following year. However representatives were present at the inaugural meeting of the SOBHD on 16th April 1950, as evidenced in the SOBHD's own minutes of the Inaugural meeting (see Appendices 5 and 6).

Gardner explained the situation as she saw it when she first joined the Association:

I used to be in that, years and years and years ago, before it was started, I think, to combat what the Official Board was trying to do at that time. Because the Official Board was writing to all the Games... telling them unless they come under their recognition, they wouldn't get any competitors... And I thought 'No, it's not gonna work. It's just not gonna work' cause by this time, the Board was taking over very, very slowly but it was creeping over (SA2003.034).

The description of the Association's members as 'free-thinking' seems to be a theme in all of their literature and publications. Similarly, the SOHDA proudly claims to be 'The dancing organisation that welcomes ALL dancers'. This, without too much linguistic analysis, implies the existence of a similar organisation which does *not* welcome 'ALL dancers'. One strives not to equate such a statement with the assertion of a younger or smaller sibling. Just as competition may be natural on the dancing boards of the Highland Games, there is surely also an element of self-reflection matched with robust attitude which finds its way into the mission statement of the organising body. This show of open-armed confidence seems somewhat feigned, as the condemnation of a larger or more popular group is implied. In September 2003 the figures for the Association's membership were as follows: three-hundred and sixty-six dancers, thirty-five teachers and thirty-one parents and interested members (SOHDA Website 2003). This, compared to approximately ten thousand members of the Board, certainly seems to confirm the Association's radical tendencies.

The Association, in their handbook, *The ABC of Highland Dancing and Games Directory*, describe the SOBHD as having been

brought about in the 1950s with the intention of, among other things, standardising the steps of the various Highland Dances. The SOBHD help to organise the dancing events at various Highland Games and competitions and, although the dancing events are advertised as 'Open/Premier', they are restricted to their own registered members. Any member found entering a non-SOBHD 'approved' event will be banned from further SOBHD venues for a specified period! (SOHDA 1994: 48).

The Association has, in this statement, prioritised certain contentious information. Also, by means of punctuation the statement seems to bear tones of sarcasm and incredulity. The date of the Board's establishment is set firmly in the 1950s, which may have been a more accurate date of its impact, in real terms, but one which does not concur with printed matter from the time of the inaugural meetings in 1949 and 1950. There is also a neglect to mention that the Board endeavours to encourage competitions, examinations, master-classes, lectures and dance-days, a remit not unlike that of the SOHDA. These points are coupled with the contrasting description of SOHDA, which is packed with positive phrases such as 'prominent dancers... encourage the art... promoting [events]... discussing [views]...' (SOHDA 1994: 48). Conversely, the Board does not seem to have any written information, publication or comment available as to the existence or nature of the Association.

Indeed, if the Association did form in 1947, then the subsequent formation of a group with the same general remit of regulating Highland dancing in Scotland for the sake of fair competition, was surely seen as

competition. And yet, perhaps surprisingly, it is the larger, and more prolific body that considers the Association to be 'a pirate organisation' (SA2003.034) and, by implication, an unprofessional or unscrupulous organisation.

4:III:ii The Rebels

In spite of the unrest in the realms of the regulating bodies, the pressure to conform was increasing on dancers and teachers alike. Despite the best efforts of the Association to combat the dominance of the Board, there were a number of members who moved to be under Board ruling, in the early 1950s. Sheila McKay who was initially a member of the Association, had moved to be under Board ruling. Her decision, as the President of Glasgow West (Highland Dancing Association), was not an easy one, but she spoke frankly of the events which took place at the time and the pressures on her to conform:

The first meeting... I wanted Glasgow West to come out right there and then. But there was that many that was firmly on the other side... Oh the *abuse* I stood when I came over to the Board. And the letters... the things that were said to me was drastic... I went to this first meeting and I said to them, I asked all their opinions and then Bobby [Cuthbertson] stood up 'I don't care what you say... the dancing's going to go *downhill* all the time... keep the HDA, keep it... don't let the other one come in at all. You stay with HDA... this is where the dancing is. The other side know nothing'... And I said... 'I didn't say there was anything wrong with HDA dancing... 'but they [SOBHD] are bringing something *in* to the dancing that we never even thought about... It's not actually for the dancing that I am changing over. It's for the way it's being run'. *I was boo'd out the hall*... So we had another meeting... 'I *have* to go Board if I want to exist as a teacher... We're not talking about dancing, we're talking about *administration*' and *that's* the reason I came into the Board... And when I came to the Board, there was about forty of them come with me (VD114b).

Forsyth admits that 'There was quite a change-over [from the Association to the Board] just at that time' (VD114b).

The main factor seems to have been the administration of the Board, compared to that of the Association (VD114b). And it was this growing efficiency and influence that seems to have inspired the disassociation, as Janet Gardner explains:

I thought 'Well, I'm not going to be outside that. If I've got kids dancing, I want them to go where they can dance... And unless they were members of the Board, they couldn't dance. And I thought 'Well, I'm no gonnae restrict my children to maybe one or two games a year, I have to let them dance'. So I packed that in and joined the Official Board. And there's a lot of times it goes on, I still don't know... one hundred percent... but, like everything else, if you can't beat them, you've got to join them! (SA2003.034).

McKay, although under Board jurisdiction, still stood firmly to her beliefs that regulation was advantageous for the sake of comparison in competition but not for dictating teaching styles:

I think I'm inclined to go back to the old way... I'll be honest... sixty-two years I've been teaching... I often go back and I'll say things like 'My mother done such-and-such a thing'... And so you know? When I explain certain things to the kids they can do it better the way that I say it - the old way, the old way had a great way of explaining (VD114b).

However not all had respect for such authority and McHarg was one such 'rebel':

I must admit, no matter where I was going I looked forward to it because I was getting to dance. And it was like that up to the last place I judged. I thought, no don't tell me. But then we were – the Board was coming in and you were to do this and do that and do the next thing. I said, 'Ah, way you go. I've been doing it for years. I'm going to do it that way'. And I did. Coming behind. I stayed where I was. Defied them. 'Cos I am a rebel (SX2003.035).

4:III:iii The New Zealand Academy of Highland and National Dance

The New Zealand Academy of Highland and National Dance (NZAND) is, according to Witta, 'an organisation which does not displace the authority of the individual performer, but which provides a stable structure for the development of the art' (Witta 1982: 52). It was created by teachers and dancers after the Second World War, with the aim of bringing continuity to the technique and execution of Highland dancing by providing a national standard in which all dancers would be assessed and taught at the same level. Although the story of its origins is almost identical to those of the Board, the technique varies in style, timing, execution and interpretation of some movements. There has been suggestion and friendly discussion between the Board and the Academy but, so far, the Academy has chosen to remain under its own jurisdiction, rather than come under that of the Board.

The NZAND and SOBHD have drawn markedly different conclusions from independent researches into the basic art, style and embellishments in Highland dancing. Thus, today, we have two techniques and styles for the performance of Highland dancing. Both organisations were unique in the history of Highland dancing as, for the first time, administrative bodies were set up to preside over the development of the art. The future of competitive Highland dancing in Scotland therefore rested on the manner in which these two organisations approached the very important task of stabilisation.

With the establishment of the Board, the Association and the Academy, the question of how these different bodies would achieve stability in the

practice of Highland dancing becomes somewhat perplexing, as the very existence of three independent bodies would imply varying ideologies. The Association shares research interests with the Academy, but the two remain independent.

A delegate from the New Zealand Academy spoke of the steps which have withstood the rigours of regulation: 'They all do their own thing out there and what a pleasure it is to see them doing different steps, it's, it was a breath of fresh air. It brought me back to dancing as it should have been, years ago... as it was' (VA2003.007). There are also, according to Melin, echoes of times past with regards to the styles which survive within the New Zealand tradition:

Someone in New Zealand once said that at one point he could tell a West Coast and an East Coast dancer by just... the way they danced especially the Fling, the West Coast was in time with the music while the East Coast tend to be either before or behind (VA2003.007).

The founder of the NZAND, I.D. Cameron, has written on the foundation of the Academy, attributing the greatest influence on the development of the dancing to the McLennan Family, especially William, the eldest of the McLennan brothers, whose

knowledged ability and finish as a dancer and knowledge of the work enable him to compete successfully in many parts of Scotland and England... demonstrate the art to a number of Courts and Royalty and Europe... [and who] had the distinction of having had two command performances before the Zarena of Russia, three... before the Empress of France and... five performances before Queen Victoria (Cameron Correspondence 1981, in Witta 1982).

He left a detailed record of Highland dancing to his brother Donald McLennan, later the author of *Highland and Traditional Scottish Dances* (McLennan 1950).

D.G. McLennan, himself a 'renowned authority on the art of Highland dancing', went to New Zealand throughout the 1930s and 1940s, establishing dancing schools and passing on 'a sound foundation of the McLennan work' (Cameron Correspondence 1981, in Witta 1982). The foundation of the New Zealand Academy of National Dancing was then thoroughly influenced by the teaching of D.G. McLennan, both in philosophy (through the research of Cameron) and in practice (as the legacy of McLennan's teaching was and is practical in its nature).

Mrs May Wilson, another founding member of the Academy, wrote of the need 'to formulate a plan of action to see co-operation and bring together the teachers and judges of dancing' and of her theory that 'unless all teachers were given the same basic theory of the dance and encouraged to use it nationally... New Zealand would remain a divided people continually at variance with each other' (Cameron Correspondence 1980, in Witta 1982). The same sentiments were echoed by both the Board and the Association with regard to harmony in the ranks of the Highland dancers and teachers.

A letter in February 1982 from Cameron to Witta describes the Highland dancers after the establishment of the Academy in comparison to pre-Academy days, claiming that 'Today in our dancers there is refinement and knowledge of the art, and they can communicate on paper the knowledge of our early dancing master which has been researched...' (Cameron Correspondence

1980, in Witta 1982). Of course Cameron is not alone in claiming certain rights of knowledge of the art for his organisation. The Board and the Association make similar claims that their dancers have 'a truly international appreciation of the definitive finer points of Highland Dancing' (SOBHD 1993: n.p.) and 'an unsurpassed wealth of information' respectively (SOHDA 1994: n.p.).

Furthermore, Witta quotes from a letter written by Mrs J.Y. Paton, who was Secretary of the Academy and a member of the Technical Committee in the early 1980s, in which she makes comparisons between the approaches to standardisation by the Board and the Academy by claiming that theory established by the Board was 'inadequate for pinpointing [technical details]... therein lies the great difference between us [the Boards and the Academy]' (Paton Correspondence 1980, in Witta 1982). She explains that 'The classes... [in Scotland] were very large and one simply learned to dance without too much refinement'. She goes on to state, with perhaps more than a little concession, that '...it is possible that the Board textbook although inadequate in our [the Academy's] eyes was indeed a great forward step' (Paton Correspondence 1980, in Witta 1982).

The Academy's New Zealand Solo Seal examination forms part of the Academy's search for better standards of technique, execution, interpretation and better overall presentation of the art. Mrs Paton, in reference to a conference remit which endeavoured to ease the rigour of the examination (which was later rejected) states that 'we must however never lower our standard' (Paton Correspondence 1981, in Witta 1982). This battle cry has been echoed by the Board as it too endeavours to achieve a standard of excellence.

The Board aims to equip its dancers 'in [their] search for that supreme level of excellence to which we all aspire' (SOBHD 1993: n.p.). However it is interesting that the Association's textbook puts forward a different focus, which is 'primarily aimed at the Highland Dance enthusiast... to encourage the art of Highland Dancing... (SOHDA 1994; n.p., 48). The message that Highland dancing should be accessible to all 'interested parties' (SOHDA Website 2003), as opposed to the inference that excellence may only be achieved by successful competitors, is consistent with the Association's publications, literature and website.

4:III:iv The Royal Scottish Country Dance Society

A similar example of regulation within the field of traditional dance is in the case of Scottish country dancing. A comparison is made by researcher and broadcaster, Alison Cairney:

It's a fact of life that what motivates many of the young people to participate in the dance classes is the lure of medals awarded in the competitions of the Official Board of Highland Dance [sic]... But, as with the Country Dance Society, the setting down of rules can impoverish the existing variety (VB057).

That variety undoubtedly existed in the days before the First World War when public and private dances played an important part in Scottish social life. They were a means by which young people could mix freely and, in the absence of other entertainment, there were frequent town and village dances. However the disruption caused by the war radically altered patterns of social life in rural areas and by 1920, the older social dances and couple dances had all but disappeared from dance programmes. The Scottish Country Dance Society (SCDS) came into being in 1924. Its mission was to rescue from decline the style of dance which, in their view, had reached its peak in the 1850s (VB057).

The Society was open in its objectives, which were to collect and improve in equal measure, as Muriel Gibson, secretary of the now Royal SCDS explains: 'The dances, those that did survive, were being done rather badly and of course in the beginning of the twentieth century there were the Foxtrot and the One-Step and so on, which were cutting out the old dances' (VB057).

The RSCDS published from eighteenth and nineteenth century manuscript sources, but there was unashamed 'cleaning-up' of irregularities and anomalies within the steps and styles, which had been particularly evident between regions. This led to a revival of the dances but in a standardised form. Local variations, such as those collected by Flett and Flett, were less encouraged and there was greater emphasis on technique. Standards of technique and performance were set from its earliest years and 'precise teaching became the hallmark of the society' (VB057).

Cairney, however, is critical of the current state of the tradition:

While traditional dance in Scotland exists in many different forms, it's the *douce*, rather sanitised version which has been accepted as standard... And putting forward the Royal Scottish Country Dance Society style is to present a restrictive, ballroomized [sic] version of our dance heritage (VB057).

Gibson suggests that the initial concept was not one of restriction but one of access:

Well, one of the things that we *wanted* to do was to standardise to a *certain* extent, obviously to get the traditional forms. But I don't think it should be rigid and Miss Milligan was very much against *any* rigidity or suggestion of it when dancing. So I think that the society itself, as in its dancing, tends to *avoid* being too rigid (VB057).

However, with the setting down of written rules, and the adoption of these as standard, there was a strong possibility of rigidity setting in. The popularity of the RSCDS's numerous publications of dance collections surely indicates that it

met a need within the dancing community, even if, as in the case of Highland dancing, this resulted in strict adherence to written instructions.

Domination was not, by any means, a conscious aim on the part of either the SOBHD or the RSCDS but, as the tradition of oral transmission gives way to written transmission, the adoption of textbook instructions becomes inevitable. Like the Highland dancing tradition then, the social dancing tradition has undergone some changes in instruction and adoption. The RSCDS has over one hundred and fifty branches and five hundred affiliated groups and is constantly growing, as the Scottish social dance tradition spreads across the globe (RSCDS 2004).

4:IV Evolution versus Regulation

4:IV:i The Inevitability of Regulation

'Few national dances are better known than those of Scotland... [they] are familiar to many an Englishman who cannot name his own Country and Morris dances' (Thurston 1954: 6). However, despite their popularity, they have not been given the attention that they warrant, whether it is academic study, media coverage or general public interest. Highland dancing is, then, something that owes its survival not to a tourism-inspired sales pitch but to the practitioners and organisers, the teachers and the non-geographically defined dancing society. This is not to say that a detailed exegesis is not necessary. On the contrary, the want of such in-depth analysis is made more evident as the tradition becomes more specialised and therefore less accessible for either participation or for appreciation. It must, however, be of the utmost contextual value, particularly in the light of the inevitably dulling influence of regulation.

For most of the Highland dancing world, competition is its essence and life-blood. Prizes for proficiency in native dances are offered at all the Highland Games, which encourage a certain 'high' standard of performance which is maintained and exhibited to the public. The value judgement that deems these manifestations as being of a 'high' quality implies that a competitive dancer is somehow superior in performance to a non-competitive or non-regulated dancer.

Whatever the case may be, it is evident that the present Highland dancing arena is fiercely competitive. Whether this originated in the days of intra-clan competition or inter-clan combat cannot be proven, but the spirit that remains today is one of such determination and perceived excellence that it would have served well the most relentless ancient chief. The standards of presentation are constantly reviewed by the regulating and organising bodies and the audiences also become increasingly critical.

No academic study or analysis has hitherto been made of the competitive Highland dancing phenomenon, either prior to or since the establishment of the two main regulating bodies in the 1950s. However Scottish historian Hugh Cheape refers to the practices of Highland Bagpipe competitions which have similarly mysterious origins, deeply embedded in Scottish society, and also manifest the themes of standardisation of technique for the sake of competition:

If such keen competition and all its rituals has not appealed to the folk musician, performer and evangelist rather than competitor, he might be forgiven for regarding piping as... far removed from folk music. He might consider that pipe music has been filtered through too many refining non-traditional influences (Cheape 1991: 138-9).

Cheape is not the first to suggest that this filtration is one which does not so much sieve out unwanted anomalies in an act of purification, as eradicate intricacies and variations through a process of gradual sterilisation. Indeed, within the ranks of teachers and competitors, matters of regulation and resultant suppression are inevitably discussed with passion.

Researcher and dancer Linda Rankine, in her dissertation on the subject of 'Issues effecting [sic] its change in style', asserts that the regulation of Highland Dancing results in it meriting a place among 'the more sophisticated areas of dance' (Rankine 1977: n.p.). This comment, in itself, shows that Rankine values the excellent standards of execution of the refined form, rather than esteeming what might be a truer expression (or interpretation) which represents the traditional dance activity.

When you move onto the international arena, however, our own folk tradition in dance appears pretty dreich and staid. What's put forward in our name seems impoverished, particularly when it's set against the verdant colour of other nationalities (VB057).

Although solo Highland dancing is, visually, quite different from the social group dances of Scotland, it is still an activity which can only be a living tradition through continued performance. However, for this performance to be maintained through time, it must have meaning to successive generations of people. This meaning can be achieved by the development of a body of dance that comprises the tradition (or traditional concept) of the form in the light of the understanding of the meaning or interpretation of the dances which make up the current repertoire. Thus, for Highland dancing to endure, it must, as Witta explains, compete for 'potential performers of the art in a milieu comprising a multitude of dance and other art forms... [in] a society which is by nature highly competitive' (Witta 1982: 40). Witta also argues that standards of technique must also be maintained apposite to the time, and this argument forms the *raison d'être* of both of the governing bodies.

Even in the late 1800s, two of the most influential dancing families, the McLennans and the MacNeils (also world champions), were in discussion as to how the future of the tradition ought to be shaped. They did in fact establish certain rules of execution and conduct in a manner similar to that which is prevalent today. It is no new idea, therefore, to attempt to standardise Highland dancing; in fact, the evidence suggests that the opposite is true. The rule-makers, as they were formed in the mid twentieth century and as they survive today, have always made this their mission. Ironically, in the sphere of a living and therefore an organic tradition, the desire to regulate also seems to have its roots in the past. Regulation cannot be condemned as an endeavour in itself, as it has been proven to be of concern to those within the society of Highland dancers. The ideal cannot be dismissed as a modern phenomenon either, because, just as the need to express, dance and compete are all accepted as part of the nature of the dancing society, so too is the need to control.

4:IV:ii The Process of Implementation

It is necessary, therefore, to explore how any such standards of technique might be maintained and, inevitably, changed. The technique is the manner in which a skilled process is carried out. The execution is the carrying out of that technique by the individual. However, the manifestation is never a straightforward reproduction of that which is prescribed, as the individual is inevitably subject to influences other than the instruction. The technique and manner of the execution is influenced not only by the individual's body, weight and personal space, but is also influenced by fashions from other disciplines (e.g. the finesse and poise of ballet technique or the strength and agility of an athletic tradition). The dancer is also limited by his or her own ability in the performance of the movements. Lastly, and perhaps the most debated element in competitive performance, is the interpretative aspect, whereby the performer translates meaning from (or gives meaning to) the dances.

Firstly, an understanding of stabilisation must be reached. The *Concise Oxford Dictionary* (1995) defines stabilisation as 'the condition of being firmly established and of not being easily altered in value'. Kim Witta believes 'there is nothing inconsistent with the concept of development and change. Thus if the value of a living art form is to continue throughout the ages it must develop with the times' (Witta 1982: 34) and that

[A] deep understanding and knowledge of the tradition of Highland Dancing... and the standards of the technique which make up its style is

the key to the preservation of the traditional form and background of the art and thus stabilisation of Highland Dancing (Witta 1982: 34).

The technique is therefore the manner of artistic execution or performance in relation to formal or practical details (as distinct from general effect, expression, sentiments etc.), mechanical skill in artistic work or the way in which a skilled process is or should be carried out. There can be no *technique* as such, or standards of technique without the existence of tradition. The execution, which is the act of skill in the manifestation, is that which shows or brings out the meaning in a manifestation and the representation of a performance.

The manifestation of Highland dancing can only take place through the medium of the individual and thus through his or her conception of the meaning of the dance. The dance is subject to interpretation since, even though the movements may be essentially the same, the understanding of the action and the *meaning* or *function* of the manifestation will change according to various factors. In performance the understanding and meaning of the Highland dances which make up the body of the tradition of Highland Dancing, that is the Highland Fling, Sword Dance, Seann Triubhas, Highland Reel and Reel of Tulloch, will be brought out by the performer according to his or her conception of their meaning. The interpretation will vary according to each individual's own understanding.

The standards by which the manifestation is either bound, by means of performance protocol or the criteria on a certain platform (e.g. the competition boards), will influence the interpretation of the movement. The standards that

are the basis for regulation of technique will inevitably be viewed as a prescribed objective of endeavour and a level of excellence will inevitably become the aim of the performance.

Witta makes the connection between matters of tradition and interpretation by offering the following useful definition of *style*:

Style: Those features of literary, art, composition etc. (*dance*) which belong to form (*technique* and *execution*) and expression (*interpretation*)... rather than to the substance of the thought or matter expressed (*tradition* and *interpretation*) [Italics mine] (Witta 1982: 39).

The following figure (Figure 4: The Stabilisation Process) shows the synthesis of the active factors in the process of stabilisation of a tradition:

Figure 4: The Stabilisation Process

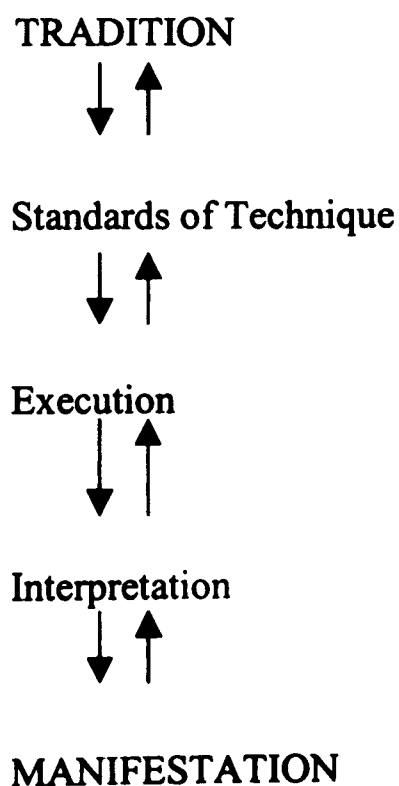

Tradition is not affected by *standardisation of technique, execution* or any degree of *interpretation* unless any of those products become more prominent in the manifestation than the original inspiration (i.e. the *tradition* itself). If this does become the case, then the new manifestations feed into the concept of tradition. This can happen, of course, as has been evidenced by the living nature of any tradition which must, for the sake of its own survival, ensure a recreation of sorts, in accordance with the nature of its usage by multiple individuals. However, the *manifestation* cannot feed directly into the *tradition* itself as the tradition evidently does to the manifestation, since the tradition of the dance form is the underlying common factor in any manifestation of this kind. Instead, it is evident in the *interpretation* and *execution* of the tradition and this will normally prompt a change in the *standards of technique*, should they be continually reassessed, as they are in this case.

This is not to say that there is a great deal of scope for individual interpretation of the traditional dances on a competitive platform, due to the inevitable effect not only of standards of technique, but also of rules and regulations which are imposed on the individual. In this case, there is not so much room for innovation as an interpretation within the aforementioned rules of either conduct or performance.

A lack of innovative performance within the Highland dancing community reflects not just on the preferences of individual performers, but also on the rule-makers. The authenticity of the tradition, which has always recreated both its place and function in Scottish life, is not so much prized as the establishment and maintenance of standards of technique. These are upheld

within this arena by exploiting the dancers' competitive motivation in order to promote the accuracy of execution. Standards have indeed improved. However all these comments are from the point of view that considers excellence in performance to be 'good practice' as opposed to an interpretative, innovative and therefore expressive performance.

4:IV:iii The Consequences

In the words of Rankine, standardisation has

necessitated a shift of emphasis to the concentration on the precision of the technique of the dance and although this has obviously raised the standard of Highland Dancing, I feel it has, to a certain extent, been at the expense of the social feeling of the dance. People no longer indulge in Highland Dancing purely for the social aspect possibly because it has, over the years, evolved basically as solo dancing. Highland Dancing is rarely danced spontaneously... Rather it is arranged as an exhibition (Rankine 1977: 16).

Practitioners of Highland dancing inevitably have their own opinions as to the perils of standardisation. One of the most common complaints is the resultant loss of variety within steps and also of dances. Fearchar MacNeil, a dancing master from the late 1920s to the late 1990s, taught Hebridean dancing²⁹ in a career which spanned a period of paradigm shift in Highland dancing. He spoke against the authority of the Board:

They *cut out* the things. What we would have done is *keep* them. But, except for competitions, except something... some certain standards for competitions and certain steps. But teach the others. What... the Official Board of Highland Dancing does, is they cut out the steps and they're not being taught... The thing... as far as I'm concerned (and I never thought I would have to say this) is that Official Board of Highland Dancing is *killing* Hebridean dancing. Simply because... they stop children from *doing* things. You know, if they compete... for Hebridean dancing, they're not allowed to compete for Highland. And you see, this is what I mean, this puts the young ones off (VB057).

²⁹ Hebridean dancing consists of solo narrative dances specific to the Hebridean Isles and, although similar in some elements of technique to Highland dancing, has retained its individual status. Although competed, it is not regulated to the same extent as Highland dancing.

Mill concurs, despite his rôle in the Association: 'once this standardisation came in, we lost all these old steps' (VA2003.007). Flett and Flett also agree:

One outstanding example of this is the Highland Fling which, today, comprises a standard of six, eight or at the most ten different steps. In the 1950s it was still possible to collect over sixty different steps! (Flett 2000: n.p.).

In defence of the Board and of the initial decisions made by the first technical committee and subsequent rulings, Forsyth [BF] suggests that the thrust of such force was not a desire to restrict, but a desire to collate. This was debated in conversation with Sheila McKay [SM]:

BF: Correct me if I'm wrong here, but what the Board have done is to bring these, and make a standard group of steps.

SM: And left the guid bit out!

BF: Well, you could say that. On the other hand, you could say that they left out the bits that were either repetitive or which didn't flow or which didn't look smooth and the way the dance moved (VD114b).

Whatever the reasons behind such decisions being made on the part of both bodies, Mill notes the loss of variety as evidenced in some of the best exponents of modern-day competitive Highland dances:

Nowadays dancers are all on this one level and... they are all so robotic that even nowadays... they're all just sheep following each other... I'll give you a good example. They're dictated to the point nowadays where they're all brain washed and they're told you must do steps A B C D etc and that's it... At one of the Games up North, two years ago... the top

man and the top woman went on stage and it was the Fling they had to do... and they said to me... 'how many steps?' and I, just naturally said... 'six steps of your choice'. And they looked at each other as if to say 'what does he mean? Six steps of our choice?'... And I said 'six steps that you're happy with' and they still looked at each other'... and they did the six steps that they had been ordered to do... No mind of their own, all brain washed... I felt sorry for them because of this dictatorial attitude over Highland dancing nowadays, it's sad but it's a fact of life (VA2003.007).

A similar testimony is given by Gardner:

Nowadays, children who are going up to dance know exactly what they've got to do. I could go up on the platform and thought [sic]... 'will I do this step?' and... Children don't do that now [i.e. think for themselves]... They know from the time they stand out there exactly what they're doing, because it's what's required now (SA2003.034).

Andrew Purves, who has researched older Highland steps for the Scottish Traditions of Dance Trust, comments on this regimentation:

Things have become a lot more... regimented I suppose, you know, like 'these are the steps that there are to do and that's it'. And I think possibly a lot of the steps have been lost... When the Board standardised it, I suppose, it was made that these other... dialects of dancing... were wrong... Because, obviously, in competition 'you dance these steps' and so... you can't dance any other steps that you want to... And so instead of keeping up the old, different steps for local areas, people now had to forget about them and dance the same steps (SA2003.033a).

Gardner, having experience of both the Association and the Board, concedes that:

Nowadays, each step has got to be done in a certain way. It's typical of the modern idea of Highland dancing. It maybe makes the judging a lot easier for the judges who sit and judge them nowadays, that every

child's up in front of them and doing exactly the same thing. So that, obviously, they pick the best one (SA2003.034).

This may seem a side issue since the dancers of today's generation are dancing in accordance with the regulations set before them, with less interest in authenticity. However, in light of McKay's following statement, it perhaps remains an underlying concern for the older members of the dancing community:

For I have been approached... and asked if I've been stopped doing the old dancing... I'm not going to mention names, because I'm taking it further. I have been asked if I have been stopped doing the old dancing such as I danced. And I want to know *why* they wanted that... the only thing that I can say, I was told that I was a registered Board teacher, so therefore I have to do Board work. That's the only thing I said. (VD114b).

Watson's pupil Alison Diack remembers his feelings on the formation and domination of the Board, and the restrictions imposed by rules written down. Similarly, Livingstone notes that, since the meetings of the early 1950s and the establishment of the regulating bodies, there were 'No variations in the way of dancing' (SA2003.035). This idea of dancers being 'copies' is echoed by Mill, who, in his capacity as a Highland dancing judge, finds that

Today's dancers are taught... to a text book level and... once they reach that point, they're not allowed to go beyond it... Now, most dancers nowadays have reached that level and they're all robots, they're all replicas of each other and it's a terrible thing to say but when you're sitting there judging, ye have literally four pieces of tartan on the board and they're all doing exactly the same... they're all dressed alike, the same hair style, they're all doing exactly the same steps and from a judging point of view, it's so boring. And this was introduced to make it

easier for the judges... Don't get me wrong - all excellent dancers, good dancers, but they're all so boring... They're all sheep, they're all cloned (VA2003.007).

This theme is recurrent in data accounts of the changes which have taken place within the style, as dancers are 'carbon copies' rather than individuals with their own styles of expression (UI2000.003).

4:IV:iv The Verdict

This loss of personality is perhaps most starkly realised when contrasted with unregulated and more inventive dancers of yesteryear, as lamented by Mill:

There's no characters nowadays... Watson and McKenzie, they're long gone, but we still speak about them and in fifty years time folk will still speak about Watson/McKenzie but they won't talk about today's dancers because there's none... there's no characters (VA2003.007).

Likewise, McKay notes the loss of expression:

You've got to express yourself... I feel the expression's gone out an awful lot, I do. That's why I hear that 'they're all like soldiers'... As I say, the first reason I came into there [the SOBHD] was for the registration... But when they started tae cut everything out altogether, I just started getting a wee bit apprehensive... Isn't this more to do with the movement, if you like, towards accuracy at the expense of individuality?... Dancing is not just technique... And that's the problem... You've got to have the technique but you've got to express it after that and that's where the problems come in... (VD114b).

This complaint has also been brought to the attention of Forsyth:

I get this on a regular basis that 'Oh, there are no personalities around nowadays'... When people talk nowadays, they keep talking about Bobby Cuthbertson and Willie Cuthbertson and all the ones that were there forty, fifty years ago (VD114b).

McKay's response to the accusation that there is no individualism on the competition boards is decisive:

I can tell you right now... I make every one an individual. There's no regimental business with me. You can tell who teaches up Tayside, cause they're a' like soldiers. I dae [don't] like that. I like each person tae show their own personality in their dancing. And *that's* the old style... I teach your technique but...! I'm teaching Board technique and mines have got personality. It's the *way* that you teach... I teach the technique but I teach the old way (VD114b).

Forsyth similarly gives a spirited defence, explaining that the Board sets guidelines, rather than restrictions of the individual's expression:

BF: A lot of dancers are, to my mind, *natural dancers*. They do things because it's the natural way of doing things. And it doesn't seem strange to them. And... they don't try and analyse it. It's when you start to analyse things...

SM: ...That they go wrong?

BF: That they go wrong! Yes, that's exactly it. And this is where you get the difference between a *dancer* and somebody who has been *taught to dance*. And there's a big difference (VD114b).

However, despite these regulations now being in place, Gardner notes the irony that matters of judging are still contentious:

It all depends on who's sitting judging that day. But again, that's very, very unpredictable as well. You could put a child up there to dance the most technical dance of their life and put somebody else up and that other person will beat them. It just all depends on... what the judge likes, what the judge wants (SA2003.034).

Again, the results are dependent on the preferences of the judges, and that which they esteem within good execution. However, Forsyth clearly states that

the position of the Board is strictly in adherence to the written guidelines for competition and gives no space for innovation within the competitive sphere:

If there is (within the rules) allowance for innovation then somebody who is innovating will obviously get additional marks... But if what we're doing is trying to keep the traditions of Highland Dance then, is *innovation* what we should bring in to competition? Or should that be something completely separate? If you go back again to the Cuthbertson brothers and of that era (we're talking about the 1920s...) at that time, there was a lot of innovation and it is very difficult to say how much of that innovation was from traditional sources. And difficult to say *now* whether or not what we're dancing *now* is a 1920s or 30s version of a Highland Fling. Or was this something that they drew from earlier times and just refined? But there's no doubt about it, the number of steps that were produced during that period were based on Highland movement and Highland technique. But I think you would find it hard today to justify them as traditional Highland steps. And this is where you get into a cross-over position - 'How far do you go in this?' and this is always the argument (SA2003.036).

The problem is perhaps not only one borne by the SOBHD and SOHDA, but rather indicative of the very nature of competition. As Jamie MacDonald Reid, dancer and social historian, states: 'Over the last one hundred years, it's been growing rigid and, for the sake of competitions, they've had to make it more precise, because you're doing it for points, you're doing it for medals' (VB057).

McHarg expresses a similarly impassioned opinion:

It wasn't fair what they [SOBHD] did to dance. It was all needing to be under one body. I said yes, there was a control needed, but not – we've two bodies now. And I don't see one's any better than the other. They've all got their ways and you must recognise that. But oh no, I think the Board went too far. They penalised people... Oh they should never have been. They should have left us as it was, free and easy, open to all. Why penalise children? They don't understand, they don't. And they're all wanting to dance. They all want to compete. Maybe not I mean, some

aren't as good as others. But they all try. And that's what you should encourage (SX2003.035).

Mill suggests a solution for the current state of what he sees as autocratic rule by the Board: 'The only way I see, is for the Official Board in some way to relent and bend some of their dictatorial rules that they have brought in and go back to, in some way, to what dancing was... 20s, 30s, 40s, 50s' (VA2003.007). However, radical change with regards to teaching or judging standards does not seem imminent on either the part of the Board or the Association. It seems that Highland dancing did indeed become standardised, and is, for now, set in the confines of print and strict competition, which was, in the words of G. Douglas Taylor, 'the last thing wanted' (Appendix 8).

The following chapter brings these written instructions to life, as they are notated using Labanotation. This forms a lasting record of the positions, steps and styles as they were recorded prior to regulation, and as they are compared to the current SOBHD textbook explanation (SOBHD 1993) and practice.

Chapter Five: Dance Structure

5:1 The Tradition Bearers

5:1:i The Teachers

Highland dancing has survived in Scotland in a general process of handing down, through the familial and military systems, often entailing a certain sense of respect and duty. However, this sense of the dancer being charged with continuing the dance does not seem to have been passed down so strongly in the twentieth century as it was in the eighteenth and nineteenth centuries. This is not least due to the fact that dancing is no longer predominantly taught in close association with local schools or specific areas which had their own distinct styles. It has been observed that it only takes two generations to make anything traditional, since that is the sense of tradition as an 'active process' (Williams 1976: 269). Those who bear the tradition must inevitably have a major rôle in this process, even if it is to teach the new doctrines of the SOBHD which, since 1950, have been passed through newly regulated generations of dancers.

There is a legacy of Highland teaching which has been left by dancing masters who, as early as the seventeenth century, were perpetuating traditional dances, old and new, in the countryside of Scotland:

The old dancing-masters do not seem to have put great emphasis on technique. It was much more important to learn the figures of the

dances, and, while they were taught steps, they were not greatly worried if their pupils could not attain great precision of polish. Indeed, great precision was impossible since many of their pupils wore ordinary outdoor shoes. The emphasis throughout traditional dancing in Scotland was, as one would expect, much more on enjoyment than... technique (Milligan & McLennan 1950: 162).

However, as Flett and Flett observed, 'In those days one learnt the dances for the joy of dancing; only later were there Highland Games... [and] prizes be won' (Flett & Flett 1996: 1). Joan Flett later made the same point: 'The old teachers do not seem to have put great emphasis on technique - it was more important to enjoy the dancing' (Flett & Flett 2000: 3).

These itinerant dancing masters would often travel on foot or by bicycle with a fiddle on their back, to small villages, as well as running permanent dancing schools in the bigger towns. Availing himself of local premises such as the school, village hall, or simply a barn, the 'Dancie' (SA2003,002) would make regular visits, sometimes for weeks at a time, to teach local children³⁰. By the late eighteenth century, dancing masters and teachers of music had never been so numerous or so prosperous. Even in the more remote mainland districts and the islands of Scotland, Dancies taught all the formal etiquette of the ballroom as well as Highland dancing. By the early twentieth century, it was usual for almost every young person to have attended such a dancing class.

However, according to Milligan & McLennan, the nature of this method of teaching meant that not only could one tell who had taught in a certain locale by the style of dancing found there, but the dancing-masters also put their mark on dances themselves which were growing in popularity: 'These step dances,

³⁰ For more information on the rôle and history of the dancing master, see Flett & Flett 1967.

coming to the cities, got into the hands of long-ago dancing masters who polished and stylised 'till the country and mountain style had completely vanished (Milligan & McLennan 1950: 9). The transmission of these dances was, therefore, in the hands of the teachers who established trends, knowingly or otherwise, of local and regional variation, that were not necessarily indigenous to those areas. However, the strong tradition they left for local 'balls' and localised teaching remains.

In present-day society however, local teaching, although geographically restricted, is somewhat centralised by the acknowledgement of and adherence to the standards set by the SOBHD textbook by the majority of teachers, who are members of the SOBHD. Effectively, nowadays, even though teachers less commonly teach outside their locality, the actual 'society' of Highland dancers has grown, linked by common culture, rather than geography.

The environment in which these Highland dances has survived is one in which 'learning, adoption, transmission, utilisation and loss [are] all processes which... clarify the connection of a dancer or dancing community to [the] dance tradition' (Felföldi 1999: 61). In the transmission of any traditional activity, there are as many narratives as there are narrators, as each tradition-bearer is subject to cultural and geographic influences and therefore interpretation.

A book such as the SOBHD textbook inevitably sets a standard in print, as does the 'Basic Key for Highland Dancing' which is presented in the following section of this chapter. That is not to say that it cannot be open to interpretation. In the words of the SOBHD Chairman, Billy Forsyth:

You can use a book as a reminder of what's at the back of it [i.e. the stories 'behind' the dance], but, at the end of the day, if you don't *see* it done, and you don't *see* it shown, expressed, then we'll lose it... [the dance 'histories'] But that's what dancing's all about, at the end of the day, is putting this interpretation in... It's all in the explanation (VD114b).

He admits the shortcomings of the written form to represent individuality or to encourage personal interpretation: 'You can try and put down in writing what you're *showing* people, but the interpretation of that is going to vary from person to person' (VD114b).

There is also the possibility of misinterpretation of the written word. The textbook essentially translates the key of the body into a written key which then goes through a physical rendering. This process of translation and interpretation is therefore open to mistranslation or misinterpretation. As with any spoken language, the original form of the mother tongue (i.e. the physical dance as it has survived through the oral tradition) will always lose some nuance or shade of meaning in translation, since a particular accent, word or phrase (i.e. a position, movement or step) is imbued with cultural significance.

McKay illustrates this point by claiming that 'The problem is, you can't teach dancing from a book... It's impossible' (VD114b). While it is perhaps true that it is not as immediate a method as face-to-face teaching, it is nevertheless a popular tutor. The individuality of the teacher must not be considered secondary to the published authority of the written word. Successful teaching methods lie deep within the roots of Highland dancing tradition and have undoubtedly been the foundations of its survival.

5:I:ii The Dancers

The issue of investing some sort of individuality into a tradition which has now passed into a comprehensive written record is still hotly debated. Inevitably, as the body changes from person to person, so too will the rendering of movement. As one teacher explained: 'Teaching a class of competitive, technical dancing... there's not two children can do exactly the same thing, because they're individuals. They could do basically the same [movements], but *how* they do it [is different]' (SA2003.034). This, matched with the individual's cultural conditioning, is to some extent unavoidable, or at least to be expected.

In modern times, dancers concern themselves with competition performance, skills development and prestige, just as their forebears concerned themselves with clan contests, combat training and feats of daring. A natural competitiveness remains prevalent and perhaps pertinent to the survival of the tradition. This competitiveness and the trend towards organised competition is what sparked the formation of both the SOBHD and the SOHDA, to offer 'a standard for competitive dancing... a uniformity of technique to which everyone must adhere' (Rankine 1977: 218-219).

However, as Milligan and McLennan realise, the established standard provides a problem for dancers who may suppress an innovative or freely expressive nature in order to succeed in competition:

Their *raison d'être* today seems to be exhibition, and owing to the rigorous training required for competition and exhibition, they have become so standardised that from Tweed to Cape Wrath dancers will give identical performances (Milligan & McLennan 1950: 9).

Similarly, fifty years later, Livingstone makes the same complaint that 'Dancing today has been standardised. No individualism. SHAME! Dancing is an art. Even art has its individualism. So why not dancing?' (Livingstone Correspondence 01/03/2000).

MacDonald Reid offers an analysis of the nature of such regularity within Highland Games dancing:

[It] grew quite directly out of the folk dancing. Of course, as the Highland Games dancing has come down as virtually a spectator sport for the sake of competition, the more balletic one is in it and the more rigid one is in it... the more prizes one gets. And so the nature of it has changed a great deal (VB057).

The perils of such rigidity, he claims, are such that

I think it's unfortunate that competition dancing is stressed to the extent that, very often, people who cannot do competition dancing are told that they cannot dance at all. I think that's a great shame, and I think that folk dancing is something that should be spread throughout the community (VB057).

Highland dancing, with its textbook definitions, highly popular competitions and strict officiating, is no longer something belonging to a community defined by locality so much as one which is defined by common interest.

When asked if Highland dancing could be made more sociable, the Director of Administration for the SOBHD replied that 'It is a solo competitive sport not to be confused with Scottish Country Dancing which is sociable'

(Appendix 11). When the same question was put to Mats Melin, formerly of the Scottish Traditions of Dance Trust, his response read as follows:

Not all Highland dances are solo such as the Highland Reel and the Reel of Tulloch which grew out of the old Scotch Reels. Solo Highland dancing can be made more sociable if the company/audience are invited to join in rather than spectate. If a number of solo Highland dancers are dancing, then they can dance in a more sociable group, such as dancing in a circle facing each other instead of dancing in a row... Highland dancing provides... a social mixing for the parents of the dancers. Most dancing schools stage their own 'shows' from which the dancers and the whole community benefit (Appendix 12).

This certainly shows a marked difference in approach. The SOBHD spokesperson assumed that, as a dancing activity, the nature of solo dancing was not social. However it would seem that the dancer, unless taught in a private lesson and performing alone, would almost certainly be part of a larger dance culture and dancing society. The activity would therefore have some element of social dynamics. This is not to say that it serves the same purpose as country dancing for social interaction on the dance floor, but that the classes, competitions, displays, and even to a certain extent, examinations, were all arranged within some sort of social group.

According to a lecture, given by a practising Highland dancing teacher, at the ninety-eighth conference of the United Kingdom Alliance of Professional Teachers of Dancing, 'A social dancer is somebody who... enjoy[s] the social aspect of learning with like-minded people' (UKA 2000: n.p.). This statement is not limited to the country dancer, as the implication is that the degree of sociability which any dancer experiences is dependent on attitude and approach and is limited by the dictates of dancing side-to-side or face-to-face.

However it is all too common to hear of dancing teachers who 'see all new dancers that come through... [the] door as potential... champions and [are] consequently at them [to compete] from day one' (UKA 2000: n.p.). Fiona Campbell, a dancer from New Zealand, testifies to the Highland dancing society as she found it in Scotland: 'It all seemed rather closed off. Quite frankly, if you're not interested in competition [teachers] are not interested in having you' (UI2000.002).

5:I:iii Judging and Examination

The dancing adjudicators, of whose comments little survives prior to the twentieth century, did not escape scrutiny. Early judging methods, in general, do not seem to have involved exhaustive critique, nor do they give much indication of the errors made by the dancers. Flett and Flett collected and reviewed surviving critiques for the 'Aberdeen University Review' of 1956:

There are frequently terse comments, 'just tolerable', 'very good', 'indifferent', the highest praise being 'capital'... Occasionally there are equally terse comments on dress... But only three times are there comments on technique. In 1829 one of the pipers... 'raises knee too high', while another competitor 'takes too big a reel' and in 1832... 'dances too high' (Flett & Flett 1956: 349-50).

It seems that the notes reveal something of a common problem, that of overstatement in the dancing. Each of the three comments, although brief, demonstrates an aversion to the nature of dancing which is 'too high... too big' (Flett & Flett 1956: 50). However it is interesting to note that it was on one of the prize winner's reports that the phrase 'too high' appears. This implies that either the dancer triumphed despite the adjudicator's distaste, or displayed other outstanding qualities of technique, or that the dancer pleased another judge, thereby proving there to be varying preferences of style and execution.

With this gradual trend toward competitive dancing, and an inconsistency amongst judges and competitors alike, the SOBHD offered a standard for competitive dancing. It offered a uniformity of technique, to which many dancers and judges adhered, and it set down the rules and regulations for

practice in competition. McLaren, who judged in competitions prior to standardisation, remembers the impact that the Board had on the quality of the dancing: 'The Board has made a big difference to the dancing' (STDT 06/10/1998). Similarly, McHarg relates the success of the Board to its sound theoretical foundation:

The theory fascinated me and you know I took my theory exams almost up to being a teacher of music. I loved to read about things... [theory is] Very important... It's very important to know when to apply that theory to the practical (SX2003.035).

However Mill admits that his pupils now face a much tougher theory examination than he did, in the years following the formation of the Board:

The exams that we did in those days was [sic] very basic in that you had to do... three or four dances and just answer maybe about half a dozen very simple questions. Nowadays it's a lot harder to get through the teacher's exam (VA2003.007).

Mill also gives an extreme example of how these new rules and regulations have affected the approach of the competitors:

I like the idea of standardisation, but... it's over the top now... I can give you a good example to show how brainwashed we are. There was a Board dancer who lived a couple of hundred yards away from me... The night before Cowal Games and the mother came up to me... about eleven o'clock one night in a panic. She'd been making a 'Flora' outfit for her wee lass and they had tartan ribbons on the sleeve... and she said to me 'Now is it an inch apart or an inch and a half apart?' And I said 'I haven't a clue... does it make any difference?'... 'oh yes'... she said... After she went away I thought 'now... a wee thing like that and she's worried about it, and she worried all weekend'... Would it make her [daughter] a better dancer if it was an inch and a half instead of an inch?... There's too many stupid little rules that they must adhere to and

it's just tumbling, tumbling towards this stupid standardisation of all being replicas of each other (VA2003.007).

McHarg is in agreement that the strictness of the Board's rules pervaded the mood of the dancing competitions as a whole: 'the[y] controlled the dancing too much. They went too far. They spoiled the tradition. How we used to do everything. We were free and easy, you know, and had correct positions' (SX2003.035).

Forsyth counters accusations of the Board having a tightening grip on the practice of Highland dancing in all spheres. He explains, diplomatically, his belief that, while the principles of movement are constant, non-competitive dancing can survive without the restraints of competitive conventions:

If we're talking about competition, than let's have a standard for the competition. If we're talking about demonstration of dance, then that's a different matter... Because you're teaching Board work for competition purposes, doesn't mean to say that you can't do anything else as far as dancing is concerned (VD114b).

However, a degree of uniformity and conformity was inevitable with the introduction of standardisation, and is evident not only in competitive Highland dancing, but also in non-competitive dancing, as teachers and dancers inevitably look to the Board's publications for instruction. Currently, adjudicators do not write down critiques of dancers' dancing in competition. Instead, a points system is employed, whereby dancers are given both a percentage rating, and a comparative position within the group in which they are dancing. This is detailed fully in the following chapter.

5:I:iv The Textbook of the SOBHD

Highland Dancing: The Textbook of the SOBHD (SOBHD 1993) was first published in 1955, five years after the official inauguration of the Scottish Official Board of Highland Dancing. As a direct result of many Technical Committee Meetings such as those held in 1950 (see Chapter Four), McLennan's basic rules for the execution of positions, movements and steps were generally accepted as standard by the SOBHD³¹. These definitions were then intricately wrought and the most detailed instructions to date of the positions, gestures, movements and steps of the five main dances of the oral tradition passed into print.

The contents of the textbook have included, since its first inception, illustrated instructions of the 'Basic Positions', i.e. Foot Positions, Arm Positions and Head Positions. There are also written instructions of around thirty 'Basic Movements' which are combinations of these positions of which the 'Basic Steps' are composed (SOBHD 1993: n.p.). The textbook sets out the precise details of technique of these steps and methods of performance. There is also a short section on the 'Rudiments of Music' and on the 'Counting of Highland Steps or Movements to Music' (SOBHD 1955: n.p.).

The stabilised technique compiled by the SOBHD was intended to be adopted by all associations and individuals connected to that body. In the words of the Introduction to the 1955 edition of *Highland Dancing: The Textbook of*

³¹ *A Guide to Teachers, Dancers and Judges* was written in 1925 and subsequently published in *Highland and Traditional Scottish Dances* (McLennan 1950).

the SOBHD, 'This is tantamount to stating that practically every qualified teacher of Highland Dancing in Scotland has adopted that technique' (SOBHD 1955: n.p.). This was indeed a huge turnaround from the unsettled meetings of 1949 and 1950 (see Chapter Four). However this statement is, by nature, a self-fulfilling prophecy, as it is a faithful assertion of dominance and authority. It remains unchanged in the current edition of the textbook (SOBHD 1993: n.p.).

Witta considers the SOBHD's approach to publication somewhat more calculated, in that the textbook would have 'administrative sanction and thereby almost the force of law behind it' (Witta 1982: 7). However, it is not the case that the textbook has remained in its original state throughout its various editions, which span the second half of the twentieth century. There have been some amendments to the text since the first edition was printed (SOBHD Amendments 1962). The majority of changes have been required to meet unexpected or inaccurate interpretations of the given denotations. This shows the difficulties of a printed notation, rather than oral transmission, but also that the instructions are now refined, according to the dancers' needs for clarity³². However, any changes which have been made did not necessarily alter the various movements described, but rather clarified the instruction³³.

Witta sardonically calls the SOBHD textbook a 'standard bearer' and accuses the organisation of 'external legitimisation and a mythological purity'

³² The SOBHD instructions must be clear and comprehensive as their overseas members often compete in Scotland, with little experience of the dances outside the competitive arena.

³³ The 1962 edition of the textbook included a loose sheet titled 'Amendments and Additions up to 1962' (SOBHD 1962: n.p.). This seems to have been provided to correct the mistakes and omissions which had been inevitable in this new medium of specific Highland dancing key. It does not, for the most part, change the essence of the text. Changes are presented, notated and analysed, where appropriate, in the following section of this thesis.

(Witta 1982: 35). However the publication does bear a standard to a great extent, there being no other such extensive collection of technique or instruction available. The Technical Committee of the SOBHD has continued to meet regularly since 1950, without interruption, and the discussion of the textbook technique is constantly reviewed. When challenged on the authority of this refining process and the supposed purity of his forebears' revisions of the textbook, Forsyth responded by saying 'But did they cut it out? Or is it just that they refined the wording of everything over the years?' (VD114b).

The SOBHD includes a disclaimer as to why the book does not include any mention of dance evolution or alternative traditional teaching methods:

Originally, it was intended also to provide a brief but authoritative account of the history of Highland dancing. Gradually, however, it became clear that the difficulties in the way of such an attempt are at present well-nigh insuperable (SOBHD 1955: n.p.; SOBHD 1993: n.p.).

One complaint about the textbook at the time of its first publication was the nature of the images used to accompany the instructions. These were initially photographs of a male Highland dancer and, by implication, showed a male style of dancing³⁴. Taylor shared his concern with Davidson:

A diagram of a woman depicting positions in a book on *traditional* Highland dancing is incongruous whereas had she been depicting female styles of Highland dancing then there would have been nothing wrong (Appendix 8).

³⁴ These were replaced by drawings in subsequent publications.

The publication of the book meant that dancers, male and female, would follow the instruction therein. Matters of accurate depiction and gender differences in execution do not seem to have been raised subsequently. It seems that the only definable difference between these styles was the difference in body weight, proportion and carriage, which varies between male and female dancers. However this principle is also true when comparing any two individuals. The differences between individual performers and their performances could not be included in a textbook which was intended as a tool for regularised, detailed and expert teaching and fair and balanced judging. The appearance of instructions in print meant that such exponential distinctions could not be made, in keeping with the nature of standardisation.

The present-day dearth of dancing males is a situation which could have been predicted, as it was inevitable that, having lost so many young fit male dancers in the two World Wars, the situation was reversed. The female dancing society inevitably made it their own, not only in the dominance of the competition platform but also in style, due to their own build and carriage. The inevitability of this reversal seems to have been generally accepted, as it failed to be mentioned on the initial agenda for either of the main Scottish governing bodies at their formation. Neither group has offered any particular incentive in the last fifty years that would encourage and inspire young boys to investigate the activity.

Emmerson alludes to the tradition of the male Highland dancer which is typified by Watson '[who] made Highland dancing [his] business and kept actively competing through the years' (Emmerson 1972: 251). This is an

interesting reference which is expanded on when Emmerson demarcates the stage performance from the competitive one. Watson's appreciation for, and use and promotion of 'a broad-based dancing past' established him as the 'last in this line... [of] well-established competitor[s] and entertainers[s] (Witta 1982: 100). It is interesting that Emmerson does not give such accolades to any male dancers who grew up within the tradition of the SOBHD, but he does lament the dearth of young male Highland dancers which was evident in the early 1970s.

The legacy of *Highland Dancing: The Textbook of the SOBHD* lives on, however, as it is the essential tool used by the current worldwide membership of the SOBHD. The organisation, being by far the largest, and evidently the most successful at recruitment, is the scientific 'control' against which other sources of instruction are inevitably compared. This is not to say that the textbook is necessarily the standard bearer, or is considered to be so, but is the most comprehensive of all tutors. In the following section, the textbook has been contrasted with other publications of a similar nature, bearing in mind that the true standard-bearers are not members of the Technical Committee of any dance organisation, nor even those who write and publish the instructions, but those who teach and practise the dances in the living tradition. This is done with a view to demonstrating the strengths and weaknesses of each rendering of these dances on the printed page.

5:II Basic Key for Highland Dancing

5:II:i General Notes and Terminology

The aim of this section is to provide the reader with an accurate key of the current positions of the head, arms and feet, in Highland dancing, as recommended by the SOBHD, and compared to McLennan's original instructions and those of the SOHDA and the NZAND. In providing this new resource, it is hoped that the dancer and dance analyst alike will find these notations useful in both practical and theoretical application, in identifying current trends and styles in the tradition. Comments have been made, where applicable, in cases where the position or movement differs between organisations or dancers. This is done with a view to establishing the degree to which there is international agreement on execution and, with the evidence of the Labanotations, some analysis of the differences is made.

The Labanotations which follow are made on the basis of the written denotations of head, arm and foot positions found in the *Highland Dancing: The Textbook of the Scottish Official Board of Highland Dancing* (SOBHD 1993: 1-16). These textbook standards are compared to the SOHDA's *ABC of Highland Dancing and Games Directory* (SOHDA 1994) and the NZAND's Examination Syllabi which are also approved by the SOHDA). Previous SOBHD publications and additional instructive material are cited where further differences in technique and style occur. It is acknowledged that this notation is by no means definitive, but it does form a lasting record of the current style of

the SOBHD (as the most vigorous regulating body) in comparison to other practices; some analysis of the differences found in execution is made later in this chapter.

Where there are records of steps given by either the NZAND or the SOHDA which differ from those given by the SOBHD, they have also been illustrated. Any changes in terminology or instruction in the series of editions of the SOBHD's publications have also been noted. Otherwise it should be assumed that the explanation cited from the 1993 textbook is the same as that in the first edition (SOBHD 1955), and has remained so over the intervening time. The reference for the full quotation is always cited first, and, where the same words are found in any other text, these are noted in italics. For example, the instructions for the 'Grouping of Fingers', according to the SOBHD and the SODHA, respectively, read as follows:

The fingers are lightly grouped and the thumb is in contact with the first joint of the middle finger (SOBHD 1955: 14; 1993: 13).

The fingers are simply spaced and the thumb touches the first joint of the middle finger (SOHDA 1994: 17).

This is presented as follows:

The fingers are lightly grouped and *the thumb* is in contact with *the first joint of the middle finger*' (SOBHD 1993: 13; SOHDA 1994: 17).

The complete quote is taken from the reference listed first in the brackets which directly follow (SOBHD 1993: 13) and the italicised words are those also found

in the subsequent reference (SOHDA 1994: 17) which is also italicised for clarity.

Significant differences in terminology have been presented as separate quotes (not italicised), although these have not always resulted in different interpretations of the gesture or movement. Comparative Labanotations have been shown where there are alternative instructions. In addition to the Labanotation, annotations and quotes have been used for clarity and comparison.

A *gesture*, by definition, has no transference of weight. The foot positions below relate to stationary positions for the sake of demonstration. However they form the component parts of *movements* which involve weight transfer. Such movements, either repeated or in combination, make up basic *steps*.

It should always be assumed that the gestures or movements are in relation to a line of direction which is, unless stated, the same from the outset. This is an imagined line passing from front to back, between the heels of the dancer when standing in First Position (the starting position) (SOBHD 1993: 2; SOHDA 1994: 31). This is with the exception of turning or travelling steps, in which case this is made clear through the use of directional symbols of floor patterns.

Head Positions are described in relation to the body. No indication is given in any written instructions as to the expression of the head movements, except for McLennan who describes the head as being 'slightly turned to the same side as the pointing foot, but not looking down' (McLennan 1950: 12).

The two positions of the head have been notated but any indication of the nature of flow of the execution has not. Similarly *Arm Positions* are given, but the manner of the positioning and movement is not indicated. This is because, as previously discussed, there are as many renderings of these movements as there are dancers. The SOBHD, SOHDA, NZAND and McLennan specify positions but give no indication of the nature of the action in the dance context. Images from the textbook (SOBHD 1955: 15; 1993: 3-17) have been inserted for head, arm and feet positions in order to give some idea of the overall effect of the components in context³⁵.

The foot supporting the weight of the body is referred to as the *supporting foot*. While dancing, it is always the ball of the supporting foot which is in contact with the ground, with the exception of assembles, disassembles, leaps, and other instances where the weight is evenly distributed on both feet³⁶. The other foot is referred to as the *working foot*³⁷. Examples of Foot Positions and Movements are given with the Left (L) as the supporting foot and the Right (R) as the working foot, with some exceptions which are noted. All movements can be mirrored on the opposite foot within the dances, and commonly are within the same step.

'Footwork', according to McLennan, should be 'Generally well up on the ball of the [supporting] foot from start to finish' with the toe of the working foot 'pointed accurately, always downward, except in the case of toe and heel steps'

³⁵ References are also made to fieldwork video recordings listed in the Bibliography.

³⁶ Please note that the terms 'assemble', 'disassemble' and 'change' are used, in keeping with the written instructions of the SOBHD textbook (1993), and not the Balletic terms 'assemblé' or 'changement'.

³⁷ These terms are generally used by the SOBHD, SOHDA and NZAND.

(McLennan 1950: 11). He also emphasises the importance of 'Neatness and precision in... positions' and that 'Movements should be clean, close... crisp [and] combine[d] spontaneously and unconsciously' (McLennan 1950: 11-12).

There are five basic *Foot Positions* and others derived from those and named in relation to them. These derivatives take the form of *closed positions*, in which the feet are either in contact with each other, or the working foot is touching the supporting leg; *open positions*, in which the working foot is not in contact with the supporting foot or leg; *ground positions*, as in the basic positions, in which both feet are in contact with the ground; *aerial positions* in which the working foot is off the ground and *rear positions*, in which the working foot is to the rear of the supporting foot.

In a ground position, the working foot may be placed on the *toe*, *half point*, *ball* or *heel*, where specified:

The *toe* is when the 'point' is in contact with the ground, without bearing any weight (SOBHD 1993: 1). In an open position the instep is arched, or in a closed position the foot is vertical. The knee of the working leg is turned out at an angle of 45° to the line of direction³⁸.

The *half point* is when the pads of the first two or three toes are in contact with the ground, with the ball of the foot off the ground. When in an open position, the instep of the working foot is arched with the knee of the working leg slightly relaxed. In a closed position, the working foot is kept as

³⁸ Turn-out, as specified here, is normally assumed in the notation. However, unlike any of the dance instructions quoted in this chapter, the turn-out illustrated is not from the ankles (as is implied by the written instructions that the feet should be turned out), but is a rotation from the hip which thereby takes into account the necessary turning out of the knees (SOBHD 1993: 1) which is also specified.

vertical as possible. The weight of the body may be partially taken on the half-point, the main weight being retained on the other foot, thus providing the impetus for any required slight elevation or travel of the supporting foot (SOBHD 1993: 2).

The *ball* is when the pads of the toes and the ball of the foot are in contact with the ground with the instep arched. The knee of the working foot is kept as straight as possible, but without strain, to allow for freedom of movement (SOBHD 1993: 2). The weight of the body may be placed on the ball, in which case the weight is transferred and a step is taken.

The *heel* can be in contact with the ground in both closed and open positions. The sole of the foot is kept straight and inclined upwards. The heel is generally placed without pressure.

It should be noted that positions are, for the most part, notated on the full-point, with the exception of First Position which can be on the balls of the feet or at rest. The supporting foot is depicted as being flat, although this is for the purposes of illustration, as this foot would normally be on the ball, unless otherwise stated. Positions have been capitalised both within the text and quotations for the sake of clarity for the reader.

The NZAND give a detailed interpretation of the *execution* of the dances: 'The dexterity, control, neatness, gracefulness and precision in the performance of all movements' (NZAND Grade Three Examination Syllabus, 31). Such execution should also incorporate 'animation, balance... co-ordination, [and] deportment' (NZAND Advanced Examination Syllabus n.d.: 19). The definition of the correct method of *deportment* reads as follows:

At all times the body must be erect, with shoulders and hips squared to the front. Arms move without any lifting of the shoulders, and head is poised naturally with a diagonal turn in the direction of the working foot when compatible with alignment; otherwise facing front. There is no inclination or forward movement from the waist and balance must be maintained throughout (NZAND Advanced Examination Syllabus n.d.: 19).

It should also be noted that the body should, according to the SOBHD, be held 'in a natural easy manner without stiffness, strain or exaggeration' (SOBHD 1993: 1). McLennan describes a body which is 'Erect and manly [with] good carriage [and] suppleness' (McLennan 1950: 12). The presentation of the kilt is paramount to McLennan, who emphasises that *legs* should be 'firm but supple, and the knees always well turned outwards so that the APRON OF THE KILT HANGS FLAT [sic]' (McLennan 1950: 11). This is the explanation given by the SOBHD:

the supporting leg turned out at an angle of 45° to the line of direction... and the working leg turned out at an angle of not less than 45°, and in many cases 90° to the line of direction... tends to keep the apron flat (SOBHD 1993: 1).

These instructions, if followed, bring about the desired effect of having a flat kilt apron, but there is an emphasis on the methods themselves, rather than (as in McLennan's case) the reasons for such methods.

This seems to be a trend, as the instructions which are presented suggest, with the more modern instructions being increasingly technical. It is for this reason that the Labanotations have been translated from the written denotations of the SOBHD, rather than from McLennan or any earlier source. This is not to say that this should necessarily be favoured as the most accurate

reference, but rather that it is the most exhaustive, and that to it other instructions are easily and effectively compared.

Where written denotations are quoted, the terminology has not been changed, and may differ between organisations. However the publications used are consistent in their terminology and phrasing. These differences are mainly in the counting of musical bars and the movements within them (i.e. 'beats' and 'counts' are normally interchangeable). Also, images from the SOBHD textbook (SOBHD 1993: 3-17) have been inserted to illustrate the head, arm and foot positions in the following section, in order to give some idea of the overall effect³⁹.

³⁹ Permission for the use of these images has been sought.

5:II:ii Head and Arm Positions

Head Positions: First

'The head faces the front with the eyes level' (SOBHD 1993: 16; SOHDA 1994: 22), unless otherwise stated⁴⁰.

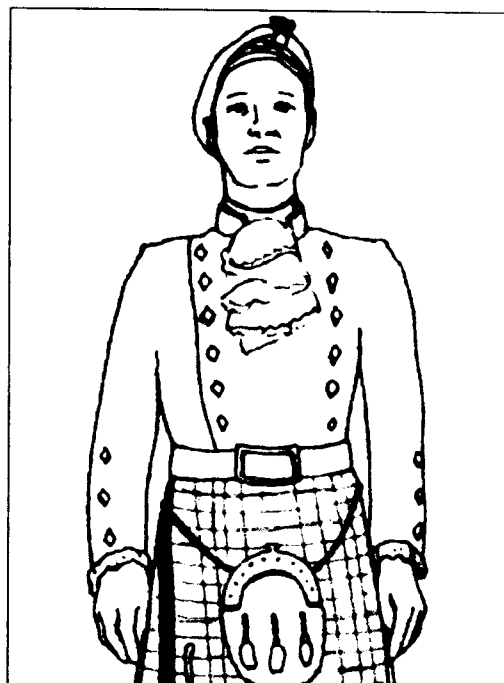
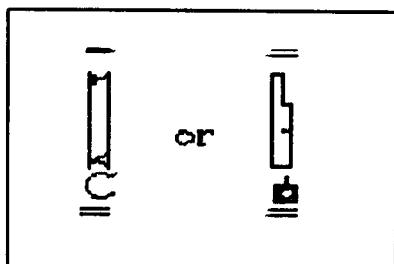

Head Positions: Second

'The head is directed diagonally to the Right (R) or Left (L)' (SOBHD 1993: 16; SOHDA 1994: 22). The SOBHD also recommend that the chin should be 'slightly raised' (SOBHD 1993: 16). When the arms are in Second Position the head is turned away from the raised arm and it should be noted that this head position never occurs in isolation from the arm movement. The notation follows the drawing, which is for illustrative purposes only. In reality,

⁴⁰ The head configuration is not normally necessary to record in Labanotation, but, since it is specified in the textbook, it is considered part of the style which is deemed worthy of illustration.

this is not a still position but a movement destination, from or passing through,
 First Head Position⁴¹.

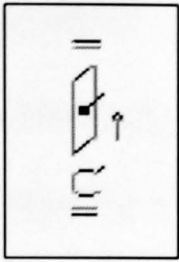

Should a L head turn position come directly after a R head position (or vice versa), the Labanotation black directional pin relates to the previous movement.

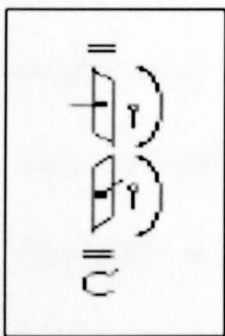

⁴¹ This position, when represented by a Labanotation white directional pin, should be judged from First (front) Position, rather than from the previous movement.

Grouping of Fingers

'In all positions of the arms except First Position, the fingers are lightly grouped and the thumb is in contact with the first joint of the middle finger' (SOBHD 1993: 13; SOHDA 1994: 17). The SOHDA describes the non-contacting fingers as 'simply spaced' and the contacting fingers as 'touching' (SOHDA 1994: 17)⁴².

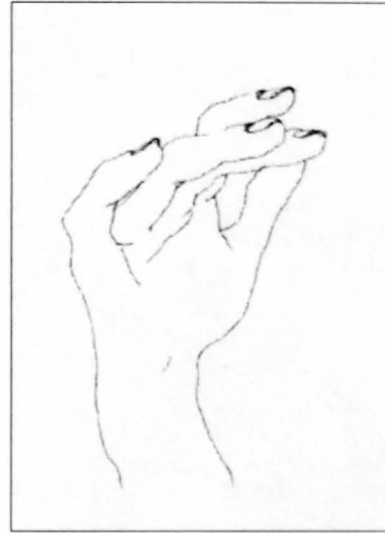
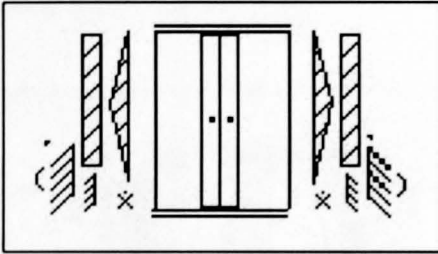

McLennan notes the finger grouping as 'thumb very lightly touching first two fingers' (McLennan 1950: 12). As it is not specified where the thumb comes in contact with the fingers, it may be assumed that the position intended was that which was most comfortable for the dancer. As the build, shape and dexterity of the hand changes from dancer to dancer, the pad of the thumb may touch the pads, first joints or the middle of the fingers, or a combination of these.

⁴² The hand is notated here without consideration for the arm, as in the illustration. However, in most positions, except Fourth and Fifth Arm Positions, the hand would be placed high, and the arm would therefore effect the curvature of the hand and the overall position.

Arm Positions: First

'Both hands rest on the hips with the back of the hands to the front, the knuckles facing the body with the wrists straight, and the elbows pointing directly out to the side' (SOBHD 1993: 13). Similarly, 'The hands are placed lightly on the hips, knuckles against the body, back of the hands facing the front. Both wrists are held firm with elbows positioned directly to the sides' (SOHDA 1994: 3).

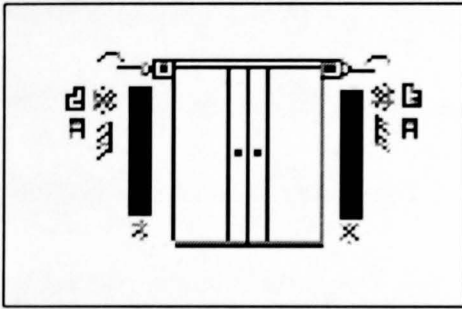

Arm Positions: Akimbo

This is an alternative name for First Position of the arms, defined by McLennan as 'knuckles against the waist side... the elbow... in a direct sloping line from the shoulder' (McLennan 1950: 12) and also similarly defined by Douglas-Taylor (Douglas-Taylor 1929: 8). However this is a misleading term, as it could, without clarification, be confused with 'hands on hips and elbows projecting outwards' (*Collins English Dictionary* 1994: 33) without an exact placing of hands or wrists. A fuller explanation is required, and is therefore

entitled 'First Position of the Arms' by the SOBHD and SOHDA (SOBHD 1993: 13; SOHDA 1994: 3). This straight wrist position eliminates any appearance of looseness, which would not be in keeping with the 'neatness and... tightness' (VB056) but this straightness must be forcibly maintained against the impact of landing.

The NZAND give full and clear instruction for the position of 'Akimbo' in which 'Closed hands are placed on the waist at the side, backs of hands facing front, wrists straight, elbows in a direct sloping line from the shoulders, shoulders down and squared to the front' (NZAND Grade One Examination Syllabus n.d.: 9-10). In this way, the wrists are a little more relaxed, in a position which Witta claims is preferable to the SOBHD's first arm position. He claims that the difference is more than linguistic: 'anatomically the knuckles fit the waist and can be held firm between the lower rib cage and the hip' and 'deportment and poise of the dancer are aided by holding the waist apart from the rib cage and the hip' (Witta 1982: 126). In this position, as the dancer hops, springs or leaps, there will inevitably be a slight movement of the wrist on landing.

Arm Positions: Second

'One arm is placed as in First Position, the other is raised at the side, with the arm and wrist slightly curved, the hand slightly above and forward from the head-line, the palm turned inwards' (SOBHD 1993: 14). 'The arms should follow a graceful curve from the shoulder to the finger-tips' (Rankine 1977: 11). Similarly, according to the SOHDA, '[one arm] is placed in First Position... The

working arm is lifted at the side, with a gentle bending of both wrist and arm... the working arm... positioned over and slightly forward of the head, with the palm facing inwards' (SOHDA 1994: 3). Fingers are grouped on the raised arm. The following notation is for the R arm raised.

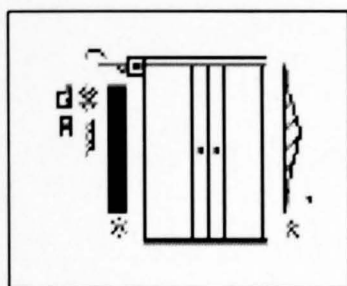

Arm Positions: Third

'Both arms are placed as described for the raised arm in *Second Position the palms facing inwards towards each other*' (SOBHD 1993: 14; SOHDA 1994: 3). The NZAND qualify the position of the arms as being 'raised in a semicircle in front of the shoulder line until the elbow is slightly higher and forward of the shoulder line' (NZAND Grade One Examination Syllabus n.d.: 12).

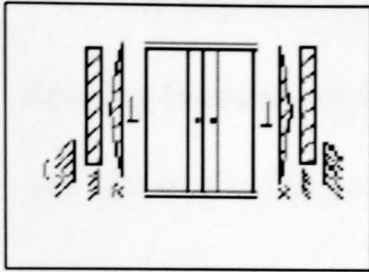

McLennan's instructions read as follows: 'Gracefully and naturally raised in semicircular form and in front of head' (McLennan 1950: 14) with 'the elbow slightly above and in front of shoulders' (McLennan 1950: 12). This positioning is the same as the SOBHD denotation, except that the palms of the hands are not turned towards each other but are 'turned partially towards the face' (McLennan 1950: 12). This slight variation in position would have been easier with McLennan's preferred relaxed finger grouping, since the angled hands would sit in a natural inward curve, rather than having the juxtaposing force of the thumbs pushing the middle finger (and wrist) upwards in contact with the first joint.

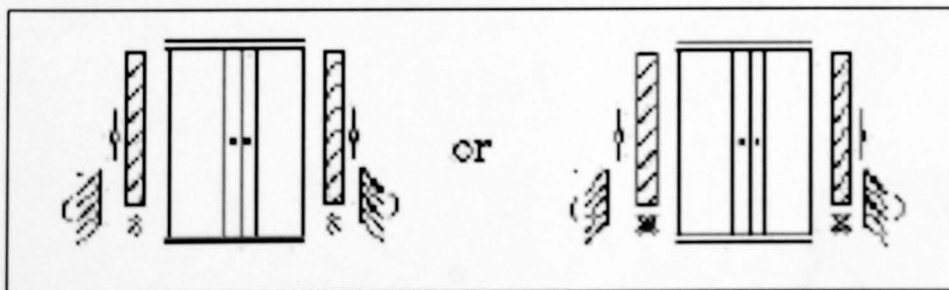

It was not until the nineteenth century that arm positions in Highland dancing became clearly defined in the form of instruction. Ladies, although still not allowed to dance in competition, were allowed to raise their arms just like the men. However, the arms positions have changed over the years and have evolved into a more balletic pose. David Anderson states in his *Ballroom Guide* that the arms when they are held up should be bent at the elbow so that the hands are approximately four inches above the head (Anderson 1900: n.p.). This is possibly because the cut of an evening jacket does not allow the hands and arms to be raised very high without spoiling the appearance of one's dress or simply being too uncomfortable. This lower position is not recognised in contemporary Highland dancing but is shown below.

Arm Positions: Fourth

'A closer and higher form of Third Position with the hands almost touching' (SOBHD 1993: 15). Similarly, the SOHDA are agreed that the position is 'closer... slightly higher' and with 'fingers almost touching' (SOHDA 1994: 3).

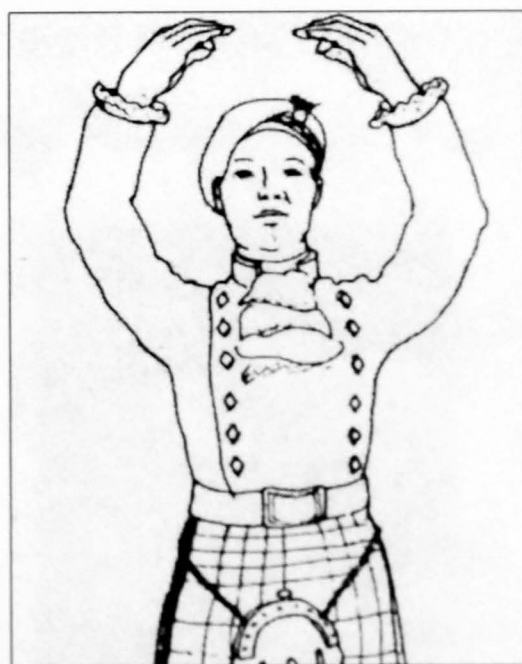
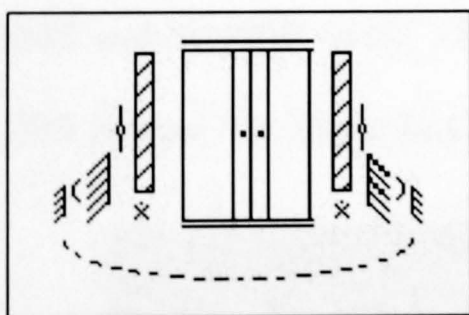

Arm Positions: Fifth

'The arms are gently curved down in front of the body with the hands quite close to each other and the little fingers almost touching the kilt' (SOBHD 1993: 15; SOHDA 1994: 3). The SOHDA describes the arms as being 'slightly curved' (SOHDA 1994: 3).

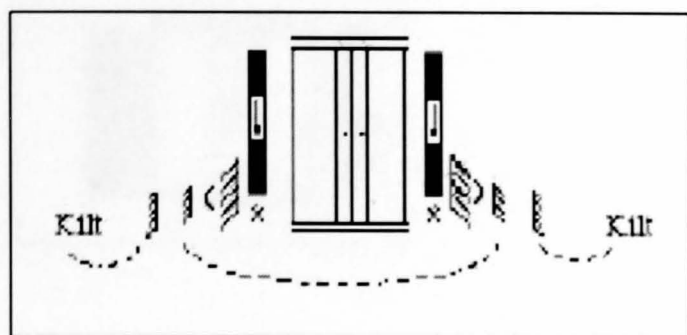

The SOBHD first published this position as 'the arms are curved in front of the body, with the fingers grouped, and the hands almost touching. The palms are facing the body at arms [sic] length, and slightly below waist-line' (SOBHD 1955: 14). In the illustrations which accompany the explanation, the dancer is shown to have both hands extended from the body (SOBHD 1955: 15), akin to the ballet position 'port de bras'. However, by 1962, the updated denotation is printed, notably without an illustration (SOBHD Amendments 1962 and SOBHD 1962: 15). There is still an absence of clarification in the 1993 edition. The illustrated version from 1955, is shown below.



Arm Positions: By the Sides

This position is given by the SOBHD (SOBHD 1993: 17) as an alternative to First Position for use in the Bow movement only (as illustrated later in this chapter). It is not recognised by the SOHDA.

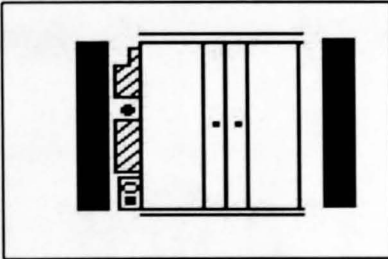

5:II:iii Foot Positions

Foot Positions: First

'The heels are together with *the weight of the body equally distributed on both feet*, which are turned out to *form an angle of 90°* (each foot being at an angle of 45° from the line of direction)' (SOBHD 1993: 3; SOHDA 1994: 19).

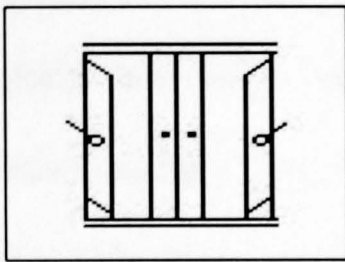

This step can also be 'poised on the balls of the feet' (SOBHD 1993: 1), as shown below.

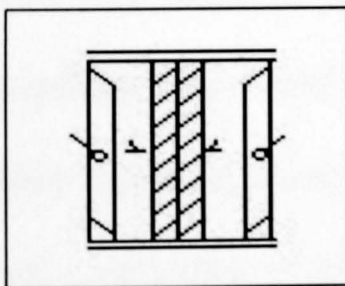

It is worth noting that the 'line of direction' as defined by the SOBHD is the imaginary line 'on the ground from front to back between the heels of the dancer when standing in First Position' (SOBHD 1975: 2) but that the NZAND concept of alignment is one which covers the whole body, taking into account 'deportment, poise and body control with head alignment' (NZAND Grade One Examination Syllabus n.d.: 15). In this respect, the SOBHD is less body-conscious than the NZAND in the presentation of the positions and steps, which are very much ground-based, rather than body-based in their manifestation. This, empirically, gives the dancer the impression that the steps should be learnt grounded and is based on footwork, rather than body-work.

Foot Positions: First Aerial

The SOBHD do not recognise this aerial position, stating in the 'General Remarks and Preliminary Definitions' that 'there is no rear or aerial equivalent to First Position' (SOBHD 1993: 2). However the NZAND recognise this position as one used in the progression of movements in The Highland Fling, the quick-time of The Seann Triubhas and in The Strathspey. It is described as one foot raised 'from First Position flat, sole of foot facing and toe almost touching side of calf of supporting leg, same height as close aerals (no higher than supporting knee line) knee splayed'. This is 'a passing through position... not... on a time count' (NZAND Grade One Examination Syllabus n.d.: 20).

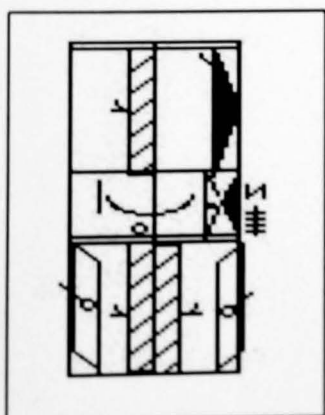

Foot Positions: Second

'The working leg is extended directly to the side at an angle of 90° from the line of direction, the toe and heel of the working foot being in line with the heel of the supporting foot' (SOBHD 1993: 3; SOHDA 1994: 19).

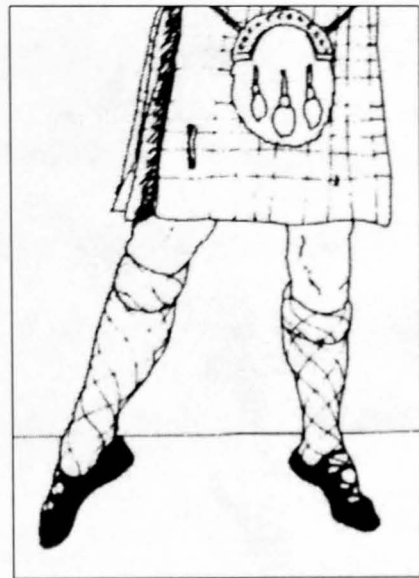
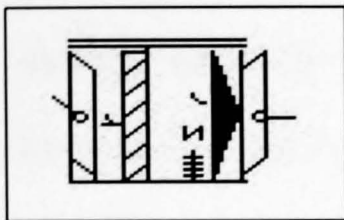

'The working foot may also be placed on the... half point, ball or heel' (SOBHD 1993: 3).

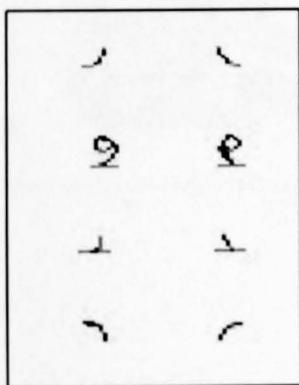

L/R Toe or 'point' (SOBHD 1993: 3)

L/R Half toe or 'half point' (SOBHD 1993: 3)

L/R Ball

L/R Heel

Foot Positions: Second Aerial

'The working leg is extended to the side as in Second Position, but raised at the required level' (SOBHD 1993: 3). The SOHDA call this required level 'a given height' (SOHDA 1994: 1), and it seems to be somewhat dependent on the previous and subsequent movements, and, inevitably, the dancer's ability to execute the sequence. For the sake of clarity, these levels have been recorded as the angle of the leg from the ground position i.e. 30°, 45° and 60° respectively (see illustrations SOBHD 1955: 4-5; SOBHD 1993: 4). Although the SOHDA do not supply a technical explanation of this position, they do recommend an unspecified 'given height' for aerial positions (SOHDA 1994: 1).

The illustration below is of 'Normal level... in line with the centre of the calf' (SOBHD 1993: 2).

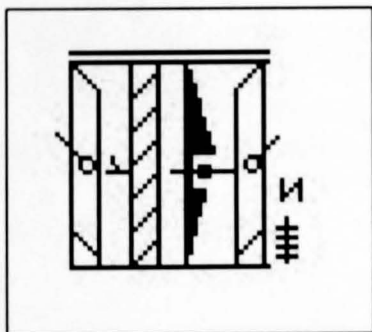

'High level... in line with the centre of the knee-cap' (SOBHD 1993: 2) is shown below.

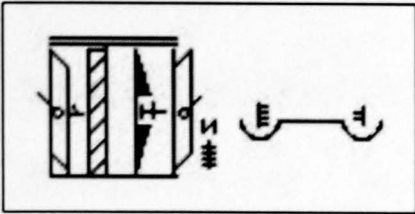

'Low level... in line with the ankle' (SOBHD 1993: 2) is shown below.

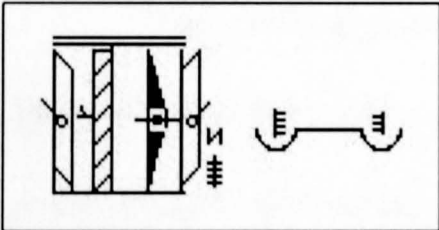

Foot Positions: Second Intermediate

The NZAND have a position termed 'second intermediate heel position' in which 'the heel is taken forward of second and placed in line with the toe of the supporting foot, knee slightly flexed' (NZAND Grade Two Examination Syllabus n.d.: 12). This step is employed in the side-heel-and-toe step in The Seann Triubhas (as shown later in this chapter). The position is shown below.

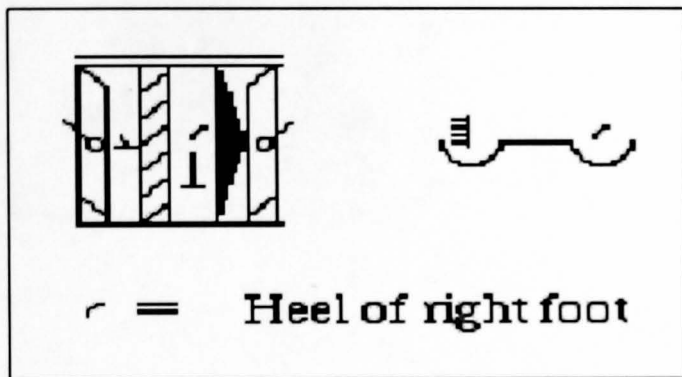

Foot Positions: Third

'The working foot, which may be placed on the toe, half point, ball or heel, touches the hollow of the supporting foot. When placed *on the toe, half point or heel*, the working foot is turned out at an angle of 90° from the line of direction' (SOBHD 1993: 5; SOHDA 1994: 19).

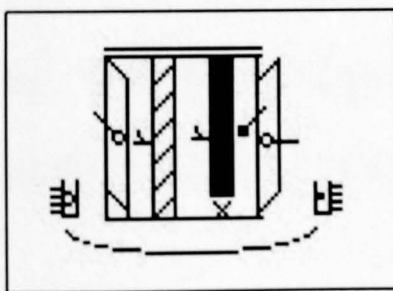

The SOBHD instructions also add that 'when the weight of the body is equally distributed on the balls of both feet, the sole of the front foot is directly over the instep of the rear foot, both feet equally turned out at an angle of not less than 45° from the line of direction' (SOBHD 1993: 5). No such detail is given by the SOHDA.

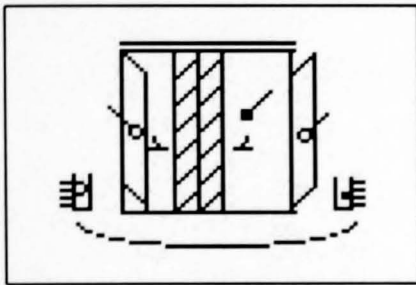

Foot Positions: Third Aerial

'The knee of the working leg [is] pressed well back, [and] the outside edge of the working foot is placed in contact with the front of the supporting leg... with the heel slightly below the level of the knee cap of the supporting leg' (SOBHD 1993: 5). This is shown below.

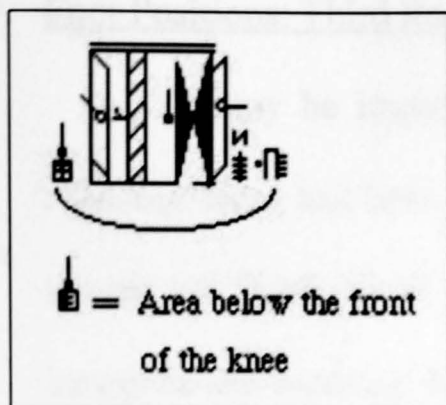

This is also described as 'the [working] toe in line with the ankle of the supporting leg' (SOBHD 1993: 5) and 'the [working] foot [is] slightly off the ground above Third Position' (SOBHD 1993: 5). These qualifications have been recorded as being 'correct' since the first publication of the SOBHD's textbook in 1955. One assumes that the above explanations are intended to be taken as full instruction for one position, rather than alternative positions. However, the difficulties of written instructions are manifest, for the interpretations inevitably differ, as has been illustrated. This aerial position is shown below.

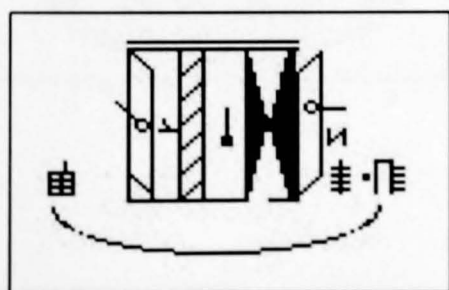

Foot Positions: Third Rear Very Low

It may be important to note that since the 1955 edition of *Highland Dancing* there has been no mention of the variation of Third Aerial Position, known as 'Third Aerial Position Very Low' (SOBHD 1955: 7), in which 'the instep of the working foot is slightly relaxed, the toe slightly off the ground, and the heel over the instep of the supporting foot' (SOBHD 1955: 29)⁴³. This position is shown below.

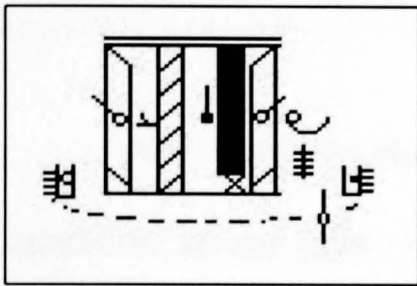

Foot Positions: Third Rear

'When placed on the toe, the hollow of the working foot touches the heel of the supporting foot. The working foot turned outwards at an angle of 90° from the line of direction' (SOBHD 1993: 6). Here is also a note that 'The working foot is never placed on the half point or the heel' (SOBHD 1993: 2).

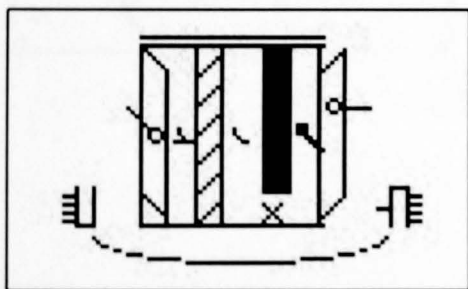

⁴³ This is similar to the passing-through position of the working foot in the 'shuffle over the buckle' movement commonly used in the Sailor's Hornpipe (UKA 1999,11) Such a passing through position should be notated as a gesture, rather than a position, in keeping with the textbook instructions.



Also, when the working foot is placed on the ball, the weight is 'equally distributed on the balls of both feet'⁴⁴. The sole of the front foot is directly over the instep of the rear foot, both feet equally turned out at an angle of not less than 45° from the line of direction' (SOBHD 1993: 6), as in Third Position danced on the ball. This is shown below.

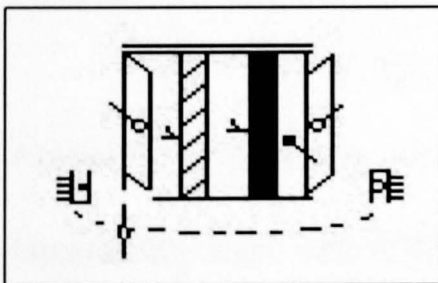

⁴⁴ The rear leg is considered the 'working' leg, even though the weight may be evenly distributed. This affects the dancer's attitude to an even weight placing, and perhaps how the weight lands, as a result of an assemble. However, in keeping with the illustration, it has been portrayed as a position, rather than as part of a movement.

Foot Positions: Third Rear Aerial

'The working foot is placed behind the supporting leg at the same height as in Third Aerial Position normal level, the inside edge of the foot being in contact with the calf of the supporting leg. The knee of the working leg is held well back, no part of the working foot being visible from the front' (SOBHD 1993: 6)⁴⁵.

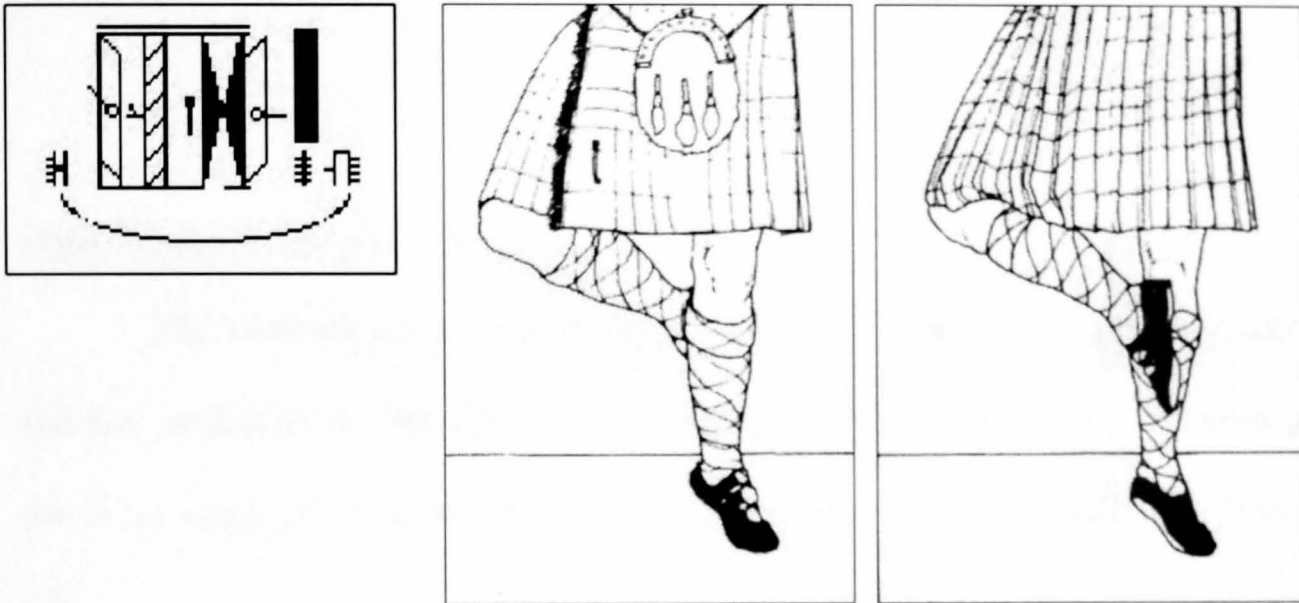

Foot Positions: Third Crossed

'The working leg is crossed in front of the supporting leg with the half point of the working foot placed near the outside edge of the instep of the supporting foot' (SOBHD 1993: 7). Also, when this position is used in the Highland Fling, 'the working foot [is] placed near the... ball' of the supporting foot (SOBHD 1993: 7), as shown below.

⁴⁵ The notation specifies that the working foot is in contact with the calf of the supporting leg.

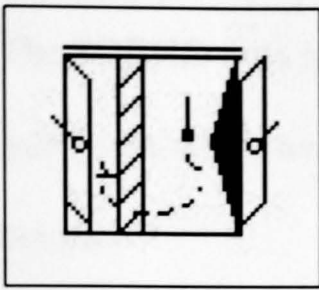

Foot Positions: Fourth

'The working leg is extended to the front with both the heels in line with the line of direction. The working foot, which is placed on the toe... is turned out at an angle of 45° to the line of direction' (SOBHD 1993: 7; SOHDA 1994: 19).

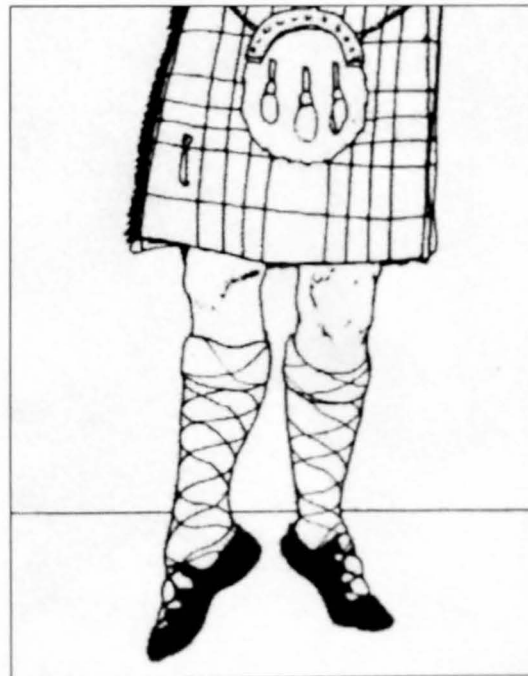
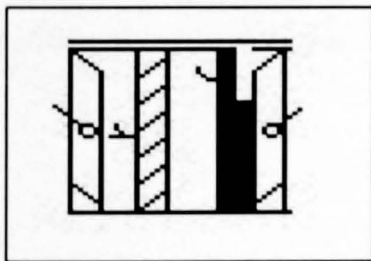

The SOBHD note an exception to this: 'The working foot... is placed on the ... half point when used in the Sword Dance' (SOBHD 1993: 7). This is shown below.

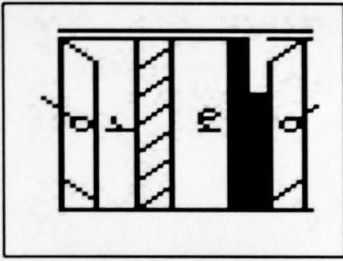

Foot Positions: Fourth Aerial

'The working leg is extended to the front as in Fourth Position, but raised at the required level' (SOBHD 1993: 8). As before, this 'level' has been illustrated as 30° from low (place being Fourth Position).

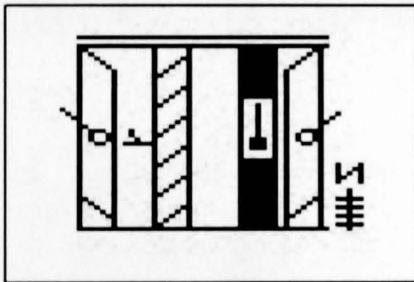

Foot Positions: Fourth Rear

'As in Fourth Position, but the working foot is taken to the rear and placed on the ball' (SOBHD 1993: 8)⁴⁶ or 'the working foot is taken to the rear, and is... flat' (SOBHD 1993: 8).

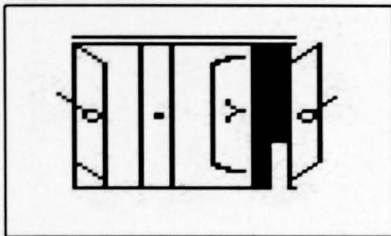

Foot Positions: Fourth Intermediate

'The working leg is extended diagonally forward at an angle of 45° from the line of direction with the working foot placed on the toe' (SOBHD 1993: 9).

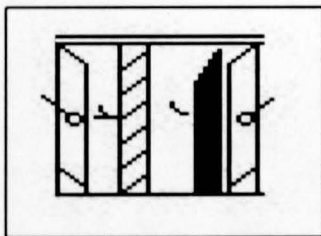

Also 'with the working foot placed on the... half point' (SOBHD 1993: 9).

⁴⁶ In the notation, slight weight is shown on the working foot (i.e. back foot), although this is probably a through position or a preparatory position. It looks a little awkward, since weight is not equally distributed, but since notation is always from the perspective of the working foot, the notation reads differently than if it had been from an equally balanced one.

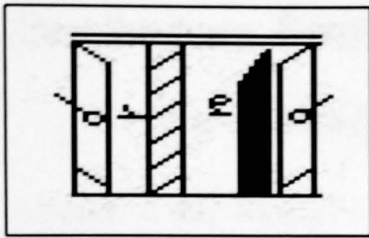

Alternatively, 'the working foot [is] placed on the... ball' (SOBHD 1993: 9).

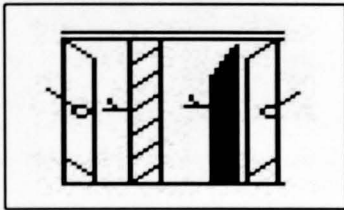

Foot Positions: Mid-Fourth

'The working leg is extended to the front, midway between Fourth Position and Fourth Intermediate Position and is placed on the toe' (SOBHD 1993: 8).

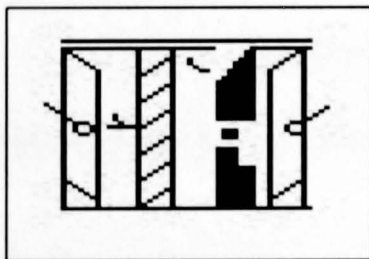

Foot Positions: Mid-Fourth Aerial

The working foot is 'Extended to the front as far as Mid-Fourth Position and raised to low aerial' (SOBHD 1993: 8). The degree of aerial low is notated here as 15° from low (place is Mid-Fourth Position).

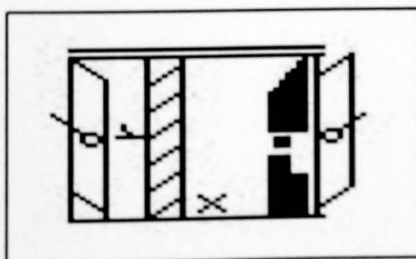

Foot Positions: Fourth Intermediate Aerial

'The working leg is extended as in Fourth Intermediate Position, but raised at the required level' (SOBHD 1993: 9). The level is represented here as 30° from low (place is Fourth Intermediate Position).

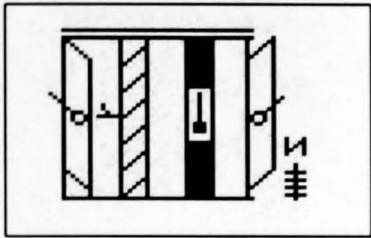

Foot Positions: Fourth Intermediate Rear

'As in Fourth Intermediate Position, but the working leg is extended to the rear and is placed only on the ball' (SOBHD 1993: 10).

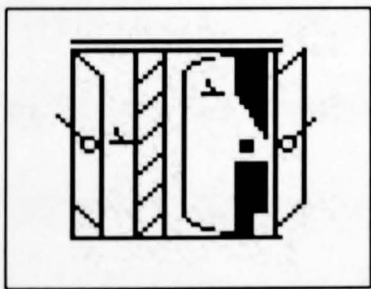

Foot Positions: Fourth Intermediate Rear Aerial

'As in fourth Intermediate Rear Position, but with the working leg raised at the required level' (SOBHD 1993: 10). The level is represented here as 30° from low⁴⁷.

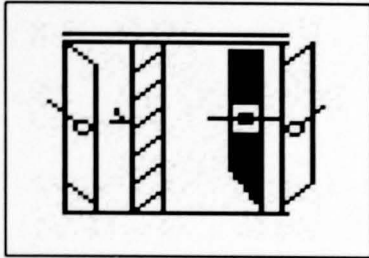

Foot Positions: Fourth-Opposite-Fifth

'The working leg is extended to the front but with the toe of the working foot in line with the heel of the supporting foot and with a slight relaxation of the knee of the working leg' (SOBHD 1993: 11). With the exception of Fourth-Opposite-Fifth Position, all other open heel positions in the textbook have a straight working leg (SOBHD 1975: 2). The working foot may be placed on the toe (SOBHD 1993: 11).

⁴⁷ This position is notated in relation to 'place' as Fourth Intermediate Rear Position.

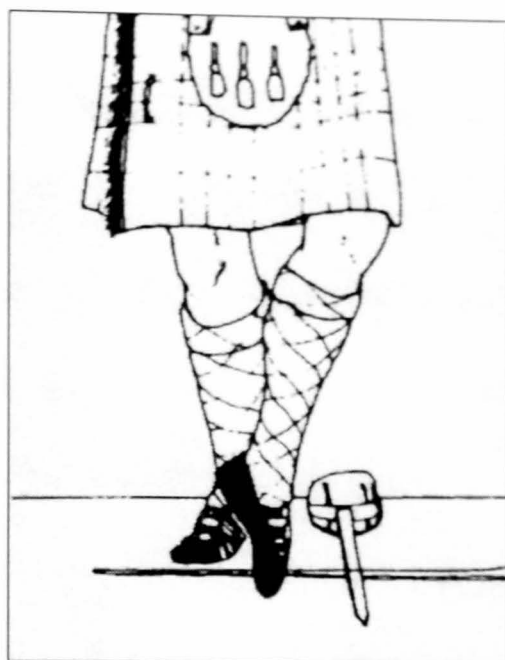
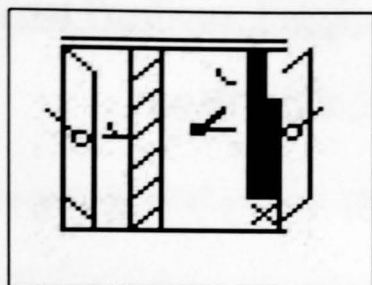

Also 'The working foot may be placed on the... half point' (SOBHD 1993: 11)⁴⁸.

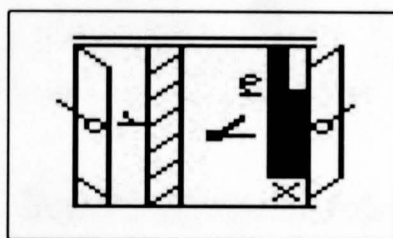

And, in the Sword Dance, 'The working foot may be placed on the... heel' in which case 'the heel is placed in line with the toe joint of the supporting foot' (SOBHD 1993: 11). This is shown below.



⁴⁸ The SOBHD textbook presents this scenario as a position, rather than a movement, and it has been recorded as a position in the notation. However, in practice, there is never weight on both feet at the same time, but rather there is a momentary or partial support placed on the 'working' foot (normally at the front), so that the 'supporting' foot (normally at the rear) can be raised.

Foot Positions: Fourth-Opposite-Third

The NZAND identify this position as one which can be danced with the working foot on the point or heel. It is similar to the SOBHD's Third Position (Heel), where the heel of the working foot is always placed in the arch of the supporting foot, in keeping with Third Position danced on the toe, half-toe or ball. However the SOBHD positioning of the heel in Third Position involves some displacement of the hip, whereas in the NZAND Fourth-Opposite-Third Position the heel is further from the supporting foot, and therefore easier to place. Either position can be used, with a high degree of accuracy.

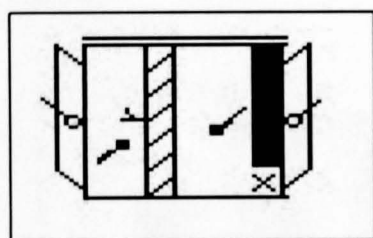

Foot Positions: Fourth-Opposite-Fifth Rear

This is the term used by the SOBHD for the position of the rear foot 'when the front foot is placed in Fourth-Opposite-Fifth Position' (SOBHD 1993: 11). Notation for this is as for Fourth-Opposite-Fifth Position, as shown above.

Foot Positions: Fifth

'The working foot is in contact with the big toe joint of the supporting foot, and may be placed on the toe' (SOBHD 1993: 12).

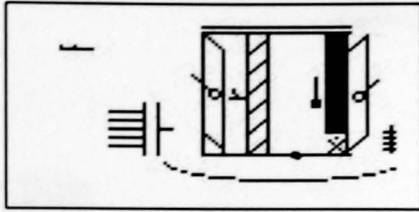

The working foot may also be placed on the heel (SOBHD 1993: 12), as shown here:

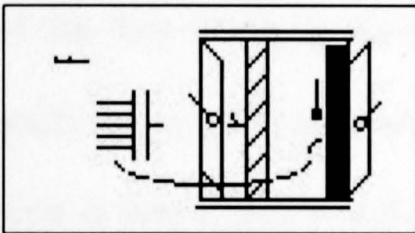

The weight of the body may also be 'equally distributed on the balls... the sole of the front foot... directly over the toes of the rear foot, both... equally turned out at an angle of not less than 45° from... line of direction' (SOBHD 1993: 12).

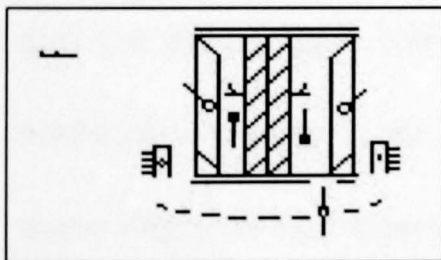

Foot Positions: Fifth Rear

This is the term used by the SOBHD for the position of the rear foot 'when it is placed on the ball and the front foot is placed in Fifth Position' (SOBHD 1993: 12). Notation for this is as for Fifth Position, as shown above.

5:II:iv Eight Basic Movements

The Bow

The opening Bow movement is one which the five main dances of the competitive Highland dancing repertoire have in common. This gesture, in which there is no transference of weight, is one which varies in tempo in each dance, according to the music. This introductory statement is then, in all cases, followed by some sort of other preparatory gesture. In The Highland Fling and The Sword Dance this is normally the raising of the feet from flat to the balls (SOBHD 1993: 31). An alternative method for The Sword Dance is the placing of the foot which is about to work, in Third or Fourth Position, on the half-point, keeping the supporting foot flat (SOBHD 1993: 35). The Seann Triubhas Bow is one which is followed directly by a step left 'towards Second Position making one-eighth turn to the right, or pivot one-eighth turn to the Right taking the weight of the body on the LF (flat)... step RF to Fourth rear Position (flat) to finish with the LF pointed in Fourth Position' (SOBHD 1993: 41).

The Bow in these cases seems to indicate the beginning of the dance and the movements described above seem to be preparatory in nature. This could be to signify to the spectator that the dancer was ready to perform, but is more likely to be a courteous gesture, presently directed towards the judge or examiner, having previously been made to a Clan Chief, in the setting of a royal court or at an assembly of some other kind.

The group dances, The Strathspey and The Reel of Tulloch, also commence with the Bow. However in these, being in a more social context, with interaction between the dancers, the Bow seems to have a different significance. The Strathspey Bow is one in which each dancer bows to their opposite in the line of four (the two outside dancers face inward and the two middle dancers stand back to back). This is a motion by which competitive dancers first acknowledge the other dancers on the platform (who, in competition, are often unknown to each other) by means of a non-verbal introduction.



The SOBHD describe this movement in isolation from the dance instructions. It is not presented as part of the complete performance and therefore there is no indication of musical interpretation:

Stand with the feet and head in First Position, arms by the sides or in first position. Bow by inclining the body forward slightly, and return to the original position. If the arms are by the sides, they should be taken to the First Position on the first count following the Bow, unless

otherwise stated the depth of the bow must not be exaggerated, and the count varies according to each dance (SOBHD 1993: 17).

The NZAND describe the same movement in simpler terms: 'A dignified movement and downward inclination of the body, with no movement of the head' (NZAND Advanced Examination Syllabus n.d.: 18). There does not seem to be any contradiction between the two instructions.

The four-bar introduction to The Highland Fling is shown below in Labanotation.

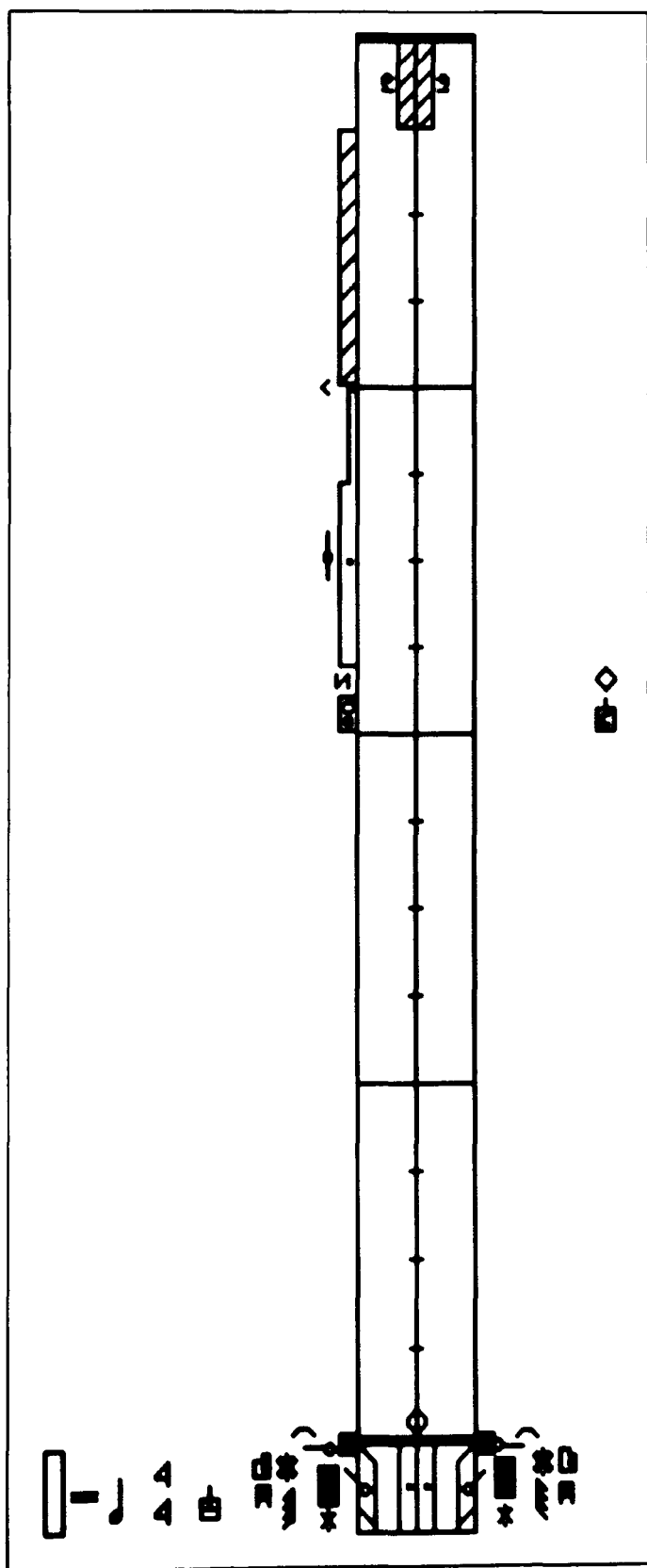

The starting position of the head, arms, feet and body is shown. This is followed by bar one in which there is no motion, bars two and three in which the bow movement is executed and bar four in which the dancer prepares for the first step (by rising on to the balls of the feet in First Position).

Hop

'A movement of elevation begun on the ball of one foot and finished by landing on the ball of the same foot' (SOBHD 1993: 18).

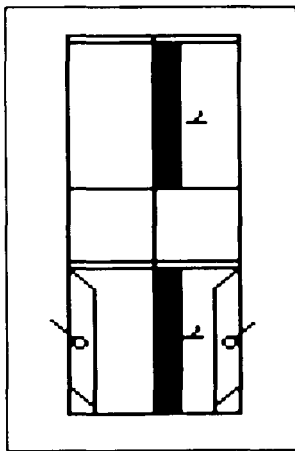

Spring

'As for a hop, but landing on the ball of the other foot' (SOBHD 1993: 18).

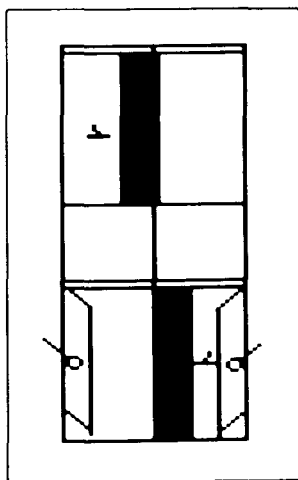

Step

'A transfer of weight from one foot on to the ball of the other foot. Can be executed with or without travel and, where specially designated, the heel may be lowered to finish on the flat foot' (SOBHD 1993: 18).

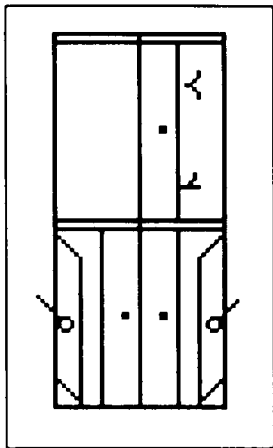

Assemble

'A movement of elevation begun on the ball of one foot and finished by landing simultaneously on the balls of both feet in third or fifth position' (SOBHD 1993: 18).

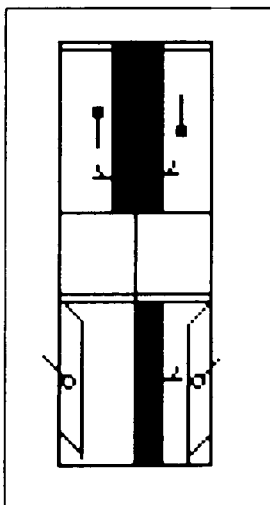

Disassemble

'A movement of elevation begun in a closed position with the weight of the body equally distributed on the balls of both feet, and finished by landing on the ball of one foot with the other placed in, or raised to, a specific

position... There is no travel in this movement, and, unless otherwise stated, during the elevation there is no extension of the foot upon which the dancer is to land' (SOBHD 1993: 18).

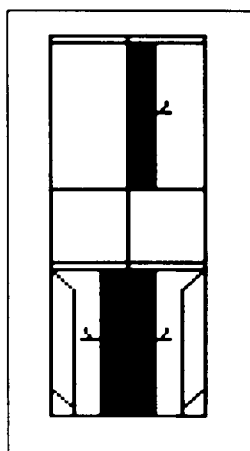

Change

'A movement of elevation begun with the weight of the body on the balls of both feet in Fifth Position and finished by landing on the balls of both feet simultaneously in Fifth Position with the other foot in front... During the elevation there is no extension towards Second Aerial Position. This movement may also be executed using Third Position' (SOBHD 1993: 19).

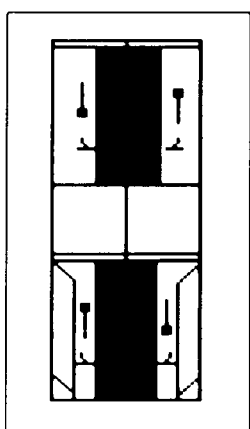

Leap

'A movement of elevation begun from the balls of both feet in Fifth Position, extending both legs towards Second Aerial Position, and finished by

landing simultaneously on the balls of both feet in Fifth Position with or without change of feet. On the extension during the elevation, both legs should be straightened. This movement may also be executed using Third Position' (SOBHD 1993: 19).

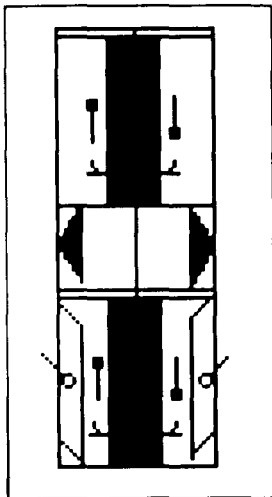

5:III The Dances

5:III:i The Highland Fling

Execution

The Celtic Monthly of 1912 provides a concise summary of The Highland Fling, as it was danced then:

The Highland Fling should be danced very 'neatly', the dancer keeping to one spot all through, never raising one foot higher than the lower edge of the knee cap of the opposite leg, as a rule letting the one foot mark time for the other (*The Celtic Monthly* 1912: XX: 209).

Another important point in the performance of this dance is 'the use of the arms in balancing the body' (*The Celtic Monthly* 1912: XX: 209). There does not seem to be any great emphasis on this function of the arms in any other records for this dance, as the arm positions are quite rigid, in First, Second and Third Positions (SOBHD 1993: 31-33). The dance described in the first publication of the textbook (SOBHD 1955) is not dissimilar to the one shown in the most recent edition (SOBHD 1993). In essence, the supporting leg hops while the working leg is placed in positions in relation to it.

The first official publication by the NZAND gives some insight into what the 'Spirit of the Dance' might be, that is

the natural expression of youthful Highland energy, joyous vitality, defiant abandon and a spirited test of physical skill. The dance is lively and the music played with a little [but] great expression. The dance is

full of character, dignity, and grace (NZAND Explanatory Notes 1947: n.p.).

This stops short, however, of explaining any narrative content of the dance, and concentrates solely on the execution of the movements and the dancer's presentation. The implication is that the character of the dance should be dictated by the steps, rather than a fresh and individual character utilising the steps for the purposes of expression.

Similarly, on the subject of execution, the NZAND state that The Highland Fling is 'executed on the spot by replacing each foot' (NZAND Grade Four Syllabus n.d.: 18) and that

All movements are clean cut, all positions precise and controlled, the working foot being well 'splayed', knees straight in all second and fourth positions. Supporting leg kept braced and elevated on the ball of the foot. 'Flinging' neat, smooth and controlled at the same height around the leg, the body bears a dignified upright stance. The entire dance to be executed in one spot (NZAND Explanatory Notes 1947: n.p.).

It is commonly accepted that 'As a general rule Fling Steps should be executed in as small a space as possible' (McLennan 1950: 11). Indeed, the 'Fourth Position of the feet is never used in this dance' (SOBHD Amendments 1962), or at least, it is not found in existing denotations of the dance. The reasons for such a restriction were discussed previously in Chapter Three, however, the technical implications give some clue as to the compass and the overall presentation for the dance.

McLennan, whose rules were written in 1925, but published in 1950, notes that 'Each supporting foot should be placed as near as possible on the

same spot' (McLennan 1950: 12) and also suggests that, for the instruction and perfection of the movements, one ought to 'Imagine the spot to be the centre of a circle with the working foot the radius' (McLennan 1950: 12). He also advises that 'if the judges do not approve of the 'Side Step', competitors should be so informed beforehand' (McLennan 1950: 12). This implies the need for communication between the judges and competitors (as discussed in Chapter Four), the prevalence of preferred styles and steps, and some sort of travelling step which involved movement off the spot⁴⁹.

The SOBHD do not give any indication of the nature of the compass of the body, except that which has been discussed at the beginning of this chapter. All dances are commenced with the head, hands and feet in First Positions, 'as for Bow' (SOBHD 1993: 31). This does not address the questions of personal preference on the part of the judges, raised at the time that McLennan was writing, other than to set an unmoving standard to which all future judges and competitors had to adhere.

Shedding, Flinging or Round-The-Leg

'Shedding', according to the SOBHD, includes a 'Round-The-Leg' movement (SOBHD 1993: 26), a phrase which is also used by McLennan (McLennan 1950: 12) and earlier by North (North 1881). It is also termed 'Flinging' (Flett & Flett 1996: 109). The nature of these terms is denotative. A similar step seems to have appeared within a Highland Schottische from the nineteenth century, in which 'The gentleman hops twice on the right foot, at the

⁴⁹ A selection of such steps are recorded by Flett and Flett (1964).

same time giving a beat before, and one behind with the left' (Flett & Flett 1996: 104).

The SOBHD describe the Shedding movement as follows:

Hop, Spring, or Disassemble pointing the working foot in second position (count '1'); hop, taking the working foot to Third Rear Aerial Position (count '2'); hop, executing a round-the-leg movement with the working foot to Third Aerial Position (count '3'); hop, executing a round-the-leg movement with the working foot to Third Rear Aerial position (count '4'). Second position of the arms is invariably used with this movement, the raised arm being on the side opposite to the working foot (SOBHD 1993: 26).

This four-beat movement is shown below.

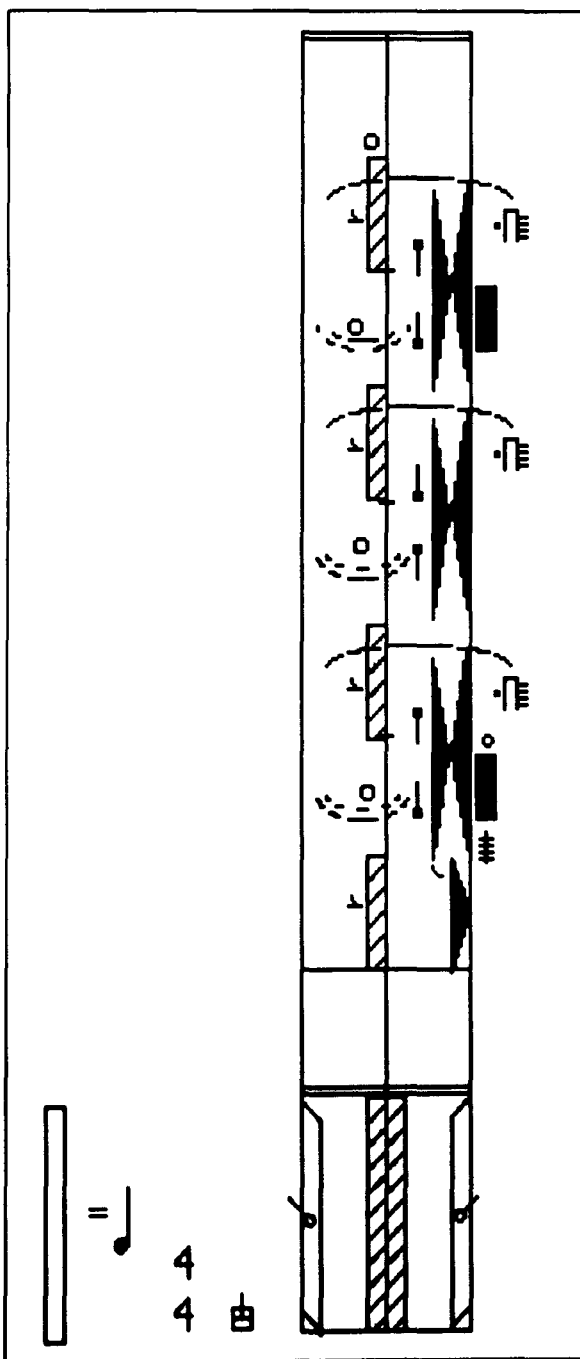

McLennan explains that 'The working foot [is] to be vertical when up against the supporting leg or going round it - heel below knee-cap - when behind, not seen from front view' (McLennan 1950: 12). Similarly, Flett and Flett describe this closeness: 'When the working foot moves round the leg from back to front or vice versa, it should be kept as close to the supporting leg as possible' (Flett & Flett 1964: 109). However, the foot position which is required in order to ensure that there is no such cross-over is not one which is defined by the SOBHD other than by the general impression given by the illustration which accompanies the denotation of 'Shedding' (SOBHD 1993: 26). The implication is therefore present, but not stipulated.

Should the working foot remain in the same curvature of point (that is, fully pointed) whilst it is taken to either Third Aerial Position or Third Rear Aerial Position, then there is, naturally, some degree of cross-over. This is termed 'clubbed foot' by Witta who claims that 'The peculiar "clubbed foot" used in the "Flinging" or "Round-The-Leg" movement by the Board in Scotland is never defined as a foot setting by the Board' (Witta 1982: 27). The same point is noted by Peter Quinn in a review of the SOBHD's textbook for *Dancing Times*:

Considering the number of steps in all danced when the working foot reaches a point between Third Aerial Position and Fourth Intermediate Aerial Position and a point between Third Aerial Position and Second Aerial Position there is no good reason for establishing two more basic positions in order to dispel any possible doubt both from the performer's and the judge's point of view (Quinn 1955: 156).

McLennan's 'Guide to Teachers, Dancers and Judges' which was published in *Highland and Traditional Scottish Dances* (1950) was adopted as standard at the Edinburgh conference of 1925. McLennan's wording seems to have been closely followed in the subsequent first publication of *Highland Dancing* (SOBHD 1955): 'no part of the working foot [should be] visible from the front' (SOBHD 1955: 8). However, in practice, Witta argues that there are two further considerations which should be taken into account: firstly, that McLennan, besides being a renowned Highland dancer, had studied under the famous Danish ballet master Alexander Genée and that, with such a background, it would seem odd if he had failed to relate such a unique foot setting in his Guide. Secondly, that the problem of 'clubbed foot' would be avoided, should the working foot be placed in Third Rear Aerial Position using a full point with the heel centred on the calf, rather than with the heel 'slightly below the level of the knee cap of the supporting leg' (SOBHD 1993: 5). This would avoid overlapping of the supporting leg.

This is an example of the deficiency of the written word in notating dance movements. It falls short of notating interpretation and does not facilitate any analysis of execution or movement flow. In this step, according to the SOBHD instruction, it is assumed that the working foot should, in a continuation of movement flow, be pointed downwards, for want of any other instruction (SOBHD 1993: 5). However, the position of the heel of the working foot would therefore be just below the knee of the supporting leg, with the toe of the working foot slightly off the calf on the far side.

The curvature of the point of the working foot, and therefore the cross-over against the supporting leg, is dependent on the individual dancer, but the problem of definition remains: should there be no part of the working foot crossing (and therefore showing) in front or behind the supporting leg (in Third Aerial and Third Rear Aerial Positions), it should be stated that the foot should be relaxed flatter than a full point, in order to align with the supporting leg. This is, however, not a natural progression of movement when coupled (particularly in The Highland Fling) with a position in which the working foot is pointed, such as in Second Position. This has yet to be considered for amendment by the SOBHD. The NZAND positioning of the working foot is shown below, in the context of the flinging movement.

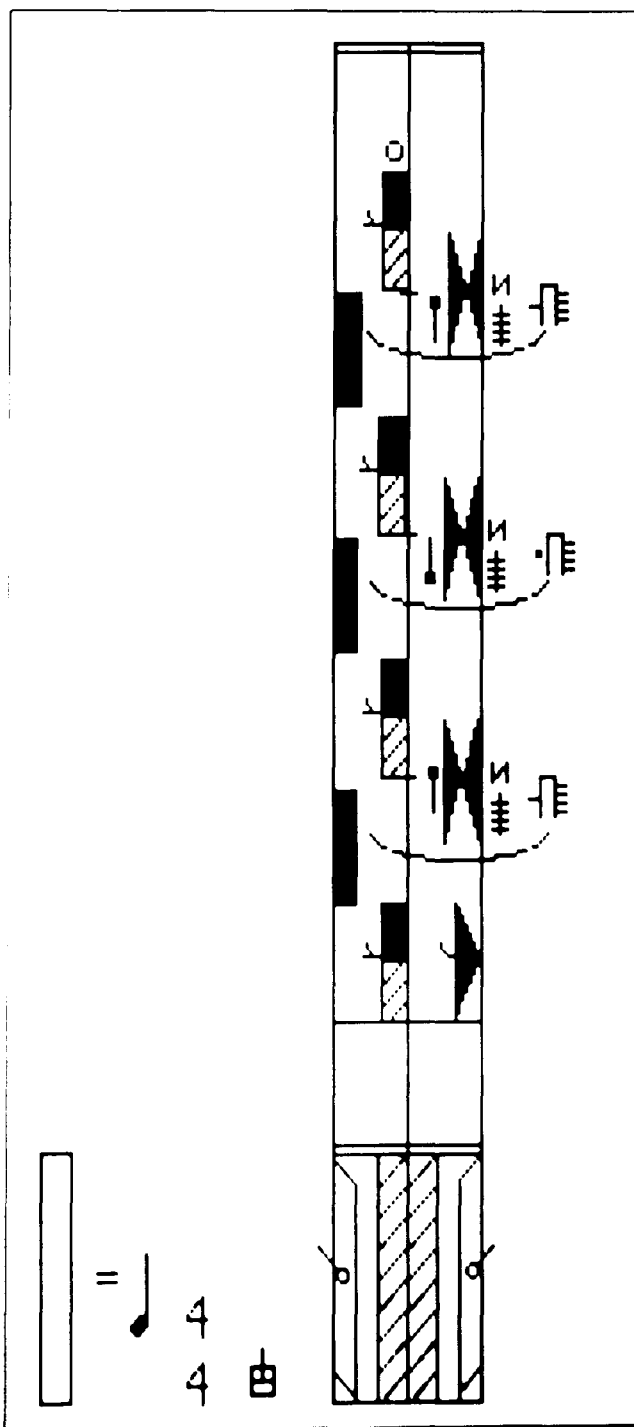

Rock

The Rocking movement is described by the SOBHD as follows:

Spring from the Third or Fifth Position to Third Rear Position, or vice versa, pointing the working foot on the landing. Rocks are usually danced in series, in which case the first rock may be executed starting from an open position. The rear foot is always pointed first. When the working foot is pointed during this movement the toe touches the ground slightly (SOBHD 1993: 25).

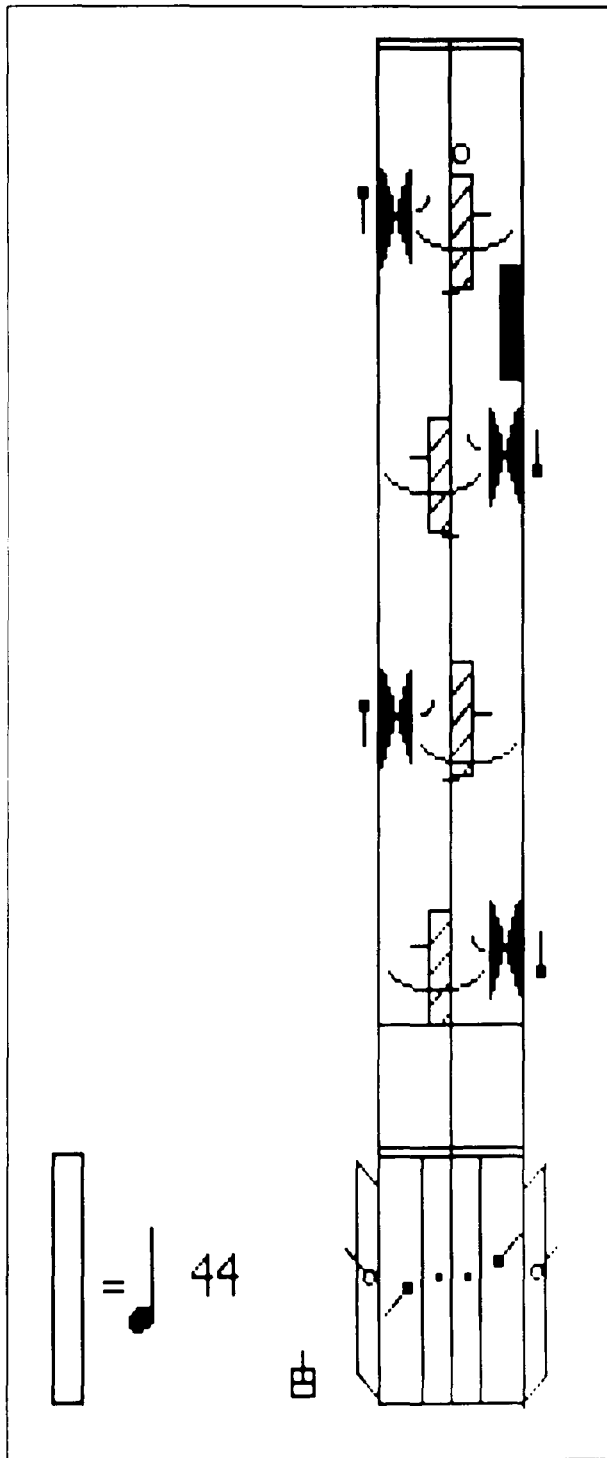

The NZAND similarly describe 'a movement in Rear Fifth and Fifth Positions on point where each foot alternately takes the point with a spring. Both feet aligned together' (NZAND Grade One Examination Syllabus n.d.: 21). Although this is essentially the same movement, the difference in approach is worth noting, in that the NZAND movement emphasises the spring of the supporting leg, rather than the work of the working foot. The implication is that the movement is comprised of a series of light springs, combined with points, rather than pointing movements facilitated by springs.

Witta raises the question of the timing of the working foot, claiming that McLennan would 'surely have noted' any simultaneous arrival of the supporting foot and the working foot (Witta 1982: 128). However, this lack of notation does not necessarily indicate that the working foot should land after the supporting foot, as Witta clearly claims. Instead, the SOBHD make the distinction that 'When the working foot has to be placed in or raised to any specified position whilst executing a movement of elevation, the dancer should land on the count except where otherwise stated' (SOBHD 1993: 1).

It must be noted that there is no indication that this has been an addition made to the written instructions following any misunderstanding of the Rocking movement, as this has appeared in the textbook since its first edition (SOBHD 1955: 1). Witta's alternative interpretation of the Rocking movement is not based on any evidence, other than a spurious claim regarding the absence of specificity within McLennan's writing. The alternative rendering of the step suggested by Witta is shown below.

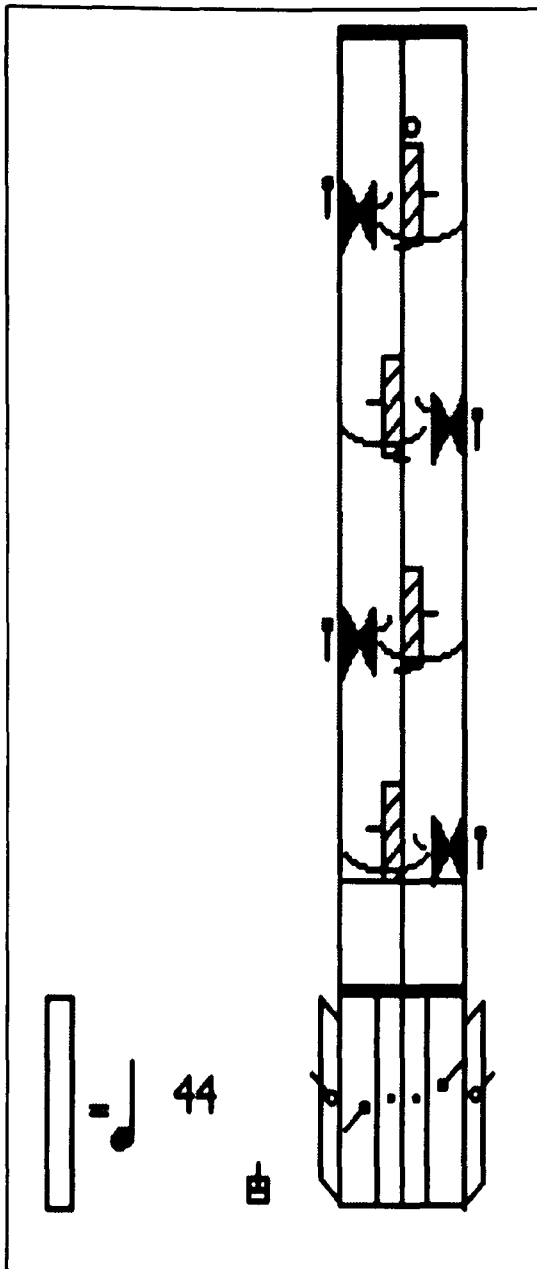

Toe-and-Heel

The SOBHD describe this movement as follows:

Hop, Spring and, almost simultaneously on landing, point the working foot in a specified position, then hop and, almost simultaneously on landing, place the heel of the working foot in the same specified position. This movement occupies two beats of music. The toe and the heel must touch the ground lightly and the working foot must be kept fairly low. The specified position for this movement may be Second, Third, Fourth-Opposite-Fifth of Fifth (SOBHD 1993: 26).

To these instructions there was added a rule that 'The 90° turn out required for the working foot in Second Position should also be aimed at in the other three

positions' (SOBHD Amendments 1962), thereby ensuring that the dancer's working foot in this movement is close to the supporting foot but kept at an angle. Third Position of the foot, which is placed both on the toe and the heel in this movement is danced in sequence. There occurs some degree of hip displacement in the execution of this, as the positioning of the working foot is perpendicular to the supporting foot.

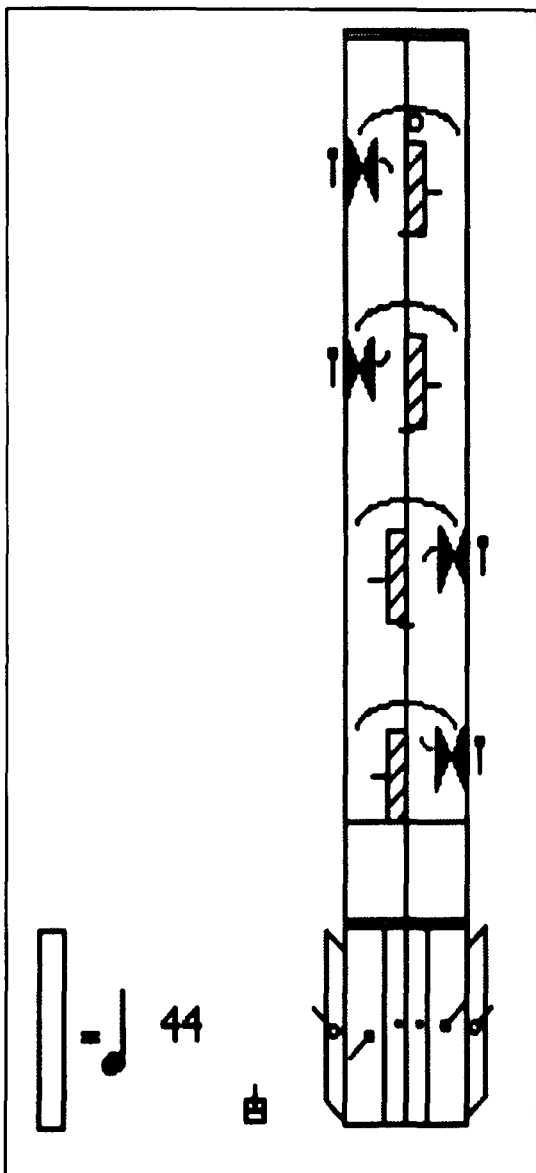

In contrast, the NZAND Fourth-Opposite-Third heel placing when used in the Toe-and-Heel gives the impression of a smoother, less jerky movement, and there is evidently less strain on the hips. This is in keeping with McLennan's recommendation that movements within The Highland Fling

should have a 'general appearance of lightness, grace and *ease*, combined with strength' [italics mine] (McLennan 1950: 12). This is shown below.

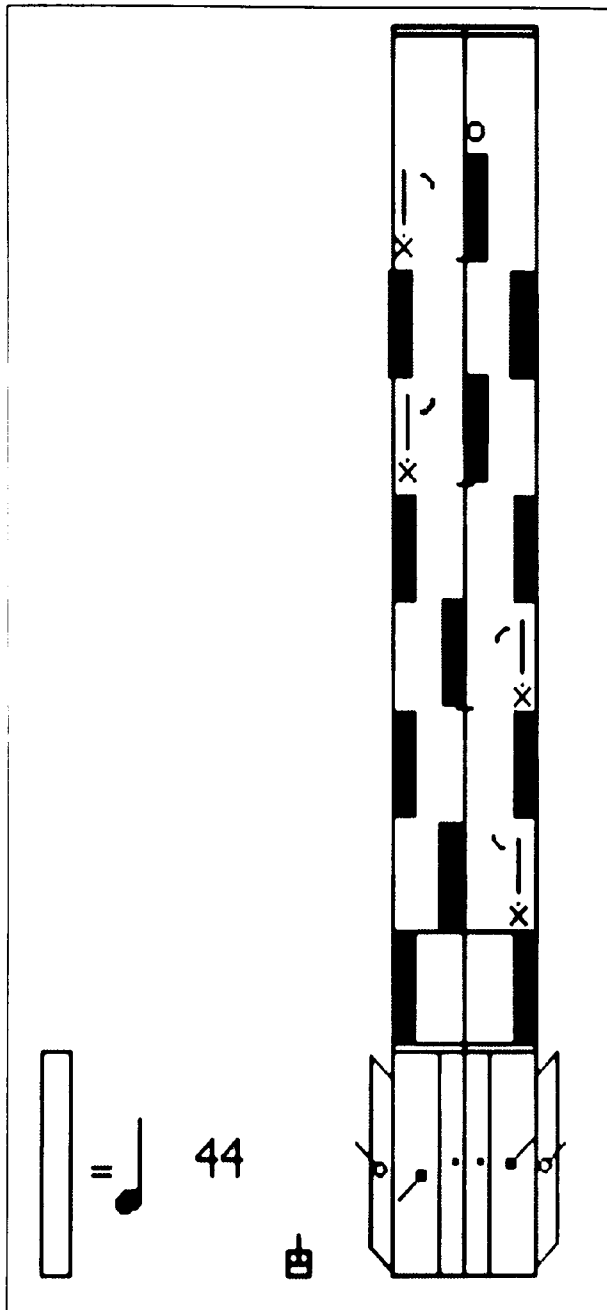

Back-Stepping

The Celtic Monthly of 1912 states that The Highland Fling consists of 'eight figures, each having a 'backstep' (*The Celtic Monthly* 1912: XX: 209). It is not clear as to the nature of this step, but the back-stepping movement as it has been known from the 1950s, is only present in a few of the steps currently danced in The Highland Fling by any of the organising bodies (SOBHD 1955:

28). This term may have been a misnomer for the shedding movement at the back of the leg, which characterises The Highland Fling.

As it is currently understood, the Back-Stepping movement includes the use of a series of aerial positions. It is described by the SOBHD as follows:

Starting with one foot in Third Aerial Position, execute a round-the-leg movement to Third Rear Aerial Position, and, with a spring, slide it down the back of the supporting leg, bringing the other foot quickly to Third Aerial Position. Repeat as required. This movement occupies one beat of music (SOBHD 1993: 26).

It is not clear where the time count is in this movement. The SOBHD general rules of execution state that:

When the working has to be placed in or raised to any specified position whilst executing a movement of elevation, that foot arrives at the specified position simultaneously with the dancer landing on the supporting foot... when executing any movement of elevation, the dancer should land on the count (SOBHD 1993: 1).

In keeping with this, one assumes that the beat is counted as the supporting foot lands and weight is transferred.

McLennan describes the same movement as follows:

The Right foot is under the Left knee; now quickly pass Right behind Left calf and spring upward, alighting on Right, and bring Left up under Right knee; counting 'and 1' (accent there); then pass Left behind and spring upward; counting 'and 2'. Repeat (McLennan 1950: 43).

He also advises that 'In Back-Stepping the working foot should be again vertical, and slipped closely round to the back of the calf of the supporting leg

before being lowered... Keep time' (McLennan 1950: 12). This denotation emphasises the upward movement of the spring, when, in fact, the supporting foot is moving downwards. This focuses on the working foot moving to the back of the leg during an aerial movement, and implies a lightness in the execution. This movement is illustrated below.

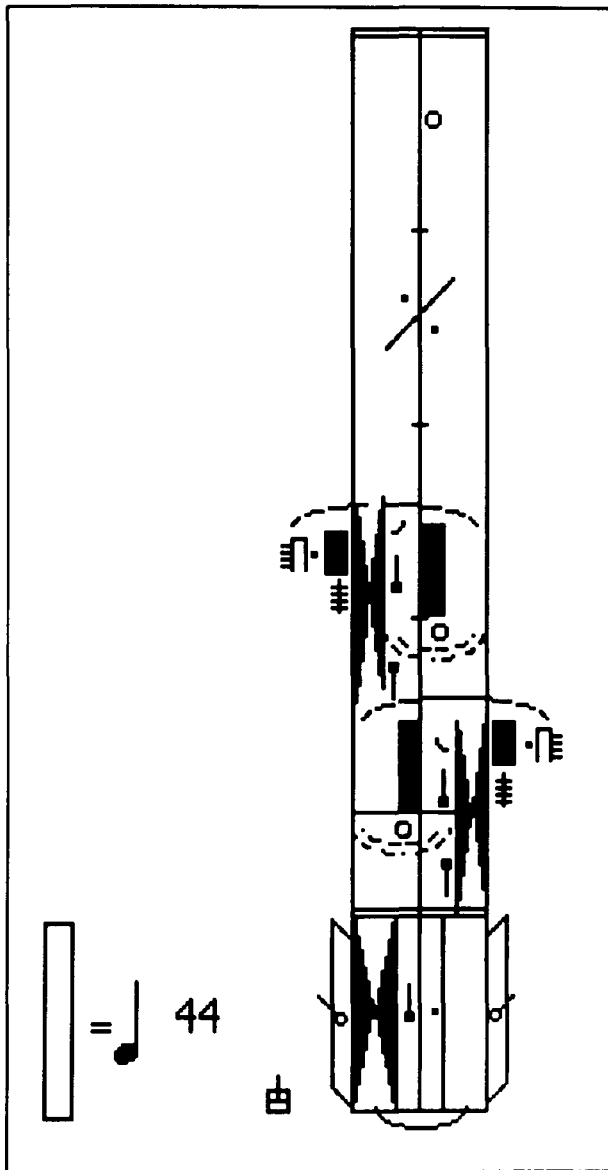

Similarly the NZAND describe a backward movement which is counted on the aerial position:

From Third Aerial the foot passing through First and Fifth aerial to slide down the back of the leg to take the weight as working foot passes through Third and moves up the front of the leg to third aerial. Each change taken with a spring, time count in Third aerial, one time count

for each Back-Step (NZAND Grade Three Examination Syllabus n.d.: 29).

This count is shown below.

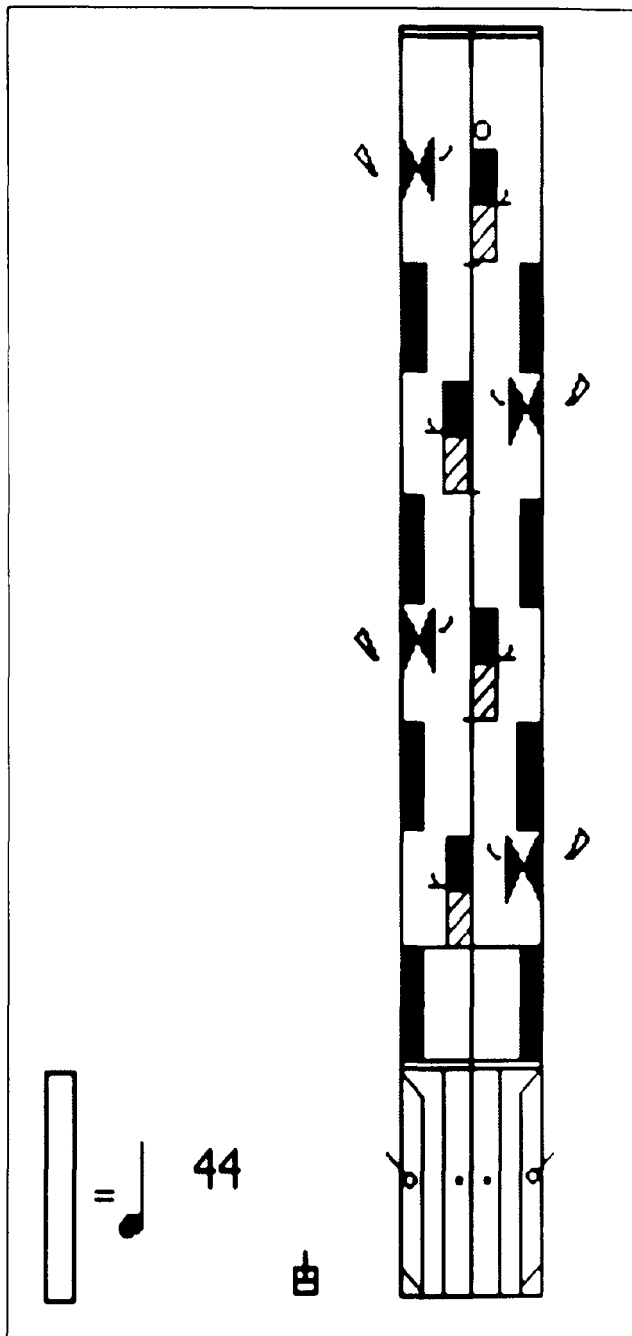

5:III:ii The Sword Dance

Pas de Basque

The Pas de Basque is 'the foundation step' in The Sword Dance (McLennan 1950: 13). This balance step, consisting of three step beats danced to two time counts, is described by the SOBHD as follows:

Preparing with an extension of the working foot to Second Aerial Position low; spring to that side, bringing the new working foot to Third or Fifth Position, placing it on the half point, then beat (without exaggeration) the ball of the other foot in Third or Fifth Rear position, at the same time sharply extending the front foot, if required, to begin the next movement (SOBHD 1993: 22).

The SOHDA describe the step similarly:

With the Right Foot extended out to Second Medium Aerial Position, spring on to the Right Foot, landing on the half-point in Third or Fifth Position (Count 1 and [sic]); Beat the ball of the Right Foot in Fifth Rear Position, simultaneously extending the Left Foot in preparation for the next movement (Count 2) (SOHDA 1994: 37).

A bar of The Sword Dance is counted in a strict '1& 2, 3& 4' rhythm made up of dotted quavers and crotchets (SOBHD 1993: 22; SOHDA 1994: 37; NZAND Initial Examination Syllabus n.d.: 8), known as 'imperfect half-beat rhythm' (SOHDA 1994: 37). This rhythm is, by nature, uneven and somewhat awkward. However, McLennan advised that the step should be executed as 'a light springing step with no exaggerated or jerky movement, with three decided beats' (McLennan 1950: 13). The SOBHD denotation emphasises that the

working foot should be extended 'sharply'⁵⁰, which, when in conjunction with a simultaneous landing of the new supporting foot, results in an unavoidably stilted movement.

There is no clarification of the nature of the extension of the working foot in the NZAND syllabus, which reads as follows: 'Counts 1&: Spring on to Right Foot Second Ball Left Foot Third on point. Count 2: Momentarily take weight on point as a beat is made in Rear Third ball... Repeat... [on] alternate feet' (Preparatory Grade Examination Syllabus n.d.: 5). McLennan's denotation clearly avoids any movement which is exaggerated (SOBHD 1993: 22) or stilted:

Extending Right Foot to Second position spring to Right side (1) bringing Left toe into R toe on floor (count and); lightly resting on Left toe beat (lightly) Right ball of foot on the spot (2) resting there; not lifting and extending Left - but only extending it for spring to Left side (McLennan 1950: 37).

The following Labanotation depicts two Pas de Basques (to the Right and Left sides) which are shown as two 2/4 bars (4 counts), following the SOBHD description of the working foot in Third Position, on the half-point.

⁵⁰ This term was deleted from the textbook instructions of the Open Pas de Basque from the 1962 edition onwards (SOBHD Amendments 1962).

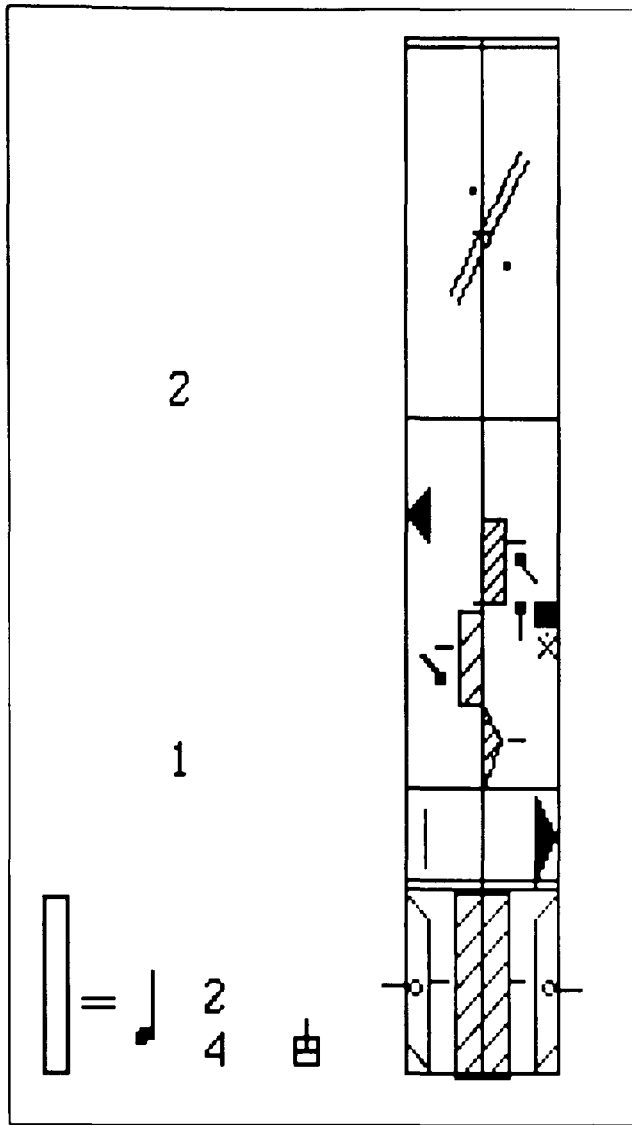

The SOHDA Pas de Basque movement in Fifth position on the ball of the working foot is shown below.

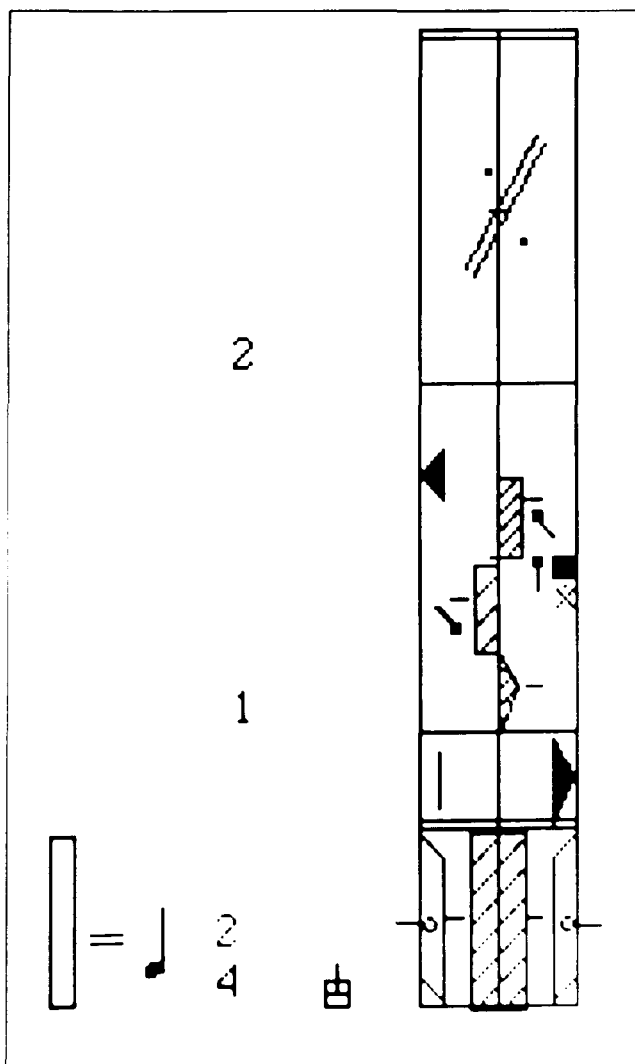

Addressing the Swords

The opening step of The Sword Dance is one in which the dancer moves around the outside of two broadswords which are placed crosswise on the ground (SOBHD 1993: 34). The travelling is achieved using a series of Pas de Basque and Spring movements. The SOBHD instructions are to be read in conjunction with the following diagram:

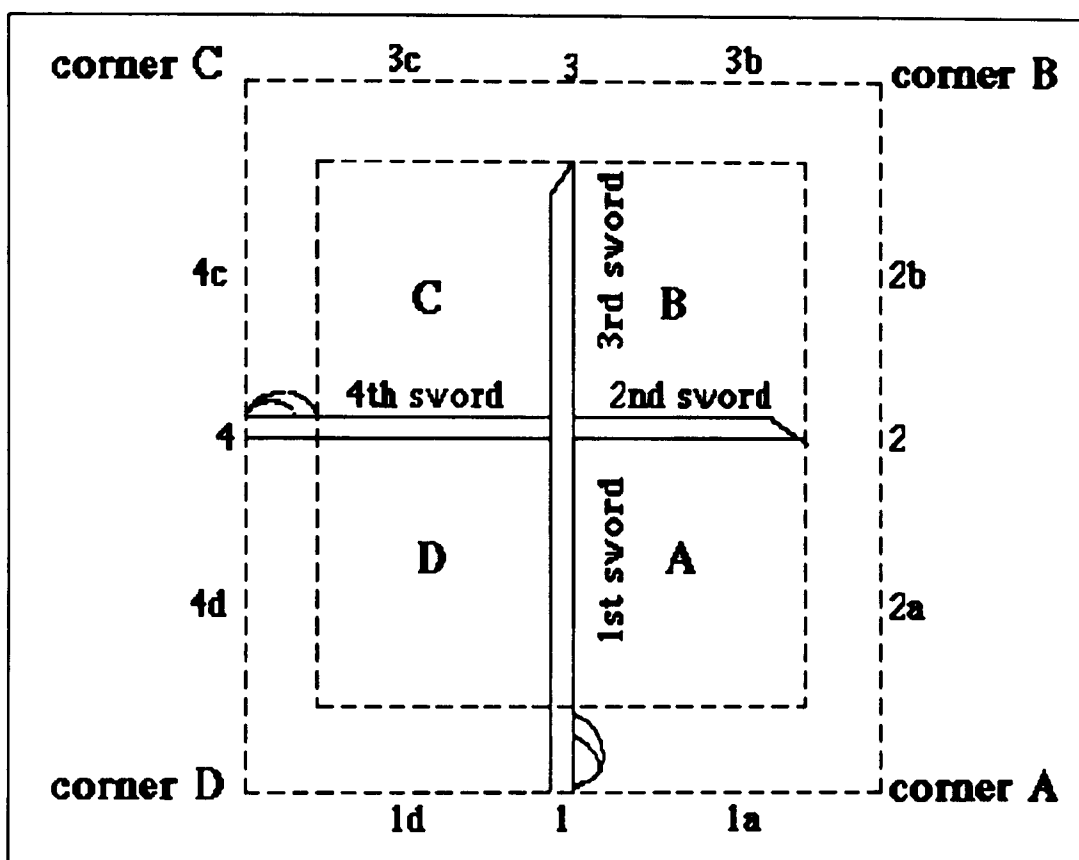

The first four bars of the first step are shown below, as described by the SOBHD.

Bar 1: Pas de Basque with RF to 1a (count '1& 2'); Pas de Basque, with the LF to 1d (count '3& 4').

Bar 2: Make three-quarters of a turn to the right with two Pas de Basque, the first with the RF to corner A, the second with LF at corner A without travel (count '5& 6, 7& 8').

Bar 3: Pas de Basque with RF to slightly beyond 2 (count '1& 2'); travelling slightly to the left, assemble at 2 with RF in Fifth Position

(count '3'); disassemble on to LF executing a high cut with RF (count '4&').

Bar 4: Execute four High Cuts at 2, springing RF, LF, RF, LF (count '5& 6& 7& 8&') (SOBHD 1993: 37).

The travelling movement is angular by nature, as the dancer turns the corner on the spot with 'three-quarters of a turn to the right with two Pas de Basque, the first with the RF to corner A, the second with LF at corner A *without travel*' (italics mine) (SOBHD 1993: 37). The floor pattern is therefore square, as the dancer travels around the outside of the sword area, turning four 'corners' (SOBHD 1993: 34) in the course of the step:

- Bars 5-8: As for bars 1-4, starting at 2 and finishing at 3.
- Bars 9-12: As above, starting at 3 and finishing at 4.
- Bars 13-16: As above, starting at 4 and finishing at 1.

The two Pas de Basques used to turn in the second bar are shown below.

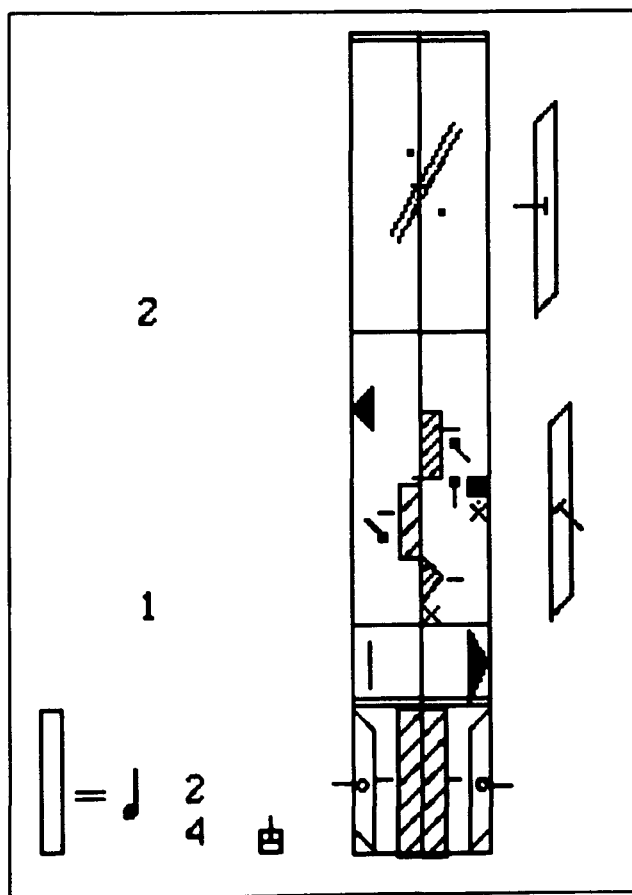

The aerial view of the resulting floor pattern is as follows:

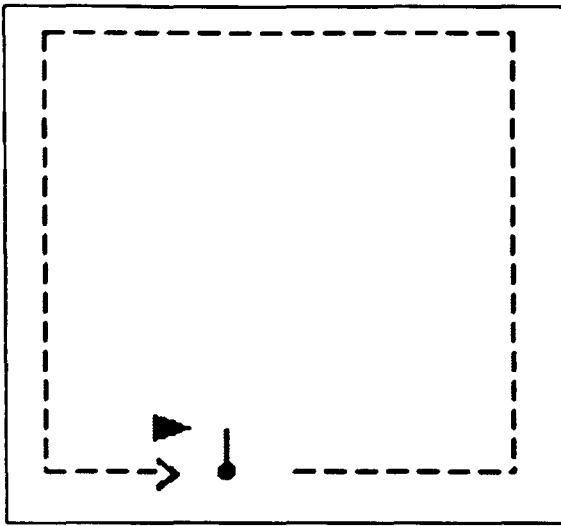

The NZAND instructions for this opening step describe a more circular movement around the swords and relate to the diagram below.

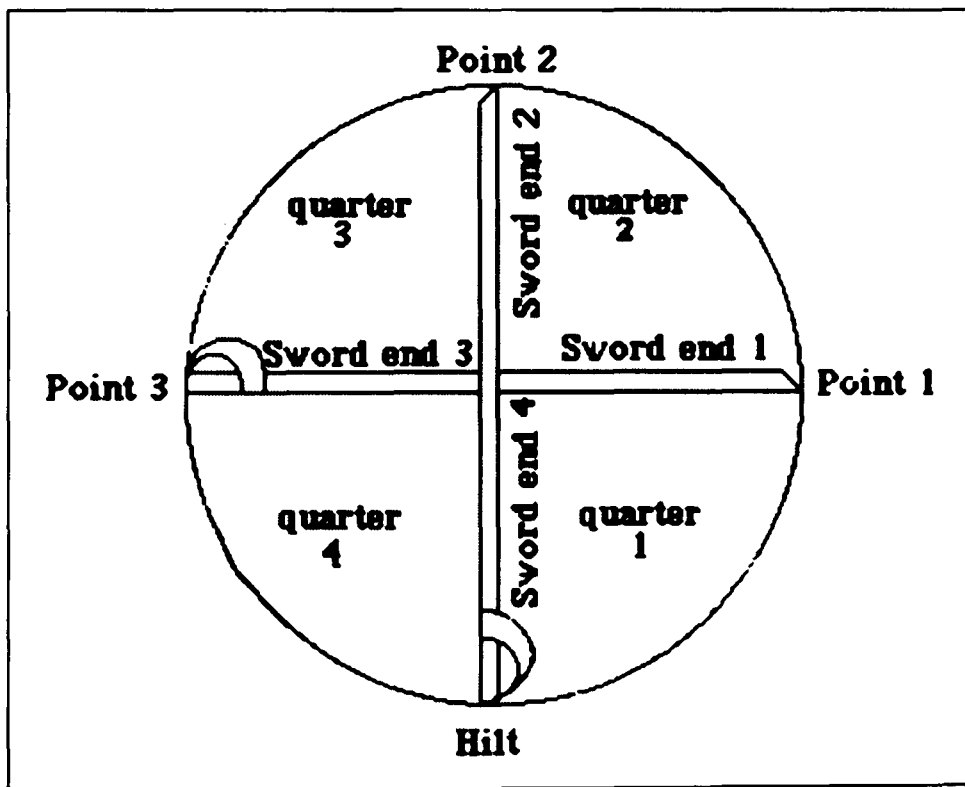

The instructions below describe the same period of movement as the SOBHD instructions in the first four bars of the First step of The Sword Dance.

Counts 1-4 Pas de Basque to R and L of 4th Sword Point [end].

5-8 Midway Turn using two Pas de Basques between the two Sword Points.

9-12 Pas de Basque to R and L of 1st Sword Point.

13-16 Four Point Shuffles at 1st Sword Point (NZAND Grade 1 Examination Syllabus n.d.: 17-18).

As with the SOBHD method, the movements from the first four bars of the step (or counts 1-16) are repeated, 'progressing round in a circle' (NZAND Grade 1 Examination Syllabus n.d.: 18), until the dancer reaches the starting position.

The movement progression is less angular and is more open to interpretation than the more extensive SOBHD instructions. There is also a variation in movements after the corner has been turned, on counts 9-16 (bars 3 and 4). The NZAND version has two Pas de Basques at the Sword Point (rather than a Pas de Basque and an assemble at the same point, called '2' by the SOBHD). This is followed by shuffles which can be replaced by High-Cuts⁵¹ as the dancer becomes more accomplished (NZAND Grade 1 Examination Syllabus n.d.: 17-18).

The NZAND offer a denotation of a midway turn as one in which the dancer executes 'A turn performed midway between two sword points on the sword circle, using two Pas de Basques' (NZAND Preparatory Grade Syllabus n.d.: 10). It is also made clear that 'On the first Pas de Basque a quarter turn is made, on the second Pas de Basque a half turn is made; this makes a three-quarter turn to complete the movement' (NZAND Preparatory Grade Syllabus n.d.: 10).

⁵¹ This movement is defined later in this section.

The floor pattern of this movement is quite different to that taught by the SOBHD. Below, Labanotation and a floor plan are used to show the fluid interpretation of the step.

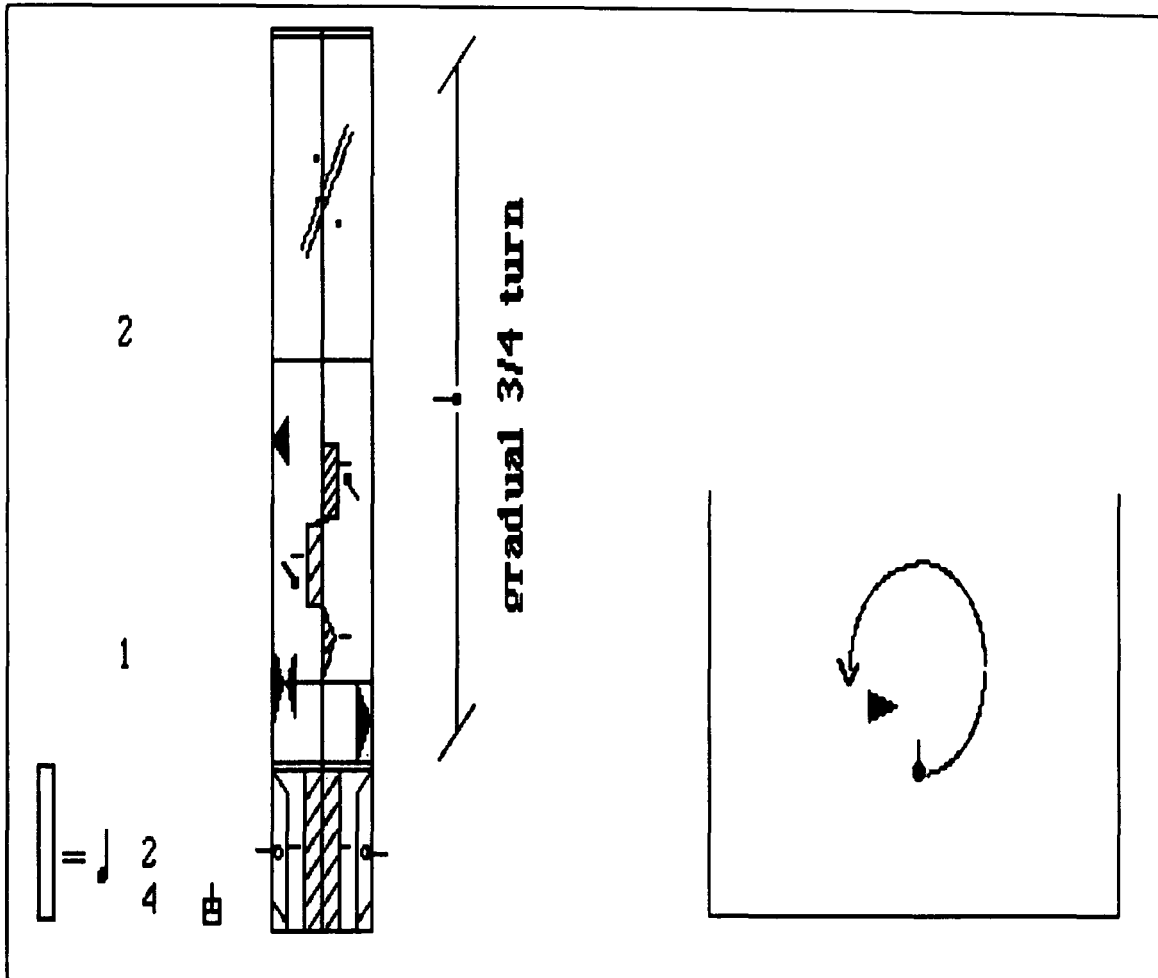

Circular travel is easier to achieve than corner turning, as the body has natural inertia which encourages onward movement. However, if the dancer has to turn on the spot, the focus of the footwork is not so much part of a progression of movement but an unnatural stiltedness. This strictness is perhaps more in keeping with the military influence which there has been on The Sword Dance in the past, but is not necessarily part of the philosophies of an organisation

which promotes the 'art' of dance, and therefore a pleasing and aesthetic movement progression⁵².

McLennan's denotations of this step offers some clarity on the nature of the movement progression as he understood it. His instructions for the same portion of the step (bars 1-4 or counts 1-16) are given below.

Pas de Basque, lightly springing to Right of hilts - same to Left (1 bar)
(A) Pas de Basque, turning in 1st square, on Right and on Left (1 bar)
(B). Again Pas de Basque, springing to face 2nd sword-point, Right and Left (1bar). Now finish the movement by (for beginners) four pointings, almost touching sword-point, or beats or cuts against the calf (1 bar).
(McLennan 1950: 46-47).

As in the SOBHD instructions, there is no specification as to the actual degrees of turning made on each of the Pas de Basques executed in bar 2 (or counts 5-8). This omission, and the lack of any indication that this portion should be danced on the spot and without linear travel, promotes an evenness of performance which is not stilted at the corner by an interruption to the flow of movement.

McLennan also states that 'In the first step turnings should be done midway between the sword points' (McLennan 1950: 13). This lends weight to the circular performance of this step preferred by the NZAND and SOHDA.

⁵² Matters of aesthetics, with regard to the composition, style or progression of the dance, have not been tackled due to restrictions of scope. Aesthetic judgement is a theme which appears throughout this thesis and particularly in sections 4:I:v, 5:I:iii and 6:II:i.

High Cut

The High Cut movement is described by the SOBHD as follows:

Spring, hop or disassemble and, simultaneously on landing, take the working foot to Third Rear Aerial position, then, (working from the knee joint only) extend the working foot towards Second Aerial Position and return it to Third Rear Aerial Position. During the elevation one or both legs are extended towards Second Aerial Position (SOBHD 1993: 22).

The SOHDA provides a similar account, but without the option of both legs extended. The extension of the leg or legs is a matter of some interest. Both versions are shown below, as described by the SOBHD.

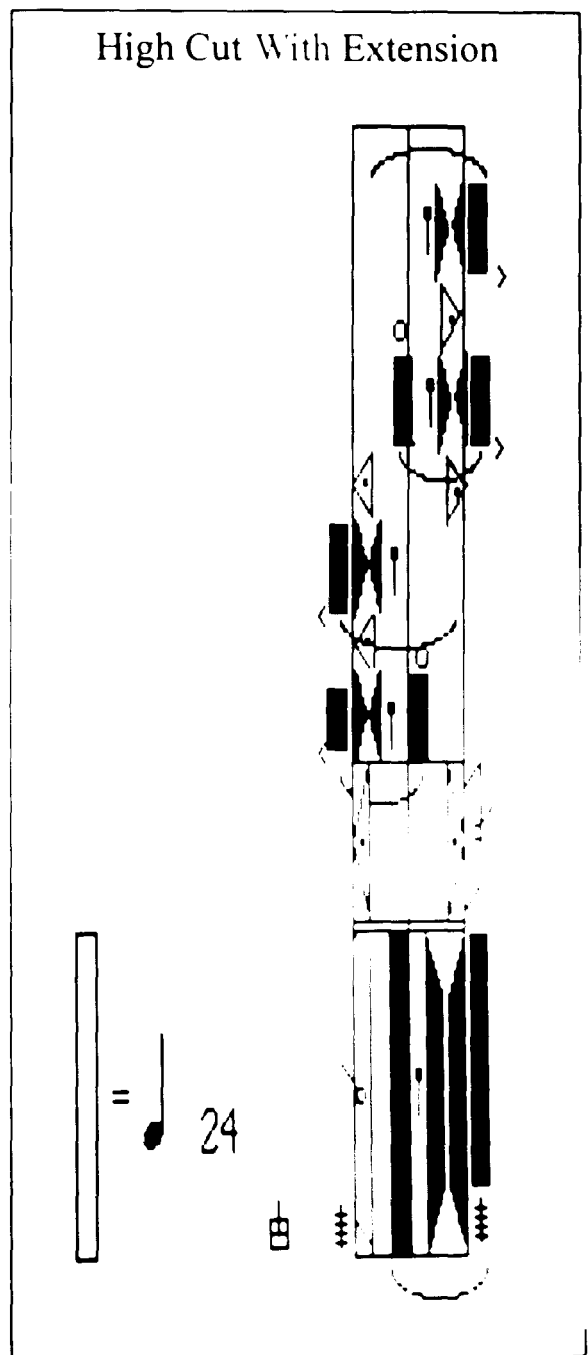
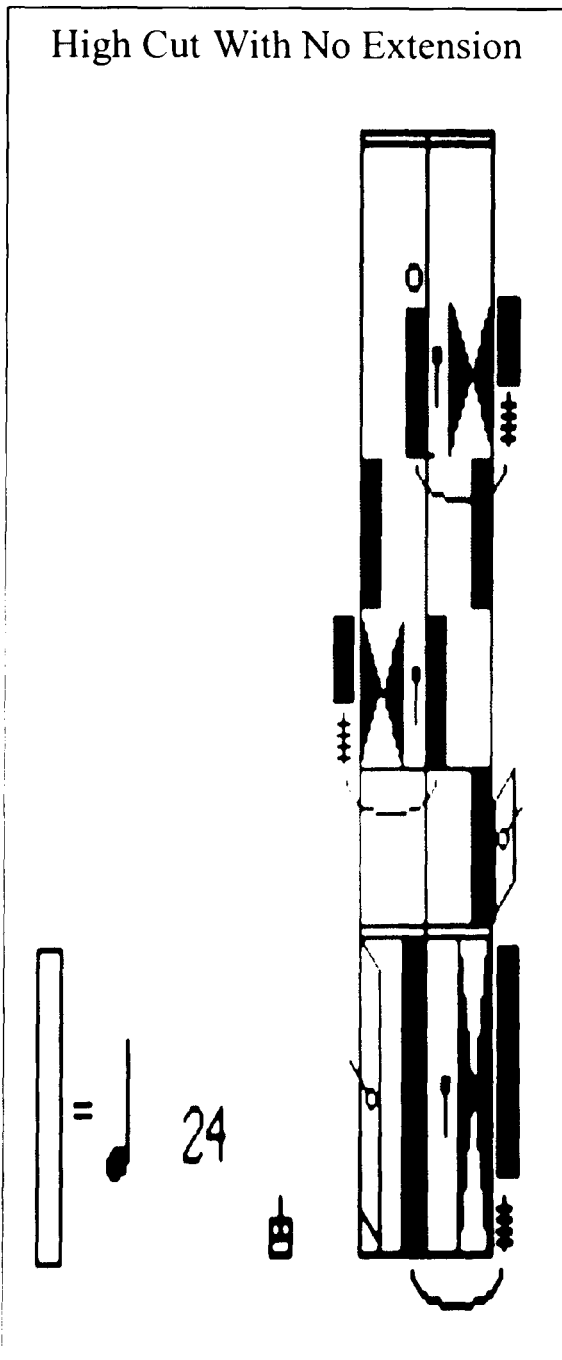

Macaffer recorded, in 2002, that 'People are springing higher. They're trying to look more elegant, using big leaps and all, and I think it's slowed down a little bit' (Macaffer 2002: n.p.). This testimony to dancers leaping at the expense of strict tempo is not alone. The Pipe-Major of the New Lanark Pipe Band made a similar claim following the Cowal World Championship dancing contest of 2001: 'You're playing that fast when they jump up there they havena time tae come doon' (VA2003.012).

This problem is widespread and widely acknowledged by both the SOBHD and the SODHA. The problem is one that, as long as the technicalities of the dance are prioritised over the musicality of the performance, will not be resolved. The late landing is shown below and, where there can be little compensation for the time lost in elevation, the take-offs and landings for a series of High-Cuts comes later after the beat each time. An example of a slowing first bar of a series is shown below.

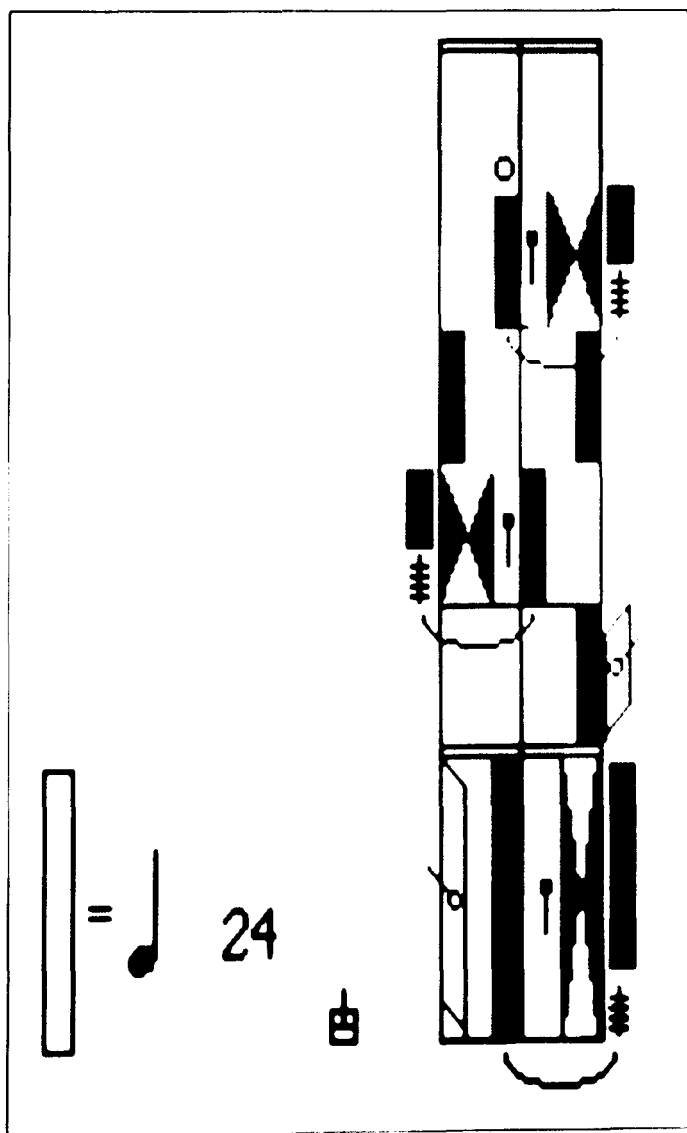

A Right working foot movement, followed by a Left working foot movement, is shown with both legs extended, with the contact with the supporting leg shown as behind the beat. This, and similar matters of timing and general musicality, are discussed in the following section.

The Clap

Alex McGuire claims that '...in bygone days, the quick steps were indicated by the dancers throwing his [sic] bonnet in the air!' (McGuire 1994: 11). This is not the only report of a dancer indicating a change in the music in this way and these additions seem also to serve as a less contrived expression of excitement. North, in *The Book of the Club of True Highlanders*, describes one of the members who danced over swords:

With thumbs and fingers cracking to urge to more rapid notes, the giddy mazes are trod more swiftly, yet safely as before, and the triumph of Gillie Callum is hailed with resounding applause (North 1881: 40).

Cameron, in his research into standardisation drafted by the McLennans and the MacNeils in the 1880s (see Chapter Three), mentions that clapping was seen as an anomaly and that it should be removed, in the light of the long steady influence of the demure French courts. This tradition most likely originated from a natural clicking of the fingers which kept time or indicated a change in tempo to the musician, whilst exciting the audience (as discussed in Chapter Three).

A clap in the current Sword Dance still exists, although it is executed at a precise point in the dance, rather than as a show of enthusiasm. This clap is

likely to have survived, or have been inserted, from the tradition Witta calls 'whoofing' (Witta 1982: 43)⁵³, as it appears on the last beat of the slow time as a warning sign to the piper that the quick time should follow.

Watson recalled the dancing of Bobby Cuthbertson:

He used to dance and when he got to the quick time in The Sword Dance, he used to let out a little 'yelp' and he would clap his hands and take his bonnet off and... like a whip all the time, and got first prize. If you did that now... no (VB056).

The function of the clap, in this case, seems to have been threefold. It indicated the precise tempo that should be played, it expressed a dancer's excitement and enjoyment of the dance, and provided a spectacle for the onlooker.

The dancer was at liberty to decide on the speed of the dance, rather than having it dictated by any outside body. It could then suit the dancer's individuality, as his build and experience allowed. However, this is now a signal on the last beat of the slow step, used by the SOBHD and SOHDA, as 'a signal for the piper to change from slow to a faster tempo' (SOHDA 1994: 10). It is performed as a matter of course and in fulfilment of competition requirements, rather than as an integral part of the tempo or rhythm, or as an inspired expression of the dance.

⁵³ This is perhaps more likely to be an onomatopoeic word for the noise a dancer would make with his mouth as 'a shout of joy', more commonly known as a 'hooch' or 'hoogh' (*Etymological Dictionary of the Scottish Language* 1808).

5:III:iii The Seann Triubhas

The Shake

The shaking of the working leg is the most recognisable element of this dance, and its execution is also one of the most disputed. As an iconic gesture, the leg-shake is part of a narrative which has survived within this dance to either represent the freedom of the kilt, or the shaking off of the triubhas (as discussed in Chapter Three). According to the SOBHD, the shake should always be executed 'in conjunction with a Hop, the working foot reaching the Open Aerial Position on the 'count', simultaneously on landing from the Hop' (SOBHD Amendments 1962). Within The Seann Triubhas, it is described as follows: 'Hop LF, extending RF with shake to Second Aerial Position high (count 'and and a 1')' (SOBHD 1993: 42). This is shown below.

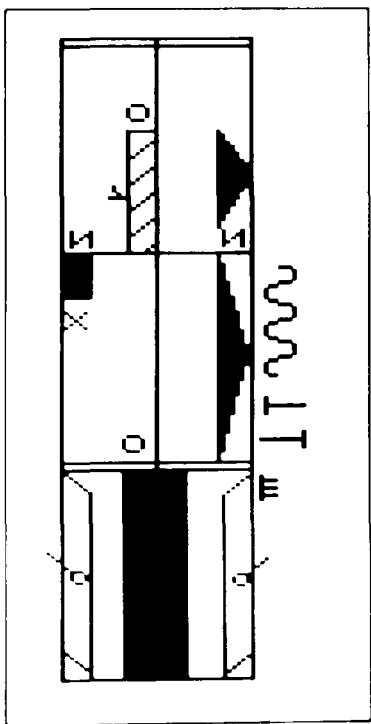

This is similar to McLennan's denotation of the movement, where the dancer must 'spring up and extend Right with shake out' (McLennan 1950: 50).

The NZAND have two versions of this movement, called, in their terminology, 'The Flourish' or 'Trouser Shake'⁵⁴ (NZAND Grade Three Examination Syllabus n.d.: 14). 'The Flourish' is 'An extra movement from knee to toe in second aerial, bringing the leg to the vertical and re-extending. Counted 1& (one time count)' (NZAND Grade Three Examination Syllabus n.d.: 14). There is a more extensive denotation of 'The Trouser Shake': 'From Second Aerial bring leg to vertical and re-extend to Second Aerial with two or three shakes of the leg. Counted 1& (one time count)' (NZAND Intermediate Examination Syllabus n.d.: 15). 'The Flourish' or 'Trouser Shake' are shown below, respectively.

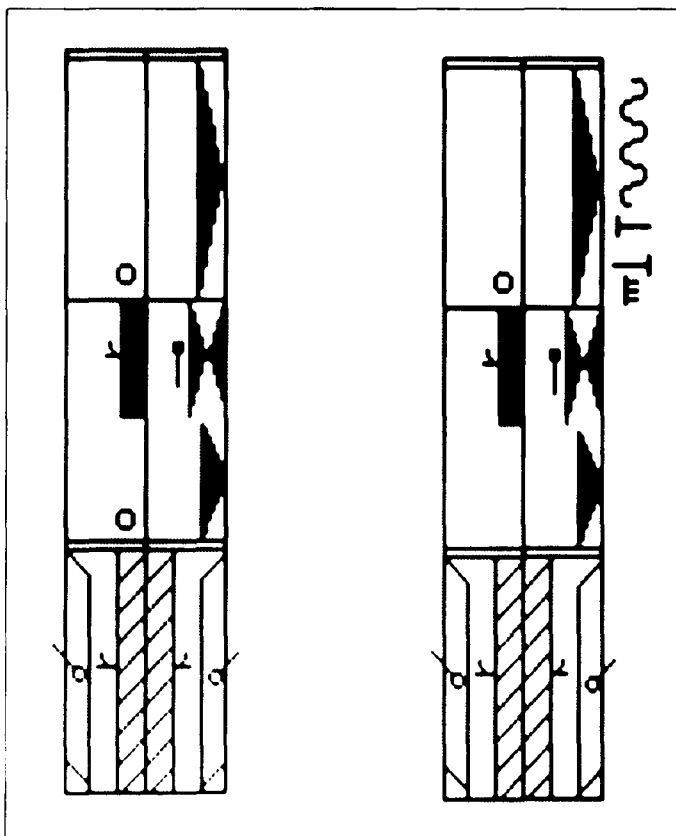

⁵⁴ The acceptance of the term 'The Trouser Shake' evidently feeds into the dancer's understanding that this dance had, and perhaps still has, a narrative function. 'Shaking the Triubhas' has been found to be the common name by which the whole dance is known (Waterston 2001).

Side Travel

There is a slight variation between the SOBHD's and the NZAND's versions of this step. The main difference is the nature of the working leg, and the degree to which it should be contracted or not. The SOBHD describe the first bar of the step, following the 'shake' movement of the first beat, as follows:

Step on to ball of RF in Fifth Rear Position (count '2'); step LF to Second Position and close ball of RF to Fifth Rear Position or Fifth Position (count '&3'); step LF to Second Position and close ball of RF to Fifth Rear Position (count '&4'). During count '&3&4' the dancer travels directly towards the left side (SOBHD 1993: 42).

The second bar repeats these movements with the opposite feet, travelling to the right (SOBHD 1993: 42).

If the knee of the working leg is to be kept 'as straight as possible' in these ball positions (SOBHD 1993: 2), then this presents a problem for the flow of travel to the side in this step. The restrictive nature of this requirement is contradicted within this same denotation, where it is stated that the knee should be 'without strain to allow for freedom of movement' (SOBHD 1993: 2). During this movement, the knee inevitably bends to allow for a momentary transference of weight from the supporting foot to the working foot, as the dancer moves along the line of direction. Two counts of this movement are shown below.

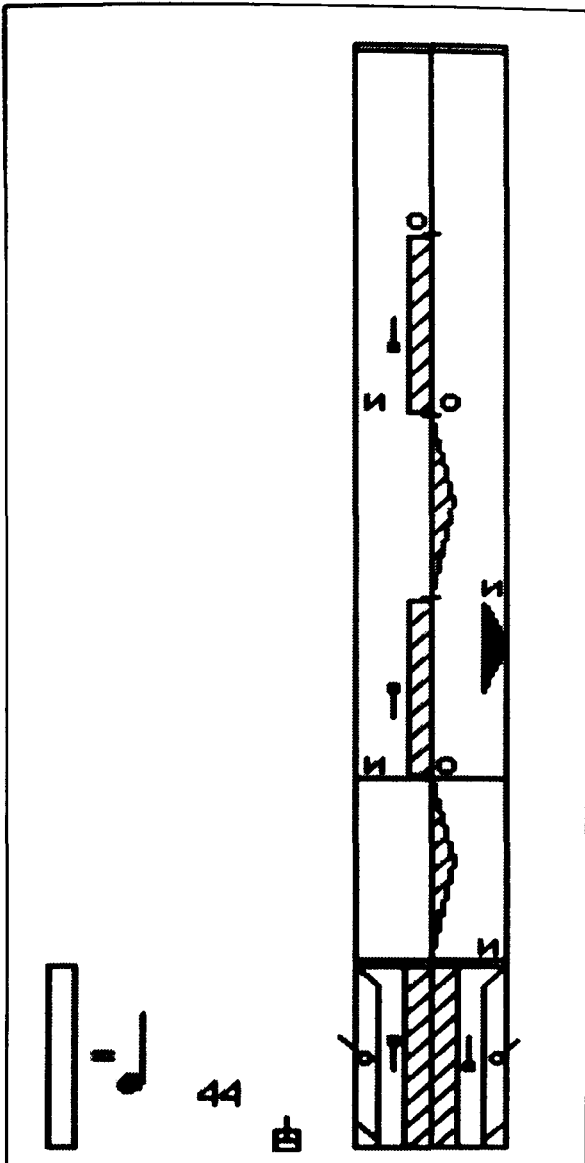

The NZAND prescribe a more relaxed approach for the 'Side Travel' movement:

A movement performed to the side using Rear Fifth ball on the time count and Second Intermediate ball on the '&' count, Second Intermediate to be taken with flexed knee. Timing and spacing even, counted '1&2&' (NZAND Grade Three Examination Syllabus n.d.: 30).

This allows the weight transference to occur as part of the natural progression of the step, as the movement is not restricted. This is shown below.

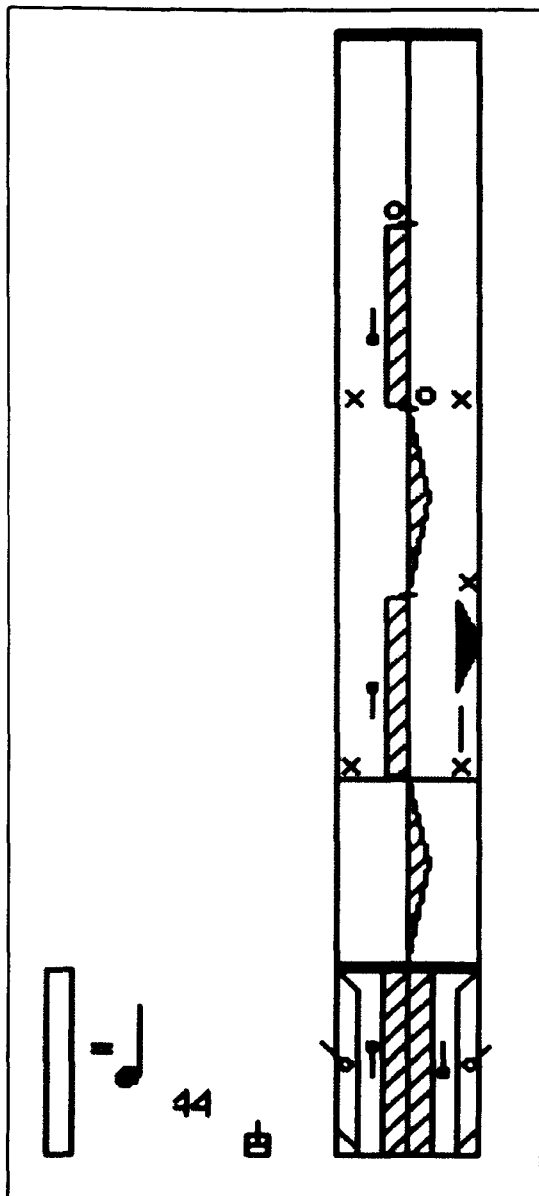

McLennan does not recommend either the straight or flexed knee, but does seem to favour a more supple use of the working leg. He describes the working foot as 'gliding' to the side (McLennan 1950: 50). The precise nature of this movement is unclear.

Arms

A qualification to *Highland Dancing* was released in 1962 in order to explain the grouping of the fingers when executing the fluid and graceful arm movements of the Side Travel Step. If the SOBHD's Fifth Position, as described previously, was maintained throughout the action, and through the circling

movements of the arms, some considerable strain would have been put on the wrists and arm ligaments. In this case, the arms would exceptionally come in front of the face and it is assumed that the fingers would be lightly grouped as the curvature for the arm dictated:

In the fourth bar of the introduction to *The Seann Triubhas*... the hands come up in front of the face as the arms are raised in front of the body from Fifth Position; and also in the First and Second *Seann Triubhas* steps... the arms are circled from First Position or Fifth Position (SOBHD 1962: 13).

This amendment in the finger positions is shown below.

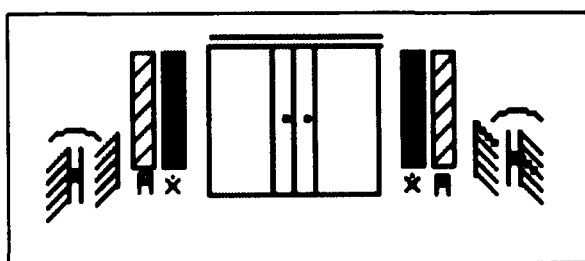

However, there is another discrepancy in the positioning of the arms in this step. The arms are described as follows:

To Fifth position on count '1' then with a circular action during counts '2&3&4' take them upwards in front of the body to Fourth Position thence through Third Position and downwards at the sides (SOBHD 1993: 42).

The NZAND do not describe any such arm positions, but recommend that 'the head, arms and feet work in harmony with each other' in order to produce a flowing performance (NZAND Advanced Examination Syllabus n.d.: 16). All parts of the body should, therefore, by implication, give aid to the deportment

and carriage of the body and in particular here, should provide support and uplift for the extension of the working leg.

However the NZAND do provide a theory of arm progression for The Seann Triubhas:

In all slow time steps the arms move in a circular manner and are raised in front and are lowered through the sides using one or more counterpart positions returning to akimbo or extra low Fifth (NZAND Advanced Examination Syllabus n.d.: 16-17).

This more fluid approach accounts for 'natural alignment, co-ordination and deportment of the movement which dictate a natural progression ' (Witta 1982: 148).

Side Heel and Toe

The SOBHD made an amendment in the 1962 edition of the *Highland Dancing*:

To ensure a correct line of travel when executing steps which travel sideways towards Second Position... the working foot is placed slightly forwards or backward (as the case may be) from Second Position to commence travel (SOBHD 1962: 2).

This straight line is not naturally achieved when placing the working foot into Second Position, as the hip inevitably pulls the working foot forward from the joint. This seems to have been the reason for this amendment, although it does imply that the dancer should over-compensate for the body's tendency to dance with the working foot forward of the line of direction, when travelling to the

side. This is not, then, a natural or fluid dance movement based on the body's gait or shape, but is imposed and somewhat affected, perhaps to give a regimental and stilted effect.

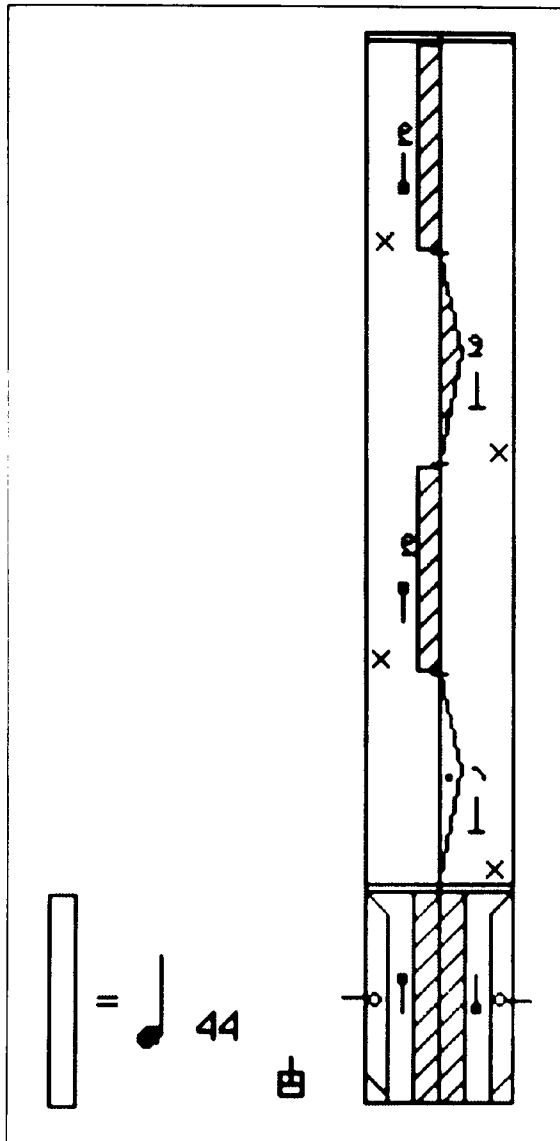

5:III:iv The Strathspey and Reel of Tulloch

Progressive Strathspey Movement or 'Travelling Step'

'When standing in a straight line in preparation for dances such as Strathspey and Highland Reel or Strathspey and Reel of Tulloch, the four dancers are said to be taking formation in a Line Set' (SOHDA 1994: 31). This is the starting position used, invariably, for The Strathspey and from which the 'Progressive Strathspey Movement' or 'Travelling Step' is commenced.

Beginning with the Right Foot in Third Aerial Position, step with that foot along the line of travel to Fourth Intermediate Position (count 1); close the ball of the Left foot to Fifth Rear Position, extending the Right Foot to Fourth Intermediate Aerial Position (count 2); Spring on the Right Foot along the line of Travel bringing the Left Foot to Third Rear Aerial position (count 3); hop RF with slight forward travel, executing a round-the-leg movement with LF to Third Aerial position (count 4) (SOBHD 1993; 29; SOHDA 1994: 40).

Flett and Flett note the travelling step taught by one itinerant dancing master, Mr. Buck, who taught in the Borders at the turn of the twentieth century, which was composed of a 'step forward on Right foot, close Left behind, step forward again on Right foot and hop on it, bringing the Left foot up in front of the Right leg, then the same with the left foot' (Flett & Flett 1957: 160). This seems to be similar to both the SOBHD and SOHDA denotations, as the working leg is raised slightly in front of the supporting leg (although the level is not specified).

However, it is also noted that among the Border people it was more usual just to swing the left foot straight through on the hop (Flett & Flett 1957:

160). This method seems to be more in keeping with the denotation found in *The Celtic Monthly*: 'the right foot is advanced, followed closely by the left, then the left foot is brought down behind, and the right raised, then two hops' (*The Celtic Monthly* 1912: XX: 209) and Morrison's memories of early twentieth century technique: 'You could do 1, 2, 3 and a hop... we just did a skipping step. 1, 2, 3 and a hop' (SC2003.003).

Diack, originally a pupil of Watson's, was taught to 'glide' into the step for Strathspey travel, creating a more flowing movement by brushing the floor before weight was placed on the supporting foot. Watson insisted that this was the correct method (UI2000.003). However, when preparing to sit her theory examination to become an Associate Member of the United Kingdom Alliance of Dancing Teachers, she was warned by her current teacher not to use certain descriptive phrases for dance steps in the theory exam. One of these such phrases was 'Step, *cut*, 3, 4' or 'step, *cut*, spring and hop', which she had previously been taught by Watson (SA2003.040). She stated in an unrecorded interview that she was warned that she would otherwise be 'penalised' for omitting to use the terminology as recommended by the SOBHD, but also for using a form of denotation which had been discredited, by not being acknowledged in the textbook.

I was told recently for my Associates Exam that we shouldn't mention the word 'cut' when we were describing that step, that we would be marked down. I think they usually just describe it as 'step, step, spring and hop'... this particular dancing teacher that I'm going to now told us, instructed us to say 'step, step... spring and hop'. Yes ... she *told* us to say that in our Dancing Associates' Exam (SA2003.040).

The Travelling step of The Strathspey is, according to Diack, 'supposed to be graceful and a lot of dancers just seem to... bounce along' (SA2003.040).

The Travelling Step as recorded by the SOBHD is shown on the left, and the gliding Travelling Step on the right, below.

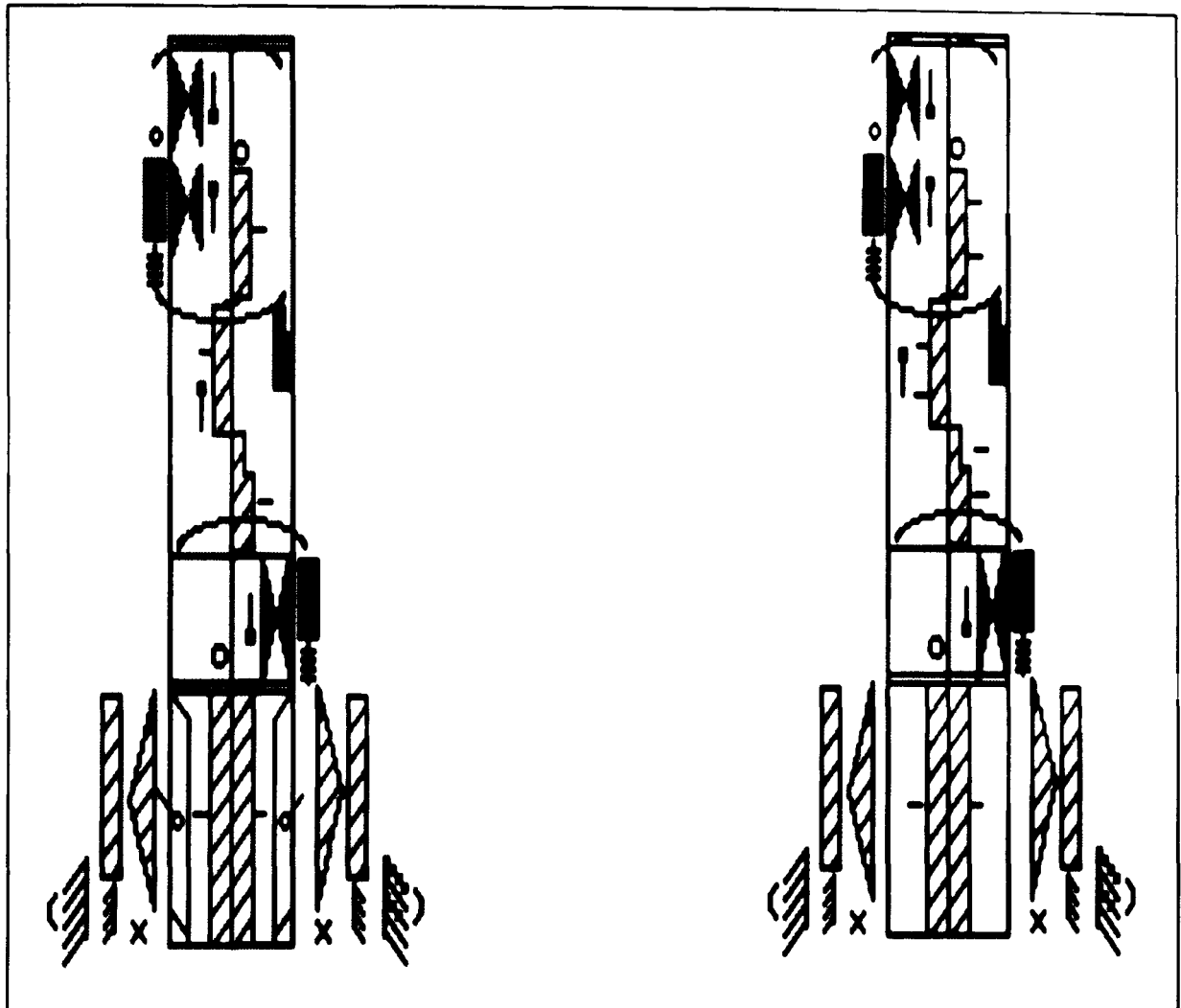

With regard to the actual floor pattern covered by the dancers in their 'Figure of Eight' (SOHDA 1993: 17) the SOBHD instructions note the following:

On the first two counts, the body is at an angle of 45° to the line of travel with the Right Shoulder leading; on the third count, the body faces the line of travel; on the fourth count, the body is at an angle of 45° to the line of travel with the left shoulder leading... The head is always directed along the line of travel (SOBHD 1993: 29).

This floor pattern is shown below, with the dancers labelled 1-4 and the direction in which they commence travel indicated by letters A-D. The actual pattern traced on the floor is shown by directional arrows.

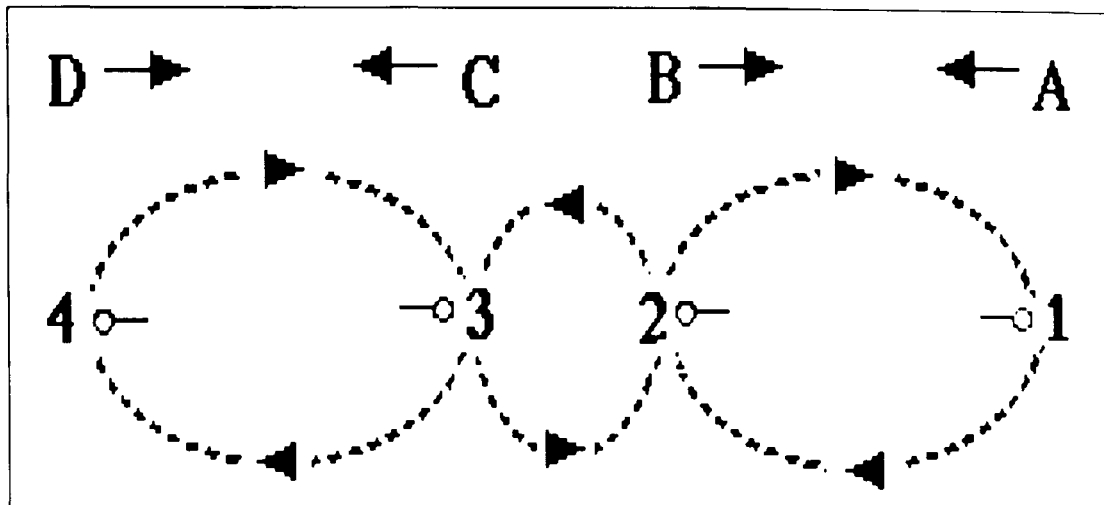

According to the SOHDA, on the first and second counts, the dancer has 'slight right shoulder lead' and 'step[s] along the Line of Travel'. On the third count, as above, the dancer is 'Facing the line of Travel', and then, again, on the fourth count there is 'a slight left shoulder lead' (SOHDA 1994: 40). This seems to be a less austere version of the movement, and it results in a slightly different floor pattern, as shown below.

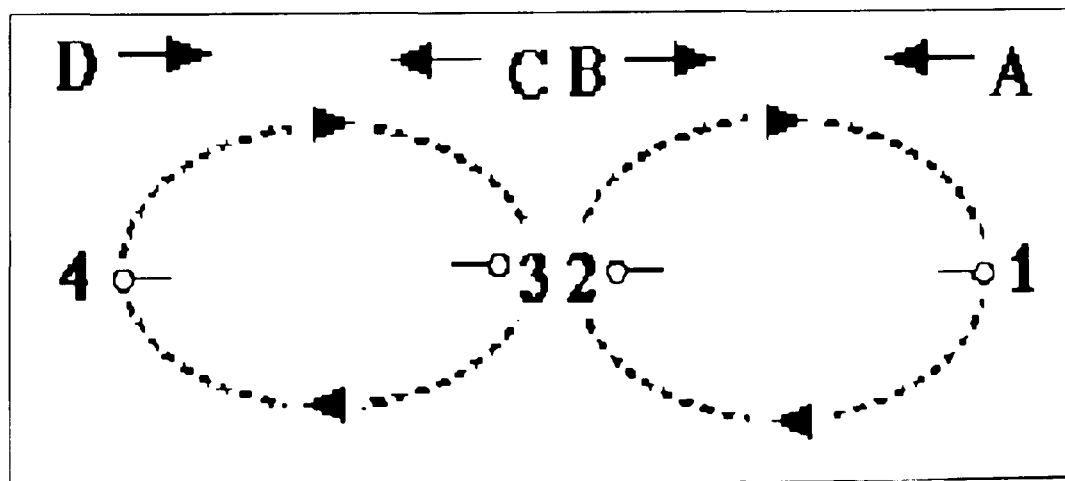

The SOHDA concede that the floor pattern does not actually 'depict... the actual shape of a figure-8... The term more accurately fits the pattern cut'⁵⁵ by three dancers dancing a 'Reel of Three' (SOHDA 1993: 17), since there are three loops traced by four dancers, and two by three dancers.

In order to preserve the floor pattern, Watson's teaching technique was to:

stand in the middle or he would sometimes get a chair... out [of] the kitchen and place that in the middle, between the two middle dancers, and sit on the chair. And this was to make us do a proper circle, a proper *loop* in the middle, so that it was supposed to be *three* loops... he said a lot of dancers just did two and hardly did any loop in the middle at all. And this was to make us do a proper loop to get the figure right (SA2003.040).

Progressive Reel Movement

It is interesting to note that Gibson uses the word 'cut', forbidden to Diack, in the following denotation: 'The major and critical cross in The Strathspey steps... they are every bit as subtle and graceful... demonstrating [the] Scottish... *cut* from Strathspey to Reel' (UI2001.004). The term seems to indicate not so much a movement of the feet, as in 'Step, cut, three, four' (SA2003.040), but a significant change in the dance which moves, or 'cuts', from Strathspey to Reel tempo.

The method of travel in The Reel, according to the SOBHD, is as follows:

⁵⁵ It is worth noting that this term, when used by the SOHDA, indicates the 'cutting' or 'carving' out of a floor pattern rather than, as Diack's terminology might suggest, the movement of a foot to a certain position.

Hop on the Left Foot taking the Right Foot to Third Aerial Position, then step with the Right Foot along the line of travel to Fourth Intermediate Position (count '&1'); close the ball of the Left Foot to Third or Fifth Rear Position then step with the Right Foot along the line of travel (count '&2') (SOBHD 1993: 31).

The SOHDA movement is similar:

On RF: Hop on the LF and, with a slight right shoulder lead, place the RF in Third Aerial Position (Count and). Step the RF along the Line of Travel to Fourth Intermediate Position (Count 1); Close the LF to Fifth Rear Position (Count and) and step with the RF along the Line of Travel (Count 2). Repeat with LF and as required (SOHDA 1994: 40).

The explanation given by the SOHDA is a little more stilted, as the timing is split into half-counts. This does not seem to demonstrate the flow of the movement as well as the SOBHD denotation, but the actual positions and step are the same.

5:IV Music and Musicality

5:IV:i The Highland Fling

The Highland Fling seems to have been performed, whatever its roots, for the value of entertainment, often as a showpiece. It is likely, therefore, that it would have been danced to the accompaniment of whatever instrument was available. It is reasonable to assume that the tunes chosen would have suited the dance and, as a matter of priority, would have matched it in rhythm and tempo, thereby complementing the performance. This could have been played on the Highland bagpipe or fiddle, and indeed there are tunes in the repertoire to imply that this was the case.

'Marquis of Huntly' and 'Monymusk' are recommended by Mozart Allen's ballroom guide, as are 'Delvinside, Braes o' Mar, Lady M. Ramsay of Perth or any Strathspey Tune' (Allen 1824: n.p.). The extensive suggestions read as a list of Strathspeys linked perhaps by popularity rather than a particular suitability as dancing tunes for The Highland Fling. Indeed, it is still common for the piper and dancer to agree on a suitable tune for competition, so long as it conforms to the basic tempo and rhythmical requirements (SOBHD 1993: 48).

However, another likely accompaniment would have been provided by an instrument which had no strings or drones to tune and one which was always on hand: the Gaelic voice. It is well documented that mouth music has been used throughout the centuries, where there were no other instruments available.

Gaelic puirt-a-beul, nonsense rhymes or non-lexical vocables were sung to suit the rhythm of the dance (Flett 1996: 25). 'An Amature Dancin' Maister', a short play found in R.H.C.'s *Scottish National Dances* (C., R.H. 1928: 15-21), gives some insight:

Davie - '...fat are we t'dee for music?'
Geordie - 'Oh we'll nae stick for that; we'll jist use fat we hae.
 There wis mou's afore there wis musical instruments; I'll
 whustle'.

The 'Plooman Dancie' also suggests 'The Braes o' Mar' as a suitable tune, drawing on, one assumes, an existing repertoire (C.,R.H. 1928: 16-17)⁵⁶.

J.L. McKenzie, a great teacher and ambassador for Highland dancing in the early twentieth century, also used Gaelic mouth music when teaching his pupils: 'It brings out the rhythm of the music... It's the natural thing with the music and the movements together...' (PV1995.003). Morrison and Livingstone also testify to the prevalence and suitability of mouth music in the performance of Highland dances (SC2003.003; SA2003.035). Livingstone also testifies to the inseparability of the dance and music:

When the Mod⁵⁷ was on in Inverness, once or twice, people from the West used to come to our house and I remember this woman [who] came to the house to get the right timing for Puirt a beul and I would have to dance The Highland Fling, so that she would get the right beat. She [sang] at the Mod, and she won a prize (SA2003.035).

It follows, then, that the dances have not survived in isolation from the

⁵⁶ It is interesting to note that it was in the Forest of Mar that Lowe sets his tale of the origins of The Highland Fling (see Chapter Three).

⁵⁷ Gaelic cultural festival.

music. The narrative or expressive form from which they may have evolved has perhaps not been as tightly bound to the actual dance movements as was the music associated with them. The steps are repetitive and well-balanced, with mirrored movement on either leg, and the strength of the overall structure being in the very nature of the dances composition. This is reflected in The Strathspey music which is made up of eight bar portions, variations and repeats.

Morrison recalls that, in the early twentieth century, 'The Marquis of Huntly's Highland Fling' was often used in performance and competition, as well as 'The Devil in the Kitchen' (SC2003.003). The latter tune is also suggested by Lowe (Lowe 1976: n.p.). Catriona Macaffer cites her father, Pipe Major Alasdair Macaffer, as having experience of there being no instruments to hand in the 1940s and 1950s: 'no... I never saw anything other than people on pipes, a solo piper, or people diddling or lulling⁵⁸ along... and it was always usually the traditional tunes in a sense' (Macaffer 2002: n.p.). She also clarifies what, in the current piping repertoire, would be considered to be the 'traditional tunes': '...there tends to be a selection of specific tunes used for each of the... dances: The Highland Fling... is usually performed to either the tune Stumpie, Orange and Blue, The Deil Amang the Tailors or The Marquis of Huntly's Highland Fling' (Macaffer 2002: 15).

Macaffer advises 40-42 bars per minute for the performance of these four suggested Strathspey tunes in 4/4 time. The four beats in the bar are almost evenly accented although there is, of course, a slightly stronger accent on the

⁵⁸ Forms of mouth music.

first beat of each bar. The SOBHD recommend the tune 'Monymusk' (SOBHD 1993: 31). There is evidence of The Highland Fling being performed at a slower pace. Early 1920s footage of J.L McKenzie (then World Champion) dancing a demonstration video for the SOBHD shows his dancing to be much faster than it is ever seen now. Pipe Major Macaffer recalls 'I can remember me, and my mother and sister dancing a little faster than they do now, like in the speed of The Highland Fling...' (Macaffer 2002: n.p.). However, it remains difficult to ascertain the actual speed at which he was dancing, as the cinefilm reel speed does not give a true indication of time, and is likely to show the dancer moving faster than he did.

Prior to 1900, it was common for ten steps of The Highland Fling to be performed. Allen records eight basic steps (Allen 1824), basic models onto which variation and interpretation could be added. David Anderson records ten (Anderson 1900). In 1912, *The Celtic Monthly* records 'Eight figures... while the time of the dance should average sixteen bars in from twenty-four to twenty-eight seconds' (*The Celtic Monthly* 1912: XX: 209). Livingstone recalls dancing 'five or six Fling steps' (Livingstone SA 2003.035) and Gardner recalls 'eight Fling steps' (Gardner SA2003.034). There does not seem to be any great debate as to which steps were danced, and, in general, the denotations given by these living informants are similar in content. Flett and Flett seem to have collected most of the complete variations of steps, with the exception of regional differences of style (see Chapter Three). One assumes then, that any dispute as to how many steps were danced in a complete dance in the early part

of the twentieth century would rise from the varying recommendations for competition entry, display purposes or for dancing practice.

By the 1955 publication of *Highland Dancing*, the number of steps danced had been reduced to 'six or eight' (SOBHD 1955: 33). Fearchar MacNeil, a Hebridean dancing master, commented that when he learned Highland dancing in the early twentieth century, he was taught that 'at least six steps were the minimum [but] now it's four.' He asserted that the current lack of variety between steps and the shrinking number of steps being danced as the years progressed was the fault of the SOBHD: 'What... the Official Board of Highland Dancing does, is they *cut out* the steps and they're not being taught' (VB057).

There are two significant lines of thought regarding the influence of the SOBHD on the remaining steps: that they standardised to the extent that variations and unusual steps were not acknowledged and left out of their syllabus, textbook and therefore competitions and practice, at the same time stagnating the components by means of legalistic petrification (VB057); or that, by means of standardisation, they preserved and promoted the remaining steps, rescuing them from foreign influence or threatening obscurity (SA2003.036).

Despite the publication of Flett and Flett's work, documenting more than sixty steps of The Highland Fling, and with many more fragments having been recorded, it remains the case that the pool of steps available to be danced (as recommended by the regulating bodies) is relatively small compared to the many regional and innovative variations which were once present on the competition boards (as discussed in Chapter Four). It is not surprising, then,

that the total number of steps danced in a single dance is also fewer than older records show.

5:IV:ii The Sword Dance

The first technical denotation of this 'traditional Scottish Solo Highland Dance for Gents' (SOHDA Dance Sheet 2) is in the *Book of the Club of True Highlanders* (North 1881: n.p.). Anderson's 1894 account varies little from this, or for that matter, from versions of today. Notably, however, North's instructions are for a clockwise progression which is no longer in the current repertoire or recognised by any regulating body. It is recognised as a part of the dance's history, although no mention is made by either the SOBHD or the SOHDA as to why such a change in the direction of the dance might have taken place (SOHDA Dance Sheet 5).

Forsyth puts forward some suggestions about what has been a paradigm shift in the performance of this dance:

The Sword Dance was in a reverse direction from the way it's done now. It went clockwise, whereas today they always dance it anti-clockwise. And you wonder... when did it change? And who changed it? Or, is the way we do it now the traditional way and that was just an aberration at some stage or another. Somebody had done it a different way and it happened to be written down in a book that's fairly widely known. So you don't know what's the story and what was the origin. It would be difficult to pin it down' (SA2003.036).

The SOHDA assert that this change took place in the mid nineteenth century: 'before 1850, The Sword Dance was originally performed in a clockwise direction round the sword' (SOHDA Dance Sheet 2). This date is further impressed on the SOHDA student as being one of change in their textbook:

The steps have undergone considerable variations during its long life - a notable change happening in approximately 1850, before which the steps were danced round the swords by left to right, not anti-clockwise as performed in today's version (SOHDA 1994: 51).

However no indication of these older steps or an ancient method is given.

An example of an anti-clockwise progression is in the 'Flinging over the Swords' step remembered by Christine Abercrombie, and taught to Andrew Purves in 1997 (PV1997.005). In this step, an anti-clockwise progression is used, as well as a Shedding step, which was perhaps imported from The Highland Fling. These elements, along with four points (Left, Right, Left, Right) to be repeated outside the crossed swords, are unfamiliar in the components of the modern Sword Dance. They may be remnants of an older step, which was perhaps part of a dance which did not go through a sudden reversal (as implied by the SOHDA), but a gradual change from clockwise to anti-clockwise. As the step grew more intricate in its crossing over of the swords, the dancer turns not in one complete circle round the swords, but traverses the blades repeatedly as the progression from one sword point to another took place. The dancer would therefore have been performing numerous turns in a small space and would perhaps have employed both directions for turning. The smaller, internal turns would have incorporated various patterns and possibilities, depending on the footwork of a certain step. The overall effect would have been that the dancer moved deftly across, through and round the swords in an overall directional progression.

The Sword Dance must have differed greatly in style from the showcase of steps within The Highland Fling, since it inevitably had integral associations

with martial activity. This would naturally have been reflected in early manifestations of this dance, and in its surviving form. The tunes with which The Sword Dance has been associated are the strongest indicators of this nature, as written denotations fail to convey a sense of strict rhythm and attack. The Gaelic puirt-a-beul (as notated in Chapter Three) certainly gives some idea of the rhythms of the music which would have been reflected in the footwork of the dance. The standard version of the tune, as it is played today, from the Standard Settings of Pipe Music Volume II (Scots Guards 1981: 172-172), is very similar to the puirt.

The martial element of this dance is a reminder that the relationship between the dancers and the pipers was a dependent one, the former needing the latter to enable their performance, but the latter able to perform alone. The suggestion that the dancing cannot stand alone has been exemplified by Ben Matthews, an ex-competitive Highland dancer and piper:

I know that they [pipers] like to play faster... than we can dance, usually. So I think that... getting the right tempo is *difficult* for them. When I was at college, we had... the pipe instructor... was a fairly good piper and he'd been... having this battle with the dancers for *years*... There was definitely a rift between the piping and dancing groups. And I was... trying to be part of both of them. And in the end I gave up, and just did dancing, 'cause I wasn't having much fun piping (SA2003.033b).

Similarly, McLaren notes that

There's lots of pipers but not many... want to play... for the dancing... [because] you've got to keep the same tempo all the time and you've got to keep repeating, it depends how many there are in the section. You've got to play The Highland Fling over and over and over and the same

with The Sword Dance and you've got to be a pretty good piper to play. I mean you could have a really good piper but if he's never played for Highland dancing I wouldn't like to have him at a competition (STDT Recording 6/10/98).

Gardner suggests that it is the dancers who are at fault when setting and keeping good, regular timing:

That is one thing I find very, very disturbing about the children nowadays, is their timing. Their timing is dreadful, a lot of them. As I said before, they're trying to work so hard, they're losing the beat (SA2003.034).

According to McHarg, a dancer must 'have a feeling for it and a feeling for music' (SX2003.035). Gray argues the same, that dancing must be 'A physical response to the music' (SA2003.039). The state of some dancing today is lamented by Mill:

Tempo wise... I think a good dancer has got to have this in-built... basic musical ability of some sort to know the difference between a Strathspey and a Reel or a Jig. It's amazing if you ask kids nowadays, is this a Highland Fling, a Strathspey or a Reel, and they look at you [as if to say] 'I haven't a clue' (VA2003.007).

Watson goes further to say that 'As far as I'm concerned, if the dancer is not dancing to the music, they are not dancing, because the two are integral' (PV1992.002). He goes on to explain that, as well as all the necessary physical expertise in 'good' dancing, an understanding of timing is fundamental:

We're looking for precision. We've got to pay very strong attention to the turn-out, the pressing back of the knees, *timing* in dancing... You've got all the positions, arm movements, use of head, *timing*. As you see,

quite a number of dancers, they dance out of time with the music and that is a crime in my book [*Italics mine*] (PV1992.002).

Diack explains the emphasis Watson would place on the understanding of rhythms and timing:

He paid great attention to practising figures like that, getting the movements, getting the movements right, getting the *timing* right, he made a big thing of having the right *timing* and right *rhythm*. And he would get us to practise these things, no matter how long we'd been dancing ... I don't know about other schools, but the dancing school I'm going to just now just doesn't take the time to go over things like that. And I think it makes all the difference to the dancing and to the dancer. As I was saying, lots of things, well, other dancers doing things, that if Mr Watson saw them he'd just... he'd just make them practise these particular exercises (SA2003.040).

An understanding of tempo and timing within both the music and the dance is imperative. This is explored further, in relation to Highland dancing, in the following chapter.

5:IV:iii The Seann Triubhas

The Seann Triubhas, as it is currently danced, in both the repertoire of the SOBHD and the SOHDA, consists of not more than eight or ten steps, with the last one or two steps danced in the quick time. The SOBHD states that, in competition, it should be performed with three slow steps to the tempo of twenty-six bars per minute, and the quick steps at thirty-one bars per minute (SOBHD 1993: 40). The SOHDA gives no instructions other than to describe it as 'start[ing]... slowly and increas[ing]... in tempo on the final two steps' (SOHDA 1994: 45). This is not to say that the tempo gradually increases, but distinguishes slow and quick steps (SOHDA 1994: 45). Likewise, the NZAND provides some idea of the nature of the relationship between the music and the dance: 'the tempo of the first part of the dance is slow, lilting and sustaining. The latter part a quick measure; both movements danced in 4/4 time' (NZAND Grade Four Syllabus n.d.: 18). The quick time in The Seann Triubhas is performed to a Strathspey rhythm (SOHDA Dance Sheet 3), where the dancers often use Highland Fling steps for this part of the dance.

The Seann Triubhas was originally danced to the fiddle tune, 'Sheann Triubhas Uillichan' (Flett & Flett 1996: 38), but when the dance was introduced to the Highland Games, the tune changed to accommodate the bagpipe. For many years now The Seann Triubhas has been danced to the Strathspey tune 'Whistle O'er the Lave O't'⁵⁹ (SOBHD 1993: 40; VA2003.002).

⁵⁹ Robert Burns claimed the tune, to which he wrote at least two lyrics, was by a celebrated violinist, John Bruce, from Dumfries (Lowe 1993: 307). It was first published in Bremner's *Scots Reels* 1759.

One factor which may have contributed to this change may possibly have come from the introduction of the Schottische. Both The Strathspey and the Schottische consist of the same 4/4 rhythm but with a difference in accentuation. The Strathspey consists of a Scotch-snap, where the *first and third beats* in each bar are heavily accented. The beats are made of a semi-quaver and a dotted quaver and the following example shows the form of two typical bars of a Strathspey:



The accents are quite different in a Scottische, where the accent falls on the *first and third beats*:

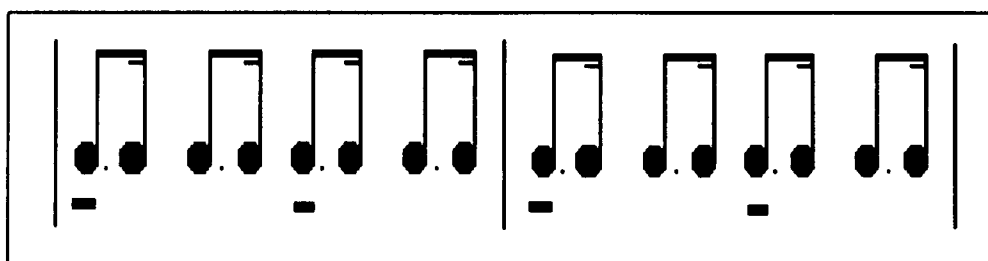

Macaffer considers that, 'with the introduction of this new rhythm, it is possible that the tempo of The Strathspey was adversely affected because of the slower and heavier Schottische. The Fletts suggest that 'Schottisches have been played at 40 bars per minute' (Fletts 1996: 90). However there is no firm evidence for such an infiltration having taken place and this remains conjecture.

It is possible that the change in tempo did not come from the players, but from the dancers. The lead from the dancers is likely to be an influence, if not the sole reason for the slowing of The Strathspey. since, for the last century,

at least, the manifestation of dance has been not a reaction to the music, but as a vehicle for performance and competition.

Livingstone has observed a change in the performance of The Seann Triubhas since the 1930s:

They seem to *jump*, it's more like, some of it's a bit like ballet dancing, sometimes when you see them doing the Sean Triubhas, they're like sort of way up... Granted, the Sean Triubhas we danced to it slowly. I don't know what speed they do it at nowadays (VA 2003.005).

In the same way as Matthews suggested that a conflict still exists between the piper and dancer, Gray claims that differing approaches to timing is still problematic in a performance involving both dancer and musician:

I'm always listening to the music and... trying to keep *with* the music... The main guy I've seen who's a competitive dancer... he was very busy in getting his kilt swinging and flinging his legs about and putting these extra beats in which the music didn't have... I happen to know the musician who was playing for him and she came off stage and she wasn't too impressed at having to put in all these extra beats into her tune (SA 2003.039).

The music therefore serves and accompanies the dance. Unlike The Highland Fling, which may well have originally been manifest as a reaction to the music, and evolved from that source of inspiration, The Seann Triubhas was probably a narrative piece in origin and therefore did not occur as an afterthought to a situation where music was manifest. Instead it demanded an accompaniment of its own, and therefore the dancer would have set the pace of the performance. The modern dancer is therefore entitled to do likewise, should the speed of the music dictate the extent to which the dancer can or cannot

express the dance in their individually preferred style. However, the reality of such manifestations is that the dancers dance more slowly in order to exaggerate movements and steps, and in order to excel physically, rather than artistically. This concept will be discussed fully in the following chapter.

5:IV:iv The Strathspey and Reel of Tulloch

The Strathspey portion of The Highland Reel is performed by members of the SOBHD to 'Any Strathspey Tune' played at 31 bars a minute (SOBHD 1993: 48) whereas the SOHDA simply recommend a '4/4 Strathspey tempo' (SOHDA 1994: 23), without reference to tempo. The Strathspey, it is generally agreed, was originally played at a steadier pace whilst retaining its defining sprightliness⁶⁰. In the early twenty-first century however, The Strathspey is not danced as a reaction to music which is peculiarly Scottish or evocative of Scottishness. The function of the dance is no longer, as it might have been, to preserve Reel steps, or to tell a story using dance narrative, nor even to provide the dancer with a vehicle for expression or creativity. It has a more elementary function: the pursuit of excellence on the part of the dancer's technique and the performance of that expertise⁶¹.

The inconsistency of timing has long been the subject of much conjecture. Some sources have suggested that the tempo was originally faster and perhaps less accented (as illustrated in the previous section). Frank Rhodes suggests that the old tempo for Strathspeys was approximately forty-four bars per minute and possibly even faster (Rhodes 1996: 188). A similar point is made by piping tutor Allan MacDonald, who is of the opinion that 'up until the mid 19th Century, the tempo of both strathspeys and reels were played in a very similar fashion, even to the extent where it became difficult to differentiate

⁶⁰ For more information on the origins of The Strathspey, see Emmerson (1972,173-4).

⁶¹ The changes in use of the Highland dances are discussed in Chapter Three.

between the two' (Macaffer 2002: 16). This is considerably faster than the Strathspeys of today. It is almost impossible to trace the speed of tunes for dances, outwith written tunes (which were, more often than not, played as solo pieces themselves, unbound by the restrictions or specifications of a dancer's interpretation). This leaves evidence drawn from physical capabilities of the dancer, technical ability of the piper and the survival of that which was pleasant both to watch and hear. Similarly, Rankine interviewed a dancing teacher, Miss Strathern, who taught in Scotland during the early twentieth century, who claimed that, 'because of the control involved throughout the body, it takes a good dancer to dance slowly. Any dancer can dance quickly' (Rankine 1977: 20). As a dancing practitioner from pre-Board days, Strathern favoured 'a more relaxed and controlled style of Highland Dancing' (Rankine 1977: 20).

If the change in tempo of The Strathspey has changed significantly during its lifetime, then the impetus must have been from either the musicians or the dancers who played, shared and interpreted the music to suit their individual and social needs. Musicians from the early eighteenth century had been influenced by an Italian mode of playing which was classical in its roots and had an emphasis on finesse and clear definition, rather than on the authenticity of depth and quality of sound. It was, as contemporary fiddler and composer Alasdair Fraser observed, 'Too far removed from the heat and the heart of the dance floor' (Fraser Correspondence 2000). Fiddler and self-titled 'Strathspey King', J. Scott Skinner, had a unique style of playing Strathspeys in a considerably slower tempo and with a more rigid structure. His influence on his contemporaries was great. He had matched a style refined by a classical

influence with melodies believed to be of Scottish provenance (as suggested in Chapter Three).

The Fletts recorded many versions of Strathspey tunes for dancing. They also recorded variations in tempo, as this excerpt from a note on a nineteenth century dancing master explains:

Mr Buck also played The Strathspey music much faster than it is now played by the Society's musicians. This is also true of every traditional fiddler we have encountered, and we do not know whether the Society has any traditional evidence for the slower tempo (Flett & Flett 1957: 161).

One complete step of The Strathspey section (one figure and one setting step) 'occupies 16 bars of music of the tune 'Orange and Blue', or any suitable tune in 4/4 Strathspey tempo, e.g. 'The Keel Row', 'The Marquis of Huntly' etc' (SOHDA Dance Sheet 4). There are four beats or counts to each bar of music and one complete step of the Reel section (one figure and one travelling step) occupies 'sixteen bars of the tune "The Fairy Dance", or any suitable tune in 4/4 [sic] Reel tempo, e.g. "Mrs McLeod of Raasay", "The Soldier's Joy", "Deil Among the Tailors"... There are 2 beats or counts to each bar of music' (SOHDA Dance Sheets 4 and 5)⁶².

The SOBHD recommend the tune of the same name for The Reel of Tulloch, stating that the tempo should be around fifty four bars per minute (SOBHD 1993: 54). Although the SOHDA make no mention of this tune in

⁶² Strathspey time signatures are in 'Common' or 4/4 timing, whereas a Reel time signature is 'Half-Common' time, which gives the player the impression that the Reel tune is double the speed of the preceding Strathspey tune, although the actual tempo may not change.

their denotation of the dance (SOHDA 1994: 41), one assumes that any suitable reel-time tune would suffice. The origins of the dance have long been disputed and the name and spelling of the famous village of 'Tulloch' have been claimed by more than one vicinity (see Chapter Three). In the same way, there are also to be found many different versions of the tune of the same name(s) which are associated with its performance.

Anderson, who gives us one of the first full technical denotations of The Reel of Tulloch, states that when it was first introduced, the tempo was slow, as were the steps, but that 'now it is danced to Reel Time throughout... [it] is considered much better' (Anderson 1900: 11). Flett and Flett also refer to this tune as being in jig time, under the Gaelic title, 'Hullachan's Jig'. According to Flett and Flett's first book, the jig time was also used for The Reel of Tulloch dance (Flett & Flett 1964: 148). Due to the faster tempo, the dance was often performed in a circle, instead of the in-line travelling position... 'This is again rather similar to the Circular Reel. Unfortunately there are not many early records which provide any further details on this' (Macaffer 2002: 18). As with the other dances, clues as to how fast any accompanying tune would have originally been played are scarce.

The following chapter illustrates each of the five dances in the context of competition. The accompanying DVD also gives an idea of the sort of musical accompaniment (including many of the tunes mentioned above) that is played by a modern-day solo piper.

Chapter Six: The Ethnography and Ethnographic Themes

6:I Textual and Visual Ethnographies

6:I:i Accessing the Event

'Will you... join the dance?' (Carroll ed. Gray 1971: 79-80)

The history and current tales of the origins of Scottish Highland dancing have been recorded in Chapter Three, and it has also been set firmly in a time scale of real or supposed history. In Chapter Five, the descriptions and analysis of the positions, gestures and steps show the elements which make up the dances as current practice of technique. However, in order to properly assess the state of the tradition's growth in the contemporary culture of transmission within Scotland, I returned to the field.

Following the interview phase, the bulk of which took place between 1999 and 2002, I set about becoming a more active member of the dancing community (as is detailed in Chapter Two). Confidences with dance practitioners were built on the foundation of a shared interest. My interview style became less question-and-answer-based and more relaxed in order to encourage trains of thought and provoke the natural excavation of often fragile memories. After initial interviews, second and sometimes third interviews were arranged. Subsequently, more relaxed meetings and letter-writing also proved to be important developmental factors in my relationship with my informants.

The social relations in such an investigation proved to be complex and I encountered many different reactions (to me), all of which developed, as hours of conversation, days of events and months of observation passed. The oldest informants were interviewed first as a matter of some urgency, many being octogenarians. They often portrayed their own knowledge as being of limited value, prefacing conversations with disclaimers. They also implied that the memories of Highland dancing they had experienced had somehow been diminished in worth by the dulling nature of time. These reminiscences, however, were anything but lack-lustre. The archival video recordings I made have exposed these treasures which shine with vibrancy and humour as the fondness of the retelling brings them to life (see fieldwork recordings listed in bibliography). Importantly, the personal experiences revealed data available from no other source.

In keeping with dance analyst Adrienne Kaeppler's advice, the physical elements of dance are thoroughly analysed in Chapter Five alongside the emotional elements in Chapter Four by considering not only the ethnographer's point of view but also that of the participant. This culminated in the recording of an event involving almost six hundred spectators and over five hundred dancers in a highly contested annual event. This chapter is therefore an up to date record of both that event and the themes arising from it.

An extensive written ethnography presents the preparations for, and the structure and conduct of, the competition. This is complemented by a film ethnography of dances, with voice-overs from dancers, teachers, parents, judges, scrutineers and a piper. The film is an edited sample of over six hours

of visual material and over four hours of audio material collected on the day⁶³. Data, informed by past fieldwork, foregrounded themes including aesthetic judgement, a narrowing in style, musicality, dancing as sport, gender themes and concepts of identity and Scottishness, all of which appear in the latter half of this chapter.

The event focussed upon was hosted by the United Kingdom Alliance Ltd. (UKA), which associates dance, drama and exercise organisations and practitioners, and is recognised by the SOBHD. Over the course of one day, Saturday 26th February 2005, the UKA hosted its annual indoor 'Highland Championship Competitions' (Programme p.1) at the Meadowbank Stadium in Edinburgh. This occasion is always popular with dancers as it is the first major event of the year and one of the largest in the Highland dancing calendar. Entry forms were available from early January. These were only for competitors registered with the SOBHD registration scheme, since all events operate under the rules of the SOBHD and the steps for each dance and age-group are as laid down by the SOBHD for 2005. In this respect, it is not an 'Open' but a 'Closed' championship (Entry Form p.2).

Dancers compete in one of four ability Pre-Championship groups, from Primary, Beginners and Novice to Intermediate. Each is split into age sections and only when a dancer wins one of these Pre-Championship events can they then compete in the Championship. For the purposes of limiting the scope of the ethnography, recording was focused on the Championship (also known as

⁶³ Film recordings and frame-summaries, interview recordings and transcripts are all available at the School of Scottish Studies Archives, University of Edinburgh.

'Premier') level dancing: Juvenile (seven to eleven years), Junior (twelve to fifteen years), Senior (sixteen to seventeen years) and Adult (eighteen years and over). The four Highland 'events' (i.e. dances) (Application Form, p.2) for each of these sections were The Highland Fling, The Sword Dance, The Seann Triubhas, and The Strathspey and Highland Reel, with different steps required for each section. Dancers sent their applications to the competition organiser, at a cost of £1.50 per dance, by 4th February. They then received the three-digit number by which they were known throughout the course of the competition⁶⁴.

My contacts for the day were the Director and President of the UKA. Both women were courteous, if brisk, by phone, and neither chaperoned or directed me. The only restriction was that I was not permitted to take flash photographs while dancers were dancing; however the Secretary of the UKA assured me that any questions that might be raised concerning child protection or privacy rights could be referred to him at the Blackpool head office.

⁶⁴ Unlike the interviews quoted in earlier chapters, informants at this event did not sign release forms, so pseudonyms have been used to ensure identity protection.

6:I:ii A Textual Ethnography

'Explain it in words' (Thomas & Barnie 1990: 51)

On the day of the meeting, the sports stadium opened at 8.30am. By this time, the two hundred and fifty space car park was already half-full and the queue of parents, teachers and dancers was fifty feet long. Over one thousand such visitors passed through the doors of the building by noon and most of these in the first thirty minutes.

Dancers were mostly under eighteen years old and from all across the UK. Each girl had tightly bound hair, often braided or in a bun, with 'no visible... adornments' (SOBHD Official Dress Code) and competitors carried holdalls, suitcases and hangers holding up to three outfits per dancer. These outfits were the full kilt dress for the four Highland dances, a lighter Aboyne outfit for the National dances and a Sailor's outfit for the Sailor's Hornpipe (SOBHD Official Dress Code n.d.: n.p.). Some dancers carried last year's trophies, which 'must be returned in good condition on or before the date specified on the receipt signed by the winner of such' (Application Form p.4).

As they were channelled by temporary 'pen'-like barriers, past a desk at which they registered their attendance and bought a programme listing events, times and numbered competitors, they passed various vendors. One such vendor displayed rows of pigeon-holed dancing shoes, outdoor competitors' cut-off wellingtons and ornamental Scottish embossed silver waistcoat and jacket buttons. Another traded in larger items: new kilt outfits, including socks, shirts and lace frills. *Highland Dancing: The Official Textbook of the SOBHD*

(SOBHD 1993) was also prominently displayed for sale. There was also a photographer taking digital photographs of competitors dressed mostly in Highland garb (although this was most popular after the awarding of prizes).

In the stadium, there was a Lesser Hall and a Main Hall. The former was used for all Pre-Championship level dancing and the latter for all Championship and Premier competitions. Filming therefore focused on the activities in the Main Hall, a floorplan of which is shown below.

Figure 5: Floorplan of Main Hall, Meadowbank Stadium, Edinburgh 26/02/05

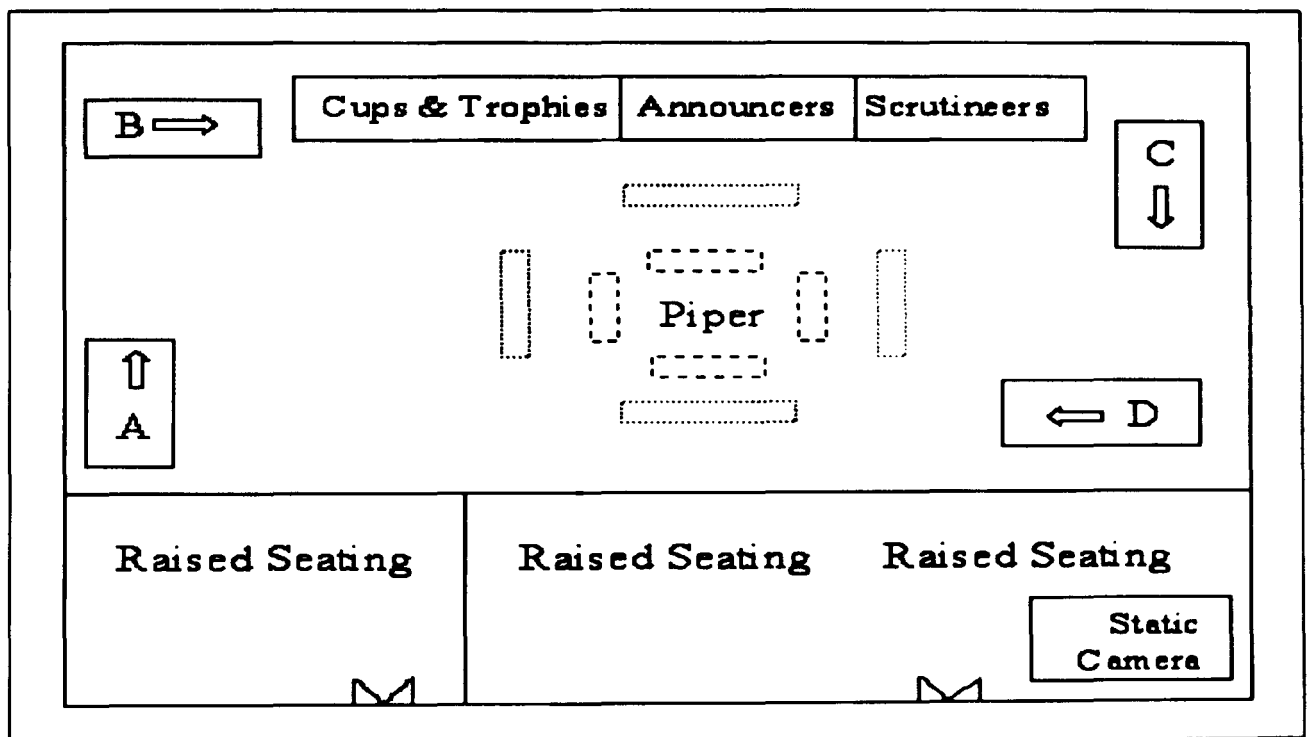

Entrance

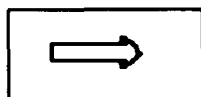

Direction faced by dancers

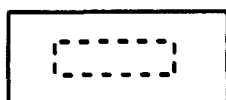

Judges' tables, facing out from piper

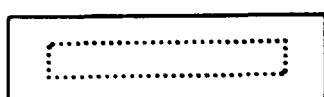

Dancers (normally groups of three or four), bowing (i.e. beginning the dance) to face the judges.

Two cameras were used: one static and directed to the stage (see Figure 5) and the other roving (for close-ups and detail). A minidisk was used for the purposes of interviewing and collecting commentaries for dances.

In the Main Hall, the raised seating area (see Figure 5), which seated eighteen hundred people, was used for spectating, changing and preparation. It was approximately half-full, with the first fifteen rows being most densely packed and strewn with programmes, bags, clothes, shoes and picnics. Here, dancers changed into full kilt outfits for the three solo Highland dances and The Strathspey and Reel. As they began their warm-up stretches and jumps in the aisles and at the edges of the performance area, the first Juvenile Highland Fling was announced. That prompt 9am start was 'a pre-cursor to a day of clockwork timing which reflected the precise and regimental nature of the dancing throughout' (Fieldnotes 26/02/02).

Dances were performed by event and in ascending age-groups i.e. The Highland Fling from seven to nine years through to eighteen years and over, followed by The Sword Dance in the same order. In this way, competitors rested for long periods between dances. Dancers descend from the seating area two dances before their group, to waiting area A (See Figure 5: Floorplan of Main Hall, Meadowbank Stadium, Edinburgh 26/02/02). Their attendance was checked by an official. From here they were instructed to go to one of four waiting areas (A,B,C,D [my designations] see Figure 5), where they were lined up in order by waiting ushers⁶⁵.

⁶⁵ One of these ushers was the current adult World Champion, who was denied entry to the competition since his mother was on the judging panel.

Four judging tables faced outward from the centre of the hall, where the piper stood and three judges sat at each. There were no scheduled changeovers or breaks for them until this first set of dances was finished at 1pm. They sat for the duration of the Highland part of the competition, even when the number of competitors did not require the full complement of judges. Tea was served, by trolley, directly to the tables during the course of the morning.

The backdrop to this scene was a long trellis table in three sections (see Figure 4). On the left (stage right) was an impressive array of cups and trophies, some of which were those that had been returned throughout the morning. On the right sat a group qualified in dancing, teaching and judging, and included two brothers (both past Cowal Highland Games world champions) and their father (a competitive piper). Their job was to collate and process dancers' placings and points on computer, for the prize-giving at 1pm. In the middle of the long table were the announcers, the main one being the President of the UKA. Interestingly, all of the important operations (i.e. scrutineering, prize-allocation and announcing) were far away from the hub of dancing activity. The gulf between the organisers at the back of the hall, and the visitors on the high raised seating seemed vast. The dancers only approached the tables in the case of an award (whether it was a dancing prize or a raffle prize at the lunch-time interval). In this way the officials from the UKA were notably elusive.

The booming announcements were not clearly audible and it was evident that competitors needed to understand the operations of waiting in the waiting area, lining up and walking to performance positions, without prompt.

There was no hesitation as each group of four dancers walked, gracefully, to their corresponding performance area (indicated by arrows, see Figure 4), the lead dancer reaching his/her position first (i.e. facing the judges) as the others fell in line with poise and accuracy. After the dance, judges gave nods of acknowledgement which indicated that the dancers might file off stage (groups A and B filed back in the direction from which they came, whereas groups C and D walked away from their waiting areas). An unwritten rule seemed to be that male dancers took a step back from their performance position, allowing the girls to walk off stage first.

Competitors therefore returned to the raised seating area during the remainder of that event and in preparation for the next. As every age-group danced each event, dancers could wait over an hour between dances. During this time there was much socialising, snacking, stretching and spectating. The bustle from the spectators' gallery mixed with the pipes which rarely stopped (since they are tuned on the drone between dances) made for a noisy atmosphere, although notably one without applause. The stage was not the focus of attention for dancers unless dancing, or for spectators unless supporting a certain dancer. The raised seating perhaps made consistent spectating difficult as it was high up and far from the intricacy of the dancers' feet. Each dancer seemed to be dancing solely for the three judges in front of him/her, so although the dance-floor was a spectacle of sixteen dancers and twelve judges, en masse, it was not for the benefit of the spectators. These dances, although in a social atmosphere, were, at their core, part of a solo

tradition and the whole operation was evidently strictly regimented in structure and style.

In the course of the first hour, the four hundred Championship dancers performed their first dance and, with a change of piper, they lined up for The Sword Dance. Officials placed the swords provided in a staggered pattern, for optimum use of space. During this dance, there were a number of operational rules. These centred around the event of a dancer touching the swords. Officially, a dancer loses five marks for a 'tiny little touch' (J05.35.1, Track 4) but is disqualified for anything more. However dancers could continue in the hope that one of the judges did not see and might still have awarded a placing in the top six for that dance, which, even if the other judges did see, could translate into a Championship point for an overall total in the age-group awards. Normally, however, judges noticed touches, especially when the swords moved or made an audible clatter, 'a real technical clanger' (J05.35.1, Track 1). In these cases, the dancer was immediately disqualified and either stepped to the 'top' of the sword, bows and leaves the stage (mid-dance) or waits to repeat the bow, and exits, with the other dancers.

It was at this point that the dancers' great investment in their training and technique became apparent: One of many disqualified dancers ran, crying, from the stage, to wail in the corridor, while another stood at the top of her sword, with her feet and arms in first (resting) position, as her shoulders shook from her quiet but deep sobbing. As competitor Eilidh Gibson described it, this judgement can 'shatter someone's hopes just because they make one mistake' (J05.35.1, Track 2) or 'the tiniest wee mistake' (J05.35.1, Track 2). The Sword

Dance still seems to embody the fear of failure (J05.35.1, Track 2) that is bound up in its supposed origins on the battlefield (J05.35.1, Track 2) (as explained in Chapter Three).

In the dances that followed, the structure does not alter. Dancers descended, danced, and were dismissed, one group after another. In The Seann Triubhas, even an untrained eye could see that the floor patterns are unlike the containment of The Highland Fling or the squareness and balance of The Sword Dance. Its sweeping circles, such as those in the 'Brushing' step (SOBHD 1993: 41), its linear travel, such as in the 'Side Travel' step (SOBHD 1993: 42) and advance and retreat steps, such as 'Leap and Highcut' or 'Leap and Shedding' (SOBHD 1993: 44) meant that the dancer uses up more space than in previous dances. The judgement of such travel often meant dancers ended the dance out of line with each other, as they often under-compensated for a forward movement with a backward movement, or indeed, forgot completely.

The Strathspey and Reel was danced in sets of four, with dancers often participating a second time, in order to 'make up numbers in a set' (Entry Form p.4). This agreement is necessary, as the dancers danced different numbers of slow and quick steps in each category, and therefore needed a certain number of phrases from the piper, which means that different age groups could not be judged to the same music. It is also reciprocal, as dancers (although they do not touch or 'swing' as in The Reel of Tulloch) judge their floor patterns and their return positions in relation to the other three dancers in the set.

During the course of the morning competition, the trophy table had not only filled up, but, as the Scrutineers processed the results, the trophies were labelled with the number of the appropriate prize-winner (J05.35.2, Track 9). An extra trolley had been wheeled in, during the last dance of the morning (Highland) section, as the space on the table was not sufficient, and there were six prizes for each dance in each age-group, and six overall prizes for the age group. The prize-giving ceremony took place after the lunch break and before the afternoon National competitions began. The competitors' numbers were then read out by an announcer and the trophies were presented by the ushers.

Individual dances were marked using a points system, whereby a First place is eighty-eight points, Second place fifty-six points, Third place thirty-eight points, Fourth place twenty-five points, Fifth place sixteen points and Sixth place ten points (Application Form, p.4). These stages of marks are recognised by the SOBHD, and are used in all large competitions, where more than one judge is present. These are collated for each dance, and do not work as in an aggregate system, but serve to place the dancers in order. Under this system, a winner may have one first place in an individual dance, some second and third places, but can be placed lower than a more consistent dancer who may have been third in every dance. Those with too few points to be in the top six are recognised as having 'Championship points', which give them some indication of their achievement. The overall winner of the age-group is therefore the one with the most points and may also be the overall Championship winner, if his/her points are higher than any other age-group winner.

Dancers lined up in their rows of six, as they collected their prizes. Applause from the 'spectators', which had been noticeably absent during the performance of these dances, eventually came, when the announcer counted 'one, two, three' and, on the fourth count, dancers bowed on cue. It was also at this point when, for the first time in the competition, the dancers in the top six in each age-group were announced not just by number, but by name. This was an operation which was executed as sharply as the 'weapon-grade steel high-cuts one would expect in... The Sword Dance' (01/04/2000 <http://mdk.krakow.linux.org>).

Laura Gibson, mother of twelve years competitor Eilidh, in a recorded group discussion, explains the effect a bad result can have on a child: 'somebody doesn't get placed and it's the end of the world and they [the judges] [are] responsible...' (J05.35.1, Track 2). It is inevitable, then, that, post-prizegiving, the judgements and awards were scrutinised by dancers, parents and teachers alike and themes of stylistic preferences were also much discussed in a time of rich ethnographic contributions. Some of the analyses are best shown visually, as explained in the following section.

6:I:iii A Visual Ethnography

'lived dance experience' (Foley 2001: 3)

For the purposes of interviewing dancers, spectators and judges about some of the main themes foregrounded in Chapter Two and detailed and analysed in the remainder of this chapter, I devised a semi-structured questionnaire (see Appendix 14) This was largely informed by existing fieldwork, especially that with older informants, so that, by attending a regulated event, I might interrogate the claims that regulation has led to impoverishing of Highland dancing (VB057; PV1992.002; VD114b). The selection and order of questions for each informant or group of informants was not rigid.

By producing an edited DVD ethnography to accompany this written account, I am foregrounding the responses I collected, considering the informants' opinions and enabling those participants to have a voice (literally) and a platform whilst, at the same time, interrogating what they say and how they say it. In this way, perceptions and interpretations can be brought to bear (i.e. what they say is going on / their perceived reality) as well as the visual material, which is illustrative. However, tellingly, one informant asked, post-recording, 'Now that that thing's switched off, can I tell you the truth?' (J05.35.2, Track 6).

With respect to this investigation, the dancers are solo performers whose movements form their individual expression (Sheppard 1987: 18). This can be manifested in intended or unintended outward communication. Indeed,

the spectators, whether or not they are active in the dance, are still participants, as the recipients of a dancer's expression. The observer may not be physically active in the dance event but nevertheless plays an active rôle as an onlooker with whom the dancer interacts on a communicatory rather than a physical level. I therefore interviewed dancers, teachers, parents, judges, scrutineers and one of the four pipers, in order that their 'Criticism, interpretation, and evaluation' (Sheppard 1987: 76) of events could be taken into account. I considered the points of view of non-dancers as being of equal bearing as dancers, in this way, ensuring the collection of both quantitative and qualitative data.

In a group that naturally centres around the practice of dance, there was a tendency to be precious about the foundations of the organised bodies, as if revealing their roots to the open air, and an atmosphere of questions, would somehow weaken their foundations. Some conversations took place explicitly on the understanding that the content could not be directly quoted or attributed.

However, most spectators were happy to commentate during any dance except The Sword Dance, during which they 'can't' talk, because, as one Mother put it '[I] hold [my] breath right the way through it' (J05.35.1, Track 4). Similarly, teachers were only keen to contribute after their pupils' performances (J0.35.2, Track 2; J05.35.2, Track 4). The apprehension that had been evident in the pupils was also evident on the part of their parents and teachers. Conversely, the teacher without dancers in that competition was happy and relaxed to comment, having been 'volunteered' by her friend who did have children competing (J05.35.2, Track 5).

6:II Main Themes

6:II:i Aesthetic Judgements

'Intentions and expectations' (Sheppard 1987: 94)

The judges at this event were all members of both the SOBHD and the UKA who had qualifications in dancing, teaching and judging. In most cases, they were also Examiners for UKA medal tests. Their ages range from early thirties to late sixties, and all had competed themselves in competitions from the late 1940s to the 1990s. At least one of the judges was also a piper.

The main reason for having multiple judges is to ensure an even spread of both expertise and 'to get a broad... view' (J05.35.1, Track 4). This also works in the dancers' favour because the judges rotate, so that each one marks a dancer in only one dance (J05.35.1, Track 2). This is to eliminate bias of any kind, since judges will, inevitably, have personal preferences.

Tracey Queen, mother of Elayne, (overall second place in age nine category), explained the difference such a system can have on a dancer's results:

There are obviously certain criteria that the judges will judge to but different judges also have their own preferences as well as to whether they prefer a dancer who is technically perfect, whether they'll drop a bit of technical perfection for somebody that's really bouncy and well elevated, whether they're fussy whether their arms are perfect or not... Elayne's a technical dancer... She struggles with elevation and there are one or two judges in those panels that do place Elayne quite high usually... And so I can only guess that they like technical dancers...

And there are... other judges that wouldn't look at Elayne because she has trouble getting off the floor sometimes... You can think her dance is beautiful and the judge on the day doesn't like them for whatever reason... em, you've got slightly more chance when it's a panel of judges, hopefully one of them likes you (J05.35.1, Track 4).

Perhaps more sceptically, competitors' mothers Laura Gibson [LG] and Linda Horseman [LH] discuss the themes of consistency in judging with competitor Eilidh [EG]:

LG I'm afraid to say it's in the lap of the gods because what one judge likes another doesn't necessarily like it. They're all very individual... because it's a championship, and they have to have three decisions.

LH ...It's just whatever the judge likes.

LG On the day...

EG A lot of it goes on the judge's personal opinion because if they like a certain dancer they'll place it (J05.35.1, Track 2).

However, despite these seeming anomalies, there is a general agreement as to the criteria for judging the positions, movements and steps, if not the style. According to the SOBHD guidelines, dancers are judged on three basic areas: timing, technique and general deportment. The timing is 'the ability to follow the rhythm of the music in the dance' and the technique is 'primarily the footwork, and co-ordination with head, arm and hand movements' (SOBHD Guidelines). The positioning of the feet is also of great importance as 'however graceful or agile the dancer, it is the neatness and accuracy of the foot positions that gives the dances their essential character' (SOBHD Guidelines).

This emphasis on the technical aspects, rather than any creative or expressive aspects, of the dance, reflects the instruction dancers are given in *Highland Dancing: The Official Textbook of the SOBHD* (1993). The competitors seem to be in agreement that a dancer who is 'technically correct' (J05.35.1, Track 2; J05.35.1, Track 4; J05.35.1, Track 7;) has good all-round technical skill (J05.35.1, Track 4; J05.35.1, Track 2; J05.35.2, Track 7) and dances 'by the book' (J05.35.2, Track 7). In the words of an ex-World Champion:

If you watch a lot of the dancers today, you probably wouldn't see many dancers... that... presented it as a performance rather than just danced technically. So... as judge, I like to see someone who's technical but who also has just got that wee bit of extra in the performance (J05.35.2, Track 9).

It seems that the dancers work towards 'excellent' performances (J05.35.2, Track 5) and 'perfection' (J05.35.2, Track 5), even though such words evoke the idea of absolutes, and it has already been documented that the judging criteria change from individual to individual. The 'perfect' is never attainable because it is 'Always getting more difficult' (Grau 29/11/04) i.e. the requirements are always changing, as the dancers and judges change.

Giurchescu theorises that, in any dance process, there are two communicative circuits which develop simultaneously: 'A short internal circuit and... a long external circuit' (Giurchescu 1973: 178). She explains her theory as follows:

The internal communicational circuit relates the dancer to himself... the physical, emotional and mental perception... as experienced by the dancer himself... The external, communicational circuit, having as starting point the same dancer, affects an indefinite number of co-dancers, musicians, and the audience' (Giurchescu 1994: 96).

While the results of movement can be seen and heard, they are primarily received by the person doing the moving, as 'felt experience, as kinesthesia' (Sklar 2000: 72). However, it is the case that, where a dance is judged by a judging panel, the focus is on specific qualities of the dance movement itself, rather than on the meaning it has for the individual dancer (Thomas 2003: 2).

However, despite the emphasis on technicalities, it seems that there is also an unknown element in a performance which is desirable in order to gain a favourable result. Theoretically, 'good' dancing may not always be the same as aesthetically pleasing dancing. Some dancers may present themselves as good dancers, but to others, they do not appear as such (Thomas 2003: 27). One mother quoted a Cowal World-Championships judge as having said that 'at this [championship] level it's... not what a dancer *doesn't* do, it's what a dancer *does* do' (J05.35.1, Track 2), meaning that the dancers do not tend toward making mistakes, but must perform something integrally different. This dancing was described by a spectating teacher and judge as having 'something extra about it' (J05.35.2, Track 5). A dancer who had this 'something' was described by one of the judges as 'stand[ing] out', as s/he has 'that little bit of something extra' (J05.35.2, Track 7). Certainly the elusiveness of the actual components of this winning attribute adds to the dancers' desire to have more

information from either the judges or organisers. In spite of my probing, a definition of this 'something' remained illusive.

In relation to this, a theme emerging in the data collected on the day was that it would be helpful to the dancers to have some feedback on their performances. The judges did not have marking sheets, with categories for analysis and space for comments, but simply placed the dancers in a ranking of one to six for each dance (J05.35.1, Track 2) without any other means of commenting on the quality of the dances. This perhaps adds to the contradictory state of the judging in which competitors understand that they need to conform to the rulebook, in aspects of technical excellence, without diversion, and at the same time, must have something 'extra' in their style (JO.35.2, Tracks 5, 7 and 9). Derek Winton, a Scrutineer at the competition, and retired six times World Championship winner and judge, called it 'a very secretive profession' due to this lack of information:

We only publish six results from each judge. And the people that come seventh or under, you just don't have a clue: did they come last, did they come seventh, did they come eighth? I think the judges again (as professionals that are qualified) need to look to say what can we do to make the competitions better, to make it more open, to make it more fair across the board (J05.35.3, Track 1).

Dancers were keen to express their desire for openness in judging, expressing the view that the judges should 'look at the dance... not just the technique' and 'Look at the whole dance, the performance... not just the technique' (J05.35.3, Track 1) and to 'Remember to judge *what* you see and not

who you see... (J05.35.1, Track 4) and 'Be fair! (J05.35.1, Track 2). It seems that, during the judging when the judges were watching a performance, that 'watching' was, in itself, a performance (Loutzaki n.d.: 1) and analysed particularly in retrospect, as their judgements are scrutinised.

In the case of competition judges, the requirements of aesthetically pleasing performances will vary (as was discussed in Chapter Four). It would be wrong to suggest that there are ever absolutes in this field; moreover, it is likely to change over time. This is not the ethos of the SOBHD, however, as the strict rules for competition and examination are absolutes, rather than the tools of creative expression. Indeed, criticism is not a discipline in itself. There is no tradition or skill of criticism in which one could be trained and no accrediting body for criticism exists (one cannot conceive how such an accrediting body could gain authority). Yet SOBHD and SOHDA among other dance bodies assert this authority with regard to judging competitions. The dances which are the focus of competition must inevitably be comparable, but the natural expression of the dancer must also be taken into account. Firstly, let us turn to the increasingly mechanistic form that is competitive dancing.

6:II:ii Narrowing of Style

'The crack dancer' (C., R.H. 1928: 11)

Essential changes in dance execution must come into acceptance in two stages: self-election and other acclamation' (McFee 1992: 86). Indeed, Highland dancing was already a dance and needed no affirmation of its status as such, but so far as it is 'cultivated' art-form, the organising bodies have both been 'self-elect[ed]' and now compete for 'other-acclamation' (McFee 1992: 86). It was originally through the establishment of the SOBHD that adjudicators aligned their standards to reward one style of dancing and eliminate others (Hall 1996: 260). Now, the acceptance of this authority is surely embodied in the dancers' readiness to be judged according to these rules (see Chapter Four).

As the judges essentially regularise the standards through the awarding of prizes (and the rewarding of certain interpretations and styles) and dancers consequently imitate winners, the form (Sheppard 1987: 38) becomes increasingly narrowly defined. Variation is limited to the aspects of the form that have not yet been regulated to standards of evaluation in order to focus on the 'dynamics of variation within a single form of dance, dance repertoires, and ways of dancing and choosing among them' (Hannah 1979: 7).

One of the Edinburgh judges puts these developments into perspective: 'Because of the textbook... it's written down now. And it's gone the very opposite direction. Instead of dancing being a free style type of Highland dance it's now a very kind of narrowed version of that... Everything is so... clinical

now... (J05.35.2, Track 7). He uses the example of a judge deliberating whether a dancer executed a position on the point or half-point of the toe: a marginal difference, and one that, if it is so difficult to ascertain, should perhaps not be a criterion for adjudication. This attention to detail is described by another Judge as the habit of 'pushing where the positions are' (J05.35.2). From a competitor's point of view, as she passes through the age groups, competing 'gets more serious... because now it's like every tiny teensy-weensy detail has to be perfect' (J05.35.1, Track 3). In these cases, the minutiae seem to take precedent over the overall performance and, as one of the mothers present noted, the dancing has turned into 'a very harsh, very physical thing and there isn't as much room now for a dancer to put... their own interpretation on a dance so everybody is aiming for exactly the same thing...(J05.35.1, Track 4).

Sparshott identifies 'distinguishable values of rightness', including 'correctness and appropriateness, goodness and beauty': ...If I do something right you can check off the things I have got right. If I do a dance right I have made no mistakes' (Sparshott 1995: 311). In reference to competitive Irish dancing, a similar phenomenon of attitude towards technique has been noted:

When an aesthetic form such as dancing is placed in the framework of competition a narrowing of style takes place. It is not a mysterious process: winners are imitated. The goal of competition is to win medals, trophies and titles. Winners receive praise, status and recognition... The [judges'] reasons given to a great extent *define* the winning form which is then taught, practiced [sic] and emulated by competitors.

Imitation of winning form is one force that narrows the range of style... The other force is consistent selection of a set of formal characteristics by adjudicators. The defining characteristics of the form, as they have been developed by adjudicators' descisions, tend to harden and admit less and less variation (Hall 1996: 258/9).

Similarly, cited in (Thomas, Helen & Jordan, Stephanie in Thomas 1997: 240): '[Ice-Dance champions] Torvill and Dean... aimed to provide the judges with the 'gimmicks' they seemed to want' (Spriggs 1994) and thereby enhance[d] their chances of winning a gold medal. Dean admitted: 'The old trick thing seems to be to get applause. As much as we don't like to do it, that's what they're [the judges are] telling us, that we must be more flamboyant but it seems they want more flourishes and show business' (Spriggs 1994). In Ice-Dance judging and in Highland alike, judges are communicating to competitors, by the way in which the marks are allocated.

This imitation (Sheppard 1987: 4) happens whenever a dance is enacted, even if it is intended to be an identical reproduction of a preceding performance, as dancers will inevitably be influenced by their idea of 'good' dancing. As Giurchescu explains, this 'new and unique creation', because of the permanent changes which occur along the 'internal' and 'external' circuits of the communication network, 'always contains an amount of new information'. (Giurchescu 1983: 23). The performer's obvious tendency to emphasise his own artistic personality and psychological reality, is framed by the social necessity to keep as close as possible to the traditional models, in order that the dance [or, in this case, dance form] receives social acceptance and recognition. This foregrounds the following marriage of dichotomies: technicality and musicality.

6:II:iii Musicality

'what it does... how it does it' (Merriam 1964: 209)

As has already been shown in Chapter Five, the relationship between music and dance plays an important rôle in the understanding of competitive Highland dancing. 'Music without dance is not in the same position as dance without music. The former also make a complex practice by uniting with words in song, but dance without music has no such alternative partner' (Sparshott 1995: 215). However, one of the themes to come out of the interviews, in response to the question 'What are the essential non-technical or musical skills which a 'good' dancer must possess?', was that some dancers had not been trained in musicality so much as technicality. The traits which were identified were either that dancers disregarded the music, or had such little awareness of it that they did not understand the symbiotic relationship between the roots of music and dance in that tradition (see Chapter Three) and therefore considered the tune to be simply a supporting factor, rather than an integral part of the performance.

Firstly, an understanding of musical structure and progression no longer seemed to be as important as it was before regulation (see Chapter Three). Informants claimed that dancers prioritised the execution of steps over keeping with the music. One of the four pipers of the day commented that

...sadly there's a lot of dancers don't appear to understand the music... It's not just a case of [the dancer saying] 'that's the [only] tempo I dance'... You've got to listen to what's being played as well... At the

end of the day they're getting judged on their timing as well as their technique... A lot of the time the dancers don't... don't adapt to the music. And I think some of them still need educated on that in their lessons, in their classes (J05.35.2, Track 6).

The practical solution to this problem seems clear: dancers should practise dancing to varying tempos so that they are not dancing either behind or ahead of the competition accompanist.

However, one of the judges who organises the pipers for the world championship, and is himself a piper, highlighted another problem: most Highland dancing teachers do not play pipes (J05.35.2, Track 7). Whereas once this was common, generations have passed since the beginnings of competitions, which were closely linked to the piping events (Chapter Three) and where the military tradition was strong (for example, the pipe-major might also be the dancing master). Students are 'trained' to pre-recorded tapes (J05.35.1, Track 2) or CDs (J05.35.2, Track 7), which narrows their understanding of 'the feel for the music' since they are not 'integrating with the music in their dance' (J05.35.2, Track 7).

Timing is therefore a consideration, as dancers not only over-exaggerate their movements, resulting in late landings (see Chapter Five), but they perhaps do not know where the intricacies of the rhythm lie. One mother explained her perception of two different groups of dancers, identified by her daughter's teacher by their understanding of rhythm: '[She] talks about up-beats and down-beats... And you get up-beat dancers and down-beat dancers... It's not off time it's just using the other half of the beat ... (J05.35.1, Track 4). A spectating teacher and judge clarified this by explaining that a dancer can make

themselves look 'sharper' when their working foot (see Chapter Five) moves 'slightly ahead of the beat so you're in the position before the beat'. (J05.35.2, Track 5). This could be considered off-time and she admits that this tendency to make the movements 'sharper and sharper' means that 'If you watched a dancer doing it, they look better... anybody would' (J05.35.2, Track 5).

This 'trend' (J05.35.2, Track 5) has also been noticed by the judges:

They're letting themselves be let down and that in itself actually detracts from the dance... When it's slow... you're pushing for lift. Now the stronger dancers find they can do that, but then... they're losing the dance. I mean the Fling's all about sharpness, being able to jump up and down on the spot. The feet are moving, the hands are moving, everything's moving in coordination, yet if all they're doing is looking for power you lose all that... The Swords, everything goes into big leaps. Now you can do big leaps fast. It's a lot harder, but it's a lot nicer (J05.35.2, Track 9).

One judge condemns the practice:

I think there is a lot of confusion in the dancing world particularly with the timing, whether you're on time, out of time, behind the beat, start of the beat, people will go on about this 'you've landed at the beginning of the beat, you've landed at the end of the beat'... the problem is that a lot of the dancers and a lot of the teachers are not actually trained in music. They're trained to dance, they know how to dance but they actually don't know the music part. And... if you don't know the music you'll lose part of the dance, and then they start losing the timing ...then they actually hit problems from there (J05.35.2, Track 9).

Similarly, another judge makes his position clear: 'You land on the beat... You can be sharp, dancers can be sharp, but to be honest you're either *on* the beat or you're *out of time*. And if you're out of time all the way through then you should expect you'll get [points] docked' (J05.35.2, Track 9).

Certainly, this practice cannot be accepted, as it inevitably means that one dancer could be in mid-air while another is landing, even though they are supposed to be doing the same dance (J05.35.1, Track 4). It is therefore of great importance that the tune is an integral part of the performance, and, rather than being made to 'fit' the steps, the steps should react to the tune. However this ideal brings in to play another vital component: the piper.

In the words of a piper who has twice played for the world championships:

There isn't a lot of good quality dancing piping going on just now. There's maybe about six [good] pipers... in the field and if any of them pass away or stop (with getting too old to play), the problem is attracting people to come in and play for the dancing because at the end of the day it's a thankless task (J05.35.2, Track 6).

This highlights problems of both quality of piping and retention of pipers. There seems to be a general acknowledgement among dancers and teachers, that a good piper makes a tremendous difference to the dancer's performance (J05.35.2, Track 5; J05.35.1, Track 2). An example of good practice would be a piper who sets the 'right' tempo and is consistent throughout the dance (J05.35.2). However, as every dancer, whether a high-elevator or a lower dancer, will have her own preference, so, once again, the variables in the definition of a 'good' piper are numerous. Inversely, 'if you get a bad piper who is slightly inconsistent in the beat, it's terrible to dance to' (J05.35.1, Track 2; J05.35.2, Track 9). One example given was of a regular competition piper who, 'at certain points in the tune, miss[es] a quarter of a beat and it throws the

dancers because they have to speed up... and they're struggling to catch up which is not fair on the dancers' (J05.35.1, Track 2).

One of the UKA Championship pipers, of whom the dancers spoke consistently highly (J05.35.2, Track 9) was Gavin Piper, an ex-judge, who held strong views on the occupation of playing for dancing. He stated that he took his lead from the dancers themselves, as the younger ones need less time (in the air) than the older ones, so the tempos would be slightly slower, the older the age-group. Similarly, in *The Seann Triubhas*, he is aware of the travelling steps which involve assembles and disassembles, and, taking his lead from 'certain [good] dancers', he therefore reduces the tempo very slightly (J05.35.2, Track 6). He does this so subtly, that 'nobody [no spectator] will notice, but the dancer will notice because they say that was good timing... the dancers do appreciate a piper that's trying to help them out' (J05.35.2, Track 6).

This example of unspoken and underlying conduct is indicative of an approach among Highland dancers, that, instead of reacting to the music (as is shown in Chapter Five) they have a more regimented approach. This attitude is seen not only in the physicality of the dance form as it has survived, but also in the mentality of the dancers. The following chapter further explores the idea that dancers are not so much artists as they are athletes.

6:II:iv Sport

'An athletic step and feet like... ferryboat[s]' (Morrison 2000: 42)

The spectators and dancers at the UKA competition seemed to be in general agreement that good dancers could perform large aerial movements and had high elevation. In the words of one teacher: 'A good dancer [is] ...somebody who's got good elevation... can get off the floor well, is nice and sharp, and presents... a good overall look... They're incredibly fit and... elevation is a big thing these days: just getting off the floor and making it look effortless. (J05.35.2, Track 5). This is inevitably someone who is athletic. And it is on this point of Highland dancing as sport that dancers seemed to agree. (J05.35.2, Track 5; J05.35.1, Track 2).

Mothers describe their daughters not only as dancers but as 'athletes' (J05.35.1, Track 2) and as showing 'good sportsmanship' (J05.35.1, Track 2). Certainly, due to both its competitive and strenuous nature, Highland dancing can be considered a sport. This is particularly pertinent, when one considers the apparent lack of artistic expression within the dances and mimetic elements that probably once had a part in their formation (of The Seann Triubhas, at least, see Chapter Three). It seems that competitive performance communicates little other than physical excellence to the audience.

Interestingly, one dancer's mother recounted an argument with her daughter's Primary School which 'refused to accept it as a sport' for a Sports Assembly (J05.35.1, Track 4). However, it is surely the case that in other sports there is much differentiation between styles of execution, but in

Highland dancing the rules are perhaps even more restrictive, as each competitor strives to the same model.

Gardner has strong views on the evolution of Highland dancing as sport:

It's a sport... It's a competitive sport. As I said, years ago, when we danced, it was a case of you don't look as if you're dancing hard. You make it look easy but you are dancing hard, but it comes over easy. But you see the dancers from abroad now, they're so athletic. It's like a sport. It's the one who can jump the highest, stretch the highest, move the most, it's like that... Well, they do, even when they're dancing, they overcompensate. You know, they go over the top... They're higher, they're wider, they're pushing, they're athletic, gymnastic. They're more gymnastic than art (SA2003.034)⁶⁶.

Similarly, Watson noted the change in approach: 'It's turned away from Highland dancing to acrobatic, and all this business of splits in mid-air and how high can I jump? You're not hurdling' (VB056). He explains further:

It's more like athletics. They're going in for leaps and splits in mid-air and all this business, you see. In the old days, we used to dance, and there was something *in* the dance that nowadays it's all, as I say, it's all leap, extension and the higher you can jump, the better, you know. (PV1992.002)

Morrison astutely observes that a dancer can, in these cases, have 'An athletic step and feet like a ferryboat' (Morrison 2000: 42). Athletic execution can be undertaken at the expense of the refined nature of the artistic presentation, as

McHarg explains with some distaste:

⁶⁶ This is not only evident in Highland dancing, but in other theatrical forms, such as American Ballet, where the drive towards getting your leg higher and higher, and the footwork sharper and faster, is the focus.

But oh, the Board [dancers] they've half of their foot on the platform... I saw a girl getting her championship last year at Cowal and she was doing high cuts and her whole foot, her very heel was on the platform – and she got the championship. I saw red. I really did... She was bound to know her whole foot was going down (SX2003.035).

These once-rural dances, having been taken out of their original environment (as shown in Chapter Three) and placed on a competitive platform, have not retained their form and content. They have, however, evolved and are employed by a society of a non-geographically defined nature. The dances' function has therefore changed and consequently so has their form, if only to restrict the number of steps in the repertoire for ease of judging and perhaps transmission. If people danced no more for themselves, but for onlookers, the aspect of the dances changed correspondingly. They often simply became different dances, at least in their expression.

Dances nowadays are stripped of their former drama (as suggested in Chapter Three). This may be consistent with the taste for pure design that persists in surviving traditional dancing in Scotland, but inevitably any dramatic or lyrical aspects to the dance manifestation are negligible. If, to be truly art, the dance should tell a story of some kind, in its communication and implication, its form may remain spatial in stress, and underlying is the 'exploitation, exploration, experience' of movement, rather than a linear narrative (Russell 1965: 59).

The difficulty of interpreting such a manifestation is that the subject matter of dance lies within the almost inaccessible oral field of vital experiences and qualitative thought and which is 'an imitation of nature through

postulating the competition between the poet, painter, musician and mime' (de Cahusac 1754: n.p.). The conveyance of the manifestation is therefore subject to the social process leading to the performance event. This used to be much more evident in the dancing styles of individuals, as presented in Chapter Four:

Well, in the old days, a dancer used to be recognised by his dancing... where you come from, Aberdeen, Glasgow, wherever, each place had their own particular brand of it, you know? And nowadays, it's all a case of clockwork. Everybody's doing the same. It gets rather monotonous, although it's very good, but it gets monotonous. It's just like a lot of puppets (PV1992.002).

The process of eliminating these inconsistencies took some time and effort:

It took a long time... It is uniform now, but to begin with there was a lot of controversy about what was right and what was wrong. But it's gradually become uniform now. There's a sameness all over the world now; where you put your feet and what you can do (PV1995.003).

However, that is not to say that these changes were generally accepted or adopted:

I believe in individuality and expression and that's what I try and tell the people and the teachers... You're doing something with your feet, legs, arms and so on, but you're not just dancing movements, you're dancing music. And it's music that makes you dance. Because you may as well do an exercise of some kind unless you are musically inclined and feel this inside you... You can't express it with your feet unless you have it inside you to do it with. So that's how I feel and I think that's how it should be (PV1995.003).

As shown in the previous chapter, this 'physical response to the music' (UI2000.002) is still seen as vital to a musical, and therefore artistic performance.

Henry Dryerre in his *Blairgowrie and Strathmore Worthies* (1903) is an example of an early commentator at Highland Gatherings, who writes of dancing prowess as incorporating athleticism and artistry. He described James Paton of Murthly, who, whilst being not only one of the best all-round athletes of his time was also 'one of the finest, most graceful dancers ever seen' (Dryerre 1903: n.p.). Emmerson comments that this was at a time when 'the public consisted of a vast majority skilled in dance... [and] athletics did not transcend dancing in importance as they unfortunately do today' (Emmerson 1972: 250).

The idea of dancing as sport was already being touted and refuted by 1950 (see Chapter Four). Bobby Cuthbertson is reported to have commented that he didn't want 'harping about this "sport" ' (VD114b). MacDonald-Reid suggests that this change was inseparable from the developments at the time: 'The Highland Games dancing has come down as virtually a spectator sport for the sake of competition' (VB057). For this reason, there is some confusion in the public mind about the nature of Highland dance, as to 'whether it is essentially a sport, or a dance form' (Anderson 1989: 1). Matthews comments that, as an American, he was amazed to find that 'ordinary Scottish people thought that Highland dance was just done for tourists and had never seen it [themselves]' (Matthews Correspondence 28/07/2000). Mats Melin, speaking as the STDT Dance Development Officer for Angus, gave the following statement: 'It is an art, but in competition it tends to be treated as a sport'

(Appendix 12). If this is true, then 'Alas there is but little poetry in the lives of most of the organisers of the Highland Gatherings today' (Emmerson 1972: 254). As Witta claimed, 'nearly all Gatherings in Scotland, and indeed overseas, officially or unofficially bear the stamp of the Board's heavy unimaginative foot' (Witta 1982: 101).

This is inevitably the case, for though Highland dancers maintain that their pursuit is the true cultural highlight of the Games, the dancing championships are still certainly fiercely contested. Dancers are concerned not so much with artistic expression as with a winning result, an approach which would have been strangely familiar to the contesting clan warrior, the soldier in battle or the victor after combat (as discussed in Chapter Three).

Craig Dunbar, President of the Scottish Games Association, recognises the contradiction: 'We may be falling between several stools, as we are seen as a sporting event by some. [A]nd a cultural or heritage event by others' (Dunbar 2003: 16). So too does a Sport Scotland spokeswoman who considered the Highland Games to be 'as much about heritage and culture as sport' (Dunbar 2003: 16).

Cowal, the SOBHD World Championship Games, and as many as thirty other Games are not part of the Scottish Games Association, who have about sixty-five member events. The hosts of these competitive dancing events are currently (2005) campaigning to have all meetings come together under their organisational control. Their argument is supposedly funding based, in the belief that a larger organisation can support smaller events and can put a stronger case for funding to the Scottish Executive. Ironically, this is

reminiscent of the establishment of the SOBHD whose aim was to stabilise the tradition.

Execution, rather than narration, is the primary aim of the Highland dancer today, a loss that is made more stark by the training of dancers to smile. In 1995, SOBHD World Champions Colleen Rintimaki and Tony Cargill both testified to finding it difficult to smile when competing. Rintimaki confessed that it was part of the performance, like any movement or step, which she had to master: 'It took me years to get it. I would go up on stage, *smile*, and as soon as I started dancing, it was gone... now I can do it' (VB056). Conversely, Cargill does not consider it a necessary part of the performance, nor one that is natural: 'I hate smiling, 'cause it puts me off. I feel dead dumb. I'm always getting told to smile. It just puts me off' (VB056).

However, as Rankine suggests, the overseas dancers who travel to Scottish championships are better trained in the task, considering it vital to a good performance:

Canadians, Americans and to a lesser extent, Australians, tend to project themselves and dance with a greater air of showmanship... There is no doubt that this style and presentation is much more pleasing to watch and this is possibly why it has made such an impact on this country (Rankine 1977: n.p.).

One judge was not impressed:

Some children will go up, and they smile all the time, which you get from the overseas dancers. It doesn't help. The Scottish judges, a lot of them think it doesn't really matter if they're smiling or not. It's the work they're doing that counts... And our children will look up and say 'what

are they smiling at?... ' And they'll go up and they'll walk on the stage so cocky. They're up there on their toes and their head's up and they're swinging their arms and they stand. It's discipline where they're concerned, very disciplined. The Scottish child will not do it... Yes, They won't smile because it's embarrassing (SA2003.034).

This seems to be an important element which is missing: an expression of enjoyment. This is not to say that dancers do not enjoy the competition, the test of stamina and both the physical and psychological results, but that this thrill does not seem to be played out on their faces. As one judge commented:

It's very, very important for people not to just go up and do all the movements... [but] You need a bit of feeling coming through, you need to see that (although the fact they are concentrating on what they're doing) you will see the enjoyment within what they're doing. So... they've got to be projecting this enjoyment (J05.35.2, Track 9).

This is, inevitably, connected to the performance aspect of the dancing:

It's a performance... it's the performance that we've lost... I think if you look at the atmosphere in the hall when the dancing was taking place, to be honest there wasn't an atmosphere today... This is one of our big championships, there wasn't an atmosphere, there was no applause when anybody finished, there was [sic] no gasps (J05.35.2, Track 9).

It seems to be acknowledged as a cultural trait that dancers do not smile as they dance:

You tend to find most Scottish dancers don't smile... Over here, it's not such a show thing. A lot of the Canadians and all when they come over... I don't know how they can smile... Maybe it's a grimace, not a smile. But they do seem to be able to smile... It's very showy and it's

lovely to watch but our kids... too busy just thinking about what they're doing... concentration (J05.35.1, Track 4).

Similarly, a teacher and judge shared her own teacher's advice:

You don't have to smile, you just have to look interested. I try and get mine to relax and smile if they can because it looks so much better but if you're in a really tense situation in a championship... It's really hard work... It's really difficult... It can look a bit false... The Canadians like to smile a bit more but it can look a bit forced (J05.35.2, Track 5).

Similarly, one of the judges commented that, in Highland choreography, the Scottish dancers do smile (since the pressure is less than in competition dancing), but that 'they're dancing with this immense smile on their face when they're facing the judge, but when they're turning their back to the platform, they're just like a normal dancer... They can turn it on the Scottish [but] tend not to turn it on [in competition] the way the American/Canadian dancers would...' (J05.35.2, Track 7). These comments both seem to indicate a slight distaste for the 'forced' smiling Canadians, but at the same time there seems to be a faint hint of jealousy that the overseas dancers can show more excitement and consistency when dancing our national dance.

However, if dancers did not enjoy their activity, it is unlikely that it would be so popular. There must be some essential elements of satisfaction within it, which, in this case, are essentially, the winning of trophies and placings. However, a piper who has seen hundreds of dancers advised that

If you don't enjoy what you do then you've got a major problem... If you don't enjoy it, you know, really question should you be doing it, but

also you do get people that are very good at what they do and maybe don't enjoy it, but I would say you've always got to enjoy... enjoy what you do (J05.35.2, Track 6).

Similarly, another piper with over four decades' experience wished that dancers would 'actually smile', since 'that would be nice to see the kids smiling when they're dancing, be[ing] happy and enjoy what ...[they]'re doing because that's what they're... supposed to be doing' (J05.35.2, Track 7). Lastly, the scrutineer, who sees the dancers when their backs are turned to the judges, would advise dancers to 'Enjoy it... and... don't get overly caught up on the technique. Get up there and actually dance. Do what you feel, make sure it's coming from here [gestures towards the heart]. Go out and *show* it... ' (J05.35.3, Track 1).

This partially explains why the art of Highland dancing has now come to be considered by many as the sport of Highland dancing, and also why, in such a time of continual change and uncertainty, the concern of the dancing bodies has been to maintain and preserve the tradition by keeping it captive within the realms of regulation. Although the situation has changed significantly since the publication of the first SOBHD textbook (1955) the regulating bodies have established a state of equilibrium, and the elements of innovation, creativity and vitality which marked the dancing as particularly and peculiarly Scottish have been unwittingly suppressed. Is it not time, then, for the dance to strike up and find a new way not just of survival, but of vital growth in order that the tradition remains alive and does not go into stagnation. The future will be discussed in Chapter Seven.

6:II:v Gender⁶⁷ Themes

'If you can walk, you can dance' (Olaf 2002: n.p.)

The predominance of female competitors and, indeed, female Highland dancers in general, is probably most easily attributable to the World Wars, since, before this time, Highland dancing was male dominated (see Chapter Three). Following sixty years of its development since 1945, and the firm regulating hand of the SOBHD, there are still relatively few (approximately less than five percent of the total) male dancers. One of the biggest stigmas in Highland dancing is that it seems to be a female-dominated and female-orientated sport, even though its origins are the opposite. The recurring theme of interviews showed that boys thought that dancing, in general, was 'sissy' (J05.35.1, Track 2; J05.35.1, Track 4), or that dancing males were 'big jessie[s]' (J05.35.2, Track 7).

For many people

a key source of contemporary prejudice is the association between male dancers and homosexuality. It is certainly true that there are a lot of gay men involved in the dance world. Although by no means all male dancers are gay, this is what prejudice suggests (Burt 1995: 12).

The numerous female teachers in Highland dancing might be cited as one reason for male dancers' effeminacy' (Burt 1995: 12). One exception to this rule is the current male adult World Champion, who is 'absolutely phenomenal' and

⁶⁷ This is a contested word and one which has changed in usage, having meant both sex and orientation. Here, I take it to mean the sex of the dancer.

would 'make most boys be embarrassed that they thought it was sissy... because he's just not a sissy' (J05.35.1, Track 2).

This idea of effeminacy seems to be reinforced by peer groups, as one mother explained: 'It's peer pressure. You do find, in dance schools, boys will start, but in any situation once they get to ten or eleven if they're the only boy in the class' (J05.35.1, Track 4). A teacher testified to the common experience of having boys who 'tend[ed] to be teased' and 'a couple of them... stopped because someone said it was... a girly thing to do' (J05.35.2, Track 5).

The irony of the situation is that boys actually have an advantage, in that the dances were originally devised for their body shapes (i.e. more sturdy, square and muscular), and they also have a greater physical strength than the girls (J05.35.1, Track 2). Indeed, as one teacher explains

some of the boys are excellent... if you can keep them at it after the first while they tend to be better because they've got more strength, and they make everything look more graceful because it's less effort for them to get off the floor, so their elevation is tremendous (J05.35.2, Track 5)

It is acknowledged among dancers that the males have to be very good and very keen to overcome these initial setbacks and compete to a championship level (J05.35.1). Iris Marion Young's paper 'Throwing Like a Girl' suggests that it may be that boys' body training gets them into this position (strong and able to jump), rather than 'natural differences' (Young 1999).

The boys who do compete have an effect on the quality of the female dancing, too. This is due to the fact that their strength shines through, so the girls compensate, where possible, by giving very powerful performances, and

'the girls have to be really strong and... really athletic... But boys can often tend to have better elevation because they're stronger...(J05.35.2, Track 5).

A future concern then, is how to keep the male dancers interested and motivated. One teacher has some tried and tested ideas:

if you tell them it's good for football... and try and make the dances interesting for them...If you do choreography for boys you do things like, things with cutlasses and swords and pirates, and things they're going to be interested in more. Rougher rather than more girly stuff (J05.35.2, Track 5).

As yet, there are no moves on the part of the SOBHD specifically to encourage young male dancers. However there is a strong element of Scottishness which seems to be somehow embodied in the dance, and the dance practice, and this is appealing to male and female dancers alike. The dancers' national, cultural and, indeed social identity are expressed in the following section.

6:II:vi Scottishness

'Manifestations of the Scottish spirit' (McLaren 1956: 57)

One teacher from the Isle of Barra sees Highland dancers as carriers of a tradition and also of modern Scottish culture:

...It stands, it stands out because of the tartan. It actually looks good because of the tartan. People of Scotland tend to be embarrassed with bagpipes and tartan, but the high quality piping and high quality dancing is really something worth, you know, exporting and shouting about, look what the Irish have done, they've just packaged it better than we have (J05.35.2, Track 5).

Another teacher is equally convinced that the dancers are performing something not only unique but to be given greater esteem and recognition:

I think... I think they do a really good job promoting this country's culture and it's not very well recognised... their treatment of them at Highland games is appalling... the conditions in which they're asked to perform/change. They're seen as money makers for the Highland games people and very often they're treated as second class citizens... whereas a lot of... they provide a lot of the colour and the pizzazz in these games... and they're treated very poorly... But they're very strong performers of Scottish culture (J05.35.1, Track 2).

However, this question of '[M]otivation... the meaning and purpose that makes the dancers ascribe to a dance...' (Sparshott 1995: 54), when put to the dancers did not yield the same result. It does not seem to be the case that dancers see themselves as having particular rôles as either promoters or ambassadors. Their main reason seems to be to compete and to win prizes. It is significant to note.

here, that many competitive dancers would consider going to lessons not to dance, but to train (Irons Correspondence, September 2004).

The Irish step-dancing tradition has been explored by critics who argue that it has become 'too competitive' and no longer bears any relation to anything Irish (Hall in Hockings 1996: 251-2). If it is true to say that 'the totems and icons of heritage are powerful signifiers of our [Scottish] identity' (McCrone, Morris & Kiely 1995: 7), then Highland dancing is one such signifier if only by association of its name, both in the Scottish circuit and in an international arena. The state of the tradition as it survives in the twenty-first century is therefore a signifier in itself, as to its health and future prosperity.

Accusations still abound regarding the controls exercised by the SOBHD: 'They controlled the dancing too much. They went too far. They spoiled the tradition... [i.e.] How we used to do everything' (SX2003.035). This perceived domination by one ruling body is seen by some as regrettable to the extent that Mill, of the SOHDA, admits that he would prefer a return to a pre-1950 state when there was no such authority:

They brought in this idea of standardisation and they just got stronger and stronger and stronger, that's our own fault I think for allowing them to get so strong and nowadays they've got the monopoly over most of the Games and, and... it's a shambles nowadays. They've put Highland dancing back 20-30 years at least. I'd love to see Highland dancing coming back the way it was where everyone had a choice of... Games. (VA2003.007).

The occupation of a non-geographically defined society such as the one which concerns itself with the practice of Highland dancing (as established in

Chapter Two) is one in which the dance, dance events and facilitation of dance are the conjoining factors. It may be the case that, although Highland dancing is no longer restricted to Highlanders, it connects dancers across the world, as it is taught, performed and esteemed on the larger scale of a global-community.

Similarly, Blacking's description of the value of music in society and culture can be related to Highland dancing, as something which is assessed 'in terms of the attitudes and cognitive processes involved in its creation, and the functions and effects of the musical [dance] product in society' (Blacking 1973: 53). Highland dancing is therefore a 'Manifestation... of the Scottish spirit' (McLaren 1956: 57), and, as Lockhart acutely observes, 'in Scotland, dancing is in the blood' (Lockhart 1986: 11).

Mill however is less flattering about the state of the tradition: 'It's just a shortbread... -tin thing' (SA2003.037). Similarly, Forsyth shows the same realism, that Highland dancing survives partly because it has echoes of heritage and past identity:

I'm sure it's expected... People come to Scotland and one of the things they must see is Highland dancing. It's like coming to Scotland and not seeing tartan. You can't come to Scotland and not see tartan. You can't go to Spain and not see some Flamenco dancing. So I think it's the same in Scotland (VD115).

Poet and playwright Liz Lochhead calls this phenomenon the 'national pastime: nostalgia' (Lochhead 1989: 11 [Act I Scene I]). There is a certain necessity in nation-making to draw on nostalgia, but, at the same time,

constantly looking backwards and inwards as an individual or, indeed, group or nation, confirms a false and perhaps deformed image of the country.

The component parts of a society's make-up ensure its efficiency as an interactive group and the emergence or perpetuation of its collective character. However the five million people⁶⁸ within Scotland do not live in a close community with each other and therefore have varying definitions of 'Scottishness' (Nadel-Klein 1997: 87). If 'representation is central to identity' (Nadel-Klein 1997: 87), then any change within the sphere of Highland dancing must arise from a focus on and promotion of national strengths, as dancers pride themselves in the tradition as it stands today. The proud utilisation of Highland dancing is vital to encouraging its growth, since culture is not just something expressed to the outside world through caricature or parody in literature or art, but is something that is evident in daily life.

⁶⁸ There were 5,062,011 people registered in Scotland in the 2001 census, information from http://news.bbc.co.uk/1/shared/spl/hi/uk/03/census_2001/html/population.stm.

Chapter 7: The Future

7:i Conclusion on Methodology

'Rigour, reflexivity... revelation' (Buckland 1999: 7)

This thesis has assessed the impact of regulation of both technique and conduct in competitive solo Highland dancing in Scotland. This work contains material which has been gathered to provide one point of reference for all sources related to the foundation and regulation of Highland dancing through the ages. This path-clearing exercise was an undertaking essential for this study, and for any subsequent academic study of Highland dancing.

The main themes explored initially were the foundations of the dances, the impact of regulation on a previously unregulated activity, and notions of tradition and authenticity. In order to do this, the research and data collection took place in such environments where Highland dancing was taught, performed or remembered.

Although Highland dancing is now a global activity, this investigation focused on Scottish competitive arenas. In this field, I examined the structure and formal organisation of competitive Highland dancing culture. Analysis particularly focused on regulation of teaching and transmission, accepted standards of conduct, conformity to rules, and areas of growth and decline within competitive dancing culture.

In order to analyse the current repertoire of five solo Highland dances, an inquiry into the origins and development of each dance was made.

Documents, articles, literature and poetry which referred to the dances were located and analysed using historical methods of research. The supposed origins and development of each of the dances was traced, as was the practice and transmission of the repertoire, as it was affected by cultural influences. This historical account and examination of competitive dancing was the starting point of the investigation.

There is little scholarly work, to date, in the area of Highland dancing, even though, in the global field of traditional dancing, there is an abundance of dance ethnography. Past research in the Scottish context was therefore outlined and the scarcity of relevant sources has been highlighted. Other than published material referenced, my primary sources were interviews with competitive and non-competitive dancers, teachers, judges, examiners and audiences and a case study of a competitive Highland dancing event. These have been drawn on extensively for personal accounts and opinions.

There was therefore a combination of the relative authority of written documentation and an ethnological representation of other peoples' truths and histories, according to individuals' versions of the truth. Although imagery can not lead to specific, concrete details, the consistency and promulgation of folk memories make them more believable or at least fondly fostered. Lack of detail suggests, at times, that there is little clarity on origins. Indeed, even though every story has an element of chain-reaction, from the narrator's viewpoint, 'authority and credibility play an important part, as well as faithfulness and respect for the tradition' (Dégh 1969: 168). The Highland dancing, I discovered, was saturated in 'Myths and controversies' (Cheape 1991: 142).

Ethnographic methods allowed me to observe closely the details of technique in practice, while also being a part of the society in which it was practised. Justification for using such a method has been manifest in the qualitative results which have been gathered. The scholarly employment of complementary disciplinary approaches in order 'to illuminate... study' (Buckland 2000: 4) is evident here, as I have drawn not only on historical, literary and ethnographic disciplines, but also the sociological. I chose to employ an historical method of investigation, to establish a firm historical footing for a tradition which, until now, has not been collated for analysis in this way, and in order to give empirical informants' accounts a background against which their inherited tradition could be understood. If Ethnography is a 'hybrid textual activity... [which] traverses genres and disciplines' (Clifford & Marcus 1984: 26), then such an ethno-choreology is a development which pushes the boundaries of previous in-depth analysis, particularly in this new field.

Ethnographic text-making formed a major part of the analysis, as data gathered from informants helped in the construction of a picture of the overall state of Highland dancing in living memory. The particular period of interest was 1950 and the formation of the Scottish Official Board of Highland Dancing. The text that was constructed, relating to this period, was informed through a collection of original letters and documents pertaining to the formation of the SOBHD. These are reproduced in the appendices.

In order to create a text of the same event, from a retrospective view fifty years on, methods ranged from unstructured to highly structured

interviews, letters, to unrecorded or anonymous interviews. This data collection yielded audio and visual recordings, which are quoted and referenced throughout.

The investigation was not without its challenges. In coming to understand the Scottish dance heritage in the light and appreciation of contemporary life and specific social background, the investigation has inevitably required deep personal involvement, in order to expose the current climate of the tradition. As a participant observer and sometimes a complete observer, I endeavoured to maintain a vantage-point which was always removed from making imperative judgements. Critical distance, in a society where there was a degree of participant-observation, was assured through a lengthy process of self-assessment. As the only ethnographer within this community I have been aware of how little research of any kind has been done in this field, especially of an ethnological nature. This privileged insight is one which carried a great responsibility of representation, as I processed material for the purposes of analysis.

The impact of my presence, as both an insider (a dancer, trained with Highland dancing terminology and technique) and an outsider (a non-competitive dancer in a competitive sphere) inevitably affected the data collected, through the questions asked and the answers received. However the advantage of existing experience of the dancing culture was that access was granted to an otherwise closed society, private events, personal opinions and correspondence. This process was aided by the presence of two gate-keepers,

whose trust I earned and whose resources, contacts and time were undoubtedly essential to accessing the close-knit world of competitive Highland dancing.

One of the most significant challenges of working with oral testimony is that verbal narrative is a component of autobiographical memory and therefore is often the only source for certain 'facts'. The structure of discourse inevitably affects the structure of recall, which in turn affects the structure of later recall. Indeed, as knowledge has been distributed through social structures, by means of parents informing children, or teachers informing students, the result is shared memories. However this method of transmission is coupled with the inevitable pitfall: that everyone has his own version of the truth and 'memories' are shared in an interesting and informative, although not necessarily accurate, way. In observing the behaviour within the society, the information gathered was sieved through a realisation that informants' interviews and their actions were not always consistent. The interpretation of this data carried with it a weighty responsibility of accuracy and integrity. With constant attention to reflexivity, much direct quotation of informants has been used both in order to give a voice to opinions on standardisation in the field and to allow this evidence to speak for itself.

In addition to a full history of the dances and the process of their initial standardisation, another main aim of this investigation was to present a working key of positions, gestures and some movements found in contemporary competitive Highland dancing. Labanotation was employed to show dynamics in time and space. A key of step variations and styles has been created in order to form a lasting record of the dance positions, gestures and movements within

the Scottish Highland dancing tradition. This was done by notating the last fifty years' of SOBHD instructions which are the most detailed, extensive and authoritative. These were compared to older descriptions, provided mainly by McLennan (who was a champion of the 1920s) and the Fletts (whose fieldwork goes back to the late nineteenth century). Additional explanations and notations are made where existing SOBHD practice differs to current SOHDA or NZAND instructions.

A comparison of elements revealed only minor changes in steps and styles in the last fifty years, with some of the most significant changes having taken place in the presentation of the steps, rather than the composition of the steps themselves. Moreover, the stylistic changes were representative of attitudinal changes which have taken place within the dancing society over the last century and, in particular, the last fifty years.

A disadvantage of setting Highland dancing in such a fixed way, was that, just as informants' testimonies and interpretations were varied, so too were the actual performances, because of the elements of build and body weight which, in turn, effect individual expression of dance movements. This highlights '[t]he notator's interpretations [which] become fixed in the instruction manual that serves as the lasting documentation of the dance and hence influence any subsequent interpretation (Van Zile 1985: 41). For these reasons, an edited film ethnography is provided to show some of these movements in action on the competition boards. The film also shows the occurrences of dancers being slow to perform beats, as this theme of the absence of musicality runs through the written data. As the steps danced, the reader turned viewer,

can see, in practice, the loss of synergy between the dance and the accompaniment. Technical feats and regimented, prescribed, steps are evident, at the expense of reaction to the music.

This thesis also contains an ethnography of a contemporary Highland dancing championship which combines both the etic conception of researcher analysis to emic definitions (Hannah 1979: 19). A textual ethnography illustrates the competitors and competition from a situated viewpoint at the event. The event was grounded in previous fieldwork among dancers, teachers, examiners and judges. Using semi-structured interviews in the context of current competition, the data collected was situated. A textual ethnography of voices was formed and, in this respect, I allowed both the voices to be 'heard'.

Extensive filming also formed a visual ethnography of people in their Highland dancing culture. The preparations, organisation, and the outworking and operation on the day illustrate the internal workings of the social sphere. The opinions of young dancers, the adjudicators, the piper and the spectators were given particular significance. The data collection, in this context of the contemporary culture of competition and transmission, was done in a way that encouraged the exploration of a range of themes. The film ethnography shows this in practice and provides a snapshot of the dancing world at the turn of the twenty-first century.

In the process of a relatively short period of study the field, in the ethnographic present, has not changed significantly. This thesis is a snapshot of how Highland dancing has arrived in the twenty-first century and the current situation of competitive dancing in Scotland. Due to the lack of previous

research or precedents in this field, the data collection has been mostly a construction of text and only a limited analysis of the styles and variations seen on competition boards has been included. Instead, this work sets the way for future investigation.

7:ii Conclusions on Regulation

'the spontaneous and the enforced' (Sparshott 1995: 41).

The regulation of Highland dancing has been put in an historical context, by tracing original dances, early dancers and the first competitions. The activity has also been put in a more recent political context, through the comparison of verbal accounts, an analysis of opinions surrounding the formation of organising bodies and retrospective analysis of such events. The dancing has also been put in a physical context, through the recording of a contemporary competition, the writing of an ethnography of that event, and the analysis of contemporary viewpoints.

It has been acknowledged that the contested dances of the earliest clansmen-competitors, the superstitious dances and the energetic victory dances of clan warriors, have all contributed to the form as it appears today. The competitive element of the dancing, which had always been inherently present within the clan or military traditions, became increasingly important in the consciousness of Highland dancers.

The popularity of this tradition has never been challenged, but the motives and incentives for dancing and competing have informed this work throughout. In the early decades of the twentieth century, the regional styles which had been passed down through families, dancing masters and the military, were being seen in locales outside their own. This resulted in competitors adopting styles to suit the preferences of the adjudicators. This theme of fairness in adjudication, aesthetic judgements and pre-disposed ideas

of correctness runs throughout the thesis. Disputes with regards to matters of adjudication and regulation were rife in the late 1940s and, while they no longer appear in public meetings or committees, they do not seem to be far beneath the surface in Highland dancing today.

As a direct result of the concerns voiced, the tradition became regulated in terms of organisation, operation and standardisation. However, the two main groups that emerged (the SOBHD and the SOHDA) remain divided in ideology to this day. The original remit of these bodies was to oversee teaching, competition and regulation, publication and registration. Original documentation which pertains to formation of these two strands, and the politics surrounding this time, can be found, for the first time in print, as appendices. The material contained herein goes some way to explaining the preciousness and secrecy I encountered as a researcher in the field.

It became clear that the standardisation of Highland dancing was not a lone phenomenon in Scots tradition. The Royal Scottish Country Dance Society was formed in the 1920s and, similarly, the New Zealand Academy of Highland and National Dance, was formed in the late 1950s. Control of these activities seems, to a certain extent, to have been inevitable, partly because individuals who are prone to compete desire equal (and therefore regulated) competition. Informants were united in their explanations of the advantages of regulation: the fairness of judging, and like comparison of dancers who all have the same style. However the disadvantages were as clear: the loss of individuality and the growth of dancing which is so regulated that it is the same (as much as it can be, physiologically) from dancer to dancer.

A change in style seemed to have taken place, since regulation inevitably meant some cutting out of steps or regional variations. However this narrowing is not only a result of controls set in place by the SOBHD textbook (SOBHD 1955; 1962; 1968; 1975; 1984; 1993), but also a result of competition in which judges encourage certain styles and execution by the placements they give competitors. The supposed 'improvement' in the standard of regulated dancing has led to exaggeration and the changing of existing steps to show increased technical ability. I argue that this technical heightening is in the name of excellence but is not creative, nor can it lead to expansion of development of the style, which was one of its attractions to the early twentieth century dancer. A move towards technical ability at the expense of musicality has resulted in a loss of essential variation and individual interpretation which will, in turn, risk leading to a stagnation within the tradition, if indeed this is not already the case. These developments are epitomised by the theme of dancers' seeming inability, or unwillingness, to smile on stage.

The idea that modern-day dancers belong to a non-geographically defined dancing culture, was clear in fieldwork interviews. Similarly, ideas of Scottishness also arose, as dancers associated their activity with something traditional, a notion which was woven throughout the data. This gave rise to the following question: Is what is danced now in any way authentic in either form or function, and is what we dance now true even to 1950? The first part of the question is answered, by the notation and comparisons of old and new steps. There are differences, although not great, in form, but the motivation and practice of these steps seem to have changed dramatically. The second part is

answered through cross-referencing the opinions voiced in interviews with older informants, and by analysing the evidence gathered which refers to the specialists who were consulted as the first SOBHD Technical Committee. There are no definite answers to these questions, other than to say that there are many influencing factors in both the maintenance and creation of tradition. This thesis therefore attempts to provide a thorough historical and contemporary picture of the development of dancing in Scotland, to show areas of augmentation and diminishment. The absolute truth can never be known, so long as there is so little written and other evidence, but this work will at least inform future generations to the state of Highland dancing at the turn of the twenty-first century.

The competitive dancers no longer go to lessons to dance, but to train. This harks back to military roots of the dance and raises questions of motivation. The impetus for dancing which may once have been rooted in a narrative tradition, where showmanship and innovation were admired, is now the enjoyment of peak physical fitness and the winning of medals and titles. The belonging that comes with being part of such a society became particularly clear in contemporary accounts. I conclude that contemporary competitive Highland dancers are ambitious for rewards and the accompanying recognition, rather than the enjoyment of physical expression alone.

Dancers' adherence to the textbook rules of execution and the unwritten rules of conduct is indicative of a group whose interest is no longer the narrative qualities of the dances but excellence and acceptance they find within the competitive culture. This is not to say that the dances no longer contain any

narrative elements, which indeed they do, but these are not recognised or expressed as part of the performance. Brief and spurious stories regarding the dances' origins circulate but play no part in informing the dance manifestation. A better understanding of the histories of the dances would surely bring out their narrative roots and encourage individual research. If dancers were equipped with the histories, or at least, supposed histories, of the dances, an appreciation of the relevant period of history would surely inform each dancer's performance. I therefore argue that athleticism, as opposed to artistry, is now the hallmark of modern day Highland dancers.

Other themes which emerge in the data, such as the rules of conduct in competition practice, are illustrated in the supporting visual material: a modern dance championship on film. This can be viewed in chapters, which are labelled for selective viewing, or a whole ethnography, in order to give a visual idea of the operations of a competition, illustrating the written account contained in Chapter Six. Such a representational film is a permanent, primary data source which is invaluable for the purposes of future data retrieval. In the same way, the Labanotation presented here is a precursor to a fuller movement analysis of the methods and steps of Highland dancing, and an analysis of steps which have been recorded but are no longer in the current repertoire. Further practical and academic development of the subject may be in the form of comparing dance and music notations and analysing the extent of their interrelations and interdependency.

It is hoped that this investigation will go some way to ensuring that study of the dance form is taken forward by academics and practitioners alike,

in order to ensure its survival as a living thing. Some element of change within Highland dancing must take place in the near future if it is to avoid 'fossilisation' (Witta 1982: 101): 'I would just really like to see something happening... I think it's *dire* and I think the tradition is just *dead* if it continues this way' (SA2003.033b). The necessary solution is perhaps

[a] stable Highland dancing [which] combines the cultural ingredients of its origin, which comprise its spirit and technique, together with a scope for the creative and talented performer to add his own unique socio-cultural dimension, thus allowing for the possibility of growth and change within the stable art form (Witta 1982: 8).

Despite the introduction of standardisation and regulation by both the SOBHD and the SOHDA, independently, in the 1950s, I conclude that the major changes within the Scottish Highland dancing tradition have evolved slowly and organically. However, a full analysis of the state of the tradition's stability with regards to expectation, innovation and vision for the future is the subject for another investigation. Further investigation and practical development in the pioneering study of Highland dancing can be made, with this work as a corner-stone for the building of future hypotheses and analyses.

This thesis not only collates and analyses existing material, but it also marries it with up to date fieldwork. It fills a notable gap in Scottish cultural history and offers a degree of analysis not yet achieved in this field. The extensive fieldwork can be found, transcribed and catalogued in School of Scottish Studies Archives for future reference, study and analysis.

It has been the case that, in this work, the horizon has ever receded as this study has advanced. This research will remain incomplete, therefore, so long as there are dancers, practitioners and enthusiasts whose communality lies in the joy they derive from creating and interpreting the dancing. This contribution to knowledge goes some way to fixing and analysing a period of a living tradition for future generations. This mammoth task has not previously been attempted, as is recognised in the following statement which has appeared in every publication of the SOBHD's textbook from 1955 to date:

In the general neglect of Scottish culture which has prevailed, until recently, in... Scottish Universities, Highland dancing has been largely ignored by learned men; and as yet little or no serious research has been done. There is an opportunity here for academic investigations which, it is to be hoped, they will not fail much longer to exploit (SOBHD 1993: n.p.).

This thesis can be considered a response to such a challenge.

Appendices

Items 1-10 are a collection of papers pertaining to the formation of the SOBHD, which were lent and reproduced by kind permission of Billy Forsyth, President (President). The material is listed chronologically and, where the original is faded or indistinct, a typed version is included. Items 14 and 15 pertain to the making of the written ethnography and the accompanying film.

1. Report of the Scottish Dance Teachers' Alliance branch meeting, 28/08/49.
2. Invitation letter addressed to Mr Lowe from the Honorary Secretary of the Scottish Dance Teachers' Alliance, 22/11/1949.
3. Letter from J.L. McKenzie to Captain Davidson, 12/01/1950.
4. Letter from Captain Davidson to J.L. McKenzie, 12/01/1950.
5. Minutes from the Inaugural Meeting of the SOBHD, held in the Plaza Ballroom, Stirling, 15/01/1950.
6. Minutes from the Continuation of the Inaugural Meeting of the SOBHD, held at 83 Leith Street, Edinburgh, 16/04/1950.
7. Letter from Captain Davidson to Mr Taylor, 20/07/1950.
8. Letter from G. Douglas Taylor to Captain Davidson, 10/08/1950.
9. Minutes from the First Meeting of the SOBHD, held at 83 Leith Street, Edinburgh, 13/08/1950.
10. 'Highland Dancing Board Comes Under Heavy Fire', article in Edinburgh Evening News, 21/11/1955.
11. Personal Correspondence from Margery Rowan, SOBHD Director of Administration, 04/04/2000.
12. Personal Correspondence from Mats Melin, Scottish Traditions of Dance Trust Dance Development Officer, Angus, 04/04/2000.
13. Position Statement read at the SOBHD/SOHDA Joint Meeting, held at the Thistle Hotel, St. James Centre, Edinburgh, 28/03/2002.

14. **Semi-Structured Interview Questionnaire used at UKA/SOBHD Highland Dancing Championships, Meadowbank Stadium, Edinburgh Saturday 26/02/2005.**
15. **Comment Key for accompanying DVD Ethnography of UKA/SOBHD Highland Dancing Championships, Meadowbank Stadium, Edinburgh Saturday 26/02/2005.**

**Appendix 1: Report of the Scottish Dance Teachers' Alliance Highland
branch meeting, 28/08/49**

SCOTTISH DANCE TEACHERS ALLIANCE HIGHLAND BRANCH

A meeting of the above branch was held in Miss J. McLellan's Studio on Sunday 28th Aug. There was a good attendance of members and a hearty welcome was extended to Miss Mary Dring from South Africa who was introduced by Mr. Douglas Thomson.

Mr. McKenzie the branch Chairman on opening the meeting stated that owing to the distance between the majority of members and himself, he found difficulty in keeping in contact. Mr. Muir then suggested that a deputy chairman be appointed, and Mr. McKenzie agreed. Mr. Turpie was then unanimously appointed deputy chairman.

The effect of the new Highland Assoc. was then gone into, and several statements were given by the members – some farcical, some serious, but it would not serve any useful purpose to disclose these here.

Proposed Highland Medal tests caused quite a sensation when it became known that should the parent body sanction these tests, there would be almost two hundred applications without delay. It was agreed to ask the parent body to grant this at the next meeting, and the medals to be on the same lines as those given for Ballroom.

Mr. McKenzie agreed to go over the syllabus at the next meeting in Edinburgh. Mr Turpie then gave instructions on his dance "Scotch Broth", and members and associates agreed to demonstrate the dance at next meeting if called upon.

The proposed formation of High-land [sic] Official Board proved the most interesting part of the meeting. The Chairman gave his opinion that it would make no difference to organisers of competitions who would continue to run these championships to suit themselves. Miss Lindsay said she could not agree entirely with Mr. McKenzie as she thought a little difficulty would occur

at the beginning, but that the time would come when the Official Board of Highland Dancing would be looked upon as the governing body.

Mr. Muir agreed entirely with Miss Lindsay, and gave a brief outline of the difficulties experienced by the Official Board of Ballroom Dancing, who had now overcome all difficulties, and are now the governing body for Ballroom Dancing.

Every member present felt quite enthusiastic about an Official Board being formed and should this come to pass the Chairman of the Board should be someone interested in Highland Dancing, but not a member of any association. After further discussion it was agreed to place the following recommendation before the parent body: - "that the S.D.T.A. get in touch with all Associations interested in Highland Dancing with a view to forming an Official Board of Highland Dancing."

Associations to be notified: -

British Association Teachers of Dancing

National Association Teachers of Dancing

Imperial Society Teachers of Dancing

U.K.A.P. Teachers of Dancing

Scottish Highland Association.

N.B.B.A. [added by hand]

Objection was taken to one of the Associations mentioned, but after a lively discussion, it was agreed to ask all associations.

The Committee then met to discuss the result of the meeting, and the business to be presented to the parent body at the next meeting.

The meeting closed with a vote of thanks to the Chairman.

SCOTTISH DANCE TEACHERS ALLIANCE
HIGHLAND BRANCH

A meeting of the above branch was held in Miss J. McLellan's Studio on Sunday 28th Aug. There was a good attendance of members and a hearty welcome was extended to Miss Mary Dring from South Africa who was introduced by Mr. Douglas Thomson.

Mr. McKenzie the branch Chairman on opening the meeting stated that owing to the distance between the majority of members and himself, he found difficulty in keeping in contact. Mr. Muir then suggested that a deputy chairman be appointed, and Mr. McKenzie agreed. Mr. Turpie was then unanimously appointed deputy chairman.

The effect of the new Highland Assoc. was then gone into, and several statements were given by the members - some farcical, some serious, but it would not serve any useful purpose to disclose these here.

Proposed Highland Medal Tests caused quite a sensation when it became known that should the parent body sanction these tests, there would be about 200 applications without delay. It was agreed to ask the parent body to grant this at the next meeting, and the medals to be on the same line as those given for Ballroom.

Mr. McKenzie agreed to go over the syllabus at the next meeting in Edinburgh. Mr. Turpie then gave instruction on his dance "Scotch Broth", and members and associated agreed to demonstrate the dance at next meeting if called upon.

The proposed formation of High-land Official Board proved the most interesting part of the meeting. The Chairman gave his opinion that it would make no difference to organisers of competitions who would continue to run these championships to suit themselves.

Miss Lindsay said she could not agree entirely with Mr. McKensie as she thought a little difficulty would occur at the beginning, but that the time would come when the Official Board of Highland Dancing

would be looked upon as the governing body. Mr. Muir agreed entirely with Miss Lindsay, and gave a brief outline of the difficulties experienced by the Official Board of Ballroom Dancing, who had now overcome all difficulties, and are now the Governing Body for Ballroom Dancing. Every member present felt quite enthusiastic about an Official Board being formed, and should this come to pass the Chairman of the Board should be someone interested in Highland Dancing, but not a member of any Association. After further discussion it was agreed to place the following recommendation before the parent body :-
"that the Highland Council, B.D.T.A., get in touch with all Associations interested in Highland Dancing with a view to forming an Official Board of Highland Dancing."
Associations to be notified:-

- ✓ British Association Teachers of Dancing
- ✓ National Association of Teachers of Dancing
- ✓ Imperial Society of Teachers of Dancing
- ✓ U. K. A. P.
- ✓ Scottish Highland Association.

✓ N.B.R.A.

Objection was taken to one of the Associations mentioned, but after a lively discussion, it was agreed to ask all associations.

The Committee then met to discuss the result of the meeting, and the business to be presented to the parent body at the next meeting.

The Meeting closed with a vote of thanks to the Chairman.

**Appendix 2: Invitation letter addressed to Mr Lowe from the Honorary
Secretary of the Scottish Dance Teachers' Alliance, 22/11/1949**

22nd. November, 1949, George B. Lowe, esq., The Herald Press, ARBROATH.

Dear Mr Lowe,

The Scottish Dance Teachers' Alliance are of the opinion, that a "board of control" of Highland Dancing should be formed, this body to be representative of all associations or individuals interested in the art of Highland Dancing.

The functions of this proposed "board of control" would probably be as follows: -

1. To standardise the technique of Highland Dancing.
2. To formulate rules governing the status of Amateur and Professional dancers.
3. To formulate laws governing all types of competitions.
4. To control the granting of championships.
5. To ensure that only those that are competent are allowed to act as judges at any championship or recognized [sic] competition.
6. To deal with any important matter relevant [art] to the art of Highland Dancing.

In order to discuss the advisability of the above project, the Scottish Dance Teachers' Alliance invite you to attend, or in the case of an association, to send 4 delegates to, a meeting to be held in the Plaza Ballroom, Stirling, on Sunday 15th. January 1950 at 2 P.M.

Since the Scottish Dance Teachers' Alliance may not be cognizant [sic] of all responsible associations or individuals who should be invited to attend this inaugural meeting, each recipient of this letter is requested to get in touch with any such responsible association or individual whom they think ought to

be included in this invitation, and if any such party has not received an invitation, they are requested to communicate with me at the above address.

Hon. Secy.

George B. Lowe, esq.,
The Herald Press,
ARBROATH.

22nd. November,

Dear Mr Lowe,

The Scottish Dance Teachers' Alliance are of the opinion, that a 'board of control' of Highland Dancing should be formed, this board to be representative of all associations or individuals interested in the art of Highland Dancing.

The functions of this proposed 'board of control' would probably be as follows:-

- 1) To standardise the technique of Highland Dancing.
- 2) To formulate rules governing the status of Amateur and Professional dancers.
- 3) To formulate laws governing all types of competitions.
- 4) To control the granting of championships.
- 5) To ensure that only those who are competent are allowed to act as judges at any championship or recognized competition.
- 6) To deal with any important matter relevant to the art of Highland Dancing.

In order to discuss the advisability of the above project, the Scottish Dance Teachers' Alliance invite you to attend, or in the case of an association, to send 4 delegates to, a meeting to be held in the Plaza Ballroom, Stirling, on Sunday 15th. January 1950 at 2 P.M.

Since the Scottish Dance Teachers' Alliance may not be cognizant of all responsible associations or individuals who should be invited to attend this inaugural meeting, each recipient of this letter is requested to get in touch with any such responsible association or individual whom they think ought to be included in this invitation, and if any such party has not received an invitation, they are requested to communicate with me at the above address.

Hon. Secy.

Appendix 3: Letter from J.L. McKenzie to Captain Davidson, 12/01/1950

3 Bridge Place, Aberdeen. 12th Jan '50

Dear Capt Davidson,

I must apologise for the delay in replying to your letters but I have been away in London and Manchester for the last fortnight. I usually have a break at the New Year.

Thank you very much for sending the Booklets etc., & also for the kind invitation to stay at your place Saturday. I am sorry I cannot accept but hope to see you Sunday. I hope there will be a good attendance and that something will transpire. I know Mr and Mrs Fairley. They are also members of the Scottish Dance Teachers' Alliance. I don't think however it should be under the jurisdiction of any particular society, but a combination of all.

I shall return these Booklets etc when I see you on Sunday.

Until then, I remain, Yours Sincerely Jas. L. McKenzie.

P.S. Being a Dancer and active competitor at these Highland Gatherings makes it very difficult for me but at the same time I feel that the art of Highland Dancing and the Competitions for same should be of a high standard.

JLMcK

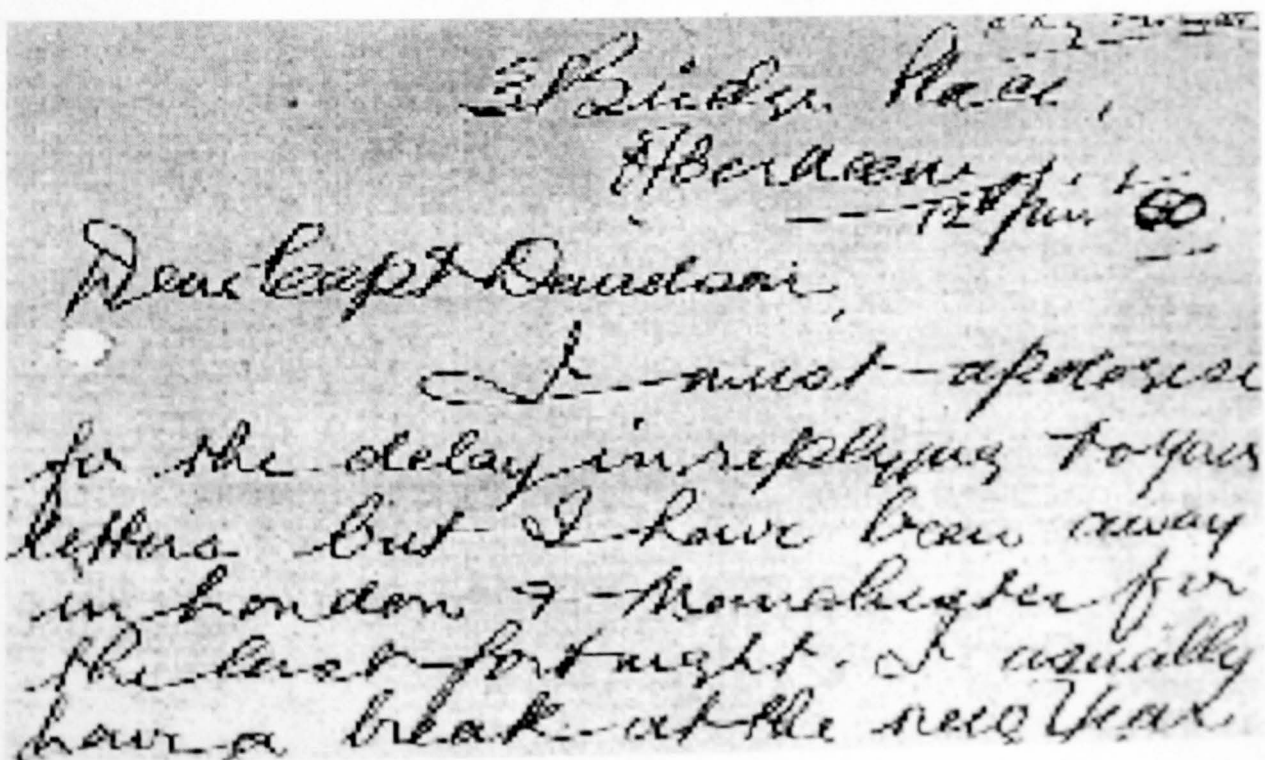

3 Bridge Place,
Aberdeen.
--- 12th Jan '50.

Dear Capt Davidson,

I must apologise
for the delay in replying to your
letters but I have been away
in London & Manchester for
the last fortnight. I usually
have a break at the New Year.

Thank you very much for
sending the Booklets etc, & also
for the kind invitation to stay
at your place Saturday. I am
sorry I cannot accept but hope
to see you Sunday. I hope there
will be a good attendance &
that something will transpire

I know Mr & Mrs Fairley, they
are also members of the Scottish
Dance Teachers Alliance, I
don't think however it should
be under the jurisdiction of
any particular Society, but a
combination of all.

I shall return these bottles
etc when I see you on Sunday
until then

I remain,
Yours sincerely,
Jack McKenzie.

75.
Being a dancer & active competitor
at these Highland Gatherings makes
it very difficult for me but at
the same time I feel that the art
of Highland Dancing & the Competitions
for same should be of a high standard
M.K.

Appendix 4: Letter from Captain Davidson to J.L. McKenzie, 12/01/1950

J L McKenzie Esq., 3 Bridge Place, Aberdeen.

12 Jan '50

Dear Mr McKenzie,

Just a hasty note to enclose copy of further letter received from I 9D Cameron. He certainly seems keen to help in any way he can. - I only hope that we are able to live up to his expectations!

Lieut. Col AGL McLean phoned me today to say that as long as this attempt to form a Board of Control is inspired by you he is willing to attend on Sunday. He is not keen on anyone else trying to run it so that's a feather in your cap!

Tried to phone you tonight but your nephew informed me that you had letter in post for me so am hoping there will be no delay in post.

Expect to get through to Stirling early Sunday. H.Q. probably Golden Lion.

Yrs aye, Davidson

12 Jan '50.

J L Mackenzie Esq.,
3 Bridge Place,
Aberdeen.

Dear Mr Mackenzie,

Just a hasty note to enclose copy of further letter received from I D Cameron. He certainly seems keen to help in any way he can. - I only hope that we are able to live up to his expectations!

Lieut) Col A G L McLean phoned me today to say that as long as this attempt to form a Board of Control is inspired by you he is willing to attend on Sunday. He is not keen on anyone else trying to run it so that's a feather in your cap!

Tried to phone you tonight but your nephew informed me that you had letter in post for me so am hoping there will be no delay in post.

Expect to get through to Stirling early Sunday. H.Q. probably Golden Lion.

Yrs aye, *Davidson*

**Appendix 5: Minutes from the Inaugural Meeting of the SOBHD, held in
the Plaza Ballroom Stirling, 15/01/1950**

SCOTTISH OFFICIAL BOARD OF HIGHLAND DANCING.

Postal Headquarters.

338 Duke Street, Glasgow, E.1.

1. The inaugural meeting of the Scottish Official Board of Highland Dancing was held at the Plaza Ballroom, Stirling, on Sunday, 15th January, at 4 p.m.
2. Mr. Jack Muir (S.D.T.A.) occupied the chair and the following were present:-

Representatives of Associations.

1. Scottish Dance Teachers' Alliance - J.L. McKenzie - J. Turpie.
Miss N. Ross.
2. British Assoc. of Teachers of Dancing. -
G. Walker - Miss Wallace.
Miss Lindsay.
3. Scottish Country Dance Society. - Miss Hadden - Mrs. Brown.
4. United Kingdom Alliance. - Miss H. Constable - J. Mowat.
Mrs. Ferguson - Miss McDonald.
5. North British Ballrooms Assoc. - H. Fairley - J.P. Stewart.
F. Robertson - G. Jamieson.
6. British Ballet Organisation. - Miss A. Calder.

Independent.

Capt. Davidson, Capt. Gibson, Major Bourne, Mr. R. Watson, Mr. D.G. McLennan, Miss E. Thompson, Brig. Clark, Mr. Furdor, Capt. Tait, Mr. W.I. Russell, Capt. Pein, Mr. V. Christie, Mr. Ross.

Apologies for inability to attend were intimated from The Highland Dance Specialists Association and Mr. J. McConnachie.

3. The chairman opened the meeting by explaining his presence and the purpose of the meeting. He drew a comparison between the position of Highland Dancing today and that of Ballroom Dancing 21 years ago; (i.e. Pre-Ballroom Official Board) He then invited discussion, the main point for consideration being "whether there existed a real need for an Official Control Board for Highland Dancing".

The representatives of several associations and many independent members spoke in favour of the project and a letter was read by Captain Davidson, from New Zealand Pipers' and Dancers' Association Inc., commending the venture and conveying their good wishes for its success.

It was unanimously decided that a board of control be formed, this body to be known as "The Scottish Official Board of Highland Dancing".

The chairman then suggested that the best way to approach the forming of an Official Board was, first of all, to appoint an "Interim Committee", and give them the task of drawing up the

constitution, deciding upon some kind of proportionate representation and various other initial business. Their findings would require to be brought to another general meeting to be passed. This was agreed and Mr. Fairley proposed, seconded by Mr. Robertson that "The Interim Committee should consist of:-

2 delegates from each of the seven dancing associations, 2 delegates from each of eight Games Committees, and eight independent members. This was carried unanimously.

The members of the Interim Committee are as follows:-

S.D.T.A.....J.L. McKenzie - J. Turpie.
B.A.T.D.....Miss Wallace and Miss Lindsey.
S.C.D.S.....Miss Milligan - Mrs. Brown.
U.K.A.....Miss McDonald & Mrs. Ferguson.
N.E.B.A.....H. Fairley - J.F. Stewart.
B.E.O.....Miss Calder - Miss Hopkins.
H.D.S.A.....(To be nominated by that body).
Captain Davidson - Miss F. Thompson, Colonel McLean -
Major Bourne, Brigadier Clark - Miss M. Aitken, Mr. R. Watson,
Mr. J. McConnachie.
(Plus 16 delegates from Games Committees - yet to be nominated)

The chairman then suggested that a chairman, secretary and treasurer of the Interim Committee should be elected. This was agreed and the following were elected:-

Chairman.....Mr. Harry Fairley.
Secretary.....Miss Joan J.C. McLellan.
Treasurer.....Mr. J.F. Stewart.

This being all the business, the meeting was terminated with a vote thanks to Mr. Adam and his staff for their hospitality.

**Appendix 6: Minutes from the Continuation of the Inaugural Meeting of
the SOBHD, held at 83 Leith Street, Edinburgh, 16/04/1950**

SCOTTISH OFFICIAL BOARD OF HIGHLAND DANCING

Postal Headquarters

338, Duke Street,
Glasgow, E.1.

1. A continuation of the inaugural meeting of the Scottish official Board of Highland Dancing was held at 83, Leith Street, Edinburgh, on Sunday, 16th April, at 2 p.m. (by kind permission of Mr. Harry Fairley).

2. Mr. Fairley was in the Chair and those present were:-

<u>Scottish Dance Teachers' Alliance</u>	Mr. J. Muir, Mr. J. McKenzie, Mr. J. Turpie, Miss E. Ross, Miss C. Robertson.
<u>British Association</u>	Mr. G. Walker, Miss E. Wallace, Miss M. Lindsay.
<u>United Kingdom Alliance</u>	Mr. J. Mowat, Miss H. Constable, Miss P. McDonald, Mrs. J. Ferguson.
<u>Highland Dance Specialists</u>	Miss C. Tucker, Miss E. Findley,
<u>North British Ballrooms</u>	Mr. J.F. Stewart, Mr. McDonald, Mr. G. Jamieson.
<u>Highland Pipers' Society</u>	Dr. A. McLaren.
<u>Scottish Country Dance Society</u>	Mrs. M. Brown.
<u>Dowal Highland Gathering</u>	Mr. J.S. Thompson.

Independent Members.

Mr. Purdon, Dr. A. Robertson, Mrs. P. Keay, Mr. D.G. McLennan, Capt. I. Gibson, Lt. Col. A. Maclean, Capt. Tait, Brig. Clark, Mr. B. Robertson, Mr. & Mrs R. Watson, Capt. T. Davidson, Capt. J. Bain, Pipe Major Anderson, Mr. Robb, Miss J. Reynolds, Major A. Bourne, Mr. B. Dew, Mr. & Mrs. Bailey.

4. Minutes

The minutes of all meetings held from Jan 15th onwards, having been circulated to members were taken as read and confirmed.

5. Interim Committee Report

The Chairman told the meeting that, as they had all received reports of the Interim Committee meetings and copies of the suggested rules and byelaws, they would be taken as read, and he then invited queries and comments on the work of the Interim Committee.

Mr. Purdon, referring to the suggested byelaws, said that, while not moving a direct negative, he thought that in principle, the byelaws did not go far enough. He would have liked to have co-operation with Piping Societies mentioned. He moved an amendment in the principle of the Interim Committee's work.

Mr. Muir, in reply pointed out that an Official Board cannot function in the same way as a Society, as it will be the Parliament of Highland Dancing. He felt that as the Board hoped to lay down rules and regulations for practical Highland Dancing, it must be Scottish.

Colonel Maclean agreed in principle with Mr. Muir but thought it wrong to be out of sympathy completely with Mr. Purdon's suggestions.

There was no seconder for Mr. Purdon's motion. Mr. Muir proposed that we deal with the proposed Rules and byelaws paragraph by paragraph. This was seconded by Mr. Mowat and agreed.

6. Rules and Byelaws

Some discussion arose regarding the use of the word 'Standardi' in Clause c, para. 2 and it was finally proposed by Capt. Davidson, seconded by Mr. J.F. Stewart and agreed that the word 'Traditional' should be substituted.

There was discussion on the paragraph under the heading 'Competitions' and Mr. Purdon, seconded by Brig. Clark propose that the rewording of this paragraph be remitted to the Committee of the O.B. when formed. Mr. Muir seconded by Mr. Mowat moved an amendment that the words 'of Competitions' be deleted.

On a vote being taken, the amendment carried by 22 votes to 14.

7. Subscriptions

Mr. Muir seconded by Miss Robertson moved that the Annual Subscriptions for Associations and Games Committees as suggested by the Interim Committee be confirmed by the meeting. This was agreed.

Brig. Clark seconded by Mr. Mowat proposed that the Annual Subscription for Independent Members be reduced to 10/6d. This alteration was passed.

Mr. J.F. Stewart seconded by Mr. Muir proposed that 12 should form a quorum for Board meetings. Agreed.

With several minor alterations the Rules and Byelaws were passed for submission to the O.B.

8. Nominations for Technical Committee

The chairman mentioned that there were 20 nominations for technical committee but Mr. Muir pointed out that this was a task for the O.B. when formed and the matter was suspended as being out of order at this meeting.

9. First Meeting.

Mr Muir seconded by Miss Robertson proposed that all Independent Members of the Interim Committee be present at the first meeting of the O.B. and entitled to vote. This was agreed.

The chairman then asked the various associations to inform the Secretary of the names of their representatives on the O.B. and also to forward nominations for Technical Committee for the consideration of the Board.

It was agreed that the next meeting (1st of the O.B.) should take place on Sunday, 13th August at 2.30 p.m. and Mr. Harry Fairley's kind offer of his premises was accepted with thanks.

Appendix 7: Letter from Captain Davidson to Mr Taylor, 20/07/1950

3 West Claremnt [sic] Street, Edinburgh 3. 20/7/50

Dear Mr Taylor,

Very many thanks for your letter and enclosures – I found these very interesting and was only glad that you had to answer them and not me!

I agree that I am in touch with McKenzie and D.G. McLennan, both of whom I admire, but neither of these gentlemen have had experience of the Argyl [sic] or Lochaber Broadwords since, as you are doubtless aware, both dances are to a great extent confined to the Army.

On the subject of the Tartan Terrors I do not think that there is anything more to add to what we have both said on the subject – I fully agree with you that the female menace has come to stay and that there is nothing that can be done about it – also, of course there is most certainly the bread and butter angle with which I fully sympathise, but I do most emphatically believe that the sexes should be segregated as I am convinced that it is anatomically impossible for a perfect male dancer to dance the same as a perfect female dancer or vice versa and consequently it is impossible to judge one against another with perfect fairness. My great ambition is to see a far greater spirit of sportsmanship amongst Highland Dancers (particularly the female of the species) than there is at present and the wiping out of the horrible and degrading practice of so many mothers dragging their wretched children round the games like performing beasts fit only to be whipped if they fail to win the prizes.

I regret that I do not altogether follow your argument or analogy on Golf. I agree that a diagram of a women [sic] golfer in a book on women's golf would not be incongruous [sic] but if it were depicting the subject of golf as a whole then it would be incongruous. Similarly a diagram of a woman depicting positions in a book on *Traditional* Highland dancing is incongruous whereas had she been depicting female styles of Highland dancing then there would have been nothing wrong. I fully appreciate your reasons for not using your son when he was sitting for exams but as the figures were only drawings could you

not have got anyone to pose and having got the arm and leg positions, filled in the details to represent a male figure? I hope you don't take offence at the above gentle criticism but I have gained the impression from your correspondence that you prefer sincerity to insincere flattery – if you don't agree with anything that I say then please say so and give your reasons and I will be more than pleased since there is nothing [I] love more than an honest and sincere discussion on matters of mutual interest with friends.

I am well aware that everyone is not in agreement with Ian Cameron's society but I think that is good and I was very pleased to hear of your appointment as Liaison Officer – congratulations. As soon as I got your letter I phoned the Chairman of the Interim Committee of the Control Board (Note the Board has not yet been authorised or formed and is only in interim stage) and told him about it. We fully agree that, in view of your appointment you should, in spite of the distance, be particularly invited to attend the next, and formative, meeting of the Interim Committee. Incidentally we have been honoured with the presence of D.G. McLennan at several of our recent meetings and his name was proposed by myself for membership of the Technical Committee. This will be voted on at the next meeting. Cuthbertson was invited to attend right from the very start but in his characteristic manner has chosen to ignore all letters and invitations without even the courtesy of a reply. In spite of this his name was permitted to go forward for the Technical Committee! I personally think that everyone who is interested to get an opportunity of having his or her say and the more divergent the individual opinions in the first instance the better, providing they are all prepared to work towards a common goal. Unfortunately not all members are of the same opinion as I am this matter and they don't like others who don't agree with them on various points and as far as Cuthbertson is concerned I am well aware that there are several who would walk right out if he came in. He has not exactly gained a reputation for popularity in Scotland but no doubt you are well aware of this and there is no need for me to enlarge on what is undoubtedly a rather unpleasant subject. However I met him recently in Edinburgh (he has taken up residence in Portobello) and I left him in no doubts regarding what I thought of his attitude in ignoring the Board's invitations and

invited him to come and state his case which he said he would do. It might clear the air a little and I think it is worth trying but unfortunately I feel that there will be so much on both side [sic] which remains unsaid that progress is likely to be small.

Will certainly be pleased to meet Mrs McInnes if she cares to contact me.

As it is now past midnight and I am very tired I will close and once again thank you most sincerely for all the trouble that you have taken on my behalf.

Kindest regards,

Yours sincerely,

Davidson.

3 West Claremont Street,

Edinburgh 3.

20/7/50

Dear Mr Taylor,

Very many thanks for your letter and enclosures - I found these very interesting and was only glad that you had to answer them and not me!

I agree that I am in touch with McKenzie and D.G. McLennan, both of whom I admire, but neither of these gentlemen have had experience of the Argyll or Lochnaber Broadwords since, as you are doubtless aware, both dances are to a great extent confined to the Army.

On the subject of the Tartan Terrors I do not think that there is anything more to add to what we have both said on the subject - I fully agree with you that the female menace has come to stay and that there is nothing that can be done about it - also, of course there is most certainly the bread and butter angle with which I fully sympathise, but I do most emphatically believe that the sexes should be segregated as I am convinced that it is anatomically impossible for a perfect male dancer to dance the same as a perfect female dancer or vice versa and consequently it is impossible to judge one against another with perfect fairness. My great ambition is to see a far greater spirit of sportsmanship amongst Highland Dancers (particularly the female of the species) than there is at present and the wiping out of the horrible and degrading practice of so many mothers of dragging their wretched children round the games like performing beasts fit only to be whipped if they fail to win the prizes.

I regret that I do not altogether follow your argument or analogy on Golf. I agree that a diagram of a women golfer in a book on women's golf would not be incongruous but if it were depicting the subject of golf as a whole then it would be incongruous. Similarly a diagram of a woman depicting positions in a book on Traditional Highland dancing is incongruous whereas had she been depicting female styles of Highland dancing then there would have been nothing wrong. I fully appreciate your reasons for not using your son when he was sitting for exams but as the figures were only drawings could you not have got anyone to pose and having got the arm and leg positions, filled in the details to represent a male figure? I hope you don't take offence at the above gentle criticism but I have gained the impression from your correspondence that you prefer sincerity to insincere flattery - if you don't agree with anything that I say then please say so and give your reasons and I will be more than pleased since there is nothing

have more than an honest and sincere discussion on matters of mutual interest with friends.

I am well aware that everyone is not in agreement with Ian Cameron's society but I think that is good and I was very pleased to hear of your appointment as Liaison Officer - congratulations. As soon as I got your letter I phoned the Chairman of the Interim Committee of the Control Board (Note the Board has not yet been authorized or formed and is only in interim stage) and told him about it. We fully agreed that, in view of your appointment you should, in spite of the Committee. This will be voted on at the next meeting. Guthbertson was invited to attend right from the very start but in his characteristic manner has chosen to ignore all letters and invitations without even the courtesy of a reply. In spite of this his name was permitted to go forward for the Technical Committee! I personally think that everyone who is interested to get an opportunity of having his or her say and the more divergent the individual opinions in the first instance the better, providing they are all prepared to work towards a common goal. Unfortunately not all members are of the same opinion as I am this matter and they don't like others who don't agree with them on various points and as far as Guthbertson is concerned I am well aware that there are several who would walk right out if he came in. He has not exactly gained a reputation for popularity in Scotland but no doubt you are well aware of this and there is no need for me to enlarge on what is undoubtedly a rather unpleasant subject. However I met him recently in Edinburgh (he has taken up residence in Portobello) and I left him in no doubts regarding what I thought of his attitude in ignoring the Board's invitations and invited him to come and state his case which he said he would do. It might clear the air a little and I think it is worth trying but unfortunately I feel that there will be so much on both sides which remains unaided that progress is likely to be small.

Will certainly be pleased to meet Mrs Mc Innes if she cares to contact me.

As it is now past midnight and I am very tired I will close and once again thank you most sincerely for all the trouble that you have taken on my behalf. Kindest regards,
Yours sincerely, *Davidson*

Appendix 8: Letter from G. Douglas Taylor to Captain Davidson,

10/08/1950

[Letterhead]

49 Highfield Drive, Ewell, Surrey. 10th August 1950

Dear Captain Davidson,

Many thanks for your letter, and I hope you receive this before the weekend.

I had a very nice letter from Miss McLennan "for which thanks to you" I was keen to accept invitation but felt I couldn't at present

Your agenda, and inaugural meeting discussion, is interesting reading. I feel, as an on-looker, any comments of mine will not be taken out of place by you. Would it not be possible to Co-opt. Piping Societies, etc. without voting privileges, [sic] if such an idea would be thought helpful to the Society.

Your idea Traditional, is the best word, Standardised is too like modern Ballroom, with [sic] is the last thing wanted.

Have you thought of a vice chairman, and your council will be pretty hefty, if they all attend. I am sorry the Imperial, and N.A.T.D. names are omitted from the list, although I know they have a big programme in hand, but I am always surprised that our Societies have such a craving for foreign traditional dances, and seldom give their own National Dances, the same keen interest, it seems to me like School pupils wanting to learn Foreign languages, before they have overcome their own.

Will you be able to enforce your authority as to rules and bye laws, a difficulty will always arise re pupils choosing teachers, very often "in the early stages at least" the cheapest [sic] is usually chosen, irrespective of ability.

I appreciate straight criticism, I have seen so much insincerity amongst Teachers and Dancers, in my long life that it is like a breath of fresh air so carry on, please.

My brother, who was Instructor, of the Royal Caledonian Schools for thirteen years, he was judging at one of our big gatherings here in june [sic], has sent me the enclosed for my opinion, what think you.

I am not finished with the Swords yet.

All success on Sunday, and, if comments are made at meetings, they are better spoken aloud, than back door comments.

It is unfortunate that Cuthbertson is so crude, I have heard so before.

I have also been told by competitors, who should have been the prize winners, they sometimes want to compete and judge the same event.

I meant women competing against men.

Kindest regards, also to Willie

Yours aye sincerely,

G. Douglas Taylor

P.S. A rule might be made as to number of dancers on Board at once, I have had six, at White City, impossible for Judges, [sic] and unfair to Dancers.

THE SCOTTISH PIPING

SOCIETY OF LONDON



President:
G. DOUGLAS TAYLOR
Hon. Treasurer:
G. D. MACDOUGALL
97, SPENCER ROAD,
WEALDSTONE, HARROW
Telephone: HARROW 4864

Hon. Asst. Secretary:
BRUCE HOBSON
OFFICER'S MESS,
ROYAL AIR FORCE,
UXBRIDGE,
MIDDLESEX.

Hon. Secretary: WILLIAM ROSS
11, CASTLETON AVENUE, WEMBLEY PARK
Telephone: ARNOLD 4278 MIDDLESEX

49 Highfield Drive,
Weybridge, Surrey.
10th August, 1950

Dear Captain Davidson,

Many thanks for your letter, and I hope you receive this before the week end.

I had a very nice letter from Miss McCallan "for which thanks to you" I was keen to accept invitation, but felt I couldn't at present.

Your agenda, and inaugural meeting discussion, is interesting reading.

I feel, as an on-looker, any comments of mine will not be taken out of place by you. Would it not be possible to Co-opt Piping Societies, etc. without voting privileges, if such an idea would be thought helpful to the Society.

Your idea Traditional, is the best word, Standardised is too like modern Ballroom, with is the last thing wanted.

Have you thought of a vice chairman, and your Council will be pretty hefty, if they all attend. I am sorry the Imperial, and R.A.F.I. names are omitted from the list, although I know they have a big programme in hand, but I am always surprised that our Societies have such a

For Foreign (and National) dances; and (seldom) give their own National Dances, the same keen interest, it seems to me like School pupils wanting to learn foreign languages, before they have overcome their own.

Will you be able to enforce your authority as to rules and bye laws, a difficulty will always arise re pupils choosing teachers, very often "in the early stages at least" the cheapest is usually chosen, irrespective of ability.

I appreciate straight criticism, I have seen so much insincerity amongst Teachers & Dancers, in my long life, that it is like a breath of fresh air so carry on, please.

My brother, who was Instructor, of the Royal Caledonian Schools for 13 years, he was judging at one of our big gatherings here in June, has sent me the enclosed for my opinion, what think you.

I am not finished with the Swords yet.

~~All success on Sunday, and, if comments are made at meetings, they are better spoken aloud, than back door comments.~~

It is unfortunate that Cuthbertson is so crude, I have heard so before.

I have also been told by competitors, who should have been the prize winners, they sometimes want to compete and judge the same event.

I meant women competing against men.

Kindest regards, also to Willie

Yours aye sincerely,

G. Douglas Taylor

P.S. A rule might be made as to number of dancers on Board at once, I have had six, at White City, impossible for Judges, and unfair to Dancers.

Appendix 9: Minutes from the First Meeting of the SOBHD, held at 83

Leith Street, Edinburgh, 13/08/1950

SCOTTISH OFFICIAL BOARD OF HIGHLAND DANCING

Postal Headquarters

83 Leith Street,
EDINBURGH.

1. The first meeting of the Scottish Official Board of Highland Dancing was held at 83 Leith Street, Edinburgh, on Sunday, 13th August, 1950 at 2.30 pm (by kind permission of Mr. Harry Pearley)

2. Those present were:-

<u>Represented Member</u>	<u>Delegates</u>
Scottish Dance Teachers' Alliance	Mr. Jack Muir Miss Jean McEllan
British Association of Teachers of Dancing ...	Miss E. Wallace Miss Mary Lindsay
United Kingdom Alliance of Professional Teachers of Dancing	Mr. James Turpie Miss Betty McEldon
Highland Dance Specialists Association	Miss Tucker Miss R. Findlay
British Ballet Organisation	Miss Madeline Calder
Scottish Country Dance Society	Mrs. K.H. Brown Lieut. James Stewart Murray
North British Ballroom Association	Mr. Harry Pearley Mr. J.P. Stewart
Highland Pipers' Society	Dr. A. McLaren
Central Highland Gathering	Mr. J.S. Thomson

Independent Members:

Mr. G.H. A. MacLean - Brig. Clark - Capt. T. Davidson - Mrs. A. Watson - J. McEwan - Mr. D.G. McLaren.

Excused for inability to attend were:-

Miss R. Thomson - Major W.K. Bourne - Lieut. Col. H. Taylor and Mrs. Taylor

3. Mr. Muir opened the meeting by proposing that the chairman of the first meeting, Mr. Harry Pearley, should act as chairman until such time as a chairman of the Official Board was elected. This was seconded by Mr. MacLean and agreed.

4. Minutes

The minutes of the 'continuation of inaugural meeting' having been circulated to members were taken as read and confirmed.

5. Elections

Acting on the suggestion of Mr. Stewart, the meeting decided to give precedence to the Election of Members (No. 5 in List of Elections) and the following were elected:-

S.P.T.A.	- proposed by Mr. Stewart	and seconded by Mr. McEwan
B.A.T.D.	- " " Mr. Muir	" " Miss McEldon
U.K.A.	- " " Miss Wallace	" " Miss Lindsay
H.T.S.A.	- " " Mr. McCornachie	" " Miss McEldon
F.R.C.	- " " Mr. Turpie	" " Miss McDonald
S.C.D.S.	- " " Capt. Davidson	" " Dr. McLaren
H.P.S.	- " " Capt. Davidson	" " Mrs. Brown
N.B.B.A.	- " " Mr. Turpie	" " Col. MacLean
CENTRAL GIGS	- " " Miss McEllan	" " Miss McDonald

Mr. Muir proposed that the eight independent members of the Interim Committee, i.e. Brigadier H.J.D. Clark, Lieut-Col. A.G.L. McLaren, O.B.E., Major W.K. Bourne, T.D., Capt. T.B. Davidson, Major. R. Yates, J. McEwan, Miss E. Thomson and Miss Mary Allen, should be elected en bloc with the addition of Mr. D.G. McLaren. This was seconded by Mr. Turpie and carried unanimously.

Mr. Muir seconded by Miss McDonald, proposed that the position of chairman should be dealt with next and this was agreed.

Mr. Stewart, seconded by Mr. Muir, proposed that voting should be by elimination. This was carried.

The following were the nominees:-

Mr. Harry Fairley	nominated by the U.K.A.
Mr. Jack Muir	" " the S.D.T.A.
Dr. McLaren	" " Capt. Davidson
Col. McLean	" " Brig. Clark
Brig. Clark	" " N.D.B.A.
Mrs M.K. Brown	" " N.D.B.A.

Both Brig. Clark and Mrs. Brown withdrew their names and the result of the voting made Mr. Harry Fairley of Edinburgh the first Chairman of the Board.

Election of Secretary

The following were the nominees:-

Miss J. McLellan	nominated by the U.K.A.
Miss Helon Constable	" " the U.K.A.
Miss E. Wallace	" " Miss Joan McLellan
Captain Davidson	" " Mr. Stewart
Col. MacLean	" " Mr. J. McConnachie

Miss McLellan and Miss Wallace withdrew their names and the result of the voting made Capt. T. Davidson the first Secretary of the Scottish Official Board of Highland Dancing.

Brig. Clark moved a warm vote of thanks to Miss Jean McLellan who had undertaken the secretarial work during the eight months it had taken to form the board. Miss McLellan thanked Brig. Clark and the members of the board for the co-operation and courtesy they had shown to her and very much regretted the necessity to relinquish the secretarial duties owing to pressure of business.

Election of Treasurer

The following were nominated:-

Mr. Thomson	nominated by Mr. Jack Muir
Mr. J.F. Stewart	" " Mrs. Brown

On a vote being taken, Mr. Thomson became the first Treasurer of the Board.

Election of Honorary President - The following were nominated

Lord James Stewart Murray	nominated by Col. MacLean
Gen. Sir A.E. Christison	" " Brig. Clark

As a result of the voting, it was decided that the board should approach Gen. Sir A.E. Christison, with view to obtaining his consent to act in this capacity.

Election of Technical Committee

Mr. Muir seconded by Mr. McConnachie moved that the technical committee should be 20 in number, and should be divided as follows:-

2 delegates from each of the Five Dancing Assoc. Members (10)
and the remainder (10) to be elected by the board.

Mr. Stewart moved an amendment that the technical committee should be 10 or 11 in number.

On a vote being taken, the proposition carried by 12 votes to 7.

Mr. Muir seconded by Miss McLellan, then moved that the election of technical committee be left on the table until the next meeting of the board.

Mr. Stewart seconded by Dr. McLaren, moved an amendment that the independent members of the technical committee be elected today.

On a vote being taken, the amendment carried.

ELECTION OF 10 INDEPENDENT MEMBERS OF TECHNICAL COMMITTEE

1	D. G. McLennan
2	Col. A.G.L. McLean C.D.E.
3	Brig. Clark
4	J.L. Mackenzie
5	A. McLaren M.D. Ch.F.
6	J. McConnachie
7	Dr. A. Robertson
8	Sydney Black
9	Miss M. Aitken
10	Angus McPherson

The above were elected.

The names of Mr. Robt. Watson and Miss Jean Reynolds being next in order of precedence by votes, were noted for reference in the event of any of the above being unable or unwilling to undertake the duties.

Mr. Muir, seconded by Drig. Clark proposed that the chairman convene the first meeting of the technical committee and act until a convener is elected, and that this convener, when elected, shall have a vote and a casting vote in the business of the technical committee. This was agreed, and the technical committee were instructed to confine themselves purely to technique and theory.

Terminology

Mr. Muir proposed that in future (a) all representatives of various Associations be referred to as "Delegates" (b) Independent Members be referred to as such and (c) Associations be referred to as Represented Members.

It was agreed that the matter should be left over till the next meeting when Mr. Muir's further proposals would be discussed.

Next Meeting

The Chairman requested that all Represented Members should submit Nominations for their representatives on Technical Committee at earliest and at any rate prior to the next meeting.

It was agreed that the next meeting should take place on Sunday, 17th September, 1100 hrs. and Mr. Harry Fairley's kind offer of his premises be accepted with thanks.

Appendix 10: 'Highland Dancing Board Comes Under Heavy Fire', article in Edinburgh Evening News, 21/11/1955

Highland dancers, their teachers, and parents, from Edinburgh, Glasgow, Fife, the Borders, and other parts of Scotland launched a new association in Edinburgh yesterday which will oppose the 'stabilisation technique policy' recently recommended by the Scottish Official Board of Highland Dancing.

The new body- the Highland Dancing Association- is the latest move in the 'war' between the Board and the dancers. Its declared aim is to put Highland dancing back on a proper footing.

In the Cathedral Hall, Albany Street, where the new Association was formed, about 100 people agreed to try to stop the 'closed shop' attitude to Highland dancing and have a more open method.

The official board was set up in 1950 to iron out the many anomalies which have crept into competitions and to lay down a basic set of rules which would simplify judging competitions wherever they are held.

But many dancers disagree with the Board's aims, and considerable controversy has arisen over three of their decisions- the stabilisation technique, the banning of fancy steps, and the introduction of a slightly longer kilt for women dancers.

THE MAN'S WAY Said 60-year old Mr R.M. Cuthbertson, the president of the new body, who was one of the greatest exponents of the art in the country: 'I want to be amicable about this. I have been a member of the technical committee of the official board, and I have not resigned- yet. I object, however, to people trying to kill tradition. Stabilisation will make every performance a robot one and will kill individuality.'

Mr Cuthbertson said that some members of the official board had never danced themselves, and, in his opinion, one could not assess the true value of dancing without being able to perform the steps. 'I don't think the board should be allowed to dictate to us.'

Referring to the proposal to make women's dress longer, Mr Cuthbertson said he thought the kilt should be worn only one way- the man's way. I do not think they should try to make it a skirt'.

To a question as to the position of the new association with the Board of Control, Mr Cuthbertson said: 'We are not enemies of the Board. We probably all object to certain things the board has laid down.'

He did not agree, however, that any board had the right to state what steps should be danced, or not. Even steps which anyone had the ingenuity to manufacture should not be ruled out, so long as they conformed to basic tradition.

'BUNCH OF AMATEURS' Mr Sidney Black, Edinburgh, another retired dancer, referred to the Official Board as a 'bunch of amateurs' He said he did not think many of them were qualified to supply judges at games. They knew insufficient about it. He had attended two of their meetings and it was clear that the few good dancers were being overruled. He thought dancing should be judged only by those who could execute what they were talking about.

Dr Archibald Macpherson, who was appointed an honorary president, thought the board had done a good job ' up to a point,' in bringing forward a simplified form of Highland dancing. The new Association could take over from there and make sure that young people with the capacity to be good dancers were encouraged to learn a more refined technique, which distinguished he or she from others.

Mr Bert Robertson, secretary, a Highland dancing teacher who convened the meeting, said: 'We should forget petty jealousies and rivalries. As long as we achieve our object of assisting young dancers we shall have done our job.'

A MOTHER'S VIEW Mrs Jenny Buchanan, mother and manager of Catriona Buchanan, who is the holder of the World Highland Dancing title, said that as far as she was concerned no girl of hers would be told what to do by a board. Who were they anyway? What were they? Were they capable of judging at games? I suggest we ask them in a friendly way what they are going to do about this' [sic].

She suggested they could answer at the same time why it was 'those and

such as those' who were invited to sit on the Official Board.

The meeting agreed to write to the Board offering to discuss their different points of view.

Office-bearers appointed were: Honorary presidents, Sir Compton Mackenzie and Dr Archibald Macpherson; president, R.M. Cuthberton; vice-president, E. Graham; secretary, Bert Robertson; treasurer, F. Forbes, Glasgow.

Edinburgh Evening News, Monday, November 21, 1933

Highland Dancing Board Comes Under Heavy Fire

Highland dancers, their teachers, and parents, from Edinburgh, Glasgow, Fife, the Borders, and other parts of Scotland launched a new association in Edinburgh yesterday which will oppose the "stabilisation technique policy" recently recommended by the Scottish Official Board of Highland Dancing.

The new body—the Highland Dancing Association—is the latest move in the "war" between the Board and the dancers. Its declared aim is to put Highland dancing back on a proper footing.

In the Cathedral Hall, Albany Street, where the new Association was formed, about 100 people strove to try to stop the "closed shop" attitude to Highland dancing and have a more open method.

The official board was set up in 1930 to bring out the many anomalies which have crept into competitions and to lay down a basic set of rules which would simplify judging competitions wherever they are held. But many dancers disagree with the Board's aims, and considerable controversy has arisen over three of their decisions—the stabilisation technique, the banning of fancy steps, and the introduction of a strictly longer set for women dancers.

THE MAN'S WAY

Said 60-year-old Mr. R. M. Cuthberton, the president of the new body, who was one of the greatest exponents of the art in the country: "I want to be amicable about this. I have been a member of the technical committee of the official board, and I have not resigned—yet. I object, however, to people trying to kill tradition. Stabilisation will make every performance a robot one and will kill the vitality."

Mr. Cuthberton said that some members of the official board had never danced themselves, and, in his opinion, one could not assess the true value of dancing without being able to perform the steps. "I don't think the board should be allowed to dictate to us."

Referring to the proposal to make women's dress longer, Mr. Cuthberton said he thought the bill should be very one way—the men's way. "I do not think we should try to make it a skirt."

As a question as to the amission of the new association with the Board of Control, Mr. Cuthberton said: "We are not enemies of the board. We probably all object to certain things the board has laid down."

He did not agree, however, that any board had the right to state what steps should be danced, or not. Even steps which anyone had the ingenuity to manufacture should not be ruled out, so long

"BUNCH OF AMATEURS"

Mr. Sidney Black, Edinburgh, another retired dancer, referred to the Official Board as a "bunch of amateurs." He said he did not think many of them were qualified to supply judges at games. They were ignorant about the art and were clear that the "closed shop" policy was being overruled. He thought dancing should be judged only by those who could appreciate what they were talking about.

Dr. Archibald Macpherson, who was appointed an honorary president, thought the board had gone a good bit "up to a point" in bringing forward a simplified form of Highland dancing. The new Association could take over from there and make sure that young people with the capacity to be good dancers were encouraged to learn a more refined technique, which distinguished it from the others.

Mr. Bert Robertson, secretary of Highland Dancing, who conducted the meeting, said: "We should forget petty jealousies and rivalries. As long as we achieve our object of assisting young dancers we shall have done our job."

A MOTHER'S VIEW

Mrs. Jenny Buchanan, mother and manager of Catharine Buchanan, who is the holder of the World Highland Dancing title, said that as far as she was concerned a girl of hers would be told what to do by a board. "Who were they, anyway? What were they? Were they capable of judging at games?" "I suggest we ask them in a friendly way what they are going to do about this."

She suggested they could contact the board and say it was "these and these" who were invited to sit on the Official Board. The meeting agreed to write to the board offering to discuss their different points of view.

Other officers appointed were: honorary presidents, Sir Compton Mackenzie and Dr. Archibald Macpherson; president, R. M. Cuthberton; vice-president, E. Graham; secretary, Bert Robertson; treasurer, F. Forbes, Glasgow.

**Appendix 11: Personal Correspondence from Margery Rowan,
SOBHD Director of Administration, 04/04/2000**

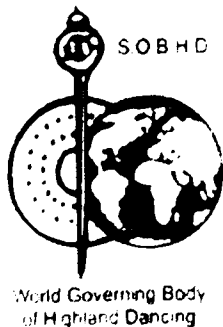

Scottish Official Board of Highland Dancing

Heritage House, 32 Grange Loan, EDINBURGH EH9 2NR, Scotland
Tel: 0131 668 3965 Fax: 0131 662 0404

Miss M Fothergill
The Adult Learning Project
184 Dalry Road
Edinburgh EH11 2EP

4 April 2000.

Dear Miss Fothergill

Thank you for your letter of 23rd ult. informing the Board of the meeting to be held on 6th April. Unfortunately, due to other commitments, I will be unable to attend.

Regarding the questions you listed. I can give you an answer to the first two

Highland Dancing is a sport recognised by Sportscotland

It is a solo competitive sport not to be confused with Scottish Country Dancing which is sociable.

Yours sincerely

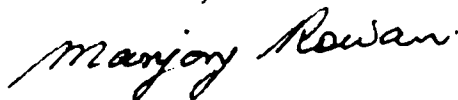

Marjory Rowan
Director of Administration

Appendix 12: Personal Correspondence from Mats Melin, Scottish Traditions of Dance Trust Dance Development Officer, Angus, 04 04 2000

FAX MESSAGE
from
STDT - ANGUS OFFICE

To: Morag Fothergill,
The Adult Learning Project.

Fax No: 0131 337 9316

From: Mats Melin,
S.T.D.T. Dance Development Officer
Angus.

Fax No: 01307 468 451.

Date: 4.04.00.

Pages: 2

Re: Highland Dancing/ Adult Education.

Thank you for your letter re. Highland Dancing. We have answered your questions in brief form as below.

Hoping that this is of some help to you.

What is Highland Dancing for? Is it a sport or art?

Traditionally a dance form performed for enjoyment showing the degree of one's fitness and agility.

Today it is performed for enjoyment with great emphasis on Medal Tests and Competitions.

It is an Art, but in competition it tends to be treated as a Sport.

Does it have to be solo or can it be made more sociable?

Not all Highland Dances are solo such as The Highland Reel and the Reel of Tulloch which grew out of the old Scotch Reels.

Solo Highland Dancing can be made more sociable if the company/audience are invited to join in rather than spectate. If a number of solo Highland dancers are dancing, then they can dance in a more sociable group, such

as dancing in a circle facing each other instead of dancing in a row.

What is the role of Highland Dancing in the community?

Highland Dancing provides an important role of providing a traditional form of dancing for children,

and in turn provides a social mixing for the Parents of the dancers.

Most dancing schools stage their own "Shows" from which the dancers and the whole community benefit.

Practically all community concerts and celebrations depend upon local dancers to perform. Here Highland Dancing plays an important part and in turn the dancers benefit by the experience of performing.

What could be the role of Highland Dancing in the 21st century and beyond?

Traditional Highland Dancing should be allowed to develop into two different forms, that of 1. COMPETITION

and 2. SOCIAL. Both forms should be allowed to co-exist being of equal value and catering for the needs of different attitudes.

Mats Melin

Appendix 13: Position Statement read and at the SOBHD/SOHDA Joint Meeting, held at the Thistle Hotel, St. James Centre, Edinburgh, 28/03/2002

SOHDA / SOBHD JOINT MEETING

HELD AT THE THISTLE HOTEL, ST. JAMES CENTRE, EDINBURGH

ON

THURSDAY 28TH MARCH, 2002, AT 1400HRS.

SOHDA POSITION STATEMENT

May I begin by reiterating (as per the previous correspondence) that the statement you are about to hear is, at the end of the day, for the future benefit of the Art of Highland Dancing. Furthermore, it is our considered view that all current barriers and restrictive practices relating to the Art are detrimental and ought to be removed. Thus, leaving the politics aside for the moment, the SOHDA strongly feels that the benefits to be derived from adopting such a positive course of action, as outlined below, would, in our view, be beneficial to both the SOHDA and the SOBHD. Notwithstanding, we must also consider the feelings and views of our friends overseas if we are to embark upon such an amicable agreement. This, also, is a genuine attempt to form a basis for future co-existence and may, one day, lead to a unified structure.

Consequently, the "Position Statement" as outlined, falls into four (4) categories, viz:

- (a) Dancers
- (b) Teachers
- (c) Adjudicators
- (d) Technique

DANCERS:

It is the considered view of the SOHDA that Highland Dancing Competition ought to be once again, "opened-up", coupled with a policy of adopting non-restrictive membership of organisations. Dancers, regardless of organisation or affiliation, ought to be free to compete one with the other, both at Open Premier and Pre-Open-Pre-Premier levels. Nowadays especially, it is not beyond the wit of men/women to work for and find a solution to this, so-called problem. Amongst other benefits, the net effect of this would be to encourage more dancers to take part in "healthy" competition (championships included), with SOBHD registered dancers jointly taking part in SOHDA competition and vice versa without fear of any boycott hanging over their heads.

Constitutionally this may seem to be a problem, however, if both organisations were diligently to effect a change in their joint constitutions, it will and can be surmountable. The SOBHD regards this as a Human Rights issue and would impress upon the SOBHD to seriously examine the points raised and to consider this problem in depth.

TEACHERS:

Also of concern and considered to be a Human Rights issue is the fact that teachers whose organisations are affiliated to the SOBHD and indeed, SOBHD members, are not allowed, under the current constitution, to join an organisation, for example, the SOHDA or, any other organisation not recognised by the SOBHD. This, the SOHDA feels to be grossly unfair and does actively prohibit "Freedom of Association". If this issue and other related issues were resolved, then both the SOHDA and organisations affiliated to the SOBHD would, without doubt, benefit.

Again, the SOHDA would impress upon the SOBHD to consider jointly a solution to this problem.

ADJUDICATORS:

As you are aware, the SOHDA have their own panels of highly qualified judges, as does the SOBHD. Therefore, if a way can be found for the two organisations to be accepting of each others panels then the SOHDA feels sure that progress, in this particular sphere can be made. Consequently, if we concentrate our minds and efforts to resolving this *so-called* problem, with a degree of determination, the benefits to be gained by both organisations would be considerable.

TECHNIQUE:

As time marches on, the SOHDA are becoming increasingly aware as we are sure the SOBHD are, that throughout the world of Highland Dance there are other valid forms of technique, especially amongst the many free-thinking overseas organisations, implanted at least a century ago by dedicated dancing masters from Scotland and gradually developed by them. Neither the SOHDA nor the SOBHD have a monopoly over these various long-established techniques but should consider them to be an important part of our heritage and should therefore be encouraged. It is the SOHDA's belief that Scottish Highland Dancing is a "living" tradition which should encompass all traditions and all techniques.

We would, therefore, very much appreciate the SOBHD working in conjunction with the SOHDA in addressing this *so-called* problem to enable a solution to be found.

Although the above is not an exhaustive list, it's at least a starting point which will require compromise from both sides. The durable art of negotiation is compromise! Furthermore, the SOHDA delegates would like to extend our sincere appreciation to the delegates from the SOBHD who had the courage and foresight to attend such a meeting this afternoon.

Finally, we would certainly appreciate the SOBHD giving the aforementioned due and full consideration and, hopefully, further meetings can be arranged in creating a more amicable environment.

**Appendix 14: Semi-Structured Interview Questionnaire used at
UKA/SOBHD Highland Dancing Championships, Meadowbank Stadium,
Edinburgh Saturday 26/02/2005.**

1. Informant's Name
2. Age
3. Experience and Qualifications [see Q4,Q5]

Dancer	Age group? Ability group? Achievements?
Judge	Experience? Previously a dancer / teacher?
Teacher	Are you supporting competitors? Which ones?
Spectator	Are you supporting competitors? Which ones? What is their relation to you?
Piper	Experience at competitions? Duties today?
Other	

4. How did you start Dancing / Judging / Teaching / Spectating / Piping?
5. What is your role today?
6. How would you describe a good dancer? [see Q7,Q8,Q9,Q10]
7. In a 'good' performance, what are the essential elements?
- 7a. How important are the following Technical criteria?

Elevation	Is this exaggerated? why? [see Q9Q,11]
Turnout	Is this exaggerated? why? [see Q9,Q11]
Fitness	Is this the prime objective / appeal? Is Highland dancing a sport? [see Q9,Q10]
Other	

7b. What are the essential Non-Technical / Musical skills which a 'good' dancer must possess?

Musicality	Is understanding musical structure and progression essential?
Timing	Strict timing? Understanding rhythms / tempos? Should the tune fit the step? Or should the step fit the tune? [see Q8]
Artistry	i.e. elements of interpretation and expression? [see Q9,Q10]
Other	

8. Can 'good' dancing be learnt, or is it a natural skill [see Q8,Q9]?

8a. What is the difference between a technically good dancer and a gifted one?

8b. To what extent is 'good' dancing dependent on the following elements?

Age	
Shape	
Size	
Experience	
Other	

9. What is a 'good' dancer's most important skill / understanding?

10. How can a dancer stand out from crowd?

11. Are there any trends which appear on competition platforms?

Fashions	Dress? Conduct? Execution?
Recurring Problems	Exaggeration of steps / positions? Misinterpretation of guidelines?
Positive trends?	
Other	

12. Is it important to smile? [What is dancer thinking about?]

13. What are the stories behind the dances origins? [Are these important? What impact do they have on performance? Does this add to the narrative quality?]

14. What is your favourite / least favourite dance? Why?

15. What has been your best / worst experience of Highland dancing?

16. Is there Unwritten Conduct at competitions?

On Platform	
Off Platform	
At Specific Events	

17. Why compete? Why does it appeal? What makes it so popular?

For Recognition?	Prizes, Placings, Championship Points, Prestige
To Improve Skills?	High standards of dancing, competing against others [as opposed to medal tests] [see Q19]
The Only platform?	Lack of other outlets? Any suggestions? [see Q19]

Career Opportunities?	National, International Championship aspirations? [see Q19,Q26]
Other	

17a. To whom does [competitive] Highland dancing appeal? [see Q18]

18. Why are there so few boys? [How could it be more appealing?]

19. Are there other Platforms / Outlets? Do you have any new ideas?

20. In what way is Highland dancing Traditional? What do you mean by this?

21. Is Highland dancing unique?

Yes	In what way?
No	What kinds of dancing are similar?

22. If you could address all dancers / judges / spectators. What would you say? [see Q23]

23. If you could change one thing about Highland dancing, what would it be?

24. What are your hopes for the future?

Personal	As Dancer / Judge / Teacher / Spectator / Piper
General	For Highland dancing / Competitions / for others

25. What would make / has made today's event successful? In what way?

[End]

**Appendix 15: Comment Key for accompanying DVD Ethnography of
UKA/SOBHD Highland Dancing Championships, Meadowbank Stadium,
Edinburgh Saturday 26/02/2005.**

1. The spectators assemble in the raised seating of main hall. This is the view from the stage.
2. The competitors assemble and warm up.
3. The adjudicators assemble in the center of the floor.
4. The solo pipers assemble.
5. A piper tunes his drones as the first group of four competitors lines up to dance.
6. The Highland Fling under nine years age group. Steps are 'Shedding', 'Back-stepping', 'Rocking' and 'Last Shedding'.
7. The adjudicators wait to judge. Note the adjudicator who 'dances' a step with her fingers.
8. The change-over. As the adjudicators write their notes, the dancers wait to be dismissed and the next group steps forward. Note the trophy table in the background.
9. The Highland Fling en masse. Steps are 'Shedding', 'Back-Stepping', 'Shake and Rock', 'Cross-over', 'Shake and Turn' and 'Last Shedding'. Note the piper standing in the middle of the judging tables, in the middle of the hall.
10. The piper accompanies The Highland Fling, beating time with his foot and turning to change his tempo according to the dancers' needs.
11. The warm-up area. Competitors refresh themselves with water spray, warm up their muscles and have their attendance checked by a steward.
12. The Highland Fling older age groups. Steps are 'Shedding', 'Toe and Heel', 'Shake and Rock', 'Second Back-Stepping', 'Cross-Over Alternative' and 'Last Shedding'. Note that, during the change-over, the male competitor lets the females leave the stage first.

13. The swords are provided by the competition organisers and are placed by a steward. Note that the handle end is approximately four inches from the ground.
14. The Sword Dance under nine years group. This clip is from the spectators' point of view. Slow steps are 'Addressing the Swords' and 'Diagonal Points'. Quick step is 'Crossing and Pointing Quickstep'. Note that the first step takes place outside the sword whereas the others are inside. The clap signifies the quick (third) step.
15. The Sword Dance under eighteen years age group. Slow steps are 'Addressing the Swords', 'Diagonal Points' and 'Pointing' (with alternative ending). Quick step is 'Crossing and Pointing Quick Step'. Note that the furthest competitor kicks sword and steps back. She waits for the dance to end, bows politely, but does not wait for marking.
16. Tea is served for the adjudicators during The Sword Dance.
17. Collecting the swords.
18. The Seann Triubhas: under nine years age group. The camera focuses on competitor number 748 who came second overall in the under nine years age group. This competitor also appears in clips 22, 29 and 30. Slow steps are 'Brushing', 'Side Travel' and 'Alternative High-Cut in Front and Balance'. Quick step is 'Heel -and-Toe and Shedding'. Note that the dancers' movements are sometimes behind the tempo set by the piper. The clap signifies the quick (fourth) step.
19. Competitors in the waiting area during The Seann Triubhas.
20. The scrutineers collate competitors' individual results and dance placings and then compute the overall results.
21. The adjudicators' reactions to a Seann Triubhas. Quick Steps are 'Heel-and-Toe and Shedding' and 'Back-Stepping'.
22. Competitor 748 warms up with her mother in the spectating area while watching the competition. This competitor also appears in clips 18, 29 and 30.
23. The trophies are arranged and competitors' numbers are inserted into the

- appropriate trophies.
24. The Strathspey and The Highland Reel under nine years age group. Strathspey setting steps are 'Toe-and-Heel', 'Cross-Over' and 'Balance and Round-the-Leg'. Reel setting step is 'High-Cutting'. Note that these young competitors stumble after landing from the leap and the line in which they finish the dance is staggered.
 25. Competitors at rest and stretching.
 26. The Strathspey and The Highland Reel under eighteen years age group. Note that the side view shows the tight formation and the symmetrical floor patterns. Strathspey setting steps are 'Back-Stepping' and 'Shake and Turn'. Reel setting steps are 'Back-Step and Travel' and 'High-Cutting'. Note the large winged extensions on the High-Cuts.
 27. Prize-winners are announced. The competitors who have been placed (first to sixth) for a dance in their age group, or who have been awarded championship points, are called by number.
 28. The Highland Fling under nine years age group prize-giving. Note that the competitors are called by number, rather than by name. This is the first applause of the day.
 29. Competitor 949 wins the under nine years age group, having been placed first in all four dances. Competitor 748 (see clips 18, 22 and 30) is in second place. Note that dancers' names are used for the first time.
 30. The proud mothers. Competitors 949 (first place overall in the under nine years section) and 748 (second overall in the under nine years section) with their trophies after the prize-giving (see competitor 748 in clips 18, 22 and 29).
 31. The merchandise: kilt outfits, SOBHD textbook (1993), soft Highland dancing shoes and hard Irish dancing shoes and sailors' hats (for national dances).
 32. The photographer takes photos of a proud competitor with his medals.
 33. A typical bag of dancing outfits.

[End]

Bibliography

Primary Sources

Manuscripts

Bobby Watson Collection (2000) Aberdeen University Library Special Collections

Manuscript of Highland Dance Music (1734) Drummond Castle Archives

Manuscripts of Dance Instruction (Hill, 1841), Aberdeen University Library Special Collections

Editions

The Holy Bible, *Authorised King James Version* (Edinburgh: Collins for the Scottish Bible Society, n.d.)

Boswell, James, *The Journal of a Tour to the Hebrides* (London: Collins, 1985) (First Published 1785)

Bremner, R., *Scots Reels* (London: Publisher Unknown, 1759)

Bremner, R., *A Second Collection of Scots Reels or Country Dances* (London: Publisher Unknown, 1768)

Burns, Robert *Poems and Songs of Robert Burns* ed James Barke (Beccles & London: Fontana/Collins, 1990)

Byron, Geroge Gordon, *Selected Poems of George Byron* ed Katherine Washburn (New York: Softback Preview, 1993)

Carroll, Lewis, *Alice's Adventures in Wonderland* Critical Edition ed Donald J Gray, (London: W.W. Norton, 1971)

Chambers, Robert, *Domestic Annals of Scotland*, Second Edition, Volume I (Edinburgh: W. & R. Chambers, 1859)

Creech, William, *Fugitive Pieces* (Edinburgh: Creech, 1815)

- Dean-Smith, Margaret, *English Tunes Common to Playford's Dancing Master, the Keyboard Books and Traditional Songs and Dances* (London: Royal Musical Association, 1953)
- Douglas, Gavin, *The Poetical Works of Gavin Douglas* (Edinburgh: Publisher Unknown, 1874)
- Forbes, Bishop, *Lyon in Mourning* (Edinburgh: Scots Historical Society, 1895)
- Gallini, Giovanni Andrea, *A Treatise on the Art of Dancing* (London: Gallini, 1772)
- Gibson, T. Ellison, (ed.), *Crosby Records: A Cavalier's Note Book, Being Notes, Anecdotes and Observations of William Blundell of Crosby, Lanarkshire, Esquire* (London: Publisher Unknown, 1880)
- Graham, Martha, *The Notebooks of Martha Graham* (New York: Harcourt Bruce Jovani, 1973)
- Grant, Elizabeth, *Memoirs of a Highland Lady 1797-1827* (London: J. Murray, 1898)
- Greig, John (ed.), *Scots Minstrelsie: A National Monument of Scottish Song Volume 6* (Edinburgh: T.C. & E.C. Jack, 1895)
- Greffin, Charles, *Life and Songs of Baroness Nairne* (London: Charles Greffin & Co., 1872)
- Lindsay, David, *The Works of Sir David Lindsay of the Mount 1490-1555* ed Douglas Hamer (Edinburgh: Scottish Text Society, 1931)
- Henderson, George, *Lady Nairne and Her Songs* Fifth Edition (Paisley: A. Gardner, 1908)
- Hogg, James, *The Jacobite Relics of Scotland* Volume I (Edinburgh: William Blackwood, 1819)
- Jaide, Walter, *Deutsche Schwerttänze* (Leipzig: Publisher Unknown, 1936)
- James VI, *Papers Relative to the Marriage of James VI* (Edinburgh: Publisher Unknown, 1828)
- Jamie, Kathleen, *Mr and Mrs Scotland are Dead: Poems 1980-1994* (Newcastle-Upon-Tyne: Bloodaxe, 2002)
- Jenkins, Thomas, *Collection of 'New', Scottish Music* (Scotland: Jenkins, 1794)

- Johnson, James, (ed.), *The Scots Musical Museum*, Six Volumes (Aldershot: Scolar, 1787-1803)
- Johnson, Alex, *The Sword Dance of Papa Stour, Shetland* (Lerwick: Johnson & Greig, 1926)
- Laing, Alexander, *Wayside Flowers, Being Poems and Songs* (Edinburgh: Publisher Unknown, 1846)
- Lochhead, Liz., *'Mary Queens of Scots got her Head Chopped Off' and 'Dracula'* (London: Penguin, 1989)
- MacIan, R., *Highlanders at Home* (London: Publisher Unknown, 1848)
- Mackay, *Act of Proscription* (Scotland: Publisher Unknown, 1884)
- Mill, Anna Jean, *Medieval Plays in Scotland* (Edinburgh: St. Andrews University Press & Blackwood, 1924)
- Milligan, Jean. C., & D.G. MacLennan, *Dances of Scotland* (London: Publisher Unknown, 1950)
- North, C.N.M., *Leabhar Comunn Nam Fìor Ghael or The Book of the Club of True Highlanders* (London: R. Smythson, 1881-2)
- Rameau, P., *The Dancing Master* Edited by C.W. Beaumont (London: C.W. Beaumont, 1931) (First published 1725)
- Ramsay, Allan & Robert Fergusson *Poems by Allan Ramsay and Robert Fergusson* eds Alexander Manson & Alexander Law (London: Scottish Academic Press, 1974)
- Ramsay, Allan, *The Tea-table Miscellany* Volume II (London: Printed for A. Moore, 1726)
- Semple, David (ed.), *The Poems and Songs of Robert Tannahill* (Paisley: Gardner, 1874)
- Smith, Alexander, *A Summer in Skye* (London: Strahan, 1865)
- Tacitus, Cornelius, *Agricola Germania* (London: Penguin, 1948)
- *Historical Works* Volume II (London: Publisher Unknown, 1932)
- Yeats, W.B., *W.B. Yeats: The Poems* ed Richard J. Finneran, (London: MacMillan, 1984)

Manuals of Instruction, Syllabi of Dances and Dance Notation

- Allan, Mozart, *Allan's Reference Guide to the Ball-Room: with a few hints on drawing room etiquette* (Glasgow: Publisher Unknown, 1824)
- Anderson, David, *Universal Ballroom and Solo Dance Guide* (Dundee: Publisher Unknown, 1900)
- Blum, Odette, *Scottish Dances* (Ohio: The Ohio State University Dance Notation Bureau, 1985)
- Cahusac, Louis de, *De la Danse Ancienne et Moderne* (Paris: La Haye, 1754)
- Comhlan Dannsa Nan Eileanach, *Hebridean Dances* (Great Britain: Acair, 1995)
- Hackney, Peggy, Sarah Manno & Muriel Topaz, *Study Guide for Elementary Labanotation* (New York: Dance Notation Bureau, 1977)
- Hutchinson-Guest, Ann, *Labanotation: A System for Recording Movement* (London: Phoenix House, 1954)
- Hutchinson-Guest, Ann & Melusine Wood, *Dances from the 12th, 13th and 14th Centuries* (London: Dance Research Committee, 1996)
- Laban, Rudolf, *Principles of Dance and Movement Notation* (London: Macdonald & Evans, 1956)
- Logan's Complete Tutor for the Highland Bagpipe* (London: Patterson's Publications, 1963)
- McConnachie, J., *Hebridean Solo Dances* (Scotland: Caberfeidh, 1972)
- *Scottish Country Dances of the Eighteenth Century* (London: Imperial Society of Teachers of Dancing, 1963)
- MacLellan, Captain J., *Bagpipe Music for Scottish Dancing* (Great Britain: Paterson, 1966)
- MacNeilage, G., *How to Dance the Eightsome Reel* (Alloa: Publisher Unknown, 1900)
- Marriett, Jane, & Muriel Topaz, *Study Guide for Intermediate Labanotation* (New York: Dance Notation Bureau Press, 1986)

- NZAND (New Zealand Academy of Highland and National Dancing), *Notes on Preparatory and Development Exercises for Highland Dancing* (New Zealand: NZAND, 1971)
- *New Zealand Academy of Highland and National Dancing. Examination Syllabi, Initial Grade – Advanced Grade* (Auckland: NZAND, 1982)
- Peacock, F., *Sketches relative to the History and Theory, but more especially to the Practice of Dancing* (Aberdeen: J. Chalmers, 1805)
- RSCDS (Royal Scottish Country Dance Society), *Manual of Scottish Country Dancing* (Edinburgh: RSCDS, 1992)
- Scots Guards, *Standard Settings of Pipe Music Volume I* (London: Paterson's Publications, 1954)
- *Standard Settings of Pipe Music Volume II* (London: Paterson's Publications, 1981)
- SOBHD (Scottish Official Board of Highland Dancing), *The Official Textbook of the SOBHD* (Edinburgh: Thomas Nelson & Sons, 1955)
- *The Official Textbook of the SOBHD* Second Edition (Edinburgh: Thomas Nelson & Sons, 1962)
- *The Official Textbook of the Scottish Official Board of Highland Dancing* Third Edition (Edinburgh: Thomas Nelson & Sons, 1968)
- *The Official Textbook of the SOBHD* Fourth Edition (Edinburgh: Holmes McDougall, 1975)
- *The Official Textbook of the SOBHD* Fifth Edition (Edinburgh: Holmes McDougall, 1984)
- *The Official Textbook of the SOBHD* Sixth Edition (Glasgow: Cromwell Press, Lindsay Publications, 1993)
- *Guidelines* (Edinburgh: SOBHD, n.d.)
- SOHDA (Scottish Official Highland Dancing Association), *Dance Sheet 1 'The Highland Fling'*, Unpublished (SOHDA, 1999)
- *Dance Sheet 2 'The Sword Dance'*, Unpublished (SOHDA, 1999)
- *Dance Sheet 3 'The Seann Triubhas'*, Unpublished (SOHDA, 1999)

- *Dance Sheet 4 'The Strathspey'*, Unpublished (SOHDA, 1999)
- *Dance Sheet 5 'The Reel of Tulloch'*, Unpublished (SOHDA, 1999)
- SOHDA (Scottish Highland Dancing Association), *The ABC of Highland Dancing and Games Directory* (Midlothian: Kinmore Music, 1994)
- STDT (Scottish Traditions of Dance Trust), *Guidelines for Dance Research* By Joan Henderson, Revised by Catriona Scott (Stirling: STDT, 2000)
- *Newsletter* (Stirling: STDT, June 2002)
- *Dance your Socks Off* (Stirling: STDT, Spring 2004)
- Taylor, G. Douglas, *Some Traditional Scottish Dances* (London: C.W. Beaumont for the Imperial Society of Teachers of Dancing, 1929)
- Thurston, Hugh A., *Scotland's Dances* (London: G. Bell & Sons, 1954)
- *Country Dances of the Recent Past* (London: E.F.D.S.S., 1960)
- UKA (United Kingdom Alliance Ltd.), *Highland Syllabus for Amateur Medal Tests and Professional Examinations* (Blackpool: UKA, 1999)
- Warner, M.J. & F.E. Warner, *Laban Notation Scores: An International Bibliography* (Michigan: International Council of Kinetography Laban, 1984)
- Wood, Melusine, *Historical Dances (12th to 19th Century): Their Manner of Performance and Their Place in the Social Life of the Time* (London: The Imperial Society of Teachers of Dancing, 1964)

Published Reports

- Peattie, Cathy, *Report on the Scottish Traditional Arts* (Edinburgh: Scottish Parliament, 2003)
- Thomas, Helen & Lesley Cooper, *Dancing into the Third Age: Social Dance as Cultural Text: A Research Report* (London: Goldsmith's College, University of London, 2003)

Events Programmes and Newsletters

- Aboyne Highland Games, *Programme* (07/08/1999)
- 124th Ballater Highland Games *Programme* (1997)
- ICBD (International Council of Ballroom Dancing), *World Dance Programme*
(London: Official Board of Ballroom Dancing, 1968)
- Lonach Highland Games, *Programme* (August 1994)
- Montessori Magazine* (Great Britain: Montessori Publications 2002)
- PDANZ (Piping and Dancing Association of New Zealand), *Competition Rules.
By-laws and Other Regulations* (New Zealand: PDANZ, 1927)
- RSCDS (Royal Scottish Country Dance Society)
——— *Annual Report 2003-2004* (Edinburgh: RSCDS, 2004)
- SAC (Scottish Arts Council) (ed.), *Scotland's Dances: A Review of the 1994
Conference on the Diversity of the Scottish Tradition of Dance* (Stirling:
Scottish Arts Council, 1994)
- SOBHD, *Official Dress Code* (SOBHD: Edinburgh, n.d.)
——— *Notes from the First Technical Committee Meeting* Unpublished
(SOBHD 1949)
——— 'Amendments and Additions up to 1962', in *Textbook of The Official
Textbook of the SOBHD* (Edinburgh: Thomas Nelson & Sons, 1962)
——— *Annual Report of the World Governing Body of Highland Dancing*
(Edinburgh, SOBHD 2001; 2002; 2003; 2004)
- SAC (Scottish Arts Council), *Step 2000 Showcase Programme* (Inverness:
SAC, 2001)
- UKA (United Kingdom Alliance), *Annual Highland Championship
Competitions, Meadowbank Stadium, Edinburgh, Entry Form and
Programme* (26/02/05)

Autobiographies and Biographies

- Duncan, Isadora, *My Life* (London: Gallancz, 1928)
- Gronow, Captain R.H., *Recollections and Anecdotes* (London: Smith Elder, 1864)
- MacFadyen, Alastair, & Florence H. Adams, *Dance With Your Soul: A Biography of Jean Callander Milligan LL.D. RSCDS* (Edinburgh: Royal Country Dance Society, 1983)
- Sibbald, S., *Memoirs of Susan Sibbald* (London: Bodley Head, 1926)
- Sillar, Eleanor, *Edinburgh's Child: Some Memories of Ninety Years* (Edinburgh: Oliver & Boyd, 1961)
- Skinner, J. Scott, *My Life and Adventures* (Aberdeen: City of Aberdeen, Arts and Recreation Division in association with Wallace Music, 1994)
- Topham, Captain E., *Letters from Edinburgh, written in the years 1774 and 1775* (London & Edinburgh: J. Dodsley, 1776)
- Victoria, Queen, *Leaves from the Journal of our Life in the Highlands from 1848-1861* (London: Smith, Elder, 1861)

Unpublished Papers and Dissertations

- Anderson, Gillan, *Highland Dance in Education Since 1945* Unpublished M.A. Thesis (Stirling: University of Stirling, 1989)
- Brennan-Corcoran, H., *Dancing on a Plate: The Sean Nos Dance Tradition of Conamara* Unpublished MA Thesis (Belfast: Queens University Belfast, 1994)
- Chisholm, Catriona, *Jesus spakna standard Aramaic: A backspeirin o the wark an wecht o Lorimer's Owersettin o the New Testament in Scots* Unpublished Honours Dissertation, (Stirling: Stirling University, 1999)
- Flett, Joan, 'A Review of Dancing in Scotland in Former Times', Article for Sheffield Caledonia Society, Unpublished Proof Copy (2000)

- Foley, Catherine E., *Irish Traditional Step Dance in North Kerry: A Contextual and Structural Analysis* Unpublished Ph.D. Thesis (London: The Laban Centre for Movement and Dance, Goldsmiths College, 1988)
- Henderson, Joan R., *The Traditional Dances of Lewis, South Uist and Barra in the Outer Hebrides* Unpublished M.A. Thesis (Belfast: Queens University, 1981)
- Keali'inohomoku, Joann W., *Theory and Method for an Anthropological Study of Dance* Unpublished Doctoral Dissertation (Indiana: Indiana University, 1976)
- Kearney, Kirsten 'An Introduction to National Identity: A History of the Term'. Extract from Unpublished Ph.D. Thesis (Stirling: University of Stirling, 2005) pp1-15
- 'Waiting for the Tartan Messiah: The State of the Nation at the turn of the New Century', Unpublished Article (2003)
- Macaffer, Catriona, *The Scottish Reel from a Social to a Competitive Dance and its Influence on Solo Dancing* Unpublished B.A. Dissertation, (Glasgow: Department of Scottish Music, Royal Scottish Academy of Music and Drama, 2002)
- MacInnes, Iain, *The Highland Bagpipe: The Impact of the Highland Societies of London and Scotland, 1781-1844* Unpublished M.Litt. Thesis, (Edinburgh: University of Edinburgh, 1989)
- Mill, Charlie, 'Splendour and Spectacle', Unpublished Article (1999) 1-6
- Morrison, Christina, 'A Gravid Romance', Unpublished Article (1999) 1-2
- *Yesterday's Child* Unpublished Memoirs (2000)
- Nilsson, Mats 'Framed Chaos: Dancing across History and Ethnography'. Unpublished Article (2004) 1-10
- Rankine, Linda, *The Evolution of Highland Dancing and Influences Effecting its Change in Style until 1977* Unpublished Honours Dissertation (Edinburgh: Moray House, 1977)
- Smith, Frank, *Mastering Innovation in the Home Office* Unpublished M.B.A. Project (London: Management School, Imperial College of Science,

Technology and Medicine, 2000)

Thomas, Helen *Movement, Modernism and Contemporary Culture: Issues for a Critical Sociology of Dance* Unpublished Ph.D. Thesis (London: London University, Goldsmiths', College 1986)

Witta, Kim, *Scottish Highland Dance: Tradition and Style* Unpublished M.A. Thesis (Belfast: Queens University Belfast, 1982)

Dictionaries, Reference Works and Bibliographies

Clark, Keith, (ed.), *Folk Song and Dance: A List of Books Selected by Keith Clark* (London: National Book League, 1972)

Daiches, David, (ed.), *The New Companion to Scottish Culture* (Edinburgh: Polygon, 1993)

Brewer's Dictionary of Phrase and Fable ed The Rev. E. Cobham Brewer (Hertfordshire: Omega Books Ltd., 1986) (First Edition 1870)

Dwelly, Edward, *The Illustrated Gaelic - English Dictionary* Eighth Edition (Scotland: Gairm Publications, 1973)

Collins English Dictionary (Glasgow: Harper-Collins, 1994)

The Concise Oxford Dictionary, Ninth Edition, ed D. Thompson, (Oxford: Clarendon Press, 1995)

An Etymological Dictionary of the Scottish Language ed John Jamieson. (Edinburgh: Archibald Constable & Company & Alexander Jamieson. 1808)

An Etymological Dictionary of the Scots Language ed Jamieson (Paisley, Alexander Gardner Ltd., 1927)

Encyclopaedia Britannica, First Edition (1768-71); Third Edition (1788-97); Ninth Edition (1875-89); Tenth Edition (1902-03); Eleventh Edition (1904-1910); Fourteenth Edition (1929-1971); Current Edition (1994). (Cambridge: University Press)

The Gail Grant Dictionary of Classical Ballet in Labanotation ed Allan Miles (New York: Dance Notation Bureau, 1976)

- Gallovidian Encyclopaedia* ed John MacTaggart (Ayrshire: Clunie Press, 1981)
(First published 1824)
- Grant, Gail, *Technical Manual and Dictionary of Classical Ballet* (New York: Dover, 1982)
- The New Grove Dictionary of Music and Musicians*, Volumes 1-20 ed Stanley Sadie, (London: 1980)
- The Oxford Companion to Music, Tenth Edition* ed P.A. Scholes, (Oxford: Oxford University Press, 1970)
- Oxford English Dictionary* (Oxford: Oxford University Press, 1985)
- The Oxford Companion to English Literature* Revised Edition, ed Margaret Drabble, (Oxford & New York: Oxford University Press, 1996)
- The Concise Oxford Dictionary of Quotations* Second Edition, ed Palmer, (Oxford: Oxford University Press, 1981)
- Roget's Thesaurus of English Words and Phrases* ed & rev D.C. Browning (London: J K Dent & Sons Ltd., 1982)
- The Concise Scots Dictionary* ed Robinson, Mairi, (Aberdeen: Aberdeen University Press, 1987)
- Scottish National Dictionary* (Edinburgh: Scottish National Dictionary Association Ltd., 1941)
- Dictionary of the Older Scottish Tongue: from the twelfth century to the end of the seventeenth century* eds Sir W.A. Craigie & A..J. Aitken (Oxford: Oxford University Press 1931)

Lectures

- Bacon, Jane, 'Roundtable Discussion: Practice as a Means of Understanding in Dance Ethnography', *Dance Ethnography Forum*, De Montford University, Leicester (29/01/2005)
- Grau, Andrée 'Dance Analysis for New Ethnochoreologists' international seminar, Norwegian University for Science and Technology, Trondheim, Norway (29/11/04)

Nilsson, Mats 'Sailing: Traditional City Dancing', Lecture, Norwegian University for Science and Technology, Trondheim, Norway (14/12/2004)

Interviews, Audio and Visual Recordings

In interviews conducted prior to 2002 the interviewer is cited as Catriona Chisholm [maiden name]. Pseudonyms are used for informants who were under the age of 18 or who did not sign a Release Form. Recording formats were cassette, mini-disk and video. The referencing system relates to the School of Scottish Studies Archives, where all material and transcripts are lodged in full.

Unrecorded [Noted] Interviews (UI)

Diack, Alison, Interviewed by Catriona Chisholm (30/10/2000), Elphinstone Institute and Marishal Museum, Historic Collection, University of Aberdeen (SA2003.040; UI2000.003)

Gibson, John, Interviewed by Catriona Chisholm (14/08/2001), Halifax Infirmary, Nova Scotia (UI2001.004)

Lowe, Martin, Interviewed by Catriona Scott (09/01/2004), School of Celtic and Scottish Studies, University of Edinburgh (UI2004.005)

McKay, Sheila, Interviewed by Catriona Chisholm (03/2000), Kirkcaldy (UI2000.001)

SMOG (Adult Learning Project Scots Music Group), Discussion Group, Chaired by Catriona Chisholm (06/04/2000), Edinburgh, Dalry (UI2000.002)

Field Audio Recordings (SC,SA,J05)

- Anonymous Dance Teacher, Interviewed by Catriona Scott (26/02 2005), United Kingdom Alliance (UKA) Highland Championships, Meadowbank Stadium, Edinburgh (J05.35.2, Track 3)
- Clark, Robert, Interviewed by Catriona Scott (26/02/2005), United Kingdom Alliance (UKA) Highland Championships, Meadowbank Stadium, Edinburgh (J05.35.2, Track 4)
- Cowal Highland Games 2001: The Scottish Official Board of Highland Dancing World Championships Commentary by Billy Forsyth, Filmed by Catriona Chisholm, (07/2001), Cowal (SA2003.013)
- Diack, Alison, Interviewed by Catriona Chisholm (30/10/2000), Elphinstone Institute & Marishal Museum, Historic Collection, University of Aberdeen (SA2003.040)
- Blackwater, Jane (Pseudonym), Interviewed by Catriona Scott (26/02/2005), United Kingdom Alliance (UKA) Highland Championships, Meadowbank Stadium, Edinburgh (J05.35.2, Track 5)
- Forsyth, Billy, Interviewed by Catriona Chisholm (17/07/2000), Bridge of Allan, Stirling (SA2003.036)
- Gardner, Janet (married name, Gallacher), Interviewed by Catriona Chisholm, (10/07/2000), Methil, Fife (SA2003.034)
- Gray, Alisdair, Interviewed by Catriona Chisholm (24/07/2000), School of Scottish Studies, Edinburgh (SA2003.039)
- Gibson, Eilidh & Laura, Karen & Linda Horseman, Elizabeth & Judith & Small, (All Pseudonyms), Interviewed by Catriona Scott (26 02/2005), United Kingdom Alliance (UKA) Highland Championships, Meadowbank Stadium, Edinburgh (J05.35.1, Track 2)
- Gibson, Eilidh & Laura (Pseudonyms), Interviewed by Catriona Scott (26/02/2005), United Kingdom Alliance (UKA) Highland Championships, Meadowbank Stadium, Edinburgh (J05.35.1, Track 3)

Livingstone, Marie (née Catherine Mary Chisholm), Interviewed by Catriona Chisholm (01/04/2000), Inverness (SA 2003.035)

Livingstone, Marie (née Catherine Mary Chisholm), Interviewed by Catriona Chisholm (01/04/2000), Inverness (SA 2003.035)

MacDonald, Ian, Interviewed by Catriona Scott (26/02/2005), United Kingdom Alliance (UKA) Highland Championships, Meadowbank Stadium, Edinburgh (J05.35.2, Tracks 7,8)

Matthews, Ben, Interviewed by Catriona Chisholm, (11/07/2000), School of Scottish Studies, Edinburgh (SA2003.033b)

Mill, Charlie, Interviewed by Catriona Chisholm & Mats Melin (Scottish Traditions of Dance Trust) (18/07/2000), Dundee (SA2003.037; SA2003.038)

Morrison, Christina Jessie, Interviewed by Catriona Chisholm (02/04/2000), Uig, Isle of Skye (SC2003.003)

Piper, Gavin (Pseudonym), Interviewed by Catriona Scott (26/02/2005), United Kingdom Alliance (UKA) Highland Championships, Meadowbank Stadium, Edinburgh (J05.35.2, Track 6)

Purves, Andrew Interviewed by Catriona Chisholm (11/07/2000), School of Scottish Studies, Edinburgh (SA2003.033a)

Robertson, Elizabeth, Interviewed by Catriona Chisholm (25/01/2000), Birkhill, Angus (SC2003.002)

Queen, Elayne & Tracy (Pseudonyms), Interviewed by Catriona Scott (26/02/2005), United Kingdom Alliance (UKA) Highland Championships, Meadowbank Stadium, Edinburgh (J05.35.1, Track 4)

Queen, Tracey (Pseudonym), Interviewed by Catriona Scott (26/02/2005), United Kingdom Alliance (UKA) Highland Championships, Meadowbank Stadium, Edinburgh (J05.35.2, Track 1,2)

Winton, Derek & Gareth (Pseudonyms), Interviewed by Catriona Scott (26/02/2005), United Kingdom Alliance (UKA) Highland Championships, Meadowbank Stadium, Edinburgh (J05.35.2, Track 9)

External Audio Recordings (STDT)

McHarg, Mary, Interviewed by Andrew Purves for the Scottish Traditions of Dance Trust (STDT), Larbert (STDT 03/06/1997)

McLaren, Lyn, Interviewed by Karen Ingram for the Scottish Traditions of Dance Trust (STDT) (1998), Borders Project (STDT 06/10/1998)

Field Video Recordings (VA,VD)

Forsyth, Billy, Interviewed by Catriona Chisholm (17/07/2000), Bridge of Allan, Stirling, (VA2003.006)

Gardner, Janet (married name, Gallacher), Interviewed by Catriona Chisholm, (10/07/2000) Methil, Fife (VA2003.004)

Livingstone, Marie (née Catherine Mary Chisholm), Interviewed by Catriona Chisholm (01/04/2000), Inverness (VA2003.005)

Matthews, Ben, Interviewed by Catriona Chisholm, (11/07/2000), School of Scottish Studies, Edinburgh (VA2003.003b)

Mill, Charlie, Interviewed by Catriona Chisholm & Mats Melin (Scottish Traditions of Dance Trust) (18/07/2000), Dundee (VA2003.007)

Morrison, Christina Jessie, Interviewed by Catriona Chisholm (02/04/2000), Uig, Isle of Skye (VA2003.002)

Pipe-Major (Anonymous), Interviewed by Catriona Chisholm (2001) Cowal Highland Games (VA2003.012)

Purves, Andrew Interviewed by Catriona Chisholm (11/07/2000), School of Scottish Studies, Edinburgh (VA2003.003a)

Robertson, Elizabeth, Interviewed by Catriona Chisholm (25/01/2000), Birkhill, Angus (VA2003.001)

External Video Recordings and Broadcasts (PV,VB,VD)

- Abercromby, Christine, Interviewed by Joan Henderson with demonstrations by Andrew Purves (28/10/1997), Edinburgh (PV1997.005)
- Cowal Highland Games 2001: The Scottish Official Board of Highland Dancing World Championships Commentary by Billy Forsyth, Filmed by Catriona Chisholm, (07/2001), Cowal (VD 116)
- English, Joan, *Early Dance 16th-19th Century: A Lecture Demonstration* (1999) The Heritage of Scotland, International Summer School, Department of Continuing Education, The University of Stirling. Independent Video Productions Ltd. (PV1999.007)
- Ex-S: That Fling Thing, Scottish Official Board of Highland Dancing (SOBHD), World Championships at Cowal Highland Games 1995 BBC TV* (02/1996) (VB056)
- MacDonald, Ena, Interviewed by Billy Forsyth (05/1995), Dunblane (VD115)
- McKay, Sheila, Interviewed by Billy Forsyth (16/10/94) Albert Halls, Stirling (VD114b)
- McKenzie, James, L., Interviewed by Doreen Wood in *The Scottish Tradition* Produced in Aberdeen for BBC Scotland (1995), (PV1995.003)
- Millenium Champions' Challenge* Commentary by Billy Forsyth & Jean Swanston, (2000) Broombank Productions, Braemar, Blair Castle, Blair Atholl (PV2000.006)
- Milligan, Jean, C., *First Lady of the Dance: The Royal Scottish Country Dance Society* Independent Video Productions Ltd. (1986), Stirling (PV1986.001)
- The Need to Dance: Footing It: Traditional Dance in Scotland* Narrated by Alison Cairney (10/02/1987) (VB057)
- Scotland's Dances: A Conference on the Diversity of the Scottish Tradition of Dance* Presented by the Scottish Arts Council (25-26/10/1994), Albert Halls, Stirling (VD114a)

STDT, Scottish Traditions of Dance Trust Launch (27/09/1996), Stirling (PV1996.004)

Watson, Bobby, Interviewed by Joan Henderson, Private Recording (05/09/1992), Braemar Highland Games (PV1992.002)

Correspondence

Chisholm, Roderick, (Ex-Drum-Sergeant) (2000-2005)

Forsyth, Billy, (President, SOBHD) (2000-2005)

Fraser, Alasdair, (Professional Fiddler) (2000)

Henderson, Joan (Dance Researcher) (1999-2005)

Irons, Frances, (Retired Highland Dancing Teacher) (2004)

Livingstone, Marie, (Ex-Dancer and Teacher) (2000-2003)

Matthews, Ben, (Competitor) (2000)

Morrison, Christina Jessie (Ex-Dancer) (2000-2004)

Rowan, Margery, (Director of Administration, SOBHD) (2000, 2005)

Website Addresses Used

British Library, Public Catalogue (blpc.bl.uk)

Consortium of Research Libraries (copac.ac.uk)

Encyclopaedia Britannica (eb.co.uk)

Highland Dancing Teachers Association of England (hdtae.freemove.co.uk)

Mitchell Library, Glasgow (mitchelllibrary.org)

MUSE Scholarly Journals (muse.jhu.edu/journals)

National Library of Scotland (nls.uk)

New York Public Library Catalogue (catnyp.nypl.org)

SCHDA Southern California Highland Dance Association (schda.com)

Scholarly Literature (uk.jstor.org/journals)

SOBHD Scottish Official Board of Highland Dancing (sobhd.com)

SOHDA Scottish Official Highland Dancing Association (sohda.org.uk)

SSCC Scottish Society of Central California: (scottishsociety.org)

Secondary Sources

Monographs

[see separate section of volumes of essays]

- Adams, David G., *Bothy Nichts and Days: Farm Bothy Life in Angus and the Mairns* (Edinburgh: John Donald, 1991)
- Adams, Ian Hugh, *The Making of Urban Scotland* (London: Croom Helm Historical Geography Series, 1978)
- Adshead-Lansdale, Janet & June Layson (eds), *Dance History: A Methodology for Study* (London: Dance Books, 1983)
- Ajello, Elvira, *The Solo Irish Jig* (London: C.W. Beaumont, 1932)
- Alburger, Mary Anne, *Scottish Fiddlers and Their Music* (London: Victor Gollancz, 1983)
- Alexander, S., *Beauty and Other Forms of Value* (London: MacMillan & Co., 1933)
- Alford, Violet, *Peeps at English Folk-Dances* (London: A. & C. Black, 1923)
- *Sword Dance and Drama* (London: Merlin Press, 1962)
- Amabile, Theresa A., *Creativity in Context: Update to The Social Psychology of Creativity* (Oxford: Westview Press, 1996)
- Anderson, Benedict, *Imagined Communities* Revised Edition. (London & New York: Verso, 1991) (first published 1983)
- Arbeau, Thoinot, *Orchesography: A Treatise in the form of a dialogue* trans. & ed C.W. Beaumont (London: Publisher Unknown, 1925)
- Atkinson, Paul, *The Ethnographic Imagination: Textual Constructions of Reality* (London: Routledge, 1990)
- Atkinson, Paul; Amanda Coffey; Sara Delamont; John Lofland & Lyn Lofland (eds), *Handbook of Ethnography* (London: Sage Publications, 2001)
- Austin-Chase, J. H., *Chance and Creativity* (New York: Columbia University Press, 1978)

- Baines, Anthony, *Bagpipes* (Oxford: Pitt Rivers Museum, Oxford University, 1960)
- Bartenieff, I., M. Davis, & F. Paulay, *Four Adaptations of Effort Theory in Research and Teaching* (New York: Dance Notation Bureau, 1970)
- Barz, G.F. & Cooley, T.J. (eds), *Shadows in the Field: New Perspectives for Fieldwork in Ethnomusicology* (Oxford: Oxford University Press, 1997)
- Bayer, R., *The Essence of Rhythm: Reflections on Art* Second Edition ed S. Langer (Oxford: Oxford University Press, 1958)
- Bendix, R., *In Search of Authenticity. The Formation of Folklore Studies* (Madison, Wisconsin: University of Wisconsin Press, 1997)
- Berkeley, George, *Works on Vision* (Indianapolis & New York: Bobbs-Merrill, 1963)
- Bernard, H.R., *Research Methods in Cultural Anthropology* (California: Publisher Unknown, 1988)
- Berne, E., *Games People Play; the Psychology of Human Relationships* (London: Penguin Books, 1968)
- Best, D., *Expression in Movement and the Arts – A Philosophical Enquiry* (London: Lepus Books, 1974)
- *Philosophy and Human Movement* (London: Unwin Educational Books, Allen & Unwin, 1978)
- Best, David, N., *Expression in Movement and the Arts* (London: Lepus Books, 1974)
- *Feeling and Reason in the Arts* (London: George Allen & Unwin, 1985)
- Blacking, John, *How Musical is Man?* (Seattle & London: University of Washington Press, 1973)
- Blacking, John, & J.W. Keali'inohomoku (eds.), *The Performing Arts: Music and Dance* (The Hague: Mouton, 1979)
- Blake, Lois, *Welsh Folk Dance and Costume* (Llangollen: Gwynn, 1954)
- *Traditional Dance and Costume in Wales* (Llangollen: Gwynn, 1972)
- Blasis, Carlo, *The Code of Terpsichore* (London: Edward Bull, 1928)

- Bochner, Arthur P. & Carolyn Ellis (eds), *Ethnographically Speaking Autoethnography, Literature and Aesthetics* (Walnut Creek: AltaMira Press, 2002)
- Bohlman, Philip V., *The Study of Folk Music in the Modern World* (Bloomington: Indiana University Press, 1988)
- Boyes, Georgina *The Imagined Village: Culture and the English Folk Revival* (Manchester: Manchester University Press 1993)
- Brake, M., *Comparative Youth Culture* (London: Routledge & Kegan Paul, 1985)
- Brinson, P., *Background to European Ballet; A Collection of Studies Relating to European Integration* (Leyden: A. W. Sijthoff, 1966)
- Brocken, Michael, *The British Folk Revival 1944-2002* (Aldershot, Ashgate 2003)
- Burt, Ramsay, *The Male Dancer: Bodies, Spectacle, Sexualities* (London & New York: Routledge, 1995)
- C., R.H., *The Scottish National Dances; Their Origin, Nature and History* (Aberdeen: D. Wyllie & Son, 1928)
- Campbell, John Francis, *Popular Tales of the West Highlands*, Four Volumes, New Edition (London, Paisley: Gardner, 1890-93)
- Campbell, Rev. John Gregorson, *Clan Traditions and Popular Tales of the Western Highlands and Islands* (London: David Nutt, 1895)
- Cannon, R.D., *The Highland Bagpipe and its Music* (Edinburgh: John Donald, 1988)
- Casciani, Elizabeth, *Oh, How we Danced: The History of Ballroom Dancing in Scotland* (Edinburgh: Mercat Press, 1994)
- Cheape, Hugh, *The Book of the Bagpipe* (Belfast: Appletree, 1999)
- *Tartan: The Highland Habit* (Edinburgh: National Museums of Scotland 1991)
- Cheape, Hugh, & Gavin Sprott, *Angus Country Life: A Companion to the Angus Folk Museum, Glamis* (Edinburgh: The National Trust for Scotland, 1980)

- Clement, Bill, *The Argyll Broadswords: The Origin and History as Danced in The Black Watch* (Edinburgh: B. Clement, 1994)
- Clifford, J. & Marcus, G.E. (Eds.), *Writing Culture: the Poetics and Politics of Ethnography* (California: University of California Press, 1984)
- Coffey, A., *The Ethnographic Self: Fieldwork and the Representation of Identity* (London: Sage Publications, 1999)
- Collie, George P., *Highland Dress* (London: Penguin Books, 1948)
- Collinson, Francis, *The Bagpipe: The History of a Musical Instrument* (London: Routledge & Kegan Paul, 1975)
- *The Traditional and National Music of Scotland* (London: Routledge & Kegan Paul, 1966)
- Colville, James, *Studies in Lowland Scots* (Edinburgh: William Green & Sons, 1909)
- Corrsin, Stephen D., *Sword Dancing in Europe: A History* (London: Hisarlik Press, 1997)
- Cowan, Jane, K., *Dance and the Body Politic in Northern Greece* (Princeton, New Jersey: Princeton University Press, 1990)
- Crawford, Thomas, *Society and the Lyric: A Study of Song Culture of Eighteenth Century Scotland* (Edinburgh: Scottish Academic Press 1979)
- Cumming, Alex. D., *Old Times in Scotland: Life, Manners and Customs* (Paisley: Alexander Gardner, 1910)
- Cuthbertson, D.C., *Highlands, Highways and Heroes; or, Wanderings in the Westlands, etc.* (Edinburgh: R. Grant & Son, 1931)
- *Romantic Scotland, the Story of the Shires* (Stirling: Eneas Mackay, 1938)
- Dalyell, Sir J.G., *Musical Memoirs of Scotland* (Edinburgh: T.G. Stevenson, 1849)
- Dégh, Linda, *Folktales and Society: Story Telling in a Hungarian Peasant Community*, Translated by Emily M. Schoosberger (Bloomington: Indiana University Press, 1969)

- Delamont, S. & Atkinson, P.A. *Fighting Familiarity* (Cresskill, New Jersey: Hampton Press, 1995)
- Desmond, Jane C. (ed.), *Meaning in Motion: New Cultural Studies of Dance* (Durham, North Carolina: Duke University Press, 1997)
- Dolby, J.T. (ed.), *An Introduction to Social Research* Second Edition (New York: Appleton-Century-Crofts, 1967)
- Dorson, Richard M. (ed.), *Folklife and Folklore: An Introduction* (Chicago & London: The University of Chicago Press, 1972)
- Douglas, M., *Rules and Meanings (The Anthropology of Everyday Knowledge)* (Harmondsworth: Penguin, 1973)
- Douglas, Ronald MacDonald (ed.), *Scottish Lore and Folklore* (New York: Beckman House, 1982)
- Dryerre, Henry, *Blairgowrie and Strathmore Worthies* (Publisher Unknown, 1903)
- Eagleton, Terry, *The Ideology of the Aesthetic* (Oxford: Basil Blackwell, 1990)
- Easterby-Smith, M., R. Thorpe & A. Lowe, *Management Research: An Introduction* (London: Sage Publications, 1991)
- Elliott, H.C., *The Shape of Intelligence: The Evolution of the Human Brain* (London: George Allen & Unwin, 1970)
- Elliott, Kenneth & Frederick Rimmer, *A History of Scottish Music* (London: BBC, 1973)
- Elton, William, *Aesthetics and Language* (Oxford: Basil Blackwell, 1954)
- Emmerson, George S., *Scotland Through Her Country Dances* (London: Johnson, 1967)
- *Rantin' Pipe and Tremblin' String: A History of Scottish Dance Music* Second Edition (London: J. M. Dent & Sons, 1971)
- *A Social History of Scottish Dance, Ane Celestial Recreation* (Montreal & London: McGill-Queens University Press, 1972)
- Farnell, B. (ed.), *Do You See What I Mean?: Plains Indian Sign Talk and the Embodiment of Action* (Austin: University of Texas Press, 1995)

- Featherstone, M. (ed.), *Global Culture: Nationalism, Globalisation and Modernity* (London: Sage Publications, 1990)
- Fittis, Robert Scott, *Sports and Pastimes of Scotland Historically Illustrated* (Paisley & London: Andrew Garner, 1891)
- Flett, J.F. & T.M., *Traditional Dancing in Scotland* (London: Routledge & Kegan Paul, 1964)
- *Traditional Step-Dancing in Scotland* (Edinburgh: Scottish Cultural Press, 1996)
- Foley, J.M., *The Singer of Tales in Performance* (Bloomington: Indiana University Press, 1995)
- Fonteyn, M., *The Magic of Dance* (London: BBC, 1980)
- Franks, A.H., *Social Dance: A Short History* (London: Routledge & Kegan Paul, 1963)
- Frith, Simon, *Performing Rites: On the Value of Popular Music* (Cambridge: Harvard University Press 1996)
- Frobenius, L., *The Childhood of Man: A Popular Account of the Lives, Customs and Thoughts of Primitive Races* (London: Seeley, 1909)
- Galeski, B., *Basic Concepts of Rural Sociology*, Translated by H.C. Stevens. (Manchester: Manchester University Press, 1972)
- Garbarino, M.S., *Socioculture Theory in Anthropology* (New York: Holt, Rhinehart & Winston, 1977)
- Garfinkel, H., *Studies in Ethnomethodology* (Cambridge: Polity Press, 1987)
- Gates, A., *A New Look at Movement – A Dancer's View* (Minneapolis: Burgess, 1968)
- Geertz, C., *The Interpretation of Cultures* (London: Hutchinson & Co., 1975)
- *Works and Lives: The Anthropologist as Author* (Cambridge, Oxford: Polity Press in Association with Basil Blackwell, 1989)
- Gellner, E., *Postmodernism, Reason and Religion* (London: Routledge, 1992)
- Gibson, John G., *Traditional Gaelic Bagpiping 1745-1945* (Montreal & Kingston: McGill-Queen's University Press, 1998)
- Giedion, S., *The Eternal Present: The Beginnings of Art* (Oxford: Oxford

University Press, 1962)

Goellner E.W. & J. Shea Murphy (eds), *Bodies of the Text: Dance as Theory, Literature as Dance* (New Brunswick, New Jersey: Rutgers University Press 1994)

Hall, Edward *Beyond Culture* (New York: Anchor Press/Doubleday 1976)

Hall, S. & Jefferson, T. (Eds.) *Resistance Through Rituals: Youth Subcultures in Post-War Britain* (London: Hutchinson 1976)

Hambly, W.D., *Tribal Dancing and Social Development* (London: Witherby, 1926)

Hammersley, M., *What's Wrong with Ethnography* (London: Routledge 1992)

Hammersley, M. & Paul Atkinson *Ethnography: Principles in Practice* Second Edition (London: Routledge, 1995)

Hammond, Peter B., *Cultural and Social Anthropology* (New York: MacMillan Co., 1971)

Hanna, Judith Lynne, *Dance, Sex and Gender: Signs of Identity, Dominance, Defiance and Desire* (Chicago & London: University of Chicago Press, 1988)

——— *To Dance is Human: A Theory of Non-Verbal Communication* (Austin, Chicago & London: University of Texas Press & University of Chicago Press, 1979)

Harding, S. (ed.), *Feminism and Methodology* (Bloomington & Milton Keynes: Indiana University Press & Open University Press, 1987)

Hardy, C.B., *Understanding Organisations* (England: Penguin, 1976)

Harker, Dave *Fakesong* (Milton Keynes, Open University Press, 1985)

Harris, M., *The Rise of Anthropological Theory* (New York: Crowell, 1968)

Harrison, J. E., *Ancient Art and Ritual* (Oxford: Oxford University Press, 1913)

Hastrup, Kirsten, & Hervik (eds), *Experience and Anthropological Knowledge* (London: Routledge, 1994)

Hebdige, D., *Subcultures: The Meaning of Style* (London: Methuen, 1979)

Heron, Patrick, *The Changing Forms of Art* (New York: The Noonday Press, 1958)

- Hoogvelt, Ankie *Globalization and the Postcolonial World: The New Political Economy of Development* (Basingstoke: MacMillan Press Ltd., 1997)
- Hood, Evelyn M., *The Story of Scottish Country Dancing: The Darling Diversion* (Glasgow: William Collins & Sons, 1980)
- Hunter, James, *The Fiddle Music of Scotland* (Great Britain: Chambers, 1979)
- Hutton, Ronald, *Rise and Fall of Merry England: The Ritual Year 1400-1700* (Oxford: Oxford University Press, 1994)
- Huysen, A. *After the Great Divide: Modernism, Mass Culture, Modernism* (Basingstoke: MacMillan, 1986)
- Jackson, A. (ed.), *Anthropology at Home* (London: Tavistock, 1987)
- Jacobson, M., M.F. Keller & S. Shuttleworth (eds), *Body/Politics: Women and the Discourse of Science* (New York: Routledge, 1990)
- Jarvie, Grant, *Highland Games: The Making of the Myth* (Edinburgh: Edinburgh University Press, 1991)
- Johnson, David, *Music and Society in Lowland Scotland in the Eighteenth Century* (London: Oxford University Press, 1972)
- *Scottish Fiddle Music in the 18th Century* (Edinburgh: Mercat, 1997)
- Johnson, M., *The Body in the Mind: The Bodily Basis of Imagination* (Chicago: University of Chicago Press, 1987)
- Junker, B., *Field Work* (Chicago, University of Chicago Press, 1960)
- Kant, Immanuel, *Critique of Judgement* (New York: Hafner, 1951)
- Keesing, R.M., *Cultural Anthropology, A Contemporary Perspective* (New York: Holt, Rinehart & Winston, 1981)
- Kelsen, H., *Society and Nature; A Sociological Inquiry* (Chicago: Chicago University Press, 1943)
- Kember, D., *Action, Learning and Action Research: Improving the Quality of Teaching and Learning* (London: Kogan Page, 2000)
- Kennedy, D., *England's Dances; Folk Dancing Today and Yesterday* (London: G. Bell & Sons, 1949)
- Kepes, G., *The Nature and Art of Motion* (London: Studio Vista, 1965)

- King, Anthony (ed.), *Culture, Globalization and the World System* (Basingstoke: MacMillan Education, 1991)
- Kunst, J., *Metre, Rhythm, Multipart Music* (Leiden: E.J. Brill, 1950)
- Laban, Rudolf, *Modern Educational Dance* (London: Macdonald & Evans, 1948)
- *The Mastery of Movement* (London: Macdonald & Evans, 1960)
- *Rudolf Laban Speaks About Movement and Dance* (Addlestone: The Laban Art & Movement Centre, 1971)
- Laban, Rudolf, & F.C. Lawrence, *Effort* (London: Macdonald & Evans, 1947)
- Lamb, W., *Posture and Gesture: An Introduction to the Study of Physical Behaviour* (London: Gerald Duckworth, 1965)
- Langerfeld, Herbert, *The Aesthetic Attitude* (New York: Harcourt, Brace & Rowe, 1920)
- Lawler, L.B., *The Dance in Ancient Greece* (London: Adam & Charles Black, 1964)
- Locke, John L., *The Child's Path to Spoken Language* (Cambridge, Mass. & London: Harvard University Press, 1993)
- Lockhart, G. W., *Highland Balls and Village Halls: A Look at the Scot and His Dancing* (Barr, Ayrshire: Luath Press, 1986)
- Logan, James, *The Scottish Gael Volume II* (Edinburgh & London: 1831)
- Lowie, R.H., *An Introduction to Cultural Anthropology* (New York: Farrar & Rinehart, 1934)
- *Culture and Ethnology*, Second Edition (New York & London: Basic Books, 1966)
- McCrone, D., *Understanding Scotland: The Sociology of a Stateless Nation* (London: Routledge, 1992)
- McCrone, D., A. Morris, & R. Keily, *Scotland the Brand: The Making of Scottish Heritage* (Edinburgh: Edinburgh University Press, 1995)
- MacDonald, K.N., *Puirt-a-Beul* (Glasgow: MacLaren, 1901)
- MacDonald, S., *Reimagining Culture: Histories, Identities and the Gaelic Renaissance* (Oxford & New York: Berg, 1997)

- McFee, Graham, *Understanding Dance* (London & New York: Routledge, 1992)
- *The Concept of Dance Education* (London: Routledge, 1994)
- McGillivray, Allister, *A Cape Breton Ceilidh* (Nova Scotia: Sea Cape Music, 1990)
- McGuigan, J. (ed.), *Cultural Methodologies* (London: Sage, 1997)
- MacKenzie, D.R., *The National Dances of Scotland* (Glasgow: MacLaren, 1910)
- McLaren, Moray, *Understanding the Scots* (London: G.B. Frederick Muller, 1956)
- McLee, Graham, *Understanding Dance* (London & New York: Routledge, 1992)
- McLennan, D.G., *Highland and Traditional Scottish Dances* (Edinburgh: Oliver & Boyd, 1950)
- *Highland and Traditional Scottish Dances* (Edinburgh: T. & A. Constable, 1952)
- McNeill, F. Marian, *The Silver Bough: A Four Volume Study of the National and Local Festivals of Scotland* (Glasgow: William MacLellan, 1959)
- McRobbie, Angela (ed.), *Postmodernism and Popular Culture* (London & New York: Routledge, 1994)
- *Back to Reality? Social Experience and Cultural Studies* (Manchester: Manchester University Press, 1997)
- *In The Culture Society: Art, Fashion and Popular Music* (London: Routledge, 1999)
- Mair, Lucy, *An Introduction to Social Anthropology* (Oxford: Clarendon Press, 1965)
- Malbon, B., *Clubbing: Dancing, Ecstasy and Vitality* (London: Routledge, 1999)
- Manuel, Peter, *Popular Musics of the Non-Western World* (Oxford: Oxford University Press, 1988)
- Marcus, G.E. & Fischer, M.J., *Anthropology as Cultural Critique: An*

- Experimental Moment in the Social Sciences* (Chicago & London: Chicago University Press, 1986)
- Marcus, George, E. *Ethnography Through Thick and Thin* (Princeton, New Jersey: Princeton University Press, 1998)
- Margolis, Joseph, *The Language of Art and Art Criticism* (Detroit: Wayne State University Press, 1965)
- Marion, Sheila, *Tap Dance* (New York: Ray Cook, 1986)
- Mauss, M., *Sociology and Psychology* (London: Routledge & Kegan Paul, 1979)
- Mayhew, H., *London Labour and the London Poor* (London: Griffin Bohn, 1861)
- Meredith, G.P., *Instruments of Communication* (Oxford: Pergamon Press, 1966)
- Merriam, Alan, *The Anthropology of Music* (Evanston: Northwestern University Press, 1964)
- *African Music in Perspective*, (New York: Garland, 1982)
- Millar, S., *The Psychology of Play* (London: Penguin Books, 1968)
- Mille, Agnes de, *The Book of the Dance* (London: Golden Press, 1963)
- Miller, C.N., (ed.), *The Nature of Dance* (New York: Universe Books, 1980)
- Miller, G. & R. Dingwall (eds), *Context and Method in Qualitative Research* (London: Sage, 1997)
- Milligan, J.C., *The Scottish Country Dance* (Great Britain: Paterson, 1924)
- *Won't You Join the Dance* (Great Britain: Paterson, 1948)
- Montagu, A., (ed.), *Man and Aggression*, Second Edition (Oxford: Oxford University Press, 1974)
- Munro, A. & M. MacLeod, *The Democratic Muse: Folk Music Revival in Scotland* (Aberdeen: Scottish Cultural Press, 1996)
- Munro, Thomas, *Toward Science and Aesthetics* (New York: Liberal Arts Press, 1956)
- Myers, Helen (ed.), *Ethnomusicology* Two Volumes (London: MacMillan, 1992)

- Nayak, P.R. & J.M. Ketteringham, *Breakthroughs!* (New York: Rawson, 1986)
- Neil, J. Murray, *The Scots Fiddle; Tunes, Tales and Traditions* (Great Britain: Moffat: Lochar, 1991)
- *The Scots Fiddle: Tunes, Tales and Traditions of the North-East and Central Highlands* (Glasgow: Neil Wilson Publishing, 1999)
- Ness, S.A., *Body Movement and Culture: Kinesthetic and Visual Symbolism in a Philippine Community* (Philadelphia: University of Pennsylvania Press, 1992)
- Nettl, B., *The Story of Dance Music* (New York: Philosophical Library, 1947)
- *Music in Primitive Culture* (Cambridge: Harvard University Press, 1956)
- *Folk and Traditional Music of the Western Continents* (Englewood Cliffs, New Jersey: Prentice Hall, 1965)
- *The Study of Ethnomusicology: Twenty-Nine Issues and Concepts* (Urbana: University of Illinois Press, 1983)
- North, M., *Personality Assessment through Movement* Second Edition (London: Macdonald & Evans, 1972)
- Novack, C., *Sharing the Dance: Contact Improvisation and American Culture* (Madison: University of Wisconsin Press, 1990)
- Noverre, J.G., *Letters on Dancing and Ballets*, Translated by C.W. Beaumont (London: C. W. Beaumont, 1930) (First published 1760)
- O'Keefe J.G., & Art O'Brien *A Handbook of Irish Dances* Seventh Edition (Dublin: Gill & MacMillan, 1914)
- O'Rafferty, Peadar & Gerald *Dances of Ireland* ed Violet Alford (London: Methuen & Company, n.d.) (first published 1953)
- Parker, D. *The First Seventy-Five Years of the Royal Academy of Dancing* (London: Royal Academy of Dancing, 1995)
- Patterson, F., *Innovation Potential Indicator: Manual and Users Guide* (Oxford: Oxford Psychologists Press, 1999)
- Pelto, Pertti J. & G. H., *Anthropological Research: The Structure of Enquiry* (Cambridge: Cambridge University Press, 1970)

- Piaget, J., *The Child's Conception of Movement and Speed* (London: Routledge & Kegan Paul, 1970) (First Published 1946)
- Piaget, J. & B. Inhelder, *The Child's Conception of Space* (London: Routledge & Kegan Paul, 1956) (First Published 1948)
- Preston, V., *A Handbook for Modern Educational Dance* (London: Macdonald & Evans, 1963)
- Preston-Dunlop, V., *Practical Kinetography Laban* (London: Macdonald & Evans, 1969)
- Purser, John, *Scotland's Music* (Edinburgh: Manistream, 1992)
- Rader, Melvin, *A Modern Book of Aesthetics* Third Edition (New York: Holt, Rinehart & Winston, 1960)
- Radin, P., *The Method and Theory of Ethnology; An Essay in Criticism* (New York & London: McGraw-Hill, 1933)
- Read, Herbert, *The Origins of Form in Art* (London: Thames & Hudson, 1965)
 ——— *Art and Society* (London: Faber & Faber, 1967)
- Redfern, Hildreth Beattie, *Dance, Art and Aesthetics* (London: Dance Books, 1988)
- Reid, L.A., *Meaning in the Arts* (London: Allen & Unwin, 1969)
- Rickards, T., *Creativity and the Management of Change* (Oxford: Blackwell, 1999)
- Rosen, E., *Dance in Psychotherapy* (New York: Teachers College, Columbia University, Bureau of Publications, 1959)
- Ross, Anne, *The Folklore of the Scottish Highlands* (London: B.T. Batsford, 1976)
- Royce, Anya Peterson, *The Anthropology of Dance* (Bloomington: Indiana University Press, 1980)
- Russell, Joan, *Creative Dance in the Primary School* (London: Macdonald & Evans, 1965)
- Rust, F., *Dance in Society* (London: Routledge & Kegan Paul, 1969)
- St. John, Charles, *The Wild Sports of The Highlands* (London: Butler & Tanner, 1948)

- Sandywell, B., et. al. (eds), *Problems of Reflexivity and Dialectics in Sociological Inquiry* (London: Routledge, Kegan & Paul, 1975)
- Schaper, Eva, *Prelude to Aesthetics* (London: Allen & Unwin, 1968)
- Sharp, Cecil J., *Sword Dances of Northern England* (London: Novello, 1912)
- *The Dance* (London: Halton & Truscott Smith, 1924)
- Sharp, Cecil J. & A.P. Oppé, *The Dance: An Historical Survey of Dancing in Europe* (London: Halton & Truscott Smith, 1924)
- Shepherd, Robbie, *Let's Have a Ceilidh; The Essential Guide to Scottish Dancing* (Edinburgh: Canongate, 1992)
- Sheppard, Anne, *Aesthetics: An Introduction to the Philosophy of Art* (Oxford: Oxford University Press, 1987)
- Shire, Helena Mennie, *Song, Dance and Poetry of the Court of Scotland Under James VI* (Cambridge: Cambridge University Press, 1969)
- Simmel, Georg *The Sociology of Georg Simmel* trans. & ed by Kurt H. Wolff (U.S.A.:The Free Press, 1964) (First Edition 1950)]
- Skinner, J. Scott, *A Guide to Bowing* (Edinburgh: Hardie Press, 1984)
- *The Harp and Claymore* (London & Glasgow: Bayley & Ferguson, 1890)
- Spalding, S.E. & Woodside, J.H., *Communities in Motion: Dance, Community, and Tradition in America's Southeast and Beyond* (Westport, Connecticut: Greenwood Press, 1995)
- Sparshott, F., *A Measured Pace: Toward a Philosophical Understanding of the Arts of Dance* (Toronto & London: University of Toronto Press, 1995)
- Spradley, James P., *Participant Observation* (Fort Worth: Harcourt Brace Jovanovich College Publishers, 1980)
- Steiner, G., *Language and Silence* (London: Faber & Faber, 1967)
- Strawson, Peter, F., *Freedom and Resentment* (London: Methuen, 1974)
- Strinati, Dominic, *Introduction to Theories of Popular Culture* (London & New York: Routledge, 1995)
- Taylor, Timothy, *Global Pop: World Music, World Markets* (London: Routledge, 1997)

- Thomas, Carolyn, *Aesthetics and Dance* (Reston, Virginia: National Dance Association, 1980)
- *Dance, Modernity and Culture: Explorations in the Sociology of Dance* (London & New York: Routledge, 1995)
- Thornton, S., *A Movement Perspective of Rudolf Laban* (London: MacDonald & Evans, 1971)
- *Club Cultures: Music, Media and Subcultural Analysis* (Cambridge: Polity Press, 1995)
- Tilghman, B.R., *The Expression of Emotion in the Visual Arts: A Philosophical Inquiry* (The Hague: Martinus Nijhoff, 1970)
- Tolstoy, Leo, *What is Art?* (London: Oxford University Press, 1950)
- Tomlinson, Kellom, *Art of Dancing* (London: Publisher Unknown, 1735)
- Turner, Victor, *Dramas, Fields and Metaphors* (Ithaca, New York: Cornell University Press, 1974)
- *From Ritual to Theatre* (New York: P.A.J. Publications, 1982)
- Veeser, H. Aram, *The New Historicism* (New York & London: Routledge, 1989)
- Vermeulen, H.F. & Alvarez Arturo Roldán, *Fieldwork and Footnotes: Studies in the History of European Anthropology* (London: Routledge, 1995)
- Weaver, J., *A Small Treatise of Time and Cadence in Dancing* (London: Weaver, 1706)
- Webster, D., *Scottish Highland Games* (Great Britain: Collins, 1959)
- Welton, Donn (ed.), *Body and Flesh: A Philosophical Reader* (Oxford: Blackwell, 1999)
- Werner, O. & G.M. Schoepfle, *Systematic Fieldwork: Foundations of Ethnography and Interviewing* (California: Sage Publications, 1987)
- Wildeblood, J., *The Polite World* (London: Davis-Poynter, 1973)
- Williams, I. E., *Scottish Country Dancing* (Great Britain: Chambers, 1991)
- Williams, Raymond, *Culture and Society 1780-1950* (London: Chatto & Windus, 1958)

- *Keywords: A Vocabulary of Culture and Society* Revised Edition (London: Flamingo, 1983)
- Williams, T.R., *Field Methods in the Study of Culture* (New York: Holt, Rinehart & Winston, 1967)
- Willis, P., *Learning to Labour: How Working Class Kids Get Working Class Jobs* (Farnborough: Saxon House, 1977)
- Willis, P., & S. Jones, J. Canaan, & G. Hurd, *Common Culture* (Milton Keynes: Open University Press, 1990)
- Wilson, T., *A Companion to the Ballroom* (London: Publisher Unknown, 1816)
- Wilson, Thomas, *An Analysis of Country Dancing*, Second Edition (London: Publisher Unknown, 1811)
- Winch, P., *The Idea of a Social Science: and its Relation to Philosophy* (London: Routledge & Kegan Paul, 1958)
- Wolf, M., *A Thrice-Told Tale: Feminism, Postmodernism and Ethnographic Responsibility* (Stanford: Stanford University Press, 1992)
- Worsdall, F., *The Glasgow Tenement: A Way of Life* (Edinburgh: W & R Chambers, 1979)
- Wosien, Maria-Gabreile, *Sacred Dance: Encounter with the Gods* (London: Thames & Hudson, 1974)
- Yates, G., *The Ball* (London: Publisher Unknown, 1829)

Volumes of Essays

- Adshead-Lansdale, Janet & June Layson (eds), *Dance History: An Introduction* Second Edition. (London: Routledge, 1996)
- Adshead, Janet (ed.), *Dance Analysis: Theory and Practice* (London: Dance Books, 1988)
- Brettell, C.B. (ed.), *When They Read What We Write: The Politics of Ethnography* (Westport, London: Bergin & Garvey, 1993)
- Buckland, Theresa, J. (ed.), *Dance in the Field: Methods and Issues in Dance Ethnography* (Houndmills, Basingstoke: MacMillan Press, 1999)

- Copeland, R. & M. Cohen (eds), *What is Dance?* (Oxford: Oxford University Press 1983)
- Cowan, E., *The People's Past* (Edinburgh: Polygon, 1991)
- Felföldi, Laszlo & Buckland, Theresa J. (eds), *Authenticity: Whose Tradition?* (Budapest: European Folklore Institute, 2002)
- Fenton, A. *The Shape of the Past: Essays in Scottish Ethnology* (Edinburgh: John Donald Publishers Ltd., 1985)
- Hammersley, Martyn, *Taking Sides in Social Research: Essays on Partisanship and Bias* (London & New York: Routledge, 2000)
- Hobsbawn, Eric & Ranger, Terence (eds), *The Invention of Tradition* (Cambridge: Cambridge University Press 1983)
- Hockings, Paul (ed.), *Principles of Visual Anthropology* (The Hague: Mouton 1975)
- Horton-Fraleigh, Sandra & Penelope Hanstein (eds), *Researching Dance: Evolving Modes of Inquiry* (Pittsburgh: University of Pittsburgh Press 1999)
- James, A. Hockey, J., & Dawson, A. (eds), *After Writing Culture: Epistemology and Praxis in Contemporary Anthropology* (London & New York: Routledge, 1997)
- Jarvie, Grant, & G. Walker, (eds), *Scottish Sport in the Making of a Nation* (Leicester: Leicester University Press, 1994)
- Keali'inohomoku, Joann W. & John Blacking (eds), *Performing Arts: Music and Dance* (The Hague: Moulton, 1979)
- Morphy, H. & Banks, M. (eds), *Rethinking Visuals in Anthropology* (New Haven & London: Yale University Press, 1997)
- Nicholson, L.J. (ed.), *Feminism/Postmodernism* (London: Routledge, 1990)
- Shusterman, Richard (ed.), *Analytic Aesthetics* (Oxford: Basil Blackwell, 1989)

- Sibley, Frank, *Approach to Aesthetics: Collected Papers on Philosophical Aesthetics by Frank Sibley* Edited by John Benson, Betty Redfern & Jeremy Roxbee Cox (Oxford: Clarendon, 2001)
- Smith, Adam. *Essays on Philosophical Subjects* (London: Cadell & Davies, 1795)
- Spencer, P. (ed.), *Society and the Dance: The Social Anthropology of Process and Performance*, Cambridge: Cambridge University Press, 1985)
- Stanley, L. (ed.), *Feminist Practice* (London: Routledge 1990)
- Stocking, G.W. (ed.), *Observers Observed: Essays on Ethnographic Fieldwork* (Wisconsin: University of Wisconsin Press, 1983)
- Thomas, Helen (ed.), *Dance, Gender and Culture* Second Edition (Basingstoke: MacMillan Press Ltd., 1995)
- *Dance in the City* (London: MacMillan Press, 1997)
- Washabaugh, William (ed.), *The Passion of Music and Dance: Body, Gender and Sexuality* (Oxford: Berg, 1998)

Essays in Books

- Butler, J., 'Performative Acts and Gender Constitution: An Essay in Phenomenology and Feminist Theory', in *Performing Feminisms: Feminist Critical Theory and Theatre* S.L. Case (ed.), (Baltimore: John Hopkins University, 1990) pp.270-782
- Bordo, S. 'Feminism, Postmodernism and Gender-Scepticism', in *Feminism Postmodernism* L. Nicholson (ed.), (London: Routledge 1990a) pp.133-156
- 'Reading the Slender Body', in *Body Politics: Women and the Discourses of Science* M. Jacobson, M.F. Keller & S. Shuttleworth (eds.), (New York: Routledge, 1990b) pp.83-112
- Bakka, Fgil, 'Or Shortly They Would Be Lost Forever Documenting For Revival and Research', in *Dance in the Field: Theory, Methods and*

- Issues in Dance Ethnography* Buckland, Theresa J., (ed.). (Houndmills, Basingstoke: MacMillan Press, 1999) pp71-82
- 'Whose Dances, Whose Authenticity?', in *Authenticity: Whose Tradition?* Felföldi, Laszlo & Buckland, T. (eds), (Budapest: European Folklore Institute, 2002) pp60-69
- Beaudry, N., 'The Challenges of Human Relations in Ethnographic Enquiry', in *Shadows in the Field: New Perspectives for Fieldwork in Ethnomusicology* Barz G.F. & Cooley, T.J. (eds), (Oxford: Oxford University Press, 1997) pp.63-83
- Berg, Shelly C., 'The Sense of The Past: Historiography and Dance', in *Researching Dance: Evolving Modes of Inquiry* Sondra Horton Fraleigh & Penelope Hanstein (eds), (Pittsburg: University of Pittsburg Press 1999) pp.225-248
- Buckland, Theresa J. (ed.), 'Introduction: Reflecting on Dance Ethnography', in *Dance in the Field: Theory, Methods and Issues in Dance Ethnography* Buckland, Theresa, J., (ed.), (Houndmills, Basingstoke: MacMillan Press 1999) pp.1-10
- Clifford, J., 'Power and Dialogue in Ethnography: Marcel Griaule's Initiation', in *Observers Observed: Essays in Ethnographic Fieldwork* G. Stocking (ed.), (Madison: University of Wisconsin Press, 1983) pp.121-56
- Cheape, Hugh 'The Pipes and Folk Music', in *The People's Past* Second Edition, Cowan, E. (ed.), (Edinburgh: Polygon, 1991) pp.137-155
- Clifford, James 'On Collecting Art and Culture', in *The Predicament of Culture* (Cambridge, Massachusetts: Harvard University Press, Cambridge, 1988) pp.215-251
- Derrida, J. & C.V. McDonald, 'Choreographies', in *Bodies of the Text: Dance as Theory, Literature as Dance* E.W. Goellner & J. Shea Murphy (eds), (New Brunswick, New Jersey: Rutgers University Press, 1995) pp.141-157

- Dingwall, R., 'Accounts Interviews and Conversations', in *Context and Method in Qualitative Research* Miller, G. & R. Dingwall (eds), (London: Sage, 1997) pp.51-65
- Dilworth, John, 'The Violin and Bow – Origins and Development', in *The Cambridge Companion to the Violin* Stowell, R. (ed.), (Cambridge: Cambridge University Press, 1992) pp.1-29
- Ellingson, T., 'Transcription', in *Ethnomusicology: An Introduction* Myers, H. (ed.), (London: MacMillan, 1992) pp.110-152
- 'Notation', in *Ethnomusicology: An Introduction* Myers, H. (ed.), (London: MacMillan, 1992) pp.153-64
- Farnell, B., 'It Goes Without Saying - But Not Always', in *Dance in the Field: Theories, Methods and Issues in Dance Ethnography* Buckland, Theresa, J. (ed.), (Houndmills, Basingstoke: MacMillan Press, 1999) pp. 145-160
- Felföldi, László, 'Folk Dance Research In Hungary: Relations Among Theory, Fieldwork and The Archive', in *Dance in the Field; Theories, Methods and Issues in Dance Ethnography* Theresa J. Buckland (ed.) (Houndmills, Basingstoke: MacMillan Press, 1999) pp.55-70
- Fenton, A., 'The Scope of Regional Ethnology', in *The Shape of the Past: Essays in Scottish Ethnology* 1 Fenton, A. (ed.), (Edinburgh: John Donald Publishers Ltd., 1985) pp.43-54
- Gibson, Magi, 'Scotland, Oh Scotland', in *Wild Women of a Certain Age* (Edinburgh: Chapman Publishing, 2000) pp.37-38
- Giurchescu, Anca, 'Past and Present In Field Research: A Critical History Of Personal Experience', in *Dance in the Field; Theories, Methods and Issues in Dance Ethnography* Theresa J. Buckland (ed.), (Houndmills, Basingstoke: MacMillan Press, 1999) pp.41-54
- Gore, G., 'Textual Fields: Representation in Dance Ethnography', in *Dance in the Field: Theory, Methods and Issues in Dance Ethnography* Buckland, Theresa J. (ed.), (Houndmills, Basingstoke: MacMillan Press, 1999) pp.208-220

- 'Traditional Dance in West Africa', in *Dance History: An Introduction*
 Second Edition, Adshead-Lansdale, Janet & June Layson (eds),
 (London: Routledge, 1996) pp.59-77
- Goss R.N, 'Dance', in *The New Companion to Scottish Culture*, Daiches, David
 (ed.), (Edinburgh, Polygon, 1993) pp.73-74
- Grau, Andrée 'Fieldwork, Politics and Power', in *Dance in the Field: Theory,
 Methods and Issues in Dance Ethnography* Buckland, Theresa, J. (ed.),
 (Houndmills, Basingstoke: MacMillan Press, 1999) pp.163-174
- Horton, R., 'African Traditional Thought and Western Science', in *Knowledge
 and Control: New Directions for the Sociology of Education* M.F.D.
 Young (ed.), (London: Collier-MacMillan, 1971) pp.208-67
- Hall, Frank, 'Madness and Recall: Storied Data on Irish Dancing', in *Dance in
 the Field: Theory, Methods and Issues in Dance Ethnography* Buckland,
 Theresa, J. (ed.), (Houndmills, Basingstoke: MacMillan Press, 1999)
 pp.123-133
- Hughes-Freeland, Felicia 'Dance on Film: Strategy and Serendipity', in *Dance
 in the Field: Theory, Methods and Issues in Dance Ethnography*,
 Theresa, J. (ed.), (Houndmills, Basingstoke: MacMillan Press, 1999)
 pp.111-122
- Kaeppler, A.L., 'Structured Movement Systems in Tonga', in *Society and the
 Dance* P. Spencer (ed.), (Cambridge: Cambridge University Press,
 1985) pp.92-119
- 'The Mystique of Fieldwork', in *Dance in the Field: Theory, Methods
 and Issues in Dance Ethnography* Buckland, Theresa, J. (ed.),
 (Houndmills, Basingstoke: MacMillan Press, 1999) pp.13-25
- Keali'inohomoku, Joann Wheeler, 'An Anthropologist Looks at Ballet as a Form
 of Ethnic Dance', in *What is Dance* Copeland & Cohen (eds), (Oxford:
 Oxford University Press, 1983) pp.533-549

- 'Folk Dance', in *Folklore and Folklife: An Introduction* Dorson, Richard M. (ed.), (Chicago & London: The University of Chicago Press 1972) pp.381-404
- Koutsouba, M., "'Outsider" in an "Inside" World, or Dance Ethnography at Home', in *Dance in the Field: Theories, Methods and Issues in Dance Ethnography* Buckland, Theresa, J. (ed.), (Houndmills, Basingstoke: MacMillan Press, 1999) pp.186-95
- MacDonald, Donald A. 'Fieldwork: Collecting Oral Literature', in *Folklore and Folklife: An Introduction* Dawson, Richard M. (ed.), (Chicago & London: The University of Chicago Press, 1972) pp.407-430
- MacDougall, D., 'Beyond Observational Cinema', in *Principles of Visual Anthropology* Second Edition, Hockings, P (ed.), (Berlin: Mouton de Gruyter, 1975) pp.115-132
- 'The Visual in Anthropology', in *Rethinking Visuals in Anthropology* Morphy, H. & M. Banks, (eds), (New Haven & London: Yale University Press, 1997) pp.276-95
- MacInnes, John, 'Gaelic Folksong', in *The New Companion to Scottish Culture*, Daiches, David (ed.), (Edinburgh, Polygon, 1993) pp.114-116
- MacMillan, Duncan, 'Old and Plain: Music and Song in Scottish Art', in *The People's Past*, Second Edition, Cowan, E. (ed.), (Polygon, Edinburgh 1991) pp.54-64
- Miller, D., 'Introduction: Anthropology, Modernity and Consumption', in *Worlds Apart: Modernity Through the Prism of the Local* D. Miller (London: Routledge, 1995) pp.1-22
- Morphy, H. & M. Banks, 'Introduction', in *Rethinking Visuals in Anthropology* Morphy, H. & M. Banks, (eds), (New Haven & London: Yale University Press, 1997) pp.1-35
- Nadel-Klein, J. 'Crossing a Representational Divide: From West to East in Scottish Ethnography', in *After Writing Culture: Epistemology and Praxis in Contemporary Anthropology* James, Allison, Jenny Hockey &

- Andrew Dawson (eds), (London & New York: Routledge, 1997) pp.86-102
- Ness, S.A., 'Observing the Evidence Fail: Difference Arising from Objectifications in Cross-Cultural Studies of Dance', in *Moving Words: Rewriting Dance* Morris, G (ed.), (New York: Routledge, 1996) pp.245-269
- Novack, C., 'Ballet, Gender and Cultural Power', in *Dance, Gender and Culture* Thomas, H. (ed.), (Basingstoke: MacMillan, 1993) pp.34-48.
- Oyortey, Zagba 'Still Dancing Downwards and Talking Back', in *Dance, Gender and Culture* Second Edition, Thomas, Helen (ed.), (Hampshire & London: MacMillan Press Ltd., 1995) pp.184-199
- Prost, J.H., 'Filming Body Behaviour', in *Principles of Visual Anthropology* Hockings, Paul (ed.), (The Hague: Mouton 1975) pp.325-363
- Ronström, Owe 'It Takes Two - Or More - To Tango: Researching Traditional Music/Dance Interrelations', in *Dance in the Field: Theories, Methods and Issues in Dance Ethnography* Buckland, Theresa, J. (ed.), (Houndmills, Basingstoke: MacMillan Press, 1999) pp.134-144
- Sprott, Gavin, 'Traditional Music: The Material Background', in *The People's Past* Second Edition, Cowan, E. (ed.), (Polygon, Edinburgh, 1991) pp.54-64
- Thomas, Helen, 'Ethnography Dances Back', in *The Body, Dance and Cultural Theory* Helen Thomas (ed.) (Basingstoke, New York: Palgrave, 2003) pp.64-88
- 'An-Other Voice: Young Women Dancing and Talking', in *Dance, Gender and Culture* Helen Thomas (ed.), (Basingstoke: MacMillan Press, 1993) pp.69-93
- 'Dancing: Representation and Difference', in *Cultural Methodologies* J. McGuigan (ed.), (London: Sage, 1997) pp.142-55
- Van Zile, Judy 'Capturing the Dancing. Why and How', in *Dance in the Field: Methods and Issues in Dance Ethnography* Buckland, Theresa, J. (ed.), (Houndmills, Basingstoke: MacMillan Press, 1999) pp.85-99

- Ward, Andrew 'Dancing in the Dark: Rationalism and the Neglect of Social Dance', in *Dance, Gender and Culture* Second Edition, Thomas, Helen (ed.), (Hampshire & London: MacMillan Press Ltd., 1995) pp.16-33
- Widdess, Richard, 'Historical Ethnomusicology', in *Ethnomusicology: An Introduction* Myers, H. (ed.), (London: MacMillan, 1992) pp.219-237
- Williams, Drid, 'Fieldwork', in *Dance in the Field: Theory, Methods and Issues in Dance Ethnography* Buckland, Theresa, J., (ed.) (Houndmills, Basingstoke: MacMillan, 1999) pp.26-40
- Williams, Drid, 'Space, Intersubjectivity and the Conceptual Imperative: Three Ethnographic Cases', in *Human Action Signs in Cultural Context: The Visible and Invisible in Movement and Dance* Farnell, Brenda (ed.) (New Jersey: Scarecrow Press, 1995) pp.44-81
- Woolgar, S. (1988) 'Reflexivity is the Ethnographer of the Text', in *Knowledge and Reflexivity: New Frontiers in the Sociology of Knowledge* Woolgar, S. (ed.), (London: Sage, 1991) pp.14-35
- Young, Iris, 'Throwing Like A Girl', in *Throwing Like A Girl* (Bloomington, Indiana: Indiana University Press, 1990) pp.141-159

Articles and Reviews in Journals, Newspapers and Events Programmes

- Amabile, T.M., 'How to Kill Creativity', *Harvard Business Review* (September-October 1998) 77-87
- Anderson, Jack, 'Idealists, Materialists, and the Thirty-Two Fouettés', *Ballet Review* 5,1 (1975-1976) 13-21
- Argyris, C., 'Teaching Smart People How to Learn', *Harvard Business Review on Knowledge Management* (1998) 81-108
- Brewer, J.D., 'The Ethnographic Critique of Ethnography: Sectarianism in the RUC', *Sociology* 28(1) (February 1994) 231-244
- Blacking, J., 'Some Problems of Theory and Method in the Study of Musical Change', *Yearbook of the International Folk Music Council (IFMC)* (1977) 148-173

- Blom, Jan-Petter & Tettef Kvifte, 'On the Problem of Inferential Ambivalence in Musical Meter', *Ethnomusicology* (Fall 1986) 491-516
- Bright, Charles & Michael Geyer, 'For a unified history of the world in the twentieth century', *Radical History Review* 39 (1987) 69-91
- Brown, Carol, 'Unpacking the Body', *Dance Research Journal* 14(4) 1998 13-16
- Buckland, Theresa J., 'Th'Owd Pagan Dance: Ritual, Enchantment, and an Enduring Intellectual Paradigm', *Journal for the Anthropological Study of Human Movement* 11(4); 12(1) (Fall 2001/Spring2002) 415-452
- Burt, Ramsay, "'Dance Theory, Sociology, and Aesthetics', from 'Dance Research: Perspectives on the Past, Outlook toward the Future', Presented at 2000 Feet: A Celebration of World Dance, Philadelphia, Pennsylvania, USA 23/06/1999", *Congress on Research in Dance (CORD) Dance Research Journal* 32(1) (Summer 2000) 125-131
- Caplan, P., 'Engendering Knowledge: The Politics of Ethnography Part I', *Anthropology Today* 14(5) (1988) 8-12
- Chilkousky, N., 'Techniques for the Choreologist', *Ethnomusicology* 5, (1961) 121-127
- Enslin, E., 'Beyond Writing: Feminist Practice and the Limitations of Ethnography', *Cultural Anthropology* 9(4) (1994) 537-68
- Foster, S.L., 'Choreographies of Gender', *Signs: Journal of Women in Culture and Society* 24(1) (1998) 1-33
- Farnell, B., 'Ethno-Graphics and the Moving Body', *MAN: The Journal of the Royal Anthropological Institute London* 29 (1994) 929-974
- Flett, J.F. & T.M. Flett, 'Some Early Highland Dancing Competitions', *Aberdeen University Press Review* 36(115) (1956) 345-58
- 'Social Dancing in Scotland 1700-1914', *Folk Song and Dance Society (FDSS)* (1957) 153-163
- Foley, Catherine E., 'Perceptions of Irish Step Dance: National, Global and Local', *Congress on Research in Dance (CORD) Dance Research Journal* 33(1) (Summer 2001) 34-45

- Garvin, D.A., 'Building a Learning Organisation', *Harvard Business Review* (July-August 1993) 78-91
- Giurchescu, Anca, 'La Danse comme objet sémiotique', *Yearbook of the International Folk Music Council (IFMC)* 5 (1973) 175-178
- 'The Process of Improvisation in Folk Dance', *Dance Studies* 7 (1983) 21-57
- 'The Dance Symbol as a Means of Communication', *Acta Ethnographica Hungarica* 39(1-2) (1994) 95-10
- 'Interpreting a Dancer's Discourse on Improvisation', in *Proceedings: 20th Symposium of the International Council for Traditional Music (ICTM) Study Group on Ethnochoreology* 32 (California, Los Angeles: ICTM, 2000) 259-274
- Giurchescu, A. & Torp, L. 'Theory and Methods in Dance Research: a European approach to the holistic study of dance', *Yearbook for Traditional Music* 23 (1991) 1-10
- Giurchescu, Anca 'Power and the Dance Symbol and its Socio-Political Use', *Proceedings: 17th Symposium of the International Council for Traditional Music (ICTM) Study Group on Ethnomusicology* 5 (Los Angeles, California: ICTM, 1973) 15-22
- Gledhill, Ruth, 'Love at First Waltz', *The Times: Weekend* (19/08/95) 1-3
- Grau, Andrée, 'John Blacking and the Development of Dance Anthropology in the UK', *Dance Research Journal* 25(2) (Fall 1993) 21-32
- 'Ritual Dance and "modernisation": The Tiwi Example', *Yearbook for Traditional Music* 33 (2001) 72-81
- 'Tiwi Dance Aesthetics', *Yearbook for Traditional Music* 35 (2002) 175-180
- Guillard, Y., 'Early Scottish Reel Setting Steps and the Influence of the French Quadrille', *Dance Studies* 12 (1989) [all]
- Hall, Frank 'Posture in Irish Dancing', *Visual Anthropology* 8,2-4 (1996) 251-266

- Hammersley, M., 'A Myth of a Myth? An Assessment of Two Ethnographic Studies of Option Choice Schemes', *British Journal of Sociology* 42,1 (March 1991) 61-94
- 'What's Wrong with Ethnography?: The Myth of Theoretical Description', *Sociology* 24(4) (November 1990) 597-615
- Hannah, Martin, 'Highland Games SOS', *Scotland on Sunday - Sports Section* (20/07/2003) 16
- Haraway, D., 'Situated Knowledge: the Science Question in Feminism and the Privilege of Partial Perspective', *Feminist Studies* 14(3) (Fall 1998) 575-99
- Hartsock, N., 'Rethinking Modernism: Minority and Majority Theories', *Cultural Critique* 7, (1987) 187-206
- Hastrup, K., 'Out of Anthropology: The Anthropologist as an Object of Dramatic Representation', *Cultural Anthropology* 7(3) (1992) 327-45
- Herbison-Evans, D., 'Dance, Video, Notation and Computers', *Leonardo* 21(1) (1988) 45-50
- Kaeppler, A.L., 'Method and Theory in Analysing Dance Structure with an Analysis of Tongan Dance', *Ethnomusicology* 16(2) (1972) 173-217
- 'Dance in an Anthropological Perspective', *Annual Review of Anthropology* 7 (1978) 31-49
- 'American Approaches to the Study of Dance', *Yearbook for Traditional Music* 23 (1991) 11-21
- " 'Dance Ethnology and the Anthropology of Dance', Presented at 2000 Feet: A Celebration of World Dance, Philadelphia, Pennsylvania, USA 23/06/1999", *Congress on Research in Dance (CORD) Dance Research Journal* 32(1) (Summer 2000) pp116-125
- Keali'inohomoku, Joann Wheeler, 'Dance Culture as a Microcosm of Holistic Structure', *Congress on Research in Dance (CORD) Dance Research Annual* 6 (1972) 99-106
- 'Review Number One - Caveat on Causes and Correlations', *Committee on Research in Dance (CORD) News* 6,2 (July 1974) 20-24

- Kennedy, D., 'England's Ritual Dances', *Journal of the International Folk Music Council* 2, (1950) 8
- Kirchenblatt-Gimblett, Barbara 'Theorizing Heritage', *Ethnomusicology* 39(Fall 1995) 368-380
- Knust, Albrecht, 'The Notation of Details in National Dances', *Dance Notation Record* 11(2) (1960) 2-3
- Knust, Albrecht, *The Principles and Basic Ideas of Kinetography Laban*, Article for the International Council for Kinetography Laban Conference (ICKL) (ICKL, 1963) n.p.
- Kurath, G.P., 'Choreology and Anthropology', *American Anthropologist* 58(1) (1956) 177-179
- 'Panorama of Dance Ethnology', *Current Anthropology* 1(3) (Chicago: 1960) 233-254
- Laidlaw, I., 'It's a Lassies', Game', *The Scots Magazine* 117(6) (September 1982) 632-651
- Levinson, A., 'The Idea of the Dance from Aristotle to Mallarmé', *Theatre Arts Monthly*, 9,8, (1927) 571-583
- Livingstone, T., Revivals: 'A Model', *Ethnomusicology* 41(1999) 66-85
- Lowe, G.B., 'Random Thoughts on Highland Music and Dancing', *Arbroath Herald and County Advertiser, Angus Christmas Number* (18/12/1976) [three pages, not numbered]
- McGuire, Alex, 'Highland Dancing: Scottish Official Highland Dancing Association', in *Scotland's Dances: A Review of the Conference on the Diversity of the Scottish Tradition of Dance 25-26/10/1994* (1994) 9-13
- MacLachlan 'Highland Dancing', *American Interest* (1998) 80-83
- Martin, György & Ernő Pesovár, 'A Structural Analysis of the Hungarian Folk Dance: A Methodological Sketch', *Acta Ethnographica* (1961) 1-27
- 'Determination of Motive Types in Dance Folklore', *Acta Ethnographica* 12(3-4) (1963) 295-331
- Meerlo, J.A.M., 'Archaic Behaviour and the Communicative Art', *Psychiatric Quarterly* 29 (1955) 60-73

- Meglin, Joellen A. 'Review of *Dance in the City*, Thomas, Helen (ed.), Basingstoke: MacMillan 1997', in *Congress on Dance Research (CORD) Dance Research Journal* 32(1) (Summer 2000) 138-141
- 'Review of *Researching Dance: Evolving Modes of Inquiry*, Fraleigh, Sandra Horton & Penelope Hanstein (eds), (Pittsburgh: University of Pittsburgh Press, 1999)', in *Congress on Dance Research (CORD) Dance Research Journal* 32(2) (Winter 2000-2001) 132-138
- Mill, Charlie, 'Dancing History - Just along the Road', in *124th Ballater Highland Games Programme* (1997) 9-11
- 'Which Tulloch?', in *153rd Lonach Highland Games Programme* (August 1994) 37
- Minton, Sandra, " 'Research in Dance: Educational and Scientific Perspectives', from 'Dance Research: Perspectives on the Past, Outlook toward the Future', Presented at 2000 Feet: A Celebration of World Dance, Philadelphia, Pennsylvania, USA 23/06/1999", *Congress on Research in Dance (CORD) Dance Research Journal* 32(1) (Summer 2000) 110-116
- Ness, S.A., 'Originality in Postcolony: Choreographing the Neoethnic Body of Phillipine Ballet', *Cultural Anthropology* 12,1 (1997) 64-108
- Nilsson, Mats, 'Sailing on the Dance Floor: A modest attempt at understanding a way of dancing', for *ICTM Study Group on Ethnochoreology: Structural Analysis of Dance* (2004) 1-15
- Öztürkmen, A., 'Folk Dance and Nationalism in Turkey', *Proceedings: 17th Symposium of the International Council for Traditional Music (ICTM) Study Group on Ethnochoreology* Los Angeles, California: ICTM, 1994) 83-86
- Pigg, Andrew, 'From Social Dancer to Social Competitor', *United Kingdom Alliance 98th Centenary Review* (2000) 18
- Porter, James, 'Harps, Pipes and Silent Stones: The Problem of Pictish Music', *Selected Reports in Ethnomusicology* 4 (1983) 243-267

- Purser, John, 'Traditional Music and Dance', in *Scotland's Dances: A Review of the Conference on the Diversity of the Scottish Tradition of Dance* (25-26/10/1994) 3-4
- Quinn, Peter, 'Review of the Scottish Official Board of Highland Dancing Textbook', *Dancing Times* Christmas Issue (1955) 156
- Ronström, O., 'Revival Reconsidered', *The World of Music: Journal of the International Institute for Traditional Music* (1996) 38,3 5-20
- Shand, Willie, 'When will we see yer like again?', *People's Friend* 6806. (01/07/2000) n.p.
- Shay, Anthony, 'Parallel Traditions: State Folk Dance Ensembles and Folk Dance in "The Field"', *Congress on Research in Dance (CORD) Dance Research Journal* 31(1) (Spring 1999) 29-56
- Sheer, N., 'Audience Evaluation and Audience Effects', *Journal of Experimental Social Psychology* (1973) 10
- Sklar, D., 'On Dance Ethnography', *Dance Research Journal* 23(1) (1991) 6-10
- ' "All the Dances have Meaning to that Apparition": Felt Knowledge and the Danzantes of Tortugas', *Dance Research Journal* 31(2) (1999) 14-33
- 'Reprise: On Dance Ethnography', *Dance Research Journal* 32(1) (2000) 70-77
- Springs, S., 'That's Show Business', *Observer: Sport* (21/01/1994) 3
- Stacey, J. & Thorne, B., 'The Missing Feminist Revolution in Sociology', *Social Problems* 324 (April 1985) 301-16
- Stacey, J., 'Can There be a Feminist Ethnography?', *Women's Studies International Forum* 11,1 (1988) 21-27
- Stanley, L., 'Doing Ethnography, Writing Ethnography: A Comment on Hammersley', *Sociology* 24,4 (November 1990a) 617-27
- Stoeltje, B.C. Fox & S. Olbrys, 'The Self in Fieldwork: A Methodological Concern', *Journal of American Folklore* 112(444) (1999) 158-182
- Strathern, M., 'An Awkward Relationship: the case of feminism and anthropology', *Signs: Journal of Women in Culture and Society* 2(2) (1987) 270-92

- Thomas, Neal & John Barnie, *Probings from Plant* Volume 80 (1990)
- Thomas, Helen, 'Mimesis and Alterity in the African Caribbean Quadrill: Ethnography meets History', in *Cultural and Social History* 1 (2004) 281-30
- Thornton, Robert, 'The Rhetoric of Ethnographic Holism', *Cultural Anthropology* 3(3) (1998) 285-303
- Van Zile, J., 'What is Dance? Implications for Notation', *The Congress on Research in Dance (CORD) Dance Research Journal* 17,2:18,1 (1985/6) 41-47
- West, M., 'State of The Art: Creativity and Innovation at Work', *The Psychologist* 3(9) (September 2000) 460-464
- Williams, D., 'Semasiology: A semantic anthropological view of human movements and actions', *Semantic Anthropology* Parkin, D. (ed.), (London: Academic Press, 1982) 161-181
- Williams, Drid, 'An Exercise in Applied Personal Anthropology', *Dance Research Journal* 9(1) (1976) 16-29
- 'The Nature of Dance: An Anthropological Perspective', *Dance Research Journal* 9(1) (1977) 42-44

Bound journal volumes

[unless cited elsewhere]

- Caledonia: A Monthly Magazine of Literature, Antiquity and Tradition* 1895
- The Celtic Review* 1907-08
- The Celtic Monthly: A Magazine for Highlanders* 1876-1901
- CORD (Congress on Research in Dance) Dance Research Journal*
- Dance Research Journal* 1988-