

**Scottish "hummocky moraine": its implications for the  
deglaciation of the North West Highlands during the  
Younger Dryas or Loch Lomond Stadial.**

**Matthew Robert Bennett**

**Thesis submitted for the degree of Doctor of Philosophy  
Department of Geology and Geophysics  
University of Edinburgh  
1991**





## Declaration

I hereby declare that this thesis has been composed by myself and the work within it is my own, except where otherwise referenced.

Matthew Robert Bennett

---

### **Frontispiece:**

The limit of the Loch Lomond Readvance in Coire nan Clach, Fisherfield [NH 040 803]. The width of the frame is about 600 metres and at its maximum the moraine is approximately 15 metres high.

"It is vital to remember that natural scientists should truly base their work on good facts, but also that we will never progress if we do not allow imagination and philosophy to be the prime features of research."

Konigston (1984)

"When you have to use [all] your energy to put these words down, you are more apt to make them count."

Raymond Chandler (1949)

"... Does that seem logical to you ?"

Sergeant Holcomb hesitated a moment, then said, "Well, that's one of those little things which are more or less inconsistent with the general interpretation of evidence."

"I see," Mason said. "And when you encounter such little things, what do you do, Sergeant ?"

"You just ignore 'em," Sergeant Holcomb said.

"And how many such little things have you ignored in reaching your conclusion . . ."

*The case of the perjured parrot,*  
Erle Stanley Gardner (1939)

"Almost the only dogmatism that Martin Hewitt permitted himself in regard to his professional methods was one of the matter of accumulative probabilities. Often when I have remarked upon the apparently trivial nature of the clues by which he allowed himself to be guided—sometimes, to all seeming, in the very face of all likelihood—he has replied that two trivialities, pointing in the same direction, become at once, by their mere agreement, no trivialities at all but important considerations."

*The case of Mr. Foggart*  
Arthur Morrison (1894)

## Abstract

A small ice cap grew and decayed in the Scottish Highlands during the Devensian Lateglacial Loch Lomond Stage (c. 11 000 to 10 000 years B.P.). Its extent has been largely determined by the distribution of Scottish "hummocky moraine" which has been interpreted in the past as stagnation terrain. This stagnation was considered merely to reflect the ice cap's rapid decay in response to the extremely rapid climatic warming at the close of the Loch Lomond Stadial with the evidence for this rapid climatic amelioration being drawn from the coleopteran record.

The analysis of 10 803 air photographs of "hummocky moraine", within the North West Highlands, has not revealed a disordered stagnation terrain, but a clear pattern of ridges which resemble those found at modern ice margins.

Detailed field investigation has shown that these ridges can be interpreted as suites of push moraines, dump moraines, flutes and outwash fans. Such landform suites are typical of many glacier margins that are actively decaying today. On a meso—scale these landforms have a spatial organisation similar to that found at modern ice margins: at a macro-scale they can be mapped over large areas to form a well integrated pattern. I suggest, therefore, that this pattern of drift ridges reflects the active decay of the Loch Lomond Stadial ice cap within the North West Highlands.

On the basis of this interpretation the extent, surface morphology and pattern of decay of the Loch Lomond Stadial ice cap within the North West Highlands has been examined. It occupied an area of 4 700 km<sup>2</sup> and incorporated a total volume of 1 900 km<sup>3</sup> of ice. The pattern of decay is strongly influenced by topography while lithology and ice cap dynamics were found to be important controls on the distribution of drift left by this ice cap.

Attention is drawn to the apparent conflict between the relatively prolonged period of decay indicated by the geomorphological record and the rapid climatic amelioration indicated by the palaeo-biological record at the close of the Loch Lomond Stadial. This is explained in terms of the glacier—climate interaction both damping and delaying the response of the glacial system to climatic change.

## Acknowledgements

I would like to thank both my supervisors Professor G. S. Boulton and Professor D. E. Sugden for the continuous support and advice which they have given over the last three years. The staff of the Air Photograph Unit at the Scottish Development Department (Scottish Office, Edinburgh) provided access to the air photographs on which this work is based. I am also grateful to the NERC for making this project possible and funding valuable fieldwork in Iceland. I wish also to thank Dr. G. C. Bennett and Miss J. E. Bullard for proof reading. Within the Department of Geology and Geophysics Mr. D. Priestly and Mrs. D. Batty provided invaluable assistance.

The following people have provided friendship, advice and discussion during the various phases of this work: Dr. J. M. Gray, Andy Poole, Chris Clark, John Hunt, Neil Glasser.

Finally I wish to thank both my parents and Joanna without whom this would not have been possible.

To all of these people and the many others not mentioned I wish simply to say, "Thank you."

## Notes

Enclosed at the rear of this thesis is a large scale map of part of the North West Highlands. It shows the location of the principle sites mentioned in this thesis and selected sites are also located by grid references within the text. The loch outlines on this map and those within the main body of this thesis predate most reservoir construction within the Highlands and were derived from reprints of the first series one inch O.S. maps (c.1896).

# Table of Contents

ABSTRACT:	IV
ACKNOWLEDGEMENTS:	V
TABLE OF CONTENTS:	VI
LIST OF FIGURES:	VII
LIST OF TABLES:	XI
LIST OF PLATES:	XI
CHAPTER 1: Introduction.	1
PART ONE: The interpretation of Scottish "hummocky moraine".	11
CHAPTER 2: Order not chaos.	12
CHAPTER 3: Data collection.	33
CHAPTER 4: Small scale evidence.	43
CHAPTER 5: Meso-scale evidence.	99
CHAPTER 6: Macro-scale evidence.	119
CHAPTER 7: Part 1: Summary & conclusions.	151
PART TWO: Implications and conclusions.	155
CHAPTER 8: The extent, surface morphology and pattern of decay of the Loch Lomond Stadial ice cap in the North West Highlands.	156
CHAPTER 9: Discussion and conclusions.	181
REFERENCES:	191
APPENDIX I: Moraine and palaeo-ice front sheets.	A1
APPENDIX II: The glacial landforms of Glen Geusachan, Cairngorms.	A49
APPENDIX III: Publications.	A64

# List of Figures

## Chapter 1

- Figure 1.1 The extent of the Loch Lomond Readvance/Advance according to Sissons and his co-workers. 10

## Chapter 3

- Figure 3.1: The Study area. 35
- Figure 3.2: Hypothetical moraine distribution in both space and time for the Scottish Highlands at the close of the last glacial cycle. 40
- Figure 3.3: A conceptual example to illustrate the method by which the outer limit of the Loch Lomond Stadial ice cap was located. 40
- Figure 3.4: Procedure for locating the outer limit of the Loch Lomond Stadial ice cap. 40
- Figure 3.5: The outer limit of the Loch Lomond Stadial ice cap in the North West Highlands. 40

## Chapter 4

- Figure 4.1: A conceptual model of ice marginal moraines. 47
- Figure 4.2: A: Ridge bifurcations within "hummocky moraine".  
B: The asymmetry of cross valley concentric ridges in "hummocky moraine". 48
- Figure 4.3: Cross valley drift ridges in Coire a' Cheud-chnoic. 49
- Figure 4.4: Folds present within cross valley concentric ridges in "hummocky moraine". 51
- Figure 4.5: Glen Thrail—end moraines, sediments and deposition. 51
- Figure 4.6: Supraglacial deposition at a site in Glen Torridon. 53
- Figure 4.7: Krumbein sphericity and roundness plots. 56
- Figure 4.8: A conceptual model for the development of outwash fans. 58
- Figure 4.9: Simplified sedimentary architecture for each of the three pathways identified in Figure 4.8. 59
- Figure 4.10: Ice contact outwash fans in the North West Highlands and in South East Iceland. 60
- Figure 4.11: An outwash fan in Glen Grudie, Torridon. 62
- Figure 4.12: An outwash fan in Glen Affric. 64

Figure 4.13:	Glen Mullardoch—an example of an outwash fan underlaid by buried ice, which melted out during continued outwash deposition.	68
Figure 4.14:	Ice—dammed lake in Upper Glen Carron.	70/71
Figure 4.15:	Conceptual model of the ice margin which dammed the glacial lake in Upper Glen Carron.	72
Figure 4.16:	The sedimentary structures at Torr Alltan na Feola.	74
Figure 4.17:	The sequence of deglaciation in the upper part of Glen Carron.	74
Figure 4.18:	Flute morphology and the lithology of the North West Highlands.	77
Figure 4.19:	A complex suite of ridges interpreted as a sequence of lateral moraines in Coire Each Knoydart.	80
Figure 4.20:	Medial moraines Glen Grudie, Torridon and Skaftafellsjökull in Iceland.	81
Figure 4.21:	Medial Moraines? Applecross.	83
Figure 4.22:	Kame terraces in Glen Carron.	85
Figure 4.23:	Ice marginal meltwater channels in Strath Carron.	87
Figure 4.24:	Meltwater channels on the eastern side of Glen Dee opposite the mouth of Glen Geusachan in the Cairngorms.	88
Figure 4.25:	A proglacial meltwater channel—Killfinnan Burn, Loch Lochy.	89
Figure 4.26:	Two examples of the patterns of distribution often observed in areas where there is little order apparent at the scale of individual mounds.	91
Figure 4.27:	Quartzite boulder density in Glen Grudie.	92
Figure 4.28:	Linear ridge backing an area of random hummocks, Strath Lungard Torridon.	92
Figure 4.29:	Fluvioglacial ice contact deposits in Glen Ling.	95
Figure 4.30:	Fluvioglacial ice contact deposits in Strath Carron.	97
Figure 4.31:	Model to explain the presence of esker—like ridges in glaciofluvial stagnation terrain.	98
 <b>Chapter 5</b>		
Figure 5.1:	Moraines reflecting glacier retreat in the Nigardsdalen Valley, south Norway.	101
Figure 5.2:	The retreat moraines formed by a Loch Lomond Stadial valley glacier in Glen Geusachan, Cairngorms.	102
Figure 5.3:	Snout gradients for selected retreat positions.	104
Figure 5.4:	Ridge asymmetry.	106

Figure 5.5:	The moraines of Glen Grudie, Torridon.	108
Figure 5.6:	The palaeo-ice fronts of Glen Grudie, Torridon.	109
Figure 5.7:	Strath na Sealga, Fisherfield.	111
Figure 5.8:	Glen Croulin, Knoydart.	112
Figure 5.9:	The pattern of deglaciation of Glen Croulin.	115
Figure 5.10:	The Loch Hourn ice limit in Glen Croulin, during the Loch Lomond Stadial.	116
Figure 5.11:	The palaeo-ice front in Gleann Laragain to the north of Loch Eil.	117

## Chapter 6

Figure 6.1:	The pattern of deglaciation of the Loch Lomond Stadial ice cap in the North West Highlands.	124
Figure 6.2:	Flow summary for striae in the North West Highlands.	125
Figure 6.3:	Strike lines and basal shear stress.	126/127
Figure 6.4:	Index to palaeo-ice front mosaics.	129
Figure 6.5:	An Teallach. A: Palaeo-ice fronts. B: Selected and interpolated palaeo-ice fronts.	131
Figure 6.6:	Loch Torridon. A: Palaeo-ice fronts. B: Selected and interpolated palaeo-ice fronts.	134
Figure 6.7:	Applecross. A: Palaeo-ice fronts. B: Selected and interpolated palaeo-ice fronts.	137
Figure 6.8:	Loch Affric. A: Palaeo-ice fronts. B: Selected and interpolated palaeo-ice fronts.	140
Figure 6.9:	Loch Hourn. A: Palaeo-ice fronts. B: Selected and interpolated palaeo-ice fronts.	143
Figure 6.10:	Loch Arkaig. A: Palaeo-ice fronts. B: Selected and interpolated palaeo-ice fronts.	146
Figure 6.11:	Loch Sunart. A: Palaeo-ice fronts. B: Selected and interpolated palaeo-ice fronts.	149

## Chapter 7

Figure 7.1:	A typical landform assemblage found within "hummocky moraine" areas.	154
-------------	--	-----

## Chapter 8

Figure 8.1:	The limit of the Loch Lomond Readvance in the North West Highlands.	159
-------------	---	-----

Figure 8.2:	A comparison of theoretical and reconstructed (moraines) glacier snout profiles.	163
Figure 8.3:	The surface morphology of the Loch Lomond Stadial ice cap in the North West Highlands.	164
Figure 8.4:	Average land elevation.	165
Figure 8.5:	Valley connectivity.	166
Figure 8.6:	The pattern of deglaciation in the North West Highlands.	168
Figure 8.7:	Hypothetical example of the adjustment of an ice divide to spatial variations in precipitation and its influence on the location of the centre of decay.	170
Figure 8.8:	One of Charlesworth's (1955) 19 maps showing the pattern of deglaciation within the North West Highlands.	171
Figure 8.9:	Drift pixel map for the Loch Lomond Stadial ice cap in the North West Highlands.	176
Figure 8.10:	Moraine frequency map.	177
Figure 8.11:	Distribution of flutes within the North West Highlands.	178
Figure 8.12:	Simplified geology of the North West Highlands.	178

## Chapter 9

Figure 9.1:	Schematic examples of synchronous and non-synchronous response of the Loch Lomond Stadial ice cap to climatic forcing during decay.	187
-------------	---	-----

## List of Tables

Table 4.1:	Classification of landforms at modern ice margins.	43
Table 5.1:	Snout gradients for selected retreat positions.	104
Table 8.1:	Asymmetry of decay for three regions of the North West Highlands.	170
Table 8.2:	Illustrates the relationship between drift cover and lithology.	173

## List of Plates

### Chapter 2

Plate 2.1:	Cross valley and down valley radial ridges within "hummocky moraine".	14
Plate 2.2:	Cross valley concentric ridges within "hummocky moraine".	15
Plate 2.3:	Glen Croulin, Knoydart—North West Highlands.	16
Plate 2.4:	Glamara, Lake District—Northern England.	17
Plate 2.5:	Loch na Sealga, Fisherfield—North West Highlands.	18
Plate 2.6:	Strath a' Bhàthaich, Torridon—North West Highlands.	19
Plate 2.7:	Coire' a' Chùndrain, Inchbae Forest—North West Highlands.	20
Plate 2.8:	Coire Dhruim nam Bò, Gleneig—North West Highlands.	21
Plate 2.9:	A: Glen Mucarnaich, Beinn Dearg—North West Highlands. B: Coire Mharconaich, Cairngorms.	22
Plate 2.10:	Further examples of the cross valley concentric ridges observed when "hummocky moraine" is examined from the air.	23
Plate 2.11:	Cross valley concentric drift ridges in Glen Geusachan, Cairngorms.	24
Plate 2.12:	Maol an Uillt Mhóir, Applecross—North West Highlands.	25
Plate 2.13:	Glas Tholl, An Teallach—North West Highlands.	26
Plate 2.14:	Drochaid Coire nan Arr, Applecross—North West Highlands.	27
Plate 2.15:	Lochan Carn na Feòla, Northern Torridon—North West Highlands.	28
Plate 2.16:	Air photograph of the eastern margin of Breiðamerkurjökull, an outlet glacier of, the Vatnajökull ice cap in South East Iceland.	32
Plate 2.17:	Oblique air photographs from Spitsbergen and Iceland.	32

## Chapter 4

Plate 4.1:	A: supraglacial and proglacial fluvioglacial sediments—Shieldaig, North West Highlands.	
	B: Bifurcating push moraines Skaftafellsjökull, South East Iceland.	
	C: A dump moraine Skeiðarárjökull, South East Iceland.	50
Plate 4.2:	Folds in a cross valley concentric ridge at the head of Loch Morar.	51
Plate 4.3:	An outwash fan in Glen Grudie, Torridon.	61
Plate 4.4:	Sedimentary structure within an outwash fan in Glen Mullardoch.	65
Plate 4.5:	Ice-dammed lakes.	75
Plate 4.6:	Flutes—Two examples (A&B) of Torridonian flutes and one of Quartzite flutes, from northern Torridon (C).	77
Plate 4.7:	Down valley radial ridges.	79
Plate 4.8:	A complex suite of ridges interpreted as a sequence of lateral moraines in Coire Each Knoydart.	79
Plate 4.9:	Meltwater channels and eskers.	87
Plate 4.10:	Synclinal sand structures beneath a kettle hole in Glen Ling.	94

• Chapter One •

Introduction

## Contents

---

1.1: Aim.	2
1.2: A Devensian Lateglacial ice cap in the Scottish Highlands.	2
1.3: The scope of this thesis	8

---

*This chapter outlines the aim of the research. Previous work on the Younger Dryas or Loch Lomond Stadial ice cap in the Scottish Highlands is reviewed, and the possible significance of its development is briefly considered.*

### **1.1: Aim.**

It has been demonstrated that reconstructions of the maximum extent and surface morphology of a former ice sheet can provide useful palaeoclimatic information (eg. Sissons 1974b, 1980b; Ballantyne 1989). However, this approach relies upon the assumption of a steady state equilibrium between the climate system and that of the ice sheet. Unfortunately, this assumption is of questionable validity during periods of rapid climatic change. During such periods, far more reliable information can be obtained by reconstructing the changing form of an ice sheet through time. This information not only concerns palaeoclimate but also the response of the glacial system to change.

This thesis examines the decay of a small ice cap which existed in the Scottish Highlands during the Younger Dryas or Loch Lomond Stadial. The evidence left behind by this ice cap has been the subject of considerable research, which has concentrated on the reconstruction of its maximum extent. In contrast, this thesis examines the evidence necessary to reconstruct the surface morphology of the ice cap as it decayed and argues that this approach can yield valuable palaeoclimatic and chronological information. The aim is not a detailed reconstruction of the glacial history of this ice cap, but an understanding of its dynamics and its general response to climatic change.

### **1.2: A Lateglacial ice cap in the Scottish Highlands.**

It is generally supposed (eg. Lowe & Walker 1984) that the Late Devensian ice sheet reached its maximum thickness over the Scottish Highlands at about 18 000 years B.P. It then decayed rapidly during a

period of warming which lasted until some time after 13 000 years B.P. It is unclear whether the ice sheet decayed completely before it was regenerated as a small ice cap during a brief return to glacial conditions. The ice cap which developed in part of the Scottish Highlands was contemporary with numerous small ice fields and corrie glaciers in other parts of the Highlands, in Wales and the Lake District (Fig. 1.1)(Gray 1982; Sissons 1980a, 1983). This brief stadial is known in many parts of the world as the "Younger Dryas" and more locally within the British Isles as the "Loch Lomond Stadial". The Younger Dryas event was a short and intense period with an abrupt termination (Coope & Brophy 1972). It has been identified throughout North West Europe and may have been present elsewhere in the world (Wright 1989; Clapperton 1990). It is of particular interest as it appears not to have been a linear response to Milankovitch radiation variation but to have been precipitated by some instability in the climate ocean system (Broecker *et al.* 1988; Harvey 1989). The Younger Dryas was terminated abruptly by rapid climatic amelioration (Coope & Brophy 1972; Dansgaard *et al.* 1989). Understanding the role and response of a small ice cap to these changes may yield important insights not only into palaeoclimate but also into the mechanisms of ice sheet-climate interaction. The abundance of evidence left by the Loch Lomond Stadial ice cap in the Scottish Highlands provides an ideal opportunity to examine these issues since it was both small and short lived.

Numerous workers have attempted to reconstruct the extent and timing of this Lateglacial advance. Two main bodies of literature can be identified, based loosely on two paradigms:

- A. The Alpine analogue—Agassiz to Charlesworth.
- B. The Scandinavian analogue—Sissons *et al.*

#### **A. The Alpine analogue—Agassiz to Charlesworth.**

On the 4th of November 1840 Agassiz presented the first paper to describe glacial phenomena in the Scottish Highlands. This Scottish evidence, along with that from the European Alps, quickly became central to the controversy between the opposing 'drift' and 'glacial' theories (Charlesworth 1957; Hallam 1983). As a consequence, there was a prolific period of research during the later part of the 19th Century.

One of the most important conclusions to stem from this initial period of research was the recognition of a distinct topography of moraines in Highland valleys attributed to a final phase of activity at the

end of the last glacial period (eg. Geikie 1863; Young 1864; Jamieson 1874; Wright 1914). This distinct topography of moraines was interpreted in terms of a simple Alpine analogue. In this model moraines were simply believed to reflect successive ice margins during active decay. The importance of such analogues is understandable, since evidence from the European Alps was of such importance in establishing the glacial theory (Hallam 1983).

This view was held throughout the first half of the 20th Century and culminated in the work of Charlesworth (1955), who presented the first detailed picture of ice retreat in Scotland. He was stimulated by the lack of "a comprehensive picture of the ice retreat", and the prevailing glacial paradigm that moraines mark successive stages of ice retreat, to produce a remarkable reconstruction of the pattern of Scotland's deglaciation (Charlesworth 1955, p. 777). This work was based on field reconnaissance during the 1930's and was undertaken before air photographs were commonly available. He presented 19 maps depicting various stages in the dissolution of the Scottish ice cap into minor corrie glaciers and recognised two major glacial phases: (i) The Highland Glaciation; (ii) The Moraine Glaciation. The moraine fragments making up these two main stages were correlated on the basis of the 100 feet, and 50 feet raised shorelines. The last phase — Moraine Glaciation — was based partly on the distinct moraine topography present in many Highland valleys, substages of which can be loosely correlated with a Lateglacial readvance. He went on to examine the former snow lines needed to support these two glacial phases, thereby illustrating the potential of such work in palaeoclimatic reconstruction.

Since its publication, this work has been subject to considerable criticism. Firstly, the 100 and 50 feet raised beaches used by Charlesworth (1955) to correlate the ice limits of his two main glacial phases are now known to be composed of a wide range of shorelines at varying elevations (Sissons 1962). Secondly, little evidence was presented to support the suggested decay patterns. For example, Sissons (1976, p. 84) states that "only occasionally do his limits bear any relation to identifiable features that can be reasonably interpreted as indicating former ice-marginal positions". Thirdly, the validity of these reconstructions has been questioned repeatedly by palynological research which has been used to constrain the extent of the Lateglacial readvance (eg. Donner 1957).

## **B. The Scandinavian analogue—Sissons *et al.***

In 1965 Sissons delineated the approximate extent of a Lateglacial ice cap in the Scottish Highlands on the basis of the distribution of a distinctive moraine topography (Fig. 1.1A). He described this distinct drift topography as "hummocky moraine" and termed the glacial event which produced it the "Loch Lomond Readvance/Advance" (following Simpson 1933). This outline has since been refined by numerous small scale studies throughout the last 25 years (Fig.1.1B). Central to this work has been an emphasis on detailed geomorphological mapping and rigorous field science.

In many areas this work has been facilitated by the presence of very clear linear moraines bordering areas of "hummocky moraine". These moraines have been dated in several locations (eg. Sutherland 1986; Rose *et al.* 1988; Rose 1989a) and have been correlated with palynological evidence to the European Younger Dryas (eg. Donner 1957). Areas occupied by Loch Lomond Readvance glaciers have been identified by the presence of "fresh hummocky moraine". In valleys lacking clear linear moraines the extent of "hummocky moraine" is used to delineate the readvance. This is justified, not on the basis of a tested process model, but on the simple observation that in most valleys "hummocky moraine" ends abruptly at the terminal moraines delineating the outer limit of the readvance. According to Sissons (1977a, p.54) this "suggests that where end moraines are absent, or of limited extent, the down valley termination of hummocky moraine may be used to reconstruct former glacier limits". The absence of a detailed process model for "hummocky moraine" has been repeatedly criticised by Sugden (1970, 1973, 1974, 1980), who argues that one must first obtain an adequate interpretation of "hummocky moraine" before using it to delineate the extent of former glaciers.

Despite the importance of "hummocky moraine" in defining the extent of the Loch Lomond Readvance and its abundance within the limits of the ice cap, it has not been used as a basis for reconstructing the pattern of ice cap decay, as others have done elsewhere (eg. Pierce 1979). This is presumably because it is regarded as a stagnation deposit (Sissons 1965, 1967, 1974a&b, 1976, 1977a; Thompson 1972) merely reflecting the ice cap's rapid decay in response to the extremely rapid climatic warming indicated by coleopteran evidence (Bishop & Coope 1977; Coope 1977; Atkinson *et al.* 1987). The apparent lack of any spatial organisation in "hummocky moraine" when viewed from the ground, coupled with its diverse

sedimentology, is often cited in support of the view that it is a large scale stagnation deposit (eg. Thompson 1972) and only in four locations could a pattern of frontal retreat, extending for more than 200 metres, be established. The four exceptions are all associated with ice-dammed lakes where exceptional circumstances existed (Sissons 1983, p. 409).

Since the deglaciation is assumed to have occurred extremely rapidly, the emphasis in the work of Sissons and his co-workers has been directed towards defining the extent of the Loch Lomond Readvance and then reconstructing the surface morphology of the associated ice bodies. From these reconstructions equilibrium line altitudes have been calculated for the various ice bodies, from which detailed palaeoclimatic inferences have been made (eg. Sissons 1974b, 1979b, 1980b; Sissons & Sutherland 1976; Sutherland 1984a; Ballantyne 1989). These reconstructions suggest that the main direction of snow-bearing winds during the Stadial was predominantly from the south east. The methods by which reconstructions are made have become increasingly more sophisticated with the introduction of periglacial trimlines and other such criteria (eg. Thorp 1981, 1984, 1986; Ballantyne 1982a, 1989), but the essential paradigm remains constant: (i) rapid deglaciation; (ii) non-genetic classification of landforms; (iii) rigorous fieldwork.

From this summary it is clear that the approach developed by Sissons (1965) is very different from that typified by the work of Charlesworth (1955). I suggest that Sisson's approach developed in response to a number of factors:

Firstly, during the 1950s, a considerable body of very influential work was published on large scale stagnation deposits both in Scandinavia and in North America (eg. Sharp 1949; Hoppe 1952, 1959; Gravenor & Kupsch 1959; Stalker 1960; Winters 1961), advancing the concept that ice sheets could decay by "areal stagnation". Consequently, there was a shift from the traditional alpine model to those developed from studies of the large palaeo-ice sheets of Scandinavia and North America. The application of these models of stagnation is well illustrated in Sugden's work in the Cairngorms (Sugden 1970).

Secondly, throughout the 1960s and 1970s, there was a growing body of palaeo-biological evidence which suggested that, following the Loch Lomond Stadial, warming was very rapid (Lowe & Walker 1984). The coleopteran record indicated a very rapid rise in air temperature at the

close of the stadial, in some cases of the order of 1° C every 10 years (Coope & Brophy 1972).

Thirdly, there was always a clear emphasis on determining the glacial history of the Scottish Highlands, as opposed to understanding the landforms and sediments present. In my view, Sissons saw the problem of "hummocky moraine" genesis to be largely intractable. Consequently rather than examining the nature of the record left by the ice cap, he concentrated on the problem of defining the extent and timing of the readvance, a problem he saw as capable of resolution.

Fourthly, Sissons clearly reacted against the imprecise methods of data collection and the speculative geomorphological interpretations common in glacial research before about 1960 (Ballantyne & Gray 1984). This is well illustrated by his attack on the loose interpretation of meltwater channels as being simply the overflow channels of numerous ice-dammed lakes (Sissons 1958 1960 1961).

Despite a growing unease with the interpretation of "hummocky moraine" as a stagnation deposit, and with the concept of "areal stagnation" (eg. Lowe & Walker 1981; Sutherland 1984a; Thorp 1984, 1991; Walker & Lowe 1985; Tipping 1988), the essential elements of this approach have been retained over the last 25 years. However, in 1982 Hodgson presented the details of the first serious investigation into the origins of "hummocky moraine". On the basis of detailed studies of erratics he concluded that much of the debris within "hummocky moraine" was derived subglacially, a point recently supported by the work of Benn (in: Ballantyne *et al.* 1991; Benn 1990). On this basis he challenged its traditional interpretation as a stagnation deposit. He went on to suggest that "hummocky moraine" may be a subglacially-deposited landform produced by ice advancing over debris-filled valleys. However, deglaciation was still assumed to have been rapid and unrecorded in the geomorphological record.

This last point has been challenged by both Eyles (1983) and Horsfield (1983), who have suggested that deglaciation may have been active and that a very different glacial and chronological regime must have been operative.

Working in the European Alps and in Iceland, Eyles (1978, 1979) demonstrated that stagnation type terrain could be formed in increments by active ice-decay and that it need not reflect widespread stagnation. Eyles applied this model to Scottish "hummocky moraine" (Eyles 1983a: also see Raper 1988, Benn 1990, Thorp 1991), but failed to address the key issue

of the model when applied on a regional scale. In order to explain the large tracts of "hummocky moraine", such as that on Rannoch Moor, amounts of supraglacial debris would be required far in excess of that which could conceivably be supplied given the size of most Scottish mountains.

Horsfield (1983) also proposed an alternative explanation for "hummocky moraine", drawing upon unpublished observations of Boulton & Eyles (see: Boulton *et al.* in press). They had noted that when "hummocky moraine" was viewed from the air, it did not appear to be a random collection of mounds but had a clear form and structure resembling features found at modern glacier margins. Horsfield (1983) mapped this structure over a large area of the Grampian Highlands and suggested that it reflected the successive ice margins of an actively decaying ice cap during the Loch Lomond Stadial. However, he failed to present any critical evidence to support this hypothesis, relying instead upon the internal consistency of his argument.

Day (1983) used palaeomagnetic remanence to examine this hypothesis he argued that "if the Scottish moraines were deposited at an actively retreating glacial margin, a set of samples, from the limits of the advance to the supposed centre, would produce a series of remanent magnetism directions which follow a cycle or cycles closely related to that found" at the palaeomagnetic types site for the Devensian Lateglacial, "if the hypothesis of mass wasting is correct then the pattern of change would be less regular" (p. 145). Working on Rannoch Moor he was able to demonstrate that cycles were present in samples taken from successive moraines and concluded that decay had probably been active. Despite the work of Day (1983) this hypothesis has not received the serious appraisal it deserves: it will, however be examined here.

### **1.3: The scope of this thesis.**

It is evident from the above review that the key to understanding the pattern of deglaciation during the Loch Lomond Stadial is the interpretation of "hummocky moraine". This is the question that I attempt to address in this thesis through a detailed examination of the case within the North West Highland region of Scotland.

This area was selected for investigation for two main reasons: firstly, in contrast to the Grampian Highlands, the Loch Lomond Readvance within the North West Highlands has been the subject of little previous

research; secondly, parts of the North West Highlands, particularly Torridon, contain some of the finest areas of "hummocky moraine" in Scotland and therefore present an ideal case study.

In the main part of the thesis I present and examine an interpretation of "hummocky moraine", from which conclusions can be drawn about the way in which the Loch Lomond Stadial ice cap decayed. In the final part, this interpretation is used to determine the extent, surface morphology and pattern of decay of the ice cap, leading in turn to conclusions about palaeoclimate and chronology.

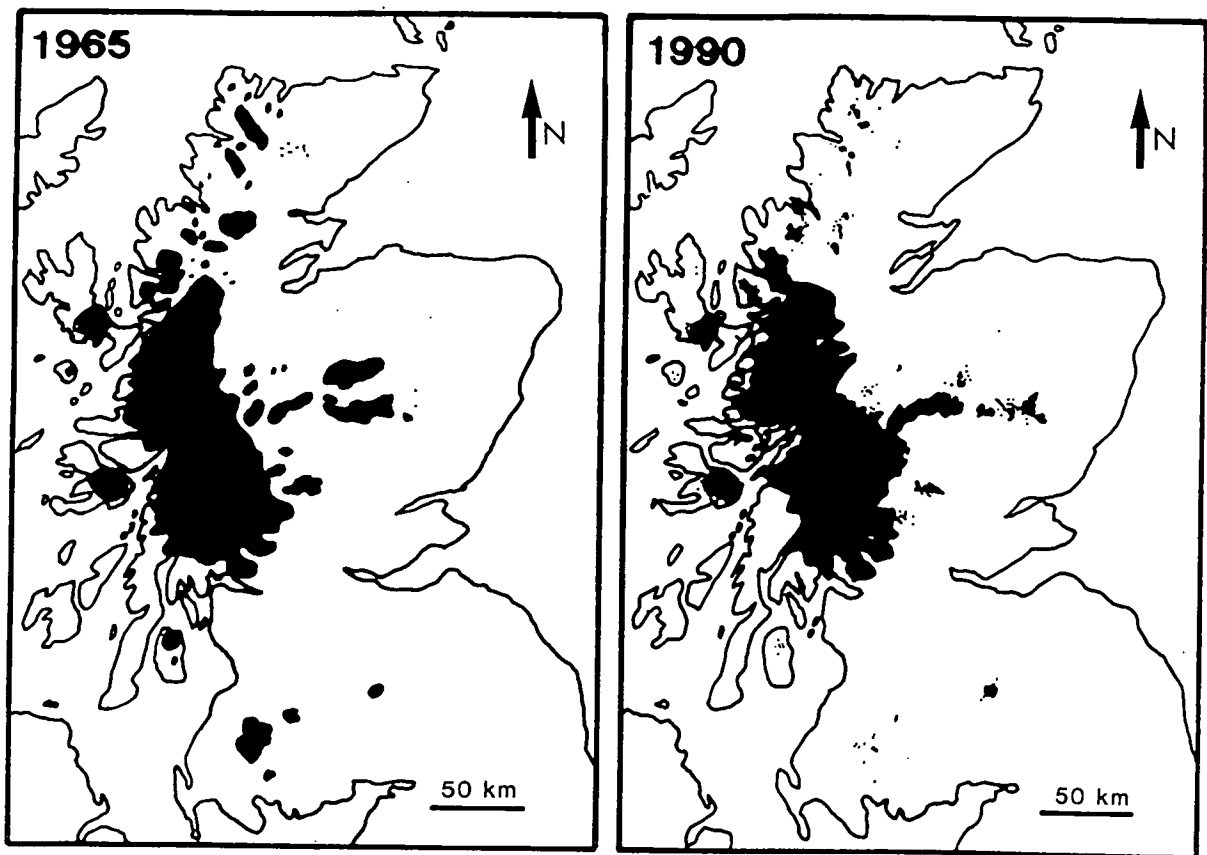

Figure 1.1: The extent of the Loch Lomond Readvance/Advance in the Scottish Highlands according to Sissons and his co-workers. A. Initial limits as defined in 1965. B. Modified limits—1990.

A. 1965—Sissons 1965 Figure 14.4, p.476.

B. 1990—compiled from the following papers:

**Outer Hebrides:** Sissons 1980c; Peacock 1984; Sutherland *et al.* 1982, 1984/**Inner Hebrides:** Gray 1972, 1975; Gray & Brooks 1972; Ballantyne & Wain-Hobson 1980; Dawson *et al.* 1987; Sissons 1977c; Gemmel 1973; Walker *et al.* 1988; Ballantyne 1989/**North West Highlands:** McCann 1966a&b; Peacock 1970, 1975; Sissons 1977 a&b; Robinson 1977; Boulton *et al.* 1981; Wain-Hobson 1981; Hodgson 1982; Ballantyne 1986; Dawson 1988/**Grampian Highlands:** Peacock 1971; Sissons 1972; Sissons & Grant 1972; Sissons 1973; Thompson 1972; Sissons *et al.* 1973; Sissons 1974b; Gray 1975; Gray & Sutherland 1977; Smith *et al.* 1978; Ballantyne 1979; Sissons 1979a; Thorp 1981, 1984, 1986, 1991; Peacock & Cornish 1989. Tipping 1989  
**Southern Uplands:** Price 1963; Cornish 1981.

• Part One •

**The interpretation of Scottish "hummocky moraine"**

In the first half of this thesis, an interpretation of the landforms previously referred to as "hummocky moraine", within the limit of the Loch Lomond Readvance, is presented. This interpretation is then examined in the light of evidence collected from throughout the North West Highlands at three spatial scales: at the scale of individual landforms, at the scale of individual glacier lobes and at the scale of the regional ice cap. From this, conclusions can be drawn about the character of the deglaciation in the North West Highlands during the Loch Lomond Stadial.

• Chapter Two •

Order not chaos

## Contents

---

2.1:	Form and structure within "hummocky moraine"	13
2.2:	Form and structure within "hummocky moraine": a visual case study.	13
2.3:	Interpreting the form and structure within "hummocky moraine".	29

---

*In this chapter an interpretation of "hummocky moraine" within the limit of the Loch Lomond Readvance is presented and forms the central argument of this research. When "hummocky moraine" is examined from the air it appears to be composed of a simple pattern of drift ridges which can be interpreted in terms of glacier retreat patterns.*

### **2.1: Form and structure within "hummocky moraine".**

When examined from the air most "hummocky moraine" can be seen to have a clear form and structure, which can be resolved into suites of ridges: it is not a random collection of mounds as has often been suggested (eg. Sissons 1967). In some cases the ridges are the product of gulling and in others they reflect bedrock structure, but it will be shown below that, taken as a whole, the ridge assemblages reflect a relatively simple pattern of linear moraines. The majority of drift lineations are either cross valley concentric ridges or down valley radial ridges. This two-fold pattern can be mapped out over very large areas of the Scottish Highlands. Only in approximately 5% of cases does "hummocky moraine" appear not to possess this simple pattern of organisation. I, therefore, identify three elements within "hummocky moraine":

1. Cross valley or concentric elements.
2. Down valley or radial elements.
3. Localised patches of complex mound systems.

These three elements are illustrated in the following section by a series of photoplates.

### **2.2: Form and structure within "hummocky moraine": a visual case study.**

"Hummocky moraine" occurs throughout the Scottish Highlands and Northern England and has been used to define the extent of the Loch Lomond Readvance. The following plates are all drawn from areas

previously documented as "hummocky moraine" areas. Four groups of photoplates are presented in this section to illustrate this form and structure:

A. Oblique photographs of "hummocky moraine" areas showing cross valley concentric elements and down valley radial ridges.

B. A selection of air photograph plates which show the range in size, spacing and frequency of the cross valley concentric elements within "hummocky moraine".

C. A selection of plates which show the relationship of cross valley concentric elements and down valley radial elements within "hummocky moraine".

D. An example of "hummocky moraine" with little or no order.

**A. Form and structure within "hummocky moraine".**

The following plates illustrate firstly the presence of form and structure within "hummocky moraine" and secondly the three principal components present: (1) cross valley or concentric drift ridges perpendicular to which there are; (2) down valley or radial elements and finally (3) small local patches of terrain with a complex organisation of mounds.

---

Plate 2.1: Cross valley concentric and down valley radial ridges within "hummocky moraine".

A. Torridon, North West Highlands. Cross valley concentric ridges in the Valley of a Hundred Hills (Coire a' Cheud-chnoic [NG 955 555]).

B. Lake District, Northern England. Cross valley concentric ridges in a valley to the north of High Street.

C. Torridon, North West Highlands. A down valley radial element [NG 915 585].

A



B



C



---

Plate 2.2: Cross valley concentric ridges within "hummocky moraine".

A. Glen Geusachan, Cairngorms. A superb sequence of cross valley ridges curve around the spur in the centre of the frame and cross the valley floor towards the photographer [NN 980 940].

B. Glen Geusachan, Cairngorms. A suite of cross valley drift ridges run diagonally, left to right, across the frame. These ridges are dissected by finer vertical series of lineations formed by the dissection of the drift slope due to gullying. The presence of more than one lineation may make identification of the true trend of ridges difficult, especially when viewed on air photographs [NN 980 940].



A



B

---

Plate 2.3: Glen Croulin, Knoydart, North West Highlands [NG 785 085]. Cross valley concentric ridges: a sequence of a dozen parallel ridges on the western flank of the glen (Bennett 1990).



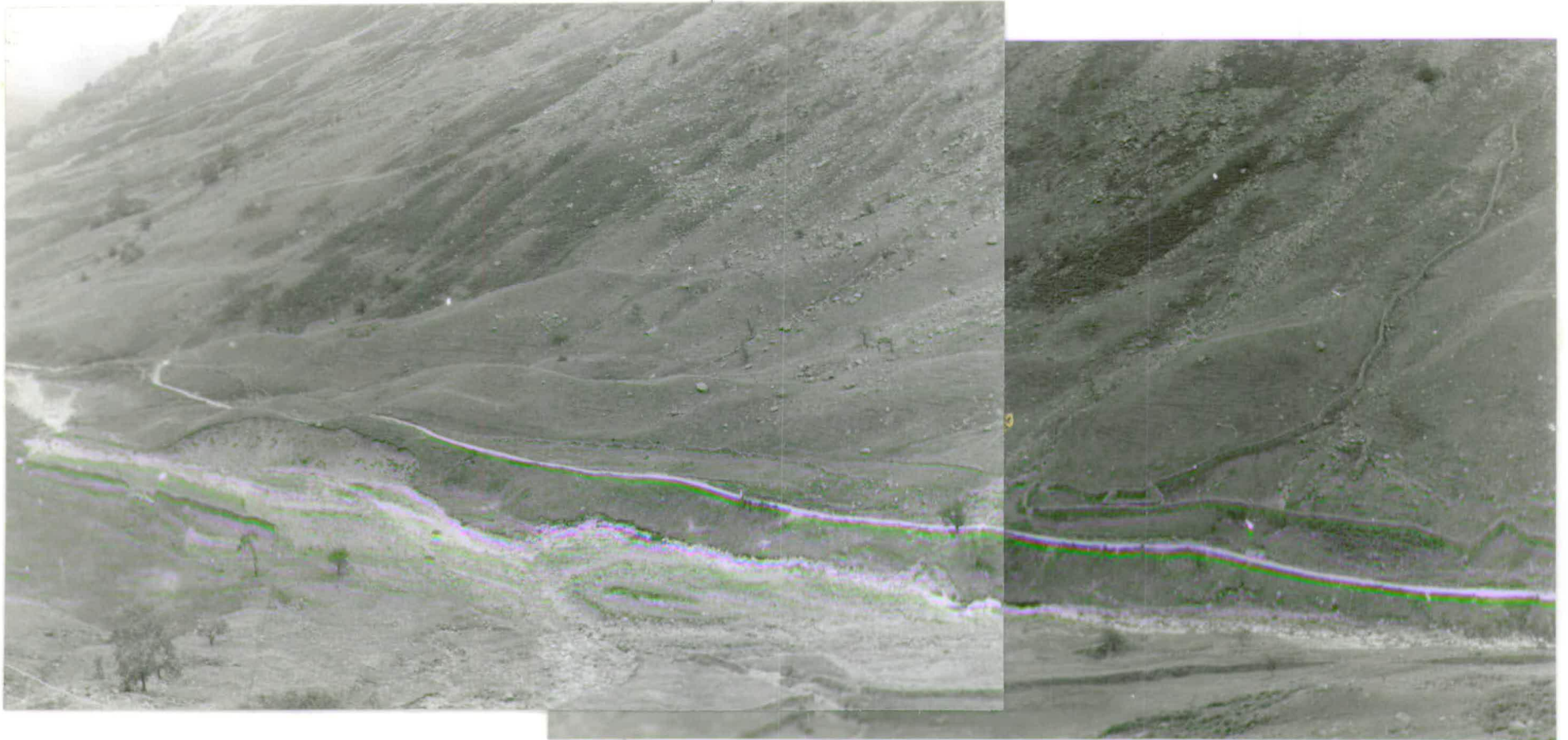

**B. The size, spacing and frequency of cross valley concentric elements within "hummocky moraine".**

The size, spacing and frequency of cross valley concentric elements varies from location to location. The following plates of air photographs also show how these cross valley concentric elements can be mapped from the air.

---

Plate 2.5: Loch na Sealga, Fisherfield, North West Highlands [NH 060 810]. This plate shows at least eight retreat moraines left by a glacier lobe retreating from the outermost moraine, which is believed to represent its maximum extent during the Loch Lomond Stadial.

Loch na Sealga, Fisherfield - (NH 035 815).

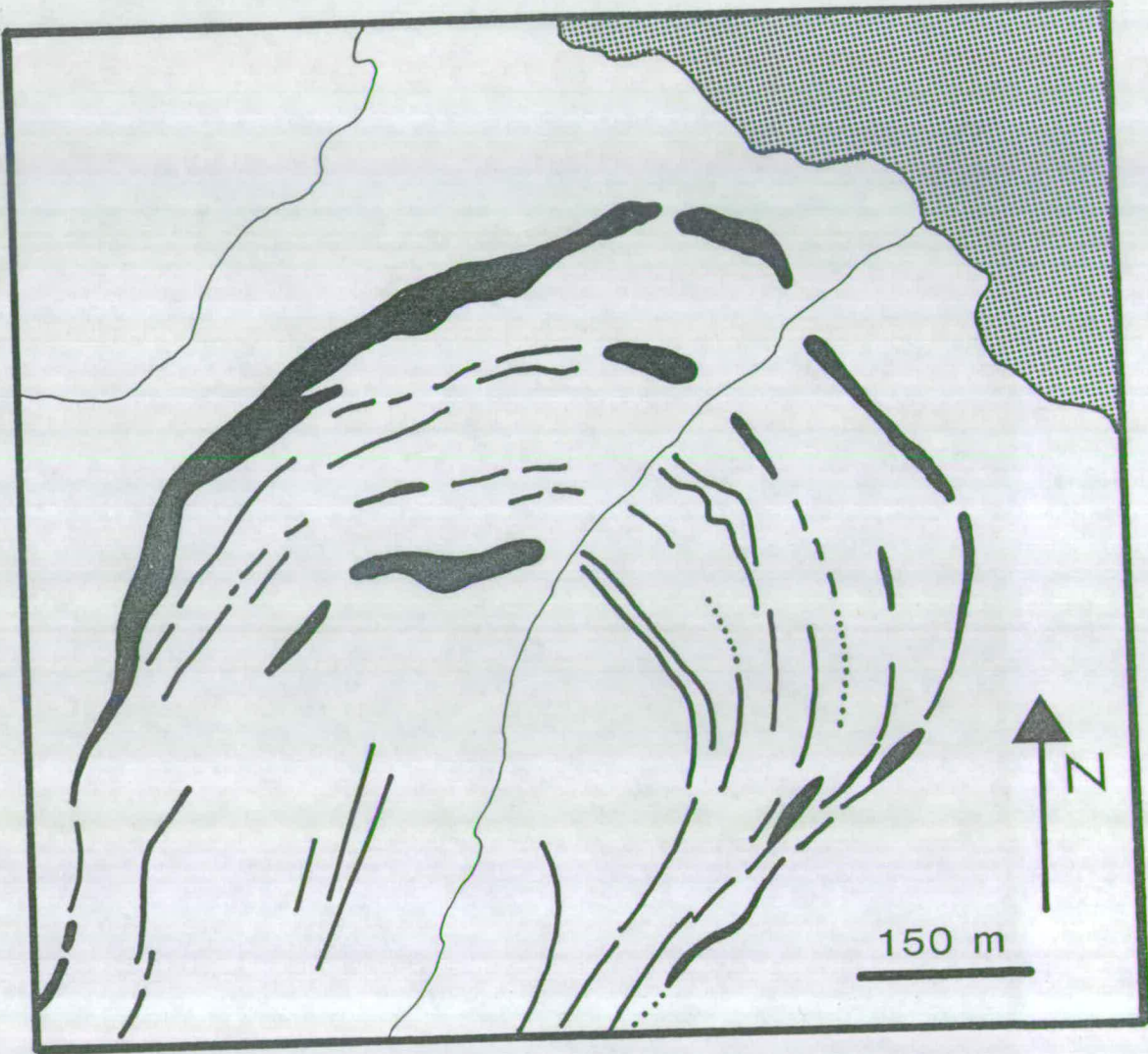



---

Plate 2.6: Strath a' Bhàthaich, Torridon, North West Highlands [NG 915 505]. This plate shows a sequence of retreat positions left by a glacier lobe retreating from the outermost moraine, which is believed to represent its maximum extent during the Loch Lomond Stadial.

Strath a' Bhàthaich, Torridon - (NG 880 470).

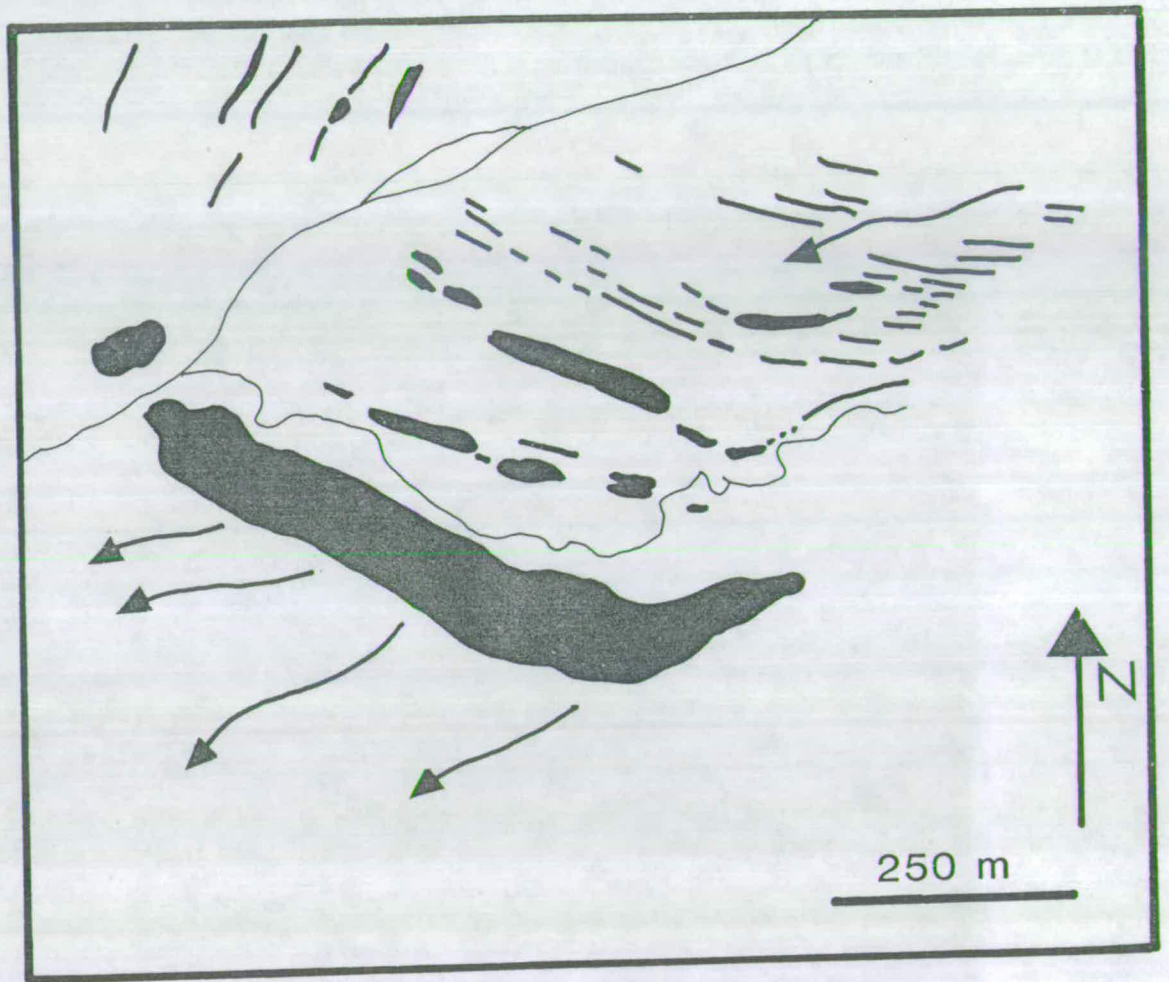

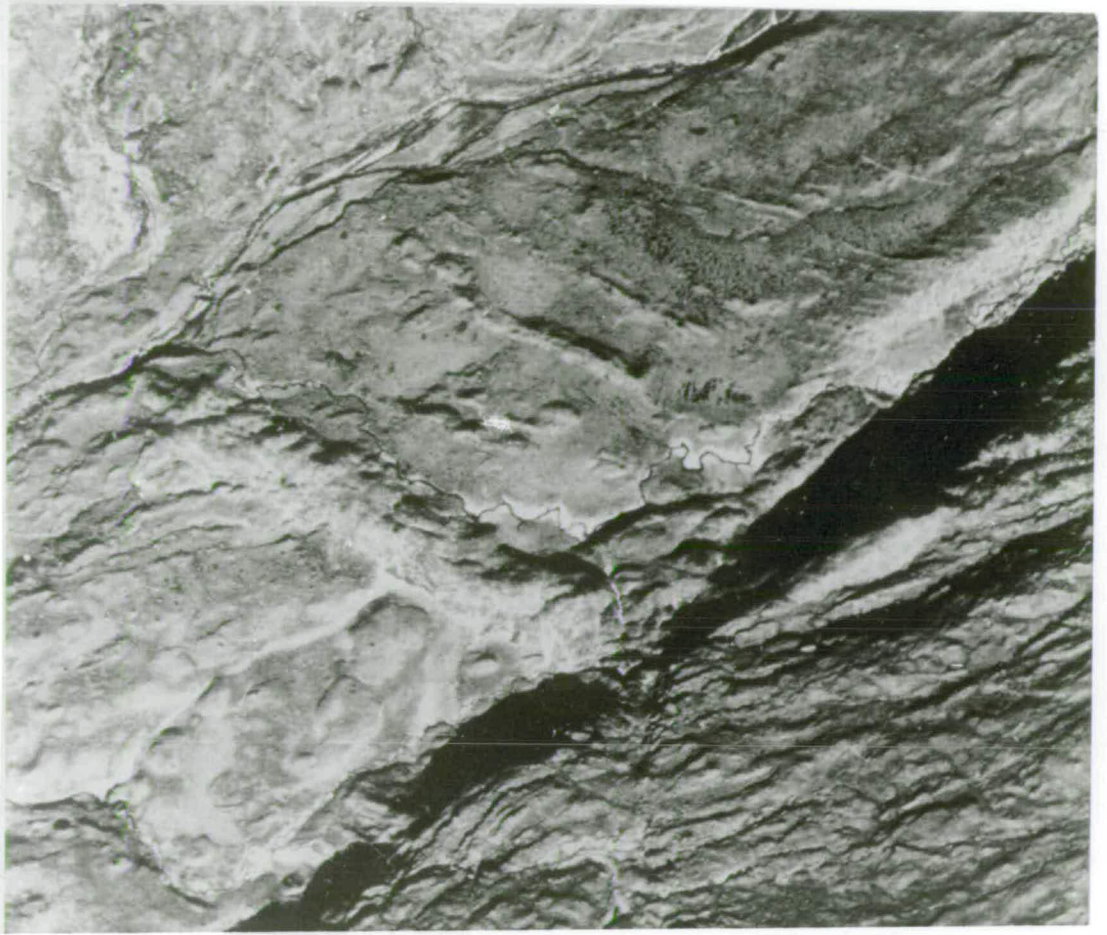

---

Plate 2.7: Coire' a' Chùndrain, Inchbae Forest, North West Highlands [NH 380 770].  
This plate illustrates a sequence of drift ridges which parallel a prominent ridge  
approximately 7 km inside the Loch Lomond Stadial Readvance limit.

Coire' a' Chùndrain, Inchbae Forest - (NH 380 780).

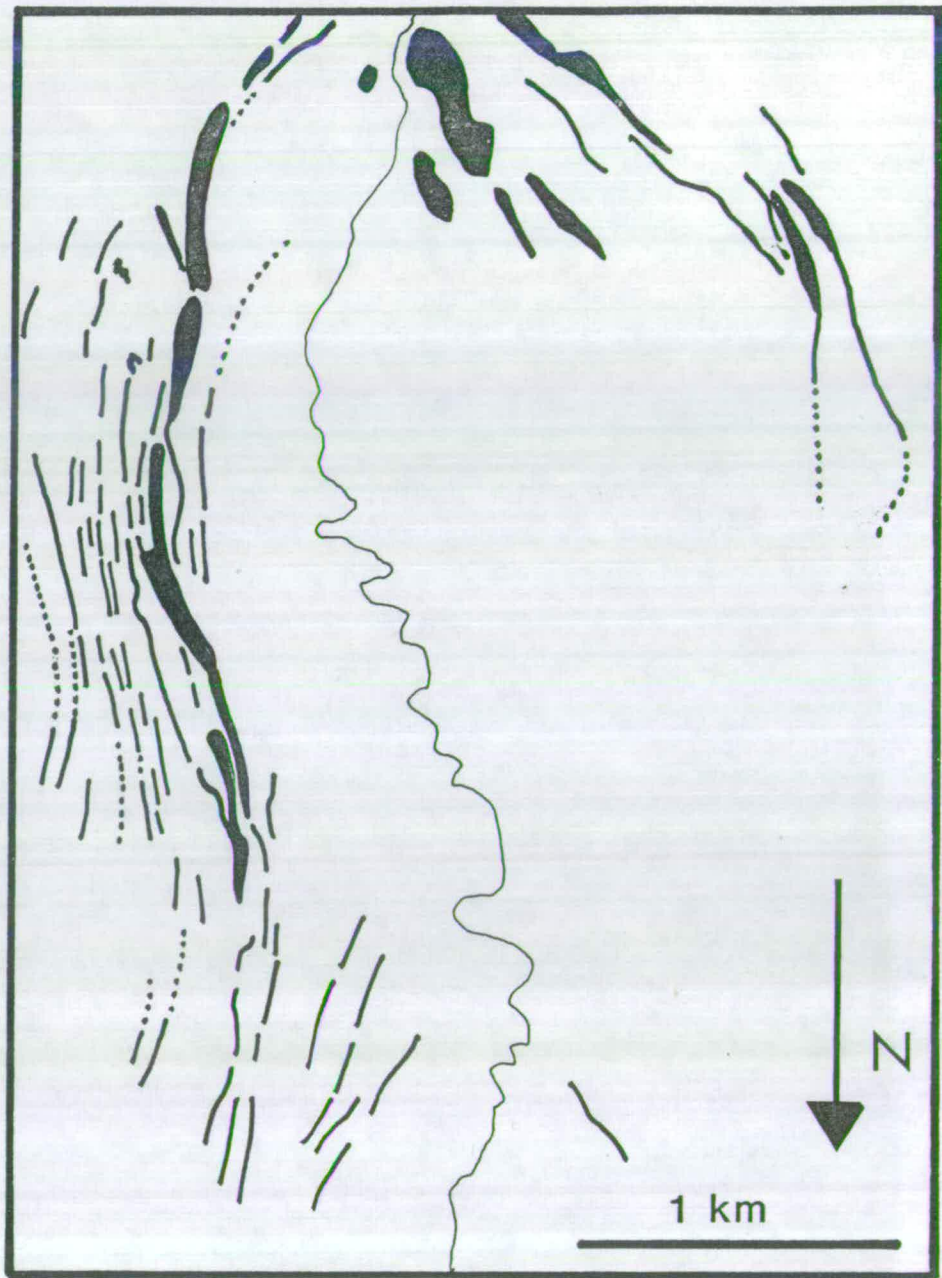

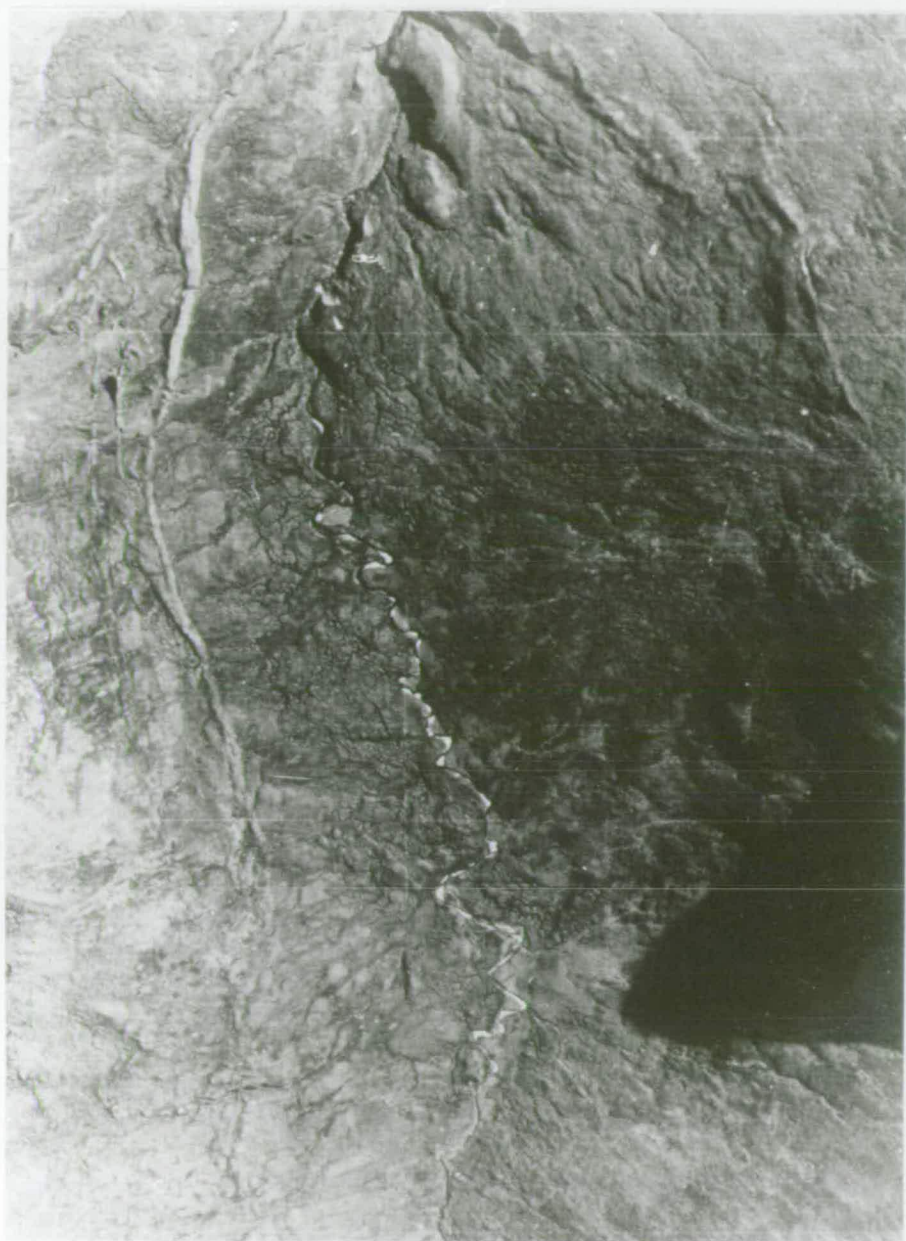

---

Plate 2.8: Coire Dhruim nam Bò, Glenelg, North West Highlands [NG 865 135]. This plate illustrates a sequence of cross valley ridges associated with small meltwater channels on the western flank of the glen and is typical of the density of evidence found in many valleys within the North West Highlands.

Coire Dhruim nam Bò, Glenelg - (NG 865 135).

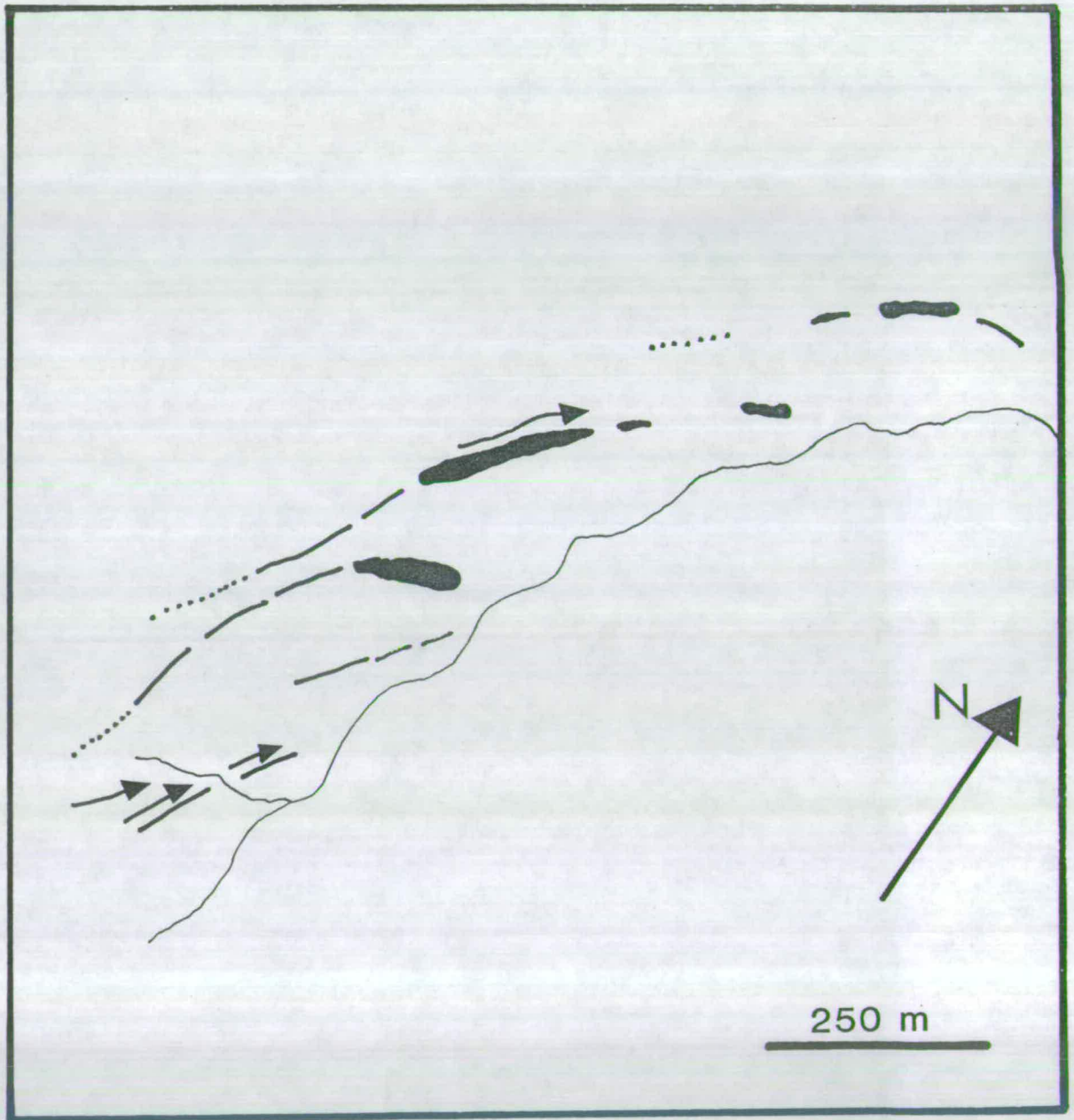



---

Plate 2.9: The size and character of the cross valley ridges vary considerably, as shown in the two examples on this plate. Both these areas have previously been mapped as areas of chaotic and unordered drift mounds (Sissons 1977a & 1979c).

A. Glen Mucarnaich, Beinn Dearg, North West Highlands [NH 245 798]. The ridges at this site are large, rounded and conical in form. The length of individual ridges is short, but they link together well to give clear lineations.

B. Coire Mharconaich, Cairngorms [NN 915 935]. At this location the cross valley concentric ridges are smaller, better defined and are much more continuous.

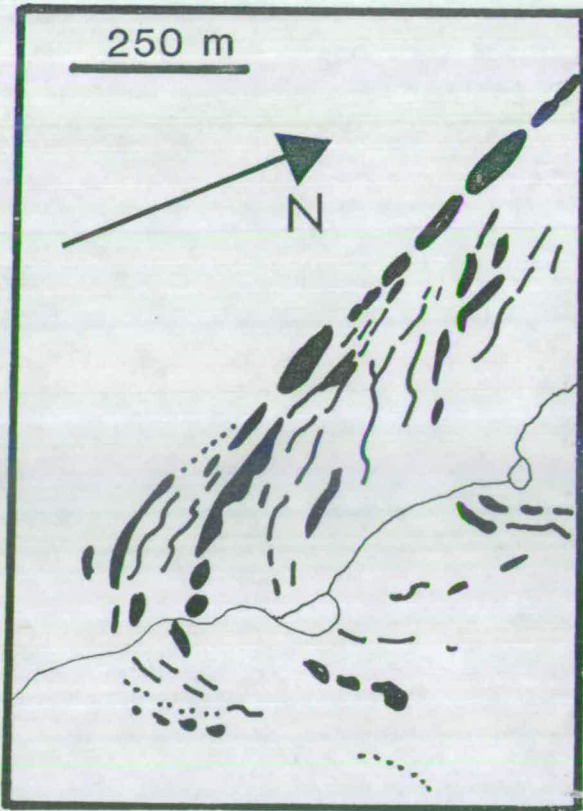

A. Glen Mucarnaich,  
Beinn Dearg - (NH 240  
800).

B. Coire Mharconaich,  
Cairngorms - (NN 910 930).

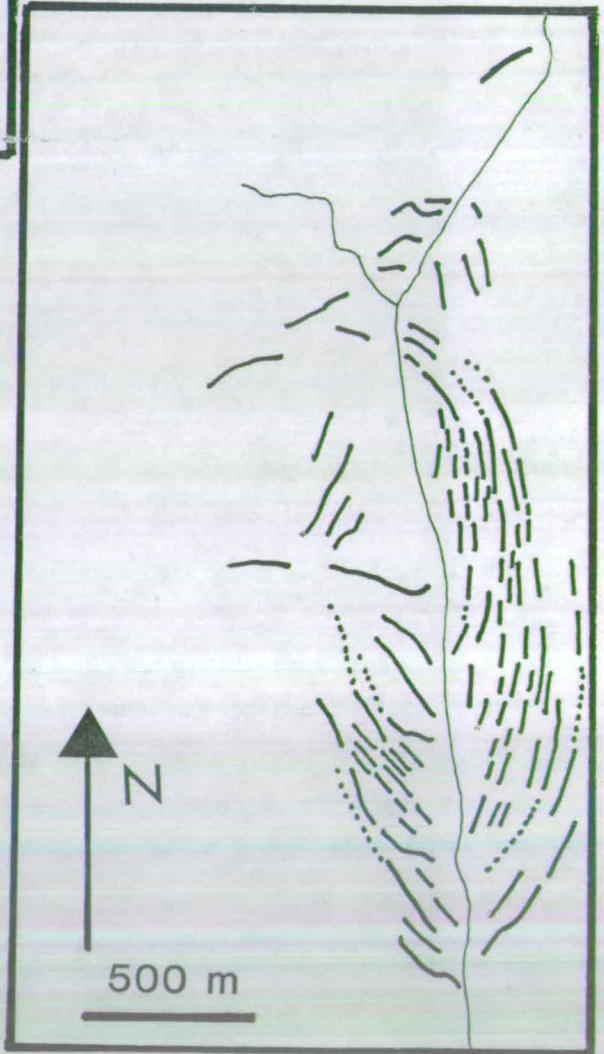



A

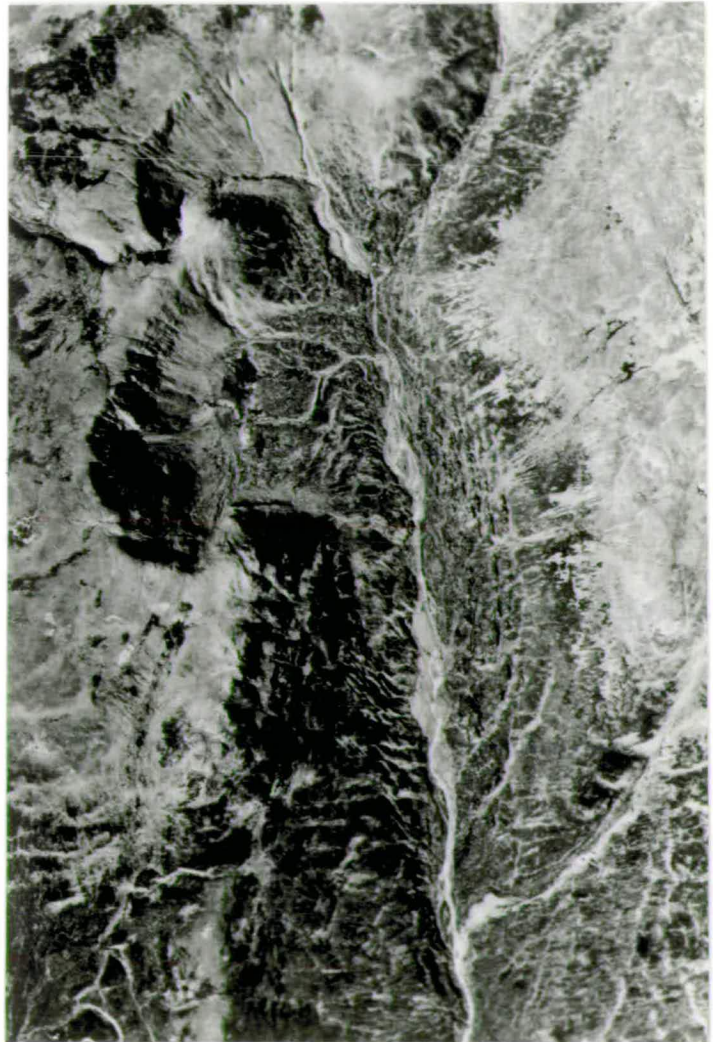

B

---

Plate 2.10: Further examples of the cross valley concentric ridges observed when "hummocky moraine" is examined from the air.

A. Strath a' Bhàthaich, Torridon, North West Highlands [NG 915 505]. In the centre of this enlarged air photograph the cross valley concentric drift ridges are particularly clear, while in the lower right hand corner there is a distinct down valley grain to the drift mounds which do not possess a simple spatial pattern of organisation.

B. Garbh Choire, Cairngorms [NN 970 985]. Of particular note here is the presence of ridges only on the north or south facing flank of this glen which has a pronounced east-west orientation. The suggested explanation for this is the insolation contrast between the south and north facing sides of this glen (See Chapter Five).

A. Strath a' Bhàthaich, Torridon - (NG 910 500).

B. Garbh Choire, Cairngorms - (NN 965 985).

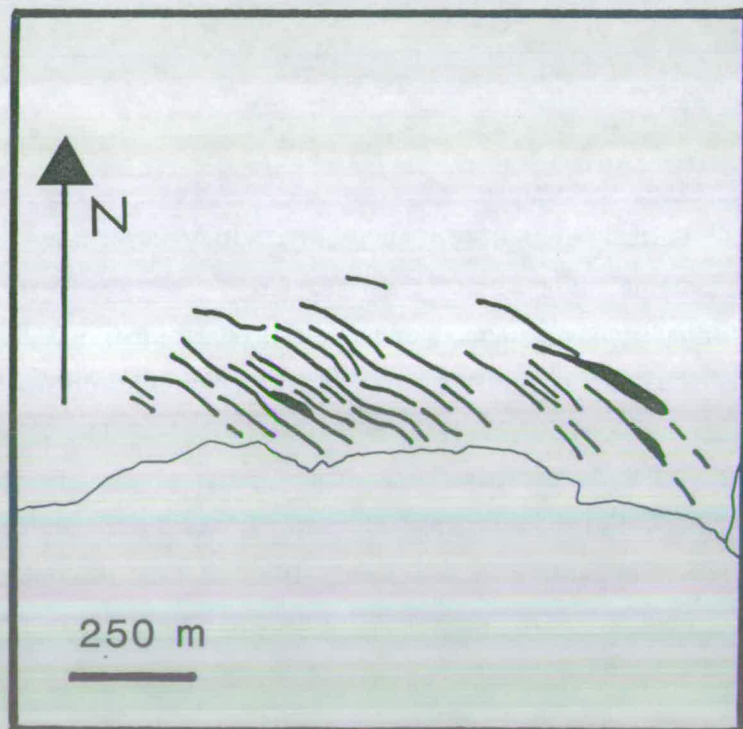
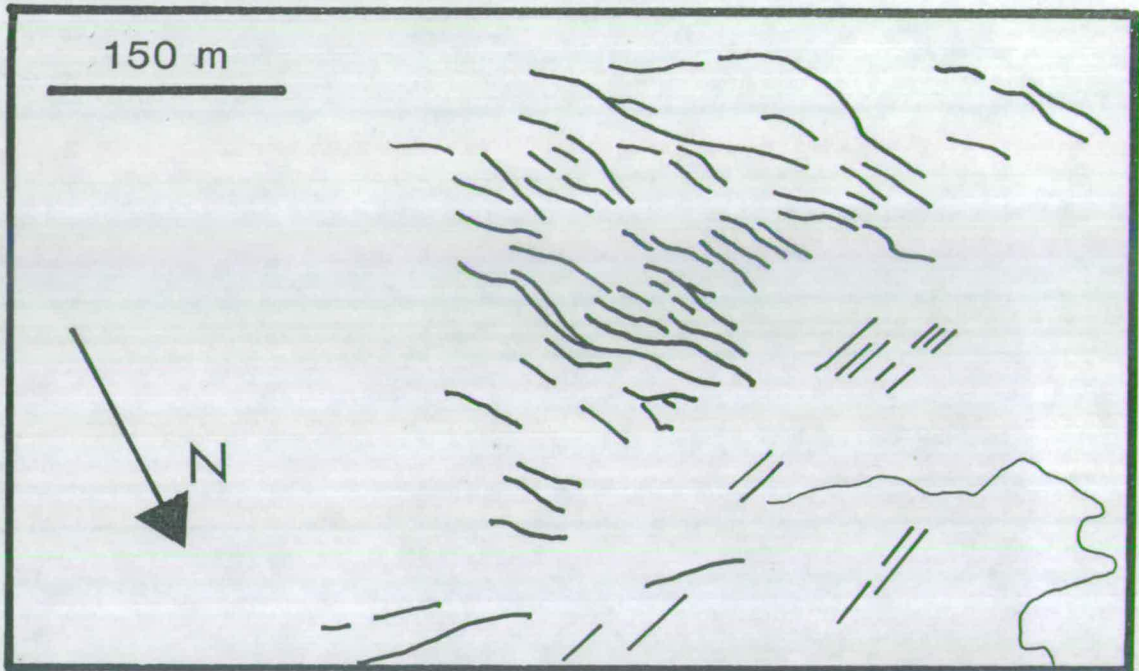

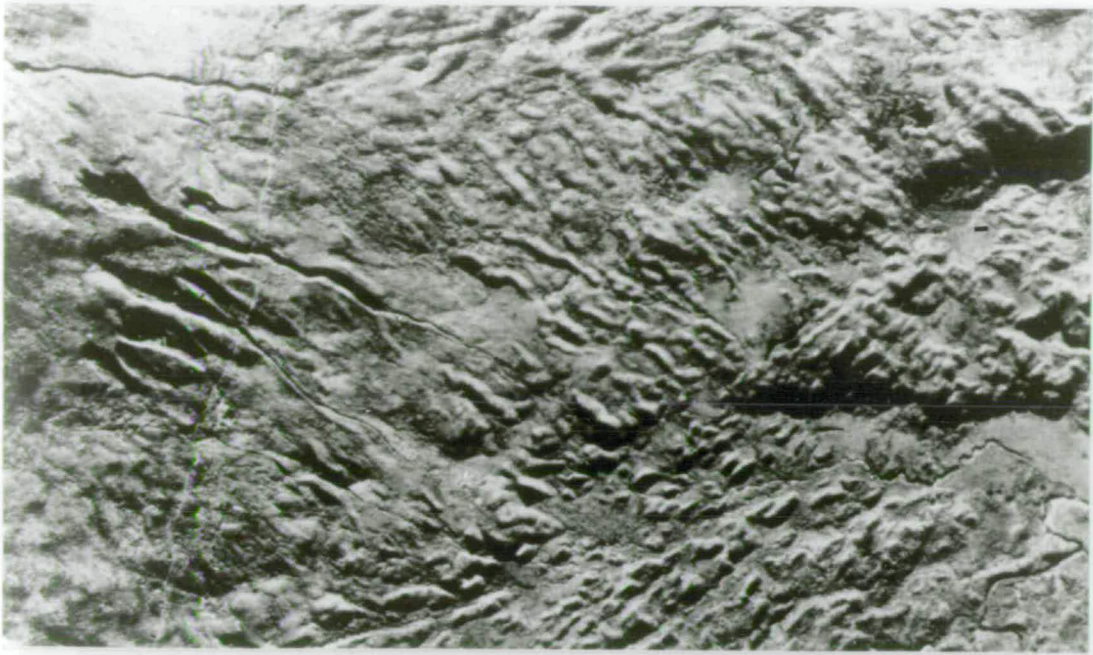

A

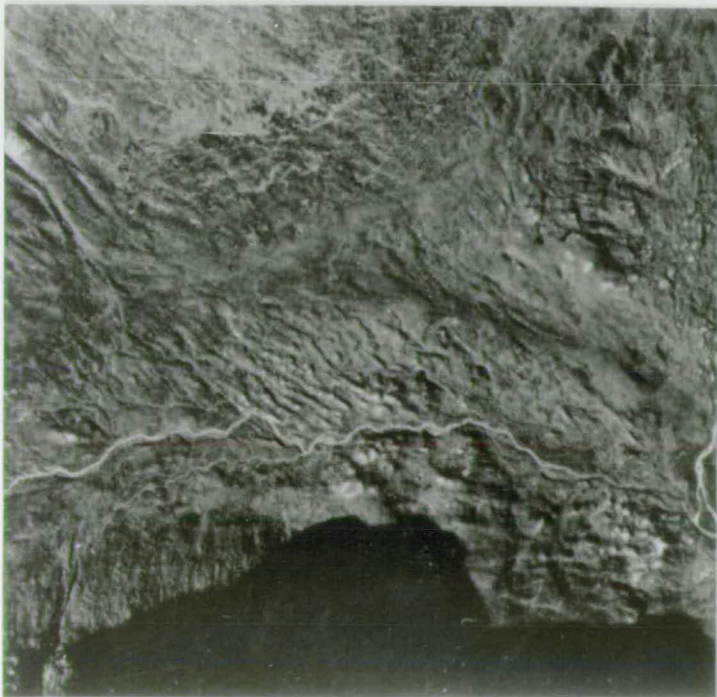

B

---

Plate 2.11: Glen Geusachan, Cairngorms [NN 980 940]. Cross valley concentric drift ridges.

Glen Geusachan, Cairngorms - (NN 960 940).

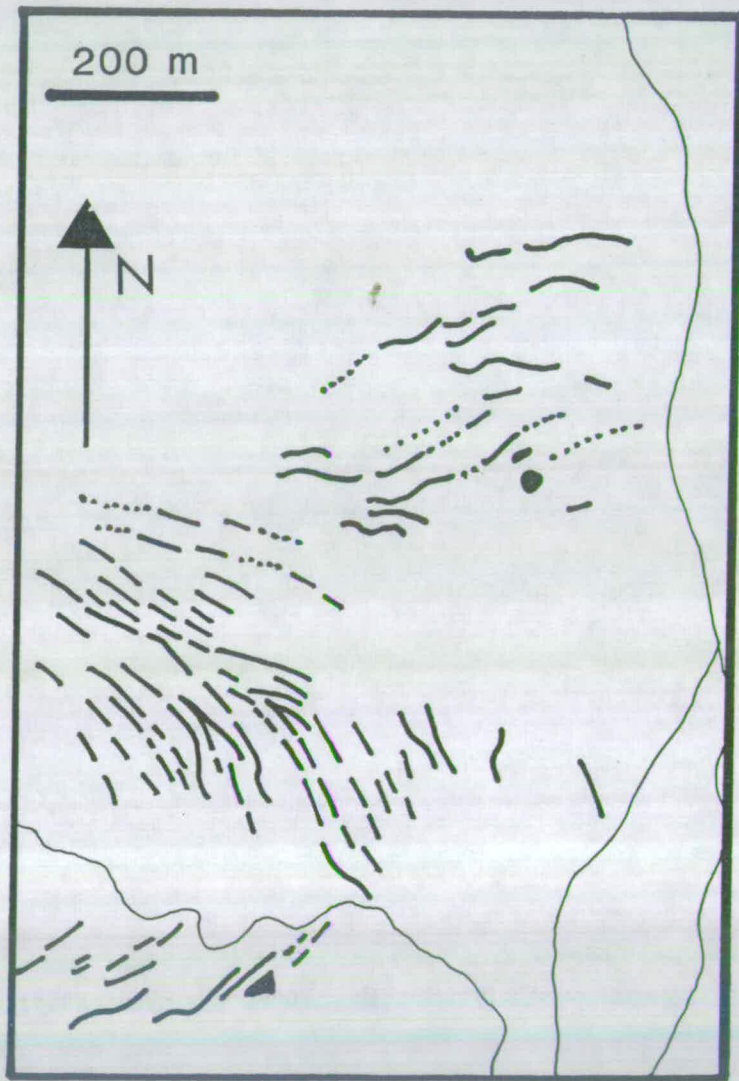



---

Plate 2.12: Maol an Uillt Mhóir, Applecross, North West Highlands [NG 750 460].  
Anastomosing cross valley concentric drift ridges.

Maol an Uillt Mhóir, Applecross (NG 750 460).

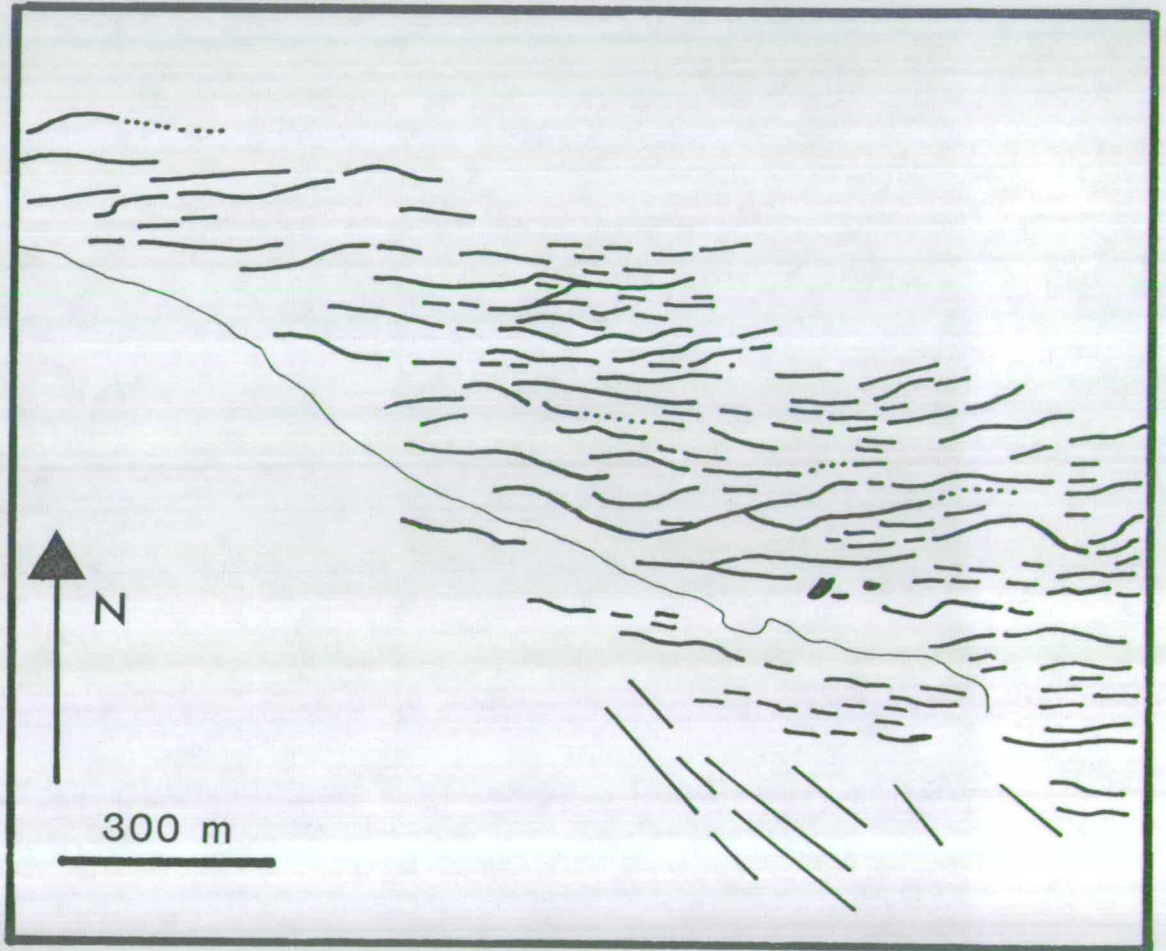

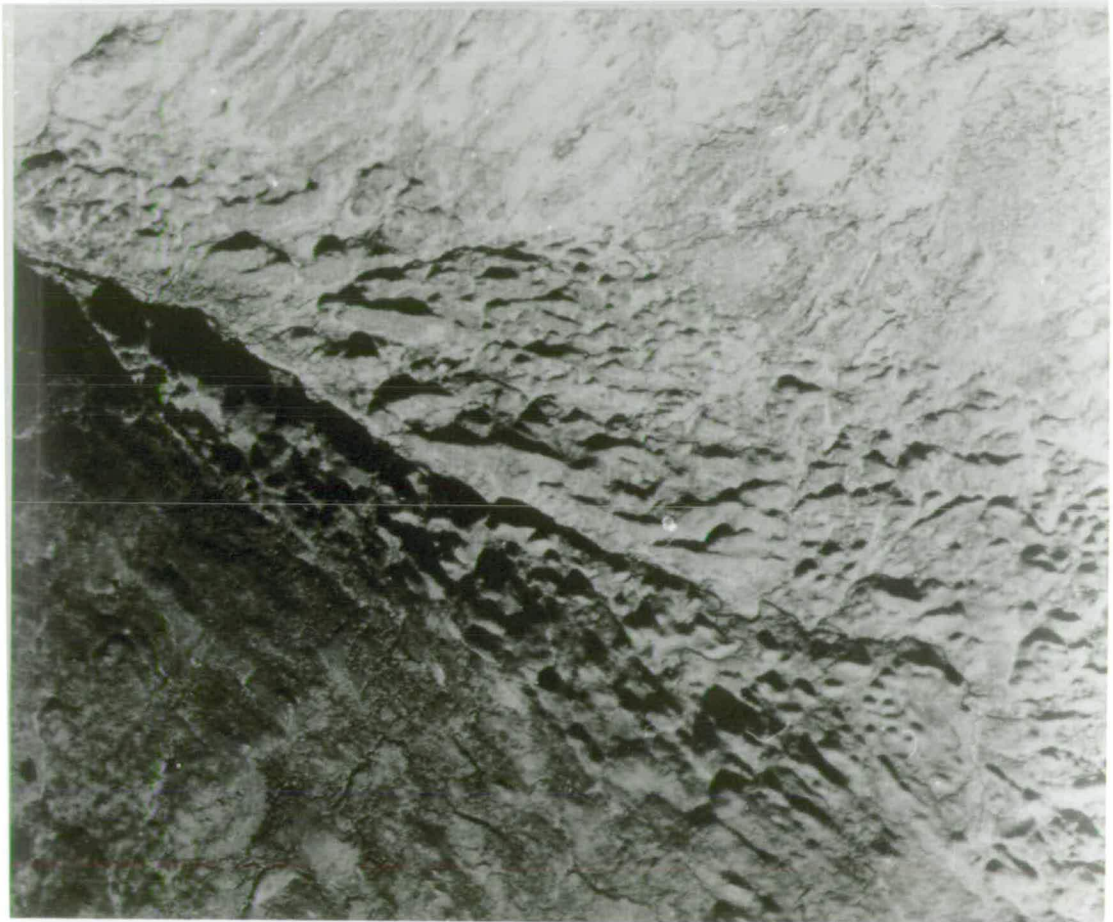

**C. Plates which show the relationship of cross valley concentric elements within "hummocky moraine" to the down valley radial elements present.**

---

Plate 2.13: Glas Tholl, An Teallach, North West Highlands [NH 085 845]. Clear down valley radial elements perpendicular to which there are a few faint cross valley ridges.

Glas Tholl, An Teallach - (NH 080 840).

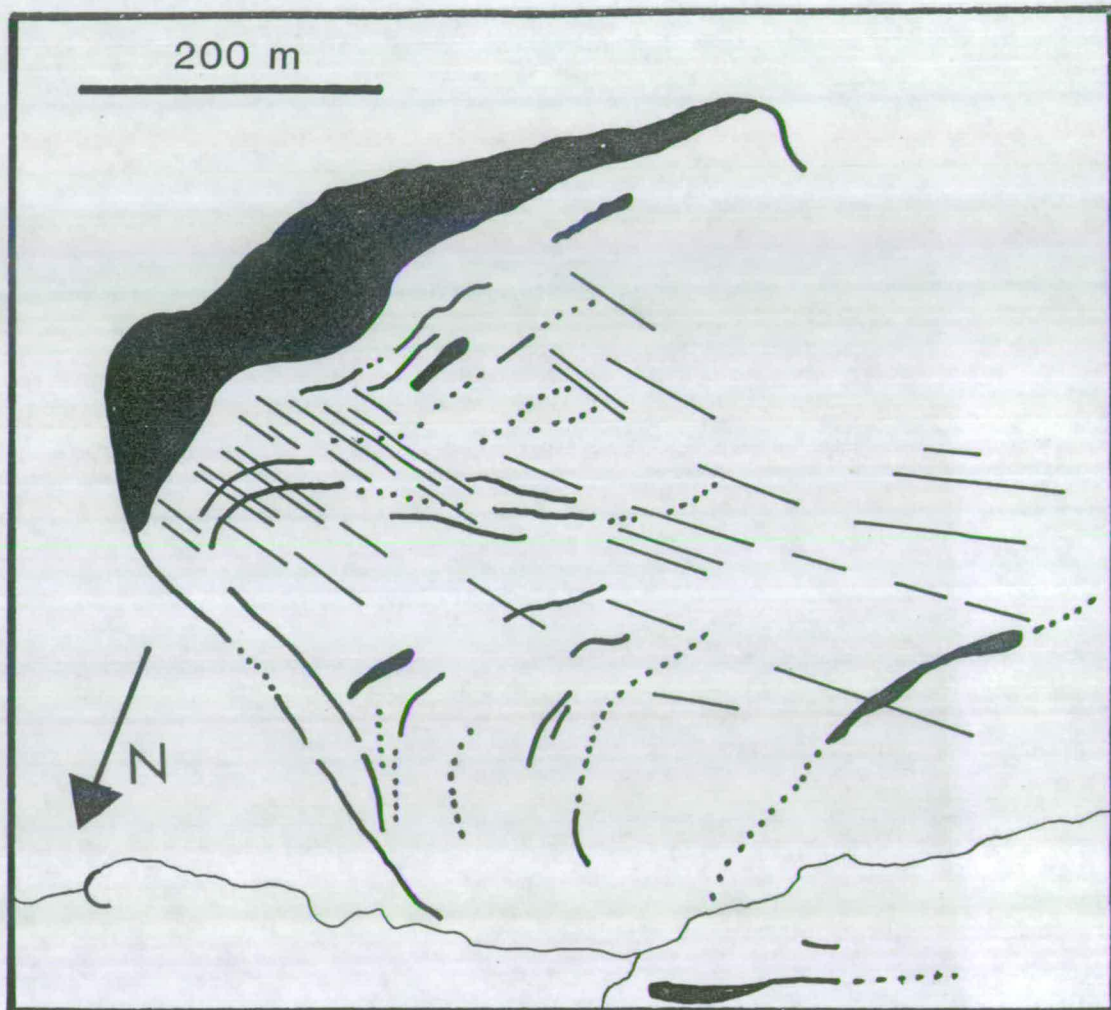

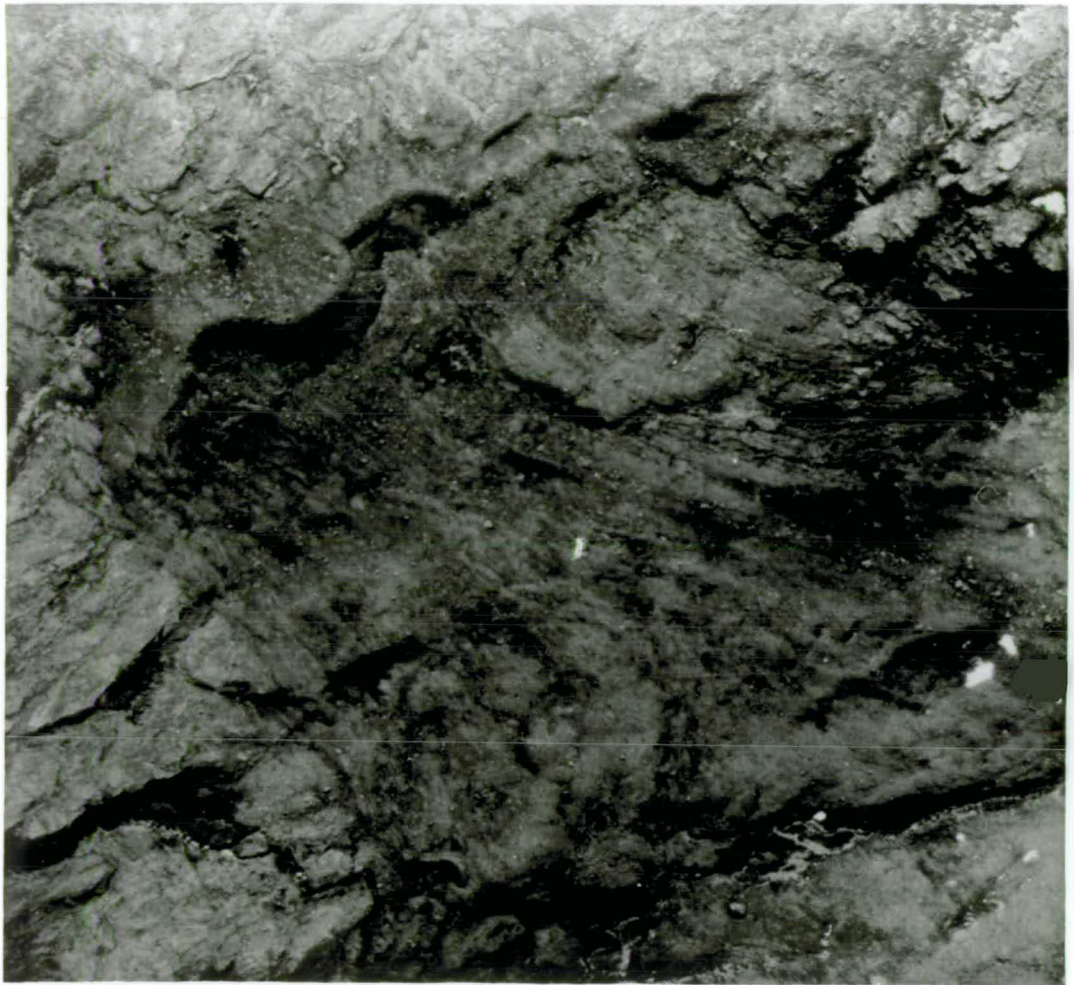

---

Plate 2.14: Drochaid Coire nan Arr, Applecross, North West Highlands [NG 815 415].  
Cross valley concentric elements and down valley radial elements.

Drochaid Coire nan Arr, Applecross - (NG 810 410).





**D. An example of "hummocky moraine" with little or no order when viewed from the air.**

---

Plate 2.15: Lochan Carn na Feòla, Northern Torridon, North West Highlands [NG 920 620]. In a very few locations "hummocky moraine" does not appear to possess any simple pattern of organisation. The site illustrated here is the largest extent of such terrain identified within the North West Highlands over an area of about a square kilometre. At this site the terrain simply consists of small, discrete and conically-shaped mounds of drift. These mounds are not organised into any apparent pattern, although there are occasional ridges with a clear orientation (marked on interpretation). The area is covered by a continuous blanket of boulders, which are just visible in the plate.

Lochan Carn na Feòla, Northern Torridon - (NG 920 620).

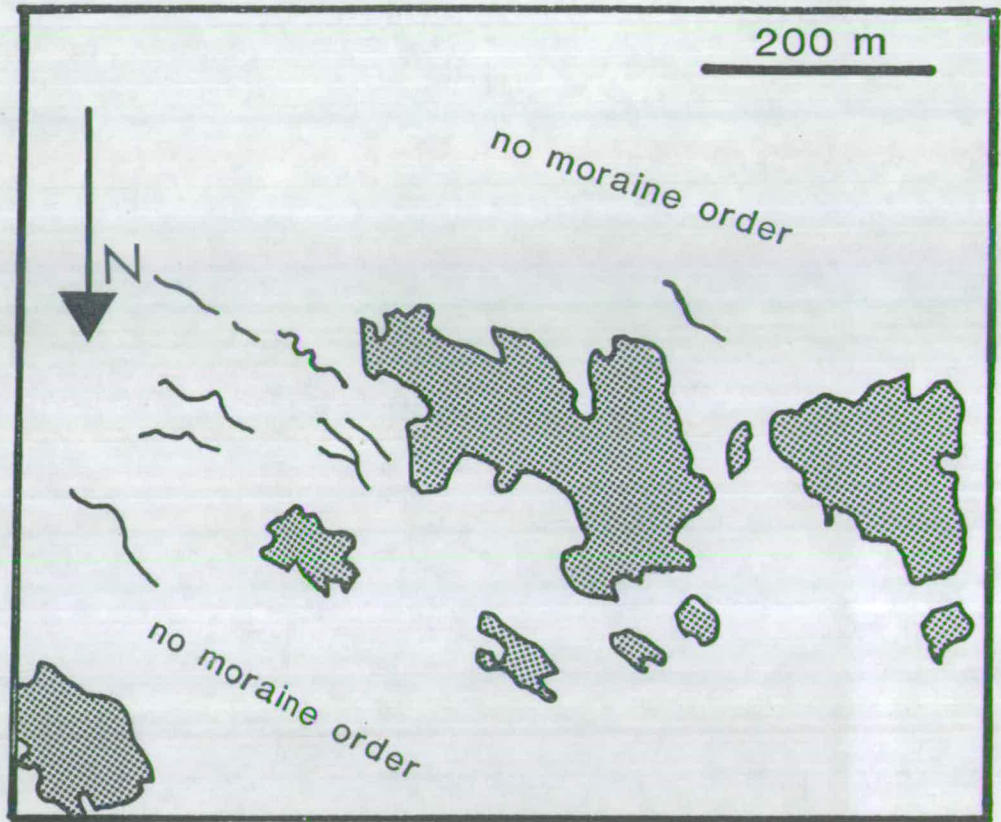

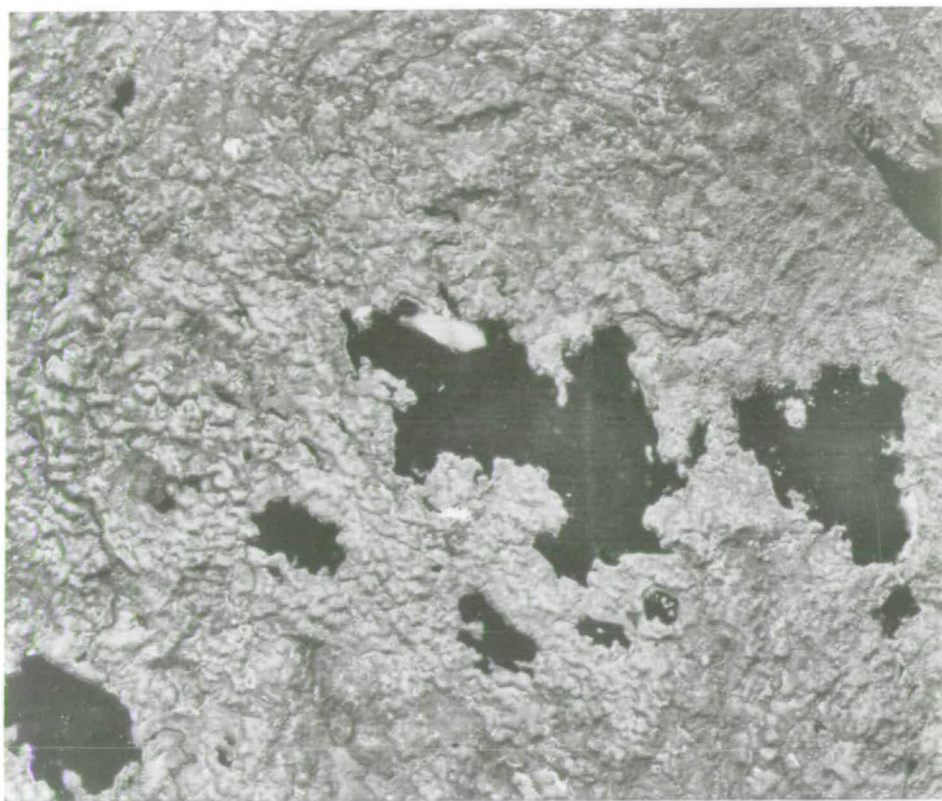

### **2.3: Interpreting form and structure within "hummocky moraine".**

Having established that "hummocky moraine" has a distinct form and structure, its interpretation and significance can now be considered. A wide variety of interpretations have been put forward for Scottish "hummocky moraine", these range from subglacial hypothesis (Hodgson 1982) through ice frontal models (Horsefield 1983) to a variety of stagnation theories (Sissons 1967; Sugden 1970, 1974; Eyles 1983a). Of these models and hypotheses I suggest that, only two are well documented and articulated in terms of clear process models and thus able to explain the structure present within "hummocky moraine".

**Hypothesis 1: Stagnation**—The structure could form during ice stagnation in either or both of two ways: subglacially through crevasse squeezing; or supraglacially due to the control of crevasse and shear plane within the glacier (Plate 2.16). As ice stagnates, subglacial debris may be squeezed into basal crevasses (Hoppe 1952; Sharp 1985; Boulton *et al.* 1989) forming a network of linear ridges. In fact, this is the traditional explanation for structure within "hummocky moraine" (Sissons 1967). During stagnation supraglacial debris on a glacier surface may become concentrated by the glaciological grain present within the ice into a series of linear mounds, the structure of which may be retained as the ice melts out to leave a structured stagnation terrain (Boulton 1971a; Boulton & Paul 1976). Both these two processes may result during either passive decay (areal stagnation) or active deglaciation (incremental stagnation)(Eyles 1979, 1983a).

**Hypothesis 2: Ice-marginal**—The structure within "hummocky moraine" may reflect a sequence of ice-marginal landforms (Horsefield 1983). Modern glacier margins display three main suites of landforms (Plate 2.17):

1. Transverse, ice-marginal landforms, such as push and dump moraines and ice-contact outwash fans.
2. Longitudinal, subglacially produced landforms, such as flutes, drumlins, eskers.
3. Localised patches of stagnation terrain, formed by glaciofluvial deposition or morainic concentration on part of the ice front.

These three components are very similar to the three structural components identified within "hummocky moraine". This hypothesis would imply that the Loch Lomond Stadial ice cap decayed in both an active and progressive fashion.

The structure present within "hummocky moraine" (Plates 2.1 to 2.15) clearly does not resemble that found in stagnation terrain (Plate 2.16), where the structure is either polygonal (Plate 2.16B&C) or is composed of poorly defined linear elements (Plate 2.16A). In Scottish "hummocky moraine" no polygonal pattern has yet been recognised and the linear cross valley elements have a more distinct form than those formed by controlled stagnation of supraglacial debris (Plate 2.16A). In contrast, the spatial organisation of landforms at modern ice margins experiencing active decay (Plate 2.17) is very similar to that present within "hummocky moraine". At modern ice margins there are cross valley or concentric landform assemblages such as push and dump moraines, perpendicular to which there are down valley or radial landforms such as flutes and drumlins. This similarity between the structure at modern ice margins and that present in "hummocky moraine" is such that one can propose the following model:

*A large proportion of the drift ridges in Scottish Highland valleys, which have been referred to as 'hummocky moraine', are individual and identifiable ice-marginal landforms formed at actively retreating ice margins. It follows from this that the Loch Lomond Stadial ice cap in the Scottish Highlands decayed as an active glacier and that the pattern of this decay can be examined by mapping the trends of these landforms.*

This model is of particular importance because, unlike other possible hypotheses of a more theoretical nature, it can provide a series of clear predictions against which it can be tested. This model yields three simple predictions at three distinct scales:

**A. Small-scale**—At modern glacier margins a range of individual landforms can be identified (eg. push moraines, flutes, drumlins etc.). A similar range of landforms should be present within "hummocky moraine".

**B. Meso-scale**—At modern glacier margins the landforms have a distinct spatial organisation; for example, different glacier lobes retreating and advancing at different rates produce frontal landforms of different spatial frequencies and organisation. Similar contrasts should occur within "hummocky moraine".

**C. Macro-scale**—On a regional scale, glacier marginal patterns inferred from transverse and longitudinal landforms should reflect an ice cap decay pattern which obeys fundamental glaciological principles.

These predictions provide a rigorous test for the ice-marginal model proposed above. The author is unable at present to suggest any alternative hypothesis which is not only well articulated but also capable of generating clear, testable predictions, though it is possible that some hitherto unknown explanation may emerge in the future.

In this thesis, therefore, I argue that within the North West Highlands there is evidence at all three spatial scales to support the interpretation of "hummocky moraine" as ice-marginal. A range of individual landforms can be identified within "hummocky moraine" similar to those at modern glacier margins, landforms which possess a similar spatial organisation and which can be used to depict the regional pattern of decay of a small ice cap. This conclusion is based on evidence collected from throughout the North West Highlands. The details of this data collection are examined in the following chapter before the data itself is present in three subsequent chapters:

Chapter 3 • Data collection.

Chapter 4 • Small scale evidence.

Chapter 5 • Meso-scale evidence.

Chapter 6 • Macro-scale evidence.

Chapter 7 • Part 1: Summary and conclusions.

---

Plate 2.16: Oblique air photographs from Spitsbergen and Iceland.  
(Courtesy of G. S. Boulton).

A. Supraglacial stagnation. This photograph shows a debris covered ice margin in Spitsbergen. The frame is approximately 2 km wide. There is a strong linear trend which runs diagonally across the frame and results from glaciological structure within the ice margin. This structure causes variations in the concentration of surface debris. When the buried ice has melted out a complex area of hummocky terrain, possessing a strong linear trend, will probably be present in this area.

B. Subglacial stagnation. This photograph shows a network of polygonal ridges along the northern flank of the Vatnajökull ice cap in South East Iceland. The frame is approximately 500 metres wide. The ridges are produced by the intrusion of debris into basal crevasses during the stagnation of a glacier lobe which has recently surged.

C. Subglacial stagnation. This photograph shows a network of polygonal ridges in an area where stagnant ice is currently melting out in contrast to photograph B where the ice has already melted out. The site is located along the northern flank of the Vatnajökull ice cap in South East Iceland and the frame shows approximately 500 metres of terrain. The debris rich ice of the basal crevasses melts out more slowly than the ice between crevasses emphasizing the polygonal structure.



A



B



C

---

Plate 2.17: Air photograph of the eastern margin of Breiðamerkurjökull an outlet glacier of the Vatnajökull ice cap in South East Iceland. The margin has three main landform components:

1. Cross valley concentric or ice transverse ridges-push moraines and dump moraines.
2. Down valley radial or ice parallel ridges-flutes and mega-flutes.
3. Unordered mounds-local patches of terrain overlaid by buried ice which is melting out.

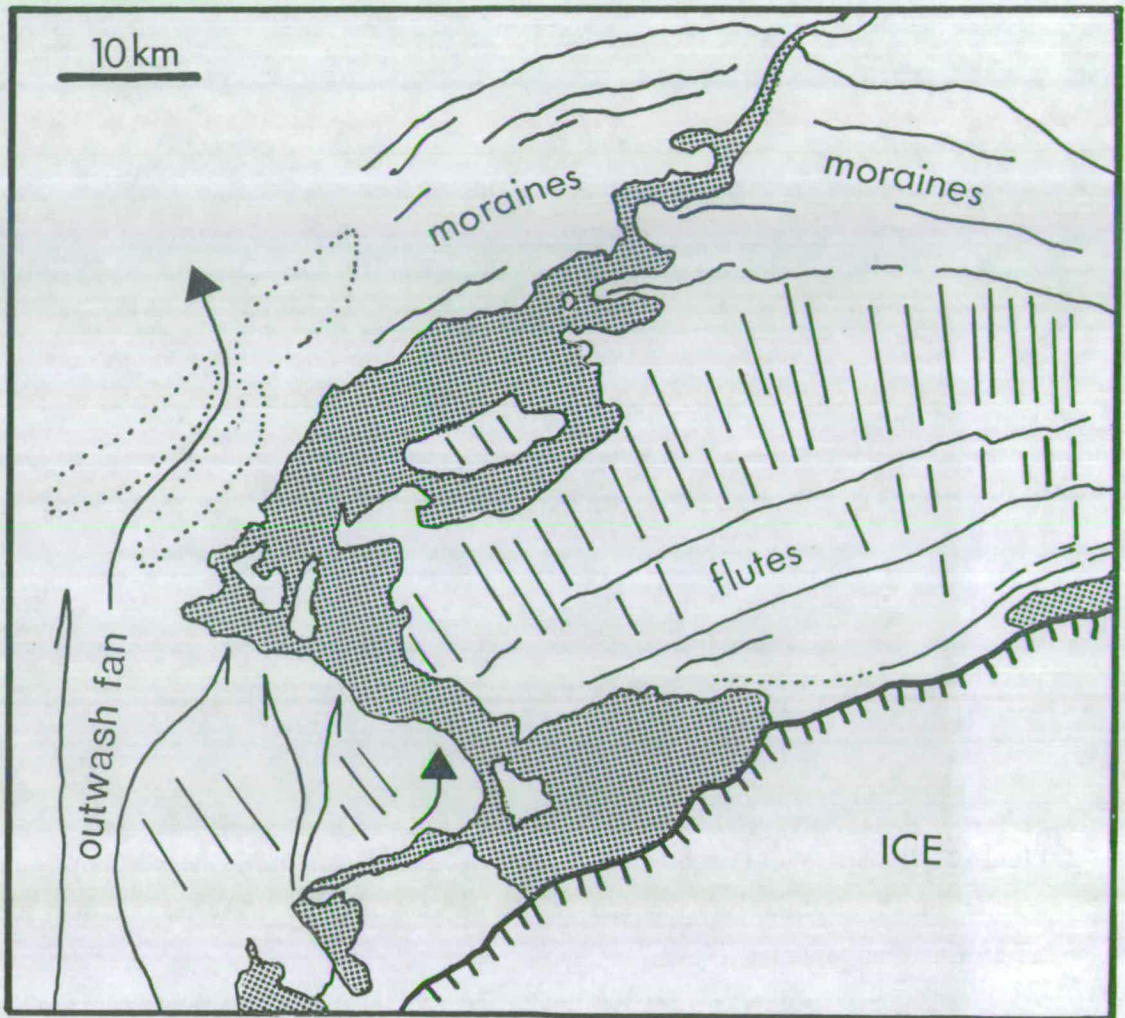

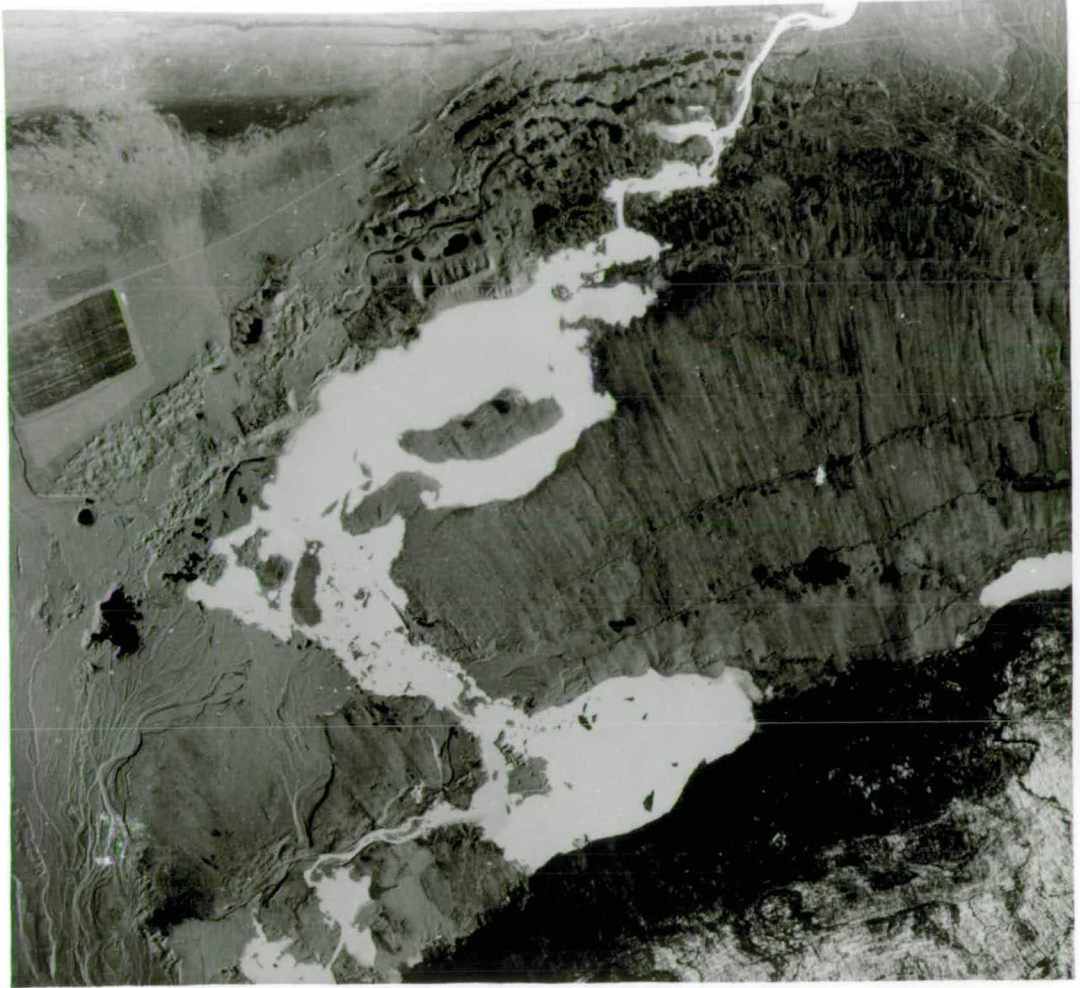

• **Chapter Three** •

**Data collection**

## Contents

3.1:	Introduction.	34
3.2:	Air photograph analysis.	36
3.3:	Delineation of the outer limit of the Loch Lomond Readvance in the North West Highlands.	37
3.4:	Detailed small scale investigations.	41
3.5:	Presentation of the data.	42

---

*This chapter describes the procedure by which the data necessary to examine the model proposed in Chapter Two was collected. There are three aspects to this: air photograph analysis, the identification of the limit of the Loch Lomond Readvance and the identification of critical areas for fieldwork.*

### **3.1: Introduction.**

The data set necessary to examine the model proposed in Chapter Two has been collected from throughout the area occupied by the main Loch Lomond Stadial ice cap in the North West Highlands, although selected evidence has also been drawn from other parts of the Scottish Highlands. There is clear evidence from pre-Loch Lomond Stadial deposits not covered by till or moraine to suggest that this ice cap did not extent further north than Ullapool (eg. Kirk & Godwin 1963). To the north of Ullapool only a few small ice fields and corrie glaciers are believed to have been present during the Stadial. The whole of the area of the North West Highlands south of Ullapool was therefore examined in this study, since it is the dynamics of the main ice cap which are of importance to this research (Fig. 3.1).

There were three stages of data collection:

- 1) Air photograph analysis.
- 2) Delineation of the maximum limit of the main Loch Lomond Stadial ice cap in the North West Highlands.
- 3) Detailed, small scale, field based investigations.

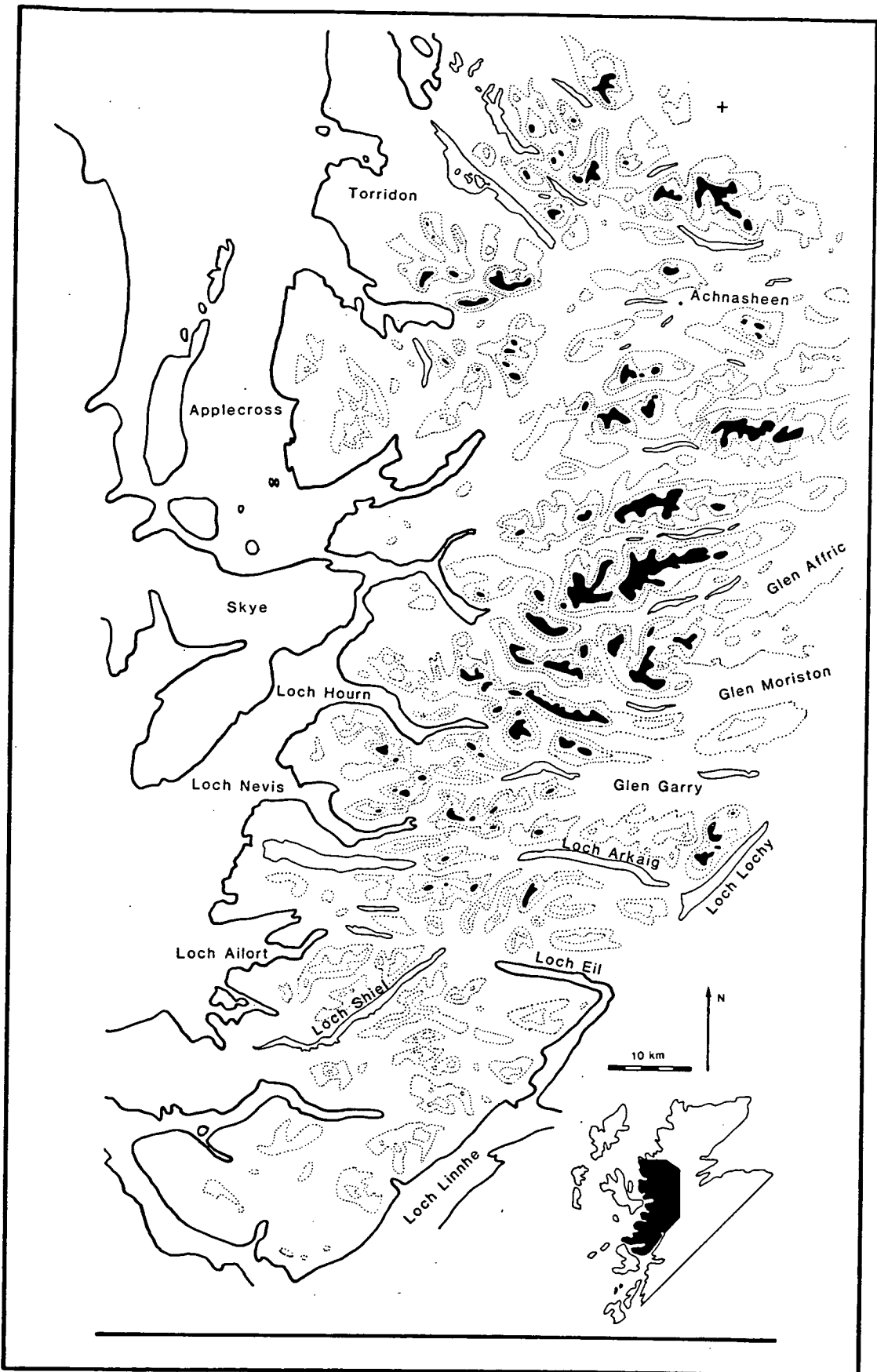

Figure 3.1: The Study area.

+ Lateglacial pollen site of Kirk & Godwin (1963). Contours at 400 m, 600 m and land over 800 m is shown in black. Loch outlines predate reservoir construction (c.1896).

### **3.2: Air photograph analysis.**

The study area was examined systematically using 1:10 000 vertical air photographs in order to establish a data base. The imagery used was taken by the R.A.F. in the 1940s and early 1950s. It therefore predates much of the afforestation and reservoir construction of recent years, although there are problems with shadow, cloud cover and distortion in this early imagery. However, with care such problems can be overcome by using a combination of different flight sorties, flown at different times of the year. The scale of 1:10 000 was found to be superior to other scales for the detailed mapping necessary.

A total of 10 803 air photographs from 26 separate sorties were analysed and approximately 40% of the total area was examined more than once. In order to obtain external corroboration for this exercise (see Chapter Six) no reference was made to published information concerning the glacial history of the North West Highlands (eg. striae, ice limits etc.). Individual runs of photographs within a sortie were selected at random, then examined systematically. As far as possible, consecutive runs were not analysed in sequence. In this way a measure of internal corroboration was also introduced into the analysis. For example, if an adjacent run of air photographs is analysed out of sequence then the inclination to subjectively project a feature from one run of photographs to the next will be avoided.

The morainic evidence on each photograph was mapped onto transparent file overlays using a series of colour coded dots, dashes and lines, along with topographic details such as streams, rivers and lochs.

These photographic interpretations were reduced from 1:10 000 to 1:25 000 using a manual planvariograph. The reduced interpretations were then traced onto 45 1:25 000 scale base maps (O.S. second series) using the topographic information recorded on the interpretations. This information was also used to estimate and correct for any photographic distortion present.

Problems were initially encountered with this procedure, since many valleys have been flooded and loch levels have been changed by the construction of reservoirs. Consequently the topographic information on the air photographs (pre-reservoir) often differed from that on the O.S. base maps used (post-reservoir). In order to overcome this difficulty, the earlier outlines of streams, rivers and lochs affected by the construction of reservoirs were obtained from reprints of the first edition of the one inch

O.S. series (C.1896) and enlarged to a scale of 1:25 000. All the maps in this thesis show the original or natural outline of lochs unless otherwise stated.

These base maps have been used as the basic working data in this investigation and were used to direct, compile and collate field data.

### 3.3: Delineation of the outer limit of the Loch Lomond Stadial ice cap in the North West Highlands.

The next stage of data collection was to identify the outer limit of the main Loch Lomond Stadial ice cap in the North West Highlands.

The outer limit of the Loch Lomond Readvance can only be identified unequivocally at a few widely spaced locations where there is palaeo-biological evidence which predates the Loch Lomond Stadial and has not been covered by glacial sediments (Gray & Coxon 1991). These isolated points cannot be unequivocally linked by a line showing the ice cap's maximum extent.

On the basis of the air photograph analysis it would appear that the whole of the North West Highlands is covered to varying degrees by a roughly concentric series of cross valley drift ridges. This concentric suite of ridges is centred along the main axis of relief. On evidence presented within this thesis, it will be argued that these moraines mark successive ice margins deposited by both the Loch Lomond Stadial and *Dimlington* <sup>Stadial</sup> ice sheets as they decayed, the moraines left by the Loch Lomond Stadial ice cap being deposited within those left by the decay of the older *Dimlington* <sup>Stadial</sup> ice sheet. Therefore the age of the concentric suite of drift ridges covering the North West Highlands should increase away from the main axis of relief (Fig. 3.2A). Identifying the outer limit of the Loch Lomond Readvance requires identification of the major time discontinuity within this sequence, a problem which is complicated by the fact that this readvance limit is not marked by a prominent and easily identifiable moraine (Fig. 3.2B).

This research is concerned with the overall geometry, mass and pattern of decay of the ice cap, given that the ice cap may have been over 50 km wide in places, then an error of a few kilometres in the location of the margin will not significantly affect estimates of ice volume or the location of ice divides.

The approach used to define the limit is illustrated conceptually in Figure 3.3. The figure depicts a hypothetical area of little relief, previously glaciated, on which a small circular ice cap grew and decayed during the

Loch Lomond Stadial leaving a sequence of retreat moraines similar to those found in the Scottish Highlands. Only at one point, to the east of the decay centre, has the limit been established unequivocally (Fig.3.3). The problem here is to identify which series of moraine fragments (1, 2 or 3) can be linked to this known point in order to define a continuous limit. This can be established by taking each possible limit in turn and qualitatively assessing the probability that it represents the maximum ice limit (Fig.3.3). For example, if one considers ice margin—1 there is little doubt that it is part of the ice cap, since it is defined by a nearly continuous moraine and can be easily linked with the known limit in the east. For similar reasons, the probability that ice margin—2 is part of the ice cap is also quite high. However, the probability of ice margin—3 being the outer ice limit is much lower, since it is defined by only a few widely spaced moraine fragments and would have defined an ice cap which was more extensive to the north, west and south than to the east (Fig.3.3). Therefore the moraines of ice margin—1 would provide the most conservative readvance limit. In all cases the most conservative margin is adopted.

This approach was applied to the complete data set of moraines in the North West Highlands and probable ice limits were identified at this regional scale. Each of these limits was then re-assessed by detailed field survey. Each of the principal valleys was considered in turn and the limit located at the furthest moraine from the ice centre which could be convincingly linked with moraines in adjacent valleys and fitted into the regional picture (Fig.3.4A). In places, this rule was broken to avoid placing the ice limit within a continuous depositional landform sequence (Fig.3.4B). In most cases a limit was identified, beyond which there was a marked decrease in drift cover. In other cases, the limit clearly truncated drift ridges which judging by their location and orientation, must date from earlier, more extensive periods of glaciation (eg. Ballantyne 1986). The principal difficulties occur in areas where the moraine cover is fragmentary and poor. Two particularly difficult cases are of note—firstly, around Loch Duich where the sides of the loch contain no hint of the location of the ice limit; and secondly, between Loch Morar and Loch Shiel where there is little drift. In such cases the limit has been interpolated between the moraine fragments available in adjacent valleys according to glaciological considerations to be discussed in Chapter Six.

Figure 3.5 illustrates the outer limit established for the Loch Lomond Stadial ice cap in the North West Highlands derived by this approach. The

ice cap coalesced with that in the Grampian Highlands across the southern end of the Great Glen, and is disposed along the main axis of relief in the North West Highlands. Several small corrie glaciers occur around the periphery of the ice cap and a small plateau ice field was present within Applecross. To the north of the ice cap, although not mapped in detail, a second plateau ice field and several corrie glaciers have been identified. Many of the limits proposed here are similar to those proposed in previous work (eg. Applecross, Torridon, Glen Moriston, Loch Nevis, Loch Morar-Peacock 1970; Robinson 1977; Sissons 1977a&b; Boulton *et al.* 1981; Ballantyne 1986), but there are also some major differences (Robinson 1977; Sissons 1977a&b). The greatest discrepancy between the limit proposed here and the limits proposed by other workers is in the north east. This results from the location of the eastern limit of the ice cap at the ice-dammed lake of Achnasheen, previously thought to predate the Loch Lomond Stadial (Sissons 1982).

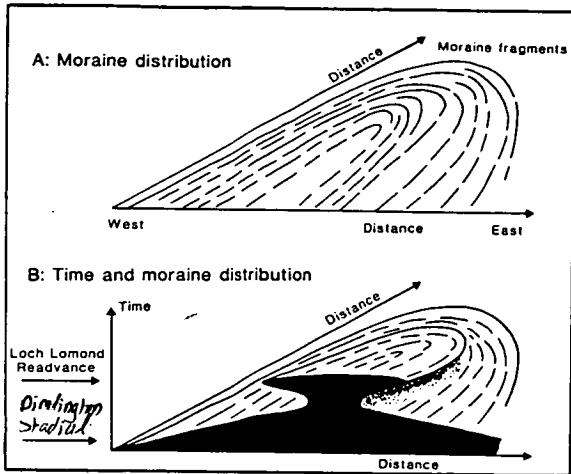

Figure 3.2

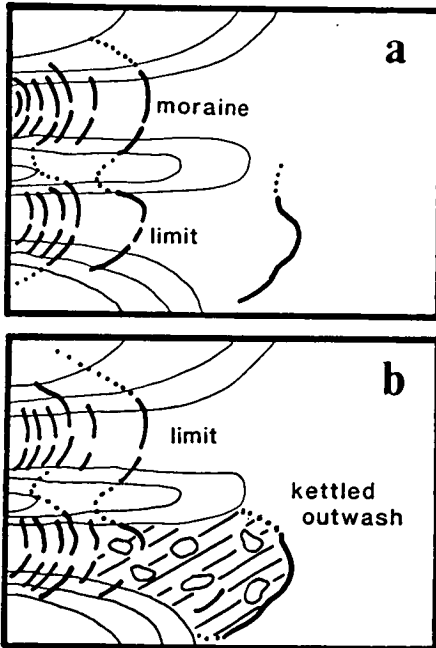

Figure 3.4

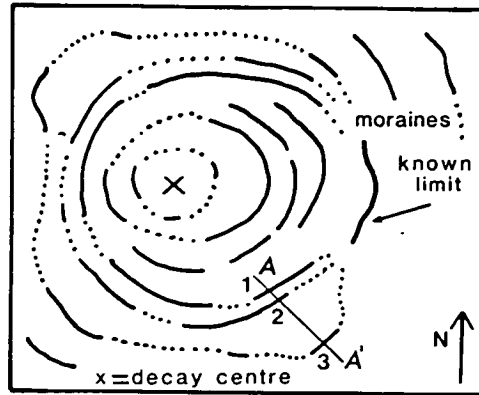

Figure 3.3



Figure 3.5

Figure 3.2: Hypothetical moraine distribution in both space and time for the Scottish Highlands at the close of the last glacial cycle, see text for details.

Figure 3.3: A conceptual example, to illustrate the method by which the outer limit of the Loch Lomond Stadial ice cap was located, see text for details.

Figure 3.4: Procedure for locating the outer limit of the Loch Lomond Stadial ice cap.

Figure 3.5: The outer limit of the Loch Lomond Stadial ice cap in the North West Highlands. Black shapes are land over 800 metres. Larger more detailed maps are presented later in this thesis.

### **3.4: Detailed small scale field based investigations.**

The aim of these investigations ranges from attempts to determine the genesis of individual mounds to examining the distribution of complete suites or assemblages of mounds in a single valley.

Interpretation can be approached in two ways:

- 1) On the basis of morphology.
- 2) On the basis of sediments.

The approach adopted here is based primarily on morphology. This reflects two factors: Firstly, within Scottish "hummocky moraine" the sedimentary exposure is poor and infrequent. Digging pits does not provide a satisfactory answer since they can be rarely dug large enough to give a realistic indication of the sediments present. I would argue that before such extreme methods are adopted one should first explore the full potential of the more accessible evidence contained within the morphology of a landform. Secondly, sedimentary evidence is not necessarily superior to morphological data, as is frequently assumed. Specific landforms do not have unique sedimentary expressions, especially in glacial environments which are characterised by a very diverse assemblage of sediments. For example, one might expect small drumlins to be characterised by subglacial tills, yet observations by Krüger and Thomsen (1984) in Iceland suggest that they may also be composed of undisturbed glaciofluvial deposits. In such cases sedimentary evidence may even be misleading.

Consequently morphological evidence has been used in the first instance to interpret landforms and where sedimentary evidence is available this has been used to test these interpretations.

Sites suitable for intensive study were identified on the air photographs on the basis of the following criteria: (1) Sites which are representative of morphologies and patterns that were recurrent on the air photographs analysed. (2) Sites with anomalous or distinctive morphologies. Investigations ranged from simple observation to quantitative survey. Landforms were mapped at a wide range of scales (1:2 000-1:25 000), on a variety of media (air photographs-maps) and described using simple field techniques (eg. clinometer, tape, level etc.). Sedimentary sequences were recorded by simple logs, coupled with field analysis of clast shape and size (a, b & c axis plus Powers (1953) and Krumbein (1941) visual roundness)(Barrett 1980; Bridgland 1986; Fisher & Bridgland 1986).

All the information obtained from these investigations was compiled on to the 1:25 000 base maps.

### **3.5: Presentation of the data.**

From each of the 1:25 000 base maps a simplified moraine map was produced and reduced to a scale of approximately 1:80 000. These reduced maps are presented in Appendix I.

• Chapter Four •

**Small scale evidence**

## Contents

---

4.1:	Introduction.	44
4.2:	Cross valley concentric ridges.	45
	A. Moraines.	45
	B. Glaciofluvial landforms.	57
	C. Lacustrine landforms.	68
	D. Section summary for cross valley or concentric ridges.	75
4.3:	Down valley radial ridges	76
	A. Glacial landforms.	76
	B. Glaciofluvial landforms.	84
	C. Section summary for down valley radial ridges.	89
4.4:	Non-linear ridges.	90
4.5:	Chapter summary.	98

---

*It has been argued above that "hummocky moraine" is an assemblage of ice-marginal landforms. If this is so, it should contain the range of individual landforms (eg. push moraines, dump moraines, outwash fans etc.) which characterise retreating ice margins. In this chapter I argue that, not only can the same range of landforms be identified, but that the controls and processes by which they form can also be identified. The range of landforms present within "hummocky moraine" is systematically described using a simple classification of ice-marginal landforms.*

### 4.1: Introduction.

Ice-marginal landforms have been classified in a variety of ways. However, most classifications make some distinction between ice transverse and ice parallel landforms (eg. Prest 1968; Embleton & King 1975; Sugden & John 1976). Table 4.1 is a simple classification of ice-marginal landforms similar to many previous schema. Landforms are classified according to three criteria: linear vs non-linear; transverse vs longitudinal and; glacial, glaciofluvial or lacustrine depositional environments. If the form and structure within "hummocky moraine" reflect glacier retreat patterns,

as argued in Chapter Two, then most or all of the landforms in Table 4.1 should be identifiable within the limits of the Loch Lomond Readvance. By taking each element of this classification in turn, this chapter attempts to show that all these ice-marginal landforms are in fact present. What follows is therefore a catalogue of landforms that can be identified within "hummocky moraine" areas. The evidence is drawn primarily from the North West Highlands, although specific examples are also presented from other parts of the Scottish Highlands.

#### **4.2: Cross valley or concentric ridges.**

At modern ice margins there are three broad groups of landforms which can be described as being predominantly ice transverse or cross valley landforms, each of which should be present within "hummocky moraine":

A: Moraines.

B: Glaciofluvial landforms.

C: Lacustrine landforms.

#### **A: Glacial landforms.**

As was illustrated in Chapter Two, it is possible to identify a simple continuum in size and spacing of cross valley concentric ridges from discrete, well spaced to closely spaced, anastomosing ridges and from ridges of a metre or so in height to some in excess of 8 to 10 metres (Plates 2.5-2.14). At modern glacier margins there are two principal types of ice-marginal moraine, push moraines and dump moraines (Plate 4.1). In Figure 4.1 a simple conceptual model is presented which describes the controls on the size and spacing of these moraines. I suggest that the size, spacing and characteristics of cross valley concentric ridges in "hummocky moraine" can be explained by this model. There are two lines of evidence to support the interpretation of these ridges as ice-marginal:

1: Planimetric evidence.

2: Sedimentological evidence.

		Glacial	Fluvioglacial	Lacustrine
Linear	Tranverse Cross valley concentric	push moraines dump moraines	ice contact outwash fans	deltas fan deltas
	Longitudinal down valley radial	flutes lateral moraines medial moraines	eskers kames meltwater channels	
Non-linear	Unordered	ice marginal stagnation terrain	ice contact fluvioglacial systems	

Table 4.1: Classification of landforms at modern ice margins, such as one would find at Icelandic, European or North American glacier margins.

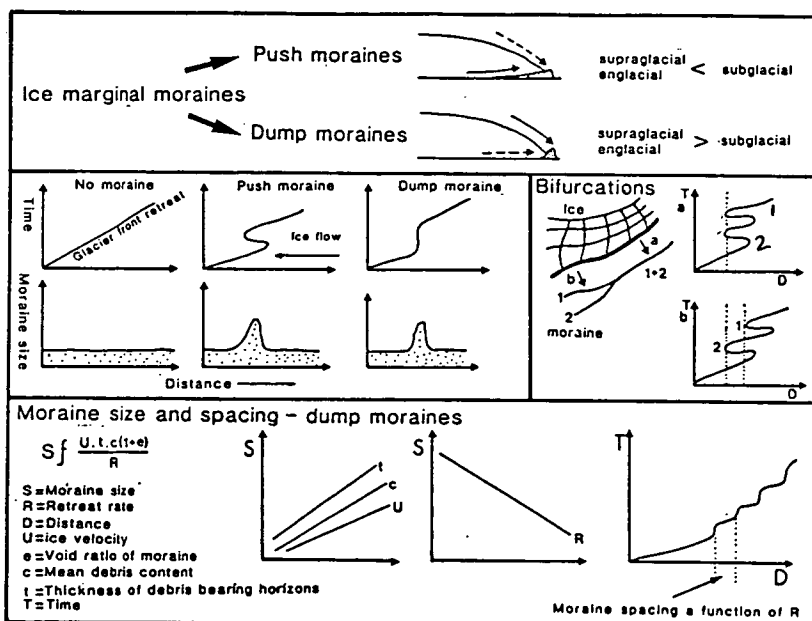

Figure 4.1: A conceptual model of ice-marginal moraines.

- 1) Main moraine types considered.
- 2) A series of graphs illustrating the fluctuation of an ice margin through time as it retreats. The X axis is the distance of the ice front from a fixed point at the graph's origin.
- 3) Shows the process by which bifurcations form through the differential retreat of different portions of the ice front.
- 4) A simple approximation of the controls on dump moraine size and spacing (after: Boulton *et al.* 1985).

## **1: Planimetric evidence.**

### **i) Bifurcations.**

The only cross valley or ice transverse landforms at modern glaciers which have a bifurcating pattern are ice-marginal moraines (Hewitt 1967; Þórarinnsson 1967; Price 1973; Matthews *et al.* 1979; Sharp 1984; Boulton 1986; Eybergen 1986; Timmis 1986)(Plate 4.1). Figure 4.1 illustrates the way in which these bifurcations form by the differential retreat of different sections of the ice front. Bifurcations are a common feature of the concentric elements in "hummocky moraine" supporting the interpretation of these ridges as moraines (Fig. 4.2A)(Appendix I). For example, Figure 4.3 shows part of the Valley of a Hundred Hills in Torridon (Corrie a' Cheud—chnoic), which has a distinct bifurcating pattern.

### **ii) Asymmetry.**

Ice-marginal moraines tend to be asymmetric, with gentler stoss (ice-contact) and steeper lee slopes (eg. Price 1973; Matthews *et al.* 1979; Matthews & Petch 1982; Shakesby 1989). The cross valley or concentric elements in "hummocky moraine" also possess a recurrent asymmetry—up valley faces are usually gentler than those which face down valley (Fig. 4.2B). Moreover, these gentler faces frequently possess small cusped hollows similar to those formed by the pressure of ice ridges lying, between longitudinal crevasses, against the ice-contact faces of contemporary moraines. These are particularly clear in Glen Affric, where the cusps between hollows are picked out by boulder concentrations [NH 194 264].

### **iii) Moraine volumes.**

According to the conceptual model for push moraines and dump moraine in Figure 4.1, increased debris supply at an ice front should increase the size of moraines produced. Consequently there should be some correlation between areas of high debris concentration and large, dense suites of moraines. At a regional scale this is particularly true. In the North West Highlands the outcrop of Torridonian sandstone is associated with some of the most impressive moraine ridges in the Highlands (see Chapter Eight). The sandstone is very erodable, being well jointed, and seems to have been the source of large quantities of drift. At a smaller scale, individual suites of dense ridges can often be correlated with the presence of individual cliff faces (Benn 1989b).

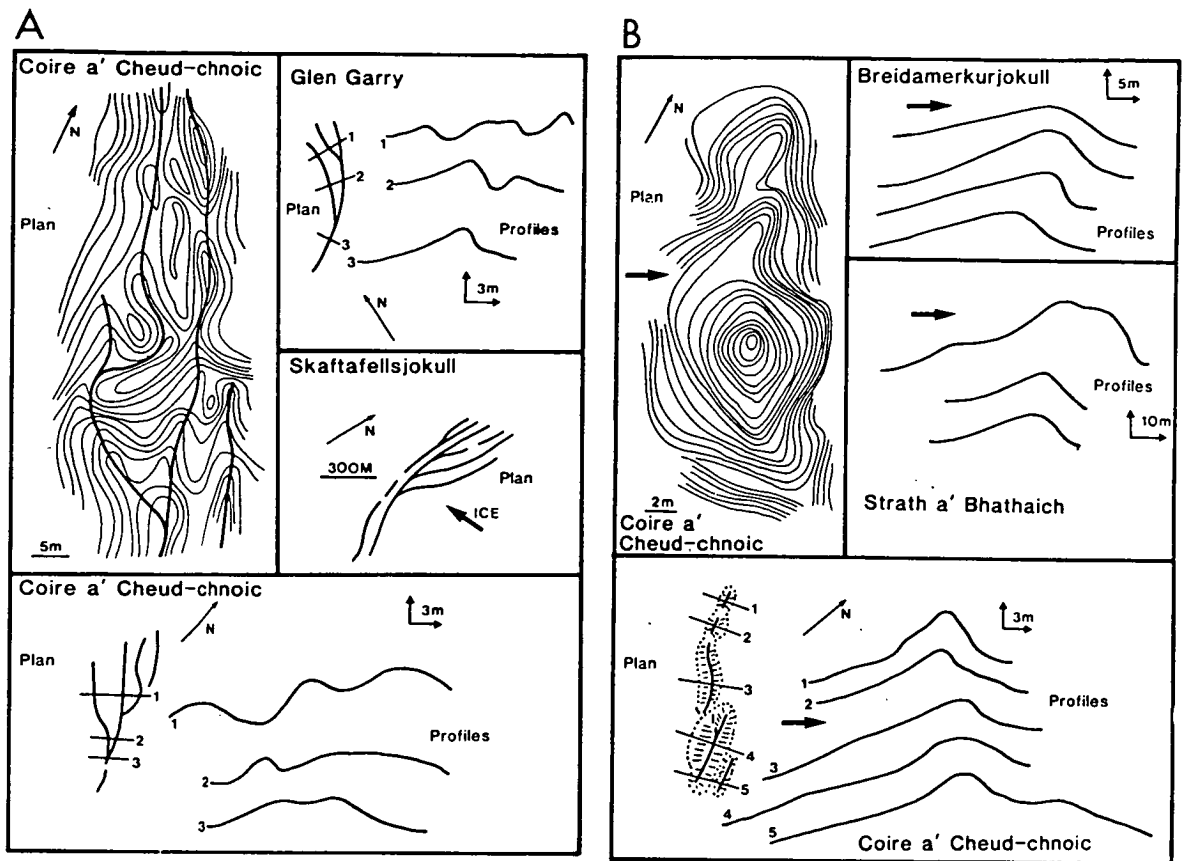

Figure 4.2: A: Ridge Bifurcations. (1) Contour map (0.5 m interval) showing a ridge bifurcation in Coire a' Cheud-chnoic, constructed from 9 levelled profiles. (2&4) A series of ridge crest plans and levelled profiles to illustrate the bifurcation of cross valley concentric ridges in "hummocky moraine". (3) Plan of ridge crests showing a bifurcating push moraine in Iceland.

B: The asymmetry of cross valley concentric ridges in "hummocky moraine" and those of modern ice margins. (1) Contour map (0.5 m interval) showing the asymmetry of a cross valley concentric ridge in Coire a' Cheud-chnoic, arrow points to the gentler up valley side of the ridge. (2) Push moraine profiles from Iceland. (3&4) Profiles of cross valley concentric ridges selected at random in Strath a' Bhathaich and Coire a' Cheud-chnoic.

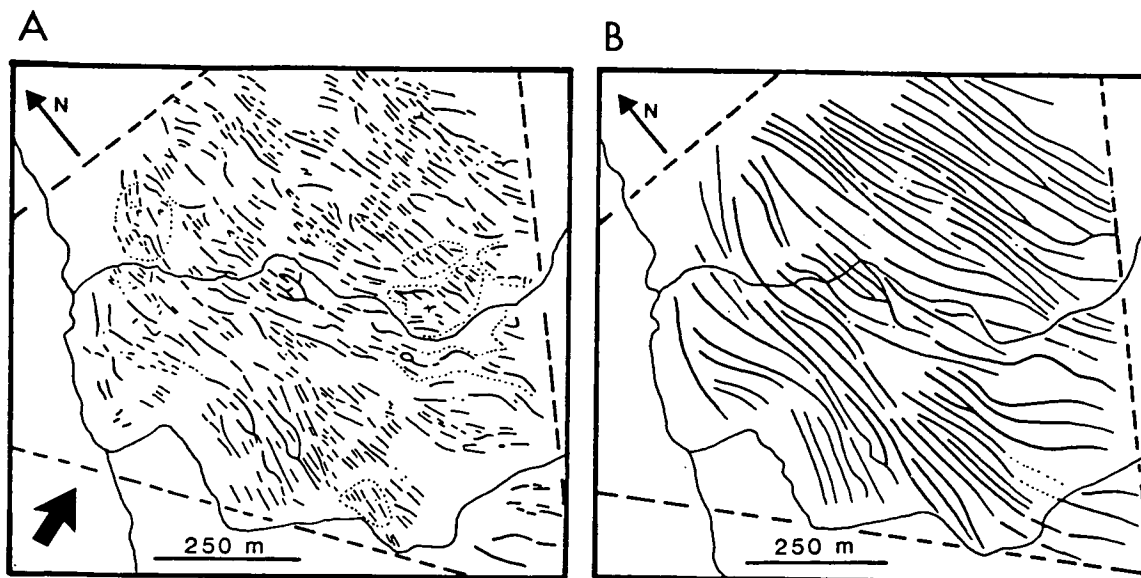

Figure 4.3: A: Detailed field map of cross valley ridges in Corrie a' Cheud-chnoic [NG 955 555]. The dotted lines demarcate the area of intensive mapping, conducted at a scale of 1:5 000. The arrow points down valley.

B: Summary of (A) produced by linking the ridge fragments in the field into more coherent lineations. This picks out the bifurcations more clearly.

---

## 2: Sedimentological evidence.

The sediment within cross valley concentric ridges tends to comprise three broad types:

- i. Sediments showing shear folding.
- ii. Heterogeneous sands, bouldery gravels and diamictons.
- iii. Homogeneous diamictons.

### i. Sediments showing shear folding.

Several sections provide evidence of ice pushing.

For example, at the west end of Loch Morar several poor exposures of silt and sand reveal a sequence of folds and thrusts within a series of ridges [NM 685 925] (Boulton *et al.* 1981) (Plate 4.2). Although the level of exposure is insufficient to examine the overall geometry of the thrusts, a number of smaller folds and shear planes can be examined (Fig. 4.4B&C). These consist of complex sets of isoclinal folds which have been sheared to varying degrees (Fig. 4.4B&C & Plate 4.2). A direct analogue for these structures was recorded in a push moraine at Heinabersgjökull in South East Iceland (Fig. 4.4A) and similar tectonic structures in push moraines have been discussed

within the literature (eg. Eyles 1978; Humlum 1985; Krüger 1985; Boulton 1986; Eybergen 1986; Boulton *et al.* 1989; Aber 1989).

A much larger fold in sands and gravel was recorded in a section in one of five prominent moraine ridges (5-15 m high) which mark the maximum extent of Loch Lomond Stadial ice in Glen Thrail, Torridon [NG 906 551]. The section contains two distinct facies. The lower facies (F1) is composed of a series of well sorted fluvial sand and gravel units which have been deformed into a single open fold. Above this, the second facies (F2) is a heterogeneous assemblage of units: (1) matrix supported diamictons with weak and irregular clast orientations, these units are often bounded by clast concentrations; (2) well sorted clast supported gravels; (3) clast supported diamictons, which are characterised by a wide range of clast sizes; (4) irregular discontinuous sand layers. All these units have ill defined boundaries and frequently merge into one another. The characteristics of this second facies are very similar to those which have been described for ice-marginal flow and dump deposits (eg. Boulton 1968, 1971; Eyles 1978, 1983a&b; Boulton & Eyles 1979; Lawson 1979a&b, 1981, 1982).

The depositional setting envisaged is illustrated in Figure 4.5. It is suggested that during decay meltwater from the former glacier was confined between earlier retreat moraines and the retreating ice margin, depositing a marginal belt of sands and gravels (Fig. 4.2C) (eg. similar to the western side of Skaftafellsjökull—Thompson 1988). A significant readvance of ice folded these fluvial sediments up to form the core of a moraine (Fig. 4.2D: Facies 1). Subsequently, supraglacial debris, flow tills, were trapped between the ridge crest and the retreating ice margin (Fig. 4.2D: Facies 2). Flowing and percolating through this debris, small melt streams caused local sorting and the deposition of sand layers.

These tectonised sequences help support the interpretation of the cross valley concentric ridges as ice-marginal moraines. Similar structures have also been found within cross valley concentric ridges in the Grampian Highlands (Day 1983; Boulton *et al.* in press).

---

Plate 4.1: Overleaf.

A. Shieldaig, North West Highlands [NG 835 505]. Supraglacial and glaciofluvial sediments, the diverse range of particle sizes suggest that deposition may have been at or close to the ice margin. The bedding is faulted and over steepened, suggesting that the sediments was deposited on to a bed of ice which melted out and caused the faulting and bed steepening.

B. Bifurcating push moraines Skaftafellsjökull, South East Iceland. The ice retreated from right to left away from the moraine.

C. A dump moraine Skeiðararjökull, South East Iceland.

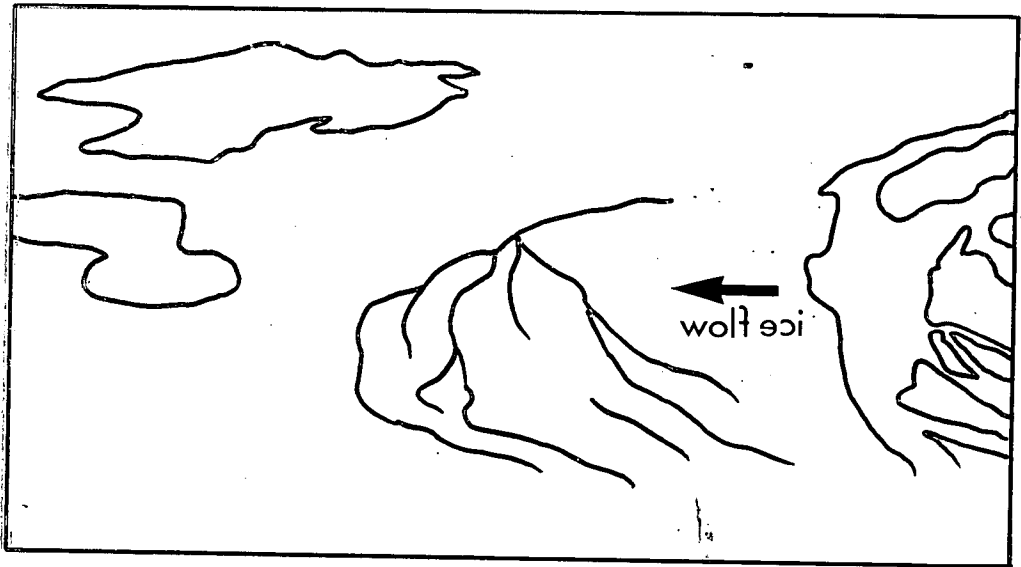



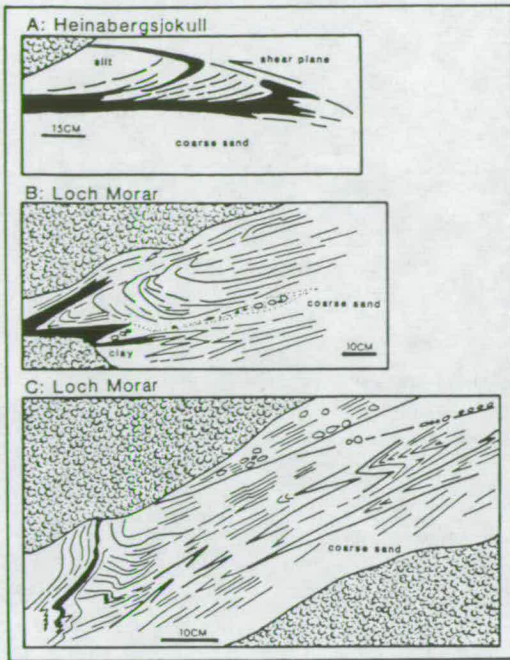

Figure 4.4: Folds present within cross valley concentric ridges in "hummocky moraine" at the head of Loch Morar [NM 685 925] and within a push moraine in South East Iceland. The random tone represents talus or the limit of the flat sediment face.

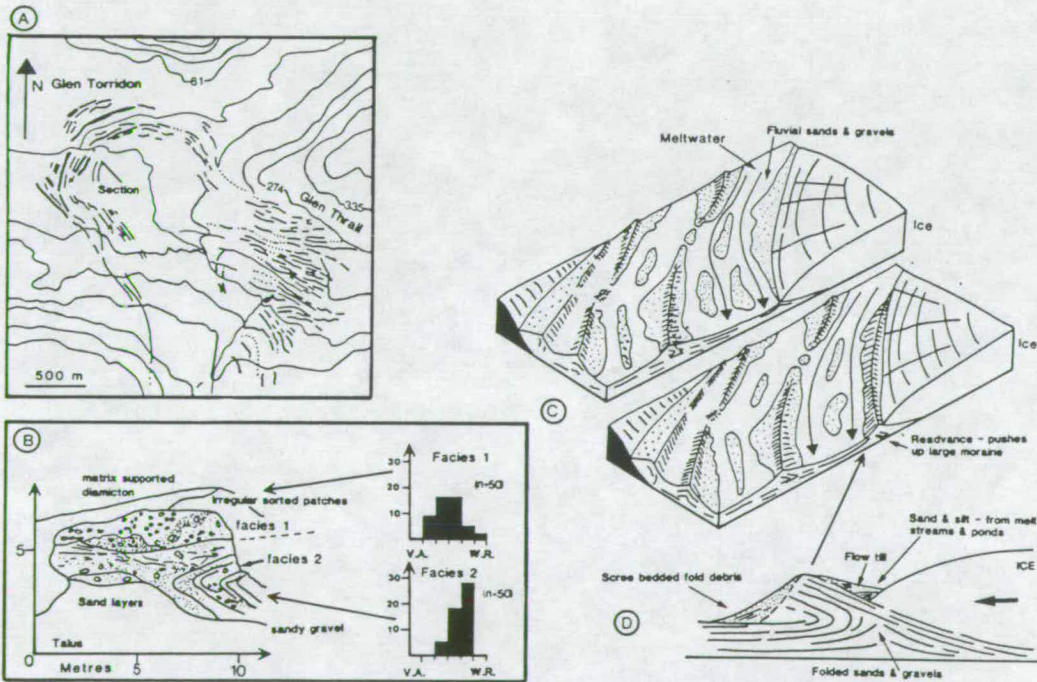

Figure 4.5: Glen Thraill—end moraines [NG 90 651]. The moraines and the section are described in parts A and B, while a possible depositional environment is illustrated in C and D.

- Stage 1: Meltwater flows between retreat moraines and the ice margin and fluvial gravel accumulate.
- Stage 2: These sediments are then folded and tectonised by a readvance of ice.
- Stage 3: As the ice retreats away from the newly formed moraine a trap develops between the moraine crest and the ice margin in which glacial debris collects.

Plate 4.2: Folds in a cross valley concentric ridge at the head of Loch Morar [NM 685 925].





A

ice advance 



B



C

## ii. Supraglacial and proglacial glaciofluvial sediments.

Some of the cross valley or concentric ridges examined contain supraglacial, ice-contact sediments similar to those described by Boulton (1972a) and Eyles (1978, 1979, 1983a&b)(Plate 4.1A). They show successions of debris flow units interbedded with massive, angular, clast supported gravels and bouldery diamictons (Fig. 4.6). The beds are for the most part conformable with the mounds surface and often possess normal faults which dip away from the mounds crest (Fig. 4.6). They <sup>are</sup> usually larger and less well defined than other cross valley ridges. Their planimetric form is also more complex being less easily connected into coherent concentric lineations.

These sediment and structures are very similar to those found at the margin of the Elisbreens glacier in Spitsbergen (Boulton 1972a). Here a combination of supraglacial and proximal outwash accumulates in troughs between ice cored moraines. As the buried ice melts out the topography is inverted—the trough becoming linear ridges and the ice cored moraines become inter ridge hollows. The result is suites of moraine like ridges composed of supraglacial and glaciofluvial sediment.

I suggest that some of the cross valley ridges containing this sort of sediment may develop in this way. A good example of such site can found in Glen Torridon and is illustrated below in Figure 4.6. This site has been used as a classic example of supraglacial ice-contact sedimentation by Eyles (1983a&b).

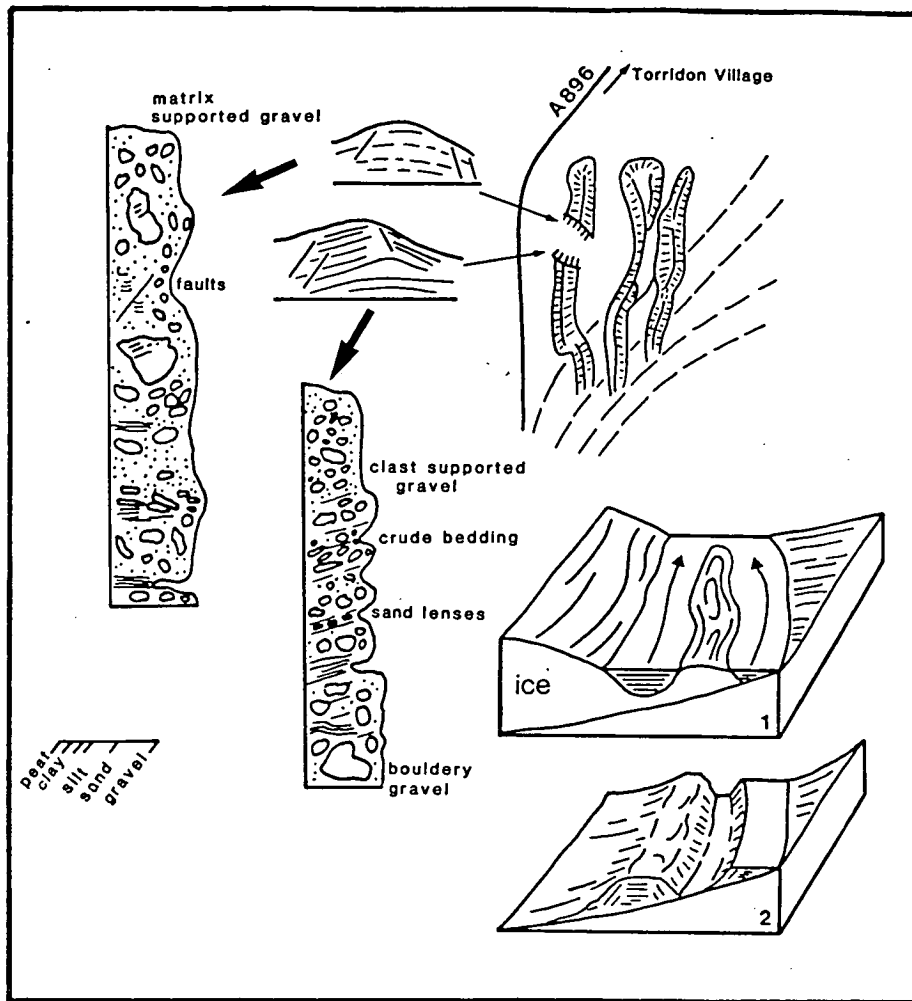

Figure 4.6: Supraglacial deposition at a site in Glen Torridon [NG 955 565]. The sediment is very diverse collection of bouldery gravels and diamictons which have a crude bedding that parallels the ridges surface. These sediments are interpreted as supraglacial deposits which may have been deposited in an ice cored trough between an ice ridge as illustrated in the block diagram.

### iii. Massive, loose, homogeneous diamictons.

The commonest type of sediment within cross valley concentric ridges is a homogeneous, loose, sandy diamicton. At many sites there is evidence of a gravel lag horizon, clast sorting and signs of re-sedimentation, which suggest that it may be a collection flow till unit (eg. Boulton 1968; Lawson 1979a). For example, a section in Corrie Briste [NG 945 655] shows a basal layer of coarse clasts overlaid by a sandy unit, with well sorted angular clasts. These clasts are frequently clustered, with small irregular sand lenses or packages in their lee. The clasts have an irregular orientation—dips  $1.5^{\circ}$  to  $83^{\circ}$  while the vector magnitude of clast orientation is only 13% (N=25). This sediment is interpreted as being an ice-marginal

collection of debris derived by processes of both fall and flow from an adjacent ice surface (cf. Lawson 1979a). This explanation accounts for the poor and variable clast orientation and the inconsistent clast sorting present. The irregular sand concentrations and layers may have formed by the percolation of meltwater through the accumulating debris. Such an explanation is consistent with the interpretation of the ridge as an ice-marginal dump moraine.

However, in most cases I believe that there is simply not enough diagnostic evidence within most of these diamictons to provide a clear interpretation of sediment and landform origin.

It is however possible in a few cases to assess whether the properties of this homogeneous diamicton are consistent with the interpretation of the ridges as being ice-marginal as opposed to subglacial. This can be done by examining the clast characteristics of the diamicton in relation to glacial transport pathways.

Numerous workers have demonstrated that the shape of clasts (ie. roundness and sphericity) reflect the glacial transport path, subglacial or supraglacial, through which the debris has passed (eg. Whalley 1974; Boulton 1978; Ballantyne 1982b; Dowdeswell *et al.* 1985; Benn 1989b; Shakesby 1989). Ice-marginal moraines will tend to be composed of a combination of both subglacial and supraglacial debris. The relative proportion of each type of debris will depend on the genesis of the moraine. For example, in very simple situations dump moraines may be composed predominantly of supraglacial debris, while push moraines may have a greater subglacial debris component.

This is illustrated by data collected from Heinabergsjökull in South East Iceland. Clast samples were taken from push moraines, flutes and a medial moraine (n=100). All the clasts were of a similar size (3-8 cm) and of a single lithology. For each sample, the three principle axes of a clast were measured and a visual assessment of its roundness was made (ie. Krumbein 1941). Krumbein's sphericity was calculated from the axial data and plotted as a scatter graph against the roundness data (Krumbein 1941). The point density on this scatter graph has been contoured by estimating the number of points per 1% of the graph's area, the contoured version is presented in Figure 4.7-1A (method followed: Boulton 1978). This graph shows that the clasts from the push moraine plot between the transport extremes of supraglacial and subglacial (lodgement till) as one would expect. The moraine point density contours are skewed towards the lodgement sample,

suggesting that the subglacial debris source was more important in the accumulation of these moraines.

This exercise has been repeated for two valleys in the North West Highlands:

1) Coire a' Cheud-chnoic [NG 955 555].

(sandstone clasts: 7 ridges sampled)(Fig. 4.7-1B).

2) Glen Croulin [NG 785 075].

(schist clasts: 1 ridge sampled)(Fig. 4.7-2).

In both these cases fresh scree was used as a surrogate for supraglacial debris (after: Benn 1989b). The lodgement till samples were taken from small sections in each valley. In both these cases the cross valley concentric ridge clasts plot between the two transport extremes, in a similar fashion to the data from Iceland. This provides circumstantial support for the interpretation of the cross valley concentric ridges as ice-marginal moraines, although it must be noted that other landforms may also be composed of combinations of both subglacial and supraglacial debris and consequently plot on Krumbein sphericity and roundness plot in the same way. What it does indicate clearly, however, is that the sediment is not wholly subglacial as one might expect if the ridges were formed subglacially as has been suggested in the past (Hodgson 1982).

**In Summary:** Both planimetric and sedimentological evidence has been presented to support the contention that many of the cross valley concentric elements within "hummocky moraine" are ice-marginal moraines. Their morphology is very similar to that of the push moraines or ice-contact moraines recorded in the Outer Hebrides by Peacock (1984, 1991).

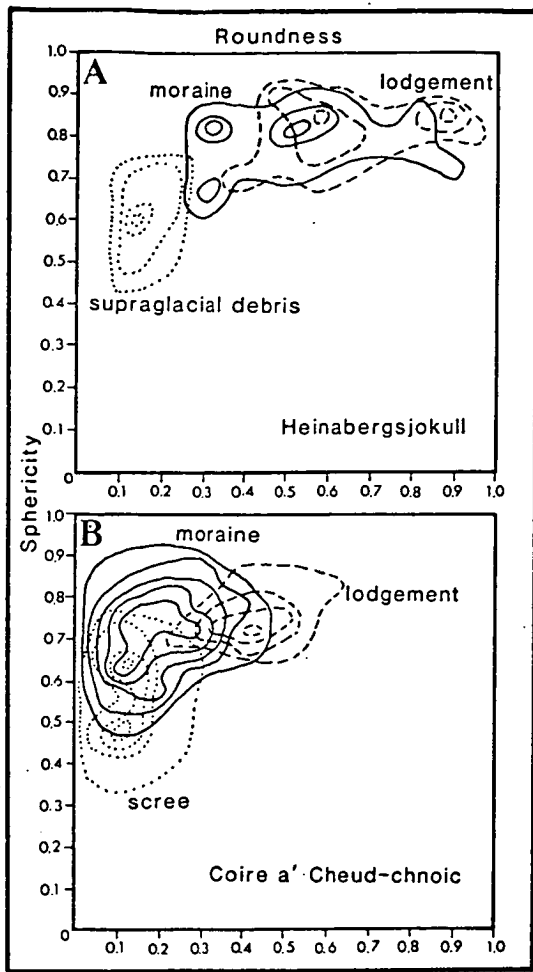

1

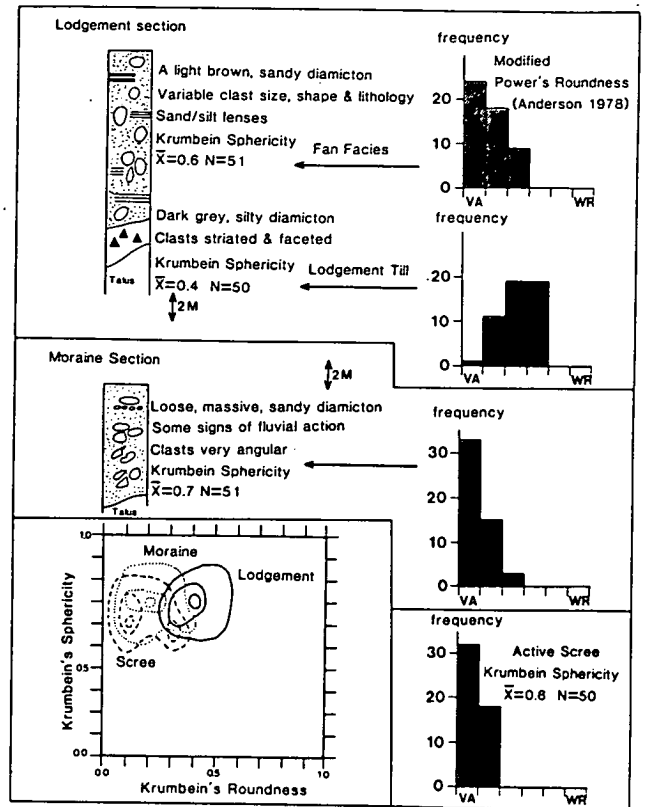

2

Figure 4.7: Krumbain sphericity and roundness plots (charts are contoured at 1, 3, 7, 9 and 11 points per 1% of the area).

Parts 1: A: Data from Heinabergsjökull, South East Iceland (Total number of clasts=300). B: Data from Coire a' Cheud-chnoic, North West Highlands (Total number of clasts=450).

Parts 2: Data from Glen Croulin, North West Highlands (Total number of clasts=150). Roundness histograms—Power's roundness (1953). The Krumbain's roundness and sphericity chart is contoured at 2, 6 and 10 points per 1% of the area.

## **B: Glaciofluvial landforms—outwash terraces and fans.**

Ice-contact outwash systems have been used to delineate the maximum ice limits in Glen Torridon, Loch Shiel and in Knoydart (Peacock 1970; Sissons 1977a; Bennett 1990). However, I suggest that outwash terraces and fans are also present inside the ice limits within "hummocky moraine" areas.

Drawing on a variety of publications, a simple conceptual model for outwash fans in Scottish Highland valleys was developed in order to illustrate the possible controls on the morphology and sedimentary architecture of these landforms (Price 1966, 1969, 1970, 1973; Shaw 1972; McDonald & Shilts 1975; Rust 1975; Hambrey 1984; Thomas 1985; Thomas *et al.* 1985; Boulton 1972a, 1986; Drewry 1986; Bryant 1991; Gray 1991). It identifies two end members of a continuum: (1) areas underlaid by buried ice and; (2) areas free from buried ice. In the case of areas underlaid by buried ice the morphology and sedimentary architecture of the fan depends upon whether the ice melted out during continued sedimentation or after the outwash fan was abandoned (Fig. 4.8 & 4.9). This model is used to structure the discussion of glaciofluvial landforms in this chapter. In this section fans with clear morphology are described (Fig. 4.8 III) while those without clear surface morphologies are discussed in Section 4.3B.

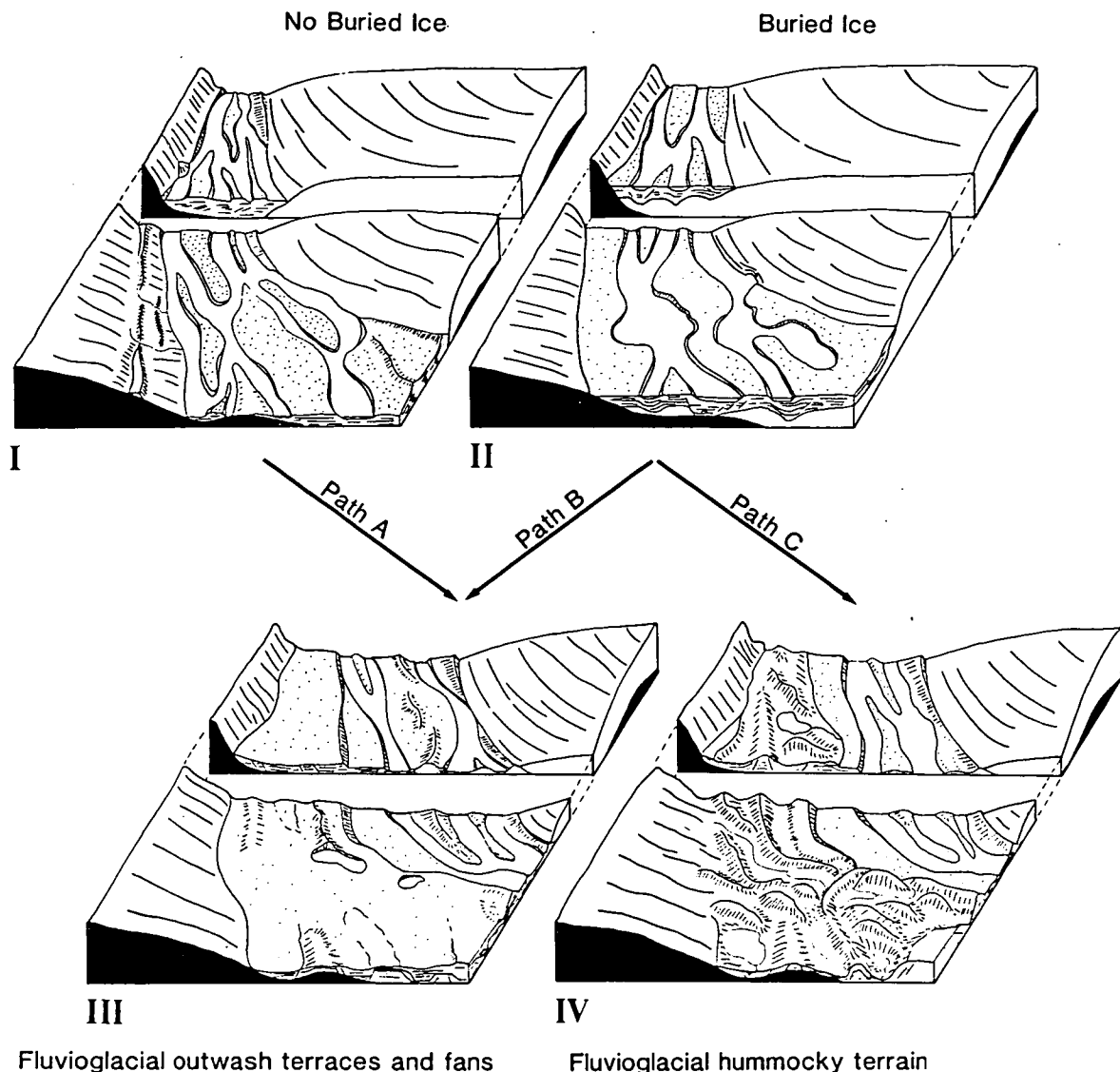

Figure 4.8: A conceptual model for the development of outwash fans in Highland valleys. The block diagrams simply represent end members of a continuum—buried ice to no buried ice.

**Path A**—Terrace or outwash surface is abandoned, leaving a fan which has a clear extent, morphology and gradient. The complexity of the sedimentary architecture will depend simply on the flow regimes experienced (eg. Boothroyd & Ashly 1975; Church & Gilbert 1975). Section 4.2B.

**Path B**—Buried ice melts out from beneath the outwash surface before the surface is abandoned and sedimentation ceases, so that kettle holes and other thermal depressions are filled in during continued deposition. Therefore the outwash fan will have a clear extent, morphology and gradient but a complex internal sedimentary architecture. Section 4.2B (Fig. 4.13: Plate 4.4).

**Part C**—Buried ice melts out from beneath the outwash surface after the surface has been abandoned. The fan will not therefore have a clear extent, morphology and gradient. Section 4.3B (Fig. 4.29 & 4.30: Plate 4.10).

## Path B

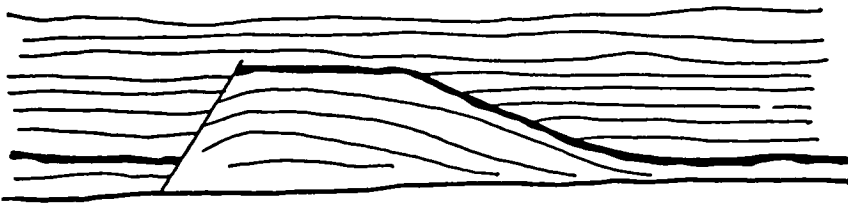

## Path C

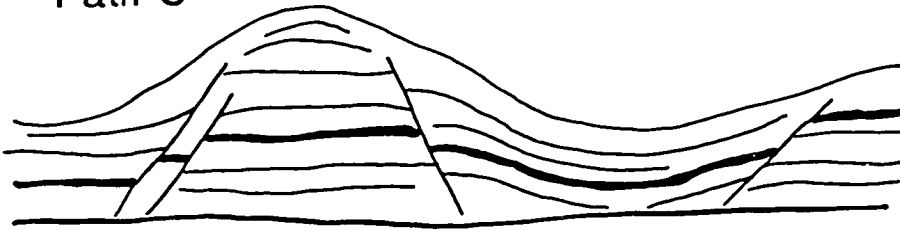

Figure 4.9: Simplified sedimentary architecture for two of the three pathways identified in Figure 4.8. Pathway B—meltout of buried ice occurred during continued deposition and consequently the outwash surface is not conformable with the subsidence structures. Pathway C—meltout of buried ice occurred after cessation of sedimentation therefore outwash surface is conformable with the subsidence structures.

---

In order to illustrate that outwash fans can be identified within areas of "hummocky moraine" four examples will be presented (Type III: Fig. 4.8):

**Strath na Sealga:** A distinct outwash fan is present within Strath na Sealga, Fisherfield [NH 070 802](Fig. 4.10). This area has previously been described simply as an area of "hummocky moraine" (Sissons 1977a). The fan has been identified on the following basis: (1) There is a large well defined area of planar terrain. (2) This surface has a uniform surface gradient of  $6^{\circ}$  to the east (Fig. 4.10). (3) Sections within this area indicate that it is made up of units of fluvial sands and gravels. (4) Finally the western end of this surface is marked by a steep slope and a belt of irregular mounds interspersed with kettle holes which can, therefore, be interpreted as an ice-contact face (see: Gray 1991)(Fig. 4.10). The overall morphology of this surface is very similar to that of the ice-contact outwash fans at Heinabergsjökull in South East Iceland (compare the long profiles in: Fig. 4.10). At Heinabergsjökull the fans have a distinct ice-contact face which is marked by a steep slope and kettle holes. The outwash surface fans out from this ice-contact face (Fig. 4.10). The formation of such outwash fans has been described by Price (1969, 1973) and is illustrated in Figure 4.10 (Stages A-B).

Figure 4.10: Long profiles of outwash fans in Strath na Sealga, Fisherfield North West Highlands [NH 070 802] and at Heinabergsjökull in South East Iceland. The formation of such fans is also illustrated—Stages A-B (formation after: Price 1969, 1973). The long profiles were surveyed down the steepest gradient.

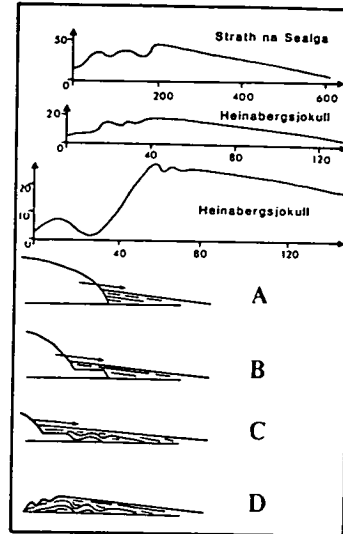

**Glen Grudie:** This sequence occurs in the centre of the Glen Grudie and consists of a well defined terrace, 400 metres long, 200 metres wide and approximately 10. to 15 metres high [NG 955 655](Fig. 4.11 & 5.5). The regional context of this terrace is illustrated in Chapter Five, Figure 5.5. Its surface has been cut by two broad channels which parallel its long axis. The clasts in one of these channels become progressively less angular to the north (Fig. 4.11A).

This terrace is separated from a smaller terrace to the north by a slight break of slope. Beyond this second terrace there is an area of irregular terrace fragments, low relief mounds and kettle holes (Fig. 4.11).

These terraces appear to be composed of glaciofluvial sediments, recorded in a number of sections the largest of which is at the northern end of the lowest terrace surface (Fig. 4.11B). This section which is illustrated in Figure 4.11C consists of four basic units which are described in stratigraphic order:

1. A massive, homogeneous, firm diamicton with a fine silty matrix and subangular to subrounded faceted clasts, which is interpreted as a lodgement till. The upper surface of this unit has been truncated by fluvial erosion, which has left a lag of clasts on part of the boundary and has scoured around several large boulders.

2. A unit of laminated silts and sands which coarsen upwards. The silts are draped onto the lower contact, indicating that they were deposited in a still water environment.

3. A massive unit of clast supported gravel. This is well sorted in the pebble to cobble range with a crude but complex stratification. It has a coarse sandy matrix and its upper surface appears to be armoured.

4. An interbedded unit of granules and well sorted sand layers which onlap the gravel surface.

The highly variable sediments recorded in this section fit the interpretation of these terraces as outwash fans.

---

Plate 4.3: An outwash fan in Glen Grudie, Torridon [NG 955 655]. Oblique photograph showing the planar upper terrace of the fan.

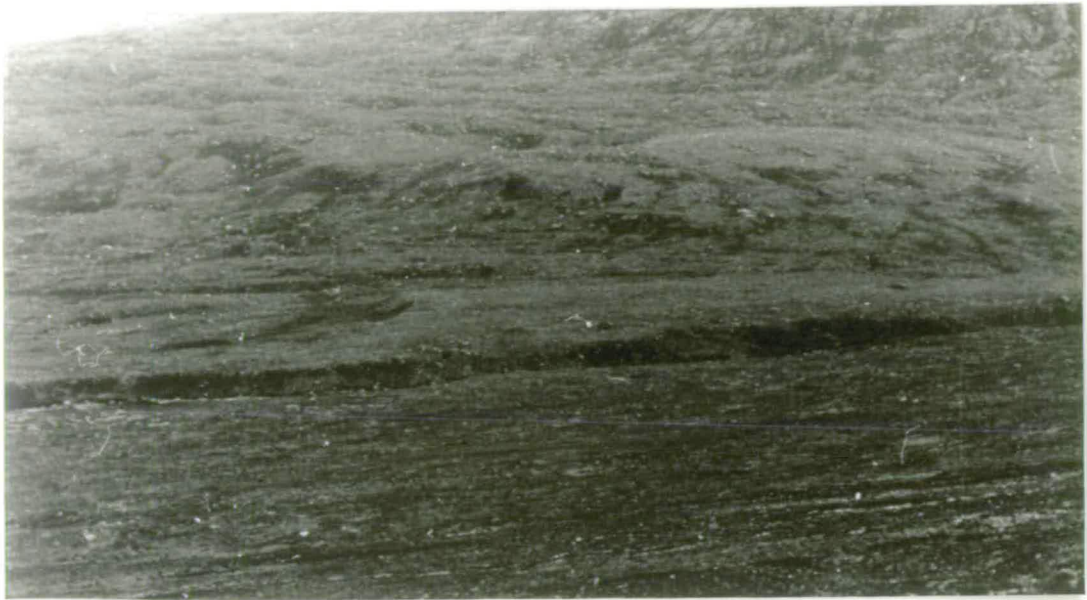

Glen Grudie – outwash fan.

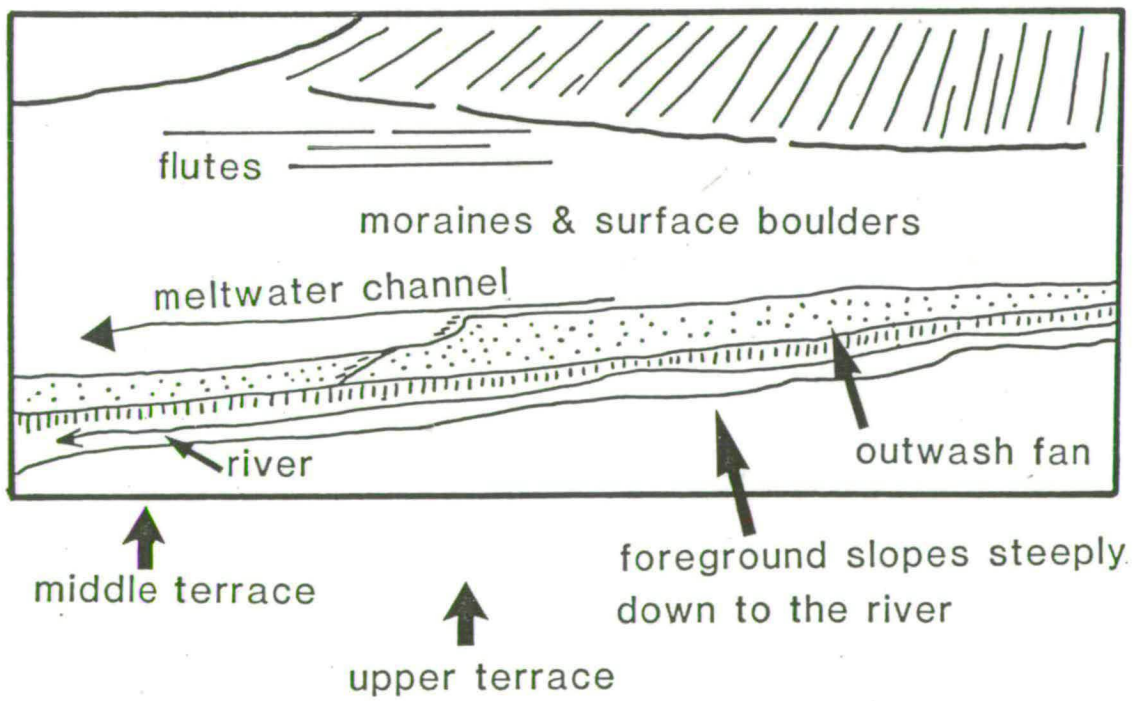

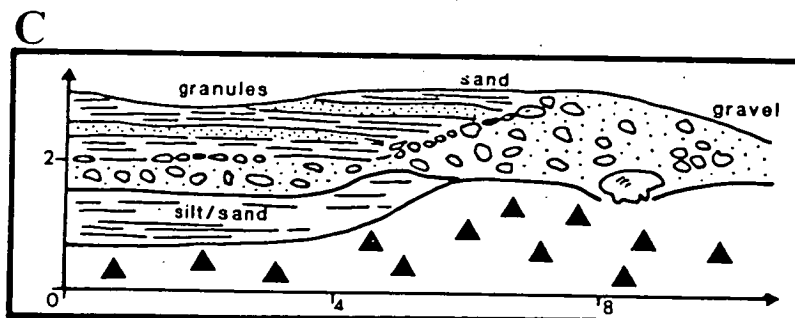
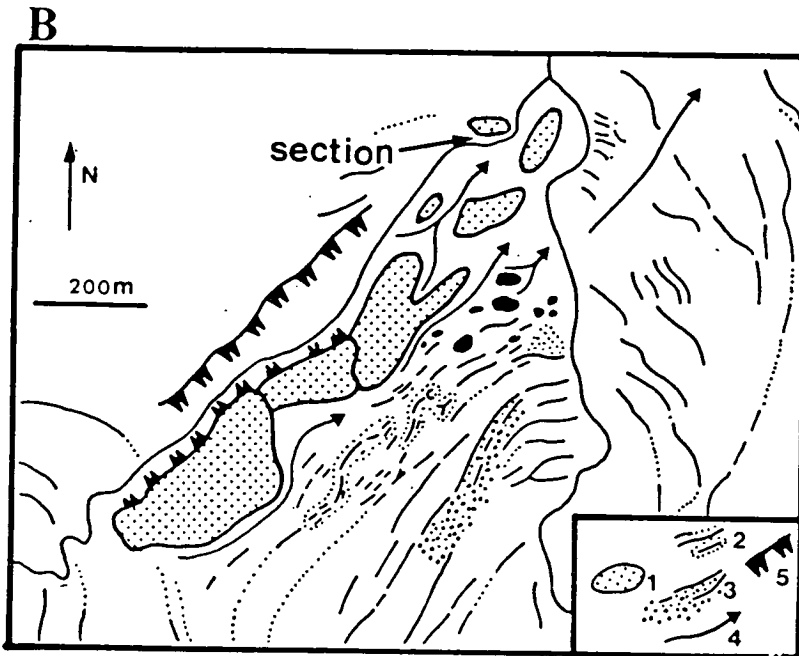
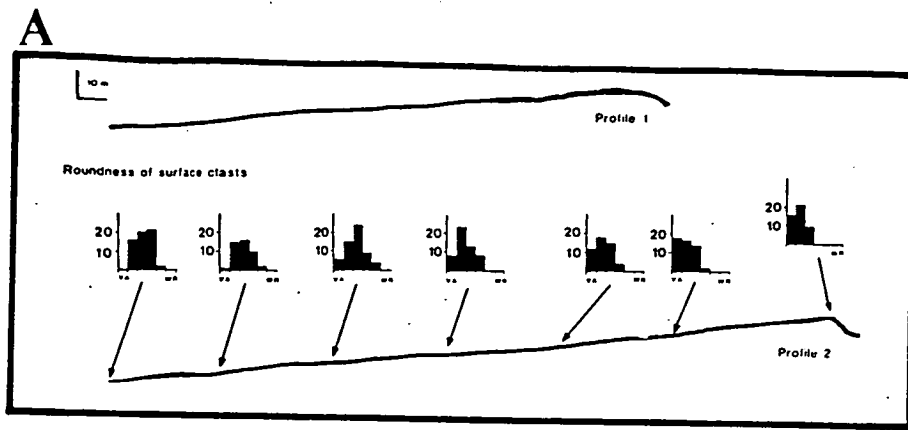

Figure 4.11: An outwash fan in Glen Grudie, Torridon [NG 955 655].

A: Long profiles of the upper or southern terrace. The particle roundness of near surface clasts was sampled along Profile Two. There is an increase in angularity from left (north) to right (south) along this profile.

B: Geomorphological map of the terraces and associated moraines (1=terrace; 2=moraine; 3=linear area of unordered mounds†; 4=meltwater channel; 5=drift cut slope). † This belt of irregular mounds is picked out by a distinctive concentration of quartzite boulders in an area dominated by sandstone blocks.

C: Sediment section within a fragment of the lower or northern terrace (scale is in metres).

**Glen Affric:** At the southern end of Loch Beinn a' Mheadhoin in Glen Affric [NH 210 240] there is a collection of small terraces in which there is an exposure of glaciofluvial sands and gravels (Fig.4.12).

Two very distinct facies can be identified in this exposure:

**Facies 1—Proximal outwash—**very poorly sorted matrix rich bouldery gravel, with crude channel sets. Strong clast imbrication indicates a southward flow.

**Facies 2—Distal outwash—**interbedded units of very well sorted sandy gravel, granules and rippled sands. These units become progressively finer as one moves up the section. Palaeo flow direction, based on ripples, is to the east.

In the west the section consists of facies F2—F1, while in east the sequence is F2—F1—F2. This is unusual, since one would expect the sequence to become more distal, facies 1 being followed by facies 2, as the ice retreated away from the site (Boulton 1972a).

This can be interpreted in one of two ways:

*Explanation 1:* If one assumes that the cross valley concentric ridges within "hummocky moraine" indicate former ice margins, based on the evidence presented at the start of this chapter, then these moraines can be mapped to give an indication of the pattern of deglaciation in this area. These moraines suggest that there were two distinct ice lobes in this area during decay (Appendix I). An ice-marginal summary based on these moraines is presented in Figure 4.12A. The terrace fragments and exposures of sands and gravels lie between these two lobes. These two lobes may have provided two distinct sources of meltwater. The narrow, confined valley in which lobe 1 is situated may have provided a higher energy meltwater flow than that from the large, more open margin of lobe 2. Palaeo-current data suggests that facies 1 was deposited by meltwater flowing to the south away from ice lobe 1 and that facies 2 was deposited by meltwater flowing towards the east away from ice lobe 2 (Fig. 4.12A&C). The switching of these two flows across this area of outwash would give a sedimentary succession similar to that shown in the section in Glen Affric. The flow from lobe 1 would be more confined, therefore may have been of a higher energy than that from lobe 2. This interpretation is consistent with the cross valley concentric elements in "hummocky moraine" being ice-marginal moraines.

*Explanation 2:* Alternatively the two facies could result simply from the lateral movement of an area of very high energy flow (facies 1) across the fan surface. This would not provide support for the deglaciation pattern

derived from the cross valley concentric ridges. This explanation does not, however, account effectively for: (1) The extreme contrast between the two facies. (2) The very different palaeo-current directions of the two facies.

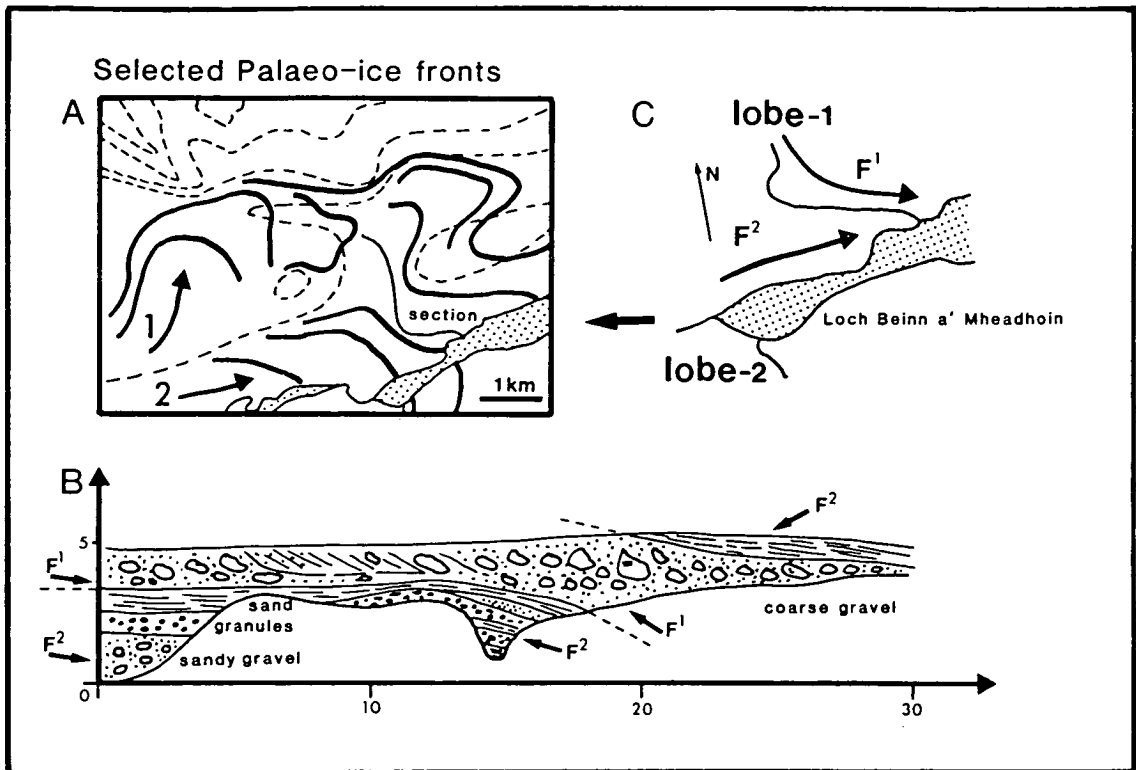

Figure 4.12 : An outwash fan in Glen Affric [NH 210 240]. A: Summary of cross valley concentric moraines. Two ice lobes 1 and 2. B: Section (F1=facies 1; F2=facies 2). C: Summary of flow directions for the two facies consistent with "Explanation 1".

**Glen Mullardoch:** There is an extensive terrace composed of glaciofluvial sands and gravels in Glen Mullardoch approximately 3 km inside the Loch Lomond Readvance limit [NH 285 335]. This outwash deposit is of particular interest since its internal sedimentary architecture is particularly complex (Fig. 4.13). All the sections present in this terrace are composed of sands and gravels which have been subject to both large and small scale subsidence, which has not been manifest in the surface of the terrace. This is illustrated in Plate 4.4 (Section A: Fig. 4.13)—the sand layers were probably deposited on the horizontal and have become inclined since the sand was deposited. The simplest explanation for this over steepening is the removal of underlying support through the meltout of buried ice (Boulton 1972a; Thomas *et al.* 1985). This meltout is not manifest on the surface of the terrace. I suggest that the development of this fan is best described by Path B in Figure 4.8. This suggests that the outwash fan was originally underlaid by buried ice which melted out before the terrace was

abandoned and consequently any thermal depressions which developed upon its surface would tend to be infilled rapidly by further deposition.

This sort of situation is occurring at present in front of Skaftafellsjökull and Skálafellsjökull in South East Iceland where the meltout of buried ice within these two sandures has caused the readjustment of the fluvial system. The main rivers now flow through these kettle holes, which are being infilled as they deepen with a diverse range of sediments including lacustrine rhy<sup>th</sup>mites, delta sets and massive gravels.

One can extend this model by arguing that the meltout of buried ice will rarely be uniform, due to such variables as differing ice thickness and bedrock topography (Nobles & Weertman 1971). Consequently, deformation or subsidence may occur in several phases. For example, subsidence may be caused by the meltout of small blocks of buried ice which may occur before large more extensive masses of ice meltout. Consequently a bed may be deformed by the meltout of small blocks of ice and then deformed for a second time by the meltout of much larger ice blocks.

I suggest that several phases of meltout may have occurred within parts of the terrace in Glen Mullardoch (Sections B & C: Fig. 4.13).

In section B there appear to be two distinct phases of meltout: (1) The meltout of small discrete block of ice, this explains the convoluted bedding on the north west side of the section (1—Section B). (2) This unit of granules has then been lowered more regionally on the south east side of the section (2—Section B).

Section C shows a similar story: (1) Small scale deformation or subsidence due to the meltout of small ice blocks (1—Section C). (2) This was followed by a more regional lowering, similar to that experience by Section B (2—Section C). This regional lowering may have caused over steepening of earlier deformation structures (see enlargement of Section C).

---

Plate 4.4: Sedimentary structure within an outwash fan in Glen Mullardoch. Meltout of buried ice, beneath the surface, occurred before the cessation of sedimentation on the outwash surface. Each sand layer was deposited on the horizontal and then over steepened by the meltout of buried ice (see Section A: Fig. 4.13)[NH 285 335].



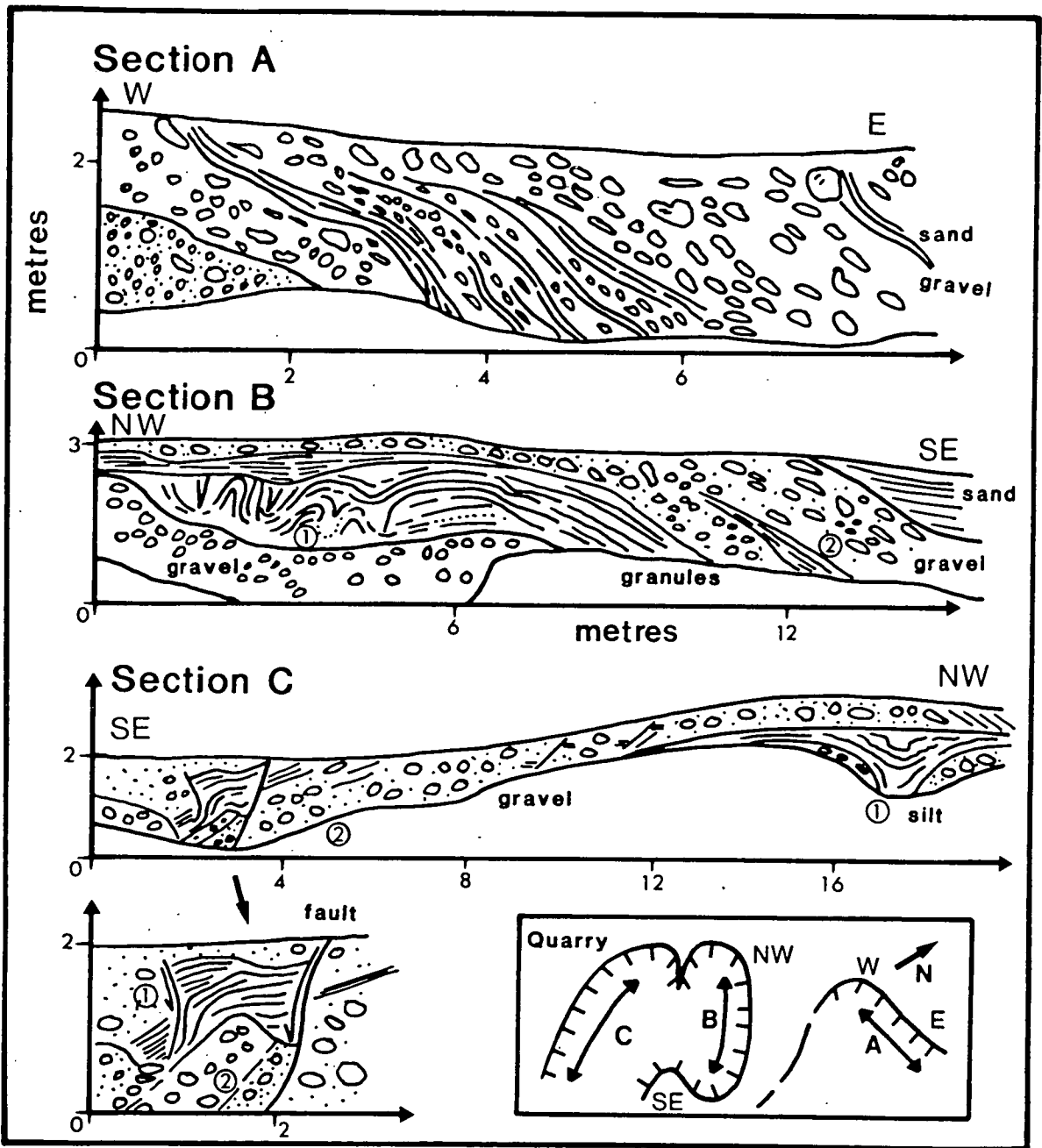

Figure 4.13: Glen Mullardoch—an example of an outwash fan underlain by buried ice, which melted out during continued outwash deposition. As the surface was lowered the depressions were in filled by continued deposition. [NH 285 335].

**In summary:** In this section (4.2B) I have attempted to show that outwash fans can be identified within area of "hummock moraine". Although I have only described four examples of such fans within the North West Highlands such features were frequently identified on the 10 803 air photographs examined (Appendix I). In some cases these fans are associated with moraine ridges and can therefore be used to demarcate former ice margin (eg. Strath na Sealga, Glen Grudie). Other fans, however, are less closely associated with moraine ridges and show signs of having been deposited onto the glacier surface and therefore need not indicate the location of recessional ice margins (eg. Glen Mullardoch).

### C: Lacustrine landforms.

Lacustrine landforms have been identified and discussed within the North West Highlands as components of the classic ice-dammed lake sequences of Glen Moriston [NH 250 120](Sissons 1977b) and Achnasheen [NH 164 586](Sissons 1982; Benn 1989a). Lake sediments, shorelines and sub-lacustrine fans of a variety of scales have been identified within "hummocky moraine" areas throughout the North West Highlands. For example, small exposure of rhythmic silts and clays have been recorded frequently throughout the study area (See Chapter Five). However, most of the small lakes associated with these deposits and the shoreline fragments appear to have been very ephemeral features and to have poor sedimentary and morphological expression.

Perhaps the most important area of lacustrine landforms within "hummocky moraine" in the North West Highlands is in Glen Carron [NH 125 540](Fig. 4.14 to 4.17). Within Glen Carron a former ice-dammed lake has been identified on the basis of: (1) widespread exposures of rhythmic silts and clays (Plate 4.5A); (2) shoreline fragments. The lake appears to have developed between the watershed in Glen Carron and an ice margin which retreated to the west. The shoreline fragments are at an elevation of 195 metres on the south side of Loch Sgamhain, an elevation which is similar to that of the watershed in Glen Carron (Fig. 4.14). The lake will have gradually grown in extent as ice continued to retreat to the west. The retreat is documented by a series of cross valley concentric ridges both above and below the former lake level (Fig. 4.14 & 4.17). No lake sediments and shoreline fragments have been located beyond Torr Alltan na Feola in the west [NH 075 515] which is located at a distinct brake in the valley floor, beyond which the elevation of the valley floor decrease rapidly. Consequently, I suggest that Torr Alltan na Feola probably represents the maximum extent of the ice—dammed lake (Fig. 4.14 & 4.17).

Within this landform assemblage there are two areas of particular interest:

- 1: The ridges to the east of Loch Sgamhain.
- 2: The landforms and sediments at Torr Alltan na Feola.

*1: Loch Sgamhain:* To the east of Loch Sgamhain there is a complex assemblage of cross valley ridges and esker fragments. Above the former lake level these drift ridges appear to be small and well defined. These ridges are composed of a homogeneous diamicton which shows few signs of

sorting or of fluvial action. In contrast these ridges are continued below the former lake level by large, irregular and discontinuous mounds. These mounds are composed not of homogeneous diamicton but matrix and clast supported gravels which are interbedded with units of laminated silts and sands. The assemblage of landforms below the former lake level is interpreted as a complex suit of sub-lacustrine fans and moraines formed at successive ice-marginal positions. These irregular fans and moraines are continued above the lake level as small, well defined ice-marginal moraines. The depositional environment just described is illustrated in the conceptual model presented in Figure 4.15A.

Within the moraines and fans below the former lake level there appears to be two distinct populations of clasts. In order to illustrate this, the clasts from six ridges below the lake level were sampled (n=66) and their sphericity (Krumbein 1941) and visual roundness (Powers 1953) were determined. These samples fall into two distinct classes: i) angular samples (sites 1, 3, 5, 7) and; ii) very well rounded gravels (sites 2, 6) (Fig. 4.13 & 4.14). A sample was also taken from one of the esker fragments (site 4). The rounded samples are very similar to the clasts taken from the esker and are in fact all located close to esker fragments. One explanation for these two distinct population is that they reflect two distinct debris sources for these sub-lacustrine fans and moraines:

- 1) Subglacial water, the importance of which is demonstrated by the number of esker fragments. Clasts from such sources may be better rounded than those from other sources.

- 2) Proglacial water, derived from the adjacent valley sides and channelled into the lake by the ice margin. Clasts from such a source may very angular, being derived from valley side talus and supraglacial debris.

This is illustrated conceptually in Figure 4.15C, facies 1 being that derived from the valley sides while facies 2 is derived subglacially. The development of this pattern in a confined ice-dammed lake, such as that in Glen Carron, is surprising. One expects such a contrast to develop only in very broad lakes in which the two water/debris sources are distinct. The development of such a pattern in Glen Carron may reflect the strength of the subglacial water/debris source in this glen, which may explain the frequency of esker fragments.

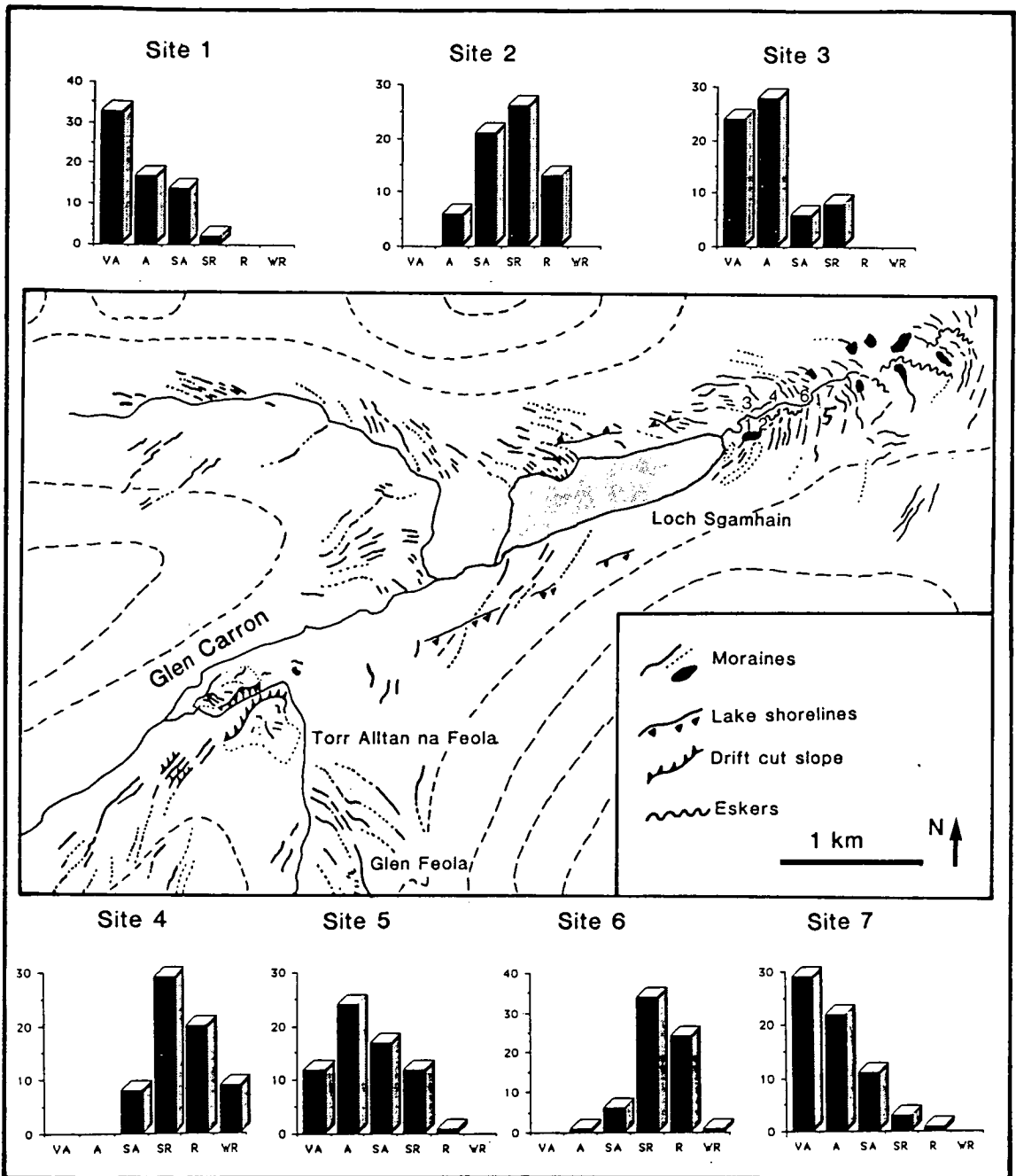

Figure 4.14: Ice-dammed lake in Upper Glen Carron [NH 125 540].

Part A: The geomorphology of Upper Glen Carron, and frequency histograms of roundness data for gravel samples taken from seven sites to the east of Loch Sgamhain (Powers 1953 roundness; n=66 per site). Site location is shown by a series of numbers on the geomorphological map.

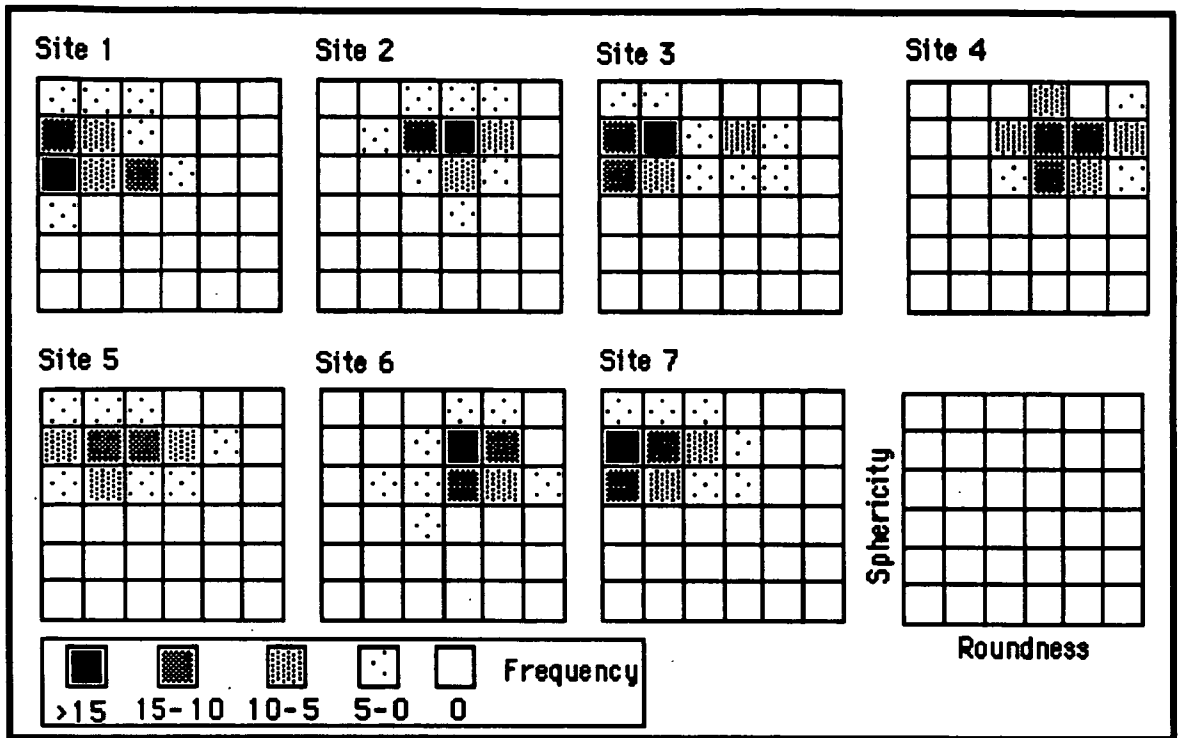

Figure 4.14: Continued.

Part B: Sphericity vs roundness plots for the seven sites to the east of Loch Sgamhain. Samples 1, 2, 3, 5, 6 & 7 are all taken from cross valley ridges east of Loch Sgamhain. Sample 4 is taken from section in an esker east of Loch Sgamhain. All site locations are shown in Part A.

Krumbein's (1941) sphericity has been divided into five equal classes.

Power's roundness values are used along the x axis.

Each sample contains 66 "fist" sized clasts.

Plotting method is modified from Croft (1974).

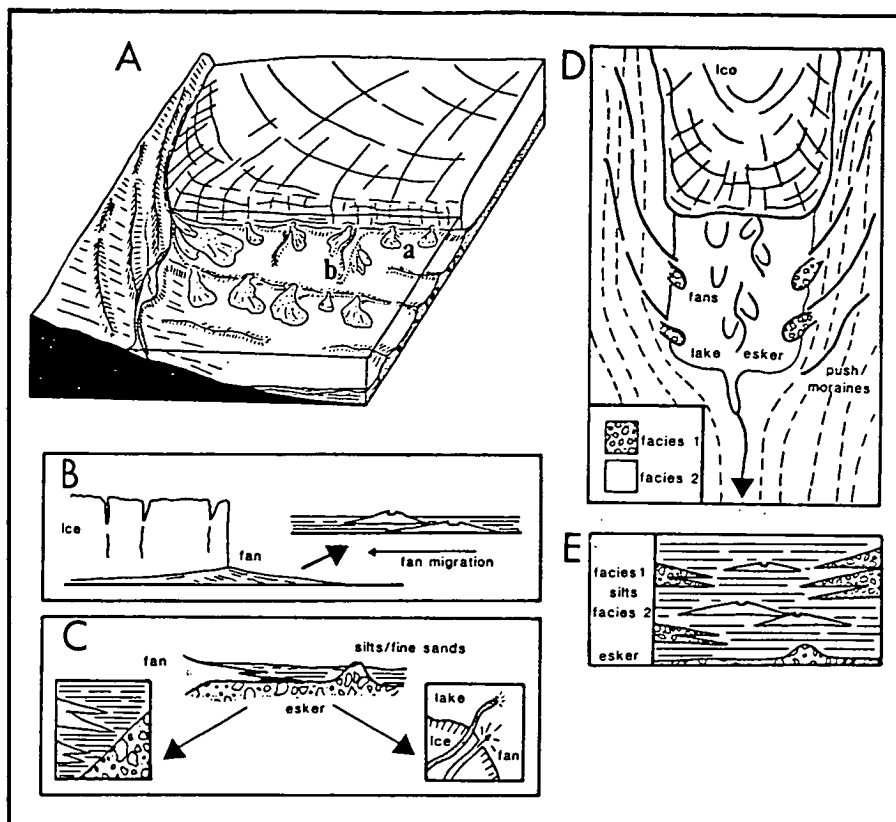

Figure 4.15: A: Conceptual model of the ice margin damming the glacial lake in Upper Glen Carron. B: Shows the migration of small ice-marginal fans and the resultant interdigitation of lake and fan sediments. C: Shows the relationship of an esker to small ice-marginal fans and lake sediments. D&E: Show the spatial distribution of the two fan facies identified within the ice-dammed lake in Glen Carron.

2. *Torr Alltan na Feola*: To the west of Loch Sgamhain at Torr Alltan na Feola there is a complex, poorly defined body of sediment which has no clear surface expression. It is composed of units of silt, sand and gravel and is interpreted as a large lacustrine fan on the basis of extensive units of silt and fine sands. In composition it is very similar to the lacustrine fan at Heinabersjökull in South East Iceland (Bullard 1991). Lacustrine fans with similar characteristics have also been described elsewhere (eg. Norddahl 1983; Drewry 1986; Fyfe 1990) The sedimentary architecture of this fan is revealed in one large section (Fig. 4.16). Here the sediment units have been down faulted to the east by a complex suite of faults (Fig. 4.16)(Plate 4.5). The scale and direction of this normal faulting suggest that large scale extension has occurred toward the east, consistent with the removal of underlying support beneath these sediments in the east. The simplest explanation for this is the meltout of buried ice from beneath the sediments. The absence of large kettle holes on the surface of this fan

indicates that most of this ice must have melted out before sedimentation over the fan ceased. The palaeo-current indicators (ripples and imbrication) suggest that the flow over the fan was towards the east, away from Glen Feola. This current direction is supported by the orientation of several channels on the fan surface.

The depositional setting envisaged for this fan is illustrated in Figure 4.17 and is described below:

Stage a: The ice-dammed lake is formed behind ice supplied from Glen Carron (1), Glen Feola (2) and from the north (3).

Stage b: As the ice retreats down Glen Carron the various lobes supplying ice to the ice-dam decrease.

Stage c: Once Torr Alltan na Feola is reached, the ice lobe in Glen Feola begins to split away from that in Glen Carron, rapid sedimentation occurred in the sediment trap formed between these two lobes. These sediments build up and back towards the east onto the ice lobe in Glen Feola, which appears to have been the main source of surface flow on the fan (palaeo-current evidence). The buried ice is likely to have melted out very quickly in this semi-lacustrine environment, leading to the subsidence and down faulting observed.

**In Summary:** Within "hummocky moraine" lacustrine landforms can be identified and their formation examined, as illustrated by the case study from Glen Carron.

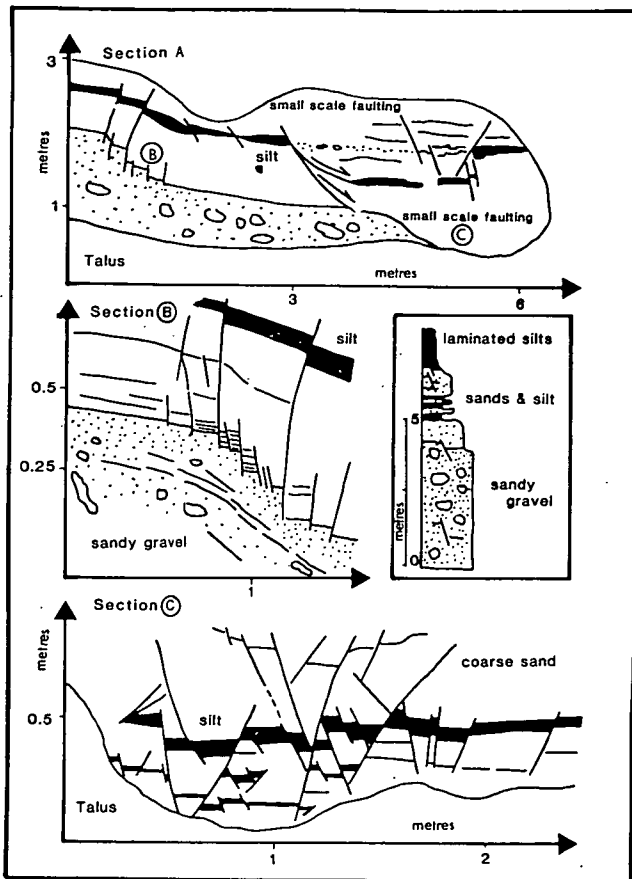

Figure 4.16: The sedimentary structures at Torr Alltan na Feola. As sediment log shows the section is composed of a sequence of sandy gravels on which rests a sequence of sand and silt units. Silts become increasingly dominant up the section.

Section A: Shows the overall geometry of the section and the location of the main faults. Most of these faults down through to the right (east).

Sections B and C: Show enlarged view of (A) in order to illustrate the fault complex in more detail.

All dimensions are in metres.

Figure 4.17: The sequence of deglaciation in the upper part of Glen Carron showing the evolution of the ice-dammed lake and the formation of the lacustrine fan at Torr Alltan na Feola. This fan accumulated between the two main ice lobes in the glen as they separated during continued decay.

1. Glen Carron lobe.
2. Glen Feola lobe.

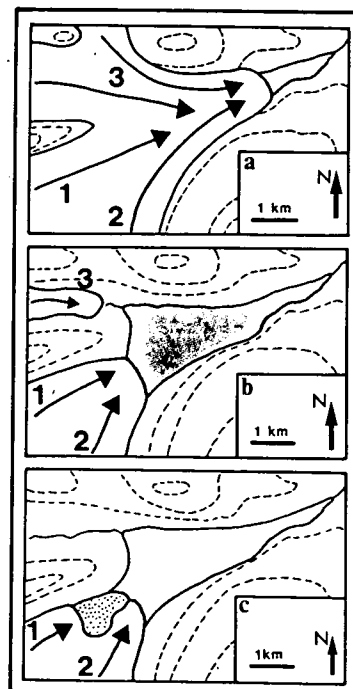

**D. Section summary for cross valley or concentric ridges.**

So far, I have attempted to show that the cross valley concentric elements within "hummocky moraine" are predominantly moraines (push and dump moraines), glaciofluvial fans and less common assemblages of lacustrine landforms. These landforms have not only been identified in the areas illustrated here, but have been identified on most of the 10 803 air photographs analysed in this research (Appendix I). What follows is a discussion of the down valley radial elements present within "hummocky moraine".

---

**Plate 4.5: Ice-dammed lakes.**

- A. Lake sediments in Upper Glen Carron [NH 112 534].**
- B. Small scale faulting in sands and silts at Torr Alltan na Feola, Glen Carron [NH 072 515].**
- C. Faulted sands and silts at Torr Alltan na Feola, Glen Carron [NH 072 515].**
- D. Subglacial meltwater channel in Glen Grudie, Torridon [NG960 642].**

A



B



C



D



### 3.3: Down valley radial ridges.

A: Glacial landforms.

B: Glaciofluvial landforms.

#### A: Glacial landforms:

Most of the down valley radial ridges examined within the "hummocky moraine" of the North West Highlands can be interpreted as one of the following landforms:

1) Flutes and drumlins.

2) Lateral moraines.

3) Medial moraines.

#### 1) Flutes and drumlins.

No drumlins have been identified within the Loch Lomond Stadial ice cap in the North West Highlands, although they have been recognised elsewhere within the Loch Lomond Readvance (Rose & Letzer 1977; Rose 1980, 1981). In contrast, flutes occur commonly and have been described widely (eg. Peacock 1967; Sissons 1967, 1977a; Hodgson 1982, 1986).

On the basis of the air photograph survey conducted for this work, I suggest that three types of flute can be identified in the North West Highlands depending on the lithology of the local bedrock (Fig. 4. 18):

1) Moinian flutes—These are small (<2m), short (10-100m) and discontinuous, with low aspect ratios (width to height). They are consequently very difficult to identify in the field, although their wide occurrence is clearly seen in air photographs.

3) Torridonian flutes—They have a diverse range of forms but are generally 4 to 6 metres high and between 100 and 600 metres long, with higher aspect ratios than Moinian ones. They occur less frequently but are much better defined.

3) Quartzite flutes—These are infrequent but extremely impressive. The best examples occur to the north of Ben Eighe in Torridon [NG 985 615]. Here the flutes emerge from a continuous spread of valley bottom debris and are 5 to 10 metres high with very large aspect ratios. In one case a flute can be traced for over 1 kilometre (Plate 4.6C & 4.7D).

These three types are believed to reflect different lithological characteristics as opposed to process. The large, angular and blocky character of Quartzite debris will tend to produce steeper forms than the finer, rounder debris produced from Moinian rocks.

These three classes ignore many of the irregular but streamlined forms present in certain areas which were described in some detail by

Hodgson 1982, who suggested that they were formed by ice advancing over irregular bodies of debris. Alternatively, I believe that in most cases these forms may result simply from the superposition of thin supraglacial debris on to a fluted surface. This results in a composite hummock which may retain a streamlined form due to the fluted subsurface. This contention is supported by several small sections in such hummocks (eg. Corrie Fionnaraich, Torridon—NG 945 500]. They reveal a distinct lower layer of a firm, silty diamicton with a strong clast fabric, typical of a basal till above which there is a loose, boulder rich diamicton. Not only are the clasts present in this diamicton very variable, but they rarely possess a common orientation. This upper layer is interpreted as the supraglacial debris overlying a lodgement till.

In terms of process, all the flutes identified tend to be larger than those found at modern glaciers (eg. Hoppe & Schytt 1953; Baranowski 1970; Boulton 1976; Karlén 1981). Moreover, they do not appear to have formed in the lee of lodged boulders and I suspect that they may form by a more general subglacial process (eg. Rose 1989b).

Figure 4.18: Flute morphology (cross profiles) and lithology in the North West Highlands.

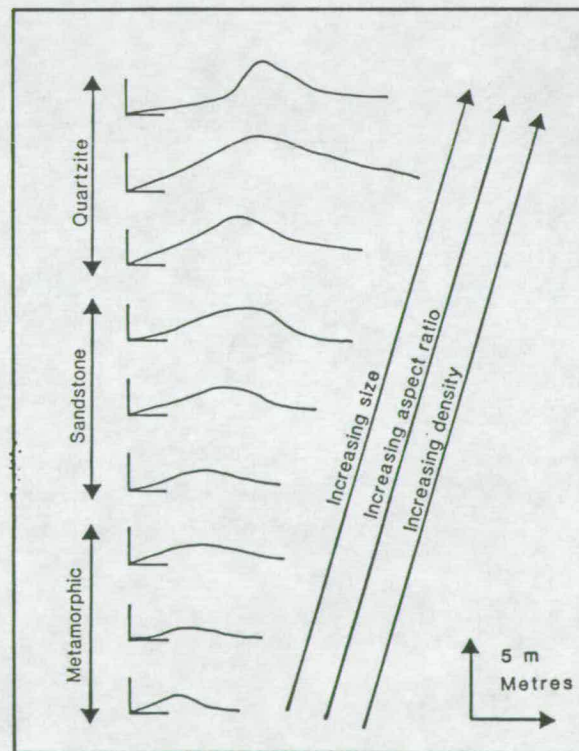
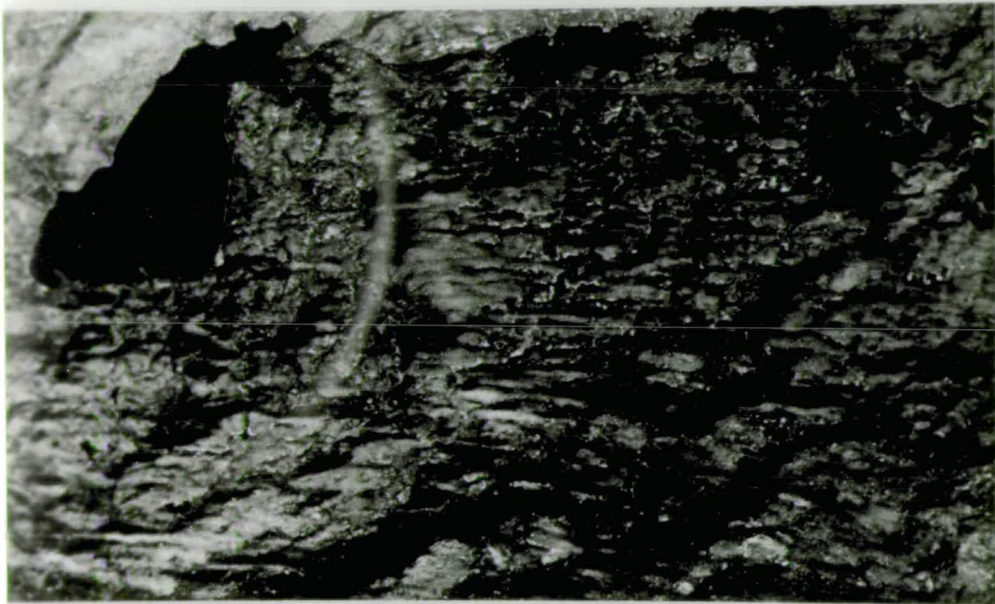

Plate 4.6: Flutes—two examples of Torridonian flutes—A: [NG 590 530] & B: [NG 920 598] and one of Quartzite flutes—C: [NG 985 615].  
Scale: approx. 1:10 000.



A



B

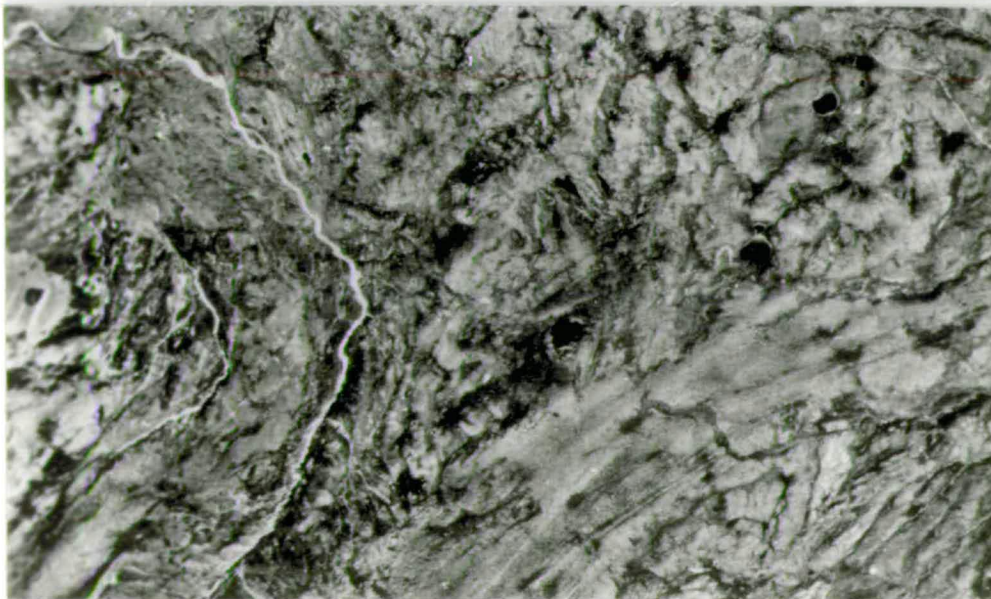

C

## 2) Lateral moraines.

Three types of lateral moraine have been identified on the air photographs examined:

1. Simple ridges with single crests (Plate 4.7C).
2. Simple ridges with multiple crests (Plate 4.7A).
3. Complex ridge suites (Plate 4.7B & 4.8).

Lateral moraines are recognisable from their topographic position and are usually less uniform, both in cross section and plan, than flutes. The first two types of lateral moraine recognised occur throughout the North West Highlands. Multi-crested ridges clearly result from a high rate of ice-marginal debris accumulation and as shown above (Fig. 4.1), this may be due to either a decrease in the retreat rate or an increase in the debris content and ice velocity of the former glacier.

The third type, however, is less common, only being recorded at three sites within the North West Highlands (Glen Grudie Plate 4.7B, Corrie Each Plate 4.8 and Corrie-breithe—NH 130 482]. It consists of dense suites of a dozen or so parallel ridges. They are 10 to 15 metres high and up to a kilometre in length. The ridge crests are characteristically beaded and may have a terrace-like form (Plate 4.8 & Fig. 4.19). In the case of Glen Grudie these ridges have been interpreted as mega-flutes and this does provide one possible explanation (Sissons 1977a)(Plate 4.7B). However, these sets of ridges may alternatively be seen as a dense suite of lateral moraines. There is some evidence to support this hypothesis:

1. The ridges bifurcate and merge as marginal moraines do at modern glacier (Plate 4.8)(Section 4.2A).

2. None of the striae on underlying bedrock, some of which occurred within 5 metres of these deposit (Glen Grudie and Corrie Each), are orientated parallel to the ridge crests as one would expect if these landforms were mega-flutes (Fig. 4.19A).

3. Small, irregular terrace fragments are interspersed between the ridges, which is again inconsistent with their interpretation as mega-flutes. One such terrace in Glen Grudie has a section with coarsely bedded sands which dip and steepen (to c. 20°) towards the centre of the valley. One explanation for these terraces is that they are small ice-marginal kames, the sand units being deposited against the ice margin and becoming over steepened as the supporting ice melted away.

Therefore there is little evidence to support their interpretation as mega-flutes, and the presence of small terraces tends to favour their interpretation as dense suites of lateral moraines.

---

Plate 4.7: Down valley radial ridges.

A. Double crested lateral moraine, 1.5 km inside the Loch Lomond Readvance limit in Glen Galmadale, North West Highlands [NM865 545].

B. Complex, beaded, linear ridges interpreted as a suite of closely spaced lateral moraines, Glen Grudie, northern Torridon [NG 950 650].

C. A discrete series of three lateral moraines, 5 km inside the Loch Lomond Readvance limit. They are located on the eastern side of Ruadh-stac Beag in northern Torridon [NG 980 620].

D. Quartzite flute to the east of Ruadh-stac Beag in northern Torridon [NG 985 620]. This flute is over 600 m long.

---

Plate 4.8: A complex suite of ridges interpreted as a sequence of lateral moraines in Corrie Each Knoydart [NG 810 050].

Scale: 1: 7 000.



A



B



C



D

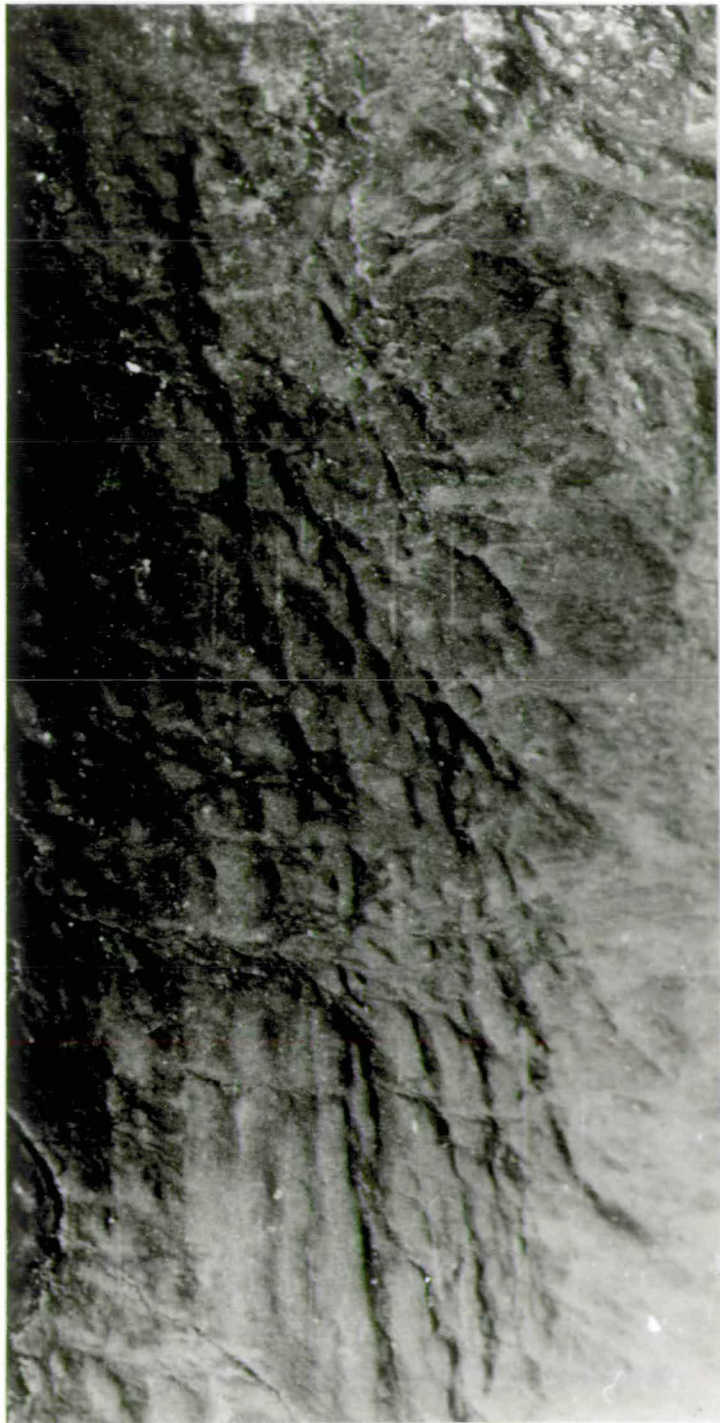

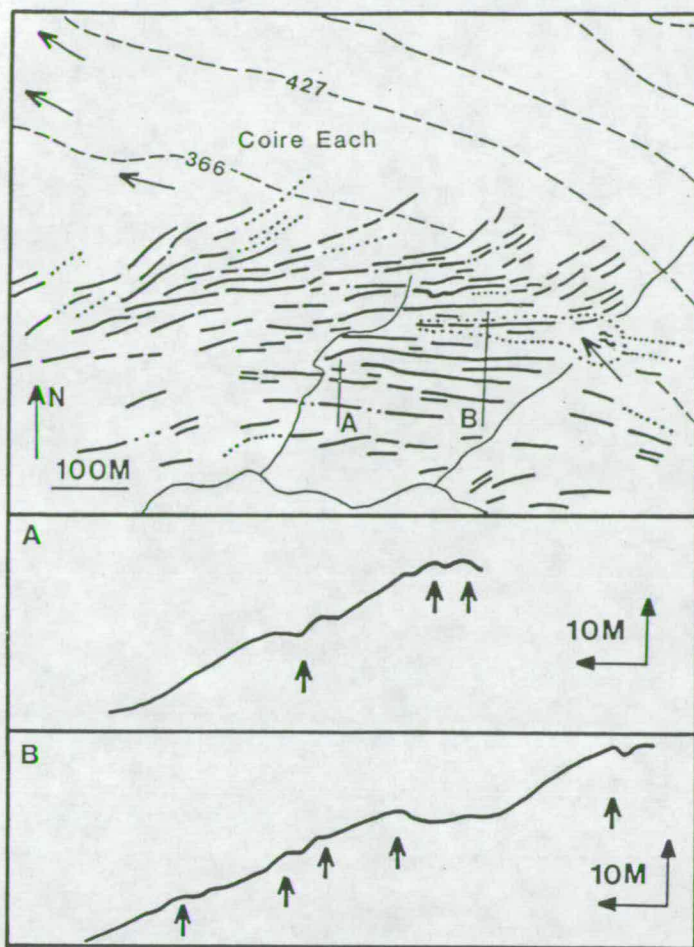

Figure 4.19: A complex suite of ridges interpreted as a sequence of lateral moraines in Corrie Each, Knoydart [NG 810 050]. The upper figure illustrates the orientation of these moraine ridges (solid and dotted lines) to striae, while the lower figures show two profiles. The arrows on these two profiles show the location of ridge crests.

### 3) Medial moraines.

Several linear features within the area covered by the Loch Lomond Stadial ice cap have been claimed as medial moraines (eg. Robinson 1977; Thorp 1986). These are pronounced, long ridges, interpreted as medial moraines purely on their occurrence below prominent rock spurs. I argue below that these interpretations are based on an over-estimation of the likely size of medial moraines when they have lost their supporting ice, and that most of these ridges are better interpreted as ice-marginal moraines. There is no theoretical support for the presence of clearly defined medial moraines within "hummocky moraine". Small and Clark (1974) noted that on modern glaciers medial moraines decrease in size and clarity as one progresses down the length of the glacier and explain this in terms of increasing ablation and glacier spreading. Consequently, by the time the moraine has reached the ice front it may have lost all clarity as a

distinct ridge. Moreover, Boulton and Eyles (1979) have argued that in most cases medial moraines have little manifestation at ice margins except as boulder plumes and local increases in drift volume, except where the rate of retreat is small or the debris supply exceptionally large. In these cases either low, discrete cones of debris are formed or whole sections of ice front stagnate (Eyles 1978, 1979). This point is reinforced by observations by the author at Skaftafellsjökull, in South East Iceland. Here a prominent medial moraine on the glacier is only manifested on the glacier forefield by a small but well defined train of boulders. This is illustrated in Figure 4.20C which is a simple map showing the medial moraine on Skaftafellsjökull and the boulders train on the glacier forefield. Each dot on this figure represents a boulder identifiable on an enlarged air photograph of the glacier margin.

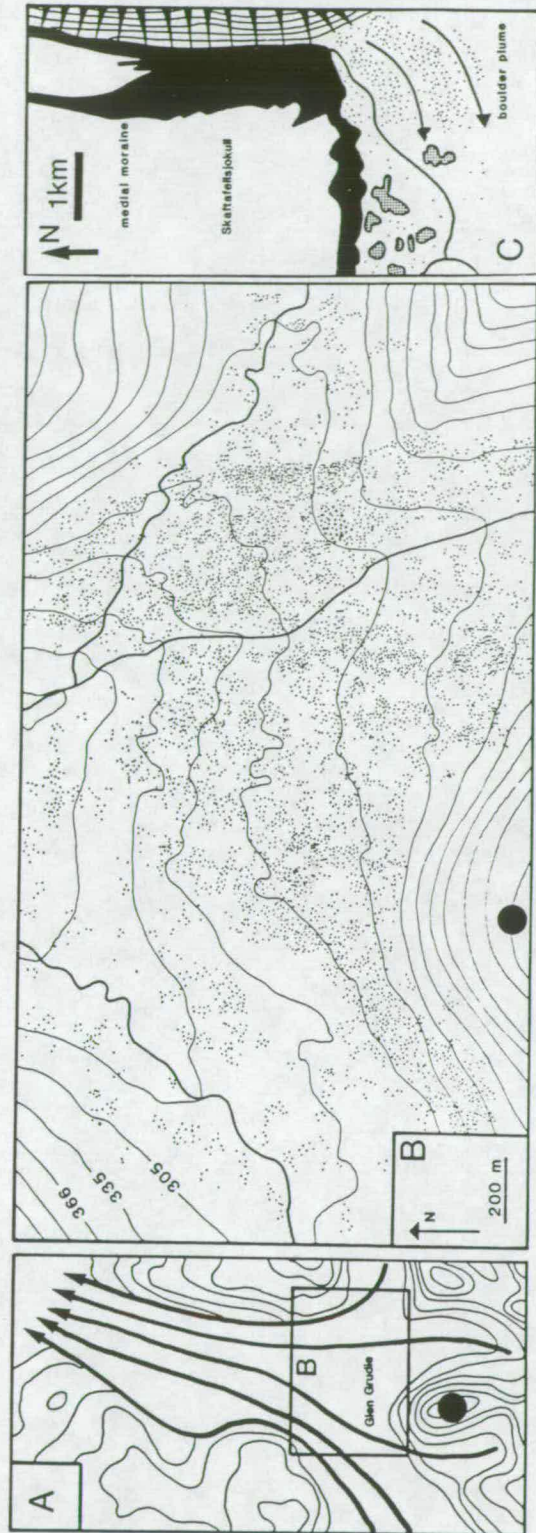

Figure 4.20: Medial moraines.

Glen Grudie, Torridon: A. Topography of Glen Grudie and flow lines. Area of (B) is shown by the box. B. Surface boulders in Glen Grudie, each dot represents a boulder identified on a 1:10 000 air photograph. A distinct plume of boulders is visible to the north of the prominent spur.

Skaftafellsjökull, South East Iceland: C. Medial moraine on the glacier surface and boulder plume on the glacier forefield. Dots represent boulders dotted from enlarged air photographs.

A similar example can be found within the "hummocky moraine" of Glen Grudie [NG 950 650]. Figure 4.20A shows the general topography of Glen Grudie and the generalised flow lines for the Loch Lomond Stadial glaciers which were present in this area. One would expect a medial moraine to have developed in front of the prominent spur at the head of the glen which probably remained above the ice surface (marked • in Fig. 4.20A&B). On the ground there are no obvious ridges of the sort interpreted as medial moraines elsewhere in the Scottish Highlands (eg. Thorp 1984). However, there is a distinct concentration of boulders below this spur. This is illustrated in part B of Figure 4.20. The extent of this figure is shown in part A and each dot represents a boulder visible on a 1:10 000 air photograph. A very distinct plume of boulders is visible below the spur, narrowing down the valley towards the north.

Many of the boulder trains present in Highland valley can be interpreted in this way.

However, on the basis of my mapping within the North West Highlands there are three examples of long linear ridges which could be interpreted as a medial moraines. Both examples occur to the east of Beinn Bhan in Applecross [NG 804 450]. Here there are four corries which were all occupied by ice during the Loch Lomond Stadial (Robinson 1977). The glaciers coalesced beneath the corries to form a single glacier lobe (Fig. 4.21). Beneath two of the three spurs between these corries there are three linear ridges, up to 600 metres long with a height that varies from one to five metres. These ridges are gently curved, diffuse and picked out by a distinct concentration of angular boulders [N=100: Angular 53%](Fig. 4.21). Two explanations can be proposed. Firstly, that they are lateral moraines formed between separate glacier lobes from each of the corries involved. However, the location of these ridges and their diffuse form weighs against this interpretation. The glacier lobes that they would define if they were lateral moraines are unrealistically long and narrow. The alternative explanation is that they are medial moraine ridges (Robinson 1977), a combination of basal debris septa and supraglacial debris concentrated and maintained as a distinct ridge during meltout by the presence of an ablation hollow between the competing glacier lobes as they retreated and separated. The mechanism by which such a hollow was maintained is uncertain but nevertheless this interpretation seems more probable.

In summary: I have argued, both on a theoretical basis and on the grounds of field observations in the North West Highlands, that medial moraines will be manifest in the geomorphological record in far more complex ways than has previously been suggested (eg. Gray 1982; Thorp 1984). Only where exceptional conditions are able to maintain coherence of the debris during meltout will a linear ridge result.

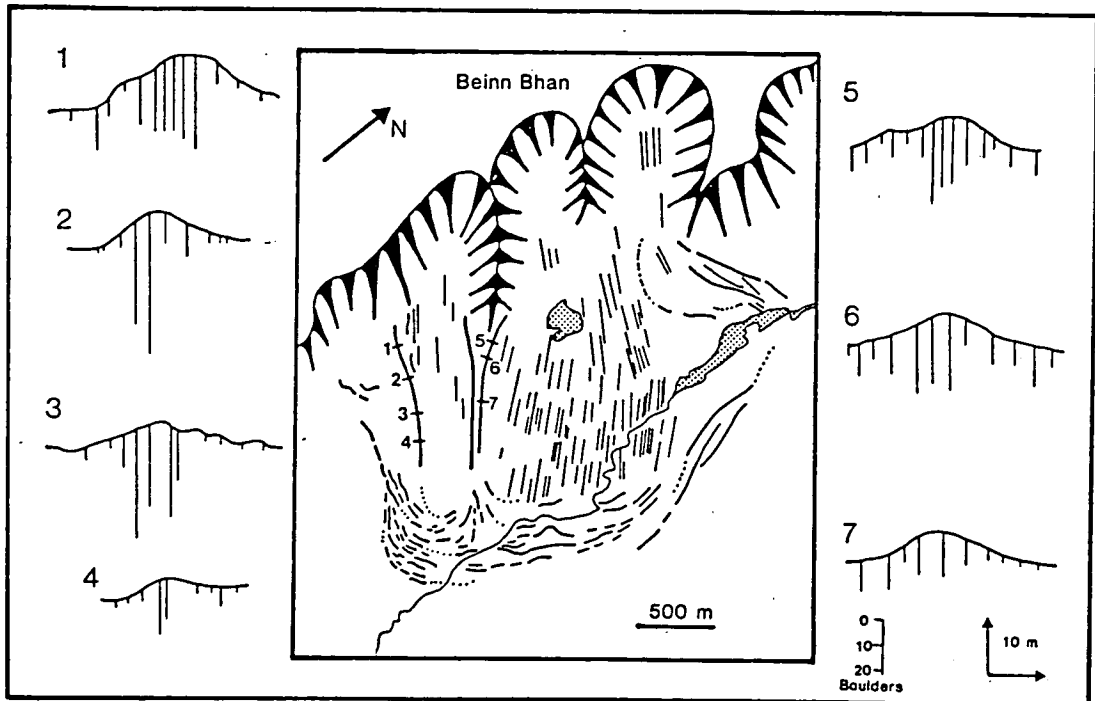





Figure 4.21: Medial Moraines? Applecross [NG 804 450].

-  Flutes.
-  Moraines.
-  Possible medial moraines.

The lines beneath the cross profiles show the number of surface boulders in an area of 10 sq. metres.

## **B: Glaciofluvial landforms:**

- 1) Kame terraces.
- 2) Meltwater channels.
- 3) Eskers.

### **1) Kame terraces.**

There are few examples in the North West Highlands as impressive as the terraces in Loch Etive (Gray 1975), although the sequence in Strath a' Sealga in Fisherfield is excellent [NH 063 812]. Of more importance here are the small terrace fragments which can be identified within "hummocky moraine". These fragments tend to be composed of a diverse range of poorly bedded glaciofluvial sands and gravels often closely associated with irregular units of diamicton. On morphological ground one can recognise two types:

1. Single terraces or benches.
2. Multiple terrace suites.

The former are discontinuous, narrow and irregular surfaces on which linear moraine ridges frequently occur. They are interpreted as outwash deposits produced by ice-marginal streams which flow periodically on the glacier surface (no terrace formed) as well as along the margin (terrace formed)(eg. Price 1973; Eyles 1978).

In contrast, the terrace suites are composed of wider terraces which are more continuous, with meltwater channels leading from and on to them. The outer edge of these terraces often possesses small hollows which are interpreted as kettle holes (see: Gray 1991). A particularly fine example occurs on the watershed in Glen Carron (Fig.4.22). The ice is believed to have retreated toward the west as indicated by a fine series of drift ridges, which parallel a succession or flight of terraces. The terraces probably formed by the diversion of meltwater along the ice margin. This meltwater was probably derived from ice retreating back into a corrie to the south of this site (corrie marked '2' inset of Fig.4.22B).

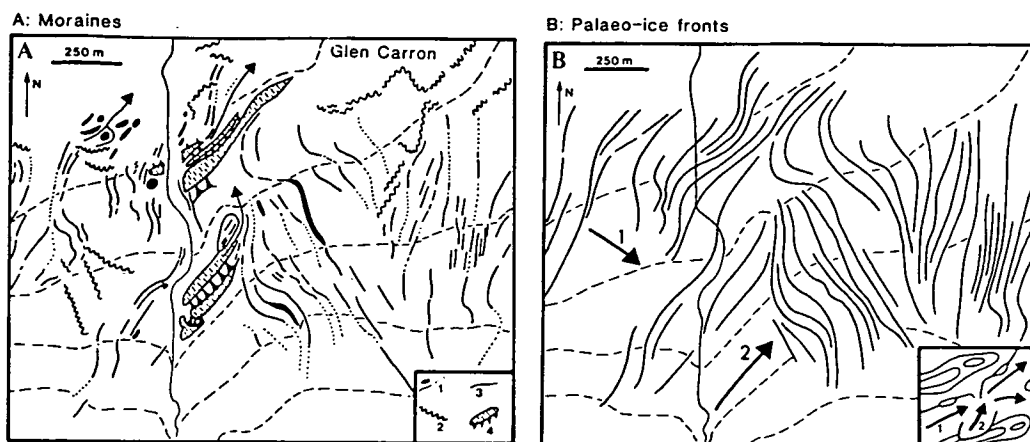

Figure 4.22: Kame terraces in Glen Carron [NH130 540].

A: Moraines and terraces (1=moraines; 2=eskers; 3=meltwater channels; 4=terraces).  
 B: Palaeo-ice front summary of (A), inset shows the topographic setting of the site and the origins of the ice lobes 1 and 2. Lobe 1 is the main ice body in Glen Carron while Lobe 2 originates in a small corrie on the south side of the glen.

## 2) Meltwater channels.

Four main types of channel may be identified (Sissons 1958):

1. Marginal and submarginal channels.
2. Proglacial channels.
3. Subglacial chutes.
4. Subglacial channels.

Examples of all four types of channel are to be found in association with the ice-dammed lake in Glen Moriston (Sissons 1977b).

Ice-marginal channels are important in this thesis because they provide information about the location of ice margins. However, there are no unambiguous criteria with which to recognise a channel as being ice-marginal (Price 1963; Sissons 1967). Consequently, the recognition of ice-marginal channels in this thesis relies upon their association with other landforms (eg. moraines and kame terraces) and the presence of half channels. Half channels have a terrace or bench like form, the outer wall of the channel having been formed by an ice margin. Although it must be noted that Sissons (1958) has suggested that such channels may also form subglacially, in the author's experience in the North West Highlands most of these channels are interspersed with sections of kame terrace which is formed at an ice margin, therefore by association the channels are also assumed to be predominantly ice-marginal.

The ice-marginal channels identified in the North West Highlands range from simple single channels on the distal flank of moraines, such as that in Gleann nam Fiadh north of Glen Affric [NH 190 265](Plate 4.9C), to complex suites of channels and kames such as that on the south side of Strath Carron [NH 030 480](Fig. 4.23)(Plate 4.9). Another example of a complex suite of channels is to be found in the Cairngorms in Glen Geusachan, formed by the decay of a small valley glacier [NN 988 935](Fig. 4.24 & Plate 4.9)(Bennett & Glasser 1991: Appendix II).

The proglacial channels mapped in the North West Highlands range from the channels and water washed rock in front of the maximum ice limit in Strath a' Bhathaich in Torridon to the channel above the Killifinan falls to the west of Loch Lochy. The latter channel is some 20 metres wide and has an average depth of 7 metres extending for over 100 metres (Fig. 4.25).

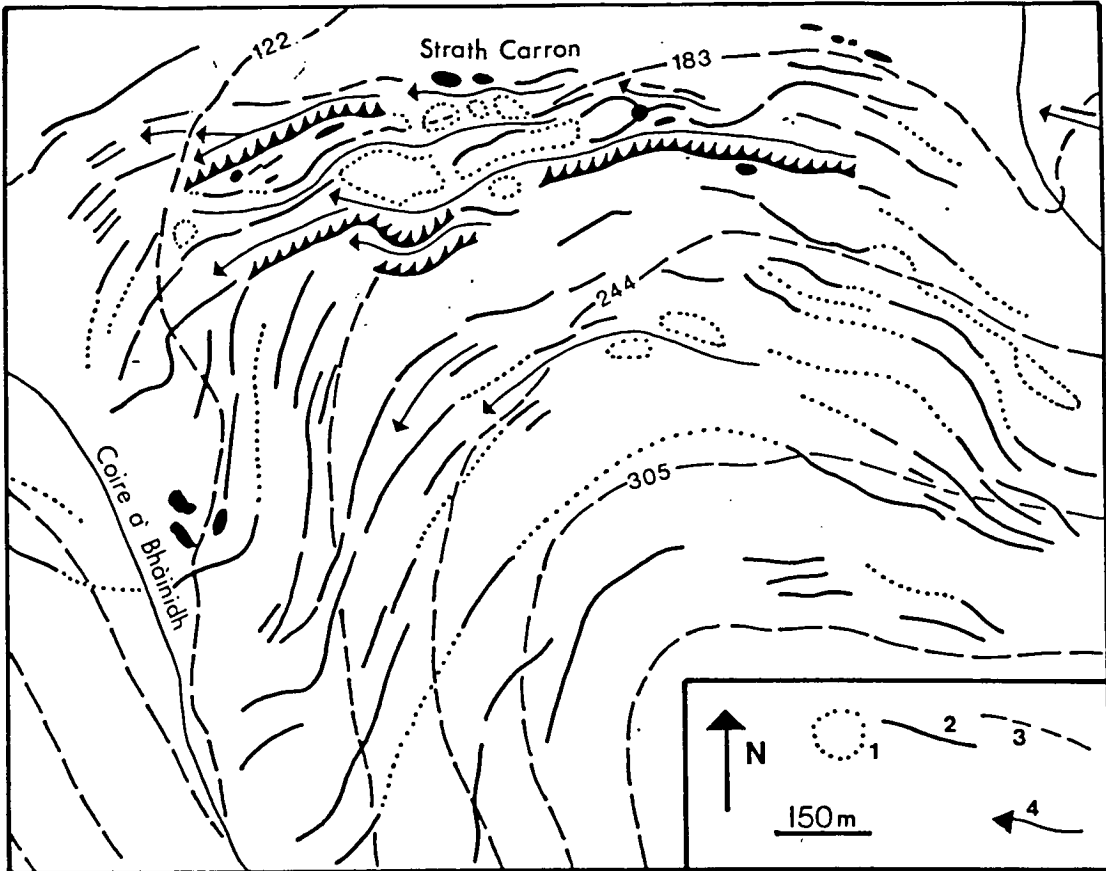

Figure 4.23: Ice-marginal meltwater channels and linear kames on the south side of Strath Carron [NH 040 480]. The valley side rises to the south and the ice margin retreated to the north. (1=poorly defined terraces; 2=moraines; 3=contours; 4=meltwater channels).

Plate 4.9: Meltwater channels and eskers.

- A. Enlarged air photograph which show a sequence of meltwater channels in Glen Geusachan (Fig. 4.24 & 5.1)[NN 985 935]. There is superb half channel in the foreground backed by a steep drift cut slope behind which there is a deep meltwater channel (1:6 000).
- B. Air photograph of part of the Breiðamerkjökull ice margin in South East Iceland. It show a complex sequence of ice-marginal channels which dissect suites of push moraines (1:15 000).
- C. A simple ice-marginal meltwater channel in Gleann nam Fiadh to the north of Glen Affric, in the North West Highlands [NH 190 250](1:8 000).
- D. Eskers (approx. 500 m long), Strath Vaich [NH 350 740](1:6 000).

### **3.4: Non-linear ridges.**

This sort of terrain can be divided into two types on the basis of sedimentology:

A: Glacial hummocks, composed mainly of diamictons

B: Glaciofluvial hummocks, composed mainly of sands and gravels.

#### **A: Glacial hummocks.**

In these areas the mounds are roughly conical in form, they are frequently associated with kettle holes and the surface is usually covered by a thin veneer of boulders (Plate 2.15). The sedimentology of these mounds is very diverse, although they are predominantly composed of loose sandy diamictons. This terrain is interpreted as stagnation terrain.

The two largest areas of this type of terrain are found in southern Torridon around Maol Chran-dearg [NG 920 500] and in northern Torridon at the head of Strath Lungard [NG 918 620](Plate 2.15). This terrain may have formed by the successive stagnation of ice frontal zones as suggested by Eyles (1983b) or alternatively it may simply have formed by widespread stagnation in these two areas.

Far more common is the occurrence of this sort of terrain in small patches amidst more ordered deposits. For example, small patches of unordered mounds are often present on a valley floor above which there are clear lateral moraines (Fig. 4.26A). One such example is found around Loch a' Chaorainn at the head of Glen Grudie [NG 940 625](Chapter Five: Fig. 5.5). The situation is similar to that of the classic glaciated valley system of Boulton and Eyles (1979). The largest concentration of debris and supraglacial cover is usually situated along the valley axis, causing local stagnation on the valley floor, while more conventional moraine formation occurs on the valley sides (Eyles 1978, 1979).

In other locations there are distinct cross valley arcuate belts of mounds and kettle holes, which have a large scale organisation but internally consist of an apparently random collection of mounds (Fig. 4.26B). I suggest that these represent ice-marginal positions which became swamped by supraglacial debris (Eyles 1978, 1979). In Glen Grudie one such belt of hummocks is picked out by a distinctive concentration of quartzite boulders. The location of this bouldery belt is shown in Figure 4.11 and this should be compared with quartzite boulder density map of Figure 4.27. Quartzite is only located on mountain tops surrounding the glen, consequently I suggest that this anomalous belt of quartzite hummocks

### 3.4: Non-linear ridges.

This sort of terrain can be divided into two types on the basis of sedimentology:

A: Glacial hummocks, composed mainly of diamictons

B: Glaciofluvial hummocks, composed mainly of sands and gravels.

#### A: Glacial hummocks.

In these areas the mounds are roughly conical in form, they are frequently associated with kettle holes and the surface is usually covered by a thin veneer of boulders (Plate 2.15). The sedimentology of these mounds is very diverse, although they are predominantly composed of loose sandy diamictons. This terrain is interpreted as stagnation terrain.

The two largest areas of this type of terrain are found in southern Torridon around Maol Chran-dearg [NG 920 500] and in northern Torridon at the head of Strath Lungard [NG 918 620](Plate 2.15). This terrain may have formed by the successive stagnation of ice frontal zones as suggested by Eyles (1983b) or alternatively it may simply have formed by widespread stagnation in these two areas.

Far more common is the occurrence of this sort of terrain in small patches amidst more ordered deposits. For example, small patches of unordered mounds are often present on a valley floor above which there are clear lateral moraines (Fig. 4.26A). One such example is found around Loch a' Chaorainn at the head of Glen Grudie [NG 940 625](Chapter Five: Fig. 5.5). The situation is similar to that of the classic glaciated valley system of Boulton and Eyles (1979). The largest concentration of debris and supraglacial cover is usually situated along the valley axis, causing local stagnation on the valley floor, while more conventional moraine formation occurs on the valley sides (Eyles 1978, 1979).

In other locations there are distinct cross valley arcuate belts of mounds and kettle holes, which have a large scale organisation but internally consist of an apparently random collection of mounds (Fig. 4.26B). I suggest that these represent ice-marginal positions which became swamped by supraglacial debris (Eyles 1978, 1979). In Glen Grudie one such belt of hummocks is picked out by a distinctive concentration of quartzite boulders. The location of this bouldery belt is shown in Figure 4.11 and this should be compared with quartzite boulder density map of Figure 4.27. Quartzite is only located on mountain tops surrounding the glen, consequently I suggest that this anomalous belt of quartzite hummocks

results from a sudden influx of quartzite on to the former glacier margin, causing part of it to stagnate. This influx was probably caused by a rockfall. The situation is analogous to that found on the margins of Kviarjökull in South East Iceland. Here a wedge of lithologically distinct debris, produced by small rock falls, can be identified on the glacier surface within a general zone of ice-marginal stagnation (Eyles 1978).

In other cases these irregular belts of hummocks have a distinct linear moraine along what is assumed to be the ice-contact face. For example, in Strath Lungard, Northern Torridon, there is one mound complex which consists of a very irregular ridge in front of which there is an apron of boulders and low relief hummocks (Fig. 4.28). One way in which this sort of landform could develop is by a mechanism similar to that described by Goldthwait (1951), although here it would need to be followed by a small readvance in order to generate the section of linear ridge.

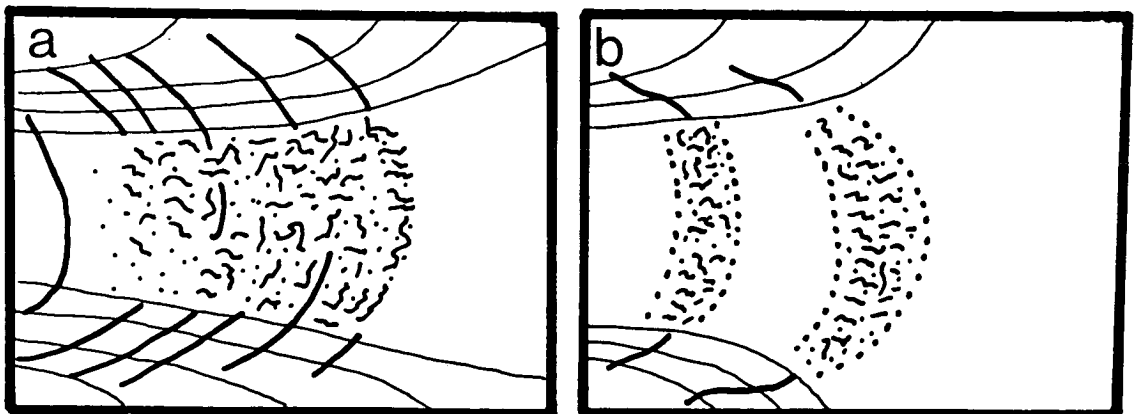

Figure 4.26: Two examples of the patterns of distribution often observed in areas where there is little order apparent at the scale of individual mounds.

results from a sudden influx of quartzite on to the former glacier margin, causing part of it to stagnate. This influx was probably caused by a rockfall. The situation is analogous to that found on the margins of Kviarjökull in South East Iceland. Here a wedge of lithologically distinct debris, produced by small rock falls, can be identified on the glacier surface within a general zone of ice-marginal stagnation (Eyles 1978).

In other cases these irregular belts of hummocks have a distinct linear moraine along what is assumed to be the ice-contact face. For example, in Strath Lungard, Northern Torridon, there is one mound complex which consists of a very irregular ridge in front of which there is an apron of boulders and low relief hummocks (Fig. 4.28). One way in which this sort of landform could develop is by a mechanism similar to that described by Goldthwait (1951), although here it would need to be followed by a small readvance in order to generate the section of linear ridge.

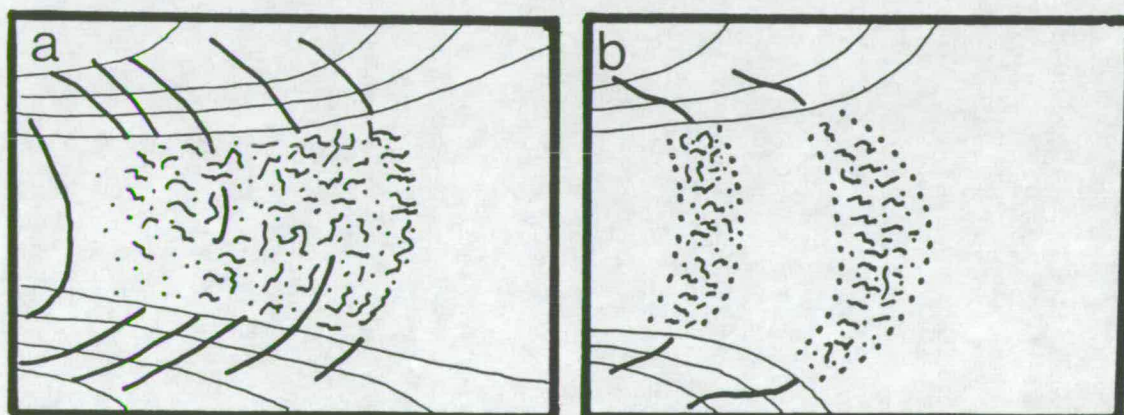

Figure 4.26: Two examples of the patterns of distribution often observed in areas where there is little order apparent at the scale of individual mounds.

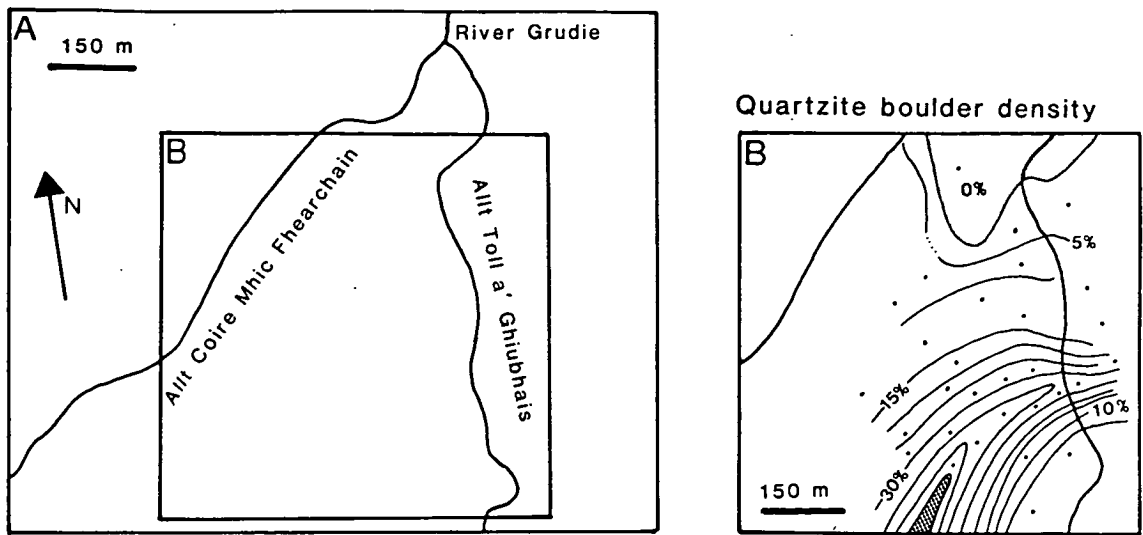

Figure 4.27: Quartzite boulder density in part of Glen Grudie [NG 955 635]. A distinct concentration of quartzite boulder is present, associated with a belt of hummocky terrain, the extent of which is shown Figure 4.11 (see also Chapter Five: Fig. 5.5). The distribution of sample sites is shown by dots. For each site the number of quartzite boulders as a percentage of the total number of surface boulders in 50 sq. metres was recorded.

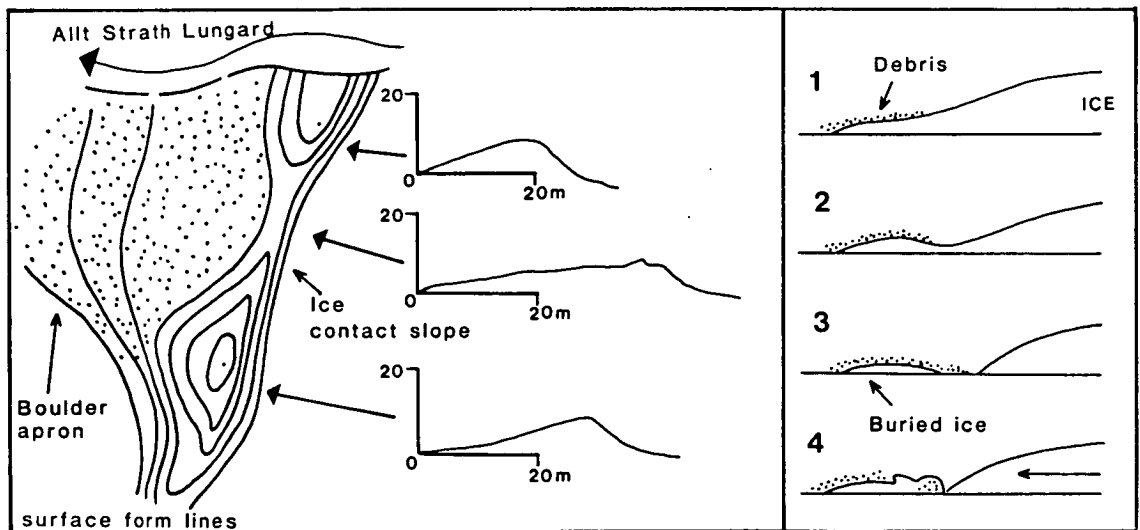

Figure 4.28: A linear ridge backing an area of random hummocks in Strath Lungard Torridon [NG 918 644]. The process of formation is illustrated on the right (stages 1 to 4). This is similar to that described by Goldthwait (1951). The linear ridge (stage 4) may be formed by a small readvance of ice pushing into the ice cored moraine.

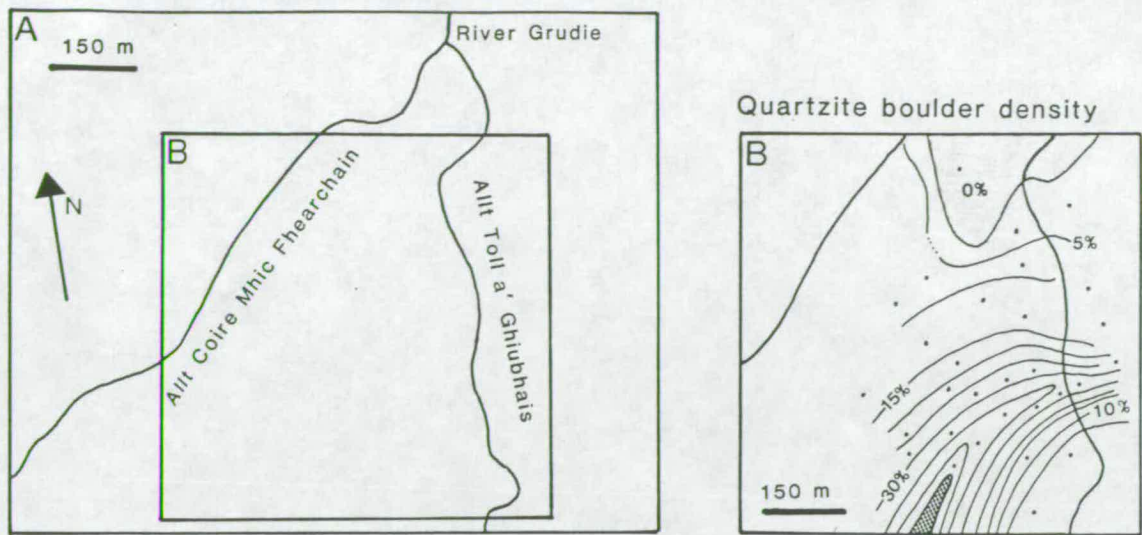

Figure 4.27: Quartzite boulder density in part of Glen Grudie [NG 955 635]. A distinct concentration of quartzite boulder is present, associated with a belt of hummocky terrain, the extent of which is shown Figure 4.11 (see also Chapter Five: Fig. 5.5). The distribution of sample sites is shown by dots. For each site the number of quartzite boulders as a percentage of the total number of surface boulders in 50 sq. metres was recorded.

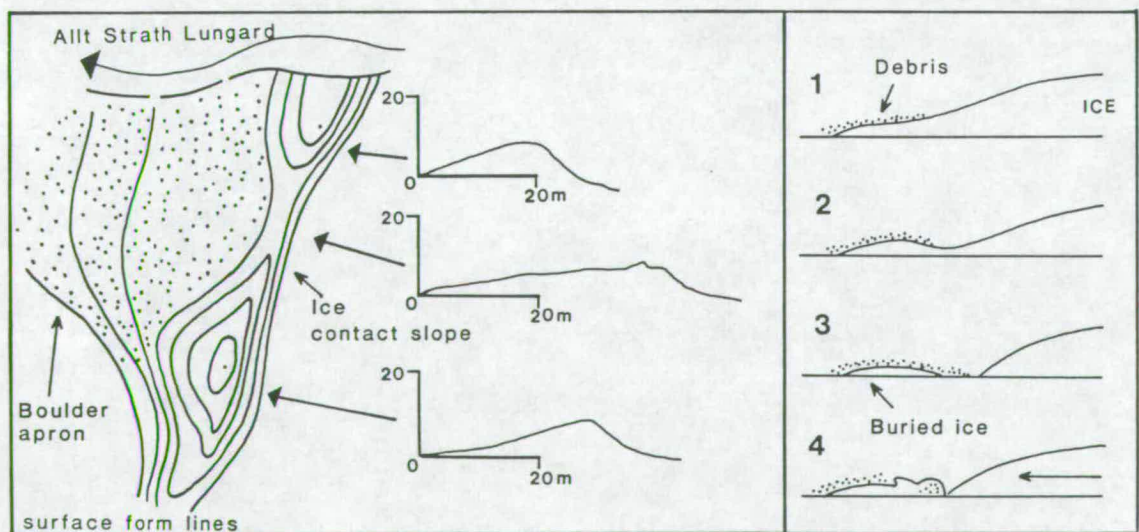

Figure 4.28: A linear ridge backing an area of random hummocks in Strath Lungard Torridon [NG 918 644]. The process of formation is illustrated on the right (stages 1 to 4). This is similar to that described by Goldthwait (1951). The linear ridge (stage 4) may be formed by a small readvance of ice pushing into the ice cored moraine.

## **B: Glaciofluvial hummocks.**

Glaciofluvial hummocky terrain consists of areas of irregular mounds, composed of sands and gravels, associated with kettled terraces. Such terrain forms where stagnant glacier ice buried beneath the outwash melts out after deposition has ceased (Path C Fig. 4.8 & 4.9). This contrasts with the outwash fans described earlier in this chapter, where meltout of any buried ice occurred before the cessation of sedimentation over the fan (Section 4.2B).

From the air photograph and ground survey, I have identified two large examples of glaciofluvial hummocky terrain, one in Glen Ling and another in Strath Carron.

**Glen Ling:** Here the glaciofluvial stagnation terrain is confined to the lower valley sides, above which there are well defined moraines (Fig. 4.29). These moraines give an impression of the former glacier gradient. This gradient was steep, and therefore inconsistent with the gentle gradient one would expect if the whole of the outlet glacier in Glen Ling had simply stagnated. Instead the glaciofluvial stagnation terrain probably developed at successive ice margins during active decay.

There are two main wedges or fans of hummocks on the valley floor, one on the north side of the glen associated with a prominent stream and a second fan on the south side associated with a second stream and meltwater channel. It is these streams and meltwater channels which appear to have fed water on to and along the ice margin, causing sediment to accumulate upon it and resulting in its stagnation (Fig. 4.29). Rapid ice retreat or major channel shifts must have caused these outwash surfaces to be abandoned before this buried ice had melted out. Consequently, meltout occurred after the surfaces were abandoned and no infilling of the thermal depressions will have therefore occurred.

Along with the numerous kettle holes, these surfaces contain sinuous, linear ridges which tend to parallel the long axis of the stagnation surface. One possible explanation for these ridges is that they are former channels (Fig. 4.31). In outwash underlaid by buried ice, the rate of meltout under a channel would tend to be greatest due to frictional heating and the ice would become disproportionately thin in these locations. Moreover, in certain cases the channels may have been sufficiently active to incise into the underlying ice. Consequently, on the complete meltout of the buried ice, the channel sediments will tend to be lowered less than

## **B: Glaciofluvial hummocks.**

Glaciofluvial hummocky terrain consists of areas of irregular mounds, composed of sands and gravels, associated with kettled terraces. Such terrain forms where stagnant glacier ice buried beneath the outwash melts out after deposition has ceased (Path C Fig. 4.8 & 4.9). This contrasts with the outwash fans described earlier in this chapter, where meltout of any buried ice occurred before the cessation of sedimentation over the fan (Section 4.2B).

From the air photograph and ground survey, I have identified two large examples of glaciofluvial hummocky terrain, one in Glen Ling and another in Strath Carron.

**Glen Ling:** Here the glaciofluvial stagnation terrain is confined to the lower valley sides, above which there are well defined moraines (Fig. 4.29). These moraines give an impression of the former glacier gradient. This gradient was steep, and therefore inconsistent with the gentle gradient one would expect if the whole of the outlet glacier in Glen Ling had simply stagnated. Instead the glaciofluvial stagnation terrain probably developed at successive ice margins during active decay.

There are two main wedges or fans of hummocks on the valley floor, one on the north side of the glen associated with a prominent stream and a second fan on the south side associated with a second stream and meltwater channel. It is these streams and meltwater channels which appear to have fed water on to and along the ice margin, causing sediment to accumulate upon it and resulting in its stagnation (Fig. 4.29). Rapid ice retreat or major channel shifts must have caused these outwash surfaces to be abandoned before this buried ice had melted out. Consequently, meltout occurred after the surfaces were abandoned and no infilling of the thermal depressions will have therefore occurred.

Along with the numerous kettle holes, these surfaces contain sinuous, linear ridges which tend to parallel the long axis of the stagnation surface. One possible explanation for these ridges is that they are former channels (Fig. 4.31). In outwash underlain by buried ice, the rate of meltout under a channel would tend to be greatest due to frictional heating and the ice would become disproportionately thin in these locations. Moreover, in certain cases the channels may have been sufficiently active to incise into the underlying ice. Consequently, on the complete meltout of the buried ice, the channel sediments will tend to be lowered less than

surrounding area since the ice beneath them will be thinner (Fig. 4.31). The result would be long linear ridges standing above the general surface and following the trend of former channels. These linear ridges are very clear on the south side of Glen Ling, where they are all orientated towards the meltwater channel from which the former outwash surface is believed to have been fed.

Most of the irregular hummocks in Glen Ling are composed of well bedded sands, although some mounds contain complex interbedded and deformed gravels. These sediments have been deformed and faulted by the differential subsidence caused by the meltout of buried ice (cf. Boulton 1972a; McDonald & Shilts 1975). Plate 4.10. shows a superb synclinal structure beneath a kettle hole on the south side of Glen Ling.

---

Plate 4.10: Synclinal sand structures beneath a kettle hole in Glen Ling [NN 988 935].

surrounding area since the ice beneath them will be thinner (Fig. 4.31). The result would be long linear ridges standing above the general surface and following the trend of former channels. These linear ridges are very clear on the south side of Glen Ling, where they are all orientated towards the meltwater channel from which the former outwash surface is believed to have been fed.

Most of the irregular hummocks in Glen Ling are composed of well bedded sands, although some mounds contain complex interbedded and deformed gravels. These sediments have been deformed and faulted by the differential subsidence caused by the meltout of buried ice (cf. Boulton 1972a; McDonald & Shilts 1975). Plate 4.10. shows a superb synclinal structure beneath a kettle hole on the south side of Glen Ling.

---

Plate 4.10: Synclinal sand structures beneath a kettle hole in Glen Ling [NN 988 935].



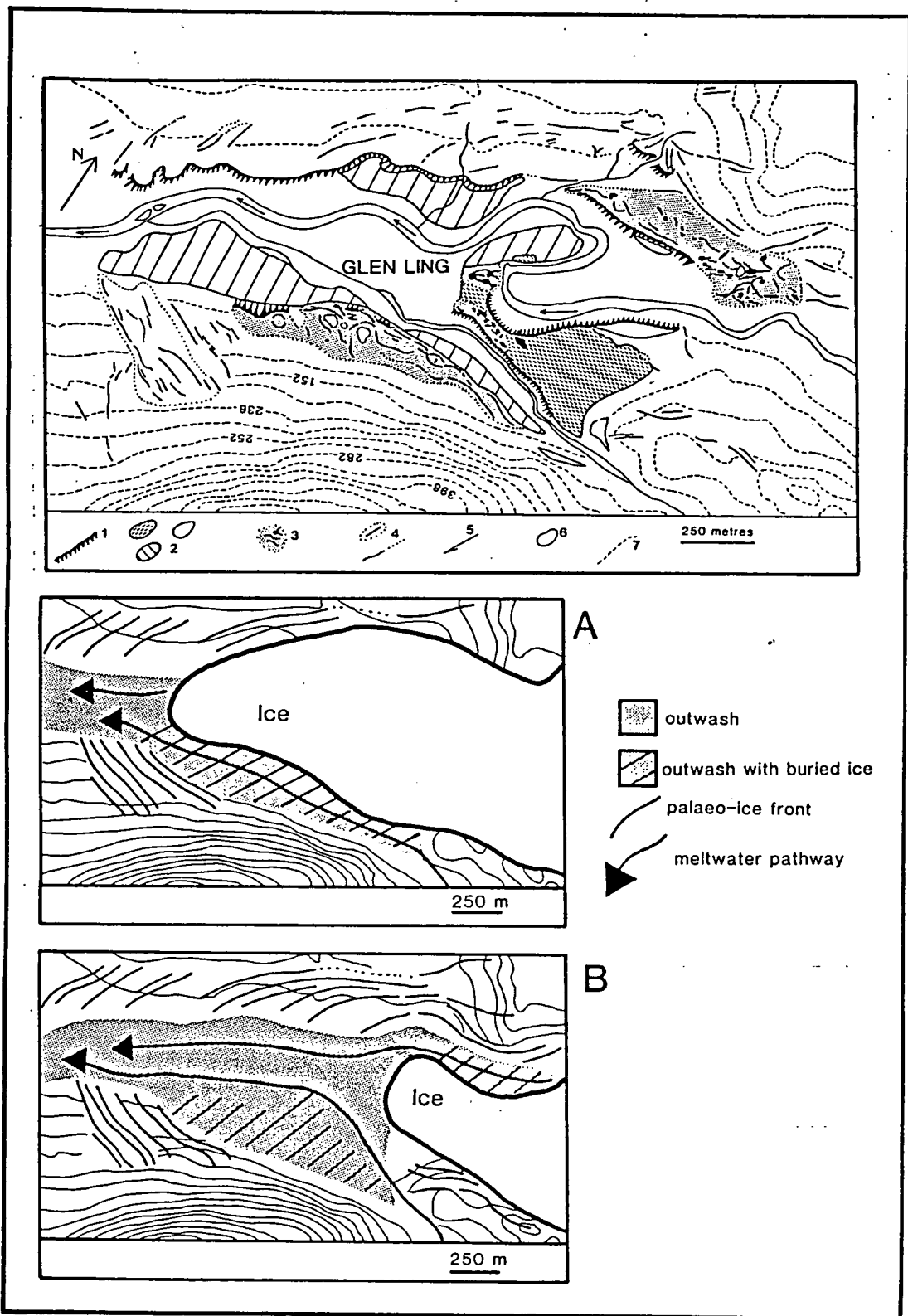

Figure 4.29: Glaciofluvial ice-contact deposits or hummocky terrain in Glen Ling [NN 988 935](1=steep drift cut slope; 2=terraces; 3=hummocky terrain; 4=moraines; 5=fans; 6=kettle holes; 7=contours).

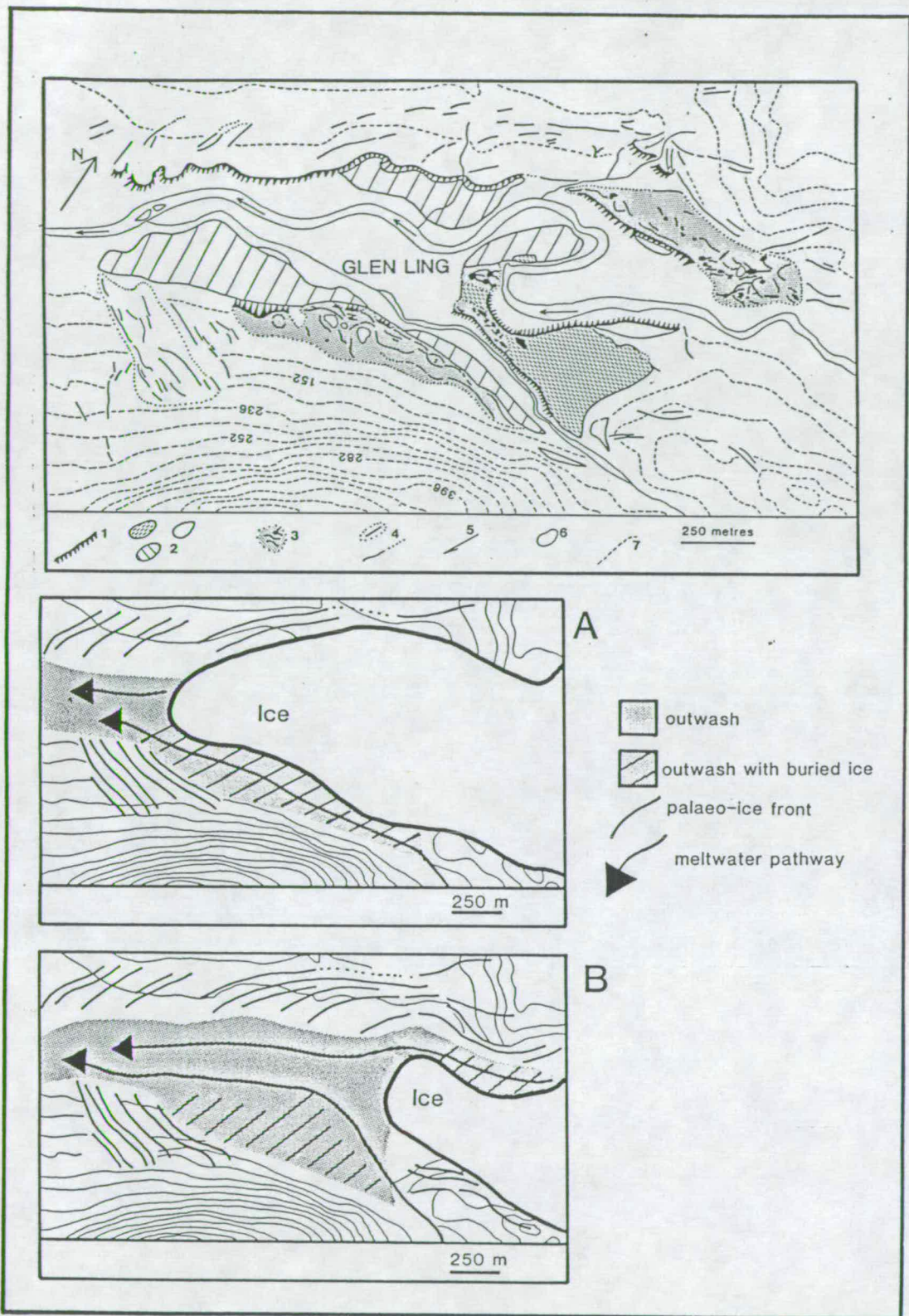

Figure 4.29: Glaciofluvial ice-contact deposits or hummocky terrain in Glen Ling [NN 988 935](1=steep drift cut slope; 2=terraces; 3=hummocky terrain; 4=moraines; 5=fans; 6=kettle holes; 7=contours).

**Strath Carron:** At this site the stagnation terrain occurs in a diagonal belt across the valley floor and may reflect a complex pattern of drainage across a former ice front [NG 950 440](Fig. 4.30). Glaciofluvial hummocks occur inside the Loch Lomond Readvance limit, which is marked by a moraine and terrace edge beyond which there are extensive areas of outwash which grade into Loch Carron (McCann 1966b; Robinson 1977). The hummocky terrain occurs in a belt running diagonally from the northern side of the glen to the south side in front of Loch Dughail. This pattern is picked out by the valley floor elevation in Strath Carron which is shown in Figure 4.30. There is a distinct belt of land >38 metres that runs diagonally across the valley floor in front of Loch Dughail. Within this belt there are several linear esker-like ridges which have an orientation that is parallel to the overall geometry of the belt of glaciofluvial stagnation terrain. These ridges like those in Glen Ling are believed to represent the location of former channels (Fig. 4.31). One can suggest that the highest ridges and mounds should correspond to the deepest and most incised channels, which will have had least buried ice beneath them and consequently will now be elevated above the surrounding terrain which will have been underlaid by greater thicknesses of ice. The highest ridges therefore give an indication of the main fluvial pathways during their deposition.

The depositional setting envisaged for this belt of stagnation terrain is illustrated in block diagrams (Fig. 4.30). There appears to have been a shift in the main meltwater flow from the south to the north side of the glen, which effectively caused the lobe of ice just within the terminus to become detached and left as a massive kettle hole (Fig. 4.30).

**Strath Carron:** At this site the stagnation terrain occurs in a diagonal belt across the valley floor and may reflect a complex pattern of drainage across a former ice front [NG 950 440](Fig. 4.30). Glaciofluvial hummocks occur inside the Loch Lomond Readvance limit, which is marked by a moraine and terrace edge beyond which there are extensive areas of outwash which grade into Loch Carron (McCann 1966b; Robinson 1977). The hummocky terrain occurs in a belt running diagonally from the northern side of the glen to the south side in front of Loch Dughail. This pattern is picked out by the valley floor elevation in Strath Carron which is shown in Figure 4.30. There is a distinct belt of land >38 metres that runs diagonally across the valley floor in front of Loch Dughail. Within this belt there are several linear esker-like ridges which have an orientation that is parallel to the overall geometry of the belt of glaciofluvial stagnation terrain. These ridges like those in Glen Ling are believed to represent the location of former channels (Fig. 4.31). One can suggest that the highest ridges and mounds should correspond to the deepest and most incised channels, which will have had least buried ice beneath them and consequently will now be elevated above the surrounding terrain which will have been overlaid by greater thicknesses of ice. The highest ridges therefore give an indication of the main fluvial pathways during their deposition.

The depositional setting envisaged for this belt of stagnation terrain is illustrated in block diagrams (Fig. 4.30). There appears to have been a shift in the main meltwater flow from the south to the north side of the glen, which effectively caused the lobe of ice just within the terminus to become detached and left as a massive kettle hole (Fig. 4.30).

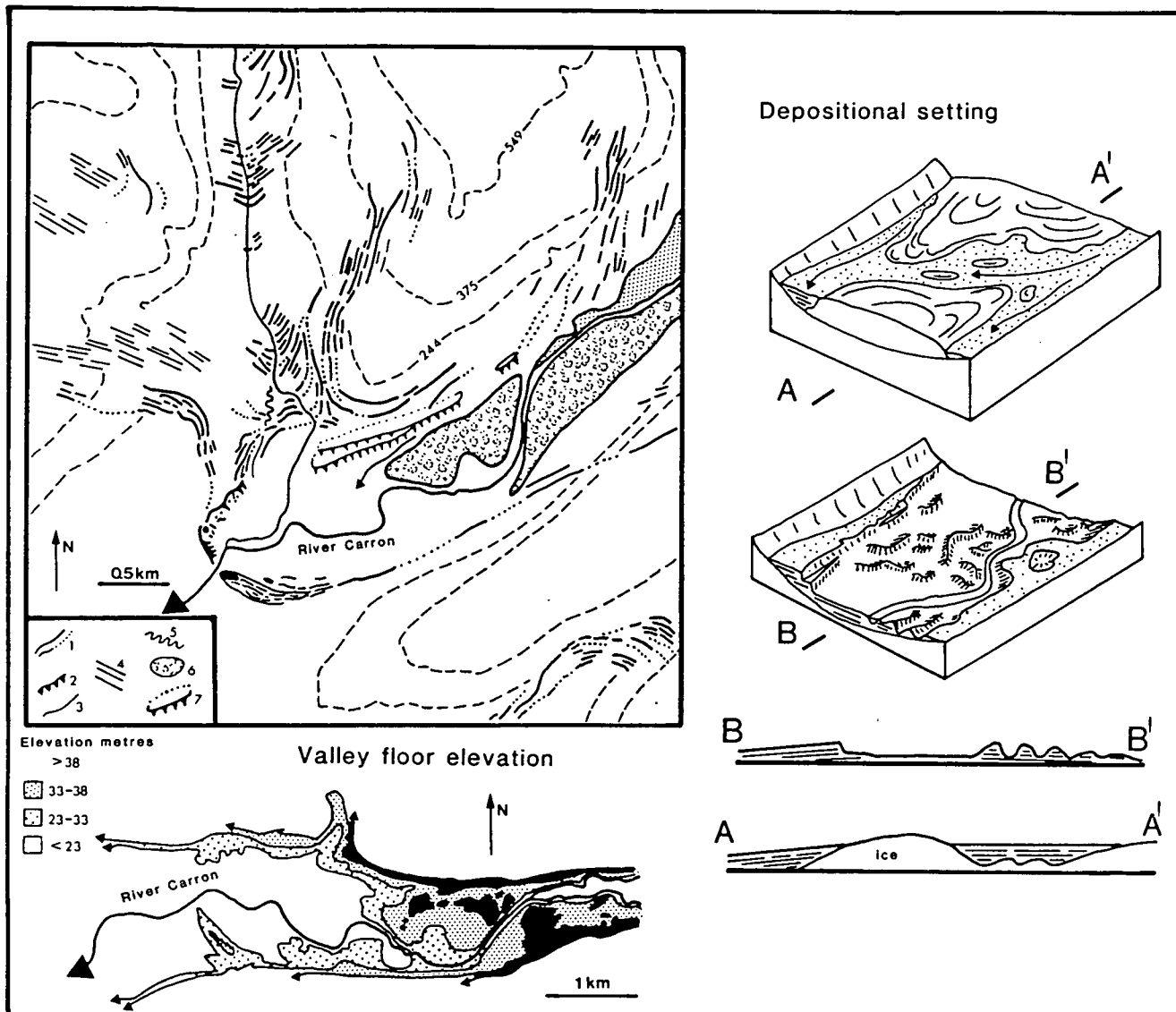

Figure 4.30: Glaciofluvial ice-contact deposits in Strath Carron [NG 950 440].

Left hand side: This shows the valley bottom geomorphology and valley floor elevation. Elevations were taken from the 1: 10 000 O.S. map of the area and are believed to reflect moraine elevation not variations in bedrock. (1=moraines; 2=drift cut slopes; 3=meltwater channels; 4=flutes; 5=eskers; 6=unordered hummocks; 7=terraces).

Right hand side: This shows the depositional environment envisaged for this area.

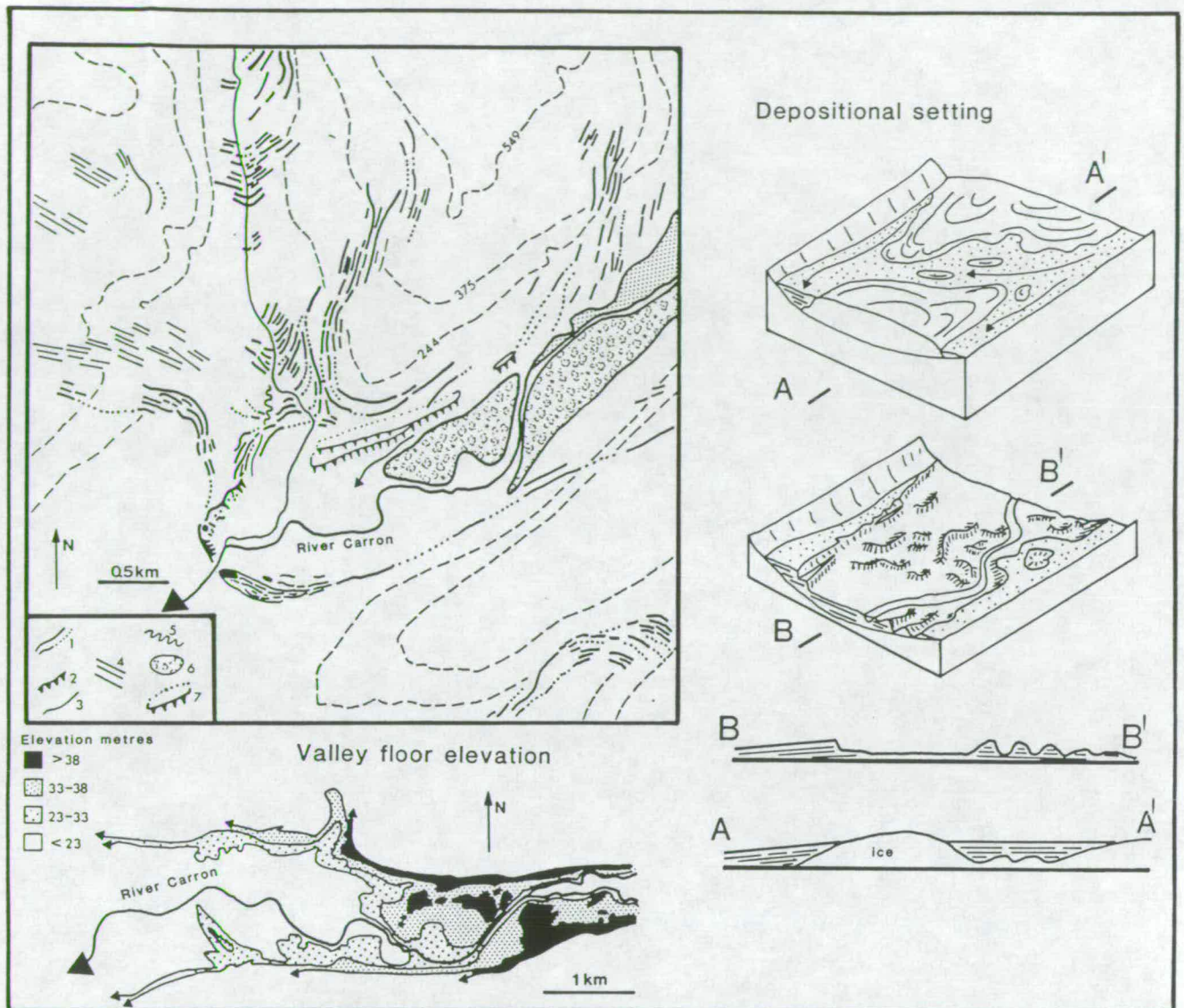

Figure 4.30: Glaciofluvial ice-contact deposits in Strath Carron [NG 950 440].

Left hand side: This shows the valley bottom geomorphology and valley floor elevation.

Elevations were taken from the 1: 10 000 O.S. map of the area and are believed to reflect moraine elevation not variations in bedrock.

(1=moraines; 2=drift cut slopes; 3=meltwater channels; 4=flutes; 5=eskers; 6=unordered hummocks; 7=terraces).

Right hand side: This shows the depositional environment envisaged for this area.

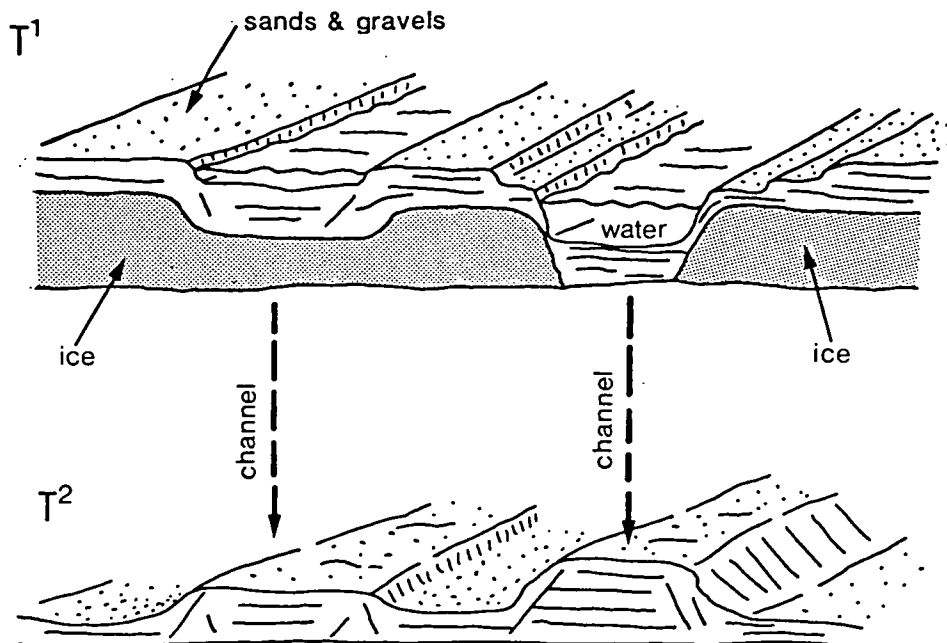

Figure 4.31: Model to explain the presence of esker-like ridges in glaciofluvial stagnation terrain. In outwash underlaid by buried ice active channels are usually underlaid by thinner ice due to frictional heating and in the case of major or catastrophic flows by incision of the channel into the buried ice. As the topography is inverted by the meltout of the buried ice the channels are elevated as ridges.

#### 4.5: Chapter summary.

In this chapter I have described a range of landforms and modes of genesis which can be identified within "hummocky moraine". This is by no means a complete list of all the genetic types of landform present, but only those which I have found to occur frequently and for which there is clear evidence. On the basis of the 10 803 air photographs examined I suggest that most "hummocky moraine" simply consists of suites of push moraines, dump moraines, ice-contact outwash fans and flutes. Nowhere are there widespread areas of stagnation terrain. It is clearly not feasible to expect to be able to map all the landforms present within an area of "hummocky moraine" and give each a genetic attribution. However, I believe that the range of possible landforms is sufficiently small for one to be confident that, by mapping the structure within ordered areas of "hummocky moraine", one is mapping the pattern of decay of an active ice cap. If this conclusion is correct, then the moraine structure mapped should have patterns of spatial organisation at a meso-scale which resemble those found at actively retreating ice margins. These patterns are discussed in the following chapter.

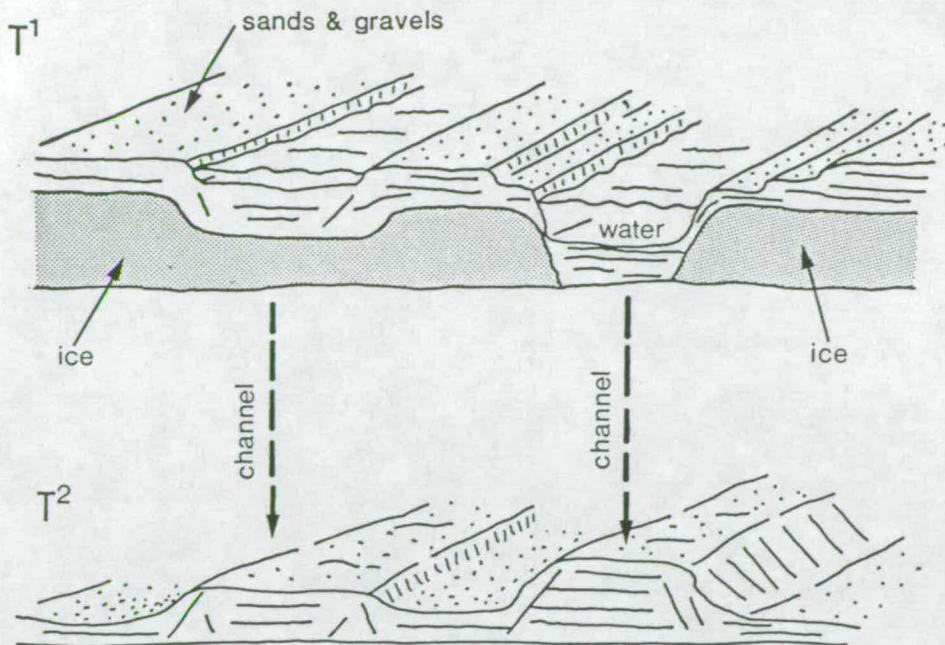

Figure 4.31: Model to explain the presence of esker-like ridges in glaciofluvial stagnation terrain. In outwash underlaid by buried ice active channels are usually underlaid by thinner ice due to frictional heating and in the case of major or catastrophic flows by incision of the channel into the buried ice. As the topography is inverted by the meltout of the buried ice the channels are elevated as ridges.

#### 4.5: Chapter summary.

In this chapter I have described a range of landforms and modes of genesis which can be identified within "hummocky moraine". This is by no means a complete list of all the genetic types of landform present, but only those which I have found to occur frequently and for which there is clear evidence. On the basis of the 10 803 air photographs examined I suggest that most "hummocky moraine" simply consists of suites of push moraines, dump moraines, ice-contact outwash fans and flutes. Nowhere are there widespread areas of stagnation terrain. It is clearly not feasible to expect to be able to map all the landforms present within an area of "hummocky moraine" and give each a genetic attribution. However, I believe that the range of possible landforms is sufficiently small for one to be confident that, by mapping the structure within ordered areas of "hummocky moraine", one is mapping the pattern of decay of an active ice cap. If this conclusion is correct, then the moraine structure mapped should have patterns of spatial organisation at a meso-scale which resemble those found at actively retreating ice margins. These patterns are discussed in the following chapter.

• Chapter Five •

**Meso-scale evidence**

## Contents

---

5.1:	Introduction.	100
5.2:	Planimetric patterns.	100
5.3:	Cross valley asymmetry.	104
5.4:	Ice front interactions:	106
	Case study 1—Differential retreat, Glen Grudie.	107
	Case study 2—Differential retreat, Strath na Sealga.	110
	Case study 3—Non-synchronicity, Glen Croulin, Knoydart.	112
	Case study 4—Non-synchronicity, Loch Eil.	117
5.5:	Chapter summary.	118

---

*In Chapter Two it was argued that the landforms at modern glacier margins have a distinct spatial organisation at a meso-scale. In this chapter, I argue that similar patterns of spatial organisation can be identified within "hummocky moraine". Three examples of such patterns of organisation are examined.*

### 5.1: Introduction.

Implicit in the model proposed in Chapter Two is that, in addition to small scale patterns typical of individual ice-marginal features, there should be well integrated, meso-scale (100s-1000s of metres) patterns of organisation similar to those found at glacier margins experiencing decay today. This point can be illustrated in relation to three examples of the distinct spatial organisation of frontal landforms at modern ice margins. One can identify three main types of pattern:

- 1) Planimetric patterns.
- 2) Cross valley asymmetries.
- 3) Ice front interactions.

### 5.1: Planimetric patterns.

Transverse, ice-marginal ridges tend to be deposited as parallel suites of ridges which have a down ice convexity or a lobate form (Fig. 5.1). Where glaciers block the mouth of ice-free valleys or retreat down, rather than up a valley, ice-dammed lakes commonly occur. Furthermore, contemporary glacier margins possess terminal gradients which are

usually less than  $10^{\circ}$  to  $15^{\circ}$  (Paterson 1980). All three of these characteristics can be identified within the planimetric patterns present in "hummocky moraine".

The cross valley or concentric ridges within "hummocky moraine" generally form parallel suites which have distinct down valley convexities. The development of strong convex patterns like those found in "hummocky moraine" is a common feature of retreating glaciers in areas of high relief (Fig. 5.1). These ridge suites are normally parallel to large terminal moraines or other glacial landform patterns. This is well illustrated in Figure 5.2, which shows the landforms deposited by a valley glacier in Glen Geusachan which existed during the Loch Lomond Stadial (Appendix II). The cross valley ridges form concentric suites of landforms which probably depict successive ice margins. They are also parallel to ice-marginal positions defined by independent evidence such as the ice-marginal meltwater channels in Glen Dee. This type of integrated pattern of moraine ridges with other glacial landforms is present throughout the North West Highlands, a point that can best be made by reference to Appendix I.

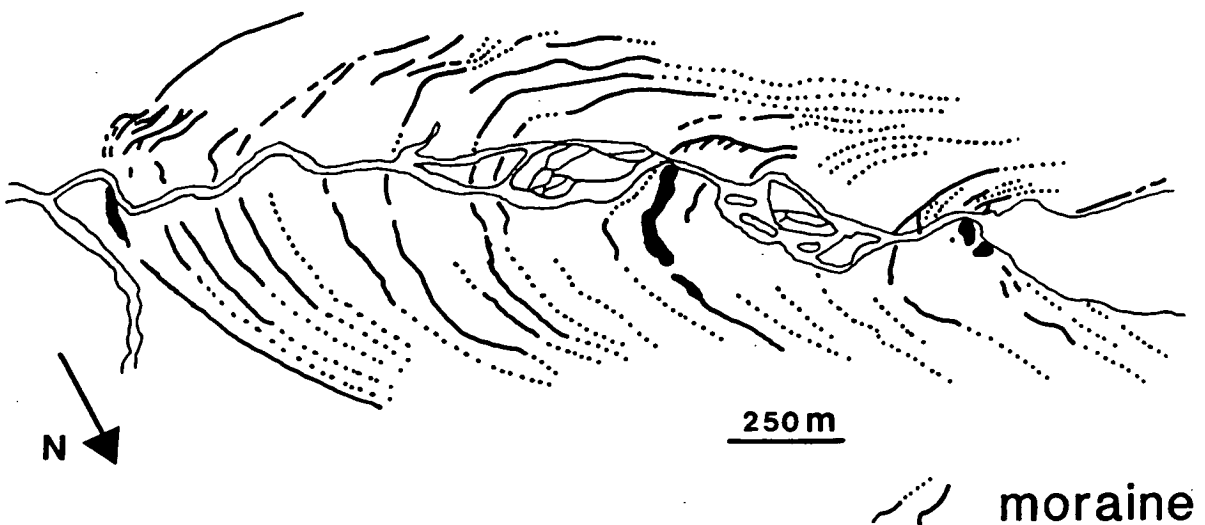

Figure 5.1: Moraines reflecting the glacial retreat in Nigardsdalen Valley, south Norway. Note the ridge bifurcations and the concentric planimetric form. Simplified from Figure 33 p. 30 Andersen & Sollid (1971).

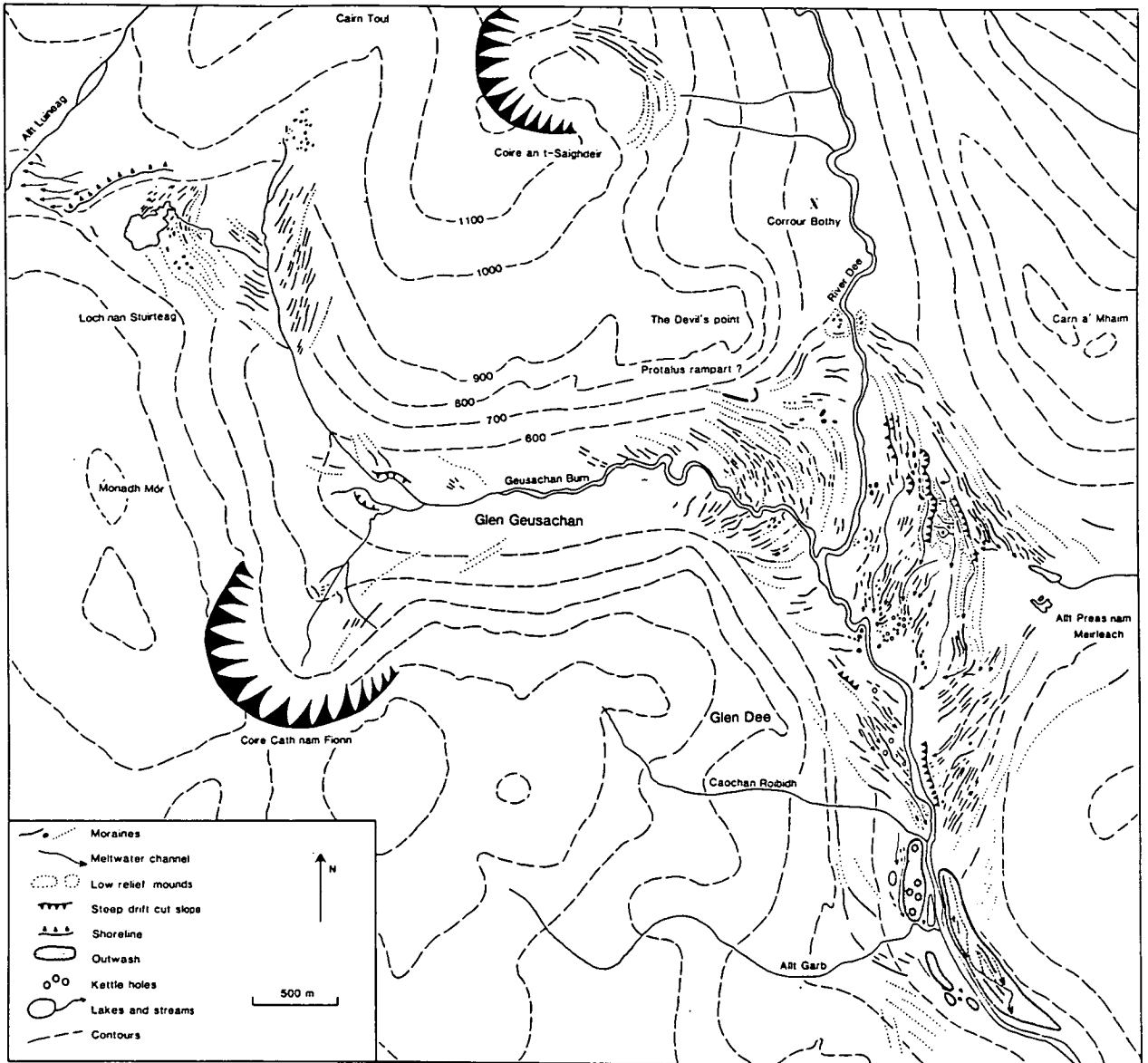

Figure 5.2: The retreat moraines formed by a Loch Lomond Stadial valley glacier in Glen Geusachan, Cairngorms [NN 980 940]. A detailed description of these landforms and their interpretation is present in Appendix II.

Where these ridge suites indicate ice retreat down a valley, the development of ice-dammed lakes or serious disruption of proglacial drainage is to be expected. The ice-dammed lake in Glen Carron provides an excellent example of this (Chapter Four). Similarly, the area around Glenfinnan provides another example [NM 910 830]. Here the cross valley pattern of drift ridges indicates that ice retreated down the valleys of Glenfinnan, Gleann Dubh Lighe and Gleann Fionnlighe to the south and into the mountains to the east of Loch Shiel. Clearly, if the ice retreated in

this way lakes would tend to form against the ice front. Detailed examination of the limited sedimentary exposure within all three of these valleys reveals the presence of finely laminated silty clays and sands typical of ice-dammed lakes in the Scottish Highlands. Moreover, at the head of Gleann Fionnlighe there are several terrace-like features which have been tentatively interpreted as a suite of delta shorelines [NM 990 840].

In Knoydart, on a col between two adjacent ice lobes to the north of Inverie, there is further evidence of ephemeral ice-dammed lakes, formed during decay [NG 765 003].

Finally, the gradients of cross valley ridges are easily determined from their intersection with valley side contours and give a direct indication of the snout gradient of the former ice fronts (cf. Murray & Locke 1989), although due to isostasy, which is discussed in Chapter Eight, these gradients are likely to be maximum estimates (Pierce 1979). Figure 5.3 shows selected profiles and a bar chart of snout gradients sampled from the North West Highlands. The mean snout gradient is  $7.6^{\circ}$  (Table 5.1), although three modes,  $5.5^{\circ}$ ,  $8.5^{\circ}$ ,  $13^{\circ}$ , are present. The central mode appears to be representative of the overall population, while the smaller mode appears to be due to the predominantly low snout-gradients in the wide, shallow valleys around Loch Arkaig, Loch Loyne and Glen Garry. The higher mode is associated with moraines at the heads of valleys. In general there is a clear tendency for the snout gradients to be steeper towards the valley heads or decay centres (Fig. 5.3). The former ice front gradients recorded in the Highlands are steeper than many found in Iceland which often have gradients of less than  $5^{\circ}$  (eg. Ives & King 1954; Bullard 1991; Boulton pers comm.). They do however resemble glacier gradients found in areas of steep terrain. For example, the McCall glacier in Alaska has snout gradients of between  $15^{\circ}$  and  $25^{\circ}$  and 65% of its surface area has a slope of between  $5^{\circ}$  and  $15^{\circ}$  (< $5^{\circ}$ —9% of the area)(Wendler & Ishikawa 1974). Similarly the average snout gradient for Storglaciären in Sweden is  $15^{\circ}$  (Hooke *et al.* 1989). One can suggest therefore that the valley side gradients of the cross valley concentric ridges in "hummocky moraine" are consistent with their interpretation as ice-marginal retreat moraines.

Figure 5.3: Snout gradients for selected retreat positions.

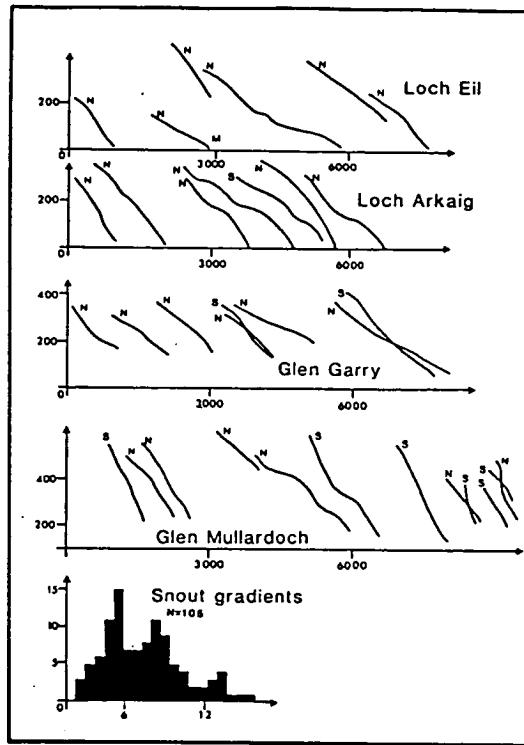

A

Valley aspect	n	mean	Coefficient of variance
West	28	7.0	32.5%
North	22	10.0	30.2%
East	55	6.83	38.2%
Total	105	7.6	38.7%

B

Valley side	n	mean	Coefficient of variance
North	60	6.8	30.4%
South	23	7.0	47.5%

Table 5.1 Snout gradients for selected retreat positions by valley aspect (A) and by valley side (B).

## 5.2: Cross valley asymmetry.

Cross valley asymmetry of glacier margins and moraines is well documented. Thome (1972) described the planimetric asymmetry of glacier margins in South East Iceland and related them to contrasts in the insolation received by opposite valley sides.

Within the North West Highlands similar patterns of asymmetry have been recorded. There tends to be a greater moraine density on the northern sides of east-west orientated valleys. This asymmetry is particularly noticeable in deeply incised valleys, clearly ones in which

strong insolation contrasts would occur (Bennett & Glasser 1991-Appendix II).

In order to examine this further, a sample of 21 valleys with a clear east-west orientation from throughout the North West Highlands were chosen and the following parameters obtained: 1) the number of palaeo-ice fronts on the north side of the valley; 2) the number of palaeo-ice fronts on the south side of the valley; 3) the average depth vs. width ratio for the valley section under consideration.

The results are presented in Figure 5.4 and show a clear trend for greater cross valley asymmetry, with increasing values of valley incision and hence insolation contrast. Northern, south-facing sides of glaciers, in deeply incised east-west valleys receive higher inputs of solar radiation and retreat by a greater distance between each winter readvance or still stand, consequently they produce a greater number of well spaced ridges. In contrast, southern, north-facing glacier flanks retreat less between each winter readvance or still stand and thus produce larger though fewer moraines, a single moraine representing several years debris accumulation. Although the correlation between valley incision and cross valley asymmetry is significant at the 99% confidence limit, it only explains 30.8 % of the total variance ( $N=21$ ;  $R=0.555$ ;  $R_{crit}=0.549$ ). This suggests that, apart from insolation contrasts, other factors such as variations in debris supply may also help to explain such asymmetry (eg. Whalley 1974; Matthews & Petch 1982; Benn 1989b).

Another contrast of similar origin to that just described is for the moraine or snout gradients to be gentler on the northern, south-facing sides of east-west valleys. I attribute this again to the greater insolation suffered by south-facing slopes (Fig.5.3 & Table 5.1).

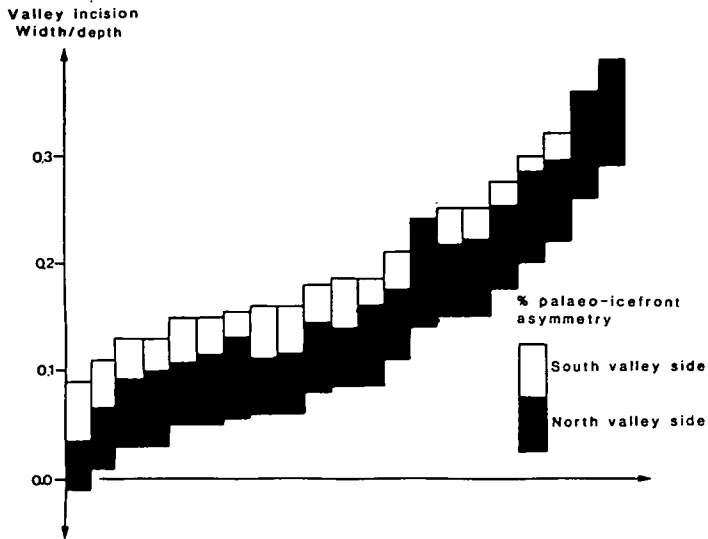

Figure 5.4: Moraine asymmetry. It shows: (1) the number of moraines or palaeo-ice fronts on the north and south sides of valley section and (2) the depth/width ratio or incision of that valley section. The diagram shows that the number of moraines on the northern sides of valleys increases as the valley incision increases.

### 5.3: Ice front interactions.

At glacier confluences, the pattern of decay and interaction of the individual glacier lobes is particularly instructive. Two extremes can be identified: (i) situations where glacier lobes retreat at different rates because different glacier basins respond at different rates to climatic forcing; (ii) situations where glacier maxima are non-synchronous, advancing and retreating at different times. Both these types of interaction are found in valleys containing "hummocky moraine". This is illustrated by the following case studies:

Case study 1: Differential retreat, Glen Grudie.

Case study 2: Differential retreat, Strath na Sealga.

Case study 3: Non-synchronicity, Glen Croulin.

Case study 4: Non-synchronicity, Loch Eil.

### **Case study 1: Differential retreat, Glen Grudie.**

Glen Grudie was occupied by an outlet glacier during the Loch Lomond Stadial [NG 955 645](Sissons 1977a). This valley contains a sequence of cross valley or concentric ridges which can be interpreted as a suite of recessional moraines on evidence similar to that outlined in Chapter Four (eg. ridge bifurcation, asymmetry etc.)(Fig. 5.5). This interpretation is also supported by the spatial organisation of these ridges. They form concentric suites which bow gently down valley in a manner reminiscent of the glacier forefields of many Norwegian valley glaciers (Fig. 5.1)(eg. Andersen & Sollid 1971; Matthews *et al.* 1979).

I suggest therefore that these landforms can be used to describe the pattern of retreat within Glen Grudie. Figure 5.6 is an ice-marginal summary based on these landforms. Of particular interest here is the complex pattern of decay at the southern end of the glen, where the valley divides into several distinct basins. The ice in each of these basins appears to have retreated at a slightly different rate. The ice lobe from Coire Ruadh-staca (lobe 1) appears to have decayed more slowly than that from Loch a' Chaorainn (lobe 2). A small outwash fan formed between these two lobes of ice as they separated during decay (Chapter Four: Fig. 4.11). Ice from Toll a' Ghiubhais (lobe 3) also appears to have decayed more rapidly than the ice from Coire Ruadh-staca (lobe 1).

Therefore lobes of ice from different glacier basins appear to have retreated at different rates as one would expect because different glacier basins are likely to respond at different rates to climatic forcing because of such variables as basin elevation, shape and size. In this case the differences in the rate of retreat can be explained by the differences in the elevation of these glacier basins. For example, the floor of Coire Ruadh-staca is 50-100 metres higher than that of Loch a' Chaorainn and may therefore have been able to support a greater volume of ice for a longer period.

A direct analogue for this can be found in South East Iceland. The Vatnajökull outlet glaciers of Skaftfellsjökull and Svínafellsjökull were confluent on the coastal plain at the turn of the century, but have subsequently retreated at very different rates. Skaftafellsjökull has retreated at over 17 metres per annum while Svínafellsjökull has only retreated at some 4 metres per annum. This reflects the greater elevation and consequently greater accumulation of the Svínafellsjökull basin (Thompson 1988).

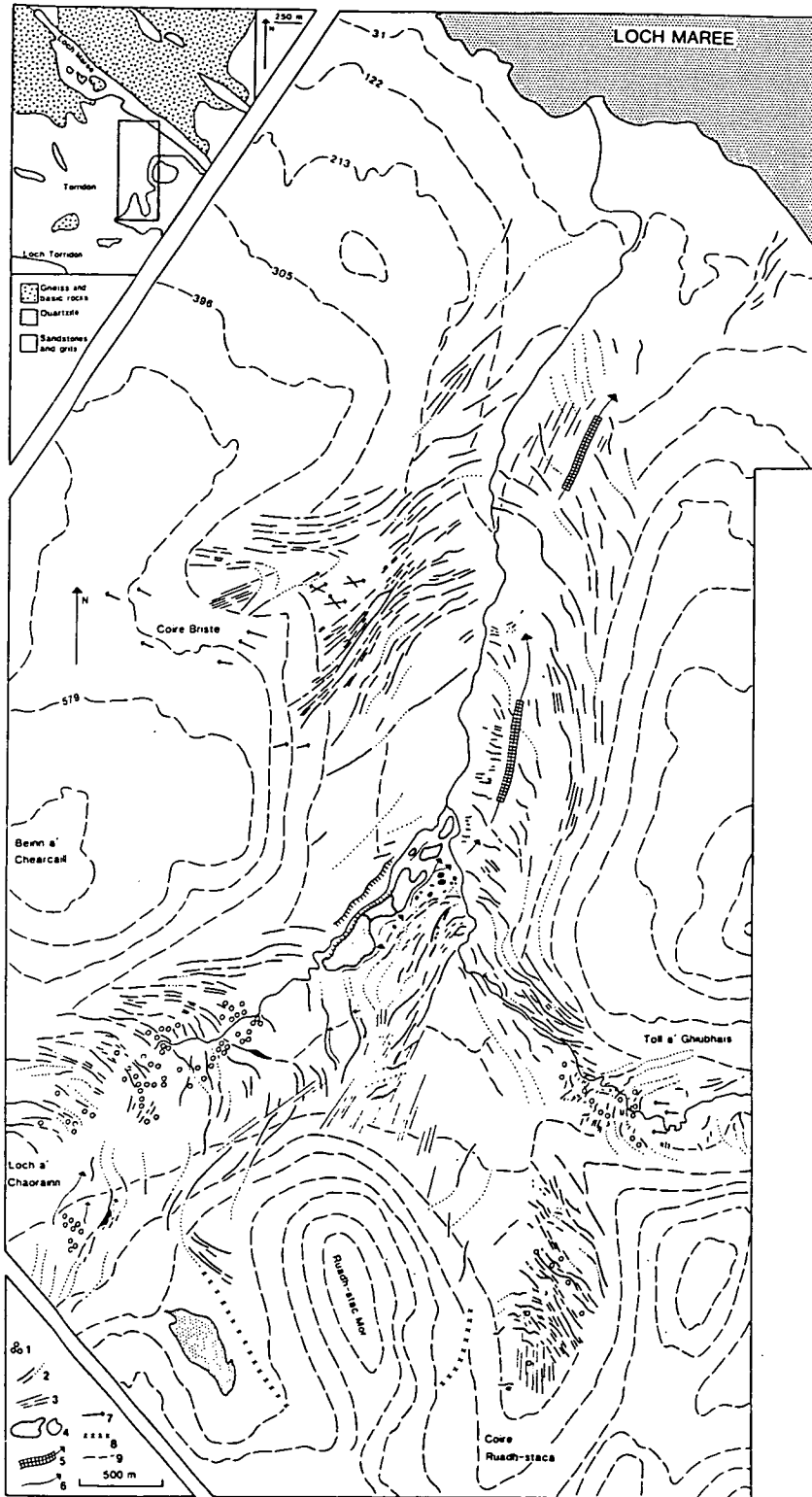

Figure 5.5: The moraines of Glen Grudie, Torridon (1=kettle holes; 2=moraines; 3=flutes; 4=terraces; 5=meltwater channels >10 m; 6=meltwater channels < 10 m; 7=striae; 8= quartzite boulder lines; 9=contours).

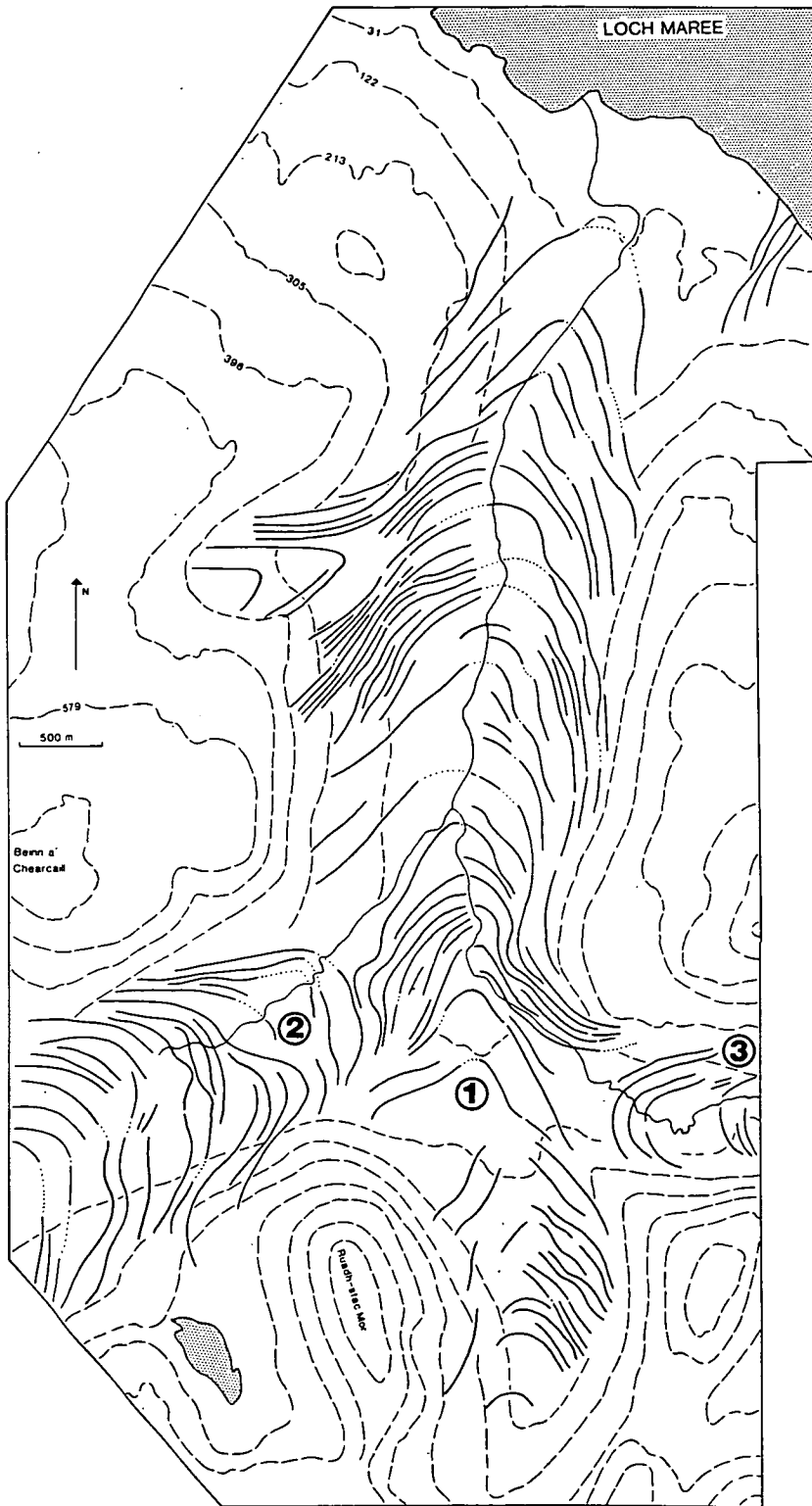

Figure 5.6: The palaeo-ice fronts of Glen Grudie, Torridon.

## **Case study 2: Differential retreat, Strath na Sealga.**

According to Sissons (1977a) there was only one ice lobe present in Strath na Sealga during the Loch Lomond Stadial [NH 055 810]. However, detailed mapping has revealed strong evidence for a second lobe of ice which was confluent with that documented by Sissons (1977a).

The principal lobe (Fig. 5.7, lobe 1) is represented by large moraines on its western side, by a suite of kame terraces to the north (mapped as a single moraine by Sissons 1977a), and by an ice-contact outwash fan and glaciofluvial stagnation terrain on its eastern side. The smaller, second lobe is recorded by prominent lateral moraines on the side of the glen and glaciofluvial stagnation terrain in the valley bottom. It is believed to be contemporary with the first lobe since the lateral moraines on the south side of the valley merge with those of lobe 1. The sediments within the outwash fan and stagnation terrain are revealed in several good sections. These sediments consist primarily of sand and gravel units. Beneath and interbedded with these units there are sequences of laminated silts and fine sands typical of a lacustrine environment. The depositional setting is illustrated in the block diagrams:

Stage 1: The two glacier lobes were once confluent as indicated by the lateral moraines on the south eastern side of the glen.

Stage 2: Lobe 2 begins to retreat before, and faster than, lobe 1. A small lake is formed between the two ice lobes leading to the deposition of the lacustrine sediments.

Stage 3: The retreat of lobe 1 allows this ponded meltwater to escape around the margin of the ice lobe. An outwash fan accumulates to the east of lobe 1 and around its northern margin as a sequence of kame terraces are formed.

The evidence suggests, therefore, that these two confluent lobes of ice retreated at different rates, resulting in a small ice-dammed lake which was then covered by the deposition of sands and gravels. Again, this pattern of differential retreat can be explained by a difference in the elevation of the two separate basins from which the two lobes were derived; lobe 1 being derived from a basin of much higher elevation than lobe 2.

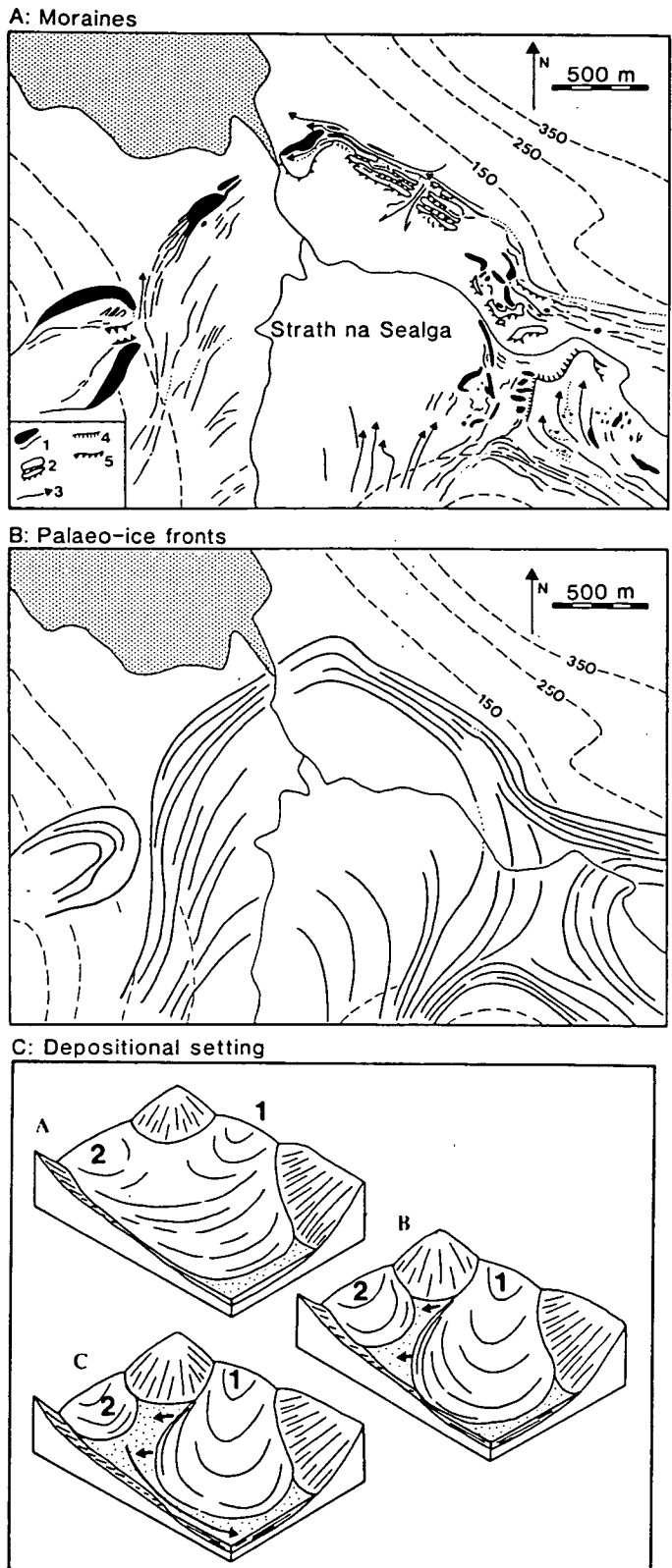

Figure 5.7: Strath na Sealga, Fisherfield (1=moraines; 2=terraces; 3=meltwater channels; 4=ice-contact slope; 5=drift cut slopes).

### Case Study 3: Non-synchronicity, Glen Croulin Knoydart.

This case study examines the complex pattern of deglaciation present in the area around Glen Croulin [NG 785 085]. A detailed description of the landforms and their interpretation has already been presented (Bennett 1990; in Appendix III).

The landforms of Glen Croulin were first described by Peach *et al.* (1910), who recorded a glacial limit at the mouth of Glen Croulin which was related to ice flowing down Loch Hourn and damming up the valley entrance (Fig. 5.8). This has become established as the Loch Lomond Stadal ice limit, although no detailed work has been published to support this conclusion (cf. Sissons 1983, Fig. 14.4).

Peach *et al.* (1910) also suggested that during some earlier, more extensive, period of glaciation the Loch Hourn ice extended even further up Glen Croulin. This conclusion was based on an exposure of silts, sands and gravels at the head of the glen at an elevation of 250 m which, it was suggested, were deposited in a glacio-lacustrine environment above the ice dam. However, these deposits have been reinterpreted here as part of an ice-marginal fan deposited in front of a glacier flowing down Glen Croulin and not up it (Appendix III). This local ice in the head of Glen Croulin appears to have been contemporaneous with the Loch Hourn ice limit at the valley entrance.

It is the interaction of this local ice body in Glen Croulin with the regional ice in Loch Hourn that is of particular interest.

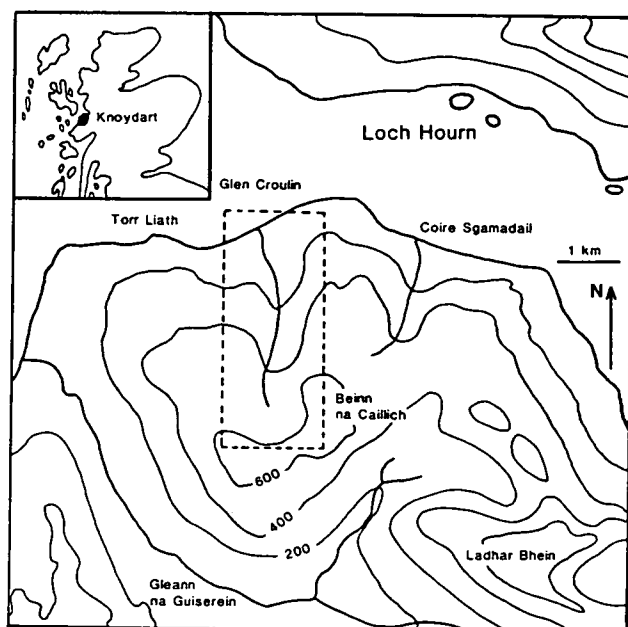

Figure 5.8: Glen Croulin, Knoydart. The location of Figure 5.9 is shown by the box.

### **A) The landform assemblages in Glen Croulin.**

*Loch Hourn ice*—The mouth of Glen Croulin is blocked by a complex of moraines and kame terraces, the distribution of which indicates that they were deposited by ice from Loch Hourn damming up the entrance of the glen (Fig. 5.9 & 5.10).

*Glen Croulin ice*—There is also strong evidence for a local corrie glacier within Glen Croulin. The ice body appears to have extended to the mouth of the glen, where several moraines are truncated by the moraines and kame terraces deposited by the Loch Hourn ice (Fig. 5.9 & 5.10). Within the glen itself there is continuous suite of recessional moraines which depict the active decay of this small glacier into the head of the corrie (see Appendix III for the details)

### **B) The pattern of deglaciation.**

The morainic evidence can be used to draw up the successive palaeo-ice fronts for these two retreating ice bodies (Fig. 5.9B). It appears that the local ice in Glen Croulin retreated successively from the moraines of palaeo-ice front C1 to those of C30 during deglaciation. Similarly, the retreat of the regional Loch Hourn ice is recorded by several palaeo-ice fronts (H1-H4, Fig. 5.9B).

This can be taken a stage further, since there is geomorphological evidence to link palaeo-ice front C6 and H1. I suggest that the regional Loch Hourn ice was at its maximum extent (palaeo-ice front H1-Fig. 5.9B) when the ice in Glen Croulin was located along the moraine marked C in Figure 5.9A or palaeo-ice front C6 in Figure 5.9B. The valley floor in front of this moraine (C on Fig. 5.9A) has a uniform surface and a constant gradient. Down slope this surface merges into the terraces of the Loch Hourn ice limit. This smooth slope contrasts with the adjacent valley sides, which are both shattered and irregular and suggest the possibility that this surface is an alluvial fan. In detail, the slope appears to consist of two fans. The upper has an apex at a deep, square cut notch in the moraine marked C in Figure 5.9A. This fan merges down valley into the highest terrace of the Loch Hourn ice limit (terrace A-Fig. 5.9A & 5.10). The second fan is smaller and more irregular. It starts in a smaller notch to the west of the first notch and grades down valley into a lower terrace (terrace D, Figs 5.9A & 5.10). For these terraces to form, the Loch Hourn ice must have been close to its maximum extent. They are not located behind moraine dams, and therefore require the presence of an ice dam. Thus, the Loch Hourn ice

was probably at its maximum when ice in Glen Croulin was located along palaeo-ice front C6 (Fig. 5.9B).

From such evidence, a detailed picture of the deglaciation of Glen Croulin can be built up. I suggest that local ice advanced down Glen Croulin to the shore of Loch Hourm early in the Loch Lomond Stadial. This ice-marginal position is marked by the moraine fragments in the mouth of the glen (marked B, Fig 5.9A & 5.10). The cross-cut striae just to the north of this moraine also support this suggestion.

Subsequently, regional ice advanced down Loch Hourm and blocked the mouth of the glen. At this point, the local ice appears to have retreated up Glen Croulin. The cause of retreat is uncertain, but it may be due to such factors as differences in catchment size and glacier response rate. When Loch Hourm ice was at its maximum the ice in Glen Croulin was located half way up the glen (palaeo-ice front C6, Fig.5.9B). The retreat of the Loch Hourm ice from this maximum position is recorded by three ice-marginal positions. Glen Croulin ice also continued to retreat actively, as recorded by a further 24 ice-marginal positions (Fig. 5.9B).

This case study provides an example of both non-synchronous glacier extent and of differential decay. It simply reflects the different rates of response of different sizes of glacier to climatic forcing.

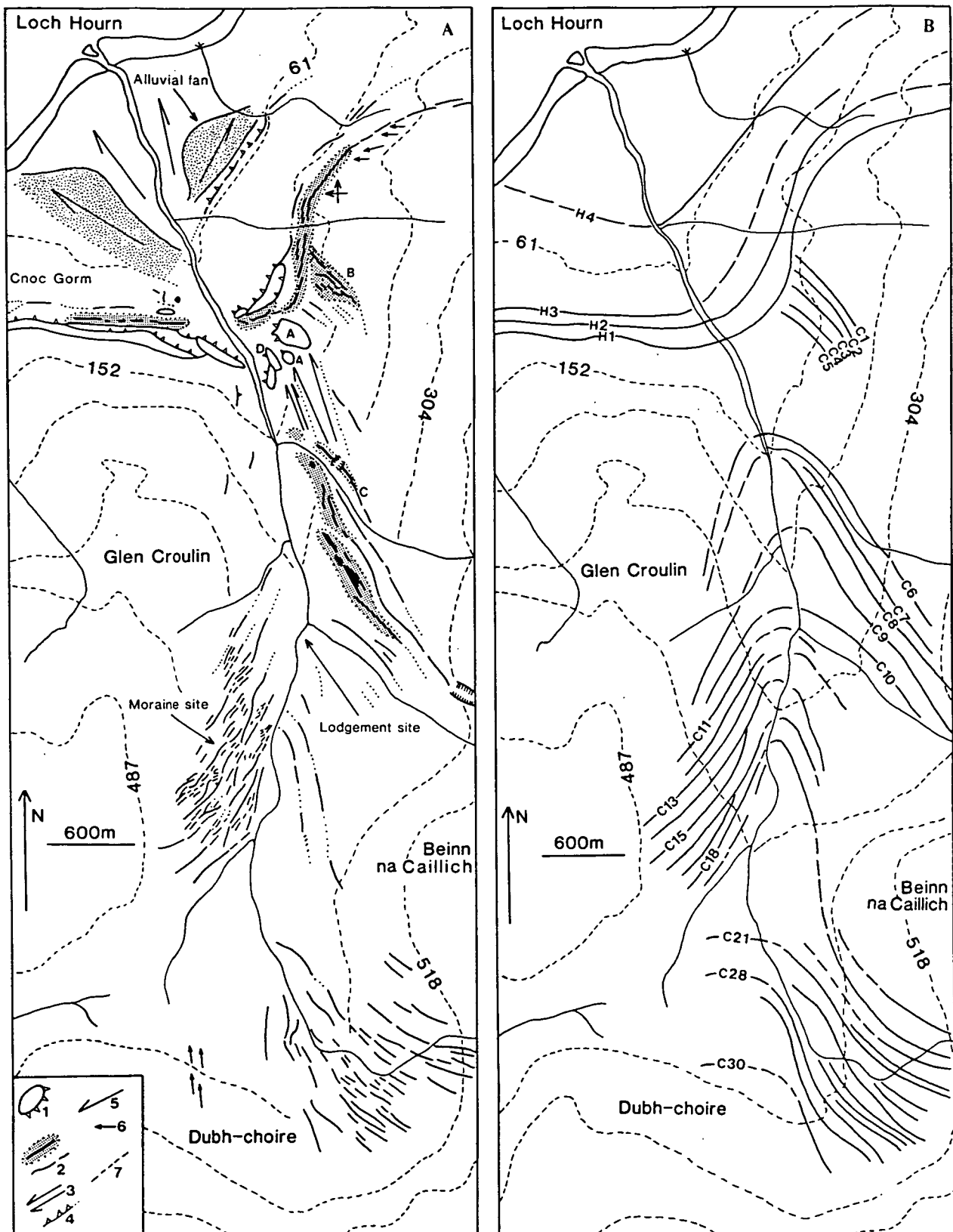

Figure 5.9: The pattern of deglaciation of Glen Croulin. A: The evidence-see Figure 5.10 for details of the Loch Hourn limit in the valley mouth (1 = clear horizontal terraces; 2 = moraines; 3 = alluvial fan; 4 = irregular drift step fragments; 5 = surface gradients; 6 = striae; 7 = contours). B: Former ice fronts of the retreating glaciers. These are formed by interpreting the morainic evidence in part A. H1-H4 Loch Hourn retreat stages, C1-C30 Glen Croulin retreat stages.

## Contents

---

8.1:	Introduction.	157
8.2:	What was the maximum extent of the Loch Lomond Stadial ice cap in the North West Highlands?	158
8.3:	What was the surface morphology of the Loch Lomond Stadial ice cap in the North West Highlands?	160
8.4:	What was the pattern of decay?	167
8.5:	What is the spatial variation of glacial landforms within the area occupied by this ice cap?	172
8.6:	What was the rate of decay?	179
8.7:	Chapter summary.	180

---

*In this chapter the extent, surface form and pattern of decay of the Loch Lomond Stadial ice cap in the North West Highlands is examined.*

### **8.1: Introduction.**

Sissons and his many co-workers delineated the extent of the Loch Lomond Stadial ice cap on the basis of the distribution of "hummocky moraine" (Sissons 1965, 1974a; Gray and Brooks 1972). Although "hummocky moraine" is abundant within the area presumed to have been occupied by the Loch Lomond Stadial ice cap, it was not used as a basis for reconstructing the pattern of decay. Presumably this neglect was derived from the view that the apparently chaotic form of "hummocky moraine" reflected its origins as a stagnation deposit (Sissons 1967, 1974a&b, 1977a; Thompson 1972). Stagnation was considered merely to reflect the ice caps' rapid decay in response to the extremely rapid climatic warming at the close of the Loch Lomond Stadial, the evidence for this rapid climatic amelioration being drawn from the coleopteran record (Coope & Brophy 1972; Bishop & Coope 1977; Coope & Joachim 1980).

I have argued in the first part of this thesis that when "hummocky moraine" is examined from the air, it is not a random collection of mounds but possesses a clear form and structure interpretable in terms of glacier retreat patterns. Detailed evidence has shown that most "hummocky

moraine" is simply composed of suites of push moraines, dump moraines, ice-contact outwash fans and flutes, all of which have patterns of spatial organisation which resemble those found at the margins of retreating modern glaciers. These landforms can be mapped over large areas to give integrated patterns of decay which reflect the response and dynamics of the Loch Lomond Stadial ice cap through time. These patterns are explored in this chapter.

Using the accumulated data, five questions can be examined:

1. What was the maximum extent of this ice cap?
2. What was its surface morphology?
3. What was the pattern of decay?
4. What is the spatial variation of morainic landforms left by this ice cap?
5. What was the rate of decay?

## **8.2: What was the maximum extent of the Loch Lomond Stadial ice cap in the North West Highlands?**

The approach used to determine the extent of the Loch Lomond Readvance has been presented in Chapter Three. The limit identified in the North West Highlands is shown in Figure 8.1. This ice cap was disposed along the main relief axis in the North West Highlands (Fig. 8.4) and coalesces with that in the Grampian Highlands across the southern end of the Great Glen. This limit defines an area of 4 700 km<sup>2</sup>.

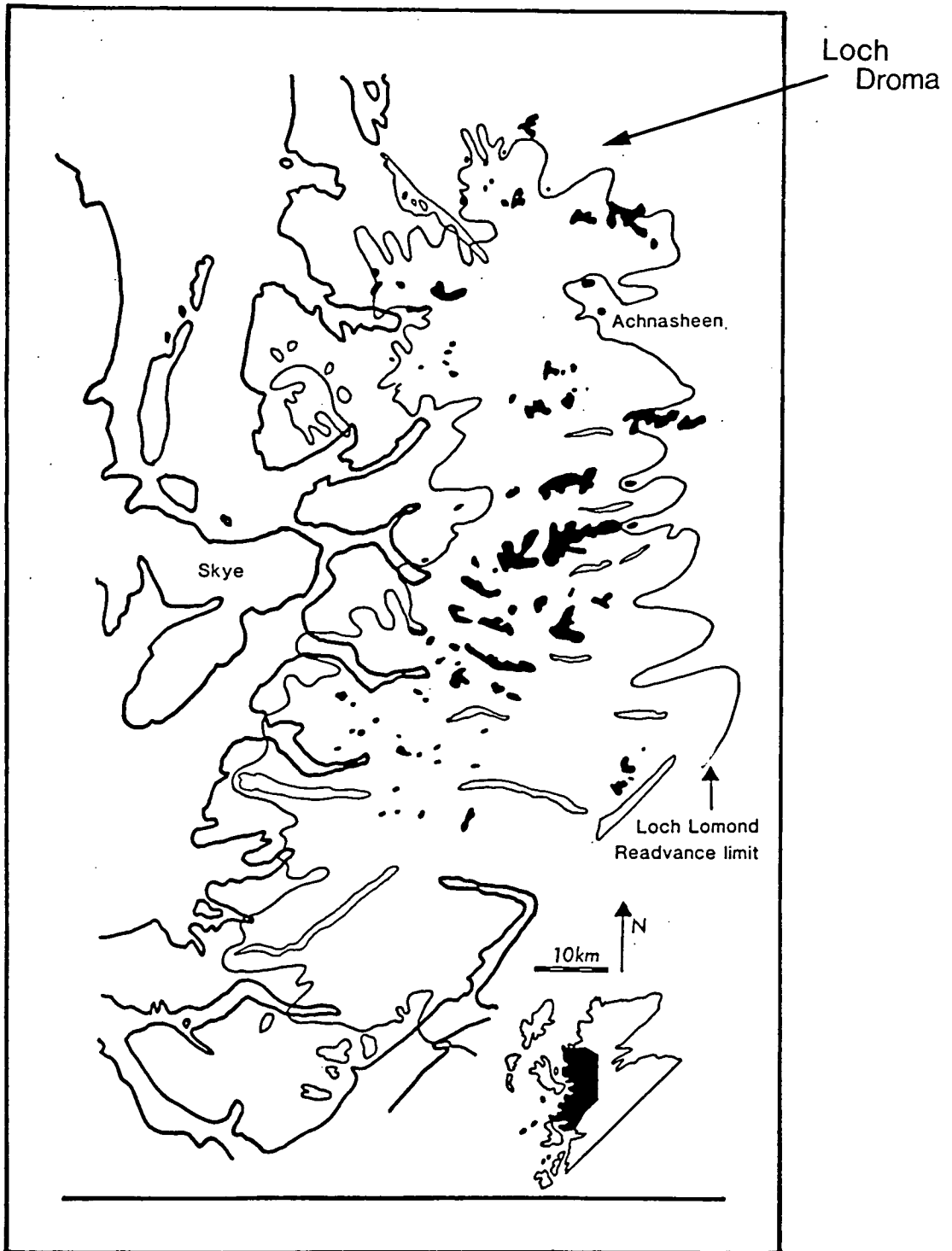

Figure 8.1: The limit of the Loch Lomond Readvance in the North West Highlands, land over 800 m shown by the black areas. No Loch Lomond Stadial ice body north of the Lateglacial pollen site of Loch Droma is shown (Kirk & Godwin 1963).

### 8.3: What was the surface morphology of the Loch Lomond Stadial ice cap in the North West Highlands?

In order to gain some impression of the ice cap's surface morphology, prior to decay, an attempt was made to reconstruct its vertical form. Geological information can be used along the maximum limit of the former ice cap to reconstruct its surface form in the marginal zone. Moraines on opposite sides of a valley are linked by lines of equal elevation, strike lines, which are then used to construct flow line profiles for the former glacier margin. Not only can these profiles be used to calculate basal shear stress distributions (Chapter Six), but the resultant two-dimensional profiles can also be extrapolated into the centre of the ice cap to form a basis from which its surface elevation can be produced. The two-dimensional model of Nye (1952a) was used to extrapolate these profiles (Schilling & Hollin 1981). The model assumes perfectly plastic ice flow and gives a parabolic ice profile. The steepness of the profile produced is controlled by a shear stress value which is assumed to be constant within the ice cap. As Figure 8.2 illustrates, there is a close agreement between the geological profile data and a Nye parabolic profile based on a shear stress value of 100 kpa (cf. Murray & Locke 1989). Consequently, a shear stress value of a 100kpa was used to extrapolate these profiles into the centre of the ice cap:

$$H = \sqrt{2 \cdot h_o \cdot s}$$

Where: H = ice altitude in metres; s = horizontal distance from ice margin in metres;  $h_o = \tau / \rho g$  and has a value of 11 for a 100kpa shear stress;  $\tau$  = basal shear stress;  $\rho$  = density of ice; g = gravity: (Nye 1952a).

A total of 56 profiles were extrapolated in this way to give a network of ice thickness values, which were then contoured to produce the ice cap reconstruction shown in Figure 8.3. The volume of the ice cap was estimated from the area volume relationship proposed by Paterson (1972), although empirical this relationship and ones similar to it have been found to give good volume estimates (eg. Driedger & Kennard 1986).

The reconstructed ice cap has an area of 4 700 km<sup>2</sup> and a maximum elevation of approximately 800 metres in the south. It incorporates a total volume of 1 900 km<sup>3</sup> of ice, the principal mass of which is concentrated in the south where the ice divide is located just to the east of the main relief axis and the regional watershed (Fig. 8.3 & 8.4).

How accurate is this reconstruction? There are two principal problems with the approach used here:

Firstly, it does not incorporate the influence of isostatic depression. The principal effect of this would be to reduce the estimates of basal shear stress upon which the extrapolations are based (Pierce 1979). This is illustrated in the two line drawings below:

1. With isostatic loading.

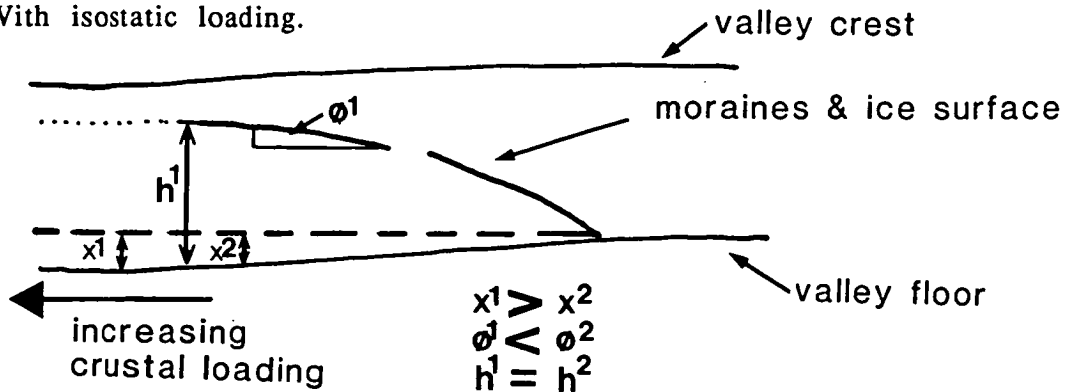

2. Without isostatic loading—present day.

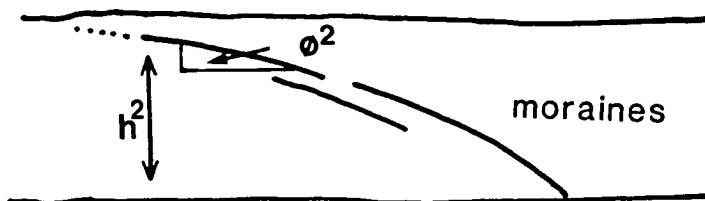

As can be seen, the thickness of ice ( $h$ ) is constant in the two cases, but, due to the effect of isostatic loading, the slope of the moraine fragments increases as the crust unloads. Therefore, glacier gradients determined from ice marginal moraine fragments may be overestimated. The significance of this problem will depend on the length of the moraine fragments used to determine the glacier slope relative to the gradient of isostatic tilting. This gradient is caused by the decrease in ice loading towards the margin of the former ice cap and is likely to be at its greatest in the marginal zone. As a consequence, the basal shear stresses calculated from the slope of moraines within the terminal zones of the ice cap may also be overestimated. This would imply that the parabola used to extrapolate the geological evidence into the centres of this former ice cap may be too steep. If a lower shear stress value is used in Nye's (1952) model,

then a lower, more gentle parabola is produced. Therefore the reconstruction in Figure 8.3 must be considered as a maximum limit on the surface elevation of the Loch Lomond Stadial ice cap in the North West Highlands. A rough estimate of the magnitude of this problem can be obtained by estimating crustal flexure from an empirical model such as that present by Brotchie & Silvester (1969) who suggest that the crust will be depressed by 0.267 times the ice thickness. If one assumes that most of the crustal depression will have occurred within the first 10 km of the ice cap's margin and combine this with an ice thickness of about 800 metres, which would depress the crust by 213 metres, then over 1 km moraine slopes and therefore the gradient of the former ice cap would be over estimated by approximately  $1^\circ$  which would lower the shear stress estimates by between 20% to 25%. In order to incorporate isostatic depression realistically into the reconstruction one would require a detailed isostatic model for the Loch Lomond Stadial ice cap. However, developing a suitable model is difficult.

Secondly, the accuracy of the reconstruction is limited by the assumption of two-dimensional flow. It does not incorporate topographic influences such as the convergence of ice flow in deep valleys. The model is most likely to be correct where the thickness of ice is large compared to topography and least accurate where ice is thin and relief strong. Consequently I believe the southern part of this reconstruction is probably more accurate than that the northern part, where the topography is much stronger.

Although the reconstruction in Figure 8.3 has limitations, it provides an approximation of the ice cap's surface morphology and therefore a datum from which to examine the pattern of decay.

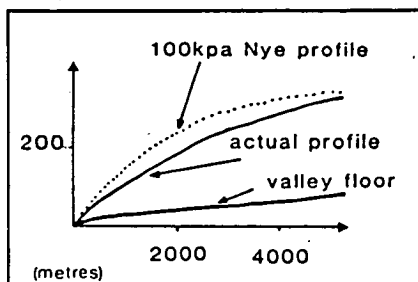
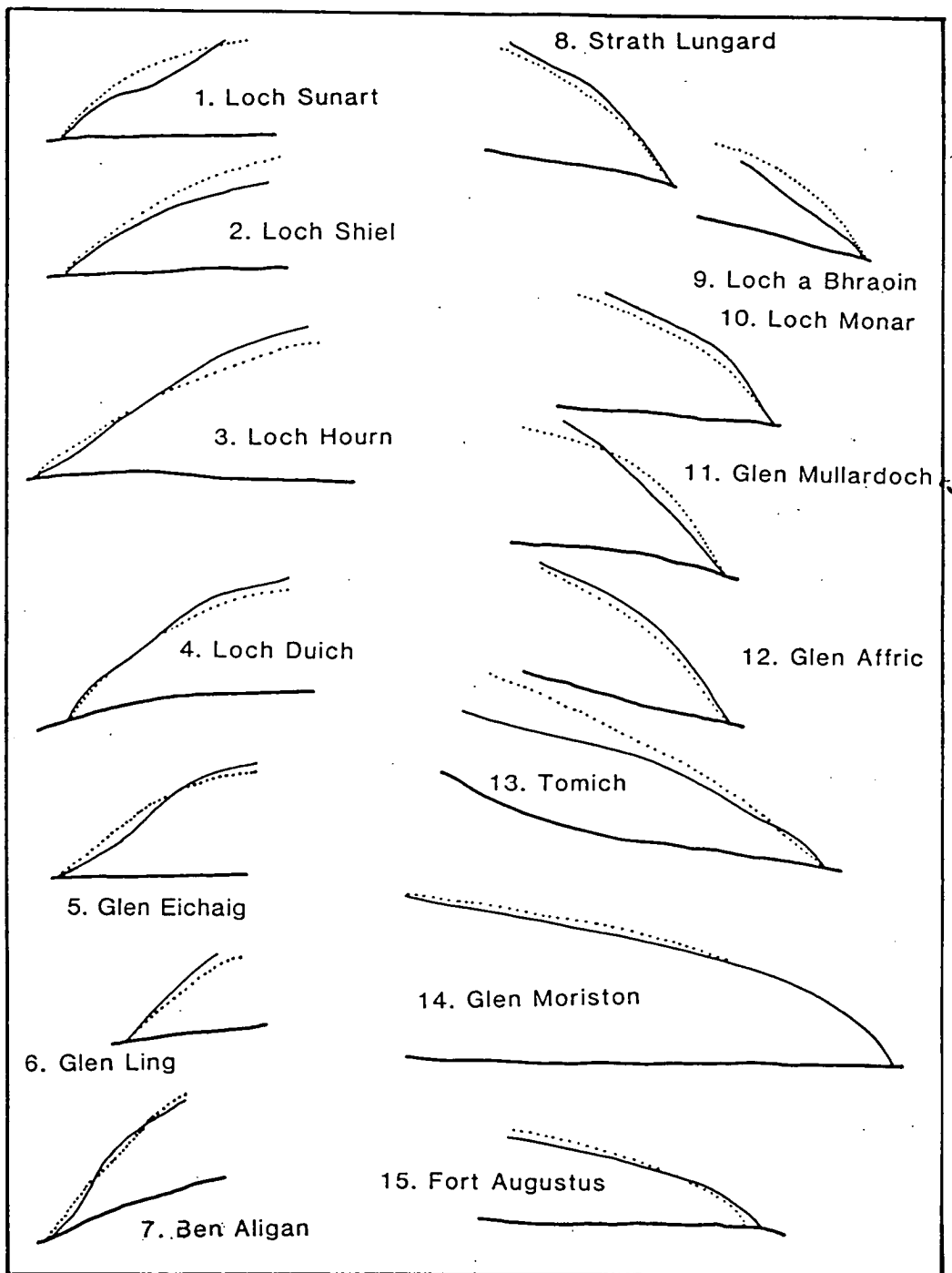

Figure 8.2: A comparison of theoretical and reconstructed (moraines) glacier snout profiles. The theoretical profiles are those of a 100 Kpa, Nye (1952), parabola.

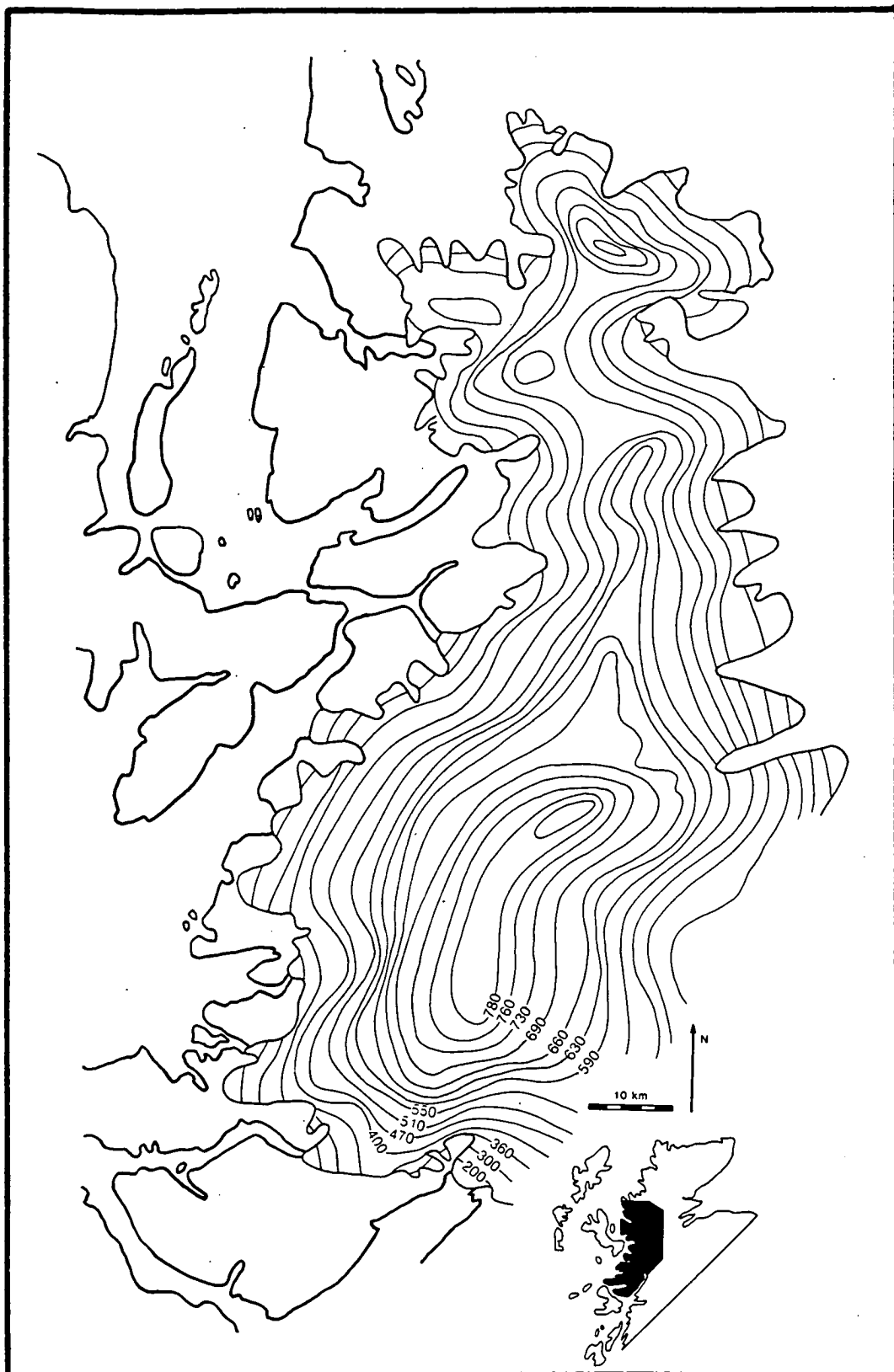

Figure 8.3: The surface morphology of the Loch Lomond Stadial ice cap in the North West Highlands. Only the main ice cap is shown here, the ice field in Applecross and the various corrie glaciers present at this time have not been reconstructed.

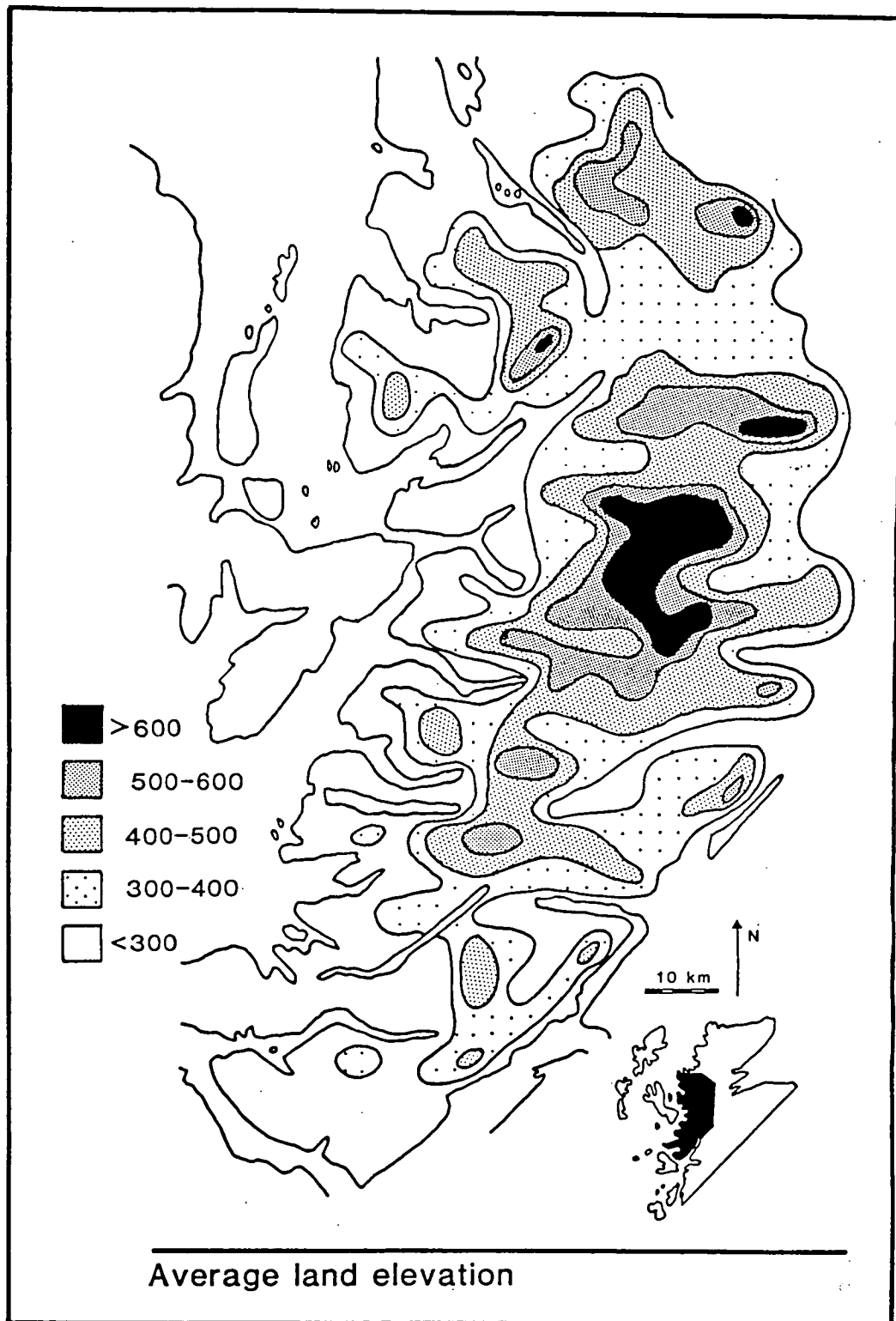

Figure 8.4: Average land elevation in metres. Relief was sampled from 1:25 000 O.S. maps at 1km intervals. An average relief value was then calculated from this sample for each square ( $25 \text{ km}^2$ ) in a grid covering the study area. These average elevations were then contoured. Within each grid the average relief was calculated from 1km point samples (for each square  $N=16$ ).

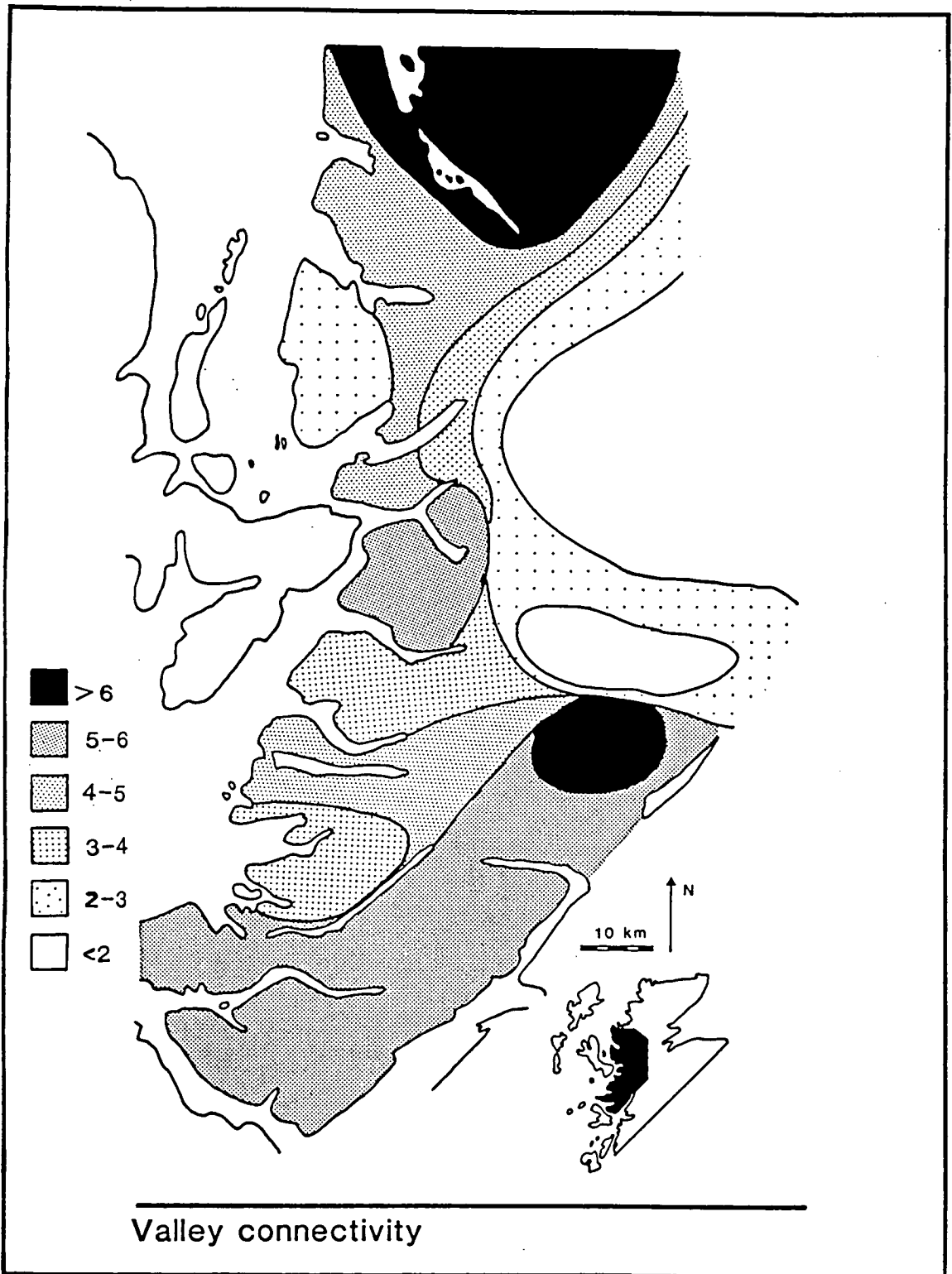

Figure 8.5: Valley connectivity. Values are taken from Haynes (1977) and are for the alpha connectivity index. The larger the value the better connected the valley system (see Haynes 1977 for details).

#### **8.4: What was the pattern of decay?**

Figure 8.6 illustrates the interpreted pattern of decay for the whole area of the Loch Lomond Stadial ice cap in the North West Highlands (See Chapter Six for details). It shows a selection of ice marginal positions, from the maximum extent of the ice cap to those which define the final areas of decay. Three main areas with different retreat characteristics can be identified:

1. Southern Area—the area south of Loch Hourm.
2. Central Area—the area between Loch Hourm and Loch Carron.
3. Northern Area—the area north of Loch Carron.

**1. Southern Area**—There are two principal final centres of decay, one to the south of Loch Quoich and a second at the head of Loch Shiel, although several smaller centres occur between them. Decay converged on an area just to the east of the main axis of relief (Fig. 8.4 & 8.6). The most noticeable characteristic of all these centres is that ice converged upon them symmetrically in contrast to the asymmetry present further north (Table 8.1).

**2. Central Area**—There are numerous small decay centres in this area in contrast to the southern and northern areas. It is coincident with an increase in relief as well as with an area of anomalously low valley connectivity (Fig. 8.4 & 8.5). Topography seems to have played a dominant role in governing the pattern of decay by dividing and fragmenting the ice cap as it melted down. It did not simply retreat into corries and valley heads, but towards the northern faces of prominent mountain ridges and away from south facing slopes, suggesting that insolation contrasts dominated the final phases of decay.

**3. Northern Area**—In this area there is a relatively simple decay pattern which seems to reflect the decrease in relief and increase in connectivity of the valley system (Fig. 8.4 & 8.5). There are only two principal decay centres— one in Torridon and another to the north of Loch Maree—although a third, smaller centre was present in northern Torridon associated with an isolated spur of the main ice cap. All these centres are associated with the northern and eastern flanks of prominent mountains and are located on the main relief axis. The location of the relief axis in the west has resulted in a particularly asymmetrical pattern of decay (Table 8.1). It implies that ice retreat in the east began earlier, or was much more rapid, than in the west.

• Chapter Seven •

Part 1: Summary and conclusions

---

*This chapter provides a summary of the arguments presented in the first part of the thesis and examines their implications.*

### **7.1: Summary and conclusions.**

The interpretation of "hummocky moraine" presented in Chapter Two is as follows:

*A large proportion of the drift ridges in Scottish Highland valleys which have been referred to as 'hummocky moraine' are individual and identifiable ice-marginal landforms formed at actively retreating ice margins. It follows from this that the Loch Lomond Stadial ice cap in the Scottish Highlands decayed as an active glacier and that the pattern of decay can be examined by mapping the trends of these landforms.*

Three predictions were made from this model in Chapter Two, each of which have been examined in three previous chapters:

#### **Chapter Four: Small-scale evidence.**

**Prediction**—at modern glacier margins a range of individual landforms can be identified. A similar range of landforms should be present within "hummocky moraine".

**Conclusion**—"hummocky moraine" appears to consist primarily of suites of push moraines, dump moraines, ice-contact outwash fans and flutes. Such a suite of landforms is typical of the active margins of modern glaciers.

#### **Chapter Five: Meso-scale evidence.**

**Prediction**—at modern glacier margins the landforms have a distinct spatial organisation; for example, different glacier lobes retreating and advancing at different rates produce frontal landforms of different spatial frequencies and organisation. Similar contrasts should occur within "hummocky moraine".

**Conclusion**—the spatial organisation of landforms within "hummocky moraine" is similar to that found at the margins of active, modern, retreating glaciers. They reflect ice margin slopes consistent with typical modern values. The pattern of retreat in individual valleys and the interaction between separate glacier lobes is similar to the patterns found around the margins of many contemporary ice caps. Patterns of decay appear to reflect controls on ice margin geometry such as insolation contrasts.

#### **Chapter Six: Macro-scale evidence.**

**Prediction**—on a regional scale, glacier marginal patterns inferred from transverse and longitudinal landforms should reflect ice cap decay which obeys fundamental glaciological principles.

**Conclusion**—landforms within "hummocky moraine" fit together at a regional scale in the way in which one would expect retreating glacier lobes to do and form a coherent reconstruction of the pattern of retreat of the Loch Lomond Stadial ice cap in the North West Highlands.

On this basis I conclude that the interpretation presented in this thesis explains the observed characteristics of "hummocky moraine". Figure 7.1 summarises the landform associations found in many valleys which contain "hummocky moraine". It illustrates a simple active ice margin depositing push and dump moraines which are associated with flutes and an outwash fan. Areas of localised stagnation terrain are rare and are usually associated with debris concentrations such as the medial moraine. The form and clarity of cross valley concentric moraines is controlled by the relationship of debris supply to retreat rate (Chapter Four: Fig. 4.1). Where the rate of retreat is high relative to the rate of debris-supply, distinct moraines form. However, where the debris supply exceeds the rate of retreat, more complex ice-marginal belts of mounds result from local stagnation. This block diagram summarises what I believe to be the commonest type of landform association found within "hummocky moraine", although there are areas dominated by glaciofluvial and lacustrine landform assemblages (Chapter Four: Fig. 4.8 & 4.15).

There are three main implications of the interpretation proposed here:

(1) The use of the term "hummocky moraine" should be discontinued, since it is simply an assemblage of identifiable ice-marginal landforms.

(2) The frontal hypothesis provides a framework within which the morainic evidence of the Loch Lomond Stadial ice cap can be examined. It provides a basis for detailed investigation into the controls of debris supply, process and basin geometry on moraine assemblages.

(3) At a macro-scale the retreat pattern established for the North West Highlands has the potential to provide information about the large scale response and behaviour of a small maritime ice cap. This potential is explored in the second part of this thesis.

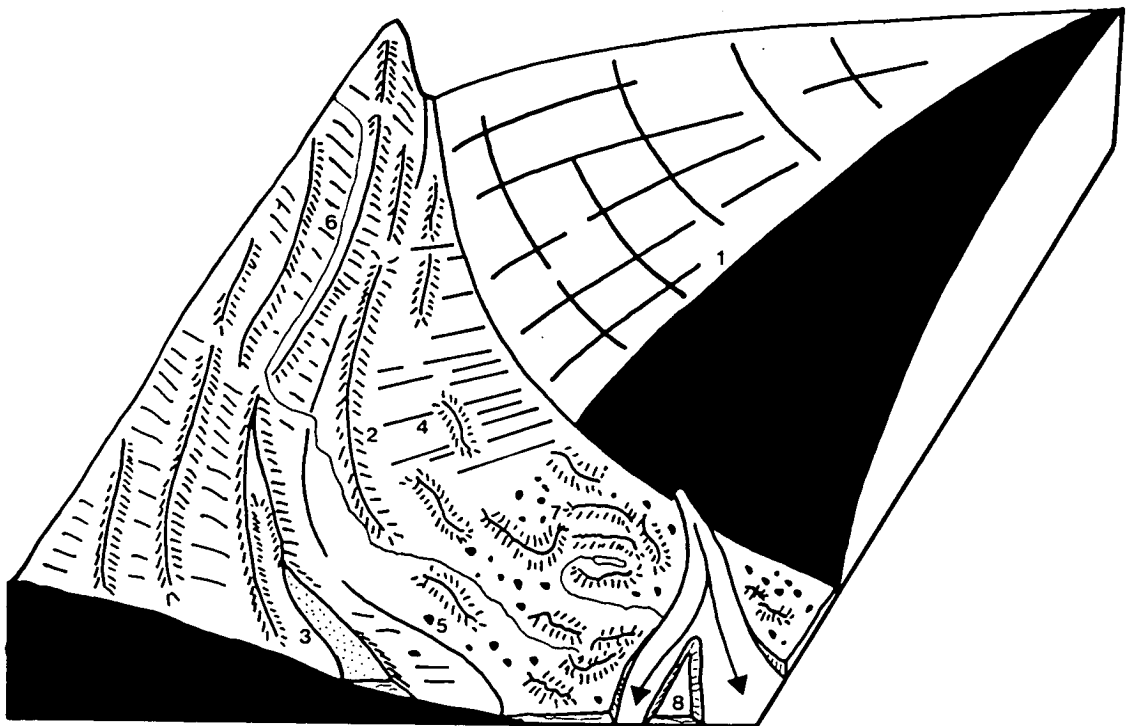

Figure 7.1: A typical landform assemblage found within "hummocky moraine" areas.

- |   |                            |
|---|----------------------------|
| 1. Medial moraine.                          | 2. Push and dump moraines. |
| 3. Kame terraces.                           | 4. Flutes.                 |
| 5. Boulders.                                | 6. Meltwater channel.      |
| 7. Irregular mounds and kettles—non-linear. |                            |
| 8. Outwash surfaces.                        |                            |

## • Part Two •

### Implications and conclusions

In the first part of this thesis an interpretation of the landforms within the limit of the Loch Lomond Readvance was presented. In the second part, this interpretation is used to examine the extent, surface form and pattern of decay of the Loch Lomond Stadial ice cap in the North West Highlands. These patterns lead to inferences about the dynamics of this ice cap and its response to climatic forcing. Conclusions are then drawn about the palaeoclimatic information inherent in this interpretation.

• Chapter Eight •

The extent, surface morphology and  
pattern of decay of the Loch Lomond  
Stadial ice cap in the North West  
Highlands.

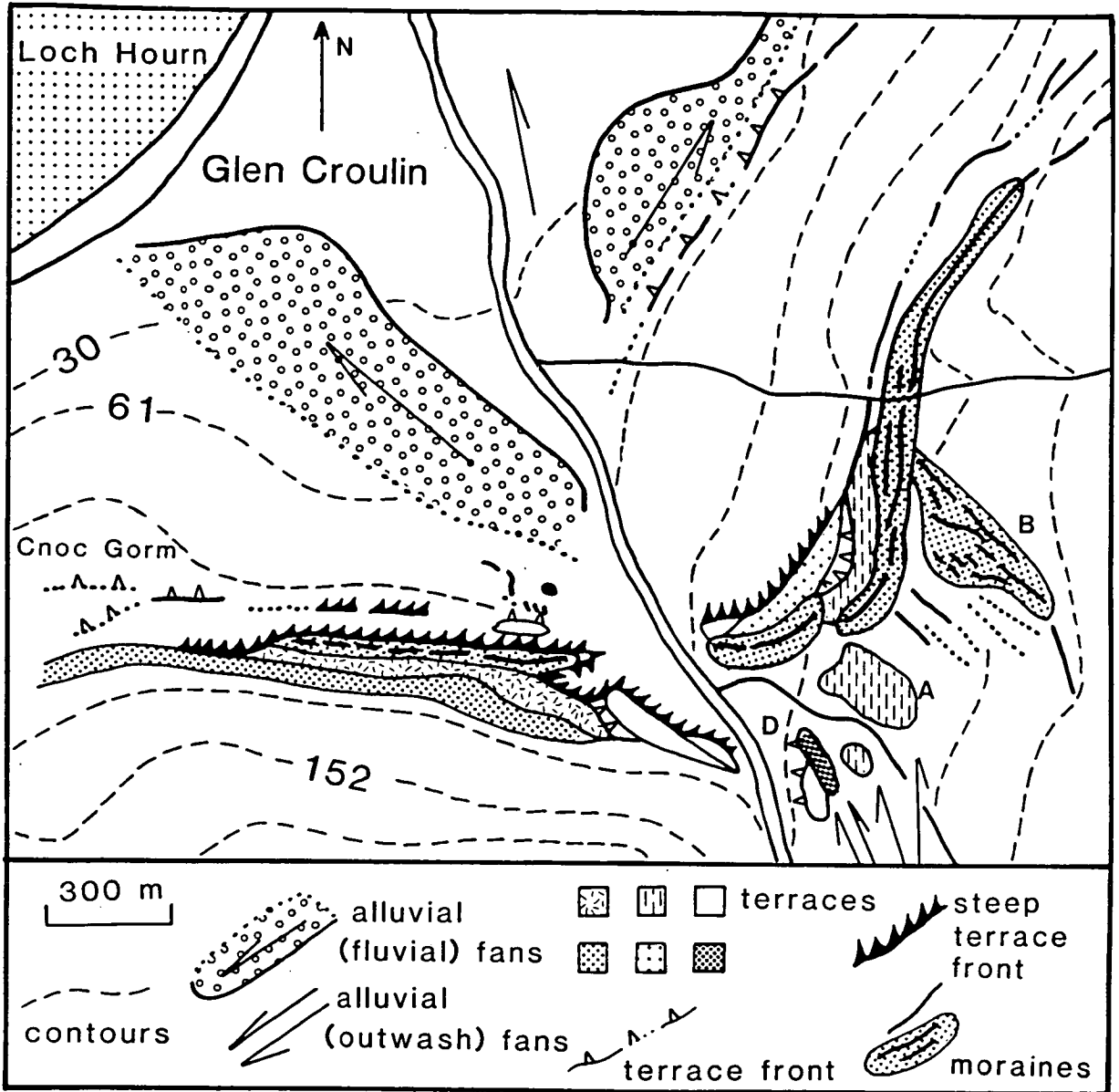

Figure 5.10: The Loch Hourn ice limit in Glen Croulin, during the Loch Lomond Stadial.

#### Case study 4: Non-synchronicity, Loch Eil.

Within the area to the north of Meall Bhanabhie, Loch Eil, the cross valley concentric elements within "hummocky moraine" are well developed and can be interpreted as ice-marginal moraines on the frequency of the ridge bifurcations present [NN 115 798]. These prominent retreat moraines provide an example of non-synchronous decay (Fig.5.11). The ice in Gleann Laragain appears to have readvanced during decay, truncating earlier retreat moraines. Readvances of small sections of ice fronts are common around the margins of most modern ice caps and can be triggered by local dynamics rather than climate differences such as local fluctuations in subglacial water pressure and bed friction.

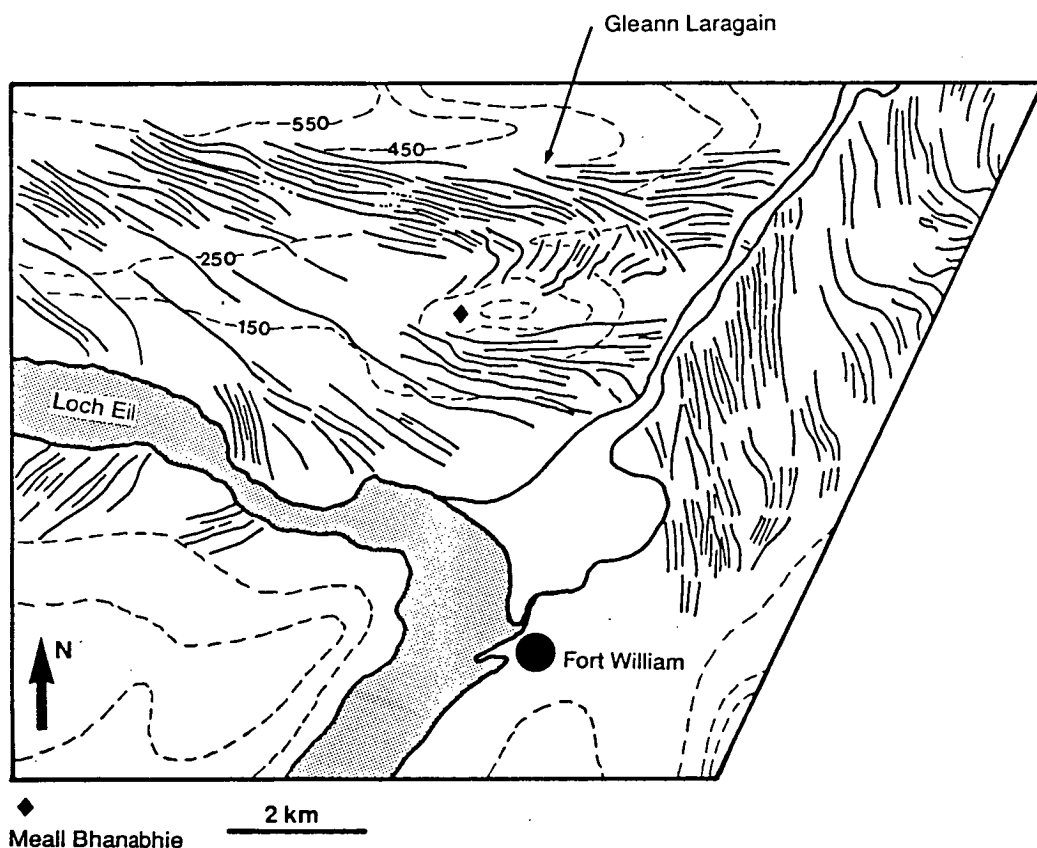

Figure 5.11: The palaeo-ice front in Gleann Laragain to the north of Loch Eil.

**In summary:** At modern ice margins individual glacier lobes do not retreat in a uniform fashion and different lobes may advance and retreat at different times. Similar characteristics are found within the decay patterns established from the cross valley or concentric elements within "hummocky moraine".

#### 5.4: Chapter summary.

Suites of moraines in the North West Highlands show patterns and gradients similar to those found at the margins of retreating glaciers at the present day. They also reflect the influence of insolation contrasts. The pattern of retreat in individual valleys and the interaction between confluent glacier lobes is similar to the patterns found in contemporary glaciated regions.

The existence of meso-scale patterns identical to those found amongst frontal moraines produced by modern glaciers helps confirm the hypothesis that "hummocky moraine" is a collection<sup>of</sup> ice frontal moraines.

• Chapter Six •

Macro-scale evidence

## Contents

---

Part 1:	The regional pattern of deglaciation.	120
6.1:	Retreat patterns.	120
6.2:	Striae data.	121
6.3:	Theoretical principles.	121
Part 2:	Palaeo-ice front mosaics.	128

---

*In Chapter Two it was argued that, at a regional scale, glacier margin reconstruction inferred from transverse and longitudinal landforms should show patterns of decay which reflect the operation of known glaciological processes. In the first part of this chapter, I argue that the cross valley drift elements within "hummocky moraine" depict the regional pattern of decay of the Loch Lomond Stadial ice cap, and go on to show that this pattern is comparable with normal glacier behaviour.*

*In the second half of this chapter the pattern of decay is illustrated through a series of seven maps.*

### **Part 1: The regional pattern of deglaciation.**

#### **6.1: Retreat patterns.**

Implicit in the model of "hummocky moraine" presented in Chapter Two is the idea that the landform assemblages can be used to map the pattern of decay of the Loch Lomond Stadial ice cap in the North West Highlands.

It has been shown in the last chapter how palaeo-ice fronts can be drawn from the moraine data in order to express the pattern of decay more clearly (eg. Fig. 5.5 & 5.6). Moraine fragments are linked together into more continuous ice margins or palaeo-ice fronts. For each of the moraine base maps presented in Appendix I, a second palaeo-ice front map was produced (Appendix I). These palaeo-ice front maps have also been tessellated into seven larger sheets and are presented in the second part of this chapter (Fig. 6.5-6.11). It is apparent from these mosaics that a regional pattern of deglaciation is depicted in the data.

However, in order to illustrate this pattern more clearly, the data have been subject to further interpretation. This is based on interpolation, where possible, between discrete palaeo-ice front fragments. The volume

of data was reduced by including only those lines which could be easily linked together and those which pick out important elements of the decay pattern. In valleys, the principle governing interpolation between palaeo-ice fronts is the assumption that, for a given glacial phase, ice margins on either side of the valley can be correlated by strike lines perpendicular to the valley axis. This principle has been used in three ways, which are illustrated in the first part of Figure 6.3-1. In this way, a more complete appreciation of the pattern of decay can be established. The interpreted data for each of the seven palaeo-ice front mosaics is also presented in the second part of this chapter (Fig. 6.5-6.11).

Figure 6.1 illustrates the interpreted pattern of decay for the whole area of the Loch Lomond Stadial ice cap in the North West Highlands.

The coherence of the reconstruction at this largest scale further <sup>regional</sup> supports the interpretation of "hummocky moraine" as an assemblage of ice-marginal landforms deposited by an active decaying ice cap. However, the retreat pattern can be further tested both using striae data and theoretical principles.

### 6.2: Striae data.

In order to provide an independent check on the pattern of decay, the mapping of "hummocky moraine" lineations was undertaken without reference to published or unpublished striae observations (see: Chapter Three). These can therefore be used to test the general validity of retreat patterns. Figure 6.2 is a flow summary of the striae evidence available for the North West Highlands. Traditionally, such information has been used to reconstruct the divide geometry of Scottish ice sheets (eg. Peacock 1970; Thorp 1986, 1987). Active decay of an ice cap will tend to produce a striae pattern which is an integration of successive ice-marginal flow patterns (Boulton *et al.* 1985). The striae flow summary is very similar to the pattern of decay and therefore provides further corroboration of the interpretation of "hummocky moraine".

### 6.3: Theoretical principles.

The form of the ice cap at its successive margins can be reconstructed from the intersection of drift lineations with hillsides. This permits us to estimate palaeo-shear stress, which should conform in magnitude and distribution with those found at modern glacier margins in similar terrain.

This approach has been used elsewhere to provide independent evaluation of ice cap reconstructions (eg. Mathews 1974; Pierce 1979). Basal shear stress have also been used by Murray and Locke (1989) as a vital part of their reconstruction of the Late Pleistocene Big Timber glacier, in Montana.

It is possible to produce a strike line or contour map of the former snout region for an individual ice margin represented on both sides of a valley (Fig. 6.3-2A). From these strike lines, flow line profiles can be established, along which basal shear stresses ( $\tau$ ) can be calculated using the equation  $\tau = \rho g h \sin \alpha$  [where:  $\rho$  = density of ice;  $g$  = gravity;  $h$  = ice thickness;  $\alpha$  = ice surface slope](Paterson 1981)(Fig. 6.3-2A). The shear stress values calculated in this way are likely to be maximum estimates due to two factors:

1) Ideally the above equation should incorporate a valley shape factor to accommodate for valley side drag (Nye 1965). The size of this shape factor depends upon the 'hydraulic radius' of the valley and the thermal state of the bed and can vary in the range of 0.5 to 0.75 (Paterson 1981). The wider and more open the valley, relative to the thickness of ice present the less important such a shape factor becomes. Nye (1965) has presented mathematical solutions for calculating the magnitude of the shape factor for different valley cross-sectional shapes (eg. parabola, semi-ellipse & rectangle). Determining the shape factor suitable for a given valley is therefore dependant on a subjective assessment of the cross-sectional shape of the valley. Consequently, a shape factor was not used in the calculations presented here in order to avoid introducing subjectivity into the analysis. The basal shear stress values calculated here must, therefore, be regarded as maximum estimates. The degree to which these values over estimate the basal shear stress was minimised by only using reconstructed ice margins from wide, open, valleys. Moreover experimentation has suggested that the basal shear stresses presented here are only over estimated by between 5% and 25%. In an area of similar relief to the Scottish Highlands Murray and Locke (1989), in their reconstruction of the Big Timber glacier, found that the shape factor only reduced their basal shear stress estimates by between 16% and 37%.

2) The estimated basal shear stresses may also be reduced by the effects of isostasy (Pierce 1979). Due to crustal loading the moraine gradients during formation may have been lower than those observed today consequently moraine gradients may slightly over estimate glacier gradient as will be

argued in Chapter Eight. Consequently, basal shear stress presented here represent an upper bound to the range of possible values.

For the vast majority of modern glaciers, empirical observations indicate that the basal shear stress is between 50 to 150 KPa (Nye 1952b; Ward 1955; Paterson 1970, 1981; Mathews 1959; Pierce 1979) although lower values (eg. 20-40 KPa) may occur in ice streams, during surging and ~~w~~<sup>b</sup>ere ice is hardly moving (Orvig 1953; Boulton & Hindmarsh 1987). Theoretically, shear stress should increase towards the terminus before decreasing to zero at the snout, as illustrated in Figure 6.3-2B (Boulton & Clark 1990). Calculated patterns of shear stress variation are present in Figure 6.3-2C for the terminal zones of Loch Lomond Stadial valley glaciers in the North West Highlands. Both the magnitudes and pattern of longitudinal variations fall within the values typical of modern glaciers and give further support to the interpretation of "hummocky moraine" presented here.

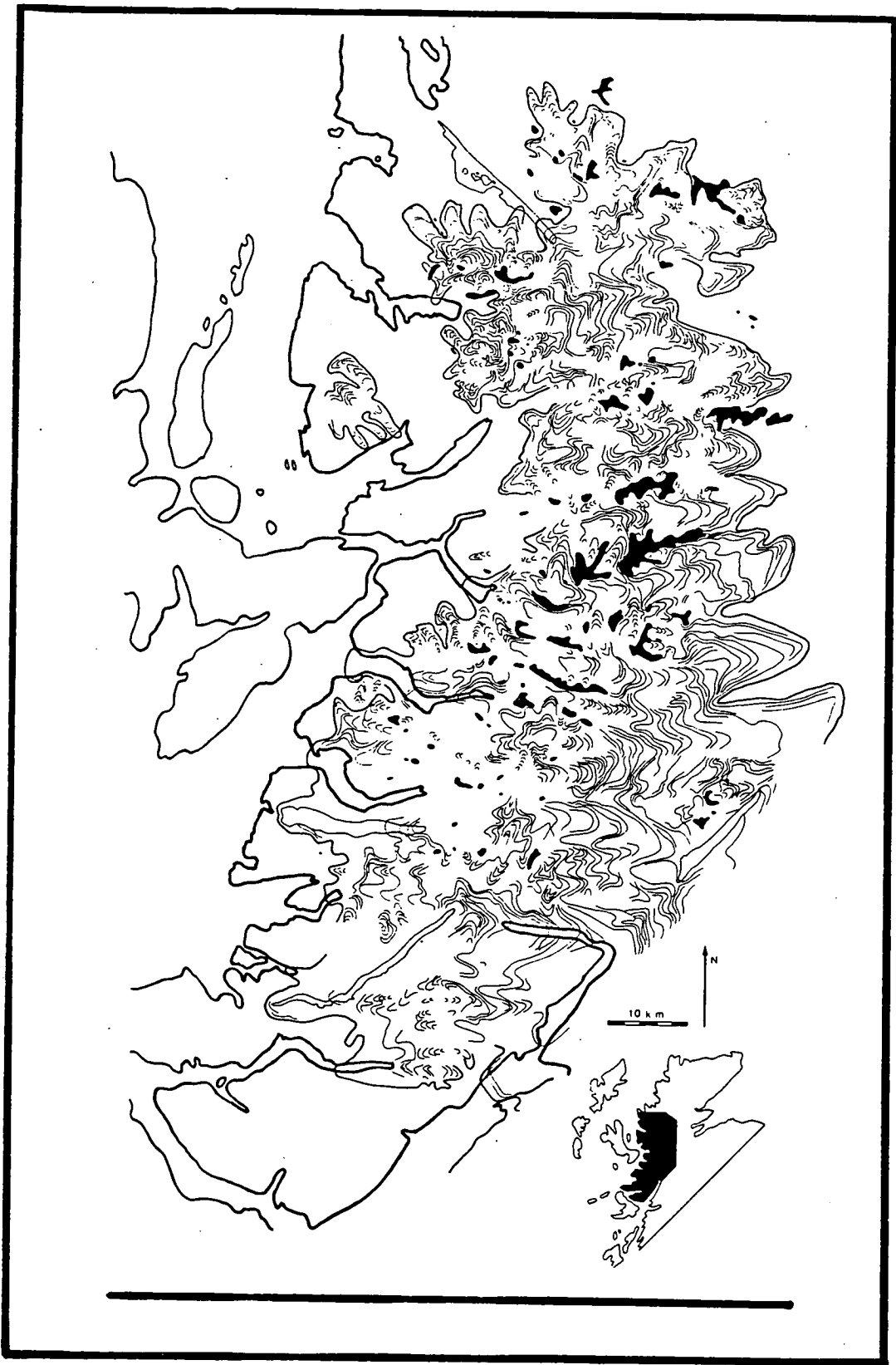
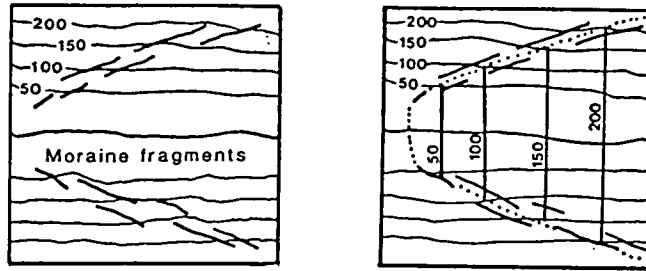

Figure 6.1: The pattern of deglaciation in the North West Highlands. Each line within the Loch Lomond Readvance limit represents an ice-marginal position during decay. Only selected stages of decay are shown and the diagram is compiled from data presented in Chapter Six. Land over 800 m shown by black areas. The decay pattern for small corrie glaciers are not shown.



Figure 6.2: Flow summary for striae in the North West Highlands, based on personal observation, Peacock (1970, 1975), and B.G.S. published and unpublished map sheets No. 52, 53, 71, 81, 82, 83, 92, 93.

## A) Strike line reconstruction.



## B) Strike lines and interpolation.

A: Palaeo-ice front data.

B: Interpreted palaeo-ice front data

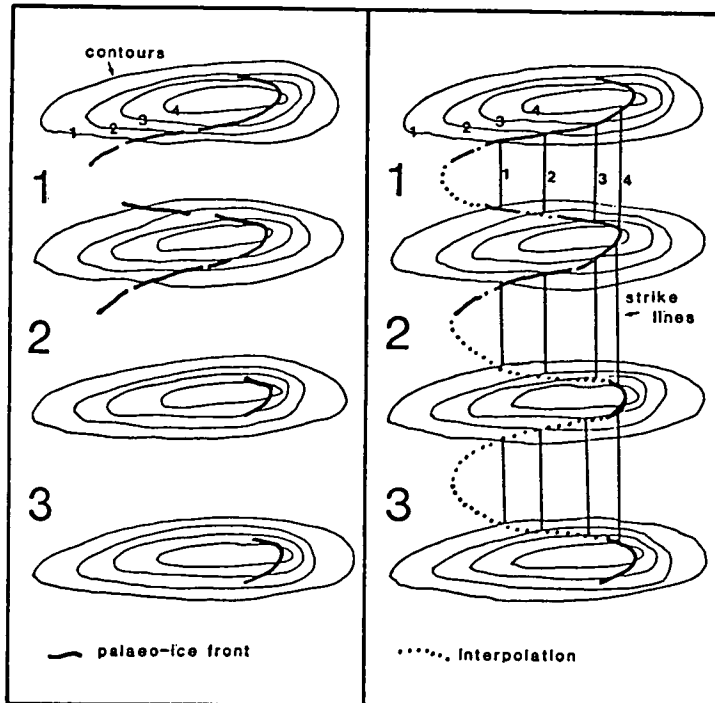

Figure 6.3: Strike lines and basal shear stress—Part 1.

A: Strike line reconstruction of a former glacier snout.

B: The use of strike lines to interpolate between palaeo-ice fronts:

**Valley 1:** Here there is palaeo-ice front evidence on both sides of the valley. The strike lines are used to link evidence on opposite sides of the valley to form a continuous ice margin.

**Valley 2:** In this case palaeo-ice front evidence is only present on the northern side of the valley. The ice margin on the south side of the valley is interpolated by assuming that the strike lines are perpendicular to the valley axis.

**Valley 3:** In this case there is little or no palaeo-ice front evidence in the main part of the valley. Strike line gradients (profiles) taken from adjacent or topographically similar valleys (eg. 1&2) are used as a guide in projecting the palaeo-ice fronts down the valley sides.

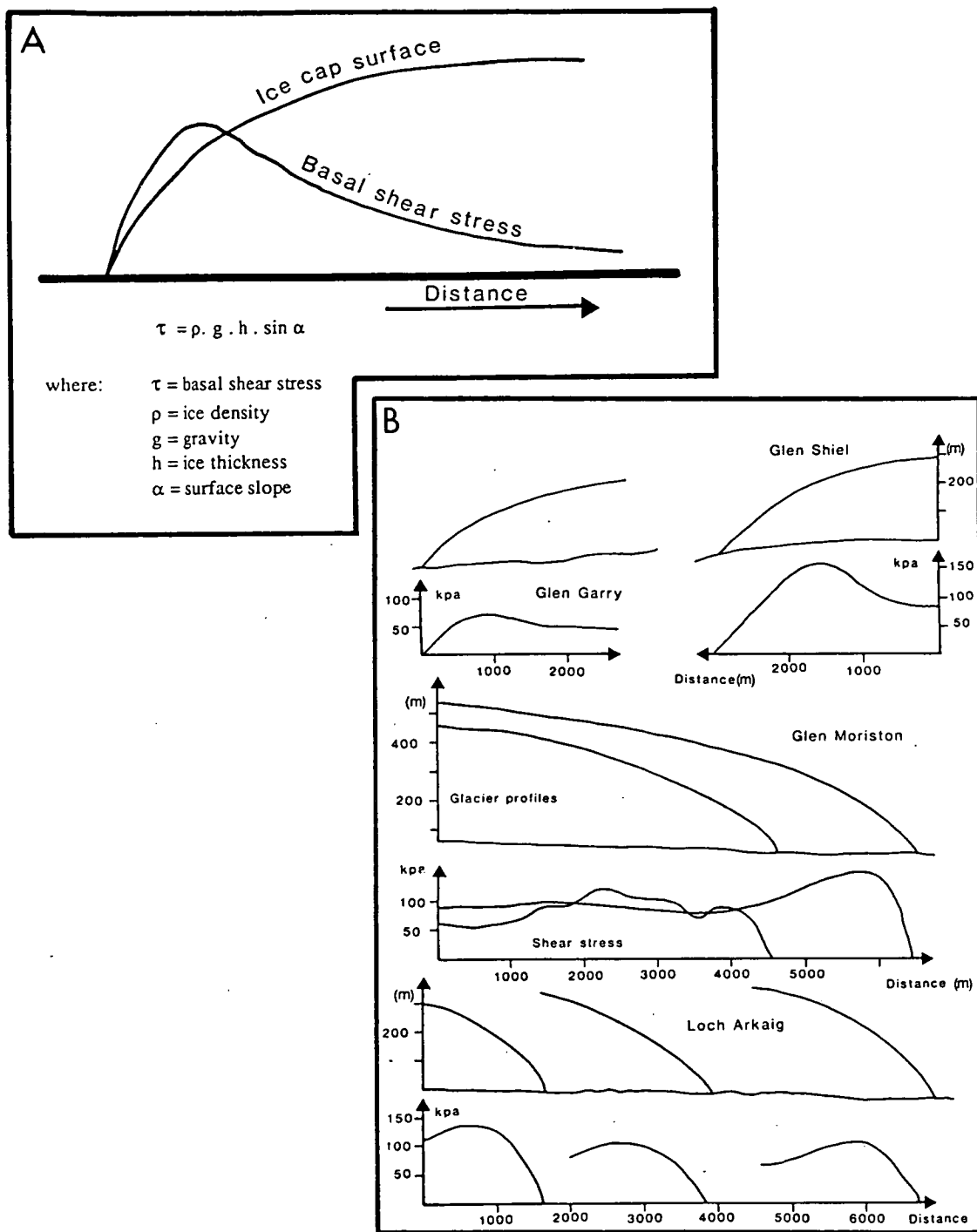

Figure 6.3: Strike lines and basal shear stress—Part 2.

A: Theoretical distribution of shear stress in terminal zones.

B: Basal shear stress distributions for strike line reconstructions of selected ice-marginal positions inside the Loch Lomond Stadial limit in the North West Highlands.

## **Part 2: Palaeo-ice front mosaics.**

In the following section seven palaeo-ice front mosaics are presented for the Loch Lomond Stadial ice cap in the North West Highlands. Accompanying these maps are some brief observations on the ice limits and patterns of decay depicted (Fig. 6.4):

- 1) Figure 6.5—An Teallach.
- 2) Figure 6.6—Loch Torridon.
- 3) Figure 6.7—Applecross.
- 4) Figure 6.8—Glen Affric.
- 5) Figure 6.9—Loch Hourm.
- 6) Figure 6.10—Loch Arkaig.
- 7) Figure 6.11—Loch Sunart.

N.B. (I) All loch outlines in the following figures pre-date reservoir construction, consequently some of the areas shown in these maps may now be submerged. (II) The contour intervals on the following diagrams are 450 m, 600 m, 750 m 900 m or 1500 ft 2000 ft 2500 ft etc. (III) Only moraines and palaeo-ice fronts believed to date from the Loch Lomond Stadial are shown.

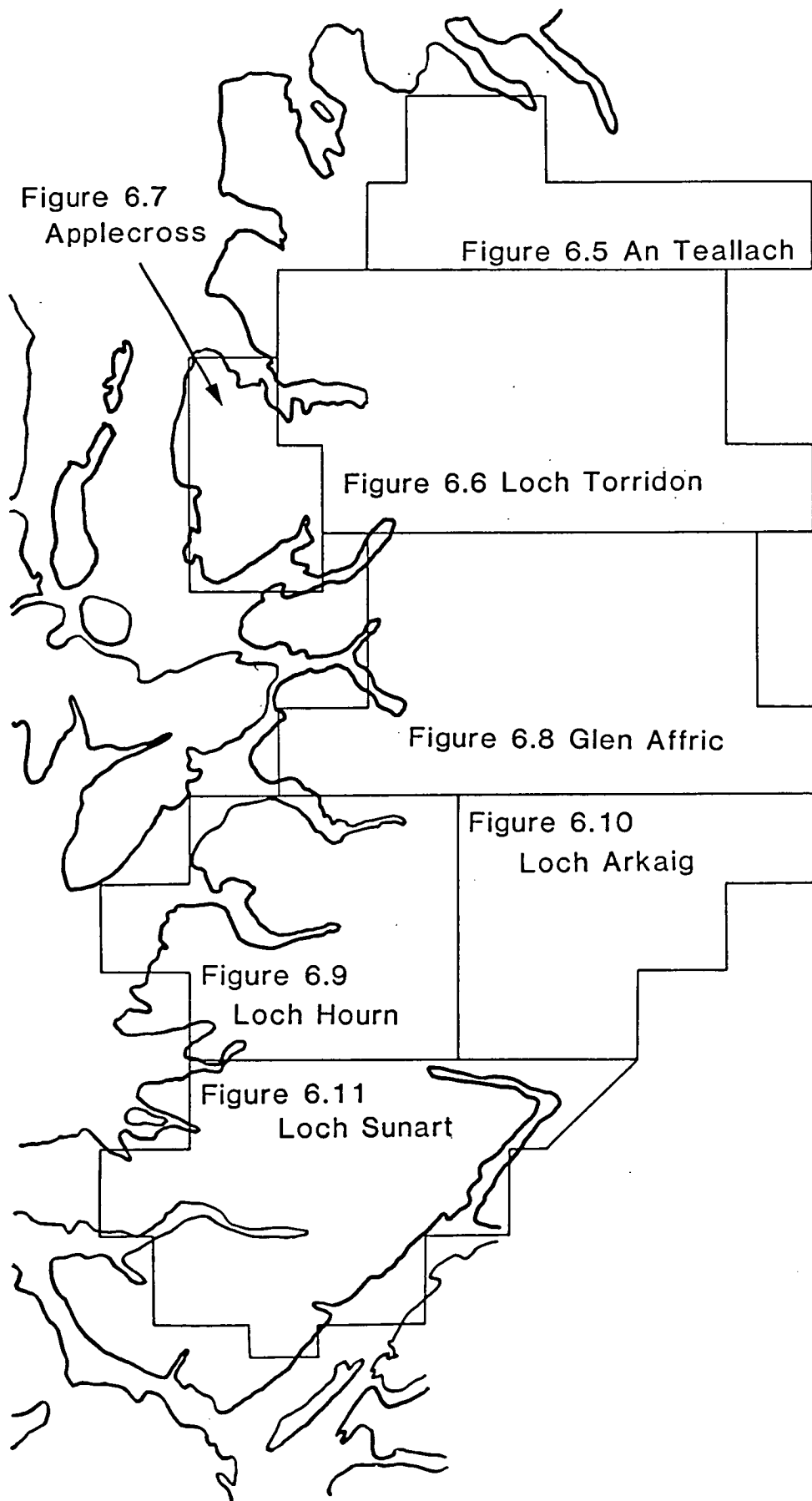
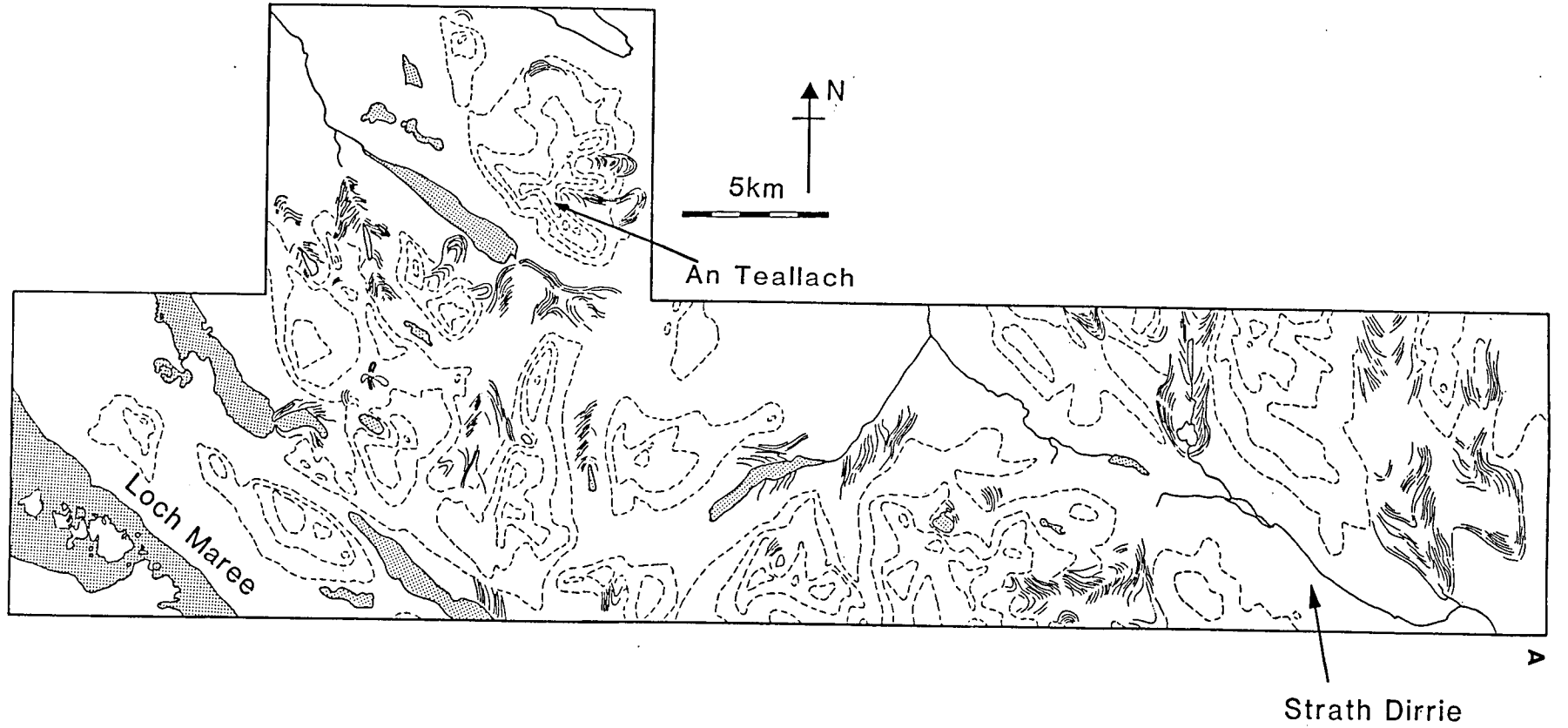

Figure 6.4: Index to palaeo-ice front mosaics.

1) **Figure 6.5—An Teallach.** This figure shows the northern extent of the Loch Lomond Readvance in the North West Highlands. The numerous discrete ice bodies identified by Sissons (1977a) in this area have been combined into the main ice cap. To the north of Strath Dirrie (now occupied by the reservoir Loch Glascarnoch-[NH 300 740]) three south facing valley glaciers have been identified which are believed to represent the southern margin of a small satellite ice field to the east of Beinn Dearg [NH 260 810]. This ice field is separated from the main ice cap by the Lateglacial pollen site of Loch Droma (Kirk & Godwin 1963).

The palaeo-ice fronts within these limits are of variable distribution and quality but allow a reasonable picture of the pattern of decay to be established.

Figure 6.5: An Teallach. A: Palaeo-ice fronts. B: Selected and interpolated palaeo-ice fronts.



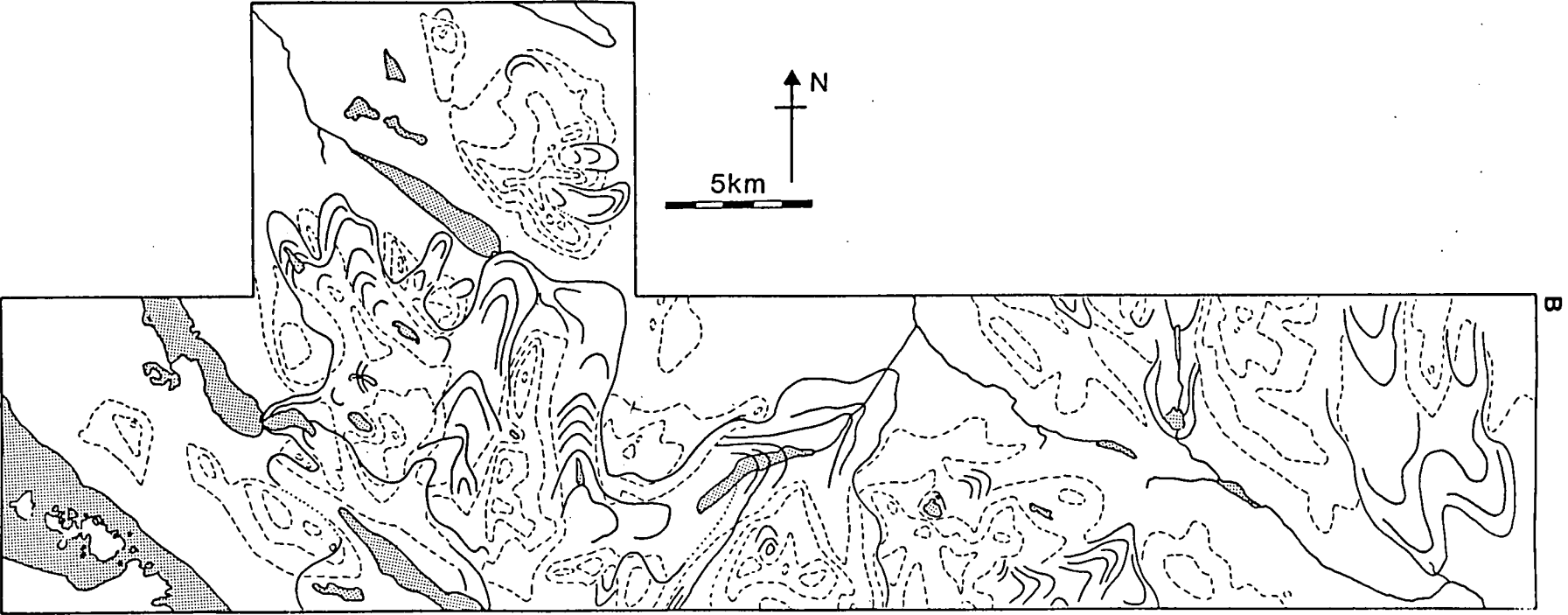

2) **Figure 6.6—Loch Torridon.** Within this area the outer limit of the Loch Lomond Readvance, identified here, is very different from that presented in previous work (eg. Sissons 1977a; Robinson 1977). The main differences follow from the location of the eastern margin of the ice cap at the former ice-dammed lake of Achnasheen. In the past, Achnasheen has been attributed to some phase of glaciation which pre-dated the Loch Lomond Stadial (Sissons 1982). However, no objective evidence has been presented to support this suggestion (Ballantyne & Sutherland 1987). In fact, I believe that the limit identified by Sissons (1977a) and Robinson (1977), 15 km to the west, is located within a continuous landform sediment assemblage which continues, unbroken, as far as Achnasheen.

Within the limits identified here there is a wealth of well integrated palaeo-ice fronts which depict a clear pattern of decay that was centred on the mountains of Torridon and Fisherfield.

Figure 6.6: Loch Torridon. A: Palaeo-ice fronts. B: Selected and interpolated palaeo-ice fronts.

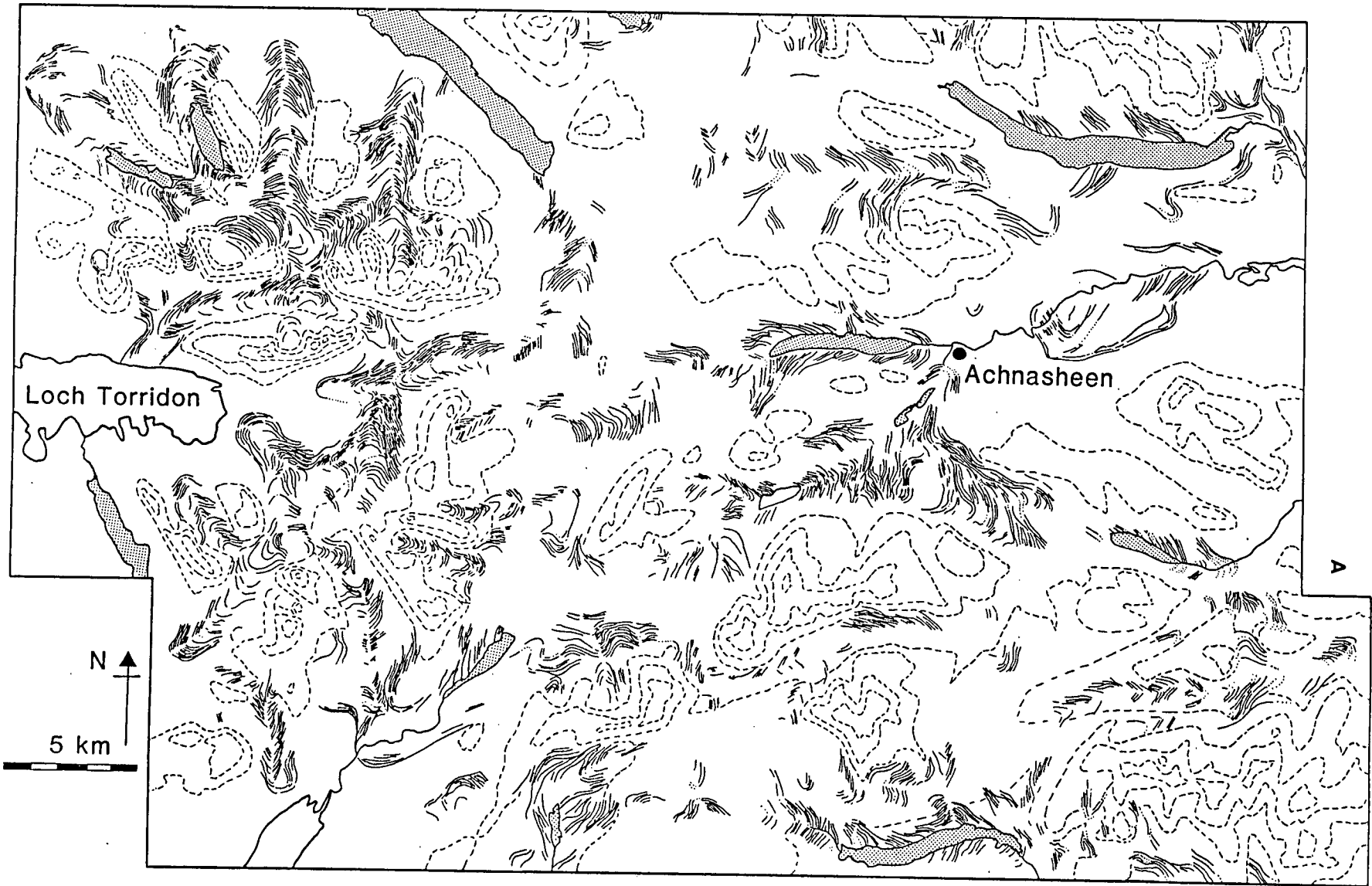

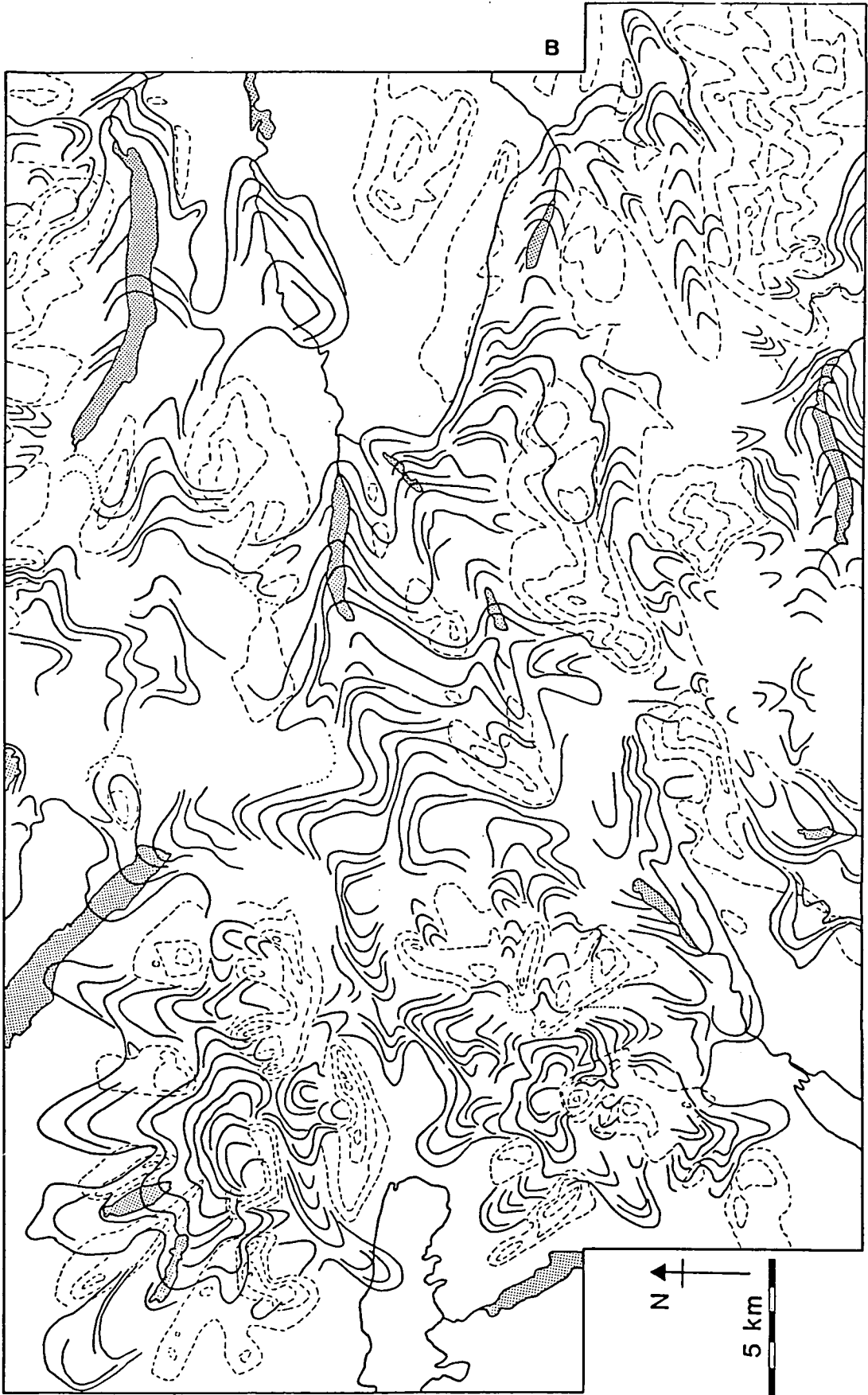

3) **Figure 6.7—Applecross.** During the Loch Lomond Readvance a discrete plateau ice field was present in Applecross. The limits of this ice field shown in Figure 6.7 are similar to that proposed by Robinson (1977). However, the exact limit in Strath Maol Chaluim is unclear, as is the origin and age of some of the moraines present in this valley. I suspect that there may be several generations of superimposed landforms in this glen, giving a particularly complex picture.

Figure 6.7: Applecross. A: Palaeo-ice fronts. B: Selected and interpolated palaeo-ice fronts.

A

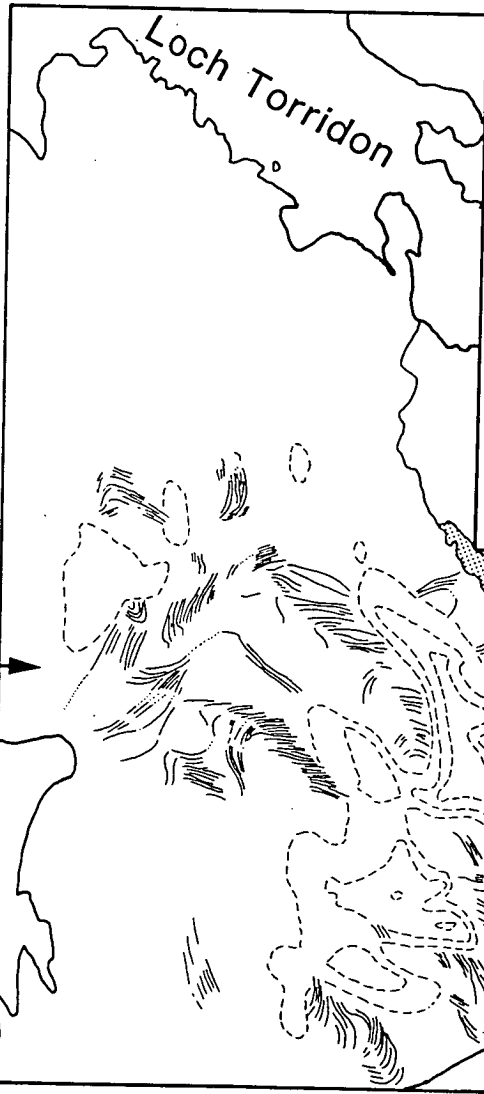

5 km

N

Strath  
Maol Chaluim

B

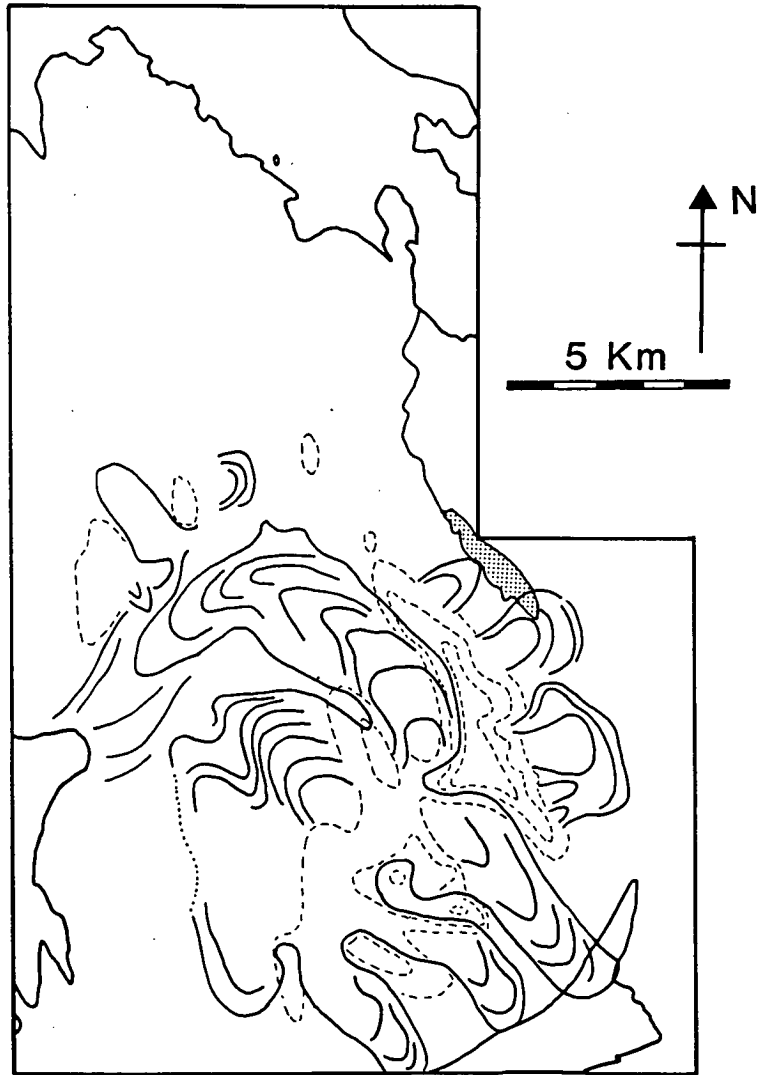

4) **Figure 6.8—Glen Affric.** In the western part of this area the Loch Lomond Readvance limit is quite clear and resembles those of previous workers (Peacock 1975; Sissons 1977b). The limit is associated with general thinning of the drift cover and is usually marked on the valley sides by clear lateral moraine ridges. In the west the limit is less apparent, primarily due to lack of clear evidence in Loch Duich. The moraines in the two small valleys to the north of Loch Duich may have been left by discrete glaciers or, alternatively, they may have been part of the main ice cap. To the north and south of Loch Duich the limit is better defined. In Glenelg, the limit is associated with complex assemblages of lacustrine and ice-contact sediments and may provide an area for future investigation.

In the eastern part of this area the retreat sequences are well developed in the main valley systems. To the west the evidence is more fragmented, reflecting not a decrease in drift cover but an increase in the complexity of the mountain relief.

Figure 6.8: Glen Affric. A: Palaeo-ice fronts. B: Selected and interpolated palaeo-ice fronts.

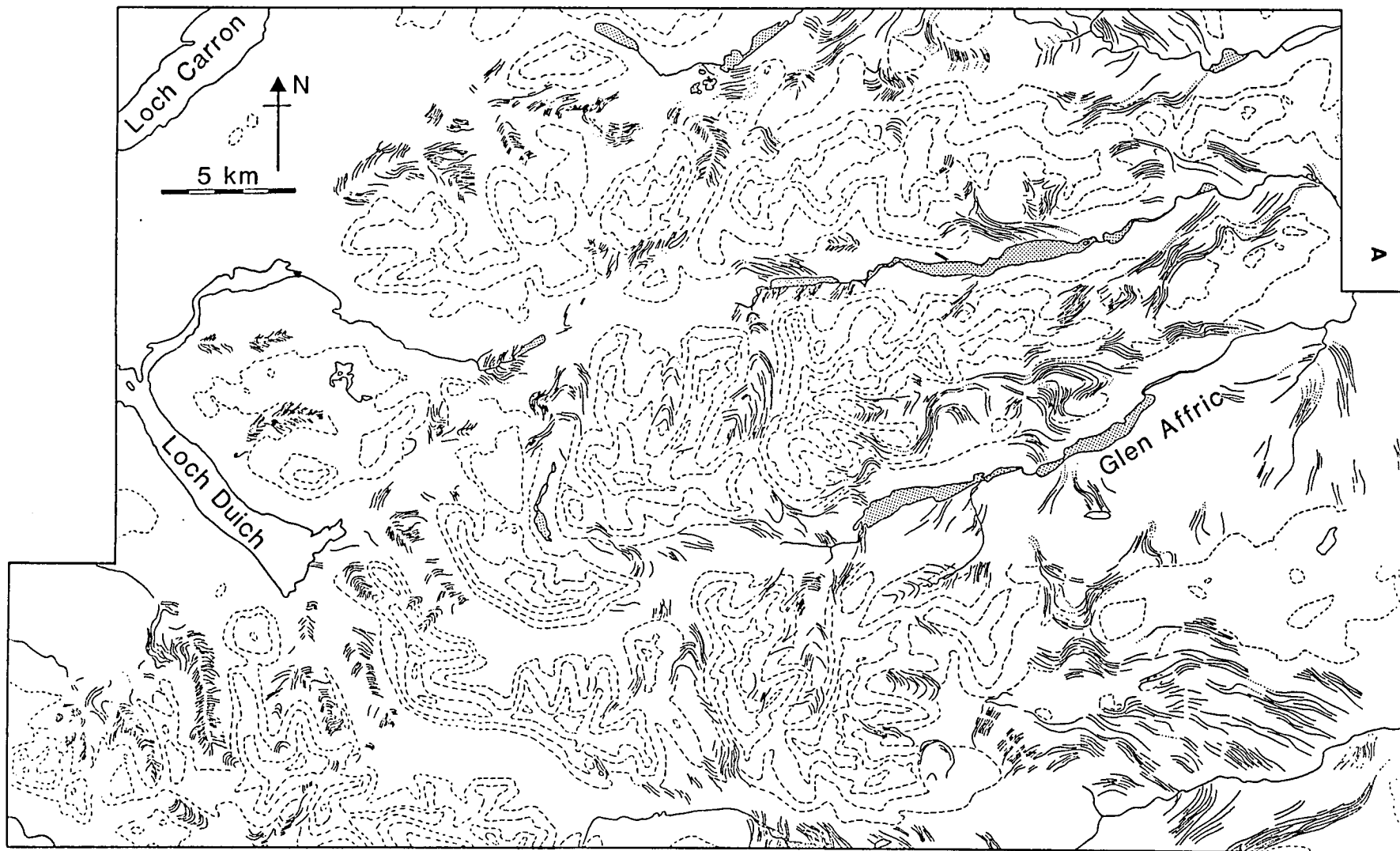

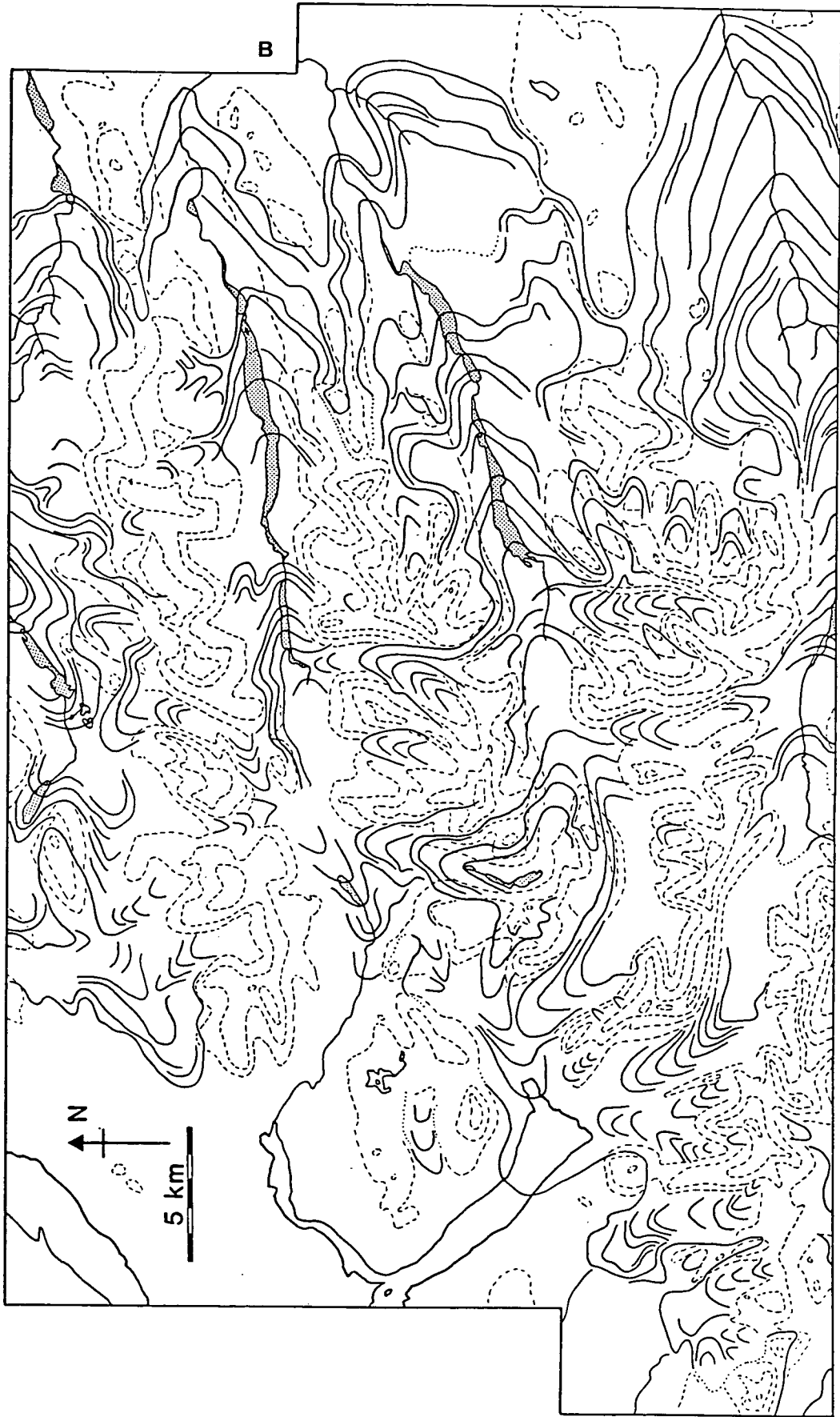

5) **Figure 6.9—Loch Hourn.** The Loch Lomond Readvance limit is clear in Knoydart, where it is marked by moraines and outwash deposits (Bennett 1990; Bennett & Langridge 1990). The limit shown in Loch Nevis is based on the geophysical data of Boulton *et al.* (1981). To the south of Loch Morar the limit becomes less clear, since the cover of morainic material decreases. Both Sissons (1976) and Boulton *et al.* (1981) have extrapolated the readvance limit into this area. Sissons (1976) places the limits well to the east of Loch nan Uamh and Loch Ailort, while Boulton *et al.* (1981) locate them within the lochs. In the case of Loch Ailort, Boulton's <sup>et al</sup> conclusions are supported by geophysical data. The limit proposed by Boulton *et al.* (1981) has been criticised by Dawson (1986), who argues that the lochs were ice free. This contention is based on the observation that they contain fragments of the main Lateglacial rock platform and can not therefore have been occupied by ice during the Loch Lomond Stadial if the rock platform dates from this period. However, such shoreline evidence is of unproven value at present, since the age and relationship of such shorelines to ice limits is an area of current contention (eg. Gray 1989; Dawson 1989). The limit presented in Figure 5.6 is a conservative extrapolation based on snout gradient reconstructions of ice limits between the moraine fragments recorded, coupled with the geophysical observations of Boulton *et al.* (1981).

Figure 6.9: Loch Hourn. A: Palaeo-ice fronts. B: Selected and interpolated palaeo-ice fronts.

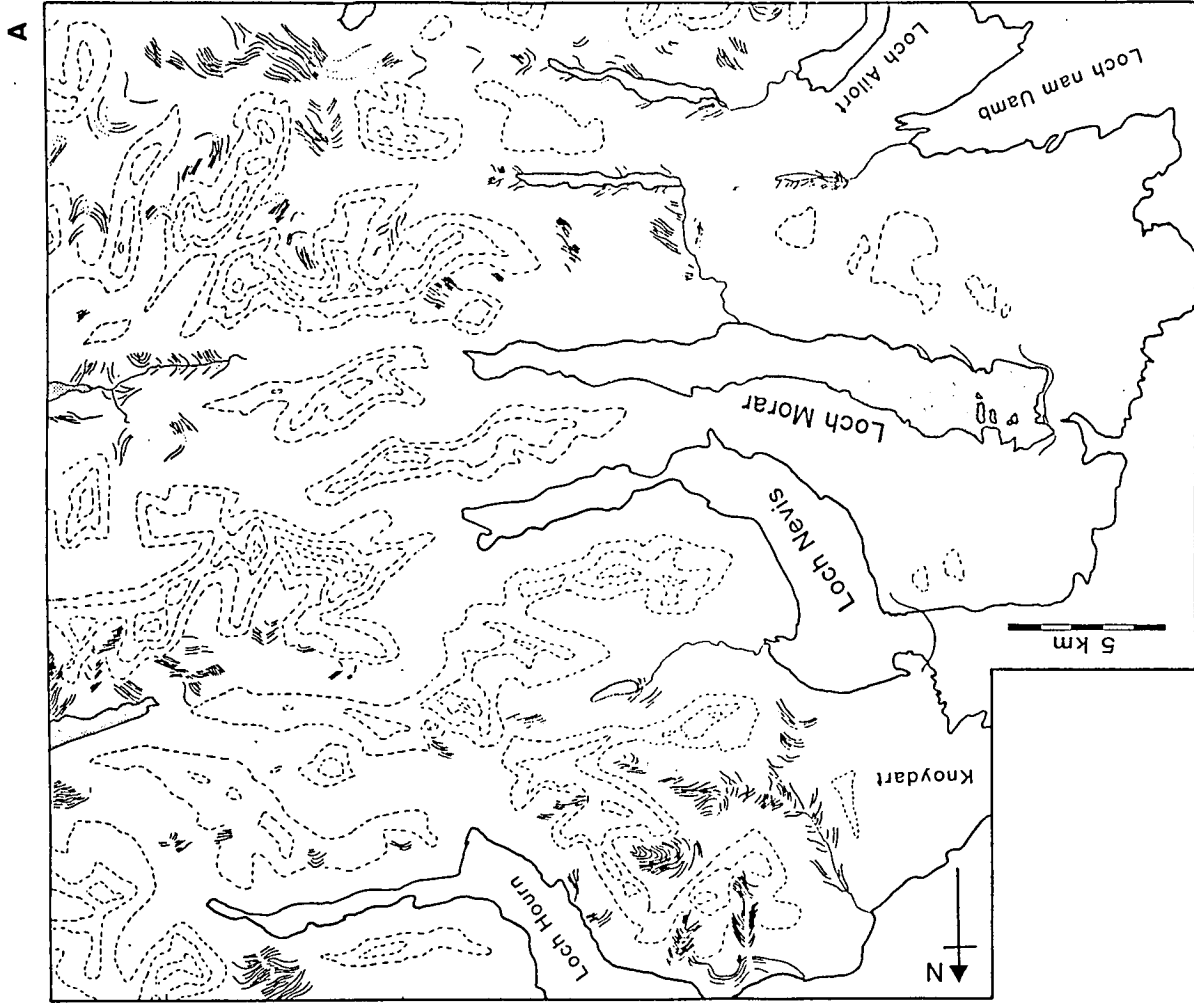

B

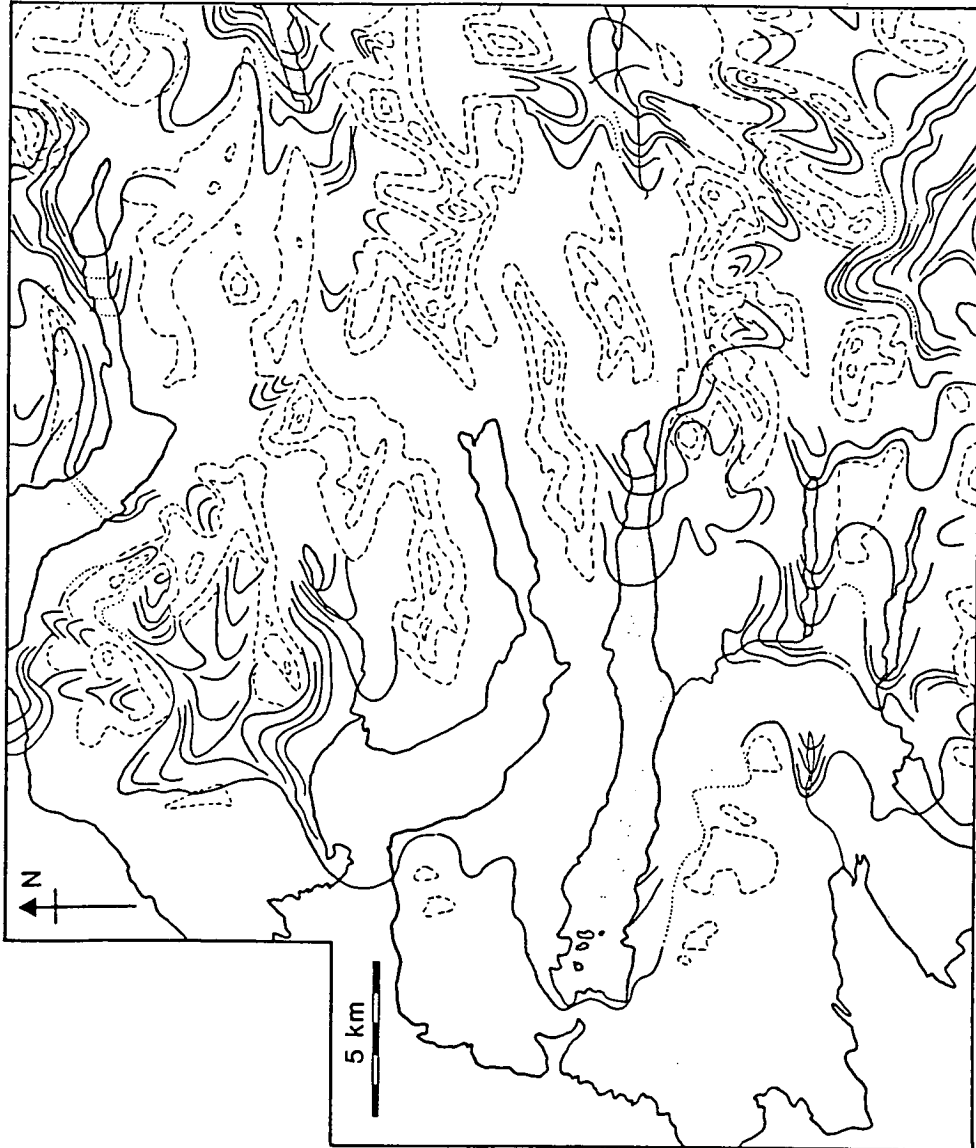

6) **Figure 6.10—Loch Arkaig.** The Loch Lomond Readvance limit in this area is similar to that proposed previously by Sissons (1977b, 1979a). Inside these limits there is a dense pattern of well integrated palaeo-ice fronts which link together well to depict a regional pattern of east-west decay. It is interesting to note that the mountains of Ben Tee, just to the west of Loch Lochy, acted as a separated, local, point of decay. The ice within the Great Glen is also of note, since it appears to have been supplied by two piedmont lobes, one from Glen Garry and another from Glen Arkaig. This may explain the low irregular ice gradient on the southern side of the Great Glen between the ice limit at Fort Augustus and those within Glen Gloy and Glen Roy (Sissons 1979a). It also illustrates the significance of the Great Glen as a topographic barrier to the eastward flow of ice in this area.

Figure 6.10: Loch Arkaig. A: Palaeo-ice fronts. B: Selected and interpolated palaeo-ice fronts.

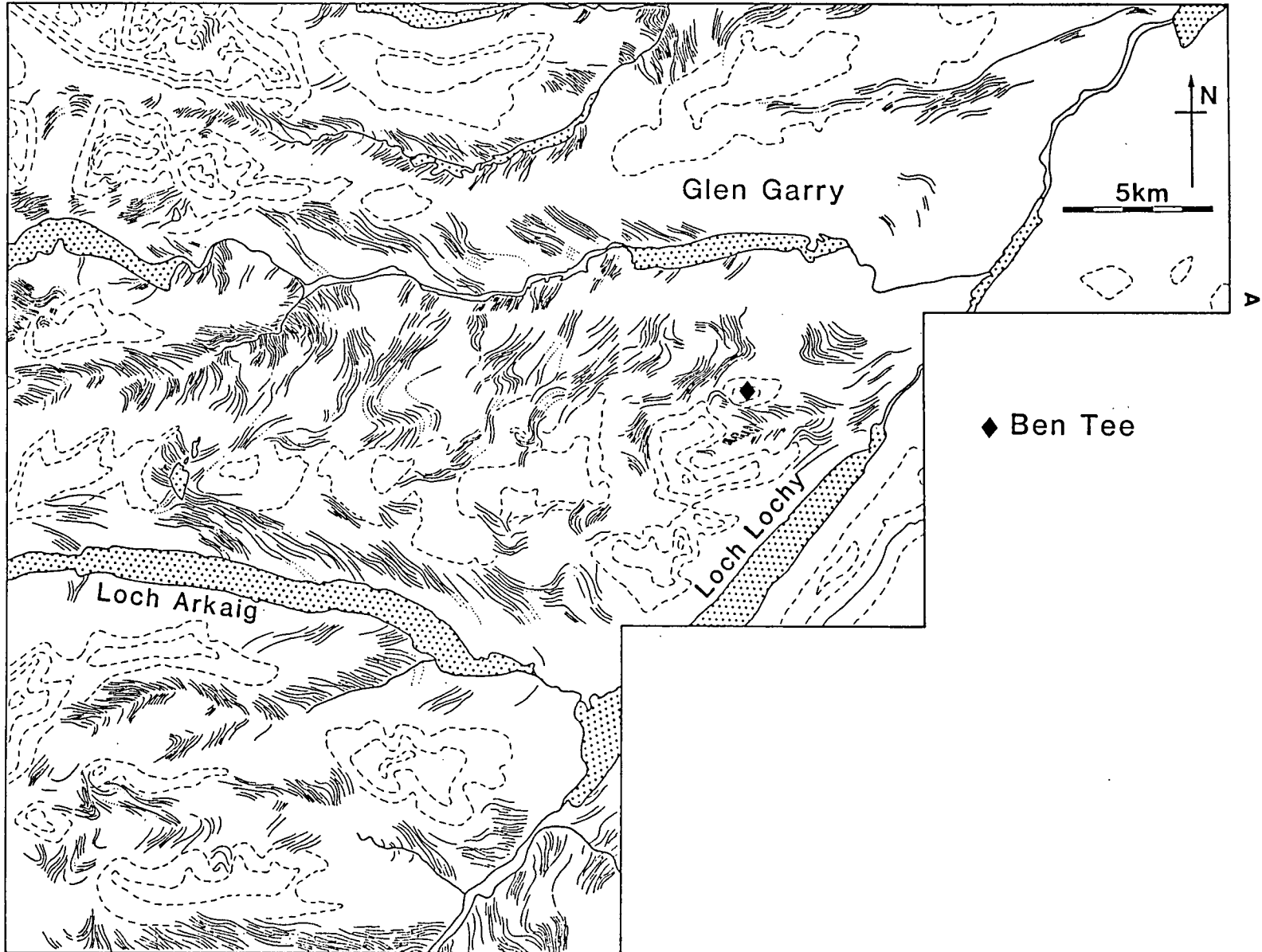

B



7) **Figure 6.11—Loch Sunart.** As noted previously the Loch Lomond Readvance limits at the end of Loch Shiel and in Loch Linnhe are marked by clear outwash fans (eg. McCann 1966; Gray 1972; Thorp 1984, 1986). However, elsewhere the limits are more tentative, particularly around Loch Sunart. The problem here is again the lack of moraine cover which is reflected in the lack of palaeo-ice fronts in southern half of this area.

Figure 6.11: Loch Sunart. A: Palaeo-ice fronts. B: Selected and interpolated palaeo-ice fronts.

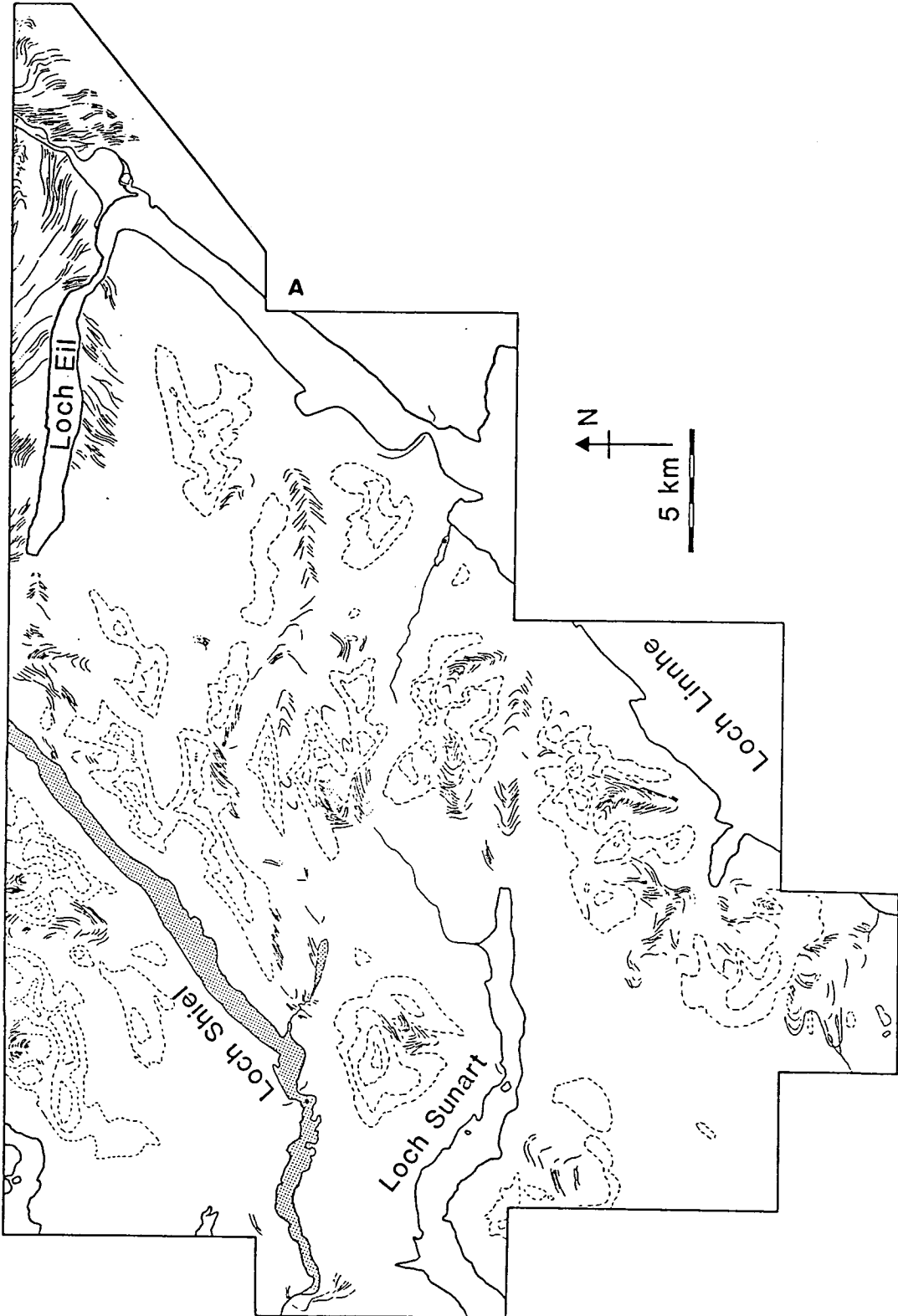

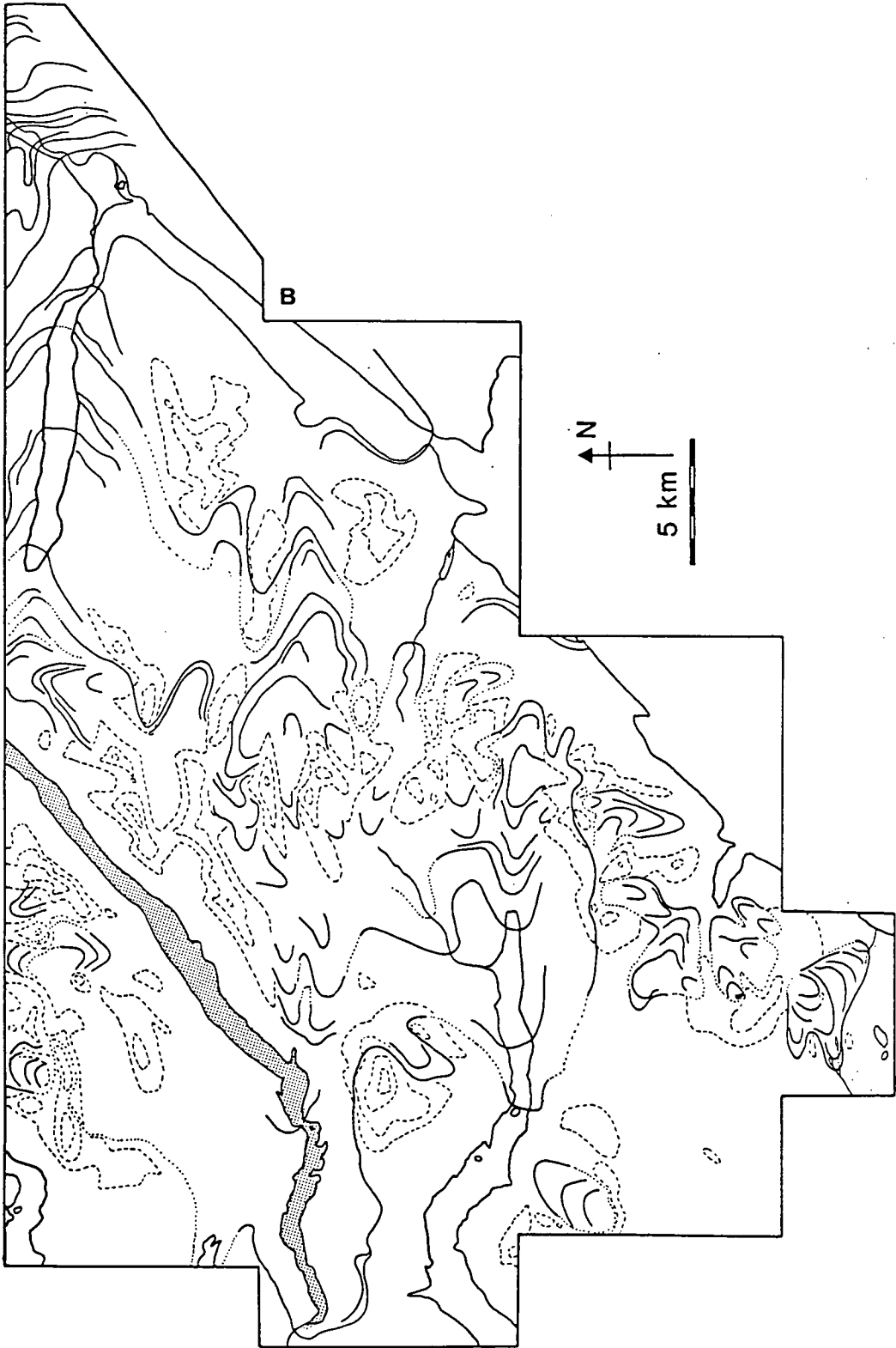

• Chapter Seven •

Part 1: Summary and conclusions

---

*This chapter provides a summary of the arguments presented in the first part of the thesis and examines their implications.*

### **7.1: Summary and conclusions.**

The interpretation of "hummocky moraine" presented in Chapter Two is as follows:

*A large proportion of the drift ridges in Scottish Highland valleys which have been referred to as 'hummocky moraine' are individual and identifiable ice-marginal landforms formed at actively retreating ice margins. It follows from this that the Loch Lomond Stadial ice cap in the Scottish Highlands decayed as an active glacier and that the pattern of decay can be examined by mapping the trends of these landforms.*

Three predictions were made from this model in Chapter Two, each of which have been examined in three previous chapters:

#### **Chapter Four: Small-scale evidence.**

**Prediction**—at modern glacier margins a range of individual landforms can be identified. A similar range of landforms should be present within "hummocky moraine".

**Conclusion**—"hummocky moraine" appears to consist primarily of suites of push moraines, dump moraines, ice-contact outwash fans and flutes. Such a suite of landforms is typical of the active margins of modern glaciers.

#### **Chapter Five: Meso-scale evidence.**

**Prediction**—at modern glacier margins the landforms have a distinct spatial organisation; for example, different glacier lobes retreating and advancing at different rates produce frontal landforms of different spatial frequencies and organisation. Similar contrasts should occur within "hummocky moraine".

**Conclusion**—the spatial organisation of landforms within "hummocky moraine" is similar to that found at the margins of active, modern, retreating glaciers. They reflect ice margin slopes consistent with typical modern values. The pattern of retreat in individual valleys and the interaction between separate glacier lobes is similar to the patterns found around the margins of many contemporary ice caps. Patterns of decay appear to reflect controls on ice margin geometry such as insolation contrasts.

#### **Chapter Six: Macro-scale evidence.**

**Prediction**—on a regional scale, glacier marginal patterns inferred from transverse and longitudinal landforms should reflect ice cap decay which obeys fundamental glaciological principles.

**Conclusion**—landforms within "hummocky moraine" fit together at a regional scale in the way in which one would expect retreating glacier lobes to do and form a coherent reconstruction of the pattern of retreat of the Loch Lomond Stadial ice cap in the North West Highlands.

On this basis I conclude that the interpretation presented in this thesis explains the observed characteristics of "hummocky moraine". Figure 7.1 summarises the landform associations found in many valleys which contain "hummocky moraine". It illustrates a simple active ice margin depositing push and dump moraines which are associated with flutes and an outwash fan. Areas of localised stagnation terrain are rare and are usually associated with debris concentrations such as the medial moraine. The form and clarity of cross valley concentric moraines is controlled by the relationship of debris supply to retreat rate (Chapter Four: Fig. 4.1). Where the rate of retreat is high relative to the rate of debris-supply, distinct moraines form. However, where the debris supply exceeds the rate of retreat, more complex ice-marginal belts of mounds result from local stagnation. This block diagram summarises what I believe to be the commonest type of landform association found within "hummocky moraine", although there are areas dominated by glaciofluvial and lacustrine landform assemblages (Chapter Four: Fig. 4.8 & 4.15).

There are three main implications of the interpretation proposed here:

(1) The use of the term "hummocky moraine" should be discontinued, since it is simply an assemblage of identifiable ice-marginal landforms.

(2) The frontal hypothesis provides a framework within which the morainic evidence of the Loch Lomond Stadial ice cap can be examined. It provides a basis for detailed investigation into the controls of debris supply, process and basin geometry on moraine assemblages.

(3) At a macro-scale the retreat pattern established for the North West Highlands has the potential to provide information about the large scale response and behaviour of a small maritime ice cap. This potential is explored in the second part of this thesis.

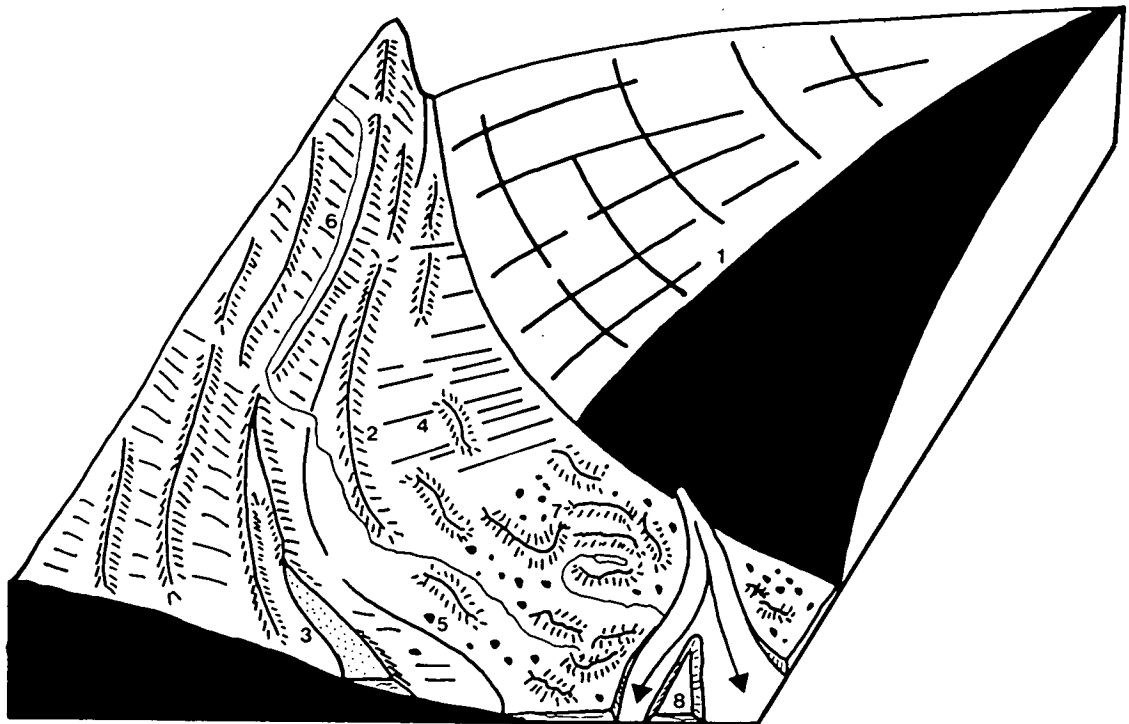

Figure 7.1: A typical landform assemblage found within "hummocky moraine" areas.

- |   |                            |
|---|----------------------------|
| 1. Medial moraine.                          | 2. Push and dump moraines. |
| 3. Kame terraces.                           | 4. Flutes.                 |
| 5. Boulders.                                | 6. Meltwater channel.      |
| 7. Irregular mounds and kettles—non-linear. |                            |
| 8. Outwash surfaces.                        |                            |

## • Part Two •

### Implications and conclusions

In the first part of this thesis an interpretation of the landforms within the limit of the Loch Lomond Readvance was presented. In the second part, this interpretation is used to examine the extent, surface form and pattern of decay of the Loch Lomond Stadial ice cap in the North West Highlands. These patterns lead to inferences about the dynamics of this ice cap and its response to climatic forcing. Conclusions are then drawn about the palaeoclimatic information inherent in this interpretation.

• Chapter Eight •

The extent, surface morphology and  
pattern of decay of the Loch Lomond  
Stadial ice cap in the North West  
Highlands.

## Contents

---

8.1:	Introduction.	157
8.2:	What was the maximum extent of the Loch Lomond Stadial ice cap in the North West Highlands?	158
8.3:	What was the surface morphology of the Loch Lomond Stadial ice cap in the North West Highlands?	160
8.4:	What was the pattern of decay?	167
8.5:	What is the spatial variation of glacial landforms within the area occupied by this ice cap?	172
8.6:	What was the rate of decay?	179
8.7:	Chapter summary.	180

---

*In this chapter the extent, surface form and pattern of decay of the Loch Lomond Stadial ice cap in the North West Highlands is examined.*

### **8.1: Introduction.**

Sissons and his many co-workers delineated the extent of the Loch Lomond Stadial ice cap on the basis of the distribution of "hummocky moraine" (Sissons 1965, 1974a; Gray and Brooks 1972). Although "hummocky moraine" is abundant within the area presumed to have been occupied by the Loch Lomond Stadial ice cap, it was not used as a basis for reconstructing the pattern of decay. Presumably this neglect was derived from the view that the apparently chaotic form of "hummocky moraine" reflected its origins as a stagnation deposit (Sissons 1967, 1974a&b, 1977a; Thompson 1972). Stagnation was considered merely to reflect the ice caps' rapid decay in response to the extremely rapid climatic warming at the close of the Loch Lomond Stadial, the evidence for this rapid climatic amelioration being drawn from the coleopteran record (Coope & Brophy 1972; Bishop & Coope 1977; Coope & Joachim 1980).

I have argued in the first part of this thesis that when "hummocky moraine" is examined from the air, it is not a random collection of mounds but possesses a clear form and structure interpretable in terms of glacier retreat patterns. Detailed evidence has shown that most "hummocky

moraine" is simply composed of suites of push moraines, dump moraines, ice-contact outwash fans and flutes, all of which have patterns of spatial organisation which resemble those found at the margins of retreating modern glaciers. These landforms can be mapped over large areas to give integrated patterns of decay which reflect the response and dynamics of the Loch Lomond Stadial ice cap through time. These patterns are explored in this chapter.

Using the accumulated data, five questions can be examined:

1. What was the maximum extent of this ice cap?
2. What was its surface morphology?
3. What was the pattern of decay?
4. What is the spatial variation of morainic landforms left by this ice cap?
5. What was the rate of decay?

## **8.2: What was the maximum extent of the Loch Lomond Stadial ice cap in the North West Highlands?**

The approach used to determine the extent of the Loch Lomond Readvance has been presented in Chapter Three. The limit identified in the North West Highlands is shown in Figure 8.1. This ice cap was disposed along the main relief axis in the North West Highlands (Fig. 8.4) and coalesces with that in the Grampian Highlands across the southern end of the Great Glen. This limit defines an area of 4 700 km<sup>2</sup>.

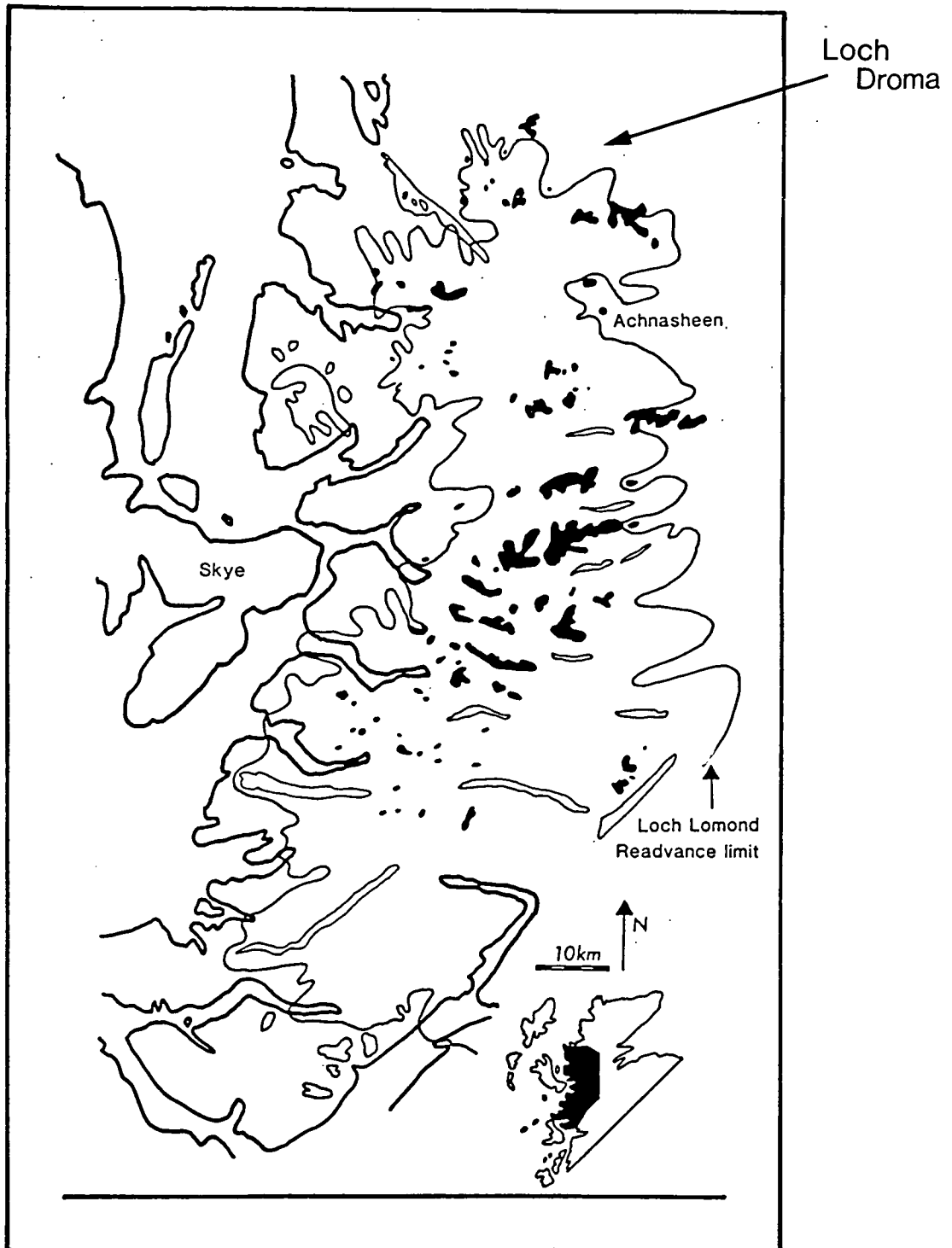

Figure 8.1: The limit of the Loch Lomond Readvance in the North West Highlands, land over 800 m shown by the black areas. No Loch Lomond Stadial ice body north of the Lateglacial pollen site of Loch Droma is shown (Kirk & Godwin 1963).

### 8.3: What was the surface morphology of the Loch Lomond Stadial ice cap in the North West Highlands?

In order to gain some impression of the ice cap's surface morphology, prior to decay, an attempt was made to reconstruct its vertical form. Geological information can be used along the maximum limit of the former ice cap to reconstruct its surface form in the marginal zone. Moraines on opposite sides of a valley are linked by lines of equal elevation, strike lines, which are then used to construct flow line profiles for the former glacier margin. Not only can these profiles be used to calculate basal shear stress distributions (Chapter Six), but the resultant two-dimensional profiles can also be extrapolated into the centre of the ice cap to form a basis from which its surface elevation can be produced. The two-dimensional model of Nye (1952a) was used to extrapolate these profiles (Schilling & Hollin 1981). The model assumes perfectly plastic ice flow and gives a parabolic ice profile. The steepness of the profile produced is controlled by a shear stress value which is assumed to be constant within the ice cap. As Figure 8.2 illustrates, there is a close agreement between the geological profile data and a Nye parabolic profile based on a shear stress value of 100 kpa (cf. Murray & Locke 1989). Consequently, a shear stress value of a 100kpa was used to extrapolate these profiles into the centre of the ice cap:

$$H = \sqrt{2 \cdot h_o \cdot s}$$

Where: H = ice altitude in metres; s = horizontal distance from ice margin in metres;  $h_o = \tau / \rho g$  and has a value of 11 for a 100kpa shear stress;  $\tau$  = basal shear stress;  $\rho$  = density of ice; g = gravity: (Nye 1952a).

A total of 56 profiles were extrapolated in this way to give a network of ice thickness values, which were then contoured to produce the ice cap reconstruction shown in Figure 8.3. The volume of the ice cap was estimated from the area volume relationship proposed by Paterson (1972), although empirical this relationship and ones similar to it have been found to give good volume estimates (eg. Driedger & Kennard 1986).

The reconstructed ice cap has an area of 4 700 km<sup>2</sup> and a maximum elevation of approximately 800 metres in the south. It incorporates a total volume of 1 900 km<sup>3</sup> of ice, the principal mass of which is concentrated in the south where the ice divide is located just to the east of the main relief axis and the regional watershed (Fig. 8.3 & 8.4).

How accurate is this reconstruction? There are two principal problems with the approach used here:

Firstly, it does not incorporate the influence of isostatic depression. The principal effect of this would be to reduce the estimates of basal shear stress upon which the extrapolations are based (Pierce 1979). This is illustrated in the two line drawings below:

1. With isostatic loading.

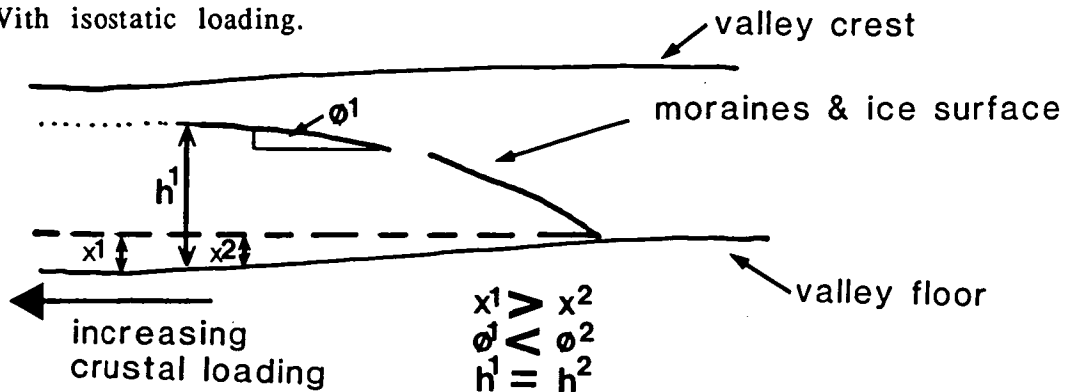

2. Without isostatic loading—present day.

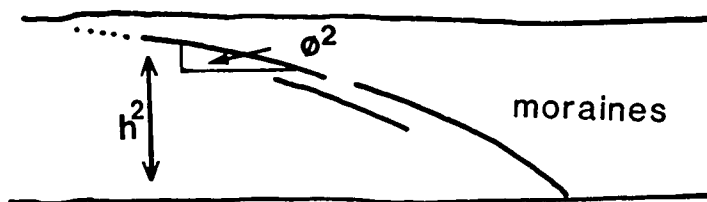

As can be seen, the thickness of ice ( $h$ ) is constant in the two cases, but, due to the effect of isostatic loading, the slope of the moraine fragments increases as the crust unloads. Therefore, glacier gradients determined from ice marginal moraine fragments may be overestimated. The significance of this problem will depend on the length of the moraine fragments used to determine the glacier slope relative to the gradient of isostatic tilting. This gradient is caused by the decrease in ice loading towards the margin of the former ice cap and is likely to be at its greatest in the marginal zone. As a consequence, the basal shear stresses calculated from the slope of moraines within the terminal zones of the ice cap may also be overestimated. This would imply that the parabola used to extrapolate the geological evidence into the centres of this former ice cap may be too steep. If a lower shear stress value is used in Nye's (1952) model,

then a lower, more gentle parabola is produced. Therefore the reconstruction in Figure 8.3 must be considered as a maximum limit on the surface elevation of the Loch Lomond Stadial ice cap in the North West Highlands. A rough estimate of the magnitude of this problem can be obtained by estimating crustal flexure from an empirical model such as that present by Brotchie & Silvester (1969) who suggest that the crust will be depressed by 0.267 times the ice thickness. If one assumes that most of the crustal depression will have occurred within the first 10 km of the ice cap's margin and combine this with an ice thickness of about 800 metres, which would depress the crust by 213 metres, then over 1 km moraine slopes and therefore the gradient of the former ice cap would be over estimated by approximately  $1^\circ$  which would lower the shear stress estimates by between 20% to 25%. In order to incorporate isostatic depression realistically into the reconstruction one would require a detailed isostatic model for the Loch Lomond Stadial ice cap. However, developing a suitable model is difficult.

Secondly, the accuracy of the reconstruction is limited by the assumption of two-dimensional flow. It does not incorporate topographic influences such as the convergence of ice flow in deep valleys. The model is most likely to be correct where the thickness of ice is large compared to topography and least accurate where ice is thin and relief strong. Consequently I believe the southern part of this reconstruction is probably more accurate than that the northern part, where the topography is much stronger.

Although the reconstruction in Figure 8.3 has limitations, it provides an approximation of the ice cap's surface morphology and therefore a datum from which to examine the pattern of decay.

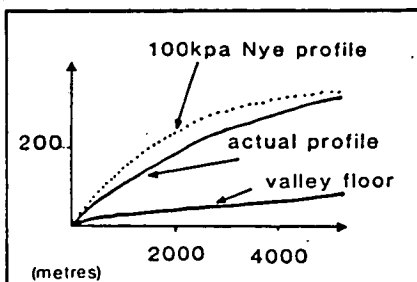
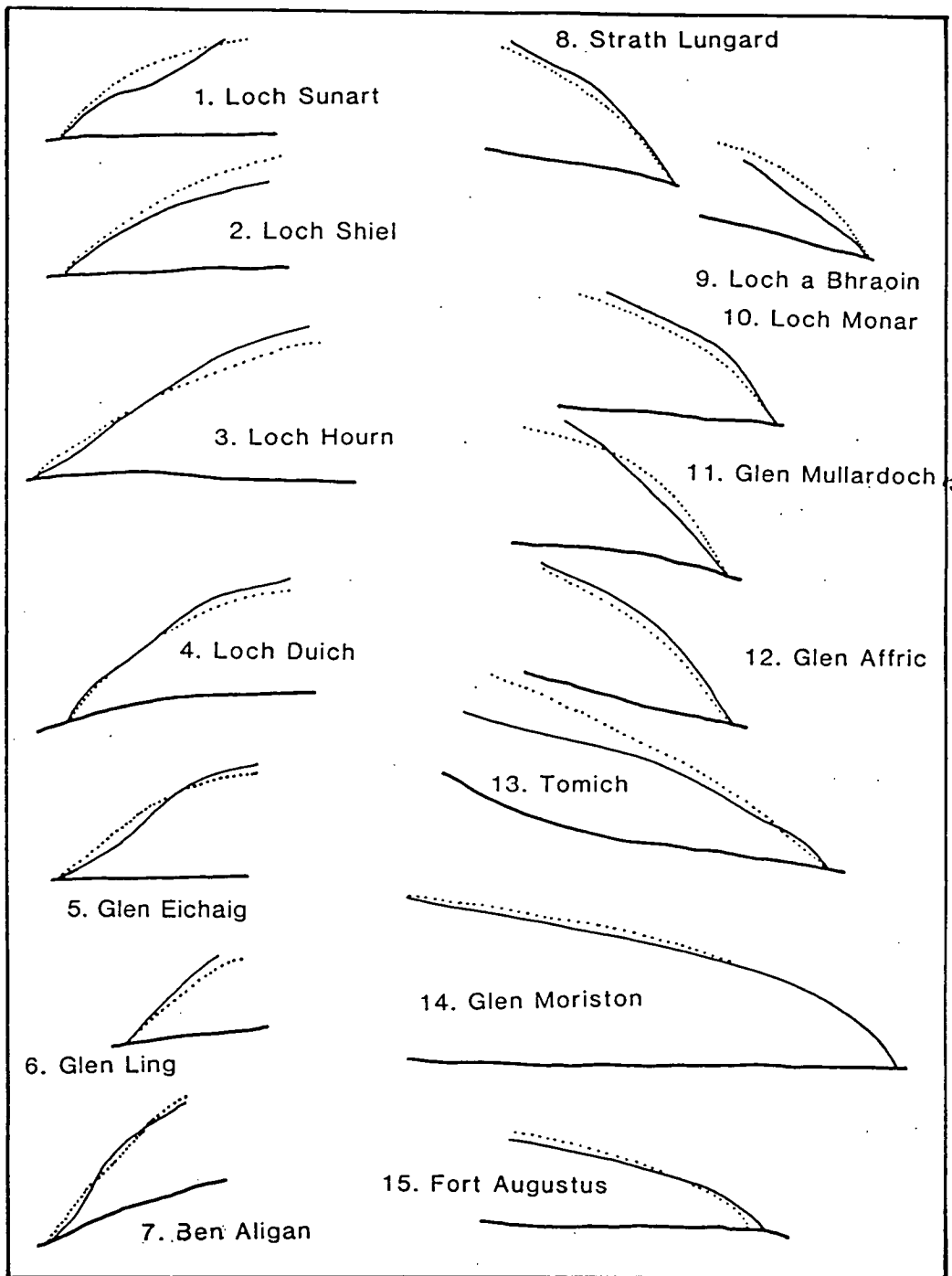

Figure 8.2: A comparison of theoretical and reconstructed (moraines) glacier snout profiles. The theoretical profiles are those of a 100 Kpa, Nye (1952), parabola.

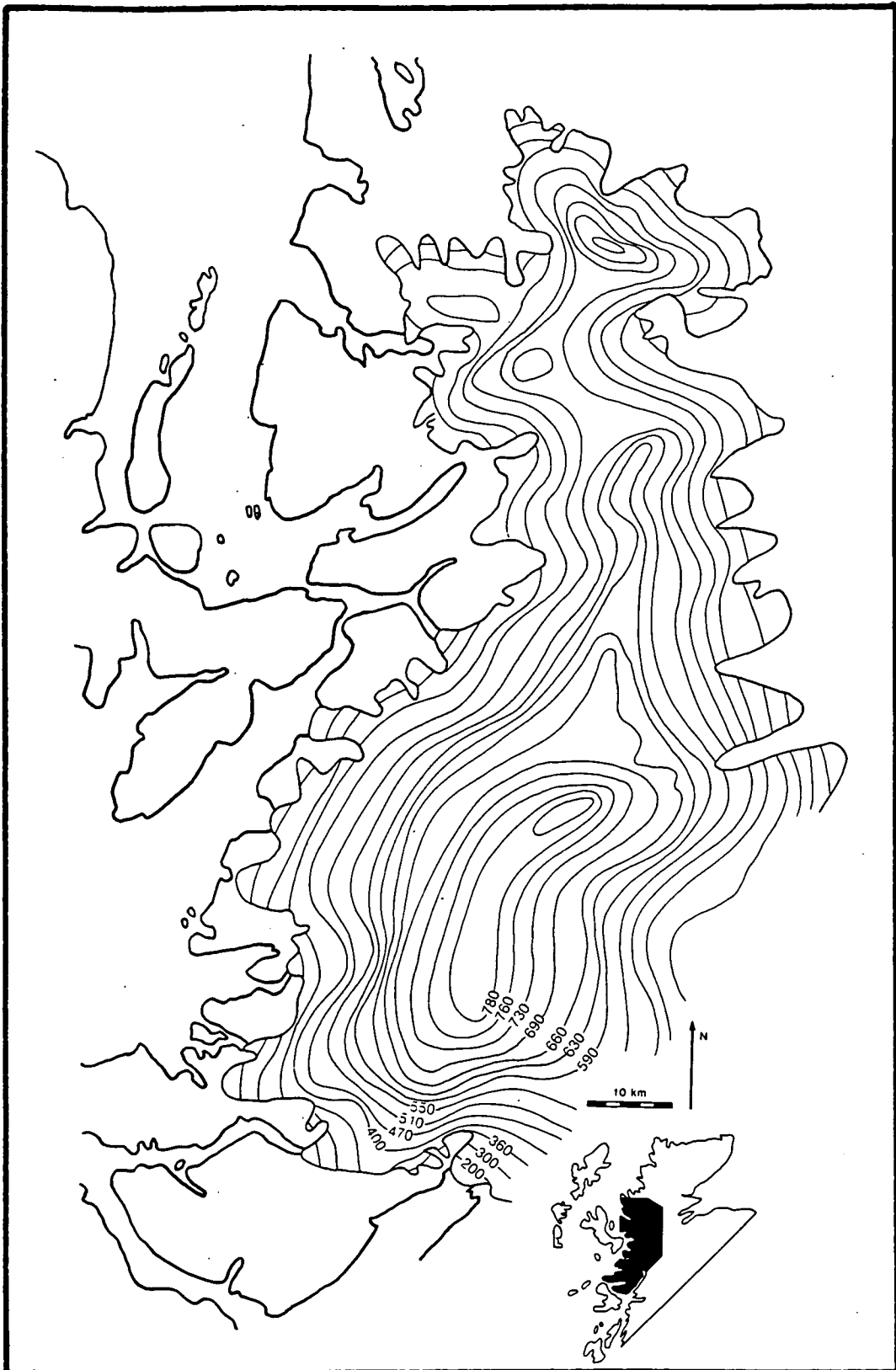

Figure 8.3: The surface morphology of the Loch Lomond Stadial ice cap in the North West Highlands. Only the main ice cap is shown here, the ice field in Applecross and the various corrie glaciers present at this time have not been reconstructed.

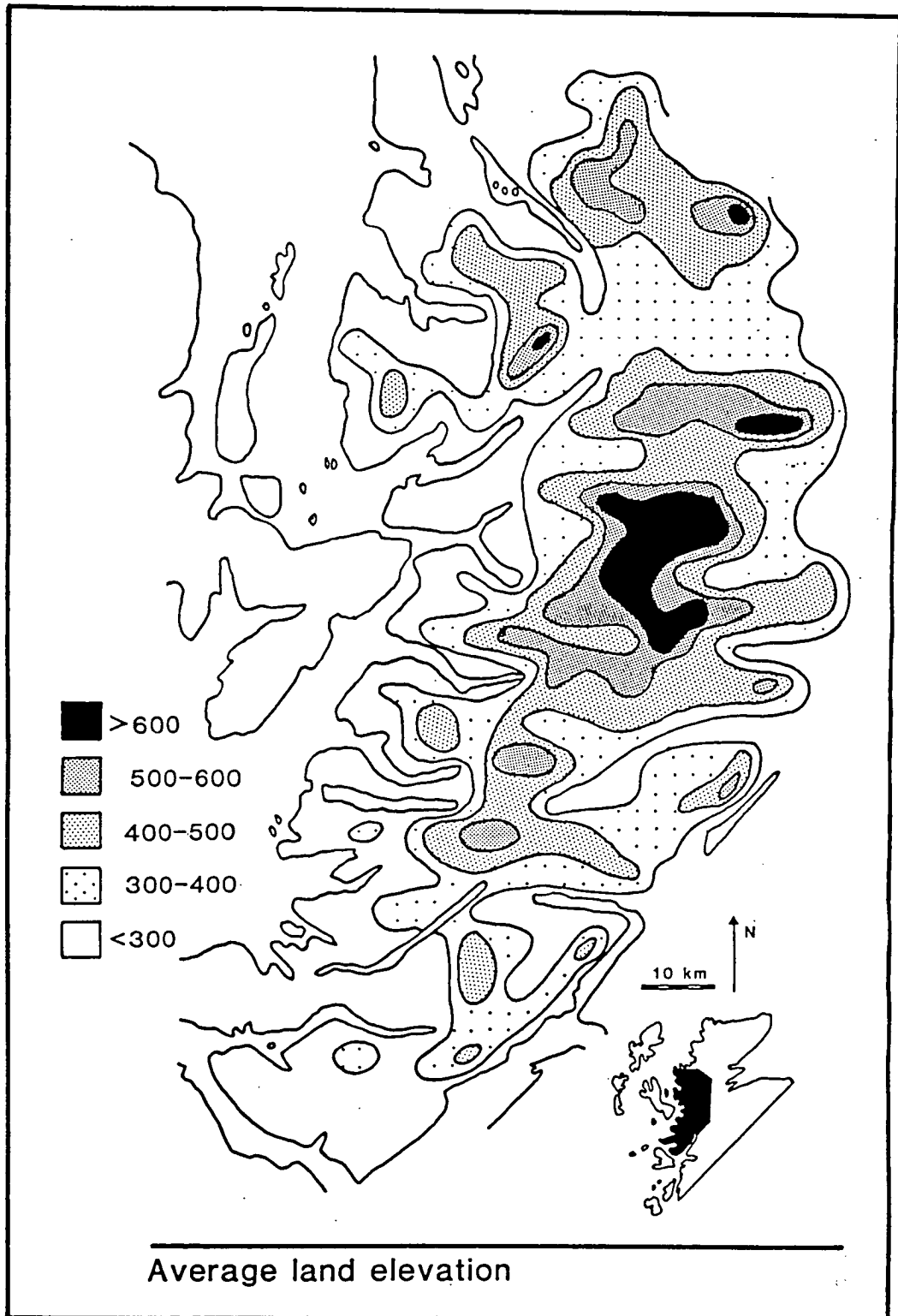

Figure 8.4: Average land elevation in metres. Relief was sampled from 1:25 000 O.S. maps at 1km intervals. An average relief value was then calculated from this sample for each square ( $25 \text{ km}^2$ ) in a grid covering the study area. These average elevations were then contoured. Within each grid the average relief was calculated from 1km point samples (for each square  $N=16$ ).

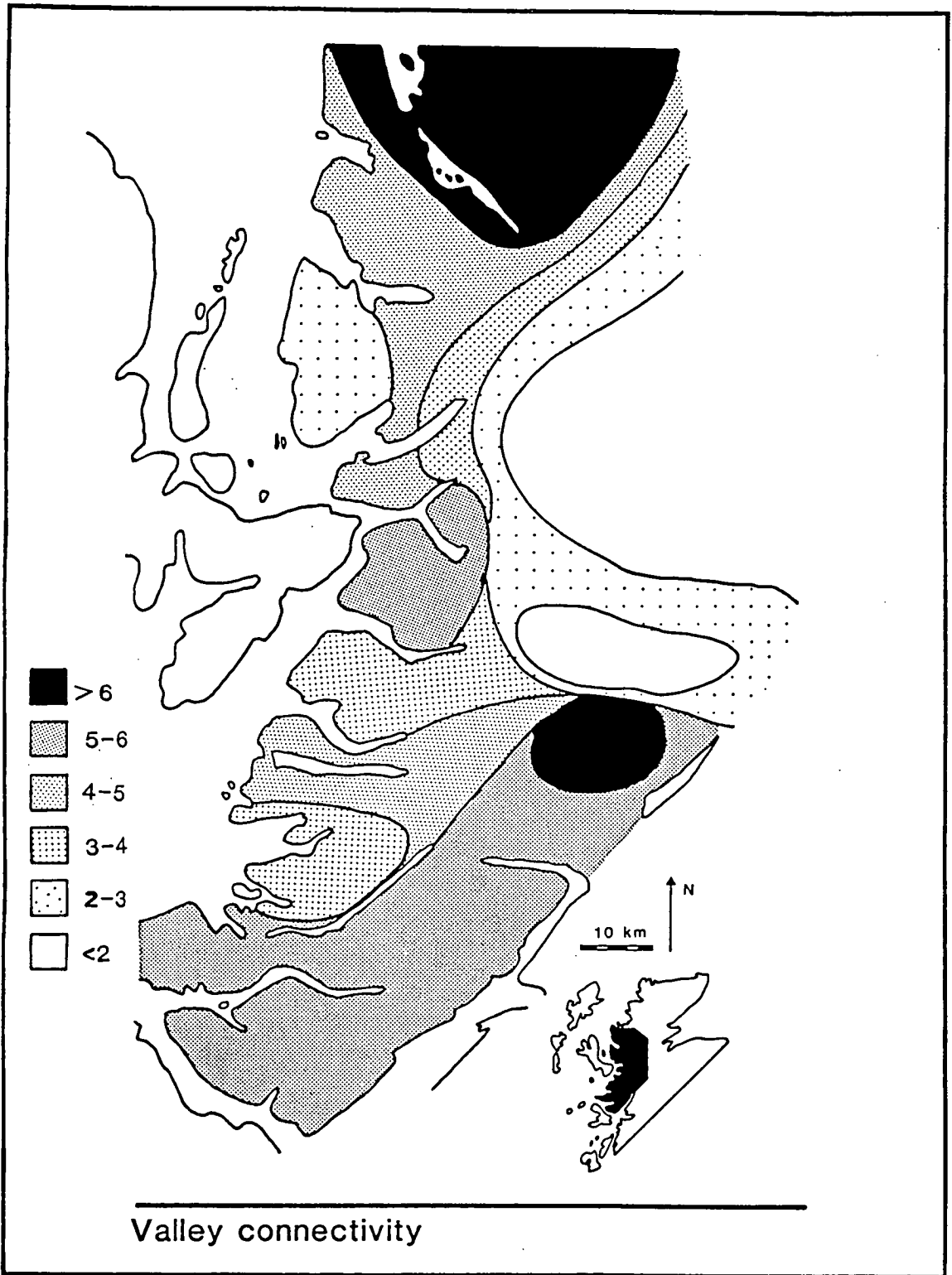

Figure 8.5: Valley connectivity. Values are taken from Haynes (1977) and are for the alpha connectivity index. The larger the value the better connected the valley system (see Haynes 1977 for details).

#### **8.4: What was the pattern of decay?**

Figure 8.6 illustrates the interpreted pattern of decay for the whole area of the Loch Lomond Stadial ice cap in the North West Highlands (See Chapter Six for details). It shows a selection of ice marginal positions, from the maximum extent of the ice cap to those which define the final areas of decay. Three main areas with different retreat characteristics can be identified:

1. Southern Area—the area south of Loch Hourm.
2. Central Area—the area between Loch Hourm and Loch Carron.
3. Northern Area—the area north of Loch Carron.

**1. Southern Area**—There are two principal final centres of decay, one to the south of Loch Quoich and a second at the head of Loch Shiel, although several smaller centres occur between them. Decay converged on an area just to the east of the main axis of relief (Fig. 8.4 & 8.6). The most noticeable characteristic of all these centres is that ice converged upon them symmetrically in contrast to the asymmetry present further north (Table 8.1).

**2. Central Area**—There are numerous small decay centres in this area in contrast to the southern and northern areas. It is coincident with an increase in relief as well as with an area of anomalously low valley connectivity (Fig. 8.4 & 8.5). Topography seems to have played a dominant role in governing the pattern of decay by dividing and fragmenting the ice cap as it melted down. It did not simply retreat into corries and valley heads, but towards the northern faces of prominent mountain ridges and away from south facing slopes, suggesting that insolation contrasts dominated the final phases of decay.

**3. Northern Area**—In this area there is a relatively simple decay pattern which seems to reflect the decrease in relief and increase in connectivity of the valley system (Fig. 8.4 & 8.5). There are only two principal decay centres— one in Torridon and another to the north of Loch Maree—although a third, smaller centre was present in northern Torridon associated with an isolated spur of the main ice cap. All these centres are associated with the northern and eastern flanks of prominent mountains and are located on the main relief axis. The location of the relief axis in the west has resulted in a particularly asymmetrical pattern of decay (Table 8.1). It implies that ice retreat in the east began earlier, or was much more rapid, than in the west.

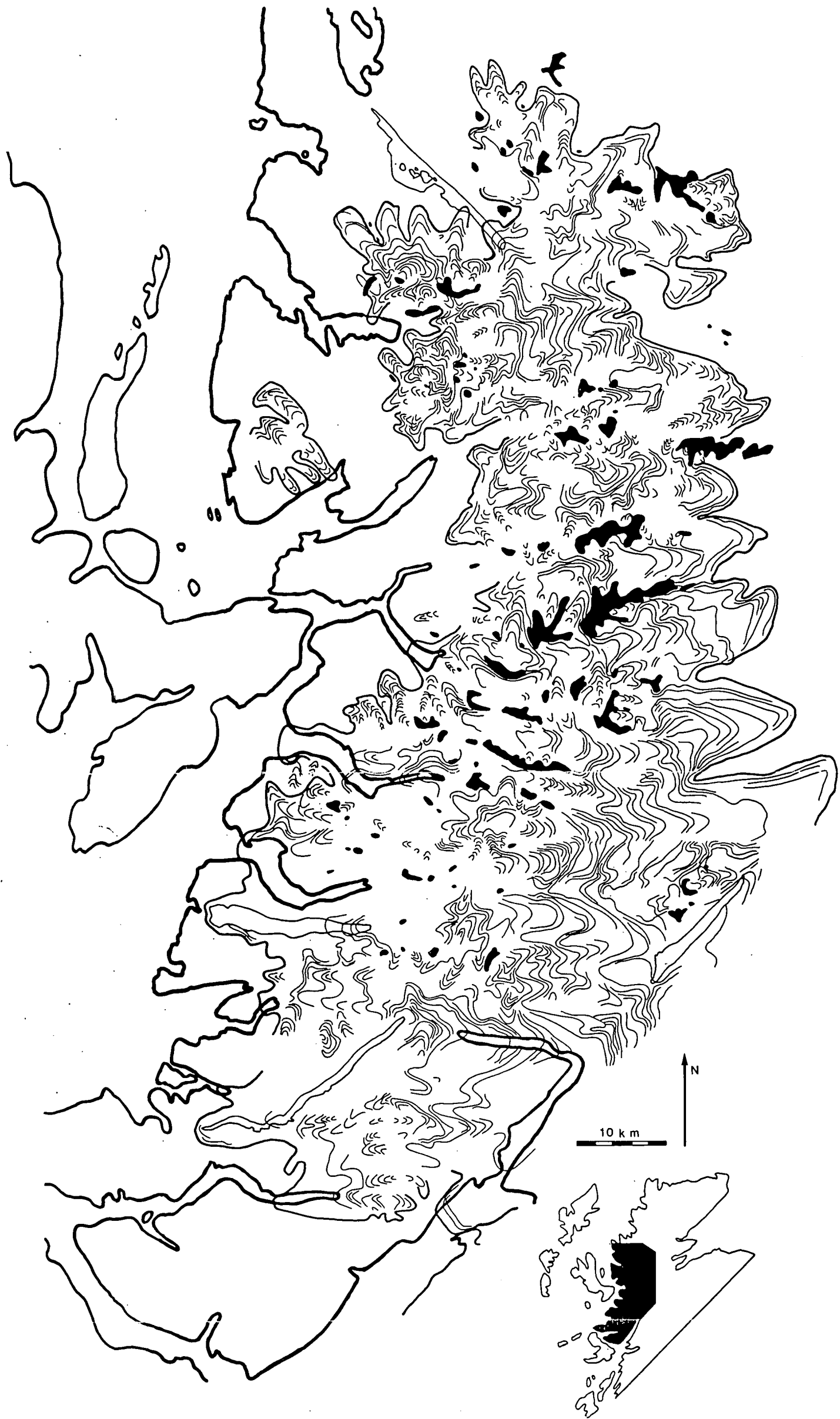

Figure 8.6: The pattern of deglaciation in the North West Highlands. Each line within the Loch Lomond Readvance limit represents an ice marginal position during decay. Only selected stages of decay are shown and the diagram is compiled from data presented in Chapter Six. Land over 800 m is shown by black areas. The decay pattern for small corrie glaciers is not shown.

From these patterns a number of important controls on deglaciation can be inferred.

Firstly, as a general rule the ice decayed back onto the main relief axis. In the north this resulted in a very asymmetric pattern of decay since the main relief axis is in the west. The theoretical reconstruction also suggests that the ice divides were located along the main relief axis (Fig. 8.3 & 8.4). In the south the ice divide and the decay centres are both located just to the east of the relief axis.

Figure 8.7 depicts a hypothetical transect across a group of mountains, to the east of which there is a pronounced increase in precipitation. At the onset of glacial conditions accumulation will start in the mountains despite the lower precipitation, because of lower temperatures at higher elevation. Only when the ice cap has a sufficient elevation relative to the topography, can its centre of mass migrate towards the area of higher precipitation. When this ice cap decays retreat will be centred on the area beneath the ice divide: that is, to the east of the mountains. One can apply this hypothetical situation to the North West Highlands. The association of the ice divide, decay centre and the relief axis in the north implies either that precipitation was at a maximum along the relief axis as it is today, or that the glacial event was not of sufficient duration for the ice divide to adjust to, and therefore reflect, any other pattern of precipitation. Further south, where relief is much lower relative to ice thickness, both the former ice divide and the decay centres are located to the east of the main mountain axis. Here the ice divide may have had a longer time period in which to adjust to spatial variations in precipitation. This would imply that precipitation, and hence accumulation, was greater on the eastern side of the ice cap.

Secondly, topography is the principal variable controlling the pattern and organisation of decay, the more diverse and less connected the valley system, the more fragmented the decay pattern becomes.

Finally, the traditional models of active deglaciation typified in the work of Charlesworth (1955), which suggest that ice caps decay firstly into a system of valley glaciers and then into corries, is not applicable to the North West Highlands. Comparison of Charlesworth's decay pattern (Fig. 8.8) for the North West Highlands with that in Figure 8.6 reveals a striking degree of dissimilarity since his pattern is controlled primarily by the location of corries. I suggest that, even in the area of very high relief,

corries were not important as local decay centres: of more importance are the northern faces of prominent east-west ridges. This suggests that the climate was not sufficiently severe to support a period of corrie glaciation at the close of the Loch Lomond Stadial.

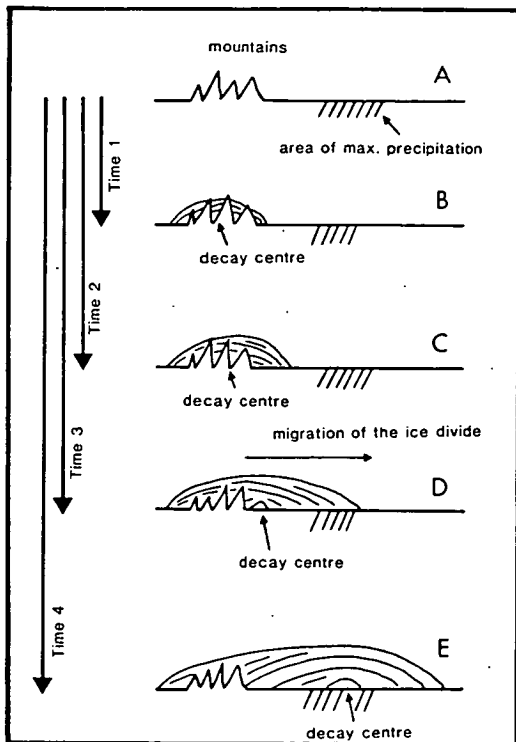

Figure 8.7: Hypothetical example of the adjustment of an ice divide to spatial variations in precipitation and its influence on the location of the centre of decay.

	West	East	South	North	West/East
Northern section	15%	48%	9.7%	23%	0.31
Central section	17%	50%	6.3%	25%	0.34
Southern section	38%	38%	7.8%	15.7%	1.0

Table 8.1: Asymmetry of decay for three regions of the North West Highlands (see text). The orientation of the decay path was assessed for individual pixels (25 km<sup>2</sup>) in each of three regions. The orientations are those of a line drawn perpendicular to the dominant trend of palaeo-ice fronts.



Figure 8.8: One of Charlesworth's (1955) 19 maps showing the pattern of deglaciation within the Scottish Highlands. The map depicts a small part of the North West Highlands.

**8.5: What is the spatial variation of glacial landforms within the area occupied by the Loch Lomond Stadial ice cap?**

There is a strong spatial variation in the distribution of glacial landforms within the area of the Loch Lomond Stadial ice cap. This distribution is shown by three drift distribution maps (Fig. 8.9, 8.10 & 8.11), each of which records a slightly different aspect of the distribution.

Firstly, the drift pixel map (Fig. 8.9) records the distribution of the total drift cover (eg. moraines, flutes, outwash) and is based on an arbitrary assessment, on a scale of 1 (no drift cover) to 5 (continuous drift cover), of glacial drift present in a 25 km<sup>2</sup> pixel.

Secondly, a moraine or palaeo-ice front frequency map (Fig. 8.10), which records areas with high moraine frequencies. The larger the frequency the larger the block of colour.

Finally, a landform distribution map picks out the distribution of flutes (Fig. 8.11).

Careful comparison of these maps reveals, not only the spatial variation in drift cover within the area occupied by the ice cap, but also its composition.

Three contrasting areas can be identified:

- 1) Torridon—Applecross. Drift concentration due to high frequencies of moraine ridges and flutes.
- 2) Loch Arkaig—Loch Eil. Drift concentration due to a high frequency of flutes.
- 3) Loch Nevis—Loch Linnhe. A distinct absence of drift cover (south western margin of the ice cap).

The obvious explanation for these variations is lithology. Within the North West Highlands one can identify four main north east to south west trending lithological groups (Leedal 1952; Clifford 1957; Brown *et al.* 1970; Johnson 1983)(Fig. 8.12):

Group 1: Torridonian sandstones and Lewisian gneises.

Group 2: Moines—Mora Division—Highly inclined psammitic schists.

Group 3: Moines—Glenfinnan Division—Highly inclined pelitic schists.

Group 4: Moines—Loch Eil Division—Gently inclined psammitic rocks.

Qualitative comparison of the distribution of these four groups (Fig. 8.12) with the pattern of drift distribution suggests that lithology may be able to explain the areas of thick drift but does not explain the lack of drift in the south west where both Groups 3 and 4 occur. In order to examine these geological controls further, each pixel on the drift pixel map was assigned to one of the four lithologies and the frequency of pixels in each drift class was estimated (Table 8.2). For each lithological group a drift score was then calculated using the simple formula presented in Table 8.2, high scores indicating high drift concentration. The table shows that lithology 1 has a relatively high score, as does lithology 4.

Class of drift cover		1	2	3	4	5	No.	Drift score
Lithology 1	Frequency	8	14	9	11	12	54	3.1
Lithology 2		18	33	29	9	0	89	2.3
Lithology 3		10	29	19	3	0	61	2.2
Lithology 4		15	23	22	13	7	80	2.7

Table 8.2: Illustrates the relationship between drift cover (Fig. 8.9) and lithology. The geology map in Figure 8.12 was superimposed onto the drift pixel map and the number of pixels in each lithology counted (No.) and their distribution between the 5 drift classes established, ie. how many class 5 squares etc. A drift score was calculated for each lithology from:  $\text{Drift score} = \frac{\sum(\text{frequency} \cdot \text{drift class})}{\text{No. of squares}}$ .

Group 1 is coincident with the high concentration of drift around Torridon and Applecross. There is an obvious causal relationship here, since Torridonian sandstone is extremely well jointed with sub-horizontal bedding and is therefore easily broken up into blocky clasts which produce a characteristically porous sediment.

Group 4, Moines—Loch Eil Division, is similar in areal extent to that of the drift concentration between Loch Arkaig and Loch Eil. The causal coupling here is less apparent. However, the bedding and structure of the Loch Eil Moines is significantly less inclined and appears in the field to be more fractured than the other two Moine divisions. This may therefore have been more easily exploited by glacier ice. Comparison of all three drift maps (Fig. 8.9, 8.10 & 8.11) illustrates that an important component of the two principal drift concentrations is the presence of heavily fluted terrain. This is particularly true of the area between Loch Arkaig and Loch Eil. I suggest that this simply reflects the size of individual patches of drift cover. In areas of almost continuous drift cover, the probability that flutes will form will be greater, and the fluted pattern more apparent, than in an area where the drift cover is concentrated into discrete patches.

In summary, there is strong evidence to suggest that lithology is an important control on the spatial distribution of drift within the area occupied by the Loch Lomond Stadial ice cap. The presence of easily exploitable lithologies and the consequent availability of subglacial sediment may result in the formation of large areas of fluted terrain.

However lithology does not appear to explain the distribution of drift in the south western part of the ice cap, since this pattern cuts across three separate lithological groups. The drift pixel map (Fig. 8.9) picks out a general deficiency of drift along the southern margin of the ice cap from Loch Nevis to Loch Linnhe, which is also reflected in the lack of clear evidence of the maximum limit of the ice cap along this margin (Fig. 8.11). However, the moraine frequency map provides more detail (Fig. 8.10). From this map four specific corridors with little or no drift can be identified, centred along Loch Hourn, Loch Shiel, Loch Linnhe and between Loch Nevis and Loch Morar.

The simplest explanation for these corridors of sparse drift is that glacial transport has matched the production of both subglacial and supraglacial debris so that these areas were stripped of debris as it was

produced. Clearly this would require very active ice flow along these corridors, consistent with the concentration and perhaps streaming of ice into and along these loch basins. At the maximum extent of the ice cap this could have been due to rapid calving into the sea lochs of Loch Hourn, Loch Nevis and Loch Linnhe and by calving during decay into Loch Shiel and Loch Morar as these lochs were uncovered by retreating ice. Subsequently, rapid retreat along these lochs, perhaps accelerated by rising sea levels, would result in little visible sign of deposition along these loch corridors. There are several lines of evidence which support this hypothesis.

Firstly, there is evidence of very active ice flow along both Loch Hourn and Loch Nevis. Along both these lochs there is a remarkable concentration of signs of glacial abrasion, exemplified at several sites by a remarkable density of striae.

Secondly, there is widespread evidence of rapid retreat up these lochs. For example, in the largest, Loch Linnhe, there is evidence of only four clear still stand positions during decay (Thorp 1986, 1991), whilst in Loch Nevis, there is evidence of no still stands on the loch sides. Moreover, the retreat pattern (Fig. 8.6) supports this idea of rapid retreat along the loch basins. For example, south of Loch Morar the orientation of the palaeo-ice fronts indicates that ice did not retreat as quickly from the upland area to the south of the loch as it did up the centre of the basin itself.

There is, therefore, some evidence to support this hypothesis, although in the area around Loch Shiel a more general and regional lack of drift may reflect the absence, in this part of the former ice cap, of high mountains and hence nunatacks that could supply supraglacial debris.

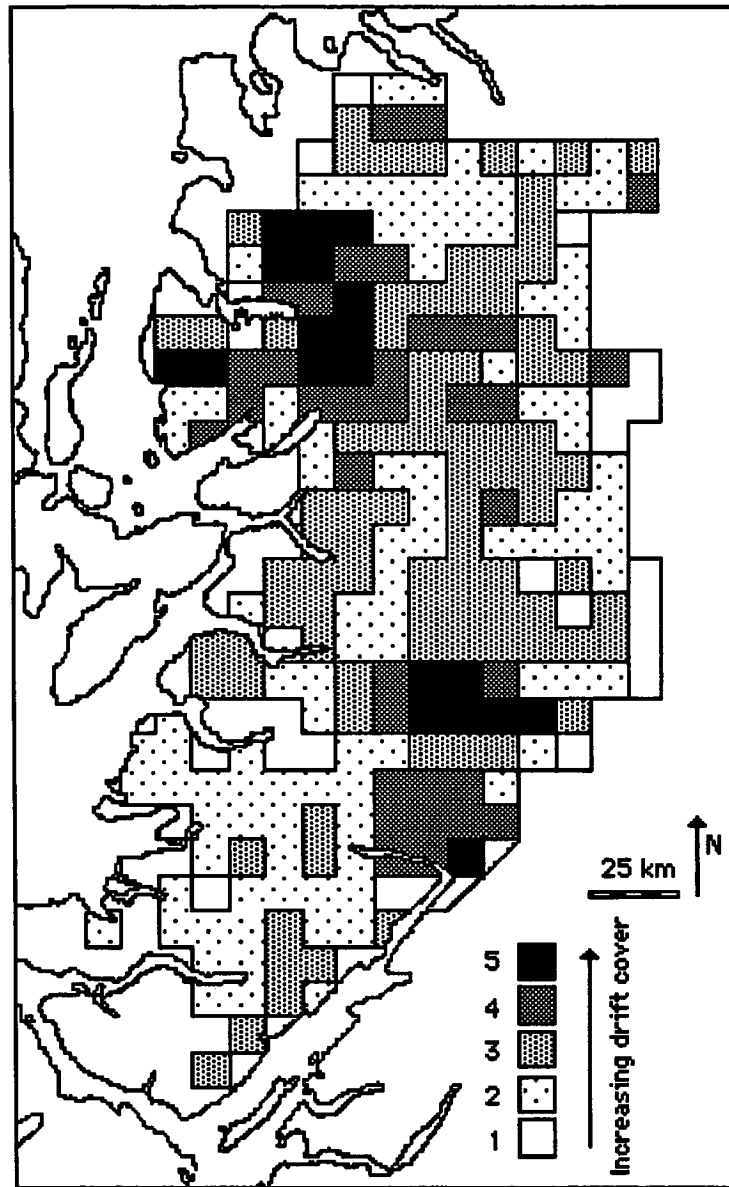

Figure 8.9: Drift pixel map for the Loch Lomond Stadial ice cap in the North West Highlands, based on a grid with 25 km<sup>2</sup> pixels and an arbitrary assessment of drift cover—scale 1 to 5 (1 = little or no drift cover; 5 = thick drift cover).

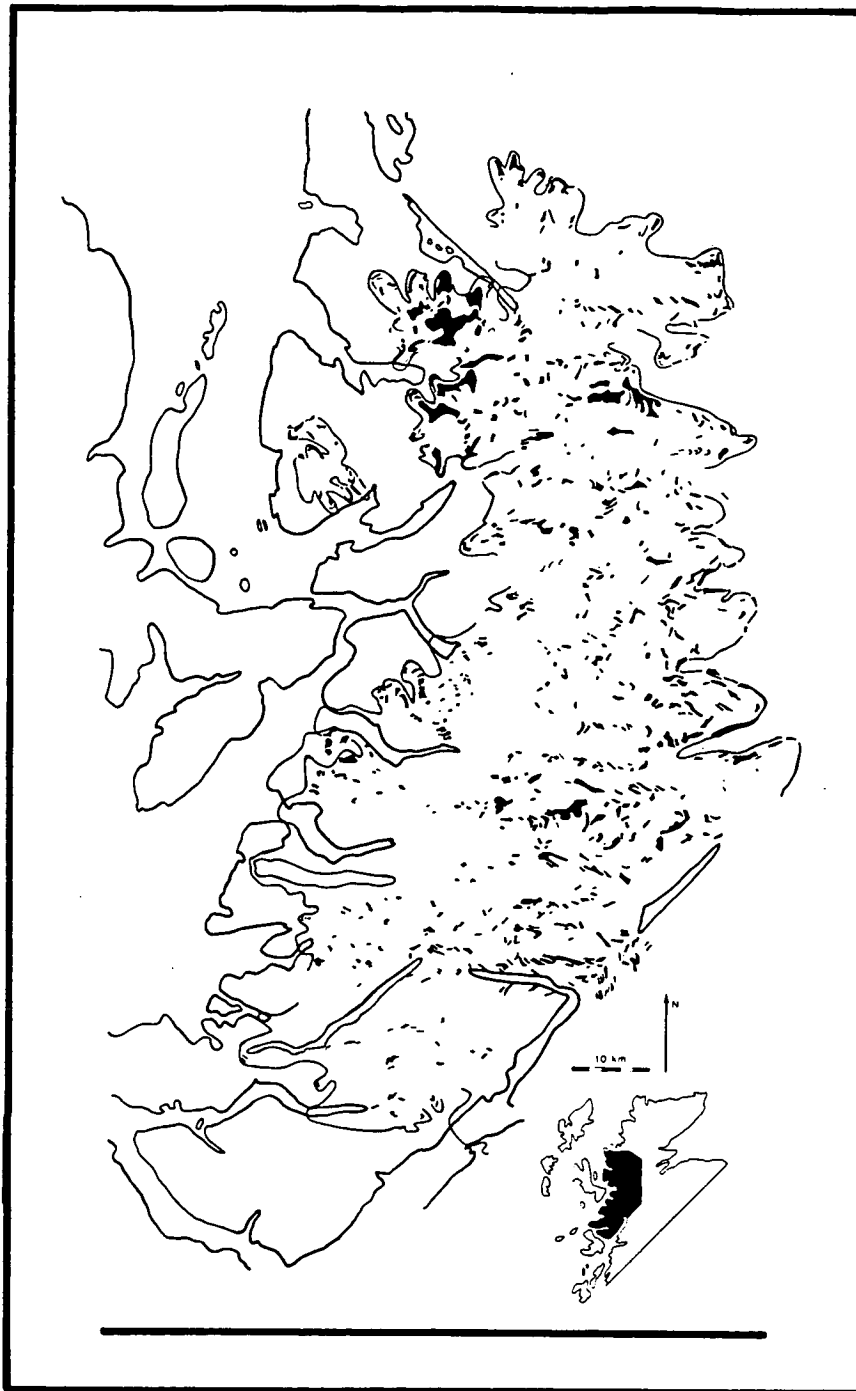

Figure 8.10: Moraine frequency map based on the palaeo-ice front data. Groups of three or more palaeo-ice fronts with less than three millimetres between each one have been replaced by blocks of colour, these blocks are bounded by breaks of greater than three millimetres in the sequence of ice margins. The map illustrates palaeo-ice front or moraine frequency, large blocks of black represent continuous sequences of high frequency moraine ridges. The parameters used were selected on the basis of trial and error.

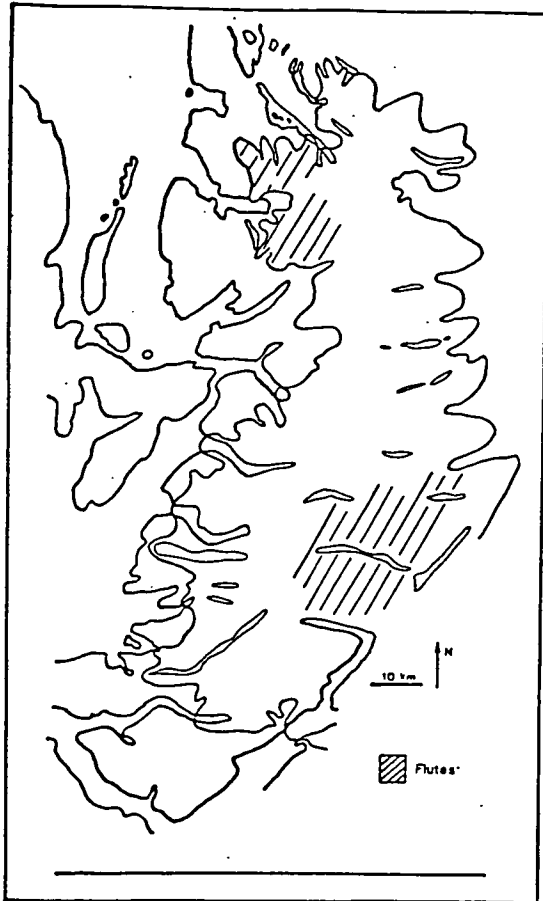
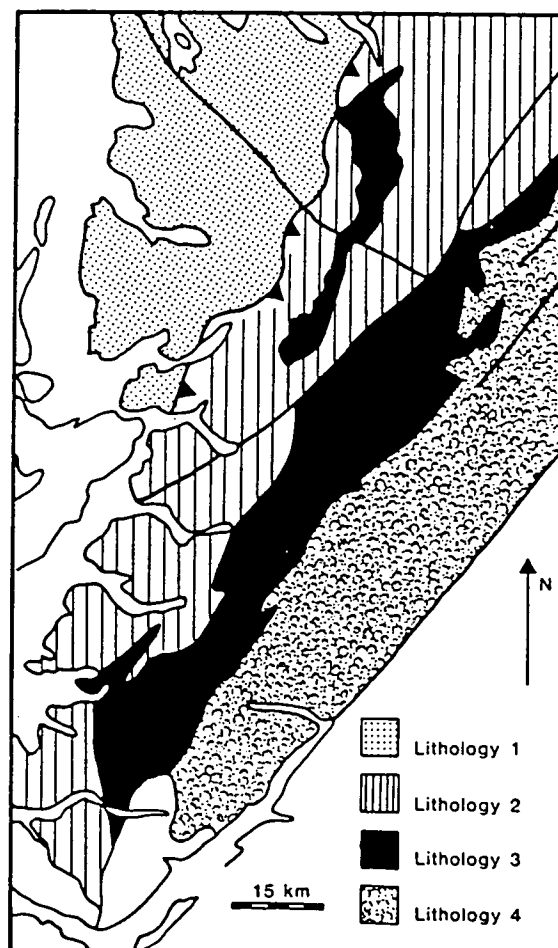

Figure 8.11. Distribution of flutes, within the North West Highlands.

Figure 8.12. Simplified geology of the North West Highlands.



### 8.6: What was the rate of decay?

In the absence of absolute dates for any part of the morphological chronology presented here it is not possible to assess the rate of retreat with any accuracy. It is clear, however, that for an ice cap to decay actively and deposit the wide range of landforms described within this thesis, deglaciation must have been more prolonged than has previously been suggested (eg. Sissons 1967, 1976).

Owing to the number of assumptions required, estimates based on the number of retreat moraines provide little information on this problem. For example, within the North West Highlands 255 retreat moraines have been recorded between the Loch Lomond Readvance limit and the centres of final decay (a distance of 40 km)(N=28; average=140 moraines on a flow line). If one assumes (unrealistically) that each of these moraines formed in one year, then the ice cap would have decayed over a period of 255 years. This corresponds to an annual loss in volume of  $7.6 \text{ km}^3$  of ice per year or to an annual rate of retreat of 156 metres. Similarly, in the Grampian Highlands, Horsefield (1983) and Day (1983) noted that, between Ba Bridge on Rannoch Moor and the Loch Lomond Readvance limit at the eastern end of Loch Rannoch (58 km), there are 370 moraine ridges. Day (1983) consequently argued that, if each moraine formed in one year, then a total of 370 years must be considered a minimum time for deglaciation up to Ba Bridge. This also corresponds to an annual rate of retreat of 156 metres per year. Despite the consistency between these estimates, however, this approach is of limited value, because three unfounded assumptions that have to be made:

Assumption 1: That the moraine record is complete. The absence of moraines in a given area does not necessarily mean that the glacier retreated rapidly, since moraines can be removed or may never form. The record is unlikely therefore to be complete.

Assumption 2: That each moraine forms in one year. The rate of formation of each retreat moraine is uncertain; though they could form as frequently as one per year, it could take several years. The problem is particularly difficult since the size of moraines gives little indication of their rate of formation. Moraine size, whether push moraine or a dump moraine, is critically dependent on the availability of debris. Consequently, comparison of moraine size between glaciated areas is not valid. For example, to argue that annual push moraines around the

Vatnajökull ice cap in South East Iceland are smaller than the retreat moraines in Scotland and therefore that Scottish moraines must form over longer periods, is invalid unless the debris supply rates, ice activity and retreat rates can all be shown to be the same.

Assumption 3: That decay is recorded only by retreat moraines. In fact, the pattern of deglaciation in the North West Highlands is not recorded solely by moraines. Outwash fans and ice-dammed lakes also form a significant part of the decay sequence. Crude assumptions about the rate of formation of this type of landforms can not be made.

It follows that estimating decay time from the number of retreat moraines is very unsatisfactory. A realistic indication of the duration of decay will only be obtained when the retreat moraines are dated.

### 8.7: Chapter summary.

During the Loch Lomond Stadial an ice cap existed in the North West Highlands with an area of 4 700 km<sup>2</sup>, a maximum elevation of at least 600 metres and incorporating 1 900 km<sup>3</sup> of ice. I argue that this ice cap decayed in an extremely active and progressive fashion and have mapped the pattern of retreat. The pattern of decay was controlled primarily by the topography beneath the ice sheet. In areas of relatively low relief, with well connected valley systems only a few large residual centres of decay were present, located on the eastern side of the main relief axis. In areas of high relief, and where the valley system is poorly connected, the pattern of decay was much more fragmented. Within the ice cap the organisation of landforms and sediment was controlled by lithology and ice sheet dynamics.

• Chapter Nine •

Discussion and conclusions

## Contents

---

9.1:	Introduction.	182
9.2:	Topography and lithology.	182
9.3:	Thermal regime.	183
9.4:	Glacier-climate interaction.	184
9.5:	The importance of producing a dated framework.	188
9.6:	Future research.	188
9.7:	Summary of conclusions.	189

---

*In the previous chapter the interpretation of "hummocky moraine" presented in this thesis was used to reconstruct the extent, surface morphology and pattern of decay of the Loch Lomond Stadial ice cap in the North West Highlands. The patterns established have a number of important implications, which are discussed in the first part of this chapter. The principal conclusions of this research are then summarised.*

### **9.1: Introduction.**

In the last chapter the proposed interpretation of "hummocky moraine" was used to examine the decay of the Loch Lomond Stadial ice cap in the North West Highlands and the landform patterns produced by it. These patterns have several important implications which are discussed in the following section.

### **9.2: Topography and lithology.**

It was shown in the last chapter that the pattern of decay of the Loch Lomond Stadial ice cap in the North West Highlands owed much to the topography of the region. In areas of high relief and poor valley connectivity deglaciation leads to numerous small centres of final decay. In such areas the pattern of decay may be so fragmented as to record little of palaeoclimatic significance. In contrast an ice cap lying in an area of low and well connected relief is likely to have a pattern of decay and distribution of decay centres reflecting climatic as opposed to topographic influences.

In a number of recent publications topography has also been recognised as an important determinant of dynamics and ice cap form (eg. Payne 1988; Payne & Sugden 1990; Hindmarsh 1990).

The spatial distribution of landforms and sediments within the Loch Lomond Stadial ice cap appears to reflect strong lithological control. The importance of lithology on subglacial processes such as erosion is well documented (eg. Sugden 1978; Boulton 1974, 1979). However, little work appears to have stressed its potential to control the large scale distribution of glacial sediment assemblages.

Geological boundary conditions such as topography and lithology are clearly important in determining ice cap form, dynamics and drift distribution within the Loch Lomond Stadial ice cap. They should be examined further in a wider context and perhaps incorporated more effectively into glacial models.

### **9.3: Thermal regime.**

The thermal regime of the Loch Lomond Stadial ice cap has not been widely discussed, although, amongst others, Hodgson (1982) and Thorp (1991) have implicitly assumed it to have been warm based.

The thermal regime of an ice cap is an important control on sedimentation and landforms produced at its margin. Consequently thermal regime can be inferred from landform assemblages (eg. Boulton 1972b; Boulton & Paul 1976; Eyles *et al.* 1983). Three main glacier thermal regimes have been identified:

1) Temperate (wet) regimes: These margins are characterised by dense suites of push moraines, dump moraines, outwash fans and eskers (eg. Boulton 1986; Boulton & Eyles 1979). They can be characterised by a complex lithofacies composed of units of till, gravel and sand (eg. Boulton 1975; Eyles *et al.* 1982, 1983).

2) Polar (cold) regimes: These margins are characterised by large shear moraines and hummocky bouldery topography (eg. Weertman 1961; Souchez 1967; Pickard 1984; Fitzsimons 1990). They can be characterised by a lithofacies composed of thick till layers between which thin interbeds of resedimented till occur (eg. Shaw 1977; Eyles *et al.* 1983).

3) Subpolar regimes: These margins often deposit hummocky kamiform topography (Boulton 1972a; Boulton & Paul 1976). They can be characterised by a lithofacies composed of very variable till units and

resediment tills interbedded with sands and gravels (eg. Boulton 1970a, 1972a; Eyles *et al.* 1983).

During decay the Loch Lomond Stadial ice cap left a dense suite of distinct ice marginal landforms. These landforms consist, for the most part, of push moraines, dump moraines, outwash fans and flutes. Assemblages of small high frequency ice marginal moraines, such as those within the Loch Lomond ice cap, are typical of wet based ice caps and glaciers (eg. Vatnajökull in South East Iceland)(Boulton & Eyles 1979; Chorley *et al.* 1984). It is therefore possible to argue on geomorphological grounds that the Loch Lomond Stadial ice cap was warm based.

#### 9.4: Glacier-climate interaction.

If the Loch Lomond ice cap in the North West Highlands decayed in the active and progressive manner described in this thesis then a number of important issues are raised. It is probable that decay was much more prolonged than previously suggested (eg. Sissons 1967, 1979b). This appears to conflict with the rapid rise in air temperature depicted in the coleopteran record at the close of the Loch Lomond Stadial (eg. Bishop & Coope 1977; Coope 1977; Atkinson *et al.* 1987). For the palaeo-air temperatures inferred from the coleopteran record to be consistent with the slow rate of active retreat inferred here a striking spatial variation in air temperature must have existed at the close of the Loch Lomond Stadial. Over the ice cap climatic conditions must have remained harsh and therefore air temperatures will have increased rapidly away from the decaying ice margins. A diverse range of environments and geomorphological processes may therefore have operated at this time, ranging from cold glacial or periglacial environments and processes close to the decaying ice margins, to much warmer, more temperate environments elsewhere (Bishop & Coope 1977; Coope 1977; Pennington 1977; Walker & Lowe 1990).

This implies that there was not a simple linear response by the Loch Lomond Stadial ice cap to climate forcing. Variations in air temperature and ice volume were not synchronous as has been assumed in the past (eg. Sissons 1979b, 1980b; Payne & Sugden 1990). Changes in ice volume may have lagged behind changes in air temperature. The glacial system appears to have damped the impact of this rapid rise in air temperature and responded to it over a much longer time period, as is indicated by the active

pattern of deglaciation described here. This is illustrated schematically in Figure 9.1. The degree to which the ice cap's response lagged the climatic forcing is unknown since the exact length of time over which the ice cap decayed is uncertain, however one can argue that degree of order and pattern maintained during the decay of the Loch Lomond Stadial ice cap is not consistent with a rapid synchronous response to climate.

The absence of a linear ice cap climate response can be explained if the ice cap was able to interact locally with the atmosphere so as to modify the climate and air circulation over it.

Contemporary ice caps provide good evidence that this occurs. For example, the Vatnajökull ice cap in South East Iceland modifies its local environment (Boulton pers comm; see also Boulton 1986). The air temperature around the ice cap is lowered by the latent heat consumed during ablation and by intermittent katabatic winds which blow from the centre of the ice cap. A similar mechanism could have operated over the Loch Lomond Stadial ice cap, so that it was able to decay in a controlled and prolonged manner despite the rapid rise in air temperature. As the ice cap decreased in size its ability to modify climate should have decreased. Consequently, the deglaciation rate should have accelerated as the ice body decreased in size. There is evidence which suggests that this occurred. Firstly, two of the large decay centres in Torridon are associated with large areas of stagnation terrain. Other decay centres tend to show similar characteristics. Secondly, in areas of high relief, decaying glaciers did not retreat into corries. Most small decay centres were simply situated on valley sides. This suggests that the "snow line" had risen above the mountain tops, so that a final corrie glacial phase did not occur.

Not only is such a conclusion important in itself, but it calls into question attempts to reconstruct the palaeoclimate of the Loch Lomond Stadial by simple modification of the contemporary synoptic pattern. This point is well illustrated by the model of the Loch Lomond Stadial ice cap recently developed by Payne (1988)(see also: Payne & Sugden 1990). This model assumes a direct response between climate and ice decay and consequently predicts very rapid deglaciation. The assumption of such a simple response between climate and ice decay is not justified on the basis of the evidence presented here.

The implications of ice cap-climate interaction for the palaeoclimatic inferences made by Sissons and his co-workers is less

certain. For the most part, these inferences are based on an analysis of the size and altitude distribution (firn line altitudes) of small ice fields and corrie glaciers that existed during the Loch Lomond Stadial (Sissons 1974b, 1979b, 1980b; Sissons & Sutherland 1976; Sutherland 1984a; Ballantyne 1989). Sissons has argued that a greater volume of ice was situated on the south side of mountain masses, particularly in the South East Grampians, than on the northern side. Reconstructions of south facing glacier were also shown to have lower firn line altitudes than those which face north. He concluded that the prevailing direction of snow-bearing wind during the Loch Lomond Stadial was from the south east and proposed a simple synoptic model to explain this pattern (Sissons 1979b, 1980b; Sissons & Sutherland 1976; Gray & Coxon 1991). Sissons suggested that the presence of the polar front off the coast of the British Isles during the Stadial resulted in a more vigorous climatic circulation and a rapid succession of depressions that crossed the British Isles with a more southerly track than at present, "warm or occluded fronts approached from the west or south west, the major snowfalls occurring with south to southeasterly winds before the fronts arrived" (Sissons 1979b, p. 519). Sissons went on to infer palaeo-temperatures using the following information: (1) reconstructions of glacier firn line altitudes for selected Loch Lomond Stadial ice masses; (2) assumed accumulation rates and; (3) the mass balance curve of Liestøl which relates accumulation to firn line temperature for six Norwegian glaciers. From this he inferred mean July sea-level temperatures of c. 6° C and 7.5° C for the South East and South West Grampians (Sissons 1979b; methods are similar to those of Manley 1959).

Two major criticisms can be levelled at these palaeoclimatic inferences:

Firstly, they are based for the most part on evidence drawn from the corrie glaciers and ice fields identified around the periphery of the main ice cap in the Scottish Highlands. The large volume of ice present within the Loch Lomond Stadial ice cap is for the most part ignored.

Secondly, although the presence of some of these north south contrasts in glacier size and altitude cannot be denied, their interpretation, may be far more complex than suggested by Sissons and his co-workers. I suggest that the synoptic model developed to explain the southeasterly snow winds must now be reconsidered in light of the evidence presented here for climate-ice cap interaction during this period.

In order to assess the importance of this last point information is required about the degree to which the Loch Lomond Stadial ice cap was able to influence circulation within the Scottish Highlands. Such information will only become available, and with it a greater understanding of the palaeoclimate, by modelling the climatic circulation for the whole of Northern Europe during the Loch Lomond Stadial. Such a model must incorporate, not only the small scale disturbances caused by an ice cap in the Scottish Highlands, but also the large scale perturbation induced by the Scandinavian ice sheet. The influence of the Scandinavian ice sheet may have been considerable if it induced atmospheric perturbations on the scale of those which have recently been suggested for the North American ice sheet (eg. Broccoli & Manabe 1987; Clark 1990; Boulton & Clark 1990; Williams pers comm.).

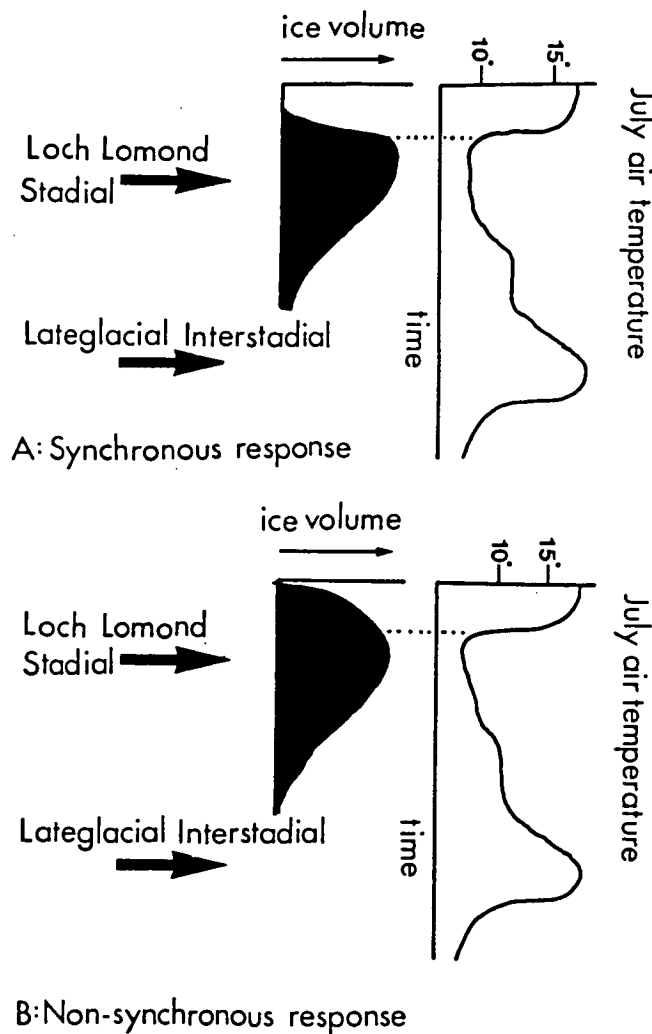

Figure 9.1: Schematic examples of synchronous and non-synchronous response of the Loch Lomond Stadial ice cap to climatic forcing during decay. The air temperature curve is taken from Coope (1977) and is the mean July temperature.

### **9.5: The importance of producing a dated framework.**

Within this thesis the pattern of decay of the Loch Lomond Stadial ice cap has been established. Dating this pattern could produce an almost uniquely comprehensive picture of the ice cap's decay in both space and time. This is illustrated by recent work on the mid-latitude ice sheets (eg. Dyke & Prest 1987; Boulton *et al.* 1985; Lundqvist 1986) which has shown that, once the decay pattern has been established, a relatively small number of deglaciation dates are required to produce a time history of decay (Boulton & Clark 1990). The significance of such a history is two-fold: firstly, it provides a basis for comparing the behaviour of one component of the climate system with the other elements of this system and with the palaeo-biological record, and secondly it has the potential to provide mass balance inferences of a resolution superior to previous estimates from palaeo-ice masses.

Is it possible to obtain such dating control? The occurrence of buried organic matter suitable for dating beneath the moraines of the Loch Lomond Stadial is rare (Lowe & Walker 1984; Rose 1989a). Dating the retreat moraines in this way could therefore prove difficult. However, Day (1983) attempted to date the till from within these retreat moraines by their palaeomagnetic remanence and this may have the potential to provide valuable results in the future. Similarly, the palaeomagnetic remanence of ice-dammed lake sediments, associated with specific phases of decay, could also provide chronological information (Lowe & Walker 1984). Tephrochronology may also be relevant in these environments (see: Long & Morton 1987; Dugmore 1989; Graham *et al.* 1990).

### **9.6: Future Research.**

I suggest that future research into the Loch Lomond Stadial ice cap should concentrate on dating the morphological chronology proposed here and developing a three-dimensional model of the ice cap, including a detailed appraisal of crustal flexure. Such investigations have the potential to provide important new insights into evolving palaeoclimate of the Devensian Glacial/Interglacial transition.

### 9.7: Summary of conclusions:

1) When viewed from the air "hummocky moraine" has a clear form and structure which has a spatial organisation resembling that found at modern ice margins which are active, though decaying.

2) A model describing "hummocky moraine" as an assemblage of individual ice marginal landforms is established. This model implies that the Loch Lomond Stadial ice cap decayed as an active glacier and that the pattern of decay can be established by mapping landforms and associated structure within "hummocky moraine".

3) The pattern present within "hummocky moraine" was examined at three spatial scales. At each of these scales the patterns observed resemble those found at modern glacier margins.

On a small scale (< 100 m) "hummocky moraine" appears to consist primarily of suites of push moraines, dump moraines, ice-contact outwash fans and flutes. Such a suite of landforms are typical of many active glacier margins today.

On a meso-scale (100-1000 m) the spatial organisation of landforms within "hummocky moraine" is similar to that found at the margins of active, modern, retreating glaciers. The ice-marginal moraines within "hummocky moraine" have gradients consistent with those of lateral moraines at modern ice margins. the pattern of retreat depicted by the landforms within "hummocky moraine" in individual valleys and the interaction between separate glacier lobes is similar to the patterns found around the margins of modern ice caps. The patterns of decay established from "hummocky moraine" appear to reflect controls on ice margin geometry such as insolation contrasts.

On a macro-scale (> 1000 m) landforms within "hummocky moraine" fit together to form as coherent pattern as one would expect if it was produced by an actively decaying ice cap.

I suggest therefore that the Loch Lomond Stadial ice cap in the North West Highlands decayed in an active and progressive manner and that "hummocky moraine" provides a record of that decay.

- 4) Using evidence in the terminal zone, the basal shear stress of the ice cap is estimated to be close to 100 Kpa and shows variation consistent with that present at modern ice margins.
  
- 5) The maximum extent and surface morphology of the Loch Lomond Stadial ice cap in the North West Highlands has been established. Using a simple numerical model to extrapolate the geological data available in the terminal areas, it was concluded that the ice cap had an area of 4 700 km<sup>2</sup> and incorporated a total volume 1 900 km<sup>3</sup> of ice.
  
- 6) The pattern of decay within the North West Highlands is strongly influenced by topography.
  
- 7) Lithology and ice cap dynamics were found to be important controls on the distribution of drift within the area occupied by the ice cap.
  
- 8) It has been argued that attempts to estimate the period of time over which the ice cap decayed by the frequency of retreat moraines are seriously limited.
  
- 9) Attention is drawn to the apparent conflict between the relatively prolonged period of decay indicated by the geomorphological record and the rapid climatic amelioration indicated by the palaeo-biological record at the close of the Loch Lomond Stadial. This is explained in terms of the glacier-climate interaction both damping the impact, and delaying the response, of the glacial system to climatic change.

## • References •

**Agassiz, L. 1840:** On the evidence of the former existence of glaciers in Scotland, Ireland and England. *Proceedings of the Geological Society of London* 3, 327-332.

**Aber, J. S., Croot, D. G. & Fenton, M. M. 1989:** *Glaciotectonic landforms and structures*. Kluwer Academic Publishers, Dordrecht.

**Andersen, & Sollid 1971:** Glacial chronology and glacial geomorphology in the marginal zones of the glaciers Midtdalsbreen and Nigardsbreen, south Norway. *Norsk Geografiska Tidsskrift* 25, 1-38.

**Atkinson, T. C., Briffa, K. R. & Coope, G. R. 1987:** Seasonal temperatures in Britain during the past 22,000 years, reconstructed using beetle remains. *Nature* 325, 587-593.

**Ballentyne, C. K. 1979:** A Sequence of late glacial ice-dammed lakes in East Argyll. *Scottish Journal of Geology* 15, 153-160.

**Ballentyne, C. K. 1982a:** Depths of open joints and limits of former glaciers. *Scottish Journal of Geology* 18, 250-252.

**Ballentyne, C. K. 1982b:** Aggregate clast form characteristics of deposits near the margin of four glaciers in the Jotunheimen Massif, Norway. *Norsk Geografiska Tidsskrift* 36, 103-113.

**Ballentyne, C. K. 1986:** Protales rampart development and the limits of former glaciers in the vicinity of Baosbheinn, Wester Ross. *Scottish Journal of Geology* 22, 13-25.

**Ballentyne, C. K. 1989:** The Loch Lomond Readvance on the Isle of Skye, Scotland: glacier reconstruction and palaeoclimatic implications. *Journal of Quaternary Science* 4, 95-108.

**Ballentyne, C. K. & Wain-Hobson, T. 1980:** The Loch Lomond Advance on the Island of Rhum. *Scottish Journal of Geology* 16, 1-10.

**Ballantyne, C. K. & Gray, J. M. 1984:** The Quaternary geomorphology of Scotland: the research contribution of J. B. Sissons. *Quaternary Science Reviews* 3, 259-289.

**Ballantyne, C. K. & Sutherland, D. G. 1987:** *Wester Ross-field guide*. Quaternary Research Association, Cambridge.

**Ballantyne, C. K., Benn, D. I., Lowe, J. J. & Walker, M. J. C. 1991:** *The Quaternary of the Isle of Skye: field guide*. Quaternary Research Association, Cambridge.

**Baranowski, S. 1970:** The origin of fluted moraine at the fronts of contemporary glaciers. *Geografiska Annaler* 52A, 68-75.

**Barrow, G.E.H., Cunningham, C. & Hinxman, L. W. 1912:** *The geology of the districts of Braemar and Glen Clova districts: explanation of sheet 65*. Memoirs of the Geological Survey of Scotland, H.M.S.O. Edinburgh.

**Barrett, P. J. 1980:** The shape of rock particles; a critical review. *Sedimentology* 27, 291-304.

**Benn, D. I. 1989a:** Controls on sedimentation in a Late Devensian ice-dammed lake, Achnasheen, Scotland. *Boreas* 18, 31-42.

**Benn, D. I. 1989b:** Debris transport by Loch Lomond Readvance glaciers in Northern Scotland: basin form and the within-valley asymmetry of lateral moraines. *Journal of Quaternary Science* 4, 243-254.

**Benn, D. I. 1990:** *Scottish Lateglacial moraines: debris supply, genesis and significance*. Ph.D. thesis (unpubl.), University of St Andrews.

**Bennett, M. R. 1990:** The deglaciation of Glen Croulin, Knoydart. *Scottish Journal of Geology* 26, 41-46.

**Bennett, M. R. & Glasser, N. F. 1991:** The glacial landforms of Glen Geusachan, Cairngorms: a reinterpretation. *Scottish Geographical Magazine* (in press).

**Bishop, W. W. & Coope, G. R. 1977:** Stratigraphical and faunal evidence for Late Glacial and early Flandrian environments in south-west Scotland. In J. M. Gray, & J. J. Lowe (Eds.). *Studies in the Scottish Late Glacial environment*, Pergamon Press, Oxford, 61-88.

**Boothroyd, J. C. & Ashley, G. M. 1975:** Processes, bar morphology and sedimentary structures on braided outwash fans, Northeastern Gulf of Alaska. In Jopling, A. V. & McDonald, B. C. (Eds). *Glaciofluvial and glaciolacustrine sedimentation*. The Society of Economic Paleontologists and Mineralogists (Special Publication 23), Tulsa, 193-222.

**Boulton, G. S. 1968:** Flow tills and related deposits on some Vestspitsbergen glaciers. *Journal of Glaciology* 7, 391-412.

**Boulton, G. S. 1970:** On the deposition of subglacial and melt-out tills at the margins of certain Svalbard glaciers. *Journal of Glaciology* 9, 231-245.

**Boulton, G. S. 1972a:** Modern Arctic glaciers as depositional models for former ice sheets. *Journal of Geological Society of London* 128, 361-393.

**Boulton, G. S. 1972b:** The role of thermal regime in glacial sedimentation. In Price, R. J. & Sugden, D. E. (Eds.). *Polar geomorphology*. Institute of British Geographers (Special Publication 4), London, 1-19.

**Boulton, G. S. 1974:** Processes and patterns of glacial erosion. In Coates, D. R. (Ed). *Glacial geomorphology*. Allen & Unwin, London, 41-87.

**Boulton, G. S. 1975:** Processes and patterns of subglacial sedimentation: a theoretical approach. In Wright, A. E. & Moseley, F. (Eds.). *Ice ages: ancient and modern*. Seel House Press, Liverpool, 7-42.

**Boulton, G. S. 1976:** The origin of glacially fluted surfaces-observations and theories. *Journal of Glaciology* 17, 287-309.

**Boulton, G. S. 1978:** Boulder shapes and grain-size distributions of debris as indicators of transport paths through a glacier and till genesis. *Sedimentology* 25, 773-799.

- Boulton, G. S. 1979:** Processes of glacier erosion on different substrata. *Journal of Glaciology* 23, 15-38.
- Boulton, G. S. 1986:** Push-moraines and glacier-contact fans in marine and terrestrial environments. *Sedimentology* 33, 677-698.
- Boulton, G. S. & Paul, M. A. 1976:** The influence of genetic processes on some geotechnical properties of glacial tills. *Quarterly Journal of Engineering Geology*, 9, 159-194.
- Boulton, G. S. & Eyles, N. 1979:** Sedimentation by valley glaciers: a model and genetic classification. In Schlüchter, C. (Ed.). *Moraines and varves*, A. A. Balkema, Rotterdam, 11-23.
- Boulton, G. S. & Hindmarsh, R. C. A. 1987:** Sediment deformation beneath glaciers: rheology and geological consequences. *Journal of Geophysical Research* 92, 9059-9082.
- Boulton, G. S. & van der Meer, J. J. M. 1989:** *Preliminary report on an expedition to Spitsbergen in 1984 to study glaciotectionic phenomena (Glacitecs' 84)*. University of Amsterdam, Amsterdam.
- Boulton, G. S. & Clark, C. 1990:** The Laurentide ice sheet through the last glacial cycle: the topology of drift lineations as a key to the dynamic behaviour of former ice sheets. *Transactions of the Royal Society of Edinburgh* 81, 327-347.
- Boulton, G. S., Chroston, P. N. & Jarvis, J. 1981:** A marine seismic study of late Quaternary sedimentation and inferred glacier fluctuations along western Inverness-shire, Scotland. *Boreas* 10, 39-51.
- Boulton, G. S., Smith, G. D., Jones, A. S. & Newsome, J. 1985:** Glacial geology and glaciology of the last mid-latitude ice sheets. *Journal of the Geological Society of London* 142, 447-474.
- Boulton, G. S., Peacock, J. D. & Sutherland, D. G. in press:** Quaternary. In G. Y. Craig (Ed.). *Geology of Scotland* (3rd Edition).

**Bridgland, D. R. 1986:** Discussion of procedures and recommendations. In Bridgland, D. R. (Ed.). *Clast lithological analysis*, Quaternary Research Association, Cambridge, 1-33.

**Bryant, I. D. 1991:** Sedimentology of glaciofluvial deposits. In J. Ehlers, P. L. Gibbard & J. Rose, (Eds.). *Glacial deposits in Great Britain and Ireland*. A. A. Balkema, Rotterdam, 437-442.

**Broccoli, H. J. & Manabe, S. 1987:** The effects of the Laurentide ice sheet on North American climate during the last glacial maximum. *Geographie physique et Quaternaire* 2, 291-229.

**Broecker, W. S., Andree, M., Wolfli, W., Oeschger, H., Bonani, G., Kennett, J. & Peteet, D. 1988:** The chronology of the last deglaciation: implications to the cause of the Younger Dryas event. *Palaeoceanography* 3, 1-19.

**Brotchie, J. F. & Silvester, R. 1969:** On crustal flexure. *Journal of Geophysical Research* 74, 5240-5252.

**Brown, R. L., Dalziel, I. W. D. & Johnson, M. R. W. 1970:** A review of the structure and stratigraphy of the Moinian of Ardgour, Moidart and Sunart. *Scottish Journal of Geology* 6, 309-335.

**Budd, W. F. & Carter, D. B. 1971:** An analysis of the relation between the surface and bedrock profiles of ice caps. *Journal of Glaciology* 10, 197-209.

**Bullard, J. E. 1991:** *Twentieth-century Glacier Fluctuations, Ice-dammed Lakes and Jökulhlaups, Heinabergsjökull, south-east Iceland: A case study*. Undergraduate dissertation (unpubl.), University of Edinburgh.

**Charlesworth, J. K. 1955:** The late-glacial history of the Highlands and Island of Scotland. *Transactions of the Royal Society of Edinburgh* 62, 103-929.

**Charlesworth, J. K. 1957.** *The Quaternary Era*. Edward Arnold, London.

- Chorley, R. J., Schumm, S. A., & Sugden, D. E. 1984.** *Geomorphology*. Methuen, London.
- Church, M. & Gilbert, R. 1975:** Proglacial fluvial and lacustrine environments. In Jopling, A. V. & McDonald, B. C. (Eds). *Glaciofluvial and glaciolacustrine sedimentation*. The Society of Economic Paleontologists and Mineralogists (Special Publication 23), Tulsa, 22-100.
- Clapperton, C. M. 1990:** Quaternary glaciations in the Southern Hemisphere: an overview. *Quaternary Science Reviews*, 9, 299-304.
- Clark, C. D. 1990:** *Reconstruction of the behaviour of the Laurentide ice sheet using satellite imagery*. Ph.D. thesis (unpubl.), University of Edinburgh.
- Clifford, T. N. 1957:** The stratigraphy and structure of part of the Kintail district. *Quarterly Journal of the Geological Society* 113, 57-92.
- Collingbourne, R. H. 1976:** Radiation and sunshine. In T. J. Chandler, & S. Gregory (Eds.): *The climate of the British Isles*, Longman, New York, 74-95.
- Coope, G. R. 1977:** Fossil coleopteran assemblages as sensitive indicators of climatic changes during the Devensian (Last) cold stage. *Philosophical Transactions of the Royal Society London B* 280, 313-340.
- Coope, G. R. & Brophy, J. A. 1972:** Late Glacial environmental changes indicated by a coleopteran succession from North Wales. *Boreas* 1, 97-142.
- Coope, G. R. & Joachim, M. J. 1980:** Late Glacial environmental changes interpreted from fossil coleoptera from St Bees, Cumbria, North West England. In J. M. Gray, & J. J. Lowe (Eds.). *Studies in the Scottish Late Glacial Environment*, Pergamon Press, Oxford, 55-68.
- Cornish, R. 1979:** *Glacial geomorphology of the west central Southern Uplands of Scotland with particular reference to "rogen moraines"*. Ph.D. thesis (unpubl.), University of Edinburgh.

- Cornish, R. 1981:** Glaciers of the Loch Lomond Stadial in the western Southern Uplands of Scotland. *Proceedings of the Geological Association* 92, 105-114.
- Croft, R. S. 1974:** A visual measure of shingle particle form for use in the field. *Journal of Sedimentary Petrology* 44, 931-934.
- Dansgaard, W., White, J. W. C. & Johnsen, S. J. 1989:** The abrupt termination of the Younger Dryas climate event. *Nature* 339, 532-534.
- Dawson, A. G. 1979:** A Devensian medial moraine in Jura. *Scottish Journal of Geology* 15, 43-48.
- Dawson, A. G. 1988:** The main rock platform (main Lateglacial shoreline) in Ardnamurchan and Moidart, western Scotland. *Scottish Journal of Geology* 24, 163-174.
- Dawson, A. G. 1989:** Distribution and development of the main rock platform: reply. *Scottish Journal of Geology* 25, 233-238.
- Dawson, A. G., Lowe, J. J. & Walker, M. J. C. 1987:** The nature and age of the debris accumulation at Gribun, Western Mull, Inner Hebrides. *Scottish Journal of Geology* 23(2), 149-162.
- Day, T. E. 1983:** *The remanent magnetism of till and other glacial sediments*. Ph.D. thesis (unpubl.), University of East Anglia.
- Donner, J. J. 1957:** The geology and vegetation of Late-glacial retreat stages in Scotland. *Transactions of the Royal Society of Edinburgh* 63, 221-264.
- Dowdeswell, J. A., Hambrey, M. J. & Wu, R. 1985:** A comparison of clast fabric and shape in late Pre-Cambrian and modern glaciogenic sediments. *Journal of Sedimentary Petrology* 55, 691-704.
- Drewry, D. 1986:** *Glacial Geologic Processes*. Arnold, London.

**Driedger, C. L. & Kennard, P. M. 1986:** Glacier volume estimation on Cascade volcanoes: an analysis and comparison with other methods. *Annals of Glaciology* 8, 59-64.

**Dugmore, A. 1989:** Icelandic volcanic ash in Scotland. *Scottish Geographical Magazine* 105, 168-172.

**Dyke, A. S. & Prest, V. K. 1987:** Late Wisconsinan and Holocene history of the Laurentide ice sheet. *Geographie physique et Quaternaire* 2, 237-263.

**Embleton, C. & King, C. A. M. 1975:** *Glacial Geomorphology* (2nd Edition). Arnold, London.

**Eybergen, F. A. 1986:** Glacier snout dynamics and contemporary push moraine formation at the Turtmannglacier, Wallis, Switzerland. In Van Der Meer, J. J. M. (Ed.). *Tills and glaciotectionics*. A. A. Balkema, Rotterdam, 217-231.

**Eyles, N. 1978:** *Facies of supraglacial sedimentation on temperate valley glaciers*. Ph.D. thesis (unpubl.), University of East Anglia.

**Eyles, N. 1979:** Facies of supraglacial sedimentation on Icelandic and Alpine temperate glaciers. *Canadian Journal of Earth Science* 16, 1341-1361.

**Eyles, N. 1983a:** Modern Icelandic glaciers as depositional models for "hummocky moraine" in the Scottish Highlands. In E. B. Evenson, C. Schluchter, & J. Rabasa (Eds.). *Tills and related deposits*, A.A. Balkema, Rotterdam, 47-59.

**Eyles, N. 1983b:** The glaciated valley system. In Eyles, N. (Ed.). *Glacial geology*. Pergamon Press, Oxford, 91-110.

**Eyles, N., Sladen, J. A. & Gilroy, S. 1982:** A depositional model for stratigraphic complexes and facies superimposition in lodgement till. *Boreas*, 11, 317-333.

**Eyles, N., Eyles, C. H., & Miall, A. D. 1983:** Lithofacies types and vertical profile models; an alternative approach to the description and

environmental interpretation of glacial diamict and diamictite sequences. *Sedimentology* 30, 393-410.

Fisher, P. F. & Bridgland, D. R. 1986: Analysis of pebble morphology. In Bridgland, D. R. (Ed.). *Clast lithological analysis*, Quaternary Research Association, Cambridge, 43-58.

Fitzsimons, S. J. 1990: Ice-marginal depositional processes in a polar maritime environment, Vesfold Hills, Antarctica. *Journal of Glaciology* 36, 279-286.

Fyfe, G. 1990: The effect of water depth on ice-proximal glaciolacustrine sedimentation: Salpausselkää I, Southern Finland. *Boreas* 19, 147-164.

Geike, A. 1863: On the phenomena of the glacial drift of Scotland. *Transactions of the Geological Society of Glasgow* 1, 1-190.

Gemmell, A. M. D. 1973: The deglaciation of the island of Arran, Scotland. *Transactions of the Institute of British Geographers* 59, 25-39.

Goldthwait, R. P. 1951: Development of end moraines in east-central Baffin Island. *Journal of Geology* 59, 567-577.

Graham, D. K., Harland, R., Gregory, D. M., Long, D. & Morton, A. C. 1990: The biostratigraphy and chronostratigraphy of BGS borehole 78/4, North Minch. *Scottish Journal of Geology* 26, 65-75.

Gravenor, C. P. & Kupsch, W. O. 1959: Ice disintegration features in western Canada. *Journal of Geology* 67, 48-64.

Gray, J. M. 1972: *The inter-, late- and post glacial shorelines and ice-limits of Lorn and Eastern Mull*. Ph.D. thesis (unpubl.), University of Edinburgh.

Gray, J. M. 1975: The Loch Lomond Readvance and contemporaneous sea-levels in Loch Etive and neighbouring areas of Western Scotland. *Proceedings of the Geological Association* 86, 227-238.

- Gray, J. M. 1982:** The last glaciers (Loch Lomond Advance) in Snowdonia, North Wales. *Geological Journal* 17, 111-133.
- Gray, J. M. 1989:** The distribution and development of the main rock platform, western Scotland: comment. *Scottish Journal of Geology* 25, 227-231.
- Gray, J. M. 1991:** Glaciofluvial landforms. In J. Ehlers, P. L. Gibbard & J. Rose, (Eds.). *Glacial deposits in Great Britain and Ireland*. A. A. Balkema, Rotterdam, 443-454.
- Gray, J. M. & Brooks, C. L. 1972:** The Loch Lomond Readvance moraines of Mull and Mentieth. *Scottish Journal of Geology* 8, 95-103.
- Gray, J. M. & Sutherland, D. G. 1977:** The "Oban-Ford moraine": a reappraisal. In J. M. Gray, & J. J. Lowe (Ed.). *Studies in the Scottish Lateglacial environment*, Pergamon Press, Oxford, 33-44.
- Gray, J. M. & Coxon, P. 1991:** The Loch Lomond Stadial glaciation in Britain and Ireland. In J. Ehlers, P. L. Gibbard & J. Rose (Eds.). *Glacial deposits in Great Britain and Ireland*. A. A. Balkema, Rotterdam, 89-105.
- Hallam, A. 1983.** *Great geological controversies*. Oxford University Press, Oxford.
- Hambrey, M. J. 1984:** Sedimentary processes and buried ice phenomena in the proglacial areas of Spitsbergen glaciers. *Journal of Glaciology* 30, 116-119.
- Harvey, L. D. D. 1989:** Modelling the Younger Dryas. *Quaternary Science Review* 8, 137-149.
- Haynes, V. M. 1977:** The modification of valley patterns by ice-sheet activity. *Geografiska Annaler* 59A, 195-207.
- Hewitt, K. 1967:** Ice-front deposition and the seasonal effect: a Himalayan example. *Transaction of the Institutes of British Geographers* 42, 93-106.

Hindmarsh, R. C. A. 1990: Time-scales and degrees of freedom operating in the evolution of continental ice-sheets. *Transactions of the Royal Society of Edinburgh* 81, 371-384.

Hodgson, D. M. 1982: *Hummocky and fluted moraines in part of North-West Scotland*. Ph.D. thesis (unpubl.), University of Edinburgh.

Hodgson, D. M. 1986: A study of fluted moraines in the Torridon area, North-West Scotland. *Journal of Quaternary Science* 1, 109-118.

Hooke, R. Leb., Per Holmlund, C. P., Nilsson, M. & Stroeven, A. 1989: A 3 year record of seasonal variations in surface velocity, Storglaciären, Sweden. *Journal of Glaciology* 35, 235-247.

Hoppe, G. 1952: Hummocky moraine regions, with special reference to the interior of Norrbotten. *Geografiska Annaler* 34, 1-72.

Hoppe, G. 1959: Glacial morphology and inland ice recession in northern Sweden. *Geografiska Annaler* 41, 193-212.

Hoppe, G. & Schyatt, V. 1953: Some observations on fluted moraine surfaces. *Geografiska Annaler* 35, 105-115.

Horsefield, B. R. 1983: *The deglaciation patterns of the western Grampians of Scotland*. Ph.D. thesis (unpubl.), University of East Anglia.

Humlum, O. 1985: Genesis of an imbricate push moraine, Höfdabrekkujökull, Iceland. *Journal of Geology* 93, 185-195.

Ives, J. D. & King, C. A. M. 1954: Glaciological observations on Morsárjökull S. W. Vatnajökull: Part 1 Ogive banding. *Journal of Glaciology* 2, 423-428.

Jamieson, T. F. 1874: On the last stage of the glacial period in Northern Britain. *Quarterly Journal of the Geological Society of London* 30, 317-337.

Johnson, M. R. W. 1983: Torridonian-Moine. In G. Y. Craig (Ed.). *Geology of Scotland*, (2nd Edition) Scottish Academic Press, Edinburgh, 49-75.

**Karlén, W. 1981:** Flutes on bare bedrock. *Journal of Glaciology* 27, 190-192.

**Kirk, W. & Godwin, H. 1963:** A lateglacial site at Loch Droma, Ross and Cromarty. *Transactions of the Royal Society of Edinburgh* 65, 225-249.

**Königsson, L. K. 1984:** The 15th Uppsala symposium: ten years of Nordic till research. *Sriae* 20, 3-4.

**Krumbein, W. C. 1941:** Measurement and geological significance of shape and roundness of sedimentary particles. *Journal of Sedimentary Petrology* 11, 64-72.

**Krüger, J. 1985:** Formation of a push moraine at the margin of Höfdabrekkujökull, South Iceland. *Geografiska Annaler* 67A, 199-212.

**Krüger, J. & Thomsen 1984:** Morphology, stratigraphy, and genesis of small drumlins in front of the glacier Myrdalsjökull, South Iceland. *Journal of Glaciology* 30, 94-105.

**Lawson, D. E. 1979a:** *A sedimentological analysis of the western terminus region of the Matanuska glacier, Alaska.* U. S. Army Cold Regions Research and Engineering Laboratory Report 79-9.

**Lawson, D. E. 1979b:** A comparison of the pebble orientations in ice and deposits of the Matanuska glacier, Alaska. *Journal of Geology* 87, 629-645.

**Lawson, D. E. 1981:** Distinguishing characteristics of diamictons at the margin of the Matanuska glacier, Alaska. *Annals of Glaciology* 2, 78-84.

**Lawson, D. E. 1982:** Mobilization, movement and deposition of active subaerial sediment flows, Matanuska glacier, Alaska. *Journal of Geology* 90, 279-300.

**Leedal, D. L. 1952:** The Cluanie igneous intrusion. *Quarterly Journal of the Geological Society of London* 108, 35-62.

- Long, D. & Morton, A. C. 1987: An ash fall within the Loch Lomond Stadial. *Journal of Quaternary Research* 2, 97-101.
- Lowe, J. J. & Walker, M. J. C. 1981: The early and Postglacial environment of Scotland: evidence from a site near Tyndrum, Perthshire. *Boreas* 10, 281-294.
- Lowe, J. J. & Walker, M. J. C. 1984. *Reconstructing Quaternary Environments*. Longman, London.
- Lundqvist, J. 1986: Late Weichselian glaciation and deglaciation in Scandinavia. *Quaternary Science Reviews* 5, 269-293.
- Manley, G. 1959: The Lateglacial climate of north west England. *Liverpool and Manchester Geological Journal* 2, 188-215.
- Mathews, W. H. 1959: Vertical distribution of velocity in Salmon glacier, British Columbia. *Journal of Glaciology* 3, 448-454.
- Mathews, W. H. 1967: Profiles of late Pleistocene glaciers in New Zealand. *New Zealand Journal of Geology and Geophysics* 10, 146-163.
- Mathews, W. H. 1974: Surface profiles of the Laurentide ice sheet in its marginal areas. *Journal of Glaciology* 13, 37-43.
- Matthews, J. A. & Petch, J. R. 1982: Within-valley asymmetry and related problems of Neoglacial lateral moraine development at certain Jotunheimen glaciers, southern Norway. *Boreas* 11, 225-224.
- Matthews, J. A., Cornish, R. & Shakesby, R. A. 1979: "Saw-tooth" moraines in front of Bødalsbreen, southern Norway. *Journal of Glaciology* 22, 535-546.
- McDonald, B. C. & Shilts, W. W. 1975: Interpretation of faults in glaciofluvial sediments. In A. V. Jopling & B. C. McDonald (Eds.). *Glaciofluvial and glaciolacustrine sedimentation*. The Society of Economic Paleontologists and Mineralogists (Special Publication 23), Tulsa, 123-131.

- McCann, S. B. 1966a:** The limits of the late glacial highland or Loch Lomond Readvance along the west Highland seaboard from Oban to Mallaig. *Scottish Journal of Geology* 2, 84-95.
- McCann, S. B. 1966b:** The main Postglacial raised shoreline of western Scotland, from the Firth of Lorne to Loch Broom. *Transactions of the Institute of British Geographers* 39, 87-99.
- Murray, D. R. & Locke, W. W. 1989:** Dynamics of the late Pleistocene Big Timber glacier, Crazy Mountains, Montana, U. S. A. *Journal of Glaciology* 35, 183-190.
- Nobles, L. H. & Weertman, J. 1971:** Influence of irregularities of the bed of an ice sheet on deposition rate of till. In R. P. Goldthwait (Ed.). *Till, a symposium*, Ohio State University Press, Ohio 117-126.
- Norrdahl, H. 1983:** Late Quaternary stratigraphy of Fnjóskadalur central north Iceland, a study of sediments, ice-dammed lake strandlines, glacial isostasy and ice-free areas. Lundqua Thesis 12.
- Nye, J. F. 1952a:** A method of calculating the thickness of the ice-sheets. *Nature* 169, 529-530.
- Nye, J. F. 1952b:** A comparison of the theoretical and the measured long profiles of the Unteraar glacier. *Journal of Glaciology* 2, 103-107.
- Nye, J. F. 1959:** The motion of ice sheets and glaciers. *Journal of Glaciology* 3, 493-507.
- Nye, J. F. 1965:** The flow of a glacier in a channel of rectangular, elliptic or parabolic cross-section. *Journal of Glaciology* 5, 661-690.
- Orvig, S. 1953:** On the variation of the shear stress on the bed of an ice-cap. *Journal of Glaciology* 2, 242-247.
- Paterson, W. S. B. 1970:** The sliding velocity of Athabasca glacier, Canada. *Journal of Glaciology* 9, 55-63.

- Paterson, W. S. B. 1972: Laurentide ice sheet: estimated volumes during the Late Wisconsin. *Review of the Geophysical Space Physics* 10, 339-349.
- Paterson, W. S. B. 1981: *The physics of glaciers*. Pergamon Press, Oxford.
- Payne, A. 1988: *Modelling former ice sheets*. Ph.D. thesis (unpubl.), University of Edinburgh.
- Payne, A. & Sugden, D. E. 1990: Topography and ice sheet growth. *Earth Surface Processes and Landforms* 15, 625-639.
- Peach, B. N., Horne, J., Woodward, H. B., Clough, C. T., Harker, A. & Wedd, C. B. 1910: The geology of Glenelg, Lochalsh and the south-east part of Skye. *Memoir of the Geological Survey of Scotland*. H.M.S.O. Edinburgh.
- Peacock, J. D. 1967: West Highland moraine features aligned in the direction of ice flow. *Scottish Journal Geology* 3, 327-373.
- Peacock, J. D. 1970: Some aspects of the glacial geology of west Inverness-shire. *Bulletin of the Geological Survey of Great Britain* 33, 43-56.
- Peacock, J. D. 1971: Terminal features of the Creran glacier of Loch Lomond Readvance age in western Benderloch, Argyll and their significance in the late-glacial history of the Linnhe area. *Scottish Journal of Geology* 7, 349-356.
- Peacock, J. D. 1975: Palaeoclimatic significance of ice-movement directions of Loch Lomond Readvance glaciers in Glen Moriston and Glen Affric. *Bulletin of the Geological Society, Great Britain* 49, 39-42.
- Peacock, J. D. 1984: Quaternary Geology of the Outer Hebrides. *British Geological Survey Reports* 16.
- Peacock, J. D. 1991: Glacial deposits of the Hebridean region. In J. Ehlers, P. L. Gibbard & J. Rose, (Eds.). *Glacial deposits in Great Britain and Ireland*. A. A. Balkema, Rotterdam, 109-119.

- Peacock, J. D. & Cornish, R. 1989: *Glen Roy area: field guide*. Quaternary Research Association, Cambridge.
- Pennington, W. 1977: The Late Devensian flora and vegetation of Britain. *Philosophical Transactions of the Royal Society of London B* 280, 247-271.
- Pierce, K. L. 1979: History and dynamics of glaciation in the Northern Yellowstone Park area. *U.S. Geological Survey Professional Paper* 729-F.
- Pórarinnsson, S. 1967: Washboard moraines in front of Skeidarjökull. *Jökull* 17, 311.
- Powers, M. C. 1953: A New Roundness Scale for Sedimentary Particles. *Journal of Sedimentary Petrology* 23, 117-119.
- Prest, V. K. 1968: Nomenclature of moraines and ice-flow features as applied to the glacial map of Canada. *Geological Survey Paper Canada*, 67/57.
- Price, R. J. 1963: The glaciation of part of Peebleshire, Scotland. *Transactions of the Edinburgh Geological Society* 19, 326-348.
- Price, R. J. 1966: Eskers near the Casement glacier, Glacier Bay, Alaska. *Geografiska Annaler* 48, 111-125.
- Price, R. J. 1969: Moraines, Sandur, Kames and Eskers near Breiðamerkurjökull, Iceland. *Transactions of the Institute of British Geographers* 46, 17-43.
- Price, R. J. 1970: Moraines at Fjallsjökull. *Journal of Arctic and Alpine Research* 2, 27-42.
- Price, R. J. 1971: The development and destruction of a sandur, Breiðamerkurjökull, Iceland. *Journal of Arctic and Alpine Research* 3, 225-237.

- Price, R. J. 1973. *Glacial and Fluvioglacial Landforms*. Oliver & Boyd, Edinburgh.
- Raper, J. F. 1988: *A methodology for the investigation of landform-sediment relationships in British glaciated valleys*. Ph.D. thesis (unpubl.), Queen Mary College, University of London.
- Reed, W. J. 1989: *The vertical dimensions of the last ice sheet and late Quaternary glacial events in northern Ross-shire, Scotland*. Ph.D. thesis (unpubl.), University of St. Andrews.
- Robinson, M. 1977: *Glacial limits, sea-level changes and vegetation development in part of Wester Ross*. Ph.D. thesis (unpubl.), University of Edinburgh.
- Rose, J. 1980: In Jardine, W. G. (Ed.). *Quaternary Research Association field guide: Glasgow region*. Quaternary Research Association, Glasgow, 44-51.
- Rose, J. 1981: Field guide to the Quaternary geology of the southeastern part of the Loch Lomond basin. *Proceedings of Geological Society of Glasgow* (1980/81), 3-19.
- Rose, J. 1989a: Stadial type sections in the British Quaternary. In J. Rose & C. Schlüchter (Eds.). *Quaternary type sections: imagination or reality?* A. A. Balkema, Rotterdam, 45-67.
- Rose, J. 1989b: Glacier stress patterns and sediment transfer associated with the formation of superimposed flutes. *Sedimentary Geology* 62, 151-176.
- Rose, J. & Letzer, J. M. 1977: Superimposed drumlins. *Journal of Glaciology* 18, 471-480.
- Rose, J., Lowe, J. J. & Switsur, R. 1988: A radiocarbon date on plant detritus beneath till from the type area of the Loch Lomond Readvance. *Scottish Journal of Geology* 24, 113-124.

**Rust, B. R. 1975:** Fabric and structure in glaciofluvial gravels. In Jopling, A. V. & McDonald, B. C. (Eds.). *Glaciofluvial and glaciolacustrine sedimentation*. The Society of Economic Paleontologists and Mineralogists (Special Publication 23), Tulsa, 238-248.

**Schilling, D. H. & Hollin, J. T. 1981:** Numerical reconstruction of valley glaciers and small ice caps. In G. H. Denton & t. J. Hughes (Eds.). *The last great ice sheets*. Wiley & Sons, New York, 207-220.

**Sharp, M. 1984:** Annual moraine ridges at Skálafellsjökull, South-East Iceland. *Journal of Glaciology* 30, 82-93.

**Sharp, M. 1985:** "Crevasse-fill" ridges-a landform type characteristic of surging glaciers? *Geografiska Annaler* 67A, 213-220.

**Sharp, R. P. 1949:** Studies of superglacial debris on valley glaciers. *American Journal of Science* 247, 289-315.

**Shakesby, R. A. 1989:** Variability in Neoglacial moraine morphology and composition, Storbreen Jotunheim Norway: within-moraine patterns and the implications. *Geografiska Annaler* 71A, 17-29.

**Shaw, J. 1972:** Sedimentation in the ice-contact environment, with examples from Shropshire (England). *Sedimentology* 18, 23-62.

**Shaw, J. 1977:** Tills deposited in arid polar environments. *Canadian Journal of Earth Science* 14, 1239-1245.

**Simpson, J. B. 1933:** The Late-glacial readvance moraines of the Highland border west of the River Tay. *Transactions of the Royal Society of Edinburgh* 61, 687-698.

**Sissons, J. B. 1958:** Supposed ice-dammed lakes in Britain with particular reference to the Eddleston valley, southern Scotland. *Geografiska Annaler* 40, 159-187.

**Sissons, J. B. 1960:** Some aspects of glacial drainage channels in Britain, Part I. *Scottish Geographical Magazine* 76, 131-146.

- Sissons, J. B. 1961:** Some aspects of glacial drainage channels in Britain, Part II. *Scottish Geographical Magazine* 77, 15-36.
- Sissons, J. B. 1962:** A reinterpretation of the literature on lateglacial shorelines in Scotland with particular reference to the Forth area. *Transaction of the Edinburgh Geological Society* 19, 83-99.
- Sissons, J. B. 1965:** Quaternary. In G. Y. Craig (Ed.). *The Geology of Scotland*, (1st Edition) Scottish Academic Press, Edinburgh, 467-503.
- Sissons, J. B. 1967.** *The evolution of Scotland's scenery*. Oliver & Boyd, Edinburgh.
- Sissons, J. B. 1972:** The last glaciers in part of the south-east Grampians. *Scottish Geographical Magazine* 88, 168-181.
- Sissons, J. B. 1973:** Delineating Zone III in the eastern Grampians. *Scottish Geographical Magazine* 89, 138-139.
- Sissons, J. B. 1974a:** The Quaternary in Scotland: a review. *Scottish Journal of Geology* 10, 311-337.
- Sissons, J. B. 1974b:** A lateglacial ice cap in the central Grampians, Scotland. *Transactions of the Institute of British Geographers* 62, 95-114.
- Sissons, J. B. 1976:** *The Geomorphology of the British Isles: Scotland*. Methuen, London.
- Sissons, J. B. 1977a:** The Loch Lomond Readvance in the northern mainland of Scotland. In J. M. Gray, & J. J. Lowe (Eds.). *Studies in the Scottish Late Glacial environment*, Pergamon Press, Oxford, 45-59.
- Sissons, J. B. 1977b:** Former ice-dammed lakes in Glen Moriston, Inverness-shire. *Transactions of the Institute of British Geographers New Series* 2, 224-242.

- Sissons, J. B. 1977c: The Loch Lomond Advance in southern Skye and some palaeoclimatic implications. *Scottish Journal of Geology* 13, 23-36.
- Sissons, J. B. 1979a: The limit of the Loch Lomond Advance in Glen Roy and vicinity. *Scottish Journal of Geology* 15, 31-42.
- Sissons, J. B. 1979b: Palaeoclimatic inferences from former glaciers in Scotland and the Lake District. *Nature* 278, 518-521.
- Sissons, J. B. 1979c: The Loch Lomond Stadial in the Cairngorm mountains. *Scottish Geographical Magazine* 95, 66-82.
- Sissons, J. B. 1980a: The Loch Lomond Advance in the Lake District, Northern England. *Transactions of the Royal Society of Edinburgh*, 71, 13-27.
- Sissons, J. B. 1980b: Palaeoclimatic inferences from Loch Lomond Advance glaciers. In J. J. Lowe, J. M. Gray, & J. E. Robinson (Ed.). *Studies in the late glacial of North West Europe*, Pergamon press, Oxford, 31-43.
- Sissons, J. B. 1980c: The Glaciation of the Outer Hebrides. *Scottish Journal of Geology* 16, 81-84.
- Sissons, J. B. 1982: A former ice-dammed lake and associated glacier limits in the Achnasheen area, central Ross-shire. *Transactions of the Institute of British Geographers, New Series* 7, 98-116.
- Sissons, J. B. 1983: Quaternary. In G. Y. Craig (Ed.). *The Geology of Scotland*, (2nd Edition) Scottish Academic Press, Edinburgh, 399-424.
- Sissons, J. B. & Grant, A. J. H. 1972: The last glaciers in the Lochnagar area, Aberdeenshire. *Scottish Journal of Geology* 8, 85-93.
- Sissons, J. B., Lowe, J. J., Thompson, K. S. R. & Walker, M. J. C. 1973: Loch Lomond Readvance in the Grampian Highlands of Scotland. *Nature* 244, 75-77.

Sissons, J. B. & Sutherland, D. G. 1976: Climatic Inferences from former glaciers in the south-east Grampian Highlands, Scotland. *Journal of Glaciology* 17, 325-346.

Small, R. J. & Clark, M. J. 1974: The medial moraines of the lower Glacier de Tsidjiore Nouve, Valais, Switzerland. *Journal of Glaciology* 13, 255-263.

Smith, D. E., Thompson, K. S. R. & Kemp, D. D. 1978: The Late Devensian and Flandrian history of the Teith Valley. *Boreas* 7, 97-107.

Souchez, R. A. 1967: The formation of shear moraines: an example from South Victoria Land, Antarctica. *Journal of Glaciology* 6, 837-843.

Stalker, A. M. S. 1960: Ice-pressed drift forms and associated deposits in Alberta. *Bulletin of the Geological Survey of Canada* 57.

Sugden, D. E. 1970: Landforms of deglaciation in the Cairngorms, Scotland. *Transactions of the Institute of British Geographers* 51, 201-219.

Sugden, D. E. 1973: Hypothesis of deglaciation in the eastern Grampians, Scotland. *Scottish Journal of Geology* 9, 94-95.

Sugden, D. E. 1974: Deglaciation of the Cairngorms and its wider implications. In C. J. Caseldine, & W. A. Mitchell (Eds.). *Problems of the deglaciation of Scotland.*, Department of Geography, University of St. Andrews, St. Andrews, 17-28.

Sugden, D. E. 1978: Glacial erosion by the Laurentide ice sheet. *Journal of Glaciology* 20, 367-391.

Sugden, D. E. 1980: The Loch Lomond Advance in the Cairngorms (a reply to J. B. Sissons). *Scottish Geographical Magazine* 96, 19-19.

Sugden, D. E. & Clapperton, C. M. 1975: The deglaciation of upper Deeside and the Cairngorms mountains. In A. M. D. Gemmel (Ed.) *Quaternary studies in north east Scotland.* Department of Geography University of Aberdeen, 30-38.

**Sugden, D. E. & John, B. S. 1976.** *Glaciers and Landscape*. Arnold, London.

**Sutherland, D. G. 1984a:** Modern glacial characteristics as a basis for inferring former climate with particular reference to the Loch Lomond Stadial. *Quaternary Science Review* 3, 291-309.

**Sutherland, D. G. 1984b:** The Quaternary deposits and landforms of Scotland and the neighbouring shelves a review. *Quaternary Science Review* 3, 157-254.

**Sutherland, D. G. 1986:** A review of Scottish marine shell radiocarbon dates, their standardization and interpretation. *Scottish Journal of Geology* 22, 145-164.

**Sutherland, D. G., Ballantyne, C.K. & Walker, M. J. C. 1982:** A note on the Quaternary deposits and landforms of St. Kilda. *Quaternary Newsletter* 37, 1-5.

**Sutherland, D. G., Ballentyne, C. K. & Walker, M. J. C. 1984:** Late Quaternary glaciation and environmental change on St Kilda, Scotland and their palaeoclimatic significance. *Boreas* 13, 261-272.

**Thomas, G. S. P., Connaughton, M. & Dackombe, R. V. 1985:** Facies variation in a Late Pleistocene supraglacial outwash sandur from the Isle of Man. *Geological Journal* 20, 193-213.

**Thomas, G. S. P. 1985:** The Late Devensian glaciation along the border of northeast Wales. *Geological Journal* 20, 319-340.

**Thome, K. N. 1972:** Asymmetries in glacier structure and their influence on glacier movement and glacier deposition. *Proceedings of the 24th International Geological Congress (Canada)* section 12, 198-211.

**Thompson, A. 1988:** Historical development of the proglacial landforms of Svinafellsjökull and Skaftafellsjökull, southeast Iceland. *Jökull* 38, 17-30.

- Thompson, K. S. R. 1972:** *The last glaciers in western Perthshire*. Ph.D. thesis (Unpubl.), University of Edinburgh.
- Thorp, P. 1981:** A trimline method for defining the limit of Loch Lomond Advance glaciers: examples from the Loch Leven and Glen Coe areas. *Scottish Journal of Geology* 17, 49-64.
- Thorp, P. 1984:** *Glacial geomorphology of part of the Western Grampians of Scotland with specific reference to the limits of the Loch Lomond Advance*. Ph.D. thesis (unpubl.), City of London Polytechnic.
- Thorp, P. W. 1986:** A mountain ice field of Loch Lomond Stadial age, western Grampians, Scotland. *Boreas* 15, 83-97.
- Thorp, P. 1987:** Late Devensian ice sheet in the western Grampians, Scotland. *Journal of Quaternary Science* 2, 103-112.
- Thorp, p. 1991.** The glaciation and glacial deposits of the western Grampians. In J. Ehlers, P. L. Gibbard & J. Rose, (Eds.). *Glacial deposits in Great Britain and Ireland*. A. A. Balkema, Rotterdam, 137-149.
- Timmis, R. J. 1986:** *Glacial changes in South Georgia and their relationship to climatic trends*. Ph.D. thesis (unpubl.), University of East Anglia.
- Tipping, R. M. 1988:** The recognition of glacial retreat from palynological data: a review of recent work in the British Isles. *Journal of Quaternary Science* 3, 171-182.
- Tipping, R. M. 1989:** Palynological evidence for the extent of the Loch Lomond Readvance in the Awe valley and adjacent areas, S. E. Highlands. *Scottish Journal of Geology* 23, 325-337.
- Wain-Hobson, T. 1981:** *Aspects of the glacial and postglacial history of north-west Argyll*. Ph.D. thesis (unpubl.), University of Edinburgh.
- Walker, M. J. C. & Lowe, J. J. 1985:** Flandrian environmental history of the Isle of Mull, Scotland. I. pollen-stratigraphic evidence and

- radiocarbon dates from Glen More, south-central Mull. *New Phytologist* 99, 587-610.
- Walker, M. J. C. & Lowe, J. J. 1990:** Reconstructing the environmental history of the last Glacial-Interglacial transition: evidence from the Isle of Skye, Inner Hebrides, Scotland. *Quaternary Science Reviews* 9, 15-49.
- Walker, M. J. C., Ballentyne, C. K., Lowe, J. J. & Sutherland, G. G. 1988:** A reinterpretation of the Lateglacial environmental history of the Isle of Skye, Inner Hebrides, Scotland. *Journal of Quaternary Science* 3, 135-146.
- Ward, W. H. 1955:** The flow of Highway Glacier. *Journal of Glaciology* 2, 592-598.
- Weertman, J. 1961:** Mechanism for the formation of inner moraines found near the edge of cold ice caps and ice sheets. *Journal of Glaciology* 3, 965-978.
- Weidick, A. 1963:** Ice marginal features in the Julienhab district, South Greenland. *Gronlands Geologiske Undersogelse* 35.
- Wendler, G. & Ishikawa, N. 1974:** The effect of slope, exposure and mountain screening on the solar radiation of McCall glacier, Alaska: a contribution to the International Hydrological Decade. *Journal of Glaciology* 13, 213-226.
- Whalley, W. B. 1974:** *The formation and characteristics of some Alpine moraines*. Ph.D. thesis (unpubl.), University of Cambridge.
- Williams, R. S. 1987:** Satellite remote sensing of Vatnajökull, Iceland. *Annals of Glaciology* 9, 127-135.
- Winters, W. A. 1961:** Landforms associated with stagnant ice. *Professional Geographer* 13, 19-23.
- Wright, H. E. 1989:** The amphi-Atlantic distribution of the Younger Dryas paleoclimatic oscillation. *Quaternary Science Review* 8, 295-306.

**Wright, W. B. 1914:** *The Quaternary Ice Age.* Macmillan, London.

**Young, J. 1864:** On the former existence of glaciers in the high grounds of the south of Scotland. *Quarterly Journal of the Geological Society of London* 20, 452-462.

• Appendix I •

**Moraine and palaeo-ice front maps**

Reference guide to sheet titles and page numbers:





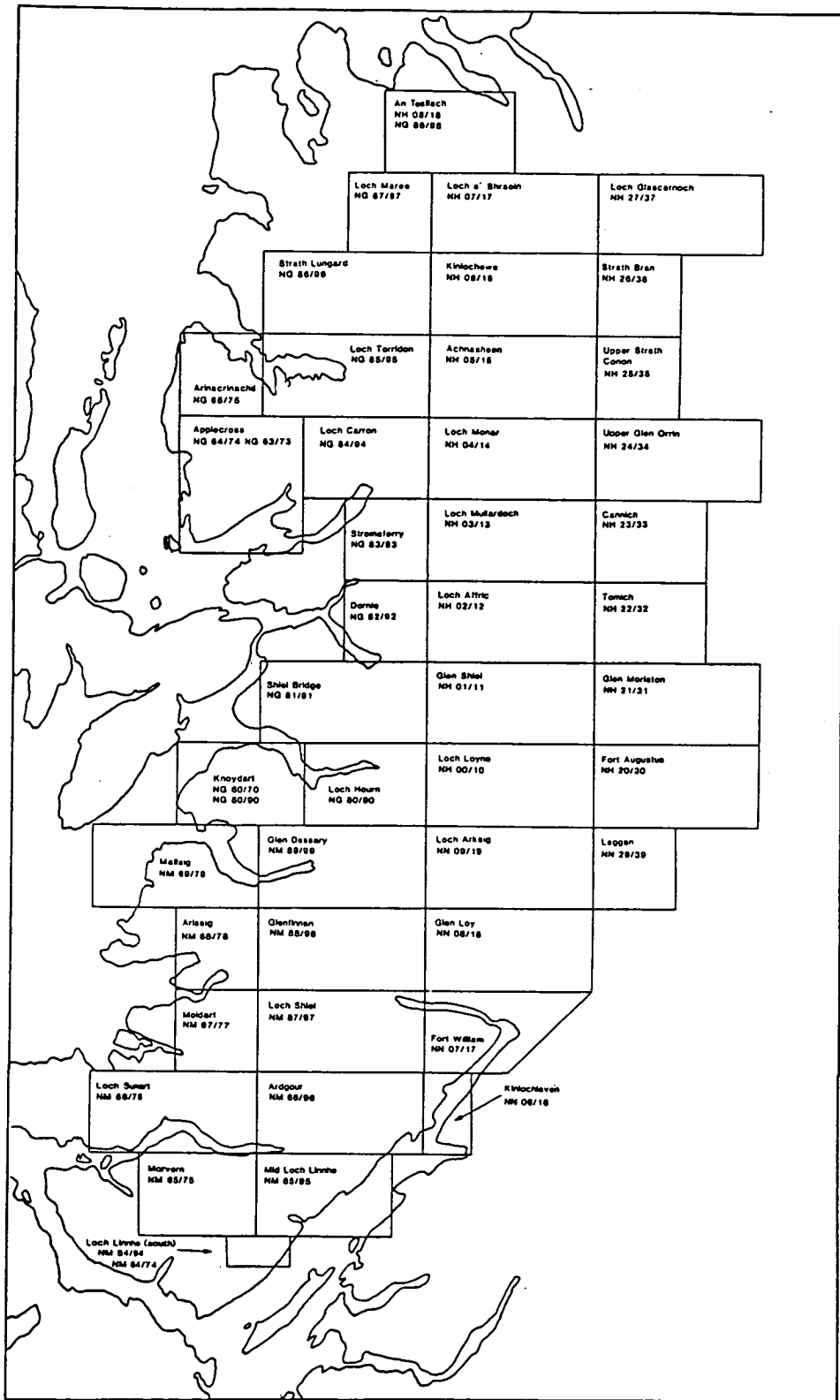







Sheet	Moraine and palaeo-ice front maps
An Teallach	Page A5
Loch Maree	Page A6
Loch a' Bhraoin	Page A7
Loch Glascarnoch	Page A8
Strath Lungard	Page A9
Kinlochewe	Page A10
Strath Bran	Page A11
Arinacrinachd	Page A12
Loch Torridon	Page A13
Achnasheen	Page A14
Upper Strath Conon	Page A15
Applecross	Page A16
Loch Carron	Page A17
Loch Monar	Page A18
Upper Glen Orrin	Page A19
Stromeferry	Page A20
Loch Mullardoch	Page A21
Cannich	Page A22
Dornie	Page A23
Loch Affric	Page A24
Tomich	Page A25
Shiel Bridge	Page A26
Glen Shiel	Page A27
Glen Moriston	Page A28
Knoydart	Page A29
Loch Hourn	Page A30
Loch Loyne	Page A31
Fort Augustus	Page A32
Mallaig	Page A33
Glen Dessary	Page A34
Loch Arkaig	Page A35
Laggan	Page A36
Arisaig	Page A37
Glenfinnan	Page A38
Glen Loy	Page A39
Moidart	Page A40
Loch Shiel	Page A41
Fort William	Page A42
Loch Sunart	Page A43
Ardgour	Page A44
Kinlochleven	Page* A45
Morvern	Page A46
Mid Loch Linnhe	Page A47
Loch Linnhe (south)	Page A48

\* No palaeo-ice front map is presented for this sheet.



Index to moraine and palaeo-ice front maps. The sheet codes refer to the 1:25 000 scale O. S. base maps used.

## Key to Moraine Maps

<p>Clear continuous moraine </p> <p>Mounds </p> <p>Eskers XXXXX </p> <p>Terraces </p> <p>Kettle holes  k</p> <p>Palaeo-ice fronts </p>	<p>Discontinuous moraine </p> <p>Meltwater channels </p> <p>Steep drift cut slopes </p> <p>Flutes </p> <p>Fossil lake shorelines </p>
<p>Areas of unordered mounds and continuous boulder cover </p>	

Scales: 1:100 000 2 km

**Contours:** The first contour on the maps is at 450 metres (1500 feet) and thereafter at 150 metre intervals (500 feet).

The contour data was obtained from 1:25 000 O.S. maps (second series). The contour data on these sheets was either surveyed in feet or metres. On some of the sheets the imperial data has been converted to metres, on other sheets it has not.

The contour intervals are as follows depending on how the sheets are marked:

Feet	Feet/metres	Metres
1 500	457	450
2 000	610	600
2 500	762	750
3 000	914	900
etc.	etc.	etc.

**Loch outlines:** All loch outlines predate reservoir construction and are based on enlarged reprints of the first edition one inch O.S. series (c.1896).

**Map insets:** In cases where the volume of information recorded is too great to be clearly shown at this scale, insets have been marked and the information is shown on larger scale maps in the main body of this thesis as referenced below:

Sheet	Reference	Chapter	Figure	Page
An Teallach	•	5	5.6	A5
Loch a' Bhraoin	•	5	5.6	A7
Strath Lungard	•	5	5.4 & 5.5	A9
Loch Torridon	•	4	4.5	A13
Achnasheen	•	4	4.22	A14
	▲	4	4.14	A14
Applecross	•	4	4.21	A16
Loch Monar	•	4	4.21	A18
Stromeferry	•	4	4.29	A20
Knoydart	•	5	5.8	A29



Sheet A: Moraine maps



Sheet B: Palaeo-ice  
front maps

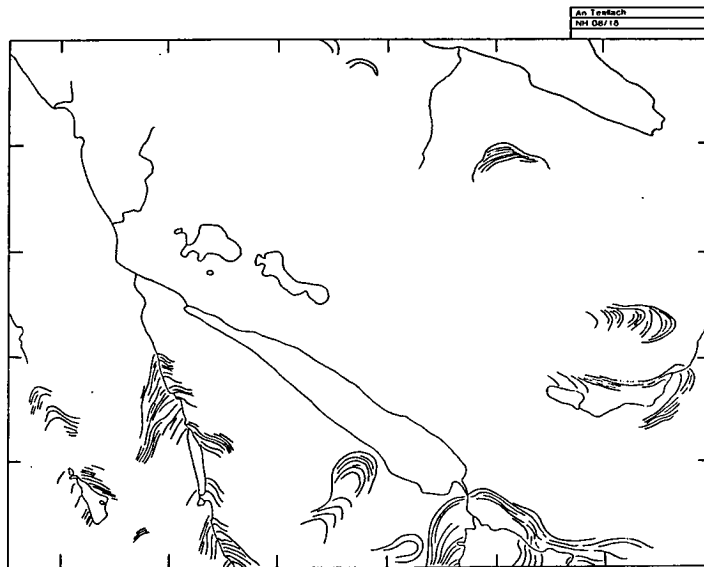
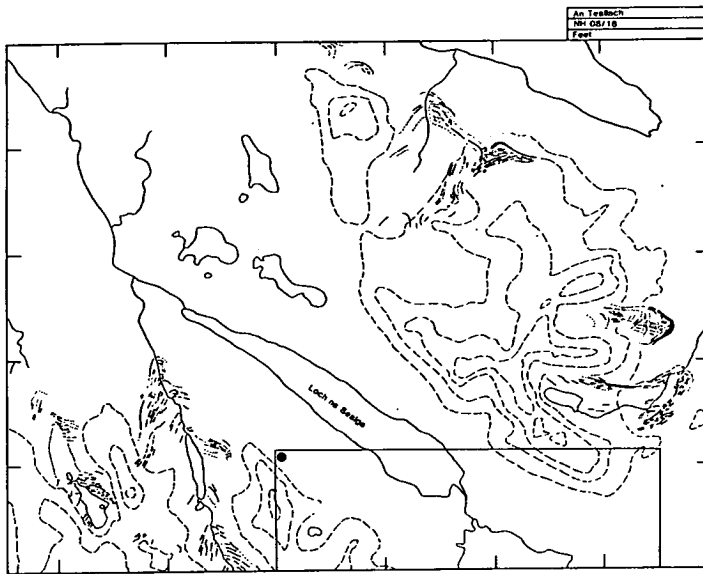

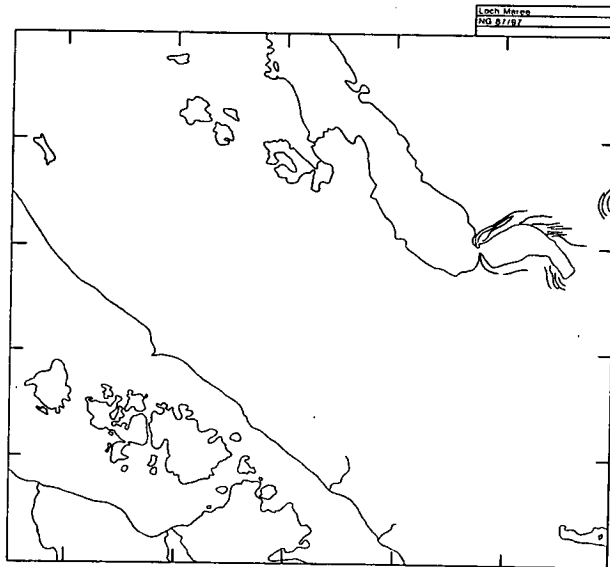
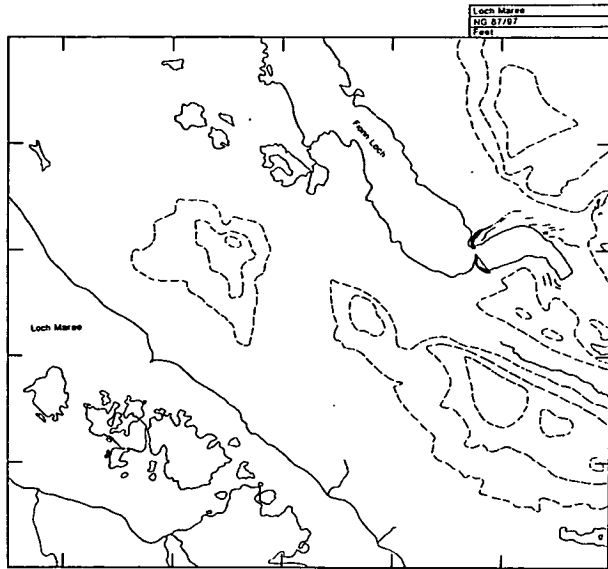

Loch a' Bhraoin  
NH 0717  
Metres

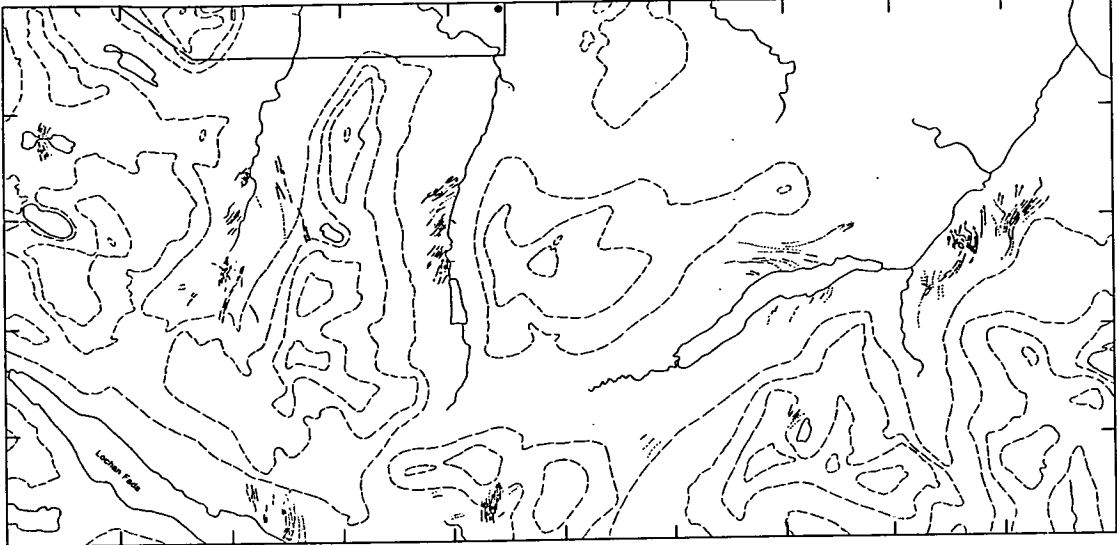

Loch a' Bhraoin  
NH 0717

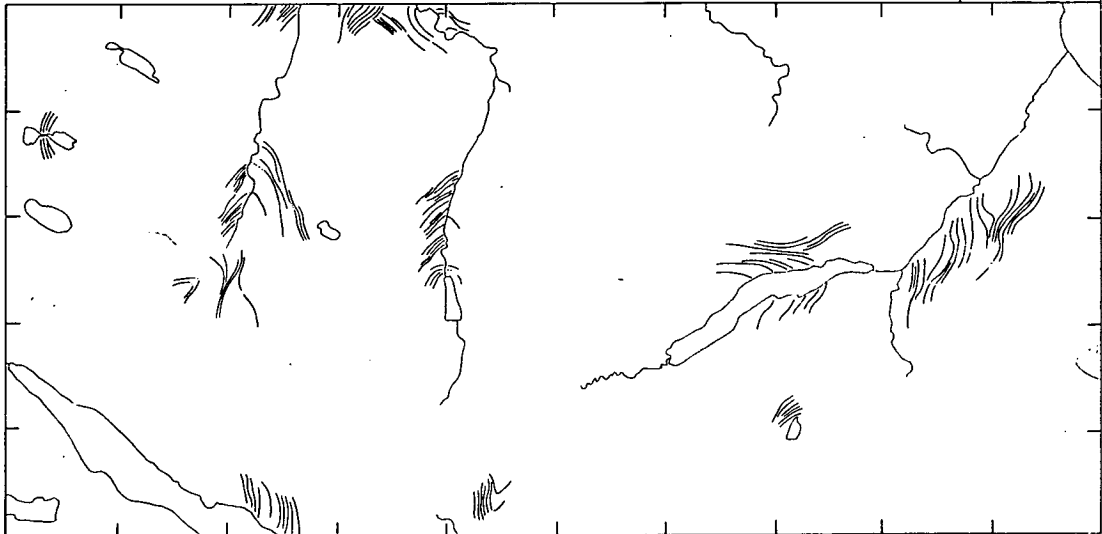

Loch Glascarnoch  
Sheet 27737  
Page

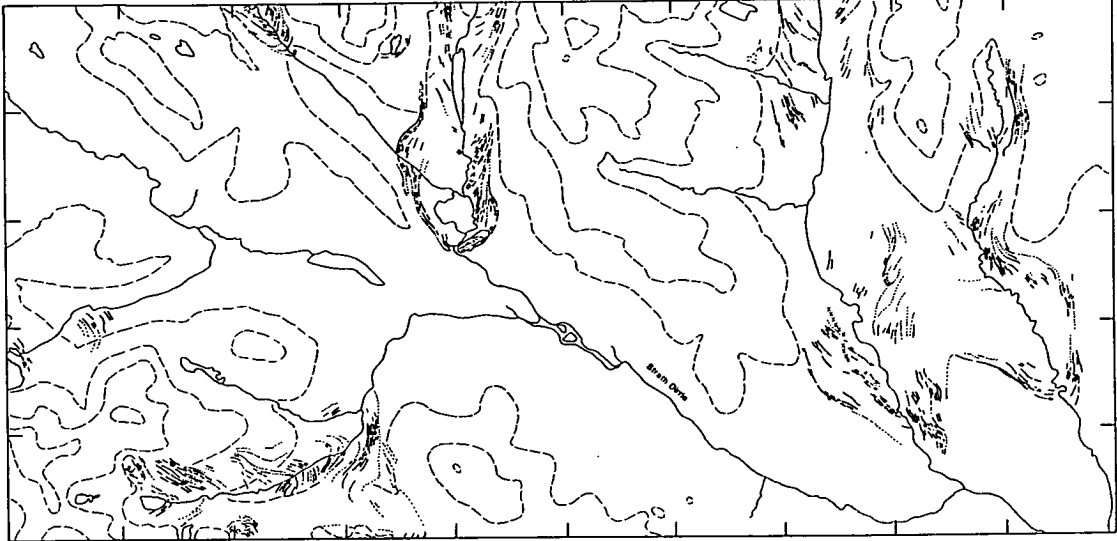

Loch Glascarnoch  
Sheet 27737

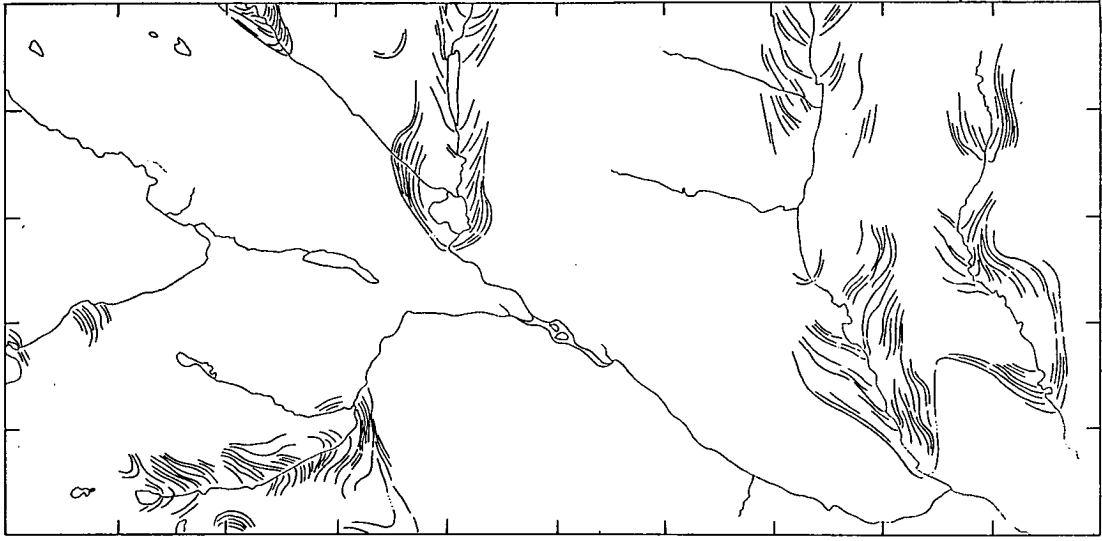

Strath Lungard  
NG 88/25  
Feet

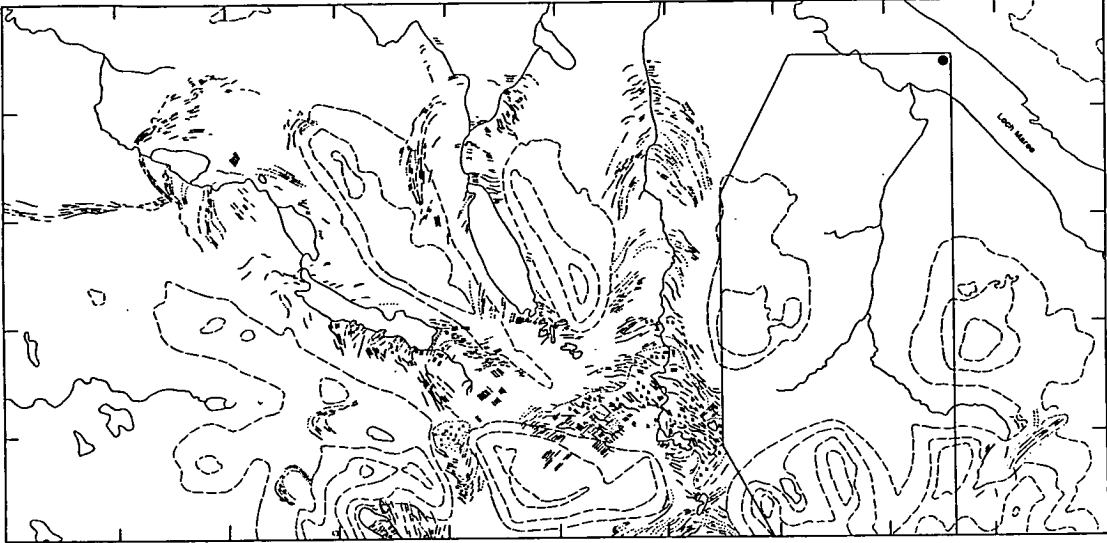

Strath Lungard  
NG 88/25



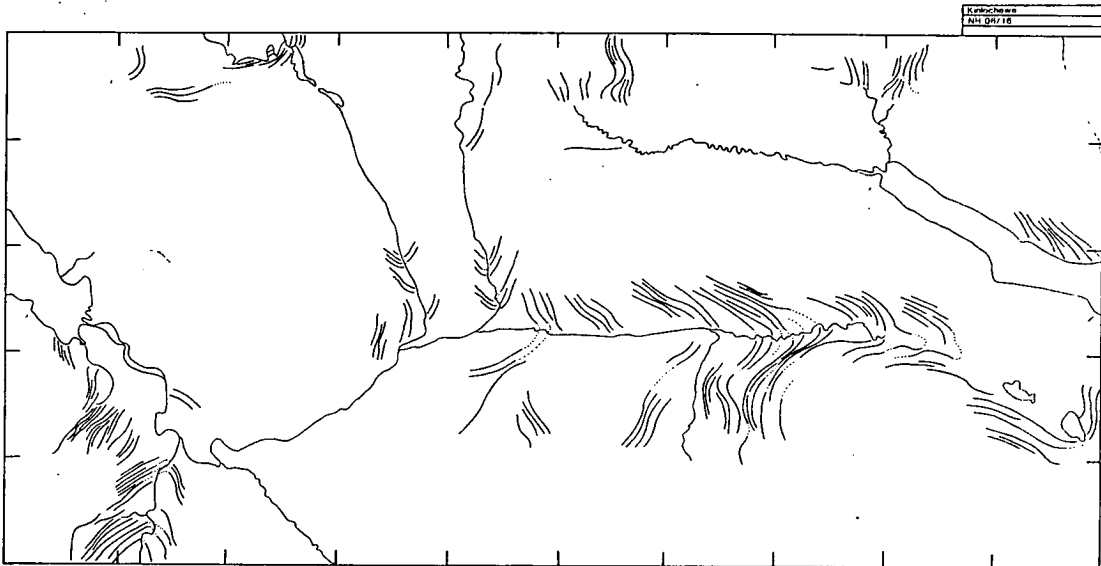
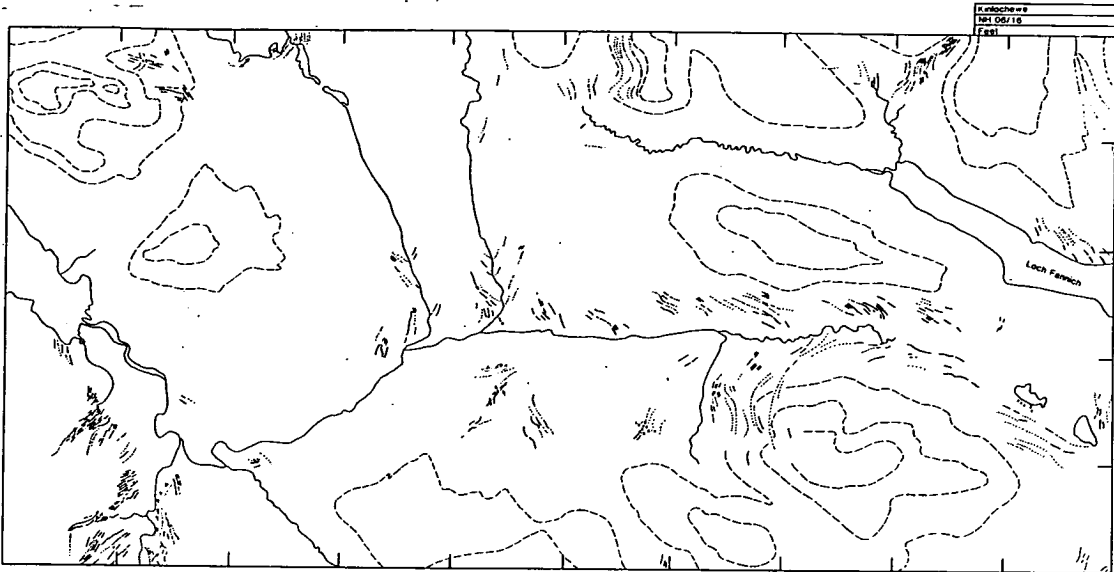

Strath Bran  
MS 26/36  
Figs

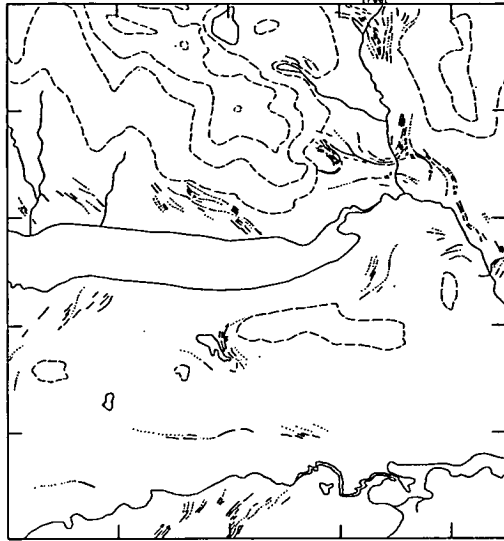

Strath Bran  
MS 26/36

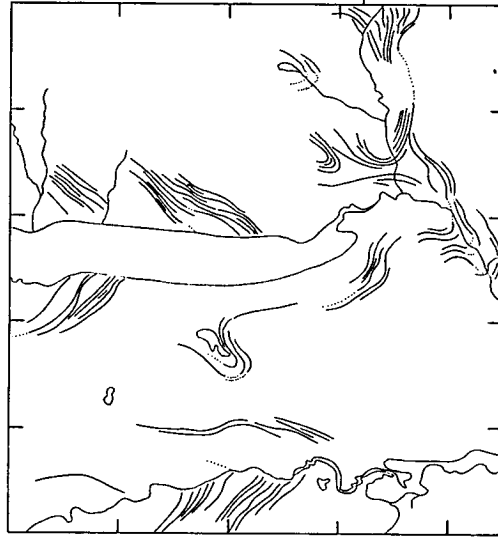

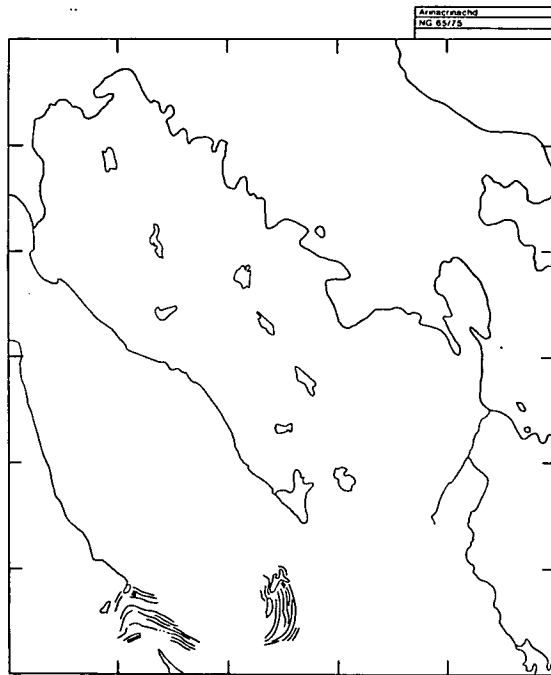
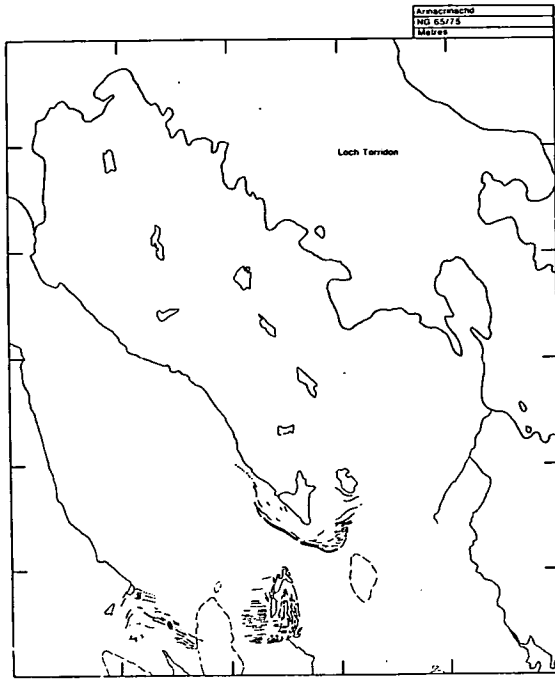

Loch Torridon  
MS. B2/22  
1:50,000

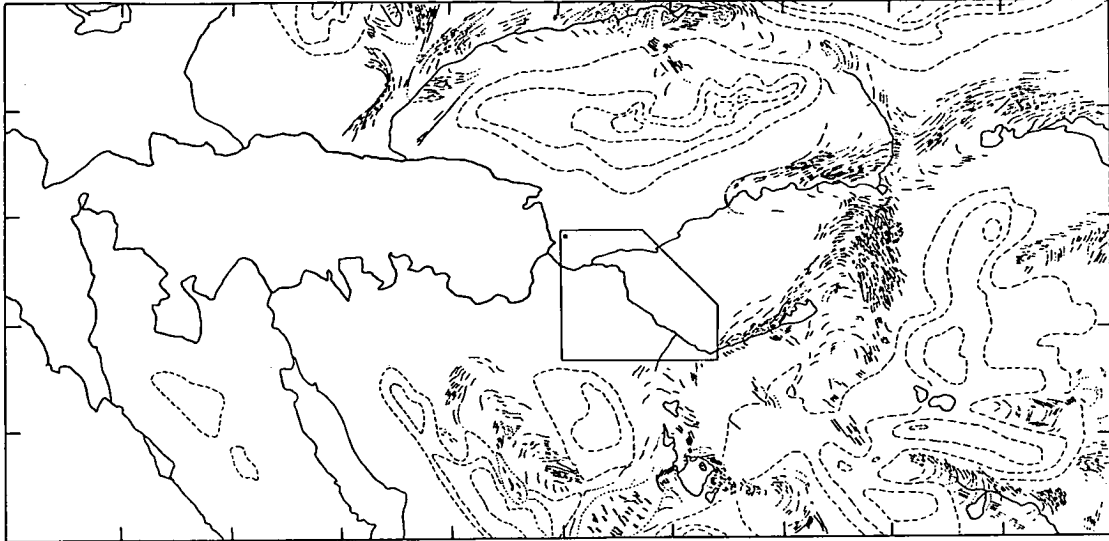

Loch Torridon  
MS. B2/22

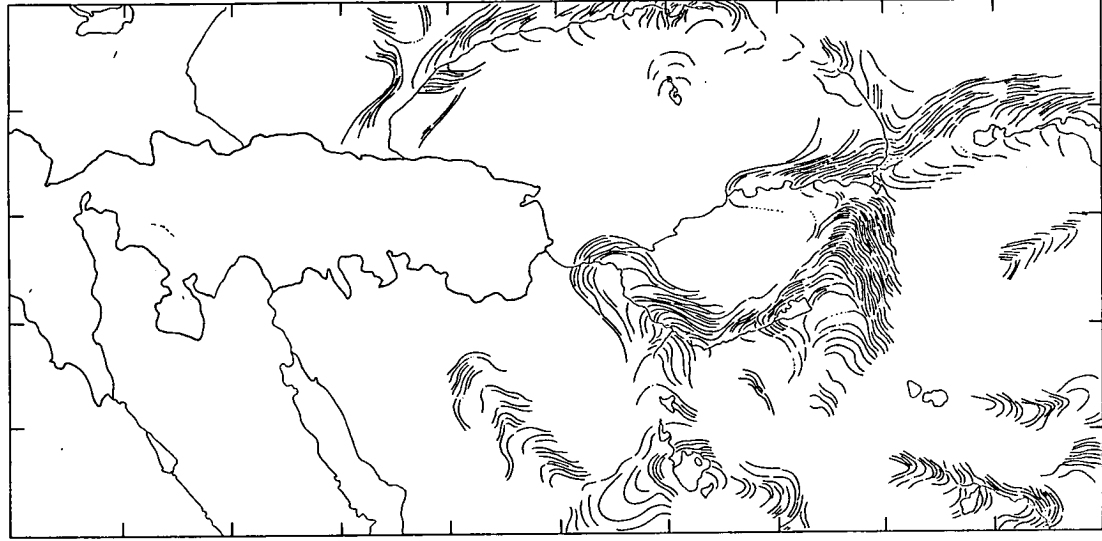

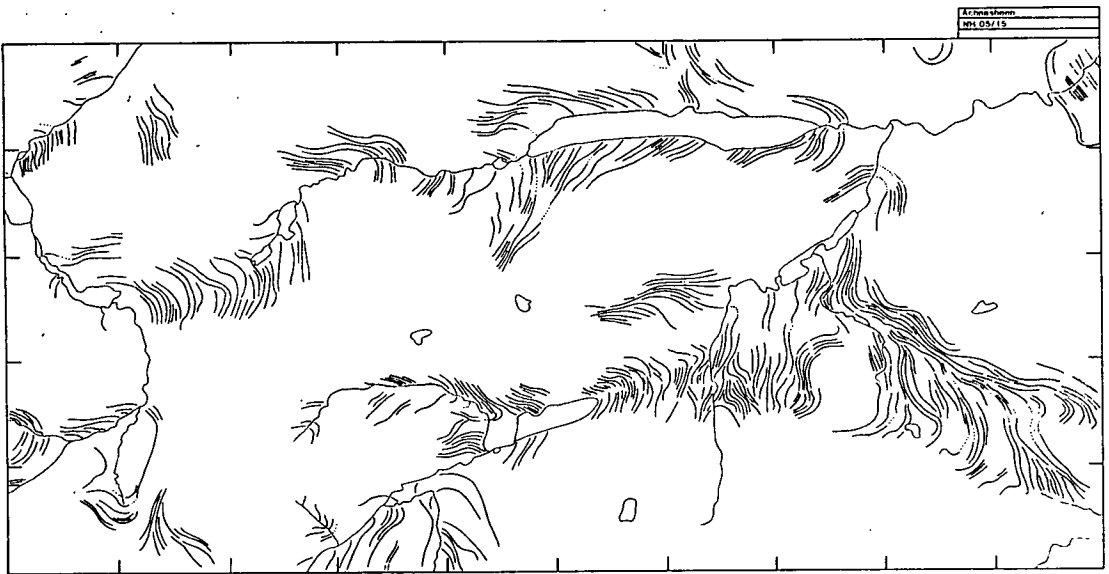
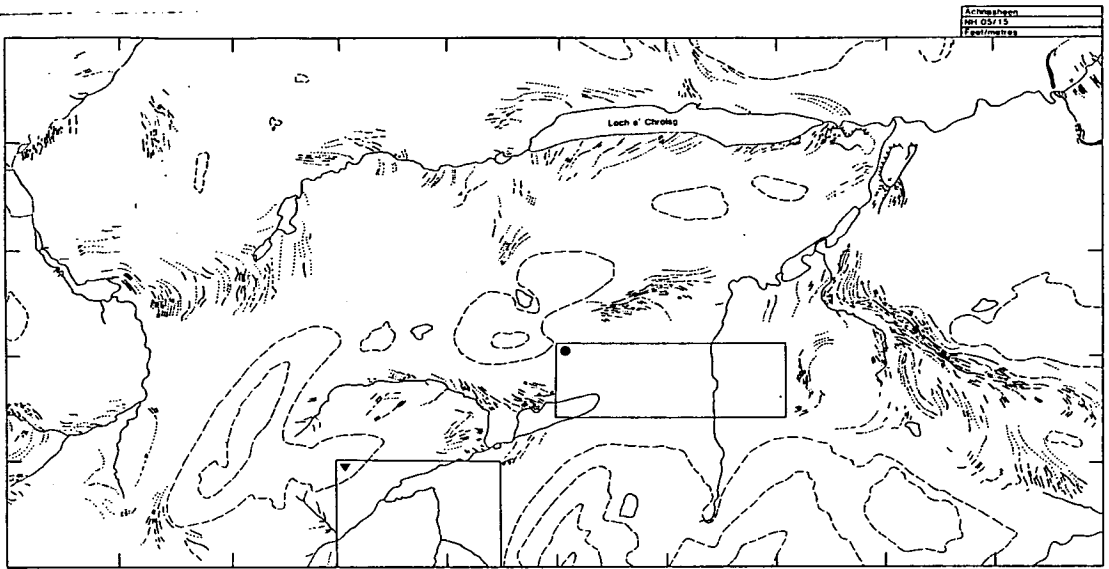



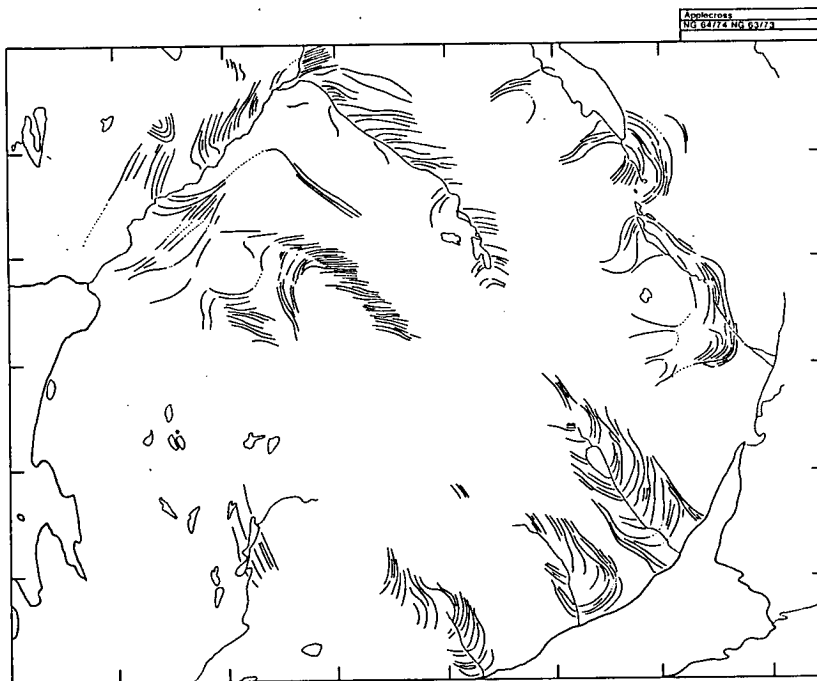
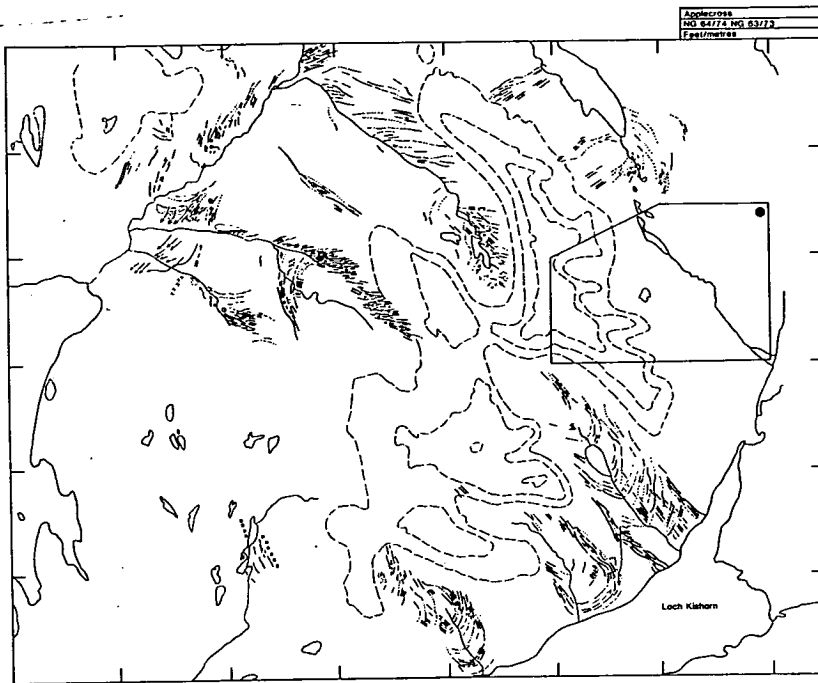

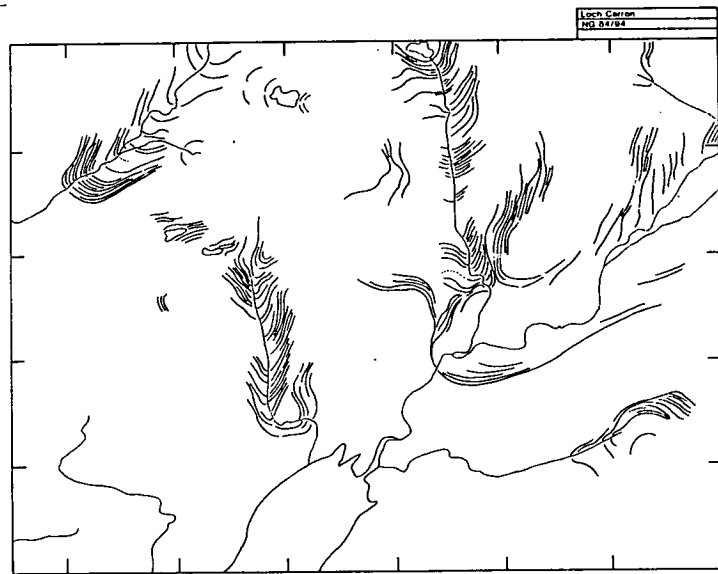
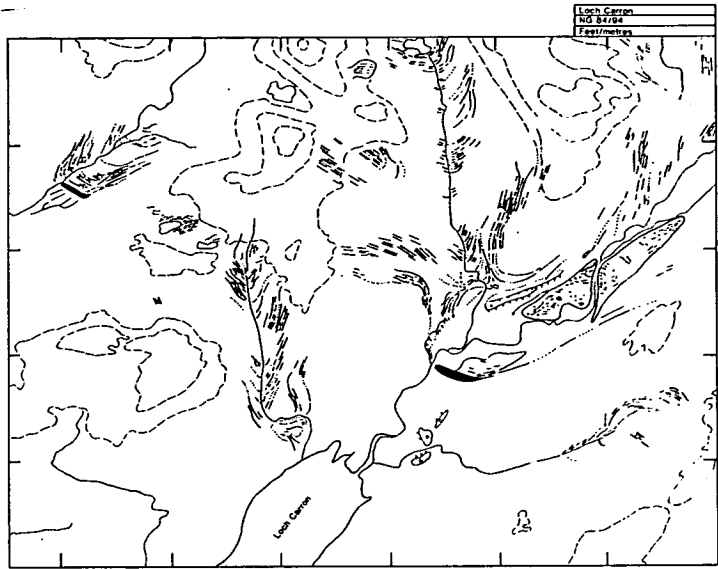

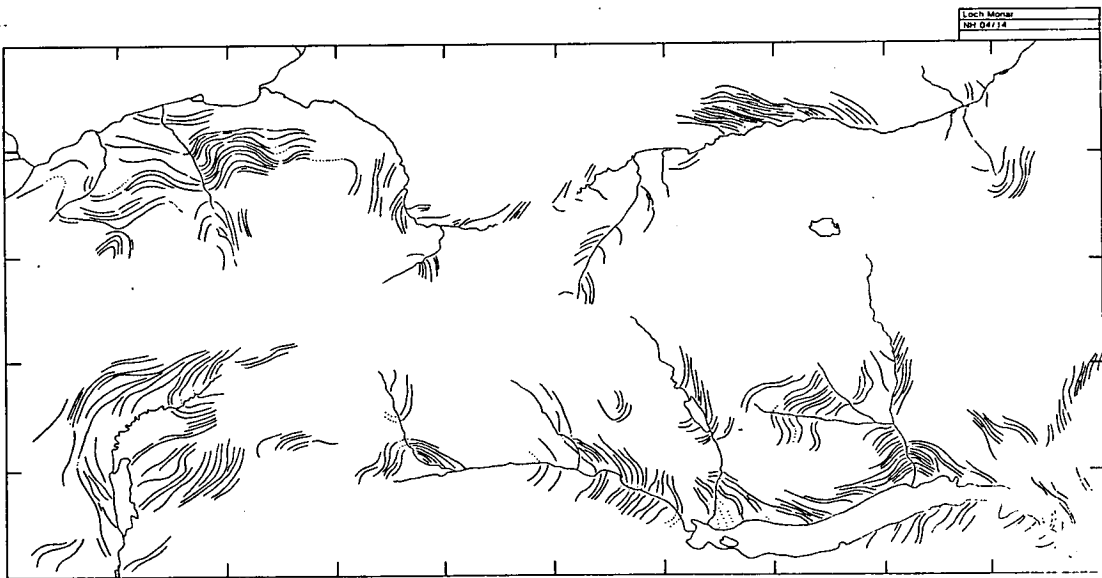
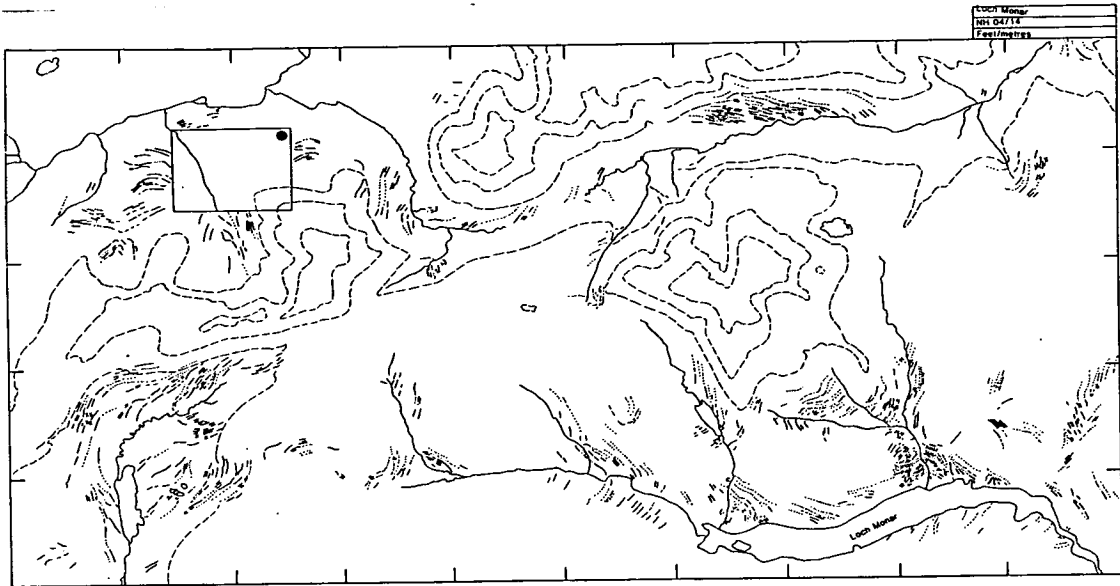

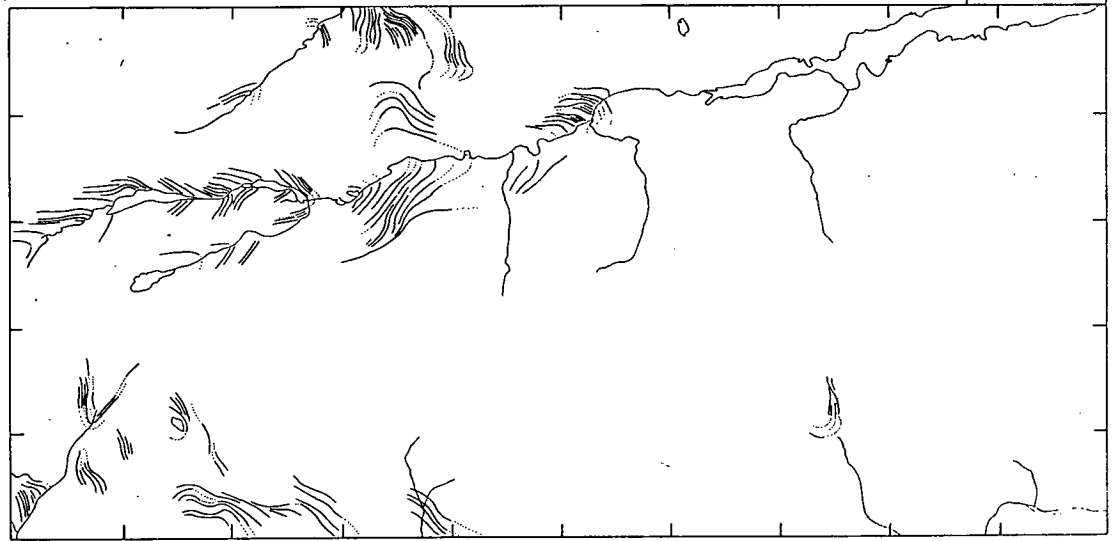
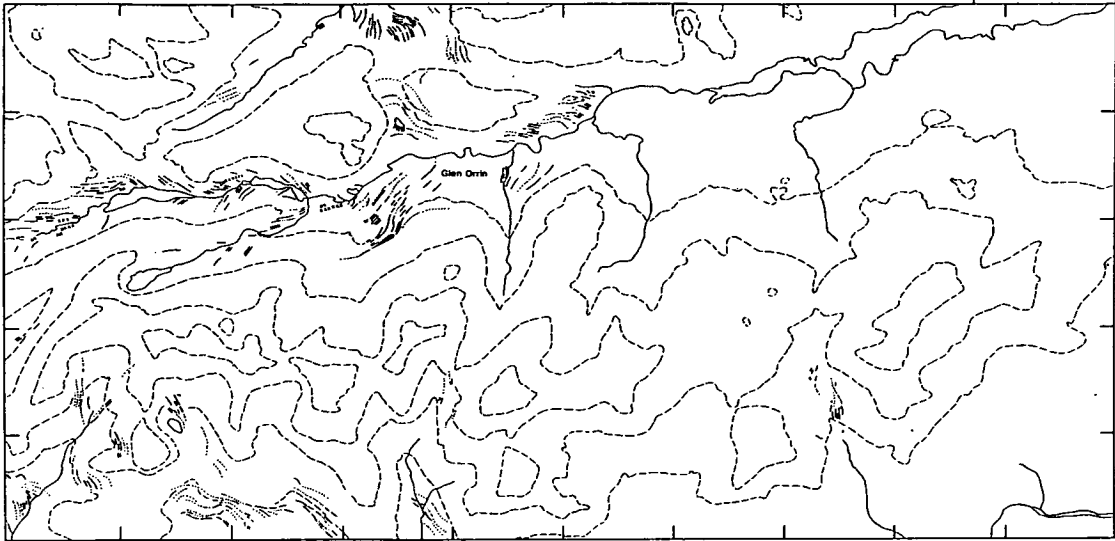

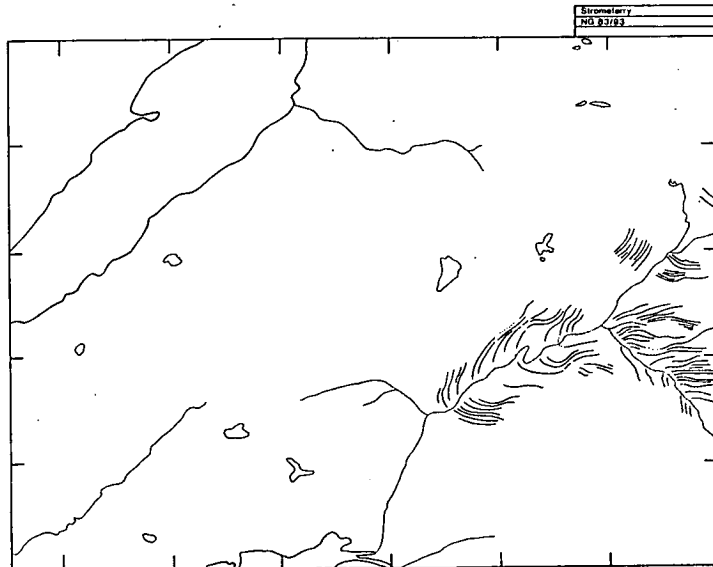
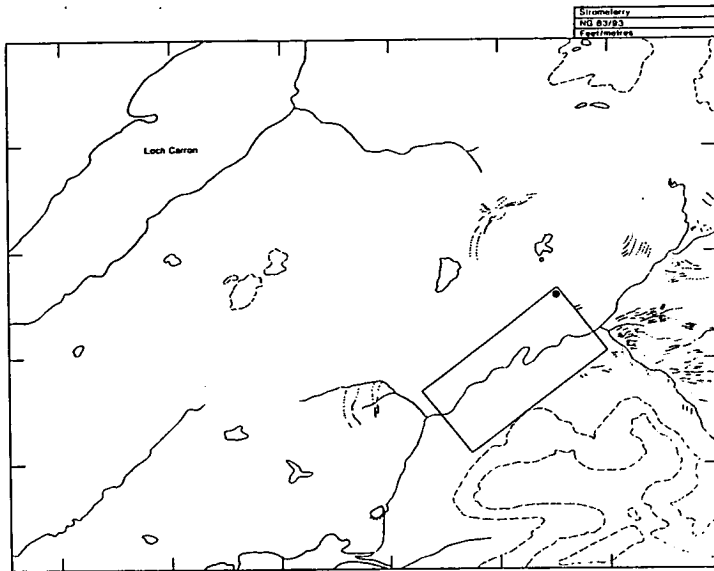

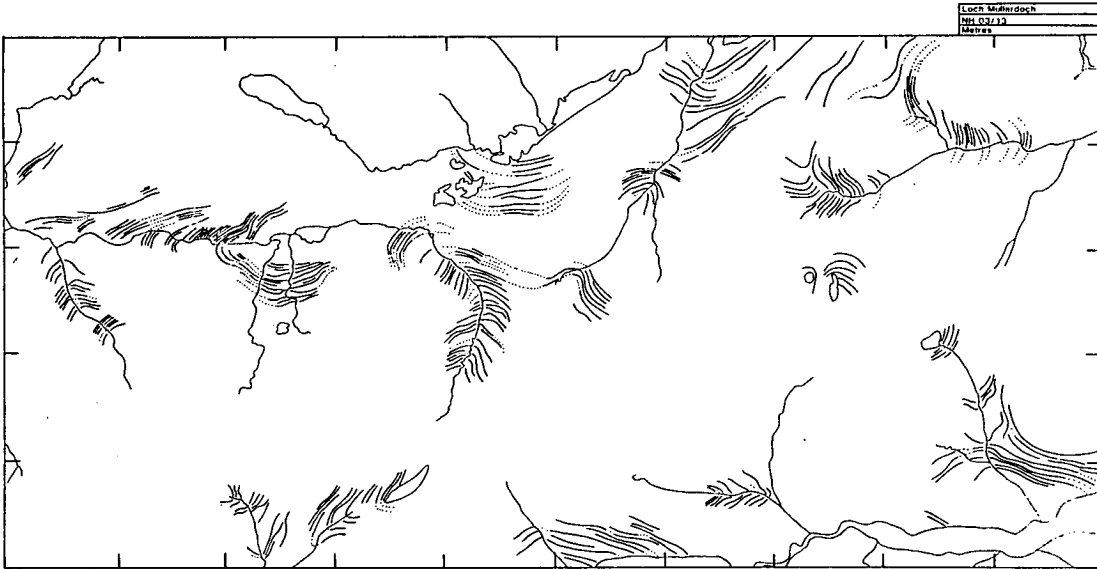
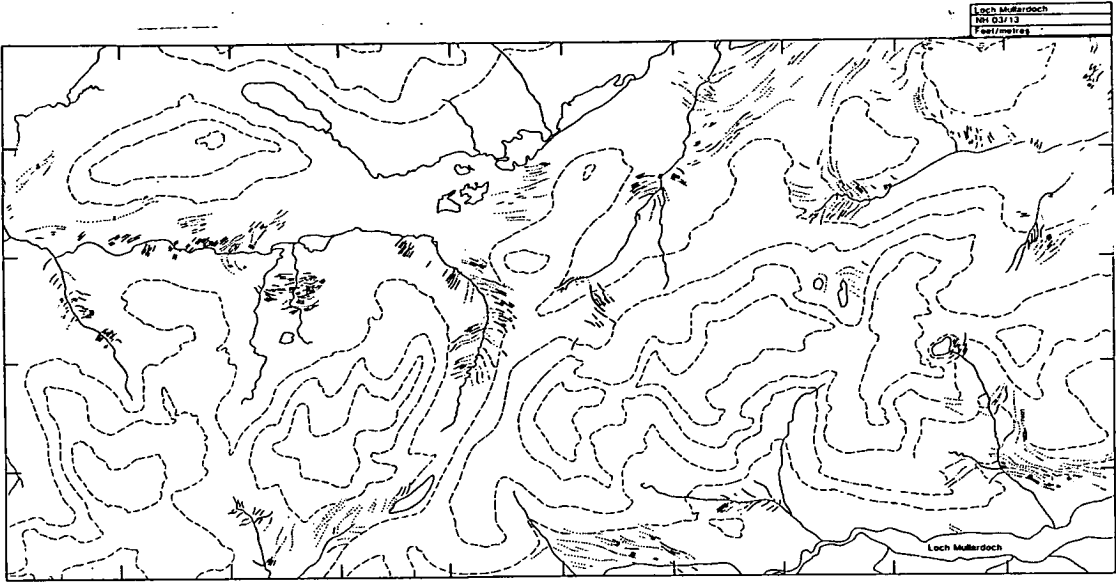

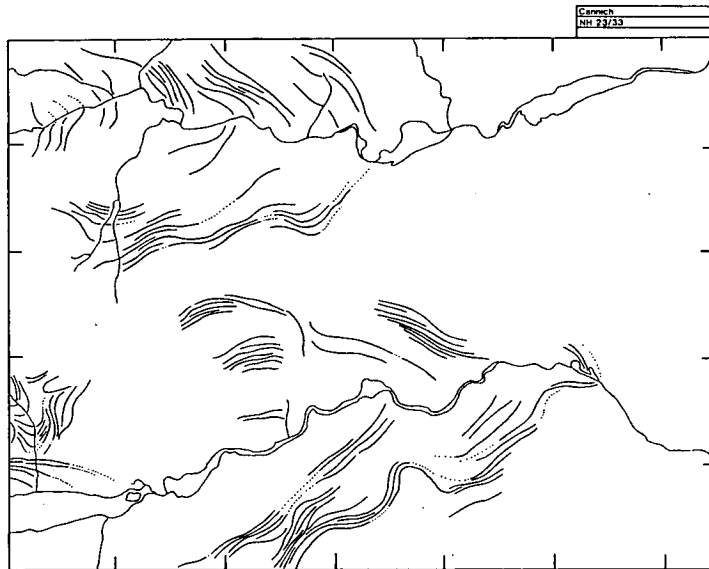
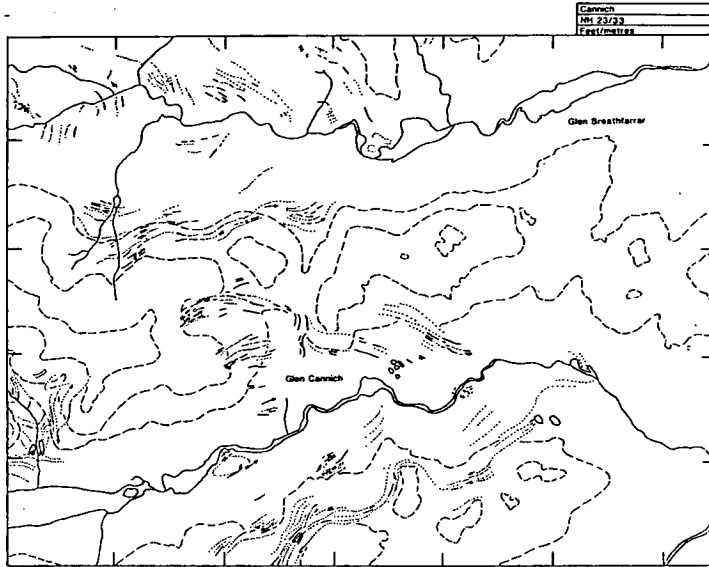

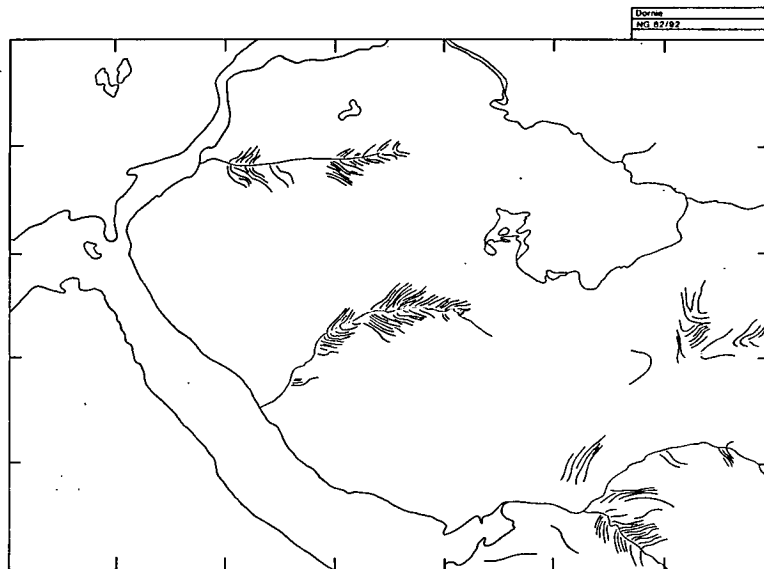
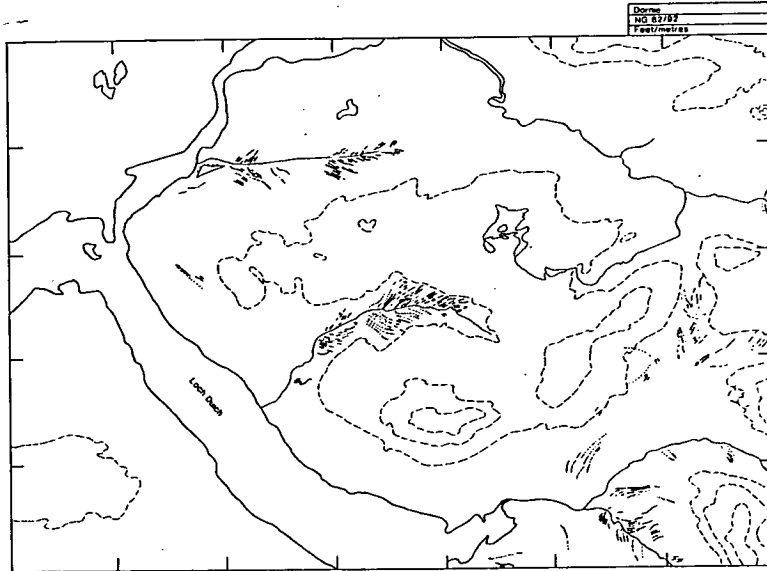

Loch Affric  
SH 02212  
Part 1/2

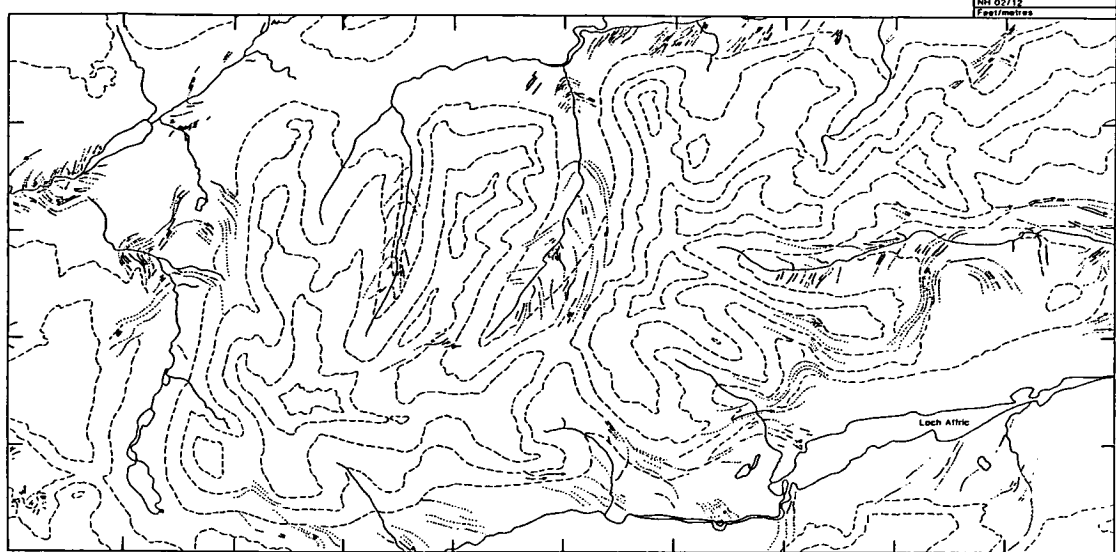

Loch Affric  
SH 02212  
Part 2/2



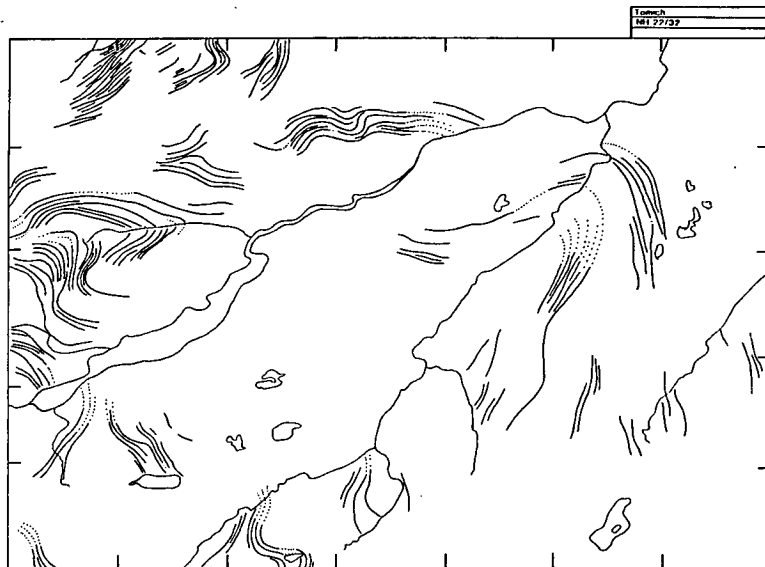
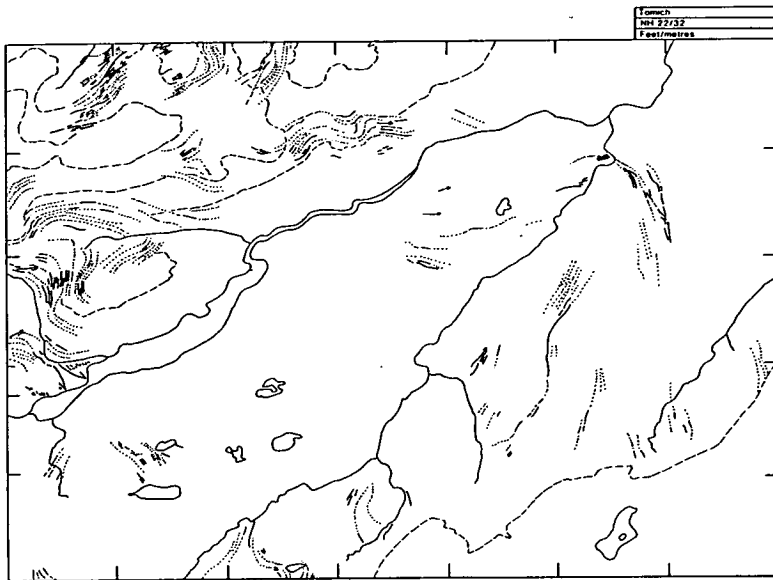

Shiel Bridge  
192 8.1/8.1

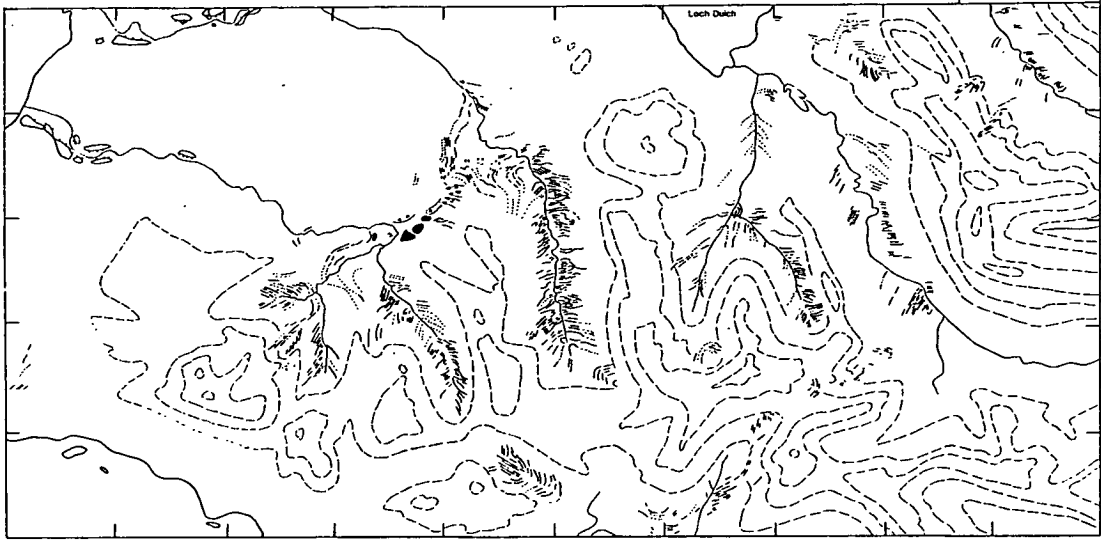

Shiel Bridge  
192 8.1/8.1

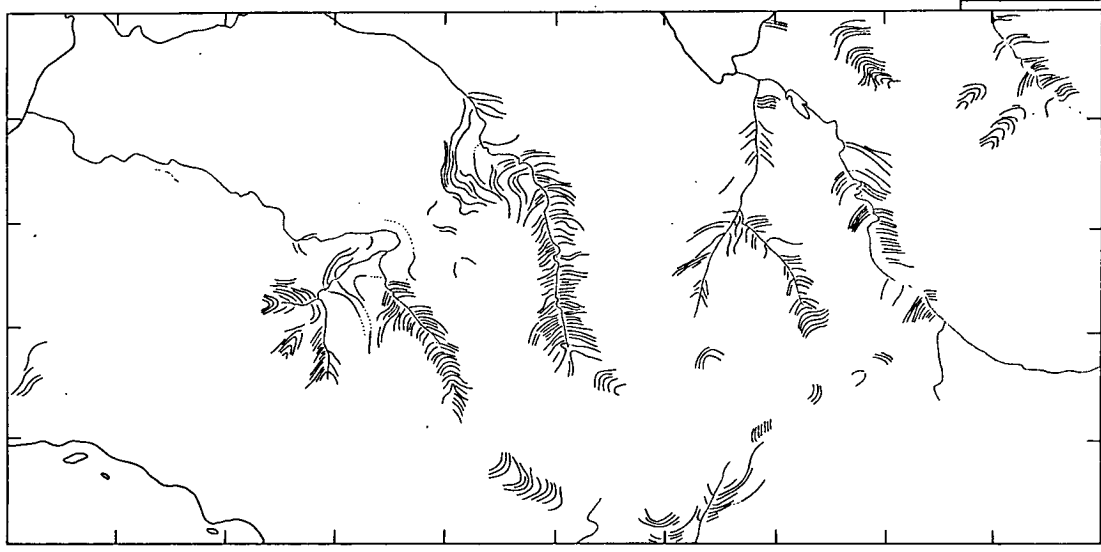

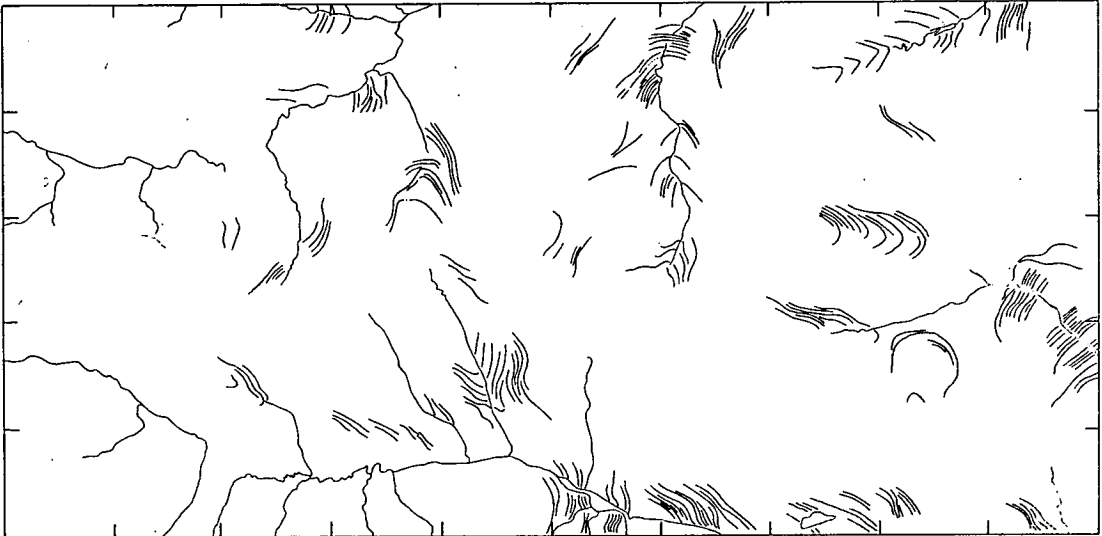
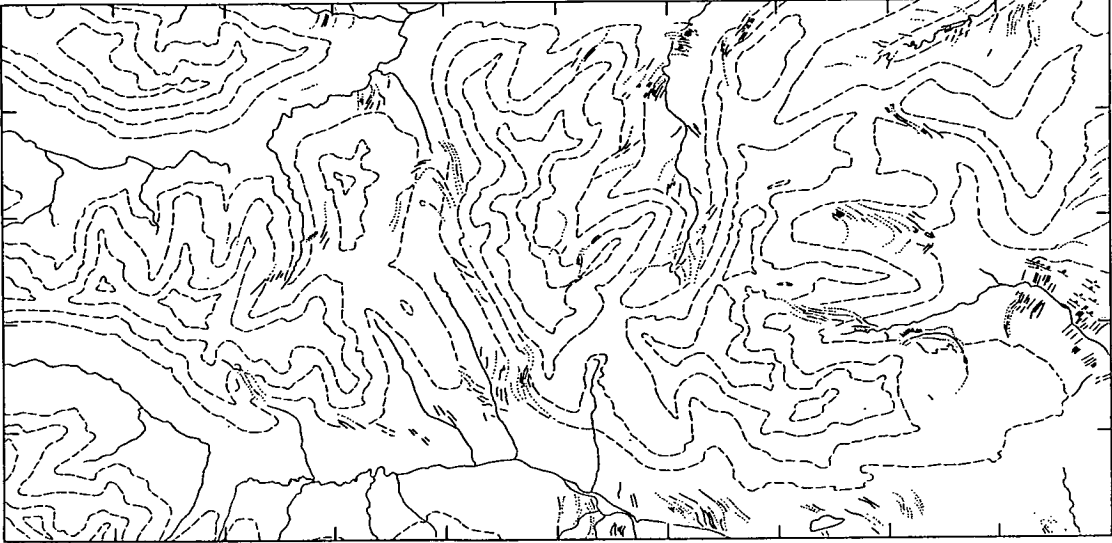

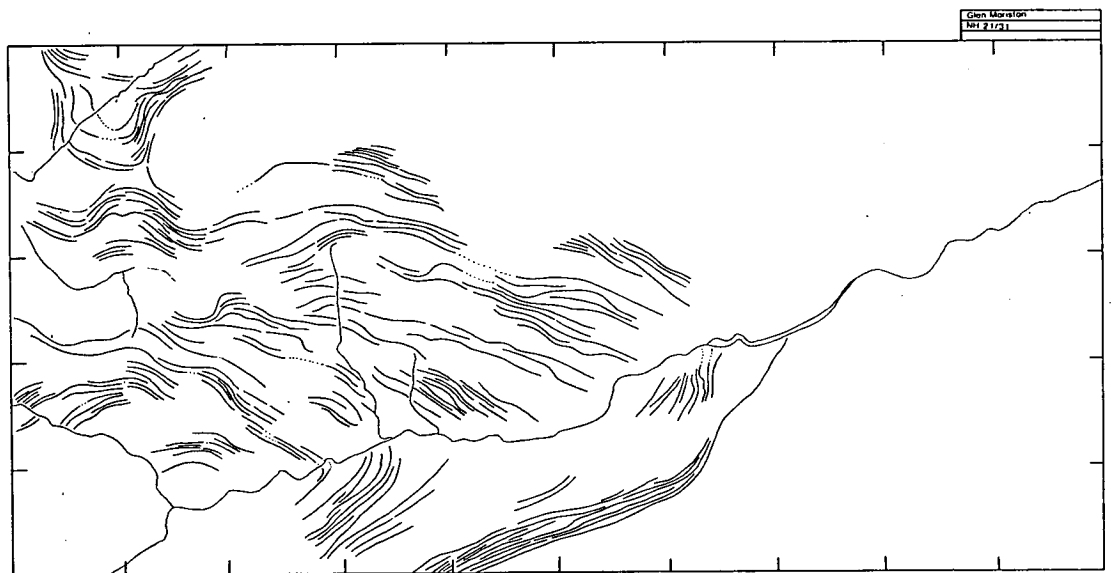
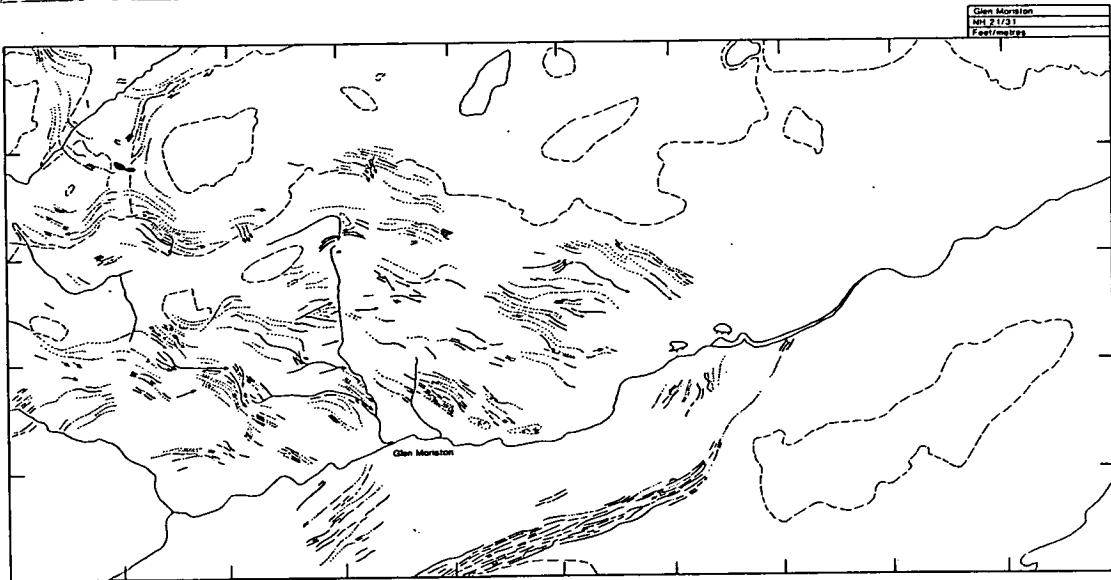

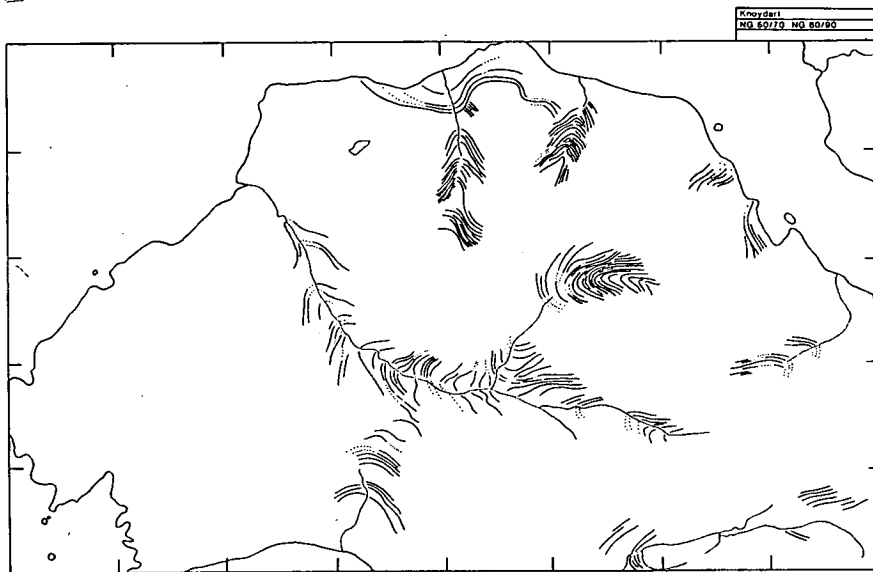
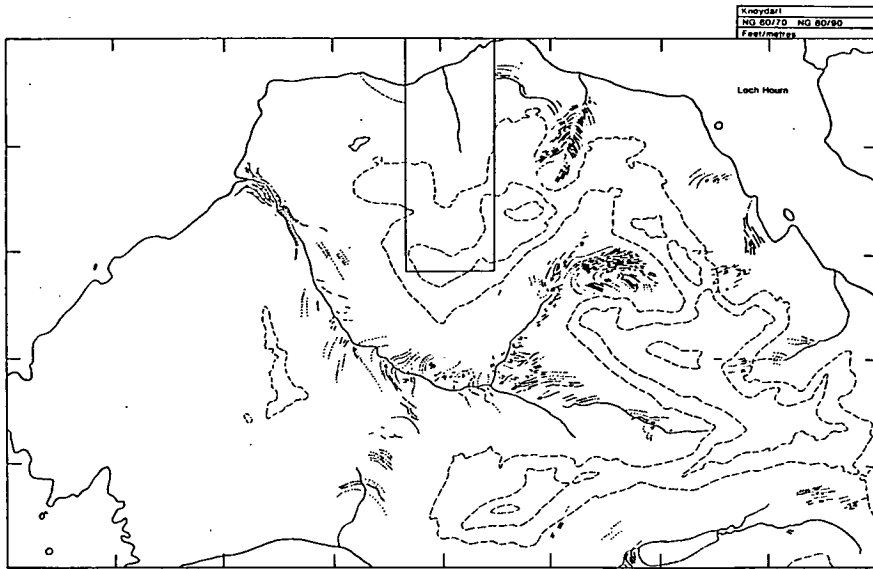

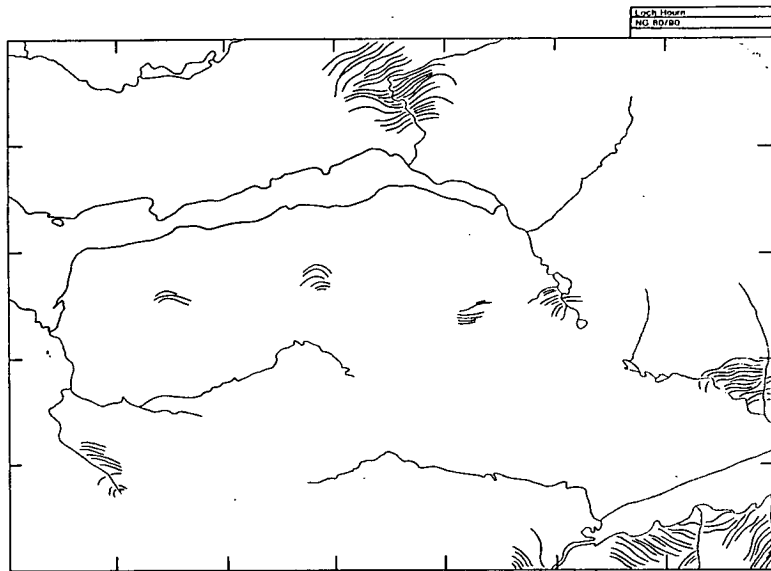
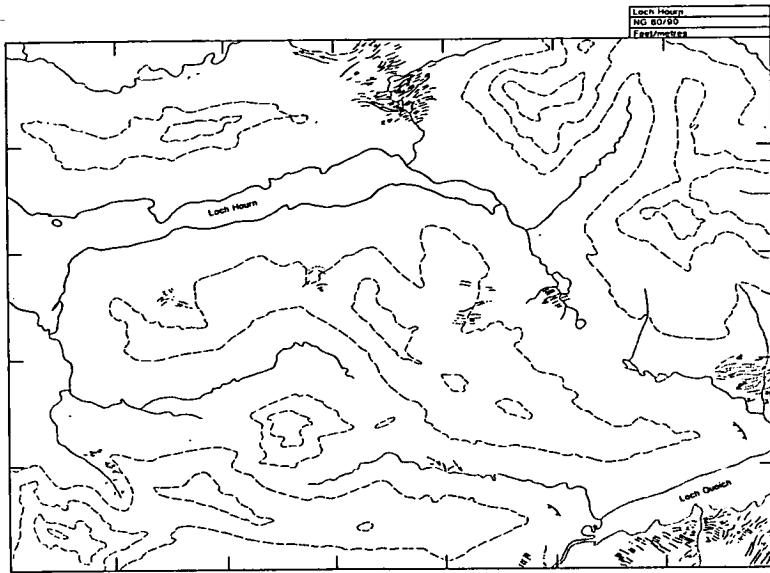

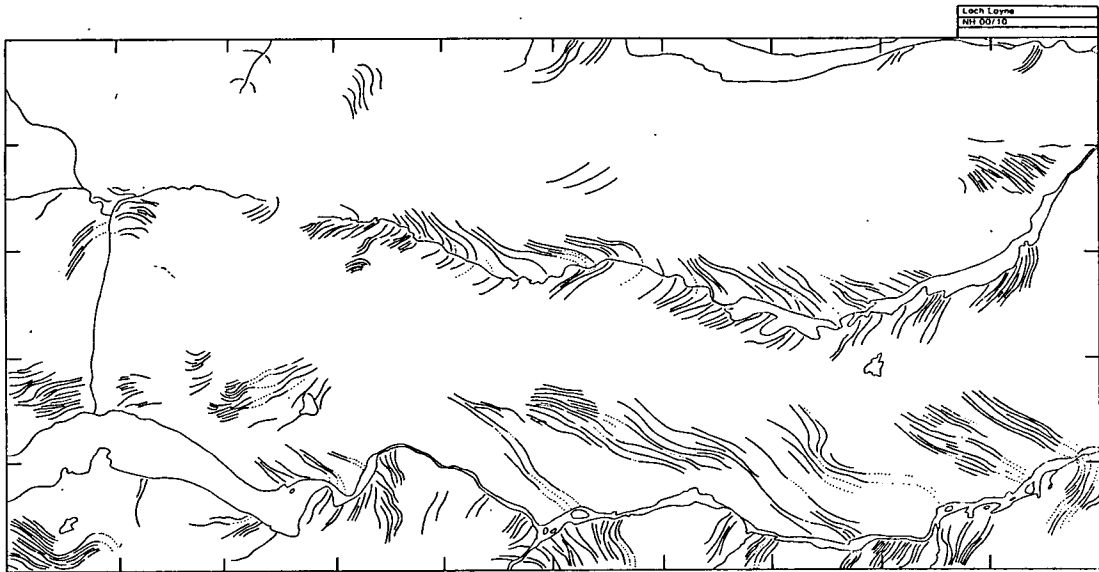
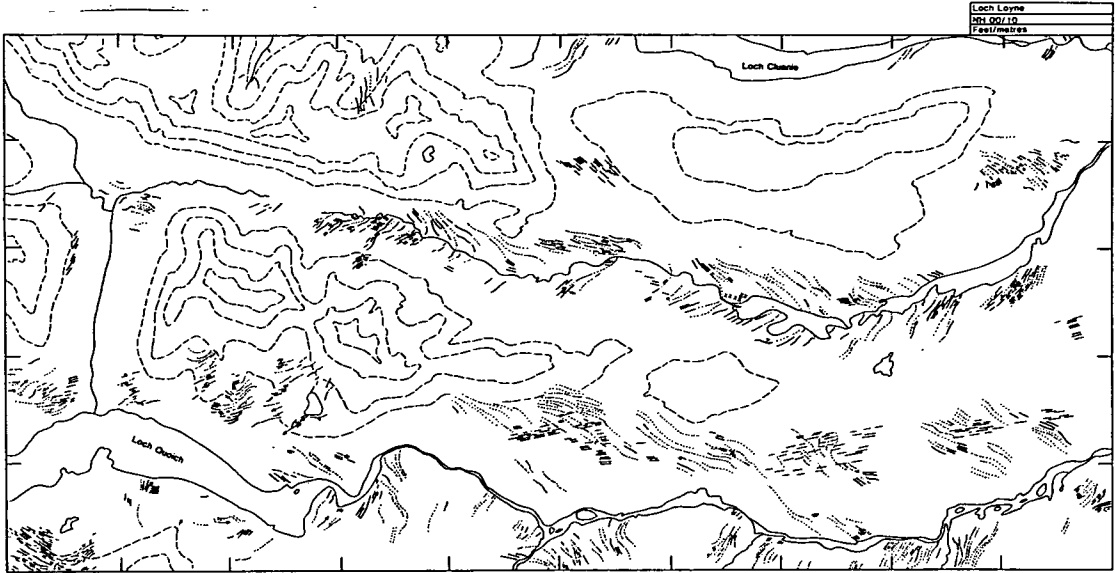

Fort Augustus  
NH 20/30  
Feet/meters

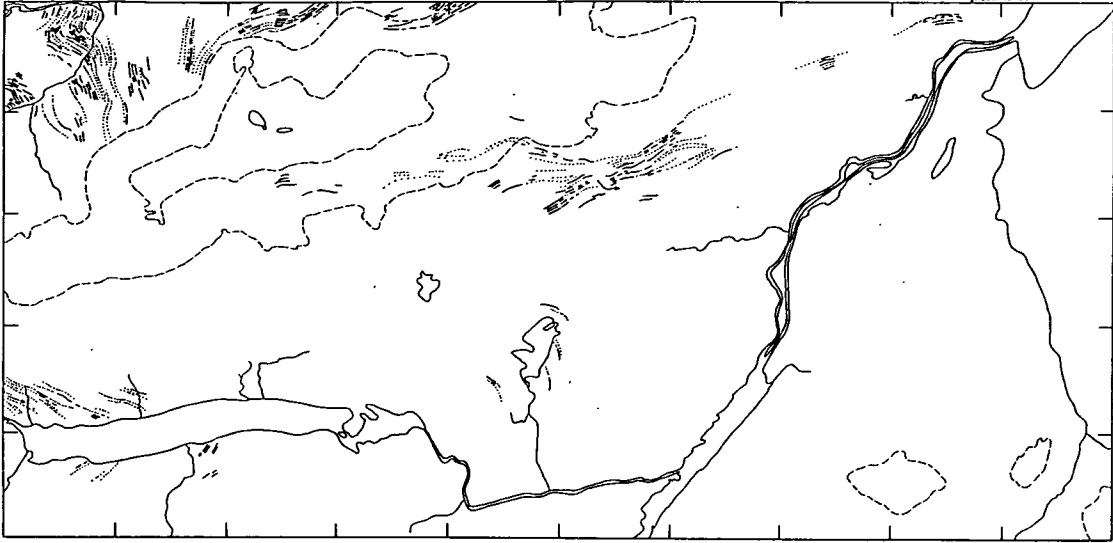

Fort Augustus  
NH 20/30

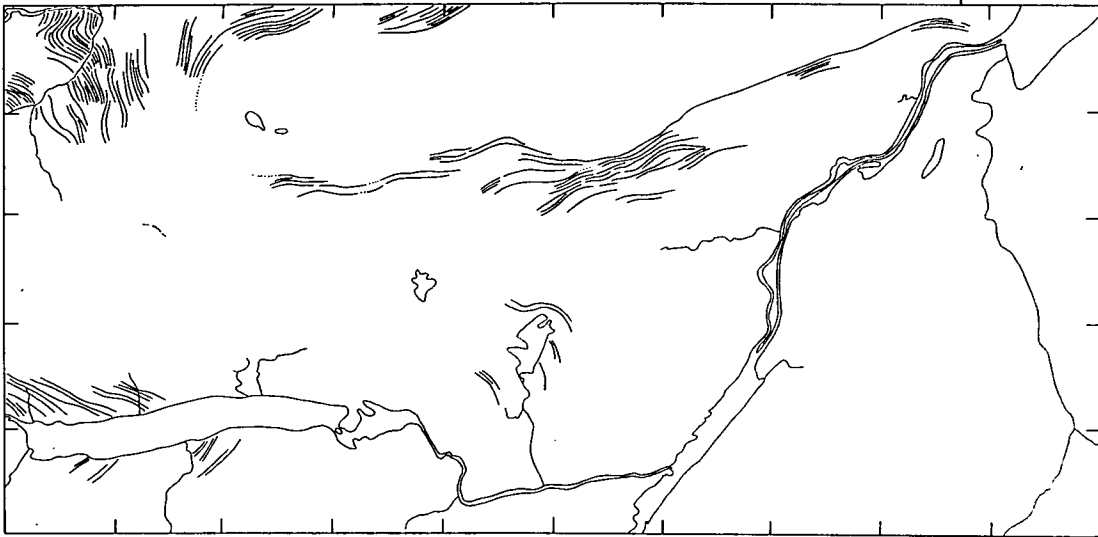

Mallaig  
NM 6079  
Feet/Metres

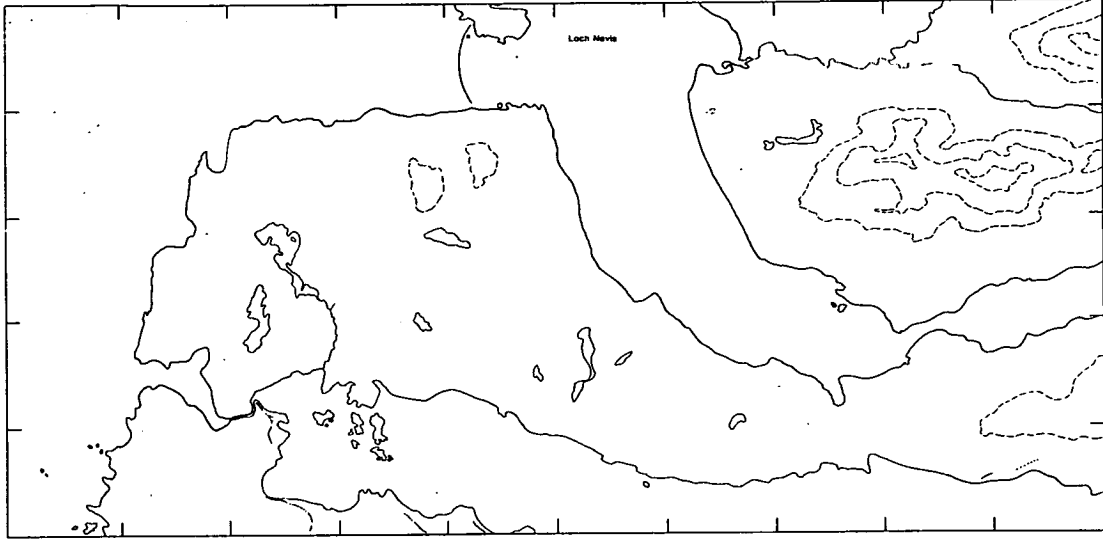

Mallaig  
NM 6078

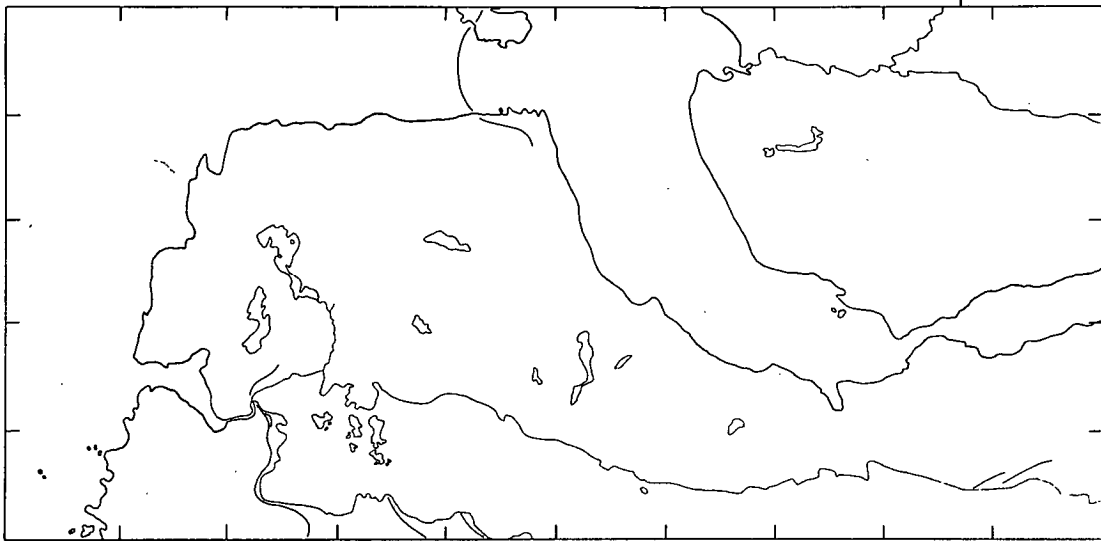

Glen Dessary  
NM 82/82  
Metres

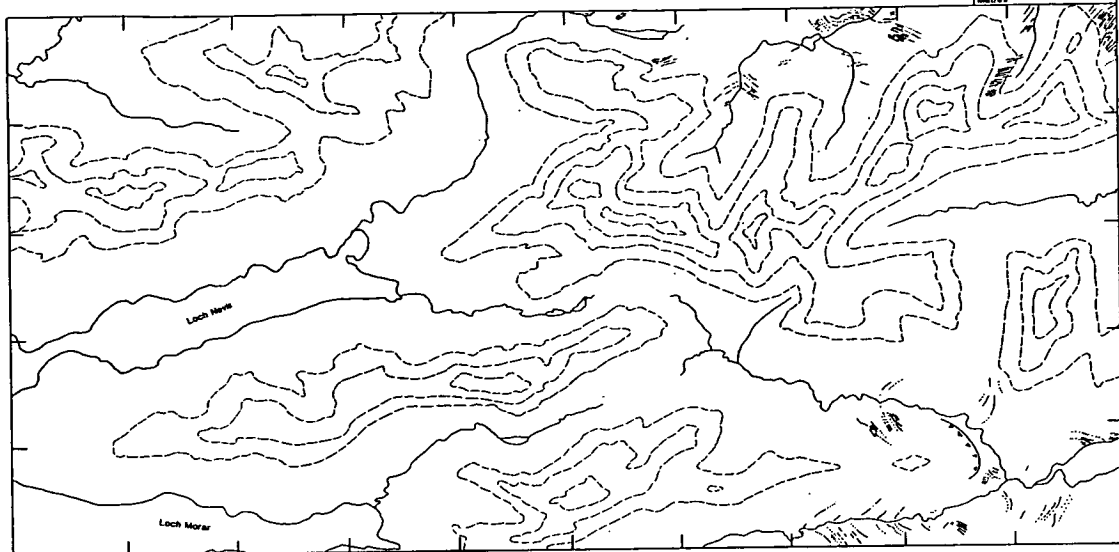

Glen Dessary  
NM 82/82

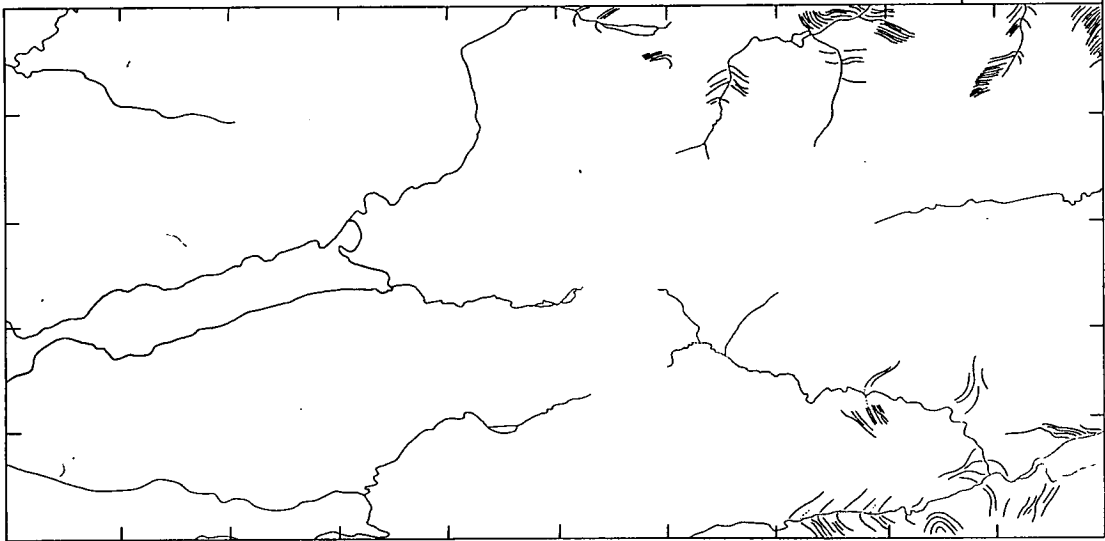

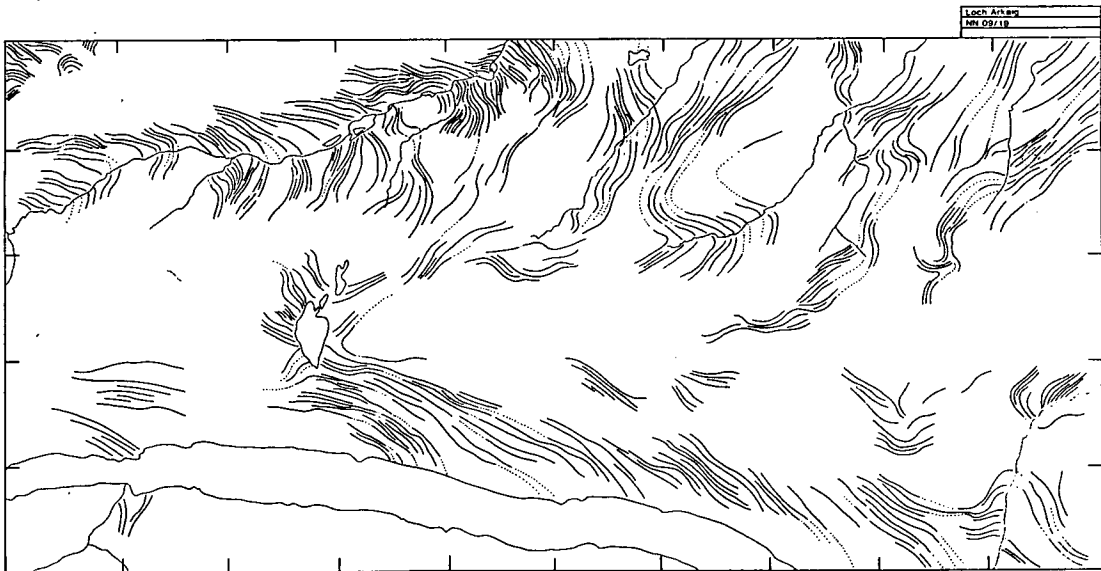
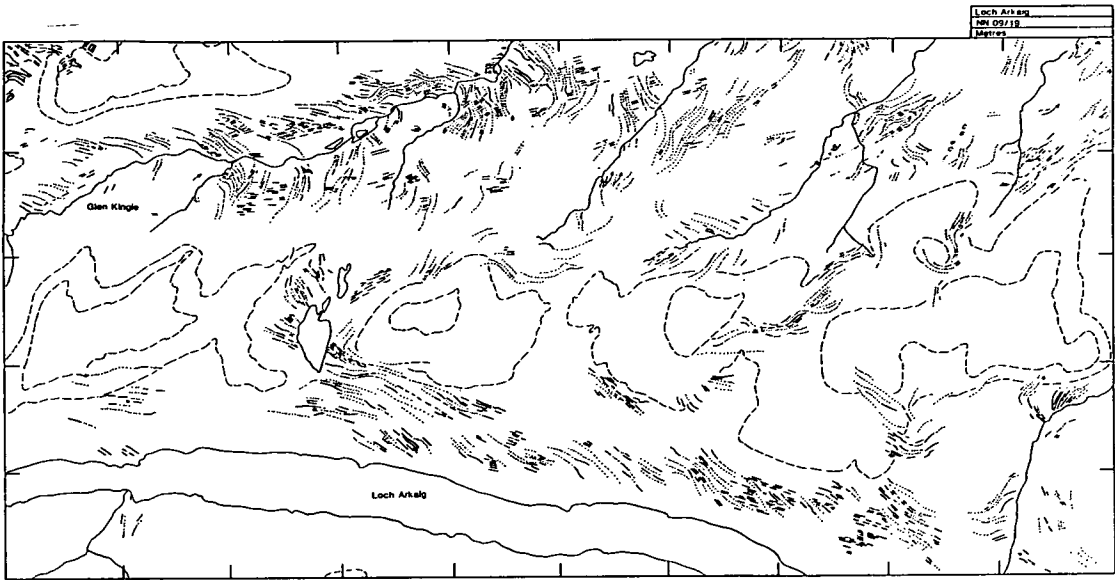

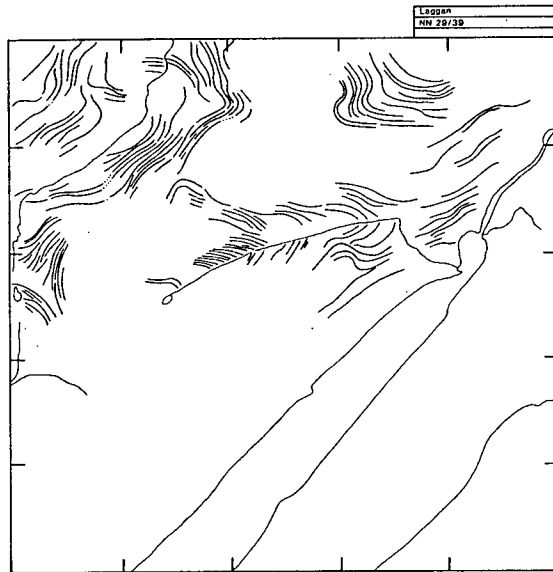
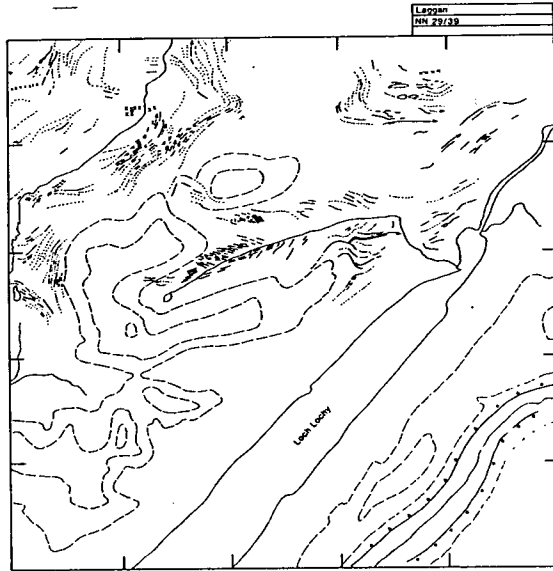

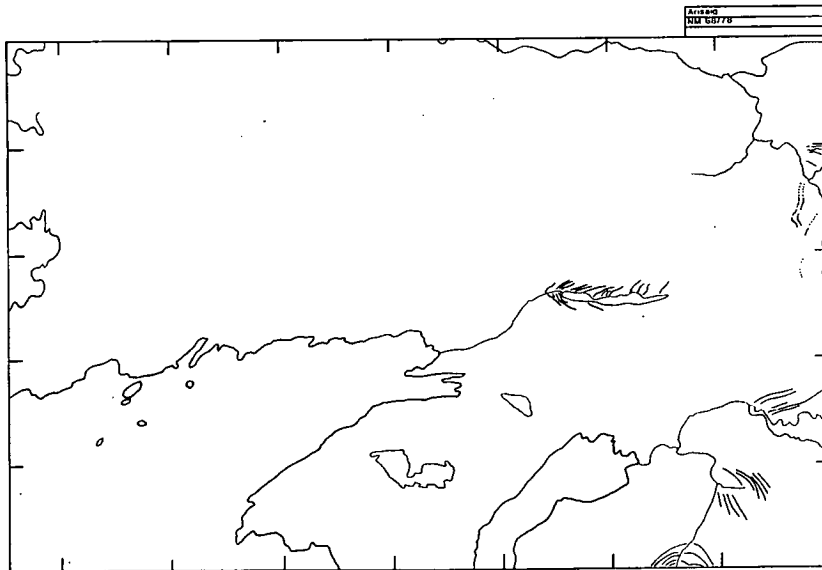

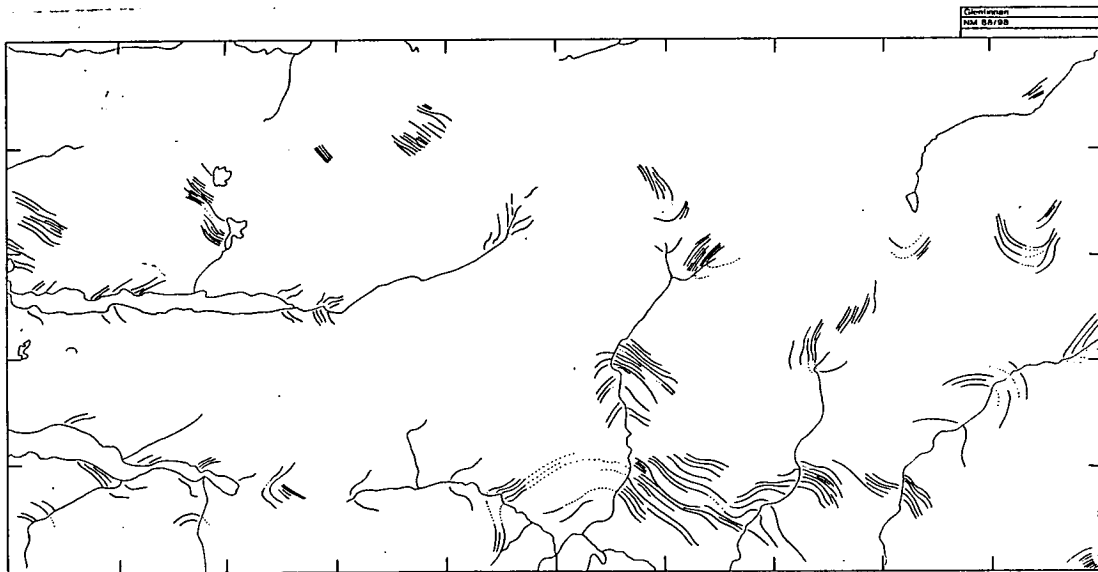
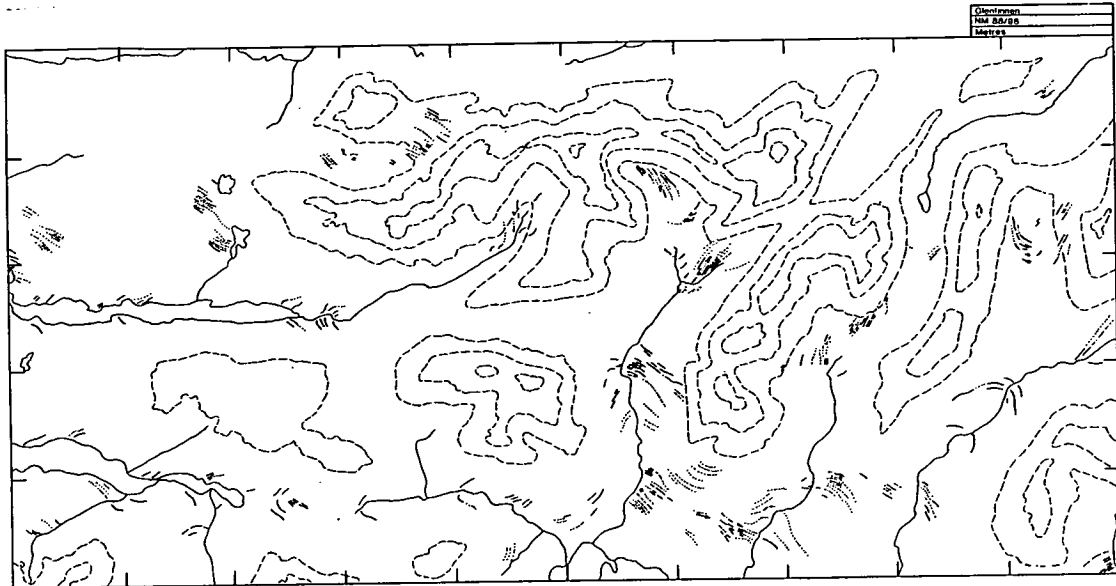

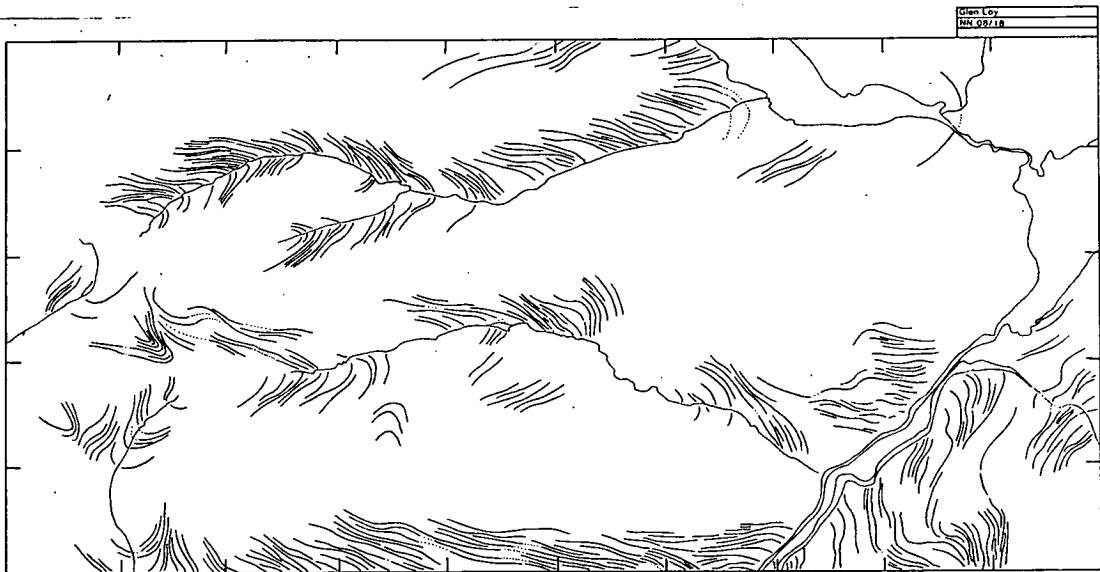
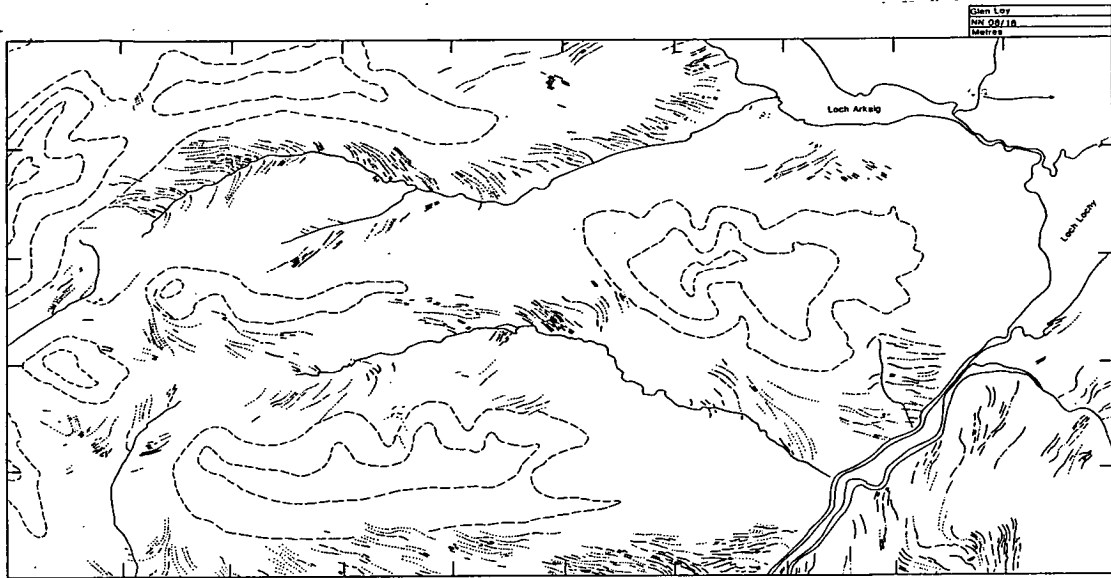

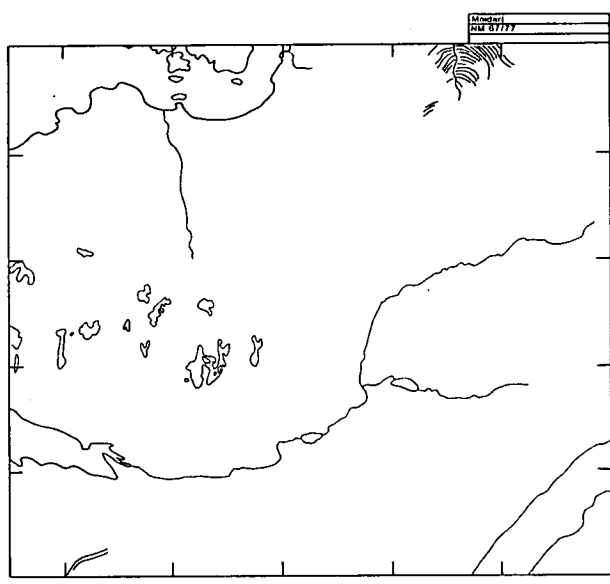
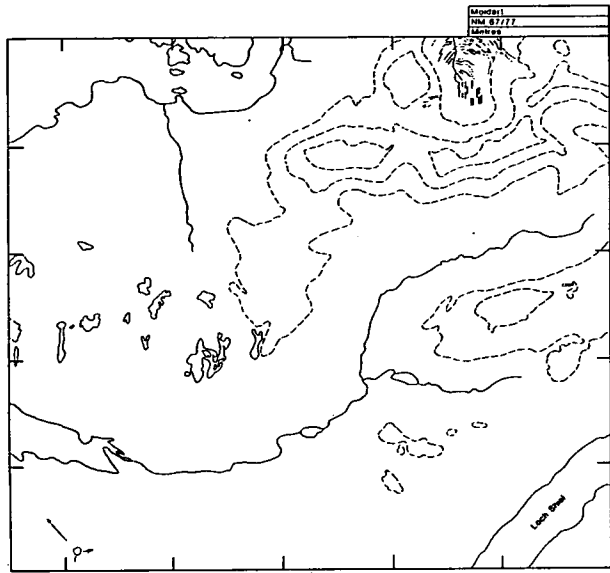

Loch Shiel  
MS 87/87

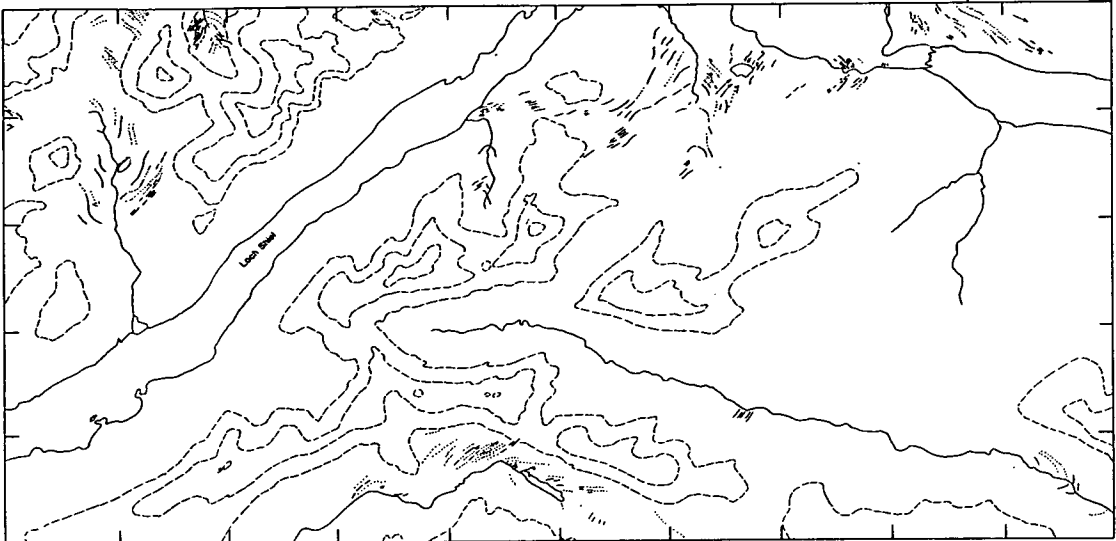

Loch Shiel  
MS 87/87

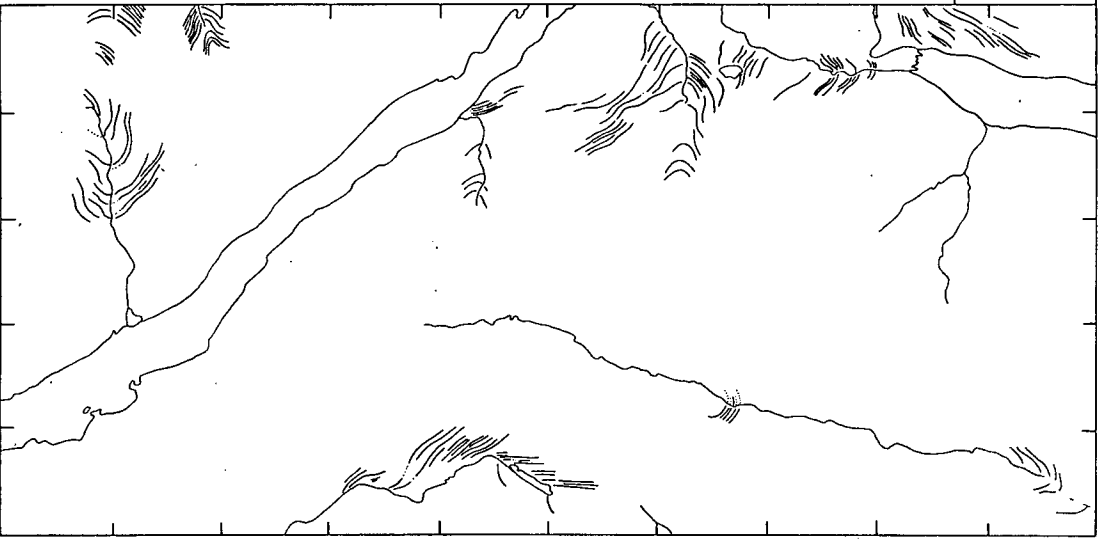

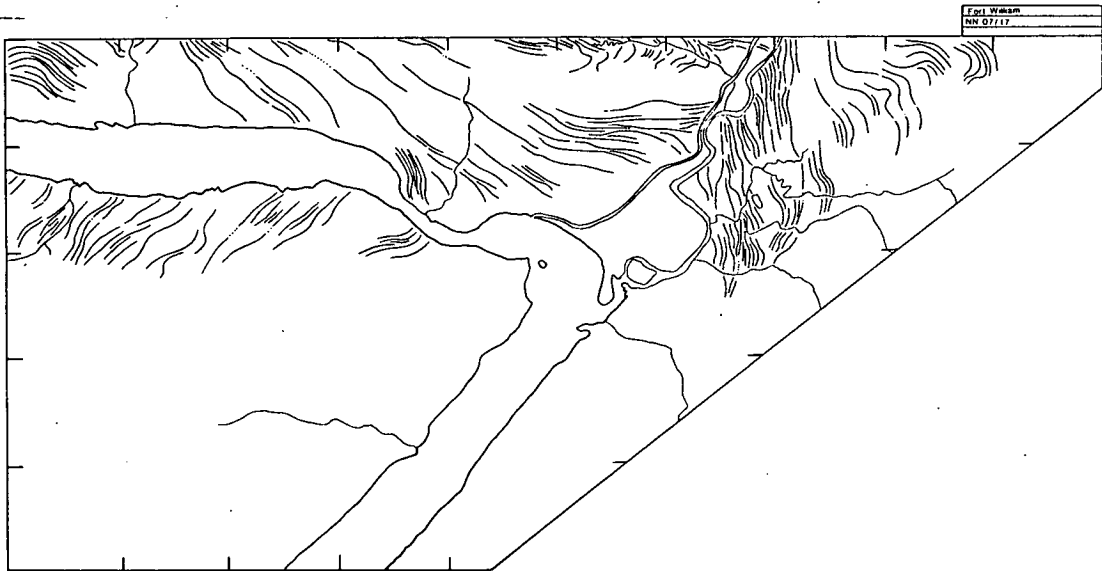
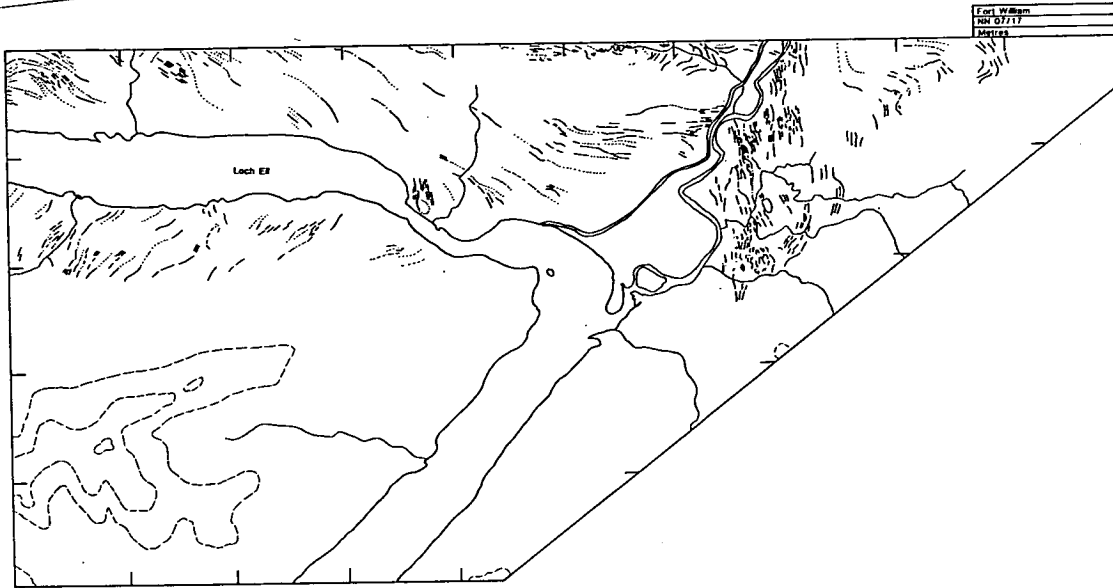

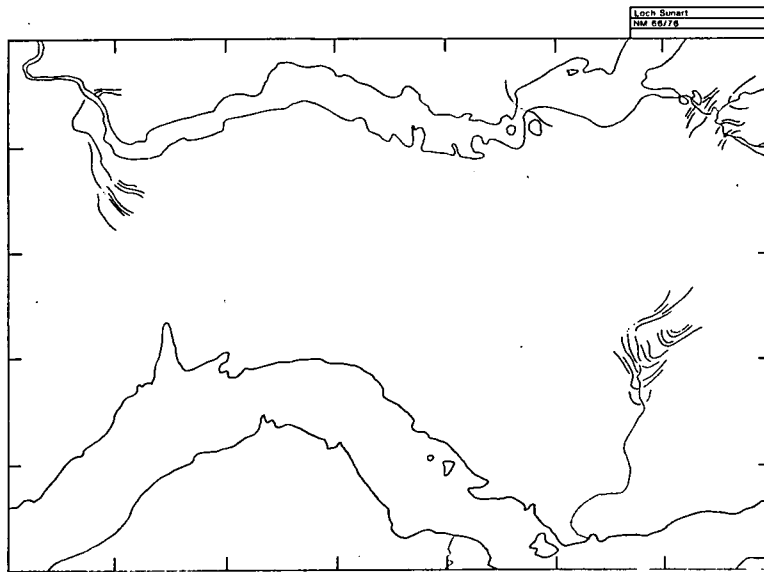
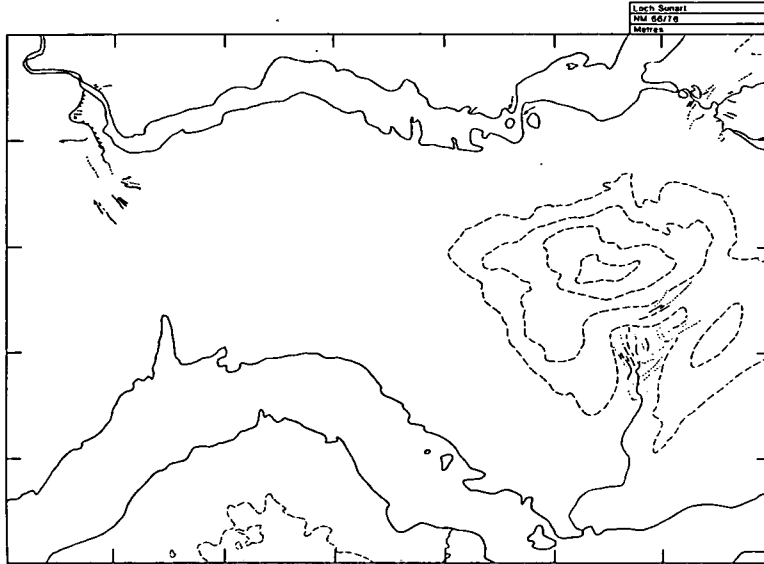

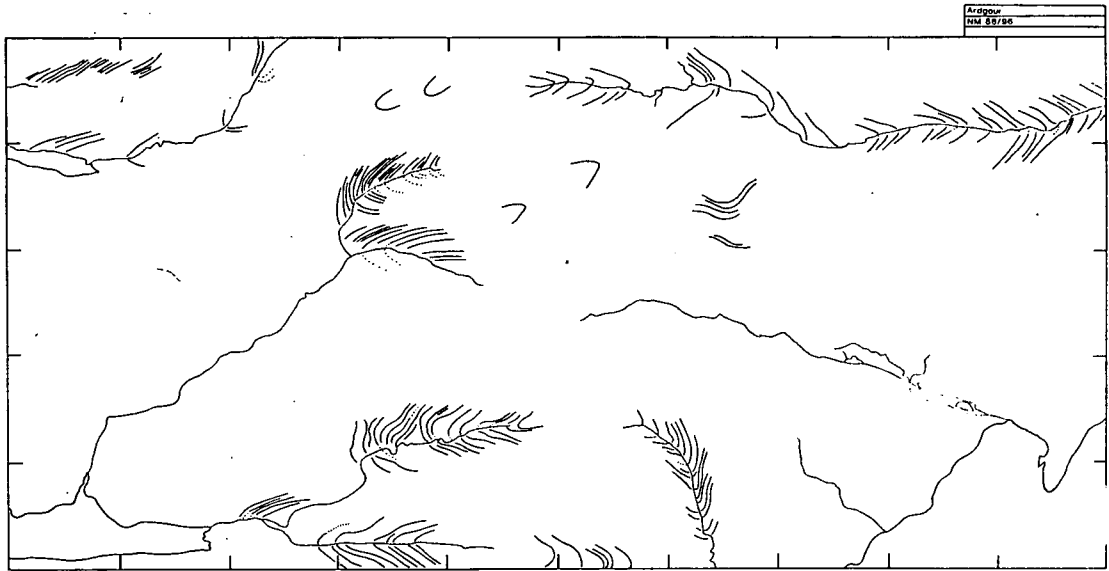
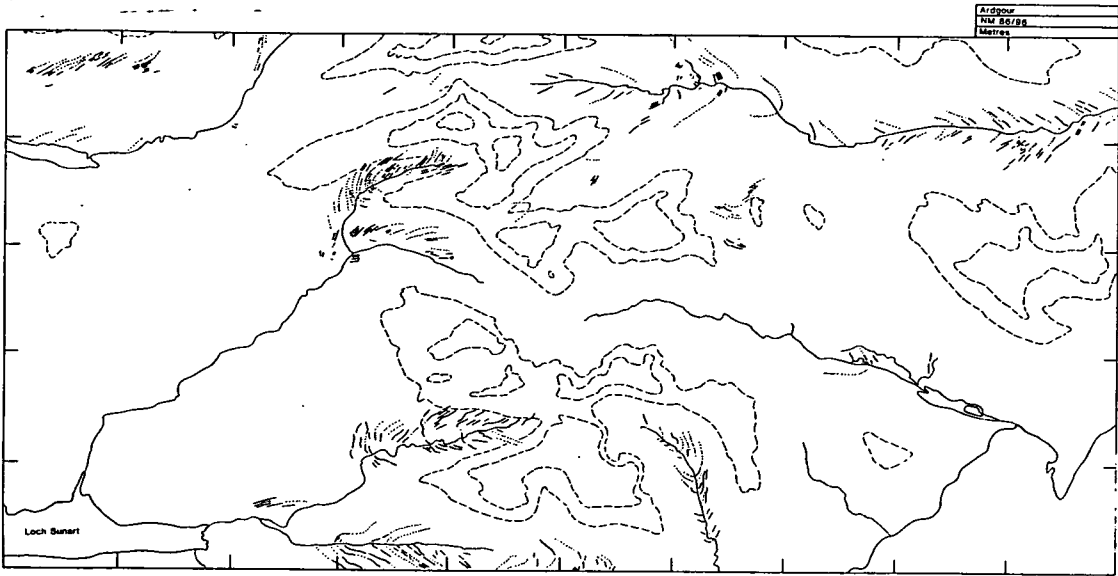

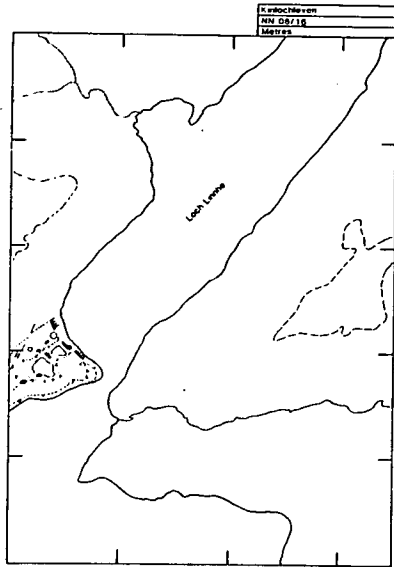

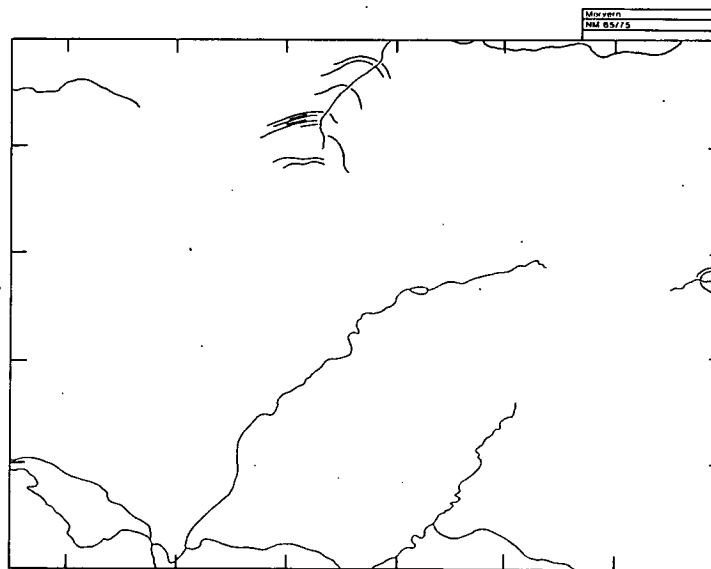
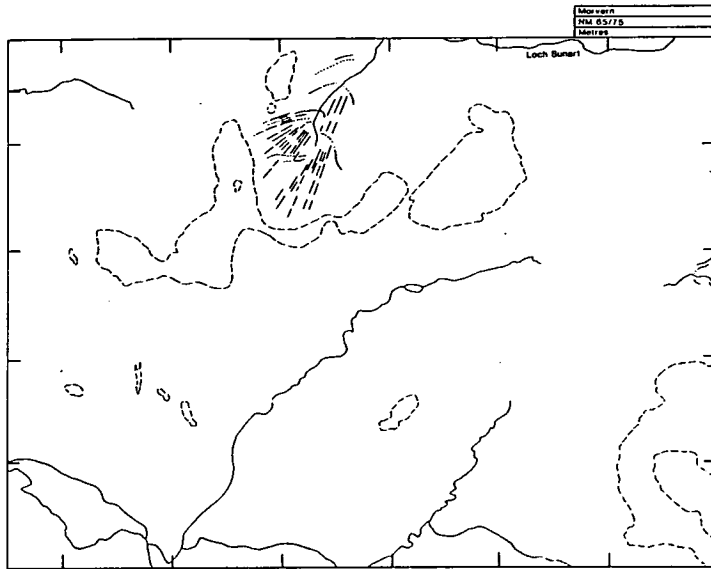

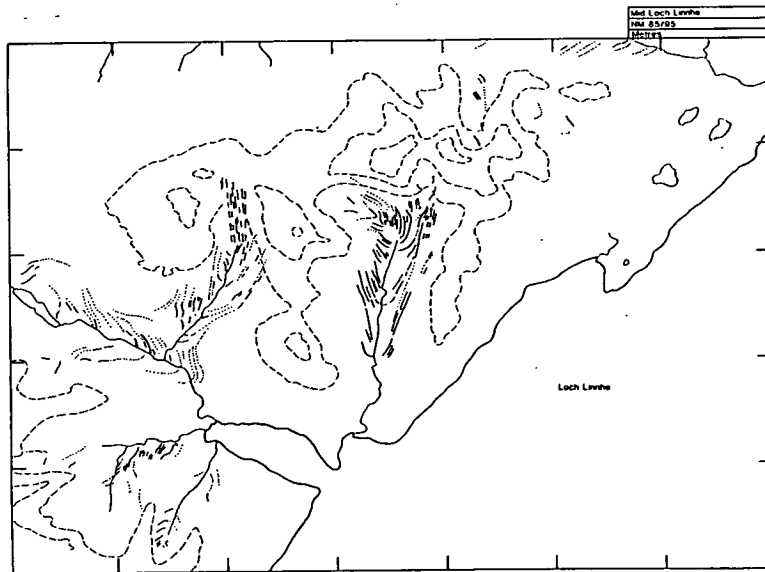

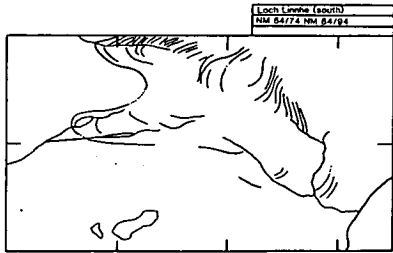
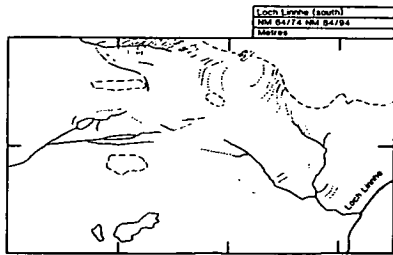

• Appendix II •

The glacial landforms of Glen Geusachan,  
Cairngorms.

**The glacial landforms of Glen Geusachan, Cairngorms: a reinterpretation.**

**Matthew R. Bennett**

(Department of Geology and Geophysics)

and

**Neil F. Glasser**

(Department of Geography, University of Edinburgh)

---

**Abstract**

A former glacier is described in Glen Geusachan similar to that identified by Sissons (1979), which probably dates from the Loch Lomond Stadial. However, the "hummocky moraine" within these glacial limits are reinterpreted here as an assemblage of individual ice-marginal landforms. It implies that the Loch Lomond Stadial deglaciation in Glen Geusachan was characterised by active retreat, the stages and pattern of which are described.

**Keywords:** Loch Lomond Stadial / "hummocky moraine" / Deglaciation / Glen Geusachan.

---

**Introduction**

Glen Geusachan is located in the centre of the Cairngorm massif and contains a complex assemblage of glacial landforms (Fig. 1). These landforms have received considerable attention (eg. Barrow *et al* 1912; Charlesworth 1955). The first detailed interpretation was attempted by Sugden (1970, 1973, 1974) who suggested that the "hummocky moraine" in the area was formed by fluvio-glacial deposition onto a stagnant ice mass. He went on to argue that this deglaciation probably occurred prior to the Loch Lomond Stadial (Sugden and Clapperton 1975).

In contrast Sissons (1979) used this "hummocky moraine" extent to delineate a valley glacier in Glen Geusachan (Fig. 1), which he interpreted

to be of Loch Lomond Stadial age. It was the largest of 17 Loch Lomond Stadial age glaciers identified in the central Cairngorms (Sissons 1979).

Sugden (1980) disputed the age of the "hummocky moraine" and its use as an indicator of glacier extent. He argued that the exact genetic characteristics of "hummocky moraine" and its relationship to the glacier front must first be established. Nevertheless both Sissons (1967, 1972, 1979) and Sugden (1970) are agreed that "hummocky moraine" is some form of stagnation terrain.

Recent work in the North West Highlands has suggested that "hummocky moraine" is in fact an assemblage of individual ice-marginal landforms, which mark the successive stages in the retreat of active ice (Bennett 1990). This hypothesis is founded on the observation that "hummocky moraine" can be resolved into a spectrum of lineated elements (Horsfield 1983). At the finest scale in this spectrum the lineations are due to drift dissection or gullies while at their broadest scale they may reflect bedrock structure. However, if such noise (eg. gullies and structure) is filtered out a simple pattern of lineated mounds and ridges is apparent. This point is illustrated in Figure 2; in which two sets of lineation are visible. Firstly there is a steep down slope component due to gullying and secondly a diagonal lineation formed by a sequence of drift ridges which run obliquely up the slope, it is these lineations that are of particular note. In general most "hummocky moraine" can be resolved into two components; cross valley or concentric ridges and down valley or radial ridges. The latter have been widely interpreted as flutes (eg. Peacock 1967; Hodgson 1986). Moreover, on the basis of modern analogues, it has been suggested that the cross valley or concentric elements can be interpreted as ice-marginal landforms (Bennett and Boulton 1989). We aim to demonstrate that the moraines of Glen Geusachan can be explained in this way.

### **The glacial landforms of Glen Geusachan.**

The landforms of Glen Geusachan were mapped using 1:10 000 scale air photographs and through detailed field work. The evidence thus gathered is presented in Figure 3, from which it is apparent that a distinct valley glacier formerly existed in Glen Geusachan. We believe that it probably dates from the Loch Lomond Stadial interval, but have no direct chronological evidence to support this opinion. The areal extent of the glacier is similar to that mapped by Sissons (1979), although the detail of evidence presented and its interpretation is very different.

It is possible to identify four key areas of interest:

- 1) Lower or southern Glen Dee.
- 2) The eastern flank of Glen Dee.
- 3) The mouth of Glen Geusachan.
- 4) The head of Glen Geusachan.

**Lower or southern Glen Dee:** The down valley limit of the Glen Geusachan glacier is most clear on the western side of Glen Dee where a prominent moraine, approximately 50 metres above the valley floor contours around the valley side before descending steeply ( $20^\circ$ ) to the valley floor to the north of Allt Garbh (Fig. 3). Above this moraine bare rock slabs are exposed and beneath it there is several metres of thick drift. On the opposite valley side several comparable moraines can be identified on the air photographs, although these are less obvious in the field. It is interesting to note that these ice limits are closely associated with the limit of schist erratics on granite, inside which schist is absent (Fig. 1). The "hummocky moraine" limit mapped by Sissons (1979) occurs 300 metres to the north of these moraines. It consists, in fact, of at least a dozen linear ridges which can be traced up the eastern valley side at angles of  $20-30^\circ$  to the horizontal. These are interpreted here as a sequence of lateral moraines, marking the successive stages of a retreating glacier. None of these moraines can be traced across the valley floor because of the presence of an extensive outwash surface.

This outwash surface extends both within and beyond the glacial limit described above and is composed of massive sand and gravel units. There are numerous kettle holes inside the glacial limit, which is probably due to fluvio-glacial deposition on to the ice margin, as described by Price (1971, 1973) (Fig. 3).

To the north of Caochain Roibidh, there are several irregular blocky ridges which are also associated with kettled outwash. These porous boulder ridges run obliquely across the valley floor and continue up the western valley side as more compact moraine ridges. They are interpreted as block moraines representing the boulder lag of moraines deposited at a fluvially active ice margin (Weidick 1963).

**The eastern flank of the Dee valley:** The eastern side of the Dee valley opposite Glen Geusachan is dominated by a suite of meltwater channels, which are associated with linear morainic ridges (Fig. 3). These

channels are probably ice-marginal since sections of them consist of only half a channel; that is the outer channel wall is low or absent. In these cases the ice margin appears to have acted as the outer channel wall (Fig. 4). The channels therefore are of particular importance as they give a clear picture of the position of the ice front and its retreat. Moreover, the channels are intimately associated with linear moraine ridges which suggests that these may also be ice-marginal.

The highest channels contour around the shoulder of Carn a' Mhain some 150 to 200 metres above the River Dee and seem to have drained eastwards via a meltwater channel which has cut into the col of Allt Preas nam Meirleach (Fig. 3). Below these channels there are four main meltwater systems, which run north-south beneath and to the west side of the col of Allt Preas nam Meirleach (Fig. 3). The first and highest of these channels is a broad (10-20 m) shallow (c. 5 m deep) channel commencing as a half channel in the north before becoming a full channel further south.

The second channel of this sequence is deeply incised and at least 1200 metres long with an average gradient of 4°. The southern and lowest end of this channel is cut into bedrock which suggests that it may mark the position of a prolonged still stand. The channel was also sufficiently deep to remain active as the ice retreated to the west since it is feed by several smaller channels (Fig. 3).

The third channel system is a spectacular half channel. It is broad (10-15 m) with an inner, steep (25°-30°), drift cut wall 10 to 15 metres high. The outer wall consists of a series of low, irregular and discontinuous ridges. This channel is also of note since it starts as a prominent basin or plunge pool, whose outer wall appears to have been formed by the ice margin (Fig. 3).

The final and lowest channel sequence is an irregular collection of channels and narrow kame terraces to the south of which lies a complex area of drift mounds and kettle holes. This is interpreted as a localised patch of stagnant ice topography, formed by fluvio-glacial deposition against the ice margin derived from the meltwater channels to the north.

**The mouth of Glen Geusachan:** On the western side of the River Dee, in the mouth of Glen Geusachan, the moraine landforms have a pronounced cross-valley continuity. Although individual ridges vary in length from 10 to 150 metres, they can be linked together to form more continuous

elements, which form a sequence of concentric lines that gently curve out and across the valley floor. The cross sectional area of these ridges varies from 7.5 m<sup>2</sup> to 32.2 m<sup>2</sup> and is often asymmetric, the down valley face being steeper than the up valley side. Although there are few good sections it appears that these ridges are composed primarily of a massive sandy diamicton which varies from a compact heterogeneous mass to a loose friable sediment. Irregular lenses of bedded sand occur frequently within these sections and suggest some degree of fluvial reworking. The clasts are of variable size, poorly sorted, very angular and have a low sphericity. It is suggested, therefore, that this debris is principally of supraglacial origin. It does not resemble the basal debris found in granitic lodgement tills elsewhere in the Cairngorms, which are characteristically homogeneous and compact deposits with a firm silty matrix.

In the past patches of ordered "hummocky moraine" have been explained by a process of crevasse filling—that is the squeezing of sediment into basal crevasses (Sissons 1967, p.67). However, crevasse-filled ridges are usually composed of basally transported debris and possess an angular or rectilinear planimetric form (eg. Sharp 1985). The ridges in Glen Geusachan do not possess such angular elements nor does their planimetric pattern appear to reflect the sort of crevasse pattern one might expect in such a location. This interpretation is also not consistent with the sediments contained in the ridges. The sedimentology and planimetric form of the ridges is also inconsistent with them being some form of subglacial rogen like moraine (Cornish 1979).

These ridges are interpreted here as recessional moraines, marking the successive positions of an actively retreating glacier in Glen Geusachan. The conical form of the crests of many of these ridges suggests that they were formed primarily by dump processes. Most of the ridges do not resemble the push moraines identified elsewhere in the Scottish Highlands (eg. Peacock 1984; Bennett unpubl.) nor those described from Iceland (eg. Sharp 1984; Boulton 1986). Push moraines are more uniform and continuous than the moraine ridges in Glen Geusachan and they usually have a distinct lobate form, with fluted or streamlined ice proximal face.

**The head of Glen Geusachan:** As the glen turns sharply to the north a sequence of low and lineated drift mounds are found (Fig. 3). There is a two fold order in these mounds, a down slope component due to dissection by

gullies and a ridge lineation running diagonally down the valley sides at angles of 15°-20° to the horizontal (Fig.2). We believe, therefore, that these latter ridges reflect the successive ice-marginal positions of an actively retreating ice front.

These moraines dam the eastern side of Loch nan Stuirteag, and occur above and to the west of the valley floor. These mounds and ridges are poorly ordered and contain numerous dead ice hollows the western limit of which is recorded as a "hummocky moraine" limit by Sissons (1979). However, Sissons (1979) failed to record a distinct terrace above the loch on its western and northern side. This horizontal terrace is narrow (1-5 m) and dips gradually (5°-6°) out of the slope. Its surface is studded with large rounded boulders, which are interpreted as a surface lag deposit. For the most part the terrace appears to be depositional, although parts of it are cut into the solifluction lobes that occur above the terrace. This terrace is interpreted as the shoreline of a glacial lake dammed by ice in Glen Geusachan (Fig. 3). This conclusion is based on the horizontal nature of the terrace and the fact that it leads into a series of meltwater channels which cut the col to the west of the present loch. These channels occur at the same elevation as the terrace, at about 899 metres.

To the west of Loch nan Stuirteag and the Allt Luineag there are several subdued, linear ridges which Sugden (1970) interpreted as moraines. The southern end of these moraines is associated with a sharp erratic limit, where granite erratics have been moved westward onto schist (Sugden 1970)(Fig.1). It is possible that this erratic and moraine limit could represent the western extent of the Glen Geusachan ice body. However it is tentatively suggested here that this limit probably pre-dates significantly those on the eastern side of Loch nan Sturiteag. This conclusion is based on the observation that the ice dammed lake was a prolonged event. The size and clarity of the shoreline coupled with the depth and frequency of the overflow channels tend to support this view. Moreover, where the overflow channels fed into the Allt Luineag there are numerous palaeo-braids or fossil bars which tend to imply that the discharge from the glacial dammed lake was prolonged.

### **The pattern of deglaciation in Glen Geusachan**

From the evidence outlined above it appears that the glacier in Glen Geusachan was characterised by active retreat recorded in a succession of ice-marginal landforms. This morainic evidence can be used to draw up a

succession of palaeo-ice fronts for the Glen Geusachan glacier (Fig. 5A). This pattern of retreat is illustrated by reconstructions of the glacier at selected ice-marginal positions (Fig. 5B, C and D).

Three important inferences follow from these patterns. Firstly, the piedmont lobe of the Glen Geusachan glacier which blocked the Dee valley was asymmetric, extending further to the south than to the north. This may be due to the presence of a glacial lake, dammed by this piedmont lobe, in the upper part of Glen Dee (Fig. 5B). The asymmetry of piedmont lobes damming glacial lakes is well documented elsewhere. For example the Strath Bran lobe which dammed the glacial lake at Achnasheen is also asymmetric (Sissons 1982; Benn 1989); Figure 6 illustrates a modern analogue from Arctic Canada for the situation envisaged in Glen Dee. This postulated lake would have been fed by meltwater from the glaciers in Garbh Coire and Coire an t-Saighdeir (Fig. 1 and 3) as these glaciers are of a similar age (Sissons 1979). The presence of a lake in Glen Dee would account for the complex meltwater channels around the eastern margin of the piedmont lobe, several of which occur at the same elevation as a number of possible shore lines identified on the eastern side of Glen Dee to the north of Corrou Bothy. It is important to note that Sissons (1979, p.71) found no exposures of lake sediments in Glen Dee which would support a lake hypothesis, however this could be due to the presence of very thick peat in Glen Dee.

Secondly, as the glacier retreated into Glen Geusachan the palaeo-ice fronts become progressively skewed to the south (Fig. 2 and 5A). Individual palaeo-ice fronts extend further down valley on the south side of Glen Geusachan than on the northern flank. The spacing between individual moraines or palaeo-ice fronts is also greater on the north side of the glen. This asymmetry probably reflects the insolation contrasts within Glen Geusachan. The north side of the glen would have received higher inputs of solar radiation and therefore experienced greater ablation than the on the southern flank of the glen. Consequently the amount of retreat between each moraine building episode would have been greater on the northern side of the glen leading to the asymmetry described above. These observations are similar to those made by Thom (1972) on Icelandic outlet glaciers.

Finally the rate at which this retreat occurred is of importance. Recent work by Dansgaard *et al.* (1989) has suggested that at the close of the Loch Lomond Stadial air temperature rose dramatically, 7° in only 50 years,

in southern Greenland. However, it is clear that the glacier in Glen Geusachan did not decay on this sort of time scale but over a much longer period and remained active in the process.

The accumulation or growth of the Loch Lomond Stadial glacier in Glen Geusachan has been the subject of extensive debate (eg. Sugden 1970, 1973, 1980; Sissons 1972, 1973, 1979; Sissons and Grant 1972). It can be explained in one of three ways:

1) The ice limits described above may simply reflect a still stand during the Loch Lomond Stadial in the decay of a local plateau ice cap in the Cairngorms (Sugden 1970, 1973).

2) The pre-Loch Lomond deglaciation was completed prior to re-accumulation of glaciers during the Loch Lomond Stadial which consequently accumulated from nothing (Sissons 1979).

3) The pre-Loch Lomond deglaciation was not completed in all the valley heads prior to the Loch Lomond Stadial and ice was simply rejuvenated in certain valleys such as Glen Geusachan and Garbh Coire.

This third hypothesis is favoured by the authors. One can envisage a situation in which the last ice sheet decayed into Glen Geusachan and Garbh Coire since their east west orientation and impressive depth would be ideal for prolonged ice survival. This would explain why the Loch Lomond glaciers of Glen Geusachan (8.9 km<sup>2</sup>) and Garbh Coire (4.7 km<sup>2</sup>) are so much larger (63% of the glacial area) than the other 15 glaciers (average area 0.54 km<sup>2</sup>) identified in the Cairngorms by Sissons (1979), since in these two glens ice readvanced from sizeable relict ice bodies while in the small adjacent corries ice had to re-accumulate completely. The hypothesis also successfully explains the apparent parallelism in certain parts of Glen Geusachan between pre-Loch Lomond and Loch Lomond age moraines. Moreover, the prolonged presence of a glacier in Glen Geusachan explains the absence of foreign erratics (schist) in the glen. No schist occurs inside the erratic limits in Glen Dee (Fig. 1). It could be argued that there is a greater likelihood that the Glen Geusachan glacier would have had sufficient time to flush out the schist erratics if it had been active since the point during deglaciation, of the last ice sheet, at which the supply of schist from the west was cut off. A glacier which had to first re-accumulate, during the Loch Lomond Stadial is less likely to have had sufficient time at its maximum extent to remove all the schist erratics from the glen. Although none of the evidence for glacier survival is very convincing and may perhaps be open to alternative interpretation, the

idea of glacier survival during the Windermere Interstadial remains an important hypothesis and should receive further attention and investigation elsewhere. The principle problem is that there is a basic lack of information available about the Lateglacial history of the Cairngorms.

### **Conclusion**

The "hummocky moraine" of Glen Geusachan can be interpreted as an assemblage of individual ice-marginal landforms. These landforms can be mapped to provide a detailed picture of the successive stages in an actively retreating glacier within Glen Geusachan. The presence of "hummocky moraine" does not therefore necessarily imply widespread glacial stagnation.

### **Acknowledgements**

Both the authors would like to acknowledge the financial assistance of the N.E.R.C. and the continuous support and advice of both G. S. Boulton and D. E. Sugden. Special thanks are also due to Joanna Bullard, Christianne Clancy and Jenny Trengove for access to unpublished data, field assistance and useful discussion.

### **References**

See main reference list.

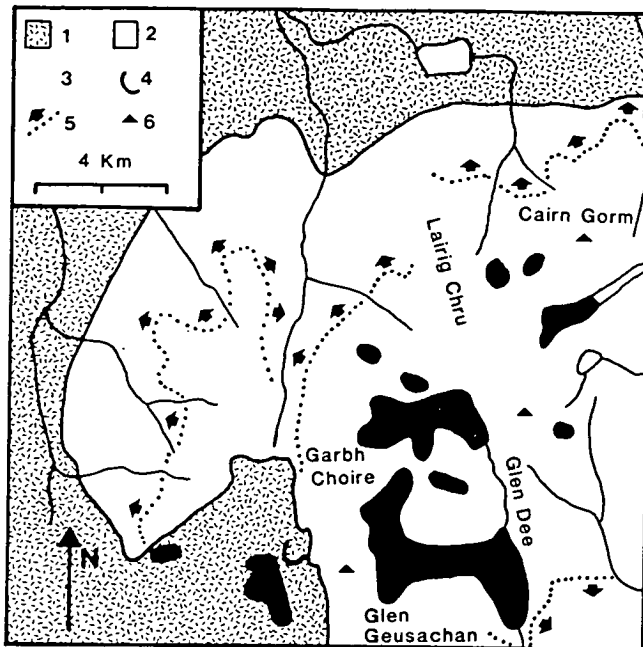

Fig. 1: The central Cairngorms. 1= Schist bedrock; 2=Granite bedrock; 3=Loch Lomond Stadial Glaciers, after Sissons (1979); 4=Limit of granite erratics on schist; S=Limit of schist erratics on granite; 6=Mountains.

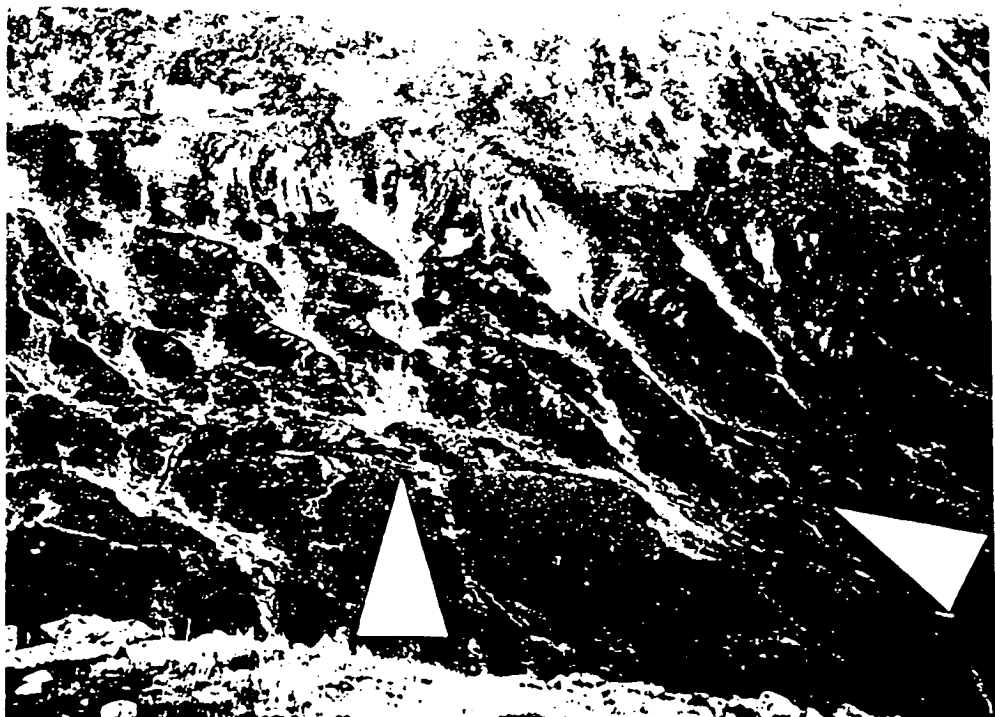

Fig.2: "Hummocky moraine" the upper part of Glen Geusachan. Two very clear drift lineations are apparent (see arrows) while one is due to gullying (vertical arrow) the other (oblique arrow) probably reflect former ice margin positions.

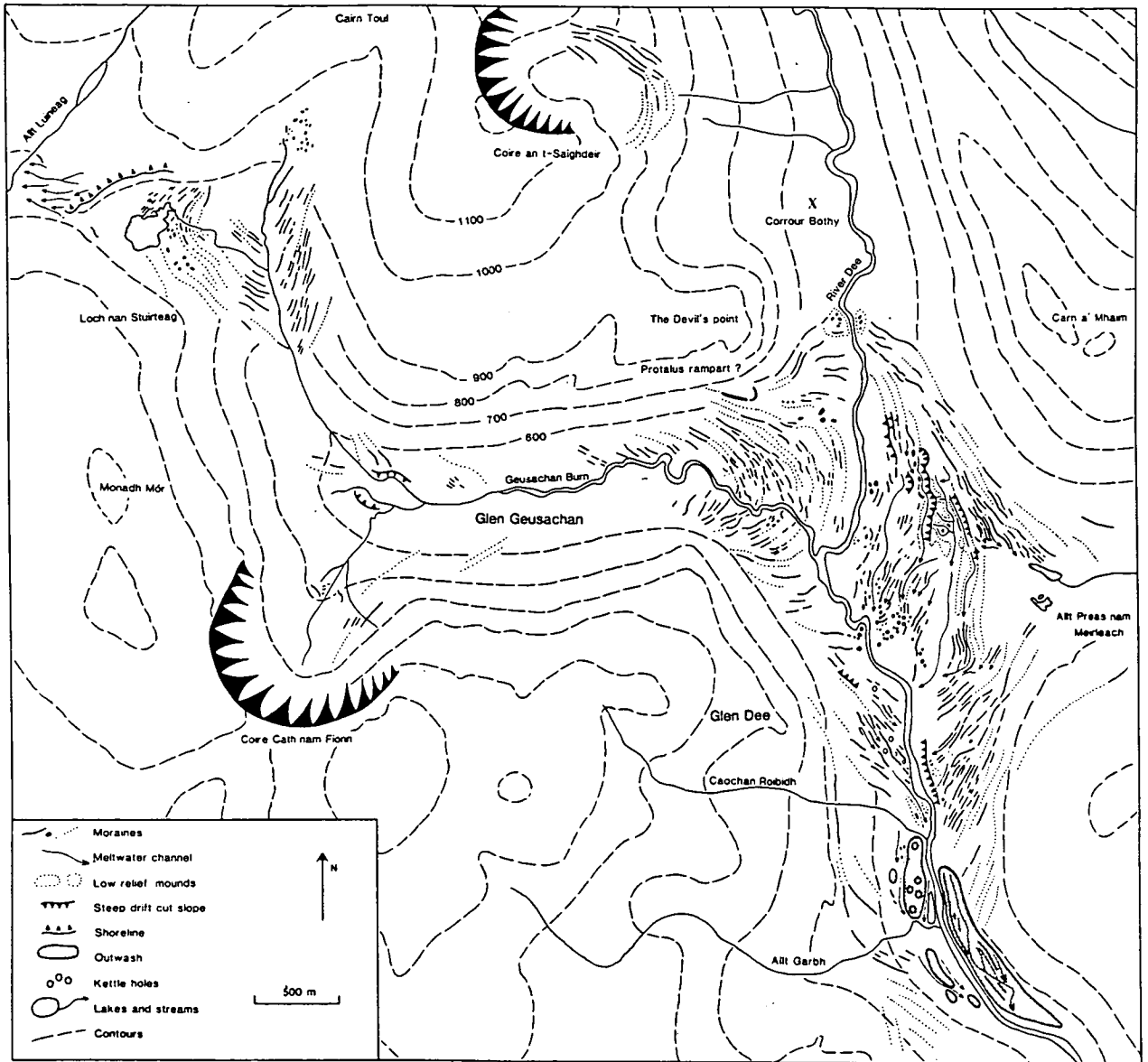

Fig. 3: The moraines of Glen Geusachan.

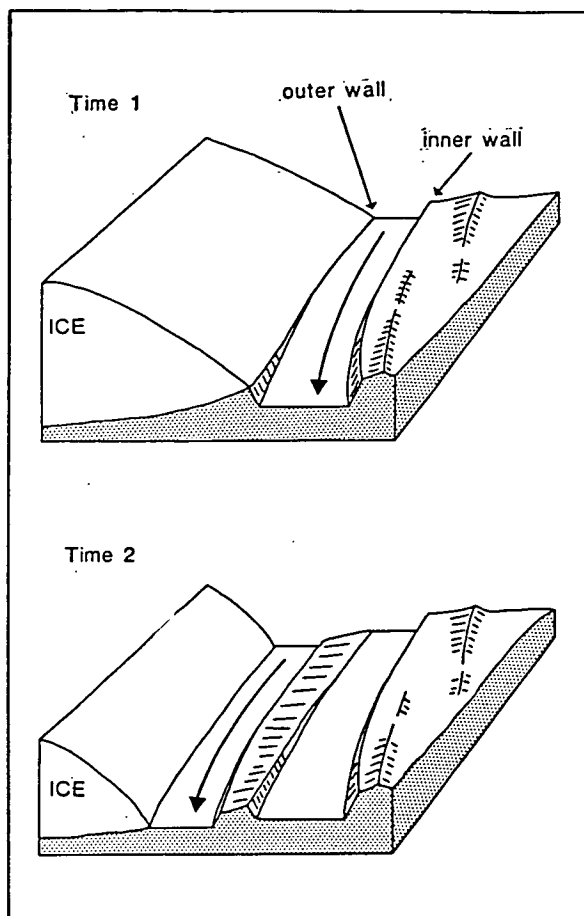
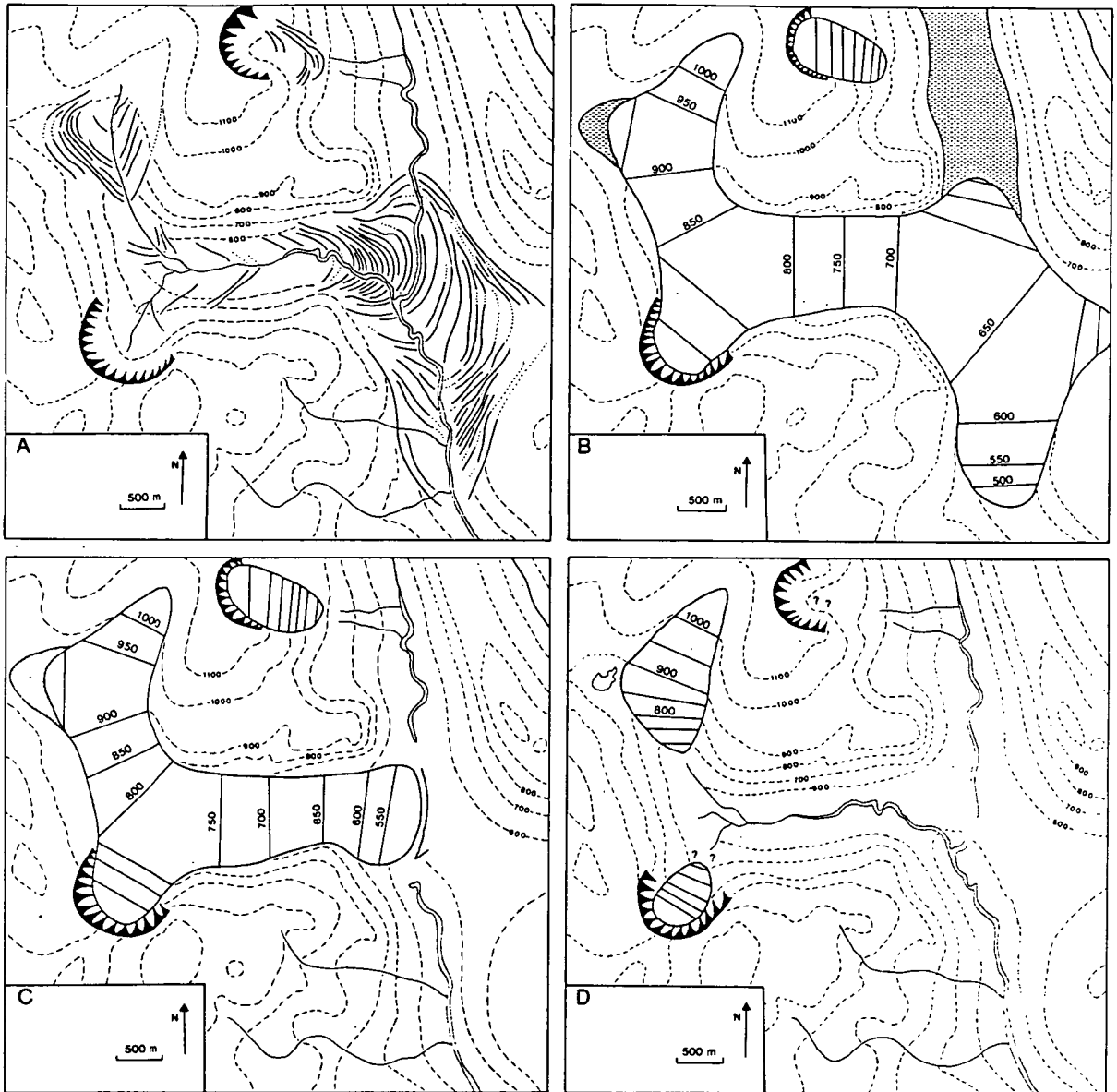

Fig. 4: A schematic block diagram of a flight of glacial half channels. The outer channel wall is either absent or low, while the inner slope usually consists of a steep drift cut slope. As the ice retreats down slope (time 1 to time 2) a sequence or flight of benches or half channels are cut by meltwater flow along the ice front.



**Fig.5: A-Palaeo-ice fronts of the Glen Geusachan glacier; B-The maximum extent of the Glen Geusachan glacier during the Loch Lomond Stadial; C-A Selected retreat stages of the glacier in Glen Geusachan; D-A further stage in the decay of the Glen Geusachan glacier, the question marks illustrate the uncertainty of correlating the retreat stages of independent ice bodies.**



Fig. 6: An inverted image of the Viking ice cap on Ellesmere Island, Arctic Canada (81° 33' N 76° 00' W).

• Appendix III •  
Publications

# The deglaciation of Glen Croulin, Knoydart

MATTHEW BENNETT

*Department of Geology and Geophysics, University of Edinburgh, West Mains Road,  
Edinburgh EH9 3JW*

## Synopsis

The remarkable glacial geology of Glen Croulin has resulted from the interaction of regional ice flowing down Loch Hourn with local ice in Glen Croulin. The regional ice in Loch Hourn dammed up the valley mouth, while local ice occupied the upper part of the glen. This interaction probably dates from the Loch Lomond Stadial. The complex assemblage of landforms in Glen Croulin is interpreted here as a suite of ice marginal moraines and terraces, implying that the deglaciation occurred by active retreat as opposed to stagnation. A detailed picture of the pattern of this decay can be established and leads to the conclusion that the local ice in Glen Croulin reached its maximum extent and had begun to retreat prior to the maximum of the regional Loch Hourn ice.



## Introduction

Glen Croulin was first described by Peach *et al.* (1910), who recorded a glacial limit in the mouth of Glen Croulin, which was related to ice flowing down Loch Hourn and damming up the valley entrance (Fig. 1). Although no detailed work has been published to support these conclusions this has become established as the Loch Lomond Stadial ice limit (cf. Sissons 1983, fig. 14.4).

Peach *et al.* (1910) also suggested that during some earlier, more extensive period of glaciation the Loch Hourn ice extended even further up Glen Croulin. This conclusion was based on an exposure of silts, sands and gravels at the head of the glen at an elevation of 250 m which, it was suggested, were deposited in a glacio-lacustrine environment above the ice dam. In this paper the lower part of these deposits is interpreted as lodgement till and the upper part, a massive heterogeneous sandy gravel with subhorizontal lenses of both sand and silt, as an ice marginal fan facies deposited into an active proglacial environment (Fig. 4). It therefore seems more probable that this gravel unit was, in fact, deposited in front of a glacier in the head of Glen Croulin (see below). This local ice appears to have been contemporaneous with the Loch Hourn ice limit at the valley entrance, during the Loch Lomond Stadial. It is the interaction of this local ice body in Glen Croulin with the regional ice in Loch Hourn that has resulted in the remarkable glacial

geology of the glen, which provides a record of the character and pattern of the deglaciation of this area (Fig. 1 and 2A).

## Loch Hourn ice

The mouth of Glen Croulin is blocked by a complex of moraines and terraces, the distribution of which indicates that they were deposited by ice from Loch Hourn damming up the entrance of the glen (Fig. 2A and 3). On the east side of the glen the maximum ice limit is recorded by a series of moraines that can be traced for over 2.5 km to the east as far as Coire Sgamadail [NG 801 089]. The prominent terrace A (Fig. 2A and 3) on the east side of Glen Croulin is associated with this main moraine. This terrace is of particular note since it occurs both inside and beyond the moraine that marks the maximum extent of the Loch Hourn ice, during the Loch Lomond Stadial. Immediately down slope of this surface there is a lower terrace (Fig. 3), whose trend is continued to the east by a line of moraines that lies parallel to the main moraine system above (Fig. 3). Further down slope, on the east side of the glen, another ice marginal position can be identified by a line of terrace and moraine fragments.

On the west side of Glen Croulin a large moraine forms the front of the main terrace (30–40 m high). This terrace consists of two narrow (<20 m), irregular surfaces which both have low, westward dipping

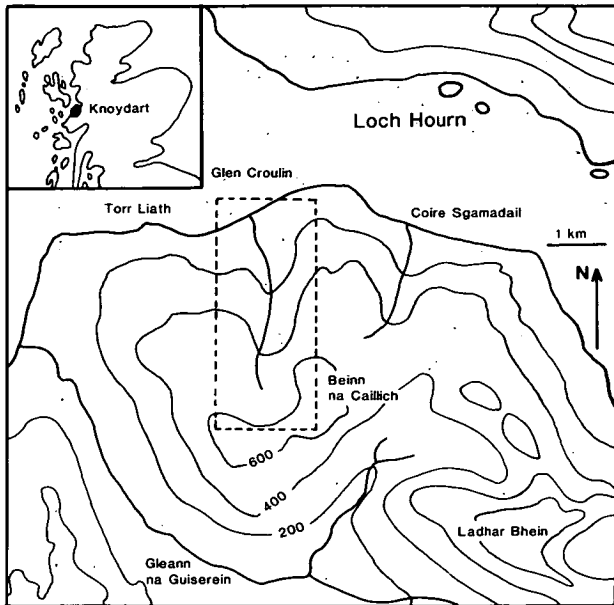

FIG. 1. Glen Croulin, Knoydart. The location of Figure 2 is shown by the box.

gradients (Fig. 2A). The higher of these two terraces becomes dominant in the west before it fades out into a short meltwater channel to the south of Cnoc Gorm [NG 775 089]. To the west of this point the limit of the ice maximum becomes uncertain, but extrapolation suggests that it should enter Loch Hourn close to Torr Liath [NG 765 094]. Close to the Croulin Burn the two terraces of the western side of the glen are truncated by another terrace which parallels the burn. This surface may be associated with other terrace fragments that occur below and down slope of the main terrace and moraine system on the west side of the glen. Finally, the Croulin burn has bisected this terrace and moraine complex to cut and deposit two broad fan surfaces. These surfaces are composed of crude sub-horizontal beds of sands and gravels.

In summary, there is strong evidence to suggest that Loch Hourn ice terminated just to the west of Glen Croulin and blocked the mouth of the glen.

### Glen Croulin ice

There is also strong evidence for local ice within Glen Croulin. This evidence is concentrated in the lower, middle and upper sections of the glen and is described in this order below.

*The mouth of Glen Croulin.* Here, on the eastern side of the glen, there is a small moraine fragment (marked B on Fig. 2A and 3) the form of which indicates that it was deposited by ice which flowed down Glen Croulin. It marks the eastern most extent of a thick drift mass, within which several linear ridges

occur. Down valley this drift mass is truncated by the moraine system produced by the Loch Hourn ice (Fig. 3). The moraine fragment must, therefore, pre-date the maximum extent of Loch Hourn ice during the Loch Lomond Stadial.

*Eastern flank of Glen Croulin.* Further up the glen on the eastern side there is a sequence of five gently curving concentric ridges that are interpreted as recessional moraines (Fig. 2A). This interpretation is supported by the fact that the first three of these ridges continue up the eastern valley side at an angle of  $30^{\circ}$ – $40^{\circ}$  to the horizontal and appear to be lateral moraines. The penultimate ridge is replaced by a gully which continues the trend of the ridge (Fig. 2A). This is interpreted as evidence of deflection of a local stream along the ice margin. Examples of such channel diversion by ice fronts were noted by Chinn (1979) in alpine areas and have also been noted in the course of my own field work in the NW Highlands.

*The western flank of Glen Croulin.* The moraines on the western side of the glen comprise at least 12 discrete, linear ridges, which run diagonally down-slope towards the centre of the glen and exceed 5 m in height. These are interpreted as lateral moraines, marking successive stages in the retreat of the Glen Croulin ice. This conclusion is based on the frequent ridge bifurcations, the presence on the ridge crests and on the up slope faces of the ridge of dead ice hollows and the fact that at modern glacier margins such characteristics are only found on ice marginal moraines (G. Boulton, pers. comm.).

The interpretation that these ridges are lateral moraines is supported by their sedimentology. This has been established from a section in one ridge. The section exposes a single massive heterogeneous unit of sandy diamicton (Fig. 4), whose matrix varies from a compact silt to a loose friable sand. Small and irregular masses of bedded sand indicated some degree of fluvial reworking. The clast density and lithology is variable, as is clast size, although 68% of the clasts fall into the pebble fraction. The clasts are very angular and possess neither striations nor faceting.

In order to assess the origin of this debris, the Krumbein sphericity and roundness (Whalley 1974, Boulton 1978) of the moraine clasts were compared to clasts from lodgement till and to those on an active scree slope. The latter is used here as a surrogate for supraglacial rockfall debris. All measurements were made on a single lithology. The control samples were collected from a site in the centre of the glen, where lodgement till occurs beneath a massive ice marginal fan unit (Fig. 4). The Krumbein roundness and sphericity plot shows a considerable overlap between clasts from the lodgement till, moraine and scree slope (Fig.

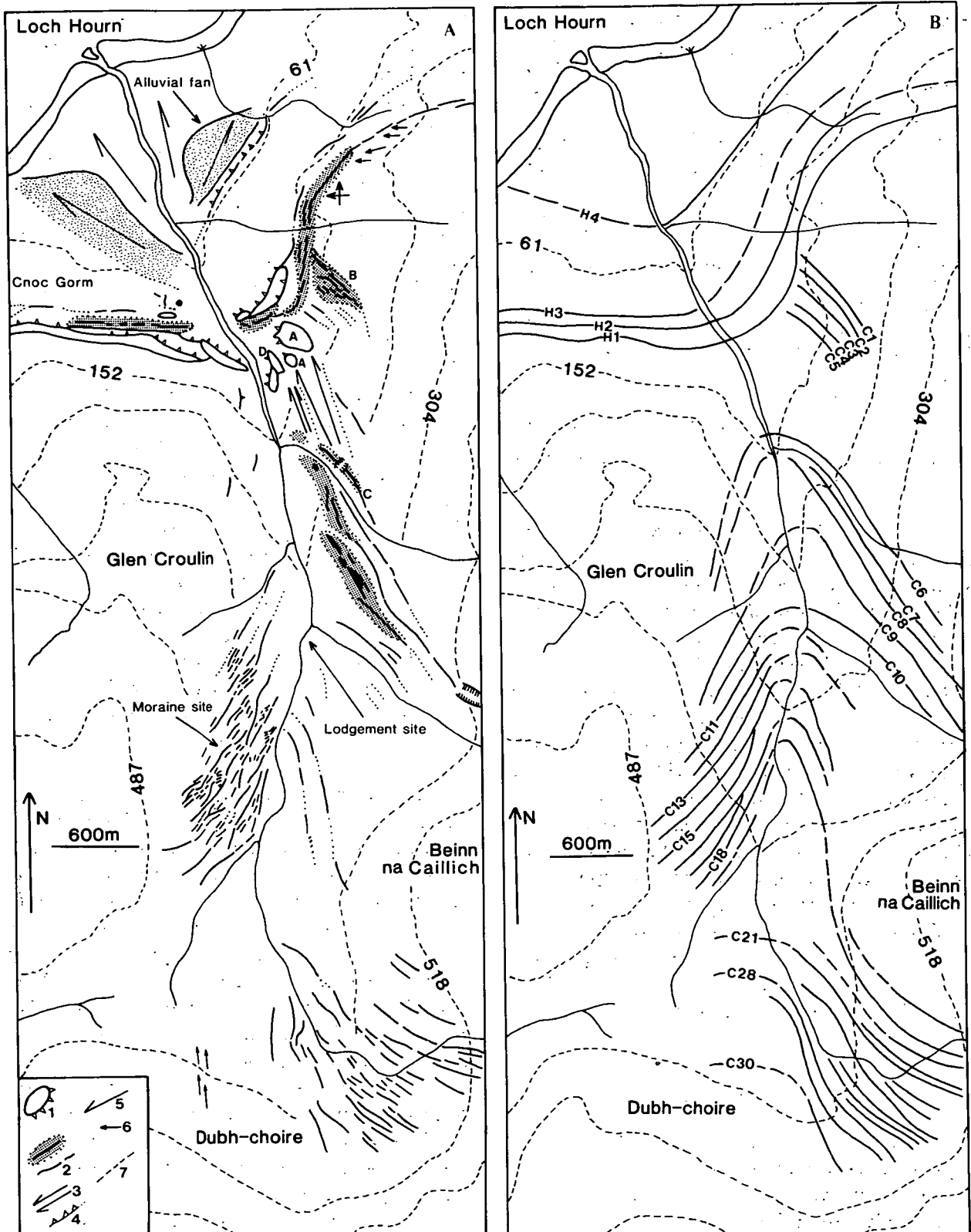

FIG. 2. The pattern of deglaciation of Glen Croulin. A: The evidence—see Figure 3 for details of the Loch Hourn limit in the valley mouth (1, clear horizontal terraces; 2, moraines; 3, alluvial fan; 4, irregular drift step fragments; 5, surface gradients; 6, striae; 7, contours). B: Former ice fronts of the retreating glaciers. These are formed by interpreting the morainic evidence in Figure 2A. H1–H4 Loch Hourn retreat stages, C1–C30 Glen Croulin retreat stages.

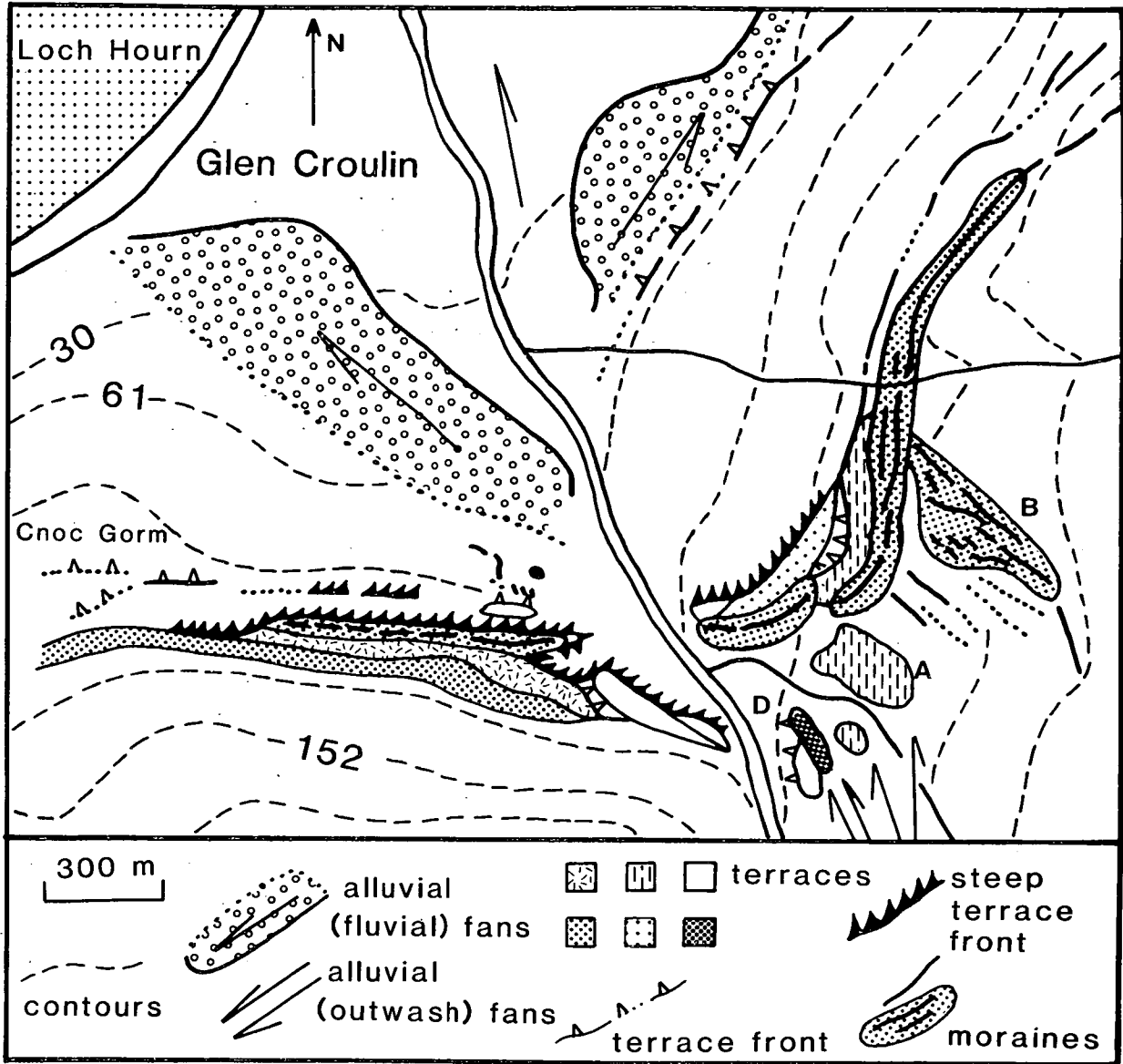

FIG. 3. The Loch Hourn ice limit in Glen Croulin, during the Loch Lomond Stadial.

4). However, the moraine clasts tend to cluster close to the scree debris.

It can be shown that the clasts in the ridge section are significantly more angular than those in the lodge-ment till ( $\chi^2 = 61.3$ ;  $\chi^2_{\text{crit}} = 11.1$ ; significant at 95% probability), but not significantly different from clasts on the active scree slope ( $\chi^2 = 2.8$ ;  $\chi^2_{\text{crit}} = 11.1$ ; not-significant at 95% probability).

Furthermore, a minimum estimate of the supraglacial clast content within the ridge section can be obtained from the proportion of very angular clasts present. This assumes that such angularity cannot survive basal transport (e.g. Rehies 1975; Anderson 1978). It is concluded, therefore, that within the ridge section at least 65% of clasts were derived supraglacially (65% very angular). The presence of such a high proportion of supraglacially derived debris supports

the contention that these ridges are in fact lateral moraines. The heterogeneous diamicton of the ridges is the result of deposition from and reworking along an ice front. These lateral moraines mark the successive margins of a tongue of ice retreating up Glen Croulin into Dubh-choire (Fig. 2A and B).

*The head of Glen Croulin, Dubh-choire.* There is further evidence at the head of the glen for the pattern of retreat. On the shattered slopes of Beinn na Caillich, several irregular boulder benches and linear moraines suggest that the ice retreated towards the south east, away from the mountain. This pattern of retreat can be explained by insolation contrasts within Dubh-choire. The ice has retreated from the south and south easterly slopes towards the section of the headwall which has a northerly and therefore shadier aspect.

In summary, I believe that there is considerable



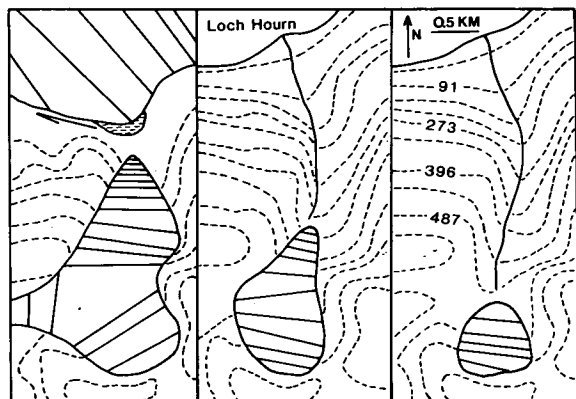

FIG. 5. Three glacier reconstructions for selected stages in the deglaciation of Glen Croulin. Glacier strike lines are used in preference to contours, which are at 33 m intervals.

and; (3) the ice activity and its climatic sensitivity. In this connection it is important to note that moraines of a similar size and form to those in Glen Croulin accumulate in as little as one to two years at the margins of Icelandic glaciers (Boulton 1986, O. Knudsen pers. comm.). Therefore, if one assumes that the moraines in Glen Croulin accumulated bi-annually and that every year of retreat is recorded, then the local glacier in the glen must have retreated within 50 years (palaeo-ice front C6–C30—Fig. 2B). Though such an estimate is speculative it illustrates that active deglaciation, as outlined above, does not necessarily conflict with the rapid rate of global warming suggested for the close of the Loch Lomond Stadial (e.g. Dansgaard *et al.* 1989).

In conclusion the pattern of deglaciation in Glen Croulin can be summarized by glacial reconstruction of selected retreat stages. In Figure 5 three such stages in the pattern of retreat have been reconstructed, which illustrate the progressive retreat of ice in Glen Croulin.

### Conclusion

The remarkable glacial geology of Glen Croulin results from the interaction of regional ice in Loch

Hourn and local ice within Glen Croulin, probably during the Loch Lomond Stadial. There is ample evidence to suggest that both these ice bodies decayed by active retreat, as recorded in a succession of ice marginal positions. Local Glen Croulin ice reached a maximum and was retreating prior the maximum extent of the regional ice in Loch Hour. Thus the maximum extent of these two independent ice bodies was not synchronous.

### Acknowledgements

The author would like to acknowledge the financial assistance of the N.E.R.C. Special thanks are also due to G.S. Boulton for his continuous support and advice.

### References

- ANDERSON, L. W. 1978. Cirque glacier erosion rates and characteristics of Neoglacial tills, Pangiirtung Fiord, Baffin Island, N.W.T., Canada. *Arctic and Alpine Res.* **10**, 749–60.
- BOULTON, G. S. 1978. Boulder shapes and grain-size distributions of debris as indicators of transport paths through a glacier and till genesis. *Sedimentology* **25**, 773–99.
- 1986. Push-moraines and glacier-contact fans in marine and terrestrial environments. *Sedimentology* **33**, 677–98.
- CHINN, T. J. H. 1979. Moraine forms and their recognition on steep mountain slopes. In Schlüchter, C. (ed.) *Moraines and varves: origin, genesis and classification*, 51–7, Balkema, Rotterdam.
- DANSGAARD, W., WHITE, J. W. C. and JOHNSEN, S. J. 1989. The abrupt termination of the Younger Dryas climate event. *Nature* **339**, 532–34.
- PEACH, B. N., HORNE, J., WOODWARD, H. B., CLOUGH, C. T., HARKER, A. and WEDD, C. B. 1910. The geology of Glenelg, Lochalsh and the south-east part of Skye. *Mem. Geol. Surv. Scot.*
- REHIES, M. J. 1975. Source, transportation and deposition of debris on Arapaho Glacier, Front Range, Colorado, U.S.A. *J. Glaciol.* **14**, 407–20.
- SISSONS, J. B. 1983. The Quaternary. In Craig, G. Y. (ed.) *The geology of Scotland*, 399–424, Scottish Academic Press.
- WHALLEY, W. B. 1974. The formation and characteristics of some alpine moraines. *Univ. Cambridge Ph.D. thesis* (unpubl.).

MS accepted for publication 13th December 1989

## Short Communication

# A two stage rock slide in Gleann na Guiseran, Knoydart

M. R. BENNETT and A. J. LANGRIDGE

*Department of Geology and Geophysics, The Grant Institute, University of Edinburgh,  
West Mains Road, Edinburgh, EH9 3JW*

### Introduction

During a detailed glacial investigation of Knoydart a remarkable rock slide was recorded on the northern slopes of Gleann na Guiseran [NG 774 057]. This failure is the largest of three slides recorded in Gleann na Guiseran. The presence of these slides have been noted elsewhere (e.g. Peach *et al.* 1910; Watters 1972; Holmes 1984). However, the remarkable morphology of this slide has received little attention.

Hitherto, the age of the slide has remained uncertain. However, a revision of the Loch Lomond Stadial ice limits in Knoydart, clearly indicates that the rock slide appears to truncate this limit (Fig. 1) (Bennett unpubl.). There is no evidence for the presence of glacier ice during failure, as has been noted elsewhere (e.g. Sissons 1975; Haynes 1977). Consequently, the rock slide must post-date the deglaciation of Gleann na Guiseran and therefore probably post-dates the Loch Lomond Stadial.

The slide occurs in closely jointed psammitic rock which is only "moderately strong" with a rock mass rating of  $r = 65$  (cf. Selby 1980). This low rock mass strength is due to the joint density and the predominance of planes dipping out of the slope.

The failure scar occurs at an elevation of 660 m to the west of the summit Meall Coire ant-Searraich. It consists of a shallow wedge shaped depression, which is 300 m long, 200 m wide and 30 m deep at its maximum. The scar is composed of a fault scarp cliff on its western side, which intersects a sheet of slabs that dip at  $33^\circ$  towards the NE and which form the extensive slip plane of the failure. The initial fault displacement which precipitated the slide may have resulted from tectonic activity associated with the isostatic recovery of the Scottish Highlands (Ringrose 1987).

Beneath this scar the slip consists of two morphologically distinct deposits; a main boulder lobe and a smaller boulder tongue (Fig. 2). We shall argue that these deposits represent not only two phases of activity, but two distinct stages of failure.

### The boulder lobe

The main boulder lobe covers an area of approximately  $40\,000\text{ m}^2$  with an average thickness of 20 m. It is composed of a collection of angular, poorly sorted boulders many of which are in excess of 5 m in length. The morphology of this lobe varies across its length. Along the north eastern edge the lobe front is steep ( $36^\circ$ – $40^\circ$ ) and its edge is sharp and distinct (Fig. 2). The boulders here are particularly well packed and form a solid mass of debris. The margin is also backed along this section by several ridges, the orientations of which are parallel to the margin of the lobe. However, where the regional or bedrock slope steepens, just to the south of Profile E-E', the frontal morphology of this boulder lobe changes (Fig. 2); notably, the steepness of the frontal slope decreases and approaches the regional slope angle. The edge of the lobe also becomes diffuse and a distinct size sorting occurs, with very large boulders forming a diffuse peripheral zone to the lobe front. Inside this section of the lobe no ridges occur and the boulders are also notably less well packed and often distinctly loose.

This contrast in the frontal morphology of the boulder lobe suggests that different sections of the lobe were deposited by different mechanisms; mass flow or individual grain flow. The steep lobe front indicates that this section of the lobe was emplaced as a single unit of debris. In such a moving body of boulders one would expect the surface horizons to have moved faster than the basal layers, which were frictionally retarded. Consequently, at the lobe front faster surface boulders would continually avalanche down over slower basal boulders, therefore maintaining a steep lobe front (Fig. 3a). In contrast, where the front is shallow and irregular the lobe seems to have moved as individual boulders and not as a collective unit. It appears, therefore, that a change from collective flow to individual grain flow occurred within the boulder lobe. As already noted this transition is associated with a distinct steepening of the regional slope. We suggest that initially the boulder mass moved as a single unit,

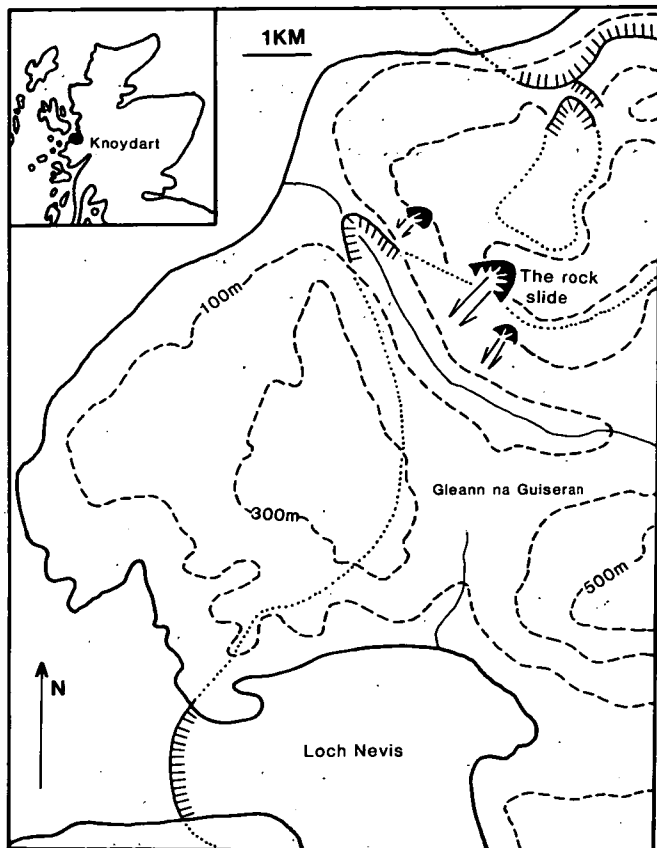

FIG. 1. Loch Lomond Stacial ice limits in Knoydart (major moraines indicated by toothed line) (after Bennett unpubl.; Boulton *et al.* 1981).

which was increasingly disrupted and accelerated by an increase in the regional slope. Faster surface boulders would have continued to avalanche over slower basal boulders at the lobe front, but instead of stopping at its base they appear to have continued to accelerate down slope as individual units (Fig. 3b).

### The boulder tongue

The western edge of the main lobe is cut by the track of a second failure, which deposited a distinct boulder tongue below the main lobe (Fig. 2). This boulder tongue is approximately 20 m thick, 150 m long and between 50 to 70 m wide. As the profiles in Figure 2 illustrate, the front and sides of this tongue are steep ( $30^{\circ}$ – $35^{\circ}$ ) and its margins are very distinct. The component boulders are notably smaller, more varied in size and better packed than those of the main lobe (1–2 m long). The void ratio in the tongue is also lower than in the main lobe. The boulder tongue issues from a track cut into the main boulder lobe, which is demarcated by two excellent levées. The levées increase in size up slope to a maximum height of 5 to 10 m, where they enclose an amphitheatre or hollow within the main boulder lobe. The western levée is

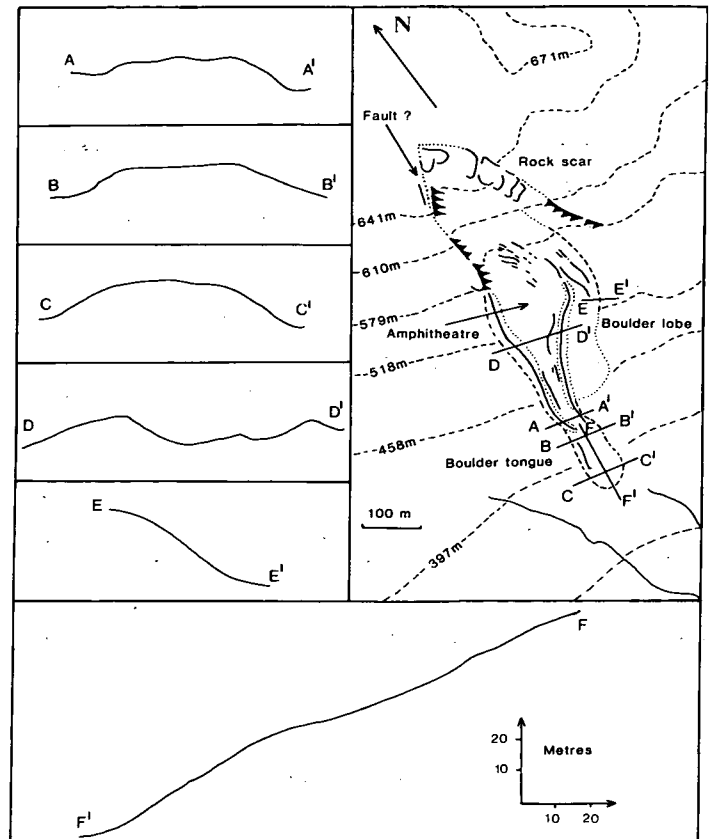

FIG. 2. The main rock slide in Gleann na Guiseran (solid lines within the lobes are boulder ridges; dashed lobe limit indicates a steep front, while a dotted limit indicates a shallow front).

asymmetric, the inner slope being steeper with fewer boulders than the outer slope, while in contrast, the eastern levée is less asymmetric.

We conclude that this second phase of activity was more dynamic than the first phase and do not believe that it was due to further failure of the rock slope. This notion is supported by the apparent similarity in volume of the main boulder lobe and the rock slide scar. This second phase of activity must, therefore, represent either a later stage of the first event, or a subsequent and distinctive failure within or beneath the boulder lobe. We shall consider each of these options.

Firstly, the second phase of activity may simply be a further stage of the initial failure. A fluid mass, such as a lava or earth flow becomes stabilized by a progressive increase in the marginal area of the depositional lobe. A lava or earth flow will form an initial lobe as its margin become stabilized. In the case of a lava flow this would occur by cooling, while the margin of an earth flow may consolidate due to the drainage of pore water. However, in both cases the inner portion of the lobe will remain mobile. If this continued mobility is sufficient, the fluid centre may push out from within the lobe to form a second tongue. As this material is removed from the first lobe

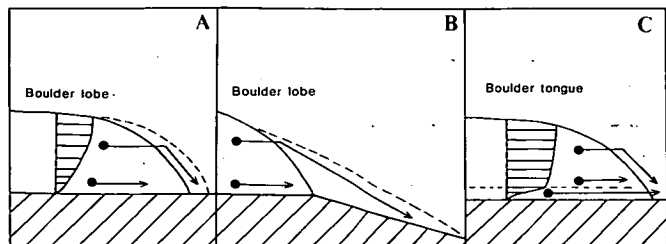

FIG. 3. Possible vertical velocity profiles within part of the slide: A; velocity and boulder movements in the main boulder lobe on a relatively flat slope. B; Boulder movements in the main boulder lobe on a steeper slope. C; Velocity and boulder movements within the boulder tongue.

it may leave a distinct hollow and levée track. The flow will become progressively stabilized as the length of the margin is steadily increased. Clearly, this hypothesis could explain many of the features and characteristics of the rock slide in Gleann na Guiseran, the principal objection being that it requires the debris to behave as a fluid mass. It is difficult to envisage the porous collection of boulders which form the lobes behaving as a saturated fluid mass of debris.

The second hypothesis is that a distinct failure occurred beneath part of the main boulder lobe after it was deposited. The amphitheatre could form the failure scar of this second event (Fig. 2). It is just deeper than the boulder lobe and is lined by fine deformable sediment. The presence of this sediment not only provides a possible mechanism for the failure, but may also reconcile the conflicting characteristics of the boulder tongue. Clearly, in order for this second slide to erode and extend the levées down-slope of the amphitheatre, it must have had a high flow rate. This idea is supported by the elongation of the boulder tongue. However, the steep sharp front of the boulder tongue suggests that the debris was deposited as a single unit. Moreover, as has already been stated, it is difficult to envisage the porous angular boulders of this lobe moving as a dynamic and fluid mass.

Such conflicting characteristics can be reconciled if the vertical velocity profile of the debris unit resembled that in Figure 3C. This would require a basal layer of highly deformable material in which the slide was first initiated and then upon which the mass was moved. There are two possible sources for this material: (i) finer sediment may have accumulated beneath the boulder lobe by percolation or the comminution of basal boulders or (ii) glacial or periglacial soil may have been buried by the main boulder lobe. This latter mechanism, that of burial, is the most likely.

One must assume that if such a buried soil exists, it occurs beneath most of the boulder lobe. However,

the failure occurred at one specific point. This is not necessarily a problem, since the amphitheatre occurs at the point at which the basal shear stress would have been greatest in the original boulder lobe. It is situated beneath the deepest section of the rock scar, the point at which the boulder lobe would have been thickest prior to the second event. The load may have also been gradually increased by the continued addition of material from the scarp-cliff above this point. Moreover, the frictional forces would be reduced here by the accumulation of water channelled by the rock scar above. A second failure could therefore have been the consequence of a progressive increase in the basal shear stress, or more likely was precipitated by some climatic extreme. The key to the dynamic nature of this event and its resultant morphology may, according to this hypothesis, be the presence of deformable fines at the base of the failure.

### Conclusions

The rock slide in Gleann na Guiseran probably post-dates the Loch Lomond Stadial and has undergone two distinct phases of activity. Firstly, the rock slope failed along the intersection of a fault and joint set, which led to the deposition of the boulder lobe as a single unit of debris. The presence of more mobile debris within this lobe may have resulted in a second phase of activity which deposited a lower boulder tongue. Alternatively, part of the initial boulder lobe may have failed after its deposition to give the Lower boulder tongue.

### Acknowledgements

Both authors would like to acknowledge the financial assistance of the N.E.R.C.

### References

- BOULTON, G. S., CHROSTON, P. N. and JARVIS, J. 1980. A marine seismic study of late Quaternary sedimentation and inferred glacier fluctuations along western Inverness-shire, Scotland. *Boreas* 10, 39–51.
- HAYNES, V. M. 1977. Landslip associated with glacier ice. *Scott. J. Geol.* 13, 337–8.
- HOLMES, G. 1984. Rock slope failure in parts of the Scottish Highlands. *Univ. Edinburgh Ph.D. thesis* (unpubl.).
- PEACH, B. N., HORNE, J., WOODWARD, H. B., CLOUGH, C. T., HARKER, A. and WEDD, C. B. 1910. The geology of Glénelg, Lóchalsh and the south-east part of Skye. *Mem. Geol. Surv. Scot.*
- RINGROSE, P. S. 1987. Fault activity and palaeoseismicity during Quaternary time in Scotland. *Univ. Glasgow Ph.D. thesis* (unpubl.).
- SELBY, M. J. 1980. A rock mass strength classification for

geomorphic purposes: with sites from Antarctica and New Zealand. *Z. Geomorphol.* **24**, 31-51.

SISSONS, J. B. 1975. A fossil rock glacier in Wester Ross. *Scott. J. Geol.* **11**, 83-6.

WATTERS, R. J. 1972. Slope stability in metamorphic rocks of the Scottish Highlands. *Imperial College, Univ. London Ph.D. thesis* (unpubl.).

*MS accepted for publication 16th October 1989*

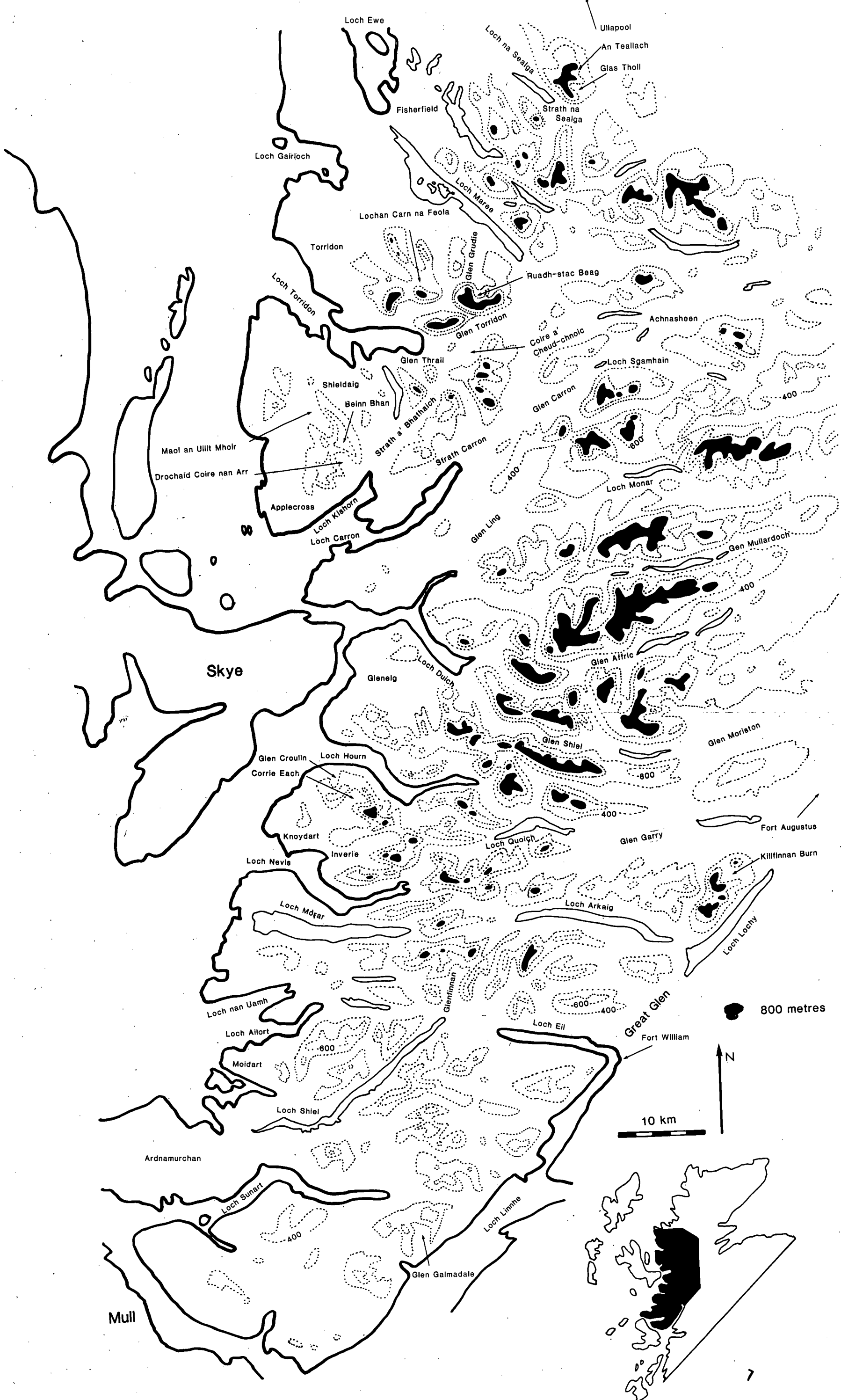

Loch Ewe

Loch na Sealga

Ullapool

An Teallach

Glas Tholl

Strath na Sealga

Fisherfield

Loch Gairloch

Lochan Carn na Feola

Loch Mares

Torridon

Glen Grudie

Ruadh-stac Beag

Loch Torridon

Glen Torridon

Achnasheen

Coire a' Cheud-choic

Loch Sgamhain

Glen Thrail

Shieldaig

Beinn Bhan

Glen Carron

Maol an Uillt Mhoir

Drochaid Coire nan Arr

Strath a' Bhathaich

Strath Carron

Applecross

Loch Kianorn

Loch Carron

Glen Ling

Loch Monar

Gen Mullardoch

Skye

Glenelg

Loch Duich

Glen Affric

Glen Croullin

Loch Hourn

Corrie Each

Glen Shiel

Glen Moriston

Knoydart

Inverie

Loch Quolich

Glen Garry

Fort Augustus

Loch Nevis

Loch Mòr

Loch Arkaig

Killfinnan Burn

Loch nan Uamh

Loch Allort

Moidart

Loch Shiel

Loch Eil

Great Glen

Fort William

Ardnamurchan

Loch Sunart

Loch Linne

Glen Galmadale

Mull

800 metres

10 km

N