

"APPLICATIONS OF A COMBINED GAS CHROMATOGRAPH-MASS
SPECTROMETER TECHNIQUE TO CATALYTIC
REACTIONS ON OXIDES"

A Thesis presented for the degree of Doctor of
Philosophy in the Faculty of Science of the
University of Edinburgh

by

PHILIP JOHN ROBERTSON, B.Sc.

October 1975.

Department of Chemistry,
University of Edinburgh,
West Mains Road,
EDINBURGH EH9 3JJ.



ABSTRACT

The development of an "on-line" computer system for data capture and processing to be used with a combined gas chromatography-mass spectroscopy (g.c.-m.s.) technique is described. The usefulness of the g.c.-m.s. technique in investigating problems which cannot be tackled by other methods was demonstrated in two types of system; firstly, the simultaneous exchange and addition reactions of ethylene were investigated over a variety of oxide catalysts and secondly, the technique was used to study the simultaneous exchange reactions of a number of hydrocarbons with deuterium. The use of the computer was shown to be less time-consuming and more accurate than the method it superseded.

In the reactions of ethylene with deuterium over a variety of oxide catalysts, a wide range of selectivities was shown by the catalysts for the two reactions, exchange and addition. Magnesium oxide accelerated the exchange of ethylene without the production of ethane even at 671K; gamma-alumina also exhibited a high selectivity for exchange. In contrast on chromium oxide (Cr_2O_3) at 197K and zinc oxide at 273K, ethylene underwent rapid deuteration with no observable exchange of the olefin. Other catalysts showed intermediate behaviour being able to promote both reactions. For the range of oxides studied the ratio of the rate constants for the exchange and addition reactions decreased in the order



An explanation for the marked differences in catalytic behaviour is suggested in relation to the activity of different types of hydrogen species on the various catalysts.

Both the g.c.-m.s. system and conventional mass spectrometric techniques were used to investigate the exchange reactions of alkanes over a gamma-alumina catalyst. The exchange activities of a series of alkanes with deuterium were found. From the different activities of the various reactants and of different types of hydrogen atoms within the same molecule, a qualitative estimate of the relative acidities was made. The results indicated that the reaction intermediates were carbanionic in character. A linear relationship between hydrogen exchange activity and the hydrocarbon acidity was obtained and was shown to be an example of the Bronsted catalysis law.

All the exchange reactions took place in a stepwise manner and, for the cycloalkanes, exchange could be followed at lower temperatures without the complications of isomerisation and addition. The cycloalkanes appeared to have an enhanced activity compared with the linear molecules.

Methods of analysing the data from catalytic exchange reactions of molecules in which different groups of hydrogen atoms exchange at different rates were required in this work. A method of determining the rate of exchange from such reactions which had already been proposed was tested using computer-generated isotopic distributions and found to be satisfactory provided the ratio of the rate constants for the two groups of exchangeable hydrogen atoms was greater than about 5. On the other hand, the derivation of rate constants and Arrhenius parameters from data obtained by temperature-programmed experiments could only be considered reliable when the rate constants for the different groups of atoms was greater than about 20.

The exchange reactions of a series of alkanes and olefins with deuterium were investigated over magnesium oxide. A large range of activity was observed; olefins which could form allyl species, e.g. propylene and isobutene, exchanged rapidly at low temperature (195K) while some of the alkanes, e.g. methane and n-butane, required temperatures above 600K. The range of activity was rationalised in terms of the possible reaction mechanisms. The results indicated that intermediates of a carbanionic nature predominate in the reactions on magnesium oxide. Like alumina, a Bronsted relationship was found between the activities for the exchange of alkanes and the hydrocarbon acidities.

All the exchange reactions were stepwise and those requiring high temperature showed evidence of poisoning. The presence of ethylene appeared to poison the exchange reactions of propylene and isobutene.

FOREWORD

This thesis describes work undertaken personally in the Chemistry Department of the University of Edinburgh between October 1972 and June 1975. Some of the results have already been published and copies of the relevant papers are included in an appendix.

Many people have helped me in the course of these studies. I am particularly grateful to my academic supervisor, Professor C. Kemball, for his direction and encouragement and to Dr. M.S. Scurrrell with whom I worked in part of this research. I am also indebted to the other members of the catalytic research group, to the Carnegie Trust for the provision of a scholarship, to the technical staff of the Chemistry Department for their various skills, to Dr. E.J.C. Read and Dr. R.S. Dowie for their help in computing matters and also to the latter whose experience of the apparatus was invaluable in diagnosing problems.

I should also like to thank my parents for their encouragement, my mother-in-law who typed the thesis and helped in many other ways and my wife, Olwen, for her patience and support over the past three years.

In the course of this work I attended the following seminars and lecture courses:-

1. Catalytic group seminars (1972-75).
2. Chemistry department seminars (1972-75).
3. Chemical Applications of Group Theory (1972).
4. ESCA and Photo-electron spectroscopy (1973).
5. Industrial R. and D. - the Management Systems (1973).
6. Thermal Analysis (1974).
7. Vibrational Spectroscopy (1975).
8. Research in the Oil Industry (1975).
9. High-speed liquid chromatography (1975).

PHILIP J. ROBERTSON

October 1975.

TO VICTORIA

CONTENTS

	<u>Page</u>
<u>CHAPTER 1. INTRODUCTION</u>	
1.1 Historical Background	1
1.2 Adsorption Processes	2
1.3 Reactions on Surfaces	5
1.4 Catalysis on Oxides	11
1.5 The Present Study	17
References	
<u>CHAPTER 2. EXPERIMENTAL</u>	
2.1 Introduction	24
2.2 Gas-Handling Apparatus	25
2.3 The Preparation of the Reactants	29
2.4 The Catalysts	31
2.5 The Mass Spectrometer	34
2.6 The Gas Chromatograph-Mass Spectrometer	36
2.7 Data Collection in the G.C.-M.S. System	39
2.6 Experimental Procedure	47
References	
<u>CHAPTER 3. THE ANALYSIS OF EXPERIMENTAL DATA</u>	
3.1 Introduction	51
3.2 Analysis of Mass Spectral Data	52
3.3 The Kinetics of Hydrocarbon Reactions	58
(a) Kinetics of Exchange Reactions	59
(b) Kinetics of Hydrogenation and Isomerisation	61
(c) Errors and Arrhenius Parameters	62
3.4 Exchange in Molecules with Non-Equivalent Hydrogen Atoms	63
(a) Derivation of the Isotopic Distributions	65
(b) Calculation of Rate Constants from Isotopic Distributions	66
(c) Temperature Programming	67
(d) Constant Temperature Results	68
(e) Temperature-programming Results	73
List of Symbols	76
References	

	<u>Page</u>
<u>CHAPTER 4. REACTIONS OF ETHYLENE WITH DEUTERIUM</u>	
<u>ON OXIDE CATALYSTS</u>	
4.1 Introduction	78
4.2 Previous Studies of Ethylene-Deuterium Reactions	79
4.3 Experimental Procedure	81
4.4 Results	82
4.5 Discussion	85
References	
<u>CHAPTER 5. EXCHANGE REACTIONS OF ALKANES OVER ALUMINA</u>	
5.1 Introduction	92
5.2 Experimental Procedure	94
5.3 Results	95
5.4 Discussion	101
References	
<u>CHAPTER 6. REACTIONS OF HYDROCARBONS OVER MAGNESIUM OXIDE</u>	
6.1 Introduction	111
6.2 Experimental Procedure	113
6.3 Results	115
6.4 Discussion	122
References	

CHAPTER I

INTRODUCTION

1.1 HISTORICAL BACKGROUND

A concise yet complete definition of catalysis is probably as elusive as the philosopher's stone which could transform base metal into gold and from which the idea of catalysis originated. A catalyst is often defined as "a substance which increases the rate at which a chemical reaction approaches equilibrium without being consumed in the process." The range and importance of catalysis and catalytic reactions in society is great, indeed life itself depends on some very specific catalytic reactions.

Although man has used catalysis for thousands of years, one of the oldest examples being in the production of alcoholic beverages, that branch of modern science known as catalysis can trace its origin to a review article⁽¹⁾ by Berzelius in 1836 in which "catalysts" are defined as "substances which by their mere presence evoke chemical reactions that would not otherwise take place." Berzelius used this concept to relate a variety of diverse observations concerning the effect of trace substances on reaction rates. One implication of his ideas was that the presence of a catalyst provided a more favourable chemical environment for a particular reaction.

Several other catalytic processes were recorded in subsequent years but the next major advance in the understanding of catalysis came in 1901 when Ostwald^(2,3) first suggested that a catalyst influences the rate of a chemical reaction but has no effect on the position of equilibrium, his definition being that "a catalyst changes the velocity of a chemical reaction without itself appearing in the products." One

important implication of these ideas is that a catalyst only affects those reactions which are already thermodynamically feasible. A catalyst may provide a new and energetically more favourable pathway for a reaction by forming intermediates with the substrate which decomposes to give various products. It is knowledge of these intermediates, their nature, formation and decomposition which yields understanding of a catalytic reaction.

Catalytic reactions can be subdivided into three categories; heterogeneous catalysis where the catalyst and reactants are in different phases, homogeneous catalysis where both are in the same phase and enzyme catalysis which controls many biological processes. The work of this thesis is solely concerned with the first category, in particular reactions between gaseous reactants on a solid catalyst.

1.2 ADSORPTION PROCESSES

Adsorption of one or more reactants on the catalyst surface is a necessary step in any reaction in heterogeneous catalysis. The processes involved in adsorption have long been studied and it is now accepted that the nature, extent and strength of adsorption can play an important role in determining reaction products. Adsorption phenomena can be subdivided into physical adsorption and chemisorption. Physical adsorption arises from weak intermolecular attractive forces. The gas molecules adsorb on the solid bound by Van der Waal type forces similar to those which give rise to the cohesive properties of liquids. Heats of physical adsorption are comparable to heats of liquefaction of the adsorbate and are of the order of $5 - 20 \text{ kJ mol}^{-1}$. The rate of physical adsorption is always fast because the process has a low

activation energy provided the adsorption sites are easily accessible. A slow rate of physical adsorption may indicate slow diffusion in a porous surface. In physical adsorption, several adsorbed layers may be formed, particularly at temperatures near the boiling point of the gas.

Physical adsorption involves weak forces and only on rare occasions, e.g. the oxidation of nitric acid on a silica catalyst⁽⁴⁾, is it important in catalytic reactions. However it is useful in the measurement of a catalyst's surface properties by the determination of the quantity of gas adsorbed under various conditions. In particular, the estimation of surface area by the method of Brunauer, Emmett and Teller (B.E.T.)^(5,6) is widely used.

Chemisorption is the result of a molecule interacting with the unsaturated valencies of the atoms at a solid surface. A molecule can be regarded as undergoing a chemical reaction in which there is a rearrangement of electrons within the molecule. Much stronger forces and more radical changes in the molecules are involved in chemisorption than in physical adsorption. Chemisorption is an essential step in the preparation of a molecule for a reaction.

Adsorption is usually exothermic. In a spontaneous process the free energy change, ΔG , is negative and from

$$\Delta G = \Delta H - T\Delta S \quad 1.1$$

it is necessary that ΔH is also negative because the entropy change, ΔS , must be negative since adsorption produces a more ordered system. If ΔH is negative it indicates an exothermic process. In chemisorption the heat of adsorption is generally in the range 40 - 800 kJ mol⁻¹. Chemisorption is necessarily limited to monolayer

coverage of available surface. Chemisorption is often rapid and in such cases the potential energy barrier to be overcome before adsorption can take place is small, e.g. adsorption of hydrogen on clean metal filaments⁽⁷⁾ proceeds rapidly at 25K. However some chemisorption processes involve slow activated adsorption, e.g. the adsorption of nitrogen on iron catalysts⁽⁸⁾ in which the rate determining step involves the breaking of the N-N bond.

The first quantitative discussion of adsorption processes was developed by Langmuir^(9,10). Working on certain assumptions that on a surface there are a fixed number of surface sites which can accommodate one adsorbed molecule and which all have the same heat of adsorption, the equation

$$\Theta = \frac{ap}{1 + ap} \quad 1.2$$

was derived in which Θ is the fraction of surface covered by adsorbed species, p is the gas pressure and a is a constant related to the heat of adsorption. This equation does not hold universally, the principal theoretical objections being that it takes no account of lateral interaction between adsorbed species and that, because of surface heterogeneity, the heat of adsorption is not uniform over the surface.

The isotherm formulated by Brunauer, Emmett and Teller⁽⁶⁾ involved similar assumptions as the Langmuir model but also accommodated the possibility of multilayer adsorption. The equation is

$$\frac{p}{V(p_0 - p)} = \frac{1}{V_m C} + \frac{(c-1)}{V_m C} \frac{p}{p_0} \quad 1.3$$

where V is the volume of gas adsorbed, V_m is the volume of

adsorbate for monolayer coverage, p is the partial gas phase pressure, p_0 is the saturated vapour pressures and c is a constant. By plotting $p/\sqrt{(p_0-p)}$ against p/p_0 for a series of readings, the volume of a monolayer can be derived which leads to a value for the number of molecules required to cover the surface. The surface area can be estimated if the area occupied by one adsorbed molecule is known. Although the model can be criticised⁽¹¹⁾, it does appear to give self-consistent results for solids with appreciable microporosity, i.e. pores smaller than 2nm and when nitrogen in a relative pressure range of 0.05-0.3 is used as the adsorbed gas. However, it should be borne in mind that the method measures the total accessible surface of a catalyst regardless of whether or not all locations are catalytically active.

Other commonly used isotherms are those of Freundlich⁽¹²⁾ and Tempkin⁽¹³⁾.

1.3 REACTIONS ON SURFACES

Two concepts are central to the consideration of surface reactions. Firstly, one of the reactants must be adsorbed on the surface probably as an organometallic intermediate species, an idea first suggested by Sabatier⁽¹⁴⁾. Secondly, the catalytic process is considered to occur at specific locations on the surface which have some property, perhaps geometric or electronic, which favours the reactions. These locations are known as active sites, a term first used by H.S. Taylor^(15,16). Much of modern research in catalysis is concerned with either the nature of the adsorbed species or the nature of the active sites.

A surface reaction is usually broken down into the following steps,

- (a) diffusion of reactants to the surface
- (b) adsorption of reactants at the surface
- (c) chemical reaction on the surface
- (d) desorption of products from the surface
- (e) diffusion of products away from the surface

These are consecutive steps and, if one is much slower than the rest, it will be the rate determining step. Steps (a) and (e) are usually rapid and, in the static system which was used in this study, the low pressure in the reactor and the size of the particles favour rapid diffusion. Diffusion-controlled reactions can be detected by their temperature dependence. Steps (b), (c) and (d) are all activated processes and behave with an $\exp(-E/RT)$ dependence with respect to temperature while diffusion processes vary as the square root of T . Step (b) is seldom rate-determining although the dissociative chemisorption of nitrogen is thought to be the slow step in the formation of ammonia from nitrogen and hydrogen⁽¹⁷⁾. Since there is little information about the rates of desorption, steps (c) and (d) are often considered together as the chemical reaction on the surface and often constitute the rate determining step.

Two mechanisms have been formulated to describe the reaction of two species at a catalyst surface. Assuming that adsorption and desorption are in equilibrium, the catalytic reaction can be considered as an interaction between adsorbed species at the catalyst surface. The reaction may be between two reactants both

adsorbed at nearby sites on the catalyst. This is the Langmuir-Hinshelwood mechanism⁽¹⁸⁻²⁰⁾ and has been successfully applied to the rate expressions of many catalytic decomposition and bimolecular reactions. An alternative approach is to consider the reaction as being between an adsorbed molecule and another molecule in the gas phase. This is the Rideal-Eley mechanism⁽²¹⁾. There is no evidence that either of these mechanisms operates to the total exclusion of the other.

In any catalytic reaction, the nature of the adsorbed intermediates, their stabilities and the possible reactions which they may undergo are all important in understanding the mechanism of the reaction. In order to be effective in a reaction an intermediate must have certain characteristics. It must be formed reversibly and also the process of formation and its reverse step must take place rapidly. A strongly adsorbed intermediate whose formation is not readily reversible may simply poison a reaction by blocking the active sites.

A wide range of adsorbed species is known. Even with a relatively simple molecule such as ethane several possibilities arise. The most straightforward adsorption involves dissociation of the alkane to give an ethyl species or adsorbed ethylene. Further dissociation will result in vinyl species, C_2H_3 , or an acetylenic intermediate, C_2H_2 . In extreme cases, adsorption may involve rupture of the carbon-carbon bond to give CH_n ($n=0-3$) fragments. The precise nature of the species formed depends on the nature of the catalyst. On metals adsorbed species tend to be radicals arising from homolytic splitting of chemical bonds. Kemball⁽²²⁾ has reviewed the relation between the stability of intermediate characteristics of a particular metal and the latter's ability to catalyse various reactions. Metals tend to form a variety of adsorbed radical

intermediates which can interconvert in a number of ways. On many oxide catalysts, ionic or at least partially polarised species are known to be important. Work on the reactions over silica-alumina catalysts which has been reviewed by Voge⁽²³⁾ has shown that carbonium ions are intermediate species. Burwell and co-workers⁽²⁴⁾ investigated the reactions of hydrocarbons on chromia gel catalysts finding evidence for the participation of allylic intermediates and also the suggestion that carbanions may be involved in some of the processes.

A useful technique for learning about the nature of adsorbed intermediates formed from hydrocarbons has been the study of exchange reactions in which hydrogen atoms in the hydrocarbon are replaced by deuterium atoms. Exchange reactions can provide useful information concerning the making and breaking of bonds on the catalyst surface, the relative stabilities of different types of intermediate and the effect of chemical environment on the reactivity of bonds.

Although exchange reactions often involve a hydrocarbon reacting with deuterium, other sources of the heavy isotope are available. Some catalysts such as titanium dioxide are relatively poor agents for activating the deuterium molecule. In such cases one cannot be sure that the rate-determining steps are associated with the hydrocarbon being studied and not with the activation of the deuterium molecule. Heavy water^(25,26) has been used as a source of deuterium in exchange reactions but has the disadvantage that it may act as a poison particularly on catalysts where active sites have been developed through the removal of surface hydroxyl groups at high temperature. Another source of labelling isotope has been treatment of the catalyst to deuterate surface hydroxyl groups^(23,27). The main drawbacks with

this method are that the amount of labelling isotope is limited and that the rate of reaction of the surface deuterium may introduce a new controlling factor. An increasingly important method of investigating exchange is by self-exchange^(28,29) i.e. exchange between a hydrocarbon and its deuterated form. This has the advantage of removing any complications associated with hydrogen-deuterium reactions while the main drawback has been the availability of deuterated reactants.

Exchange reactions can be classified in two ways. In simple or stepwise exchange reactions, only a single hydrogen atom is replaced by a deuterium atom in each molecule which reacts on the surface of the catalyst. Isotopic species containing two or more deuterium atoms are formed only by successive reactions. In multiple exchange reactions more than one deuterium atom is introduced into the hydrocarbon molecule on each interaction of the molecule with the catalyst.

Both these exchange processes have several possible mechanisms. For simple exchange reactions the mechanism may involve

- (a) the hydrocarbon is not chemisorbed except during the actual exchange which takes place with a chemisorbed deuterium atom (or ion).

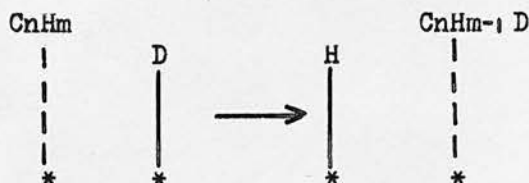

1.4

where * represents a surface site.

- (b) the reaction may be dissociative and involve adsorbed radicals or ions of the type C_nH_{m-1}
- (c) the mechanism may be associative and involve adsorbed species of the type C_nH_{m+1} which may be radicals or possibly ions.

The possible mechanisms for multiple exchange are necessarily more complicated. Schemes similar to (a), (b) and (c) for stepwise exchange are possible but now involving more than one hydrogen atom in the molecule. Another possibility is the existence of two or more types of adsorbed species of different states of hydrogenation with multiple exchange resulting from the interconversion of these species on the surface of the catalyst.

In practice, data on the kinetics of the exchange reaction, the nature of the adsorption of the reacting gases and the probable stability of the different kinds of intermediate are required to determine which mechanism is operative. Most of the work reported in this thesis is concerned with the exchange reactions of hydrocarbons with deuterium over oxide catalysts, in particular over alumina and magnesium oxide.

The field of exchange reactions on metals⁽³⁰⁻³²⁾ has been extensively reviewed while a review of exchange reactions on oxide catalysts⁽³³⁾ has recently appeared. In addition, a survey of the uses of deuterium in heterogeneous catalysts⁽³⁴⁾ has been published. However, tracer studies are not limited to reactions involving deuterium. The replacement of ^{14}N by ^{15}N has proved useful in the study of reaction mechanisms⁽¹⁷⁾. Another branch of this topic involves the use of ^{14}C and tritium isotopes which are radioactive, a property which can be used in their detection. Investigations using this technique include the mechanism of the Fischer-Tropsch synthesis using ^{14}C -labelled alcohols⁽³⁵⁾ and the catalyst poisoning studies of Thomson and colleagues^(36,37). A review of the use of isotopic tracers in catalysis has recently been published⁽³⁸⁾.

1.4 CATALYSIS ON OXIDES

Great interest has been shown in the properties of oxides as catalysts during the last two decades. In this section some of the results are summarised with particular reference to alumina and magnesium oxide which were the principal catalysts used in this work. Although this is not an exhaustive review it will illustrate the range of modern techniques used in catalysis research.

Both adsorption processes and reaction mechanisms over gamma-alumina have been studied. The dehydration of aluminium hydroxides produces a series of transition aluminas of which gamma-alumina is one. The exact nature of these transition aluminas is dependent on the history of the hydroxide, the temperature of dehydration, particle sizes and other factors. Many of these transition aluminas possess high catalytic activity. Prolonged dehydration produces the stable alpha-alumina form which is relatively inactive as a catalyst. A general review⁽³⁹⁾ of the various aluminas, their preparation and properties is available. Unless otherwise specified, alumina refers to the transition gamma-alumina.

As with other oxide catalysts, alumina requires activation before being used as a catalyst. Usually this involves heating in vacuo which removes some of the surface hydroxyl groups leading to the creation of surface sites. The exact nature of these sites, which even now is not fully understood, has been the subject of great study. X-ray diffraction techniques have been used to investigate the surface structure of alumina⁽⁴⁰⁾, particularly for information concerning crystallite size. The work of Peri⁽⁴¹⁻⁴³⁾, largely using the technique of infra-red spectroscopy, has revealed information about the hydration and dehydration of alumina surfaces and a model⁽⁴⁴⁾ has been postulated to account for

these observations. Removal of hydroxyl groups has been suggested as creating strained sites on the surface which are catalytically active.

The acid-base properties of the alumina surface have also aroused interest. Adsorption experiments involving ammonia⁽⁴³⁾ and pyridine⁽⁴⁵⁾ revealed the existence of strong Lewis acid-base sites. Ammonia may adsorb on alumina in a variety of ways including hydrogen-bonding with hydroxyl groups, co-ordination at Lewis sites and chemisorption to give NH_2^- groups. Several types of Lewis-acidic sites have been proposed to explain observed adsorption behaviour. The importance of the acidic properties in relation to the catalytic activity of alumina was investigated for the dehydration of alcohols⁽⁴⁶⁾. Both aspects of acidity, viz. the strength of acidic sites and their relative numbers were considered. The dehydrating ability of the alumina was found to be closely related to its acid-base properties. In later work⁽⁴⁷⁾, it was concluded that hydrogen molecules dissociate heterolytically on alumina, the hydride ion being associated with Lewis acid sites and the proton with oxygen ions. Acidic and basic sites on the surface of alumina can be pictured according to this scheme⁽⁴⁸⁾,

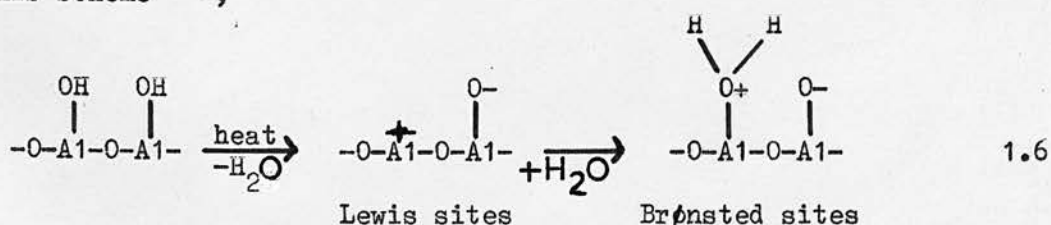

The Lewis acid site is visualised as an incompletely co-ordinated aluminium atom formed by dehydration and the weak Brønsted site as a Lewis site which has adsorbed moisture while the basic site is considered to be a negatively charged oxygen atom. Nuclear magnetic resonance techniques⁽⁴⁹⁾ have also been used to investigate the dehydroxylation and the acid-base properties of alumina. The existence of Lewis acidic

sites has been confirmed and the density of surface hydroxyl groups is estimated at $1.5 - 4.5 \times 10^{18} \text{ m}^{-2}$.

A vast range of reactions has been investigated over alumina catalysts; these include isomerisation of olefins⁽⁵⁰⁻⁵⁷⁾, cracking reactions⁽⁵⁸⁾, ortho-para hydrogen conversion⁽⁵⁹⁾, hydrogenation reactions^(48,60), dehydration of alcohols⁽⁶¹⁾ and exchange reactions. Despite intensive study, the mechanism of olefin isomerisation which is usually monitored by gas chromatography is not fully understood and a variety of possible reaction schemes have been suggested. Associative intermediates of a carbonium ion nature⁽⁵⁰⁻⁵³⁾ as well as dissociative π -allyl intermediates which may be carbonium ions^(54,55) or carbanions^(55,56) have been suggested. In a recent paper⁽⁵⁷⁾, the double bond shift was concluded to occur via an intramolecular proton transfer. The cracking ability of alumina at temperatures in excess of 673K is attributed to "passive" Bronsted sites which, although always present, only become active at elevated temperatures⁽⁵⁸⁾. Ortho-para hydrogen conversion is believed to take place at exposed aluminium nuclei⁽⁵⁹⁾. Hydrogenation of ethylene which is preadsorbed occurs at two different types of acidic site⁽⁶⁰⁾. The activity for the dehydration of alcohols by alumina is attributed to its acid-base properties⁽⁶¹⁾. Dehydration leads to formation of olefins and is, in general, accompanied by isomerisation of the double bond. The isomerisation occurs at strong acid centres while dehydration occurs at weak dual Lewis acid-base sites. Exchange reactions over alumina are discussed in chapter 5.

Other important information about alumina has been obtained from electron spin resonance studies which have been used to investigate the redox properties of surfaces and their influence on catalysis⁽⁶²⁻⁶⁶⁾.

Electron transfer processes are known to occur on alumina surfaces and are promoted by its oxidising-reducing properties. Direct evidence has been found for more than one type of active site on alumina; the use of carbon dioxide as a selective poison completely eliminates deuterium exchange in butene while having little effect on the isomerisation reaction⁽⁶⁷⁾. Microwave spectroscopy which enables the location of the deuterium in the deuterated species to be determined confirms that the sites for isomerisation and isotopic mixing are independent⁽⁶⁸⁾.

Temperature desorption work has revealed the presence of five types of adsorbed hydrogen on alumina surfaces⁽⁶⁹⁾ and two types of active site for ethylene hydrogenation⁽⁷⁰⁾.

Adsorption processes and catalytic reactions have not been so extensively studied on magnesium oxide. The catalyst is known to exhibit basic properties and the presence of several types of basic centres on the surface of partially hydrated magnesium hydroxide has been discussed in the light of studies of adsorption and isotope exchange of carbon dioxide on the catalyst⁽⁷¹⁾. The acid-base properties have also been investigated^(72,73). Infra-red studies reveal the presence of free and combined hydroxyl groups on the surface and potentiometric titration studies with pyridine show the presence of centres of various acid strengths. Electron resonance spectroscopy has also been used to investigate the electron donor properties of the surface. Electron donor centres⁽⁷⁴⁾ are associated with hydroxyl groups on the surface of the oxide activated below 573K. During dehydration at higher temperatures weakly coordinated oxygen ions are formed which are responsible for the reducing properties of the surface. Radical anions have been detected on clean magnesium oxide surfaces but not on those which have water or

carbon dioxide present⁽⁷⁵⁾. Infra-red spectroscopic studies⁽⁷⁶⁾ of ammonia adsorption of dehydrated magnesium oxide suggest that NH_3 is probably hydrogen-bonded to an oxide ion. No evidence of Lewis or Brønsted acid sites was found. On the hydrated magnesium oxide surface, ammonia is hydrogen-bonded to hydroxyl groups⁽⁷⁷⁾.

Magnesium oxide is a very active catalyst for hydrogen-deuterium equilibration at low temperatures^(78,79). The active sites are closely associated with positive paramagnetic centres, probably proton impurities. The exchange of propane, however, requires temperatures in excess of 623K⁽⁶⁶⁾. Butene isomerisation is another reaction which proceeds rapidly at low temperature over magnesium oxide^(80,81). It is suggested that the reaction intermediate is carbanionic and the pattern of behaviour conforms to that of a base-catalysed reaction involving an allylic species. A correlation has been noted between catalytic activity and the concentration of surface electron donor sites. The concentration of active sites depends on pretreatment temperature reaching a maximum at ca. 1000K. The slow exchange of 3-3-dimethylbutene⁽⁸²⁾ suggests that carbonium ions are not readily formed on magnesium oxide.

An oxide catalyst which attracted early interest was silica-alumina⁽²³⁾ on which carbonium ions are readily formed and seem to feature in several reactions of which catalytic cracking is probably the most important. A variety of reactions have been investigated over chromia⁽²⁴⁾. The catalyst requires activation by pretreating at high temperatures which involves the elimination of water and the formation of coordinatively unsaturated chromium atoms. Double-bond migration, deuterium exchange, isomerisation and olefin hydrogenation are among the reactions studied.

Hydrogenation and isomerisation have also been studied over zinc oxide catalysts⁽⁸³⁾ using a combination of spectroscopic and kinetic techniques together with the use of isotopic tracers and adsorption measurements. The group of aluminosilicates known as zeolites have been studied from many aspects in the last fifteen years and are now of great importance in industrial applications of catalysis especially as cracking catalysts. Recent reviews⁽⁸⁴⁻⁸⁶⁾ illustrate the range and variety of research on these catalysts.

1.5 THE PRESENT STUDY

The usefulness of a combined gas chromatography-mass spectroscopy system has already been demonstrated^(87,88). However, limitations on the amount of mechanistic information which could be obtained arose from two factors. Sometimes, as in the case of platinum, the rate of exchange of reactant with deuterium was so fast that both reactant and product were isotopically equilibrated. Alternatively, as was found on iron, some of the reactant and product were fully deuterated. It was felt that these difficulties might be avoided with oxide catalysts because these tend to favour ionic mechanisms and modes of adsorption which do not vary as widely in strength which lead to the problems with metal catalysts. Alumina has exhibited interesting catalytic behaviour but the nature of the reaction mechanisms and adsorbed species are not yet fully understood. Experiments using the g.c.-m.s. technique might prove useful in elucidating some of these factors. Although surface properties of magnesium oxide have been the subject of study, few catalytic reactions have been investigated on this catalyst. It was felt that further examination would prove fruitful and that it might be interesting to compare the

properties of alumina and magnesium oxide as catalysts.

An attempt was made to select problems which could be investigated more effectively by g.c.-m.s. techniques than by other methods. One system which lends itself to g.c.-m.s. study is the competitive and simultaneous exchange of a series of hydrocarbons. Provided that a suitable temperature range could be found within which all the reactants exchanged at a convenient rate, it was hoped that an experiment could follow the exchange of as many as five hydrocarbons without too much difficulty. Comparative data can be obtained and the relative reactivities might be related to some parameter indicative of the reaction mechanism. Thermodynamic data for the formation of radicals and ions is now available which may be useful in deciding about intermediates. Such studies may reveal the role of the nature of the reactant in determining the rate of exchange.

The second type of problem which can be investigated is a system where a single reactant participates in more than one process, e.g. combined exchange and hydrogenation. A variety of oxide catalysts exhibit a wide range of selectivities for the exchange-addition reactions of ethylene with deuterium and a comparative study of these catalysts would be well-suited to the g.c.-m.s. technique. In this case the influence of the nature of the catalyst on a reaction would be investigated.

It was also hoped to improve the g.c.-m.s. technique, in particular to develop an on-line computer link for data collection. Previously one of the most time-consuming stages in an experiment was the measurement and processing of data. By collecting data by computer and then processing, it was intended to speed up the turnover of results from an experiment.

REFERENCES

- (1) J. Berzelius, *Jahresberichte fur Chemie*, 13, 237, 1836.
- (2) W. Ostwald, *Zeit. Elektrochem.*, 7, 995, 1901.
- (3) W. Ostwald, *Phys. Z.*, 3, 313, 1902.
- (4) J.J.F. Scholten and F. Zweitering, *Actes II Congr. Intern. Catalyse, (Technip, Paris)*, 2, 389, 1961.
- (5) S. Brunauer and P.H. Emmett, *J. Am. Chem. Soc.*, 59, 1553, 1937.
- (6) S. Brunauer, P.H. Emmett and E. Teller, *J. Am. Chem. Soc.*, 60, 309, 1938.
- (7) J.K. Roberts, *Some Problems in Adsorption*, (London, Cambridge University Press, 1939).
- (8) P.H. Emmett and S. Brunauer, *J. Am. Chem. Soc.*, 56, 35, 1934.
- (9) I. Langmuir, *J. Am. Chem. Soc.*, 38, 2219, 1916.
- (10) I. Langmuir, *J. Am. Chem. Soc.*, 40, 1361, 1918.
- (11) P.H. Emmett, *Adv. in Catalysis*, 1, 65, 1948.
- (12) Freundlich, *Kapillarchemie*, Leipzig, 1909.
- (13) S. Brunauer, K.S. Love and R.G. Keenan, *J. Am. Chem. Soc.*, 64, 751, 1942.
- (14) P. Sabatier, *La Catalyse en Chimie Organique*, (Paris and Liege), 1920.
- (15) H.S. Taylor, *J. Phys. Chem.*, 30, 145, 1926.
- (16) H.S. Taylor, *Proc. Royal Soc.*, A108, 105, 1925.
- (17) J.T. Kummer and P.H. Emmett, *J. Chem. Phys.*, 19, 289, 1951.
- (18) I. Langmuir, *J. Am. Chem. Soc.*, 37, 1139, 1915.
- (19) I. Langmuir, *Trans. Faraday Soc.*, 17, 621, 1921.
- (20) C.N. Hinshelwood, *The Kinetics of Chemical Change*, (Clarendon Press, Oxford), 1940.

- (21) D.D. Eley and E.K. Rideal, Proc. Royal Soc., A178, 429, 1941.
- (22) C. Kemball, Catalysis Rev., 5, 33, 1971.
- (23) H.H. Voge, Catalysis (Ed. P.H. Emmett) Volume 6, (Rheinhold Publishing Corporation, New York), 1958.
- (24) R.L. Burwell Jr., G.L. Haller, K.C. Taylor and J.F. Read, Adv. in Catalysis, 20, 1, 1969.
- (25) I.R. Shannon, I.J.S. Lake and C. Kemball, Trans. Faraday Soc., 67, 2760, 1971.
- (26) C. Kemball and R. McCosh, Proc. Royal Soc., A321, 259, 1971
- (27) H. Kloosterziel, Chemisorption (Ed. W.E. Garner), (Butterworths, London), 1957, p.76.
- (28) J.G. Larson and W.K. Hall, J. Phys. Chem., 69, 3080, 1965.
- (29) P.C. Saunders and J.W. Hightower, J. Phys. Chem., 74, 4323, 1970.
- (30) C. Kemball, Adv. in Catalysis, 11, 223, 1959.
- (31) G.C. Bond, Catalysis by Metals, (Academic Press, London), 1962, chapters 9 and 10.
- (32) R.L. Burwell Jr., Acc. Chem. Research, 2, 289, 1969.
- (33) C. Kemball, The Use of Tracers to Study Heterogeneous Catalysis, (N.Y. Academy of Sciences Vol. 213), 1973, p.90.
- (34) R.L. Burwell Jr., Catalysis Rev., 7, 25, 1972.
- (35) J.T. Kummer and P.H. Emmett, J. Am. Chem. Soc., 75, 5177, 1953.
- (36) S.J. Thomson and J. Wishlade, Trans. Faraday Soc., 58, 1170, 1962.
- (37) D. Cormack, S.J. Thomson and G. Webb, J. Catalysis, 5, 224, 1966.
- (38) P.H. Emmett, Catalysis Rev., 7, 1, 1972.
- (39) Alumina Properties, Technical Paper No.10, Aluminium Co. of America, 1960.

- (40) M.H. Jellinek and I. Fankuchen, Ind. Eng. Chem., 37, 158, 1945.
- (41) J.B. Peri and R.B. Hannan, J. Phys. Chem, 64, 1526, 1960.
- (42) J.B. Peri, J. Phys. Chem, 69, 211, 1965.
- (43) J.B. Peri, J. Phys. Chem., 69, 231, 1965.
- (44) J.B. Peri, J. Phys. Chem., 69, 220, 1965.
- (45) E.P. Parry, J. Catalysis, 2, 371, 1963.
- (46) H. Pines and W. Haag, J. Am. Chem. Soc., 82, 2471, 1960.
- (47) H. Pines and J. Ravoire, J. Phys. Chem, 65, 1859, 1961.
- (48) S.G. Hindin and Weller, J. Phys. Chem., 60, 1501, 1956.
- (49) E.G. Derouane, J. Fraissard, Catalysis Rev., 7, 121, 1972.
J.J. Fripiat and
W.E.E. Stone,
- (50) C.L. Thomas, Ind. Eng. Chem., 41, 2564, 1949.
- (51) A.G. Oblad, J.U.Messenger and J.N. Brown, Ind. Eng. Chem., 39, 1462, 1947.
- (52) W.O. Haag and H. Pines, J. Am. Chem. Soc., 82, 2488, 1960.
- (53) P.J. Lucchesi, D.L. Baeder and J.P. Longwell, J. Am. Chem. Soc., 81, 3235, 1959.
- (54) N.F. Foster and R.J. Cventanovic, J. Am. Chem. Soc., 82, 4274, 1960.
- (55) J.B. Peri, Actes II Congr. Intern. Catalyse, (Technip, Paris), 1961, p.1333.
- (56) M. Tanaka and S. Ogasawara, J. Catalysis, 16, 164, 1970.
- (57) G. Gati and H.Knozinger, Proceedings 5th Intern. Congr. Catalysis (North Holland, Amsterdam), 1973, Vol.1 p.819.
- (58) S. Tung and E. McIninch, J. Catalysis, 3, 229, 1964.
- (59) F.H. Van Cauwelart and W.K. Hall, Trans. Faraday Soc., 66, 454, 1970.

- (60) Y. Amenomiya, J.H.B. Chenier and R.J. Cventanovic J. Catalysis, 9, 28, 1967.
- (61) H. Pines and J. Manassen, Adv. in Catalysis, 16, 49, 1966.
- (62) B.D. Flockhart, J.A.N. Scott and R.C. Pink, Trans. Faraday Soc., 62, 730, 1966.
- (63) B.D. Flockhart, I.R. Leith and R.C. Pink, Chem. Comm., 885, 1966.
- (64) B.D. Flockhart, I.R. Leith and R.C. Pink, J. Catalysis, 9, 45, 1967.
- (65) B.D. Flockhart, I.R. Leith and R.C. Pink, Trans. Faraday Soc., 65, 469, 1970.
- (66) B.D. Flockhart, S.S. Uppal and R.C. Pink, Trans. Faraday Soc., 67, 513, 1971.
- (67) M.P. Rosynek, W.D. Smith and J.W. Hightower, J. Catalysis, 23, 204, 1971.
- (68) Y. Sakurai, T. Onishi and K. Tamaru, Trans. Faraday Soc., 67, 3094, 1971.
- (69) R.J. Cventanovic and Y. Amenomiya, Adv. in Catalysis, 17, 103, 1967.
- (70) Y. Amenomiya, J. Catalysis, 22, 109, 1971.
- (71) O.V. Krylov and E.A. Fokina, Kinetics and Catalysis (English translation), 6, 128, 1965.
- (72) S. Malinowski, S. Szczepanska, A. Bielanski and J. Sloczynski, J. Catalysis, 4, 324, 1965.
- (73) S. Malinowski, S. Szczepanska and J. Sloczynski, J. Catalysis, 7, 67, 1967.
- (74) M. Che, C. Naccache and B. Imelik, J. Catalysis, 24, 328, 1972.
- (75) A.J. Tench and R.L. Nelson, Trans. Faraday Soc., 63, 2254, 1967.
- (76) A.J. Tench and D. Giles, J.C.S. Faraday I, 68, 193, 1972.

- (77) A.J. Tench, J.C.S. Faraday I, 68, 193, 1972.
- (78) J.H. Lunsford and T.W. Leland, J. Phys. Chem., 66, 2591, 1962.
- (79) M.Boudart, A.Delbouille, E.G.Derouane, V.Indovine and A.B. Walters, J. Am. Chem. Soc., 94, 6622, 1974.
- (80) I.R.Shannon. C.Kemball and H.F. Leach, Symposium on Chemisorption and Catalysis, (Institute of Petroleum, London), 1970.
- (81) M.J. Baird and J.H. Lunsford, J. Catalysis, 26, 440, 1972.
- (82) C. Kemball, H.F. Leach, B.Skundric and K.C.Taylor, J. Catalysis, 27, 416, 1972.
- (83) R.J. Kokes and A.L. Dent, Adv. in Catalysis, 22, 1, 1972.
- (84) J. Turkevich, Catalysis Rev. 1, 1, 1968.
- (85) J.Turkevich and Y.Ono, Adv. in Catalysis, 20, 135, 1969.
- (86) H.F. Leach, Ann. Reports A, 68, 195, 1971.
- (87) R.S.Dowie, C.Kemball, J.C.Kempling and D.A.Whan, Proc. Royal Soc., A327, 491, 1972.
- (88) R.S. Dowie, D.A. Whan and C. Kemball, J.C.S. Faraday I, 68, 2150, 1972.

CHAPTER 2EXPERIMENTAL2.1 INTRODUCTION

Tracer studies involving isotopic substitution in one or more of the reactants in a chemical process are long-established as a means of elucidating catalytic mechanisms. The principal application of this technique in heterogeneous catalysis has been in studying the exchange reactions of the hydrogen in hydrocarbons with deuterium. The incorporation of deuterium is usually followed by mass spectrometry, the reactants and products being chemically similar but of different isotopic composition.

Exchange reactions of hydrocarbons with deuterium can be investigated using a direct leak from the reaction vessel to a mass spectrometer⁽¹⁾. This technique was extensively used in this work; the reaction vessel was connected to an AEI MS10 mass spectrometer via a capillary leak thus allowing mass analysis of the reaction mixture at various times during the reaction. This method is satisfactory when one hydrocarbon is being studied and when exchange is the only significant reaction occurring at the ambient temperature.

However the direct leak method proves to be inadequate for more complex catalytic systems. When reaction mixtures contain two or more hydrocarbons whose mass spectra overlap, accurate analysis of isotopic distributions is impossible. Such a situation can arise in two ways; firstly, when the competitive reaction of two or more hydrocarbons is being followed and also when a single reactant can form two or more products. The combination of gas chromatography for separation of the

reactants and products and fast-scanning mass spectroscopy to analyse the elutants from the chromatograph⁽²⁾ provides a method for investigating both these types of reaction. A schematic representation of the experimental set-up is shown in figure 2.1. The development of the gas handling system, gas chromatograph and mass spectrometer have been reported⁽³⁾ while the introduction of "on-line" computer capture of data and its development have taken place over the course of this work. These facilities have greatly reduced the time and the tedium involved in data processing and have produced a more efficient system.

Whenever possible in this work, exchange reactions were investigated using the direct leak method for several reasons. The g.c.-m.s. system involves a much more complicated experimental set-up which is more expensive, time-consuming and intricate to operate. In addition, the problem of "bleed" from the chromatograph column makes it less accurate in estimating isotopic distributions.

2.2 GAS HANDLING APPARATUS

Two separate vacuum lines were used in this work, line A which was connected to the g.c.-m.s. system and line B which led into the capillary leak of the MS10 spectrometer. A diagram of gas line A is shown in figure 2.2. Line B was of similar design to this, the differences being in minor details such as the position of bulbs, taps etc. and that line B incorporated two reaction vessels one of which was designed for work with metal films.

Both vacuum lines were constructed of "Pyrex" glass and all the ground glass joints and stopcocks were lubricated with Apiezon L high vacuum grease (vapour pressure $< 1.3 \times 10^{-8} \text{ Nm}^{-2}$ at room temperature).

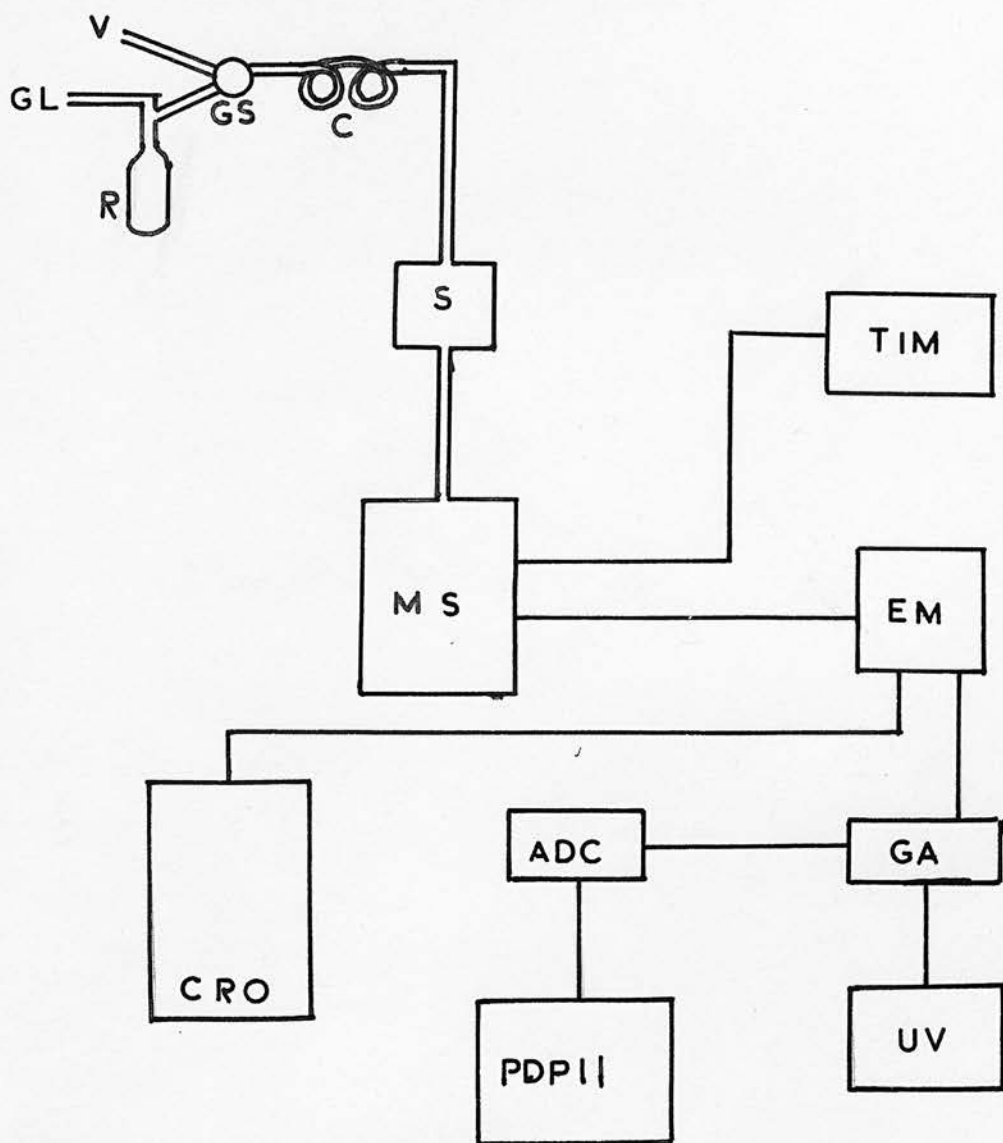

FIGURE 2.1 : Block Diagram of G.C.-M.S.System.

ADC Analogue-to-Digital Converter; C Gas Chromatograph Column;
 CRO Cathode Ray Oscilloscope; EM Electron Multiplier; G Galvanometer
 Drive Amplifier; GL Gas Handling Line; GS Gas Sampling Valve; MS
 Mass Spectrometer; PDP11 Mini Computer; R Reaction Vessel; S Molecu-
 lar Separator; T Total Ion Monitor; UV Ultra-Violet Recorder; V
 Pumping System.

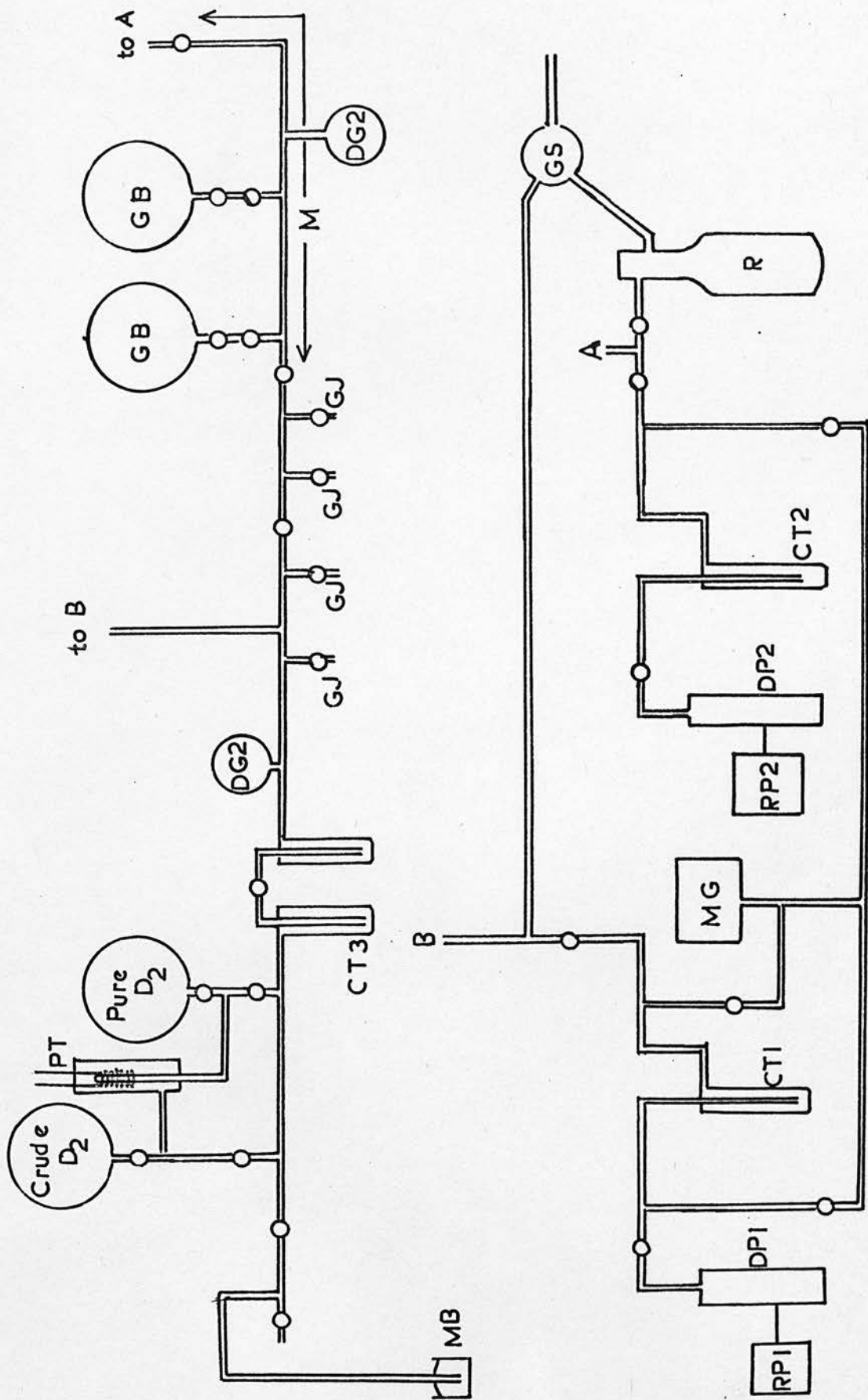

FIGURE 2.2 : GAS HANDLING LINE : (Key to symbols in text)

Evacuation of the gas line was achieved by an electrically heated, Admiralty type mercury diffusion pump, DP1, backed by a two stage "Speedivac" rotary pump, RP1; this combination attained a pressure of $6.7 \times 10^{-4} \text{ Nm}^{-2}$ while mercury contamination from the diffusion pump was prevented by the liquid nitrogen cold trap, CT1. To maintain a consistently good vacuum, maintenance of the rotary pump, cleaning of the cold traps and checks for "streaking" in the tap grease were carried out regularly.

For coarse pressure readings such as needed in making up a reaction mixture, diaphragm pressure gauges, DG1 and DG2, which were calibrated in Torr ($=133.3 \text{ Nm}^{-2}$), were used. To check the high vacuum of the system, e.g. when outgassing a catalyst sample, the pressure was measured by a McLeod gauge, MG⁽⁴⁾. Reaction mixtures were prepared in the mixing volume, M. The constituents of the mixture were either stored on the line in the permanently mounted glass bulbs, GB, or fed into the system via glass ground joints, GJ, from detachable bulbs or gas cylinders. The mixture could then be admitted to the reaction vessel, R.

Volume calibration was carried out by successive expansions of hydrogen from a bulb of known volume ($5.753 \times 10^{-4} \text{ m}^3$ determined with distilled water at 298k). By applying Boyle's Law, the volumes of the mixing volume and associated parts of the vacuum line could be determined. Since not all the reaction vessels were of a standard size, the best estimate of the number of molecules in the reaction vessel was the difference between the number of molecules in the mixing volume before and after admission of the reaction mixture to the reaction vessel. Thus for line A, the number of molecules in the reaction vessel, n , is given by

$$n = \frac{9.66 \times 10^{18}}{T} (126.4p_0 - 139.7p_1) \quad 2.1.$$

while for line B,

$$n = \frac{9.66 \times 10^{18}}{T} (740.6p_0 - 773.7p_1) \quad 2.2.$$

where p_0 and p_1 are the partial pressures of hydrocarbon before and after admission to the reaction vessel and T is the laboratory temperature.

Two types of reaction vessel were used. In reactions over alumina, a cylindrical silica vessel (volume ca. $3 \times 10^{-4} \text{ m}^3$) was used while for reactions over magnesium oxide, the reaction vessel was of similar design but made of "Pyrex". Both vessels, approximately 35-40 mm in diameter and 0.12-0.15 m in length, could be attached to the gas handling line by means of a B24 ground glass joint which fitted into a water-cooled jacket. The vessels were pumped down by a diffusion pump, DP2, backed by a rotary pump, RP2, with a liquid nitrogen cold trap, CT2, again preventing mercury contamination of the line. The pressure in the reaction vessel was measured by the McLeod gauge, MG. After an experiment, reaction vessels were washed out with chromic acid, repeatedly rinsed with distilled water and then dried in an oven before being used again.

The reaction vessel was heated by a close-fitting electrical furnace which consisted of a silica tube about 0.06m in diameter which was wound with resistance wire. The temperature of the furnace was controlled by a Eurotherm proportional controller with a chromel-alumel thermocouple. This device could maintain a steady temperature within 1K but the temperature scale of the Eurotherm was inaccurate at higher temperatures. To monitor the correct temperature, a chromel-alumel thermocouple attached to a digital voltmeter with a cold junction in ice was used. The correct temperature could be obtained from a chromel-alumel calibration chart⁽⁵⁾. One feature of the glass reaction vessels was a tube down the centre of the

vessel into which the thermocouple fitted. A temperature probe in this position will give a more accurate estimate of the catalyst temperature.

On the capillary leak system, a fine glass tube led from the top of the reaction vessel into the mass spectrometer. Thus sampling was continuous. The glassware from the reaction vessel to the MS10 inlet was wrapped in heating tape and kept at 373K to minimise gas adsorption on the glass. The rate of leakage from the reaction vessel was ca. $1-2\% \text{ h}^{-1}$ so that depletion of the reaction mixture was never an important factor.

In the g.c. - m.s. system, removal of samples from the reaction vessel at suitable stages in the course of a reaction was carried out by a three-way glass stopcock and a Perkin-Elmer gas sampling valve, GS, fitted with a P.T.F.E. rotor (see figures 2.1 and 2.2) which was connected to a stainless steel loop (volume $5 \times 10^{-6} \text{ m}^3$). The steps involved in sampling were as follows:

(1) Before taking a sample, the three-way stopcock and sampling valve were set such that the steel loop was evacuated by the gas line pumping system.

(2) On sampling, the three-way tap was turned to link the reaction vessel and the sampling loop for ten seconds.

(3) The tap was closed and the sampling valve rotated to seal the loop from the gas line and to link it to the carrier gas supply for the chromatograph column. This was done for one minute to allow the contents of the sample loop to be flushed into the g.c. column.

(4) Finally, the stopcock and valve were returned to their original positions.

The sample size was ca. 2% of the reacting material which had to be considered in deciding how many samples could be taken from the

reaction mixture without disturbing the kinetics of the system under study. In practice, no more than about ten samples were taken in the course of an experiment.

2.3 THE PREPARATION OF THE REACTANTS

The source and purity of each of the reactants are listed in table 2.1.

TABLE 2.1
SOURCE AND PURITY OF REACTANTS

SUPPLIER	REACTANT	PURITY
Cambrian Chemicals Ltd.	Deuterium, ethane ethylene, isobutane, propylene, isobutene	99.5%
Cambrian Chemicals Ltd.	Methane	99.9%
Phillips Petroleum Co.	N-butane, propane	research grade
Koch-Light Laboratories Inc.	Cyclopentene, cyclopentane	puriss
British Oxygen Co. Ltd.	Cyclopropane	-
K and K Laboratories	Methylcyclopropane	-
Phasesep Ltd.	Cyclobutane	contained n-butane

Purification and handling of gases was only carried out in the presence of a "sticking" vacuum measured by the McLeod Gauge, MG (figure 2.2).

Before the admission of any gas, those sections of the line involved were first evacuated and then flushed with the gas to remove adsorbed impurities. Gases could be introduced to the system either directly at ground glass joints, GJ, or via the mercury bubbler, MB.

Purification of deuterium was achieved by diffusion through an electrically heated palladium-silver alloy thimble, PT. The line was isolated from the pumps and cold trap, CT3, was surrounded by liquid nitrogen, which not only prevented the mercury vapour reaching the hot thimble but removed any condensible impurities in the deuterium. The thimble was heated by applying a voltage of about 15V. across a resistance heater which resulted in a diffusion rate of about $2.5 \text{ kN m}^{-2} \text{ h}^{-1}$.

The purification of hydrocarbons involved a repeated cycle of freezing down the gas, pumping and then thawing. On the final distillation step only the middle section of the sample was retained, the higher and lower boiling point fractions being pumped away. Methane has an appreciable vapour pressure at liquid nitrogen temperature (2.67 kN m^{-2} at 78K) and cannot be completely frozen down. In this work, ultra-high purity methane was used direct from the lecture bottle without further purification.

Reaction mixtures were prepared in the mixing volume section, M, of the vacuum line. After it had been evacuated, a known pressure of hydrocarbon measured on the diaphragm gauge, DG, was admitted. An adequate head of deuterium pressure was built up on the other side of the stopcock separating the mixing volume from the rest of the gas-handling line; the tap was opened slightly until the desired total pressure was reached. The excess of deuterium prevented any back diffusion of hydrocarbon from the mixing volume. When two or more hydrocarbons were required

in the mixture, for example in g.c.-m.s. experiments, it was possible to freeze down the first component into a sample tube and add the other components before introducing deuterium. Before a reaction was started, the reaction mixture was kept in the mixing volume for at least 30 minutes to obtain a homogeneous mixture.

In the studies over gamma-alumina, the reaction mixture for experiments on the MS10 system was generally $1-2 \text{ kNm}^{-2}$ of hydrocarbon and 12.0 kNm^{-2} of deuterium in the mixing volume. This corresponded to about 3×10^{19} molecules in the reaction vessel. Exceptions to this standard mixture were generally those higher in deuterium content and were used in experiments where the effect of extensive exchange was being studied. For experiments followed by g.c.-m.s. when more than one hydrocarbon was involved, reaction mixtures were chosen to give approximately the same number (3×10^{19}) hydrocarbon molecules and the same total pressure in the reaction system. Similar reaction mixtures were used for reactions over magnesium oxide, the pressures of hydrocarbon being $0.8-1.2 \text{ kNm}^{-2}$ and of deuterium $9.6-12.0 \text{ kNm}^{-2}$ giving $2-3.5 \times 10^{19}$ hydrocarbon molecules in the reaction vessel. In g.c.-m.s. experiments mixtures were chosen by the same criteria. For the ethylene-deuterium reactions on oxides, a 10:1 ratio of deuterium to ethylene was admitted to each oxide, the resulting initial gas phase pressure being in the range $1.9-2.8 \text{ kNm}^{-2}$.

2.4 THE CATALYSTS.

Transition aluminas which are formed by partial thermal dehydration of aluminium hydroxides and oxide hydroxides possess high catalytic activity. The gamma-alumina used in this work was prepared by calcining a high-purity boehmite (Laporte Industries Ltd.) at 900K in air for 16h.

Two batches of gamma-alumina were prepared having surface areas of 90 and 120 m²g⁻¹ respectively. The catalyst pretreatment followed the pattern of some earlier work⁽⁶⁾. After evacuation to 723K, the catalyst was treated with 20kNm⁻² pressure of oxygen for 15 minutes, then evacuated, treated with a fresh dose of oxygen for 90 minutes and finally outgassed at 723K for at least 16 hours. The oxygen was admitted to "burn off" any carbon residues on the catalyst while the overall pretreatment had the effect of partially dehydroxylating the alumina which led to the creation of active sites. With the exception of experiments involving cyclopropane and methylcyclopropane when 0.1g catalyst was used, the standard amount of catalyst was 1g.

Magnesium oxide was prepared by dissolving magnesium (Johnson Matthey Chemicals Ltd.) in nitric acid, adding ammonium carbonate to precipitate magnesium carbonate which was then filtered out and dried in an oven at 393K overnight. The carbonate was decomposed to the oxide by heating in vacuo at 1120K for 16h. Three batches of oxide were prepared having surface areas of 30, 30 and 50 m²g⁻¹ respectively. The catalyst pretreatment consisted of outgassing at 723K for 16h to dehydroxylate the surface. In reactions of alkanes and cycloalkanes over magnesium oxide, 0.5g of catalyst were used while for reactions of olefins, 0.1g was used.

The details of the catalysts which were studied in the ethylene-deuterium reactions are given in table 2.2. Masses of catalyst used in these experiments were in the range 0.2-3.0g.

TABLE 2.2

DETAILS OF CATALYSTS FOR ETHYLENE REACTIONS

OXIDE	SOURCE	PRETREATMENT	SURFACE AREA $\text{m}^2 \text{g}^{-1}$
rutile	Tioxide International Ltd.	evacuated (723K, 16h); O_2 (2.7 kNm^{-2} , 723K 30min); cooled to 298K, evacuated (298K, 30min)	25 ⁽⁷⁾
iron oxide	Johnson Matthey Chemicals Ltd., grade 1	evacuated (673K, 16h)	2.62 ⁽⁸⁾
cobalt oxide	Johnson Matthey Chemicals Ltd., grade 1	evacuated (523K, 45min) ⁽⁹⁾	0.65 ⁽⁸⁾
zirconia	I.C.I.Ltd. (containing 0.02% sulphur)	evacuated (723K, 20h)	2 ⁽¹⁰⁾
zinc oxide	New Jersey Zinc Co. (Kadox 25)	evacuated and heated to 573K; H_2 (20 kNm^{-2} , 573K, 30min); evacuated (573K, 5 min, then 723K, 16h)	10 ⁽¹¹⁾
chromia	similar to sample I and II described elsewhere ⁽¹²⁾		100 ⁽¹³⁾

The surface areas of catalysts were determined by gas adsorption using nitrogen at 78K. The adsorption isotherm is obtained and, assuming that the B.E.T. equation (see section 1.2) holds, the volume of monolayer coverage can be determined. If the cross-section of the adsorbate

molecule is known, the surface area of the catalyst can be calculated. The apparatus used to obtain the adsorption isotherm is fully described elsewhere⁽⁷⁾. It operated on a constant volume principle viz. that a measured volume of gas was admitted to the sample and, after equilibrium had been established, the pressure in the system was measured from which the amount of gas remaining in the gas phase could be calculated. From these values the volume of nitrogen adsorbed on the catalyst could be deduced. A series of results for different pressures was recorded. Using equation 1.3 the volume of an adsorbed monolayer was determined and hence the surface area of the catalyst.

2.5 THE MASS SPECTROMETER

In exchange reactions involving a single hydrocarbon, continuous sampling from the reaction vessel could be carried out via a capillary leak into an AEI MS10 mass spectrometer, a detailed description of which is given in the appropriate handbook⁽¹⁴⁾. This is a high sensitivity, low resolution instrument but which can resolve species differing in mass by one unit which is satisfactory for exchange reactions.

Gas molecules within the spectrometer are ionised by a crossbeam of electrons generated by an electrically heated rhenium filament. The electrons are accelerated to a predetermined energy (in this work typically $10\text{ eV} = 1.6 \times 10^{-18}\text{ J}$) and aligned by a magnetic field. The ions are accelerated out of the ionisation region by application of a potential, V . After acceleration, the ions traverse a magnetic field, H , where they are deflected through 180° . A series of slits ensures that only those ions which have travelled on a path of radius, r , arrive at the ion collector electrode. The mass of the ions arriving at the collector is given by

$$m = \frac{H^2 r^2 e}{2V} \quad 2.3$$

where e is the charge on the ion. Different masses can be studied by varying the magnetic field or the accelerating voltage. In this instrument, the magnetic field was varied by means of an electromagnet the poles of which were positioned round the source.

The electrode assembly, filaments, slits etc. were supported from the top flange of the mass spectrometer vacuum chamber. The flange also carried a glass-metal seal which served as the inlet from the reaction vessel. The mass spectrometer chamber was made of non-magnetic stainless steel and the whole apparatus could be baked out at 580K.

A Bayard-Alpert ionisation gauge was located directly below the mass spectrometer chamber and a liquid nitrogen cold trap separated the high vacuum region from an oil diffusion pump. The vacuum was obtained by means of a backing rotary pump, a water-cooled oil diffusion pump and the cold trap. The trap had two functions; firstly, to trap condensable gases in the spectrometer source and secondly, to prevent oil vapour from the pump contaminating the source. The chief advantage of oil over mercury was that it had a lower vapour pressure whilst its major disadvantage was that its decomposition products might find their way into the high vacuum region. A further disadvantage was that if large quantities of air entered the mass spectrometer the oxidation of the pump oil necessitated a complete overhaul of the apparatus. In order to "clean" the spectrometer source the vacuum chamber was baked out for twenty-four hours.

The background pressure in the mass spectrometer when it had cooled after baking and when the cold trap had been filled was less than 10^{-5} Nm^{-2} . The pressure was monitored by an AEI VC3 Ionisation Gauge which operated on the ionisation effect resulting when a low pressure of gas is bombarded with electrons. The degree of ionisation is proportional

to the pressure of gas present. The instrument operated in the pressure range $10^{-1} - 10^{-7}$ Nm⁻². The gauge head was of a Bayard-Alpert type because, at low pressure, electrons hitting the grid in a conventional triode-type valve cause X-rays to be passed to the collector thereby releasing photoelectrons which effectively set up a current opposed to the ion current which results in a misleading pressure reading.

The electromagnet allowed the mass spectrometer to operate in the range $m/e = 1-400$, with a field strength up to 9 kilogauss. With an ion accelerating voltage of 250v. the MS10 had a resolving power of about 300 (10% valley). The time taken to scan the complete mass range could be varied from 5000 to 100 seconds in six steps. The scan could be started, stopped or reversed at any point. Typically in this work, a range of interest might be twenty mass units which could be scanned in one to two minutes.

The intensity of collector current for a particular mass was $10^{-9} - 10^{-12}$ amps. This current was monitored by an electrometer head and then amplified. The output from the amplifier was displayed on a chart recorder. A mass spectrum consisted of a series of peaks corresponding to different mass numbers whose relative intensities were proportional to the sizes of the peaks.

2.6 THE GAS CHROMATOGRAPH - MASS SPECTROMETER

In reaction mixtures where two or more constituents are of interest and have overlapping cracking patterns in the mass spectrometer it is necessary to separate the various hydrocarbons before they are admitted to the spectrometer.

Gas chromatography offers a means to this end. The procedure

of sampling the reaction mixture has been described in section 2.2. On flushing out the sample loop the contents were fed into a gas chromatograph column using helium as the carrier gas. Three columns were principally used in this work. Firstly, to separate acyclic alkanes, an 8m column of bis-2-methoxyethyladipate (13.5%) and di-2-ethylhexylsebacate (6.5%) on 60/80 mesh Chromosorb P operating at 273k was used for C_1 - C_3 alkanes and the same column operated at room temperature was satisfactory for higher alkanes. With a carrier gas pressure of 310 kNm^{-2} complete baseline separation of all the saturated hydrocarbons could be achieved. Olefins, cycloalkanes and their isomerisation products were separated on a 4m column of propylene carbonate on 60/30 mesh Chromosorb P operating at 273K. The column was also used to separate the components of the cyclobutane and n-butane mixture. The only compounds which proved difficult to resolve completely were methylcyclopropane and isobutene. Fortunately the isomerisation of methylcyclopropane of which isobutene is a possible product was not an important reaction and the difficulty was largely avoided. Separation of ethylene and ethane was achieved by using a 2m column of squalane (3%) on activated alumina type H, 100/200 mesh. The column was maintained at 263K by immersion in a bath of ice and ethanol while the carrier gas pressure was 140 kNm^{-2} . Under these conditions, typical retention times for ethane and ethylene were 6 and 7.5 minutes respectively.

In combined g.c.- m.s. studies the chromatograph gave rise to two problems. Even at room temperature there was considerable elution of water from the column and a smaller amount of bleed from the stationary phase which both made contributions to the background spectra. Although the background was useful as a source of reference peaks, experiments involving C_1 and C_2 hydrocarbons were complicated by relatively large

backgrounds in the mass ranges of interest. The second problem arose from the ability of the chromatographic column to bring about the partial separation of deuterated alkanes. No single mass spectrometric scan of a chromatographic peak was representative of the isotopic distribution in that sample. To determine the true distribution a number of mass spectrometric analyses were taken at equal intervals of time as each component emerged from the column. To achieve this a rapid-scanning mass spectrometer was required.

The effluent from the chromatographic column was passed via a stainless steel capillary tube (33mm bore) which reduced the pressure between the column and the source into an all-glass Biemann-Watson molecular separator⁽¹⁵⁾ which acted as the interface between the gas chromatograph and the mass spectrometer. The purpose of the separator was to remove as much of the carrier gas from the stream of gas entering the spectrometer but, at the same time, not to pump away too much of the hydrocarbon. The separator consisted of a glass frit through which the column effluent passed and was mounted in a glass diffusion chamber which was evacuated by a rotary pump. The sizes of the pores in the frit were such that passage of the carrier gas would occur more easily than that of the larger hydrocarbon molecules. Use of helium with its low molecular weight gave the maximum differential in pumping rates. The hydrocarbon-enriched sample then passed into the mass spectrometer via a glass re-entrant.

The mass spectrometer used in the combined g.c.- m.s. system was an AEI MS20 "Rapide" which is a single-focussing, pi-radian deflection instrument with rapid magnetic scanning. The design of the MS20 is based on that of the MS10 and much of the description of that apparatus

in section 2.5 is also applicable here. A detailed review of the MS20 and its operation may be found in the manufacturer's manual⁽¹⁶⁾.

The vacuum system involved a rotary pump and a water-cooled diffusion pump with liquid nitrogen cold trap giving a pressure of less than 10^{-5} Nm⁻² after baking. The theory of ion behaviour within the spectrometer source is similar to that for the MS10. The principal difference between the apparatus was that the MS20 had the facility to complete a mass scan in a much shorter time. The variable electromagnet which was positioned round the source performed an exponential scan from high to low mass number at the fastest rate available viz. one second per decade of mass with an electromagnet reset time of one second. Thus, for mass range $m/e = 100$ to 10 which was most frequently used in this work, about thirty mass scans could be recorded for a sample with an elution period of one minute from the chromatographic column.

In operation, the ionisation energy of the electrons was set at 20eV which was chosen to give reasonable sensitivity without causing ionisation of residual helium (ionisation potential = 24.6 eV). An additional feature of the MS20 was the total ion monitor plate which intercepted about 15% of the ion current. Its output, after amplification, was displayed on a current meter and a chart recorder. The trace reflected fluctuations in pressure as each hydrocarbon entered the source and thus acted as a chromatographic detector. When a hydrocarbon sample was detected the electromagnet was switched into the repetitive scanning mode for the duration of the sample, thereby collecting a set of mass spectra.

2.7 DATA COLLECTION IN THE G.C.- M.S. SYSTEM

Three routes were available for the collection and presentation

of mass spectra in the g.c.- m.s. system as indicated in figure 2.1. The output of the mass spectrometer, i.e. the individual ion currents produced at the collector for each m/e ratio was fed initially to an electron multiplier operated at 3kV with a 1kHz bandwidth for faster scanning speeds.

The first route for the output of the electron multiplier was to a cathode ray oscilloscope. As each spectrum was produced it could be displayed on the oscilloscope screen, the sweep of the oscilloscope beam being triggered at the start of each magnetic scan. This gave a rapid visual check on the spectra which could be useful in gauging the rate of a reaction during an experiment but which did not provide any lasting means of data collection.

The second outlet was for the current to be fed to a set of six galvanometer drive amplifiers. Each of these was capable of amplifying the incoming signal intensities to a different level. The visual display of these intensities was on an SE3006 ultra-violet chart recorder. Fluctuations in intensities from the amplifiers caused deflections in the associated spots in the u-v recorder producing peaks in the spectra. Although six ranges were available, in practice the width of the chart paper made the use of only three ranges feasible. Ion peaks were monitored at attenuation levels of 2, 10 and 100. In this manner the mass spectra were recorded as a series of peaks on the u-v sensitive chart paper. After the spectra had been calibrated, usually by some recognisable reference masses in the background, the intensities of the peaks were measured manually from the peak heights, a process which might involve thousands of measurements and was therefore both tedious and time-consuming.

The third method of data collection bypassed these difficulties.

The signal from the electron multiplier was fed via a unity gain high impedance buffer to an analog-to-digital converter (a.d.c.) of a mini-computer, in this case a PDP11 machine (Digital Equipment Corporation). At the start of each scan an electronic pulse was automatically generated by the mass spectrometer magnet control unit and directed to the a.d.c. in order to activate the data collection procedure. During an experiment the signal generated by the electron multiplier was sampled by the a.d.c. at 5000 Hz. A threshold level was preset at a value such that baseline noise from the multiplier and signals due to random ion peaks were not stored by the computer. For each mass spectrometer scan every a.d.c. sample number above threshold was recorded and each spectrum was assigned a number for identification purposes.

At the conclusion of an experiment the first step in the reduction of the data was the identification of peaks. A peak location routine was used to analyse the changes in the pattern of intensities observed at the a.d.c.. A steady increase in signal intensity for three consecutive a.d.c. samples enabled a mass spectrometric peak to be recognised; a subsequent decrease in intensity over two a.d.c. samples determined the termination of a peak. For each peak thus defined the initial sample numbers and signal intensities in the computer-stored data were used to assign

- (a) a centroid value which accurately defined the position of the peak in relation to the start of the spectrum. This value was used in the mass interpolation of the spectrum.
- (b) an integrated intensity value for the peak. Integration of the peak area rather than measuring the highest individual intensity was found to produce more reliable results.

In this way the spectrum finally recorded comprised a series of centroid and intensity values.

TABLE 2.3

DIGITAL REPRESENTATION OF MASS SPECTRA

(Spectrum of mixture of deuterated ethylenes)

centroid	intensity	mass †
2365	112	33.0
2436	5717	32.0
2509	5474	31.0
2579	2798	30.0
2655	1200	29.0
2737	2191	28.0
2819	516	27.0
2904	178	26.0
3737	581	18.0

† Mass numbers subsequently assigned during data processing.

Table 2.3. shows a typical mass spectrometric scan which was one of twenty-four recorded for a sample of ethylene during an exchange reaction with deuterium over magnesium oxide. At this stage the data was transferred via a telephone link or as binary data on paper tape to an ICL 4-75 computer for further processing.

The next stage in the data reduction was to assign mass numbers to the intensities in the spectra. The array of time and intensity values had to be converted into a list of mass numbers and associated intensities

which was accomplished by setting up a mass calibration table. Reference peaks in the initial scans of a data file were used; satisfactory referencing could be achieved in two ways. Firstly, use was made of the background spectra which were recorded before the elution of hydrocarbon samples from the gas chromatograph. The most prominent peaks in the background spectra were usually due to the presence of traces of water, nitrogen and oxygen in the mass spectrometer source which could be assigned to mass numbers 18, 28 and 32. Also present in the spectrometer were peaks arising out of "bleed" from the g.l.c. column. The relation between mass numbers and centroid values throughout the spectrum was interpolated from the positions of the reference masses, the a.d.c. sampling rate and the rate of the electromagnetic scan. In this way each centroid value could be converted into a mass number (see table 2.3). The use of background peaks as references had the advantage that they were always present in the system and, if for any reason the experiment was interrupted, it was a relatively simple task to reset the calibration table. However, the method also had its drawbacks. Firstly, it was a poor approach because it required the background spectrum to be of fairly high intensity. A more serious disadvantage arose if the mass range of interest was higher than the largest available reference mass. In those circumstances the reference table would have to be extrapolated to determine the mass numbers which proved to be an unsatisfactory procedure. For peaks whose mass number was ten or more greater than the largest reference peak, misinterpretation was likely. This necessitated the use of some reference compound prior to the experiment. The vapour of a pure hydrocarbon was introduced to the ion chamber of the spectrometer source via a capillary inlet. A suitable compound was 2-methyl-pentane which gave reference peaks at mass

numbers 86, 71, 56 and 41 which could be used for calibration in experiments involving C_3-C_6 hydrocarbons. This method had the advantage that the normal background of the spectrometer could be very low. Once the few spectra required for referencing had been collected, the vapour was pumped from the system in a few minutes. The disadvantage with this method of referencing was that it had to be done prior to the experiment. To summarise, the referencing required a set of reference peaks which covered the mass range of interest and were of sufficient intensity to be recognised. Ideally the peaks were spaced at intervals of about 15 mass numbers.

The interpolation of mass numbers also depended on other factors. In order that peaks were assigned to their correct mass numbers the spectrometer had to scan in a reproducible fashion, in particular to start from the same point each time. Any drift in the peak positions would result in incorrect mass interpolation. Changes in the spectrometer's characteristics were likely as the temperature of the instrument increased. A warming-up period of about an hour with the machine in a fully-operational state was allowed before the start of an experiment to allow the instrument to stabilise. The interpolation program was also adapted to cater for slight fluctuations in the positions of the mass numbers during an experiment.

However the system was not able to cope with sudden, relatively large changes in the magnet scan which invalidated the calibration table. When background spectra were being used to reference scans it was a relatively simple matter to recalibrate and continue. However, if a reference compound was being used or if the discontinuity escaped unnoticed, which was likely, useful information could be lost. It was discovered that the first scan of a batch taken from the MS20 by switching on the automatic

repetitive scanning mode was atypical of the subsequent scans in its mass/time characteristics. Therefore an additional switch was incorporated to control the transmission of the start switches to the PDP11. The magnet was allowed to scan continuously and the start pulses to the a.d.c. were interrupted at the second switch when spectra were not being collected.

Stray pulses "seen" by the a.d.c. which often arose when electrical apparatus was switched on elsewhere in the laboratory were another source of difficulty. To avoid this, only operations which were necessary for the collection of data were carried out when scans were being recorded.

Facilities for mass interpolation were available on both the PDP11 and ICL4-75 machines, the same method being used on both systems. Although all spectra were eventually collected and processed on the PDP11 and 4-75 machines, a few scans were still recorded on ultra-violet paper during an experiment to afford an immediate indication of the progress of a reaction. During the development of the computer facility both methods of data acquisition were used and the results compared in order to assess the reliability of the on-line capture technique.

The course of an exchange process on magnesium oxide was used to compare data from the PDP11 and from the u.-v. recorder. The methods of processing the mass spectra into isotopic distributions were the same for both sets of data and are described in chapter 3. Figure 2.3 gives a comparison of isotopic distributions obtained for the exchange of ethylene with deuterium over magnesium oxide at 298 K. Clearly there is very good agreement between the isotopic distributions obtained from the two sources. In addition the isotopic distributions obtained from the computer captured data are in much closer agreement with the calculated binomial distribution as shown in table 2.4.

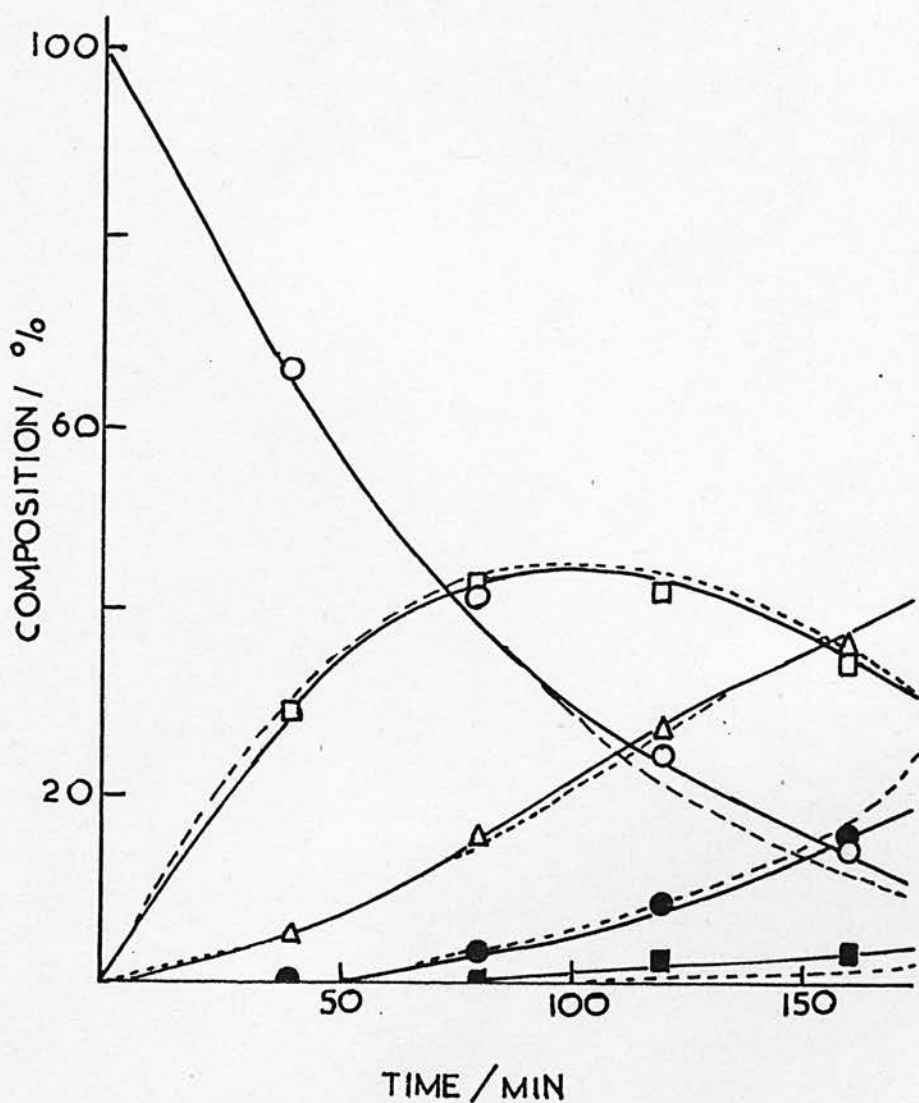

FIGURE 2.3 : Comparison of isotopic distributions obtained for the exchange of ethylene with deuterium on magnesium oxide at 298 and 373K.

—, data from PDP11; - - , data from photographic paper; also shown are calculated binomial distributions:

○, ethylene $-d_0$; □, $-d_1$; Δ, $-d_2$; ●, $-d_3$; ■, $-d_4$.

The parameter ϕ represents 100 times the mean number of deuterium atoms present per molecule of hydrocarbon.

TABLE 2.4

TYPICAL DISTRIBUTION DURING ETHYLENE EXCHANGE

	d_0	d_1	d_2	d_3	d_4	
$\phi = 130$	20.7	40.2	29.6	7.9	1.6	PDP11
	20.9	40.0	28.8	9.2	1.1	binomial
$\phi = 133$	17.7	41.9	30.9	8.9	0.6	u-v charts
	19.9	39.6	29.5	9.8	1.2	binomial

The ϕ value represents 100 times the mean number of deuterium atoms present per molecule of hydrocarbon. When data were collected on ultraviolet paper the disagreement was mainly due to an underestimate of the percentage of ethylene- d_4 present. The error was attributed to the presence of the peak at $m/e = 32$ in the background spectrum. Although the two ions O_2^+ and $C_2D_4^+$ have nominal mass 32, examination of accurate atomic masses showed that the former ion is about 0.2% lighter. Consequently partial resolution of the two mass peaks occurred when recording spectra of exchanged ethylenes. When examining the spectra on ultraviolet paper it was very difficult to establish that part of the total intensity due to the presence of ethylene- d_4 and since measurements of peak heights were used, an underestimated intensity value resulted. The sampling rate of the a.d.c. of the PDP11 was sufficiently high that an accurate integrated intensity for each component at mass 32 could be determined.

To summarise, the results indicate that data acquisition via the PDP11 computer enables isotopic distributions to be calculated with an accuracy which is as high as, and in certain cases, higher than that obtained by previous methods.

2.8 EXPERIMENTAL PROCEDURE

Whenever it was practical a set routine was followed for both systems. The steps in this routine are outlined below.

(a) preparation; (carried out the day before an experiment)

(1) the rotary pumps and diffusion pumps were switched on in the gas line and the cold traps filled with liquid nitrogen.

After a suitable time the pressure was checked using the McLeod gauge (sticking vacuum desirable).

(2) the rotary and oil diffusion pumps of the mass spectrometer were switched on, as were the external heaters if the instrument required baking. When baking was complete the liquid nitrogen cold trap was filled and, after two hours which was required for the spectrometer to cool, the pressure in the source was checked (less than 10^{-5} Nm⁻²).

(3) for g.c.-m.s. experiments, helium was set flowing through the chromatographic column at the required rate overnight to allow it to stabilise.

(4) the catalyst was weighed out and put into a clean reaction vessel which was then attached to the gas line. The vessel was evacuated and then brought up to the temperature required for the pretreatment which was then carried out.

(b) procedure before experiment.

(1) the pressure in the gas line and spectrometer were checked.

(2) the reaction mixture was prepared and allowed to stand in the mixing volume.

(3) the source connections plug and electrometer amplifier head were attached to the top of the mass spectrometer stack and the

electromagnet moved into position around the source.

(4) in g.c.-m.s. experiments the column was connected to the inlet capillary of the MS20 with the helium flowing and a throttling tap was adjusted to give the operational pressure of ca. $7 \times 10^3 \text{ Nm}^{-2}$ in the spectrometer.

(5) the magnet was energised and the electron beam control unit, amplifiers and chart recorder switched on and made operational. The filament was then switched on and a few trial scans were run to check that everything was working properly. At this point, the MS20 was tuned for maximum sensitivity. The magnetic field was locked at some recognisable m/e value. The ion repeller voltage and deflector plate voltage were adjusted to give maximum spot deflection on the chart recorder.

(6) the MS10 was then ready to operate; a few background scans of the mass range of interest were taken, the appropriate scale on the amplifier chosen and then steps (8) and (9) carried out.

(7) before a g.c.-m.s. experiment was started, the collection link to the computer had to be set up. The appropriate connections were made and the system logged onto the computer which was then programmed to remain in an "activated" state awaiting the first pulses from the spectrometer.

(8) the furnace was now removed from around the reaction vessel which was closed to the pumps and allowed to settle at the chosen reaction temperature.

(9) the reaction mixture was admitted to the reaction vessel. In experiments on the MS10 the continuous leak meant that samples of the reaction mixture were available at any time during the

experiment. In the g.c.-m.s. system, samples had to be withdrawn from the reaction vessel at suitable time intervals. Before each sample reached the mass spectrometer a few background scans were recorded.

REFERENCES

- (1) C. Kemball, Proc. Royal Soc., A207, 539, 1951.
- (2) R.S. Dowie, C. Kemball, J.C. Kempling and D.A. Whan, Proc. Royal Soc., A327, 491, 1972.
- (3) R.S. Dowie, Ph.D. Thesis, University of Edinburgh, 1973.
- (4) J.H. Leck, Pressure Measurements in Vacuum Systems, (Chapman and Hall), 1964.
- (5) Handbook of Chemistry and Physics, Section E-92.
- (6) J.G. Larson and W.K. Hall, J. Phys. Chem., 69, 3080, 1965.
- (7) B.I. Brookes, Ph.D. Thesis, University of Edinburgh, 1972.
- (8) I.R. Shannon, Ph.D. Thesis, University of Edinburgh, 1969.
- (9) D.L. Harrison, D.Nicholls, J. Catalysis, 7, 359, 1967. and H. Steiner,
- (10) B.T. Hughes, D. Taylor J.C.S. Faraday I, 71, 1285, 1975. and C. Kemball,
- (11) S. Naito, H. Shimizu, Trans. Faraday Soc., 67, 1519, 1971. E. Hagiwara, T. Onishi and K. Tamaru,
- (12) N.E. Cross and H.F. Leach, J. Catalysis, 21, 239, 1971.
- (13) H.F. Leach, personal communication.
- (14) MS10 Series Instruction Manual, Associated Electrical Industries Ltd.
- (15) J.T. Watson and K. Biemann, Anal. Chem., 36, 1135, 1964.
- (16) MS20 Series Instruction Manual, Associated Electrical Industries Ltd.

CHAPTER 3THE ANALYSIS OF EXPERIMENTAL DATA3.1 INTRODUCTION

This chapter describes the methods used to convert the raw data obtained in experiments into results from which useful information could be derived. In essence the same methods were used for data from experiments using the MS10 apparatus and using the g.c.-m.s. system, the reduction of data from mass spectrometric studies of exchange reactions following an established pattern⁽¹⁾. Relevant corrections were made to the raw spectral data to produce isotopic distributions corresponding to various times during the experiment. From the changes in these distributions the rate of exchange could be calculated.

Many of the calculations were carried out using a computer for which programs had already been written⁽²⁾. The calculations were worked through either on an IBM 370/158 machine or on an ICL 4/75 machine. Except for minor alterations necessitated by using different systems these programs were used in their original forms.

One development in this field which was carried out in the course of my work was the testing of a method of analysing data from exchange reactions of molecules with non-equivalent hydrogen atoms. Computer-generated data for which the correct results were known were used to test the reliability of the technique.

The methods of analysis for isomerisation and hydrogenation reactions are also described in this chapter.



3.2 ANALYSIS OF MASS SPECTRAL DATA

The initial treatment of mass spectral data from MS10 experiments and g.c.-m.s. experiments differed as a result of the methods of recording the data.

For experiments using the MS10 spectrometer, the spectra consisted of a number of peaks of varying intensity which corresponded to species of different masses. A kinetic run at fixed temperature consisted of a number of these spectral scans taken at definite time intervals. The heights of the peaks were measured to the nearest millimetre and converted to a common sensitivity. The peak height corresponding to each mass was then plotted against the times at which scans had been recorded. In fast reactions particularly, it was necessary to recognise that, even within one spectrum, the peaks for different masses were separated by definite time intervals. Typically the mass range of interest would be scanned by the magnet in one minute. In general the rate of reaction and the frequency of sampling were low enough for this not to be an important factor but, in the exchange of olefins on magnesium oxide for example, these corrections were necessary. Smooth curves were then drawn through the points for each mass to show up any variations in mass spectrometer sensitivity and also any minor fluctuations in the recorder. To analyse the data, the peak heights for each mass at a series of times during the experiment were read from the graph. At this stage correction was made for background. The intensities of the peaks corresponding to the various background masses were measured prior to the experiment and subsequently subtracted from each set of readings.

The g.c.-m.s. system produced a much larger volume of raw data which had to be reduced before computing isotopic distributions. The

computer output, as described in chapter 2.7, consisted of a series of spectra of mass numbers and corresponding intensities. As has been explained, no single scan was representative of the overall isotopic distribution. To determine the average distribution the peak heights were integrated over the series of scans using Simpson's rule⁽³⁾ to produce an average intensity value for each mass number. The error involved in this numerical integration was sensitive to the number of mass spectral scans recorded during the elution of the hydrocarbon. Previous investigation⁽⁴⁾ has shown that a scanning frequency which produced about fifteen scans per hydrocarbon component had an associated 95% confidence level of $\pm 1\%$. In this work typically thirty scans were recorded for each hydrocarbon peak. It was necessary to correct for background peaks arising from residual gases in the spectrometer source and from "bleed" from the chromatograph column. Before each g.c.-m.s. sample five background scans were recorded, the peak heights of those masses present were averaged and then subtracted from the integrated intensity values to which they contributed in the hydrocarbon spectra. At this stage the data consisted of a series of intensities over the mass range of interest, each set corresponding to a sample time during the experiment.

The remainder of the processing was common to both types of data. Both carbon and hydrogen have more than one stable isotope. The occurrence of ^{13}C and deuterium in the spectra of hydrocarbons must be taken into account because the presence of either of these isotopes will result in peaks at mass numbers greater than that of the parent molecule. Since exchange reactions involve changes in isotopic distributions it is essential to correct for the natural presence of heavy isotopes in the reactants. The isotopic abundances of heavy carbon and deuterium are 1.069% and 0.016%

respectively⁽⁵⁾ and for the molecule C_nH_m , the binomial expression

$$(0.98931 + 0.01069x)^n (0.99984 + 0.00016x)^m \quad 3.1$$

can be used to yield the intensity ratios for peaks containing natural isotopes relative to that of the parent hydrocarbon. The term in x^0 corresponds to the fraction of parent peak (mass number P), the term in x^1 to the (P + 1) peak, etc. For a range of deuterated products these values will vary with the extent of exchange. For the species $C_nH_{m-r}D_r$, expression 3.1 can be used with m replaced by (m-r). Isotopic corrections were made on a systematic basis starting with the lowest mass number and working upwards to higher masses using the corrected intensity at each mass to calculate the contribution to the next highest mass.

The final correction to be made was to account for fragmentation of molecules in the mass spectrometer source. The molecules entering the source collided with a crossbeam of electrons and fragmentation processes were the result of encounters between these electrons and the molecules⁽⁶⁾. Some of the electrons had sufficient energy to rupture carbon-hydrogen bonds giving rise to peaks in the hydrocarbon spectrum at mass numbers below that of the parent molecule. The characteristics of the fragmentation pattern were principally determined by the molecule itself and the energy of the ionising electrons. In this work the electron voltage was kept as low as possible to minimise fragmentation but at a sufficiently high value to give adequate sensitivity. In general an electron energy of 10eV (1eV = 1.6×10^{-19} J) was used on the MS10 and 20eV on the g.c.-m.s. system.

The simplest approach to fragmentation correction was on a statistical basis. If it was assumed that the relative probability of breaking a carbon-hydrogen and a carbon-deuterium bond were equal then only

the fragmentation pattern of the light (i.e. undeuterated) hydrocarbon was required. The pattern was obtained by admitting a sample of the light hydrocarbon to the mass spectrometer, recording the mass spectrum and correcting for background and natural isotope. The spectrum then consisted of a parent peak intensity and intensities corresponding to some mass numbers lower than that of the parent. The pattern was then normalised with the parent peak intensity equal to unity and the fractions corresponding to the various fragments were recorded. When dealing with spectra of deuterated products it was assumed that loss of hydrogen or deuterium occurred on a statistical basis. This method which is described in detail elsewhere^(7,8) was adequate in situations where the extent of fragmentation was not great and where highly deuterated products were not involved.

The method has been found to be inadequate in cases where heavily deuterated products are formed. The chief causes for its failure are that, in reality, it is easier to rupture a carbon-hydrogen bond than a carbon-deuterium bond and that the fragmentation of a particular bond is influenced by the nature of the other bonds in the molecule. An empirical method⁽⁹⁾ has been devised to account for these factors. When experiments in this work produced highly deuterated products this procedure was adopted but, in other cases, the statistical procedure proved adequate. A modification to the usual procedure for fragmentation correction was necessary when considering the case of highly deuterated isobutane. In the mass spectrometer the most likely hydrogen atom to be removed from the molecule in a collision with the ionising electrons was the methine hydrogen which, as the results indicated, had little likelihood of being deuterium. Thus it was assumed that the fragment with the loss of one hydrogen atom was always

one mass unit less than its parent ion. Fragmentation from the other positions in the molecule was considered in the usual way.

For each of the methods fragmentation corrections were made in a systematic fashion starting with the highest mass peak and working in order of decreasing mass by making corrections on the basis of each newly corrected peak intensity and taking into account all possible fragmentation processes. The fragment ion contributions from each peak were calculated by multiplying the intensity for that particular peak by the relevant fragmentation factors and subtracting the products from the appropriate peak intensities at lower mass numbers.

The fragmentation - corrected peaks were then summed and the amount of each isotopic species expressed as a percentage. This gave a series of isotopic distributions for various time intervals during the experiment. It was often useful to compare the experimental distribution with a binomial product distribution calculated from the mean deuterium content of the experimental distribution. The usefulness of such a comparison was that, in processes where the incorporation of deuterium was by a stepwise process, the distribution of isotopic species remained binomial throughout the reaction⁽¹⁰⁾. Good agreement or the lack of it between the experimental and binomial distributions might indicate whether or not stepwise exchange was involved. The mean deuterium content is defined by

$$M_D = \frac{\sum id_i}{100} \quad 3.2$$

where d_i is the percentage of hydrocarbon with i deuterium atoms. The binomial distribution is simply the expansion of

$$100 (h + d)^n \quad 3.3$$

where h and d are the probabilities of any hydrogen atom being an H or a D atom respectively and N is the total number of replaceable hydrogen atoms in the hydrocarbon. h and d are defined by

$$d = \frac{M_D}{N} \quad 3.4$$

$$h = (1 - d) \quad 3.5$$

The term in d^i in the binomial expansion gives the percentage of isotopic species with i deuterium atoms in the molecule.

It is important to have some estimate of how accurate and successful these correction methods are and to realise the likely sources of error. It has been shown⁽⁴⁾ that the Simpson's Rule integration is satisfactory if the number of scans per hydrocarbon peak is greater than fifteen. Background corrections particularly in the g.c.-m.s. system are a possible source of error. In the MS10 overnight baking proved to be sufficient to give a background spectrum which, in most cases, was negligible in the mass range of interest. The likely background peaks were at $m/e = 18, 28, 32, 44$ (corresponding to water, nitrogen, oxygen and carbon dioxide respectively) and, if necessary, corrections were made for these peaks. It was assumed that there was a linear superposition of the hydrocarbon and background peak intensities in each spectrum. i.e. that there was no suppression of background intensities on admission of the hydrocarbon sample.

However in the g.c.-m.s. system background peaks were seldom negligible. In many cases they were outwith the mass range of interest and did not present any problem but for methane, ethane and ethylene background peaks at $m/e = 18, 28$ and 32 , corresponding to water, nitrogen and oxygen respectively, had to be taken into account. In most cases the relative intensities of the hydrocarbon peaks and background peaks were such

that processing could be carried out albeit with a greater uncertainty than in MS10 experiments. In one case (see chapter 6.2) the size of the hydrocarbon peaks was of the order of the background peaks and alternative measures were required.

It is difficult to estimate the errors involved in making the fragmentation corrections. It was assumed that fragmentation patterns were reproducible in the lifetime of a filament in the mass spectrometer source. However on renewal of a filament new fragmentation patterns were recorded. Little error would be introduced as a result of fluctuations in the mass spectrum during an experiment. The accuracy of the final results was considered to depend mostly on the scheme used for corrections. The reliability of isotopic distributions was gauged from two factors; in the early stages of a reaction the self-consistency of the fragmentation pattern was checked in that peak intensities corresponding to fragment ions should be close to zero after correction. Secondly, in experiments involving a stepwise mechanism comparison of the experimental and binomial distributions helped to reveal errors.

It was also assumed that the mass spectrometer was equally sensitive to the various isotopic species of the same hydrocarbon with the exception of methane for which different sensitivities of CH_4 and CD_4 have been recorded⁽⁴⁾ in the g.c.-m.s. system. One possible reason for the difference in sensitivities may be differential pumping in the molecular separator of the deuteromethanes.

3.3 THE KINETICS OF HYDROCARBON REACTIONS

Most of this work involved a study of the kinetics of various hydrocarbon reactions, in particular exchange reactions. From the relative

rates of reaction of different species, information could be deduced concerning the possible reaction paths and the nature of the intermediates. Therefore methods were required to calculate reaction rates from the experimental data and these are described in this section. Three types of reaction were encountered in this work, exchange, addition and isomerisation, of which the first had the greatest importance.

(a) The Kinetics of Exchange Reactions.

The treatment of data from exchange reactions has been detailed elsewhere⁽¹⁾ and the relevant equations and definitions are summarised here. The course of an exchange reaction could be followed in two ways, either by the rate of incorporation of deuterium into the molecule or by the rate of disappearance of the light hydrocarbon.

The deuterium content of a hydrocarbon was defined by the parameter, ϕ ,

$$\phi = \sum_i^N i d_i \quad 3.6$$

where d_i was the percentage of hydrocarbon with N exchangeable hydrogens of which i were deuterium. The rate of entry of deuterium into the hydrocarbon was given by

$$-\log(\phi_{\infty} - \phi) = \frac{k_{\phi} t}{2.303 \phi_{\infty}} - \log(\phi_{\infty} - \phi_0) \quad 3.7$$

where k_{ϕ} was a rate constant equivalent to the number of deuterium atoms entering 100 molecules of hydrocarbon in unit time and where ϕ_0 , ϕ_{∞} were respectively the initial and equilibrium values of ϕ . In using equation 3.7 it was assumed that all the hydrogen atoms in the hydrocarbon were equally susceptible to exchange and that the influence of isotopes on the rate of exchange could be ignored.

In a "well-behaved" reaction a plot of $\log(\phi_{\infty} - \phi)$ against time should have been a straight line. Before this could be tested the value

of ϕ_{∞} had to be chosen. In those experiments in which the reaction was followed to equilibrium the value could be determined from the final isotopic distribution. An estimate of ϕ_{∞} based on the assumption that, in the equilibrium distribution, the hydrogen and deuterium are randomly dispersed in the hydrocarbon and hydrogen mixture was given by

$$\phi_{\infty} = X_D \times N \times 100 \quad 3.8$$

where X_D was the fraction of deuterium atoms in the total number of hydrogen and deuterium atoms in the system and N was the total number of exchangeable hydrogens in the molecule. In practice an equilibrium isotope effect operated whereby the deuterium was preferentially found in the hydrocarbon giving a larger value of ϕ_{∞} than that calculated from equation 3.8.

Deviations from a straight line in the plot of equation 3.7 could reveal interesting information. Non-linearity might simply be a result of a poor choice of ϕ_{∞} . An overestimation resulted in the line flattening out and appearing convex with respect to the origin. An underestimation had the opposite effect giving a line which was concave with respect to the origin. Another reason for failure to give a straight line was poisoning of the catalyst. In such cases the usual behaviour was for the line to be curved with a decreasing gradient. A third cause was that not all the hydrogen atoms in the hydrocarbon were equally active for exchange. This situation is discussed in section 3.4.

A second rate constant, k_0 , was defined by

$$- \log (X - X_{\infty}) = \frac{k_0 t}{2.303(100 - X_{\infty})} - \log (100 - X_{\infty}) \quad 3.9$$

where k_0 referred to the rate of disappearance of the light hydrocarbon of which X , 100 and X_{∞} were the percentages present at time t , initially and at equilibrium respectively. In this case a plot of $\log (X - X_{\infty})$

versus time yielded a straight line with gradient $-k/2.303(100-X_{\infty})$.

The ratio of the two rate constants, M , was a useful parameter because it represented the mean number of hydrogen atoms replaced by deuterium atoms in each molecule of hydrocarbon undergoing exchange in the initial stages of the reaction. In the case of stepwise exchange, the value of M was close to unity while for multiple exchange it had some larger value.

It is important to realise that the rate constants, k_{ϕ} and k_o differ from the normal definition of chemical rate constants. Strictly speaking they are relevant only to a particular mixture of reactants. The course of a particular reaction can be given by a first-order equation. However if the true kinetics of an exchange process are required a series of experiments involving different reaction mixtures must be carried out. The dependence of the rate constant for exchange, k , on the pressure of hydrocarbon, P_{HC} , and deuterium P_{D_2} , must be measured and the values of x and y evaluated from the equation

$$k = \text{constant} \times P_{HC}^x \times P_{D_2}^y \quad 3.10$$

The values of x and y often indicate the strength of adsorption of the reactants. Strong adsorption results in an index tending to zero, whereas a value of x or y close to unity would indicate a weak form of chemisorption.

(b) Kinetics of Hydrogenation and isomerisation.

Of particular interest in this work was the addition of deuterium to ethylene over a variety of oxide catalysts. Two possible reactions were observed, namely exchange of the olefin and hydrogenation to produce ethane. The rate constant for the addition reaction, k_a , was derived from the integrated first-order rate equation

$$-\log(1 - X_a) = \frac{k_a t}{2.303} \quad 3.11$$

where the fractional conversion of ethylene to ethane at time t is X_a . The rate constant for exchange was obtained from equation 3.9 which is applicable if the exchange reaction is first order in ethylene pressure⁽¹¹⁾. The linear relations predicted by these rate equations were well obeyed except in two cases and hence the assumptions were considered to be justified.

In those reactions where isomerisation was being investigated the rate constant, k_I , was derived from the first-order equation

$$\log (1 - X) = \frac{k_I t}{2.303} \quad 3.12$$

where the fraction of reactant which has isomerised at time t is X .

(c) Errors and Arrhenius Parameters.

Errors in rate parameters obtained graphically were estimated from the spread of points in the plots. Gradients of straight lines were calculated by a least squares method using which the uncertainty could also be calculated. Care had to be taken in considering points which deviated from the general pattern. It had to be decided whether they were simply the result of "poor" data or the consequence of some change in the reaction conditions from which useful information might be derived.

The usual practice was to follow exchange reactions at a series of different temperatures. Rate constants could be converted to units of molecules $s^{-1} m^{-2}$ from knowledge of the catalyst surface area and the number of molecules in the reaction system. The apparent activation energy, E , for the exchange process could be derived from the Arrhenius equation,

$$\log k = \log A - \frac{E}{2.303RT} \quad 3.13$$

where A was the frequency factor, R was the gas constant and T was the

temperature. If the Arrhenius equation held, a plot of $\log k$ versus the inverse temperature was a straight line.

The activation energy observed was only the true activation energy for the chemical process if other factors, principally surface coverage, were temperature independent. In cases where the surface coverage was high the observed activation energy was close to the true value but in cases where surface coverage was low and varied with temperature, the observed activation energy, E_{obs} , was given by

$$E_{\text{obs}} = E + \Delta H \quad 3.14$$

where ΔH is the heat of adsorption of the gas.

3.4 EXCHANGE IN MOLECULES WITH NON-EQUIVALENT HYDROGENS ATOMS

In exchange reactions of hydrocarbons and other substances with deuterium the various hydrogen atoms in the molecule frequently react at different rates, e.g. with the alkylbenzenes a marked difference is observed in the reactivity of the side group and of the ring hydrogen atoms over a wide range of catalysts⁽¹²⁾. It is desirable that the maximum amount of information about the rates of exchange of the different types of hydrogen atoms should be obtained from experimental data for such systems but the selection of a reliable method of analysing the data may be difficult.

The problem has been solved for the case of molecules having hydrogen atoms in two groups both exchanging in a stepwise fashion but at different rates⁽¹³⁾. Bolder, Dallinga and Kloosterziel⁽¹⁴⁾ gave a general treatment for multiple exchange but limit it to molecules with a single group of exchangeable hydrogen atoms. They also considered a method for molecules with non-equivalent hydrogen atoms involved in multiple exchange but subject to two conditions; firstly, the reaction starts with undeuterated

hydrocarbon molecules and secondly, the fraction of deuterium in the deuterating agent remains constant. This latter condition implies that the analysis cannot be applied to experimental situations, commonly found in heterogeneous catalysts, in which the dilution of the deuterium by hydrogen from the reactant hydrocarbon cannot be neglected.

Approximate methods of obtaining rate constants from experimental data were proposed by Crawford and Kemball⁽¹⁵⁾ and subsequently improved by Harper, Siegel and Kemball⁽¹⁶⁾. The latter method, which shall be referred to as the HSK method, could be applied to cases with two or more groups of hydrogen atoms reacting at different rates by either stepwise or multiple mechanisms. Intuitively one expected the HSK method to give reliable results in the limit of one group exchanging very much faster than the next group but some doubt existed as to how well the method worked when the rates of exchange of different groups were comparable. The first objective of the present section was to attempt to determine the conditions under which the HSK method was reliable.

Temperature-programmed catalysis has been used as a technique for following the exchange of groups of non-equivalent hydrogen atoms⁽¹⁷⁾ and the analysis of the results involves an extension to the HSK method. The technique provides information from a single experiment which could only be obtained from several experiments carried out in a conventional manner at constant temperature. Arrhenius parameters as well as the relative rates of reaction of the different groups of hydrogen atoms can be obtained but the limits of reliability of the approach had not been established. This problem was also investigated.

The method of investigating both problems involved the use of equations derived by Dallinga et al.⁽¹³⁾ to compute distributions of isotopic

species for exchange reactions for a molecule with two groups of hydrogen atoms reacting in a stepwise manner. These computed distributions were taken as "experimental data" then analysed by the HSK method and its extension for temperature-programmed catalysis and finally the calculated rates were compared with the actual rates used to generate the "experimental data". In this way, information about the useful limits of the HSK method was obtained. A list of symbols used in this section is given at the end of the chapter.

(a) Derivation of the Isotopic Distributions.

The treatment set out by Dallinga et al.⁽¹³⁾ applies to any molecule in which the hydrogen atoms can be subdivided into two groups, A and B, the latter reacting more slowly but with the exchange of both groups occurring by a stepwise process. Their theory was adapted in this study to enable the distribution of products during an exchange reaction to be calculated.

Expressions for the variation with time of D_A and D_B , the deuterium content in Group A and group B respectively, were found in equations (20) and (21) of reference 13. The expressions involved k_A and k_B , the rate constants for the exchange of groups A and B respectively, the mole fraction of the reacting molecule in the total system and the initial fraction of deuterium in the labelling compound. Thus, if the experimental conditions, i.e. the reaction mixture and the rate constants for exchange in groups A and B were specified, D_A and D_B could be calculated for a series of values of time. Then using the binomial expressions which apply for stepwise exchange, the distribution of isotopic species in the two groups could be derived and, on combination of the results for the two groups, an isotopic distribution for the molecule as a whole could be obtained.

Many of the calculations were repetitive using the same relationship several times. A computer program, a listing of which is included in the appendix, was written to calculate the distributions for the required times. Facilities were incorporated in the program to specify the number of hydrogen atoms in each group, N_A and N_B , the rate constants, k_A and k_B , and the composition of the reaction mixture. Most calculations were carried out with $N_A = N_B = 4$, corresponding to a molecule such as naphthalene with eight exchangeable hydrogen atoms in two groups of four. In this way, sets of distributions of products at specified times were generated to be used as "experimental" distributions for which the kinetic and other experimental details were known.

(b) Calculation of Rate Constants from Isotopic Distributions.

The HSK method of obtaining rate constants has been described in detail elsewhere⁽¹⁶⁾ and involves an extension to the case where all hydrogen atoms in a molecule exchange at the same rate (see section 3.3(a)). In cases where groups of hydrogen atoms exchange at different rates the plots of equations 3.7 and 3.9 are no longer linear and the HSK method is required. With the exception of using k for the total rate constant rather than k_ϕ , the same nomenclature is used here as in reference (16).

The total rate constant is the sum of the individual group rate constants, k_A and k_B . An approximation is used to obtain k_B by assuming that $k_B \ll k_A$ and hence that the formation of the isotopic compounds from d_5 and d_8 is due to the exchange of hydrogen atoms in group B. The quantity ϕ_B is defined by

$$\phi_B = 100 \sum_{i=5}^8 (i-4) \frac{d_i}{\sum_{i=4}^8 d_i} \quad 3.15$$

and the values are used in an equation analogous to equation 3.7 to

estimate k_B . Provided $\phi_{B\infty}$ is chosen appropriately, a satisfactory linear plot can be obtained. The choice of $\phi_{B\infty}$ is based on the equilibrium distribution corresponding to a random distribution of deuterium atoms between the source of deuterium and all the exchangeable positions of the molecule. The value of ϕ_B , calculated from equation 3.15 for this equilibrium distribution, can be used as $\phi_{B\infty}$.

In order to find the faster rate constant k_A , ϕ_A is defined by

$$\phi_A = \sum_{i=1}^4 id_i + 4 \sum_{i=5}^8 d_i \quad 3.16$$

and used as ϕ in equation 3.7 to obtain the total rate constant, k .

Subtraction of the slower rate constant k_B from the total rate constant then gives k_A . The choice of $\phi_{A\infty}$ is discussed later.

(c) Temperature Programming.

Temperature-programmed catalysis is used as a rapid means of comparing the rates of exchange of different kinds of hydrogen atoms in a molecule when the ratio of the reaction rates is so great that it is impossible to choose a single temperature at which both reactions can be observed accurately and conveniently. The usual method is to increase the temperature linearly with time so that the reaction of both groups of hydrogen atoms can be followed in a single experiment. The distributions of products are obtained at equal intervals of time and analysed by a procedure based on the HSK method⁽¹⁷⁾.

In order to generate suitable data for studying this technique distributions must be calculated which correctly reflect the increase in the reaction rate as the temperature increases. It was assumed that the rate constants, k_A and k_B , obeyed the Arrhenius equation and, for simplicity, that both groups had the same activation energy, E .

The computer program was capable of calculating distributions of products at various times in the exchange reaction with specified rate constants; however, it had no facility to deal with a changing rate constant. The problem was circumvented by defining an expanded time scale, t_c , a computer time related to laboratory time, t_1 , by the equation

$$\frac{dt_c}{dt_1} = \frac{k}{k_0} \quad 3.17$$

where k_0 is the rate constant at T_0 , the initial temperature, and k is the rate constant at temperature, T , and laboratory time, t_1 . The temperature was assumed to increase linearly with time. In this way the extent of reaction for a system which had reacted under laboratory conditions for a time, t_1 , during which the rate constant was increasing with temperature would be equivalent to that calculated for a reaction with a fixed rate constant, k_0 , for time, t_c . Integration of equation 3.17 gave the values of t_c which corresponded to the selected values of t_1 for which distributions were required. Once a list of the required values of t_c had been obtained product distributions were calculated as before.

(d) Constant temperature results.

Distributions of products were calculated at various time intervals for an arbitrary mixture of 22.6 parts of deuterium to one part of hydrocarbon and for values of the ratio k_A/k_B of 100, 20, 10, 5 and 1. These were then used as "experimental data".

The analysis of the results of an actual experiment required firstly the recognition that not all the hydrogen atoms were exchanging at the same rate and secondly, the determination of how many hydrogen atoms were in each group. Figures 3.1 and 3.2 show distributions of products during reaction for values of k_A/k_B of 20 and 5 respectively. The fact

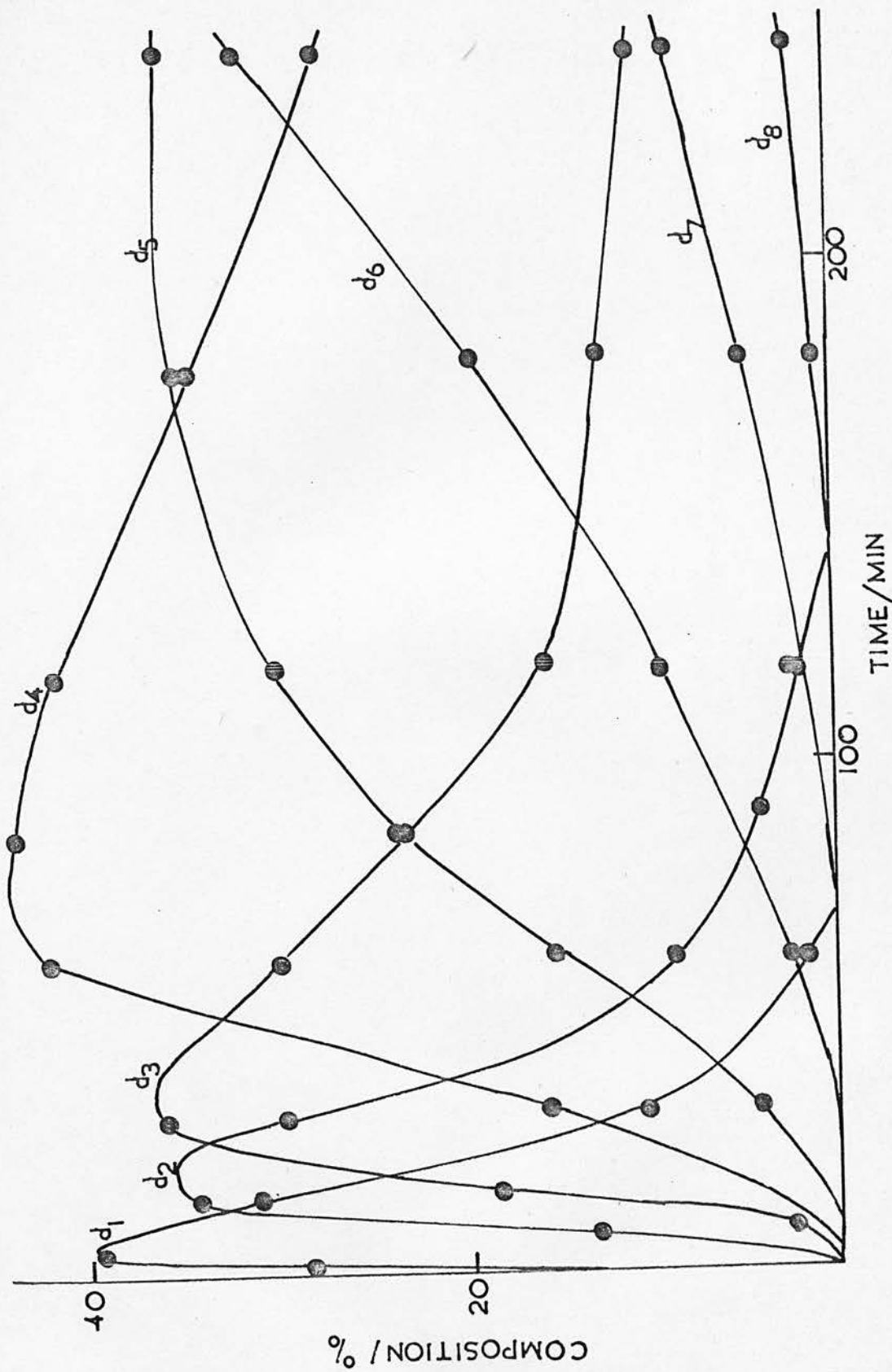

FIGURE 3.1 : Calculated isotopic distributions during reaction with $k_B = 0.6$ D atoms/
 100 molecules min^{-1} and $k_A/k_B = 20$.

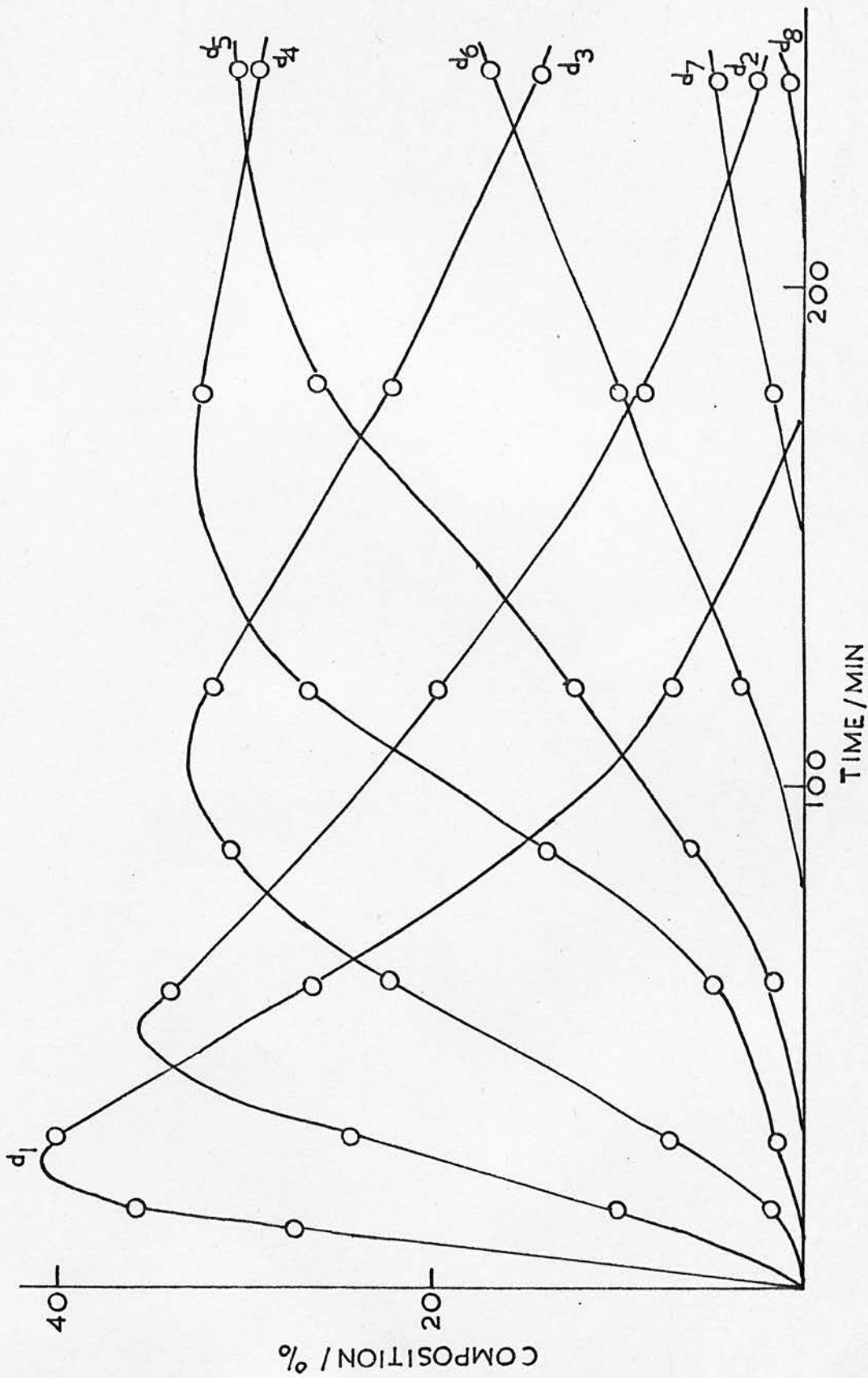

FIGURE 3.2 : Calculated isotopic distributions during reaction with k_B as for figure 3.1 but $k_A/k_B = 5$.

that four hydrogen atoms were replaced more rapidly than the second four is clear in figure 3.1 but obscured in the latter.

Another method of distinguishing non-equivalent groups in a stepwise exchange reaction was to compare product distributions with the calculated binomial distributions for the same value of ϕ . This could only be applied to stepwise exchange processes for which the binomial distribution corresponds to the case where all the hydrogen atoms in the molecule exchange at the same rate.

TABLE 3.1

COMPARISON OF PRODUCT DISTRIBUTIONS WITH BINOMIAL DISTRIBUTIONS FOR DIFFERENT VALUES OF k_A/k_B

k_A/k_B	ϕ	d_0	d_1	d_2	d_3	d_4	d_5	d_6	d_7	d_8
20	319.0	0.4	4.5	18.9	37.0	31.2	7.3	0.7	0.0	0.0
(binomial)	319.0	1.7	9.0	21.0	27.9	23.1	12.3	4.2	0.8	0.1
10	312.9	0.7	6.3	21.3	34.6	26.9	8.8	1.4	0.1	0.0
(binomial)	312.9	1.9	9.7	21.8	28.0	22.5	11.6	3.7	0.7	0.1
5	299.5	1.5	9.3	24.0	31.7	22.7	8.8	1.8	0.2	0.0
(binomial)	299.5	2.3	11.2	23.5	28.2	21.1	10.1	3.0	0.5	0.0

Distributions are in percentage values.

The results in table 3.1 indicate that the experimental distributions had more d_3 - and d_4 - species and less d_5 - and higher products than the corresponding binomial distributions. The test worked well for $k_A/k_B = 20$ or 10 and gave some indication of the division of atoms into groups even with a ratio of 5. This test only worked well at the appropriate stage of the reaction; at the beginning the distributions were accurately binomial,

discrepancies appeared when the slower group was starting to exchange and they disappeared again as equilibrium was approached. An appropriate stage to make the comparison was when the binomial distribution showed about 10% of the isotopic product with one more deuterium atom than the number of hydrogen atoms in the rapidly exchanging group, i.e. d_5 in this case.

TABLE 3.2

COMPARISON OF ESTIMATED^a AND CHOSEN RATE CONSTANTS^b

k_A/k_B		k		k_B		$\phi_{A\infty}$
chosen	est.	chosen	est.	chosen	est.	
20	21.5	14.0	14.1	0.6	0.62	370
10	11.3	7.3	7.38	0.6	0.60	380
5	5.8	4.00	4.07	0.6	0.60	400
1	4.4	1.3	1.56	0.6	0.29	400

^a rate constants calculated to ± 3 in the third significant figure.

^b units: D atoms per 100 molecules min^{-1} .

The rate constants obtained by the HSK method are compared in table 3.2 with the actual values used to generate the data. The choices of $\phi_{A\infty}$ and $\phi_{B\infty}$ were important in estimating the rate constants and the procedure for obtaining an adequate value of $\phi_{B\infty}$ has been explained. If $\phi_{A\infty}$ was correctly chosen, a linear plot was obtained using equation 3.16 and the derivation of the rate constant from the gradient presented no problem. Curvature of the ϕ -plot convex to the time axis implied that the reaction was slowing down and that $\phi_{A\infty}$ had been over-estimated.

The reverse behaviour indicated an under-estimation of the equilibrium value.

Fortunately the range of possible values of $\phi_{A\infty}$ was limited. If it was assumed that only four hydrogen atoms were reacting and that the remaining four were inert, the calculated value of $\phi_{A\infty}$ was 367 for the reaction mixture used. If the corresponding procedure to that for estimating the value in group B was employed, $\phi_{A\infty}$ was 400 which was the maximum possible value. The ϕ -plots are shown in figure 3.3 and the selected values of $\phi_{A\infty}$ are given in table 3.2. It is not surprising that a lower value of $\phi_{A\infty}$ was more satisfactory for the case of $k_A/k_B = 20$ and that the higher values were better for the case where there was less difference between the rates of reaction of the two groups of atoms.

Figure 3.4 illustrates the plots of ϕ_B in the appropriate form of equation 3.15 to determine the rate of exchange of the slower group of hydrogen atoms. It was not possible to evaluate ϕ_B satisfactorily for distributions with less than 10% of the total hydrocarbon present as d_5 or higher species. Each of these plots showed similar behaviour and fell into three sections. The first part was curved and the curvature was more pronounced and lasted longer for the lower values of k_A/k_B . The second sections were reasonably linear particularly for the higher ratios and were used to estimate the rates given in table 3.2. In the final sections which occurred at substantially longer times and are not shown in figure 3.4 the plots merged into a common line with a gradient corresponding to a slightly slower rate of 0.56 D atoms per 100 molecules min^{-1} .

It is clear that the HSK method gives a good estimate for the total rate of exchange and only fails in the extreme case where $k_A = k_B$ and the two groups of hydrogen atoms react at the same rate. In practice

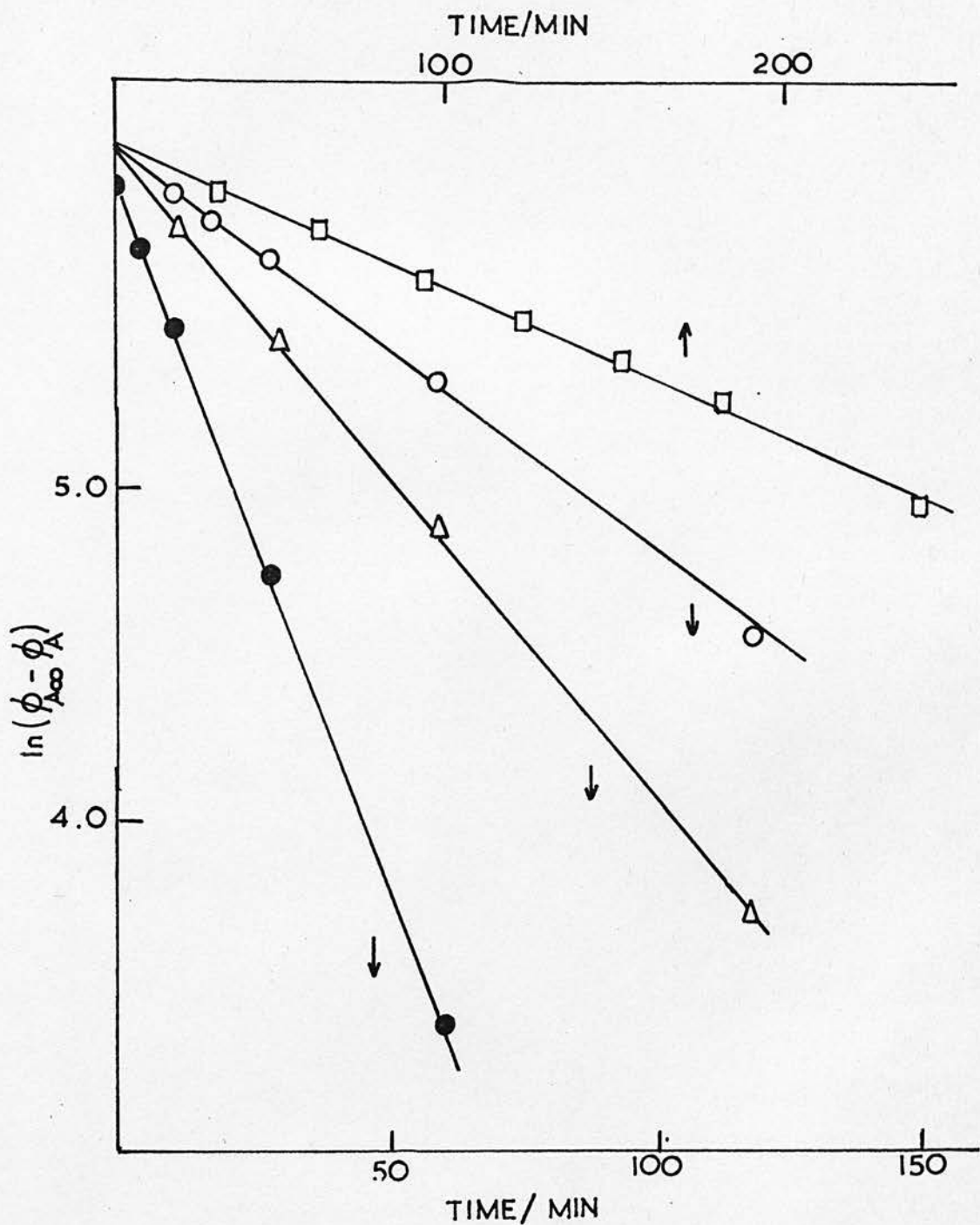

FIGURE 3.3 : Appropriate plots of ϕ_A to determine k with values of k_A/k_B of 1 (\square), 5 (\circ), 10 (Δ) and 20 (\bullet).

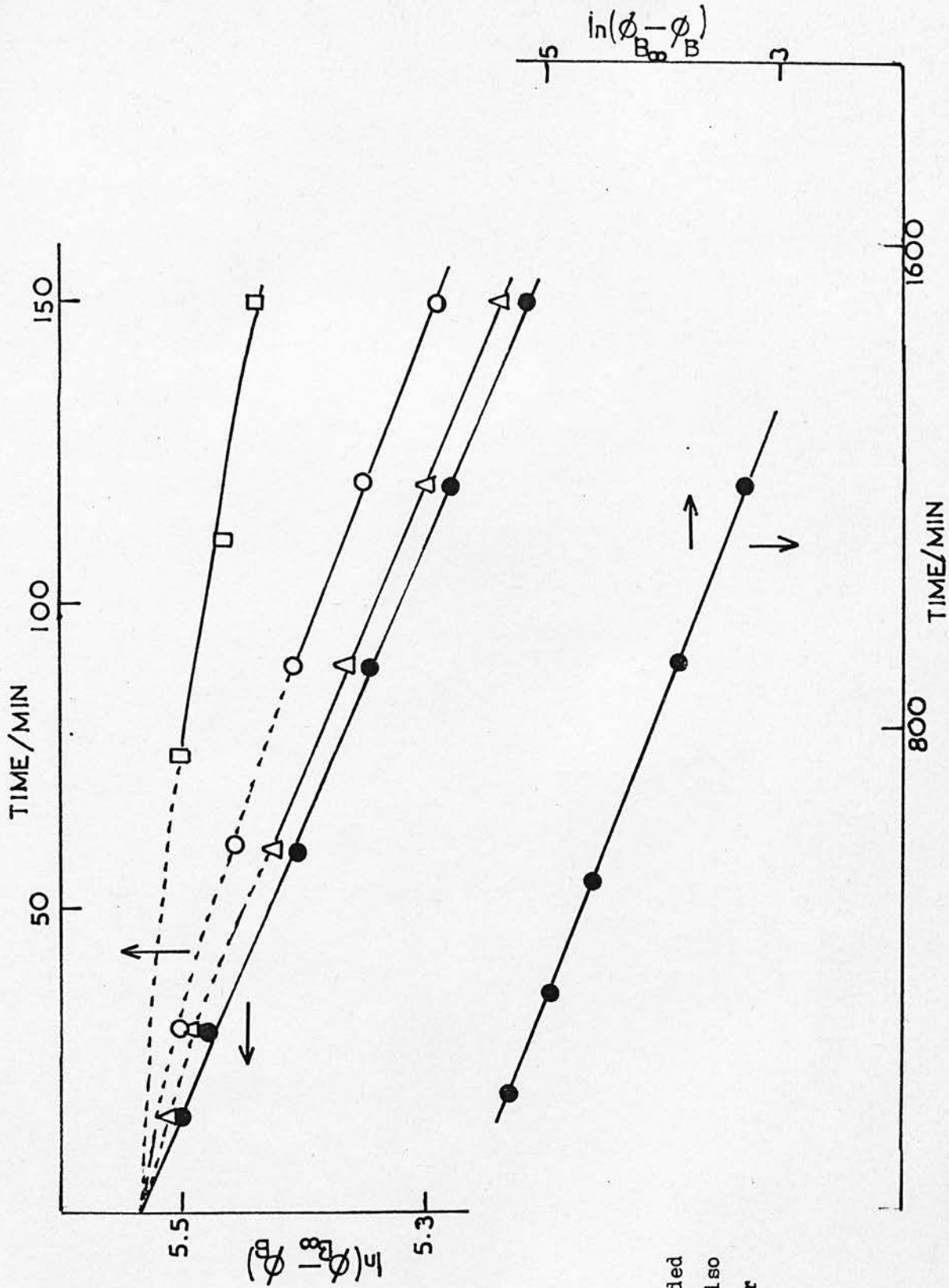

FIGURE 3.4 :
 Appropriate plots of ϕ_B
 (upper and left-hand scales)
 to determine k_B with values
 of k_A/k_B of 1 (\square), 5 (\circ),
 10 (Δ) and 20 (\bullet); an extended
 plot for the last value is also
 shown for longer times (lower
 and right-hand scales).

the method would never be applied to such a case which would be analysed by standard methods⁽¹⁾.

The estimated values of k_B were all low compared with the chosen values but the deviation was not greater than 10% if k_A/k_B was 5 or higher. The reason for this discrepancy was that the deuterium pool had become diluted as a result of the exchange of the first group by the time the second group started to react. The method made no allowance for this and consequently the calculated value of k_B was slightly low. A correction for this factor could have been made. The underestimation of k_B led to a slight overestimation of the ratio k_A/k_B by about 10% rising to 20% for $k_A/k_B = 5$.

It is fortunate that the HSK method is satisfactory for cases where it is possible to distinguish different groups of hydrogen atoms by inspection of the experimental results. Where such differences can be seen, corresponding to $k_A/k_B > 5$, reasonably accurate results for the rate constants can be obtained, the accuracy improving for higher values of k_A/k_B . The method only fails for cases where it is difficult to distinguish the different groups of atoms because they have similar reactivities.

This investigation was necessarily limited to testing the HSK method for two groups of hydrogen atoms exchanging in a stepwise fashion because it was not feasible to calculate distributions of products involving multiple exchange. However, it seemed probable that the HSK method would work at least as satisfactorily for cases of multiple exchange as it did for stepwise exchange. The determination of the total rate should have been as reliable for multiple exchange and the estimation of k_B might be improved because the multiple exchange would increase the production of d_4 at an early stage and enable the exchange of the second group to be

followed more efficiently than in the case of stepwise exchange.

The HSK method was put forward originally for molecules containing three groups of hydrogen atoms. Our examination of its validity was restricted to the case of two such groups because the theory for calculating distributions was available only for two groups. However, on the basis of the present work, it would be reasonable to assume that the HSK method could be applied to more groups provided the value of $k_L/k_M > 5$ for successive groups L and M. But corrections for isotopic dilution would then be essential.

(e) Temperature-programming results.

The method of generating "experimental data" was first tested for the case where all hydrogen atoms in the molecule exchange at equivalent rates. Values of ϕ at a series of values of t_1 were obtained from data generated with a chosen activation energy of 40 kJ mol^{-1} , an initial rate of exchange of 1.0 D atoms per 100 molecules min^{-1} at 273K and a rate of increase of temperature of 1.0 K min^{-1} . The average rate of reaction was evaluated for each time interval from

$$k = \phi_{\infty} \left[\ln(\phi_{\infty} - \phi_{i+1}) - \ln(\phi_{\infty} - \phi_i) \right] / \Delta t_1 \quad 3.18$$

with ϕ_{i+1} and ϕ_i representing successive values of ϕ . Then $\ln k$ was plotted against the reciprocal of the mean temperature for each time interval. The fact that a good straight line was obtained with a gradient corresponding to an activating energy of $39.2 \pm 0.8 \text{ kJ mol}^{-1}$ confirmed that the method of generating data was satisfactory.

The method was next applied to the case of two groups of hydrogen atoms with values of k_A/k_B of 6, 11 and 21, all activation energies being chosen as 40 kJ mol^{-1} . The "experimental data" was used to determine k and k_B by expressions analogous to equation 3.18 and the corresponding

activation energies were estimated from Arrhenius plots. The comparison between the estimated values of k/k_B and the estimated activation energies with the respective chosen values was used to assess the validity of the method of handling the data from temperature-programmed catalysis. Some Arrhenius plots are shown in figure 3.5 and the results are summarised in table 3.3

TABLE 3.3

RESULTS FOR TEMPERATURE-PROGRAMMED CATALYSIS

chosen	k/k_B		$E/kJ\ mol^{-1}$	
	est. when $d_5 = 10\%$	est. when $d_5 = 20\%$	for k	for k_B
21	22.6	22.2	41.4	40.3
11	13.5	13.1	42.6	37.3
6	7.7	7.4	43.8	33.4

Satisfactory straight lines were obtained in the Arrhenius plots for the total rate of exchange and the agreement between the derived activation energies and the chosen values was better the higher the value of k/k_B .

The results for k_B were much less satisfactory, particularly for the lowest value of $k/k_B = 6$. The Arrhenius plot in this case was curved and only approximated to a straight line at a comparatively late stage in the reaction. The derived activation energy from this line was too low and the estimated values of k/k_B , whether determined when there was 10% or 20% of d_5 formed, were too high. Better results were obtained for $k/k_B = 11$ and the most satisfactory results for $k/k_B = 21$. The

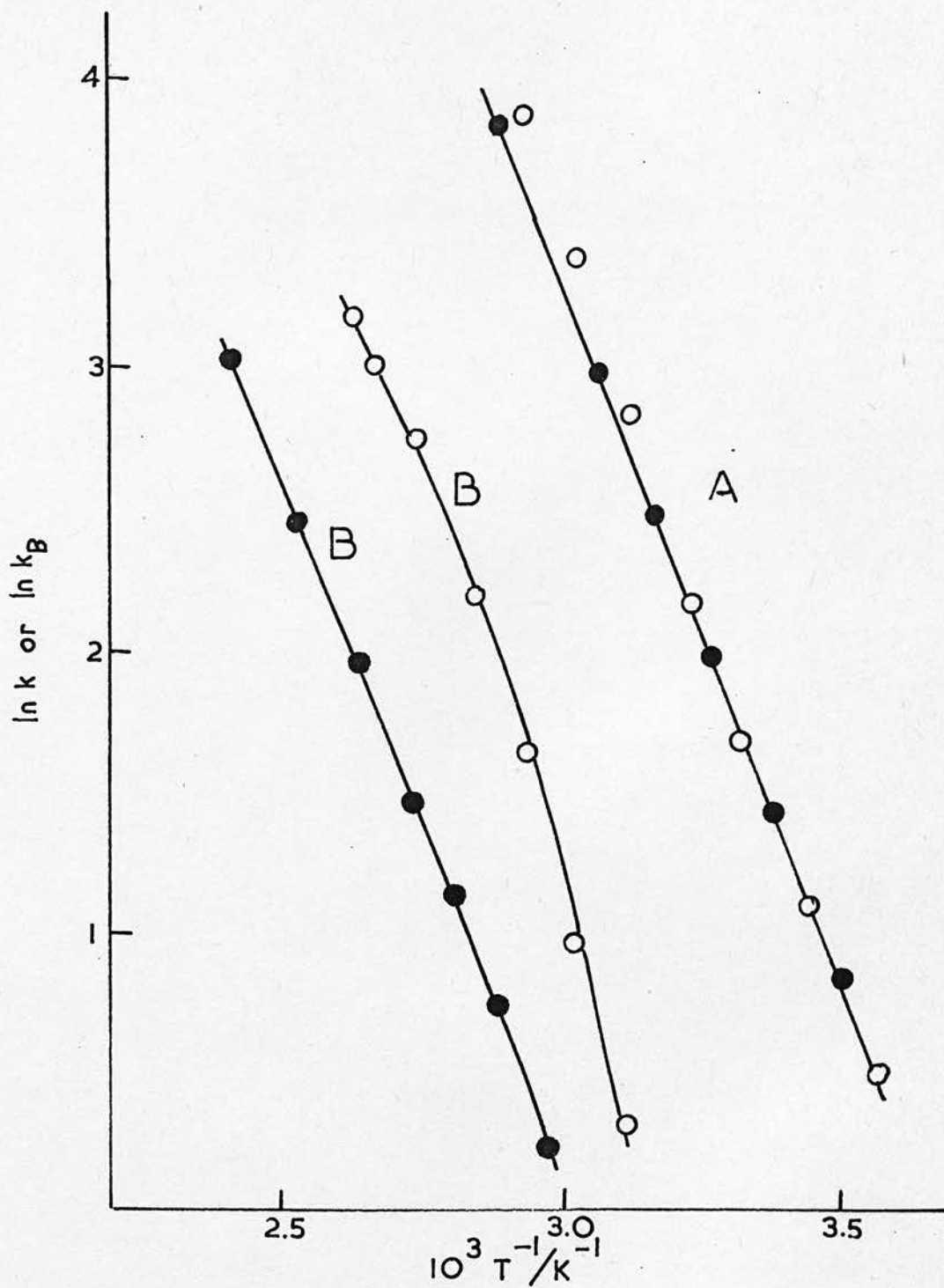

FIGURE 3.5 : Arrhenius plots for the estimated rates of exchange from temperature-programmed results with values of k/k_B of 6 (O) and 21 (●); A represents k , the total rate of exchange and B the rate of the slower group, k_B .

difficulties associated with the Arrhenius plots of k_B for the lower values clearly arose from the type of behaviour illustrated in figure 3.4 of the plots of k_B in the constant temperature experiments. The estimates for k_B are much too low at the stage where the slower hydrogen atoms begin to exchange but become more reliable as the reaction proceeds.

The conclusion is that the HSK method works satisfactorily for temperature-programmed catalysis when the ratio of the rate constants of the two groups of hydrogen is greater than about 20 and is definitely unreliable if the ratio is less than 10.

LIST OF SYMBOLS

- D_A, D_B mean deuterium content in groups of hydrogen atoms, A and B respectively.
- d_i percentage of isotopic species containing i deuterium atoms.
- E activation energy for exchange of hydrogen atoms.
- k total rate constant for exchange of hydrocarbon.
- k_A rate constant for exchange of hydrogen atoms in group A.
(Similar definitions for k_B, k_n, k_m)
- k_o initial value of k in temperature programming experiment.
- N_A, N_B number of hydrogen atoms in group A and group B respectively.
- T temperature of reaction.
- T_o initial temperature in temperature programming experiment.
- t_c computer time scale.
- t_l laboratory time scale.
- ϕ_A, ϕ_B measure of extent of deuteration in group A and group B respectively.

REFERENCES

- (1) C. Kemball, Adv. in Catalysis, 11, 223, 1959.
- (2) R.S. Dowie, "Computer Programs for Catalytic Studies", Chemistry Department, University of Edinburgh, 1973.
- (3) A. Ralston, "A First Course in Numerical Analysis", (McGraw-Hill, New York), 1965.
- (4) R.S. Dowie, Ph.D. Thesis, University of Edinburgh, 1973.
- (5) J.H. Beynon and A.E. Williams, "Mass and Abundance, Tables for Use in Mass Spectrometer", (Elsevier, Amsterdam), 1963.
- (6) F.H. Field and J.L. Franklin, "Electron Impact Phenomena", (Academic Press, New York), 1957.
- (7) C. Kemball, Proc. Roy. Soc., A223, 377, 1954.
- (8) A. Jagers, Ph.D. Thesis, University of Edinburgh, 1970.
- (9) R.S. Dowie, D.A. Whan and C. Kemball, J.C.S. Faraday I, 68, 2150, 1972.
- (10) R.J. Mikovosky and J. Wei, Chemical Engineering Science, 18, 253, 1963.
- (11) C. Kemball and C.T.H. Stoddart, Proc. Roy. Soc., A241, 208, 1957.
- (12) R. McCosh and C. Kemball, J.C.S., 1555, 1968.
- (13) G. Dallinga, A.A. Verriijn Stuart, P.J. Smit and E. Mackor, Z. Elektrochem., 61, 1019, 1957.
- (14) H. Bolder, G. Dallinga and H. Kloosterziel, J. Catalysis, 3, 312, 1964.
- (15) E. Crawford and C. Kemball, Trans. Faraday Soc., 58, 2452, 1962.
- (16) R.J. Harper, S. Siegel and C. Kemball, J. Catalysis, 6, 72, 1966.
- (17) R. McCosh and C. Kemball, Chem. Comm., 802, 1969.

CHAPTER 4REACTIONS OF ETHYLENE WITH DEUTERIUM ON OXIDE CATALYSIS4.1 INTRODUCTION

Ethylene reacts with deuterium in two ways over oxide catalysts; either addition occurs to produce ethane or exchange takes place to give deuterated ethylenes. Over a variety of catalysts a wide range of selectivities is observed. Systems in which a reactant has more than one possible product are well suited to analysis by combined gas chromatography - mass spectroscopy. The behaviour of ethylene with deuterium was chosen as a suitable system to test the computer link-up for data acquisition in the g.c.-m.s. technique (see Chapter 2.7). The technique is particularly useful in that it enables very small quantities of ethane to be detected for a reaction in which the predominant process is exchange of ethylene while, conversely, in a system showing high selectivity for hydrogenation it is possible to measure the rate of any accompanying exchange reaction.

Of particular interest in this section was the behaviour on alumina and magnesium oxide because these catalysts were the subject of the other work described in this thesis. Not all the reactions were being studied for the first time and some of the work simply involved repeating already recorded results. However, the general pattern of behaviour and its relation to different types of intermediates were of interest and it was felt that a set of results recorded for different catalysts by the same technique was to be preferred to a collection of data taken from the literature.

The reactions of ethylene with deuterium over zinc oxide⁽¹⁾, chromia⁽²⁾, cobalt oxide⁽³⁾, rutile (titanium dioxide)⁽⁴⁾ and alumina⁽⁵⁾ have already been reported. In this work new catalysts studied were magnesium oxide, iron oxide and zirconium oxide.

4.2 PREVIOUS STUDIES OF ETHYLENE-DEUTERIUM REACTIONS.

The interaction between ethylene and deuterium over transition metal catalysts has been widely studied and, in particular, the extent to which exchange and hydrogenation of the olefin occur. The mechanisms of the two reactions are closely related and are believed to involve the same kind of intermediate viz. ethyl radical species^(6,7). It is suggested that the fate of these ethyl species, whether they return to adsorbed ethylene or go on to become ethane, determines the product distribution. A range of activities has been observed; on iron and nickel catalysts olefin exchange is the more important process but on tungsten and platinum, ethane production predominates while other metal catalysts, e.g. rhodium and ruthenium, intermediate behaviour is observed.

More recently the reactions of ethylene and deuterium over certain metal oxides have been examined and the results reveal some interesting contrasts in catalytic action. Three main types of behaviour have been noted. Firstly, it has been found over some catalysts that simple addition occurs to produce $C_2H_4D_2$ as the principal initial product with little or no accompanying exchange of the olefin. Zinc oxide⁽¹⁾, chromia⁽²⁾ and cobalt oxide⁽³⁾ show this behaviour. In the case of zinc oxide it is suggested that the important step is the formation of the half-hydrogenated ethyl species C_2H_4D which takes place irreversibly. Consequently all the ethyl species are converted to ethane molecules and

none revert to ethylene. Adsorption of hydrogen is believed to occur at zinc-oxygen pair sites. The reactions over cobalt oxide and chromia have been considered in terms of the relation between the degree of coordinative unsaturation at the active sites and the possible reactions between the olefin and deuterium which may occur at the site⁽⁸⁾. Suggested mechanisms for related homogeneous catalytic reactions are used to illustrate the possible reaction pathways and the relative abilities of different types of sites to promote the various reactions are considered. In this treatment it is noted that the oxidation state of the transition metal will be an important parameter in the reactivity of an active site. The reactions over zinc oxide and chromia indicate almost exclusive addition with no exchange being observed. However, on cobalt oxide although the predominant reaction was still addition the exchange reaction could be followed. Whether or not cobalt oxide should be classed with zinc oxide and chromia or with the next group of oxides is perhaps debatable. This work may help resolve the question.

The second type of behaviour is observed over titanium dioxide which supports the exchange of ethylene and the production of ethane at similar rates⁽⁴⁾. This behaviour can be compared to that on some metal catalysts and the simplest explanation is that the formation of surface ethyl species is reversible.

The third type of behaviour is that found over alumina catalysts. Ethylene and other olefins exhibit rapid exchange with deuterium without significant formation of saturated hydrocarbons; for this reason, alumina has been used to produce perdeutero-olefins⁽⁵⁾. Elsewhere it has been shown that hydrogenation of ethylene can be effected but at somewhat higher temperatures than those required for exchange⁽¹⁰⁾. Hydrogenation takes

place at or below room temperature if ethylene is preadsorbed on the catalyst⁽¹¹⁾ but at higher temperatures exchange is much faster than the addition reaction⁽¹²⁾. The behaviour on alumina appears paradoxical because a catalyst which is capable of activating both ethylene and hydrogen might be expected to catalyse hydrogenation as well as the exchange reaction because the former is thermodynamically more favourable.

4.3 EXPERIMENTAL PROCEDURE

These experiments were investigated using the combined gas chromatography - mass spectrometry system details of which have been given in Chapter 2. The reaction vessel used in this work was made of silica (volume ca. $2.70 \times 10^{-4} \text{ m}^3$). The mass spectrometer operated at an ionising voltage of 20eV and about 15 - 20 scans per hydrocarbon component were recorded.

The data were collected using the "on-line" computer link and indeed the results involving magnesium oxide were used to test the system (see Chapter 2.7). Details of all the catalysts and their respective pretreatments are given in table 2.2. At the end of their experiments the iron oxide and cobalt oxide samples were allowed to cool to room temperature whereupon they showed no apparent ferromagnetism. This procedure was to check that none of the oxide had been reduced to metal during the experiment.

Fragmentation patterns and relative sensitivities for ethylene-d₀ and ethane-d₀ were measured at regular intervals during the course of the work. Corrections for background, natural isotope occurrence and fragmentation followed the scheme described in Chapter 3.2. When correcting spectra for fragmentation it was assumed that loss of hydrogen and

deuterium took place in a statistical manner and that the fragmentation patterns for all isotopic hydrocarbons were identical.

Over some of the catalysts one or other of the possible reactions was predominant; therefore it was important to know the lower rate limit which might be determined. For exchange reactions mass spectra were used to determine the rate constant. The apparatus enabled identifiable mass spectra to be obtained for 6×10^{14} molecules entering the g.c.-m.s. system which corresponds to 3×10^{16} molecules in the reaction vessel or a product yield of 0.3%. Reliable isotopic distributions could be obtained such that the presence of less than 0.5% ethylene- d_1 in ethylene d_0 could be detected.

4.4 RESULTS

TABLE 4.1

ACTIVITIES OF THE OXIDES FOR ETHYLENE-DEUTERIUM REACTIONS

Catalyst	addition reaction, k_a /molecules $s^{-1}m^{-2}$	exchange reaction, k_e /molecules $s^{-1}m^{-2}$	k_e/k_a	T/K
MgO	$< 2.7 \times 10^{11}$	^a 1.9×10^{15}	> 6900	671
Al ₂ O ₃	^b 3.2×10^{11}	4.7×10^{14}	1500	289
TiO ₂	5.1×10^{12}	1.3×10^{13}	2.5	641
Fe ₂ O ₃	5.8×10^{13}	6.6×10^{13}	1.1	468
Co ₃ O ₄	8.1×10^{16}	1.1×10^{16}	0.13	293
ZrO ₂	7.8×10^{14}	3.6×10^{13}	0.046	297
ZnO	1.5×10^{14}	$< 2.8 \times 10^{12}$	< 0.020	273
Cr ₂ O ₃	1.5×10^{15}	$< 1.9 \times 10^{13}$	< 0.012	195

a k_e obtained from extrapolation of data measured at 298 - 373K.

b k_a obtained from extrapolation of data measured at 428 - 563K.

The results obtained for the eight oxides are summarised in table 4.1. The linear relations predicted by the rate expressions (equations 3.7 and 3.4) were obeyed well except in two cases. For cobalt oxide a slight curvature of the plot indicating a decrease in the rate was observed for the addition reaction. A similar effect has been attributed to the irreversible adsorption of hydrogen on the catalyst⁽³⁾. No curvature of the plot for the exchange data was observed which is illustrated in figure 4.1. For iron oxide both the addition and exchange reactions showed a high initial rate followed by a period of lower activity during which the linear relations were obeyed. Rates of reaction reported for this oxide are applicable to the later stages of the reaction.

All the exchange reactions observed were stepwise, i.e. one hydrogen atom was replaced at a time as evidenced by the close agreement between experimental isotopic distributions and the corresponding binomial distributions throughout the experiments.

TABLE 4.2

DISTRIBUTION OF ISOTOPIC ETHYLENES
DURING EXCHANGE REACTION OVER MgO

	d_0	d_1	d_2	d_3	d_4	
experimental	12.4	32.4	36.9	16.0	2.4	$\phi = 164.0$
binomial	12.2	33.8	35.3	16.2	2.5	

As an example table 4.2 shows a distribution during ethylene exchange over magnesium oxide.

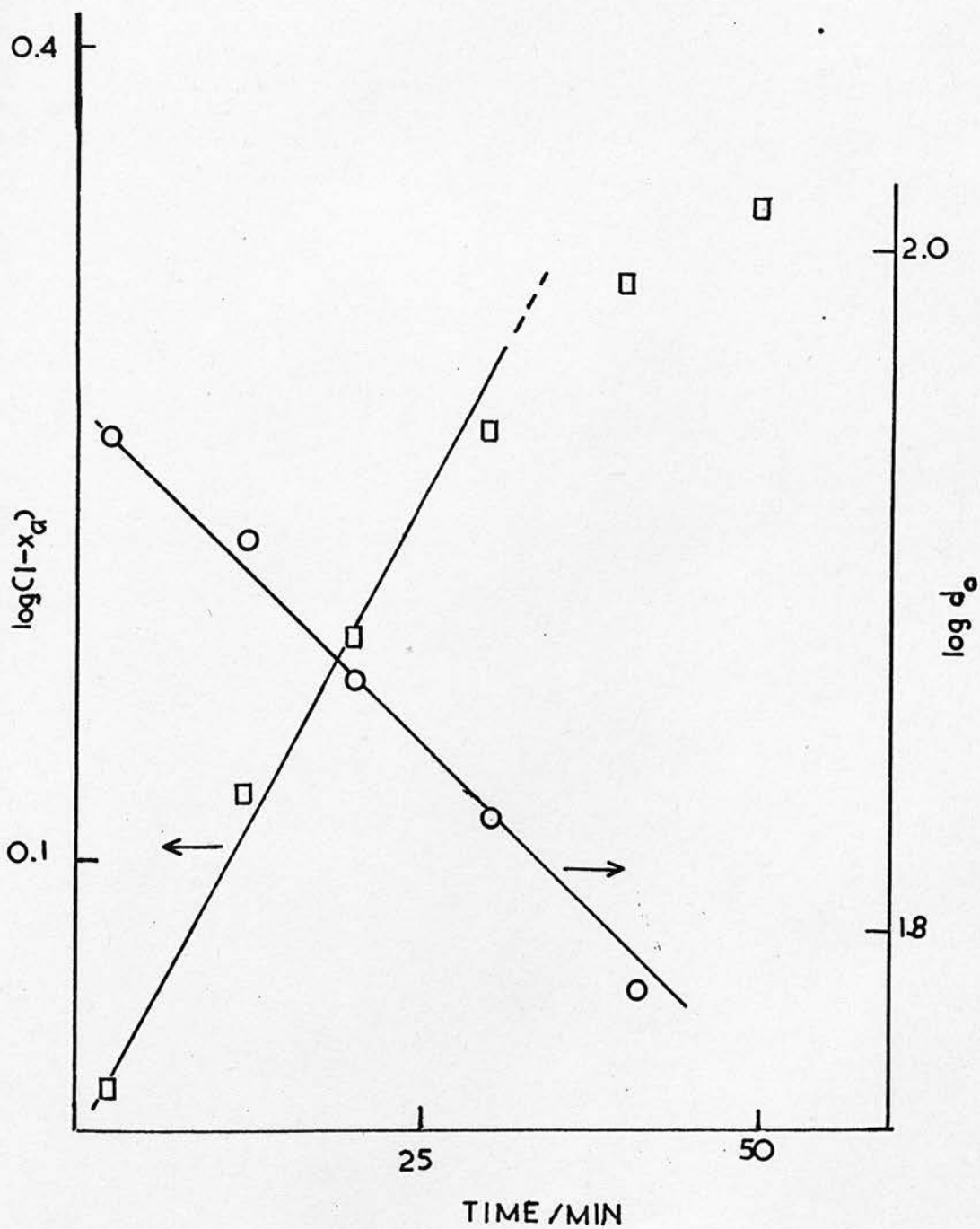

FIGURE 4.1 : Exchange and Addition Rate Plots for the Reaction of Ethylene with Deuterium on Cobalt Oxide.

○, exchange data; □, addition data.

All the results could be fitted into one of the three categories previously described. For alumina and magnesium oxide the exchange reaction predominated. As an example, the rate plot for exchange over magnesium oxide is shown in figure 4.2. The rate of addition was too slow to be observed even at elevated temperatures. Any ethane produced during one hour at 671K was below the limits of detection although exchange was rapid at room temperature. Thus less than 0.3% ethane was present and the rate of addition was less than 2.7×10^{11} molecules $s^{-1} m^{-2}$. In table 4.1 the rates of exchange measured at lower temperatures are compared with rates of addition at high temperature. The exchange of ethylene with deuterium over magnesium oxide was followed at a series of temperatures in the range 248 - 373K to give a rate expression,

$$r = 10^{16.5} \exp(-16 \times 10^3/RT) \text{ molecules } s^{-1} m^{-2} \quad 4.1$$

Similarly for the addition reaction over alumina the rate was given by

$$r = 10^{16.1} \exp(-25 \times 10^3/RT) \text{ molecules } s^{-1} m^{-2} \quad 4.2$$

The intermediate category for which both exchange and hydrogenation occurred at comparable rates comprised rutile, iron oxide, cobalt oxide and zirconia. Whereas previous results over rutile⁽⁴⁾ were confirmed, the data for cobalt oxide suggested that exchange was more important than previously suggested⁽³⁾. These results indicated that cobalt oxide belongs with titanium dioxide, iron oxide and zirconia rather than with zinc oxide and chromia. The rate plots for cobalt oxide are illustrated in figure 4.1.

The third type of behaviour viz. the predominance of the addition reaction was exhibited over zinc oxide and chromia. In both these cases ethylene-d₁ was not present above the detection limit of 0.5%. Determining the absence of ethylene-d₁ was necessarily more difficult than

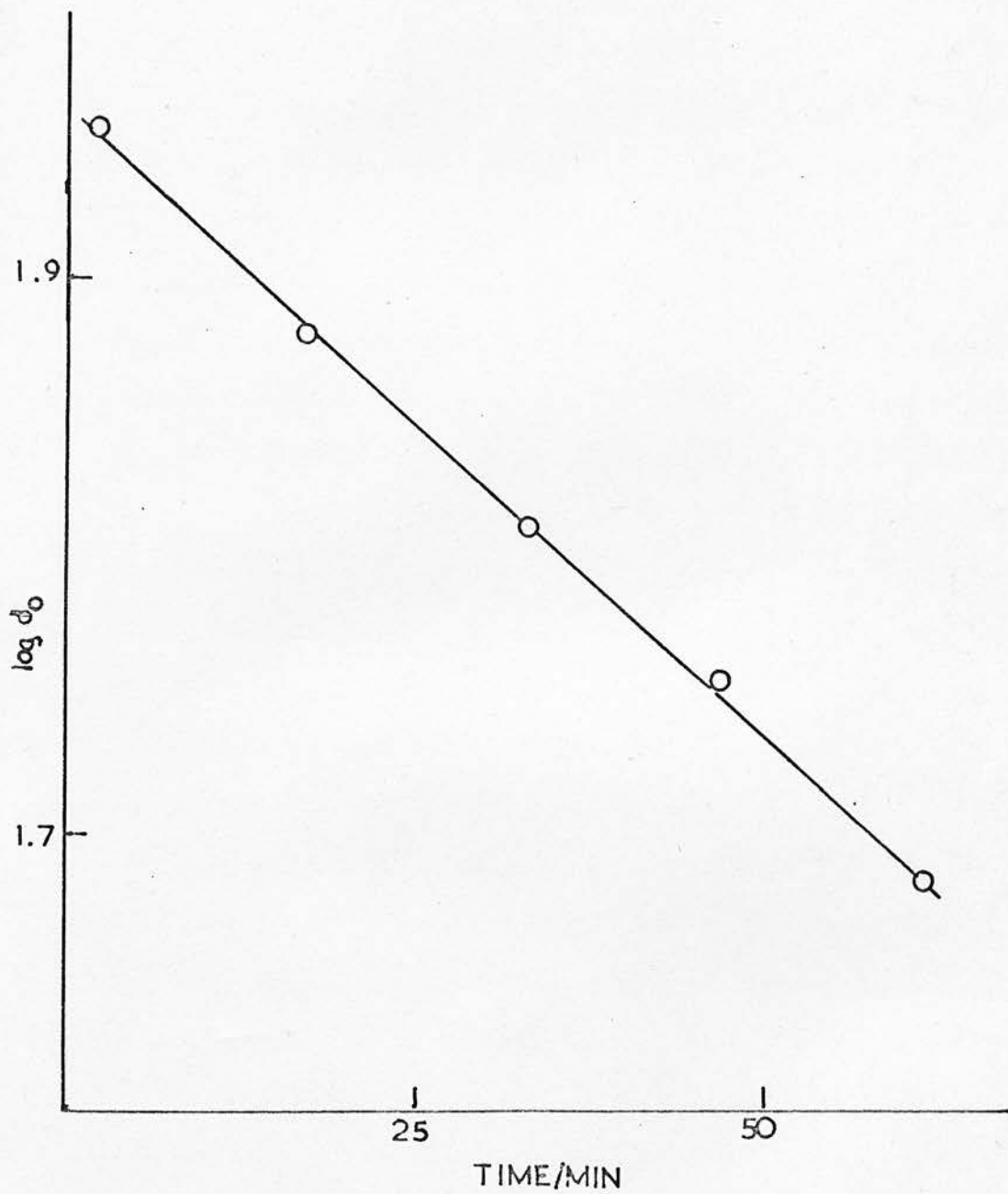

FIGURE 4.2 : Rate Plot for the Exchange of Ethylene with Deuterium on Magnesium Oxide at 298K.

establishing the highest limit to which ethane was present as a reaction product as was the case with magnesium oxide because the concentration of only one isotopic species was being examined in a supply of reactant which was steadily undergoing conversion to ethane. Data for chromium oxide were particularly difficult to obtain because of the high activity of the catalyst for the addition reaction even at 195K. In view of these limitations the ratio k_e/k_a is probably considerably lower than the upper limits shown in table 4.1. The data for the addition reaction over zinc oxide were not so troublesome and the rate plot is shown in figure 4.3.

4.5 DISCUSSION

Two features of the reaction are worthy of consideration; firstly, the relative activities of the different oxides for the ethylene-deuterium reaction and secondly, the different selectivities with respect to exchange and addition exhibited by these catalysts.

The activity pattern obtained with the eight oxides for the ethylene-deuterium reaction is illustrated in figure 4.4 and is very similar to that found for hydrogen-deuterium equilibration. For oxides of the first transition period there appeared to be a simple correlation between the catalytic activity per unit surface area and the electronic configuration of the metal ion⁽¹³⁾ and a twin peaked activity pattern was obtained. The condition for high activity appeared to be that the oxide should possess some but not too many unpaired d-electrons. The activity pattern has been interpreted in terms of crystal field effects on the electronic levels of the metal ion⁽¹⁴⁾. The behaviour was confirmed in a later study where the reaction rates were determined at a standard temperature of 298K⁽¹⁵⁾. The activities of a series of oxides towards ethylene

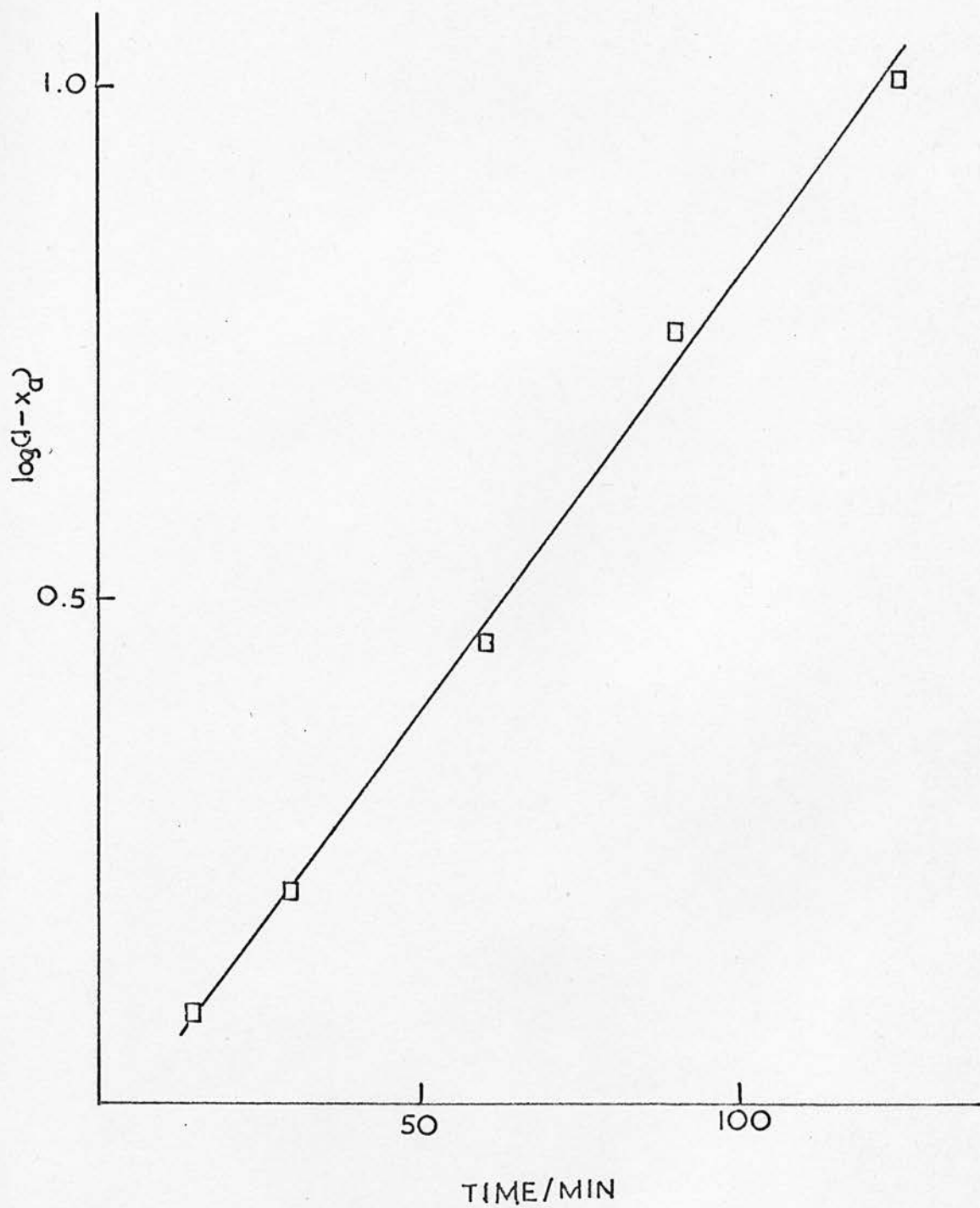

FIGURE 4.3 : Rate Plot for the Addition Reaction of Ethylene and Deuterium on Zinc Oxide at 273K.

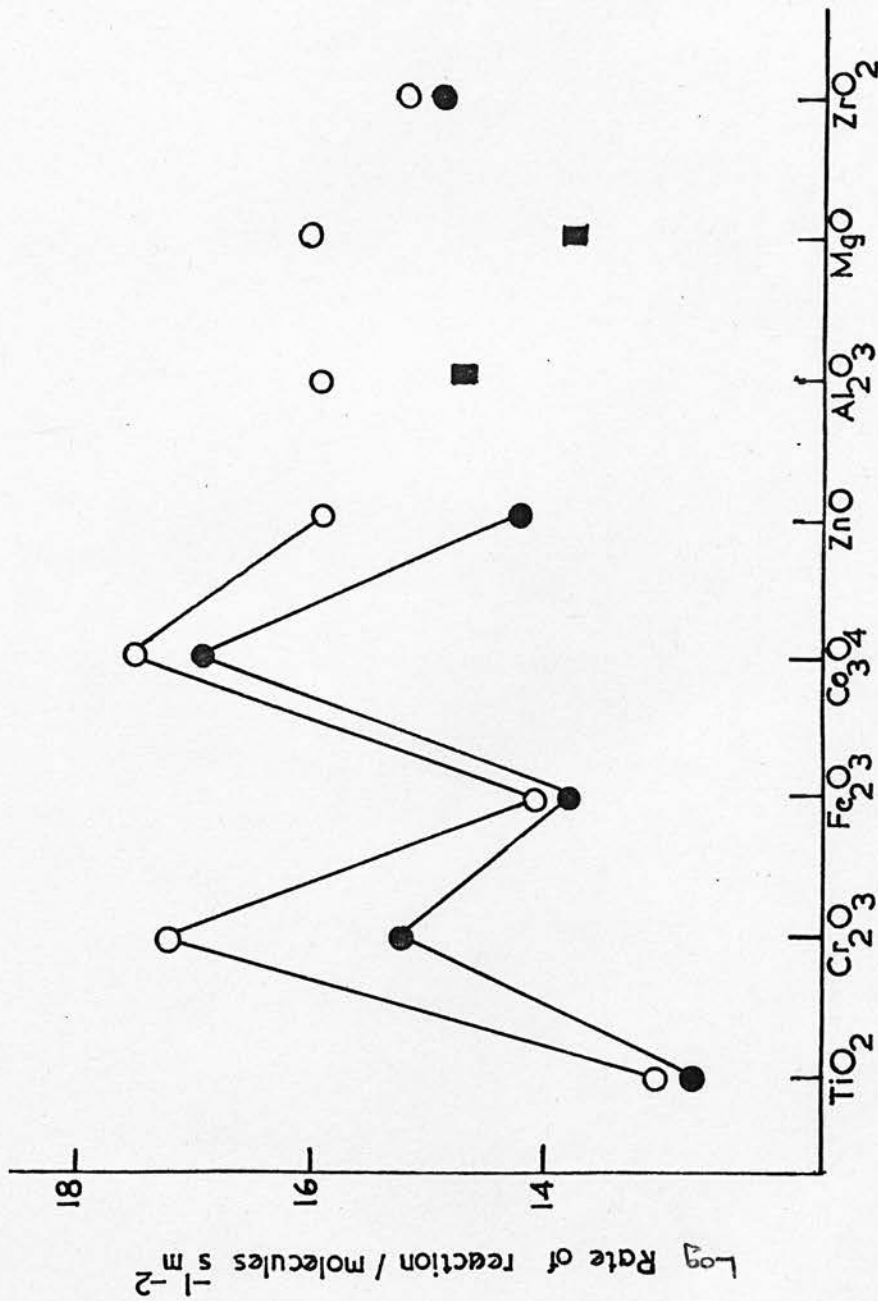

FIGURE 4.4 : Comparison of the activities of the oxides for hydrogen-deuterium equilibration and ethylene-deuterium reactions. The temperatures used to measure either (●) $\text{C}_2\text{H}_4\text{-D}_2$ (addition) or (■) $\text{C}_2\text{H}_4\text{-D}_2$ (exchange) were 298K for magnesia and as given in table 4.1 for the other oxides. The $\text{H}_2\text{-D}_2$ equilibration rates (○) were determined as follows: Al_2O_3 , reference 23; MgO , reference 24; ZrO_2 , reference 25; other oxides, reference 15.

hydrogenation⁽¹⁶⁾ and isotopic mixing⁽¹⁷⁾ have also been investigated.

The present results substantiate the observations that the relative rates for ethylene conform to the twin-peaked activity for these oxides and establish that the agreement may be extended to include reactions on alumina, magnesium oxide and zirconia. In figure 4.4, the oxides of the first transition series are grouped together in order of their position in the periodic table. The other three oxides are included for comparison purposes only. Thus for each of the eight oxides under investigation it was concluded that the rate of the ethylene-deuterium reaction (exchange or addition, whichever was faster) reflected the ability of the catalyst to activate deuterium.

In order to explain the marked differences in the selectivities for the addition and exchange reactions it is necessary to examine the nature of the adsorbed hydrogen (or deuterium) on these oxides. The argument developed here is an extension of one presented elsewhere⁽¹⁸⁾.

Those oxides for which exchange is the predominant reaction will be considered first. Two principal factors may contribute to the situation whereby alumina catalyses ethylene exchange more readily than the thermodynamically favoured hydrogenation reaction. The exchange of ethylene probably occurs via the formation of adsorbed vinyl species for which there is good evidence from exchange of olefins with deuterium over alumina^(19,20). In both cyclic and acyclic olefins, vinyl hydrogens were preferentially exchanged and the mechanism suggested involves dissociative adsorption on acid-base or ion-pair sites. The absence of hydrogenation over alumina is easier to understand if it is unnecessary to assume the presence of adsorbed ethyl groups for the exchange of ethylene. Another factor has to be considered. As will be more fully explained in Chapter 5,

alkyl species almost certainly possessing carbanionic character are responsible for alkane exchange over alumina. Thus adsorbed ethyl species can, in the right circumstances, be formed readily and reversibly on alumina. It is therefore surprising that ethyl species cannot be formed readily from ethylene. A possible explanation can be given in terms of the differing reactivities of electrophilic and nucleophilic hydrogen atoms on alumina. The dissociative adsorption of a hydrogen molecule on an oxide catalyst probably takes place by a heterolytic fission of the H - H bond,



The exchange of ethylene and ethane can be represented as

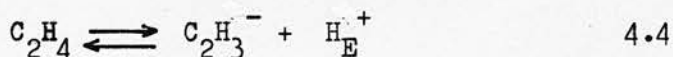

and

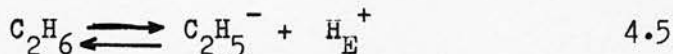

If electrophilic hydrogen atoms react readily both of these reactions should occur with ease. On the other hand the formation of ethyl carbanions from ethylene would involve nucleophilic hydrogen,

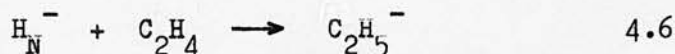

which may take place more slowly. To summarise, only one kind of adsorbed hydrogen, H_E^+ , will be needed for exchange of both ethane and ethylene but both kinds are necessarily involved in hydrogenation.

It is now necessary to consider the other type of behaviour, viz. those oxides over which the addition reaction predominates. In the above discussion reference has been made to fully charged species. In reality such intermediates very probably possess only a partial electronic charge and in fact it is the extent of the charge on the reactive adsorbed species which may well enable the results of this study to be explained.

Alumina and magnesium oxide may lead to the formation of adsorbed hydrogen atoms with a high fractional charge. In contrast on zinc oxide and chromia a neutralisation of the potential charge on the adsorbed forms of hydrogen may be facilitated. Thus the hydrogenation of chromia is envisaged in two stages (figure 4.5). First adsorption of the olefin, possibly at coordinatively unsaturated Cr^{3+} sites, takes place together with heterolytic dissociative adsorption of hydrogen on ion pair sites. Secondly adsorbed ethyl groups are produced with subsequent formation of ethane by the reaction sequence shown. The important feature of the scheme is that neutralisation of the charge on the nucleophilic and electrophilic forms of adsorbed hydrogen occurs and thus both hydrogen atoms are in a radical form when the addition steps II and IV take place and are therefore equally reactive. Once adsorbed ethyl groups are produced by reaction involving the first hydrogen atom (step II), ethane is readily formed by reaction with the second hydrogen atom. The overall effect is analogous to that presented to Dent and Kokes⁽²¹⁾ where addition of deuterium to ethylene occurs with the absence of exchange in the olefin because the alkyl reversal (reverse of step II) is not operative on oxides such as chromia and zinc oxide. The production of neutral adsorbed hydrogen is facilitated by the ability of chromium ions to undergo a reversible change in oxidation state between Cr^{3+} and Cr^{2+} . The importance of the participation of Cr^{2+} ions in hydrogenation and dehydrogenation reactions on chromia has been noted⁽²²⁾.

The argument developed here for chromia may be applied to the other transition metal oxides under investigation. The selectivity ratio k_e/k_a (table 4.1) for each oxide is thought to reflect the inability of the catalyst and the transition metal ion in particular to produce neutral

Adsorption of ethylene and hydrogen:

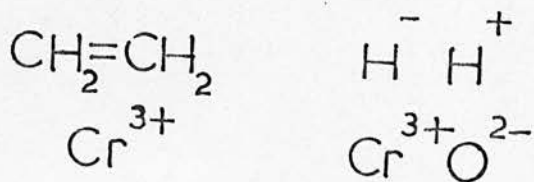

Formation of ethane:

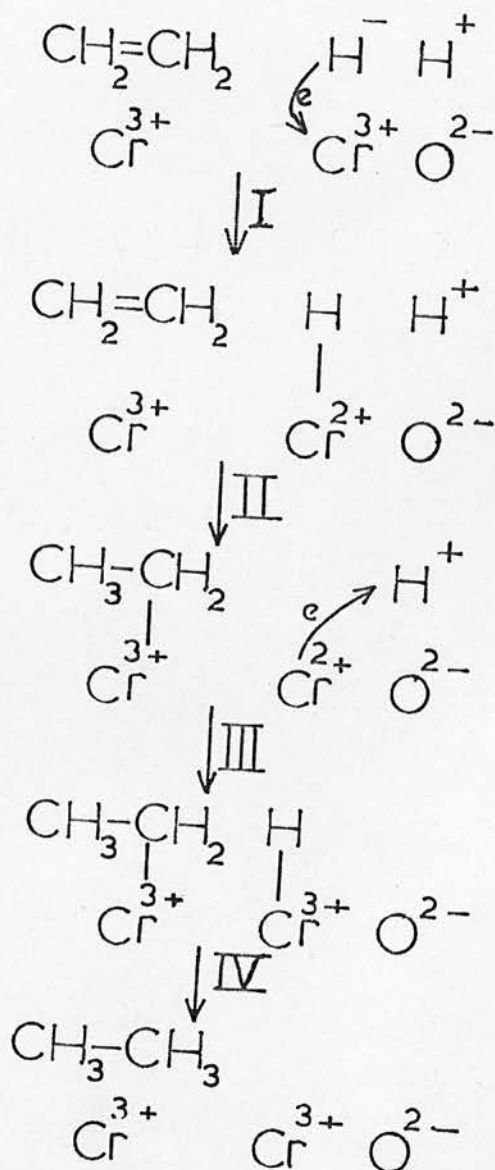

FIGURE 4.5 : Scheme for adsorption and reaction of ethylene and hydrogen on chromia.

adsorbed hydrogen. Thus a complete charge transfer may be effected on zinc oxide and chromia and high selectivity for addition results. On the other oxides the effect is less complete and exchange and addition occur simultaneously. On alumina and magnesium oxide where a change in the oxidation state of the surface cation is unfavourable adsorbed hydrogen remains in the H^+ and H^- forms.

This work has shown that the g.c.- m.s. technique can be very useful in studying two simultaneous reactions, in this case addition and exchange and also served to check the reliability of the computer link-up to collect data. The results themselves illustrate how important the interaction between catalyst and reactants is in determining the nature of the reaction products.

REFERENCES

- (1) R.J. Kokes and A.L. Dent, Adv. in Catalysis, 22, 1, 1972.
- (2) R.L. Burwell, A.B. Littlewood, J. Am. Chem. Soc., 82, 6272, 1960.
M. Cardew, G. Pass and
C.T.H. Stoddart,
- (3) K. Tanaka, H. Nihira and J. Phys. Chem., 74, 4510, 1970.
A. Ozaki,
- (4) I.J.S. Lake and C. Kemball, Trans. Faraday Soc., 63, 2535, 1967.
- (5) J.G. Larson, J.W. Hightower J. Org. Chem., 31, 1225, 1966.
and W.K. Hall,
- (6) C. Kemball, J. Chem. Soc., 735, 1956.
- (7) G.C. Bond and P.B. Wells, Adv. in Catalysis, 15, 91, 1964.
- (8) S. Siegel, J. Catalysis, 30, 139, 1973.
- (9) A.L. Dent and R.J. Kokes, J. Phys. Chem., 74, 3653, 1970.
- (10) S.G. Hindin and S.W. Weller, J. Phys. Chem., 60, 1501, 1956.
- (11) Y. Amenomiya, J.H.B. Chenier J. Catalysis, 9, 28, 1967.
and R.J. Cventanovic,
- (12) Y. Amenomiya, J. Catalysis, 12, 198, 1968.
- (13) D.A. Dowden, N. Mackenzie Proc. Roy. Soc., A237, 245, 1956.
and B.M.W. Trapnell,
- (14) D.A. Dowden and D. Wells, Actes Congr. II^{me} Intern. Catalysis
(Technip, Paris), 1961, p.1497
- (15) D.R. Pearce, P.C. Richardson Proc. Roy. Soc., A310, 121, 1969.
and R. Rudham,
- (16) D.L. Harrison, D. Nicholls J. Catalysis, 7, 359, 1967.
and H. Steiner,
- (17) A. Ozaki, H. Ai and K. Kimura, Proc. 4th Intern. Congr. on Catalysis,
(Akademiai Kiado, Budapest), 1971, p.552.
- (18) C. Kemball, Ann. New York Acad. Sci., 213, 90, 1973.
- (19) J.W. Hightower and W.K. Hall, J. Catalysis, 13, 161, 1969.

- (20) J.W. Hightower and W.K. Hall, Trans. Faraday Soc., 66, 477, 1970.
- (21) A.L. Dent and R.J. Kokes, J. Phys. Chem., 73, 3781, 1969.
- (22) E.K. Rideal, Concepts in Catalysis, (Academic Press, London), 1968, p.155.
- (23) F.H. Van Cauwelaert and W.K. Hall, Trans. Faraday Soc., 66, 454, 1970.
- (24) D.D. Eley and M.A. Zammit, J. Catalysis, 21, 377, 1971.
- (25) B.T. Hughes, D. Taylor and C. Kemball, J.C.S. Faraday I, 71, 1285, 1975.

CHAPTER 5EXCHANGE REACTIONS OF ALKANES OVER ALUMINA5.1 INTRODUCTION

Exchange reactions can reveal useful information concerning the nature of intermediate species and of important steps in a catalytic reaction. In this chapter, the results of a study of the exchange reactions of alkanes and cycloalkanes with deuterium over alumina are described.

In an investigation of the exchange of hydroxyl groups of alumina with deuterated methane⁽¹⁾, isotopic mixing was observed at room temperature. The reaction was catalysed by a small number of active sites and involved exchange with only about 1% of the catalyst hydroxyl groups. The rate-determining step was found to involve dissociation of a carbon-hydrogen bond. The exchange of ethane over alumina has also been reported⁽²⁾. Higher temperatures were required (390-500K) and the exchange involved a stepwise mechanism. The effect of partial pressures of the reactants on the rate of exchange was also investigated. Lewis acidity is reported as being the property of an alumina catalyst which best correlates with its activity for the exchange of propane⁽³⁾. Exchange activity was confined to catalysts activated in the temperature range 673-1073K with a maximum activity for pretreatment temperatures around 820K. This fitted best with changes in the Lewis acidity of the catalyst. Reducing centres on the surface were found to play an important role in the exchange but the hydroxyl groups on alumina did not appear to be involved.

Alumina is also reported to be an excellent catalyst for the exchange of cyclopropane⁽⁴⁾. Isomerisation and hydrogenation reactions do not occur to any great extent and the catalyst has been used to prepare cyclopropane-d₆ of high isotopic purity. It is also pointed out that the purity of the alumina is an important factor. Small amounts of transition metals are sufficient to catalyse saturation while the presence of alkali metal impurities may inhibit the exchange process. Recent work⁽⁵⁾ has shown that after alkali treatment, alumina with traces of iron impurity can catalyse the hydrogenation of unsaturated hydrocarbons.

In this study, the exchange reactions of five acyclic and four cycloalkanes were investigated. Information concerning reaction intermediates has been obtained not only from the relative rates of exchange of various reactants but also from the reactivities of different hydrogens within the same molecule. In previous work only one hydrocarbon has been investigated in any experiment. The g.c.-m.s. technique permits examination of the exchange of a series of reactants simultaneously making it possible to obtain relative rates of exchange for different alkanes over the same catalyst sample, thereby eliminating possible problems in reproducing catalytic performance. In addition, the exchange of cycloalkanes with deuterium may readily be studied even if other reactions take place. Using the g.c.-m.s. system, the processes of addition, exchange and isomerisation may be followed simultaneously.

The exchange reactions of methane, ethane, propane and cyclopropane were all repeated. It was felt that this was necessary if valid comparisons of relative reactivity were to be made. Not only were the previous catalysts⁽¹⁻⁴⁾ derived from a variety of sources but they were not subjected to a standard pretreatment which is an important factor in determining catalyst activity.

5.2 EXPERIMENTAL PROCEDURE

Exchange reactions involving a single reactant were followed using a direct capillary leak from the reaction vessel to an AEI MS10 spectrometer. The procedure followed has been described in detail in Chapter 2. In experiments involving more than one reactant hydrocarbon or in those in which a single reactant could exhibit different reactions, the standard mass spectrometric technique was inadequate. In such cases, the combined g.c.-m.s. apparatus linked to an on-line computer was employed. Details of this technique have also been described in Chapter 2.

Because of the relatively high reactivity of cyclopropane and methylcyclopropane, in experiments involving these molecules 0.1g of catalyst was used; in other experiments 1g was the standard amount. The reaction mixture usually consisted of 0.96 kN_m^{-2} hydrocarbon and 9.5 kN_m^{-2} deuterium which was made up in the mixing volume. Exceptions to these proportions were required in experiments where extensive deuteration was being followed. For n-butane, propane and isobutane exchange reactions, deuterium enriched mixtures were prepared. Deuterium to hydrocarbon ratios of 25:1 for the first two and 50:1 for isobutane were prepared. In experiments involving more than one hydrocarbon, reaction mixtures were chosen to give roughly the same number of hydrocarbon molecules and the same total pressure in the reaction vessel as in individual experiments. The sample of cyclobutane used in this work contained fairly large amounts, 40-60%, of n-butane. The g.c.-m.s. technique allowed the exchange of these molecules to be followed simultaneously without prior separation of the individual components.

For reaction temperatures above room temperature the silica furnace (see Chapter 2.3) was used. When temperatures below room temperature

were required, the following standard baths were used; ice (273K), ice/ethanol (255K), carbon tetrachloride slush (250K) and solid carbon dioxide (195K).

The methods of data collection and processing were as outlined in Chapters 2 and 3. Mass spectra were corrected for the presence of background peaks, for naturally occurring deuterium and heavy carbon and for fragmentation in the mass spectrometer source. When the exchange reaction was not followed past the initial stages, the fragmentation was assumed to involve statistical loss of hydrogen and deuterium from the molecule. However if extensive exchange was involved the method of Dowie et al.⁽⁵⁾ was used. A further modification in the usual fragmentation correction procedure was required for analysis of highly deuterated isobutane. In the mass spectrometer the most likely hydrogen atom to be lost after initial ionisation of the molecule is that of the methine groups which as results indicate had little chance of being a deuterium atom. Thus it was assumed that the fragment produced by loss of hydrogen atom was always one mass unit less than its parent ion. Fragmentation by loss of hydrogen (or deuterium) from other positions in the molecule was considered in the usual manner.

5.3 RESULTS

Exchange of acyclic alkanes

The exchange reactions of single hydrocarbons were generally followed in the temperature range 273-373K. Some general points emerged for all the experiments; all reactions followed the usual equation for exchange processes giving linear $\log(\phi_{\infty} - \phi)$ and $\log d_0$ plots and all gave M values near unity, indicating the stepwise nature of the exchange. The

courses of the exchange reactions of n-butane, isobutane, propane and methane are shown in figure 5.1. The exchange reactions were followed at a series of temperatures and activation energies and frequency factors could be derived. The results are summarised in table 5.1 while the Arrhenius plots are shown in figure 5.2. All rates quoted subsequently are k_0 values.

TABLE 5.1

EXCHANGE REACTIONS OF ACYCLIC ALKANES OVER ALUMINA

Reactant	E /kJ mol ⁻¹	log (A/ molecules s ⁻¹ m ⁻²)	Temperature Range /K
methane	17	16.5	284-360
propane	36	19.6	292-363
isobutane	33	19.4	273-370
n-butane	35	20.1	273-335

Data refers to the most reactive type of hydrogen atoms in each molecule. Since certain reactions exhibited exchange of different groups of hydrogen atoms at different rates (see below) the data in table 5.1 refer to the most active hydrogens. The uncertainty in values of the activation energy is estimated at ± 4 kJ mol⁻¹; that in the logA values is ± 0.6 .

The most interesting aspect of the exchange of n-butane was that six of the hydrogen atoms in the molecule were exchanged more readily than the other four. The distribution of isotopic species with time (figure 5.3) shows a marked discontinuity between the appearance of the d₆- and d₇ isomers.

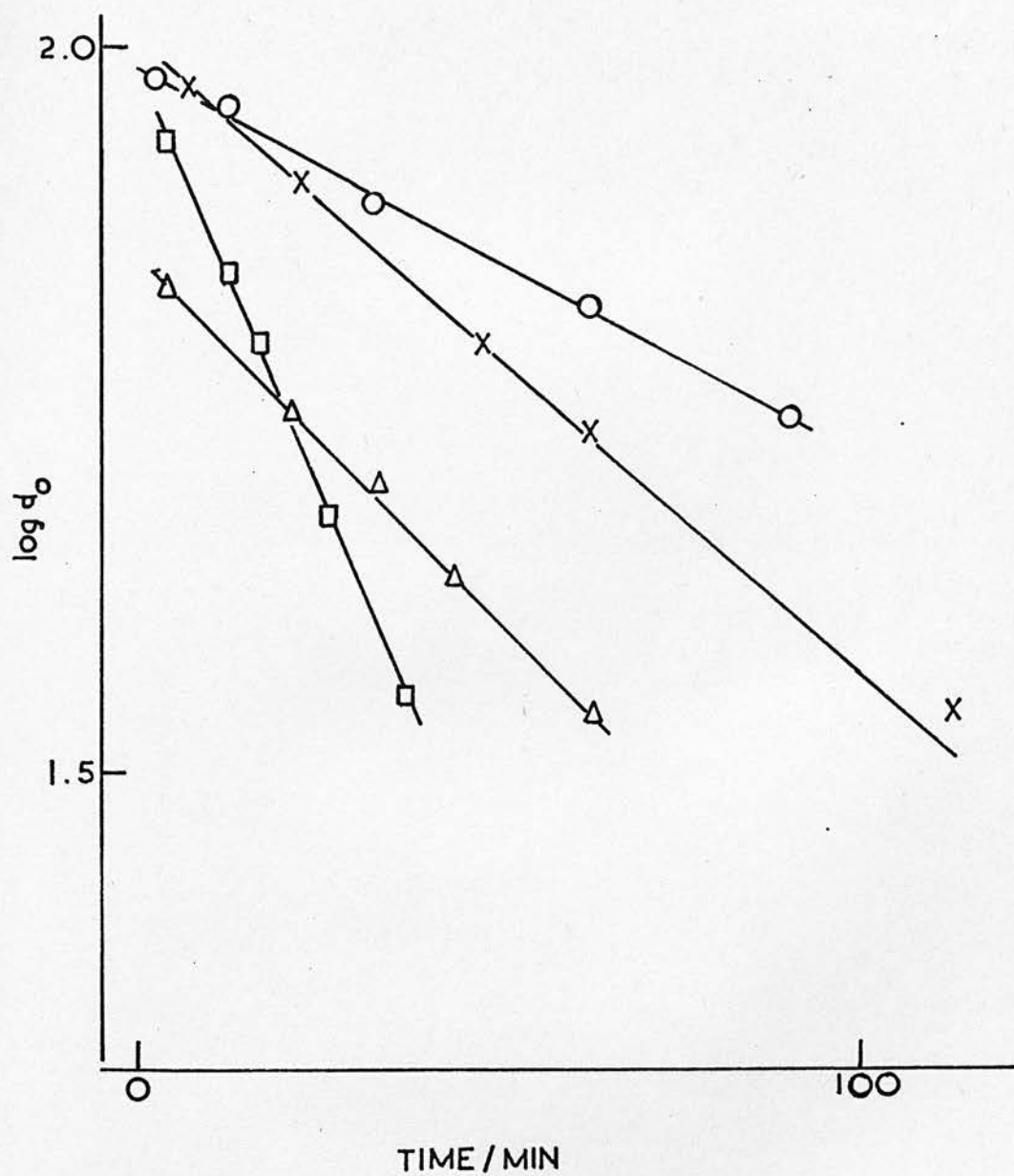

FIGURE 5.1 : Rate plots for the exchange of acyclic alkanes with deuterium on alumina.

○, methane at 284K; X, propane at 299K;
 □, isobutane at 323K; Δ, n-butane at 286K.

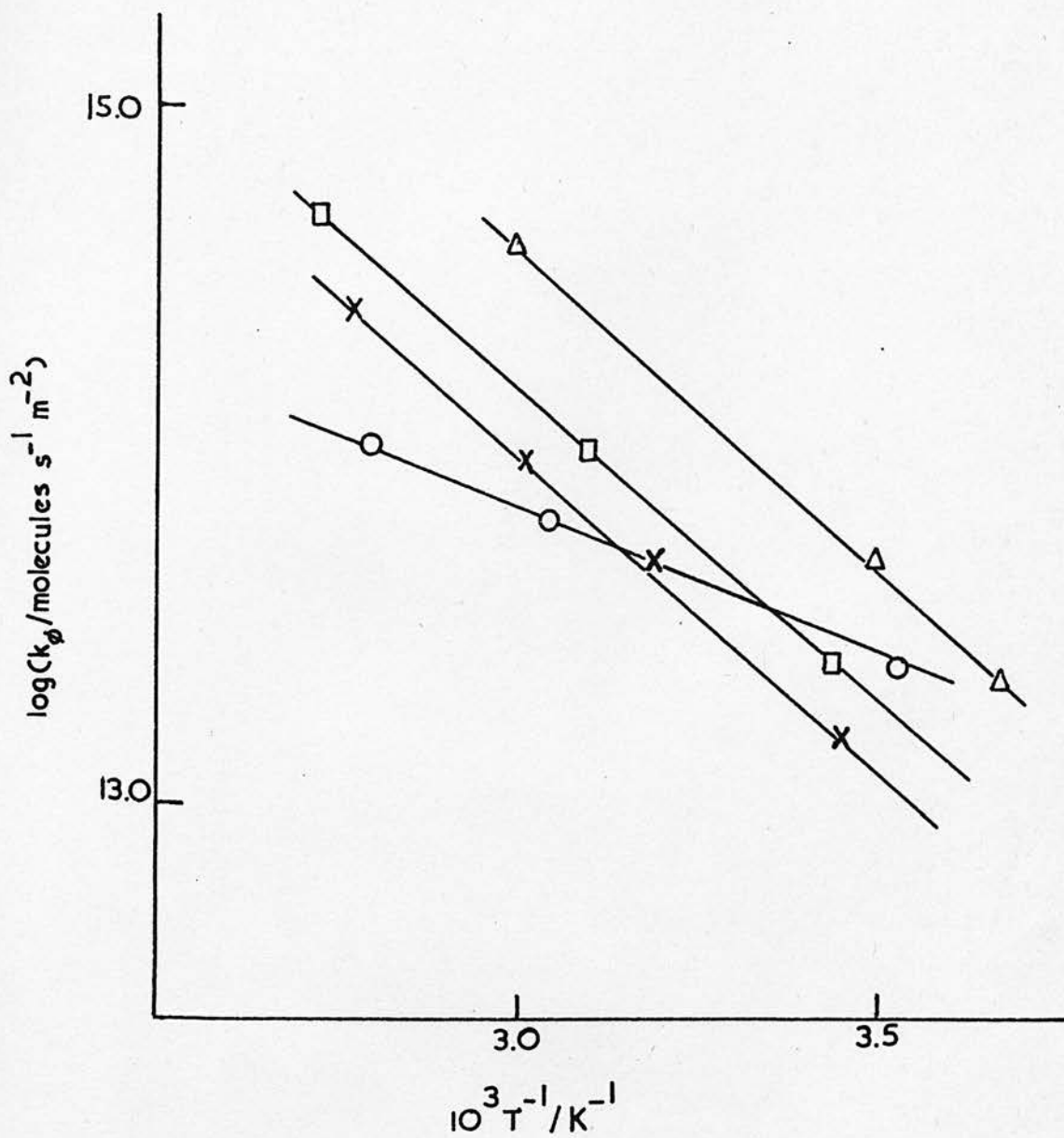

FIGURE 5.2 : Arrhenius plots for the exchange reactions of acyclic alkanes on alumina.

O, methane; X, propane; □, isobutane; Δ, n-butane.

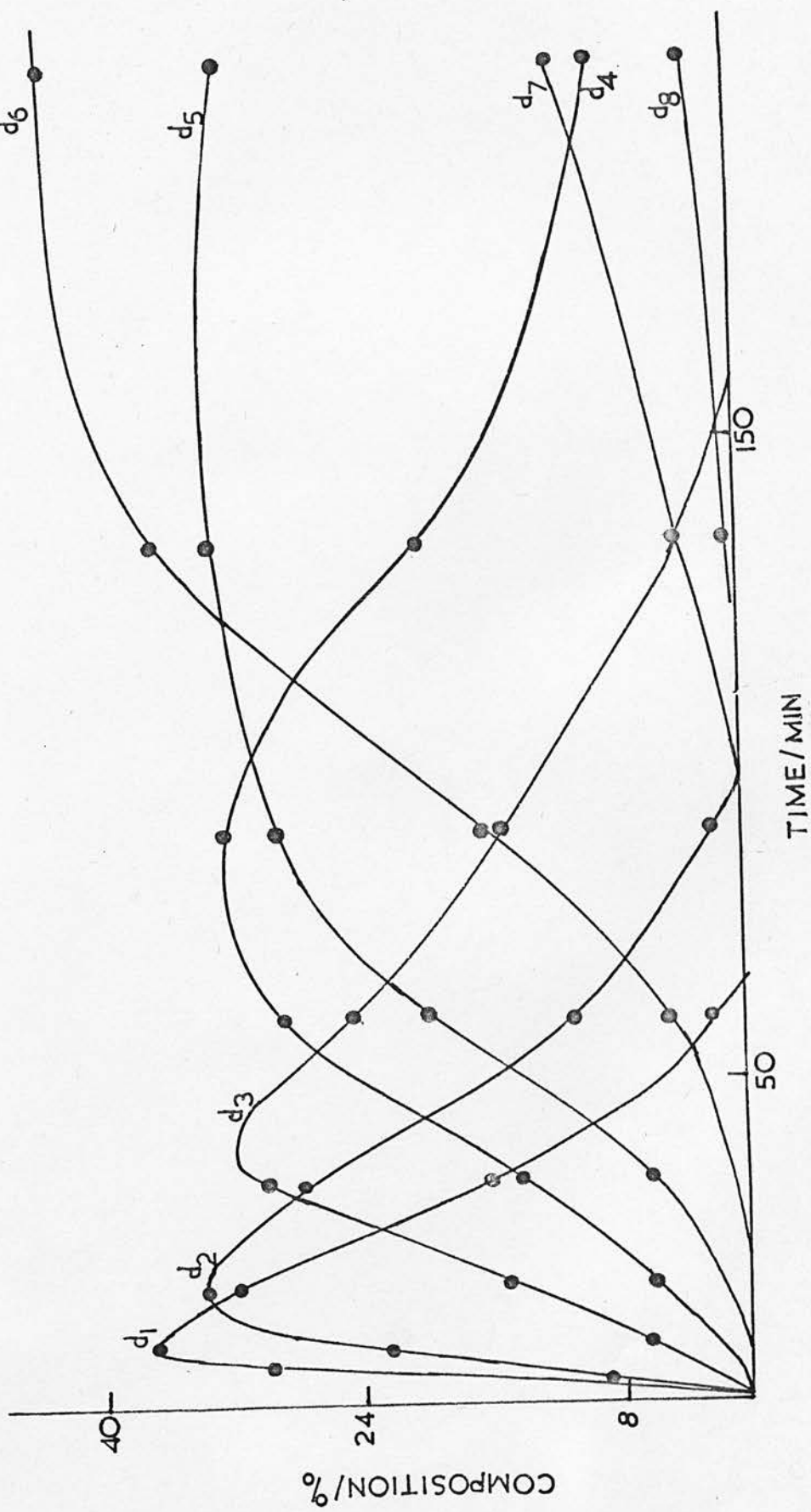

FIGURE 5.3 : Isotopic distributions during the exchange reaction of n-butane on alumina at 286K.

Exchange in the second group of hydrogen atoms was studied in greater detail by using a higher deuterium:hydrocarbon ratio in the reaction mixture. Analysis of the results indicated that the methyl hydrogen atoms in n-butane (type A) exchanged about sixty times faster than those in the methylene groups (type B) at 316K. The computer program which was written to generate distributions to check the HSK method (see Chapter 3) was used to calculate theoretical isotopic distributions at various times for molecules in which different groups of atoms exchanged at different rates. By specifying that type A hydrogens exchanged sixty times faster than type B, a set of distributions was generated for n-butane such that for similar extents of exchange experimental and calculated distributions could be compared (table 5.2). Also shown in the table is the binomial distribution calculated for ten equally reactive hydrogen atoms.

TABLE 5.2

PRODUCT DISTRIBUTIONS FOR EXCHANGE OF n-BUTANE

isotopic species/%	d ₂	d ₃	d ₄	d ₅	d ₆	d ₇	d ₈	∅ ^c
experimental	3.6	15.2	29.5	33.8	16.1	1.4	0.1	446.6
calculated ^a	4.5	15.4	29.9	31.9	15.7	1.7	0.0	442.2
calculated ^b	8.3	14.4	24.2	23.0	15.2	6.9	2.0	446.6

- a. Assuming 6 hydrogen atoms (type A) reacting more rapidly than the remaining 4 (type B) with $k_A/k_B = 60$.
- b. Assuming all 10 hydrogen atoms reacting at the same rate.
- c. ∅ represents the extent of exchange; $10^{-2}\emptyset$ is the average number of deuterium atoms per molecule.

From these results it was suspected that the six methyl hydrogens in propane might exchange more readily than the two methylene atoms. A similar analysis was carried out with the data for propane exchange. Again the hydrogen atoms in the primary positions were much more active than those in the secondary groups and k_A/k_B was found to be about 170 at 355K. It is necessary to accept a fairly large uncertainty (± 30) in this value because the reaction only produced about 7% of the highly deuterated species which may not be enough to give entirely satisfactory results. However it is also known that the results are best for molecules with large differences in reactivities and, in this experiment, reasonably linear plots were obtained.

In the case of isobutane no evidence for the production of d_{10} -species was obtained during the experiment. A deuterium enriched mixture was reacted at 423K in an attempt to produce some perdeuteroalkane. Even after pumping off the diluted deuterium and continuing the reaction with a fresh dose, no isobutane- d_{10} was formed although the mixture contained over 70% of d_8 - and d_9 - isomers, see table 5.3.

TABLE 5.3

EXCHANGE OF ISOBUTANE; PRODUCT DISTRIBUTION AFTER EXTENSIVE REACTION

isotopic species/%	d_6	d_7	d_8	d_9	d_{10}	β
experimental	7.7	18.5	40.0	33.6	0.05	798.1
calculated ^a	7.7	22.0	37.1	28.9	2.2	790

- a. Based on 9 hydrogen atoms (type A) reacting more rapidly than the remaining 1 (type B) with $k_A/k_B = 100$.

The other distribution shown in the table is that calculated for a molecule like isobutane in which the tenth hydrogen atom exchanges 100 times more slowly than the other nine. For a ϕ -value of 790 it predicts that over 2% of the d_{10} -species should be present in the product mixture. This quantity would certainly have been detectable in the mass spectrometer and thus for isobutane we estimate that k_A/k_B is greater than 100.

The simultaneous exchange of different alkanes was also studied. A mixture of methane, ethane and propane was reacted with deuterium at 308K and a mixture of propane, n-butane and isobutane was exchanged at 290K. The results for these experiments are summarised in table 5.4. Also listed are the rates obtained in the individual exchange experiments. No corrections have been made for the effect of different partial pressures of reactants in the mixture.

TABLE 5.4
SIMULTANEOUS AND INDIVIDUAL EXCHANGE OF ALKANES

reactant	simultaneous rate $10^{-13} k_{\phi}$ /molecules $s^{-1} m^{-2}$	individual rate $10^{-13} k_{\phi}$ /molecules $s^{-1} m^{-2}$	temperature T/K
methane	3.4	3.9	308
ethane	1.9	-	308
propane	9.6	3.8	308
propane	1.5	1.5	290
isobutane	6.3	3.8	290
n-butane	6.6	6.7	290

Exchange of cycloalkanes

All the cycloalkanes studied underwent exchange by a stepwise mechanism. Cyclopropane and methylcyclopropane were the most reactive molecules and the kinetic data is given in table 5.5. Also included in the table is an indication of the temperature required to give an isomerisation rate in excess of 10^{13} molecules $s^{-1} m^{-2}$.

TABLE 5.5EXCHANGE REACTIONS OF CYCLOALKANES OVER ALUMINA

reactant	$E/kJ mol^{-1}$	$10 \log (A/$ molecules $s^{-1} m^{-2}$	temperature range/K	temperature/K for $k_I = 10^{13}$ molecules $s^{-1} m^{-2}$
cyclopropane	26	19.9.	250-289	355
methylcyclopropane (type A)	17	18.1	273-348	355
(type B)	25	18.4	273-348	-
cyclobutane	45	21.4	273-317	335
cyclopentane	42	20.6	289-339	-

The exchange of cyclopropane was followed in the temperature range 250-290K when all the hydrogen atoms were found to exchange readily and at the same rate. A temperature of 358K was required before the production of propylene was observed and at this temperature the rate of exchange was calculated to be more than 1000 times that of isomerisation.

Interesting results were obtained in the exchange of methylcyclopropane. The eight hydrogen atoms could be classified into three

groups, A, B and C according to their different rates of exchange. The four hydrogens at the C_2 and C_3 positions (type A) were the most reactive, followed by the single ring hydrogen at the substituted C_1 position (type B). The least active were those atoms in the methyl group (type C). The ratio of rate constants $k_A:k_B$ was about 10:1 at room temperature. The type C hydrogens did not appear to exchange even at temperatures in excess of 350K. The rate of exchange of the type A hydrogens at 287K (1.3×10^{15} molecules $s^{-1}m^{-2}$) was very similar to that of the hydrogens in cyclopropane itself (1.4×10^{15} molecules $s^{-1}m^{-2}$) measured at the same temperature. A temperature of 355K was required in order to achieve isomerisation at a measurable rate, the initial product being transbut-2-ene. At this temperature, the rate of isomerisation was about 100 times slower than that for exchange of type B hydrogens.

The exchange of cyclobutane was studied using a reaction mixture consisting of cyclobutane and n-butane in approximately equal amounts. All the hydrogens in cyclobutane exchanged at the same rate in the temperature range 273-355K. Even at high temperatures in this range only a trace of butene could be detected and the rate of isomerisation was at least 150 times slower than that of exchange.

In the exchange of cyclopentane all the hydrogens reacted at an equal rate and in a stepwise manner.

5.4 DISCUSSION

The rate of exchange of methane with deuterium on this alumina catalyst (4.0×10^{13} molecules $s^{-1}m^{-2}$ at 301K) is somewhat slower than that found by Larson and Hall⁽¹⁾ (3.6×10^{14} molecules $s^{-1}m^{-2}$ at 301K) but a higher pretreatment temperature was employed in their work. For

the exchange of propane⁽³⁾, Flockhart et al. found a rate of 1.1×10^{13} molecules $s^{-1}m^{-2}$ for an alumina catalyst pretreated at the temperature used in the present work (723K). Using the pressure dependencies quoted, their catalyst would be expected to show a rate of 2.7×10^{13} molecules $s^{-1}m^{-2}$ in this system and this compares favourably with the observed rate of 1.6×10^{13} molecules $s^{-1}m^{-2}$. The observations of the relative rates of exchange of the different hydrogen atoms in propane does however disagree with the same workers suggestion that the secondary hydrogens are more rapidly replaced.

It has been shown⁽¹⁾ that in the exchange of methane with deuterium over alumina, the rate determining step involves fission of a carbon-hydrogen bond and it seems very probable that dissociative adsorption is involved for all the alkanes studied in the present work.

It seems unlikely that the alkanes exchange via radical intermediates. It has been established⁽⁷⁻⁹⁾ that the adsorption of saturated hydrocarbons to form surface alkyl species plays an important role in the exchange process on metal catalysts. Figure 5.4 shows that for the exchange of alkanes on tungsten there exists a rough correlation between the ease of exchange and the dissociation energy of the alkyl-hydrogen bond which must necessarily be broken to produce the adsorbed alkyl groups. In particular, the high bond dissociation energy of the carbon-hydrogen bond in methane results in a rate of exchange which is about 1000 times slower than that of the other alkanes. In contrast, on alumina, methane exchanges as readily as the other alkanes and no such distinction in behaviour is observed. In addition the most weakly bound hydrogens in isobutane (the methine hydrogen) and in n-butane (the secondary hydrogen) are the least active for exchange. For the cycloalkanes, the observed

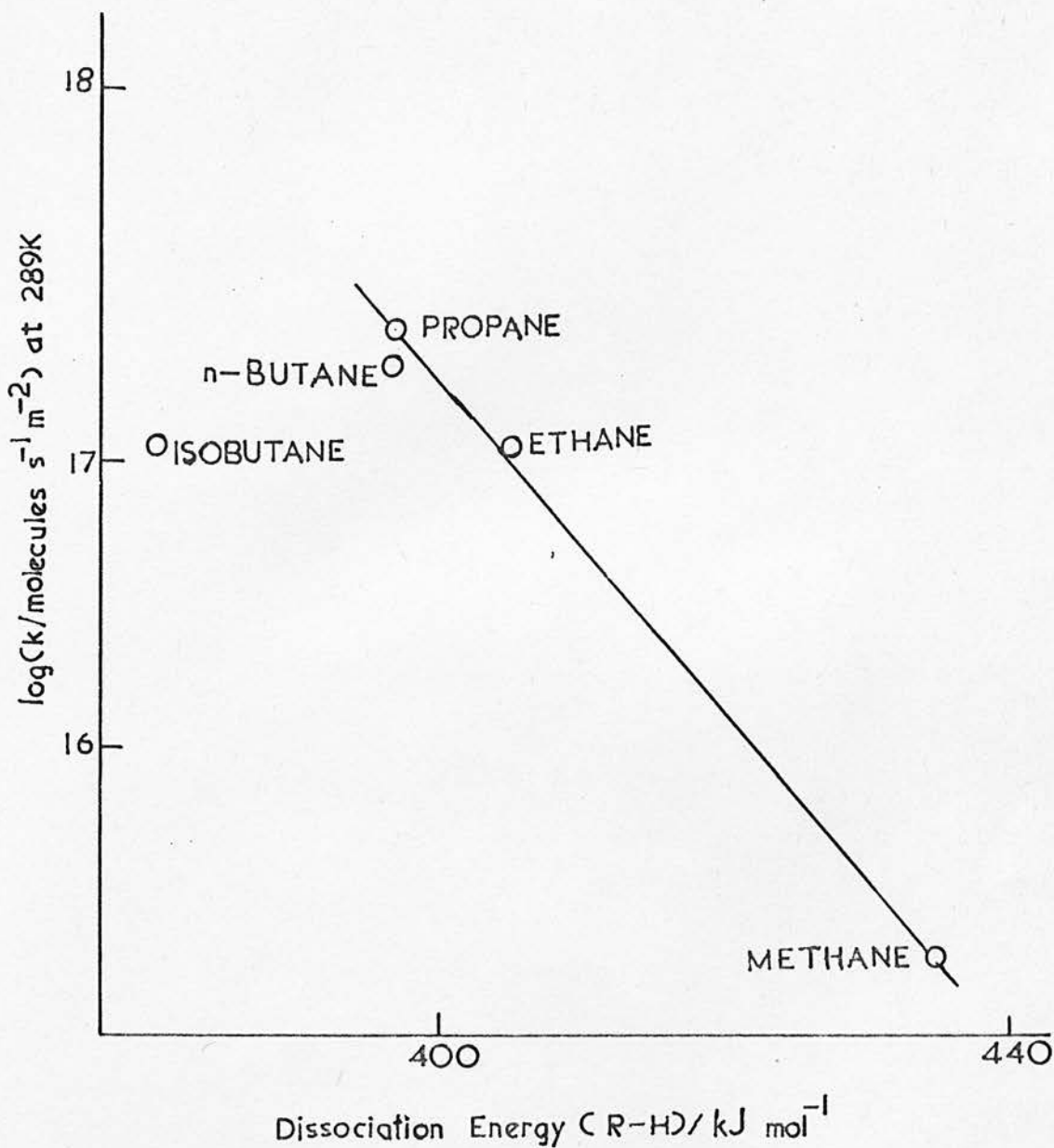
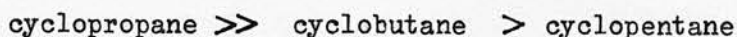

FIGURE 5.4 : Alkane exchange reactions over tungsten; $\log k_0$ at 289K as a function of the dissociation energy⁽¹⁰⁾ of the C-H bond for methane⁽⁷⁾, ethane⁽⁷⁾, propane⁽⁷⁾, isobutane⁽⁸⁾ and n-butane⁽⁹⁾.

rate of reaction decreases in the sequence:



and this order is the reverse of that expected for radical intermediates since the bond dissociation energies⁽¹¹⁾ are 431, 414 and 397 kJ mol⁻¹ for cyclopropane, -butane and -pentane respectively.

Exchange via carbonium ion or partially positively charged intermediates may also be ruled out. Exchange of saturated hydrocarbons on silica-alumina is generally regarded as involving carbonium ion intermediates. On silica-alumina, isobutane will exchange at 393K⁽¹²⁾ but n-butane requires a temperature in excess of 550K. In contrast, on alumina at room temperature the two butane molecules undergo exchange at similar rates. A much higher rate would be expected for isobutane if formation of the tertiary carbonium ion were important for exchange.

The general behaviour of the alkanes on alumina suggests that the intermediate species are adsorbed alkyl groups which possess carbanionic character. Many of the differences in reactivities can be qualitatively explained by consideration of the effects of alkyl substituents on the stabilities of carbanions. Alkyl group replacement of hydrogen in methane leads to a decrease in the stability of the carbanion as a result of the electron releasing nature of the substituent, e.g. the ethyl carbanion CH_3CH_2^- would be less stable than the methyl anion CH_3^- and indeed the exchange rate for ethane is lower than that observed for methane. Increasing the length of the alkyl chain tends to decrease the degree of destabilisation (see for example reference 13) such that the anion $\text{CH}_3\text{CH}_2\text{CH}_2^-$ is more stable than CH_3CH_2^- . This is in accord with the observation that propane exchanges at a greater rate than ethane.

The operation of such inductive effects can also assist in

explaining the different reactivities found for various groups of hydrogen atoms in the same molecule. For both propane and n-butane, the methylene hydrogens exchanged much more slowly than the primary hydrogens, the effect being more marked in the case of propane. The $(\text{CH}_3)_2\text{CH}^-$ carbanion has two methyl groups adjacent to the central carbon atom on which the negative charge is visualised and thus there is a pronounced destabilising influence. The magnitude of the effect is reduced in the carbanion $(\text{CH}_3)(\text{C}_2\text{H}_5)\text{CH}^-$ formed from n-butane since, in this case, one of the substituent groups is larger and therefore less destabilising. By similar reasoning it can be seen why the methine hydrogen in isobutane is very inactive for exchange; the inductive effect of three substituent methyl groups causes the $(\text{CH}_3)_3\text{C}^-$ anion to be particularly unstable.

It would be useful to attempt a more quantitative correlation between alkane exchange activity and carbanion stability. If this is a major factor in determining the reactivity of the alkanes the rate determining step which occurs on the surface may be written

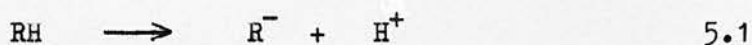

This reaction may be considered to involve three basic processes.

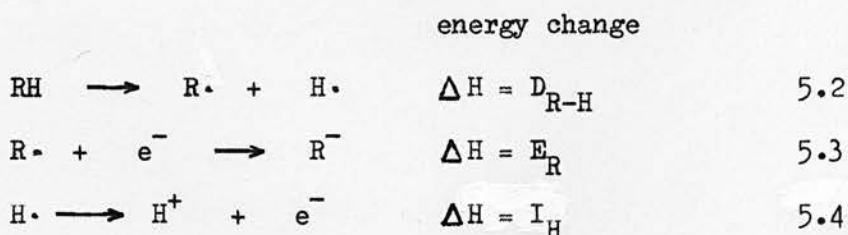

where $D_{\text{R-H}}$ is the bond dissociation energy of the alkyl-hydrogen bond which is broken in the adsorption process, E_{R} is the electron affinity of the alkyl radical and I_{H} is the ionisation potential of the hydrogen atom. For a series of alkanes, provided that the respective carbanionic species are equally strongly adsorbed, the ease of occurrence of reaction 5.1 will

be determined by the value of $(D_{R-H} - E_R)$. Unfortunately precise values of E_R for the radicals under discussion are not known at present, reported values often having an uncertainty exceeding several tenths of an electron volt⁽¹⁴⁾. Such a degree of uncertainty precludes the assessment of relative carbanion stabilities based on thermochemical data. Indeed catalytic studies similar to those reported here may have some value in assessing relative values of electron affinities for hydrocarbon and other radicals.

It is more fruitful to consider the reactivities of the alkanes as a function of hydrocarbon acidity. As with electron affinity data, the assignment of pK_a values for such weak acids is not without question. The pK_a values used in this work have been derived from equilibrium studies by Dessy and colleagues⁽¹⁵⁾ and Cram⁽¹⁶⁾. Dessy et al.⁽¹⁵⁾ have argued that in establishing a rank of carbanion stabilities the use of kinetic acidity values is not to be recommended. These values were mostly determined by competitive exchange reactions of organometallic or alkyl-halogen compounds in basic media. These reactions can be used to define a relative scale of acidities and an absolute scale of pK_a values can be drawn up if some standard molecule is defined as having a given pK_a value. Alkanes are weak carbon acids having large values of pK_a and belong to that part of the scale where there is most uncertainty. In the relevant pK_a range, 30-50, relative values of acidity appear to be reasonably accurate but absolute magnitudes may have an uncertainty of one or two units. The conditions under which most pK_a values were obtained may also be queried, namely whether thermodynamic properties in basic solutions are relevant to the formation of carbanions in gas-phase exchange reactions. Probably an accurate scale of kinetic acidities which refers to the rates

at which acids donate protons to a reference base would be more desirable. However techniques by which organic anions may be observed in the gas phase⁽¹⁷⁾ have only been recently developed and, as yet, only a relative acidity scale has been established.

Figure 5.5 shows the relationship between the exchange activity of alkanes and their pK_a values where these are known. The rate constants used in the figure are taken from tables 5.1 and 5.5 except for the secondary hydrogens in propane and n-butane. For these less active hydrogen atoms Arrhenius data were not available and thus the rates of their exchange, k_B , were estimated at 289K using the values of k_A/k_B obtained at slightly higher temperatures.

The figure shows that a linear relationship of the form

$$\log k = -a(pK_a) + b \quad 5.5$$

is found to hold where a and b are constants.

For the acyclic molecules, a and b were found to be 0.64 and 38.7 respectively, while for the cycloalkanes their values were 0.38 and 29.5. Also included in figure 5.5 is the rate of exchange of ethylene which appears to fit quite well on the line for acyclic alkanes.

Equation 5.5 is essentially the Brønsted relation⁽¹⁸⁾ originally proposed to relate the effectiveness of an acid catalyst to its acid strength,

$$k_A = G_A K^x \quad 5.6$$

where k_A denotes the rate constant observed for the catalysed reaction, K is the dissociation constant of the acid, G_A is a constant and x is a parameter taking values between zero and unity which indicates the sensitivity of the catalysis to acid strength. As Bell⁽¹⁹⁾ has indicated, the Brønsted relationship, although normally applied to the catalysis of

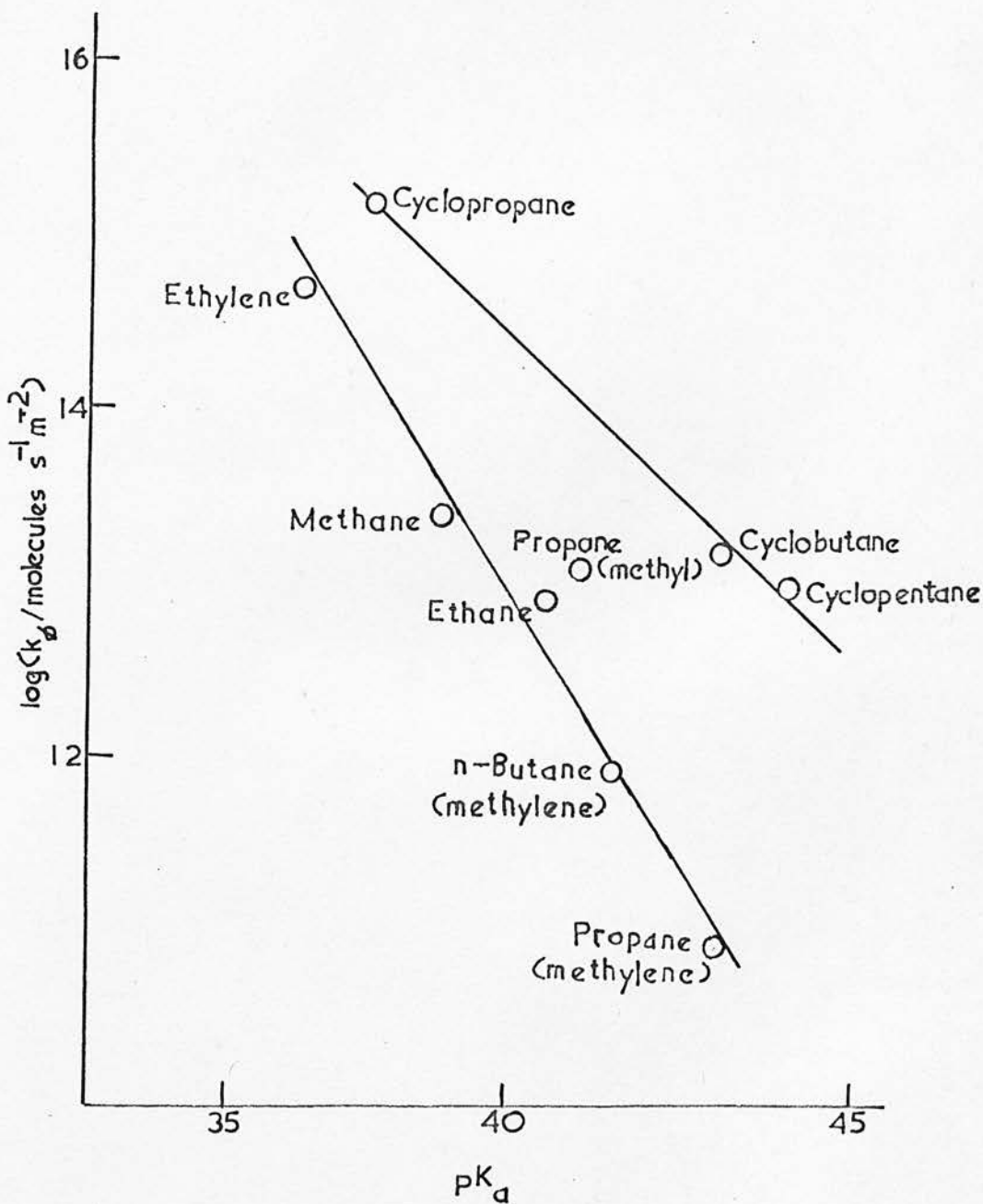

FIGURE 5.5 : Alkane exchange reactions over alumina; $\log k_\phi$ at 289K as a function of the pK_a of the hydrocarbon. The values of pK_a are given to the nearest half-integer for ethane and n-butane and to the nearest integer for the other compounds^(15,16).

a given reaction by a series of acid catalysts, is also expected to hold for the case where one catalyst is used with a series of acid reactants. Thus x , the sensitivity factor in equation 5.6, is analogous to the parameter a in equation 5.5. For acyclic molecules $a = 0.64$ but for cycloalkanes the dependence of the exchange rate on pK_a is less marked with $a = 0.38$. Thus it is clear that an additional factor influences the activity of the cycloalkanes and causes an enhancement in the rate of exchange, particularly for cyclobutane and cyclopentane. The origin of the increased rate of exchange is difficult to explain. The enhanced rate of exchange of cyclopropane over chromia⁽²⁰⁾ has been attributed to the operation of a hyperconjugative effect. It is unlikely that such an effect is present in exchange on alumina since cyclopropane is only marginally faster in exchange than predicted on the basis of the rate-acidity relationship for acyclic molecules (figure 5.5). This close agreement also precludes the attribution of high exchange rates in cycloalkanes to enhanced chemisorption via π -bonding interaction with the catalyst surface. The absence of π -bonding influences is also ruled out by the fact that the relative exchange activity of ethylene is satisfactorily explained by acidity alone. Perhaps it is due to some effect which enables the hydrogens in cyclobutane and cyclopentane to be more accessible. The origin of the effect may possibly lie in the orientation of the adsorbed reactant at the surface. A deeper understanding will require further experimentation.

The linear free energy relationship depicted in figure 5.5 demonstrates that alkanes exchange on alumina via the formation of adsorbed alkyl groups with carbanionic character and that exchange activity is largely controlled by hydrocarbon acidity. The extension of the idea to

include ethylene is in accord with the dissociation mechanism for ethylene exchange proposed by Hightower and Hall⁽²¹⁾.

In addition the relationship may be used to estimate pK_a values for the methyl hydrogens in the butane molecules since these are not included in the data from references 15 and 16. Both n-butane and isobutane exhibit similar rates of exchange and giving an estimate of the pK_a value for the primary hydrogen in both molecules of approximately 39.

The results of the experiments in which more than one alkane underwent simultaneous exchange over the same catalyst indicate that the reaction rates were little affected by the presence of other alkanes. Results were also free from effects due to dilution of the deuterium pool which might have occurred, for example, if a large hydrocarbon underwent rapid exchange in competition with smaller and less reactive molecules. The applicability of gas chromatography - mass spectroscopy to competitive studies of catalytic reactions was confirmed by these experiments.

REFERENCES

- (1) J.G. Larson and W.K. Hall, *J. Phys. Chem.*, 69, 3080, 1965.
- (2) A.J. Trokhimets and S.V. Markevich, *Russ. J. Phys. Chem.*, 39, 1055, 1965.
- (3) B.D. Flockhart, S.S. Uppal and R.C. Pink, *Trans. Faraday Soc.*, 67, 513, 1971.
- (4) J.G. Larson, J.W. Hightower and W.K. Hall, *J. Org. Chem.*, 31, 1225, 1966.
- (5) P.A. Sermon, G.C. Bond and G. Webb, *J.C.S. Chem. Comm.*, 417, 1974.
- (6) R.S. Dowie, D.A. Whan and C. Kemball, *J.C.S. Faraday I*, 68, 2150, 1972.
- (7) C. Kemball, *Adv. in Catalysis*, 11, 223, 1959.
- (8) A. Cortes Arroyo and C. Kemball, *J.C.S. Faraday I*, 68, 1029, 1972.
- (9) C. Kemball, *Catalysis Rev.*, 5, 33, 1971.
- (10) D.M. Golden and S.W. Benson, *Chem. Rev.*, 69, 125, 1969.
- (11) J.G. Calvert and J.N. Pitts, *Photochemistry*, (J. Wiley and Sons, New York), 1966, p.824.
- (12) R.C. Hansford, P.G. Waldo, L.C. Drake and R.E. Honig, *Ind. Eng. Chem.*, 44, 1108, 1952.
- (13) J.I. Brauman and L.K. Blair, *J. Am. Chem. Soc.*, 93, 4315, 1971.
- (14) L.G. Christophorou, *Atomic and Molecular Radiation Physics*, (J. Wiley and Sons, New York), 1971, p.564
- (15) R.E. Dessy, W. Kitching, T. Psarras, R. Salinger, A. Chen and T. Chivers, *J. Am. Chem. Soc.*, 88, 460, 1966.
- (16) D.J. Cram, *Fundamentals of Carbanion Chemistry*, (Benjamin, New York), 1965, chapter 1.

- (17) D.K. Bohme, E.Lee-Ruff
and C.B. Young, J. Am. Chem. Soc., 94, 5153, 1972.
- (18) J.N. Brønsted, Chem. Rev., 5, 231, 1928.
- (19) R.P. Bell, The Proton in Chemistry, (Methuen,
London), 1959, chapter 10.
- (20) R.L. Burwell, Jr., A.B.
Littlewood, M. Cardew,
G. Pass and C.T.H.
Stoddart, J. Am. Chem. Soc., 82, 6272, 1960.
- (21) J.W. Hightower
and W.K. Hall, J. Catalysis, 13, 161, 1969.

CHAPTER 6REACTIONS OF HYDROCARBONS OVER MAGNESIUM OXIDE6.1 INTRODUCTION

The properties of magnesium oxide as a catalyst have been studied for a limited number of reactions but from these it is obvious that it is a catalyst which shows a great range of activity - from the rapid isomerisation of butene at low temperature^(1,2) to the slow exchange of propane at much higher temperatures⁽³⁾. In this work the range of reactions studied was increased and it was hoped that an understanding of the reaction intermediates and the nature of the surface of magnesium oxide would make it possible to rationalise the pattern of behaviour exhibited by the catalyst. The results of several experiments over alumina catalysts have indicated that intermediates of a carbanionic nature are important. Magnesium oxide is regarded as a basic catalyst⁽⁴⁾ on which similar intermediates may be formed. It was thought that consideration of the similarities and differences in behaviour of these two catalysts would be of interest. It should be remembered that any comparison of the catalysts will refer to the general pattern of behaviour. It would not be possible with the information available to make direct comparisons of the intrinsic activities of the oxides. One cannot determine whether the same fraction of surface sites is active for both catalysts or whether the respective pretreatments produce the same degree of activation. Indeed the latter is almost certainly not the case.

Almost all this study was concerned with the exchange reactions of either alkanes or alkenes with deuterium over magnesium oxide. As

described in Chapter 5, the exchange of alkanes over alumina provides evidence for the formation of alkyl species with carbanionic character as intermediates in the reaction. The presence of carbanionic species as intermediates on magnesium oxide has been suggested for butene isomerisation⁽²⁾ and it was considered likely that if such species were to be involved in exchange reactions over magnesium oxide, the relative rates of exchange of different alkanes and of different types of hydrogen atoms within the same molecule should exhibit a similar pattern to that obtained for alumina. Both acyclic and cycloalkanes were studied.

The exchange of olefins has also been investigated over magnesium oxide. The exchange of propylene⁽⁵⁾ has provided interesting results; at 195K rapid exchange of the five terminal hydrogen atoms occurred but the sixth hydrogen was not replaced. The suggested mechanism involved the abstraction of a proton by the basic sites on the magnesium oxide to form an allyl anion which underwent a rapid double bond shift with scrambling of deuterium between the five terminal positions. It should be noted that a carbonium ion intermediate could conceivably give rise to a product labelled in the same manner but this seemed an unlikely process on this catalyst.

The evidence from the isomerisation of 3,3-dimethylbut-1-ene⁽⁶⁾ which almost certainly involves a carbonium ion suggests that such a species is unlikely to be formed on magnesium oxide at low temperature. Further evidence regarding the ease or difficulty of double bond shift was expected to be obtained from the exchange reactions of isobutene and cyclopentene. The exchange of the latter over alumina⁽⁷⁾ is largely limited to the two vinyl hydrogens indicating that the double bond remains fixed during the exchange process.

A series of alkane and olefin reactions was investigated. It was necessary in some cases to repeat or to complement previous results to obtain data which could be compared for the same catalyst. Again it was felt that valid comparisons could only be made between results obtained over the same type of catalyst. The combined gas chromatograph - mass spectrometer system was used to study the simultaneous exchange of some of the alkanes and olefins.

6.2 EXPERIMENTAL PROCEDURE

The experimental procedure followed the general pattern described in Chapter 2. Reactions involving a single hydrocarbon were followed using the MS10 apparatus while those involving more than one reactant or with more than one possible product were studied using the g.c.-m.s. technique.

0.5g of magnesium oxide was used for the exchange reactions of alkanes. The reaction mixture was prepared with a deuterium:hydrogen ratio of 5:1 which resulted in ca. 1.5×10^{19} hydrocarbon molecules in the reaction vessel. For the simultaneous exchange reactions of methane, ethane and propane and of propane, isobutane and n-butane the total number of hydrocarbon molecules in the reaction mixture was roughly the same as that in the individual experiments. In reactions involving olefins which tended to be more reactive, 0.1g of catalyst was used. The reaction mixtures for experiments involving a single reactant were the same as those used with the alkanes. However in the simultaneous exchange experiments the number of molecules of each hydrocarbon in the mixture was roughly the same as in the individual exchange reactions. This gave improved sensitivity for g.c.-m.s. experiments.

Three batches of catalyst were used in the experiments, having surface areas of 30, 30 and $50 \text{ m}^2 \text{ g}^{-1}$ respectively. The second and third samples had similar activities; the exchange of ethylene was followed over both catalysts and the rates obtained at 273K were found to be in good agreement (2.8×10^{13} and 3.2×10^{13} molecules $\text{s}^{-1} \text{ m}^{-2}$). Most of the experiments were followed using these batches of catalyst. The first sample however appeared to have a lower activity than the other two. The exchange of methane at 623K was reduced by a factor of three over the first sample. This difference in activity is very probably a result of slight differences in the preparation of the magnesium oxide, e.g. during the decomposition of the carbonate. The only experiments which involved this sample of catalyst were the simultaneous exchange of the alkanes. In all cases the pretreatment of the catalyst involved outgassing at 723K overnight.

When reaction temperatures above room temperature were required the silica furnace was again used. When lower temperatures were required the following cold baths were used; solid carbon dioxide (195K), carbon tetrachloride slush (250K) and an ice/ethanol mixture (255K).

The collection and processing of experimental data followed the scheme described in Chapters 2 and 3. The mass spectra were corrected for the presence of background peaks, for naturally occurring deuterium and heavy carbon and for fragmentation in the mass spectrometer source. In general for the alkanes the fragmentation was simply calculated on a statistical model for the loss of hydrogen and deuterium which seemed to be satisfactory. However for the olefins in which exchange was much more extensive the more sophisticated scheme of Dowie et al.⁽⁸⁾ was employed.

In the simultaneous exchange reactions of methane, ethane and propane difficulty was experienced in obtaining accurate isotopic distributions

for methane because of the relatively large background contribution particularly at $m/e = 18$. However the rate of exchange of methane can be followed from the decay of the d_0 -peak assuming no fragment from the water background interferes. The rates quoted for methane are therefore k_0 values while other constants and derived parameters refer to the k_ϕ rate constants.

6.3 RESULTS

The exchange reactions of two acyclic alkanes, n-butane and methane, and of two cycloalkanes, cyclopropane and methylcyclopropane, were investigated in detail while the exchange of five alkanes exchanging simultaneously were followed using the g.c.-m.s. system.

The details of the individual experiments are given in table 6.1.

TABLE 6.1

KINETIC DATA FOR EXCHANGE OF ALKANES

reactant	E^a / kJmol^{-1}	$\log (A^b$ / $\text{molecule s}^{-1} \text{m}^{-2})$	temperature range/K
methane	35.2	17.4	623-683
n-butane	44.6	17.8	620-700
cyclopropane	25.2	17.5	478-677
methylcyclopropane (A)	17.5	17.1	450-560
(B)	~ 20	~ 16	450-560
(C)	~ 23	~ 15.5	450-560

^a uncertainty in activation energies $\pm 3 \text{ kJ mol}^{-1}$

^b uncertainty in \log (frequency factor) ± 0.5

The results for n-butane are calculated for the overall rate of exchange. The relevant rate plots and Arrhenius graphs are illustrated in figures 6.1 and 6.2 respectively. All the alkanes exchanged in a stepwise fashion giving good agreement between the experimental and binomial distributions in the early stages of the reaction.

The exchange of n-butane and methane required temperatures which were close to the pretreatment temperature of the catalyst. It was originally hoped to follow the exchange of n-butane until appreciable amounts of highly deuterated species were present. However the reaction appeared to poison at later stages and only small amounts of d_7 - and d_8 -species were obtained. A curvature in the ϕ -plot can be seen after about one hour (figure 6.1). Nevertheless there was evidence that the six methyl hydrogens in n-butane exchanged more rapidly than the four methylene ones. If the value of ϕ_{∞} is chosen assuming ten equally exchangeable hydrogen atoms in the molecule, the $\log(\phi_{\infty} - \phi)$ plots were curved. However if it was assumed that six hydrogens were exchanging more rapidly than the others the resulting value of ϕ_{∞} gave much better plots which were linear at least in the initial stages and from which the rate constants were calculated. In addition the computer program which was developed for the work described in Chapter 3 was able to calculate the predicted distributions for a molecule with ten exchangeable hydrogen atoms of which six exchange fifty times faster than the other four. The calculated distributions follow the experimental values quite well (table 6.2). Also included with the final set is the corresponding binomial distribution for ten equally reactive hydrogen atoms.

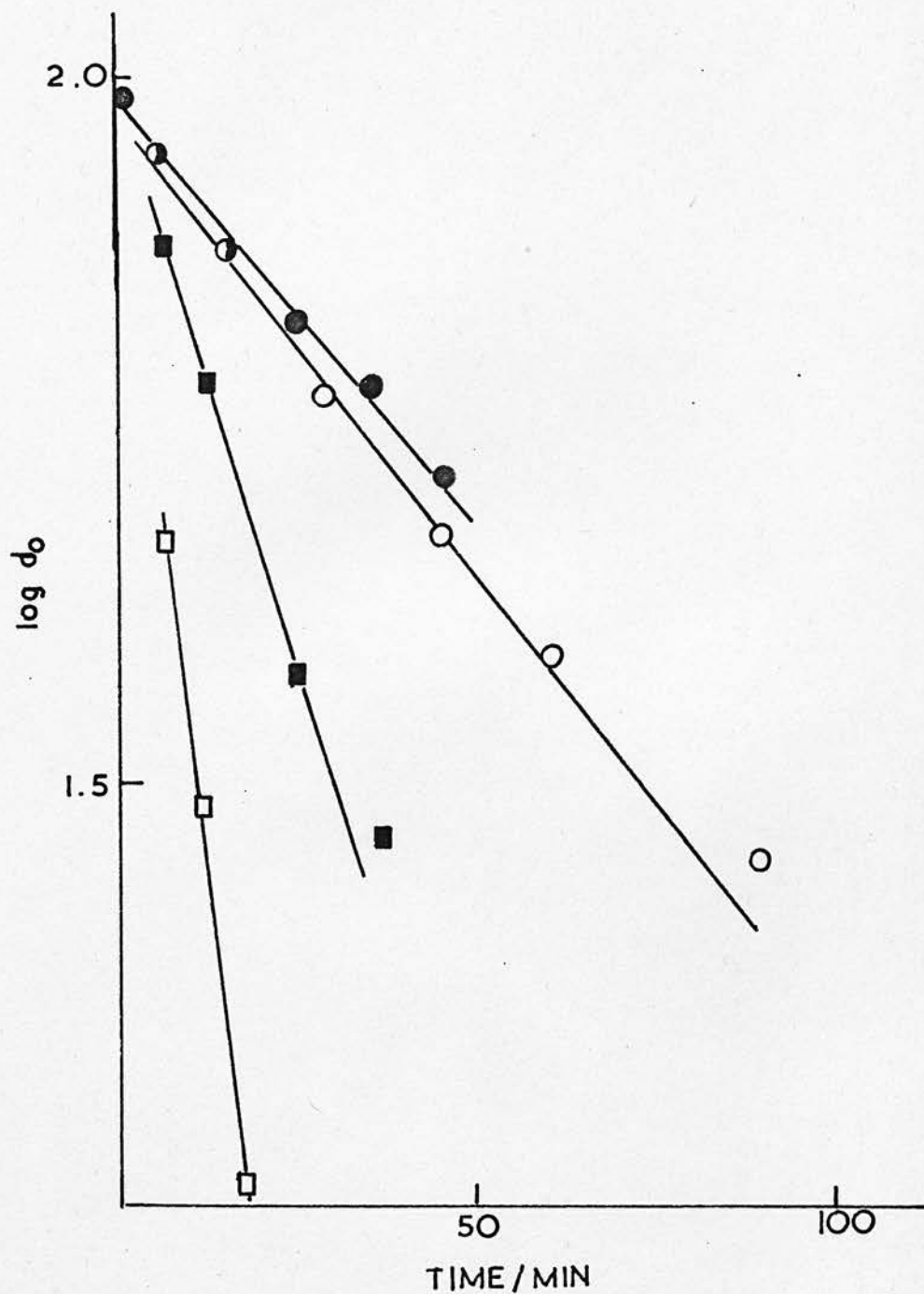

FIGURE 6.1 : Rate plots for the exchange reactions of alkanes with deuterium on magnesium oxide.

■, cyclopropane at 478K; ○, n-butane at 691K;
 ●, methane at 623K; □, methylcyclopropane at 519K.

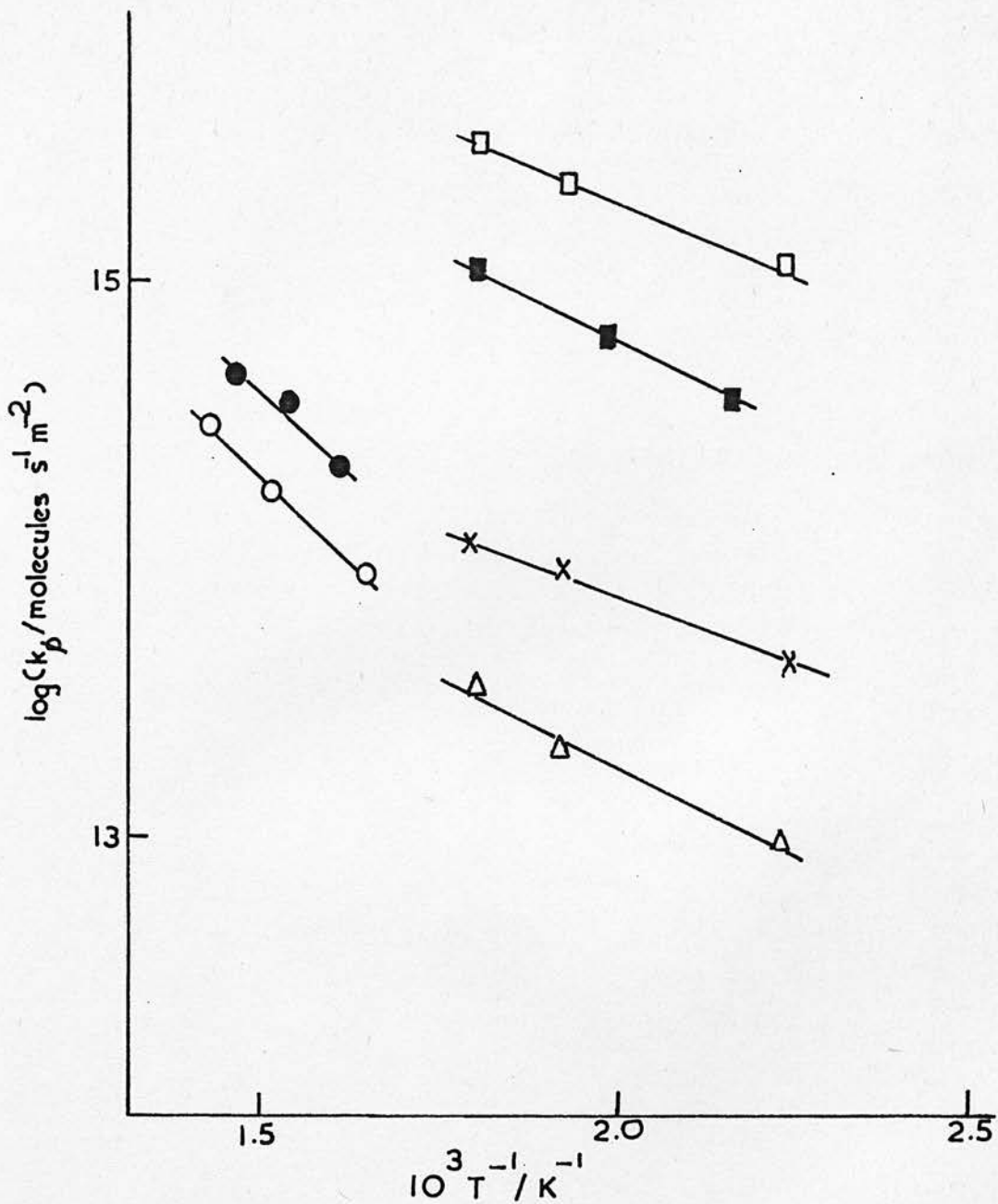

FIGURE 6.2: Arrhenius plots for the exchange reactions of alkanes on magnesium oxide.

■, cyclopropane; ●, methane; ○, n-butane;
 □, methylcyclopropane (A); X, (B); △, (C).

TABLE 6.2

COMPARISON OF EXPERIMENTAL AND COMPUTER-GENERATED
DISTRIBUTIONS FOR N-BUTANE

ϕ		d_0	d_1	d_2	d_3	d_4	d_5	d_6	d_7	d_8	d_9	d_{10}
177	calculated	12.4	30.8	32.0	17.9	5.8	1.0	0.1	0.0	0.0	0.0	0.0
186	experimental	11.2	31.4	30.8	18.1	5.2	2.1	1.2	0.0	0.0	0.0	0.0
303	calculated	1.6	9.3	23.0	30.6	23.3	9.9	2.0	0.1	0.0	0.0	0.0
301	experimental	0.0	10.2	26.3	31.1	20.6	8.1	3.7	0.0	0.0	0.0	0.0
393	calculated	0.2	2.2	9.8	23.2	31.5	23.7	8.5	0.8	0.0	0.0	0.0
399	experimental	0.0	0.4	9.7	24.9	31.7	22.9	9.1	1.2	0.0	0.0	0.0
399	binomial	0.6	4.0	12.1	21.5	25.1	20.1	11.1	4.2	1.1	0.2	0.0

Values calculated for $k_A/k_B = 50$

Methane exchange was poisoned in the early stages of the reaction before settling to a steady rate after about twenty minutes. The Arrhenius data (table 6.1) is calculated from these steady rate conditions.

The simultaneous exchange of alkanes was studied in two experiments using the g.c.-m.s. technique, the first involving methane, ethane and propane at 627K while in the second experiment the exchange of propane, isobutane and n-butane was followed. The rate constants for the larger molecules were calculated assuming that six hydrogen atoms exchange faster than the other two in propane, nine faster than one in isobutane and six faster than four in n-butane. Again this assumption resulted in the best

straight lines in the rate plots. The order of reactivity of the five alkanes was found to be methane (6.8) > butanes (4.9) > propane (2.5) > ethane (1.0).

(The numbers give the relative rates with respect to ethane at 627K.)

Magnesium oxide proved to be a more active catalyst for the exchange reactions of the cycloalkanes. Whereas temperatures in excess of 600K are required for acyclic alkanes, the exchange reaction of cyclopropane with deuterium was followed at 478K. The exchange reaction was studied using the g.c.-m.s. system and appeared to proceed without any interference from isomerisation. Initially a trace of propylene appeared in the total ion trace but it was not enough for mass spectral analysis. However no further olefin production was observed during the course of the reaction even after one hour at 677K. The propylene was not an impurity in the cyclopropane and probably arose from some fast initial reaction which poisoned. There was however no evidence of poisoning in the exchange reaction.

As on alumina the exchange reaction of methylcyclopropane produced interesting results. The eight hydrogen atoms in the molecule could be divided into three groups; the four hydrogens at the C₂ and C₃ positions (type A) were the most reactive followed by the single ring hydrogen at the substituted position C₁ (type B), while the three least reactive hydrogen atoms were those in the substituent methyl group (type C). The data for the second and third types of hydrogen atoms in table 6.1 is only approximate for two reasons. Firstly, the difference in reactivity between types B and C is fairly small and the methods of analysis are known to be least reliable in such circumstances (Chapter 3.4). In addition, the middle type involves only one hydrogen atom and will be subject to greater uncertainty.

However, the ratio of the rate constants was $k_A:k_B:k_C = 100:5:1$ which remained approximately the same over the temperature range because the activation energies for the different types of hydrogen atoms were roughly similar. At 500K the overall rate of exchange of methylcyclopropane (1.8×10^{15} molecules $s^{-1}m^{-2}$) is slightly faster than that for cyclopropane (7.8×10^{14} molecules $s^{-1}m^{-2}$). No evidence for isomerisation of methylcyclopropane was observed. At the ambient temperature the isomerisation products viz. butenes would rapidly equilibrate with deuterium giving anomalous amounts of highly deuterated species. This effect was never seen.

Of the olefins the exchange reactions of ethylene, propylene, isobutene and cyclopentene with deuterium were investigated. The results for ethylene exchange have already been presented (Chapter 4) and the results for propylene include some data from another source⁽⁵⁾. Also studied were the simultaneous exchange reactions of ethylene, propylene and isobutene. Again all the exchange reactions were found to be stepwise and the results are summarised in table 6.3. The rate plots for the exchange reactions are shown in figure 6.3 while the Arrhenius graphs are given in figure 6.4.

TABLE 6.3

KINETIC DATA FOR EXCHANGE OF OLEFINS

reactant	E^a /kJmol ⁻¹	$10 \log (A^b$ /molecules $s^{-1}m^{-2})$	temperature range/K
ethylene	16.0	16.5	273-373
propylene	13.6	19.4	195-273
isobutene	20.5	21.0	195-273
cyclopentene	21.4	19.1	273-330

^a uncertainty in activation energies $\pm 3 \text{kJ mol}^{-1}$

^b uncertainty in frequency factor ± 0.5

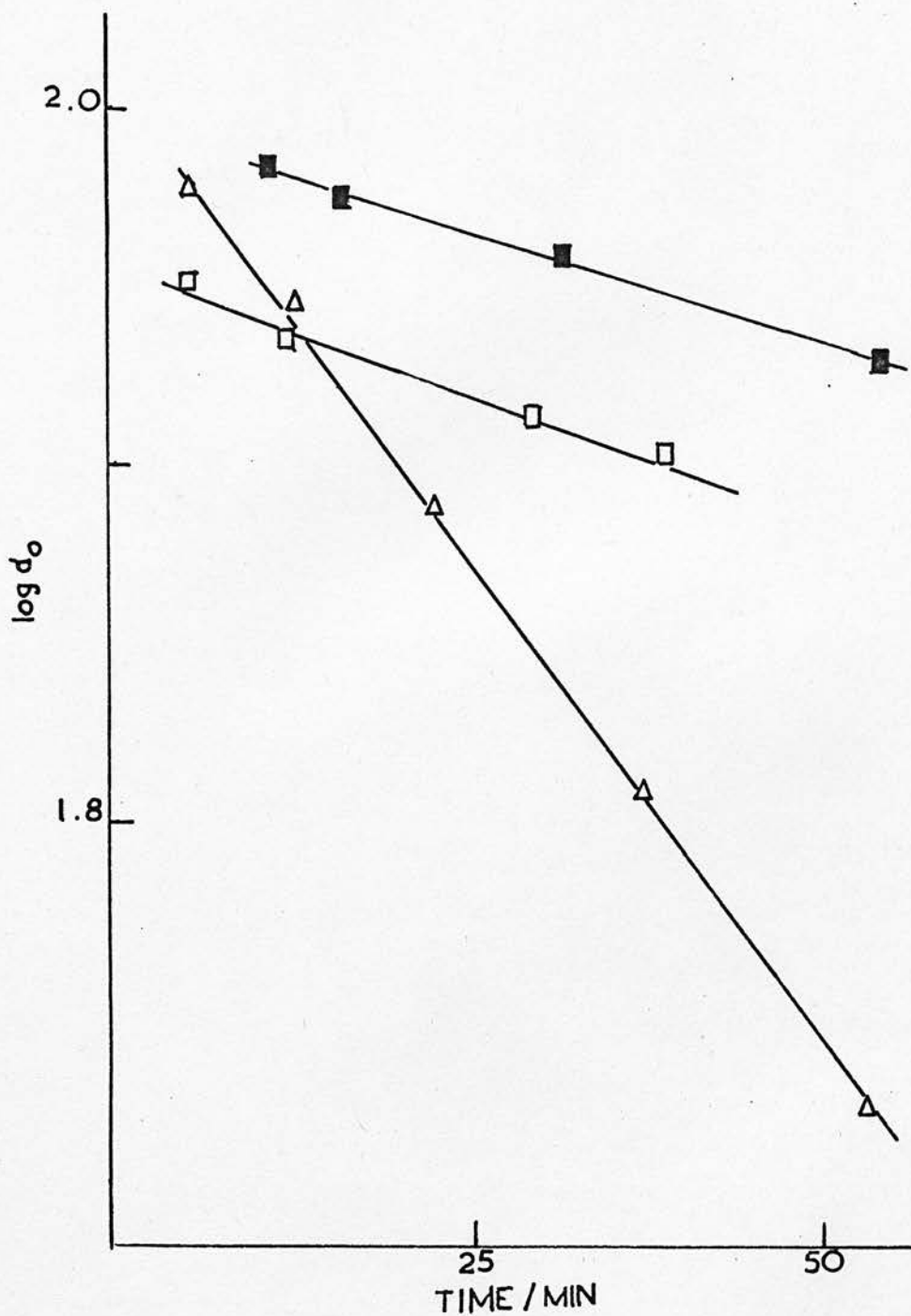

FIGURE 6.3 : Rate plots for the exchange reactions of olefins with deuterium on magnesium oxide.

□, cyclopentene at 330K; Δ, isobutene at 195K;
 ■, ethylene at 370K.

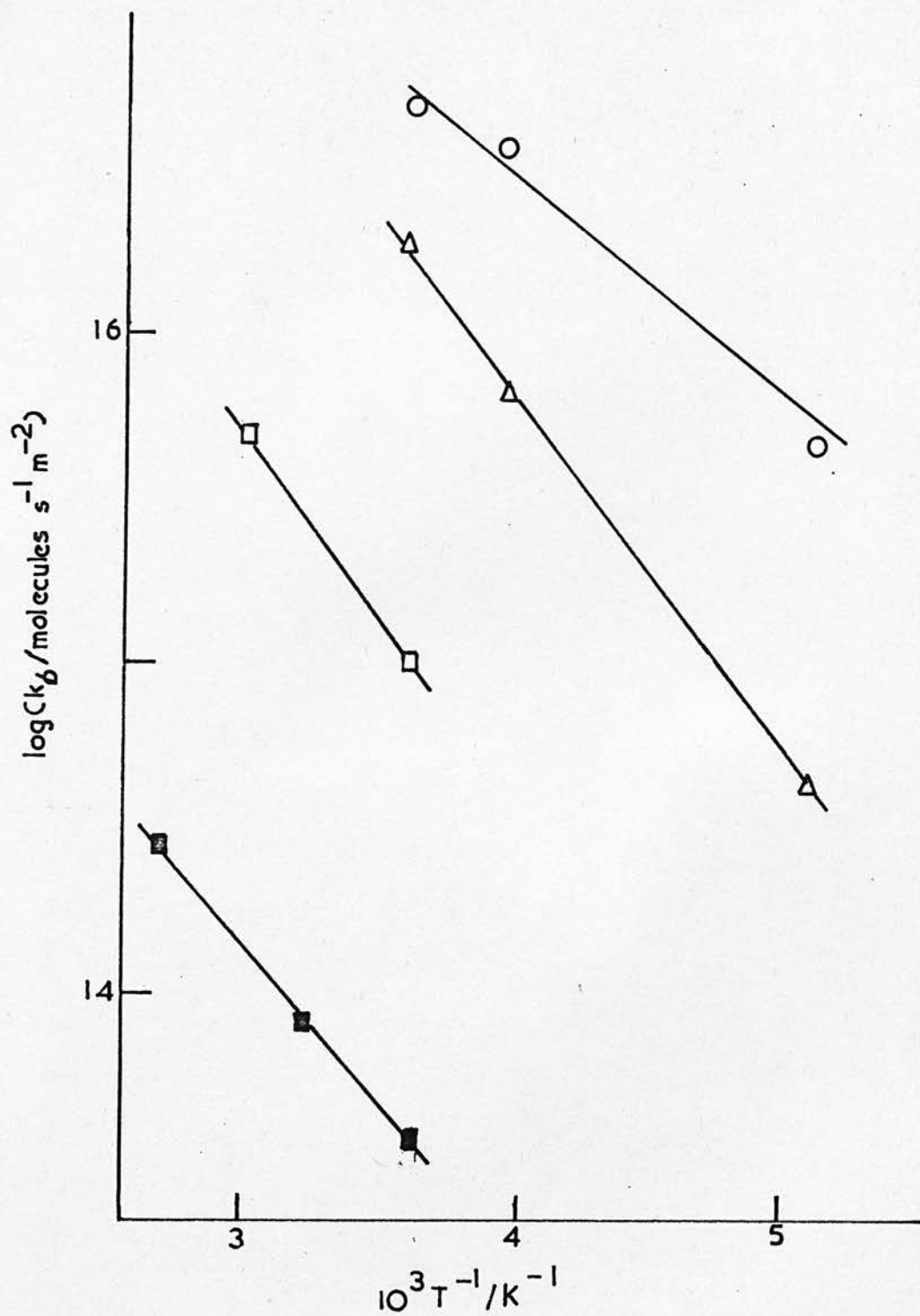

FIGURE 6.4 : Arrhenius plots for the exchange reactions of olefins on magnesium oxide.

□, cyclopentene; △, isobutene; ○, propylene;
 ■, ethylene.

All four hydrogen atoms in ethylene appeared to exchange at the same rate. The initial experimental distribution indicated small amounts of d_3 - and d_4 - species present in the reaction mixture. This multiple-exchange proceeded no further and the overall exchange settled down to a steady rate involving a stepwise mechanism. The reaction was repeated using ethylene from a different gas cylinder and the same behaviour was observed thereby eliminating the presence of impurities in the first gas sample giving rise to the extra peaks in the mass spectrum.

Propylene exchange with deuterium occurs readily over magnesium oxide. Five of the hydrogen atoms can be replaced. A similar activity for exchange was found with isobutene where all eight hydrogen atoms appeared to exchange at the same rate.

In the cyclic olefin, cyclopentene, two hydrogen atoms were observed to exchange more readily than the other six atoms. A pronounced break in the experimental distribution when compared with the binomial distribution was obvious between the d_2 - and the d_3 - exchanged species. At 330K, the ratio of the rate constants for exchange of the two types of hydrogen atoms was fifteen.

The simultaneous exchange of olefins produced some unexpected results. The presence of ethylene in the reaction mixture appeared to retard the exchange of propylene and isobutene. The results are summarised in table 6.4. Also included are the rate constants for exchange of the individual molecules at the relevant temperatures. The effect is most dramatic in reaction (1) where the rates of isobutene and propylene are reduced by a factor of about 500. In reaction (2) the exchange of propylene in the presence of ethylene was followed at a series of temperatures and the activation energy was calculated as 26.5 kJ mol^{-1} which is

almost twice that for the exchange of propylene by itself (13.5 kJ mol^{-1}). After this reaction the catalyst was evacuated at 473K for 30 minutes. A fresh mixture of propylene and deuterium was introduced and the exchange reaction followed. At 250K the rate of exchange was 2.5×10^{16} molecules $\text{s}^{-1} \text{ m}^{-2}$ which was close to that obtained previously (4×10^{16} molecules $\text{s}^{-1} \text{ m}^{-2}$) and indicated that the activity of the catalyst had been restored. The presence of ethylene in the reaction mixture appeared to be important because in a reaction involving propylene and isobutene the rates of exchange of the olefins were close to those obtained in the individual experiments. It was noted that in none of these reactions was there appreciable loss of reactant from the gas phase other than by adsorption at low temperature which was reversible.

TABLE 6.4

SIMULTANEOUS EXCHANGE REACTIONS OF OLEFINS

reactant	temperature /K	(1) $10^{-15} \text{ k}\phi$ /molecules $\text{s}^{-1} \text{ m}^{-2}$	(2) $10^{-15} \text{ k}\phi$ /molecules $\text{s}^{-1} \text{ m}^{-2}$	individual $10^{-15} \text{ k}\phi$ /molecules $\text{s}^{-1} \text{ m}^{-2}$
propylene	195	< 0.01	0.15	5.0
isobutene		< 0.01	-	4.0
propylene	273	0.9	2.0	50
isobutene		0.8	-	21
ethylene	330	< 0.01	0.05	0.21
propylene		2.3	20	> 100
isobutene		3.5	-	> 100

Reaction mixtures: (1) ethylene, propylene and isobutene.

(2) ethylene and propylene.

6.4 DISCUSSION

The results of the exchange reactions confirm the wide range of activity of magnesium oxide as a catalyst. In this discussion an arbitrary classification of the reactions has been made; high activity refers to those reactions which can be observed below room temperature, moderate activity to those followed between 273K and 423K, low activity describes the reactions occurring above 450K while very low activity refers to those reactions which took place very slowly even at 700K which is close to the pretreatment temperature used in this work. It should be noted that a higher pretreatment temperature would probably have produced greater overall activity in the catalyst but it is assumed that the general pattern of relative activities would be the same. Evidence from hydrogen/deuterium equilibration⁽⁹⁾ and butene isomerisation reactions⁽²⁾ indicates that the activity of magnesium oxide catalysts is sensitive to the pretreatment temperature.

High activity:- Reactions which can be put into this category are hydrogen-deuterium equilibration⁽⁹⁾, butene isomerisation^(1,2) and the exchange of propylene and isobutene.

The hydrogen-deuterium reaction occurs over a catalyst similar to the one used in this work at 78K and it is assumed for the exchange reactions that the rate-determining step will not be associated with activation of the deuterium. The active sites for this hydrogen-deuterium reaction are thought to be associated with positive paramagnetic centres.

A mechanism for propylene exchange⁽⁵⁾ has already been suggested, involving the dissociative adsorption of the propylene to form an allyl species. The absence of multiple exchange ($M = 0.9 - 1.2$) suggests that the step which involves replacement of hydrogen by deuterium should be

rapid and reversible which is supported by the low activation energy for propylene exchange. The mechanism of the scrambling process is not clear. It may be intramolecular or intermolecular which might only be determined from further research. A similar sort of scheme for olefin exchange can be suggested for isobutene, in this case all eight hydrogens being accessible, which was confirmed in the exchange experiments. If a carbonium ion mechanism were involved it is likely that the rate of isobutene exchange would be markedly faster than that of propylene because of the increased stability of the intermediate. In reality the rate of exchange of isobutene is slightly slower which is probably a reflection of the greater stability of the anion formed from propylene.

Moderate activity:- The exchange reactions of ethylene and cyclopentene can be included in this category. The exchange of ethylene can be understood as involving dissociative adsorption to give a carbanionic vinyl species which collects a deuterium atom on desorption. If this type of mechanism held for all olefins one would expect an order of reactivity

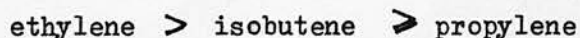

However the abilities of the larger olefins to form allyl species and of the catalyst to promote a double bond shift upset this order. Ethylene, of course, cannot form an allyl species.

The exchange reactions of olefins over alumina and magnesium oxide show distinctly different patterns. Table 6.5 shows a comparison of some of the exchange reaction data over the two catalysts. Because a large temperature range was involved in the work it is difficult to choose a suitable method of comparing rates of reaction. The comparison of rates of exchange at a given temperature required the extrapolation of Arrhenius data for some of the values. In this case a temperature of 289K was

chosen because most of the data were available around this temperature. This reduced the degree of extrapolation to a minimum.

TABLE 6.5

COMPARISON OF RATES OF EXCHANGE ON ALUMINA AND MAGNESIUM OXIDE

reactant	$k_{Al_2O_3} : k_{MgO}$ T = 289K	temperature required for rate of exchange of 10^{15} molecules $s^{-1} m^{-2}/K$	
		on MgO	on Al_2O_3
propylene	0.003	160	$\sim 325^b$
ethylene	10	465	310
cyclopropane	150	524	272
methane	220	840	606

a rate constants/molecules $s^{-1} m^{-2}$

b rate of exchange of propylene with deuterium from reference (10).

A large range of relative rates for alumina and magnesium oxide was found. The other method of comparing the catalysts' activities was to tabulate the temperature required for a given rate of exchange with each particular reactant. These temperatures are also recorded in table 6.5 for both alumina and magnesium oxide. This again illustrates the disparity in the activities of the two catalysts from the exchange of propylene through to the reaction with methane.

Olefin exchange over alumina is known to occur more readily in vinyl hydrogen atoms particularly terminal ones⁽⁷⁾. In propylene⁽⁵⁾ itself the results of exchange with deuterium indicate a preferential replacement of the methylene hydrogen atoms followed by exchange of the central and

methyl hydrogen atoms. There is no evidence of a double bond shift mechanism being operative over alumina which pinpoints one of the striking differences in the behaviour of alumina and magnesium oxide as catalysts. In the exchange reaction of ethylene a similar reaction process is believed to operate on both oxides. However in the case of larger olefins which can accommodate an allylic species as a reaction intermediate, rapid exchange with deuterium occurs over magnesium oxide but not over alumina. As table 6.5 indicates propylene exchanges much faster than ethylene over magnesium but slightly slower than ethylene over alumina. Exchange over the two catalysts probably involves different types of intermediates⁽⁵⁾: on magnesium oxide π -allyl carbanions are believed to be important while on alumina, 1-propenyl species seems likely to be the principal intermediate with some 2-propenyl and σ -allyl species also present. The relative properties of the intermediates explain why double-bond shift is favoured on magnesium oxide.

The strength of interaction between the intermediate species and the surface may also be important as may be the degree of reversibility of the adsorption step. The adsorbed species may be more tightly bound to the active sites on alumina. Little quantitative data is available and direct methods of measuring the acid-base properties of surfaces under reaction conditions are not available. From the adsorption studies of pyridine and ammonia, strong Lewis-acid sites where ammonia appears to coordinate to metal ions are believed to exist on alumina⁽¹¹⁾. However much weaker interactions with ammonia occur on magnesium oxide⁽¹²⁾.

The exchange reaction of cyclopentene with deuterium over alumina was restricted to the vinyl hydrogen atoms of temperatures below 473K.⁽⁷⁾ Double bond migration was restricted to molecules which incorporated a three

carbon atom chain including the double bond which could appear concave when viewed from outside the molecule. This was believed to reflect the geometric properties of the surface sites. The computer program developed for the work described in Chapter 3 was used to calculate distribution for a molecule like cyclopentene where two hydrogens react faster than the other eight. In order to match the experimental distributions for the exchange of cyclopentene over alumina the ratio of rate constants for exchange in the vinyl hydrogen atoms and in the other ring positions had to be in excess of 750. The distinction between the two types of hydrogen atoms is not so sharp over magnesium oxide. However, the double bond shift is still not so rapid within the molecule as in propylene exchange because the results clearly indicate that the vinyl hydrogens are more readily exchanged with deuterium than are the other ring hydrogen atoms. Exchange in the vinyl positions possibly occurs by a similar mechanism over both catalysts, perhaps involving a dissociative intermediate of carbanionic nature. The double bond migration is probably an independent process which is more easily promoted by magnesium oxide than by alumina. This may be a result of some geometric property whereby the former catalyst can better accommodate the cyclic molecules.

Low activity:- The exchange reactions of alkanes and cycloalkanes can be put into this category. The relatively high activity of methane in comparison with the other alkanes suggests that a radical mechanism can be dismissed for the same reasons as those discussed in relation to alumina (Chapter 5.4). In addition the arguments against carbonium ion intermediates are also relevant to magnesium oxide.

A direct comparison with the propane exchange results of Flockhart et al.⁽³⁾ is not possible. They obtained a rate of 5.6×10^{16} molecules

$s^{-1} m^{-2}$ at 713K which compares with our value at that temperature of 3×10^{15} molecules $s^{-1} m^{-2}$. The difference in the rates of reaction is not unreasonable since, in this work, a lower pretreatment temperature (623K as against 750K) was used which would probably result in this catalyst not being activated to the same extent.

A similar relationship between the rate of exchange of the alkanes and their pKa values (where available) to that for alumina was found to hold for magnesium oxide. This is shown in figure 6.5 in which the rate constants, where they are known, refer to individual exchange experiments. For ethane and propane the relative rates with respect to methane were used. At 627K, the Brønsted relationship can be written as

$$\log k_{\phi} = -0.63 \text{ pKa} + 38.3 \quad 6.1$$

At this temperature the rate of exchange of ethylene (extrapolated from Arrhenius data obtained between 273 and 373K) also fits the straight line and, as with alumina, the rate of the exchange reaction of cyclopropane appears to be enhanced when compared with acyclic alkanes. This all seems to be good evidence to support the suggestion that alkane exchange over magnesium oxide involves dissociative adsorption to give an alkyl species which has some degree of negative charge. The results of the combined exchange experiments would indicate that the presence of other alkanes in the reaction system does not greatly affect the exchange of any particular alkane.

With regard to exchange reactions of alkanes, the behaviour of alumina and magnesium oxide as catalysts is similar. The reactions required a higher temperature over magnesium oxide but the general relative pattern was the same and indeed the Brønsted relationships indicate that the catalysts have similar sensitivities to the acid strengths of the reactants.

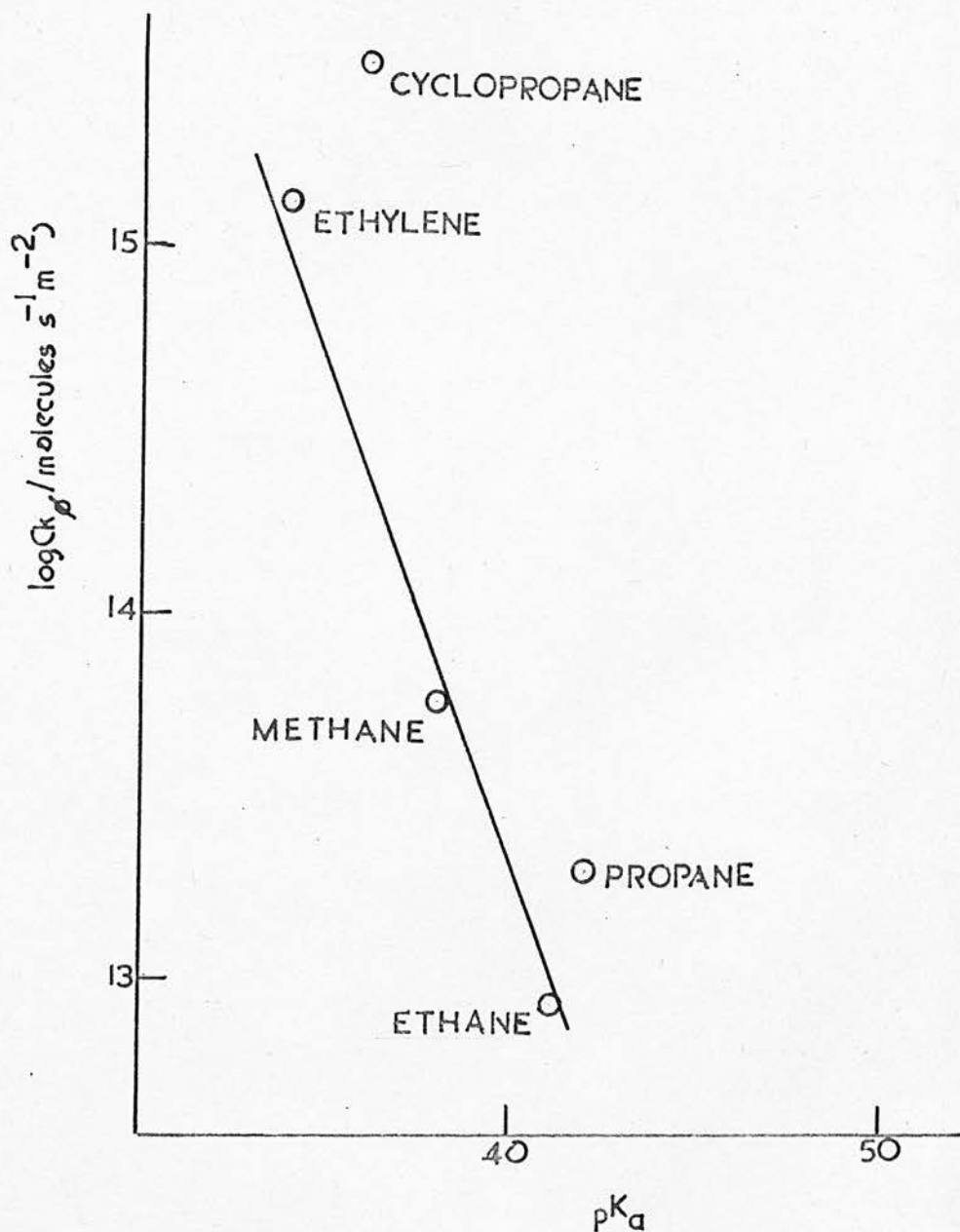

FIGURE 6.5 : Alkane exchange reactions over magnesium oxide; rate of deuterium exchange at 627K as a function of the pK_a of the hydrocarbon. Values of pK_a are from same sources as those in chapter 5.

The lesser activity of magnesium oxide may be attributable to different degrees of activation during the pretreatments of the catalysts. Another possible cause of the difference may be the formation of intermediates on magnesium oxide which are strongly adsorbed such that surface exchange is retarded. In an examination of the kinetics of the exchange reaction of cyclopropane with deuterium over magnesium oxide⁽¹³⁾, the reaction was found to be approximately first order with respect to the alkane and zero order with respect to deuterium. The simplest interpretation of these results is that the rate-determining step in the exchange of ^{cyclo}propane is the adsorption of the alkane itself. Deuterium will play no part in this and hence will have a zero-order dependence. The deuterium must be readily available on the magnesium oxide surface even at low temperature for the exchange of the olefins.

Very low activity:- No evidence was found for the isomerisation of cycloalkanes over magnesium oxide even at the highest temperatures allowed by the system. It is possible that, like the isomerisation of 3,3 dimethylbut-1-ene⁽⁶⁾, these reactions involve carbonium ions as intermediates which are unlikely to be formed on magnesium oxide.

Of the two catalysts alumina seems to be the more likely to accelerate reactions which involve carbonium ions. The relative reactivities for exchange and isomerisation of 3-3 dimethylbut-1-ene tend to support this⁽¹⁴⁾. Over alumina isomerisation occurred at 328K while exchange with deuterium required a slightly higher temperature. However on magnesium oxide no isomerisation of the butene was detected at 493K even though exchange of the methyl hydrogen atoms could be observed at this temperature. Exchange of the vinyl hydrogens takes place at lower temperatures⁽⁶⁾. Similarly in the isomerisation of methylcyclopropane which may

involve a carbonium ion intermediate the isomerisation reaction over alumina occurs before the exchange of the hydrogen atoms in the methyl group but over magnesium oxide all eight hydrogen atoms will exchange without any evidence of isomerisation.

Poisoning and Inhibition:- The most dramatic poisoning effects with magnesium oxide occurred in the simultaneous exchange of the olefins. The presence of ethylene in the reactions involving propylene and isobutene seemed to drastically affect the rate of the exchange reactions. Propylene and isobutene do not seem to greatly affect one another. The possibility of a "dirty" ethylene sample can be dismissed because ethylene from two different sources gave the same rates for the exchange reactions. One possible explanation is that some dimerisation or polymerisation involving an adsorbed ethylene species and some larger grouping occurs and the product is irreversibly adsorbed on the catalyst thereby poisoning the reaction. There was no evidence from the total ion monitor trace of material loss from the reaction mixture but perhaps only a small number of species would be required to poison the active sites and any losses of material would be imperceptible. Alternatively, the inhibition of the olefin exchange reactions may be a result of competition for sites. The reaction mixture contained ca. 10^{20} molecules over 0.1g of catalyst in which case the number of molecules in the reaction vessel was probably greater than the number of active sites. However the fact that propylene and isobutene when reacting together did not interfere greatly with each other would suggest that any effect due to competition for the sites was small. It should be noted that the activation energy for the exchange of propylene with deuterium in the presence of ethylene is about twice that when propylene reacts on its own. Both propylene and isobutene have low activation energies for

exchange and the presence of ethylene causes this to be increased perhaps as a result of the strong adsorption of a $C_2H_3^-$ species which competes for sites with the allylic species. The size of the ethylene species and its ability to coordinate terminal vinyl hydrogens, which is known to be important over alumina, may also be effective in this case.

The other poisoning effects which occurred in reactions with magnesium oxide were found in the alkane exchange reactions at high temperatures. Again the possible causes of this must remain speculative. It is unlikely that the poisoning was due to the main product of the reaction, namely the deuterated alkanes but, at such elevated temperatures, it was possible that other species are formed on the catalyst possibly involving carbon-carbon bond rupture to give irreversibly adsorbed species. This was supported by the fact that poisoning appeared to be worse at higher temperatures.

REFERENCES

- (1) I.R. Shannon, C. Kemball and H.F. Leach, 'Symposium on Chemisorption and Catalysis', (Institute of Petroleum, London), 1971, p.46.
- (2) M.J.Baird and J.H.Lunsford, *J. Catalysis*, 26, 440, 1972.
- (3) B.D. Flockhart, S.S. Uppal and R.C. Pink, *Trans. Faraday Soc.*, 67, 513, 1971.
- (4) K. Tanabe, T. Yamaguchi and T. Takeshita, *J. Res. Int. Catalysis, Hokkaido*, 16, 425, 1968.
- (5) B.T. Hughes, J.K. Tyler and C. Kemball, *J.C.S. Faraday I*, 71, 1285, 1975.
- (6) C. Kemball, H.F. Leach, B.Skundric and K.C.Taylor *J. Catalysis*, 27, 416, 1972.
- (7) J.W.Hightower and W.K.Hall, *Trans. Faraday Soc.*, 66, 477, 19
- (8) R.S. Dowie, D.A. Whan and C. Kemball, *J.C.S. Faraday I*, 68, 2150, 1972.
- (9) M. Boudart, A. Debouille, E.G. Derouane, V.Indovina and A.B. Walters, *J. Am. Chem. Soc.*, 94, 6622, 1972.
- (10) J.D. Nesbit, Honours Project, Chemistry Dept., University of Edinburgh.
- (11) J.B. Peri, *J. Phys. Chem.*, 69, 231, 1965.
- (12) A.J. Tench and D. Giles, *J.C.S. Faraday I*, 68, 193, 1972.
- (13) H. McLaren, Honours Project, Chemistry Dept., University of Edinburgh.
- (14) M.S. Scurrrell, unpublished results.

**Evidence for Carbanionic Intermediates During Exchange Between Butanes
and Deuterium on Alumina**

By PHILIP J. ROBERTSON, MICHAEL S. SCURRELL, and CHARLES KEMBALL*

(Department of Chemistry, University of Edinburgh, West Mains Road, Edinburgh EH9 3JJ)

Reprinted from

**Journal of The Chemical Society
Chemical Communications
1973**

The Chemical Society, Burlington House, London W1V 0BN

Evidence for Carbanionic Intermediates During Exchange Between Butanes and Deuterium on Alumina

By PHILIP J. ROBERTSON, MICHAEL S. SCURRELL, and CHARLES KEMBALL*

(Department of Chemistry, University of Edinburgh, West Mains Road, Edinburgh EH9 3JJ)

Summary Examination of the exchange reactions between isobutane and deuterium, and n-butane and deuterium on alumina has revealed that the reactive hydrocarbon intermediates possess carbanionic character.

STUDIES of hydrogen-deuterium exchange reactions involving saturated hydrocarbons on alumina have been confined to propane,¹ methane,² and ethane.³ In the case of propane¹ and methane² it appears that the exchange process takes place *via* adsorbed alkyl groups which are attached to electron-deficient centres. We report here the results obtained for the exchange of isobutane and n-butane on alumina because they provide direct evidence for the participation of carbanionic intermediates in these reactions.

The experimental technique was essentially that described previously.⁴ The γ -alumina was prepared by heating a high purity boehmite (Laporte Industries Ltd.) at 900 K in air for 16 h (surface area by N_2 adsorption at 77 K = 120 m² g⁻¹). The catalyst (1.0 g) was treated with oxygen at 723 K prior to evacuation at this temperature (pressure < 2 × 10⁻⁴ N m⁻²) for at least 15 h. The mixture usually consisted of hydrocarbon and deuterium at initial pressures of 0.95 and 9.6 kN m⁻² respectively in a silica vessel (3 × 10⁻⁴ m³).

The initial rate of reaction of n-butane (1.4 × 10¹⁵ molecules s⁻¹ m⁻²) at 273 K was 2.3 times faster than the rate for isobutane, both compounds exhibiting stepwise exchange. After extensive exchange of isobutane at 425 K, the amounts of the [²H₈]-, [²H₉]-, and [²H₁₀]-isomers were 40, 34, and <0.5% respectively showing that 9 of the

hydrogen atoms were exchanging at least 100 times more rapidly than the tenth. Analysis of results for n-butane at 316 K by standard methods⁵ showed that 6 hydrogen atoms were replaced 55 times more rapidly than the remaining 4.

These results indicate that the alkyl intermediates in the exchange reactions possess carbanionic character and that neither carbonium ions nor radical species are involved. If exchange occurred *via* alkyl radicals, the methine hydrogen would have been expected to react more rapidly than those in the methyl groups in isobutane on the basis of relative dissociation energies for the two types of carbon-hydrogen bonds⁶ and, similarly, the methylene hydrogens would have reacted at least as rapidly as the methyl hydrogens in n-butane. Participation of carbonium ion intermediates, although compatible with the observation that 9 hydrogen atoms of isobutane exchange readily,⁷ is not consistent with the similar rates found for isobutane and n-butane. Formation of carbonium ions would occur much more easily for isobutane.

Additional evidence for the involvement of alkyl carbanionic species is provided by the fact that the methyl hydrogens in n-butane exchange at a much higher rate than those in the methylene groups. This result is expected on the basis of the relative acidities for these two types of hydrogen atoms.⁸

We acknowledge the support of the Carnegie Trust for the award of a scholarship (to P.J.R.) and Imperial Chemical Industries Ltd., for a postdoctoral fellowship (to M.S.S.).

(Received, 17th August 1973; Com. 1194.)

¹ B. D. Flockhart, S. S. Uppal, I. R. Leith, and R. C. Pink, Proc. Fourth Int. Congress on Catalysis, Akademiai Kaido, Budapest, 1971, vol. 2, p. 398; B. D. Flockhart, S. S. Uppal, and R. C. Pink, *Trans. Faraday Soc.*, 1971, **67**, 513.

² J. G. Larson and W. K. Hall, *J. Phys. Chem.*, 1965, **69**, 3080.

³ A. I. Trokhimets and S. V. Markevich, *Russ. J. Phys. Chem.*, 1965, **39**, 1055.

⁴ C. Kemball, *Proc. Roy. Soc.*, 1951, **A**, **207**, 539.

⁵ R. J. Harper, S. Siegel, and C. Kemball, *J. Catalysis*, 1966, **6**, 72.

⁶ J. G. Calvert and J. N. Pitts, jun., 'Photochemistry', Wiley, New York, 1966, p. 824.

⁷ S. G. Hindin, G. A. Mills, and A. G. Oblad, *J. Amer. Chem. Soc.*, 1951, **73**, 278.

⁸ D. J. Cram, 'Fundamentals of Carbanion Chemistry', Academic Press, New York, 1965, p. 21.

Development of a gas chromatograph-mass spectrometer with 'on-line' computer for studies in catalysis

Reactions of ethylene and deuterium on oxides

BY C. KEMBALL, F.R.S., J. D. NISBET, P. J. ROBERTSON
AND M. S. SCURRELL

*Department of Chemistry, University of Edinburgh, West Mains Road,
Edinburgh EH9 3JJ, Scotland*

(Received 27 November 1973)

The development of an 'on-line' computer for use with a combined gas chromatography-mass spectroscopy (g.c.-m.s.) technique in the study of heterogeneous catalysis is described and discussed with reference to the reactions of ethylene and deuterium on oxides. Emphasis has been placed on the selectivities shown by a number of catalysts for the exchange and addition reactions. Magnesium oxide effects the exchange of ethylene without production of ethane even at 671 K; γ -alumina also exhibits a high selectivity for exchange. In contrast, on chromium oxide (Cr_2O_3) at 197 K and zinc oxide at 273 K, ethylene undergoes rapid deuteration with no observable exchange of the olefin. For the range of catalysts studied the ratio of rate constants for the exchange and addition reactions decreases in the order: $\text{MgO} > \text{Al}_2\text{O}_3 \gg \text{TiO}_2 \sim \text{Fe}_2\text{O}_3 > \text{Co}_3\text{O}_4 > \text{ZrO}_2 \gg \text{ZnO} \sim \text{Cr}_2\text{O}_3$. An explanation for the marked differences in catalytic behaviour within this group of oxides is provided.

INTRODUCTION

The application of a combined gas chromatograph-mass spectrometer to studies of catalytic reactions has been described (Dowie, Kemball, Kempling & Whan 1972). The technique has been successfully applied to studies of deuterium exchange processes on surfaces (Dowie, Gray, Whan & Kemball 1971; Dowie, Whan & Kemball 1972; Kemball & Kempling 1972) but the quantities of data produced in an experiment are large and the analysis complex and tedious. This problem has now been overcome by means of an 'on-line' computer using analog-to-digital conversion for data capture. This method of data acquisition is described and discussed in this paper with particular reference to the reactions of ethylene and deuterium on oxide catalysts.

There have been several previous investigations into the reactions of ethylene and deuterium on oxides but perhaps the most interesting results are those shown by alumina. Ethylene and other olefins undergo rapid exchange with deuterium on this catalyst (Larson, Hightower & Hall 1966) without significant formation of the corresponding saturated hydrocarbon. The high selectivity displayed by alumina has led to its use in the preparation of perdeutero-olefins. Elsewhere (Hindin & Weller 1956) it has been shown that the hydrogenation of ethylene can be effected but at somewhat higher temperatures than those required for exchange. Hydrogenation takes place at or below room temperature if ethylene

is preadsorbed on the catalyst (Amenomiya, Chenier & Cvetanovic 1967) but at higher temperatures exchange is much faster than the addition reaction (Amenomiya 1968).

The behaviour of alumina appears paradoxical, since a catalyst which is capable of activating both ethylene and hydrogen might be expected to catalyse the hydrogenation reaction which is thermodynamically more favourable and takes place with very high selectivity on zinc oxide (Kokes & Dent 1972) and chromia (Burwell *et al.* 1960). Intermediate behaviour with both exchange and addition taking place at similar rates is found for titania (rutile) (Lake & Kemball 1967).

The present work was aimed at a comparative study of the natures of the ethylene-deuterium reactions on these and other oxides to examine the general pattern of the results and in particular to explain the anomalous character of alumina. The relative rates of the exchange and addition processes have been measured for eight oxide catalysts. The combined gas chromatograph-mass spectrometer is particularly useful for this purpose since it enables very small quantities of ethane to be detected for a reaction in which the predominant process is the exchange of ethylene. Conversely in a system showing high selectivity for hydrogenation it is possible to measure the rate of any accompanying exchange reaction.

EXPERIMENTAL

Apparatus

The apparatus used for this work was basically that described earlier (Dowie *et al.* 1972). The reactor was constructed of silica and was of volume $2.70 \times 10^{-4} \text{ m}^3$. The mass spectrometer used ionizing electrons at 20 eV and about 15–20 scans per hydrocarbon component were recorded.

In previous work (Dowie *et al.* 1972) mass spectra were recorded on photographic paper. An improved method of data capture has now been developed with the aid of an 'on-line' computer. The signal from the electron multiplier to the ultraviolet recorder (see Dowie *et al.* 1972, figure 1) was fed via a unity gain high impedance buffer to the analog-to-digital converter (a.d.c.) of the computer (PDP 11, Digital Equipment Corporation, Maynard, Massachusetts, U.S.A.). In this way mass spectra could be collected simultaneously by the computer and the ultraviolet recorder. During the development of the computer facility both methods of data acquisition were used and the results compared in order to assess the reliability of the 'on-line' capture technique.

Data acquisition

At the start of each scan an electronic pulse was automatically generated by the mass spectrometer magnet control unit and directed to the a.d.c. in order to 'activate' the data collection procedure. During an experiment the mass spectrometer scanning rate was 1 s per decade of mass, the spectra were scanned between preset mass limits of 100 and 10, and the signal generated by the electron multiplier

was sampled by the a.d.c. at 5000 Hz. A threshold level was preset at a value such that baseline noise from the multiplier and signals due to random ion peaks were not stored by the computer. For each mass spectrometric scan every a.d.c. sample number together with the corresponding signal intensity above threshold was recorded and each spectrum was assigned a number for identification purposes.

TABLE 1. DIGITAL REPRESENTATION OF MASS SPECTRA

(Spectrum of mixture of deuterated ethylenes.)

centroid	intensity	mass†
2365	112	33.0
2436	5717	32.0
2509	5474	31.0
2579	2798	30.0
2655	1200	29.0
2737	2191	28.0
2819	516	27.0
2904	178	26.0
3737	581	18.0

† Mass numbers subsequently assigned during data processing.

At the conclusion of an experiment a peak location routine was used to analyze changes in the pattern of the intensities observed by the a.d.c. A steady increase in signal intensity for three consecutive a.d.c. samples enabled a mass spectrometric peak to be recognized; a subsequent decrease in intensity over two a.d.c. samples established the termination of the peak. For each peak thus defined the initial sample numbers and signal intensities were used to assign (*a*) a centroid value, which accurately defined the position of the peak in relation to the start of a spectrum and (*b*) an integrated intensity value. In this way each spectrum recorded finally comprised a series of centroid and intensity values and table 1 shows a typical mass spectrometric scan which was one of 24 recorded for a sample of ethylene after exchange with deuterium on magnesium oxide.

All spectra were produced in this form by the PDP 11 and simultaneously recorded as binary data on paper tape. The tape was subsequently processed by means of an I.C.L. 4-75 computer. First, mass numbers were assigned to the centroid values in each spectrum. Use was made here of the background spectra which were always recorded immediately before elution of the hydrocarbons from the gas chromatograph. The three most prominent peaks in these background scans could be assigned mass numbers 18, 28 and 32, their occurrence being due to the presence of traces of water, nitrogen and oxygen in the mass spectrometer. The relation between mass number and centroid value throughout the spectrum was interpolated from the positions of the three reference masses, the a.d.c. sampling rate and the scan rate per decade of mass. In this way each centroid value in the remaining spectra could be converted into a mass number.

After all spectra had been processed to the mass number-intensity stage, isotopic

distributions were obtained for each hydrocarbon sample by the methods previously described (Dowie *et al.* 1972) by means of 4-75 computer.

Although all spectra are now processed by the PDP 11 and 4-75 machines, a few scans are recorded on ultraviolet paper during an experiment to afford an immediate indication of the progress of a reaction. It is hoped that in future all data processing will be achieved by means of the PDP 11 computer alone. This will obviate the need for an intermediate transfer of data and will lead to an even more rapid and reliable calculation of isotopic distributions from experimental data.

Materials

Details of the catalysts used are given in table 2.

Ethane, ethylene (99%) and deuterium (99.5%) were supplied by Cambrian Chemicals Ltd. The hydrocarbons were further purified by distillation from traps immersed in liquid nitrogen before storage, and again immediately before use. Deuterium and hydrogen (Air Products Ltd) were passed through a heated palladium-silver alloy thimble before use. Oxygen (Air Products Ltd) was dried by passage through traps held at 77 K.

TABLE 2. THE CATALYSTS

oxide	source	pretreatment	surface area/m ² g ⁻¹ (by N ₂ adsorption at 77 K)
γ -alumina	boehmite (Laporte Industries Ltd) calcined (923 K, 15 h)	O ₂ (20 kPa, 723 K, 15 min); evacuated; O ₂ (20 kPa, 723 K, 1½ h); evacuated (723 K, 16 h)	90
MgO	magnesium (Johnson Matthey Chemicals Ltd, 'Specpure') via nitrate and carbonate (decomposed 1120 K, 12 h)	evacuated (723 K, 16 h)	30
TiO ₂ (rutile)	Tioxide International Ltd	evacuated (723 K, 16 h); O ₂ (2.7 kPa, 723 K, 30 min); cooled to 298 K; evacuated (298 K, 30 min)	25 (Brookes 1972)
Fe ₂ O ₃	Johnson Matthey Chemicals Ltd, grade 1	evacuated (673 K, 16 h)	2.62 (Shannon 1969)
Co ₃ O ₄	Johnson Matthey Chemicals Ltd, grade 1	evacuated (533 K, 45 min) (Harrison, Nicholls & Steiner 1967)	0.65 (Shannon 1969)
ZrO ₂	I.C.I. Ltd (contained 0.02% S)	evacuated (723 K, 20 h)	2 (Hughes, Taylor & Kemball)
ZnO	New Jersey Zinc Company (Kadox 25)	evacuated and heated to 573 K; H ₂ (20 kPa, 573 K, 30 min) evacuated (573 K, 5 min, then 723 K, 16 h)	10 (Naito <i>et al.</i> 1971)
Cr ₂ O ₃	similar to samples I and II described elsewhere (Cross & Leach 1971)	evacuated (723 K, 20 h)	100 approx. (Leach 1973, pers. comm)

Procedure

After each catalyst had been activated as described (table 2) the reaction vessel was held at reaction temperature (table 3). Masses of catalyst used in these experiments were in the range 0.2–3.0 g.

A 10:1 ratio of deuterium to ethylene was admitted to each oxide at reaction temperature and the resulting initial gas phase pressure was in the range 1.9–2.8 kPa. For the measurement of the rates of reaction of deuterium with ethylene on alumina the initial pressure was approximately 5.2 kPa. Samples (approximately 2%) were removed from the gas phase intermittently and introduced into the gas chromatographic column.

Separation of ethylene and ethane was achieved by using a 2 m column of squalane (3%) on activated alumina type H, 100/200 mesh. The column was maintained at 263 K by immersion in a bath of ice and ethanol and helium carrier gas was passed at a pressure of 140 kPa. Under these conditions typical retention times for ethane and ethylene were 6 and 7.6 min respectively.

Mass spectra were corrected for the presence of background peaks, for naturally occurring deuterium and 'heavy' carbon and for fragmentation. All analyses were made in terms of the parent ion for each isomer present. Fragmentation patterns and relative sensitivities for ethylene- d_0 and ethane- d_0 were measured at regular intervals during the course of the work. When correcting spectra for fragmentation it was assumed that loss of hydrogen and deuterium took place in a statistical manner and that the fragmentation patterns for all isomeric hydrocarbons were identical. It was not found necessary to adopt the procedure developed by Dowie, Whan & Kemball (1972).

The apparatus enabled identifiable mass spectra to be obtained for 6×10^{14} molecules entering the g.c.-m.s. system. This corresponds to 3×10^{16} molecules in the reaction vessel or a product yield of 0.3%. Reliable isotopic distributions could be obtained such that the presence of $> 0.5\%$ ethylene- d_1 in ethylene- d_0 could be detected.

RESULTS

The results obtained for the eight oxides used are summarized in table 3.

The integrated first-order rate equation

$$-\lg(1 - x_a) = k_a t / 2.303, \quad (1)$$

was used to calculate the value of k_a , the rate constant for the addition reaction. The fractional conversion of ethylene to ethane at time t is x_a . The rate constant for exchange, k_e was obtained from the equation

$$-\lg d_0 = k_e t / 230.3 - \lg 100, \quad (2)$$

where d_0 is the percentage of light ethylene present at time t . This equation is applicable to an exchange reaction which is first order in ethylene pressure (Kemball & Stoddart 1957).

The linear relations predicted by these rate equations were well obeyed except in two cases and hence the assumptions made above are considered to be justified. For cobalt oxide a slight curvature of the plot indicating a decrease in rate was observed for the addition reaction. A similar effect has been attributed to irreversible adsorption of hydrogen on the catalyst (Tanaka, Nihira & Ozaki 1970). No curvature of the plot for the exchange data was detected. For iron oxide both the addition and exchange reactions showed a high initial rate followed by a period of lower activity during which the linear relations were obeyed. Rates of reaction reported for this oxide are applicable to the latter stage of reaction.

TABLE 3. ACTIVITIES OF THE OXIDES FOR ETHYLENE-DEUTERIUM REACTIONS

catalyst	addition	exchange	k_e/k_a	T/K
	reaction, k_a	reaction, k_e		
	molecules $s^{-1} m^{-2}$	molecules $s^{-1} m^{-2}$		
MgO	$< 2.7 \times 10^{11}$	$1.9 \times 10^{15} \dagger$	> 6900	671
Al ₂ O ₃	$3.2 \times 10^{11} \ddagger$	4.7×10^{14}	1500	289
TiO ₂ (rutile)	5.1×10^{12}	1.3×10^{13}	2.5	641
Fe ₂ O ₃	5.8×10^{13}	6.6×10^{13}	1.1	468
Co ₃ O ₄	8.1×10^{16}	1.1×10^{16}	0.13	293
ZrO ₂	7.8×10^{14}	3.6×10^{13}	0.046	297
ZnO	1.5×10^{14}	$< 2.8 \times 10^{12}$	< 0.020	273
Cr ₂ O ₃	1.5×10^{15}	$< 1.9 \times 10^{13}$	< 0.012	195

$\dagger k_e$ obtained from extrapolation of data measured at 298–373 K.

$\ddagger k_a$ obtained from extrapolation of data measured at 428–563 K.

For alumina and magnesium oxide where $k_e \gg k_a$, rates of exchange measured at low temperatures were compared with rates of addition at high temperatures (table 3). For magnesium oxide any ethane produced during 1 h at 671 K was below the limits of detection although exchange was rapid even at 298 K. Thus $< 0.3\%$ ethane was present and k_a was calculated as $< 2.7 \times 10^{11}$ molecules $s^{-1} m^{-2}$.

For zinc oxide and chromium oxide where $k_a \gg k_e$ ethylene- d_1 was not present above the detection limit (0.5%). Determining the absence of ethylene- d_1 is necessarily more difficult than establishing the highest limit to which ethane as a reaction product is present (as for magnesium oxide) since the concentration of only one isotopic species is being examined in a supply of reactant which is steadily undergoing conversion to ethane. Data for chromium oxide were particularly difficult to obtain because of the high activity of the catalyst for the addition reaction, even at 195 K. In view of these limitations the ratio k_e/k_a is probably considerably lower than the upper limits shown in table 3.

Arrhenius parameters derived from the data obtained for the addition and exchange reactions on alumina and magnesium oxide respectively are shown in table 4.

All the exchange reactions were stepwise, one hydrogen atom being replaced at a time, as evidenced by the close agreement between experimental isotopic distributions and the binomial distributions throughout the experiments.

TABLE 4. ARRHENIUS PARAMETERS FOR ETHYLENE-DEUTERIUM REACTIONS ON MAGNESIUM OXIDE AND ALUMINA

oxide	temperature range/K	$E/\text{kJ mol}^{-1}$	$\lg(A/\text{molecules s}^{-1}\text{m}^{-2})$
MgO (exchange)	298-373	16	16.5
Al ₂ O ₃ (addition)	428-563	25	16.1

DISCUSSION

Evaluation of computer captured data

The course of the exchange process on magnesium oxide is shown in figure 1, where data obtained from the PDP 11 and 4-75 computers are compared with those from the ultraviolet recorder. Clearly there is very good agreement between the isotopic distributions obtained from the two sources of raw spectral data. In addition, the isotopic distributions obtained from the computer captured data are in much closer agreement with the calculated binomial distributions also shown in figure 1. This is particularly clear at ϕ values above 100. The parameter ϕ represents 100 times

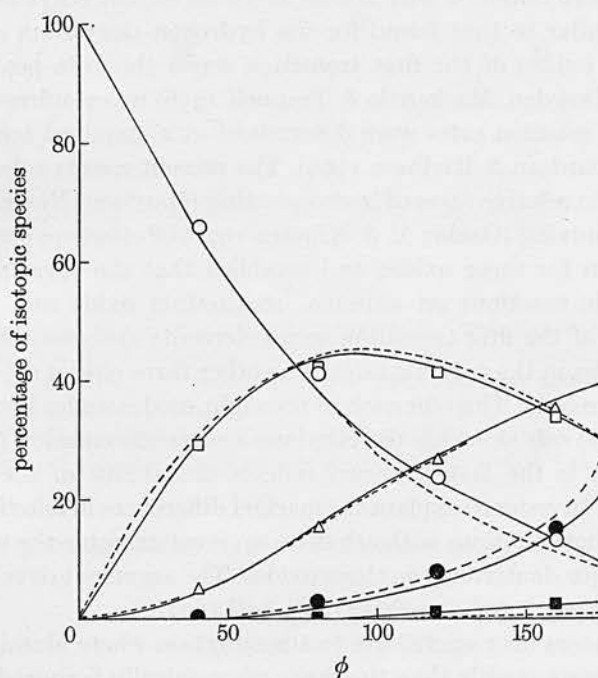

FIGURE 1. Comparison of isotopic distributions obtained for the exchange of ethylene with deuterium on magnesium oxide at 298 and 373 K; —, data from PDP 11; ---, data from photographic paper. Also shown are calculated binomial distributions; O, ethylene $-d_0$; □, $-d_1$; Δ, $-d_2$; ●, $-d_3$; ■, $-d_4$. The parameter ϕ represents 100 times the mean number of deuterium atoms present per molecule of hydrocarbon.

the mean number of deuterium atoms present per molecule of hydrocarbon. The disagreement found here is mainly due to an underestimate of the percentage of ethylene- d_4 present when data are collected on ultraviolet paper. This point was investigated further and the error is attributed to the presence of the peak at 32 in the background spectrum of the mass spectrometer. Although the two ions O_2^+ and $C_2D_4^+$ have nominal mass 32, examination of accurate atomic masses shows that the former ion is about 0.2% lighter. Consequently, partial resolution of the two mass peaks occurs when recording spectra of exchanged ethylenes. When examining the spectra on ultraviolet paper it is very difficult to establish that part of the total intensity due to the presence of ethylene- d_4 and since measurements of peak heights are used an underestimated intensity value results. The sampling rate of the a.d.c. of the PDP 11 is, however, sufficiently high that an accurate integrated intensity for each component at mass 32 can be determined.

To summarize, the results indicate that data acquisition via the PDP 11 computer enables isotopic distributions to be calculated with an accuracy which is as high as, and in certain cases higher than that obtained before.

Activity of the oxides

The activity pattern obtained with the eight oxides for the ethylene-deuterium reaction is very similar to that found for the hydrogen-deuterium equilibration (figure 2). For the oxides of the first transition series the twin-peaked activity obtained initially (Dowden, Mackenzie & Trapnell 1956) was confirmed by a later study in which the reaction rates were determined at a standard temperature of 298 K (Pearce, Richardson & Rudham 1969). The present results substantiate the observations that the relative rates of hydrogenation (Harrison, Nicholls & Steiner 1967) and isotopic mixing (Ozaki, Ai & Kimura 1971) of ethylene conform to the twin-peaked pattern for these oxides and establish that the agreement may be extended to include reactions on alumina, magnesium oxide and zirconia. In figure 2 the oxides of the first transition series elements are grouped together in order of their position in the periodic table. The other three oxides are included for comparison purposes only. Thus for each of the eight oxides under investigation it is concluded that the *rate* at which the ethylene-deuterium reaction (exchange or addition, whichever is the faster) occurs reflects the ability of the catalyst to activate deuterium. In order to explain the marked differences in *selectivities* for the addition and exchange reactions with ethylene we must examine the nature of the adsorbed hydrogen (or deuterium) on these oxides. The argument developed here is an extension of that presented elsewhere (Kemball 1973).

Two principal factors may contribute to the situation where alumina catalyses ethylene exchange more readily than the thermodynamically favoured hydrogenation reaction. The exchange of ethylene may occur dissociatively through the formation of adsorbed vinyl species for which there seems good evidence (Hightower & Hall 1969, 1970). The absence of hydrogenation is easier to understand if it is unnecessary to assume the presence of adsorbed ethyl groups for the exchange

of ethylene. But another factor must be considered because alkyl species, almost certainly possessing carbanionic character (Robertson, Scurrall & Kemball 1973) must be responsible for alkane exchange and so form readily and reversibly. It is therefore perhaps surprising that the adsorbed ethyl species is not also formed readily from ethylene. A possible explanation can be given in terms of the differing reactivities of electrophilic and nucleophilic hydrogen atoms on alumina. The dissociative adsorption of a hydrogen molecule on an oxide catalyst probably takes place by a heterolytic fission of the H—H bond

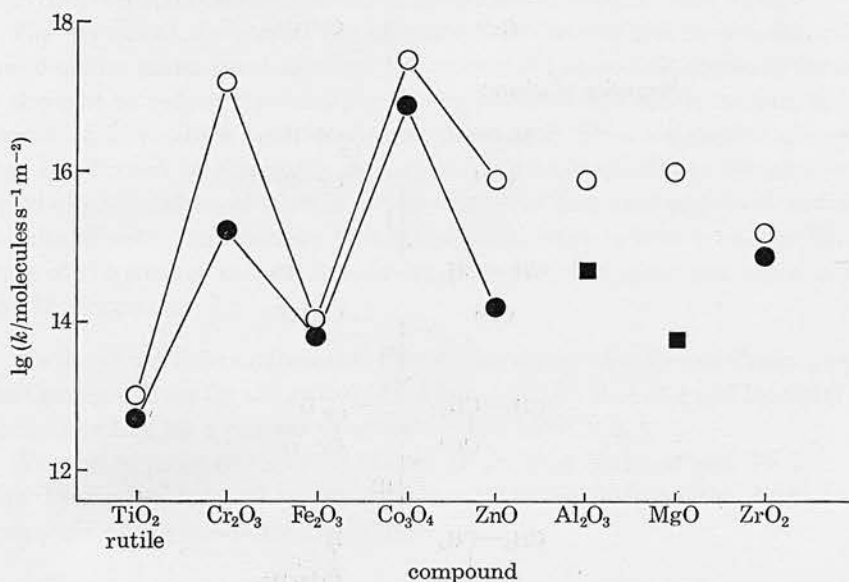

FIGURE 2. Comparison of the activities of the oxides for hydrogen-deuterium equilibration and ethylene-deuterium reactions. The temperatures used to measure either (●) C₂H₄-D₂ (addition) or (■) C₂H₄-D₂ (exchange) were 298 K for MgO and as given in table 3 for the other oxides. The H₂-D₂ equilibration rates (O) were determined as follows: Al₂O₃ at 273 K (Van Cauwelaert & Hall 1970); MgO at 273 K (Eley & Zammitt 1971); ZrO₂ at 298 K (Hughes *et al.*); other oxides all at 297 K (Pearce *et al.* 1969).

The exchange of ethylene and ethane can be represented as



If electrophilic hydrogen atoms react readily, both of these reactions should occur with ease. On the other hand, the formation of ethyl carbanions from ethylene would involve nucleophilic hydrogen



and it may react more slowly. Restating the argument briefly, only one kind of adsorbed hydrogen H_{E}^{\pm} or H_{N}^{-} is needed for exchange, but both kinds are necessarily involved in hydrogenation.

In the above discussion reference has been made to fully charged species. In reality such intermediates very probably possess only a partial electronic charge and in fact it is the extent of the charge on the reactive adsorbed species which may well enable the results of our present investigations to be explained. Alumina

Adsorption of ethylene and hydrogen:



Formation of ethane:

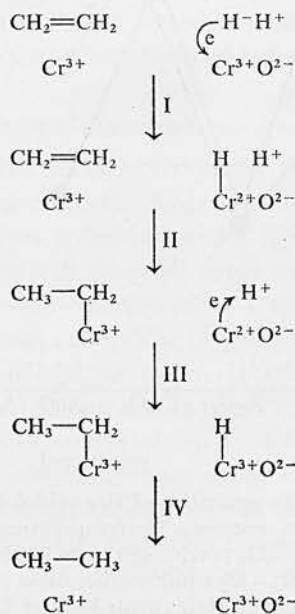

FIGURE 3. Scheme for adsorption and reaction of ethylene and hydrogen on chromia.

and magnesium oxide may lead to the formation of adsorbed hydrogen atoms with a high fractional charge. In contrast, on zinc oxide and chromia a neutralization of the potential charge on the adsorbed forms of hydrogen may be facilitated. Thus the hydrogenation of ethylene on chromia is envisaged in two stages (figure 3). First, adsorption of the olefin, possibly at coordinatively unsaturated Cr^{3+} sites, takes place together with heterolytic dissociative adsorption of hydrogen on ion pair sites. Secondly, adsorbed ethyl groups are produced with subsequent formation of ethane by the reaction sequence shown. The important feature of this scheme is that neutralization of the charge on the nucleophilic and electrophilic forms of

adsorbed hydrogen occurs and thus both hydrogen atoms are in a radical form when the addition steps II and IV take place and are therefore equally reactive. Once adsorbed ethyl groups are produced by reaction involving the first hydrogen atom (step II), ethane is readily formed by reaction with the second hydrogen atom. The overall effect is analogous to that presented by Dent & Kokes (1969), where addition of deuterium to ethylene occurs with the absence of exchange in the olefin because the 'alkyl reversal' (reverse of step II) is not operative on oxides such as chromia and zinc oxide. The production of neutral adsorbed hydrogen is facilitated by the ability of chromium ions to undergo a reversible change in oxidation state between Cr^{3+} and Cr^{2+} . The importance of the participation of Cr^{2+} ions in hydrogenation and dehydrogenation reactions on chromia has been noted (Rideal 1968).

The argument developed for chromia may be applied to the other transition metal oxides under investigation. The selectivity ratio k_e/k_a (table 3) for each oxide is thought to reflect the inability of the catalyst and the transition metal ion in particular to produce neutral adsorbed hydrogen. Thus a complete charge transfer may be effected on zinc oxide or chromia and high selectivity for addition results. On the other oxides the effect is less complete and exchange and addition occur simultaneously. On alumina and magnesium oxide where a change in oxidation state of the surface cations is unfavourable adsorbed hydrogen remains in the H^+ and H^- forms.

We thank the Science Research Council for a grant for the purchase of equipment, the Carnegie Trust for the award of a scholarship (to P. J. R.) and Imperial Chemical Industries Ltd for a postdoctoral fellowship (to M. S. S.).

We also express our sincere thanks to Dr E. J. C. Read and Dr R. S. Dowie of this Department for their invaluable advice and help in the development and operation of the computing facilities.

REFERENCES

- Amenomiya, Y. 1968 *J. Catalysis* **12**, 198.
Amenomiya, Y., Chenier, J. H. B. & Cvetanovic, R. J. 1967 *J. Catalysis* **9**, 28.
Brookes, B. I. 1972 Ph.D. Thesis, University of Edinburgh.
Burwell, Jr. R. L., Littlewood, A. B., Cardew, M., Pass, G. & Stoddart, C. T. H. 1960 *J. Am. chem. Soc.* **82**, 6272.
Cross, N. E. & Leach, H. F. 1971 *J. Catalysis* **21**, 239.
Dent, A. L. & Kokes, R. J. 1969 *J. phys. Chem.* **73**, 3781.
Dowden, D. A., Mackenzie, N. & Trapnell, B. M. W. 1956 *Proc. R. Soc. Lond. A* **237**, 245.
Dowie, R. S., Gray, M. C., Whan, D. A. & Kemball, C. 1971 *Chem. Commun.* p. 88.
Dowie, R. S., Kemball, C., Kempling, J. C. & Whan, D. A. 1972 *Proc. R. Soc. Lond. A* **327**, 491.
Dowie, R. S., Whan, D. A. & Kemball, C. 1972 *J.C.S. Faraday I*, **68**, 2150.
Eley, D. D. & Zammit, M. A. 1971 *J. Catalysis* **21**, 377.
Harrison, D. L., Nicholls, D. & Steiner, H. 1967 *J. Catalysis* **7**, 359.
Hightower, J. W. & Hall, W. K. 1969 *J. Catalysis* **13**, 161.
Hightower, J. W. & Hall, W. K. 1970 *Trans. Faraday Soc.* **66**, 477.
Hindin, S. G. & Weller, S. W. 1956 *J. phys. Chem.* **60**, 1501.
Hughes, B. T., Taylor, D. & Kemball, C. (To be published.)

- Kemball, C. 1973 *Ann. New York Acad. Sci.* **213**, 90.
Kemball, C. & Kempling, J. C. 1972 *Proc. R. Soc. Lond. A* **329**, 391.
Kemball, C. & Stoddart, C. T. H. 1957 *Proc. R. Soc. Lond. A* **241**, 208.
Kokes, R. J. & Dent, A. L. 1972 *Adv. Catalysis* **22**, 1.
Lake, I. J. S. & Kemball, C. 1967 *Trans. Faraday Soc.* **63**, 2535.
Larson, J. G., Hightower, J. W. & Hall, W. K. 1966 *J. org. Chem.* **31**, 1225.
Naito, S., Shimizu, H., Hagiwara, E., Onishi, T. & Tamaru, K. 1971 *Trans. Faraday Soc.* **67**, 1519.
Ozaki, A., Ai, H. & Kimura, K. 1971 *Proc. 4th Int. Congress on Catalysis*, vol. 1, p. 522.
Budapest: Akademiai Kaido.
Pearce, D. R., Richardson, P. C. & Rudham, R. 1969 *Proc. R. Soc. Lond. A* **310**, 121.
Rideal, E. K. 1968 *Concepts in catalysis*, p. 155. London: Academic Press.
Robertson, P. J., Scurrell, M. S. & Kemball, C. 1973 *J.C.S. Chem. Comm.* p. 799.
Shannon, I. R. 1969 Ph.D. Thesis, University of Edinburgh.
Tanaka, K., Nihira, H. & Ozaki, A. 1970 *J. phys. Chem.* **74**, 4510.
Van Cauwelaert, F. H. & Hall, W. K. 1970 *Trans. Faraday Soc.* **66**, 454.

An Examination of the Reliability of Methods of Analyzing the Experimental Data from Exchange Reactions of Molecules with Nonequivalent Hydrogen Atoms

R. S. DOWIE, P. J. ROBERTSON, AND C. KEMBALL

Department of Chemistry, University of Edinburgh, Edinburgh EH9 3JJ, Scotland

Received December 6, 1973

Methods of analyzing the data from catalytic exchange reactions of molecules in which different groups of hydrogen atoms exchange at different rates have been tested using computer-generated isotopic distributions. The method of determining rates of exchange from such reactions at constant temperature, proposed by Harper, Siegel, and Kemball, is found to be satisfactory provided that the ratio of the rate constants for two groups of exchangeable hydrogen atoms is greater than about 5.

On the other hand, the derivation of rate constants and Arrhenius parameters from data obtained by temperature-programmed experiments can only be considered reliable when the ratio of rate constants for the different groups of atoms is greater than about 20.

INTRODUCTION

In exchange reactions of hydrocarbons and other substances with deuterium, the various hydrogen atoms in the molecule frequently react at different rates, e.g., for the alkylbenzenes, a marked difference is observed in the reactivity of the side group and of the ring hydrogen atoms over a wide range of catalysts (1). It is desirable that the maximum amount of information about the rates of exchange of the different types of hydrogen atoms should be obtained from experimental data for such systems, but the selection of a reliable method of analyzing the data may be difficult.

The problem has been solved for the case of molecules having hydrogen atoms in two groups, both exchanging in a stepwise fashion but at different rates (2). Bolder, Dallinga, and Kloosterziel (3) gave a general treatment for multiple exchange but limited it to molecules with a single group of exchangeable hydrogen atoms. They also considered a method for molecules with nonequivalent hydrogen atoms involved in multiple exchange but subject to two conditions: Firstly, the reaction starts with undeuterated hydrocarbon molecules and,

secondly, the fraction of deuterium in the deuterating agent remains constant. This latter condition implies that their analysis cannot be applied to experimental situations, commonly found in heterogeneous catalysis, in which the dilution of the deuterium by hydrogen from the reactant hydrocarbon cannot be neglected.

Approximate methods of obtaining rate constants from experimental data were proposed by Crawford and Kemball (4) and subsequently improved by Harper, Siegel, and Kemball (5). The latter method which we shall call the HSK method can be applied to cases with two or more groups of hydrogen atoms reacting at different rates by either stepwise or multiple mechanisms. Intuitively, one would expect that the HSK method gives reliable results in the limit of one group exchanging very much faster than the next group, but some doubt exists as to how well the method works when the rates of exchange of different groups are comparable. The first objective of the present research was to attempt to determine the conditions under which the HSK method is reliable.

Temperature-programmed catalysis has

been used as a technique for following the exchange of groups of nonequivalent hydrogen atoms (6), and the analysis of results involves an extension of the HSK method. The technique provides information from a single experiment which could only be obtained from several experiments carried out in a conventional manner at constant temperature. Arrhenius parameters as well as relative rates of reaction of the different groups of hydrogen atoms are obtained, but the limits of the reliability of the approach have not been established. Investigation of this problem is the second objective of the present paper.

The method of investigating both problems involved the use of equations derived by Dallinga *et al.* (2) to compute distributions of isotopic species for exchange reactions for a molecule with two groups of hydrogen atoms reacting in a stepwise manner. These computed distributions were taken as "experimental data," analyzed by the HSK method and its extension for temperature-programmed catalysis, and the calculated rates were then compared with the actual rates used to generate the "experimental data." In this way, information about the useful limits of the HSK method was obtained.

NOMENCLATURE

D_A, D_B	Mean deuterium content in groups of hydrogen atoms, <i>A</i> and <i>B</i> , respectively. [These correspond to <i>D</i> and Δ in Ref. (2).]
d_i	Percentage of isotopic species containing <i>i</i> deuterium atoms
<i>E</i>	Activation energy for exchange of hydrogen atoms
<i>k</i>	Total rate constant for exchange of hydrocarbon
k_A	Rate constant for exchange of hydrogen atoms in group <i>A</i> . (Similar definitions for k_B, k_L, k_M .)
k_0	Initial value of <i>k</i> in temperature-programming experiment
\bar{k}, \bar{k}_A , etc.	Mean values of <i>k, k_A</i> , etc., over time intervals in temper-

	ature-programming experiment
N_A, N_B	Number of hydrogen atoms in group <i>A</i> and group <i>B</i> , respectively
<i>T</i>	Temperature of reaction
T_0	Initial temperature in temperature-programming experiment
t_c	Computer time scale
t_l	Laboratory time scale
ϕ_A, ϕ_B	Measure of extent of deuteration in group <i>A</i> and group <i>B</i> , respectively
$\phi_{A_\infty}, \phi_{B_\infty}$	Equilibrium values of ϕ_A and ϕ_B
ϕ	Measure of extent of deuteration in hydrocarbon molecule

DERIVATION OF THE ISOTOPIC DISTRIBUTIONS

The treatment set out by Dallinga *et al.* (2) applies to any molecule in which hydrogen atoms can be subdivided into two groups, *A* and *B*, the latter reacting more slowly but with the exchange of both groups occurring by a stepwise process. Their theory was adapted to enable us to calculate the distribution of products during an exchange reaction.

Expressions for the variation with time of D_A and D_B , the deuterium content in group *A* and group *B* hydrogens, respectively, can be found from Eqs. (20) and (21) of Ref. (2). These expressions involve k_A and k_B , the rate constants for the exchange of groups *A* and *B*, respectively, the mole fraction of the reacting molecule in the total system, and the initial fraction of deuterium in the labeling compound. Thus, if the experimental conditions, i.e., the reaction mixture and the rate constants for exchange in groups *A* and *B*, are specified, D_A and D_B can be calculated for a series of values of time. Then, using the binomial expressions which apply for stepwise exchange, the distribution of isotopic species in the two groups can be derived and, on combination of the results for the two groups, an isotopic distribution for the molecule as a whole can be obtained.

Many of the calculations are repetitive using the same relationship several times.

A computer program was written to calculate the distributions. Facilities were incorporated in this program to specify N_A and N_B , the rate constants k_A and k_B , and the reaction mixture. Most calculations were carried out with $N_A = N_B = 4$, corresponding to a molecule such as naphthalene with eight exchangeable hydrogen atoms in two groups of four. In this way, sets of distributions of products at specified times were generated to be used as "experimental" distributions for which the kinetic and other experimental details were known.

CALCULATION OF RATE CONSTANTS FROM ISOTOPIC DISTRIBUTIONS

The HSK (5) method of obtaining rate constants from experimental distributions of isotopic species has been described elsewhere. With the exception of using k for the total rate constant rather than k_ϕ , we follow the same nomenclature.

To obtain the slower rate constant, k_B , it is assumed that the second group of hydrogen atoms exchanges much more slowly than the first group, group A . It was one of the aims of this work to investigate the lower limits of k_A/k_B for the HSK method to work satisfactorily. To obtain linear plots when deriving rate constants, correct values for ϕ_∞ must be chosen. The choice of ϕ_{B_∞} on similar lines to that described in (5) proved to be satisfactory, while the choice of ϕ_{A_∞} will be discussed in the section with the results.

TEMPERATURE PROGRAMMING

Temperature-programmed catalysis is used as a rapid means of comparing the rates of exchange of different kinds of hydrogen atoms in a molecule when the ratio of the rates is so great that it is impossible to choose a single reaction temperature at which both rates can be observed accurately and conveniently. The usual method is to increase temperature linearly with time so that reaction of both groups of hydrogen atoms can be followed in a single experiment. The distributions of products are obtained at equal intervals of time and analyzed by a procedure based on the HSK method (6).

In order to generate suitable data for

studying this technique, distributions must be calculated which correctly reflect the increase in the reaction rate as the temperature increases. We have assumed that the rate constants k_A and k_B will obey the Arrhenius equation and, for simplicity, that both groups have the same activation energy, E .

The computer program was capable of calculating distributions of products at various times in the exchange reaction but with specified rate constants; it had no facility to deal with a changing rate constant. This problem was solved by defining an expanded time scale, t_c , computer time, related to laboratory time by the equation

$$\frac{dt_c}{dt_l} = \frac{k}{k_0} \quad (1)$$

where k_0 is the rate constant at T_0 , the initial temperature, and k is the rate constant at temperature T and laboratory time t_l . The temperature was assumed to increase linearly with time. In this way the extent of the reaction for a system which had reacted under laboratory conditions for a time t_l during which the rate constant was increasing with temperature would be equivalent to that calculated for a reaction with a fixed rate constant, k_0 , for time t_c . Integration of Eq. (1) gives the values of t_c which correspond to the selected values of t_l for which distributions are required. Once a list of the required values of t_c had been obtained, product distributions were calculated as before.

RESULTS AND DISCUSSION

Constant Temperature

Distributions of products were calculated at various time intervals for an arbitrary mixture of 22.6 parts of deuterium to 1 part of hydrocarbon and for values of the ratio k_A/k_B of 100, 20, 10, 5, and 1. These were then used as "experimental data."

The analysis of the results of an actual experiment requires, firstly, the recognition that not all the hydrogen atoms are exchanging at the same rate and, secondly, the determination of how many hydrogen atoms are in each group. Figures 1 and 2 show

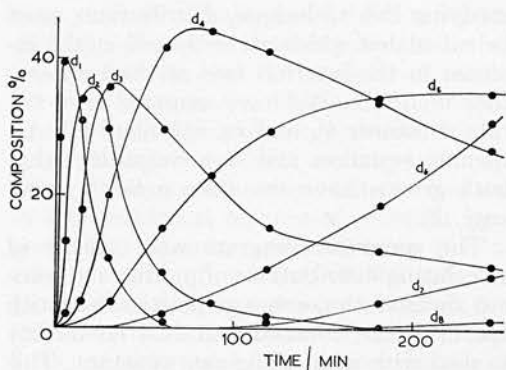

Fig. 1. Calculated isotopic distributions during reaction with $k_B = 0.6$ D atoms/100 molecules min^{-1} and $k_A/k_B = 20$.

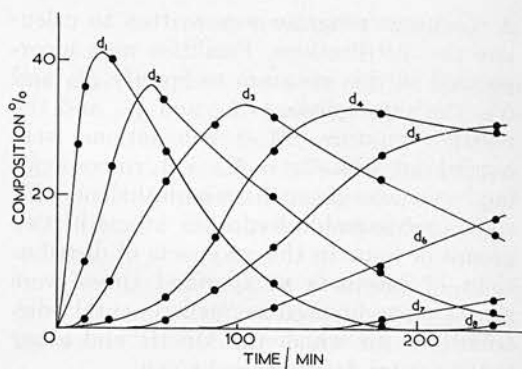

Fig. 2. Calculated isotopic distributions during reaction with k_B as for Fig. 1, but $k_A/k_B = 5$.

distributions of products during reaction for values of k_A/k_B of 20 and 5, respectively. The fact that four hydrogen atoms were replaced more rapidly than the second four is clear in Fig. 1 but obscured in Fig. 2.

Another method of distinguishing non-equivalent groups in a stepwise exchange is to compare product distributions with calculated binomial distributions for the same value of ϕ . The results in Table 1 show that the experimental distributions have more d_3 and d_4 species and less d_5 and d_6 species than the corresponding binomial distributions. This test works well for $k_A/k_B = 20$ or 10 and gives some indication of the division of the atoms into groups even with the ratio of 5. This test only works well at the appropriate stage of the reaction; at the beginning the distributions will be accurately binomial, but discrepancies will appear when the slower group are starting to exchange and

they disappear again as equilibrium is approached. An appropriate stage to make the comparison is when the binomial distribution shows about 10% of the isotopic product with one more deuterium atom than the number of hydrogen atoms in the rapidly exchanged group, i.e., d_5 in our case.

The rate constants obtained by the HSK method are compared in Table 2 with the actual values used to generate the "experimental data." The choices of ϕ_{A_∞} and ϕ_{B_∞} are important in estimating the rate constants, and the procedure for obtaining an adequate value of ϕ_{B_∞} has been described (5). If ϕ_{A_∞} is correctly chosen, a linear plot should be obtained for $\log(\phi_{A_\infty} - \phi_A)$ vs time, and the derivation of the rate constant from the gradient presents no problem. Curvature of the ϕ plot convex to the line axis implies that the reaction is slowing down and that the equilibrium value of ϕ_A has been

TABLE 1
COMPARISON OF PRODUCT DISTRIBUTIONS WITH BINOMIAL DISTRIBUTIONS
FOR DIFFERENT VALUES OF k_A/k_B

k_A/k_B	ϕ	d_0	d_1	d_2	d_3	d_4	d_5	d_6	d_7	d_8
20	319.0	0.4	4.5	18.9	37.0	31.2	7.3	0.7	0.0	0.0
(Binomial)	319.0	1.7	9.0	21.0	27.9	23.1	12.3	4.2	0.8	0.1
10	312.9	0.7	6.3	21.3	34.6	26.9	8.8	1.4	0.1	0.0
(Binomial)	312.9	1.9	9.7	21.8	28.0	22.5	11.6	3.7	0.7	0.1
5	299.5	1.5	9.3	24.0	31.7	22.7	8.8	1.8	0.2	0.0
(Binomial)	299.5	2.3	11.2	23.5	28.2	21.1	10.1	3.0	0.5	0.0

TABLE 2
 COMPARISON OF ESTIMATED^a AND CHOSEN RATE CONSTANTS

k_A/k_B		k		k_B		ϕ_{A_∞}
Chosen	Est.	Chosen	Est.	Chosen	Est.	
		(D atoms/100 molecules min ⁻¹)				
20	21.5	14.0	14.1	0.6	0.62	370
10	11.3	7.3	7.38	0.6	0.60	380
5	5.8	4.00	4.07	0.6	0.60	400
1	4.4	1.3	1.56	0.6	0.29	400

^a Rate constants calculated to ± 3 in the third significant figure.

overestimated. The reverse behavior indicates that ϕ_{A_∞} has been underestimated.

Fortunately, the range of possible values for ϕ_{A_∞} was limited. If it was assumed that only four hydrogen atoms were reacting and that the remaining four were inert, the calculated value of ϕ_{A_∞} is 367 for the reaction mixture used. If the corresponding procedure to that for estimating ϕ_{B_∞} was employed, $\phi_{A_\infty} = 400$, which is the maximum possible value of ϕ_A . The ϕ plots for ϕ_A are shown in Fig. 3, and the selected values of ϕ_{A_∞} are given in Table 2. It is not surprising that a lower value of ϕ_{A_∞} was more satisfactory for the case of $k_A/k_B = 20$ and that the higher values were better for the case where there was less difference between the rates of reaction of the two groups of atoms.

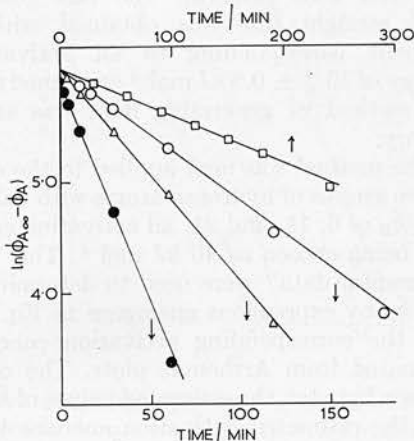

FIG. 3. Appropriate plots of ϕ_A to determine k with values of k_A/k_B of 1 (\square), 5 (\circ), 10 (\triangle), and 20 (\bullet).

Figure 4 shows the plots for ϕ_B in the appropriate form to determine the rate of exchange of the slower group of hydrogen atoms. It was not possible to evaluate ϕ_B satisfactorily for distributions with less than 10% of the total hydrocarbon present as d_5 or higher species. Each of these plots showed similar behavior and fell into three sections. The first part was curved and the curvature was more pronounced and lasted longer for the lower values of k_A/k_B . The second sections were reasonably linear, particularly for the higher values of k_A/k_B , and were used to estimate the rates given in Table 2. In the final sections, which occurred at substantially longer times and are not shown in Fig. 4, the plots merged into a common line with a gradient corresponding to a slightly slower

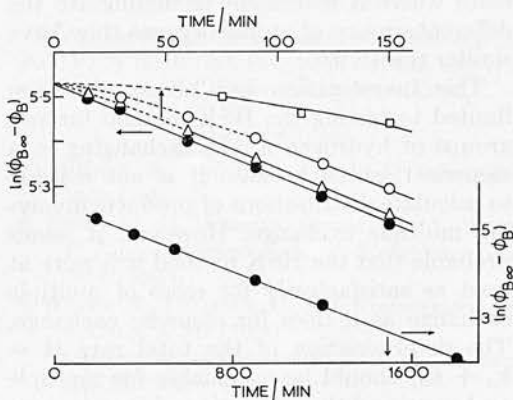

FIG. 4. Appropriate plots (upper and left-hand scales) of ϕ_B to determine k_B with values of k_A/k_B of 1 (\square), 5 (\circ), 10 (\triangle), and 20 (\bullet); an extended plot for the last value is also shown for longer times (lower and right-hand scales).

rate of 0.56 D atoms/100 molecules min^{-1} .

It is clear that the HSK method gives a good estimate for the total rate of exchange and only fails in the extreme case where $k_A = k_B$ and the two groups of hydrogen atoms react at the same rate. In practice, the method would never be applied to such a case, which would be analyzed by standard methods (7).

The estimated values of k_B are all low compared with the chosen value, but the deviation is not greater than 10% if k_A/k_B is 5 or higher. The reason for the discrepancy is that the deuterium pool has become diluted as a result of the exchange of the first group by the time that the second group starts to react. The method makes no allowance for this, and consequently the calculated value for k_B will be slightly low. A correction for this factor could easily be made. The underestimation of k_B leads to a slight overestimation of the ratio k_A/k_B by about 10%, rising to 20% for $k_A/k_B = 5$.

It is fortunate that the HSK method is satisfactory for cases where it is possible to distinguish different groups of hydrogen atoms by inspection of the experimental results. Where such differences can be seen, corresponding to $k_A/k_B > 5$, reasonably accurate results for the rate constants can be obtained, the accuracy improving for higher values of k_A/k_B . The method only fails for cases where it is difficult to distinguish the different groups of atoms because they have similar reactivity.

This investigation has necessarily been limited to testing the HSK method for two groups of hydrogen atoms exchanging in a stepwise fashion because it is not feasible to calculate distributions of products involving multiple exchange. However, it seems probable that the HSK method will work at least as satisfactorily for cases of multiple exchange as it does for stepwise exchange. The determination of the total rate ($k = k_A + k_B$) should be as reliable for multiple exchange, and the estimation of k_B may even be improved because the multiple exchange would increase the production of d_4 at an early stage and enable the exchange of the second group to be followed more efficiently than with stepwise exchange.

The HSK method was put forward originally (5) for molecules containing three groups of hydrogen atoms. Our examination of its validity has been restricted to the case of two such groups because the theory for calculating distributions was available for only two groups. However, on the basis of the present work, it would be reasonable to assume that the HSK method can be applied to more groups provided the value of $k_L/k_M > 5$ for successive groups L and M . But corrections for isotopic dilution will be essential.

Temperature Programming

The method of generating "experimental data" was first tested for the case where all hydrogen atoms in the molecule exchange at equivalent rates. Values of ϕ at a series of values of t_i were obtained from data generated with a chosen activation energy of 40 kJ mol^{-1} , an initial rate of exchange of 1.0 D atoms/100 molecules min^{-1} at 273 K, and a rate of increase of temperature of 1.0 K min^{-1} . The average rate of reaction was evaluated for each time interval from

$$\bar{k} = \phi_\infty [\ln(\phi_\infty - \phi_{i+1}) - \ln(\phi_\infty - \phi_i)] / \Delta t_i \quad (2)$$

with ϕ_{i+1} and ϕ_i representing successive values of ϕ . Then $\ln \bar{k}$ was plotted against the reciprocal of the mean temperature for each time interval. The fact that a good straight line was obtained with a gradient corresponding to an activation energy of $39.2 \pm 0.8 \text{ kJ mol}^{-1}$ confirmed that the method of generating data was satisfactory.

The method was next applied to the case of two groups of hydrogen atoms with values of \bar{k}/\bar{k}_B of 6, 11, and 21, all activation energies being chosen as 40 kJ mol^{-1} . The "experimental data" were used to determine \bar{k} and \bar{k}_B by expressions analogous to Eq. (2) and the corresponding activation energies estimated from Arrhenius plots. The comparison between the estimated values of \bar{k}/\bar{k}_B and the estimated activation energies with the respective chosen values was used to assess the validity of the method of handling the data from temperature-programmed catalysis. Some Arrhenius plots are shown in

TABLE 3
 RESULTS FOR TEMPERATURE-PROGRAMMED CATALYSIS

Chosen	\bar{k}/\bar{k}_B		E^a kJ mol ⁻¹	
	Est. when $d_5 \approx 10\%$	Est. when $d_5 \approx 20\%$	for k	for k_B
21	22.6	22.2	41.4	40.3
11	13.5	13.1	42.6	37.3
6	7.7	7.4	43.8	33.4

^a Chosen activation energies were 40 kJ mol⁻¹ in all cases.

Fig. 5, and the results are summarized in Table 3.

Satisfactory straight lines were obtained from the Arrhenius plots for the total rate of exchange, and the agreement between the derived activation energies and the chosen value was better the higher the value of \bar{k}/\bar{k}_B .

The results for \bar{k}_B were much less satisfactory, particularly for the lowest value of $\bar{k}/\bar{k}_B = 6$. The Arrhenius plot in this case was curved and only approximated a straight line at a comparatively late stage in the reaction. The derived activation energy from this line was too low, and the estimated

values of \bar{k}/\bar{k}_B , whether determined when there was 10 or 20% of d_5 formed, were too high. Better results were obtained for $\bar{k}/\bar{k}_B = 11$ and the most satisfactory results for $\bar{k}/\bar{k}_B = 21$. The difficulties associated with the Arrhenius plots for \bar{k}_B for the lower values of \bar{k}/\bar{k}_B clearly arise from the type of behavior exhibited in Fig. 4 for the plots for \bar{k}_B in the constant-temperature experiments. The estimates for \bar{k}_B are much too low at the stage when the slower hydrogen atoms begin to exchange but become more reliable as the reaction proceeds.

The conclusion is that the HSK method works satisfactorily for temperature-programmed catalysis when the ratio of the rate constants of the two groups of hydrogen is greater than about 20 and is definitely unreliable if the ratio is less than 10.

ACKNOWLEDGMENTS

We acknowledge the awards of a studentship (to R.S.D.) by the British Petroleum Co. Ltd. and of a scholarship (to P.J.R.) by the Carnegie Trust.

REFERENCES

1. McCOSH, R., AND KEMBALL, C., *J. Chem. Soc.*, 1555 (1968).
2. DALLINGA, G., VERRIJN STUART, A. A., SMIT, P. J., AND MACKOR, E. L., *Z. Elektrochem.* **61**, 1019 (1957).
3. BOLDER, H., DALLINGA, G., AND KLOOSTERZIEL, H., *J. Catal.* **3**, 312 (1964).
4. CRAWFORD, E., AND KEMBALL, C., *Trans. Faraday Soc.* **58**, 2452 (1962).
5. HARPER, R. J., SIEGEL, S., AND KEMBALL, C., *J. Catal.* **6**, 72 (1966).
6. McCOSH, R., AND KEMBALL, C., *Chem. Commun.* 802 (1969).
7. KEMBALL, C., *Advan. Catal.* **11**, 223 (1959).

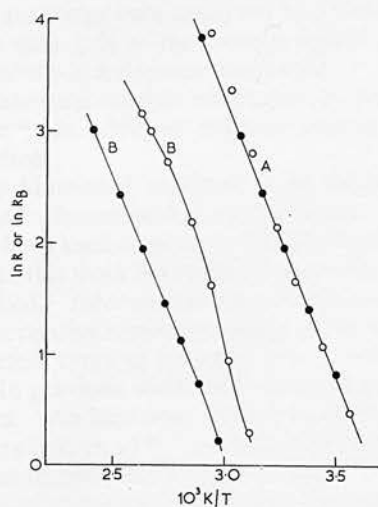

Fig. 5. Arrhenius plots for the estimated rates of exchange from temperature-programmed results with values of \bar{k}/\bar{k}_B of 6 (○) and 21 (●); A represents \bar{k} , the total rate of exchange, and B the rate of the slower group, \bar{k}_B .

Exchange of Alkanes with Deuterium over γ -Alumina

A Brønsted Linear Free Energy Relationship

BY PHILIP J. ROBERTSON, MICHAEL S. SCURRELL AND CHARLES KEMBALL*

Department of Chemistry, University of Edinburgh,
West Mains Road, Edinburgh EH9 3JJ

Received 27th September, 1974

The exchange behaviour of a series of alkanes, including cycloalkanes, with deuterium over γ -alumina has been investigated. Different types of hydrogen atoms within the same molecule are found to exchange at different rates and in some cases a quantitative estimate of the relative activities has been made. These results and a comparison of reaction rates of different molecules indicate that the reaction intermediates are carbanionic in character. A linear relation between hydrogen exchange activity and hydrocarbon acidity has been obtained and is shown to be an example of the Brønsted catalysis law.

All the exchange reactions took place in a stepwise manner and, for the cycloalkanes, exchange could be followed at lower temperatures without complication from isomerization and addition.

Recent results¹ suggest that the intermediates in the exchange of butanes over γ -alumina possess carbanionic character. The present work which involves the examination of the exchange reactions of a series of acyclic and cyclic alkanes seeks to relate rates of reaction to the stabilities of the carbanions formed from the respective molecules.

Larson and Hall² investigated the exchange reactions of methane over alumina. The reactions were catalyzed by a small number of active sites and involved exchange with only 1 % of the catalyst hydroxyl groups. Ethane is reported to exchange on alumina via a stepwise mechanism.³ Lewis acidity was found to be the property of the alumina catalyst which best correlated with its activity for the exchange of propane.⁴ In addition, reducing centres on the surface played an essential role in the reaction.

γ -Alumina is reported to be an excellent catalyst for the exchange of cyclopropane.⁵ Isomerization and hydrogenation reactions are not extensive and the catalyst has been used to prepare [²H₆]cyclopropane of high isotopic purity.

In this work the exchange reactions of five acyclic and four cyclic alkanes have been studied. Information concerning reaction intermediates has been obtained not only from relative rates of exchange of the various reactants, but also from the reactivities of different types of hydrogen atoms within the same molecule.

In previous work only one hydrocarbon has been investigated in any one experiment. An improved method involving combined gas chromatography-mass spectrometry (g.c.-m.s.)^{6, 7} has now been used and permits examination of the exchange of a series of reactants simultaneously. It has, therefore, been possible to obtain relative rates of exchange for different alkanes over the same catalyst sample, thereby eliminating possible problems of reproducibility of catalytic performance. In addition the exchange of cycloalkanes with deuterium may readily be studied even if other reactions take place. Using g.c.-m.s. the processes of addition, exchange and isomerization may be followed simultaneously.

EXPERIMENTAL

APPARATUS AND PROCEDURE

Exchange reactions involving a single reactant were followed in a conventional manner⁸ using a direct capillary leak from the reaction vessel to an A.E.I. MS10 mass spectrometer. Mass spectral analyses of the hydrocarbon products were carried out for the parent ions using an electron beam of energy 10 eV. With the exception of experiments involving cyclopropane and methylcyclopropane when 0.1 g samples of catalyst were used the usual procedure was to treat 1.0 g γ -alumina in oxygen at 723 K prior to evacuation at this temperature for at least 15 h. The reaction mixture usually consisted of 0.96 kN m⁻² hydrocarbon and 9.5 kN m⁻² deuterium in a silica reaction vessel, giving *ca.* 3×10^{19} molecules of hydrocarbon in the reaction vessel. Exceptions to these proportions are indicated in the Results section.

In experiments involving more than one reactant hydrocarbon or in those in which a single reactant could exhibit different reactions, the standard mass spectrometric method proved inadequate. In such cases the combined g.c.-m.s. apparatus linked to an "on-line" computer^{6,7} was employed. Separation of acyclic alkanes was achieved using an 8 m column of bis-2-methoxyethyl adipate (13.5 %) and di-2-ethylhexyl sebacate (6.5 %) on 60/80 mesh Chromosorb P, operating at 273 K for C₁ to C₃ alkanes and at room temperature for higher alkanes. Cycloalkanes and their isomerization products were separated on a 4 m column of propylene carbonate on 60/80 mesh Chromosorb P operating at 273 K. This column was also used to separate the components of the cyclobutane and n-butane mixture. For experiments followed by g.c.-m.s., the reaction mixtures were chosen to give approximately the same number (3×10^{19}) of hydrocarbon molecules and the same total pressure in the reaction system as for those experiments followed by mass spectrometry alone. The catalyst received the same pretreatment.

The method of data acquisition was identical to that described previously⁷ except that the use of reference masses 18, 28 and 32 proved inadequate for the accurate analysis of mass spectra of C₃ and C₄ alkanes. It was found necessary to employ reference masses such that the mass range of interest was included, thereby permitting mass numbers to be assigned by an interpolation method. Two techniques were available for the production of suitable reference masses. First, liquid phase bleed from the chromatographic column sometimes gave rise to a suitable reference spectrum. Second, when this was not the case, a reference spectrum was obtained by insertion into the mass spectrometer of a hydrocarbon with a known fragmentation pattern, e.g. *o*-xylene. This procedure was carried out before the start of an experiment and all traces of the hydrocarbon allowed to evacuate from the system before collecting further spectra.

MATERIALS

The γ -alumina was prepared by heating a high purity boehmite (Laporte Industries Ltd.) at 900 K in air for 16 h. The specific surface area, determined by nitrogen adsorption at 77 K, was 120 m² g⁻¹.

All hydrocarbons and deuterium were of high purity. The hydrocarbons were distilled from traps held in liquid nitrogen before use while the deuterium was purified by diffusion through a heated palladium-silver alloy thimble. The cyclobutane sample was a mixture of approximately equal amounts of cyclobutane and n-butane and was without prior separation of the individual components.

TREATMENT OF RESULTS

Mass spectra were corrected for the presence of background peaks, for naturally occurring deuterium and "heavy" carbon and for fragmentation in the mass spectrometer source. When the exchange reaction was not followed past the initial stages, the fragmentation was assumed to involve statistical loss of hydrogen and deuterium from the molecule. However, if extensive exchange was involved the method of Dowie *et al.*⁹ was used. A further modification in the usual fragmentation correction procedure was required for analysis of highly

deuterated isobutane. In the mass spectrometer the most likely hydrogen atom to be lost after initial ionization of the molecule is that of the methine group, which as results indicate had little chance of being a deuterium atom. Thus it was assumed that the fragment produced by loss of one hydrogen atom was always one mass unit less than its parent ion. Fragmentation by loss of hydrogen (or deuterium) from other positions in the molecule was considered in the usual manner.

In the exchange reactions where all the hydrogen atoms of the reactant exchanged at the same rate standard methods¹⁰ were used to determine the initial rate for deuterium entry (k_ϕ) and loss of the [²H₀]-isomer (k_0). Values of the parameter $M (= k_\phi/k_0)$ were calculated to determine the multiplicity of the exchange process.

However, for some hydrocarbons different types of hydrogen atoms exchanged at different rates. To analyse the data in these cases a method¹¹ involving approximations in the standard treatment was required. The exchange in different groups of hydrogen atoms was considered separately and equations analogous to those devised by Kemball¹⁰ were derived. This method is known to be satisfactory if the ratio of rate constants for exchange in the different groups is greater than 5 : 1.¹²

Initial rates for isomerization, k_I were calculated where appropriate assuming first order loss of reactant.

RESULTS

EXCHANGE OF ACYCLIC ALKANES

Some general points emerged for all the experiments involving the individual exchange of a reactant. All reactions followed the usual equations for exchange processes¹⁰ and all gave M values near unity, indicating the stepwise nature of the exchange. All rates quoted subsequently are k_ϕ values and the derived Arrhenius parameters are given in table 1. Since certain reactants exhibited exchange of different groups of hydrogen atoms at different rates (see below) the data in table 1 refer to the most active hydrogen atoms. The uncertainty in values of the activation energy E is estimated as ± 4 kJ mol⁻¹; that in the log A values is ± 0.6 .

TABLE 1.—KINETIC DATA FOR EXCHANGE OF MOST REACTIVE HYDROGEN ATOMS IN ALKANES

reactant	$E/\text{kJ mol}^{-1}$	$\log(A/\text{molecule s}^{-1} \text{m}^{-2})$	temperature range/K	temperature/K for $k_I = 10^{13}$ molecule $\text{s}^{-1} \text{m}^{-2}$
methane	17	16.5	284-360	—
propane	36	19.6	292-363	—
isobutane	33	19.4	273-370	—
n-butane	35	20.1	273-335	—
cyclopropane	26	19.9	250-289	355
methylcyclopropane (type A)	17	18.1	273-348	—
methylcyclopropane (type B)	25	18.4	273-348	>355
cyclobutane	45	21.4	273-317	>335
cyclopentane	42	20.6	289-339	—

The most interesting aspect of the exchange of n-butane was that six of the hydrogen atoms in the molecule were exchanged more readily than the other four, the distribution of isotopic species as a function of time showing a marked discontinuity between the appearance of the [²H₆]- and [²H₇]-isomers. Exchange in the second group of hydrogen atoms was studied in greater detail by using a higher deuterium : hydrocarbon ratio of 25 : 1. Analysis of the results indicated that the methyl hydrogen atoms in n-butane (type A) exchanged about sixty times faster than those in

the methylene groups (type B) at 316 K. A computer program¹² was used to calculate theoretical isotopic distributions at various times for molecules in which different groups of atoms exchanged at different rates. By specifying that type A hydrogen atoms exchanged sixty times faster than type B (i.e. $k_A/k_B = 60$) a set of distributions was generated for n-butane such that for similar extents of exchange experimental and calculated distributions could be compared (table 2). Also shown in table 2 is the binomial distribution calculated for ten equally reactive hydrogen atoms.

TABLE 2.—PRODUCT DISTRIBUTIONS FOR EXCHANGE OF n-BUTANE

isotopic species/%	[² H ₂]	[² H ₃]	[² H ₄]	[² H ₅]	[² H ₆]	[² H ₇]	[² H ₈]	ϕ^c
experimental	3.6	15.2	29.5	33.8	16.1	1.4	0.1	446.6
calculated ^a	4.5	15.4	29.9	31.9	15.7	1.7	0.0	442.2
calculated ^b	8.3	14.4	24.2	23.0	15.2	6.9	2.0	446.6

^a Assuming 6 hydrogen atoms (type A) reacting more rapidly than remaining 4 (type B) with $k_A/k_B = 60$; ^b assuming all 10 hydrogen atoms reacting at same rate; ^c ϕ represents the extent of the exchange, $10^{-2}\phi$ being the average number of deuterium atoms per molecule.

A similar analysis was carried out with the data for propane exchange. Again those hydrogen atoms in the primary positions were much more active than those in the secondary group and k_A/k_B was found to be about 170 at 355 K.

TABLE 3.—EXCHANGE OF ISOBUTANE: PRODUCT DISTRIBUTION AFTER EXTENSIVE REACTION

isotopic species/%	[² H ₆]	[² H ₇]	[² H ₈]	[² H ₉]	[² H ₁₀]	ϕ
experimental	7.7	18.5	40.0	33.6	<0.05	798.1
calculated ^a	7.7	22.0	37.1	28.9	2.2	790

^a Based on 9 hydrogen atoms (type A) reacting more rapidly than the remaining 1 (type B) with $k_A/k_B = 100$.

In isobutane no evidence for the production of the [²H₁₀]-species was obtained during the experiment. A deuterium enriched mixture (D₂: isobutane = 50:1) was treated at 423 K in an attempt to produce some perdeuteroalkane. Even after pumping off the diluted deuterium and continuing the reaction with a fresh dose no

TABLE 4.—SIMULTANEOUS AND INDIVIDUAL EXCHANGE OF ALKANES

reactant	simultaneous rate $10^{-13}k_\phi/\text{molecule}$ $\text{s}^{-1}\text{m}^{-2}$	individual rate $10^{-13}k_\phi/\text{molecule}$ $\text{s}^{-1}\text{m}^{-2}$	temperature T/K	
methane	3.4	3.9	308	
ethane	1.9	—	308	experiment A
propane	9.6	3.8	308	
propane	1.5	1.5	290	
isobutane	6.3	3.8	290	experiment B
n-butane	6.6	6.7	290	

[²H₁₀]isobutane was formed, although the mixture then contained over 70% of [²H₈]- and [²H₉]-isomers (table 3). The other distribution shown in the table is that calculated for a molecule like isobutane in which the tenth hydrogen atom exchanges 100 times more slowly than the other nine. For a ϕ value of 790 it predicts that over

2 % of the $[^2\text{H}_{10}]$ -species should be present in the product mixture. This quantity would certainly have been detectable in the mass spectrometer and thus for isobutane we estimate that $k_A/k_B > 100$.

Results for the simultaneous exchange of the alkanes are summarised in table 4. A mixture of methane, ethane and propane was reacted with deuterium at 308 K and a mixture of propane, n-butane and isobutane was reacted at 290 K. The rates derived from the results of these experiments are listed together with those obtained in the individual exchange experiments.

EXCHANGE OF CYCLICALKANES

All the cycloalkanes studied underwent exchange by a stepwise mechanism. Cyclopropane and methylcyclopropane were the most reactive molecules and kinetic data are given in table 1. Also included in the table is an indication of the temperature required to give an isomerization rate in excess of 10^{13} molecule $\text{s}^{-1} \text{m}^{-2}$.

The exchange of cyclopropane was followed in the temperature range 250-290 K when all the hydrogen atoms were found to exchange readily and at the same rate. A temperature of 358 K was required before the production of propylene was observed and at this temperature the rate of exchange was more than 1000 times that of isomerization.

Interesting results were obtained in the exchange of methylcyclopropane. The eight hydrogen atoms could be classified into three groups A, B and C according to their different rates of exchange. The four hydrogens at the C(2) and C(3) positions (type A) were the most reactive, followed by the single ring hydrogen at the substituted C(1) position (type B). The least active were those atoms in the methyl group (type C). The ratio of rate constants $k_A : k_B$ was *ca.* 10 : 1 at room temperature. The type C hydrogen atoms did not appear to exchange even at temperatures in excess of 350 K. The rate of exchange of the type A hydrogen atoms at 287 K (1.3×10^{15} molecule $\text{s}^{-1} \text{m}^{-2}$) was very similar to that of the hydrogen atoms in cyclopropane itself (1.4×10^{15} molecule $\text{s}^{-1} \text{m}^{-2}$) measured at the same temperature. A temperature of 355 K was required in order to achieve isomerization at a measurable rate, the initial product being *trans*-but-2-ene. At this temperature, the rate of isomerization was *ca.* 100 times slower than that of the exchange of type B hydrogens.

The exchange of cyclobutane was studied using a reaction mixture consisting of cyclobutane and n-butane in approximately equal amounts. All the hydrogen atoms in cyclobutane exchanged at the same rate in the temperature range 273-355 K. Even at the high temperatures in this range only a trace of butene could be detected and the rate of isomerization was at least 150 times slower than that of exchange.

In the exchange of cyclopentane all the hydrogens reacted at an equal rate and in a stepwise manner.

DISCUSSION

The rate of exchange of methane with deuterium on our alumina catalyst (4.0×10^{13} molecule $\text{s}^{-1} \text{m}^{-2}$ at 301 K) is somewhat slower than that found by Larson and Hall^{2, 26} (3.6×10^{14} molecule $\text{s}^{-1} \text{m}^{-2}$ at 301 K) but a higher pretreatment temperature was employed in their work. For the exchange of propane at 293 K, Flockhart *et al.*⁴ found a rate of 1.1×10^{13} molecule $\text{s}^{-1} \text{m}^{-2}$ for an alumina catalyst pretreated at the temperature used in the present work (723 K). Using the pressure dependencies quoted we would expect their catalyst to show a rate of 2.7×10^{13} molecule $\text{s}^{-1} \text{m}^{-2}$ in our system and this compares favourably with the observed rate of 1.6×10^{13} molecule $\text{s}^{-1} \text{m}^{-2}$. Our observation of the relative rates of exchange

of the different hydrogen atoms in propane does however disagree with the suggestion of Flockhart *et al.*⁴ that the secondary hydrogen atoms are more rapidly replaced.

It has been shown⁵ that in the exchange of methane with deuterium over alumina, the rate determining step involves fission of a C—H bond and it seems very probable that dissociative adsorption is involved for all the alkanes studied in the present work.

It seems unlikely that the alkanes exchange via radical intermediates. It has been established^{10, 13, 14} that the adsorption of saturated hydrocarbons to form surface alkyl species plays an important part in the exchange process on metal catalysts. Fig. 1 shows that for the exchange of alkanes on tungsten there exists a rough correlation between the ease of exchange and the dissociation energy of the alkyl-hydrogen bond which must necessarily be broken to produce the adsorbed alkyl groups. In particular, the high bond dissociation energy of the C—H bond of methane results in a rate of exchange which is about 1000 times slower than that of the other alkanes. In contrast, on γ -alumina, methane exchanges as readily as the other alkanes and no such distinction in behaviour is observed. In addition, the most weakly bound hydrogen atoms in isobutane (the methine hydrogen) and in *n*-butane (the secondary hydrogen atoms) are the least active for exchange. For the cycloalkanes the observed rate of reaction decreases in the sequence:

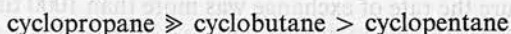

and this order is the reverse of that expected for radical intermediates since the bond dissociation energies¹⁶ are 431, 414 and 397 kJ mol⁻¹ for cyclopropane, cyclobutane and cyclopentane respectively.

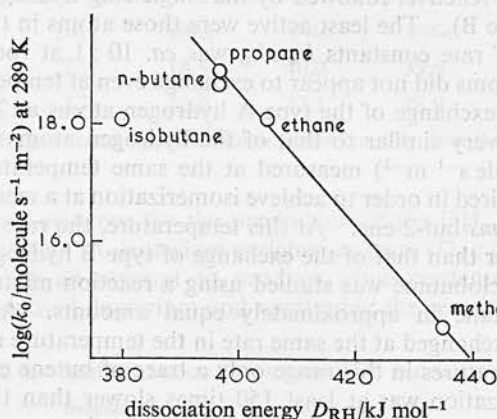

FIG. 1.—Alkane exchange reactions over tungsten; $\log k_0$ at 289 K as a function of the dissociation energy¹⁵ of the C—H bond for methane,¹⁰ ethane,¹⁰ propane,¹⁰ isobutane¹³ and *n*-butane.¹⁴

Exchange via carbonium ion or partially positively charged intermediates may also be ruled out. Exchange of saturated hydrocarbons on silica-alumina is generally regarded as involving carbonium ion intermediates. On silica-alumina isobutane will exchange at 393 K¹⁷ but *n*-butane requires a temperature in excess of 550 K. In contrast, on γ -alumina at room temperature the two butane molecules undergo exchange at similar rates. A much higher rate would be expected for isobutane if formation of tertiary carbonium ion were important for exchange.

The general behaviour of the alkanes on alumina suggests that the intermediate species are adsorbed alkyl groups which possess carbanionic character. Many of the differences in reactivities can be qualitatively explained by consideration of the

effects of alkyl substituents on the stabilities of carbanions. Alkyl group replacement of hydrogen in methane leads to a decrease in the stability of the carbanion as a result of the electron releasing nature of the substituent e.g. the ethyl carbanions CH_3CH_2^- would be less stable than the methyl anion CH_3^- , and indeed the exchange rate for ethane is lower than that observed for methane. Increasing the length of the alkyl chain tends to decrease the degree of destabilization [see for example ref. (18)] such that the anion $\text{CH}_3\text{CH}_2\text{CH}_2^-$ is more stable than CH_3CH_2^- . This is in accord with the observation that propane exchanges at a greater rate than ethane.

The operation of such inductive effects can also assist in explaining the different reactivities found for various groups of hydrogen atoms in the same molecule. For both propane and n-butane, the methylene hydrogen atoms exchanged much more slowly than the primary hydrogen atoms, the effect being more marked in the case of propane. The $(\text{CH}_3)_2\text{CH}^-$ carbanion has two methyl groups adjacent to the central carbon atom on which the negative charge is visualized and thus there is a pronounced destabilizing influence. The magnitude of the effect is reduced in the carbanion $(\text{CH}_3)(\text{C}_2\text{H}_5)\text{CH}^-$ formed from n-butane since, in this case, one of the substituent groups is larger and therefore less destabilizing. By similar reasoning it can be seen why the methine hydrogen in isobutane is very inactive for exchange; the inductive effect of three substituent methyl groups causes the $(\text{CH}_3)_3\text{C}^-$ ion to be particularly unstable.

It would be useful to attempt a more quantitative correlation between alkane exchange activity and carbanion stability. If this is the major factor in determining the reactivity of the alkanes the rate determining step which occurs on the surface may be written



This reaction may be considered to involve three basic processes

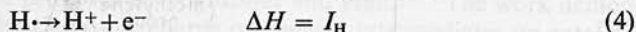
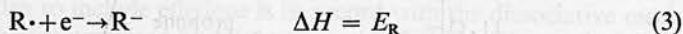
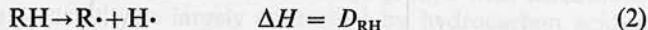

where D_{RH} is the bond dissociation energy of the alkyl-hydrogen bond which is broken in the adsorption process, E_{R} is the electron affinity of the alkyl radical and I_{H} is the ionization potential of the hydrogen atom. For a series of alkanes, provided that the respective carbanionic species are equally strongly adsorbed the ease of occurrence of reaction (1) will be determined by the value of $(D_{\text{RH}} - E_{\text{R}})$. Unfortunately precise values of E_{R} for the radicals under discussion are not known at present, reported values often having an uncertainty exceeding several tenths of an electron-volt.¹⁹ Such a degree of uncertainty precludes the assessment of relative carbanion stabilities based on thermochemical data. Indeed catalytic studies similar to those reported here may have some value in assessing relative values of electron affinities for hydrocarbon and other radicals.

It is more fruitful to consider the reactivities of the alkanes as a function of hydrocarbon acidity. As with electron affinity data, the assignments of $\text{p}K_{\text{a}}$ values for such weak acids is not without question. The $\text{p}K_{\text{a}}$ values used in this work have been derived from *equilibrium* studies by Dessy *et al.*²⁰ and Cram.²¹ Dessy *et al.*²⁰ have argued that in establishing a rank of carbanion stabilities the use of *kinetic* acidity values is not to be recommended.

Fig. 2 shows the relationship between the exchange activity of alkanes and their $\text{p}K_{\text{a}}$ values where these are known. The rate constants used in the figure are taken from the data of table 1 except for the secondary hydrogen atoms in propane and n-butane.

For these less active hydrogen atoms Arrhenius data were not available and thus the rates of their exchange k_B were estimated at 289 K using the values of k_A/k_B obtained at slightly higher temperatures.

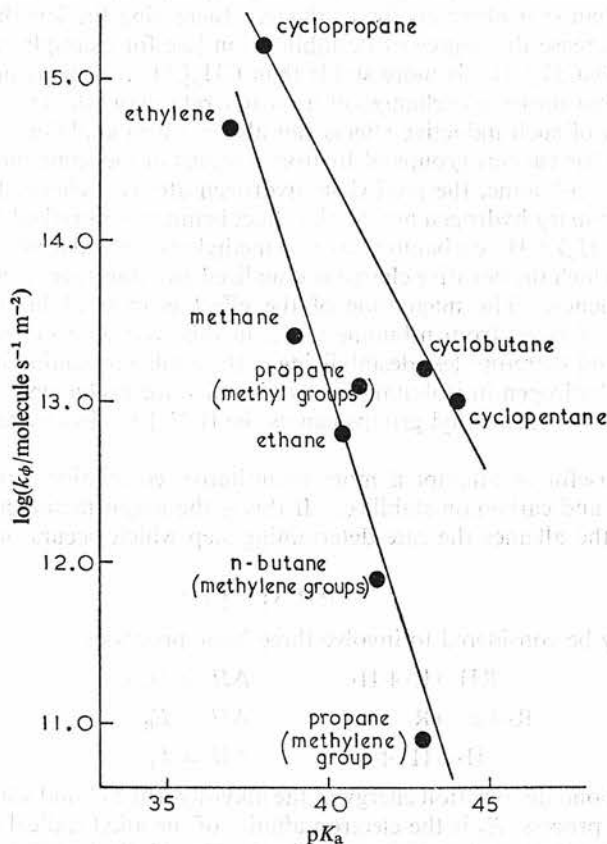

FIG. 2.—Alkane exchange reactions over γ -alumina; $\log k_\phi$ at 289 K as a function of the pK_a of the hydrocarbon [k_ϕ for ethylene taken from ref. (7)]. The values of pK_a are given to the nearest half-integer for ethane and n-butane, and to the nearest integer for the other compounds.^{20, 21}

The figure shows that a linear relationship of the form

$$\log k_\phi = -a(pK_a) + b \quad (5)$$

holds, where a and b are constants.

For the acyclic molecules

$$\log k_\phi = -0.64(pK_a) + 38.7. \quad (6)$$

For the cycloalkanes

$$\log k_\phi = -0.38(pK_a) + 29.5. \quad (7)$$

Eqn (6) appears to hold for ethylene exchange on alumina.

Eqn (5) is essentially the Brønsted relation²² proposed to relate the effectiveness of an acid catalyst to its acid strength:

$$k_A = G_A K^a \quad (8)$$

where k_A denotes the rate constant observed for the catalyzed reaction, K is the dissociation constant of the acid, G_A is a constant and α is a parameter taking values between zero and unity and indicates the sensitivity of the catalysis to the acid strength.²³ As Bell²² has indicated, the Brønsted relationship, although normally applied to the catalysis of a given reaction by a series of acid catalysts, is also expected to hold for the case where one catalyst is used with a series of acid reactants. Thus α , the sensitivity factor of the Brønsted equation (8) is analogous to the parameter a in eqn (5). For the acyclic molecules $a = 0.63$, but for the cycloalkanes the dependence of exchange rate on pK_a is less marked with $a = 0.38$. Thus it is clear that an additional factor influences the activity of the cycloalkanes and causes an enhancement in the rate of exchange, particularly for cyclobutane and cyclopentane. The origin of the increased rate of exchange is difficult to explain. Burwell *et al.*²⁴ have attributed the enhanced rate of exchange of cyclopropane on chromia to the operation of a hyperconjugative effect. It is unlikely that such an effect is present in exchange on alumina since cyclopropane is only marginally faster in exchange than predicted on the basis of the rate-acidity relationship for acyclic molecules (fig. 2). This close agreement also precludes the attribution of high exchange rates in cycloalkanes to enhanced chemisorption via π -bonding interaction with the catalyst surface. The absence of π -bonding influences is also confirmed by the fact that the relative exchange activity of ethylene is satisfactorily explained by acidity alone. We must therefore conclude that an effect operates which enables the hydrogen atoms in cyclobutane and cyclopentane to be more accessible. The origin of this effect may possibly lie in the orientation of the adsorbed reactant at the surface but a deeper understanding must await the results of further experimentation.

The linear free energy relationship depicted in fig. 2 demonstrates that alkanes exchange on alumina via the formation of adsorbed alkyl groups with carbanionic character and that exchange activity is largely controlled by hydrocarbon acidity. The extension of this idea to include ethylene is in accord with the dissociative mechanism for ethylene exchange proposed by Hightower and Hall.²⁵ The work demonstrates the importance of the electronic charge of reactive intermediates on catalytic processes occurring on alumina.⁷

In addition we may use the relationship to provide pK_a values for the methyl hydrogen atoms in the butane molecules, since these are not included in the data from ref. (20) and (21). Both n-butane and isobutane exhibit similar rates of exchange (tables 1 and 4) and we calculate the pK_a value for the primary hydrogens in both molecules as approximately 39.

The results of the experiments in which more than one alkane underwent simultaneous exchange over the same catalyst indicate that the reaction rates were little affected by the presence of other alkanes. Results were also free from effects due to dilution of the deuterium pool which might have occurred, for example, if a large hydrocarbon underwent rapid exchange in competition with smaller and less reactive molecules. The applicability of g.c.-m.s. to competitive studies of catalytic reactions is thus demonstrated.

We acknowledge the support of the Carnegie Trust for the award of a scholarship (to P. J. R.) and Imperial Chemical Industries Ltd., for a postdoctoral fellowship (to M. S. S.).

¹ P. J. Robertson, M. S. Scurrrell and C. Kemball, *Chem. Comm.*, 1973, 799.

² J. G. Larson and W. K. Hall, *J. Phys. Chem.*, 1965, **69**, 3080.

³ A. I. Trokhimets and S. V. Markevich, *Russ. J. Phys. Chem.*, 1965, **39**, 1055.

- ⁴ B. D. Flockhart, S. S. Uppal and R. C. Pink, *Trans. Faraday Soc.*, 1971, **67**, 513; B. D. Flockhart, S. S. Uppal, I. R. Leith and R. C. Pink, *Proc. 4th Int. Congr. Catalysis* (Akademiai Kiado, Budapest, 1971), vol. 2, p. 398.
- ⁵ J. G. Larson, J. W. Hightower and W. K. Hall, *J. Org. Chem.*, 1966, **31**, 1225.
- ⁶ R. S. Dowie, C. Kemball, J. C. Kempling and D. A. Whan, *Proc. Roy. Soc. A*, 1972, **327**, 491.
- ⁷ C. Kemball, J. D. Nisbet, P. J. Robertson and M. S. Scurrill, *Proc. Roy. Soc. A*, 1974, **338**, 229.
- ⁸ C. Kemball, *Proc. Roy. Soc. A*, 1951, **207**, 539.
- ⁹ R. S. Dowie, D. A. Whan and C. Kemball, *J.C.S. Faraday I*, 1972, **68**, 2150.
- ¹⁰ C. Kemball, *Adv. Catalysis*, 1959, **11**, 223.
- ¹¹ R. J. Harper, S. Siegel and C. Kemball, *J. Catalysis*, 1966, **6**, 72.
- ¹² R. S. Dowie, P. J. Robertson and C. Kemball, *J. Catalysis*, in press.
- ¹³ A. Cortés Arroyo and C. Kemball, *J.C.S. Faraday I*, 1972, **68**, 1029.
- ¹⁴ C. Kemball, *Catalysis Rev.*, 1971, **5**, 33.
- ¹⁵ D. M. Golden and S. W. Benson, *Chem. Rev.*, 1969, **69**, 125.
- ¹⁶ J. G. Calvert and J. N. Pitts, *Photochemistry* (Wiley, New York, 1966), p. 824.
- ¹⁷ R. C. Hansford, P. G. Waldo, L. C. Drake and R. E. Honig, *Ind. Chem. Eng.*, 1952, **44**, 1108.
- ¹⁸ J. I. Brauman and L. K. Blair, *J. Amer. Chem. Soc.*, 1971, **93**, 4315.
- ¹⁹ L. G. Christophorou, *Atomic and Molecular Radiation Physics* (Wiley, New York, 1971), p. 564.
- ²⁰ R. E. Dessy, W. Kitching, Th. Psarras, R. Salinger, A. Chen and T. Chivers, *J. Amer. Chem. Soc.*, 1966, **88**, 460.
- ²¹ D. J. Cram, *Fundamentals of Carbanion Chemistry* (Benjamin, New York, 1965), chap. 1.
- ²² R. P. Bell, *The Proton in Chemistry* (Methuen, London, 1959), chap. 10.
- ²³ J. N. Brønsted, *Chem. Rev.*, 1928, **5**, 231.
- ²⁴ R. L. Burwell, Jr., A. B. Littlewood, M. Cardew, G. Pass and C. T. H. Stoddart, *J. Amer. Chem. Soc.*, 1960, **82**, 6272.
- ²⁵ J. W. Hightower and W. K. Hall, *J. Catalysis*, 1969, **13**, 161.
- ²⁶ W. K. Hall, personal communication.

PROGRAM TO CALCULATE DISTRIBUTIONS IN MOLECULES

 WITH GROUPS OF NON-EQUIVALENT HYDROGEN ATOMS.

SYMBOLS IN PROGRAM

=====

NMOL -NO OF MOLECULES BEING CONSIDERED
 N -TOTAL NO OF EXCHANGEABLE HYDROGENS
 NGROUP -NO OF GROUPS
 NSET(I) -NO OF HYDRQGENS IN EACH GROUP
 PRATIO -RATIO OF DEUTERIUM TO HYDROCARBON
 S -MOLE FRACTION OF D IN D-H POOL
 AB -MOLE FRACTION OF HYDROCARBON
 NRATS -NO OF RATIOS TO BE CONSIDERED
 RATC -SLOWEST RATE CONSTANT (% MIN)
 REGIT(I) -RATIO OF RATE CONSTANTS
 NS -NO OF STEPS IN TEMP INCREASE
 H -INTERVAL BETWEEN STEPS
 ND -INTERVAL BETWEEN SAMPLES
 TIME(I) -TIME OF SAMPLE (HRS)
 T -INITIAL TEMP (K)
 E -ACTIVATION ENERGY (KJ MOLE)
 B -RATE OF INCREASE OF TEMP (DEG MIN)

=====

DECLARATIONS

DIMENSION C(5,5),A(5),DED(5),DOT(5,1000),D(20,1000),NSET(5
)
 DIMENSION TIGER(5),P(2),COMT(1000),TLAB(1000),TIME(1000)
 DIMENSION PMET(1000),REGIT(5),MDTEMP(30),TEMPIN(30)
 COMMON COMT,TLAB,H,NS,J,PMET
 DATA BLANK/' '/

SET CONDITIONS

READ,NMOL
 DO 20 IMOL=1,NMOL
 READ,N,NGROUP,(NSET(I),I=1,NGROUP)
 READ,PRATIO
 READ,S
 AB=1.0/(1.0+PRATIO)
 READ,NRATS
 DO 20 NCATS=1,NRATS
 READ,RATC
 SRC=RATC*0.6/(1.0*NSET(NGROUP))
 READ,(REGIT(I),I=1,NGROUP)
 DO 21 J=1,NGROUP
 TIGER(J)=REGIT(J)/(1.0*NSET(J))
 DO 22 J=1,NGROUP

```

22 TIGER(J)=TIGER(J)/TIGER(NGROUP)
DO 23 J=1,NGROUP
K=J-1

WRITE(6,1000) J,NSET(J)
1000 FORMAT('0',20X,'GROUP ',I1,' CONTAINS ',I2,' HYDROGEN ATOM
S')
IF(J.EQ.1) GO TO 117
WRITE(6,1001) K,J,REGIT(K)
1001 FORMAT('0',20X,'RATIO OF RATE CONSTANTS:- GROUP ',I1,' :
GROUP ',
W I1,' = ',F5.2)
117 DO 23 L=1,NGROUP
C(J,L)=-SRC*(1-IABS(J-L)+NSET(J)*AB)/(1+AB)*TIGER(J)
23 CONTINUE
WRITE(6,1002) NGROUP,RATC
1002 FORMAT('0',20X,'RATE CONSTANT FOR GROUP ',I1,' = ',E
10.4)
XXX=(C(1,1)+C(2,2))/2
YYY=((C(1,1)+C(2,2))*2)/4
ZZZ=C(1,1)*C(2,2)-C(1,2)*C(2,1)
A(1)=XXX+SQRT(YYY-ZZZ)
A(2)=C(1,1)+C(2,2)-A(1)
M=1
IF(NCATS.GT.1) GO TO 100
READ,NS
READ,H
100 CONTINUE
C
C CALCULATE TIMES FOR RISING TEMPERATURE
C
IF(H.EQ.0.0)GO TO 101
IF(NCATS.GT.1)GO TO 102
CALL CALTIM
READ,ND
X=ND
102 IF(M/X.EQ.M/ND)GO TO 103
GO TO 112
103 TIME(M)=COMT(M)/60.0
GO TO 104
C
C READ TIMES FOR CONSTANT TEMPERATURE
C
101 IF(NCATS.GT.1) GO TO 105
PMET(M)=000.0
READ,TIME(M)
105 IF(TIME(M).GT.999.0)GO TO 20
C
C CALCULATE PRODUCT DISTRIBUTION
C
104 MAMA=0
DO 24 J=1,NGROUP
IF(NSET(J).EQ.0) GO TO 24
L=NGROUP-J+1
MAMA=MAMA+NSET(J)
DGL=S/(1+N*AB)
IF(M.GT.1) GO TO 106
WRITE(6,1003)DGL
1003 FORMAT('0',' DGL = ',F12.6)
PHIIN=DGL*100.*NSET(J)

```

```

WRITE(6,1004)PHIIN
1004  FORMAT('0',' PHI(INFINITY) = ',F12.6)
106   P(1)=NSET(1)
      P(2)=NSET(2)
      UUU=DGL/(2*A(J)*A(L)-C(J,J)*A(L)-C(L,L)*A(J))
      VVV=C(J,L)*C(L,J)+P(L) /P(J) *C(J,L)*(C(L,L)-A(L))
      WWW=(C(J,J)-A(J))*(C(L,L)-A(L))+P(L)/P(J)*C(J,L)*(C(L,L)-A
(L))
      DED(J)=DGL+UUU*(VVV*EXP(A(J)*TIME(M))-WWW*EXP(A(L)*TIME(M)
))
      WRITE(6,1005)DED(J)
1005  FORMAT('0',' D= ',F12.6)
24    CONTINUE
      DO 25 J=1,NGROUP
      IF(NSET(J).EQ.0) GO TO 25
      DOT(J,1)=(1-DED(J))*NSET(J)
      NN=NSET(J)+1
      DO 25 I=2,NN
      DOT(J,I)=DOT(J,(I-1))*DED(J)*(NN -I+1)/(1-DED(J))/(I-1
)
25    CONTINUE
      NNN=N+2
      NN=NSET(1)+1
      PHI=0.0
      DO 26 J=2,NNN
      K=J-1
      D(J,M)=0.0
      DO 26 I=1,K
      IF(I.GT.NN.OR.(J-I).GT.(NNN-NN)) GO TO 107
      IF((NNN-NN).EQ.1) DOT(2,(J-I))=1.0
      D(J,M)=D(J,M)+DOT(1,I)*DOT(2,(J-I))*100
107   IF(I.NE.K) GO TO 26
      PHI=PHI+D(J,M)*(J-2)
26    CONTINUE
      IF(H.EQ.0.0)GO TO 108
      WRITE(6,1006)PMET(M)
1006  FORMAT('0','TEMPERATURE IS ',F6.2,'K')
      GO TO 109
108   IF(NCATS.GT.1) GO TO 109
      WRITE(6,1007)
1007  FORMAT('0','TEMPERATURE IS CONSTANT')
109   CONTINUE
      XTIM=TIME(M)*60.
      WRITE(6,1008)XTIM
1008  FORMAT('0',25X,'PRODUCT DISTRIBUTION AT ',F12.5,' MINUTES
')
      WRITE(6,1009) (BLANK,LULU=1,N)
1009  FORMAT('0',5X,'D0',5X,A1,'D1',5X,A1,'D2',5X,A1,'D3',5X,A1,
'D4',5X,
      WA1,'D5',5X,A1,'D6',5X,A1,'D7',5X,A1,'D8',5X,A1,'D9',5X,A1,
'D10',5X
      W,A1,'D11',5X,A1,'D12')
      WRITE(6,1010) (D(J,M),J=2,NNN)
1010  FORMAT('0',13F8.1)
C
C   CALCULATE PHI VALUES FOR DIFFERENT GROUPS
C
      AZ=0.0

```

```

BZ=0.0
CZ=0.0
DZ=0.0
NAZ1=NSET(1)
NBZ1=NSET(1)+1
J123=NBZ1+2
DO 27 J=1,NAZ1
27  AZ=AZ+J*D(J+2,M)
DO 28 J=NBZ1,N
28  BZ=BZ+NSET(1)*D(J+2,M)
HIA=AZ+BZ
DO 29 J=NBZ1,N
IF(D(J123,M).LT.0.1) GO TO 110
29  CZ=CZ+(J-NSET(1))*D(J+2,M)
DO 30 J=NAZ1,N
30  DZ=DZ+D(J+2,M)
HIB=CZ/DZ*100.0
GO TO 111
110  HIB=0.0
111  CONTINUE
WRITE(6,1011)HIA,HIB
1011  FORMAT('0','          PHI(A)=      ',F10.4,'          PHI(B)=      ',F10.4)
C
C   COMPARE CORRESPONDING BINOMIAL DISTRIBUTION
C
WRITE(6,1012) PHI
1012  FORMAT('0',20X,'BINOMIAL DISTRIBUTION WITH PHI = ',F7
.2)
YY=PHI/100/N
XX=1.0-YY
D(2,M)=100*XX**N
DO 31 J=3,NNN
31  D(J,M)=D(J-1,M)*(NNN-J+1)*YY/XX/(J-2)
WRITE(6,1009) (BLANK,LULU=1,N)
WRITE(6,1010) (D(J,M),J=2,NNN)
112  M=M+1
IF(H.EQ.0.0)GO TO 101
IF(M.EQ.NS)GO TO 20
GO TO 102
20  CONTINUE
STOP
END
SUBROUTINE CALTIM
C
C   CALCULATES COMPUTER TIME DISTRIBUTION
C
DIMENSION COMT(1000),TLAB(1000)
DIMENSION PMET(1000)
COMMON PMET
COMMON COMT,TLAB,H,NS,J
R=8.317E-03
READ,T,E,B
P=0.0
FP=1.0
FFP=0.0
AR=0.0
P1=0.0

```

```

WRITE(6,1013)
1013  FORMAT('0',' LAB  TIME',10X,'COMPUTER  TIME')
      WRITE(6,1014)
1014  FORMAT('0',4X,' 0.0000',19X,'0.0000')
      J=0
113   J=J+1
      IF(J.EQ.NS)GO TO 114
      P=P+H
      Y=(E/(R*T)-E/(R*(T+B*P)))
      PP=EXP(Y)
      IF(J.LT.3) GO TO 115
      X=J/2.0
      Y=J/2
      IF(X.GT.Y)AR=AR+H*(5*FP+2*PP-FFP)/6.0
      IF(X.EQ.Y)AR=AR+H*(FP+PP)/2.0
      GO TO 116
115   AR=H*(FP+PP)/2.0+AR
116   FFP=FP
      FP=PP
      PMET(J)=T+B*P
      COMT(J)=AR
      TLAB(J)=P
      IF(INT(P).EQ.INT(P1))GO TO 117
      WRITE(6,1015)P,AR
1015  FORMAT('0',5X,E10.4,15X,E10.4)
117   P1=P
      GO TO 113
114   RETURN
      END

```