

*clm to 1000*

MILITARY SANITATION

on the

WESTERN FRONT.

By

James. A. R. Thompson,

M.B. Ch.B. D.P.H.

Capt. R.A.M.C.

*M. D. 1920.*



## MILITARY SANITATION on the WESTERN FRONT.

Foreword:- Preventive Medicine as practised today by the Medical Services is of comparatively recent growth. The expression used by Nelson in one of his dispatches to the Admiralty - "I think you will agree with me that it is easier for us to keep a man healthy than for a physician to cure him" - shows that, little over a century ago, preventive medicine was not yet considered the province of the medical profession. This is interesting in view of the rapid strides made by the profession in this direction even since the South African War.

The Measures adopted to reduce sick wastage are numerous; some of them not coming directly into the province of the sanitarian. They are of two kinds:-

- A. Measures to maintain in good health the individual soldier, thus increasing his resistance.
- B. Measures to prevent the spread of infection from the sick to the healthy.

Feasibility. While in training and rest areas, these measures can be adopted in their entirety; they are not always practicable under active conditions.

Summary of Measures taken. These can be summarised as follows:-

- A. Measures to maintain the soldier's health:-

(1) Regularity in everyday concerns of life, - work, - meals, - leisure, - sleep.

(2) Meals - good, varied, and well cooked.

(3) Suitable clothing and change of underclothing.

Drying sheds for wet clothing.

(4) Regular ablutions and baths.

(5) Good sanitary conditions generally.

(6) Attention to teeth, eye, and ear defects.

(7) Feet - provision of good, well-fitting boots; chiropodists; clean dry socks, and treatment with oil to prevent "trench feet"; blisters treated on the march.

(8) Provision, in forward areas, of hot drinks to men returning from the trenches, and others in need thereof.

(9) Recreation and Study - gymnastics, sports, concerts, etc.; lectures, and schools of instruction on suitable subjects.

N.B. The sports should be well varied, and instruction in sanitation, elementary physiology, cooking, etc., made as interesting as possible.

B. Prevention of the spread of disease to the Healthy:-

This is brought about by:-

(1) Measures rendering the Individual less susceptible.

(2) Measures preventing disease microbes reaching the healthy individual.

(1) Measures rendering the Individual less susceptible:-

These are as follows:-

- (a) Measures for developing the normal resistance to its fullest capacity, as in A, bringing him into, and maintaining him in good health.
- (b) Individual Prophylaxis; e.g. quinine in malarial districts.
- (c) Inoculation and Vaccination, conferring immunity; e.g. typhoid, small pox.

N.B. The prophylactic inoculation of anti-tetanic serum in cases of wounds is an important development of this method of treatment.

B. The Measures employed to prevent disease germs reaching the healthy individual, and of which I now propose to give a brief description, may be discussed under the following headings:-

- (a) Water.
- (b) Food.
- (c) Insects.
- (d) Refuse, ground soil, manure.
- (e) Sick, sick contacts, and Disinfection.

N.B. Although this classification is made for the sake of convenience, it must be borne in mind that all measures are interdependent and that the failure of any one may have far-reaching effects. Even where scrupulous care is employed in the cookhouse, the possibility of food becoming contaminated from infected

water, or flies, is an obvious example of how efforts in one direction may be negated by a breakdown in another.

B. (a) Water.-

In considering the subject of water-supply and water-borne disease, it is not proposed here to give a lengthy account of established ideas and methods, but simply to state the results of personal observation of a few points of practical importance while the writer was on the Western front.

I contend that the comparatively low incidence among our troops of water-borne diseases, in that germ-impregnated battlefield area, where drinking-water is often impregnated with cesspool leakage, is distinct evidence to the excellence of the prophylactic measures employed. The importance of these measures can not be over-estimated, as soil-borne diseases may become water-borne. When one recalls to mind that such diseases as Typhoid Fever, Cholera, Dysentery, and Diarrhoea are conveyed by water, the necessity for the strict supervision of all water-supplies is obvious, combined with adequate measures for its sterilisation.

In addition to the microbic diseases already mentioned, it is possible that water containing a considerable proportion of mud may mechanically assist in causing Diarrhoea of an irritative nature. In the autumn of 1917, I investigated an outbreak of Diarrhoea accompanied by a slight rise in temperature, which

occurred after a period of heavy rain. On having an accumulation of mud removed from the reservoirs, the outbreak immediately ceased.

Nature of country occupied:-

In considering the water-supplies of the Western front it must be borne in mind that, with the exception of the actual fighting zone,-

1. The whole area consists of cultivated land.
2. That, except in upland districts, the civilian water-supply (which must necessarily form the nucleus for that of the Army) consists of shallow wells.
3. That danger of contamination of water-supplies is increased by the average low standard of civilian sanitation which exists.
4. That a large proportion of French villages are situated in river valleys.

N.B. The highly suspicious character of water derived from the germ-impregnated battlefield zone is obvious.

The country occupied may be roughly divided into two areas:-

1. Area North of Bethune:-

Here the country becomes quite flat and the surface consists of alluvium formed by deposition of sand, gravel, clay, silt and peat in alternating layers. These alluvial flats are below flood level but slightly above the level of water in the rivers, dykes and

canals. The subsoil water, in winter time, is often barely one foot from the surface.

Here the water is not only very apt to be contaminated by sewage but also from the presence of decaying organic matter in the alluvium. The water-supplies are mostly shallow wells, a large proportion of which show evidence of sewage contamination when examined chemically and microscopically.

## 2. Area South of Bethune:-

In this area chalk forms the main mass of the large ranges of hills, either reaching the surface, or being thinly covered by tertiary deposits.

Hill Crests:- Here the gravel or sand often contains considerable quantities of water retained in cups in the underlying clay.

Upland Valleys:- Here water derived from the chalk is generally a pure but hard water. As, however, the chalk is extensively fissured, many of these high valleys are waterless. Springs situated in the sides of these valleys are of good quality.

River Valleys:- Here the water is usually derived from shallow wells, and as these alluvial flats are heavily cultivated, this water is generally greatly contaminated.

## Sources of Contamination.

Situation of Wells in general:- With the exception of public wells, which are generally situated at intervals in the village streets, wells are usually

situated in the courtyards of buildings, in close proximity to the manure-heap (where present) and the house privy. The danger from these sources, especially if the privy cesspool is in a leaky condition, and from surface drainage, is further increased by the custom of French housewives to scrub the courtyard pave with liquid manure, thus avoiding the use of soap.

Faults in Well Construction:- Another factor which increases the danger of contamination, where present, is faulty construction of the well itself.

1. Stonework which is not properly cemented or steined; and
2. Defects of the superstructure: both permitting surface-water to gain access to the well.

In addition, as 50% of the wells are fitted with windlass and bucket instead of a pump, these wells can be further contaminated:-

1. By dust gaining access through openings in the superstructure -
2. Mud gaining access from the foot of the bucket.

This addition of extraneous matter is further added to where miscellaneous vessels are used for the purpose of drawing water.

The prevention of the use of these unauthorised vessels for this purpose is one of the duties of the Water Police.

Sterilisation of Water:- The necessity of obtaining water from such suspicious sources as I have just

described, renders the adoption of adequate measures for sterilisation absolutely essential. While, of course, under peace conditions many methods of sterilising water are available for use, in the field the simplest method, combined with efficiency, must be employed.

This is fortunately available, as Calcium Chloro-hypochlorite, commonly known as Bleaching Powder, forms an invaluable and effective agent for water sterilisation and when added in the correct proportion renders water sterile in half an hour.

Action of Bleaching Powder:- When exposed to the action of humid air containing Carbon Dioxide, Bleaching Powder breaks up, and liberates chlorine according to the equation -

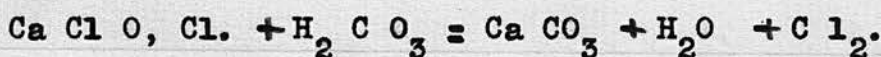

In solutions, the reaction is entirely different, Chloride and Hypochlorite of Lime being formed -

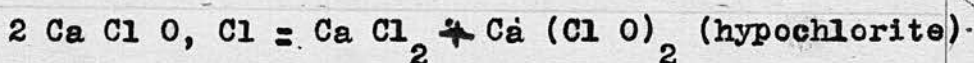

The hypochlorite thus formed is a powerful oxidising agent, being converted into Calcium Chloride by the loss of all its oxygen.-



The sterilising action of Bleaching Powder in water appears to be due to two causes:-

1. Toxic action of the Hypochlorite of Calcium.
2. Oxidation

Owing to this tendency of Bleaching Powder to lose its efficiency on exposure to air, it is essential that all tins showing signs of deterioration, namely rust and dampness, be discarded.

Eau de Javel, the hypochlorite solution used by the French Army for water sterilisation, has the advantage that its strength remains constant, but it is doubtful if this counterbalances the need for extra transport which its use entails.

Horrocks' Test Case:- This case, devised by Col. Horrocks, provides a portable and rapid method of ascertaining the amount of Bleaching Powder which a given water requires.

It consists of a set of enamelled cups and glass pipettes and is so arranged that the addition of one drop of Bleaching Powder solution to a cup of water by means of a pipette, is equivalent to the addition of one measure (2 grams) of Bleaching Powder per 100 gallons.

An indicator (Zinc Iodide and Starch solution) is provided of such a strength that 3 drops of the solution give a definite blue colour with a cup of water containing 1 part per 1,000,000 of free chlorine.

The 6 enamel cups are filled with water and have added to them 1, 2, 3, 4, 5, and 6 drops of Bleaching Powder solution. Indicator is then added, and the cup containing the smallest amount of Bleaching Powder, which retains its blue colour for half an hour, gives the amount of Bleaching Powder which is required, - one

drop corresponding to 1 measure of Bleaching Powder.

Supervision of Water-Supplies:- Having given a brief description of the nature of the sources from which water is derived, and the method of sterilisation adopted, I shall now describe briefly the method of supervision adopted and the means which, as a sanitary officer, I found useful. The question of the purity of water used for drinking and cooking is a most important duty of the Medical Services.

The examination of water-supplies by Horrocks' test, previously described, is conducted by: 1. Regimental Medical Officers. These select water-supplies for use by their units, and insure that clarification by alum is carried out where necessary.

Poisoning and Pollution of Water by the Enemy:- In districts evacuated by the enemy, examinations for metallic poisons are also conducted, as well as examination and treatment of polluted wells. These examinations are absolutely essential.

Polluted Wells:- The water in these is treated by the addition of Unslaked Lime or Bleaching Powder, after removal of all debris from the well. After being well mixed it is allowed to stand for 24 hours, and then pumped dry. This is repeated, the well sides being well scrubbed down with the solution. The well is then repeatedly pumped dry until all trace of lime has disappeared.

The Bleaching Powder should be in a 1% solution. The amount of water in the well is calculated from

this formula -

$$D^2 \times .7854 \times d \times 6.23 = \text{gallons}$$

where D = diameter of well in feet

d = depth of well in feet.

I, personally, have no experience of chemically poisoned wells, but have used the method indicated above for polluted wells on several occasions with excellent results. The absolute necessity of these examinations can never be overlooked, as the drinking of untested water involves the gravest risk, and cannot be permitted.

2. Area Sanitary Officer:- The work of the Regimental Medical Officer, though considerable, is necessarily confined to the area occupied by his unit. The greater part of the supervision of water-supplies devolves upon the Area Sanitary Officer, who is further assisted by the officers in charge of mobile Bacteriological and Hygienic laboratories, who examine and report upon supplies, where necessary, and investigate disease outbreaks.

The Area Sanitary Officer, with his sanitary section, is situated more or less permanently in an area, and can thus organise systematically the necessary steps to ensure that all water when consumed is of as good quality as possible.

I have acted in this capacity for a considerable period, and the system I adopted is as follows:-

Water Sub-section:- For this most important duty

of water supervision, I carefully selected a few trustworthy N.C.O's. to act as a water sub-section of the Sanitary section. These men were selected on account of their previous experience, in addition to their general intelligence and trustworthiness. My reason for doing so was to ensure that all investigations should be conducted with the most scrupulous care.

The system of procedure which I adopted, in any area, may be divided into what I may term (1) Preliminary work, and (2) Routine work, the former consisting in obtaining all information regarding the area water-supplies. This duty is a most important one, and one in which I always insisted on the greatest care being taken.

The work of investigation may be thus tabulated:-

A. Preliminary Work:-

for the purpose of:-

- (a) Obtaining any necessary alterations.
- (b) Providing information by -
  1. Tabulated list of water-supplies, water map,
  2. etc. map, etc.
2. Suitable labelling of wells.

B. Routine Work:-

consisting of -

- (a) Supervision of water-supplies with regard to -
  1. Adequacy.
  2. Quality.
  3. Defects.
  4. Suggested improvements and alterations.

(b) Supervision of Water Police in charge of same, as to -

1. Sufficiency of numbers.
2. Knowledge of water duties.
3. Trustworthiness.

(c) Supervision of water-carts:-

1. Condition of cart and spaces.
2. Presence of an orderly.
3. Number of tins of Alum and Bleaching Powder carried on the cart.
4. Evidence of satisfactory chlorination.

N.B. The test I adopted to demonstrate satisfactory chlorination was the addition of 3 drops of a solution of Zinc Iodide and Starch to a cupful of the water being examined. If satisfactory, a blue colour developed which persisted for at least half an hour. All water must be chlorinated at the water point.

(d) Supervision of water-cart orderlies:-

1. Is the man detailed for regular duty with the cart - or, is he frequently changed?  
(The importance of having a regular attendant is obvious.)
2. Does he perform any sanitary duties?  
(This must never be permitted.)
3. Has he ever suffered from Dysentery or Enteric Fever? (This renders him unsuitable owing to the risk of transmission of disease by means of a carrier.)
4. Does he know his duties, and is he intelli-

gent and trustworthy?

3. Instruction of the Personnel employed in Water duties.

Preliminary Work:-

On taking charge of any new area, my routine practice was to obtain immediately detailed information upon its water-supplies.

By making use of a special form for this purpose the information was easily tabulated (see Appendix).

In addition, I embodied the information in a Water Map where, by the simple expedient of using a different colour for different qualities of water, and signs for types of water-supplies, one could see at a glance the supplies of any part of the area. This was very useful for anyone desiring information on this point.

An immediate result of having this information at my disposal was that I could, without loss of time, suggest any necessary alterations, and thus have the work put in hand with the least possible delay.

The systematic testing of water-supplies, which formed part of the investigation, was accompanied by "Labelling of Wells" - thus also putting the information gained to practical use.

The notices affixed at water-points were as follows:-

1. Wells which by test show that 1 measure of B.P. or less per water-cart (110 gallons) is required = "This water must be chlorinated with 1m. B.P. per Water Cart."

1. Wells requiring over 1 m. B.P. - 3 m. B.P.

= "Washing Water Only."

3. Wells over 3 m.

= "Out of Bounds."

The actual standard fixed varies, of course, with the supplies available, but it is very rarely necessary to use as drinking water any which requires more than 1 m. B.P. (2 grammes) per water-cart, as examined by Horrocks' test.

Before recommending any extensive constructional work in regard to a water-supply, or using doubtful supplies, it is wise to obtain a chemical and bacteriological analysis from the Mobile Laboratories of the area.

Routine Work:-

Though, for the sake of convenience in description, I have distinguished this from preliminary work, the one naturally merges into the other, and they are carried on conjointly. It may be briefly described as -

Supervision:- And this surveillance is exercised over the whole water-supply in all its different stages en route to the consumer. It is, therefore, obvious that both the water-points and the water-carts are included in this supervision, as are also the personnel in charge.

Routine Inspection of Water-supplies:- This is a continuation of the preliminary investigation and is carried out on similar lines. I made use of a similar form for the inspection of water-carts. This latter

inspection is a most important one, as here the water reaches its final stage before consumption.

Supervision and Instruction of Personnel:-

As so much of the water-service's efficiency depends on its personnel, the importance of instructing these in their duties cannot be over-estimated.

This instruction was carried out by the Water Sub-section, and included:-

1. Sources of water.
2. Sources of contamination.
3. Dangers of bad water; Water-borne diseases.
4. Horrocks' Water Test for chlorination.
5. Instruction in Chlorination.

The method I adopted consists in rubbing up the Bleaching Powder into a smooth paste in a cup with a few drops of water, then adding sufficient water to make it of the consistency of thin cream. This is then added to the water in the cart during the process of filling, and becomes thoroughly incorporated. After half an hour the water is fit for use.

I attach copies of the forms used for inspecting water-supplies.

As the provision of good water is a vital one, the conduction of adequate and careful supervision is absolutely essential.

Report on Water-Supplies for the Village of -----?

Position of Well.	Type of Well.	Depth of Well.	Amount of Bleaching Powder required per 100 galls.	State of Repair and requirements.	Condition of surroundings.	Remarks.
<p><u>e.g.</u> In yard of Billet 34 Rue Lafayette</p>	<p>Windlass and Bucket</p>	<p>25 metres</p>	<p>1 measure ( 2 grams )</p>	<p>Good, but windlass drum requires brake</p>	<p>Satisfactory</p>	<p>Can be repaired with little trouble.</p>



Disinfection:— Many methods of disinfection are employed, the chief being the use of the Hoden Thresh Disinfector. Other methods, use the Serbian Barrel; Russian Pit; and Clayton's machine for disinfection by Sulphur di. oxide. Whatever method is employed efficiency is essential. The presence of living lice in so-called disinfected clothing, not only reveals the failure of disinfection but has a discouraging effect upon individual initiative in regard to cleanliness. The causes may be 1. Faults during disinfection

2. Faults after disinfection

1. In the case of the Thresh disinfector usually employed these may consist in
  - a. Contents of the cages too tightly packed
  - b. Too great a charge
  - c. Sufficient steam pressure not maintained in the cylinders (a badly working inlet valve is sometimes the cause of this)
  - d. Clothes not exposed in the chamber for a sufficient time (an average time is 40 minutes)
2. This consists in allowing disinfected clothing to come in contact with verminous

clothing, or sites which have become contaminated by verminous clothing. Adequate supervision to ensure that disinfection is carried out satisfactorily is absolutely essential whatever method of disinfection is employed.

Col. William Hunter in the British Medical Journal of August 24th 1918 describes the methods employed by him in the Eastern War areas. The method of disinfection on the largest possible scale which he made use of is the Railway Van Disinfector which he claims to be easily improvised and worked besides being absolutely efficacious. In this method a railway van is used as the disinfecting chamber, & current steam from the engine is used as the disinfecting agent.

Col. Hunter claims remarkable disinfecting powers for this disinfector due to:-

1. The fact that current steam (at ordinary atmospheric pressure) is the easiest and most potent disinfectant which we possess
2. The great force under which the steam is driven into the van (60-110 lbs) from the boiler of the engine enabling the steam to penetrate the largest bundles

N.B. no attempt is made to develop any

pressure in the van itself.

3. The large amount of steam available

Difficulties:- The difficulties in combat-  
ing the louse problem successfully  
consist in:-

1. The necessity for disinfection on a very large scale (Col. Hunter's method would provide this)
2. The ordinary flannel thick shirt which forms a suitable place for the deposit of ova, and which after washing is difficult to dry.
3. The fact that the uniform becomes infest-  
ed with lice in addition to the under-  
clothing and blankets etc.

N.B. The wearing of short drawers during the summer months, also tends to infestation of the uniform.

Suggestions:- To meet these difficulties I recommended the following:-

1. The wearing of cotton shirts and long cotton drawers during the summer months, the wearing of drawers to be compulsory.

2. Washing in the summer months of under-

- clothing to be done by the men themselves wherever possible, and at other seasons if conditions permit.

3. The provision of washing places on the French "Lavoir" principle, scrubbing brushes and soap being provided. Temporary washing places of this nature would be easily provided.

+ Drying sheds could be erected near if conditions were favourable.

I suggested also that washing parades be established, the period of time between each depending upon the state of the men's underclothing.

Verminous Men:- Here the men themselves should be isolated, and their underclothing washed every second and third day until perfectly vermin free.

The uniform at the same time could be repeatedly ironed until free from lice. Where irons were not available for this purpose, a flame (eg. candle) passed along the seams of the clothing daily until the clothing is free from lice will answer the same purpose.

The solution of the louse problem seems to resolve itself into an encouragement of the individual in regard to personal cleanliness, in addition to methods of disinfection on a large scale. Whenever possible the interchange of under clothing blankets etc. should be avoided, even after disinfection. The method employed by Colonel Hunter, of disinfecting each man's effects in a clearly marked bundle is a practice which offers many advantages the chief being, that in case of a breakdown in disinfection, the clothing is returned to its original wearer, thus safeguarding as far as possible, the men who are reasonably clean and free from vermin.

Cotton Underclothing:- This type of under-clothing is easily washed and can be dried even when conditions are not very favourable.

The use of long cotton drawers would aid in keeping the uniform vermin free. Men wearing this underclothing during the summer months would be at the commencement of the cold season practically vermin free and could thus be maintained more easily in a cleanly condition

### Food.

I do not propose to enter here into the question of disease conditions produced by monotony or defects in dietary, or to the Deficiency diseases, as Scurvy, caused by a dietary lacking in "Vitamines" from the want of fresh meat and vegetables.

In my capacity as Sanitary Officer, I was chiefly concerned with:-

1. The quality of food issued.
2. The steps taken to prevent its contamination.

Quality of Food:- Though this does not strictly come under the classification I have adopted, the detection of unsound food is a step very necessary to prevent sickness arising from this cause. Owing to the great care which is taken in respect to food-supplies, the danger from this cause is reduced to a minimum. The possibility of such changes as putrefaction in meat, bacon, tinned foods, must be remembered, and also the presence of mould in bread or biscuits. Putrefaction changes in meat after cooking and opened tins of preserved meat must not be overlooked.

Protection of Food from Contamination:- The risk of contamination of food-supplies is a very constant danger, and the most careful supervision is necessary to prevent this. This supervision is necessary both at the distribution centre and at the cookhouse itself. Even at temporary ration dumps the use of a sheet for placing meat and other food upon prevents its contamin-

ation with soil.

In addition to contamination taking place before distribution the food may be contaminated in the cookhouse itself. This may be brought about through the agency of water, flies, dust, directly from an infected cook, or the want of cleanliness in the cookhouse or its personnel. Food may be infected directly from a contaminated water-supply used in cooking, or indirectly through washing cooking utensils in a contaminated water.

It is most essential that cookhouses, food-stores, etc., be inspected daily by the Medical Officer.

N.B. The tables and woodwork can be maintained in a beautifully white condition if scoured daily with a mixture of Bleaching Powder and washing soda.

Selection of Cooks:- In selecting these care must be taken that they have not previously suffered from Typhoid or Dysentery, owing to the risk of the spread of infection by Carriers. No man suffering from Diarrhoea must be permitted in the cookhouse.

N.B. Similar care must be taken in the selection of Water personnel.

Cleanliness of Cooks:- These must be provided with a regular change of clean overalls, and must make systematic use of washing requisites provided outside the kitchen, including nail-brushes. Their nails must be cut short, and they must be strictly cleanly in all their habits and keep themselves, their utensils and the cookhouse itself in a cleanly condition. They must

wash their hands after each visit to the latrine.

Cleanliness of Cookhouse, etc:- In addition to maintaining the cookhouse, chopping tables, utensils, etc., in a state of perfect cleanliness and having the walls regularly lime-washed, it is essential that no articles of personal equipment or clothing be kept in the cookhouse, which must not be used as a sleeping-place.

They must not be in the vicinity of the latrines or incinerator.

The kitchen must not be used as a food-store, and must be protected from flies during the summer and autumn.

Cutlery and utensils must be protected against dust.

Water used for scouring-up must be sterile, and sand used for scouring should be baked previously.

Dish-cloths must be washed out and dried daily.

All refuse must be kept in covered receptacles and regularly removed from the cookhouse.

Greasy waste-water must be taken some distance off and passed through a suitable trap for removal of grease and sediment before being discharged into a soakage pit.

Adequate measures against flies must be taken.

Allusion to this will be made under "Insects."

### Insects.

The well-established fact of the part played by insects in the transmission of disease need only be

mentioned.

Direct Infection:- Plague (*pulex cheopis*), Sleeping Sickness (tsetse fly), and Malaria, Dengue and Yellow Fever by members of the mosquito family, are familiar examples of diseases conveyed directly through the bite of an infected insect.

Indirect Infection:- Disease may also be conveyed indirectly; and this method plays a large part on the Western front.

The insects which here require the greatest amount of attention are:-

1. Flies, and
2. The Body Parasites:-
  - (a) *Acarus Scabiei*.
  - (b) *Pediculus Corporis* (louse).

Flies:- The danger of fly-borne infection is an indirect one and is due to the habits of these insects, which breed in filth and feed indiscriminately on filth and food.

By adopting adequate sanitary measures we both reduce the numbers of these insects and remove the germ containing filth which they carry to food. The discharges from persons suffering from specific disease, e.g. Cholera vomit, Enteric stools, are a grave source of danger, and their adequate protection against flies is absolutely essential.

An additional safeguard is added by the proper protection of foodstuffs, and active measures for its destruction taken against the adult fly.

Method of Transmission:- This is usually through the insect's dejecta, but it may be conveyed, in addition, on their legs, wings and bodies. It may thus be carried directly to the lips of man or, indirectly, through his food.

Diseases conveyed by Flies:- The chief diseases conveyed in this manner are Enteric Fever, Cholera, Diarrhoea, Erysipelas, and Conjunctivitis, though it is quite possible that others, e.g. Tubercle, Gas Gangrene, Anthrax, Bacillary Dysentery and Tetanus may be conveyed by them.

The House fly (Musca) is the one that plays the chief part in the transmission of disease. It breeds chiefly in horse manure.

Latrine fly:- In Gallipoli the active agent in the transmission of Dysentery was the Latrine fly, which breeds in human excreta.

The chief varieties of flies which I have had to deal with may be classified under the family Muscidae - belonging to the family Diptera.

Muscidae:- (a) Stable flies (Stomoxys)

(b) Horse flies (Tabanidae or Hippoboscidae)

(c) House flies (Musca)

(d) Carcass flies:-

Blue Bottles (Cynomyia)

Green Bottles (Lucilia)

Grey Bottles (Sarcophaga).

The best general methods of combating these I have found as follows; though to some methods in particular I will refer to later:-

1. Measures against the eggs and larvae.

2. Measures against the adult fly.

1. Measures against the eggs and larvae:-

Removal of Breeding-places:- Moist horse manure between the temperatures of 30°C and 40°C is the favourite breeding-place of the House fly, at least 90% of eggs being laid there. Human excreta and animal refuse may also be used for this purpose.

To prevent fly-breeding, therefore, it is essential that no uncovered material suitable for breeding-places be left fit for flies to breed in.

These steps will be described later under "Refuse."

To check breeding of Carcase flies, burial of carcases and garbage must be immediately attended to. Where burial is impossible owing to hostile action carcases should be sprayed frequently with "C" solution.

All latrines must be fly-proof.

Protection of Food:- This forms an important link in the chain of defence against fly-borne disease, and may be briefly described as strict cleanliness and the adoption of every measure necessary to prevent the entrance of flies to food, food-stores, cookhouses, dining-rooms, etc. Windows should be protected with gauze netting, and doors should have muslin curtains. Meat-safes and receptacles for food must be provided, and measures taken in dining-halls, etc., to protect

jam, milk, etc., by muslin protectors.

2. Steps against the adult fly:-

These consist of:-

1. Mechanical means, as fly-traps, e.g. the balloon trap, flappers, tanglefoot fly-papers, etc.

2. Poisons: 3% Formalin in sweetened alkaline solution for indoor use, as it is not dangerous to man or domestic animals.- Sodium Arsenite

( $\text{Na}_2\text{H,As O}_3$ ) in 1% solution adequately sweetened.

This is very toxic to man, and great care must be employed in its use.- Pyrethrum Powder: This is very effective when dusted over the parts frequented by flies, causing them to become mummified and innocuous. It is rather irritating to the throat and nose.

3. The washing of walls, window-frames, etc., with a cresol solution is a useful deterrent. I have found that paraffin smeared along window-frames, etc., is most useful for this purpose.

4. The application of a flame to the parts on which flies rest is a simple method but has to be carefully employed to guard against fire.

I have not endeavoured to do more than indicate these methods against the adult fly. The fly danger is a very real one and affords scope for much careful thought.

Acarus Scabiei:- The importance of prompt treatment of cases of scabies in their early stages consists

in the fact that blankets, clothing, etc., are immediately infected and the disease rapidly spreads. To prevent this, prompt isolation and treatment is necessary, with disinfection of all infected blankets, clothing, etc. This condition is often accompanied by Pediculosis and, when neglected, a dermatitis is set up, which usually takes on an impetiginous nature.

The further necessity for early treatment is thus indicated, as when the affected are evacuated from this cause they are temporarily lost as effectives.

Body Parasites:- (Pediculus Corporis and Acarus Scabiei):- The part played by lice in the terrible Serbian epidemic of Typhus and relapsing fever is still fresh in the memory, and the findings of the Government Commission on Trench Fever show that this insect is also the cause of transmission of Trench Fever.

The presence of lice in the clothing and under-clothing of a considerable proportion of men at the Front conveys an ever-present warning that disease is never far away, and that no slackening of preventive measures can ever be permitted. Quite apart from the menace of the diseases transmitted by its means, the irritation set up by this insect, and the subsequent scratching, must have a depressing effect on the general health.

#### Refuse (and its disposal).

This part of the subject is important, for many of the points I have observed, and some of the methods

I have experimented with, have reference to the great necessity of dealing with the fly-problem. In disposing satisfactorily of filth, in which the fly is born, grows up and lives its life, we are to some extent getting nearer a solution of that problem. A great part of my duties have lain in this direction, and the branch of sanitary work in question has always had interest for me.

For the purpose of condensing the question of the disposal of refuse in the field, we can broadly divide the waste products of any body of men roughly as follows:-

1. Liquid.

2. Solid.

Another classification might be:-

1. Excreta and Urine.

2. Other camp refuse.

Disposal of Refuse:- The main essential in refuse disposal is efficiency, as in view of the large part taken by flies in the production of disease it is essential that all filth be immediately dealt with, so as to prevent it from becoming a breeding or feeding ground.

Special attention must be paid to preventing:-

1. Any accumulation of refuse becoming accessible to flies.

2. To keep latrines and urinals in a clean condition - the former properly fly-proofed, and the urine gutter treated daily with a disinfectant.

Whatever may be the nature of the waste material to be disposed of, there are two fundamental methods of dealing with the same, namely:-

1. Incineration.

2. Burial.

Incineration:- This is the simplest and most effective purifying agent, and has been used for this purpose since time immemorial. The "Great Fire of London" is a classical example of the usefulness of fire in stamping out disease. It should be employed wherever circumstances permit and the waste material is suitable for burning. The incinerators used should be so constructed that bad smells and empyreumatic vapours are not emanated in the process of combustion.

The incineration of ordinary camp refuse presents no difficulty, nor does that of the small amount of solid deposit and soap-curd removed by means of a trap from kitchen, or ablution water. Care must always be taken to put damp material on the fire only in small quantities at a time, after the fire is well alight. The incineration of excreta presents greater difficulties and is not practicable to any extent in other than fixed camps.

For the incineration of damp material and excreta, incinerators should be provided with a drying tray on which drying can take place before the material is added to the fire. Incinerators of many types are employed, the Horsfall being a useful type, though the opening for the removal of burnt material is rather limited.

Type of Incinerator recommended:- The type of incinerator which I adopted, and which I found to be more practicable than any other for dealing effectively with moist material and excreta, has the following features:-

1. Construction - square, brick, closed-in type.
2. Centrally placed sheet-iron chimney of tapering pattern, having a wide entrance for smoke and a narrow exit. This position and shape ensured good draught and excellent combustion.
3. An opening for filling and a large opening for clearing out burnt material, placed at opposite sides of the incinerator, thus ensuring rapid emptying and avoiding the mixing of burnt and unburnt refuse
4. Sufficient provision for the entrance of air.
5. A drying tray for the preliminary drying of wet rubbish and excreta.

N.B. The tray is loose and can be removed when not required for use. It is supported on rails sufficiently strong to prevent bending under the intense heat evolved; light narrow-gauge tramway rails I found suitable and available. The quality of these rails determines the life of the incinerator, as rails which bend under the weight of the tray contents cause the brickwork to collapse.

For use of smaller camps I constructed a similar incinerator of sheet-iron, which was most effective in practice.

Incineration of Excreta:- The incineration of excreta presents greater difficulties than that of ordinary refuse owing to its moist nature and the necessity for having sufficient refuse or other fuel to ensure sufficient heat for complete combustion.

The requisites for success are:-

1. Permanent Incinerator personnel.
2. Sawdust, or other suitable material to aid incineration.
3. Suitable incinerator of closed-in type provided with a tray on which the excreta can be dried before being burnt. I have constructed a large number of the type described, which gave most satisfactory results.
4. A strainer or other means for separating faeces from urine.
5. A shed for storing sawdust and protecting refuse from rain. It should be provided with a concrete floor on which sawdust and excreta can be mixed.

A shed should be provided in all camps close to the incinerator, even though excreta is not incinerated.

Excreta of Infected Persons:- Wherever possible, this should always be incinerated. The evaporation of infected urine presents greater difficulties, but should always be adopted where possible. If incineration is impossible, infected excreta and urine must have sufficient disinfectant added to ensure sterilisation before burial.

Other Incinerators:- Although I have sketched the type of incinerator which I have found most suitable for fixed camps, the type of incinerator adopted must depend to a large extent on the material and the time and labour available.

Refuse can be satisfactorily burnt on a grating of expanded metal supported on a framework of iron pickets and surrounded by a piece of wire netting.

Wherever possible, a small shed should be built to prevent refuse from becoming wet. This is very important owing to the great difficulty in the incineration of wet rubbish.

It is most essential that all rubbish be burnt daily, and careful supervision of incinerator sites must, therefore, be conducted, otherwise they become breeding-places for flies.

Where excreta is disposed of by incineration, this is liable to break down:-

1. If there is any scarcity of sawdust or material suitable for admixture.
2. When a camp in which the method of disposal of excreta by burning is evacuated by the unit in occupation, it is frequently difficult through lack of time available for the purpose, to burn all excreta. The latrine pails are thus left full and, if not properly fly-proofed, may become breeding-places for flies.

Burial:- This method must, in certain circum-

stances, be adopted for the disposal of solid refuse, where, owing to military considerations, incineration is not permissible.

Deep Pits:- The refuse must be burned in deep pits suitably marked and covered daily with earth. When within  $2\frac{1}{2}$  feet of the surface the pits must be filled in and marked "Foul Ground."

Shelled Areas:- A shell hole suitably marked may be used for burial, but wherever possible refuse should not be buried in a spot likely to be re-disturbed by enemy action.

Burial of Liquids;- (Soakage). The method employed to dispose of the waste from a camp is that of absorption into the soil by means of soakage pits.

Soakage Pit:- The construction of these pits, whether used for urine soakage or that of waste kitchen or ablution water, is similar in nature.

It consists of a pit filled with such material as burnt tins, either flattened or perforated so that they will retain no liquid. This filling material keeps the sides apart, thus allowing the liquid to come into contact with as great an amount of soil as possible.

Size of Pit:- The size of the pit depends both on the amount of liquid to be disposed of and the nature of the soil. A useful size is 4 feet square by 6 feet deep.

Kitchen Waste Water:- This must be passed through a grease trap, to remove solid particles and fat from

the water to as great an extent as possible before being passed into the pit.

Ablution Waste Water:- The water from washing-places, ablution trenches, etc., must be similarly passed through a soap trap to remove soap curd, as the presence of grease and soap and particles of food in the pit tends to prevent soakage, and their accumulation and subsequent fermentation would in hot weather cause a grave nuisance.

Urine:- Here the urine voided into a urinal is conducted directly by a pipe into the soakage pit. This removes it immediately from flies which might otherwise settle upon it.

Some Practical Points:- During my experience as a Sanitary Officer I found that it was practically impossible to get excreta burnt in areas where the troops were constantly changing. In inspecting camps where incineration of excreta was nominally conducted, one almost invariably found a pit where excreta was buried.

Part, no doubt, was burnt, but on days when the fire did not burn well, or when sufficient dry material was not available for burning, the pit formed a convenient spot on which to dump any excess of excreta.

Short duration of Stay:- I also found that it was impracticable to have a properly constructed incinerator and storage shed for rubbish erected by units who are continually moving, as by the time material for construction is obtained they are again on the move.

In addition, an incoming unit does not always take over a camp evacuated by a previous unit; and with open warfare this will become even less frequent.

Latrines:- The essential factor in the disposal of excreta is that it must, under all circumstances, be protected from flies. No uncovered excreta must ever be exposed, but protected with what is available, e.g. a little earth, a piece of sacking, etc., where nothing else is available. Indiscriminate defecation, however, is strictly forbidden.

Shallow Trenches:- This type of latrine is useful while on the march, owing to their rapidity of construction. Owing, however, to the extent of ground that they foul, they are not suitable for permanent use.

Deep-trench Latrine:- This type of latrine, when fitted with fly-proof seats having self-closing lids, is the most suitable type of latrine for general use. It lasts some time when properly constructed, and thus both reduces labour to a minimum and ensures that the excreta is protected from flies.

The pits used should be as deep and wide as practicable, as the life of the latrine is thereby prolonged and fouling of the ground is thus reduced to a minimum.

The actual width of the trench and the construction of the seat and superstructure depend on the amount of material available. It is, however, essen-

tial that the seats are fly-proof and that self-closing lids are fitted. To prevent fouling by urine or faeces, a tin lining is required to the interior of the seat.

Construction:- As in the field timber and other material is not always available at short notice, the ability to make use of any material available is an important qualification for Sanitary personnel. (See Appendix.)

Many Ration boxes are suitable for latrine seats. The gap between the seats can be covered over, where necessary, by brushwood<sup>and</sup> turf. Where material is available, more satisfactory sanitary equipment, including latrines, can be constructed.

Standardisation:- This equipment should be standardised as far as possible to facilitate construction. In fixing the type of latrine for a special area, the conditions there must be borne in mind.

Design of Seat for pails, or trench:- While in charge of an area having a very high ground water level in winter, the writer adopted a type of seat which could be used equally for pails or trench.

This permitted of the trench type of latrine being used during the summer months, and the bucket type during late autumn and winter by merely removing to a fresh site.

It is most important in the use of deep pits that these should be placed at some distance from a water-supply. The practice of conducting the urine by a pipe

into the latrine pit, while ensuring the longer life of the latrine, should not be adopted where there is any risk of contamination, owing to the greater risk of soakage from the more liquid contents of the pit.

Liquefaction of the excreta is hastened by the regular addition of a little surface soil to the trench, thus commencing aerobic bacterial action.

Disposal of Horse Manure:- As this forms the favourite breeding-place of flies, it is most essential to take adequate measures to counteract this danger.

The first essential is, that all manure be removed at least 600 yards from the nearest camp, or occupied house, or billet.

This distance has been fixed after experiments to determine the distance which a fly can travel, and is for the purpose of preventing occupied quarters becoming infected by flies hatched in the manure heap.

The methods of dealing with manure are as follows:-

1. Direct application to the land:- This is the best method of disposal, and here the manure is spread upon the land and then covered with earth by ploughing. This method, however, is not available during the summer months, as the ground is then under cultivation.
2. Burning:- I have not found this satisfactory, owing to the uncertain nature of the climate. Some form of grid or other method for the admission of air to the burning mass is necessary, and many types have been adopted.

3. Robaud's Process:- This method has for object the destruction of the fly larvae by heat engendered in fermenting manure. The manure added daily is covered with hot manure of the previous day to the depth of 1 foot. This layer of hot manure prevents the larvae from escaping to the exterior, and they are destroyed in the subsequent fermentation.

I have had considerable experience of this method of treating manure, and have studied very carefully the results obtained. It is difficult in practice to get the method properly carried out; but after many failures I adopted a method of stacking which has proved, in my experience, quite satisfactory.

The disadvantage of Robaud's method of treating manure is that it requires considerable labour and is liable to break down if not carefully supervised.

4. Stacking:- This I have found from experience to be the method of treating horse manure, apart from direct application to the land, which gives the most satisfactory results. It is simple and can be carried out by anyone of average intelligence.

The manure is most conveniently stacked in sections 10 feet square by 5-6 feet in height, with sloping sides. As one section is completed another can be added lengthwise. The manure should be well beaten with spades and sprayed daily with a cresol solution, to prevent flies from laying their eggs upon it. On completion, the dump should be covered with a layer of one foot of earth, well beaten in.

I have found this method most satisfactory when adopted, and the small number of flies found where it is satisfactorily carried out proves its value.

### Conclusions.

The subject of Preventive Medicine is a wide one, and I have endeavoured to restrict myself merely to a description of those methods which I have found practically useful and which I have myself recommended in my capacity of Sanitary Officer. Many points have not been mentioned, or only briefly alluded to, e.g., the isolation of sick of contacts, and disinfection of premises in cases of infectious disease. My object, however, has been to point out that the steps necessary to reduce sick wastage to the absolute minimum are:-

1. The maintenance in full health of each individual soldier.
2. Safeguarding him against infection.

With regard to the latter, I would again emphasise the following:-

#### WATER.

1. That a large proportion of the water-supplies on the Western front show chemical and bacteriological evidence of sewage pollution, and that owing to this fact the danger of water-borne infection is an ever-present one, and precautions against this must never be relaxed. Water used for drinking or cooking must be invariably sterilised. The sterilising agent which has proved its reliability is Bleaching Powder (Hypo-

chlorite of Calcium) added after previous clarification by Alum, when necessary.

2. That upon entering any new area it is absolutely essential to obtain immediate information upon the state and quality of the water-supplies, and that in districts previously occupied by the enemy examinations for chemical poisons must be made in addition to Horrocks' test for amount of chlorination required.

In cases of doubt, chemical and bacteriological examinations of the water-supply must be made.

3. Water duty personnel must be intelligent, trustworthy men, and be carefully instructed in their duties. They must not have had Typhoid or Dysentery, or be suffering from Diarrhoea.

4. All water-supplies should be invariably marked with a label indicating their suitability for use and the amount of chlorination required.

5. Full information regarding the water area supplies should be collected by the Sanitary Officer in charge. This is important in view of any possible fluctuation in population. The system of forming a tabulated list of information and also a water map of the area, which I adopted, is an excellent one for this purpose.

#### FOOD.

1. Strictest care must be taken in ensuring the good quality of food and its freedom from contamination. The proper supervision of the food-supply is a duty to which I attach the greatest importance.

2. No personnel who have suffered from Typhoid or Dysentery, or who are suffering from Diarrhoea, must be employed in the cookhouse.

3. Strict cleanliness is absolutely essential and must be enjoined upon all who have the care of the handling, storing or preparation of food.

4. All water used in the cookhouse must be sterilised by Bleaching Powder, including that used for washing-up.

5. All food-supplies, kitchens, dining-rooms, etc., must be adequately protected against flies.

#### INSECTS.

##### Flies.

1. The fly danger is a very real one in view of the large part which it plays in the transmission of disease.

2. The anti-muscid measures which give the greatest results are the proper disposal of horse manure, refuse or filth, thus preventing fly-breeding.

3. Measures must be taken to prevent flies from having access to either food or filth (including excreta).

4. Latrines must be fly-proof and fitted with self-closing lids.

5. Measures against adult flies must also be taken.

##### Body Vermin.

1. The louse is a very real danger in view of the diseases which can be transmitted by its agency.

2. Large sick wastage is caused by the *Acarus Scabiei* and the many forms of dermatitis which become super-

added to the original lesion when not immediately treated. Pediculi and lack of bathing facilities aggravate the condition.

3. The louse problem, with that of scabies, is best combated -

(a) By making each soldier personally responsible for his own cleanliness, and wash his own under-clothing, wherever possible.

(b) By the provision of more adequate means of disinfection. That recommended by Colonel William Hunter, previously described, seems to afford a satisfactory solution. It should be possible to adapt steam lorries to the purpose, and these could serve areas at some distance from the railway.

#### REFUSE and SCAVENGING.

##### Latrines.

All latrines used by troops should be fly-proof and fitted with self-closing lids. They should, wherever possible, be of the deep trench pattern with fly-proof seats and self-closing lids, as this possesses the following advantages:-

1. Saving of labour.
2. Access of flies to excreta prevented.
3. Ground fouled by latrine reduced to a minimum.

Excreta of infected persons should be burnt.

##### Manure.

1. As 90% flies breed in horse manure, adequate steps must be taken for its satisfactory disposal.
2. Close packing is the method of manure disposal

which, from experience, I have found gives the best results.

3. Roband's Process of treating the manure by fermentation also gives satisfactory results, when carried out as I have described in the Appendix.

#### Refuse.

All refuse should be disposed of by burning, wherever possible. If this is impossible, burial must be adopted.

Strict measures are necessary to prevent flies having access to refuse and using it as a breeding-place.

I am strongly of opinion that whatever be the measures employed to prevent the spread of infection it is most essential to obtain the intelligent co-operation of the individual soldier. This co-operation is best secured by instituting courses of instruction in Sanitation. A school, which I instituted, was most successful and was reflected in the better sanitation of the area, which speedily became evident. Practical instruction in making the different sanitary appliances I found also very helpful, combined with hints as to the best method of making use of whatever material was available. In view of the changed form of warfare, this type of instruction would be of very great value, as to a much greater extent, units will require to rely on their own resources.

APPENDIX I.

Destruction of Fly Larvae.

Robaud's Process.

I found from experience that this method was perfectly impracticable, owing to the labour involved and the uncertainty of the results attained.

During the summer of 1916 I instituted a method of stacking, which made the work of supervision much easier, and which gave good results, but which did not justify the extra amount of labour involved.

The accompanying diagrams explain the measures taken.

-----

I am adding a series of diagrams of sanitary equipment -

- (1) Of a simple nature, made from packing-cases and other materials available - which can be constructed quickly by the men themselves.
- (2) Of a permanent nature, suitable for a fixed camp.

-- Also a map.

-----

N.B. These have been drawn to my designs. Those for a permanent camp are types which I standardised, and with which I fitted up the areas, of which I had sanitary supervision.

# "Anti-Fly" Measures:-

## Robaud's Process:-

### Scheme of Stacking Adopted:-

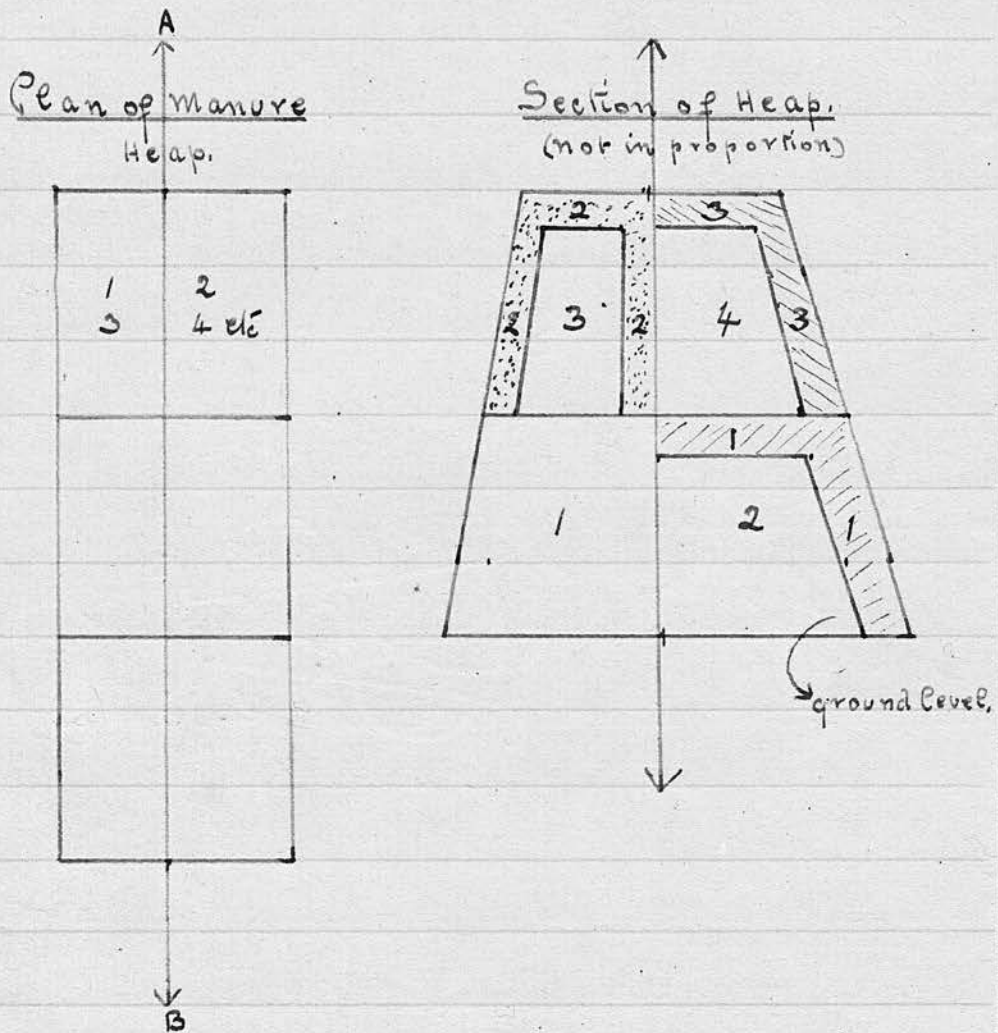

Note:- 1, 2, 3, 4 etc = manure of 1st and 3rd, 4th etc days stacked on alternate sides of the middle line AB daily:-

Sectional Diagram:- shews method of applying 1ft hot manure of previous day to manure added daily, not exceeding  $2\frac{1}{2}$ ft in height. N.B. The manure must not be packed.

SANITARY DIAGRAMS.

1. Temporary Camp Equipment.
  2. Permanent Camp Equipment.
-

# FLY - PROOF LATRINE

IMPROVISED FROM BISCUIT OR SIMILAR BOXES

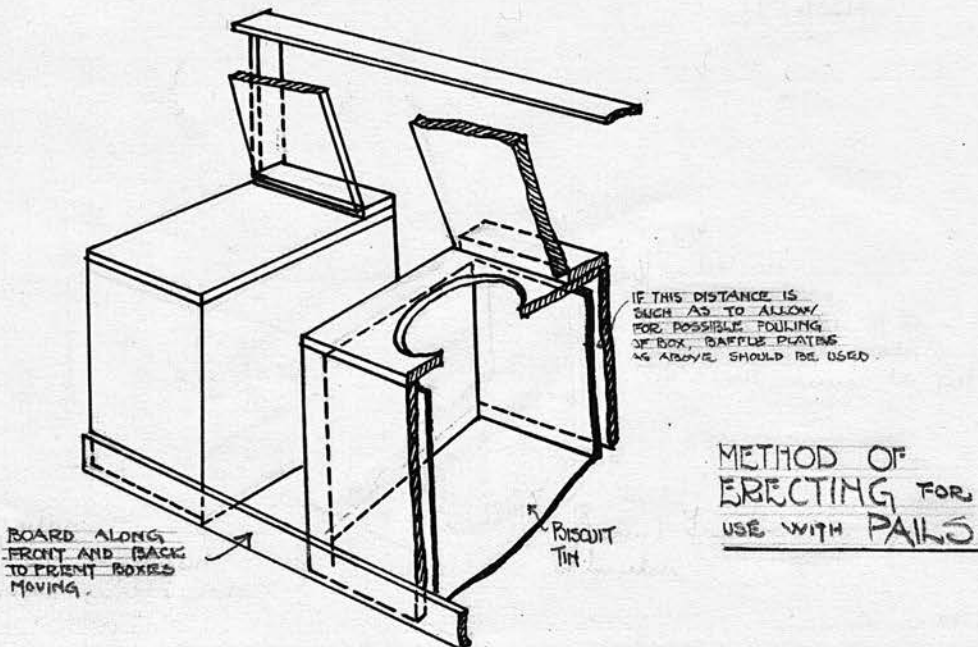
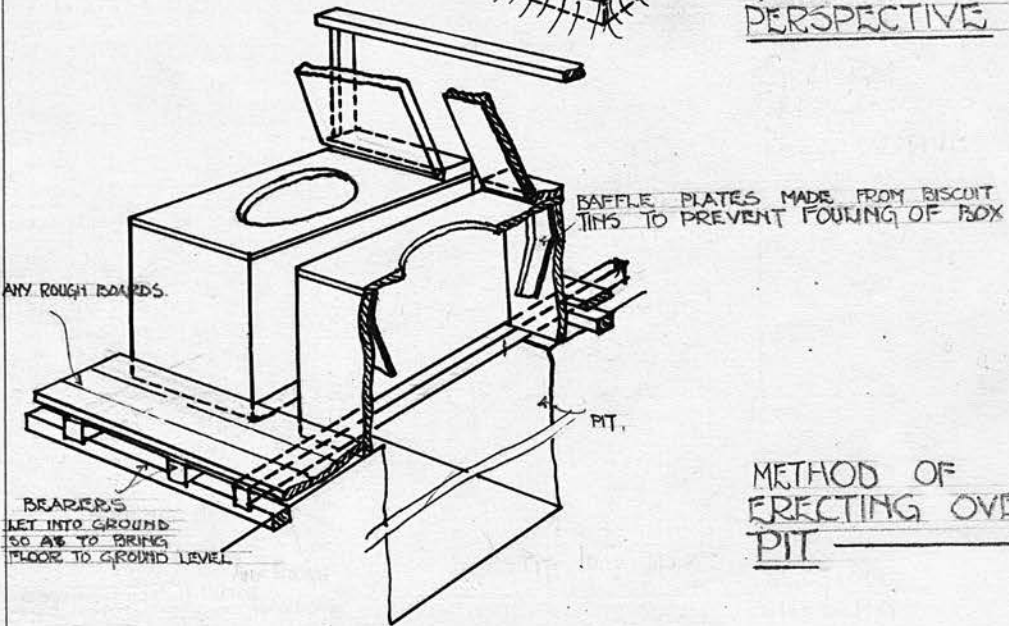
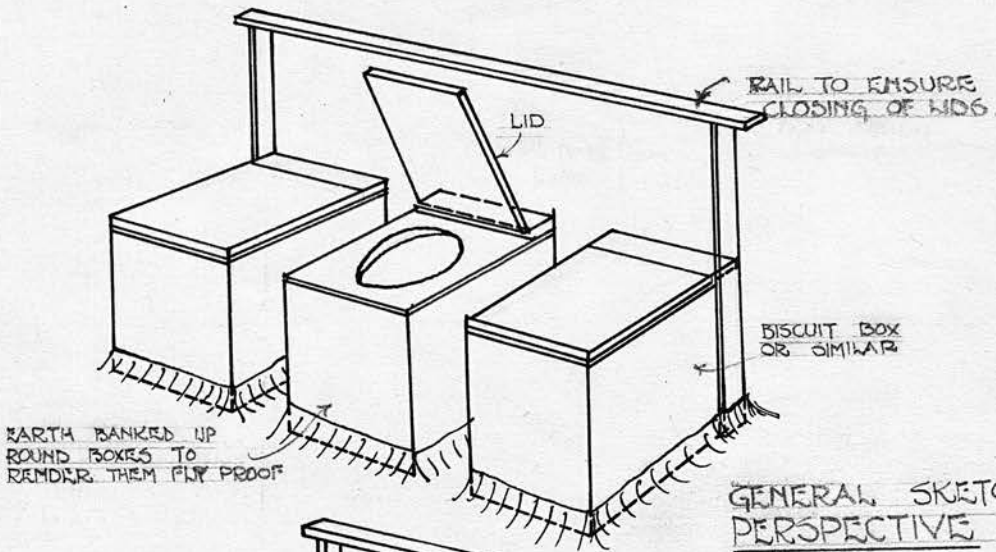

# IMPROVISED URINALS.

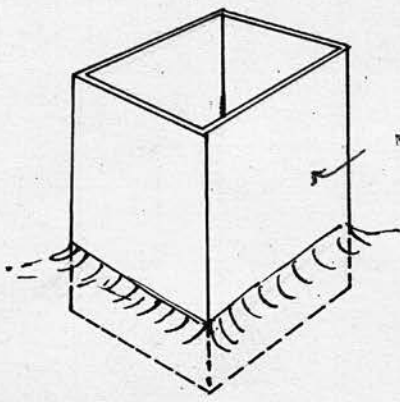

BISCUIT TIN

BOTTOM PIERCED

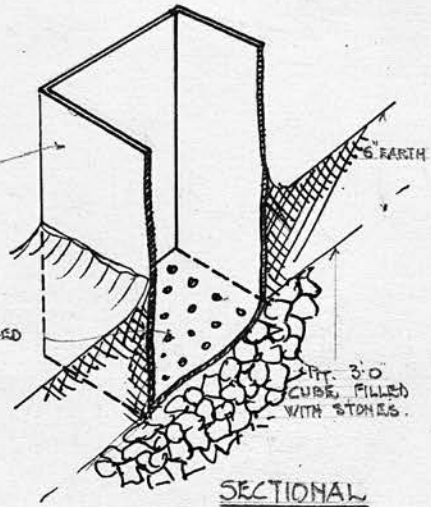

G. EARTH

FT. 3-0  
CUBE, FILLED  
WITH STONES.

SECTIONAL  
VIEW.

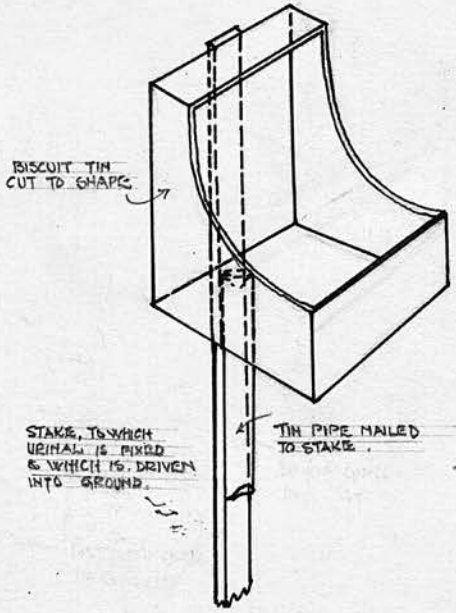

BISCUIT TIN  
CUT TO SHAPE

STAKE, TO WHICH  
URINAL IS FIXED  
& WHICH IS DRIVEN  
INTO GROUND

TIN PIPE NAILED  
TO STAKE

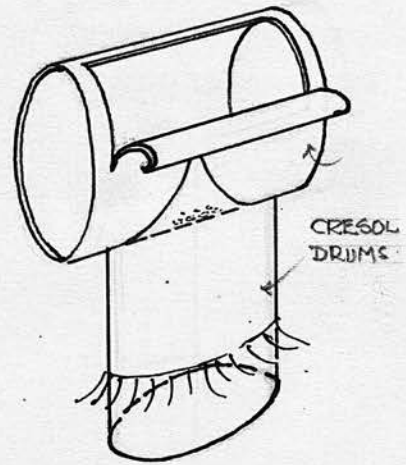

CREOSOL  
DRUMS

PERSPECTIVE  
VIEWS. :

# IMPROVISED OPEN INCINERATOR OF ANGLE IRON PICKETS & CORRUGATED IRON

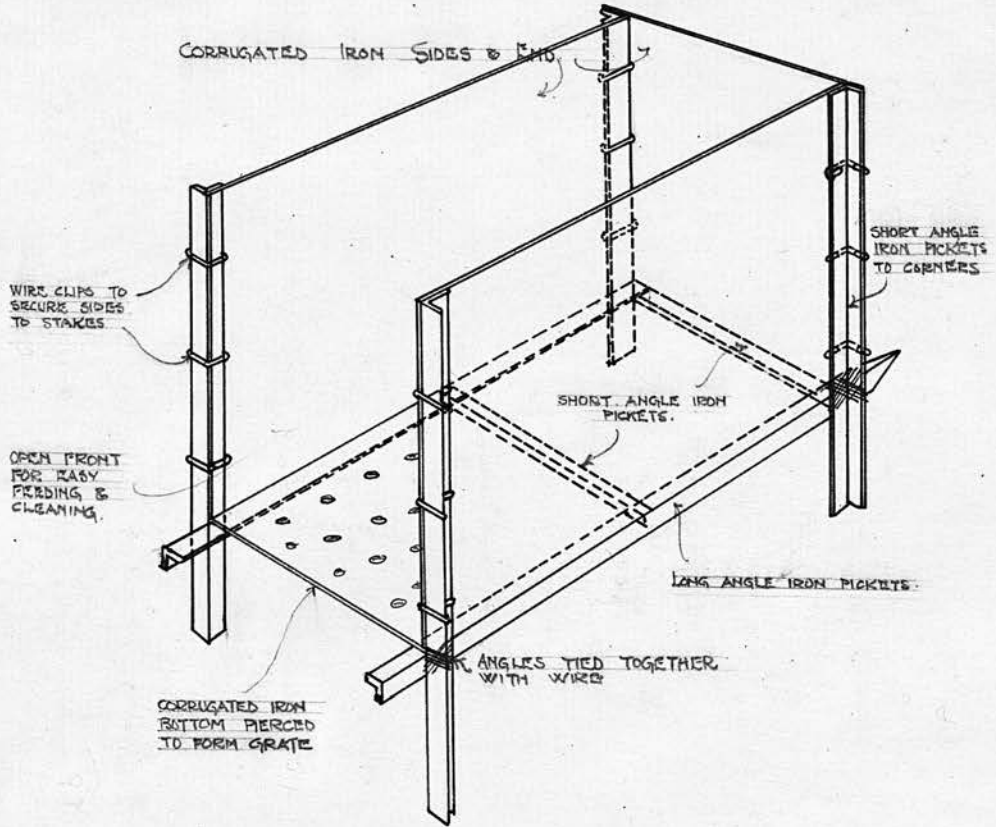

SKETCH  
PERSPECTIVE :

NOTE :

A SIMILAR INCINERATOR CAN BE MADE  
WITH SCREW PICKETS & REVETTING WIRE

# URINALS

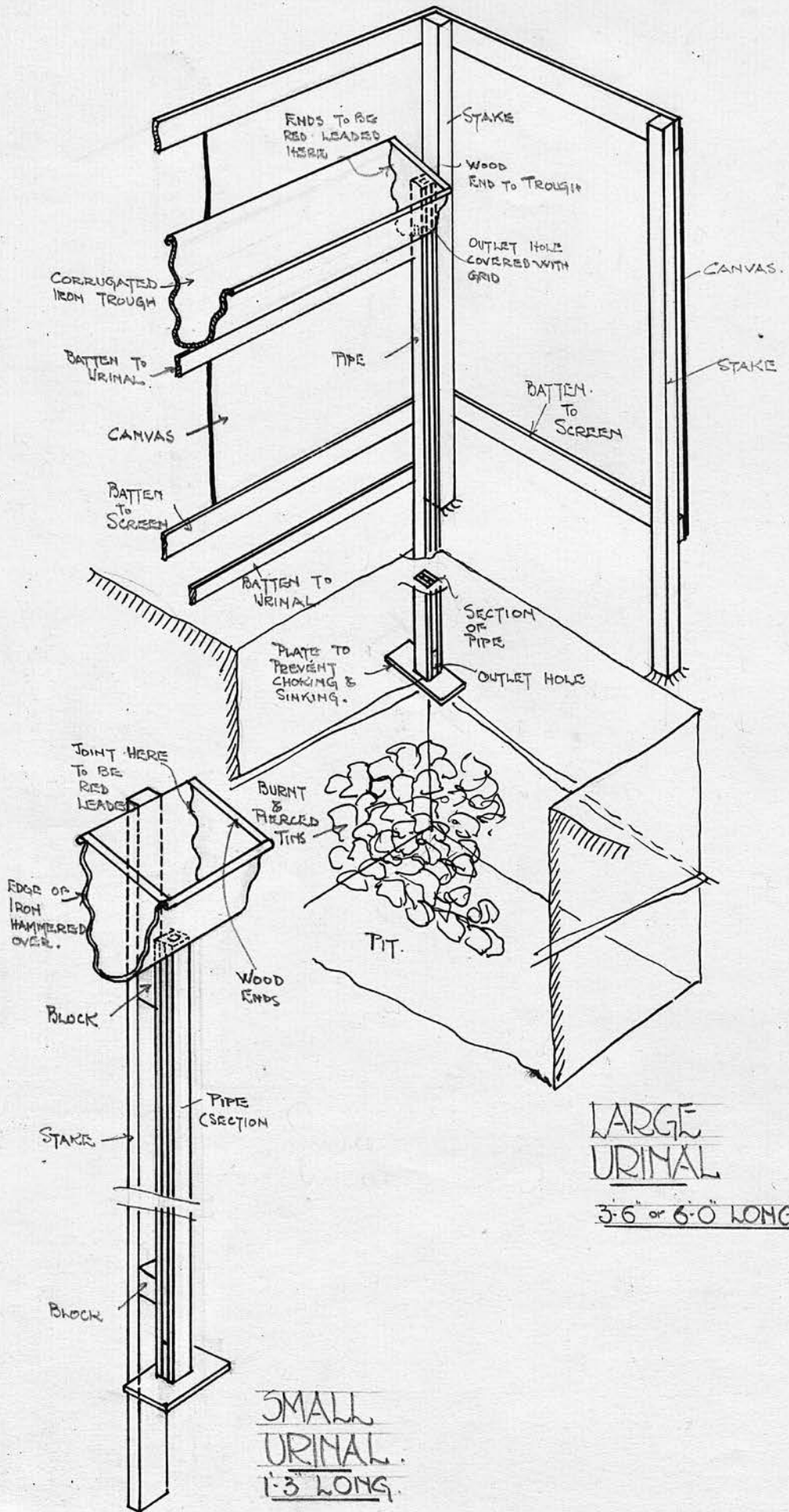

# PERMANENT FLY-PROOF LATRINE

FOR USE WITH PAIS OR PIT.

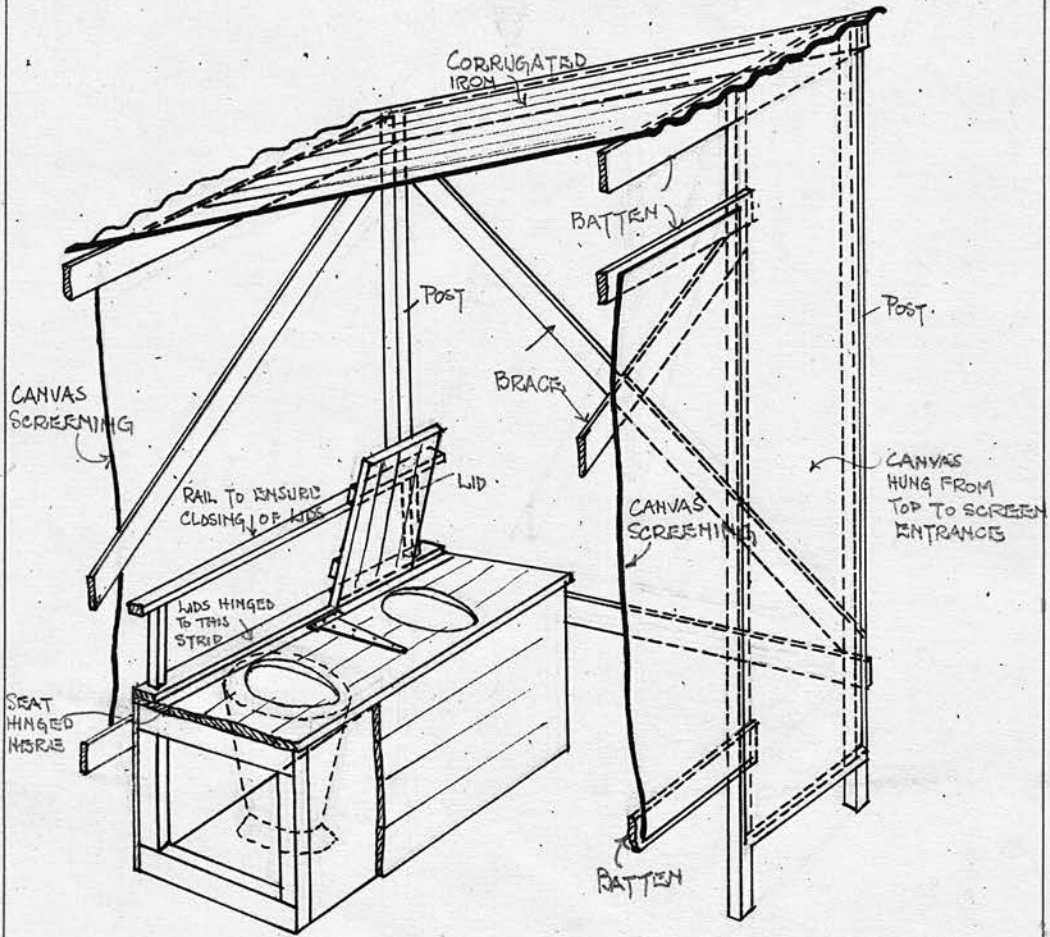

SECTIONAL PERSPECTIVE OF LATRINE & SCREEN

NOTE: METHOD OF ERECTING OVER PIT IS SHOWN IN SKETCH OF BISCUIT BOX LATRINE

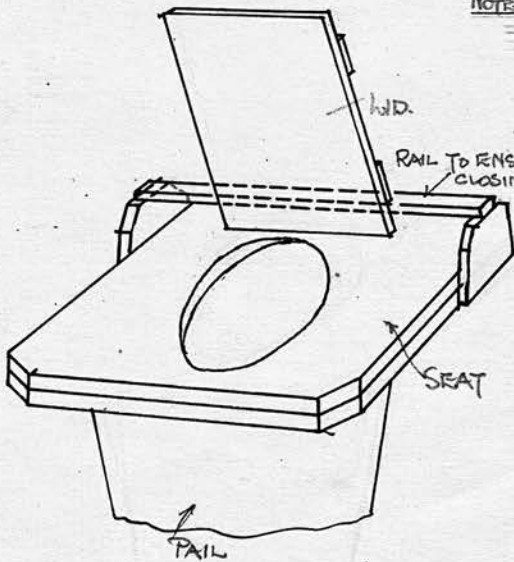

PERSPECTIVE SKETCH

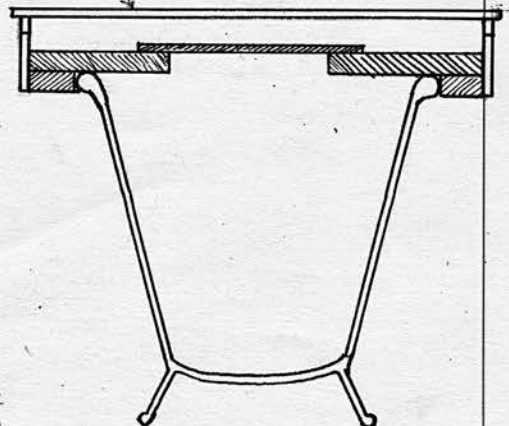

SECTION

SINGLE FLY-PROOF SEAT TO FIT ON TOP OF PAIS

# BRICK DESTROYER.

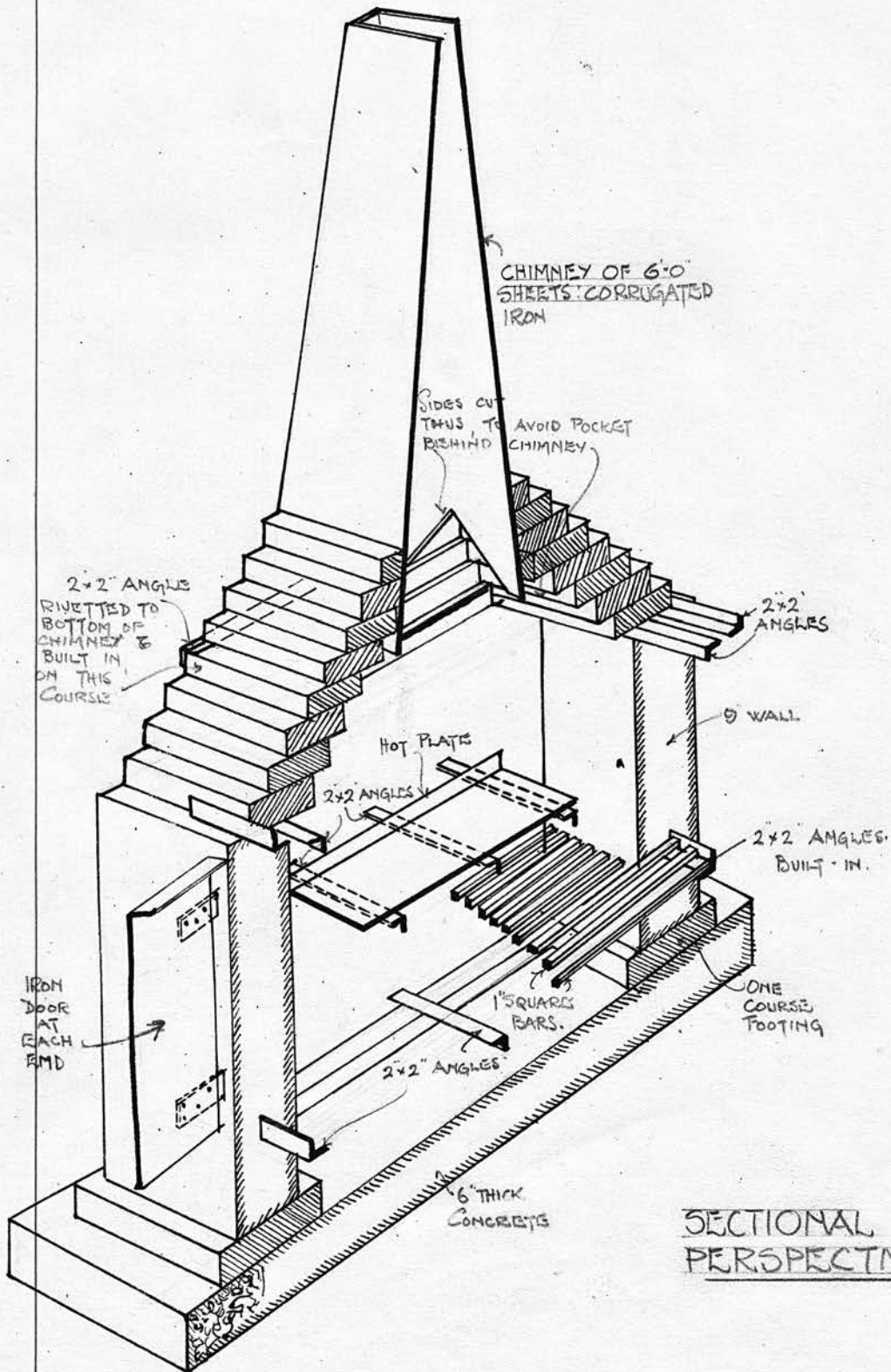

# CORRUGATED IRON INCINERATOR

NOTE: CORRUGATIONS ARE OMITTED FOR THE SAKE OF CLEARNESS.

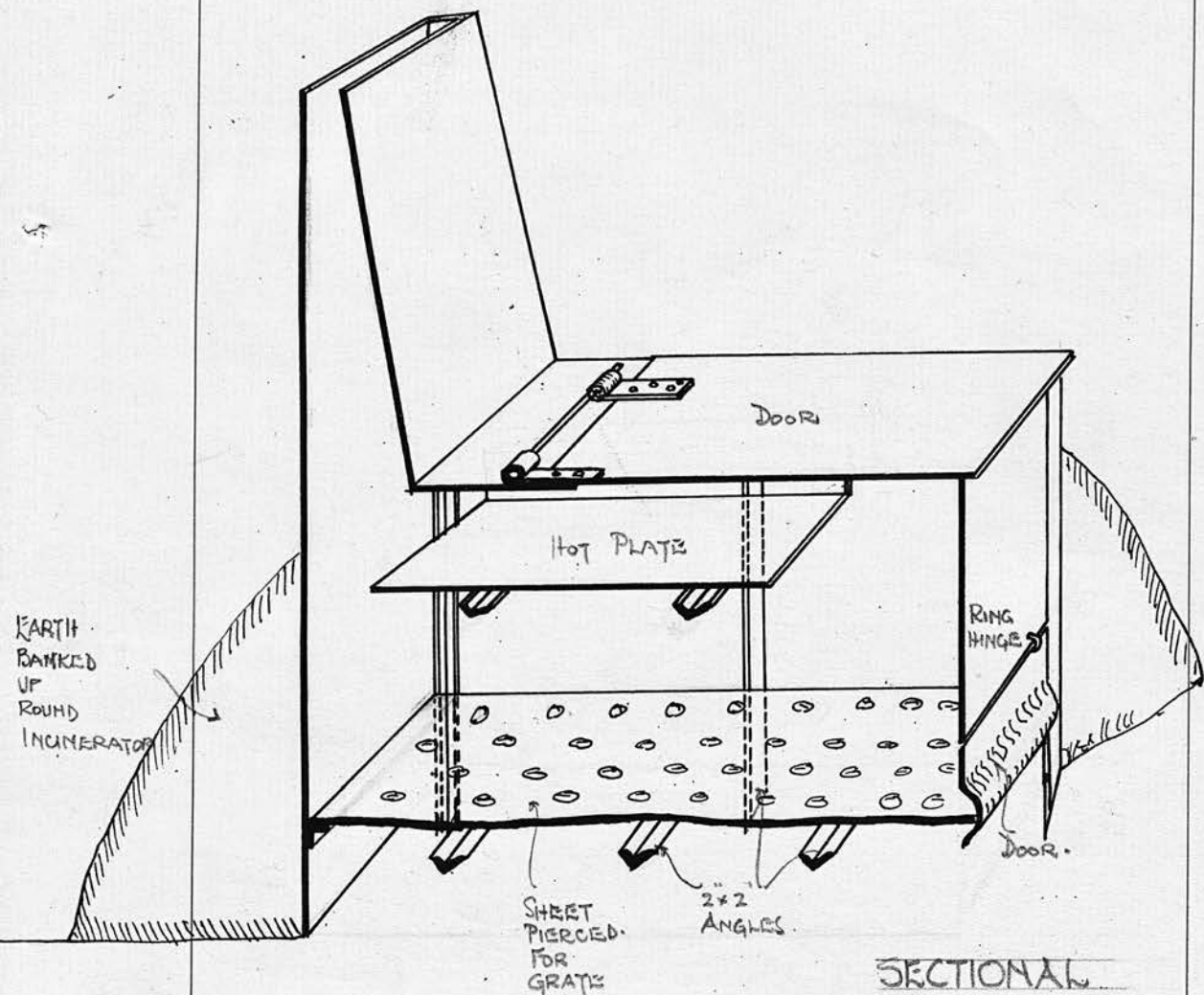

SECTIONAL PERSPECTIVE

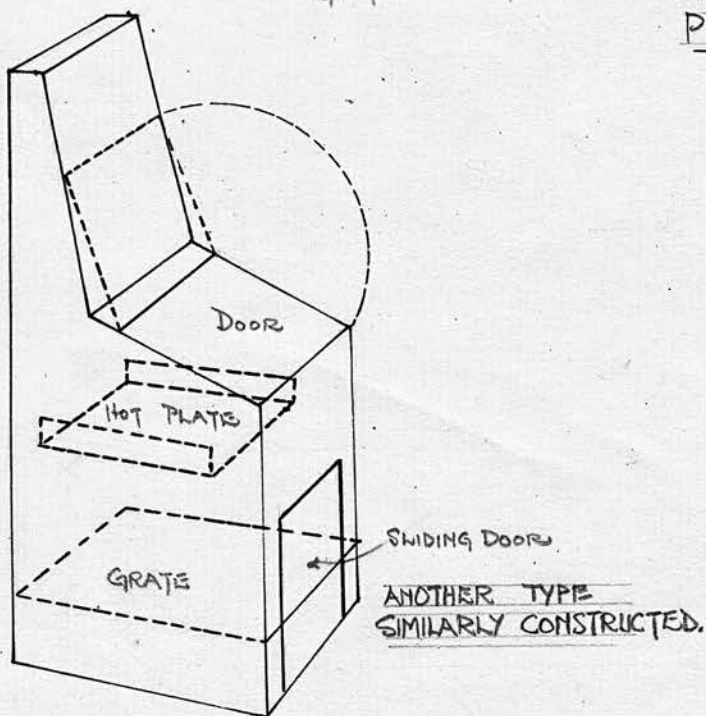

# SOAP TRAP

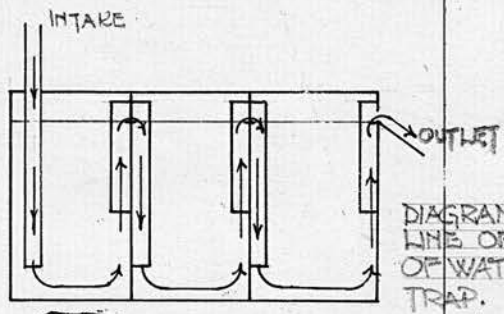
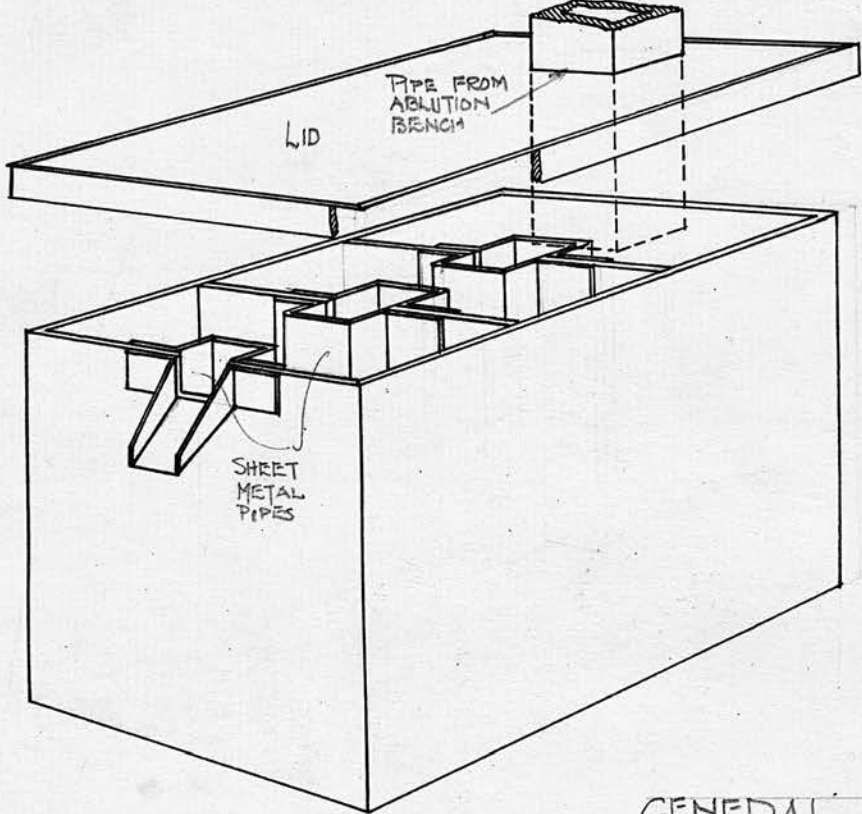
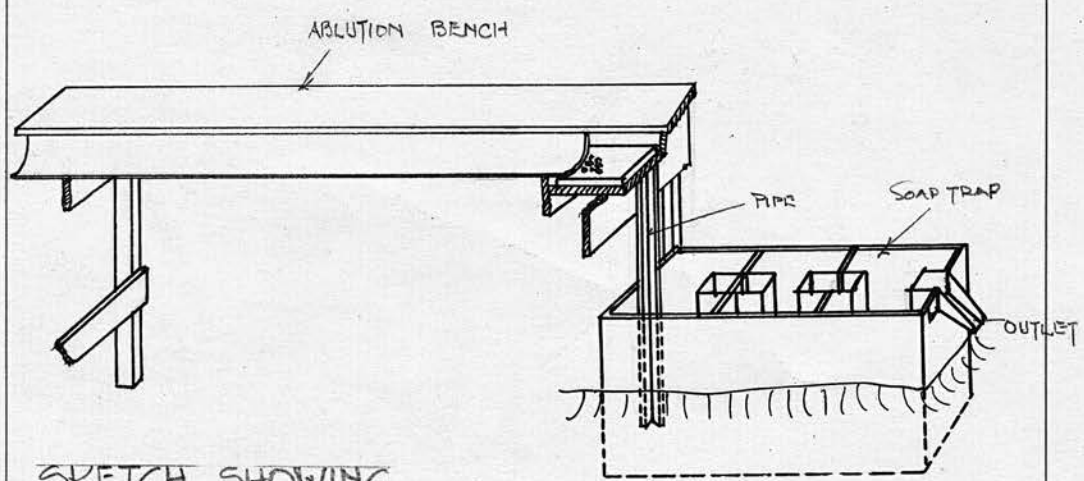

DIAGRAM SHOWING LINE OF PASSAGE OF WATER THROUGH TRAP.



GENERAL PERSPECTIVE

NOTE  
FOR SECTION THROUGH TRAP, SEE GREASE TRAP WHICH IS SIMILAR BUT WITH HOPPER AND CANVAS SIEVE ADDED.



SKETCH SHOWING TRAP IN POSITION.

# GREASE TRAP.

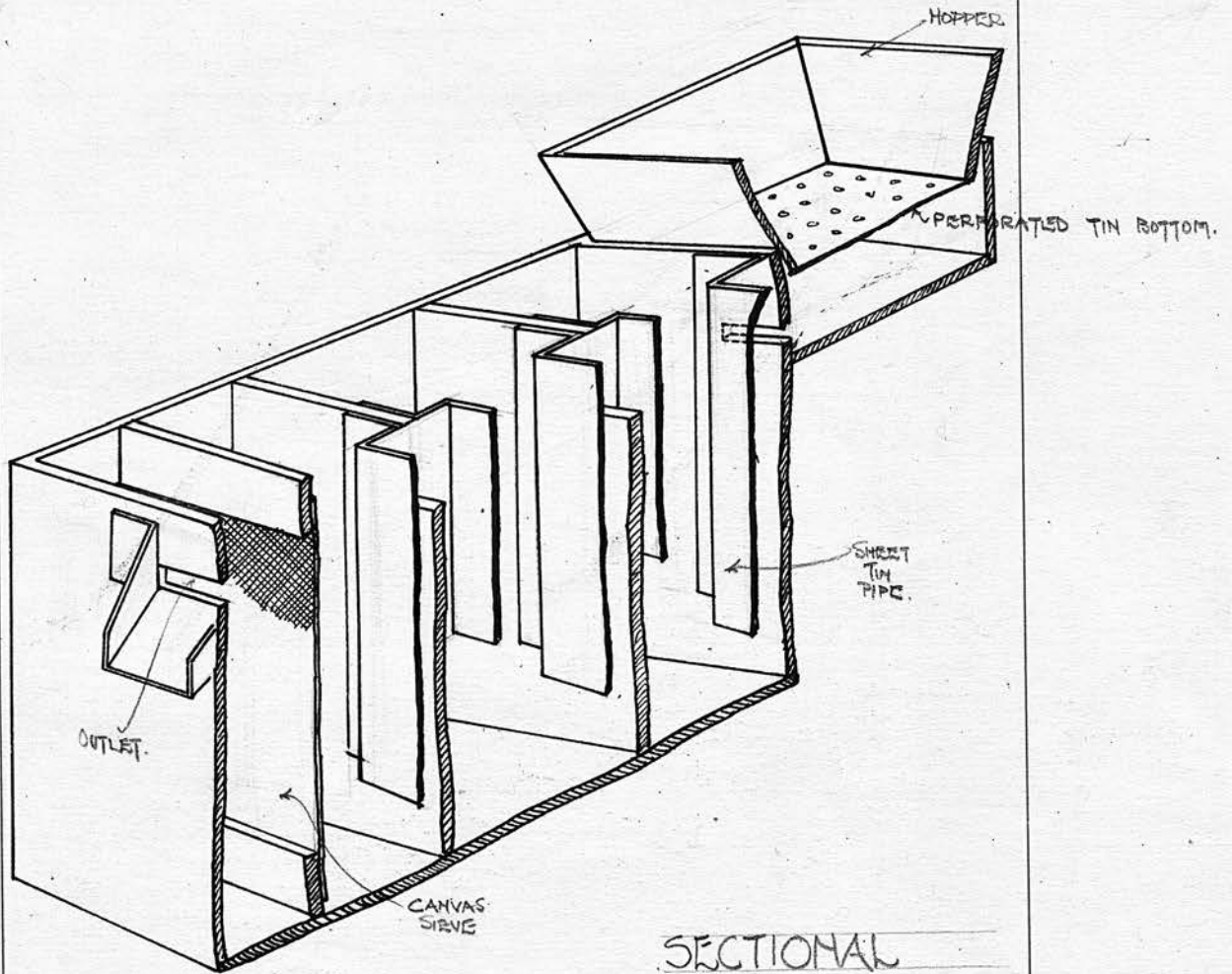

SECTIONAL  
PERSPECTIVE

# MEAT SAFE

MADE FROM TWO TOBACCO OR SIMILAR BOXES

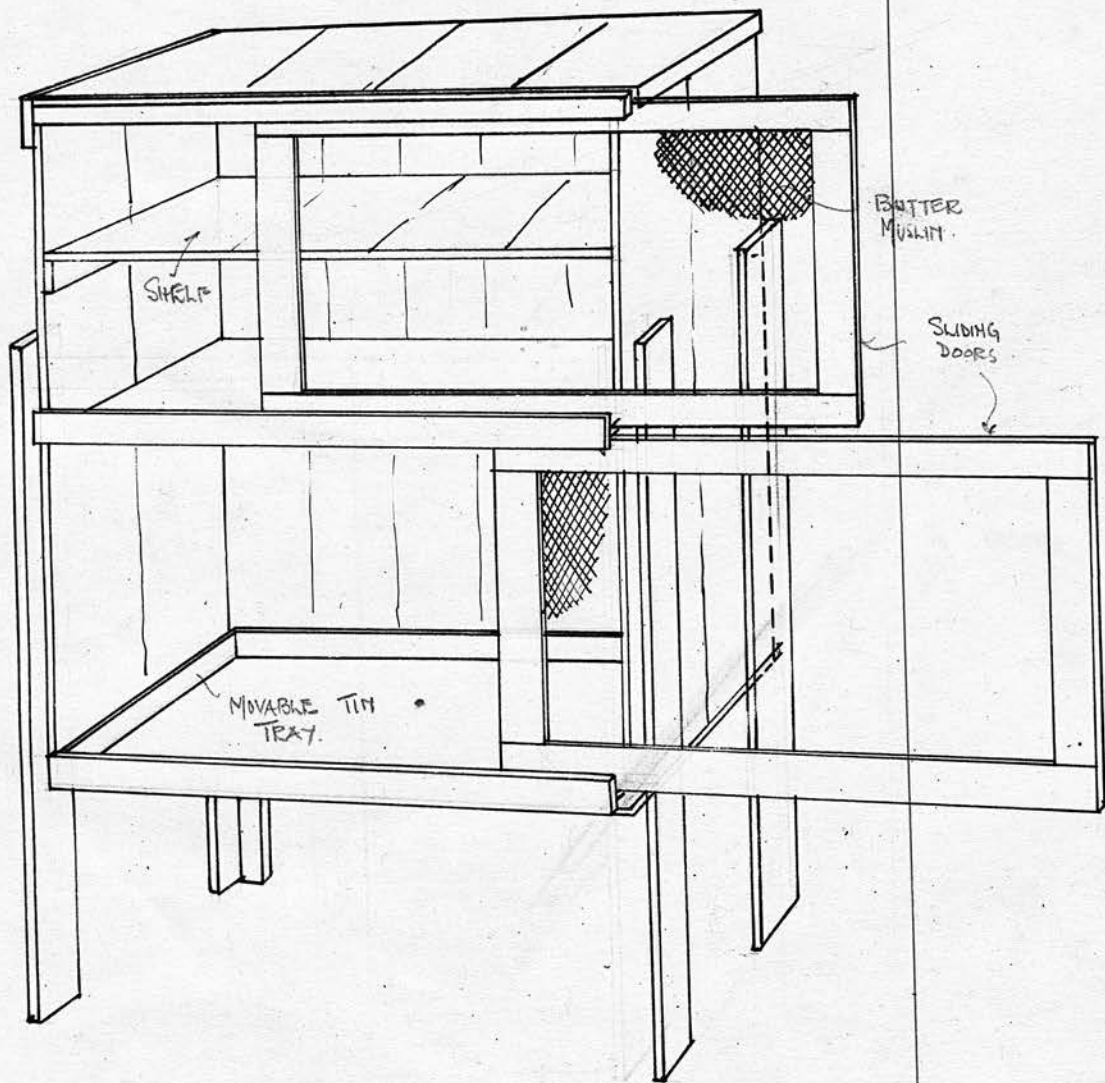

PERSPECTIVE  
VIEW. :

# SKETCH MAP OF — AREA SHOWING WATER SUPPLIES

## REFERENCE

- WATER POINT ■ 324 (No. OF POINT)
- STERILIZING PLANT ●
- BILLET WITH WELL ● 25 (No. OF BILLET)
- PIPE LINE - - - - -

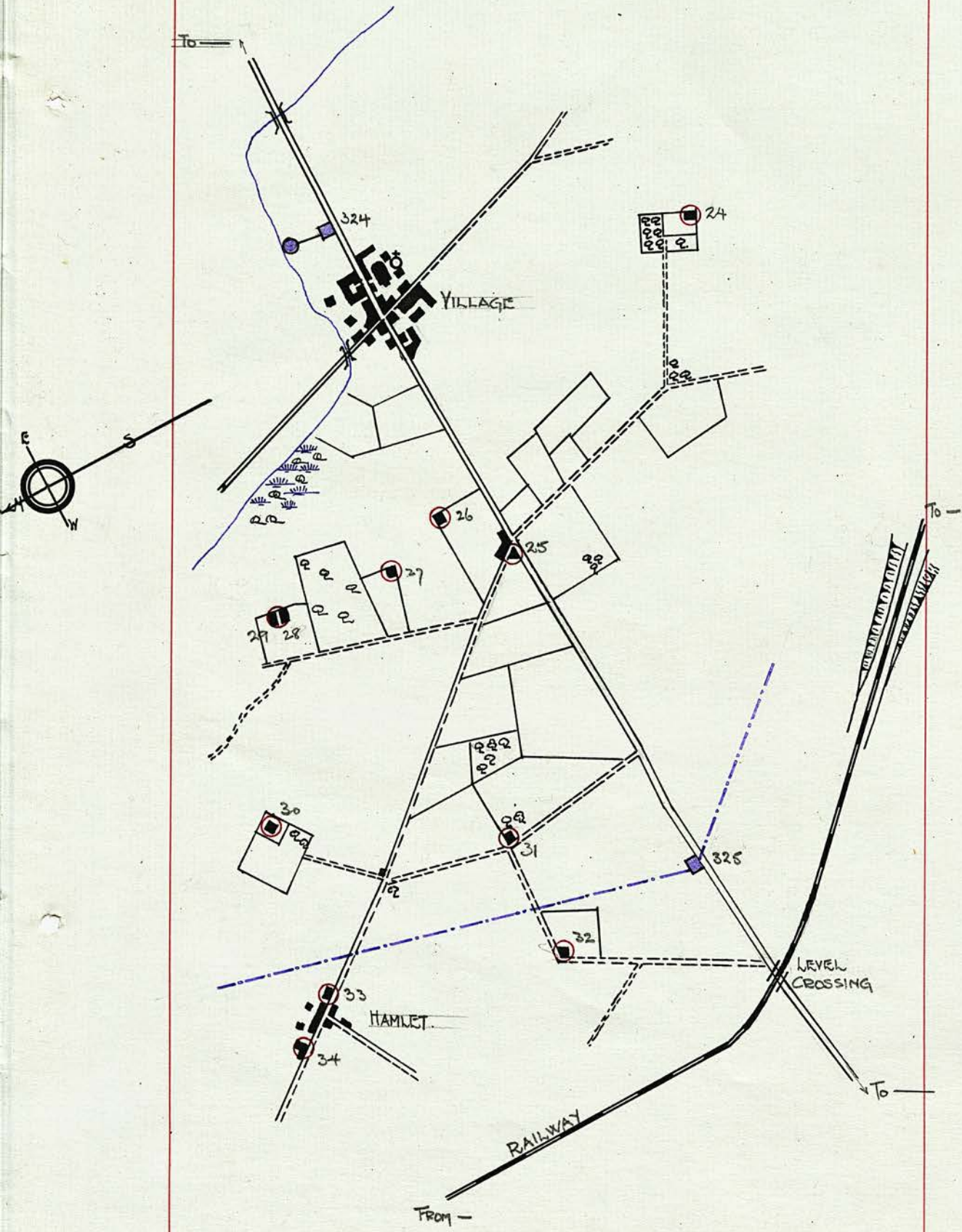

MILITARY SANITATION

on the

WESTERN FRONT.

By

James. A. R. Thompson

M.B. Ch.B. D.P.H.

Capt. R.A.M.C.