



THE UNIVERSITY *of* EDINBURGH

This thesis has been submitted in fulfilment of the requirements for a postgraduate degree (e.g. PhD, MPhil, DClinPsychol) at the University of Edinburgh. Please note the following terms and conditions of use:

This work is protected by copyright and other intellectual property rights, which are retained by the thesis author, unless otherwise stated.

A copy can be downloaded for personal non-commercial research or study, without prior permission or charge.

This thesis cannot be reproduced or quoted extensively from without first obtaining permission in writing from the author.

The content must not be changed in any way or sold commercially in any format or medium without the formal permission of the author.

When referring to this work, full bibliographic details including the author, title, awarding institution and date of the thesis must be given.

The Historical Analysis and Remaking of Two
German Keyed Guitars from the Romantic Period
Using Traditional and Digital Technologies

Daniel James Wheeldon



Thesis presented for the degree of Doctor of Philosophy

The University of Edinburgh

2020



Arts and
Humanities
Research Council



Scottish Funding Council
Promoting further and higher education

SCOTTISH GRADUATE SCHOOL FOR ARTS & HUMANITIES

Acknowledgements

I am indebted to many for the completion of this thesis. Above all I thank God for any successes over the course of the project.

I am grateful for the support, advice and encouragement of my supervisors, Elaine Kelly and Jenny Nex, my first-year supervisor Darryl Martin, and my unrecognised supervisor who helped with everything relating to instrument making, Jonathan Santa Maria Bouquet.

I am particularly indebted to Rainer Krause for his generosity in making his keyed guitar available to me, and for his ongoing support, providing photographs for my 2020 article in the *Metropolitan Museum Journal*. I likewise thank the Department of Musical Instruments at the Metropolitan Museum of Art for access to their keyed guitar and their continued support of my research. I am grateful to the *Friends of St. Cecilia's Hall* for a bursary for purchasing materials.

I would like to thank my family. My wife Hannah, who effortlessly wrote her dissertation while nursing our new-born, showing me that I too might succeed. I also acknowledge my son John for keeping me active during a lock-down write-up period. I am thankful to my parents for their continual encouragement from the earliest times. I am particularly grateful to my father Leslie Wheeldon for the many hours he has given in sharing his linguistic expertise in eighteenth- and nineteenth-century French and German, I have thoroughly enjoyed our long phone calls discussing translations.

Individuals I would like to thank are Crinan Alexander, Brian Applegate, Elizabeth Benjamin, Dick Boak, Markus Brosig, Tim Caster, Richard Collins, Malcolm Cruikshank, Samuel Cunnington, Paul Diamond, Jayson Dobney, Marian Eines, Bernard Emery, Peter Fielding, Josef Focht, Cat Gilbert, Gary Grobler, Stefan Hackl, Martin Hurrting, Will Howson, Lewis Jones, Sebastian Kirsch, Andreas Michel, Gregg Miner, Ken Moore, Gabriel Macedo Nocchi, Panagiotis Pouloupoulos, John Raymond, Philip Redfern, Jennifer Schnitker, Anton Sprenger, Bradley Strauchen-Scherer, Ron Street, Pam Summey, Gillian Suss, Taro Takeuchi, Gerda and Gisela Treue, Delphine Tonglet, James Westbrook, and many others.

Lay Summary of Thesis

This creative practice PhD examines and reconstructs two nineteenth-century German guitars: one made in Mittenwald by Mathias Neüner in 1810; the other bearing the names F. Fiala and Matteo Sprenger, probably made in Karlsruhe in 1843. The only nineteenth-century keyed guitars known to survive, these two instruments are like ordinary guitars of the period in that they have six strings of gut and silk of the usual string length. Each, however, has a removable piano hammer mechanism within the guitar body that enables hammers to strike the strings through a hole in the front of the guitar.

Although it seems that keyed guitars were known of throughout the nineteenth century, accounts of them are inconsistent and vague. This thesis combines a thorough study of sources with examination of the surviving instruments, placing them within a context of nineteenth century music and musical inventions. I demonstrate that keyed guitars have their origins in the trade for domestic musical instruments and were preceded by similar instruments (pianoforte guitars) in London in the 1780s. Their role and reception in Germany, however, were quite different, being marketed to a smaller more dispersed audience and chiefly to the nobility.

Reconstructing these instruments has allowed an in-depth analysis of the surviving objects, from a maker's perspective, and offers a better understanding of why various design elements were made the way they were. Each instrument has had a complex and contrasting history, which can only be understood through a study of the objects themselves. Some elements have required reinvention, to best represent the originals as functioning keyed guitars. Full-scale 3D drawings of the instruments were made, from which it has been possible to directly apply the use of digital technologies to assist the process of manufacture.

This multifaceted study brings a wealth of new information, and a means of experiencing a niche of musical culture hitherto lost to obscurity.

Abstract

This creative practice PhD examines and reconstructs two nineteenth-century German guitars: one made in Mittenwald by Mathias Neüner in 1810; the other bearing the names F. Fiala and Matteo Sprenger, probably made in Karlsruhe in 1843. The only nineteenth-century keyed guitars known to survive, these two instruments are like ordinary guitars of the period in that they have six strings of gut and silk of the usual scale length. Each, however, has a removable piano hammer mechanism within the guitar body that enables hammers to strike the strings through a hole in the soundboard.

Although it seems that keyed guitars were known of throughout the nineteenth century, accounts of them are inconsistent and vague. This thesis combines a thorough study of historiographical sources with examination of the surviving instruments, placing them within a context of nineteenth-century music and musical inventions. I demonstrate that keyed guitars have their origins in the trade for domestic musical instruments and were preceded by similar keyed citterns (pianoforte guittars) in London in the 1780s. Their role and reception in Germany, however, were quite different, being marketed to a smaller more dispersed audience and chiefly to the nobility.

Reconstructing these instruments has allowed an in-depth analysis of the surviving objects, from a maker's perspective, and offers a better understanding of why various design elements were incorporated into these hybrid instruments. Each instrument has had a complex and contrasting material history, which can only be understood through a study of the objects themselves. Some elements have required reinvention, to best represent the originals as functioning keyed guitars. Full-scale 3D drawings of the instruments were made, from which it has been possible to directly apply the use of digital technologies to assist the process of manufacture.

The process of researching and recreating these instruments shines new light on nineteenth-century instrument culture, making obscure instruments available to contemporary audiences, and allowing for the incorporation of and reflection of the efficacy of new technologies in instrument reconstruction. This multifaceted study brings a wealth of new information, and a means of experiencing a niche of musical culture hitherto lost to obscurity.

Table of Contents

Acknowledgements.....	i
Lay Summary of Thesis.....	ii
Abstract	iii
Table of Contents.....	iv
List of Abbreviations	vi
List of Illustrations.....	vii
List of Tables	xii
Introduction.....	1
Research methods	2
Summary of Chapters	3
Chapter 1: Keyed Guitars in Context.....	6
Literature Review	8
The Pianoforte Guittar in Georgian London.....	14
Inventing the Pianoforte Guittar.....	15
The Design of the Pianoforte Guittar	18
Keyed Spanish Guitars	33
Spanish Guitars	33
Keyed guitars in historiographical sources	35
A German Artisan in London.....	37
Bachmann’s alleged Keyed Guitars	45
Known instruments.....	51
Keyed Guitar in the Collection of Rainer Krause	51
Keyed Guitar at the Metropolitan Museum of Art.....	57
The Leipzig Guitar	69
Conclusion	74
Chapter 2: Reproduction	76
Measurement equipment.....	77
Redesigning the Keyed Guitar by Neüner	79
The Keyed Guitar by Sprenger with Fiala.....	82
Conversion and repair history	84
Redesigning Matteo Sprenger’s keyed guitar	91
Making the keyed guitars.....	99
Mathias Neüner from the collection of Rainer Krause.....	100
Matteo Sprenger at the Metropolitan Museum of Art.....	124

Chapter 3: 3D Digital Technologies for the Reproduction of Historical Musical Instruments	142
Literature Review	142
Inflated expectations	142
Capturing data	145
Disseminating Data	147
3D scanning	150
3D Printing for the reproduction of musical instruments	155
Preston's Guittar Tuners	156
Lacôte Decacorde ' <i>Pedals</i> '	163
Prototype mechanisms	168
Conclusion	172
Chapter 4: Results and Conclusion	174
A comparison of the function of the piano mechanisms	174
Demonstration of the reproduction keyed guitar by Mathias Neüner	176
Conclusion	183
Appendices	186
Appendix I: Social media comments	186
Appendix II: Other keyed instruments	201
Inventions relating to the pianoforte guittar	201
Adolphe le d'Huy's <i>Lyre-Organisée</i> (ca. 1800)	207
The Orphica (1795)	212
Frédéric Fischer's Piano-Lyre (1839)	214
Villeroi's Guitare harmonique	217
Appendix III: Instrument diagrams	218
Bibliography	219

List of Abbreviations

AHRC	Arts and Humanities Research Council
AMIS	American Musical Instrument Society
BL	British Library
BSB	Bayerische Staatsbibliothek
CAD	Computer aided design
CAM	Computer aided manufacture
CDC	Centre for Data, Culture & Society
CNC	Computer numeric control
CT	Computed Tomography
DMLS	Direct metal laser sintering
DMM	Danish Music Museum
ET	Equal temperament
GNM	Germanisches Nationalmuseum
GSJ	Galpin Society Journal
MIMB	Musée des Instruments de Musique, Brussels
MIMEd	Musical Instrument Collection, University of Edinburgh
MIMO	Musical instrument museums online
MIMSIM	Musikinstrumenten-Museum im Staatlichen Institut für Musikforschung, SPK Berlin
MIMUL	Musical Instrument Museum, University of Leipzig
MINIM	Musical Instruments Interface for Museums and Collections
MIT	Massachusetts Institute of Technology
MMA	Metropolitan Museum of Art
<i>MUSICES</i>	Musikinstrumenten-Computertomographie-Examinierungs-Standard
OCR	Optical character recognition
SGSAH	Scottish Graduate School for the Arts and Humanities
SLM	Selective laser melting
TNA	The National Archives (Kew)
UCL	University College London
V&A	Victoria & Albert Museum
ZfI	Zeitschrift für Instrumentenbau

List of Illustrations

Figure 0.1 Keyed guitar by Mathias Neüner, Mittenwald 1810, Collection of Rainer Krause	xiii
Figure 0.2 Keyed guitar by Matteo Sprenger and F. Fiala, Karlsruhe 1843, MMA 89.4.3145.....	xiv
Figure 1.1 Three types of pianoforte guittar: Pianoforte Guittar attributed to John Goldsworth, working for Culliford & Co. MIMEd, 308 (left); Pianoforte Guittar by Christian Claus, MMA, 89.4.1013 (centre); Unmarked Guittar with ‘Smith’s Patent Box’ MMA 89.4.1014 (right)	13
Figure 1.2 Americus Backers, ‘English grand action’ London, 1772	19
Figure 1.3 Diagram of square piano mechanism by Johannes Zumpe, MIMEd 4335	20
Figure 1.4 Diagram of a pianoforte guittar mechanism with dampers (shown in red), as sold by Longman and Broderip	21
Figure 1.5 Two pianoforte guittars at the MIMUL	22
Figure 1.6 Mechanism for an unmarked pianoforte guittar, (MIMUL 628).....	23
Figure 1.7 Diagram of the pianoforte guittar mechanism by Christian Claus	24
Figure 1.8 Claus’s mechanism, Victoria and Albert Museum, V&A 240-1881.....	25
Figure 1.9 Smith's patent box on a guittar by John Preston, courtesy of Gregg Miner	27
Figure 1.10 Stamp reading ‘SMITH’S PATENT BOX’, above a Royal crest and ‘LONDON’ beneath, courtesy of Gregg Miner	27
Figure 1.11 Diagram of the mechanism use in Smith’s Patent Box	28
Figure 1.12 William Jackson's 1784 Patent, no. 1449	29
Figure 1.13 Square piano by John Preston ca. 1789, MMA 1980.217	30
Figure 1.14 Wettengel, 1828, Figs. 145-150 refer to the keyed guitar	39
Figure 1.15 Wettengel’s diagrams from the revised 1869 edition.....	40
Figure 1.16 Interpreted mechanism diagram (approximation)	41
Figure 1.17 Illustration by Eduard Fack (1884).....	42
Figure 1.18 Plate III from Otto Bachmann's Theoretisch-praktisches Handbuch des Geigenbaues, 1835	43
Figure 1.19 Keyed guitar by Mathias Neüner, Mittenwald, 1810. View showing the keyboard mechanism. Collection of Rainer Krause.....	50
Figure 1.20 Keyed guitar makers label. Collection of Rainer Krause	51
Figure 1.21 Mechanism diagram for the keyed guitar by Mathias Neüner	53
Figure 1.22 Guitar by Johann Gottlieb Knöβing, Leipzig 1807, MIMUL 1098.....	54

Figure 1.23 Keyed guitar by Matteo Sprenger and F. Fiala, Karlsruhe, 1843. View showing the keyboard mechanism. MMA 89.4.3145	56
Figure 1.24 MMA 89.4.3145, makers' labels.....	57
Figure 1.25 Lesson from Felice Chabran's 1813 guitar tutor.....	62
Figure 1.26 Mechanism diagram for the keyed guitar by Sprenger and Fiala, MMA 89.4.3145.....	64
Figure 1.27 Two views of the Leipzig guitar.....	68
Figure 1.28 English action described in the Paul de Wit's Zeitschrift für Instrumentenbau.....	70
Figure 1.29 Possible mechanism design for the Leipzig Keyed Guitar.....	71
Figure 1.30 Guitar by Carl Ludwig Bachmann 1801; MIMSIM SPK Berlin, no. 4238, Photo: Harald Fritz, 2009.....	72
Figure 2.1 Profiling block: L70mm W25.4mm D25.4mm	77
Figure 2.2 Dimensions of the measuring block	77
Figure 2.3 Front, side and back views of the current head by Neüner, courtesy of Rainer Krause	78
Figure 2.4 Wettengel's guitar head, 1828, Table XI.....	79
Figure 2.5 New head design for the Mathias Neüner keyed guitar reproduction	80
Figure 2.6 Comparison of original design (left) and altered design (right).....	82
Figure 2.7 Diagram of back bracing. Traces of previous braces shown with dashed line	83
Figure 2.8 View into the mechanism opening, MMA 89.4.3145	84
Figure 2.9 View of lower block (soundboard side at the top).....	85
Figure 2.10 Probable proportions of design.....	86
Figure 2.11 Franz Barthioli's 1833 diagram of a Wappenform guitar	87
Figure 2.12 View of the bridge on the keyed guitar at the MMA.....	88
Figure 2.13 View of the key well and bridge on the keyed guitar at the MMA	89
Figure 2.14 Piano hammer mechanism of the keyed guitar at the MMA	90
Figure 2.15 View of balance rail and pins of the keyed guitar at the MMA	90
Figure 2.16 View of the back of the guitar body, showing three screws on the keyed guitar at the MMA.....	91
Figure 2.17 - Chart of the fret spacing compared to equal temperament spacing	93
Figure 2.18 Comparison of the head profiles: original profile (left); new design (right)	94
Figure 2.19 Proportions of the new head design.....	95
Figure 2.20 Dimensions of the new bridge design.....	96

Figure 2.21 The Golden ratio (ϕ) used to position the decorative ends.....	97
Figure 2.22 Angled perspective view of new bridge design.....	97
Figure 2.23 Bridge decoration from Wettengel's 1828 treatise; Plate XI	97
Figure 2.24 Centre bridge dimensions and cross-section from Wettengel's 1828 treatise, Plate XII.....	98
Figure 2.25 Diagram showing the supporting structures to receive the mechanism	100
Figure 2.26 Layout of back braces: Lateral braces, A—D; Mechanism support braces, 1–5; internal blocks shown with diagonal hatching.....	101
Figure 2.27 Clamping the back bracing to the back.....	102
Figure 2.28 Bending the sides with a bending iron.....	102
Figure 2.29 Back of the guitar attached with spool clamps	103
Figure 2.30 Showing the mechanism support braces before ribs are cut away	104
Figure 2.31 Mechanism guides being clamped during gluing	104
Figure 2.32 Guitar ribs marked out ready to cut out	105
Figure 2.33 Cutting the mechanism opening with a veneer saw.....	106
Figure 2.34 Veneering the pine neck in ebony	107
Figure 2.35 Binding the veneer onto the pine neck	107
Figure 2.36 Hammering iron nail to attach neck	108
Figure 2.37 Soundboard layout, internal braces shown with a dashed line A and B; Internal blocks shown with hatching.....	109
Figure 2.38 Hammer hole dimensions, with border outside in ebony	110
Figure 2.39 Attaching the soundboard with spool clamps.....	111
Figure 2.40 Soundboard attached and decorated	111
Figure 2.41 Components attached to the baseboard	112
Figure 2.42 Plan diagram of the keys. Keys numbered 1–6 matching the conventional numbering of strings (right to left).....	113
Figure 2.43 CNC router prepared to mill the keys.....	114
Figure 2.44 Finished CNC milling.....	114
Figure 2.45 Balance pin tool	115
Figure 2.46 Assembling the keys and attaching the key guides	116
Figure 2.47 Hammer arms and hinges prepared	117
Figure 2.48 Escapement hinged with bushing cloth added.....	117
Figure 2.49 View of completed escapement mechanism.....	118
Figure 2.50 View of original instrument's hammer hinge.....	118
Figure 2.51 Diagram of Neüner's escapement mechanism	119

Figure 2.52 Adding leather toppings to escapement.....	119
Figure 2.53 View of escapement screw	120
Figure 2.54 View of escapement springs and balance pins	120
Figure 2.55 Adding the hammer leathers.....	121
Figure 2.56 View of the finished hammers.....	122
Figure 2.57 View of mechanism from above.....	122
Figure 2.58 Finished mechanism within the reproduction instrument.....	123
Figure 2.59 View through the soundboard into the MMA guitar body	124
Figure 2.60 Adding the diagonal brace	125
Figure 2.61 Clamping the corner blocks. Diagonal brace, upper and lower blocks added	126
Figure 2.62 Attaching the lining with spring clamps.....	126
Figure 2.63 Gluing the bridge plate with go bars.....	127
Figure 2.64 Marking out the back for braces and pine patch.....	128
Figure 2.65 Mechanism pine patch added	129
Figure 2.66 Cutting the binding and purfling channels.....	129
Figure 2.67 Body assembled without back, soundboard decorated.....	130
Figure 2.68 Neck made from wild service wood	130
Figure 2.69 Pre-drilling the nail attachment of the neck.....	130
Figure 2.70 Back attached with spool clamps, ruler used to ensure the correct mechanism angle was maintained during clamping.....	131
Figure 2.71 3D technical drawing of the mechanism used for construction.....	132
Figure 2.72 Baseboard marked out for the balance rail and keys	132
Figure 2.73 Balance pin hole shaped with tool, clamp used to prevent splitting.....	133
Figure 2.74 Keys shaped to fit mechanism, cover fitted.....	134
Figure 2.75 Artificial ivory key fronts added.....	135
Figure 2.76 Escapement and key lever cut for a parchment hinge	135
Figure 2.77 Parchment hinges added to keys.....	136
Figure 2.78 Keys in place with escapement springs fitted.....	137
Figure 2.79 Leather added to hammer arms.....	137
Figure 2.80 Fitting hammers with axels to the brass kapseln	138
Figure 2.81 Bridge pin holes predrilled in soundboard	139
Figure 2.82 Attaching the bridge	139
Figure 2.83 Temporary strings used to calculate the position of the hammers.....	140

Figure 2.84 Cloth was added to the mechanism to reduce noise	140
Figure 2.85 View of escapement positioning with hammer arm	140
Figure 2.86 Completed mechanism within instrument	141
Figure 3.1 Economist front cover 12 February, 2011	143
Figure 3.2 Photogrammetry of a guitar by Stauffer, MMA 1979.390	150
Figure 3.3 Outline of central cross section of MMA 1979.390	151
Figure 3.4 Stauffer heel, MMA 1979.390: Photogrammetric image (left); Photograph (right).....	151
Figure 3.5 Scanning a guittar rose with Next engine HD ultra, MIMEd 1067	152
Figure 3.6 Scanning a pianoforte guittar rose with Next engine HD ultra, MIMEd 308	152
Figure 3.7 3D MIMEd 1067: Computer model (left); photograph (right).....	153
Figure 3.8 MIMUL 628: CT scan data (left); photograph (right)	153
Figure 3.9 Plastic 3D printed copy of a pianoforte guittar brass rose, MIMUL 628	154
Figure 3.10 Preston tuners on a guittar in the author's collection	157
Figure 3.11 Diagram of Preston tuners	157
Figure 3.12 Portuguese Guitar by Antonio Duarte, twentieth century, MIMEd 2765	159
Figure 3.13 Tapping the Shapeways traveller	160
Figure 3.14 Milling the square end of the tension screw on a model makers' lathe	161
Figure 3.15 Assembly of prototype Preston tuners	161
Figure 3.16 Partial assembly of replica tuners	162
Figure 3.17 Completed assembly of Preston tuners with watch-key	162
Figure 3.18 Restored decacorde by Lacôte, MIMEd 767	163
Figure 3.19 Lacôte patent diagram of the back of the head	164
Figure 3.20 Exploded drawing of reproduction pedal	165
Figure 3.21 Reproduction components for a decacorde pedal	165
Figure 3.22 View of restored Lacôte decacorde, MIMEd 767	166
Figure 3.23 Back view of restored Lacôte decacorde, MIMEd 767	167
Figure 3.24 3D computer model of the Neüner mechanism	168
Figure 3.25 Part assembly of prototype mechanism	169
Figure 3.26 3D printed escapement hinged with bushing cloth.....	169
Figure 3.27 Assembled 3D printed prototype mechanism for the guitar by Neüner	170
Figure 3.28 Computer model of the key mechanism by Sprenger, MMA 89.4.3145	170

Figure 3.29 Two views of 3D printed prototype mechanism, MMA 89.4.3145	171
Figure 4.1 Mechanism locations: Mathias Neüner (left); MMA 89.4.3145 (right) .	174
Figure 4.2 Mechanism openings: Sprenger copy (left); Neüner copy (right)	175
Figure 4.3 Demonstrating the reproduction keyed guitar by Mathias Neüner at the 2019 AMIS conference in Greenville, SC, USA	177
Figure 4.4 Frame taken from Dick Boak’s video.....	179
Figure 4.5 An Instagram meme created from the video originally uploaded by Dick Boak	181

List of Tables

Table 1 - Fret Measurements, Mathias Neüner	81
Table 2 - Fret Measurements: distance from nut, MMA 89.4.3145	92



Figure 0.1 Keyed guitar by Mathias Neüner, Mittenwald 1810, Collection of Rainer Krause



Figure 0.2 Keyed guitar by Matteo Sprenger and F. Fiala, Karlsruhe 1843, MMA 89.4.3145

Introduction

This creative practice PhD examines and reconstructs two nineteenth-century German guitars: one made in Mittenwald by Mathias Neüner in 1810 (Figure 0.1); the other bearing the names F. Fiala and Matteo Sprenger, probably made in Karlsruhe in 1843 (Figure 0.2). The only nineteenth-century keyed guitars known to survive, these two instruments are like ordinary guitars of the period in that they have six strings of gut and silk of a usual scale length. Each, however, has a removable piano hammer mechanism within the guitar body that enables hammers to strike the strings through a hole in the soundboard.

The keyed guitar by Neüner from 1810, is currently in the private collection of Rainer Krause,¹ and has only recently gained public attention.² The instrument by Sprenger and Fiala is located at the Metropolitan Museum of Art (MMA) and was part of the collection of musical instruments originally established by Mary Elizabeth Adams Brown in 1889.³ This instrument, despite being in a public collection for a long period of time, has entirely avoided academic coverage. The ingenuity of its design has long been overshadowed by the instrument's peculiarity, current state of deterioration, and plainness.⁴

The history of keyed guitars has been misunderstood even from the beginning, as early sources provide conflicting narratives of their origin and design. The two surviving instruments have not informed any previous history of the keyed guitar yet are essential for understanding and contextualising the sparse body of nineteenth-century literature on the subject. This topic has not been given any focused academic attention, leaving many basic questions about this instrument's history unanswered: Who made

¹ I am indebted to Rainer Krause for his ongoing support and generosity for this project. I am also grateful to Panagiotis Pouloupoulos and James Westbrook for introducing me to Rainer Krause after seeing his keyed guitar in Munich in May 2017.

² A photo of this guitar appears in Hackl 2016, p. 45, however this dissertation and my 2020 *Metropolitan Museum Journal (MMJ)* article are the first study of this object in relation to historiographical sources. Wheeldon 2020.

³ Metropolitan Museum of Art (MMA), no. 89.4.3145.

⁴ It was included in an early catalogue of the instrument collection (Morris 1904, p. 264) and mentioned in Groce 1991, p. 147.

keyed guitars? When and where were they made? In what context were they used and how were they perceived?

Given the scarcity of primary source material and instruments, the emphasis of this project has been in making copies of the two keyed guitars known to survive. They are likely the first keyed guitars of this style to be made since 1843 and provide an unparalleled opportunity to access an obscure part of musical history.

The process of reconstructing these instruments allows an in-depth analysis of the surviving objects from a maker's perspective and offers a better understanding of why various design elements were incorporated into these hybrid instruments. The reproductions that have been created of these keyed guitars can be played without the usual concerns associated with restoring historical instruments to playing condition, introducing an experiential element in the study of an abandoned musical practice.

Research methods

This thesis combines the reconstruction of the surviving instruments with a thorough study of historical sources, placing them within a context of nineteenth-century music and musical inventions. To inform the history of the instruments I have relied on nineteenth-century encyclopaedias,⁵ German state records,⁶ instrument makers' texts,⁷ and contemporary newspaper articles.

A thorough study of both extant keyed guitars informs the reading of primary source material, but moreover is an essential preliminary step in their reconstruction. The original objects have been available for examination and I have travelled to New York and Munich to study them and to make full scale 3D technical drawings. The two instruments have had contrasting object histories, and this detailed study goes far in illuminating the uncertain journey of each since their original manufacture.

⁵ Koch 1802; 1807; Gerber 1812; Lichtenthal 1826; Schneider 1834; Fétis 1835; Schilling 1835; Fétis 1868; Ledebur 1861; Barberi 1872.

⁶ *Hofmusikus Franz Fiala*, Landesarchiv Baden-Württemberg, Archive No. 4-798450; Großherzoglich Badisches Staats- und Regierungsblatt, 1820.

⁷ Wettengel 1828; Bachmann 1835; Gretschel and Wettengel 1869.

The emphasis of this study is the key mechanism, and the design of the reconstructed instruments supports the functionality of this component. Consequently, this project does not attempt to produce exact copies of the surviving instruments in their current state.

While building these instruments, this thesis considers the use of digital manufacturing technologies more generally for the reproduction of historical musical instruments. In 2017, I was awarded a grant from the Dutch 3D printing firm *Shapeways*, enabling me to experiment with various processes including printing in metals for usable instrument parts, and in plastics for working prototype piano mechanisms. In addition to these processes I have used CNC milling, laser cutting and 3D scanning. For this project, these technologies are considered as part of a wider toolset, complementing rather than replacing traditional crafts.

Finally, this project gains from experiencing the function of the reproduction instruments. This is particularly valuable for understanding the original instrument at the MMA which is unplayable, but now able to be experienced vicariously through the replica instrument. Functional instruments provide a valuable new perspective on a history that has so far been a silent and disjointed study of historical sources.

Summary of Chapters

This dissertation comprises four chapters. Chapter 1 examines the history of the nineteenth-century keyed guitar, establishes the provenance of the surviving instruments, and places them within a historical narrative. This narrative begins with the keyed cittern or ‘pianoforte guittar’⁸ made in London during the 1780s and expands to explore other references to keyed guitars in the late eighteenth- and early nineteenth-centuries.

This study draws from a wide range of sources in various media and provides an unprecedented history of these instruments. Here, I provide the first critical evaluation

⁸ The term ‘pianoforte guittar’ refers to various types of keyed cittern. The spelling *guittar* is retained from early sources to differentiate the wire strung cittern-like ‘English guittar’ from the gut strung ‘Spanish guitar’. In eighteenth-century Britain, either ‘guitar’ or ‘guittar’ would typically refer to these citterns, though the term ‘English guittar’ has been used from as early as 1760, particularly when requiring distinction from the Spanish guitar. See Christopher Page 2020; Appendix I.

of these sources, explaining the inconsistencies and providing a methodology for reading these seemingly contradictory accounts. I challenge the prevalent idea that Carl Ludwig Bachmann invented and made keyed guitars—an idea introduced and repeated from the beginning of the nineteenth century.⁹

This chapter lays the groundwork for reading and contextualising primary source material and provides an entry point for any future research in this area. If other nineteenth-century keyed guitars are identified in the future or new source material surfaces, this research will provide a means to locate them within this history.

Chapter 2 documents the process of designing and making the two replica instruments, supplemented by Appendix III, which contains further detailed diagrams of both keyed guitars. It is intended that the reproduction instruments would be easily identifiable with their models while adapting the designs to support the functionality of the piano mechanism. In this chapter I discuss the reasons why elements of the surviving instruments have not been incorporated into the new designs and explain the process of producing appropriate alterations. I offer the necessary information for others to recreate either instrument by documenting the making process, providing measurements, diagrams, and photographs. Much has been written on traditional guitar construction, and so this section focuses on the piano hammer mechanism.

Chapter 3 examines the nature of 3D technologies including technical drawing, scanning, 3D printing and CNC manufacture for the reproduction of historical musical instruments. From early in the project it became clear that to reproduce these instruments I would depend upon 3D drawings to understand the complex geometry involved in locating the key mechanisms inside the guitar bodies.

I describe my experience as a subject specialist within the Digital Humanities and explore ways in which 3D imaging and manufacture can be used within a field that largely relies on traditional crafts. 3D printing in metals, or in wax for lost-wax casting has enabled the manufacture of reproduction parts for working watch-key ‘Preston’ guitar tuners and for the restoration of a *decacorde* by Pierre-René Lacôte.

⁹ Sources attribute the invention of the keyed guitar to either Anton Bachmann or his son Carl Ludwig Bachmann in Berlin.

I examine common pitfalls and inflated expectations common when engaging with new technologies and propose realistic applications for researchers, instrument makers, and institutions. Crucially, this chapter describes the usefulness and limitations of 3D technical drawings and manufacturing technologies in fabricating the two keyed guitars in this project.

Chapter 4 explores information gained from the two replica instruments. From insights into the process of manufacture I compare their function, considering more subtle differences in the arrangement and design of the mechanisms. Having working instruments has allowed me to discuss the nature of the instrument from the perspective of the player and highlight areas where performance is aided or potentially hindered. These experiences are compared with nineteenth-century descriptions of the function and use of the keyed guitar.

This chapter discusses the reception of the keyed guitar by Neüner when demonstrated at the 2019 annual conference of the *American Musical Instrument Society (AMIS)* in Greenville SC, USA, and a subsequent video demonstration which was circulated on various social media, reaching an unexpectedly large audience.¹⁰

This is a much-needed study of a hitherto forgotten corner of musical history and is the first study of its kind. As well as being the first attempt to reproduce keyed guitars from this period, this is also the first history of the nineteenth-century German keyed guitar, and of the integration of 3D digital technologies for the reproduction of historical musical instruments.

¹⁰ With the first video being viewed over 110,000 times, and subsequent adaptations made by other internet users multiplying this reach still further.

Chapter 1: Keyed Guitars in Context

For context, the keyed guitars in the nineteenth century ought to be considered alongside other hybrid instruments and the increasing musical presence of both the piano and the Spanish guitar. After its invention by Bartolomeo Cristofori at the turn of the eighteenth century, the piano had grown steadily in popularity, and by the late 1760s the affordability and novelty of the square piano in particular made it a highly successful domestic instrument in London.¹¹ The cittern-like English guittar was then also in vogue throughout the United Kingdom, and was the first instrument of the guitar type to be fitted with piano hammers.¹² These pianoforte guittars gained speedy admiration, and maintained their success, throughout the 1780s.

At this time, London was a lively cosmopolitan port city where the materials necessary for musical instrument manufacture were readily available, as was a skilled workforce from across Europe. Many London-based makers of pianos and guittars were first-generation German immigrants. Most prominent among them was Johannes Zumpe who, in addition to being a guittar maker, is credited with inventing the square piano.¹³ Given the strong presence of German instrument makers in London towards the end of the eighteenth century, it is likely that knowledge of the London-made pianoforte guittar would have travelled back to Germany. As will be discussed, Mathias Neüner—named on the maker’s label of one of the surviving keyed guitars—was active in instrument-making communities in London towards the end of the eighteenth century and would doubtless have seen pianoforte guittars.

After this time, around the turn of the nineteenth century, the Spanish guitar was starting to take precedence over the English guittar in popularity. The guitar fulfilled many of the same amateur functions for a short period while music sellers arranged the same kinds of popular music for it, but musicians such as Fernando Sor and Niccolò Paganini helped to make it an instrument of virtuosity.

¹¹ Pollens 1995, p. 43.

¹² By ‘guitar type’, is meant plucked fretted stringed instruments, although the history of the cittern-like guittar is distinct from that of the guitar.

¹³ Pouloupoulos 2011b.

During the earlier period in London and onwards into the nineteenth century, other experimental and hybrid instruments were being invented. In Vienna in 1795, Carl Leopold Röllig invented the Orphica—a small portable piano.¹⁴ In London from 1800, Edward Light promoted various musical inventions including his harp-guitar, arch-lute-guitar, and harp-lute-guitar.¹⁵ In 1817 François Chanot patented a new design for a violin with a fixed bridge instead of a tail piece and a cornerless guitar shaped-body. These violins likewise influenced contemporary guitar makers who made instruments with arched soundboards and similar bridges, most notably Francesco Molino.¹⁶ 1823 saw the invention of the arpeggione—a bowed six-string guitar—with multiple makers claiming to be the first, most famously Johann Georg Stauffer.¹⁷

The keyed guitar is therefore in good company, with experimental and hybrid instruments being made across Europe at this time. Many of these instruments have only remained in the consciousness of specialised musical communities, but the keyed guitar is exceptional in being almost entirely overlooked or misunderstood.

This chapter begins by outlining the history of the pianoforte guittar invented in London during the 1780s, then goes on to discuss separate attempts to add keys to guitars in the early nineteenth century, most significantly establishing a context for the instruments known to survive. I will then discuss the possible provenance of the keyed guitar lost from the Musical Instrument Museum, University of Leipzig (MIMUL) during the Second World War. Importantly, here I confront two prevalent misunderstandings of the keyed guitar in Germany that have arisen from confusions in nineteenth-century literature and still puzzle modern writers. Namely, the keyed guitar in the Spanish form described by Gustav Adolph Wettengel in 1828, and the role played by Carl Ludwig Bachmann in the history of the keyed guitar. Other related guitar-like instruments with keyboard and hammer mechanisms, of which there are a few, will be discussed further in Appendix II.

¹⁴ Röllig 1795.

¹⁵ See Sugimoto 2015, pp. 103-151.

¹⁶ These associations have recently been demonstrated in Pouloupoulos 2018.

¹⁷ An arpeggione by Stauffer from 1824 is in the Musical Instrument Museum, University of Leipzig (MIMUL) no. 609.

Literature Review

The history of the keyed guitar has never been fully understood. Today the instrument is largely unheard of and entirely puzzling to the few who have heard of it, but even at the time the surviving instruments were made, the accounts are various, limited, and conflicting. In fact, all nineteenth-century sources can be grouped and confined within three isolated narratives of the German keyed guitar: one refers to Carl Ludwig Bachmann's guitar with keys, derived from sources appearing as early as 1799;¹⁸ a second selection of sources can be most easily grouped by their common attribution of a keyed guitar in a Spanish form to a 'German artisan in London', first appearing as early as 1802;¹⁹ a third line of research is founded upon the surviving instruments, which in turn can be associated with the historiographical sources surrounding Fiala in his role as Baden court musician.²⁰

This third narrative is the most compelling yet the most overlooked. Outside of the original source material there has been no reference to Franz Fiala at all until the Museum of Musical Instruments, University of Leipzig's (MIMUL) 2016 catalogue, which names Franz Fiala as the possible maker of the keyed guitar lost from their collection during the Second World War.²¹ On the other hand, recent literature has given full credit to the nineteenth-century accounts that name the Berlin instrument maker Carl Ludwig Bachmann (or his father Anton Bachmann) as the inventor, despite significant reasons to doubt the credibility of the source material, as will be discussed below (p. 45).

One limiting factor in this recent literature, is that the authors do not pursue keyed guitars as a primary research objective, and only have incidental connections to

¹⁸ Rochlitz 1799, p. 655. Living authors have likewise given credit to nineteenth-century accounts and accepted either Carl Ludwig Bachmann or his father Anton Bachmann as a maker or even the inventor of the keyed guitar. See Elste, Droysen-Reber, and Haase 1987, p. 12; Lomtev 2014, p. 17; Pouloupoulos 2015, p. 47; Wheeldon 2017a, p. 98.

¹⁹ Koch 1802, p. 708.

²⁰ Another known instrument is the enigmatic lost instrument from Leipzig catalogued by Paul de Wit and Georg Kinsky. de Wit 1892, pp. 9–10; 1903, p. 81; Kinsky 1912, p. 172.

²¹ Michel and Neumann 2016, pp. 260–62. This catalogue makes no reference to either of the surviving instruments. The only prior mention of the instrument by Neüner is a photograph in Hackl 2016, p. 45; a footnote also cites the keyed guitar at the MMA in Pouloupoulos 2015, p. 47.

German keyed guitars. For example, Martin Elste, writing in 1987, gives a history of the Bachmann workshop and repeats earlier sources which state outright that he was the inventor and maker of keyed guitars. This work however is part of a larger study of instrument makers in Berlin, and not focused on keyed guitars.²² Both Panagiotis Pouloupoulos' 2011 PhD dissertation and my 2017 *Galpin Society Journal (GSJ)* paper, concentrated on the English guittar and the pianoforte guittar in London during the 1780s rather than keyed six-string guitars of the nineteenth century, and so did not provide a thorough examination of the nineteenth-century literature.²³

In fact, the earliest sources do not attribute keyed guitars or citterns to Carl Ludwig Bachmann, but rather place him as an importer of instruments probably made in London.²⁴ Other German sources which refer to the inventor as a 'German artisan in London' doubtless have confused the London-made pianoforte guittars with six-string instruments.²⁵ Stuttgart-born Christian Claus, working in London, was awarded a patent for a pianoforte guittar before other contenders and has consequently been recognised as the inventor.²⁶

After some initial ambiguity in the early source material, mid-nineteenth-century literature goes further and unequivocally names Bachmann the inventor of the keyed guitar.²⁷ These later sources also add further errors, like Schneider's 1834 *Historisch-technische Beschreibung der musicalischen Instrumente*, wherein he introduces the idea that the piano mechanism protected the player's fingers, as 'ladies usually complain and moan that their delicate little fingers hurt when they are supposed to pluck the strings.'²⁸

²² Elste, Droysen-Reber, and Haase 1987, p. 12.

²³ Pouloupoulos 2011a, p. 442; Wheeldon 2017a, p. 98.

²⁴ Rochlitz 1799, pp. 654–5. This point will be discussed further (see p. 45).

²⁵ Koch 1802, p. 708.

²⁶ Christian Clauss, *An Improvement Upon the Instrument Commonly Called the Guittar* (London, 1783), Patent no. 1394. The spelling Claus is not standardised, his patent document and numerous newspaper articles use the spelling 'Clauss' which has also been used in Nex 2013. However, Pouloupoulos 2011, uses the spelling 'Claus' as it appears on his instruments.

²⁷ The earliest source that does this is Fétis 1835, p. 26.

²⁸ Schneider 1834, p. 86. Original: *Die Damen klagen und jammeren gewöhnlich, daß ihre zarten Fingerchen schmerzen, wenn sie mit der rechten hand die Saiten scharf anreißen...*

Towards the end of the nineteenth century, the quality of the research by instrument collectors and historians improved. The accounts clearly differentiate between six-string German keyed guitars and the London pianoforte guitar. For example, Paul de Wit writing in 1884 gives notice that he has collected a keyed cittern with a removable piano box, and refers to its invention by Claus and gives the correct patent date of 1783.²⁹ Also in 1884, Gustave Chouquet's *Catalogue of the Conservatoire national de musique* also gives accurate information about Claus and his patent in reference to a guitar with an external piano box, describing it as 'this bastard instrument' (no doubt reflecting on its hybrid nature), and explains that 'English or German luthiers seem to be the only ones that made it'.³⁰

In 1912, Georg Kinsky published an illustrated catalogue of Wilhelm Heyer's instrument collection in Cologne. This catalogue includes a photograph and descriptive text of an unnamed keyed guitar and attributes it to Carl Ludwig Bachmann.³¹ Georg Kinsky was a well reputed historian, and this attribution has no doubt given more weight to accounts naming Bachmann as a maker of keyed guitars. Unless the instrument is recovered it is not possible to verify Kinsky's attribution, but I will hereafter demonstrate that it is unlikely to be correct.

Twentieth-century sources, including Kinsky's catalogue, seem to repeat information given in nineteenth-century encyclopaedias. In his one sentence on keyed guitars, Francis Galpin likewise affirms Bachmann's authorship,³² and in Josef Zuth's *Handbuch der Laute und Gitarre*, 1978, the entry for the keyed guitar seems to be entirely derived from Kinsky's catalogue.

In the last decades, short accounts of keyed guitars have continued to appear from time to time but are no more accurate. In 2000, Franz Jahnel's *Manual of Guitar Technology* gives a surprisingly ill-informed account of these instruments: 'In 1787 Clauss of

²⁹ de Wit 1884, p. 346. Though as will be discussed this piano box 'Smith's Patent Box' was not Claus's invention.

³⁰ Chouquet 1884, p. 64. Original: *Cet instrument bâtard*.

³¹ Kinsky 1912, p. 172. Wilhelm Heyer's collection later became the foundation to the musical instrument museum at the University of Leipzig, and this keyed guitar is the instrument lost during the Second World War.

³² Galpin 1937, p. 118.

London invented the keyboard-cittern and keyboard-guitar, which became known in Italy as the *chitarra pianoforte*, and in Germany as the Bachmann pianoforte-guitar, with six mechanical keys (1795).³³

This account gives very little usable information, it is an approximated history which is at the same time better informed than many accounts (demonstrating knowledge of keyed guitars in addition to citterns, and Italian sources) and yet without a clear grasp of the dates involved—being that 1787 has no special significance in Claus’s history, yet is within his years of activity in London.³⁴ Furthermore, this source introduces the new idea that Claus made keyed guitars as well as citterns.

In the *New Grove Dictionary of Music and Musicians* entry ‘English Guitar’, Robert Spencer and Ian Harwood also show a relaxed approach to the history of the pianoforte guitar in London.

To help those too lazy to acquire a right-hand technique, during the 1770s a certain Smith patented a key-box housing six keys similar to those of a piano, which when depressed caused leather-covered hammers to strike down onto the strings. In 1783 Christian Claus of London patented a more sophisticated ‘keyed guitar’, whose mechanism was housed inside the sound box instead of being poised above the strings; the hammers struck upwards through holes in the soundhole rose. This type of instrument was called a ‘piano forte guitar’ by Longman & Broderip in 1787.³⁵

The authors’ opinion of the motives for this development have no basis in historical sources and there is no evidence ‘Smith’s patent box’ was being made before 1784. Claus did patent his pianoforte guitar in 1783, but has never to my knowledge referred to it as a “keyed guitar”.³⁶ These insertions further complicate this history and show that a flexibility with the facts about pianoforte guitars and keyed guitars persists in relatively recent and reputable sources as well as in nineteenth-century texts. This

³³ Jahnel 2000, p. 35.

³⁴ Panagiotis Pouloupoulos notes that the error of dating Claus’s patent to 1787 might originate with Baines 1968, p. 48. As cited by Pouloupoulos 2011a, p. 42.

³⁵ Spencer and Harwood 2001, p. 245.

³⁶ In preparing my 2017 *GSM* article, I read many documents and advertisements by Claus. He refers to his instruments as pianoforte guitars, fortepiano guitars, but never to my knowledge as ‘keyed guitars’.

tendency means that rather than becoming clearer and more substantial, writings on the keyed guitar have become more complicated and less trustworthy.

Keyed guitars and pianoforte guitars have suffered from their association with domestic music, the importance of which is often undervalued. In Tyler and Sparks' important book *The Guitar and its Music*, 2002, pianoforte guitars get the following description: 'these inventions enjoyed a brief popularity and doubtless improved the state of the nation's manicure, but they also increased the perception of the English guitar as a toy rather than a serious musical instrument.'³⁷ This comment while being dismissive also creates a musical instrument hierarchy, differentiating between serious instruments and 'toys'.³⁸ In fact, the pianoforte guitar had a significant weight of influence in musical life in London in the 1780s and is an essential part of the history of the guitar.

This thesis starts from the earliest source material and provides context for reading early literature on the keyed guitar by laying out the essential facts of the period of pianoforte guitar production. Until recently, little has been known about the origins of the pianoforte guitar either, but Panagiotis Pouloupoulos' 2011 PhD dissertation provided an unprecedented survey of surviving instruments and patent documents; Jenny Nex in her 2013 PhD dissertation gave further insight into essential documents surrounding the principal characters of this history namely: Christian Claus, Charles Pinto, and Longman & Broderip. In my 2017 article in the *Galpin Society Journal* (*GSJ*), I provided an outline of the extent of the pianoforte guitar's manufacture in London, drawing into question Claus's authorship of this invention.

³⁷ Tyler and Sparks 2002, p. 227.

³⁸ This distinction is problematic, as it creates a gender and class divide in our perception of music history. This divide is not the intention of the authors but shows an inherited legacy of sexism in a musical hierarchy that is still very much present, and from which I am not exempt. While this is far beyond the scope of this project, it would be worthwhile examining the perception of domestic music in modern histories with this in mind.



Figure 1.1 Three types of pianoforte guitar: Pianoforte Guittar attributed to John Goldsworth, working for Culliford & Co. MIMEd, 308 (left); Pianoforte Guittar by Christian Claus, MMA, 89.4.1013 (centre); Unmarked Guittar with 'Smith's Patent Box' MMA 89.4.1014 (right)

The Pianoforte Guittar in Georgian London

The English guittar is a six-course,³⁹ wire-strung cittern, which achieved its greatest success in Britain in the second half of the eighteenth century. During this period it had some success with Royalty, but its popularity was driven by its relative affordability and was associated mostly with the middle-classes.⁴⁰ The pianoforte guittar was first manufactured in 1783 and both Christian Claus and the firm Longman & Broderip have claim to its invention.

Like the guittar without keys, these keyed examples would have been used almost exclusively in the home and were popular among both men and women, despite being advertised chiefly for young women to use as an accompaniment for the voice.⁴¹ Compared to other domestic instruments such as the square piano, the pianoforte guittar was almost exclusively an amateur instrument; with the tuning set to an open chord of C major, it was relatively easy for a beginner to make a pleasant sound. What is more, its piano-like sound, produced by striking wire strings with a hammer as opposed to plucking them with the fingers, would likely have been considered fashionable.⁴²

Three types of pianoforte guittar were made in London during the 1780s (see Figure 1.1 above): those primarily being sold by Longman & Broderip, initially supplied by Charles Pinto and subsequently by John Goldsworth who was awarded a patent for his instruments in 1785; those made by the German Christian Claus often credited with inventing the pianoforte guitar; and those with an external piano box, derived from

³⁹ With respect to stringed instruments, a course refers to a playable unit of strings (commonly two) either of the same pitch or an octave apart. A typical guittar, with single strings in each of the two lowest-pitched courses, is a six-course instrument with ten strings and has the following tuning: c – e – g g – c' c' – e' e' – g' g'.

⁴⁰ Pouloupoulos 2011a, p. 128.

⁴¹ Ghillini di Asuni's published tutor for the pianoforte guittar describes it as an instrument 'adapted to the Ladies for its delicacy, and esteem'd a very compleat accompaniment to the female voice.' di Asuni 1784, p. 1.

⁴² In the second half of the eighteenth century the piano was an increasingly popular instrument, and by the nineteenth century, harpsichord production was greatly reduced. The prominent Kirkman firm 'is said to have made its last harpsichord in 1809.' Ripin et al. 1989, p. 97. Guittar makers also often added a third string to the two highest-pitched courses, increasing the similarity to the piano in tone and structure.

William Jackson's patent of 1784, known as 'Smith's Patent box', found on instruments by various makers.⁴³ Although the instruments with internal mechanisms appear similar from the exterior, their piano actions are entirely distinct in design, probably as a result of multiple lawsuits that forced their makers to differentiate their work.

Pianoforte guitars by Claus and Longman & Broderip have several similarities. The shape of the guitar bodies are both of a tear drop shape and the keyboards mounted on the same part of the soundboard are likewise very similar. Both Claus and Longman & Broderip used triple stringing in the upper courses, which is a unique feature of pianoforte guitars. This stringing would have made plucking the strings with the fingers more difficult but remained an enduring design feature suggesting its success. Guitars with key boxes typically were of the usual stringing, but since the external mechanism was removable it follows that they were expected to be played as an ordinary guitar without keys as well.

Inventing the Pianoforte Guitar

The first reference to the pianoforte guitar comes in advertisements by Longman & Broderip, as early as 17 April 1783.⁴⁴ It appears, without special mention, in a list of instruments advertised for sale. Four months later Claus also advertised his 'guitar forte piano' in an advertisement dedicated to it alone and described himself as 'the sole inventor of that celebrated and admired instrument'.⁴⁵ Claus's patent, of 2 October 1783, was contested by Longman & Broderip and Charles Pinto, who was most likely making the instruments at the time, but the court ruled in favour of Claus.⁴⁶ This victory does not prove authorship of the invention, as the patent document itself is far from comprehensive and only entitles Claus to peripheral parts of the mechanism, including stops to alter the sound of the hammers hitting the strings, and would not

⁴³ John Goldsworth 1785, Patent no. 1491; Christian Claus 1783, Patent no. 1394; William Jackson 1784, Patent no. 1449.

⁴⁴ *English Chronicle or Universal Evening Post*, 17 April 1783, issue no. 674. Repeated in at least seven issues spanning from 17 April to 15 July 1783.

⁴⁵ *Morning Post and Daily Advertiser*, 22 July 1783, issue no. 3259.

⁴⁶ *Morning Herald*, 6 November 1783, issue no. 944.

have hindered Longman & Broderip from continuing to make their instruments. Claus compared his pianoforte guitars to other makers' instruments in his patent text, and did so publicly in the newspapers:

Before he [Claus] solicited for this Patent, his first efforts and inventions inadvertently were made public, whereby, in point of law, he lost his exclusive right to them; but his last and grand improvements he retains by virtue of his said patent, and which therefore cannot be imitated or sold.⁴⁷

Claus's business partner Joseph Levy, who financed the 1783 patent, writing in 1787 about a dispute between him and Claus, describes Claus as a 'very ingenious workman; that he had made a great improvement on the Piano Forte Guittar, by inventing stops, by which the notes were much softened.'⁴⁸ Levy's description that Claus invented improvements to the pianoforte guittar rather than the thing itself is noteworthy, and provides significant grounds to doubt that Claus really was the first maker of pianoforte guittars.

Whether or not Claus was the inventor, he has been remembered as such. He regularly made the claim himself, employing a vigorous advertising campaign in newspapers and branding it on his instruments.⁴⁹ Certainly for the study of nineteenth-century keyed guitars, it is only important to state that, at least outside of London, Claus was universally recognised as the inventor, and is most definitely the 'German artisan in London' that many sources describe.

These lawsuits and controversies give us a wealth of information to study this history. The contest between Christian Claus and Longman & Broderip in 1783 provides the account that it was Charles Pinto that first supplied Longman & Broderip with pianoforte guittars and was influential in its invention. We learn more about the patent holder, John Goldsworth, through his association with Thomas Culliford and Culliford

⁴⁷ *Morning Herald and Daily Advertiser*, 6 March 1784, issue no. 1048. As quoted in Wheeldon 2017a, p. 101.

⁴⁸ *The Times*, 12 July 1787, issue no. 795. As quoted in Wheeldon 2017, 101.

⁴⁹ For example, at the MMA, the soundboard of a pianoforte guittar bears a large royal crest encircled with the text 'Claus the only inventor of the patent instrument.' MMA no. 89.4.1013.

& Co, and consequently in the case brought against Culliford, Rolfe & Barrow by Longman & Broderip in November 1795.⁵⁰

Pianoforte guitars with an external mechanism, ‘Smith’s Patent Box’, were distinct from instruments with internal mechanisms and appear to have avoided any legal action. Although no patent can be attributed to anyone named Smith, Pouloupoulos makes a compelling case linking William Jackson’s aforementioned patent of 1784 for the *British Lyre*, to Smith’s patent box.⁵¹

The external mechanisms are found on guitars by various makers, though most commonly on instruments by John Preston who also regularly advertised pianoforte guitars for sale.⁵² Pouloupoulos also notes that these mechanisms ‘were often retro-fitted [to customers’ guitars] and could be added or removed at pleasure’.⁵³

It is very likely that the pianoforte guitar was used just like guitars without keys, as the amateur repertoire would have been directly transferable to all types of pianoforte guitar. In contemporary music published for the guitar, only a few works explicitly state that they are intended to be played on the pianoforte guitar, for example Thomas Bolton’s *Twenty Four easy and pleasing Lessons for the Guitar or Piano Forte Guitar*, published by Longman & Broderip after 1783.⁵⁴ Claus advertised music adapted for the pianoforte guitar for sale, but it is unclear what specifically this refers to.⁵⁵ Only one work appears to have been published expressly for the pianoforte guitar, entitled *New and Complete Instructions for the Piano-Forte Guitar* by Ghillini di Asuni.⁵⁶ Although this consists of the kinds of music typically published for the guitar without

⁵⁰ TNA E112/1771/5631. See Nex 2004; 2011; Wheeldon 2017a, p. 102.

⁵¹ Pouloupoulos 2011a, pp. 521–36.

⁵² Pouloupoulos 2011a, p. 528.

⁵³ Pouloupoulos 2011a, p. 532.

⁵⁴ A copy of this is available at the British Library (BL) no. b.61.(1.). The library catalogue lists the publication date as 1798, but this is not possible as Longman & Broderip were bankrupted in 1795.

⁵⁵ *Morning Herald*, 13 August 1785, issue no. 1497.

⁵⁶ A copy is available at Yale University Library, no. MT580 D541 N5+. The library catalogue date reads c. 1795 but it was first advertised in 1784: *Public Advertiser*, 4 October 1784, issue no. 15712, as cited in Wheeldon 2017a, p. 113.

keys—popular songs and simple lessons—the author adapts the right hand fingering for the key mechanism.⁵⁷

It is important to emphasise the contrast between the simple repertoire and utility of the pianoforte guittar with the marvellous sophistication of its hammer mechanism. The type of piano hammer mechanism used on Longman & Broderip’s guittars, for example, was breathtakingly complex, and new in design in relation to contemporary piano actions. The pianoforte element of the guittar must be seen in this context, as a fashionable curiosity more impressive for the intricacy of its design than for the music that would have been played on it.

The pianoforte guittar had success throughout the 1780s but was not in production for much longer. Claus, fleeing his creditors, emigrated to New York in 1789. It is not clear when Longman & Broderip stopped selling pianoforte guittars, but they were ultimately bankrupted in 1795, and judging from the newspapers, from about 1790, all adverts for came from other sellers and were for second-hand instruments.⁵⁸

The Design of the Pianoforte Guittar

The mechanisms for the three types of pianoforte guittar were distinct from one another and from the contemporary piano actions. It is rare to find pianoforte guittars today with fully working mechanisms, and these are typically those with the external ‘Smith’s Patent Box’. On the instruments with internal mechanisms the hammers are often broken or are misaligned with the holes in the rosette due to warpage in the mechanism and guitar body.

Contemporary piano actions

By the time pianoforte guittars were manufactured in London, the English grand action was well established, with Americus Backers widely credited with its invention in 1771.⁵⁹ Likewise, the square piano had remained a highly popular instrument since the

⁵⁷ An analysis of Ghillini’s tutor is given in Wheeldon 2017a, pp. 114–5.

⁵⁸ Wheeldon 2017a, p. 99. The success of ‘Smith’s Patent Box’ was linked to that of the other pianoforte guittars and does not appear to have outlasted them.

⁵⁹ Ripin et al. 2001, sec. 4.

first instruments were made in London in the 1760s.⁶⁰ Actions in these instruments had hammers mounted above the key levers, activated by a ‘pilot’ or ‘escapement’, causing the hammers to flick up and strike the string (see Figure 1.2 and Figure 1.3 below). The English grand action included a check attached to the end of the key lever which caught the hammer when it fell back after striking the string.

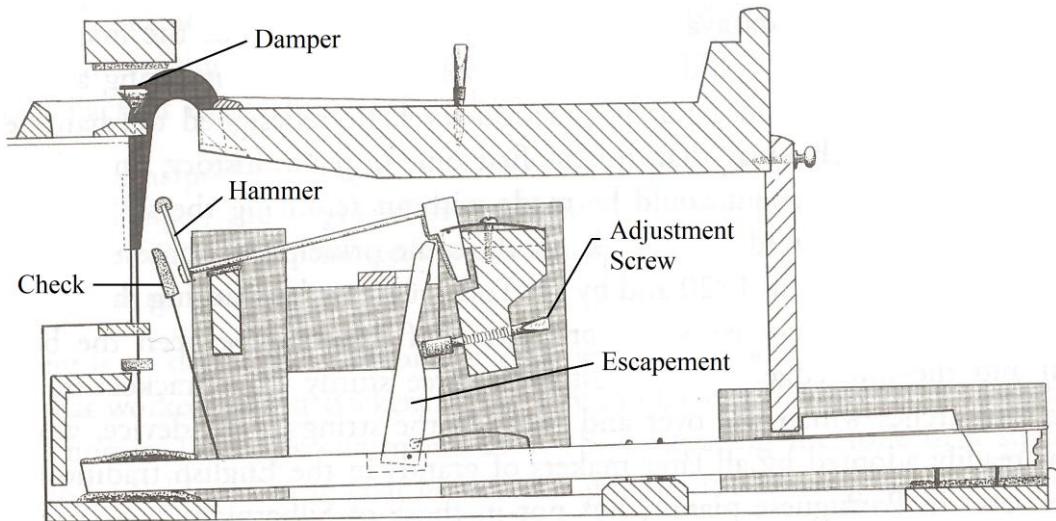

Figure 1.2 Americus Backers, ‘English grand action’ London, 1772⁶¹

⁶⁰ Ripin et al. 2001, sec. 4.

⁶¹ Cole 1998, p. 120. Annotation added by the author.

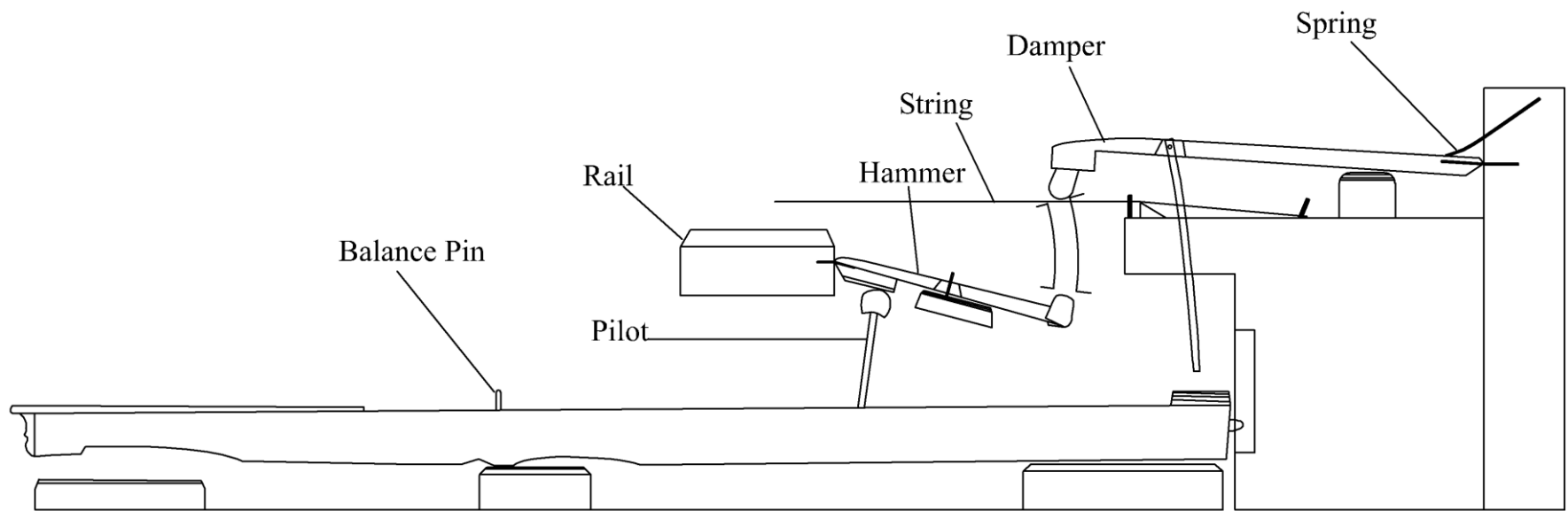

Figure 1.3 Diagram of square piano mechanism by Johannes Zumpe, MIMEd 4335

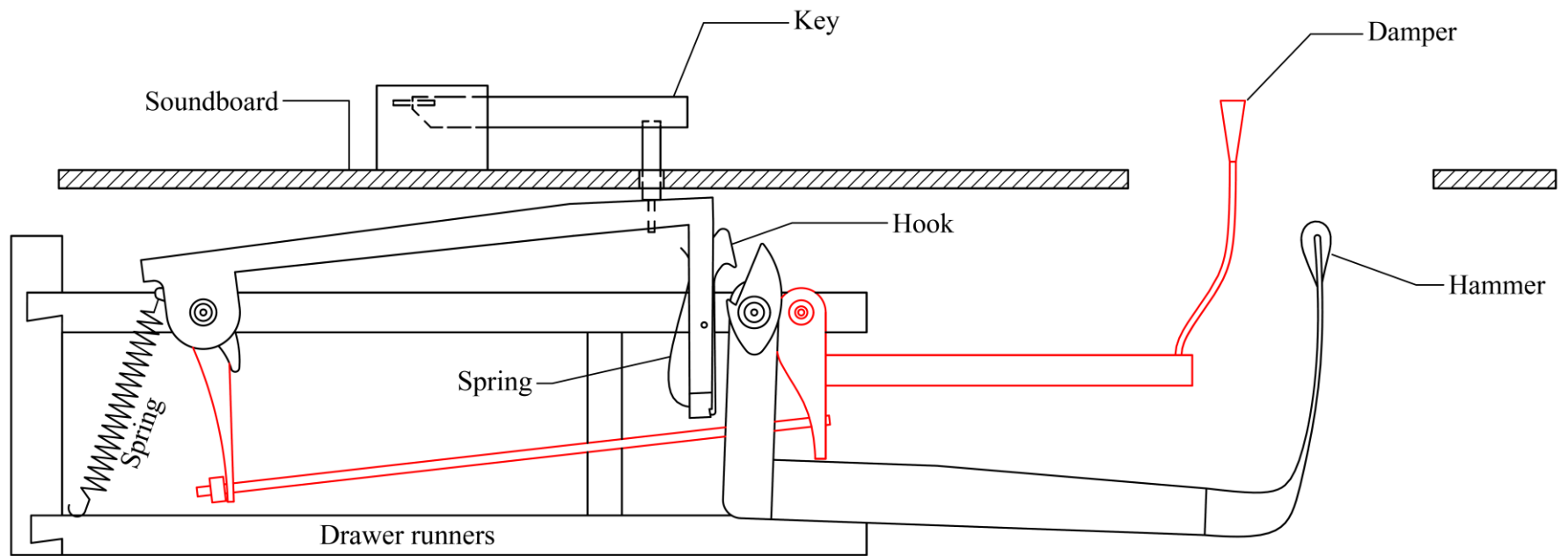

Figure 1.4 Diagram of a pianoforte guitar mechanism with dampers (shown in red), as sold by Longman and Broderip

Pianoforte guitars as sold by Longman & Broderip

The pianoforte guitars made for Longman & Broderip are by far the most intricate in design. The hammer actions are entirely different from those of contemporary square pianos and English grands. Whoever designed these instruments, likely Charles Pinto, did not adapt a pre-existing piano action but rather designed something entirely new.⁶² A great deal of effort and thought went into designing and making these instruments, even though they were made for an amateur market.

Figure 1.4 above, shows a single key system in isolation, this is based on a pianoforte guitar mechanism in the author's own collection. The keys are mounted to the soundboard while the mechanism is suspended within, on a removable drawer. The keys operate the mechanism by means of small wooden rods passing through the soundboard. When depressed, a hook catches the hammer arm which rotates and strikes the string. At the same time, the damper is lowered—being connected to the key lever with a wire. A switch on the neck also controls the dampers, removing them from the strings, acting like a damper pedal on a piano (not shown in Figure 1.4).



Figure 1.5 Two pianoforte guitars at the MIMUL

Pianoforte guitar by Longman & Broderip, no. 627 (left); Unmarked pianoforte guitar no. 628, (right)

⁶² Goldsworth's 1785 patent shows enough similarity in form to surviving instruments to demonstrate a clear association between Goldsworth and instruments supplied to Longman & Broderip. Appendix II analyses this patent document in greater detail.



Figure 1.6 Mechanism for an unmarked pianoforte guitar, MIMUL 628

Figure 1.6 shows the mechanism with dampers for an unmarked pianoforte guitar in MIMUL.⁶³ For the six courses of the guitar there is a complex mechanism involving a system of twelve rollers interconnected by springs, hooks, and wires. With so much going on inside, it is understandable that access to the mechanism was required, allowing it to be regularly calibrated.⁶⁴

⁶³ MIMUL no. 628. It is possible that unsigned instruments like this were made by Culliford & Co. and sold without going through Longman & Broderip, see Wheeldon 2017a, p. 102.

⁶⁴ Having a removable mechanism creates a problem of its own, as removing it poses a significant risk to the hammers and particularly to the dampers—which protrude higher and maintain upwards pressure on the strings. In this case (MIMUL 628), many of the damper arms and hammer heads have been damaged and repaired, some multiple times. This is mitigated against on surviving pianoforte guitars by Longman & Broderip with bracing on the soundboard and the back arranged differently to guitars without keys, to allow the mechanism to be drawn in and out more easily and safely. There was also a release mechanism which lowered the dampers before the mechanism drawer could be taken out, see Wheeldon 2017a, pp. 110–11.

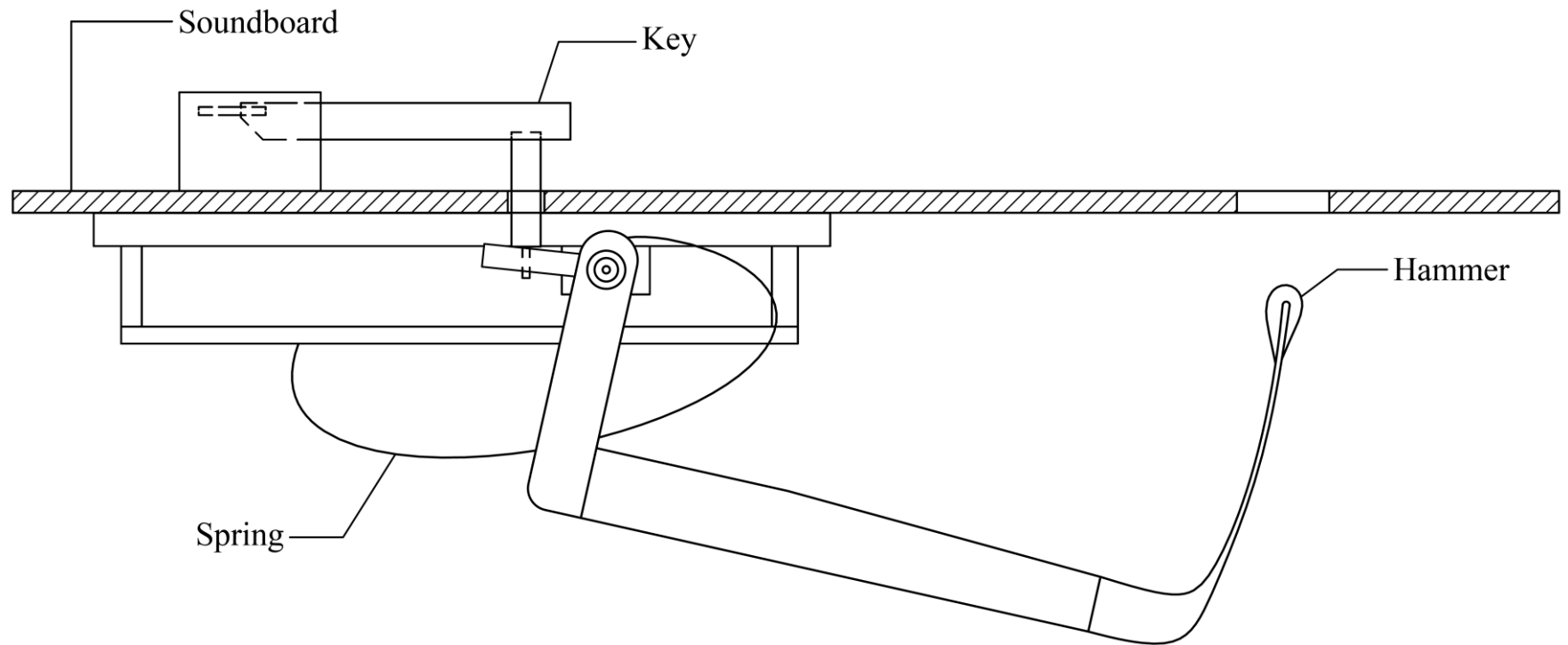

Figure 1.7 Diagram of the pianoforte guitar mechanism by Christian Claus



Figure 1.8 Claus's mechanism, Victoria and Albert Museum, V&A 240-1881

Christian Claus's pianoforte guittars

Compared to those sold by Longman & Broderip, pianoforte guittars by Claus have mechanisms that are less complex. The action is mounted on rails and fixed to the soundboard, inside the instrument, and is not accessible without removing the back (see Figure 1.8).⁶⁵ Figure 1.7 above, shows a single key system used by Claus. The hammer arm, attached to a roller, was directly connected to the keyboard by a short wooden dowel, and does not appear to have any escapement.⁶⁶ This would mean that if the player continued to press the key, the hammer would remain against the string causing the sound to be stifled. In this circumstance the player would have to flick the keys with their fingers, and the hammers would return assisted by a brass wire spring. Despite the instruments' external similarities, players who were used to Longman & Broderip's pianoforte guittar, which required the player to keep the key pressed to prolong the sound of the note, would have used the opposite technique on instruments by Claus. Longman & Broderip's action is then more like that of the piano, but Claus's action may have required a technique more akin to plucking with the fingers.

Claus's 1783 patent contains diagrams and a technical description which closely match the pianoforte mechanisms found in his surviving instruments.⁶⁷ The patent however does not cover the fundamental parts of the piano action. Rather, it focuses on the method of attaching the mechanism to the soundboard, and separate stops which alter the sound. The official purpose of the patent then is chiefly for a harp stop, piano stop, and a trumpet stop—outlined in detail in Appendix II.

Practically however, Claus regularly made use of his patent to portray himself as the inventor. 'Claus and Co. the only inventor and proprietors of the Patent Forte Piano Guittar, having obtained a second verdict against Longman and Broderip, confirming

⁶⁵ The back on instruments by Claus are only decorated with inked-on lines and could be more easily removed than instruments sold by Longman & Broderip which are commonly decorated with rope-binding, inlaid into a rebate around the perimeter.

⁶⁶ Escapement is a feature of a piano mechanism that allows the hammer to fall away while the key is depressed.

⁶⁷ Christian Claus, *An Improvement Upon the Instrument Commonly Called the Guittar* (London, 1783), Patent no. 1394.

the Patentee's right to this inimitable improvement of the Guittar, and establishing their patent for the same...'.⁶⁸ This is the preamble to what is essentially an advert for his instruments, and goes much further than the patent text itself. Whether or not he was being truthful, these claims had much wider reaching consequences than for his immediate market audience.



Figure 1.9 Smith's patent box on a guittar by John Preston, courtesy of Gregg Miner



Figure 1.10 Stamp reading 'SMITH'S PATENT BOX', above a Royal crest and 'LONDON' beneath, courtesy of Gregg Miner

⁶⁸ *Morning Herald*, 13 August 1785, issue no. 1497.

Smith's Patent Box

Smith's Patent Box is known as such because it is typically stamped with those words on the top, along with a royal crest further implying a patent was held (see Figure 1.10). The maker of these mechanisms is still an open question. Guittar maker and music seller John Preston, advertises for sale 'Guittars of his own manufacture, with the new improvement of the Piano Forte Box, and at half the price usually paid for Piano Forte Guittars.'⁶⁹ This might be taken to mean he also made the piano mechanisms, but there is no definite association.

The box was mounted with two brass screws to the front of the guittar, poised above the strings, see Figure 1.9. It could be fitted to any ordinary guittar, by adding the two fittings needed to receive the screws. This conversion would have probably required access to the insides of the instrument, involving the removal of the back of the guittar.

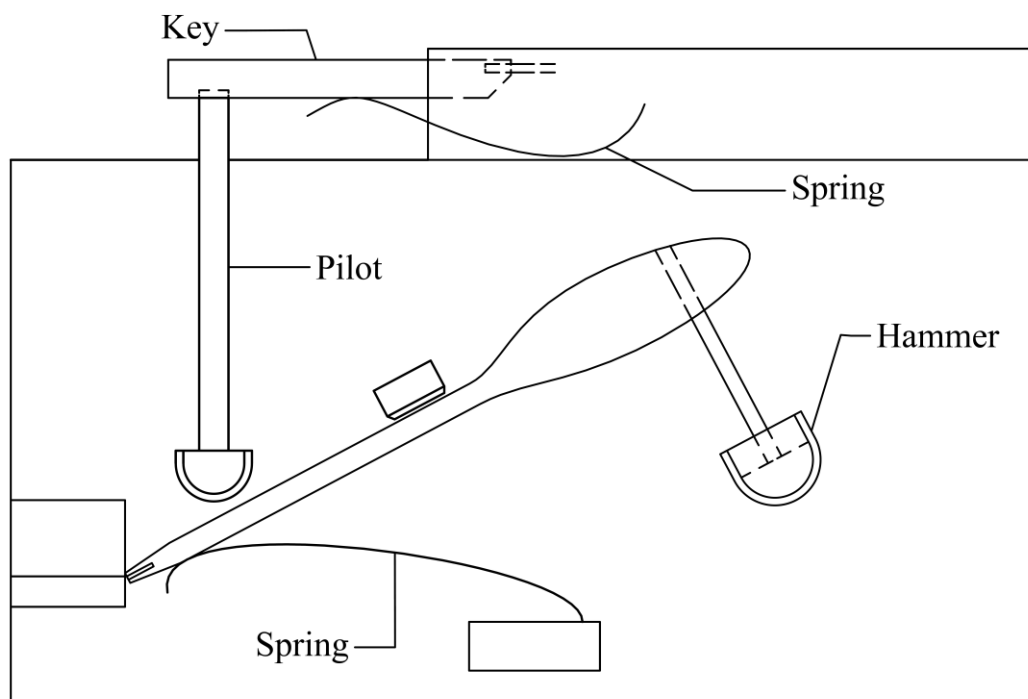

Figure 1.11 Diagram of the mechanism used in Smith's Patent Box

⁶⁹ *Morning Herald*, 29 December 1786, issue no. 1928. As quoted in Wheeldon 2017a, p. 99.

As opposed to the pianoforte guitar with internal mechanisms, Smith's Patent Box took some inspiration from contemporary piano actions—being like a square piano action but upside-down, (see Figure 1.3 above). The key contacts the hammer arm by means of the pilot. When the key is pressed, the hammer strikes down on the string and returns by means of a spring. Although there was no escapement mechanism, the hammers had space to fall away from the string back to the pilot while the key remained depressed (see Figure 1.11).

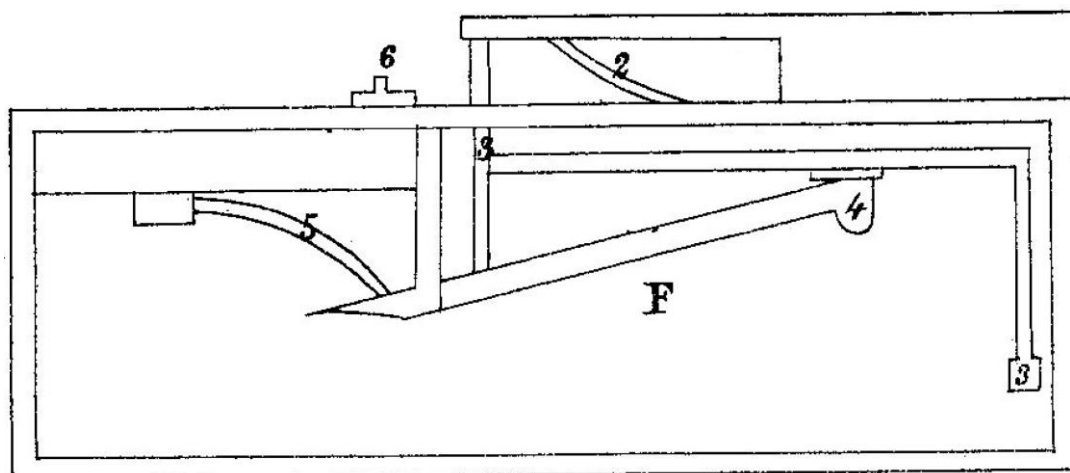

Figure 1.12 William Jackson's 1784 Patent, no. 1449

William Jackson's 1784 patent is quite clearly of the same design as Smith's patent box as found on surviving instruments. Numbered elements on the patent document have corresponding parts in surviving instruments: (2), the spring supporting the key; (3), the pilot; (4) the hammer; (5) the spring supporting the hammer. The patent mechanism also includes a damper connected to the pilot (3), and a slider (6) which would adjust the strength of the attack by moving the point at which the pilot contacted the hammer arm, these two are not typically found on surviving mechanisms.⁷⁰

Although it has not yet been possible, it would likely be worth comparing components within a square piano action made by John Preston, with components of Smith's patent box. A surviving instrument by Preston is in the MMA (see Figure 1.13 below).

⁷⁰ The closer the pilot is to the hammer arm hinge the faster the hammer will move relative to the key.



Figure 1.13 Square piano by John Preston ca. 1789, MMA 1980.217

Conclusions about the pianoforte guittar

It seems that the main rivalry was between the two types of guittar with an internal mechanism, which were chiefly marketed on their ingenuity. Instruments with external mechanisms are more common today, but were originally marketed chiefly on their price, with Preston offering instruments at half the price of his competitors.

For reference, Claus's pianoforte guittars cost on average around seven guineas,⁷¹ which was the price of the most expensive guittars without keys.⁷² These were still less than half the price of square pianos—costing sixteen guineas for an instrument by a respected maker.⁷³ Though they do not refer to the price of their instruments when advertising, Longman & Broderip may have charged more for their pianoforte guittars than Claus, who in many cases used cheaper materials and a simpler mechanism.

In 1789, when Claus was out of the picture, Longman & Broderip put out an advert attacking Smith's Patent Box, and promoting the merits of their own:⁷⁴

PATENT PIANO FORTE GUITARS,-On an entire new Principle, different from any others, and divested of that aukward [sic] Appearance which the temporary Key-Box forms on the Belly of the Instrument: The Machinery is also so curiously contrived, that it acts with amazing Facility, and produces a Tone far beyond Conception, and nearly equal to that of a Piano Forte. The Machinery may be drawn out with Ease, to rectify any Impediment in the Movement. The great Demand for them, in preference to other, plainly evinces their superlative Degree of Merit.⁷⁵

Certainly, Longman & Broderip hoped to establish their instruments as superior, which they were likely successful in doing on account of the complexity the mechanism and its careful integration into the guittar body. Longman & Broderip were a large firm

⁷¹ Nex 2013, p. 151.

⁷² Galpin writes that 'in 1760 the prices [of guittars] varied from 1½ guineas to 6 or 7 guineas.' Galpin 1910, p. 26.

⁷³ Cole 1986, p. 563. Quoting Charles Burney in 1774, who recommends a small square piano by Pohlmann for '16 or 18 guineas'. Square pianos in turn were undercutting harpsichords and grand pianos in price.

⁷⁴ Longman & Broderip, whose business was valued at £29,377 11s 11d in August 1783, had robust supply networks and may have been able to produce instruments at a lower cost of manufacture. See Nex 2013, p. 282.

⁷⁵ As quoted in Pouloupoulos 2011a, p. 487.

and are well known to have exported instruments with partnerships across Europe.⁷⁶ There is also evidence that pianoforte guitars manufactured in London were auctioned to British expatriates in Calcutta in 1786.⁷⁷ These instrument appear to have had the greatest commercial success in London, but the export market would doubtless have influenced instrument makers around the world.

The success of the London pianoforte guitar is evident in the relatively large number of surviving instruments—most instrument collections around the world can boast of at least one example. Yet their success was limited to perhaps only one decade of manufacture, from 1783 to the early 1790s. There is no evidence that London makers made keyed Spanish guitars, and though the idea of adding a piano mechanism to an instrument traditionally plucked with the fingers would persist into the future, this was to take place elsewhere.

There are a few examples of keyed citterns of the London style to have been made on the continent. Pouloupoulos lists three such guitars: one by Johann Nicolai Scherr⁷⁸ of Copenhagen dated 1796 in the Danish Music Museum (DMM), Copenhagen, no. C 138; an external mechanism with nine keys, mounted to an arch-cittern by Deleplanque at the Musée des Instruments de Musique, (MIMB) no. 2916; and a guitar that appears to have been converted into a pianoforte guitar after Claus's design at the Musikmuseet, Stockholm, no. M2577.⁷⁹

The decline of the keyed cittern coincides with the decline of the cittern in general, and references to the keyed six-string Spanish guitars begin at around the turn of the nineteenth century.

⁷⁶ See Nex 2013, p. 95.

⁷⁷ Woodfield 2000, p. 7. Pouloupoulos shows that the guitar and pianoforte guitar were well known in Calcutta in the 1780s. See Pouloupoulos 2011a, p. 219.

⁷⁸ Johan Nicolai Scherr was an organ and piano builder (ca. 1751–1804). See Libin 1985, p. 130.

⁷⁹ Pouloupoulos 2011, pp. 543–44.

Keyed Spanish Guitars

Spanish Guitars

The term *Spanish guitar* has been used differently across the centuries in different countries. Today it is often used interchangeably with the term *classical guitar* and is certainly not limited to instruments made in Spain. In this study it is important to highlight that the modern perception of the classical guitar was formed throughout the nineteenth century with the arrival of the six-string guitar, and its subsequent use by virtuosi including Fernando Sor and Niccolò Paganini. Many small alterations took place in the first half of the nineteenth century, all leading up to what can be described as the concert guitar, exemplified in the work of Antonio de Torres. Workshops introduced raised fingerboards, bridges with saddles, and new designs for the soundboard.⁸⁰ Torres, whose work began in the 1850s, standardized many of these features and produced instruments that received speedy recognition for their merits.

In 1920, Andrés Segovia—one of the great twentieth-century classical guitarists—described the guitar in the Spanish pattern as being ‘immutably fixed by Torres and Ramírez as the violin had been fixed by Stradivarius and Guarnerius.’⁸¹ At the beginning of the nineteenth century however guitars varied wildly, even among six-string guitars—which were by no means ubiquitous, since the five-course guitar was in use into the first quarter of the nineteenth century.⁸² The Spanish guitar is of a different tradition to guitars or citterns, which, in the eighteenth century, were often of a shorter scale length, with wire stringing and had distinct body shapes—often tear-drop or onion shaped, as shown in Figure 1.1 (p. 13). Guitars on the other hand, had figure-of-eight body shapes, were strung with gut or overwound silk, and were tuned in fourths with a standard tuning: E – A – d – g – b – e’.⁸³

⁸⁰ Wheeldon 2017b.

⁸¹ Quoted in Romanillos 1987, p. 56.

⁸² It has been observed by Tyler and Sparks that ‘between 1800 and 1810 concerted attempts were made by composers and publishers [in France] to notate guitar music so that it could be played on either five of six strings and therefore appeal to a wider market.’ Tyler and Sparks 2002, p. 246.

⁸³ This is the ‘standard tuning’ though often the sixth string was tuned to G or D. Six-course guitars sometimes paired an octave string in the bass courses or had two octave strings for re-entrant tuning.

The popularity of the English guittar in the eighteenth century has parallels in Germany and Austria, where, in the second half of the eighteenth century, the cittern and lute were more popular than the Spanish guitar until ca. 1790 onwards.⁸⁴ In both Britain and Germany, the Spanish guitar began to take the place of citterns and overtake them in popularity. In Britain, this transition is exemplified clearly in published music namely by Thomas Bolton⁸⁵ and Felice Chabran,⁸⁶ both of whom published similar kinds of music for the guittar, pianoforte guittar, and the Spanish guitar, demonstrating the line of succession in the social dominions of these instruments.⁸⁷

The earliest music published in Germany for the six-string guitar was Giuseppe Millico's *Sei ariette italiane con parole allemande per l'arpa, o piano-forte o guitarra* (1795),⁸⁸ while in England the publication of Sophia Dussek's *Three Favorite Canzonetts, Arranged with Accompaniment for the Piano Forte or Guitar* (1799) came not long after.⁸⁹ In the nineteenth century, the idea of adding keys to a guitar would more naturally have been applied to six-stringed instruments. Although, five-course instruments were still used, they would have been seen as more traditional and a less

⁸⁴ Tyler and Sparks 2002, p. 227. A similar type of cittern was also popular in France, known as the *guitarre Allemande*.

⁸⁵ Bolton published his *Lessons for Guitar or Pianoforte Guitar* with Longman & Broderip (BL no. b.61.(1.)), and in 1808 he published music for the pianoforte with selections for accompaniment with six-stringed guitar (BL no. h.103.(35.)). Bolton published widely for many popular instruments including a tutor for the tambourine (BL no. g.443.mm.(11.)), Apollo Lyre (lyre-guitar) (BL no call number), as well as numerous songs and vocal tutors.

⁸⁶ Chabran is best known for his tutors on the Spanish guitar: five-string guitar, 1795 (BL no. b.124.a.); six-string guitar, 1813 (BSB no. 4 Mus.pr. 2011.5529), and 1816 (BL no. h.259.p.). He also arranged music for the English guittar and pianoforte guittar ca. 1795 (BL no. G.604.a.).

⁸⁷ This transition is simply illustrated by a book of instruction on the Spanish guitar, written and published by Felice Chabran in 1795, who describes himself as 'teacher of the Spanish & Piano Forte Guitar...', published for Culliford Rolfe & Barrow. BL (no. b.124). This tutor follows the exact template used by earlier tutors for the guittar and pianoforte guittar published by multiple music sellers, and the opening instruction uses nearly identical phraseology. For example, there are significant sections of Chabran's 1795 *Compleat Instructions for the Spanish Guitar containing the most modern directions with proper examples for learners to obtain a speedy proficiency...* that use paragraphs of text repeated verbatim from John Preston's *Complete Instruction for the [English] Guitar containing the most useful directions & examples for learners to obtain a speedy proficiency*. Certainly, there are some concessions to differentiate the English guittar and the Spanish guitar, but it is largely a rerun of the same tutor. It seems that Chabran's contribution focused on the music included after the instructional text at the front, which is of a very different arrangement. Chabran writes for a five-stringed guitar, with a range two octaves and a fourth, from A – d''. d'' being played on the tenth fret of the first string (e').

⁸⁸ Tyler and Sparks 2002, pp. 285.

⁸⁹ Page 2020, p. 93.

likely target for innovation. In fact, all known references to keyed Spanish guitars are to six-stringed instruments.⁹⁰

Keyed guitars in historiographical sources

Early sources indicate that there were several different types of Spanish-style keyed guitar developed at the end of the eighteenth and at the start of the nineteenth centuries. French-born piano maker Juan Puyol, who moved from London to Madrid in the 1790s, advertised himself as a maker of both pianoforte guitars and keyed Spanish-style guitars. An advertisement from 18 November 1790 highlights his arrival in Madrid:

Juan Puyol, of French nationality, a master builder of organs and other instruments, who has arrived from London, informs readers that he has settled in Madrid, on the ground floor of 5 Calle de la Ballesta, manzana 369. He makes... English guitars played with keys. He makes Spanish-style guitars, which are played with keys like the English ones and can at the same time be played in the Spanish way.⁹¹

Although no instruments from this tradition survive, this account is direct evidence that London-made pianoforte guitars had an international influence.

In 1812, a certain Mr. Pertosa, from Naples, gave a poorly reviewed performance in Königsberg (present-day Kaliningrad, Russia) on a keyed guitar he claimed to have invented. The review is critical of both the performance and the instrument itself.

How anyone would think it worthwhile to travel all the way from Naples to the North for such singing and pitiful playing is almost incomprehensible. The invention of Mr P., to give his guitar six keys, which when pressed, the strings would sound, (Pianoforte-Guitar!!!) is by the way not new (see Koch's musical Lexicon) and is without the slightest benefit.⁹²

⁹⁰ The piano mechanism on Adolphe le d'Huy's organized lyre only covered the strings on the fretted of the ordinary guitar scale length, but with the additional neck and floating bass strings it had a total of fifteen strings, see page 205.

⁹¹ As quoted in de Pascual 1983, p. 216.

⁹² Forkel 1812, p. 479 Original: *Wie man eines solchen Gesanges und eines solchen elenden Spiels wegen von Neapel nach dem Norden kommen kann, ist kaum zu begreifen. Die Erfindung des Hrn. P., seiner Guitarre 6 Tasten zu geben, durch deren Niederdrücken die Saiten zum Klingen gebracht werden, (Pianoforte-Guitarre!!!) ist übrigens nicht neu (man s. Kochs mus. Lexik.) und ohne den mindesten Nutzen.*

These instances have little source material and were likely isolated and short lived, and so a distinction should be made between these and other accounts which continued to influence writings on the topic throughout the nineteenth century: namely, the accounts of the Bachmann workshop in Berlin,⁹³ and the anonymous keyed Spanish guitars by ‘a German artisan in London’ mentioned before.⁹⁴ Special attention will be given to addressing these accounts as they have puzzled even the most recent authors. An outlier to this narrative is Adolphe le d’Huy’s *Lyre-Organisée* for which he was granted a French patent in 1806. This seems to have had only a brief period of activity, from which we have two rich sources of information: a patent document with annotated diagrams, and a detailed book of instruction showing how to play the instrument. An overview of Adolphe le d’Huy’s music and inventions is given in Appendix II.

Presently, it is sufficient to say that there was substantial activity in the early nineteenth century to mechanise the guitar. Though examples of this are dispersed across a wide area, with accounts spanning from Spain to Russia, these sources demonstrate that keyed guitars were known and written about, but perhaps not properly understood.

⁹³ Gerber 1812, p. 225; Fétis 1835, p. 209; Schilling 1835, p. 309; Gassner 1849, p. 89; Kinsky 1912, p. 170; Ruth-Sommer 1916, p. 36; Lütgendorff 1922, pp. 24–25.

⁹⁴ Koch 1802, p. 708; Lichtenthal 1826, p. 167; Wettengel 1828, p. 460; Schneider 1834, p. 86; Bachmann 1835, p. 65; Brockhaus 1877, p. 371.

A German Artisan in London

A reference to a keyed guitar in the Spanish form comes as early as 1802 in Heinrich Koch's *Musikalisches Lexikon*. In the entry under 'Gitarre', Koch says the following:

The instrument is strung with six strings; the four higher ones are ordinary gut strings, but the lower ones are made of overwound silk. The tuning of these strings is: G A d g h e... This instrument has been provided with a kind of keyboard by a German artisan in London, which means that it remains a guitar for the left hand, but turns into a piano for the right hand, hence the name Pianoforte guitar. The mechanical arrangement of this improvement is consisted in that as many piano keys are attached to the lower right side of the soundboard as the instrument has strings.⁹⁵

The phrase 'German artisan in London' almost certainly refers to the Stuttgart-born Christian Claus; furthermore, the description that the piano keys are attached to the soundboard corresponds to pianoforte guitars with internal mechanisms. Yet, this entry clearly describes a guitar with six gut strings with tuning congruous with the Spanish guitar at this time. This is simply a conflation of two different instruments and shows that the author had only partial knowledge of keyed guitars, probably relying on second-hand information to construct their account. The essence of this entry was preserved in the 1807 edition by Koch and the confusions went on to influence other authors abroad. Koch's entry is cited by the reviewer of Mr. Pertosa's poor performance in Königsberg in 1812, showing two things: firstly, how little-seen keyed guitars were, and secondly, how well-known Koch's dictionary was. There is little doubt that this early misunderstanding laid the path for further confusion.

In 1826, Pietre Lichtenthal in Milan published the *Dizionario e bibliografia della musica*, wherein his entry under 'Chitarra' included what was essentially a paraphrased translation of Koch's 1802 account: a six stringed guitar, with keys attached to the

⁹⁵ Koch 1802, p. 708. The Original: *Das Instrument ist mit sechs Saiten bezogen; die vier höhern sind gewöhnliche Darmsaiten, zu den beyden tiefern bedient man sich aber überspinner Saiten, die aus Schlußseide verfertigt werden. Die Stimmung dieser Saiten ist, G A d g h e... Dieses Instrument ist von einem deutschen Künstler zu London mit einer Art von Claviatur versehen worden, wodurch es in Ansehung seiner Behandlung für die linke Hand Gitarre bleibt, für die rechte aber sich in ein Pianofort verwandelt, daher man ihm auch den Namen Pianofortgitarre gegeben hat. Die mechanische Einrichtung dieser Verbesserung bestehet darinne, daß an dem untern rechten Backen der Resonanzdecke so viel Claves angebracht sind, als das Instrument Saiten hat.*

soundboard, invented by a German artisan in London.⁹⁶ Perhaps the most significant text in this vein is the 1828 treatise by Gustav Adolph Wettengel on acoustics, music theory, and making and repairing violins and guitars.⁹⁷ It provides a cumbersome six-page description of how to construct the key mechanism for a guitar in the Spanish form invented by a German artisan in London.

Wettengel described himself as a violin bow maker in Neukirchen bei Adorf (present day Markneukirchen) and used observations from others to describe violin and guitar making. Jan Tulacek notes that Wettengel described the guitar in a typical ‘Biedermeier’ context, that its appeal was as a functional, inexpensive instrument that could be conveniently taken out to the countryside.⁹⁸ Wettengel’s work is among the most influential books on instrument making in the nineteenth century, and was condensed by Otto Bachmann in 1835 and a revised edition was published by Heinrich Gretschel in 1869.⁹⁹

Wettengel begins his section on the keyed guitar by explaining the trill, and how it is much harder to play it on the guitar than on the violin. He explains that after many unsuccessful attempts by guitar makers to allow trills to be played on the guitar, the keyed guitar was invented.¹⁰⁰ This rather bizarre introduction to the keyed guitar is the prelude to a very convoluted description of how to make one. It is doubtful whether this text could really be used to reproduce a keyed guitar, and in the versions by Otto Bachmann and Heinrich Gretschel, the section is reduced to two concise paragraphs, without attempt to explain the construction.¹⁰¹

⁹⁶ Lichtenthal 1826, p. 167. Koch also likely influenced the French *Biographie universelle des musiciens, et bibliographie générale de la musique* by Fétis in 1835, discussed below (p. 47).

⁹⁷ Wettengel 1828, pp. 460–66.

⁹⁸ Bieber, Buckland, and Tulacek 2010, p. 27.

⁹⁹ Bachmann 1835; Gretschel and Wettengel 1869.

¹⁰⁰ Wettengel 1828, p. 460.

¹⁰¹ Wettengel 1828, pp. 460–6.

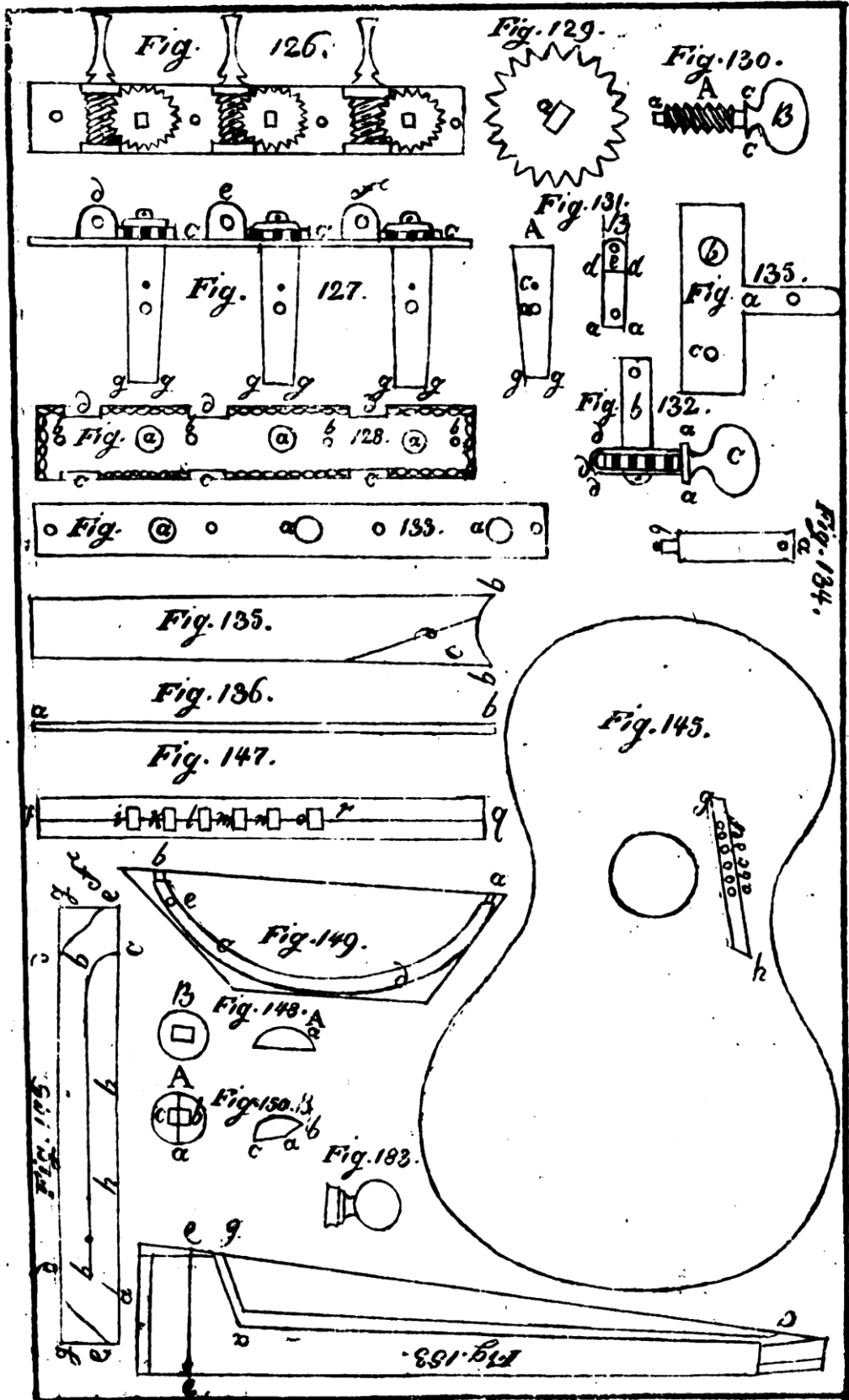

Figure 1.14 Wettengel, 1828, Figs. 145-150 refer to the keyed guitar

Wettengel provides diagrams to accompany his text, shown above in Figure 1.14. He provides five figures, 145–150, in a system which most resembles the mechanism used by Christian Claus, discussed earlier. His drawings of the key mechanism, shown beside more familiar elements of guitar construction, are comparatively meagre and leave many questions unanswered. It is still largely unclear what the mechanism should look like fully assembled. Wettengel describes arced hammer arms which were suspended by and pivoted on a brass wire in a frame mounted to the soundboard. The design differs enough to demonstrate that he had not seen Claus’s instruments: instead of the brass box with rectangular keys neatly located on the soundboard, there are round buttons on the ends of the hammer arms which protrude through holes in the soundboard—the hammer arms and the keys are the same component.

Judging from his text and diagrams it is difficult to imagine his design working. Each of the hammer arms would have been very short, particularly the key for the first string. The depicted location of the keys on the soundboard likewise seem quite awkward for the hammers to strike the correct string through the sound hole. To work, the design would require either a much larger sound hole, or else the hammer arms could not be parallel to one another. Claus accommodated for this by having the hammers spaced out with rollers, enabling each hammer arm to remain of largely equal length. Wettengel supposedly was giving technical drawings that should have corresponded to real-world measurements, at least in proportion, but in this case his system would not be able to function.

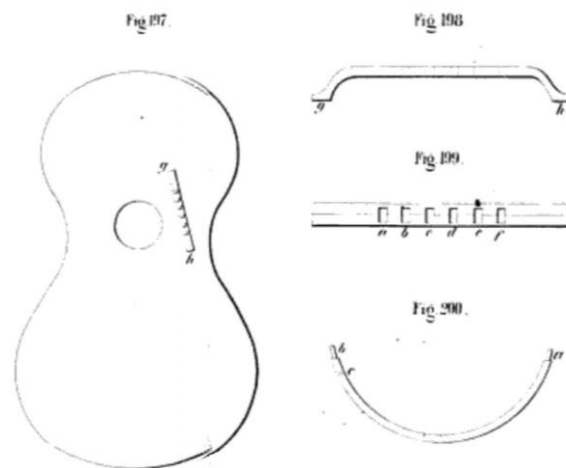

Figure 1.15 Wettengel’s diagrams from the revised 1869 edition

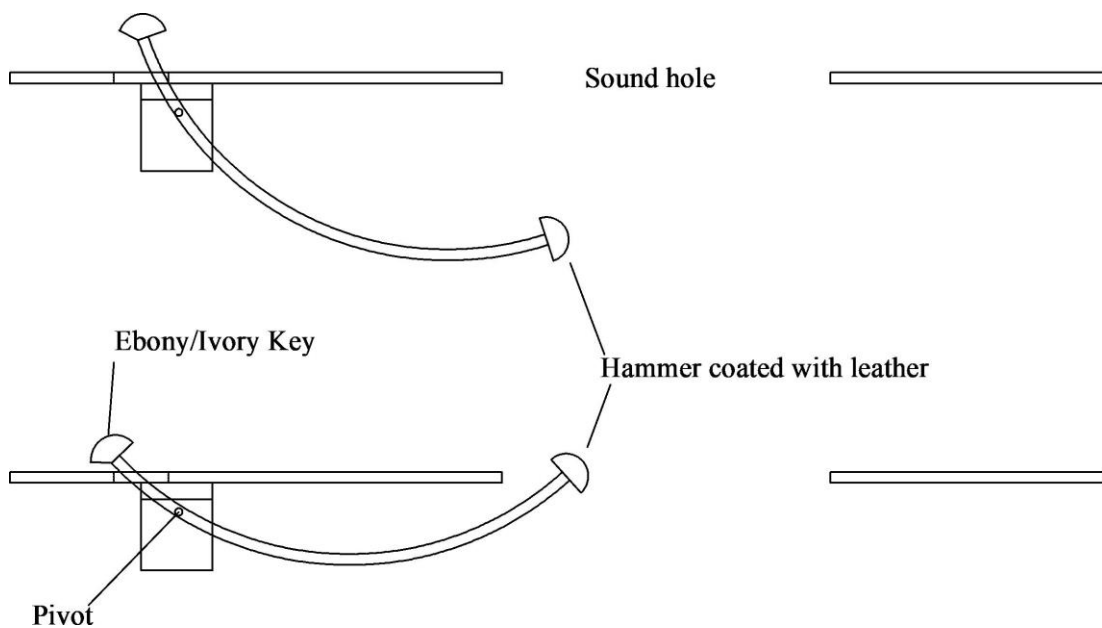

Figure 1.16 Interpreted mechanism diagram (approximation)¹⁰²

Given that Wettengel would have relied on violin makers and guitar makers for this book, it is possible that he had no personal experience of keyed guitars. His text may have come from correspondence, depending on second-hand accounts of pianoforte guitars. In many ways it reads like a distorted description of Claus's mechanism. The round holes for the keys on the soundboard would not work in his design, which seem to require space for the hammer to move (see Figure 1.16); Claus's instruments did in fact have circular holes under the keys. The arched hammer arms are also alike, though on the pianoforte guitar these were made from three jointed pieces of pine at right angles to one another.

Perhaps Wettengel is describing another kind of keyed guitar hitherto unknown, but even so, his description is unlikely to be accurate. It would be odd that he included keyed guitars in his treatise if he had never seen one, but one way or another his text is puzzling. Without an obvious surviving instrument to associate with Wettengel, it seems just as likely that this description was of his own imaginary invention, compiled from second-hand accounts of Claus's instruments. Perhaps he is expanding on the

¹⁰² This is a just one attempt to interpret Wettengel's text. It is a challenging read which would have benefitted from clearer illustrations and need not have been so long.

brief description of a keyed guitar erroneously introduced by Koch in 1802, who conflated the English guittar with the six-stringed Spanish guitar.

With the new editions, reprints, adaptations, plagiarisms and elaborations, this strand of the history becomes very muddy. For example, at first glance the sketch in Eduard Fack' 1884 manuscript (Figure 1.17, below) seems to be clear supporting evidence for the existence of Wettengel's style of keyed guitar. Yet, when compared with Otto Bachmann's 1835 work (a paraphrased version of Wettengel), it is clearly an amalgamation of various instruments illustrated there (see Figure 1.18, below).

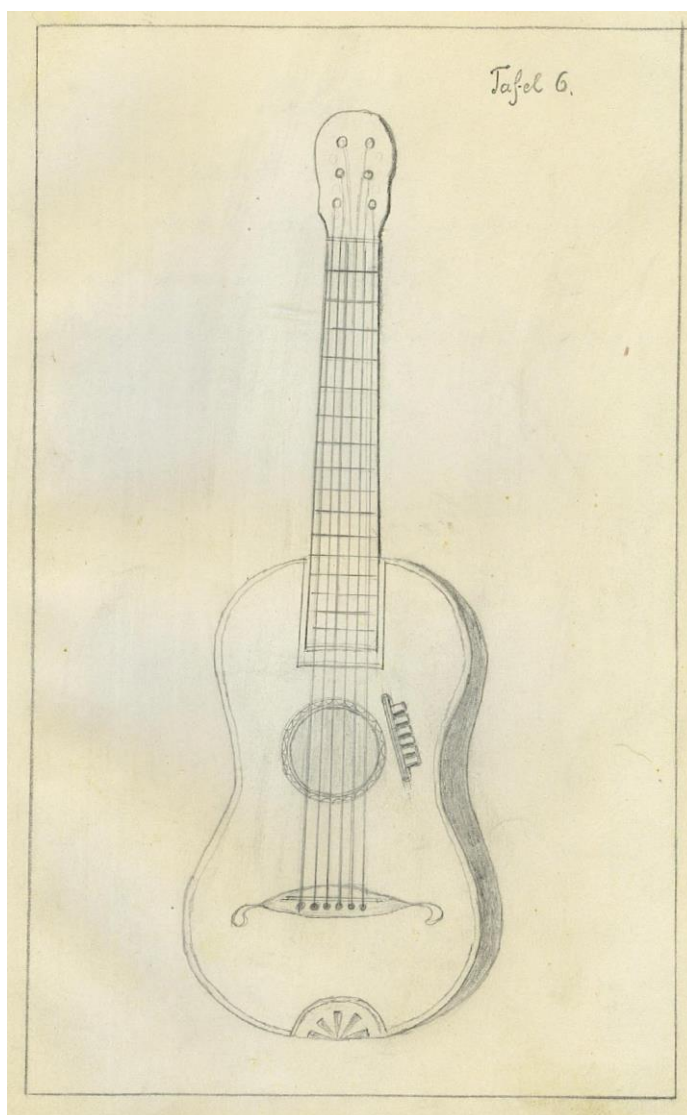

Figure 1.17 Illustration by Eduard Fack (1884).¹⁰³

¹⁰³ Fack 1884, p. 353. Courtesy of Martin Hurttig.

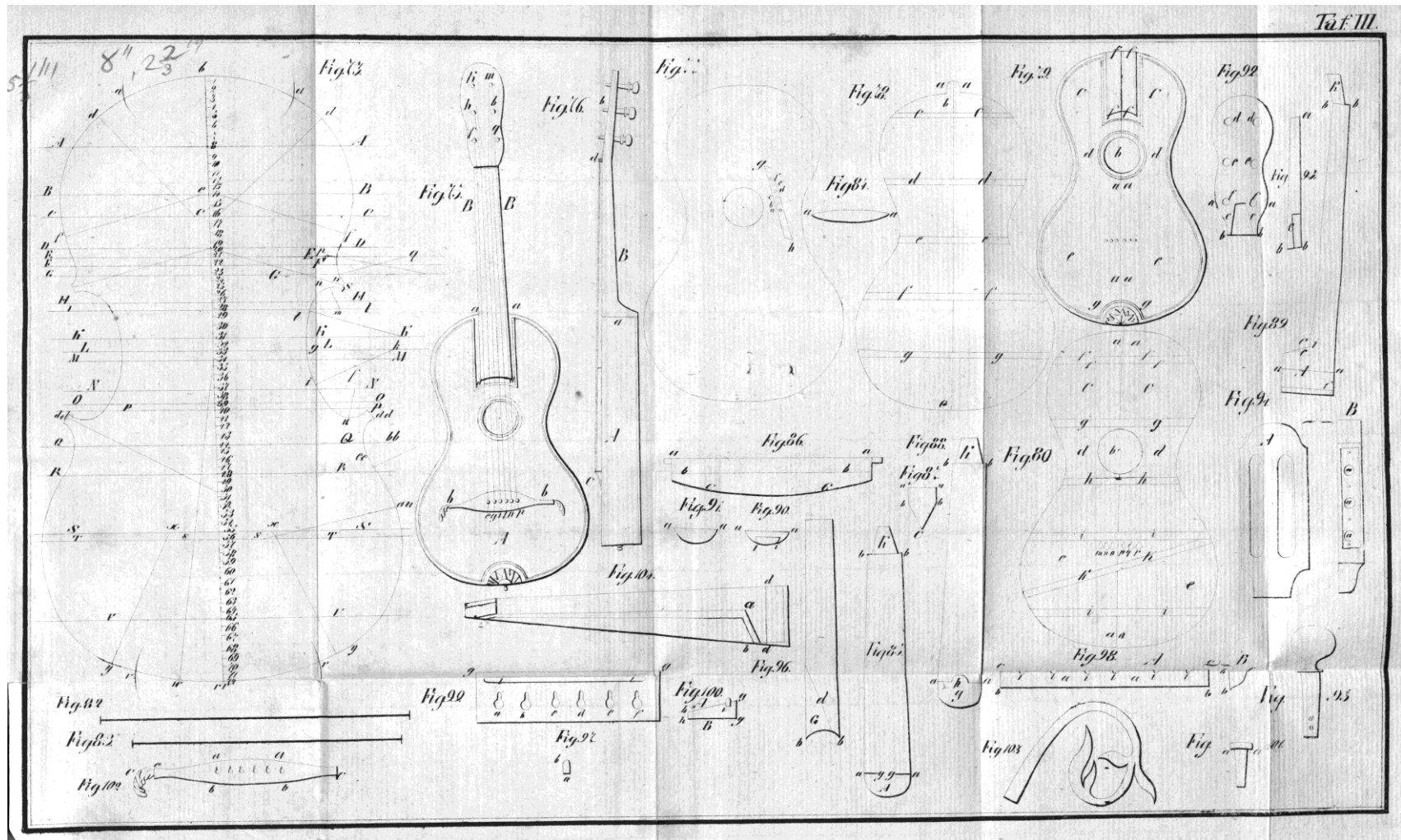

Figure 1.18 Plate III from Otto Bachmann's *Theoretisch-praktisches Handbuch des Geigenbaues*, 1835

In 1877, Herman Brockhaus also wrote about the keyed guitar in what was largely a synopsis of Wettengel's 1828 text. Brockhaus interprets Wettengel's phrase that the keyed guitar was invented only 'a few years ago' to mean the invention was made in the 1820s, and likewise credits a German artisan in London.¹⁰⁴ Heinrich Schneider's *Historisch-technische Beschreibung der Musicalischen Instrumente* of 1834, repeats Koch's original entry, adding that the sound hole was elongated (längliche Schallloch), and most significantly introduces the idea that the key mechanism was invented to protect women's fingernails.

The ladies usually complain and moan that their delicate little fingers hurt when they are supposed to pluck the strings sharply with their right hand and press the strings roughly with the fingers of their left hand.¹⁰⁵

This assertion is perhaps the origin of a myth repeated by various authors regarding the origins of the invention of the pianoforte guitar.¹⁰⁶ Ultimately, Koch's original dictionary entry of 1802, despite being wildly inaccurate, was repeated and adapted throughout the nineteenth century.

¹⁰⁴ Brockhaus 1877, p. 371.

¹⁰⁵ Schneider 1834, p. 86. Original: *Die Damen klagen und jammeren gewöhnlich, daß ihre zarten Fingerchen schmerzen, wenn sie mit der rechten hand die Saiten scharf anreißen und mit der Fingern der linken Hand etwas derb die Saiten neiderdrucken sollen.*

¹⁰⁶ Pouloupoulos accurately remarks how there is no historical basis for the idea that the mechanism was invented to protect 'ladies fingernails' though much repeated: Kinsky 1912, p. 190; Baines 1968, p. 48; Michel 1999, p. 61; Tyler and Sparks 2002, p. 214. See Pouloupoulos 2011, p. 41.

Bachmann's alleged Keyed Guitars

The idea that Carl Ludwig Bachmann or his father Anton Bachmann made or perhaps even invented the keyed guitar is widely accepted today in the few modern references.¹⁰⁷ However, it is important to consider that these modern sources have not tested this hypothesis by examining original sources with this question in mind, but have largely repeated this claim, which has existed from the first half of the nineteenth century. I contest this theory, and suggest that, as with early accounts stemming from Koch, this has grown out of ambiguous early texts and subsequent misunderstandings, compounded by the tendency of nineteenth-century encyclopaedias to rehash the same material. Here follows a critical examination of this claim.

Anton Bachmann (1716-1800) was instrument maker and violinist to the Prussian court.¹⁰⁸ His son, Carl Ludwig Bachmann (1748-1809), worked with him in his workshop and was also a court musician.¹⁰⁹ After the death of Jacob Meinertzen in 1713, the Bachmanns were the only lute makers in Berlin during the eighteenth century, and at the time were lauded for their instruments and inventions.¹¹⁰

As far as I can see, the first reference associating the Bachmanns with keyed guitars comes in an 1799 *Allgemeine musikalische Zeitung* where Johann Freidrich Rochlitz recommends Carl Bachmann's guitars and says as an aside: 'You can also have some from him with keys.'¹¹¹ From this source alone it would seem simply that he made them available and was perhaps the supplier importing London-made instruments.

¹⁰⁷ Elste, Droysen-Reber, and Haase 1987, p. 12; Lomtev 2014, p. 17; Pouloupoulos 2015, p. 47; Wheeldon 2017a, p. 98.

¹⁰⁸ Elste, Droysen-Reber, and Haase 1987, p. 11.

¹⁰⁹ C. L. Bachmann was described in 1779 as a royal chamber musician, and a good concert musician living on Leipzigerstrasse. Nicolai 1779, p. 1037.

¹¹⁰ Elste, Droysen-Reber, and Haase 1987, p. 11. Elste notes that Anton Bachmann's instruments today are regarded as mediocre but were highly regarded at the time. The Bachmann workshop is credited with inventing worm and gear tuners ca. 1778 (although these were in use elsewhere). Certainly, they were ingenious instrument makers and significant in their time. Elste and Helm 2001, p. 436.

¹¹¹ Rochlitz 1799, pp. 654–655. Original: *...die Guitarren zu empfehlen, die Hr. Carl Bachmann in Berlin zo grosser Vollkommenheit verfertigt und die vor den französischen sehr viele Vorzüge haben. Man kann auch welche mit Tasten von ihm haben.* The *Allgemeine musikalische Zeitung* was a music magazine that ran from Oct 1798 to December 1848, Rochlitz was a leading editor for the magazine. See Barbour 1948, p. 325.

Certainly, it has been proved that London makers were actively exporting their instruments and were sometimes partnered with other firms in major cities.¹¹²

The most significant early source material comes in the 1812 *Neues Historisch-Biographisches Lexikon der Tonkünstler* by Ernst Ludwig Gerber. In his entry for Carl Ludwig Bachmann, Gerber begins by stating that his text needs corrections, and goes on to confuse Carl Ludwig's birth date with his father Anton's as 1716:

...what has been attested to concerning the quality of his ... instruments ... still stands ... particularly in respect to his invention of a screw for tuning violins, which he himself showed to me in the year 1793, operating as a mechanism on several instruments. Another new invention that he showed me at that time, consisted of various new guitars with piano keys. These keys were located on the right side of the belly of the *cither*, and by pressing down on them with the right hand, little hammers caused the strings to make a sound.¹¹³

Again, here Gerber does not explicitly say that the invention was Bachmann's but rather that it was new and that there were various guitars like it. What is more, his use of the word *cither* strongly suggesting that his instruments were of the style made in London, and so probably imports.¹¹⁴

Sources after these are less ambiguous about the relationship Bachmann had with keyed guitars. Fétis' *Biographie universelle des musiciens, et bibliographie générale de la musique*, 1835, repeats the same information given by Gerber, but unequivocally

¹¹² See Nex 2013, p. 95. Josef Zuth describes C. L. Bachmann as an 'enthusiast and manufacturer of keyed guitars', '*Liebhaber und Verfertiger*'. Although it is unclear why he is described as an enthusiast, early sources can confirm that there was some association, but proof that he made them is still wanting. Zuth 1978, p. 68. This may be a confusion with C. L. Bachmann's *LiebhaberKonzerte* which he established with J. F. E. Benda in 1770, see Elste and Helm 2001, p. 436.

¹¹³ Gerber 1812, p. 225. Original: *Was hingegen von der Güte seiner verfertigten und reparirten Instrumente im a. l. angeinerkt worden, bleibt in voller kraft, besonders in Ansehung seiner Erfindung der Schraubenstimmung an den Violons, wovon er mir im J. 1793 den Machanismus an mehreren Instrumented selbst gewiesen hat. Eine andere neue Erfindung, welche er damals vorzeigte, bestand in verschiedenen neuen Guitarren mit Klaviaturen. Diese Tasten befanden sich an der rechten Seite des Bauchs der Cither, durch deren Niederdruck mit der rechten Hand kleine Hämmerchen die Saiten zum Erklingen brachten.*

¹¹⁴ Martin Elste notes that Anton Bachmann was 'possibly not only a violin maker, but also a dealer for foreign instruments. His labels are found in several violins of different types, so that the question arises whether he also inserted his labels as company labels in instruments from other workshops.' Elste, Droysen-Reber, and Haase 1987, p. 12. Original: [Anton] *Bachmann war möglicherweise nicht nur Geigenbauer, sondern auch Händler für Fremdinstrumente. In mehreren Violinen unterschiedlicher Bauart befinden sich seine Zettel, so daß sich die Frage stellt, ob er seine Zettel auch als Firmenetiketten in Instrumente aus fremder Werkstatt eingefügt hat.*

attributes the invention to Carl Ludwig Bachmann and adds the date of c. 1780. It seems likely that this date was given with partial knowledge of the London instruments. Other small errors are in Fétis' entry, including conflated information with Carl Ludwig's father Anton Bachmann.¹¹⁵ Gustav Schilling's *Universal-Lexicon der Tonkunst*, 1835, being a later edition of Gerber's 1812 dictionary, gives similar information but states clearly that it was Bachmann's invention. He writes that the invention achieved little success, confining it to the past tense, and retains Gerber's word *cither*.¹¹⁶

The 1861 edition entitled simply *Tonkünstler-Lexicon* by Carl Freiherrn von Ledebur makes changes from the previous editions. Most notably this edition rectifies the errors which confused Anton Bachmann and his son Carl Ludwig Bachmann, and in dividing this previously merged biography he portions the invention of the keyed guitar to Anton.¹¹⁷ It is remarkable in all editions of these dictionaries that no attempt was made to associate these guitars with, or mention in any way, Wettengel's description. In fact, the only cross-over between these two texts is a pre-publication manuscript by Eduard Fack dating from 1884.¹¹⁸ Here Fack describes and depicts an instrument clearly based on Wettengel's concept (shown before, Figure 1.17), but at the same time demonstrates knowledge of accounts of Carl Ludwig Bachmann:

It is quite common to find the instrument maker Carl Ludwig Bachman named as the inventor, but this is a case of mistaken identity with the instrument maker

¹¹⁵ Fétis 1835, p. 26. Original: *BACHMANN (CHARLES-LOUIS): ... Il imagine aussi vers 1780 une espèce de guitare à clavier qui portait vers la droite de la table un mécanisme au moyen duquel on faisait frapper les cordes par de petits marteaux. Cet instrument eut peu de succès.* This account is repeated in the 1868 edition by Fétis, and in Pontécoulant 1861, p. 293.

¹¹⁶ Schilling 1835, pp. 390–91. Original: *Weniger Glück machten eine Tastenguitarren oder Gitarrenclaviaturen, so sinnreich auch deren ganze Einrichtung ausgedacht war. Um das Spiel der Gitarre oder Cither zu erleichtern hatte er nämlich an der rechten Seite des Bauchs derselben Tasten (so viele als Seiten) angebracht, durch deren Niederdruck mit den Fingern der rechten hand kleine hämmerchen die Saiten zum Erklängen brachten.* This entry is further reduced in the following 1849 edition: Gassner 1849, p. 89.

¹¹⁷ Ledebur 1861, p. 26.

¹¹⁸ Fack 1884, pp. 47–50. Transcribed and made available by Martin Hürtig: <http://www.lautenbau-leipzig.de/projekte.html>

O[tto] Bachmann who made such instruments and who writes about it in his book on violins and guitars.¹¹⁹

Fack seems to speak with authority about Otto Bachmann as a maker of keyed guitars, but since he seems to be unaware that his book was a paraphrase of Wettengel's text, it is doubtful that he was in possession of the most important facts and probably should not be relied upon. His scepticism is important, as it is a common theme with other authors along the Bachmann narrative. As discussed above, Ledebur in 1861 speaks of the confusions of previous entries which conflate Anton and Carl Ludwig Bachmann, and perhaps most significantly Gerber's original entry of 1812, begins with the caveat that his account needs correction.

Ultimately, keyed guitars have never been clearly understood, even during their period of manufacture. Their peculiarity has given creative license to authors both formal and informal, historical and modern. It is as difficult to justify from historical sources Schneider's claim, in 1834, that keyed guitars were developed to spare ladies' fingernails,¹²⁰ as it is to corroborate Spencer and Harwood in 2001, who claim that it was for those too lazy to learn proper technique.¹²¹ Of the three keyed guitars known of today, none appears to relate to the nineteenth-century canon of literature and Fiala, Sprenger, and Neüner have completely avoided the attention of Germany's chroniclers.

Another important author in establishing Bachmann as a maker of keyed guitars is Georg Kinsky, in his 1912 catalogue of the Wilhelm Heyer collection in Cologne. There he documents a keyed guitar within the collection giving a non-committal attribution, 'perhaps Karl Ludwig Bachmann', and includes a photograph, shown below in Figure 1.27 (p. 68).¹²² This attribution is understandable given the source material available to Kinsky at the time but, as will be discussed, it is almost certainly

¹¹⁹ Fack 1884, pp. 47–48. Original: *Man findet oftmals den Instrumentenmacher Carl Ludwig Bachmann als Erfinder genannt, daß ist aber eine Verwechslung mit dem Instrumentenmacher O. Bachmann welcher solche Gitarren Ferigte und darüber in seinem Buche über den Bau der Geigen u. Guit. wie folgt schreibt.*

¹²⁰ Schneider 1834, p. 86.

¹²¹ Spencer and Harwood 2001, p. 245.

¹²² Kinsky 1912, p. 170. Original: *Vielleicht von Karl Ludwig Bachmann.*

incorrect. The fact that the guitar was subsequently lost during the Second World War means that a disproportionate amount of weight is given to this catalogue entry—currently the most substantial surviving information on the missing object.

Francis Galpin's 1937 *Textbook of European musical Instruments* talks of London-made pianoforte guitars and as an aside says that a 'very similar device was adopted in Bachmann's *Tastengitarre* (c. 1795).'¹²³ No further justification or context is given and so it is very likely he is just repeating the generally accepted narrative. Nineteenth-century errors were taken up by twentieth-century authors, perhaps most significantly Kinsky and Galpin. From the surviving texts it seems quite probable that Bachmann was simply a dealer of London-made pianoforte guitars. If in fact he did manufacture his own instruments, they were of the cittern type, not of the kinds described in nineteenth-century encyclopaedias and photographed in Kinsky's catalogue.

¹²³ Galpin 1937, p. 118.



Figure 1.19 Keyed guitar by Mathias Neüner, Mittenwald, 1810. View showing the keyboard mechanism. Collection of Rainer Krause

Known instruments

Of the three known keyed guitars, all are of German manufacture. The instrument lost from the Leipzig collection will be discussed last as its analysis benefits from knowledge of the two surviving instruments.¹²⁴

Keyed Guitar in the Collection of Rainer Krause

The earliest known surviving keyed guitar is by Mathias Neüner. Made in Mittenwald, 1810, it is now in the collection of Rainer Krause. It is a typical early Romantic guitar with six strings and a fingerboard level with the soundboard (see Figure 0.1), and it is made in a style better associated with France and Britain, e.g. Guiot or Pons. It has had minor repairs, namely to the mechanism, but is in excellent condition. The head is most likely a later replacement, as the graft joint is visible on the neck and unlikely to be the intended original attachment, discussed more in Chapter 2.



Figure 1.20 Keyed guitar makers label. Collection of Rainer Krause

The handwritten portion of the label date has bled into the surrounding area, and it has been suggested that the date should be read 1830.¹²⁵ It is my opinion that it seems more clearly to read 1810. Furthermore, there is a pencil marking inscribed on the base of the mechanism reading ‘Winkler, München 1827’. If the label date were to read 1830, it implies that the mechanism was made by Winkler, which seems unlikely given that it is an English piano-action. Rather it seems more likely that Winkler repaired it for the owner at that date.¹²⁶

¹²⁴ For simplicity, this instrument will be referred to as the Leipzig guitar.

¹²⁵ Hackl 2016, p. 45. The extent of this reference is a captioned photograph with no analysis.

¹²⁶ The address on the label, no. 138, does not help clarify this. Another address that appears on labels is no. 94, but this address like no. 138 is found on instruments from around this time. Lütgendorff gives an example label at no. 94 at 1812 (Lütgendorff 1922, p. 351) but likewise in March 2015 (lot. 64) Bromptons sold a violin dated 1812 at no. 138.

When viewed from the front, this instrument looks like an ordinary guitar. The small opening for the hammers between the sound hole and the bridge is not immediately obvious. The mechanism is accessed through an opening in the ribs, on the lower left side of the instrument (see Figure 1.19).

It is a well-made instrument of premium materials: the back and sides are of highly flamed maple or sycamore; the soundboard is decorated with strips of ebony and mother of pearl; and the neck is pine veneered in ebony. No reference to this type of keyed guitar is found in nineteenth-century literature, which invariably describes an instrument with the mechanism on the right side of the body. It is of a very different tradition to the keyed guitars described by Wettengel, which were by comparison utilitarian and certainly not fine instruments like this.

According to Lütgendorff Mathias Neüner was 'a skilful violin maker, but a fundamentally better businessman' active in Mittenwald from ca. 1795.¹²⁷ The firm Neüner & Hornsteiner grew out of this period and only Neüner's earlier instruments were made by him; from 1812 the firm was called *Gebr. Neüner & Co.*¹²⁸ It is difficult to determine what his business in Mittenwald would have looked like in 1810, but, it is likely that this instrument came from a period before he had established active production lines, and had more flexibility to make more eccentric instruments.

In a magazine article from 1873 we read that Neüner lived in London, working as a violin maker from 1762, and that he travelled extensively in Russia to expand the business.¹²⁹ Lütgendorff confirms his connection to England, showing that before he established his workshop in Mittenwald, ca. 1800, he would have become familiar with instrument makers and sellers in London, and so he certainly would have seen all the various types of pianoforte guittar there at that time.

¹²⁷ Lütgendorff 1922, p. 351.

¹²⁸ Lütgendorff 1922, p. 351. In an 1818 census Mathias Neüner is described as a dealer of violins rather than a maker (*Geigenhändler*). *Königlich-bayerisches Intelligenzblatt für den Isarkreis* 1818, p. 1000.

¹²⁹ Noé 1873, p. 10.

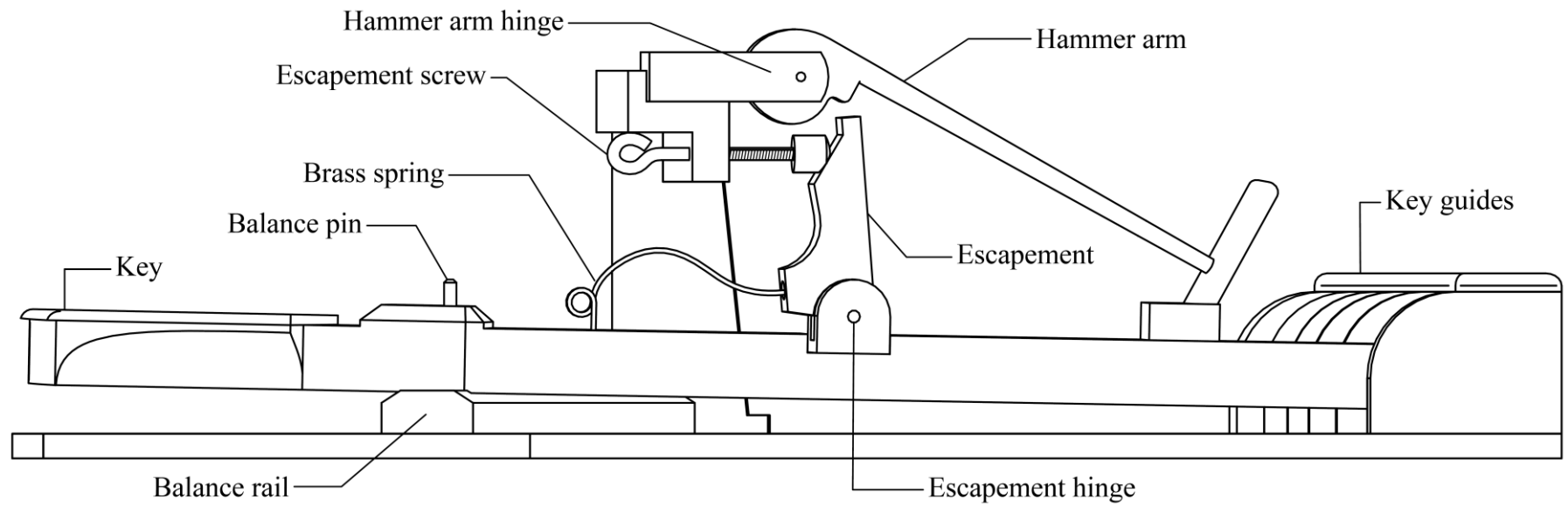

Figure 1.21 Mechanism diagram for the keyed guitar by Mathias Neüner

There is very little documentary evidence around the early years of Neüner's work in Mittenwald, and we can only rely on later accounts about his time in London. Yet, there is no reason to doubt these accounts, especially given the significant presence of German instrument makers in London in the eighteenth century. These makers, as a rule, demonstrated versatility in adapting to various workshop outputs.¹³⁰ Although Neüner was a violin maker, his entrepreneurial disposition would likely have brought him into contact with the large London firms and many types of instrument making, including piano making and guittar making.

The piano mechanism in Neüner's keyed guitar further indicates a London influence: it is an English action, common in Britain at the end of the eighteenth century;¹³¹ and removable, like those sold by Longman & Broderip. English actions usually also contain a check mounted to the back of the key, which serves to catch the hammer as it returns from striking the string.



Figure 1.22 Guitar by Johann Gottlieb Knöbging, Leipzig 1807, MIMUL 1098

¹³⁰ Beck, Lucas, and Zumpe made guittars and square pianos; Rauche and Hoffman made guittars and lutes; Liessem made guittars and violins; and guittar maker Hintz is also known for his fine furniture. See Pouloupoulos 2011a, pp. 271–73.

¹³¹ Although German and Austrian pianos have used systems similar to the English action (*stossmechanik*), in Vienna square pianos sometimes had this kind of mechanism, but the *prellmechanik* was more common, see Huber 2002.

Except for the piano mechanism, the overall design was not out of place in Germany at this time, where violin makers often also made guitars. The materials of the body are like those found on a violin. The ebony binding too is stuck to the outside making the soundboard and the back appear to be overhanging the ribs.

Figure 1.22 shows an instrument of the same period made in Leipzig, this is another example of the influence violin design had on the guitar. On the soundboard between the sound hole and the bridge, is a decorative scratch plate typical on some guitars and mandolins at this time. This in part resembles the opening for the piano hammers on Neüner's guitar (though mirrored). Although the head of Neüner's guitar is likely a replacement, it is now in the style of violin-family instruments—with tuning pegs entering through the sides.¹³²

The current head is the only non-original part of the instrument, which has otherwise had quite a straightforward object history. It has likewise had quite an uncomplicated provenance—being made in Mittenwald, currently owned by Rainer Krause in Ebersburg, who bought it in Hausham, and has probably never resided outside of Bavaria. In contrast, the origins and history of the keyed guitar at the MMA are more complex.

¹³² The head of Neüner's guitar is a carved head of a lion, though less common than a scroll, it is still typical for violins, particularly in Bavaria and Austria.



Figure 1.23 Keyed guitar by Matteo Sprenger and F. Fiala, Karlsruhe, 1843. View showing the keyboard mechanism. MMA 89.4.3145



Figure 1.24 MMA 89.4.3145, makers' labels

Keyed Guitar at the Metropolitan Museum of Art

The keyed guitar at the MMA has an uncertain object history. It most likely began its life as an ordinary guitar without keys and underwent an invasive conversion into a keyed guitar. It is not clear either who made the original instrument, or who enacted the conversion. The two labels inside, reading 'Matteo Sprenger / fece à Carlsruhe'¹³³ 1843' and 'F. Fiala' (see Figure 1.24), appear on a pine plate attached to the back of the instrument added as part of its conversion, suggesting their association with this later stage in the instrument's life, but it is not clear whether these parts were made for this instrument or taken from another.

Apart from the key mechanism, this instrument is typical for an early Romantic German guitar: it is fretted, with six strings of the usual scale-length, and the *plantilla* (body profile) is in *Wappenform*—being in the shape of an escutcheon, or coat of arms (see Figure 1.23).¹³⁴ The raised and curved fingerboard is a later addition and has been

¹³³ Today spelled 'Karlsruhe'.

¹³⁴ This shape was popularised in Southern Bavaria and Austria.

glued on top of an earlier flat fingerboard that was level with the soundboard. The soundboard itself is a replacement and currently has a trapezoidal sound hole positioned to allow the piano hammers to strike the strings. The reinforcement bracing on the back, typical for guitars, has been cut to allow space for the mechanism, and traces of the original bracing footprint can still be seen on the back.

The bridge is crudely carved and spills over the decoration of the hammer/sound hole, indicating that it was replaced at a still later stage, as it does not suit the replacement soundboard. The thick brass frets have been roughly filed, scratching the fingerboard around it. As well as three overspun silk strings in the bass, plausible for a mid-nineteenth-century guitar, there is currently one metal string on the first course, this is anachronistic (see p. 88). The instrument is also strikingly asymmetrical—the left side of the body has a more pronounced curve as compared to the right (see Figure 0.2, p. xiv). For this conversion, the instrument would have been almost entirely disassembled, and possibly during this time the asymmetries were introduced.¹³⁵

The mechanism exhibits a greater level of precision and skill in construction than the rest of the instrument, which has many design defects and may not be able to function in its current state. While it may never be possible to understand this particular object with satisfaction, much can be learned by combining a study of Sprenger and Fiala, with a detailed analysis of the instrument. In fact, as will be shown, both individuals named on these labels can be located in early source material and associated with keyed guitar manufacture, and although this guitar somewhat baffles analysis, there is an intrinsic significance in finding these labels paired together next to a piano mechanism inside a guitar.

‘Mattias’ Sprenger is described in Lütgendorff as ‘A skilled violin maker, probably from Mittenwald, who lived in Karlsruhe for a time, and emigrated to America on August 19, 1846.’¹³⁶ He was highly regarded in America and in *Musical instrument makers of New York* Nancy Groce notes that in ‘1850, he was awarded a silver medal

¹³⁵ A more complete study of the object in its current condition is given in Chapter 2.

¹³⁶ Lütgendorff 1922, p. 477. Original: *Ein tüchtiger, wahrscheinlich aus Mittenwald stammender Geigenmacher, der einer Zeitlang in Karlsruhe ansässig war, und am 19. August 1846 nach Amerika auswanderte.*

for “Excellent Violins” exhibited at that year’s American Institute Fair.’¹³⁷ William Henley’s *Universal dictionary of violin and bow makers* says that he made ‘[violins] in the Mittenwald style (the town of his apprenticeship)’.¹³⁸ Sprenger’s Mittenwald roots are confirmed in local archives, which show that he was born on 21 February 1815, five years after Neüner had made his keyed guitar.¹³⁹ Moreover, according to Anton Sprenger (a living descendant of Matteo Sprenger’s brother), Matteo worked for Neüner & Hornsteiner with his brothers, as did most violin makers there.¹⁴⁰ This connection to Mittenwald and probable ties to Neüner’s workshop reveals a substantial link between the two surviving keyed guitars.

The other label on the MMA’s keyed guitar reads ‘F. Fiala’, and refers to Franz Fiala (1782—1858), a court musician in Karlsruhe at the time the instrument was made, and son of the renowned cellist and viol player Joseph Fiala, and Maria Josepha Prohaska. His father’s busy career around the time of his birth meant that his early years were likely spent in Salzburg, Vienna and St. Petersburg, settling in Donaueschingen in 1792.¹⁴¹ In 1798, at around the age of sixteen, he was listed as a copyist in the court chapel in Donaueschingen, where his father also worked as court musician.¹⁴² In May 1812, he asked for a salary allowance in an additional capacity as chamber musician, and reportedly ‘achieved some perfection on the guitar in order to please the Prince by

¹³⁷ Groce 1991, p. 147.

¹³⁸ Henley 1959, p. 79.

¹³⁹ Anton Sprenger continues the family tradition of violin making and lives and works in the same house in Mittenwald as Matteo Sprenger did 200 years ago. I am grateful to him for providing me with a copy of these local records.

¹⁴⁰ According to Anton Sprenger, Matteo had four brothers, two of which were instrument makers. Bonifaz Karl, Andreas, Johann, and Georg Sprenger, and a sister Susanna Katharina. Bonifaz Karl moved to Nuremberg setting up shop on a main high street.

¹⁴¹ Reinländer 2001.

¹⁴² Reinländer 2001; Loy 2018, pp. 77, 97.

changing instruments in the chamber music.’¹⁴³ In 1813, he went as a violist court musician to Karlsruhe with his brother Maximilian.¹⁴⁴

In December 1819, Fiala was publicly awarded a *privilegium* from the Grand Duke of Baden granting him sole rights to manufacture and sell ‘Tasten Gitarren’ or keyed guitars for four years beginning 1 January 1820.¹⁴⁵ The Baden state archives show that Fiala had previously been awarded a *privilegium* for this in May 1818, but did not have the funds to make use of it or to publicise his inventions in the newspapers.¹⁴⁶

The court documents and Fiala’s *privilegium* describe him as the inventor of the keyed guitar though, given Neüner’s earlier instrument of 1810 which has no label for Fiala, this is not likely to be true. As historical sources, patents do not provide proof of the origins of an invention as has been discussed earlier regarding Christian Claus; often the publicity they generated was more important to instrument makers than the legal security. These sources do however distinguish Fiala as an important character in the history of the keyed guitar. It is likely that in his prestigious role as court musician, Fiala acted as the promoter of instruments that were designed and made by others.

In 1820, immediately following his *privilegium*, there are multiple articles mentioning his invention. In the *Weimarische Zeitung* a simple note acknowledges Fiala’s permit and describes the sound of the instrument as being more melodic than an ordinary guitar. It describes the sound as coming closer to that of the human voice, and notes that the keys give more variety during a performance.¹⁴⁷ In a short paragraph in the *Allgemeine Zeitung*, Munich, Fiala himself writes about his instruments giving more information about his role:

¹⁴³ Loy 2009, p. 59. Original: *Er habe auch auf der Gitarre einige Vollkommenheit erreicht, um das Vergnügen Euer Hochfürstlichen Durchlaucht bey Kammermusicken durch Abwechslung in den Instrumenten zu erhöhen.* He appears in the Baden state archives as a court musician in entries spanning from 1812 to 1843. Landesarchiv Baden-Württemberg, ‘Hofmusik Franz Fiala’, no. 4-798450.

¹⁴⁴ Reinländer 2001. By violist it is meant that he played the viola, as opposed to the viol which his father was famous for.

¹⁴⁵ Großherzoglich Badisches Staats- und Regierungsblatt 1820, p. 7.

¹⁴⁶ ‘Hofmusik Franz Fiala,’ Landesarchiv Baden-Württemberg, Archive no. 4-798450. In December 1819 Fiala requests that his *privilegium* be renewed on the grounds that he has not had the funds to make use of it or publicise it. I am grateful to Gerda and Gisela Treue for their help in transliterating text from the Baden state archives from *Kurrentschrift* into modern German.

¹⁴⁷ Rüder 1820, p. 207.

In as much as the undersigned is bringing this to public attention, he also recommends himself for good contracts, and assures not only prompt, but also cheap and solid manufacture, as he has established contact with a skilful instrument maker for this purpose.¹⁴⁸

This account may explain (in part) why few of these instruments survive, as it indicates he was making his instruments to order, rather than distributing instruments to shops for sale. Fiala's emphasis of his instruments' 'cheap and solid manufacture', suggests that, in this article at least, he hoped for wider appeal than just for the royal courts. It is also important to note that while at times he is called the inventor, he never pretended to have his own workshop or to be the one doing the work.

In another, more substantial article at this time Fiala celebrates his recent endorsement from the Grand Duke in the *Morgenblatt für gebildete Stände*, where he addresses the merits of the keyed guitar specifically for the German nobility.¹⁴⁹ Fiala's status as court musician would have given him credibility in this social sphere, and his article, which mentions several members of the nobility by name, was intended to create a high-end market for the keyed guitar.

Earlier, Mr Fiala already had the honour of presenting his invention to Her Royal Highness the widowed Grand Duchess and Their Royal Highnesses the Marchionesses Amalie and Friedrich, and in so doing he earned the applause of these august connoisseurs as well as enjoying that of several other distinguished personalities. There are already several of these guitars in Leipzig, and he has received several orders.¹⁵⁰

There are notable differences in Fiala's approach from that of his London-based predecessors, who marketed the pianoforte guittar for a wider range of society. Although in describing the player Fiala confines himself to male pronouns, he also

¹⁴⁸ "Beilage zur Allgemeinen Zeitung, Nr. 22" 1820, p. 88. Original: *Indem der Unterzeichnete dieses zur öffentlichen Kenntniß bringt, empfiehlt er sich zu gütigen Aufträgen und versichert nicht nur prompte, sondern auch billige und solide Fertigung, da er sich mit einem geschickten Instrumentenmacher zu dem Ende in Verbindung gesetzt hat.*

¹⁴⁹ The article describes Franz Fiala in the third person, but the detail and subject matter of the piece strongly suggest he was the author.

¹⁵⁰ *Morgenblatt für gebildete Stände* 1820, p. 144. Original: *Herr Fiala hatte schon früher die Ehre, seine Erfindung den Ihre Königl. Hoheit der verwittweten Frau Großherzogins so wie der Frau Markgräfinnen Amalie und Friedrich Hoheiten, zu produzieren, und sich des Beyfalls dieser erhabenen Kennerinnen so wie mehrerer ausgezeichneteter Personen zu erfreuen. Bereits befinden sich solche Guitarren in Leipzig, und er hat schon mehrere Bestellungen erhalten.* I am grateful to Andreas Michel for pointing out that in referencing Leipzig, this would have been understood to mean the Leipzig Fair, 'Leipziger Messe'.

mentions his female patrons, implying that he anticipated the instrument's appeal to both genders. Similar to the pianoforte guitar, however, Fiala envisioned the keyed guitar for amateurs, albeit in this case primarily among the nobility. He states that 'every guitar player, as long as he is familiar with the piano, can play this instrument without much practice so comfortably that he will be in a position to play arpeggios much faster than normal.'¹⁵¹ Fiala describes that the left hand uses the ordinary chord positions and compares the use of the keyboard mechanism to strumming. As a highly esteemed court-musician and guitarist his demonstration of this instrument would have been more spectacular, but in his article, he appeals to his audience's desire for speedy learning and modest ambition.

Fiala's praise of his keyed guitar's capacity to play arpeggios is directly relevant to his audience. Arpeggios comprised the foundation for guitar playing throughout the nineteenth century. Figure 1.25 below, shows a lesson in playing arpeggios on an ordinary six-string guitar, from Felice Chabran's 1813 guitar tutor. This feature of guitar playing has been familiar to guitar players from the earliest tutors for the six-string guitar to the present day.¹⁵² In many ways they characterise amateur music and accompaniment for songs.



Figure 1.25 Lesson from Felice Chabran's 1813 guitar tutor¹⁵³

¹⁵¹ *Morgenblatt für gebildete Stände* 1820, p. 144. Original: *jeder Gitarrespieler, zumal wenn er mit dem Klavier bekannt ist, kann solche ohne große Uebung in kurzer Zeit so bequem spielen, das er im Stande ist, die Harpeggios weit schneller als gewöhnlich hervorzubringen.*

¹⁵² Christopher Page links the development of overspun silk strings, providing a more sonorous bass, with the development of guitar techniques like the arpeggio, which provide a form of continuo bass. Page 2020, pp. 67–8.

¹⁵³ Chabran 1813, p. 8.

In the article addressed to the nobility, Fiala still mentions the low price of his instruments but in more florid language: ‘In its price, the keyed guitar differs little from that of a normal one, and the inventor proves his modesty even in this respect.’¹⁵⁴ Given that the price of a ‘normal’ guitar differs and would mean different things to various levels of society, it is not clear if Fiala’s endorsed instruments were of the same material quality as keyed guitar by Neüner.

¹⁵⁴ *Morgenblatt für gebildete Stände* 1820, p. 144. Original: *Im Preise unterscheidet sich die Tasten-Gitarre nur wenig von einer gewöhnlichen, und der Erfinder bearkundet auch darin seine Bescheidenheit.*

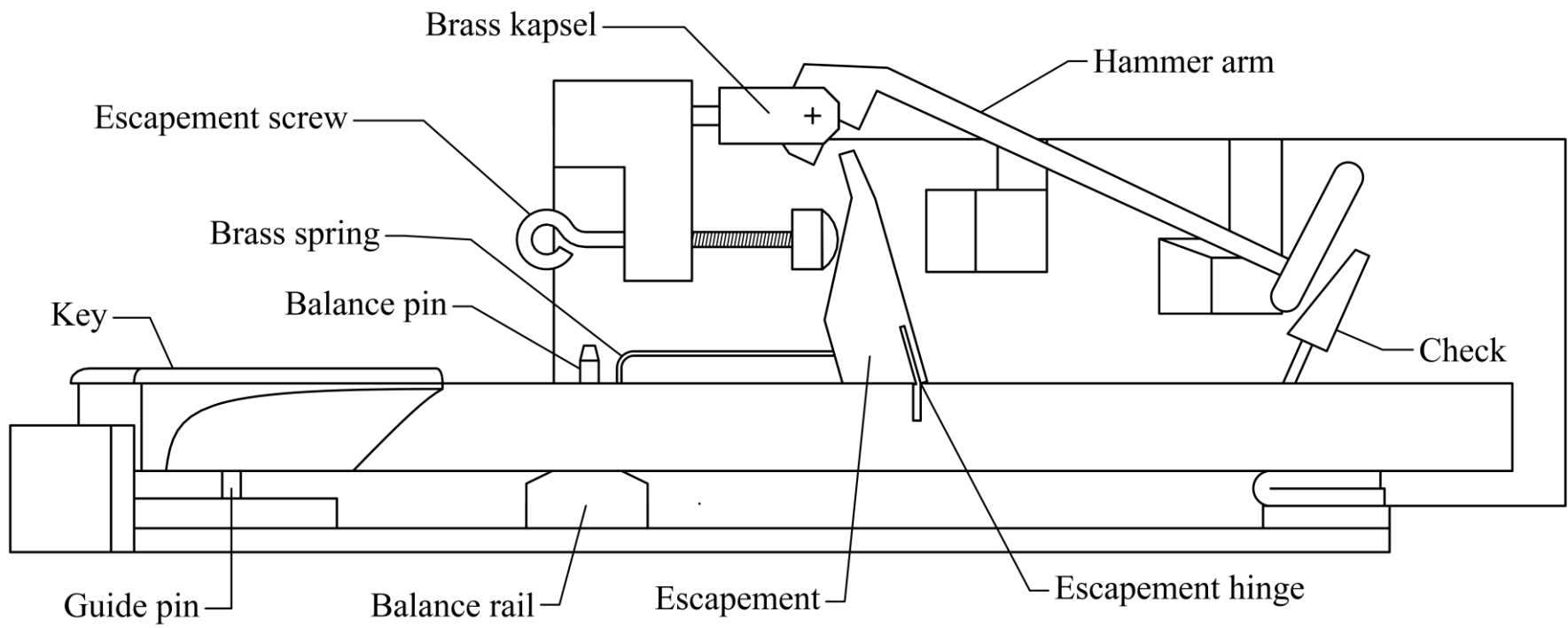

Figure 1.26 Mechanism diagram for the keyed guitar by Sprenger and Fiala, MMA 89.4.3145

The hammer action on the instrument at the MMA is nearly identical to that by Neüner (see Figure 1.26). The only differences are the check located on the back of the key lever; and the brass *kapseln* used to hinge the hammer arms.¹⁵⁵ As well as Sprenger's label and his known links to Mittenwald and to Neüner, the design of the mechanism and its position on the keyed guitar at the MMA demonstrate a clear link to this legacy. Likewise, Fiala's role—contracting with guitar makers to promote and sell keyed guitars—indicates that the labels found on this instrument chiefly relate to the piano mechanism.

This does not mean that Sprenger enacted this conversion, or that Fiala was involved in brokering it (though neither scenario can be completely ruled out). Apart from the mechanism, the keyed guitar at the MMA is poorly made, and, given that Sprenger was a highly reputed master violinmaker, and Fiala was a court musician with a history of selling these instruments to the German nobility, it is likely the conversion was conducted by a third party.

It is possible is that the mechanism was salvaged together with the makers' labels and added to this guitar by an unscrupulous dealer, a surprisingly common practice, and one that might explain the instrument's poor condition and craftsmanship. The current fingerboard and bridge may never have been usable for playing and might have been added merely in preparation for sale. The makers' labels inside have a demonstrable association with the key mechanism and were relocated at the time of its conversion whoever enacted it.

This hypothesis, though seemingly drastic, provides an answer for the questionable association between a master violin maker and a poorly made instrument. Sprenger most likely did make the mechanism—which was executed with precision and stands apart from the shoddy construction of the guitar body.¹⁵⁶ Fiala was likely involved too, and if these labels were transferred from another instrument, it is most likely that they

¹⁵⁵ *Kapseln* are typical in Viennese piano actions. Whereas the hammer actions of the pianoforte guitar in London were built according to an entirely new principle in relation to contemporary piano actions, the mechanisms in the two surviving keyed guitars have a piano hammer action essentially identical in design to early English grand pianos. It is nearly identical to the grand piano action by Americus Backers (1772), on loan to the Wellington Collection, Apsley House, London.

¹⁵⁶ Though, in its current state the mechanism is held in place by small brass screws entering through the back of the guitar.

had also been grouped together in the first place. The label date of 1843 only gives a 46-year window between its manufacture and accessioning into the MMA. Towards the end of the nineteenth century, it was a known practice for dealers to prepare instruments to sell to private collectors like Mary Elizabeth Adams Brown—founder of the collection of the musical instruments at the MMA.¹⁵⁷ The authenticity of the keyed guitar at the MMA is severely compromised. Yet it is still an important object in understanding the history of the keyed guitar. Without it, it would not have been possible to associate the documentary evidence surrounding Fiala's 1820 *privilegium* with Neüner's surviving instrument.

It is not clear how Franz Fiala began his association with keyed guitars, or who his suppliers were and what his instruments were like during the period of this *privilegium*. His later involvement with Sprenger indicates that he was in some way in association with Neüner, but this does not mean that instruments for Fiala were made in Neüner's workshop.

Fiala gives some description of his instruments in his 1820 article in *Morgenblatt für gebildete Stände*:

This instrument has the same stringing, tone, and application as the normal six string guitar, to which it is to the greatest extent identical in form. On the diagonal left side of the sound box, there is fitted, by means of an incision in the sound board, a keyboard of six keys, whose hammers each strike a corresponding string from the inside.¹⁵⁸

If Fiala had spoken accurately that several of these instruments had been made in 1820, presumably they were not in *Wappenform* like the keyed guitar at the MMA.¹⁵⁹ However, we read that the mechanism 'in no way encumbers the instrument, but rather

¹⁵⁷ The most famous fraudulent dealer was Leopoldo Franciolini who sold counterfeit instruments to many of the leading collectors at the end of the nineteenth century. See Ripin 2001a. Elsewhere Ripin notes the 'enormous boom that took place in the market for art and antiques, beginning in the 1880s, produced a parallel increase in the efforts of forgers and unscrupulous dealers to meet the new demand by providing counterfeit or altered objects.' Ripin 1972, p. 196.

¹⁵⁸ *Morgenblatt für gebildete Stände* 1820, p. 144. Original: *Dieses Instrument hat die Besaitung, Stimmung und Applikatur der gewöhnlichen sechssaitigen Gitarre, der es auch in der Form größtentheils gleichkommt. Auf der linken Quer-Seite des Tonkastens befindet sich, mittelst Einschnitts am Resonanz-Boden, eine Klaviatur von sechs Tasten, deren Hämmer von innen heraus jeder auf eine korrespondirende Saite anschlagen.*

¹⁵⁹ *Morgenblatt für gebildete Stände* 1820, p. 144. Referring to Fiala's claim that several of his instruments were shown in Leipzig. As quoted on p. 60.

is in some measure decorative'.¹⁶⁰ Since in Neüner's instrument, the keyboard is entirely concealed within the guitar (see Figure 0.1), from Fiala's description here it appears that by 1820 the keyboard was inset into the body being visible from the front, with the soundboard cut away to better enable access (see Figure 1.23).

Although there are only two keyed guitars known to survive, more had certainly been made in the 1820s, and perhaps still more leading up to Sprenger's keyed guitar of 1843. At this point in time, Sprenger also emigrated to New York, and it is doubtful whether Fiala could have been able to commission any more instruments after this point. Given the relatively large period of time over which these instruments were made (1810-1843), it is difficult to say how many others were built and whether other makers were involved. Still, it is entirely possible that more keyed guitars will surface in the future.

¹⁶⁰ *Morgenblatt für gebildete Stände* 1820, p. 144. Original: *...die Klaviatur, welche das Instrument keineswegs beschwert, sondern gewisserim aßen ziert...*



Figure 1.27 Two views of the Leipzig guitar¹⁶¹

¹⁶¹ The first image, left, comes from de Wit 1892, Plate XIII; the second, right, comes from Kinsky, 1912, p. 83.

The Leipzig Guitar

The keyed guitar referred to in Kinsky's catalogue is the third known example from this period. For ease, it will be referred to simply as 'the Leipzig guitar', as it was lost from the University of Leipzig's collection during the Second World War.

The first references to this instrument come at the end of the nineteenth century, around the time it was acquired by Paul de Wit in Leipzig. A photograph is included in his 1892 catalogue: *Perlen aus der Instrumenten-Sammlung von Paul de Wit in Leipzig*, (see Figure 1.27). The photograph shows it to be significantly different to any surviving keyed guitar and does not match any other nineteenth-century text description. In relation to the photographs, the keys are on the top right section of the soundboard near the neck, the opposite side to those by both Neüner and Sprenger. A description in de Wit's more comprehensive catalogue of 1903 gives a description revealing more about the mechanism:

Keyed guitar, from the beginning of the 19th century, undoubtedly a German work. The top is decorated with embossed leather rings, the core of which is a mother-of-pearl plate. Apart from the fingers, this guitar can also be played by pressing six mother-of-pearl buttons connected to a hammer mechanism working from below.¹⁶²

The entry goes on to compare the instrument to keyed citterns, noting that it is extremely rare and describes it as a 'gimmick' (*Spielerei*). The account of the buttons being connected to the hammer mechanism, is certainly reminiscent of keyed citterns, and sets it apart from the description of Wettengel—where the keys and the hammer arms were one in the same.

In 1905, de Wit sold his collection to paper manufacturer Wilhelm Heyer in Cologne. Heyer expanded the collection and appointed Georg Kinsky as curator in 1909, who subsequently published his catalogue in 1912.¹⁶³ Kinsky's catalogue includes a

¹⁶² de Wit 1903, p. 81. Original: *Tasten-Guitarre, aus dem Anfang des 19. Jahrhunderts, zweifellos eine deutsche Arbeit. Die Decke ist mit gestanzten Lederringen, deren Kern ein Perlmutterplättchen bildet, verziert, Ausser mit den Fingern kann diese Guitarre auch durch Drücken auf sechs Perlmutterknöpfchen, welche mit einem von unten wirkenden Hammermechanismus in Verbindung stehen, gespielt werden.*

¹⁶³ Albrecht and Zahn 2001; Ott 2001.

photograph of the instrument at a slight angle, giving a view of a drawer or door for the mechanism near the neck (see Figure 1.27).

The ambiguity of his attribution, ‘probably Carl Ludwig Bachmann ca. 1805’, shows that it was not based on explicit evidence found on the instrument showing that there was no maker’s label or inscription.¹⁶⁴ Likewise, de Wit had not provided any specific provenance in his catalogue. Kinsky repeats some of de Wit’s description but makes some crucial additions. While also stating that the buttons on the soundboard move a key mechanism beneath, he goes on to say that ‘the mechanism corresponds to the ‘English’ or ‘Stössermechanik’ of the Pianoforte, and it is also fitted with escapement and checks.’¹⁶⁵

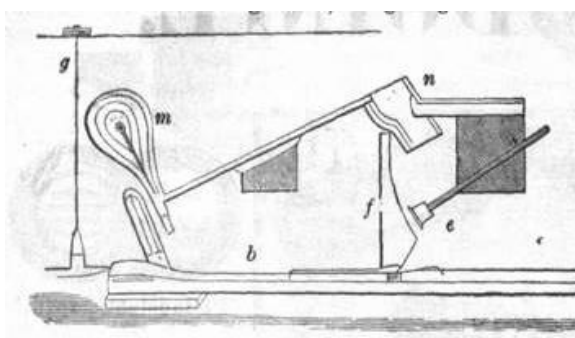

Figure 1.28 English action described in Paul de Wit’s *Zeitschrift für Instrumentenbau*¹⁶⁶

The mechanisms by Sprenger and Neüner are English actions, Sprenger’s action in the same way also includes checks. An article from the *Zeitschrift für Instrumentenbau* in the 1890s gives a diagram of a Stössermechanik nearly identical to that of the keyed guitar at the MMA (see Figure 1.28). Since, the shared mechanism design is substantial enough proof to connect the guitars by Neüner and Sprenger, despite their differences in appearance, it might also be said that the lost Leipzig guitar is also somehow connected to this lineage. Even with the keys raised to soundboard level, the hammer

¹⁶⁴ Kinsky 1912, p. 170.

¹⁶⁵ Kinsky 1912, p. 172. Original: *Der Anzahl der Saiten entsprechend sind auf der rechten oberen Seite der Decke sechs als Tasten dienende mit Perlmutter belegte Knöpfe angebracht, die beim Niederdrücken einen von unten anschlagenden Hammermechanismus in Tätigkeit setzen; die Mechanik entspricht der „englischen“ oder „Stössermechanik“ des Pianoforte und ist mit Auslösung und Fängern versehen.*

¹⁶⁶ de Wit 1885, p. 192.



Figure 1.30 Guitar by Carl Ludwig Bachmann 1801; MIMSIM SPK Berlin, no. 4238, Photo: Harald Fritz, 2009

Kinsky's proposed a date of manufacture of ca. 1805 was probably given to fit his attribution to Carl Ludwig Bachmann, who died in 1809.¹⁶⁹ Various features of the instrument, including the raised fingerboard and the bridge pins, suggest that it was made later in the nineteenth century. In fact, this instrument is very different to surviving guitars by Bachmann. A guitar by Bachmann from 1801 is in the Berlin Musikinstrumenten-Museum im Staatlichen Instituts für Musikforschung (MIMSIM), no. 4238 (see Figure 1.30). The head is ornately carved, and the fingerboard is level with the soundboard, the decoration of the soundbox is simple and refined. In contrast, the Leipzig guitar has a crudely carved head, rectangular bridge, and a raised fingerboard, while the decorations of leather and mother-of-pearl on the soundboard, though elaborate, are gaudy rather than refined.

The Leipzig guitar is not by Bachmann and does not provide evidence one way or another as to whether he ever made keyed guitars. Kinsky's attribution was based solely on the confused narrative in nineteenth-century literature and unless this instrument is recovered it will not be possible to satisfactorily attribute a maker.

In 1926, Wilhelm Heyer sold his collection including the keyed guitar to the University of Leipzig, and it was subsequently lost during the Second World War. A 2016 catalogue of guitars at the MIMUL includes the lost keyed guitar, retracts the attribution to Bachmann, and lists sources surrounding Fiala.¹⁷⁰ This new suggested attribution seems to be supported by the two surviving keyed guitars even though no reference was made to them.

¹⁶⁹ Elste and Helm 2001, p. 436.

¹⁷⁰ Michel and Neumann 2016, pp. 260–62. It seems the attribution was made simply by referring to Franz Fiala's 1820 ducal permit.

Conclusion

The production of keyed guitars in Germany during the nineteenth century was far less substantial than that of the pianoforte guittar in London during the 1780s. The considerably long period of manufacture, spanning the first half of the century, combined with the instrument's relatively small presence in music history, suggests that its popularity was sporadic at best. Like the pianoforte guittar before it, the keyed guitar was designed to impress by its nature more than by the music that could be played on it. Its greatest publicity was put forward by Fiala whose career as a musician did not depend on high instrument sales, but rather noble patronage and recognition. His article to the German nobility promoting his instruments references esteemed personages by name and is as much self-promotion as it is an advertisement for his instruments.

The two surviving keyed guitars provide points of relative clarity in this otherwise opaque nineteenth-century history. Without the keyed guitar at the MMA, there would be no way of associating Neüner's guitar with Fiala and articles describing his instruments. Likewise, Matteo Sprenger, who does not appear to be a driving force behind this innovation, provides a tangible link between these characters, and association with Neüner provides a convincing link to the pianoforte guittars made in London during the 1780s, grounding these instruments in a wider historical narrative.

The three known keyed guitars, including the missing Leipzig guitar, all seem to fit into the same lineage yet have been entirely overlooked by all nineteenth-century sources outside the few surrounding Franz Fiala's permit of 1820. Today, full credit is often given to the dubious accounts of Bachmann's keyed guitars. Even if Bachmann was something more than a dealer of keyed citterns, none of his instruments survive and so no more emphasis should be given to him than to Adolphe le d'Huy, Mr. Pertosa, or Juan Puyol, all of whom we have much greater reason to be called keyed guitar makers.

Having studied errors perpetuated by nineteenth-century historians, I am self-consciously aware that this narrative might be radically reinterpreted again as new evidence emerges or if I have neglected some crucial piece of information. Yet, I

believe that I have been able to locate known instruments within a compelling narrative, which should serve to contextualise any new information or instruments that emerge. There is certainly more room for research, namely into the individuals involved: Franz Fiala, Matteo Sprenger, Mathias Neüner. Local archives, particularly in Mittenwald and Karlsruhe might be able to give a fuller understanding of this history.¹⁷¹

¹⁷¹ For example: Bayerisches Hauptstaatsarchiv, 'Mathias Neüner', no. MF 25976; Landesarchiv Baden-Württemberg, 'Hofmusikus Franz Fiala', no. 4-798450.

Chapter 2: **Reproduction**

This chapter discusses the process of reproduction, beginning with the design methodology: from taking measurements of the original instruments and creating technical drawings, to elements of their design which I have changed for the purposes of this project. I have used traditional means to take the measurements and used 3D modelling software (*Autodesk Inventor*) to make full-scale technical drawings of the instruments.

The fundamental investigative principle of this thesis has been to understand keyed guitar making, and so the process of planning and designing the reproduction instruments centres around the functionality of the key mechanism. In both cases I have not created exact copies of the original instruments in their present condition, but rather I have introduced my own historically informed design elements to best represent them as keyed guitars. In practice it has meant that for the reproduction of Mattias Neüner's keyed guitar from 1810, I did not copy the current head, primarily since it was most likely a later adaptation, but also because it introduced other design complications which were tangential to the purpose of my research. It would not be appropriate to copy the keyed guitar at the MMA in its current condition since it is now not in a playable condition, but likewise, as has been argued in the previous chapter, the piano mechanism is likely a later addition, and so it would not be appropriate to try and reproduce it in its earliest form. My designs try to represent it from a period where it would have operated at its best.

For this process, the unique design challenges surrounding the hybridisation have required a thorough knowledge of the surviving instruments and traditional guitar construction. The mechanisms need to be able to fit within the complex curves of the guitar body and strike the strings through a small hole in the soundboard. Fortunately, the original piano hammer actions have been well preserved in both instruments and can be relied upon for usable dimensions, yet their final proportions have had to be adapted to relate to their guitar bodies.

The making process has been documented in so far as it relates to elements unique to keyed guitars. This is the first attempt to copy nineteenth-century German keyed

guitars, and it is hoped that this dissertation will provide information for others to replicate the work.

Measurement equipment

For measurements, I have relied on rulers and callipers. To record the body profiles, I used a profiling block to trace the curves onto paper in pencil. The profiling block was purposely made to hold a pencil lead at right angles to the paper.¹⁷² The guitar was placed face down upon a large sheet of paper and supported by foam wedges so that the soundboard was parallel to the worksurface at approximately the height of the profiling block. The block can then be used to trace the profile of the soundboard onto paper.

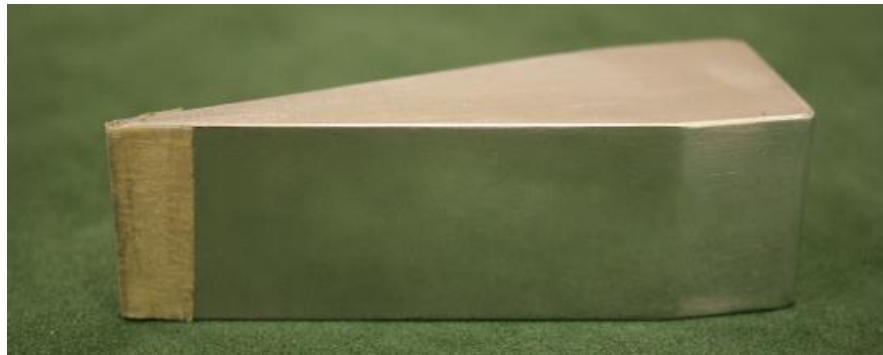

Figure 2.1 Profiling block: L70mm W25.4mm D25.4mm

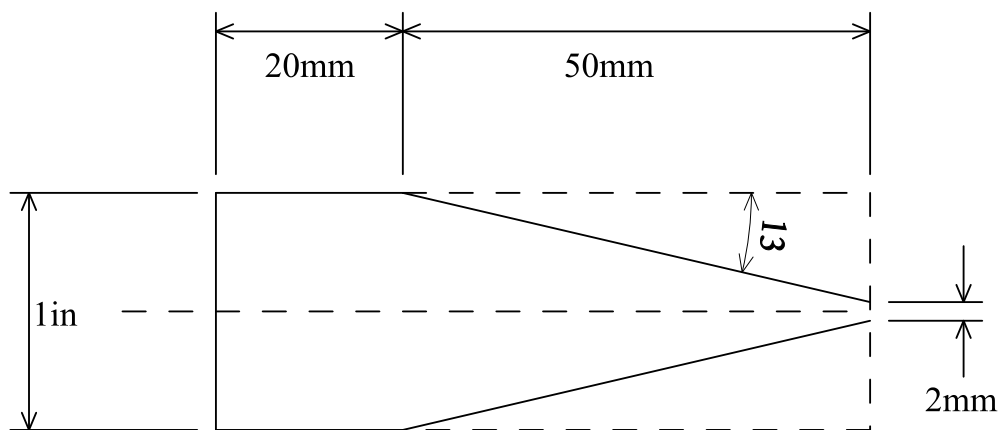

Figure 2.2 Dimensions of the measuring block

¹⁷² It is not possible to rely on photographs for this profile as the camera lens distorts the 2D profile of the instrument. Tracing a profile with a pencil lead is often done with a small engineer's square, but I find this problematic—often the square is too tall and takes a measurement from halfway up the rib in places and does not provide a suitable template for either the soundboard or the back.

I then drew an accurate scale on both the width and length of the paper and scanned the page on a large page feed scanner.¹⁷³ This was repeated for the back, and then scans were used to create digital profiles in Autodesk Inventor. I took all measurements and profiles *in situ* and subsequently compiled full-scale drawings.



Figure 2.3 Front, side and back views of the current head by Neüner, courtesy of Rainer Krause

¹⁷³ It is especially important to correctly scale both axes on a page feed scanner as the feed rate can create unequal distortions on each axis.

Redesigning the Keyed Guitar by Neüner

The keyed guitar by Mathias Neüner has a relatively straightforward object history and has consequently warranted quite a direct reproduction. Only two elements have been intentionally altered from my measurements of the original object, namely the head, and fret spacing.

The current head has a joint with the neck clearly visible from the back and is made from a stained hardwood. The neck on the other hand is likely made from pine or spruce and veneered in ebony. Although this current head is interesting in its own right, the complexity of reproducing the brass tuners even with the possibilities afforded by 3D printing outweighed the usefulness of reproducing this feature. Furthermore, the head is tangential to my research into keyed guitars and still less relevant since it is likely a later alteration.

My design for the head aimed to be unobtrusive and fitting for the context of the original construction. I therefore chose to base it on a popular design form in a figure-of-eight shaped head, common in France, Germany, and Italy throughout the early- and mid-nineteenth century. This type of head was included in Wettengel's 1828 treatise (see Figure 2.4) and is visible on many extant instruments from that period.



Figure 2.4 Wettengel's guitar head, 1828, Table XI

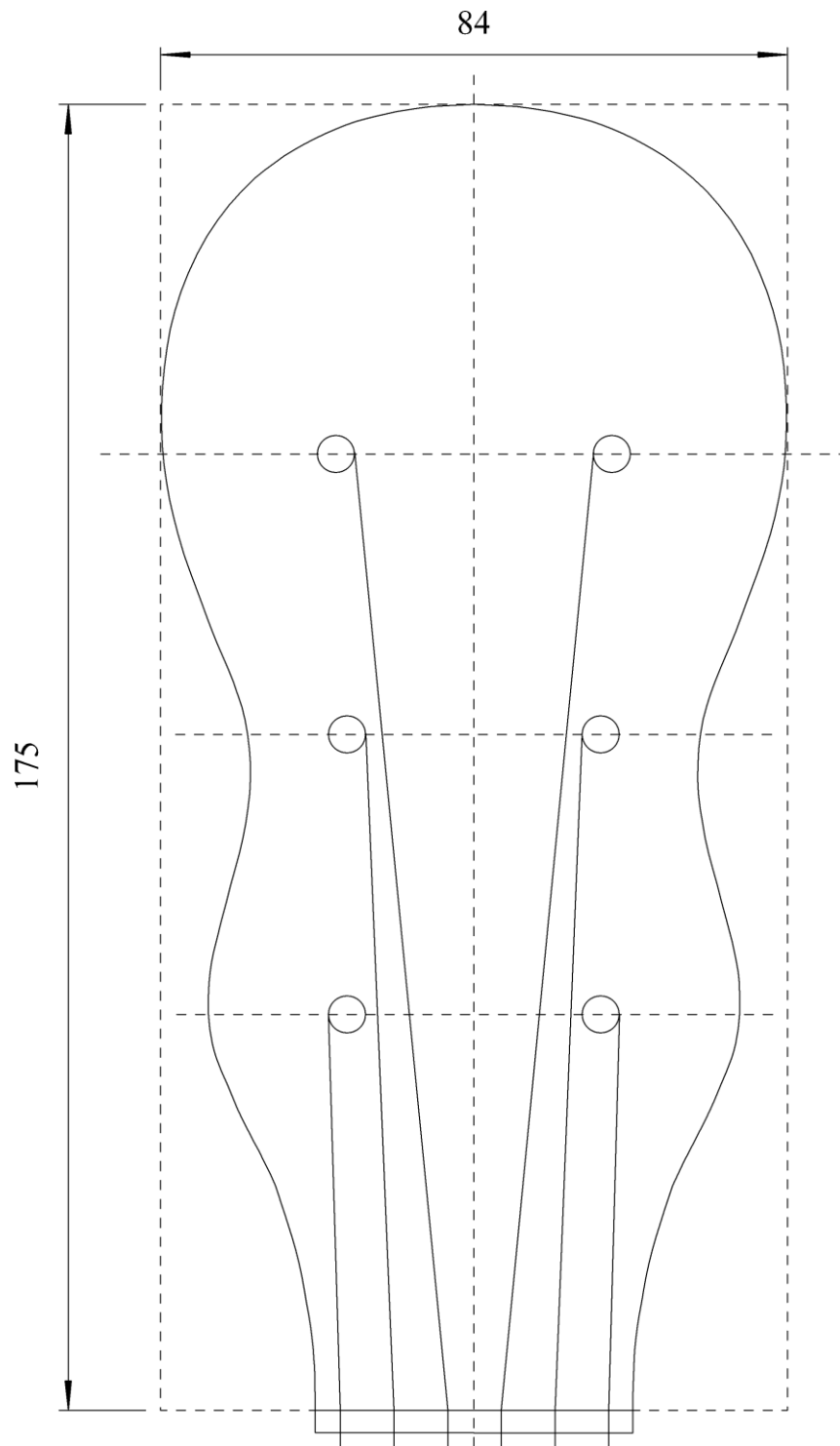

Figure 2.5 New head design for the Mathias Neiner keyed guitar reproduction

Table 1 - Fret Measurements, Mathias Neüner			
Fret	Object Measurements	Deviation (ET cents) ¹⁷⁴	New Measurements
1	34	0.0	34.3
2	65	-3.6	66.8
3	96	-1.4	97.4
4	124.5	-1.9	126.3
5	151.5	-2.0	153.5
6	177.5	0.0	179.3
7	202.5	4.1	203.5
8	226	8.0	226.5
9	247.5	8.8	248.1
10	267.75	9.5	268.5
11	285.75	4.1	287.8
Estimated Scale Length	606		612

Neüner's guitar has eleven frets in a placement within an expected tolerance for fixed-fret instruments suited for equal temperament. However, I have recalculated the fret placements, on the basis that the current measurements deviate from Neüner's intended placement both within an acceptable margin of error and from two centuries of ageing.¹⁷⁵ Therefore, it seems more sensible to work on the same scaling principles rather than meticulous copying.

¹⁷⁴ These values have been calculated based on the estimated scale length of the original instrument.

¹⁷⁵ For a full explanation of these calculations see the discussion of Table 2 on p. 93.

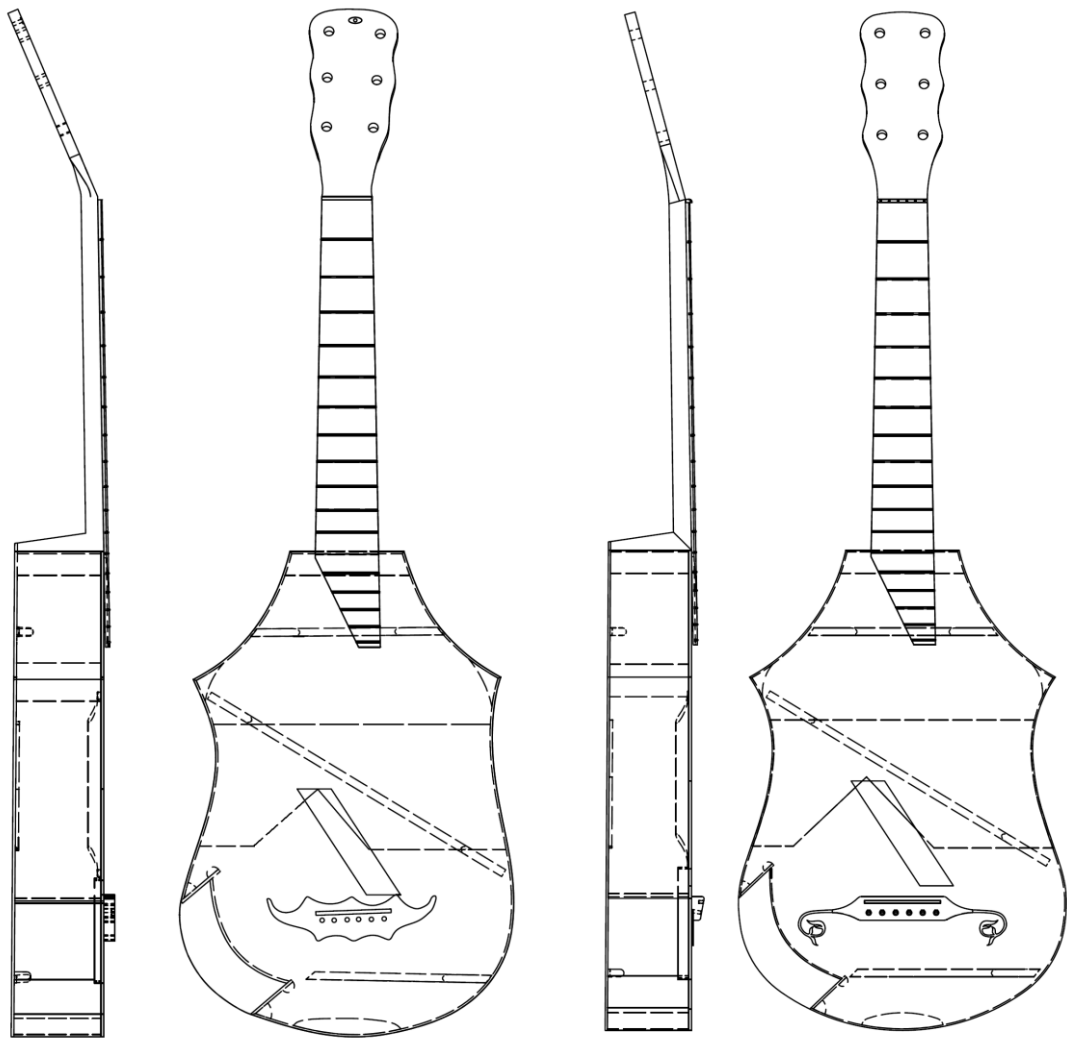

Figure 2.6 Comparison of original design (left) and altered design (right)

The Keyed Guitar by Sprenger with Fiala

The keyed guitar at the MMA has many peculiarities as described in part in Chapter 1. Figure 2.6 above, shows both plan view based on the original measurements (left) and my new design (right). The internal bracing layout, sound hole placement and overall size has been maintained, while I have removed asymmetries from both the body and the head. The bridge too has been entirely redesigned, while keeping its position relative to the sound hole.

The new designs are firmly based upon measurements of the original instrument, but these measurements have been reinterpreted to represent it at its best. As a historically informed reproduction, my design needed to remain faithful to the design principles of

the original instrument, but it would be odd to apply a meticulous copying method to an instrument that had been poorly repaired and altered at various points throughout its life.

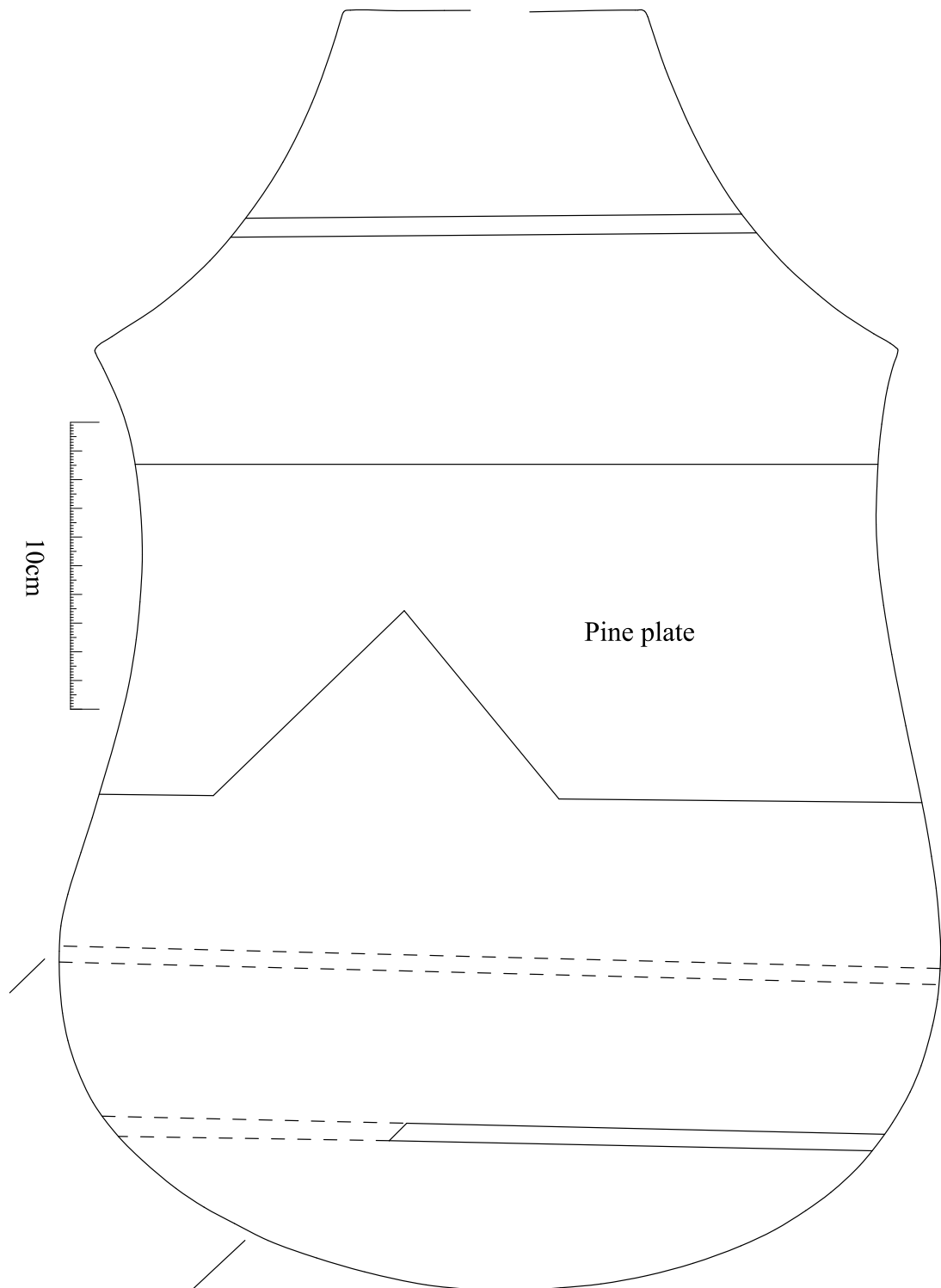

Figure 2.7 Diagram of back bracing. Traces of previous braces shown with dashed line

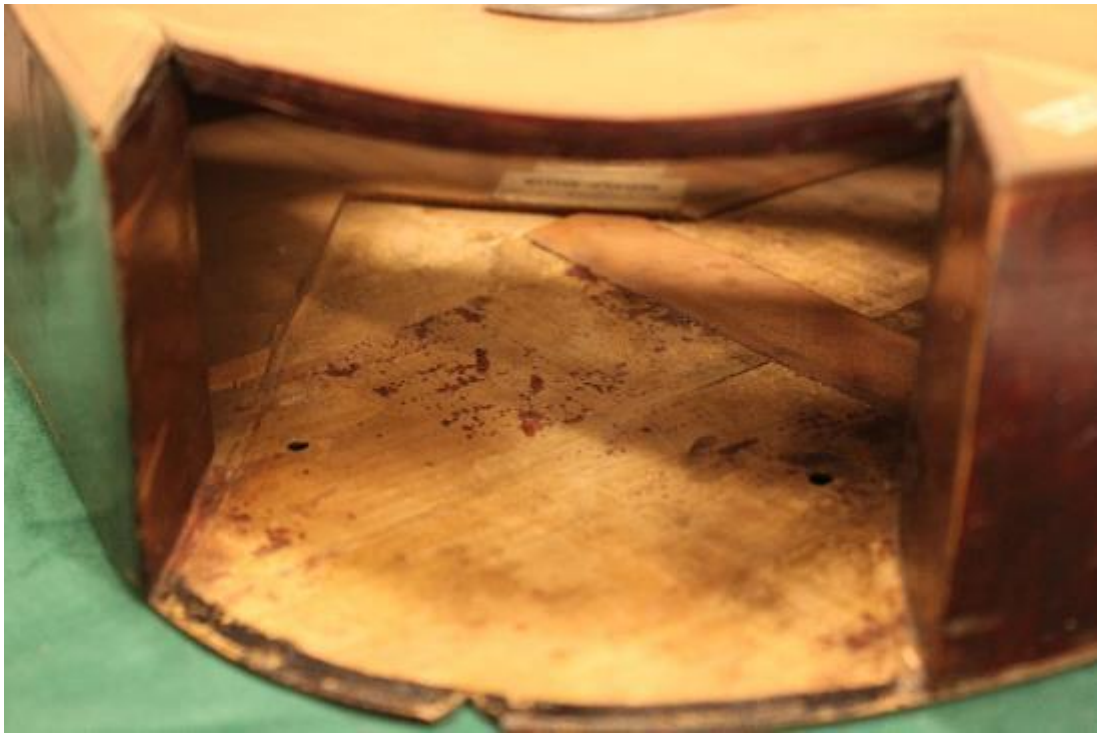

Figure 2.8 View into the mechanism opening, MMA 89.4.3145

Conversion and repair history

For the keyed guitar at the MMA, the conversion history is complex. The current fingerboard has been added on top of an earlier ebony one, which was level with the soundboard. The frets have been roughly filed and consequently have square tops, and the fingerboard itself has scratching all over, perhaps also from crude filing. The neck is made from a light hardwood, possibly pear or wild service wood, stained black. X-ray photographs from the MMA show that there is no reinforcement, and that the neck's attachment to the body is just a butt-joint without a securing nail or mortice.¹⁷⁶

The strongest evidence that this instrument was not originally a keyed guitar is the internal bracing on the back (see Figure 2.7). It is evident that braces have been cut and removed to make space for the piano mechanism. The original footprints of these missing sections of bracing can be seen spanning the entire width of the back (see Figure 2.8).

¹⁷⁶ I am grateful to MMA conservator Manu Frederickx for making these x-ray photographs for me. For rights reasons I am not able to reproduce these photographs in this dissertation.

There are many oddities inside the instrument. A 116mm wide, 3mm thick pine plate spans the entire width of the body, with a shape cut out to fit the mechanism. This is certainly not original, and it is on this plate that the makers' labels are placed. The pine lower block has been glued to the ribs only, with a sizable gap between it and the soundboard and although it might be touching the back, its chamfered edges do not provide any significant gluing surface (see Figure 2.9). A thick white paint has been liberally applied inside, perhaps with the purpose of filling cracks.

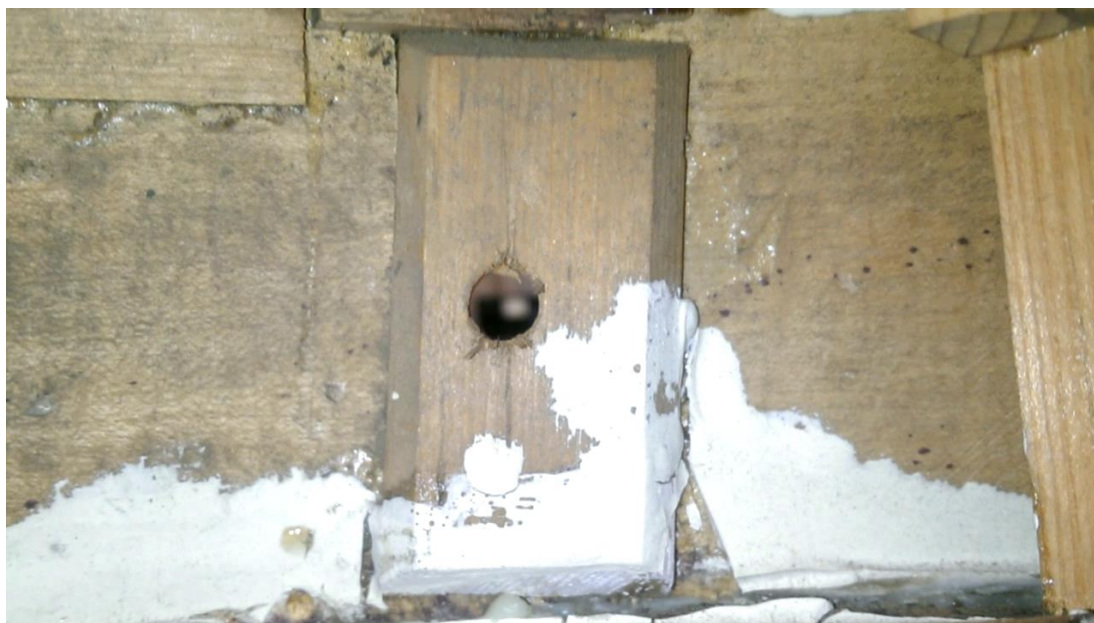

Figure 2.9 View of lower block (soundboard side at the top)

In the recessed opening for the mechanism (shown in Figure 2.8), the two guiding walls were possibly made from the rib material removed to create the opening. One explanation for the asymmetry of the body could be that too much was cut out in error, forcing the craftsman to change the bend of the ribs of the right side to have a more efficient and relaxed bend.¹⁷⁷ Though there are complications with this theory too, as it would require the back to have originally been larger than the current profile, which is unlikely.

¹⁷⁷ The idea that the ribs were cut to make the guides for the mechanism was suggested by Deborah Wythe in the MMA's object file for 89.4.3145, 1979.

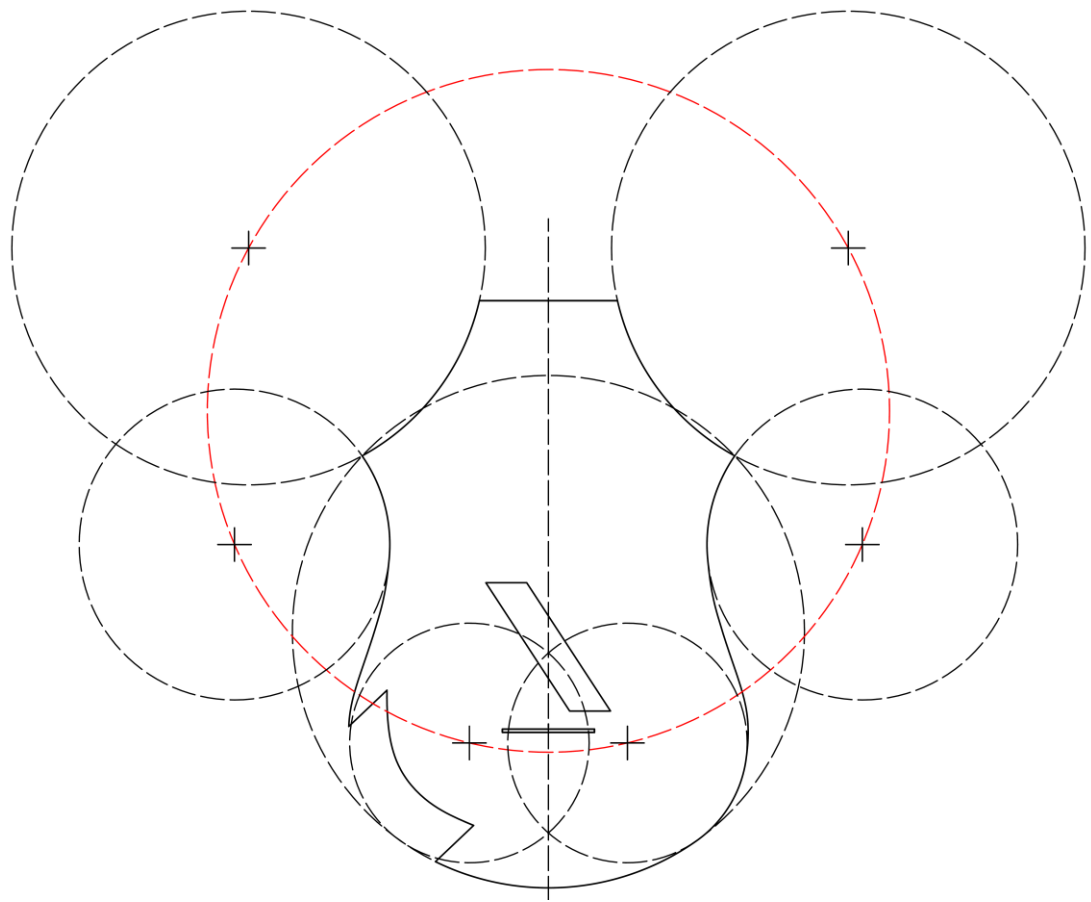

Figure 2.10 Probable proportions of design

The current left-side profile, if mirrored as shown in Figure 2.10, follows the theoretical proportions of design that are typical for workshops suited to the use of dividers.¹⁷⁸ This pre-conversion body profile can be reconstructed almost entirely from circles arrayed on the circumference of a common circle, seen in the diagram in red. The curve of the bottom of the guitar is a perfect arc which, if continued, would intersect precisely with the corners of the upper bout.¹⁷⁹

¹⁷⁸ In the study of objects from traditional workshops, it is often useful to consider dimensions in terms of proportion rather than individual measurements recorded in a given unit (e.g. inches or millimetres). Dividers have been an essential tool for artisanal crafts since antiquity when proportionality and scaling were more highly regarded and more immediately practical than the assignment of a unit value to each element of design. In the nineteenth century, dividers were still an important tool for instrument makers who had a strong tradition in theorizing and using the proportions of art. See Coates 1993; Santa Maria Bouquet 2017, p. 245.

¹⁷⁹ *Bout* refers to the curvature of the guitar body, which typically has an upper bout (near the neck), and a lower bout (containing the bridge).

Ultimately, the body shape being in *Wappenform* is typical for guitar makers in southern Bavaria and Austria, and is an expected design form for Matteo Sprenger who was apprenticed in Mittenwald, near the Austrian border, close to Innsbruck. Instruments in *Wappenform* would allow better access to the higher frets and comes from the idea that the upper part of a guitar adds little to the production of sound, and so could be omitted.¹⁸⁰

Franz Barthioli, writing his *Guitare-Flageolett-Schule* in 1833, in Vienna, describes the proportions of a guitar in *Wappenform* as having the ratio between the body width and length as $\frac{2}{3}$, and the ratio of body length to string length as $\frac{3}{4}$.¹⁸¹ These ratios on the Met's guitar match for the body dimensions, which are close to $\frac{2}{3}$, but the ratio between the string and body lengths is closer to one half.¹⁸² Barthioli constructs the profile of the lower bout of his *Wappenform* guitar with an ellipsis, centred around the saddle of the bridge, see Figure 2.11.¹⁸³

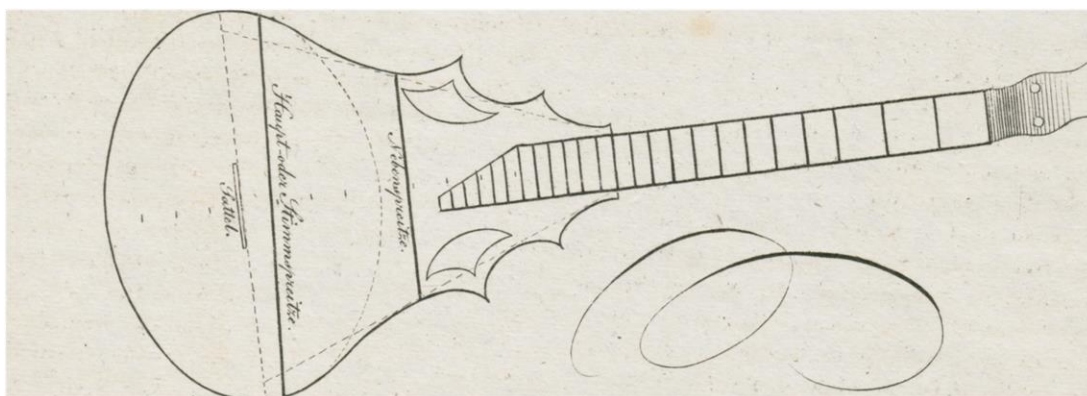

Figure 2.11 Franz Barthioli's 1833 diagram of a *Wappenform* guitar¹⁸⁴

The Met's keyed guitar doubtless has a replacement soundboard, as there is currently no sound hole except the opening for the piano hammers to strike the strings. This also means that the soundboard decoration would also have been a later adaptation. After the conversion, the body of this instrument might have been unrecognisable from its

¹⁸⁰ Turnbull 1974, p. 73.

¹⁸¹ Barthioli 1833, p. 3.

¹⁸² Maximum body width (307mm) divided by the body length (446mm) gives a ratio close to $\frac{2}{3}$ (0.688). The body length divided by the string length (650mm) gives a ratio less than one half (0.47).

¹⁸³ An ellipsis almost works on the lower bout for Sprenger's mirrored profile (Figure 2.10).

¹⁸⁴ Barthioli 1833, p. 4.

original form, and it is possible the body profile was something entirely different to the surviving instrument.



Figure 2.12 View of the bridge on the keyed guitar at the MMA

The current bridge is certainly a replacement. It is crudely carved, made from a stained hard wood, and was not made by an experienced instrument maker. The placement of the bridge spills over the decorative purfling around the hammer hole, strongly suggesting it was an adaptation still later than the conversion to a keyed guitar. There is no visible evidence of a previous bridge outline but given that the current design is not even an attempt at a familiar pattern but something outside of traditional guitar making, it is likely the invention of an ill-informed repairer.

Presently, there are four strings fitted: three overwound silk bass strings and one plain wire treble string.¹⁸⁵ The wire string was most likely added to the instrument in error as guitars in the middle of the nineteenth century were strung with gut.¹⁸⁶ The presence of this wire string begs explanation since the instrument was accessioned in 1889. In the 1904 catalogue of the MMA's musical instrument collection, the instrument is said to have been on public display and is said to have '6 strings as in the ordinary guitar'.¹⁸⁷

¹⁸⁵ The strings have the following gauges: 1st course, 0.28mm; 4th course, 0.89mm; 5th course, 0.89mm; 6th course, 1.20mm. I am grateful to Manu Frederickx for sending me these measurements.

¹⁸⁶ Over wound silk is usual for the bass strings of gut strung nineteenth-century instruments. Historically there are many examples of metal strings on guitar and lute family instruments (e.g. bandora, orpharion, aforementioned citterns and guitars, mandolins and chitarra battente). The conversion of baroque guitars to chitarra battente (popular in the nineteenth century) involved shortening the scale length considerably, the scale length of the MMA's guitar (650mm) also strongly suggests gut stringing. See Martin 2006.

¹⁸⁷ Morris 1904, p. 264.

Whether this is stating that in principle that it should be strung with six strings or that it had six strings at that time is not clear, but ordinary guitars in 1904 would be strung in gut. It is possible that the strings were added while at the museum, or that the cataloguer compared the stringing to ‘ordinary guitars’ in error.



Figure 2.13 View of the key well and bridge on the keyed guitar at the MMA

In truth, most of the existing instrument has been poorly made, with the important exception of the piano hammer mechanism which is comparatively clean and in good condition. The mechanism fits neatly into the key well, and internally the mechanism looks well made and it would not need much work to make it operational.



Figure 2.14 Piano hammer mechanism of the keyed guitar at the MMA

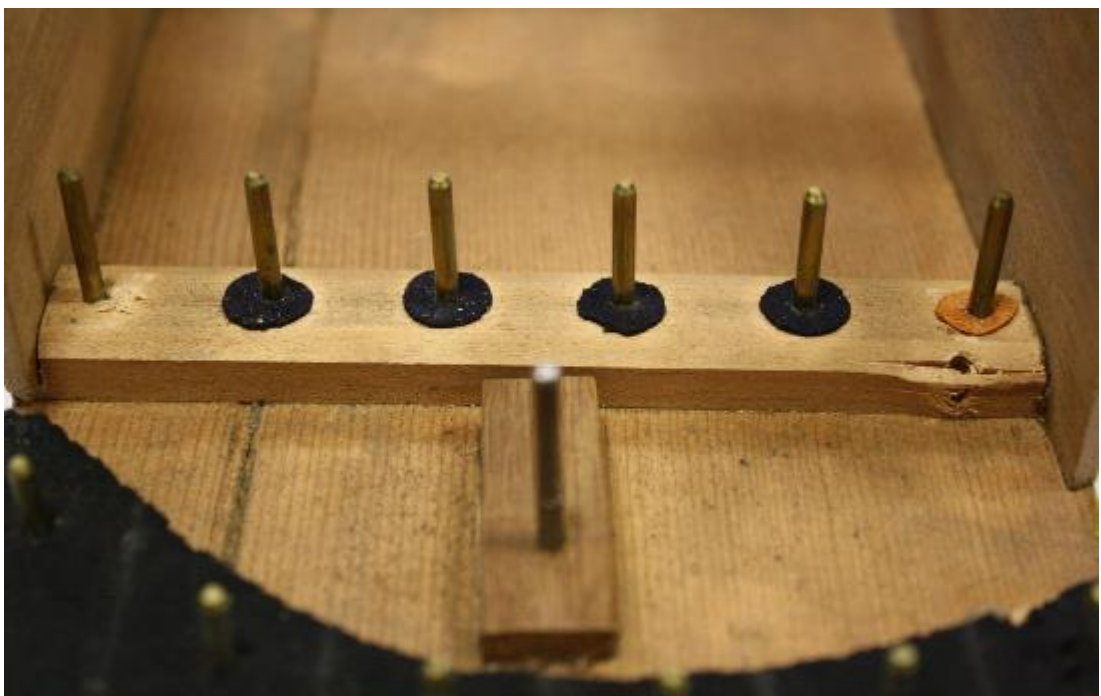

Figure 2.15 View of balance rail and pins of the keyed guitar at the MMA



Figure 2.16 View of the back of the guitar body, showing three screws on the keyed guitar at the MMA

The mechanism is largely made from hardwoods, built up on a pine base board. The only damage has been caused by three brass screws which have been inserted through the back to hold the mechanism in place. The contrast between the neatness of the mechanism and the general sloppiness of the rest of the guitar construction is important. Given that the labelled maker Matteo Sprenger (discussed in Chapter 1) was a respected master violin maker, he would surely have produced a much finer instrument. Nevertheless, as it has already been established that he was involved in keyed guitar making, it seems likely that some elements of this instrument were by him. The question is in determining how much.

Redesigning Matteo Sprenger's keyed guitar

I have intended my reproduction instrument to be immediately identifiable with the keyed guitar in the MMA. Nevertheless, I have changed certain unusual features, namely the bridge and the internal lower block, opting to replace them with more traditional alternatives. Otherwise, my designs have removed asymmetries and introduced proportion and possible design ratios appropriate for the period and context of the instrument.

The fretting has been completely recalculated too, though unlike Neüner's guitar, the fret positions on the MMA guitar demonstrate an inexperienced hand at work. The

frets are not at right angles to the strings, and measuring from their centres to the nut shows that they are irregularly spaced (see Table 2, below).

Table 2 - Fret Measurements: distance from nut, MMA 89.4.3145			
Fret	Object Measurements	Deviation (ET cents) ¹⁸⁸	New Measurements
1	34.64	-4.6	36.48
2	67.27	-9.6	70.92
3	100.61	-6.9	103.42
4	129.05	-14.2	134.10
5	159.2	-10.2	163.05
6	186.46	-10.4	190.38
7	212.03	-11.3	216.18
8	236.44	-11.0	240.53
9	260.86	-4.6	263.51
10	284.08	3.0	285.20
11	305.44	8.4	305.67
12	324.33	7.1	325.00
13	342.68	8.8	343.24
14	358.66	2.5	360.46
15	372.39	-12.7	376.71
16	386.09	-23.8	392.05
17	398.29	-40.5	406.53
Estimated Scale Length¹⁸⁹	646		650

¹⁸⁸ These values have been calculated based on the estimated scale length.

¹⁸⁹ The scale length of the original instrument cannot be derived from measuring the fret placement, and so has been calculated as being 4mm shorter than the measured string length: 650mm.

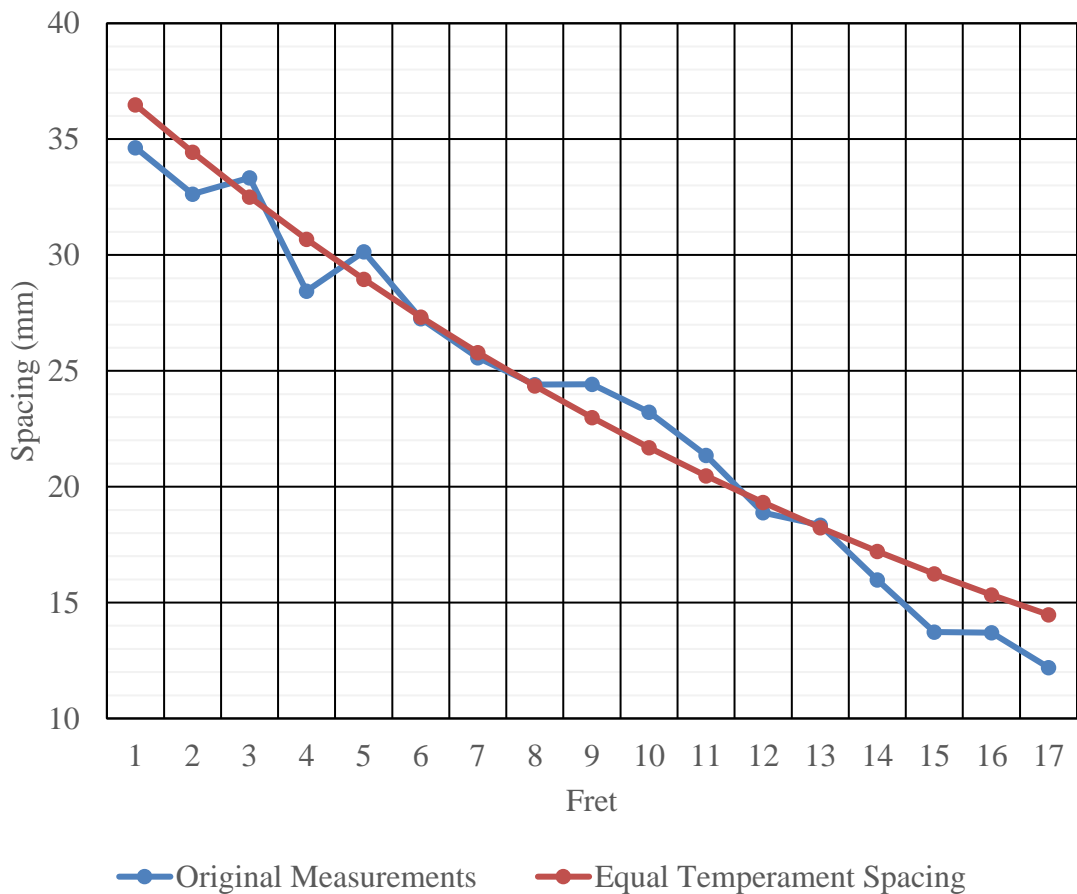

Figure 2.17 - Chart of the fret spacing compared to equal temperament spacing

Mid-nineteenth-century instruments largely used equally tempered fret spacing, where the spaces decrease by an even factor.¹⁹⁰ Figure 2.17 compares the existing fret spacing (from fret to fret) on the keyed guitar at the MMA to a calculated equal temperament spacing. The space between frets ought to get smaller moving up the fingerboard, in some cases the spacing is larger than the preceding fret: namely the third, fifth, and ninth frets.¹⁹¹ Rather than copy the original fret spacing, I have used the measurements based on equal temperament for a scale length of 650mm, see Table 2 above.

¹⁹⁰ For equally tempered fret spacing it is possible to calculate the distance to the subsequent fret by dividing the vibrating string length by the equal temperament constant (17.81715).

¹⁹¹ This could be considered an attempt for an alternate temperament. Certainly, the third and fifth frets on English guitars are often disproportionately large for equal temperament, e.g. guitar by Hintz, MIMEd 310, and an unsigned pianoforte guitar MIMEd 308. However, given the otherwise untidy assembly of the fingerboard with skewed frets, it seems more likely to have been unintentional.

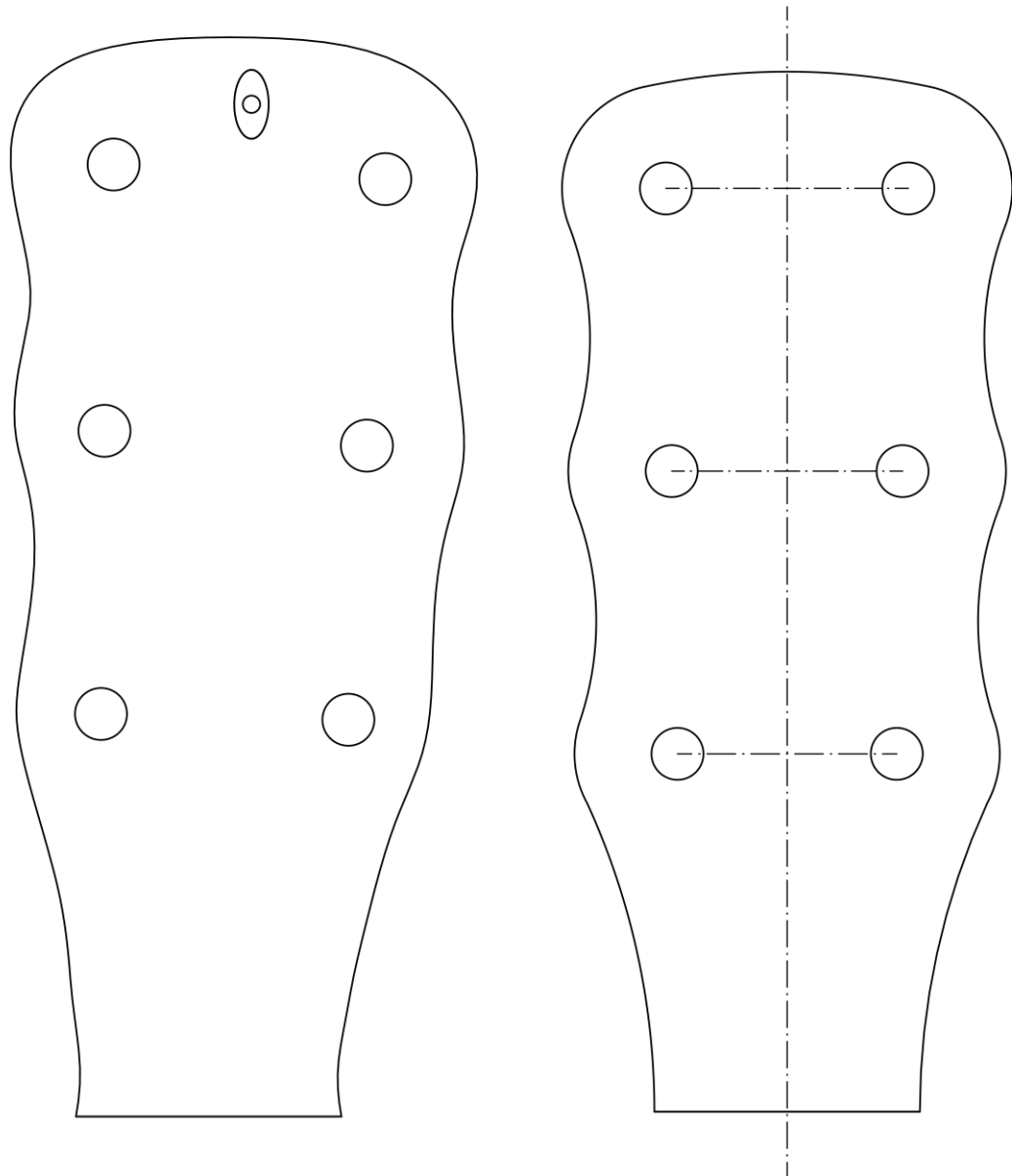

Figure 2.18 Comparison of the head profiles: original profile (left); new design (right)

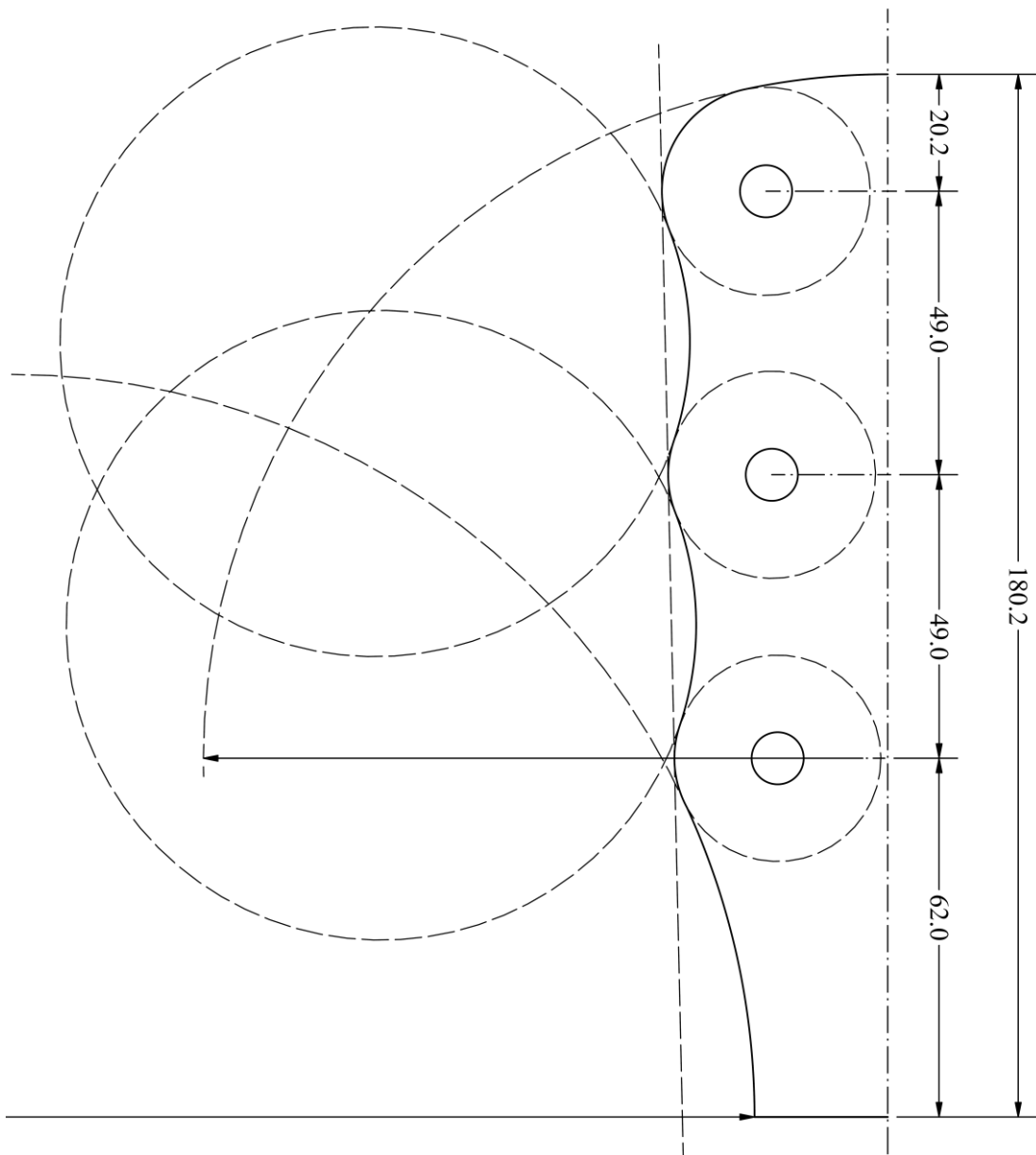

Figure 2.19 Proportions of the new head design

The original head profile has several elements which show an amateur maker: the entire angle lists to the right; there is no centreline symmetry; and there is undercutting on the lower section near the nut. Keeping the approximate shape of the head I created a symmetrical head profile constructed from arcs with even spaced holes for the tuning pegs (see Figure 2.19, above). After first locating the peg holes at regular intervals the waving pattern was inferred from circles concentric to the peg holes. These were then connected with circular arcs at a depth comparable to the original. The curved end to the head was constructed from an arc centred at the lowest peg hole.

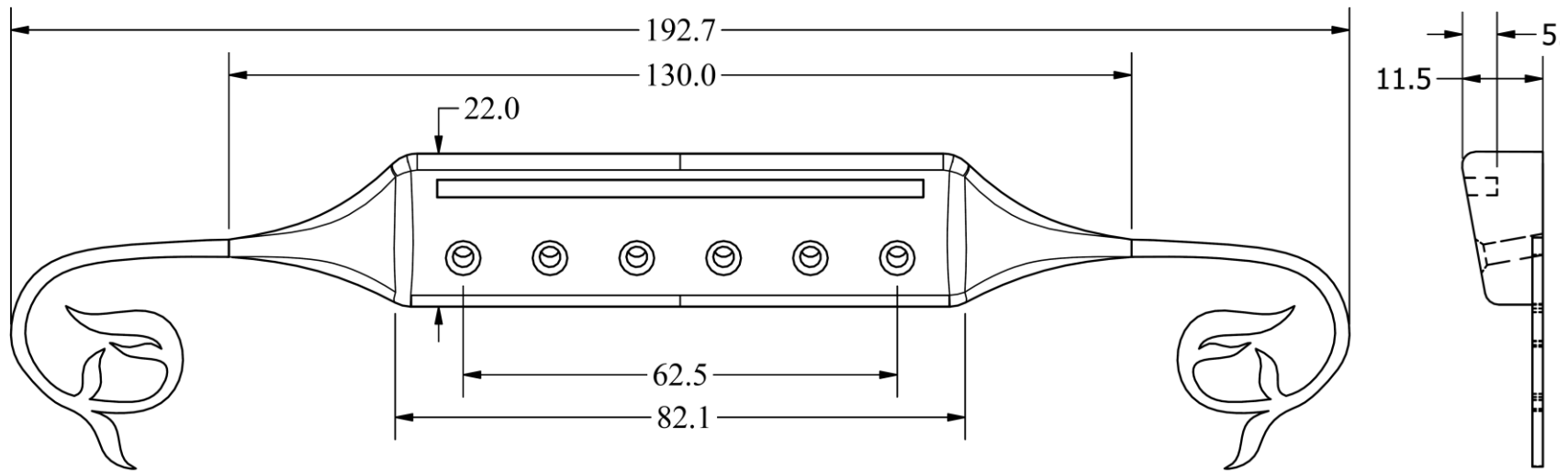

Figure 2.20 Dimensions of the new bridge design

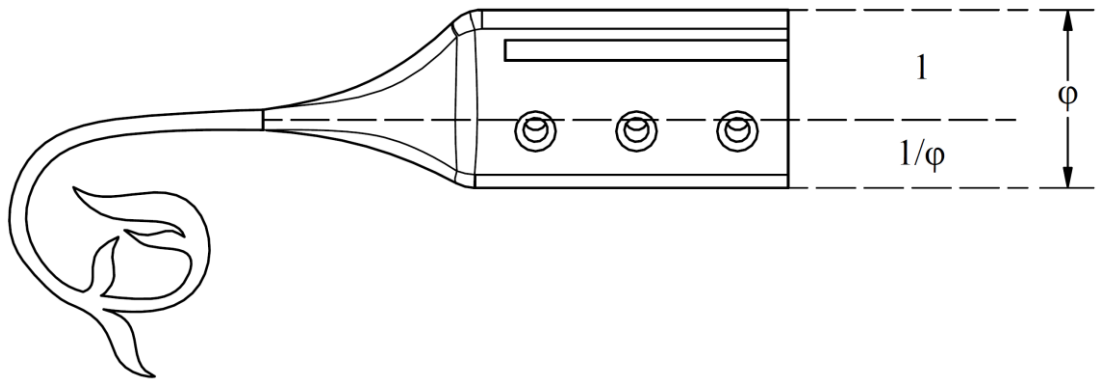

Figure 2.21 The Golden ratio (ϕ) used to position the decorative ends

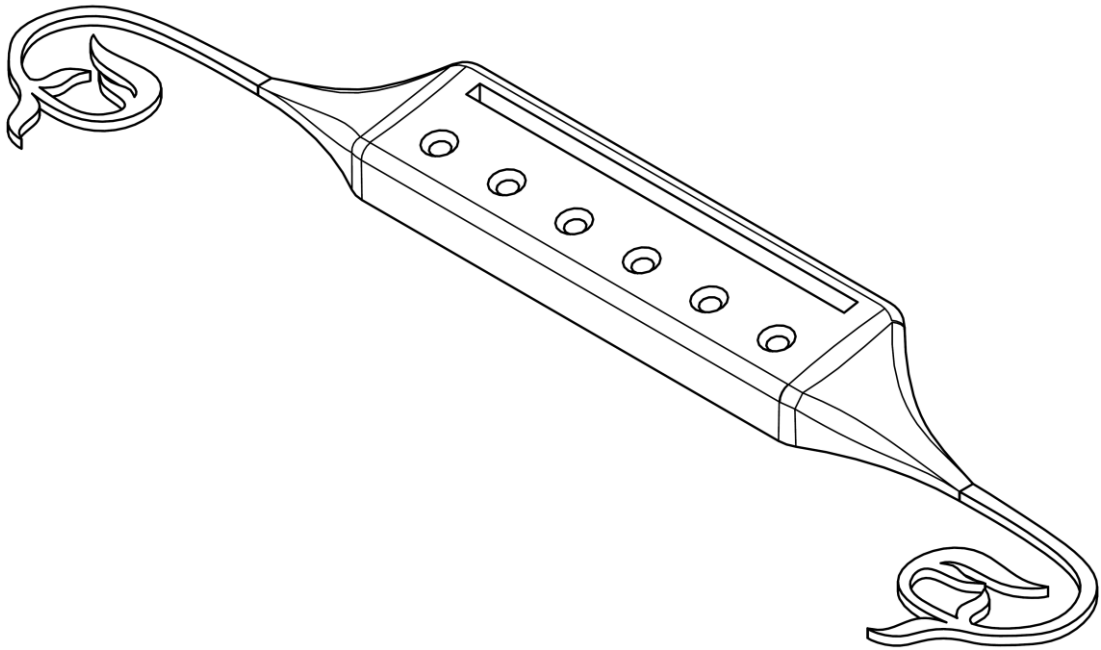

Figure 2.22 Angled perspective view of new bridge design

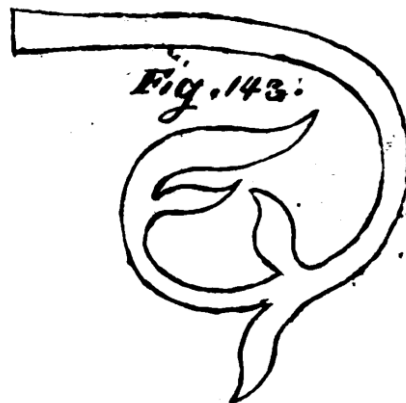

Figure 2.23 Bridge decoration from Wettengel's 1828 treatise; Plate XI

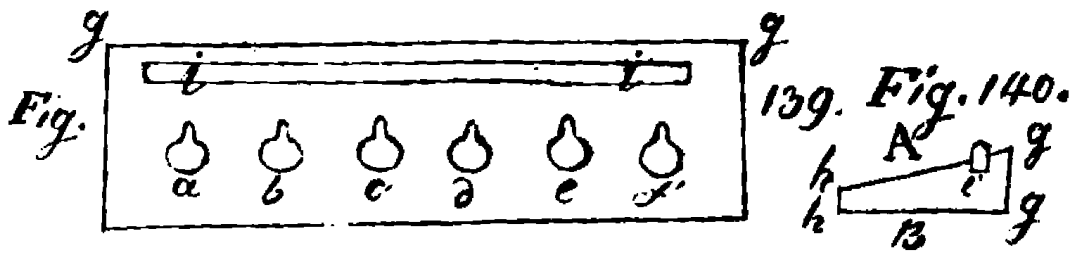

Figure 2.24 Centre bridge dimensions and cross-section from Wettengel's 1828 treatise, Plate XII

Since, the bridge is quite a bad later addition to the guitar, and no markings can be found of a previous bridge shape, I designed an entirely new bridge based on Wettengel's 1828 instrument-making treatise.¹⁹² Taking the string spacing from the previous bridge, balanced with the projection from the dimensions of the neck and fingerboard, the bridge pins were arranged along a more appropriate oblong bridge shape. To this was added characteristic decorations on each end (see Figure 2.20 above).

The Golden ratio (1.618) was used to position the points of the decorations (see Figure 2.21). Although there is debate about whether the golden ratio was used in the Renaissance and even the ancient world, by the nineteenth century, notably in Germany, this proportion was being discussed in practical design applications.¹⁹³ Although there is no specific association with the keyed guitar it seems appropriate to use it here. The designs for the decorative ends of the bridge were based on Wettengel's treatise on guitar making discussed in Chapter 1.¹⁹⁴ In my discussion of this source I have discounted its importance for information on the keyed guitar, but to acknowledge its significance within this history I have included it in homage.

Inside the guitar body, I have intended to keep things in largely the same arrangement as in the original. This is except for the lower block, which is changed to contact the soundboard and the back as well as the ribs and will not use brass screws to secure the mechanism. If I copied the internal blocks on the original, I would be concerned for

¹⁹² Wettengel 1828.

¹⁹³ 'The myth of the Golden Section became a fixture of the burgeoning field of art history in the second half of the nineteenth century when Germanic scholars declared that it was used in major monuments, such as the Great Pyramid of Khufu at Giza.' Gamwell 2016, p. 93.

¹⁹⁴ Wettengel 1828, p. Plate XI.

the longevity of my reproduction instrument. The brass screws seem to have been added later, and the mechanism was likely held in place by friction. If the mechanism in the reproduction instrument becomes loose over time, screws might well be added at that point.

Due to the extensive deterioration of the original object it is difficult to say how much the reproduction will relate to an actual period of the object's history. Nevertheless, my adaptations have been thoughtfully introduced, enabling the construction of a functional keyed guitar. The keyed guitar at the MMA provides only tenuous information about this history, but it is nonetheless important given the scarcity of surviving instruments. Having two working instruments will enable a comparison of their function and offers another perspective to assess keyed guitars in general. Fortunately, the guitar by Mathias Neüner is in far better condition and gives a clearer idea of how these instruments were made.

Making the keyed guitars

Much has been written on how to make guitars, but the focus of this study—the addition of a keyboard mechanism—is unprecedented and will doubtless be of use to anyone wishing to replicate this work. The ways in which the two guitars incorporate the piano mechanisms within their bodies affects the overall construction of the instruments. Therefore, I will describe the overall construction of the instrument as far as it relates to the adaptation of the key mechanism.

Given the differences in quality and provenance of the two instruments, each reproduction instrument has required a different approach for manufacture. The quality of craftsmanship displayed on Neüner's surviving instrument provides a strong motivation to remain faithful to the original dimensions and detail. The keyed guitar at the MMA, has a complex history and slapdash construction style, and so I have assumed a greater creative license to pursue my own preferences in design and manufacturing techniques. Yet, the mechanism in this instrument is neat and well-made and exhibits a contrasting level of precision to the rest of the object and so warrants more exact reproduction.

Mathias Neüner from the collection of Rainer Krause

Traditional guitar construction often uses the soundboard as the foundation for building up the rest of the instrument. In contrast, however, Neüner's keyed guitar supports the piano mechanism with bars and bracing cut to shape on the back, with two guides attached either side of the opening in the ribs (see Figure 2.25). These features, it seemed, needed to be assembled together and required the soundboard to be added last, and so I began with the back and the ribs.

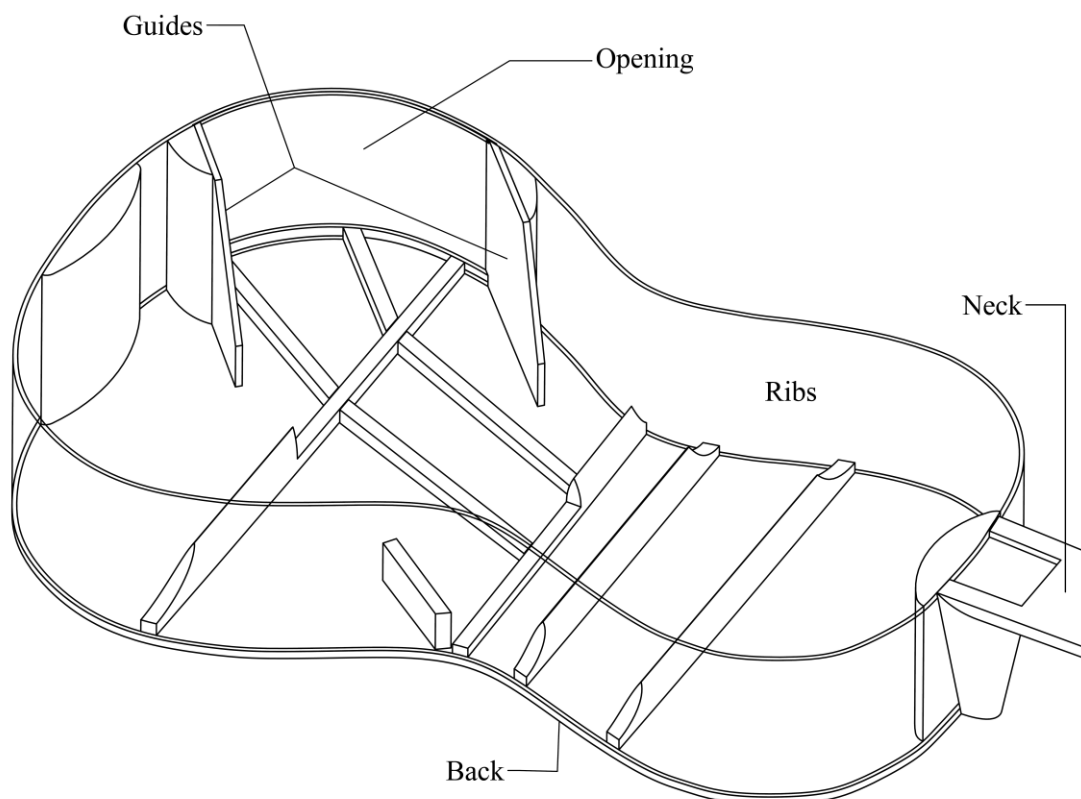

Figure 2.25 Diagram showing the supporting structures to receive the mechanism

The back was made from one single piece of figured maple, planed to a thickness of approximately 2mm all over.¹⁹⁵ Lateral braces were curved to the back radius and glued on first. (Figure 2.26 shows the back-bracing layout.) Lateral braces *A*, *C* and *D* are positioned where you might expect to find braces on an ordinary guitar. Braces *C* and *D* have been cut to receive the mechanism, providing a flat plane on which the

¹⁹⁵ I am grateful to Jonathan Santa Maria Bouquet for the loan of a toothed blade plane to work with the highly figured maple.

mechanisms rests. Brace *B* was most likely added to provide extra support for the reduced brace *C*, and the other mechanism support braces (*1*, *2*, *4* and *5*) add strength to an area weakened by the material removed from brace *D*.

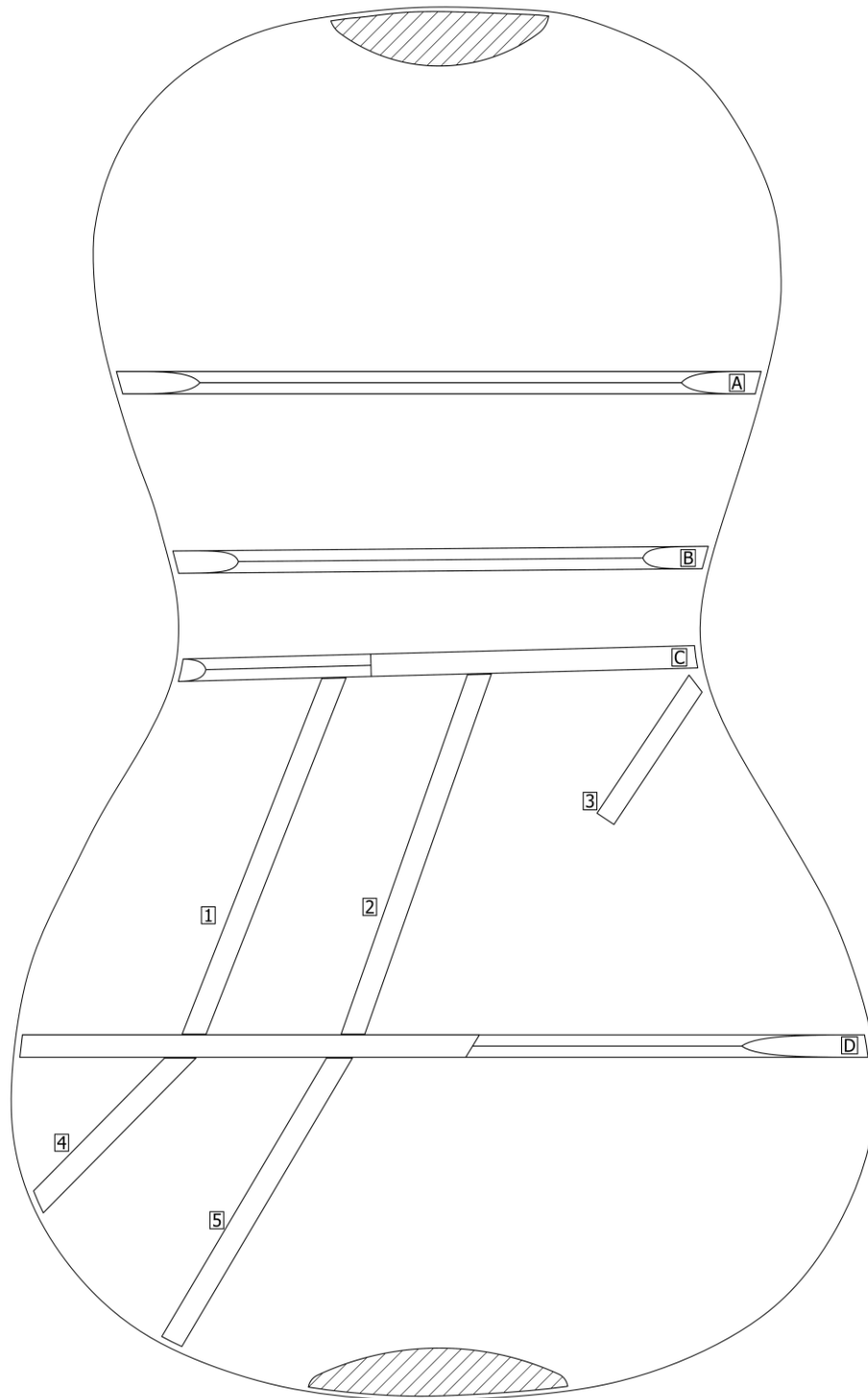

Figure 2.26 Layout of back braces: Lateral braces, A—D; Mechanism support braces, 1–5; internal blocks shown with diagonal hatching



Figure 2.27 Clamping the back bracing to the back



Figure 2.28 Bending the sides with a bending iron

The sides of the guitar were made from one single rib as on the original instrument. A hot aluminium iron was used to heat the wood and bend it (see Figure 2.28), checking frequently against a template. In the same way strips of elm wood lining were bent to provide a larger gluing surface when attaching the back and soundboard. Upper and lower blocks were added, and the back was attached with spool clamps (see Figure 2.29).

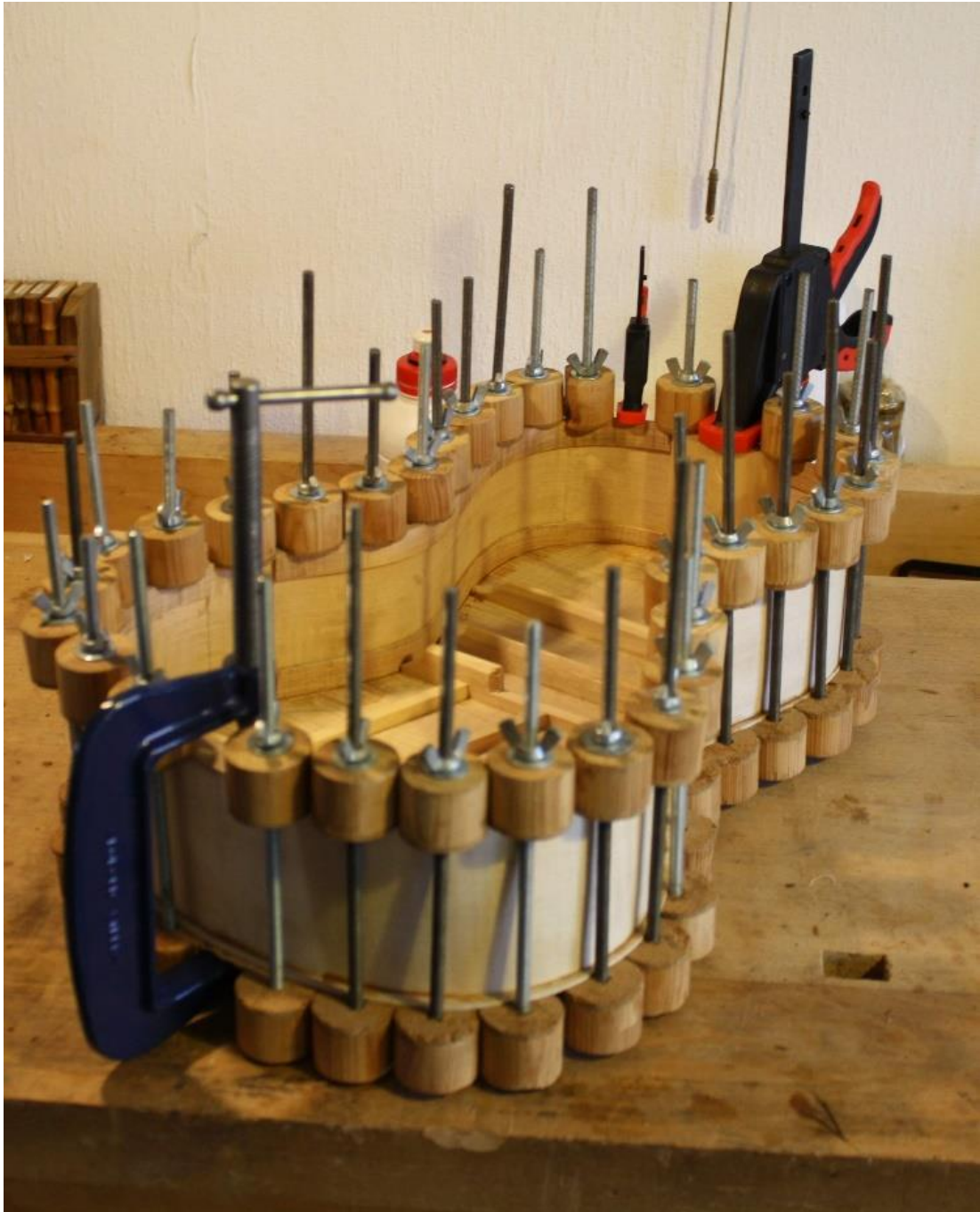

Figure 2.29 Back of the guitar attached with spool clamps



Figure 2.30 Showing the mechanism support braces before ribs are cut away



Figure 2.31 Mechanism guides being clamped during gluing

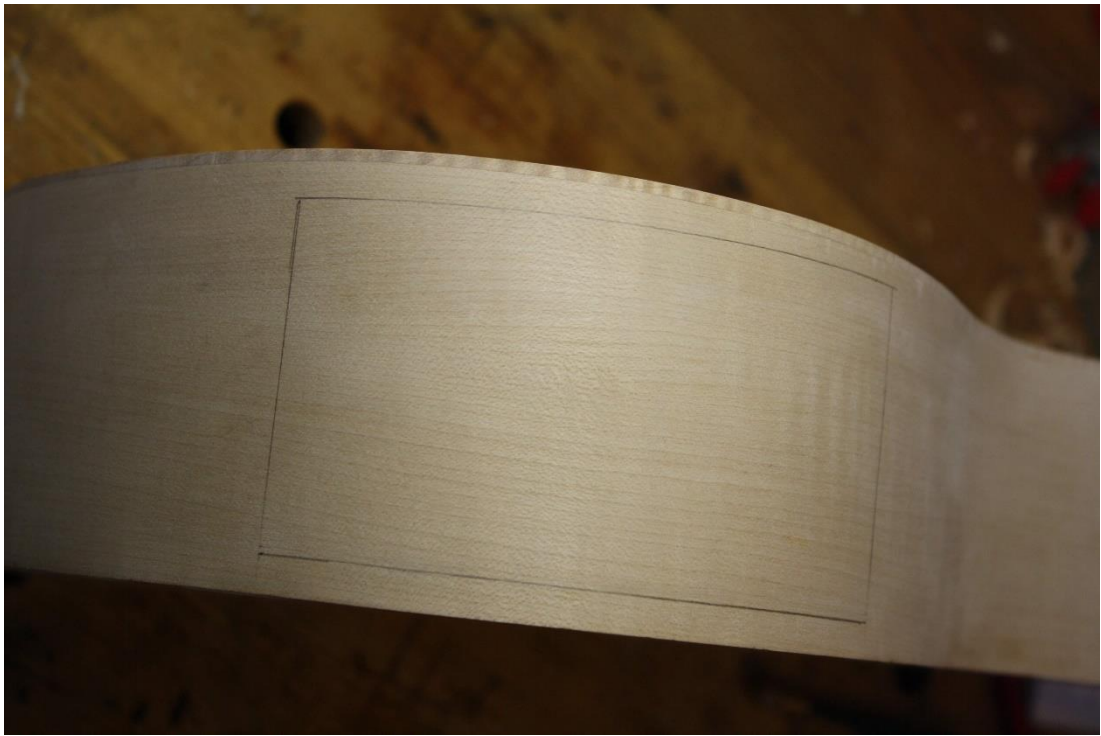

Figure 2.32 Guitar ribs marked out ready to cut out

Once the back was attached, the two guiding walls for the mechanism were glued into place, cutting away the lining where necessary (see Figure 2.31). It was important to have as much of the guitar body assembled as possible to provide greater rigidity for cutting the hole for the mechanism. This was done, firstly by carefully marking the placement of the hole with a pencil, then scoring with a knife. A veneer saw was finally used to make the cut, which was then neatened with a sharp chisel and knife (see Figure 2.33).



Figure 2.33 Cutting the mechanism opening with a veneer saw

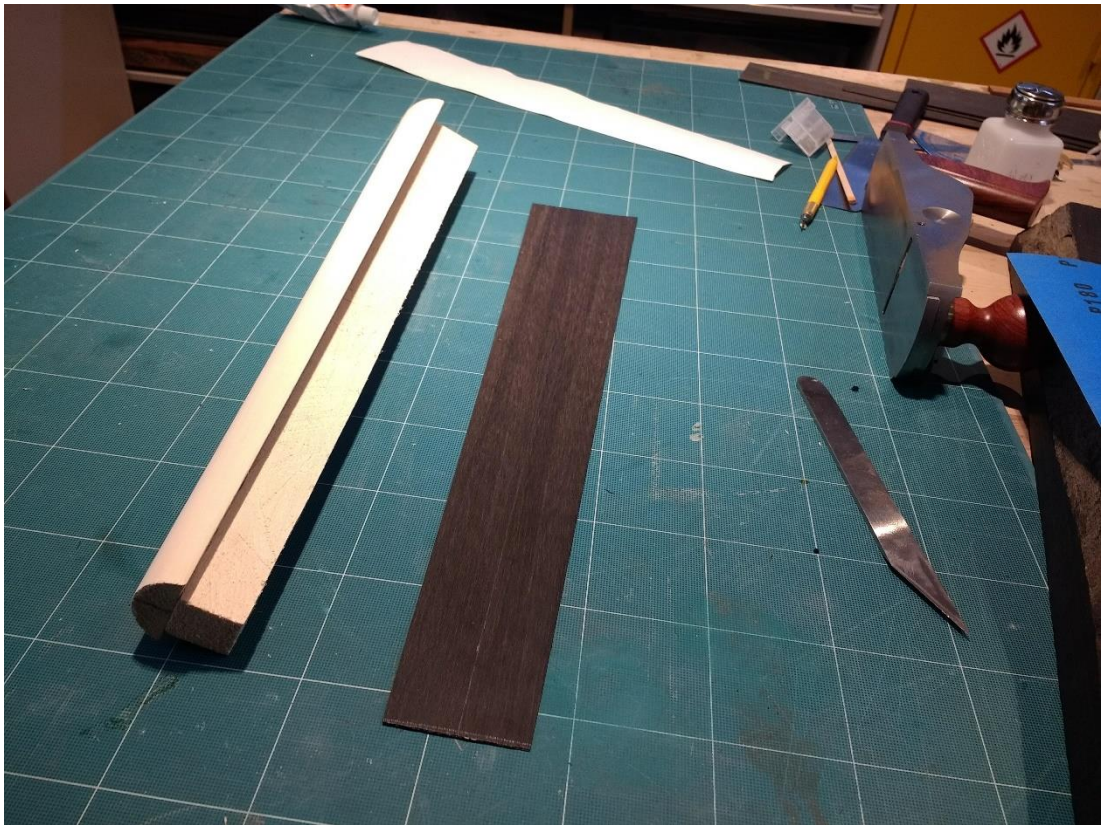

Figure 2.34 Veneering the pine neck in ebony



Figure 2.35 Binding the veneer onto the pine neck

The neck had to be attached to the guitar body before the soundboard. The neck was made from pine veneered in ebony. The pine core was carved to shape and a slab-sawn sheet of 1mm ebony veneer was cut to size. The veneer was laminated with paper to prevent splitting, and then heated before being glued to the neck and bound with cord to apply an even pressure while the glue dried.¹⁹⁶ The neck then has the light weight and lateral strength of pine combined with the hard, durable, and beautiful surface of ebony. The heel was prepared in the same way and attached to the neck with a mitre joint. This was glued with a butt joint to the guitar body and secured with an iron nail through the top block (see Figure 2.36).



Figure 2.36 Hammering iron nail to attach neck

¹⁹⁶ I am grateful to Jonathan Santa Maria Bouquet, for working with me at this stage in his workshop at St. Cecilia's hall.

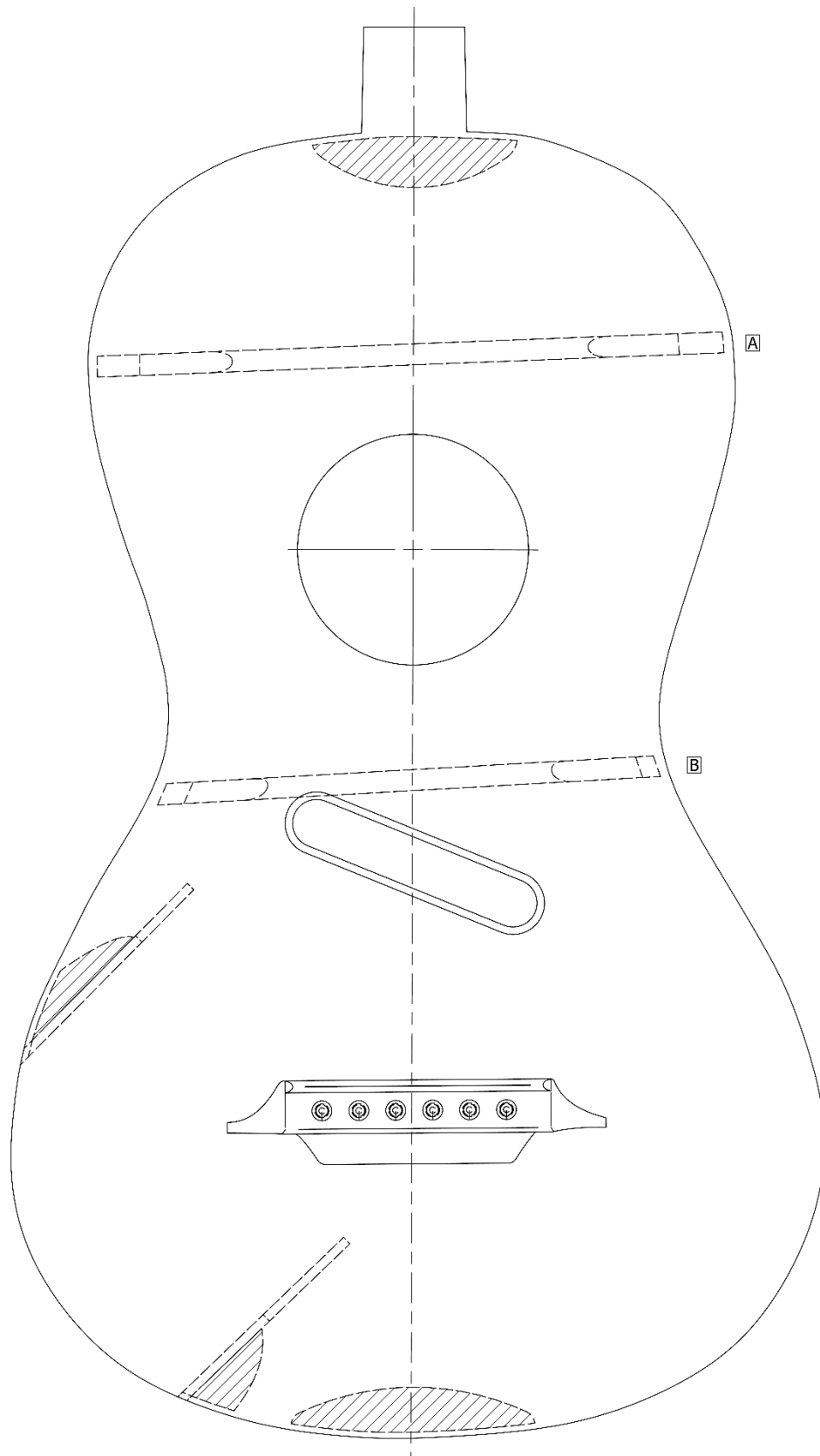

Figure 2.37 Soundboard layout, internal braces shown with a dashed line A and B; Internal blocks shown with hatching

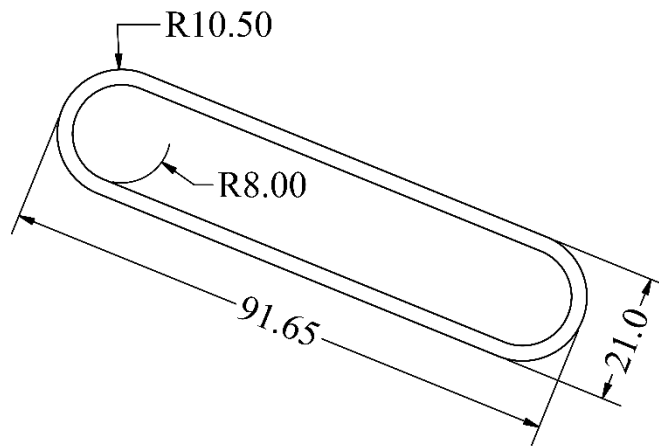

Figure 2.38 Hammer hole dimensions, with border outside in ebony

The soundboard was made from two pieces of spruce joined along the centre. The sound hole was decorated with a pattern of ebony and mother-of-pearl and two lateral braces were added above and below (Figure 2.37 A and B). The hammer hole was cut out undersize so the final position could be finely corrected after the soundboard was attached. After marking the position of the hammer hole on with a pencil, two holes were drilled at each end of the hammer hole. These holes were then connected with straight cuts of a knife. Final shaping of the hammer hole took place once the soundboard had been attached, and an ebony boarder was added.

The soundboard was attached to the ribs with spool clamps (Figure 2.39). The section of the soundboard over the mechanism opening had to be glued with smaller spring clamps since spool clamps would likely break the ribs. The soundboard was then trimmed flush with the ribs and decorated with ebony and mother-of-pearl.

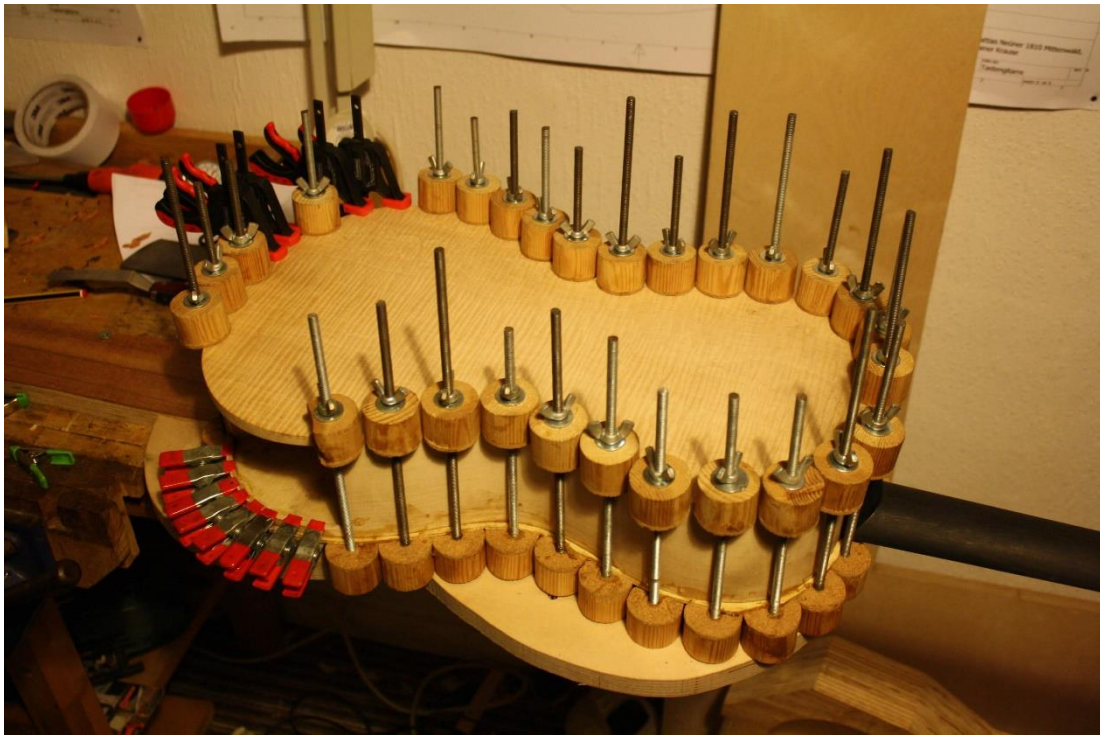

Figure 2.39 Attaching the soundboard with spool clamps



Figure 2.40 Soundboard attached and decorated

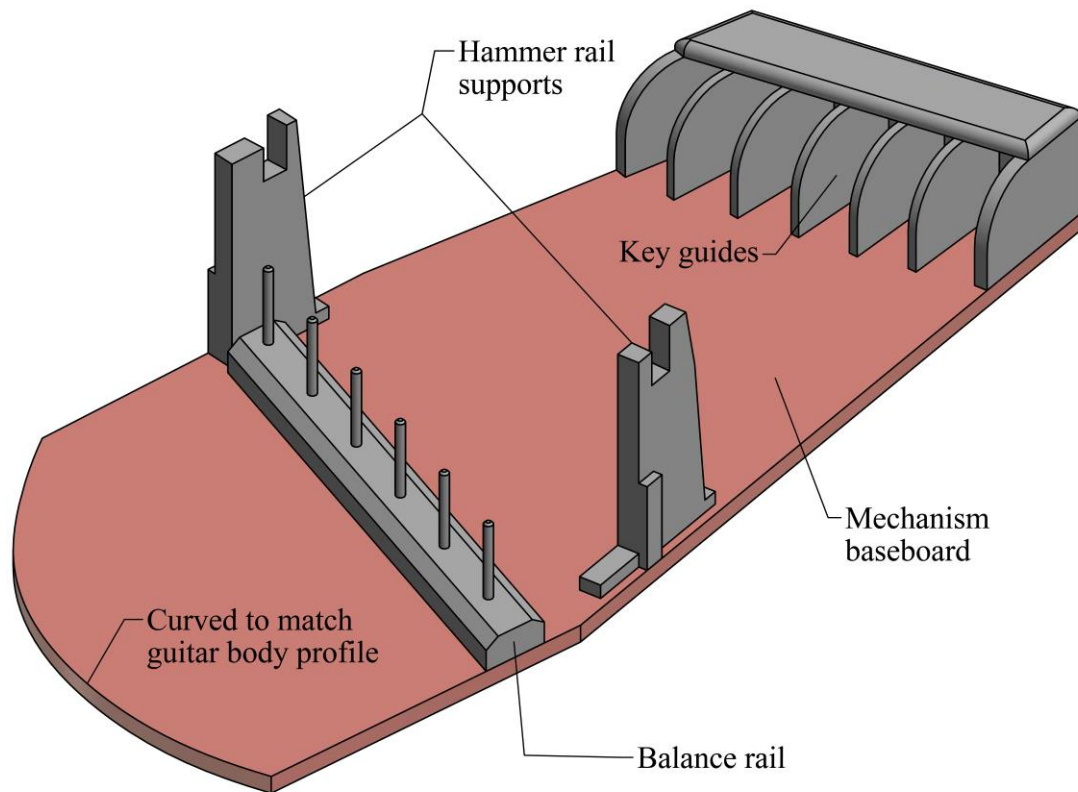

Figure 2.41 Components attached to the baseboard

The mechanism baseboard was made from a 4mm pine board. There is no locking system keeping the mechanism within the guitar, and since during performance the whole instrument will be angled upward, it was important to achieve a secure fit. The tapered profile of the mechanism baseboard must be wedged in place within the supporting brace structure inside the guitar.

The balance rail was positioned at an angle, to compensate for unequal lengths of the key levers (shown below in Figure 2.42). Supports were attached either side of the baseboard to hold the hammer rail, and the front was shaped to match the guitar body profile (see Figure 2.41).

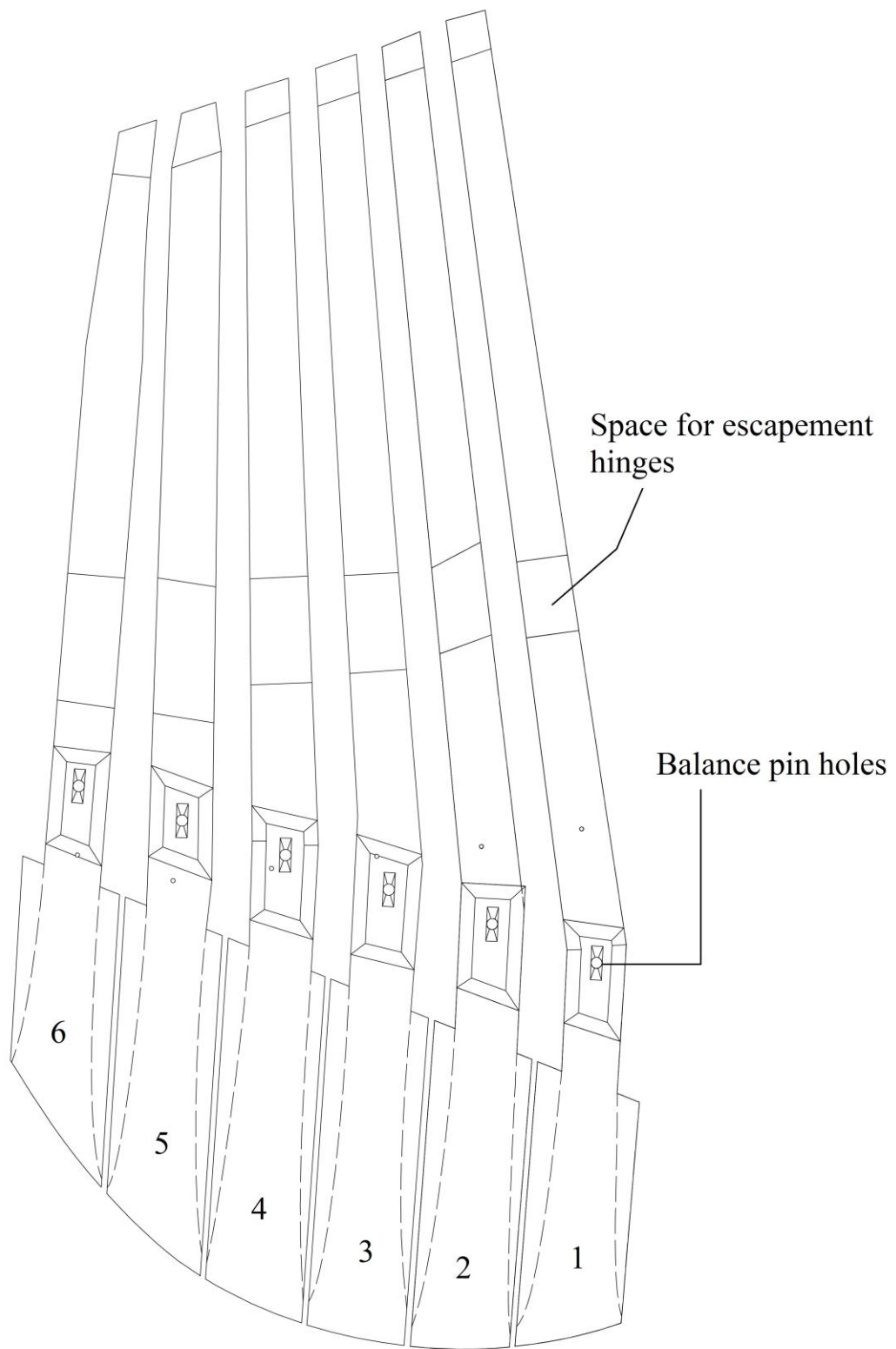

Figure 2.42 Plan diagram of the keys. Keys numbered 1–6 matching the conventional numbering of strings (right to left)



Figure 2.43 CNC router prepared to mill the keys



Figure 2.44 Finished CNC milling

The profile of the key levers is not straight, making it difficult to achieve precision (see Figure 2.42). The complex shape of a guitar body and the accuracy required to ensure the mechanism will strike the string correctly, highlight the importance of having 3D drawings of the entire instrument, making it possible to locate and correctly dimension the mechanism before beginning work. These drawings were easily usable on a CNC milling machine to carve out the key levers, perhaps not saving time but certainly providing effortless precision (see Figure 2.43). The strong grain in pine makes it prone to splitting when routing, but with hand finishing using planes, chisels, and files the key levers were still usable.¹⁹⁷

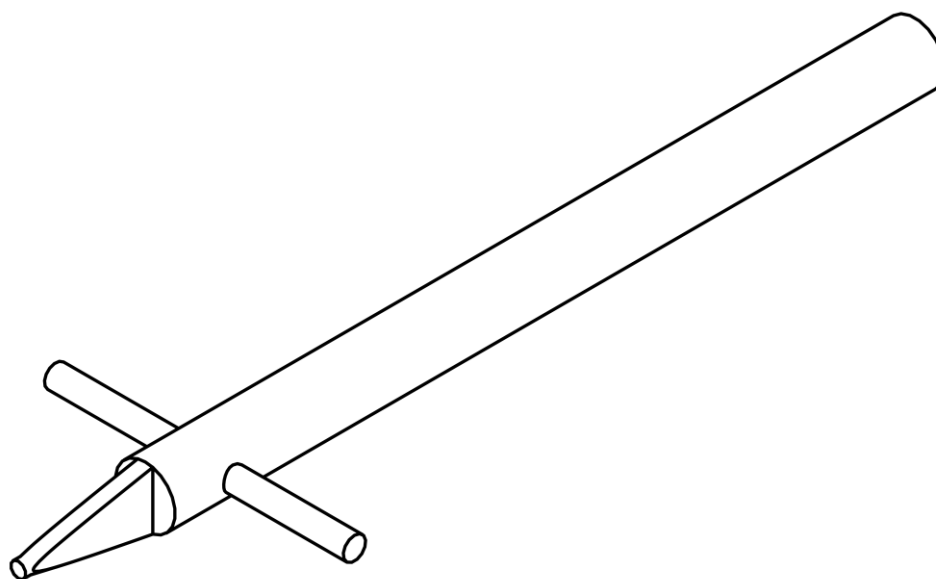

Figure 2.45 Broaching tool

Holes for the balance pins were drilled in each key and a ‘broaching’ tool (Figure 2.45) was hammered into the space, compressing the wood fibres into a roughly triangular cross-section.¹⁹⁸ This space allows the keys to pivot on the balance rail while holding them in place. The keys were fronted and topped with artificial ivory (polyester) which provides a hard and convincing ivory finish. Guides at the back of mechanism were added to align the keys and prevent them from coming into contact with each other (Figure 2.46).

¹⁹⁷ One of the keys had a clean split which could be easily glued closed.

¹⁹⁸ I am grateful to Darryl Martin for the loan of this specialist tool.



Figure 2.46 Assembling the keys and attaching the key guides

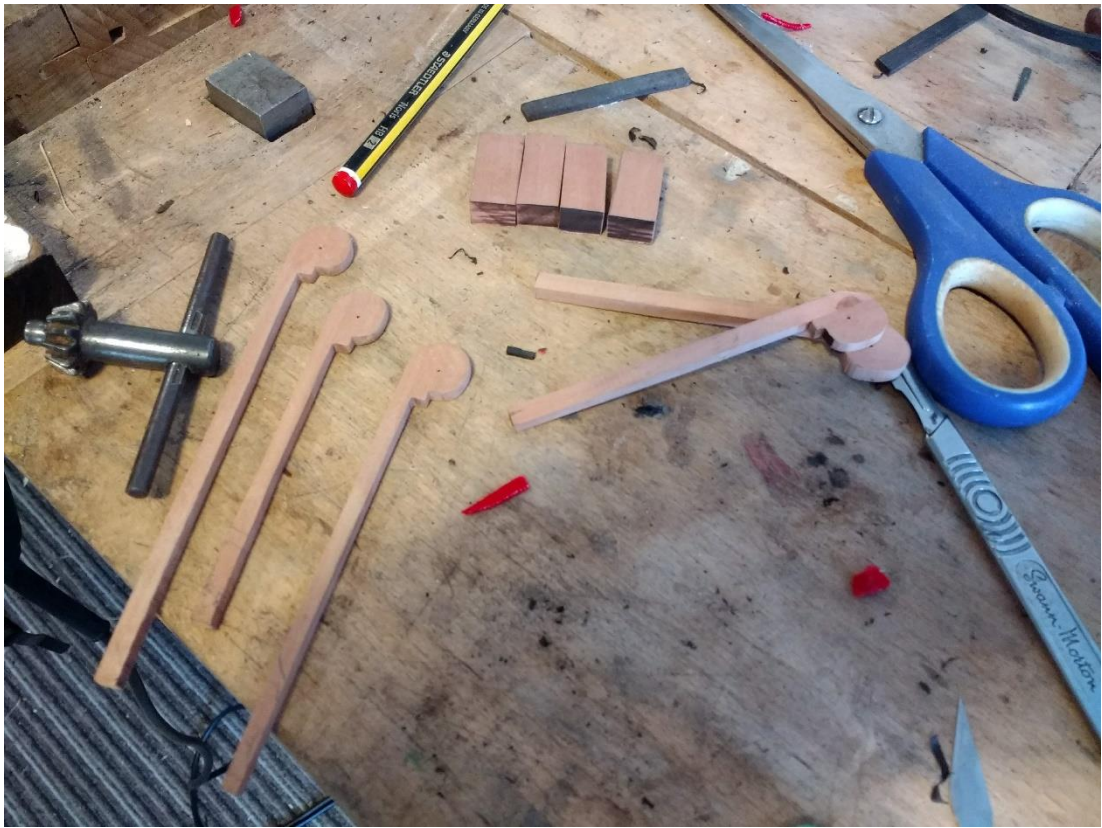

Figure 2.47 Hammer arms and hinges prepared



Figure 2.48 Escapement hinged with bushing cloth added



Figure 2.49 View of completed escapement mechanism

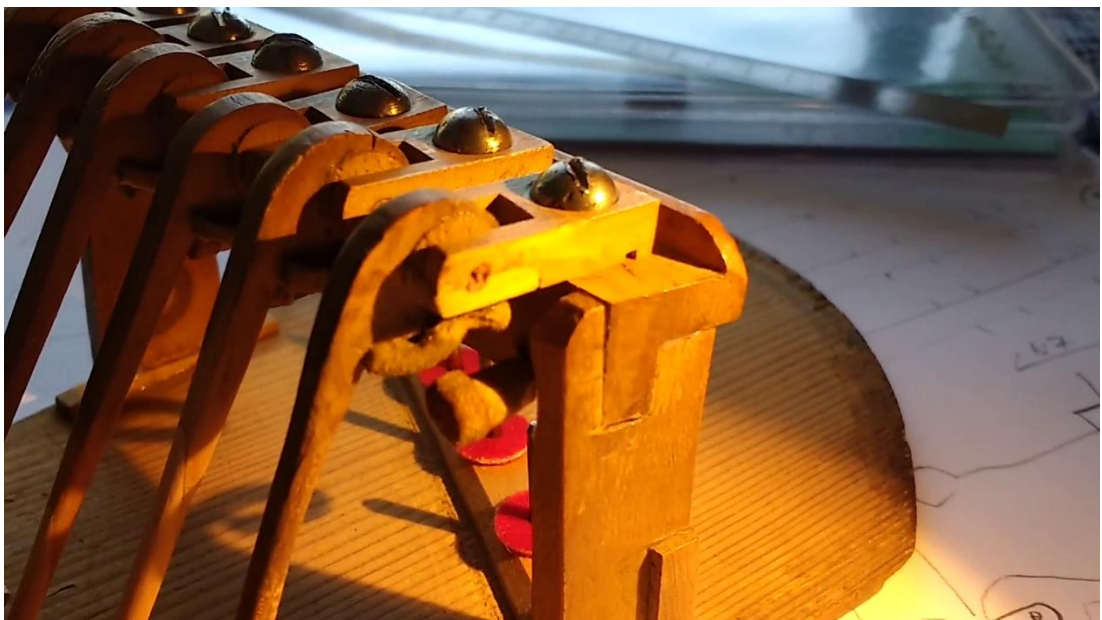

Figure 2.50 View of original instrument's hammer hinge

The hammer arms, escapement and hinges were all made from pear wood to match Neüner's original instrument. The hinges use bushing cloth to rotate the hammer arm and provide a low friction motion. It is possible that Neüner used parts from contemporary piano actions for these hinges; the grooves in the underside are also found in ordinary piano hammer hinges from nineteenth-century actions but also in modern actions today (see Figure 2.50).

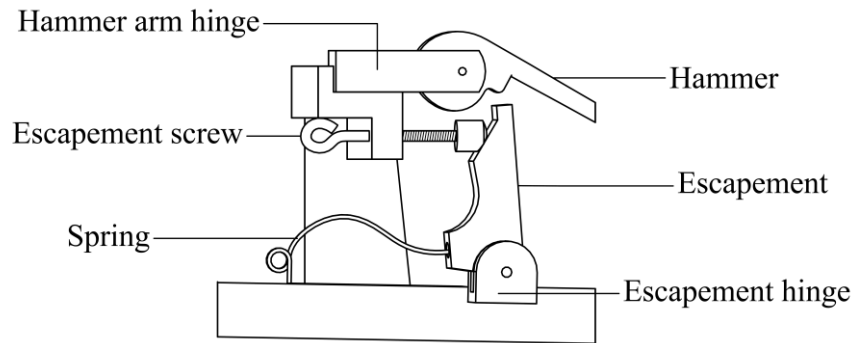

Figure 2.51 Diagram of Neüner's escapement mechanism

The escapement, which allows the hammer to fall away after the key is pressed, is the most crucial part of the mechanism for the feeling and response of the hammer. It can be regulated in four ways: (1) by adjusting the escapement screw forwards or backwards to make it meet the hammer arm at the correct position (see Figure 2.53); (2) by increasing the height of the escapement with leather toppings or cutting it down to make it shorter (see Figure 2.52); (3) by altering the angle of the slanted side of the escapement; and (4) by altering the position of the escapement along the key lever.

I set the action to achieve similar attack across the keys with as little friction and noise as possible. Points of contact within the mechanism were padded with cloth to reduce noise. If the hinges stick at all, the bushing cloth can be compressed by inserting the point of a bradawl.



Figure 2.52 Adding leather toppings to escapement

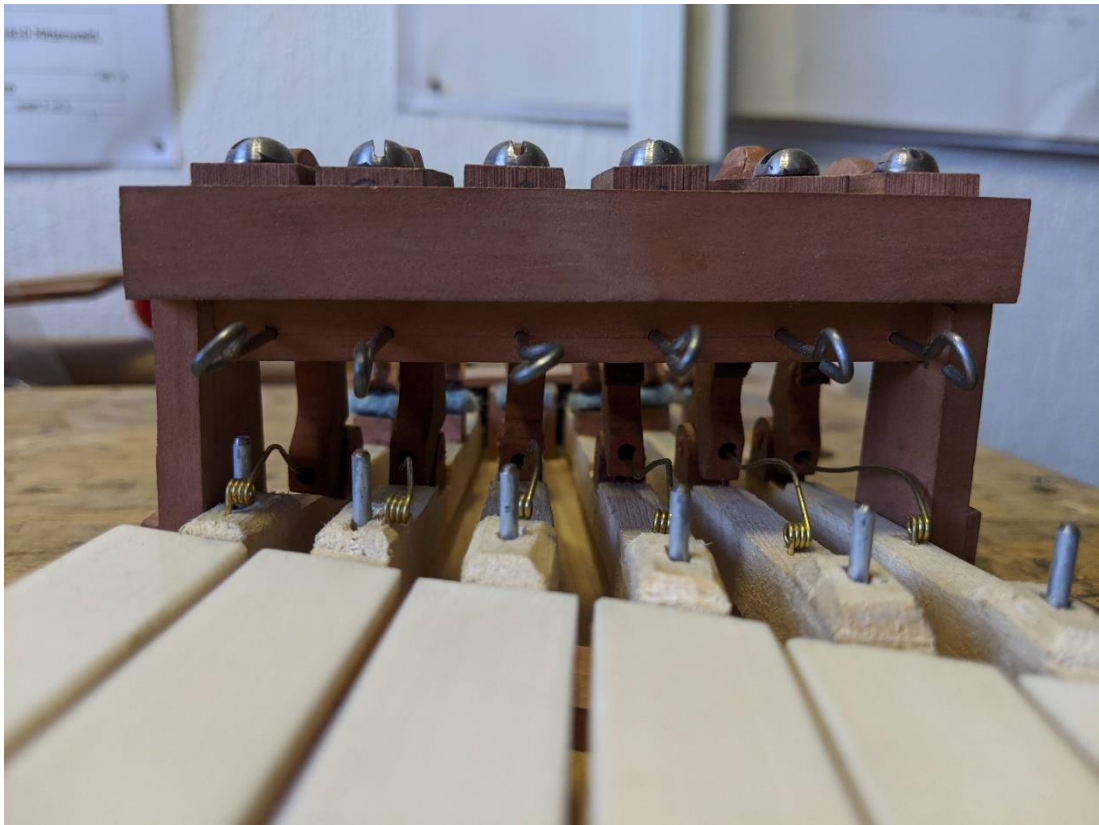

Figure 2.53 View of escapement screw



Figure 2.54 View of escapement springs and balance pins



Figure 2.55 Adding the hammer leathers

The pear wood hammer heads were topped with leather with a layer of cloth underneath. Holes for the hammer arms were drilled at an angle to accommodate for the oblique angle of the mechanism with the strings. The hammer arms were carved with a knife to a circular cross-section to fit into the hole in the hammer heads. Leather was also added to the bottom ends of the hammer heads to match the original mechanism. This is intended to reduce any sound made by the hammers as they fall back onto the keys.

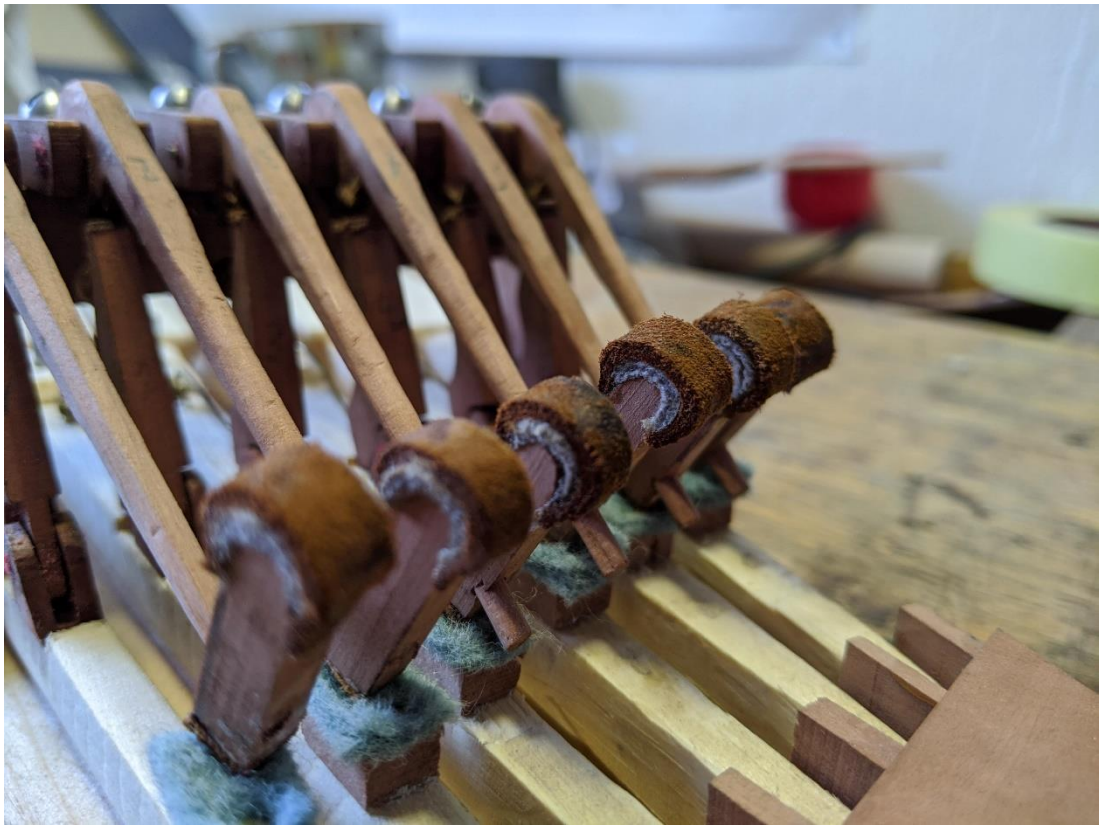

Figure 2.56 View of the finished hammers



Figure 2.57 View of mechanism from above



Figure 2.58 Finished mechanism within the reproduction instrument

The final regulation of the mechanism had to be done once the instrument was complete and fully strung. The hammers were finally cut to length and each hammer was angled to strike the correct string by rotating the hammer hinges. The hammers did not need to be glued into place; the tapered shape of the hammer arms fits tightly into the holes in the hammers.

Matteo Sprenger at the Metropolitan Museum of Art

The keyed guitar at the MMA has a very different design to that made by Neüner. It has therefore warranted a different approach to its construction. Given that it has very little support structure to hold the mechanism in place within the instrument, it was possible to build it up from the soundboard side. Furthermore, the shape of the instrument, being in *Wappenform*, divides the sides of the guitar into five separate ribs and lends itself to this method of construction, with the internal blocks being added first directly to the flat soundboard.

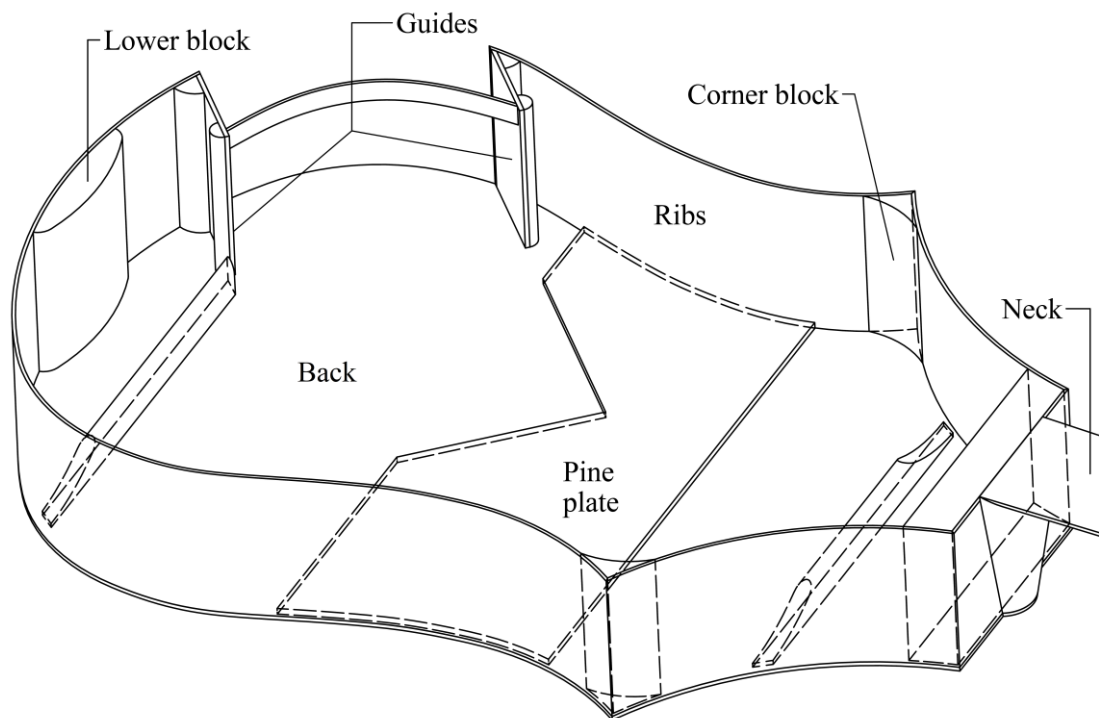

Figure 2.59 View through the soundboard into the MMA guitar body

The back of the guitar is completely flat (though not parallel with the soundboard), offering a plane for the mechanism to rest. The mechanism is mainly held in place by the inset guiding walls by the opening and a pine plate—shaped to receive the mechanism, stopping it from going too far into the instrument and supporting its angular position (see Figure 2.59).



Figure 2.60 Adding the diagonal brace

After the two-piece soundboard was joined, thickened, and cut roughly to shape, the single diagonal brace was attached (see Figure 2.60). Unlike the instrument by Neüner, which comes from a clear tradition of guitar making, the brace on the soundboard is not a common feature to other guitars of the time, but given the size of the soundboard and the unusual placement of the sound hole (in this case doubling as the hammer hole), the soundboard doubtless needs unusual bracing.

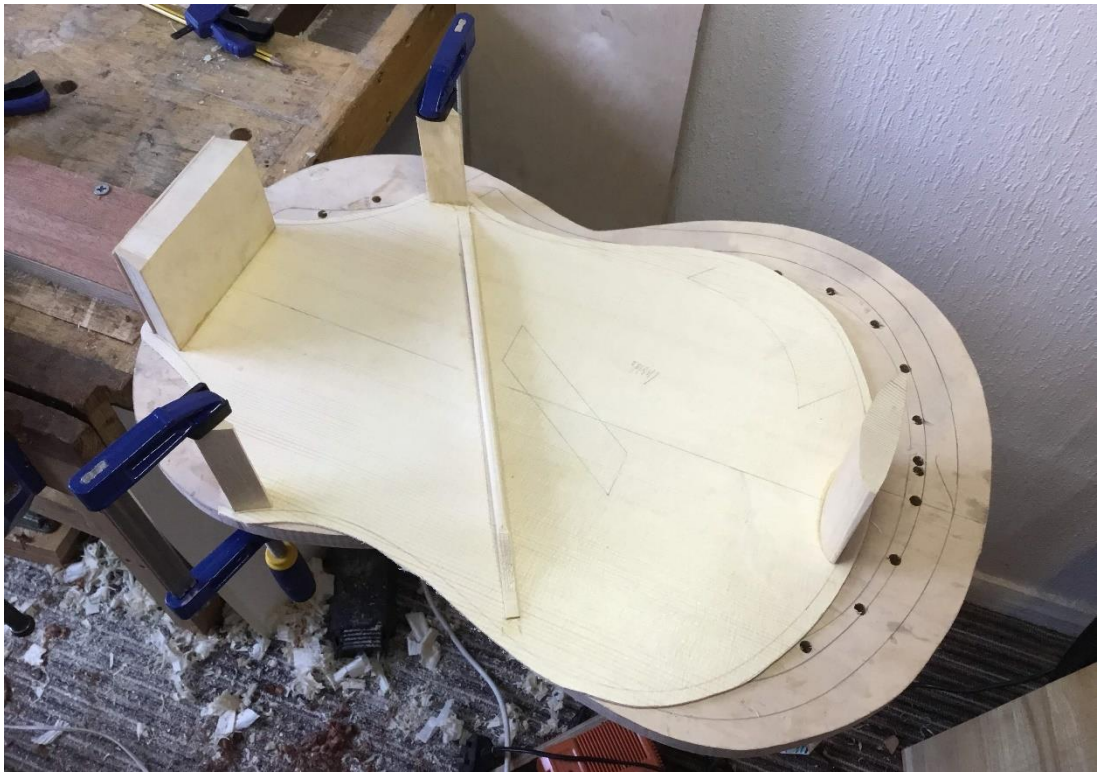

Figure 2.61 Clamping the corner blocks. Diagonal brace, upper and lower blocks added



Figure 2.62 Attaching the lining with spring clamps

The internal blocks were shaped and glued to the soundboard before the ribs (see Figure 2.61). Afterwards, the ribs were individually bent and attached to the internal blocks. Small triangular pieces of mahogany were used to line the soundboard side, while strips of elm wood were bent to shape and glued along the ribs on the back side (see Figure 2.62). Once the sides had been added, go bars, extending to the ceiling, were used to apply pressure on the bridge plate while gluing, (see Figure 2.63).



Figure 2.63 Gluing the bridge plate with go bars



Figure 2.64 Marking out the back for braces and pine patch



Figure 2.65 Mechanism pine patch added

The back plate was made from two pieces of highly flamed maple. It was thickened and roughly cut to shape before being marked out for the braces and the mechanism location (see Figure 2.64). The 4mm pine plate was cut to shape to receive the mechanism and glued on with the grain perpendicular to that of the back plate (see Figure 2.65). Having the grain of the back at right angles to the grain of the pine plate adds significant strength to the back of the guitar.



Figure 2.66 Cutting the binding and purfling channels



Figure 2.67 Body assembled without back, soundboard decorated



Figure 2.68 Neck made from wild service wood

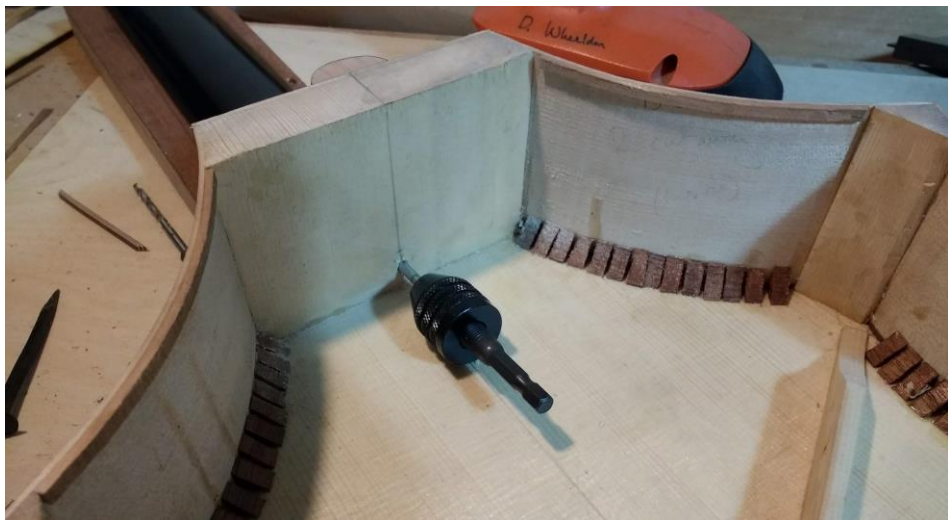

Figure 2.69 Pre-drilling the nail attachment of the neck

Before the back was attached, the hammer hole was cut out of the soundboard, and the decorative binding was added (see Figure 2.66). The neck also had to be attached before the back, which protrudes over the heel. The neck was made from wild service wood (similar in properties to pear wood) and stained black with spirit stain. I decided to use a nail to reinforce the neck joint for added security, though x-ray photographs show that the original instrument did not have this.¹⁹⁹

A steel rule was temporarily attached to the back to help maintain its position relative to the mechanism opening during clamping and gluing (see Figure 2.70). Fish glue was used to attach the back, since it has a long open time compared with hot hide glue.²⁰⁰ As each clamp was added it was necessary to check the position of the back, which had a tendency to drift as pressure was applied. In fact, after the glue had fully dried it was necessary to heat a section of the back near the mechanism opening, to finely adjust the positioning.



Figure 2.70 Back attached with spool clamps, ruler used to ensure the correct mechanism angle was maintained during clamping

¹⁹⁹ I am grateful to Manu Frederickx at the MMA for making the x-ray images of the guitar. For copyright reasons, these images cannot be reproduced here.

²⁰⁰ ‘Open time’ refers to the length of time glue can be applied to the work and exposed to the air before it becomes unusable.

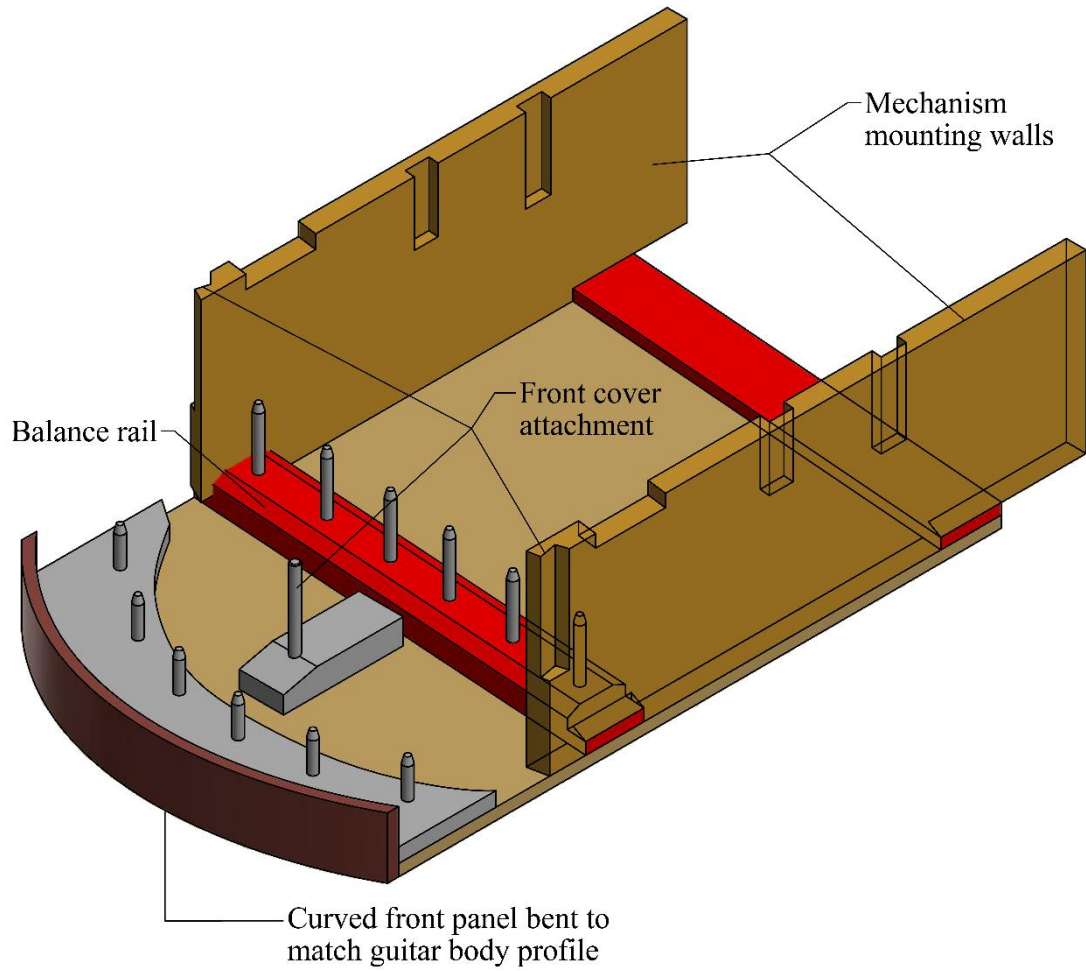

Figure 2.71 3D technical drawing of the mechanism used for construction

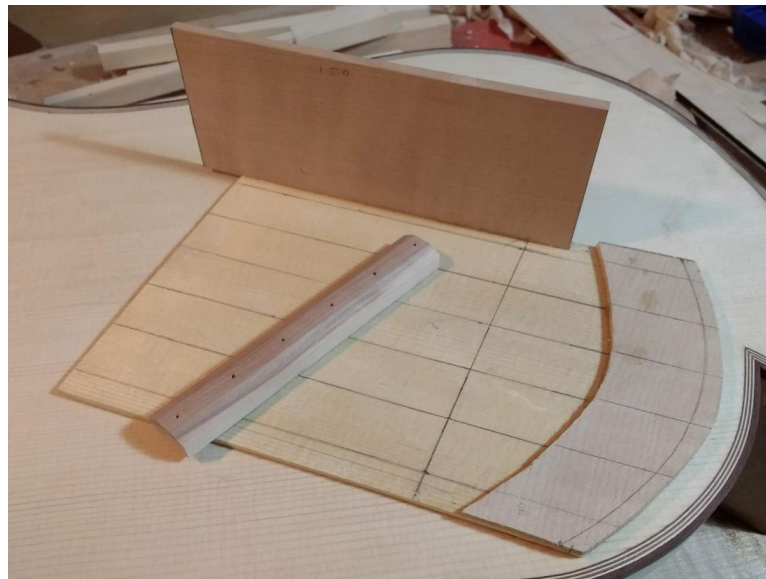

Figure 2.72 Baseboard marked out for the balance rail and keys

Once the back was attached, the mechanism baseboard could be shaped and fitted with the curved front panel and sides to match the opening in the guitar body. The baseboard was made from pine and closer to a rectangle in shape than Neüner's mechanism. A plate of maple was added to reinforce the front of the mechanism, and to support the front guide pins that serve to keep the keys in line without contacting one another. The tall sides made it necessary to drill the holes for the balance pins before gluing in the balance rail (see Figure 2.72).

The keys in this mechanism are all straight and so were comparatively simple to make without templates, and, matching the original materials, were made from wild service wood as opposed to the pine in Neüner's mechanism. The hole for the balance pin was drilled and then widened using the steel balance hole tool. This was driven into the hole with a hammer, compressing the wood fibres to the correct shape (see Figure 2.73). The holes at the front of the keys were also drilled and compressed with the balance hole tool, used on the top and bottom of the key. The front guide pins were much more effective at noiselessly keeping the keys straight than the rear guide rails of Neüner's mechanism.



Figure 2.73 Balance pin hole shaped with tool, clamp used to prevent splitting

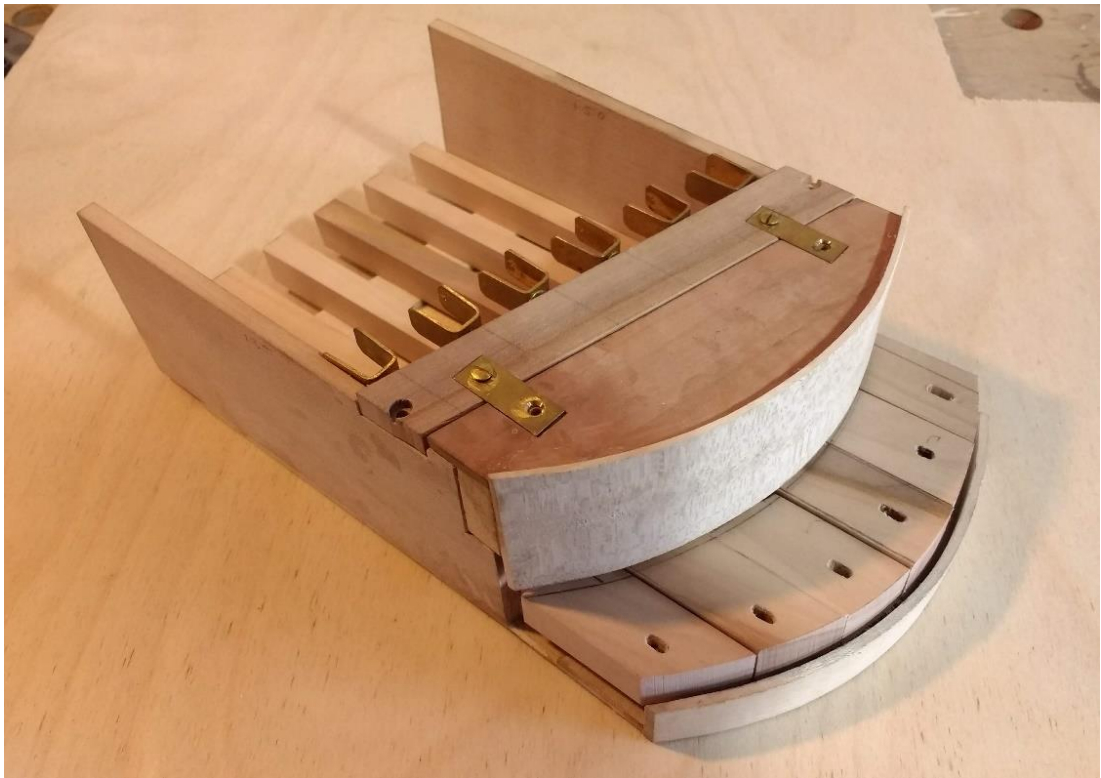

Figure 2.74 Keys shaped to fit mechanism, cover fitted

The hammer rail was shaped and fitted to the side walls of the mechanism. Brass *kapseln* were used instead of the wooden hammer hinges of Neüner's mechanism (see Figure 2.74).²⁰¹ These were screwed into the hammer rail angled to be in line with each corresponding key beneath. The artificial ivory (polyester) key fronts and tops were attached with cyanoacrylate (superglue).

²⁰¹ These were bought from Claudio Casiglia: www.claudiocasiglia.it

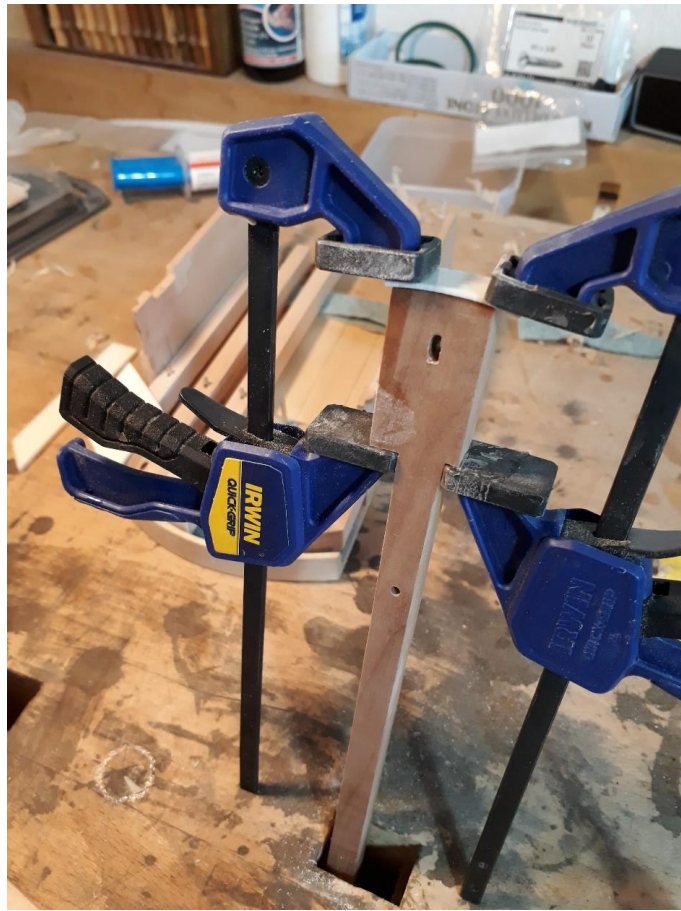

Figure 2.75 Artificial ivory key fronts added



Figure 2.76 Escapement and key lever cut for a parchment hinge



Figure 2.77 Parchment hinges added to keys

The escapement was attached to each key with a parchment hinge (see Figure 2.76). For this, a cut was made in the upper surface of each key and in the escapement, using a saw the same thickness as the parchment.²⁰² This is a very quick and effective method of hinging, but if it becomes necessary to adjust the position of the escapement, a new slot would need to be cut into the key, making it in principle more difficult to adjust than Neüner's escapement which could be removed with heat.

The hammers arms rest on a bar supported on either end by the mechanism walls. This raises the hammers from the keys, keeping them in place until the key is pressed (see Figure 2.78).

²⁰² I am grateful to Jonathan Santa Maria Bouquet for providing me with parchment and an appropriate saw for this.



Figure 2.78 Keys in place with escapement springs fitted



Figure 2.79 Leather added to hammer arms



Figure 2.80 Fitting hammers with axels to the brass kapseln

The hammers arms were cut out of pear wood, with a drilled hole for the axel which was pressed into place using a partially opened drill press chuck to protect the sharpness of the axel point. Strips of leather were glued to the contact points on the underside of the hammer arms (see Figure 2.79). This is to reduce the noise of the mechanism but also to stabilise the movement of the hammer action, giving extra grip as the escapement comes into contact. Before the hammers could be adjusted and cut to the final length, the bridge needed to be attached to allow correct calibration and alignment with the strings.



Figure 2.81 Bridge pin holes predrilled in soundboard

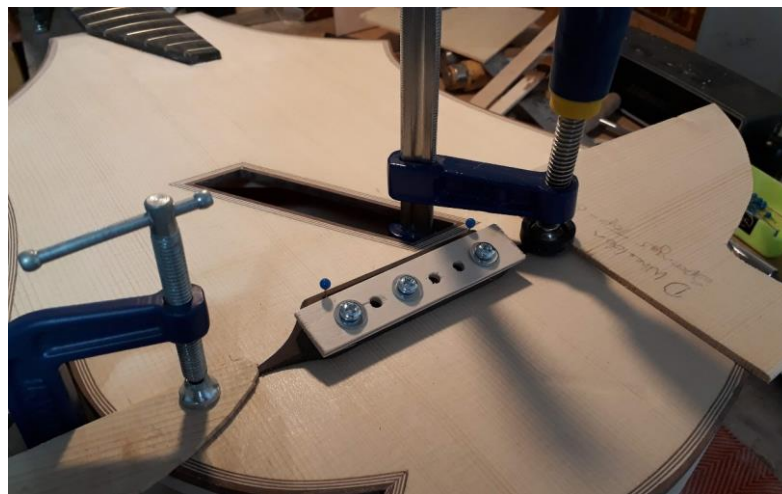

Figure 2.82 Attaching the bridge

The bridge was made from pear wood and ebonised with iron acetate, made from dissolving fine wire wool in vinegar. Holes for the bridge pins determine the position and spacing of the strings. The positions of these holes were transferred from the bridge to the soundboard and drilled out separately before the bridge was attached (see Figure 2.81). Once the bridge had been glued on, temporary strings were attached to determine the final hammer arm length (see Figure 2.83). The position of the checks depends entirely on the length of the hammer arms. The checks were made from pear wood and fronted in leather and, with the hammer arms cut to length, were fixed to the keys with thick wire pins which could be bent a little if necessary to ensure they did not coming into contact with the hammer at rest but caught the returning hammer while the key remained depressed.

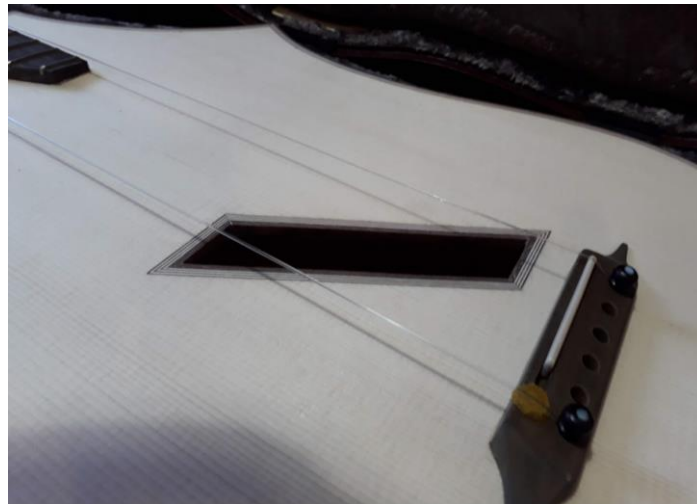

Figure 2.83 Temporary strings used to calculate the position of the hammers



Figure 2.84 Cloth was added to the mechanism to reduce noise



Figure 2.85 View of escapement positioning with hammer arm



Figure 2.86 Completed mechanism within instrument

While the various component parts of this instrument might differ slightly to Neüner's design, the assembly and regulation are the same. The escapement screws were made in the same way and were mounted on the hammer rail under the hammer arms. Despite the subtle differences the mechanisms of both keyed guitars are of the same principle.

Chapter 3: 3D Digital Technologies for the Reproduction of Historical Musical Instruments

Towards the beginning of this project, the prospect of reproducing the two keyed guitars was daunting, since they are complex composite objects that come from long traditions of knowledge and handcrafts. Producing a piano hammer mechanism is a feat in itself but integrating one into a guitar body so as to strike each string through a small opening within the soundboard requires meticulous thought and planning. I do not believe I would have been able to visualise (either in my mind or on paper) this intersection of moving and static parts without the aid of 3D technical drawings and 3D printed prototype mechanisms.

In the early stages of the work, 3D digital technologies were investigated in relation to the reproduction of musical instruments more widely. These technologies can be divided into two sections: building digital models, including 3D drawing, digital scanning, and x-ray photography; and computer aided manufacture (CAM), including 3D printing, CNC milling, and laser cutting.²⁰³ I discuss the role of CAM within the wider toolset of an instrument maker, highlighting areas which can benefit even the most conservative traditional workshop practices.

Literature Review

Inflated expectations

CAM is traditionally associated with mechanised mass production, in which context it serves to offer more flexibility, being more customisable than fixed hardware. Today, digital technologies for manufacture are incredibly sophisticated and are both more affordable and user friendly than ever before, allowing more applications to a wider user base. Premature hyperbole and misinformed communication about the available applications of digital manufacturing technologies put the wrong emphasis on the benefits of new technologies and threaten to damage confidence in technological innovation in a field already besotted by romantic ideals of handicraft. The inflated expectations of the benefits of technology have meant that some projects

²⁰³ 3D printing is another term for ‘additive manufacture’.

unaccountably attempt to rely solely on 3D digital technologies. All the while, others avoid modern technologies altogether.²⁰⁴

The former is most immediately visible in second rate clickbait articles which have been circulating since hyperbole about 3D printing began, in the mid-2000s.²⁰⁵ For example, Harris Matzaridis' ViolinoDigitale project, is an interesting look into applications of wood filament 3D printing.²⁰⁶ However, a 2017 article by Luke Dormehl about the project on digitaltrends.com, is entitled *3D-printed Stradivarius replica is nearly indistinguishable from the real thing*.²⁰⁷ Although it might have a wider reach, the impact of the research is severely dampened by such fantastic claims. Matzaridis' project is useful research portrayed in an unhelpful way.²⁰⁸



Figure 3.1 Economist front cover 12 February, 2011

²⁰⁴ This is not to say that all practices conform to one or the other extreme, but that given the exclusivity that comes with the specialist training in either digital technologies or traditional instrument making, practices do tend towards this divide. CNC milling is well established in small scale instrument workshops, but more often by makers producing instruments of their own design rather than by makers of historical instruments.

²⁰⁵ 'Clickbait' refers to internet content, often with a misleading title, the chief purpose of which is to encourage visitors to open it—to 'click' on the article.

²⁰⁶ Matzaridis 2016, www.violinodigitale.com. Accessed 6 June, 2020.

²⁰⁷ Dormehl 2017, www.digitaltrends.com/cool-tech/3d-printed-violin-stradivarius. Accessed 27 Feb, 2019.

²⁰⁸ To my knowledge there has been no academic publication of Matzaridis' research. This project appears in Jeri Freedman's *Future Uses and Possibilities of 3D Printing*, 2017, pp. 91–2, but with no deeper analysis. There are plenty of other examples of 3D printed Stradivarius violins including Laurent Bernadac's *3Dvarious*, described on wired.com as looking 'more like an avian skeleton than a stringed instrument', though praised for its durability. Margaret Rhodes, Wired, www.wired.com/2015/08/3d-various/; Accessed on 6 June 2020. See also www.3d-various.com. Another 3D printed 'Stradivarius' is the Hovalin, by Matt and Kaitlyn Hova.

Mostly, these cases of hyperbole are publicity stunts by 3D printing firms, whose chief objective is either selling 3D printing services or the printers themselves. For example, the German 3D printing firm EOS made a printed Stradivarius copy solely to demonstrate their capabilities (featured by *The Economist*, see Figure 3.1). For them, the success of the instrument was not its likeness to a violin by Stradivarius, but its ability to interest a wide audience. These projects have provoked some interesting discussions like the 2013 TEDx talk by Joanna Wronko who makes an interesting comparison of a 3D printed Stradivarius copy by Sander Smit and her own instrument.²⁰⁹

In his 2011 article in the *Journal of New Music Research*, Amit Zoran outlined his project of 3D printing a concert flute among other instrument parts. This work, undertaken at MIT, is discussed from an engineering perspective and he makes valid observations about the merits of 3D printing musical instruments: that they are more customisable, and able to be designed freeform with more potential for ergonomic compatibility. However, his test case instruments represent a clean break from traditional manufacturing techniques, and materially rely solely on 3D printing.

Zoran attempts to represent 3D printing as the inevitable future of instrument design which ‘may have come to an evolutionary impasse’.²¹⁰ This is an ambitious claim and unlikely to be true. The important and skilled work of this project might have had a much wider relevance if it had more thoughtfully incorporated historical designs and workshop practices. The conclusions of the study admit poor results, that the instruments had bad resolution, material quality, and stability, and pin the successful findings of the study on the inevitability that one day the technology will be good enough.²¹¹

3D printing has most effectively been applied to wind instruments, perhaps because the acoustical properties of the material are less important than the airspace. For over

²⁰⁹ Joanna Wronko, TEDxAmsterdam, *Playing the 3D-printed violin*: <https://www.youtube.com/watch?v=uHmdVmKX9x8>; accessed on 6 June 2020.

²¹⁰ Zoran 2011, p. 379. In his introduction he attempts to contextualise his research within a traditional history of musical instrument making, citing organological titans of the twentieth century (viz. Curt Sachs and Anthony Baines) out of context.

²¹¹ Zoran 2011, p. 386.

ten years now, 3D printing of cornetts has been a line of cogent research, most famously done by Simian and Savan, who published their research on the Renaissance cornett in 2014.²¹² The cornett, lends itself to alternate methods of manufacture, and cornettists today are well acquainted with the resin injection moulded instruments by Christopher Monk, who began replicating historic cornetts this way in the 1960s. Simian's 3D printed instruments are commercially available today, and are comparable in price to those designed by Monk. In 2014 Simian admitted that a good deal of hand finishing is still required to remove the porous and rough texture of the instrument, but the accuracy of the prints and the flexibility of the design make them easily customisable allowing a wide range of instruments at various pitch standards to be made. Simian has also been able to engage with museums to reproduce unique instruments including a bone flute from ca. 1400 A.D. at the Willisau Instrument Collection.²¹³

Capturing data

Various studies in the last decade have used computed tomography (CT) and 3D printing to study instrument mouthpieces.²¹⁴ Doubrovski studied various materials for printing saxophone mouthpieces with the hope of ultimately investigating the acoustics 'without geometrical restrictions imposed by traditional manufacturing methods.'²¹⁵ For this CT was used to create a foundational design, from which different materials were used and small alterations were made and the results were tested by musicians. Other projects have been more interested in historical reproduction rather than modern experimentation in freeform design. Cottrell and Howell have produced working mouthpieces from original manufacturers' design specifications, using 3D printing to experiment with various materials.²¹⁶ Howe used CT scanning to create models of rare clarinet, saxophone and ophicleide

²¹² Savan and Simian 2014.

²¹³ Described on Simian's website: <http://research.3dmusicinstruments.com/knochenflote-willisau.html>; Accessed on 9 June 2020.

²¹⁴ Doubrovski et al. 2012; Doubrovski, Lorenzoni, and Verlinden 2013; Howe et al. 2014; Cottrell and Howell 2019.

²¹⁵ Doubrovski et al. 2012, p. 1.

²¹⁶ Cottrell and Howell 2019.

mouthpieces.²¹⁷ This was primarily a computer-based analysis of the CT data, though some playable mouthpieces were made with 3D printing, often requiring hand finishing.

In the field of musical instruments, CT scanning is well established and can be used to offer exceptional insight into the construction and history of an instrument, like those discussed above. The *MUSICES* project²¹⁸ was focused on just this and aimed to establish comprehensive guidelines for carrying out 3D-CT of musical instruments. The motivation behind producing guidelines specifically for musical instruments was caused by the complex material structure of the objects. Instruments often have complex geometry with hidden internal cavities and consist of materials with wildly variant densities. For example, the keyed guitar by Neüner has brass tuning gears (relatively high density) with a spruce or pine soundboard (comparatively low density). Having standardised guidelines for producing repeatable scans of such complex objects is surely of benefit. However, although the *MUSICES* project explains how to scan instruments, it does not offer much insight as to why we should scan instruments, and how the data can be made available.

The use of CT to study the history and construction of musical instruments is exemplified beautifully by the study of the late fifteenth-century Lamont and Queen Mary harps at the National Museum of Scotland, published in Karen Loomis's 2015 Ph.D. dissertation.²¹⁹ By combining CT scanning and detailed external analysis, it was possible for Loomis to establish a substantial body of new information about the instruments. CT analysis made it possible to see the interiors, survey their construction and assess the condition of the wood, and made it possible to see various stages of damage and hidden repairs. Importantly, this data showed the grain of the wood, from

²¹⁷ Howe et al. 2014. Mostly a computer-based analysis of the μ CT data.

²¹⁸ The project lasted from November 2014 until October 2017, funded by the *Deutsche Forschungsgemeinschaft* (DFG) as a collaboration between the Germanisches National Museum (GNM) in Nuremberg and the EZRT (Development centre for X-ray Technology) of the Fraunhofer Institute for Integrated Circuits (IIS). The recommendations are publicly available at: <https://music.es.gnm.de/>, Bär et al. 2018.

²¹⁹ Loomis 2015; Loomis et al. 2012. These two harps are of great significance in Gaelic (Irish and Scottish), cultural and musical history being early examples with august histories.

which she suggests that changes should be made in the choice and cut of woods used up until that point in modern reproductions.²²⁰

Disseminating Data

3D digitisation, be it CT scanning, photogrammetry or even 3D technical drawing, has huge potential for communicating physical objects in research collections online. For print media, digitisation has made sources available to an international audience and provided the means to locate them. Digitisation combined with online access and optical character recognition (OCR) and search capabilities has changed the way researchers operate but also has opened collections to a broader audience. Tim Sherratt notes that in the 2015-16 annual report of the National Archives of Australia, 111,526 records were accessed in the reading rooms, while 10,579,254 records were accessed online. He also observes the democratisation of collections, saying:

This is not simply a matter of convenience. People who might never identify as ‘researchers’, who might never have thought of visiting a major cultural institution, can explore their collections without having to brave the intimidations of architecture or the questioning of gatekeepers, however well-intentioned.²²¹

Musical instrument museums have been actively digitising their collections, uploading photographs and audio files of their instruments to common databases, for example in the MIMO-international and MINIM-UK projects.²²² The full potential of online databases like these is still not fully realised—there are volumes of object meta-data, museum object case files, x-ray photographs and CT data which is not available, and may remain unused for years or perhaps forever. One problem is the space needed to store this information as these data files are often very large, and questions of ownership of the data can be raised depending on how it was acquired. Nevertheless,

²²⁰ The grain of the wood is seen to match the profile of the neck, indicating that the shape derived from a carefully chosen arched branch rather than being cut to shape.

²²¹ Sherratt 2019, p. 117. It is important to note that Sherratt’s chapter focuses on the limits of online access and the above quote must be balanced by arguments that warn against accepting digitisation wholesale. For example, Sherratt notes that ‘access to Indigenous cultural collections should be subject to community consultation and control’, and that digitisation might emphasise certain histories while ignoring others (Sherratt 2019, p. 118).

²²² Musical Instrument Museums Online (MIMO) <https://mimo-international.com>; Musical Instruments Interface for Museums (MINIM) <http://minim.ac.uk/>.

copyright is an important part of this conversation which needs to draw from as many stakeholders (cultural heritage institutions) as possible.²²³

Perhaps leading the way in displaying 3D data is the private company *sketchfab*, where institutions (as well as individuals) can subscribe and upload their 3D data in compressed formats for easy online viewing in a space that can be embedded into other websites. However, there are ethical issues with private companies holding cultural heritage data, especially that of a public collection. Additionally, the site itself is just a hosting site and its data stores are populated by millions of users from amateurs to institutions, and so the subject matter ranges from historic cultural heritage and art, to cartoon characters and pornography—it is not a site to let children explore.²²⁴

All this highlights that in engaging with new technologies it is not merely a question of how to gather data, but to understand why we gather it, how best to use it, and make it accessible. This is increasingly important at a time where computer literacy is booming, and where research collections can engage a broad audience with previously exclusive technical data. It is important for collections to know the purposes and limitations of the information they collect, which means understanding the technologies and having clear motivations for their use.

A chapter by John Hindmarch, Melissa Terras, and Stuart Robson in the 2019 *Routledge International Handbook of New Digital Practices* discusses the use of 3D models for public facing cultural heritage institutions.²²⁵ Although not specifically dealing with musical instruments, the chapter discusses the viability of the idea of digital surrogacy—where a virtual model has the same informational content as its subject. Importantly this paper emphasises that ‘a digital model cannot serve as a substitute for a physical object for *all* purposes’, but rather suggests that a clearer definition might be that ‘the model is a digital surrogate if it can substitute for the object *for the purpose of x*.’²²⁶ The authors discuss whether a digitised object can

²²³ Future-proofing these databases is also an important consideration. File types of various media may need upgrading when technology moves on.

²²⁴ Other hosting platforms are available (e.g. 3D Heritage Online Presenter ‘3D HOP’; and Babylon.js, both of which are open source) but are currently less popular.

²²⁵ Hindmarch, Terras, and Robson 2019, pp. 243–256.

²²⁶ Hindmarch, Terras, and Robson 2019, p. 244. Emphasis retained from source.

inherit some of the original object's 'aura'—defined as 'an affectual power to engender an emotional response in the viewer'.²²⁷

This idea becomes more tangible when considering musical instruments—multifaceted objects, which certainly cannot offer the same multi-sensory experience through a virtual model. This pragmatic approach for the application of digital technologies is vital when considering musical instruments, which, as objects of art, offer diverse routes for digitisation. Pitch, timbre, feel, weight, etc. are all vital elements for understanding any musical instrument and cannot all be simultaneously reproduced digitally. A virtual object could mean a photographic 3D model, a recording of all possible notes for sampling, or a dimensionally accurate model for measurements, and each requires a different process for capturing and representing the data. Some instruments lend themselves to audio sampling, but even an accurate digital reproduction of a 1740s Kirkman harpsichord played through a modern digital keyboard will only represent the sounds of the instrument and will inevitably miss the experience of tactile engagement with an original keyboard.²²⁸ Arguably, it is even more difficult to give a virtual musical object the affectual power of its original subject, than objects in other areas of cultural heritage.

In some cases, digitisation can offer more information than consulting the object in person. Multispectral imaging and CT scanning gives information concealed from the human eye, but whatever the method of imaging, it must be carried out with a specific purpose in mind. The better subject specialists understand the advantages and limitations of various technologies, the more meaningful the uses can be. Conversely, if tasks are driven by technology without input from subject specialists the information gathered will be of uncertain usefulness.

In my case I have approached technologies as a subject specialist with a utilitarian mindset: using 3D imaging and manufacturing technologies as parts of a larger toolset in a small-scale instrument workshop. I have used 3D printing to reproduce working

²²⁷ Hindmarch, Terras, and Robson 2019, p. 243.

²²⁸ Comparatively, harpsichords are among the more straightforward instruments to sample, as they have few variants in tone between players. Sampling a cornett or bassoon, for example can be much more complicated when each note can be played in many ways and is dependent on the decisions, style, and ability of the player.

parts for historical instruments and prototype piano mechanisms for the keyed guitars in this study. I have used laser cutting to produce an array of templates, and CNC routing to carve various parts of the instruments. In part my access to these technologies has been through the University of Edinburgh, but I have worked with private workshops and third-party services to reach my goals. In some cases, these methods were merely time saving, in others they increased my accuracy, but in the cases of 3D printing for usable metal parts I have been able to work in areas normally beyond my ability.

3D scanning

There are a variety of ways to gather 3D data including white light scanning, laser scanning, photogrammetry, and CT scanning. Like printing, there are third party services which specialise in different sectors within cultural heritage, from large-scale architectural scanning to smaller objects. Although larger institutions can engage with 3D scanning technology, it is still quite complex to operate the equipment and process the data in a way which produces high quality results. For this project I experimented with various scanning methods accessible through the University of Edinburgh, and explored the potential for CAM, but finally I decided to rely on traditional data gathering to produce 3D computer models.

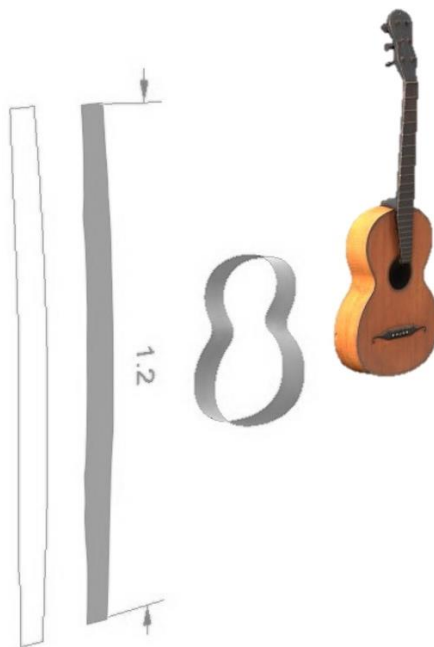

Figure 3.2 Photogrammetry of a guitar by Stauffer, MMA 1979.390

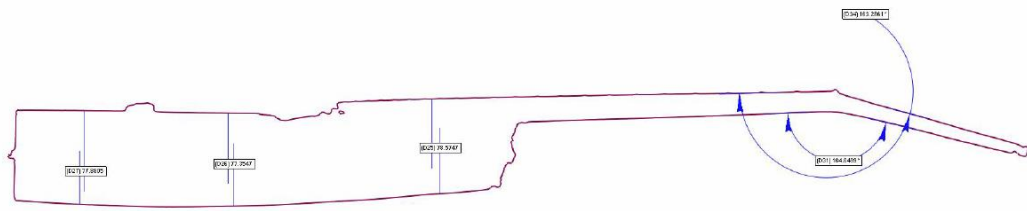

Figure 3.3 Outline of central cross section of MMA 1979.390

I have previously been involved with digitisation projects at the MMA, scanning whole instruments using photogrammetry, but the results were of mixed success.²²⁹ Some useful information was produced: the ribs were able to be measured and digitally unfolded to produce a 2D template (Figure 3.2); likewise a central cross section could be made showing the body shape in relation to the neck angle (Figure 3.3).



Figure 3.4 Stauffer heel, MMA 1979.390: Photogrammetric image (left); Photograph (right)

²²⁹ This project, in 2016, was mainly focused on discovering the potential uses of photogrammetry for the study of musical instruments and did not have any specific objective in mind. As a Chester Dale fellow in art history within the department of musical instruments, my main input was in suggesting ways in which the data could be used rather than in collecting it. I played a minor role in the project which was run by Ronald Street who worked across the museum with multiple departments.

However, despite the need for expensive equipment and extensive post-production editing, the results were poor, with reflective surfaces or small parts (especially the strings) causing sometimes drastic distortion. Figure 3.4 shows a comparison of the photogrammetric data and an object photograph. There are significant errors in the dimensions and colouring of the data, making me hesitant to trust other aspects of the results.



Figure 3.5 Scanning a guitarr rose with Next engine HD ultra, MIMEd 1067



Figure 3.6 Scanning a pianoforte guitarr rose with Next engine HD ultra, MIMEd 308

Towards the beginning of this project I investigated the efficacy of 3D scanning technologies available at the University of Edinburgh. I used a *Next engine HD ultra* laser scanner to scan a brass rose on both a guitar by John Preston and an unsigned pianoforte guitar.

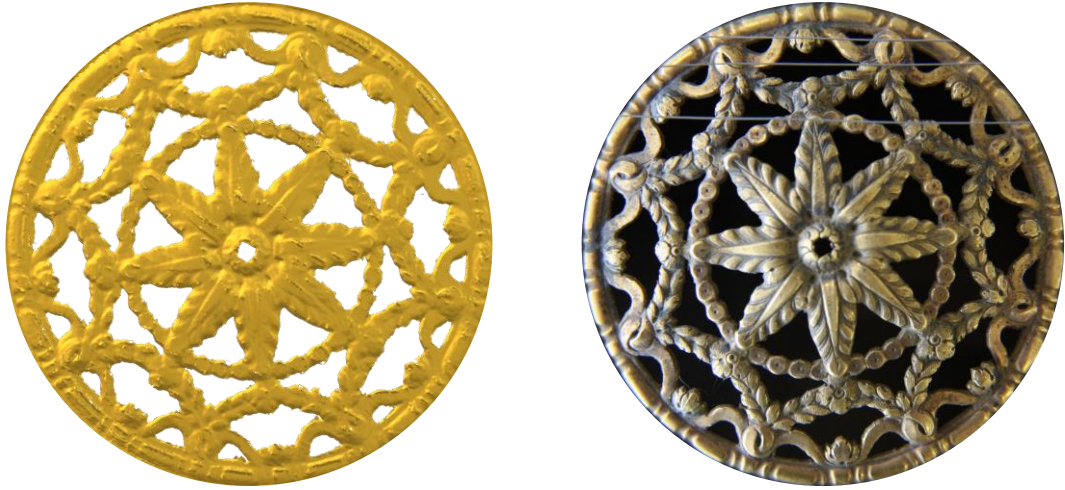

Figure 3.7 3D MIMEd 1067: Computer model (left); photograph (right)

The results needed significant processing to be usable for 3D printing and given that it was only one face of the rose, the model had no thickness. The results for the guitar by John Preston (Figure 3.7), were almost usable, with the general pattern being accurately copied. However, on close inspection of the model, there were many gaps and protrusions on the surface. Perhaps with more work they could have been usable but given the immediate pressures of the project it did not seem practical to pursue this methodology.



Figure 3.8 MIMUL 628: CT scan data (left); photograph (right)

At the same time, I received comparable CT data of a similar brass rose, which, even in its raw form, was much more usable. CT data generally has several advantages over laser scanning: reflective surfaces do not create distortions in the data, the unique material density makes the data easier to isolate, and it gives a complete 3D model rather than just a surface viewed from one side.²³⁰



Figure 3.9 Plastic 3D printed copy of a pianoforte guitar brass rose, MIMUL 628

Without altering the raw data, the CT scan file was uploaded to the *Shapeways* website as a .stl file, from where it was printed out. There is clear potential for this data to be used by makers and restorers of musical instruments, and with the growing digital collections within museums there is increasing potential to contribute to the faithful reproduction of instruments. Although 3D printing does not instinctively associate itself with traditional crafts, where services offer printing in metals for functioning parts there are many applications for the practical use of this data.

²³⁰ I am grateful to Josef Focht, Markus Brosig and Sebastian Kirsch for providing the CT data.

3D Printing for the reproduction of musical instruments

No 3D printed parts have been used in the two reproduction instruments; however I have depended on 3D printed prototype mechanisms for the process of manufacture, and crucially for my own understanding of how these parts fit together and function within a larger instrument. Early in the project I set out to investigate the usefulness of 3D printing technologies for the manufacture of historical musical instruments and, while not all were suitable for this specific project, I was encouraged to see practical and exciting applications in this field. Without having experimented with these prototype mechanisms it is doubtful whether I would have been able to successfully build the two keyed guitars.

3D printing offers new possibilities in designing shapes that are not possible using conventional techniques; this was the motivation of Dobrovski's saxophone mouthpiece project discussed before.²³¹ However, it also allows us to have access to historical manufacturing capabilities which would otherwise be out of reach. The reproduction of historical musical instruments is often carried out by small workshops, often of just one person, attempting to reproduce instruments originally made by the hands of many specialists. Not only did well-established instrument-making firms like Mathias Neüner or Longman & Broderip have a large workforce with substantial workshop infrastructure, but they also relied on strong external supply chains that are no longer available.

Shapeways offers the service to print metal parts, either through direct metal laser sintering (DMLS) or selective laser melting (SLM).²³² This is where successive thin layers of fine metal powder are fused together with a laser, building up the model layer by layer based on a series of 2D cross sections. This is limited in the types of metals: aluminium, stainless steel, titanium, cobalt aluminium and Inconel.²³³ However, they also offer inhouse casting and processing from 3D printed wax models. This service is

²³¹ Dobrovski et al. 2012.

²³² The idea of having a 3D printer in every home is largely outdated, though there are still plenty of low-end machines marketed for personal use. Third-party 3D printing firms like *Shapeways* and *3Dhubs* allow experimentation with various technologies without having to invest in expensive machinery.

²³³ This is quite expensive, for example stainless steel 316L powder can cost from \$350 - \$450 USD per kilogram. Redwood, Schöffner, and Garret 2017, p. 129.

of vital importance for the way individuals and institutions should approach 3D printing technologies. By using third party 3D printing services, technologies which were previously limited to established industrial processes are now available for one-off parts. Instead of spending large sums of money running and maintaining various 3D printers, as well as the often prohibitive start-up costs, it is possible to have small parts made to order from 3D data files—these could either be made from CT scans or from technical drawings.

I have used this process to produce working copies of English Guittar watch-key tuning gears such as those found of the pianoforte guittars of the 1780s, and also specialist brass parts for a conservation project of the Lacôte *decacorde* (MIMEd 767).

Preston's Guittar Tuners

John Preston's watch key guittar tuning mechanism is a good example of a historical technology that is difficult to make today. The system required the guittar string to be cut closely to length with a wound loop at each end. This would have made it more difficult for guittarists to replace their own strings but had the advantage of fitting ten or more strings on a relatively small head, since each travelling hook takes up considerably less space than a tuning peg or gear mechanism. In 1766, around the time of the invention, John Preston claimed that guitars with his patent tuners would only need tuning once a month, doubtless an exaggeration, but suggesting they were perhaps more stable than wooden friction pegs like those found on violins.²³⁴

²³⁴ Lasocki 2010, p. 131.



Figure 3.10 Preston tuners on a guitar in the author's collection

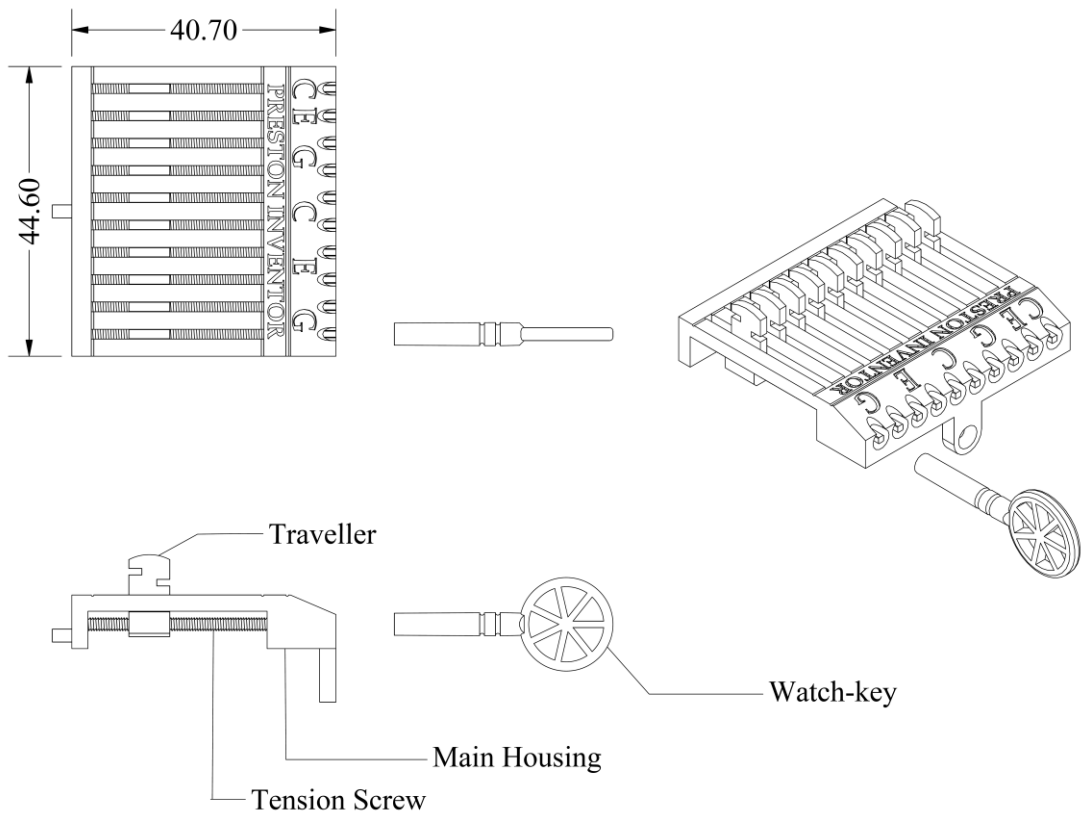

Figure 3.11 Diagram of Preston tuners

The tensioning screws of Preston's tuners were turned by a small watch key, which was used for each string, this feature also enabled the mechanism to be more compact. As the traveller moves up the screw, the string is stretched, and the pitch is raised (see Figure 3.11). This invention became an iconic feature of the English guittar and is found on all pianoforte guittars with internal mechanisms. It went on to influence the Waldzither and more significantly the Portuguese guitar which is still made today.²³⁵ However the construction techniques are different, Preston's tuners are much smaller and are housed in a body made from one solid piece of brass. Waldzithers and Portuguese guitars use larger tension screws and are housed in assembled bodies and usually soldered together.

²³⁵ The tuning mechanism for the Portuguese guitar is often called a Preston mechanism or Preston tuners.



Figure 3.12 Portuguese Guitar by Antonio Duarte, twentieth century, MIMEd 2765

The Portuguese guitar is closely related to the eighteenth-century guittar in London, and closely resembles it. The distinctive fan shaped head is a necessity of having tuning knobs at the end of each gear (see Figure 3.12). Although Portuguese tuning mechanisms are being made today, it is very different to the process of making historical copies of the eighteenth-century tuners. There have been various attempts to reproduce these today by hand, but each introduces compromises to the original

design.²³⁶ In 2010, I had attempted to cast the parts for this mechanism based on hand-made wooden models, but the project was a failure due to the fine degree of tolerance needed. During this project I asked the advice of several machinists and foundries in London, who were all sceptical about the feasibility of the project.

This style of tuners is an ideal case study to demonstrate the efficacy of 3D printing in metals. In 2017, I constructed 3D technical drawings on *Autodesk Inventor* taking measurements from an original Preston tuning mechanism (Figure 3.10). To begin with I ordered a single traveller in brass, and the main housing in plastic. It was not feasible to cast the part with the screw thread on the traveller, so it was necessary to tap the hole manually (Figure 3.13).

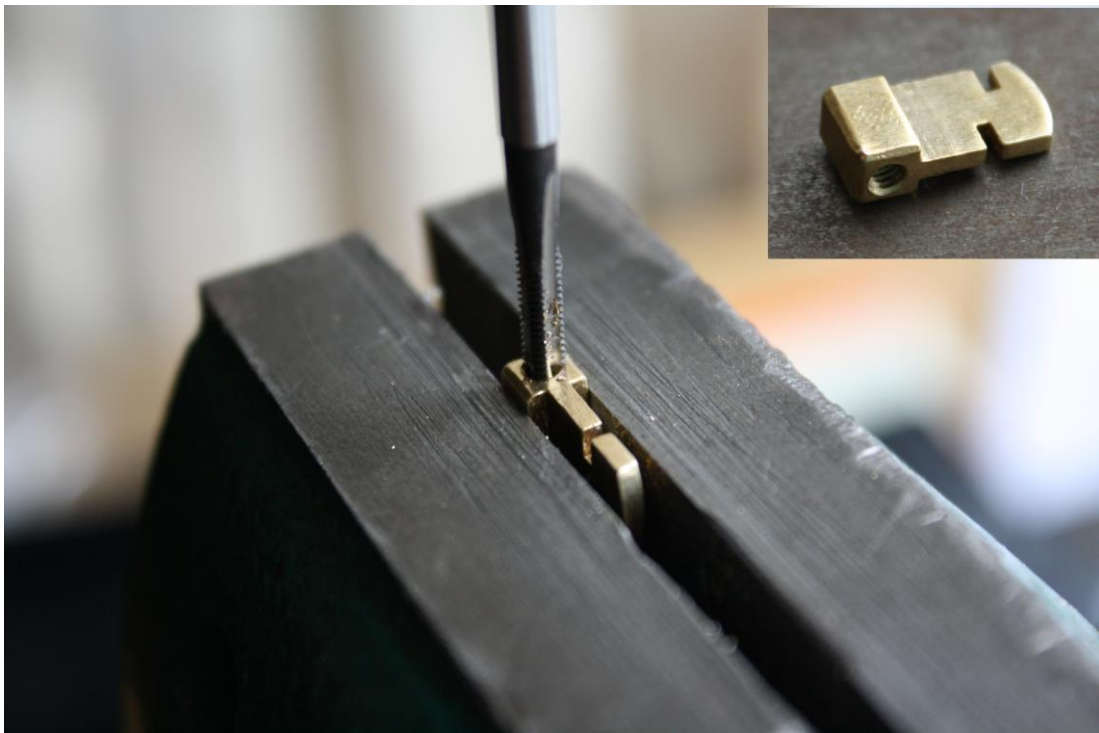

Figure 3.13 Tapping the Shapeways traveller

The tension screw was automatically rejected by *Shapeways*' website interface, which analyses the uploaded 3D models for compatibility with the manufacturing process.

²³⁶ Makoto Tsuruta produced excellent copies in 2004, but of his two types, one uses silver solder to assemble the body, and the other has rounded ends to the slots. <http://www.crane.gr.jp/more/parts-reproduction/indexE.html>; Accessed 11 November 2020.

This part had to be made on a lathe and was quite time consuming (see Figure 3.14). The watch-key requires a square end section to the tension screw which is difficult to reproduce accurately on so small a screw.

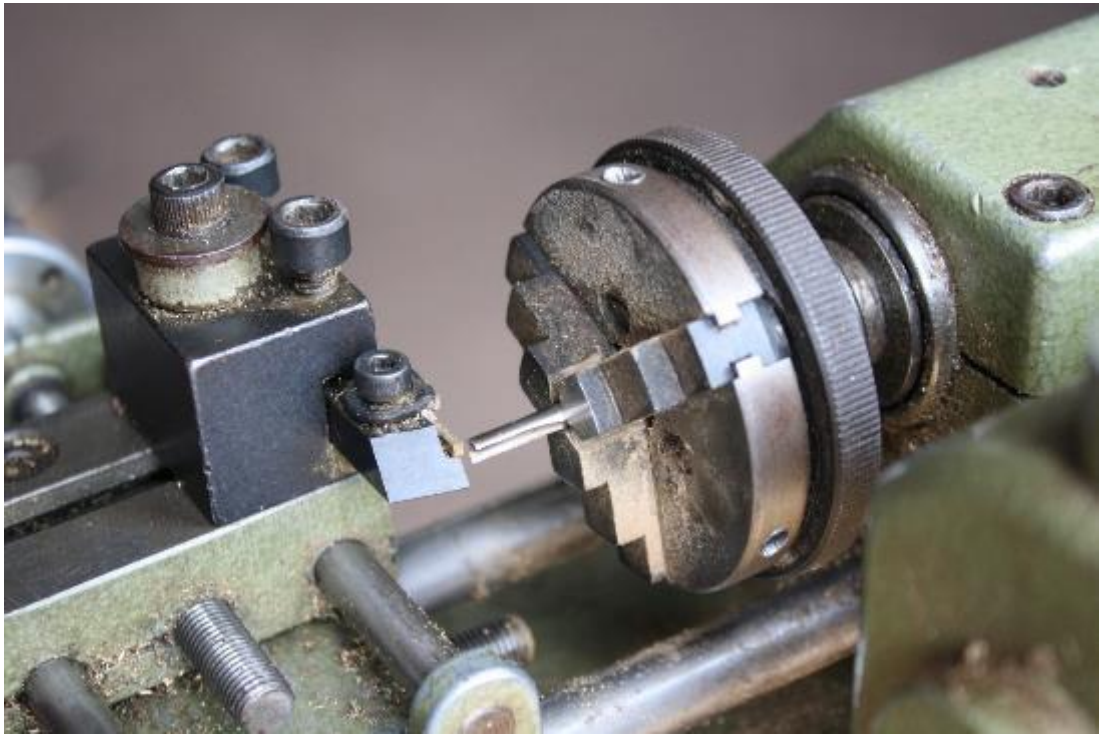

Figure 3.14 Milling the square end of the tension screw on a model makers' lathe

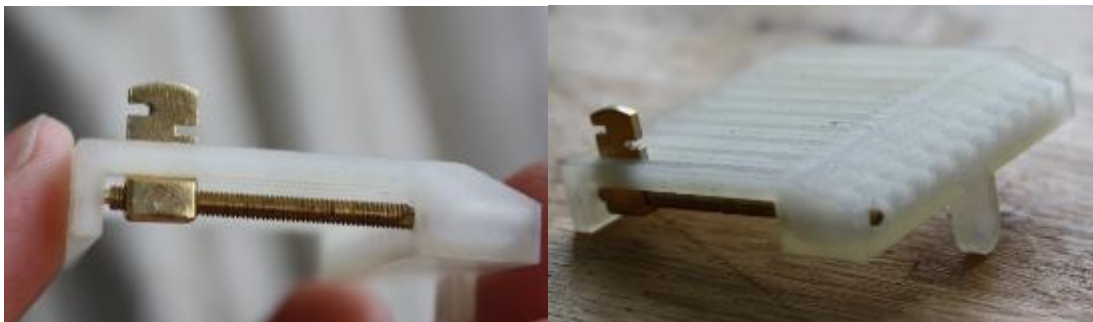

Figure 3.15 Assembly of prototype Preston tuners

The prototype worked excellently and so I ordered the necessary additional parts and repeated the process for each tension screw and traveller. The main housing in brass arrived and needed moderate clean-up and flattening, but the engraved lines were clearly visible, and the accuracy was impeccable.

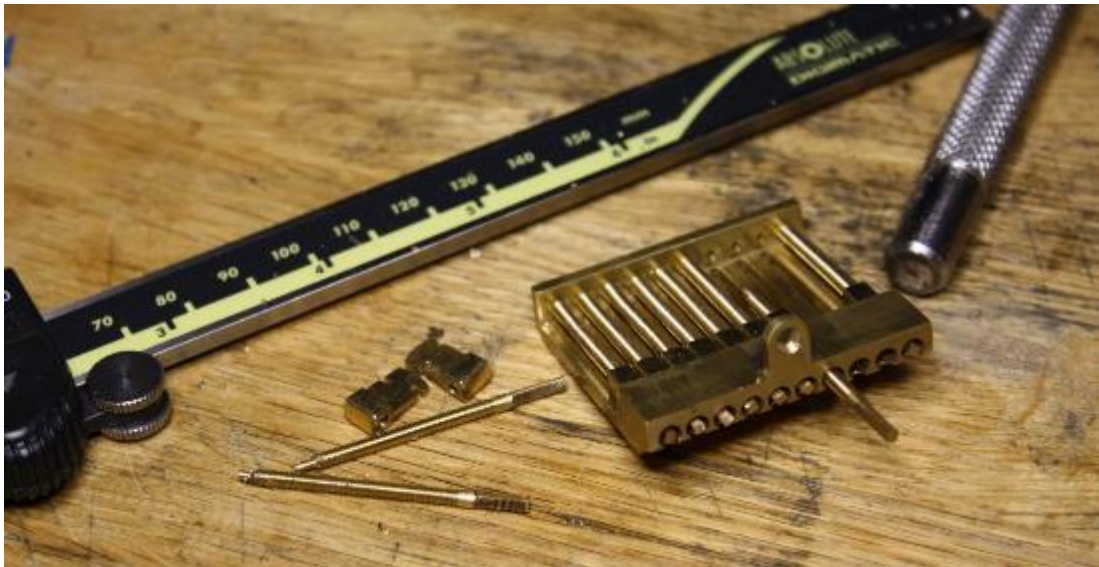

Figure 3.16 Partial assembly of replica tuners

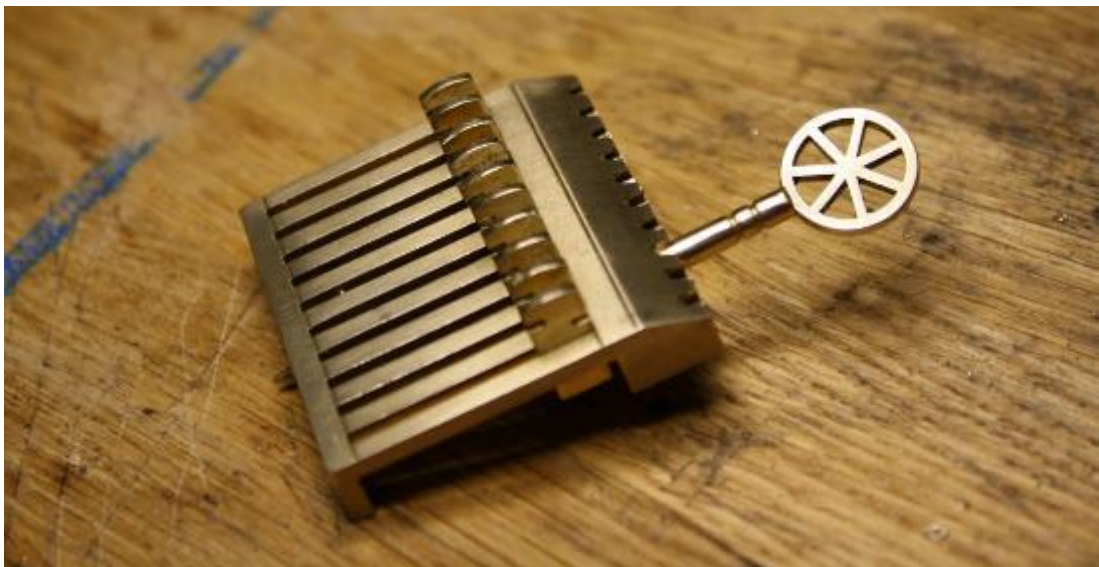

Figure 3.17 Completed assembly of Preston tuners with watch-key

The results of the project are high-quality accurate reproduction Preston tuners, which, in my case, were not reproducible without 3D printing services. However, far from being an autonomous process which removed the need for handicrafts, they required specialist knowledge to make the copies work. *Shapeways* were able to provide the parts by coupling their 3D printing capabilities with traditional lost-wax casting, and the parts were only usable by careful hand finishing.

In the eighteenth century, many subtly different iterations of these tuners were made, and today this method of reproduction enables complete flexibility since parts can be

made to measure. Although in this project I used computer drawing, there is no reason 3D scanning (e.g. CT data) could not have provided the base model. The implications for conservation are obvious, and immensely practical.

Lacôte Decacorde ‘Pedals’

While researching these technologies I had the opportunity to apply this process to a conservation project at St Cecilia’s Hall—assisting conservator Jonathan Santa Maria Bouquet, in restoring the 1826 *decacorde* by Pierre-René Lacôte (MIMEd 767). As its name suggests, this is a ten-stringed instrument, with five floating bass strings and five strings over a conventional guitar fingerboard. In summer 2017, this instrument was undergoing thoughtful restoration to playing condition at St Cecilia’s Hall by the conservator with help from Fabio Bonardi.



Figure 3.18 Restored decacorde by Lacôte, MIMEd 767

One necessary step in the restoration was to replace some missing hardware on the head: the tuning pegs and the brass chromatic ‘pedals’. Originally the decacorde had three so called ‘pedals’, each of which served to shorten the vibrating string length of

a floating bass string by the measure of one semitone, effectively acting like the pedal of a harp.²³⁷ I was tasked with reproducing the two missing brass ‘pedals’, for which I depended on measurements of the existing holes in the instrument, complemented by the one surviving original, and diagrams from the original patent document.

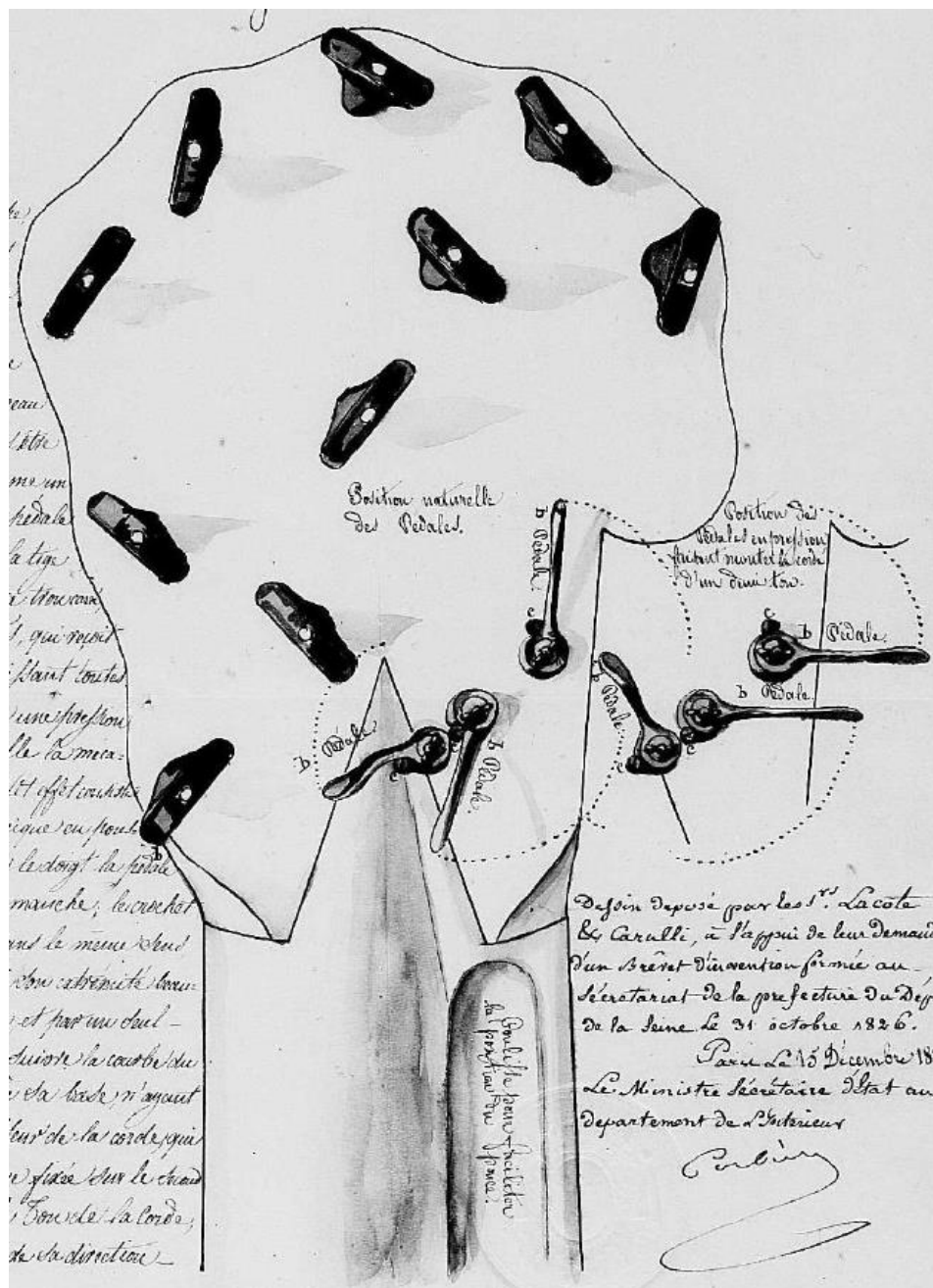

Figure 3.19 Lacôte patent diagram of the back of the head

²³⁷ Lacôte uses the word *pedale* in his 1826 patent for this instrument (no. 1BA2514), they are not foot operated. There is very little resemblance to harp pedals in their design.

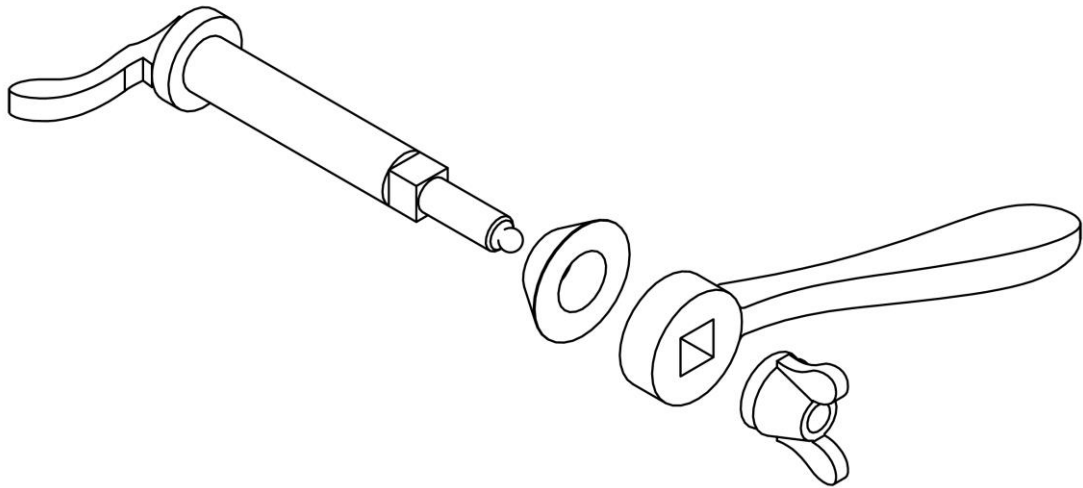

Figure 3.20 Exploded drawing of reproduction pedal

As with the Preston tuning machines, my drawings were printed and cast by *Shapeways*. The screw thread likewise needed to be done by hand, but the parts were of a very high quality, and needed minimal hand processing. Suffice to say it was a successful project, and these obscure parts would have otherwise been a laborious and doubtless expensive project (see Figure 3.23).



Figure 3.21 Reproduction components for a decacorde pedal



Figure 3.22 View of restored Lacôte decacorde, MIMEd 767



Figure 3.23 Back view of restored Lacôte decaorde, MIMEd 767



Figure 3.25 Part assembly of prototype mechanism



Figure 3.26 3D printed escapement hinged with bushing cloth

In a project which involved producing a piano hammer mechanism in an awkward shape—to fit within the body of a guitar—and one which had never been reproduced before, it was an invaluable learning experience to construct this prototype. I gained a

clearer understanding of the principle and function of the escapement and learned how to regulate the action. This was vital experience that was much more cheaply afforded by 3D printing than by hand-making a prototype.

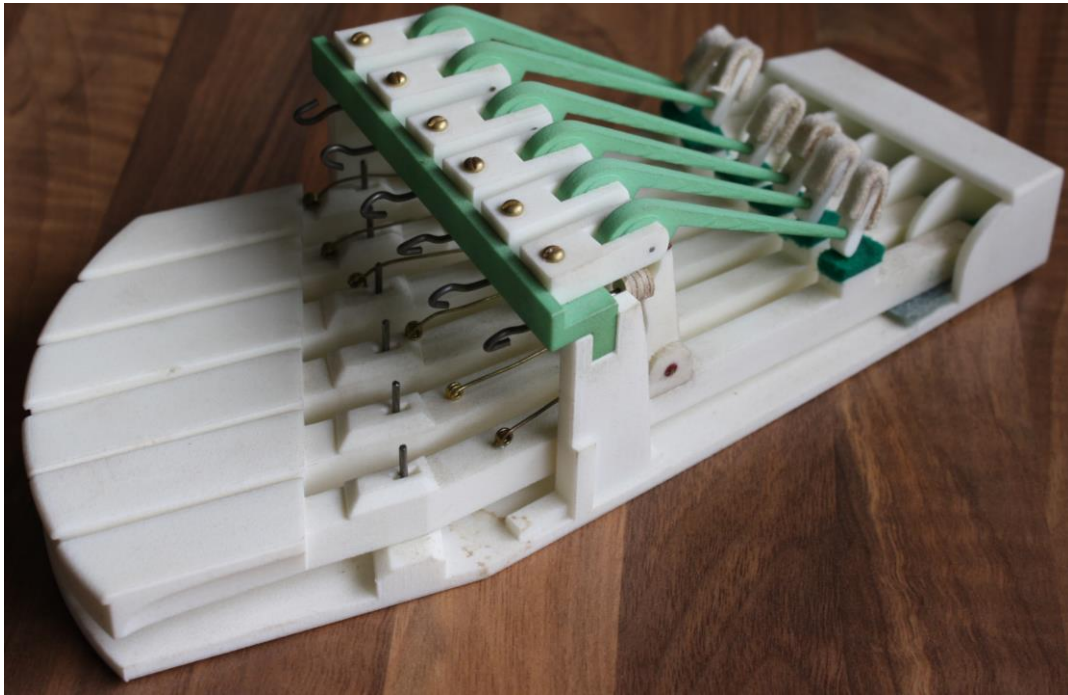

Figure 3.27 Assembled 3D printed prototype mechanism for the guitar by Neüner

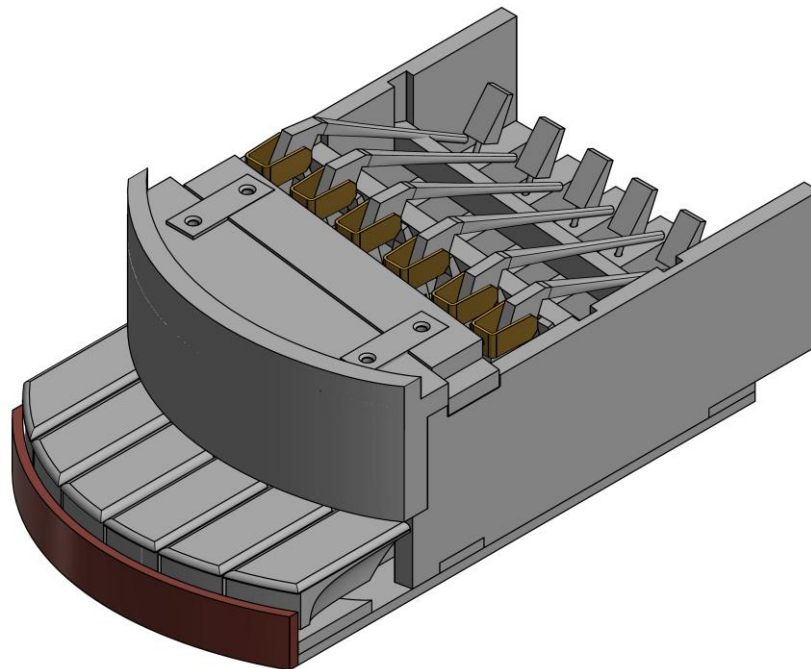

Figure 3.28 Computer model of the key mechanism by Sprenger, MMA 89.4.3145

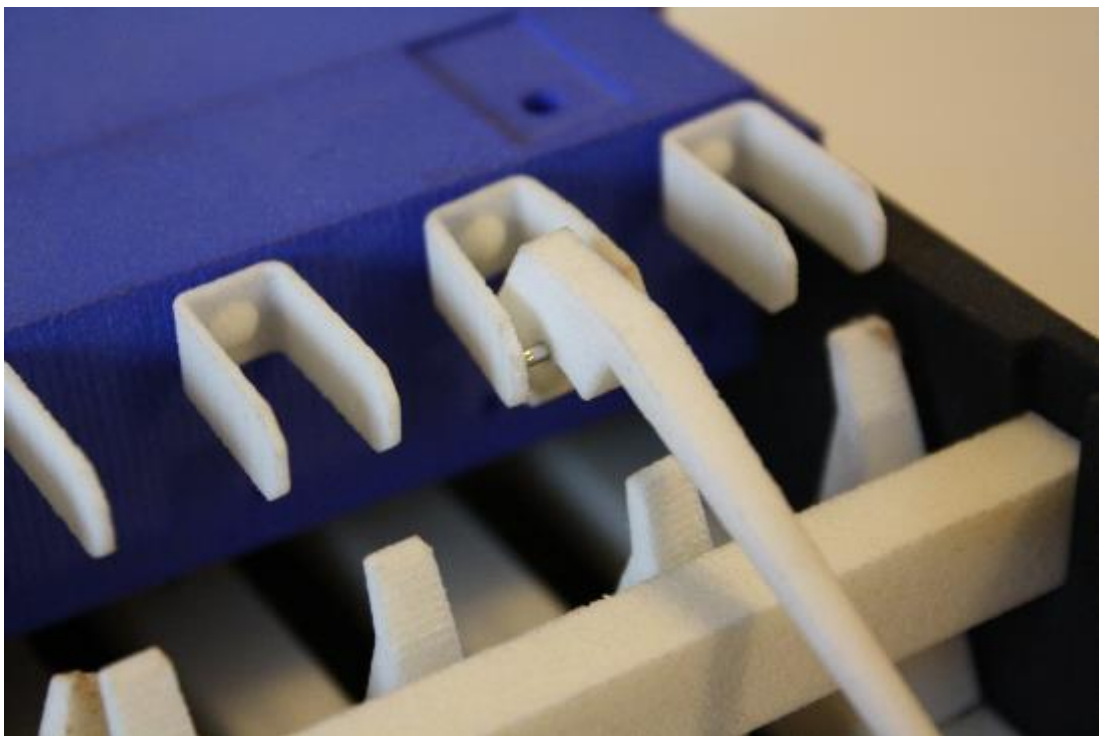

Figure 3.29 Two views of 3D printed prototype mechanism, MMA 89.4.3145

The reproduction of the mechanism by Matteo Sprenger was less successful (see Figure 3.29), since the plastic copies of what would be brass *kapseln* could not cope with the force of the key mechanism and the hammer arm was ejected from the mechanism each time a key was pressed. It was nevertheless valuable to have a 3D model to consult in reproducing the working copy.

Conclusion

Mark Miadownik, materials scientist, engineer and Director of the Institute of Making at UCL, was a panellist in the V&A's proceedings *What is the Future of 3D Printing?* in the 2013 London Design Festival, where he said:

In our Institute we have lots of 3D printers but we also have all the basic tools: we have the chisels and the screwdrivers and we have all the drilling and the bandsaw, and we have exotic things too like laser cutters. ...[Newcomers using 3D printing alone,] can't do what they wanted to do in every case, in most cases in fact—then we say “well actually you can do that on the lathe or you can do that on a milling machine, or you can just do that with a...”²³⁸

Even in a context free from the expectations of traditional workshop practice, new technologies are not seen as the solution to all problems. Once demystified, technologies like 3D printing and scanning can take their place as part of a wider toolset. Far from replacing traditional crafts, they offer opportunities to achieve more ambitious goals. From the perspective of historical instrument reproduction, we are able in some cases to replace long lost supply chains and accomplish as individuals, similar outputs as historical makers who depended on large highly skilled workforces.

The ability to have metal parts made with 3D printing opens a wide range of applications in copying most types of instruments: keys for flutes, handles for harpsichord stops, sound hole rosettes, brass mouthpieces, to name but a few. There are still more materials available for printing, including ceramics and sandstone, offering still wider applications, and with third-party printing companies it is not necessary to invest heavily in the machinery itself.

In each case where I have used 3D printing, I have depended on my specialist understanding of the instrument parts to produce the 3D drawings, but also I have needed to work with the printed parts using more traditional tools. The printed Lacôte *decacorde* ‘pedals’ needed little work—only cutting the screw threads—but producing the designs required hands-on measurement of the instruments and knowledge of the original patent documents. The reproduction Preston tuners needed more than just cutting the screw threads: since some parts were too delicate for the printer and needed

²³⁸ Bowyer et al. 2013.

to be made by hand. For the prototype keyed guitar mechanisms, various additional parts were needed in assembling the printed elements: springs, screws, pins, felt, and leather. Specialist knowledge of the objects and a wider understanding of available making processes are indispensable prerequisites when engaging with automated digital manufacturing technologies for the reproduction of historical musical instruments.

As well as the material assistance these technologies provide, 3D technical drawing has been an essential tool for developing my understanding of the physical objects. It allowed me to build up a working model, part by part, and provided a platform for me to think and grasp the composition of these complex objects. These drawings could be exported as reliable 2D plans for templates which could be transferred directly onto my building materials. It is difficult to say whether this project would have been possible without using 3D drawings, certainly the alternative would have required a lot of trial and error. Furthermore, the 3D printed prototype mechanisms, derived from these drawings, not only provided models for reference but provided invaluable hands-on experience of the mechanisms as they required careful thought and effort in assembly.

Chapter 4: Results and Conclusion

This chapter discusses new information gained from the reproduction instruments and the process of their manufacture. With both instruments able to be played, a comparison can be made between their function and playability, giving further insight into why the design differs between instruments. Although no formal performance element has been incorporated into this project, the instruments have still been tested privately and through public demonstrations providing initial ideas of the kinds of music and contexts to which they might be best suited.

A comparison of the function of the piano mechanisms

The piano hammer elements of the two instruments are clearly of the same principle, yet there are some important differences. Figure 4.1, below, shows the shape and location of the mechanisms within each instrument.

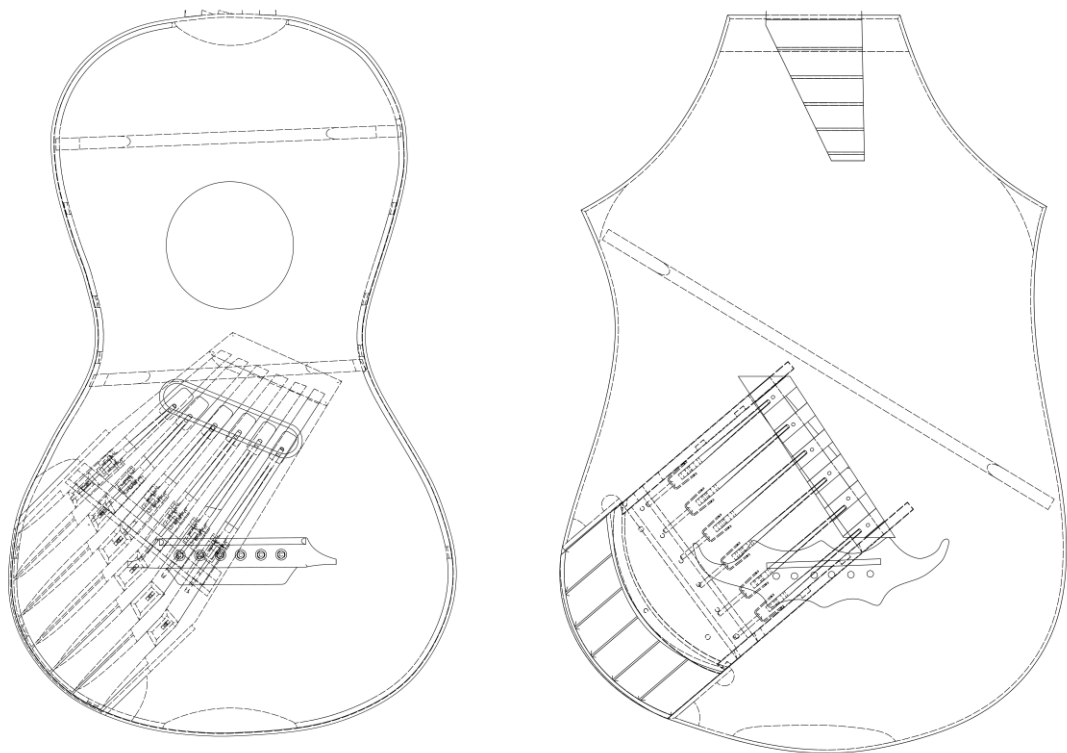

Figure 4.1 Mechanism locations: Mathias Neüner (left); MMA 89.4.3145 (right)

One significant difference between the mechanisms is the variance in strike point along each string on both guitars. In the guitar by Sprenger, the key system strikes the string much closer to the bridge on the treble side than the bass—giving a relatively quiet

treble. In contrast, Neüner's instrument has a comparatively similar strike point across all the strings. A general convention in piano making is to attempt to keep the strike point as equal in position across the strings as conveniently possible, proportional to the string length (with fine tuning and deviation typically no more than a few millimetres).²³⁹

However, it is not to say that one system is better than another, since to achieve the more consistent strike point, Neüner's mechanism requires hammer arms of increasing length towards the treble. This is a different inequality altogether. A longer hammer arm will strike the string faster than a shorter one, relative to the force applied to the key. For keyed guitars—with their mechanisms placed at an oblique angle to the strings—a decision must be made between maintaining a consistent hammer arm length or in having a similar strike point across the strings. This difference between the two mechanisms also accounts for the comparatively square shape of Sprenger's mechanism; further added to by Sprenger's use of front guide pins instead of the guide rails elongating the back.



Figure 4.2 Mechanism openings: Sprenger copy (left); Neüner copy (right)

Although Neüner's instrument is more ornate and well made, Sprenger's mechanism is more substantially incorporated within the body. Firstly, it is inset into the body profile and visible from the front, but it is also fully enclosed, with frontage made from

²³⁹ As it is a fretted instrument, the strike point on a keyed guitar has its own unique problems—as the string length varies depending on which fret the string is stopped. Generally speaking, the higher pitched strings have more activity up and down the fingerboard. This is often evinced by wear on the frets and an extended fingerboard in the treble, as on the keyed guitar at the MMA. This would align with having a strike point closer to the bridge in the treble strings.

the same material as the ribs. This design allows the player more space above the keys for the right hand, but limits the key length available to the player compared to Neüner's mechanism.

The introduction of checks in Sprenger's mechanism make a noticeable difference to the playability. Certainly, the absence of checks is noticeable in the earlier instrument by Neüner, where, if a note is played with force, the hammer rebounds to strike the string additional times.²⁴⁰

The importance of the differences between the two instruments becomes apparent only when playing the reproductions. A study of the original instruments gives object information, but none of the implications for performance. Of all the barriers in the way of understanding the keyed guitar, the lack of playable instruments is surely the greatest. While the changes between the mechanism types seem small, they show that thought had gone into the development of the keyed guitar in the period between the two instruments' manufacture. The instruments themselves were cleverly devised and function remarkably well.

Demonstration of the reproduction keyed guitar by Mathias Neüner

The reproduction of Mathias Neüner's keyed guitar was demonstrated at the 2019 annual *American Musical Instrument Society (AMIS)* conference in Greenville, SC, USA. During the conference, a separate demonstration of the instrument was filmed by Dick Boak, this was uploaded to *Facebook* and unexpectedly reached hundreds of thousands of people through various social media platforms.²⁴¹

For both of these demonstrations I performed two lessons by Julio S. Sagreras: Lesson 72 in *Las Primeras Lecciones de Guitarra*, 1922; and Lesson 6 in *Las Segundas Lecciones de Guitarra*, 1933. The reproduction instrument was finished in Edinburgh the day before I flew to the USA for the *AMIS* conference, and there was no time to practise anything new. These two lessons were chosen from what I was able to play from memory. While they are twentieth-century compositions, they share similarities with nineteenth-century guitar tutors, but they were chosen because they are interesting

²⁴⁰ This is more noticeable in the treble strings which have longer hammer arms.

²⁴¹ Original video posted 22 May 2019: www.facebook.com/dick.boak/posts/10157294381981613

but relatively simple—without much time to practise it was difficult to use the key mechanism for anything more than chordal music.



Figure 4.3 Demonstrating the reproduction keyed guitar by Mathias Neüner at the 2019 AMIS conference in Greenville, SC, USA

While operating the key mechanism, it is not possible to support the guitar with the right-forearm, as would be done while playing with an ordinary technique. It was necessary to use a strap and support the guitar body with my left knee with my foot placed on the guitar case (see Figure 4.3). Nevertheless, even with this assistance, it was difficult to hold the instrument in the correct position while playing, particularly when required to move the left hand either up or down the fingerboard. A more experienced player with time to become acquainted with the key mechanism might be able to expand upon the performance techniques, though the mechanism does seem to favour chordal music.

In Franz Fiala's 1820 article promoting his instrument in the *Morgenblatt für gebildete Stände*, he offers a rare glimpse of the kinds of music to be played:

[The keyed guitar] is quite easy to handle, and every guitar player, as long as he is familiar with the piano, can play this instrument without much practice so comfortably that he will be in a position to play the arpeggios much faster than normal. Namely one is to hold the instrument with the left hand on the fretboard

like a common guitar, and align with the fingers of the left hand on the normal finger positions for every chord, while the right hand is laid upon the keyboard²⁴²

In my experience, it was indeed much easier to play arpeggios with the keyboard than with ordinary technique, and faster than normal. Fiala, by mentioning ordinary chord positions, also seems to identify this to be its chief function.

Certainly, it was not possible to translate everything I could play in the ordinary way onto the keyed guitar. This however may not have been a problem for Fiala's readership in 1820. As a modern guitarist, I might well experience some restrictions. Today, the guitar is a highly popular solo instrument and has a vast repertoire, but at the start of the nineteenth century in Germany (as in London) it would have been much more readily perceived as an instrument for accompaniment, particularly for singing, and had a natural disposition to chords and arpeggios.

The design of Neüner's instrument is such that during performance the mechanism is concealed from the audience. Multiple spectators at the *AMIS* meeting afterwards remarked that at first it was shocking, and the instrument seemed to produce sound of itself without using the right hand. The performance was simple, yet the instrument gripped the attention of the room. This effect is perhaps in part due to the technical sophistication of the instrument, but probably more to do with the novelty, and it is debatable whether this reaction would continue with more familiarity.²⁴³

In his article, Fiala also claims that his invented instrument had received praise from specific members of the German nobility 'and several other distinguished personalities', and describes his instrument in the flattering terms that 'the sound is made more melodically and with a greater variety in performance [compared with

²⁴² *Morgenblatt für gebildete Stände* 1820, p. 144. Original: *Die Behandlung ist ganz einfach, und jeder Gitarrespieler, zumal wenn er mit dem Klavier bekannt ist, kann solche ohne große Uebung in kurzer Zeit so bequem spielen, das er im Stande ist, die Harpeggios weit schneller als gewöhnlich hervorzubringen. In dem man nämlich das Instrument, wie die gemeine Gitarre mit der linken Hand am Griffbrette fasst, und die linke auf den Positionen den gewöhnlichen Fingerfaß für jeden Accord anbringt legt man die rechte Hand auf die Klaviatur...*

²⁴³ During the performance the 3D printed prototype mechanism was passed around the audience, enabling them to experience and visualise the mechanical nature of the instrument. This provided hands on experience of the mechanism without risk to the instrument itself.

ordinary guitars].’²⁴⁴ By ‘greater variety’ it is likely that these instruments were intended to be played with the fingers as well as the key mechanism. Fiala had in fact reassured his audience that the keyboard element of his invention would in no way obstruct the ‘old method of playing and making sounds by directly touching the strings with the fingers.’²⁴⁵



Figure 4.4 Frame taken from Dick Boak’s video

The video demonstration circulated on social media received hundreds of comments.²⁴⁶ For a modern audience, these two playing styles were largely set in opposition to each other. ‘Frankly I don’t see the interest for a guitarist unless you have a broken nail, but I find the touch of his fingers much better than the touch of the keyboard...’²⁴⁷ ‘Its a piano in a box. For me the guitar is unique in that fingers form

²⁴⁴ *Morgenblatt für gebildete Stände* 1820, p. 144. Original: ‘...daß auf der Tasten-Guitarre der Ton melodischer gebildet und zugleich eine Abwechslung im Vortrage bewirkt werde.’

²⁴⁵ *Morgenblatt für gebildete Stände* 1820, p. 144. Original: *Übrigens ist der Spielende dadurch nicht gehindert, abwechslungsweise die alte Methode bey-zubehalten und die Saiten wieder durch unmittelbare Berührung der Finger ertönen zu lassen.*

²⁴⁶ These comments have been anonymised and reproduced in Appendix I; citations for quoted comments will refer to a comment number as arranged therein.

²⁴⁷ Appendix I, Comment 78. Original: *‘Franchement je ne vois pas l’intérêt pour un guitariste à moins que tu aies un ongle cassé mais je trouve que le toucher des doigts bien meilleur que le toucher de cet espèce de clavier est marqué mais en plus de ça en dehors du côté de gadget de luthier franchement je passerai pas ma guitare.’*

the notes and fingers pluck the notes. There are no mechanisms between the artist and the sound. Consequently no two people play it exactly alike'.²⁴⁸

In contrast, I do not think this would have been a common critique for a nineteenth-century audience. Certainly, the keyed mechanism was never framed as a rival for the ordinary style of playing. It is perhaps most helpful to consider the keyed guitar in a grouping of musical instrument inventions and adaptations which attempted to expand the timbral range of instruments. The keyed guitar did not have to be as good as an ordinary guitar played with the fingers so long as it could do something which might not be achieved by fingers alone.

The key mechanism certainly does offer something new. For the player there is assistance for certain playing styles and for listeners the sound is very distinct from the sound made by plucking. In the 1802 Lexicon entry on the keyed guitar by Heinrich Koch, the mechanism's limitations in tonal range is seen as a benefit: 'This arrangement gives the instrument the advantage of a more fixed and more definite tone, more complete harmony and with respect of the right hand, easier handling.'²⁴⁹ A 'fixed and definite tone' is an accurate description of the sound produced by the hammer mechanism. While Koch sees this as an advantage, this characteristic further limits its usefulness for more melodic playing—where a line of notes needs emphasis above the harmony.

Although many commenters online preferred the sound produced by traditional plucking with the fingers, there was still significant praise for the tone qualities of the keyboard mechanism: 'Keyboard style playing gives a richer percussive tone but quite hard style to play at the start. Finger style is good also!'²⁵⁰

Perhaps most surprisingly, one internet commenter writes that 'now you can finally play the guitar without ruining your expensive nails'.²⁵¹ This comment, written by a

²⁴⁸ Appendix I, Comment 9.

²⁴⁹ Koch 1802, p. 708. Original: *Durch diese Einrichtung erlangt das Instrument den Vortheil eines festern und bestimmtern Tones, mehr Vollstimmigkeit, und, in Rücksicht auf die rechte hand, ein leichteres Traktement.* As has been discussed, this source is not reliable, and is conflating keyed citterns with keyed Spanish guitars (see p. 37).

²⁵⁰ Appendix I, Comment 200.

²⁵¹ Appendix I, Comment 31, Reply III.

male user, was accompanied by a photograph of elaborate feminine fingernails.²⁵² It is clearly a joke, and directed it seems, at another male user. It suggests that long fingernails are feminine and that a man being effeminate is bad.

The idea that key mechanisms were added to guitars to help women, is an oft repeated error that has its origins in the nineteenth century. In 1834 an encyclopaedist speaks of the advantage of keyed guitars for female players who ‘usually moan and complain that their delicate little fingers hurt’ playing in the ordinary style.²⁵³ The online commenter is doubtless unaware of any precedent for his remarks, and so it is astonishing that the same idea was reintroduced and likewise steeped in sexism.²⁵⁴

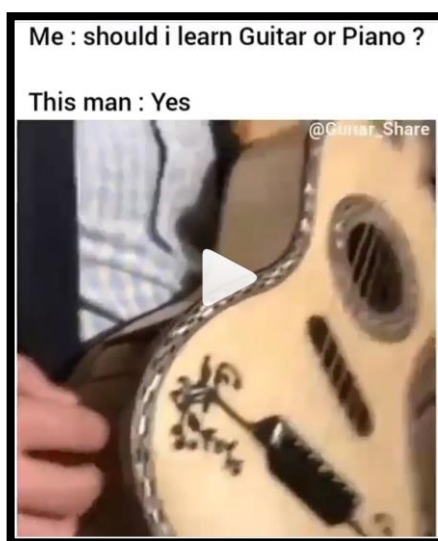

Figure 4.5 An Instagram meme created from the video originally uploaded by Dick Boak²⁵⁵

The reaction to the reproduction instrument on social media elicited strong feelings (mostly positive) from many of the commenters. Given the nature of social media, comments (though numerous) rarely exceeded a few lines. The original video posted by Dick Boak generated over 110,000 views. This was truncated and reposted by a

²⁵² The quoted commenter publicly lists themselves as male on Facebook.

²⁵³ Schneider 1834, p. 86. Full quote: ‘Die Damen klagen und jammeren gewöhnlich, daß ihre zarten Fingerchen schmerzen, wenn sie mit der rechten hand die Saiten scharf anreißen und mit der Fingern der linken Hand etwas derb die Saiten neiderdrucken sollen.’

²⁵⁴ Another commenter helpfully reminds us that ‘a pick would be much more convenient [for] finger nails,’ succinctly and persuasively suggesting that this cannot have been the motivation for the use of a keyboard mechanism. Appendix I, Comment No. 185.

²⁵⁵ Accessed on 8 September 2020: www.instagram.com/p/B9IGB3_nzPS/

small guitar repair business.²⁵⁶ This version cuts out the spoken introduction and to a greater degree crossed language barriers and had over 180,000 views. This in turn was adapted as a ‘meme’²⁵⁷ and gained over 310,000 views (see Figure 4.5). It seems the shorter the video, the wider its reach, though it is perhaps more descriptive of the nature of social media than specifically the keyed guitar.

While it is not helpful to project a modern reception of these instruments onto a nineteenth-century audience, this unprompted online activity demonstrates the keyed guitar had at least the capacity to excite. Compared with the eighteenth-century pianoforte guitar, the small number of surviving instruments does not necessarily mean that they were less popular or functioned less well.

These earlier instruments in London enjoyed the energetic promotion of prominent instrument makers whose livelihoods depended on instrument sales. Franz Fiala was neither an instrument maker, nor was he the designer or inventor of the keyed guitar. He had a long career of over thirty years as a salaried court musician and did not depend upon the commercial success of these instruments. It is quite possible that short term notoriety was in fact the chief end of his involvement with keyed guitars, and such terms it might be deemed a success. The other labelled maker, Matteo Sprenger, it seems was working to fulfil orders placed with Fiala and did not have personal stakes in manufacture.

While in London during the 1780s, Mathias Neüner would have been personally aware of the significant role the pianoforte guitar played in the instrument trade. In Mittenwald, he was a highly successful businessman, but while he was clearly open to the idea of making keyed guitars at some stage, he is remembered for establishing a large firm focused on violin-making and mass production, rather than small and perhaps one-off orders of a musical novelty.

²⁵⁶ Original video: www.facebook.com/luthieriabr/videos/603031066848152

²⁵⁷ The term ‘meme’ refers to captioned images designed to replicate and propagate across the internet.

Conclusion

Doubtless the keyed guitar was seen as a fashionable curiosity as much as a musical instrument. They were prominent enough to be mentioned in German encyclopaedias, but the unreliability of these entries demonstrate that the chroniclers probably did not have personal experience of them. From as early as Heinrich Koch's 1802 encyclopaedia, sources confuse the London-made pianoforte guitars with six-string keyed guitars.²⁵⁸ This mistake ultimately has undermined subsequent attempts to document this history. The stories of a 'German artisan in London', though clearly referring to Christian Claus, were repeated and later became confused with accounts of Carl Ludwig Bachmann of Berlin, who was likely no more than a dealer in pianoforte guitars made in London.

At the same time, Mathias Neüner and Matteo Sprenger have, until now, been omitted from the established histories of these instruments, while Franz Fiala, though he publicised his keyed guitars and indeed himself, exists in history in isolation without being recognised by contemporary authors, and has remained in obscurity until recently. Even the comparatively smaller accounts of keyed guitar makers, namely Juan Puyol in Madrid,²⁵⁹ and Mr. Petosa of Naples,²⁶⁰ have had more claim to recognition than Bachmann, and yet have remained hidden.

The keyed guitar lost from the Leipzig collection is very likely associated with the two surviving keyed guitars, and an obvious line of continuation for this project would be to recreate this instrument. This has been beyond the scope of this thesis. Although the original instrument is not available for consultation, it should be possible to arrive at suitable plans from the photos reproduced in this dissertation (Figure 1.27, p. 68), supplemented by information gained from the two surviving keyed guitars.

The proposed probable mechanism diagram given earlier (Figure 1.29, p. 71) is likely to be accurate to the original, but still creative licence would be required to locate it in the opposite quarter of the guitar body compared with the keyed guitars by Neüner and

²⁵⁸ Koch 1802, p. 708.

²⁵⁹ de Pascual 1983, p. 216.

²⁶⁰ Forkel 1812, p. 479.

Sprenger. A reconstruction would not have been possible without Kinsky's text description, but likewise without an understanding of the surviving instruments the significance of this description would be lost.

The two surviving keyed guitars are essential for contextualising all nineteenth-century literature on the topic. The maker of the earlier instrument from 1810, Mathias Neüner is seen to be active in London at the end of the eighteenth century and is a probable link to the earlier pianoforte guitar. Through the second instrument, made in 1843, now at the MMA, Neüner can be linked to Matteo Sprenger and the Baden court through Franz Fiala with all the historiographical sources surrounding him.

It is likely that other keyed guitars survive from this period, and if any emerge in the future they can be set against these surviving instruments and located within the limited source material. The production of keyed guitars in Germany during the nineteenth century was far less substantial than that of the pianoforte guitar in London during the 1780s. Its considerably long period of manufacture, spanning the first half of the nineteenth century, combined with the instrument's relatively small presence in music history, suggests that its popularity was sporadic at best. Its novelty value and promotion by Franz Fiala were central to its success in the period but were no foundation for a lasting legacy, accounting for why it is nearly unheard-of today.

The process of recreating these instruments has made use of 3D digital data and manufacturing technologies, alongside other traditional workshop practices. The complex geometry of these hybrid instruments provides an excellent opportunity to explore how new technologies can be incorporated into a traditional workshop practice.

3D printing for metals offers usable brass parts from CT data or technical drawings and makes time consuming and specialist processes more readily available. Rare parts like John Preston's watch-key tuning mechanism or the so called 'pedals' for Lacôte's *decacorde* were successfully reproduced and could be fine-tuned and customised for any instrument they might be required for.

For more common parts however, like the brass *kapseln* used in the reproduction hammer mechanism of the keyed guitar by Sprenger and Fiala, it was more sensible to rely on traditionally made parts, given their availability today. These were more cost

effective, reliable and did not require any hand finishing. Just because parts can be made with new technologies, does not mean they ought to be. Depending on the application, traditional manufacturing processes may be preferable to 3D printing, but judging between them requires knowledge of both.

These technologies have not played an essential part in the reproduction of the two keyed guitars, but they have greatly improved the accuracy and quality of the work. Although arguably CNC manufacture is as time consuming as traditional crafts for one-off manufacture, the accuracy and reliability are significant advantages. The 3D printed prototype mechanisms were of material use for my own understanding of their intricate workings. They acted as visual references supplementing 2D technical diagrams as I copied each part from comparable materials to the original object.

Far from replacing traditional crafts, these technologies are best utilised by those with a thorough understanding of the processes and material properties of the object being manufactured. 3D printing does not endanger specialist knowledge and crafts but rather increases the scope for their application.

The reproductions in this study are of intrinsic importance, given the scarcity of the original instruments. They are likely the first keyed guitars of this style made since 1843 and provide an unparalleled opportunity to access this obscure part of musical history. Information provided in this dissertation and the scale drawings in Appendix III, will make it possible for others to reproduce this work more easily, and it is hoped that many will do so.

Considering the dearth of source material and few surviving instruments, hands-on experience—examination and reproduction—adds an important new dimension to this narrative. Having more playable instruments increases the prominence of this history and provides sound and function to an otherwise silent study.

Appendices

Appendix I: Social media comments

The following is an anonymised list of comments posted in response to Dick Boaks video uploaded to Facebook on 22 May 2019, reproduced in chronological order with oldest posts first. Only personal names have been removed [redacted] except for Dick Boak, Taro Takeuchi and the author.²⁶¹ Many comments have been used to ‘tag’ someone to show them the video and so they appear with only the redaction.

These comments are by no means comprehensive and there are many online reactions that are beyond my access. The video was directly reposted over 1,700 times, so any reactions to those posts cannot be included here.

<https://www.facebook.com/dick.boak/posts/10157294381981613>

- | | |
|----------------|--|
| Comment No. 1. | Thank you for sharing this Dick...WOW! |
| Comment No. 2. | A very cool adventure |
| Comment No. 3. | So is this still considered an instrument of the Stringed family, or would it belong to the Percussion family (as does the piano, with its hammered strings)? |
| Reply I. | [redacted] Yes. |
| Reply II. | [redacted] a Guitar is technically a percussion instrument. |
| Reply III. | [redacted] Citation, please? |
| Comment No. 4. | The original, and may I say far classier, keytar? |
| Comment No. 5. | Oooohhh! |
| Comment No. 6. | Cool beans |
| Comment No. 7. | Considerably more elegant than the Keetar. |
| Comment No. 8. | very cool |
| Comment No. 9. | Its a piano in a box. For me the guitar is unique in that fingers form the notes and fingers pluck the notes. There are no mechanisms between the artist and the sound. Consequently no two people play it exactly alike |
| Reply I. | [Cont.] Still a fun video tho |

²⁶¹ Initials are used to indicate when comment was written by either Dick Boak [DB] or myself [DW].

- Reply II. [redacted] I want one, though!
- Comment No. 10. [redacted]
- Comment No. 11. [redacted]
- Comment No. 12. [redacted]
- Reply I. [redacted] fantástico
- Comment No. 13. Daniel i need one of those
- Comment No. 14. This is amazing!
- Comment No. 15. Daniel Wheeldon you are amazing! I love this, and so glad the video has been made. I remember you showing me your prototype piano keys box years ago and it's great to see how that has developed into this fully grown instrument!
- Comment No. 16. Well done Daniel!
- Comment No. 17. So cool! Well done Daniel Wheeldon
- Comment No. 18. Fascinating
- Comment No. 19. [DB] By the way, this little video was made at the American Musical Instrument Society (AMIS) conference held at the Carolina Music Museum in Greenville, SC. I was fortunate to attend.
- Comment No. 20. I was able to play one of the originals in Cremona a few years ago and it was a treat. A very delicate sound that was lovely, but maybe not the future of guitar playing.²⁶²
- Reply I. [DB] I'm guessing that may be the original upon which Daniel's instrument is based. It certainly appears so.
- Reply II. There can't be too many of these around, so it may well be the same guitar he based his on. The card for the guitar is behind it, not in the foreground. It reads that it was made by Matthias Neuner II, in Mittenwald around 1810.
- Reply III. [DW] It's the same instrument. Not the future you're right but a fascinating snapshot of a musical past.
- Reply IV. [DW cont.] As in a copy of the instrument, only the head was changed in design.
- Comment No. 21. That is really cool!

²⁶² The original guitar by Mathias Neüner was on loan from Rainer Krause to the Paganini Guitar Festival in Parma in 2019.

- Comment No. 22. This is Amazing! Well done!
- Comment No. 23. Very cool ... thanks for posting Dick!
- Comment No. 24. Amazing
- Comment No. 25. Very cool!
- Comment No. 26. I would love to see plans!
- Comment No. 27. Wonderful human.
- Comment No. 28. Dick Boak Thanks for sharing this with us.
- Comment No. 29. Can you make one for a Tele ???
- Reply I. [DW] you should check out the hammer jammer
- Reply II. [DW cont.] <http://thehammerjammer.com/index.html>
- Reply III. Daniel Wheeldon Wow!
- Comment No. 30. Dick Boak This not only blows my mind, but also raises many questions, like: 1) why is the key mechanism removable, or why would one want to remove it?, 2) what effect do the openings on the top and side have on the sound/tone of the guitar?, 3) where can one of these be purchased?, and 4) Do you think the Martin Custom Shop would or could build one? And that's just for starters!!
- Reply I. [DB] I doubt the Martin Custom Shop would want to do one.
- Reply II. [commenter] Dick Boak Yeah, I just threw that one in there for laughs. What about the 1st 3 questions though?
- Reply III. [DB] 1. The mechanism needs occasional adjustment that requires accessibility. 2. The guitar sounds great and does not seem to be impacted by the two "ports." 3. There are none available, but maybe this will inspire some makers.
- Comment No. 31. [redacted] (there was no Share tab)
- Reply I. [redacted] - sounds lovely but...um...what's the point?
- Reply II. [commenter] it's academic
- Reply III. [to Responder I] Now you can finally play the guitar without ruining your expensive nails 😂😂
- Comment No. 32. Lol, I want/need one of those!! Who's making them?
- Comment No. 33. [redacted] !! 🎵
- Reply I. [to commenter] ThAnks! Fantastic!
- Reply II. Thanks [redacted]!
- Comment No. 34. [redacted]

Comment No. 35. Anyone know the music he's playing?
Reply I. [DW] Hi Paul, they are two exercises from Julio Sagreras' tutors. I'm not sure which ones, I've known them by heart since I took guitar lessons.

Comment No. 36. [redacted]

Comment No. 37. Why need an alternative for plucking vs right hand fingers?
Reply I. [to commenter] Sounds different....

Comment No. 38. Wow [redacted] amazing

Comment No. 39. Very interesting I wonder how many of those are still out there.

Comment No. 40. Whoa! Did not know about that! Very interesting!!

Comment No. 41. [redacted]
Reply I. That's just kittens mittens right there. Really cool! Thank you I've never seen or heard of them. Very unique.

Comment No. 42. [redacted]

Comment No. 43. A transition instrument for piano players who want to play guitar

Comment No. 44. Can you make a baroque lute version?
Reply I. [to commenter] with a foot keyboard for the 16" strings ? 😊

Comment No. 46. Sweet

Comment No. 47. [redacted] this is really cool

Comment No. 48. Really awesome Daniel! Hope you're doing well. And hello from Texas!
Reply I. Beautiful Daniel!! Love from [commenter]'s mom in OHIO!!

Comment No. 49. Cool. But still sounds better finger-picked.

Comment No. 50. [redacted]
Reply I. That's neat! Cool idea.

Comment No. 51. [redacted]
Reply I. I WANT THIS!!!!

Reply II. [to responder] I knew it 🤩

Comment No. 52. [redacted]

Comment No. 53. Both Interesting & Awesome... Kind of changes one's look at the musician playing his guitar instrument. Must definitely be less painful on one's fingertips to play keys instead of plucking strings. Beautiful tone. 🙌🎵🎶 Thanks for sharing.

Comment No. 54. [redacted]

- Comment No. 55. That was very cool. He made it look so easy playing it on the keys. I like the difference in tone and sound from keys to fingers. And the hammers and keys just pops out all in a cartridge.
- Comment No. 56. [redacted] what the actual fuck
- Comment No. 57. [redacted]
- Comment No. 58. [redacted]
- Comment No. 59. Le hacemos esto a una de las tuyas, [redacted] ??
- Comment No. 60. [redacted]
- Comment No. 61. [redacted]
- Comment No. 62. [redacted]
- Comment No. 63. In the context of the times (no electricity, no recorded music, etc.) this must have been considered by some (many?) as a mind blowing innovation. Surely, one of a kind...and hopefully, got the inventor patronage and/or many gigs and commissions. Bravo.
- Comment No. 64. I've tried to do this from above with a Xylophone stick before. It didn't sound good enough to try again obviously 😞
- Comment No. 65. What do you think of this, [redacted]?
- Comment No. 66. Sounds brilliant and could catch on!
- Comment No. 67. [redacted]
- Reply I. the missing link between the eternal enemies EXISTS!
- Comment No. 68. [redacted] check it out
- Comment No. 69. Pianoforte guitars (English guitars with keyboard attachments) were made from c1770 and some cistres (of that era) had keyboard attachments too. Taro Takeuchi plays a pianoforte guitar.
- Reply I. [DW] From around 1781 - 1789 in London but was continued a little longer around the world. Taro Takeuchi plays a guitarr with an external mechanism (Smith's patent box), I believe he is the only guitarist who uses a keyed guitar. If you're interested in this, read my article Galpin Society Journal, 2017.
- Reply II. [Taro Takeuchi] Thank you for mentioning me. Here is the video of the piano fore guitarr playing (around 6:00) <https://www.youtube.com/watch?v=N4HxtTR49Js>
- Comment No. 70. [redacted]
- Comment No. 71. An additional sound that is useful.
- Comment No. 72. [redacted] New Jazz night guitar? This is actually incredible 🎸👏

- Comment No. 73. [redacted]
- Comment No. 74. [redacted]
- Comment No. 75. An amazing example of the art of lutherie - a virtuoso player could be dubbed 'the Horowitz/Segovia' of the guitar.
- Comment No. 76. [redacted]
- Reply I. [to commenter] INCRÍVEL!!
- Comment No. 77. <https://mobile.twitter.com/classclgtrmag/status/991098944720658434>
- Comment No. 78. Franchement je ne vois pas l'intérêt pour un guitariste à moins que tu aies un ongle cassé mais je trouve que le toucher des doigts bien meilleur que le toucher de cet espèce de clavier est marqué mais en plus de ça en dehors du côté de gadget de luthier franchement je passerai pas ma guitare.
- Comment No. 79. Amazing
- Comment No. 80. Great
- Comment No. 81. [redacted]
- Comment No. 82. Apart!
- Comment No. 83. They now have a device called the "Hammer Jammer" which I suppose must have been inspired by this that you can retro fit to your guitar. Really cool!
- Comment No. 84. [redacted] ...I wanted to share this with you. I have never seen a guitar like this, have you?
- Comment No. 85. Fantastic
- Comment No. 86. [redacted]
- Comment No. 87. Chitarra con tastiera...un'altra monata 😂 [redacted] potresti pensarci però
- Reply I. [to commenter] Figata! Utile soprattutto!! 😂👉
- Comment No. 88. [redacted]
- Reply I. Because tone doesn't matter. Interesting nonetheless.
- Reply II. Haha when he started playing with his finger I was like, "yeah... umm just keep doing it that way."
- Comment No. 89. [redacted]
- Reply I. [redacted] alv wifi
- Comment No. 90. [redacted]
- Comment No. 91. [redacted]...Selby would have fun with this!

Reply I. Big time!!

Comment No. 92. Awesome!

Comment No. 93. [redacted]

Comment No. 94. [redacted] ...I need one of these!

Comment No. 95. [redacted]

Comment No. 96. That's awesome!!

Comment No. 97. [redacted]

Comment No. 98. [redacted]

Comment No. 99. The sound of this guitar is far better when it is played with the fingers...

Comment No. 100. [redacted]

Comment No. 101. [redacted]

Comment No. 102. Thank you for posting this. it's remarkable and ...beautiful.

Comment No. 103. [redacted] increíble!!

Reply I. [to commenter] mt top mano mds

Comment No. 104. [redacted]

Comment No. 105. [redacted]

Reply I. Es similar al mecanismo que te había mostrado hace tiempo ¿no? es buena idea para cuando uno se aburre de tocar de manera tradicional, las dos piezas que toca son estudios que llevé pero ahorita no recuerdo si son de Sor, o Sagregas, los voy a buscar, debo tenerlas entre mis partituras.

Reply II. [cont.] Ya, los 2 son de J Sagreras el 1ero es del libro 2 estudio 6 y el 2do es del libro 1 estudio 72.

Comment No. 106. [redacted]

Comment No. 107. Como tocará en teclado el tremolo?

Comment No. 108. [redacted] lej kitara na tipke 🤔

Reply I. [redacted] watafak xD

Comment No. 109. [redacted] guarda

Comment No. 110. [redacted] space

Comment No. 111. [redacted]

Comment No. 112. [redacted] Edinburgh!!!

Comment No. 113. [redacted]

Comment No. 114. I want one

Comment No. 115. [redacted]

Comment No. 116. Does anyone know the name of the song he played?
Comment No. 117. [redacted]
Comment No. 118. [redacted]
Comment No. 119. Quelle petite merveille!
Comment No. 120. Very cool!
Comment No. 121. Like it!
Comment No. 122. [redacted]
Comment No. 123. [redacted]
Comment No. 124. I want to make one now
Comment No. 125. [redacted]
Comment No. 126. [redacted]
Reply I. [redacted] holy hell!
Comment No. 127. [redacted] violão pra vc
Comment No. 128. [redacted]. This could be you mate.
Comment No. 129. [redacted]
Comment No. 130. [redacted]
Comment No. 131. I have never seen a guitar with a keyboard-very cool thanks for sharing!

Comment No. 132. A portable harpsichord!
Comment No. 133. Ala, encontrado! Ya sabemos de dónde sale [redacted]
Reply I. No lo veooooo
Comment No. 134. [redacted]
Comment No. 135. A bit different from the button-operated Chord attachment for fingerboards which I seem to remember from the 1960s!

Comment No. 136. Very interesting - love to try it!! Bring one to ICFC!!
Comment No. 137. [redacted]
Comment No. 138. [redacted]
Comment No. 139. The work of a genius!
Comment No. 140. [redacted], show dad. Pretty cool. [redacted]
Comment No. 141. [redacted]
Comment No. 142. [redacted]
Comment No. 143. And...he is ingenious.
Comment No. 144. [redacted] 😊
Comment No. 145. [redacted]

Comment No. 146. I played music for years(guitar/bass) I'm intrigued,trying to find new avenues to broaden musical horizons

Reply I. John Bieser check out Hammer Jammer. They make a device that does something similar.

Comment No. 147. Suena bien la pianarra.

Comment No. 148. Now there's you a project [redacted]

Comment No. 149. [redacted] my next guitar

Comment No. 150. That's so cool, I finally I would be able to fingerpick

Comment No. 151. [redacted]

Comment No. 152. [redacted]

Reply I. That's so cool, I finally I would be able to fingerpick

Comment No. 153. [redacted]

Comment No. 154. [redacted]

Comment No. 155. [redacted], look!

Comment No. 156. [redacted]

Comment No. 157. [redacted]

Reply I. Its a mini-piano. I like that it would make you play differently, mostly likely. I don't think it is BETTER than a guitar; there are cool things you can do with your bare fingers against strings that you can't by hitting a key, I wonder if you could do those three-note piano riffs like Elton John does in Benny and the Jets. Interesting.

Comment No. 158. [redacted]

Comment No. 159. [redacted]

Comment No. 160. A whole phd on that one thing ???

Reply I. [redacted] and your PhD was on ...

Reply II. [redacted] 🤔🤔 bet yah when he's done with that hell be at home chillin

Reply III. And I though my research topic was questionable

Reply IV. Applies at a job oh what was your PhD? Oh I studied a piano guitar from 200years ago Get outta here

Reply V. [redacted] interviews for a job; Interviewer "How are your language skills"? [redacted] "Get the fk outta here" Interviewer "Next"!

- Reply VI. interviewer : Shelly first question how's your grammar Shelly :
cORe OrEgunIon Interviewer: Are you okay? Or you retarded ?
- Comment No. 161. [redacted] ist das die echte Keytar?
- Reply I. [redacted] haha geil, aber Narcotic klingt wahrscheinlich ned so fetzig drauf 😊
- Reply II. nein, weil keiner würd ein phd projekt darüber machen 😊
- Reply III. Still dre geht sicher super😂
- Comment No. 162. How cool is that!?
- Comment No. 163. Amazing. 🎵🎵🎵👍
- Comment No. 164. I wonder if you moved the hammers closer to the bridge would it give it more of a hammered dulcimer kind of sound... Regardless, quite an intriguing instrument.
- Comment No. 165. [redacted]
- Comment No. 166. Very cool!
- Comment No. 167. [redacted]
- Comment No. 168. [redacted]
- Comment No. 169. [redacted] ça a je veux ça! Futur projet!!^^
- Reply I. [redacted] rigolo! Mais bon.. compliqué pour rien non?
- Reply II. [redacted] c'est encore plus compliqué quand on y ajoute un système qui permet de jouer avec la guitare dans toutes les positions. Cet instrument est superbement réalisé, mais le concept a déjà été fait par moi-même il y a déjà pas mal d'année sur une guitare électrique en aluminium et manche en bois clipé entièrement démontable . Néanmoins, bravo et beau travaillent.
Plus on est de fou, plus on rit ! 🎵
- Comment No. 170. [redacted]
- Comment No. 171. I'm proud to say this young man is one of my dearest friends Daniel Wheeldon ❤️❤️❤️
- Comment No. 172. [redacted]
- Comment No. 173. Whats the point... how does that give you more control then havibg your finger directly on the strings.
- Comment No. 174. [redacted]
- Comment No. 175. [redacted]
- Comment No. 176. [redacted]
- Comment No. 177. [redacted]

- Comment No. 178. One curiosity is that his keyboard fingering habits are identical to finger picking.
- Comment No. 179. Ok, now I have to have one! 🤔🎸🤔
- Comment No. 180. So beautiful. So glad that people like you exist, recreating human ingenuity. Made my day, seeing and listening. 😊🌸❤️
- Comment No. 181. [redacted]
- Reply I. i think that's one of the best instruments I've ever seen. I want one now
- Comment No. 182. I like this
- Comment No. 183. [redacted]
- Comment No. 184. [redacted]
- Comment No. 185. A pick would be much more convenient or finger nails. I see why it didn't catch on
- Comment No. 186. [cont.] Still a piece of guitar history
- Comment No. 187. [redacted]
- Reply I. [redacted] amk banaye dis
- Comment No. 188. [redacted]
- Reply I. [redacted]
- Reply II. Class!
- Reply III. [redacted] mental man 😂
- Comment No. 189. [redacted]
- Comment No. 190. [redacted]
- Comment No. 191. WOW thats amazing and will totally help with does damn arpeggios!!! 🙌🙌🙌🙌
- Comment No. 192. [redacted] check it out
- Comment No. 193. [redacted]
- Comment No. 194. It may have been created by someone who was suffering RSI in their right hand but still wanted to play. Seems to me like it may have been developed for someone with a disability of some kind who was no longer able to play guitar. Of course I could be wrong.
- Reply I. Hammer Jammer makes a device that you can attach to your guitar that creates basically the same effect.
- Reply II. [redacted], that was my first impression, to overcome a disabled right hand - and furthermore that a second person could more

- easily have cooperated to supply the right hand parts with this mechanism.
- Comment No. 195. [DB] Vermeer painted a similar shaped instrument...
- Reply I. This instrument is actually a vihuela, having five pairs of strings.
- Reply II. And every painter needs a theme
song: <https://www.youtube.com/watch?v=D1iWz7sCbsY>
Jonathan Richman- "No One Was Like Vermeer"
- Reply III. Indeed
- Reply IV. Granted...
- Reply V. [redacted] it's a Baroque guitar. It first had five pairs of strings and eventually got a sixth pair. Dick Boak, the instrument in the video is much more a kind of customized (!) Romantic guitar
- Reply VI. I thought I had a romantic guitar, until it cleared out my checking account.
- Comment No. 196. Vermeer!!!
- Reply I. [DB] Our hero!
- Comment No. 197. [redacted]
- Comment No. 198. [redacted]
- Comment No. 199. Kinda cool
- Comment No. 200. Keyboard style playing gives a richer percussive tone but quite hard style to play at the start. Finger style is good also!
- Comment No. 201. Lovely
- Comment No. 202. [redacted]
- Comment No. 203. Certainly helpful when you have problems growing nails
- Comment No. 204. [redacted]
- Reply I. That is incredible. Never seen anything like it before. Sounds amazing too!
- Comment No. 205. [redacted]
- Reply I. [redacted] build one?
- Comment No. 206. Wow this is pretty cool
- Comment No. 207. [redacted] mira we
- Comment No. 208. [redacted]
- Reply I. [redacted] way cool!!
- Comment No. 209. Cool!

Comment No. 210. [redacted] La que necesitaba
Reply I. [redacted] asombroso !!

Comment No. 211. Now that's something

Comment No. 212. Does anyone know the name of the song?

Comment No. 213. [redacted] woah!

Comment No. 214. [redacted]

Comment No. 215. It'll never really catch on. Hehe

Comment No. 216. [redacted]

Comment No. 217. Beautiful thing

Comment No. 218. Sounds similar to most midi acoustic guitar samples

Comment No. 219. [redacted]

Comment No. 220. [redacted]

Comment No. 221. A guitar piano ,crazy 👍😊

Comment No. 222. Q maravilla!!

Comment No. 223. [redacted]

Comment No. 224. [redacted]

Reply I. [redacted] 大开眼界

Comment No. 225. [redacted]

Comment No. 226. [redacted]

Comment No. 227. [redacted]

Comment No. 228. [redacted] this is a bit different lol

Reply I. im into it

Comment No. 229. [redacted] who does this remind you of

Reply I. Dead ringer for [redacted]'s second dad innit

Comment No. 230. [redacted] look at this guitar omg

Comment No. 231. [redacted] I WANT ONE

Reply I. [redacted] this is the future

Comment No. 232. AMAZING!

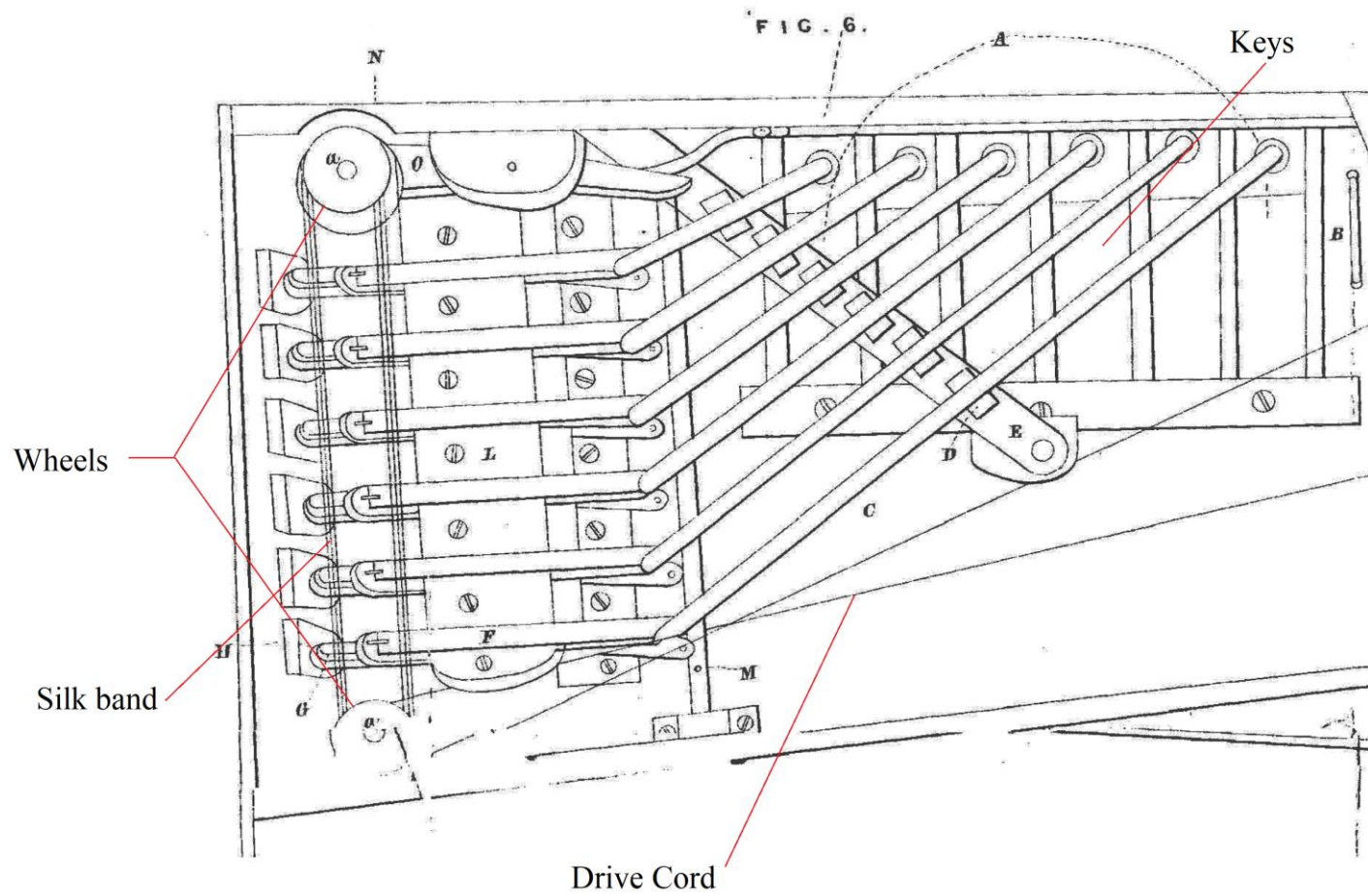

Figure A-II: 2: Cremona stop from Goldsworth's patent no. 1491 (shown from beneath), annotated by the author

Appendix II: Other keyed instruments

Inventions relating to the pianoforte guitar

John Goldsworth's 1785 Patent

John Goldsworth is known to have worked with Thomas Culliford and John Geib, and is listed as a harpsichord maker in his insurance documents.²⁶³ In 1785, while he was part of Culliford & Co., Goldsworth was granted a patent for an *Entire New Improvement upon the Musical Instrument called the Guittar*.²⁶⁴ The patent document contains four separate adaptations for the guittar: a piano hammer mechanism, a bowing mechanism (*Cremona stop*), an enharmonic fret layout, and mechanical tuners.

The pianoforte mechanism, contains hammers, dampers (called the hautboy stop), and a release mechanism (see Figure A-II: 1, above). There are enough similarities to allow us to form a clear association between Goldsworth and instruments supplied to Longman & Broderip.²⁶⁵ The Cremona stop, (see Figure A-II: 2, above) is described in the patent text as a continuous band of silk moving around two wheels which could be engaged against the strings with a similar keyboard to that of the pianoforte guittar. It was powered by a driving spring, charged by a cord attached to a pedal operated by the foot of the performer. This mechanism appears to have been entirely external to the guittar.

Longman & Broderip do not advertise this invention for sale, but in November 1783, during the dispute between Claus and Charles Pinto, we read that 'Mr Pinto has entered a caveat against a patent for a new invented guittar, stating, that he was the sole inventor of the improvement of the *Serestini* stop, lately advertised by another

²⁶³ Wheeldon 2017a, p. 102.

²⁶⁴ John Goldsworth, *Entire New Improvement upon the Musical Instrument called the Guittar*, London, 1785, no. 1491.

²⁶⁵ The damper mechanism is similar to surviving mechanisms, but uses what appears to be a wooden connector rather than a wire; the release mechanism (so called because of how it appears in the diagram below) is described only as the control for the dampers; and most significantly the key's relationship to the piano hammer arm is very different and would have necessitated the keyboard to have been located much closer to the bridge. Instead of the hook action shown in Figure 1.4, it used a seesaw type lever—M, F, N (shown in Figure A-II: 1)—which would push up at point F. This would require the keys to be placed at the left side of the mechanism rather than on the right.

person.²⁶⁶ The name *Serestini* might be a distortion of *celestina*, a bowing mechanism invented by Adam Walker in 1772. This mechanism could be added to a harpsichord or could be made as an instrument in its own right. Most significantly, Thomas Jefferson is known to have had this stop fitted to his Kirkman harpsichord (1786), and remarked that it ‘suits slow movements, and as an accompaniment to the voice’.²⁶⁷ Walker’s patent document gives the following description:

The tone is produced from those strings by ... threads ... of silk, flax, wire, gut, hair, leather ... [which] are kept circulating above or under the strings by a weight, spring, or traddle ... [and produces] tones from the strings as a bow does from a violin.²⁶⁸

Since both Pinto and Goldsworth supplied Longman & Broderip with pianoforte guitars—Pinto first, then Goldsworth—it follows Goldsworth’s patent contained elements already in use by Pinto. It is possible these instruments were made, though none is known to survive. From the patent diagram Goldsworth’s Cremona stop appears to be quite large and delicate and would probably be difficult to store and so easily damaged and so lost.

Claus’s pianoforte guitar stops

Christian Claus used his 1783 patent to establish himself as the inventor of the pianoforte guitar. However, the chief object of this patent was various stops, and not the piano mechanism.

In which Plan or Drawing the several parts marked, distinguished, or referred to by the several letters, A, B, E, F, G, H, and M, although my own proper Invention, yet having been before my applying for the said Patent made public, are not the objects thereof...²⁶⁹

In this text, A and B refer to the keys and the brass box that holds them, E, F, G, and H, all refer to the hammer arm and the roller it is attached to. It is certainly true from the study of surviving pianoforte guitars that these elements are common to both Claus’s instruments and those of Longman & Broderip. ‘M’, in the patent document

²⁶⁶ Gazetteer and New Daily Advertiser, 4 November 1783, issue no. 17129.

²⁶⁷ Ripin 2001b.

²⁶⁸ Adam Walker, *Musical Instrument called "Celestina."* (London, 1772), Patent no. 1020, p. 2.

²⁶⁹ Claus’s patent (no. 1394), p. 2.

refers to a band of string, stretched between two pins, that catches the hammers when they fall so they do not knock against the back of the guittar. This is not usually found on surviving instruments, and it was more common for both types to use a mesh pad, fitted over the braces of the back, instead.

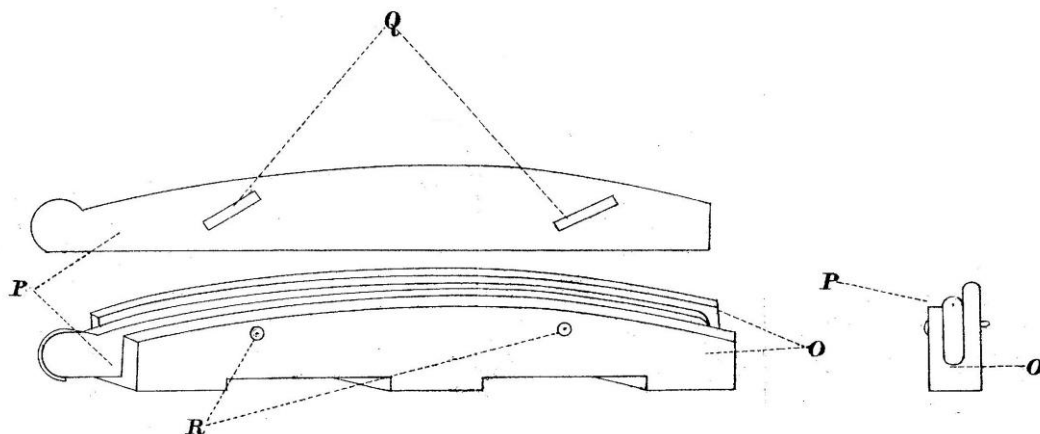

Figure A-II: 3: Harp stop from Claus's patent no. 1394



Figure A-II: 4: Harp stop with red felt, present on guittar by Claus, MMA 1013 90-E

Claus's patent included details for a harp stop, piano stop, and a trumpet stop for his instrument. Before Charles Pinto's caveat, it presumably included some kind of 'serestini' stop mentioned before.²⁷⁰ The harp stop (Figure A-II: 3) is built into the

²⁷⁰ Claus's trumpet stop has not been found on surviving instruments. It was by far the most complicated stop and required an additional mechanism to be in place with different hammer heads, which ostensibly would have sounded like a trumpet when hitting the strings.

bridge, and could slide into contact with the strings immediately next to the saddle and would have muted the sound and removed higher partials. The piano stop, would have affected the sound by placing cloth between the impact of the hammers and the strings (Figure A-II: 5). Only the harp stop has been seen to survive on known instruments (Figure A-II: 4), though there is evidence on a guittar at the MMA that show it may once have had a piano stop (Figure A-II: 6).

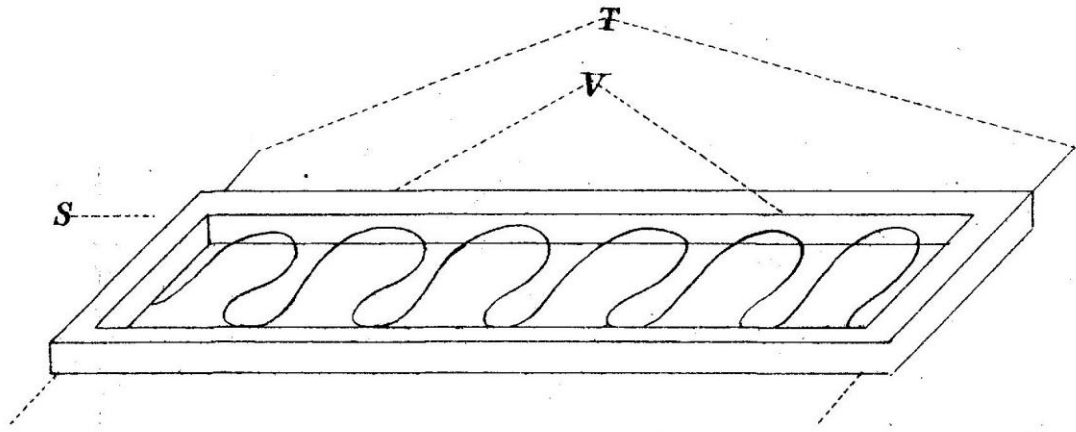

Figure A-II: 5: Piano stop from Claus's patent no. 1394

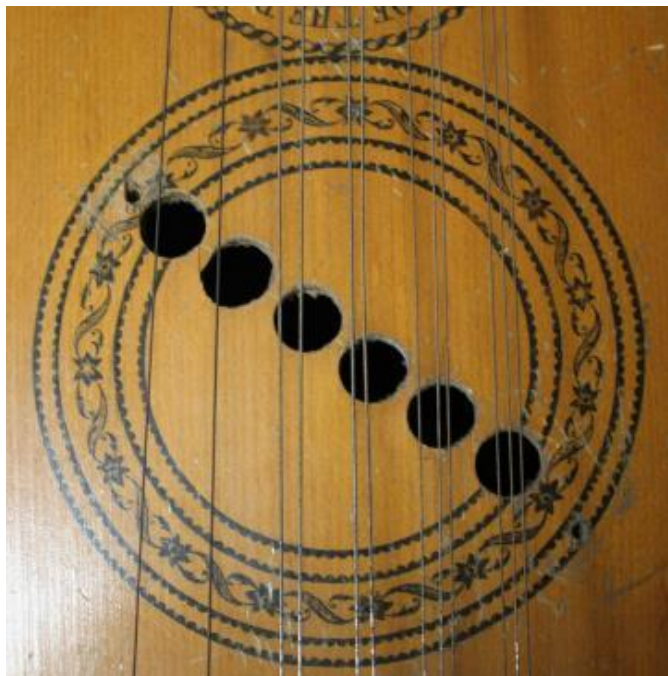

Figure A-II: 6: Detail of guittar by Claus showing possible mounting holes for the piano stop (at either end of the line of hammer holes), MMA 1013 90-E

Figure A-II: 7, shows the type of keyboard used by Longman & Broderip, probably made by John Goldsworth. Figure A-II: 8, shows the keys used by Christian Claus, which are nearly identical, with the exception that they are sprung with metal wire instead of boar bristle. The similarities of the brass boxes might suggest that both makers bought in boxes from the same supplier. Boar bristle is commonly used in harpsichord making, to return the quill of the jack, this feature supports John Goldsworth's continued involvement in manufacturing pianoforte guittars.



Figure A-II: 7: Keys of the style used by Longman & Broderip. MIMEd 308

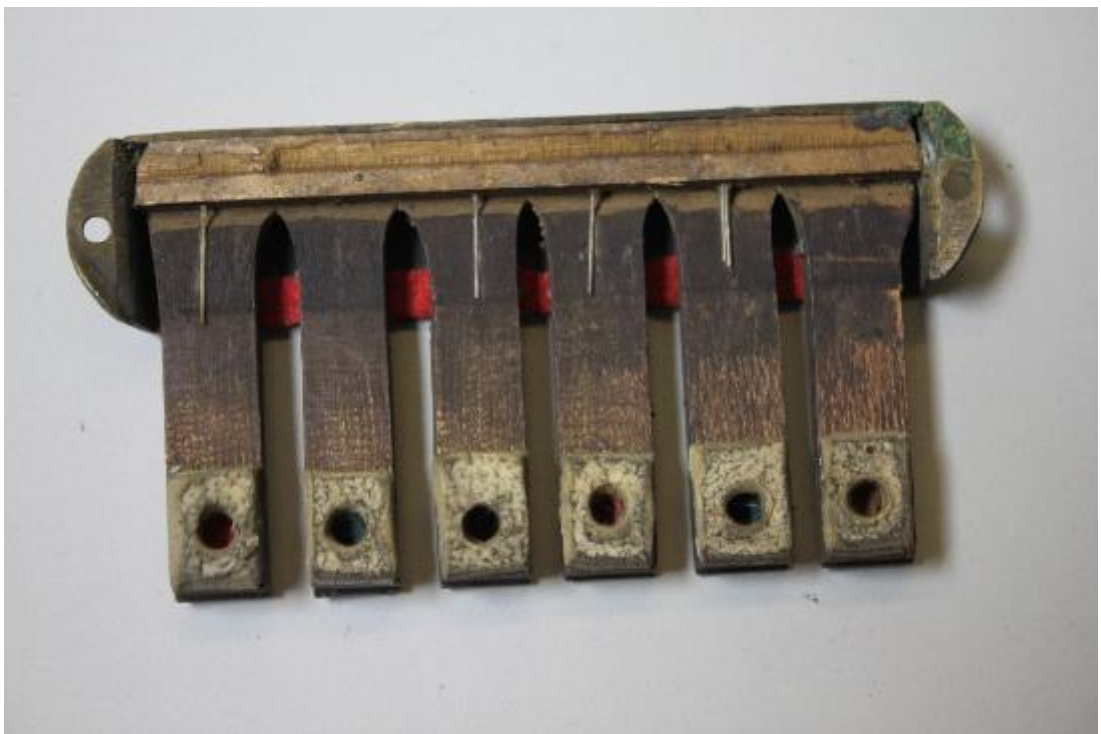
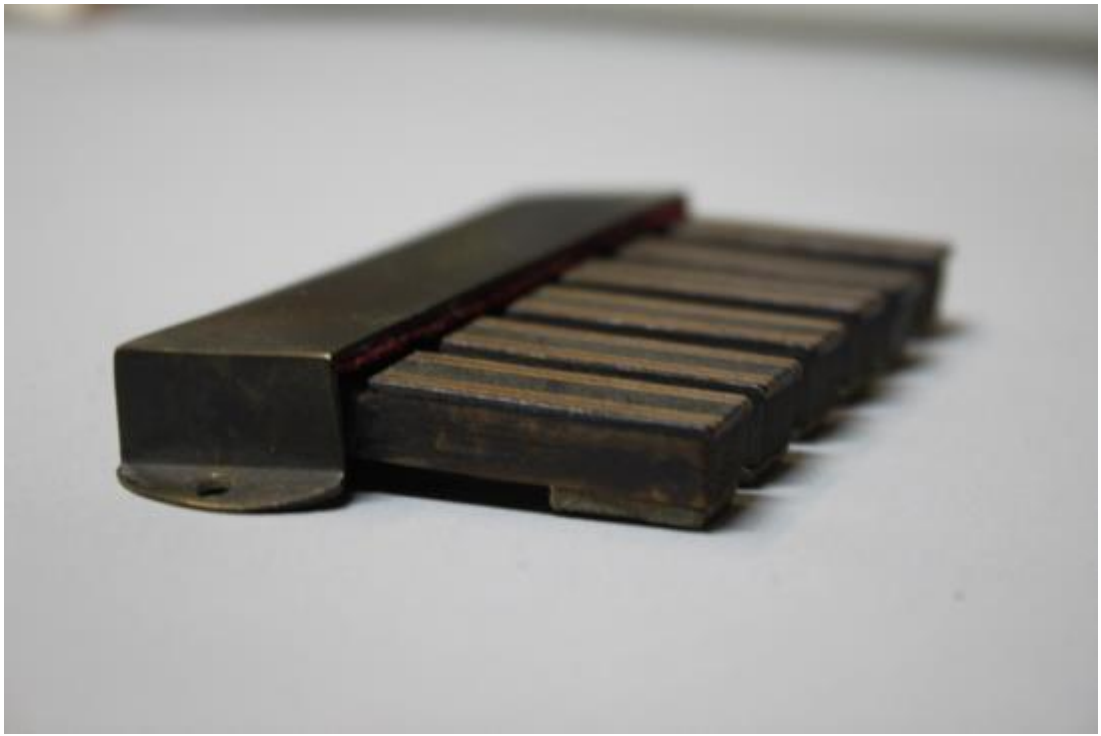

Figure A-II: 8: Keys used by Christian Claus, MMA 1013 90-E

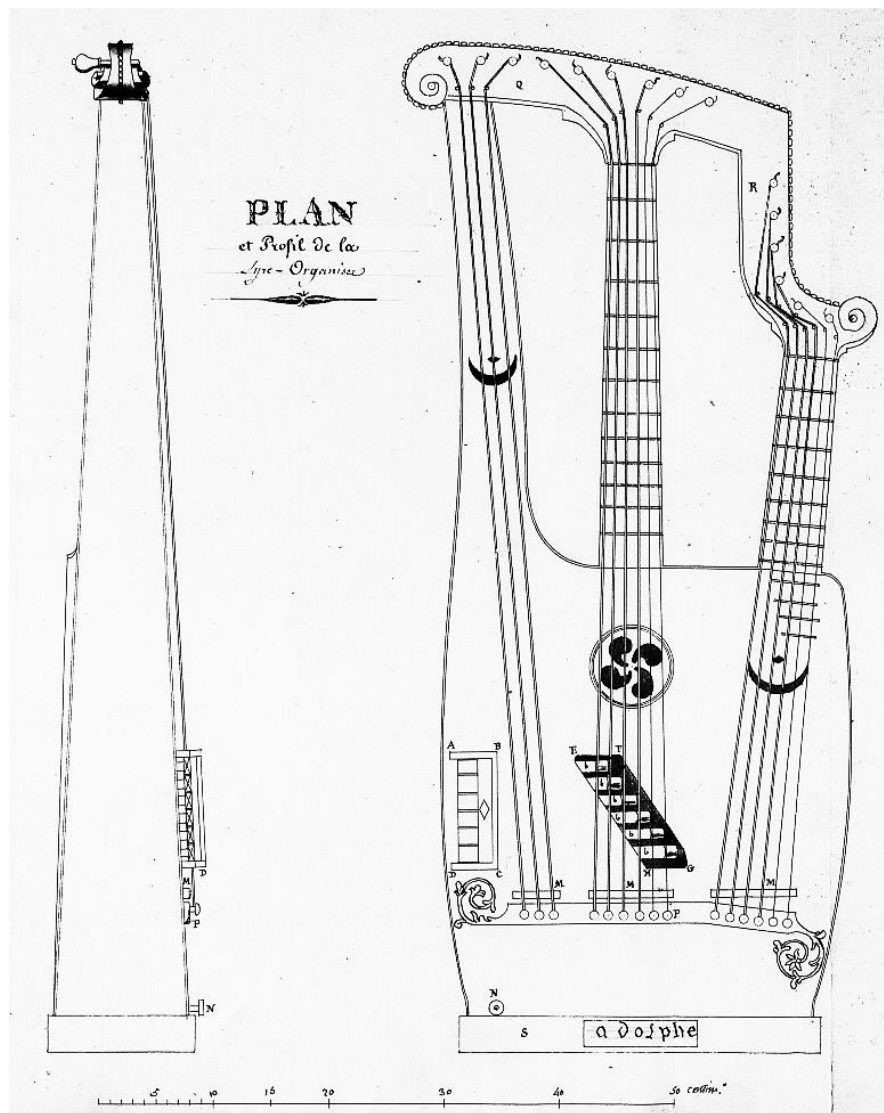

Figure A-II: 9: Le d'Huy's 1806 patent drawing no. 1BA373

Adolphe le d'Huy's *Lyre-Organisée* (ca. 1800)

At the beginning of the nineteenth century, Adolphe le d'Huy developed his *Lyre-Organisée*, receiving a patent for it on 21 November 1806.²⁷¹ The instrument had fifteen strings grouped in three sections: three bass strings (D – C – B); six strings tuned as an ordinary guitar operated by a piano hammer mechanism; and *quint* neck with six short-scale strings tuned a fifth higher than standard tuning (see Figure A-II: 9).²⁷²

²⁷¹ Joseph-Anne-Adolphe le d'Huy, Paris, 21 November 1806, no. 1BA373.

²⁷² Miner 2012.

It had a flat lower end, allowing it to be stood on a table, typical for the lyre-guitar, popular in France at this time.²⁷³ Likewise, its lyre-shape—having two arms additional to the neck, connected by a sweeping ‘yoke’ headstock—was a popular design form, reminiscent of the Classical lyre of antiquity, and in France this form was the basis for the first the attempts at making six-string guitars.²⁷⁴

There were three sound holes in addition to the hole for the hammers, one for each set of strings. The two outer groups of strings had sound holes in the shape of a star and crescent moon; and the central strings had a sound hole in the shape of a *swastika*. Le d’Huy takes this classical symbolism further in his published tutor where he designates a muse each between the three sets of strings; naming the floating bass strings *Hypate*, the middle neck *Mese*, and the treble *Nete*.²⁷⁵

DESSUS.	{	La première or chanterelle	Si.	}	Sur le petit manche
		La seconde	Fa.		
		La troisième	Ré.		
		La quatrième	La.		
		La cinquième	Mi.		
		La sixième	Si.		
INTERMÉDIAIRE.	{	La chanterelle	Mi.	}	Sur la plus long manche
		La seconde	Si.		
		La troisième	Sol.		
		La quatrième	Ré.		
		La cinquième	La.		
BASSE.	{	La première	Mi.	}	Sur le bass
		La seconde	Re.		
		La troisième	Ut.		
		La quatrième	Si.		

Figure A-II: 10: Tuning given in Le d’Huy’s 1806 tutor²⁷⁶

²⁷³ For a contemporary comparison, see the Lyre Guitar ca. 1805 attrib. Joseph Pons, MMA no. 1998.121.

²⁷⁴ Tyler and Sparks 2002, p. 220.

²⁷⁵ The seven strings of the lyre were named according to their position on the instrument. They are not named after muses, but simply with adjectives in the feminine (to agree with *chordē* ‘string’), so: *hypate* (*chordē*): topmost (string); *mese*: middle; *nete*: bottom; etc. *Hypate* is the topmost string of the lyre in terms of position (it is the one closest to player), but the lowest one in pitch (therefore, the bass note). Conversely, *nete* is the bottom string, inasmuch as it is placed the farthest from player, but plays the highest note. I am grateful to Gabriel Macedo Nocchi for this information. See West 1992, pp. 64, 219.

²⁷⁶ Le d’Huy 1806, p. 5.

For the guitar, the use of these three registers was entirely unique at the time. The combination of floating bass strings on a lyre-form guitar is almost unheard-of, but not new for fretted stringed instruments or for the guitar.²⁷⁷ The *bisex* (twice six), was an instrument with six strings tuned like a guitar, and six floating bass strings, made in Paris during the 1770-80s, by makers such as Jean-Henri Naderman and Jean-François Thiphanon.²⁷⁸

The purpose of the *quint* neck may have been to address some perceived shortcomings of the lyre-guitar. Charles Doisy, a critic of the lyre-guitar writing in 1801 gives the following harsh review of that popular instrument:

And without a doubt, if those who would play this instrument, and who look with pleasure upon eighteen to twenty Frets, had my real conception of the obstacles preventing performance on so long a Fretboard, with six strings, they would be disheartened right from the start. Since the five-string guitar (surely easier to play and hold than the lyre-guitar, and on which most amateurs – even most artists – do not play above the 10th Fret) is already supported by such weight of opinion, I can truly say this lyre-guitar is barely fit for strumming second-rate accompaniments.²⁷⁹

Playing on the higher frets of a lyre guitar was no doubt difficult, as the two pillars would hinder the left hand and wrist. This quint neck, which le d’Huy explains is usually played in isolation, would allow the player to reach the highest notes. Part of the underlying motivation for this instrument was to ‘improve’ the lyre guitar, which like Doisy, le d’Huy was quite critical of: ‘the Lyre-Guitar is considered by some people to be an improvement on the Guitar, but it certainly cannot be considered as such since it is nothing other than a six-string guitar, disfigured.’²⁸⁰ The term *organisée* has a double meaning, on the one hand ‘mechanised’, having a piano hammer action inside, but also literally ‘organised’—made more orderly—in contrast to the lyre-guitar, which in le d’Huy’s opinion did not benefit through being lyre shaped. Doisy and le d’Huy both seem to consider the five-string guitar ordinary. In fact le d’Huy’s

²⁷⁷ Gregg Miner, records that a hitherto unique lyre-guitar with three floating strings is in the Tiroler Landesmuseum Ferdinandeum, Innsbruck. Miner 2015.

²⁷⁸ Miner 2014.

²⁷⁹ Par Doisy, *Principes Generaux de la Guittare a cinq et a six cordes et de la Lyre*, Paris, 1801. As quoted and cited in Bonner 1972, p. 62.

²⁸⁰ le d’Huy 1806, pp. i–ii.

describes his instrument as five stringed instrument, counting the low E-string along with the three floating bass strings despite the fact this string appears to be fully fretted (see Figure A-II: 10).²⁸¹

In addition to the piano mechanism, there was a mute, which was to be pressed with the arm while playing the *quint* neck ‘which is precisely at the place where the arm rests habitually on the instrument, and to increase or diminish this pressure till the mute produces the desired effect’.²⁸² The instrument’s case also would have been used by the player during play, firstly to rest the foot upon and secondly with an adjustable folding music stand which would rise out of the case. All these design features were very much *à la mode*, and so it is noteworthy that the instrument also featured a piano mechanism for the middle six strings. It is helpful for showing that keyed guitars emerged from a context of experimental instrument design.

Although a full study of le d’Huy’s instruction book has not been possible for the purposes of this project, an initial reading has provided no description of the key mechanism. From the engraving, however, it seems that a keyboard of six keys rests on top of the soundboard like those of the pianoforte guitar in London, and the hammer arms get progressively shorter towards the bass. There does not appear to be any way of accessing the mechanism through the side of the guitar and so it may have most closely resembled the instruments by Christian Claus.

Further study of le d’Huy’s guitar tutor would certainly be fruitful. Any description of the technique for the use of the keys or thoughts about the role and function of the keyed mechanism would be directly relevant to our understanding of German keyed guitars, by inference. Le d’Huy’s also includes music specifically for the keyboard in his 1806 guitar tutor. In the future I will seek to work with guitarists (particularly those used to the piano too), using these instruments to explore repertory and consider how the technique might be developed. This has been far beyond the scope of this project, but is a natural next step now having these reconstructed instruments.

²⁸¹ Lacôte *decacorde* of 1826 was also a five stringed guitar, with five floating bass strings.

²⁸² Nicholson 1808, p. 372.

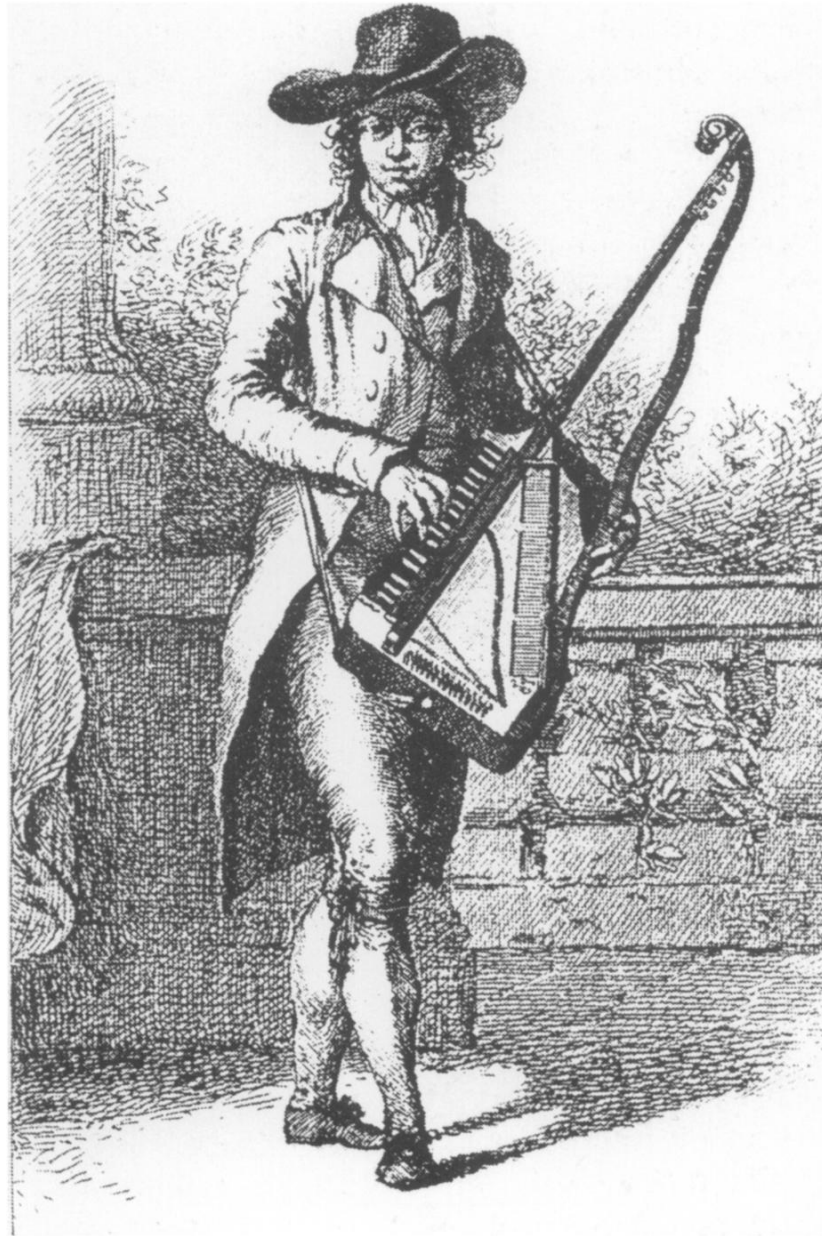

Figure A-II: 11: Engraving of an Orphica from Carl Leopold Rollig's 1795 pamphlet²⁸³

²⁸³ As cited in Vogel 2004, p. 19.

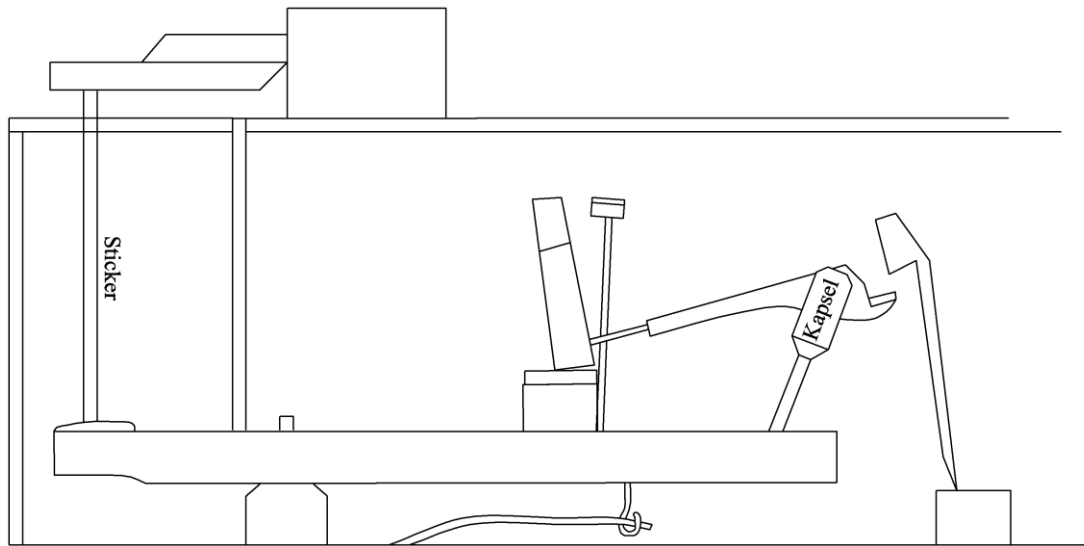

Figure A-II: 12: Orphica Mechanism, GNM MIR1179

The Orphica (1795)

The orphica is a small portable piano with a Viennese action, invented in Vienna ca. 1794 by Carl Leopold Röllig (*b.* Hamburg, before 1754, *d.* Vienna, 1804).²⁸⁴ Its name comes from the tragic hero Orpheus, who played his lyre in the fields of Thrace, and so was marketed as an instrument to be taken outdoors, and appealed to the noble and romantic sentiments of late-eighteenth-century Austria (see Figure A-II: 11).

The Orphica, like the Theorbo and the Lute, is a bass instrument on which the most felicitous ratios of string lengths are attached. It is by nature designed for calm and gentle feelings—created for the night, friendship, love.²⁸⁵

The identity of the orphica needs to be understood within the context of neoclassicism in the eighteenth and nineteenth centuries, which was not missed by instrument makers. The idea of building an instrument in the shape of a Greek lyre was not unique to the orphica; guitars were made in lyre form, so were pianos and music stands. The orphica also was portable like a lyre but must be understood to be a small piano and not a keyed guitar.

²⁸⁴ Vogel 2004, p. 20.

²⁸⁵ Röllig 1795, pp. 13–14. Original: *Die Orphica, ist wie die Theorbe und die Laute, ein Bass Instrument, auf welchem die glücklichsten Verhältnisse der Saitenlängen angebracht sind. Sie ist ihrer Natur nach für die Ruhe und die sanften Gefühle geschaffen - geschaffen für die Nacht, die Freundschaft, die Liebe.*

The few occasions in modern literature which refer to keyed guitars, often form an association with it to the orphica, which is not helpful for studying these instruments and understanding their history.

As a new construction, the Bachmann workshop also produced a keyboard guitar, in which little hammers strike each string from below. The instrument was one of many similar experiments (e.g. *orphica*, harp-piano) to apply the Pianoforte hammer mechanism to plucked instruments.²⁸⁶

Poulopoulos who acknowledges the orphica's prime function as a lyre-form instrument, suggests that it inspired the various inventors of keyed guitars in the early nineteenth century.²⁸⁷ It is difficult to find clear supporting evidence for this claim, and it is certainly more likely that the pianoforte guittar of London inspired the keyed guitars of the nineteenth century.

The orphica was a piano, and although it was given some superficial, aesthetic features to aid in its association with the lyre of Orpheus, a portable piano is all it was. It could not be played like a harp or lyre. Röllig certainly wanted to encourage the association with plucked instruments. In the 1795 pamphlet quoted above, he compares it to the theorbo and lute, but this is marketing only.

The fact that the instrument could be carried bears a similarity to guitars, and in London the pianoforte guittar was sometimes marketed as a 'portable piano',²⁸⁸ but this was also simply marketing. A portable instrument trying to associate itself with the then very fashionable piano, rather than a piano trying to associate itself with the lyre. 'The male player, particularly when he wants to play while walking or standing, can take the Orphica in his left arm and play as he likes with his right hand.'²⁸⁹ There

²⁸⁶ Elste, Droysen-Reber, and Haase 1987, p. 12. Original: *Als Neukonstruktion har die Bachmann-Werkstatt auch eine Tastengitarre hervorgebracht, bei der Hämmerchen jede Saite von unten anschlagen. Das Instrument war einnes von vielen ähnlichen Experimenten (z. B. Orphika, Klavierharfe), den Hammermechanismus des Pianoforte auf Zupfinstrumente anzuwenden.*

²⁸⁷ Poulopoulos 2015, pp. 47–48.

²⁸⁸ *Morning Herald and Daily Advertiser*, 23 November 1784, issue no. 1272.

²⁸⁹ Röllig 1795, pp. 16–17. Original: *Der männliche Spieler besonders wenn er gehend oder stehend spielen will kann die Orphica auf den linken Arm nehmen und mit der einzelnen rechten Hand nach Wohlgefallen behandeln.* This image of the 'male player' who might carry the instrument while playing to demonstrate his masculinity is somewhat contradicted by contemporary lexicons which describe the orphica as 'playable only by children or at the most by a lady's hands because of the small keyboard.' As quoted in Vogel 2004, p. 25.

is a gulf between how instruments are marketed and how they were inspired or eventually used. The image associated with the instrument can be as important as the object itself.

Another reason to doubt that it was the Orphica that inspired the nineteenth-century keyed guitar, is the type of piano mechanism. Orphicas universally used a Viennese action (see Figure A-II: 12), opposed to the English action used on both surviving keyed guitars and the missing Leipzig guitar. Nevertheless, the Orphica may have had a secondary influence on the keyed guitar. The later instrument from 1843, now at the MMA uses brass *kapseln* common to the Viennese action of the Orphica. Likewise, the Leipzig guitar, which has keys at soundboard level shows a similarity to many Orphica with the same feature. Though these features are not unique the Orphica.

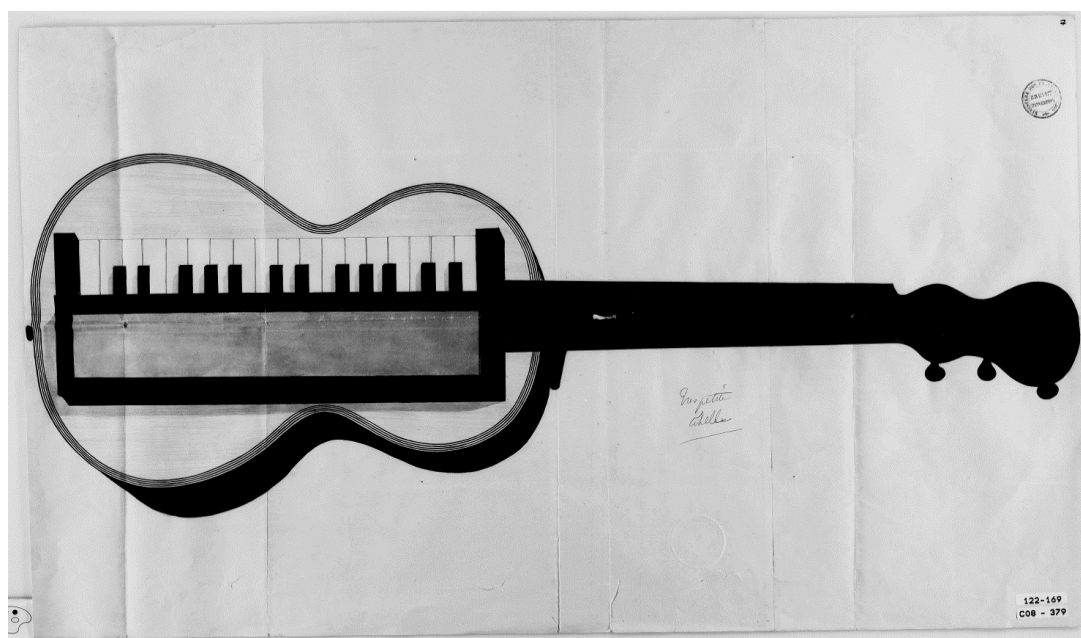

Figure A-II: 13: Drawing from Frédéric Fischer's 1839 patent Piano-Lyre

Frédéric Fischer's Piano-Lyre (1839)

In Paris in 1839, Frédéric Fischer patented his *Piano-Lyre*. This however is not a keyed guitar as understood in the terms of this study. Like keyed guitars however it is a very little understood instrument and has entirely avoided study. Pouloupoulos says that ‘despite its name, this was neither a piano nor a lyre-shaped instrument, but a common

guitar with a keyboard mounted on the top.²⁹⁰ Otherwise, this invention has not been mentioned at all in academic literature.

However, even this is a misunderstanding, and the confusing instrument is not even a guitar but an accordion-like reed organ. The patent description says:

The music is produced by a mechanism made up of copper blades which correspond with the external keyboard, and the sounds are produced by the pressure of the bellows in the left hand and the touch of the keyboard in the right.²⁹¹

When describing the keys, Fischer says it ‘resembles those of the ordinary piano’, explaining at least the ‘piano’ part of its name. As for ‘lyre’ Fischer says it ‘resembles a guitar by its form and its construction, and cannot be distinguished from the said instrument other than by the absence of strings, and further by the absence of a circular opening worked into the middle section of the guitar.’²⁹² By the date of this patent, 1839, there had been a long association between the lyre and guitar in France. The earliest French six-string guitars had been made in lyre-shape and called lyre-guitars.²⁹³

Regarding the history of the keyed guitar, this invention—albeit a free reed instrument—can serve to exhibit the popular status of both the guitar and the piano. It is nevertheless uncertain whether any of these instruments were ever made. Outside of the patent document there are not known references to it in historic sources.

²⁹⁰ Pouloupoulos 2015, pp. 47–8. Original: *Trotz seines Namens war das weder ein Klavier noch ein lyraförmiges Instrument, sondern eine übliche Gitarre mit einer Tastatur, die auf der Decke montiert war.*

²⁹¹ Frédéric Fischer, *Piano-Lyre*, Paris, 1839, no. 1BA7309. Original: *La musique est produite par un mécanisme composé de lames en cuivre qui correspondent avec le clavier extérieur, et dont les sons se produisent par la pression du soufflet de la main gauche et le toucher du clavier de la droite.*

²⁹² Frédéric Fischer, *Piano-Lyre*, Paris, 1839, no. 1BA7309. Original: *Le piano-lyre ressemble, par sa forme et sa construction, à une guitare, et ne se distingue de ce dernier instrument que par l'absence des cordes, et celle de l'ouverture circulaire pratiquée dans le milieu des guitares.*

²⁹³ Tyler and Sparks 2002, p. 220.

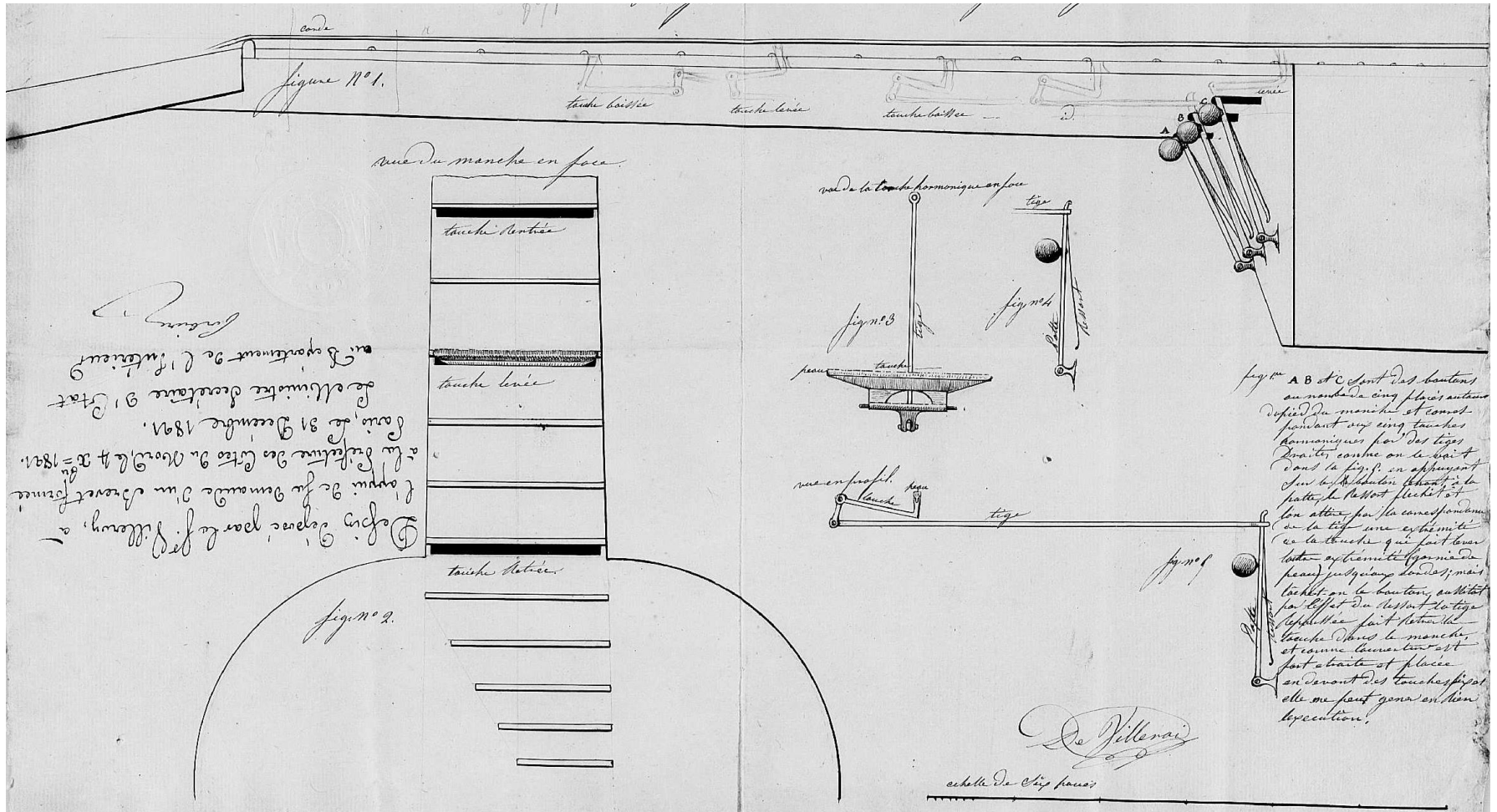

Figure A-II: 14: Patent drawing of Brutus Villeroy's 'Guitare harmonique', 1821

Villeroi's Guitare harmonique

In 1821, Brutus Villeroi patented his *Guitare harmonique*.²⁹⁴ Like Frédéric Fischer's Piano-Lyre, very little is known about this invention. The patent document describes this as a mechanical adaptation of the guitar neck to execute harmonic notes on the guitar.

Buttons placed on the heel of the guitar would operate a mechanism within the neck. Each button corresponded to a thin pad spanning the width of the fingerboard (see Figure A-II: 14). Each pad would be raised from within the fingerboard into contact with all the strings at such a point intended to isolate various harmonic vibrations of the strings. They were located on the bridge side, immediately next to the 3rd, 5th, 7th, 9th, and 12th frets.

It is not likely that this invention had much success. In my opinion, the button locations—on the heel—would be quite inconvenient and make it harder to execute harmonic notes compared with ordinary technique.

²⁹⁴ Brutus Villeroi, *mécanisme propre à être adapté au manche de la lyre ou guitare*, Paris, 1821, no. 1BA1610.

Appendix III: Instrument diagrams

This consists of scale drawings of both keyed guitars and is provided in a second document due to the varying page size.

Contents:

(a): Guitar by Mathias Neüner 1810, Mittenwald

Page 1:	Plan view of the whole instrument	Size A0
Page 2:	Soundboard layout	Size A1
Page 3:	Back layout	Size A1
Page 4:	Dimensions of the bridge	Size A4
Page 5:	Mechanism layout	Size A2
Page 6:	Mechanism parts dimensions	Size A3

(b): Guitar by Sprenger and Fiala 1843, Karlsruhe

Page 1:	Plan view of the whole instrument	Size A0
Page 2:	Soundboard and back layout	Size A1
Page 3:	Dimensions of the internal braces	Size A2
Page 4:	Dimensions of the neck and fingerboard	Size A2
Page 5:	Dimensions of the bridge	Size A4
Page 6:	Mechanism Layout	Size A3
Page 7:	Mechanism parts dimensions	Size A4

Bibliography

- Albrecht, O., and Robert von Zahn. 2001. 'Heyer, (Friedrich) Wilhelm'. In *Oxford Music Online*. Oxford: Oxford University Press: www.doi.org/10.1093/gmo/9781561592630.article.12970. Accessed 6th May 2020.
- di Asuni, G. 1784. *New and Complete Instructions for the Piano-Forte Guitar*, London: Longman & Broderip.
- Bachmann, O. 1835. *Theoretisch-praktisches Handbuch des Geigenbaues*, Quedlinburg: Leipzig: Basse.
- Baines, A. 1968. *Catalogue of Musical Instruments: Non-Keyboard Instruments*, Vol. II. London: HMSO.
- Bär, F., T. Fuchs, R. Wagner, S. Kirsch, M. Wolters, K. Fischeidl, G. Scholz, C. Kretzer, M. Raquet, M. Fichtner, M. Firsching, S. Wagner, M. Zepf, R. Schielein, M. Böhnel, N. Reims, G. Brennhäuser, and V. Weizel. 2018. *Recommendations for the Three-Dimensional Computed Tomography of Musical Instruments and Other Cultural Artefacts*. Nuremberg: Germanisches Nationalmuseum, Nuremberg; Fraunhofer Entwicklungszentrum Röntgentechnik, Fürth: www.musices.gnm.de/sites/default/files/downloads/2018-10-11_MUSICES_Recommendations.pdf.
- Barberi, A. 1872. *Dizionario della musica*, Milan: L. di Giacomo Pirola.
- Barbour, J. M. 1948. 'Allgemeine Musikalische Zeitung: Prototype of Contemporary Musical Journalism,' *Notes*. Vol. 5, no. 3: pp. 325–337.
- Barthioli, F. 1833. *Guitare-Flageolett-Schule*, Vienna: Diabelli & Co.
- Beilage zur Allgemeinen Zeitung, Nr. 22. 1820. in *Allgemeine Zeitung München: 1820*, Munich.
- Bieber, A., J. Buckland, and J. Tulacek. 2010. 'A Review of Three Old Lutherie Books with an Emphasis on Their Guitar Sections: "Manuel Du Luthier," by J. C. Maughin,' *American Lutherie - The Quarterly Journal of the Guild of American Luthiers*, Tacoma, WA, USA. no. 104.

- Bonner, S. 1972. *The Classic Image: European History and Manufacture of the Lyre Guitar, 850-1840*, First ed. Harlow: Bois de Boulogne.
- Bowyer, A., P. Reeves, R. Hague, P. Hough, and M. Miadownik. 2013. 'What Is the Future of 3D Printing?' Panel discussion as part of the London Design Festival at the Victoria & Albert Museum: www.vam.ac.uk/content/exhibitions/london-design-festival-at-the-v-and-a-2013/what-is-the-future-of-3d-printing/. Accessed 9 June 2020.
- Brockhaus, H. 1877. *Allgemeine Encyclopädie der Wissenschaften und Künste*, Vol. I. Leipzig: F. A. Brockhaus.
- Chabran, F. 1813. *A New Tutor for the Spanish Guitar*, London: Goulding, D'Almaine, Potter & Co 20 Soho Square.
- Chouquet, G. 1884. *Le musée du Conservatoire national de musique : catalogue descriptif et raisonne*, Paris: Firmin-Didot.
- Coates, K. 1993. *Geometry, Proportion and the Art of Lutherie*, Oxford: Clarendon Press.
- Cole, M. 1998. *The Pianoforte in the Classical Era*, Oxford: Clarendon Press.
- Cole, W. H. 1986. 'The Early Piano in Britain Reconsidered,' *Early Music*. Vol. 14, no. 4: pp. 563–566.
- Cottrell, S., and J. Howell. 2019. 'Reproducing Musical Instrument Components from Manufacturers' Technical Drawings Using 3D Printing: Boosey & Hawkes as a Case Study,' *Journal of New Music Research*. Vol. 48, no. 5: pp. 449–457.
- Dormehl, L. 2017, May 22. '3D-Printed Stradivarius Replica Is Nearly Indistinguishable from the Real Thing,' *Digital Trends 2017*: www.digitaltrends.com/cool-tech/3d-printed-violin-stradivarius. Accessed 27 February 2019.
- Doubrovski, Z., V. Lorenzoni, and J. Verlinden. 2013. 'Embracing the Digital in Instrument Making: Towards a Musician-Tailored Mouthpiece by 3D Printing.' Presented at: Stockholm Music Acoustics Conference, Stockholm.
- Doubrovski, Z., J. Verlinden, J. Geraedts, I. Horvath, and V. Konietzschke. 2012. 'Acoustic Investigation of Novel Saxophone Mouthpiece Designs Produced by Additive

Manufacturing,' Presented at: Tools and Methods of Competitive Engineering, Karlsruhe, Germany.

Elste, M., D. Droysen-Reber, and G. Haase. 1987. *Handwerk im Dienste der Musik : 300 Jahre Berliner Musikinstrumentenbau*, Berlin: Staatliches Institut für Musikforschung Preussischer Kulturbesitz.

Elste, M., and E. Helm. 2001. 'Bachmann, Carl Ludwig.' In *The New Grove Dictionary of Music and Musicians*, edited by Stanley Sadie. Vol. II. London: Macmillan Publishers Limited.

Fack, E. 1884. *Materialien zu einer Geschichte der Guitarre und ihre Meister*, Berlin. Transcribed and made available by Martin Hürttig: www.lautenbau-leipzig.de/projekte.html. Accessed 6 April 2021.

Fétis, F. 1835. *Biographie universelle des musiciens, et bibliographie générale de la musique*, Vol. II. VIII vols. Paris and Brussels: Meline, Cans et Compagnie.

———. 1868. *Biographie universelle des musiciens et bibliographie générale de la musique*, 2nd ed. Vol. I. VIII vols, Paris: Firmin-Didot.

Forkel, J. N. 1812. *Allgemeine musikalische Zeitung*, Leipzig: Breitkopf & Härtel.

Galpin, F. W. 1910. *Old English Instruments of Music: Their History and Character*, London: Methuen & Co.

———. 1937. *Textbook of European Musical Instruments*, London: Ernest Benn.

Gamwell, L. 2016. *Mathematics and Art: A Cultural History*, Princeton: Princeton University Press.

Gassner, F. S. 1849. *Universal-Lexikon der Tonkunst*, Stuttgart: Köhler.

Gerber, E. L. 1812. *Neues historisch-biographisches Lexikon der Tonkünstler*, Vol. I. Leipzig: A. Kühnel.

Gretschel, H., and G. A. Wettengel. 1869. *Lehrbuch der Geiger- und Bogenmacherkunst*, 2nd Edition. Weimar: Bernhard Friedrich Voigt.

- Groce, N. 1991. *Musical Instrument Makers of New York: A Directory of Eighteenth and Nineteenth Century Urban Craftsmen*. Annotated Reference Tools in Music, no. 4. Stuyvesant, NY: Pendragon Press.
- Hackl, S. 2016. *Guitaromanie: Kleines Panoptikum der Gitarre von Allix bis Zappa*, Rinn: Self published.
- Henley, W. 1959. *Universal Dictionary of Violin and Bow Makers*, 1st ed. Vol. V. VII vols. Brighton: Amati Pub. Ltd.
- Hindmarch, J., M. Terras, and S. Robson. 2019. 'On Virtual Auras: The Cultural Heritage Object in the Age of 3D Digital Reproduction,' in *The Routledge International Handbook of New Digital Practices in Galleries, Libraries, Archives, Museums and Heritage Sites*. Routledge. pp. 243–256.
- Howe, R., S. Shahbazmohamadi, R. Bass, and P. Singh. 2014. 'Digital Evaluation and Replication of Period Wind Instruments: The Role of Micro-Computed Tomography and Additive Manufacturing,' *Early Music*. Vol. 42, no. 4: pp. 529–536.
- Huber, A. 2002. 'Was the "Viennese Action" Originally a Stossmechanik?,' *Galpin Society Journal*. Vol. 55: pp. 169–182.
- le d'Huy, A. 1806. *Essais Sur l'amélioration de La Lyre-Guitare, Ou Description Méthodique de La Lyre-Organisée*, Paris: Savary & Porro.
- Jahnel, F. 2000. *Manual of Guitar Technology: The History and Technology of Plucked String Instruments*, Westport: Bold Strummer.
- Kinsky, G. 1912. *Musikhistorisches Museum von Wilhelm Heyer in Cöln*, Leipzig: Breitkopf & Härtel.
- Koch, H. C. 1802. *Musikalisches Lexikon*, Frankfurt am Main: August Hermann dem Jüngern.
- . 1807. *Kurzgefasstes Handwörterbuch der Musik für praktische Tonkünstler und für Dilettanten*, Leipzig: J.F. Hartknoch.
- Königlich-bayerisches Intelligenzblatt für den Isarkreis. Publisher not identifiable. 1818. Available on Google books: <https://books.google.co.uk/books?id=dvtEAAAACAAJ>.

- Lasocki, D. 2010. 'New Light on Eighteenth-Century English Woodwind Makers from Newspaper Advertisements,' *Galpin Society Journal*. Vol. 63: pp. 72–142.
- Ledebur, C. F. von. 1861. *Tonkünstler-Lexicon*, Berlin: Ludwig Rauh.
- Libin, L. 1985. *American Musical Instruments in the Metropolitan Museum of Art*, New York: Metropolitan Museum of Art.
- Lichtenthal, P. 1826. *Dizionario e bibliografia della musica*, Vol. I. Milan: Antonio Fontana.
- Lomtev, D. 2014. *Karl Wirths Notizbücher: Ideenwelt eines Musikinstrumentenbauers*, Vol. II. Munich: Deutsches Museum.
- Loomis, K. 2015. 'The Organology of the Queen Mary and Lamont Harps' (PhD Diss. University of Edinburgh).
- Loomis, K., D. Caldwell, J. Tate, T. Ogilvie, and E. J. R. Van Beek. 2012. 'The Lamont and Queen Mary Harps,' *Galpin Society Journal*. Vol. 65: pp. 113–167.
- Loy, F. 2009. 'Harmoniemusik in der Fürstenbergischen Hofkapelle zu Donaueschingen' (PhD Diss. Universität Tübingen).
- . 2018. 'Die Hofmusik Am Fürstlich Fürstenbergischen Hof Zu Donaueschingen Im 18. Jahrhundert,' in *Süddeutschen Hofkapellen im 18. Jahrhundert*, ed. S. Leopold and B. Pelker, Heidelberg: Heidelberg University Publishing, pp. 55–104.
- Lütgendorff, W. L. 1922. *Die Geigen und Lautenmacher vom Mittelalter bis zur Gegenwart*, Frankfurt am Main: Frankfurter Verlagsanstalt A. G.
- Martin, D. 2006. 'The Early Wire-Strung Guitar,' *Galpin Society Journal*. Vol. 59: pp. 123–256.
- Matzaridis, H. 2016. 'ViolinoDigitale', www.violinodigitale.com.
- Michel, A. 1999. *Zistern: europäische Zupfinstrumente von der Renaissance bis zum Historismus : Katalog*, Instrumentarium Lipsiense. Leipzig: Universität Leipzig, Musikinstrumenten Museum.
- Michel, A., and P. Neumann. 2016. *Gitarren 17. Bis 19. Jahrhundert*, Instrumentarium Lipsiense. Leipzig: Universität Leipzig, Musikinstrumenten Museum

- Miner, G. 2012, March 11. 'Ledhuy's Organized-Lyre' *Gregg's Blog* (blog): www.harpguitars.net/blog/2012/03/ledhuys-organized-lyre. Accessed on 15 May 2020.
- . 2014, April. 'Organology: Harp Guitar-Related Instruments' *Gregg's Blog* (blog): www.harpguitars.net/history/org/org-hybrids.htm. Accessed on 22 May 2020.
- . 2015, March. 'Lyre Guitars & Related Instruments' *Gregg's Blog* (blog): www.harpguitars.net/history/org/org-lyres.htm. Accessed on 22 May 2020.
- Morgenblatt für gebildete Stände. 1820. Vol. XIV. Stuttgart und Tübingen.
- Morris, F. 1904. *Catalogue of the Crosby Brown Collection of Musical Instruments of All Nations*, New York: Metropolitan Museum of Art.
- Nex, J. 2004. 'Culliford & Co: Keyboard Instruments Makers in Georgian London,' *Early Keyboard Journal*. Vol. 22: pp. 7–48.
- . 2011. 'Longman & Broderip,' in *The music trade in Georgian England*, edited by Michael Kassler. Farnham, Surrey; Burlington, VT: Ashgate.
- . 2013. 'The Business of Musical-Instrument Making in Early Industrial London' (PhD Diss. Goldsmiths College, University of London).
- Nicholson, W. 1808. 'Organized Lyre by Mr. Adolphus Ledhuy'. In *Journal of Natural Philosophy, Chemistry and the Arts*. Vol. XIX. London: G. G. and J. Robinson.
- Nicolai, F. 1779. *Beschreibung der Königlichen Residenzstädte Berlin und Potsdam*.
- Noé, H. 1873. 'Eine Heimstätte deutschen Fleißes,' *Die Gartenlaube: illustriertes Familienblatt*, Leipzig: Ernst Keil.
- Ott, A. 2001. 'Kinsky, Georg Ludwig,' In *Oxford Music Online*. Oxford: Oxford University Press.
- Page, C. 2020. *The Guitar in Georgian England: A Social and Musical History*, New Haven: Yale University Press.
- de Pascual, B. K. 1983. 'English Square Pianos in Eighteenth-Century Madrid,' *Music & Letters*. Vol. 64, no. 3/4: pp. 212–217.

- Pollens, S. 1995. *The Early Pianoforte*, Cambridge: Cambridge University Press.
- Pontécoulant, A. le D. comte de. 1861. 'Guitare a Clavier.' In *Organographie*. Paris: Castel.
- Poulopoulos, P. 2011a. 'The Guittar in the British Isles, 1750-1810' (PhD Diss. University of Edinburgh).
- . 2011b. 'A Comparison of Two Surviving Guittars by Zumpe and New Details Concerning the Involvement of Square Piano Makers in the Guittar Trade,' *Galpin Society Journal*. Vol. 64: pp. 49–60 .
- . 2015. 'Das Musizieren im Freien in der Zeit des Biedermeier,' *Phoibos - Zeitschrift für Zupfmusik*. Vol. 15. pp. 43–68.
- . 2018. 'The Impact of François Chanot's Experimental Violins on the Development of the Earliest Guitar with an Arched Soundboard by Francesco Molino in the 1820s,' *Early Music*. Vol. 46, no. 1. pp. 67–86.
- Redwood, B., F. Schöffler, and B. Garret. 2017. *The 3D Printing Handbook*, Amsterdam: 3D Hubs B.V.
- Reinländer, C. 2001. 'Fiala, Joseph.' In *Die Musik in Geschichte Und Gegenwart, Online*. Kassel, Germany: Bärenreiter. <https://www.mgg-online.com/mgg/stable/57613>.
- Ripin, E. M. 1972. 'A Suspicious Spinnet,' *The Metropolitan Museum of Art Bulletin* 30, no. 4: p. 196.
- . 2001a. 'Franciolini, Leopoldo'. In *Oxford Music Online*. Oxford: Oxford University Press.
- . 2001b. 'Celestina.' In *Oxford Music Online*. Oxford: Oxford University Press.
- Ripin, E. M., S. Pollens, P. R. Belt, M. Meisel, A. Huber, M. Cole, G. Hecher, B. K. de Pascual, C. A. Hoover, C. Ehrlich, E. M. Good, R. Winter, and J. B. Robinson. 2001. 'Pianoforte,' In *Oxford Music Online*. Oxford: Oxford University Press.
- Ripin, E. M., D. Wraight, G. O'Brien, H. Ferguson, J. Caldwell, H. Schott, and W. Dowd. 1989. *Early Keyboard Instruments*, The New Grove Musical Instruments Series. London: MacMillan London Ltd.

- Rochlitz, J. F. 1799. *Allgemeine musikalische Zeitung*, Leipzig: Breitkopf und Härtel.
- Röllig, C. L. 1795. *Orphica: ein musikalisches Instrument*, Vienna: Blumauer.
- Romanillos, J. L. 1987. *Antonio de Torres: Guitar Maker – His Life & Work*, Shaftsbury: Element Books.
- Rüder, F. A. 1820. ‘Kurze Nachrichten,’ *Oppositions-Blatt oder Weimarische Zeitung*. 1820.
- Ruth-Sommer, H. 1916. *Alte Musikinstrumente: ein Leitfaden für Sammler*, Berlin: R. C. Schmidt & Co.
- Santa Maria Bouquet, J. 2017, November 28. ‘Reconstructing a lute by Sixtus Rauwolf’ (PhD Diss. University of Edinburgh).
- Savan, J., and R. Simian. 2014. ‘CAD Modelling and 3D Printing for Musical Instrument Research: The Renaissance Cornett as a Case Study,’ *Early Music*. Vol. 42, no. 4: pp. 537–544.
- Schilling, G. 1835. *Universal-Lexicon der Tonkunst*, Stuttgart: Köhler.
- Schneider, W. 1834. *Historisch-technische Beschreibung der musicalischen Instrumente*, Reibe & Leipzig: Theodor Hennings.
- Sherratt, T. 2019. ‘Hacking Heritage: Understanding the Limits of Online Access,’ in *The Routledge International Handbook of New Digital Practices in Galleries, Libraries, Archives, Museums and Heritage Sites*, Routledge. pp. 116–130.
- Spencer, R., and I. Harwood. 2001. ‘English Guitar.’ In *The New Grove Dictionary of Music and Musicians*, edited by Stanley Sadie, Vol. VIII, Macmillan: pp. 244–46.
- Sugimoto, H. 2015. ‘Harp lutes in Britain, 1800-1830: study of the inventor, Edward Light and his instruments’ (PhD Diss. University of Edinburgh).
- Turnbull, H. 1974. *The Guitar, from the Renaissance to the Present Day*, New York: C. Scribner’s Sons.
- Tyler, J., and P. Sparks. 2002. *The Guitar and Its Music: From the Renaissance to the Classical Era*, Oxford: Oxford University Press.

- Vogel, B. 2004. 'Orpicas: Genuine, Less Genuine and Fakes,' *Galpin Society Journal*. Vol. 57: pp. 19–205.
- West, M. L. 1992. *Ancient Greek Music*, Oxford: Oxford University Press.
- Wettengel, G. A. 1828. *Lehrbuch der Anfertigung und Reparatur aller noch jetzt gebräuchlichen Gattungen von Italienischen und deutschen Geigen*, Ilmenau: Bernhard Friedrich Voigt.
- Wheeldon, D. 2017a. 'Makers of the Pianoforte Guittar in London 1780–1789,' *Galpin Society Journal*. Vol. 70: pp. 97–116.
- . 2017b. 'The Spanish Guitar' Heilbrunn Timeline of Art History, The Metropolitan Museum of Art: www.metmuseum.org/toah/hd/spgu/hd_spgu.htm. Accessed May 2017.
- . 2020. 'The Met's German Keyed Guitar,' *Metropolitan Museum Journal*. Vol. 55: pp. 145–155.
- de Wit, P. 1884, 1885. 'Die Pianoforte-Mechanik', in *Zeitschrift für Instrumentenbau* Leipzig: Paul de Wit, p. 346.
- . 1892. *Perlen aus der Instrumenten-Sammlung von Paul de Wit in Leipzig*, Leipzig.
- . 1903. *Katalog des Musikhistorischen Museums von Paul de Wit, Leipzig*, Leipzig.
- Woodfield, I. 2000. 'The Calcutta Piano Trade in the Late Eighteenth Century,' in *Music and British Culture, 1785-1914: Essays in Honor of Cyril Ehrlich*. Oxford: Oxford University Press.
- Wronko, J. 2013. *Playing the 3D-printed violin: Joanna Wronko at TEDxAmsterdam*. 2013. Amsterdam: TEDxAmsterdam: www.youtube.com/watch?v=uHmdVmKX9x8. 2013. Accessed 6 June 2020.
- Zoran, A. 2011. 'The 3D Printed Flute: Digital Fabrication and Design of Musical Instruments,' *Journal of New Music Research*. Vol. 40, no. 4: pp. 379–387.
- Zuth, J. 1978. *Handbuch der Laute und Gitarre*, Hildesheim: Georg Olms Verlag.