

**MOLECULAR STUDIES ON THE  
RADIATION-RESISTANT BACTERIA  
DEINOCOCCUS RADIODURANS AND DEINOBACTER GRANDIS**

**VICKI MANNERS**

**A THESIS PRESENTED FOR THE DEGREE OF  
DOCTOR OF PHILOSOPHY  
UNIVERSITY OF EDINBURGH  
AUGUST 1989**



## DECLARATION

I hereby declare that this thesis has been composed by myself and that all the work reported is my own.

## ABSTRACT

Members of the genus *Deinococcus* are characterised by their extreme resistance to both the lethal and mutagenic effects of ionizing and ultraviolet (U.V.) radiations. It is known that the Deinococci have unusual excision repair for eliminating radiation-induced lesions in their DNA, but very little is known about their recombination repair, which, in many other bacteria, involves a protein analogous to the RecA protein of *Escherichia coli*.

Cloning the equivalent of the RecA gene from *Deinococcus radiodurans* was attempted by the construction of gene libraries and the use of their ability to complement *recA* mutations or their analogue in *E.coli* and *Bacillus subtilis*. Several vectors were employed; three *E.coli* vectors, viz, the high copy number plasmid pAT153, the expression vector pDR540 and the cosmid pJBFH; and a *B.subtilis* expression vector pPL608. The libraries were screened for recombination proficient phenotypes by selecting recipient bacteria for resistance to DNA-damaging chemicals, (either methyl methanesulphonate, 4-nitroquinoline-1-oxide or mitomycin C), using either the *recA* hosts *E.coli* HB101, DH5 $\alpha$  or JC10289 or the *recE* host *B.subtilis* IA422. Some libraries were also screened in *E.coli* JC14604, where Lac<sup>+</sup> colonies are formed by introduction of a functional recombination gene which can be identified by the formation of blue colonies on media containing 5-bromo-4-chloro-3-indolyl-B-D-galactoside (X-gal). Restoration of the recombinational ability of *D.radiodurans* mutant *rec30* by complementation was also attempted.

A *D.radiodurans recA* gene analogue was not isolated using these techniques so direct selection methods were tried. Southern blotting

was employed, using the *E.coli* *recA* gene on the plasmid pDR1453 as a probe, and also Western blotting, using polyclonal antibodies to *E.coli* K12 RecA protein. Both gave negative results.

Alkaline sucrose gradients were performed on *D.radiodurans* after a U.V. dose, and showed the first physical proof of recombination repair in the excisionless *D.radiodurans* strain UVS78. The use of this mutant also allowed the time taken to replicate past a pyrimidine dimer to be measured at 10 seconds, as in *E.coli*.

Initial characterisation of the recently isolated ionising radiation-resistant bacterium *Deinobacter grandis*, thought to be closely related to *D.radiodurans*, was begun. *D.grandis* strains KS 0460 and KS 0485 contained many plasmids of very diverse sizes. Chromosomal DNA from rifampicin-resistant strains of either could transform *D.radiodurans* to rifampicin resistance. However, *D.grandis* DNA could only transform its respective parental strain to rifampicin resistance. *D.grandis* was also found to be resistant to U.V., and also, unusually for radiation-resistant bacteria, mutable by U.V. The construction of a shuttle plasmid between *D.radiodurans* and *E.coli* was attempted using plasmids from *D.grandis* and *E.coli*.

## CONTENTS

	Page No.
Title.....	i
Declaration.....	ii
Abstract.....	iii
List of Tables.....	ix
List of Figures.....	x

### CHAPTER ONE. INTRODUCTION

#### 1.1 The genus Deinococcus

1.1.1 Habitat and isolation.....	1
1.1.2 Classification.....	3
1.1.3 DNA of the Deinococci.....	6
1.1.4 Genetics.....	8
1.1.5 Radiation resistance.....	11

#### 1.2 The genus Deinobacter

1.2.1 Isolation.....	14
1.2.2 Classification.....	15

#### 1.3 DNA repair

1.3.1 Photoreactivation.....	19
1.3.2 Excision.....	21
1.3.3 Recombination repair.....	24
1.3.4 The SOS response.....	25

#### 1.4 Aspects of the RecA protein

1.4.1 Recombination and the rôle of the RecA protein.....	29
1.4.2 Isolation of RecA-equivalents.....	32
1.4.3 Cloning strategies.....	36
1.4.4 Recombination deficient strains of <i>D.radiodurans</i> .....	38

1.5 Aims of the Ph.D.....	39
---------------------------	----

### CHAPTER TWO. MATERIALS AND METHODS

2.1 Bacterial strains.....	41
2.2 Plasmids, cosmids and bacteriophages.....	41
2.3 Maintenance of cultures.....	41
2.4 Media.....	45
2.5 Buffers.....	48
2.6 Chemicals and reagents.....	52
2.7 Antibiotics and nutritional supplements.....	53

2.8	Radioactively-labelled compounds.....	54
2.9	Enzymes.....	54
2.10	Measurement of bacterial growth.....	54
2.11	Cleaning and precipitating DNA.....	55
2.12	Isolation of chromosomal DNA	
	(i) from <i>Deinococcus</i> .....	56
	(ii) from <i>Deinobacter</i> .....	57
2.13	Large scale isolation of plasmid DNA	
	(i) from <i>Deinococcus</i> and <i>Deinobacter</i> .....	58
	(ii) from <i>D.grandis</i> KS 0485.....	59
	(iii) from <i>E.coli</i> - caesium chloride.....	60
	(iv) from <i>E.coli</i> - Birnboim.....	60
	(v) from <i>B.subtilis</i> .....	61
2.14	Small scale isolation of plasmid DNA	
	(i) from <i>Deinococcus</i> - method 1.....	62
	(ii) from <i>Deinococcus</i> and <i>Deinobacter</i> - method 2.....	62
	(iii) from <i>E.coli</i> - boiling method.....	63
	(iv) from <i>E.coli</i> and <i>B.subtilis</i> - alkaline lysis.....	64
2.15	Genetic transformation	
	(i) transformation of <i>D.radiodurans</i> .....	64
	(ii) transformation of <i>Deinobacter</i> .....	65
	(iii) transformation of <i>E.coli</i> - method 1.....	66
	(iv) transformation of <i>E.coli</i> - method 2.....	67
	(v) transformation of <i>B.subtilis</i> .....	67
2.16	Dye buoyant density centrifugation.....	68
2.17	Agarose gel electrophoresis.....	69
2.18	Determination of DNA concentration.....	70
2.19	Sizing DNA molecules and fragments from agarose gels.....	71
2.20	Sizing plasmids using electron microscopy.....	71
2.21	Digestion of DNA with restriction enzymes.....	71
2.22	Phosphatase treatment of DNA.....	74
2.23	Ligation of DNA.....	74
2.24	Formation of <i>D.radiodurans</i> gene libraries	
	(i) in cosmid pJBFH.....	75
	(ii) in pAT153.....	77
	(iii) in pDR540.....	77
	(iv) in pPL608.....	80
2.25	Storage of cosmid libraries.....	80

2.26	Determination of DNA sequence representation in a genomic library.....	82
2.27	Screening genomic libraries.....	82
	(i) using MMS.....	83
	(ii) using MTC.....	84
	(iii) using NQO.....	84
	(iv) using minimal media.....	84
	(v) using X-gal.....	85
2.28	Polyacrylamide gel electrophoresis (SDS-PAGE).....	85
2.29	Visualisation of proteins on SDS-PAGE.....	86
2.30	Preparation of total cell proteins for SDS-PAGE.....	87
2.31	Western blotting.....	88
2.32	Antibody detection of proteins.....	89
2.33	Nick translation.....	91
2.34	Southern transfer.....	92
2.35	Hybridisation of Southern filters.....	93
2.36	Exposure of <i>D.radiodurans</i> to DNA-damaging chemicals	
	(i) MTC or MMS treatment.....	94
	(ii) MNNG treatment.....	94
2.37	Exposure of cells to irradiation	
	(i) U.V.....	95
	(ii) Gamma.....	95
2.38	Alkaline sucrose gradients.....	96
2.39	Preparation of cells for alkaline sucrose gradients.....	96
2.40	Measurement of <sup>3</sup> HdThd uptake.....	98
2.41	Analysis of sucrose gradients.....	98
2.42	Calculation of the molecular weight of DNA from alkaline sucrose gradients.....	99
2.43	Bacteriophage titres.....	102
2.44	Preparation of labelled bacteriophage T <sub>4</sub> DNA.....	102
2.45	Preparation of labelled bacteriophage λ DNA.....	103
2.46	Isolation of novel <i>Deinococcus</i> species.....	104
2.47	Mutability test for <i>D.radiodurans</i> .....	105

## CHAPTER THREE. RESULTS

3.1	<i>D.radiodurans</i> genomic libraries.....	106
	(i) using pJBFH.....	106
	in <i>E.coli</i> HB101.....	106
	in <i>E.coli</i> JC14604.....	107
	in <i>D.radiodurans</i> recombination deficient mutants.....	107
	(ii) using pAT153.....	110
	in <i>E.coli</i> HB101.....	110
	in <i>E.coli</i> JC14604.....	121
	in <i>E.coli</i> JC10289.....	121
	in <i>D.radiodurans</i> recombination deficient rec30.....	122
	(iii) using pDR540.....	122
	in <i>E.coli</i> DH5 $\alpha$ .....	123
	in <i>E.coli</i> JC14604.....	123
	(iv) using pPL608.....	124
	(v) summary of gene libraries.....	125
3.2	Isolation of the <i>recA</i> equivalent using Southern blots.....	127
3.3	Isolation the <i>RecA</i> equivalent using Western blots.....	130
3.4	Sedimentation in alkaline sucrose gradients.....	134
	(i) recombination repair.....	134
	(ii) excision repair.....	142
3.5	Transformation in rec30.....	145
3.6	Isolation of novel <i>Deinococcus</i> species.....	147
3.7	Plasmids in <i>D.grandis</i> .....	149
	(i) plasmid isolation.....	149
	(ii) plasmid characterisation.....	152
	(iii) estimation of plasmid size using E.M.....	155
	(iv) attempts to construct a <i>D.radiodurans-E.coli</i> shuttle vector using a <i>D.grandis</i> plasmid.....	160
3.8	Transformation of <i>D.grandis</i>	
	(i) using the <i>D.radiodurans</i> method.....	161
	(ii) using electroporation.....	163
3.9	U.V. survival of <i>D.grandis</i> .....	167
3.10	U.V. mutability of <i>D.grandis</i> .....	167

**CHAPTER FOUR. DISCUSSION**

**4.1 The Deinococci**

4.1.1 Isolation of a *recA*-equivalent.....169  
4.1.2 Sedimentation in alkaline sucrose gradients.....173  
4.1.3 Nature of the mutation forming *rec30*.....175  
4.1.4 Isolation of novel species.....177

**4.2 The Deinobacter**

4.2.1 Plasmid content.....177  
4.2.2 Transformation.....178  
4.2.3 U.V. mutability.....179

Acknowledgements.....181

Bibliography.....182

**LIST OF TABLES**

1.1 Plasmids in *Deinococcus* species.....8  
1.2 Comparison of gene regulatory regions.....11  
1.3 Features of *recA*-like genes from heterologous sources  
expressed in *E.coli*.....34  
2.1 Strains of *D.radiodurans* and *D.grandis* used.....42  
2.2 Strains of *E.coli* used.....43  
2.3 Other strains of bacteria used.....44  
2.4 Plasmids, cosmids and bacteriophages used.....44  
2.5 10 x Enzyme buffers.....72  
3.1 Insert sizes in MMS-resistant isolates 3 and 10.....116  
3.2 Percentage of t.v.c. able to grow on selective media.....119  
3.3 Summary of the results of screening the gene libraries of  
*D.radiodurans* for recombination genes.....126  
3.4 *RecA*-type protein induction treatments.....133  
3.5 Soil sources.....148  
3.6 Restriction products of *D.grandis* KS 0460 plasmids.....153  
3.7 Restriction products of *D.grandis* KS 0485 plasmids.....154  
3.8 Plasmid sizes in *D.grandis* KS 0460 as determined by E.M...157  
3.9 Plasmid sizes in *D.grandis* KS 0485 as determined by E.M...157  
3.10 Comparison of the estimated plasmid sizes in *D.grandis*....160  
3.11 Transformation of *D.grandis* using the *D.radiodurans*  
method.....162

3.12	Transformation of <i>D.grandis</i> using electroporation.....	166
------	---	-----

**LIST OF FIGURES**

1.1	U.V. survival of <i>Deinococcus</i> species.....	12
1.2	Dendrogram for <i>Deinobacter grandis</i> and <i>Deinococcus</i> species based on SAB values of 16S rRNA catalogues.....	15
1.3	Phase contrast photographs of <i>D.radiodurans</i> and <i>D.grandis</i> .	17
1.4	Resistance to gamma irradiation of <i>D.grandis</i> KS 0460, KS 0485 and <i>D.radiodurans</i> R1.....	18
1.5	Excision repair.....	20
1.6	Recombination repair.....	23
1.7	SOS repair.....	27
1.8	Recombination pathways.....	30
2.1	Agarose gel electrophoresis of the products of partial digestion of <i>D.radiodurans</i> R1 DNA with <i>Mbo</i> I.....	73
2.2	Construction of a gene library in pJBFH.....	76
2.3	Construction of a gene library in pAT153.....	78
2.4	Construction of a gene library in pDR540.....	79
2.5	Construction of a gene library in pPL608.....	81
2.6	Visualisation of proteins on Western blots.....	90
2.7	Apparatus for loading alkaline sucrose gradients into centrifuge tubes.....	97
2.8	Sucrose gradient calibration.....	99
2.9	Molecular weight of DNA found in each sucrose gradient fraction.....	101
3.1	U.V. survival of isolates 3 and 10.....	114
3.2	Gamma survival of isolates 3 and 10.....	114
3.3	Comparison of plasmids from isolates 3 and 10.....	115
3.4	Southern blot of <i>D.radiodurans</i> chromosomal DNA using a <i>recA</i> probe.....	128
3.5	Western blot of total cell extracts from <i>D.radiodurans</i> and <i>D.grandis</i> using antibody to RecA.....	131
3.6	Incorporation of thymidine into R1 DNA after U.V.....	136
3.7	Incorporation of thymidine into UVS78 DNA after U.V.....	136
3.8	Incorporation of thymidine into <i>rec1</i> DNA after U.V.....	137
3.9	Incorporation of thymidine into <i>rec30</i> DNA after U.V.....	137
3.10	Incorporation of thymidine into R1 DNA after U.V. - pulse chase.....	138

3.11	Incorporation of thymidine into UVS78 DNA after U.V.	
	- pulse chase.....	138
3.12	Incorporation of thymidine into rec1 DNA after U.V.	
	- pulse chase.....	139
3.13	Incorporation of thymidine into rec30 DNA after U.V.	
	- pulse chase.....	139
3.14	Uptake in UVS78.....	141
3.15	Formation of single strand breaks in R1 DNA after U.V.....	143
3.16	Formation of single strand breaks in UVS78 DNA after U.V..	143
3.17	Formation of single strand breaks in rec1 DNA after U.V...	144
3.18	Formation of single strand breaks in rec30 DNA after U.V..	144
3.19	Single strand breaks in DNA after U.V.....	142
3.20	MTC survival of rec30 transformed to MTC resistance.....	146
3.21	Plasmids in <i>D.grandis</i> KS 0460 and KS 0485.....	151
3.22	Distribution of <i>D.grandis</i> KS 0460 plasmid measurements 7 to 9.2 kb.....	155
3.23	The 93.1 kb plasmid of <i>D.grandis</i> KS 0485.....	156
3.24	Distribution of <i>D.grandis</i> KS 0485 plasmid measurements 6 to 9.6 kb.....	159
3.25	Distribution of <i>D.grandis</i> KS 0485 plasmid measurements 82 to 100 kb.....	159
3.26	Electroporation survival of <i>D.grandis</i> KS 0460.....	165
3.27	Electroporation survival of <i>D.grandis</i> KS 0485.....	165
3.28	<i>D.grandis</i> KS 0460 and KS 0485 U.V. survival curve.....	167
3.29	<i>D.grandis</i> KS 0460 mutation frequency.....	168
3.30	<i>D.grandis</i> KS 0485 mutation frequency.....	168

## **CHAPTER ONE**

### **INTRODUCTION**

## 1.1 THE GENUS *DEINOCOCCUS*

### 1.1.1 HABITAT AND ISOLATION

The first evidence that highly radiation-resistant bacteria existed other than as endospores was the isolation of red-pigmented, Gram-positive cocci in pure culture from cans of beef in Oregon, U.S.A (Anderson *et al.* 1956). The meat had previously been 'sterilized' by gamma irradiation, yet, upon storage, spoilage occurred. The organism isolated from the cans was later also found near the canning factory, in creek-water upstream from the meat plant, on the hide and hair of live cattle and on samples of ground meat from the processing plant (Krabbenhoft *et al.* 1965). The bacterium was appropriately named *Micrococcus radiodurans* (Anderson *et al.* 1961), but has since been redesignated *Deinococcus radiodurans* R1 (from the Greek meaning 'strange berry that is radiation resistant').

Since then a number of other confirmed isolations have been reported; in Japan from gamma-irradiated sawdust (Ito 1977), in Sweden from irradiated suture materials (Österberg 1974) and as an aerial hospital contaminant in Ontario (Murray and Robinow 1958). The latter isolate, however, was shown to be a different strain and was named *D. radiodurans* SARK. A further four new strains have recently been isolated from irradiated soil suspensions from Nottingham, England (Masters 1988).

In addition, organisms resembling *D. radiodurans* have been found in several irradiated materials. For example; soil (Erikson and Emborg 1978); chicken (Welsh and Maxcy 1979); ground peat (Parker and Vincent 1981); air (Christensen and Kristensen 1981) and textiles (Kristensen and Christensen 1981). Desiccation resistance,

another unusual feature shown by this genus, has also been used to isolate Deinococci-like organisms, for example, from food (Sanders and Maxcy 1979b).

Other cocci with similar properties to *D.radiodurans* have also been isolated and identified: *D.radiopugnans*, formerly *M.roseus* ATCC 19172, from gamma-irradiated haddock tissue (Davis *et al.* 1963) and from weathered granite (Counsell and Murray 1986); *D.radiophilus*, formerly *M.radiophilus*, from irradiated Bombay duck (Lewis 1971) and sawdust (Ito 1977, identified in Ito *et al.* 1983); *D.proteolyticus*, formerly *M.radioproteolyticus*, from irradiated Llama faeces (Kobatake *et al.* 1973) and gamma irradiated sewage and animal feeds (Ito *et al.* 1983).

The reason for the remarkable radiation resistance shown by the Deinococci is unknown as they inhabit no areas where this might be an advantage. This, and their immutable nature (Chapter One 1.1.5), has lead to the suggestion that they have survived relatively unaltered since primordial times, when radiation levels would have been much higher than today due to the lack of a protective atmosphere (Berkner and Marshall 1964). This theory is supported by their ancient phylogenetic lineage (Stackebrandt and Woese 1981).

The arrival of the Deinococci on earth from space has even been considered (Hoyle and Wickramasinghe 1981), being able to survive the desiccation and irradiation exposure involved in long periods of space travel!

The wide range of habitats from which the Deinococci have been isolated suggests no specific biological niche. Most, however, have required irradiation as a selection pressure to remove the background of competing, faster growing organisms. With the

increased use of radiation as a sterilization procedure and in food preservation these radiation-resistant organisms must surely be isolated more frequently.

### 1.1.2 CLASSIFICATION

Using morphological and physiological characteristics (involving mainly negative features), *D. radiodurans* was initially aligned with *Micrococcus roseus* and the genus *Micrococcus* (Hill 1959), being designated a new species primarily due to its radiation resistance. Baird-Parker (1965, 1970) carried out further taxonomic studies which indicated that reclassification was needed on the basis of the bacterium's unusual cell wall. Sleytr *et al.* (1973) recommended a new taxon after work on *M. radiodurans*, and a new genus after further work on *M. radiophilus* and *M. radioproteolyticus* (Sleytr *et al.* 1976).

In 1980, Brooks *et al.* reviewed the evidence and Brooks and Murray (1981) suggested the formation of a novel family, the *Deinococcaceae*, containing one genus *Deinococcus* (type strain *D. radiodurans* R1). This reclassification, which has now been widely accepted and is used in this thesis, was based upon the following distinct features of the Deinococci.

The cell envelope of *D. radiodurans* is comprised of several layers of distinct components, (Work and Griffiths 1968, Thornley *et al.* 1965, Sleytr *et al.* 1973, Thompson *et al.* 1980, Thompson and Murray 1982, and Baumeister *et al.* 1982), possibly up to five different layers (Lancy and Murray 1978). The cell envelopes of the other Deinococci have not been as extensively studied, but Sleytr *et al.* (1976) found they were comprised of several different layers but were not as complex structurally. The multi-layered nature of

the deinococcal cell envelope is uncharacteristic of Gram-positive bacteria which generally show only a single thick homogeneous component external to the plasma membrane.

The chemical composition of the cell envelope is also very complex and the Deinococci all contain ornithine-containing peptidoglycan (Orn-Gly<sub>2</sub>), unusual in Gram-negative bacteria, (Work 1964, Work and Griffiths 1968, Schleifer and Kandler 1972, Sleytr *et al.* 1973, 1976, Brooks *et al.* 1980, Brooks and Murray 1981).

In the cell membrane the predominant fatty acid in the Deinococci is palmitoleate (C<sub>16:1</sub>), although *D. radiodurans* and *D. radiopugnans* also contain substantial amounts of C<sub>15:1</sub> and C<sub>17:0</sub> respectively, and no branched chain fatty acids are found, except as a minor component in *D. radiopugnans* (Knivett *et al.* 1965, Work and Griffiths 1968, Girard 1971, Jantzen *et al.* 1974, Rebeyrotte *et al.* 1979, Thompson *et al.* 1980, Brooks and Murray 1981, Anderson 1983). The fatty acid profile is unlike most Gram-positive bacteria and resembles Gram-negative organisms in that a high proportion of even-numbered, straight-chain, saturated and unsaturated fatty acids are found. However, in contrast to many Gram-negative bacteria *D. radiodurans* contains little or no oleic acid (Girard 1971). The unusual composition of the cell envelope of *D. radiodurans* is confirmed yet again by the isolation from the cell wall of the first phosphoglycolipid from nature (Anderson and Hansen 1985).

The simple morphologies of bacteria has lead to difficulties in reliable classification when using these features, especially when unremarkable physiological attributes are also found. Advances in molecular biology have made additional techniques available and relationships between the 16S ribosomal RNA were found to be ideal

for the elucidation of genealogical relationships (Stackebrandt and Woese 1981). This technique involves the digestion of the 16S rRNA by T<sub>1</sub> ribonuclease to produce a series of oligonucleotides, from which the RNA association coefficient, the S<sub>AB</sub> value, (the degree to which the oligonucleotides produced from two different species are related, Fox *et al.* 1977), is calculated. When applied to *Deinococcus* species this method produced striking evidence for the creation of a new genus and demonstrates that they are an extremely ancient line of bacteria, one of the eight major groups of the Eubacteria (Stackebrandt and Woese 1981). The S<sub>AB</sub> values also indicate surprising relationships with other bacteria, the recently isolated *Deinobacter* (Oyaizu *et al.* 1987), and the *Thermus* genus (Hensel *et al.* 1986), both of which also show a relationship using other classification methods. The relationship between *Thermus* and *Deinococcus*, however, is distant, although both share the same peptidoglycan type. The relationships to *Deinobacter* are discussed in Chapter One 1.2.2.

It has also become apparent that the respiratory quinones are a class of lipids with potential use in chemotaxonomy (reviewed by Collins and Jones 1981), as they are widely distributed, vary within different taxonomic groups and are now easily isolated and characterised. Also known as the isoprenoid quinones, they are important constituents of bacterial plasma membranes with central roles in electron transport and oxidative phosphorylation. Study of the Deinococci revealed a menaquinone system of MK-8 type, (Yamada *et al.* 1977), different from that of the rest of the micrococci (Collins and Jones 1981).

A fifth member of the genus *Deinococcus*, *D. erythromyxa*, was

proposed by Brooks and Murray (1981), but this has now been excluded after studies on its phospholipids and peptidoglycan layer (Counsell and Murray 1986).

### 1.1.3 DNA OF THE DEINOCOCCI

The genome size of *D. radiodurans* has been calculated as  $2 \pm 0.3 \times 10^9$  daltons (or  $3 \times 10^6$  base pairs) by DNA renaturation kinetics (Hansen 1978). Hansen also estimated, from the amounts per cell and the size, that there were 4 genome equivalents per stationary phase cell and up to 10 in exponentially growing cells. This was confirmed by Moseley and Evans (1981) who found  $4.7 \pm 0.9$  genome complexes per non-replicating cell and showed that the genome equivalents existed separately in a single nucleoid.

The DNA base composition of the Deinococci is high for guanine and cytosine (G + C) at 62 to 70%, *D. radiodurans* being 67% (Brooks *et al.* 1980, Brooks and Murray 1981). No methylated bases have been detected in *D. radiodurans*, nor any methyltransferase activity (Schein *et al.* 1972, Störl *et al.* 1979). However, Mackay (1983) found, but did not identify, unusual modified bases in strain R1. Some form of protection against restriction endonucleases must be present as DNA from *D. radiodurans* is cleaved by its own restriction enzyme after passage through *E. coli* (Mackay 1983).

The DNA/DNA similarity between the *Deinococcus* species is not significant, being only 18% homology or less (calculated by renaturation kinetics). The only significant relationship exists between *D. radiodurans* strains SARK and R1 at 33% (Brooks *et al.* 1980).

Two *Deinococcus* species possess characterised type II

restriction endonucleases, *D.radiodurans* R1 and *D.radiophilus*. *D.radiodurans* has the enzyme *MraI*, recognizing the sequence 5'-CCGCGG-3' (Wani *et al.* 1982), an isoschizomer of *SacII* and *SstII*. *D.radiophilus* has several, an isoschizomer of *AhaIII* named *DraI* (Purvis and Moseley 1983), and also *DraII* and *DraIII* (de Witt *et al.* 1985, Grosskopt *et al.* 1985), the recognition sequences being 5'-TTT<sup>↓</sup>AAA-3', 5'-PuG<sup>↓</sup>GNCCPy-3' and 5'-CACNNN<sup>↓</sup>GTG-3' respectively, (where Pu is any purine, Py any pyrimidine, N any nucleotide and <sup>↓</sup> the cutting site). Five of the Deinococci-like organisms isolated by Masters (1988) also showed restriction endonuclease activity, three containing an isoschizomer of either *PvuI*, *XhoI* or *BstEII*. In contrast to this plethora of enzymes *D.radiodurans* SARK is thought to possess no restriction system and so is especially useful in some transformation situations (M.D. Smith, personal communication).

A number of plasmids (Table 1.1) have been found in the *Deinococcus* species. Attempts to cure the strains have been largely unsuccessful (Mackay 1983), so no characteristics have yet been ascribed to any plasmid. The plasmids have been used as a basis for the construction of a vector system by several workers.

The plasmid pS16 from *D.radiodurans* R1 (Smith *et al.* 1988) was not isolated prior to 1988 despite an extensive search (Mackay 1983, Mackay *et al.* 1985). The copy number of pS16 was estimated at  $\leq 0.1$  copies per chromosome (Smith *et al.* 1988) which could explain the difficulty in isolation as only an estimated 0.5 plasmids per cell in stationary phase would be present. With such a low copy number this may not be a 'true' plasmid able to replicate autonomously but merely a segment of the chromosome, especially as pS16 shares some chromosomal homology (Smith *et al.* 1989).

TABLE 1.1 PLASMIDS IN DEINOCOCCUS SPECIES

Strain	Plasmid size (kb)	Designation
<i>D. radiodurans</i> R1	60.0 <sup>a</sup>	pS16
<i>D. radiodurans</i> SARK	37.0 <sup>b</sup>	pUE10
	44.9 <sup>b</sup>	pUE11
<i>D. radiophilus</i>	10.8 <sup>b</sup>	pUE1
	27.5 <sup>b</sup>	pUE2
	92.0 <sup>b</sup>	pUE3
<i>D. proteolyticus</i>	99.4 <sup>b</sup>	pUE20
	138.8 <sup>b</sup>	pUE21
<i>D. radiopugnans</i>	2.5 <sup>b</sup>	pUE30
	28.6 <sup>b</sup>	pUE31

Notes

<sup>a</sup> Smith *et al.* 1988, size determined by agarose gel electrophoresis.

<sup>b</sup> Mackay *et al.* 1985, size determined by electron microscopy.

1.1.4 GENETICS

The genetics of the *Deinococcus* species have remained limited, despite extensive efforts over the years; however, the development of a shuttle vector system between *D. radiodurans* and *E. coli* by Smith *et al.* (1988, 1989) promises to bring about great changes.

*D. radiodurans*, the only transformable member of the genus *Deinococcus*, was first demonstrated as being transformable by Moseley and Setlow (1968). The frequency of transformants was later greatly improved by the addition of a calcium chloride treatment step by Tirgari and Moseley (1980), producing greater than 1% transformants using a single marker, for rifampicin resistance.

Although limited in its use, transformation has been useful for strain construction (Moseley and Evans 1983), the characterisation of mutants (for example Moseley and Copland 1975b), and for cloning

wild type genes by showing complementation of mutants (Al-Bakri *et al.* 1985). It is especially useful in that the cells remain competent throughout the growth cycle, so that, for example, transformation can be used to determine the recombinational ability of the cell.

Despite a long search no bacteriophages have been isolated that plaque on *D.radiodurans* nor have efforts to develop a conjugation system succeeded (Moseley 1983). The development of a protoplast fusion technique by Al-Bakri (1985) was also unfruitful, despite the cells being protoplasted and regenerated.

However, Tirgari (1977) showed that *D.radiodurans* has no barrier to plasmid uptake by transformation, prompting many efforts to try to introduce plasmids by this method from a variety of sources containing different heterologous markers (Tirgari 1977, Mackay 1983, Purvis 1984). This was followed by an attempt to construct a shuttle vector by joining the relatively small <sup>(see Table 1.1)</sup> pUE1 $\lambda$  to an *E.coli* plasmid carrying ampicillin resistance (Mackay *et al.* 1985). A suitable vector was not isolated. The main problem was thought to be the lack of a suitable selectable marker, so Masters (1988) added the *mtcA* gene (mitomycin C resistance, isolated by Al-Bakri *et al.* 1985) as a homologous gene marker in a *mtcA*<sup>-</sup> host. No success was achieved, although *mtcA*<sup>+</sup> cells were isolated.

These abortive efforts were followed by the successful experiments of Smith *et al.* (1988) who obtained expression from heterologous *E.coli* genes integrated into the chromosome of *D.radiodurans*. This was achieved by cloning *D.radiodurans* DNA into *E.coli* plasmids containing resistance to either kanamycin (*aphA*) or chloramphenicol (*cat*), this was found to be very similar to the

insertion of heterologous DNA in, for example, *Bacillus subtilis* (Haldenwang *et al.* 1980). The *D. radiodurans* DNA allows recombination into the chromosome at the homologous region, known as duplication insertion as the homologous region is repeated in the chromosome (one repeat originating from the recombinant plasmid, also known as the insertion unit). Up to 30 copies of the original unit (10% of the total genomic DNA) can be formed in tandem fashion in *D. radiodurans*, which has been shown to be capable of recombination out of the chromosome to form various derivations of the original insertion unit.

Recently, Smith *et al.* (1989) used pUE10 and pUE11 as a basis for a vector system by inserting an *E. coli* plasmid containing a kanamycin resistance gene. The resultant 'shuttle' plasmids were able to replicate and express drug resistance in both *D. radiodurans* and *E. coli*. The *E. coli* plasmid, however, required to be inserted in the middle of a *D. radiodurans* plasmid sequence so that expression could work from the *D. radiodurans* promoter when in *D. radiodurans*. This system is currently under further development by Smith *et al.*

Several *D. radiodurans* genes have been cloned, but only two have been shown to express a phenotype in *E. coli*, the *leuB* gene (Al-Bakri *et al.* 1985) and a major surface protein (Peters and Baumeister 1986). The other genes isolated (*mtcA*, *mtcB*, *uvrC*, *uvrD* and *uvrE*, Al-Bakri *et al.* 1985) are involved in a DNA excision repair system which is different from that of *E. coli* so even if the genes were expressed complementation should not be expected. (Chapter One 1.3.2). In both cases where the expression of the *D. radiodurans* genes were observed in *E. coli* it was not demonstrated that a *D. radiodurans* promoter was used. However Smith *et al.* (1989), using

a promoter probe, found that at least some *D.radiodurans* promoters were not recognized in *E.coli*, but did not quantify the results. Peters *et al.* (1987) sequenced the first *D.radiodurans* gene, the major surface protein, and found sequences similar to the Shine-Dalgarno (S-D) sequence and the -10 and -35 regulatory regions of *E.coli* (Table 1.2 below). However, a highly non-random codon usage was found, with the predominant use of CCC for proline, unusual even in rich G + C genes (Grosjean and Fiers 1982). In *E.coli* the CCC codon is only found at levels of 1% in strongly expressed genes, which may explain the weak expression of the cloned gene in *E.coli*.

TABLE 1.2 COMPARISON OF GENE REGULATORY REGIONS

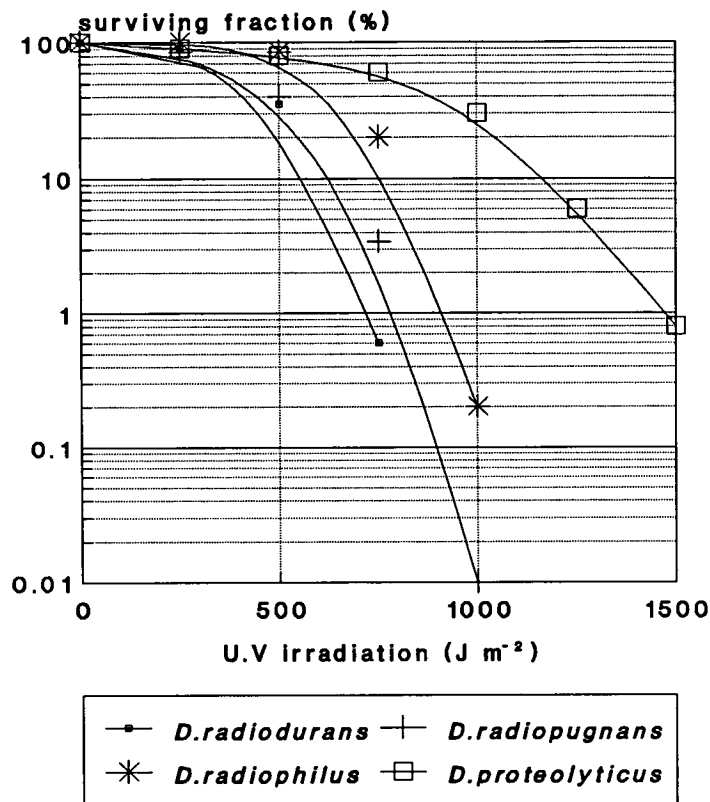
Strain	S-D	-10	-35
<i>E.coli</i>	5'AGGAGGT 3'	5'TATAAT 3'	5'TTGACA 3'
<i>D.radiodurans</i>	5'GGAGG 3'	5'TAACCT 3' or 5'TATGCT 3'	5'TTG 3'

#### 1.1.5 RADIATION RESISTANCE

In addition to their extreme resistance to the lethal effects of ionising radiation, the Deinococci also possess resistance to the lethal effects of ultra-violet (U.V.) irradiation and the mutagenic effects of both (Sweet and Moseley 1974, 1976, Kersman 1975 Tempest and Moseley 1982). The U.V. survival of the Deinococci is shown in Figure 1.1 (from Tempest 1978) and the gamma survival of strain R1 in Figure 1.2 (Chapter One 1.2.2). The photobiology of the Deinococci is reviewed by Moseley (1983).

Both the ionising and U.V. radiation survival curves possess a large shoulder, which indicates that the bacteria can initially

**FIGURE 1.1 U.V. SURVIVAL  
OF *DEINOCOCCUS* SPECIES**



absorb energy with no loss of viability. Because of the random nature of radiation damage to DNA potentially lethal lesions are scattered, so that, at a radiation dose which would theoretically kill the whole bacterial population, (were it evenly distributed), 37% of the population will survive having received less than an inactivating dose, while, of the 63% killed, most will have received a dose in excess of that needed to inactivate them (Moseley 1984). This figure, known as the D<sub>37</sub>, is used to compare the radiation sensitivity (or resistance) of bacteria.

It is widely accepted that a particularly efficient DNA repair mechanism is the cause of radiation resistance in *D. radiodurans* (first suggested by Setlow and Duggan 1964). However, since the

1950's many alternative explanations have also been proposed, and, although these factors may contribute, they seem to be of minor importance. The unusual cell wall has been implicated, (Sanders and Maxcy 1979a), perhaps in a subsidiary protective role (Mitchel 1979). Also the cell pigmentation (Kilburn et al. 1958); the presence of an intracellular radioprotective material (for example a high sulphhydryl content, Bruce 1964); or the association of the chromosome with manganese ions (Leibowitz et al. 1976).

Recently Kitayama et al. (1985) isolated a protein which converts Z-DNA to B-DNA from *D. radiodurans*. DNA can exist in a number of conformations, of which B-DNA is the normal configuration, being a right-handed helix, while Z-DNA is more unusual, being a left-handed helix. The formation of Z-DNA is favoured in organisms with a high G + C level, as alternating G and C sequences more easily form Z-DNA. The DNA conformation is suggested to be involved in DNA damage and repair as various reagents produce dramatically different products when acting upon the different configurations. This may explain the susceptibility of *D. radiodurans* to some chemicals more than others.

The presence of multiple genome copies in the nucleoid has also been suggested to be involved in radiation resistance. They may be arranged so the homologous regions of each could be available to undergo recombination repair to provide one complete, intact copy. This would allow error-free repair in the presence of extensive lesions in the DNA, such that overlapping single-strand gaps (Sedgwick 1976) in all copies would only occur at high doses (Moseley and Evans 1981).

However, the presence of many genome equivalents is not unique

to radiation resistant bacteria; for example *Azotobacter vinelandii* has up to 40 equivalents per cell (Sadoff et al. 1979) but is radiation sensitive (Moseley 1983). When the number of genome copies in *D. radiodurans* is varied from 5.4 to 9.4 per cell, (by growth in different media), both the U.V. and gamma irradiation resistance is altered but the differences do not correlate to the changed number of genome copies (Harsojo et al. 1981).

## 1.2 THE GENUS DEINOBACTER

### 1.2.1 ISOLATION

Strains of Gram-negative, radiation-resistant, rod-shaped bacteria were recently isolated from animal faeces and freshwater fish by Oyaizu et al. (1987). The organisms were first noted because of their unusual cell wall composition, which prompted identification attempts. Oyaizu et al. found that classification into any known genus proved impossible and so proposed the creation of a new genus, *Deinobacter*, containing only a single species, *D. grandis* (type strain KS 0485).

Four strains were isolated. The red-pigmented *D. grandis* KS 0492, KS 0485 and KS 0488 originated from freshwater fish in a research laboratory in Tokyo, Japan, (KS 0492 from the skin of *Anguilla japonica*, KS 0485 from the intestines and KS 0488 from the skin of *Cyprinus carpio*). The pink-pigmented KS 0460 originated from Elephant faeces in the Ueno Zoological Gardens, Tokyo, Japan.

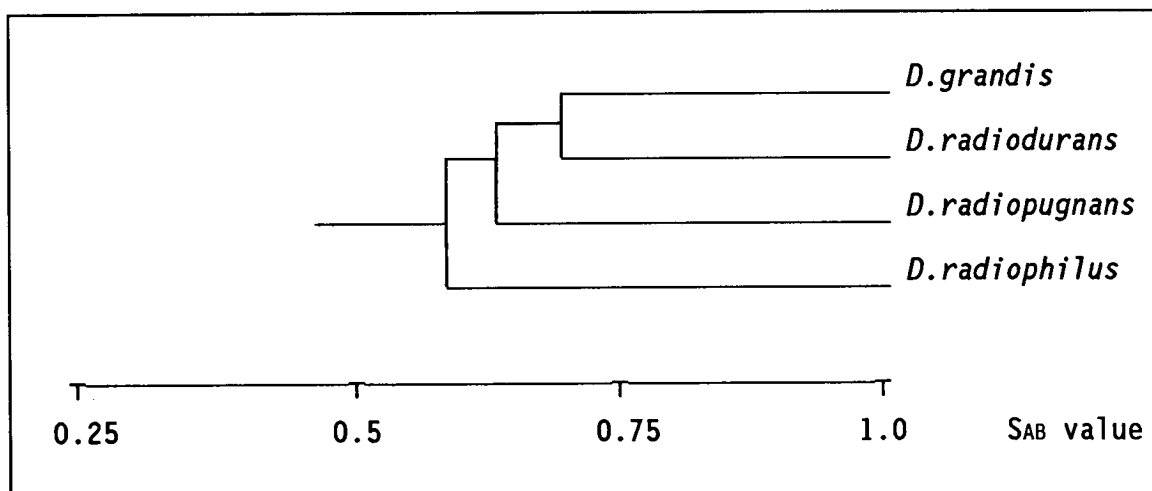
Other reports of the isolation of red-pigmented, radiation-resistant, rod-shaped bacteria have been made. For example Yamada et al. (1977) partially characterised such an isolate, finding a G + C content of 65.7% and a MK-8 menaquinone system, but did not

attempt further identification.

### 1.2.2 CLASSIFICATION

Despite classification proving difficult, both chemotaxonomic and phylogenetic studies on the isolates indicated a relationship between *Deinobacter* and *Deinococcus* species. *D.grandis* contains a high level of fatty acids (mainly of C<sub>15:0</sub>, C<sub>15:1</sub>, and C<sub>16:1</sub>), a high G + C content of 68.4 to 69.4%, a menaquinone system of MK-8 and ornithine-containing peptidoglycan (Orn-Gly<sub>2</sub>), all unusual features shared with the members of the genus *Deinococcus* (Chapter One 1.1.2). In addition Oyaizu *et al.* (1987) found a highly significant degree of relationship between the RNase T<sub>1</sub> catalogue of the 16S rRNA (Figure 1.2), which indicates that *D.grandis* KS 0485 is more closely related to *D.radiodurans* than the other members of the *Deinococcaceae*!

FIGURE 1.2 DENDROGRAM FOR *DEINOBACTER GRANDIS* AND *DEINOCOCCUS* SPECIES BASED ON S<sub>AB</sub> VALUES OF 16S rRNA CATALOGUES



(from Oyaizu *et al.* 1987)

Despite chemotaxonomic and phylogenetic analysis being widely used in bacterial classification phenotypic and morphological features are also important. Phenotypically no distinctive characteristics distinguish either the *Deinococcus* species or *Deinobacter* from other groups. Morphologically, *Deinobacter* possesses an unusual cell wall structure, having, outside the plasma membrane, a thick homogeneous layer surrounded by a membranous layer, (very similar to the cell wall structure of members of the genus *Deinococcus* as described by Brooks *et al.* 1980, Sleytr *et al.* 1976). However, one area of significant difference between *Deinobacter* and *Deinococcus* is the gross cell morphology (Figure 1.3), considered to be an important taxonomic criterion.

The two organisms also show a different Gram-reaction, *Deinobacter* being Gram-negative and *Deinococcus* Gram-positive. However, extensive work on the unusual and complex *Deinococcus* cell envelope responsible indicated that *Deinococcus* species have both biochemical and ultrastructural characteristics of Gram-negative organisms (Chapter One 1.1.2).

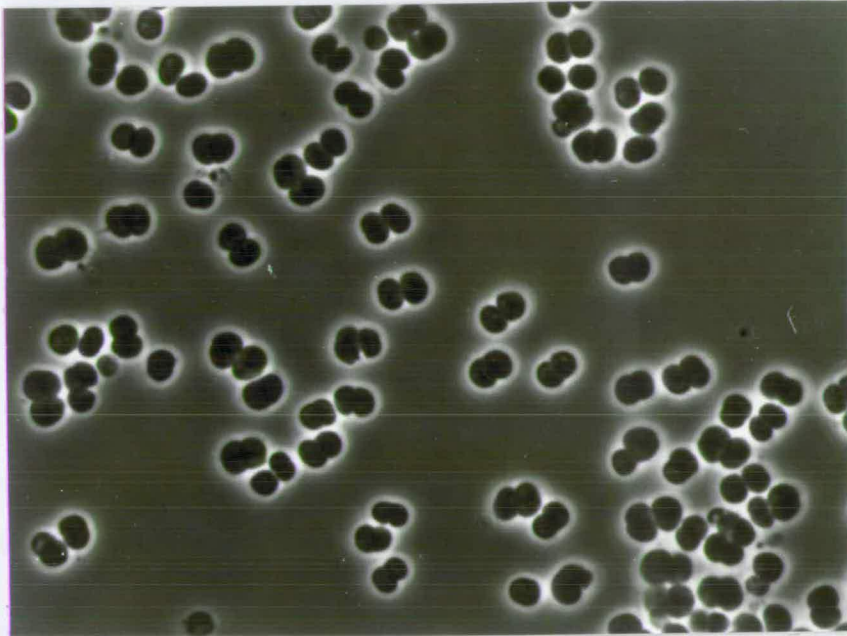
In addition to the relationships described between the members of the genus *Deinococcus* and *Deinobacter*, both show resistance to ionising radiation. This is compared in Figure 1.4 using *Deinobacter* data from Oyaizu *et al.* (1987) and *D.radiodurans* data from Ito *et al.* (1983), both using a <sup>60</sup>Co gamma source under similar aerobic conditions. The approximate D<sub>37</sub> value in this situation for *D.radiodurans* R1 is 600 krad (Moseley 1983), and for *D.grandis* KS 0460 250 krad and *D.grandis* KS 0485 75 krad (the latter value being similar to that of the other two *Deinobacter* strains).

FIGURE 1.3 PHASE CONTRAST PHOTOGRAPHS OF *D.RADIODURANS* AND *D.GRANDIS*

Photographs were taken from x 400 magnification of the negative.

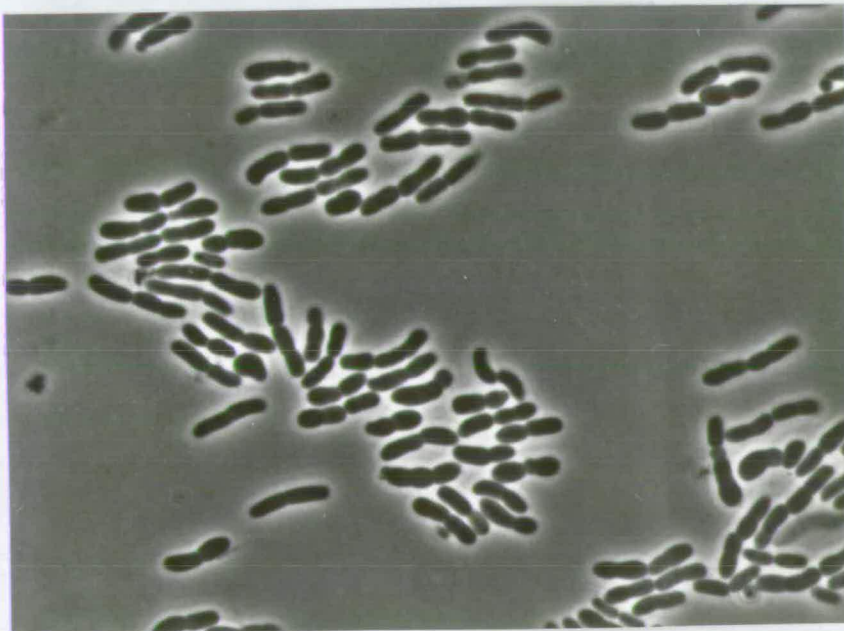
(a) *D.radiodurans* R1

*D.radiodurans* cells occur mainly in pairs with less than 10% in the form of tetrads, rarely observed as single cells (Hansen 1978).

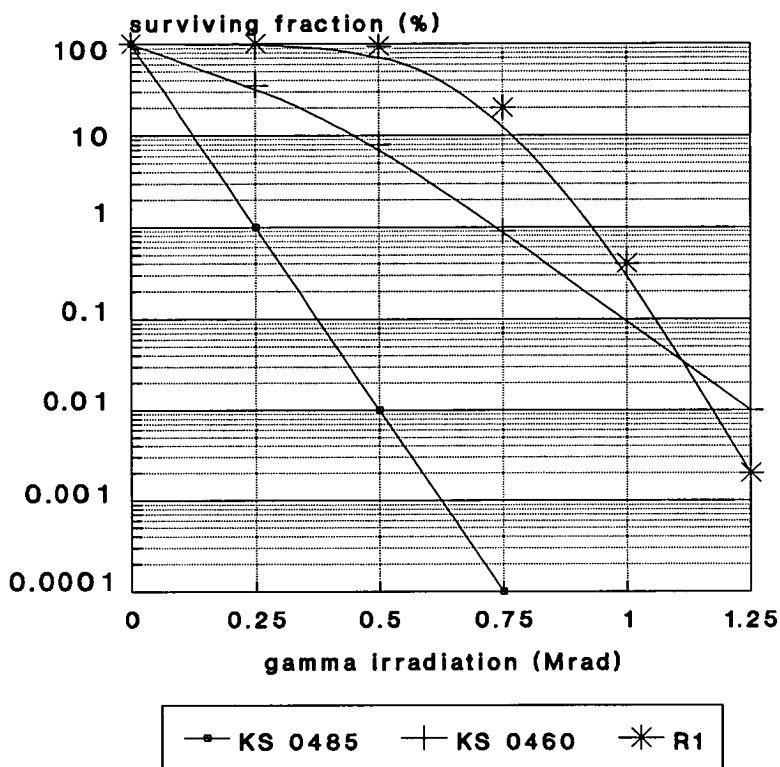


(b) *D.grandis* KS 0485

*Deinobacter* cells are rod-shaped and can occur in chains of up to 4 cells, especially in older cultures.



**FIGURE 1.4 RESISTANCE TO GAMMA IRRADIATION OF *D.GRANDIS* KS 0460, KS 0485 AND *D.RADIODURANS* R1**



Oyaizu *et al.* (1987) concluded that *D.grandis* is the nearest relative to the members of the genus *Deinococcus* found to date, having little specific relationship with any other bacteria. However, as the gross cell morphology is so unrelated and so far few *Deinococcus* species have been isolated for comparison the new genus *Deinobacter* was proposed.

### 1.3 DNA REPAIR

DNA is very sensitive to damage by both environmental radiation and chemicals. A number of repair mechanisms have evolved to cope with this and ensure survival, the fine details of which have primarily been determined in *Escherichia coli*. The following section outlines DNA repair mainly in *E.coli* and compares it with the limited information available on repair in *D.radiodurans*. More substantial general reviews of repair can be found in Moseley and Williams (1977), Hanawalt *et al.* (1979), Moseley (1984) and Sancar and Sancar (1988).

#### 1.3.1 PHOTOREACTIVATION

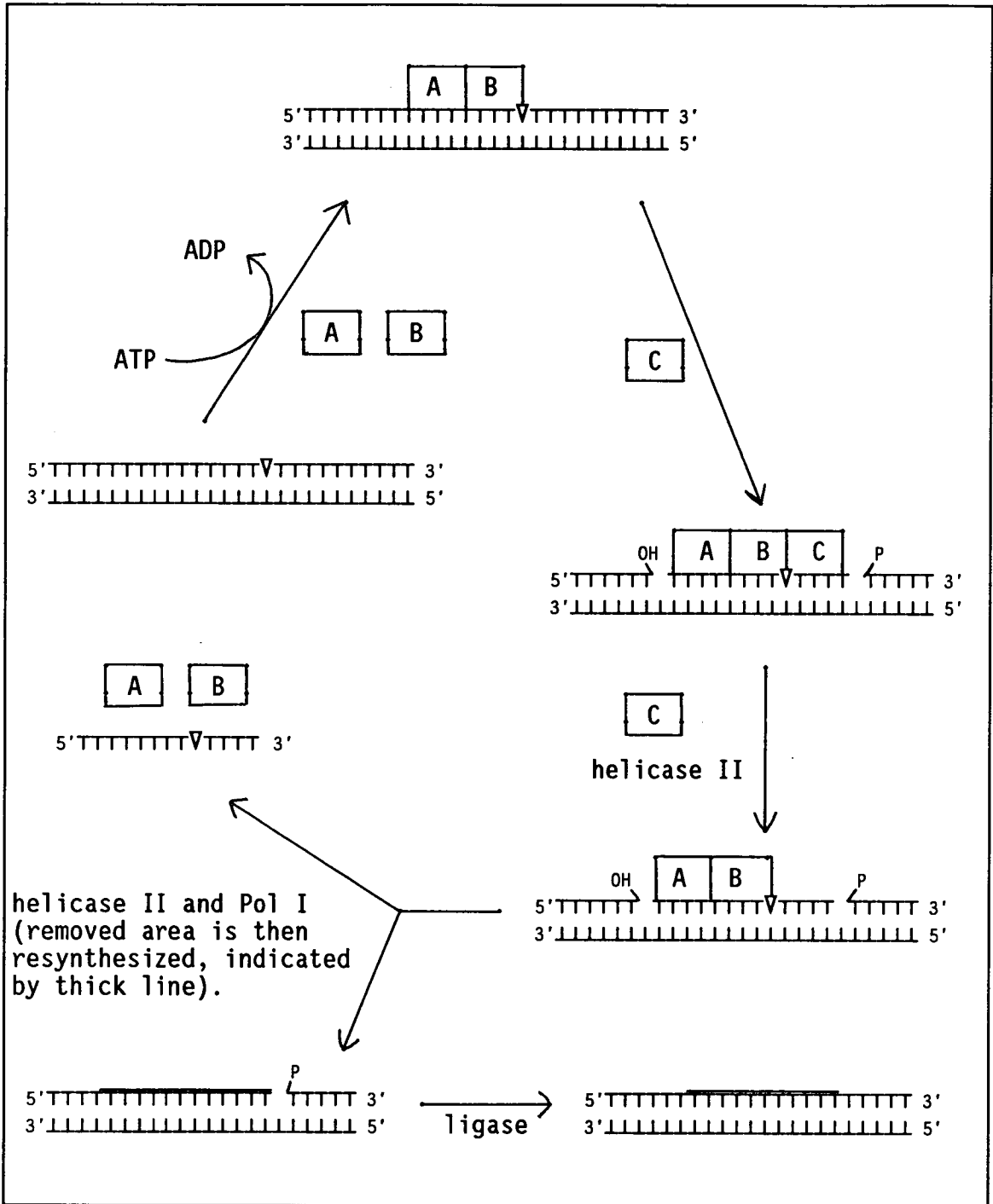
Enzymatic photoreactivation is the process whereby U.V.-induced cyclobutane pyrimidine dimers in DNA are monomerized *in situ* by an enzyme using the energy of light.

The photoreactivation enzyme recognizes the distortion in the DNA caused by the dimer and binds to the dimer in the dark or light. This forms a chromophore, a stable complex, able to absorb visible light from 300 to 550 nm. A photon of light is absorbed and the energy used to catalyse the cleavage of the cyclobutane ring without breaking the phosphodiester bonds between the bases, after which the enzyme dissociates.

In an evolutionary sense, enzymatic photoreactivation is probably the most primitive DNA repair mechanism. It has been identified in many organisms, although few photoreactivating enzymes have been characterised in detail. However it is not universal and *D.radiodurans* (Moseley 1983) lacks this form of repair, in common with some other organisms, for example *Bacillus subtilis* and

**FIGURE 1.5 EXCISION REPAIR**

For explanation see text.



(after Husain et al. 1985)

**Notes**

- A - UvrA protein
- B - UvrB protein
- C - UvrC protein
- ∇ - damage in DNA producing localized distortion

## *Haemophilus influenzae*.

### 1.3.2 EXCISION

This is a major form of repair in most organisms. Although a multi-enzyme process most excision events in *E.coli* are performed by the product of the *uvrA*, *uvrB* and *uvrC* genes, the ABC excinuclease (excision nuclease), shown in Figure 1.5.

In *E.coli* the UvrA and UvrB proteins recognize the damaged DNA region by the localized DNA distortion caused. Such damage includes pyrimidine dimers and a variety of other lesions that cause similar helical deformities, for example, the base adducts of mitomycin C (MTC) and 4-nitroquinoline-1-oxide (NQO). UvrC then attaches to the complex and the phosphodiester bonds on each side of the damage are broken. The UvrABC complex is then dislodged by helicase II (the product of the *uvrD* gene) and DNA polymerase I (Pol I), and the excised oligomer released. Pol I then resynthesizes the missing nucleotides and the final gap is sealed by DNA ligase.

Other unusual or modified bases are removed by DNA glycosylases, (extensively reviewed by Lindahl 1982), which hydrolyse the N-glycosylic bond between the deoxyribose and the base. This produces an apurinic or apyrimidinic (AP) site. Such sites are also formed by alkylation, U.V. and ionising radiations and the spontaneous loss of bases. An AP endonuclease then hydrolyses the phosphodiester bond next to the AP site and the damaged region is removed. This is then thought to be repaired in a similar manner as, for example, a pyrimidine dimer.

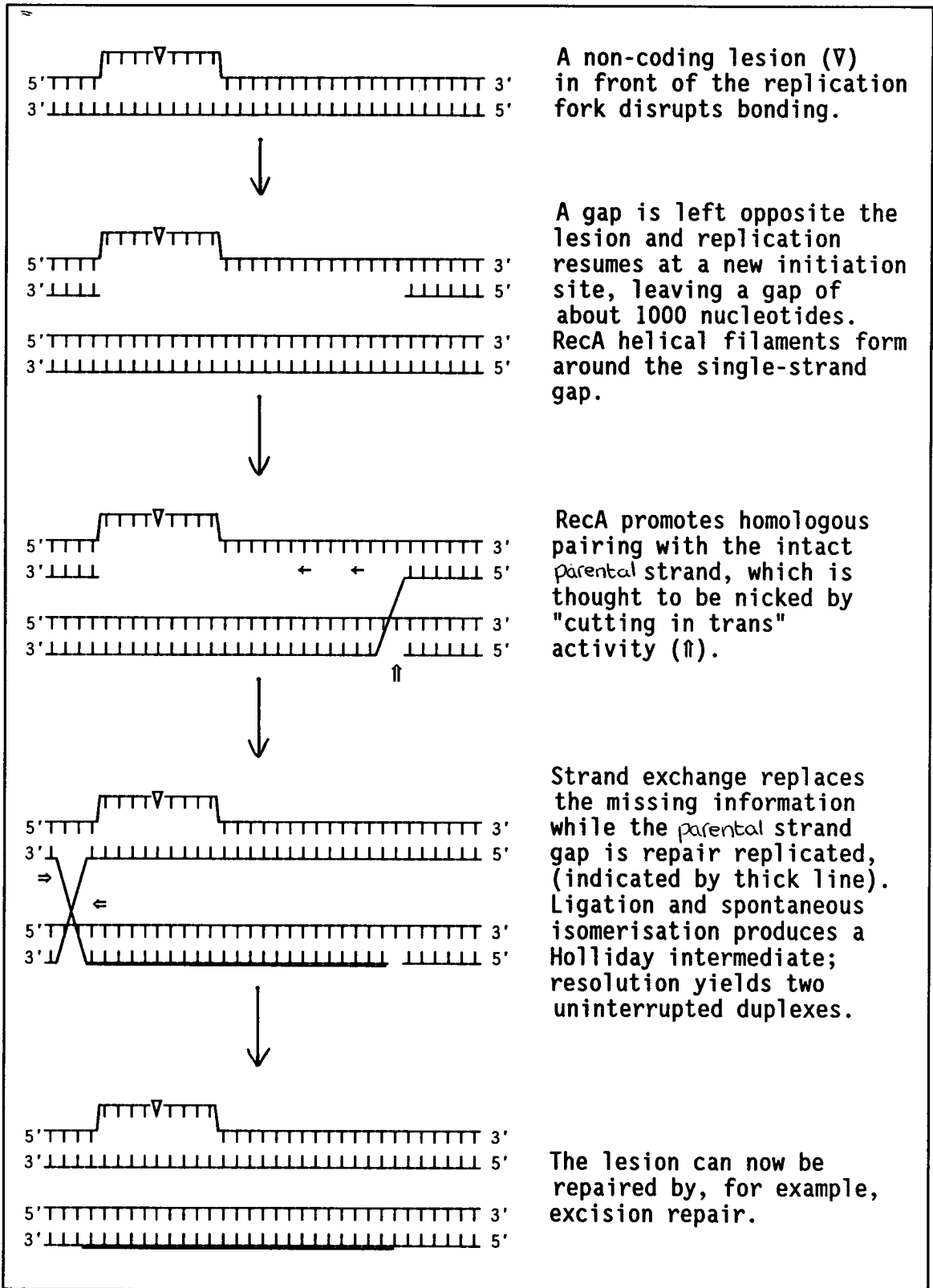
The excision repair system was considered universal until several species of the *Archaeobacteria* were found to be deficient in

removing pyrimidine dimers by excision, though these organisms were later found to possess an especially efficient enzymatic photoreactivation system (Sancar and Sancar 1988).

Organisms which vary from the excision repair mechanism described for *E.coli* have been found. For example, *Micrococcus luteus*, *D.radiodurans* and bacteriophage T<sub>4</sub>. *M.luteus* is unusual in that pyrimidine dimers are removed either by a glycosylase or a repair enzyme of wide substrate range. Bacteriophage T<sub>4</sub> also possesses a glycosylase specific for pyrimidine dimers, with associated AP endonuclease activity. In *D.radiodurans* a novel situation exists in that two functionally equal excision repair pathways are present (Evans and Moseley 1983, Moseley and Evans 1983), operated by two pyrimidine dimer-recognizing endonucleases,  $\alpha$  and  $\beta$ .

The two pathways made it impossible to isolate a totally excision defective mutant until done by accident (Moseley and Evans 1983), which allowed the excision repair pathways to be postulated. Endonuclease  $\alpha$  is the product of the *mtcA* and *mtcB* genes, and recognizes and incises in response to lesions produced by MTC cross-links and alkylating agents, as well as pyrimidine dimers. This is considered to be functionally equivalent to the *E.coli* ABC excinuclease (Sancar and Sancar 1988). Endonuclease  $\beta$  is the product of the *uvrC*, *uvrD* and *uvrE* genes, and incises only in response to pyrimidine dimers. This enzyme has been partially purified and characterised and is analogous to the pyrimidine dimer glycosylases of *M.luteus* and bacteriophage T<sub>4</sub> in that it has a narrower substrate range than  $\alpha$  (Evans and Moseley 1985). However, endonuclease  $\beta$  is unusual in that it has a requirement for the divalent cation Mn<sup>2+</sup>.

FIGURE 1.6 RECOMBINATION REPAIR



(after West et al. 1981)

The five genes encoding the two "U.V. endonucleases" have been isolated from *D.radiodurans* (Al-Bakri *et al.* 1985). DNA-DNA hybridisation studies have been carried out suggesting that *mtcA*, and therefore endonuclease  $\alpha$ , is highly conserved throughout the *Deinococcus* species but that *uvsC*, *uvsD* and *uvsE*, and so endonuclease  $\beta$ , have diverged greatly or been lost, if they were ever present (Masters 1988).

### 1.3.3 RECOMBINATION REPAIR

Recombination repair, also known as post-replication recombination repair or daughter-strand gap repair, occurs in the replicating regions of the cell (Figure 1.6). This model was originally formulated for *E.coli* by Rupp *et al.* (1971) and has been little changed since.

In *E.coli* the RecA protein plays a central rôle in both recombination and recombination repair, (other genes involved are considered in Chapter One 1.4.1). The purification and characterisation of RecA (reviewed in Cox and Lehman 1987) showed the protein to catalyse a number of reactions *in vitro*. These results indicated that the RecA protein, given the appropriate substrates, can transfer a DNA strand from one homologous partner to another. In recombination repair this involves the transfer of the 3' hydroxyl end of a nicked duplex into a single-strand gap, promoting strand exchange, which proceeds 5' to 3' with respect to the gap (Figure 1.6). Later, physical details were determined indicating that the RecA protein achieves this by multiple aggregation into spiral filaments around DNA duplexes and synaptic structures, (mechanistic aspects reviewed by Kowalczykowski 1987).

This is not true repair in that the damaged area is not removed, but it contributes to survival by by-passing adducts that block replication, allowing excision repair by constructing a double-stranded region. If the strain is excision defective the damage is diluted out by further growth.

Recombination repair is found in all species so far examined, working in concert with excision repair in wild type bacteria. It is an error-free process, so bacteria only employing the main repair mechanisms of excision and recombination repair are not <sup>highly</sup> mutable.

An excision-deficient mutant of *D.radiodurans* can successfully repair (or circumvent) approximately 700 pyrimidine dimers per genome. The contribution that recombination repair makes to the cell is therefore considerable, if recombination repair is the sole residual repair mechanism (Moseley and Evans 1981). However, evidence for this repair process, (of the kind produced for *E.coli* using sucrose gradients, Rupp and Howard-Flanders 1968, Rupp *et al.* 1971), has not yet been produced for *D.radiodurans*. The possibility of recombination repair playing a major rôle in the radiation resistance of the *Deinococcus* species is certainly plausible, given the reservoir of at least five genome equivalents per cell.

#### 1.3.4 THE SOS RESPONSE

The SOS response, best understood in *E.coli*, consists of co-ordinated events to save the cell after so much DNA damage has taken place that it can not be repaired by constitutive mechanisms (reviewed extensively by Witkin 1976, Walker 1984, 1985 and briefly by Kenyon 1983 and Sedgwick 1986). It includes the inhibition of cell division to allow more time for repair, post-irradiation DNA

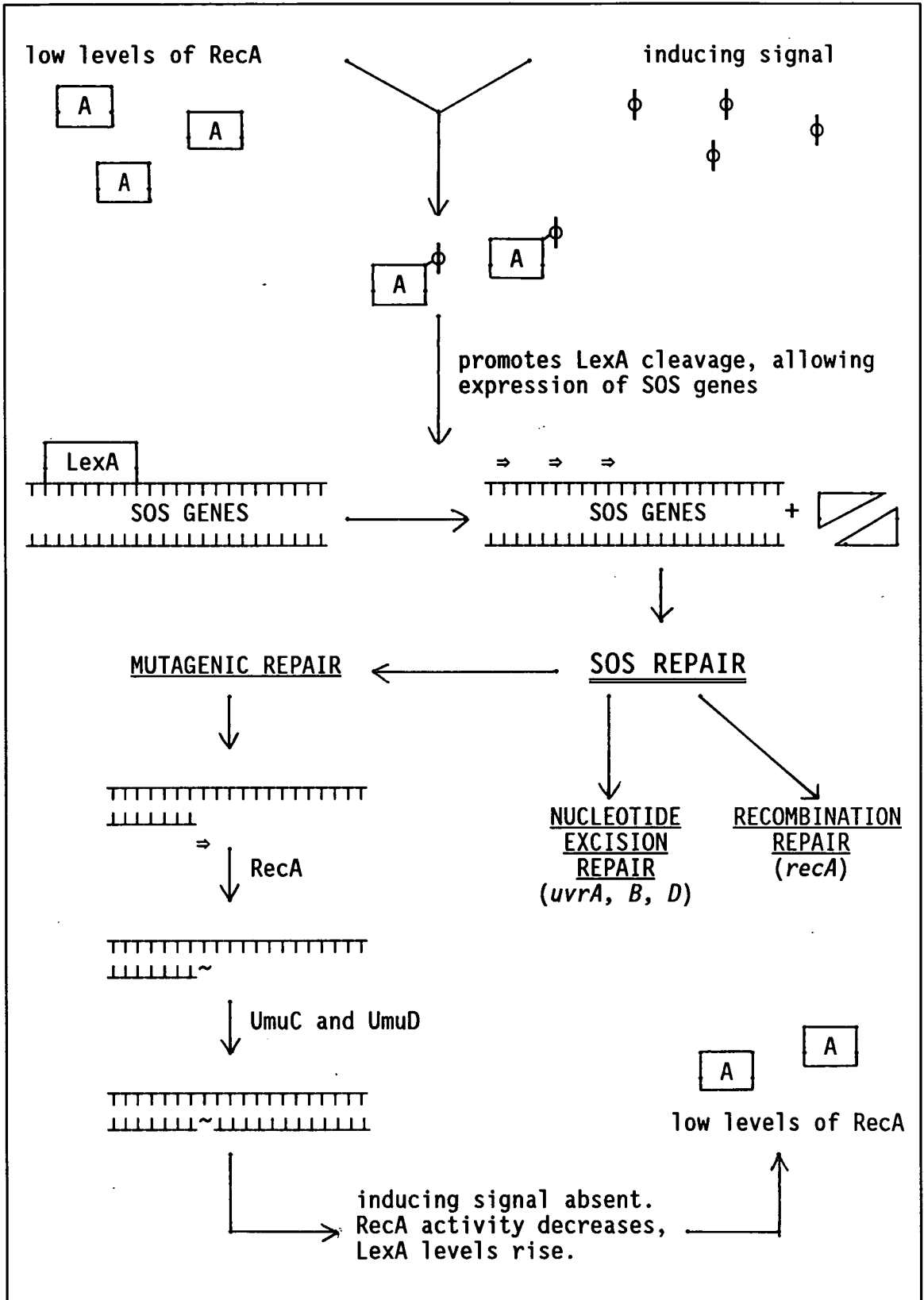
degradation, prophage induction and bacterial mutagenesis. The genes responsible for these reactions in *E.coli* are controlled by the products of the *recA* and *lexA* genes.

The LexA protein is a repressor of all SOS genes (approximately 20 discovered to date, including *lexA* and *recA*), by binding to a similar region in the gene promoter, termed the SOS box. The RecA protein has a low constitutive level in the cell, being involved in recombinational events. Upon DNA damage that produces single-stranded DNA, RecA is activated, apparently by binding to the single-stranded DNA in conjunction with a nucleoside triphosphate. This accelerates the autocatalytic cleavage and inactivation of the LexA protein by allosteric interaction between RecA and LexA. Cleavage of LexA occurs at a single peptide bond linking the molecular domains for DNA binding and co-operative interaction. The removal of the repressor then allows expression of the SOS genes (Figure 1.7).

Repressors of lambdoid bacteriophages are also cleaved by an activated RecA protein, resulting in bacteriophage induction. Thymine starvation, nalidixic acid treatment (which inhibits replication by action upon DNA gyrase and involves the selective degradation of newly synthesized DNA), U.V. irradiation or the products of DNA degradation at, or near, the replication fork or incision sites also activate RecA and starts the SOS response.

The cleavage of LexA turns on the regulator genes themselves, *lexA* and *recA*, and the regulated genes such as *uvrA*, *uvrB* and *uvrD*, (involved in excision), *su1A* and *su1B* (concerned with cell division), *umuC* and *umuD* (mutagenic repair) and a number of genes of yet unknown function (damage inducible or *din* genes). This increases

FIGURE 1.7 SOS REPAIR



levels of recombination repair as RecA levels rise, excision repair as UvrA, UvrB and UvrD levels rise and enables mutagenic repair to occur. Once RecA is no longer activated the levels of LexA build up in the cell. The different SOS boxes have different affinities for the LexA protein so the SOS genes are shut off in sequence, the regulatory region of *lexA* itself is the weakest (requiring the most repressor) so is turned off last.

Mutagenic repair, or error-prone repair, involves DNA replication past lesions via the relaxation of the 3'-5' editing function of DNA polymerase, producing errors in the daughter strand. The details of how this occurs is unknown, but it involves the *umuC*, *umuD* and *recA* gene products.

There is considerable functional conservation of SOS responses in bacteria. Damage-inducible synthesis of RecA-like proteins has been seen in many species, for example, *Salmonella*, *Erwinia* and *Citrobacter* (Chapter One 1.4.3). *Bacillus subtilis* possesses a system analogous to that of *E.coli*, termed the SOB response (Save Qur Bacillus), where the *recA* equivalent is known as *recE*. A functionally expressed *E.coli recA* gene in a *recE*<sup>-</sup> *B.subtilis* allows induction of the SOB response (but not prophage induction) and almost fully restores recombinational ability and DNA repair, although the proteins are physically different (de Vos *et al.* 1983, Love and Yasbin 1986, Lovett *et al.* 1988).

Some species are <sup>considered virtually</sup> immutable, for example, *Haemophilus influenzae*, *Proteus mirabilis* and *Deinococcus* species and it has been suggested that they lack a *umu* function (Tempest and Moseley 1982). The *umu* genes are thought to originate from a transposon (Sedgwick *et al.* 1988), and so absence is not surprising.

*D. radiodurans* is thought not to possess SOS repair due to the lack of inducible repair mechanisms (Moseley 1983). However, four uncharacterised proteins are induced in *D. radiodurans* in response to DNA damage but not nalidixic acid treatment, (Hansen 1980), protein synthesis is required for X-ray repair (Driedger and Grayston 1971), and an inducible repair system is suggested for some forms of U.V. damage (Caimi and Eisenstark 1986) and MTC cross-links (Kitayama 1982).

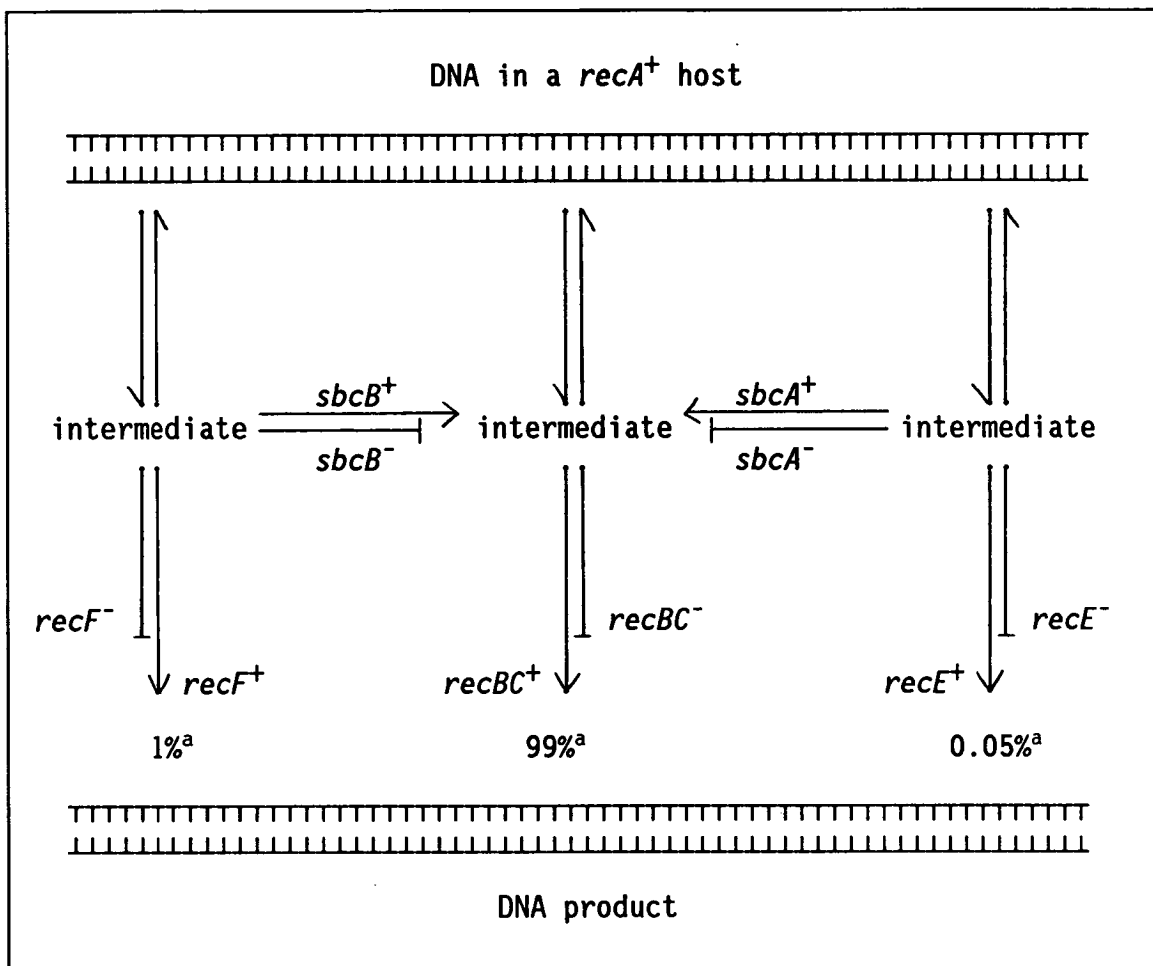
## 1.4 ASPECTS OF THE RECA PROTEIN

### 1.4.1 RECOMBINATION AND THE RÔLE OF THE RECA PROTEIN

Many genes are involved in recombination and recombination repair. These include *lexA* (the *recA* repressor), and the *rec* genes *A* through to *H*, *recJ*, *K*, *L* and *N*, *dnaG* and both *polA* and *polC* (DNA polymerase genes coding for Pol I and III). Recombination repair does, however, require some biochemical functions not needed in general recombination, since *recF* and *lexA* mutations inhibit daughter-strand gap repair but not genetic recombination. In *E. coli* the *recA* gene product plays a central rôle in homologous genetic recombination (reviewed by Radding 1981, Dressler and Potter 1982, Cox and Lehman 1987, Smith 1988), acting early in the recombination pathways of the cell, (Figure 1.8).

Little detail is known about many of the products of the genes involved in these recombination pathways. The best characterised, other than RecA, is the *recB*, *C* and *D* gene product, exonuclease V (Exo V), a complex, multi-functional nuclease with helicase properties. Until recently Exo V was thought to be comprised only of the products of the *recB* and *recC* genes, but *recD* has now been discovered (Amundsen *et al.* 1986). Details of the involvement of

FIGURE 1.8 RECOMBINATION PATHWAYS



(after Horii and Clark 1973)

Note<sup>a</sup> - recombination frequency.

Exo V in recombination are arguable, but it is known to be able to cleave linear double-stranded DNA in the region of *chi* sites, (possibly creating single-strands for recombinational exchange). *Chi* sites are recombinational hot-spots in *E.coli* and lambdoid bacteriophages that enhance general recombination in their vicinity. The nuclease activity of Exo V could also be responsible for the processing of Holliday intermediates to produce the final products of recombination.

A *recB* or *recC* mutant of *E.coli* produces only 1% of wild type

recombination, but this can be restored to 50% by an additional mutation in *sbcA* or *sbcB*. These two latter mutations act either by removing the *sbcA* gene product, (which then allows *recE* expression producing exonuclease VIII), or inactivating the *sbcB* gene product (exonuclease I). If *recB* or *recC* and *sbc* double mutants are used more recombination deficient strains can be isolated, identifying other loci including *recF*, *recK* and *recL*. Mutations in any one of these three genes (as well as at *recB* or *recC* and *sbc*), gives reduced recombination to approximately 0.05% of the wild type levels, by the *recE* pathway. Exo VIII is non-functional in a wild type background, as expression is blocked by a functional *sbcA* gene. However, if expressed, Exo VIII may act early in the RecF pathway (Gillen et al. 1981) allowing residual *recF* activity to produce a low recombination frequency.

Recombination deficiency produces a wide range of phenotypic effects, in eukaryotes as well as prokaryotes. These include increased sensitivity to DNA-damaging agents (such as X-rays and U.V.), reduced cell viability (probably due to inefficient DNA repair) and altered bacteriophage behaviour, as recombination is often important in bacteriophage replication. In *E.coli*, lesions in the *recA* gene also produce other pleiotropic effects, a decreased mutation frequency, aberrant regulation of cell division, inability to induce bacteriophages and the rapid degradation of damaged DNA (termed "reckless" DNA degradation). Other mutants possess some of these properties but not all. Mutants in *recB* or *recC* produce indistinguishable phenotypes, but leave a residual recombinational ability, are less sensitive to U.V. and X-rays than *recA* mutations and demonstrate "cautious" DNA degradation following DNA damage. For

example, following DNA damage in a *recA*<sup>-</sup> mutant 75% of the labelled DNA will be acid-insoluble in approximately 2 hours, in a *recB* or *C*<sup>-</sup> mutant only 5% will have been degraded.

Recombination can occur independently of the RecA protein, termed non-homologous or illegitimate. This is site specific, mediated by system-specific proteins, usually only involving 5 to 6 base pair homology (reviewed by Sadowski 1986 and Craig 1988).

Recombination seems likely to be as complex in other organisms as in *E.coli*, but, as yet, little information is available for comparisons to be made. A number of RecA-like genes and proteins have been isolated from very diverse sources, considered below.

#### 1.4.2 ISOLATION OF RECA-EQUIVALENTS

The phenotypes of many recombination deficient mutants of different species indicated that RecA-like proteins may be conserved throughout a wide variety of both eukaryotes and prokaryotes. Consistent with this view is the large number of *recA*-like genes that have been able to restore RecA functions in *E.coli*, although not always completely (Table 1.3). Furthermore, the inducible expression of many of these genes is influenced by the *E.coli* *lexA* gene. The list of *recA*-like genes is ever increasing plus RecA-like protein activities have been found in several eukaryotes including human cells (Hseih *et al.* 1986), *Ustilago maydis* (Kmeic and Holloman 1982 and 1986) and *Saccharomyces cereviseae* (Augulo *et al.* 1985). Enzyme activities from these eukaryotes and also from a number of other organisms including *Proteus mirabilis* (West *et al.* 1983), *Salmonella typhimurium* (Pierré and Paoletti 1983), *Bacillus subtilis* (Lovett and Roberts 1985) and bacteriophage T4 (Formosa and Alberts 1986)

have been isolated and shown to promote DNA-exchange reactions coupled to nucleoside triphosphate hydrolysis, although the detail of the reactions differ.

Much information is now known about the *E.coli* RecA protein and gene. Physically, it is composed of 352 amino acids and has a molecular weight of 38 kDa (Sancar *et al.* 1985). Originally named Protein X the normal level in the cell is about 2000 molecules per cell, rising to about 50,000 when induced (or approximately 6% of the total cellular protein). As present in such high levels RecA isolation, and of RecA-like proteins from other sources, is not difficult. Found as a monomer it acts by polymerising on to single-stranded DNA, one monomer per 3 to 5 nucleotides. The coated DNA then repeatedly binds to double-stranded DNA until around 50 base pairs homology is found, followed by the displacement of the non-complementary strand.

Cloned RecA homologs usually restore U.V. resistance and recombinational ability to *recA* mutants of *E.coli*. However SOS or prophage induction is not so universal, suggesting the homologs fail to aid autodigestion of LexA<sup>and</sup> of the bacteriophage repressors. Thus, although there is considerable nucleotide sequence divergence amongst the *recA*-like genes of bacterial strains - both structurally and functionally, the RecA protein and many other components of the SOS response have been conserved throughout evolution (Table 1.3).

In addition, the RecA-like gene of *B.subtilis* has now been isolated (Marrero and Yasbin 1988). The protein produced by this gene has an estimated size of 45 kDa and demonstrates cross-reactivity using antibodies to *E.coli* RecA. It has not been reported to function in *E.coli* but *E.coli* RecA functions in *B.subtilis*.

TABLE 1.3 FEATURES OF *recA*-LIKE GENES FROM HETEROLOGOUS SOURCES EXPRESSED IN *E. COLI*

Gene origin	Nucleotide sequence <sup>a</sup>	Structural <sup>b</sup> conservation	Size kDa	Phenotype restored	Other <sup>c</sup> information	Reference
<b>CYANOBACTERIA</b>						
<u>Anabaena variabilis</u>	?	?	40	Recombination <sup>d</sup> MMS <sup>r</sup> + U.V. <sup>r</sup> Prophage induction	HB101, MMS <sup>r</sup> . Sequence results indicate related to <i>E.coli recA</i> .	Owtrim and Coleman (1987)
<u>Gloeocapsa alpicola</u>	?	?	39	U.V. <sup>r</sup> + MMS <sup>r</sup>	S.17, MMS <sup>r</sup> .	Geoghegan and Houghton (1987)
<u>Synechococcus</u> sp. strain PCC 7002	Yes	Yes	38	Recombination <sup>d</sup> U.V. <sup>r</sup>	Detected by DNA hybridisation. Protein sequence indicates 55% homology to <i>E.coli RecA</i> .	Murphy <u>et al.</u> (1987)
<b>PURPLE (SULPHUR AND NON SULPHUR) BACTERIA</b>						
<u>Agrobacterium tumefaciens</u>	Yes	?		U.V. <sup>r</sup> + MMS <sup>r</sup>	CLR207, MMS <sup>r</sup>	Miles <u>et al.</u> (1986)
<u>Bacteroides fragilis</u>	No	Yes	38	Recombination <sup>d</sup> U.V. <sup>r</sup> , NQO <sup>r</sup> + MMS <sup>r</sup> Prophage induction	HB101, MMS <sup>r</sup> .	Goodman <u>et al.</u> (1987)
<u>Erwinia carotovora</u>	Yes	Yes		Recombination <sup>d</sup> U.V. <sup>r</sup> + NQO <sup>r</sup> SOS induction <sup>e</sup> Prophage induction	HB101, NQO <sup>r</sup> .	Keener <u>et al.</u> (1984)
<u>Haemophilus influenzae</u>	?	?		Recombination <sup>d</sup> U.V. <sup>r</sup>	Isolated in <i>H.influenza</i> by complementation of a mutant.	Setlow <u>et al.</u> (1988)
<u>Methylophilus methylotrophus</u>	No*	?	36	U.V. <sup>r</sup> , MTC <sup>r</sup> SOS induction <sup>e</sup>	PF14, MTC <sup>r</sup> .	Finch <u>et al.</u> (1986)
<u>Neisseria gonorrhoeae</u>	?	?		Recombination <sup>d</sup> U.V. <sup>r</sup> + MMS <sup>r</sup>	HB101, MMS <sup>r</sup> .	Koomey and Falkow (1987)
<u>Proteus vulgaris</u>	No	Yes	40	Recombination <sup>d</sup> U.V. <sup>r</sup> + NQO <sup>r</sup> SOS induction <sup>e</sup> Prophage induction	HB101, NQO <sup>r</sup> .	Keener <u>et al.</u> (1984)

Gene origin	Nucleotide sequence <sup>a</sup>	Structural <sup>b</sup> conservation	Size kDa	Phenotype restored	Other <sup>c</sup> information	Reference
<u>Proteus mirabilis</u>	?	Yes*	38	Recombination <sup>d</sup> SOS induction <sup>e</sup> Prophage induction	AB2463, U.V. <sup>r</sup> . Sequence shows some similarity to <u>E.coli recA</u> and <u>E.coli RecA</u> can also function in <u>P.mirabilis</u> .	Eitner <u>et al.</u> (1982) West <u>et al.</u> (1983)
<u>Pseudomonas aeruginosa</u>	?	Yes	38	Recombination <sup>d</sup> U.V. <sup>r</sup> + MMS <sup>r</sup> SOS induction <sup>e</sup> Prophage induction	HB101, MMS <sup>r</sup> . When sequenced found at least 71% amino acid residues the same as <u>E.coli recA</u> .	Kokjohn and Miller (1985) Sano and Kageyama (1987) Miller and Kokjohn (1988)
<u>Pseudomonas syringae</u>	No*	?		Recombination <sup>d</sup> U.V. <sup>r</sup> , MMS <sup>r</sup> + MTC <sup>r</sup>	HB101, U.V. <sup>r</sup> .	Hickman <u>et al.</u> (1987)
<u>Rhizobium meliloti</u>	Yes	?		Recombination <sup>d</sup> U.V. <sup>r</sup> and MMS <sup>r</sup>	HB101, MMS <sup>r</sup> .	Better and Helinski (1983)
<u>Shigella flexneri</u>	Yes	Yes		Recombination <sup>d</sup> U.V. <sup>r</sup> + NQO <sup>r</sup> SOS induction <sup>e</sup> Prophage induction	HB101, NQO <sup>r</sup> .	Keener <u>et al.</u> (1984)
<u>Thiobacillus ferrooxidans</u>	?	Yes	40	Recombination <sup>d</sup> U.V. <sup>r</sup> , MMS <sup>r</sup> + NQO <sup>r</sup>	HB101, MMS <sup>r</sup> .	Ramesar <u>et al.</u> (1988)
<u>Vibrio cholerae</u>	No	Yes	44	Recombination <sup>d</sup> MMS <sup>r</sup> + U.V. <sup>r</sup>	HB101, MMS <sup>r</sup> .	Goldberg and Mekalanos (1986) Hamood <u>et al.</u> (1986)
<b>EUKARYOTES</b>						
Rice mitochondria	?	?		U.V. <sup>r</sup>	KY705, U.V. <sup>r</sup> .	Yamaguchi <u>et al.</u> (1986)

### Notes

- <sup>a</sup> - Southern blot hybridisation to an *E.coli* K12 *recA* probe unless marked \* where the cloned gene itself is used as a probe against *E.coli*.
- <sup>b</sup> - cross reaction to polyclonal antibody raised against *E.coli* K12 RecA protein using Western blotting, except where marked \* by Ouchterlony double diffusion.
- <sup>c</sup> - contains the *E.coli recA* strain and selection technique involved, if isolated in *E.coli*.
- <sup>d</sup> - determined mainly by Hfr crosses.
- <sup>e</sup> - restores at least some function of *E.coli* RecA in the SOS response.

### 1.4.3 CLONING STRATEGIES

To isolate a particular gene it must be localized on a discrete fragment stably maintained within a vector. The fragment can then be isolated, usually by complementation (either complete or partial), antibody cross-reactivity or by DNA-DNA hybridisation. Most *recA*-like genes have been isolated by the restoration of the *recA*<sup>-</sup> phenotype in *E.coli* (Table 1.3). This, however, requires expression, which is affected by many different factors (considered more fully in Old and Primrose 1985 and Saunders and Saunders 1987). The gene promoter must be recognised by the RNA polymerase of *E.coli* for transcription to occur, the -35 and -10 regions being important as the strength of the promoter is partly determined by the degree of homology with the consensus sequences for this region. Transcription termination is also important as, without this gene expression may become an energy drain upon the cell or interfere with the expression of essential genes adjacent to the cloned DNA. The mRNA secondary structure is also crucial, affecting the stability of the RNA in the cell, the access of the ribosomal subunit to the Shine-Dalgarno sequence to commence translation, and translation continuation. The codon choice of the template is also involved, for example, a requirement for a 'rare' charged tRNA molecule will slow translation or increase the chance of an incorrect amino acid being inserted into the protein.

Other factors which affect the rate of expression include translation termination, ensuring the correct reading frame, the number of gene copies, (weak expression requires many copies to detect the product, excessive production, however, can be lethal), and vector stability. Vector instability usually involves a

reduction in the copy number, eventually leading to the loss of recombinant vectors in some cells. These cells quickly become predominant in the culture as they usually possess a faster growth rate. Structural instability may also be a problem, as homologous recombination can occur between short, direct repeats, especially when dealing with recombination-proficient host strains.

The restoration of the ability to repair DNA damage in recombination deficient cells is the usual method of isolating RecA-like proteins, as these strains are sensitive to most DNA damaging agents including U.V. irradiation, MTC, methyl methanesulphonate (MMS) and NQO.

The U.V. photoproduct of prime biological importance is the cyclobutane pyrimidine dimer, where two adjacent pyrimidine bases in the same DNA strand are linked by carbon-carbon bonds. This produces a major distortion in the DNA helix, and, since it cannot form hydrogen bonds with the appropriate purines, acts as major block to DNA replication. The carcinogen and mutagen NQO possesses U.V. mimetic characteristics in that the major DNA-NQO product produces a similar situation and both U.V. and NQO damage are removed by excision repair. MMS, a common alkylating agent, reacts with DNA primarily by the addition of a methyl group to purine residues. The alkylated purine moiety tends to split off to form an apurinic site, again usually mended by excision repair.

The antitumour drug, antibiotic and alkylating agent MTC, however, forms cross-links by covalently bonding to complementary DNA strands. Only one in five to ten molecules form cross-links, the others form, less significantly, monoadducts. Cole (1973) proposed that the repair of such cross-links involved the excision of one

strand, producing a situation similar to that of recombination repair in that a block to DNA replication is still present in the DNA.

A more sophisticated sensitive measure of recombination in *E.coli* is the formation of Lac<sup>+</sup> recombinants from a Lac<sup>-</sup> strain containing two partially deleted *lac* operons (Zeig and Kushner 1971). The operons each contain a small deletion in different areas, so in a Lac<sup>-</sup>, *recA* host Lac<sup>+</sup> cells can only arise by the introduction of a functional recombination gene. This has been little used in the isolation of genes from heterologous sources involved in recombination but is an ideal method.

#### 1.4.4 RECOMBINATION DEFICIENT STRAINS OF *D.RADIODURANS*

In *D.radiodurans*, three recombination deficient strains exist, as measured by transformability, designated *rec30*, *rec1* and *ts1*.

Strain *ts1* is temperature sensitive for DNA synthesis (Moseley *et al.* 1972b), and gradually becomes sensitive to radiation when held at its restrictive temperature of 39°C, the shoulder of the survival curve eventually disappearing. The rate of sensitization (loss of shoulder) is correlated with the rate of loss of recombination, measured by transformability (Moseley *et al.* 1972a). When given sublethal doses of U.V. or ionizing radiation followed by incubation at the restrictive temperature (depleting recombinational ability) before plating at the permissive temperature, loss of disciplined cell division was seen (Moseley and Copland 1975a). Although most of the irradiated bacteria survived and produced colonies extra incubation time was required and the colonies were highly sectored and irregular. The radiation survival curves for

normal colony formation under these conditions were virtually identical to those of *rec30*.

*Rec30* was isolated as a non-transformable strain, later found to be fifteen times more sensitive to U.V., one hundred times more sensitive to gamma irradiation and three hundred times more sensitive to MTC than the wild type (Moseley and Copland 1975b). It exhibits "cautious" DNA degradation, similar to *recB* or *recC E.coli* mutants.

*Rec1* was isolated by Evans (1984), when it was originally known as strain 112. It is non-transformable and is five times more sensitive to MTC and twice as sensitive to U.V. as the wild type. It exhibits "reckless" DNA degradation, similar to that shown by *recA E.coli*. However, *rec1* also possesses an ability for excessive incision, as seen in, for example, *uvrA E.coli*.

### 1.5 AIMS OF THE Ph.D.

Very little is known about recombination repair in *D.radiodurans*. It may be the secret of the radiation resistance exhibited by this organism as other DNA repair mechanisms proposed, including excision repair, do not entirely account for it. The suggestion of recombination occurring between the genomes to provide an intact copy is certainly attractive, as recombination repair can cope with high levels of DNA damage. When the levels of damage rise to above the recombination repair capacity the cells would have died from other physiological effects.

The first step in the study of recombination repair in *D.radiodurans* was considered to be the isolation of a *recA*-equivalent gene (if present), to compare the product to that of

other bacteria. If this was not possible, physical proof of the existence of recombination repair (such as that obtained for *E.coli*) should be obtained.

Initial characterisation of the recently isolated close relative of the genus *Deinococcus*, *Deinobacter grandis*, was begun to investigate the future possibilities for studying the DNA repair capacity of this organism.

## **CHAPTER TWO**

### **MATERIALS AND METHODS**

## 2.1 BACTERIAL STRAINS

Strains of *D.radiodurans* and *D.grandis* used are listed in Table 2.1, *E.coli* strains in Table 2.2. and other bacteria in Table 2.3.

## 2.2 PLASMIDS, COSMIDS AND BACTERIOPHAGES

All plasmids, cosmids and bacteriophages used are listed in Table 2.4.

## 2.3 MAINTENANCE OF CULTURES

*D.radiodurans*, *D.grandis* and *P.vulgaris* were grown at 30°C and *E.coli* and *B.subtilis* at 37°C, unless otherwise stated. Stocks were maintained on agar plates kept at 4°C whilst in routine use, and subcultured approximately every 6 weeks. Permanent stocks were kept at -70°C as small aliquots of 20% v/v glycerol or 5% v/v DMSO liquid cultures. Genetically-marked strains and those carrying plasmids were checked prior to use on the appropriate selective medium. All liquid cultures were grown in an orbital incubator or shaking water bath; 0.2 to 2 ml, 10 to 100 ml and 300 ml to 1 l volumes in 25 ml, 250 ml or 2 l Erlenmeyer flasks respectively; or 0.2 to 3 ml in 15 ml (0.5 oz) bottles and 5 to 10 ml in 25 ml (1 oz) bottles.

TABLE 2.1 STRAINS OF *D.RADIODURANS* AND *D.GRANDIS* USED

Strain	Genotype	Isolation
<i>D.radiodurans</i> R1	Wild type	Anderson <i>et al.</i> (1956)
" R1 Rf <sup>r</sup>		
" UVS78	<i>uvrE, mtcA</i>	Moseley and Evans (1983)
" 302	<i>mtcA</i>	Moseley and Copland (1978)
" <i>rec1</i> <sup>a</sup>	<i>mtcA, rec-1</i>	Evans (1984)
" <i>rec30</i>	<i>rec 30</i>	Moseley and Copland (1975b)
" <i>ts1</i>	<i>ts-1</i>	Moseley <i>et al.</i> (1972b)
" SARK	Wild type	Murray and Robinow (1958)
" SARK Rf <sup>r</sup>		
" Krase <sup>b</sup>		Tirgari and Moseley (1980)
<i>D.grandis</i> KS 0460	Wild type	Oyaizu <i>et al.</i> (1987)
" KS 0460 Rf <sup>r</sup>		This study
" KS 0485	Wild type	Oyaizu <i>et al.</i> (1987)
" KS 0485 Rf <sup>r</sup>		This study

Notes

All strains (apart from those isolated in this study) were obtained as freeze dried cultures from Prof. B.E.B. Moseley, present address Agricultural & Food Research Council Institute of Food Research, Shinfield, Reading, RG2 9AT.

<sup>a</sup> formerly known as mutant 112.

<sup>b</sup> resistant to 30 µg kanamycin ml<sup>-1</sup>, 100 µg rifampicin ml<sup>-1</sup>, 5 µg acriflavin ml<sup>-1</sup>, 100 µg streptomycin ml<sup>-1</sup> and 30 µg erythromycin ml<sup>-1</sup>.

Rf<sup>r</sup> - resistant to at least 50 µg rifampicin ml<sup>-1</sup>.

TABLE 2.2 STRAINS OF *E. COLI* USED

Strain	Genotype or Phenotype
HB101 <sup>abe</sup>	<i>leuB</i> , <i>hsdR</i> , <i>hsdM</i> , <i>recA1</i> , <i>ara-14</i> , <i>proA2</i> , <i>xyl-5</i> , <i>lacY1</i> , <i>galK2</i> , <i>rpsL20</i> (Sm <sup>r</sup> ), <i>mtl-1</i> , <i>supE44</i> , $\lambda^-$
DH5 $\alpha$ <sup>b</sup>	F <sup>-</sup> , <i>endA1</i> , <i>hsdR17</i> (r <sub>K</sub> <sup>-</sup> , m <sub>K</sub> <sup>+</sup> ), <i>supE44</i> , <i>thi-1</i> , $\lambda^-$ , <i>recA1</i> , <i>gyrA96</i> , <i>relA1</i> , $\phi$ 80dI <sub>lacZ</sub> $\Delta$ M15
JC10289 <sup>cf</sup>	F <sup>-</sup> , <i>thr-1</i> , <i>ara-14</i> , $\Delta$ ( <i>gpt-proA</i> )62, <i>lacY1</i> , <i>tsx-33</i> , <i>supE44</i> , <i>galK2</i> , k <sup>-</sup> , <i>rac-</i> , <i>hisG4</i> (Oc), <i>rfbD1</i> , <i>mg1-51</i> , $\Delta$ ( <i>recA-sr1</i> )306, <i>sr1-301::Tn10-84</i> , <i>rpsL31</i> , <i>kdgK51</i> , <i>xyl-5</i> , <i>mtl-1</i> , <i>argE3</i> , <i>thi-1</i> , <i>leuB6</i> , Tc <sup>r</sup>
JC14604 <sup>d</sup>	F <sup>-</sup> , $\Delta$ ( <i>sr1R-recA</i> )306::Tn10, <i>hsr-</i> , <i>argE3</i> , <i>his-4</i> , <i>thi-1</i> , <i>xyl-5</i> , <i>mtl-1</i> , <i>lacMS286</i> $\phi$ 80dII <sub>lacBK1</sub> , Tc <sup>r</sup> , Sm <sup>r</sup>
MM294 <sup>cg</sup>	F <sup>-</sup> , <i>supE44</i> , $\lambda^-$ , <i>endA1</i> , <i>thi-1</i> , <i>hsdR17</i>
AB266 <sup>d</sup>	F <sup>-</sup> , <i>thr-1</i> , <i>leu-6</i> , <i>thi-1</i> , <i>supE44</i> , <i>lacY1</i> , <i>ara-14</i> , <i>xyl-5</i> , <i>mtl-1</i> , <i>proA2</i> , $\lambda^-$ , <i>galK2</i>
B/C2 <sup>a</sup>	
B/C2/LT <sup>ah</sup>	<i>thy</i> (low)
D5683 <sup>a</sup>	F <sup>-</sup> , Sm <sup>r</sup> , Bi <sup>-</sup> , <i>lig</i> <sup>+</sup> , <i>lop8</i> , <i>thy</i> (low), $\lambda$ CI857,5
CSH25 <sup>a</sup>	B <sup>-</sup> , <i>SupF</i>

**Notes**

Nomenclature as Bachmann (1983).

<sup>a</sup> obtained from Prof. B.E.B. Moseley, address as in Table 2.1.

<sup>b</sup> obtained from Dr M. Smith, Uniformed Services University of the Health Sciences, 4301 Jones Bridge Road, Bethesda, MD 20814-4799.

<sup>c</sup> obtained from Barbara Bachmann, *E. coli* Genetic Stock Centre, Dept. Biology 255 OML, Yale University, P.O. Box 6666, New Haven, CT 06511-74444.

<sup>d</sup> obtained from Dr A.J. Clark, Dept. Molecular Biology, University of California, Berkley, CA 94720.

<sup>e</sup> Boyer and Roulland-Dussoix (1969).

<sup>f</sup> Csonka and Clark (1979).

<sup>g</sup> Meselson and Yuan (1968).

<sup>h</sup> Evans (1984).

Tc<sup>r</sup> - resistant to 10  $\mu$ g tetracycline ml<sup>-1</sup>

Sm<sup>r</sup> - resistant to 25  $\mu$ g streptomycin ml<sup>-1</sup>

TABLE 2.3 OTHER STRAINS OF BACTERIA USED

Strain	Genotype or Phenotype
<i>Proteus vulgaris</i> <sup>a</sup>	Wild type
<i>Bacillus subtilis</i> 1A166 <sup>b</sup>	<i>trpC2, sacT3</i>
" " 1A422 <sup>b</sup>	<i>leuB6, recE4, r(-), m(-)168, trp</i>
" " 1E32 <sup>b</sup>	hosts plasmid pPL608

Notes

<sup>a</sup> obtained from Mrs A. Robertson, Microbiology Dept., Edinburgh University.

<sup>b</sup> obtained from the *Bacillus* Genetic Stock Centre, The Ohio State University, Dept. of Microbiology, 484 West 12th Avenue, Columbus, Ohio 43210.

TABLE 2.4 PLASMIDS, COSMIDS AND BACTERIOPHAGES USED

Vector	Marker	Host	Reference
pDR540 <sup>a</sup>	Ap <sup>r</sup>	<i>E.coli</i>	Russell and Bennett (1982)
pAT153 <sup>b</sup>	Tc <sup>r</sup> , Ap <sup>r</sup>	<i>E.coli</i>	Twigg and Sherratt (1980)
pJBFH <sup>c</sup>	Ap <sup>r</sup>	<i>E.coli</i>	Al-Bakri <i>et al.</i> (1985)
pDS6 <sup>d</sup>	Ap <sup>r</sup> , Cm <sup>r</sup>	<i>E.coli</i>	Stueber <i>et al.</i> (1984)
T4 <sup>e</sup>		<i>E.coli</i>	
pDR1453 <sup>f</sup>	Tc <sup>r</sup>	<i>E.coli</i>	
pPL608 <sup>g</sup>	Kn <sup>r</sup> , Cm <sup>r</sup>	<i>B.subtilis</i>	Williams <i>et al.</i> (1981)

Notes

<sup>a</sup> Dr G. Reid.

<sup>b</sup> Dr I. Masters.

<sup>c</sup> Dr G.H. Al-Bakri.

<sup>d</sup> Miss E. Ellis.

<sup>e</sup> Dr I.W. Dawes.

} Address when strains donated, Microbiology Dept., Edinburgh University.

<sup>f</sup> Dr S.G. Sedgwick, National Institute of Medical Research, Mill Hill, London.

<sup>g</sup> *Bacillus* Genetic Stock Centre, address as in Table 2.3.

Tc<sup>r</sup> - resistant to 20 µg tetracycline ml<sup>-1</sup>

Ap<sup>r</sup> - resistant to 50 µg ampicillin ml<sup>-1</sup>

Kn<sup>r</sup> - resistant to 10 µg kanamycin ml<sup>-1</sup>

Cm<sup>r</sup> - resistant to 10 µg chloramphenicol ml<sup>-1</sup>

## 2.4 MEDIA

The following recipes were used, made up in distilled water. Media was solidified as required by adding 15 g agar l<sup>-1</sup>, or 7 g l<sup>-1</sup> for sloppy agar, unless otherwise stated. Agar No. 1 was used for minimal media and Agar No. 3 for routine use. Sterilisation was by autoclaving at 15 lb in<sup>-2</sup> for 15 minutes, or by 0.45 µm filters (marked F/S). All media were obtained from Oxoid, Basingstoke, Hants., unless noted from Difco, East Molesey, Surrey.

### (1) TGY for the growth of *D.radiodurans* and *D.grandis*

	g l <sup>-1</sup>
tryptone	10
yeast extract	5
D-glucose	1
Or	
Bacto tryptone (Difco)	5
yeast extract (Difco)	2.5
D-glucose	1

### (2) LB for the growth of *E.coli* and *B.subtilis*

	g l <sup>-1</sup>
tryptone	10
yeast extract	5
D-glucose	1
NaCl	5

### (3) NB (Nutrient Broth) for the growth of *P.vulgaris*

Nutrient Broth	13 g l <sup>-1</sup>
----------------	----------------------

(4) TYM for the growth of *E.coli* CSH25

LB where 2 g l<sup>-1</sup> maltose was substituted for glucose to induce the formation of  $\lambda$  receptors on the cell surface.

(5) NB2 (Nutrient Broth No. 2) for the isolation of novel

*Deinococcus* species

Nutrient Broth No. 2	25 g l <sup>-1</sup>
----------------------	----------------------

(6) M9 minimal medium for *E.coli*

	ml l <sup>-1</sup>
M9 salts (10 x concentrate)	100
20% w/v D-glucose	20
0.1 M MgSO <sub>4</sub>	10
0.01 M CaCl <sub>2</sub>	10

Each solution was autoclaved separately and cooled to 50°C before mixing aseptically immediately before use. Sterile supplements were then added to 50  $\mu$ g ml<sup>-1</sup>.

(7) M9-CA medium for the growth of *E.coli* D5683

M9 plus the following

	ml l <sup>-1</sup>
aneurine HCl (2 mg ml <sup>-1</sup> , F/S)	1
15% w/v casamino acids (Difco)	10
thymine (1 mg ml <sup>-1</sup> , F/S)	0.06

(8) M9 salts (10 x concentrate)

	g l <sup>-1</sup>
Na <sub>2</sub> HPO <sub>4</sub>	60
KH <sub>2</sub> PO <sub>4</sub>	30
NaCl	5
NH <sub>4</sub> Cl	10

Dissolved in order indicated and pH adjusted to 7.4.

(9) Antibiotic medium for the growth of *B.subtilis*

	g l <sup>-1</sup>
peptone	6
tryptone	4
yeast extract	3
Lab-Lemco powder	1.5
D-glucose	1

(10) SMMP media

4 x strength Antibiotic medium

2 x strength SMM buffer

Autoclaved separately and equal volumes mixed

(11) Minimal medium for *B.subtilis*

	ml l <sup>-1</sup>
Spizizen salts (10 x concentrate)	100
40% w/v D-glucose	10
tryptophan (50 mg ml <sup>-1</sup> , F/S)	1

Each solution was sterilised separately and mixed at 50°C before use. Sterile supplements were then added to 50 µg ml<sup>-1</sup>.

(12) Spizizen Salts (10 x concentrate)

	g l <sup>-1</sup>
K <sub>2</sub> HPO <sub>4</sub>	140
KH <sub>2</sub> PO <sub>4</sub>	60
(NH <sub>4</sub> ) <sub>2</sub> SO <sub>4</sub>	20
tri-sodium citrate	10
MgSO <sub>4</sub>	2

(13) DM3 regeneration medium for *B. subtilis* protoplasts

	ml l <sup>-1</sup>
4% w/v agar	200
1 M sodium succinate pH 7.3	500
5% w/v casamino acids (Difco)	100
10% w/v yeast extract (Difco)	50
3.5% w/v K <sub>2</sub> HPO <sub>4</sub> :1.5% w/v KH <sub>2</sub> PO <sub>4</sub>	100
20% w/v D-glucose	25
1 M MgCl <sub>2</sub>	20
2% w/v BSA (F/S)	5

Solutions were sterilised separately and mixed at 55°C immediately before use.

## 2.5 BUFFERS

Commonly used buffers are listed, others are noted in the protocols as they arise. All were made up in distilled water and sterilised if necessary as for media or made from sterile components.

(1) PB (phosphate buffer), 0.067 M, pH 7.0

g l<sup>-1</sup>

KH<sub>2</sub>PO<sub>4</sub> 4.56

Na<sub>2</sub>HPO<sub>4</sub> 4.73

(2) PEB (phosphate-EDTA buffer), pH 7.0

g l<sup>-1</sup>

KH<sub>2</sub>PO<sub>4</sub> 4.56

Na<sub>2</sub>HPO<sub>4</sub> 4.73

EDTA 0.34

(3) BSPB (1-butanol saturated phosphate buffer)

PB containing 9% v/v 1-butanol

(4) BSPEB (1-butanol saturated phosphate-EDTA buffer).

PEB containing 9% v/v 1-butanol

(5) TE buffer, pH 7.4

10 mM Tris.Cl pH 7.4

1 mM EDTA pH 8.0

(6) BLSB (Birnboim low salt buffer)

0.1 M sodium acetate

1 mM EDTA

0.1% w/v SDS

40 mM Tris.HCl pH 8.0

(7) TEG

25 mM Tris.Cl pH 8.0

10 mM EDTA

50 mM D-glucose

(8) TES

20 mM Tris.Cl pH 8.0

1 mM EDTA

50 mM NaCl

(9) SMM buffer, pH 6.5 (adjusted using NaOH)

	g l <sup>-1</sup>
0.5 M sucrose	171
0.02 M sodium maleate	2.76
0.02 M MgCl <sub>2</sub>	4

(10) TBE buffer (10 x), pH 8.0

0.89 M Tris base	108 g l <sup>-1</sup>
0.89 M boric acid	55 g l <sup>-1</sup>
0.02 M EDTA	40 ml l <sup>-1</sup> 0.5 M, pH 8.0

(11) TAE buffer (10 x), pH 8.0

0.4 M Tris base	48.4 g l <sup>-1</sup>
0.2 M sodium acetate	27.2 g l <sup>-1</sup>
0.01 M EDTA	20 ml l <sup>-1</sup> 0.5 M, pH 8.0

(12) STOP loading buffer

30 mM SDS  
10 mM EDTA pH 8.0  
0.2% w/v bromophenol blue  
20% w/v Ficoll

(13) SDS-PAGE resolving gel buffer (4 x), pH 8.8

	g l <sup>-1</sup>
1.5 M Tris base	181.6
0.4% w/v SDS	4

pH was adjusted to 8.8 with approximately 10 ml concentrated HCl.

(14) SDS-PAGE stacking gel buffer (4 x), pH 6.8

	g l <sup>-1</sup>
0.5 M Tris base	60.6
0.4% w/v SDS	4

pH was adjusted to 6.8 with approximately 30 ml concentrated HCl.

(15) SDS-PAGE running buffer (10 x), pH 8.6

	g l <sup>-1</sup>
0.25 M Tris base	30.3
2 M glycine	144.25
1% w/v SDS	10

(16) SSC (20 x), pH 7.0

	g l <sup>-1</sup>
3 M NaCl	175.3
0.3 M tri-sodium citrate	88.2



(17) SMO buffer, pH 7.5

	g l <sup>-1</sup>
20 mM Tris base	2.4
7.5 mM MgCl <sub>2</sub>	1.5
100 mM NaCl	5.8

(18) TNE (10 x)

	ml l <sup>-1</sup>
0.1 M Tris.Cl	100 1 M, pH 7.2
1 M NaCl	200 5 M
0.01 M EDTA	20 0.5 M

## 2.6 CHEMICALS AND REAGENTS

Sodium dodecyl sulphate (SDS), ethylene diamine tetra-acetic acid disodium salt (EDTA), tris (hydroxymethyl) aminomethane (Tris base or Trizma), tris (hydroxymethyl) aminomethane hydrochloride (Tris.HCl), bromophenol blue, trichloroacetic acid (TCA) and other routine chemicals were obtained from BDH Chemicals Ltd., Poole, Dorset, unless otherwise stated.

Ficoll, agarose Type 1A-6013, ethidium bromide, spermidine, 4-nitroquinoline-1-oxide (NQO), bovine serum albumin (BSA), deoxyadenosine 5'-triphosphate (ATP), PAGE blue 83, polyethylene glycol (PEG), isopropyl-B-D-thiogalactopyranoside (IPTG), 5-bromo-4-chloro-3-indolyl-B-D-galactoside (X-gal), N-methyl-N'-nitro-N-nitrosoguanidine (MNNG) and ethyl methanesulphonate (EMS) were obtained from Sigma Chemical Company Ltd., Poole, Dorset.

Dithiothreitol (DTT) and N,N,N'-tetramethylethylenediamine

(TEMED) were obtained from Bethesda Research Laboratories (BRL) Ltd., Cambridge; caesium chloride from Boehringer Mannheim, Lewes, East Sussex; dimethyl sulphoxide (DMSO) from Koch-Light Laboratories Ltd., Colnbrook, Bucks.; methyl methanesulphonate (MMS) from Eastman-Kodak and Co., Rochester, New York. Agarose gel molecular weight markers of  $\lambda$  bacteriophage DNA digested with *Hind*III and  $\phi$ X174 bacteriophage DNA digested with *Hae*III were obtained from Northumbria Biologicals Ltd., Cramlington, Northumberland and BRL respectively. Sephadex G-75 originated from Pharmacia Inc., Piscataway, New Jersey.

Distilled water was used in all cases.

## 2.7 ANTIBIOTICS AND NUTRITIONAL SUPPLEMENTS

Sterilisation was by filters, pore size 0.45  $\mu$ m, if necessary. All nutritional supplements and antibiotics were obtained from Sigma, apart from streptomycin sulphate which was from Evans Medical, Liverpool. Rifampicin (Rf) was dissolved in DMSO at 50 and 500 mg ml<sup>-1</sup> and mitomycin C (MTC) was made up in 50% methanol at 50 and 500  $\mu$ g ml<sup>-1</sup>, both were stored in the dark at 4°C. Excess MTC was disposed of into x 10 volume 10% w/v sodium thiosulphate and left overnight before discarding. Chloramphenicol (Cm) was made up in ethanol at 34 mg ml<sup>-1</sup>, ampicillin (Ap, sodium salt) in water at 50 mg ml<sup>-1</sup>, tetracycline (Tc) in methanol at 12.5 mg ml<sup>-1</sup>, streptomycin (Sm) and kanamycin (Kn) in water at 20 mg ml<sup>-1</sup> and 25 mg ml<sup>-1</sup> respectively and all were stored at -20°C in small aliquots.

## 2.8 RADIOACTIVELY-LABELLED COMPOUNDS

[6-<sup>3</sup>H]Thymidine (<sup>3</sup>HdThd), 777 GBq mmol<sup>-1</sup> (21 Ci mmol<sup>-1</sup>), 37 MBq ml<sup>-1</sup> (1 mCi ml<sup>-1</sup>) in water was purchased from Amersham International plc., Bucks. [ $\alpha$ -<sup>32</sup>P]deoxycytidine 5'-triphosphate ([ $\alpha$ -<sup>32</sup>P]dCTP), tetra (triethylammonium) salt, 111 TBq mmol<sup>-1</sup> (3,000 Ci mmol<sup>-1</sup>), 370 MBq ml<sup>-1</sup> (10 mCi ml<sup>-1</sup>) in 0.01 M Tricine (N-tris [hydroxymethyl] methylglycine), pH 7.4, was purchased from New England Nuclear Research Products, Boston, MA 02118.

## 2.9 ENZYMES

Restriction enzymes were purchased from a variety of sources; *Bam*HI from BRL, *Mbo*I from Pharmacia, Milton Keynes, Bucks. and *Hind*III, *Pst*I and *Eco*RI from Anglian Biotechnology Ltd., Colchester, Essex. Boehringer Mannheim supplied *Sau*3A, *Nru*I, *Ba*131, *Sca*I, calf intestine alkaline phosphatase (CIP) and T<sub>4</sub> DNA ligase, although T<sub>4</sub> DNA ligase was also used from BRL. Lysozyme, proteinase K, DNase and pancreatic RNase were obtained from Sigma. RNase was dissolved in water at 10 mg ml<sup>-1</sup> and placed in a boiling water bath for 20 minutes, cooled slowly and stored at -20°C until use. Lysozyme and proteinase K were always made up fresh to the required concentration. DNase was made up in distilled water at a concentration of 1 mg ml<sup>-1</sup> and stored at -20°C.

## 2.10 MEASUREMENT OF BACTERIAL GROWTH

The growth of *D.radiodurans* and *D.grandis* was determined by measuring the turbidity of cultures in a nephelometer with an orange filter (Evans Electroselenium Ltd., Halstead), using 250 ml side-arm Erlenmeyer flasks. The growth of *E.coli* and *B.subtilis* was measured

in a Pye Unicam 5P6-500 U.V. spectrophotometer at 600 nm ( $A_{600}$ ).

## 2.11 CLEANING AND PRECIPITATING DNA

In the following protocols DNA was cleaned by phenol treatment, which precipitates proteins into the interphase layer between the upper aqueous and lower solvent phase. Traces of the phenol are then removed by chloroform treatment. Occasionally, chloroform treatment alone was used.

Phenol treatment involved adding to the DNA in solution an equal volume of phenol:chloroform (if volumes less than 100  $\mu$ l were involved the DNA solution was made up to 100  $\mu$ l with TE). The phenol:chloroform was made by mixing an equal volume of redistilled phenol with chloroform:isoamyl alcohol (24:1 v/v) and adding 1 mg ml<sup>-1</sup> 8-hydroxyquinoline followed by approximately one quarter the total volume of TE to buffer the mixture. The hydroxyquinoline was added to colour the phenol mixture pale yellow. Should the phenol be oxidised the dye turns straw yellow and should be discarded. Volumes of the phenol mixture used to clean DNA ranged from 100  $\mu$ l to 10 ml in Eppendorf tubes or 25 ml screw top Corex tubes, as appropriate. Aliquots of 15 ml of the phenol mixture were made up and stored at -20°C; the aliquot in use was stored at 4°C. The DNA-phenol:chloroform mixture was emulsified gently, which could take some time, and spun at 4,000 g for 15 minutes in a swing out rotor to separate the layers, or for 2 minutes in a microcentrifuge, depending upon the volumes involved. The top, aqueous layer containing the DNA was carefully removed to a clean tube, without any of the interface layer, for chloroform treatment.

Chloroform treatment involved adding an equal volume of cold

chloroform:isoamyl alcohol (24:1 v/v), mixing and spinning again as before. However, if volumes totalling more than 20 ml were involved the mixture was spun at 10,000 g at 5°C for 20 minutes.

This was followed by DNA precipitation where the top aqueous layer was removed to a clean tube and the DNA precipitated by adding, if no salt was present, 0.1 volume of 3 M sodium acetate pH 4.8, followed by twice the total volume of cold ethanol or 2-propanol. Plasmid preparations were left for 20 minutes at -20°C to ensure all the DNA was precipitated and spun for 20 minutes at 10,000 g at 5°C, or at 8,000 g for 10 minutes at 5°C if in Corex tubes or for 15 minutes in a microcentrifuge at 4°C if in Eppendorf tubes. Plasmid preparations that were not to be put through a caesium chloride gradient were washed with 70% v/v ethanol to remove excess salt, briefly spun as before and dried in a desiccator using a vacuum pump. Chromosomal DNA, however, was not spun after precipitation, but was immediately wound out of the solution using glass rods, and air dried. The DNA was finally dissolved in TE buffer or distilled water, ideally at a concentration of 1 mg ml<sup>-1</sup>, and stored at 4°C. Addition of two drops of chloroform to chromosomal preparations ensured no contamination whilst in storage.

## 2.12 ISOLATION OF CHROMOSOMAL DNA

### (i) FROM *DEINOCOCCUS*

DNA was isolated by a modification (Evans 1984) of Marmur's method (1961). Two litres of a *D. radiodurans* Rf<sup>r</sup> stationary phase culture was centrifuged at 8,000 g for 10 minutes and resuspended in 50 ml BSPEB, to aid the action of lysozyme upon the cell wall (Driedger and Grayston 1970). The suspension was left on ice for 45 minutes,

again centrifuged, and the pellet drained well before resuspension in 50 ml PEB. Lysozyme was then added to  $1 \text{ mg ml}^{-1}$  and the mixture incubated at  $37^\circ\text{C}$  for 45 minutes, or until a  $250 \mu\text{l}$  aliquot lysed upon the addition of  $25 \mu\text{l}$  PEB containing 11% w/v SDS. Addition of 5 ml of PEB-11% SDS lysed the remainder to produce a deep red gel within 5 minutes of gentle mixing. To extract the DNA 13 ml of a sodium perchlorate solution (70.25 g  $\text{NaClO}_4 \cdot \text{H}_2\text{O}$  plus 4.4 g NaCl per 100 ml water) was added followed immediately by 73 ml chloroform:isoamyl alcohol (24:1 v/v), and the mixture shaken gently for 30 minutes to produce a pink liquid. After centrifugation at 10,000 g at  $5^\circ\text{C}$  for 30 minutes the upper aqueous layer was removed, (being careful to leave the middle and lower layers containing denatured proteins behind), ethanol precipitated and dissolved in 15 to 20 ml of TE. Chloroform treatment and ethanol precipitation followed and the DNA was wound out and dissolved in approximately 10 ml TE. RNase was added to 0.1 volume and the mixture incubated for 1 hour at  $37^\circ\text{C}$  with occasional gentle shaking. This was followed by phenol treatment and a further chloroform treatment and ethanol precipitation, after which the DNA was dissolved in TE buffer. This protocol yielded approximately 10 mg chromosomal DNA.

(ii) FROM *DEINOBACTER*

The cells from 100 ml of a stationary phase  $\text{Rf}^+$  culture were collected by centrifugation at 8,000 g for 10 minutes, the pellet resuspended in 5 ml of 50 mM Tris.HCl pH 8.0, 50 mM EDTA, and frozen at  $-20^\circ\text{C}$ . Once frozen,  $0.5 \text{ ml}$  of  $10 \text{ mg ml}^{-1}$  lysozyme in 0.25 M Tris.HCl pH 8.0 was added and the mixture thawed in a water bath at room-temperature before placing on ice for 45 minutes. This

was followed by the addition of 1 ml STEP (0.5% w/v SDS, 50 mM Tris.HCl pH 7.5, 0.4 M EDTA, 1 mg ml<sup>-1</sup> proteinase K). The mixture was left at 50°C for 60 minutes with occasional, gentle agitation before phenol treatment and ethanol precipitation after adding salt. If the aqueous phase could not be cleared by centrifugation after phenol treatment the volumes of each phase was doubled, mixed and spun again. The pellet was dissolved in 5 ml of TE, which often took some time, followed by RNase treatment (0.1 volume of RNase solution, incubated at 37°C for 1 hour with occasional shaking). The DNA was cleaned by chloroform treatment and ethanol precipitation and finally dissolved in TE buffer to give a concentration of 0.1 mg ml<sup>-1</sup>. This method yielded approximately 0.2 mg and 0.5 mg of DNA from strains KS 0460 and KS 0485 respectively.

### 2.13 LARGE SCALE ISOLATION OF PLASMID DNA

Most of the following methods (including small scale isolation of plasmid DNA) were originally based upon the technique devised by Birnboim and Doly (1979). The principle involved was selective alkali denaturation of high molecular weight chromosomal DNA whilst covalently closed circular plasmid DNA stayed double stranded. Upon neutralisation the chromosomal DNA renatured to form an insoluble clot, leaving the plasmid DNA in solution.

#### (i) FROM *DEINOCOCCUS* AND *DEINOBACTER*

Two litres of stationary phase cells were harvested by centrifugation at 8,000 g for 10 minutes, resuspended in 50 ml BSPEB and left on ice for 30 minutes before centrifugation again. The

pellet was drained well and resuspended in 30 ml TEG before adding 10 ml of 8 mg ml<sup>-1</sup> lysozyme in TEG. After incubation on ice for 30 minutes 80 ml 0.2 M NaOH containing 1% w/v SDS was added and mixed by inversion, followed 5 minutes later by the addition of 60 ml 3 M sodium acetate pH 4.8. After gentle, thorough mixing, and 1 hour on ice, centrifugation at 10,000 g at 5°C for 20 minutes produced a cloudy supernatant. This was strained, the DNA ethanol precipitated (adding no salt) and the pellet dissolved in 25 ml 0.1 M sodium acetate pH 6 before a final ethanol precipitation. The pellet was finally dissolved in 5.4 ml TE buffer for density gradient purification.

(ii) FROM *D.GRANDIS* KS 0485

Methods were based upon small-scale plasmid isolations 2.14(ii) and 2.13(iv).

The cells from 100 ml stationary phase culture were collected by centrifugation, resuspended in 25 ml BSPEB and held on ice for 20 minutes. Again the cells were collected and washed in 5 ml TES before resuspending in 4 ml TES containing 10% w/v sucrose and 2.5 mg ml<sup>-1</sup> lysozyme. After incubation at room temperature for 30 minutes the cells were lysed by the addition of 8 ml 0.2 M NaOH containing 1% w/v SDS, left on ice for 5 minutes before adding 6 ml 3 M sodium acetate pH 4.8, thoroughly mixed and left on ice for 10 minutes. Centrifugation at 11,000 g at 5°C for 30 minutes cleared the supernatant, which was removed for phenol and chloroform treatment and ethanol precipitation. The precipitate was dissolved in 5 ml BLSB and again subject to phenol and chloroform treatment and ethanol precipitation. The pellet was finally resuspended in TE

buffer to  $1 \text{ mg ml}^{-1}$ . This normally yielded variable amounts of plasmid DNA of approximately  $10 \text{ }\mu\text{g}$ .

(iii) FROM *E. COLI* - CAESIUM CHLORIDE

The method is that described by Ish-Horowicz and Burke (1981). Cells were grown in 1 l of medium plus the relevant selective pressure. Amplification was occasionally used when chloramphenicol was added to a final concentration of  $150 \text{ }\mu\text{g ml}^{-1}$  once the  $A_{600}$  of the culture had reached 0.6 to 0.7. The mixture was then left shaking overnight. The cells were collected by centrifugation at  $8,000 \text{ g}$  for 10 minutes and resuspended to 9 ml in TEG. Lysozyme was then added, 1 ml of a  $15 \text{ mg ml}^{-1}$  solution in TEG, and the mixture left on ice for 15 minutes before adding 30 ml  $0.2 \text{ M NaOH}$  containing 1% w/v SDS. The solutions were mixed by inversion and left on ice for 5 minutes, 22.5 ml  $3 \text{ M}$  sodium acetate pH 4.8 added, the mixture inverted again and left on ice for 1 hour. After centrifugation at  $12,000 \text{ g}$  at  $5^\circ\text{C}$  for 50 minutes 90 ml 2-propanol was added to the supernatant, mixed well and stood on ice for 5 minutes before centrifugation at  $8,000 \text{ g}$  at  $5^\circ\text{C}$  for 20 minutes. The position of the pellet on the tube was marked and the pellet drained for 20 minutes before dissolving in 5.4 ml of TE buffer for density gradient centrifugation.

(iv) FROM *E. COLI* - BIRNBOIM

The cells from 40 ml of culture, grown overnight under a selection pressure, were collected and resuspended in 1 ml TEG before adding 1 ml of  $4 \text{ mg ml}^{-1}$  lysozyme in TEG. The mixture was left on ice for 30 minutes and vortexed before quickly adding 4 ml

0.2 M NaOH containing 1% w/v SDS, again vortexed briefly and left on ice. After 5 minutes 3 ml 3 M sodium acetate pH 4.8 was added and mixed by inversion, left on ice for 1 hour and centrifuged at 8,000 g at 5°C for 30 minutes. The supernatant was removed, the DNA ethanol precipitated and the pellet dissolved in 2 ml BLSB. This was followed by phenol treatment and the DNA was re-extracted with 2 ml BLSB. Both aqueous layers were combined, the DNA ethanol precipitated and the pellet dissolved in 0.4 ml TE buffer and transferred to an Eppendorf tube. The DNA was again ethanol precipitated and the pellet dissolved in 200  $\mu$ l TE and 0.1 volume RNase solution added. After 1 hour at 37°C with occasional shaking the volume was doubled with water before phenol and chloroform treatment and a final ethanol precipitation. The pellet was then dissolved in TE buffer, typically yielding 20 to 40  $\mu$ g of plasmid DNA.

(v) FROM *B. SUBTILIS*

This protocol was developed by Niaudet and Ehrlich (1979). The cells from 250 ml of overnight culture, <sup>grown</sup> with the relevant selection pressure, were collected by centrifugation at 8,000 g for 10 minutes, washed once in TEN (50 mM Tris.HCl pH 7.4, 1 mM EDTA, 100 mM NaCl), and resuspended in 10 ml TNS (50 mM Tris.HCl pH 7.4, 100 mM NaCl, 25% w/v sucrose) before adding 0.25 ml of a 20 mg ml<sup>-1</sup> solution of lysozyme in water. Following incubation at 37°C for 20 minutes the following solutions were added in order; 2.4 ml 5 M NaCl, 0.6 ml 0.5 M EDTA pH 8.0, plus 12.5 ml fresh 2% w/v SDS in 0.7 M NaCl. The solutions were gently mixed and left overnight at 4°C before centrifugation at 35,000 g at 5°C for 30 minutes. The

supernatant was collected and the salt adjusted to 1 M by adding 5 M NaCl, followed by one third volume 40% v/v PEG 6000 to precipitate the DNA. After incubation on ice for 1 hour the DNA was collected by centrifugation at 8,000g at 5°C for 20 minutes and resuspended in 5.4 ml TE buffer for density gradient centrifugation.

#### 2.14 SMALL SCALE ISOLATION OF PLASMID DNA

The mini preparations described were spun in a microcentrifuge at 12,000 g unless otherwise noted.

##### (i) FROM *DEINOCOCCUS* - METHOD 1

From Mackay (1983). Liquid cultures were grown for 24 hours, the cells from 1.5 ml collected and resuspended in 300  $\mu$ l BSPEB and left for 10 minutes at room temperature. The cells were collected, drained well and resuspended in 100  $\mu$ l 2 mg ml<sup>-1</sup> lysozyme in TEG and left on ice for 30 minutes. The cells were then lysed by the addition of 200  $\mu$ l 0.2 M NaOH containing 1% w/v SDS. The tube was inverted gently and maintained on ice for 5 minutes before adding 150  $\mu$ l 3 M sodium acetate pH 4.8 and gently mixing. After 1 hour on ice and centrifugation for 5 minutes at 4°C the supernatant was removed to another tube, the DNA ethanol precipitated and the pellet collected, dried and resuspended in 100  $\mu$ l 0.1 M sodium acetate pH 6.0. The DNA was again ethanol precipitated and the pellet finally dissolved in 10  $\mu$ l TE buffer.

##### (ii) FROM *DEINOCOCCUS* AND *DEINOBACTER* - METHOD 2

This method was originally only used for *D. radiodurans* and is a modification of Mackay (1983) as used by Smith *et al.* (1988). The

cells from 5 ml (10 ml *D.grandis*) overnight culture were collected at 4,000 g in a bench centrifuge and washed in 1 ml BSPB, followed by washing in 1 ml TES and resuspended in 200  $\mu$ l TES containing 10% w/v sucrose and 2.5 mg ml<sup>-1</sup> lysozyme. After 30 minutes at room temperature the cells were checked for lysis by removing an aliquot and adding an equal volume of TES containing 2% w/v SDS and 10% w/v sucrose. If the cells lysed the procedure was repeated with the whole cell suspension. After briefly vortexing 400  $\mu$ l chloroform:isoamyl alcohol (24:1 v/v) was added, the mixture shaken and spun for 10 minutes. The supernatant was removed into 400  $\mu$ l chloroform:isoamyl alcohol (24:1 v/v), shaken and spun as before. The supernatant was again removed and added to 40  $\mu$ l 3 M sodium acetate pH 4.8, followed by 400  $\mu$ l 2-propanol for DNA precipitation. The pellet was finally dissolved in 40  $\mu$ l TE or water.

In some cases the Eppendorf tubes were unable to withstand the chloroform centrifugation step so the following modification was used. After cell lysis 200  $\mu$ l 3 M sodium acetate pH 4.8 was added and mixed. After 5 minutes on ice and centrifugation at 4°C for 10 minutes the supernatant was removed for ethanol precipitation and the DNA pellet was collected and dissolved in 250  $\mu$ l BLSB for phenol and chloroform treatment and a repeat ethanol precipitation. The collected DNA was finally dissolved in 40  $\mu$ l TE buffer or water.

### (iii) FROM *E.COLI* - BOILING METHOD

This method of extraction originates from Holmes and Quigley (1981). An overnight culture of 5 ml was grown (containing the appropriate selective pressure), and the cells were harvested and resuspended in 350  $\mu$ l of STET (50 mM Tris.Cl pH 8, 50 mM EDTA,

5% v/v Triton X-100, 8% w/v sucrose, not autoclaved), followed by 25  $\mu$ l of 10 mg ml<sup>-1</sup> lysozyme in STET. The solutions were mixed by inversion and placed in boiling water for 1 minute, before centrifugation at 4°C for 15 minutes. The gelatinous pellet was immediately removed and discarded using a toothpick, while to the supernatant 0.1 volume 3 M sodium acetate pH 4.8 and an equal volume of cold 2-propanol was added and inverted to mix. After 10 minutes at -20°C the DNA precipitate was collected and resuspended in 40  $\mu$ l TE or water.

#### (iv) FROM *E.COLI* AND *B.SUBTILIS* - ALKALINE LYSIS

This method was developed by Ish-Horowicz and Burke (1981). Cells were grown overnight in 5 ml LB, plus the relevant selection pressure, centrifuged at 4,000 g for 10 minutes in a bench centrifuge and resuspended in 100  $\mu$ l TEG. To lyse the cells 200  $\mu$ l 0.2 M NaOH containing 1% w/v SDS was added, the solution vortexed briefly and left on ice for 10 minutes, followed by 150  $\mu$ l 3 M sodium acetate, pH 4.8. After mixing by inversion the solution was left on ice for a further 5 minutes and then spun at 4°C for 10 minutes. The supernatant was removed for phenol and chloroform treatment and was ethanol precipitated by adding 0.1 volume 3 M sodium acetate pH 4.8 and 2 volumes of ethanol. After standing for 5 minutes at room temperature the precipitate was collected and resuspended in 40  $\mu$ l water or TE.

## 2.15 GENETIC TRANSFORMATION

### (i) TRANSFORMATION OF *D.RADIODURANS*

This was based upon the method developed by Tirgari and Moseley

(1980). The cells from 10 ml of an exponentially growing culture, turbidity 30 to 50 in a nephelometer, were collected and resuspended in 5 ml TGY and 2 ml cold 0.1 M CaCl<sub>2</sub>. After leaving on ice for 10 minutes, 0.3 ml was removed to 0.5 oz bottles and 1 µg of plasmid or 10 µg of chromosomal DNA added. The cells were left at 30°C for 90 minutes in a gently shaking water bath before either adding 2.7 ml TGY for overnight expression in liquid media, or immediately making a dilution series for expression in solid media. The latter was done by adding 1 ml of the appropriate dilution to 9 ml of TGY agar at 48°C, mixing well and pouring into a plate. After 4 to 6 hours the plate was overlaid with TGY at 48°C, some containing the selection pressure. If left for overnight expression in liquid media a dilution series was made the following day onto the relevant media. In both cases viable counts were made to calculate transformation efficiencies, using Rf<sup>r</sup> (20 µg ml<sup>-1</sup>) from chromosomal DNA as a control. Colonies were scored after 3 or 4 days.

Transformation frequencies obtained when using *D. radiodurans* R1 were in the order of  $1 \times 10^{-3}$  for Rf<sup>r</sup>, however, frequencies up to  $1 \times 10^{-2}$  were occasionally obtained.

#### (ii) TRANSFORMATION OF *DEINOBACTER*

This was done using electroporation involving a Gene Pulser Transfection apparatus, obtained from Bio-Rad Laboratories, Richmond, California, CA 94804, using a method derived from Potter *et al.* (1984) and a Bio-Rad technical publication (1987).

Electroporation involves high-voltage, high-current exponential electric pulses across a cuvette containing a cell sample and DNA. Cultures were grown to the required turbidity, the cells collected,

washed twice in electroporation buffer (272 mM sucrose, 7 mM sodium phosphate pH 7.4, 1 mM MgCl<sub>2</sub>), and resuspended in ice cold buffer at approximately 1 x 10<sup>8</sup> c.f.u. One ml of this solution was then placed in a Gene Pulser cuvette and left on ice for 10 minutes before adding 15 µg of Rf<sup>r</sup> chromosomal DNA, followed by a further 10 minutes on ice. Electroporation was then carried out, the capacitor being set at a constant 25 µFD (microfarads), but a variable voltage of up to 2.5 kV was used. After treatment the cuvettes were again stood on ice for 10 minutes, the cells then added to 9 volumes TGY and incubated overnight for the expression of the marker before diluting onto the appropriate media (transformants being scored on Rf plates at 20 µg ml<sup>-1</sup>). Colonies were scored after 3 to 4 days.

### (iii) TRANSFORMATION OF *E. COLI* - METHOD 1

Both methods are based upon Mandel and Higa (1970), Maniatis *et al.* (1983) and Humpreys *et al.* (1979). Competent cells were made by diluting an overnight culture 1:100 in LB and growing up to an A<sub>600</sub> of 0.3 (2 to 3 hours). The cells were collected in a bench centrifuge at 4,000 g for 10 minutes, resuspended in half the original volume of ice cold 100 mM CaCl<sub>2</sub> and stood on ice for 20 minutes. The cells were again collected and resuspended in 0.1 original volume 100 mM CaCl<sub>2</sub> for immediate use or 100 mM CaCl<sub>2</sub> containing 20% v/v glycerol for storage in aliquots at -70°C. DH5α and HB101 stored well at -70°C, but not all cells did, notably JC14604.

After thawing frozen cells on ice, if necessary, 200 µl competent cells were resuspended in 100 µl 10 mM Tris.HCl pH 7.0, 10 mM MgCl<sub>2</sub>, 10 mM CaCl<sub>2</sub>; 10 to 200 ng of plasmid were added and the

mixture left for 30 minutes on ice. The cells were then heat shocked for 2 minutes in a water bath at 42°C, followed by 2 minutes at room temperature and the addition of 1 ml LB. After 1 hour at 37°C (without shaking) the cells were collected and resuspended in 100 µl LB and spread onto the appropriate selective media for overnight incubation.

#### (iv) TRANSFORMATION OF *E.COLI* - METHOD 2

The competent cell culture was grown as in (iii) above, but differs mainly in that all pipettes and tips are used at -20°C to prevent the cells becoming warm and in using fresh CaCl<sub>2</sub>.

The A<sub>600</sub> was allowed to rise to 0.36 to 0.44 before the cells were collected and resuspended in 0.1 volume 50 mM ice cold, fresh, filter-sterilised CaCl<sub>2</sub>. The cells were immediately collected and resuspended in 0.1 original volume of 50 mM CaCl<sub>2</sub> as before but containing 20% v/v glycerol, and were frozen quickly by placing 0.5 ml aliquots in ethanol pre-cooled to -20°C, or lower, by the addition of dry ice. The competent cells were stored at -70°C until thawed on ice before use.

The DNA (1 to 60 ng) was added to 100 µl competent cells, left on ice for 30 minutes, heat shocked at 37°C for 2 minutes followed by 900 µl LB and stationary incubation for 1 hour. 100 µl was then plated onto the appropriate selective media and the rest stored at 4°C for up to 7 days, for plating if necessary.

#### (v) TRANSFORMATION OF *B.SUBTILIS*

This method was developed by Chang and Cohen (1979) and involves PEG-induced DNA uptake by protoplasts. The cells were grown to

mid-exponential phase when 20 ml were harvested and resuspended in 2 ml SMMP<sup>media</sup>. Lysozyme was added to 2 mg ml<sup>-1</sup> and the suspension incubated at 37°C for 2 hours while being gently shaken. The resulting protoplasts were centrifuged at 2,600 g for 15 minutes in a swing-out rotor, washed once in SMMP<sup>media</sup> and the pellet resuspended in 2 ml SMMP<sup>media</sup>. Samples of 500 µl were taken and added to 5 µg plasmid DNA in 50 µl SMM, quickly followed by 1.5 ml 40% w/v PEG 6000 in SMM. After 2 minutes 5 ml SMMP<sup>media</sup> was added and mixed and the mixture centrifuged at 2,600 g for 15 minutes in a swing-out rotor. The pellet was resuspended in 1 ml SMMP<sup>media</sup> and incubated for 90 minutes at 30°C with gentle shaking for phenotypic expression, before plating onto DM3 media containing the relevant selection pressure.

Transformants were scored after 2 to 3 days. Non-protoplasted units and a total viable count were taken to check transformation efficiencies.

## 2.16 DYE BUOYANT DENSITY CENTRIFUGATION

This method of purifying plasmid DNA was developed by Radloff *et al.* (1967). To the plasmid DNA in 5.4 ml of TE, 5.94 g of caesium chloride and 0.54 ml of 10 mg ml<sup>-1</sup> ethidium bromide in water were added (1.1 g ml<sup>-1</sup> and 0.1 ml ml<sup>-1</sup> respectively). The refractive index was then checked to ensure it was below 1.3925 (density 1.625 g ml<sup>-1</sup>) using an Abbe 60 Refractometer (Bellingham and Stanley Ltd., England), or, using a positive displacement pipette, the density of a given volume of the solution was determined, again to ensure that it was below 1.62 g ml<sup>-1</sup>. The solution was left at 4°C for a few hours or overnight before centrifugation at 7,000 g at 5°C for 30 minutes, to remove the precipitate. The supernatant density was

again checked, and, if it had altered, caesium chloride or TE was added to achieve a density of between 1.54 and 1.62 g ml<sup>-1</sup> again. The mixture was then loaded into a 10 ml ultracentrifuge polypropylene tube, covered with liquid paraffin and spun at 130,000 g at 18°C for at least 18 and up to 60 hours.

Two bands formed in the middle of the gradient, (visualised by U.V. light at 300 nm), the lower containing covalently closed circular (ccc) plasmid DNA which was removed using a 2 ml syringe and a 19 gauge needle through the side of the tube just below the band. The upper band contained chromosomal DNA, open circular (oc) and nicked forms of the plasmid. The ethidium bromide was then removed from the DNA by extraction with 5 M NaCl saturated 2-propanol several times, until the solution looked colourless. The DNA was ethanol-precipitated by adding 3 ml TE and twice the total volume of cold ethanol. The collected pellet was then dissolved in water or TE at a concentration of 1 mg ml<sup>-1</sup> and stored at 4°C.

## 2.17 AGAROSE GEL ELECTROPHORESIS

Agarose gels were run horizontally, essentially as described in Maniatis *et al.* (1983). They were made up and run <sup>submerged</sup> in 1 x TBE or TAE buffer normally at an agarose concentration of 0.8% w/v. Samples of 10 to 20 µl were mixed with one tenth their volume of STOP loading buffer before loading onto gels. Gels usually took 2-4 hours to run at a voltage gradient of 10 V cm<sup>-1</sup>, or overnight at 1 to 2.5 V cm<sup>-1</sup>, depending upon the resolution required and gel thickness. Gels were either run containing 0.5 µg ml<sup>-1</sup> ethidium bromide within the agarose, or stained after running in water or running buffer containing 10 µg ml<sup>-1</sup> ethidium bromide for 1 hour, (after the latter

1 hour destaining in buffer or water alone was required). The DNA was visualised by U.V. light at 300 nm from a transilluminator (Fotodyne Inc., Wisconsin). As a permanent record photographs were taken as soon as possible using a Polaroid MP-4 camera with type 55 film and a Kodak Wrattan filter.

## 2.18 DETERMINATION OF DNA CONCENTRATION

Concentrations were either determined using a Pye Unicam 5P6-500 U.V. spectrophotometer or via comparison with a known concentration of  $\lambda$  standard on an agarose gel.

The spectrophotometric method involved adding a known volume of the DNA sample (2 to 15  $\mu\text{l}$ ) to 1 ml of 0.2 M NaOH in a silica cuvette and taking absorbance readings at 260 nm, (making the assumption a reading of 1 corresponded to a DNA concentration of 50  $\mu\text{g ml}^{-1}$ ). More often the absorbance was measured at 260 and 280 nm, and, using a nomograph, the DNA content could be calculated more accurately and this also gave an indication of the protein content of the solution.

The agarose gel method involved running several wells of known volumes of the sample (usually 1 to 5  $\mu\text{l}$ ) alongside a known concentration of  $\lambda$  *Hind*III digest (2 to 5  $\mu\text{l}$ , depending upon the gel, at 0.2  $\mu\text{g } \mu\text{l}^{-1}$ ). Upon visualisation under U.V. the DNA concentration present can be estimated by direct comparison with the  $\lambda$  23 kb fragment (equivalent to approximately half the total  $\lambda$  loaded). Obviously, this method is not as precise as the spectrophotometric method but it uses less DNA.

## 2.19 SIZING DNA MOLECULES AND FRAGMENTS FROM AGAROSE GELS

DNA molecules were sized from agarose gels by comparison with the restriction patterns produced by bacteriophage  $\lambda$  or  $\phi$ X174 standards. *Hind*III restriction of bacteriophage  $\lambda$  producing 23.13, 9.42, 6.56, 4.36, 2.32, 2.03 and 0.56 kb fragments and *Hae*III restriction of bacteriophage  $\phi$ X174 producing 1.35, 1.08, 0.87, 0.6 and 0.31 kb fragments. Although not as accurate as the equation described by Southern (1979) the graphical method\* was faster and so easier, where accuracy was not so important.

\*Where the migration rates of the DNA molecules is proportional to the logarithms of the molecular weights.

## 2.20 SIZING PLASMIDS USING ELECTRON MICROSCOPY

Plasmids isolated from *D.grandis* were examined in an electron microscope (Siemens Elmiscope 101) using the protein film technique (Kleinschmidt 1968) as modified by Davis *et al.* (1971). Purified plasmid DNA was dissolved in 0.1 M Tris buffer pH 8.5 containing 0.01 M EDTA, 50% v/v formamide and 0.02% w/v cytochrome c. The contour lengths of the molecules were measured by photographic enlargement with a Ferranti digitiser using an Olivetti P6040 minicomputer. Plasmid pAT153, 4.37 kb, was used as an internal standard.

## 2.21 DIGESTION OF DNA WITH RESTRICTION ENZYMES

After Maniatis *et al.* (1983). Plasmid DNA was digested with various restriction endonucleases by taking approximately 0.2 to 2  $\mu$ l DNA in water and adding 0.5  $\mu$ l 5 mg ml<sup>-1</sup> BSA and 2  $\mu$ l of the appropriate 10 x enzyme buffer (both BSA and buffer stored at -20°C in small aliquots).

TABLE 2.5 10 X ENZYME BUFFERS

Buffer	NaCl	Tris.HCl pH 7.5	MgCl <sub>2</sub>	DTT
low salt buffer	0	10 mM	10 mM	1 mM
medium salt buffer	50 mM	10 mM	10 mM	1 mM
high salt buffer	100 mM	50 mM	10 mM	1 mM

Note *Sma*I, which was not used, requires a specific buffer.

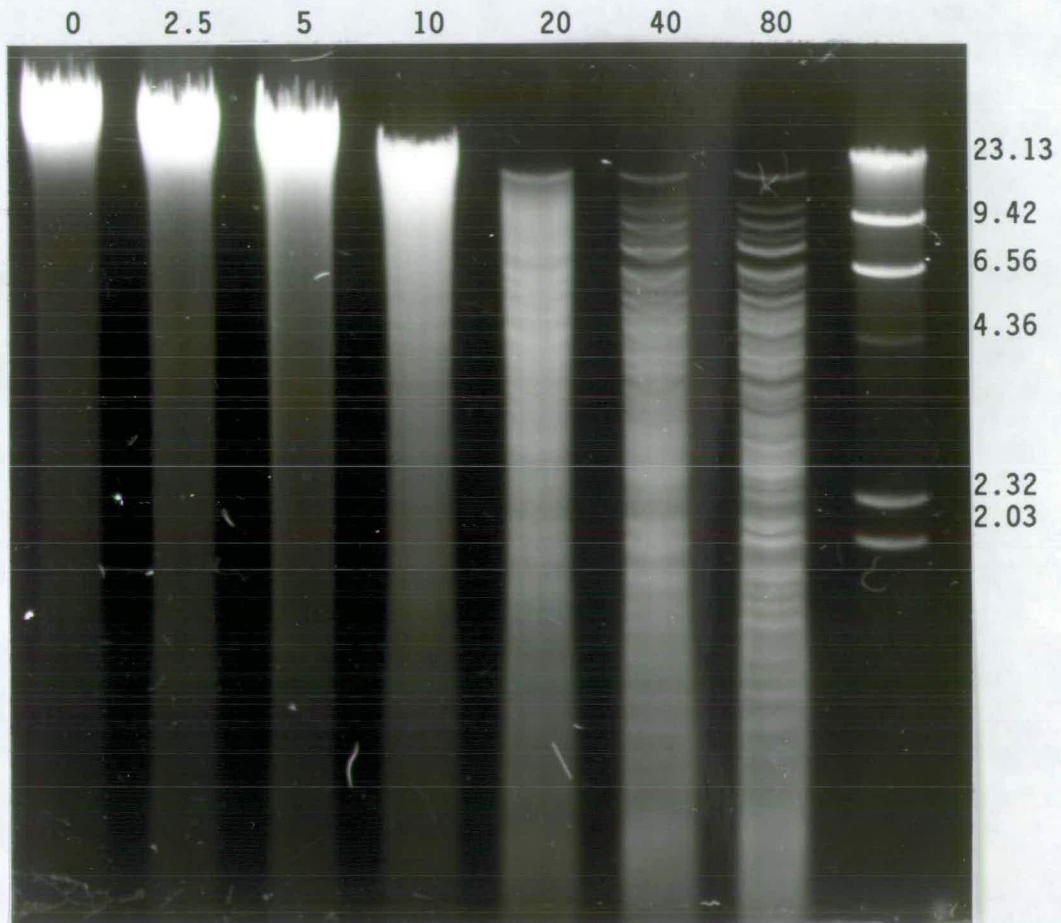
Sterile distilled water was then added to make a final volume of 20  $\mu$ l once 2 to 5 units of the enzyme were added. The enzyme was added and the solutions mixed and incubated at 37°C (unless specified otherwise on the enzyme instructions) for 3 to 4 hours. Checking for complete digestion was carried out by agarose gel electrophoresis (linear DNA moving slower than ccc plasmid DNA on 0.8% gels) and transformation into the appropriate host where possible. Mini preparations were incubated with RNase (1  $\mu$ l of 10 mg ml<sup>-1</sup> per 20  $\mu$ l total reaction mix).

Chromosomal digests were carried out involving larger quantities, 5 to 10  $\mu$ g, in reaction mixtures as above but of 100  $\mu$ l volume.

Partial chromosomal digests were carried out using a much higher DNA concentration of approximately 50  $\mu$ g per 100  $\mu$ l reaction mix, and was generally done by taking samples at various time intervals, (from 2.5 to 80 minutes in doubling steps), adding 0.1 volume STOP loading buffer and leaving on ice until all the samples were collected. An alternative method was used involving different amounts of enzyme from 0.02 to 2 units, again in doubling steps, for 1 hour at 37°C. Samples were then run on a gel (Figure 2.1). The conditions giving the appropriate size range were used to prepare

FIGURE 2.1 AGAROSE GEL ELECTROPHORESIS OF THE PRODUCTS OF PARTIAL DIGESTION OF *D.RADIODURANS* R1 DNA WITH *Mbo*I

Photograph showing partial digestion products on an 0.8% agarose gel, with  $\lambda$  *Hind*III molecular weight markers on right (sizes shown in kb). Samples were taken after, left to right, 0, 2.5, 5, 10, 20, 40 and 80 minutes from a reaction mix containing 1.25 units *Mbo*I per 100  $\mu$ l per 50  $\mu$ g of DNA.



more partially digested DNA for ligation mixtures.

Finally, all digests (other than those run immediately on a gel) were cleaned by two phenol treatments followed by chloroform treatment and ethanol precipitation.

## 2.22 PHOSPHATASE TREATMENT OF DNA

After Maniatis *et al.* (1983). Plasmid DNA involved in the construction of gene banks was treated with CIP to remove the 5' terminal phosphate groups produced by endonuclease digestion and so prevent re-circularisation without an insert in the ligation mixture.

The ethanol-precipitated DNA was resuspended in 44  $\mu\text{l}$  sterile water followed by the addition of 5  $\mu\text{l}$  10 x CIP buffer (0.5 M Tris.HCl pH 9.0, 10 mM  $\text{MgCl}_2$ , 1 mM  $\text{ZnCl}_2$ , 10 mM spermidine, made in aliquots using sterile components and stored at  $-20^\circ\text{C}$ ). One unit CIP (made fresh in water at 1 unit  $\text{ml}^{-1}$ ) was added to 2  $\mu\text{g}$  of DNA. After incubation at  $37^\circ\text{C}$  for 1 hour the reaction was stopped by adding 40  $\mu\text{l}$  sterile water and 10  $\mu\text{l}$  STE (100 mM Tris.Cl pH 8.0, 1 M NaCl, 10 mM EDTA) and 5  $\mu\text{l}$  10% w/v SDS and heating to  $65^\circ\text{C}$  for 15 minutes. The DNA was then cleaned by two phenol treatments, chloroform treatment and ethanol precipitation and checked for the removal of phosphatase groups by ligation and transformation into the appropriate host.

## 2.23 LIGATION OF DNA

As described in Maniatis *et al.* (1983). Precipitated DNA was resuspended in 39  $\mu\text{l}$  sterile distilled water and 5  $\mu\text{l}$  10 x ligation buffer (0.5 M Tris.HCl pH 7.4, 0.1 M  $\text{MgCl}_2$ , 0.1 M DTT, 10 mM

spermidine, 10 mM ATP, 1 mg ml<sup>-1</sup> BSA, made using sterile components and stored at -20°C). This was followed by the addition of 5 µl 20 mM ATP (in water, F/S and stored at -20°C) and 1 unit T<sub>4</sub> ligase. The mixture was then left overnight at room temperature before transformation into the host. If all the mixture was not used immediately it was cleaned before storage at 4°C as, if not, the transformation frequency was decreased.

Gene banks were made <sup>using</sup>  $\lambda$  plasmid:chromosome DNA ratios of 1:3, (found to be more successful than other ratios such as 3:1); containing a total DNA content per 50 µl ligation mix of approximately 2 to 5 µg. If more or less DNA was used the volume was altered accordingly.

## 2.24 FORMATION OF *D.RADIODURANS* GENE LIBRARIES

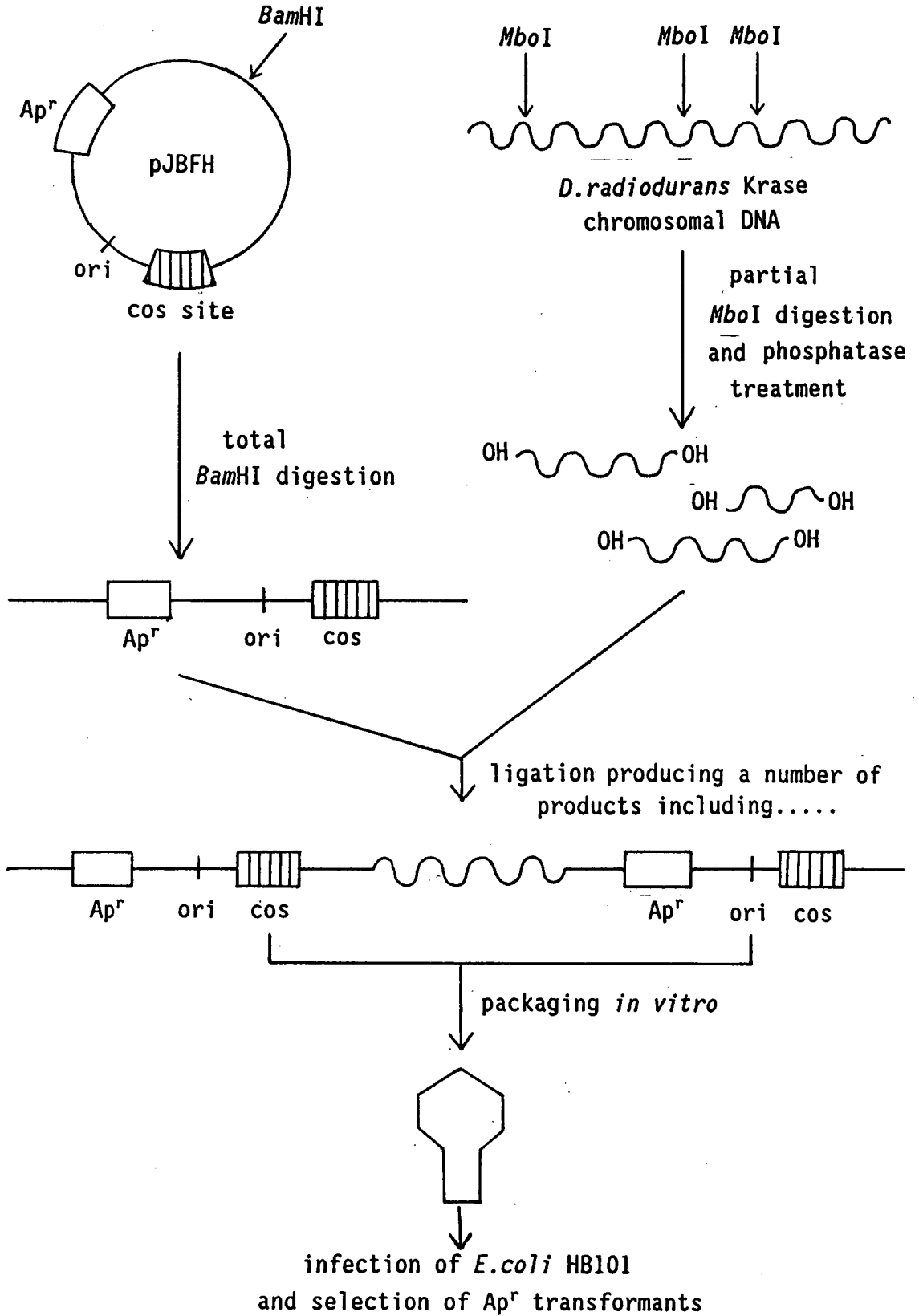
### (i) IN COSMID pJBFH

A gene library of *D.radiodurans* Krase in pJBFH was provided by Dr G.H. Al-Bakri, (now at the Department of Biology, College of Science, University of Basrah, Basrah, Iraq), in the form of 320 Ap<sup>r</sup> *E.coli* HB101 colonies which had been stored as in Section 2.25.

The cosmid vector pJBFH used was a 3.75 kb derivative of pJB8 (Ish-Horowicz and Burke 1981), made by a deletion of the *HpaI-AvaI* fragment. 10 µg was linearised by *Bam*HI and ligated to 10 µg partially *Mbo*I-digested, phosphatase-treated *D.radiodurans* Krase DNA, (prepared by 50 units *Bam*HI and 0.04 units *Mbo*I respectively, each for 1 hour at 37°C). The formation of the gene library is shown in Figure 2.2 (from Al-Bakri *et al.* 1985).

Cosmids are plasmids which contain bacteriophage  $\lambda$  cohesive ends (cos), (Collins and Hohn 1978), a very small region recognized by

FIGURE 2.2 CONSTRUCTION OF A GENE LIBRARY IN pJBFH



the  $\lambda$  packaging system. A length of DNA containing two cos sites in the correct orientation separated by 35 to 45 kb can be packaged *in vitro* into  $\lambda$  heads and transduced at high efficiency. Once inside the cell the cosmid circularises and behaves as a plasmid vector, being unable to enter the lytic cycle due to the lack of genes essential for this function. As the cos region and other essential plasmid genes are contained within a relatively small region the large insert size enables a gene library to be formed with relatively few colonies.

(ii) IN pAT153

Two gene libraries were made in the *E.coli* plasmid pAT153 using *D.radiodurans* UVS78 DNA digested with *Hind*III or partially digested with *Mbo*I. Chromosomal DNA was ligated to the vector previously digested with either *Hind*III or *Bam*HI, as appropriate, (Figure 2.3) using approximately 5  $\mu$ g of pAT153 and 15  $\mu$ g chromosomal DNA per gene library. Insertion into either site leads to inactivation of the Tc<sup>r</sup> gene, which can be used to assess cloning efficiency (insertional inactivation). However, as the vector was phosphatase treated to prevent recircularisation this was not necessary.

The vector pAT153 is a 3.6 kb, well characterised, high copy number derivative of pBR322, constructed by the deletion of two *Hae*II fragments (Twigg and Sherratt 1980).

(iii) IN pDR540

Two gene libraries were made in the expression vector pDR540, by inserting either *Bam*HI restricted DNA or *Mbo*I partially-digested DNA from *D.radiodurans* R1 into the unique *Bam*HI site (Figure 2.4). This

FIGURE 2.3 CONSTRUCTION OF A GENE LIBRARY IN pAT153

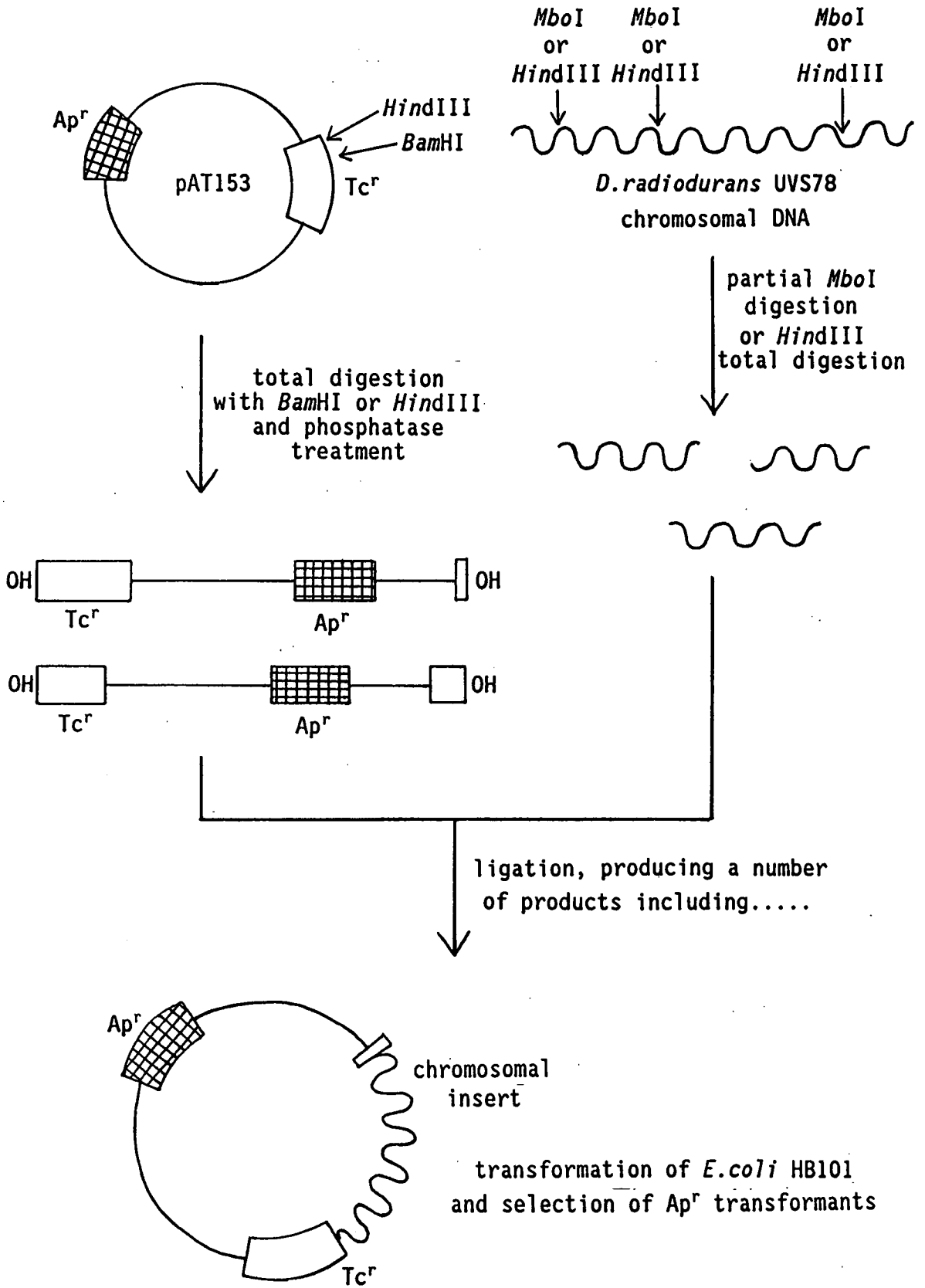
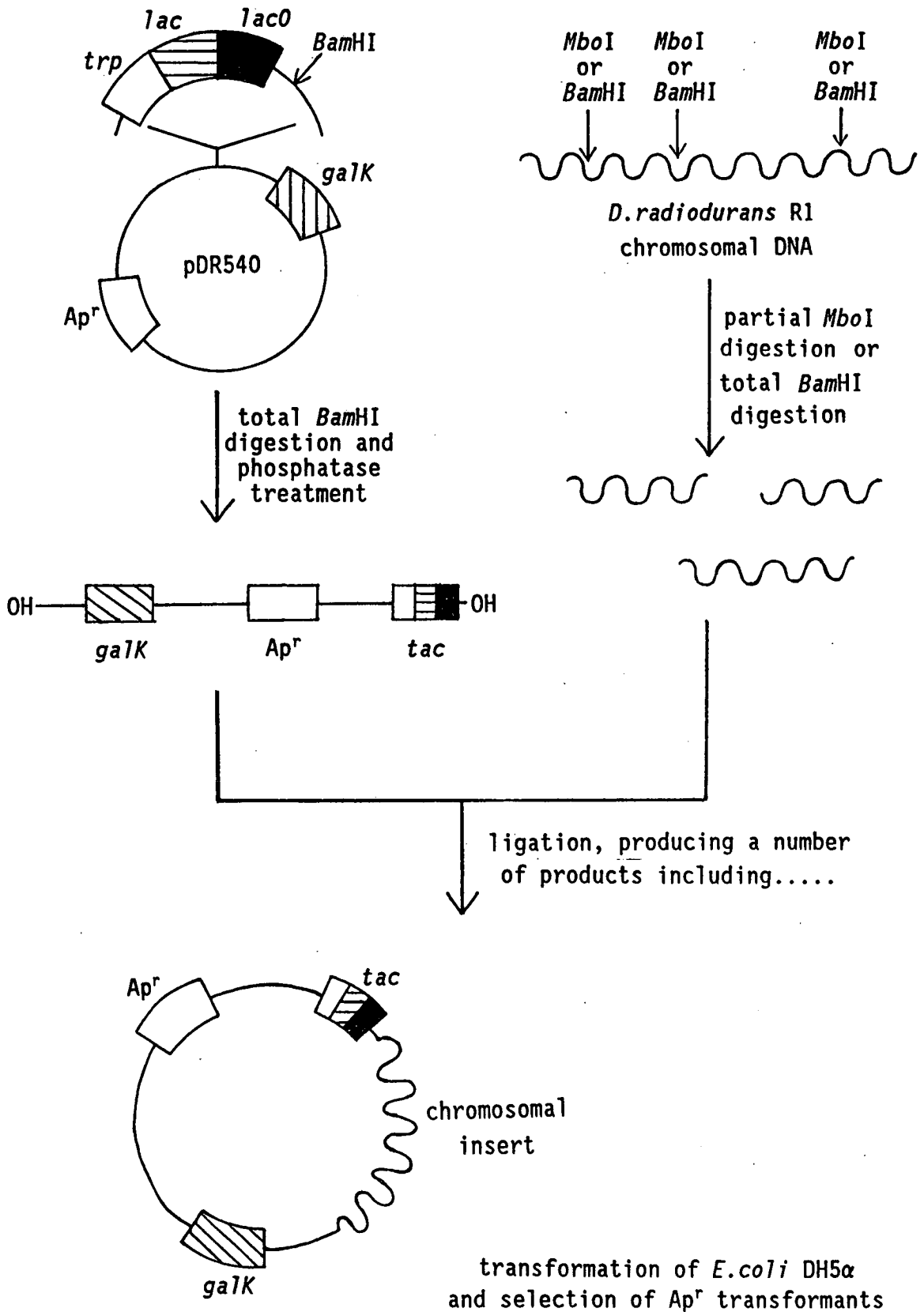


FIGURE 2.4 CONSTRUCTION OF A GENE LIBRARY IN pDR540



involved using approximately 10  $\mu$ g of pDR540 to 30  $\mu$ g of chromosomal DNA per gene library.

The plasmid pDR540 is a well characterised *E.coli* vector of 4 kb, containing the strong *tac* (or *trp-lac*) promoter comprised of the *trp* "minus 35" region and the *lac* UV-5 "minus 10" region. The *Bam*HI site is situated 35 bases downstream from the transcription initiation site and 5 bases downstream from the *lac* ribosome binding site.

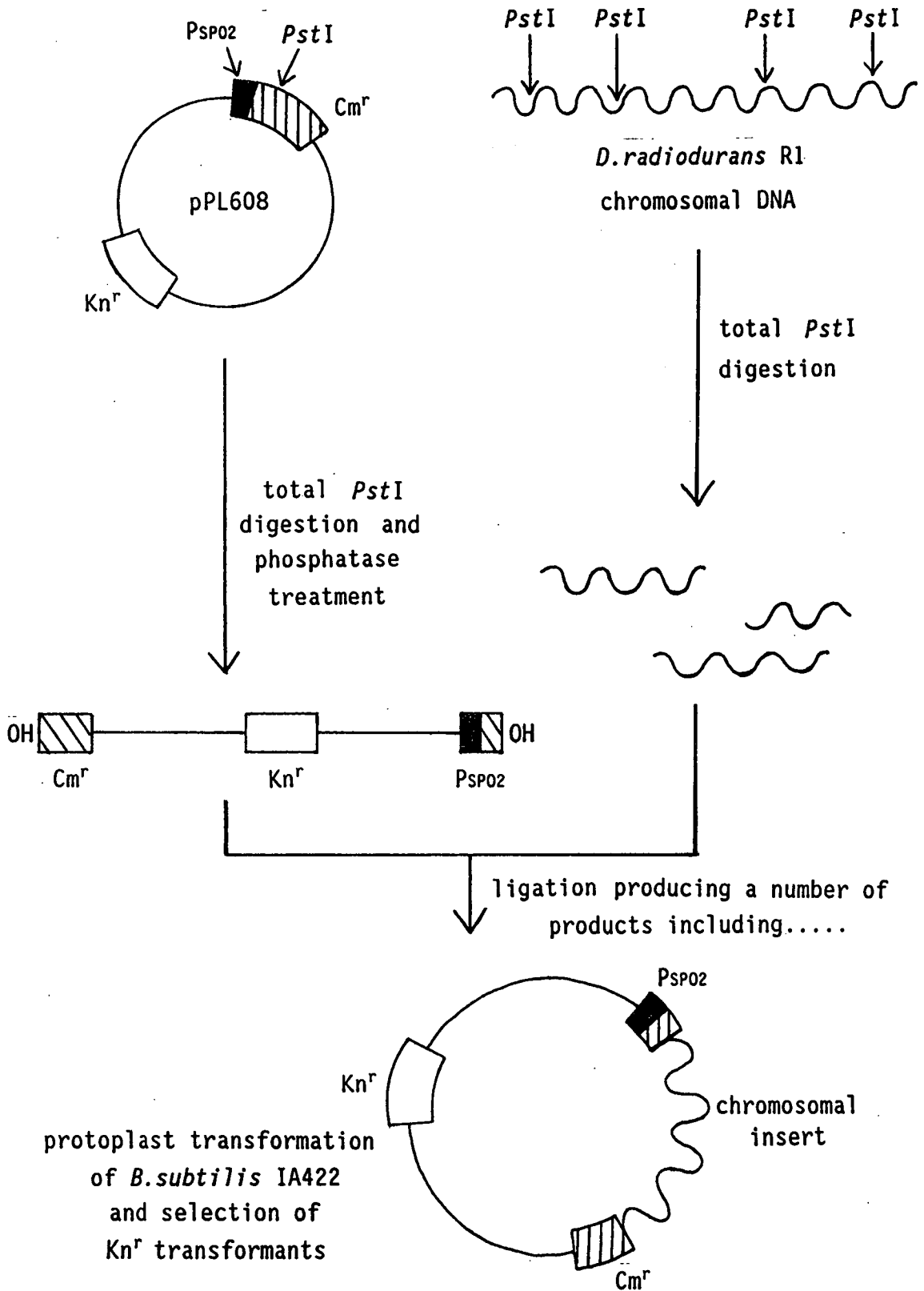
#### (iv) IN pPL608

One gene library was made in the *B.subtilis* expression vector pPL608, using *D.radiodurans* R1 DNA into the *Pst*I site (Figure 2.5), involving 10  $\mu$ g of pPL608 and 30  $\mu$ g of chromosomal DNA in total. The plasmid pPL608 is a 5.0 kb *B.subtilis* expression vector containing the strong SPO2 promoter (Yoneda *et al.* 1979). Inserts into sites within the Cm gene (either *Pst*I, *Xba*I and *Hind*III) can be expressed by read-through transcription from the bacteriophage promoter.

## 2.25 STORAGE OF COSMID LIBRARIES

After Maniatis *et al.* (1983). To keep the library viable it was stored in *E.coli* at -70°C as 8 x 40 separate colonies. The colonies were stored on nitrocellulose filters (HATF type, Millipore, 7cm diameter, SA 67120 Molsheim, France) on media containing 25% w/v glycerol. To revive the colonies the plates were defrosted and the nitrocellulose replica plated directly onto media or on to Whatman 3MM filters. The master nitrocellulose filters were replaced onto fresh plates and incubated for 2 hours before resealing and freezing as before.

FIGURE 2.5 CONSTRUCTION OF A GENE LIBRARY IN pPL608



## 2.26 DETERMINATION OF DNA SEQUENCE REPRESENTATION IN A GENOMIC LIBRARY

The exact probability of having any DNA sequence represented in the genomic library was calculated from the formulae

$$N = \frac{\ln(1 - P)}{\ln\left(1 - \frac{1}{f}\right)}$$

where P was the desired probability, f the fractional proportion of the genome in a single recombinant and N was the necessary number of recombinants (Clarke and Carbon 1976). For easy use the equation can be rearranged as

$$P = 1 - \left(1 - \frac{1}{f}\right)^N$$

In addition an assumption could be made that the length (x) of a required DNA segment was small in comparison with the length (L) of the inserts thus reducing the effects of random breaks occurring within length (x). The equation can therefore be modified to

$$f^* = \left(1 - \frac{x}{L}\right)f$$

with the  $f^*$  value including the effect of random breaks, these being particularly important if the size of the average cloned fragment is small.

## 2.27 SCREENING GENOMIC LIBRARIES

Bacterial populations containing the gene libraries were screened by direct methods. This selection was by phenotype based upon the suppression or either total or partial complementation of a mutation in the host by a cloned DNA fragment.

The cells containing the genomic libraries were initially selected on LB agar containing antibiotic (unless otherwise stated),

either 50  $\mu\text{g ml}^{-1}$  Ap for pAT153, pDR540 and pJBF8, or 10  $\mu\text{g ml}^{-1}$  Cm for pPL608. This was followed by replica plating onto agar containing the secondary selection pressure (either MMS, MTC, NQO, minimal media or X-gal). Alternatively, the cells were pooled from the LB antibiotic agar or grown in LB broth containing the antibiotic to produce a culture containing approximately  $1 \times 10^5$  c.f.u.  $\text{ml}^{-1}$  (or as stated) and spread onto LB agar plus secondary selection pressure. In both cases the plates were incubated overnight; if no growth appeared the plates were re-incubated for a stated period of time. In all cases likely clones were streaked onto their respective selective plates after initial isolation for confirmation by the growth of single colonies. In the case of likely recombination-proficient clones the U.V. resistance was determined.

In the case of *D. radiodurans* containing gene libraries screening only employed MTC selection and initially involved three days incubation.

(i) USING MMS

Concentrations of 0.05% w/v MMS (made immediately before use) were used to screen gene libraries contained within *E. coli* HB101, DH5 $\alpha$  or JC10289 (by replica plating) for the occurrence of recombinational ability as indicated by the restoration of MMS resistance. This approach has been used to clone a number of *recA*-like genes in *E. coli* HB101 from various micro-organisms, (including Better and Helinski 1983, Kokjohn and Miller 1985, Geoghegan and Houghton 1987 and Ramesar *et al.* 1988).

Strain JC10289 was also screened by plating cultures in LB

antibiotic broth onto LB agar containing MMS levels of 0.015 and 0.03%.

(ii) USING MTC

To screen the gene library constructed in *B.subtilis* IA422 for recombination proficiency (as indicated by MTC resistance) MTC levels of 0.02  $\mu\text{g ml}^{-1}$  in LB agar (made fresh) were used.

*D.radiodurans* rec30 and rec1 were also screened for MTC resistance using a concentration of 0.01 or 0.03  $\mu\text{g ml}^{-1}$  respectively in TGY agar. In this case no primary antibiotic screening was employed and the bacteria were plated from a TGY broth culture containing approximately  $1 \times 10^6$  c.f.u.  $\text{ml}^{-1}$ .

(iii) USING NQO

NQO has also been used in the isolation of genes similar to *recA* (Keener *et al.* 1984) from gene libraries contained in *E.coli* HB101; again, resistance indicates recombinational ability. In this study libraries were screened in JC10289 by replica plating on NQO levels of 10  $\mu\text{g ml}^{-1}$  in LB agar.

(iv) USING MINIMAL MEDIA

As a control the gene libraries were tested for restoration of a wild-type phenotype by allowing growth on minimal media containing no leucine supplement (after washing in minimal media broth). This was done using *E.coli* HB101 (*leuB*) or DH5 $\alpha$  (*leu* deletion) and *B.subtilis* IA422 (*leuB6*). It is known that the *D.radiodurans leuB* gene is expressed in *E.coli* (Al-Bakri *et al.* 1985) and so is a useful indicator of cloning efficiency.

(v) USING X-GAL

Gene libraries made in *E.coli* vectors were transferred to *E.coli* JC14604, which contains two defective copies of the lactose operon. This specially constructed duplication (Konrad 1977) contains *lacMS286*, having a small deletion in the proximal portion of the *lacZ* gene, and  $\phi$ 80dII*lacBK1*, deleted in the distal portion of the *lacZ* gene. The strain itself is Lac<sup>-</sup> but Lac<sup>+</sup> cells can arise by recombination if a functional recombination gene is inserted. This was easily indicated by the presence of a blue colour after overnight growth on LB agar containing X-gal and IPTG, (or using a X-gal and IPTG containing overlay). The LB was made up containing per 100 ml 0.2 ml X-gal (2% w/v in DMSO, stored at -70°C) and 1 ml IPTG (100 mM in water, F/S, stored at -70°C), where the X-gal acts as the substrate and colour indicator and IPTG the *lac* inducer.

2.28 POLYACRYLAMIDE GEL ELECTROPHORESIS (SDS-PAGE)

One dimensional SDS-PAGE gels (10%) were run to separate proteins (as in Hames 1981) from cell extracts prior to Western blotting. Constructed between 4 mm thick glass plates 180 mm x 200 mm (separated by 1.5 mm perspex spacers and sealed with paraffin), the gel was poured in two parts. The bottom (resolving) gel consisted of the following solutions (stored at 4°C), mixed in the order indicated by swirling the solutions together to limit the amount of oxygen added to the liquid.

resolving gel buffer (4 x)	10 ml
distilled water	16.4 ml
ammonium(NH <sub>4</sub> )persulphate (APS), less than 2 weeks old, 100 mg ml <sup>-1</sup>	0.253 ml (continued)

acrylamide:bisacrylamide (30%:0.8% w/v)	13.3 ml
TEMED	0.04 ml

Once poured, the resolving gel was covered with water saturated 1-butanol to form a smooth surface and the gel left to set for up to 18 hours. Shortly before use the 1-butanol was totally removed by washing with water, draining the water and the resolving gel was overlaid with the top (stacking) gel. This consisted of a 5% acrylamide gel, made using the following solutions, again mixed in the order indicated.

stacking gel buffer (4 x)	3.3 ml
distilled water	7.8 ml
APS (100 mg ml <sup>-1</sup> )	0.04 ml
acrylamide:bisacrylamide (30%:0.8% w/v)	2.19 ml
TEMED	0.0133 ml

A comb of 20 wells was then immediately inserted. Once set it was removed along with the bottom spacer, the gel fixed in place on the running apparatus, 1 x running buffer added and the wells thoroughly washed in the buffer using a 10 ml syringe and needle. The gels were immediately loaded (including protein molecular weight markers obtained from Bio-Rad Laboratories Ltd., Watford, Hertfordshire) and run at a voltage of 10 to 15 V cm<sup>-1</sup> over 3 to 4 hours.

## 2.29 VISUALISATION OF PROTEINS ON SDS-PAGE

The gel was removed from the glass plates, the stacking gel discarded and the resolving gel placed in PAGE blue 83 stain, 2 g ml<sup>-1</sup> in destain (20% v/v methanol, 7.5% v/v glacial acetic acid), and left overnight with gentle agitation. The stain was then

tipped off back into the bottle for re-use and the gel placed in destain, again with gentle agitation, until the gel background was clear, leaving the proteins blue. This required several changes of destain, (over approximately 12 hours), which were not discarded but filtered through a 3MM Whatman filter containing powdered activated charcoal to remove the PAGE blue 83. To keep a permanent record the gel was dried under vacuum onto 3MM Whatman filter paper.

### 2.30 PREPARATION OF TOTAL CELL PROTEINS FOR SDS-PAGE

The cells from 10 ml of stationary phase culture were collected, washed in 0.5 ml PB buffer, and resuspended in 100  $\mu$ l 2 x Laemmli sample buffer

6.25 ml 0.5 M Tris.HCl, pH 6.8

2 g SDS

9 ml glycerol

5 ml mercaptoethanol

1 ml 0.1% w/v bromophenol blue

distilled water to 50 ml.

The suspensions were then immediately placed in a boiling water bath for 3 minutes, centrifuged, and the supernatant removed to a fresh tube. If the supernate was too viscous it was diluted by adding more sample buffer. The protein solution was then used immediately or stored at -20°C. After storing the solutions were re-boiled from frozen and spun before use.

A rough idea of the protein concentration was then determined by spotting 2  $\mu$ l of each sample onto a 3MM Whatman filter paper in an empty Petri dish (to avoid protein contamination from fingers). The filter was air dried and then flooded with 10% w/v TCA to fix the

spots. The excess was removed and the filter air dried again before staining with PAGE blue 83 and destaining with destain (20% v/v methanol, 7.5% v/v glacial acetic acid) for a few minutes. The amount of protein within each sample could then be easily seen and compared allowing even loading on to the gel. The amounts loaded varied from 5  $\mu$ l for *E.coli* to up to 75  $\mu$ l for *D.radiodurans*, depending upon the extract source.

### 2.31 WESTERN BLOTTING

The Western blotting procedure used originated from Towbin *et al.* (1979), essentially modified as in the technical publication by Amersham (1988), (supplied with Hybond-H). The proteins were separated on an SDS-PAGE gel, the stacking gel discarded and the bottom left hand corner of the resolving gel marked. Without trapping any air bubbles the following components were then fitted together in order, after having been soaked for 5 minutes in 1 x transfer buffer (10 x stock being 250 mM Tris.HCl pH 8.3, 1.5 M glycine).

transfer tank holder

transfer tank sponge

3MM Whatman filter paper

nylon membrane (Hybond-H obtained from Amersham International plc., Bucks., cut to the same size as the gel)

SDS-PAGE gel

3MM Whatman filter paper

transfer tank sponge

transfer tank holder

This 'sandwich' was then placed in the transfer tank

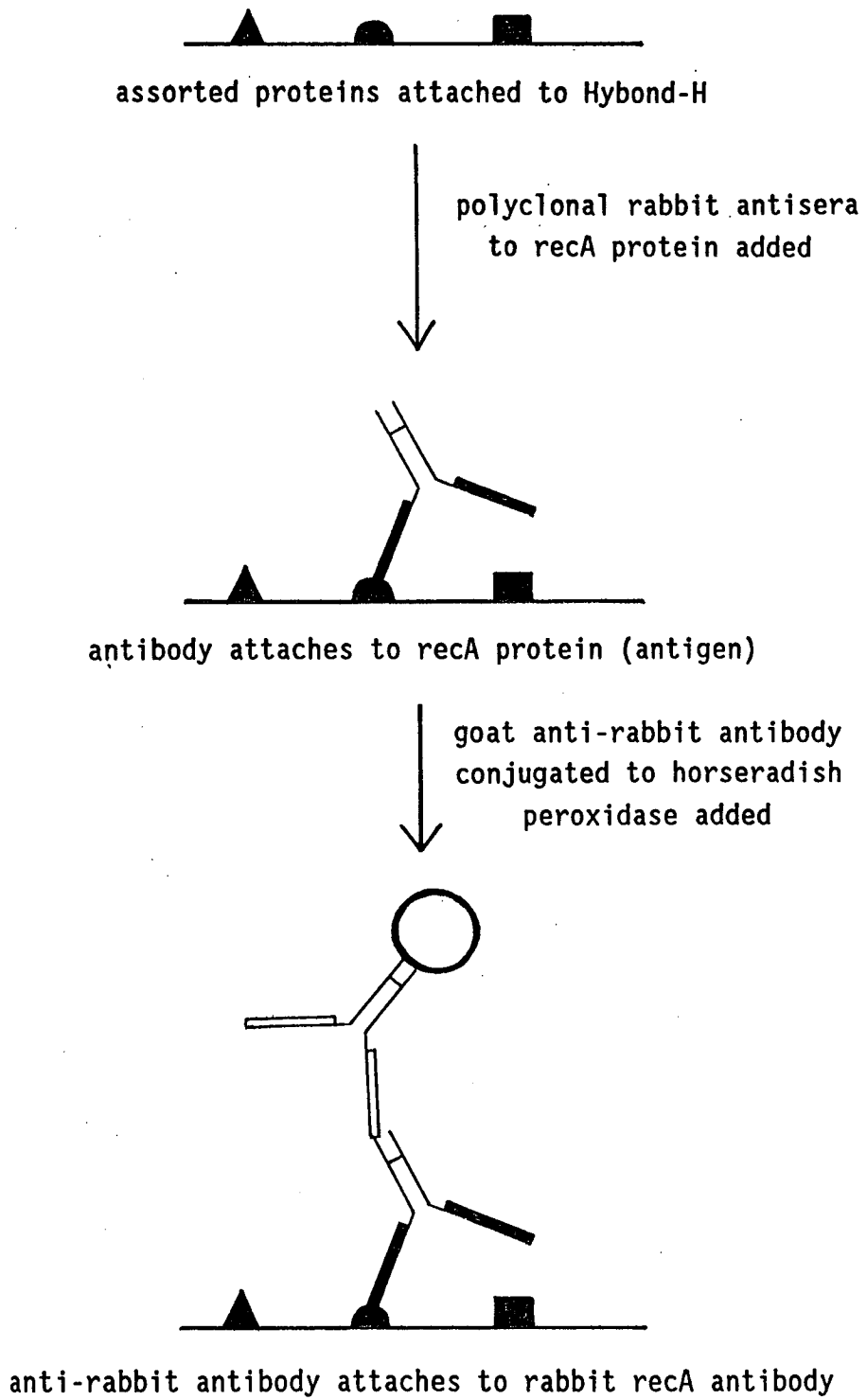
(2005 Transphor, LKB Instruments Ltd., South Croydon, Surrey) filled with 5 l 1 x transfer buffer, making sure the gel was nearest to the negative terminal. The proteins were then transferred for approximately 2 hours at 1 to 1.5 amps.

After this time the gel and membrane were removed, the gel was stained and destained to check the transfer efficiency of the proteins and the membrane was treated for antibody detection.

## 2.32 ANTIBODY DETECTION OF PROTEINS

Proteins were detected essentially as described by Glass *et al.* (1981), modified by Johnson *et al.* (1984), (Figure 2.6). Immediately after Western blotting the nylon membrane was placed in 100 ml 20% w/v skim milk powder (Oxoid) in TBS (10 mM Tris.HCl pH 7.5, 150 mM NaCl) and left overnight shaking gently to block the unbound sites on the membrane. The membrane was then placed in 20 to 40 ml 5% w/v skim milk powder in TBS and 30  $\mu$ l polyclonal rabbit antisera to *E.coli* RecA added, (a gift from Dr Roger Cox, MRC Radiobiology Unit, Harwell, Oxon). After 5 hours shaking gently the milk solution was tipped off and the membrane washed, again with gentle shaking, four times for 5 minutes each in TBS. To allow visualisation of the bound RecA antibody 20 to 40 ml of 5% w/v skim milk powder in TBS was added to the membrane followed by 10  $\mu$ l of horseradish peroxidase-conjugated anti-rabbit antibody (Western blotting grade, affinity purified goat anti-rabbit IgG[H+L] horseradish peroxidase conjugate, obtained from Bio-Rad Laboratories Ltd., Watford, Hertfordshire). After 2 hours shaking gently the milk solution was tipped off and the membrane washed, again with gentle shaking, four times for 5 minutes each in TBS, before discarding the TBS and

FIGURE 2.6 VISUALISATION OF PROTEINS ON WESTERN BLOTS



immediately adding the following solution made up in a test tube;

0.5 ml dianisidine (Sigma), 5 mg ml<sup>-1</sup>, made fresh

1 ml 0.1 M imidazole, pH 7.4

0.1 ml 30% v/v fresh H<sub>2</sub>O<sub>2</sub>

8.4 ml distilled water

The membrane and above solution were agitated gently by hand, watching for a brown colour to develop. Immediately this occurred the membrane was flooded with distilled water, left for 15 minutes, air dried and protected from light to prevent the colour fading. As soon as possible a photograph was taken as a more permanent record. The brown colour was formed by the hydrogen peroxide acting as the membrane substrate for the horseradish peroxidase and dianisidine and imidazole acting as electron donors. This reaction produces a brown, highly insoluble product.

### 2.33 NICK TRANSLATION

Plasmid pDR1453, (derived from pLC18-42 Clarke and Carbon (1976) by deletion of 6.3, 3 and 1.2 kb *Pst*I fragments, Dr S. Sedgwick, personal communication) was used as a probe for homology between *E.coli recA* and *D.radiodurans* DNA. This 12.9 kb plasmid contains *recA*, *srl* and some upstream regions inserted into the *Pst*I site of pBR322. One  $\mu$ g was nick translated using the method of Rigby et al. (1977) using a BRL nick translation kit.

The reaction mix containing the labelled probe was passed through a column formed by 10 g Sephadex G-75 in TNE. This was made by gently rinsing the Sephadex four times in 500 ml distilled water, allowing the Sephadex to fall out of solution each time, and finally resuspending in 500 ml 1 x TNE and autoclaving. Five ml 10 mg ml<sup>-1</sup>

low molecular weight DNA in 1 x TNE was added, mixed, and enough solution packed into a 10 ml plastic pipette with the top broken off to form a 5 ml column. The passage of the ( $\alpha$ -<sup>32</sup>P)dCTP labelled DNA through the column was followed by a Geiger counter, allowing collection of the appropriate fraction at the bottom. A sample of the labelled probe was taken to determine the incorporation.

#### 2.34 SOUTHERN TRANSFER

Southern transfer was carried out as Smith *et al.* (1988). Agarose gels of 0.8% w/v were run containing 50 to 200 ng of plasmid and 1.5  $\mu$ g chromosomal *D. radiodurans* DNA. The stained gel was photographed and soaked in several volumes of 0.4 M NaOH for 1 hour with occasional shaking. Whatman 3MM paper was placed over a solid support, upon which the gel rested, with 2 ends into a tray to act as a wick. The tray was filled with approximately 1 l 0.4 M NaOH, almost to the top of the support, and the gel placed face down onto the 3MM paper. Gene Screen-Plus (New England Nuclear Corp., Boston, Mass.) was placed over the gel, after marking a corner and wetting in distilled water, and was covered by 2 pieces of wet Whatmann 3MM paper, ensuring that no air bubbles had been formed. A stack (10 cm high) of paper towels was placed over the 3MM paper and weighted down for 12 to 24 hours. The gel was checked for transfer of DNA and discarded. The gel slots were marked on the filter using a soft pencil and the gel was transferred to 200 ml 10 x SSC containing 0.2 M Tris.HCl pH 8.0 for 5 minutes before air drying and covering until hybridisation.

## 2.35 HYBRIDISATION OF SOUTHERN FILTERS

As described in Smith *et al.* (1988). The dry filter was slipped into a heat-sealable plastic bag and 15 ml prehybridisation fluid was added. Prehybridisation fluid contained the following solutions, mixed by gentle heating below 37°C.

150 ml 20 x SSC

50 ml 50 x Denhardt's Solution (see below)

5 ml 10 mg ml<sup>-1</sup> yeast t-RNA

250 ml formamide

50 ml 10% SDS (F/S)

12.5 ml 2 M Tris.HCl pH 8.0

distilled water to 500 ml

Denhardt's solution was composed of 5 g Ficoll, 5 g polyvinyl pyrrolidone, 5 g BSA and water to 500 ml. This solution was F/S and stored at -20°C.

After adding the prehybridisation fluid as much air as possible was removed and the bag sealed and incubated for 24 hours on a rotary shaker at 37°C. The solution was then discarded from the bag, and hybridisation solution (not less than  $5 \times 10^5$  c.p.m. ml<sup>-1</sup>, ideally between  $5 \times 10^7$  and  $1.5 \times 10^8$ ) and enough prehybridisation fluid to wet the filter was added. The bag was again sealed and incubated overnight at 37°C on a rotary shaker. The filter was washed three times by submerging and gently shaking in 2 x SSC containing 0.5% SDS for 15 minutes each at 42°C, and transferred to 0.1 x SSC containing 0.1% SDS for 1 hour at a variable temperature depending upon the homology between the probe and probed DNA (starting at 42°C). The filter was briefly air dried, wrapped in cling film and exposed to X-ray film for a variable period of time

at -70°C. If the 1 hour washing was not strict enough it was repeated at a higher temperature to remove more probe from the filter in approximately 8°C steps.

### 2.36 EXPOSURE OF *D. RADIODURANS* TO DNA-DAMAGING CHEMICALS

Overnight cultures were diluted 1 ml to 20 ml TGY broth and grown to a turbidity of 30 to 40 (approximately  $1 \times 10^8$  viable units  $\text{ml}^{-1}$  in exponential phase). Samples of the cultures were centrifuged at 4,000 g for 10 minutes and then treated as below.

#### (i) MTC OR MMS TREATMENT

The culture was resuspended in an equal volume of TGY broth and MTC or MMS was added to the required concentration. If necessary, the mixture was then incubated at 30°C in a shaking water bath for the required period of time. Samples were taken at intervals, appropriately diluted, plated out and the surviving fractions calculated as usual.

#### (ii) MNNG TREATMENT

This treatment was used to prepare mutated populations for screening. The culture was washed and resuspended in the same volume of PB buffer. MNNG (in PB at  $1 \text{ mg ml}^{-1}$ , F/S and stored at -20°C in aliquots until use) was added to a final concentration of  $20 \mu\text{g ml}^{-1}$  and the mixture incubated at 30°C for 45 minutes in a shaking water bath. 0.2 ml of this mixture was then added to 20 ml of TGY broth and incubated overnight at 30°C. Glycerol was added to 20% v/v and the mixture stored in aliquots at -70°C until use. The mutation induction rate was determined by comparing a treated and non-treated

culture total viable counts and viable counts from TGY agar containing  $20 \mu\text{g ml}^{-1}$  Rf.

## 2.37 EXPOSURE OF CELLS TO IRRADIATION

### (i) U.V.

Cultures were prepared as for DNA damaging agents, washed, resuspended in the same volume of PB buffer and irradiated with 254 nm U.V. light from a Hanovia germicidal lamp (Hanovia Lamps Ltd., Slough, Bucks) at a dose rate of  $1.05 \text{ Jm}^{-2} \text{ sec}^{-1}$ . For the measurement of survival and mutation rates 10 ml of the suspension was irradiated in a glass Petri dish, with stirring. Smaller volumes were irradiated in 5 cm diameter glass dishes, also with stirring. Samples were taken at intervals, appropriately diluted and plated out and the surviving fractions were calculated as usual.

A quick, simple method to compare U.V. survival levels was also used. This involved streaking cells across an appropriate agar plate and exposing the streaks to different levels of U.V. irradiation by covering the plate in a number of steps (for example, after 0, 2, 4, 8 and 16 minutes U.V.). After incubation the relative resistance can be easily seen.

### (ii) GAMMA

Cultures were prepared as for DNA damaging agents, washed and resuspended in the same volume of PB. The cells were then irradiated (using a cobalt-60 source at  $1.06 \text{ krad min}^{-1}$ ) in 3 ml aliquots with oxygen bubbling through.

## 2.38 ALKALINE SUCROSE GRADIENTS

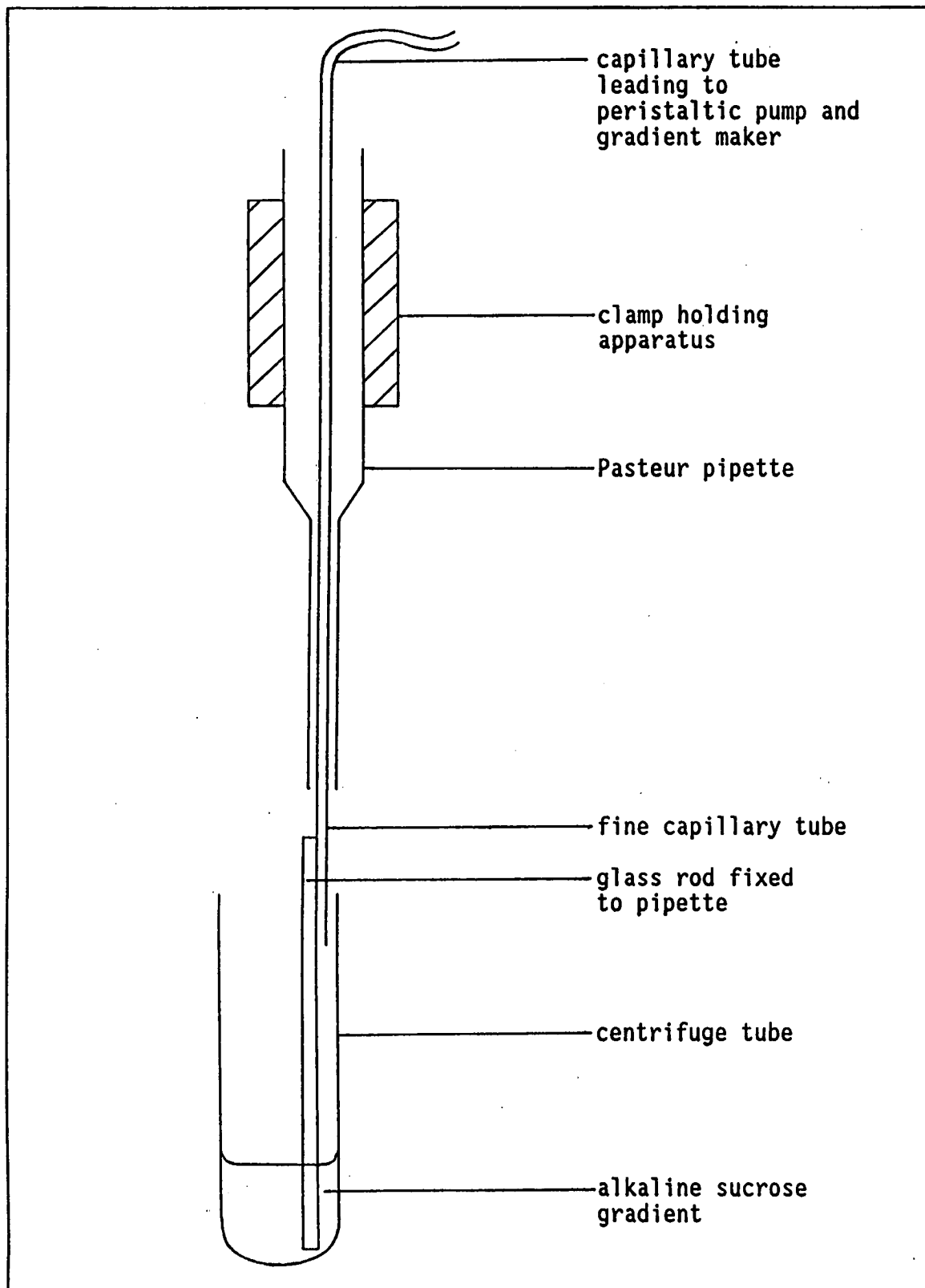
Alkaline sucrose gradients were constructed, the cells prepared for and the gradients analysed essentially by the method of Evans (1984) after McGrath and Williams (1966). Gradients of 4.5 ml were made in 5.5 ml polypropylene tubes. A shelf of 200  $\mu$ l 40% w/v sucrose in NNE (0.7 M NaCl, 0.3 M NaOH, 1 mM EDTA) was placed in the bottom of the tube. A linear gradient of 5 to 20% w/v sucrose in NNE (using 2.25 ml of each) was constructed on top of this using a gradient maker and peristaltic pump, the gradient was added to the tube in a smooth flow using a glass rod (Figure 2.7). The gradient was carefully overlaid in the centre with 0.2 ml 0.5 M NaOH followed by PEB buffer containing approximately  $10^7$  cells.

## 2.39 PREPARATION OF CELLS FOR ALKALINE SUCROSE GRADIENTS

To label DNA, 500  $\mu$ l of an exponential culture of turbidity 30 to 50 was added to approximately 15  $\mu$ l  $^3\text{HdThd}$  followed by incubation. To label the total or parental DNA the cells were incubated overnight, to label DNA produced after irradiation the cells were irradiated as usual, 500  $\mu$ l removed, resuspended in TGY and added to  $^3\text{HdThd}$  and incubated for the required period.

Once the required labelling time had elapsed, 200  $\mu$ l was taken and resuspended in 100  $\mu$ l BSPEB and left on ice for 4 minutes. The cells were again collected and resuspended in 100  $\mu$ l lysozyme (0.5 mg ml<sup>-1</sup> in PEB) and incubated at 37°C for 25 minutes before carefully adding 50 to 100  $\mu$ l to the centre of the top of a sucrose gradient.

FIGURE 2.7 APPARATUS FOR LOADING ALKALINE SUCROSE GRADIENTS  
INTO CENTRIFUGE TUBES



## 2.40 MEASUREMENT OF $^3\text{HdThd}$ UPTAKE

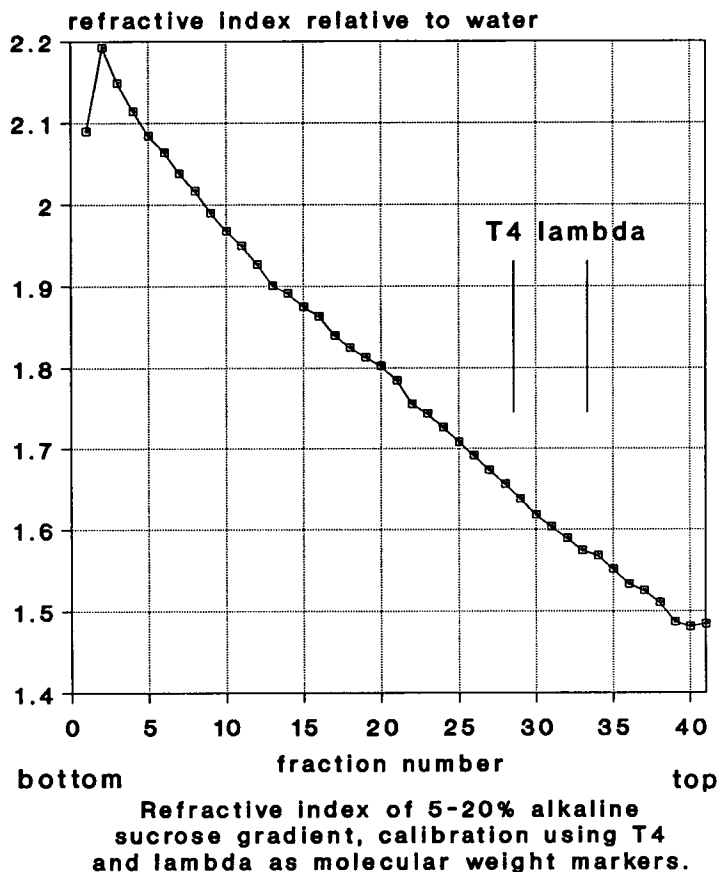
500  $\mu\text{l}$  exponential culture (treated as required) was added to 15  $\mu\text{l}$   $^3\text{HdThd}$ , incubated and 10  $\mu\text{l}$  samples were taken at appropriate intervals directly onto Whatman IMM discs 2 cm in diameter. The discs were air dried and each washed twice in 10 ml 5% w/v TCA for at least 10 minutes followed by two treatments with ethanol at  $-20^\circ\text{C}$ . After air drying again the discs were counted for  $^3\text{HdThd}$  as for analysis of sucrose gradients.

A total of at least 5000 c.p.m. were considered to be required per gradient; total counts loaded were measured by placing 50  $\mu\text{l}$  of the cell suspension onto a Whatman 3MM disc of diameter 2 cm, followed by treatment as above.

## 2.41 ANALYSIS OF SUCROSE GRADIENTS

The gradients were immediately centrifuged for 105 minutes at 30,000 rpm in a MSE 6 x 5.5 ml swing out rotor at  $18^\circ\text{C}$ . Fractions were collected from the gradients by careful insertion of a fine capillary through the centre of the gradient to the bottom of the tube, the capillary being held steady in a pasteur pipette (similar to the gradient construction apparatus). The gradient was pumped out using a peristaltic pump and dripped onto Whatman 3MM chromatography paper strips, marked at 1 inch intervals, (approximately 125  $\mu\text{l}$  per 1 inch square segment). The strips were dried and washed in two changes of 5% w/v TCA at  $4^\circ\text{C}$  for 20 minutes each, followed by two changes of ethanol at  $-20^\circ\text{C}$  before air drying. The squares were cut up and each placed in a scintillation vial with 10 ml of a toluene based scintillant (NE233, Nuclear Enterprises, Sighthill, Edinburgh) for radioactivity determination in a Beckman LS100C scintillation

**FIGURE 2.8 SUCROSE GRADIENT CALIBRATION**



counter. The linearity of the gradients was determined by measuring the refractive index of fractions in an Abbe 60 Refractometer (Bellingham and Stanley Ltd., England) and is shown in Figure 2.8.

#### 2.42 CALCULATION OF THE MOLECULAR WEIGHT OF DNA FROM ALKALINE SUCROSE GRADIENTS

To calculate the molecular weight of *D. radiodurans* DNA in any fraction the gradients were calibrated using DNA of a known size, bacteriophage T4 and  $\lambda$  (where the molecular weight of one strand is  $6 \times 10^7$  and  $1.7 \times 10^7$  daltons respectively). The distance this DNA travels in the gradient allows the calculation of the constant  $\beta$  in the formula -

$$B = \frac{S D}{\text{rpm}^2 h} \quad \text{equation 1 (Evans 1984)}$$

where S is the sedimentation coefficient of the DNA, D the distance travelled (the number of fractions the DNA has moved from the top of the gradient), rpm the rotor speed and h the centrifugation time. When B is known substitution of the distance travelled by DNA of unknown size gives a value of S which is related to the molecular weight (MW) by equation 2 from Studier (1965) and Korba *et al.* (1981).

$$S = 0.0528 (MW^{0.41}) \quad \text{equation 2}$$

The values of B made in this way are only correct if an estimate of the starting fraction of the gradient is made. This can be determined accurately by using two MW markers, since the distance they travel from the top of the effective gradient is different by a theoretical constant factor k, which, calculated from equations 1 and 2 is 1.677 (that is  $1.677 = D_{T4} + D_{\lambda}$ ). By comparing the number of fractions the standards moved through from the top of the gradient, using increasing distances from the top of the gradient as the start point of the measurement, the value of k changes, (Figure 2.8, where T<sub>4</sub> is found in fraction 29 and λ in fraction 33, having moved 12 and 8 fractions respectively). If the top two fractions are ignored in calculations (or  $D_{T4} + D_{\lambda} = 10 + 6$ ) then  $k = 1.667$  which is closest to the theoretical value obtainable.

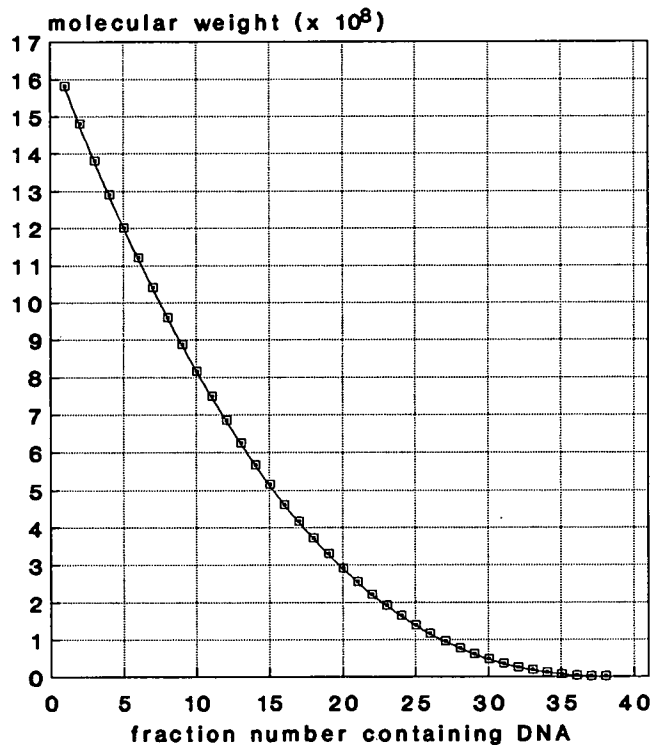
Once the true start point of the gradient is known the value of B can be calculated from each standard and an average obtained. B is then used to calculate the MW that corresponds to each gradient fraction by rearranging equation 1 and 2

$$MW = \{(116.522 D)^{1+0.41}\}^2$$

where D is the fraction number from the top of the effective gradient. Figure 2.9 shows the molecular weight of DNA found in each fraction, calculated using the above formulae.

The DNA sediments over a wide range of fractions and a measure of the average MW must be obtained either as the "weight average molecular weight" ( $MW_w$ ) or the "number average molecular weight" ( $MW_n$ ) (Lett 1981).  $MW_n$  is required for the estimation of the number of strand breaks but is sensitive to errors introduced by the inherent difficulties of measuring accurate molecular weights and distances in the upper part of the gradients.  $MW_w$  is less sensitive

**FIGURE 2.9 MOLECULAR WEIGHT OF DNA FOUND IN EACH SUCROSE GRADIENT FRACTION**



to errors and  $MW_n$  can be obtained from the relationship  $MW_w = 2MW_n$ , which should apply for random size distribution of DNA. However, the relationship does not hold for heavier distributions of DNA which

should be nearest to  $MW_w = 2MW_n$  and so  $MW_n$  was calculated directly from equation 3

$$MW_n = \frac{\sum W_i}{\sum W_i / \sum MW_i} \quad \text{equation 3}$$

where  $W_i$  is the weight of DNA in the fraction (or the % of total radioactivity) and  $MW_i$  the molecular weight which corresponds to that fraction.

#### 2.43 BACTERIOPHAGE TITRES

A serial dilution of the bacteriophage was made in SMO buffer, 0.1 ml of the dilutions was mixed with 0.1 ml of the appropriate *E.coli* strain resuspended in LB broth (B/C2) or TYM broth (CSH25). The indicator strain used for bacteriophage T<sub>4</sub> was *E.coli* B/C2 grown in LB, for bacteriophage  $\lambda$  *E.coli* CSH25 grown in TYM (as bacteriophage originally prepared from *E.coli* D5683 contains a lysis mutation which is suppressed by an amber suppressor mutation in *E.coli* CSH25). The bacteriophage-strain mixtures were incubated at 37°C for 15 minutes before adding 2.5 ml of sloppy LB at 46°C, and, after mixing well, poured onto LB agar plates pre-warmed to 37°C. After incubation overnight at 37°C the multiplicity of infection (m.o.i.) could be determined.

#### 2.44 PREPARATION OF LABELLED BACTERIOPHAGE T<sub>4</sub> DNA

Evans (1984). 3 ml of an overnight culture of *E.coli* B/C2/LT, grown in M9 containing 3  $\mu\text{g ml}^{-1}$  thymine, was used to inoculate 300 ml of M9 containing 37 kBq  $\text{ml}^{-1}$  (1  $\mu\text{Ci ml}^{-1}$ ) of <sup>3</sup>HdThd. The culture was grown to an A<sub>600</sub> of 0.5 (approximately 1 x 10<sup>9</sup> viable cells  $\text{ml}^{-1}$ ) and bacteriophage T<sub>4</sub> was added to a m.o.i.

of 3. The culture was grown for a further two hours, during which time the cells lysed. The lysate was then cleared by centrifugation at 12,000 g for 10 minutes, the pellet discarded, and 12 g NaCl, 1 mg DNase and 1 mg RNase was added. After 1 hour at 37°C 30 g PEG 8000 was added and the lysate left overnight at 4°C. The precipitate was then collected by centrifugation at 12,000 g for 10 minutes at 5°C and resuspended in 10 ml of SMO. The solution was cleared of any cell debris by centrifugation at 12,000 g, at 5°C, for 10 minutes and the supernate layered onto a three 1.5 ml step CsCl gradient of densities 1.3, 1.5 and 1.7 (0.87, 1.59 and 2.53 g of CsCl in 2 ml of water respectively). The gradient was then spun in a 3 x 15 ml MSE swing out rotor at 22,000 rpm for 1 hour when the T<sub>4</sub> appears as an opaque band in the middle step, which was removed using a syringe through the tube side. The bacteriophage was dialysed against SMO overnight and was stored at 4°C.

#### 2.45 PREPARATION OF LABELLED BACTERIOPHAGE $\lambda$ DNA

Evans (1984). 3 ml of an overnight culture of *E. coli* D5683 grown at 30°C (at this temperature the bacteriophage will not go into the lytic cycle) in M9-CA medium was added to 300 ml of the same medium plus 250  $\mu\text{g ml}^{-1}$  deoxyadenosine and 37 kBq  $\text{ml}^{-1}$  (1  $\mu\text{Ci ml}^{-1}$ ) of  $^3\text{HdTd}$ . The culture was grown to an  $A_{600}$  of 0.5 at 30°C and then transferred to a shaking water bath at 42°C for 30 minutes to induce the prophage, after which the temperature was reduced to 37°C and the incubation continued for another 2 hours. The bacteriophage is lysis defective and accumulates in the bacteria during this period. The bacteria were then collected by centrifugation at 6,000 g for 4 minutes, the pellet washed and

resuspended in 10 ml of SMO and permeabilised by adding 10 drops of chloroform to release the bacteriophage overnight at 4°C. After this step the bacteriophage were further purified by CsCl steps as for bacteriophage T<sub>4</sub>, but the band appears at the interphase between the two top steps.

#### 2.46 ISOLATION OF NOVEL *DEINOCOCCUS* SPECIES

Soil samples from various sites were screened for the presence of novel *Deinococcus* species, essentially as described by Masters (1988). This was done by mixing approximately 2 g of the sample vigorously with 15 ml PB and allowing the vial to stand for 25 minutes to let the soil and debris settle out. If a large amount of material was present in suspension the supernatant was removed to another vial for spinning in a bench top centrifuge for 30 seconds, or, if most material had separated out, immediately removed for irradiation.

Once reasonably clear, volumes of 7 ml were irradiated in a glass Petri dish with 254 nm U.V. light from a Hanovia germicidal lamp, at a dose rate of  $1.05 \text{ J m}^{-2} \text{ sec}^{-1}$ , stirred by a sterile magnetic bar, and samples taken at doses of 630, 945 and 1260  $\text{J m}^{-2}$ . Ten 100  $\mu\text{l}$  samples were taken at each dose and plated on five NB2 and five TGY plates for subsequent incubation at 30°C for 3 to 6 days. Any likely red, pink or orange colony was picked, streaked on TGY or NB2 agar to isolate single colonies, Gram-stained and quickly checked for radiation resistance. Any U.V. resistant colonies were then further characterised by a U.V. survival curve.

#### 2.47 MUTABILITY TEST FOR *D.RADIODURANS*

Cells were grown up (including positive and negative control strains) to mid-log phase, a 1 ml sample taken and approximately 15  $\mu$ l EMS added. Incubation at 30°C followed for 45 minutes, 0.1 ml was then placed in 10 ml TGY broth and incubated overnight; after which the neat culture was plated onto TGY agar containing 20  $\mu$ g ml<sup>-1</sup> Rf. This allows a comparison of mutated and non-mutated cultures, providing a positive or negative test.

## **CHAPTER THREE**

### **RESULTS**

### 3.1 *D.RADIODURANS* GENOMIC LIBRARIES

Several genomic libraries were constructed and screened for the isolation of *D.radiodurans* gene(s) responsible for recombination repair.

#### (i) USING pJBFH

The cosmid gene library provided by Dr Al-Bakri in the form of 320 *E.coli* HB101 colonies, had been stored as recommended (Maniatis *et al.* 1983). Soon after construction the insert sizes were calculated to be between 30 and 46 kb, with an average of 35 kb (as measured by agarose gel electrophoresis of 24 boiling mini-preparations digested with *Eco*R1, Al-Bakri *et al.* 1985). Screening 320 clones therefore gave a 97.7% probability of the gene library containing a unique *D.radiodurans* sequence.

As it is known that cosmid libraries may deteriorate during extended storage or propagation in *E.coli recA* hosts, (for example, see Ishiura *et al.* 1989), the colonies were again analysed for the presence of hybrid cosmids before the library was used. DNA was prepared from 12 samples by the boiling method, subjected to *Eco*R1 restriction analysis and run on an agarose gel. The insert sizes obtained varied, from no inserts (one sample) to 45.3 kb, with an average of only 24.4 kb. The probability of the gene library containing a unique sequence in the 320 colonies after storage was now 92.7%.

The library was screened in several different strains.

#### in *E.coli* HB101

The cosmid library was screened to isolate a clone which increased resistance to MMS of *recA*<sup>-</sup> HB101 (by restoring recombination proficiency). Colonies were resuscitated from storage

by replica plating onto agar containing Ap, incubated overnight, harvested from these plates into broth and  $2.1 \times 10^7$  bacteria were plated directly onto medium containing MMS. The level of MMS used, 0.05% v/v, was the calculated minimum inhibitory concentration for HB101 and DH5 $\alpha$ , but allowed the growth of *E.coli* K12, the HB101 *recA*<sup>+</sup> parent AB266, HB101 carrying the *recA*-containing plasmid pDR1453, and, presumably, other putative *recA*<sup>+</sup> cells.

As an indication of the quality of the gene library  $1 \times 10^7$  bacteria were also plated onto minimal medium plates lacking leucine, (HB101 being *leu*<sup>-</sup>, *pro*<sup>-</sup>), since the *D.radiodurans leuB* is expressed in *E.coli* (Al-Bakri *et al.* 1985). A similar number of colonies were also plated onto minimal medium lacking proline.

The gene bank produced no MMS resistant colonies. However, 0.42% of the population was found to be Ap<sup>r</sup> and *leuB*<sup>+</sup> (as indicated by the production of single colonies on minimal medium lacking leucine). No colonies were found to be *proA2*<sup>+</sup> (confirming the results of Mackay 1983 and Al-Bakri *et al.* 1985).

#### in *E.coli* JC14604

The cosmid gene library was also transformed into JC14604, which has two copies of the *lac* gene, mutated in different places so that the introduction of a functional recombination gene can cause a *lac*<sup>+</sup> isolate to be produced, creating blue colonies in X-gal overlays. Approximately  $6 \times 10^3$  Ap<sup>r</sup> transformants were isolated and overlaid with X-gal. No blue colonies (and hence no functional recombination genes) were found.

#### in *D.radiodurans* recombination deficient mutants

The recombination deficient strain *rec30* was found to show a low level of transformation and could be transformed to MTC<sup>r</sup> with

*D. radiodurans* R1 DNA (see 3.5).

The isolation of *rec30* MTC<sup>r</sup> colonies was attempted using plasmid DNA prepared from the cosmid bank, using the caesium chloride method, in the form of DNA from eight lots (pools) of 40 colonies each (8 x 40 = 320), so that an original cosmid containing *D. radiodurans* DNA which caused *rec30* to become MTC<sup>r</sup> could eventually be traced. This does not require the cosmid to be maintained in *D. radiodurans rec30* as the low recombination frequency of this strain may be enough to incorporate the cosmid, (or part of it), into the chromosome and restore recombination proficiency, (measured by MTC<sup>r</sup>). Working back through the cosmid library like this is a technique which was used in *D. radiodurans* to isolate *mtcA*, *mtcB*, *uvrC*, *uvrD* and *uvrE* (Al-Bakri *et al.* 1985), but it does require recombination proficiency to be successful. Large quantities of DNA were used to try and ensure the isolation of positive clones, over 10 µg per transformation (as the gene restoring MTC<sup>r</sup> may only be represented infrequently in the library, especially since the deterioration of the library in storage).

In all,  $1.84 \times 10^8$  colonies were plated per DNA pool. No MTC-resistant colonies were found after the usual incubation period, but after 6 days one colony was isolated. This experiment would have been expected to yield approximately  $7 \times 10^{-3}$  MTC<sup>r</sup> colonies per DNA pool, if frequencies found with chromosomal DNA were obtained. Instead a negligible transformation frequency in the order of  $10^{-9}$  was found from pool 8 only (based on the appearance of 1 MTC<sup>r</sup> colony).

However, the transformation was repeated with DNA from pool 8. A total of  $8.62 \times 10^7$  colonies were screened. Extensive incubation for 7 days was required to produce one MTC<sup>r</sup> colony, again a negligible

transformation frequency in the order of  $10^{-8}$ .

As this, if successful, was such a straightforward method of obtaining a gene involved in recombination the experiment was repeated by screening a further  $8.8 \times 10^7$  colonies, but no more suspected  $MTC^r$  colonies were found, even after an extended incubation period of 6 days.

When further characterised the two putative  $MTC^r$  *rec30* colonies exhibited *rec30*  $MTC^r$  and transformation levels. The most likely explanation for the appearance of these 'rogue' *rec30* colonies was considered to be the deterioration of the MTC in the medium after extended incubation times. This method of isolating the *rec30* mutated gene was also attempted using the first pAT153 gene bank (see 3.1 (ii)).

The approach used with *rec30* could not be used with *rec1* as no residual recombination was present, as indicated by transformation frequency. However, *rec1* was transformed with R1 DNA in the hope that the incoming DNA could be expressed before degradation and so provide the means to be incorporated into the chromosome and produce  $MTC^r$  colonies. If this occurred it would be followed by transformation with a gene library to isolate the *rec1* mutant gene in the same way as for *rec30*. Over  $2.4 \times 10^7$  colonies were screened for possible  $MTC^r$  transformants. After 5 days incubation 1 colony was isolated, giving a negligible transformation frequency of the order of  $10^{-8}$ .

This colony was further tested for the ability to produce single colonies on plates containing MTC, and showed more sensitivity than strain R1 but less than *rec1*. It was proposed that this might be a *mtcA*<sup>+</sup> mutant (*rec1* being *mtcA*<sup>-</sup>). This was tested via the mutability

test and found that this colony was immutable, as are *mtcA*<sup>+</sup> strains, yet showed Rf<sup>r</sup> transformation levels characteristic of *rec1*. Hence the colony isolated was considered to be a *rec1* mutant of genotype *mtcA*<sup>+</sup> *rec-1*.

The transformation was repeated, screening a further  $5.6 \times 10^7$  colonies. No transformants were isolated, even after 7 days incubation.

This method of obtaining the *rec1* mutant gene was abandoned and must wait until a vector system is established for *D.radiodurans*.

#### (ii) USING pAT153

Two gene libraries were constructed in the *E.coli* vector pAT153 (Chapter Two 2.24 (ii)) as searching the cosmid gene library was not successful in isolating a *D.radiodurans* gene of interest. Again, several strains were used to screen the libraries.

The first library was made using chromosomal DNA digested with *HindIII* and, when transformed into *E.coli* HB101, produced over  $5 \times 10^3$  Ap<sup>r</sup> colonies ( $1.1 \times 10^3$  Ap<sup>r</sup> transformants  $\mu\text{g}^{-1}$  pAT153). DNA was prepared from 24 samples by the boiling method and subjected to agarose gel electrophoresis, after *HindIII* restriction analysis, to determine the insert size. The average insert size was calculated as 9.3 kb, with inserts ranging from 3.2 to 13.5 kb. With the high number of transformants this gave approximately a 99% probability of the gene library containing a unique *D.radiodurans* sequence.

#### in *E.coli* HB101

The colonies were replica plated onto medium containing MMS and also onto minimal medium lacking leucine (as an indicator of cloning efficiency). When selecting possible resistant isolates only

colonies showing irregular boundaries were chosen, (colonies which show limited discrete growth with a perfect round shape indicates that they have probably originated from a mutant cell in a replica plated colony).

The minimal medium plates yielded 23 suspected *leuB*<sup>+</sup> HB101, of which 20 grew on further subculturing on minimal medium lacking leucine and also on media containing Ap. This indicates that 0.4% of the Ap<sup>r</sup> transformants contain a *D.radiodurans leuB* gene capable of being expressed in *E.coli*.

On the medium containing MMS, 106 replica plated colonies produced growth, 70 of which showed further growth on media containing Ap only. When the 70 Ap<sup>r</sup> transformants were further streaked on media containing both MMS and Ap, only 42 (0.84% of the total number of Ap<sup>r</sup> transformants) were capable of growth.

The 42 Ap<sup>r</sup> MMS<sup>r</sup> colonies were grown up overnight in broth containing both Ap and MMS for mini DNA preparations. Six isolates failed to grow under these conditions which was thought to be due to the selective pressures being greater in liquid than in solid cultures, although used in the same concentrations. The boiling method of DNA preparation was attempted twice upon the isolates, but was not successful in either case. The alkaline lysis method of mini plasmid preparation was then used to check the putative *rec*<sup>+</sup> clones. When analysed on an agarose gel *Hind*III restriction patterns were obtained for 27, 9 failing to produce DNA by alkaline lysis (but this did not necessarily mean that plasmids were not present in the isolates).

The failure to yield plasmid DNA even using alkaline lysis preparation techniques was later found to be a common occurrence in

cultures grown in the presence of MMS. The boiling method of plasmid preparation was never found to be successful under these conditions and so was abandoned. The failure of both extraction procedures seemed to be due<sup>to</sup> the difficulty of lysing the culture, often after extreme difficulty in pelleting the cells, assumed to be due to MMS in the growth medium. The difficulty in obtaining mini preparations from the RecA<sup>+</sup> phenotype of *E. coli* HB101 has not been reported before in the isolation of other *recA*-homologues.

From the restriction patterns obtained, the insert sizes ranged from 7.1 to 13.5 kb, with an average of 10.5 kb. Eight isolates contained only approximately 7.1 kb inserts, and a further 12 contained the 7.1 kb fragment plus others, (7 not containing an approximately 7.1 kb insert). This suggests that the gene responsible for MMS<sup>r</sup> may be contained within this fragment.

To confirm that the MMS resistance was plasmid born, four isolates were chosen, all containing the approximately 7 kb fragment, designated 2, 3, 6, and 10, containing respective insert sizes of 11.2 kb (7.1 and 4.1 fragments); 10.3 kb (7 and 3.3 fragments); 7.1 kb and 13.5 kb (7 and 6.5 fragments). Plasmid DNA was prepared by alkaline lysis from each and transformed into HB101. Transformants were selected upon media containing Ap, MMS and both Ap and MMS. No transformants were found on plates containing MMS, but many Ap<sup>r</sup> colonies were found. It was therefore assumed that a longer expression time was required before growth in the presence of MMS could occur, and so three Ap<sup>r</sup> transformant colonies of each isolate were picked off the Ap plates and streaked onto media containing MMS and both Ap and MMS. Isolates 2 and 6 produced no growth but 3 and 10 produced strong growth and single colonies from

all 3 colonies on all media containing MMS. This was considered to be confirmation that the MMS<sup>r</sup> was carried upon a plasmid which required extra expression time to show MMS<sup>r</sup>, and also that the plasmid was unstable and was likely to lose MMS<sup>r</sup> if no selection pressure was applied. The original isolates were then stored at -70°C.

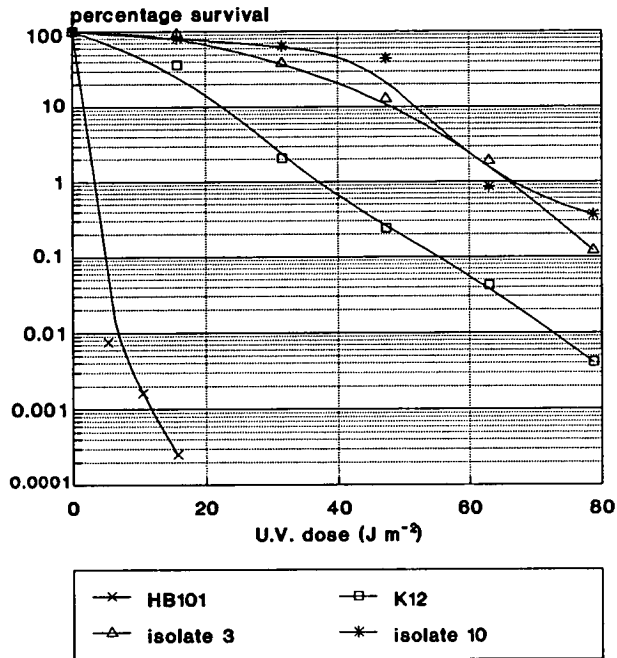
Difficulty was found in keeping cells of isolates 3 and 10 MMS<sup>r</sup> when subcultured and stored at 4°C on media containing Ap for any length of time, which was considered to be another indication of plasmid instability in the absence of MMS selection pressure.

Due to this instability the original isolates were resuscitated from the frozen stocks. Both U.V. and gamma survival curves were performed upon 3 and 10 grown in the presence of MMS, (Figures 3.1 and 3.2 respectively). Both isolates showed greater resistance to both U.V. and gamma irradiation than did *E.coli* K12 (grown in medium only).

Large scale caesium chloride plasmid preparations of isolates 3 and 10 were then carried out so that the plasmids could be stored in a stable form other than in cells at -70°C. This was done by using a starter culture from the frozen stock and growth in media containing Ap<sup>r</sup> selection only (due to the problems of large culture volumes containing MMS). The resulting plasmids were not capable of transforming HB101 to MMS<sup>r</sup> but could transform them to Ap<sup>r</sup>.

Because of the anomaly in the transfer of MMS<sup>r</sup> to transformants the caesium chloride DNA preparations were compared to plasmids prepared by alkaline lysis from the frozen stock culture, grown overnight in the presence of either Ap or MMS, and also to plasmids prepared by alkaline lysis from cells transformed to Ap<sup>r</sup> by the

**FIGURE 3.1 U.V. SURVIVAL OF ISOLATES 3 AND 10**



**FIGURE 3.2 GAMMA SURVIVAL OF ISOLATES 3 AND 10**

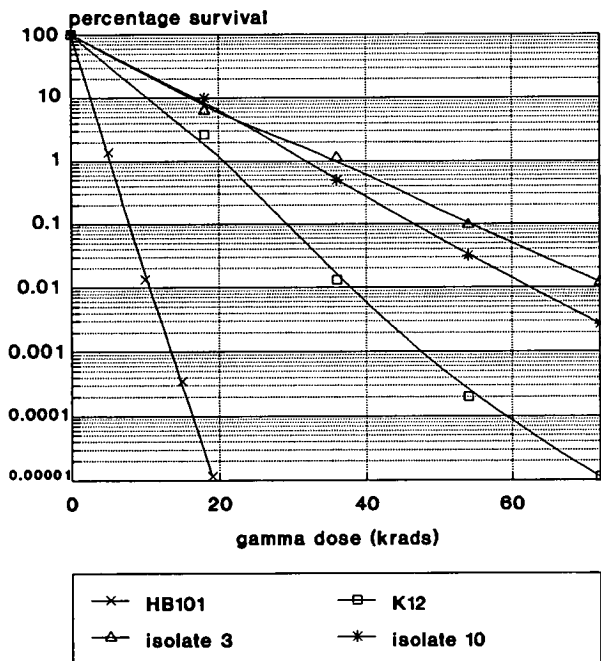


FIGURE 3.3 COMPARISON OF PLASMIDS FROM ISOLATES 3 AND 10

Agarose gel showing plasmid DNA restricted with *Hind*III.

Lane 1 - HB101 containing no plasmid.

Lane 2 - Isolate 10 - Caesium chloride preparation from frozen stock. Grown under Ap selection pressure.

Lane 3 - Isolate 10 - Frozen stock. Grown under Ap selection pressure.

Lane 4 - Isolate 10 - Frozen stock. Grown under MMS selection pressure.

Lane 5 - Isolate 10 - Ap<sup>r</sup> transformant produced by transformation with DNA from caesium chloride preparation as shown in Lane 2. Grown under Ap selection pressure.

Lane 6 -  $\lambda$  standard (23.13, 9.42, 6.56, 4.36, 2.32, 2.03, 0.56 kb)

Lane 7 - pAT153 (3.6 kb)

Lane 8 - Isolate 3 - Caesium chloride preparation from frozen stock. Grown under Ap selection pressure.

Lane 9 - Isolate 3 - Frozen stock. Grown under Ap selection pressure.

Lane 10 - Isolate 3 - Frozen stock. Grown under MMS selection pressure.

Lane 11 - Isolate 3 - Ap<sup>r</sup> transformant produced by transformation with DNA from caesium chloride preparation as shown in Lane 8. Grown under Ap selection pressure.

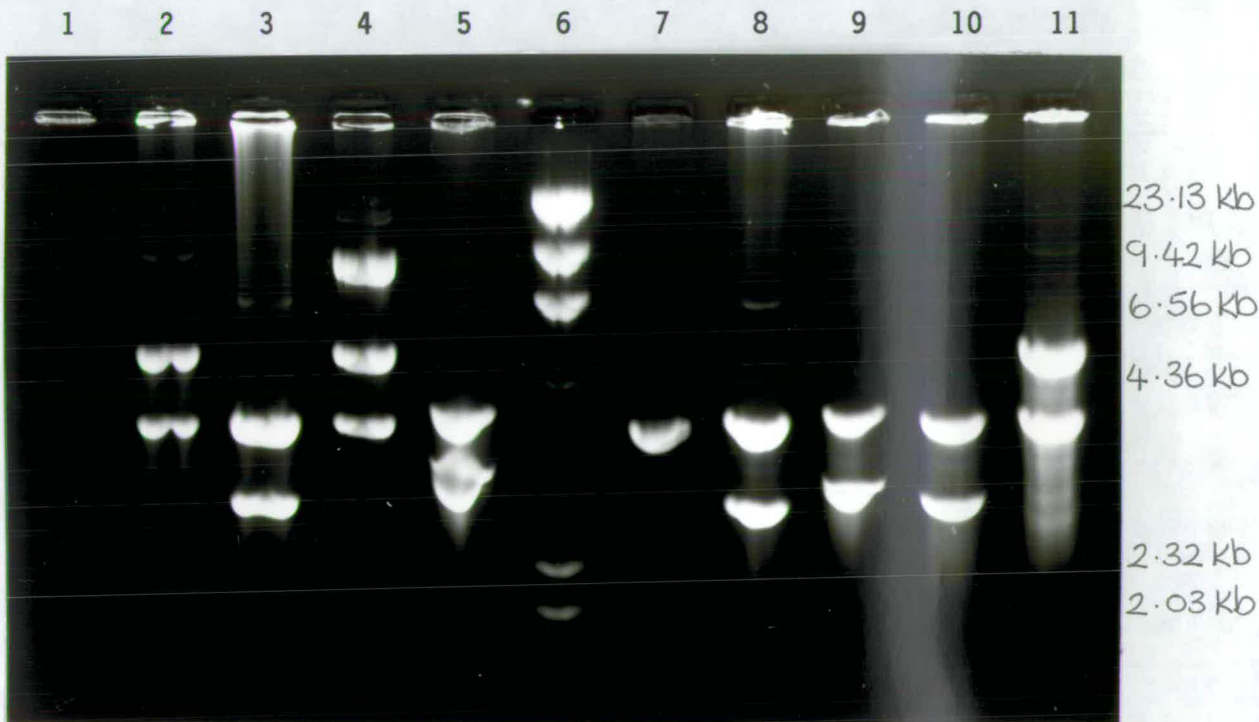


TABLE 3.1 INSERT SIZES IN MMS-RESISTANT ISOLATES 3 AND 10

Fragment sizes were calculated from Figure 3.3, where a full explanation of the origin of each is found.

Isolate 10					
Lane	2	3	4	5 <sup>a</sup>	Original <sup>b</sup>
Origin	Caesium chloride	Stock grown in Ap	Stock grown in MMS	Ap <sup>r</sup> transformant	Grown in Ap and MMS
Fragment size (kb)	5.5	3.6	8.0	3.6.	7.0
	3.6	2.9	5.5	2.9	6.5
			3.6		3.6

Isolate 3					
Lane	8	9 <sup>c</sup>	10	11	Original <sup>b</sup>
Origin	Caesium chloride	Stock grown in Ap	Stock grown in MMS	Ap <sup>r</sup> transformant	Grown in Ap and MMS
Fragment size (kb)	3.6	3.6	3.6	5.5	7.0
	2.9	2.9	2.9	3.6	3.6
					3.3

**Notes**

<sup>a</sup> considered to run as Lane 3 - distortion is probably due to the lane being overloaded and the plasmid preparation poor.

<sup>b</sup> fragment sizes found in original characterisation of MMS<sup>r</sup> Ap<sup>r</sup> colonies.

<sup>c</sup> considered to run as Lanes 8 and 10, distortion as <sup>a</sup>.

caesium chloride DNA itself (Figure 3.3). From this Figure it can be seen that considerable variation is shown by plasmids that originate from the same source even after short independent growth periods under different conditions. The fragment sizes obtained are listed in Table 3.1.

Although the fate of *D.radiodurans* DNA in *E.coli* has not been expressly studied before it may be that some *D.radiodurans* DNA is unstable in certain situations in this host. Genes isolated and manipulated previously, (Al-Bakri *et al.* 1985, Peters and Baumeister 1986), have relied upon propagation in *E.coli* and no problems of this sort were noted so that explanation seems highly unlikely. However, Mackay (1983) reported the loss of Leu<sup>+</sup> characteristics from *E.coli* HB101 containing recombinant plasmids of pAT153, and Purvis (1984) found instability of pAT153 recombinant plasmids carrying *leuB* from *D.radiophilus*, also in *E.coli* HB101.

Figure 3.3 shows results that are very confusing. The alkaline lysis plasmid preparations and the gel were repeated to confirm that the isolations or gel lanes had not become mis-labelled during preparation or running, but the same result was obtained. It is interesting to note that an unaltered pAT153 band is found in each case and similar sized inserts are involved in both 3 and 10. These results cannot be logically explained, but were taken as an indication of, if not MMS<sup>r</sup>, the instability of *D.radiodurans* DNA in a plasmid in *E.coli* HB101.

The problem of the further isolation of the *D.radiodurans* gene causing MMS<sup>r</sup> was addressed. In retrospect, it was considered that returning to the original isolates of 3 and 10 which were stored frozen and not further characterising the cells transformed to MMS<sup>r</sup>

using plasmids from 3 and 10 (which initially suggested that the MMS<sup>r</sup> was plasmid carried), was hasty. Further study on the transformants should have been carried out, especially plasmid isolation and characterisation. It is possible that the MMS<sup>r</sup> resulted from a chromosomal mutation and was not a plasmid-born characteristic, the contradictory results (transfer of MMS<sup>r</sup> and Ap<sup>r</sup> from 3 and 10 by plasmid isolation and transformation and the common 7 kb insert size in the original MMS<sup>r</sup> isolates), being merely aberrations. The fact that both isolates showed increased resistance to both U.V. and gamma irradiation (compared to K12) in Figure 3.1 and 3.2 could be due to the bacteria being grown in medium containing MMS and so SOS repair may have been induced. The difficulty found in preparing plasmid DNA by the mini-preparation methods could have been due to the isolates being mutants.

In an attempt to resolve the question of the origin of the MMS<sup>r</sup> the stability of strains 3 and 10 was investigated. After growth in broth containing no selection pressure, subculturing 10  $\mu$ l into 10 ml approximately every 12 hours, growth of 3 and 10 was scored on LB only (taken to be a total viable count or t.v.c. of 100%) and compared to the number of colonies found on solid media containing either Ap and MMS (Table 3.2).

Table 3.2 shows that both Ap<sup>r</sup> and MMS<sup>r</sup> showed considerable fluctuation but, as MMS<sup>r</sup> did not rapidly decrease to very low levels it indicated that this characteristic was not as unstable as expected. When Purvis (1984) carried out a similar experiment on Ap<sup>r</sup> shown by *E.coli* HB101 carrying pAT153 containing a *D.radiodurans* fragment, grown without selection pressure, 100% of the population remained Ap<sup>r</sup> over 100 generations, which does indicate some instability in isolates 3 and 10.

TABLE 3.2 PERCENTAGE OF t.v.c. ABLE TO GROW ON SELECTIVE MEDIA

Isolate 3			Isolate 10		
No. genera- tions	Ap <sup>r</sup>	MMS <sup>r</sup>	No. genera- tions	Ap <sup>r</sup>	MMS <sup>r</sup>
22	18	89	22	82	46
44	11	52	44	69	51
66	10	29	66	72	55
88	40	18	88	79	50

The initial controls involved in isolating the MMS<sup>r</sup> clones were repeated extensively by replica plating *E.coli* HB101 onto media containing MMS. Over  $6 \times 10^3$  bacteria were involved, 31 possible MMS<sup>r</sup> colonies were isolated, but only 9 (0.15% of the cells replica plated) were capable of producing single colonies on media containing MMS. This is lower than the 0.84% found when the gene library in HB101 was similarly treated, and indicates that the gene library may have yielded some colonies that are MMS<sup>r</sup> due to the presence of recombinant plasmids.

To resolve the question of the nature of the MMS<sup>r</sup> the 42 gene library isolates were subcultured in broth only, as with isolates 3 and 10 previously but for 10 days. Fifty colonies were picked from a dilution series of each isolate to find, if possible, 3 that were Ap<sup>s</sup> (containing no plasmid as indicated by the lack of antibiotic resistance). The Ap<sup>s</sup> colonies were then further tested for MMS<sup>r</sup> or MMS<sup>s</sup> on the basis that if the mutation was chromosomal the bacteria would still be MMS<sup>r</sup>, as chromosomal alterations are more stable than

plasmids in the absence of a selection pressure. The occurrence of Ap<sup>s</sup> differed wildly, from a maximum of 47 to a minimum of 2 colonies from the 50 tested. However, all showed MMS<sup>r</sup> compared to that shown by HB101 but varied in the ability to produce single colonies on media containing MMS at 0.05% v/v. Alkaline lysis DNA preparation of 10 Ap<sup>s</sup> MMS<sup>r</sup> colonies from different original isolates showed that no plasmids were present. Therefore the MMS<sup>r</sup> was considered to be chromosomally located.

As the failure to isolate a gene involved in recombination from *D. radiodurans* may have been due to the gene library itself, a second gene library was constructed in pAT153. *Mbo*I partially digested DNA was ligated to *Bam*HI digested pAT153 (Chapter Two 2.24 (ii)). Only 964 HB101 Ap<sup>r</sup> transformants were isolated, ( $1.1 \times 10^2$  transformants  $\mu\text{g}^{-1}$  of pAT153), with an average insert of 6.2 kb (from 24 alkaline lysis mini DNA preparations, restricted with *Hind*III to give a single cut in the vector). The probability of the library containing a unique DNA sequence was 86.6%, which was considered to be worth screening.

When replica plated onto MMS 21 colonies grew, 6 of which were able to form single colonies upon media containing both MMS and Ap (0.62% of the Ap<sup>r</sup> transformants). Alkaline lysis plasmid preparation and *Hind*III restriction analysis revealed variable insert sizes from 2.9 to 6 kb. However, none of the recombinant plasmids were able to transform HB101 to MMS<sup>r</sup>, (even after extended expression times of up to 5 hours), but could transform to Ap<sup>r</sup>. Ap<sup>s</sup> colonies were found as previously noted in the treatment of the pAT153-*Hind*III gene library by subculturing in broth. All were again MMS<sup>r</sup>, but when plasmid DNA was prepared by alkaline lysis from the MMS<sup>r</sup> Ap<sup>s</sup> colonies a plasmid

was found in one isolate of approximately 4.4 kb. This plasmid was, however, unable to transform HB101 to either MMS<sup>r</sup> or Ap<sup>r</sup> and was not investigated further.

Again the MMS<sup>r</sup> isolates were considered to be chromosomal mutants as no evidence to the contrary can be offered.

in *E.coli* JC14604

The first gene library made in pAT153, (with a probability of approximately 99% of containing a unique *D.radiodurans* DNA sequence), was isolated from *E.coli* HB101 by the caesium chloride method. The library was then transformed into JC14604 and screened for recombination proficient clones, after initial Ap selection, using X-gal overlays. Approximately  $2.5 \times 10^4$  transformants were screened but no blue colonies (hence no recombination proficient isolates) were found.

in *E.coli* JC10289

This strain was used as it has a deleted *recA* gene and so the possibility of MMS<sup>r</sup> chromosomal mutants (presumably *recA* mutants) arising during screening is removed, (both DH5 $\alpha$  and HB101 are *recA*<sup>-</sup> but are not deletion mutants).

The number of Ap<sup>r</sup> transformants was decreased approximately 70 fold when using pAT153 originating from HB101 compared to that from DH5 $\alpha$  due to restriction of the plasmid DNA, (JC10289 being *r*<sup>+</sup> *m*<sup>+</sup>, HB101 *r*<sup>-</sup> *m*<sup>-</sup> and DH5 $\alpha$  *r*<sup>-</sup> *m*<sup>+</sup>). Therefore the first gene library in pAT153, isolated in the form of plasmid DNA from HB101 by caesium chloride, was transformed into DH5 $\alpha$ . A Birnboim plasmid preparation from DH5 $\alpha$  was then carried out to increase the number of transformants when transforming into JC10289. Strain JC14604 could have been used as is *r*<sup>-</sup> and has a *recA* deletion, but was not

available at the time.

Approximately  $6.59 \times 10^4$  colonies were screened by replica plating onto plates containing MMS and also onto plates containing NQO as a varied selection method. No colonies which later were able to support growth upon medium containing MMS and Ap (at a lower level of  $30 \mu\text{g ml}^{-1}$ ), or on any medium containing NQO, were isolated.

in *D. radiodurans* recombination deficient *rec30*

Attempts were made to transform *rec30* with plasmid DNA from the first pAT153 gene bank as with the cosmid bank (Chapter Three 3.1 (i)). The first caesium chloride DNA preparation was used from HB101 to try and minimise the loss of certain gene sequences, which may be unstable or made less competitive in a mixed culture.

Approximately  $1.12 \times 10^8$  colonies were screened on medium containing MTC. However, no MTC<sup>r</sup> colonies were found although incubation was extended to 6 days.

(iii) USING pDR540

As no recombination genes were isolated from the gene libraries made in pAT153 the expression vector pDR540 was used, as the difficulty was thought most likely to be the recognition of *D. radiodurans* gene promoters by *E. coli*. Two gene libraries were constructed using either *Mbo*I partial or *Bam*H1 total chromosomal digests into the *Bam*H1 site of the *E. coli* expression vector pDR540.

The *Bam*H1 chromosomal gene library yielded a total of 1031 Ap<sup>r</sup> transformants in DH5 $\alpha$ , ( $1 \times 10^2$  transformants  $\mu\text{g}^{-1}$  of pDR540). These were found to have an average insert size of 6.3 kb, (from 24 alkaline lysis plasmid preparations restricted once with *Hind*III and

run upon an agarose gel). This gave a calculated probability of the gene library containing a *D.radiodurans* single gene copy of 88.5%.

The second gene library was constructed using *Mbo*I partially digested chromosomal DNA into the *Bam*HI site of pDR540. Using conditions as for the pDR540-*Bam*HI gene library  $2.1 \times 10^2$  DH5 $\alpha$  Ap<sup>r</sup> transformants were isolated, ( $3.5 \times 10^2$  transformants per  $\mu\text{g}^{-1}$  pDR540) with an average insert size of 4.2 kb, giving a probability of the gene library containing a unique *D.radiodurans* gene of 94.7%.

Again, the libraries were screened using different strains.  
in *E.coli* DH5 $\alpha$

When the first pDR540 gene library was screened using replica plating onto medium containing MMS 10 colonies grew, 2 of which were capable of forming single colonies upon medium containing Ap and MMS, or 0.19% of the Ap<sup>r</sup> transformants. This was very similar to the control levels of 0.1% found when approximately  $1 \times 10^3$  colonies of DH5 $\alpha$  only were replica plated onto MMS. The two isolates contained recombinant plasmids. However, they could not transform DH5 $\alpha$  to MMS<sup>r</sup> but could to Ap<sup>r</sup> using plasmid prepared by alkaline lysis. The Ap<sup>r</sup> transformants were subject to alkaline lysis plasmid preparation and plasmids of 4.1 kb were found in both cases, indicating that the plasmids contained a very small insert (or none at all). Further work upon these two isolates was not carried out.

The colonies of the second gene library were screened by replica plating onto medium containing NQO. No resistant colonies were found.

in *E.coli* JC14604

The *Mbo*I-pDR540 gene library was prepared from DH5 $\alpha$  by a Birnboim plasmid preparation and transformed into JC14604.

Approximately  $4 \times 10^3$  colonies were screened using X-gal overlays, but no Lac<sup>+</sup> (hence recombination proficient) isolates were found.

(iv) USING pPL608

A gene library was made in the *B.subtilis* expression vector pPL608 in strain IA422 (*leu*, *recE*). *B.subtilis* was used as both *D.radiodurans* and *B.subtilis* are Gram-positive. An expression vector was involved as the transcription system in *B.subtilis* is complex and was thought unlikely to operate from a *D.radiodurans* promoter (reviewed by Doi 1984).

Selection was made using plates containing MTC as MMS selection was not appropriate (as no clear, cut-off point was found between *recE*<sup>+</sup> and *recE*<sup>-</sup> strains). A concentration of  $0.02 \mu\text{g ml}^{-1}$  MTC was found to be the best level for replica plating.

Approximately 1410 Cm<sup>r</sup> transformants were isolated on DM3 medium ( $1.41 \times 10^2 \mu\text{g}^{-1}$  plasmid). The average insert sizes, obtained by alkaline lysis plasmid preparation of 24 colonies restricted with *Pst*I and run on an agarose gel, was found to be 3.2 kb. This gave a 75.6% probability of the gene library containing a *D.radiodurans* single gene copy. This was low but was considered to be worth screening.

When screened by replica plating onto medium containing MTC, 35 colonies produced growth (1.6% of the number of transformants, similar to control levels), but none were able to produce growth when streaked onto medium containing MTC. The library was also replica plated onto minimal medium lacking leucine, to test for the restoration of *B.subtilis* Leu<sup>+</sup> by *D.radiodurans*. Twenty two colonies were isolated (1% of the Cm<sup>r</sup> transformants) which were later able to

produce growth on minimal medium lacking leucine. However, this was similar to values obtained in a control using IA422 only. Why such a high level was found can only be speculated on. When alkaline lysis plasmid preparations were carried out on the 22 isolates no recombinant plasmids were found.

Regeneration frequencies of 20% of the colony forming units found initially were obtained, as experienced by other workers (for example Chang and Cohen 1979). Difficulty in obtaining a gene library containing a sizable proportion of the *D. radiodurans* genome was experienced and was thought to be due to being unfamiliar with the techniques involved in the manipulation of *Bacillus*.

#### (v) SUMMARY OF GENE LIBRARIES

The screening procedures, strains and vectors involved in the gene libraries are noted in Table 3.3.

The cosmid library in HB101 yielded 0.42% of transformants as *leuB*<sup>r</sup>, the pAT153-*Hind*III library in HB101 0.4% *leuB*<sup>r</sup> and 0.84% MMS<sup>r</sup>, pAT153-*Mbo*I in HB101 0.62% MMS<sup>r</sup> (compared to background levels of 0.15% MMS<sup>r</sup>), pDR540-*Eco*RI in DH5 $\alpha$  0.19% MMS<sup>r</sup> (compared to background levels of 0.1% MMS<sup>r</sup>).

The isolation of MMS<sup>r</sup> colonies above the background levels cannot be explained, the only possible suggestion being that a *D. radiodurans* gene had been isolated and had inserted itself into the host's chromosome, which was thought to be extremely unlikely, or that some feature of the gene library screening procedure resulted in the isolation of MMS<sup>r</sup> resistant colonies above background levels. It must be noted that no possible recombination proficient clones were isolated by any other screening method.

TABLE 3.3 SUMMARY OF THE RESULTS OF SCREENING THE GENE LIBRARIES OF *D.RADIODURANS* FOR RECOMBINATION GENES

Host and vector	Chromosome restriction	Insert size (kb)	No. transformants	P(%) <sup>a</sup>	Screen
<i>E.coli</i> cosmid pJBFH	<i>Mbo</i> I	24.4	HB101 320	92.7	HB101 MMS HB101 MM-leu <sup>b</sup> JC14604 X-gal rec30 MTC HB101 MM-pro <sup>c</sup>
<i>E.coli</i> pAT153	<i>Hind</i> III	9.3	HB101 5,000		HB101 MMS HB101 MM-leu <sup>b</sup> rec30 MTC JC14604 X-gal JC10289 MMS JC10289 NQO
<i>E.coli</i> pAT153	<i>Mbo</i> I	6.2	HB101 964	86.6	HB101 MMS
<i>E.coli</i> pDR540	<i>Bam</i> HI	6.3	DH5 $\alpha$ 1031	88.5	DH5 $\alpha$ MMS JC14604 X-gal
<i>E.coli</i> pDR540	<i>Mbo</i> I	4.2	DH5 $\alpha$ 2100	94.7	DH5 $\alpha$ NQO JC14604 X-gal
<i>B.subtilis</i> pPL608	<i>Pst</i> I	3.2	IA422 1410	75.6	IA422 MTC IA422 MM-leu <sup>b</sup>

**Notes**

<sup>a</sup> probability of the library containing a unique gene copy.

<sup>b</sup> minimal medium lacking leucine.

<sup>c</sup> minimal medium lacking proline.

Where HB101, DH5 $\alpha$ , JC14604 and JC10289 are *E.coli*, IA422 *B.subtilis* and rec30 *D.radiodurans*.

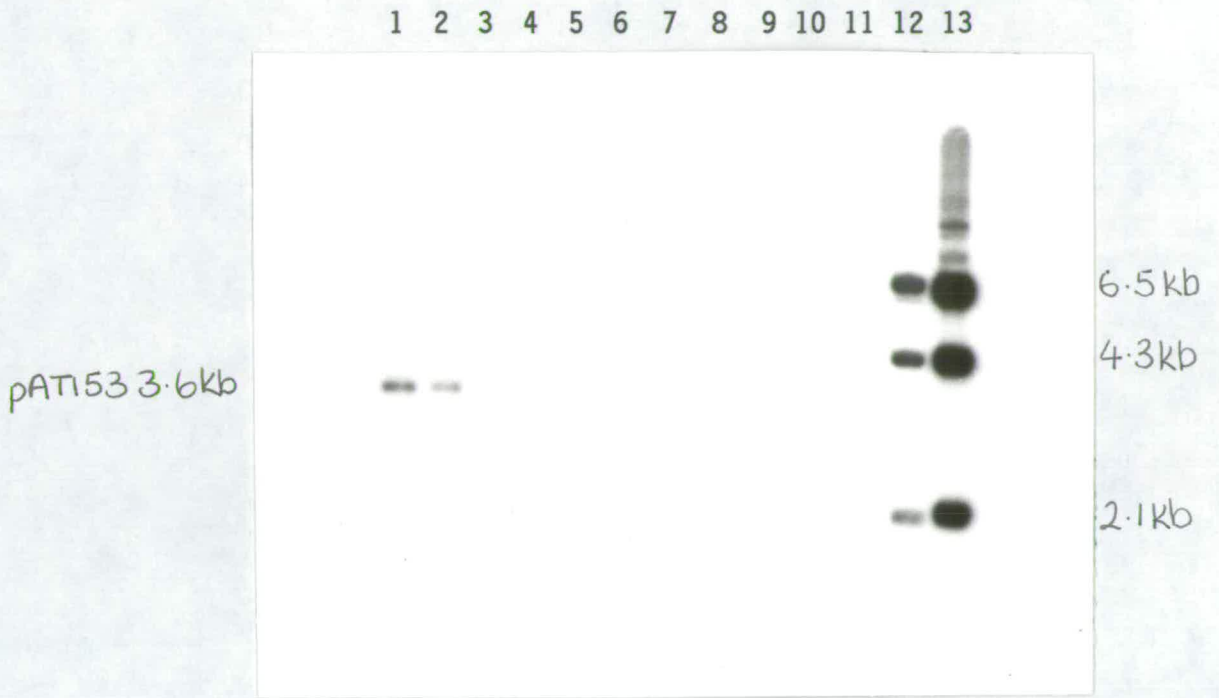
### 3.2 ISOLATION OF THE *recA* EQUIVALENT USING SOUTHERN BLOTS

As no genes involved in recombination were isolated from the gene libraries Southern blotting was employed to see if a gene homologous to *E.coli recA* could be isolated from *D.radiodurans* chromosomal DNA. If positive, a *D.radiodurans* gene library could be screened to pick out individual positive clones. This method would not require expression of *D.radiodurans* genes in a foreign host but only their maintenance.

Figure 3.4 shows the results of a Southern blot using plasmid pDR1453 as a probe. This plasmid was restricted with *Pst*I to give fragments of 4.3, 6.5 and 2.1 kb, containing pBR322, *sr1* and *recA* respectively. Chromosomal DNA restricted with *Eco*RI, from *D.radiodurans* RI, SARK, Krase and UVS78 was probed, (four strains were used as levels of chromosome homology between individual *D.radiodurans* strains is low), along with approximately 500 ng plasmid from the caesium chloride preparation of the MMS<sup>r</sup> isolates 3 and 10 from the pAT153-*Hind*III gene library (isolated in 3.1 (ii)). Washing at 42°C produced general hybridisation to the Gene Screen-Plus, so Figure 3.4 shows the results after washing at 50°C, after 1 hour and 18 hours exposure to X-ray film ((a) and (b) respectively).

The probe did not hybridise to *D.radiodurans* chromosomal DNA at all, even though (b) shows general hybridisation to the Gene Screen-Plus in some areas. Both (a) and (b) show hybridisation to the vector in isolates 3 and 10, as both pDR1453 and pAT153 originate from pBR322. Figure (b) also shows hybridisation to the uncut vector.

(a)



(b)

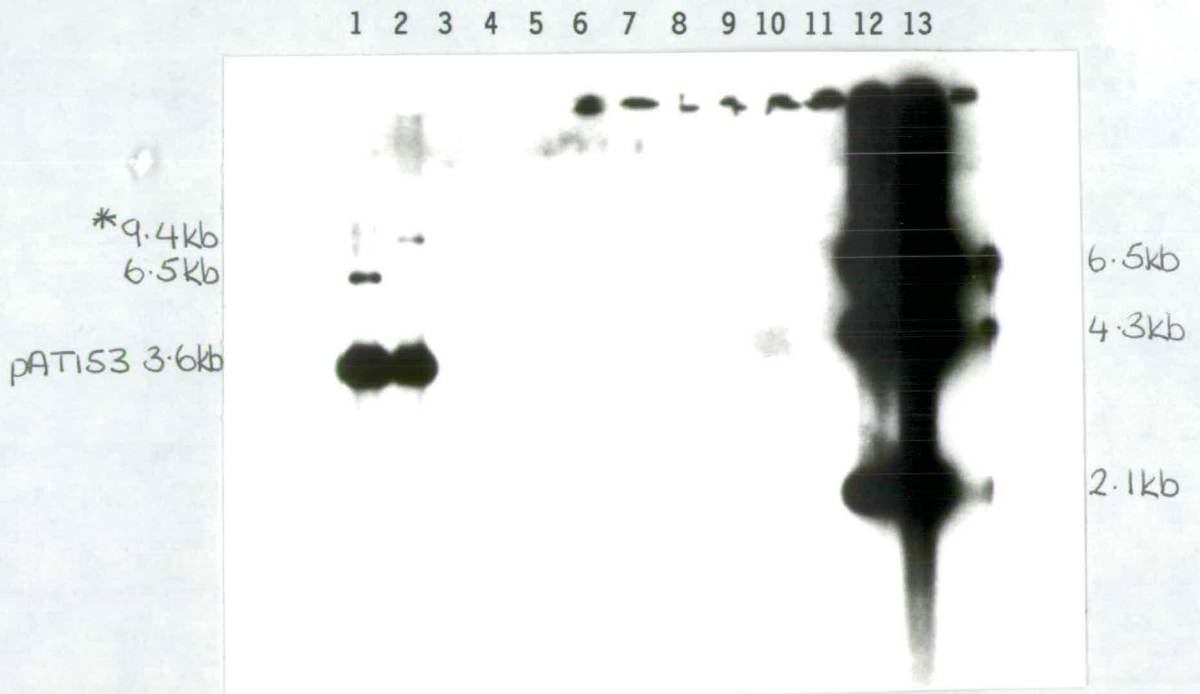


FIGURE 3.4 SOUTHERN BLOT OF *D. RADIODURANS* CHROMOSOMAL DNA  
USING A *recA* PROBE

Lane 1 Isolate 3 }  
Lane 2 Isolate 10 } from first pAT153 *Hind*III gene library  
Lane 3 Lambda *Hind*III and  $\phi$ X174 *Hae*III standards  
Lane 4 and 5 blank lanes  
Lane 6 RI DNA }  
Lane 7 UVS78 } *D. radiodurans* chromosomal DNA  
Lane 8 SARK } restricted with *Eco*RI  
Lane 9 Krase }  
Lane 10 blank  
Lane 11 Lambda *Hind*III and  $\phi$ X174 *Hae*III standards  
Lane 12 pDR1453 50 ng restricted with *Pst*I }  
Lane 13 pDR1453 200 ng restricted with *Pst*I } positive controls

(a) 1 hour exposure

(b) 18 hours exposure

\* uncut isolates of approximately 9.4 kb (isolate 10) and 6.5 kb (isolate 3).

This technique should be sensitive enough to pick up a D.radiodurans gene of interest from chromosomal DNA, even if only present as a single copy. There must be a very low level of homology between the recA probe and the recA-analogue of D.radiodurans (if one exists) for this not to have occurred.

### 3.3 ISOLATION OF THE RecA EQUIVALENT USING WESTERN BLOTS

As no genes with DNA homology to *recA* had been isolated from *D.radiodurans* chromosomal DNA Western blotting was tried, using polyclonal antibody to *E.coli* K12 RecA. For immuno-screening polyclonal antibody is recommended, as monoclonal antibodies may detect a common antigenic determinant (epitope) in more than the

FIGURE 3.5 WESTERN BLOT OF TOTAL CELL EXTRACTS FROM D.RADIODURANS AND D.GRANDIS USING ANTIBODY TO RecA

Lane 1	<i>E.coli</i> K12	Lane 6	<i>D.radiodurans</i> ts1
Lane 2	<i>E.coli</i> JC10289	Lane 7	<i>D.radiodurans</i> rec30
Lane 3	<i>Proteus vulgaris</i>	Lane 8	<i>D.radiodurans</i> rec1
Lane 4	<i>D.radiodurans</i> R1	Lane 9	<i>D.grandis</i> KS 0460
Lane 5	<i>D.radiodurans</i> SARK	Lane 10	<i>D.grandis</i> KS 0485



protein of interest. It was considered more probable that protein homology between RecA and a *D.radiodurans* recombination protein would be found than DNA homology between the two genes (Chapter One, 1.4.2). As with Southern blotting, if homology was found in total protein extracts from *D.radiodurans* a gene library could then be screened to isolate the clones of interest. The isolation of putative *recA*-like clones from a gene library by Western blotting does not rely upon a *D.radiodurans* gene product being functional in a foreign host, but the protein must be produced.

Both positive and negative controls were run alongside *D.radiodurans* and *D.grandis*. These were *P.vulgaris* and *E.coli* K12, (positive controls), and *E.coli* JC10289 (a negative control as the *recA* region has been deleted).

Protein extracts from *D.radiodurans* R1, SARK, *rec1*, *rec30*, *ts1* and *D.grandis* KS 0460 and KS 0485 were run and subjected to Western blotting. The antibody bound to the positive controls but did not bind to any other protein extracts (see Figure 3.5), apart from very weak background homology in *E.coli* JC10289, *D.grandis* and *D.radiodurans* R1, which is not observed very well in this Figure.

This was not specific enough to further the screening of a genomic library in *E.coli* as if the weak homology picked up in *D.radiodurans* was the RecA protein equivalent it would be masked by non-specific binding to *E.coli* proteins. To ensure that the weak homology seen could not be enhanced by producing more of the RecA protein, conditions were used under which it would be expected that a RecA-type protein would be induced as in *E.coli* (Gudas and Pardee 1976). This was U.V. treatment which gave approximately 90% survival, followed by an incubation period to allow for expression.

TABLE 3.4 RECA-TYPE PROTEIN INDUCTION TREATMENTS

Strain	U.V. dose (J m <sup>-2</sup> )	Incubation period
<i>E.coli</i> K12	30	30 mins, 37°C
<i>D.radiodurans</i> SARK and R1	350	} 60 mins, 30°C
" rec1 and rec30	59	
" ts1 <sup>a</sup>	350	
" ts1 <sup>b</sup>	59	
<i>D.grandis</i> KS 0460 and KS 0485	125	

Notes<sup>a</sup> 30°C for 4 hours before U.V. dose<sup>b</sup> 39°C for 4 hours before U.V. dose

The proteins were prepared as indicated in Table 3.4 and run on SDS-PAGE gels alongside the proteins isolated from non-U.V. treated cultures. The gels were then Western blotted as before and, again, no areas of strong homology were found except in the positive control *E.coli* K12 (not shown), where an increase in the level of RecA was seen.

To ensure that a RecA-like protein was induced, if present, in *D.radiodurans* R1 the following treatments were tried, followed by a Western blot. Protein was prepared after U.V. doses of 252, 504 and 756 J m<sup>-2</sup>. Samples given a dose of 504 J m<sup>-2</sup> were further incubated at 30°C for 30 minutes, 1 and 2 hours before preparing protein. Still no increase above the background levels of homology was found.

### 3.4 SEDIMENTATION IN ALKALINE SUCROSE GRADIENTS

Sucrose gradients are a means of separating molecules of different sizes. They rely upon the construction of a sucrose gradient onto which the molecules are carefully layered. During centrifugation the molecules migrate through the gradient at a speed relative to their size, (larger molecules moving faster and so further down the gradient). After centrifugation the gradient is removed in a stepwise fashion and the content of each fraction determined. Keeping the same conditions throughout several experiments allows comparisons of size to be made with known standards.

In this thesis the molecules to be separated are different sizes of DNA. To detect breaks or discontinuities in only one of the DNA strands alkaline sucrose gradients were used (the alkaline conditions separating the double stranded DNA). The fractions were removed from the bottom of the gradient, so the larger DNA fragments are contained within the lower numbered fractions and the smaller fragments within the higher numbered fractions.

The DNA from an untreated, control cell will peak in a certain fraction, being fairly high molecular weight, but other sizes of DNA will also be found due to, for example, DNA replication or repair. Certain mutants of E.coli deficient in DNA metabolism show different distributions of DNA in sucrose gradients. These experiments try to demonstrate the different distributions of DNA sizes throughout the fractions for some D.radiodurans mutants and compare them to what is thought to be occurring to the DNA within the cell, hoping to shed light on the nature of the mutations in rec1 and rec30 especially.

### 3.4 SEDIMENTATION IN ALKALINE SUCROSE GRADIENTS

Variation in the position of unirradiated control peaks was found from fraction 13 to 18 in the four *D.radiodurans* strains used, (though most peaks were found in fraction 14 or 15), despite conditions being as constant as possible. The reason for this is unknown, but this variation has been previously observed by Smith and Meun (1970) and Kapp and Smith (1970) in alkaline sucrose gradients of *E.coli*. Because of this the following figures show the results of sucrose gradients obtained from the same experiment (involving the same culture and run at the same time). This variation obviously puts doubt upon the accuracy of DNA molecular weight measurements taken from the figures, but when the two standards,  $\lambda$  and T<sub>4</sub>, were run twice each on separate occasions they were found in the same fraction each time. Despite the possible explanation that the DNA in a cell is in a much more dynamic situation than that in an isolated bacteriophage, (and so variations in the gradients or running conditions are not responsible), measurements taken from gradients are considered only to be estimates.

#### (i) RECOMBINATION REPAIR

DNA synthesized after U.V. irradiation contains defects, so when U.V. treatment is followed by DNA labelling and analysis upon alkaline sucrose gradients, lengths of DNA shorter than those found in unirradiated cells are seen. This is due to replication occurring past damage in the parental DNA, leaving gaps in the daughter strand where the template cannot be read (Chapter One, Figure 1.6). The newly synthesized DNA then increases in size (and so sediments in a

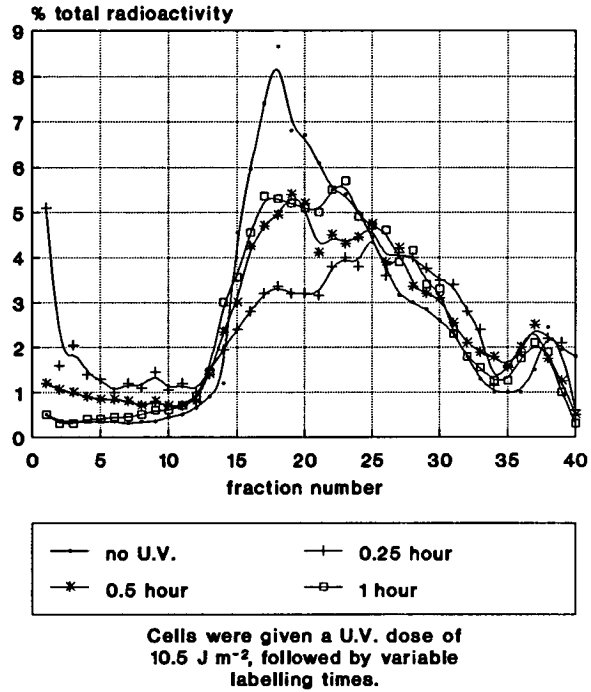
lower fraction) due to recombination repair filling the gaps, gradually reaching the size of unirradiated controls. Excision repair is not observed by this labelling method, but affects the gradient profile as damage may be removed before the replication fork reaches it.

Difficulty was experienced when *D. radiodurans* was labelled after U.V. irradiation in obtaining gradient profiles which showed a distinct peak, or even low counts in the lower or higher fractions. The pulse chase of UVS78 in Figure 3.11 shows a mild example of this. This was also found by Evans (1984) and by Moseley *et al.* (personal communication) and, at the time, prevented such experiments from being carried out.

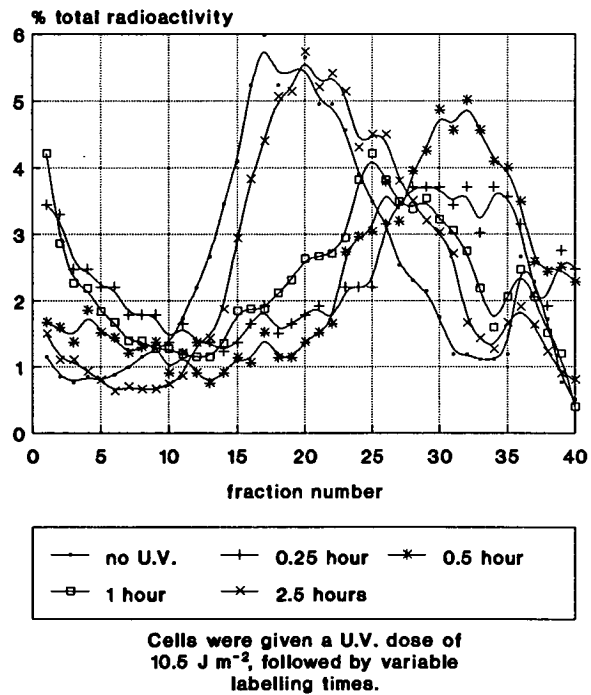
Figures 3.6, 3.7, 3.8 and 3.9 show the results of alkaline sucrose gradients of *D. radiodurans* R1, UVS78, *rec1* and *rec30* respectively, where the DNA was labelled after a U.V. dose of  $10.5 \text{ J m}^{-2}$ . Pulse chase results, Figures 3.10, 3.11, 3.12 and 3.13, (where cells were labelled for 0.5 hour and followed by 1.5 hours in TGY only), confirmed that newly synthesized DNA increased in size in each case to give a DNA distribution similar to that of the unirradiated control. When the DNA was labelled for variable amounts of time all four strains also showed a return (after incubation) to a gradient peak approaching that of unirradiated DNA, but via very different profiles.

The strains R1 (wild type) and *rec30* (recombination deficient) produced very similar gradient profiles. Both showed only a small proportion of DNA at times 0.25, 0.5 and 1 hour in the higher fractions than in their respective unirradiated controls, and further incubation of 2 and 3 hours respectively fully cures this.

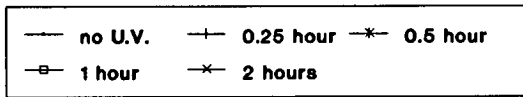
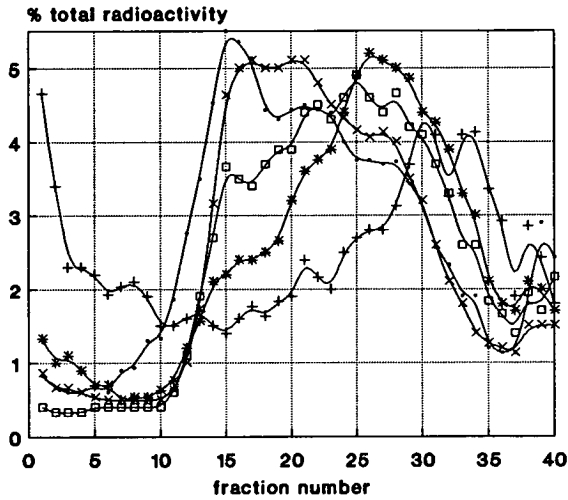
**FIGURE 3.6 INCORPORATION OF THYMIDINE INTO R1 DNA AFTER U.V.**



**FIGURE 3.7 INCORPORATION OF THYMIDINE INTO UVS78 DNA AFTER U.V.**

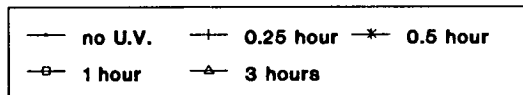
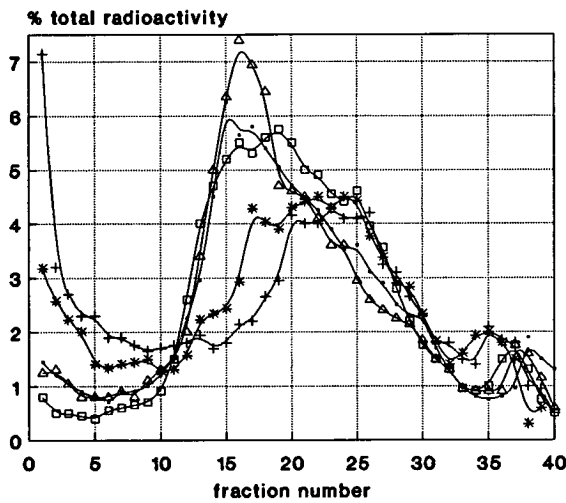


**FIGURE 3.8 INCORPORATION OF THYMIDINE INTO REC1 DNA AFTER U.V.**



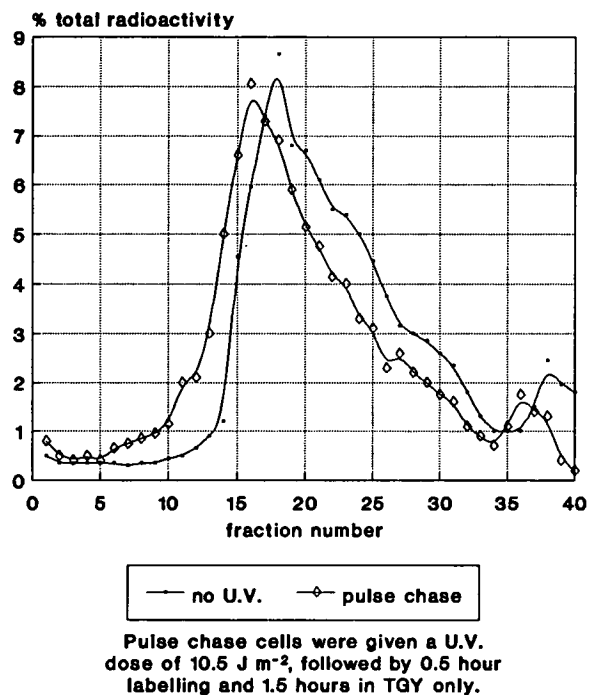
Cells were given a U.V. dose of  $10.5 \text{ J m}^{-2}$ , followed by variable labelling times.

**FIGURE 3.9 INCORPORATION OF THYMIDINE INTO REC30 DNA AFTER U.V.**

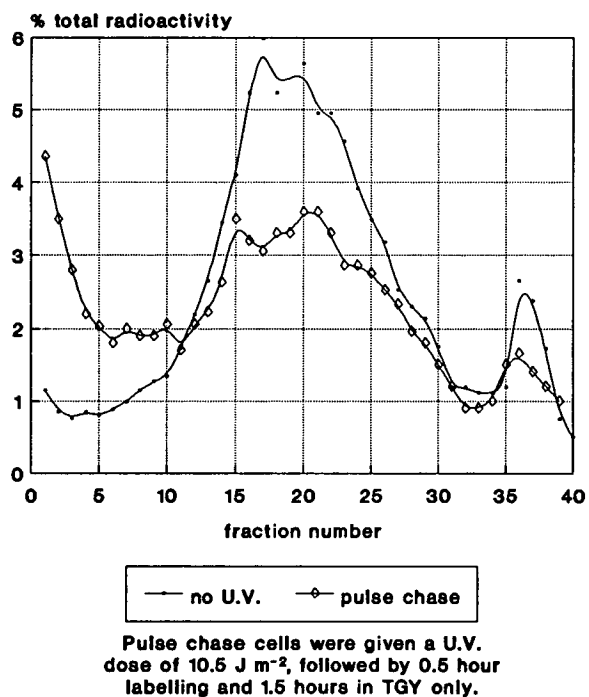


Cells were given a U.V. dose of  $10.5 \text{ J m}^{-2}$ , followed by variable labelling times.

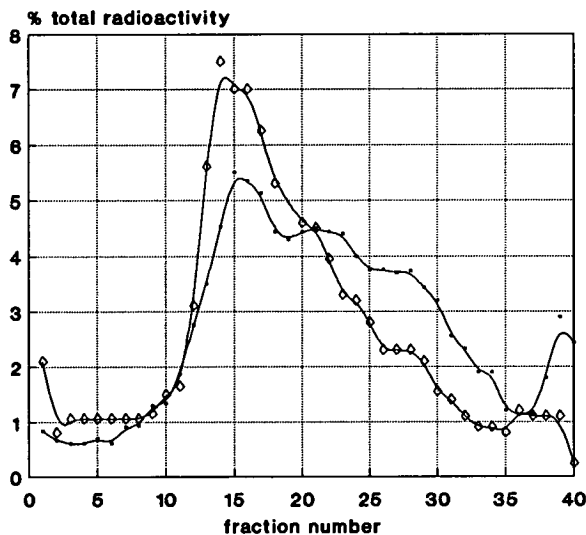
**FIGURE 3.10 INCORPORATION OF THYMIDINE INTO R1 DNA AFTER U.V. - PULSE CHASE**



**FIGURE 3.11 INCORPORATION OF THYMIDINE INTO UVS78 DNA AFTER U.V. - PULSE CHASE**



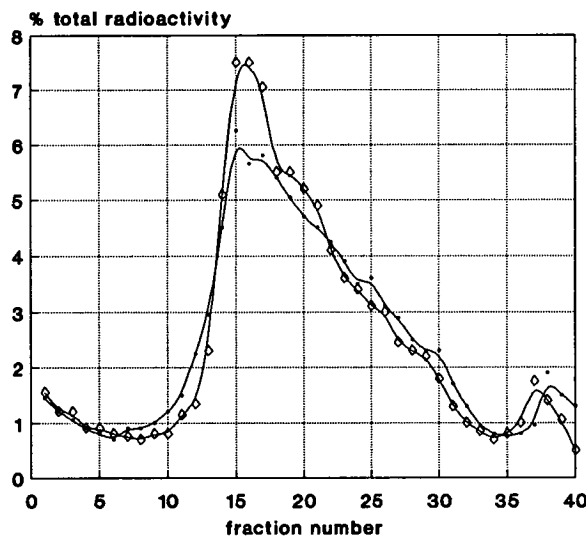
**FIGURE 3.12 INCORPORATION OF THYMIDINE INTO REC1 DNA AFTER U.V. - PULSE CHASE**



— no U.V.    ◊ pulse chase

Pulse chase cells were given a U.V. dose of  $10.5 \text{ J m}^{-2}$ , followed by 0.5 hour labelling and 1.5 hours in TGY only.

**FIGURE 3.13 INCORPORATION OF THYMIDINE INTO REC30 DNA AFTER U.V. - PULSE CHASE**



— no U.V.    ◊ pulse chase

Pulse chase cells were given a U.V. dose of  $10.5 \text{ J m}^{-2}$ , followed by 0.5 hour labelling and 1.5 hours in TGY only.

In UVS78 (no excision repair) and ~~rec1~~ (recombination deficient) strains all profiles showed a greater proportion of DNA in higher fractions than in the control, this was not remedied even after 2.5 and 2 hours post-U.V. incubation respectively.

Evans (1984) obtained the number of pyrimidine dimers formed by a given U.V. dose. The relationship is linear and allows the calculation of the dose required to produce one pyrimidine dimer, which is  $0.0227 \text{ J m}^{-2}$ . The dose of  $10.5 \text{ J m}^{-2}$  used here therefore produces approximately 462 pyrimidine dimers per genome of  $2 \times 10^9$  Daltons.

Strain UVS78 showed a high proportion of DNA after 0.5 hour labelled in the 30 to 33 fractions, between 4.69 and  $1.74 \times 10^7$  Daltons (average  $3.21 \times 10^7$ ). This equals approximately 62 breaks in the genome ( $2 \times 10^9$  divided by  $3.21 \times 10^7$ ). The doubling time of UVS78 in these conditions was 3.8 hours; 0.5 hours approximates to 13% of the doubling time, or 13% of the number of dimers formed have been passed by the replication fork, (assuming that they are evenly distributed throughout the genome), introducing the corresponding number of breaks into the daughter DNA. This is 60 dimers in total, very near the estimated level of 62.

Similarly, a large proportion of the DNA labelled after 0.25 hour was found in fractions 27 to 35, from 9.47 to  $0.65 \times 10^7$  Daltons (average  $5.06 \times 10^7$ ), or 39 breaks in the chromosome. Labelling for 0.25 hours (6.5% of the doubling time), assuming the pyrimidine dimers are evenly distributed, means that 6.5% of the number of dimers formed (30 dimers) have been replicated past, still not very far away from the estimated figure of 39.

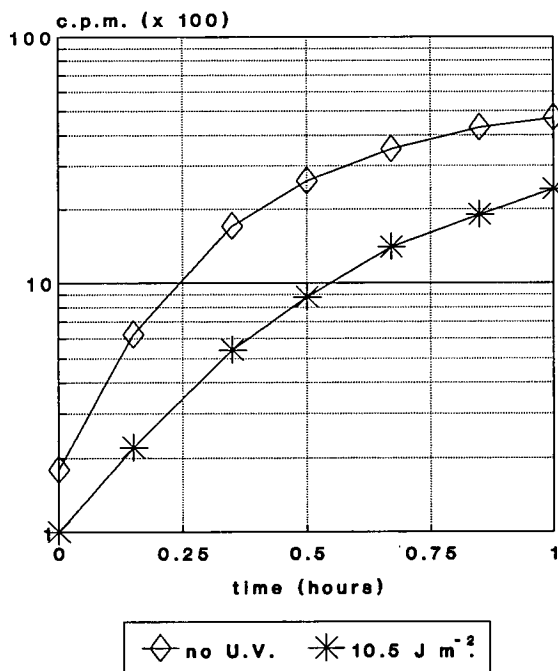
Both indicate that the size of DNA synthesized after U.V. is

approximately the same as the estimated distance between pyrimidine dimers in irradiated DNA strands, as in the classic experiments upon *E.coli* (Rupp and Howard-Flanders 1968, Rupp et al. 1971).

The doubling time of UVS78 can also be used to calculate the time required for the replication fork to by-pass a dimer and continue replication. In these conditions with no U.V. the doubling time was 2.5 hours, and after  $10.5 \text{ J m}^{-2}$  U.V. 3.8 hours, or an extra 80 minutes. It can therefore be estimated, assuming the 462 dimers to be evenly distributed, that there is approximately a 10.39 second pause at each dimer. This is very similar to the 10 seconds required in *E.coli* (Rupp and Howard-Flanders 1968, Rupp et al. 1971).

The calculations above rely upon the low U.V. dose having negligible effect upon DNA replication in UVS78. Figure 3.14 shows the effect on DNA replication after  $10.5 \text{ J m}^{-2}$  U.V., as indicated by the incorporation of  $^3\text{H}$ -thymidine into TCA-insoluble material, and shows

FIGURE 3.14 UPTAKE IN UVS78



no time lag and little decrease in DNA synthesis.

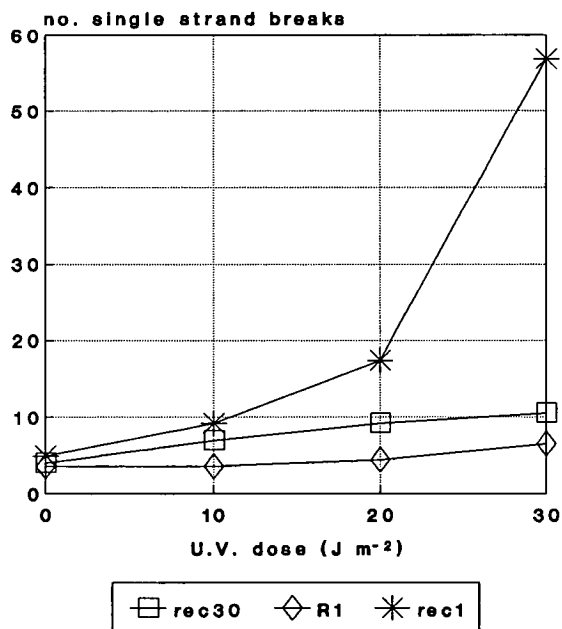
## (ii) EXCISION REPAIR

If the DNA of *D. radiodurans* is labelled, the bacteria irradiated and then the DNA is subject to an alkaline sucrose gradient excision repair is observed, or, more correctly, the incision event associated with such repair.

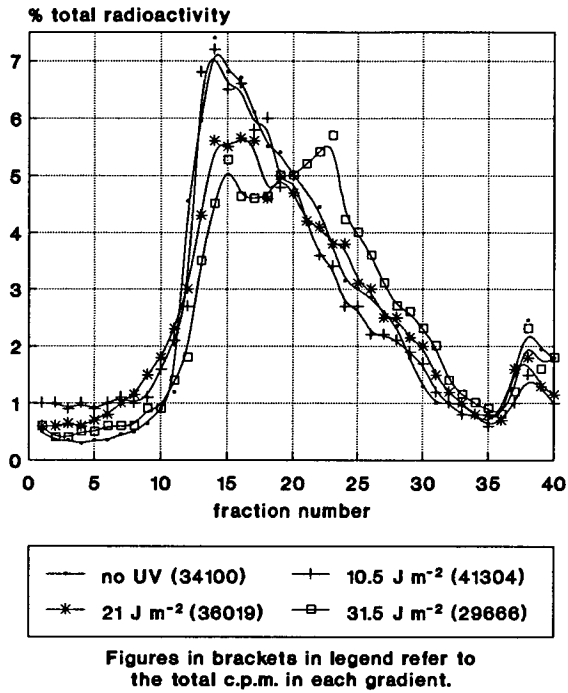
Cells from *D. radiodurans* strains R1, UVS78, rec1 and rec30 were given U.V. doses of 10.5, 21 and 31.5 J m<sup>-2</sup> and the incision events observed are shown in Figures 3.15, 3.16, 3.17 and 3.18 respectively. Strain UVS78 shows no incision at all, as it is incapable of excision repair (Evans 1984). The other strains do show single strand breaks in response to U.V. damage to variable extents.

Figure 3.19 compares the number of single strand breaks

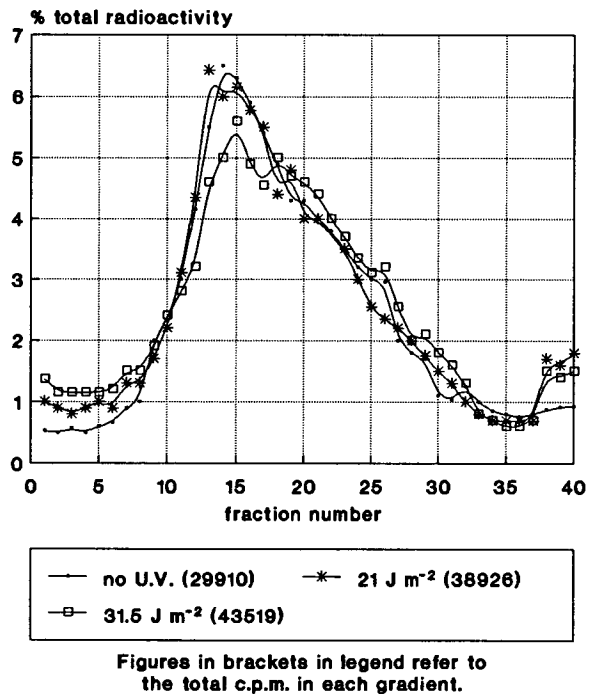
**FIGURE 3.19 SINGLE STRAND BREAKS  
IN DNA AFTER U.V.**



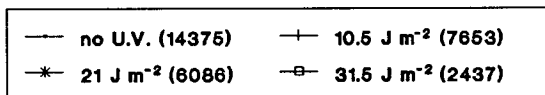
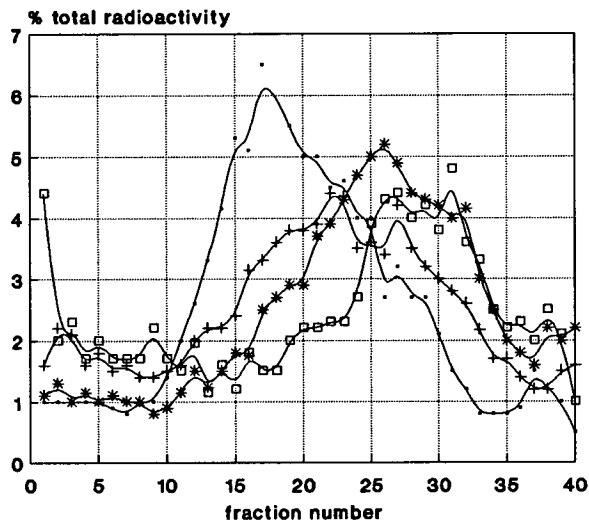
**FIGURE 3.15 FORMATION OF SINGLE STRAND BREAKS IN R1 DNA AFTER U.V.**



**FIGURE 3.16 FORMATION OF SINGLE STRAND BREAKS IN UVS78 DNA AFTER U.V.**

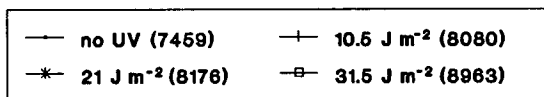
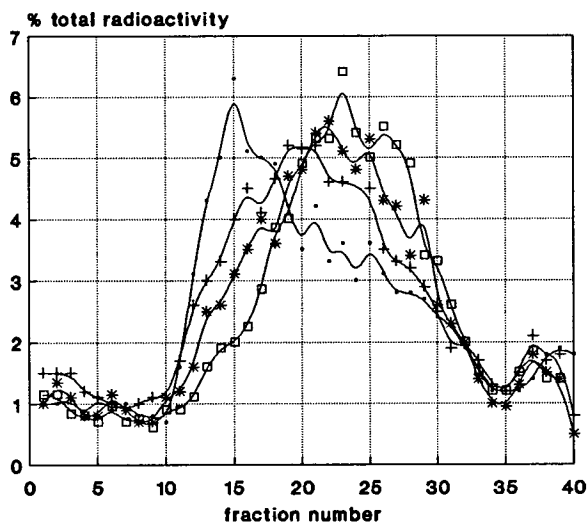


**FIGURE 3.17 FORMATION OF SINGLE STRAND BREAKS IN REC1 DNA AFTER U.V.**



Figures in brackets in legend refer to the total c.p.m. in each gradient.

**FIGURE 3.18 FORMATION OF SINGLE STRAND BREAKS IN REC30 DNA AFTER U.V.**



Figures in brackets in legend refer to the total c.p.m. in each gradient.

introduced into the chromosome after various U.V. doses and shows that *rec1* has excessive incision (as found by Evans 1984), and that *rec30* has approximately double the incision rates as the wild type.

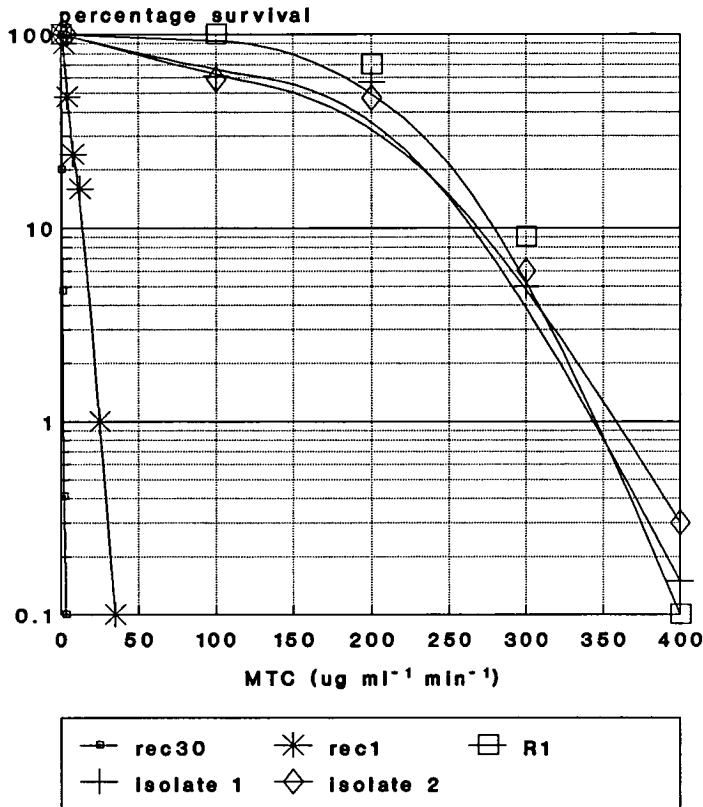
### 3.5 TRANSFORMATION IN REC30

The recombination deficient strain *rec30*, previously thought to be totally recombination deficient (Moseley and Copland 1975b), was found to show a low level of transformation. Transformation frequencies approximately ten-fold below that of *D. radiodurans* R1 were found when using Rf resistance ( $10^{-4}$  compared to levels of  $10^{-3}$  to  $10^{-2}$ ). This was thought to be due to improvements in the transformation procedure since isolation, as *D. radiodurans* R1 Rf<sup>r</sup> transformation frequencies have increased from levels of  $1 \times 10^{-4}$ , obtained when transformation was first reported by Moseley and Setlow (1968), to the present levels after calcium treatment was investigated by Tirgari and Moseley (1980).

As a low level of transformation was found the question of the uniformity of the *rec30* population was raised. Perhaps the transformed cells were totally recombination proficient but were only a small proportion (approximately 10%) of the whole *rec30* population. This was tested by obtaining Rf<sup>r</sup> *rec30* by transformation (using DNA from R1) and testing these bacteria for MTC<sup>r</sup> by growth on medium containing different levels of MTC. If the population of cells that are transformable were different from *rec30* then they will show an increased MTC<sup>r</sup>. Thirty *rec30* Rf<sup>r</sup> colonies were tested and all showed the same sensitivity as *rec30*.

Two colonies were further subject to a MTC survival curve, the same curve was obtained with *rec30* and the Rf<sup>r</sup> *rec30* (not shown).

**FIGURE 3.20 MTC SURVIVAL OF REC30  
TRANSFORMED TO MTC RESISTANCE**



In addition a MTC survival curve was carried out on rec30 to obtain colonies which grew after prolonged MTC exposure, (working on the basis that these colonies were most likely to be MTC resistant and not recombination deficient mutants). A second MTC survival curve was performed on the colonies growing after MTC exposure and an identical shape to rec30 was found (not shown). Both results confirm that rec30 is not a mixed population.

Transformation of rec30 with *D. radiodurans* R1 DNA and selection for recombination proficient cells via MTC resistance produced significant numbers of cells with R1 MTC<sup>r</sup>, (transformation frequency to MTC<sup>r</sup> of  $3.8 \times 10^{-5}$ ). Twenty suspected rec30 MTC<sup>r</sup> colonies were further streaked onto MTC plates for the production of single

colonies, all grew. Two colonies (isolates 1 and 2) were picked at random and subject to a MTC survival curve, Figure 3.20, (the shape of which is characteristic for a particular mutant or strain). This Figure shows the two isolates to have a similar, if not identical, MTC<sup>r</sup> as *D.radiodurans* R1. The transformation rate to Rf<sup>r</sup> was also obtained for the two MTC<sup>r</sup> rec30 and was found to be at levels associated with *D.radiodurans* R1. The transformed rec30 were taken to be wild type.

As MTC<sup>r</sup> recombination proficient transformants had been isolated the procedure was then attempted using gene libraries constructed in cosmid pJBFH and plasmid pAT153 (Chapter Three 3.1 (i) and (ii) respectively).

### 3.6 ISOLATION OF NOVEL *D.RADIODURANS* SPECIES

Soil was collected from various sites and tested for the isolation of novel *Deinococcus* species, as shown in Table 3.5.

A total of 28 soil samples were collected, mostly from exposed positions in the Lake District with poor soil characteristic of such areas. Soil was taken largely from high level sites where an organism spread by air currents might be found. Attempts were also made to isolate *D.radiodurans* from soil which had been enriched for radiation resistant bacteria by being exposed to irradiation over a long period of time, soil from the Sellafield Nuclear site (formerly Windscale) was obtained which had been given a very low gamma dose over 25 years.

Despite the success of Masters (1988) in the isolation of new *Deinococcus* species none were found in the samples tested.

TABLE 3.5 SOIL SOURCES

Source	Grid reference	Height (feet) <sup>a</sup>	Notes
High Raise Summit	282095	2500	Peaty
Easedale Tarn	310087	900	Damp, peaty soil
Torver	285945	358	
Torver Bridge	270965	1400	Fine, dry soil
Walna Scar	258965	2000	Fine, dry soil, much vegetable matter
Dow Crags Summit	263977	2500	Fine, dry soil, much vegetable matter
Coniston Old Man	273978	2631	Much vegetable matter
Levers Hause	271996	2100	
Dalton-in-Furness	231740	100	Garden soil
Grassmere	334083	300	Gritty, poor soil
Killy Crag	295993	1200	
Millom	185800	50	Garden soil
Swirl How	273005	2650	
Stickle Tarn	288078	1500	
Harter Fell	201025	1000	Peaty soil
Brown Tongue	198074	1400	Dry soil
Whitehaven	982184	50	Garden soil
Wasdale Green	186087	250	Dry soil
Scawfell Pike	215073	3200	Peaty, much sediment
River Ehen - Pumphouse	092156	300	Damp soil from near river
River Ehen - North Brow	"	"	" " " " "
River Ehen - Outflow	"	"	" " " " "
River Ehen - Weir	"	"	" " " " "
Anglers Crag	105145	500	
Gosforth	061037	50	Garden soil
Sellafield Nuclear site	020037	25	Total Gray 0.66, 2.5 $\mu$ Sv
" " "	"	"	Total Gray 2, 7.5 $\mu$ Sv
" " "	"	"	Total Gray 6.6, 25 $\mu$ Sv

Note <sup>a</sup> height above sea level.

### 3.7 PLASMIDS IN *D.GRANDIS*

On the basis that plasmids are prevalent in the *Deinococci* (Mackay 1983) it seemed reasonable to assume that *D.grandis* would contain extrachromosomal elements.

#### (i) PLASMID ISOLATION

The *Deinococcus* methods of plasmid isolation were used on the basis of the close relationship between the deinococci and *Deinobacter*.

Centrifugation of cleared lysates in caesium chloride gradients was found to yield plasmid DNA bands fairly frequently with KS 0485 (approximately 3 in 4 succeeded). However the KS 0460 success rate was only approximately 1 in 4. A common problem encountered was the cell lysis of both strains; bulk volumes were found to be more difficult to lyse than those involved in small scale plasmid isolations. Optimisation of lysis conditions was not attempted, but should not prove too difficult. KS 0460 was disappointing in that commonly the extraction procedure appeared to work as expected yet no plasmid bands were seen, even if the portion of the gradient where they might be expected was removed as usual and run on an agarose gel. The DNA yields were low when the procedure was successful, being approximately 30 and 20  $\mu\text{g l}^{-1}$  for KS 0485 and KS 0460 respectively, compared to approximately 50  $\mu\text{g l}^{-1}$  for *D.radiodurans* SARK and 100 to 500  $\mu\text{g l}^{-1}$  for various *E.coli* plasmids. The caesium chloride gradients, after running, were also very dirty, (KS 0460 being worse than KS 0485), suggesting that the protein extraction procedure was not as efficient as for *D.radiodurans*, (this may be related to the low plasmid yields as

they may be affected by the presence of nucleases).

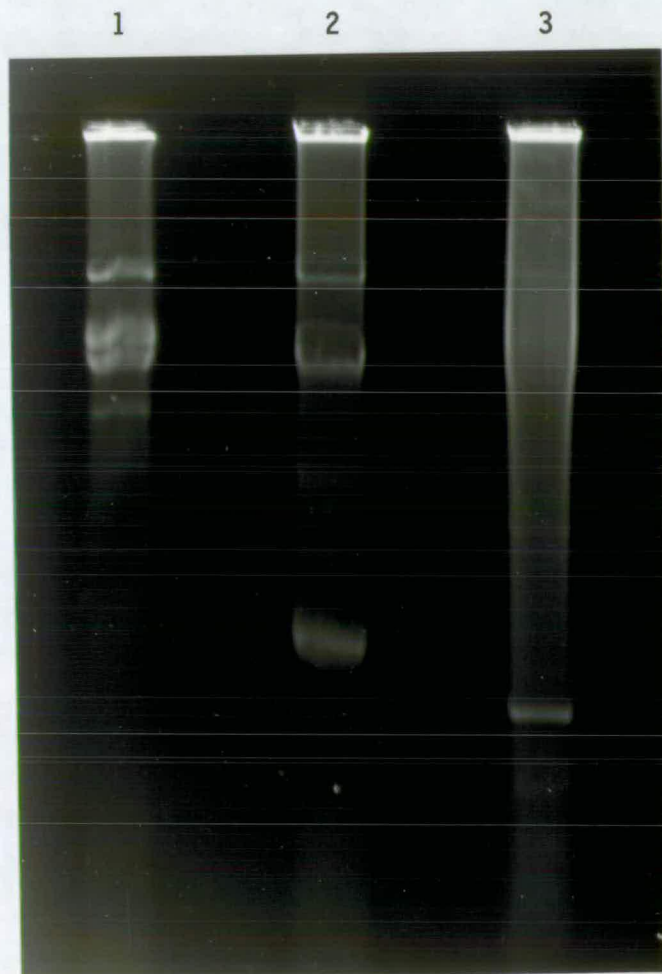
A large scale plasmid extraction procedure for *D.grandis* KS 0485 (Chapter Two 2.13 (ii)) was derived from a combination of the *E.coli* Birnboim preparation (Chapter Two 2.13 (iv)) and the *D.radiodurans* mini preparation (Chapter Two 2.14 (ii)). This method, although tried numerous times (being relatively quick compared to the caesium chloride method) did not work at all with KS 0460, yielding an insoluble, white, "chalky" deposit containing no DNA although extraction had seemed to proceed as normal. KS 0485, however, gave more reproducible results with this method, yielding approximately 10 µg per 100 ml of culture, excellent yields compared to the caesium chloride method (it may be speculated that this method, being faster, restricted the action of nucleases upon plasmid DNA).

In addition both *Deinococcus* plasmid mini preparations were tried, as was the *E.coli* alkaline lysis method. The most consistent results were obtained with the *Deinococcus* method 2, (Chapter Two 2.13 (ii)), although KS 0460 still gave only a 50% success rate. Again, when KS 0460 failed to yield plasmid DNA extraction had seemed to proceed as expected. The mini preparation methods, however, produced "dirty" preparations which were not suitable for restriction digestion and so could probably be improved. KS 0460 and KS 0485 plasmid preparations obtained by the *Deinococcus* method 2 are shown in Figure 3.21.

FIGURE 3.21 PLASMIDS IN D.GRANDIS KS 0460 AND KS 0485

Agarose gel showing the products of plasmid mini preparations

- Lane 1 *D.radiodurans* SARK showing uncut open circular plasmids of sizes 37.0 and 44.9 kb, and a dimer of the 37 kb plasmid at 74.2. The band running in front of the 37 kb band is thought to be the supercoiled 37 kb plasmid. Sizes from Mackay (1983).
- Lane 2 *D.grandis* KS 0485 plasmids of approximate size 90, 30.3, 14.6 and 8.0 kb. Plasmid sizes calculated from other gels by comparison with  $\lambda$  HindIII standards.
- Lane 3 *D.grandis* KS 0460 plasmids of approximate size 90\* and 7.4 kb\* and estimated size (from this Figure only) of approximately 25 kb.\* Calculated from other gels by comparison with  $\lambda$  HindIII standards.



## (ii) PLASMID CHARACTERISATION

When the isolated *D.grandis* plasmids were run on agarose gels several bands were seen (Figure 3.21). Small plasmids of both KS 0460 and KS 0485 were always observed, with estimated sizes (by graphical method only) of 7.4 and 8.0 kb respectively. Larger plasmids of approximately 90 kb were also always found in both strains, but this large size cannot be accurately measured by agarose gel electrophoresis methods (Southern 1979).

Other plasmid species were occasionally seen in KS 0485 of approximately 30.3 and 14.6 kb. Additional plasmids not seen in KS 0460, probably as mini plasmid preparations were not as good quality as those of KS 0485, and very few caesium chloride gradients were successful. Figure 3.21, however, shows an extra band (of estimated size 25 kb) than those seen on the gel itself due to the exposure and enlargement involved in producing the photograph. Even more plasmids bands may be present, but it is difficult to be sure.

To further characterise and more accurately size the plasmids restriction enzyme analysis was carried out, but patterns were obtained (Table 3.6 and 3.7) that were not compatible with the approximate sum of the plasmid totals (even if the possibility of multimers is considered). This, and the transitory nature of the appearance of other plasmids from mini preparations, led to sizing using electron microscopy.

TABLE 3.6 RESTRICTION PRODUCTS OF *D.GRANDIS* KS 0460 PLASMIDS

Using plasmid prepared by a caesium chloride preparation.

	Restriction enzyme used			
	<i>EcoRI</i>	<i>PstI</i>	<i>BamHI</i>	None
Fragment size (kb)	24	7.1	9.4	90
	11	6	6.3	7.4
	9.4	5.6	5.2	
	6.3s	4.5	4.4	
	5.6	3.4	4.15	
	2.9	3.1	3.75	
	1.3	2.9	3.35	
		2.6	3.2	
		2.3	2.95	
		2.2	2.7	
		2.05s	2.6	
		1.95	2.5	
		1.9	2.3	
		1.8	2	
		1.65s	1.8	
		1.6	1.65	
		1.5	1.45	
		1.45	1.4	
		1.4	1.3	
		1.3s	1.2	
	1.2	1.1		
	1.1s			
	1			
Total (kb)	60.5 66.8 <sup>a</sup>	59.6 65.7 <sup>a</sup>	64.7	97.4

Notes

s especially bright bands on agarose gel of restriction products.

<sup>a</sup> if bright bands are counted twice.

TABLE 3.7 RESTRICTION PRODUCTS OF D.GRANDIS KS 0485 PLASMIDS

Plasmids prepared by *D.grandis* KS 0485 method (Chapter Two 2.13 (ii)).

	Restriction enzyme used						
	<i>Xho</i> I	<i>Bst</i> EI	<i>Sa</i> I	<i>Pst</i> I	<i>Bam</i> HI	<i>Eco</i> RI	None
	17	8.2	21	9.2	17	12.2	90
	14.6	7.6	12	8.4	12	10.6	14.6
	11.2	6.3	9.4	6.9	6	8.3	8.0
	6.9	5.3	8.3	5.7	5	7	
	6.2	4.7	6.6	4.7	4.1	6.5	
	3.7	4	6	4.3	4	6.2	
	3	3.6s	5.2	4.1	3.8	5.4	
Frag- ment size (kb)	2.4	3.3	5	2.9	3.1	5.1	
		3.2	4.4	2.8	3	4.2	
		2.9s		2.5	2.8	4	
		2.6		0.7	2.7	2.8	
		2.5				2.4	
		2.3				2.1	
		1.6				2	
		0.8					
Total (kb)	65.0	58.9 65.4 <sup>a</sup>	77.9	52.2	70.0	72.3	112.6

Notes

s especially bright bands on agarose gel.

<sup>a</sup> if bright bands are counted twice.

(iii) ESTIMATION OF PLASMID SIZE USING E.M.

The plasmid species of D.grandis measured using the E.M. indicated a variety of sizes, shown on Tables 3.8 and 3.9 on page 157. However, the standard deviation associated with some plasmid species was high in relation to the plasmid size and the number counted. The question arose, was one plasmid species being measured or were a group of similarly sized plasmids being included together?

To try and count more plasmid species and so reduce the standard deviation and resolve the question merely increased the standard deviation still further, so a different approach was tried. The measurements that were within a certain range were plotted on graphs to see the distribution of the sizes (Figures 3.22, 3.24 and 3.25). If a normal distribution curve was seen then it would be assumed that only one plasmid species was being measured, yet if two plasmids, for example, were being counted then a distribution curve with two peaks would be expected.

Where the distribution curve indicated that more than one plasmid species was present the measurements within a range around each peak were analysed by a simple statistical method, the t-test, to try and suggest the number of different plasmid species present.

FIGURE 3.23 THE 93.1 kb PLASMID OF *D.GRANDIS* KS 0485

The 93.1 kb plasmid of KS 0485 is shown below, visualised by E.M. as are a number of pAT153 standards and smaller KS 0485 plasmid molecules.

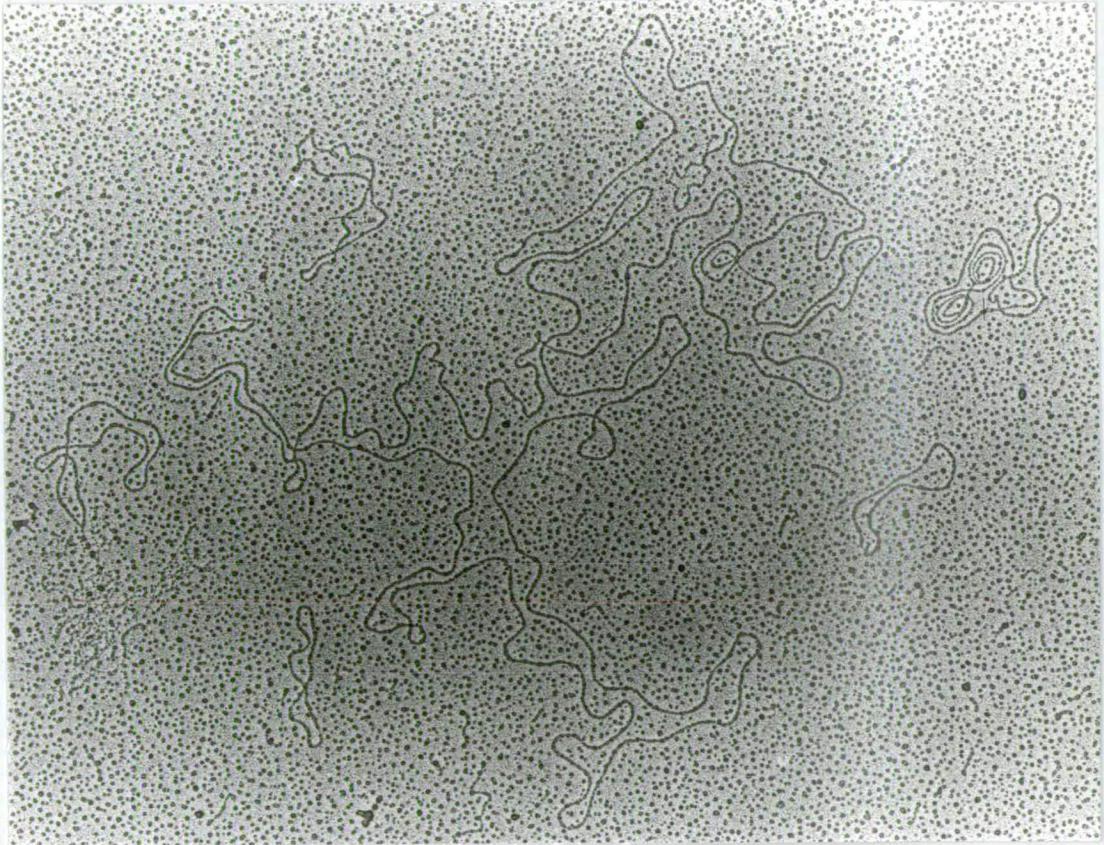


TABLE 3.8 PLASMID SIZES IN *D.GRANDIS* KS 0460 AS DETERMINED BY E.M.

Plasmid size ± S.D. (kb)	No. of molecules measured	95% probability level (kb)
94.7 ± 3.34	4	105.3 to 84.1
40.3 ± 0.30	2	44.1 to 36.5
27.0	1	
17.0 ± 0.69	6	18.7 to 15.2
9.05 ± 0.05	4	9.16 to 8.84
7.9 ± 0.39	70	8.29 to 7.12
6.2	1	

TABLE 3.9 PLASMID SIZES IN *D.GRANDIS* KS 0485 AS DETERMINED BY E.M.

Plasmid size ± S.D. (kb)	No. of molecules measured	95% probability level (kb)
93.1 ± 3.32	18	101.1 to 87
83.4	1	
66.9	1	
54.8	1	
49.6 ± 0.30	2	45.8 to 53.4
30.9	1	
24.6 ± 0.10	2	23.3 to 25.9
13.9	1	
9.5	1	
9.1 ± 0.08	3	8.75 to 9.45
7.77 ± 0.43	46	8.64 to 6.9
6.6	1	

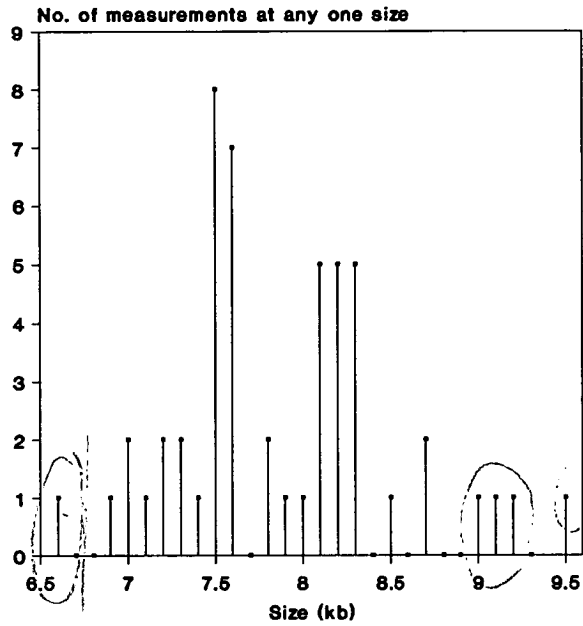
expected that with over 70 plasmid counts a more "classical" distribution curve would be expected.

The same situation occurs in KS 0485 with Figures 3.24 and 3.25, the distribution curve of the plasmid measurements from KS 0485 from 6 to 9.6 kb and 82 to 101 kb respectively. Neither shows the expected "classical" distribution curve and both can be further subdivided into separate plasmids on the basis of 95% confidence limits. Figure 3.24 indicates four separate plasmids with an average size of 6.6, 7.8, 9.1 and 9.5 kb. Though, again, there may be more within the 6.9 to 8.8 range as with 46 counts of a plasmid of the same size a distribution curve of this shape would not be expected. However, the distribution curve cannot be further subdivided into the two peaks suggested by Figure 3.24 of 6.9 to 7.9 and 8 to 8.8 kb using 95% confidence limits. Figure 3.25 also indicates the possibility of more than one plasmid being present at 83 kb and centring on 93.1 kb. Again the graph cannot be further subdivided on the basis of 95% confidence limits though there may be more than one plasmid species present.

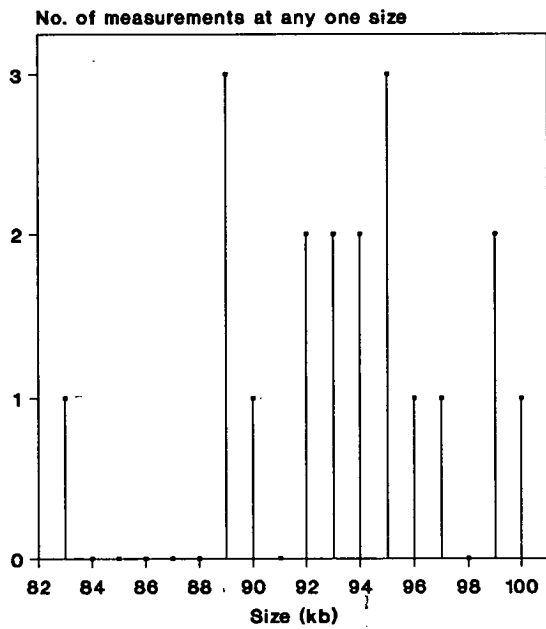
That 95% confidence limits were used to suggest the size of different plasmids found on the basis of the measurements made may seem arbitrary. However, it was used as simple analysis of a complex situation as many more plasmids would require counting to fully solve the problem. This was attempted but the more plasmids counted the more single counts were made of plasmids of a unique size.

The reason that many plasmid species were not observed upon agarose gel electrophoresis was thought to be due to their low copy number, (as suggested by the few molecules seen in E.M. preparations), and the fact that to see such plasmids the agarose

**FIGURE 3.24**  
**DISTRIBUTION OF *D.GRANDIS* KS 0485**  
**PLASMID MEASUREMENTS 6 TO 9.6 kb**



**FIGURE 3.25**  
**DISTRIBUTION OF *D.GRANDIS* KS 0485**  
**PLASMID MEASUREMENTS 82 TO 100 kb**



gel would have had to have been heavily overloaded and the DNA would therefore not have run correctly. Infrequent observation of the 30.9 and 13.9 kb plasmids of KS 0485 was probably due to the variability in the quality of the individual plasmid preparations. However, the estimated size of those plasmids that could be measured by both agarose gel electrophoresis and the electron microscopy compared well and are shown in Table 3.10.

TABLE 3.10  
COMPARISON OF THE ESTIMATED PLASMID SIZES IN *D.GRANDIS*

	E.M.	Agarose	E.M.	Agarose
	KS 0460	KS 0460	KS 0485	KS 0485
Plasmid size (kb)	94.7	90	93.1	90
	27	25	30.9	30.3
	7.9	7.4	13.9	14.6
			7.8	8.0

(iv) ATTEMPTS TO CONSTRUCT A *D.RADIODURANS* - *E.COLI* SHUTTLE VECTOR USING A *D.GRANDIS* PLASMID.

The *E.coli* vector pDS6 was used in attempts to isolate a shuttle vector between *E.coli* and *D.radiodurans* using a *D.grandis* plasmid. Plasmid pDS6 is an *E.coli* vector of 3.5 kb which carries Cm<sup>r</sup>, (which has been shown by Smith *et al.* (1988) to be expressed in *D.radiodurans*), and also Ap<sup>r</sup>.

Plasmid pDS6 (from a Birnboim preparation) was ligated to the restriction products of plasmids from KS 0485, (prepared using caesium chloride density centrifugation). Three restriction enzymes

were used independently, *Hind*III, *Pst*I or *Bam*HI, and the plasmids were ligated together using a ratio of 1  $\mu$ g pDS6 to 2  $\mu$ g KS 0485 plasmid. All three enzymes cut after a promoter in pDS6 and before a weak terminator to prevent read-through into *cat* (chloramphenicol resistance). The ligation was monitored by the use of agarose gels.

The ligated mix was then transformed into *E.coli* HB101 and Ap<sup>r</sup> transformants were selected. A Birnboim plasmid preparation was performed using the transformants and the resulting DNA was transformed into *D.radiodurans* SARK (using approximately 10  $\mu$ g plasmid per transformation mix). Approximately  $3 \times 10^8$  *D.radiodurans* transformants were plated out onto media containing 3  $\mu$ g ml<sup>-1</sup> Cm. After overnight expression and the normal incubation period 1 Cm<sup>r</sup> colony appeared. A plasmid mini preparation was performed and transformed into *E.coli* HB101 and Ap<sup>r</sup> transformants selected. Two resistant transformants were isolated containing recombinant plasmids, but these were not characterised further. This is a promising avenue in the development of a *D.radiodurans* vector system, but a shortage of time prevented further work.

### 3.8 TRANSFORMATION OF *D.GRANDIS*

Attempts were made to transform *D.grandis* to Rf<sup>r</sup> using chromosomal DNA via the methodology established for *D.radiodurans* and also using electroporation.

#### (i) USING THE *D.RADIODURANS* METHOD

The method of transformation was as described for *D.radiodurans* in Chapter Two 2.15 (i). An excess of Rf<sup>r</sup>-containing chromosomal DNA was used to ensure that DNA concentration was not a limiting factor; approximately 20  $\mu$ g of *D.grandis* or 15  $\mu$ g of *D.radiodurans* DNA was

used per transformation. Incubation overnight allowed for expression. Table 3.11 shows the transformation frequencies to  $20 \mu\text{g ml}^{-1}$   $\text{Rf}^r$  obtained.

TABLE 3.11  
TRANSFORMATION OF *D.GRANDIS* USING THE *D.RADIODURANS* METHOD

	Transformation frequency			
Strain	Origin of DNA			
	KS 0460	KS 0485	R1	SARK
KS 0460	$2.4 \times 10^{-7}$	$4.9 \times 10^{-8}$	$2.9 \times 10^{-8}$	$1.27 \times 10^{-7}$
KS 0485	$4.2 \times 10^{-8}$	$1.27 \times 10^{-7}$	$7.05 \times 10^{-8}$	$4 \times 10^{-8}$
R1	$1.26 \times 10^{-7}$	$4 \times 10^{-7}$	$6.8 \times 10^{-3}$	$8.6 \times 10^{-6}$
SARK	$7.7 \times 10^{-6}$	$2.3 \times 10^{-5}$	$4.67 \times 10^{-3}$	$6.62 \times 10^{-3}$
Strain	No DNA			
KS 0460	$1.07 \times 10^{-8}$			
KS 0485	$3.49 \times 10^{-8}$			
R1	$3.2 \times 10^{-8}$			
SARK	$5.98 \times 10^{-8}$			

The results show that both *D.radiodurans* SARK and R1 can be transformed to  $\text{Rf}^r$  using both KS 0460 and KS 0485 DNA. The levels are low but, no doubt, could be improved. *D.radiodurans* R1 shows only a small increase in the  $\text{Rf}^r$  frequency ten-fold above that of the background when transformed using *D.grandis* DNA, but, as R1 possesses a restriction system and SARK does not this is not surprising and indicates that a different restriction-modification

system is operating in *D.grandis*. Levels approximately ten-fold above background were also found in both *D.grandis* strains when each was transformed with its respective DNA, though not when transformed with DNA from the other strain, indicating that *D.grandis* is transformable. *D.grandis* KS 0460 was also transformed to Rf<sup>r</sup> by DNA from SARK, although, again, at a low level. To try and improve the transformation frequencies electroporation was employed.

#### (ii) USING ELECTROPORATION

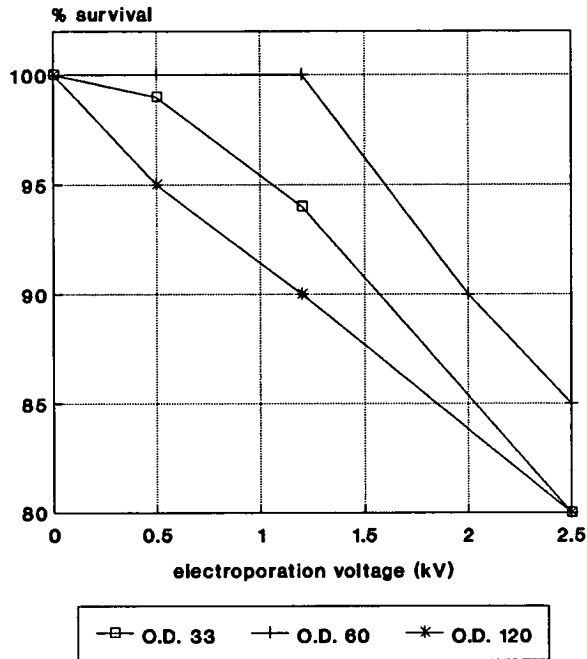
The mechanism by which electroporation causes DNA to be introduced into the cells is not fully understood, but is thought to involve the electric pulse causing holes to be formed in the cell membrane due to differences in potential across the membrane (Potter *et al.* 1984).

For each particular cell species the DNA uptake must be optimised by altering the variables involved; these include the capacitor size, the resistance of the circuit, the voltage and the cells themselves, (Bio-Rad Technical Publication 1987). The capacitor is used to deliver the electric pulse (an exponential decay waveform), the larger the capacitor the larger the discharge and the greater the damage caused to the cell. In attempts to electroporate *D.grandis* the capacitor was set at the maximum of 25  $\mu$ FD as, due to the unusual thickness of the cell wall, it was anticipated that *D.grandis* would be difficult to electroporate. The resistance of the circuit through which the current had to pass could be easily altered by using different buffers, the higher the ionic strength of the solution the less resistance offered and the faster the current passes through the cells. One of two buffers is

commonly used, either a sucrose or a phosphate buffered saline electroporation buffer. Sucrose buffer was used for *D.grandis* as it is the most resistant of the two (being the least ionic) and was thought to be more likely to cause membrane damage, allowing higher transformation frequencies to be obtained. Voltage affects the efficiency of electroporation through affecting cell survival (approximately 10% of cells are required to die before maximum transformation frequencies are found). The cells themselves also affect electroporation, the cell type, growth rate and growth phase are all usually important.

The effects of voltage on cell survival at various stages of cell growth are shown in Figures 3.26 and 3.27. KS 0485 in Figure 3.27 shows results as expected in that the higher the optical density of the cell solution (the older the culture) the more resistant to cell death the cells become. Figure 3.26 shows that KS 0460 is more resistant generally and that age has little effect, surprisingly, upon the sensitivity of the cells to an increased voltage. This difference between the two strains is presumably due to minor variations in the cell wall.

**FIGURE 3.26 ELECTROPORATION SURVIVAL OF *D.GRANDIS* KS 0460**



**FIGURE 3.27 ELECTROPORATION SURVIVAL OF *D.GRANDIS* KS 0485**

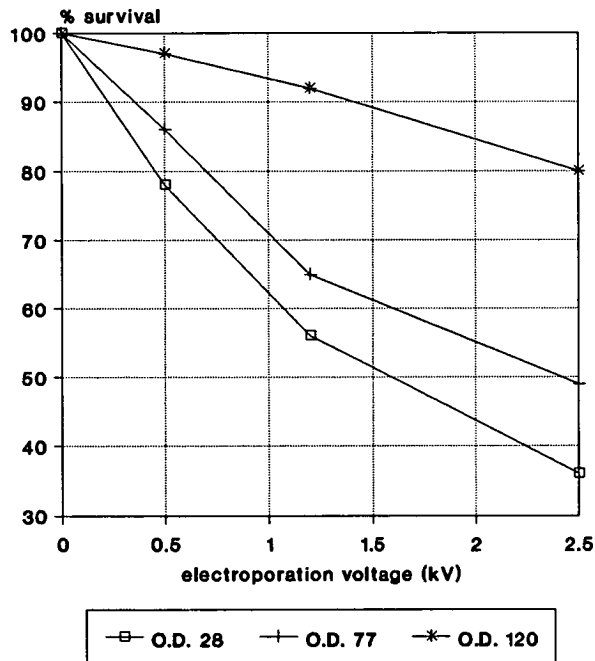


TABLE 3.12 TRANSFORMATION OF *D.GRANDIS* USING ELECTROPORATION

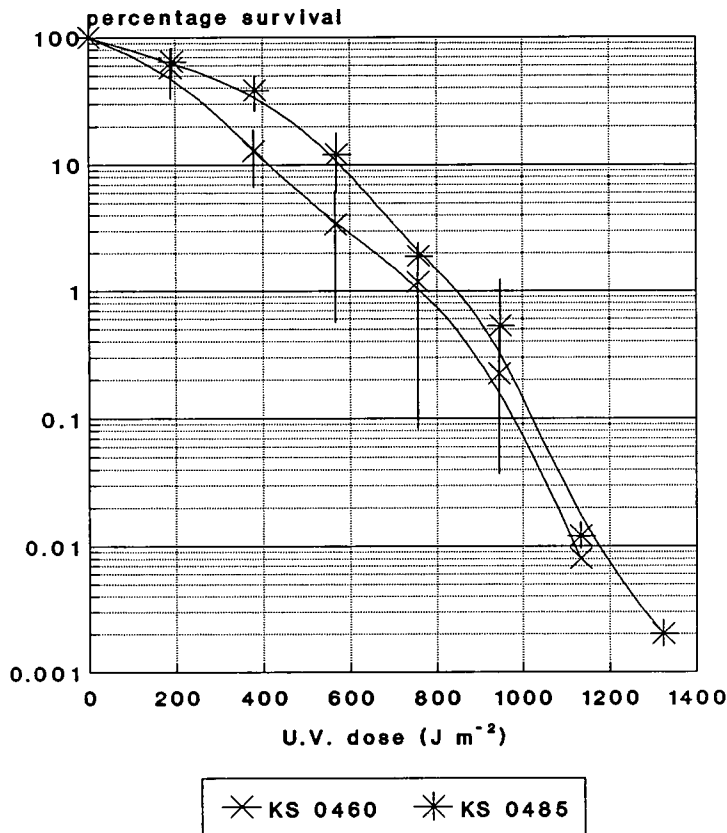
				Transformation frequency		
Strain	O.D.	kV	% survival	Origin of DNA		
				KS 0460	KS 0485	R1
KS 0460	20	2.5	87	$1.4 \times 10^{-8}$	$3.34 \times 10^{-9}$	$1.33 \times 10^{-8}$
"	60	2	90	$3.5 \times 10^{-9}$	$1.5 \times 10^{-8}$	$1.16 \times 10^{-8}$
"	120	0.5	95	$5.3 \times 10^{-8}$	$2.04 \times 10^{-9}$	$1.03 \times 10^{-8}$
KS 0485	15	0.5	84	$8.37 \times 10^{-8}$	$2.4 \times 10^{-8}$	$1.24 \times 10^{-7}$
"	70	0.5	80	$9.1 \times 10^{-8}$	$6.67 \times 10^{-8}$	$5.36 \times 10^{-7}$
"	120	2.5	75	$2.85 \times 10^{-8}$	$3.33 \times 10^{-8}$	$5.6 \times 10^{-8}$

The electroporation results show that KS 0485 can be transformed to Rf<sup>r</sup> by *D.radiodurans* R1 DNA, although at very low levels. No transformation of *D.grandis* to Rf<sup>r</sup> by *D.grandis* DNA is seen by electroporation.

### 3.9 U.V. SURVIVAL OF *D.GRANDIS*

The U.V. survival curve of *D.grandis* KS 0460 and KS 0485 is shown below in Figure 3.28. From this the U.V. D<sub>37</sub> can be calculated as 260 J m<sup>-2</sup> for KS 0460 and 400 J m<sup>-2</sup> for KS 0485.

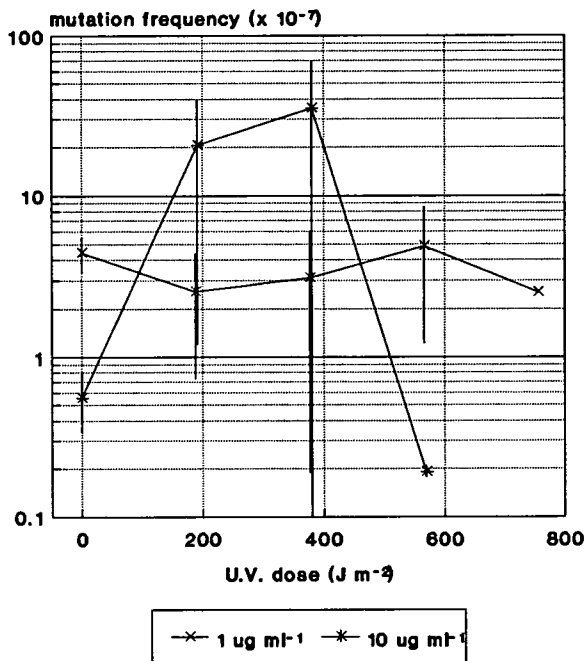
FIGURE 3.28 *D.GRANDIS* KS 0460 AND KS 0485 U.V. SURVIVAL CURVE



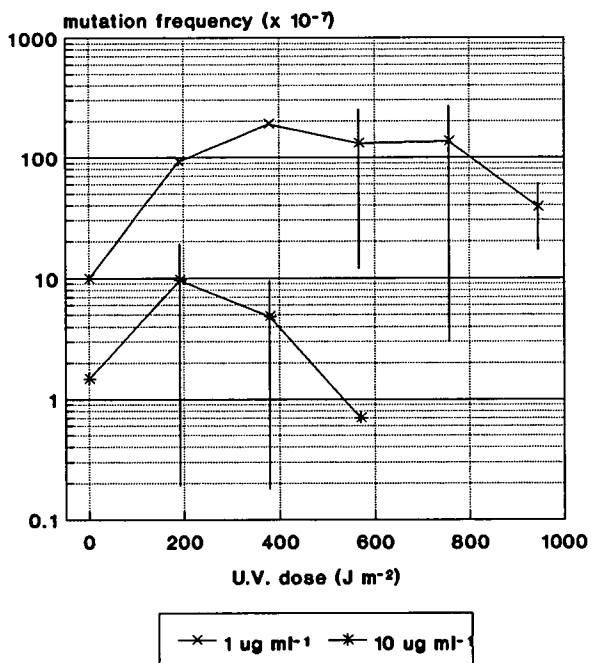
### 3.10 U.V. MUTABILITY OF *D.GRANDIS*

Figures 3.29 and 3.30 show the U.V. mutability of KS 0460 and KS 0485 respectively to Rf levels of 1 and 10 µg ml<sup>-1</sup>, the mutation frequency being calculated from the U.V. survivors. Both strains are mutable by U.V., though, unusually, the mutation frequency drops to 'normal' levels after 580 J m<sup>-2</sup> U.V. or after approximately 90% of the bacteria have died.

**FIGURE 3.29 *D.GRANDIS* KS 0460  
MUTATION FREQUENCY**



**FIGURE 3.30 *D.GRANDIS* KS 0485  
MUTATION FREQUENCY**



**CHAPTER FOUR**

**DISCUSSION**

## 4.1 THE DEINOCOCCI

### 4.1.1 ISOLATION OF A *recA*-EQUIVALENT

The failure to isolate from *D.radiodurans* a gene capable of restoring at least some functions of the RecA protein in *recA*<sup>-</sup> strains of *E.coli* could be due to many factors, and with so little information suggestions can be merely supposition.

Expression seems likely to be a problem as with many genes in a heterologous host, commonly thought to be caused by promoter differences. Consideration of the two *D.radiodurans* genes expressed in *E.coli* suggests that the *D.radiodurans* promoters were used in each case, (although neither vector was an expression vector, read-through from a vector promoter could have been responsible). Smith *et al.* (1989) reported that some *D.radiodurans* promoters were expressed in *E.coli* and sequencing work on the cloned major surface protein does demonstrate that regions similar to the Shine-Dalgarno sequence and -10 and -35 regulatory regions of *E.coli* are present (Peters *et al.* 1987). The *leuB* gene of the close relative *D.radiophilus* has also been expressed in *E.coli* and partially sequenced. It was found that the -10 regulatory region was similar to that of *E.coli* (Purvis 1984). So it would seem that promoter differences are not necessarily responsible for the inability of *D.radiodurans* genes to be expressed in *E.coli*.

When the DNA and protein sequences of the cloned *D.radiodurans* surface protein were compared an unusual codon usage was found (Peters *et al.* 1987), which may explain the weak expression of this gene in *E.coli*. This may also prevent the detection of products of cloned genes in other situations. However, it must be remembered that with so little data available upon the similarities of

*D.radiodurans* genes to those of *E.coli* it is dangerous to draw conclusions. For example, the *D.radiodurans* genes *uvrC*, *uvrD* and *uvrE* could not complement *E.coli* *uvrA*<sup>-</sup> strains (Al-Bakri et al. 1985). This is more likely to be due to problems in the dissimilar nature of the excision repair systems of *D.radiodurans* and *E.coli* than to expression difficulties.

It is also possible that the gene libraries did not contain the gene of interest. This is unlikely to be due to the presence of restriction sites within the gene as partial chromosomal digests were used whenever possible. Given the number of gene libraries screened, the absence of a RecA analogue within at least one of them is also considered improbable. Additionally, the use of expression vectors may result in the creation of a fusion protein unable to function and so unable to be identified by complementation.

Alternatively, the cloned gene may be lethal to the *E.coli* host, but, given the nature of recombinase genes, this was thought to be unlikely. To use a low copy number vector to overcome this is difficult as it may create problems in identifying possible recombinant clones. However, if a recombinase from *D.radiodurans* is so potent as to cause lethality this might be the ideal solution.

The possibility of the instability of a vector containing a gene involved in recombination must also be considered. Owtrim and Coleman (1987) reported the isolation of U.V. resistant cells from *E.coli* HB101 containing a gene library of *Anabaena variabilis*, but that the cells contained no plasmids. This was excused as vector instability in a host now considered recombination proficient due to the isolation of an *A.variabilis* *recA*-equivalent. This study found instability in the cosmid library of *D.radiodurans* in the *recA*<sup>-</sup> host

*E. coli* HB101 and unusual rearrangements in some recombinant plasmids. The explanation may be that the vector inserts were inverted repeat sequences, which can be lost during propagation in *E. coli*, even if *recA*<sup>-</sup>. This can be cured by using a host mutant in *recB*, *recC*, *sbcB*, *recJ* or *recN*, which blocks both the RecBCD and RecF recombination pathways, at the cost of low vector yield and a low transduction frequency (Ishiura *et al.* 1989). This could not be used to isolate *recA*-equivalent genes by complementation, but could be used for vector propagation only.

The inability to isolate a gene from *D. radiodurans* with some DNA homology to *E. coli recA* by DNA-DNA homology (Southern blotting) was not expected given the low levels of DNA homology seen between other *recA*-equivalents, (Table 1.2, Chapter One 1.4.2), and also the low levels of chromosomal DNA homology found between the different *Deinococcus* species. The absence of structural conservation (recognised by polyclonal antibody to *E. coli RecA*), however, was more surprising, given the many RecA-equivalents that are identified by this technique, including *Saccharomyces cerevisiae* (Augulo *et al.* 1985) and *Bacillus subtilis* (Lovett and Roberts 1985).

To isolate a RecA-equivalent from *D. radiodurans* further work should concentrate upon the isolation of the recombinase protein rather than the gene, such as was done, for example, with *B. subtilis* (Lovett and Roberts 1985) and *Salmonella typhimurium* (Pierré and Paoletti 1983) before cloning the gene responsible.

Alternatively, full use should be made of the wide range of sophisticated vectors available to try and attain expression in *E. coli* (listed, for example, in Pouwels *et al.* 1985). These include methods to remove such problems as insertion in an incorrect reading

frame in expression vectors and the prevention of read-through in strongly expressed genes. The development of a *D.radiodurans* vector by Smith *et al.* may occur soon, which would allow the cloning of the genes mutant in the *D.radiodurans* recombination deficient strains.

Two further possibilities exist. *D.radiodurans* may not possess a *recA*-like gene or gene product, but have a combination of several different, totally independent pathways. Alternatively, the enzyme central to recombination may be comprised of the products of different genes, similar, for example, to RecBCD. The possibility of confirming the existence of such an enzyme other than by biochemical isolation, followed by *in vitro* characterisation, is extremely remote.

The model proposed for recombination in *E.coli* seems to be valid for a wide variety of organisms (if not all) as *recA*-like genes and gene products have been isolated from many different sources (Chapter One 1.4.2). The phenotypic characteristics of mutants deficient in their respective RecA-equivalents are also very similar, suggesting the same central rôle for the RecA-homologue in many organisms. However, it must be remembered that it is not unknown for *D.radiodurans* to be an exception to the general rule! Consideration of Table 1.2 shows the isolation of *recA*-like genes by the complementation of *recA*<sup>-</sup> *E.coli* strains from members of two of the eight eubacterial groups (Stackebrandt and Woese 1981), indicating widespread conservation of a RecA-like protein. These are the cyanobacterial group (*Gloeocapsa*, *Synechococcus*, and *Anabaena*) and the purple (sulphur and non sulphur) bacterial group (including *Escherichia*, *Proteus*, *Rhizobium*, *Vibrio*, *Pseudomonas*, *Neisseria*, *Bacteriodes*, *Thiobacillus*, *Agrobacterium*, *Erwinia* and

*Shigella*). The *E.coli* RecA product also restores most RecE functions in a *recE*<sup>-</sup> *B.subtilis* host, a member of a third major eubacterial group containing the clostridia, actinomycetes and respective relatives. As yet no RecA-homologues have been isolated from the other five groups, the Spirochaeta, *Chlorobium*, *Leptospira*, *Chloroflexus* and *Deinococcus*.

#### 4.1.2 SEDIMENTATION IN ALKALINE SUCROSE GRADIENTS

The alkaline sucrose gradients of *D.radiodurans* R1, *rec1*, *rec30* and UVS78, where the DNA was labelled after U.V. irradiation, all show evidence of recombination repair. This was unexpected as *rec1* was considered to be totally recombination deficient, (as measured by transformation, Evans 1984). *Rec30* is also recombination deficient, but a similar ability for recombination repair as seen in strain R1 was demonstrated.

Comparison of the alkaline sucrose gradients produced with those of *E.coli* under similar conditions (Smith and Meun 1970) show that both R1 and UVS78 strains behave as anticipated given their known genotype. The results from UVS78 show the first physical evidence of the recombination repair of DNA damaged by U.V. irradiation in *D.radiodurans*.

Smith and Meun (1970) also performed a number of experiments with *E.coli* *recA*, *recB* and *recC* mutants. *E.coli* *recA* mutants have no recombinational ability, (and are therefore totally recombination repair deficient), so the DNA remains in fractions containing higher molecular weights, despite extensive incubation. *Rec1* and *rec30* show no similarity to this as both are capable of repairing damage, but with different profiles. However, results from an *E.coli* mutant in

either *recB* or *recC* showed that initially the DNA sedimented more slowly than that of the unirradiated controls, but increased incubation does return the sedimentation rate to that of the unirradiated DNA. This is similar to the situation found with *rec1* and *rec30*, *rec1* being the slower of the two. This suggests that *D. radiodurans* may perhaps have two recombination pathways, one involved in all aspects of recombination, operating in *rec30*, and another capable of recombination repair, but not recombination involved in transformation, operating in *rec1*. Alternatively, both mutations may be involved in the same pathway, but act at different stages.

Since the earlier work on recombinational repair the involvement of many different pathways has been suggested, as in homologous recombination, (for example, see Youngs and Smith 1976, Lloyd et al. 1988). Therefore, detailed characterisation of mutants using sedimentation in alkaline sucrose gradients is not really possible, given the large number of mutations that can cause minor alterations and that the gradients do not always reproduce the same peak positions. These results, however, do not contradict the suggestion that *rec30* may be analogous to *E. coli* strains lacking RecBCD, but confirm that *rec1* is not a *D. radiodurans* equivalent of either *E. coli* RecA or RecBCD mutants.

The classification of *rec30* as a strain mutant in the RecBCD equivalent is supported by its sensitivity to double-stranded DNA breaks (indicated by sensitivity to gamma irradiation), probably being inactivated by a very low number of double-strand breaks. These lesions are known to be repaired mainly by the RecBCD recombination pathway (Wang and Smith 1983).

The study of recombination repair in *D.radiodurans* has been hampered by the few recombination-deficient mutants available and the difficulty in characterising them. The isolation of more was attempted (data not reported) but no strains were found that could be considered totally recombination deficient (as determined by lack of transformation). Characterisation of those showing intermediate transformation frequencies was time consuming and considered not to be useful.

The sucrose gradients used to investigate excision repair confirm that, after a U.V. dose, *rec1* has excessive incision and UVS78 shows none, (as found by Evans 1984). However, *rec30* shows approximately double the incision rate of R1 at low U.V. doses.

#### 4.1.3 NATURE OF THE MUTATION FORMING REC30

Despite extensive work on *rec30* the nature of the mutation forming this strain is still an enigma. It has been suggested that *rec30* was formed by a double mutation. This would explain the inability of a recombinant vector from a gene library to restore recombination proficiency to this strain, (as the likelihood of a single recombinant vector containing both genes is extremely unlikely).

When *rec30* was originally isolated spontaneous revertants to MTC and U.V. resistance were found, but none were discovered to have intermediate levels of resistance as would be expected with a double mutant (Moseley and Copland 1975b). In this study recombination proficient cells obtained by transformation of *rec30* with R1 DNA were obtained at levels ten-fold below that of Rf resistance transformation frequencies. This lower level is not surprising and

does not indicate the presence of two mutations, as Rf transforms very well when compared with other antibiotic markers. For example, the comparative frequencies at maximum expression for the resistance markers Rf and Kn are 64 and 1 respectively (Tirgari and Moseley 1980). Also, when the recombination proficient cells formed are tested for MTC survival the same resistance to that of R1 is found, if two mutations were involved only a partial restoration of resistance might be expected.

Firm evidence for rec30 being comprised of two mutations originates from unsuccessful attempts to transfer the rec<sup>-</sup> phenotype from rec30 to other *D. radiodurans* strains (Masters 1988). <sup>Either</sup>  $\lambda$ MtcA or mtcB<sup>\*</sup> mutations were transferred, yet rec30 could not be transformed to exhibit an increased level of MTC resistance using plasmids containing either mtcA or mtcB (Masters 1988). In addition sucrose gradient profiles demonstrating excision repair indicate that rec30 shows an increased incision level (this study), suggesting that rec30 is not mtcA<sup>-</sup> at least, as strains exhibiting this mutation exhibit a wild type incision ability (Evans 1984).

The transfer of mtcA or mtcB<sup>mutations</sup> from rec30 cannot, therefore, be easily explained. It could, of course, originate from a contaminant in the rec30 chromosome preparation. Alternatively, rec30 may be a double mutant but possess an inability to undertake plasmid recombination as do *E. coli* RecF mutants, (this pathway being responsible for most, if not all, cellular plasmid recombinational events, Kolodner et al. 1985, Smith 1988). This would ensure the failure of all attempts to complement any rec30 mutation using a *D. radiodurans* gene library or plasmids containing mtcA or mtcB.

The inability of the rec<sup>-</sup> mutation to be transferred from rec30

\* mtcA and mtcB are involved in one D. radiodurans excision repair pathway (see page 22). Both mtcA<sup>-</sup> and mtcB<sup>-</sup> cells exhibit an increased sensitivity to MTC.

and also from recombination can also not be adequately explained (Masters 1988). One suggestion is that the mutants were formed by a deletion event, removing areas of homology vital for recombination into the chromosome. This, however, is unlikely as both were formed by MNNG mutagenesis which causes mutation mainly by mispairing.

#### 4.1.4 ISOLATION OF NOVEL SPECIES

That no novel *Deinococcus* species were isolated was disappointing given the success of Masters (1988), who found five samples containing possible *Deinococcus* isolates from a total of seventeen. The possible positive isolates (of which four were later confirmed as new *D. radiodurans* strains) originated from damp, wet habitats. These sites were thought to be nutrient rich due to the amount of organic debris in the samples.

In contrast the twenty-eight samples screened in this study were mainly from peaty, acidic regions or areas which were well drained, and, consequently, dry. The former are likely to be nutrient poor and *D. radiodurans* is known to have a limited action on many substrates and require some amino acids for good growth (Raj *et al.* 1960, Shapiro 1977). Thus the plausible suggestion by Masters (1988) that the common *Deinococcus* habitat is soil with mainly airborne transfer to other areas could be modified to specify nutrient rich damp soil only.

## 4.2 THE DEINOBACTER

### 4.2.1 PLASMID CONTENT

Plasmids are found in virtually every bacterial genus examined, including all four species of *Deinococcus*, so it was not surprising

(insert in page 178B)

The statistical treatment used to determine the number of plasmid species of approximately similar sizes was very simple and only gives a degree of confidence in predictions. To more fully resolve the issue many more plasmids of the size in question, (plus more control plasmids), would have to be counted to allow more complex statistical treatments. This was outside the scope of this thesis.

to find plasmids in *Deinobacter*. What was unusual was the large number of plasmids found only infrequently.

The high number of measurements made of the smaller plasmids of 7.9 and 7.8 kb in KS 0460 and KS 0485 respectively indicates (but is not positive evidence) that both are high copy number plasmids. Similarly the 93.1 kb plasmid of KS 0485 may be of an unusually high copy number for such a large plasmid. (insert paragraph from page 178A).

The high population of heterogeneous plasmids is unusual and cannot be fully explained, (KS 0460 having at least 6 and KS 0485 at least 10). Perhaps they should not be termed "plasmids" as yet, as no evidence is available to prove their ability for replication independent of the chromosome. This could be similar to the situation found in *Bacillus megaterium* (Carlton and Helinski 1969), where a large number of extrachromosomal heterogeneous circular DNA elements are found. Alternatively, excessive recombination between the plasmids present could be responsible, generating a full spectrum of plasmid monomers (Potter and Dressler 1977). It seems that none are concatamers (multiples) from their sizes, however, the restriction patterns necessary to confirm this were not carried out.

If the plasmids isolated are compared to those found in the *Deinococcus* strains (Mackay 1983) there are no similarities in terms of size or number of plasmids found.

#### 4.2.2 TRANSFORMATION

The low levels of transformation obtained in *D. grandis* using *D. radiodurans* DNA and vice versa indicates that the two species are closely related. The ability to transform *D. radiodurans*, albeit at a low frequency, was not unexpected given the close relationship

between the two organisms, as *D.radiodurans* can also be transformed to Rf resistance using DNA from the other members of the *Deinococcus* genus (Moseley 1983). However, *D.radiodurans* is the only transformable *Deinococcus* species (B.E.B. Moseley, personal communication). The transformability shown by *Deinobacter* indicates that initial genetical manipulation can be employed to study this organism.

#### 4.2.3 U.V. MUTABILITY

That *Deinobacter* can be mutated by U.V. (to give approximately a ten-fold increase in the level of Rf mutants) is unusual given the close relationship to the genus *Deinococcus*, which are immutable.

U.V.-induced mutation is considered to be due to a misrepair process acting upon the damaged DNA involving the *umuC*, *umuD* and *recA* gene products (Chapter One 1.3.4). Thus immutable bacteria, including *Deinococcus* species, have been suggested to lack the *umu* function (Tempest and Moseley 1982), which concurs with the hypothesis that *umu* originates from a transposon (Sedgwick *et al.* 1988) and so will not necessarily be present in all organisms. Recent work upon mutation repair indicates that UmuD must be cleaved by an activated RecA protein in a similar manner to LexA and bacteriophage repressors (Nohmi *et al.* 1988), so non-mutagenic bacteria may possess *umuC* and *umuD* but be unable to activate the proteins.

The ability of *D.grandis* to undergo mutagenic repair and also demonstrate resistance to both U.V. and gamma irradiation is therefore very unusual and has not been found in any other radiation resistant bacteria examined (six species from three different

genera, Tempest and Moseley 1982).

The ability to repair DNA by a mutagenic function suggests that both SOS repair and the *umuC* and *umuD* genes may be present in *Deinobacter*. However polyclonal antibodies to *E.coli* RecA failed to highlight a protein in total cell extracts from *D.grandis*, even after treatment which would be expected to induce the SOS system, if present.

## ACKNOWLEDGEMENTS

I would like to thank Bev Moseley for his advice, encouragement and optimism over the course of this Ph.D.

Thanks also to all members of the Microbiology Department for their companionship and help, especially the past and present members of 'Team Moseley' (Ghalib Al-Bakri, Ian Masters, Margaret Rogers, Steve Moore and Lynn Kennedy); 'Team Reid' (Caroline Sinnett-Smith, Michelle Lloyd and Elizabeth Ellis).

I must also remember friends over the sea, notably Ken Minton, (especially for funding my visit to the U.S.A.), Eileen Lennon, Mike Smith and Leslie McNeil for assistance and patience and for introducing me to the American way of life.

I am indebted to many other workers elsewhere, especially; S. Sedgwick, M.R.C., London, for advice and plasmids; R. Cox, M.R.C. Radiobiology Unit, Harwell, for RecA antibody; D. Jackson, Environmental Protection Group, British Nuclear Fuels p.l.c., for soil samples; P. Beattie, Dept. of Molecular Biology, Edinburgh University, for E.M. work and gardening advice.

Finally, especial thanks to J. Farrar for constant moral and financial support.

## **BIBLIOGRAPHY**

- AL-BAKRI, G.H. (1985). Genetic studies on *Deinococcus* species using spheroplasts and gene cloning. Ph.D. Thesis, University of Edinburgh.
- AL-BAKRI, G.H., MACKAY, M.W., WHITTAKER, P.A. and MOSELEY, B.E.B. (1985). Cloning of the DNA repair genes *mtcA*, *mtcB*, *uvsC*, *uvsD*, *uvsE* and the *leuB* gene from *Deinococcus radiodurans*. *Gene*. 33:305-311.
- AMERSHAM technical publication. (1988). Membrane transfer and detection methods. Amersham International plc., Bucks.
- AMUNDSEN, S.K., TAYLOR, A.F., CHAUDHURY, A.M. and SMITH, G.R. (1986). *RecD*: The gene for an essential third subunit of exonuclease V. Proceedings of the National Academy of Sciences U.S.A. 83:5558-5562.
- ANDERSON, R. (1983). Alkylamines: Novel lipid constituents in *Deinococcus radiodurans*. *Biochimica et Biophysica Acta*. 753:266-268.
- ANDERSON, R. and HANSEN, K. (1985). Structure of a novel phosphoglycolipid from *Deinococcus radiodurans*. *Journal of Biological Chemistry*. 260:12219-12223.
- ANDERSON, A.W., NORDAN, H.C., CAIN, R.F., PARRISH, G. and DUGGAN, D. (1956). Studies on a radio-resistant micrococcus. I. Isolation, morphology, cultural characteristics and resistance to gamma irradiation. *Food Technology*. 10:575-578.
- ANDERSON, A.W., RASH, K.E. and ELLIKER, P.R. (1961). Taxonomy of a recently-isolated radiation-resistant micrococcus. *Bacteriological Proceedings*, pg 56.
- AUGULO, J.F., SCHWENCKE, J., MOREAU, P.L. and MOUSTACCHI, E. (1985). A yeast protein analogous to *Escherichia coli* RecA whose cellular level is enhanced after U.V. irradiation. *Molecular and General Genetics*. 201:20-24.

- BACHMANN, B. (1983). Linkage map of *Escherichia coli* K-12. Edition 7. Microbiological Reviews. 47:180-230.
- BAIRD-PARKER, A.C. (1965). The classification of staphylococci and micrococci from world-wide sources. Journal of General Microbiology. 38:363-387.
- BAIRD-PARKER, A.C. (1970). The relationship of cell wall composition to the current classification of staphylococci and micrococci. International Journal of Systematic Bacteriology. 20:483-490.
- BAUMEISTER, W., KARREBERG, F., RACHEL, R., ENGEL, A., TEN HEGGLER, B. and SAXTON, W.O. (1982). The major cell envelope protein of *Micrococcus radiodurans* (R1). Structural and chemical characterization. European Journal of Biochemistry. 125:535-544.
- BERKNER, L. and MARSHALL, L. (1964). Origins and evolution of the oceans and atmosphere, pg 102-126. Edited by P.J. Branzio and A.G.W. Cameron. Wiley, New York.
- BETTER, M. and HELINSKI, D.R. (1983). Isolation and characterisation of the *recA* gene of *Rhizobium meliloti*. Journal of Bacteriology. 155:311-316.
- BIO-RAD technical publication. (1987). Gene pulser transfection apparatus operating instructions and applications guide. Bio-Rad Laboratories, Richmond, California CA 94804.
- BIRNBOIM, H.C. and DOLY, J. (1979). A rapid alkaline extraction procedure for screening plasmid DNA. Nucleic Acids Research. 7:1513-1523.
- BOYER, H.W. and ROULLAND-DUSSOIX, D. (1969). A complementation analysis of the restriction and modification of DNA in *Escherichia coli*. Journal of Molecular Biology. 41:459-472.

- BROOKS, B.W. and MURRAY, R.G.E. (1981). Nomenclature for "*Micrococcus radiodurans*" and other radiation-resistant cocci: *Deinococcaceae* fam. nov. and *Deinococcus* gen. nov., including five species. *International Journal of Systematic Bacteriology*. **31**:353-360.
- BROOKS, B.W., MURRAY, R.G.E., JOHNSON, J.L., STACKEBRANDT, E., WOESE, C.R. and FOX, G.E. (1980). Red-pigmented micrococci: A basis for taxonomy. *International Journal of Systematic Bacteriology*. **30**:627-646.
- BRUCE, A.K. (1964). Extraction of the radioresistant factor of *Micrococcus radiodurans*. *Radiation Research*. **22**:155-164.
- CAIMI, P. and EISENSTARK, A. (1986). Sensitivity of *Deinococcus radiodurans* to near-ultraviolet radiation. *Mutation Research*. **162**:145-151
- CARLTON, B.C. and HELINSKI, D.R. (1969). Heterogeneous circular DNA elements in vegetative cultures of *Bacillus megaterium*. *Proceedings of the National Academy of Sciences U.S.A.* **64**:592-599.
- CHANG, S. and COHEN, S.N. (1979). High frequency transformation of *Bacillus subtilis* protoplasts by plasmid DNA. *Molecular and General Genetics*. **168**:111-115.
- CHRISTENSEN, E.A. and KRISTENSEN, H. (1981). Radiation resistance of microorganisms from clean air premises. *Acta Pathologica et Microbiologia Scandinavica*. **89** (Section B):293-301.
- CLARKE, L. and CARBON, J. (1976). A colony bank containing synthetic ColE1 hybrid plasmids representative of the entire *E.coli* genome. *Cell*. **9**:91-99.

- COLE, R.S. (1973). Repair of DNA containing interstrand crosslinks in *Escherichia coli*: Sequential excision and recombination. Proceedings of the National Academy of Sciences U.S.A. 70:1064-1068.
- COLLINS, J. and HOHN, B. (1978). Cosmids: A type of plasmid gene-cloning vector that is packageable *in vitro* in bacteriophage  $\lambda$  heads. Proceedings of the National Academy of Sciences U.S.A. 75:4242-4246.
- COLLINS, M.D. and JONES, D. (1981). Distribution of isoprenoid quinone structural types in bacteria and their taxonomic implications. Microbiological Reviews. 45:316-354.
- COUNSELL, T.J. and MURRAY, R.G.E. (1986). Polar lipid profiles of the genus *Deinococcus*. International Journal of Systematic Bacteriology. 36:202-206.
- COX, M.M. and LEHMAN, I.R. (1987). Enzymes of general recombination. Annual Review of Biochemistry. 56:229-262.
- CRAIG, N.L. (1988). The mechanism of conservative site-specific recombination. Annual Review of Genetics. 22:77-105.
- CSONKA, L.N. and CLARKE, A.J. (1979). Deletions generated by the transposon Tn10 in the *srI recA* region of the *Escherichia coli* K-12 chromosome. Genetics. 93:321-343.
- DAVIES, N.S., SILVERMAN, G.J. and MASUROVSKY, E.B. (1963). Radiation-resistant, pigmented coccus isolated from haddock tissue. Journal of Bacteriology. 86:294-298.
- DAVIES, R.W., SIMON, M. and DAVIDSON, N. (1971). Electron microscope hereroduplex methods for mapping regions of base sequence homology in nucleic acids. In: Methods in Enzymology. 21 (part D):413-428. Edited by L. Grossman and K. Moldave. Academic Press.

- DE VOS, W.M., DE VRIES, S.C. and VENEMA, G. (1983). Cloning and expression of the *Escherichia coli* *recA* gene in *Bacillus subtilis*. *Gene*. **25**:301-308.
- DE WITT, C.M., DEKKER, B.M.M., NEELE, A.C. and DE WAARD, A. (1985). Purification and characterization of endonucleases *DraII* and *DraIII* from *Deinococcus radiophilus*. *FEBS Letters*. **180**:219-223. Correction *FEBS Letters*. **184**:177.
- DOI, R.H. (1984). Genetic engineering in *Bacillus subtilis*. *Biotechnology and Engineering Reviews*. **2**:121-155.
- DRESSLER, D. and POTTER, H. (1982). Molecular mechanisms in genetic recombination. *Annual Review of Biochemistry*. **51**:727-761.
- DRIEDGER, A.A. and GRAYSTON, M.J. (1970). Rapid lysis of cell walls of *Micrococcus radiodurans* with lysozyme: Effects of butanol pretreatment on DNA. *Canadian Journal of Microbiology*. **16**:889-893.
- DRIEDGER, A.A. and GRAYSTON, M.J. (1971). The effects of nalidixic acid on X-ray induced DNA degradation and repair in *Micrococcus radiodurans*. *Canadian Journal of Microbiology*. **17**:501-505.
- EITNER, G., ADLER, B., LANZOV, V.A. and HOFEMEISTER, J. (1982). Interspecies *recA* protein substitution in *Escherichia coli* and *Proteus mirabilis*. *Molecular and General Genetics*. **185**:481-486.
- ERIKSEN, W.H. and EMBORG, C. (1978). Increase of radiation resistance of a soil microflora exposed to long-term gamma irradiation. *Applied and Environmental Microbiology*. **36**:618-619.
- EVANS, D.M. (1984). Repair of DNA damage in *Deinococcus radiodurans*. Ph.D. Thesis, University of Edinburgh.

- EVANS, D.M. and MOSELEY, B.E.B. (1983). Roles of the *uvrC*, *uvrD*, *uvrE* and *mtcA* genes in the two pyrimidine dimer excision repair pathways of *Deinococcus radiodurans*. *Journal of Bacteriology*. **156**:576-583.
- EVANS, D.M. and MOSELEY, B.E.B. (1985). Identification and initial characterisation of a pyrimidine dimer UV endonuclease (UV endonuclease  $\beta$ ) from *Deinococcus radiodurans*: A DNA repair enzyme that requires manganese ions. *Mutation Research*. **145**:119-128.
- FINCH, P.W., BROUGH, C.L. and EMMERSON, P.T. (1986). Molecular cloning of a *recA*-like gene of *Methylophilus methylotrophus* and identification of its product. *Gene*. **44**:47-53.
- FORMOSA, T. and ALBERTS, B.M. (1986). Purification and characterization of the T4 bacteriophage *uvrX* protein. *Journal of Biological Chemistry*. **261**:6107-6118.
- FOX, G.E., PECHMAN, K.R. and WOESE, C.R. (1977). Comparative cataloguing of 16S ribosomal ribonucleic acid: Molecular approach to prokaryotic systematics. *International Journal of Systematic Bacteriology*. **27**:44-57.
- GEOGHEGAN, C.M., and HOUGHTON, J.A. (1987). Molecular cloning and isolation of a cyanobacterial gene which increases the UV and methyl methanesulphonate survival of *recA* strains of *Escherichia coli*. *Journal of General Microbiology*. **133**:119-126.
- GILLEN, J.R., WILLIS, D.K. and CLARK, A.J. (1981). Genetic analysis of the RecE pathway of genetic recombination in *Escherichia coli* K-12. *Journal of Bacteriology*. **145**:521-532.
- GIRARD, A.E. (1971). A comparative study of the fatty acids of some micrococci. *Canadian Journal of Microbiology*. **17**:1503-1508.

- GLASS, W.F., BRIGGS, R.C. and HNILICA, L.S. (1981). Identification of tissue-specific nuclear antigens transferred to nitrocellulose from polyacrylamide gels. *Science*. 211:70-72.
- GOLDBERG, I. and MEKALANOS, J.J. (1986). Cloning of the *Vibrio cholerae recA* gene and construction of a *Vibrio cholerae recA* mutant. *Journal of Bacteriology*. 165:715-722.
- GOODMAN, H.J.K., PARKER, J.R., SOUTHERN, J.A. and WOODS, D.R. (1987). Cloning and expression in *Escherichia coli* of a *recA*-like gene from *Bacteroides fragilis*. *Gene*. 58:265-271.
- GROSJEAN, H. and FIERS, W. (1982). Preferential codon usage in prokaryotic genes: The optimal codon-anticodon interaction energy and the selective codon usage in efficiently expressed genes. *Gene*. 18:199-209.
- GROSSKOPT, R., WOLF, W. and KESSLER, C. (1985). Two new restriction endonucleases *DraII* and *DraIII* from *Deinococcus radiophilus*. *Nucleic Acids Research*. 13:1517-1528.
- GUDAS, L.J. and PARDEE, A.B. (1976). DNA synthesis inhibition and the induction of protein X in *Escherichia coli*. *Journal of Molecular Biology*. 101:459-477.
- HALDENWANG, W.G., BANNER, C.D.B., OLLINGTON, J.F., LOSICK, R., HOCH, J.A., O'CONNOR, M.B. and SONENSHEIN, A.L. (1980). Mapping a cloned gene under sporulation control by insertion of a drug resistance marker into the *Bacillus subtilis* chromosome. *Journal of Bacteriology*. 142:90-98.
- HAMES, B.D. (1981). Gel electrophoresis of proteins. A practical approach. Edited by B.D. Hames and D. Rickwood. I.R.L. Press, Oxford.
- HAMOOD, A.N., PETTIS, G.S., PARKER, C.D. and McINTOSH, M.A. (1986). Isolation and characterization of the *Vibrio cholerae recA* gene. *Journal of Bacteriology*. 167:375-378.

- HANAWALT, P.C., COOPER, P.K., GANESAN, A.K. and SMITH, C.A. (1979). DNA repair in bacteria and mammalian cells. *Annual Review of Biochemistry*. 48:783-836.
- HANSEN, M.T. (1978). Multiplicity of genome equivalents in the radiation-resistant bacterium *Micrococcus radiodurans*. *Journal of Bacteriology*. 134:71-75.
- HANSEN, M.T. (1980). Four proteins synthesized in response to deoxyribonucleic acid damage in *Micrococcus radiodurans*. *Journal of Bacteriology*. 141:81-86.
- HARSOJO, KITAYAMA, S. and MATSUYAMA, A. (1981). Genome multiplicity and radiation resistance in *Micrococcus radiodurans*. *Journal of Biochemistry*. 90:877-880.
- HENSEL, R., DEMHARTER, W., KANDLER, O., KROPPENSTEDT, R.M. and STACKEBRANDT, E. (1986). Chemotaxonomic and molecular-genetic studies of the genus *Thermus*: Evidence for a phylogenetic relationship of *Thermus aquaticus* and *Thermus ruber* to the genus *Deinococcus*. *International Journal of Systematic Bacteriology*. 36:444-453.
- HICKMAN, M.J., ORSER, C.S., WILLIS, D.K., LINDOW, S.E. and PANOPOULOS, N.J. (1987). Molecular cloning and biological characterization of the *recA* gene from *Pseudomonas syringae*. *Journal of Bacteriology*. 169:2906-2910.
- HILL, L.R. (1959). The Adansonian classification of the staphylococci. *Journal of General Microbiology*. 20:277-283.
- HOLMES, D.S. and QUIGLEY, M. (1981). A rapid boiling method for the preparation of bacterial plasmids. *Analytical Biochemistry*. 114:193-197.

- HORII, Z.I. and CLARK, A.J. (1973). Genetic analysis of the RecF pathway of genetic recombination in *Escherichia coli* K-12: Isolation and characterization of mutants. *Journal of Molecular Biology*. 80:327-344.
- HOYLE, F. and WICKRAMASINGHE, C. (1981). *Space travellers - the bringers of life*. University College Cardiff Press
- HSIEH, P., MEYN, M.S., CAMERINI-OTERO, R.D. (1986). Partial purification and characterization of a recombinase from human cells. *Cell*. 44:885-894.
- HUMPREYS, G.O., WESTON, A., BROWN, M.G.M. and SAUNDERS, J.R. (1979). Plasmid transformation of *Escherichia coli*. In: Transformation 1978, Proceedings of the Fourth European Meeting on Bacterial Transformation and Transfection, pg 287-312. Edited by S.W. Glover and L.O. Butler. Cotswold Press Ltd., Oxford.
- HUSAIN, I., VAN HOUTEN, B., THOMAS, D.C., ABDEL-MONEM, M. and SANCAR, A. (1985). Effect of DNA polymerase I and DNA helicase II on the turnover rate of UvrABC excision nuclease. *Proceedings of the National Academy of Sciences U.S.A.* 82:6774-6778
- ISH-HOROWICZ, D. and BURKE, J.F. (1981). Rapid and efficient cosmid cloning. *Nucleic Acids Research*. 9:2989-2998.
- ISHIURA, M., HAZUMI, N., KOIDE, T., UCHIDA, T. and OKADA, Y. (1989). A *recB recC sbcB recJ* host prevents *recA*-independent deletions in recombinant cosmid DNA propagated in *Escherichia coli*. *Journal of Bacteriology*. 171:1068-1074.
- ITO, H. (1977). Isolation of *Micrococcus radiodurans* occurring in radurized sawdust culture medium of mushroom. *Agricultural and Biological Chemistry*. 41:35-41.

- ITO, H., WATANABE, H., TAKEHISA, M. and IIZUKA, H. (1983). Isolation and identification of radiation-resistant cocci belonging to the genus *Deinococcus* from sewage sludges and animal feeds. *Agricultural and Biological Chemistry*. 47:1239-1247.
- JANTZEN, E., BERGANT, T. and BØVRE, K. (1974). Gas chromatography of bacterial whole cell methanolysates. VI. Fatty acid composition within *Micrococcaceae*. *Acta Pathologica et Microbiologica Scandinavica*. 82B:785-798.
- JOHNSON, D.A., GAUTSCH J.W., SPORTSMAN J.R. and ELDER, J.H. (1984). Improved technique utilizing nonfat dry milk for analysis of proteins and nucleic acids transferred to nitrocellulose. *Gene Analysis Techniques*. 1:3-8.
- KEENER, S.L., McNAMEE, K.P. and McENTEE, K. (1984). Cloning and characterization of *recA* genes from *Proteus vulgaris*, *Erwinia carotovora*, *Shigella flexneri* and *Escherichia coli* B/r. *Journal of Bacteriology*. 160:153-160.
- KENYON, C.J. (1983). The bacterial response to DNA damage. *Trends in Biochemical Sciences*. 8:84-87.
- KERSMAN, G. (1975). Induction of mutation to streptomycin resistance in *Micrococcus radiodurans*. *Mutation Research*. 28:9-14.
- KILBURN, R.E., BELLAMY, W.D. and TERNI, S.A. (1958). Studies on a radiation-resistant pigmented *Sarcina* sp. *Radiation Research*. 9:207-215.
- KITAYAMA, S. (1982). Adaptive repair of cross-links in DNA of *Micrococcus radiodurans*. *Biochimica et Biophysica Acta*. 697:381-384.
- KITAYAMA, S., MATSUMURA, O. and MASUDA, S. (1985). A Z-DNA binding protein isolation from *Deinococcus radiodurans*. *Biochemical and Biophysical Research Communications*. 130:1294-1300.

- KLEINSCHMIDT, A.K. (1968). Monolayer techniques in electron microscopy of nucleic acid molecules. In: *Methods in Enzymology*. 12 (part B):361-377. Edited by L. Grossman and K. Moldave. Academic Press.
- KMIEC, E. and HOLLOMAN, W.K. (1982). Homologous pairing of DNA molecules promoted by a protein from *Ustilago*. *Cell*. 29:367-374.
- KMIEC, E. and HOLLOMAN, W.K. (1986). Homologous pairing of DNA molecules by *Ustilago* Rec1 protein is promoted by sequences of Z-DNA. *Cell*. 44:545-554.
- KNIVETT, V.A., CULLEN, J. and JACKSON, M.J. (1965). Odd-numbered fatty acids in *Micrococcus radiodurans*. *Biochemical Journal*. 96:2C-3C.
- KOBATAKE, M., TANABE, S. and HASEGAWA, S. (1973). Nouveau *Micrococcus* radioresistant à pigment rouge, isolé de fèces de *Lama glama* et son utilisation comme indicateur microbiologique de la radiostérilisation. *Comptes Rendus des Séances de la Société de Biologie*, (English abstract). 167:1506-1510.
- KOKJOHN, T.A. and MILLER, R.V. (1985). Molecular cloning and characterization of the *recA* gene of *Pseudomonas aeruginosa* PAO. *Journal of Bacteriology*. 163:568-572.
- KOLODNER, R., FISHEL, R.A. and HOWARD, M. (1985). Genetic recombination of bacterial plasmid DNA: Effect of RecF pathway mutations on plasmid recombination in *Escherichia coli*. *Journal of Bacteriology*. 163:1060-1066.
- KONRAD, E.B. (1977). Method for the isolation of *Escherichia coli* mutants with enhanced recombination between chromosomal duplications. *Journal of Bacteriology*. 130:167-172.

- KOOMEY, J.M. and FALKOW, S. (1987). Cloning of the *recA* gene of *Neisseria gonorrhoeae* and construction of gonococcal *recA* mutants. *Journal of Bacteriology*. 169:790-795.
- KORBA, B.E., HAYS, J.B. and BOEHMER, S. (1981). Sedimentation velocity of DNA in isokinetic sucrose gradients: calibration against molecular weight using fragments of defined length. *Nucleic Acid Research*. 9:4403-4412.
- KOWALCZYKOWSKI, S.C. (1987). Mechanistic aspects of the DNA strand exchange activity of *E.coli* *recA* protein. *Trends in Biochemical Sciences*. 12:141-145.
- KRABBENHOFT, K.L., ANDERSON, A.W. and ELLIKER, P.R. (1965). Ecology of *Micrococcus radiodurans*. *Applied Microbiology*. 13:1030-1037.
- KRISTENSEN, H. and CHRISTENSEN, E.A. (1981). Radiation-resistant micro-organisms isolated from textiles. *Acta Pathologica et Microbiologia Scandinavica*. 89 (Section B):303-309.
- LANCY, P. and MURRAY, R.G.E. (1978). The envelope of *Micrococcus radiodurans*: Isolation, purification and preliminary analysis of the wall layers. *Canadian Journal of Microbiology*. 24:162-176.
- LEIBOWITZ, P.J., SCHWARTZBERG, L.S. and BRUCE, A.K. (1976). The *in vivo* association of manganese with the chromosome of *Micrococcus radiodurans*. *Photochemistry and Photobiology*. 23:45-50.
- LETT, J.T. (1981). Measurement of single-strand breaks by sedimentation in alkaline sucrose gradients.  
In: DNA repair: A laboratory manual of research procedure. Volume I, (part B):363-378. Edited by E.C. Friedberg and P.C. Hanawalt. Marcel Dekker, New York.

- LEWIS, N.F. (1971). Studies on a radio-resistant coccus isolated from Bombay duck (*Harpoden nehereus*). *Journal of General Microbiology*. 66:29-35.
- LINDAHL, T. (1982). DNA repair enzymes. *Annual Review of Biochemistry*. 51:61-87.
- LLOYD, R.G., PORTON, M.C. and BUCKMAN, C. (1988). Effect of *recF*, *recJ*, *recN*, *recO* and *ruv* mutations on ultraviolet survival and genetic recombination in a *recD* strain of *Escherichia coli* K12. *Molecular and General Genetics*. 212:317-324.
- LOVE, P.E. and YASBIN, R.E. (1986). Induction of the *Bacillus subtilis* SOS-like response by *Escherichia coli* RecA protein. *Proceedings of the National Academy of Sciences U.S.A.* 83:5204-5208.
- LOVETT, C.M., LOVE, P.E., YASBIN, R.E. and ROBERTS, J.W. (1988). SOS-like induction in *Bacillus subtilis*: Induction of the RecA protein analogue and a damage-inducible operon by DNA damage in Rec<sup>+</sup> and DNA repair-deficient strains. *Journal of Bacteriology*. 170:1467-1474.
- LOVETT, C.M. and ROBERTS, J.W. (1985). Purification of a RecA protein analogue from *Bacillus subtilis*. *Journal of Biological Chemistry*. 260:3305-3313.
- MACKAY, M.W. (1983). On the molecular genetics of the members of the genus *Deinococcus*. Ph.D. Thesis, University of Edinburgh.
- MACKAY, M.W., AL-BAKRI, G.H. and MOSELEY, B.E.B. (1985). The plasmids of *Deinococcus* spp. and the cloning and restriction mapping of the *D. radiophilus* plasmid pUE1. *Archives of Microbiology*. 141:91-94.
- MANDEL, M. and HIGA, A. (1970). Calcium-dependant bacteriophage DNA infection. *Journal of Molecular Biology*. 53:159-162.

- MANIATIS, T., FRITSCH, E.F. and SAMBROOK, J. (1983). Molecular cloning - a laboratory manual. Cold Spring Harbor Laboratory. Cold Spring Harbor, New York.
- MARMUR, J. (1961). A procedure for the isolation of deoxyribonucleic acid from micro-organisms. *Journal of Molecular Biology*. 3:208-218.
- MARRERO, R. and YASBIN, R.E. (1988). Cloning of the *Bacillus subtilis* *recE*<sup>+</sup> gene and functional expression of *recE*<sup>+</sup> in *B.subtilis*. *Journal of Bacteriology*. 170:335-344.
- MASTERS, C.I. (1988). Aspects of shuttle vector construction in *Deinococcus radiodurans* and purification of its A.P. endonuclease. Ph.D. Thesis, University of Edinburgh.
- McGRATH, R.A. and WILLIAMS, R.W. (1966). Reconstruction *in vivo* of irradiated *Escherichia coli* deoxyribonucleic acid; the rejoining of broken pieces. *Nature*. 212:534-535.
- MESELSON, M. and YUAN, R. (1968). DNA restriction enzyme from *E.coli*. *Nature*. 217:1110-1114.
- MILES, C.A., MOUNTAIN, A. and SASTRY, G.R.K. (1986). Cloning and characterisation of the *recA* gene of *Agrobacterium tumefaciens* C58. *Molecular and General Genetics*. 204:161-165.
- MILLER, R.V. and KOKJOHN, T.A. (1988). Expression of the *recA* gene of *Pseudomonas aeruginosa* PAO is inducible by DNA-damaging agents. *Journal of Bacteriology*. 170:2385-2387.
- MITCHEL, R.E.J. (1979). On the mechanism of oxygen protection against ionizing radiation damage in the cell wall of *Micrococcus radiodurans*. *Radiation Research*. 79:63-76.
- MOSELEY, B.E.B. (1983). Photobiology and radiobiology of *Micrococcus (Deinococcus) radiodurans*. In: *Photochemistry and Photobiology Reviews*. 7:223-275. Edited by K.L. Smith. Plenum, New York.

MOSELEY, B.E.B. (1984). Radiation damage and its repair in non-sporulating bacteria. In: The revival of injured microbes, pg 147-174. Edited by M.H.E. Andrews and A.D. Russell. Academic Press.

MOSELEY, B.E.B. and COPLAND, H.J.R. (1975a). Involvement of a recombination repair function in disciplined cell division of *Micrococcus radiodurans*. Journal of General Microbiology. 86:343-357.

MOSELEY, B.E.B. and COPLAND, H.J.R. (1975b). Isolation and properties of a recombination-deficient mutant of *Micrococcus radiodurans*. Journal of Bacteriology. 121:422-428.

MOSELEY, B.E.B. and COPLAND, H.J.R. (1978). Four mutants of *Micrococcus radiodurans* defective in the ability to repair DNA damage by mitomycin-C, two of which have wild-type resistance to ultraviolet radiation. Molecular and General Genetics. 160:331-337.

MOSELEY, B.E.B. and EVANS, D.M. (1981). Use of transformation to investigate the nuclear structure and segregation of genomes in *Micrococcus radiodurans*. In: Transformation 1980, Proceedings of the Fifth European Meeting on Bacterial Transformation and Transfection, pg 371-379. Edited by M. Polsinelli and G. Mazza. Cotswold Press Ltd., Oxford.

MOSELEY, B.E.B. and EVANS, D.M. (1983). Isolation and properties of strains of *Micrococcus (Deinococcus) radiodurans* unable to excise ultraviolet light-induced pyrimidine dimers from DNA: Evidence for two excision pathways. Journal of General Microbiology, 129:2437-2445.

MOSELEY, B.E.B., MATTINGLY, A. and COPLAND, H.J.R. (1972a). Sensitization to radiation by loss of recombination ability in a temperature-sensitive DNA mutant of *Micrococcus radiodurans* held at its restrictive temperature. Journal of General Microbiology. 72:329-338.

MOSELEY, B.E.B., MATTINGLY, A. and SHIMMIN, M. (1972b). Isolation and some properties of temperature-sensitive mutants of *Micrococcus radiodurans* defective in DNA synthesis. *Journal of General Microbiology*. 70:399-409.

MOSELEY, B.E.B. and SETLOW, J.K. (1968). Transformation in *Micrococcus radiodurans* and the ultraviolet sensitivity of its transforming DNA. *Proceedings of the National Academy of Sciences U.S.A.* 61:176-183.

MOSELEY, B.E.B. and WILLIAMS, E. (1977). Repair of damaged DNA in bacteria. *Advances in Microbial Physiology*. 16:99-156.

MURPHY, R.C., BRYANT, D.A. PORTER, R.D. and DE MARSAC, N.T. (1987). Molecular cloning and characterization of the *recA* gene from the cyanobacterium *Synechococcus* sp. strain PCC 7002. *Journal of Bacteriology*. 169:2739-2747.

MURRAY, R.G.E. and ROBINOW, C.F. (1958). Cytological studies of a tetrad-forming coccus. In: VIIth International Congress for Microbiology, Stockholm, Abstracts of Paper Sessions, pg 427-428. Edited by G. Tunevall. Almqvist and Wiksells, Uppsala.

NIAUDET, B. and EHRLICH, S.D. (1979). *In vitro* labelling of the *Bacillus subtilis* cryptic plasmid pHV400. *Plasmid*. 2:48-58.

NOHMI, T., BATTISTA, J.R., DODSON, L.A. and WALKER, G.C. (1988). RecA-mediated cleavage activates UmuD for mutagenesis: Mechanistic relationship between transcriptional derepression and post-translational activation. *Proceedings of the National Academy of Sciences U.S.A.* 85:1816-1820.

OLD, R.W. and PRIMROSE, S.B. (1985). Principles of gene manipulation. Blackwell Scientific Publications.

- ÖSTERBERG, B. (1974). Radiation sensitivity of the microbial flora present on suture material prior to irradiation. *Acta Pharmacologica Suecica*. 11:53-58.
- OWTTRIM, G.W. and COLEMAN, J.R. (1987). Molecular cloning of a *recA*-like gene from the cyanobacterium *Anabaena variabilis*. *Journal of Bacteriology*. 169:1824-1829.
- OYAIZU, H., STACKEBRANDT, E., SCHLEIFER, K.H., LUDWIG, W., POHLA, H., ITO, H., HIRATA, A., OYAIZU, Y. and KOMAGATA, K. (1987). A radiation-resistant rod-shaped bacterium, *Deinobacter grandis* gen. nov., sp. nov., with peptidoglycan containing ornithine. *International Journal of Systematic Bacteriology*. 37:62-67.
- PARKER, F.E. and VINCENT, J.M. (1981). Sterilization of peat by gamma radiation. *Plant and Soil*. 61:285-293.
- PETERS, J. and BAUMEISTER, W. (1986). Molecular cloning, expression, and characterization of the gene for the surface (HPI)-layer protein of *Deinococcus radiodurans* in *Escherichia coli*. *Journal of Bacteriology*. 167:1048-1054.
- PETERS, J., PETERS, M., LOTTSPEICH, F., SCHÄFER, W. and BAUMEISTER, W. (1987). Nucleotide sequence analysis of the gene encoding the *Deinococcus radiodurans* surface protein, derived amino acid sequence, and complementary protein chemical studies. *Journal of Bacteriology*. 169:5216-5223.
- PIERRÉ, A. and PAOLETTI, C. (1983). Purification and characterisation of RecA protein from *Salmonella typhimurium*. *Journal of Biological Chemistry*. 258:2870-2874.
- POTTER, H. and DRESSLER, D. (1977). On the mechanism of genetic recombination: The maturation of recombination intermediates. *Proceedings of the National Academy of Sciences U.S.A.* 74:4168-4172.

- POTTER, H., WEIR, L. and LEDER, P. (1984). Enhancer-dependant expression of  $\kappa$  immunoglobulin genes introduced into mouse pre-B lymphocytes by electroporation. Proceedings of the National Academy of Sciences U.S.A. 81:7161-7165.
- POUWELS, P.H., ENGER-VALK, B.E. and BRAMMAR, W.J. (1985). Cloning vectors: A laboratory manual. Elsevier.
- PURVIS, I.J. (1984). Gene expression in the genus *Deinococcus*. Ph.D. Thesis, University of Edinburgh.
- PURVIS, I.J. and MOSELEY, B.E.B. (1983). Isolation and characterisation of *Dra*I, a type II restriction endonuclease recognizing a sequence containing only A:T basepairs, and inhibition of its activity by UV irradiation of substrate DNA. Nucleic Acids Research. 11:5467-5474.
- RADDING, C.M. (1981). Recombination activities of *E.coli* RecA protein. Cell. 25:3-4.
- RADLOFF, R., BAUER, W. and VINOGRAD, J. (1967). A dye-buoyant density method for the detection and isolation of closed circular DNA in HeLa cells. Proceedings of the National Academy of Sciences U.S.A. 57:1514-1521.
- RAJ, H.D., DURYEE, F.L., DEENEY, A.M., WANG, C.H., ANDERSON, A.W. and ELLIKER, P.R. (1960). Utilization of carbohydrates and amino acids by *Micrococcus radiodurans*. Canadian Journal of Microbiology. 6:289-298.
- RAMESAR, R.S., WOODS, D.R. and RAWLINGS, D.E. (1988). Cloning and expression in *Escherichia coli* of a *recA*-like gene from the acidophilic autotroph *Thiobacillus ferrooxidans*. Journal of General Microbiology. 134:1141-1146.

- REBEYROTTE, N., REBEYROTTE, P., MAVIEL, M.J. and MONTAUDON, D. (1979). Lipids and lipopolyosides of *Micrococcus radiodurans*. *Annales de Microbiologie (de l'Institut Pasteur)*, (English abstract). 130B:407-414.
- RIGBY, P.W.J., DIECKMANN, M., RHODES, C. and BERG, P. (1977). Labelling deoxyribonucleic acid to high specific activity *in vitro* by nick translation with DNA polymerase. *Journal of Molecular Biology*. 113:237-251.
- RUPP, W.D. and HOWARD-FLANDERS, P. (1968). Discontinuities in the DNA synthesized in an excision-defective strain of *Escherichia coli* following ultraviolet irradiation. *Journal of Molecular Biology*. 31:291-304.
- RUPP, W.D., WILDE, C.E., RENO, D.L. and HOWARD-FLANDERS, P. (1971). Exchanges between DNA strands in ultraviolet-irradiated *Escherichia coli*. *Journal of Molecular Biology*. 61:25-44.
- RUSSELL, D.R. and BENNETT G.N. (1982). Construction and analysis of *in vivo* activity of *E.coli* promoter hybrids and promoter mutants that alter the -35 to -10 spacing. *Gene*. 20:231-243.
- SADOFF, H.L., SHIMEI, B. and ELLIS, S. (1979). Characterisation of *Azotobacter vinelandii* deoxyribonucleic acid and folded chromosomes. *Journal of Bacteriology*. 138:871-877.
- SADOWSKI, P. (1986). Site-specific recombinases: Changing partners and doing the twist. *Journal of Bacteriology*. 165:341-347.
- SANCAR, A. and SANCAR, G.B. (1988). DNA repair enzymes. *Annual Review of Biochemistry*. 57:29-67.
- SANCAR, A., STACHELEK, C., KONISBERG, W. and RUPP, W.D. (1985). Sequences of the *recA* gene and protein. *Proceedings of the National Academy of Sciences*. 77:2611-2615.

- SANDERS, S.W. and MAXCY, R.B. (1979a). Patterns of cell division, DNA base composition, and five structures of some radiation-resistant vegetative bacteria found in food. *Applied and Environmental Microbiology*. **37**:159-168.
- SANDERS, S.W. and MAXCY, R.B. (1979b). Isolation of radiation-resistant bacteria without exposure to irradiation. *Applied and Environmental Microbiology*. **38**:436-439.
- SANO, Y. and KAGEYAMA, M. (1987). The sequence and function of the *recA* gene and its protein in *Pseudomonas aeruginosa* PAO. *Molecular and General Genetics*. **208**:412-419.
- SAUNDERS, V.A. and SAUNDERS, J.R. (1987). Principles and techniques of gene transfer and manipulation. Croom Helm.
- SCHEIN, A., BERDAHL, B.J., LOW, M. and BOREK, E. (1972). Deficiency of the DNA of *Micrococcus radiodurans* in methyladenine and methylcytosine. *Biochimica et Biophysica Acta*. **272**:481-485.
- SCHLEIFER, K.H., and KANDLER, O. (1972). Peptidoglycan types of bacterial cell walls and their taxonomic implications. *Bacteriological Reviews*. **36**:407-477.
- SEDGWICK, S.G. (1976). Misrepair of overlapping daughter strand gaps as a possible mechanism for UV induced mutagenesis in *uvr* strains of *Escherichia coli*: A general model for induced mutagenesis by misrepair (SOS repair) of closely spaced DNA lesions. *Mutation Research*. **41**:185-199.
- SEDGWICK, S.G. (1986). Inducible DNA repair in microbes. *Microbiological Sciences*. **3**:76-83.
- SEDGWICK, S.G. ROBSON, M. and MALIK, F. (1988). Polymorphisms in the *umuDC* region of *Escherichia* species. *Journal of Bacteriology*. **170**:1610-1616.

- SETLOW, J.K. and DUGGAN, D.E. (1964). The resistance of *Micrococcus radiodurans* to ultraviolet irradiation. I. Ultraviolet induced lesions in the cell's DNA. *Biochimica et Biophysica Acta*. 87:664-668.
- SETLOW, J.K., SPIKES, D. and GRIFFIN, K. (1988). Characterisation of the *rec-1* gene of *Haemophilus influenzae* and behaviour of the gene in *Escherichia coli*. *Journal of Bacteriology*. 170:3876-3881.
- SHAPIRO, A., DILELLO, D., LOUDIS, M.C., KELLER, D.E. and HUNTER, S.H. (1977). Minimal requirements in defined media for improved growth of some radio-resistant pink tetracocci. *Applied and Environmental Microbiology*. 33:1129-1133.
- SLEYTR, U.B., KOCUR, M., GLAUERT, A.M. and THORNLEY, M.J. (1973). A study by freeze-etching of the fine structure of *Micrococcus radiodurans*. *Archives für Mikrobiologie*. 94:77-87.
- SLEYTR, U.B., SILVA, M.T., KOCUR, M. and LEWIS, N.F. (1976). The fine structure of *Micrococcus radiophilus* and *Micrococcus radioproteolyticus*. *Archives of Microbiology*. 107:313-320.
- SMITH, G.R. (1988). Homologous recombination in prokaryotes. *Microbiological Reviews*. 52:1-28.
- SMITH, M.D., ABRAHAMSON, R. and MINTON, K.W. (1989). Shuttle plasmids constructed by the insertion of an *E.coli* cloning vector into two *Deinococcus radiodurans* plasmids. *Journal of Bacteriology*. In press.
- SMITH, M.D., LENNON, E., McNEIL, L.B. and MINTON, K.W. (1988). Duplication insertion of drug resistance determinants in the radioresistant bacterium *Deinococcus radiodurans*. *Journal of Bacteriology*. 170:2126-2135.

- SMITH, K.C. and MEUN, D.H.C. (1970). Repair of radiation-induced damage in *Escherichia coli*. I. Effect of *rec* mutations on post-replication repair of damage due to ultraviolet irradiation. *Journal of Molecular Biology*. 51:459-472.
- SOUTHERN, E.M. (1979). Gel electrophoresis of restriction fragments. In: *Methods in Enzymology*. 68:152-175. Edited by R. Wu. Academic Press.
- STACKEBRANDT, E. and WOESE, C.R. (1981). The evolution of prokaryotes. In: *Molecular and Cellular Aspects of Microbial Evolution*, pg 1-31, S.G.M. Symposium 32. Edited by M.J. Carlile, J.F. Collins and B.E.B. Moseley. Cambridge University Press, Cambridge.
- STÖRL, H.J., SIMON, H. and BARTHELMES, H. (1979). Immunochemical detection of N<sup>6</sup>-methyladenine in DNA. *Biochimica et Biophysica Acta*. 564:23-30.
- STUDIER, F.W. (1965). Sedimentation studies of the size and shape of DNA. *Journal of Molecular Biology*. 11:373-390.
- STUEBER, D. IBRAHIM, I. and CUTLER, D. (1984). A novel *in vitro* transcription-translation system: Accurate and efficient synthesis of single proteins from cloned DNA sequences. *The EMBO Journal*. 3:3143-3148.
- SWEET, D.M. and MOSELEY, B.E.B. (1974). Accurate repair of ultraviolet induced damage in *Micrococcus radiodurans*. *Mutation Research*. 23:311-318.
- SWEET, D.M. and MOSELEY, B.E.B. (1976). The resistance of *Micrococcus radiodurans* to killing and mutation by agents which damage DNA. *Mutation Research*. 34:175-186.
- TEMPEST, P.R. (1978). Mutagenesis and DNA repair in *Micrococcus radiodurans*. Ph.D. Thesis, University of Edinburgh.

- TEMPEST, P.R. and MOSELEY, B.E.B. (1982). Lack of ultraviolet mutagenesis in radiation resistant bacteria. *Mutation Research*. 104:275-280.
- THOMPSON, B.G., ANDERSON, R. and MURRAY, R.G.E. (1980). Unusual polar lipids of *Micrococcus radiodurans* strain Sark. *Canadian Journal of Microbiology*. 26:1408-1411.
- THOMPSON, B.G. and MURRAY, R.G.E. (1982). The fenestrated peptidoglycan layer of *Deinococcus radiodurans*. *Canadian Journal of Microbiology*. 28:522-525.
- THORNLEY, M.J., HORNE, R.W. and GLAUERT, A.M. (1965). The fine structure of *Micrococcus radiodurans*. *Archives für Mikrobiologie*. 51:267-289.
- TIRGARI, S. (1977). Studies on the genetics of *Micrococcus radiodurans*. Ph.D. Thesis, University of Edinburgh.
- TIRGARI, S. and MOSELEY, B.E.B. (1980). Transformation in *Micrococcus radiodurans*. Measurement of various parameters and evidence for multiple, independently segregating genomes per cell. *Journal of General Microbiology*. 119:287-296.
- TOWBIN, H., STAHELIN, T. and GORDON, N.J. (1979). Electrophoretic transfer of proteins from polyacrylamide gels to nitrocellulose sheets: Procedure and some applications. *Proceedings of the National Academy of Sciences U.S.A.* 76:4350-4354.
- TWIGG, A.J. and SHERRATT, D. (1980). Trans-complementable copy number mutants of plasmid ColE1. *Nature*. 283:216-218.
- WALKER, G.C. (1984). Mutagenesis and inducible responses to deoxyribonucleic acid damage in *Escherichia coli*. *Microbiological Reviews*. 48:60-93.
- WALKER, G.C. (1985). Inducible DNA repair systems. *Annual Review of Biochemistry*. 54:425-457.

- WANG, T.V. and SMITH, K.C. (1983). Mechanisms for *recF*-dependent and *recB*-dependent pathways of postreplicational repair in UV-irradiated *Escherichia coli uvrB*. *Journal of Bacteriology*. **156**:1093-1098.
- WANI, A.A., STEPHENS, R.E., D'AMBROSIO, S.M. and HART, R.W. (1982). A sequence specific endonuclease from *Micrococcus radiodurans*. *Biochimica et Biophysica Acta*. **697**:178-184.
- WELSH, A.B. and MAXCY, R.B. (1979). Characteristics of some radiation resistant haemolytic micrococci isolated from chicken. *Journal of Food Science*. **44**:673-675.
- WEST, S.C., CASSUTO, E. and HOWARD-FLANDERS, P. (1981). Mechanism of *E.coli* RecA protein directed strand exchanges in post-replication repair of DNA. *Nature*. **294**:659-662.
- WEST, S.C., COUNTRYMAN, J.K. and HOWARD-FLANDERS, P. (1983). Purification and properties of the *recA* protein of *Proteus mirabilis*. *Journal of Biological Chemistry*. **258**:4648-4654.
- WILLIAMS, D.M., DUVALL, E.J. and LOVETT, P.S. (1981). Cloning restriction fragments that promote expression of a gene in *Bacillus subtilis*. *Journal of Bacteriology*. **146**:1162-1165.
- WITKIN, E.M. (1976). Ultraviolet mutagenesis and inducible DNA repair in *Escherichia coli*. *Bacteriological Reviews*. **40**:869-907.
- WORK, E. (1964). Amino-acids of walls of *Micrococcus radiodurans*. *Nature*. **201**:1107-1109.
- WORK, E. and GRIFFITHS, H. (1968). Morphology and chemistry of cell walls in *Micrococcus radiodurans*. *Journal of Bacteriology*. **95**:641-657.

- YAMADA, Y., TAKINAMI, H., TAHARA, Y. and KONDO, K. (1977). The menaquinone system in the classification of radiation-resistant micrococci. *Journal of General Applied Microbiology*. 23:105-108.
- YAMAGUCHI, H., TANG, X. and TANO, S. (1986). Cloning and expression of *recA*<sup>+</sup>-like gene from rice mitochondria. *Rice Genetics Newsletter*. 3:122-124.
- YONEDA, Y., GRAHAM, S. and YOUNG, F.E. (1979). Restriction-fragment map of the temperate *Bacillus subtilis* bacteriophage SP02. *Gene*. 7:51-68.
- YOUNGS, D.A. and SMITH, K.C. (1976). Genetic control of multiple pathways of post-replicative repair in *uvr* strains of *Escherichia coli* K-12. *Journal of Bacteriology*. 125:102-110.
- ZEIG, J. and KUSHNER, S.R. (1977). Analysis of genetic recombination between two partially deleted lactose operons of *Escherichia coli* K-12. *Journal of Bacteriology*. 131:123-132.