

S.

.61776

COAL MINERS' NYSTAGMUS

THESIS for the degree of M.D.

by

H. BALLINGALL WATSON,

M.A., Edin., M.B., Ch.B., Edin., 1908.
(2nd Class Hons.)

October, 1915.



COAL MINERS' NYSTAGMUS.

PART I.

	<u>Page.</u>
1. Introductory.	1
2. Historical.	5
3. Diagnosis.	8
4. Symptomatology.	9
5. Varieties of the disease.	10
6. Signs & Symptoms considered in detail:-	
A. Signs	11
B. Symptoms.	24

COAL MINERS' NYSTAGMUS.

INTRODUCTORY.

The Prosperity of a country bears a direct ratio to the organisation of its Industry and this again in the ultimate is closely bound up with the Health and Efficiency of the individual of the Industrial Population. A healthy capable workman is an asset to any country.

For the past three years I have been acting as one of the Medical Advisers to the Scottish Mine Owners' Defence and Mutual Insurance Association which insures against Accidents and Trade Diseases peculiar to the coal miner over 120,000 workmen, and my attention has been closely drawn to a consideration of the working conditions of the collier, the Accidents to which he is subject, and the Trade Diseases affecting his fitness and so diminishing his working capacity.

Weekly visits to mining stations for the purpose of examining workmen alleging incapacity and claiming Compensation have brought me into contact with the managers and mining officials who have from time to time conducted me through the underground workings with a view to my becoming acquainted with the internal arrangements with special reference to the demands made upon the different classes of workmen in the several branches/

branches of mining. This experience has been of much service to me in advising the Association as to validity of claims lodged, and in understanding the manner in which the alleged accidents have occurred as described technically by the miner. I have also found it a great help in the estimating of restored capacity for the several classes of mining work.

From an interesting study of the outlines of the various Mines Acts, and a survey of the history of progress in mining methods, one is struck with the great improvements in underground conditions which have taken place since Dr. Angus Smith (1) published in 1865 his paper on "Air and Rain", and their bearing upon the air of mines. At that time the methods of ventilation, the hours and general conditions of work were, to say the least, highly unsatisfactory and injurious to the workmen. Sir John Simons (2) in his Public Health Reports, in writing on the subject, says "The miner..... often spends his days in ill ventilated work places: but the non-ventilation from which he suffers is associated in its existence and in its consequences with conditions special to the subterranean employment".

Twenty-five years later, Dr. Nasmyth (3) records the great improvement in Mining Ventilation by Fan Systems, etc. He points out the Mining Law on the subject, makes note of the shortening of working hours and quotes statistics proving that the conditions of/

of miners' work are as favourable to good general health as are those in the occupation of any other workman. In closing, he remarks "In fact I know of no disease peculiar to miners, or any disease existing in excess among miners".

Another twenty-five years have passed since then, and Legislation has been busy in regard to ^{the} Mining Industry. Ventilation has been further improved.

The Daily Reports by Firemen (Deputies in England and Weathermen on the Continent) as to the amount of gases present and the general safety of the working places, the keeping of charts noting temperatures, barometric pressures etc., all go to show the elaborate and careful supervision now in force.

Safety devices maintain in shafts roads and working places, a great variety of lamps is on the market, and an eight hours' day and a minimum wage for all underground workers are the outcome of relatively recent Legislation.

In short, much has been done to render the working conditions as favourable as may be compatible with practicability with a view to increasing the output of coal, minimising accidents and securing the general comfort of the miner.

All this might lead one to think that the miner is among the favoured classes of the Industrial population. His general health, in my experience, is good and the incidence of major and fatal accidents is on the decline. But/

But, in working in conjunction with the Statistical Department of the Association on the cost to the Mining Industry of the various sources of incapacity, it was a great surprise indeed to realise the extent to which coal miners are incapacitated through suffering from Nystagmus. The condition is infrequently seen in the clinics of our larger hospitals, for the simple reason that the workmen very seldom appear there for treatment but to the general practitioner in the mining areas, and to those of us who are in daily touch with miners and mining, the condition seems to amount almost to a calamity of the Mining Industry.

While Nystagmus cannot be said to endanger life directly, the perplexing feature about it is that it leads to diminished capacity for work, and occasionally prevents the patient altogether from following his avocation. Another point of note is that this lessened capacity happens at the most useful time of life, and entails much suffering in the home and loss to the mining industry as a whole.

In spite of the improved conditions referred to there has been a steady increase of cases since first the condition was recognised, and within recent years the increase has been so marked that its socio-economic significance has rendered it a subject, not only of medical, but also of political investigation, and it has now been scheduled under the diseases for which a miner may claim the benefits of the Workmen's Compensation Act/

Act 1906 (Secretary of State's order 22nd May, 1907 - Schedule iii).

It is in this connection that I have come primarily into contact with cases of this disease, both in the West and the East of Scotland Coalfields, and the notes which I have made during those years form the basis of this Thesis on Coal Miners' Nystagmus.

HISTORICAL.

In setting down, in brief, a survey of the History of the Literature, I do not attempt to place in chronological sequence each writer, but mainly to indicate that the subject has claimed considerable attention from competent observers since first the condition was recognised.

One finds that now and again there have been intervals when the interest in the subject seems to have fallen off, only to be followed by periods marked by animated discussion in this country and on the Continent of Europe. Miners' Nystagmus began to attract attention about the middle of the last century.

It is disputed as to whether the English, French or Germans may claim the honour of the discovery. The observations on the disease made by Dr. Gillot of Sheffield, 1854-58, to which reference is made by Snell (4) in his monograph published in 1892, are probably the first.

Von/

Von Graëfe relates, as also does Nieden, that in Germany Peppmüller met with and described cases in Zwickan 1860-1863: but the literary priority belongs to the Belgian oculist Dr. Décondé (5) of Luttich, who, in 1861, published his "Note sur la nystagmus" a paper dealing with Nystagmus in general and making reference to two cases occurring in miners.

It was not, however, till the seventies of last century that the first real scientific investigation on the subject began, and this is associated with the names of Snell 1875, C. Bell Taylor, Oglesby and Jeaffreson in England.

In Germany Nieden, Von Graëfe and Wilbrand were the leaders. In France Dransart, 1877, was the early representative; and in Belgium Romiée and Nuel carried out their investigations into the subject. These observers worked in the midst of extensive colliery areas and had at their disposal considerable material. The late Simeon Snell of Sheffield was in the forefront to the end and his work published in 1892 may be said to have given a great impetus to English observers.

1890-1892 was one of those very active periods when Snell, Tatham Thompson, Court, Butler, and others played their part in this country in the effort to throw light on the nature and origin of the disease. In France, Pechdo brought forward his theory in 1893; and in Germany, Nieden published his observations in 1894.

Italy/

Italy added a new stimulus through the Labyrinthine theory of Trombetta, published in 1900; and in Germany, Peters endeavoured from a study of the Literature to enunciate a theory of the condition.

The contributions of Reid to the volumes of "Brain", in 1906, attracted considerable attention to the subject. In recent years, Belgium has added to the Literature through the observations of Coppez and Weekers. Ohm has paid special attention to the disease as occurring in Germany. In England Harrison Butler, Tomlin, Elworthy and Cridland have taken part in discussions and published articles from time to time in the leading Journals; and Court, Llewellyn, Meehan and others have given evidence before Departmental Committees.

The most recent publication is that of T. Lister Llewellyn, 1912, who, as Tyndall research mining student of the Royal Society, has devoted much careful study to the subject and has written, in conjunction with Dr. J. S. Haldane, many valuable papers contributed to the Transactions of the Royal Society, and of the Institutes of Mining Engineers.

Reference will be made to the views expressed by many of those observers throughout the Thesis.

DEFINITION.

Miners' Nystagmus is an occupational disease confined to workers in coal mines. The characteristic sign/

sign of the condition is oscillatory movements of the bulbi, involuntary and rhythmic in type, varying in rate, direction of swing, and amplitude.

Nystagmus is, in a sense, an unfortunate nomenclature for the disease, and in fact is in a way misleading. The word Nystagmus, from the Greek, refers simply to the "nodding" or oscillations of the eyeballs and is but a symptom of a symptom complex. Quite recently, J. Jameson Evans has suggested to Harrison Butler (6), in his review of Tomlin's paper on the subject, published in the Medical Chronicle October 1911, the name "Coal Miners' Neurosis" as more completely describing the actual condition, since, as he points out, the classical feature may be at times almost entirely absent in cases of the disease. I use the word "Nystagmus" throughout as inclusive of all the symptoms associated in the clinical picture.

DIAGNOSIS.

In many cases of Miners' Nystagmus the diagnosis can be made at a glance. The patient enters the room with the head tilted backwards to a varying degree and with, at times, a tendency to an oblique turning of the head to right or left. The eyelids droop somewhat and there may be associated spasm of the lids and face muscles. As he comes nearer, a fine tremor of the head may be noted and usually can be felt. Oscillations of the eyeballs are evident in straight forward gaze/

gaze and the patient may show some hesitancy in finding his way to a chair.

In other cases, however, none of those objective phenomena are evident on his entering, and the patient complains of "objects dancing" and makes special reference to the trouble which the "lights" underground occasion. In such cases the diagnosis is by no means so clear at first.

SYMPTOMATOLOGY.

As in all diseased conditions this problem has to be viewed from the two-fold stand-point:-

A. Objective, and B. Subjective.

Objectively we have to note:-

1. The Oscillations of the Eyeballs.
2. Spasm of the Eyelids (Blepharospasm).
3. Twitching of the facial muscles.
4. Tremors of the head, neck and hands.
5. Confused vision and at times Photophobia.

Subjectively there falls to be noted the complaints of:-

1. Movements of surrounding objects.
2. Dazzling.
3. Headache.
4. Night Blindness (Hemeralopia).
5. General nervous symptoms, including mental disturbance.

In such a complex clinical picture it is to be expected that/

that in any one case many of those features will be absent: and this is just what happens.

The pathognomonic oscillations of the eyeballs and the classical complaint of the movements in surrounding objects are the two main phenomena and the two most often met with.

VARIETIES OF THE DISEASE.

At this point it may be well to note that two distinct varieties are to be recognised:-

I. Where the subjective phenomena are absent or latent, and no disability is apparently suffered.

In fact the workman is unaware that he is the subject of Nystagmus, and the diagnosis is made as he presents himself for some other condition.

II. The man makes a specific complaint of his eyes. "His eyes are not right" he says, and he is more or less incapacitated. This group, in contradistinction to the other, is called the manifest.

There are so many stages, in other words the course of onset is generally so prolonged, that the manifest group may be subdivided into three forms:-

A. The slight, where the workman is conscious of a degree of disability due to the state of his eyes, but continues at his work; the miner being generally a long suffering mortal and not given to introspection.

B. The ordinary - a more advanced stage - when he finds himself unequal to the more skilled part of his/

his work underground.

C. C. The severe, when he is in danger from accident himself and may be a source of danger unwittingly to his fellow workmen, and when he is totally incapacitated.

SIGNS AND SYMPTOMS CONSIDERED IN DETAIL.

SIGNS.

The outstanding feature of the disease objectively is, as has already been noted, the oscillations of the bulbi, the "Augenzittern" of the German observers.

The observation of these is conducted either by means of the Examiner's naked eye, assisted by a magnifying glass, or by means of the ophthalmoscope, or by some such instrument as the nystagmograph used by Buys and Coppez (7). By those methods one eye only can be examined at one and the same time.

Ohm (8), in his treatise on the subject, describes what he calls his "binokularem augenspiegels" - his binocular glass, by the aid of which the two eyes can be kept under observation at one and the same time. In all the cases I have examined the ophthalmoscope was used. The movements of a sharply defined object like the 'disc', or the vessels on or around it, admit of a closer study than do the movements of any point on the anterior surface of the eyeball. No doubt, so far/

so far as diagnosis is concerned, the naked eye method is sufficient in marked cases. There are, however, cases which, owing to the smallness of the amplitude, the rate of the movements and it may be, the shortness of the duration of the attack, would be liable to be missed by such a method of examination.

The ophthalmoscope eliminates this and is really necessary when the type of the oscillation is to be fixed with any accuracy.

Direction.

Nieden (9) distinguishes between three kinds of oscillations:-

1. Horizontal, which he calls the pure oscillatory: an oscillation of the eyeball about the vertical axis of the bulbi - the External and Internal Recti functioning.- He estimates this class at 12.5 - 15.5%.
2. Rotatarius. The revolution taking place at the axis of the plane of turning of the oblique. 72 - 75.5%.
3. Mixtus. The oscillations taking place at one time in the perpendicular, at another on the oblique, whereby an irregular 'whirl' of the eye results. 7 - 15%.

Nieden remarks that the form of vertical nystagmus often observed by Snell and Romiée has been met by him in so few cases that he cannot set it down as a form of Miners' Nystagmus.

Romiée/

Romiée (10) classifies the varieties:-

- | | | |
|----|------------------------------------------|-----|
| 1. | Nystagmus Oscillatoire (Horizontal) | 17% |
| 2. | " Rotatoire (Rotatory) | 70% |
| 3. | " Vertical | 11% |
| 4. | " Mixte - of which he gives no estimate. | |

In this classification he has gone into the question of muscle pairs involved.

The most comprehensive and detailed classification which I have met with in the Literature of the subject is that given by Ohm (8 p. 16-17).

He distinguishes two main varieties:-

- A. A Rectilinear or straight-lined form.
- B. A Curvilinear or "bent-lined" form; [the direction being based upon the tract or orbit traversed by the disc.

In A, there is a to and fro phase, both taking place in the same plane and taking the same time.

In B, the optic disc describes a circular or elliptical tract, the path appearing to be traversed in all parts with equal velocity so far as observation can follow.

Under A he describes:-

- | | | |
|----|--------------------------|--------|
| 1. | Perpendicular (vertical) | 29.92% |
| 2. | Horizontal | 17.55% |
| 3. | Oblique | 21.07% |

Under B he describes:-

- | | | |
|----|------------|--------|
| 1. | Circular | 12.96% |
| 2. | Elliptical | 18.33% |

The Elliptical he further elaborates into:-

- | | |
|----|-----------------------------------|
| 1. | Those with greater vertical axis. |
| 2. | " " " horizontal axis. |
| 3. | " " " oblique axis. |





Further/

Further, he finds evidence of clockwise and counter-clockwise direction of swing in the circular and elliptical groups.

Some general notion may be got of the varieties described from the following schematic representation.

A. | — \ /

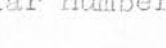
There are as many varieties of oblique as there are angles between perpendicular and horizontal.

B. 1.  2. 
 2.  3. 
 3.  

and again a similar number of varieties between 2 and 3.

In some cases the ellipse approximates to a circle and in others to a straight line.

In my reported cases I have classified the eyeball movements under three varieties:-

1. Rotatory. 2. Horizontal. 3. Vertical.

The "Oblique" I have included under Class 1, since I have never definitely found it of a pure character, but always accompanied, to some extent, by axial rotatory movement.

It is further to be noted that in many cases of the Horizontal and Vertical there is a rotary element with a large lateral or vertical excursion respectively. Having this in view, I have discarded the Elliptical classification, and have included those cases which definitely depart from the pure Oscillatory (Horizontal and Vertical) under the head of/

of Rotatory.

Analysis of cases:-

Direction of Swing.	Series A.	Series B.
Rotatory	75%	60%
Horizontal	15%	25%
Vertical	10%	15%

Apart from the ordinary forms there are to be noted at times extra movements of an irregular nature when one finds it impossible to describe the path followed by the object fixed.

The Direction of Swing is by no means constant. It varies in the same case and in the same eye during one examination.

Amplitude. The amplitude varies greatly, the measure being the range of movement of the disc. In very small oscillations, i.e. in oscillations of very small amplitude, it is preferable to fix a retinal vessel. There are still smaller movements when only a tremor of the vessel is appreciable. The amplitude not only differs in different cases, but varies in the same case and in the same eye during one examination, as was found to be true of the Direction of Swing.

In that class of case where repeated stooping, strong upward gaze, or even rotation of the body, has had to be resorted to, to bring out the oscillations, it is to be noted that the oscillations begin first of all at/

at the highest point of upward gaze and as the level is lowered the movements cease at a definite point.

As the case gets worse the 'quiver' is to be noted in a downward spreading direction.

In some cases it is noticeable in a straight forward gaze and in more severe cases downward gaze to a few degrees below the horizontal does not bring the eyes to rest. In only the severest type however does strong downward gaze not bring the movements to rest. Romiée (11) has suggested that the angle of regard above or below the primary horizontal position at which the oscillations are most marked may be taken as a measure of the condition. With gradual improvement, the area of gaze where oscillations persist recedes upwards more and more. There is this further to note that the amplitude is usually smallest with downcast gaze and increases with upward gaze. It is however capable of change with no alteration in gaze.

Side turning or Glancing has an effect on the type of oscillations as to direction, rate, amplitude and what I have called "gaze area". In some cases where the maximum oscillation is to be noted in straight forward gaze it quietens down or may cease if an oblique element of gaze is introduced. Case 1. Series A. In some cases again the very opposite maintains.

Speed or Rate. With regard to this, different observers have given different estimates. Romiée (11) gives 120/

120 - 500 per minute; Shell (4) 60 - 100; Nieden (9, p.32) 80 - 100 and in a few cases 560.

I have been able to count oscillations as frequent as 350 per minute. There are cases however the rate of which exceeds this. They seem to be so rapid that one cannot count them.

I have counted oscillations which fall as low as 80. It is to be noted that during one and the same examination, taken minute for minute, that the rate varies, fast becomes slow and vice versa, and at times there are periods of stillness with no change of gaze. The oscillation rate is usually more frequent and stronger in the dark room than in the ordinary daylight.

In some cases where no movement of the eye balls can be made out in the dark room with a strong upturned and oblique gaze, a few stooping movements will be followed by the onset of the oscillations.

Further the fixation of a near object will often bring on an attack.

I have also seen cases where an effort of this kind has quietened the oscillations.

To sum up, we note that the Rotatory form of oscillation is the most common: the direction of swing the rate and amplitude are liable to frequent alteration, induced, it would appear, by change of gaze, stooping, rotating, and change of light.

All this points to the complex nature of the mechanism which must be deranged to admit of such variety/

variety of loss of co-ordination as evidenced by the oscillations.

Blepharospasm. An intimate relation to Nystagmus is borne by another muscle derangement called Lid-spasm or Blepharospasm.

It takes on the clonic form and consists of fibrillary contractions of the orbicularis palpebrarum with a seeming cramp of the levator. In some cases it is of a transient nature brought on when the patient has been tested by stooping, or when he is taken at first into the dark room, but a marked type often complicates the serious cases and persists long after the oscillations have ceased, thereby prolonging the incapacity of the workman.

It is not an indispensable phenomenon, a considerable percentage of cases show no trace of it.

	Traces.	Severe.
Series A.	45%	7%
Series B.	15%	1%

It occurs in all possible types of oscillation, is simultaneous in both eyes, and equally strong in both. In the severe cases, the brow and mouth muscles are often implicated, and there may be Blepharoptosis. It appears worse when the patient is submitted to examination. This has led to the view that it is very often simulated.

Many of the circumstances which bring about or exaggerate/

exaggerate the oscillations also set up or increase the Lid-cramp, e.g. bending, raising gaze, entering dark room, fatigue etc.

Examination of the Eyes is particularly difficult in such cases, but often in the very severe form of the Blepharospasm only a slight tremor of the eyeballs is to be noted.

Many views have been held as to the true nature and origin of this symptom.

Dransart (12) recalls the anatomical and physiological relationship between the Rectus Superior and the Levator Palpebrarum, and believes that the excitement of the former which induces the oscillations is communicated to the latter, resulting in Blepharospasm. For him it is a question of fatigue manifested in fibrillary twitchings. But Blepharospasm appears not only in cases of vertical nystagmus.

Further, when one tries to open the eyelids in a severe or marked case with the fingers the resistance experienced indicates that the cause must lie in the lid muscles themselves, i.e., directly. Ohm (8, p.43) puts forward the explanation that the mechanical irritation caused by the movements of the eyeballs to the sensory nerves of the lid calls forth the spasm. He points out that he was led to form this view from noting the effect of cocaine in quieting a Lid-spasm which had gone on for months. In eight days it ceased/

ceased as the result of this line of treatment.

He explains this in two ways:-

1. The soothing effect of the cocaine upon the fine sensory nerves.
2. The stimulation of the smooth muscle of Müller which is antagonistic to the orbicularis.

Nieden (9, p.115) has advanced the view that the Blepharospasm takes place in the instinctive intention of eliminating the apparent dancing of the light or objects caused by the oscillation of the globes.

No doubt the clonic spasm of the lids is capable of inducing of itself a feeling as if lights were "bobbing up and down", and so this theory might seem open to question.

There is to be noted, however, in many patients belonging to the milder groups, in whom the oscillations can hardly be said to be fully developed, an effort at manipulating the lids with the seeming purpose of repressing the oscillations. Case 1. Series A. When the glance is raised, the oscillations set in followed by the Blepharospasm.

It would sometimes appear as if the clonic spasm of the lids tended to lowering of the gaze and a quietening of the 'zittern'.

I have to note that it was suggested to me by a colliery manager, as well as by three workmen who suffered from the condition, that when at the face, with each swing of the pick, the eyes are closed or 'blinked' just as the pick meets the coal, the purpose being to avoid/

avoid 'sparks' injuring the eyes. They add that the habit of doing so makes the miner 'blink'.

I think there is really nothing in this suggestion, otherwise a larger percentage of miners would suffer from the condition. It would amount to nothing more, if this were the case, than a Habit Spasm, such as is found in nervous school children etc.

I consider the Blepharospasm as compensatory to the oscillations, since patients with the strongest lid-spasm have usually oscillations of very minute amplitude or, as it would sometimes appear, none at all. Again, when the Blepharospasm gets better, it is often to be noted that the oscillations appear more marked.

I have gone somewhat fully into this phenomenon, since it has now an additional importance owing to the fact that the Industrial Disease Committee (13) has had under consideration, as recently as last Autumn, the adding of Clonic Spasm of the eyelids apart from Nystagmus to Schedule iii of the Workmen's Compensation Act 1906.

Dr. Llewellyn (13), in his evidence before that committee, held:-

1. "I do not think it occurs in miners as a result of their occupation apart from the presence of Nystagmus.
2. It is a sign very easily simulated.
3. It is a sign which is found in so many diseased conditions of the ocular apparatus, that it possesses no pathognomonic feature."

Head/

Head Nodding and Head Tremor. This is very commonly met with in association with nystagmic patients. An antero-posterior and a lateral (side to side) nodding is to be met with.

In milder forms of the disease it is oftener a "head tremor" which is more easily felt than seen and can be brought out with upward gaze when the head is strongly flexed by the examiner's hand. This Head Tremor is of some value as a diagnostic test. Many cases in which I have felt or noted this Tremor or Nodding have shown no oscillations till examined in the dark room.

The view has been expressed that those head movements are compensatory, to prevent or check the sensation of movements of light and objects.

Ohm traces them to Alcoholism. This I do not consider an adequate explanation, for few of my patients were alcoholic, and the head tremor was noted in a high percentage. Further, if alcohol were the cause, it would be found in a considerable number of miners examined who have none of the symptoms associated with nystagmus. Tomlin (23) and Butler (14) of the Neurosis School put it down to the general neurosis. Cridland (14) shares this view.

I think it very probably compensatory in origin. It is a sign of the extension of the loss of co-ordination, a sequel to the eye troubles.

Twitching/

Twitching of the neck and shoulder girdle muscles is occasionally seen, and tremors of the hands, and in rare cases of the body generally, are to be noted. Snell (4) cites a case where Torticollis was associated. These may be considered as cases which have been so prolonged and of such a severe symptomatic type as to induce the grafting on of a general neurosis. The head tremor is found in some of the cases in the earliest stages where no true nervous element is to be noted.

Photophobia is another symptom occasionally met with. In some cases it is a true intolerance of light as is to be noted by the conduct of the patient while under examination in the dark room. There is case iv, series A., where trouble was experienced on entering the lighted kitchen after walking home in the dark. There are cases which volunteer the statement that they feel worse in sunlight, and in the village streets such men can be noted walking about with their caps well drawn down over their eyes.

Oftener, however, it amounts to nothing more than a sense of discomfort and confusion caused by the apparent rapid oscillating movements of objects, and chiefly, ^{of} the bright points of artificial lights.

SYMPTOMS/

SYMPTOMS.

I will now pass on to a consideration of the detail of the Subjective side of the Clinical Picture of the disease.

In early cases a complaint of Dazzling and Headache with confusion of sight is often made, and this when no manifest oscillations are to be made out even after the usual methods have been applied for the purpose of inducing them. Repeated examination may be necessary before oscillations are noted.

The classical feature however on this side of the clinical study is:-

Movements in Surrounding Objects.

Miners' Nystagmus gives rise to the sensation that all objects are in rapid movement. The "lights in the mine dance" and the collier suffers from vertigo, has trouble in doing his work and in marked cases is totally incapacitated.

In contradistinction to this, ordinary and congenital cases of Nystagmus make no such complaint. Nuel (15) however, has noted that these oscillations trouble the patient less and less the longer the Nystagmus has lasted. He quotes the case of an old man who had been the subject of the condition for over forty years when the movements of objects were no longer perceived.

Butler (16) has remarked, in this connection, that such a case would amount to a chronic stage setting in with marked oscillations in a patient who has grown used/

used to the movements in objects, and who, in consequence, suffers very little inconvenience.

Norman (17) offers the suggestion that such cases would be very similar to that of an Albino who has no sensation of ocular movements because by long practice his visual centres have learned to interpret the moving images as if they were stationary. Such cases would be rare I should fancy. I have only met one:-

A man, aged 69, who was employed underground at the coal face - an exceptional age - but he was hale and hearty. He had had his little finger crushed and was examined on that account. The oscillations were very evident, but he said that he suffered no inconvenience.

He knew that he had been the subject of the "Glenny Blink" -(Clanny lamp)- Nystagmus. He had suffered in a mild degree for 25 years, but the discomfort was now gone. As a younger man he used to be off now and again suffering from headache and difficulty with sight on account of the "dancing of the light".

The degree of the oscillations bears no constant ratio to the degree of symptomatic trouble from the movements of objects. Very often, in mild cases, it is only in the dark room that this sensation is produced, contemporaneous with the onset of the "zittern". This is of some importance when we come to consider the question of Incapacity. Like most of the/

the other phenomena this sensation of movement in objects is increased with exertion, fatigue, stooping etc.

The Headache varies in degree from a slight sense of fullness in the head to severe temporal and occipital pain. Stooping exaggerates it. Some cases have complained to me of pain in the neck and down between the shoulder blades.

That patients who suffer from Nystagmus should be subject to giddy attacks is not to be wondered at. Stooping and exertion increase this symptom, and men have told me that they have now and again had to get up and rest for a few minutes to "drive away the giddy feeling".

Llewellyn (18) remarks that in some cases the giddiness assumes such a severe form as to amount to ataxy.

Diplopia is a rare symptom.

I have only met one such case and there the oscillations were of different types in the two eyes. In other cases, where a difference of direction of swing in the two eyes has been noted as present, no such similar complaint was made.

Hemeralopia (Night Blindness).

Is Hemeralopia a symptom of the disease? On this apparently simple question there seems to be the very widest divergence of opinion.

Nuel/

Nuel, Court, Dransart and Nieden include it as a symptom, Court (19) finding it present in 127 out of 164 tested. Dransart (20) estimates it as present in 5% of his cases. Butler (6) found it in 60%, and Llewellyn (18 p.2) in 74.9%.

On the other hand, Romi e (21) says that among several thousands of cases he has never found one example of Hemeralopia. This difference of opinion may, of course, depend on the different views of the definition of night blindness. I have taken it to mean men who suffer more by night than by day.

It is at bottom, I think, a question of what might be termed 'sense of light'. Many of the subjects of Nystagmus volunteer the statement that they are worse at night time, in the grey of the morning and in the twilight or "between the lights", as Llewellyn has put it.

It is often an early symptom. There are varying degrees of the trouble occasioned, many men suffering only on going down and coming up from their work, whereas when at the 'face workings' they feel fairly right. When asked if they see well in the dark they usually answer "No, the lights dazzle, objects dance and I feel giddy".

Others again describe the sensation as if a grey mist were closing in around them and they stumble about. This happens quite apart from the fact that any point of/

of light dazzles them at night. Some men complain that they have difficulty in finding their way about in the open country in a degree of diffused light which was once amply sufficient for them.

From an analysis of my reported cases I find

in Series A (certified cases)	Hemeralopia	50%.
in Series B (latent and mild manifest)	"	35%.

With reference to this important symptom the work of Weekers (22) is very interesting and instructive. Under the guidance of Nuel he has made experiments as to adaptation capacity of miners with special reference to those suffering from Nystagmus. "Recherches sur l'adaptation retinienne chez les houilleurs dans le Nystagmus professionnel." He speaks of the "two retinae in each eye", meaning thereby that there is an area of rods and an area of cones in each retina. The cones serve for seeing in full light and in feeble and lowered light the rods function. The Fovea has no rods and the retina immediately around it has only a few.

The visual acuity of the rods is at its maximum in a retinal band surrounding the Fovea at a distance of from 15° - 20° . In this annular ring the visual acuity is practically everywhere of the same value. In a good light we fix with the Fovea but in the poorer light of the mine the workman can fix at any place on this perifoveal ring. He has therefore no retinal directing point or, as one might put it, the necessity for/

for accurate central fixation is absent.

In consequence of this, Nuel (15, p.47) has suggested that there may be failure of co-ordination. By means of "Nagel's Adaptometer" Weekers has recorded the feeblest luminous intensity perceived by the patients tested.

This he has determined from minute to minute and has mapped out the "march of adaptation" and set it out in graphs. The examination in each case lasted for over an hour.

He finds that miners not affected with Nystagmus have, in general, an excellent adaptation, often superior to the normal, probably due to their being accustomed to darkness. The results obtained from testing Nystagmic miners is variable, he adds.

In certain cases the curve is normal, rising after the normal period (usually 10 minutes) to attain the same level as in a healthy person. This is found to be the case particularly in nystagmics who experience little or no subjective trouble.

Often the curve is altered.

- "A. The adaptation curve reaches a normal level but only after a certain delay.
- B. Adaptation is defective, the curve rises only after a notable delay and attains a lower level."

It is worthy of note that it is in men who complain the most of being inconvenienced in their work by the ocular affection that the alteration in adaptation is most/

most marked and not in those where the oscillations are most marked. The parallelism is as it were between the disturbance of the adaptation and the discomfort complained of by the patient.

This should place us on our guard against the error of regarding as simulators men with moderate oscillations who appear to be distinguished by excessive complaint. I have not been able to make any such tests by the adaptometer but have referred in some detail to the treatise because many of my cases have declared that they felt worse in lowered lights.

From my own observations I have further noted that on entering the dark room both the oscillations and the symptoms associated were brought on or aggravated and in a prolonged examination the severity diminished. This could be explained in the light of adaptation setting in.

So we find it possible by Weekers' method to analyse and estimate one of the symptoms and so calculate the degree of incapacity to work at the pit bottom - an incapacity which it is useful to expose since it renders the men dangerous both to themselves and to others.

General Nervous Phenomena. The head nodding and general tremors have already been referred to.

There are however cases where mental disturbance is to be noted. In some instances it is a matter of general depression and in others of excitement and tearfulness/

tearfulness.

In Series A., Cases 2, 7, 9, 10, 15 and 17, these nervous phenomena were noted.

Tomlin (23) remarks that Nystagmus is found in a special type of miner, the nervously liable type, possessing a nervous system easily influenced by loss of fixation desire and by other associations of pit life. The views of Cridland (14) and Butler (6), regarding the 'unknown quantity' of the personal factor have been already referred to.

Such extreme nervous phenomena are rare and occur only in severe and protracted cases. The nervous temperament is not the cause of the nystagmus, though it is quite conceivable that it is capable of complicating individual cases and prolonging the incapacity.

PART II.

A E T I O L O G Y.

	<u>Page.</u>
1. Theories as to Causation	32.
2. Position	46.
3. Illumination	57.
4. Nystagmus and Accident	77.
5. Nystagmus and Alcohol	80.
6. Mechanism of Nystagmus	81.

Theories as to Causation.

I will enumerate the chief Theories put forward in the Literature on the subject, making reference to the causal factors embodied in each theory and giving their chief supporters.

I. Theory of Organic Disease of the Brain.

Oglesby (24), among the earliest observers in this country, maintains that there is a central change, consequent upon a disturbance of the circulation induced by the unnatural position of the head to the trunk whilst at work in the mines. He traces it to a venous engorgement of the Medulla and adds that the Nystagmus which is at first transitory becomes permanent later. He (25) cites a case where he has seen a combination of Nystagmus with Epilepsy.

Jeaffreson (26) points out that in his district in Durham the men sit about on their haunches in cramped positions with at times the head thrown back whereby a compression of the Basilar arteries induces an anaemia of the occipital lobes - the recognised site of the higher visual centres.

There is further, he adds, "a dissociation of the naturally associated centres" of the elevators of the eyes and the neck muscles when a miner gazes above the horizontal median plane, with the head flexed on the chest. Nystagmus is for him a neuropathy. He holds that the Myopathic Theory is "seductive" but not in keeping/

keeping with all the facts of the case.

II. Myopathic Theory.

(Theory of fatigue of eye muscles)

Snell (27), in his earliest observations, drew attention to the position assumed by the miner at work, and postulated it as being at the basis of the whole trouble. In his Monograph (4, p.97) he says "Nystagmus is occasioned by fatigue of the Superior Rectus, Inferior Oblique, and Rectus Externus and Internus, induced as a consequence of the miners' work in the pit necessitating an upward and more or less oblique gaze". He adds "it occurs irrespective of the mode of illumination". At page 8 he states "I have seen nothing to lead to a supposition that the affection is dependent on a central disease".

For him it is a local myopathy due to chronic fatigue of the external ocular muscles (mainly the elevator group) similar to writers' cramp.

Dransart's (28) observations led him to a similar view which he expounded to the Congress of Havre in 1877. He states "Je considérerais donc le nystagmus comme une myopathie des muscles éleveurs intimement liée à l'anémie et à la parésie de l'accommodation et du muscle droit interne". He departs later from the part played by anaemia.

The position factor, in Dransart's opinion (29), is a question of "Height of seam". He notes that those who/

who work in high seams have the head thrown back and the eyes slightly upturned, while those working in low seams are forced to take up a cramped attitude inducing a strong upward and obliquely directed gaze.

He adds (30) in a letter to Tatham Thompson:-

"If we are not mistaken, the disease will be found rare or in its lighter forms in pits where the seams are high and on the contrary frequent and 'severe' where the seams are low, whatever the illumination." He concedes later to the method of illumination a secondary place when he says "Other things being equal Nystagmus in mines with safety lamps should be more frequent than in those with open lights."

In contrast to this, a considerable portion of Snell's monograph is devoted to discount the influence of feeble illumination as a causal factor.

Nieden (9, p.105) says:-

"dass es sich bei dieser Affektion um einen Schwächezustand der Muskel resp. Nervengruppen handelt, die die Bewegung des Bulbus nach oben vermitteln, indem dieselben nicht mehr, bei Fixierung des Blickes in dieser gewünschten Richtung in gleichmässiger kontinuierlicher Zugkraft angespannt werden, sondern nach kurzer Intention der Blickrichtung nach oben erschlaffen und dann nur noch in kurzen, bei fortgesetzter Anstrengung immer rascher aufeinander folgenden Zuckungen antworten". As opposed to Dransart, Neiden, though accepting the fatigue theory, looks for the seat in/
in/

in the central nervous apparatus which furnishes the innervation of the affected muscle groups. He locates the floor of the fourth ventricle as the probable site. He is not a pure myopathist. He also concedes a share to the illumination inasmuch as working in a feeble light induces fatigue.

III. The Lighting Theory.

(Illumination)

The influence of the lighting in the pit came early under consideration by no less an observer than Nieden, who has been classed among the supporters of the Fatigue Theory. In his earlier writings (31) he based the Pathology of the disease, so far as Hemeralopia is concerned, to a particular condition of Torpor of the Retina induced by feeble light. Later, he withdrew from this position. Court, Butler, Romi e, Elworthy and others have pointed out that it is more than coincidence that the Davy Lamp was first used about 1850, and that D cond 's observations were published in 1861. They trace a significant relationship, and Butler (16, p.528) says "Nystagmus began to be described at the time when the safety lamp was first introduced and did not become frequent until it was enforced by law, and yet the surgeons of the past generation were at least as good observers as we are and we cannot suppose that they would have overlooked such a very obvious symptom as Miners' Nystagmus".

In/

In England, Court is the champion of the defective illumination theory. He maintains that it is the primary causal factor.

(32)
He gives statistics from the Derbyshire mines:-

	Men.	Lights.	Nystagmus.	Percentage.
Holing done	524	Safety Lamps	164	31%
in each	573	Open Lamps	32	5.6%

He adds that 29 of the 32 had previously used safety lamps.

Court concludes "Inquiry has satisfactorily convinced me that it is the want of a good light that is the only cause of the mischief".

Tatham Thompson (33) gives his experience in the South Wales colliery districts.

He contrasts:-

- A. House Coal pits where the seams are low and candles (open lights) are used.
- B. Steam Coal pits where the seams are high and safety lamps are used.

He points out that in spite of the conditions in A, which favour the view of the supporters of the "ocular muscle strain", the disease is rare, whereas it is frequent in B class of pits.

He collects evidence from Colliery Managers, Miners, and Mining Engineers, and comes to the conclusion:- "I would submit that visual strain with insufficient illumination is at any rate as great a factor in the causation as strain of the ocular muscles

."

Elworthy/

Elworthy (34), Llewellyn (13) and many modern writers support this illumination theory.

Nuel (35) states that the frequency of nystagmus varies in "inverse ratio" to the illumination of the mines.

IV. Theory of Disturbance of Equilibration.

(Reid's)

Reid (36) puts forward in a most interesting paper contributed to "Brain" his equilibration disturbance hypothesis.

He is not satisfied with the Myopathic theory and lays bare what he considers to be its weak points:-

1. The voluntary normal excursion of the eyeballs in nystagmic patients is not diminished.
2. The absence of Hyperphoria (Maddox Rod test).
3. The different types of oscillations at one and the same time in the two eyes is not explainable by the myopathic theory.

Further, the Rotatory character of the oscillations made him sceptical.

With reference to Nieden's view regarding "fatigue of the nerve centres", he holds that it is misleading as it would seem to indicate that the centres have been worked too hard.

He says "I cannot but think that the underlying common causal factor in all kinds of Nystagmus is a disturbance of the centres whose normal action is to maintain the equilibrium of the globes in whatever position they are placed".

The/

The two factors in the miner's working conditions which appear to Reid to break down or derange this equilibrium are:-

1. Imperfect fixation, the influence of bad lighting, when the macula is placed outside activity. Darkness does away with the possibility of superior macular images, causing instability of the globes.
2. The constant tendency while at work to disturb the equilibrium of the body, e.g. lying on the side, sitting on the haunches, balancing on tops of hutches, and stumbling about on uneven ground.

It cannot be doubted that there is an association between the equilibrium of the eyes and that of the body, e.g. Romberg's test.

He refers further to the rhythmic series of movements performed in swinging the pick, the eyes remaining fixed. These factors, he adds, induce a defective central co-ordination. In a sense, this theory closely resembles a combination of theories II and III, a point of difference being that the myopathists (Snell, Dransart, etc.) held that the "elevation of regard" was the chief factor and not the strain thrown on the centres of equilibrium by the position at work.

V. Accommodation Theory. (Romiée)

Romiée (10) in his *Étude sur le nystagmus des houilleurs*, page 265, says "Pour nous le nystagmus est le résultat d'une fatigue exagérée du muscle accommodateur: cette fatigue amène insensiblement des contractions/

contractions cloniques des muscles des globes oculaires". It is occasionally to a slight degree 2 D but in some cases as high as 6 D.

He ascribes a vital rôle to Bad Lighting and the strong accommodation efforts which are necessitated thereby.

This theory is scouted by Ohm (8).

Nuel also has criticised it adversely. "No one supports Romiée in his view" says Butler (16, p.526), quoting Nuel.

Llewellyn (37) supports Romiée. At page 698 he says "This personal factor seems to have been too much neglected in the past."

He adds that 90% of his cases suffered from refractive error. A. C. Norman (17) finds 90% in 200 cases. Parsons (38) gives a table showing the percentage of ametropia in the general populace to be 70%. From Llewellyn's and Norman's statistics it would therefore appear that error of refraction is 20% more frequently met with in nystagmics than in the general population.

Butler (6, p.682) finds 45%, including many where the error was only +1.0 D. With him the incidence of error among nystagmic miners is the same as among normal miners. Cridland (14) in reviewing 24 of his recent cases finds Refractive Error present in a small percentage, Hypermetropia and Hypermetropic Astigmatism predominating. He is convinced that Refractive/

Refractive error has no special connection with the disease.

Unfortunately, I have had no opportunities for carrying out Refraction Tests. The three cases of Series A, in two of which Hypermetropia, and in the other Myopia is noted, were examined for me by an ophthalmic surgeon.

There can be no doubt that the presence of error of refraction in a bad light will exert an influence in increasing the eye strain. It has to be remembered, however, that in near work such as the coal getter is employed at, no great accommodation effort would be expected to be called for.

VI. Labyrinthine Theory.

Trombetta (39), who published his work in 1900, was the first to connect Nystagmus of Miners with the ear apparatus. He holds that the condition is caused by impulses from the semicircular canals whose functions have been modified by the positions assumed by the miner at his work.

His experiments upon dogs as to the effect of alcoholic, Faradic and Thermic stimuli applied to the ampulla led him to form the opinion that the oscillation of the eyeballs is not a question of paralysis, but an irritation phenomenon.

He thus ascribes to the noises of blasting, picking and the general noises of the mine inducing changes in the/

the pressure of the air currents, a causal relation to the onset of the condition.

Peters (40), from a study of the Literature chiefly of Nieren and of the diseases of the Labyrinth, has answered the question "Ist der Nystagmus der Bergleute labyrintharën Ursprungs" in the positive. He points out that the semicircular canals exert an important influence in the maintaining of statical balance.

With reference to the phenomenon of backward tilt of the head, frequently met with in nystagmic subjects, he is of opinion that this is a primary and not a secondary matter.

Through a change of the position of the head he explains that there is a displacement of the endolymph and when the backward movement of the head lasts for many hours per diem during months and years there comes into play a new condition of balance. He adds that when the miner ceases work and the head and eye position approximates more to that when in the upright position, then there arises an irritation which reflexly influences the nuclei of the eye muscles.

The muscle tone is in this way altered through the increased innervation of the elevator and external muscles of the eyeball.

The work of Buys and Coppez (7) discusses the otogenous theory of nystagmus.

The art of nystagmography, as practised by Coppez,(7) admits/

admits of the making of graphic records, a few of which he submits in his paper to the International Medical Congress at Budapest, August 1909. From a careful analysis of these, it is maintained that the "Vestibular" and "Non-Vestibular" modalities of Nystagmus can be differentiated and a precise classification of the affection established. Reference in this work is made to the views of Barany and of Bartels, who hold that the tonus of the eye muscles is reflexly affected through the ear.

The general finding is that Miners' Nystagmus is fundamentally of a different type from the true Orogenous.

VII. Toxic Theory.

The inhalation of pit gases has been held responsible for the condition. Among the earlier writers, the association of general anaemia consequent upon the bad air of the mine probably gave rise to the view of a causal relationship between nystagmus and a toxæmia. In the Literature this view has been summarily dismissed, but Butler (6 p.683) holds that it is by no means inconceivable that Hydrocarbons in small doses long continued may exercise a harmful influence upon the co-ordinating centres of the brain. He points out that we have mercurial and arsenical tremors, and draws attention to the fact that candle lit/

lit mines are free from gas and from Nystagmus. Ohm (8 p. 63-64) gives interesting statistics of temperatures and percentages of gases in mines, and holds that though workmen are exposed to unwholesome gases, all proof is wanting that nystagmus could be caused thereby. On the contrary, he notes, it would be worthy of notice that nystagmus should be the sole symptom of bad air, while the other systems, in spite of long sojourns in the pit, remain sound.

I have gone over the files of cases of men who have alleged incapacity as resulting from gas poisoning during the years 1910 - 1912. There were 35 such cases and in no single case is reference made in the notes to the patient suffering from nystagmus.

I have personally examined nine of those cases and found no trace.

Of two more cases, recently examined in Fife, I have noted rapid, jerky, intermittent movements of the eyeballs in one.

J.B., a brusher, aged 48.

He was overcome by bad air but was able, after resting, to walk home. His complaint was giddiness, disinclination for food, and frontal headache.

His pulse was rapid and a slight pallor of the mucous membranes was noticeable.

The eyeball movements were such as are frequently to be met with in nervous persons when asked to look to the extreme laterally. They were by no means equal/

equal in the two phases, and induced no symptoms. They resembled the 'nystagmoid' jerky eye movements noted by Snell in some of his "neurotic and asthenopic composers".

It is interesting to note, in connection with this theory, that one of H.M.'s assistant Mine Inspectors for Scotland, with whom I have been frequently in communication regarding mining matters, holds very firmly to the belief that nystagmus is very frequent in Gassy or Fiery mines. Of course the reduction of general health from working for prolonged periods among pit gases is possible, and, so far as debilitated health influences the nystagmic state, pit gas is a factor to be kept in mind. The fact however that Ventilation has been so much improved would remove that as a direct causal factor had it ever had any weight.

Reference will be made later to a relationship between 'bad air' and illumination as influencing the onset of Nystagmus.

Of the many factors suggested as being at the root of the mischief, it is to be noted from a survey of the seven Theories dealt with, that the two upon which the majority of observers lay the greatest weight are A. Position: B. Illumination.

It is further noteworthy that under those two headings it is possible to classify all seven theories.

Under A. falls:-

Theory I. Disturbance of Cerebral Circulation.

Theory II. The Myopathic.

Theory IV. (in part) Reid's Equilibration disturbance.

Theory VI. Labyrinthine.

Under B. falls:-

Theory III. Lighting.

Theory IV. (in part) Reid's.

Theory V. Romiée's Accommodation:

and I hope to show that the alleged cause of the Toxaemia in Theory VII is at basis a question of influence upon Illumination.

No data have ever been brought forward in support of the theory of Oglesby and Jeaffreson, and the fact that the "relative position of head to trunk" which they made so much of is common to many classes of workmen not employed in mining, in whom no trace of the disease has ever been noted, is, I think sufficient to rule it out of further consideration. Moreover, the Pathology/

Pathology is left in what one might term a realm of speculation.

Butler (16 p.527) remarks "Neither Ischaemia nor Hyperaemia of the brain has ever been shown to produce any form of nystagmus.

The Orogenous factor, closely associated with "Position" has been gone into, the finding being that it does not constitute the cause of nystagmus as found in miners.

POSITION.

The question of Position really resolves itself into a consideration of the Occupation of the workman. In the sets of statistics available there is one point upon which all are in agreement - that men who work at the 'coal face', the hewers or miners proper, are more liable to nystagmus than any of the other classes of underground workmen.

Snell (4) finds that of 127 cases, 119 were 'coal getters' = 93.7%.

Dransart (12) gives 97%. Court (19,p.838) quotes 45%. Jeaffreson (26) says:- "the condition is confined to Coal Hewers practically without exception".

Of the 186 cases already referred to among my material, 146 were Hewers = 78.5%,

19 were Brushers = 10.2%.

7 were Repairers = 3.7%.

and the following table represents the several classes of/

of workmen affected, and the numbers.

Miners 146	Drivers 3	Roadsmen 2	Machinemen 1	152
Brushers 19	Drawers 2	Bottomers 1	Runners 1	23
Repairers 7	Firemen 2	Wheelers 1	Braemen 1	11
172	7	4	3	186

An analysis of Series A and B of reported cases shows the following:-

<u>Series A.</u>		<u>Series B.</u>	
Hewers	70%	Hewers	65%
Brushers	15%	Strippers & Brushers	15%
Repairers	5%	Drivers	10%
Firemen	5%	Bottomers	5%
Wheelers	<u>5%</u>	Roadsmen	<u>5%</u>
	<u>100</u>		<u>100</u>

By way of explanation, it might be well to state that the "Brusher" levels down the roofs and walls in the roadways, and builds into the spaces from which the coal has been taken, the stones and other debris, to clear and make the roads. His 'shift' follows that of the miner so that 'coal getting' may be proceeded with next shift. Different sections are brushed in routine so that there is no loss of time for either class of workmen. The duty is arduous and skilled. No 'Holing' is done and there is no call for prolonged upward or oblique gaze. Careful and exacting eye work however is demanded.

The/

The "Repairer" is really in the main a "Timberman". He attends to the propping of the roofs and sides of the roadways and repairs any holes resulting from "falls" of material. He works often in conjunction with the Brusher, the two types of work being classed as 'oncost work'. The work is heavy, of a skilled nature and often hazardous. No 'Holing' is done. An illustration of this class of work is given showing that an upward glance is often necessitated, and yet relatively few suffer from Nystagmus. (See page of illustrations)

The "Drawer and Wheeler" are engaged in 'pushing' and turning the full and empty hutches which are filled by the "Fillers" at the face and taken to and from the main haulage road. The work is at times arduous, depending on the gradient but is not skilled and calls for no special effort of the eyes.

The "Bottomer" works in open high spaces at the foot of the up-let shaft and attends to the transference of the full hutches to the cage which conveys the coal to the surface. He also marshals the empty hutches which are taken partly by mechanical haulage and partly by drawers to the 'face' for refilling. The work requires care but no special skill. There is no cramped position called for.

The "Roadsman's" duty is to lay rails and haulage apparatus and to attend to repairs in the same.

The/

The "Driver's" time is spent mostly in the main and side roads, his work being to direct the ponies. This he does usually walking behind the "race of hutches" or sitting in or on a hutch when the height of the roadway admits.

The "Fireman's" work,^{which} is to examine the roofs, etc., of working places, and to test for the presence of "gas" by means of his lamp, requires very often an upward glance and calls for special effort of the eyes.

It was the preponderance of case incidence among hewers which first led Snell (4) to postulate his Position Theory. He says at p.33:-

"Nystagmus is associated with a particular class of collier performing a particular kind of work".

The Myopathists ascribe to the operation of 'Holing' a very important rôle in the production of the disease, since, they maintain, it necessitates a prolonged upward and oblique direction of gaze, thus straining the elevator group of muscles.

Holing.

This is the technical mining term for undercutting the lower portion of the coal or the underlying 'clod'. The position assumed in so doing naturally varies with the exact level in the seam at which the operation is carried out, and depends also on the distance to which it is necessary to carry the process inwards under the coal.

Bottom/

To render more precise the description of the Holing Position and to make clear the question of gaze, I have been able, by the courtesy and kind permission of the Colliery Guardian Co., Ltd., London, to reproduce the following illustrations.

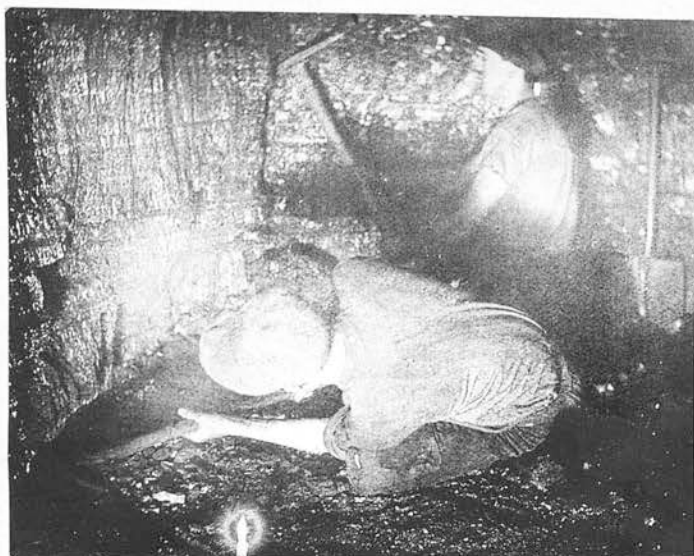

1. Coal getter in semi-reclining position undercutting or Bottom Holing to a distance of 12"; and a "Ripper" freeing the side of the coal which has been undercut.

The 'Gaze' of the hewer is downwards, that of the ripper is forwards and downwards.



2. A Hewer 'Holing' in the bottom of the coal; gaze is downwards and forwards.



3. A miner "middle holing" on the knees; Angle of regard is downwards.



4. "Top holing" in a high seam; gaze is slightly upwards.



5. Timberman setting a pair of Timbers; angle of regard is upwards.

Bottom Holing.

In moderately thin seams of 2' - 3', the workman kneels, keeping his body in a somewhat oblique position with his head against the roof and his angle of gaze directed downwards.

In thinner seams, which are to be met with in all districts, and specially so in South Yorkshire and South Wales, and the East Coast of Fife, a semi or complete reclining lateral position is called for. This is the "Mining Position" which Snell (4) made so much of.

When the miner starts the process, he may either kneel or adopt a position similar to that of the rifleman who is target shooting at intermediate distances - sitting on the one heel or foot, the other being partially extended in front.

As his pick works further in, he gradually adopts a semi-recumbent attitude with one leg flexed and drawn up under him, the other extended behind him, the under elbow or arm resting on the under knee and the under shoulder just clear of the ground or 'pavement' so that he may have as much freedom as possible for the swinging of his pick. When the process is carried on for a distance of 5' - 6' under the coal, his body is dragged more or less completely under the ledge of coal and he is then in a full reclining position, on his side, the under shoulder at times resting on the floor or pavement.

The/

The vertical amount of coal removed varies from 18" - 2 $\frac{1}{3}$ ' outside, and tapers back to about 4" - 6".

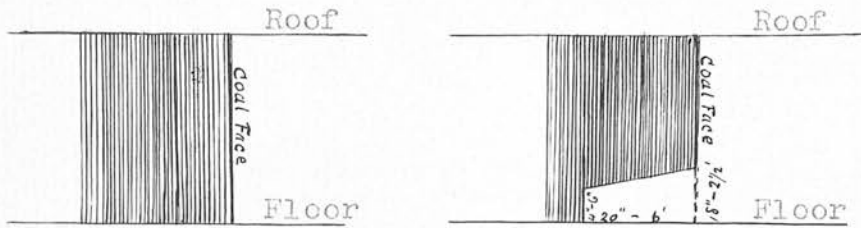

The clear space indicates the under cut.

At times the process is carried inwards for only 18" - 20". When the coal has been undercut to the extent ordered by the under manager, a length of coal face is freed by cutting at right angles to the surface inwards for a distance equal to the holing distance, and the coal is finally got by wedging the masses down.

"Boring and blasting" is often resorted to, depending on the nature of the roof etc.

Middle Holing.

This is sometimes carried out when, as it may happen, there is a layer of 'clod' between two thin seams, or the coal may be much softer in mid seam.

Top Holing.

The 'top rock' again may be softer than the bottom, in which case Top Holing is preferred. The Holing is really done in that place which offers the least resistance to the pick, consistent with safety in working.

In Bottom Holing, the relative position of the head/

head to the trunk is no index of the direction of gaze or rather of the relative position of the eyes to the head. The workman must strike the coal at or below the level of his eyes if he wishes to take full advantage of the swing of his pick.

A skilled miner delivers his blows very rapidly and with a certain amount of regularity. No doubt from time to time he has to glance up to see that he is in no immediate danger from a "fall" of material, but when actually at work he looks at the point he is about to strike, and gradually alters the position of his head so that his eyes may look straight forward or slightly downwards.

In this way he accommodates himself so that all the advantage possible may be with him in placing his blows accurately and thereby he unconsciously avoids the alleged straining of his ocular muscles.

Workmen make no complaint of feeling the eyes strained upwards. When they are asked to put themselves in the "Holing Attitude" in the consulting room and to demonstrate with a piece of wood for a pick, the Holing process, the direction of gaze is not "constantly" upwards, nor is it "prolonged" in an oblique direction.

The gradual tilting of the head backwards and sideways and the elevating of the face brings the eyes to the level of the object looked at and about to be struck.

From/

From watching miners so employed on my many visits to the underground workings, I have been led to conclude that an upward and oblique gaze is not called for nor practiced by men engaged in Bottom Holing, and the mine managers I have met corroborate this view. The men strike the coal with great accuracy with a full swing of the pick, at a point at or below the level of their eyes.

In the class of work done in "Middle Holing" the gaze is certainly not upwards.

When "Top Holing" is necessary the work at times is done above the level of the eyes.

In neither of these two types of work is a cramped position of Trunk and Head assumed and, in the latter in spite of frequent raised angle of regard, I do not find that the proportional incidence is great. Moreover, there are many occupations in which the worker adopts a cramped position, (mineral miners, boiler makers and menders, and many classes of work done in shipyards) and there are many other occupations in which a prolonged upward gaze is required - ceiling decorators, painters, riveters (the class called "holders"), and even sculptors, yet those workers do not develop nystagmus. Snell, I think, has overstated considerably the discomfort of gaze in the Holing attitude.

Reid (36) and Butler (16) in criticising the fatigue/

fatigue of the Elevator group of eye muscles, as already referred to, have pointed out the absence of Hyperphoria.

An analysis of my cases has shown a preponderance of the rotatory type of oscillation, and a relatively small frequency of vertical swing of the eyeballs. We have to add to this now the fact that Brushers and Repairers are subject to the disease, and that many classes of workmen whose working hours are spent in the main roads, and who are not called upon to depart much from the erect position for any length of time, also suffer from the condition.

I have analysed Series A as to Height of workmen and find the following:-

Height.	No. of men.	Percentage.
5' - 5.6"	10	50
5.7" - 5.8"	4	20
5.9" - 5.10"	3	15
<u>5.11" - 6'</u>	<u>3</u>	<u>15</u>
5'.6 ⁴ /5 " Average height.	20	100

The number of cases is too small from which to draw any conclusion, but so far as it goes there would appear to be a relationship between incidence and men of small stature. Of course one must not forget that the number of miners over 5'.10" employed is small.

When one looks into the figures regarding Height or Thickness of seams, it is difficult to get definite results/

results. Men go from one seam to another and in Lanarkshire especially it is no uncommon thing for several seams of varying thickness to be open in one and the same pit.

In Series A I find that five Hewers state that their head room was over 6' - 8': other four Hewers admit to working in seams averaging $4\frac{1}{2}'$ - 6'. In Series B 30% of the Hewers did no Holing, 15% a little Holing, and 20% a good deal of Holing.

The use of the Coal Cutting Machine is gradually substituting Mechanical for Manual Holing in the thinnest seams.

For mining report purposes Scotland is divided into two districts - East and West.

I have noted the numbers of certified cases occurring in each of those districts from July 1907 - December 1912, the following is a tabulated result:-

East of Scotland.		West of Scotland.	
Counties.	Cases.	Counties.	Cases.
Fife	10	Dumbarton	2
Lanark E.	7	Lanark W.	161
Lothians	2	Renfrew	1
Stirling E.	0	Stirling W.	3
Total	19	Total	167

It is quite impossible to get at the exact height of seam in each district, but I am informed by Messrs Kerr, Smith & Colvin, Mining Engineers of the Mine Owners' /

Owners' Association, that the average seam in the East is lower than that in the West.

This much, however, can be added, that along the East Coast of Fife, including Dysart, Wemyss, etc., where the average seam is thin, I have not met with a single case of Nystagmus.

Further, the statistics of Tatham Thompson (33), in his comparison between the House Coal Pits and Steam Coal Pits in South Wales, bring out the fact that in the former, where the seams are low, the incidence is low, and in the latter, where there is good "head room", the case incidence is high.

All this points to the conclusion that the influence of unnatural position has been made too much of by Myopathists.

There is one sense in which Holing is of importance and in which the type of Occupation bears a relationship to causation of Nystagmus and that is in the general bodily fatigue induced, the greater liability to accident, and the greater demand for accurate vision in varying degree among the different classes of workmen. In order, however, to bring all the facts of the case to a closer bearing upon causation, I think it is necessary to look to some other condition maintaining in the underground workings and one likely to be more potent.

ILLUMINATION.

We come now to consider the different methods of lighting in the mines and the rôle played by defective illumination in the causation of nystagmus. From the subterranean nature of the work, artificial light only is available and here we are dealing with a factor which I would suggest is more widely operative among all classes of underground workers than is any particular "occupational position". One of the first impressions got from a visit to a mine is the general gloom in which the work is carried on and the blackness which surrounds more especially the isolated miner.

In a very few of the more modern mines, the main road, for a distance, is lighted by electricity but in the great majority the light available in main and side roads and at the coal face is from lamps carried by the individual workmen. From the illumination standpoint there are two classes of coal mines.

- I. Those in which "open or naked lights" are used.
- II. Those which require the use of "closed or safety lamps".

It has to be noted however that in some mines a "mixed light" system maintains, the naked light being found suitable for one section and the safety lamp being necessary in another section of the same mine, depending on the absence or presence of inflammable pit gases.

Naked/

Naked light mines.

In this class of mine the source of light is from candles, torches (on the continent) and small open oil lamps.

In Scotland, the open oil lamp only is in use - called by the miner the "wee Scot". I have figured it in the page of illustrations at $\frac{2}{3}$ the actual size.

The Scotch Oil Lamp consists of a receptacle for the fuel and the wick and is provided with a hook or spike for the purpose of attachment to the cap of the workman or to the "timbering".

Animal and mineral oils are used such as horse tallow, bears' grease, paraffin, paraffin wax, etc. Such a lamp when freshly lighted and clean is capable of giving in good air an illumination approximating .9 - 1. candle power. Were it not for the presence of "Fire damp", the lighting of the workings would present no serious difficulty and this type of lamp would be universal in Scotland. When the danger from gas exists, the safety lamp must of necessity be used.

The Closed or Safety Lamp.

The first of this class was the Davy Safety Lamp introduced about 1850 and devised to allow of work being proceeded with in the presence of mine gases. The principle depends on the fact that "flame" when brought into contact with fine wire gauze will not pass through owing/

owing to the rapidity with which the gases are cooled.

The "Davy" consists of a cylindrical vessel for the oil and wick.

Upon this and surrounding it is a cylinder of fine wire gauze made double at the top the whole being supported by four small iron rods which carry a cover or bonnet to which is attached a handle for convenience in carrying. This lamp gives .28 of a candle power when freshly lighted but this may fall as low as .12 of a candle power. I have given a sketch of a "Tin-Can Davy Lamp" built on the same principle but covered in to a considerable extent with a view to its use in air currents of a velocity higher than usual.

Of the Non-Shielded Davy 549 were in use in Scotland in 1910 and of the Shielded variety 232: - Mines Report (63).

Modifications of the Davy have appeared from time to time. I will give some idea of four of the main types in use in Scotland.

The Clanny - (called by miners - the "Glenny"). Here the modification consists in the substitution of a glass cylinder for the lower portion of the wire gauze of the Davy. The upper gauze portion, is exposed as is the whole gauze of the Davy. Through this gauze the lamp gets its air supply, the bye products escaping from under the bonnet through an aperture protected by gauze. When fresh and clean, the clanny gives/

gives an illumination of .3 candle power.

221 of this class were in use in Scotland in 1910.

The Mueseleur. In this type a single exposed gauze is also used. The chief difference between this lamp and the Clanny is the fitting of a conical shaped metal chimney or funnel inside and just above the glass cylinder. This is for the purpose of assisting in carrying away the bye products.

When fresh and clean this lamp gives .48 - .6 candle power. 475 Mueseleur lamps were reported in use in Scotland in 1910.

The Marsaut. This lamp closely resembles the Clanny. It is slightly larger and heavier and instead of a single gauze has two and usually three sets fitted into one another for the purpose of increasing the safety. An iron shield completely surrounds the gauze portion, the air supply being admitted through small apertures in this shield. The bye products find their way out as in the other types through outlets, under the cover, guarded by gauze.

The candle power of this lamp when fresh is .37 - .4. 4561 were reported in use, and of a non shielded type of the Marsaut no fewer than 11,058.

The Hipplewhite-Gray.

This lamp differs somewhat from the others. The iron supporting rods - three in number in this lamp - are tubular and down these the air passes to an annular chamber/

chamber over the oil vessel. This chamber is guarded by gauze. The glass surrounding the flame is conical and is higher than in the other forms. Above the glass level, the single gauze is slightly conical and is protected all round by a metal coat. A shield plate projects over the top of the air inlet to prevent the lamp being easily extinguished. The bye products of combustion pass out through holes in the side of the hood.

Various estimates of its candle power are given, the average being .5 - .7 c.p. 34 of this class were in use in 1910.

In the diagrams, I have indicated the direction of air current in the lamps by means of an arrow and have coloured the glass cylinders blue, and the rods in section mauve. With the exception of the Scotch oil lamp, the others are figured at $\frac{1}{5}$ actual size (approximately).

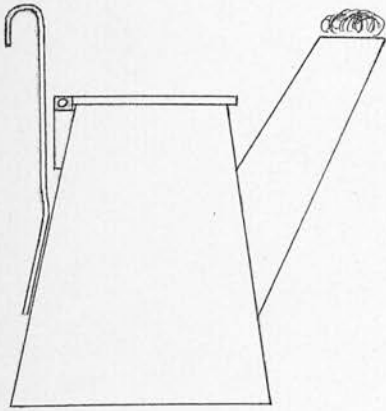

SCOTCH OIL LAMP

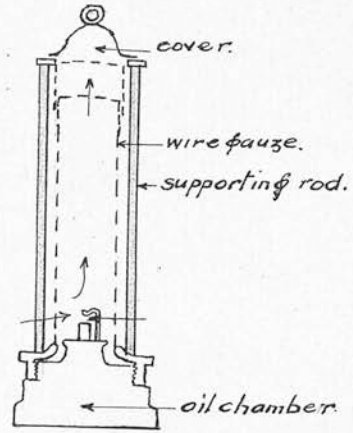

DAVY SAFETY LAMP

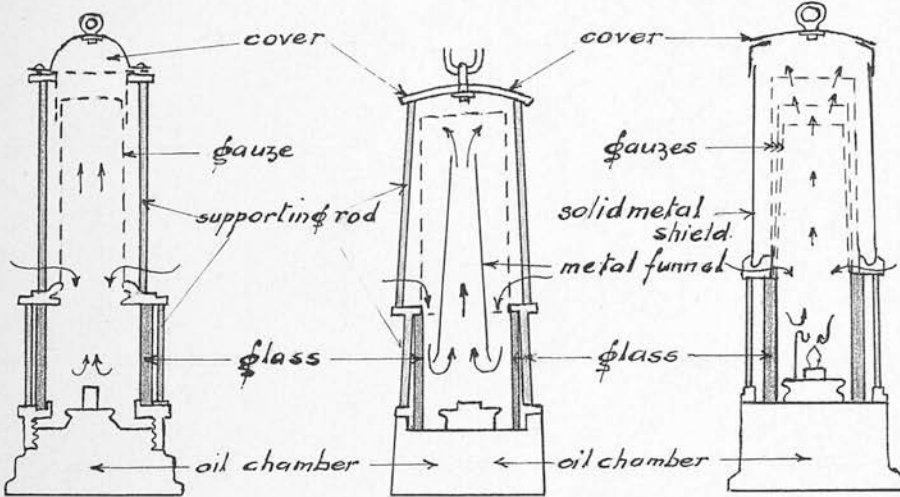

CLANNY LAMP

MUESELEUR LAMP

MARSAUT LAMP

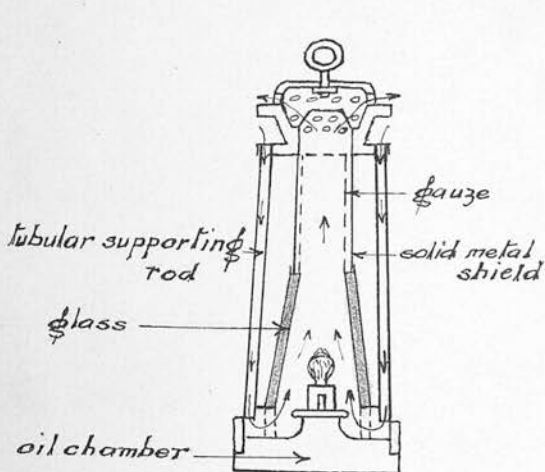

HEPPLEWHITE-GRAY LAMP

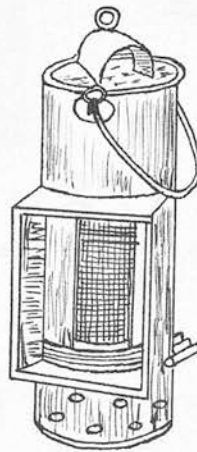

TINCAN DAVY LAMP

The Illumination available from any source of light in the mine depends mainly on four factors:-

1. The Candle-power of the source of light used.
2. The Distance at which this light has to be placed from the work being done.
3. The Character of the surroundings.
4. The Composition of the air.

From what has already been said regarding lamps, it will be seen that the change from a naked light source to a safety or closed light source means a considerable reduction in candle power. But the comparison between the two sources does not end here.

The open light gives radiations in all directions whereas the closed light, from the nature of its construction, gives no upward radiation in consequence of the shadow cast by the bonnet. There are also secondary shadows cast by the iron supporting rods. The thick glass cylinder gets obscured, during the "shift", by dust, dirt, smoke and oil, the result being that there is a gradually diminishing field of illumination. So it happens that towards the end of the eight hours a safety lamp may give only one third of the light it was capable of giving when in a freshly lighted and clean condition.

Llewellyn (64) has taken photometric measurements of a large number of safety lamps at the face and has found the candle power to vary from 0.36 to 0.1 of a candle/

candle power. In only one lamp was there more than 0.36 c.p. given and the reading was taken during a holiday period after all dust had subsided. He says "the oil safety lamp rarely gives more than a third of a candle-power when clean and much less when dirty".

Passing on now to a consideration of the second factor - the Distance of the source - we have a further point in the contrast of the two types of lamps.

The open light, whether it be a Scotch oil lamp or an English Candle, is small and light and easily moved about. It can be readily fixed in the cap or placed at a distance of 12 - 18 inches from the work without any danger. If it should be knocked over and go out through falling it is easily relighted. The Safety Lamp is much heavier and there is a strong temptation for the men to leave it fixed in one position for long periods, so that as they move forwards there is a gradual diminution of available illumination from the source. By law, safety lamps must be placed beyond the reach of danger from the pick, for should the gauze get broken, the lamp would become, to all intents and purposes, an open or naked light with all the dangers associated.

The regulation distance is $2\frac{1}{2}$ - 3 feet but at times it is no uncommon thing to see a workman 6 feet from his lamp. Now the Illuminating power of any source/

source of light varies inversely as the square of the distance, so the advantage of the open light becomes even more apparent.

But illumination in a mine is much more than a question of the Source of the light and the Distance at which that source is placed, there is the third factor:-
The Character of the Surroundings.

Elworthy (34) considers this factor so important that he bases his observations on an examination of the physical conditions of the different coal mines and finds in the differences of those physical conditions an explanation of the varying frequency of nystagmus in different districts.

The leading physical condition in a mine is the black uniform surface of the walls, roofs, etc. Colour is really that property which gives a distinct character to the stimulus which sets up the sensation of light in the eye. Light in the absence of all colour and in the absence of reflection from the surface is useless for vision.

On the other hand, colour without light is useless. In the walls of the gloomiest coal mine there is at least a trace of colour so that the condition maintaining in a mine may be said to be one of light with little or no colour and a consequent low degree of Surface Brightness. In different mines and in different parts of the same mine the quality of the Surface Brightness varies.

The/

The matter of real importance is therefore the amount of light that is reflected back from the surface into the workman's eyes rather than the amount of light thrown on the surface.

The question as to whether Light or Colour is the more powerful stimulus to vision is by no means easy to answer, but the general opinion would seem to be that, on the whole, there is a slight advantage with double the Light and half the Colour.

Nieden, Elworthy and Llewellyn have taken measurements of the reflecting power of the walls, etc., in mines.

Llewellyn in so doing compared the readings with those from a standard white screen placed against the coal face at the same distance from an equal source of light.

I will quote here one such comparative reading given by him (64 p.276).

"	Reading of light reflected from screen	0.070
"	" " " " " coal	<u>0.005</u>
	Absorption =	<u>0.065</u>

This is equivalent to an absorption of over 90 per cent." The coal absorbs almost all the light which falls upon its surface and further sets of readings go to show that anything up to 97 per cent of the incident light may be absorbed.

Similar experiments show that tin ore absorbs

80 per cent and gold quartz 77 per cent. In view of those facts it is of some interest to note that Nystagmus is unknown among the Tin miners of Cornwall.

I have not met with a single case among the Shale miners in the Broxburn district; the lights used are "naked" but I have never come across any estimate of the absorptive power for light of the walls. The gloom is certainly far less than that in an ordinary coal mine.

There is one more factor to consider as influencing any source of illumination underground and that is The Composition of the Air.

A very valuable contribution to this aspect of the subject of illumination has been made by Dr. Haldane and Dr. Llewellyn (64) under the title "Oxygen and the light of a safety lamp". They prove by a series of experiments that the light of a safety lamp falls off as the oxygen percentage of the air in the mine is diminished, and point out that considerable confusion has arisen through attributing the effects of vitiated air on a flame to the increase of percentage of Carbon Dioxide instead of to the diminution in the oxygen percentage. Air in a mine is however hardly ever vitiated by simple addition of CO₂.

They estimate that, roughly speaking, every diminution of 0.1 per cent of Oxygen causes a diminution of 3.5 per cent of the value of light in pure air. Further/

Further, the light emitted and the point of extinction of the flame are considerably affected by the percentage of Moisture present. An addition of 1.0 per cent of moisture diminishes the true oxygen percentage in pure air by 0.21. But we know that the amount of aqueous vapour varies in a direct ratio to the Temperature.

Fiery mines, in which safety lamps must of necessity be used, have a higher temperature than gas-free mines and in consequence the aqueous vapour percentage is higher and in proportion, the true oxygen percentage will be reduced and the illumination be decreased. This, I consider, is the link between Fiery mines and the incidence of nystagmus already referred to.

It is not a question of the toxic effect of the pit gases on the miner, but ^{of} the impaired illumination, resulting from the unsatisfactory atmospheric conditions which increase the nystagmus in Fiery mines.

To sum up, the factors in the atmospheric condition influencing the lighting in a mine are:-

1. Oxygen percentage.
2. Amount of Moisture present.
3. Presence of pit gases.

As the result of the combined action of the four main factors considered, the candle power of any source of illumination in a mine falls far short of the standards quoted in the report of the Mines Commission, the figures of which were taken when giving the candle power/

power of the various lamps. The President of the Mining Institute of Great Britain in 1912 in his closing remarks noted that it was deplorable to have to admit that the average light given to coal miners using safety lamps was less than .5 of a candle power at best and in response to this, much is being done in the way of perfecting types of Electric lamps and introducing them into the various safety lamp districts.

Let us now consider a few of the statistics available as to the frequency of nystagmus relative to the two types of mines. I would again refer to Court's(32) figures given at p.36 of the thesis where he finds 31 per cent of nystagmus among 524 men who had worked with safety lamps: and 5.6 per cent among 573 men who worked with naked lights.

Tatham Thompson (33) who has already been referred to as finding the condition more prevalent in the high seamed Steam Coal pits of S. Wales as compared with the low seamed House Coal pits in the same district, notes that in the former, safety lamps are used as against the naked light system maintaining in the latter.

Llewellyn (18 p.282) tells us that nystagmus is practically unknown in the purely naked light districts of the Black Country, the Forest of Dean,^y Somerset and rare in the naked light pits of S. Wales.

In the two districts where my observations have been made an analysis of the 186 certified cases will show/

show the relationship which I have found existing between the frequency and the two lighting systems.

East of Scotland.

Counties.	Cases.	Safety Lamp Pits.	Naked light Pits.	Mixed light Pits.	Men underground.
Fife	10	2	52	2	20,000
Lanark E.	7	0	100	2	13,000
Lothians	2	1	54	0	11,000
Stirling E.	0	0	20	0	2,000
	119	3	226	4	46,000

West of Scotland.

Counties.	Cases.	Safety Lamp Pits.	Naked light Pits.	Mixed light Pits.	Men underground.
Lanark W.	161	25	69	16	30,000
Stirling W.	3	6	8	4	4,500
Dumbarton	2	2	2	4	2,000
Renfrew	1	0	3	-	7,500
	167	33	82	24	44,000

The number of pits, the lighting and the underground men employed was calculated from figures given in the Royal Commission on Mines (65).

The East of Scotland is practically an "open light" district with its 226 naked light pits as compared with 82 in the West division. More noteworthy is the relative number of Safety Lamp pits in the two districts: the East with three and four mixed systems, the West with 33 and 24 mixed systems.

The/

The relative frequency of nystagmus is very striking (19 in the East as compared with 167 in the West) the numbers of underground men employed, as insured with the Association, being very similar. To state the matter in terms of safety lamps,

E. of Scotland 46,000 men underground 4,042 safety lamps.

W. of Scotland 44,000 men underground 22,800 safety lamps.

An analysis of Series A and B of recorded cases shows the following results:-

Lamps used	Series A.		Series B.	
	Cases.	Percentage.	Cases.	Percentage.
1. Safety	13	65	12	60
2. Mixed	5	25	5	25
3. Open	2	10	3	15

I have already noted that no case of nystagmus has been certified along that strip of the East coast of Fife where the seams are low and some of the workings are under the Firth. I have now to add that this is a purely open light area. Again, of the ten cases occurring in Fife, six came from the Glenraig and Cowdenbeath area where most of the safety lamps in Fife are to be met with: two were from pits where mixed lights are used and two had never used closed lights. These two ^{naked light} cases were from the same pit where the ventilation is not very efficient and where considerable expense has been recently incurred in an effort to comply with the Government demands.

It will be seen that nystagmus is not entirely unknown/

unknown in mines where naked lights only are used. The two cases noted is proof of this; but when we find that seven cases were certified in Lanark E. where no safety lamps were used an explanatory note is necessary. In districts where safety lamp pits and naked lamp pits are close together, cases of nystagmus are commonly found in both classes of pit, chiefly I think for the reason that men migrate from the one class to the other and often deliberately, because they are unable to work any longer with the safety lamps on account of trouble with their eyes.

Of the seven cases in Lanark E. four of the number worked in Lanark W. - a safety lamp district - up to within one year of making a claim for compensation in lieu of incapacity resulting from nystagmus.

I will close this somewhat weighty evidence in favour of the illumination factor with the wider comparison of that between Scotland and the rest of the United Kingdom, as given by Llewellyn (18 p.57). The year is not stated, but from the figures, I conclude that it is for 1910.

	Scotland	Rest of Kingdom.
Number of cases of Nystagmus	55	1,563
Percentage of cases to men underground	0.05	0.21
Percentage of safety lamps used . .	28.2	91.6

He adds "Nystagmus is four times more common in England and Wales, and closed lamps are used three times more frequently, than in Scotland".

All/

All this goes to prove that nystagmus is frequent in districts where safety lamps are used and is rare in open light areas: and when we call to mind the great advantage in candle power of the open lamp over the closed I do not think it can be doubted that the darkness of the mine is a powerful adjunct in the production of nystagmus.

If this be so, it might be asked, are there any figures bearing out that a reduction of the incidence of the disease has been consequent upon an improved lighting scheme?

Nieden (9) was in a position to contrast the results of a changed lighting system in a district. In 1877 open lights were used in the Rheinelb pits and at that time 7 per cent was estimated as the frequency of nystagmus. In 1890, after safety lamps had been in use for some years, the frequency was placed at 3.05 per cent.

Romiée (21 p.46) states that the frequency of nystagmus in Belgium, where the Muescleur lamp with its .4 candle power is used, is much greater than in Germany where the .69 c.p. Westphalian lamp is in use: and again in the same article at page 80 he adds that where the powerful Wolf Benzine lamp has been introduced the case incidence of the disease has fallen by 50 per cent. It may be explained that the Wolf Benzine is being gradually introduced into this country/

country. It has a candle power of .89 and oil of a high flash point is used under pressure.

The question now arises can we, on the basis of defective illumination as chief causal factor, explain the preponderance of case incidence among hewers?

The hard and skilled work which this class of collier is called upon to perform is rendered ever so much more difficult in an insufficient light. As already stated, he has to place his blows accurately and when he lies in a cleft in which the only three sides he can see are composed of the highly light-absorptive coal surface, he strains his vision and makes a considerable call on his accommodation.

As a rule the efficiency of ventilation in the working places at the coal face does not average that at the parts nearer the main air course, and so the best conditions for the lamp do not exist at the "Face". Again, accidents are more common among men at the face and they are more numerous in safety lamp mines than in those where the open light is used.

The question of the relationship between Nystagmus and accident will be noted later as will also the effect of alcohol upon the nystagmic subject. The "Brushers," who figure next in frequency among my material, labour under the same disadvantage as the coal getters, as do all classes of underground workers who have skilled work to do and principally work calling for accurate vision, e.g. Timberers, Repairers, etc.

Those/

Those colliers whose working hours are spent in the main roadways where the ventilation is better and the "Surface Brightness" higher suffer less frequently. Again the Hewer or miner proper works in an isolated position and has to depend on the light of his own lamp. Other classes work in groups or near to each other with the result that the source of illumination from the combined lamps renders vision easier and work less fatiguing.

Now with regard to correlating the clinical picture!

The oscillations are usually more marked in the dark room and often only set in when the patient enters it.

It might be asked, what of the test of Upward and Oblique gaze to induce oscillations, during examination, in cases where the movements are not apparent in straight forward gaze?

In answer to this it has to be remembered that the eyes are in a position of maximum stability when depressed and converged and in the position of minimum stability when elevated and diverged.

Assuming now that the centres governing the associated movements of the eyes are deranged it would follow that the effects would be first and chiefly noticed when the eyes are elevated.

Elepharospasm is often induced by a change of light.

Headabhe/

Headache results from visual strain involved through working in feeble illumination.

Hemeralopia is in keeping with working under such a condition and the main feature, the failure of coordination, is due to imperfect fixation in the feeble illumination leading to the transmission of indefinite impulses to the brain thereby deranging the centres whose duty is to maintain the equilibration of the ocular group of eye muscles.

Under Mechanism will be given a more detailed explanation of how this is probably brought about.

Nystagmus and Accident.

Dransart (12 p.33) was among the first of the observers to note this relationship. He puts it thus:- "Nystagmus must be a cause and an effect of accident". With regard to its being a cause of accident, what is said later on at page 94 regarding the Incapacity of Nystagmic Firemen may be sufficient to establish the connection: though of course, it must always be a difficult matter to point the finger to any actual case.

However, one so often meets with cases of Nystagmus, where no complaint of the condition is made, in association with minor accidents, that it cannot be doubted that the giddiness and impaired vision seems to be a very likely cause for the happening. From an analysis of Series A of reported cases, I find the following:-

4 Head injuries	=	18.1%
3 Back & general body injuries	=	13.6%
2 Eye injuries	=	9%.

Case No. 7 is interesting. He sustained a fracture of the occipital and the onset of nystagmus took place while he was convalescent and was sudden in nature.

No. 8. The case of a lad of 21 is of some interest in as much as a fright aggravated the nystagmic symptoms.

No. 15. Sustained an eye injury, developed cataract and was found to be suffering from nystagmus.

It/

It may be concluded that Trauma in general, and especially of the Head, determines the onset of the disease, and is capable of converting a latent attack into a manifest one.

It would appear as if the strain broke down the co-ordination or upset the condition of equilibrium in the centres governing the associated movements of the eyes, this equilibrium being, as it were, already in an unstable condition from the other causes suggested.

In my experience, the relationship of Eye injuries to nystagmus has not been so close as the figures given by Dransart (12) would have led one to expect. He includes contusions, foreign bodies, ulceration of the cornea and lesions of the conjunctiva. The point has frequently been raised by legal gentlemen while I have been giving medical evidence in Court, and some time ago I went into the figures available. I found that from 1st July 1911 - 30th June 1912 450 workmen claimed compensation in respect of eye injuries sustained. During that year the total number of claims for all kinds of non fatal accidents was 12,195, so that the eye cases represented 3.69% of the total.

The following table sets out the periods of incapacity:-

Less than 2 weeks.	2 weeks & less than 3.	3 weeks & less than 4.	4 weeks & less than 7.	7 weeks & less than 13.	13 weeks & less than 26.	26 weeks & less than 1 year.
11	105	82	85	40	11	5
2.44%	23.34%	18.22%	18.89%	8.89%	2.44%	1.11%

45 were redeemed by Lump sum payment and 66 were still in receipt of weekly payment when the Table was drawn up.

If it were true that through minor eye accidents Latent Nystagmus was made manifest and manifest was aggravated so that the miner was forced to give up work, we would expect the majority of miners who sustained such injuries to return later complaining of nystagmic symptoms. One would further expect that the return would be during the healing process or soon after resuming work.

Further, it is somewhat difficult to understand how that the small changes which are so often met with in miners' eyes;—"the results of sparks from the coal face"—could, after months or years, induce such a striking disease as Nystagmus.

In cases, however, where central opacities develop as the result of the accident, and where the media have been impaired, the effect of robbing the workman of the available illumination, which we have already noted to be insufficient at best, can quite well be traced to a bearing upon a probable onset or aggravation of a nystagmic condition.

From keeping a watch on the record of nystagmic cases, I found that four of the 450 cases have since their injury lodged a claim in lieu of incapacity through nystagmus. In two of those cases oscillations of/
of/

of the eyeballs had been noted the previous year when they were examined, the one for an injury to the left hand, the other for a bruise to the right knee. In those two cases the question of aggravation was admitted.

Of the other two, one returned five weeks after the eye injury with bilateral oscillations equally marked in both eyes: the other reported himself at the end of the eleventh week with bilateral nystagmus but more marked in the injured eye.

I have not met with a case of unilateral nystagmus where the oscillations could not be brought out in the other eye, in a dark room, after repeated examinations.

Nystagmus and Alcohol.

In the literature on Nystagmus very little note is taken of this relationship.

Dransart (54) says that the intensity is increased at the end of excess:-

"a la suite des excès de boissons, le nystagmus augmente d'intensité."

C. Bell Taylor (55) reports one of his patients as saying that the taking of alcohol quietens both the spasm of the lids and the unsteadiness of the eye.

Décondé (5) suggested that excess of alcohol was, in part, the cause of Nystagmus in the two cases described by him in two miners.

I have made it a custom to question colliery managers/

managers as to their views on the causation of Nystagmus, and it is interesting to note that quite a number of them make reference to alcohol as "having something to do with it". In series A of reported cases, four of the 20 admitted that they took alcohol to excess. Two others admitted that they had at one time been rather fond of it.

The cases 5, 6, 7, 11 bear out the view expressed by Dransart.

In Case 6, I was unable to find any trace of ocular oscillations while he was under the influence of alcohol. On examination, some days later when he was absolutely sober the oscillations were very manifest.

I am of opinion however that Alcohol per se is not a causal factor. Its effects are more in the direction of aggravation. Some men take to alcohol because they are the subjects of Nystagmus, e.g. Case xx, Series A.

Again, if Alcohol were a direct cause the condition would be found pretty frequently in classes of workmen other than coal miners.

Mechanism of Nystagmus.

After what has been said as to the chief aetiological factors it may be of interest to note in brief the views of some of the leading authorities on the question of the Mechanism.

Wilbrand/

Wilbrand (57), some thirty years ago, explained it on the basis of a want of Harmony between the volitional impulse and the state of the common reflex centre for the eyeballs.

A disorder of either of those two factors was capable of inducing the oscillations, but the reflex centre was the more likely to be altered owing to the great number of influences acting upon it.

An interesting communication on the subject is that by Sir W. R. Gowers (58). He bases his view on a study of Sherrington's series of researches on the "Reciprocal Action of Antagonistic Muscles".

Sherrington found that the arrest of action in muscles of the hind limbs of an animal, in which the spinal cord had been divided in the cervical region, was due to the inhibition of the spinal centre of the acting muscles, produced by a nerve impulse from the Antagonists. The alternation is thus due to an automatic muscle reflex process.

Gowers concludes "that near the nuclei of the ocular muscles there must be structures which constitute a centre analogous to the centres of the spinal cord, and subserve binocular combination and reflex action, including muscle reflex action, and through this the will must act". It is therefore only when the balance is normal that the will can secure the due synchronous action of the opponents.

Priestly/

Priestly Smith (60) states that Fixation is largely a Reflex Automatic Act.

He adds that the oscillations are the outcome of a disordered action of the motor apparatus of the eyes, the nature of the movements proving that the seat of the disturbance is in the brain centres which control the co-ordinating movements. In his opinion, the insufficient stimulation of the Retina disposed to the onset of nystagmus.

Reid (36) supports this view that the illumination of the pit makes fixation difficult, and so tends to an escape of the movements of the eyeballs from control.

Maddox (61), in a contribution to the Ophthalmoscope, gives a detailed scheme of his twelve Binocular Innervations, with reference to a study of "Ocular muscle balance". For him the feeble illumination in the mine, and the black and almost uniform surface of the walls, etc., play an important rôle. In his "Tests and Studies of Ocular Muscles" (62) he says "In the dark and with an absolutely homogenous field before them, the eyes are always moving. The difficulty of fixation of a point on a uniform surface is such that it cannot be accurate. As the result of working for long periods in the comparative darkness of the mine sufficiently strong impulses are not sent to the retinal cells".

The weight of evidence, I think, is in support of the/
the/

the view that Imperfect fixation due to the defective illumination induces the trouble. By this means indefinite impulses are transmitted to the brain, the lower reflex centre becomes deranged, cerebral association requires reinforcing and so failure of co-ordination results and nystagmus ensues.

PART III.

SOCIO ECONOMIC.

	<u>Page.</u>
1. Frequency	85
2. Age Incidence	88
3. Incapacity	90
4. Duration of Incapacity (Prognosis)	95
5. Cost of the Disease	100
6. Malingering	103
7. Treatment	104

CONCLUSIONS

107

SOCIO ECONOMIC.Frequency of the Disease.

In a subject so controversial, it is not to be wondered ^{at} that we meet with various estimates of the frequency. It has to be remembered, of course, that these estimates have been made by observers in districts where very different conditions of work maintained.

Dransart and Famechon (41) in their paper "sur le nystagmus des mineurs dans le bassin houiller du Nord de la France pendant les années 1908 et 1909" report having had under treatment 211 cases of nystagmus in a population of 40,000 miners. They estimate the proportion of severe nystagmus at 3 per mille of the total population, and of nystagmus of all types at 10% of all workmen employed underground.

Nieden (9), from an examination of 27,932 miners, came to the conclusion that the frequency was 5% of all underground workers.

Court (32, p.837) found 34.75% affected.

Romiée (11) and Nuel (35) estimated it at 20%, and Snell (4) has given the figure of 4%.

In a sense they are all correct, no doubt, but to come to a truer estimate it would be better to take into account only those cases that are compelled to be off work for some time, and those who have trouble with/

with their eyes while at work.

From what has already been said regarding the
the
Latent and ~~Manifest~~ type with its subdivisions, it is
practically impossible to get at anything like a
figure approximating accuracy.

The only method would be to have a routine exam-
ination of all workmen made from time to time.

I have examined the records of incapacitated work-
men from all causes in the S. M. O. Association from
July 1907 - December 1912, and have extracted the
cases certified as suffering from Nystagmus. (The
order allowing of a claim for Compensation came into
force in July 1907.)

I find 186 such cases:-

1907 July to December	1
1908 January to December	17
1909 January to December	29
1910 January to December	42
1911 January to December	45
1912 January to December	<u>52</u>
Total	186.

These 186 cases in five years occurred in an average
insured list of 90,000 underground workers, giving an
estimate of Nystagmus inducing total incapacity of
.4 per mille or .04%.

In contrast to this figure, I append statistics
compiled from Blue Books on Compensation, and have to
acknowledge the courtesy of the Home Office in giving
the/

the references (42).

For Great Britain:-

Year.	Cases of Nystagnus.	% to underground workers.
1908	460	.057
1909	1011	.123
1910	1618	.19
1911	2519	.29
1912	3205	.36

From these figures it will be seen that a steady increase has been maintained since 1907 and, in further proof of this, I have permission to quote figures supplied to me by the General Manager of the Yorkshire Coal Owners' Mutual Indemnity Co., Ltd., for his district. In writing me on the subject, 11th December, 1911, he says "A claim comes on our Permanent Accident Fund after 26 weekly payments have been made. The number of men on our P. A. Fund since July 1st 1898 (for the next 13 years) was 610; and the number of Nystagnus/^{cases} since 1st July 1907 was 231".

1907	July to December	15
1908	January to "	61
1909	" " "	95
1910	" " "	138
1911	" to October	<u>130</u> (not complete)
		489 total.

In Yorkshire about 92,000 underground workmen are employed, so that we have a figure working out at 1.6/

1.6 per mille, or .16%.

It has been suggested, and I understand that the order is soon to be put on statute, that all cases of men complaining of the condition be reported by Mine Managers and local Colliery Practitioners to the Home Office. Then a more accurate estimate of all men subject to the disease will be available.

Whatever estimate may then be arrived at, and it is not likely to be small, the figures quoted give proof of the fact that the frequency of the disease is considerable, and varies in different districts.

Age Incidence.

For the fixing of this we have to depend largely on the evidence given by the patient.

When cases appear with symptomatic trouble to the extent of producing incapacity, as a rule the patient makes a guess as to when he had his 'first trouble with the eyes'. Generally one finds that it dates back a good time. One man told me that he had had trouble for over ten years, another five years, and so on.

The youngest patient who has come under my notice was 21 years of age. He was the subject of high myopia (Series A. R.K., No.viii).

Llewellyn (18, p.37) says that it may be taken as a general rule that the longer a man works in the pit the more likely he is to get nystagmus.

He/

He quotes Neiden's (9) Table:-

I.

Age.	Per Cent. of Nystagmus.
15 - 25	1.4
25 - 35	23.4
35 - 45	43.2
45 - 55	25.3
55 - 65	6.65

Ohm (8, p.5) has worked out the following figures:-

II.

Age	Cases.	Per Cent. of Nystagmus.
Under 20	10	2.4
20 - 24	30	7.2
25 - 29	80	19.1
30 - 34	113	27.
35 - 39	85	20.3
40 - 44	55	13.1
45 - 49	31	7.4
50 - 54	10	2.4
55 - 59	1	0.2
60 - 64	2	0.4
65 - 70	1	0.2

From an analysis of the 186 already noted among my material, I have drawn up the following table:-

III./

III.

	Under 20 years	20 yrs & under 25	25 & under 30	30 & under 40	40 & under 50	50 & under 60	60 & under 70	70 & under 75	Ages not stated	Total
Cases	2	9	13	49	52	31	7	1	22	186
Per cent	1.07	4.84	6.99	26.34	27.96	16.67	3.76	0.54	11.83	100

In the list of reported cases the following point regarding age is to be noted.

IV.

Series A. Average age at which total incapacity induced 41.2 years.

Series B. " " " " examination took place 40.6 "

These averages would certainly be lower were it possible to get at the age when the first symptoms appeared.

From these sets of tables there is to be noted a close approximation to the rule that the age incidence is very low under 20 years, considerable at 30, rises gradually till a maximum is attained somewhere between the ages of 35 and 45, after which a fall sets in more or less abruptly, with a sharp decrease after 55 years.

Nystagmus is thus a disease affecting the miner at what should be the strongest and most useful period of his working days.

Incapacity.

This is a point naturally of considerable importance to Mining Insurance Associations.

In its directions to Certifying Factory Surgeons and to Medical Referees, the Compensation Act of 1906 says that/

that both officials must be satisfied that the claimant for compensation is quite incapacitated for work at the time of giving up employment: otherwise the Court may be asked to set aside the certificate. This holds since July 1907 for Nystagmus, which is looked on in the light of an accident in the legal interpretation, "as arising out of and in the course of the employment".

The diagnosis of the condition is a relatively simple matter as compared to the estimating of the incapacity induced; and the fact that there is no constant relationship between the severity of the objective phenomena and the functional troubles renders this estimation a very real difficulty.

As will be noted from Series B of reported cases, workmen appear for examination for other conditions, when the oscillations are markedly manifest and no complaint is made. At times such cases admit, on direct questioning, that now and again they have trouble with the eyes; but they keep at work. Miners, as a class, are not inclined to expose physical defects. They are fully aware that recent legislation has given rise to more than a tendency, on the part of Employers, to reject men who do not give promise of at least a normal standard of physical fitness.

In those cases where Headache, Giddiness, and trouble in the dark are complained of, where Blepharospasm and Tremors are noted, and where there is a superadded/

superadded neurosis, with it may be associated mental disturbance, one has no hesitation in certifying total incapacity.

On the other hand, it is not to be forgotten that cases present themselves with a history of marked trouble and difficulty in carrying on their work and with very slight objective phenomena to account for it. From what was said regarding Weekers' Adaptation test, it would be a mistake to refuse such men a certificate of Incapacity.

Even in such cases one has always two points upon which weight may be laid in the estimating:-

1. The angle of regard at which the oscillations set in (the lower, the more severe generally).
2. The state of the visual acuity;

but, of course, as is easily to be understood, no absolute finding can be based upon either.

Severe cases are certainly quite unfit for any work of marketable value.

Llewellyn (18, p.18) holds that moderately manifest cases can do any work "on the surface" which does not involve much stooping, while latent and mild manifest cases can work underground.

Court (43) is of opinion that there is an important question which should be brought to the notice of the Home Secretary - "There are hundreds of men earning full wages in the collieries who are affected with nystagmus to a much greater degree than many of those men/

men drawing compensation money who are off work altogether or working on the pit head and in receipt of partial compensation." Only a man of very strong convictions on the subject can make such a sweeping statement I think. The ability to work on may, and often does, depend on the personal equation which may be in some cases the mental attitude.

While admitting that the addition of Nystagmus to the schedule of Industrial Diseases has had a tendency to increase the claims, it has to be remembered that only since that date have we had any actual figures to go upon. It is certainly one thing to be the subject of nystagmus, and another to suffer from it, but in the great majority of certified cases the history of the workman is that of a struggle for months and even years to keep at work in face of the growing incapacity.

From the fact that quite a percentage of cases appear in association with Trauma or are aggravated at least by this, it is to be concluded that whatever work the latent and mild manifest cases are capable of, such men are liable from injury, fatigue, fright, shock, etc., to develop a more severe type of the disease, and though they may be working, there is all the time a reduction of their full powers.

Further, there is the liability to accident through impaired vision, giddiness, etc., and there is the liability of a source of danger to fellow workmen.
Specially/

Specially so is this the case with Firemen. Their duty is to look to the safety of working places, roofs, walls, etc., and what is as important, to test for gas. Snell (44) has given a record of examination of this class of workman and the incapacity suffered at work from nystagmus.

G. B. Whalley (45) gives an analysis of 41 Firemen, at work daily, who were examined by Dr. D. E. Dickson of Lochgelly, Fife.

Of the number, eleven had no nystagmus; ten were very slightly affected; seven slightly affected; six distinctly suffered and seven had the disease in a severe form.

Llewellyn (18, p.25) gives a table comparing the accuracy of "Cap" detection among normal and nystagmic firemen.

The "Cap", it may be explained, is the blue colour which appears upon top of the flame of the Safety lamp turned low, when gas is present. An estimate is made of the percentage of gas present from noting the height of flame when the discolouration first appears, and this is compared with a graduated scale fixed inside the lamp.

Table:-

Normal firemen	49.	Correct estimate	28.
Nystagmic firemen	41.	"	"
			4.

Here we have evidence of men the subjects of nystagmus, making no complaint and yet incapacitated in a serious sense/

sense. Certainly, the professional value of the fireman is lessened and the danger in the mine heightened thereby.

The capacity of the skilled hewer or coal getter is also lessened, even in the milder forms of the disease, and so is it to a more or less degree with all classes of workmen; the more skilled the work, the sooner will the incapacity be experienced.

With regard to men who feel unfit for underground work, the question of taking up light duties on the surface is a problem complicated by the policy of the Employer and the Workman.

The owners are unwilling to give lighter employment to a man who is in receipt of a large weekly wage for underground work, since they have to make up the reduced wage for the changed employment by way of half the difference between it and the past rate of weekly wages.

Duration of Incapacity. (Prognosis)

This varies greatly with the individual case and depends upon various factors such as the degree of the trouble present, the age, the treatment, the constitution and the nature of the work the patient has been accustomed to. A few men are able to return in a few weeks. The minimum period I have noted is nine weeks in the case of a man aged 33, a coal cutting machine man. Other examples of short periods are:-

Miner/

Miner	aet.	27	11	weeks.
Wheeler	"	30	15	"
Miner	"	34	12	"
Miner	"	53	16	"
Brusher	"	32	6 ¹ / ₆	"

From an analysis of the 186 cases already referred to, I find 37 cases averaged 35¹/₄ weeks.

74 " " 56¹/₂ "

66 " were not closed by the end of the year.

In a few of those cases, a partial rate of compensation was paid in lieu of some light employment which the workman had undertaken.

In the evidence given before the Departmental Committee in 1907, the outset limit maintained was 12 months, and many witnesses mentioned a few weeks.

From experience, I have found it quite impossible to estimate how long an individual case will be incapacitated, and I have noted quite a number which exceeded the 12 months' limit referred to.

Analysis/

Analysis of Series A..

	Name.	Age.	Occupation.	Period of Incapacity.	Claim.
i	J.J.	47	Miner	14 months	redeemed.
ii	J.C.	66	Miner	15 "	"
iii	H.W.	42	Miner	10 "	resumed work.
iv	G.H.	37	Miner	6 "	" "
v	W.G.B.	35	Miner	(3 months light) 12 months	redeemed.
vi	W.M.	32	Repairer	4 "	resumed work.
vii	E.G.	49	Brusher	7 "	in statu quo.
viii	R.K.	21	Bogie-lad	4 "	redeemed.
ix	W.S.	37	Miner	10 weeks	resumed work.
x	P.F.	34	Miner	12 "	resumed. "
xi	M.McN.	47	Miner	54½ "	redeemed.
xii	J.D.	52	Brusher	11 months	not closed.
xiii	T.B.	29	Miner	6 " (3 light)	resumed work.
xiv	R.K.	54	Miner	12 months	redeemed.
xv	F.McC.	65	Miner	10 "	not closed.
xvi	J.H.	39	Brusher	3 "	" "
xvii	J.D.	41	Brusher	11½ "	redeemed.
xviii	J.B.	34	Fireman	10 weeks	resumed work.
xix	E.C.	22	Miner	11 "	" "
xx	P.H.	41	Miner	3 years	redeemed.

At the Ophthalmological Congress held in Oxford on 18th July 1912, an interesting question was discussed/

discussed:- "Should a man who has suffered from the condition, has been incapacitated and has recovered return to work in the mine?"

Llewellyn (37) holds that one attack of nystagmus should not be taken as a bar to working underground.

Tomlin (23) holds that a cured case may return to work.

The Report of the Departmental Committee (46) brings out the fact that the medical opinion that pit work should be entirely relinquished was inconclusive.

Court (43) points out that this Departmental Report, 1907, states at page 10:- "the patient, though he may not at the time be actually unable to continue his work, ought to discontinue it if he is not to get worse". This council of perfection, Court is not quite able to agree with.

Butler (6) holds that even after a reasonable period of rest, when the miner has lost all his symptoms, return to the pit is "contraindicated".

My experience has been too limited to admit of my offering an opinion on the question. The liability to recurrence is considerable, as will be noted from record of cases given. Many men, after resting, start light surface work and in a few months report themselves as severely incapacitated as ever.

The custom of Insurance Companies to redeem claims which show a tendency to being protracted does not end the/

the matter. The men remove to another district and begin underground work again, sometimes under a new name. Should a recurrence overtake them, we have a tiresome form of Litigation, where the employer is entitled, as a defence, to prove that the disease was not contracted in his employment. I have taken part in four such "reviews".

Douglas Knocker (47) reports many such cases, and in a recent work by W. C. Craig (48) the legal aspect of such cases is fully dealt with.

Llewellyn (17, p.19) puts it that exceptional cases should not return to underground work. "Men who have failed several times before; very young lads; old men with commencing cataract; men with high degrees of refractive error; and cases where the attack has been marked with exceptional severity with movement persisting below the horizontal."

To sum up:- Mild or slight cases do often recover quickly and completely, at least one does not hear of them again as claiming compensation. Severe cases may be incapacitated for years. A personal equation is naturally at work, in association with factors already noted.

Age: Generally speaking, the younger the patient, the better the prognosis.

Pohl (50), however, has found that "precocious cases" tend to be protracted; Butler (16) has quoted cases of young men whose incapacity was long, and I have/

have noted two such cases in my records.

The men who remain at work, struggling against the disease, take the longest time to recover and specially so if old.

General condition. Men who are debilitated and have any constitutional weakness recover slowly.

Visual Acuity. The better the vision the better the prognosis.

Error of Refraction. If this be great, the prognosis is bad.

Alcohol. There can be no doubt that men suffering from Nystagmus aggravate the condition and prolong the incapacity by taking alcohol.

Neurosis. In cases where this is superadded, the prognosis is bad.

Cost of the Disease.

This naturally bears a direct ratio to the number of men certified as incapacitated totally and partially, and to the period of incapacity of these cases.

Referring again to the 186 cases, the following estimate/

estimate is made:-

No. of case.	Average period off work.	Average cost per case.	
37	35 $\frac{1}{4}$ weeks	£48: 3: 4	<u>Settled by Weekly Payments.</u> £1,782: 4: 2
74	56 $\frac{1}{2}$ "	£134:8: 3	<u>Settled by Lump Sums after weekly payments.</u> £9,946: 8: 3
1	-	-	<u>Lump Sum.</u> <u>No weekly payments.</u> £ 113:13: - <u>£11842: 5: 5 Total.</u>

66 Cases not closed.
8 closed without receiving payment.

Quoting again from the letter of the Manager of the Yorkshire Company, the following has a bearing on the question of Cost:-

"Supposing the Act had come into force on 1st January 1911, leaving out of account all the claims where the date of the accident (or the date of suspension) was prior to the 1st January 1911, 39% of the compensation paid out of the Permanent Accident Fund up to 30th November 1911 is in respect of Nystagmus.

Therefore the disease costs already nearly half as much as the whole of the serious accidents put together."

He adds that the compensation paid per Home Office return, by his Association, was as follows:-

1908	£1,576
1909	£3,408
1910	£6,380

As/

As will easily be understood, those figures do not indicate the whole charge of the Disease, since the real cost is not the payments made in a year, but these payments plus the future payments until the claims are ended.

Llewellyn (49) has estimated the cost to the country at £100,000 per annum.

He explains (18, p.16) how he arrives at this figure by taking the year 1910 as a basis for his calculation. He found that the cost of the 1618 cases certified in 1910 was £51,853, and adds:-

"In addition to the compensation charges, there is the loss to the Employers of the profit on the work which would have been done by these men, and further, the workmen lose a sum in wages which may well be double the sum quoted".

Further, in many cases the men naturally are not fit to earn as much during say twelve months or so preceding their failure to work.

The cost is going up annually and in view of this I understand that representation is about to be made by the Coal Trade to secure from the Home Secretary some modification in the order of 1907; the idea being that something in the nature of a time limit to liability is called for as has been obtained in Bottle-makers' Cataract where, by the order of 2nd December, 1908, when this was added to the Schedule, a limit of six months was placed to a claim for compensation.

Malingering.

I have touched on this subject in a general way when dealing with the Incapacity of the nystagmic and its Duration. The problem in its wider sense is a very real one. It began to attract attention soon after the passing of the Employers' Liability Act of 1880, and since the Workmen's Compensation Act came into force in 1906, a considerable literature has sprung up. Recently Sir John Collie (51) has dealt with the matter, and Dr. A. McKendrick (52) has written a short treatise on its detection.

In Germany a name has been coined "Rentenhysterie" - Income Neurosis - and at present a Departmental Committee is investigating the subject with reference to the National Health Insurance Act.

From my experience of the past few years, so far as Nystagmus is concerned, I cannot say that I have found much malingering.

To simulate the oscillations of the eyeballs is impossible I think.

It is somewhat different when we consider Blepharospasm, but the fact that this symptom is aggravated by fixation and tends to lessen with inattentive gaze may have led some observers to lay at the door of some men the charge of "putting it on". No doubt here and there one comes across a workman who tends to exaggerate his symptoms with a view to remaining idle for a longer period/

period than his condition would seem to call for.

There is always this further point to be noted, that workmen, when once they have been laid aside from their arduous daily routine, tend to become introspective. Long periods of enforced idleness are not beneficial to any type of workman. A superadded neurosis is very prone to show itself, and this complicates nystagmic cases.

Again, during idleness there is ample time for indulging in alcohol with the consequent bad results.

Such men are more of the type of the "unconscious malingerer" who is in a class distinct from the real malingerer. It has always to be remembered that trouble with the eyes in any shape gives rise to mental disturbance, and to an anxious hard worker, with domestic responsibilities, the idleness enforced by nystagmus tends to induce the type of neurosis referred to.

Generally speaking, malingering in nystagmus, considering the opportunities afforded, is rare.

TREATMENT.

Since Nystagmus is an occupational disease, the first thing that strikes one as likely to have a beneficial influence is discontinuation of the prejudicial work, the removal of the patient from his injurious surroundings. Snell (4) does not think it necessary, in/

in the great majority of cases, for work to be given up.

For him a change of work is sufficient, a discontinuing of that type of work calling for a constrained or cramped position. He quotes cases where improvement has followed upon this line of treatment.

I have not found this so. I think that when the disease produces symptoms the pit should be given up for a varying period and as has been noted in prognosis, the sooner this course is followed the sooner are the symptoms likely to recede.

In severe cases complete rest is wanted. The exhibition of tonics is thought to be beneficial and, from conversations with mining practitioners, I find Nux Vomica and Iron are very often prescribed.

Elworthy's (56) medical treatment is mainly on conventional lines, viz., "rest, sedatives (Bromides) at first followed by tonics, later on eye shades, coloured glasses and the correction of any error of refraction present".

Percival (53) has recommended Formic acid, and Atropine instillation has met with little or no success, Ohm (9).

Preventive Measures.

Along this line I think the greatest hope lies. From what has been concluded regarding the main causal factor of the disease, an increase of the candle power of/
of/

of the safety lamp should be aimed at. As the number of electric lamps used increases I expect a proportional fall in the case incidence of the disease.

All lamps should be kept clean and repairs should be attended to regularly.

The effect of ventilation upon the lighting power of any lamp has been noted, consequently careful attention should be paid to this with a view to maintaining the efficiency of the sources of illumination.

The 'colouring' of the roofs, leeward sides of posts, collars, cogs etc., as recommended by Elworthy (56) does not recommend itself as practicable to any of the colliery managers to whom I have mentioned this suggestion.

Another impracticable suggestion "to send tall men to high seams, and small men to low seams," (Dransart, 12) is, in my opinion, unnecessary, as no beneficial results would be likely to follow. The extensive introduction of coal cutting machines during the past years, for the working of low seams, reduces the actual amount of Holing or under-cutting to be done by the men, and so far there has been no tendency to affect the case incidence.

Additions to safety devices, the elimination of workmen with defective vision by means of routine examination, and attention to all mining conditions likely to maintain the general health of the miners, occur to me as some of the secondary points along this prophylactic line of treatment likely to be followed by beneficial results.

SUMMARY & CONCLUSIONS.

Miners' Nystagmus is an occupational disease peculiar to the Coal Miner. No cases have been met with among Shale Miners nor has the condition been recognised among the Tin Miners of Cornwall.

The Clinical Picture is complex: and the diagnosis is based upon a study both of the Objective and Subjective phenomena.

Objectively, oscillation of the eyeballs is the main feature. Of the varieties mentioned, the Rotatory is the most common. Next in order of frequency are the Horizontal and Vertical. The Direction of Swing, the Rate and the Amplitude are very variable, changing during one and the same examination and at times being different in the two eyes.

Change of gaze, stooping, change of light etc. are capable of inducing alteration in any and all of those elements of an oscillation.

All this leads one to conclude that the disease is not a local myopathy of any group of ocular muscles but a central change affecting those nerve centres whose function it is to maintain ocular balance.

Upon the absence or presence of the Subjective phenomena and the degree to which they are present a classification of cases is made into the two varieties.
Latent/

Latent: and Manifest with its subdivisions of mild, moderate and severe.

In Latent cases oscillations may be present in straight forward gaze and no complaint made.

In mild Manifest cases a complaint of some of the symptoms is made, e.g. dancing of lights, giddiness, confusion of sight, but oscillations are only elicited with difficulty and after careful ophthalmoscopic examination.

From this it is to be concluded that the diagnosis does not rest solely upon the presence or absence of oscillations. This is emphasised in the change recently made in the Secretary of State's order 1907, Schedule iii, which read "Nystagmus - Mining" and now in August 1913 has been altered to read "The disease known as miners' nystagmus whether the symptom of oscillation of the eyeballs be present or not".

I have only met with one case where oscillations could not be elicited on ophthalmoscopic examination, after the patient had stooped down several times, Case VI, Series A, where the patient was under the influence of Alcohol.

Aetiology. The Theories in the Literature are capable of being grouped under two headings - Position and Illumination.

The presence of pit gases exerts no direct casual influence/

influence upon the disease.

The Position question is at basis one of Occupation. The men who work at the coal face (Hewers) are affected in the greatest proportion. Brushers and Repairers are next in order of frequency among my cases: these men do no Holing nor do any of the other classes of underground workmen, except Hewers, yet no class is exempt from the condition.

Holing in naked light pits does not produce nystagmus. ||

A prolonged upward and oblique gaze is not called for in the Holing position.

Vertical oscillations are relatively rare.

The working in low seams, per se, in East Fife and in the East of Scotland generally, does not induce the condition.

The statistics of Llewellyn and Tatham Thompson bear out the same view regarding the effect of Height of Seam.

Holing, as such, or Occupation does not bear any direct causal relation to the production of the disease except in so far as skill is called for and a demand is made on the vision.

Defective Illumination seems to me to be the main causal factor.

The evidence in support of this hypothesis is:-

1. The Davy Lamp was introduced in 1850 and Décondé records the first cases recognised in 1861.

2./

2. The advantage of the naked light over the safety, as a source of illumination, is considerable.
3. Nystagmus is rare in the East of Scotland where the open light system chiefly maintains, and is frequent in the West of Scotland where the safety lamp is so much in use. Cases from open light pits usually complain of the bad air, and this, in view of the effect of atmospheric conditions on the lights, is what might be expected. Further, many of the cases from open light districts have migrated from safety lamp areas in the vicinity, e.g. from Lanark W. to Lanark E.
4. Llewellyn reports that, in the purely naked light districts of the Forest of Dean and Somerset, Nystagmus is unknown and Tatham Thompson gives statistics showing that the condition is relatively frequent in S. Wales pits where the seams are high and safety lights are used.
5. Improvement in illumination, as recorded by Romi e, has led to a diminution in the case incidence.
6. Hemeralopia is found in a considerable percentage of cases.

The working for prolonged periods in the defective illumination, which from the nature of the surroundings renders fixation difficult and strains the vision, has the effect of transmitting imperfect stimuli to the cells of the mid brain whose function it is to innervate those/

those muscles which subserve ocular balance. The presence of ocular defects may act as predisposing causes to the onset of Nystagmus.

There are other secondary factors at work. The Relationship of Accident to Nystagmus is established. Injuries to the head and eyes and general body injuries are capable of converting a Latent into a Manifest type; while frights have been known to aggravate the symptoms and a period of debility due to Influenza, Pleurisy, etc. may carry a case over to a severe type inducing total incapacity.

Alcohol has a deleterious influence: primarily a transitory beneficial effect is felt, followed by an aggravation of the condition.

The estimate of the Frequency or Case Incidence depends on whether only cases totally and partially incapacitated are included or whether to this figure are added all cases which have been noted as presenting oscillation of the eyeballs. This is certain, that the number of claims lodged in Scotland, and more so in England and Wales where safety lamps are used three times more frequently, has increased annually since 1907 and is still increasing.

Age. Nystagmus is a disease which affects the miner at the time of his greatest usefulness. The maximum/

maximum incidence falls between the ages of 35 and 45, so far as total incapacity is concerned.

Incapacity. This is proportional to the degree of symptomatic trouble. The skilled workman at the face is affected to a greater extent than is the underground labourer.

Severe cases are unfit for any work of marketable value.

The milder cases are unequal to their full duties, run greater risk of injury and may be a source of danger to their fellow workmen.

Duration of Incapacity. This is variable and depends on the factors noted in the text. The disease comes on gradually. The mean average period of underground work before onset of symptoms in Series A of cases was 26.5 years. A condition with such a slow onset cannot be expected to pass off quickly.

With the exception of 'precocious cases', the general rule holds good that the younger the man the better the prognosis: the older the man and the longer he has struggled against the incapacity the worse the prognosis. When marked nervous phenomena co-exist the prognosis is bad. The presence of severe Blepharospasm prolongs the incapacity. The average period lies between 8 - 12 months inclusive of a period of a few months of light work. There are many/

many cases incapacitated for longer periods and a few who never again resume work. The custom of redeeming claims by lump sum payments affects considerably any estimate which I have been able to make.

Cost of Disease. This is increasing rapidly.

Malingering. In my experience this is rare.

Treatment. General constitutional treatment should of course be carried out, but Preventive Measures in the direction of improved illumination, efficient ventilation and attention to eye troubles, are the likeliest to be followed by a reduction in case incidence of this disease which is lowering the working standard of so many men, is reducing their wage earning capacity, rendering so many totally incapable of supporting themselves and their homes.

PART IV.

RECORD OF CASES.

(Series A)

Page
114.

(Series B)

128.



RECORD OF CASES.

(Series A)

The following twenty cases were certified as incapacitated, suffering from Nystagmus, and were in receipt of Compensation for varying periods.

1. J. J. 47. Miner, 5' 7".

Complaint. Pains in back of head and neck: difficulty in seeing when at work, "lights rocking".

History. Has had increasing trouble for past 4½ years. At first, a blurring of objects, "something like a mist rising before his eyes". Could control this sensation by "blinking and squinting outwards to right". Trouble greater in Winter months with "lights" below and above ground.

No longer able to check the sensation by blinking. Gets giddy at times and is now unfit.

Examination, December 1910.

Head tilted backwards to left: twitching of orbicularis: fine rotatory oscillations in straight forward gaze: fixing of near object sets up head tremor: Blepharospasm with upturned gaze: downward gaze checks oscillations and lidspasm.

V.A. 6/36 in both eyes.

In dark room, increased rate of oscillations, with degree of Photophobia and spasm of lids.

History of Work. Began as a Filler, aet 16. Filler and Drawer - 11 years with open lights. Miner - 20 years with closed lights (clanny): Good head room, seams averaging 4' 8" - 6": very little actual holing.

General Health good: no excess of alcohol or tobacco.

Progress. April 1911.

Oscillations only at high level of upward gaze: head tilt diminished: head tremor present: troubled with lamp in dark room, "circling sensation" passes off soon.

July/

July 1911. No complaint: oscillations only elicited after stooping: V.A. $\frac{1}{3}$.

Resumed surface work at own request, four months after cessation of work.

November 1911. Returns to say trouble at night in the dark increasing. Complains that stooping makes him giddy: oscillations easily induced. Continued at work.

February 1912. Has given up surface work: oscillations in straight forward gaze: head tremor: tremors of hands and marked Blepharospasm as he walks in.

Claim was redeemed by lump sum payment, six weeks later.

14 months under observation, recurrence and getting worse.

2. J. C. 66. Miner 5' 11".

This man had been off work for a year on account of Nystagmus before he came under my notice.

Complaint. Giddy sensation after taking a long walk: says he feels bad in the "half light" and cannot then recognise his friends unless by their voice.

History. Has had trouble for the past five years. At first it was giddiness, with occasional circling of the lights: "dazzling" when walking behind a lamp. Matters became serious through injury to the left Parietal region - severe scalp wound resulting from a fall of stone from the roof - 15 months ago. Resumed work ten weeks later: after four shifts had to give up: severe trouble with the eyes.

Examination. December 1910. Tremor of head and hands: depressed and distinctly apathetic. No oscillations in straight forward gaze: stooping and looking up induces giddiness and a rapid vertical type, stronger in the right eye. V. A. admits only $\frac{6}{60}$. No Blepharospasm.

History of Work. Underground 56 years: Holing done, moderate height of seam: Safety Lamps.

General Health. Under par: senile circulatory system: no excess of alcohol or tobacco.

Progress. March 1911. Feels no better: vision bad. Claim redeemed after 15 months.

3. H. C. 42. Miner, 5' 5".

Complaint. "Difficulty with his eye sight": says that "but for his eyes he is as good as ever".

History. Trouble began 15 months ago: lights dancing on way to working place: later giddiness with pain in back of head. Wife began to notice that he was "blinking": he was not conscious of this. Gave up work two weeks ago.

Examination, December 1910.

Blepharospasm markedly present: difficulty in examining the globes. Lid spasm most marked when trying to fix an object and when he is being addressed: head tremor and photophobia in dark room: eyeballs roll up under the lids: imperfect adaptation.

History of Work. Underground 27 years: 2 years with open light: 25 years with safety lamps. Low seams, much holing.

General Health good, takes alcohol sparingly: non-smoker.

Progress. February 1911. Blepharospasm absent as he walks in: slow rotatory oscillations in both eyes. In dark room, spasm of lids sets in severely.

April 1911. Resumed light surface work of own accord.

August 1911. Free from complaint: an occasional "blink" is noticed.

Resumed work underground and has made no further complaint to my knowledge.

Light work resumed in five months.

In ten months case closed.

4. G.H. 37. Drawer, 5' 7".

Complaint. Unfit for work, feeling of "lightness" in the head and dancing of lights in the pit.

History. Trouble started suddenly ten months ago: had been working in a "very hard place" and suddenly felt as if he had gone blind: rubbed his eyes every now and again to set them right. Difficulty increased and he began to have trouble when he entered his lighted kitchen on going home: "had to sit and rest and cover his eyes for a bit". Doctor told him he must give up, as suffering from Nystagmus.

Examination, October 1910.

Slow horizontal oscillations: stooping sets up
a rapid oblique type *Q* *Q* in upward gaze.
The/

The horizontal type persists on gaze depressed below horizontal level. No Blepharospasm. V.A. $\frac{6}{6}$.

History of work. Filler for 12 years. Drawer ever since. No Holing. Safety lamps all the time.

General Health good: takes a few glasses of beer weekly (4 - 5): smokes $2\frac{1}{2}$ oz. of black twist.

Progress. January 1911. Says he feels all right: anxious to resume work: oscillations difficult to elicit.

Started light work on surface, and in April 1911 reported himself as "going below". No recurrence.

Light work resumed in three months.

Case closed in six months from start.

5. W.G.B. 35. Miner, 5' 3".

Complaint. "Jumping of lights on looking to left side" and difficulty with his sight.

History. May 1911, Struck on head and back, fall of coal: examined June 1911, no nystagmus, no complaint of eyes: fit to resume. After ten shifts at work (i.e., ten days) gave up.

Examination, July 1911.

Rapid head tremor, lateral. No oscillations in straight forward gaze, upward and oblique left gaze sets up rapid rotatory type. Giddy after stooping, with twitching of orbicularis. In dark room, complains of lamp, passing off soon: increase of trouble on returning to lighted room. V.A. $\frac{4}{6}$.

General Health. Nervous: reflexes active: pulse rapid.

Takes alcohol to excess at times: smokes in moderation.

History of work. 20 years underground. 4 years filler: 10 years drawer: 6 years hewer. Open lights, bad ventilation.

Progress. November 1911. Health improved, eyes giving less trouble.

February 1912. No complaint: no oscillations, even in dark room. Resumed work after seven months.

May 1912. Recurrence with Blepharospasm. (In April 1912 he suffered from an attack of Influenza.)

October 1912. Not improving.
Case redeemed after 15 months (less 3 months).

6. W.M. 32. Repairer, 5' 9".

Complaint. Rolling sensation in his eyes: says he is conscious that his eyes are moving: feels giddy and unfit for work.

History. Symptoms set in 8 - 9 months ago: at first difficulty with his sight: then objects and lights "rocking" left off work 2nd July, 1912.

Examination, 31st July 1912. Enters with "peering gaze", blinking of eyelids and general tremulousness. No oscillations by any test, including Reid's rotation test. Smells strongly of fresh alcohol and says he has been seeing his brother-in-law off to Canada this morning.

Examined 6 days later. Says he is very bad with his eyes. Vertical type of oscillations in both eyes, more marked in left with upward gaze.

In dark room, left eye takes on an oblique elliptical type. On prolonged examination, Elepharospasm sets in. Unable to read ordinary Snellen: with illiterate card he admits $\frac{1}{6}$.

General Health poor. Alcoholic subject: smokes moderately.

History of work. 18 years underground: no holing: safety lamps.

Progress, November 1912. Improved. V.A.⁶/9: oscillation difficult to elicit.

Says to-day that he has always had trouble after a few days' drinking, when he keeps off the drink he is able for his work and his eyes do not trouble him much. Resumed work after four months' incapacity.

N.B. I have a note from a colleague that Moffat has had two recurrences since then, with short periods of incapacity; both occasions being associated with alcoholic indulgence.

7. E.G. 49. Brusher, 5' 4".

Complaint. Feels giddy at times and sees objects revolving.

History. Sudden onset. On 29th July 1912 sustained depressed fracture of right occipital: dangerously ill. November 1912, while sitting in the house watching for a baker's van, he had occasion to glance strongly round the edge of the window at a passing vehicle. Objects began to dance suddenly and he has had trouble ever since: can't bear to read in a lighted room, the print gets/

gets blurred and the "letters start to race".

Examination, 6th December 1912.

No oscillations in horizontal gaze or in strong upward angle of regard. On looking up to left a horizontal type of oscillation sets in.

Reflexes active: no clonus: no Babinsky sign. Hearing not impaired: headache occasional: no vomiting.

In dark room, some photophobia and head shaking when light thrown into the eyes.

This case was sent for examination to an ophthalmic surgeon. Report = no error of refraction.

A case of Miners' Nystagmus.

History of work. 37 years underground: safety lamps.

General Health. In a nervous condition.

Progress, August 1913. In statu quo.

8. R.K. 21. Bogie lad. 5' 6".

Complaint. Impaired vision and giddiness.

His History is interesting. Started pit work when aet. 14, as a filler, and three years later as a miner: closed lights. When aet 17 had trouble with eyes - rotation of lights and objects, with giddiness.

Resumed, after seven months' rest, miner's work in open light mine as it had been suggested to him by some friends that the safety lamps caused his trouble: four months later took to surface work because of trouble with eyes.

Six months later resumed at Face, but six months afterwards had to give up. Has been acting as a Bogie lad every since, his duties being to couple hutches and make up races of empty "tubs" to be returned for filling. Has never been actually free from eye trouble for past few years.

Four weeks ago he had a big fright, just escaping from being crushed between a stationary and a running hutch. Eyes have been very bad since. He is a myopic subject.

Progress. Examined two months later - no improvement. At end of four months his claim was redeemed.

9. W.S. 37. Miner 5' 11".

Complaint. Frontal headache: swinging of lamps.

History/

History. Onset one week ago. Had been speeding up to get a certain piece of work finished to let the Brushers in. When he got up after four hours' hard work, he suffered from headache and noticed the "lights" swinging. He felt giddy and had to be helped to the pit bottom. Says he was in best of health when he started "the shift".

Examination. Eyes prominent, pulse rapid, reflexes brisk: no enlargement of Thyroid. No oscillations of eyes in straight forward gaze. When put into "mining position" he feels comfortable. After stooping, a rotatory type of quiver sets in, with twitching of the frontalis, contraction of pupils and clonic spasm of the under eyelids. Eyes come to rest slightly below horizontal position. V.A. 8/6.

General Health good, teetotaler and non smoker: nervous temperament.

History of Work. 20 years under ground: Holing at times: safety lamps.

Progress. Examined 8 weeks later. Oscillations difficult to induce: pulse quieter but still inclined to be active.

Resumed full work after ten weeks' incapacity.

10.

P.F. 34. Miner, 5' 6".

Complaint. "Blurring of eye sight", difficulty in doing his pick work: occasional giddiness and trouble with the lamps "dancing".

History. Gave up two weeks ago. Trouble began three months ago with "blurring" and "dazzling".

Examination. Twitching of Frontalis: slight tremor of head, (antero-posterior nodding). Fine rotatory oscillations only on upward gaze. In dark room, Blepharospasm sets in and a slower rate of quiver with wider radius. V.A. good.

General Health good, non smoker, moderate alcohol.

History of work. 19 years under ground: four years Holing: safety lamps: Fiery mine.

Progress. Resumed work after twelve weeks' incapacity. No further claim.

11./

11. A. McI. 47. Miner, 5' 10".

In March 1911 examined for minor injury to right index finger. Rotatory oscillations noted: no symptomatic trouble.

October 16th, 1911, body crushed between wall and a falling pit prop: confined to bed for two weeks. Resumed work five weeks later. After five shifts, had to give up and comes to-day complaining of unsteadiness of objects, dancing of lights, giddiness and Hemeralopia. Admits that eight years ago he often suffered from "glass glare" from the lamps and now and again after a holiday, when he took alcohol freely, he had a little trouble with the eyes.

On resuming after the body injury he felt giddy the first shift, objects "rocked" and he had to be helped home. He rested two days and, after one more half shift, had to give in. He had trouble crossing the open country to his cottage in the dark.

His doctor advised him to give up.

Examination, November 1911.

Tremor of Head: Blepharospasm. The lid spasm in this case is of an "opening type" and he looks as if he were being constantly startled. When one keeps the lids closed, the effort to open them is felt in a clonic fashion. Only a tremor of the eyeballs to be noted which persists in extreme downward gaze into a head mirror.

V.A. very bad. Giddy on walking along a line.

General Health good: addicted to alcohol: smokes 4 oz. per week strong tobacco.

History of Work. 37 years underground, 34 of which hewing: safety lamps.

Progress, February 1912. Blepharospasm less marked: distinct horizontal oscillations (elliptical) in straight forward gaze. On looking up it approximates closely to circular type. On prolonging examination, blepharospasm becomes marked.

July 1912. Blepharospasm and oscillations present.

December 1912. Making nothing of it: admits that he is taking alcohol regularly and at times to excess: is depressed and says he is "sick of life".

Case redeemed January 1913, after 54½ weeks' incapacity.

12. J.D. 52. Brusher, 5' 4".

Left eye corneal injury 11th July 1912, corneal opacity resulting: impaired vision in left eye.

Resumed seven weeks later.

History. In November 1911 began to suffer from "lights shaking" and at times felt as if a "haze like a grey mist" floated before him when in the dark. Had trouble in the twilight and in the early morning: gave up work March 1912, after four months of symptoms.

After four months' rest he resumed on surface, and I examined him, September 1912, with a view to estimating his capacity for work.

Examination.

Head tremor: Rotatory oscillations easily induced in dark room: says the stooping at work, filling waggons with cut pit props, makes him giddy and he has to rest till the shaking of his eyes quietens. He continued his light work.

General Health. Good: nervous: vessels thickened.

History of work. 40 years under ground: no holing: safety lamps.

Progress, December 1912, worse: Blepharospasm marked: rotatory oscillations present: Retrograding.

February 1913. In statu quo. I understand an effort is to be made soon to redeem his claim.

13. T.B. 29. Miner, 5'8".

Complaint. Unsteadiness of lights and headache.

History. Trouble started three months ago with occipital and temporal headache and giddiness.

In December 1911 caught a chill and suffered from Pleurisy. When convalescent he used to play carpet bowls in the village recreation hall. Sudden onset of trouble after playing an exciting game in a dim light and saw objects swinging from side to side. A few weeks later he resumed work and during the first shift he felt giddy and noticed the lamps "circling".

Kept at work: trouble increased and his doctor advised him to give up and to report his case to the colliery manager.

Examination/

Examination. 10th February, 1912. Well marked vertical type of oscillation: slow rate: onset at a small angle of regard above the horizontal. V.A. $\frac{6}{6}$.

Hypermetropic astigmatism found present by ophthalmic surgeon.

General Health fairly good: teetotaler and non smoker.

History of work. 15 years under ground: 8 years a Hewer: High seams: Safety lamps.

Progress. Six months later resumed surface work and after three months at this reported himself as "going below". No further claim made and case closed.

14. R.K. 54. Miner, 6'.

Complaint. Impaired vision: circling lights.

History. Trouble began 8 - 9 months ago with a "tired feeling" in the eyes. Three months ago felt giddy and "eyes began to dance": increasing trouble and gave up 20th January 1911.

Examination, February 1911. Albino of a marked type. Peering gaze: Blepharospasm: Horizontal oscillations in all directions of gaze. Says he feels most comfortable in a subdued light - this is exceptional. V.A. $\frac{3}{60}$ admitted.

General Health good, temperate.

History of Work. Started as a filler, aet 16. Drawer for eight years. Deputy (Fireman) in Durham four years. Safety lights except for nine months ten years ago when he used candles in England: low seams.

Progress. at repeated examinations - oscillations always present: Blepharospasm: trouble in the dark.

Redeemed January 1912 - 12 months.

15. F. McC. 65. Miner, 5'5".

Complaint. Difficulty in getting about above and below ground because of bad vision.

History. Says he has had trouble off and on for six years or so, and adds that some years ago, when in the habit of drinking heavily on the Saturday, he felt discomfort in his eyes on the following Monday: paid no attention to it. Twelve months ago right eye was injured/

injured - piece of coal from pick. Resumed in three weeks.

Later on (a few months) sight became bad and lights were noticed to "bob up and down". Four months ago left index finger injured: septic mischief: amputated five weeks ago.

Examination. Finger healed. Cataract in right eye. Incipient cataract in left eye.

In straight forward gaze rotatory oscillations equally in both eyes.

General Health. Under par: depressed: temperate now.

History of work. 53 years underground: Hewer most of time: 10 years open lights: 43 years safety lights.

Progress. In statu quo: Prognosis bad.

16. J.H. 37. Brusher, 5' 9".

Complaint. Unsteadiness of head: giddiness: dancing of lights and objects.

History. For many years has had trouble less marked than now and as a child had "weak eyes" he says. Injured March 1913, struck by wooden bar on back and knocked head against "workings". Resumed eight weeks later.

Examination. June 1913. Eyes injected, well marked vertical oscillation in right eye. Left eye none. Ophthalmoscopic Examination - fine tremor in left eye.

V.A. L.E. $\frac{6}{6}$
R.E. $\frac{6}{9}$

General Health good: smokes heavily: temperate in alcohol.

History of work. 26 years under ground: high seams: no holing: open lamps.

Progress. August 1913. Still incapacitated: injection of vessels less marked: an occasional "blink" noted: vertical oscillations easily produced in left eye now but slower rate in right eye.

17. J.D. 14. Brusher 5' 4".

Complains bitterly of giddiness, movements in objects, difficulty in walking about. States that he has had trouble in getting through the traffic in the town to come for examination.

History/

History. Was all right till six months ago: difficulty has increased rapidly.

Examination. Head tilted: gaze downwards: halting uncertain gait: nervous, gets easily excited and becomes tearful when relating his troubles: head tremor.

Right eye, rotatory fine oscillations: rapid.

Left eye, oblique, elliptical, relatively slow. With upturned gaze, rate increases and he sways. Oscillations persist in gaze a few degrees below horizontal. Transient Blepharospasm after stooping: delayed adaptation in dark room: gets more tremulous, neck muscles jerk.

General Health. Nervous, alcoholic a bit.

History of Work. 21 years underground: no holing: open light: ventilation bad.

Seven years in army: denies venereal disease: no evidence of same.

Progress. Four months later, improved: takes a more cheerful outlook: oscillations difficult to bring out: difference between the two eyes still noted.

Four weeks later resumed light work of own accord. He asked to be allowed to return as he had a large family to support.

Ten weeks later gave up - recurrence - tearful. Case redeemed $10\frac{1}{2}$ months from first stop.

18. J.B. 34. Fireman, 5' 5".

Complaint. "Quivering of eyes": dazzling by lights.

History. Onset eight months ago: gradually getting worse: four weeks ago the under manager had to find fault with him about his examinations of roofs and gas detection.

Examination. No oscillations even after stooping and upward gazing.

In dark room, fine vertical type in straight forward gaze. No Blepharospasm. V.A. = $\frac{5}{6}$.

General Health good: smokes in moderation and seldom takes alcohol.

History of work. Was a miner till three years ago when he took up Fireman's duty: low seam: has done Holing. Fiery mine: safety lamps.

Progress/

Progress. Ten weeks later resumed as a miner. It was suggested that he give up Fireman's work.

19. Ed. Campbell. 22. Miner, 5' 6".

Complaint. Giddiness, feels "dazed and lost" when walking behind a lighted lamp.

History. Trouble dates back three months. Head and eyes became easily tired at first.

Examination. Very fine rotatory type in straight forward gaze. V.A. $\frac{5}{6}$.

In strong upward gaze, his eyes seem to roll, so wide is the range, and slow.

When asked to read from a book held in his hand he tilts his head backwards. No diplopia.

General Health good.

History of Work. Eight years under ground: five years miner: safety lamps: seam averaging 3' - 4': very little holing.

Progress. In eleven weeks all symptoms disappeared: oscillations still present: resumed work twelve weeks after stop and has had no recurrence.

20. P.H. 41. Miner, 5' 7".

History. In March 1910 a colleague certified him unfit. Rotatory type of oscillations with marked Blepharospasm and complaint of Hemeralopia: had had increasing trouble for twelve months prior to this.

When examined by me, 26th April 1911, he had been at light work for two months, and had just given up.

Complaint. Giddy attacks, quivering of lights in street as well as in pit: trouble increased at twilight. Says he has pain in his eyeballs at times.

Examination. Rapid and severe Blepharospasm: difficulty in noting the state of eyeballs. Fine rotatory oscillations: eyes look injected.

In dark room, twitching of neck muscles.
V.A. $\frac{6}{60}$ admitted.

General Health good: nervous type: has not smoked for past year: takes alcohol sparingly he says.

History of work. 27 years under ground: 11 years mining: high seams: safety lamps.

Progress/

Progress. August 1911. No improvement: Blepharospasm marked.

December 1911. Somewhat improved: says he thinks he will try light work as he is tired of going about idle.

March 1912. Says he was only able for three weeks light work: states his eyes are worse: Blepharospasm very marked: stopped work.

July 1912. No improvement: complains that he suffers when he walks about in the sunlight. Dark spectacles advised.

November 1912. Blepharospasm not improved: complaints as before. A general neurosis to be noted.

January 1913. Has made no improvement. Claim redeemed after 31 months.

March 1913. I met Hooligan accidentally to-day in Hamilton: had not resumed work: Blepharospasm marked: depressed. Says life is a burden to him and the money he got of no use since he cannot with safety go far from the door. Admits that he "takes a dram" pretty frequently now since he has given up all hopes of recovering and being able to go back to the pit to work.

SERIES B.

This series consists of 20 cases of men examined for minor injuries.

In the great majority the symptomatic side of the disease was Latent, while others belonged to the mild group of the Manifest class and were able to be at work though suffering some incapacity at times. Two cases belonged to the severer manifest type and were advised to give up work.

No claim made in any case for Compensation.

1. R.P. 54. Miner. Left Index finger crushed.

Examination. Horizontal oscillations on upward oblique gaze: slight head tremor: makes no complaint of eyes. V.A. good. Admits that for past six years has at times experienced "lights dancing" underground and in Winter months has had trouble with lights on pit head. No giddiness. Has left "coal face" and done Bottomer's work on three occasions to rest till his eyes got easier. He says the lights are better there than at the "face".

History of work. 28 years underground: Holing: 12 years naked lights: 26 years safety lamps.

Progress. Resumed work in four weeks.

2. W.P. 25. Miner. "Beat Hand" - Palmar subcutaneous cellulitis - (Trade disease)

Examination. Makes no complaint of eye: ^{Symptoms.} / head tremor when V.A. tested = $\frac{2}{6}$. Vertical oscillations easily induced when V.A. falls to $\frac{1}{6}$.

History of work. 11 years underground: open lights two years: safety lamps nine years: moderate seams: little holing.

Progress. Resumed work in eight weeks: hand condition cleared up.

3. A.T. 34. Drawer. Inguinal Hernia.

No complaint of eyes. V.A. $\frac{6}{12}$. When fixing a near object tilts head backwards slightly: stooping induces a rotatory type of oscillation. Has noticed "lights circling" when he was fatigued. In dark room, a slight Blepharospasm.

History/

History of work. 22 years underground: safety lamps: no holing.

Progress. Operated on: resumed work in twelve weeks.

4. W.J. 35. Miner. Teno synovitis, right wrist,
(Trade disease)

Examination. Head tremor: oblique elliptical oscillations on raising gaze: present in straight forward gaze after stooping. Admits an occasional "dazzling" sensation. V.A. 6/6.

History of work. 21 years underground: safety lamps: some holing.

Progress. Resumed work in six weeks.

5. T.W. 32. Pony driver. Right ankle kicked by
pony.

Examination. V.A. good. Fine rotatory oscillations, with twitching of frontalis: some "nictitation". Admits that at times "lights dance" at close of day's work, but he thinks nothing of it.

History of work. 18 years underground: closed lights.

Progress. Resumed in three weeks.

6. W.H. 64. Miner. Sprained left wrist.

Examination. Vertical oscillations induced after "rotation test" when he experiences objects "rocking", passing off soon. Admits that when a younger man he suffered slightly from "Miners' Blink" but no trouble for many years.

History of work. 51 years underground: high seams: naked lights.

7. W.D. 38. Stripper. Cut finger.

Examination. Rotatory oscillations on looking upwards. No complaint of eyes. V.A. good. Admits an occasional "dazzling of lights".

History of work. Closed or safety lamps 4 $\frac{1}{2}$ years. Open lights 19 years.

Progress. Resumed in 16 days.

8./

8. W.N. 49. Miner. Left side bruised.

Examination. No complaint of eyes: peering gaze: head nodding: tremulous: V.A. $\frac{6}{9}$. In dark room, twitching of eye lids, well defined oblique rotatory type of oscillations.

History of work. 14 years with safety lamps: some holing.

Progress. Resumed in eight weeks.

9. W.L. 50. Miner. crushed great toe (L.).

Examination. Rotatory oscillations in straight forward gaze. Admits that has had trouble with lights for past four years, and difficulty in getting about in the dark.

History of work. 38 years underground: high seams: 5 years open lights: 38 years safety lamps:

Progress. Resumed in eight weeks.

10. A. McL. 49. Miner. Compound fracture, 2nd metacarpal. R.

Examination. Makes no complaint of eyes. Right eye, well defined rotatory oscillations. Left eye, only noted in dark room after stooping. No subjective complaint of eyes.

History of work. 34 years safety lamps: Holing.

Progress. Finger had to be amputated: resumed in $3\frac{1}{2}$ months.

11. G.B. 45. Roadsman. Left ankle twisted.
No complaint of eyes.

Examination. Fine rotatory oscillations persisting in slightly downward gaze. In dark room, more marked with greater radius when he complains of the lamp moving in a circle.

History of work. 32 years underground: safety lamps.

Progress. Resumed in seven weeks.

12./

12. A. Easton. 37. Surface worker. Abrasion of L. shin.

Worked with closed lights as a miner till $2\frac{1}{2}$ years ago. Felt "dancing of lights" with "dizziness" for 12 months before he went to the surface. Made no claim as he did not know what was wrong with him.

Examination. Vertical oscillations after stooping, and an occasional "blink" of the lids.

This man shows numerous healed scars; says he comes up against objects when on the "back shift" in the dark.

N.B. I find this man sustained injury to left eye $3\frac{1}{2}$ years ago. Slight corneal opacity present. He has been advised to give up work for a time and to rest.

13. T.K. 53. Miner - one eyed. Right thumb injured.

Lost sight of left eye 25 years ago; returned to work three months later.

Examination. Admits that the "lights dance" when he feels out of order and has been working too hard. Definite rotatory oscillations, the blind eye stump following closely the movements of the right eye. Says he feels able for his work.

History of work. 41 years underground: safety lamps.

Progress. Resumed in three weeks.

14. W. McK. 57. Miner. Left ankle injured through stumbling down a hole.

Says that only a few weeks ago he got a nasty knock against a stationary hutch. His eyes trouble him but he adds that this is an old story.

Examination. In straight forward gaze, a well defined rotatory oscillation: increased on looking upwards. V.A. $\frac{20}{60}$ - $\frac{1}{3}$. Head nodding: states that all last Winter his son helped him to the pit and to his working place. The boy was acting as his filler.

Intended resuming after ankle better but was advised to give up.

History of work. 45 years underground, mostly with closed lights.

15./

15. R.G. 31. Brusher. Back bruised.

Examination. No complaint of eyes. Head tremor. V.A. good. In dark room, rotatory oscillations most marked in right eye. In a nervous condition. A distinctly latent case.

History of work. 17 years with safety lamps: no holing.

Progress. Resumed 11 weeks later.

16. Henry Sharp. 26. Miner. Right knee bruised.
No complaint of eyes.

Examination. Peering gaze: tremors of head: twitching of frontalis. Stooping induces an oblique rotatory oscillation. Myopic subject: so far has had no symptomatic trouble.

History of work. 11 years underground. 3 years open light: 8 years safety.

Progress. Resumed six weeks later.

17. T.P. 39. Bottomer. Racked back.

Examination. Vertical oscillation in straight forward gaze, assuming an oblique rotatory phase after stopping, in upturned angle of regard. Slight "blink" of lids and slow adaptation to change of light. Admits that for past twenty months has had trouble with eyes, dazzling, headache, and "shaking of lights".

History of work. 25 years underground: safety lamps all the time: no holing.

Progress. Resumed eight weeks later.

18. A.P. 31. Brusher. Left elbow bruised.

No complaint of eyes. V.A. good.

Examination. Rotatory oscillations easily induced. Admits, at times difficulty with sight, for an hour or so after he has got to his working place.

History of work. Closed lights: no holing.

Progress. Resumed in 18 days.

19./

19. J.B. 50. Miner. Left knee twisted.

No complaint of eyes.

Examination. Tremor of head (lateral nodding). Horizontal oscillations in all directions of gaze, even downwards. Has never seen lamps dancing: says he has been told that his "eyes rock about". Tells me that his maternal uncle and a cousin suffered from "shaking of the eyes" and that neither of them was ever off work on that account.

This man is the subject of Retinitis Pigmentosa. A note was taken of this case in view of a possible claim in future for compensation due to Nystagmus.

History of work. 35 years open lights: past 3 years closed lights.

Progress. Resumed in $9\frac{1}{2}$ weeks.

20. F.N. 24. Miner. Right elbow cut by hutch.

Examination. Vertical oscillations in straight forward gaze, more definite on looking upwards. V.A. $\frac{6}{12}$. Admits having at times a "hot tired feeling" in the eyes, and states that for quite a year past has experienced now and again a "blurring" with "whirling of the lights" underground.

History of work. 9 years underground: safety lamps.

Progress. Resumed in four weeks.

In some cases of this series, the minor accidents noted would appear to be consequent upon the eye trouble arising from a nystagmic condition.

B I B L I O G R A P H Y.

1. Dr. Angus Smith. Air and Rain, 1863.
2. Sir John Simons. Public Health Reports: Sanit. Inst. Grt. Brit. Vol.II, p.37.
3. Nasmyth. B.M.J., 1888. Vol.II, p.222.
4. Snell. Miners' Nystagmus, 1892, p.15.
5. Décondé. Annal. d'Occult. 1861.
6. Butler. Ophthalmoscope, 1st December 1912, p.680.
7. Buys & Coppez. Graphic records of Nystagmus. Ophth. 1909, p.808.
8. Ohm. Das Augenzittern der Bergleute. Arch. für Oph. Von Graëfe, October 1912. p.p.25 & 39.
9. Nieden. Der Nystagmus der Bergleute, 1894, p.p.25-30.
10. Romiée. Annal. d'Occult. T.CVIII, 1892, p.196.
11. Romiée. Bull. de l'Acad. de Méd. de Belg. 1892, Série VI, p.299.
12. Dransart. Bull. de la Société Belg. d'oph. 1908, No. 24. p.38.
13. Iron & Coal Trade Review, August 15th, 1913. p.227.
14. Trans. Ophth. Congress, Oxford, July 1912. (Ophth. Dec. 1912).
15. Nuel. Bull. de la Société Belg. d'Oph. 1908, No.24. "(De la vision du nystagmique)"
16. Butler. Ophthalmoscope 1909. p.524.
17. Norman, A.C. B.M.J. 1912. Vol.II. p.69.
18. Llewellyn. Miners' Nystagmus, 1912. p.2.
19. Court. B.M.J. 1892. Vol.II, p.835.
20. Dransart & Famechon. Bull. de l'Acad. Roy. de Belg. 1908. p.3.
21. Romiée. Bull. de la Société Belg. d'Oph. 1908. No. 24. p.73.
- 22./

22. Weekers. Bull. de la Soc. Belg. d'Oph. 1910.
Nov. 29. p.210.
23. Tomlin. Medical Chronicle, October 1911.
24. Oglesby. Brain, 1880, Vol.II. p.177.
25. Oglesby. Trans. Oph. Soc. United Kingdom, Lancet
1882, Vol.II. p.103.
26. Jeaffreson. B.M.J. July 16, 1887.
27. Snell. Lancet, 1875. Vol.II, p.281.
28. Dransart. Journ. d'Ocult du Nord de la France,
August 1891. pp. 37 - 42.
29. Dransart. Annal. d'Ocult 1877. Vol.II, p.121.
30. Dransart. Letter to T. Thompson. B.M.J. 1891,
Vol.II, p.448.
31. Nieden. Über Nystagmus als Folgezustand von
Hemeralopie, Berlin Klin., No.47, November 1874.
32. Court. B.M.J. 1891. Vol.II, p.78.
33. Tatham Thompson. B.M.J. 1891, Vol.I, p.287.
34. Elworthy. Ophthalmoscope 1st December 1912, p.688.
35. Nuel. Bull. de la Société Belg. d'Oph. 1909. No.
24, p.47.
36. Reid. Brain, 1906. Vol. XXIX, p.356.
37. Llewellyn. Ophthalmoscope 1st December 1912, p.
698.
38. Parsons' Pathology of the Eye. Vol.III, p.921.
39. Trombetta. Clinica Moderna. 1900. Vol.I. Nr.31-35.
40. Peters. Archives für Augenheilk XLIV. p.301.1902.
41. Dransart & Famechon. Bull. de la Soc. Belg. d'Oph.
1910. No.29, p.147.
42. Statistics of Compensation (Cd. 4894, 1908): (Cd.
5386, 1909) (Cd. 5896, 1910) (Cd. 5794, 1911).
43. Court. Ophthalmoscope, December 1912. p.687.
44. Snell. B.M.J. 1908. Vol.II. p.241.
- 45./

45. Whalley. Report Roy. Comm. on Mines (Cd.4551,1909)
pp. 90 - 95.
 46. Depart. Committee Report, Indust. Diseases (Cd.
3495, 1907).
 47. Douglas Knocker (Butterworth's Compensation cases).
 48. W.T.Craig. Case Law (Compensation). Green & Sons,
1913.
 49. Llewellyn. Proc. Roy. Soc. B576. Vol.85. p.10.
 50. Pohl. Bull. de la Société Belg. d'Oph. No.24,1908.
 51. Sir John Collie. Medico-legal exam. Workmen's
Compensation Act 1912.
 52. Dr. A. McKendrick. Malingering and its detection,
1912.
 53. Percival. Ophthalmic Review. 29. 1909, p.229.
 54. Dransart. Du Nystagmus chez les mineurs, 1877,
p.13. (Étude clinique et pathogénique)
 55. C. Bell Taylor. Lancet, 12th June, 1875. p.821.
 56. Elworthy. Ophthalmoscope, 1st February,1911.p.150.
 57. *Wilbrand (quoted by Gowers) Über den Nystagmus,1884.
 58. Gowers. Ophthalmoscope, 1908, p.412.
 59. Report of Ophthalmological Soc., United Kingdom -
Ophth. 1909. p.305.
 60. Priestly Smith. B.M.J. 1892. Vol.II, p.840.
 61. Maddox. Ophthalmoscope. March 1912. p.124.
 62. Maddox. Tests and Studies of Ocular Muscles,
2nd Edit., 1907. p.98.
 63. Mines & Quarries Report (Scotland) 1911 (Cd.5676,
p.28)
 64. Trans. Instit. Mining Engineers, 1912-1913: Vol.
XLIV Pt.I p.255.
-