

**CARDIOVASCULAR FUNCTION AND AUTONOMIC ACTIVITY
IN THYROID DISEASE**

JOHN COLIN FORFAR

BSc (hons) 1972; MBChB 1975; MRCP (UK) 1977.

THESIS PRESENTED FOR DEGREE

OF DOCTOR OF MEDICINE

UNIVERSITY OF EDINBURGH 1984



"There is one malady which I have in five cases seen with what appeared to be enlargement of the heartThis malady to which I allude is enlargement of the thyroid gland,"

Caleb Hillier Parry 1786.

FORMAL DECLARATION

I declare that I have written the dissertation presented to the University of Edinburgh for the degree of Doctor of Medicine and that it is based on my own observations. The studies were planned, executed and analysed by myself except as indicated in the thesis.

J. COLIN FORFAR

CONTENTS

	page
Acknowledgements	2
Abstract	3
Chapter 1 Introduction.	4
Chapter 2 Idiopathic Atrial Fibrillation and Occult Hyperthyroidism; The Significance of Isolated Suppression of the Pituitary-Thyroid Axis.	26
Chapter 3 Target Organ Function with Isolated Suppression of the Pituitary-Thyroid Axis; is the Pituitary Thyrotroph Uniquely Sensitive to Thyroid Hormones?	48
Chapter 4 Left Ventricular Function in Hyper- and Hypothyroidism assessed by Radioisotope Ventriculography: Impaired Contractile Performance with Thyroid Hormone Excess and Deficiency.	63
Chapter 5 Delayed Normalisation of Left Ventricular Function During Antithyroid Therapy; Echophonocardiographic Analysis of Responses to Isometric Exercise and Autonomic Blockade.	99
Chapter 6 Cardiovascular Responses in Hyperthyroidism before and during Beta-Adrenoceptor Blockade; Evidence against Adrenergic Hypersensitivity.	134
Chapter 7 Thyroid Hormone Action on Paracetamol Pharmacokinetics; Implications for Rational Therapeutics in Thyroid Disease.	163
Chapter 8 Summary and conclusions	186
Papers published and presentations	194
References	196

ACKNOWLEDGEMENTS

I am principally indebted to Dr Anthony Toft, Senior Lecturer, Department of Medicine, for support and encouragement throughout these studies that were conducted by myself in the Department of Cardiology and the University Department of Medicine, The Royal Infirmary, Edinburgh. I am also grateful to Prof Michael Oliver, Dr Alexander Muir, Dr Laurie Prescott, Dr Hugh Miller, Dr Robert Marquis and Dr James Irvine for advice and constructive criticism during different stages of this thesis. These and several other physicians have readily agreed to allow their patients to be studied.

Dr David Matthews and Dr Stewart Sawers participated in the investigations of ventricular function, Dr Gordon Bell in the studies of isolated thyroid stimulating hormone suppression and Dr Anthony Pottage in the pharmacokinetic analyses.

Propranolol assays were performed by Dr McAinsh of ICI Pharmaceuticals, Macclesfield, paracetamol assays by Dr Prescott, Department of Therapeutics and Clinical Pharmacology and thyroid hormone assays by Dr Radcliffe, Stobhill Hospital, Glasgow and the Department of Clinical Chemistry, The Royal Infirmary, Edinburgh.

Finally, the willing cooperation of the technical staff of the Departments of Cardiology and Medicine and the typing skills of Christine Winney, Inez Johnstone and Joyce Bell are greatly appreciated.

ABSTRACT

Cardiovascular function and autonomic activity have been investigated in hyperthyroid, hypothyroid and euthyroid subjects with varying degrees of thyroid hormone abnormality.

Twelve out of 90 patients (13%) presenting to a cardiology clinic with apparently idiopathic atrial fibrillation were demonstrated to have occult hyperthyroidism with suppression of the pituitary-thyroid axis. Sinus rhythm was reestablished after specific antithyroid therapy in 7 out of 8 patients with thyroid hormone concentrations outwith the normal range and in all 4 patients in whom concurrent illness or drug therapy had normalised hormone levels. Clinically occult hyperthyroidism is a treatable cause of "idiopathic" atrial fibrillation in a significant proportion of patients and can be identified consistently only with the thyrotrophin-releasing hormone test. Isolated suppression of the pituitary-thyroid axis was achieved by thyroxine feeding in 7 normal subjects and was associated with a significant nocturnal and daytime tachycardia and reductions in the ratio of day:night urinary flow and sodium excretion, compared to the same subjects as controls. Important abnormalities in target organ function therefore occur with changes in peripheral hormone concentrations within the normal range.

Isovolumetric and ejection phase indices of left ventricular contractile function have been investigated using isotope ventriculography and echophonocardiography at rest and on exercise in 24 hyperthyroid and 8 hypothyroid subjects before and after corrective therapy. Left ventricular ejection fraction (LVEF) and velocity of circumferential fibre shortening (Vcf) are increased in hyperthyroidism at rest with a reduced pre-ejection period (PEP) but LVEF and Vcf fall significantly during dynamic and static exercise to a level significantly less than occurs in the same patients euthyroid for at least 3 months. LVEF is reduced in hypothyroid patients but responses to exercise are maintained. Directional changes in contractility were not influenced by autonomic blockade. Sequential analysis of myocardial contractility during antithyroid therapy showed that normalisation of responses to exercise could be delayed for many weeks after a biochemical euthyroid state had been achieved. It is hypothesised that myocardial contractile function is depressed in both hyper- and hypothyroidism and that the hyperthyroid responses at rest reflect the peripheral actions of thyroid hormone excess.

Analysis of heart rate and blood pressure responses on exercise and over 24 hours in 10 hyperthyroid and matched euthyroid subjects before and during beta-adrenoceptor blockade showed parallel variations in these parameters independent of activation of the cardiac neurosympathetic axis. These findings support the concept that thyroid hormone-sympathetic interactions are additive and not synergistic and that adrenergic hypersensitivity does not occur in clinical hyperthyroidism.

Paracetamol pharmacokinetics have been analysed in 7 hyperthyroid and 4 hypothyroid subjects before and after corrective therapy. The substantial differences in absorption and metabolism of this compound in these states highlights the importance of changes in systemic autonomic activity in thyroid disease.

CHAPTER 1

Introduction.

Disorders of thyroid function have been recognised to involve the cardiovascular system for almost two hundred years. Indeed, the first account of a patient with hyperthyroidism described a cardiovascular manifestation (Parry, 1786) that in retrospect suggested atrial fibrillation preceeding by some years the classical endocrine manifestations of the disease. The close relationship between thyroid disease and the heart has been well documented for over fifty years (Levine and Sturgis, 1924) and many of the clinical descriptions of this period are still valid. Some of the cardiovascular manifestations of hyperthyroidism and hypothyroidism are among the most characteristic abnormalities found in these conditions.

Despite the recognition of the haemodynamic alterations that occur with differing thyroid function, the precise mechanism or mechanisms responsible for these changes have not been adequately identified. The similarities between the effects of excess thyroid hormones and stimulation of the sympathetic nervous system suggested some thyroid-sympathetic interrelationship (Brewster, 1956). An adrenergic contribution to the clinical manifestations of hyperthyroidism was first suggested by the finding that sympathetic blockade produced by injection of procaine into the subarachnoid space could successfully relieve or prevent hyperthyroid

crisis (Knight, 1945). The successful use of sympatholytic agents such as reserpine (Canary et al, 1957) guanethidine (Waldstein et al, 1966) and more recently beta-adrenoceptor blocking drugs (Howitt and Rowlands 1966; Shanks et al, 1969; Toft et al, 1978) in controlling some of the peripheral manifestations of hyperthyroidism has further strengthened this view. These drugs reduce tachycardia, pulse pressure, cardiac output and oxygen consumption towards normal in hyperthyroid patients.

Thyroid Hormone-Sympathetic Nervous System Interactions

Tyrosine is the parent amino acid to both catecholamine neurotransmitters and the thyroid hormones thyroxine (T₄) and triiodothyronine (T₃) (figure 1.1). It is therefore not surprising that catecholamines and thyroid hormones have synergistic actions on a range of metabolic processes. Theoretically thyroid-sympathetic interactions can occur at several sites.

Fluorescence histochemical techniques have shown fairly dense adrenergic innervation of the thyroid gland in experimental animals (Melander et al, 1974a, 1975a) and in man (Melander et al, 1974b, 1975b). Electrical stimulation of sympathetic nerves, drug-induced release of noradrenaline and direct administration of catecholamines can all induce secretion of thyroid hormones (Melander et

al, 1974a, 1976). It is likely, however, that this pathway is a means of rapid but transient alteration in thyroid hormone secretion in response to certain stimuli rather than a vehicle for the sustained changes in hormone production characteristic of thyroid gland dysfunction.

Release of neurotransmitter from sympathetic nerve terminals may be modified by thyroid hormone actions on central neuro-sympathetic outflow, presynaptic control of catecholamine release or re-uptake, or metabolism and removal mechanisms after catecholamine release. Each of these mechanisms would result in increased or decreased noradrenaline concentrations at the adrenergic nerve terminal and consequently increased or decreased post-synaptic adrenoceptor activation.

Alternatively, thyroid hormones may alter target cell sensitivity to released catecholamines. Such an adaptation can arise from a primary change in adrenoceptor density and or binding affinity to the target cell, or alteration of intracellular readout systems such as adenylyl-cyclase activation and cyclic adenosine monophosphate (cAMP) production.

Finally, thyroid hormones may act independently but in parallel with the sympathoadrenal system resulting in a biologically similar response through a quite separate mechanism. Apparent sympathoadrenal overactivity in hyperthyroidism would result from summation of the effects of sympathetic activity and excess thyroid hormones. Removal of either contribution to the overall biological

FIGURE 1.1 Biosynthesis of catecholamines and thyroid hormones; tyrosine is the parent amino acid for both groups.

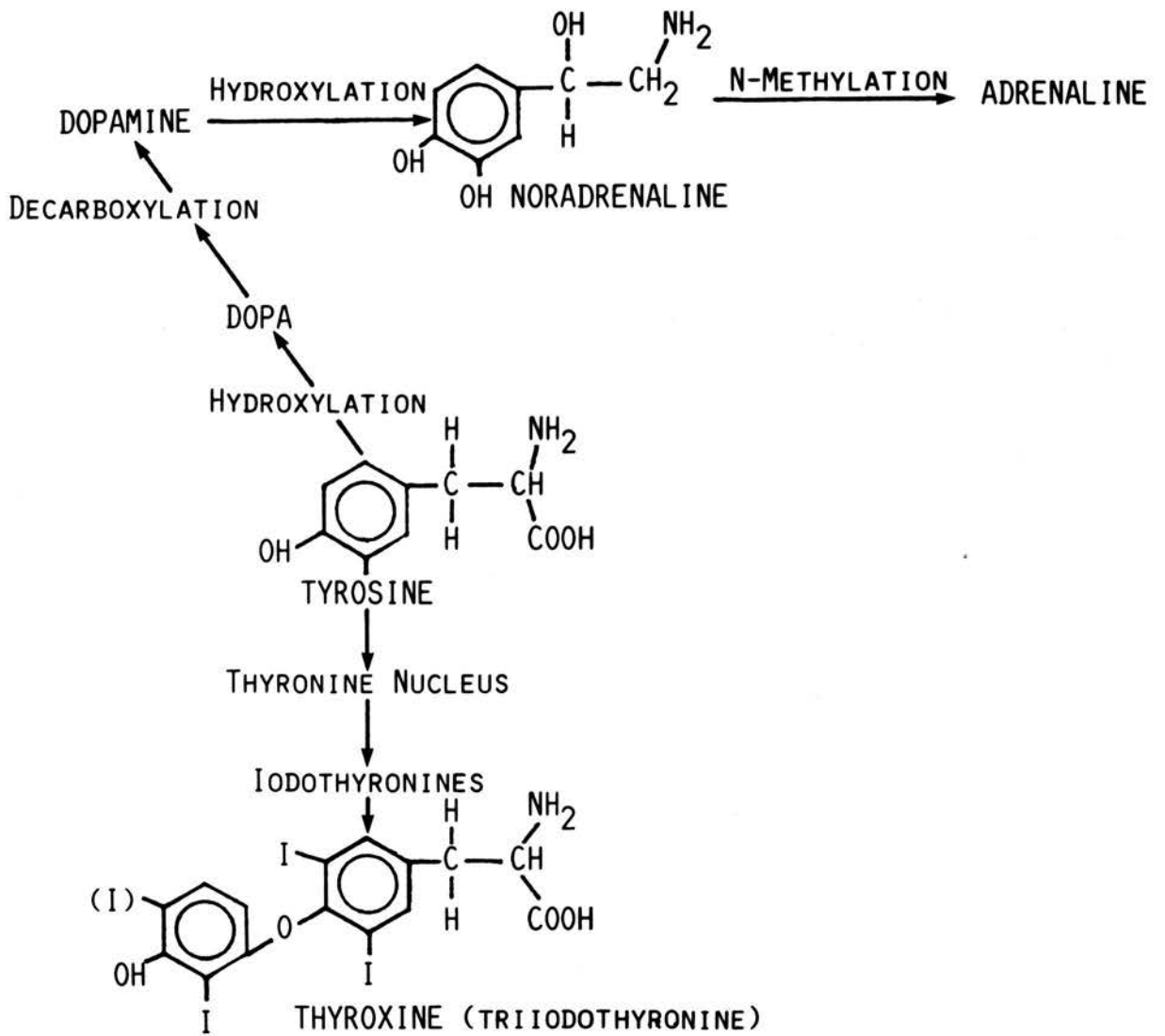

response by sympatholytic or antithyroid agents would alleviate some but not all of the clinical manifestations of the disease.

There is no direct evidence that the sympathetic nervous system or adrenal medulla are overactive in hyperthyroidism. Myocardial noradrenaline turnover is either normal (Beaven et al, 1963) or reduced (Beley et al, 1973) in experimental hyperthyroid animals with no change in the activity of catechol-o-methyl transferase or monoamine oxidase (Wurtman et al, 1963). Urinary noradrenaline and adrenaline excretion is similarly normal or low in hyperthyroid patients (Wiswell et al, 1963; Bayliss and Edwards, 1971; Coulombe et al, 1976). Plasma levels of noradrenaline are either low or normal (Christensen, 1973; Stoffer et al, 1974) and levels of dopamine beta-hydroxylase, a marker of neuronal catecholamine release, are reduced (Nishizawa et al, 1974; Noth and Saulding, 1974).

In contrast, experimental thyroid deficiency increases cardiac noradrenaline turnover suggesting increased sympathetic neural activity (Landsberg and Axelrod, 1968). Urinary noradrenaline excretion is normal or increased in hypothyroid patients (Wiswell et al, 1963; Bayliss and Edwards, 1971) and plasma noradrenaline and dopamine beta-hydroxylase levels are increased (Christensen, 1973; Stoffer et al, 1973; Ghione et al, 1974; Nishizawa et al, 1974).

Available evidence thus suggests normal or depressed sympathetic activity in hyperthyroidism and some increase in activity in hypothyroidism. Is it therefore unlikely that thyroid hormone augmentation of neuro-sympathetic outflow can explain the circulatory manifestations of hyperthyroidism. Plasma and urinary catecholamines are, however, an indirect assessment of the functional activity of adrenergic nerve terminals. Direct turnover data in patients is lacking.

Many early experimental studies suggested that both chronotropic and pressor responses to exogenous catecholamines were potentiated in hyperthyroidism (Harrison, 1964). However, these studies did not measure responses over a variety of catecholamine concentrations and therefore target cell hypersensitivity cannot be assumed. More recent data in a variety of experimental hyperthyroid animals have defined dose-response relationships to catecholamine infusions and sympathetic nerve stimulation and failed to show evidence of cardiovascular adrenergic hypersensitivity (Buccino et al, 1967; Cairoli and Crout, 1967; Levey et al, 1969; Anton and Graveststein, 1970; Brus et al, 1970; Turner and Shenfield, 1980). Isolated tissue studies, however, have not shown uniform agreement. Wildenthal (1972, 1974) showed that isolated foetal mouse hearts exposed to T3 in organ culture became more sensitive to the chronotropic effects of beta-adrenoceptor stimulation. The interpretation of these studies remains difficult because

hearts in organ culture are effectively denervated and depleted of endogenous catecholamines. Denervation hypersensitivity might thus be expected. Several investigators have shown increased rat myocardial phosphorylase A activation by catecholamines in hyperthyroidism (Hornbrook et al, 1965; McNeil and Brodie 1968; Hornbrook and Cabral, 1972).

Changes in cardiovascular sensitivity to catecholamines have been studied much less frequently in man. Early studies again suggested adrenergic hypersensitivity in hyperthyroidism with potentiated catecholamine effects on heart rate and blood pressure that returned to normal after antithyroid treatment (Schneckloth et al, 1953; Murray and Kelley, 1959). More recent studies in hyperthyroid and hypothyroid patients have documented changes in inotropic and chronotropic responses during graded catecholamine infusion (Amidi et al, 1968; Grossman et al, 1971). Although chronotropic responses were shown to be mediated partly through the beta-adrenoceptor, myocardial contractility in thyroid dysfunction appeared to be independent of neuro-sympathetic activity as responses were not substantially altered by catecholamine depletion using reserpine or by beta-adrenoceptor blockade with sotalol. Detailed haemodynamic studies by Aoki et al (1967) in healthy volunteers before and during T3 feeding failed to show an augmented haemodynamic response to graded infusions of

adrenaline and noradrenaline. Although resting heart rate and cardiac index were increased 41 per cent and 56 per cent respectively by T3, with a 39 per cent fall in peripheral vascular resistance, the increments in these parameters with adrenaline infusions (from 0.04 to 0.30 ug/kg/min) were similar in both euthyroid and hyperthyroid states. More recently, McDevitt et al (1978) have examined heart rate responses to graded infusions of isoprenaline in hyperthyroid, hypothyroid and euthyroid subjects. No shifts in the dose-response curves were detectable with differing thyroid function.

Over the past few years, radioligand-binding methods have been developed for the direct study of receptors and these have been successfully applied to adrenergic receptors (Maguire et al, 1977). Binding of high specific activity iodine 125 and tritium labelled beta-adrenoceptor antagonists to cardiac tissue is saturable, reversible and stereospecific (Lefkowitz, 1975). Adrenergic receptors are subject to regulation both by hormones or agonists that normally interact with these receptors ("homologous") and by influences such as other types of hormones or drugs that do not normally interact with the receptor ("heterologous").

Thyroid status has been shown to alter both alpha- and beta-adrenoceptor binding characteristics in cardiac tissue. Banerjee and Kung (1977), Ciaraldi and Marinetti (1977) and Williams et al (1977) all noted an increase in beta-adrenoceptor numbers in experimental hyperthyroidism

with no change in binding affinity. In contrast, cardiac alpha-adrenoceptor binding declined in hyperthyroidism and increased in hypothyroidism (Fregly et al, 1975; Ciaraldi and Marinetti, 1977; Sharma and Banerjee, 1978a; Williams and Lefkowitz, 1979). Other membrane components such as sialic acid content, Na-K adenosine triphosphatase (ATPase) and Ca-K-ATPase activities were unchanged in the hearts from hyperthyroid animals (McConnaughey et al, 1979). It has been suggested that the changes in adrenergic sensitivity may represent a thyroid hormone induced allosteric change in a single adrenergic receptor (Kunos et al, 1974). Alternatively, thyroid hormones may induce de novo synthesis of new beta-adrenoceptors or may induce insertion or activation of preformed beta-adrenoceptors (Kempson et al, 1978) into the cell membrane. Thyroid disorders are one of several pathophysiological states that change adrenoceptor density or binding affinity (Lefkowitz, 1979). Receptor regulation may thus be an important mechanism controlling tissue sensitivity to drug and hormone action. An increase in beta-adrenoceptor density, provided such receptors remain physiologically active, implies increased tissue responsiveness or sensitivity to catecholamines irrespective of whether the maximum biological response is achieved with complete or incomplete receptor occupation. As indicated above, there has been no clear physiological evidence of alteration of catecholamine sensitivity in

vivo with differing thyroid function. As radioligand binding techniques progress, molecular and biochemical aspects of autonomic receptors are recognised as being increasingly complex (Watanabe et al, 1982). Subcellular distribution of adrenoceptors in myocardial cells (Jones et al, 1978, 1979; Misselwitz et al, 1979) or the ratio of high to low affinity agonist binding sites on the sarcolemma (Kent et al, 1980; Hoffman and Lefkowitz, 1980) may be important determinants of an apparent change in total receptor density. Thus, an assessment of the functional significance of a change in adrenoceptors is an important element before firm conclusions can be drawn.

An alternative explanation of a change in catecholamine sensitivity involving beta-adrenoceptors has been suggested by Malbon et al, (1978) to explain the lipolytic response to adrenaline from normal, hypothyroid and hyperthyroid rats. Although there was no detectable difference in the number of beta-adrenoceptors obtained from these fat cells, the catecholamine-stimulated adenylyl cyclase activity, as measured by the accumulation of cyclic adenosine monophosphate (cAMP), varied directly with thyroid status. Tissue lipolysis, estimated by glycerol release, was proportional to cAMP accumulation. Thus thyroid hormones may modulate the amplification of the beta-adrenoceptor signal at the level of the cell membrane by regulating receptor-adenyl cyclase interactions. Whether such a mechanism operates in the myocardium is unknown, although Levey and Epstein (1969)

have suggested activation of myocardial adenyl cyclase in vitro by thyroid hormones.

Direct Cardiac Effects of Thyroid Hormones

Direct effects of thyroid hormones on the heart were demonstrated by Markowitz and Yater in 1932. Thyroxine added to heart fragments of chick embryos that were devoid of functioning adrenergic tissue caused a significant increase in the beating rate of these cells after twelve hours of hormone exposure. Thyroxine also enhanced the rate of contraction of isolated guinea-pig atrium even in the presence of adrenergic blockade (Murayama and Goodkind, 1968). Antiadrenergic agents have been shown to decrease the tachycardia of hyperthyroidism, but the heart rate does not return to control levels (Cairolì and Crout, 1967). Right ventricular papillary muscles from experimental hyperthyroid cats showed increased contractility as reflected by an upward shift in the myocardial force-velocity curve with increased velocity of myocardial fibre shortening. Time to peak tension during isometric contraction was reduced with augmented peak tension development (Buccino et al, 1967). Non-invasive indices of ventricular function derived from systolic time intervals showed no major changes in hyperthyroid patients following beta-adrenoceptor blockade (Grossman et al, 1971).

The tachycardia of hyperthyroidism is probably secondary to direct thyroid hormone effects on the sinoatrial node. There is an increased rate of diastolic depolarisation and shortened action potential duration in these cells that persists in the presence of propranolol (Johnson et al,1973). The increased risk of development of arrhythmias in hyperthyroidism, particularly atrial fibrillation, may relate to a shortened refractory period and reduced electrical stimulation threshold in atrial cells in experimental hyperthyroidism (Arnsdorf and Childers, 1970). Changes in ventricular refractoriness in hyperthyroidism are reflected by reduction of the corrected QT interval (Sandler, 1959; Hoffman and Lowry, 1960). Interatrial conduction disturbances, manifest by abnormal P wave morphology or prolongation of the PR interval on the surface electrocardiogram, occur in 15 and 5 per cent of hyperthyroid patients respectively. Intraventricular conduction disturbances, most commonly right bundle branch block, occur in about 15 per cent of hyperthyroid patients in the absence of associated heart disease (Benker et al, 1974). The cause of the atrioventricular conduction disturbances is not clear since animal experiments have shown shortening of the functional refractory period of the conduction system in hyperthyroidism and reciprocal changes in hypothyroidism (Goel et al, 1972). These electrocardiographic abnormalities may reflect a true thyroid cardiomyopathy (Sandler and Wilson, 1959; Staffurth and Morrison, 1968),

an aspect discussed further in chapters 4 and 5.

As thyroid hormones affect many tissues and stimulate a variety of biochemical processes, the question arises as to whether all of the observed effects are the consequence of the induction of a common cellular event, or whether they represent different responses elicited by the hormone at several cellular levels (Bernal and Refetoff, 1977). Furthermore, the concentration of thyroid hormones needed to elicit a response in vitro is usually far in excess of the concentration operative in vivo (Goldfine et al, 1975). Dosage may be particularly important in experimental studies as some thyroid hormone effects are biphasic, being stimulatory at low doses and inhibitory at high doses (Hoch 1974; Vonderhaar, 1975). Several mechanisms of action of thyroid hormone have been suggested (Sterling, 1979) and these are summarised diagrammatically for the heart in figure 1.2. Thyroid hormone stimulation of protein synthesis has been demonstrated in whole animals as well as cultured cells (Kurtz et al, 1976; Martial et al, 1977; Shapiro et al, 1978). The effect involves increased transcription of DNA information and increased RNA polymerase activity (Tata and Widnell, 1966), possibly through association of the thyroid hormone-receptor complex with nucleolar chromatin (Gardner, 1975). Thyroid hormones also stimulate the cell membrane enzyme, sodium-potassium ATPase (the sodium pump) and may induce local changes in cardiac membrane

FIGURE 1.2 Theoretical model for thyroid hormone action on a cardiac muscle cell (diagrammatic). Events are probably similar for T₄ and T₃. The unbound hormone (circled) diffuses or is transported into the cell and is bound by cytoplasmic binding proteins (CBP). This T₃-CBP complex is in reversible equilibrium with intracellular unbound T₃ that can interact with binding proteins of the effector loci on the cell nucleus, mitochondria or sarcolemma, as shown. The dominant effects on myocytes appear to be mediated through alteration of nuclear transcription. See text for further discussion.

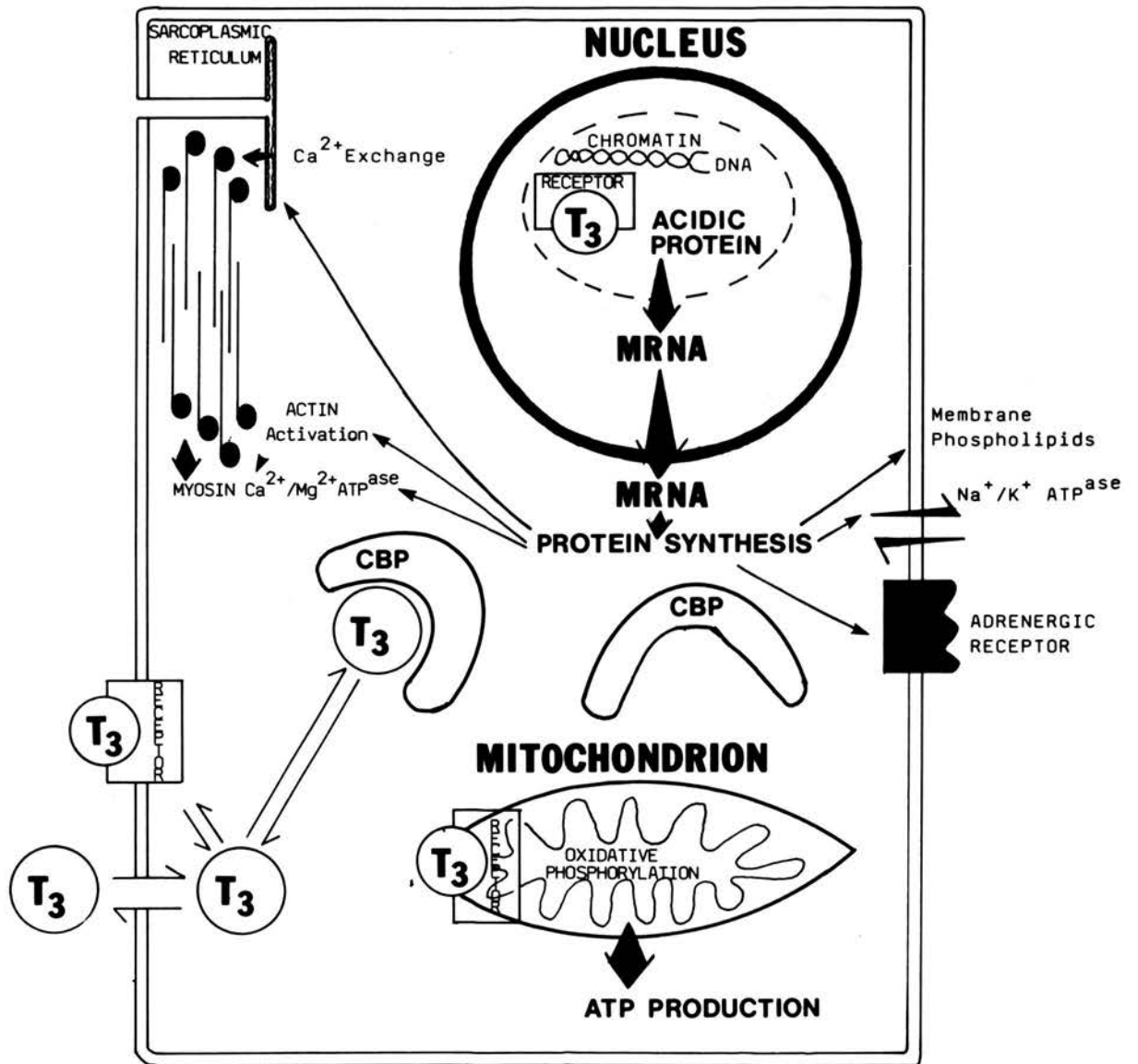

phospholipids (Philipson and Edelman, 1977). Since approximately 40 per cent of the oxygen consumption in many normal mammalian tissues, including the myocardium, appears to be dependent on membrane sodium transport, this may be an important final pathway of energy expenditure in response to thyroid hormones (Edelman, 1974). This effect is more likely to be due to an increased number of pump units than alteration of pre-existing enzyme molecules (Lo et al., 1976; Lo and Edelman, 1976), and hence may be secondary to stimulation of nuclear transcription, rather than a primary effect on enzyme activity. Red cell sodium concentration has been suggested as a sensitive index of peripheral thyroid hormone action in hyperthyroidism with increases up to 50 per cent from the euthyroid state (Goolden et al, 1971). Thyroid hormones can increase the synthesis of cardiac myosin and alter its structure (possibly by the appearance of a new myosin isoenzyme) increasing its intrinsic contractile properties (Thyrum et al., 1970; Yazaki and Raben, 1975; Banerjee et al., 1976). Augmented myosin ATPase activity and/or augmented actin-activation of myosin ATPase may contribute to the enhanced contractile response of the hyperthyroid heart (Banerjee and Morkin, 1977), since the activity of this enzyme is thought to regulate the turnover of actin-myosin cross-bridge links in cardiac muscle (Morkin 1979). Sarcoplasmic reticulum from hyperthyroid animals also accumulates and exchanges calcium at an increased rate resulting in increased

availability of calcium to the myofibrils during activation as well as an enhanced rate of myofibrillar relaxation (Nayler et al., 1971; Suko, 1973). The role of thyroid hormones in altering adrenergic receptor density on target cell membranes has already been briefly discussed.

Although it is unlikely that alteration of protein synthesis per se can account for all of the observed changes in cell function with thyroid hormones, this mechanism may be fundamental to several of the changes in myocardial function in thyroid disease.

The mitochondrion has been considered a possible subcellular locus of thyroid hormone action for many years in view of the crucial role of mitochondria in energy metabolism. High affinity saturable binding of thyroid hormones to mitochondrial membranes has been demonstrated (Sterling and Milch, 1975; Sterling et al., 1978), similar to that reported previously for the cell nucleus (Degroot and Torresani, 1975; Macleod and Baxter 1976). This specific receptor is a macromolecule arising from the inner mitochondrial membrane, which is known to be the site of oxidative phosphorylation (Lehninger, 1975). The precise manner in which hormone binding to this receptor site might enhance oxidative phosphorylation is unknown. The effect is, however, independent of the cell nucleus as it can be demonstrated in isolated mitochondrial preparations (Sterling, 1977). Increased mitochondrial

ATP production has been observed as early as 30 minutes after the intravenous injection of triiodothyronine to hypothyroid rats. Increased ATP production persists despite blockade of protein synthesis with cycloheximide (Sterling et al., 1977).

An intriguing hypothesis for the mechanism of action of thyroid hormones has proposed that they function as amino acid analogues of tyrosine (Dratman, 1974). Thyroxine and triiodothyronine (halogen-substituted aromatic amino acid analogues) can be incorporated into protein fractions and accelerate protein degradation with secondary stimulation of protein synthesis and turnover. As triiodothyronine is concentrated in peripheral adrenergic nerves and localised and metabolised within synaptosomes (Dratman et al., 1976), it is conceivable that iodothyronines may enter into catecholamine biosynthetic pathways and act as precursors for alternate adrenergic neurotransmitters.

It is most likely that multiple cellular mechanisms and an integrated response underly the effects of thyroid hormones on the myocardium (figure 1.2). The relative importance of the various mechanisms discussed is, however, unknown.

Systemic Autonomic Activity and Thyroid Disease

Some of the cardiovascular effects of thyroid disease are manifest by alteration in specific organ function.

This has important implications for rational drug prescribing in the management of thyroid dysfunction and its cardiovascular complications. Changes in regional blood flow (Degroot and Leonard, 1970) for example may result in altered drug disposition by influencing the rate and extent of drug absorption, speed of onset and magnitude of drug effect and drug distribution and elimination. These processes are further modified by primary disturbances of gastrointestinal motility (Holdsworth and Besser, 1968; Thomas et al, 1973; Javitt, 1978) and alteration of hepatic drug metabolising enzyme activity (Pitot and Yatvin, 1973).

Hypermotility of the small and large bowel has been demonstrated in hyperthyroidism by both radiographic techniques (Javitt, 1978) and study of bowel electrical activity (Christensen et al, 1964; 1966). Gut motility disturbances may be major features of thyroid hormone deficiency (Bacharach and Evans, 1957; Baker and Harvey, 1971) and in advanced cases may be associated with colonic enlargement, paralytic ileus and serous effusions (Kocen and Atkinson, 1963; Boruchow et al, 1966).

The metabolism and excretion of many drugs are accelerated in hyperthyroidism. Maintenance therapy with 0.5mg oral digoxin daily has been shown to result in substantially lower plasma digoxin levels in hyperthyroid than hypothyroid patients (mean levels of 0.9 and 1.9 nmol per litre respectively) with a reduced plasma digoxin half

life in the former group. The reduction probably reflects both an increased glomerular filtration rate and increased rate of digoxin metabolism in the hyperthyroid patients (Croxon and Ibbertson, 1975). Thus, persisting tachycardia in some patients with hyperthyroidism and atrial fibrillation despite standard maintenance digoxin dosage may be due to inadequate plasma digoxin concentrations in addition to impaired digoxin-induced slowing of atrioventricular conduction. Significant differences in the pharmacokinetics of propranolol and practolol after oral dosage have also been shown in hyperthyroid and hypothyroid subjects (Bell et al, 1977).

Purpose of Thesis

This thesis documents several aspects of cardiovascular function in hyperthyroid, hypothyroid and euthyroid subjects. Where possible, control studies have been repeated on the same patient when euthyroid after specific treatment to avoid some of the problems of inter-patient variability and allow comparison of paired data.

Chapter 2 investigates an aspect of cardiovascular function in hyperthyroidism, atrial fibrillation, that highlights the prevalence of this abnormality in patients with relatively minor disturbances of plasma thyroid hormone concentrations and underlines the value of the plasma thyrotrophin (TSH) response to thyrotrophin releasing hormone (TRH) in routine diagnosis. Clinical

evidence is presented for a reassessment of the threshold for antithyroid therapy in patients with atrial fibrillation and isolated suppression of the pituitary-thyroid axis and this is supported in chapter 3 by abnormalities in cardiovascular function in normal subjects on physiological thyroxine replacement with similar pituitary-thyroid axis suppression.

Chapters 4 and 5 identify abnormalities in left ventricular function in thyroid disease and responses to corrective therapy using two non-invasive techniques, namely isotope ventriculography and combined echocardiography and systolic time interval measurements. Analyses have been performed at rest and during dynamic and isometric exercise before and during autonomic blockade. Left ventricular contractile performance under stress may be impaired in hyperthyroidism, in direct contrast to the commonly held view, and both the extent and time-course of this impairment and its relationship to autonomic influences have been examined.

The studies presented in chapter 6 have been designed principally to assess whether there is a change in adrenergic sensitivity in hyperthyroidism. In view of the importance of neural mechanisms in cardiovascular control, responses to exercise and beta-adrenoceptor blockade have been used in preference to systemic catecholamine infusions.

Finally, in chapter 7, the extent and magnitude of

the circulatory and metabolic disturbances are assessed by detailed measurement of paracetamol absorption, distribution and metabolism in patients with differing thyroid function.

CHAPTER 2

'Idiopathic' atrial fibrillation and occult hyperthyroidism: the functional significance of isolated suppression of the pituitary-thyroid axis.

Overt hyperthyroidism has been recognised as a cause of atrial fibrillation for many years (Goodall, 1920; Wilson, 1924; Nahum and Hoff, 1935) and accounted for 14 percent of cases in an early series (Campbell, 1947). Despite being one of the most frequent disorders of cardiac rhythm, the electrophysiological mechanism of atrial fibrillation remains uncertain (Abildskov et al, 1971). Although spontaneous reversion to sinus rhythm may be expected in approximately two thirds of patients after antithyroid treatment (Teoh et al, 1974; Nakazawa et al, 1980), some, particularly the elderly, require cardioversion to sinus rhythm when euthyroid (Symons, 1979; Nakazawa et al, 1980).

The most striking electrophysiological abnormality in experimental hyperthyroidism is a reduction in the duration of the action potential recorded from individual atrial cells associated with an increased rate of diastolic depolarisation (Freedberg et al, 1970; Johnson et al, 1973). In contrast, action potential duration is prolonged in hypothyroidism (Freedberg et al, 1970). A reduction in action potential duration increases the electrical excitability of the atrium, evidenced by a reduction in stimulation threshold for a given coupling interval (Arnsdorf and Childers, 1970), and thus increases any tendency to develop fibrillation. These data are supported by clinical studies suggesting that the duration

of the monophasic action potential, a technique for recording depolarisation and repolarisation phenomena in cardiac muscle in situ, is an important predictor of recurrent atrial fibrillation after cardioversion (Olson et al, 1971; Cotoi et al, 1972). Monophasic action potential duration correlates fairly closely with direct recordings from studies using intracellular electrodes (Hoffman et al, 1959). Patients with a persistently short monophasic action potential duration following the re-establishment of sinus rhythm have a higher incidence of recurrent atrial fibrillation than those in whom it is normal (Cotoi et al, 1972).

The early diagnostic tests for hyperthyroidism were relatively crude and in many instances the diagnosis rested primarily on clinical grounds. With the advent of sophisticated tests of thyroid function, an accurate biochemical diagnosis can be made independent of clinical findings.

This study was undertaken to identify the incidence of hyperthyroidism in a selected population of consecutive patients referred to a cardiology clinic for paroxysmal or persistent atrial fibrillation in whom the diagnosis of hyperthyroidism was not made by the referring practitioner or with confidence by the consulting cardiologist.

Methods

Ninety consecutive patients (58 men and 32 women)

with an age of 59 +/- 12 years (mean +/- standard deviation) were studied. They were referred to the Department of Cardiology over an eighteen month period between August 1977 and January 1979 with sustained atrial fibrillation that could not be satisfactorily explained on the basis of known cardiovascular disease. This population was selected from a total of approximately 350 patients with atrial fibrillation seen over this period.

In each of the 90 patients, atrial fibrillation was confirmed by a routine electrocardiogram or by ambulatory outpatient electrocardiographic monitoring. The arrhythmia was considered to be 'idiopathic' in 65 patients and an unexpected development in the natural history of an established cardiac disease in 25 patients. The possible cardiovascular causes of atrial fibrillation in these patients are summarised in table 2.1. Mitral stenosis was excluded, where appropriate, by single element echocardiography. A clinical diagnosis of hyperthyroidism was considered in two patients each of whom had slight diffuse thyroid gland enlargement.

In each of the 90 patients, blood was withdrawn for the estimation of serum total thyroxine (T4), triiodothyronine (T3) and thyrotrophin (TSH) level before and 20 minutes after the intravenous administration of 200 ug of thyrotrophin -releasing hormone (TRH) (Synder and Utiger, 1972; Hershman, 1974). In an attempt to exclude abnormal concentrations of thyroid hormone binding

proteins, the effective thyroxine ratio (ETR, Malinckrodt (UK) ltd) was also measured (Thorson et al, 1972). Serum total T4 and T3 were measured by specific radioimmunoassays (Seth et al, 1976), where the interassay precision level using anonymous control sera averaged 7.9 per cent for T3 and 11.7 per cent for T4, expressed as the coefficient of variation. Serum TSH was also measured by radioimmunassay in which the between assay coefficient of variation was 11.2 per cent (Irvine et al, 1973). The normal laboratory reference range for serum total T3 was 1.1 to 2.8 nanomoles/litre and for serum total T4 60 to 150 nanomoles/litre. The normal range for serum total TSH was less than 0.7 to 5.7 milliUnits per litre and the normal range of response 20 minutes after the intravenous administration of 200 ug of TRH was 3.9 to 25.3 milliUnits/litre (Toft et al, 1978).

For the purposes of this study the diagnosis of hyperthyroidism was made not on clinical grounds but on the basis of lack of a serum TSH response to intravenous TRH with or without raised levels of serum total T3 or T4. Lack of response was defined as a failure of the 20 minute level of TSH to increase by more than 0.5 milliUnits/litre above the basal level.

A thyroid scan was performed in 11 of the 12 patients with hyperthyroidism using technetium-99m pertechnetate.

DIAGNOSIS	PATIENTS (NO)	
	Male	Female
Ischaemic heart disease		
suspected angina of effort	4	2
previous myocardial infarction	3	2
Hypertension	1	1
Congenital heart disease		
persistent ductus arteriosus	-	1
divided ductus arteriosus	-	1
mild pulmonary valve stenosis	1	1
aortic valve prosthesis	1,1*	-
Rheumatic heart disease		
trivial mitral stenosis	-	1
mild aortic regurgitation	1	-
Other		
mild mitral regurgitation	-	1*
alcoholic cardiomyopathy	2	-
previous viral myocarditis	1*	-
Total	15	10

* patients with biochemical hyperthyroidism

TABLE 2.1 Possible cardiovascular causes of atrial fibrillation in 25 of the 90 patients studied.

Results

An absent serum TSH response to intravenous TRH was documented in 12 of the 90 patients (13 per cent), five women and seven men, including three with associated heart disease in the form of aortic and mitral valve lesions and previous viral myocarditis respectively (table 2.1).

The age, sex, levels of serum total T4 and T3, serum TSH responses to TRH, thyroid scan appearances, the treatment and the cardiac rhythm after antithyroid therapy in the eight patients with thyroid hormone concentrations outwith the normal range are shown in table 2.2. With the exception of cases one and seven, thyroid hormone levels were only modestly elevated. The highest serum total T4 was recorded in case seven, where the dominant clinical feature was extreme apathy. This patient died suddenly from a presumed cerebral embolus 10 days after hospital admission. Atrial fibrillation persisted during this period. In seven of the eight patients, stable sinus rhythm was re-established after antithyroid treatment, five spontaneously and two after elective DC cardioversion. Sinus rhythm has persisted in these seven patients over a 15-38 month follow-up period. In all of them, serum total T3 and T4 and the TSH response to TRH were normal at the time of or during the weeks preceding the re-establishment of sinus rhythm.

CASE NO	AGE (YR) & SEX	SERUM T3 (nmol/l)	TOTAL T4	SERUM TSH RESPONSE basal	TSH (mU/l) TO TRH 20min	THYROID SCAN	Rx	RHYTHM AFTER TREATMENT
1	58F	5.4	242	1.1	1.2	normal	I131	spont SR at 2 months
2	51M	3.0	127	0.9	1.2	aut nodule	I131	spont SR at 3 months
3	51M	4.5	188	1.7	2.0	aut nodule	I131	CV to SR 6 months
4	73M	4.3	193	1.2	1.0	normal	I131	spont SR at 3 months
5	76M	2.8	162	1.0	<0.7	-	CARB	spont SR at 1 month
6	47M	4.1	190	<0.9	<0.9	normal	I131	spont SR at 1 month
7	65M	3.8	312	<0.7	<0.7	normal	CARB	death from cerebral emb at 10 days
8	70F	3.7	192	1.0	1.0	normal	I131	CV to SR 8 months

SR sinus rhythm; CV cardioverted; CARB carbimazole

TABLE 2.2 Age, sex, serum total T3 and T4 levels, TRH test, thyroid scan results, treatment and eventual cardiac rhythm in the eight patients with hyperthyroidism and elevated thyroid hormone concentrations.

Four patients (33 per cent) showed an absent TSH response to TRH but serum total thyroid hormone concentrations within the normal laboratory reference range (table 2.3). On the basis of the lack of TSH response to TRH, specific antithyroid therapy was instituted. One patient (no. 10) reverted spontaneously to sinus rhythm after six weeks and the other three were successfully cardioverted to sinus rhythm between six and nine months after starting antithyroid therapy. At the time of return to sinus rhythm, serum thyroid hormones had fallen significantly although still within the normal range, and intravenous TRH produced a normal rise in plasma TSH at 20 minutes (table 2.4). Direct current cardioversion (maximum 400 joules) had been unsuccessful in three patients (nos. 9, 11 and 12) before specific antithyroid therapy and had not been attempted in the fourth (no. 10). Each patient merits brief clinical description.

Case 9: A 46 year old woman was referred from another hospital because of atrial fibrillation with an uncontrolled ventricular rate associated with dyspnoea on exertion. Tachycardia persisted despite therapeutic serum digoxin levels and administration of oral propranolol 10 mg every 8 hours. There were no clinical or historical features of hyperthyroidism and no clinical, radiographic or echocardiographic evidence of mitral valve disease. Serum total T4 levels had been repeatedly normal along with serum total T3, the latter estimated for the first time after the administration of propranolol (table 2.3). Several attempts at DC cardioversion at a maximum of 400 joules failed to establish sinus rhythm. Because of the lack of serum TSH response to TRH and the presence of a non-palpable autonomous thyroid nodule detected with scintigraphy, a therapeutic dose of iodine-

CASE NO	AGE (YR) & SEX	SERUM TOTAL		ETR	SERUM TSH (mU/l)		THYROID SCAN
		T3	T4		RESPONSE TO TRH basal	20 min	
9	46F	2.4	102	1.00	1.5	1.3	aut nodule
10	67F	1.8	125	1.07	0.8	1.0	normal
11	66F	2.2	134	1.09	<0.7	<0.7	aut nodule
12	55M	2.6	104	1.05	1.2	1.0	aut nodule

TABLE 2.3

Age, sex, serum total T3 and T4 levels, ETR, TRH test and thyroid scan results in the four patients with isolated suppression of the pituitary-thyroid axis.

131 was administered. Nine months later DC cardioversion was successful at 100 joules. Serum total T4 had decreased from 102 to 97 nmol/l and serum total T3 from 2.4 to 1.6 nmol/l with a normal TSH response to TRH (table 2.4). It was assumed that the patient had a T3 hyperthyroidism associated with an autonomous thyroid nodule but that the serum total T3 level was lowered by administration of propranolol.

Case 10: A 67 year old woman had severe heart failure and bilateral pleural effusions associated with atrial fibrillation and an uncontrolled ventricular rate. The tachycardia and heart failure responded to treatment with bed rest and administration of digoxin and diuretic agents. Propranolol therapy was not instituted because of the presence of heart failure. Because of the lack of serum TSH response to TRH (table 2.3), carbimazole was added to the therapeutic regime. The atrial fibrillation reverted to sinus rhythm six weeks later, when the serum total T4 had fallen from 125 to 86 nmol/l and serum total T3 from 1.8 to 1.5 nmol/l with a normal TSH response to TRH (table 2.4). It was felt that this patient also had a T3 hyperthyroidism and that the severity of the heart failure resulted in a lowering of the serum T3 level.

Case 11: A 66 year old woman had documented atrial fibrillation over a five year period. The ventricular rate had always tended to be rapid, although this had been partially controlled by digoxin and propranolol 40 mg every 6 hours. Initial cardioversion (maximum 400 joules) was unsuccessful. Following the detection of an absent TSH response to TRH (table 2.3), iodine-131 was administered and the patient cardioverted to sinus rhythm (50 joules) seven months later. Serum total T4 decreased from 134 to 86 nmol/l and serum total T3 from 2.2 to 1.4 nmol/l at the time of successful cardioversion (table 2.4).

Case 12: A 55 year old man developed persistent atrial fibrillation six months after an acute febrile illness diagnosed as a viral myocarditis, from which he had apparently made a full recovery. An attempt at cardioversion was unsuccessful and maintenance therapy with digoxin and propranolol was continued. Full thyroid function tests showed an absent TSH response to TRH and an autonomous thyroid nodule detected by scintigraphy and therefore iodine-131 was administered (table 2.3). Nine months later, when serum total thyroid hormones had fallen sufficient to allow a normal TSH response to TRH (table

CASE NO	THERAPY	SERUM TOTAL		SERUM TSH (mU/l)	
		T3	T4	RESPONSE TO TRH basal	20 min
9	15mCi I131	1.6	97	1.8	1.3
10	carbimazole	1.5	86	3.7	10.1
11	15mCi I131	1.4	86	6.6	-
12	15mCi I131	1.7	90	1.5	8.2

TABLE 2.4 Therapy, serum total T3 and T4 levels and TRH test at time of conversion to sinus rhythm.

2.4), repeat cardioversion established sinus rhythm at 200 joules.

Stable sinus rhythm has persisted in two patients (nos 10 and 11) over a follow-up of 28 and 36 months respectively. One patient (no. 9) developed recurrent atrial fibrillation 46 months after a period of persistent sinus rhythm when serum total thyroid hormones and the serum TSH response to TRH were normal. The fourth patient (no. 12) re-developed atrial fibrillation four months after successful cardioversion despite normal thyroid function. As his resting electrocardiogram, chest x-ray and echocardiogram showed some left atrial enlargement, further cardioversion has not been attempted.

In each of the remaining 78 patients, there was a normal serum total T3, T4 and TSH response to TRH.

Discussion

The physiological basis for atrial fibrillation has not been conclusively established. Two general electrophysiological mechanisms have been proposed; firstly, the development of intrinsic pacemakers within the atrium or automaticity (Scherf et al, 1953; Prinzmetal et al, 1955) and secondly, reentry of atrial excitation without continuing pacemaker function (Garrey, 1914). Experimental evidence suggests that while atrial fibrillation can be induced by abnormal pacemaker activity, it is maintained by the development of multiple

reentrant circuits (Abildskov et al, 1971). Resting diastolic transmembrane potentials in the sino-atrial node may be reduced in experimental hyperthyroidism (Lenfant et al, 1966) although this observation was not confirmed by the studies of Freedberg et al (1970) performed at constant heart rate. Any variability in recovery of electrical excitation across the atrium will increase the likelihood of development of fibrillation, a tendency that may be enhanced by endogenous sympathetic tone. Vagal stimulation produces a shortening of the atrial action potential and refractory period in a non-uniform way. Such electrical inhomogeneity could favour reentrant excitation and atrial fibrillation (Alessi et al, 1958; Moe and Abildskov, 1959; Langendorf et al, 1965). Atrial fibrillation occurs in 10 percent of patients with clinically overt hyperthyroidism (Sandler and Wilson, 1959). It has hitherto been considered an unusual cause of atrial fibrillation in clinically euthyroid patients (Symons et al, 1978). Although the role of hyperthyroidism in precipitating atrial fibrillation in the 12 patients described is not certain, it is likely to be a cause and effect relationship because of the reestablishment of stable sinus rhythm following antithyroid therapy. These patients were elderly, with a mean age of 60 years, and this may reflect both a reduction in the threshold for atrial fibrillation with age in the apparently normal heart (Campbell et al, 1974),

possibly because of the relationship between atrial size and the occurrence and persistence of atrial fibrillation (Moore et al, 1965), and an increase in the incidence of occult ischaemic and degenerative heart disease (Kitchin and Milne, 1977). In a study of 200 unselected hyperthyroid patients, Summers and Surtees (1961) showed that 30 percent had a cardiac abnormality and that the incidence of coexisting heart disease increased with age. In a Danish study of the prevalence of hyperthyroidism in patients attending a county hospital (Ronnov-Jessen and Kirkegaard, 1973), 25 per cent of patients with hyperthyroidism who were over the age of 60 years had atrial fibrillation with or without cardiac decompensation. This contrasted with a 5 per cent prevalence of atrial fibrillation in hyperthyroid patients under the age of 60 years. It is well recognised that atrial fibrillation is unusual in the young hyperthyroid patient often despite markedly increased levels of thyroid hormones. Diagnosis and treatment, however, are usually undertaken promptly in this group, in contrast to the elderly where the disease may have been undetected over many years. A hypothetical scheme relating thyroid hormone levels, age and atrial fibrillation in the younger and older patient is shown in figure 2.1.

None of the patients presenting to the cardiology clinic with atrial fibrillation was considered to be hyperthyroid by the referring medical practitioner. Furthermore, only two of the 12 patients ultimately found

FIGURE 2.1 Schematic representation of the relationship between thyroid hormones, age and atrial fibrillation (AF) in the young and elderly hyperthyroid patient. Early recognition and treatment make AF unusual in the young whereas late diagnosis with prolonged but mild elevation of thyroid hormones, coupled with the fall in AF threshold with age, make this arrhythmia more common in the old. Antithyroid therapy usually restores sinus rhythm, but AF can recur at a later date despite normal thyroid function.

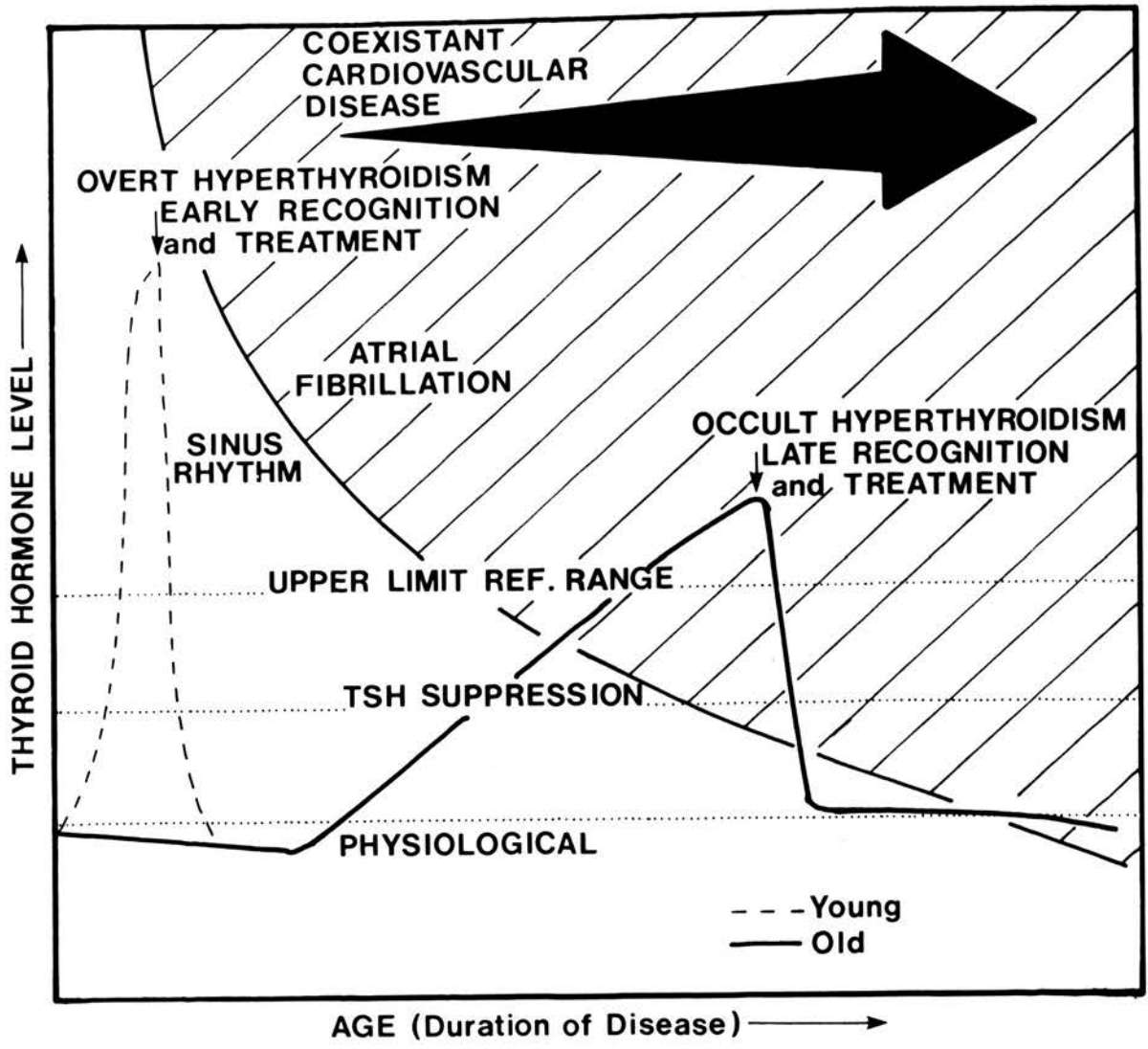

to be hyperthyroid on the basis of biochemical criteria were suspected of having the disease by the consulting cardiologist. It is well recognised that the typical signs of hyperthyroidism may be absent in the older patient where the course of the disease may be dominated by heart failure and gastrointestinal symptoms (Ronnov-Jessen and Kirkegaard, 1973). In some elderly patients with hyperthyroidism, illustrated by case no. 7, the major features are those of extreme apathy and weight loss (Lahey, 1931; Thomas et al, 1970).

Measurement of a single thyroid hormone is clearly not a sufficient screening test for hyperthyroidism in patients with atrial fibrillation. If the measurement of serum total T4 were the only thyroid function test employed in patients with atrial fibrillation secondary to T3-hyperthyroidism, the condition would remain undetected. Indeed, this study has revealed an unexpectedly high proportion of hyperthyroid patients with hyperfunctioning solitary thyroid nodules (five out of 11 or 45 per cent). It is well recognised that there is a high incidence of preferential secretion of T3 by such 'hot' nodules (Marsden et al, 1975). The association of an autonomous thyroid nodule with isolated suppression^s of the pituitary-thyroid axis, present in three of the four patients in this category, is also well recognised (Ridgway et al, 1973; Carpi et al, 1977) although it has been widely assumed that these patients are 'euthyroid' and that inhibition of the thyrotrophin-producing cells of the

anterior pituitary, the thyrotrophs, reflects their unique sensitivity to minor changes in circulating thyroid hormones within the normal range. Untreated, however, overt toxicity develops in approximately 10 percent of these nodules over a one to six year follow-up (Hamberger, 1980).

Measurement of serum total T3 levels in isolation would be equally unsatisfactory. Isolated elevation of serum total T4 is a recognised clinical entity (Ahmad and Cohen, 1981), present in 16 per cent of hyperthyroid patients in a recent series (Caplan et al, 1980). It is of interest that almost 50 per cent of these patients were over 65 years of age. Most circulating T3 is derived from the peripheral monodeiodination of T4. Non-thyroidal illness, however, causes a reduction in serum levels of active thyroid hormones and an increase in concentration of the metabolically inactive isomer 'reverse' T3 (Burger et al, 1976). The rise in 'reverse' T3 shows a close temporal relationship to the fall in T3, reflecting either an alternative peripheral monodeiodination of T4 to the inactive isomer (Burger et al, 1976) or possibly decreased production of T3 and removal of 'reverse' T3 from reduction in 5'deiodinase enzyme activity (Kaplan and Utiger, 1978; Eisenstein et al, 1978). Similar changes in peripheral thyroid hormone metabolism can occur as a result of drug therapy with propranolol (Harrower et al, 1977; Lotti et al, 1977) or

corticosteroids (Burr et al, 1976) although serum T3 levels tend to normalise after prolonged therapy (Kristensen and Weeke, 1977). The fall in circulating total T3 with propranolol is independent of initial thyroid status (Wiersinga and Touber, 1977).

Thus, hyperthyroid patients with heart failure (no. 10) or those receiving propranolol (nos. 9,11,12). may have serum total T3 levels within the normal range (Birkhauser et al, 1977; Engler et al, 1978). Furthermore, serum total T3 levels are lowered with increasing age in healthy subjects over the age of 65 years (Rubenstein et al, 1973), but normal reference ranges cited by laboratories are usually based on levels found in healthy young adults. Free thyroid hormone levels should mirror thyroid status more accurately than total hormone levels as it is this fraction that is metabolically active. Although free hormone assays are becoming more widely available, the commercial kits produce disparate results in patients with non-thyroidal illness (Captein et al, 1981). In all forms of hyperthyroidism, there is a lack of response of serum TSH to intravenous TRH, and this response is unaffected by the previously described factors influencing thyroid hormone levels. A lack of response of TSH to TRH may occur in an apparently euthyroid patient whose serum total T3 and T4 levels are abnormal for that person but still within the accepted normal range (Snyder and Utiger, 1972).

None of the eight patients with overt hyperthyroidism

showed recurrence of atrial fibrillation when euthyroid. However, two of the four patients with isolated pituitary-thyroid axis suppression redeveloped atrial fibrillation four and 46 months after successful cardioversion when unequivocally euthyroid. It may be that these patients continued to show reductions in atrial myocardial cell action potential duration after antithyroid therapy and hence a greater tendency to redevelop atrial fibrillation (Olson et al, 1971). Alternatively, permanent structural changes in the myocardium or a true thyroid cardiomyopathy cannot be excluded. Although the duration of hyperthyroidism in these four patients is not known, it is probable that symptoms from atrial fibrillation had been present for several years in at least three of the patients, a factor that may have been relevant to any structural abnormalities in the heart. Symons et al (1971) demonstrated occult hyperthyroidism in eight patients presenting with cardiovascular abnormalities; four showed atrial fibrillation. Overt hyperthyroidism developed in all of these patients with follow-up of up to seven years although sinus rhythm was apparently achieved in only one patient after anti-thyroid therapy.

Although the use of long-term anticoagulant agents in patients with rheumatic heart disease and atrial fibrillation is widely accepted (Rogers and Sherry, 1976), anticoagulant therapy is less consistently administered to patients with atrial fibrillation secondary to

hyperthyroidism. Over an 18 year period, Staffurth et al, (1977) treated 238 patients with hyperthyroidism and atrial fibrillation and documented 26 episodes of arterial embolism in 21 patients (nine per cent of the total). The embolic events occurred during active hyperthyroidism (12 events), on reversion to sinus rhythm (3 events) or after the euthyoid state was established (11 events). In a Scottish survey of in-patient hospital statistics (Parker and Lawson, 1973) 31 deaths with a primary diagnosis of hyperthyroidism were identified over a ten year period. Atrial fibrillation was documented in 19 patients (61 per cent), the majority associated with heart failure. Eight patients (26 per cent) presented with a major arterial embolus. Based on these analyses, it is now reasonable to anticoagulate all patients with atrial fibrillation secondary to hyperthyroidism (intravenous heparin followed by oral warfarin) unless specifically contraindicated. Embolism is particularly prevalent in the elderly and age should not in itself be a contraindication to therapy (Forfar, 1978; 1982).

This study not only demonstrates that a significant proportion of patients with apparently 'idiopathic' atrial fibrillation have biochemical evidence of hyperthyroidism, but also confirms that the diagnosis may be readily missed in the older patient. Although the majority of such patients will be detected with measurement of both serum total T3 and T4 levels, the most reliable screening test for hyperthyroidism is measurement of the serum TSH

response to TRH. If this test is not performed, then a significant proportion of patients with hyperthyroid atrial fibrillation (in this study 33 per cent) will not be identified. 'Idiopathic' atrial fibrillation is a common clinical diagnosis and does not carry the benign prognosis once suggested (Kannel et al, 1982). Minor but inappropriate elevations of thyroid hormones in this situation cannot be recognised without recourse to assessment of the pituitary-thyroid axis by the TRH test. It is important to recognise and treat this correctable form of atrial fibrillation in view of the haemodynamic disturbances from loss of atrial systole and the rapid ventricular rate (Morris et al, 1963; Gilbert et al, 1963), and the risks of systemic embolism associated with this arrhythmia. Atrial fibrillation with an absent TSH response to TRH should be considered sufficient grounds for antithyroid therapy even if serum total T3 and T4 are within the expected normal range.

CHAPTER 3

**Target Organ Function with Isolated Suppression of the
Pituitary-Thyroid Axis: is the Pituitary Thyrotroph
Uniquely Sensitive to Thyroid Hormones?**

The evidence presented in chapter 2 suggests that important abnormalities in target organ function may be triggered by minor increases in circulating thyroid hormones within the normal range. This suggests that the anterior pituitary may not be uniquely sensitive to small increases in plasma total T3 and T4. With the more widespread use of the TSH response to TRH in assessment of adequacy of thyroxine replacement therapy (Jackson, 1982), it has been appreciated that the dose required for hormonal replacement, based on preservation of the TSH response to TRH, is substantially less than that previously recommended (Evered et al, 1973; Stock et al, 1974; Maeda et al, 1976). Hoffman et al (1977) have shown that a mean replacement dose of thyroxine of 172 +/- 53 ug per day is sufficient to cause TSH suppression in patients with thyroid disorders where TSH suppressive therapy is required. Interestingly, triiodothyronine replacement therapy may be less effective in suppressing pituitary TSH secretion than thyroxine (Erfurth and Hedner, 1982), possibly because of the higher capacity for monodeiodination of thyroxine in the pituitary compared to other tissues (Larson, 1982).

The administration of small quantities of thyroid hormones to normal subjects, however, is known to impair the TSH response to TRH without raising plasma total T3 and T4 above the normal range. Snyder and Utiger (1972)

showed that administration of 15 ug triiodothyronine and 60 ug thyroxine daily over three weeks substantially inhibited the TSH response to TRH. Braverman et al, (1973) reported that administration of as little as 300 ug thyroxine per day (which does not induce clinical hyperthyroidism) to normal female subjects was associated with increases in concentration of total and free T4 and T3 and with a small increase in basal metabolic rate. It is not known whether thyroid hormone therapy sufficient to cause isolated suppression of the pituitary-thyroid axis is associated with this state of "subclinical hyperthyroidism" in normal subjects.

In order to investigate further the relationship between thyroid hormones and target organ responses, this study assessed changes in cardiac and renal function in normal individuals administered thyroxine in a dose sufficient to impair the TSH response to TRH without increasing thyroid hormone levels into the hyperthyroid range.

Methods

Seven normal subjects (6 men and 1 woman), aged 25 to 34 years agreed to take part in this study. None had evidence of cardiac or renal disease and all had normal resting ECG, plasma urea, electrolytes and negative urinalysis. No subject received any drug therapy and all took a normal unrestricted diet during the study period.

Continuous 24 hour ambulatory ECG monitoring, day and night urine collections for four consecutive 24 hour periods and measurement of serum total T3, T4 and TSH response to 200 ug TRH given intravenously were performed under control conditions (when the TSH response to TRH was normal) and during the 22nd - 26th days of oral thyroxine administration (when the TSH response to TRH was inhibited). Four subjects received thyroxine after and three received thyroxine before the control period. The dose of thyroxine was calculated from body weight such that individuals less than 62.5 kg received 150 ug daily and those over 62.5 kg 200 ug daily as a single dose. Two subjects under 62.5 kg required the higher dose of thyroxine to achieve complete TSH suppression; data obtained at the lower dose of thyroxine was not included in the analysis.

Heart rate was recorded continuously as an out-patient over 24 hours using an Oxford Medilog recording system and a modified lead V5 chest electrode. Variations in tape recorder speed were minimised by using the same recorder for each subject and by incorporation of a fixed frequency timing signal into the recorder (Department of Medical Physics). Each recording was analysed at high speed (Pathfinder II high speed ECG analyser, Reynolds Medical) and R-R interval displayed continuously on a Devices chart recorder. Maximum and minimum heart rates (defined as the peak or trough rates over 30 seconds) and mean heart rate (from the integral of the beat to beat R-R



interval) over each one hour recording period was calculated. For the purposes of this analysis, day-time was 0700-2300 hours and night-time 2300-0700 hours.

Separate containers were provided for day and night urine collections. Subjects voided as required during the day but were requested to empty their bladders immediately before retiring at night and on rising in the morning. After volume measurement, aliquots were refrigerated at 4°C prior to analysis for sodium by flame photometry (Bell et al, 1982a). The mean day/night (D:N) ratios for urinary sodium excretion and flow were calculated for each subject before and during thyroxine administration (Dr Gordon Bell, Medical Renal Unit). The night values related to night recumbancy while day values related to the period between rising in the morning and retiring in the evening. There was no difference in the period of night recumbancy before or during the thyroxine administration (8.4 +/- 1.2 hours and 8.5 +/- 1.1 hours respectively).

Plasma total T3, T4 and TSH were measured by specific radioimmunoassay (chapter 2). The normal range for total T3 was 1.1 - 2.8 nanomoles/litre, for total T4 60-150 nanomoles/litre, and for TSH less than 0.7 to 5.7 milliUnits/litre. The normal range of response of TSH 20 minutes after the intravenous administration of 200 ug of TRH was 3.9 to 25.3 milliUnits/litre.

Students 't' test for pair differences was used for

SUBJECT	BEFORE THYROXINE				DURING THYROXINE			
	PLASMA T3 (nmol/l)	TOTAL T4	TSH(mU/l) RESPONSE TO TRH basal	TSH(mU/l) 20min	PLASMA T3 (nmol/l)	TOTAL T4	TSH(mU/l) RESPONSE TO TRH basal	TSH(mU/l) 20min
1	2.0	93	2.9	13.8	1.8	141	<0.9	2.5
2	1.6	69	2.5	14.2	1.7	99	<0.9	1.1
3	1.4	96	2.0	9.9	1.4	136	<0.9	<0.9
4	1.5	87	2.3	20.0	2.4	120	<0.9	1.7
5	1.7	77	2.0	9.1	1.8	109	<0.9	2.9
6	1.9	116	4.1	12.2	2.1	146	<0.9	1.5
7	1.7	112	2.3	8.8	2.2	144	<0.9	1.2
MEAN +/-SEM	1.7 +/-0.1	93 +/-6	2.6 +/-0.3	12.6 +/-1.5	1.9 +/-0.1	128 +/-7	<0.9 -	1.7 +/-0.3

TABLE 3.1 Plasma total thyroid hormones and the TSH response to intravenous TRH before and during thyroxine administration.

FIGURE 3.1

Mean + SEM (upper panel), maximum and minimum (lower panel) hourly heart rates over each recording period in the presence (closed circles) and absence (open circles) of sufficient oral thyroxine to cause isolated suppression of the pituitary-thyroid axis.

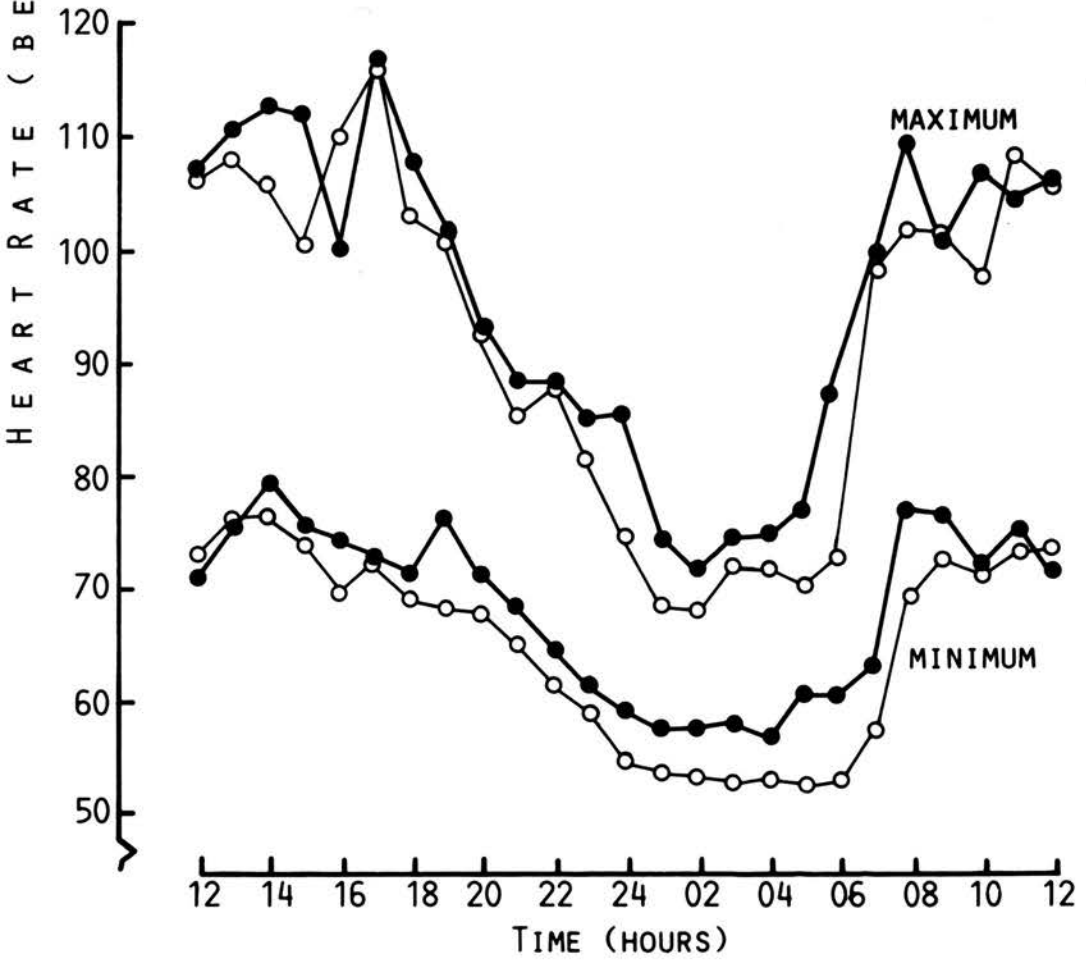
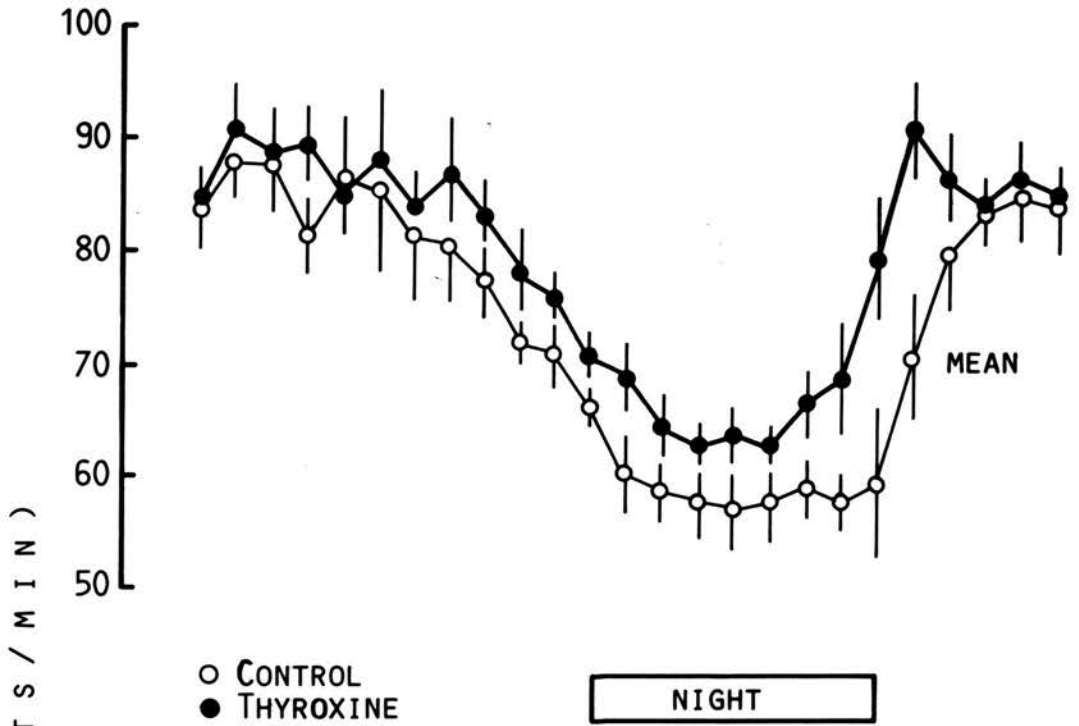

statistical analyses with a 5 per cent confidence limit for statistical significance.

Results

The levels of the plasma total T4, T3 and TSH responses to TRH before and during the 24th day of thyroxine administration are shown in table 3.1. In each case, thyroxine caused a small but significant ($P < 0.005$) rise in total T4, although well within the normal range, and impaired the TSH response to TRH. Changes in total T3 were minor and not statistically significant.

Mean, maximum and minimum heart rates during each hour of the 24 hour recording are shown in figure 3.1. Both the mean and minimum heart rates were consistently faster during therapy compared to controls, with less consistent increases in maximum heart rate. Figure 3.2 shows the average increases in day-time (0700-2300 hours) and night-time (2300-0700 hours) mean, maximum and minimum heart rates following thyroxine. It can be seen that increases are consistently greater at night (7.1 ± 0.7 beats/minute) than during the day (3.1 ± 0.6 beats/minute) but that at all times (except the maximum day-time heart rate when changes were not statistically significant), thyroxine administration has induced a relative tachycardia.

Figure 3.3. shows the individual and mean values for the D:N ratios of urinary flow and sodium excretion before

and during days 22-26 of thyroxine administration. Day:Night ratios of urinary flow and sodium excretion fell significantly from 2.2 +/- 0.3 and 2.4 +/- 0.2 to 1.4 +/- 0.2 and 1.6 +/- 0.2 respectively with thyroxine ($P < 0.01$). These changes reflected a 21 per cent decrease in day-time urine flow (from 78 +/- 12 to 60 +/- 12 ml/hour) and a 10 percent increase in nocturnal urine flow (from 43 +/- 8 to 47 +/- 5 ml/hour), associated with a 22 per cent decrease in day-time sodium excretion (from 8.8 +/- 1.6 to 6.9 +/- 1.0 mmol/hour) and a 22 per cent increase in nocturnal sodium excretion (from 3.8 +/- 0.6 to 4.6 +/- 0.7 mmol/hour).

Discussion

Normal thyroid hormone levels with an absent TSH response to TRH have been documented in several circumstances. It is a not uncommon finding in patients who have been apparently successfully treated by antithyroid drugs, radioiodine or subtotal thyroidectomy (Clifton-Bligh et al, 1974; Buerklin et al, 1976, Irvine and Toft, 1976; Toft et al, 1978) and has been described in patients with non-toxic nodular goitre, ophthalmic Graves' disease, autonomous thyroid nodules, euthyroid subjects with a family history of Graves' disease and patients receiving thyroxine replacement therapy (Lawton et al, 1971; Ridgway et al, 1973; Carpi et al, 1977;

FIGURE 3.2. Increments in day-time and night-time mean, maximum and minimum heart rates following thyroxine administration.

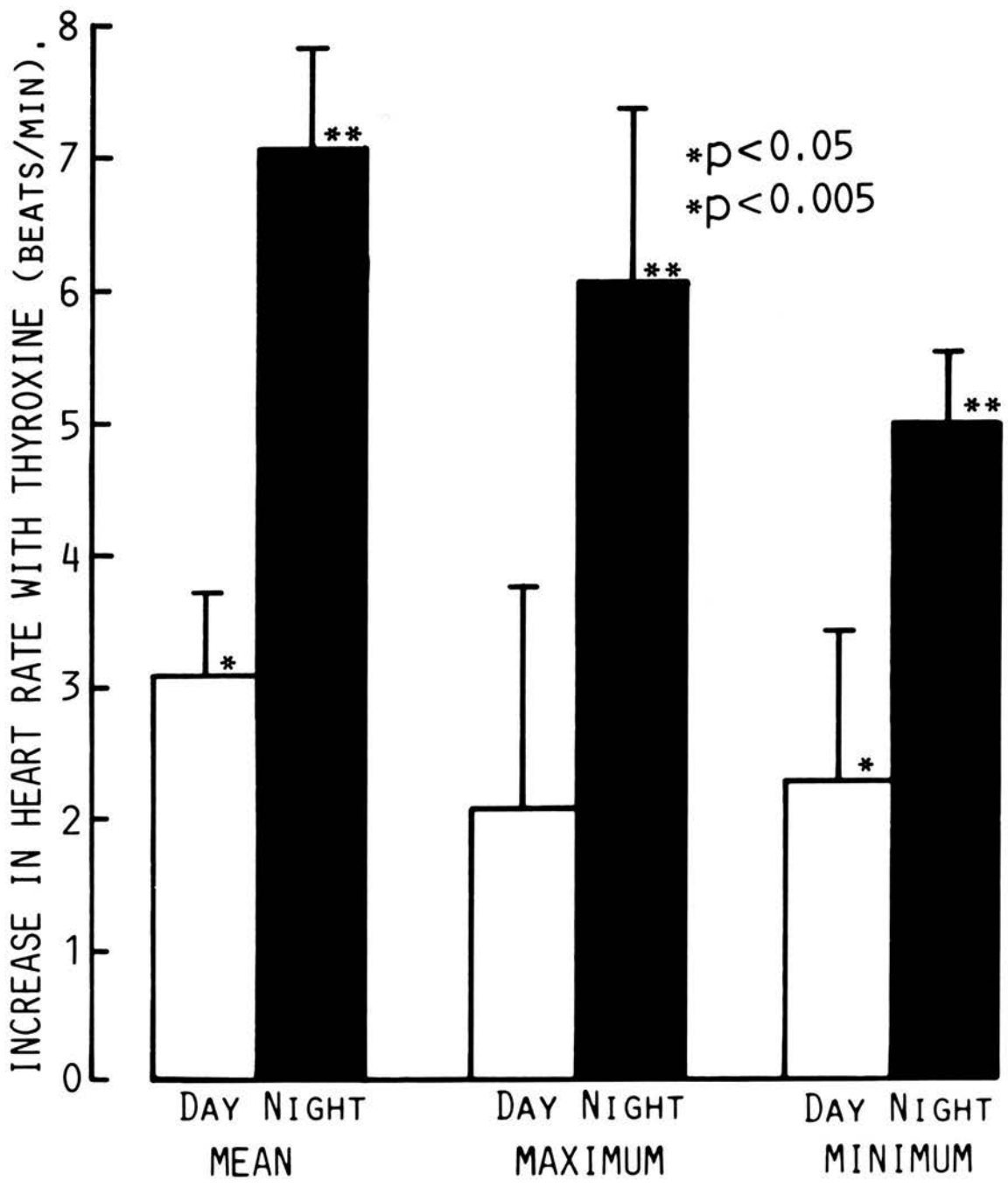

Tamai et al, 1978). It is currently believed that the pituitary thyrotroph is the most sensitive target organ for thyroid hormones and is alone in recognising a state of subclinical hyperthyroidism when these hormones increase within the normal range. Subclinical hyperthyroidism of this type has not hitherto been considered an indication for antithyroid therapy although it is recognised that some of these patients are at increased risk of developing overt hyperthyroidism (Hamberger et al 1980).

The present study suggests that both the heart and the kidney are as responsive as the pituitary thyrotroph to minor increases in circulating thyroid hormone levels within the normal range. The changes in urine flow and sodium excretion may be related to direct effects of thyroid hormones on renal tubular membrane sodium exchange (De Wardener, 1978); alternatively, the increase in nocturnal heart rate, which might be expected to be combined with a small fall in peripheral vascular resistance (Zaimis et al, 1969) may have led to an increase in cardiac output and renal blood flow, with consequent enhancement of nocturnal urinary flow and sodium excretion. Increments in night-time heart rate (and presumably cardiac output) after thyroxine were greater than those during the day, reflecting lower sympathetic tone at night and hence less overall contribution to heart rate. This is probably also the explanation for greater increases in minimum than in

FIGURE 3.3. Ratios of day-time (D) and night-time (N) urinary flow and sodium excretion before and during thyroxine administration sufficient to cause isolated suppression of the pituitary-thyroid axis (after Bell et al 1982b).

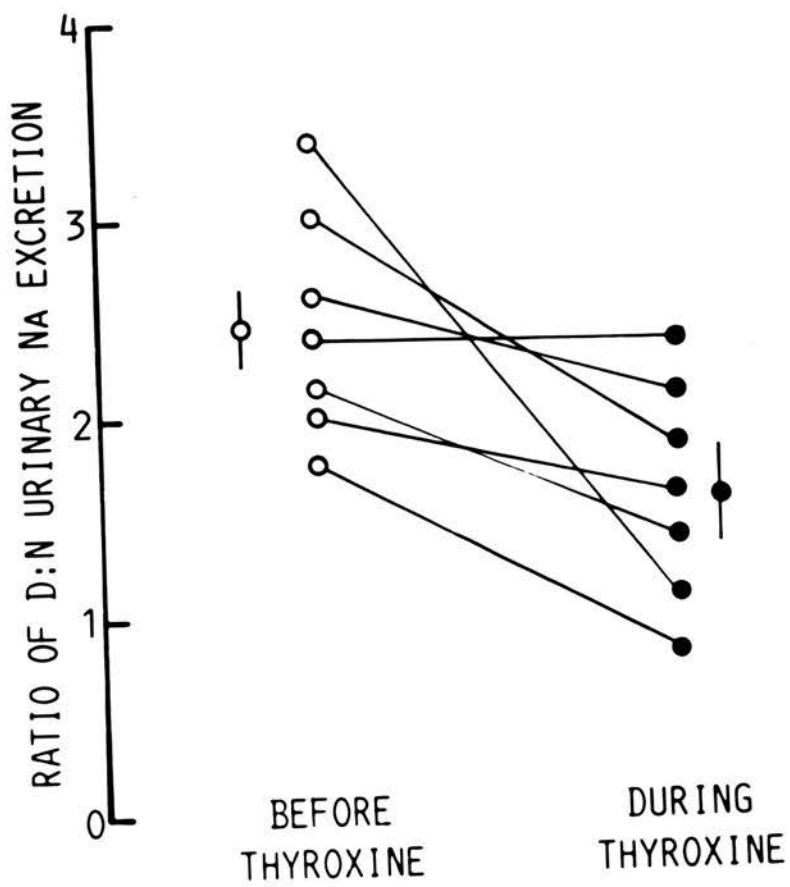
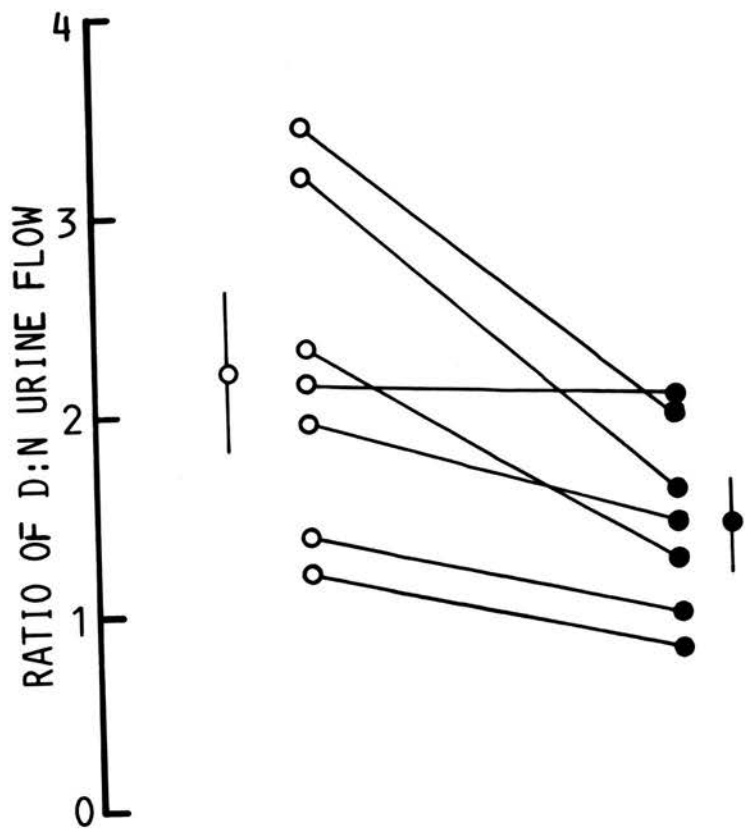

maximum heart rates with thyroxine. Reversal or abolition of the day:night pattern of urinary sodium excretion occurs in overt hyperthyroidism (Bell et al, 1982a), cardiac failure (Goldman 1951), the nephrotic syndrome and chronic renal failure (Borst and DeVries, 1950; Hillier et al, 1980). In these conditions, the relative increase in nocturnal renal blood flow and glomerular may be the explanation (Wesson, 1964).

Apart from the early weeks after surgical or radioiodine treatment of hyperthyroidism when there is a transient suppression of pituitary thyrotrophs (Toft et al, 1974), an impaired TSH response to TRH reflects widespread target organ recognition of inappropriately high levels of thyroid hormones, irrespective of whether they lie within the accepted reference range. This stage is subclinical only in as much as the physician is unable to detect evidence on clinical grounds of the peripheral manifestations of thyroid hormone excess. Thus, in the absence of a carefully matched control group, Hoffman et al (1977) cannot conclude that a nocturnal heart rate of 69 beats per minute (over 10 beats/min faster than in this study) is normal in patients with TSH suppression. Indeed, had Hoffman et al studied the same patients without TSH suppression, it is highly likely that the nocturnal heart rate would have been significantly lower. Whether the cardiac and renal changes demonstrated are sufficient evidence for a reassessment of the threshold for antithyroid therapy depends upon proof that subclinical

hyperthyroidism is detrimental to the patient. The patients with a cardiological diagnosis of 'idiopathic' atrial fibrillation in whom there was biochemical evidence of subclinical hyperthyroidism described in chapter 2 could be restored to sinus rhythm after appropriate antithyroid therapy (Forfar et al, 1981), thus avoiding risks of systemic embolisation and heart failure. Under certain circumstances, therefore, cardiotoxic effects of minor increases in thyroid hormones are evident. Abnormal left ventricular function in overt hyperthyroidism is described in chapters 4 and 5 (Forfar et al, 1982) and it is possible that similar cardiac dysfunction may occur in patients with unrecognised subclinical hyperthyroidism. Ridgway et al (1981), have recently shown changes in myocardial contractile function in patients with subclinical hypothyroidism (isolated plasma TSH elevation) following thyroxine administration although these authors did not exclude the possibility that therapy induced subclinical hyperthyroidism as the TSH response to TRH was not assessed. It has not been established whether the alteration in the normal diurnal pattern of sodium excretion may be a contributing factor in some patients with unexplained oedema.

Just as hyperthyroidism is a graded phenomenon (Evered et al, 1973; Tunbridge et al, 1977), there is a spectrum of hyperthyroidism characterised in its early stages by thyroid hormones within the accepted reference

range but which are recognised by the pituitary, heart, kidneys and presumably many other organs as inappropriately high for the individual patient. This stage of subclinical hyperthyroidism must have existed for a variable period of time in all patients presenting with overt hyperthyroidism. The evidence presented is sufficient for a reassessment of the indications for antithyroid therapy. It may also be necessary to assess optimum dosage of thyroxine replacement therapy more accurately than at present by using the TSH response to TRH, so that a state of subclinical hyperthyroidism is not induced.

CHAPTER 4

**Left Ventricular Function in Hyper- and Hypothyroidism
Assessed by Radioisotope Ventriculography: Impaired
Contractile Performance with Thyroid Hormone Excess and
Deficiency.**

The mechanism of altered myocardial contractile function in hyper- and hypothyroidism has been the subject of clinical and experimental investigation over several decades. Most of the experimental studies in vitro have documented enhanced myocardial contractility in hyperthyroid states and depressed contractile function in hypothyroid states (Buccino et al, 1967; Murayama and Goodkind, 1968; Pannier, 1968; Taylor et al, 1969). However, in these and in other experimental studies with an intact circulation, changes in thyroid status were induced over a relatively short period of time (a few weeks) and therefore may not be strictly comparable to spontaneous hyperthyroidism and hypothyroidism in humans.

A few studies have demonstrated reductions in myocardial contractility with thyroid hormone feeding. In rat papillary muscle, Korecky and Beznak (1971) recorded small increases in rate of tension development and shortened time to maximum tension, but noted that maximum developed tension was unchanged. When thyroxine levels were increased further, maximum tension decreased with a further shortening in the time to peak tension. These authors suggested that the response to thyroxine may have been related to intrinsic heart rate. In species with fast heart rates, the lowered turnover was the result of failure of contraction velocity to increase in proportion to the decrease in the duration of contraction. Taylor (1970) confirmed the importance of contraction frequency

on the inotropic effects of thyroxine on cat papillary muscle. At low rates, indices of contractility (rate of tension development, time to peak tension, peak tension, velocity of isotonic shortening) were greater in papillary muscles from hyperthyroid animals. With an increase in contraction frequency from 12 to 60 beatsperminute, an inotropic response was noted in hyperthyroid and euthyroid groups but over the subsequent minutes, indices of contractility decreased more rapidly in the hyperthyroid muscles. This author attributed his results to a true reduction in activity of the contractile muscle elements from more profound hypoxia in hyperthyroid muscles at high contraction frequencies. There is no evidence that hyperthyroidism alters series and parallel elastic and viscous components in heart muscle (Buccino et al, 1967; Parmley et al, 1968). Oxygen requirements of cardiac muscle in vitro are substantially increased in hyperthyroidism (Ullrick and Whitehorn, 1952). With an intact circulation, sinus tachycardia or atrial fibrillation with a rapid ventricular response may further exacerbate hypoxia through increasing myocardial oxygen demand and reducing diastolic coronary perfusion (Piatnek-Leunissen and Olson, 1967). It has been estimated that myocardial oxygen utilisation increases about 30 to 40 per cent per unit mass of myocardium (which itself may be increased) in the average hyperthyroid patient (Leight et al, 1956; Rowe et al, 1956). Tse et al (1980) have

recently shown reductions of 40 per cent in ATP levels in the hyperthyroid rat heart, providing a biochemical basis for the contractile responses observed. This ATP depletion was no longer evident after regression of the hyperthyroid state.

The mechanism of altered myocardial contractile function in hypothyroidism has been less intensively studied. Clinically, the bradycardia and cardiomegaly of myxoedema are familiar (Fahr, 1932; Keating, 1961) and experimentally, impaired myocardial contractility is well documented (Buccino et al, 1966; Taylor et al, 1969; Straver and Schulze, 1976). Similarly, the influence of the sympathetic nervous system in maintaining myocardial contractile function in states of thyroid hormone deficiency is unknown. Although early studies suggested that alterations in cardiac sensitivity to catecholamines could not explain the hypodynamic circulatory state characteristic of the condition (Benforado and Wiggins, 1965; Margolius and Gaffney, 1965), radioligand binding studies (discussed in chapter 1 and chapter 6) have shown that both beta- and alpha-adrenoceptor density is decreased in ventricles from propylthiouracil-treated rats, thus providing a mechanism for reduced adrenergic sensitivity.

The purpose of this study was to examine left ventricular contractile function and its response to exercise and beta-adrenoceptor blockade in untreated hyperthyroid and hypothyroid patients and in the same

patients when euthyroid after appropriate anti-thyroid or thyroxine replacement therapy. In the absence of major changes in preload and afterload, left ventricular ejection fraction (LVEF) reflects the intrinsic contractile state of the heart. Radionuclide ventriculography provides a sensitive and non-invasive technique for assessment of ventricular function at rest and on exercise.

Methods

A total of 17 patients agreed to participate in the investigation. Nine were hyperthyroid (eight women and one man: mean age 48 years [range 19-58 years]) and eight hypothyroid (all women: mean age 53 years [range 37-69 years] at the time of initial study.

The diagnosis of hyperthyroidism was made clinically and on the basis of raised levels of plasma total thyroxine (T4) and triiodothyronine (T3) associated with an absent plasma thyrotrophin (TSH) response 20 minutes after 200 ug thyrotrophin releasing hormone (TRH) given intravenously (table 4.1). None of the patients were receiving medication at the time of study; all were clinically free from heart failure and had no evidence of concurrent cardiovascular disease based on history, clinical examination, electrocardiogram and chest radiograph. All remained in sinus rhythm during

PATIENT	AGE(YR) & SEX	HYPERTHYROID					EUTHYROID				1st-2nd STUDY (month)
		WT (kg)	T3 (nmol/l)	T4	TRH test(mU/l) basal	20min	WT (kg)	T3 (nmol/l)	T4	TSH (mU/l)	
1	42F	32.3	15.0	382	<1.0	<1.0	48.5	1.3	94	1.7	10
2	44F	44.9	12.7	342	1.7	0.9	48.6	1.7	114	1.0	11
3	58F	40.7	5.3	207	<0.8	<0.8	42.5	1.5	74	1.0	6
4	19F	45.0	12.4	310	<0.9	<0.9	-	-	-	-	-
5	57F	45.1	4.7	201	0.9	0.8	53.0	1.4	69	6.8	6
6	57F	55.0	6.0	225	1.0	1.0	58.5	1.8	99	0.8	12
7	49F	60.5	7.2	218	1.1	1.1	62.0	1.9	75	3.1	8
8	54M	66.0	9.1	193	1.1	1.0	73.0	2.1	125	1.8	9
9	53F	47.2	6.8	240	<0.7	<0.7	54.6	1.9	108	2.0	9

TABLE 4.1 Age at presentation, sex, weight and thyroid function tests at the time of angiographic investigation in patients when hyperthyroid and euthyroid.

diagnosis, investigation and treatment. Eight of the nine patients were restudied when euthyroid after specific antithyroid therapy (10-15 mCi radioiodine I131 in patients 1-3 and 5-9; subtotal thyroidectomy in patient 4) to allow paired data analysis. Studies were repeated a minimum of six months and a maximum of 12 months after antithyroid treatment. All patients had been biochemically euthyroid for at least three months before repeat investigation.

The diagnosis of hypothyroidism was made clinically and on the basis of reduced levels of plasma T4 associated with elevation of plasma TSH (table 4.2). No patients were receiving medication at the time of the first investigation. Seven had primary hypothyroidism and one (patient 17) developed hypothyroidism following 15 mCi radioiodine I131 for hyperthyroidism four months previously. One patient (no. 11) gave a history of mild chest pain on exertion compatible with angina pectoris but specific cardiac symptoms were absent in the remainder. All were clinically free from heart failure at the time of study. Cardiomegaly (CTR 55 per cent) was noted on routine chest radiograph in patient 16. Seven of the eight patients showed non-specific ST/T wave changes on the resting electrocardiogram. Each patient was restudied between four and eight months after thyroxine replacement therapy when clinically and biochemically euthyroid (table 4.2). All patients had been biochemically euthyroid for

PATIENT	AGE	HYPOTHYROID			EUTHYROID			THYROKINE (ug/day)	1st-2nd STUDY (mth)
		WT (kg)	T4 (nmol/l)	TSH (mU/l)	WT (kg)	T4 (nmol/l)	TSH (mU/l)		
10	46	55.0	<20	>85.0	50.9	88	3.9	150	5
11	57	65.0	35	51.7	61.5	116	3.9	150	8
12	59	125.0	<20	>85.0	105.0	120	3.6	150	8
13	37	81.0	28	63.5	80.0	78	3.8	100	5
14	59	69.6	26	74.0	64.7	90	3.0	150	4
15	50	67.4	<20	64.0	64.8	79	2.3	100	6
16	69	74.5	24	>81.0	75.8	83	2.6	150	4
17	44	49.6	<20	36.3	48.6	114	1.7	100	5

TABLE 4.2 Age at presentation, weight and thyroid function at the time of angiographic investigation in patients when hypothyroid and euthyroid.

at least eight weeks before restudy. Chest pain on exertion was transiently more frequent in patient 11 and for this reason thyroxine replacement was increased gradually over six months and combined with propranolol and long-acting nitrates. Both of these drugs were discontinued in this patient before repeat study.

Isotope ventriculography was performed in the supine position with cardiac imaging in the 30 degree left anterior oblique projection with 10 degrees caudal tilt using either a Nuclear Enterprises Mark 5HR or a Searle (LEM) mobile gamma camera (figure 4.1). Following an intravenous bolus injection of 15 mCi of technetium 99m electrolytically labelled human serum albumin (Millar et al, 1979), praecordial counts were transferred and stored in 20 msec frame format in a PDP 11/34 computer (Digital Equipment Corporation). The accumulation was triggered by the R wave of the patients electrocardiogram, recorded from chest lead V5, each 20 msec frame being updated by successive cardiac cycles until 300-500 beats had been accumulated. At the end of the accumulation period, the frames were displayed in rapid sequence or movie format on a purpose built display screen. The provisional ventricular outline was selected from the display using a joy-stick and data from within this outline displayed to produce the uncorrected ventricular volume curve. the ventricular region displayed could be checked and where necessary altered by displaying the volume curves from

FIGURE 4.1 Gamma camera positioned in 30 degree left anterior oblique position with patient supine.

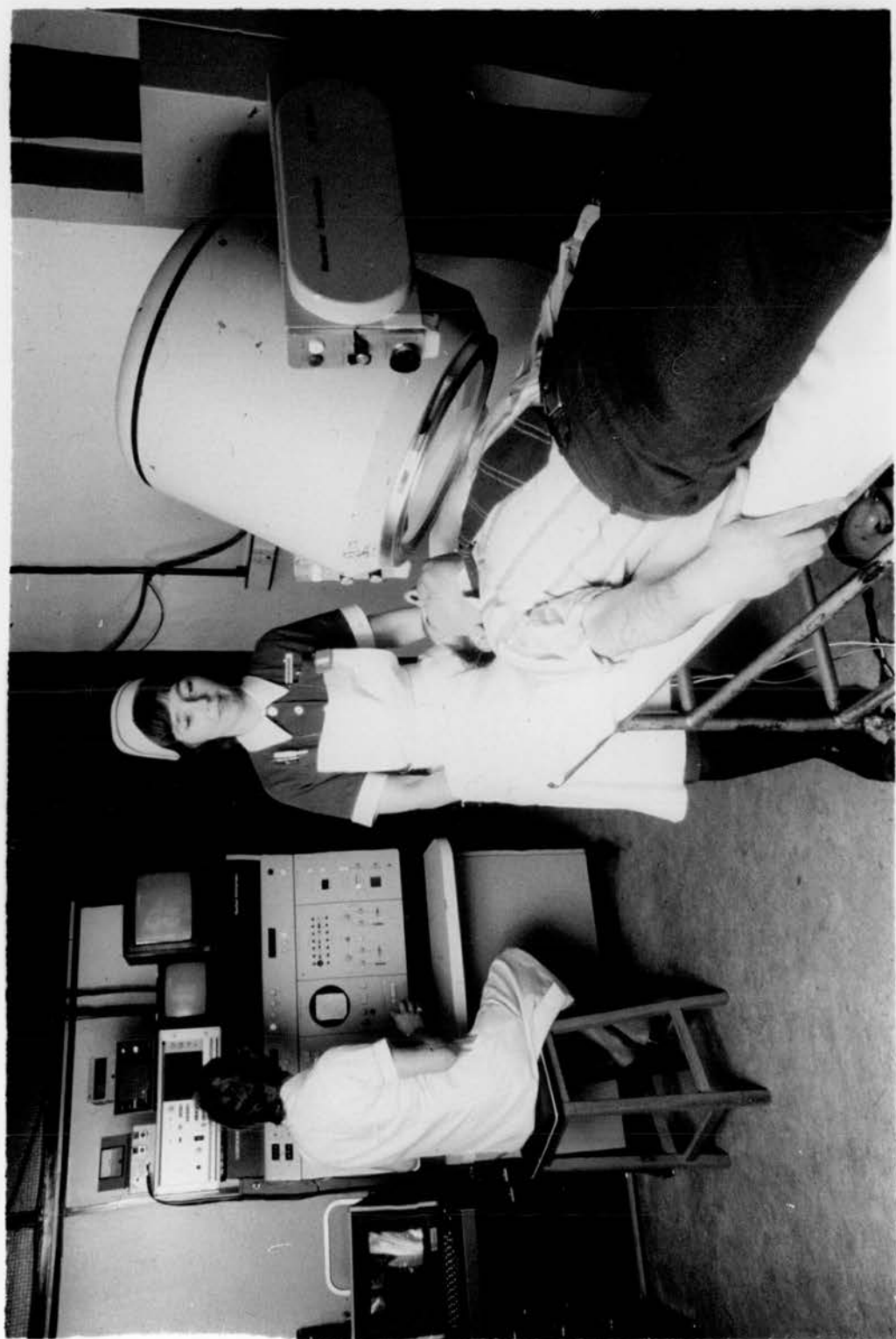

individual picture-cell elements. Background subtraction was made from a crescentic shell of the lateral and inferior ventricular border corrected to provide an area equal to the left ventricle and the LVEF was calculated from this corrected time-activity curve (Muir et al, 1977). Left ventricular wall motion was examined from the continuous movie display.

A further index of ventricular function was calculated as the mean ejection time (TS), expressed as a proportion of left ventricular ejection time (LVET). The mean ejection time was defined by:

$$TS = \frac{\sum_i \frac{(V_i - V_{i+1}) \cdot (t_i + t_{i+1})}{2}}{\sum_i (V_i - V_{i+1})} \text{ msec}$$

where V_i is the relative ventricular volume at time t_i during systole. T_s was therefore derived from the sum of the products of successive volume changes and the average time between these frames. LVET was taken to be the time during which greater than 98 per cent of the total volume change during systole took place. The TS : LVET ratio is therefore a measure of the shape of the volume curve during systole (Muir et al, 1980); if a greater proportion of the volume empties in early systole then the ratio will be reduced. Regional myocardial fibre shortening and the ratio should thus correlate closely

(and inversely) to the intrinsic contractile state of the heart.

Patients rested for 15 minutes before the start of each study. Ventricular volume curves were constructed over 500 beats at rest and over 300-500 beats during supine exercise on a bicycle ergometer. The work rate was adjusted for each patient between 300-600 kpm/minute and exercise continued for two to three minutes before initiating data accumulation. This time was sufficient to achieve steady state in hyperthyroid, hypothyroid and euthyroid groups, assessed by a constant heart rate (\pm 5 per cent) during the data accumulation period. After a further 30 minute rest period, propranolol 0.15 mg/kg (ICI Pharmaceuticals, England) was given by intravenous injection over five minutes and the same protocol repeated after a further 15 minutes. Systolic blood pressure was measured by the same observer (JCF) using a mercury sphygmomanometer at rest and on exercise before and after propranolol. The same protocol at the same work loads was used for each patient at restudy when euthyroid.

Thyroid function tests were undertaken before each study as described in chapter 2. The normal range for plasma total T4 is 60 to 150 nmol/l, for plasma total T3 1.1 to 2.8 nmol/l, and for plasma TSH less than 0.7 to 5.7 mU/l with the normal range of response 20 minutes after the intravenous administration of 200 ug TRH 3.9 to 25.3 mU/l.

FIGURE 4.2 LVEF at rest and on exercise in the same patients hyperthyroid and euthyroid before (closed symbols) and after (open symbols) propranolol. LVEF falls on exercise when hyperthyroid before and after beta-adrenoceptor blockade in contrast to a rise on exercise when euthyroid.

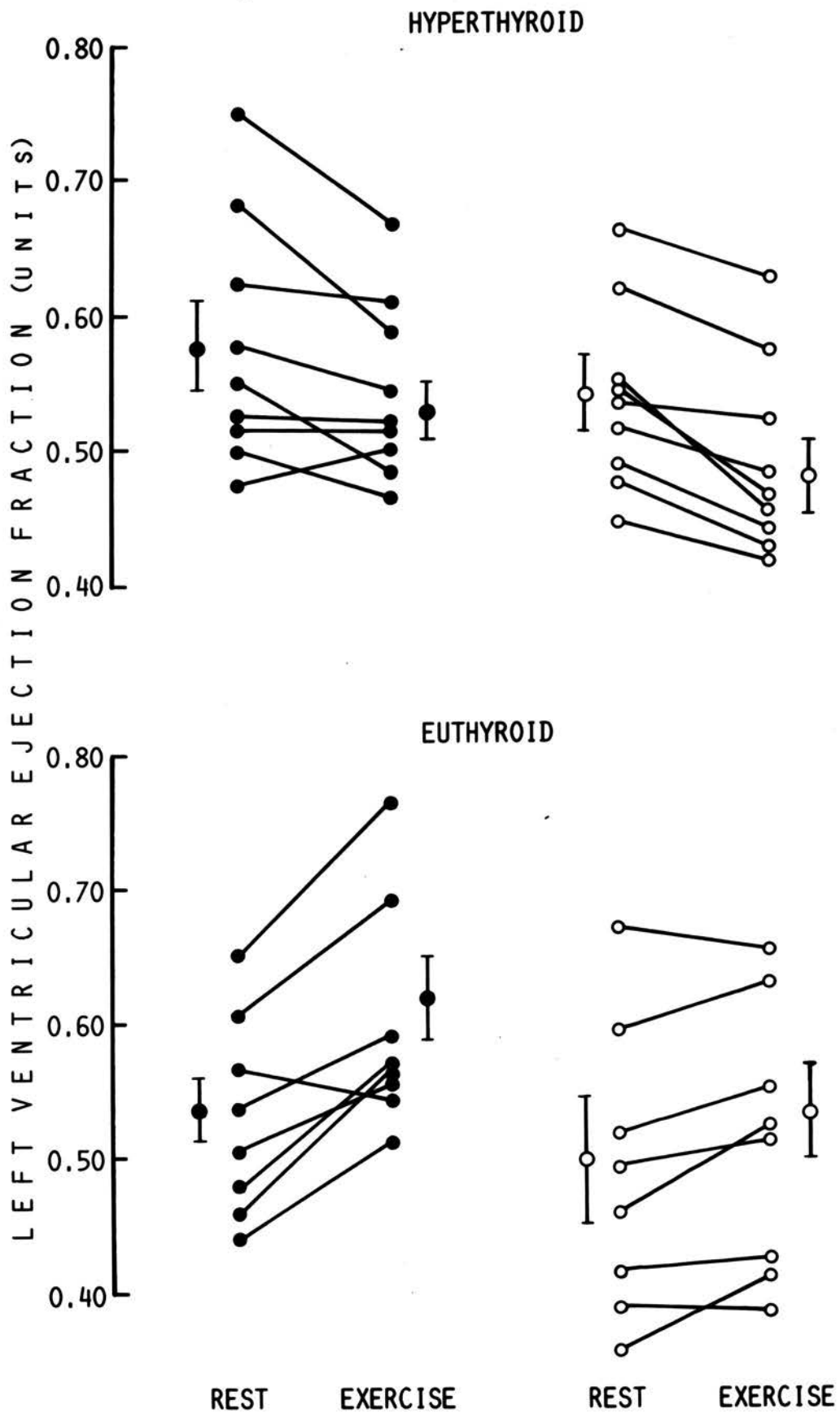

Statistical analysis used the Wilcoxon ranked sum and signed-rank two-tailed test for matched pairs and two samples. Correlations between thyroid hormone concentrations, LVEF and heart rate used a linear regression co-efficient with least squares method of analysis and computed t-statistic.

Results

The resting LVEF was significantly (10 per cent) greater when hyperthyroid compared to the same patients when euthyroid (figure 4.2). Mean (\pm SEM) resting LVEF hyperthyroid was 0.58 ± 0.03 compared to 0.53 ± 0.02 euthyroid ($P < 0.02$). On exercise, LVEF decreased in eight of the nine hyperthyroid patients and was unchanged in the remaining patient (LVEF on exercise 0.55 ± 0.02 : $P < 0.01$ compared to resting LVEF). In contrast, LVEF increased in seven out of the eight patients when euthyroid and fell slightly in the eighth patient. LVEF on exercise (euthyroid) was 0.61 ± 0.03 ($P < 0.01$ compared to resting LVEF). The LVEF on exercise when hyperthyroid was significantly less ($P < 0.02$) than when euthyroid.

Directional and absolute changes in LVEF when hypothyroid were different to those in the hyperthyroid state. Resting LVEF was significantly (12 per cent) less when hypothyroid compared to the same patients when euthyroid (figure 4.3). Mean resting LVEF hypothyroid

FIGURE 4.3 LVEF at rest and on exercise in the same patients hypothyroid and euthyroid before (closed symbols) and after (open symbols) propranolol. A rise in LVEF with exercise is maintained when hypothyroid although attenuated by beta-adrenoceptor blockade.

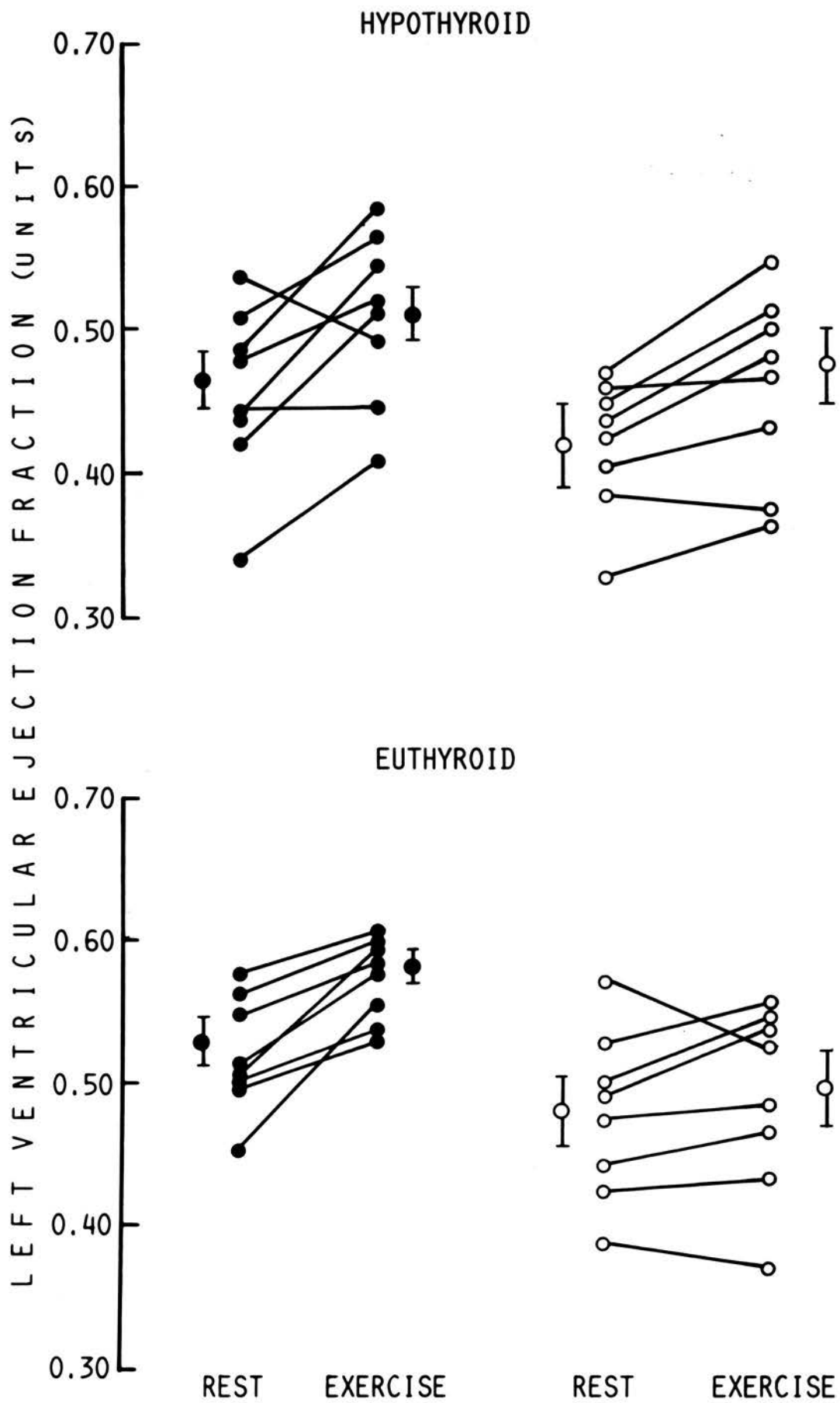

was 0.46 ± 0.02 compared to 0.53 ± 0.02 euthyroid ($P < 0.05$). Resting LVEF was the same in both euthyroid groups and therefore independent of initial thyroid status. On exercise, LVEF increased in hypothyroid patients to 0.51 ± 0.02 ($P < 0.05$ compared to resting LVEF). One patient (no. 17) showed no change in LVEF on exercise and patient 11 showed a modest fall from 0.53 to 0.49. All patients showed an increase in LVEF on exercise when euthyroid (exercise LVEF 0.58 ± 0.01 : $P < 0.01$ compared to resting LVEF). The magnitude of the rise in LVEF with exercise was not significantly different between the two groups.

The fall in LVEF on exercise when hyperthyroid was maintained after intravenous propranolol (figure 4.2). The rise in LVEF with exercise when hypothyroid was slightly reduced after propranolol although differences did not achieve statistical significance. In both euthyroid groups, the rise in LVEF on exercise was attenuated by beta-adrenoceptor blockade ($P < 0.05$). These changes with exercise are summarised in Figure 4.4.

At rest, there was a significant fall in LVEF after propranolol ($P < 0.01$) that was similar in hyperthyroid, hypothyroid and euthyroid groups and therefore appeared to be independent of thyroid status (Figure 4.5). On exercise, the fall in LVEF after propranolol was increased in euthyroid patients but was not significantly changed in these patients when hyperthyroid or hypothyroid. In effect, propranolol has attenuated the rise in LVEF with

FIGURE 4.4 Change in LVEF with exercise in hyperthyroid and euthyroid patients and in hypothyroid and euthyroid patients before and after propranolol. The fall in LVEF with exercise when hyperthyroid, and the rise in LVEF with exercise when hypothyroid is not influenced by beta-adrenoceptor blockade. The increase in LVEF with exercise when euthyroid is attenuated by beta-adrenoceptor blockade. (*P <0.05).

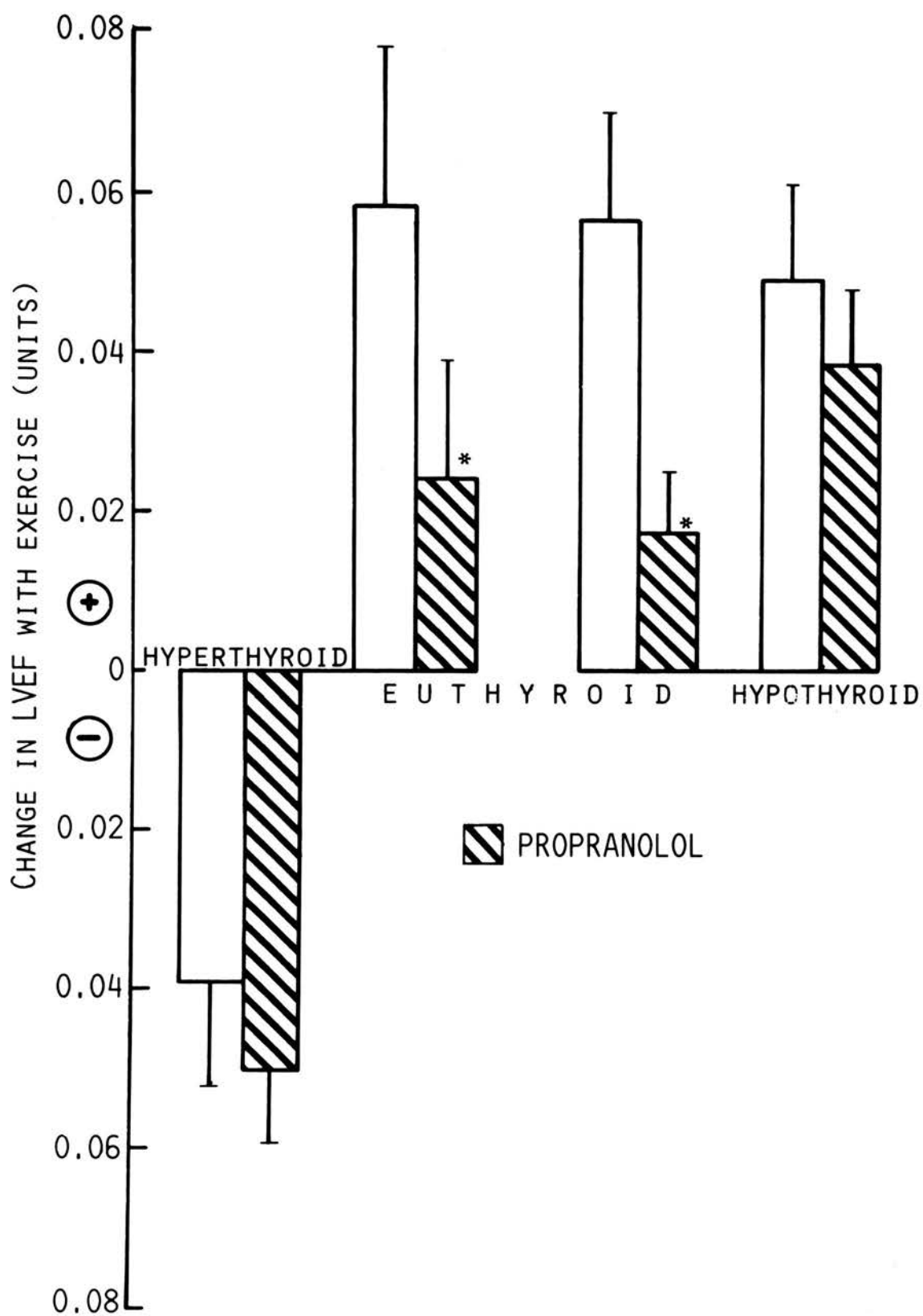

exercise only when euthyroid. Beta-adrenoceptor activation is thus involved in the rise in LVEF during exercise in the euthyroid state but does not appear to play an important role in the fall in LVEF in the hyperthyroid state or the rise when hypothyroid.

Directional changes in the TS:LVET ratio were in close agreement with and paralleled the LVEF data (Figure 4.6). In the hyperthyroid state, the ratio increased on exercise (reflecting a reduction in myocardial contractile activity) both before (from 0.44 ± 0.02 to 0.47 ± 0.02 ; $P > 0.05$ < 0.10) and after (from 0.44 ± 0.02 to 0.49 ± 0.02 ; $P < 0.05$) propranolol. When hypothyroid, the ratio reduced from 0.56 ± 0.02 at rest to 0.52 ± 0.02 on exercise ($P < 0.05$) in keeping with the rise in LVEF. After propranolol, the resting TS:LVET ratio increased to 0.59 ± 0.02 ($P = 0.10$) in the hypothyroid group and the fall on exercise (to 0.56 ± 0.02) was somewhat reduced. In the euthyroid state, the TS:LVET ratio fell significantly on exercise ($P < 0.05$) irrespective of initial thyroid status and this fall was maintained after beta-adrenoceptor blockade (Figure 4.6).

Changes in systolic blood pressure and mean heart rate are detailed in Table 4.3. No significant differences in resting or exercise systolic blood pressure were detectable with differing thyroid status. As expected, mean heart rate was increased in the hyperthyroid state at rest (104 ± 5 beats/minute against

FIGURE 4.5 The fall in LVEF after propranolol in hyperthyroid and euthyroid groups at rest and on exercise. The fall in LVEF with beta-adrenoceptor blockade is similar at rest and on exercise in the hyperthyroid and euthyroid state, but is greater on exercise when euthyroid.
(* $P < 0.05$).

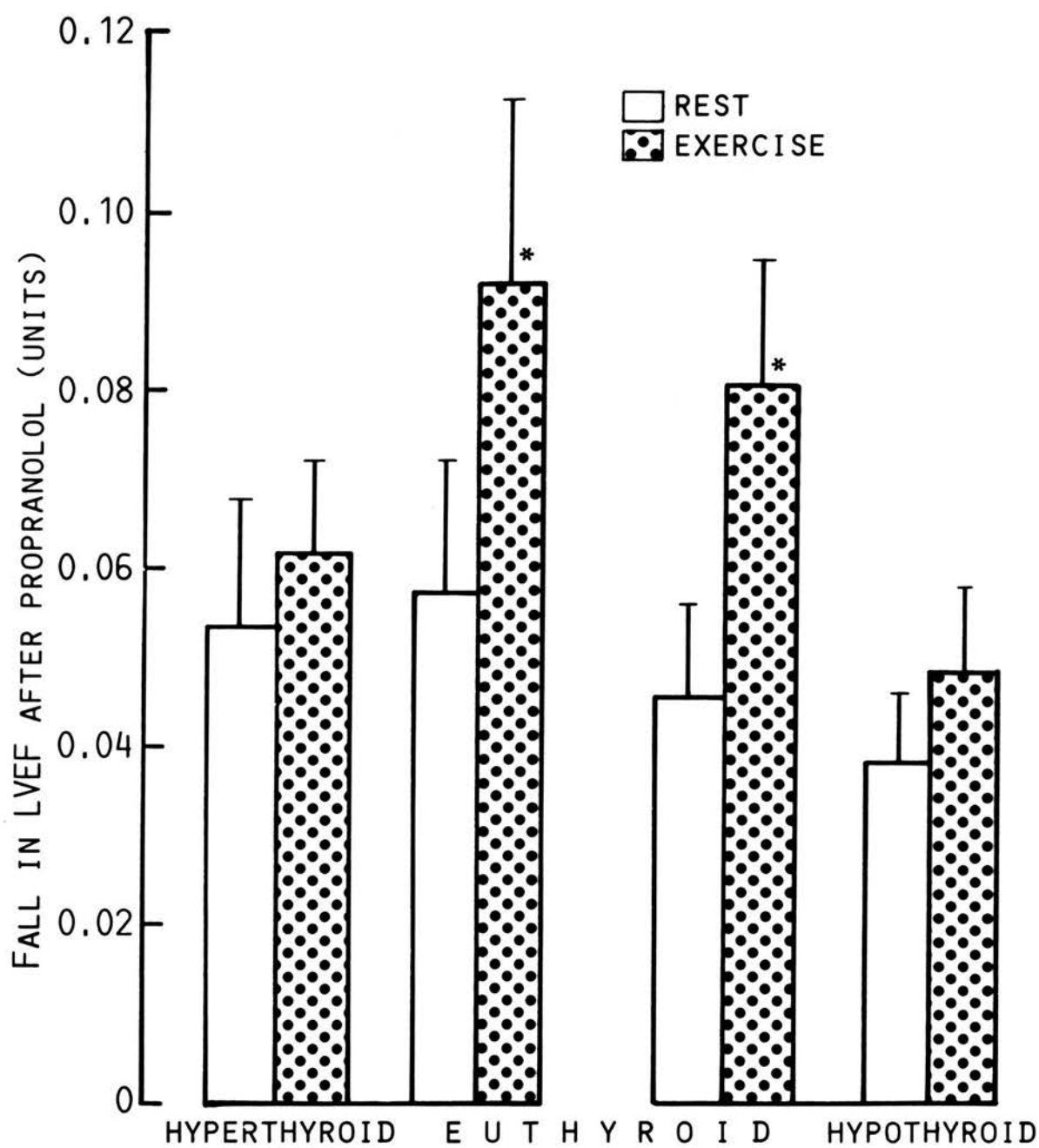

	HYPERTHYROID		EUTHYROID		HYPERTHYROID		EUTHYROID	
	Mean HR	Syst EP	Mean HR	Syst EP	Mean HR	Syst EP	Mean HR	Syst EP
REST	104 +/-5	125 +/-5	76 +/-6	132 +/-6	67 +/-4	135 +/-6	79 +/-2	128 +/-6
EXERCISE	134 +/-6	160 +/-6	118 +/-6	170 +/-7	97 +/-5	167 +/-6	106 +/-4	167 +/-8
REST (PROPRANOLOL)	93 +/-5	120 +/-5	65 +/-4	128 +/-5	59 +/-4	131 +/-6	71 +/-4	123 +/-5
EXERCISE (PROPRANOLOL)	118 +/-5	145 +/-6	99 +/-5	153 +/-6	82 +/-6	151 +/-8	90 +/-3	151 +/-5

TABLE 4.3 Heart rate (beats/minute) and systolic blood pressure (mmHg) responses to exercise and beta-adrenoceptor blockade in hyperthyroid and euthyroid patients before and after corrective therapy.

76 +/- 6 beats/minute euthyroid; $P < 0.005$) and reduced when hypothyroid at rest (67 +/- 4 beats/minute against 79 +/- 2 beats/minute euthyroid; $P < 0.05$). Relatively similar changes were observed on exercise. Propranolol caused a similar reduction in resting heart rate (between 10 and 15 per cent) and exercise heart rate (12 - 16 per cent) in all groups and attenuated the rise in heart rate with exercise between 6 and 20 per cent. No significant differences in the relative change in heart rate with exercise before or after beta-adrenoceptor blockade were detectable between the groups.

LVEF showed a positive linear correlation with heart rate for group data in the hypothyroid and euthyroid patients and the hyperthyroid patients at rest ($r = 0.85$; $P < 0.001$). On exercise, however, the hyperthyroid patients showed an unexpectedly low LVEF for heart rate both before and during beta-adrenoceptor blockade (Figure 4.7). Despite similar heart rates, LVEF on exercise at the same work load was 20 per cent lower ($P < 0.002$) in the hyperthyroid group after propranolol (heart rate 118 +/- 5 beats/minute) compared to the same patients euthyroid prior to beta-adrenoceptor blockade (heart rate 118 +/- 6 beats/minute).

There was no correlation between LVEF or TS:LVET ratio and plasma thyroid hormone concentrations at any level of thyroid activity. Resting heart rate was related to log plasma total thyroxine at all levels of thyroid dysfunction ($r = 0.67$; $P < 0.005$); the relationship was

FIGURE 4.6 Ts:LVET ratio at rest and on exercise before and after propranolol in hyperthyroid, hypothyroid and euthyroid groups. An increase in the ratio indicates a decrease in myocardial contractile performance (see methods) and is noted in hyperthyroid patients on exercise before and after propranolol in contrast to a reduction in euthyroid and hypothyroid patients.

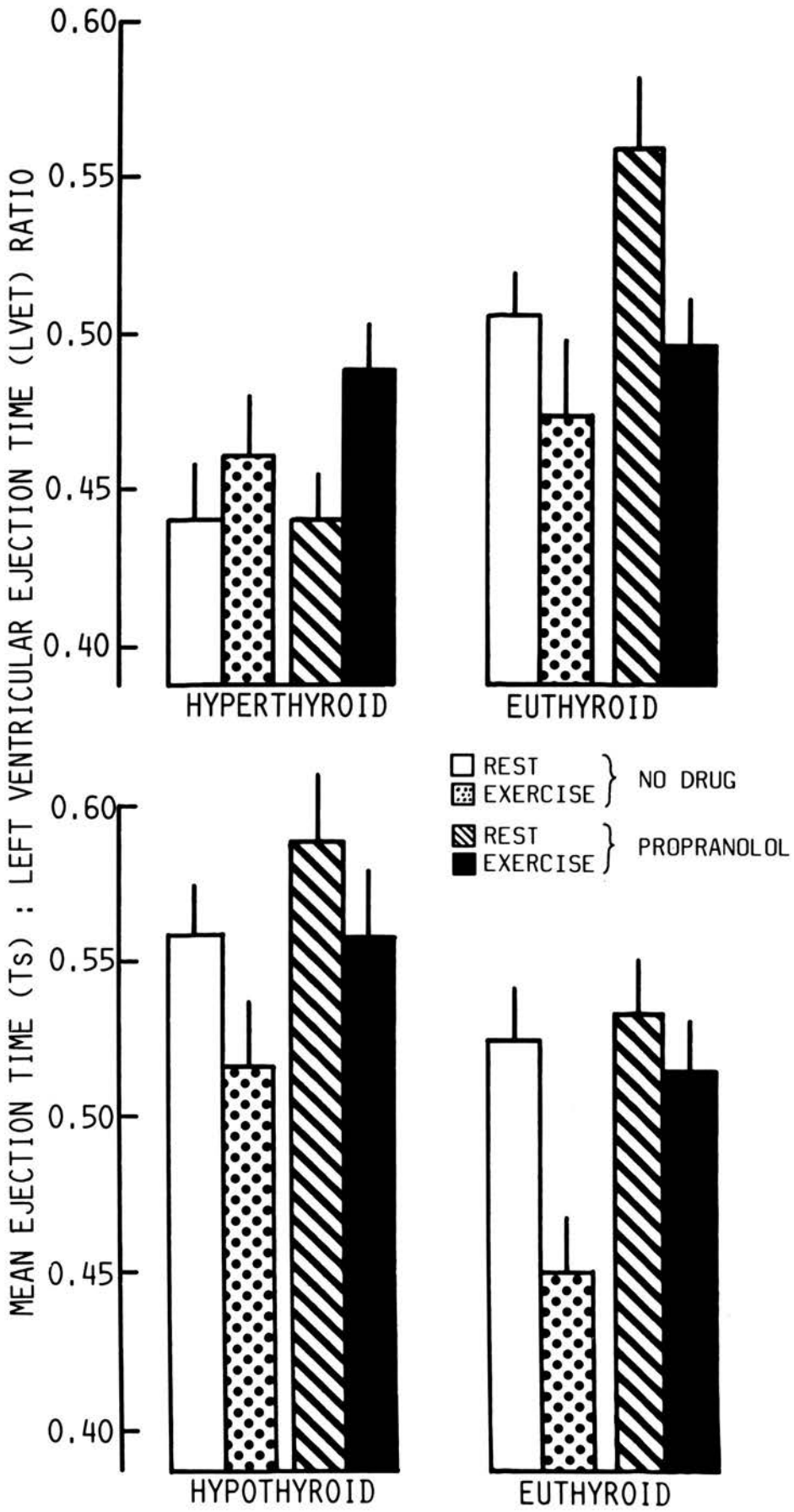
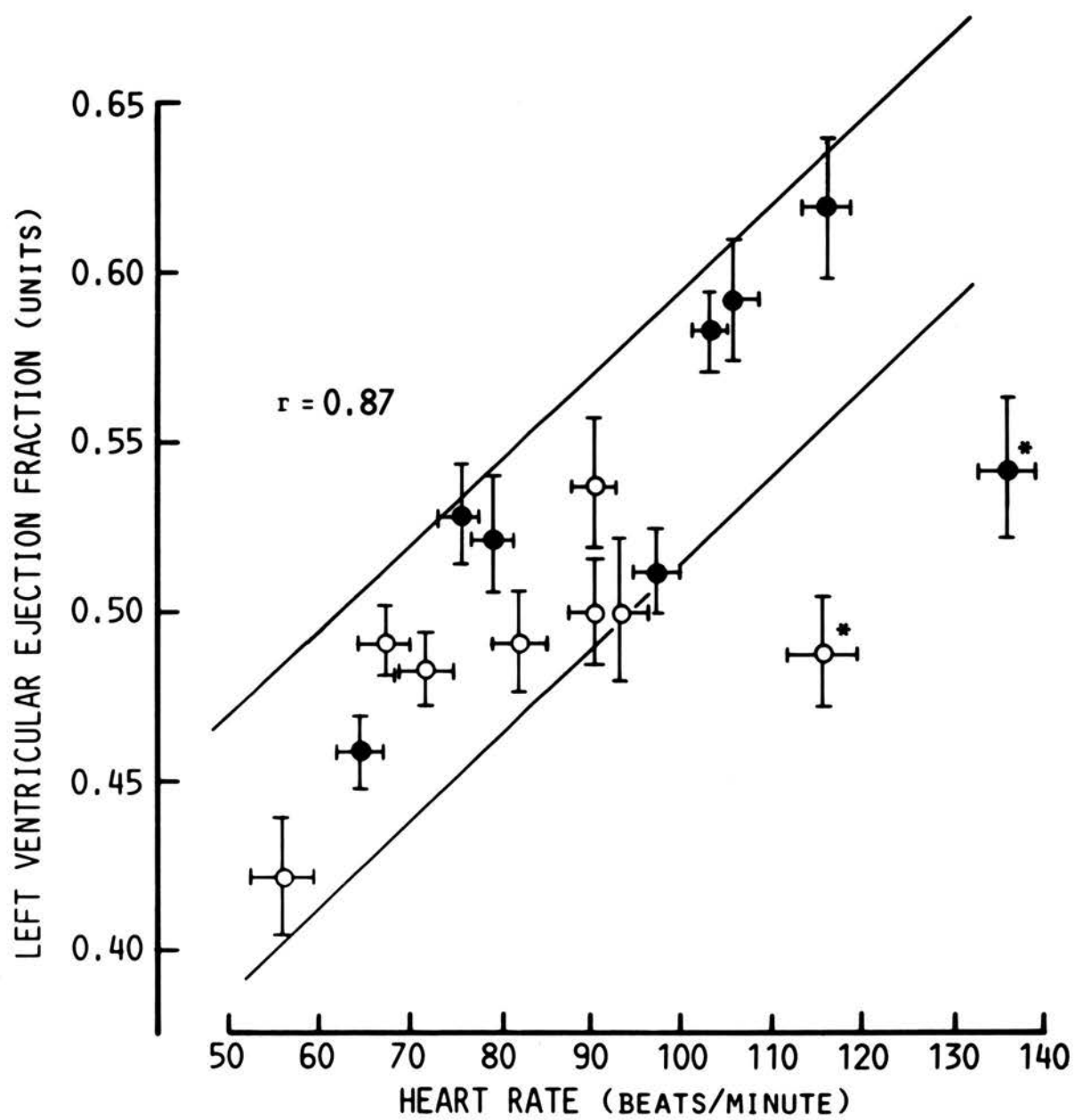

FIGURE 4.7 The relationship between LVEF and heart rate in hyperthyroid, hypothyroid and euthyroid groups before (closed symbols) and during (open symbols) beta-adrenoceptor blockade. LVEF is lower than anticipated for heart rate in the hyperthyroid patients during exercise (asterisks).



closer following propranolol ($r = 0.76$; $P < 0.001$) reflecting removal of the contribution of variable endogenous sympathetic tone to basal heart rate (Figure 4.8) and therefore greater dependence on thyroid hormone activity. Correlation between exercise heart rates and thyroid hormone concentrations did not achieve statistical significance at a 5 per cent level of confidence.

No abnormalities in regional wall motion were detected in any patient at rest or on exercise before or after propranolol.

DISCUSSION

The crucial role of thyroid hormones in adaptive hypertrophy of the heart has been recognised for many years (Beznak, 1963). Thyroid hormone feeding in several animal species leads to myocardial hypertrophy with up to a 50 per cent increase in heart weight (Sandler and Wilson 1959a; Beznak, 1962; Cohen et al, 1966; Skelton and Sonnenblick, 1974). Changes are reversible and independent of sympathetic innervation as they are unchanged following neuronal blockade with reserpine or 6-hydroxydopamine (Cohen et al, 1966; Cohen, 1974). Although no systematic measurements of heart mass before and after treatment have been made in clinical hyperthyroidism, electrocardiographic studies have noted increases in R wave amplitude in up to 30 per cent of hyperthyroid patients with resolution of changes following

FIGURE 4.8 The relationship between resting heart rate after beta-adrenoceptor blockade and plasma total thyroxine in hyperthyroid (n=9), hypothyroid (n=8) and euthyroid (n=16) subjects.

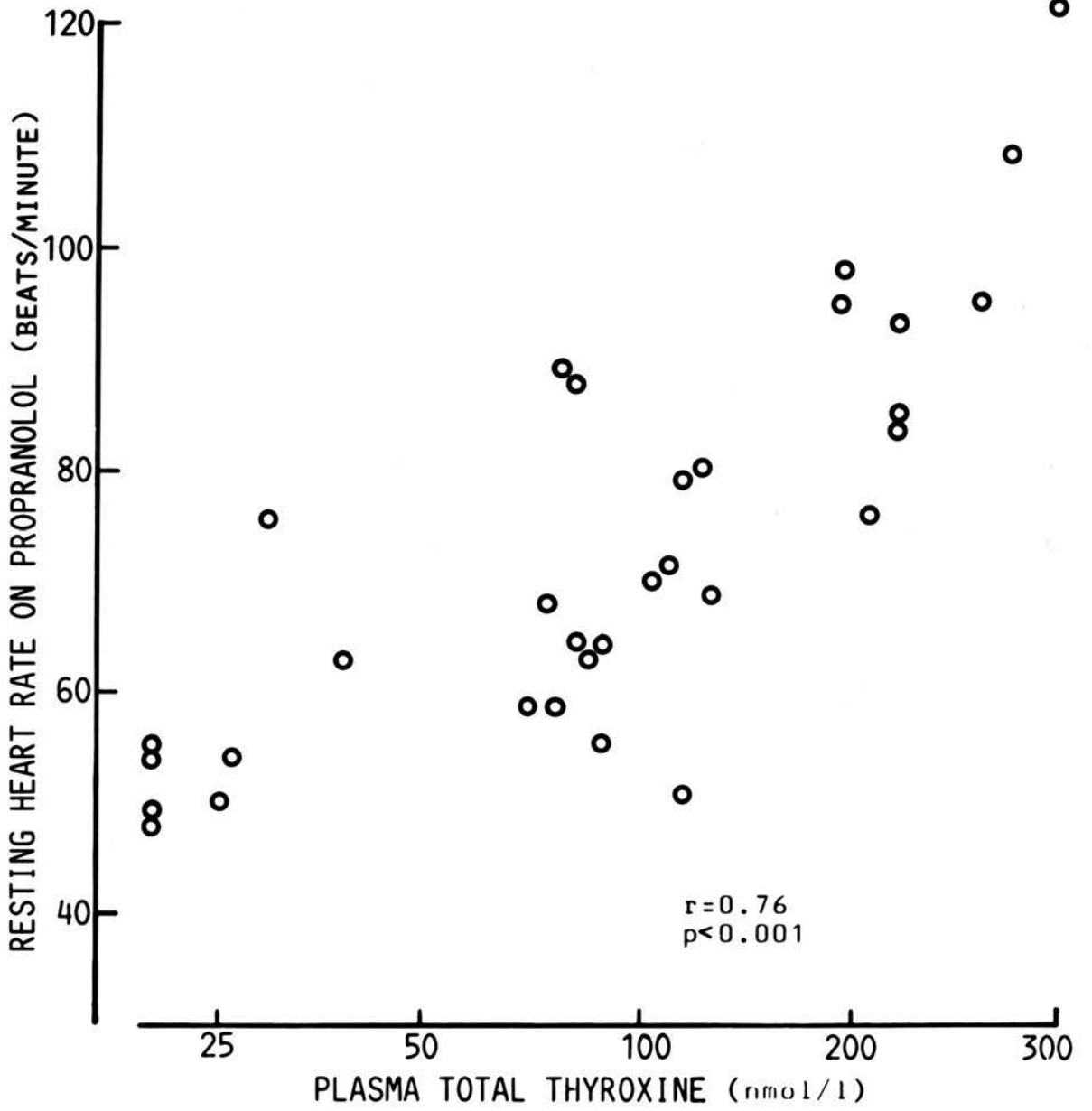

antithyroid therapy (Sandler, 1959; Motoki et al, 1966; Zgliczynski, 1966; Wong et al, 1979). The reduction in left ventricular voltages in hypothyroidism has been attributed to minimal pericardial effusion (Kerber and Sherman, 1975) or increase in electrical resistance of myxoedematous skin (Hallock, 1933). Although this may be part of the explanation in selected patients, voltages return towards normal within 24 hours of triiodothyronine feeding (Zondek, 1964) favouring a direct effect of thyroid hormone deficiency on the electrical properties of cardiac muscle. All of the changes in myocardial structure described regress following the re-establishment of a euthyroid state (Skelton and Sonnenblick, 1974). The presence of myocardial hypertrophy, however, is not necessarily associated with enhanced contractile performance (Skelton and Sonnenblick, 1974).

Several investigators have suggested enhanced myocardial contractile performance in the hyperthyroid state and impaired performance when hypothyroid (De Groot et al, 1961; Aoki et al, 1967; Amidi et al, 1968; Howitt et al, 1968). Indices of myocardial contractility derived from measurements of systolic time intervals have shown a shortened pre-ejection period and isovolumetric contraction time in hyperthyroidism (Parisi et al, 1974; Burckhardt et al, 1978) and reciprocal changes in hypothyroidism (Burckhardt et al, 1978; Paulus et al, 1980) that both return towards normal during therapy.

None of these studies, however, have assessed myocardial performance under stress.

The resting observations in the hyperthyroid state in our study are also in keeping with increased myocardial contractility. LVEF can, however, be influenced by changes in preload and afterload as well as contractile performance. Several haemodynamic studies in hyperthyroidism at rest have documented a major reduction in peripheral vascular resistance (Abrahamsen et al, 1963; Ueda et al, 1965; De Groot and Leonard, 1970; Funatsu, 1976) and an increase in circulating blood volume (Gibson and Harris, 1939), each of which would lead to an increase in LVEF independent of changes in myocardial contractility. Merillon et al, (1981), investigated left ventricular function in hyperthyroidism at rest by cardiac catheterisation. These workers noted an increase in cardiac output, LVEF, maximum rate of rise of left ventricular pressure (dp/dt max) and mean velocity of fibre shortening in hyperthyroidism associated with no change in mean aortic pressure and a 50 per cent reduction in peripheral vascular resistance. However, comparison of hyperthyroid and euthyroid subjects atrially paced to the same heart rate revealed that the increase in cardiac output during hyperthyroidism was primarily related to an increase in left ventricular end-diastolic volume and that rises in dp/dt max could be secondary to this increase (Mahler et al, 1975). Their data therefore imply that an

increase in the inotropic state of the ventricle does not occur in hyperthyroidism and that many of the findings of previous investigators could be explained on the basis of the peripheral effects of thyroid hormone excess, analogous to changes in other high output states (Duke and Abelmann, 1969).

The major finding in the present investigation of an exercise-induced fall in LVEF in hyperthyroidism extends the studies of Merillon et al to suggest abnormally depressed myocardial contractile activity. The fall in LVEF with exercise is not dependent on beta-adrenoceptor activation because it is similar before and after propranolol. The absolute LVEF on exercise (at the same workload) is significantly less in the hyperthyroid compared to the euthyroid state despite a lower heart rate in the latter. At the same heart rate (118 beats/min) exercise LVEF was 20 per cent lower in the hyperthyroid group after propranolol compared to the same patients euthyroid before beta-adrenoceptor blockade (figure 4.7). The changes in LVEF on exercise in the hyperthyroid patients contrast with the normal responses to exercise after specific antithyroid therapy, that is a rise in LVEF on exercise attenuated by beta-adrenoceptor blockade. This pattern was the same as in the euthyroid patients after initial hypothyroidism and is well within the normal range of response in our laboratory.

Although changes in left ventricular volumes have not been specifically studied in these patients, it is

unlikely that a change in peripheral vascular resistance on exercise would explain our results. Peripheral vascular resistance falls on exercise and should thus increase LVEF, the opposite of what was observed. Total end-diastolic counts and the number of cells in the region of interest of the ventricular volume curve give an index of diastolic volume: no significant differences with exercise were detectable between hyperthyroid and euthyroid groups.

The results in hypothyroidism show, as expected, an absolute reduction in myocardial contractile performance at rest and on exercise that appeared to be independent of beta-adrenoceptor activation and therefore presumably a direct effect of thyroid hormone deficiency. There were, however, no significant differences in left ventricular contractile responses to increased sympathetic tone (exercise) or to resting sympathetic blockade (propranolol) in the hypothyroid and euthyroid state. Attenuation of the rise in LVEF on exercise with propranolol was less marked when hypothyroid, possibly reflecting greater sympathetic activation on exercise in the hypothyroid state, in keeping with increases in systemic catecholamines discussed in chapter 1.

Heart rate per se may be a determinant of LVEF in man (Erhardt et al, 1977; Port et al, 1980) although the increase in heart rate with atropine has little effect on LVEF or Ts:LVET ratio (Muir et al, 1980). A fall in LVEF

might be caused either by a depression of intrinsic contractility or a reduction in heart rate. The fall in LVEF on exercise in the hyperthyroid state occurred despite an increase in heart rate of approximately 30 beats/minute. Exercise LVEF when hypothyroid was still slightly less than resting LVEF when euthyroid despite a substantially higher heart rate in the former group. It is thus likely that the results reflect a true reduction in myocardial contractile performance in both states of thyroid dysfunction.

The development of heart failure in hyperthyroidism without complicating tachydysrhythmias has now been established both clinically and experimentally. Piatnek-Leunissen and Olson (1967) observed that during treatment of dogs with thyroxine over a period of eight months, 25 per cent of animals developed objective signs of mild congestive heart failure with a relatively reduced cardiac output, elevated ventricular end-diastolic pressure and varying degrees of passive congestion of the lungs and heart. Clinical (Likoff and Levine, 1943) and autopsy (Sandler and Wilson, 1959) evidence in man supports the existence of heart failure in hyperthyroidism in the absence of any other complicating heart disease, although most patients had developed atrial fibrillation prior to cardiac decompensation. Atrial fibrillation is, however, very uncommon in neonatal hyperthyroidism, where heart failure may be a prominent feature (Shapiro et al, 1975). Ikram (1977) studied seven patients with hyperthyroid

heart failure and noted significant reductions in cardiac output, heart rate and right ventricular dP/dt max, compared to matched patients with uncomplicated hyperthyroidism. Acute beta-adrenoceptor blockade with propranolol caused a 30 per cent fall in cardiac output to subnormal levels in the heart failure group while in the controls, cardiac output fell by only 13 per cent and remained above normal. It is assumed that sinus rhythm persisted during the investigations described in Ikram's study. It is likely that these differences would be even greater during exercise (Graettinger et al, 1959). Histological study of hearts from hyperthyroid patients and experimental animals does not show a specific pattern of abnormality, although foci of lymphocytic and eosinophilic infiltration have been described. Electron microscopic abnormalities have been mainly confined to the mitochondria which are frequently increased in number, hypertrophied, and contain areas of vacuolization and disorientation of the cristae (Callas and Hayes, 1974). Changes appear totally reversible on return to the euthyroid state.

It is probable that isolated hypothyroidism rarely causes heart failure in the absence of complicating cardiac disease (Aber and Thompson, 1964), although there are often clinical difficulties in distinguishing between "myxoedema heart" and true congestive heart failure. The ability of LVEF to increase normally on exercise in

hypothyroidism contrasts with responses in heart failure (Epstein et al, 1967). Non-invasive assessment of isolated hypothyroid heart disease is complicated by clinical (Vanhaelst et al, 1967) and autopsy (Steinberg, 1968) evidence that coronary artery disease occurs more frequently in hypothyroid patients than in controls matched for age, sex, blood pressure and associated extra-thyroidal disorders. This agrees with experimental data to show that thyroid hormone deficiency consistently potentiates the development of atherosclerosis in cholesterol-fed animals (Malmros and Swahn, 1953) and that thyroid hormone administration can inhibit atherogenesis (Myasnikov and Zaitzev, 1963). Thyroid hormone deficiency is associated with raised plasma levels of very low and low density lipoproteins and impaired free fatty acid mobilisation principally due to impaired lipoprotein catabolism (Kritchevsky, 1960; Levy et al, 1974). These alterations in circulating lipids parallel those associated with the premature development of coronary artery disease (Kannel et al, 1976). The incidence of coronary disease in the hypothyroid patients reported in this chapter is unknown but it is of interest that the patient in whom a clinical diagnosis of angina pectoris was made was the only patient to show a small fall in LVEF on exercise in the hypothyroid state. A fall in LVEF on exercise is readily demonstrable in patients with coronary disease (Marshall et al, 1981). Intriguingly, LVEF increased normally in this patient when euthyroid.

Histological study of the myocardium in cases of severe hypothyroidism shows non-specific changes of myofibrillar swelling, oedema and interstitial fibrosis (Douglas and Jacobson, 1957). Although it is possible that irreversible impairment of cardiac function may develop in such extreme cases, all of our patients showed a return to normal function a maximum of eight months after starting oral thyroxine.

Previous studies into the effects of propranolol on resting LVEF in normal subjects have yielded conflicting results, showing either no effect or a depressant effect on resting ventricular performance (Helfant et al, 1971; Frishman et al, 1975; Shubrooks et al, 1975; Baron et al, 1980; Marshall et al, 1981). Differences are probably related to variability in drug dosage and route of administration, subject selection and methods of assessment of contractile performance. On exercise, propranolol consistently depressed left ventricular performance probably independent of its effect on heart rate (Sonnenblick et al, 1965; Erhardt et al, 1977). Our studies have shown that propranolol did not modify the pattern of change in contractile performance on exercise, in either the hyperthyroid or euthyroid state, although the rise in heart rate on exercise was attenuated. The exercise-induced tachycardia in hyperthyroidism is associated with enhanced beta-adrenoceptor mediated sympathetic activity, while the fall in LVEF on exercise

is not. It is not clear what components of the complex central and peripheral circulatory adjustments to exercise (including sympathetic activation and vagal withdrawal) are involved in the abnormal responses that have been documented. It is likely that it is the direct effects of excess or deficient circulating thyroid hormones that are the dominant influence on the myocardium.

Propranolol metabolism (Bell et al, 1977) and plasma protein binding (Kelly and McDevitt, 1978) are not influenced by thyroid status to any major extent (see chapter 7). It is thus unlikely that there would be major differences in plasma propranolol concentrations after intravenous administration at the three levels of thyroid activity. A reduction in peak exercise tachycardia of 13 per cent and 16 per cent in the hyperthyroid and euthyroid patients and of 16 per cent and 15 per cent in the hypothyroid and euthyroid patients respectively suggests similar functional beta-adrenoceptor antagonism in both groups. The dose of propranolol used (0.15 mg/kg) has been shown to cause a 20 to 30 fold increase in the isoprenaline dose required to increase the heart rate by 25 beats/min and to give plasma propranolol concentrations in the range 50-100 ng/ml (Coltart and Shand, 1970), suggesting satisfactory beta-adrenoceptor blockade over the study periods. Chronic propranolol administration causes a fall in levels of circulating T3 and a rise in levels of the metabolically inactive stereoisomer 'reverse' T3 (see chapter 2). It is

unlikely, however, that acute drug administration would alter plasma thyroid hormone levels sufficient to influence the cardiovascular responses at rest or on exercise through this mechanism.

The results highlight the major differences in cardiovascular effects of anti-thyroid or thyroxine replacement therapy on one hand and beta-adrenoceptor blockade on the other. None of the thyroid hormone related abnormalities in myocardial contractility were modified by beta-adrenoceptor blockade whereas all were restored to normal following attainment of the euthyroid state.

The clinical significance of these observations is unclear but may provide an explanation for the common symptoms of impaired exercise tolerance in hyperthyroidism. A fall in ventricular contractile performance on exercise is readily demonstrable in patients with coronary artery disease although the pathophysiological basis for this finding is more easily understood (Battler et al, 1979; Marshall et al, 1981). An abnormal LVEF on exercise has been suggested as an early index of left ventricular dysfunction in patients with asymptomatic aortic regurgitation (Borer et al, 1978) and with chronic iron overload (Leon et al, 1979). It may be that left ventricular dysfunction induced by exercise represents an intermediate state between normal left ventricular function and left ventricular dysfunction

at rest. It is at present unknown whether hyperthyroid patients, if untreated, would develop resting abnormalities and a true thyroid cardiomyopathy.

Our data provide evidence for the existence of a form of reversible cardiomyopathy in all patients with hyperthyroidism, manifest as an abnormal fall in LVEF on exercise, independent of beta-adrenoceptor activation. Left ventricular function is also reversibly depressed by thyroid hormone deficiency but relative responses to exercise before and during beta-adrenoceptor blockade are unimpaired. There is no evidence of altered adrenergic sensitivity in the control of myocardial contractile function during thyroid dysfunction. Thus, changes in adrenoceptor density, if they occur in man, are not associated with a change in the contractile response of the heart to altered sympathetic tone. Depression of myocardial contractile activity is detectable in different forms in both hyper- and hypothyroidism. Clinical evidence of contractile dysfunction in thyroid disease may simply represent one end of the spectrum of abnormality common to all patients with this disorder.

Addendum:

Since this thesis was completed, LVEF has been assessed in eight of the nine patients, initially hyperthyroid, who were restudied during exercise to the same heart rate as that achieved when hyperthyroid (134 +/- 6 beats / min). Exercise LVEF at this heart rate when euthyroid was 0.66 +/- 0.03, substantially greater than when hyperthyroid (0.55 +/- 0.02 ; $P < 0.01$). This data also supports the concept of depressed myocardial contractile function in hyperthyroidism independent of changes in heart rate.

CHAPTER 5

Delayed normalisation of ventricular function during antithyroid therapy: echophonocardiographic analysis of responses to isometric exercise and autonomic blockade.

As discussed briefly in the previous chapter, assessment of intrinsic contractile function of the heart in hyperthyroidism is complicated by changes in preload from increased circulating blood volume and changes in afterload from reduced peripheral vascular resistance. Thus, Merillon et al (1981) noted a 34 per cent increase in left ventricular end-diastolic volume and a 46 per cent fall in peripheral vascular resistance in hyperthyroid subjects compared to euthyroid subjects atrially paced to the same heart rate. Interpretation of indices of ventricular function at rest is therefore unreliable. Isovolumetric phase indices of contractility such as the maximum rate of rise of ventricular pressure (dp/dt max), dp/dt at a given pressure, or pre-ejection period indices from systolic time intervals appear to be particularly affected by alteration in preload (such as acute volume overload), whereas ejection phase indices such as ejection fraction or mean velocity of circumferential fibre shortening (Vcf) are more influenced by changes in afterload (such as phenylephrine infusion) (Mahler et al, 1976). It has been claimed that ejection phase indices such as Vcf are independent of preload (Ross and Peterson, 1973; Quinones et al, 1975) and are preferable to isovolumetric indices in the detection of patients with diffuse myocardial disease (Karlner et al, 1971; Peterson et al, 1974).

Isometric exercise, such as sustained handgrip, provides a convenient means of inducing a significant stress on the myocardium. Myocardial oxygen consumption is increased through a combination of increased afterload, inotropic activity and heart rate, the latter mediated as much by vagal withdrawal as by sympathetic activation (Freyschuss, 1970). In these respects, isometric exercise differs considerably from dynamic exercise and may be a more effective and reproducible form of stress on the heart (Lindquist et al, 1973). It is readily applicable to echocardiographic techniques that provide an accurate, simple and non-invasive assessment of myocardial dimensions and contractile function (Cooper et al, 1972; Belenkie et al, 1973; Fortuin et al, 1977).

The purpose of this investigation was to examine simultaneously isovolumetric and ejection phase indices of myocardial contractile function before and during isometric exercise in hyperthyroid patients using the combined technique of echophonocardiography. This totally non-invasive method of assessment can be repeated at intervals during antithyroid therapy to establish the pattern of change in ventricular function with respect to thyroid activity. In addition, the effect of autonomic blockade was examined to determine the influence of vagosympathetic activity on the responses to isometric exercise. The study was

designed both to confirm or refute the abnormalities on dynamic exercise shown in chapter 4, and to determine by prospective longitudinal analysis whether there was a direct temporal relationship between thyroid hormone concentrations and myocardial function, as has been claimed by other investigators (Paulus et al, 1980; Cohen et al, 1981).

METHODS

Fifteen hyperthyroid patients, all women, with a mean age of 45 years (range 23-65 years) were studied in the untreated hyperthyroid state and at intervals during antithyroid therapy. Eleven patients had Graves' disease and four had a toxic multinodular goitre. Hyperthyroidism was diagnosed clinically and on the basis of raised levels of plasma total thyroxine (T4) and triiodothyronine (T3) associated with an absent response of plasma thyrotrophin (TSH) 20 minutes after the intravenous injection of 200ug thyrotrophin-releasing hormone and increased four hour uptake of iodine 132 by the thyroid gland. No patient had evidence of concurrent cardiovascular disease based on clinical examination, ECG and chest X-ray although two patients (nos. 2 and 6) had clinical evidence of mitral valve prolapse, confirmed by echocardiography^p. The echocardiographic appearances were not modified by antithyroid therapy. All patients were restudied when a

biochemical euthyroid state had been achieved for at least three months. Eleven patients received a therapeutic dose of iodine 131, two patients received carbimazole and one underwent a subtotal thyroidectomy. A euthyroid state developed spontaneously in patient no. 3. In addition, nine of these patients were studied on a total of 19 occasions at 3-6 week intervals during antithyroid therapy prior to the establishment of a stable euthyroid state.

At each outpatient attendance, blood was withdrawn for estimation of plasma total T4, T3 and plasma TSH immediately prior to the echophonocardiographic study. Plasma thyroid hormones and TSH were measured by specific radioimmunoassay (Irvine et al, 1973; Seth et al, 1976) as described in chapter 2.

All patients gave informed consent to participate and were familiarised with the recording equipment prior to the first study. After a ten minute rest period and insertion of a peripheral venous infusion cannula, systolic time interval measurements were recorded in the supine position according to established techniques (Lewis et al, 1977) using a Kontron Irex Mark III combined echocardiography / phonocardiography instrument with appropriate frequency filters. All recordings were made at a paper speed of 100mm per second (Spodick et al, 1969) and averaged over at least 10 cardiac cycles to minimise respiratory variation. From simultaneous recordings of

the electrocardiogram (lead II), phonocardiogram and carotid pulse tracings, the following parameters were measured:

- 1) Left ventricular ejection time (LVET) - from the beginning of the initial upstroke to the trough of the incisural notch of the carotid pulse tracing.
- 2) Total electromechanical systole (QS_2) - from the beginning of the Q wave of the electrocardiogram to the first high frequency component of the aortic component of the second heart sound.
- 3) Electromechanical delay (QS_1) - from the beginning of the Q wave of the electrocardiogram to the first high frequency component of the first heart sound.

From these measurements, the preejection period (PEP) [QS_2 -LVET] and the isovolumetric contraction time (ICT) [PEP- QS_1] were determined (figure 5.1). Heart rate-corrected indices for LVET, QS_2 and PEP were derived from the standard regression equations of Weissler et al (1968), based on measurements from resting normal subjects and also on the studies of Lindquist et al (1973) with normal subjects during isometric exercise. Only those recordings clearly showing the onset of the Q-wave, the first high frequency vibrations of the heart sounds and a sharp upstroke and incisura of the carotid tracings were used for measurement of the above parameters. All measurements were made to the nearest five milliseconds (msecs).

FIGURE 5.1 Simultaneous determination of systolic time intervals from carotid pulse, phonocardiogram and electrocardiogram tracings (upper panel) and determination of left ventricular dimensions from M-mode echocardiogram (lower panel).
LVET-left ventricular ejection time: QS_1 -electromechanical delay: PEP-preejection period: ICT-isovolumetric contraction time: LVEDD/LVESD-left ventricular end-diastolic / end-systolic dimensions: RV-right ventricle: IVS- interventricular septum: LV-left ventricle: LVPW-left ventricular posterior wall.

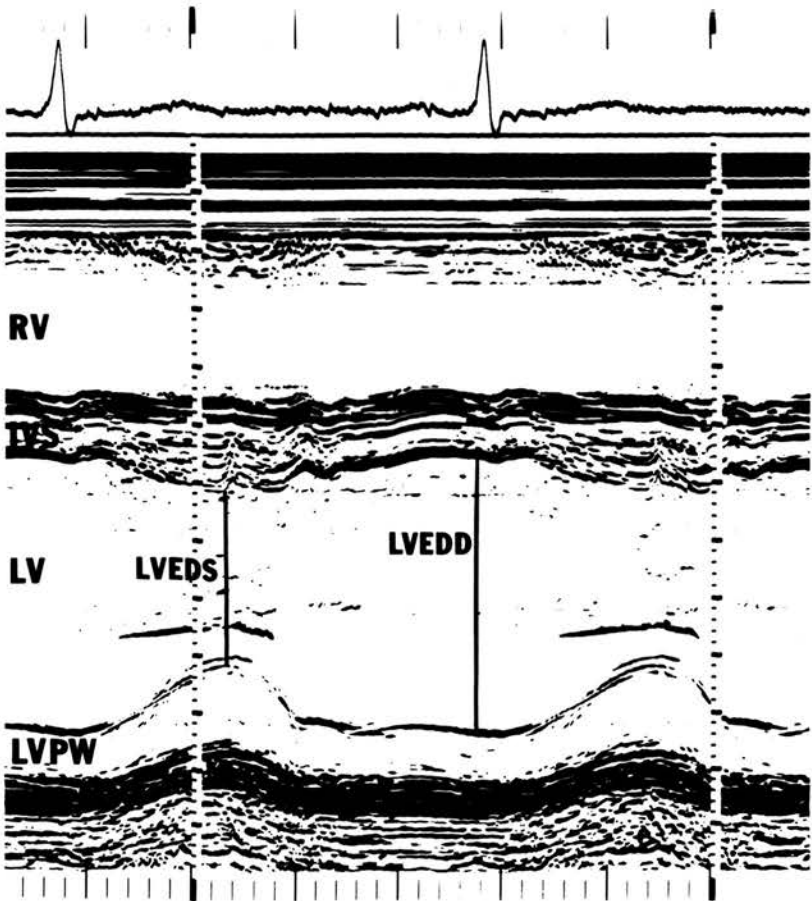
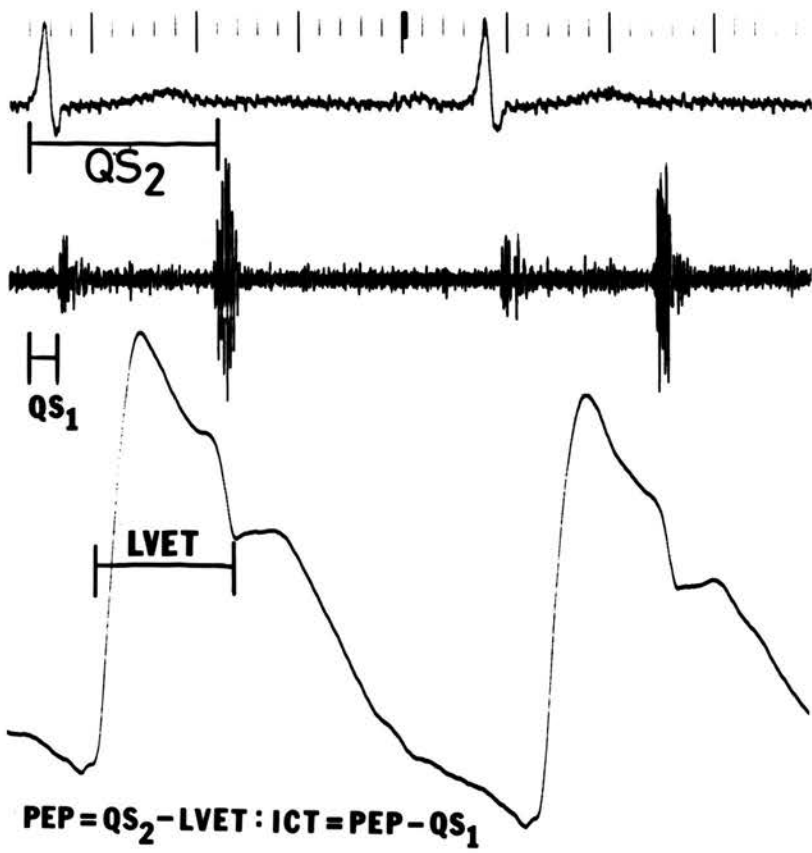

Echocardiography was performed from the third or fourth intercostal space either supine or in the 30° left lateral decubitus position immediately following the systolic time interval measurements. An initial two-dimensional examination using a phased array scanner was used for orientation of the M-mode examination of the left ventricular chamber. Thereafter, a 2.5 megahertz single element transducer was used and left ventricular wall motion recorded with the ultrasound beam directed at the chamber between the mitral valve echoes and the papillary muscle echoes (figure 5.1; Sahn et al, 1978). Left ventricular end-diastolic dimension (LVEDD) was taken from the trailing edge of the left side of the interventricular septum to the leading edge of the posterior endocardial echo at the R wave of the electrocardiogram and left ventricular end-systolic dimension (LVESD) from the same sites at the time of peak upward motion of the posterior left ventricular endocardium (Feigenbaum, 1981). From these measurements, the mean velocity of circumferential shortening of the left ventricle (Vcf) was derived according to the following equation:-

$$Vcf = \frac{LVEDD - LVESD}{LVEDD \times LVET} \quad (\text{circumferences /sec.})$$

The patient and transducer position for optimal

recording were noted for each subject at the time of initial study, and these were duplicated for subsequent echocardiograms. All values were averaged over a minimum of five consecutive cardiac cycles. Systolic blood pressure was determined at rest using a mercury sphygmomanometer, the cuff being placed on the arm not used for the isometric test.

Following the basal measurements, isometric exercise was performed with a handgrip dynamometer (Department of Medical Physics, RIE) held at arms length with the arm supported. After first determining maximum voluntary contraction (MVC) each patient squeezed the dynamometer at 30 per cent of the MVC for a period of three minutes. Systolic blood pressure measurements were repeated after two minutes and the echophonocardiographic analysis between the second and third minutes of handgrip. Care was taken to ensure that the orientation of the transducer was similar during the rest and exercise echocardiogram.

In most patients, after a further 15 minute rest period, propranolol 0.15 mg/kg was given intravenously over five minutes followed by intravenous atropine 0.02 mg/kg over a similar period. Fifteen minutes later, the above protocol was repeated both at rest and during isometric exercise.

Identical studies were repeated at intervals during antithyroid therapy and when a biochemical euthyroid state had been achieved for at least three months. Acute

autonomic blockade was omitted in patient no. 1 because of mild asthma and in patient no.5 for studies 2, 3 and 4 because of dizziness during the initial study. In addition, patients receiving concurrent oral beta-adrenoceptor blocking agents as part of the routine early management of hyperthyroidism (patient no. 4, study 2; patient no. 11, studies 2, 3 and 4) were not subject to additional autonomic blockade. The data obtained at these times were included with the other studies during autonomic blockade.

Echophonocardiographic measurements were therefore repeated at intervals over several months. Although reproducibility studies were not performed on these patients, others (Lewis et al, 1974; Clark et al, 1980; Cohen et al, 1981) have demonstrated a small mean standard deviation for systolic time intervals (e.g. \pm 5 msec for LVET; \pm 4.3 msec for PEP) and Vcf (\pm 0.05 circumferences per sec) when repeated over days and weeks in the same healthy subjects. A preliminary study undertaken on four normal subjects on four separate occasions using the above protocol showed similar day to day variability in these parameters.

All measurements of ventricular function during antithyroid therapy were made without knowledge of thyroid hormone concentrations or current antithyroid treatment. Statistical analysis used Student's t-test for pair differences. Correlations between thyroid hormones and

indices of ventricular function used a linear regression coefficient with least squares method of analysis and computed t-statistic after semilog transformation. Experimental data are quoted as mean \pm SEM.

RESULTS

Untreated hyperthyroidism

Details of systolic time intervals, systolic blood pressure, heart rate, ventricular dimensions and the derived indices of ventricular function at rest and during isometric exercise are shown in tables 5.1 and 5.2. Systolic time interval indices (corrected for heart rate) for QS_2 , LVET and PEP have been calculated according to theregression equations of Weissler et al (1968) at rest and from those of Lindquist et al (1973) during isometric exercise.

At rest, absolute mean LVET was relatively short at 253 \pm 6 msec but LVETI was not significantly different from that predicted (418 \pm 11 msec) either before (413 \pm 5 msec) or during (408 \pm 7 msec) autonomic blockade. LVET did not change with isometric exercise, and LVETI, using the Lindquist equation (based on normal subjects during isometric exercise) was not significantly different from normal either before (exercise LVETI 377 \pm 6 msec) or after (exercise LVETI 374 \pm 3 msec) autonomic blockade (predicted LVETI 379 \pm 14 msec).

Mean QS_2 was also relatively short at rest, but

	UNTREATED		AUTONOMIC REST	BLOCKADE EXERCISE
	REST	EXERCISE		
Patients	15	15	14	14
Syst BP(mmHg)	126 +/-5	151 +/-5	115 +/-4	126 +/-3
HR(beats/min)	99 +/-4	108 +/-5	85 +/-4	90 +/-4
LVET (msecs)	253 +/-6	252 +/-5	266 +/-6	266 +/-6
LVETI (Weissler)	413 +/-5	-	408 +/-7	-
LVETI (Lindquist)	-	377 +/-6	-	374 +/-3
QS ₂ (msecs)	324 +/-8	331 +/-8	348 +/-8	362 +/-8
QS ₂ I (Weissler)	522 +/-14	-	518 +/-12	-
QS ₂ I (Lindquist)	-	525 +/-6	-	520 +/-7
PEP (msecs)	71 +/-4	79 +/-5	81 +/-5	95 +/-5
PEPI (Weissler)	111 +/-4	-	117 +/-5	-
PEPI (Lindquist)	-	144 +/-4	-	149 +/-5
ICT (msecs)	30 +/-3	37 +/-3	39 +/-3	46 +/-3
PEP:LVET	0.28 +/-0.02	0.31 +/-0.01	0.30 +/-0.02	0.36 +/-0.02

TABLE 5.1 Systolic blood pressure, heart rate and systolic time interval measurements (mean+/-SEM) in untreated hyperthyroid patients at rest and during handgrip isometric exercise before and after autonomic blockade (see text for abbreviations).

unlike the ejection time values, QS_2 was significantly less than predicted (resting QS_2I 522 \pm 14 msec; predicted QS_2I 549 \pm 3 msec; $P < 0.01$). In contrast, QS_2I was significantly greater than predicted during isometric exercise (exercise QS_2I 525 \pm 6 msec; predicted QS_2I 514 \pm 6; $P < 0.05$). Mean QS_2 at rest increased by 24 msec during autonomic blockade in keeping with a fall in heart rate from 99 to 85 beats per minute. QS_2I at rest was not influenced by autonomic blockade. On exercise after autonomic blockade, however, the QS_2I was also greater than predicted (520 \pm 7 msec; $P < 0.05$).

As a consequence of the changes in electromechanical systole, both PEP and PEPI were shorter than predicted in the resting hyper^hthyroid state before (PEPI 111 \pm 4 msec; predicted PEPI 133 \pm 10 msec) and during (PEPI 117 \pm 5 msec) autonomic blockade. On exercise, PEP increased from 71 \pm 4 to 79 \pm 5 msec with a substantial increase in PEPI from 111 \pm 4 to 144 \pm 4 msec ($P < 0.005$). The exercise PEPI was 9 msec longer than predicted from the regression equation (predicted PEPI 135 \pm 13 msec). This increase resulted mainly from an increase in isovolumetric contraction time (table 5.1). The pattern of prolongation in PEP and PEPI on exercise was similar during autonomic blockade. PEPI increased from 117 \pm 5 to 149 \pm 5 msec ($P < 0.005$). The PEP:LVET ratio increased on exercise before and after autonomic blockade (table 5.1).

Left ventricular end-diastolic dimensions were not

	UNIREATED		AUTONOMIC BLOCKADE	
	REST	EXERCISE	REST	EXERCISE
LVID (cms)				
DIASTOLE	4.2 +/-0.2	4.3 +/-0.1	4.2 +/-0.1	4.2 +/-0.1
SYSTOLE	2.7 +/-0.1	3.2 +/-0.2	3.2 +/-0.1	3.3 +/-0.1
Vcf (circ/sec)	1.40 +/-0.10	1.01 +/-0.09	0.90 +/-0.05	0.78 +/-0.05

TABLE 5.2 Left ventricular systolic and diastolic dimensions and derived velocity of circumferential fibre shortening (Vcf) in untreated hyperthyroid patients at rest and during isometric exercise before and after autonomic blockade.

influenced by exercise or autonomic blockade (table 5.2). Exercise and autonomic blockade alone increased left ventricular end-systolic dimensions (2.7 +/- 0.1 cms rest; 3.2 +/- 0.2 cms exercise; 3.2 +/- 0.1 cms autonomic blockade [P<0.01]) with a further minor increase in combination (3.3 +/- 0.1 cms). As a result, mean Vcf decreased on exercise by 30 per cent before and by 13 per cent after autonomic blockade. As might be anticipated, resting Vcf also decreased (by 33 per cent) with autonomic blockade (table 5.2).

The changes in these parameters with exercise are summarised in figure 5.2. Systolic time intervals have been presented as indices, with predicted values (+/- 1 SD) shown for comparison. PEPI has thus changed substantially with exercise from 21 +/- 3 msec less than predicted to 9 msec greater than predicted (P<0.01), with similar/prolongation/on/exercise/with autonomic blockade.

Established euthyroid state

The same parameters of ventricular function in the same patients after a euthyroid state had been achieved for at least three months are presented in tables 5.3 and 5.4 and summarised in figure 5.3. Compared to the hyperthyroid state, resting LVETI was unchanged but QS₂I was significantly prolonged both before (Δ QS₂I 20 +/- 11 msec; P<0.05) and after (Δ QS₂I 36 +/- 12 msec, P<0.02) autonomic blockade. A striking prolongation of the PEPI was also observed in the euthyroid patients at rest (Δ

FIGURE 5.2 Mean (+/- SEM) systolic time interval indices (LVETI, QS₂I, PEPI) and velocity of circumferential shortening of the left ventricle (Vcf) in 15 hyperthyroid patients at rest and with isometric exercise before (Cont.) and after (Aut. Bl.) autonomic blockade. Predicted values (+/- SD) for normal subjects are also indicated. See text for abbreviations.

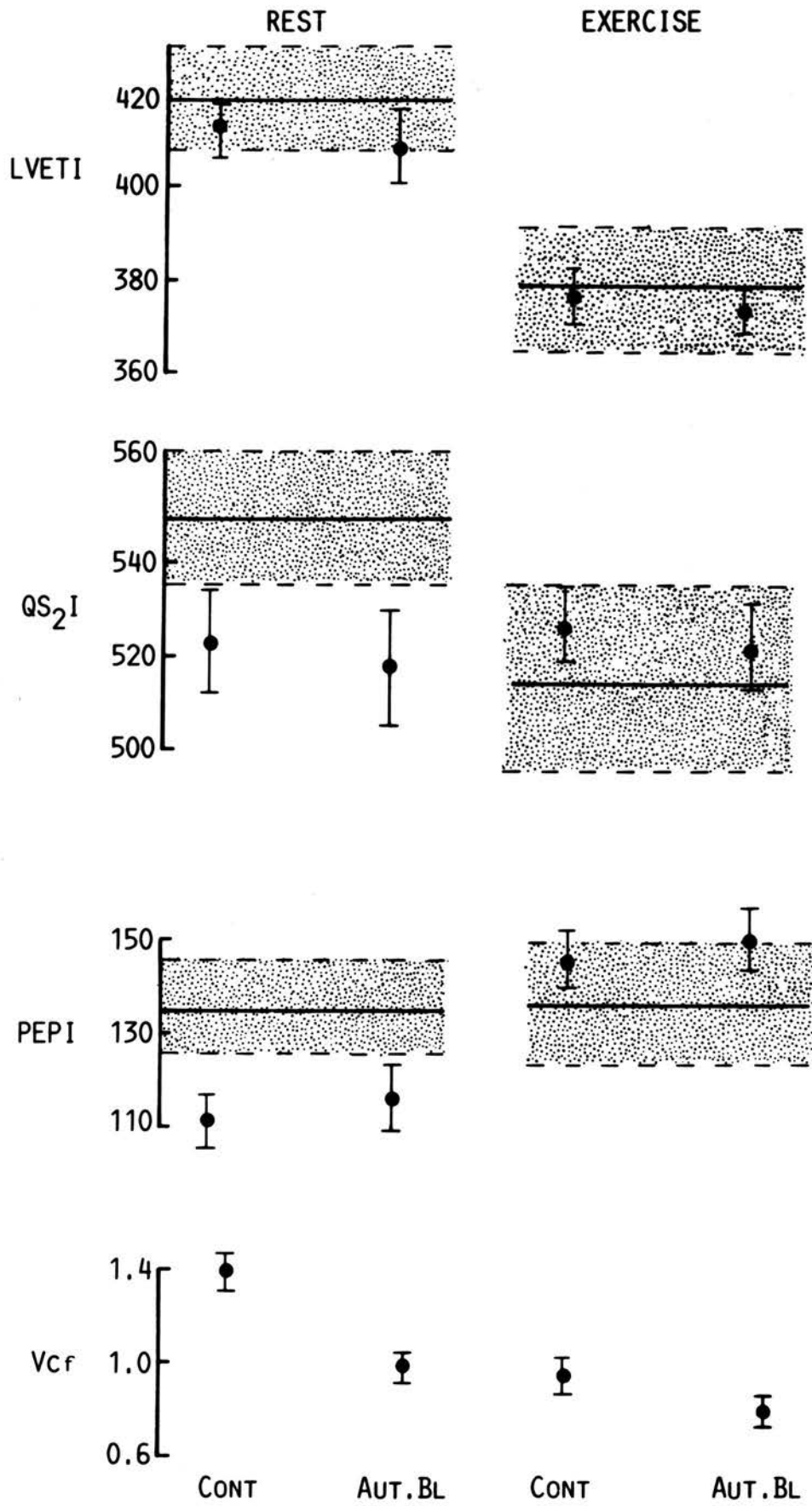

	REST	EXERCISE	REST	EXERCISE
Patients	15	15	13	13
Syst BP (mmHg)	119 +/-6	144 +/-10	114 +/-6	130 +/-8
HR (beats/min)	82 +/-6	93 +/-7	71 +/-4	74 +/-7
LVET (msecs)	279 +/-7	280 +/-8	295 +/-5	298 +/-7
LVETI (Weissler)	410 +/-6	-	409 +/-6	-
LVETI (Lindquist)	-	387 +/-8	-	384 +/-8
QS ₂ (msecs)	378 +/-9	363 +/-10	410 +/-10	393 +/-6
QS ₂ I (Weissler)	542 +/-13	-	554 +/-11	-
QS ₂ I (Lindquist)	-	526 +/-11	-	522 +/-7
PEP (msecs)	98 +/-8	80 +/-5	118 +/-9	95 +/-5
PEPI (Weissler)	130 +/-6	-	146 +/-9	-
PEPI (Lindquist)	-	135 +/-4	-	139 +/-4
ICT (msecs)	56 +/-5	41 +/-4	72 +/-7	69 +/-7
PEP:LVET	0.34 +/-0.02	0.29 +/-0.02	0.39 +/-0.03	0.32 +/-0.02

TABLE 5.3 Systolic blood pressure, heart rate and systolic time interval measurements (mean+/-SEM) in patients when euthyroid at rest and during isometric exercise before and after autonomic blockade (see text for details).

	CONTROL		AUTONOMIC BLOCKADE	
	REST	EXERCISE	REST	EXERCISE
LVID (cms)				
DIASTOLE	4.0 +/-0.2	4.1 +/-0.2	4.1 +/-0.2	4.2 +/-0.2
SYSTOLE	3.0 +/-0.1	2.9 +/-0.2	3.2 +/-0.2	3.2 +/-0.2
Vcf (circ/sec)	0.90 +/-0.10	1.02 +/-0.10	0.73 +/-0.14	0.79 +/-0.16

TABLE 5.4 Left ventricular systolic and diastolic dimensions and derived velocity of circumferential fibre shortening (Vcf) in euthyroid patients at rest and during isometric exercise before and after autonomic blockade.

PEPI [euthyroid - hyperthyroid] 19 +/- 6 msec before and 29 +/- 9 msec after autonomic blockade). On exercise LVETI in the euthyroid patients was slightly longer than when hyperthyroid but results did not achieve statistical significance at a 5 per cent level of confidence. In direct contrast to the hyperthyroid data, however, exercise PEPI was shorter in the euthyroid state both before (exercise PEPI euthyroid 135 +/- 4 msec; exercise PEPI hyperthyroid 144 +/- 4 msec; $P < 0.05$) and after (exercise PEPI euthyroid 139 +/- 4 msec; exercise PEPI hyperthyroid 149 +/- 5 msec; $P < 0.05$) autonomic blockade. This is reflected in an 11 per cent prolongation of PEP on exercise when hyperthyroid, compared with an 18 per cent reduction in PEP when euthyroid, despite similar increases in heart rate at both levels of thyroid function. It is likely that the majority of these differences are accounted for by changes in isovolumetric contraction time (table 5.3).

Mean resting Vcf fell when euthyroid by 36 per cent (table 5.4) but in contrast to the exercise-induced fall in the hyperthyroid state, Vcf did not change with exercise either before or after autonomic blockade. Propranolol and atropine increased left ventricular end-systolic diameter at both levels of thyroid function but end-diastolic diameter was unchanged. There was a trend for an increased left ventricular end-diastolic diameter in the hyperthyroid state but this increase did not quite

FIGURE 5.3 Systolic time interval indices and velocity of circumferential shortening of the left ventricle in the same patients as shown in figure 5.2 after a biochemical euthyroid state had been achieved for at least three months.

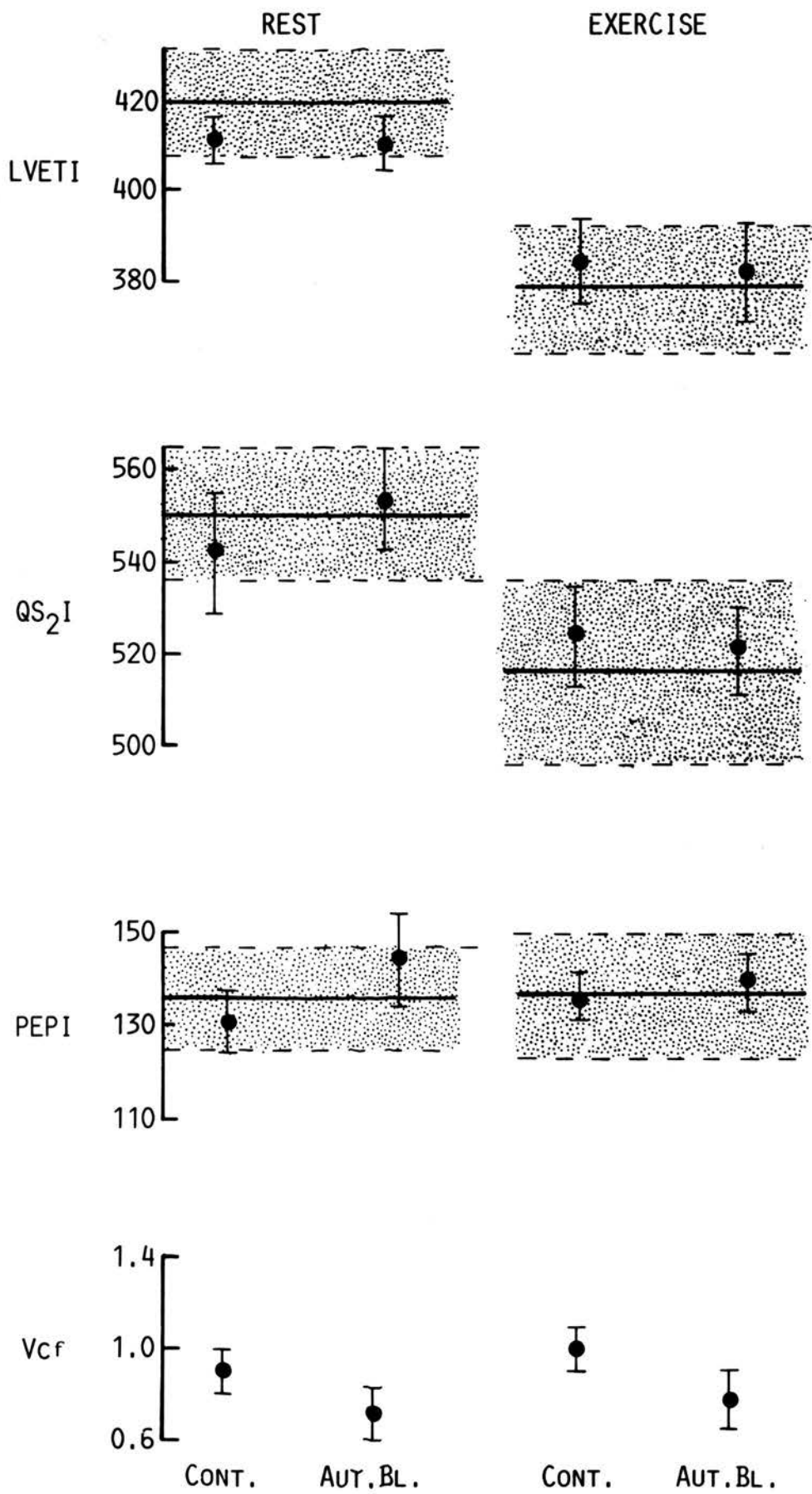

achieve statistical significance ($0.1 > P > 0.05$). Left ventricular end-systolic diameter was less than control when hyperthyroid at rest but slightly greater than control on exercise. Thus, mean Vcf on exercise was similar in both hyperthyroid and euthyroid groups (table 5.2 and table 5.4).

All of the systolic time interval index measurements in the euthyroid patients at rest and on exercise prior to autonomic blockade were within one standard deviation of the expected mean, based on analysis of normal subjects.

Ventricular function - thyroid hormone relationships

A fairly close inverse correlation was observed between resting PEPI and levels of thyroid hormones in hyperthyroid and euthyroid patients, both before and during autonomic blockade (figure 5.4). A similar but direct relationship existed for Vcf (figure 5.5). Although triiodothyronine is the physiologically more active hormone, plasma thyroxine has been used for correlations because of the relatively large number of patients (6 out of 15) on permanent thyroxine replacement therapy when euthyroid.

On exercise, and in contrast to the resting data, neither isovolumetric nor ejection phase indices of ventricular function correlated significantly with plasma thyroid hormones before or after autonomic blockade. However, the change in PEPI and Vcf with exercise correlated with thyroid hormone level before and during

FIGURE 5.4 Plasma thyroxine and resting preejection period index in hyperthyroid patients and the same patients euthyroid before (upper panel) and during (lower panel) autonomic blockade (semi-log scale).

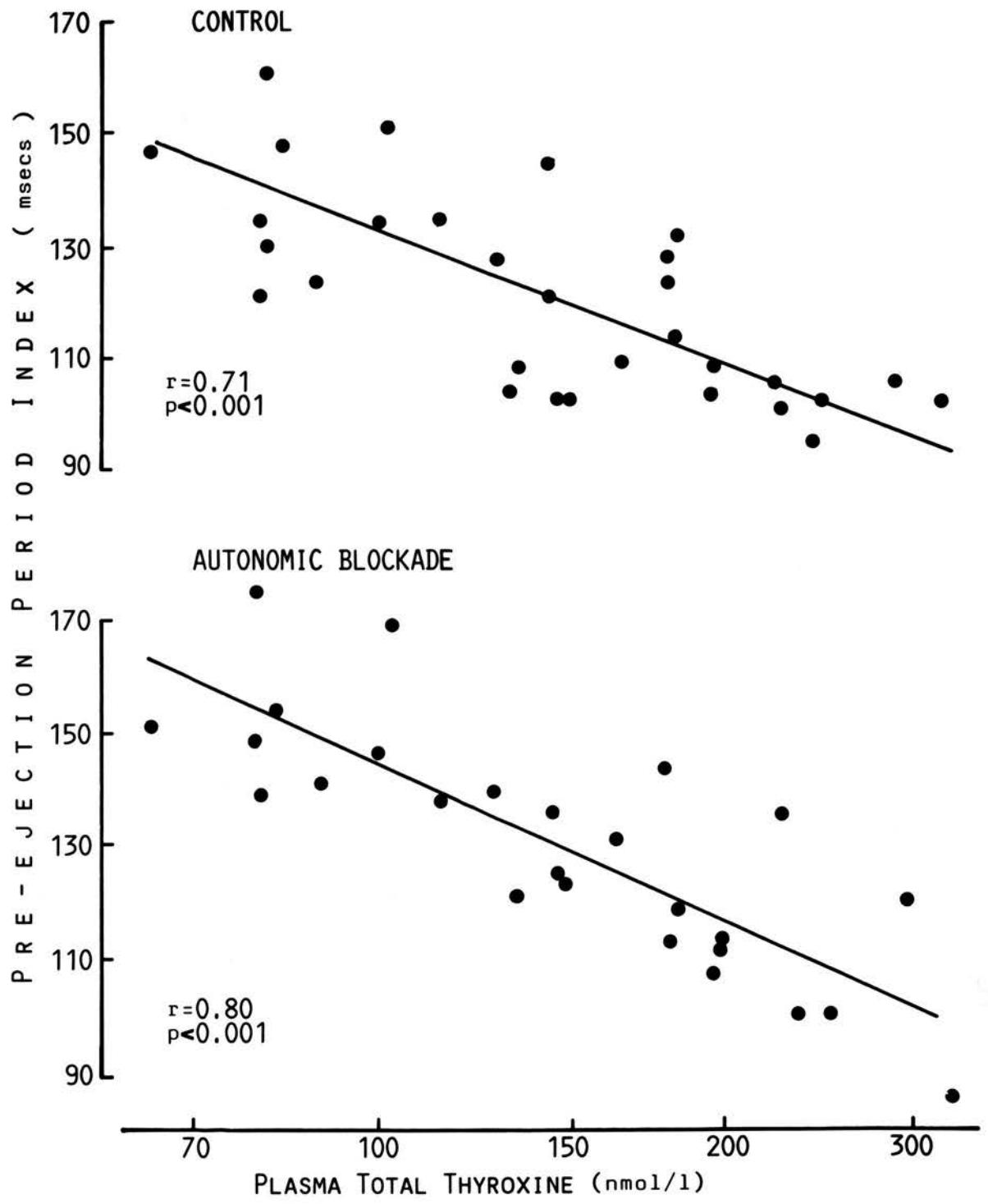
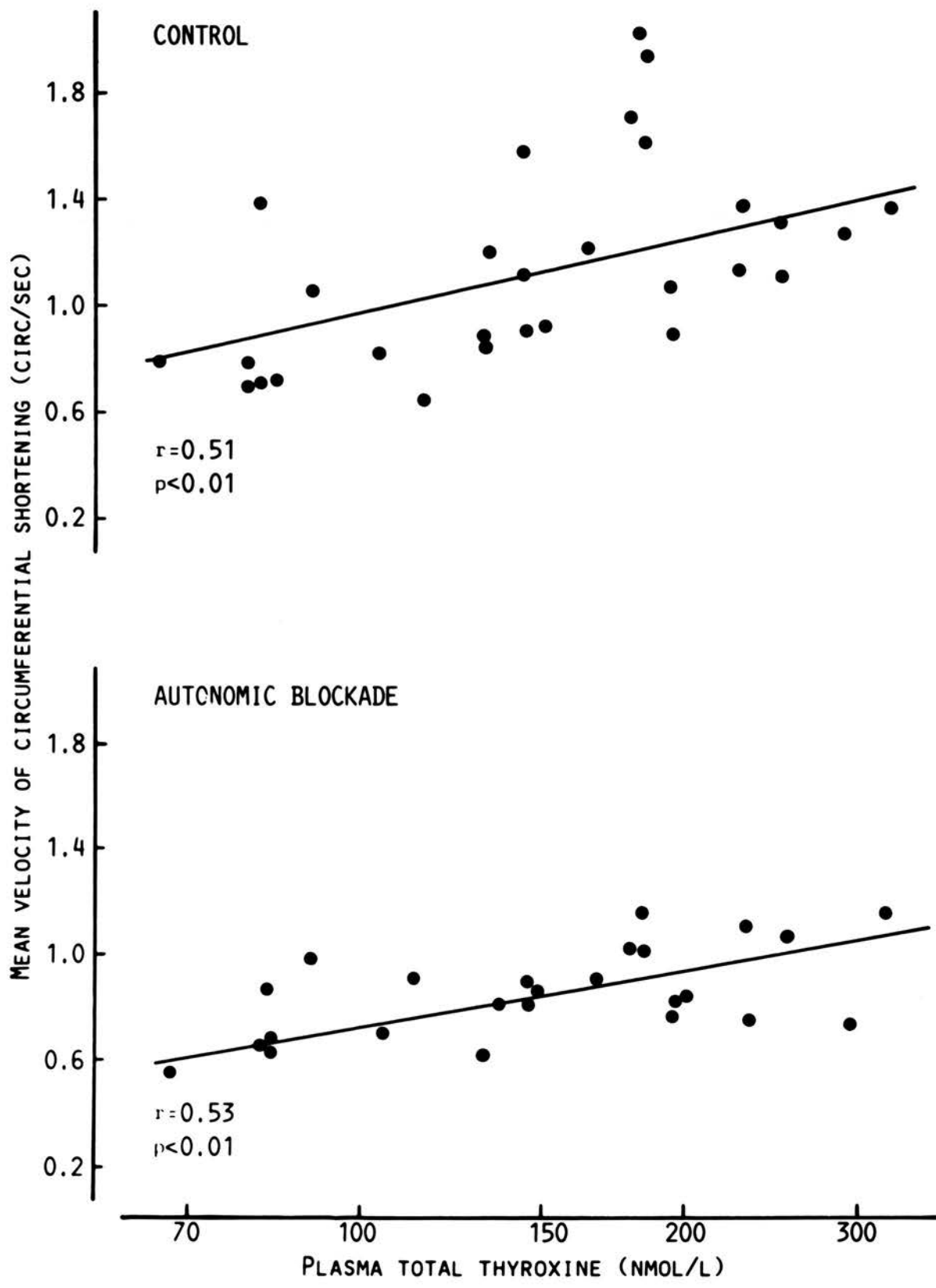

FIGURE 5.5 Plasma thyroxine and resting mean velocity of circumferential shortening of the left ventricle in hyperthyroid patients and the same patients euthyroid before (upper panel) and during (lower panel) autonomic blockade (semi-log scale).



autonomic blockade, the relationship being closest after propranolol and atropine (figure 5.6).

Ventricular function during antithyroid therapy

In four of the nine patients studied on 4-6 occasions during antithyroid therapy, temporal dissociation was evident between the fall in thyroid hormone concentrations towards normal and improvement in myocardial contractile function on exercise. An example of this dissociation (patient no.11) is shown in figure 5.7. Thyroid hormone levels returned to normal 60 days after antithyroid therapy (I131) but ventricular function on exercise remained abnormal for several weeks thereafter and did not fall with the expected normal range until 140 days after initial radioiodine treatment.

A similar dissociation was evident in patient no. 9, who developed hypothyroidism after radioiodine (figure 5.8). Responses to exercise were similar to the response when initially hyperthyroid during the first study when biochemically hypothyroid but similar to responses when euthyroid during the second study despite similar depression of thyroid activity.

Clear dissociation between thyroid hormone concentrations and ventricular function during antithyroid therapy could not be identified in the other patients, probably because echophonocardiographic analysis was not undertaken sufficiently frequently for adequate assessment of this relationship.

FIGURE 5.6 Plasma thyroxine and exercise-induced changes in isovolumetric (PEPI) and ejection (Vcf) phase indices of ventricular function during autonomic blockade in hyperthyroid and euthyroid patients (semi-log) scale.

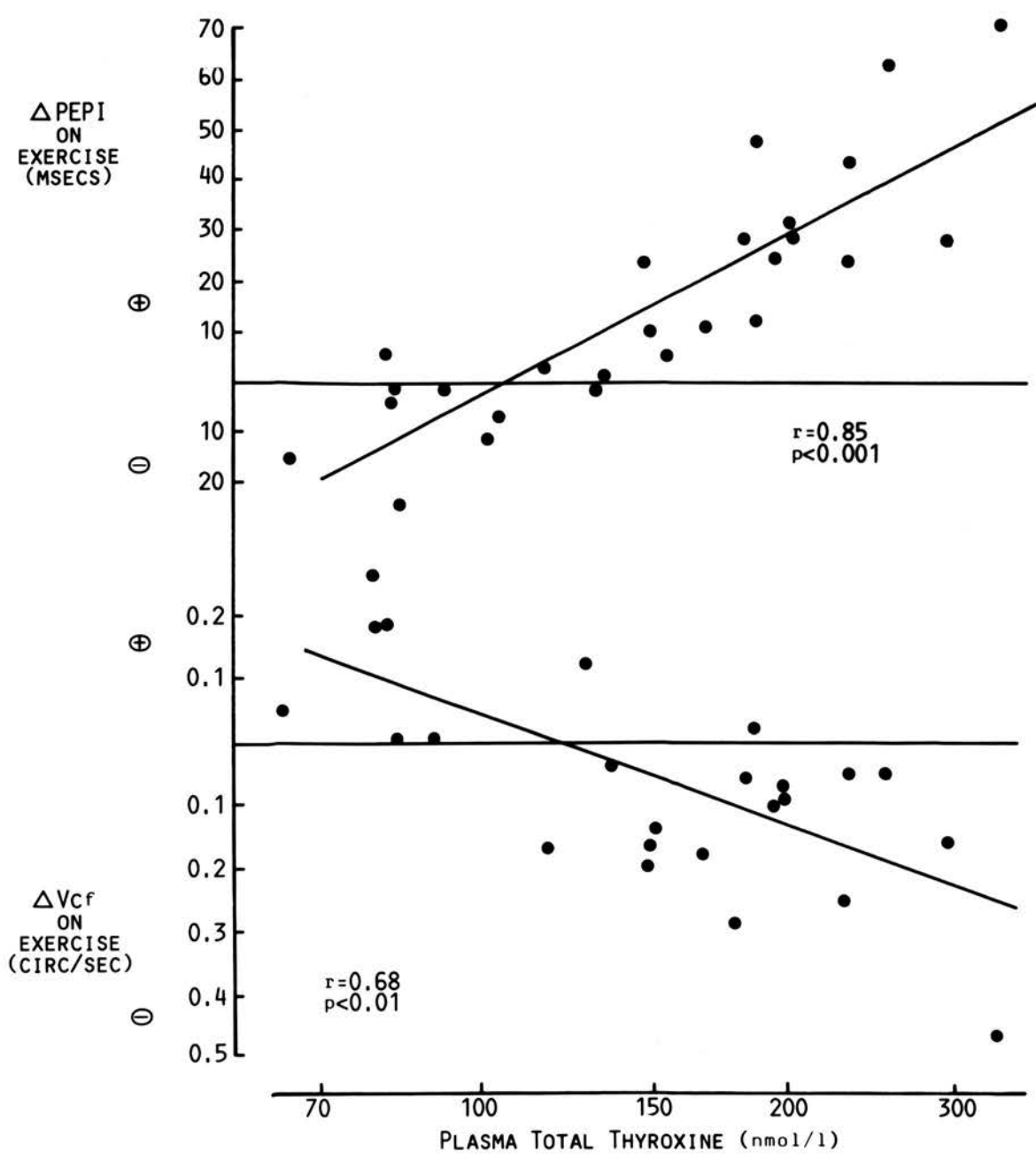
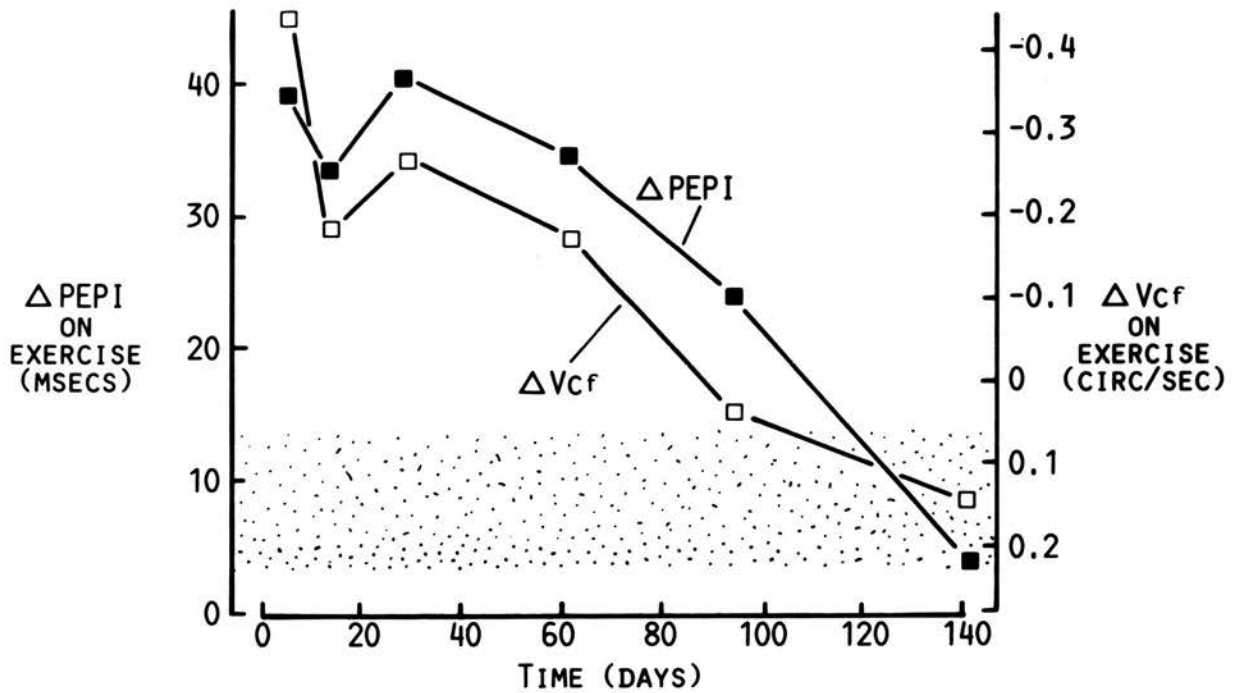
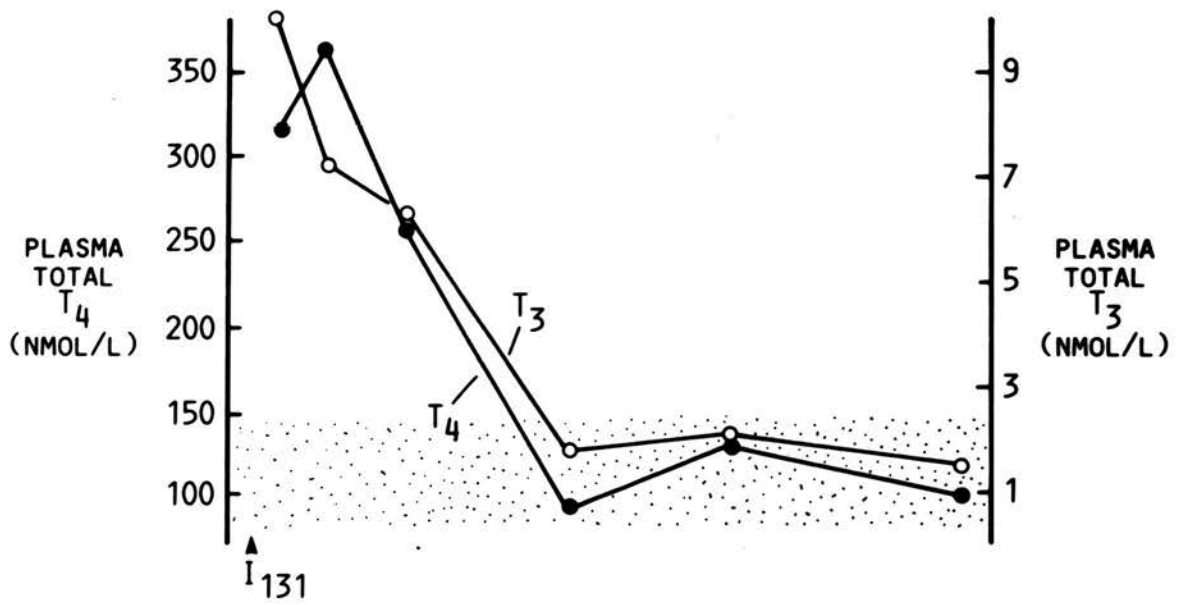

FIGURE 5.7

Comparison between thyroid hormone concentrations and responses of isovolumetric and ejection phase indices of ventricular contraction to exercise in one hyperthyroid patient (no.11) during antithyroid therapy. A positive change in preejection period index (PEPI) with exercise and a negative change in mean velocity of circumferential shortening (Vcf) on exercise both represent reductions in myocardial contractile function. Plasma thyroid hormones return to normal within 60 days of starting antithyroid therapy but ventricular function on exercise is not within the normal euthyroid range for 140 days.



DISCUSSION

Several previous studies have documented similar changes in resting systolic time interval and echocardiographic measurements of ventricular function to those reported here. Nearly all investigators have shown reductions in the PEP (Parisi et al, 1974; Hillis et al, 1975; Burckhardt et al, 1978; Chakravarty et al, 1978; Paulus et al, 1980; Cohen et al, 1981) in hyperthyroidism from a reduction in electromechanical systole and usually little change in left ventricular ejection time. In all studies, the PEPI has been 20-40 msec less than that predicted for heart rate, a reduction that has generally been interpreted to be secondary to an increase in intrinsic myocardial contractile activity. Similarly, echocardiographic indices of myocardial contractile function at rest have uniformly shown augmented velocity of shortening of the left ventricle that returns to normal after a stable euthyroid state has been achieved (Lewis et al, 1979; Cohen et al, 1981). The interpretation of these data solely in terms of increased intrinsic contractile activity of the heart is simplistic and cannot be upheld in the light of the peripheral haemodynamic effects of thyroid hormones. Thus, the substantial reduction in peripheral vascular resistance at rest (Graettinger et al, 1959; Merillon et al, 1981) and increases in circulating

FIGURE 5.8 Comparison between thyroid hormone concentrations and responses to exercise of isovolumetric and ejection phase indices of ventricular function in patient no.9. Hypothyroidism developed after the second dose of radioiodine and persisted for studies 3 and 4; responses to exercise at these times were markedly different.

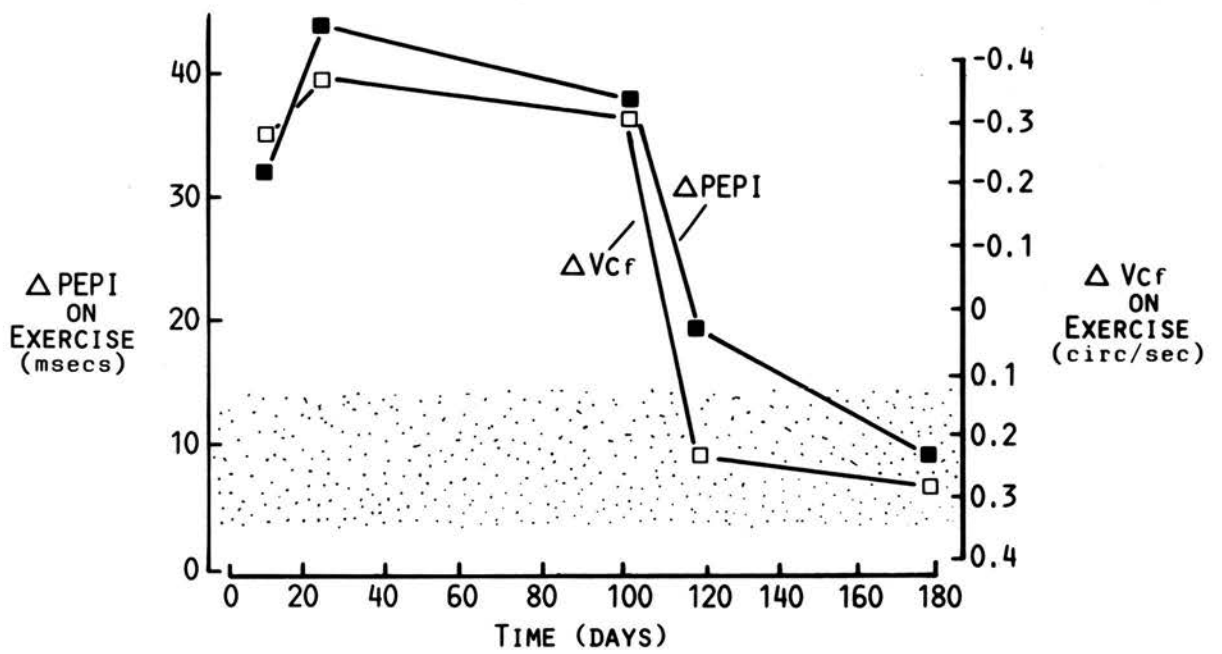
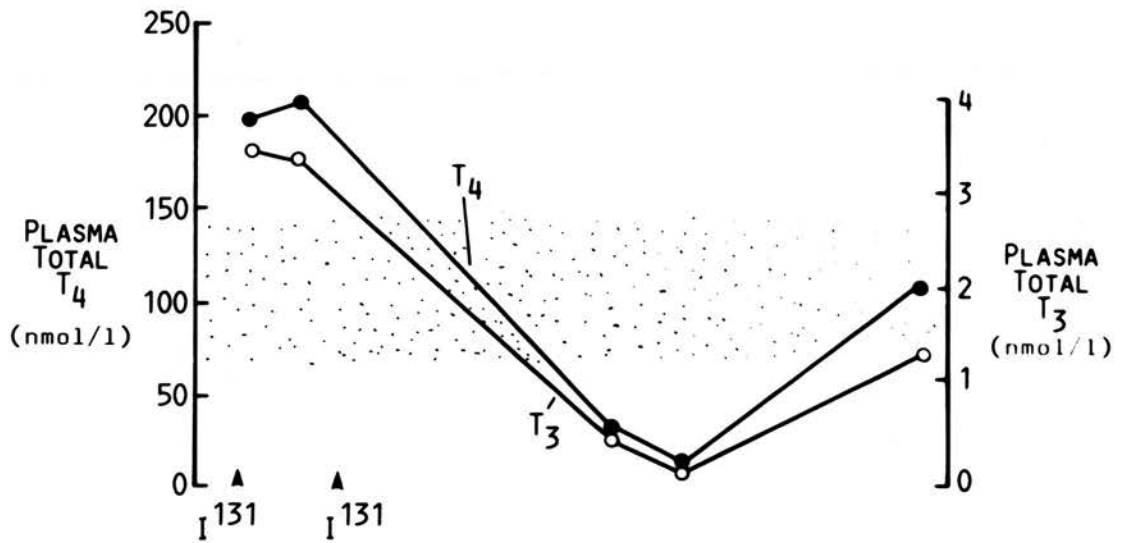

blood volume (Gibson and Harris, 1939) would tend to shorten isovolumetric phase indices and increase ejection phase indices of myocardial contractility **independent** of any true change in the contractile state of the heart. In this regard, it is of interest that the extent of the shortening in PEPI in hyperthyroidism is greater than that shown with specific inotropic agents (Weissler et al, 1965; Weissler et al, 1972). Graettinger in 1959 reported a normal cardiac output in hyperthyroid patients who had congestive heart failure in contrast to an increased output in patients without evidence of heart failure. Although the maximum rate of rise of left ventricular pressure (dp/dt) and left ventricular ejection fraction (LVEF) were increased in hyperthyroidism at rest in the study of Merillon et al (1981), comparison with euthyroid controls atrially paced to the same heart rate showed that LVEF, dp/dt as a proportion of total pressure, mean Vcf and the ratio of left ventricular end-systolic pressure and volume were similar in both groups. The latter parameter of ventricular function in particular provides a sensitive index of performance of the left ventricular pump (Suga and Sagawa, 1974). One study (Ueda et al, 1965) has noted a dilated left ventricle (increased end-diastolic volume) with a normal or reduced LVEF in hyperthyroidism. Interpretation of resting parameters of ventricular function is thus unreliable in this condition.

In contrast, during isometric exercise, this study

has shown substantial prolongation of the PEP and PEPI and fall in Vcf in hyperthyroid patients. The isovolumetric phase index increased with exercise to a level significantly greater than that predicted for heart rate from normal subjects according to the regression equation of Lindquist et al (1973) and the reduction in ejection phase index of contractility on exercise contrasted with no change in the velocity of ventricular shortening when euthyroid. Both of these independent observations suggest impairment of intrinsic myocardial contractile performance under stress in hyperthyroidism, and support the data presented in chapter 4. External measurement of the preejection period correlates closely with direct internal measurements of this interval under a variety of different loading conditions of the heart (Martin et al, 1971). The prolongation in PEP and PEPI on exercise contrasts with either no change or reductions in these measurements in the same patients when euthyroid and in other studies in normal subjects and those with coronary artery disease (Siegel et al, 1972; Quarry and Spodick, 1974). Invasive assessment of responses to isometric handgrip exercise have shown no changes in stroke volume or stroke index in normal subjects, contrasting with a significant fall in these parameters in patients with heart disease (Helfant et al, 1971). Although isolated increases in afterload (e.g. with angiotensin infusion) tend to reduce Vcf in normal subjects (Quinones et al, 1975), this is offset during isometric exercise by increases in cardiac

sympathetic tone and contractility, and hence little net change in Vcf is observed with this manoeuvre, in contrast to responses in hyperthyroidism.

Several studies have demonstrated a correlation between levels of peripheral thyroid hormones and indices of ventricular function at rest before and after antithyroid therapy (Parisi et al, 1974; Crowley et al, 1977; Paulus et al, 1980; Cohen et al, 1981) a relationship confirmed here. It is likely, however, in view of responses to exercise, that this reflects dose dependent effects of thyroid hormones on peripheral vascular haemodynamics, rather than on the heart itself. It is probable that many of the clinical features of hyperthyroidism reflect this action of thyroid hormone excess (Merillon et al, 1981). The relationship would be closest for free triiodothyronine but is maintained for total thyroxine both before and after autonomic blockade (figure 5.4 and 5.5).

No such relationship for PEPI and Vcf is evident on exercise although the change in these parameters on exercise is related to levels of thyroid hormones (figure 5.6) such that the greater the levels of hormones, the greater the impairment of exercise response. These results suggest that at least a component of this abnormal response on exercise is dependent on the degree of hyperthyroidism, as reflected by peripheral hormone concentration.

Acute autonomic blockade and antithyroid therapy with establishment of a euthyroid state have fundamentally different actions on the heart in hyperthyroidism. While both interventions were associated with an increase in resting PEPI the magnitude of change in PEPI was over three times greater after antithyroid therapy than autonomic blockade. Changes in resting Vcf were however, similar with autonomic blockade and antithyroid therapy, again highlighting the importance of peripheral factors in determining isovolumetric parameters of ventricular function. The increase in resting left ventricular end-systolic diameter was the major factor contributing to the fall in Vcf with autonomic blockade, while the fall with antithyroid therapy depended on a combination of a decrease in left ventricular end-diastolic diameter and increase in end-systolic diameter. These changes are in agreement with the invasive studies of Merillon et al (1981). On exercise, the contrast between autonomic blockade and antithyroid therapy is more striking. Directional changes in parameters of ventricular function were not influenced by autonomic blockade in hyperthyroidism, with the increase in PEPI and reduction in Vcf on exercise similar to that prior to autonomic blockade. Antithyroid therapy, however, led to normalisation of responses to exercise, provided that a euthyroid state had been achieved for some months.

While the magnitude of the reduction in myocardial contractile activity on exercise was related to peripheral

hormone concentrations in the untreated hyperthyroid state (figure 5.6), the relationship broke down during antithyroid therapy (figures 5.7 and 5.8) suggesting that factors other than hormone concentration per se determine contractile activity at this time. This delayed normalisation of left ventricular function supports the concept of structural changes in the hyperthyroid heart (determined perhaps as much by the duration of hyperthyroidism as by the levels of thyroid hormones) that resolve at a rate significantly slower than the hyperthyroidism itself. Young et al (1976) noted delays of up to two months in normalisation of the arterial sound times in hyperthyroid subjects studied repeatedly during antithyroid therapy, in keeping with the observation of Chakravarty et al (1978) that plasma thyroxine levels returned to normal some weeks before PEPI when hypothyroid patients were followed during thyroxine replacement therapy. No previous studies have assessed responses to exercise in thyroid disease.

The results presented in chapters 4 and 5 permit the development of a new hypothesis of myocardial function in hyperthyroidism that may be stated as follows:-

"Left ventricular function is reversibly depressed in hyperthyroidism evidenced by abnormalities in isovolumetric and ejection phase indices of contractile activity during static and dynamic exercise that return to normal only after a stable euthyroid state has been

achieved for at least three months. The apparent changes in indices of contractile activity at rest are spurious and are primarily related to the profound peripheral effects of thyroid hormones. Autonomic blockade causes similar reductions in myocardial contractile function in the hyperthyroid and euthyroid state without influencing directional responses to exercise. No evidence of a specific thyroid autonomic interaction is observed."

This hypothesis has the advantage of explaining the well established clinical observation of heart failure in uncomplicated hyperthyroidism (Graettinger et al, 1959; Ueda et al, 1965; Ikram, 1977) that may be considered one end of a range of depression of myocardial contractility, rather than an idiosyncratic reaction to thyroid hormone excess. The studies are, however, at variance with results in experimental hyperthyroidism suggesting that these may have limited application to man either because of the uniformly short duration of thyroid hormone feeding or because of some unidentified cardiodepressant factor operative clinically but not when the disease is mimicked by thyroxine or triiodothyronine administration. Ideally, further resting studies in hyperthyroid and euthyroid groups during similar loading conditions of the heart would be necessary to confirm abnormal ventricular function at rest but this would require combined volume loading and substantial afterload reduction in the latter group, both of which would be difficult to achieve. The studies underline further the importance of early

diagnosis and treatment of hyperthyroidism as one may speculate that ,left untreated, the abnormalities in myocardial function described may progress to overt cardiac decompension.

CHAPTER 6

Cardiovascular Responses in Hyperthyroidism before and during Beta-adrenoceptor Blockade: Evidence against Adrenergic Hypersensitivity.

A relationship between excessive sympathoadrenal activity and hyperthyroidism has been suggested for many years because of the similar clinical effects of catecholamines and thyroid hormones discussed in chapter 1. Despite extensive study, controversy remains about the effects of thyroid hormones on myocardial sensitivity to catecholamines (Van der Schoot and Moran, 1965; Levey, 1971).

It has been tempting to infer adrenergic hypersensitivity in experimental hyperthyroidism from radioligand binding studies showing increased beta-adrenoceptor density in hyperthyroid hearts (Ciaraldi and Marinetti, 1977; Williams et al, 1977; Kempson et al, 1978) and increased sensitivity of myocardial adenylate cyclase (Will-Shahab et al, 1975) and phosphorylase activation (Hornbrook et al, 1965; McNeill and Brody, 1968; Hornbrook and Cabral, 1972) in response to catecholamines in hyperthyroidism. Thyroid hormone treatment also augments adenylate cyclase stimulation by a non-hydrolysable guanosine triphosphate analogue (Will-Shahab et al, 1975) and thus may be involved in the regulation of the affinity state of the beta-adrenergic receptor.

This type of experimental evidence, however, appears contradictory to some clinical reports, discussed in chapter 1, and does not allow the conclusion of adrenergic hypersensitivity without more direct analysis of the

sympathoadrenal-cardiac axis. Furthermore, rat heart physiology differs in many important respects from that of man and therefore extrapolation to the clinical situation with an intact circulation may not be valid.

Propranolol has been shown to alleviate some but not all of the clinical manifestations of hyperthyroidism (Wilson et al, 1964; Grossman et al, 1971b; Ikram, 1977). While, in the short term it does exert some effect on thyroid hormone levels (see chapter 2), its major action is mediated via the beta-adrenoceptor. The functional effect of varying sympathetic activity can be investigated using propranolol to antagonise sympathetic effects mediated via the beta-adrenoceptor.

This study was designed to assess the relative contribution of the sympathetic nervous system in hyperthyroid patients by measuring variations in heart rate, and the heart rate and blood pressure responses to exercise, before and during beta-adrenoceptor blockade. A once daily preparation of propranolol was chosen because relatively constant plasma propranolol concentrations had been demonstrated in euthyroid volunteers over 24 hours following oral dosage (McAinsh et al, 1978).

Methods

Ten hyperthyroid patients, nine women and one man with a mean age of 33 years (range 22-51) were studied. The diagnosis of hyperthyroidism was made on clinical grounds and on the basis of raised levels of plasma total thyroxine (T4) and triiodothyronine (T3) (table 6.1). In addition, all patients had an absent response of plasma thyrotrophin 20 minutes after the intravenous injection of 200 ug of thyrotrophin-releasing hormone and increased four hour uptake of iodine-132 by the thyroid gland. Nine of the 10 patients had Graves' disease and the tenth had a solitary autonomous thyroid nodule. No patient had evidence of any concurrent cardiovascular or any other disease based on clinical examination, ECG and chest x-ray and all remained in sinus rhythm throughout the study. Control data were obtained from 10 age-matched normal euthyroid subjects (three women and seven men) and eight of these volunteers also received propranolol.

Informed consent was obtained from all patients prior to participation in the investigations. Baseline measurements of plasma total T4, T3 and 'reverse'T3 (rT3) were made in hyperthyroid subjects and a submaximal exercise test performed using a bicycle ergometer according to a standard protocol. All subjects were

familiarised with the exercise equipment prior to the definitive test. Work load was increased at three minute intervals (250, 450, 600, 750 kpm/minute for females: 300, 600, 900, 1050 kpm/minute for males) to a symptomatic limit. Chest leads V2, V4 and V5 were recorded continuously using a Mingograf (Siemens Elema) three channel recorder. Mean heart rate was calculated over 10 beats at the end of each minute of exercise and for five minutes of recovery. Systolic blood pressure was recorded by the same observer at rest and at two-minute intervals during exercise using a mercury sphygmomanometer. Heart rate was subsequently recorded continuously as an out-patient over 24 hours with an Oxford Medilog recording system using a modified lead V5 chest electrode. The light weight and portability of these instruments allowed patients to undertake normal activities during the recording period. Variations in tape recorder speed were minimised by using the same recorder for each subject over the taping periods and by incorporation of a fixed frequency timing signal into the recorder. Each 24 hour recording was analysed at sixty times real speed (Pathfinder II high speed ECG analyser, Reynolds Medical) and divided into one hour periods with the mean heart rate for each period calculated.

The protocol was repeated in all patients and in eight of the control subjects following administration of a slow-release oral propranolol preparation (Inderal-

PATIENT	AGE(YR) &SEX	BEFORE PROPRANOLOL TREATMENT			DURING PROPRANOLOL TREATMENT			PLASMA PROPRANOLOL (ng/ml)
		T4	T3	rT3	T4	T3	rT3	
1	44F	382	>15.0	4.20	345	<15.0	3.07	455
2	25M	218	7.4	0.92	203	5.2	0.95	17
3	25F	262	11.6	2.14	232	8.7	1.93	116
4	27F	188	9.2	0.69	222	7.9	1.80	55
5	27F	175	6.2	0.98	200	5.1	1.71	179
6	30F	182	5.8	0.62	208	4.9	1.07	681
7	39F	129	4.2	0.30	145	3.3	0.68	68
8	22F	253	10.2	2.19	300	14.0	2.45	116
9	33F	204	10.2	1.75	246	10.6	1.48	54
10	51F	226	10.2	2.37	285	9.4	2.65	43

TABLE 6.1 Age, sex, plasma total T4, T3 and rT3 before and during propranolol treatment and plasma propranolol levels in hyperthyroid patients.

LA, ICI Pharmaceuticals, England) in a single daily dose of 320 mg for six days. Blood samples for estimation of plasma thyroid hormones and propranolol were withdrawn six hours after the sixth dose of propranolol and the exercise test undertaken at the same time during the day with an identical workload to that performed prior to beta-adrenoceptor blockade. Subjects were asked to continue their normal daily routines during the two taping periods.

Plasma samples were stored at -20 C for later in-batch analysis. Plasma total T4 and T3 and rT3 were each measured by specific radioimmunoassays (Challand et al, 1975; Ratcliffe et al, 1976). The normal levels ranged between 55 and 144 nmol/l for T4, 0.9 and 2.8 nmol/l for T3 and 0.15 and 0.42 nmol/l for rT3. Plasma propranolol was measured by a gas-liquid chromatographic method (McAinsh et al, 1978). Briefly, 1 ml of oxalated whole blood was mixed with 4-methyl propranolol (as internal standard), mixed, centrifuged and precipitated in sulphuric acid. After buffering in a sodium hydroxide - chloroform/ether solvent mixture, the drug residue was evaporated to complete dryness at room temperature under nitrogen. Anhydrous diethyl ether and heptafluorobutyric anhydride were added to the drug residue and after evaporation to dryness under nitrogen, ethyl acetate was added and the solution analysed using an electron capture gas-liquid chromatographic machine (Pye GCV). The inter-

assay coefficient of variation for the propranolol estimation was seven per cent.

The mean percentage reduction in peak exercise heart rate (EHR) was calculated by the following equation:

$$\% \text{ reduction in EHR} = \frac{\text{EHR (prepropranolol)} - \text{EHR (post propranolol)}}{\text{EHR (prepropranolol)}} \times 100$$

Differences in heart rate, blood pressure and thyroid hormone levels during sympathetic blockade were assessed by Student's t test for paired observations. A five per cent level of confidence was considered statistically significant. Correlations between heart rate and log propranolol or thyroid hormone concentrations used a linear regression coefficient with least squares method of analysis. Data are quoted as mean +/- standard error of the mean.

One patient (no. 6) showed frequent multifocal ventricular extrasystoles with several periods of sinus arrest of up to two seconds during monitoring (see figure 6.7). She was excluded from nocturnal and resting heart rate analysis because of these abnormalities.

Results

Nyctohemeral heart rate response

Figure 6.1 (upper panel) shows the mean heart rate during each hour of the 24 hour period of monitoring in

the hyperthyroid and control subjects before and during propranolol therapy. In untreated hyperthyroidism, heart rate was relatively higher during the day (0700 - 2300 hours) than during the night (2300 - 0700 hours) ($P < 0.001$). This pattern of nyctohemeral variation in heart rate was strikingly similar to that seen in the euthyroid state. Thus, when untreated hyperthyroid patients were compared to untreated euthyroid controls, the increase in heart rate with hyperthyroidism during the day (27.9 ± 1.0 beats/minute) was the same as that during the night (26.7 ± 0.8 beats/minute). In effect, the baseline heart rate in hyperthyroidism is increased but with no change in the pattern of response over 24 hours. Propranolol reduced the mean heart rate at all times of the day and night, although in both hyperthyroid and euthyroid groups the fall in heart rate was significantly greater during the day than during the night ($P < 0.01$). Propranolol decreased the overall variation in heart rate during the 24 hour period, leaving a relative nocturnal tachycardia in the hyperthyroid subjects. During beta-adrenoceptor blockade, the increase in heart rate with hyperthyroidism was constant during the 24 hour period and hence independent of higher (daytime) or lower (night-time) sympathetic activity.

The percentage reduction in heart rate with propranolol over 24 hours in the hyperthyroid and euthyroid groups is shown in figure 6.1 (lower panel).

FIGURE 6.1 Heart rate variation (mean +/- SEM) over 24 hours in untreated hyperthyroidism (n=9) and euthyroid controls (n=8) before and after six days of slow-release propranolol (upper panel). The adrenergic component of heart rate (percentage reduction after propranolol) over 24 hours in hyperthyroid and euthyroid subjects is shown in the lower panel.

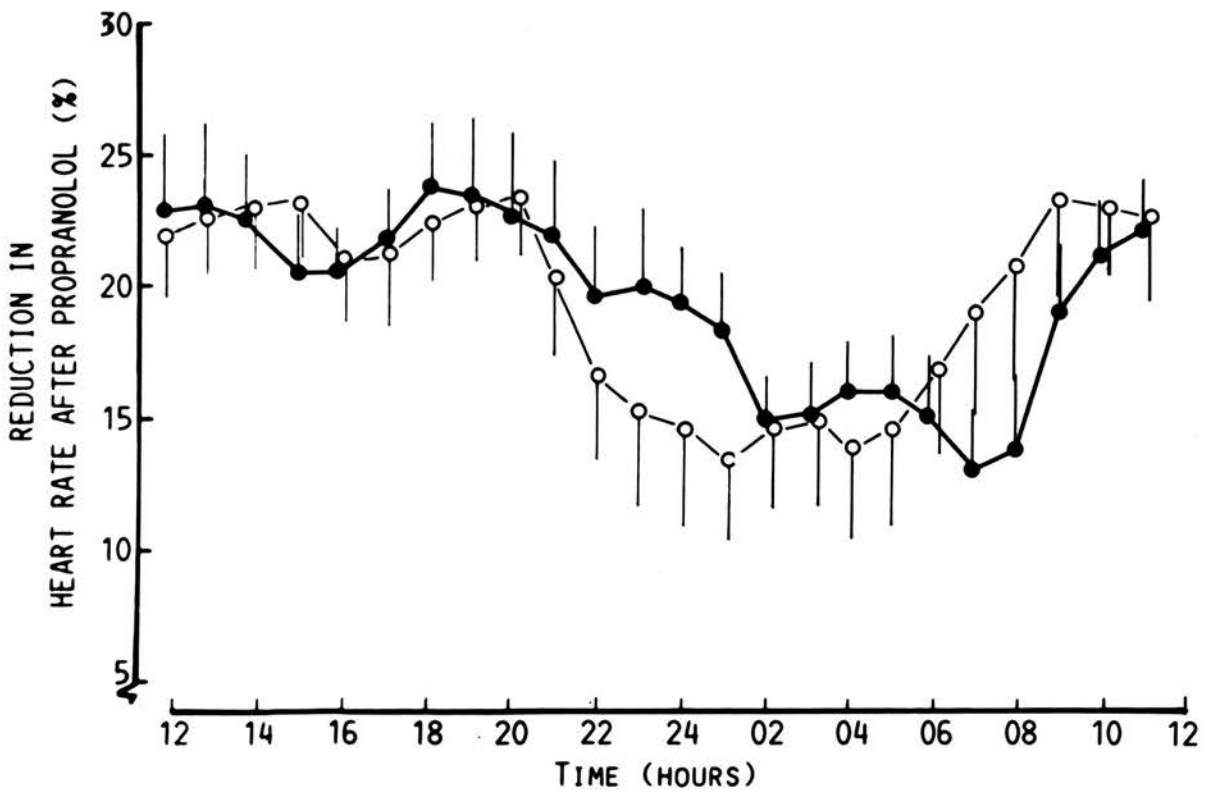
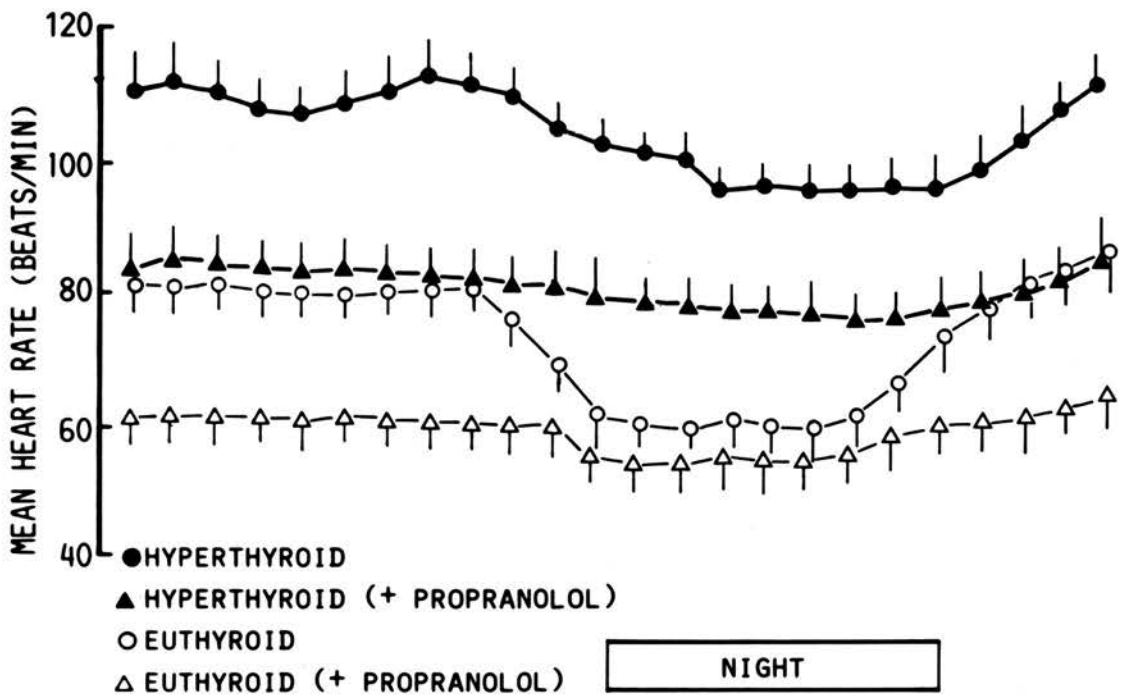

No differences are apparent between the groups either during the day or night despite the variation in sympathetic activity over this time, reflected in a greater percentage reduction in heart rate during the day (22 +/- 1% hyperthyroid; 22 +/- 1% euthyroid) than during the night (16 +/- 1% hyperthyroid; 15 +/- 1% euthyroid).

Exercise Response

Parallel heart rate responses to exercise were also observed in the hyperthyroid and euthyroid subjects (figure 6.2, upper panel). The mean peak EHR was increased from 168 +/- 7 beats/minute in the euthyroid subjects to 193 +/- 9 beats/minute in the hyperthyroid subjects ($p < 0.01$) but this increase (25 +/- 5 beats/minute) was similar to the difference in resting heart rate between hyperthyroid and euthyroid individuals (32 +/- 4 beats/minute). In contrast, propranolol therapy caused a greater fall in peak EHR than in resting heart rate in both the hyperthyroid and euthyroid groups. These changes are summarised in table 6.2. Hyperthyroidism increases heart rate equally at rest and on exercise with a blunted response during beta-adrenoceptor blockade.

The percentage reduction in heart rate with propranolol during exercise and recovery (figure 6.2 lower panel) showed no major differences in hyperthyroid and euthyroid subjects. As expected, the anti-adrenergic effect of propranolol is increased progressively during

FIGURE 6.2 Heart rate responses (mean \pm SEM) during and after graded exercise on a bicycle ergometer in untreated hyperthyroidism (n=10) and euthyroid controls (n=8) before and after six days of slow-release propranolol (upper panel). The adrenergic component of heart rate responses during exercise and recovery (percentage reduction after propranolol) in hyperthyroid and euthyroid subjects is shown in the lower panel.

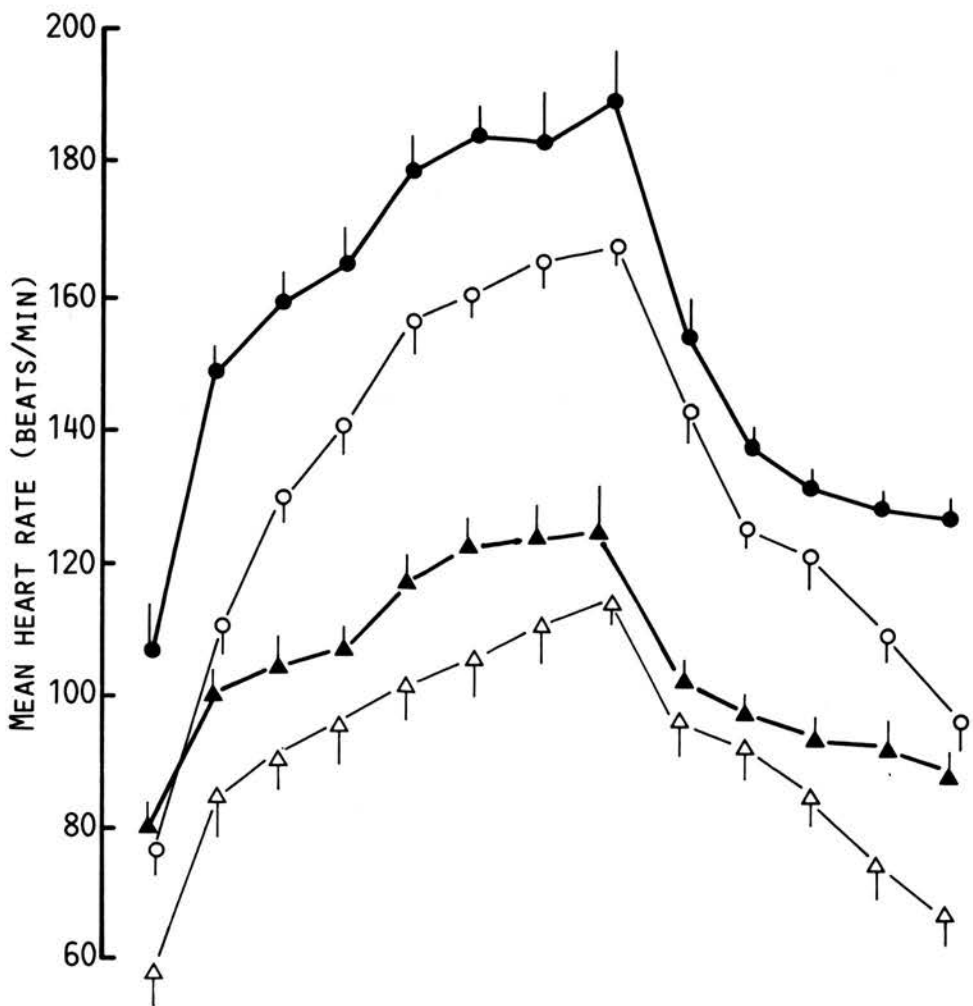

- HYPERTHYROID
- ▲ HYPERTHYROID (+PROPRANOLOL)
- EUTHYROID
- △ EUTHYROID (+PROPRANOLOL)

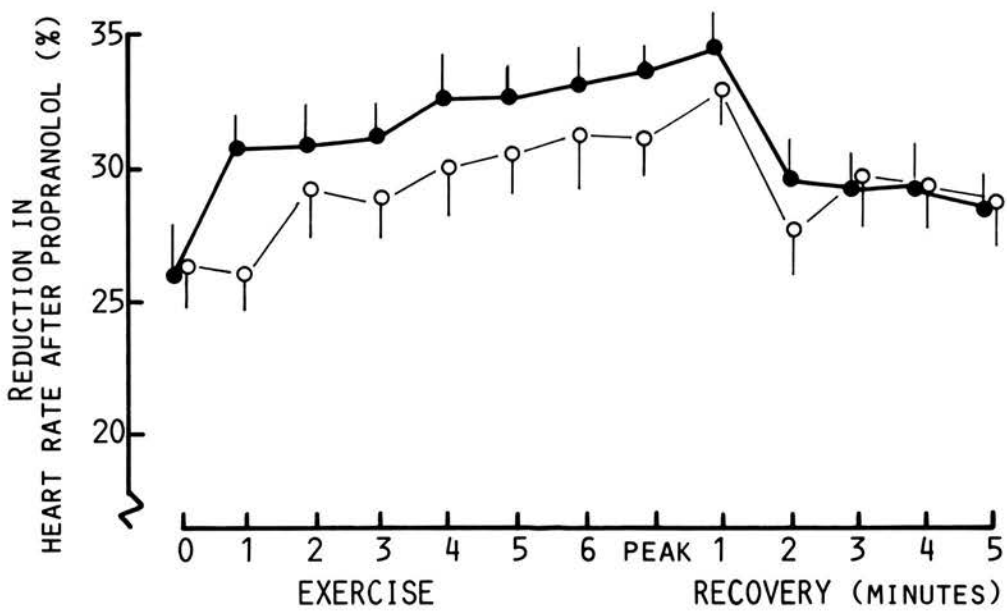

	HYPERTHYROID	EUTHYROID
REST	28.2 +/-4.5	19.8 +/-2.7
PEAK EXERCISE	62.3 +/-6.9*	54.4 +/-3.4**

*P <0.005

COMPARED TO REST

**P <0.001

TABLE 6.2 Mean (+/-SEM) fall in heart rate (beats/minute) with propranolol therapy at rest and on peak exercise in hyperthyroid and euthyroid groups.

exercise, reflecting augmented overall sympathetic activity at this time. The slope of this line during exercise is, in effect, a dose-response curve and is a measure of adrenergic sensitivity. The slope on exercise was similar in both hyperthyroid (slope = 0.85; $r = 0.87$) and euthyroid (slope = 0.84; $r = 0.95$) groups.

The maximum rise in systolic blood pressure on exercise was similar in the hyperthyroid subjects (43 +/- 5 mmHg) and euthyroid controls (48 +/- 6 mmHg). After beta-adrenoceptor blockade, the reduction in systolic blood pressure was independent of thyroid status at all levels of exercise and recovery (figure 6.3).

Heart Rate/Thyroid Hormone Relationship

As shown in figure 6.4a and 6.4b, a highly significant linear correlation existed between mean heart rate between 0400 and 0600 hours and log plasma T3 and T4 during propranolol treatment in hyperthyroid patients. Endogenous sympathetic activity would be expected to be low during this period and with additional pharmacological sympathetic blockade, heart rate was closely related to circulating thyroid hormones, in particular T3. A slightly less good correlation existed between these parameters in hyperthyroidism in the absence of propranolol (figure 6.4c and 6.4b) reflecting a small but variable component of endogenous sympathetic activity in the basal heart rate at this time.

Resting heart rate on propranolol immediately prior

FIGURE 6.3

The reduction in systolic blood pressure during exercise and recovery following beta-adrenoceptor blockade with slow-release propranolol in hyperthyroid (n = 10) and euthyroid (n = 8) subjects.

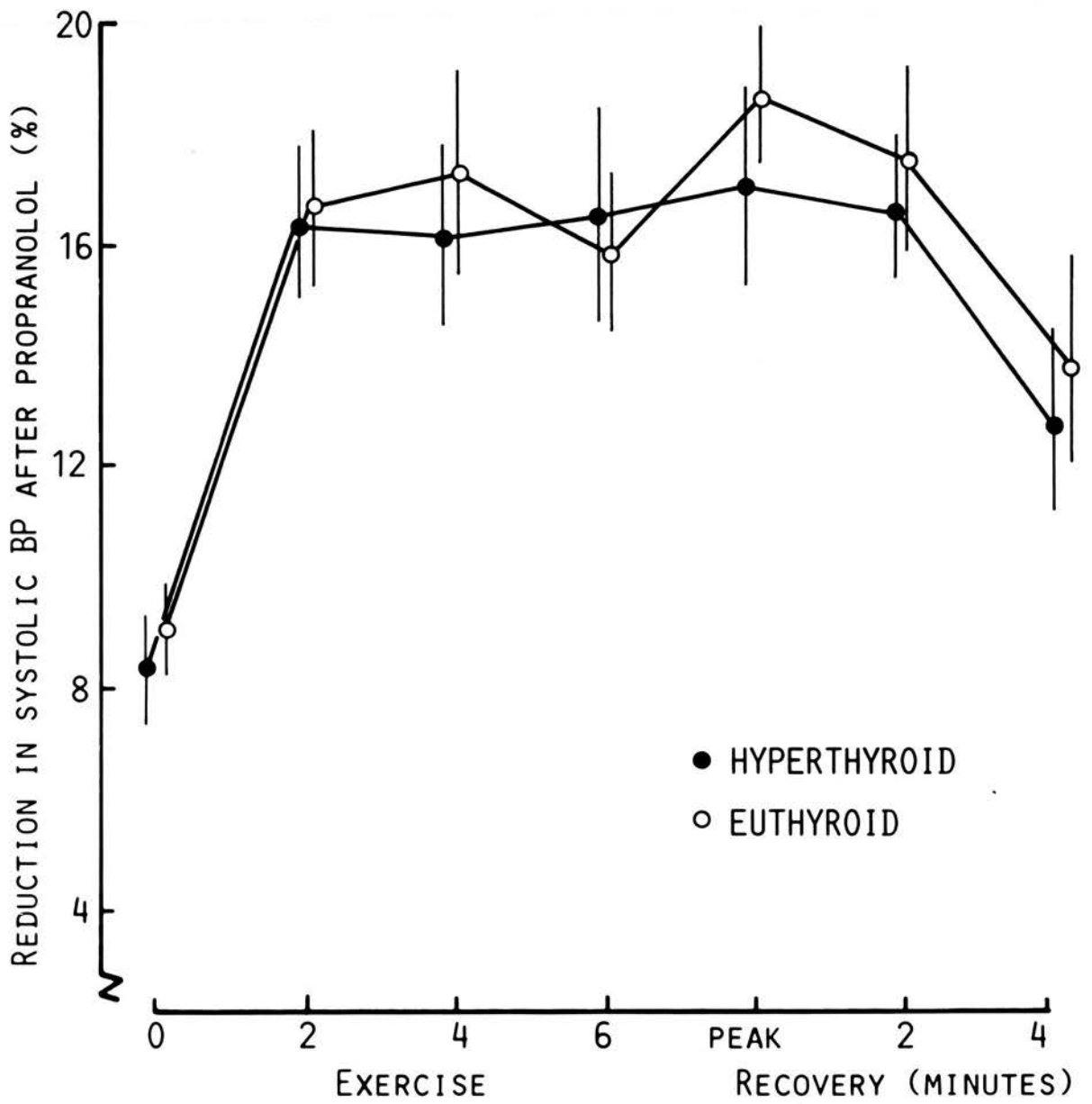

FIGURE 6.4 Mean heart rate between 0400 hours and 0600 hours correlated with plasma total T3 (a) and T4 (b) while on propranolol and plasma total T3 (c) and T4 (d) in untreated hyperthyroidism (semi-log scale).

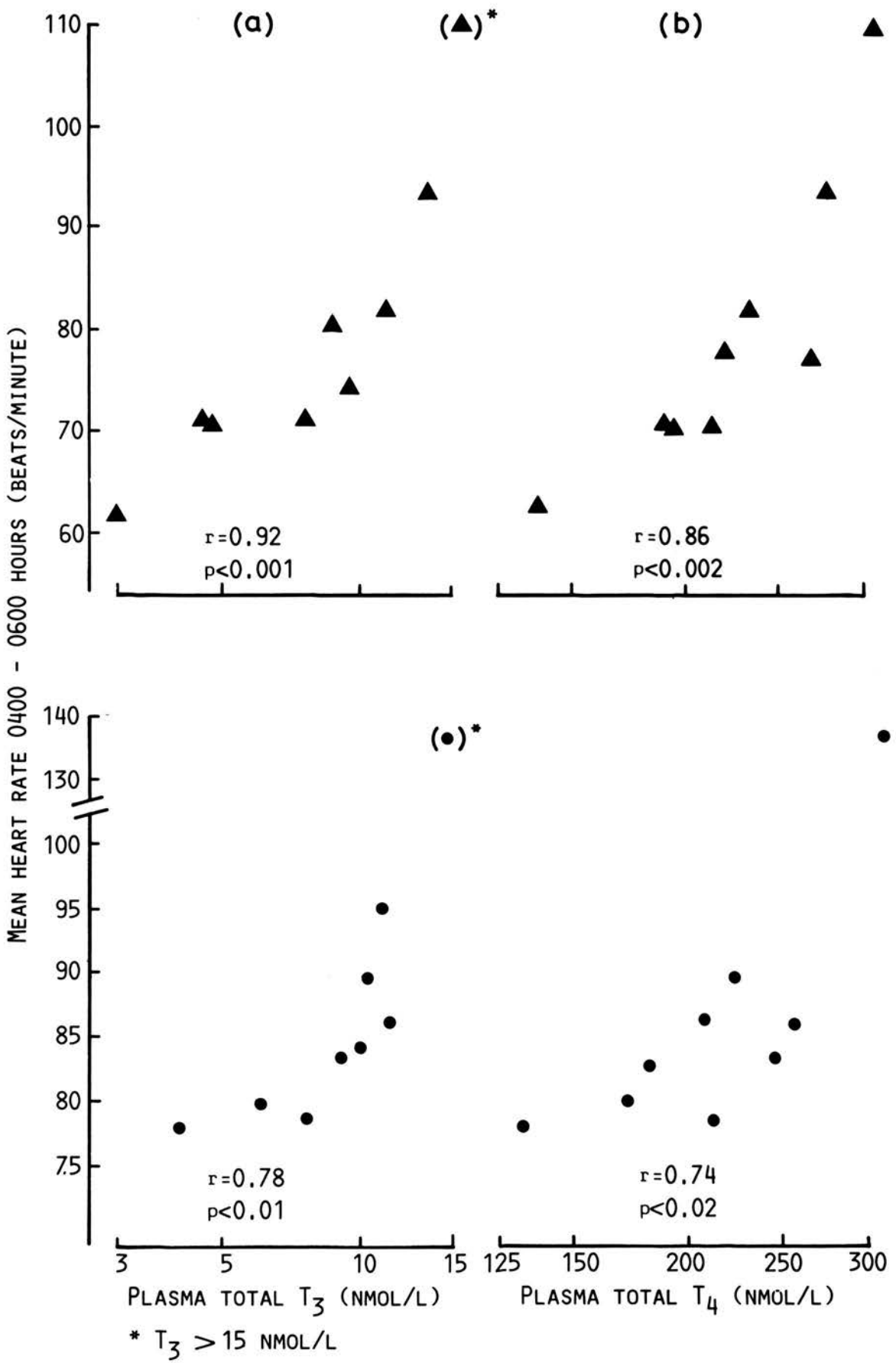
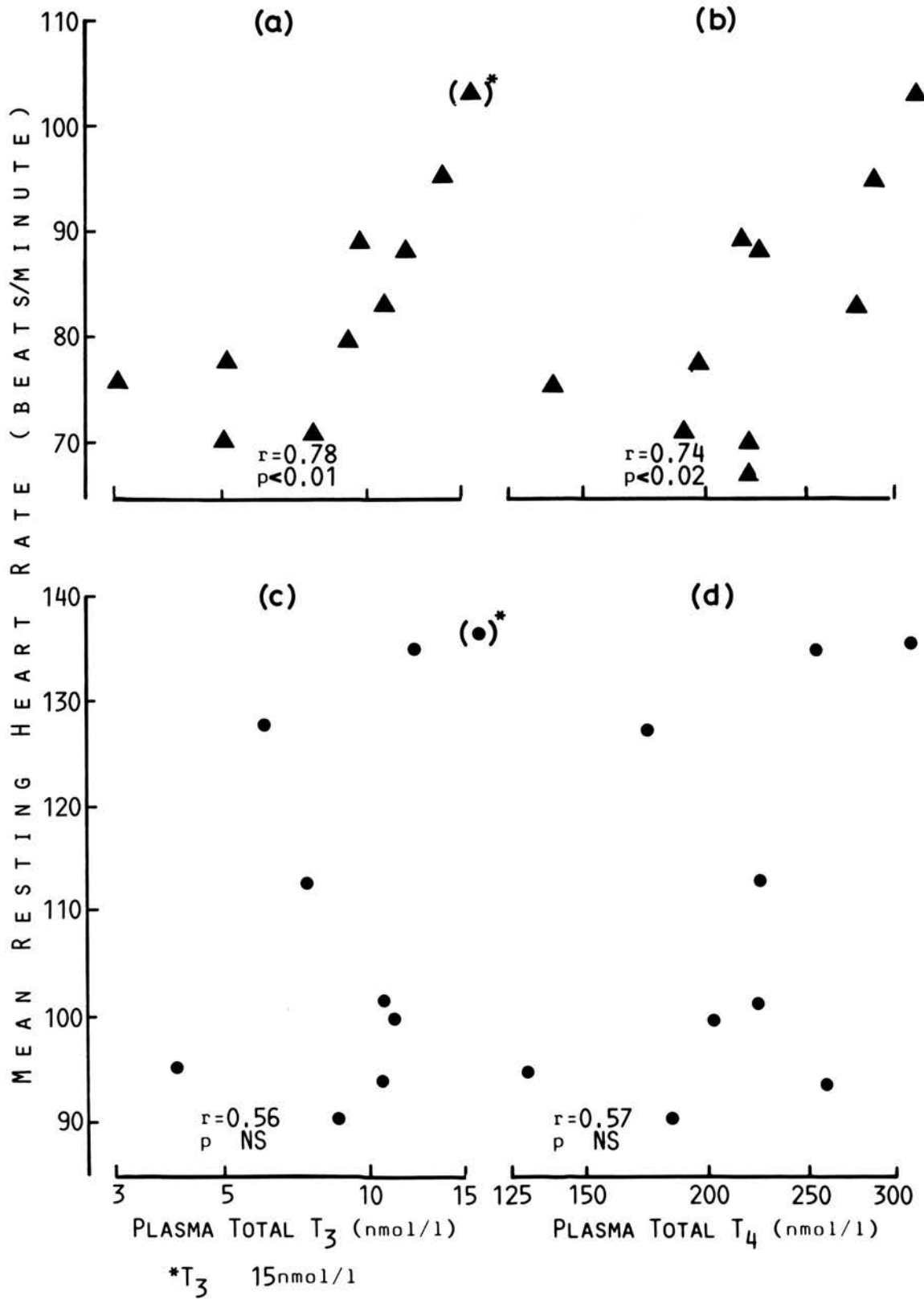

FIGURE 6.5 Mean resting heart rate prior to the exercise test correlated with plasma total T3 (a) and T4 (b) while on propranolol and plasma total T3 (c) and T4 (d) in untreated hyperthyroidism (semi-log scale).



to the exercise test was also linearly related to log plasma total T3 and T4 (figure 6.5a and 6.5b). However, a clear linear relationship between these parameters was not identified in the absence of propranolol (figure 6.5c and 6.5d) when it is likely that a variable sympathetic component to heart rate obscured its dependence on thyroid hormone concentrations.

No correlation was identified between peak EHR and log thyroid hormone concentrations with or without propranolol.

Heart Rate/Propranolol Relationship

Plasma propranolol concentrations measured six hours after the sixth oral dose showed a 40-fold variation in hyperthyroid individuals. There was no obvious relationship between propranolol concentrations and levels of thyroid hormones (table 6.1). Despite these variations in plasma propranolol in the hyperthyroid group, there was a mean percentage reduction in peak EHR of 33 per cent with a minimum reduction in peak EHR of 25 per cent suggesting satisfactory functional beta-adrenoceptor blockade in these subjects. In the euthyroid controls plasma propranolol varied three-fold from 54 to 160 ug/ml. A mean percentage reduction in peak EHR of 32 per cent was achieved with a minimum reduction of 26 per cent also suggesting adequate beta-adrenoceptor blockade. The percentage reduction in peak EHR showed a positive correlation with log plasma propranolol

concentrations in both groups (figure 6.6). There was no correlation between the percentage reduction in resting heart rate and log plasma propranolol concentration in either group (hyperthyroid $r = 0.18$; euthyroid $r = 0.34$; $P=NS$).

Thyroid Hormone Levels During Propranolol Treatment

The levels of T3, T4 and rT3 before and during propranolol treatment are detailed in table 6.1. The mean T3 fell from 9.0 ± 1.0 to 8.4 ± 1.2 nmol/l following propranolol while the mean T4 rose from 222 ± 22 to 239 ± 18 nmol/l and rT3 rose from 1.62 ± 0.37 to 1.78 ± 0.56 nmol/l. None of these changes achieved statistical significance.

ECG Abnormalities on Exercise

Two patients showed unequivocal ECG abnormalities during the exercise test in the untreated hyperthyroid state when both denied specific cardiovascular symptoms. The first (No. 1) developed asymptomatic 2 mm horizontal ST segment depression during exercise and for two minutes in recovery (figure 6.7, upper panel). She had markedly elevated plasma thyroid hormone levels (table 6.1) and achieved a peak heart rate of 199 beats/minute after only 2 1/2 minutes exercise at 250 kpm/minute. ECG abnormalities were not detected on exercise after treatment with propranolol and subsequent testing when the patient was euthyroid showed no abnormality (figure 6.7). This patient showed a relatively large (14 per cent) fall in left ventricular ejection fraction on exercise

FIGURE 6.6 Percentage reduction in peak exercise heart rate (EHR) in relationship to plasma propranolol concentration in hyperthyroid (n=10) and euthyroid (n=8) subjects (semi-log scale).

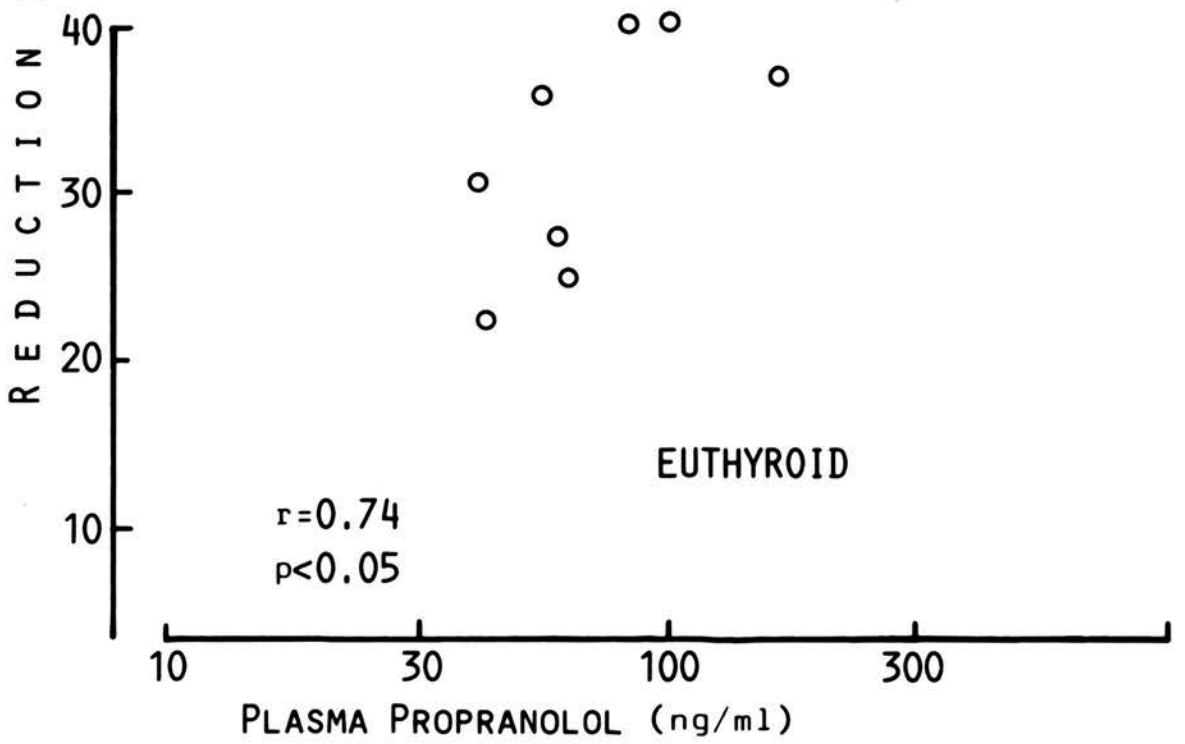
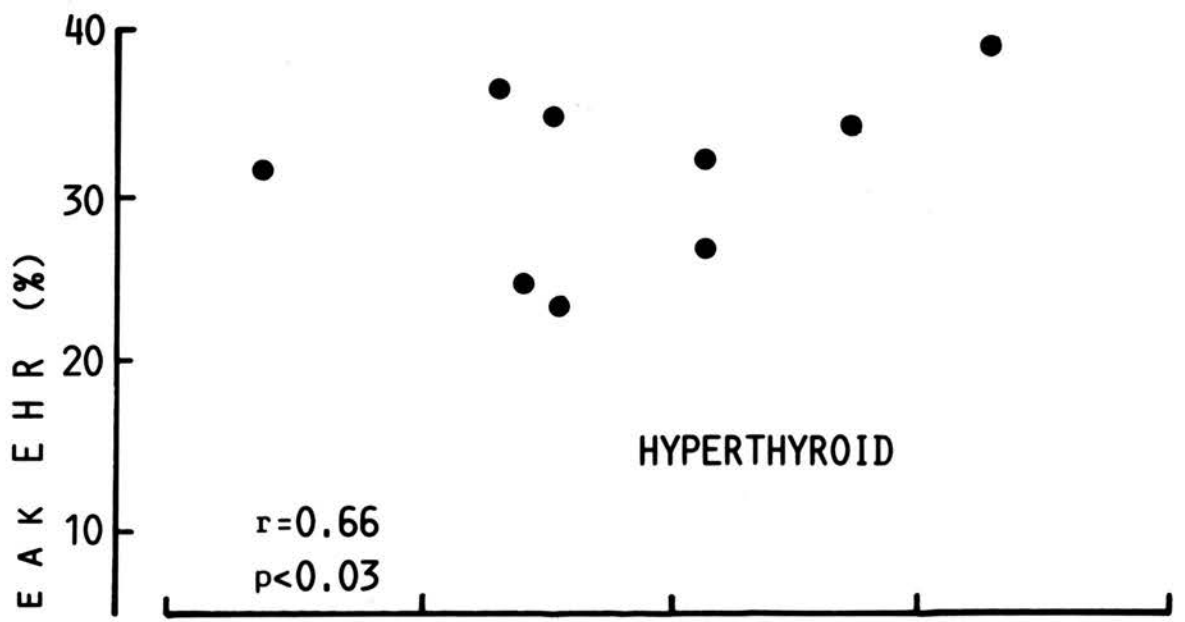

(discussed in chapter 4) when hyperthyroid that contrasted with a 23 per cent rise when subsequently euthyroid.

The second patient, a 30 year old woman (No. 6), developed first degree heart block and achieved a heart rate of 222 beats/minute after five minutes of exercise when hyperthyroid on no therapy. Asymptomatic ST segment elevation was detected in the inferior leads for two minutes in recovery (figure 6.7, lower panel). ECG monitoring over 24 hours showed frequent multifocal ventricular extrasystoles with periods of sinus arrest. Exercise testing and ECG monitoring when hyperthyroid on propranolol and subsequently when euthyroid showed no abnormalities.

Discussion

The hypothesis that the circulatory manifestations of hyperthyroidism were mediated through the sympatho-adrenal-medullary system lost some credibility with the demonstration of direct inotropic and chronotropic effects of thyroid hormones on the myocardium (Symons 1979). This has been strengthened by the knowledge that binding sites for thyroid hormones that best fulfilled the criteria for hormone receptors were in the cell nucleus and not the cell membrane. (Degroot and Torresani, 1975; Oppenheimer et al, 1976; Surks and Oppenheimer, 1977).

FIGURE 6.7 Upper panel: ECG abnormalities on exercise in patient no.1 in the untreated hyperthyroid state (14/6/79) and at the same heart rate when euthyroid (31/8/79). Two mm. ST segment depression is detected only when hyperthyroid. Lower panel: ECG at rest (left) and immediately after exercise (right) and trace from daytime ECG monitoring in patient no.6 in the untreated hyperthyroid state. Exercise testing and ECG monitoring when euthyroid were normal.

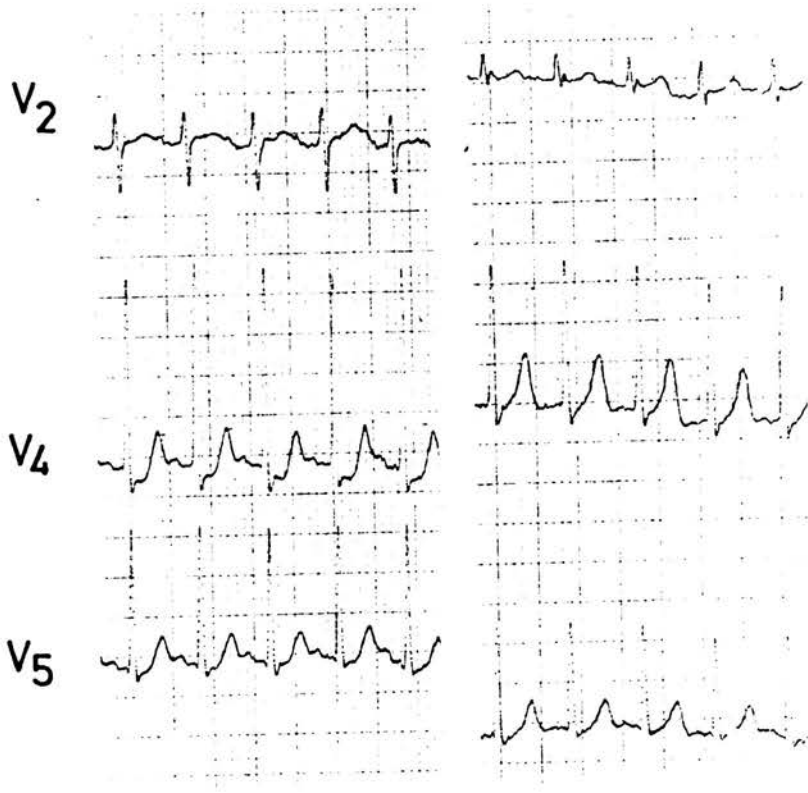

14 - 6 - 79

31 - 8 - 79

HYPERTHYROID

EUTHYROID

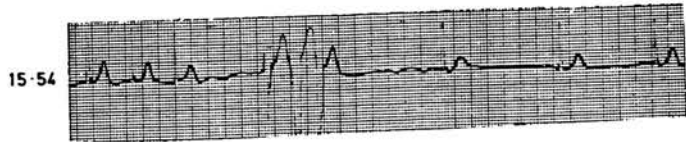
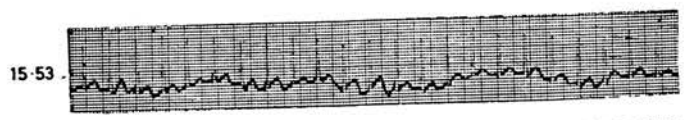
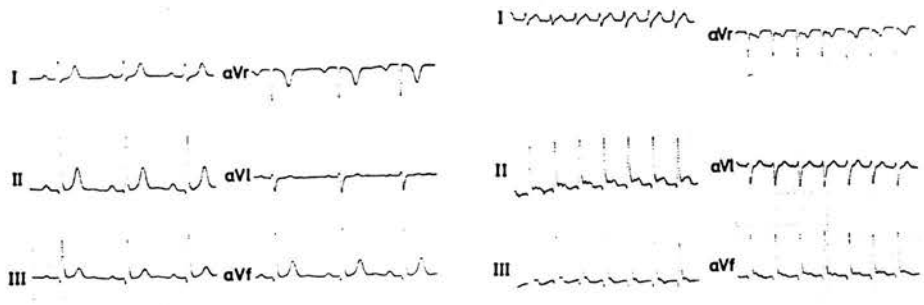

T3 appears to be the physiologically important ligand with T4 and the circulating products of T4 metabolism playing a physiologically less active role.

An increase in beta-adrenoceptor density in experimental hyperthyroidism does, however, imply adrenergic hypersensitivity, i.e. an increase in target organ response for a given adrenergic stimulus (Lefkowitz 1979), provided that such receptors remain physiologically responsive to both neural and humoral stimuli. In vitro studies cannot resolve this important question. This study, therefore, has examined this relationship by measuring nyctohemeral and exercise-induced heart rate responses in hyperthyroid patients before and during beta-adrenoceptor blockade with propranolol and by comparing the results to those obtained with age-matched euthyroid controls.

Endogenous sympathetic neural activity fluctuates during the day, being greatest during physical exertion and lowest during sleep. Untreated hyperthyroid patients showed a strikingly parallel heart rate response compared to euthyroid controls (figure 6.1). If there were any augmentation of adrenergic sensitivity in hyperthyroidism, a greater increase in heart rate would be expected during the day (a time of increased sympathetic neural activity) than during the night (when sympathetic activity is relatively low). This did not occur. Similarly, there was no greater heart rate or blood pressure response to

exercise in untreated hyperthyroidism compared to euthyroid controls. Following propranolol, the percentage reduction in heart rate (figures 6.1 and 6.2) and systolic blood pressure (figure 6.3) appeared to be independent of thyroid status. In effect, dose-response curves have been constructed relating varying sympathetic activity (day and night; exercise) to the adrenergic response (percentage change after beta-adrenoceptor blockade). The similarity of the results suggests normal adrenergic responsiveness in hyperthyroidism.

As expected, the reduction in heart rate in both hyperthyroid and euthyroid subjects on propranolol was greater during the day than at night. Assuming adequate beta-adrenoceptor antagonism (vide infra) the nocturnal heart rate in hyperthyroid patients on propranolol (when functional adrenergic activity is lowest) can be considered to reflect a direct chronotropic effect of thyroid hormones independent of the sympathetic nervous system - beta-adrenoceptor axis. It could thus be anticipated that the closest linear correlation would exist between plasma thyroid hormones and nocturnal heart rate in the presence of beta-adrenoceptor blockade (figure 6.4 a,b). It is the 'free' T3 concentration that principally determines the tissue responses, so the relationship is closer for plasma total T3 than for plasma total T4. With increased daytime sympathetic activity, the relationship is less good (figure 6.5 a,b) despite propranolol. In the absence of beta-adrenoceptor

blockade, there is a reduced correlation at night (figure 6.4 c,d) and a further reduction during the day (figure 6.5 c,d). The similarity in daytime heart rate between propranolol treated hyperthyroid patients and untreated euthyroid controls simply reflects the similarity in chronotropic response of the heart to excess circulating thyroid hormones on one hand and normal daytime sympathetic neural activity on the other.

As demonstrated previously, a substantial individual variation in plasma propranolol concentration has been shown in hyperthyroid patients (Feely et al, 1977; Rubenfeld et al, 1979). The variability appears to be similar for both conventional and slow-release formulations of this drug. Despite this, slow-release propranolol caused a satisfactory reduction in heart rate throughout the day with no evidence of loss of heart rate control with increasing time from the previous dose. In addition, a reasonable reduction in peak EHR was achieved even in patients with propranolol levels below 50-100 ng/ml, a level considered necessary for maximal beta-adrenoceptor blockade in normal subjects (Coltart and Shand, 1970; Zacest and Koch-Weser, 1972). The percentage reduction in peak EHR still correlated with plasma propranolol levels despite the variable influence of thyroid hormones on heart rate (figure 6.6). It is unlikely that the relative nocturnal tachycardia after propranolol is related to inadequate beta-adrenoceptor

blockade at this time. Plasma propranolol levels and maximum reduction in peak exercise tachycardia are maintained for over 30 hours following a single dose of 160 mg slow-release propranolol (McAinsh et al, 1978), half the dose used in this study. Furthermore, the percentage reduction in heart rate at night was the same in the hyperthyroid and euthyroid groups. The reasons for the variation in propranolol levels in hyperthyroidism are not clear. Thyroid dysfunction has been shown to alter the absorption, metabolism and elimination of several drugs (Croxson and Ibbertson, 1975; Bell et al, 1977; Forfar et al, 1980). Although the kinetics of propranolol may be altered in hyperthyroidism, plasma protein binding appears to be constant (Kelly and McDevitt, 1978). There was no obvious relationship between propranolol levels and the severity of hyperthyroidism as judged by the levels of plasma total T4 and T3 (table 6.1). There is no certainty, however, that either of these measurements reflects its influence at a cellular level.

Propranolol has been shown to produce a fall in plasma total T3 concentrations (Wiersinga and Touber, 1977) associated with a rise in plasma total rT3 (Verhoeven et al, 1977). While the pattern of change conformed to the expected trend in our patients, changes were not statistically significant possibly due to the numbers studied. It is unlikely that these minor changes in thyroid hormone concentrations contribute to the

haemodynamic effects of propranolol in hyperthyroidism (Nilsson et al, 1980).

The presence of occult coronary artery disease cannot be totally excluded in the two patients in whom ECG abnormalities were manifest on exercise but it is likely that hyperthyroidism was the major precipitating factor in view of normal results after specific antithyroid therapy. Metabolic symptomatic myocardial ischaemia with normal coronary arteries has been suggested in hyperthyroidism (Resnekov and Falicov, 1977), possibly related to thyroid hormone actions on myocyte ATP production (Tse et al, 1980). This would be exacerbated in the two patients described by pathological exercise-induced tachycardia 20-30% greater than that achieved by the same patients when euthyroid. Coronary artery spasm (Wei et al, 1979), myocardial infarction (Proskey et al, 1971), ventricular arrhythmias and heart block (Campus et al, 1975) and sudden death (Parker and Lawson, 1973) have all been sporadically reported in hyperthyroidism. It is of interest that no abnormalities were detectable during propranolol therapy in the patients in this series despite persisting hyperthyroidism. Although some specific thyroid hormone-sympathetic nervous system interaction cannot be excluded, it is equally possible that the protective effect of propranolol was mediated simply by the reduction in exercise-induced tachycardia to more physiological levels. It is unlikely that the minor

changes in plasma thyroid hormone levels following propranolol would contribute to this effect.

It has been argued that the presence of normal sympathetic and adrenal medullary activity in hyperthyroidism is inappropriate, and that the peripheral effects of thyroid hormones should lead to inhibition of central neurosympathetic outflow. Although direct data on thyroid hormone action on central neurosympathetic activity is lacking, small doses of thyroid hormone can enhance the speed of recovery from depressive illness, particularly in combination with drugs that increase the availability of brain catecholamines (Prange et al, 1969; Wheatley, 1972). It should be stressed, however, that even if thyroid hormones promote transmission in central noradrenergic pathways (Whybrow and Prange, 1981), peripheral adrenergic hypersensitivity would not occur unless catecholamine responses to sympathetic activation were increased. This has not been demonstrated (see chapter 1).

Okada et al, (1980) have recently shown that plasma cyclic AMP responses to hypoglycaemia are potentiated in hyperthyroidism suggesting increased beta-adrenoceptor responsiveness, in contrast to our findings. It has been suggested that cardiac (beta 1) adrenoceptors (mediating changes in heart rate) are closely related to adrenergic nerve terminals whereas peripheral (beta 2) smooth muscle adrenoceptors may be more widely distributed and more responsive to circulating catecholamines. It may be,

therefore, that hyperthyroidism has a differential effect on sub-types of beta-adrenoceptors with augmented metabolic responses but no change in neurally mediated cardiac responses. Indeed, the formation of cyclic AMP and activation of cyclic AMP dependent protein kinase in the hyperthyroid rat heart in the absence and in the presence of isoprenaline is lower than in the euthyroid rat heart (Tse et al, 1980).

This study suggests that sympathetic neural sensitivity, defined in terms of heart rate and blood pressure responses, is normal in hyperthyroidism. Baseline heart rate is reset secondary to the levels of circulating thyroid hormones, but the rate and magnitude of the sympathetic response is unchanged from the euthyroid state. Propranolol administration abolishes the sympathetic component of the heart rate response, unmasking a direct dose-related thyroid hormone effect. Any increase in beta-adrenoceptor number secondary to hyperthyroidism does not therefore seem to influence cardiac sympathetic neural responsiveness.

CHAPTER 7

Thyroid Hormone Action on Paracetamol Pharmacokinetics: Implications for Rational Therapeutics in Thyroid Disease.

It is now well established that drug metabolism may be substantially altered by disease. Chronic liver disease (Blaschke, 1977), renal disease (Dettli, 1976), pulmonary disease (Du Souich et al, 1978) and congestive heart failure (Nies et al, 1976) can all impair different components of drug disposition following oral or parenteral administration. Many physiological and autonomic changes affecting most organ systems are associated with thyroid disease (Werner and Ingbar, 1978), giving several different mechanisms of alteration in drug absorption, metabolism and elimination (Eichelbaum, 1976; Shenfield, 1981). Despite this, few studies have reported on the effects of thyroid disease on drug disposition and yet changes in drug handling in patients with abnormal thyroid function may have important therapeutic implications in the management of the cardiovascular consequences of thyroid dysfunction. Altered gut motility in hyperthyroidism (Shirer, 1933; Christensen et al, 1964; Thomas et al, 1973) and hypothyroidism (Bacharach and Evans, 1957, Wohl and Nixon, 1965; Christensen et al, 1966; Holdsworth and Besser, 1968) may influence the rate and extent of drug absorption and therefore the speed of onset and magnitude of drug effect. Similarly, changes in gut mucosal function (Siurala et al, 1966; Bernstein and Ridings, 1970), changes in regional blood flow

(DeGroot and Leonard, 1970) or alteration in drug metabolising enzyme activity (Kato and Takahashi, 1968; Pitot and Yatvin, 1973) may modify drug distribution and elimination and thereby influence the magnitude and duration of drug effect.

This study has investigated the influence of thyroid function on paracetamol disposition after oral administration. Paracetamol was used because of its safety in single dosage, ease of measurement and reported use as a marker of drug disposition in other disease states (Pottage et al, 1974; Nimmo, 1976; Forrest et al, 1979). It is a weak acid (pKa 9.5) that is largely unionised in both gastric and intestinal fluids, and the rate of absorption in man is directly related to the gastric emptying rate (Heading et al, 1973). Anticholinergic agents such as propantheline or narcotic analgesics greatly increase gastric emptying time and delay the time to reach peak paracetamol concentrations (Nimmo et al, 1973; Nimmo et al, 1975) whereas metoclopramide stimulates gastric emptying and increases drug absorption in normal subjects (Nimmo, 1975).

Methods

Eighteen drug disposition profiles were obtained in eight patients (mean age 49 years, range 35-66 years) each studied on two or three separate occasions; seven when

hyperthyroid, seven when euthyroid and four when hypothyroid. Each patient therefore acted as his or her own control. Hyperthyroidism was diagnosed clinically and on the basis of a raised level of serum total thyroxine (T4) or triiodothyronine (T3) or both, associated with lack of response of serum thyrotrophin 20 minutes after the intravenous injection of 200 ug of thyrotrophin-releasing hormone. Hypothyroidism was confirmed by a reduced serum total T4 with raised serum TSH, and was spontaneous in one patient, followed the administration of therapeutic iodine 131 in two patients and subtotal thyroidectomy in one patient. Normal thyroid function was confirmed biochemically after treatment. A minimum period of three months elapsed after each treatment to allow biological adjustment to the change in thyroid hormone levels. Serum total T3, T4 and TSH levels were measured by specific radioimmunoassay (Irvine et al, 1973; Seth et al, 1976) as described in chapter 2. The laboratory reference ranges for T3 were 1.1 - 2.2 (male) or 2.6 (female) nmol/l, for T4 60-150 nmol/l and for TSH less than 0.7 to 5.7 mU/l.

Patient details and thyroid hormone levels, with their respective normal ranges are shown in table 7.1. No patient had evidence of concurrent cardiac, hepatic or gastrointestinal disease and all drug therapy was withdrawn 48 hours before each study. Patients 1, 4 and 8 had been on long-term thyroxine replacement therapy (100-150 ug per day) when euthyroid: patient 2 had been

PATIENT	AGE(YR) &SEX	HYPERHYROID			EUTHYROID			HYPOTHYROID		
		WT (kg)	T4 (nmol/l)	T3	WT (kg)	T4 (nmol/l)	TSH (mU/l)	WT (kg)	T4 (nmol/l)	TSH (mU/l)
1	52M	73.5	127	3.0	81.0	68	4.5	83.0	<20	40.8
2	51M	83.0	188	4.5	84.0	99	1.0	-	-	-
3	38F	52.5	230	5.5	55.0	80	1.0	-	-	-
4	35F	49.5	195	5.8	55.0	107	0.8	55.5	<20	63.0
5	50M	74.0	238	6.9	85.0	89	0.9	75.0	34	55.8
6	66M	67.0	248	5.7	80.5	67	9.9	-	-	-
7	36F	60.5	256	4.5	-	-	-	-	-	-
8	62F	-	-	-	72.0	92	2.5	69.0	<20	96.0

TABLE 7.1 Age at initial diagnosis, sex, weight and levels of thyroid hormones and serum TSH at times of study.

on digoxin 0.25 mg per day when hyperthyroid (although atrial fibrillation had not been documented) and patient 6 had been on propranolol 10 mg three times per day when hyperthyroid and a thiazide diuretic (cyclopenthiiazide/potassium chloride) when euthyroid.

After an overnight fast, paracetamol solution at room temperature (20 mg/kg dissolved in 400 ml water) was given orally over two minutes, and venous blood samples were taken from an indwelling cannula at 0, 3, 6, 10, 15, 20, 25, 30, 40, 50, 60, 75, 90 and 120 minutes and 3, 4, 6 and 8 hours after drug administration. Patients continued to fast lying supine in bed for the first two hours, but thereafter were permitted food, fluids and normal activity. Smoking was not permitted throughout each study.

Plasma (3 ml) was separated, stored frozen and later assayed in duplicate for paracetamol content using high performance liquid chromatography according to the method of Adriaenssens and Prescott, (1978). Briefly, aliquots of plasma (1ml) were mixed with 100 ul internal standard/protein precipitant solution (containing 300 ug/ml propionyl-4-amino phenol in 30 per cent aqueous perchloric acid) and injected with a solvent flow (0.1M potassium dihydrogen phosphate; 98% formic acid and isopropanol [100:0.1:1.7v/v/v]) of 0.9 ml perminute. An Orlita pump with a Waters model 440 UV absorbance detector (254nm filter) were used and peak areas measured with a Hewlett-Packard HP3370 A integrator. The columns were

stainless steel tubes 100mm x 4.9mm packed with Hypersil-OOS (Shandon Southern Products) and fitted with a septum injector. The chromatogram peaks for paracetamol and the sulphate and glucuronide conjugates were distinct and separate samples could be injected every 18 minutes. The limit of measurement with a 5 ul injection was 1ug per ml. The standard deviation of replicate assays of paracetamol was less than 3 per cent on a concentration range of 1-250 ug per ml. Day to day reproducibility was 3 to 4 per cent.

Drug absorption was assessed by measurement of the peak plasma concentration achieved and the time to peak concentration. Total body clearance was estimated from the area under the plasma concentration-time curve extrapolated to infinity and assuming 100 per cent bioavailability and the half-life ($T_{1/2}$) estimated from the terminal slope (4-8 hours).

In addition, estimates of the absorption, distribution and elimination rate constants, and the central and peripheral compartment volumes were obtained by non-linear regression analysis of the plasma concentration-time curves in terms of a two compartment open pharmacokinetic model with first order absorption (Gibaldi and Perrier, 1975). This model, shown schematically in figure 7.1, adequately describes the fate of many drugs in man and its mathematical solutions are consistent with intuitive notions of drug behaviour in

biological tissues (Riegelman et al, 1968; Greenblatt and Koch-Weser, 1975 a,b).

Statistical comparisons between the groups were made using standard parametric techniques for paired observations (two-tailed). All data are quoted as mean +/- SEM.

Results

Mean plasma paracetamol concentration-time curves showed three distinct patterns in the hyperthyroid, euthyroid and hypothyroid groups (figures 7.2 and 7.3). The time to peak concentration was significantly shortened in the hyperthyroid, compared to euthyroid group (14 minutes compared to 25 minutes; $P < 0.001$), and was prolonged in the hypothyroid groups (33 minutes) although differences did not achieve statistical significance at a 5 per cent level of confidence. The absorption half-life was correspondingly shortened in the hyperthyroid group with a trend for prolongation when hypothyroid (figure 7.4). In contrast, the mean peak paracetamol concentration was lower in the hyperthyroid group ($P < 0.05$) than in the other two groups and there was a more rapid whole body clearance ($P < 0.005$) and a shorter plasma half-life ($P < 0.05$) in these patients (figure 7.4).

There were no significant differences between the groups in distribution rate constants or the apparent volume of the peripheral compartment. The overall

FIGURE 7.1

Schematic diagram of open two-compartment model for analysis of paracetamol pharmacokinetics.

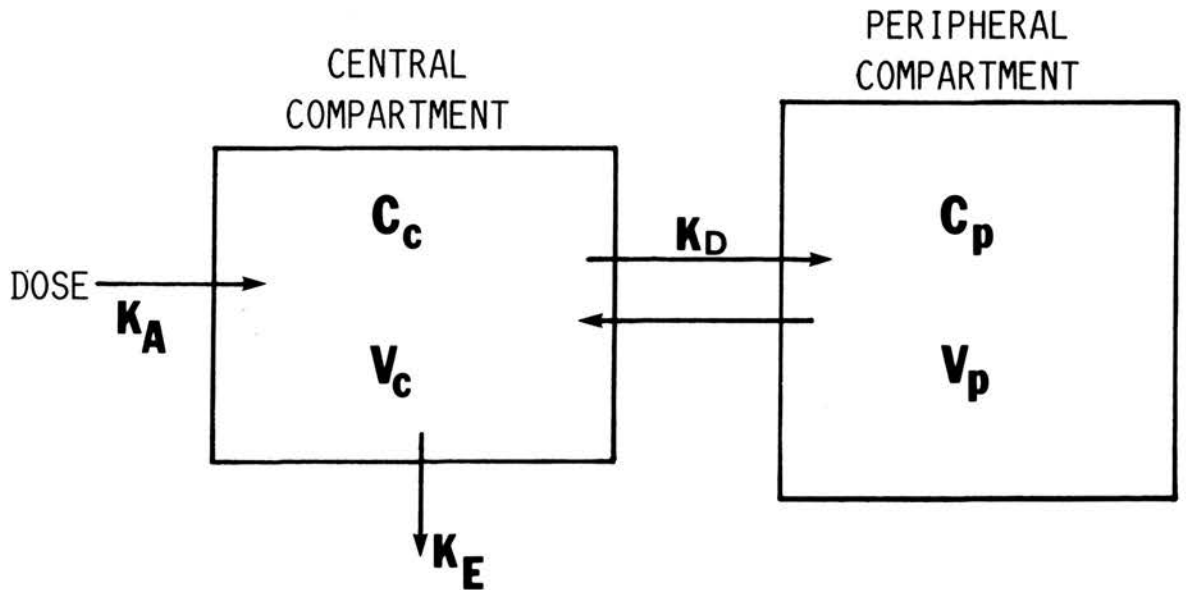

C_c AND C_p REPRESENT DRUG CONCENTRATIONS IN, AND V_c AND V_p APPARENT VOLUMES OF CENTRAL AND PERIPHERAL COMPARTMENTS. FIRST-ORDER RATE CONSTANTS OF DRUG ABSORPTION (K_A) AND ELIMINATION (K_E) FROM THE CENTRAL COMPARTMENT AND HYBRID DISTRIBUTION RATE CONSTANT (K_D) BETWEEN CENTRAL AND PERIPHERAL COMPARTMENTS ARE INDICATED.

FIGURE 7.2

Plasma paracetamol concentration (mean \pm SEM) time curves in hyperthyroid, euthyroid and hypothyroid patients over the first hour after oral administration (absorptive phase).

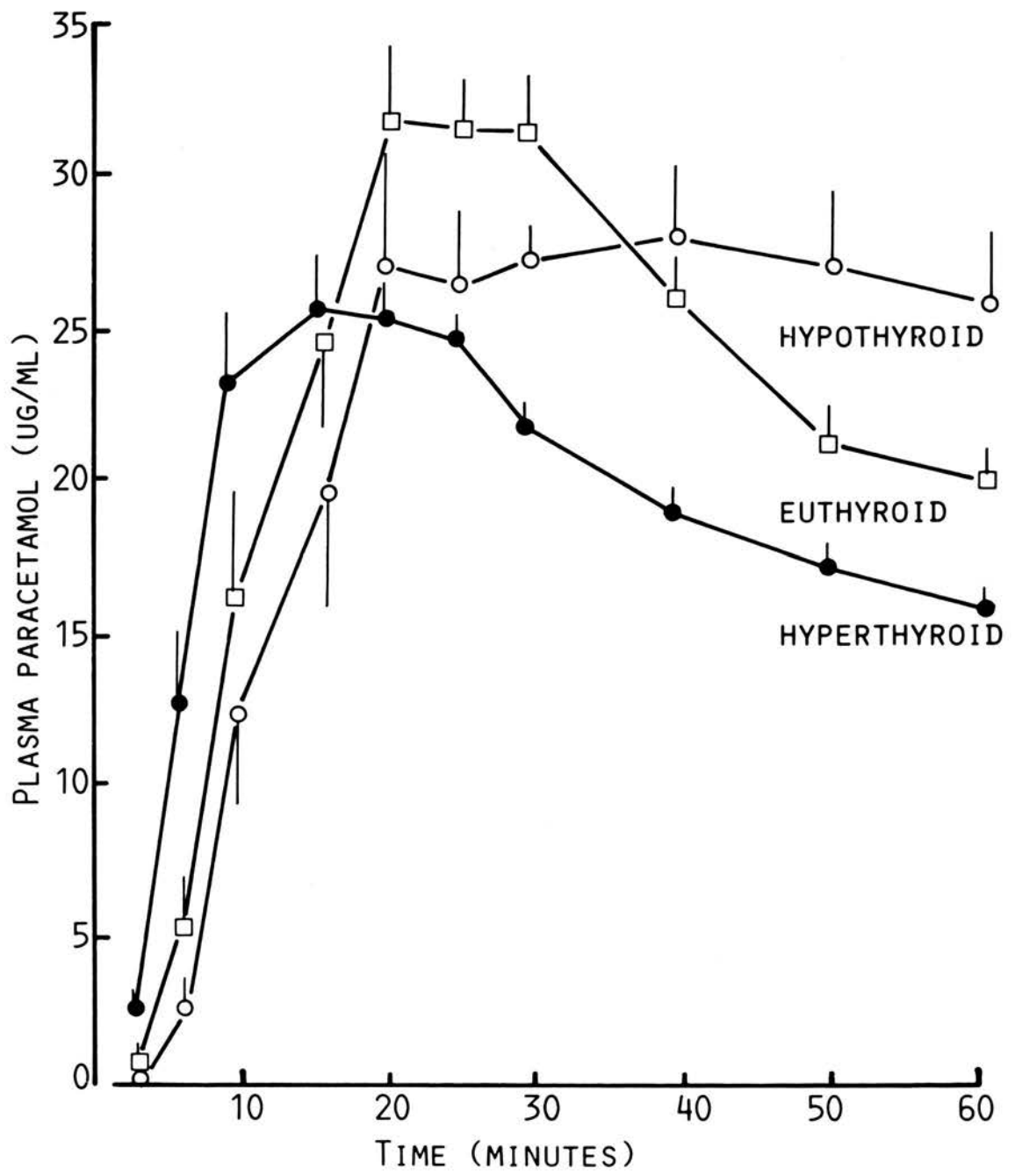
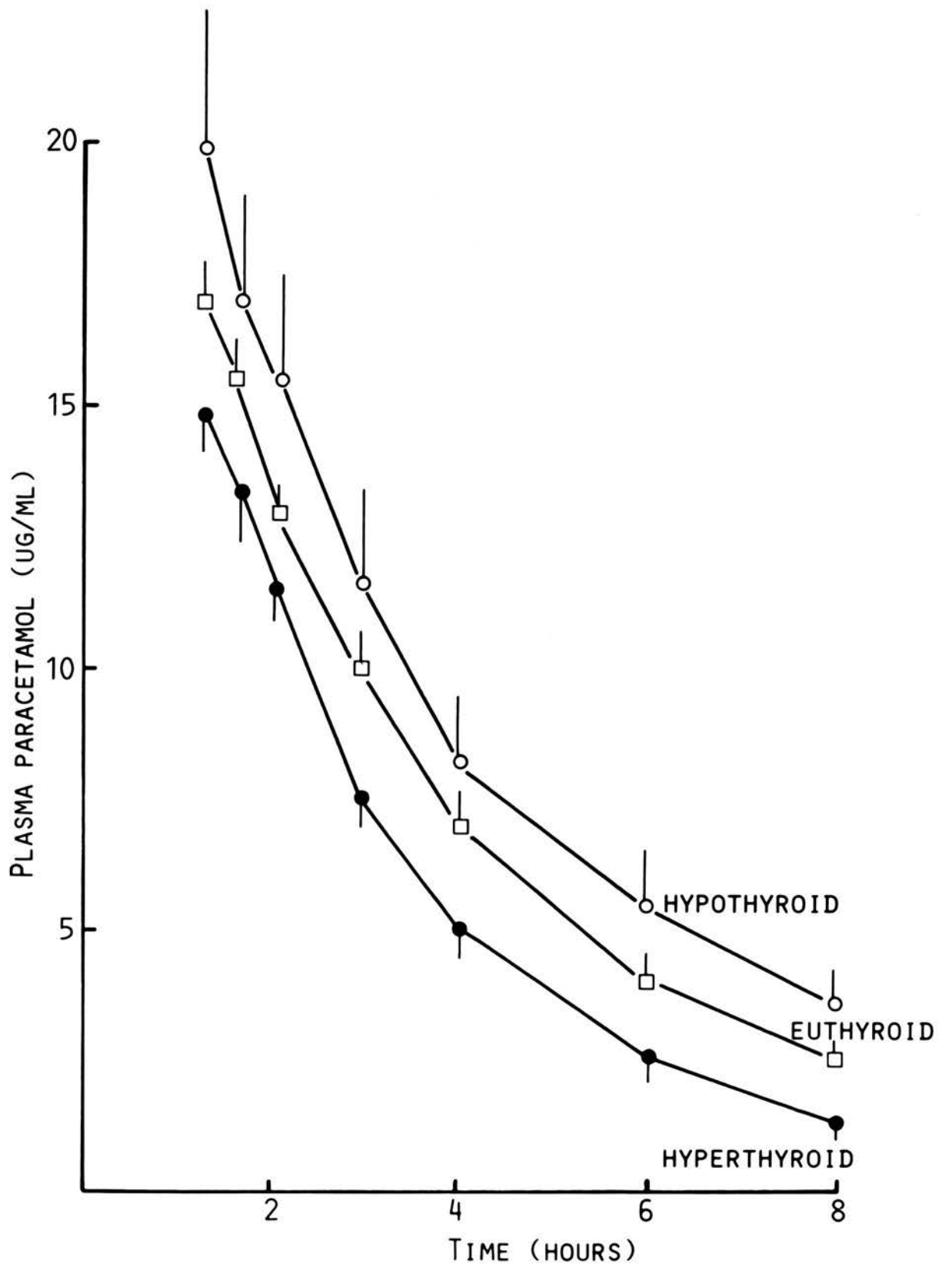

FIGURE 7.3

Plasma paracetamol concentration - time curves in hyperthyroid, euthyroid and hypothyroid patients over 1-8 hours after oral administration (post absorptive phase).



apparent volume of distribution, however, was largest in the hyperthyroid group, but the differences were not significant. This trend was due to differences in the volume of the central compartment, which was significantly greater in the hyperthyroid group than in the other two ($P < 0.025$). A summary of those pharmacokinetic variables is shown in table 7.2.

Discussion

Despite the profound effects of altered thyroid activity on the function of many organs, few attempts have been made to investigate the influence of thyroid disease on drug disposition. In general, most of the changes would tend to increase plasma and tissue drug concentrations in hypothyroidism and lower them in hyperthyroidism. Drug effects may be further modified by thyroid hormone induced changes in target organ responsiveness, for example altered drug-receptor binding or cellular enzymic activity may substantially modify drug efficacy.

Drug absorption may be accelerated by the increase in gut motility in hyperthyroidism, as demonstrated in this investigation using a drug whose absorption is dependent on the rate of gastric emptying (Nimmo, 1976). Conversely, drug absorption may be slowed by the hypomotility associated with thyroid hormone deficiency. The site of absorption, however, is a major determinant of

FIGURE 7.4

Time to peak concentration, peak paracetamol concentration and half life (upper panel) and total body clearance and plasma half-life in hyperthyroid (T), euthyroid (E) and hypothyroid (H) groups (mean +/- SEM).

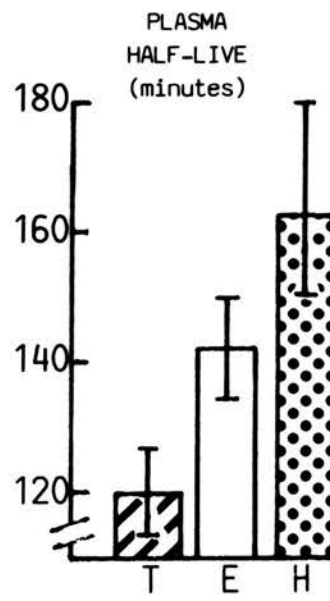
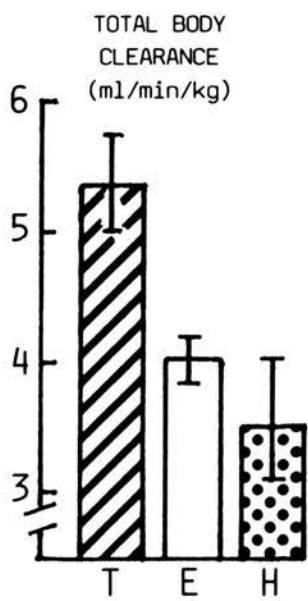
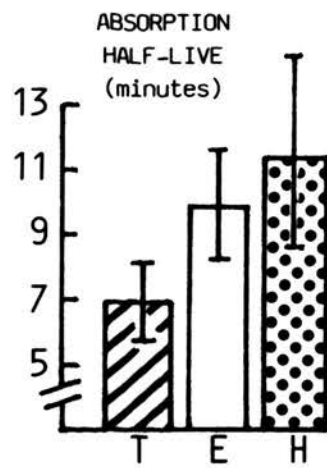
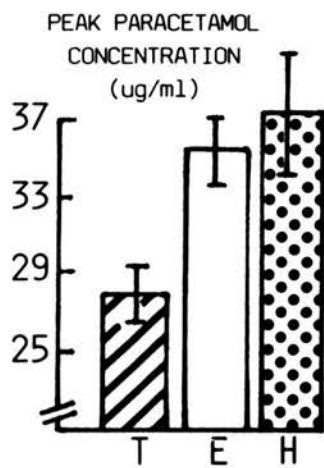
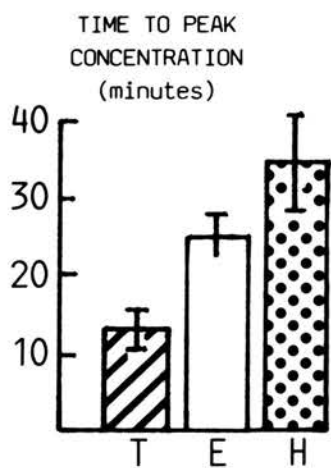

PHARMACOKINETIC PARAMETER	C L I N I C A L S T A T U S		
	HYPERTHYROID	EUTHYROID	HYPOTHYROID
Max conc (ug/ml)	28.3 +/-1.5	34.9 +/-2.3	36.6 +/-4.3
Time to peak conc (min)	13.6 +/-1.8	25.0 +/-1.9	33.8 +/-6.9
K_A (min^{-1})	0.13 +/-0.03	0.08 +/-0.01	0.07 +/-0.02
K_D (min^{-1})	0.050 +/-0.003	0.054 +/-0.002	0.050 +/-0.003
K_E (min^{-1})	0.006 +/-0.001	0.005 +/-0.001	0.004 +/-0.001
$T_{1/2}$ (min)	122.5 +/- 10.5	143.4 +/- 8.7	166.4 +/-18.4
TBC (ml/min/g)	5.4 +/-0.3	4.1 +/-0.2	3.6 +/-0.6
TOTAL V_D (l/g)	0.94 +/-0.06	0.83 +/-0.04	0.81 +/-0.07
V_C (l/g)	0.50 +/-0.02	0.41 +/-0.03	0.38 +/-0.04
V_P (l/g)	0.45 +/-0.07	0.43 +/-0.03	0.43 +/-0.05

K_A , K_D , K_E : absorption, distribution and elimination rate constants.
 $T_{1/2}$: plasma half-life. TBC: total body clearance. V_D , V_C , V_P :
volumes of distribution of total, central and peripheral compartments.

TABLE 7.2 Pharmacokinetic parameters derived from computer analysis of plasma paracetamol concentration - time curves using a two compartment open model with first order input.

the effect of changes in gastrointestinal transit time. Riboflavin, for example, is absorbed by a specialised, saturable transport system in the small intestine and the extent of absorption is a function of its duration of contact with the absorptive sites (Levy and Jusko, 1966). Prolongation of intestinal transit time using an anticholinergic drug thus increased riboflavine absorption (Levy et al, 1972a) and, since it was not metabolised, urinary excretion was similarly enhanced (Jusko et al, 1970). Levy et al, (1972b) have also investigated riboflavine absorption in children with thyroid disease and shown that urinary excretion (and hence drug absorption) was highest in the hypothyroid (16% of dose) and lowest in the hyperthyroid (4% of dose) groups. Values in both groups were similar when euthyroid (8% of dose). Urinary excretion of riboflavine was not influenced by thyroid status after intramuscular administration suggesting that intestinal transit time was the factor accounting for the differences.

In this study, paracetamol concentrations peaked earlier and tended to decline more rapidly in hyperthyroid than in euthyroid patients, and the same pattern was observed when euthyroid patients were compared to those with hypothyroidism. No single factor appeared to be the major cause of these differences. A reduced time to peak concentration can be due either to accelerated absorption or accelerated distribution and elimination,

and in this study both absorption and elimination rate constants were greater in hyperthyroid than in euthyroid patients and to a lesser extent in euthyroid than in hypothyroid patients. The combination of an increase in both absorption and elimination may have been sufficient to produce the large reduction in time to peak drug concentration seen in the hyperthyroid group.

Drug elimination may be accelerated in hyperthyroidism and slowed in hypothyroidism. Antipyrine metabolism has been used as an index of hepatic microsomal enzyme function in several studies. In all of these, changes in the volumes of distribution with differing thyroid function were minimal, whereas plasma clearance was significantly enhanced in hyperthyroidism (Crooks et al, 1973; Eichelbaum et al, 1974; Vessell et al, 1975) and decreased in hypothyroidism (Vesell et al, 1975). The alteration in clearance is probably due to changes in hepatic metabolism and this is supported by the studies of Eichelbaum et al, (1973) who showed that urinary excretion of the hepatic metabolite 4-hydroxyantipyrine was decreased in hypothyroid patients and returned to normal as the patients became euthyroid. Experimentally, thyroid hormones influenced mixed function oxidase enzyme activity in liver microsomes, although results varied with the substrate used and the sex of the animal (Conney and Garren, 1961; Kato and Takahashi, 1968). Enhanced drug elimination in hyperthyroidism and reduced elimination in hypothyroidism has been shown for cortisol (Peterson,

1958; Linquette et al, 1975) and for methimazole (Balzer et al, 1975; Vessel et al, 1975) although inconsistencies remain (Skellern et al, 1980). The half-life of thyroxine and T3 themselves is similarly affected (Gilman and Murad, 1975; Bianchi et al, 1977). The increase in paracetamol elimination demonstrated here is in keeping with the known effect of thyroxine on drug metabolising enzyme activity.

In contrast, the metabolism of testosterone was increased in hypothyroidism with increased conversion to androstenedione and reduced levels of plasma testosterone (Gordon et al, 1969). The reverse occurred in hyperthyroidism and after treatment, values returned to normal. These differences cannot be explained on the basis of enzyme induction but may be secondary to changes in sex hormone binding globulin production. Hepatic production of this protein is enhanced in hyperthyroidism (Vermeulen and Verndonck, 1972) and levels of oestrogen, testosterone and the protein return towards normal after antithyroid therapy (Akande and Anderson, 1975).

The significant reduction in peak paracetamol concentration in the hyperthyroid group merits further consideration. Accelerated absorption produces early peaks of increased magnitude whereas accelerated elimination produces early peaks of decreased magnitude. The effects of enhanced elimination on peak concentration would therefore be mitigated by increased absorption in

these patients. An explanation of the reduced peak concentration is provided by the increase in the apparent volume of the central compartment in hyperthyroidism, which would tend to reduce early plasma concentrations. However, the central compartment volume (and the total body clearance to which it is directly related) was calculated assuming that absorption was complete and systemic availability 100% in all groups. It is likely that the systemic availability of oral paracetamol is less than complete (Rawlins et al, 1977; Perucca and Richens, 1979). Further, if systemic availability changed with differing thyroid function by altered 'first-pass' elimination, then the changes in distribution volume may be more apparent than real. Such changes in systemic availability would be consistent with the observed effects of thyroid function on paracetamol elimination, particularly as the effects of increased hepatic clearance would be greater during absorption than in the post-absorption phase because the total drug dose is initially presented to the liver. Resolution of these alternatives is not possible with the present data.

Alterations in pre-systemic clearance (the 'first pass' effect) may be of considerable importance in determining the efficacy of beta-adrenoceptor antagonists in patients with thyroid disease. Several authors have noted variable plasma propranolol concentrations in hyperthyroid subjects (Rubenfeld et al, 1979; Feely et al, 1980; Forfar et al, 1982) after oral administration.

Most studies, however, have failed to show a significant change in the serum half-life of propranolol with differing thyroid status (Bell et al, 1977; Riddell et al, 1979; Riddell et al, 1980; Aro et al, 1982). Since propranolol has a significant pre-systemic hepatic clearance (Johnsson and Regardh, 1976) which is flow dependent (Branch et al, 1973), alteration in hepatic blood flow could theoretically alter propranolol kinetics. In support of this premise, Aro et al, (1982) observed a significant reduction in the bioavailability of propranolol during hyperthyroidism, while the pharmacokinetics of sotalol were unaffected. Hallengren et al, (1982) also noted reductions in the area under the drug concentration-time curve in hyperthyroidism after oral propranolol and metoprolol but no change after atenolol or methimazole. Sotalol and atenolol have a low hepatic extraction ratio and the major route of elimination is excretion via the kidney. It is thus possible that the influence of hyperthyroidism on drug oxidation becomes apparent mainly for drugs with a high hepatic extraction ratio that are subject to extensive presystemic clearance.

The coumarin group of oral anticoagulant drugs are metabolised in the liver and one might anticipate the need for increased dosage in hyperthyroidism and reduced dosage in hypothyroidism. However, clinical evidence suggests that thyroid hormones potentiate the anticoagulant effect

of warfarin (Solomon and Schrogie, 1967) and that this effect occurs at doses which have no effect on the rate of metabolism of the drug (Schrogie and Solomon, 1967). It has been suggested by these authors that warfarin binding to its receptor may be increased by thyroid hormones, but it seems more likely that the prolongation of prothrombin time in hyperthyroidism and the reduction in hypothyroidism is due to altered catabolism of the vitamin K dependent clotting factors. Thyroxine increased the rate of degradation of factor II by 40 per cent and its biological half-life fell from 28 to 21 hours (Weintraub et al 1973). Hyperthyroidism shortened the biological half-life of factors II, VII, IX and X with reciprocal changes in hypothyroidism. This explains the need for a reduced dose of anticoagulants in hyperthyroidism (Self et al 1975; Vagenakis et al 1972).

The digitalis glycosides remain the primary agent for control of the ventricular rate in hyperthyroid atrial fibrillation although several factors complicate their use. Clinically, it has been known for many years that hyperthyroid patients appear resistant to glycosides whereas hypothyroid patients are more sensitive to the actions of these drugs (Boas 1931; Frye and Braunwald, 1961). Experimentally, hyperthyroidism reduces the enhancement of myocardial contractility and the prolongation of atrioventricular refractory period after ouabain (Morrow et al, 1963). Until more recent studies, it was believed that these alterations were entirely

pharmacodynamic in nature and reflected thyroid hormone induced changes in myocardial function. In 1966, however, Doherty and Rerkuis investigated 3H-digoxin kinetics after intravenous injection and observed that plasma concentrations were lower than control in the hyperthyroid group and higher than control in the hypothyroid group, a finding since confirmed by several investigators using both oral and intravenous routes of administration (Croxson and Ibbertson 1975; Shenfield et al 1977; Bonelli et al 1978). Several reasons for these differences are available. Changes in renal blood flow (Bradley et al, 1974) and glomerular filtration rate modify renal digoxin clearance (Lawrence et al 1977), an explanation favoured by Eichenbusch et al (1970), Croxson and Ibbertson (1975), Gilfrish (1976) and Bonelli et al 1978. However, increased hepatic metabolism (Varcedi and Foldes, 1976; Huffman et al 1978), reduced bioavailability (Watters and Tomkin 1975), or more likely a combination of these factors (as shown for paracetamol) contribute to important pharmacokinetic differences with thyroid dysfunction. Furthermore, the kinetics of digoxin binding to the myocardium are altered in hyperthyroidism (Veroni and Shenfield 1980 a,b) giving increased glycoside accumulation. It is probable that binding is to the specific glycoside receptor Na^+/K^+ ATPase (Kushinsky et al 1967), which is increased in both cardiac and skeletal muscle in hyperthyroid animals (Curfmann et al 1977;

Sharma and Banerjee 1978b). Thus part of the apparent digoxin resistance in hyperthyroidism must reflect a primary effect of thyroid hormone on the heart.

The magnitude of the changes in paracetamol pharmacokinetics in thyroid disease highlights the importance of altered drug handling in disease. This can have important practical consequences and although the changes demonstrated are clearly not applicable to all drugs, certain therapeutic guidelines may be appropriate. Despite the widespread use of oral propranolol for symptomatic relief in hyperthyroidism and for the preparation of patients for thyroidectomy (Michie et al 1974; Toft et al 1978), therapeutic failures with this drug are well documented (Ljunggren and Persson, 1975; Eriksson et al 1977). It is likely that a major component of these failures results from inadequate dosage secondary to increased pre-systemic clearance of the drug. Beta-adrenoceptor blocking drugs with a low hepatic extraction ratio such as sotalol (Aro et al, 1982) atenolol (McDevitt and Nelson, 1978) or nadolol are likely to give more reproducible plasma levels in thyroid disease and to show less variability in pharmacokinetics after oral administration, as shown recently for sotalol (Aro et al 1980). Indeed, sotalol has specific therapeutic actions, namely prolongation of the cardiac action potential (Edwardsson et al, 1980), that may make it the beta-adrenoceptor blocking drug of choice in hyperthyroidism particularly if associated with atrial

fibrillation. It does not influence peripheral thyroid hormone metabolism (Wahlberg and Carlsson, 1978). The resting pulse rate is a poor guide to adequacy of beta-adrenoceptor blocking drug therapy which requires assessment of plasma concentration usually coupled with assessment of the per cent inhibition of exercise-induced tachycardia. Oral anticoagulant therapy in hyperthyroidism requires particular care to avoid excessive prolongation of the prothrombin time. Digitalisation remains as much an art as a science although measurement of plasma levels should provide a guideline for individual adjustments of dose. As with all therapeutic agents, knowledge of pharmacokinetic and pharmacodynamic profiles allows a more rational approach to drug prescribing in thyroid disease.

CHAPTER 8

Summary and Conclusions

Many of the most important consequences of thyroid dysfunction affect the heart and circulation. Although the mode of action of thyroid hormones is incompletely understood, physiological and biochemical research from several investigations suggests that direct thyroid hormone effects on the heart and interactions with the neurosympathetic axis are of importance. The extent to which thyroid hormone excess or deficiency may alter cardiac autonomic control is discussed in addition to the pathophysiological consequences of thyroid disease for the circulation.

Serum total thyroxine, triiodothyronine and the thyrotrophin response to thyrotrophin-releasing hormone were measured in ninety consecutive patients presenting to a cardiology clinic with atrial fibrillation that could not be satisfactorily explained on the basis of known cardiovascular disease. The arrhythmia was considered to be "idiopathic" in sixty five patients and an unexpected development in the natural history of an established cardiac disease in twenty five patients. A lack of response of thyrotrophin to thyrotrophin-releasing hormone, indicative of hyperthyroidism, was documented in twelve of the ninety patients (13 percent), including three with associated heart disease, only eight of whom had thyroid hormone concentrations outwith the laboratory reference range. In seven of these eight patients (predominantly male), stable sinus rhythm was reestablished after antithyroid therapy. In four patients thyroid hormone levels were normal, probably due to the effects of concurrent illness or drug therapy on peripheral thyroid hormone metabolism, and initial cardioversion failed to establish sinus rhythm in three of these patients. Following specific antithyroid therapy to lower thyroid hormone levels sufficient to allow a normal thyrotrophin response to

thyrotrophin-releasing hormone, sinus rhythm was reestablished in all four patients, one spontaneously and three after cardioversion. Clinically occult hyperthyroidism can be identified consistently only with the thyrotrophin-releasing hormone test and is a treatable cause of "idiopathic" atrial fibrillation in a significant proportion of patients. In the presence of atrial fibrillation, an absent thyrotrophin response to thyrotrophin-releasing hormone should be considered sufficient grounds for antithyroid therapy even if peripheral thyroid hormone concentrations are within the expected normal range.

The effects of oral thyroxine in a dose sufficient to substantially inhibit the thyrotrophin response to thyrotrophin-releasing hormone **without** increasing plasma total thyroxine and triiodothyronine outwith the normal range were investigated in seven normal subjects. After three weeks of therapy, significant ($P < 0.01$) increases in night-time (7.1 ± 0.7 beats/minute) and daytime (3.1 ± 0.6 beats/minute) mean and minimum hourly heart rates were observed compared to the same subjects off thyroxine. Increases were consistently greater at night. In addition, increases in night-time urinary flow and sodium excretion and reductions in daytime urinary flow and sodium excretion occurred such that the day:night ratio of urinary flow and sodium excretion fell from 2.2 ± 0.3 and 2.4 ± 0.2 respectively off thyroxine to 1.4 ± 0.2 and 1.6 ± 0.2 during thyroxine ($P < 0.01$). These results suggest that biologically significant changes in target organ function occur with minor increases in thyroid hormone concentrations within the normal range and that this state of subclinical hyperthyroidism is only subclinical in as much as the

physician is unable to detect the changes in target organ function that develop. Hyperthyroidism is therefore a graded phenomenon and may be characterised in its early stages by thyroid hormone concentrations still within the normal range but recognised by the pituitary, heart, kidney and presumably other organs as abnormal. Reassessment of the threshold for antithyroid therapy is indicated in all patients with isolated suppression of the pituitary-thyroid axis.

Left ventricular contractile function at rest and responses to dynamic exercises have been examined in nine hyperthyroid and eight hypothyroid patients before and after specific corrective therapy. Isotope ventriculography using gated blood-pool imaging (technetium 99m labelled HSA) was performed supine before and after propranolol 0.15mg/kg intravenously. The same protocol at the same exercise work loads was used for each patient at restudy when euthyroid. Hyperthyroidism was characterised by a high resting left ventricular ejection fraction ([LVEF] 0.58 ± 0.03 compared to 0.53 ± 0.02 euthyroid; $P < 0.01$) but paradoxically by a significant exercise-induced fall in LVEF (0.55 ± 0.02 ; $P < 0.01$ compared to resting LVEF). In contrast, LVEF increased on exercise when euthyroid (exercise LVEF 0.61 ± 0.03 ; $P < 0.01$ compared to resting LVEF) to a level significantly greater than when hyperthyroid ($P < 0.02$). Resting LVEF was reduced in the hypothyroid patients (0.46 ± 0.02 compared to 0.53 ± 0.02 euthyroid) but the increase in LVEF with exercise was similar in both hypothyroid and euthyroid groups. Resting LVEF in the euthyroid groups was similar and independent of initial thyroid status. Pretreatment with intravenous propranolol caused a similar reduction in resting LVEF in hyperthyroid, euthyroid and hypothyroid groups. Propranolol attenuated the rise in LVEF with exercise when euthyroid but did not

influence the rise when hypothyroid or the fall when hyperthyroid. Directional changes in a second index of myocardial contractile function based on the shape of the volume curve during systole paralleled the LVEF data. LVEF showed a positive correlation with heart rate for all subjects except the hyperthyroid patients on exercise where LVEF was unexpectedly low for heart rate both before and after propranolol. These results suggest that intrinsic myocardial contractile function may be depressed in both hyper- and hypothyroidism, manifest in the former by exercise-induced reductions in myocardial contractility and in the latter by reductions both at rest and on exercise.

As part of the further study of myocardial contractile responses under stress in hyperthyroidism, sequential studies of systolic time intervals, left ventricular dimensions and the derived indices of isovolumetric and ejection phase indices of myocardial contractility were undertaken in fifteen hyperthyroid patients at rest and during isometric exercise before and after autonomic blockade. In addition, nine patients were studied on up to six occasions each during antithyroid therapy. As noted previously, hyperthyroidism at rest was characterised by a shortened preejection period index (PEPI 111 ± 4 msec; predicted PEPI 130 msec) and total duration of electromechanical systole (QS_2I 522 ± 14 msec; predicted QS_2I 549 msec) but little change in left ventricular ejection time index (LVETI 413 ± 5 msec; predicted LVETI 418 msec). A small increase in PEPI was noted following autonomic blockade. Mean velocity of circumferential fibre shortening (Vcf) was increased in hyperthyroid patients at rest (1.4 ± 0.10 circ/sec compared to 0.90 ± 0.10 circ/sec euthyroid; $P < 0.01$) from a combination of increased end-diastolic and reduced end-systolic

diameter in hyperthyroidism. During isometric exercise, however, PEPI increased substantially to 144 ± 4 msec (P<0.005), and was longer than that predicted from regression equations from normal subjects during isometric exercise. Mean Vcf decreased 30 per cent on exercise when hyperthyroid to 1.01 ± 0.09 circ/sec. Directional changes in these parameters were similar after autonomic blockade. In contrast, both PEPI and Vcf were unchanged during the same isometric exercise in these patients after a stable euthyroid state had been achieved for at least three months. The increase in PEPI and the fall in Vcf on exercise were directly related to levels of thyroid hormones. Comparison between these responses on exercise and thyroid status during antithyroid therapy showed that a biochemical euthyroid state could be achieved many weeks before normalisation of contractile responses to exercise.

It is hypothesised that left ventricular function is reversibly depressed in hyperthyroidism evidenced by abnormalities in isovolumetric and ejection phase indices of contractile activity during static and dynamic exercise that return to normal only after a stable euthyroid state has been achieved for at least three months. The apparent changes in contractility at rest primarily reflect peripheral effects of thyroid hormones. Autonomic blockade causes similar reductions in myocardial contractile function in the hyperthyroid and euthyroid state without influencing directional responses to exercise.

The relationship between the sympathetic nervous system and cardiovascular responses has been studied in ten hyperthyroid patients and age-matched euthyroid controls by measuring nyctohemeral variations in heart rate and heart rate and blood pressure responses to exercise before and after beta-adrenoceptor blockade with slow-release propranolol. Both groups showed a parallel variation in heart rate

over 24 hours, with an increase in heart rate in the hyperthyroid group that was similar during the day (28 +/-1 beats/minute) and during the night (27 +/-1 beats/minute). Similarly, the increase in resting heart rate (32 +/-4 beats/minute) in the hyperthyroid group was close to the increase in peak-exercise induced heart rate (25 +/-5 beats/minute). Adequate beta-adrenoceptor blockade was achieved in all subjects as evidenced by a percentage reduction in peak exercise heart rate of 25-45 percent. Propranolol caused a greater reduction in day-time than night-time heart rate in both groups and blunted the response to exercise. Following beta-adrenoceptor blockade, the mean percentage reduction in heart rate and systolic blood pressure during exercise and heart rate responses over twenty four hours were similar in hyperthyroid and euthyroid groups. The shape of the adrenergic component of heart rate responses during exercise and recovery was independent of thyroid status. The closest correlation between thyroid hormone levels and heart rate was that of plasma total triiodothyronine and nocturnal heart rate during beta-adrenoceptor blockade ($r=0.92$; $P<0.001$). Excess circulating thyroid hormones therefore exert a direct effect on the cardiovascular system additive to the sympathetic nervous system. There is no evidence of adrenergic hypersensitivity in hyperthyroidism.

The effects of thyroid disease on systemic autonomic activity have been examined by analysis of the absorption, distribution and elimination of oral paracetamol before and after treatment of hyperthyroidism (7 patients) and hypothyroidism (4 patients) according to an open two compartment pharmacokinetic model with first order absorption. Absorption was faster in patients with untreated

hyperthyroidism than when subsequently euthyroid. The peak paracetamol concentration, however, was lower in hyperthyroid patients due to an apparent increase in the total body clearance and a shorter plasma half-life. Both absorption and elimination rates were reduced in hyperthyroid patients but they were not significantly different from the euthyroid results. The total volume of distribution and the hybrid distribution rate constants were unrelated to thyroid status, but the apparent volume of the central compartment was significantly greater in the hyperthyroid group. These changes in drug handling highlight the extent of alteration in systemic autonomic function in thyroid disease and have important implications for rational drug prescribing in both hyper- and hypothyroidism.

Parts of the material and concepts presented in this thesis have been published or presented to conferences or learned societies:-

Forfar JC, Miller HC, Toft AD (1979). Occult thyrotoxicosis: a correctable cause of "idiopathic" atrial fibrillation. *American Journal of Cardiology* 44 9-12 (also presented to the Scottish Society of Physicians, Dumfries, 1979).

Forfar JC, Pottage A, Toft AD, Irvine WJ, Clements JA, Prescott LF (1979). The effect of thyroid disease on paracetamol absorption. *International Conference on Drug Absorption, Edinburgh.*

Forfar JC, Toft AD (1980). Thyroid disease and the heart: problems in diagnostic recognition. *Practical Cardiology* 6 31-35.

Forfar JC, Pottage A, Toft AD, Irvine WJ, Clements JA, Prescott LF (1980). Paracetamol pharmacokinetics in thyroid disease. *European Journal of Clinical Pharmacology* 18 269-273.

Forfar JC, Feek CM, Miller HC, Toft AD (1981). Atrial fibrillation and isolated suppression of the pituitary-thyroid axis: response to specific antithyroid therapy. *International Journal of Cardiology* 1 43-48.

Forfar JC (1981). Heart disease and occult thyroid dysfunction in the elderly. *Internal Medicine* 2 25-32.

Forfar JC, Sawers JSA, Toft AD (1982). Cardiovascular responses in hyperthyroidism before and during beta-adrenoceptor blockade: evidence against adrenergic hypersensitivity. *Clinical Endocrinology* 16 441-452.

Forfar JC, Muir AL, Toft AD (1982). Left ventricular function in hypothyroidism: responses to exercise and beta-adrenoceptor blockade. *British Heart Journal* 48 278-284

Forfar JC, Muir AL, Toft AD (1982). Left ventricular function in hyperthyroidism: evidence for a reversible cardiomyopathy? *New England Journal of Medicine* 307 1165-1170

Toft AD, Forfar JC (1982). Atrial fibrillation in hyperthyroidism: pathogenesis, features and management. Internal Medicine 3 35-39

Forfar JC, Toft AD (1982). Hyperthyroid atrial fibrillation- an underdiagnosed condition? British Medical Journal 285 909-910

Bell GM, Sawers JSA, Forfar JC, Doig A, Toft AD (1982). Heart rate and urinary sodium excretion in subclinical hyperthyroidism. Clinical Endocrinology 18 511-516

Forfar JC, Muir AL, Toft AD (1982). Influence of thyroid hormones on left ventricular function: evidence for impairment of myocardial contractility in both hyper- and hypothyroidism. 12th Annual Meeting of the European Thyroid Association, Brussels.

Forfar J C, Matthews D M, Toft A D (1984). Delayed recovery of left ventricular function after antithyroid treatment: further evidence for reversible abnormalities of contractility in hyperthyroidism. British Heart Journal 52 215 - 222.

REFERENCES

Aber CP, Thompson GS (1964). The heart in hypothyroidism. Am Heart J 68 429.

Abildskov JA, Millar K, Burgess MJ (1971). Atrial fibrillation. Am J Cardiol 28 263.

Abrahamsen AM, Haarstad J, Oulie C (1963). Haemodynamic studies in thyrotoxicosis before and after treatment. Acta Med Scand 174 463.

Adriaenssens PI, Prescott LF (1978). High performance liquid chromatographic estimation of paracetamol metabolites in plasma. Br J Clin Pharmacol 6 87.

Ahmad N, Cohen MP (1981). Thyroid storm with normal serum triiodothyronine level during diabetic ketoacidosis. JAMA 245 2516.

Akande EO, Anderson DC (1975). Role of sex hormone binding globulin in hormonal changes and amenorrhoea in thyrotoxic women. Br J Obstet Gynaecol 82 557.

Alessi R, Nusynowitz M, Abildskov JA, Moe GK (1958). Nonuniform distribution of vagal effects on the atrial refractory period. Am J Physiol 194 406.

Amidi M, Leon DF, DeGroot WJ, Kroetz FW, Leonard JJ (1968). Effect of thyroid state on myocardial contractility and ventricular ejection rate in man. Circulation 38 229.

Anton AH, Gravestain JS (1970). Studies on thyroid-catecholamine interactions in the isolated rabbit heart. Eur J Pharmacol 10 311.

Aoki VS, Wilson WR, Theilen EO, Lukensmeyer WW, Leaverton PE (1967). The effects of triiodothyronine on hemodynamic responses to epinephrine and norepinephrine in man. J Pharmacol Exp Ther 157 62.

Arnsdorf MF, Childers RW (1970). Atrial electrophysiology in experimental hyperthyroidism in rabbits. Circ Res 26 257.

- Aro A, Antilla M, Korhonen T, Sundquist H (1982). Pharmacokinetics of propranolol and sotalol in hyperthyroidism. *Eur J Clin Pharmacol* 21 373.
- Bacharach T, Evans JR (1957). Enlargement of the colon secondary to hypothyroidism. *Ann Intern Med* 47 121.
- Baker JT, Harvey RF (1971). Bowel habit in thyrotoxicosis and hypothyroidism. *Br Med J* 1 322.
- Balzer J, Lahrtz HG, Van Zwieten PA (1975). Serum spiegel und urinausscheidung von ¹⁴C-thiamazol bei patienten mit schilddrusenuberfunktion. *Deut Med Woch* 100, 548.
- Banerjee SK, Flink IL, Morkin E (1976). Enzymatic properties of native and N-ethylmaleimide-modified cardiac myosin from normal and thyrotoxic rabbits. *Circ Res* 39 319.
- Banerjee SP, Kung LS (1977). Beta-adrenergic receptors in the rat heart: effects of thyroidectomy. *Eur J Pharmacol* 43 207.
- Banerjee SK, Morkin E (1977). Actin-activated adenosine triphosphatase activity of native and N-ethylmaleimide-modified cardiac myosin from normal and thyrotoxic rabbits. *Circ Res* 41 630.
- Baron DW, Clements IP, Becker GP, Harrison CE, Brown ML (1980). Radionuclide ventricular volumes during supine and upright exercise in normal men before and after propranolol. *Circulation* 62 Supp III, 102.
- Bayliss RIS, Edwards OM (1971). Urinary excretion of free catecholamines in Graves disease. *Endocrinology* 49 167.
- Beaven MA, Costa E, Brodie BB (1963). The turnover of norepinephrine in thyrotoxic and nonthyrotoxic mice. *Life Sci* 4 241.
- Belenkie I, Nutter DO, Clark DW, McCraw DB, Raizner AE. (1973) Assessment of left ventricular dimensions and

function by echocardiography. Am J Cardiol 31 755.

Beley A, Rochette L, Bralet J (1973). Influence de traitement par la thyroxine et le propylthiouracile sur le taux de renouvellement de la noradrenaline dans huit organes peripheriques du rat. Arch Int Physiol Biochim 81 287.

Bell GM, Sawers JSA, Toft AD, Doig A (1982a). Nocturnal natriuresis in hyperthyroidism. Clin Endocrinol 16 177.

Bell GM, Sawers JSA, Fofar JC, Doig A, Toft AD (1982b). Heart rate and urinary sodium excretion in subclinical hyperthyroidism. Clin Endocrinol (in press).

Bell JM, Russell CJ, Nelson JK, Kelly JG, McDevitt DG (1977). Studies on the effect of thyroid dysfunction on the elimination of beta-adrenoceptor blocking drugs. Br Clin Pharmacol 4 79.

Benforado JM, Wiggins LL (1965). Contractility, heart rate and response to norepinephrine of isolated rat myocardium following I 131 induced hypothyroidism. J Pharmacol Exp Ther 149 329.

Benker VG, Preiss H, Kreuser H (1974). EKG-Veranderugen hyperthyroeoese. Utersuchungen als 542 patienten. Zeit Kard 63 799.

Bernal J, Refetoff S (1977). The action of thyroid hormone. Clin Endocrinol 6 227.

Bernstein A, Ridings WD (1970). Hyperthyroidism and steatorrhoea. Postgrad Med J 46 318.

Beznak M. (1962). Cardiovascular effects of thyroxine treatment in normal rats. Can J Biochem Physiol 40 1647.

Beznak M. (1963). Cardiovascular effects of thyroxine treatment in hypophysectomized rats. Circ Res 12 333.

Bianchi R, Zucchelli GC, Giannessi D, Pilo A, Mariani G, Carpi A, Toni MG (1977). Evaluation of triiodothyronine

(T3) kinetics in normal subjects, in hypothyroid and hyperthyroid patients using specific anti-serum for the determination of labelled T3 in plasma. J. Endocrinol Metab 46 203.

Birkhauser M, Burer Th, Busset R, Burger A (1977). Diagnosis of hyperthyroidism when serum thyroxine alone is raised. Lancet 2 53.

Blaschke TF (1977). Protein binding and kinetics of drugs in liver disease. Clin Pharmacokinet 2 32.

Boas EP (1931). Digitalis dosage in auricular fibrillation. Am Heart J 6 788.

Bonelli J, Haydi H, Hruby K, Kaik G (1978). The pharmacokinetics of digoxin in patients with manifest hyperthyroidism and after normalisation of thyroid function. Int J Clin Pharmacol Biopharm 16 302.

Borer JS, Bacharach SL, Green MV et al (1978). Exercise-induced left ventricular dysfunction in symptomatic and asymptomatic patients with aortic regurgitation: assessment with radionuclide cineangiography. Am J Cardiol 42 351.

Borst JGG, DeVries LA (1950). The three types of "natural" diuresis. Lancet ii 1.

Boruchow IB, Miller TD, Fitts WT Jr (1966). Paralytic ileus in myxedema. Arch Surg 92 960.

Bradley SE, Stephens FG, Coelho JB, Reville P (1974). The thyroid and the kidney. Kidney Int 6 346.

Brauch RA, Nies AS, Shand DG (1973). The disposition of propranolol VIII: General implications of the effects of liver blood flow on elimination from the perfused rat liver. Drug Metab Disposit 1 687.

Brewster WR Jr, Isaacs JP, Osgood PF, King TL (1956). Haemodynamic and metabolic interrelationships in the activity of epinephrine, norepinephrine and the thyroid hormones. Circulation 13 1.

Brus R, Hess ME, Jacobowitz D (1970). Effect of 6-hydroxydopamine and thyroxine on chronotropic response to norepinephrine. Eur J Pharmacol 10 323.

Buccino RA, Spann JR Jr, Poole PE, Braunwald E (1967). Influence of thyroid state on the intrinsic contractile properties and energy stores of the myocardium. Clin Invest 46 1669.

Buerklin EM, Schimmel M, Utiger RD (1976). Pituitary-thyroid regulation in euthyroid patients with Graves' disease previously treated with antithyroid drugs. J Clin Endocrinol Metab 43 419.

Burckhardt D, Staub JJ, Kraenzlin M, Raeder E, Engel U, Cloppenburg P (1978). The systolic time intervals in thyroid dysfunction. Am Heart J 95 187.

Burger A, Nicod P, Suter P, Vallotton MB, Vagenakis A, Braverman L (1976). Reduced active thyroid hormone levels in acute illness. Lancet 1 653.

Burr WA, Ramsden DB, Griffiths RS, Black EG, Hoffenberg R, Meinhold H, Wenzel KW (1976). Effect of a single dose of dexamethasone on serum concentrations of thyroid hormones. Lancet 2 58.

Cairolì VJ, Crout JR. (1967). Role of the autonomic nervous system in the resting tachycardia of experimental hyperthyroidism. J Pharmacol Exp Ther 158 55.

Callas G, Hayes JR (1974). Alterations in the fine structure of cardiac muscle mitochondria induced by hyperthyroidism. Anat Rec 178 539.

Campbell M (1947). The paroxysmal atrial tachycardias. Lancet 2 641.

Campbell A, Caird FI, Jackson TFM (1974). Prevalence of abnormalities of electrocardiogram in old people. Br Heart J 36 1005.

Campus S, Rappelli A, Malavasi A, Satta A (1975). Heart block and hyperthyroidism. Arch Intern Med 135 1091.

Canary JJ, Schaff M, Duffy BJ Jr, Kyle LH (1957). Effects of oral and intramuscular administration of reserpine in thyrotoxicosis. *New Engl J Med* 257 435.

Caplan RH, Pagliara AS, Wickus G (1980). Thyroxine-toxicosis: a common variant of hyperthyroidism. *JAMA* 244 1934.

Captein EN, Macintyre SS, Weiner JM, Spencer CA, Nicoloff GT (1981). Free thyroxine estimates in non-thyroidal illness: comparison of eight methods. *J Clin Endocrinol Metab* 52 1073.

Carpi A, Bianchi R, Zucchelli GC, Toni MG, Coli A, Levanti C, Mariani G (1977). Thyroid hormone concentrations and inhibition of thyroid stimulating hormone secretion in euthyroid subjects with autonomous thyroid nodules. *Eur J Clin Invest* 7 421.

Chakravarty J, Guansing AR, Chakravarty S, Hughes CV (1978). Systolic time intervals (STI) as indicators of myocardial thyroid hormone effect: a correlative study in hypothyroid and hyperthyroid patients. *Acta Endocrinol* 87 507.

Challand GS, Ratcliffe WA, Ratcliffe JG (1975). Semi-automated radioimmunoassays for thyroxine and tri-iodothyronine. *Clin Chem Acta* 60 25.

Christensen NJ (1973). Plasma noradrenaline and adrenaline in patients with thyrotoxicosis and myxoedema. *Clin Sci Mol Med* 45 163.

Christensen J, Clifton JA, Schedl HP (1966). Variations in the frequency of the human duodenal basic electrical rhythm in health and disease. *Gastroenterology* 51 200.

Christensen J, Schedl HP, Clifton JA (1964). The basic electrical rhythm of the duodenum in normal human subjects and in patients with thyroid disease. *J Clin Invest* 43 1659.

Ciaraldi T, Marinetti GV (1977). Thyroxine and propylthiouracil effects in vivo on alpha and beta adrenergic receptors in rat heart. *Biochem Biophys Res Commun* 74 984.

Clark RD, Korcusk K, Cohn K (1980). Serial echocardiographic evaluation of left ventricular function in valvular disease, including reproducibility guidelines for serial studies. *Circulation* 62 564.

Clifton-Bligh P, Silverstein GE, Burke G (1974). Unresponsiveness to thyrotropin-releasing hormone (TRH) in treated Graves' hyperthyroidism and in euthyroid Graves' disease. *J Clin Endocrinol Metab* 38 531.

Cohen J (1974). Role of endocrine factors in the pathogenesis of cardiac hypertrophy. *Circ Res* 18 388.

Cohen J, Aroestry JM, Rosenfeld MG (1966). Determinants of thyroxine-induced cardiac hypertrophy in mice. *Circ Res* 18 388.

Cohen MV, Schulman IC, Spenillo A, Surks MI (1981). Effects of thyroid hormone on left ventricular function in patients treated for thyrotoxicosis. *Am J Cardiol* 48 33.

Coltart DJ, Shand DG (1970). Plasma propranolol levels in the quantitative assessment of beta-adrenergic blockade in man. *Br Med J* 3 731.

Conney AH, Garren L (1961). Contrasting effects of thyroxine on zoxazolamine and hexobarbital metabolism. *Biochem Pharmacol* 6 257.

Cooper RH, O'Rourke RA, Karliner JS, Peterson KL, Leopold GR (1972). Comparison of ultrasound and cineangiographic measurements of the mean rate of circumferential fibre shortening in man. *Circulation* 46 914.

Cotoi S, Gavrilescu S, Pap T, Vicas E (1972). The prognostic value of right atrium monophasic action potential after conversion of atrial fibrillation. *Eur J Clin Invest* 2 472.

Coulombe P, Dussault JH, Letarte J, Simard SJ (1976). Catecholamine metabolism in thyroid disease I: Epinephrine secretion rate in hyperthyroidism and hypothyroidism. J Clin Endocrinol Metab 42 125.

Crooks J, Hedley SJ, Macnee C, Stevenson IH (1973). Changes in drug metabolising ability in thyroid disease. Br J Pharmacol 49 156P.

Crowley WF, Ridgway EC, Bough EW et al (1977). Non-invasive evaluation of cardiac function in hypothyroidism: response to gradual thyroxine replacement. N Engl J Med 296 1.

Croxson MS, Ibbertson HK (1975). Serum digoxin in patients with thyroid disease. Br Med J 3 566.

Curfman GD, Crowley TJ, Smith TW (1977). Thyroid induced alterations in myocardial sodium and potassium activated adenosine triphosphatase, monovalent active transport and cardiac glycoside binding. J Clin Invest 59 586.

Degroot WJ, Leonard JJ (1970). Hyperthyroidism as a high cardiac output state. Am Heart J 79 265.

Degroot WJ, Leonard JJ, Paley H, Johnson JE, Warren JV (1961). The importance of autonomic integrity in maintaining the hyperdynamic circulatory dynamics of human hyperthyroidism J Clin Invest 40 1033.

Degroot WJ, Torresani J (1975). Triiodothyronine binding to isolated liver cell nuclei. Endocrinology 96 357.

Dettli L (1976). Drug dosage in renal disease. Clin Pharmacokinet 1 126.

De Wardener HE (1978). The control of sodium excretion. Am J Physiol 235 F163.

Doherty JE, Perkins WH (1966). Digoxin metabolism in hyper- and hypothyroidism. Ann Intern Med 64 489.

Douglas RC, Jacobson SD (1957). Pathologic changes in adult myxedema - survey of 10 necropsies. J Clin Endocrinol Metab 17 1354.

Dratman MB (1974). On the mechanism of action of thyroxine on amino acid analog of tyrosine. J Theoret Biol 46 225.

Dratman MB, Crutchfield FL, Axelrod J, Colburn RW, Thoa N (1976). Localisation of triiodothyronine in nerve ending fractions of rat brain. Proc Nat Acad Sci USA 73 941.

Duke M, Abelmann WH (1969) The hemodynamic response to chronic anemia. Circulation 39 503.

du Souich P, McLean AL, Lalka D, Erill S, Gibaldi M (1978). Pulmonary disease and drug kinetics. Clin Pharmacokinet 3 257.

Edelman IS (1974). Thyroid thermogenesis. New Engl J Med 290 1303.

Edvardsson N, Hirsch I, Emanuelsson H, Ponten J, Olsson SB (1980). Sotalol-induced delayed ventricular repolarization in man. Eur Heart J 1 335.

Eichelbaum M (1976). Drug metabolism in thyroid disease. Clin Pharmacokinet 1 339.

Eichelbaum M, Bodem G, Gugler R, Schneider-Deters C, Deugler HJ. (1974) Influence of thyroid status on plasma half-life of antipyrine in man. N Engl J Med 29 1040.

Eichelbaum M, Bodem G, Schneider-Deters C (1973). Antipyrine half-life time, antipyrine metabolism and thyroid function in man. Naunyn-Schmeideberg's Arch Pharmacol 277 (suppl), R14.

Eichenbusch W, Lahrtz HG, Seppelt U, Van Zwieten PA (1970). Serum concentration and urinary excretion of 3H-ouabain and 3H-digitoxin in patients suffering from hyperthyroidism at hypothyroidism. Klin Woch 48 270.

Eisenstein Z, Balsam A, Ingbar SH (1978). Studies indicating the identity of the 5'-monodeiodinating enzymes for thyroxine (T4) and 3,3',5'-triiodothyronine (rT3) in rat liver. *Endocr Soc Abstr* 60 83.

Engler D, Donaldson EB, Stockigt JR, Taft P (1978). Hyperthyroidism without triiodothyronine excess: an effect of severe nonthyroidal illness. *J Clin Endocrinol Metab* 46 77.

Epstein SE, Beiser GD, Stampfer M et al (1967). Characterization of the circulatory response to maximal upright exercise in normal subjects and patients with heart disease. *Circulation* 35 1049.

Erfurth EM, Hedner P (1982). Importance of thyroxine in suppressing secretion of thyroid-stimulating hormone after thyroidectomy. *Br Med J* 284 941.

Erhardt JC, Verani MS, Marcus ML (1977). Exercise isotope ventriculogram: use in assessing changes in left ventricular function. *Circulation* 56 Suppl III, 141.

Eriksson M, Rubinfeld S, Garber AJ, Kohler PO (1977). Propranolol does not prevent thyroid storm. *N Engl J Med* 296 234.

Evered DC, Ormston BJ, Smith PA, Hall R, Bird T (1973). Grades of hypothyroidism. *Br Med J* 1 657.

Evered D, Young ET, Ormston BJ, Menzies R, Smith PA, Hall R (1973). Treatment of hypothyroidism: a reappraisal of thyroxine therapy. *Br Med J* 3 131.

Fahr G (1932). Myxoedema heart. A report based upon a study of 17 cases. *Am Heart J* 8 91.

Feely J, Forrest AL, Gunn A, Hamilton WFD, Stevenson, IH, Crooks J (1977). Beta-blocking drugs and thyroid function. *Br Med J* 2, 1352.

Feely J, Stevenson IH, Crooks J (1980). Propranolol dynamics in thyrotoxicosis. *Clin Pharmacol Ther* 28, 40.

Feigenbaum H (1981). Echocardiography 3rd Edition: Lea and Febiger, Philadelphia, p 119.

Forfar JC (1978). A seven year analysis of haemorrhage in patients on long-term anticoagulant treatment. Br Heart J 42, 128.

Forfar JC (1982). Prediction of hemorrhage during long-term oral coumarin anticoagulation by excessive prothrombin ratio. Am Heart J 103 445.

Forfar JC, Feek CM, Miller HC, Toft AD (1981). Atrial fibrillation and isolated suppression of the pituitary-thyroid axis: response to specific antithyroid therapy. Int J Cardiol 1, 43.

Forfar JC, Pottage A, Toft AD, Irvine WJ, Clements JA, Prescott LF (1980). Paracetamol pharmacokinetics in thyroid disease. Eur J Clin Pharmacol 18, 269.

Forfar JC, Sawers JSA, Muir AL, Toft AD (1982). Left ventricular function in hyperthyroidism: evidence for a reversible cardiomyopathy? N Engl J Med 307 1160-1170

Forfar JC, Sawers JSA, Toft AD (1982). Cardiovascular responses in hyperthyroidism before and during beta-adrenoceptor blockade: evidence against adrenergic hypersensitivity. Clin Endocrinol 16 441.

Forrest JAH, Adreianssens P, Finlayson NDC, Prescott LF (1979). Paracetamol metabolism in chronic renal disease. Eur J Clin Pharmacol 15 427.

Fortuin NJ, Pawsey CGK (1977). The evaluation of left ventricular function by echocardiography. Am J Med 63 1.

Freedberg AS, Papp J Gy, Vaughan-Williams EM (1970). fThe effect of altered thyroid state on atrial intracellular potentials. J Physiol 207 357.

Fregly MJ, Nelson EL, Resch GE, Field EP, Luthier LO (1975). Reduced beta-adrenergic responsiveness in hypothyroid rats. Am J Physiol 229 916.

Freyschuss U (1970). Cardiovascular adjustment to somatomotor activation. Acta Physiol Scand Suppl 342, 20.

Frishman W, Smithen C, Befler B, Kligfield P, Killip T (1975). Non-invasive assessment of clinical response to oral propranolol. Am J Cardiol 35 635.

Frye RL, Braunwald E (1961). Studies on digitalis III. The influence of triiodothyronine on digitalis requirements. Circulation 23 376.

Funatsu T (1976). Hemodynamics of hyperthyroidism: The effects of autonomic nervous blocking and anti-thyroid drug treatment. Jpn Heart J 17 12.

Gardner RS (1975). Nuclear thyroid hormone receptors: evidence for association with nucleolar chromatin. Bio Biophys Res Commun 67 625.

Garrey WE (1914). The nature of fibrillatory contraction of the heart: its relation to tissue mass and form. Am J Physiol 33 397.

Ghione S, Pellegrini M, Buzzigoli G, Carpi A, Valori C, Donato L (1974). Plasma and urinary catecholamine levels and thyroid activity in relation to cardiovascular changes in hyper- and hypothyroids. Horm Metab Res 6 93.

Gibaldi M, Perrier D (1975). Drugs and the pharmaceutical sciences, Vol 1: Pharmacokinetics. Marcle Dekker, New York p 80.

Gibson JG, Harris AW (1939). Clinical studies on the blood volume: V Hyperthyroidism and myxedema. J Clin Invest 18 59.

Gilbert R, Eich RH, Smulyan H, Keighley J, Auchincloss JH (1963). Effect on circulation of conversion of atrial fibrillation to sinus rhythm. Circulation 27 1079.

Gilfrich HJ (1976). Untersuchungen zur pharmacokinetik von digoxin bei hyperthyreoten patienten. Verh Dtsh Ges Inn Med 82 1726.

Gilman AG, Murad F (1975). Thyroid and antithyroid drugs: in Goodman and Gilman (Eds). The Pharmacological Basis of Therapeutics 5th Edition, Macmillan, New York p 1403.

Goel BG, Hanson CS, Han J (1972). A-V conduction in hyper- and hypothyroid dogs. Am Heart J 83 504.

Goldfine ID, Simons CG, Ingbar SH (1975). Stimulation of the uptake of alpha-aminoisobutyric acid in rat thymocytes by l-triiodothyronine: a comparison with insulin and dibutyryl cyclic AMP Endocrinology 96 802.

Goldman R (1951). Studies in diurnal variation of water and electrolyte excretion: nocturnal diuresis of water and sodium in congestive cardiac failure and cirrhosis of the liver. J Clin Invest 30 1191.

Goodall JS (1920). The heart in Graves' disease. Practitioner 105 37.

Goolden AWG, Bateman D, Torr S (1971). Red cell sodium in hyperthyroidism. Br Med J ii 552.

Gordon GG, Southren AL, Tochimoto S, Raud JJ, Olivo J (1969). Effect of hyperthyroidism and hypothyroidism on the metabolism of testosterone and androstenedione in man. J Clin Endocrinol 29 164.

Graettinger JS, Muenster JJ, Selverstone LA et al (1959). A correlation of clinical and haemodynamic studies in patients with hyperthyroidism with and without congestive heart failure. J Clin Invest 38 1316.

Greenblatt DJ, Koch-Weser J (1975a). Clinical Pharmacokinetics I. N Engl J Med 293 702.

Greenblatt DJ, Koch-Weser J (1975b). Clinical Pharmacokinetics II. N Engl J Med 293 964.

Grossman W, Robin NI, Johnson LW, Brooks HL, Selenkow HA, Dexter L (1971). The enhanced myocardial contractility of thyrotoxicosis. Ann Int Med 74 869.

Hallengren B, Nilsson OR, Karlberg BE, Melander A, Tegler L, Wahlin-Boll E (1982). Influence of hyperthyroidism on the kinetics of methimazole, propranolol, metoprolol and atenolol. *Eur J Clin Pharmacol* 21 379.

Hallock P (1933). The heart in myxedema, with a report of two cases. *Am Heart J* 9 196.

Hamberger JI (1980). Evaluation of toxicity in solitary non-toxic autonomously functioning thyroid nodules. *J Clin Endocrinol Metab* 50 1089.

Harrison TS (1964). Adrenal medullary and thyroid relationships. *Physiol Rev* 44 161.

Harrower ADB, Fyffe JA, Horn DB, Strong JA (1977). Thyroxine and triiodothyronine levels in hyperthyroid patients during treatment with propranolol. *Clin Endocrinol* 7 41.

Heading RC, Nimmo J, Prescott LF, Tothill P (1973). The dependence of paracetamol absorption on the rate of gastric emptying. *Br J Pharmacol* 47 415.

Helfant RH, DeVilla MA, Meister SG (1971). Effect of sustained isometric handgrip exercise on left ventricular performance. *Circulation* 44 982.

Helfant RH, Herman MV, Gorlin R (1971). Abnormalities of left ventricular contraction induced by beta-adrenergic blockade. *Circulation* 43 641.

Hershman JM (1974). Clinical application of thyrotrophin releasing hormone. *N Engl J Med* 290 886.

Hillier P, Knapp MS, Cove-Smith R (1980). Circadian variations in urine excretion in chronic renal failure. *Quart J Med NS* 49 461.

Hillis WS, Bremner WF, Lawrie TDV, Thomson JA (1975). Systolic time intervals in thyroid disease. *Clin Endocrinol* 4 617.

Hoch FL (1974). Metabolic effects of thyroid hormones: in Handbook of Physiology section 7, volume III, American Physiological Society, Washington DC, p391.

Hoffman BF, Cranefield PF, Lapeschkin E, Surawicz B, Herrlich HC (1959). Comparison of cardiac monophasic action potentials recorded by intracellular and suction electrodes. Am J Physiol 196 1297.

Hoffman BB, Lefkowitz RJ (1980). Radioligand binding studies of adrenergic receptors: New insights into molecular and physiological regulation. Ann Rev Pharmacol Toxicol 20 581.

Hoffman I, Lowrey RD (1960). The electrocardiogram in thyrotoxicosis. Amer J Cardiol 6 893.

Hoffman DP, Surks MI, Oppenheimer JH, Weitzman ED (1977). Response to thyrotropin releasing hormone: an objective criterion for the adequacy of thyrotrophin suppression therapy. Clin Endocrinol Metab 44 892.

Hohl RD, Nixon RK (1965). Myxedema ileus Arch Intern Med 115 145.

Holdsworth CD, Besser GM (1968). Influence of gastric emptying-rate and of insulin response on oral glucose tolerance in thyroid disease. Lancet 2 700.

Hornbrook KR, Cabral A (1972). Enhancement of thyroid hormone treatment of norepinephrine-induced phosphorylase activation in the rat heart. Biochem Pharmacol 21 897.

Hornbrook KR, Quinn PV, Siegel JH, Brody TM (1965). Thyroid hormone regulation of cardiac glycogen metabolism. Biochem Pharmacol 14 925.

Howitt G, Rowlands DJ (1966). Beta-sympathetic blockade in hyperthyroidism. Lancet I 628.

Howitt G, Rowlands DJ, Leung DYT, Logan WFWE (1968). Myocardial contractility and the effects of beta-adrenergic blockade in hypothyroidism and hyperthyroidism. Clin Sci 34 485.

Huffman DH, Klaassen CD, Hartman CR (1978). Digoxin in hyperthyroidism. Clin Pharmacol Ther 22 533.

Ikram H (1977). Haemodynamic effects of beta-adrenergic blockade in hyperthyroid patients with and without heart failure. Br Med J 1 1505.

Irvine WJ, Toft AD (1976). The diagnosis and treatment of thyrotoxicosis. Clin Endocrinol 5 687.

Irvine WJ, Toft AD, Hunter WM, Kirkham KE (1973). An assessment of plasma TSH radioimmunoassay and of the TSH stimulation test in the diagnosis of 100 consecutive patients with suspected hypothyroidism. Clin Endocrinol 2 135.

Jackson IMD (1982). Thyrotropin-releasing hormone. N Engl J Med 306 145.

Javitt NB (1978). Gastrointestinal Tract: in The Thyroid, a fundamental and clinical text. Eds Werner SA, Ingbar SH, 4th edition, Harper and Row, Maryland, p699.

Johnson PN, Freedberg AS, Marshall JM (1973). Action of thyroid hormone on the transmembrane potentials from sinoatrial cells and atrial muscle cells in isolated atria of rabbits. Cardiology 58 273.

Johnsson G, Regardh C-G (1976). Clinical Pharmacokinetics of beta-adrenoceptor blocking drugs. Clin Pharmacokinet 1 233.

Jones LR, Besch HR Jr, Fleming JW, McConnaughey MM, Watanabe AM (1979). Separation of vesicles of cardiac sarcolemma from vesicles of cardiac sarcoplasmic reticulum. Comparative biochemical analysis of component activities. J Biol Chem 254 503.

Jones LR, Besch HR Jr, Watanabe AM (1978). Subcellular localisation of cardiac adenylate cyclase: Sarcolemma or sarcoplasmic reticulum? In: Recent Advances in Studies on Cardiac Structure and Metabolism Vol II, Eds Kobayashi T, Sano T, Dhalla N. University Park Press, Baltimore, p 227.

- Jusko WJ, Levy G, Yaffe SJ (1970). Effect of age on intestinal absorption of riboflavin in humans. *J Pharm Sci* 59 487.
- Kannel WB, Abbott RD, Savage DD, McNamara PM (1982). Epidemiologic features of chronic atrial fibrillation: The Framingham Study. *N Engl J Med* 306 1018.
- Kannel WB, McGee D, Gordon T (1976). A general cardiovascular risk profile: The Framingham Study. *Am J Cardiol* 38 46.
- Kaplan MM, Utiger RD (1978). Iodothyronine metabolism in rat liver homogenates. *J Clin Invest* 61 459.
- Karliner JS, Gault JH, Eckberg D, Mullins CB, Ross J Jr (1971). Mean velocity of fibre shortening: a simplified measure of left ventricular myocardial contractility. *Circulation* 44 323.
- Kato R, Takahashi A (1968). Thyroid hormone and activities of drug-metabolizing enzymes and electrical transport systems of rat liver microsomes. *Mol Pharmacol* 4 109.
- Keating R (1961). Heart disease associated with myxedema. *Prog Cardiovasc Dis* 3 364.
- Kelly JG, McDevitt DG (1978). Plasma protein binding of propranolol and isoprenaline in hyperthyroidism and hypothyroidism. *Br J Clin Pharmacol* 6 123.
- Kempson S, Marinetti GV, Shaw A (1978). Hormone action at the membrane level VII. Stimulation of dihydroalprenolol binding to beta-adrenergic receptors in isolated rat heart ventricle slices by triiodothyronine and thyroxine. *Biochem Biophys Acta* 540 320.
- Kent RS, Delean A, Lefkowitz RJ (1980). A quantitative analysis of beta-adrenergic receptor interactions: Resolution of high and low affinity states of the receptor by computer modeling of ligand binding data. *Mol Pharmacol* 17 14.

- Kerber RE, Sherman B (1975). Echocardiographic evaluation of pericardial effusion in myxedema: incidence and biochemical and clinical correlations. *Circulation* 52 823.
- Kitchin AH, Milne JS (1977). Longitudinal survey of ischaemic heart disease in randomly selected sample of older population. *Br Heart J* 39 889.
- Knight RA (1945). The use of spinal anesthesia to control sympathetic overactivity in hyperthyroidism. *Anesthesiology* 6 225.
- Kocen RS, Atkinson M (1963). Ascites in hypothyroidism. *Lancet* 1 527.
- Korecky B, Beznak M (1971). Effect of thyroxine on growth and function of cardiac muscle In: *Cardiac Hypertrophy* Ed Alpert NR, New York, Academic Press, p 55.
- Kristensen BO, Weeke J (1977). Propranolol-induced increments in total and free serum thyroxine in patients with essential hypertension. *Clin Pharmacol Ther* 22 864.
- Kritchevsky D (1960). Influences of thyroid hormones and related compounds on cholesterol biosynthesis and degradation: a review. *Metabolism* 9 984.
- Kunos G, Vermes-Kunos I, Nickerson M (1974). Effects of thyroid state on adrenoceptor properties. *Nature* 250 779.
- Kurtz DT, Sippel A, Fiegelson P (1976). Effect of thyroid hormones on the level of the hepatic mRNA for alpha 2u globulin. *Biochemistry* 15 1031.
- Kushinsky K, Lahartz H, Lullman H, Van Zweiten PA (1967). Accumulation and release of 3H-digoxin by guinea-pig heart muscle. *Br J Pharmacol* 30 317.
- Lahey FH (1931). Non-activated (apathetic) type of hyperthyroidism. *N Engl J Med* 204 747.

Landsberg L, Axelrod J (1968). Influence of pituitary, thyroid and adrenal hormones on norepinephrine turnover and metabolism in the rat heart. *Circ Res* 22 559.

Langendorf R, Pick A, Katz LN (1965). Ventricular response in atrial fibrillation. *Circulation* 32 69.

Larson PR (1982). Pituitary-thyroid interaction: feedback regulation of thyrotropin secretion by thyroid hormones. *N Engl J Med* 306 23.

Lawrence JR, Sumner DJ, Kalk WJ et al (1977). Digoxin kinetics in patients with thyroid dysfunction. *Clin Pharmacol Ther* 22 7.

Lawton NF, Ekius RP, Nabarro JDN (1971). Failure of pituitary response to thyrotrophin-releasing hormone in euthyroid Graves' disease. *Lancet* ii 14.

Lefkowitz RJ (1975). Identification of adenylate cyclase-coupled beta-adrenergic receptors with radiolabelled beta-adrenergic antagonists. *Biochem Pharmacol* 24 1651.

Lefkowitz RJ (1979). Direct binding studies of adrenergic receptors: biochemical, physiologic and clinical implications. *Ann Int Med* 91 450.

Lehninger AL (1975). In: *Biochemistry: The Molecular Basis of Cell Structure and Function* Second Edition, Worth, New York, p. 477.

Leight L, De Fazio V, Talmers FN, Regan TJ, Hellems HK (1956). Coronary blood flow, myocardial oxygen consumption and myocardial metabolism in normal and hyperthyroid human subjects. *Circulation* 14 90.

Lenfant J, Gargouil YM, Trichoche R (1966). Hormones thyroïdiennes et électrogénèse du centre de l'automatisme cardiaque du lapin. *J Physiol (Paris)* 58 247.

Leon MB, Borer JS, Bacharach SL et al (1979). Detection of early cardiac dysfunction in patients with severe beta-thalassemia and chronic iron overload. *N Engl J Med* 301 1143.

Levey GS (1971). Catecholamine sensitivity, thyroid hormone and the heart: a re-evaluation. *J Pharmacol Exp Ther* 158 55.

Levey GS, Epstein SE (1969). Myocardial adenyl cyclase: activation by thyroid hormones and evidence for two adenyl cyclase systems. *J Clin Invest* 48 1663.

Levey GS, Skelton CL, Epstein SE (1969). Influence of hyperthyroidism on the effects of norepinephrine on myocardial adenyl cyclase activity and contractile state. *Endocrinology* 85 1004.

Levine SA, Sturgis CC (1924). Hyperthyroidism masked as heart disease. *Boston Med Surg J* 190 233.

Levy G, Gibaldi M, Procknal JA (1972a). Effect of an antiadrenergic agent on riboflavin absorption in man. *J Pharm Sci* 61 798.

Levy G, Jusko WJ (1966). Factors affecting the absorption of riboflavin in man. *J Pharm Sci* 55 25.

Levy G, MacGillivray MH, Procknal JA (1972b). Riboflavin absorption in children with thyroid disorders. *Pediatrics* 50 896.

Levy RI, Morganroth J, Rifkind BM (1974). Treatment of hyperlipidemia. *N Engl J Med* 290 1295.

Lewis BS, Ehrenfeld EN, Lewis N, Gotsman MS (1979). Echocardiographic left ventricular function in thyrotoxicosis. *Am Heart J* 97 460.

Lewis RP, Leighton RF, Forester WF, Weissler AM (1974). Systolic time intervals: in *Noninvasive Cardiology*, ed Weissler AM, Grune and Stratton, New York, p 311.

Lewis RP, Rittgers SE, Forester WF, Boudoulas H (1977). A critical review of systolic time intervals. *Circulation* 56 146.

Likoff WB, Levine SA (1943). Thyrotoxicosis as the sole cause of heart failure. *Am J Med Sci* 206 425.

Lindquist VAY, Spangler RD, Blount SG (1973). A comparison between the effects of dynamic and isometric exercise as evaluated by the systolic time intervals in normal man. *Am Heart J* 85 227.

Linguette M, Lefebvre J, Racadot A, Cappoen JP (1975). Taux de production, clearance metabolique et concentration plasmatique moyenne du cortisol dans l'hyperthyroidie. *Ann Endocrinol (Paris)* 36 35.

Ljunggren JC, Persson B (1975). Pre-operative treatment of thyrotoxicosis with a beta-blocking agent. *Acta Chir Scand* 141 715.

Lo CS, August TR, Liberman UA, Edelman IS (1976). Dependence of renal (Na⁺ + K⁺)-adenosine triphosphatase activity on thyroid status. *J Biol Chem* 251 7826.

Lo CS, Edelman IS (1976). Effect of triiodothyronine on the synthesis and degradation of renal cortical (Na⁺ + K⁺)-adenosine triphosphatase. *J Biol Chem* 251 7834.

Lotti G, Delitala G, Devilla L, Alagna S, Masala A (1977). Reduction of plasma triiodothyronine (T₃) induced by propranolol. *Clin Endocrinol* 6 405.

MacLeod KM, Baxter JD (1976). Chromatin receptors for thyroid hormones; interactions of the solubilized proteins with DNA. *J Biol Chem* 251 7380.

Moeda M, Kuzuya N, Masuyama Y et al (1976). Changes in serum triiodothyronine, thyroxine and thyrotropin during treatment with thyroxine in severe primary hypothyroidism. *J Clin Endocrinol Metab* 43 10.

Maguire ME, Ross EM, Gilman AG (1977). Beta-adrenergic receptor ligand binding properties and the interaction with adenylyl cyclase. *Adv Cycl Nucl Res* 8 1.

Mahler F, Ross J, O'Rourke RA, Covell JW (1976). Effects of changes in preload, afterload and inotropic state on ejection and isovolumic phase measures of contractility in the conscious dog. *Am J Cardiol* 35 626.

Malbon CC, Moreno FJ, Cabelli RJ (1978). Fat cell adenylate cyclase and beta-adrenergic receptors in altered thyroid states. *J Biol Chem* 253 671.

Margolius HS, Gaffney TE (1965). The effects of injected norepinephrine and sympathetic nerve stimulation in hypothyroid and hyperthyroid dogs. *J Pharmacol Exp Ther* 149 329.

Markowitz G, Yater WM (1932). Response of explanted cardiac muscle to thyroxine. *Am J Physiol* 100 162.

Marsden P, Facer P, Acosta M, McKerron CG (1975). Serum triiodothyronine in solitary autonomous nodules of the thyroid. *Clin Endocrinol* 4 327.

Marshall RC, Wisenberg G, Schelbert HR, Henze E (1981). Effect of oral propranolol on rest, exercise and post-exercise left ventricular performance in normal subjects and patients with coronary artery disease. *Circulation* 63 572.

Martial JA, Baxter JD, Goodman HM, Seeburg PH (1977). Regulation of growth hormone messenger RNA by thyroid and glucocorticoid hormones. *Proc Nat Acad USA* 74 1816.

Martin CE, Shaver JA, Thompson ME, Reddy PS, Leonard JJ (1971). Direct correlation of external systolic time intervals with internal indices of left ventricular function in man. *Circulation* 44 419.

McAinsh J, Baber NS, Smith R, Young J (1978). Pharmacokinetic and pharmacodynamic studies with long-acting propranolol. *Br J Clin Pharmacol* 6 115.

McConnaughey MM, Jones LR, Watanabe AM, Besch HR Jr, Williams LT, Lefkowitz RJ (1979). Thyroxine and propylthiouracil effects of alpha- and beta-adrenergic receptor number, ATPase activities, and sialic acid content of rat cardiac membrane vesicles. *J Cardiovasc Pharmacol* 1 609.

McDevitt DG, Nelson JK (1978). Comparative trial of atenolol and propranolol in hyperthyroidism Br J Clin Pharmacol 6 233.

McDevitt DG, Riddell JG, Hadden DR, Montgomery DAD (1978). Catecholamine sensitivity in hyperthyroidism and hypothyroidism. Br J Clin Pharmacol 6 297.

McNeill JH, Brody TM (1968). The effect of triiodothyronine pretreatment on amine-induced rat cardiac phosphorylase activation. J Pharmacol Exp Ther 161 40.

Melander A, Ericson LE, Sundler F, Ingbar SI (1974a). Sympathetic innervation of the mouse thyroid and its significance in thyroid hormone secretion. Endocrinology 94 959.

Melander A, Ericson LE, Ljunggren JG et al (1974b). Sympathetic innervation of the normal human thyroid. J Clin Endocrinol 39 713.

Melander A, Sundler F, Westgren U (1975a). Sympathetic innervation of the thyroid: variation with species and age. Endocrinology 96 102.

Melander A, Ericson LE, Sundler F, Westgren U (1975b). Intrathyroidal amines in the regulation of thyroid activity. Rev Physiol 73 39.

Melander A, Bulow K, Burer A et al (1976). Influence of the sympathetic nervous system on thyroid activity in man. Thyroid Research (Proc 7th International Thyroid Conference, Boston, 1975) Excerpta Medica, Amsterdam p 100.

Merillon JP, Passa Ph, Chastre J, Wolf A, Gourgon R (1981). Left ventricular function and hyperthyroidism. Br Heart J 46 137.

Michie W, Hamer-Hodges DW, Pegg CAS, Orr FGC, Bewsher PD (1974). Beta-blockers and partial thyroidectomy for thyrotoxicosis. Lancet 1 1010.

Miller AM, Hannan WJ, Sapru RP, Muir AL (1979). An evaluation of six kits of technetium 99m human serum albumin injection for cardiac blood pool imaging. Eur J Nucl Med 4 91.

Misselwitz NJ, Will H, Schulze W, Will-Shahab L, Wollenberger A (1979). Mass isolation of cell surface membrane fragments from pigeon heart. Biochim Biophys Acta 553 197.

Moe GK, Abildskov JA (1959). Atrial fibrillation as a self-contained arrhythmia independent of focal discharge. Am Heart J 58 59.

Moore EN, Fisher G, Detweiler DK et al (1965). The importance of atrial mass in the maintenance of atrial fibrillation. In Proceedings of an International Symposium on Comparative Medicine, Ed Tashjian, Eaton Labs, Norwich New York, p 229.

Morkin E (1979). Stimulation of cardiac myosin adenosine triphosphatase in thyrotoxicosis. Circ Res 44 1.

Morris JJ, Entman ML, Thomson HK (1963). Cardiac output in atrial fibrillation and sinus rhythm. Circulation 28 772.

Morrow DH, Gaffney TE, Braunwald E (1963). Studies on digitalis VII. Influence of hyper- and hypothyroidism on the myocardial response to ouabain. J Pharmacol Exp Ther 140 324.

Motoki Y, Kawamata K, Izumi K (1966). Studies on spatial vector analysis of the electrocardiogram in hyperthyroidism. J Exp Med 13 146.

Muir AL, Hannan WJ, Brash HM, Balduo W, Miller HC, Ogilvie B (1977). The assessment of left ventricular ejection fraction in patients with ischaemic heart disease by contrast ventriculography and nuclear angiography. Clin Sci Mol Med 53 55.

Murayama M, Goodkind MJ (1968). Effect of thyroid hormone on the frequency-force relationship of atrial myocardium from the guinea pig. Circ Res 23 743.

Murray JF, Kelley JJ Jr (1959). The relation of thyroidal hormone level to epinephrine response: a diagnostic test for hyperthyroidism. *Ann Int Med* 51 309.

Myasnikov AL, Zaitzev VF (1963). The influence of thyroid hormones on cholesterol metabolism in experimental atherosclerosis in rabbits. *J Atheroscler Res* 3 295.

Nahum LH, Hoff HE (1935). Auricular fibrillation in hyperthyroid patients. *JAMA* 105 254.

Nakazawa HK, Sakurai K, Momotani N, Hamada N, Ito K (1980). Timing of cardioversion in thyrotoxic atrial fibrillation. *Circulation* 62 III-296.

Naylor WG, Merrillies NCR, Chipperfield D (1971). Influence of hyperthyroidism on the uptake and binding of calcium by cardiac microsomal fractions and on mitochondrial structure. *Cardiovas Res* 5 469.

Nies AS, Shand DG, Wilkinson GR (1976). Altered hepatic blood flow and drug disposition. *Clin Pharmacokinet* 1 189.

Nilsson OR, Melander A, Tegler L (1980). Effects and plasma levels of propranolol and metoprolol in hyperthyroid patients. *Eur J Clin Pharmacol* 18 35.

Nimmo J (1973). The influence of metoclopramide on drug absorption. *Postgrad Med J* 49 supp 4, 25.

Nimmo J, Heading RC, Tothill P, Prescott LF (1973). Pharmacological modification of gastric emptying: effects of propantheline and metoclopramide on paracetamol absorption. *Br Med J* 1 587.

Nimmo WS (1976). Drugs, diseases and altered gastric emptying. *Clin Pharmacokinet* 1 189.

Nimmo WS, Heading RC, Wilson J, Tothill P, Prescott LF (1975). Inhibition of gastric emptying and drug absorption by narcotic analgesics. *Br J Clin Pharmacol* 2 209.

Nishizawa Y, Hamada N, Fujii S, Morii H, Okuda K, Wada M (1974). Serum dopamine-beta-hydroxylase activity in thyroid disorders. *J Clin Endocrinol Metab* 39 599.

Noth RH, Saulding SW (1974). Decreased serum dopamine-beta-hydroxylase in hyperthyroidism. *J Clin Endocrinol Metab* 39 614.

Okada F, Ide H, Hata S, Honma M, Ui M (1980). Plasma cyclic nucleotide response to insulin-induced hypoglycaemia and methacholine in patients with hyperthyroidism. *Eur J Clin Invest* 10 81.

Olson SB, Cotoi S, Varnauskas E (1971). Monophasic action potential and sinus rhythm stability after conversion of atrial fibrillation. *Acta Med Scand* 190 381.

Oppenheimer JH, Schwartz HL, Surks MI (1976). Nuclear receptors and the initiation of thyroid hormone action. *Rec Prog Hor Res* 32 529.

Pannier JL (1968). The influence of thyroid hormone on myocardial contractility. *Arch Int Physiol Biochem* 76 477.

Parisi AF, Hamilton BP, Thomas CN, Mazzaferri EL (1974). The short cardiac pre-ejection period: an index to thyrotoxicosis. *Circulation* 49 900.

Parker JLW, Lawson DH (1973). Death from thyrotoxicosis. *Lancet* 2 894.

Parmley WW, Spann JF, Taylor RR, Sonnenblick EH (1968). Series elasticity of cardiac muscle in hyperthyroidism, ventricular hypertrophy and heart failure. *Proc Soc Exp Biol Med* 127 606.

Parry CH (1786) In: Collections from the Unpublished Works of the late Caleb Hillier Parry, Underwood, London, 1825 Vol I p 478.

Paulus WJ, Ranguin R, Parizel G (1980). Systolic time intervals: a valuable parameter of thyroid function. *Angiology* 31 100.

Perucca E, Richens A (1979). Paracetamol disposition in normal subjects and in patients treated with antiepileptic drugs. Br J Clin Pharmacol 7 201.

Peterson RE (1958). The influence of the thyroid on adrenal cortical function. J Clin Invest 37 736.

Peterson KL, Skloven D, Ludbrook P, Uther JB, Ross J Jr (1974). Comparison of isovolumic and ejection phase indices of myocardial performance in man. Circulation 49 1088.

Philipson KD, Edelman IS (1977). Characteristics of thyroid-stimulated $\text{Na}^+ - \text{K}^+ - \text{ATPase}$ of rat heart. Am J Physiol 232 c202.

Piatnek-Leunissen D, Olson RE (1967). Cardiac failure in the dog as a consequence of exogenous hyperthyroidism. Circ Res 20 242.

Pitot HC, Yatvin MB (1973). Interrelationships of mammalian hormones and enzyme levels in vivo. Physiol Rev 53 228.

Port S, Cobb FR, Jones RH (1980). Effects of propranolol on left ventricular function in normal men. Circulation 61 358.

Pottage A, Nimmo J, Prescott LF (1974). The absorption of aspirin and paracetamol in patients with achlorhydria. J Pharm Pharmacol 26 144.

Prange AJ, Wilson JC, Wabon AM et al (1969). Enhancement of imipramine antidepressant activity by thyroid hormone. Am J Psychiatry 126 457.

Prinzmetal M, Rakita L, Borduas JL, Flamm E, Goldman A (1955). The nature of spontaneous auricular fibrillation in man with comments on the action of antiarrhythmic drugs. JAMA 157 1175.

Proskey AJ, Saksena F, Towne WD (1971). Myocardial infarction associated with thyrotoxicosis. Chest 72 109.

Quarry VM, Spodick DH, Nutter DO, Schlant RC, Hurst JW (1972). Use of isometric handgrip for the indirect assessment of left ventricular function in patients with coronary atherosclerotic heart disease. Am J Cardiol 30 48.

Quinones MA, Gaasch WH, Cole JS, Alexander JK (1975). Echocardiographic determination of left ventricular stress-velocity relations in man. Circulation 51 689.

Ratcliffe WA, Marshall J, Ratcliffe JG (1976). The radioimmunoassay of 3,3',5'triiodothyronine (reverse T3) in unextracted human plasma. Clin Endocrinol 5 631.

Rawlins MD, Henderson DB, Hijab AR (1977). Pharmacokinetics of paracetamol after intravenous and oral administration. Eur J Clin Pharmacol 11 283.

Resnekov L, Falicov RE (1977). Thyrotoxicosis and lactate-producing angina pectoris with normal coronary arteries. Br Heart J 39 1051.

Ridell JG, Niell JD, Kelly JG, McDevitt DG (1980). Propranolol kinetics in hyperthyroidism. Br J Clin Pharmacol 4 386P.

Ridell JG, Niell JD, Kelly JG, McDevitt DG (1980). Effects of thyroid dysfunction on propranolol kinetics. Clin Pharmacol Ther 28 565.

Ridgway EC, Cooper DS, Walker H, Rodbard D, Maloof F (1981). Peripheral responses to thyroid hormone before and after L-thyroxine therapy in patients with subclinical hyperthyroidism. J Clin Endocrinol Metab 53 1238.

Ridgway EC, Weintraub BD, Cevallas JL, Rack MC, Maloof F (1973). Suppression of pituitary TSH secretion in the patient with a hyperfunctioning thyroid nodule. J Clin Invest 52 2783.

Riegelman S, Loo JCK, Rowland M (1968). Shortcomings in pharmacokinetic analysis by conceiving the body to exhibit properties of a single compartment. *J Pharm Sci* 57 117.

Rogers PH, Sherry S (1976). Current status of antithrombotic therapy in cardiovascular disease. *Prog Cardiovasc Dis* 19 235.

Ronnov-Jessen V, Kirkegaard C (1973). Hyperthyroidism- a disease of old age? *Br Med J* 1 41.

Rowe GG, Huston JH, Weinstein AB, Tuchman H, Brown JF, Crumpton CW (1956). Haemodynamics of thyrotoxicosis in man with special reference to coronary blood flow and myocardial oxygen metabolism. *J Clin Invest* 35 272.

Rubinfeld S, Silverman VE, Welch KMA, Mallette LE, Kohler PO (1979). Variable plasma propranolol levels in thyrotoxicosis. *N Engl J Med* 300 353.

Rubenstein HA, Butler VP, Werner SC (1973). Progressive decrease in serum triiodothyronine concentrations with human aging: radioimmunoassay following extraction of serum. *J Clin Endocrinol Metab* 37 247.

Sahn DJ, DeMaria A, Kisslo J, Weymann A (1978). Recommendations regarding quantification in M-mode echocardiography: results of a survey of echocardiographic measurements. *Circulation* 58 1072.

Sandler G (1959). The effect of thyrotoxicosis on the electrocardiogram. *Br Heart J* 21 111.

Sandler G, Wilson GM (1959). The nature and prognosis of heart disease in thyrotoxicosis. *Quart J Med* 28 347.

Sandler G, Wilson GM (1959a). Production of cardiac hypertrophy by thyroxine in the rat. *Quart J Exp Physiol* 41 282.

Scherf D, Shaffer AI, Blumenfeld S (1953). Mechanism of flutter and fibrillation. *Arch Intern Med* 91 333.

Schneckloth RE, Kurland GS, Freedberg AS (1953). Effect of variation in thyroid function on the pressor response to norepinephrine in man. *Metabolism* 2 546.

Schrogie JJ, Solomen HM (1967). The anticoagulant response to bishydroxycoumarin II. The effect of D-thyroxine, clofibrate and norethandrolone. *Clin Pharmacol Exp Ther* 8 70.

Self T, Weisburst M, Wooton E, Straughn A, Oliver J (1975). Warfarin-induced hypoprothrombinemia: potentiation by hyperthyroidism. *JAMA* 231 1165.

Seth J, Toft AD, Irvine WJ (1976). Simple solid-phase radioimmunoassays for total triiodothyronine and thyroxine in serum, and their clinical evaluation. *Clin Chim Acta* 68 291.

Shanks RG, Hadden DR, Lowe DC, McDevitt DG, Montgomery DAD (1969). Controlled trial of propranolol in thyrotoxicosis. *Lancet* 1 993.

Sharma VK, Banerjee SP (1978a). Alpha-adrenergic receptor in rat heart: effects of thyroidectomy. *J Biol Chem* 253 5277.

Sharma VK, Banerjee SP (1978b). Specific 3H-ouabain binding to rat heart and skeletal muscle. Effects of thyroidectomy. *Mol Pharmacol* 14 122.

Shapiro LE, Samuels HH, Yaffe BM (1978). Thyroid and glucocorticoid hormones synergistically control growth hormone mRNA in cultured GH1 cells. *Proc Nat Acad Sci USA* 75 45.

Shapiro S, Steiner M, Dimich I (1975). Congestive heart failure in neonatal thyrotoxicosis. A curable cause of heart failure in the newborn. *Clin Pediat* 14 1155.

Shenfield GM (1981). Influence of thyroid dysfunction on drug pharmacokinetics. *Clin Pharmacokinet* 6 275.

Shenfield GM, Thompson J, Horn DB (1977). Plasma and urinary digoxin in thyroid dysfunction. *Eur J Clin Pharmacol* 12 437.

Shirer JW (1933). Hypermotility of the gastrointestinal tract in hyperthyroidism. Am J Med Sci 186 73.

Siegel W, Gilbert CA, Nutter DO, Schlant RC, Hurst JW (1972). Use of isometric handgrip for the indirect assessment of left ventricular function in patients with coronary atherosclerotic heart disease. Am J Cardiol 30 48.

Skellern GG, Knight BI, Low CKL, Alexander WD, McLarty DG, Kalle WJ (1980). The pharmacokinetics of methimazole after oral administration of carbimazole and methimazole in hyperthyroid patients. Br J Clin Pharmacol 9 137.

Skelton CL, Sonnenblick EH (1974). Heterogeneity of myocardial contractile function in cardiac hypertrophy. Circ Res 35Suppl II II-83.

Snyder PJ, Utiger RD (1972). Inhibition of thyrotropin response to thyrotropin-releasing hormone by small quantities of thyroid hormones. J Clin Invest 51 2077.

Snyder PJ, Utiger RD (1972a). Response to thyrotropin-releasing hormone (TRH) in normal man. J Clin Endocrinol Metab 34 380.

Solomen HM, Schrogie JJ (1967). Change in receptor site affinity: a proposed explanation for the potentiating effect of D-thyroxine on the anticoagulant response to warfarin. Clin Pharmacol Exp Ther 8 70.

Sonnenblick EH, Braunwald E, Williams JF, Glick G (1965). Effect of exercise on myocardial force-velocity relations in intact unanesthetized man: relative roles of changes in heart rate, sympathetic activity and ventricular dimensions. J Clin Invest 44 2051.

Spodick DH, Kumar S, Flessas AP, Sriratanban GS, Klints RV, Meunch H (1969). Relationship of paper speed to precision of pulse wave measurements: a multiple observer study of left ventricular ejection time. Aerospace Med 40 907.

Staffurth JS, Gibberd JS, Ng Tang Fui S (1977). Arterial embolism in thyrotoxicosis with atrial fibrillation. Br Med J 3 688.

Staffurth JS, Morrison NDW (1968). Heart size in thyrotoxicosis. Postgrad Med J 44 885.

Steinberg AD (1968). Myxedema and coronary artery disease- a comparative autopsy study. Ann Intern Med 68 3388.

Sterling K (1977). The mitochondrial route of thyroid hormone action. Bull N Y Acad Med 53 260.

Sterling K (1979). Thyroid hormone action at the cell level (part 1). N Engl J Med 300 117.

Sterling K, Lazarus JH, Milch PO, Sakurada T, Bremner MA (1978). Mitochondrial thyroid hormone receptor: localisation and physiological significance. Science 201 1126.

Sterling K, Milch PO (1975). Thyroid hormone binding by a component of mitochondrial membrane. Proc Nat Acad Sci U S A 723225.

Sterling K, Milch PO, Bremner MA, Lazarus JH (1977). Thyroid hormone action: the mitochondrial pathway. Science 197 996.

Stoffer SS, Jiang NS, Gorman CA, Pikler GM (1973). Plasma catecholamines in hypothyroidism and hyperthyroidism. J Clin Endocrinol Metab 36 587.

Stock JM, Surks MI, Oppenheimer JH (1974). Replacement dosage of l-thyroxine in hypothyroidism: a reevaluation. N Engl J Med 290 529.

Straver BE, Schulze W (1976). Experimental hypothyroidism: depression of myocardial contractile function and haemodynamics and their reversibility by substitution with thyroid hormones. Basic Res Cardiol 71 624.

Suga H, Sagawa K (1974). Instantaneous pressure-volume relationships and their ratio in the excised supported canine left ventricle. *Circ Res* 35 117.

Suirala M, Jukinen H, Lamberg BA (1966). Gastrointestinal tract in hyperthyroidism before and after treatment. *Scand J Gastroenterol* 1 79.

Suko J (1973). The calcium pump of cardiac sarcoplasmic reticulum. Functional alterations at different levels of thyroid state in rabbits. *J Physiol(Lond)* 228 563.

Summers VK, Surtees SJ (1961). thyrotoxicosis and heart disease. *Acta Med Scand* 169 661.

Surks MI, Oppemhiemer JH (1977). Concentration of l-thyroxine and l-triiodothyronine specifically bound to nuclear receptors in rat liver and kidney: quantitative evidence favouring a major role of T3 in thyroid hormone action. *J Clin Invest* 60 555.

Symons C (1979). Thyroid heart disease. *Br Heart J* 41 257.

Symons C, Myers A, Kingstone D, Boss M (1978). Response to thyrotrophin-releasing hormone in atrial dysrhythmias. *Postgrad Med J* 54 658.

Symons C, Richardson PJ, Wood JB (1971). Unusual presentation of thyrocardiac disease. *Lancet* 2 1163.

Tamai H, Suematsu H, Ikemi Y et al (1978). Responses to TRH and T3 suppression tests in euthyroid subjects with a family history of Graves' disease. *J Clin Endocrinol Metab* 47 475.

Tata JR, Widnell CC (1966). Ribonucleic acid synthesis during the early action of thyroid hormones. *Biochem J* 98 604.

Taylor RR (1970). Contractile properties of cardiac muscle in hyperthyroidism: analysis of behaviour of hyperthyroid cat papillary muscle in vitro relevant to thyrotoxic heart disease. *Circ Res* 27 539.

Taylor RR, Covell JW, Ross J Jr (1969). Influence of the thyroid state on left ventricular tension-velocity relations in the intact sedated dog. *J Clin Invest* 48 775.

Teoh PC, Cheah JS, Chia BL (1974). Effect of adrenergic blockade and specific antithyroid therapy on electrocardiographic changes in hyperthyroidism. *Am J Med Sci* 268 157.

Thomas FB, Caldwell JH, Greenberger NJ (1973). Steatorrhea in thyrotoxicosis. *Ann Intern Med* 78 669.

Thomas FB, Mazzaferri EL, Skillman TG (1970). Apathetic thyrotoxicosis: a distinctive clinical and laboratory entity. *Ann Intern Med* 73 679.

Thorson SC, Mincey EK, McIntosh HW, Morrison RT (1972). Evaluation of a new in-vitro test for determining thyroid status: the effective thyroxine ratio. *Br Med J* 2 67.

Thyrum PT, Kritcher EM, Luchi RJ (1970). Effect of l-thyroxine on the primary structure of cardiac myosin. *Biochim Biophys Acta* 197 335.

Toft AD, Irvine WJ, Hunter WM, Ratcliffe JG, Seth J (1974). Anomalous plasma TSH levels in patients developing hypothyroidism in the early months after I131 therapy for thyrotoxicosis. *J Clin Endocrinol Metab* 39 607.

Toft AD, Irvine WJ, Sinclair I, McIntosh D, Seth J, Cameron EHD (1978). Thyroid function after surgical treatment of thyrotoxicosis. Report of 100 cases treated with propranolol before operation. *New Engl J Med* 298 643.

Tse J, Wrenn RW, Kuo JF (1980). Thyroxine-induced changes in characteristics and activities of beta-adrenergic receptors and adenosine 3'5'-monophosphate and guanosine 3'5'-monophosphate systems in the heart may be related to reputed catecholamine supersensitivity in hyperthyroidism. *Endocrinology* 107 6.

Tunbridge WMG, Evered DC, Hall R et al (1977). The spectrum of thyroid disease in a community: the Wickham survey. Clin Endocrinol 7 481.

Turner CW, Shenfield GM (1980). The effect of thyroid dysfunction on chronotropic responses to noradrenaline. Eur J Pharmacol 68 295.

Ueda H, Sugishita Y, Nakanashi A et al (1965). Clinical studies on the cardiac performance by means of trans-septal left heart catheterisation II. Left ventricular function in high output heart diseases, especially in hyperthyroidism. Jpn Heart J 6 396.

Ullrick WC, Whitehorn WV (1952). Influence of thyroid hormone on respiration of cardiac tissue. Amer J Physiol 171 407.

Vagenakis AG, Cote R, Miller ME, Braverman LE, Stohlman F Jr (1972). Enhancement of warfarin-induced hypoprothrombinemia by thyrotoxicosis. Johns Hopkins Med J 131 69.

Van der Schoot JR, Moran NC (1965). An experimental evaluation of the reputed influences of thyroxine on the cardiovascular effects of catecholamines. J Pharmacol Exp Ther 149 336.

Vanhaelst L, Neve P, Chailly P, Bastenie PA (1967). Coronary artery disease in hypothyroidism. Lancet 2 800.

Varadi A, Foldes J (1976). Serum digoxin in patients with thyroid disease. Br Med J 3 175.

Verhoeven RP, Visser TJ, Docter R, Henneman G, Schalekamp MADH (1977). Plasma thyroxine, 3,3',5-triiodothyronine and 3,3',5'-triiodothyronine during beta-adrenergic blockade in hyperthyroidism. J Clin Endocrinol Metab 44 1002.

Vermeulen A, Verdonck L (1972). Some studies on the biological significance of free testosterone. J Steroid Biochem 3 421.

- Veroni M, Shenfield GM (1980a). The effects of thyroid status on digoxin distribution in the rat. Clin Exp Pharmacol Physiol 7 159.
- Veroni M, Shenfield GM (1980b). The influence of thyroid function on ouabain accumulation by the rat heart. Pharmacol Res Commun 12 769.
- Vessell ES, Shapiro JR, Passananti GT, Jogensen H, Shively CA (1975). Altered plasma half-lives of antipyrine, propylthiouracil and methimazole in thyroid dysfunction. Clin Pharmacol Ther 17 48.
- Vonderhaar BK (1975). A role for thyroid hormones in differentiation of mouse mammary gland in-vitro. Biochem Biophys Res Commun 67 1219.
- Wahlberg P, Carlsson SA (1978). Long-term control of thyrotoxicosis with the beta-blocker sotalol- a model of untreated hyperthyroidism. Acta Endocrinol 87 734.
- Waldstein SS, West GH, Lee WY, Bronsky D (1964). Guanethidine in hyperthyroidism. J A M A 189 609.
- Watters K, Tomkin GH (1975). Serum digoxin in patients with thyroid disease. Br Med J 4 102.
- Wei JY, Genecin A, Greene HL, Achuff SC (1979). Coronary spasm with ventricular fibrillation during thyrotoxicosis: response to attaining euthyroid state. Am J Cardiol 43 335.
- Weintraub M, Breckenridge RT, Griner PF (1973). The effects of dextrothyroxine on the kinetics of prothrombin activity: proposed mechanism of the potentiation of warfarin by D-thyroxine. J Lab Clin Med 81 273.
- Weissler AM, Harris WS, Schoenfeld CD (1968). Systolic time intervals in heart failure in man. Circulation 37 149.
- Weissler AM, Kamen AR, Bornstein RS, Schoenfeld CD, Cohen S (1965). The effect of deslanoside on the duration of the phases of ventricular systole in man. Am J Cardiol 15 153.

Weissler AM, Lewis RP, Leighton RF (1972). The systolic time intervals as a measure of ventricular performance in man: in Progress in Cardiology Vol 1, Eds Yu PN, Goodwin JF, Lea and Febiger, Philadelphia, p155.

Werner SA, Ingbar SH (1978). The Thyroid: a fundamental and clinical text. 4th Edition, Harper and Row, New York.

Wesson LG (1974). Electrolyte excretion in relation to diurnal cycles of renal function. Medicine 43 547.

Wheatley D (1972). Potentiation of amitriptyline by thyroid hormone. Arch Gen Psychiatry 26 229.

Whybrow PC, Prange AJ (1981). A hypothesis of thyroid-catecholamine-receptor interaction. Arch Gen Psychiatry 38 106.

Wiersinga WM, Touber JL (1977). The influence of beta-adrenergic blocking agents on plasma thyroxine and triiodothyronine. J Clin Endocrinol Metab 45 293.

Will-Shahab I, Wollenberger A, Schulze W (1975). Modulation by thyroid hormone of catecholamine binding sites and of adenylate cyclase activity in heart muscle. In Properties of Purified Cholinergic and Adrenergic Receptors, Ed Wollenmann M, North-Holland, Amsterdam p107.

Wildenthal K (1972). Studies of isolated fetal mouse hearts in organ culture. J Clin Invest 51 2702.

Wildenthal K (1974). Studies on fetal mouse hearts in organ culture: influence of prolonged exposure to triiodothyronine on cardiac responsiveness to isoproterenol, glucagon, theophylline, acetylcholine and dibutyryl cyclic 3'5'-adenosine monophosphate. J Pharmacol Exp Ther 109 272.

Williams LT, Lefkowitz RJ, Watanabe AM, Hathaway DR, Besch HR Jr (1977). Thyroid hormone regulation of beta-adrenergic receptor number. J Biol Chem 252 2767.

Williams LT, Lefkowitz RJ (1978). Receptor binding studies. In *Adrenergic Pharmacology*, Raven Press, New York.

Wilson FN (1924). The cardiac disturbances associated with diseases of the thyroid gland. *J A M A* 82 1754.

Wilson WR, Theilen EO, Fletcher FW (1964). Pharmacodynamic effects of beta-adrenergic receptor blockade in patients with hyperthyroidism. *J Clin Invest* 43 1697.

Wilson WR, Theilen EO, Hege JH, Valenca MR (1966). Effects of beta-adrenergic receptor blockade in normal subjects, during and after triiodothyronine-induced hypermetabolism. *J Clin Invest* 45 1159.

Wong TCY, Barzilai DC, Smith RE, McConahay WM (1979). Electrocardiographic voltage changes during hyperthyroidism. *Mayo Clin Proc* 54 763.

Wurtman RJ, Kopin KJ, Axelrod J (1963). Thyroid function and the cardiac disposition of catecholamines. *Endocrinology* 73 63.

Yazaki Y, Raben MS (1975). Effect of thyroid state on the enzymatic characteristics of cardiac myosin. *Circ Res* 36 208.

Young RT, Van Herle AJ, Rodbard D (1976). Improved diagnosis and management of hyper- and hypothyroidism by timing the arterial sounds. *J Clin Endocrinol Metab* 42 330.

Zacest R, Koch-Weser J (1972). Relation of plasma propranolol level to beta-blockade during oral therapy. *Pharmacology* 7 178.

Zaimis E, Papadaki L, Ash ASF, Larbi E, Kakari S, Matthew M, Paradelis J (1969). Cardiovascular effects of thyroxine. *Cardiovasc Res* 3 118.

Zgliczynski S (1966). The significance of electrocardiographic changes in hyperthyroidism. *Pol Med* 5 7.

Zondek H (1964). The electrocardiogram in myxoedema. Br
Heart J 26 227.