

I N D E X.

	<u>Page</u>
Introduction	1
1. <u>General Introduction</u>	2
2. <u>History of Embryology</u>	3
3. <u>The properties of Embryo Extract</u>	4
4. <u>The chemical nature of the</u> <u>embryo extracting prin-</u>	5
<u>BIOCHEMICAL INVESTIGATIONS ON CELLULAR</u>	6
<u>PROLIFERATION.</u>	7

5. <u>Embryonic growth</u>	38
6. <u>Embryonic effects</u>	45

A Thesis presented for the degree of

Doctor of Science

by

J. NORMAN DAVIDSON, B.Sc.(Hons.), M.D.

Sept. 1944.



I N D E X.

	<u>Page.</u>
<u>INTRODUCTION</u>	1
<u>PART I. <u>Tissue Culture Work</u></u>	2
1. <u>Review of Literature</u>	3
The properties of Embryo Extract	
A. The chemical nature of the growth-promoting prin- ciples of embryo extract	8
B. The effect of proteoses, etc., on tissue growth	38
C. Miscellaneous effects ...	45
D. Methods of measuring the growth of tissue cultures	50
2. <u>Experimental</u>	
Methods employed 	56
3. <u>Results</u>	
A. With Tyrode solution as fluid phase 	73
B. With chick embryo extract as fluid phase	75
C. Method of expressing results 	76
D. Experiments with embryo extract 	79
a. Preparation of embryo extracts 	79
b./	

	<u>Page.</u>
b. Comparison of chick embryo extract with sheep embryo extract	80
c. Effect of heat on embryo extract	81
d. Effect of storage on embryo extract ...	82
e. Effect of drying ...	82
f. Effect of de-fatting ..	85
g. Effect of ribonuclease on embryo extract ...	87
h. Effect of mucinase on embryo extract ...	89
i. Comparison of the growth promoting properties of extracts from various organs and tissues of the embryo	91
j. Precipitation of the protein fraction of embryo extract ...	93
k. The nucleoproteins of embryo extract ...	96
Discussion	100
E. Extracts and preparations from adult organs ...	106
a. Effect of pituitary extract	106
b. Adult heart extracts .	107
c. Liver extract ...	108
d. Pancreas extract ...	108
e./	

e.	Boiled kidney extract	109
F.	The effect of other substances -	
a.	Peptones	110
b.	Amino acid mixture .	111
c.	Histone	111
d.	Preparations from irradiated yeast ..	114
e.	Nucleic acids ...	114
f.	Ribonucleotides ...	114
g.	Adenylic acid ...	115
h.	Desoxyribonucleotides	115
i.	Nucleosides ...	116
j.	Biotin	116
	Discussion	117
	Summary	118
G.	Factors in pancreatin which influence the nucleoprotein content of fibroblasts growing in vitro	121
	Summary	143
<u>PART II.</u>	<u>"Wound Hormones"</u>	145
1.	<u>Review of Literature</u> ...	146
2.	<u>Experimental Methods and Results</u>	165
3./		

3. Discussion	172
Summary	176
<u>PART III. The Relationship of Nucleic Acids and their Derivatives to Tissue Growth</u>	
1. <u>Review of Literature</u>	179
A. Structure of the nucleic acids	180
B. Methods of differentiating between the two types of nucleic acid	190
C. The distribution of nucleic acids in animal and plant tissues	192
D. Distribution of the two types of nucleic acid in the individual cell	195
i. The nucleus	195
ii. The nucleolus	204
iii. The cytoplasm	205
E. Phospholipin-ribonucleo-protein complexes	208
F. The nucleic acid content of tissues	212
G. The nucleotide content of tissues	221
H. The biological importance of the nucleic acids in relation to growth	223

	<u>Page.</u>
2. <u>Embryonic Material</u>	234
A. Experimental methods	234
B. Results	246
a. Total nucleic acid	246
b. Ribonucleic acids	251
c. Ribonuclease experi- ments	256
d. Nucleotides, nucleo- sides and free purines	257
Discussion	260
Summary	264
3. <u>The Isolation and Properties of Liver Ribonucleic Acid</u>	266
A. Experimental methods	268
B. Properties of the nucleic acid	271
C. Discussion	282
4. <u>The Histochemical Demonstration of Ribonucleic Acid in Liver</u>	286
5. <u>The Nucleic Acid and Nucleo- tide content of Liver Tissue</u>	291
A. Experimental methods	294
B. Results	302
C. Discussion	307
6. <u>The Nucleic Acid and Nucleo- tide Content of Tumours</u>	312
A./	

	<u>Page.</u>
A. Experimental methods ...	312
B. Results ...	315
C. Discussion ...	320
General Summary and Conclusions ..	326
Acknowledgements ...	329
References ...	331

INTRODUCTION.

The investigations described here were begun at the suggestion of Professor G. F. Marrian and Professor J. R. Learmonth to examine the relationship between ribonucleic acids (and their derivatives) and the processes of tissue growth (including wound healing).

Examination of the literature suggested that ribonucleic acid derivatives might be present in rapidly growing tissues, be released by living cells on injury, and be present in the growth-promoting factors of embryo juice. The investigation falls into three parts. In Part I the growth promoting properties of various substances, including ribonucleic acid derivatives, are investigated with the aid of a tissue culture test. In Part II the question of the release of such compounds by injured cells is examined. In Part III the ribonucleic content of tissues, especially rapidly growing tissues, is dealt with.

TISSUE CULTURE WORK.I. REVIEW OF LITERATURE.

Although many investigators had worked with sur-
viving tissue it was not until Ross Harrison in 1907

PART I.

succeeded in studying nerve regeneration outside the
organism, in lymph, that tissue culture may be said to
have originated. In 1908, the same year, the

TISSUE CULTURE WORK.

careful distinction was drawn between "surviving"
tissue in protective solutions and "in vitro" cul-
ture. The latter is culture in which actually
growth of tissue is observed. The former method is exemplified
by the experiments of Lewis and Lewis (1911) who
showed that fragments of tissue could live in Ringer's
solution and be reattached to the tissue, and
very often, but in some cases all the vitality was lost
which is contained in the tissue itself.
"In vitro" culture has been defined as "the growth of
tissue in a nutrient medium, under aseptic conditions,
and in the absence of the organism from which it was
derived." (Lewis and Lewis, 1911). This, however, is not
the case in tissue culture. In the tissue culture the cells are

TISSUE CULTURE WORK.1. REVIEW OF LITERATURE.

Although many investigators had worked with surviving tissues it was not until Ross Harrison in 1907 succeeded in studying nerve regeneration outside the organism, in lymph, that tissue culture may be said to have originated. As Fischer (1925) points out, a careful distinction must be drawn between "surviving tissue in protective solutions" and "the in vitro cultivation of tissue in culture media which actually promote the growth". The former method is exemplified by the experiments of Lewis and Lewis (1911) who showed that fragments of tissue could live in Ringer's solution, could show outwandering of the cells, and could even multiply at the expense of the growth promoting substances contained in the tissue itself. Cell multiplication might even occur "without increase in protoplasmic matter due to the presence of substances stimulating mitosis and the absence of the proper nutritive elements in the culture medium" (Hueper et al., 1933). This, however, is not real tissue culture. In true tissue culture the cells not

only survive; they show increase both in cell size and in cell number by the formation of new protoplasm. The culture increases in mass, in protein content and in nucleoprotein or nucleic acid content. For true tissue culture two factors are required - (a) a supporting medium, (b) the growth promoting substances.

(a) Many different substances have been tried as supporting framework for the cultures but none have proved so successful as the plasma clot introduced by Burrows. The plasma is usually considered to provide merely a supporting framework for the growing cells. It has little or no growth promoting power, although it may supplement the action of embryo extract (c.f. Willmer, 1935, p.61).

(b) In 1912 Carrel showed that extracts of various tissues stimulated the growth of fibroblasts to a very marked degree. Of them all, extracts of embryonic tissues proved to be most satisfactory, and the stimulation of the growth of tissue cultures by means of embryonic extracts has become a standard routine in tissue culture technique. Cultures of fibroblasts maintained in embryo juice and subcultured at suitable intervals can be maintained for many years and, indeed, apparently indefinitely.

"Among the many agents used in the culture medium for the promotion of cell multiplication and sustenance of unlimited life, embryo extract holds a pre-eminent and almost unique position since it contains not only substances for the stimulation of cell division but also nutritive material which can be assimilated by the explanted cells and used for the synthesis of new protoplasmic matter." (Hueper et al., 1933.)

Embryo extract is, of course, a very complex mixture from the chemical point of view, and its effect on tissue cultures is certainly a multiple one. It provides a complete diet for the growing cultures. Its effect may be considered from three different aspects:-

(1) It provides the necessary nutrients for the growing cells, the bricks out of which the new structure is built.

(2) Embryo extract may be singularly free from growth inhibitors which are known to be present, for example, in adult tissue (Simms & Stillman, 1937) and in the serum of older animals (Carrel & Ebeling, 1921, 1922, 1923; c.f. Willmer, 1935, pp. 61-62).

(3) It may contain a factor (or factors) with a specific growth stimulating action, a true biocatalyst

or "growth hormone". The possible existence of such a substance (or substances) has led to sharp differences of opinion; and early views that embryo juice contained a special "growth hormone" did not survive. Carrel and Baker (1926), for example, considered it "probable that for cell multiplication a specific hormone is not required and is not contained in embryonic juice". Needham (1931) adopts the same view:- "This growth promoting factor was for long believed to be a hormone or even a vitamine (sic) but it now seems to be much more probably a special collocation of the right nutrient substances probably protein break down products", and further, "..... All these facts led Carrel and Baker to conclude that there was no justification for speaking of a 'growth-promoting hormone'. The growth promoting factor is probably no more than a right conjunction of nutrient materials and the appropriate capacities for making use of them. The particular position taken by unhydrolysed embryo tissue juice is of course very important from the embryological point of view and merits much further research." Later (Needham, 1942) he modifies his views and does not exclude the possible participation of biocatalytic agents - "..... a

substance of nucleotide structure might act either as a carrier for the requisite peptone 'bundle' ---- or else possibly as a 'bricklaying' mechanism at the site of the protein synthesis".

Willmer (1935) adopts a somewhat similar view:-

"The hypothetical substance for growth might be a food substance but is probably more likely to be something which alters the metabolism of the cell in some way."

In any case it is obvious that if a growth promoting factor of true biocatalytic type, or if a metabolic agent is present among the various constituents of embryo juice, it will exert its effect only if the necessary cell nutrients are present as well.

That embryo extract owes its peculiar growth promoting potency to the presence of a true biocatalytic agent is suggested by the recent work of Fischer which will be discussed later (p. 33).

Whatever the explanation of its action, the position of embryo extract in tissue culture work is so important that many attempts have been made to examine it chemically and if possible to isolate active fractions.

General accounts of tissue culture methods and

results are to be found in the books of Fischer (1925, 1930), Willmer (1935), Cameron (1935), and Parker (1938).

A. The chemical nature of the growth promoting principles of embryo juice.

Carrel's (1912, 1913) early work emphasised the lability of the active principles of embryo juice. The growth promoting activity was easily reduced by heat, and filtration through a Berkefeld or Chamberland candle caused serious loss in activity.

In 1925 Fischer described a series of investigations into the chemical nature of the materials present in embryo juice. Although his chemical manipulations were carried out aseptically much of his technique was crude when compared with modern methods for handling labile materials, e.g. enzymes.

He examined various protein fractions prepared by ammonium sulphate precipitation, carbon dioxide precipitation, precipitation by organic solvents, and purification by various adsorption procedures, without, however, obtaining any clear cut results. ("It made practically no difference how an extract was treated, its activity was lowered anyhow;" Fischer, 1941b.)

The only procedure which gave any satisfactory results was precipitation with alcohol, the precipitate being very quickly centrifuged down, washed with ether and dissolved in Ringer's solution. This precipitate contained nearly all the activity of the fresh extract. This solution was not successful. The

Similar results were obtained by Carrel and his collaborators at the Rockefeller Institute. (Carrel and Baker, 1926; Baker and Carrel, 1926.) The protein of embryo juice was precipitated in various ways and dissolved in a volume of Tyrode solution equal to the volume of tissue juice originally taken. The protein precipitate, if freed from precipitating reagent and redissolved, contained some of the growth stimulating action of the original extract. Ammonium salts, trichloroacetic acid, picric acid, pyridine, etc., were difficult to remove and were toxic, but carbon dioxide, ethyl, methyl and isopropyl alcohol, acetone and acetic acid all yielded active precipitates none of which was as active as the original material. For purposes of comparison, solutions of equal nitrogen concentration either of precipitate or of original extract were used. The precipitates obtained with small concentrations of

alcohol were most active. When an equal volume of alcohol was added, both precipitate and filtrate were active. Somewhat similar results were reported later by Fischer (1941b).

Charcoal, kaolin and alumina adsorbed the active principles but elution was not successful. When the proteins were purified by repeated precipitation, the activity diminished. The protein fraction from embryo tissue juice was reported to be a mixture of nucleoprotein and a glycoprotein with mucin like properties but detailed experimental evidence for this statement is not given. When these proteins were partially purified they were inactive^{*}.

Pure sodium nucleate from embryo pulp was inactive, as also were egg albumin, egg globulin, "nucleoalbumin", "lecithoalbumin" and thymus nucleic acid. The active material was not extracted by ether.

In 1933 Hueper et al. published a long paper on the growth promoting factors of embryo extract. To test the assumption that the growth promoting factor might be a non-species-specific protein (probably a

^{*}Simple proteins when tested alone were inactive (Smyth, 1914; Swezy, 1915).

globulin) they attempted to prepare an antiserum by semi-weekly injections of 1 ml. chick embryo extract into the ear vein of a rabbit. Precipitins were produced which reacted with chick, but not with mouse, embryo extract, but the plasma of the "anti-embryo-extract rabbit", while inhibitory to the growth of chick tissues, was not inhibitory to cultures of mammary cancer. The results suggested that the active substances were not of a protein nature giving rise to specific non-species-specific antiproliferative antibodies. Polysaccharides from embryo pulp and "pentose nucleotide D96" were inactive.

Irradiation of embryo extract with ultraviolet light, but not with X-rays or radium, decreased its growth promoting power. The former but not the latter, tend to destroy glutathione but the authors found no evidence that the -SH group had a selective mitosis stimulating effect or that suboxidised sulphur was a growth inhibitor.

The effect of sulphhydryl (-SH) groupings.

The importance of -SH groups in tissue growth has been emphasised by a number of workers (c.f. Riley, 1940; Hammett, 1934, 1936; Hammett and Chapman, 1938; Reimann, 1931; Hammett and Reynolds,

1937; Ellis, 1934) in connection with plant growth (Hammett, 1929), wound healing (Riley, 1940; Hammett and Reimann, 1929; Reimann, 1929, 1930, 1931, 1936; Fearon, 1942; Brunstig and Simonsen, 1933), and the development of sea urchin eggs (Shearer, 1922).

Embryo extract contains reduced sulphur (Borger and Peters, 1933; Hueper and Russell, 1933) which disappears during ageing concurrently with the diminution in growth promoting power of the extract (Ephrussi, 1931), but Hueper et al. (1933) have concluded that the -SH group has no selective mitosis stimulating effect nor do sulphhydryl compounds, when added to cultures, stimulate growth.

Adsorption of the active principles.

Carrel (1913) found that some growth promoting activity was lost when embryo juice was passed through a Berkefeld candle, while all activity was lost with a Chamberland filter, presumably owing to adsorption of the active materials by the filter. Nielson (1939) and Meyerhof and Zironi (1940) obtained active materials after filtering calf embryo extract through a Berkefeld candle and a Chamberland filter respectively. Embryos ground with Kieselgur gave less active extracts than embryos pulped alone (Fischer, 1925).

Baker and Carrel (1926) adsorbed the active principles on charcoal, kaolin and alumina but could not elute them.

This power of adsorption has been applied recently in the preparation of the commercial material "Epicutan" which consists of the active principles adsorbed in kaolin (Fischer, 1940) and which has been used to accelerate wound healing (see p. 29).

Fischer (1942^a), however, found adsorption and chromatographic adsorption methods useless in the purification of the active agent.

Shaking and oxygenation.

Fischer (1925) found that the activity of embryo extract was lost on shaking, and Friedheim (1929) considered that this was due to ease of oxidation.

The point was subsequently taken up by Hueper et al. (1933) who considered four possible effects:-

1. Denaturation of active substances in the froth formed.
 2. Destruction of the delicately balanced colloidal status of embryo extract.
 3. Enhancement of oxidation processes.
 4. Inactivation of important enzymes.
- Embryo extract shaken with air, and without air but with oil and glass beads, retained its activity. Shaking, in fact, did not appear to

have any effect, but embryo extract which had been oxygenated for an hour was less able to maintain cultures through many passages than unoxygenated extract. Paterson (1938), however, states that loss of activity under these conditions is not due to oxidation.

The effect of heat.

Early descriptions of the properties of embryo juice emphasised the ease with which the growth promoting activity is destroyed by heat. Carrel (1913) found that one-third of the activity was lost at 50° for 10 min. while all activity was destroyed at 70° for 10 minutes. Even incubation for a few hours at 39° caused great loss in activity (Carrel, 1925).

While Shibata (1929) found that 96 hrs. at 37° did not decrease the activity of embryo extract although after 9 days there was marked decrease, on the other hand Cracium (1931) stated that 48 hrs. at 37° is sufficient to destroy all activity.

Later workers, however, ascribed a greater stability to heat to embryo extracts. Hueper et al. (1933) found that heating to 70° for 15 min. rendered the extract unsuitable for stimulating the growth of fresh cultures, although it was satisfactory for well established cultures for as many as 29 passages. The

same temperature was employed by Lasnitzky (1937) who found that heating for 10 or 30 min. decreased but did not abolish the growth promoting power.

On the other hand, Paterson (1938) found a much greater stability to heat. One hour at 70° and 15 min. at 100° caused no loss in activity but one hour at 100° caused a definite reduction in growth promoting power. Fischer (1939, 1940, 1941b) observed that earlier statements on the extreme lability of the active principles were erroneous, but the purified preparations which he obtained were very labile, being destroyed by 15 min. at 56° or by boiling for a few minutes.

Tennant, Liebow and Stern (1941) obtained remarkably heat stable growth promoting material from embryonic tissue in the ultra-centrifuge. Later they found (Tennant, Stern and Liebow, 1942) that nucleic acids in a concentration of 1:50,000 had a stimulating effect on the growth of mouse heart fibroblasts in vitro. Such a concentration might be supplied by the breakdown of the materials prepared in the ultracentrifuge. On the other hand, Miller (1937) found that thymonucleic acid under certain conditions caused inhibition of the growth of mouse embryo heart

fibroblasts in vitro.

The effect of drying.

Early workers, e.g. Fischer (1925), were unable to dry embryo juice without serious loss in activity, but Borger and Zenker (1932) succeeded in preparing active dried preparations, and Paterson (1938) dried extracts in vacuo without loss. Hetherington and Craig (1939) prepared frozen dried preparations of both plasma and embryo juice in the lyophile apparatus of Flosdorf and Mudd (1935) and found full activity after three months, but later (1940) they recommended frozen dried whole embryos as source of extract. Peacock and Shukoff (1940) recommended embryo extract frozen dried in vacuum desiccators which Shukoff (1942) found to have retained full activity after more than two years. Fischer (1941b) reported that embryo extract dried in vacuo over sulphuric acid showed poor activity owing to its insoluble nature, but he made extensive use of material from embryo juice dried at room temperature by an electric fan. Such material was not very soluble and extracts made by dissolving it in Ringer's solution were less active than the original solution. When lipins were removed from the powder by extraction with chloroform or benzene,

Extracts from 11, 14 and 19 day chick embryos.

the activity was increased and the resulting material, after solution, could be passed through a Berkefeld candle without loss. Benzene or chloroform treatment could also be used to sterilise the powder^{*}.

Extracts from different organs and tissues. Effect of age of the embryo.

No very conclusive work has been done on the relative growth promoting power of different tissues and organs of the chick embryo. Fowler (1937) compared the effects of the head and neck of chick embryo with extracts from the trunk region and found the former to be very slightly more growth promoting. Hueper et al. (1933) found extracts made from the heads, eyes and bodies of chick embryos to be equally active but Fischer (1941b), comparing extracts of different anatomical regions of the chick embryo, found that extract of the body was most active; next came extracts of eyes and brain. Extracts of the internal organs were least effective. The growth promoting factor is present in embryo blood (Zifferblatt and Seelaus, 1931) and also in the maternal tissues, e.g. serum, of pregnant animals (Centanni, 1932; Pybus and Fawns, 1931). A growth promoting factor is also present in tumour tissue (Horning and Richardson, 1930).

Extracts from 11, 14 and 17 day chick embryos

* C.f. British Patent 534, 454.

were more effective than those from 8 day embryos (Fowler, 1937). This is in agreement with the results of Gaillard (1932) and of Andai (1932), but Miszurski (1938) recorded that extracts from 7 day embryos were more effective than those from 13 or 19 day embryos. Extracts from older embryos appeared to contain an inhibitory factor which could be removed on standing for several days at 0°.

It has generally been found that extracts of adult tissues were less effective than those from embryos (Carrel, 1913; Walton, 1914; Ebeling, 1924). Carrel (1913), however, found that extracts from adult spleen were effective, slightly less so than embryonic extracts but more so than extracts from kidney or heart. Thyroid extracts were also potent (Carrel, 1913; Ebeling, 1924; Semura, 1931). Not only extracts of thyroid but also those from testicle, muscle and spleen were found by Walton (1914) to stimulate growth, while extracts of liver inhibited. The growth promoting properties of extracts from tissues of the adult fowl were thoroughly investigated by Trowell and Willmer (1939) who found the following order of potency:- brain, thyroid, thymus, testis, ovary, bone marrow, liver, kidney and muscle. None were so

potent as embryo extract. There appeared to be no regular relationship between the age of the donor and the growth promoting activity of a tissue extract. Extracts from the spleen of adult cocks for example, were more effective than those from the spleens of young birds. In the case of testis, liver and muscle, activity diminished with age, but both spleen and brain showed definite increase in growth promoting power with age. No correlation could be found between the growth promoting power of a tissue and the activity of cell division normally in that tissue or the nuclear content of the tissue, but the high activity of brain tissue^{*} suggested a possible correlation between the growth promoting power of a tissue and its power of non-phosphorylating glucolysis (see also p. 32). The validity of this conception is doubted by Needham (1942).

The peculiar potency of brain extracts, which presumably contain much lipoid material, is surprising, since lipins are inhibitory to growth, but is interesting in view of the isolation of phospholipin-

^{*} Maisin and Pourbaix (1935) reported that brain tissue contains both growth promoting and growth inhibiting factors for tumours.

ribonucleoprotein complexes from brain tissue (Taylor et al., 1943), from embryonic tissue (Claude, 1940; Taylor et al., 1942) and of the isolation of a phospholipid-ribonucleoprotein complex as the active tumour producing agent in cell free extracts of the Rous sarcoma (Claude, 1938, 1939, 1940) (see p.208).

Brain extracts were also favourably reported on by Doljanski, Hoffman and Tenenbaum (1939) who found that extracts of adult brain and smooth muscle were even more effective than the potent extracts of adult fowl heart prepared by Doljanski and Hoffman (1939) and reported to be more active than chick embryo extract. Extracts of adult ovary, lung, pancreas, testicle and bone marrow were also effective but slightly less so than those from heart. Rous sarcoma extracts were also active (Hoffman, Tenenbaum and Doljanski, 1939b). Liver and kidney extracts were less potent. Liver, indeed, contains an inhibitory factor (c.f. Walton, 1914; Heaton, 1926; Brues, Jackson and Aub, 1936; Medawar, 1938; Brues, SubbaRow, Jackson and Aub, 1940).

Hoffman, Tenenbaum and Doljanski (1939a, 1940) found that the growth of chick heart fibroblasts was stimulated by extracts of adult chick tissues, even

those which were mitotically inactive, and that extracts of adult chick brain were especially potent, being three times more active than chick embryo extract; but when the tissues of the adult rat were used as source of extracts, the effect on chick heart fibroblasts was very poor (Hoffman, 1940). Rat brain alone provided an active extract, heart had no effect, while extracts of rat kidney, liver, lung and spleen were inhibitory. Extracts of rat embryos were however very potent. The poor response with extracts of rat heart should be contrasted with the later results of Doljanski, Hoffman and Tenenbaum (1942) who found that extracts of adult heart muscle of many species (sheep, cow, rabbit, dog) stimulated growth of chick heart fibroblasts and of human epithelium in vitro, while Werner and Doljanski (1942) purified these preparations from the heart of the adult sheep or fowl by precipitating saline extracts of the minced tissue with alcohol. The precipitate was slightly soluble in Ringer solution, more so in Tyrode solution, and much more so in very dilute ammonia. The solution in Tyrode was powerfully growth promoting and activity could be increased by previous extraction of the dry powder with ether or petroleum ether which presumably

removed inhibitory lipoid materials. The active material could be further purified by ammonium sulphate precipitation.

Effect of homologous and heterologous tissue extracts.

In his original statement Carrel (1913) stated that the growth promoting power of tissue extracts did not apply to tissues of the heterologous animal, but later Carrel and Ebeling (1923) found that extracts from chick, guinea pig and rabbit embryos were equally effective in promoting growth of chick heart fibroblasts. Extracts from the homologous adult tissues had growth promoting power but the effect did not persist. Duck fibroblasts grew well in chick embryo extract (Fischer, 1922, 1924) and conversely (Kaufmann, 1926), rat tissues in chick embryo extract (Mottram, 1927) and human tissues in rabbit embryo extract (Timofeivski and Benevolenskaia, 1927). For large scale work pig embryos (Gey and Gey, 1936) and bovine embryos (Gey and Gey, 1936; Hueper et al., 1933; Fischer, 194^b) have been employed. In an attempt to settle the question of species specificity, Hueper et al. (1933) prepared an anti-embryo extract serum with the aid of which they demonstrated that the growth promoting substances were apparently not of a

protein nature giving rise to specific non-species-specific anti-proliferative antibodies. The purified nucleoproteins described by Fischer (1940) were prepared from beef embryos and tested on chick fibroblasts.

Although Hoffman (1940) found that extracts of adult rat heart did not stimulate the growth of chick heart fibroblasts, the active preparations made by Doljanski, Hoffman and Tenenbaum (1942) from both homologous and heterologous adult heart tissue were all equally effective.

The effect of dialysis.

When Wright (1925) dialysed embryo extract and egg yolk (Wright, 1926) against distilled water for 72 hours in collodion sacs sterilised by autoclaving, the dialysate had a marked power of stimulating mitosis (confirmed by Tazima, 1940), but his claim that the dialysate was as effective as the dialysed material was not confirmed by Jacoby (1937).

Baker and Carrel (1926) dialysed embryo extract in collodion sacs and found that dialysis reduced the activity of the extract to a considerable extent, either on account of the loss of amino acids and other dialysable constituents, or because some denaturation of protein occurred. In an ultrafiltrate from embryo

extract tissues lived no longer than in Tyrode solution alone, although the area of growth was slightly greater. The ultra filtrate behaved in fact like the artificial mixture of amino acids prepared by Carrel and Ebeling (1924). When 10% embryo juice was added to the ultra filtrate and also to the Tyrode solution, a larger area of growth was obtained in the presence of the ultra filtrate although the mass of the tissue was not increased. The ultra-filterable constituents (amino acids, etc.) of embryo juice appeared therefore to cause only an increase in area of migration but not in mass of tissue. The residue from the ultra filtration process showed some growth promoting action but much protein was insoluble and had become denatured.

When the ultra-filtrate was added to dialysed embryo extract, some, but not all, of the diminished activity was restored. As some denaturation occurred during dialysis, full activity was not expected. The same effect was obtained when a mixture of 16 unspecified amino acids was added to the dialysed extract. Amino acids were always found to increase area without increasing mass. Baker and Carrel concluded that the characteristic growth promoting

substances of embryo juice are not to be found among its dialysable or ultrafilterable components. These components cannot support cell life in vitro but they stimulate cell migration and multiplication without increasing tissue mass (see also Ebeling, 1924).

Baker and Carrel's results were confirmed by Jacoby (1937) who found that dialysed embryo juice was slightly less effective than undialysed embryo juice, and that the dialysate (and amino acids) caused increased migratory activity.

The problem was carried a stage further when Fischer (1941a) found that cultures would not grow in a medium consisting of aseptically dialysed plasma or serum and dialysed embryo juice, but that normal growth could be induced either by the addition of an ultra filtrate or dialysate of serum or by a suitable amino acid mixture (see p. 44).

The importance of thermostable and dialysable cofactors for the growth of tissues in vitro was demonstrated by the report of Fischer (1942b) and of Fischer and Astrup (1942) that, while cultures did not proliferate in a medium of thoroughly dialysed constituents (plasma, embryo extract, etc.), the addition of a small amount of boiled ox kidney extract was sufficient

to establish normal growth and proliferation. The nature of these co-factors was not established and fractionation experiments were only partially successful, but it was clearly shown that several factors were involved. When kidney extract was employed in dilutions too great to be effective, the addition of a supplement formed by the amino acid mixture previously employed (Fischer, 1941a) restored activity. Of the amino acids, cystine, lysine and glutamic acid were especially important.

Embryo extract in the ultracentrifuge.

Fischer (1940) states that pellets which sediment out from embryo extract in the ultracentrifuge are inactive, but Tennant, Liebow and Stern (1941) found that similarly prepared material was very actively growth promoting and was surprisingly stable to heat. Fischer (1941b), however, suggests that the results of Tennant et al. can be explained by the presence in their material of nutrient substances stable to heat rather than to the presence of the actual growth promoting factor. He points out that Lasnitzky (1937) has shown that heated embryo juice still retains some residual activity, attributable, presumably, to the presence of heat stable nutrient factors which remain

after destruction of the catalytic agent.

The enzymes in embryo juice.

The effectiveness of proteoses as growth promoting factors (see p.38) led to the suggestion (Carrel and Baker, 1926) that proteoses or protein breakdown products might have to be formed from the embryo juice before its growth promoting power could be manifested. The enzymes responsible might be found in the cells but they might even be in the juice itself, or even the plasma (which contains a protease). Borger and Zenker (1932) found some correlation between the growth promoting power of embryo juice and its proteinase activity, but later Borger and Peters (1933) found only a weak dipeptidase and aminopolypeptidase, and no protease, in embryo juice. Hueper et al. (1933) demonstrated a feeble cathepsin activity. The active nucleoprotein isolated by Fischer (1941b) from embryo juice had no dipeptidase, polypeptidase or cathepsin activity.

Sachs (1934) found xanthinoxidase, succinic dehydrogenases, lactic dehydrase, glucose dehydrase, citric dehydrase in embryo juice. Hyaluronidase (the spreading factor) is present in embryonic tissue (Boyland and McClean, 1935) and in other rapidly

proliferating cells, in tumours (Pirie, 1942) in testis, and in bacteria.

Miscellaneous effects of embryo extract.

Embryo extract accelerates the growth of planarians (Pettibone and Walzen, 1934) but not of mammals (mice) after birth (Kaufman, 1932). Injected into guinea pigs and rats it inhibits the growth of the testes but not general growth and development of the female sex organs (Meyerhof and Zironi, 1940). In dogs and cats, embryo extract has no toxic effect and does not influence body temperature, blood pressure, and heart rate, but it increases the red cell and reticulocyte count and the haemoglobin concentration, causing a marked haematopoietic action after haemorrhage (Rubinstein, 1939). Injection into unilaterally nephrectomised animals is followed by much increased compensatory hypertrophy of the remaining kidney (Carnot and Carnot, 1927), while regeneration of the severed tails of tadpoles is reported (Nakamura, 1930) to be accelerated by embryonic tissues. Metamorphosis of tadpoles is reported to be accelerated by embryo extract (Pugliese, 1927) which is therefore suggested for the treatment of obesity. Embryo extract also accelerates "tryptic haemolysis" (Hermann and Fischer,

1939) and stimulates contractions in cardiac tissue (Törö, 1938-39). Its action on the cardiovascular system has also been investigated by Rasoumov and Nicolskaja (1928).

Embryo extract in wound healing.

Twenty years ago Carrel (1924) showed that embryo extracts might be applied to accelerate the healing of wounds and subsequently the growth promoting properties of embryo juice have led to its employment in the acceleration of wound healing by a number of other workers, e.g. by Carnot and Terris (1926), Roulet (1926), Wallich (1926), Bergami (1925), Kiaer (1927), Nakamura (1930), Bugliari (1927), Nakamura (1930), Amrosi (1931), Schloss (1926) and Morosov and Striganova (1934), with some degree of success. The results of Dvorak and Byram (1930) and of Doljanski and Auerbach (1944) were unfavourable.

Danish workers (Nielsen, 1939) reported very successful results using the active material from calf embryo (the result of Fischer's (1939) purification experiments) adsorbed on kaolin and such adsorbate, put on the market under the commercial name of "Epicutan"^{*}, received favourable comment by Waugh (1940).

^{*} Lundbeck & Co., Copenhagen. British Patent 534, 454.

The results of both Nielsen and Waugh were severely criticised by Young, Fisher and Young (1941). In the healing of experimental wounds in rats "Epicutan" was found by Dann, Glucksman and Tansley (1941) to have but little effect, nor did it have more than a feebly stimulating action on tissue cultures of epithelium (Willmer, 1942).

Embryonal emulsion has been used as an ointment in the treatment of wounds in Russia (Egorov, 1943).

The growth promoting protein fractions prepared by Doljanski and his colleagues from adult heart muscle have also been applied to the acceleration of wound healing (Doljanski, Hoffman and Tenenbaum, 1942; Werner and Doljanski, 1942; Mandl and Maybaum, 1943, Kerr and Werner (private communication)), but have more recently been reported by Doljanski and Auerbach (1944) to have no accelerating effect on the healing of experimental wounds in the rat.

The mode of action of embryo extract.

Both Carrel and Ebeling (1921) and Baker and Carrel (1926) have shown that the growth promoting power of embryo juice increases with the concentration, while Jacoby, Trowell and Willmer (1937) found the concentration of embryo extract to be more important

than the time for which it is allowed to act. The lowest effective concentration was found to be 5-10%.

Baker and Carrel (1926) were at first inclined to locate the growth promoting power of embryo juice in the protein fraction, but later (Carrel and Baker, 1926), rejecting the theory that embryo juice contained a specific hormone for cellular proliferation, they suggested that growth activating substances are not preformed in embryo juice, but are continuously made from its protein, perhaps in the cells themselves, as the result of enzyme action. The high growth promoting activity of proteoses supports this view, although proteoses were reported to be active only in the presence of embryo extract, albeit in very small concentration.

Needham (1931) also rejected the view that any one particular factor is responsible for the growth promoting properties of embryo juice which he regarded as "a special collocation of the right nutrient substances probably protein breakdown products", but later (Needham, 1942) he did not exclude the possibility of the intervention of "some carrier substance of nucleotide type".

Interesting information on the mode of action of

embryo juice has been reported by Jacoby, Trowell and Willmer (1937). They found that cells could divide in the absence of embryo juice provided that they had been treated with embryo juice some 10-12 hours previously. The minimum effective dose was 5% embryo juice acting for 3 hours. Higher concentrations acted when applied for only 1 hour but the concentration of the juice was more important than the time for which it was applied. Only one crop of mitoses occurred unless the juice acted for more than 10 hours. The daughter cells produced during the first crop of mitoses were those which divided again during the second crop.

The finding by Willmer and Trowell (1939) that a high growth promoting activity was to be found in extracts of adult brain and other tissues which tend to show non-phosphorylating glucolysis, led Willmer and Wallersteiner (1939) and Pomerat and Willmer (1939) to examine the effect of glyceraldehyde which is known to inhibit this type of carbohydrate breakdown. They found that growth was inhibited not only by glyceraldehyde, but also by several other aldehydes, although not by the corresponding acids. Sodium fluoride and sodium iodoacetate in the concentrations which

inhibit glycolysis did not inhibit growth. Growth was not immediately inhibited by an atmosphere of 95% CO and 5% O₂ nor by 0.002 M HCN, 0.002 M sodium azide nor 0.01 M sodium malonate, and was not accelerated by 0.006 M sodium fumarate.

The problem of the mode of action of embryo juice has been ably reviewed by Willmer (1935). In later work (Willmer, 1942 ab, 1943) he brought forward evidence that one of the first effects of embryo extract on cultures is to increase their nucleoprotein content. This increase coincides with increased cell activity, but precedes mitotic division by several hours.

The recent work of A. Fischer.

The whole question of the growth promoting properties of embryo juice has been reopened by the recent work of Albert Fischer (1939, 1940, 1941a & b, 1942^{ab}) who has brought forward evidence, admittedly not conclusive, that an active biocatalytic agent is present in embryo juice as well as purely nutritive factors.

Using beef embryo extract Fischer (1939) prepared a most active growth promoting fraction by isolating the nucleoproteins by the method of Hammersten

(1920). The P/N ratio in the active fraction was about 12% as against 33% in Hammarsten's pancreas nucleoprotein. The nucleic acids in the active nucleoproteins were of both thymo- and ribo-nucleic acid types but the growth promoting activity seemed to follow the latter. Activity was destroyed by tryptic digestion and also by boiling for a few minutes. Fischer also stated that full activity was restored after coupling of two inactive components, one thermostable and the other thermolabile (presumably protein). The analogy with enzymes is obvious (c.f. Warburg, 1938). In a subsequent paper (1940) containing no experimental details, the chemical nature of the active materials is less sharply defined. The activity of the isolated nucleoproteins is stated to be completely destroyed by heating at 56° for 15 min. Moreover, repeated reprecipitation of the nucleoproteins reduced their activity although it increased their ultra-violet absorption at 2600 Å (an absorption band characteristic of nucleic acids, see p.197). The role of the nucleoproteins is not therefore fully established. Analysis of the active material showed a higher P content than could be accounted for by the nucleic acids. Sulphur was also

present, presumably derived from such substances as chondroitin or mucoitin sulphuric acids.

The active nucleoprotein fraction had little effect on cultures in dialysed serum although it exerted a powerful growth promoting action in presence of fresh undialysed serum. Fischer (1941a) concluded that the active fraction is not a nutrient material of the protein breakdown product type, but is a true biocatalytic agent. Its preparation was described later in some detail (Fischer, 1941b) when methods of fractionating embryo extract were also discussed.

Fischer obtained some success by precipitating the proteins of embryo juice with cold alcohol and washing with ether, by precipitating with $\frac{1}{2}$ vol. acetone, and by precipitating with acetic acid at pH values between 7.3 and 4.8, but no fraction was as active as the original solution. In the case of ammonium sulphate precipitation, the fraction obtained at 0.4 saturation was most active.

For large scale work Fischer used bovine embryo extract crudely dried at room temperature with an electric fan. The dried powder was extracted with chloroform or benzene to remove fats (5-10% of the total). Such extraction, if prolonged, could

sterilise the powder^x; it also increased the growth promoting activity, and the solution obtained from such a powder could be passed through a filter candle without loss, owing, in part, to the fact that mucin-like materials which tend to clog candles did not re-dissolve. The amount of dried powder which went into solution depended on the method of drying, but was always relatively small.

Fischer used this dried powder to prepare the nucleoproteins by Hammarsten's (1920) procedure which consists in extraction with cold dilute HCl for 24 hours followed by extraction of the residual material with cold dilute NaOH and precipitation of the nucleoproteins from the extract with HCl. The nucleoprotein fraction so obtained was much more active than the original material, although the yield was poor.

The active nucleoprotein fraction was not very soluble in pure water but could be dissolved by careful addition of alkali. The solution so obtained could be sterilised by passage through a filter candle without loss. The active material could not be further purified in the Beams air driven ultracentrifuge;

^x c.f. British Patent 534, 454.

attempts at purification by repeated reprecipitations resulted in loss of activity.

Fission of the nucleoprotein was attempted in the following manner. A nucleoprotein solution was boiled for five minutes and precipitated with HCl. Its activity was reduced to zero. Another portion of the solution was not boiled, but was precipitated by HCl whereby some activity was lost. When these two solutions were mixed 100% activity was restored.

Fischer suggests that these experiments show the necessity for the presence of two components, one thermostable and the other thermolabile, but the evidence is by no means conclusive. In his later papers (Fischer, 1942; Fischer and Astrup, 1942) this interesting nucleoprotein is unfortunately not further discussed.

It will be obvious from all these considerations that the problem of the growth promoting power of embryo juice is still obscure. It appears certain that its effect is due to the synergistic action of several components. Some of them are obviously nutrient materials, e.g. proteoses or amino acids and other dialysable constituents. The function of the non-dialysable protein constituents is more doubtful. While some may act as simple nutrients or as precursors

of simple nutrients, the possibility that others may have a biocatalytic action is increased by the discovery of Fischer's nucleoprotein. It is possible also that different factors may be concerned in the two processes of protoplasmic growth and cell division (Willmer, 1935, p. 54).

B. The effect of proteoses, peptones and amino acids.

Apart from products derived from embryonic tissues, other substances of biological origin may play an important part in stimulating tissue growth. Of these, the protein break down products are of paramount importance.

Carrel and Baker (1926) investigated the effect of the higher cleavage products of the protein molecule on cell multiplication. Embryo pulp, egg white, rabbit brain and commercial fibrin were digested with pepsin for varying lengths of time and the products tested. The materials obtained from embryo pulp were toxic unless the digestion time was very short, when the materials had some stimulating effect. The materials obtained by the peptic digestion of egg white and fibrin, especially the latter, had a very pronounced

growth promoting action and some cultures of exceptionally large area were obtained. Peptic digests of rabbit brain were active, as also were the hydrolytic products obtained by autoclaving egg white and fibrin in an acid medium for a short time. With long autoclaving, the products were toxic or inactive. Of commercial peptones, Armour's peptone was almost inactive, Parke Davis's and Fairchild's peptones had low activity, while Witte's peptone was very potent.

Fractionation of Witte's peptone was attempted. The fraction precipitated at pH 6.0, and the substances precipitated by 2.5% trichloroacetic acid, had some growth stimulating action, but not as much as the remaining fractions.

The higher components of the Witte's peptone, including some proteoses, were precipitated with 2.5% trichloroacetic acid. In the filtrate the remaining proteoses were separated from the peptones and lower degradation products by saturating at 33° with sodium sulphate after removal of trichloroacetic acid^{*}. After removal of sulphate by dialysis, the preparation of pure proteoses was tested on fibroblasts. The

^{*} This method of separating proteoses is essentially that of Wastenays and Borsook (1924).

pure proteoses were almost as potent as the mixture of proteoses, peptones, etc., in the trichloroacetic acid filtrate and gave rise to fewer fat globules. Tryptic digestion of peptic digests gave products of low activity.

In continuation of this work, Carrel, Baker and Ebeling (1927) found that although digests of casein and egg albumin had some growth promoting effect on chick embryo heart fibroblasts, they had only a very slight effect on sarcomatous fibroblasts. The effect was however improved by the addition of glyco-coll, or glycocoll with digested gelatine, and the addition of thymonucleic acid improved conditions still further.

When peptic digests were made from pure proteins (Baker and Carrel, 1928) such as crystalline egg albumin, edestin or purified fibrin, they were found to be just as active as those from the impure proteins. The activity did not therefore lie in any impurity present in the crude material, but the digests of pure proteins were deficient in certain substances, and did not meet the entire nutritive requirements of the cells for an unlimited period of time. Some of those supplementary substances are present in fresh

embryonic heart tissue, hence the reason for the more favourable growth of fresh explants than of pure strains. Glycocoll and nucleic acid acted as supplementary substances. All the essential constituents for the cultivation in vitro of sarcomatous fibroblasts were found in peptic digests of calf liver or anterior pituitary gland. Normal chick fibroblasts proliferated in both digests, but eventually underwent fatty degeneration.

Towards both normal and sarcomatous rat fibroblasts, α and β proteoses had equal growth promoting power (Baker and Carrel, 1928). A mixture of peptones^{*}, peptides^{*} and amino acids containing negligible amounts of proteoses^{*} produced temporary proliferation of normal fibroblasts, and an unlimited multiplication of sarcomatous fibroblasts, provided the substances were derived from liver tissue which is reported to contain products of unknown nature which complete the nutritive effect of the protein degradation products.

Peebles (1929) suggested that a growth promoting factor found in echinoderm embryo might be a proteose.

^{*} These terms are used in the usual text-book sense.

Prepared from Witte's peptone by a method similar to that of Wasteneys and Borsook.

The growth promoting power of proteoses was confirmed by Fischer and Demuth (1927) and the subject was later investigated in some detail by Willmer and Kendal (1932). They found that the growth of chick heart fibroblasts in Tyrode solution alone was not materially increased by addition of pure proteoses^x but in the presence of plasma, proteoses caused increased growth probably owing to their slow digestion by plasma enzymes. If even very small amounts of embryo extract were present as well, the effect of proteoses was strikingly increased, and cultures of very large area were obtained.

These workers also separated from Witte's peptone and from fibrin, a thermostable substance associated with, or perhaps identical with, a heteroproteose which was capable of stimulating cells to increased activity and division. Its action was independent of the presence of plasma and was probably due to stimulation of the cells in some unknown way.

The importance of the protein degradation products was further emphasised by Fischer (1941b, 1942a, b) who found that the higher protein split products

^x Prepared from Witte's peptone by a method similar to that of Wasteneys and Borsook.

of the homologous proteins (serum proteins) were more effective in stimulating fibroblast growth than the lower split products, whereas the effect was reversed with the corresponding products of the heterologous proteins. Moreover these higher split products produced by the action of pepsin on heterologous proteins were almost without effect, whereas those produced by the action of pepsin on homologous proteins were very effective. But when the products from heterologous proteins were further degraded with erepsin very active materials were obtained.

Higher protein split products are present in the boiled kidney extract of Fischer and Astrup (1942) and may be responsible in part for its growth promoting activity (Fischer, 1942b).

Proteoses and peptones are also reported to accelerate wound healing (Roulet, 1926; Wallich, 1926; Kiaer, 1927).

Amino acids.

From the early work of Burrows and Neymann (1917), Baker and Carrel (1926), Carrel and Ebeling (1924) and of Ebeling (1929) it is known that amino acids alone while causing increased migratory activity in tissue cultures do not increase the mass of tissue to any

appreciable extent (see p. 23). Fischer (1941a, 1942a, b) carried the matter further. Using a procedure for the aseptic dialysis of plasma without protein denaturation, he found that while dialysed plasma proteins could not sustain tissue cultures for long, addition of dialysates or ultrafiltrates of normal serum, or of digestion products of the plasma proteins, restored activity. The dialysates could be replaced by a mixture of 9 amino acids provided they were supplied in the relative amounts present in fibrin as shown by the analyses of Bergmann and Niemann (1936). In equal amounts or in Rose's amino acid mixture, they were almost without effect.

The amino acid mixture which Fischer used had the following composition:-

d-lysine dihydrochloride	15.1 mg.
d-arginine	7.7 "
l-tryptophane	5.0 "
dl-methionine	2.6 "
l-histidinemonohydrochloride	3.1 "
glutamic acid	14.1 "
l-asparagin	5.9 "
l-proline	5.1 "
l-cystine	1.5 "

dissolved after neutralisation in 25 ml. physiological sodium chloride solution.

(Total N = 31 mg.% Amino N = 22.2 mg.%.)

This amino acid mixture alone had no effect, but

it was able to restore the activity of dialysed plasma and embryo extract.

The activity of the boiled kidney extract of Fischer and Astrup (1942) is due also in part to its amino acid content.

C. Miscellaneous factors.

(i) The effect of the plasma.

It has been emphasised by Carrel (1924) that when tissue cultures are grown in plasma clot with embryo extract, it is the latter and not the former which promotes growth. The plasma acts essentially as a supporting medium, the meshwork of its clot being peculiarly suitable for the purpose. Other supporting media have been tried (Fischer, 1925) including cotton wool fibres, spiders webs, agar, etc., but none has proved satisfactory. The plasma, however, may influence the growth of the cultures to some extent.

The age of the animal providing the plasma is important, but the donor need not be of the same species as the donor of the cells (Walton, 1915). Fresh plasma was claimed by Walton (1915) to contain both inhibiting and stimulating substances, the latter

being in excess. Freezing for 1-3 days appeared to decrease the amount of inhibiting factor, but freezing for 6-8 days destroyed the stimulating substance.

Carrel and Ebeling (1921, 1922) took up the subject in some detail and found that the rate of growth of fibroblasts and their duration of life varied inversely as the age of the donor of the plasma. With increasing age there was an increase in the concentration of an inhibiting factor. This factor increased in amount in the serum of a young animal when the serum was heated (Carrel and Ebeling, 1923) but remained below the level found in the serum of an old animal. The precipitate obtained by the action of CO_2 on serum had pronounced proliferative activity when the serum of a young, but not of an old, animal was used. After removal of this stimulating factor, the inhibitory action of the serum of young animals, but not of old animals, was increased. Baker and Carrel (1927) finally concluded that with increasing age there was a decrease in the amount of growth stimulating factors (associated with the proteins) in serum, and an increase in the amount of growth inhibitors, presumably associated with the lipin fraction. It is known that as age advances the

concentration of all protein fractions in serum increases as also does the total lipin (including lecithin) concentration, although the cholesterol concentration decreases.

In view of these observations it is of some interest to note that Zakrzewski (1932) has reported that prothrombin has a growth stimulating action while heparin acts as an inhibitor (Fischer, 1936).

(ii) The effect of the age of the donor of the tissue.

The capacity for growth of cells decreases during embryonic and post natal development and the latent period increases. Tissue from young embryos grows more rapidly, and has a shorter latent period, than that from older embryos (Cohn and Murray, 1925; Hoffman, Goldschmidt and Doljanski, 1937; Medawar, 1937). Cells from adult tissues are less suitable than those from embryonic tissues for tissue culture work and have a longer latent period.

(iii) Inhibitors.

The inhibitory effect of lipins on tissue cultures has been known since the early work of the Rockefeller group (Baker and Carrel, 1925, 1927) who ascribed the inhibitory effect of serum from old

animals partly to the presence of an increased lipin content. The mode of action of the lipins is unknown, but Mayer (1937) considered the possibility of a direct injurious action on the cells.

Aldehydes including glyceraldehyde, methyl glyoxal, propaldehyde, butaldehyde and benzaldehyde, heptaldehyde and citral, have been shown by Willmer and Wallersteiner (1939) and Pomerat and Willmer (1939) to be inhibitory (see p. 32).

Of the tissue extracts examined by Walton (1914), liver was the only one which exerted an inhibitory action (see also Brues et al., 1940). Heaton (1926) found that liver extracts and yeast contained a factor (perhaps allied to some member of the vitamin B group) which stimulated the growth of epithelia, and also a factor which inhibited fibroblastic, but not epithelial growth. This inhibitory factor also delayed tadpole metamorphosis and the regeneration by newts of parts lost by amputation, and caused arrest of growth of young animals. It had no prophylactic value against implanted tumours. A similar factor was investigated by Medawar (1937). It was present in malt, ungerminated grain and oranges and was present in the normal diet. Although it inhibited the

growth of mesenchyme derivatives it had no direct effect on the growth of epithelia. Similar properties were found in the case of synthetic hexenolactone (Medawar et al., 1943).

A full discussion of growth inhibitors is, however, outside the scope of the present investigation.

(iv) The effect of individual purified chemical substances on the growth of tissue culture has been investigated in many cases including members of the Vitamin B group (yeast) (Burrows, 1925; Heaton, 1929; Rossi, 1935; Paterson and Thompson, 1943), carotene (Verne and Verne Soubiran, 1939), biotin (Tennant, Stern, Liebow and Carter, 1939; Hamilton and Plotz, 1942; Fischer, 1942; Burt, 1943), auxin (Kögl, Haagen-Smit and Tonnis, 1933; Fischer, 1942), insulin (Latta and Bucholz, 1938), lactogenic hormone (Salle and Strechmeister, 1936), allantoin (Chu, 1938; Calkins, Bullock and Rohdenberg, 1912; Pomerat, 1942; Shipp and Hetherington, 1936-37; Brailey, 1912), heparin (Fischer, 1936); thrombin (Fischer and Astrup, 1939), nucleic acids (Tennant, Stern, Liebow and Carter, 1942), glutathione (Verne and Verne-Soubiran, 1939), sulphonamides (Jacoby, Medawar and Willmer, 1941), sulphathiazole (Reed, Orr

and Anderson, 1942), alcohol (Singer and Hoder, 1929), chloroform (Carleton and Haynes, 1927-28), ether (Rosenfeld, 1931-32; Carleton and Haynes, 1927-28), morphine (Semura, 1931), deuterium oxide (Fischer, 1936), methyl cholanthrene (Earle and Voegtlin, 1938, 1940), benzpyrene (Lebenzon, 1940), methylene blue (Ludford, 1935), steroids (Moellendorff, 1939, 1941, 1943; Lettré, 1943; Lettré and Fernholz, 1943), chlorophyll (Smith, 1943).

D. Methods of measuring the growth of tissue cultures.

Several methods are available for measuring the growth of tissue cultures quantitatively.

(1) Measurement of surface area. Ebeling in 1921 described a method which has subsequently been extensively used. By means of a projectoscope an outline of the culture is projected on to a sheet of paper on which it is drawn. The area is then measured with a planimeter. The method is not suitable for direct explants (Parker, 1938).

Area measurements have been used in the very extensive researches of Fischer. In his most recent work (Fischer, 1941a) he used cover slip cultures

grown in one drop each of plasma, clotting substance, and growth substance dissolved in Ringer or Tyrode solution. In the controls the growth substance was omitted. Outlines of the cultures were drawn every 24 hours during the course of three days. The results were expressed as follows:-

$$K = \frac{B - A}{A} ; \quad E = \frac{B_1 - A_1}{A_1} ; \quad \frac{E}{K} = i$$

where K and E refer respectively to the control and the experimental culture, B and B_1 are the areas of the control and experimental cultures respectively after three days of growth, A and A_1 are the areas of the control and experimental cultures respectively at the beginning of the experiment, and i is the rate of growth and increases with increasing activity of the particular growth promoting substance.

The growth curve, however, is not linear when activity is plotted against concentration of growth-promoting substance. The increase in growth rate when the concentration of embryo juice rises from 0 to 10% is greater than when the increase in concentration is from 10 to 80%. This is held by Fischer to indicate that the active agent is probably catalytic in nature rather than a simple nutrient.



The growth promoting activity of a given substance could be expressed by Fischer in one of three ways:-

1. The rates of growth of two culture halves, one in test substance and the other in plasma plus Tyrode only could be compared and the latter taken as zero.
2. To the control an arbitrary growth promoting substance could be added.
3. The activity of a standard growth promoting substance of constant concentration in the control could be compared with the activity of the unknown growth promoting substance at arbitrary concentrations in terms of nitrogen content.

$$\text{Then } i \frac{N_K}{N_E} = I$$

where i = growth rate, and N_K and N_E are the N contents of standard and unknown respectively. Experiments with serial dilutions of the active agents are essential when this procedure is employed.

Tennant and Liebow (1942) calculated what they term "expansion rate factors" from area measurements. The expansion rate factor (E.R.F.) is given by $\frac{B - A}{B} \times 100,000$ divided by the number of hours in the experimental period, where A and B are the areas at

the beginning and end of the experimental period respectively.

(ii) Estimation of the mitotic index. This method, which has been used by Willmer and Kendal (1932) and others, involves measurement of the mitotic coefficient, $\frac{M}{C} \times 1000$, where M is the number of dividing cells and C is the number of resting cells. In this method it is usual for the cultures to be fixed and stained.

(iii) Measurement of dry weights of tissue. The actual weight of tissue used can be measured (Meier, 1931; Laser, 1932, 1933; Wilson, Jackson and Brues, 1942) but the procedure is very tedious and not very accurate (Willmer, 1942).

(iv) Measurement by metabolic activity. The amount of tissue present can also be estimated by measuring its glycolytic activity in manometric experiments (Meier, 1931; Laser, 1932, 1933; Lipmann, 1932, 1933). The method is rather indirect and suffers from the defect that glycolytic activity depends on several factors other than the amount of tissue present.

(v) Cunningham and Kirk's method. A procedure for the measurement of growth of tissue cultures which is

free from many of the defects of other methods was proposed by Cunningham and Kirk (1942). A specially prepared portion of an implant in the 3rd to 5th subculture is examined, the following measurements being made:- (i) Area, (ii) Thickness, (iii) Total number of cells, (iv) Average cell size.

The method is elaborate and time consuming but is claimed to give a very accurate estimation of the rate of growth of the cultures.

(vi) Estimation of nucleic acid phosphorus (nucleo-protein phosphorus; N.P.P.). This measurement was proposed by Willmer (1942) who used the analytical procedure of Berenblum, Chain and Heatley (1938). The method is assumed to give an estimate of the amount of nuclear material present, but it has two defects - (i) in most tissues the cytoplasm contains nucleic acids, and (ii) the analytical procedure employed estimates "residual phosphorus", i.e. phosphorus not extracted by lipid solvents and by dilute acids, and may include substances other than nucleic acids.

Nevertheless, if carried out with due regard to its possible limitations, it forms one of the most satisfactory methods of growth estimation (c.f.

Cunningham and Kirk, 1942) and is the method chosen for the purposes of this investigation.

The exact nature of the "residual phosphorus" of tissues and the question of the distribution of nucleic acids between cytoplasm and nucleus, are discussed in some detail in Part III (see p.205).

2. EXPERIMENTAL METHODS.

It must be emphasised that any biological method, involving the use of tissue culture, for the investigation of the tissue growth-promoting activity of a substance must inevitably in the present state of our knowledge be relatively crude in comparison with the recognised methods for examining growth promoting factors for yeast or many types of bacteria. In the case of many micro-organisms the investigator can start with a basal medium of known composition to which he can add suitable concentrations of the necessary known growth-promoting factors so that the growth response is, as far as possible, proportional to the concentration of the factor under test. In the case of a tissue culture test such simple conditions are not possible. In the first place, growth occurs on a two phase system consisting of plasma clot and fluid medium. The composition of the plasma varies from bird to bird and comparison can only be drawn when the same batch of plasma is used in all tests. Moreover the plasma contributes a multitude of factors of unknown composition to the medium. Secondly the growing tissue requires a large number of factors,

Figure 1.

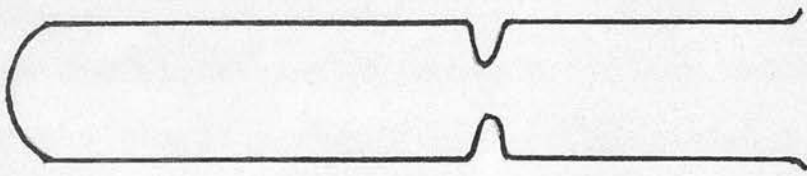

Roller tube.

Reflux
condenser

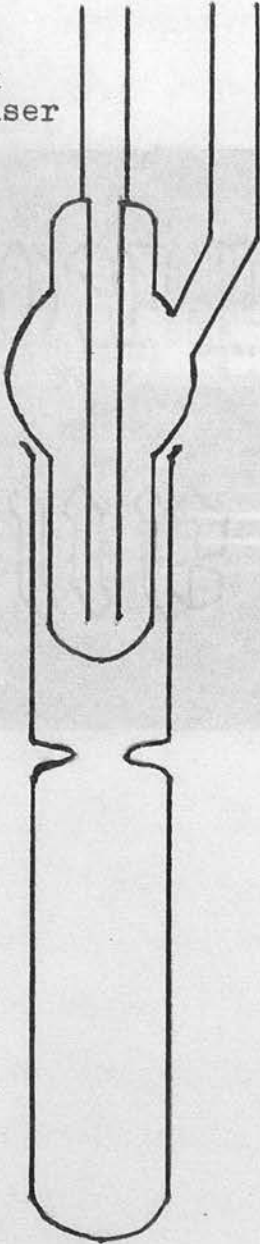

Stopper for
use during
ashing.

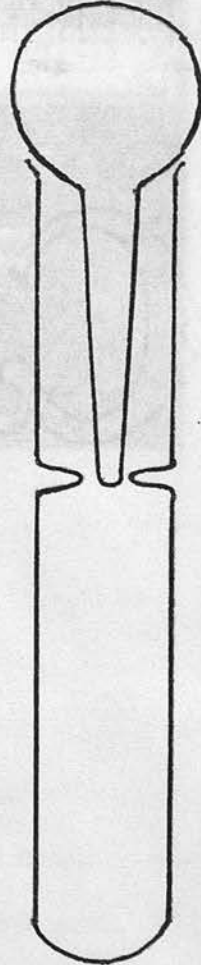

Roller tube.

Figure 1.

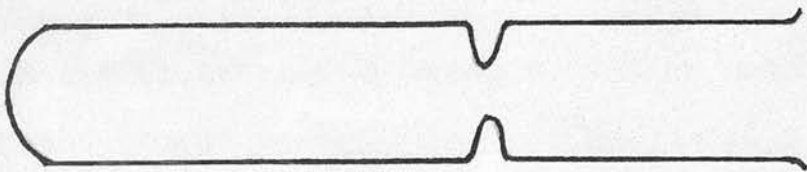

Roller tube.

Reflux
condenser

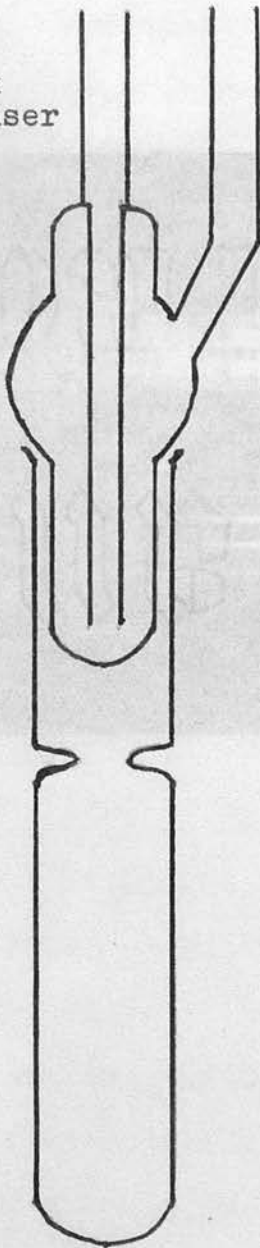

Stopper for
use during
ashing.

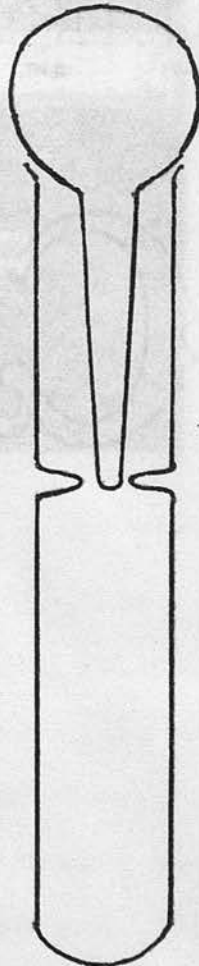

Roller tube.

Plate 1.

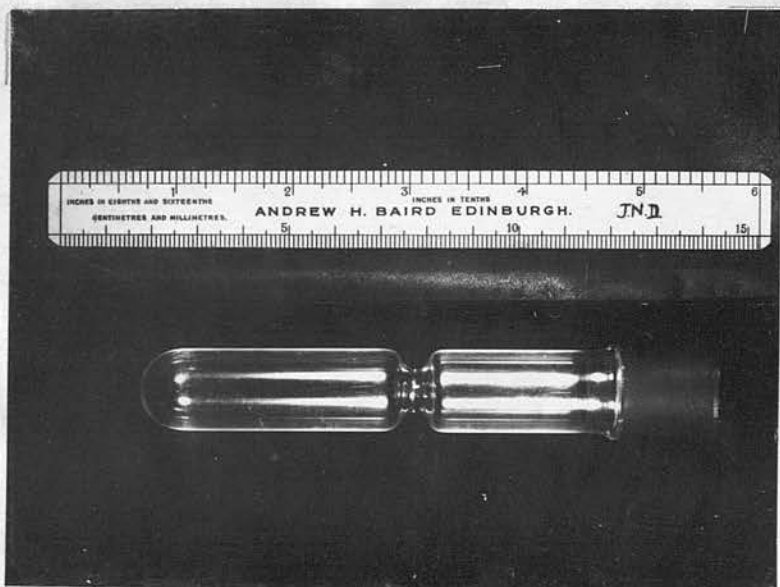

Roller tube.

nutrient and biocatalytic, whose nature is unknown. Thirdly the tissue itself cannot be implanted in the same quantitatively accurate amounts as a cellular suspension (of yeast or bacteria) can be used to seed a medium. And unless a pure strain of cells is available (and it was not in the present investigation), the tissue used for the original explants will be variable in composition and in potential growth capacity.

For these reasons the present investigation is aimed at detecting gross differences only, in the growth promoting power of the materials tested.

Materials required.

Roller tubes.

The use of roller tubes for tissue culture work was first described by Gey (1936), and the particular roller tube technique used in these experiments is that described by Willmer (1942). The roller tubes (Fig. 1 and Plate 1) are made of Pyrex glass and are about 10 cm. in length and of external diameter 1.8 cm. They are shaped like a test tube and have a constriction about 5.5-6.0 cm. from the closed end. The constriction divides the tube into two portions, a closed

Plate 2.

18.

capacity of about 2 ml. capacity and an inner volume of about 1 ml. capacity. They are placed in a solution of strong sodium carbonate solution, and after being washed with water, allowed to stand overnight in 2% sodium carbonate solution and then removed very carefully.

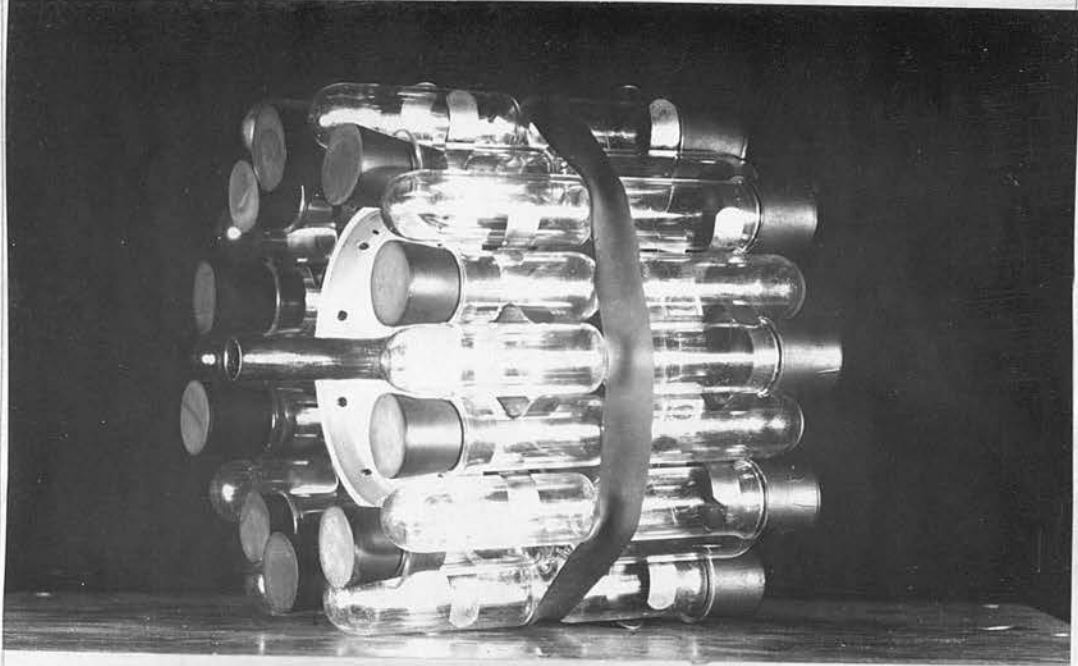

From this drum a roller tube is removed and placed in a solution of strong sodium carbonate solution, and after being washed with water, allowed to stand overnight in 2% sodium carbonate solution and then removed very carefully.

Synclock N.B.S.

Drum carrying 20 roller tubes.

portion of about 8 ml. capacity and an open portion of about 6 ml. capacity. They are cleaned by heating them in strong sodium carbonate solution, rinsing with water, allowing them to stand overnight in 5% hydrochloric acid and then rinsing very thoroughly with glass distilled water. They are then dried, plugged with cotton wool, and sterilised in the hot air oven.

With roller tubes of this type, the contents come in contact with nothing but an unbroken glass surface.

Drum.

While the cultures are growing, the roller tubes are mounted horizontally on a drum carrying ten pairs of Terry clips. A second set of ten tubes can be mounted between the clips and held in place with a broad rubber band so that the drum can be made to carry a total of 20 roller tubes (Plate 2). The drum fits into a special bearing on the inside of the incubator door (Plate 3) and is driven by a small electric synchronous motor^{*} mounted on the outside of the door. The speed of the drum is one revolution per minute. With each revolution of the drum the

^{*} Synclock M.B.3.

Plate 3.

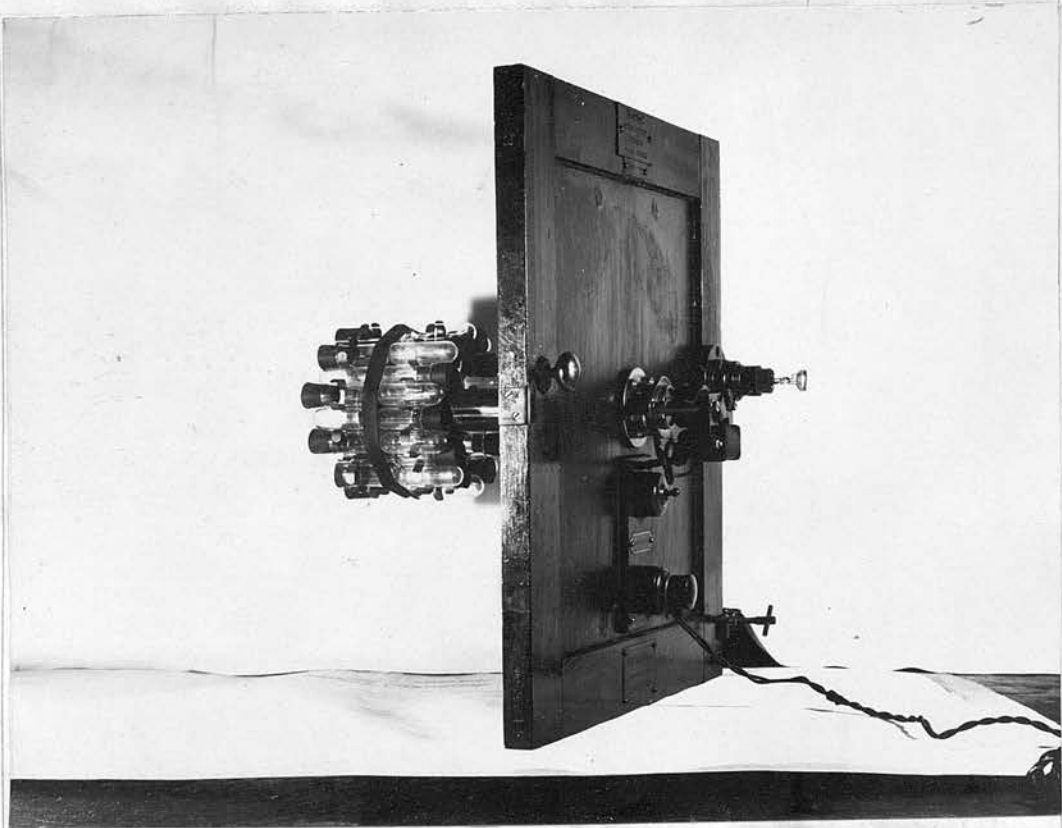

Incubator door showing drum with roller tubes on inner side and motor on outer side.

fluid in the tubes washes over the growing cultures. The temperature of the incubator is 38° .

Plasma.

The plasma used in these experiments was obtained from young cockerels supplied by Dr A. W. Greenwood. To obtain plasma the birds are anaesthetised with ether and the carotid arteries exposed and dissected out as described by Strangeways (1924). The arterial blood is collected in sterile ice-cold waxed centrifuge tubes which are immediately stoppered with sterile corks, packed in ice in large centrifuge buckets and centrifuged for 10 minutes at 2500 r.p.m. The plasma layer is then pipetted off by means of a sterile capillary pipette into sterile waxed test tubes. The plasma is stored in the refrigerator. It is not used if it is more than a month old. One bird yields about 40 ml. plasma.

Tyrode solution.

The Tyrode solution (T) is made up according to the directions of Willmer and Kendal (1932) and has the following composition.

NaCl	0.8%	NaH ₂ PO ₄ .2H ₂ O	0.0065%
KCl	0.02%	MgCl ₂ .6H ₂ O	0.0215%
CaCl ₂	0.02%	glucose	0.1%
NaHCO ₃	0.05%		

The pH of the solution is 7.5. It is sterilized by filtration through a Berkefeld candle under very low negative pressure to avoid loss of CO₂ and is stored in the refrigerator in Pyrex test tubes stoppered with sterile rubber bungs. Special glass filtration vessels have been devised for sterilising this and other solutions. A stock of sterile Tyrode solution of double strength (2T) is also kept.

Embryo extract.

When chick embryo extract is used it is prepared as follows:- The nine day chick embryos from which the hearts have been removed for culture purposes are transferred with sterile forceps to sterile graduated 15 ml. centrifuge tubes (2-3 embryos per tube). They are then pulped with a sterile glass rod. The volume of the pulp is noted (it is usually 1.5 ml. per embryo) and an amount of sterile Tyrode equal to that of the pulp is added. The tube is then stoppered with a sterile rubber bung, is placed in a freezing-mixture till the contents are solid, is allowed to

thaw, and is then centrifuged for five minutes. The supernatant fluid is pipetted off into sterile Pyrex test tubes which are stoppered with sterile rubber bungs and stored in the refrigerator. This represents 50% embryo extract (E.E.). Total N content = 60-80 mg. per 100 ml.: 100% embryo extract, made by centrifuging embryo pulp, has a nitrogen content of about 200 mg. per 100 ml.

Setting up the tissue cultures.

Most of the apparatus required is sterilised in the hot air oven or in the autoclave. Instruments are boiled. All tissue culture work is carried out in an operating room set aside for the purpose. The general technique described by Strangeways (1924) is followed, and the culture table is covered with a sterile black cloth and set out as described by Strangeways (1924) and by Parker (1938). In all experiments fresh explants from the nine day chick embryo heart have been employed. The eggs have been incubated by Dr A. W. Greenwood and sent by him on the ninth day. The eggs are opened as described by Strangeways and the hearts removed and cut up into at least 12 pieces in the usual way. Tissue fragments from a number of hearts are pooled.

The roller tubes are set out in horizontal racks. To set up the cultures, the cotton wool is removed from the mouth of a roller tube and the mouth flamed. Into the roller tube is pipetted 0.2 ml. sterile fowl plasma and the roller tube is then placed horizontally in a rack and a series of six pieces of tissue quickly implanted in a row in the plasma layer with a platinum wire mounted in a glass rod and flattened at the end. The tube is then stoppered and set aside till the plasma is firmly clotted. 0.5 ml. sterile Tyrode is then added to the tube which is stoppered with a sterile rubber bung and is ready for mounting on the drum.

For each test 20 tubes are set up. Some of them (6-8) may contain plasma alone (clotted by addition of a small piece of tissue which is subsequently removed) to provide control figures for the N.P.P. of the plasma alone. The remainder contain six pieces of tissue each. Each test therefore involves the use of 70-80 pieces of tissue.

All the tests have been carried out with fresh explants from the heart of the nine day chick embryo. No experiments have been carried out on cultures maintained as a pure strain. This must be kept in

mind when considering the results.

As the composition of plasma is variable, direct comparisons of the effects of two substances on the tissue N.P.P. are made only where control and test series are grown in plasma from the same sample at the same time. For a similar reason, when embryo extract with and without some supplement is tested, comparisons are only drawn when a single sample of extract is used throughout. The effect of any lack of uniformity, due to inherent variations in potential growth capacity between different hearts, is reduced by using in each test pieces from a mixed sample from 6-8 hearts.

The tubes are mounted on the drum and rotated for two days in the incubator at 38°. The "residual growth energy" is reported to be exhausted by this time (Trowell and Willmer, 1939). The test proper then begins. The fluid in the tubes (Tyrode + serum + metabolic products) is removed with a curved sterile capillary pipette, and the test substances are added. Some of the tubes contain Tyrode solution alone, others contain combinations of Tyrode and test substance with or without embryo extract, the total volume being 0.5 ml. The tubes are replaced on the

drum and rotation recommenced. At the end of one to three hours ("time 0"), when the fluid has permeated the plasma clot, some of the tubes are removed to provide figures for the initial N.P.P. value. The remainder are allowed to rotate for a further period of time, usually two days ("time t"). The N.P.P. is then determined and the amount of growth calculated.

For each tube (as many duplicates as possible are setup) containing a test substance and tissue grown to "time t", at least three controls are set up (preferably in triplicate) containing that same test substance. One contains tissue and is removed at "time 0", the second and third are plasma controls for "time 0" and "time t" respectively. For each test substance similar sets of controls are necessary. When the N.P.P. is estimated, the values for the plasma blanks are subtracted and the increase in N.P.P. in the tissue between "time 0" and "time t" can be calculated. The method of expressing results is discussed later (p. 76).

At "time t" all the tubes are removed from the drum and those containing tissue are placed (when area measurements are desired) in an Edinger's apparatus which projects a silhouette of the culture

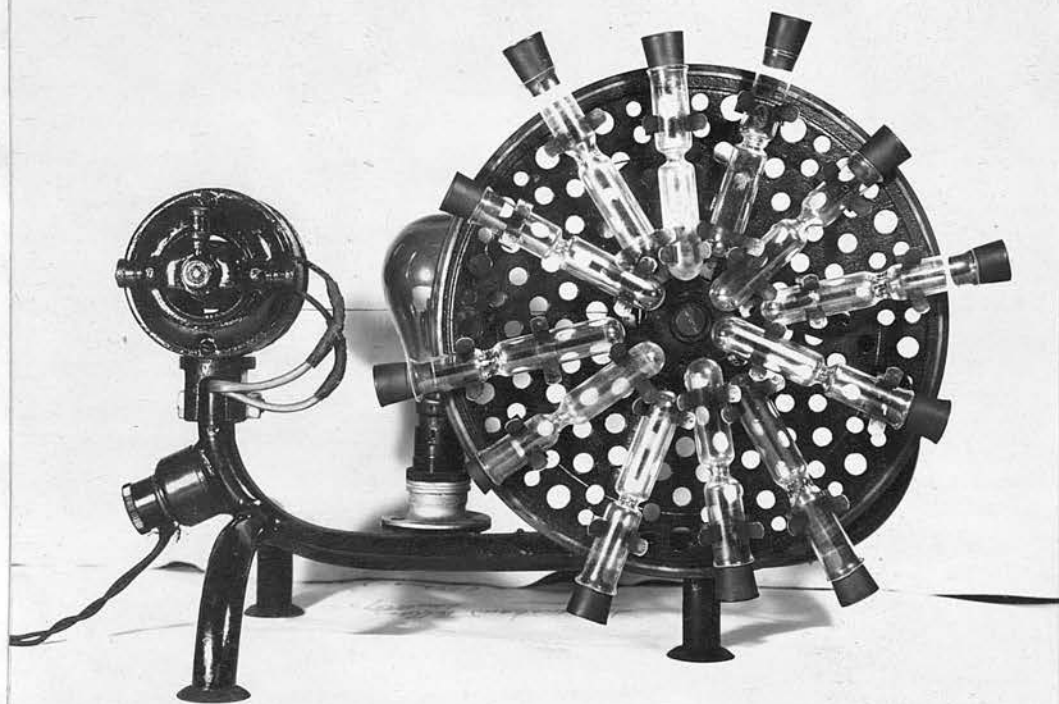

Rotating disc carrying roller tubes during extraction of acid soluble phosphorus.

magnified 15 times on to paper. The outline of the culture is drawn, the area subsequently being measured with a planimeter. Rough photographs can also be taken if necessary by projecting the silhouette of the culture on to the sensitised surface of Ilford Reflex Document paper but the curvature of the tubes renders accurate projection difficult. The tubes are then ready for the estimation of N.P.P.

Estimation of the growth of tissue cultures by N.P.P. determinations.

Principle. The tissue is extracted as recommended by Berenblum, Chain and Heatley (1939) so that lipoid phosphorus and acid soluble phosphorus are removed and the residue is then ashed and phosphorus determined by the ultra-micro method of Berenblum and Chain (1938). The estimation is carried out in the roller tube which now serves as a test tube.

Method. The fluid in the roller tube is removed and the tube rinsed quickly with distilled water. It is then filled with ethanol-chloroform mixture (3:1) and heated on an air bath under a small reflux condenser at 65° for two hours (Fig. 1). The air bath is constructed to hold 14 tubes at one time and the small cold finger condensers are arranged in series.

The extraction is repeated with fresh ethanol-chloroform mixture for a further two hours. This process removes lipoid phosphorus. The roller tubes are then filled with 0.1 N hydrochloric acid for the extraction of inorganic and acid-soluble organic phosphorus.

During the extraction gentle agitation of the tubes is carried out by mounting the stoppered tubes radially on a vertical disc which is slowly rotated by a motor (Plate 4). (The rubber stoppers used at this stage are stored in 0.1 N HCl when not in use.) The extraction is carried out for three hours and is then repeated for a second period of three hours with fresh acid. As the ashing process was accompanied on one occasion by a violent explosion, it has subsequently been carried out behind a triplex glass screen.

0.15 ml. 60% A.R. perchloric acid is added to the tube, a weighted glass stopper (Fig. 1) is loosely inserted and heating is conducted over a microburner till the remaining fluid is straw coloured. The tube is cooled, 0.4-0.5 ml. of water is added and the tube is heated in the water bath for 15 min. at 100° to break down pyrophosphate. Total phosphorus is then estimated in the fluid by a modification of the method of Berenblum and Chain (1938).

Figure 2.

Solutions required:

1. 5% ammonium molybdate solution (see page 14 in a 100 ml. bottle).
2. Stock stannous chloride solution: 10 g. stannous chloride are dissolved in 20 ml. concentrated hydrochloric acid and the solution kept in a brown glass stoppered bottle.
3. Dilute stannous chloride solution: The amount of stannous chloride in a 100 ml. solution is 1 g. It is used as follows:

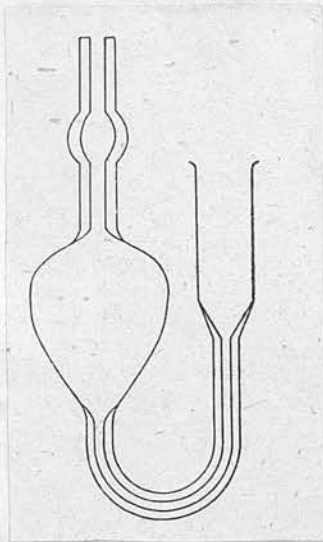

Mixing vessel for phosphate estimation.

The time of the mixing is very short. The vessel is washed out with first 0.5 ml. water and then with 0.5 ml., the washings being transferred to the mixing pipette.

$\frac{2}{3}$ actual size.

Solutions required.

1. 5% ammonium molybdate AnalaR (kept in a waxed bottle).
2. Stock stannous chloride solution; 10 g. stannous chloride are dissolved in 25 ml. concentrated hydrochloric acid and the solution kept in a brown glass stoppered bottle.
3. Dilute stannous chloride solution. The stock solution is diluted 200 times with 1 N sulphuric acid. It is made up fresh as required.
4. Iso-butanol.
5. Ethanol.
6. 10 N sulphuric acid (approx.). 28% conc. sulphuric acid.
7. N sulphuric acid.

Procedure. The method as described by Berenblum and Chain involves the use of a mixing pipette in which each estimation is separately carried out in turn. An improved type of mixing pipette has therefore been devised (Fig. 2). A battery of these pipettes may be mounted on a rack and used together so that six estimations and one standard may be carried through at one time. This results in a great saving of time.

The acid digest is transferred into the short limb of the mixing pipette and the roller tube washed out with first 0.2 ml. water and then with 0.3 ml., the washings being transferred to the mixing pipette.

All addition and removal of reagents is done through the short limb. 0.25 ml. 5% ammonium molybdate is then added followed by 1 ml. isobutanol. Gentle suction is applied to the long limb of the pipette and the fluids are sucked up into the bulb and mixed. On standing, the aqueous layer settles to the bottom and fills the curved capillary. A capillary pipette attached to a reservoir to which gentle suction is being applied from a pump, is then introduced into the cup of the short limb and the aqueous layer is sucked away till the isobutanol-water interface just reaches the end of the capillary. The iso-butanol layer is then washed with two lots of 1 ml. of N sulphuric acid added and removed through the cup on the short limb, and finally with 1.5 ml. dilute stannous chloride solution for 30 seconds. The aqueous layer is sucked away and the blue alcoholic solution poured away through the cup into a small test tube graduated at 1 ml. The mixing pipette is rinsed out with small amounts of ethanol which are used to make up the coloured solution to the 1 ml. graduation mark. The ethanol brings into solution emulsified droplets of water. The colour may be read off in a Hilger "Spekker" Absorbtiometer against a standard curve

(using micro cups), or it may be compared with a standard solution prepared simultaneously from a stock phosphate solution. With a battery of seven mixing pipettes six estimations and one standard may be prepared at the same time.

To prepare the standard the following solutions are required:-

- A) Stock solution. 2.193 g. KH_2PO_4 in 500 ml. water
1 ml. = 1 mg. P.
- B) Solution containing 10 μg . per ml. (solution A diluted 100 times).
- C) Solution containing 1 μg . per ml. (solution A diluted 1000 times).

The acidity during the estimation is important. The standard should contain the same amount of perchloric acid as the unknown.

The method gives good results with amounts of P down to 0.2 μg . representing approximately 1.8 μg . nucleic acid or 0.3 mg. tissue (wet weight).

The method of expressing the results is discussed later (p. 76), and full protocols of some individual tests are shown in Table 11.

In all cases, also, the amount of growth of the culture was assessed in arbitrary units as judged by the general naked-eye appearance. In most cases the

N.P.P. figures were found to run parallel with these units to a remarkable degree.

Sugar utilisation and lactic acid production.

In some cases, glucose and lactic acid were estimated in the fluid phase.

0.3 ml. fluid from each roller tube were added to 4.9 ml. 3% sodium sulphate. 0.4 ml. 7% CuSO_4 and 0.4 ml. 10% Na tungstate were added. After centrifuging, 2 ml. supernatant fluid were taken for estimation of sugar by the method of King et al. (1937), and 2 ml. for estimation of lactic acid by the method of Barker and Summerson (1941) modified thus:-

2 ml. of the deproteinised fluid were added to 1 ml. 20% CuSO_4 + 2 ml. water and about 1 gm. solid Ca(OH)_2 added. A rubber bung was placed in the mouth of the tube and the mixture allowed to stand for 30 min. with occasional shaking. The tube was centrifuged and 2 ml. supernatant fluid taken. To this was added in a glass stoppered pyrex tube 0.05 ml. 4% CuSO_4 and 8 ml. conc. H_2SO_4 (AnalaR). The mixture was heated for 5 min. in a boiling water bath, cooled to below 20° in water and 0.1 ml. (3 drops) 1.5% p-hydroxydiphenyl in 0.5% NaOH added. The colour

was developed by standing the tube in the water bath at 30° for $\frac{1}{2}$ hr. with occasional shaking. The tube was placed in the boiling water bath for exactly 90 seconds and cooled.

A reagent blank with water gave a slight colour. A calibration curve was prepared for the Hilger absorbtimeter, using green filters, and reading against the reagent blank.

Fixation and embedding of tissue cultures.

(Modified from Parker, 1938)

The cultures grown in roller tubes were fixed in formol-saline (1 part 40% formaldehyde, 9 parts 0.9% sodium chloride) for several days. The tubes were then crushed in a vice. If this apparently drastic step were cautiously carried out, a large part of the plasma clot with its contained cultures could be obtained attached to one of the larger fragments of the glass. The plasma containing the cultures was then carefully detached from the glass with a cataract knife, the operation being conducted in a large dish of saline solution. The plasma clot was floated away and washed with saline. It was then cut into fragments containing one piece of tissue each.

On a mica coverslip was placed a drop of plasma which was clotted by means of embryo extract. The culture was floated on to this clot and covered with a second layer of plasma which was then clotted with embryo extract. The coverslip and culture were then transferred to 50% alcohol for 1 hr., to 75% alcohol for 1 hr., to absolute alcohol overnight, to alcoholic eosin for 10 minutes, to absolute alcohol for 20 min., into two changes of 2% celloidin in methyl benzoate, and finally into benzene. The plasma layer was detached from the mica coverslip with a cataract knife and transferred by means of a section lifter into a mixture of equal parts of benzene and paraffin wax at 37°. It was then embedded in paraffin wax in the usual way and sections cut.

3. RESULTS.

(A) With Tyrode solution as fluid phase.

The results obtained when the fluid phase consisted of Tyrode solution alone are shown in Table 1. In agreement with Willmer (1942) a drop of N.P.P. was found in the course of the experiment. The mean fall in the course of two days was $0.11 \mu\text{g.}$ per roller tube (Table 1). No significant alteration in N.P.P. occurred in the tubes containing plasma and Tyrode without tissue (Table 1).

It is probable that this fall was due to the presence in the plasma of nucleases which break up the nucleic acid such of the cells as die in the course of the two days.

The presence of such nucleases has been demonstrated in cockerel plasma and serum. A mixture of 0.2 ml. cockerel plasma with 0.3 ml. veronal acetate buffer pH 7.6 and 0.1 ml. 2% thymonucleic acid or ribonucleic acid (as Na salts) was incubated at 37° . At suitable intervals portions were treated with an equal volume of 0.25% uranyl acetate in 2.5% trichloroacetic acid. The precipitate of unhydrolysed nucleic acid was centrifuged down, washed with half strength

Table 1.

Changes in N.P.P. (nucleoprotein P) in roller tubes containing Tyrode solution alone as fluid phase.

All tubes run for 2 days with Tyrode solution alone before test begins. Fresh Tyrode then introduced (time 0) and initial N.P.P. measurements made. Final N.P.P. estimation carried out 2 days later (time t).

	Time	N.P.P. mg. arithmetic mean	No. of expts.	Standard deviation	Standard error
Tubes with plasma alone	0	0.27	27	± 0.062	± 0.012
Tubes with plasma alone	t	0.26	25	± 0.056	± 0.011
		Difference - 0.01			
Tubes with plasma + tissue	0	1.39	34	± 0.275	± 0.047
Tubes with plasma + tissue	t	1.28	55	± 0.218	± 0.029
		Difference - 0.11			

Table 2.

Influence of

Incubation with cockerel plasma on nucleic acids.

0.1 ml. 2% nucleic-acid solution (as Na salt)
incubated with 0.2 ml. cockerel plasma and
0.3 ml. veronal-acetate buffer pH 7.6 at 37°.

Hydrolysis (%)								
					Ribonucleic acid		Thymonucleic acid	
Time hr.	With plasma	Without plasma	With plasma	Without plasma				
2	12.2	6.8	0	0				
6	36.0	15.0	5.3	1.4				
24	74.0	20.4	20.4	7.0				

Figure 3.

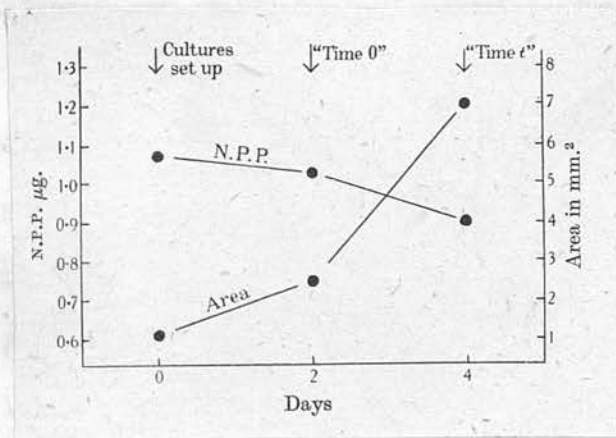

Decrease in nucleoprotein P (N.P.P.) and increase in area in cultures grown in Tyrode solution alone for 4 days. N.P.P. in $\mu\text{g./roller tube}$ (plasma blanks subtracted). Area in mm./individual culture.

Increase in N.P.P. in tissue grown in embryo extract (N = 30) during 3 days' test period.

uranyl acetate reagent and dissolved in sodium carbonate solution. Total phosphorus was determined in this solution by a modification of the method of Allen (1940). Some spontaneous decomposition of nucleic acids takes place at this pH. This was allowed for by a control series incubated for the same period of time without plasma. The results are shown in Table 2. Both types of nucleic acid are hydrolysed by plasma to compounds no longer precipitable by the uranyl acetate reagent. The ribonucleic acid suffers more decomposition than the thymonucleic acid. Cockerel plasma therefore contains enzymes of the nuclease type such as, for example, ribonuclease (Kunitz, 1940) and thymonucleodepolymerase (Fischer, Böttger and Lehmann-Echternacht, 1941; Greenstein and Jenrette, 1941), as well as nucleotidases, phosphatase, etc.

A similar fall in N.P.P. occurred during the first two days after the cultures are set up during which no measurements are normally made (Fig. 3).

It is noteworthy that although the amount of nuclear material as measured by the N.P.P. diminished continuously, the area of the cultures increased and might at the end of four days be as much as 6-10 times

Table 3.

Increase in N.P.P. in tissue grown in embryo
extract (N = 30) during 2 days' test period.
Plasma blanks subtracted.

Test No.	Initial N.P.P. μ g.	Final N.P.P. μ g.	Increase in N.P.P. μ g.	Relative increase in N.P.P.
25	1.53	1.96	0.43	0.28
45	1.50	1.91	0.41	0.27
44	1.34	1.71	0.37	0.28
49	1.23	1.68	0.45	0.36
56	1.14	1.56	0.42	0.37
82	1.12	1.44	0.32	0.29
61	0.90	1.29	0.39	0.43
69	0.89	1.22	0.33	0.37
75	0.89	1.33	0.44	0.49
67	0.86	1.23	0.37	0.43
Mean			0.39 \pm 0.014	0.36 \pm 0.024

and 48 hours (Table 2) in a total of 30 roller-tubes with tissue, and in the corresponding plasma blanks. A mean rise of 0.36 μ g. per roller-tube (standard deviation = 0.045, standard error = 0.014) was found with this concentration of extract, in a series of six roller-tubes (corrected) initial N.P.P. = 1.33 μ g. N.P.P. in the series (Table 3).

The rise in N.P.P. was greater with increasing

greater than it was when the cultures were first set up (Fig. 3) owing to the migration of cells from the original explant. The area of cultures from fresh explants is not, however, of great significance (Parker, 1938).

(B) With chick embryo extract as fluid phase.

When the Tyrode solution was replaced by embryo extract during the second two days of the test (i.e. the days of the test proper) very marked growth of the tissue occurred accompanied by a rise in N.P.P. (Table 5(B)). The final area instead of being of the order of 7-10 sq. mm. per culture was of the order of 20 sq. mm. per culture.

In a series of 10 tests with embryo-extracts containing 30 mg. N/100 ml., N.P.P. was estimated at 3 and 48 hours (time 0 and time t) in a total of 35 roller-tubes with tissues, i.e. in 215 pieces of tissue, and in the corresponding plasma blanks. A mean rise of $0.39 \mu\text{g.}$ per roller-tube (standard deviation = ± 0.045 , standard error = ± 0.016) was found with this concentration of extract, in spite of the wide range of (corrected) initial values ($0.86-1.53 \mu\text{g. N.P.P.}$) in the series (Table 3).

The rise in N.P.P. was greater with increasing

Figure 4.

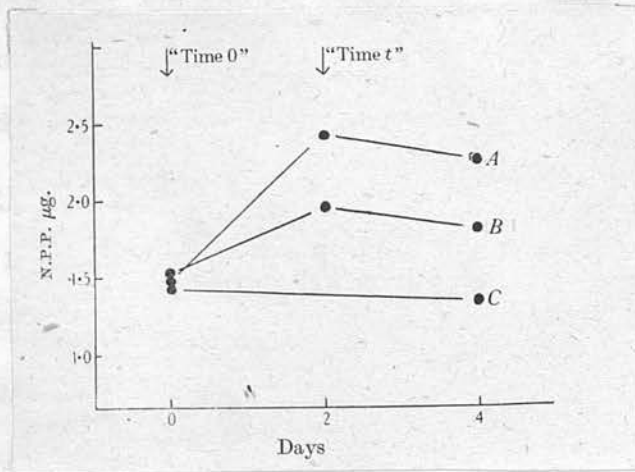

Influence of different concentrations of embryo extract on the nucleoprotein P (N.P.P.) of tissue cultures. N.P.P. in $\mu\text{g./roller tube}$ (plasma blanks subtracted). All cultures grown for 2 days in Tyrode solution alone before addition of embryo extract. Curve A: fluid phase in roller tube, embryo extract 30 mg. % N (approx.). Curve B: embryo extract 10 mg. % N (approx.). Curve C: fluid phase, Tyrode solution alone. The explants used in this experiment were rather larger than usual.

concentrations of embryo extract. The effects of different concentrations of embryo extract are shown in Fig. 4. In this case some of the tubes were allowed to run for a further two days. During this time no further rise in N.P.P. occurred - in fact a slight fall was observed (Fig. 4). All tests have subsequently been restricted to two days after addition of the test substances.

(C) Method of expressing results.

The results of a series of individual experiments with embryo extract (nitrogen concentration = 30 mg. per 100 ml.)^{*} are shown in Table 3 in which the figures are arranged in decreasing order of initial N.P.P. values. These initial values cover a wide range (0.86 - 1.53 μ g.). The table also shows the increase in N.P.P. in the course of 24 hours expressed in two ways, (i) as an absolute increase per roller tube and (ii) as a relative increase. These ten tests involved the use of 35 roller tubes, i.e. 215 pieces of tissue with the corresponding plasma blanks. It will be seen from the table that there is a smaller range of variation in the increases in N.P.P. expressed as

*

In the following pages the convention will be adopted that N = 30 represents the final concentration in milligrams total nitrogen per 100 ml. of fluid added to the roller tubes.

Table 4.

Change in N.P.P. in tissue grown in Tyrode solution alone during 2 days' test period. Plasma blanks subtracted.

Test No.	Initial N.P.P. μ g.	Final N.P.P. μ g.	Change in N.P.P. μ g.	Relative change in N.P.P.
33	1.75	1.29	- 0.46	- 0.26
39	1.70	1.19	- 0.51	- 0.30
45	1.46	1.38	- 0.08	- 0.05
44	1.42	1.01	- 0.41	- 0.29
50	1.36	1.25	- 0.11	- 0.08
47	1.35	1.34	- 0.01	- 0.01
48	1.25	1.08	- 0.17	- 0.14
46	1.22	1.22	± 0	± 0
38	1.20	1.25	+ 0.05	+ 0.04
55	1.20	0.92	- 0.28	- 0.23
91	1.19	1.14	- 0.05	- 0.04
68	1.12	0.99	- 0.13	- 0.12
42	1.06	1.20	+ 0.14	+ 0.13
41	1.04	1.10	+ 0.06	+ 0.06
34	0.99	0.99	± 0	± 0
61	0.86	0.79	- 0.07	- 0.08
67	0.78	0.70	- 0.08	- 0.10
69	0.56	0.59	+ 0.03	+ 0.05
60	0.55	0.44	- 0.11	- 0.20
Mean - 0.11 \pm 0.04				- 0.08 \pm 0.03

an absolute increase than expressed as a relative increase. The effect of embryo extract therefore seems to be the production, during the two day growth period, of a definite amount of nuclear material which is not proportional to the amount of tissue present initially. The limiting factor for growth here lies apparently in the medium and not in the tissue.

On the other hand when tissue is grown in tubes with Tyrode alone as fluid phase the results are of a rather different type. Individual figures for a series of experiments are shown in Table 4, where the figures are again arranged in descending order of initial N.P.P. values. In this case the change in N.P.P. (usually a fall) is greater for higher initial values of N.P.P. Where the initial figures are high ($> 1.0 \mu\text{g.}$) the absolute differences are greater than the relative differences. Where the initial figures are low ($< 1.0 \mu\text{g.}$), the absolute differences are less than the relative differences. Here the tissue itself appears to be the factor which controls the magnitude of the change in N.P.P.

It has therefore been concluded that the most satisfactory method of expressing the results is in the form of absolute increases in N.P.P. per roller

tube rather than in the form of relative increases. This method has been adopted in the case of growth promoting media derived from embryonic tissue and has been assumed to be valid for other types of growth promoting media as well. It should be emphasised that the differences in initial N.P.P. values are, of course, never so gross in a normal test as the range shown in Table 4. (In some cases the index $\frac{100 Y}{X}$ has also been calculated where X and Y are the figures for the N.P.P. at "time 0" and "time t" respectively.)

In the experiments recorded here, large differences are sought and a positive change of $> 0.2 \mu\text{g.}$ per roller tube is taken as indicating definite growth promoting properties in the medium under test. A rise of $> 0.5 \mu\text{g.}$ indicates very good growth. In each experiment at least 2, and in most cases 3 or more, roller tubes are used with each time and with each test substance, i.e. the number of pieces of tissue is at least 12 and in most cases is 18 or more.

Full illustrative protocols of a few individual tests are shown later in Table 11. For the most part the results are expressed in the tables in condensed form as the mean change in N.P.P. per roller tube.

The number of tubes which can be carried on the

drum is limited to 20 for any one test. Plasma blanks have therefore been dispensed with in some experiments after it has been established that with the preparations under test their use made no significant difference to the results.

(D) Experiments with embryo extract.

(a) Preparation of embryo extract. The preparation of sterile chick embryo extract has already been described (p. 60).

Extracts from the embryos of other species have also been used, e.g. from cattle, pig, cat, rat and human embryos, but the chief source of embryonic material has been the sheep. In the spring it has been possible to obtain large quantities of sheep embryos of 9-10 weeks, a stage at which growth is very rapid (Gurlt, 1847). The embryos were finely minced and the pulp allowed to stand overnight in the refrigerator with an equal volume of either water or Tyrode solution or 0.9% sodium chloride solution. The suspension was then filtered through muslin and centrifuged. The extract obtained in this way was, of course, not sterile and had to be sterilised before use. This was usually achieved by the use of large Berkefeld candles. The extract is viscous and tends

to clog the candles easily, but by using candles with a large surface area, sufficient sterile material could readily be obtained before the candles became clogged. A loss of 40% total N in the extract accompanied candling. The sterile extract was suitably diluted with sterile Tyrode before use.

In a few cases the candling was avoided by preparing the extract aseptically. The complete uterus was brought from the slaughter house to the laboratory and was opened aseptically. The embryo was transferred to a sterile glass vessel and minced with sterile scissors. An equal volume of sterile Tyrode was added and the mixture centrifuged. The sterile 50% embryo extract was then pipetted off and stored in sterile tubes.

(b) Comparison of chick embryo extract with sheep embryo extract. A comparison was made of the growth promoting power of chick and sheep embryo extracts. Both were prepared aseptically from sterile embryos, i.e. candling was avoided. As previously mentioned 50% chick embryo extract had a total N content of 60-80 mg. per 100 ml. while 50% sheep embryo extract contained 100-120 mg. N per 100 ml. They were both diluted to the same nitrogen content before being

Table 5.

Effect of various substances on nucleoprotein P (N.P.P.) content of tissue cultures

All cultures grown for 2 days in Tyrode solution alone before introduction of test substance and estimation of initial N.P.P. (X). Final N.P.P. (Y) estimation 2 days later.

Material under test	Fluid phase in roller tubes	Alteration in N.P.P. $\mu\text{g./tube}$ (100Y)/X
A Tyrode solution	Tyrode solution alone	-0.15 88
B Chick embryo extract	Embryo extract	+0.31 120
C Crystalline ribonuclease	Embryo extract after exposure to heat	+0.34 124
	Tyrode solution alone	-0.14 87
	Crystalline ribonuclease in Tyrode solution (final conc. of enzyme = 9.4 mg. %)	-0.08 91
D Crystalline ribonuclease	Chick embryo extract	+0.42 137
	Chick embryo extract + crystalline ribonuclease (final conc. = 9.4 mg. %)	+0.35 148
E Crystalline ribonuclease (Dr Kunitz)	Tyrode solution alone	-0.13 76
	Chick embryo extract	+0.11 114
	Chick embryo extract + crystalline ribonuclease (final conc. = 12.5 mg. %)	+0.09 114
	Tyrode solution + crystalline ribonuclease (conc. as above)	-0.10 82
F Crystalline ribonuclease (Dr Kunitz)	Tyrode solution alone	-0.07 92
	Chick embryo extract	+0.39 143
	Chick embryo extract + crystalline ribonuclease (final conc. = 50 mg. %)	+0.32 157
G Crude ribonuclease in pancreatic extracts	Tyrode solution alone	-0.09 92
	Chick embryo extract	+0.45 136
	Chick embryo extract + preparation from pancreatin	+1.03 173
H Mucinase	Chick embryo extract	+0.44 149
	Chick embryo extract + mucinase (final conc. of mucinase = 168 mg. %)	+0.07 107
J Mucinase	Tyrode solution alone	-0.08 90
	Chick embryo extract	+0.37 143
	Chick embryo extract + mucinase (final conc. of mucinase = 160 mg. %)	+0.14 116
K Embryo cartilage extract	Tyrode solution alone	+0.06 106
	Cartilage extract	+0.35 125
L Anterior pituitary extract	Tyrode solution alone	-0.15 91
	Pituitary extract	-0.10 86

tested at N = 20, 30, and 50.* In all cases chick embryo extract was more potent than sheep embryo extract (Table 6, Tests 128/1 and 130/1).

(c) Effect of heat on embryo extract. It is usually stated that the active principles of embryo extract are easily destroyed by heat (Carrel, 1913; Lasnitski, 1937).

The effect of heating chick embryo extract to 100° for 10 min. has been examined. To minimise the pH changes due to bicarbonate decomposition the extract, prepared by pulping the embryonic tissue with water instead of Tyrode solution, was divided into two portions one of which was heated while the other was kept as a control. The salt concentrations (including bicarbonate) in both extracts were then adjusted by adding appropriate amounts of sterile concentrated saline medium. Tissue cultures gained as much in nucleoprotein phosphorus in this heated material as in the unheated control extract (Table 5(B)).

Similar effects were obtained with extracts of sheep embryos.

* The convention employed in expressing N concentrations is explained on p. 76.

Table 6 .

Test No.	Test substance	Nitrogen conc. mg./100 ml. in roller tubes	Change in N.P.P.
128/1	Chick embryo extract (E.E.)	30	+ 0.44
	Sheep " "	30	+ 0.24
130/1	Sheep E.E.	50	+ 0.46
	" "	20	+ 0.16
	Chick E.E.	50	+ 1.00
	" "	20	+ 0.37
125/1	Sheep E.E. candled and stored 9 months at -30°	30	+ 0.73
	Sheep E.E. stored 9 months at -30° and candled	30	+ 0.38
	Sheep E.E. made from embryos stored 9 months at -30°	30	+ 0.16
95/1	Sheep E.E., vacuum dried, reconstituted, candled	-	+ 0.16
	ditto diluted 1 in 10	-	+ 0.06
	Sheep E.E., vacuum dried, benzene extracted, reconstituted, diluted 1 in 10	-	+ 0.36
98/1	Sheep E.E., dried in Cambridge, reconstituted, candled	9	+ 0.11
	Sheep E.E., dried in Cambridge, benzene extracted, reconstituted, candled	9	+ 0.18
127	Sheep E.E., fresh, candled	30	+ 0.23
	Sheep E.E., de-fatted, frozen dried, reconstituted and candled (Pasteur-Chamberland L3)	30	+ 0.58
	ditto (Berkefeld)	30	+ 0.48
129/1	Sheep E.E., fresh, candled	40	+ 0.29
	Sheep E.E., de-fatted, frozen dried, reconstituted, candled	40	+ 0.61
	Sheep E.E., de-fatted, frozen dried, reconstituted, benzene sterilised	-	+ 0.28
89	Extracts of sheep embryo tissue de-fatted with ether at -30° in cold room at Torry		
	Liver	39	- 0.06
	Muscle	39	+ 0.07
	Brain	19	- 0.11
	Heart	37	- 0.32

Table 6 [continued]

Test No.	Test substance	Nitrogen conc. mg./100 ml. in roller tubes	Change in N.P.P.
90	Extracts of sheep embryo tissue de-fatted with ether in Cardice-alcohol mixture		
	Whole embryo (1 ether extraction)	-	+ 0.51
	" " (2 ether extractions)	-	+ 0.74
	Muscle	-	+ 0.44
	Heart	-	+ 0.40
	Brain	-	+ 0.45
	Liver	-	+ 0.12
57	Extracts from 12 day chick embryos		
	Brain	20	+ 0.28
	Viscera	20	+ 0.64
	Cartilage	20	+ 0.49
	Muscle	20	+ 1.09
52	Extracts from 13 day chick embryos		
	Cartilage	20	+ 0.28
	Viscera	20	- 0.06
	Brain	20	+ 0.15
	Carcass	20	- 0.04
39	Extracts from sheep embryo, candled		
	Cartilage	42	+ 0.29
	Viscera	43	+ 0.04
	Skin and Muscle	41	+ 0.22
36	ditto		
	Cartilage	30	+ 0.26
83	ditto		
	Liver	10	+ 0.12
	Muscle	10	+ 0.31
84/1	ditto		
	Heart	10	+ 0.27
	Lung	10	+ 0.14
	Cartilage	10	+ 0.04
	Brain	10	± 0
	Serum	10	+ 0.17

(d) Effect of storage on embryo extract. The effect of storage on the growth promoting properties of sheep embryo extract was examined. Storage was carried out for nine months in a cold chamber at -30° in the Torry Research Station. Whole sheep embryo extract, candled, sealed up in ampoules and stored, retained powerful activity after nine months. When embryo extract was stored in the non-sterile state and candled after storage for nine months the activity was considerably reduced. When whole embryos were stored for nine months and then converted into extract and candled, the extract had very poor growth promoting properties. (Table 6, Test 125/1.) It is apparently advisable, therefore, to store embryo extract in the sterile state in sealed ampoules.

(e) The effect of drying. Sheep embryo extract was dried by a number of methods:-

(i) Portions of 30-50 ml. were dried from the frozen state in an apparatus similar to that described by Christensen (1942) or by Hays and Koch (1942). The extract was frozen in a thin layer spread out over the wall of a 2 or 3 litre round-bottomed flask which was attached by a B34 ground glass joint to a wide tube leading to a condensing vessel immersed in a vacuum

flask containing a mixture of alcohol and solid CO_2 . The whole apparatus was evacuated by a Hyvac pump and gentle heat (insufficient to melt the frozen material) was applied to the flask from a distance by means of electric bulbs. A procedure such as this yields a product which readily redissolves in water ("Frozen dried extract").

(ii) A large batch of about 5 litres was sent in the frozen state in a refrigerated container to the Low Temperature Research Station at Cambridge where it was dried from the frozen state. The product was not so easily soluble as that obtained in (i) above ("Cambridge dried extract").

(iii) A large amount of material was dried at room temperature in thin layers in Petri dishes in vacuum desiccators over concentrated sulphuric acid. The dry product was scraped off the dishes and finely powdered. It did not dissolve readily in water ("Vacuum dried extract").

(iv) Samples dried at room temperature in thin layers in flat dishes in the blast of an electric fan according to the method of Fischer (1941b) gave a similar material also of poor solubility.

In most cases the dried material was redissolved

in water, the insoluble residue centrifuged off, the chloride content determined and adjusted by addition of suitable amounts of double strength Tyrode, the reconstituted extract diluted to a suitable total N concentration with ordinary Tyrode solution, and sterilised by passage through a small Berkefeld candle. It filtered readily. In some cases the dried powder was extracted with benzene to remove lipoid materials before being reconstituted.

Attempts to sterilise the dried powder by allowing it to stand for some days under benzene, chloroform, acetone or ethanol (c.f. Fischer, 1941b; Brit. Pat. No. 534, 454) were not uniformly successful.

An attempt was also made to dry embryo extract in the spray-drier described by Edwards, Kay and Davie (1940) but even a 50% extract was too dilute to yield satisfactory results. Attempts at spray drying in the Low Temperature Research Station in Cambridge were equally unsuccessful.

The preparation of extracts more concentrated than 50% was not feasible but attempts were made to concentrate such extracts by freezing out water as has been done by Antopol, Glaubach, Goldman and Katzin (1943) with plasma and serum. This was unsuccessful.

All fractions obtained during the thawing of frozen embryo extract contained approximately the same nitrogen content.

Examples of some results obtained with dried embryo extract are shown in Table 6 (Tests 95/1, 98/1, 127, and 129/1). The frozen dried material when reconstituted gave a very active extract. Owing to the poor solubility of vacuum dried material, concentrated extracts could not be obtained on reconstitution and such solutions as were made, had poor growth promoting power. Preliminary extraction of the dry powder with benzene before reconstitution gave a more potent preparation at the same N concentration (Tests 95/1, 98/1). This effect is probably due to the removal of inhibitory lipid materials.

Removal of lipid material could also be conveniently carried out by freezing with ether as described in the next section. When an extract was de-fatted in this way, frozen dried, and reconstituted, the powder dissolved very readily, filtered easily through a candle and had very high activity (Table 6, Tests 127, 129/1). The most active preparations of embryo extract were, in fact, made in this way.

(f) The effect of de-fatting. The removal of

lipoid material from liquid embryo extract was carried out by freezing with ether according to the method used by McFarlane (1942) for serum. Popjak and McCarthy (1943) have shown that this treatment removes from serum all the cholesterol, approximately 2/3 of the phospholipids and 2/3 of the neutral fats. The osmotic pressure of the serum is almost unaltered but there may be some diminution of the β -globulins.

100 ml. sheep embryo extract were shaken with 30 ml. ether and frozen to a temperature below -25° by immersing the flask in a cardice alcohol mixture. On thawing and centrifuging, a very fatty top layer appeared. The clear lower aqueous layer was sucked off and the extraction process with ether repeated. The clear extract was then freed from ether in a vacuum desiccator, refrozen, thawed and filtered through paper. Such a de-fatted extract filtered easily through a Berkefeld candle and had an activity greater than that of the original. Two extractions with ether produced a more potent preparation than one single extraction (Table 6, Test 90). The de-fatted extract could be frozen dried to yield a powder which had very high activity after resolution in water and sterilisation by candling (Tests 127, 129/1).

De-fatted extracts of individual organs were prepared. Of these, liver was least active and extracts of other organs were all less active than extract of whole embryos (Test 90) (see also p. 92).

All these de-fatted extracts were prepared by the quick freezing of small amounts of extract in a cardice-alcohol mixture. When the process was carried out on a large scale using large amounts of extract and freezing with ether overnight in the cold room at -30° at Torry, the preparations obtained contained considerable amounts of denatured protein and had poor activity after candling (Test 89). Quick freezing for a short time is apparently essential to avoid denaturation of the proteins of embryo extract.

(g) The effect of ribonuclease on embryo extract. In view of Fischer's (1939) suggestion that the growth promoting power of embryo extract is located in the ribonucleoprotein fraction, it was thought appropriate to examine the action of the enzyme ribonuclease on the growth promoting power of chick embryo juice. Ribonuclease has been prepared in the crystalline state from pancreas by Kunitz (1940) and attacks specifically the ribonucleic acids bringing about partial hydrolysis. The enzyme is strikingly

thermostable and aqueous solutions can be sterilised by heat.

Chick embryo extract incubated with crystalline ribonuclease (prepared from cattle pancreas) overnight at 37°, was then tested on the tissue cultures. Extract so treated showed no diminution in activity as compared with control embryo extract incubated without enzyme (Table 5 (C and D)). A sample of crystalline ribonuclease kindly supplied by Dr M. Kunitz gave the same result even when the enzyme concentration was as high as 50 mg. % final concentration in the roller tubes (Table 5 (E and F)).

Ribonuclease in Tyrode solution alone appeared to have no effect on the living cells (Table 5 (C and E)).

On the other hand crude preparations of ribonuclease prepared by extracting commercial pancreatin with 50% acetone (c.f. Dubos and Thompson, 1938) and sterilised by heating to 100° for 10 mins. gave a very different response. Cultures grown in a mixture of this medium and embryo extract showed a characteristic dense type of growth with a sharply demarcated margin. Growth appeared to be abundant but cell migration was not so pronounced as in the controls grown in embryo

extract alone which had a considerably larger area. The cultures grown with the addition of the pancreatin extract, showed a much greater increase in N.P.P. than did the controls (Table 5 (G)). This increased growth is not caused by the ribonuclease in the pancreatin extracts, but is due to another factor, the nature of which is discussed later (p.121).

(h) The effect of mucinase on embryo extract.

In view of the large amount of mucin-like substances in embryonic material (c.f. Baker and Carrel, 1926), of the good growth promoting power of embryonic cartilage extracts, and of Fischer's (1940) suggestion that the active principle may contain S, it was decided to test the effect of a highly purified preparation of the enzyme mucinase (Madinaveitia, 1941) prepared from bull testicle, to see whether hydrolysis of some of the muco- or sulpho-polysaccharides in embryo extract affected its activity.

Dr J. Madinaveita kindly presented a sample of mucinase which besides acting as a diffusing factor with hyaluronidase activity and with the power to reduce the viscosity of some muco-polysaccharides (of synovial fluid, vitreous humour, and umbilical cord, but not of saliva and gastric mucin), also had a low

Figure 5.

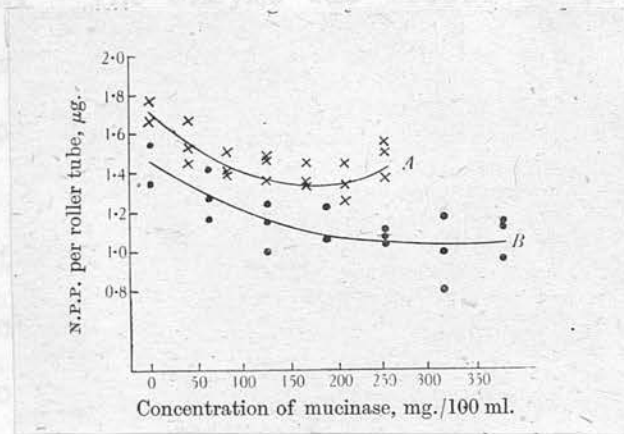

The effect of increasing concentrations of mucinase on the nucleoprotein P (N.P.P.) of tissue cultures grown in embryo extract. N = 25 mg. % for embryo extract in all cases. Ordinate: N.P.P., µg./roller tube. Abscissa: final concentration of mucinase in roller tube, mg./100 ml. Embryo extract and mucinase incubated for 2½ hr. at 37° before being added to roller tubes. Curve A (test 74): cultures grown for 2 days. Curve B (test 76): cultures grown for 1 day. Plasma blanks not subtracted. All cultures grown for 2 days in Tyrode solution alone before addition of embryo extract and mucinase.

glucosaminidase activity. Testicular mucinase is stated by Meyer, Chaffee, Hobby and Dawson (1941) to hydrolyse chondroitin sulphuric acid, the mucopolysaccharides of skin, and the polysaccharide (or its sulphuric acid ester) of the cornea as well as hyaluronic acid. The enzyme was dissolved in Tyrode solution and sterilised by passage through a small Berkefeld candle. A slight loss in N content resulted but the sterile solution still retained powerful enzyme activity as measured by the diffusion test with haemoglobin on rabbits (Madinaveitia, 1938).

Embryo extract was mixed with the mucinase solution and incubated at 37° for $2\frac{1}{2}$ hours before being added to the roller tubes. Embryo extract incubated at the same concentration without mucinase served as a control. A slight precipitate sometimes appeared in the mucinase mixture.

The cultures grown in embryo extract plus mucinase showed a smaller increase in N.P.P. than did the controls (Table 5 (H and J)). As the effect seemed to vary considerably with the concentration of mucinase, experiments were carried out in which constant amounts of embryo extract were incubated with increasing concentrations of mucinase. The results are plotted

in Fig. 5. It will be seen that the maximum effect was obtained when the mucinase concentrations were 170-250 mg. per 100 ml. In one test (curve A) higher concentrations were rather less effective.

(i) Comparison of the growth promoting properties of extracts from various organs and tissues of the embryo. Nine day chick embryos were too small for the preparation of extracts of individual organs. In the case of 12 or 13 day embryos aseptic dissection of the embryos was possible and extracts of individual tissues were prepared and tested at the same N concentration (Table 6, Tests 57, 52). The results were rather inconclusive but muscle and cartilage appeared to be superior to extracts of viscera, particularly liver.

Extracts of different organs of sheep embryos were prepared by mincing the embryonic organs finely in a large Latapie mincer, adding 1 vol. Tyrode solution, allowing the mince to stand over-night at 0° and centrifuging. The extracts were candled and tested at the same N concentration (Table 6, Tests 39, 36, 83, 84/1). Skin, muscle and cartilage showed a definite superiority, while the abdominal viscera, especially liver, gave extracts with poor activity.

Table 7 (continued)

Table 7 .		Nitrogen conc.	Change
Test No.	Test substance	mg./100 ml.	N.P.P.
Test No.	Test substance	Nitrogen conc. mg./100 ml. in roller tubes	Change in N.P.P.
130/2	Ethanol precipitates from tissue extracts dissolved in Tyrode	10	- 0.03
	Adult sheep heart (candled)	20	+ 0.11
	Embryo " " (candled)	24	+ 0.37
131	Whole sheep embryo (candled)	36	+ 0.33
	" " " (candled)	14	+ 0.11
	" " " (heated)	36	+ 0.33
	" chick " (candled)	1	- 0.03
	" " " (heated)	8	- 0.14
	Adult sheep heart (candled)	14	+ 0.07
	" " " (heated)	7	+ 0.05
132/1	Whole sheep embryo	25	+ 0.17
	" " " (ethanol ether washed)	25	+ 0.20
	Adult sheep heart	25	+ 0.09
	" " " (ethanol ether washed)	25	+ 0.01
	" " " (ethanol ether washed)	45	+ 0.15
133	Sheep embryo brain	13	+ 0.54
	" " heart	13	+ 0.25
	" " liver	13	+ 0.18
	" " muscle	13	+ 0.24
	" " heart	21	+ 0.44
	" " liver	21	+ 0.22
	" " muscle	21	+ 0.55
134	Whole sheep embryo (benzene sterilised)	12	+ 0.57
	" " " (candled)	12	+ 0.14
	Sheep embryo brain (candled)	12	+ 0.17
	" " heart (candled)	12	+ 0.11
	" " muscle (candled)	12	- 0.02
	" " " (candled)	35	+ 0.36
84	Acetone ppte. of sheep E.E. (candled)	10	- 0.27
46	Acid ppte. of chick E.E.	25	+ 0.07
38	Sheep embryo cartilage extract	41	+ 0.46
	Acid ppte. of above	8	- 0.21
	Ethanol ppte. of above	8	+ 0.37
	Ethanol ppte. + acid ppte. (all candled)	16	+ 0.21

Table 7 [continued]

Test No.	Test substance	Nitrogen conc. mg./100 ml. in roller tubes	Change in N.P.P.
92/2	Sodium sulphate precipitates from sheep E.E.	-	- 0.23
122/2	ditto	28	- 0.25
126/1	ditto	10	- 0.03

When de-fatted extracts of different organs were compared (Table 6, Tests 89, 90) again the marked superiority of muscle over liver was evident.

Ethanol precipitates (see p.93) were prepared from extracts of different organs and tested for growth promoting power (Table 7, Tests 130/2, 131, 132/1, 133, 134). These again demonstrated the good growth promoting properties of muscle and the poor results obtained from liver.

Embryo cartilage extracts.- As whole extracts prepared by mincing the complete embryos contained an undesirably large amount of blood, embryo cartilage was examined and found to give a very satisfactory extract.

The embryos were dissected and the cartilage of the vertebral column, skull, pelvic and shoulder girdles freed as far as possible from muscle and connective tissue. The cartilage was minced and the mince allowed to stand with an equal volume of water overnight at 0° before being filtered through muslin. The filtrate was centrifuged and treated with half a volume of double strength Tyrode solution. To check the salt concentration a chloride estimation was carried out and final small adjustments of salt concentration

made as required.

Embryo cartilage extract could be sterilised by filtration through a Berkefeld candle, and kept well at 0° or, better, at -30° .

Results obtained with cartilage extract are shown in Table 5 (K).

(j) Precipitation of the protein fraction of embryo extract with ethanol, acetone, acid or sodium sulphate.

(1) Ethanol. Whole sheep embryo extract was precipitated in the cold with 4 volumes ice cold ethanol. The precipitate was centrifuged down quickly and dried in vacuo over CaCl_2 . In some cases the precipitate was washed with absolute ethanol and ether before being dried. The dried precipitates were ground finely, extracted once with ether, and dried. Dry powders were made in this way by extracting minced embryo organs with one volume of 0.9% NaCl and precipitating the extracts with ethanol. Dry powders were made also in this way from extracts of adult sheep heart (see p.107).

The powders were allowed to stand in 100 mg. portions with 10 ml. Tyrode solution for four hours at 0° . The suspensions were then centrifuged and

the supernatant fluids passed through L₃ Pasteur-Chamberland candles. In the sterile extracts total N was determined and they were then diluted before use.

Such ethanol powders were but slightly soluble in water. After suspending 100 mg. of the powders of brain, heart, liver and muscle in 10 ml. Tyrode, the N concentrations in solution were 13, 21, 28 and 39 mg. per 100 ml. respectively. Precipitates which were ethanol-ether washed before drying were slightly more soluble.

To obtain a more concentrated solution and to sterilise the solution without the use of filter candles portions of these ethanol powders were dissolved in water with the aid of heat, and the supernatant fluid obtained on centrifuging was sterilised by heating to 100° for eight minutes. After cooling, one volume double strength Tyrode was added.

To avoid the use of candles or of heat in obtaining a sterile preparation, portions of 50 mg. of the ethanol powders were transferred with the aid of a sterile platinum scoop to sterile 15 ml. Pyrex centrifuge tubes which were filled with AnalaR benzene stoppered with a sterile plug of cotton wool and

allowed to stand for seven days. The benzene was then decanted off and the powder dried in vacuo. To the dry powder, now sterile, 5 ml. sterile Tyrode solution were added and the tube set aside for four hours at 0° before being centrifuged. The supernatant fluid was then analysed for total N and tested.

Sterilisation of ethanol powders by benzene in this way was found to be more successful than in the case of powders of dried embryo extract (see p. 84).

The results (Table 7, Tests 130/2, 131, 131/2, 133, 134) show that active preparations can be prepared from these ethanol precipitates both from whole sheep embryo extract and from extracts of individual organs. Extracts of brain and muscle were very potent and much superior to extracts of liver. Extracts of adult heart were much inferior to extracts of embryo heart (see also p.108). Preliminary washing of the precipitate with ethanol and ether before drying increased solubility and activity very slightly. The results obtained with preparations sterilised by benzene were similar to those from candled preparations.

(2) Acetone. Ice cold sheep embryo extract was treated with 4 vols. ice cold acetone and the

precipitate immediately centrifuged down and dissolved in ice cold water. Almost the whole precipitate dissolved yielding a red solution with no trace of the brown colour which develops when the operation is carried out at room temperature. The solution was frozen dried and a fluffy reddish powder obtained. It was freely soluble in water and was sterilized by a Berkefeld candle.

It had little or no activity (Table 7, Test 84).

(3) Acid. The precipitate obtained by acidifying embryo extract to pH 4.6 by adding dilute acetic acid had little or no activity (Table 7, Test 38) (see also p. 99).

(4) Sodium sulphate precipitation. The protein fraction of embryo extract by the sodium sulphate precipitation method of Deutsch, Eggleton and Eggleton (1938). It was dissolved in water, dialysed at 4° till salt free and then dried from the frozen state. The fluffy powder so obtained was freely soluble in water but had little activity, even when combined with dialysable constituents of embryo extract (Table 7, Tests 92/2, 122/2, 126/1).

(k) The Nucleoproteins of embryo extract.

Prepared by:-

(1) Hammarsten's method. The nucleoprotein fraction of embryo tissue extract was obtained by Hammarsten's (1920) method as described by Fischer (1941b) using chiefly the powder of frozen dried or vacuum dried extract as starting material, usually after benzene extraction to remove fat. An example of one such preparation is as follows:-

2 grams of vacuum dried sheep embryo extract were weighed out into a 50 ml. centrifuge tube: 25 ml. cold 0.06 N HCl were added and the mixture left in the refrigerator overnight. The tube was spun next day and the supernatant fluid poured off. The residue was stirred with 25 ml. ice cold glass distilled water and centrifuged. The clear slightly yellow supernatant fluid was discarded. The residue was treated with a little ice cold distilled water and, while cooled in ice, was treated with cold 0.06 N NaOH till the reaction was slightly alkaline (faint blue to litmus; $\text{pH} < 9$). Almost the whole residue dissolved. The solution was centrifuged and the small residue discarded. The supernatant was brought just to neutrality. A small turbidity was centrifuged off. The solution while cooled in ice was then treated with cold N/10 HCl. A very heavy precipitate appeared

when the solution was just slightly acid. It was centrifuged off. To the supernatant more acid was added. A faint precipitate appeared which tended to redissolve as more acid was added. This precipitate was centrifuged down. Both precipitates while cooled in ice were dissolved in 0.06 N NaOH added till the solution was just alkaline to litmus. The solutions were combined (10 ml.). A very slight residue was left undissolved and was centrifuged down.

The slightly turbid brown solution was analysed for N and P.

$$\begin{aligned} \text{N} &= 197 \text{ mg. } \% \\ \text{P} &= 10 \text{ mg. } \% \end{aligned}$$

$$\text{Weight ratio } \frac{\text{P}}{\text{N}} = \frac{10}{197} = 5\%$$

5 ml. of the solution were treated with 5 ml. double strength Tyrode and the mixture was candled with great difficulty: N = 100 mg. % (approx.).

All such nucleoprotein preparations were dissolved in the minimum amount of very dilute alkali till the solution was neutral to litmus, two volumes of double strength Tyrode were added, and the solution centrifuged and sterilised by a small filter candle.

The weight ratio $\frac{\text{P}}{\text{N}}$ for most samples of the nucleoprotein was of the order of 5%.

Table 8 .

Test No.	Test substance	Nitrogen conc. mg./100 ml. in roller tubes	Change in N.P.P.
81	Nucleoprotein fraction prepared by Hammarsten's method from ethanol ether powder of calf embryo	- -	- 0.04
93/2	from dried sheep E.E. + amino acid mixture	0.5 + 1	+ 0.07
	from dried sheep E.E. + amino acid mixture	0.125 + 1	+ 0.15
	from dried sheep E.E. + amino acid mixture	0.0125 + 1	+ 0.11
95/2	from dried sheep E.E.	10	- 0.02
	" " " "	1	+ 0.39
97	from dried sheep E.E.	10	- 0.19
	" " " "	1	- 0.26
125/2	from dried sheep E.E. (L3 candle)	10	+ 0.67
	" " " " (Berkefeld candle)	7	+ 0.41
	" " " " (Berkefeld candle) + boiled kidney extract	4 + 25	+ 1.58
	Boiled kidney extract alone	25	+ 0.97
126/2	from dried sheep E.E. (sample 2)	6	+ 0.04
	" " " " (sample 1)	5	- 0.28
	" " " " + kidney extract	5 + 25	+ 0.19
	Kidney extract alone	25	+ 0.57
29	Nucleoprotein fraction prepared by Greenstein's method from sheep E.E. (candled)	9	- 0.12
35	from sheep embryo cartilage extract (heated)	9	- 0.33

The nucleoprotein solutions were tested in varying concentrations with and without the addition of amino acid mixture (p.111) and/or nucleotides (p.114) (Table 8, Tests 81, 93/2, 95/2, 97, 125/2, 126/2).

The results were rather inconclusive, different batches prepared in the same way having variable activity. In many cases high concentrations of the nucleoprotein produced a much poorer response than lower concentrations. A few preparations were definitely inhibitory.

(2) Greenstein's method. The nucleoprotein fraction of fresh sheep embryo extract was prepared by the method of Greenstein and Jenrette (1940). This method is designed to avoid, as far as possible, protein denaturation during the isolation of the nucleoprotein fraction. The product was frozen dried, dissolved in Tyrode solution and candled. It had no activity (see Table 8, Tests 29 and 35).

(3) Acid precipitation. The precipitate obtained by acidifying embryo extract at 0° to pH 4.3 or 4.6 with acetic acid had little or no activity when dissolved in the minimum amount of cold dilute alkali, and candled after addition of double strength Tyrode (Table 7, Tests 46, 38) (see also p. 96).

A considerable proportion of the total nitrogen of these nucleoprotein preparations was retained by the filter candles. Seitz filtration resulted in almost complete adsorption of the nucleoproteins on the filter pad.

To avoid the use of candles which might adsorb the active materials, preparations of nucleoprotein were also made by aseptic acid precipitation. To ice cold sterile chick embryo extract, ice cold dilute hydrochloric acid (0.001 - 0.01 N) or acetic acid, was added to pH 4.3 and the precipitate centrifuged down. It was washed with sterile ice cold water (slightly acidified) and dissolved in the minimum amount of ice cold sterile 0.001 N NaOH. All operations were of course conducted with sterile glassware. To the solution, one volume of double strength Tyrode was added. It had no activity.

Discussion.

It must be emphasised that all the tests have been carried out in fresh explants from the nine-day embryo chick heart and not on pure strains of fibroblasts. The term "fibroblast" is used here in the usual tissue culture sense of cells characterised by a network arrangement (c.f. Mayer, 1939). Moreover the tests

are designed to measure large increases, occurring within two days, in the nucleoprotein content of the cells and not to determine the power of the medium to maintain the cultures over long periods of time.

Willmer's (1942a) results were obtained mainly with chick periosteal fibroblasts but in a few experiments with heart fibroblasts he found a fall in N.P.P. in Tyrode solution, while the effect on embryo extract was rather to prevent the fall than to cause a definite increase. In most of our experiments embryo extract produced a very appreciable rise in N.P.P. and this effect was not appreciably diminished with extract which had been heated to 100° for a few minutes or at 38° overnight. Although Carrel's (1913) original emphasis on the labile nature of the active principles has been supported by later workers, e.g. Craciun (1931), Hueper et al. (1933) and Lasnitski (1937) who found a decrease in activity on incubation at 70° for 10-30 minutes, recent workers have reported a greater heat stability, e.g. Paterson (1938). Tennant, Liebow and Stern (1941) prepared in the ultracentrifuge a growth promoting fraction from embryonic tissue the activity of which was not diminished by heating at 100° for several minutes. The effect of heated embryo

extract on the N.P.P. of pure strains of fibroblasts, is, of course, undetermined.

Although both chick and sheep embryo extract are active in promoting chick embryo fibroblast growth, extracts of the homologous tissue are definitely superior when tested at the same concentration under the same conditions. Previous workers have not compared the potencies of extracts of the embryos of different species quantitatively but Fischer (1941b, 1942b) has noted that higher degradation products of homologous proteins were more effective than those of heterologous tissues.

It is apparent that sterile embryo extract can be stored at -30° for long periods without losing its activity. At this temperature bacterial action is almost negligible (Reay, private communication) as also is enzyme action, but over long periods it is possible that sufficient bacterial action may occur in non-sterile extract to reduce its activity to some extent. The reason for the poor activity of extracts of stored embryos is more obscure. It is unlikely to be due to bacterial action since only the skins of the embryos are not sterile, but it might be due to the action of enzymes associated with the insoluble tissue proteins.

Of all the dried preparations, only those dried from the frozen state were easily soluble. Those dried at room temperature were very poorly soluble, although they retained some activity. The improvement in activity after benzene extraction suggests that the dried extract contains inhibitory lipoid materials (c.f. Mayer, 1937). Their removal would also account for the high activity of the extracts defatted by freezing with ether at low temperatures provided the freezing and thawing were quickly carried out. Prolonged freezing with ether appears to cause some protein denaturation.

Ribonuclease attacks specifically ribonucleic acids but its precise mode of action is unknown. Its action may be modified by the presence of protein to which the nucleic acid is bound. For example, Loring (1942) found that ribonuclease was unable to split up the nucleic acid of tobacco mosaic virus, a rubonucleo-protein, so long as the nucleic acid remained attached to the protein although it could inactivate the virus by forming an enzyme virus complex containing 14% enzyme. This complex could subsequently be decomposed with liberation of intact and active virus. Although in the present experiments ribonuclease even

in high concentrations has not influenced the growth of cultures in embryo extract, the participation of ribonucleoproteins as growth promoting agents cannot be completely eliminated on account of the possibility of the reversible formation of enzyme-ribonucleoprotein complexes.

The effect of mucinase is only produced when the enzyme concentration is very high. Both in this case and in the ribonuclease experiments, the enzymes were still active in the roller tubes at "time t" and one cannot therefore exclude the possibility that, in the case of mucinase, the lower N.P.P. found in presence of the enzyme might be due to a direct action of the enzyme on the cells rather than on the embryo extract. These experiments do, however, suggest that the mucosulpho-polysaccharides may be responsible for at least some part of the growth promoting power of embryo extract.

Comparison of extracts of different embryonic organs confirms the poor activity of liver extracts (c.f. Walton, 1914; Heaton, 1926; Brues, Subbarow, Jackson and Aub, 1940). Of the other tissues, cartilage, skin and muscle were all very effective. It may be significant that all these contain large amounts

of muco- or sulpho-polysaccharides. The high activity of sheep embryo muscle extracts is in striking contrast to the almost complete absence of activity found by Trowell and Willmer (1939) in extracts of adult fowl muscle. Like extracts of adult brain (Trowell and Willmer, 1939), extracts of embryo brain have high activity. There appears to be no relationship between the nucleic acid content (or the nucleotide content) of a tissue (see p.212) and the growth promoting activity of extracts of that tissue.

Of all the precipitating agents used, ethanol was most effective in producing an active precipitate. Fischer (1941b) also obtained active ethanol precipitates. Like the vacuum dried extract, ethanol precipitates were very poorly soluble. Despite the precautions taken, considerable denaturation of proteins appeared to be unavoidable.

Precipitation of the proteins by sodium sulphate is a very mild procedure and yields almost the whole protein fraction. Yet this material, while freely soluble in water and showing little or no sign of denaturation, was without activity. This suggests that the presence of non-protein components, not precipitable with sodium sulphate but precipitable by

ethanol, is essential for activity. This would be in agreement with the results obtained by Fischer (1942b) with dialysed embryo extract (p. 25).

Results with nucleoprotein preparations have not been satisfactory. The nucleoprotein fractions are very unstable but this fact alone is not sufficient to account for the variable results obtained.

(E) Extracts and preparations from adult organs.

(a) The effect of pituitary extract. In view of the well known action of extracts of the anterior pituitary gland in stimulating the growth of young animals (c.f. Young, 1941) the effect of pituitary extracts on the nucleoprotein content of fibroblasts in vitro was examined. Saline extracts prepared according to the method described by Marks and Young (1940), were kindly supplied by Dr F. G. Young. The salt concentrations were adjusted to that of Tyrode before the extracts were tested. In no case did the pituitary extract cause any increase in the N.P.P. of the cultures (Table 5(L)).

This is in agreement with the findings of Trowell and Willmer (1939) who, contrary to Semura (1931), found that pituitary extracts had no growth promoting

power to tissue in vitro.

(b) Adult heart extracts. Extracts of adult sheep heart were prepared by the method described by Werner and Doljanski (1943) and by Kerr and Werner (private communication). Fresh adult sheep heart was finely minced, treated with five volumes of 0.9% NaCl solution, shaken for an hour, allowed to stand for 24 hours in the refrigerator and centrifuged. The supernatant fluid was precipitated with four (in some batches two) volumes of ethanol and the precipitate centrifuged down and dried in vacuo over CaCl_2 (see the preparation of ethanol precipitates, p. 93). The dry powder was extracted with ether, dried again, and treated with Tyrode solution as previously described (p. 94). Extracts from powders prepared in this way were compared with extracts from powders prepared in the same way from embryo sheep heart. The powders were either dissolved in Tyrode and the solution candled or were dissolved in water, the solution heated, centrifuged, sterilised by heat and treated with one volume double strength Tyrode. The powder was also sterilised by benzene (p. 94) in some cases and dissolved in sterile Tyrode. All preparations of adult sheep heart dissolved but slightly in Tyrode solution

Table 9 .

Test No.	Test substance	Nitrogen conc. mg./100 ml. in roller tubes	Change in N.P.P.
121/1	Liver extract ("Examen")	40	- 0.02
	" " (" " ")	14	+ 0.42
118/2	"Padutin"	50	+ 0.95
	"	120	+ 0.32
120	"Padutin"	25	+ 0.63
	"	75	+ 0.56
122/1	Boiled kidney extract	25	+ 0.56
125/2/1	Boiled kidney extract	25	+ 0.97
126/2/1	Boiled kidney extract	25	+ 0.57
121/2	Peptone (commercial)	50	+ 1.27
	"	20	+ 0.86
129/2	Peptone (commercial)	41	+ 0.55
92	Amino acid mixture	1	+ 0.06
124	Histone (A) candled + chick E.E.	6.5 + 30	+ 0.71
	" " " " " "	1 + 30	+ 0.92
	" (B) " " " "	4 + 30	+ 0.79
	" " " " " "	1 + 30	+ 0.35
	" (A) heated " " "	4 + 30	+ 0.61
	" (B) " " "	5 + 30	+ 0.77
	Chick E.E. alone	30	+ 0.56
121/3	Material from irradiated yeast	50	+ 0.56
115	Material from irradiated yeast		+ 0.46

or in water. The solubility of ethanol ether washed powders (p. 94) was slightly greater.

The results are shown in Table 7, Tests 130/2, 131, 132/1 (see also p. 95).

In all cases preparations from adult sheep heart had poor activity and were inferior to the corresponding preparations from embryo sheep heart and to the corresponding preparations from whole embryo extract.

(c) Liver extract. The commercial preparation of purified liver extract "Examen" (Glaxo) was employed (2 ml. = 100 gm. liver). It was shaken (2 ml.) with ether to remove phenolic preservative, taken to dryness on the water bath and dissolved in water (4 ml.) N = 50 mg. %. The solution was sterilised at 100° for 10 minutes, cooled, and treated with an equal volume of double strength Tyrode. Its growth promoting power was marked at low concentration (N = 14) but was less evident at higher concentrations. (Table 9, Test 121/1).

(d) Pancreas extract. The purified commercial preparation "Padutin" was employed. It was shaken with ether to remove phenolic preservatives before use, the ether was removed in vacuo, the solution was sterilised at 100° for 10 minutes, cooled and treated

with an equal volume of double strength Tyrode. This preparation had good growth promoting properties (Table 9, Tests 118/2, 120) (see also p.121).

(e) Boiled kidney extract (Fischer and Astrup, 1942). 45 gm. kidney tissue (ox or sheep) was finely minced and boiled with 100 ml. water containing 0.5 ml. glacial acetic acid. The solution was cooled, filtered, neutralised and filtered. The total N was 140-180 mg. %. It was sterilised by heating to 100° for 10 minutes. After cooling, it was treated with one volume double strength Tyrode and suitably diluted with ordinary Tyrode solution. It had good growth promoting properties (Table 9, Tests 122/1, 125/2/1, 126/2/1).

Discussion.

The claims of Doljanski and Hoffman (1939) and Doljanski, Hoffman and Tenenbaum (1942) for the powerful growth promoting action of extracts of adult heart have not been confirmed. The alcohol precipitate of adult sheep heart extract prepared by Werner and Doljanski's (1942) method had poor activity and was greatly inferior to material prepared in exactly the same way from embryo sheep ^{heart} or from whole sheep embryo.

The extracts of liver and pancreas tested were not tissue extracts prepared in the same way as extracts of embryonic tissues, but were commercial preparations, purified to a high degree, of the anti-anaemic factor and kallikrein respectively. The activity of both is probably due to their content of protein degradation products. The activity of "Examen" is in striking contrast to the poor response usually obtained with preparations from liver, including embryo liver (see p. 91). Higher concentrations of liver extract had, however, poor activity, owing, perhaps, to the presence of inhibitors.

(F) The effect of other substances.

(a) Peptones. Boiled kidney extract and such preparations as "Padutin" are likely to contain protein breakdown products. In view of their pronounced growth promoting activity and in view of the results obtained by Willmer and Kendal (1932) and by Fischer (1942a, b) with protein breakdown products, it was thought desirable to test the activity of simple peptone preparations. Commercial peptone was dissolved in water, sterilised by heat, treated with one volume double strength Tyrode solution and tested on the cultures. It showed very strong activity in raising

the N.P.P. of the cultures. Cultures grown in peptone presented a very fine delicate appearance and had exceptionally large areas. All the cultures were grown without addition of embryo extract (Table 9, Tests 121/2, 129/2).

(b) Amino acid mixture. The ultimate products of protein digestion, the amino acids, were tested in the form of the amino acid mixture of Fischer (1941a) (for composition see p. 44). The acids were dissolved in water and the solution made up to 83 ml. Total N = 62 mg. %. Amino N = 44 mg. %. The solution was diluted with an equal volume of double strength Tyrode and the mixture was diluted to ten times its volume with ordinary Tyrode. It had no effect on the growth of cultures when tested alone or in combination with other materials (Table 9, Test 92; Table 8, Test 93/2).

(c) Histone. In view of the suggestion of Stedman and Stedman (1943c) "that a high content of histone in the nucleus of a cell produces an inhibition of both the processes which lead to mitosis and those which lead to the synthesis of chromosomin necessary for the duplication of the chromosomes", it was thought advisable to test the effect of histones on the growth

of tissue cultures.

Histones were prepared by two different methods from two sources:-

1) Thymus histone was prepared from calf thymus by the method of Felix and Harteneck (1926). The minced gland was shaken with $2\frac{1}{2}$ volumes of water and allowed to stand overnight in the refrigerator. It was then strained through muslin and 10% acetic acid added (1.0 - 1.5 ml.) to the filtrate till the colour changed from iron gray to pearl gray. The precipitate of nucleohistone was filtered off and shaken into a pulp with 100 ml. water. Dilute sodium hydroxide was added till the reaction was feebly alkaline and the mixture was shaken for an hour. One ml. 10 N sulphuric acid was then added (reaction acid to congo red) and the precipitate of nucleic acid centrifuged down. To the supernatant fluid three volumes of ethanol were added and the histone centrifuged down and dissolved in 50 ml. warm water. Sodium hydroxide was added till the pH was 8.5 and one volume 85% ethanol was added. The precipitate was centrifuged down, washed with alcohol, then ether, and dried in vacuo: Yield 150 mg. The histone contained no phosphorus.

2) For the second method of preparation sheep spleen was used as source of material and the nucleohistone prepared by the method of Mirsky and Pollister (1942). The histone was separated from the nucleic acid by the chloroform-octyl method of Sevag, Lackman and Smolens (1938).

The minced sheep spleen was extracted with 0.9% NaCl and the extract discarded. The residue was extracted three times with 10% NaCl for five minutes each time at room temperature. The combined extracts (200 ml.) were poured into six volumes of water. The nucleohistone was precipitated as a stringy mass which was collected on a glass rod and dissolved in 100 ml. 5.4% NaCl. To this solution 0.25 vol. chloroform and 0.1 vol. sec. octyl alcohol were added and the mixture was shaken for ten minutes and centrifuged. A histone-chloroform gel was formed with an aqueous layer above and a chloroform layer below. The latter two layers were removed and the gel was dissolved in ethanol. The precipitated histone was centrifuged down, washed with ethanol and ether and dried in vacuo.

These preparations had no inhibitory action. Their effect was indeed to cause some activation of

Table 10.

Test No.	Test substance	Nitrogen conc. mg./100 ml. in roller tubes	Change in N.P.P.
94/1	Ribonucleic acid (pancreas)	0.2	+ 0.10
	" " + nucleoprotein (Hammarsten)	0.2 + 10	- 0.23
118/2	" " + nucleoprotein (Hammarsten)	2	- 0.12
	" " + nucleoprotein (Hammarsten)	0.2	- 0.04
97	Ribonucleotides	5	+ 0.41
77/2	" " + nucleoprotein (Hammarsten)	5 + 10	- 0.21
	" " + nucleoprotein (Hammarsten)	5 + 1	- 0.20
100	Ribonucleotides	30	+ 0.05
	" "	15	+ 0.16
	" "	5	± 0
	" "	2.5	+ 0.02
	" "	1.0	+ 0.09
	" "	0.25	- 0.02
99	Ribonucleotides	3	+ 0.22
	Desoxyribonucleotides	3	+ 0.07
	" " + ribonucleotides	3 + 3	+ 0.22
	Chick E.E.	5	+ 0.37
	" " + ribonucleotides	5 + 3	+ 0.36
	" " + desoxyribonucleotides	5 + 3	+ 0.11
	" " + " "	5 + 3 + 3	+ 0.22
98/2	Chick E.E.	30	+ 0.35
	" " + desoxyribonucleotides	30 + 10	+ 0.52
	Nucleoprotein (Hammarsten) + desoxyribonucleotides	3 + 10	+ 0.36
	Nucleoprotein (Hammarsten) + desoxyribonucleotides + chick E.E.	3 + 10 + 30	+ 0.41
	Nucleoprotein (Hammarsten) + chick E.E.	3 + 30	+ 0.29
101	Desoxyribonucleotides	10	- 0.03
	" " + nucleoprotein (Hammarsten)	10 + 3	- 0.05
	Desoxyribonucleotides + chick E.E.	10 + 8	+ 0.21
	Chick E.E.	8	+ 0.16
	Nucleoprotein (Hammarsten)	3	± 0

growth (Table 9, Test 124).

(d) Preparations from irradiated yeast. The material prepared from irradiated yeast cells as described in Section II (p.167) was tested and found to have good growth promoting properties (Table 9, Tests 121/3, 115). This is probably attributable to its content of protein disintegration products (see p.168).

(e) Nucleic acids. In view of the statement by Tennant, Stern and Liebow (1942) that nucleic acids in low concentration (1 in 50,000) stimulate tissue growth, nucleic acids were tested in the present series. No striking results were obtained either with the nucleic acids alone or in combination with nucleoproteins. Results of a test with pancreas ribonucleic acid are shown in Table 10, Test 94/1.

(f) Ribonucleotides. A mixture of all four nucleotides of yeast ribonucleic acid was made by allowing 2.66 gm. of yeast nucleic acid to stand in alkaline solution (20 ml. N NaOH) overnight at room temperature. This procedure is sufficient to hydrolyse ribonucleic acid to the constituent nucleotides (Stuedel and Peiser, 1922; Jones and Perkins, 1924; Loring, 1939). The solution was neutralised with HCl,

made up to 40 ml. with water and diluted 1 in 50.
 N = 19.1 mg. per 100 ml. A portion was sterilised
 in the boiling water bath and treated with an equal
 volume of double strength Tyrode.

Again the results were variable but in most cases
 moderate concentrations (3-15 mg. N per 100 ml.) pro-
 duced a definite growth promoting effect (Table 10,
 Tests 94/1, 97, 100, 99).

(g) Adenylic acid. Yeast adenylic acid and muscle
 adenylic acid in concentrations of 1 mg./100 ml. were
 without effect (Table 10, Test 115/2). Flavine
 adenine dinucleotide was also without effect.

(h) Desoxyribonucleotides. Pyrimidine
 desoxyribonucleotides were prepared from Thymonucleic
 acid by the method of Levene (Levene and Bass, p.237):
 1 gram nucleic acid was hydrolysed by boiling with
 10 ml. 2% H_2SO_4 for two hours under a reflux condenser.
 The solution was cooled, and neutralised with barium
 hydroxide. Barium sulphate was centrifuged off and
 excess barium hydroxide removed by passing CO_2 into
 the supernatant fluid. The barium carbonate was
 centrifuged down and the supernatant fluid taken to
 dryness in a vacuum desiccator. The residue was
 dissolved in 5 ml. water, centrifuged, and the

nucleotides precipitated with neutral lead acetate. The lead salts were washed on the centrifuge with water several times and were decomposed with H_2S . The lead sulphide was centrifuged down and H_2S removed from the supernatant with a current of air. The solution was taken to dryness and the residue dissolved in 2.5 ml. water. It gave a positive diphenylamine test for desoxypentoses. Total N (60 mg. %) was determined in the solution which was subsequently diluted with an equal volume of double strength Tyrode (N = 30 mg. %).

Pyrimidine desoxyribonucleotides were less effective than the mixed ribonucleotides both in the presence and in the absence of embryo extract (Table 10, Tests 99, 98/2, 101).

(i) Nucleosides. Adenosine and guanosine were active in concentrations of 1 mg. per 100 ml. In higher concentrations (5 mg. per 100 ml.) they were less effective (Table 10, Tests 115/3, 118/2).

(j) Biotin. Biotin has been found to have a stimulating action on cultures by Hamilton and Plotz (1942) but negative results were reported by Tennant, Stern and Liebow (1942), by Fischer (1941b), and by Burt (1943).

A sample of biotin (kindly presented by Professor V. du vignaud) in a concentration of 0.33 $\mu\text{g./ml.}$ had no influence on the growth promoting power of embryo extract (Table 10, Test 77/2).

Discussion.

It is obvious that the higher protein degradation products have pronounced growth promoting action in raising the N.P.P. of the cultures even in the absence of embryo extract. This is in agreement with the observations of other workers (e.g. Willmer and Kendal, 1932; Fischer, 1942a, b) who used area measurements as index of growth. On the other hand amino acids alone even in the proportions found in fibrin are without effect. Some degree of polypeptide, peptone or proteose structure is apparently essential for activity. The presence of higher protein split products is probably also responsible for the growth promoting activity of the preparations from irradiated yeast, and of "Padutin" and "Examen".

The break-down products of the nucleic acids (nucleotides) also appear to have a similar, but much less pronounced, growth-promoting effect, (c.f. Calkins, Bullock and Rohdenburg, 1912). It is, however, doubtful if this factor plays any important part in

vivo in stimulating the growth of rapidly growing tissues. Such tissues are remarkable for their low simple nucleotide content (see Section III, p. 221).

SUMMARY.

1. The effect of various substances on the nucleoprotein phosphorus content (N.P.P.) of fresh explants from the embryo chick heart growing in vitro in roller tubes has been examined.
2. Cultures grown in Tyrode solution alone showed a fall in N.P.P. The addition of embryo extract to the cultures caused a definite rise in N.P.P. and this rise was unaltered when the embryo extract was heated to 100° for five minutes.
3. Extracts of mammalian embryos (sheep) also stimulated tissue growth, but sheep embryo extract was less effective than chick embryo extract at the same concentration in terms of total nitrogen.
4. Sheep embryo extract retained its activity after storage for nine months at -30° in the sterile state. When extract was stored in the non-sterile state, or when it was prepared from embryos stored in the non-sterile state, much

lower activity was found.

5. Embryo extract could be dried from the frozen state without loss of activity. Material dried in air or in vacuo at room temperature had low solubility and poor activity.
6. The growth promoting activity of embryo extract could be enhanced by defatting the extract by freezing with ether to -25° .
7. Crystalline ribonuclease had no effect on the growth-promoting properties of embryo extract, but crude ribonuclease preparations from pancreatin contained factors which caused marked stimulation of nucleoprotein synthesis in the presence of embryo extract.
8. Cultures grown in embryo extract to which mucinase had been added in high concentration showed a smaller rise in N.P.P. than control cultures grown in embryo-extract without mucinase.
9. Embryo skin, muscle and cartilage yielded more potent extracts than did viscera, e.g. liver.
10. Of all the precipitating agents employed, only ethanol yielded a precipitate with active growth promoting properties.
11. Nucleoproteins prepared from embryonic tissue

had variable, and never great, growth promoting activity.

12. Extracts of adult pituitary and heart had little or no growth promoting activity but purified liver extract ('Examen'), purified pancreas extract (kallikrein, 'Padutin'), boiled kidney extract and peptones had powerful growth promoting properties as measured by their ability to cause an increase in N.P.P. in the cultures.
13. Nucleic acids had little or no effect, but ribonucleotides had some growth promoting activity.
14. The significance of these results has been discussed.

The roller-tube tissue-culture technique was employed as described previously. Each roller-tube contained six fresh explants of the nine day chick-embryo heart in 0.2 ml. fetal plasma. All tubes were rotated in the incubator at 38° with 0.5 ml. Tyrode solution alone as fluid phase for 48 hrs. The fluid was then removed and replaced by 0.5 ml. medium consisting of a suitable combination of Tyrode solution, embryo-extract and test substances and the tubes replaced in the incubator. After a preliminary period of 1-2 hours some of the tubes were removed to give

(G) Factors in Pancreatin which influence the Nucleoprotein Content of Fibroblasts growing in vitro.

In the course of the experiments just described on the chemical nature of the growth-promoting principles of embryo-extract, it was shown (p. 89) that commercial pancreatin, which is prepared by extracting pancreas glands with dilute alcohol appeared to contain factors which exert a profound influence on the growth of chick heart fibroblasts in vitro. These factors have been partially purified and some of their properties and effects are now described.

Methods.

The roller-tube tissue-culture technique was employed as described previously. Each roller-tube contained six fresh explants of the nine day chick-embryo heart in 0.2 ml. fowl plasma. All tubes were rotated in the incubator at 38° with 0.5 ml. Tyrode solution alone as fluid phase for 48 hrs. The fluid was then removed and replaced by 0.5 ml. medium consisting of a suitable combination of Tyrode solution, embryo-extract and test substance and the tubes replaced in the incubator. After a preliminary period of 1-3 hours some of the tubes were removed to give

values for the initial amount of tissue present. The remainder were allowed to rotate for a further 24 or 48 hours or other suitable period. Control tubes with plasma but no tissue were also run. Determinations of nucleoprotein phosphorus (N.P.P.) were made at the beginning ("time 0") and at the end ("time t") of each test period as previously described, two or three roller-tubes being used at each time and with each test substance. The number of tubes which could be accommodated on the rotating drum in any test was limited to 20. Plasma blanks were therefore dispensed with in some experiments, after it had been established that with the preparations under test, their use made no significant difference to the results. Growth was assessed by the increase in N.P.P. during the test period. This method was found to be valid for determining the growth-promoting activity of embryo-extract, and its use was therefore extended to experiments with other growth promoting substances.

The pancreatin preparations were thermostable. Aqueous solutions were therefore sterilised by heating for 10 min. at 100° and treated with an equal volume of sterile double strength Tyrode solution before being added to the cultures.

The factors can be prepared from fresh ox pancreas but a more convenient starting material is commercial pancreatin. Crude solutions were prepared at first by a method similar to that used by Dubos and Thompson (1938) for the preparation of crude ribonuclease, by extracting commercial pancreatin with 50% acetone and increasing the concentration of acetone in the extract to 67%. The oily precipitate was dissolved in water, extracted with ether, and heated to 100° for 10 minutes. The precipitate which appeared was centrifuged down and discarded. The supernatant fluid was dialysed in cellophane sacs, sterilised by heat and treated with an equal volume of double strength Tyrode solution.

Later it was found more convenient to incubate commercial pancreatin overnight with water, filter the mixture, heat the filtrate to 100° for 10 minutes, cool, discard the precipitate and treat the supernatant fluid with 6 vols. ethanol. The sticky precipitate which fell out was washed with ethanol, then ether and dried. Portions were dissolved in glass distilled water as required, sterilised by heat, and treated with an equal volume of double strength Tyrode solution.

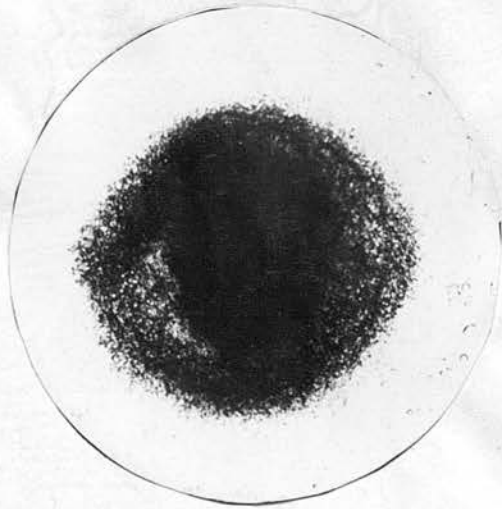
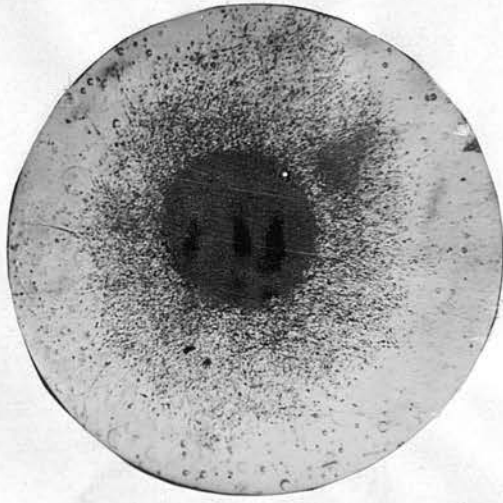

Cultures grown

A in embryo extract alone

B in embryo extract + pancreatin factor.

Plate 6.

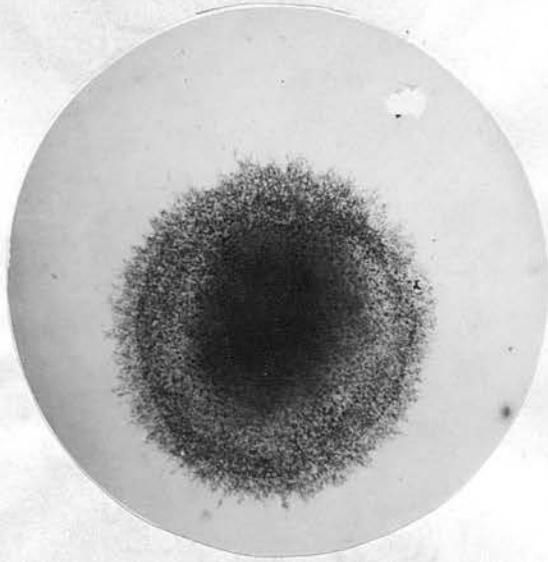

Cultures grown in embryo extract + pancreatin factor.

x 15

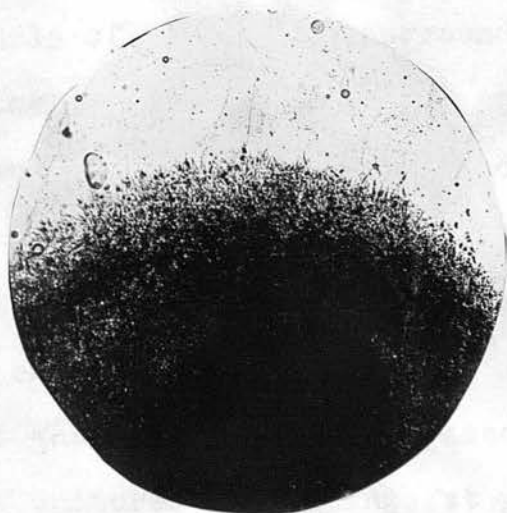
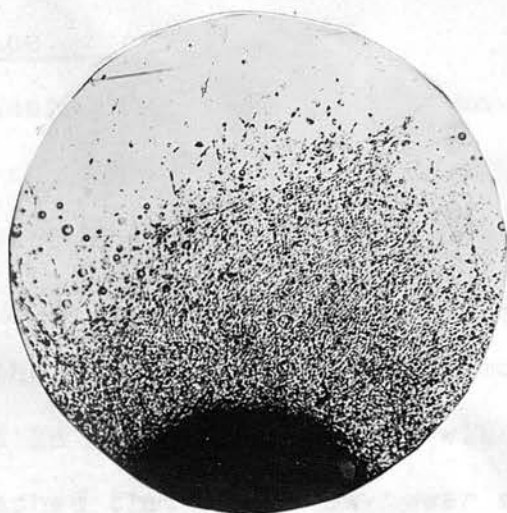

Cultures grown

A in embryo extract alone

B in embryo extract + pancreatin factor.

Results.1. Appearance of cultures.

The appearance of cultures grown in embryo-extract in the presence and absence of the material from pancreatin is shown in Plates 5, 6 and 7. As the curvature of the roller-tubes renders accurate photography difficult, the tube, filled with formol-saline fixative, was immersed in a trough of water with a glass bottom and photographed through a low power microscope. The control cultures grown in embryo-extract alone present the normal appearance of proliferating fibroblasts, and a fine halo of new growth surrounds the remnant of the original explant. Cultures grown in embryo-extract to which the test material had been added show abundant growth of quite a different type. They are rather smaller in area, and of a dense compact appearance with a sharply demarcated edge. At first sight they present the appearance often associated with degenerating cultures containing fat globules, but microscopic examination of the cells shows that no signs of degeneration are present.

Sections of the cultures were also made after fixation in formol-saline and embedding by the method described by Parker (1938). The presence of the

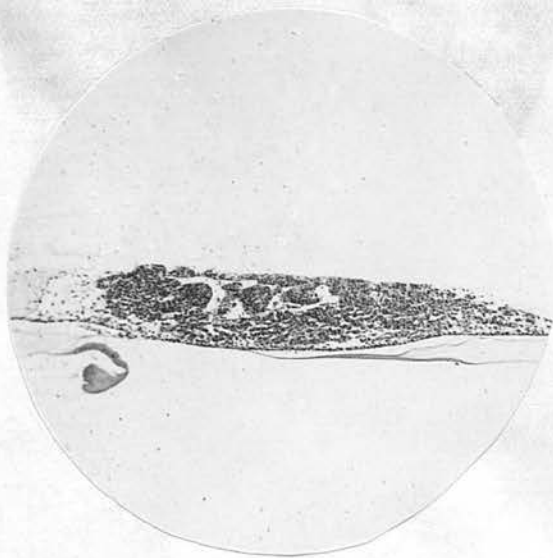
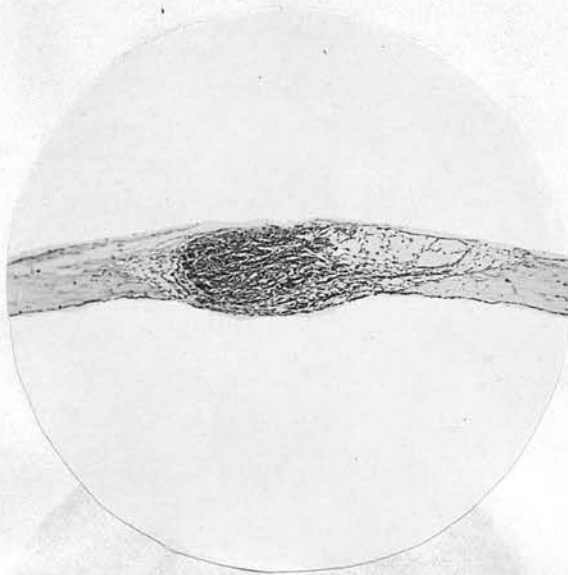

Sections of cultures grown

A in embryo extract alone

B in embryo extract + pancreatin factor.

Stained haematoxylin eosin x 50

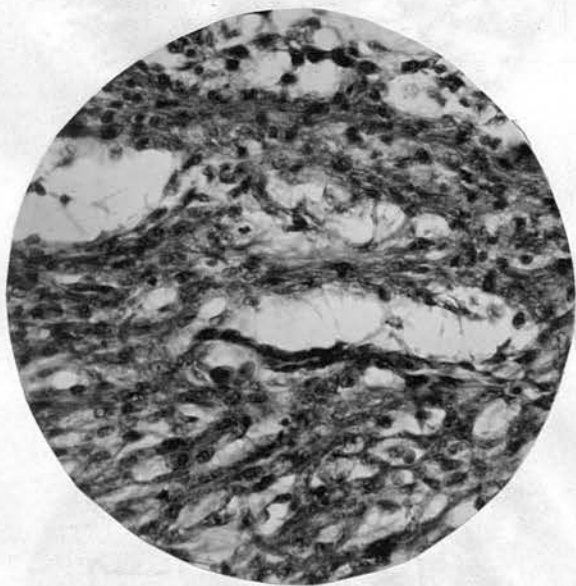

Section of 9 day chick embryo heart.
Stained haematoxylin eosin x 310

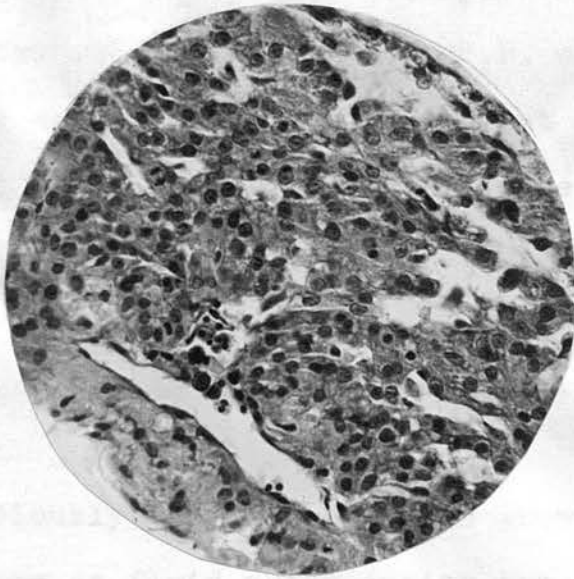
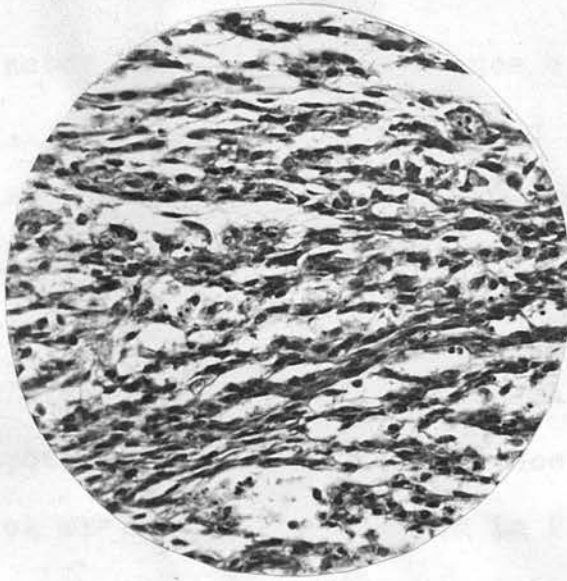

Sections of cultures grown

A in embryo extract alone

B in embryo extract + pancreatin factor.

Stained haematoxylin eosin x 310

pancreatin factor alters the appearance of the cells considerably. As shown in Plates 8 and 10 the control cultures present the usual network appearance of elongated cells with oval nuclei, whereas the cultures grown in the presence of the pancreatin preparation consist of well nourished polyhedral cells with rounded nuclei. Mitotic figures are clearly seen. A section of fresh chick embryo heart is shown in Plate 9 for comparison.

2. Nucleoprotein content of the cultures.

As in earlier work, direct comparisons of the effects of two substances on the N.P.P. of the cultures are normally made where control and test cultures are grown in the same plasma at the same time. In Table 11 the complete results of three such tests are quoted while in Tables 12 and 13 the results are summarised in terms of the alteration in N.P.P. during the test period.

As previously reported cultures grown in Tyrode solution alone as fluid phase during the test period usually show a slight fall in N.P.P. (e.g. Table 11, Test 61). On the other hand, with embryo-extract (containing 30 mg.% total N) an appreciable rise in N.P.P. (0.35-0.45 μ g. per roller tube) occurs (Tables

Table 11.

-EXAMPLES OF TISSUE CULTURE TESTS WITH N.P.P. VALUES FOR TUBES WITH AND WITHOUT TISSUE AT THE BEGINNING (3 HOURS) AND END (48 HOURS) OF THE TEST PERIOD.

Test No.	Test substance in fluid phase in roller-tube.	N concentration mg./100 ml.	N.P.P. μ g. per roller-tube.				Change.	Morphological changes.
			Initial.		Final.			
			Plasma + tissue.	Plasma alone.	Plasma + tissue.	Plasma alone.		
61	Tyrode solution alone	0	1.05	0.26	1.03	0.24	-0.07	-
			1.20		1.03			
	Embryo-extract + Tyrode	30 + 0	1.33	0.41	1.44	0.29	+0.39	-
			1.29		1.73			
44	Embryo-extract + Tyrode	30 + 0	1.63	0.29	2.13	0.30	+0.37	-
					1.90			
	Embryo-extract + crude pancreatin preparation	30 + 16	1.66	0.32	2.80	0.28	+0.91	++
					2.27			
82	Embryo-extract + Tyrode	30 + 0	1.48	0.36	1.79	0.32	+0.32	-
					1.73			
	Embryo-extract + phenol soluble fraction (i)	30 + 2	1.25	0.34	2.04	0.33	+0.47	+
			1.65		1.92			
	Embryo-extract + phenol soluble fraction (ii)	30 + 20	1.54	0.37	2.20	0.30	+0.48	++
			1.38		1.90			
					1.51			

Table 12.

EFFECT OF CRUDE PANCREATIN PREPARATIONS ON THE N.P.P. OF TISSUE CULTURES. EACH FIGURE IS DERIVED FROM SEVERAL ROLLER-TUBES. PLASMA BLANKS HAVE BEEN SUBTRACTED.

Test No.	Test substance.	Nitrogen concentration mg./100 ml.	Test period, hours.	Change in N.P.P. μ g. per roller-tube.	Morphological changes.
44	Embryo-extract + Tyrode	30 + 0	48	+ 0.37	-
	Embryo-extract + crude pancreatin preparation	30 + 16	48	+ 0.91	++
45	Embryo-extract + Tyrode	28 + 0	48	+ 0.41	-
	Embryo-extract + crude pancreatin preparation	28 + 8	48	+ 0.54	++
	Tyrode + crude pancreatin preparation	0 + 8	48	+ 0.05	-
49	Embryo-extract + Tyrode	32 + 0	48	+ 0.45	-
	Embryo-extract + crude pancreatin preparation	32 + 15	48	+ 1.28	++
51	Embryo-extract + Tyrode	20 + 0	24	+ 0.36	-
	Embryo-extract + crude pancreatin preparation	20 + 15	24	+ 0.82	++

11 and 12). Much greater increases are found when this concentration of embryo-extract is supplemented by the pancreatin material (Table 11, Test 44; Table 12). Crude preparations are rich in ribonuclease, but the presence of this enzyme alone is not responsible for the effect. It has already been shown (p. 88) that crystalline ribonuclease produces little or no effect on the growth-promoting properties of embryo juice.

Although the factor causing the morphological changes is stable at 100° in neutral or slightly acid solution its power to produce the characteristic dense appearance in the cultures is destroyed by heating at 100° for 30 min. at pH 8-10. The ribonuclease activity of the material is completely lost during this treatment.

3. Purification of the material.

It has been found that the material can be partially purified by extraction from aqueous solution with phenol, solution of the phenol extract in ether and extraction of the ethereal phenol solution with water. The activity passes back into the aqueous layer. During phenol extraction most of the colour and about 40% of the nitrogen and 20% of the P present

in the crude extract pass into the phenol layer. The residue does not produce the characteristic morphological changes although it may stimulate culture growth to some extent and cause a slight rise in N.P.P. above that produced by embryo-extract alone. The purification process is as follows:-

Twenty-five grams of commercial pancreatin are mixed with 120 ml. of distilled water and are left overnight in the incubator at 37° . The mixture is then heated at 100° for 10 minutes, cooled, and centrifuged. The slightly turbid supernatant fluid is treated with six volumes of ethanol, and the precipitate allowed to settle overnight in the refrigerator. It is then centrifuged down, and washed with ethanol and ether. Weight 500-700 mg. This material is deliquescent and is stored in a desiccator. For the next stage 100 mg. are dissolved in 10 ml. water, brought to 100° , cooled and centrifuged. The precipitate is discarded and the supernatant fluid is extracted with three successive three gram portions of phenol. At each extraction the phenol layer is separated by centrifuging. The phenol extracts are combined and centrifuged at 3000 r.p.m. for 15 min. A layer of white material which settles out on top of

the phenol is discarded. The clear phenol extract is dissolved in 100 ml. ether and the ethereal phenol solution is then extracted four times with small portions of water. The clear yellow aqueous extracts are combined (total volume about 15 ml.), and extracted three times with small amounts of ether to remove the last traces of phenol. The aqueous solution is then heated on the water bath to remove traces of ether and to bring the volume down to about 5 ml. The aqueous solution is cooled and centrifuged to remove a small amount of insoluble matter. Six volumes of ethanol are then added and the mixture allowed to stand in the refrigerator for an hour. The precipitate is then centrifuged down, washed with ethanol and ether and dried in vacuo. The yield is about 10-20 mg.

4. The effect of the phenol soluble fraction (P.S.F.)
on the growth of the cultures.

The addition of the P.S.F. to embryo-extract in the tissue culture medium caused, as with the crude material, a greater increase in N.P.P. than the same concentration of embryo-extract alone. (Table 11, Test 82; Table 13, Tests 77, 102, 103, 104.) Low concentrations of the material, although able to cause

Figure 6.

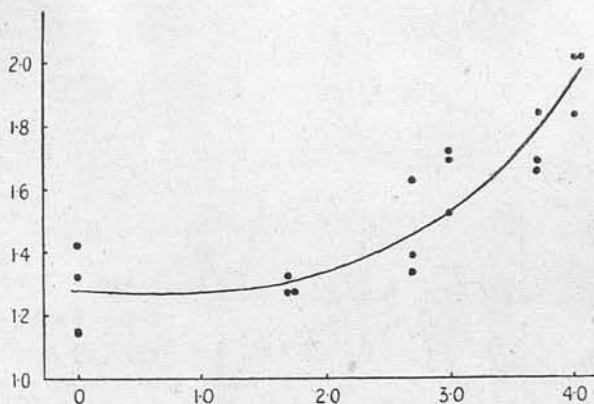

—Effect of varying concentrations of P.S.F. with dilute embryo-extract (N=3-6) on the N.P.P. of cultures in a single experiment.

Abscissa: Log concentration of P.S.F. in mg. N per 100 ml. in medium added to roller-tubes. Ordinate: Final N.P.P. figures in $\mu\text{g.}$ per roller-tube. Test period 48 hours. Plasma blanks not subtracted.

the changes in the morphology of the cultures, did not appreciably increase the power of a high concentration of embryo-extract ($N = 30$)^{*} to raise the N.P.P. An experiment with dilute embryo-extract ($N = 3.6$) and varying concentrations of the P.S.F. suggested that the effects of the extract and of the factor on the N.P.P. are really independent and additive. Embryo-extract alone at this dilution ($N = 3.6$), although it gives rise to marked migrational outgrowth, does not significantly increase the N.P.P. of the cultures, but with the addition of a high concentration of the P.S.F. ($N = 100$), the rise of N.P.P. in the 48 hr. growth period was $0.65 \mu\text{g.}$ or more than 50% of the initial N.P.P. ($1.32 \mu\text{g.}$). The effect of increasing concentrations of the P.S.F. in the presence of embryo-extract of $N = 3.6$ is shown in Fig. 6, Test 103.

The results of tests with a series of concentrations of the P.S.F., without embryo-extract, confirmed the capacity of this fraction alone to cause a rise in N.P.P., and showed that the magnitude of the effect is

*

N concentration in mg./100 ml. of the fluid phase added to the cultures.

Figure 7.

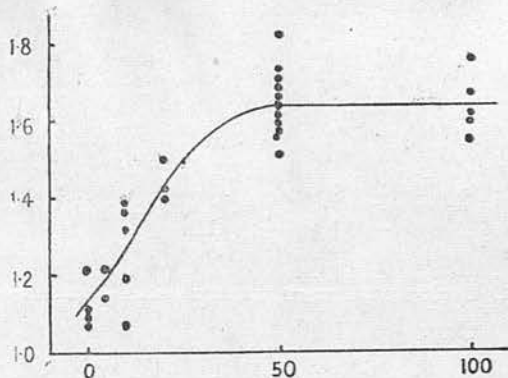

Figure 7.—Effect of varying concentrations of P.S.F. (without embryo-extract) on the N.P.P. of cultures in several experiments.

Abscissa: Concentration of P.S.F. in mg. N per 100 ml. in medium added to roller-tubes. Ordinate: Final N.P.P. figures in $\mu\text{g.}$ per roller-tube. Test period 24 hours. Plasma blanks not subtracted.

dependent on the amount of fraction present. With one sample at $N = 150$, an increase in N.P.P. equal to about 100% of the initial value was obtained in 48 hours. Lower concentrations produced proportionately smaller increases (Figs. 7 and 8).

The characteristic alterations in the morphology of the cultures, observed with the P.S.F. and embryo-extract, were also found with the P.S.F. alone (Plate 11). It appears that neither these morphological changes nor the effect on the N.P.P. require the presence of embryo-extract. Cells damaged during the preparation of the heart explants will release into the medium disintegration products which constitute in effect an embryo-extract, but these are not likely to be present, after the preliminary two day period of washing in Tyrode solution alone, in sufficient amount to play any part in these effects. If traces of such cell products are in fact essential to the activities observed, their presence could not be entirely eliminated under the experimental conditions, for proliferating tissue-cultures are bound to contain some disintegrating cells, continually releasing such products in small amounts.

It was observed that at the end of the three hours

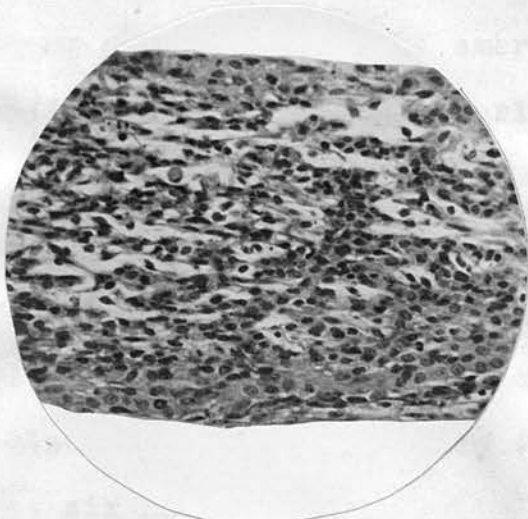
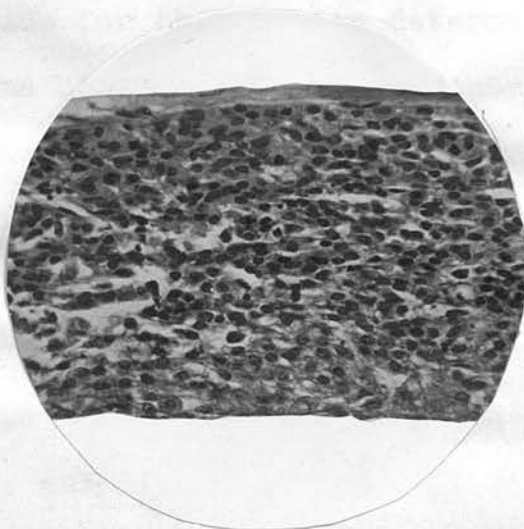
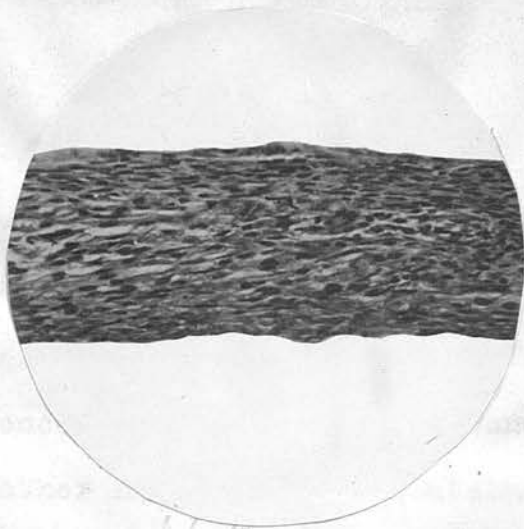

Sections of cultures grown

A in Tyrode solution alone for 24 hrs.

B in purified pancreatin factor alone
(N = 25 mg.%) for 24 hrs.

C in purified pancreatin factor alone
(N = 25 mg.%) for 9 hrs.

Stained haematoxylin eosin x 310

All cultures grown for 48 hours in Tyrode
solution alone before addition of test materials.

usually allowed for the attainment of equilibrium ('time 0'), the N.P.P. with high concentrations of the P.S.F. was greater than that with Tyrode solution alone. Small differences of this kind are found with embryo-extract and other nucleoprotein-containing media, owing to adsorption on the plasma coagulum, and correction is made for them by the determination of N.P.P. in the 'plasma blanks'. Since a control experiment showed that no corresponding rise occurred in tubes containing plasma and the P.S.F. but no tissue, the increase in N.P.P. detected in three hours, and clearly demonstrated in six hours, must therefore be due to an actual increase in nucleic acid in the tissue. This increase very probably precedes cell division and is in agreement with the observation of Willmer (1942b) that with strong concentrations of embryo-juice "there is a considerable rise (in N.P.P.) during the first three hours, so that the nucleoprotein increase anticipates the onset of nuclear division by some hours and more closely parallels in time the general increase in cellular activity". The altered appearance of the cultures is also produced at an early stage, and can be detected at six hours.

The results of N.P.P. determinations after the

Figure 9.

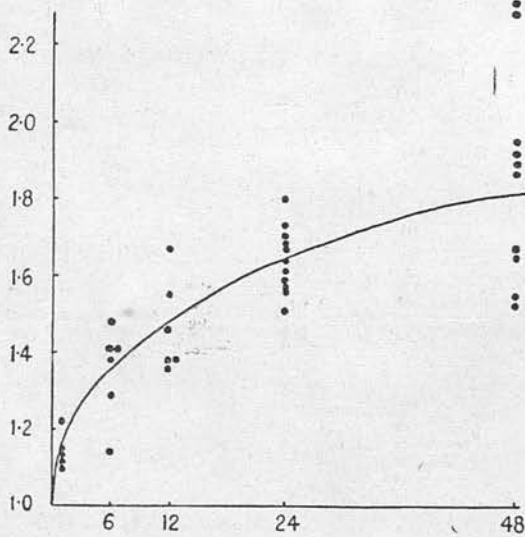

FIG. 9.—Effect of P.S.F. (without embryo-extract) on the N.P.P. of cultures at varying times in several experiments. The medium added to the roller-tubes contained the P.S.F. at a concentration of 50 mg. N per 100 ml.

Abscissa: Test period in hours. Ordinate: Final N.P.P. figures in $\mu\text{g.}$ per roller-tube. Plasma blanks not subtracted.

application of the P.S.F. at a concentration of N = 50 for varying lengths of time are shown in Fig. 9. The points plotted are derived from several experiments and relate to three different batches of material. Although there is a wide variation in the individual values, it is clear that a progressive rise in N.P.P. occurs. The time intervals selected are too great to detect whether the rise is in fact a continuous one or whether there is a step-wise increase, associated with the cycles of mitosis.

The variation of N.P.P. with concentration of P.S.F. is shown in Figs. 7 and 8. Especially with high concentrations the rise in N.P.P. in 48 hours is considerably greater than that produced by the same concentration in 24 hours. The initial N.P.P. may even be doubled. Such an increase is as great as can be obtained in the same time with a very potent preparation of embryo-juice but still greater increases can be obtained when both embryo-juice and P.S.F. are present (e.g. Test 123, Table 13).

Although the P.S.F. can produce a sharp rise in N.P.P. in a short time it does not appear to be able to maintain the growth of cultures over long periods in the same way as does embryo-juice. We have not

attempted to maintain a strain of fibroblasts through several passages with the aid of the material.

Roller-tube cultures in which the P.S.F. was renewed daily for five days showed a lower N.P.P. content than did cultures grown for only 48 hours without renewal (Table 13, Test 116).

The power of the purified material, as well as that of the crude preparations, to produce the changes in the morphology of the cultures, is destroyed by heating at 100° for 30 min. at pH 8-10. The same result is obtained with material autoclaved for 20 min. at 132° . Such material is still able in the absence of embryo-extract to produce a very appreciable rise in N.P.P., only slightly less than that produced by the untreated purified factor (Table 13). The addition of crystalline ribonuclease does not restore the ability of the treated material to produce the dense type of culture (Table 13, Test 119).

5. The chemical nature of the phenol soluble fraction.

The partially purified material is a light brown non-deliquescent powder freely soluble in water, acids and alkalies. The aqueous solution is slightly acid in reaction and shows a blue fluorescence by ultraviolet light. It gives positive biuret and

ninhydrin tests. Trichloroacetic acid produces a slight turbidity and tungstic and phosphotungstic acids heavy precipitates. The material gives faint precipitates with lead and mercury salts, and heavy precipitates with picric and flavianic acids. Tests for sulphur, pentoses and desoxypentoses (diphenylamine test) are positive. A trace of ribonuclease activity is still present. The material responsible for the dense type of growth dialyses very slowly through cellophane membranes and is partially precipitated by ammonium sulphate at 0.8 saturation. It is adsorbed readily by alumina, charcoal, kaolin and Fuller's earth but poorly by Decalso.

Several samples of commercial pancreatin from different sources have been used as starting material. Even with the same sample, the purification process did not give a product of constant composition. Different batches of purified material contain 8.3-13.6% N and 1.6-2.7% P. In one sample, 13% of the total N was in the form of amino N as determined by the gasometric method of Van Slyke (1929). After hydrolysis in 5 N HCl at 100° for 24 hours the amino N rose to 60% of the total N and hydrolysis for a further 24 hours caused no further increase. About

20% of the P is liberated at pH 8.4 in inorganic form by the action of snake venom containing an active 5-nucleotidase (Gulland and Jackson, 1938). Estimation of total purine N by the method of Graff and Maculla (1935) showed that 10.4% of the total N was present as purine N. Analysis by the method of Kerr (1940) revealed that almost the whole of the purine N was present in the form of nucleotide, nucleoside and free purine, mostly as nucleotide.

The phosphorus was resistant to alkaline hydrolysis. No inorganic P was split off after incubation with 0.25 N NaOH at 37° in the course of 96 hours.

6. The effect of other substances on the cultures.

A large number of known substances has been tested to see whether they were capable of producing the morphological changes in the cultures. They included crystalline insulin, Witte's peptone, sulphur-containing compounds such as glutathione, thiourea, and thiohydantoin, histamine, rubonucleic acid prepared from pancreas (Jorpes, 1934), from liver (p. 266) and from yeast, all four mononucleotides of yeast nucleic acid (prepared according to Steudel and Peiser, 1922, and Jones and Perkins, 1924), pyrimidine desoxyribosides (Levene and Bass, 1931); adenosine, guanosine,

yeast adenylic acid, muscle adenylic acid, the amino acid mixture described by Fischer (1941a), and phosphoprotein prepared from casein (Levene and Hill, 1933). None of them produced an effect similar to that associated with the pancreatin factor.

Some of the properties of the P.S.F. bear a resemblance to those of the anti-anemic principle of liver as described by Karrer (1941), Erdos (1942) and Subbarow (1942) but a specimen of liver-extract (Examen) produced none of the characteristic cellular changes although it brought about a small rise in N.P.P. (Table 13, Test 121). Boiled ox-kidney extract prepared by the method of Fischer and Astrup (1942) caused both cell migration and a rise in N.P.P. without however producing the characteristic dense appearance (Table 13, Tests 122, 125). A similar effect was produced by a preparation of the material obtained by the irradiation of living yeast cells (see p.168), and by commercial peptone (Table 13, Test 121).

The vasodilator substance kallikrein (Dale, 1933) differs from the pancreatin material in being thermolabile, but as it is also derived mainly from the pancreas (Frey, Kraut and Schultz, 1930; Frey, 1932)

it was thought advisable to examine its effects on the tissue cultures. A commercial preparation of kallikrein from pancreas (Padutin, Bayer) sterilised by heating for ten minutes at 100° was tested out on the cultures at varying nitrogen concentrations and was found to bring about a very marked rise in N.P.P. (Table 13, Tests 118, 120). It did not however appear to contain the thermostable material responsible for the morphological changes.

Crude preparations of ribonuclease made from pancreatin would also contain the enzyme lecithinase A which hydrolyses lecithin to lysolecithin (Delesenne and Fourneau, 1914) and which, like ribonuclease, is remarkably stable to heat in slightly acid solution (Hughes, 1935; Gronchi, 1936). A preparation of lecithinase A made from pancreatin by the method of Gronchi (1936) was able to bring about the morphological changes in the cultures. As such a preparation is far from pure, the effect of lecithinase from another source, snake venom, was investigated. Hughes (1935) has shown that lecithinase from snake venom will survive prolonged boiling at pH 5.9 although in slightly alkaline solution it is easily destroyed by heat. A sample of Russell's viper venom was dissolved

in water and sterilised by heating at 100° for ten minutes. A large amount of denatured protein which appeared during the heating was centrifuged down and discarded. The supernatant fluid was tested at several dilutions (7.5, 0.75 and 0.075 mg. N/100 ml.) in the presence of embryo-extract and found to produce the characteristic morphological picture even at the highest dilution.

From the dry venom of the rattlesnake, Crotalus t. terrificus, Slotta and Fraenkel-Conrat (1938a & b) have isolated ^{the} neuro-toxic principle as a crystalline protein which they have named "crotoxin". This material appears to be pure lecithinase A. It has been proved to be homogeneous when examined in the ultra-centrifuge and in diffusion apparatus (Gralen and Svedberg, 1938), and when subjected to electrophoresis experiments (Li and Fraenkel-Conrat, 1942).

A sample of pure crystalline crotoxin obtained through the kindness of Dr H. Fraenkel-Conrat, was dissolved in water, sterilised by heat, treated with an equal volume of double strength Tyrode and tested in serial dilutions for its effect on cultures growing in embryo extract. Even at the highest dilution tested (N = 0.001) the crotoxin caused the production

Plate 12.

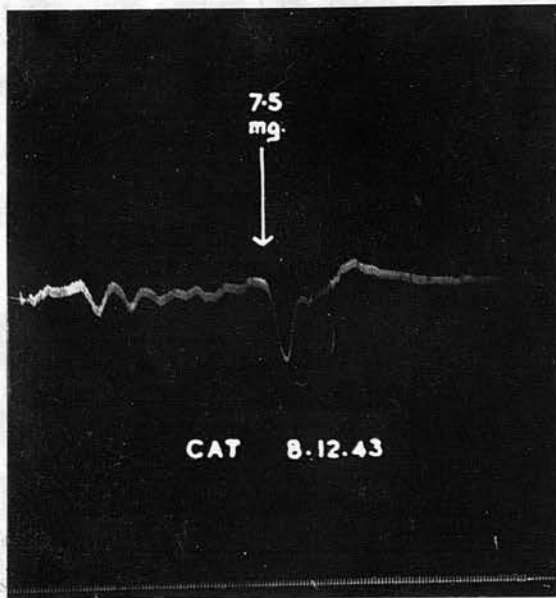

Effect of intravenous injection of phenol soluble fraction on the blood pressure of the cat.

of the characteristic dense appearance in the cultures without having any effect on the N.P.P.

The effect of the P.S.F. on the blood pressure was also investigated. In relatively large doses it caused a pronounced fall in the blood pressure of the cat (Plate 12) but this is probably of little significance. The fall is similar to that caused by such compounds as adenosine (Bennet and Drury, 1931; Drury, 1936) which, in any case, are probably present in the fraction.

Discussion.

In considering the effects produced by the pancreatin factor or factors it is important to remember Williams' (1941) warning to distinguish "between an extract which contains some biologically active principle and a preparation which contains a single biologically active substance". The pancreatin material obviously falls into the former category.

Kazal, Westfall, Ciereszko, Risley and Arnow (1942) have recently described a material prepared from pancreas which White and Sayers (1942) have shown to exert a powerful growth-promoting effect when fed to young rats. This material, prepared by extracting frozen beef pancreas with acid-alcohol and then acetone

and pulverizing the residue, is of course very crude in comparison with the P.S.F. but would probably nevertheless contain the same factors. Daily intra-peritoneal injection of 8 mg. of P.S.F. into weanling rats over a period of several weeks caused no difference in growth rate as compared with controls.

The solubility of the active material in phenol gives but little clue to its composition since some proteins and their derivatives and also nucleotides are soluble in this reagent. Phenol has been used as a solvent in the purification of antigens (Palmer and Gerlough, 1940; Morgan and Partridge, 1941), of anterior pituitary hormones (Freud, Laqueur and Mühlbock, 1939), of the anti-anaemic principle of liver (Karrer, 1941) and of nucleotides (Warburg and Christian, 1938; Emmerie, 1938).

The properties of the purified material suggest the presence of protein and nucleic acid disintegration products which may be responsible, as nutrients, for the nucleoprotein synthesis.

Similar large increases in N.P.P. have been found with protein breakdown products such as peptones (Table 9) and the phosphopeptide of casein.

The growth-promoting action of protein

disintegration products has been known for some time (Carrel and Baker, 1926; Willmer and Kendal, 1932) and has been emphasised by the recent work of Fischer (1941ab, 1942ab). The "X-substance" which Willmer and Kendal (1932) found to stimulate tissue cultures is also apparently a protein disintegration product but differs from the pancreatin material in being insoluble in pure water. Although these heat-stable substances do produce stimulation of growth, their action is to amplify the effect of embryo-extract rather than to produce the dense type of culture with exceptionally high nucleoprotein content characteristic of the action of the pancreatin material. The growth-promoting action of proteoses, peptones and polypeptides in combination with nucleotides is envisaged by Needham (1942) who suggests "that a substance of nucleotide structure might act either as a carrier for the requisite peptone 'bundle' or else possibly as a 'bricklaying' mechanism at the site of protein synthesis". The action in the present instance is however not merely a quantitative increase in nucleoprotein synthesis during the normal process of growth. The qualitative change in the morphological character of the cells must also be taken into account. That

the material exerts its effect by the action of at least two components is suggested by some of the experimental evidence. After autoclaving, for instance, the material still retains most of its power to cause nucleoprotein synthesis although it can no longer produce the dense type of culture. Again the dense appearance of the cultures is very marked in concentrations of factor which are too low to produce any detectable change in N.P.P. This suggests an enzymatic effect. Trypsin, which may stimulate the growth of adult tissue in vitro (Simms and Stillman, 1937), would appear to be connected only indirectly, if at all, with the factor since it would scarcely survive the purification process. Commercial pancreatin is of course rich in trypsin which may no doubt play a part in producing the protein disintegration products which compose the crude material but the active agent (or agents) is obviously resistant to tryptic digestion, as for example are the phosphopeptones (Lowndes, Macara and Plimmer, 1941; Rimington, 1941; Posternak and Pollaczec, 1941).

It is possible that one effect of the P.S.F. is not directly on the cells of the culture but on the plasma clot. Such an action would presumably be

enzymatic in nature although the purification process is sufficiently drastic to destroy all but the most resistant of enzymes. Ribonuclease activity is still evident in the P.S.F. but as far as can be ascertained, ribonuclease, which is a remarkably heat resistant enzyme, appears to have little connection with the activity. It is, however, destroyed by heating in alkaline solution.

The enzyme lecithinase A possesses a resistance to heat similar to that of ribonuclease. The activity of preparations of lecithinase from two different sources - pancreatin and snake venom - in producing the morphological changes described suggests that this enzyme may be one of the active factors in the pancreatin fraction. This view is supported by the fact that the changes are produced by crystalline crotoxin (lecithinase).

SUMMARY.

Material has been prepared from pancreatin which influences the growth of fresh explants of the nine day chick embryo heart in roller-tubes. Cultures grown in a mixture of this material and embryo-extract show a much higher nucleoprotein phosphorus (N.P.P.)

content than do control cultures grown in embryo-extract alone. They also have a characteristic dense compact appearance and are composed of well nourished polyhedral cells with numerous mitotic figures.

A method for the partial purification of the factor (or factors) responsible for these phenomena is described. It appears that at least two components are involved, one of which is responsible for the characteristic morphological changes in the cells, while the other can produce even in the absence of embryo-juice a very marked rise in N.P.P., as great as that produced under similar conditions by a very concentrated extract of embryonic tissue. Such nucleoprotein synthesis appears to be a necessary preliminary to cell division in cultures stimulated by the factor. This would be in accordance with the views of Willmer (1942b, 1943).

Some chemical properties of the purified material are described. It appears to consist mainly of polypeptides and nucleotide derivatives. Preparations of lecithinase A from pancreatin and snake venom produce the morphological changes described and this enzyme appears to be one of the active components.

"WOUND HORMONES"I. REVIEW OF LITERATURE.

The suggestion that injured cells liberate substances, for which the name "wound hormones" has been proposed, which stimulate proliferation in the neighbourhood of the injury has given rise to much speculation and to a considerable volume of experimental work.

PART II."WOUND HORMONES"

Although the hypothesis was first postulated by Wisser in 1892 in connection with plant tissues and although the most clear-cut results in this field have been obtained with botanical material, attempts have been made to extend the hypothesis to animal tissues and to apply it to the healing of wounds in animals and in man. Of the several biologically active substances which are possibly liberated by damaged living cells, e.g. histamine, thromboplastin, "leucotoxin" - the permeability-promoting polypeptide discovered by Ussing (1940) in inflammatory exudates, and factors responsible for or associated with impaired

Other names which have been suggested for these or similar substances include: elastin, extralin, adrenomones, archonia, trophobin, chemobin, etc.

"WOUND HORMONES"1. REVIEW OF LITERATURE.

The suggestion that injured cells liberate substances, for which the name "wound hormones"^x has been proposed, which stimulate cellular proliferation in the neighbourhood of the injury has given rise to much speculation and to a considerable volume of experimental work. Although the wound hormone hypothesis was at first postulated by Wiesner in 1892 in connection with plant tissues and although the most clear-cut results in this field have been obtained with botanical material, attempts have been made to extend the hypothesis to animal tissues and to apply it to the healing of wounds in animals and in man. Of the several biologically active substances which may possibly be liberated by damaged living cells, e.g. histamine, thrombokinase, "leucotaxine" - the permeability promoting polypeptide discovered by Menkin (1940) in inflammatory exudates, and factors responsible for or associated with impairment

^x Other names which have been suggested for these or similar substances include blastin, attraxin, necrohormones, archusia, trephones, desmones, etc.

of renal function after crush injuries (Bywaters and Beall, 1941; Eggleton et al., 1942), none can be regarded as falling into the category of wound hormones. It is undoubtedly attractive to suppose that living cells can actually elaborate as a specific response to injury an agent or agents which might play a part in initiating the early stages of wound healing by causing proliferation of intact cells. Although there is no doubt that injured cells can and do set free nitrogenous material, it is difficult to prove that this material is other than disintegration products of dying and dead cells. Much of the experimental evidence is not easy to interpret, and the conclusions must of necessity be rather speculative. An attempt is here made to examine critically from the biochemical point of view the evidence put forward in favour of the wound hormone hypothesis.

A. Plant Wound Hormones.

Wiesner's original suggestion was made as the result of observations on the proliferation of plant cells in the neighbourhood of injuries, and the problem was subsequently taken up by other workers including Haberlandt (1921, 1922) and Reiche (1924)

who investigated the repair of plant wounds to which crushed plant tissues had been applied. The results of these investigations left no doubt that when plant tissues are injured substances are produced which can, under suitable circumstances, stimulate renewed growth and proliferation of uninjured mature cells in the neighbourhood (English and Bonner, 1937). These so-called "wound hormones" have the power of producing intumescence due to cell proliferation and enlargement in the parenchymatous lining of the seed chambers of young string bean pods (Wehnelt, 1927), and this fact is the basis of a method of quantitative physiological assay for wound hormones devised by Bonner and English (1937, 1938). As a measure of the wound hormone activity they use the height of intumescence produced which is known to be linearly proportional to the concentration of the wound hormone solution expressed in terms of arbitrary units. The test is not given by other substances such as vitamins, growth promoting substances or auxins, unless they are used in sufficiently toxic concentrations to cause injury to the test cells with liberation of wound hormones themselves. For the isolation from plant tissue of the wound hormone for which the name "traumatin" has been

proposed (English and Bonner, 1937), bean pods were used as starting material, and as the result of a lengthy process involving extraction with water, acetone, ethyl acetate and chloroform, precipitation as barium salt, and the formation of a methyl ester, the wound hormone was isolated in the pure state. After hydrolysis a crystalline dibasic acid was obtained, $C_{12}H_{20}O_4$, m.p. $165.5^\circ - 166^\circ$, to which the name "traumatic acid" was applied (English, Bonner and Haagen-Smit, 1939). A ten thousandth of a milligram of the pure acid can promote cell division and enlargement in the tissue of the bean mesocarp, and the activity is greatly enhanced by the presence of co-factors such as glutamic acid and sucrose which themselves possess little or no activity. Traumatic acid also promotes wound periderm formation in the potato and inhibits germination of tomato and other seeds.

The structure of traumatic acid was elucidated by English, Bonner and Haagen-Smit (1939) who showed it to be \triangle^1 -decene-1: 10-dicarboxylic acid

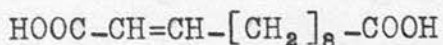

and proved its constitution by synthesis. English (1941) has recently synthesised some of its analogues such as \triangle^5 -undecene-1: 11-dicarboxylic acid

and $\Delta^{1,7}$ -octadiene-1:8-dicarboxylic acid and demonstrated that they also have wound hormone activity as shown in the bean test.

B. Evidence from Yeast.

An approach to the problem from a different angle has been made in America in a long series of papers by Loofbourow and his colleagues (1938-1943) who have exposed living yeast cells to a number of injurious agencies which, they claim, cause the cells to release into the surrounding medium factors termed "proliferation promoting intercellular hormones" or wound hormones which cause marked stimulation of the growth of fresh yeast cells.

The destructive effects of irradiation on cells and tissues are well known and have recently been reviewed by Laurens (1941) and by Harvey (1942). In the hands of the American workers ultraviolet irradiation of living yeast cells has formed a very convenient method of injuring the cells without either causing gross mechanical damage or adding any chemical agent which would subsequently complicate growth tests and chemical analyses. Suspensions of Saccharomyces cerevisiae in water or an appropriate saline medium

were exposed to ultraviolet light for several hours till the bulk of the cells were killed as shown by appropriate staining reactions. Unlike bacteria, yeast cells can be injured without being killed outright by ultraviolet irradiation (Wyckoff and Luyet, 1941; Euler et al., 1942). Cell free extracts from such suspensions, when added to cultures of fresh uninjured yeast cells in Reader's saline medium caused very pronounced stimulation of cell proliferation which was much more marked than in the case of cultures to which cell-free extracts of control (non-irradiated) cells had been added (Fardon et al., 1937; Sperti, Loofbourow and Dwyer, 1937). The growth-promoting factors produced by the irradiated yeast cells were stable to heat.

Similar thermostable substances were also shown to be produced as the result of injury by chemical agents, e.g. β -indolylacetic acid, by mechanical means, by heat and by X-rays. Moreover, ultraviolet irradiation of bacteria (Loofbourow and Morgan, 1940) and of algae (Giersch and Cook, 1941) also resulted in the liberation of growth promoting factors.

Evidence as to the chemical nature of the materials liberated by the cells exposed to ultraviolet light was

provided by spectrographic methods. The ultraviolet absorption spectrum of the materials showed a maximum at 2600 Å (and a minimum at 2360 Å) characteristic of purines and pyrimidines of the nucleic acid complexes (see p.197). Chemical tests revealed the presence of adenine, guanine, pentose and phosphorus and the absence of protein, pyridine and sulphur, and the suggestion was therefore put forward that the proliferation-promoting factors consisted of nucleic acid-like substances of the pentose nucleotide type. In subsequent experiments an increased yield of nucleic acid-like substances was obtained from the irradiated suspensions, and photomicrographs taken with the aid of a quartz microscope revealed a progressive increase in the ultraviolet absorption of the cells during irradiation, the wavelengths employed being in the range highly absorbed by purines and pyrimidines (Loofbourow et al., 1938-42).

Partial purification of the materials by chromatographic adsorption has yielded potent extracts which do not show selective ultraviolet absorption (Cook and Fardon, 1942).

Attempts to incorporate the active materials into preparations for topical application to healing

wounds^{*} have not produced successful results (Hirshfeld, Pilling and Maun, 1943; Smith and Livingstone, 1943).

It is important to stress the fact that a large number of substances are known which stimulate the growth of yeast even in minute concentrations. These substances include amino acids (Mitchell and Williams, 1940), and the large group of compounds belonging to the bios group recently reviewed by Williams (1941). Many such substances must obviously be present in the nitrogenous material from the irradiated cells and must account in part at least for its growth promoting activity. Cook, Hart and Stimson (1940) as the result of investigations on bios fractions obtained from yeast suggest either that the proliferants produced as a response to injury differ in nature from proliferants of the normal bios type or that predominance of a certain fraction of proliferants results from injury. More recently Cook and Cronin (1942) have shown that when yeast is grown in a saline medium supplemented by inositol, thiamin, pantothenic acid, biotin, pyridoxin, riboflavin, uracil, choline, acetyl

* So-called "Bio-dyne" ointment.

choline, ethanolamine, nicotinic acid, p-aminobenzoic acid and twenty different amino acids, the addition of cell-free extracts from irradiated yeast cells was still able to bring about increased proliferation, and the extracts therefore appeared to contain materials differing from all the known yeast growth-promoting substances.

Leonian and Lilly (1943) suggest that these effects might be due merely to the raising of the levels of pantothenic acid, inositol, and biotin but this explanation is doubted by Cook, Cronin, Kreke and Walsh (1943) who found that even when the levels of these three substances were raised, the "wound hormone" preparations could still bring about further growth.

Some of the known components of the bios complex are undoubtedly present in the materials from irradiated yeast cells which have been shown (Loofbourov, 1942) to contain appreciable quantities of biotin, pantothenic acid, pyridoxin, nicotinic acid and folic acid, while these substances are absent from the extracts from control cells. Moreover, the addition of adenosine, muscle adenylic acid and adenylyl pyrophosphate to well supplemented media, brings about a stimulation of the growth of yeast which is in some

ways comparable to that produced by the material from irradiated cells.

The addition of adenosine and guanosine, but not yeast adenylic acid, to well supplemented basal media stimulated yeast growth (Cook, Cronin, Kreke and Walsh, 1943) and the yield could be still further increased by addition of the material from irradiated cells.

Other adenine compounds, the diphospho- and triphospho-pyridine nucleotides, have so far proved to be absent from the wound hormone preparations (Loofbourow, Webb, Loofbourow and Abramowitz, 1942) and the proliferating promoting activity of the preparations is apparently not concerned with the effect of these nucleotides on cellular respiration. It may, however, be significant that the increased growth promoting activity of materials from injured cells over those from control cells can only be manifested if the test cultures to which the materials are added are well aerated (Loofbourow et al., 1942).

An attempt to determine whether the nitrogenous material from irradiated yeast cells is (a) the result of the release of dead cell disintegration products, (b) due to increased permeability of the cell membrane

or (c) synthesised as the result of a specific response to injury was made by Loofbourow, Dwyer and Cronin (1941). They found:

1. That when the cells were irradiated in such a way that 90% were killed, the yield of proliferants was proportional, within limits, to the time of exposure to the injurious influence, and the activity therefore did not depend on the number of cells killed.

2. That the yield of active material from cells irradiated while suspended in various media, was greatest when the medium contained materials useful to the cell in its metabolism such as carbohydrate, nitrogenous substances, phosphates, etc.

3. That cells irradiated and then destroyed mechanically or by heat yielded more growth-promoting substance than cells irradiated after being destroyed. They suggest that these results favour the hypothesis that the growth-promoting factor is probably a product synthesised by the living cell.

C. Evidence from Animal Tissues in vitro.

Stimulation of the growth of yeast is caused not only by extracts of irradiated yeast cells but also by

extracts from irradiated animal tissues. Loofbourow, Dwyer and Lane (1940) have claimed that when the cells of newt, chick and rat embryos are irradiated thermo-stable materials stimulating yeast growth are produced. They appear to be chemically very similar to the materials obtained from irradiated yeast cells. It has also been claimed that similar factors from irradiated chick embryonic tissue stimulate the growth of chick heart fibroblasts in tissue culture to a greater extent than do extracts from non-irradiated embryos. (Loofbourow, Cueto and Lane, 1939.) In these experiments the embryonic tissues were submitted to such severe mechanical trauma before being irradiated or used as controls that the evidence in favour of the production of wound hormones as the result of irradiation is not altogether satisfactory.

Other evidence obtained from the use of tissue cultures has been put forward by Fischer (1930) who showed that the infliction of wounds on tissue cultures caused the production of substances which accelerated growth.

"Beim Anlegen von Wunden entstehen wachstumfordernde Stoffe von denen vermutet wird dass sie Wachstumbeschleunigen dienen."

Cultures which were repeatedly wounded mechanically grew more quickly than controls. If the colony consisted of old, vacuolated cells, the regenerating cells at the edge of the wound were fresh and unvacuolated. When the wound healed the new young cells took on the appearance of the old cells of the original culture.

Moreover, saline extracts of wounded tissue cultures were able to revive growth in other cultures in which growth was latent from lack of embryo juice. Fischer (1930) therefore concluded that the injured cells produced a chemical growth stimulant. "Among the factors involved in a simple process of regeneration as the wound-healing (sic) is the liberation of substances with growth promoting properties which are set free by the mutilated cells..." (Fischer, 1941b).

This view is however by no means universally accepted. Willmer (1935, p.18) states that the results of experiments on tissue cultures, parts of which were exposed to the injurious action of ultra-violet light, do "not argue in favour of the liberation of growth stimulating substances by the injured or dead cells".

Cameron (1935) states that the growth of tissue cultures can also be stimulated by extracts from inflamed tissue, while Menkin (1941) has produced evidence that injured cells liberate one or possibly several proliferation promoting factors into inflammatory exudates. When injections of sterile inflammatory exudates were repeatedly made into the subcutis of a rabbit's ear over a long period of time, a severe inflammatory reaction resulted. Months after cessation of the injections, marked proliferative activity characterised by hyperplasia and metaplasia of the normal epithelial layer occurred. The cartilage of the ear at the site of the injections also showed marked proliferative activity. In some cases the proliferation response was definitely neoplastic in type. The nature of the substances liberated into inflammatory exudates by injured cells is unknown.

The metabolism of cells and tissues is of course altered by injury. This problem has been reviewed by Fleischmann (1939). Increases in respiration and glycolysis as the result of the action of substances released by injured cells are reported by Cook and Fardon (1942). These factors are stated to be distinct from the growth promoting factors liberated

at the same time.

The metabolism of healing wounds in skin has actually been measured by Gaza and Gissel (1932) and found to be high during the active repair process.

D. Wounds in the intact organism.

Direct evidence of the production of growth-promoting substances when the intact organism is injured locally or generally is much more difficult to obtain. As the result of observations on the healing of wounds in an insect, Rhodnius prolixus Hemiptera, Wigglesworth (1937) concluded that the injured cells produced chemical substances which caused "activation" or enlargement of the surrounding epidermal cells and provided a chemotactic stimulus to their migration and concentration round the wound. Information about the chemical nature of these substances is scanty, but they are believed to be protein degradation products produced by autolysis of proteins in the injured cells. The migration of activated cells is stimulated not only by these products but by proteins and especially by peptones from many sources, while amino acids and simple peptides appear to be inactive.

Carrel (1922, 1924, 1930) concluded that similar

explained his observation that repeated wounds and fractures in man appeared to heal more quickly than primary ones. The factors which accelerated ossification in fractures were claimed to appear in the blood within five or six days and to be destroyed by heating for 30 minutes to 70°C. Apparently similar materials termed "cytopoiétines" by Carnot and Terris (1926) were extracted from regenerating skin and applied successfully to the acceleration of wound healing.

The presence of such substances in regenerating tissue is also suggested by the work of Mackenzie and Rous (1941) who found that while the application of a carcinogenic tar to rabbit skin rendered many more epidermal cells neoplastic or potentially neoplastic than ever gave rise to tumours, yet the stimulus of wound healing in such a tarred area could suffice to cause some such cells to multiply and form tumours.

The existence of such growth activators in damaged or regenerating tissue is, however, still obscure and no attempts at isolating them have succeeded.

As Young, Fisher and Young (1941) point out, "so far as wound healing in the living animal is concerned these growth-promoting substances are still

theoretical and highly speculative because no precise means are available of demonstrating them either chemically or biologically". If these substances exist they might be expected to be abundant at the stage of wound healing when proliferative activity is most vigorous. With this in mind, Young, Fisher and Young (1941) measured the rate of healing of both primary and secondary experimental wounds in rabbits, the secondary wounds being inflicted some ten or twelve days after the primary ones. In a statistically significant number of cases the secondary wounds healed at a greater rate than the primary wounds and the authors suggest that the latter may be the source of a factor or factors which tend to accelerate the healing of the secondary wounds. This factor may be a chemical agent, a growth-promoting substance elaborated by the primary wound, or it may be a by-product of a general or tissue immunity or it may act in some quite different way.

Menkin (1943a,b,c) has reported the presence in inflammatory exudates of at least two factors liberated at the site of recent injury. One, a "euglobulin", has been termed "necrosin". It induces severe tissue injury accompanied by lymphatic blockade and a marked

leucopenia. The other, a "pseudoglobulin", is a leucocytosis promoting factor which acts on the bone marrow causing a marked hyperplasia of the myeloid elements and releasing immature leucocytes into the blood stream.

Menkin's work has been reported in a long series of papers (Menkin, 1937-1943; Menkin and Kadish, 1938, 1943) which cannot adequately be summarised here.

The liberation by damaged cells of substances with the activity of the embryonic inductor responsible for neurulation has been suggested by the recent work of Holtfreter (quoted by Berrill, 1943).

The release of adenylic compounds, e.g. adenosine or adenylic acid (see p.189) by injured tissues has been reviewed by Drury (1936). Bennet and Drury (1931) found evidence for the release of adenylic compounds in cardiac muscle injured by heat. In the same way, adenylic compounds may be liberated during surgical operations, thermal, X-ray and ultraviolet burns, and may play a part in the onset of shock (Drury, 1936). The possibility that adenosine triphosphate released by injured muscle tissue might influence the onset of shock has recently been suggested by Green (1943). An adenylic compound is

reported to be released as the result of tissue injury by trypsin (Trethewie, 1942).

If protein derivatives are found among the products of injured cells, it would not be surprising that nucleic acid derivatives should accompany them. To what extent the adenylyl compounds mentioned above are derived from the breakdown of nucleic acid is unknown (adenosine triphosphate is of course a normal constituent of muscle), but it has been shown that, when living skin is exposed to moderately high temperatures, some nucleoprotein is lost from the nuclei of the epidermal cells (Leach, Peters and Rossiter, 1943).

2. EXPERIMENTAL METHODS AND RESULTS.

Loofbourow's conclusions concerning the chemical nature of the growth promoting substances are based mainly on qualitative tests and on spectrographic evidence. It therefore seemed desirable to carry out quantitative chemical analyses of the products released by yeast cells injured by ultraviolet irradiation.

150 g. fresh D.C.L. bakers' yeast (Saccharomyces

cerevisiae) were washed twice on the centrifuge with 0.9% NaCl solution and were then suspended in 750 ml. of the same solution. The suspension was divided into three equal portions. One portion (a) was autoclaved at 120° for 20 min. Such treatment destroyed cell structure. The second portion (b) was exposed for 6 hr. at 13 cm. distance to ultraviolet light from a quartz mercury vapour lamp (3.5 amp., burner volts 150) by being repeatedly run through the rack of quartz tubes described by Stiven (1930) at such a rate that the temperature of the suspension never exceeded 40°. A third portion (c) was kept for the same time and at the same temperature as a control but without exposure to ultraviolet light.

The effect of irradiation was followed by withdrawing a drop of the suspension from time to time, treating it with methylene blue and examining microscopically. Living yeast cells are not stained by methylene blue while injured and dead cells stain deeply (Richards, 1932; Mills, 1941). At the outset only 1% of the cells stained, but at the end of irradiation 60% stained. The cells were shrunken. In the control suspension 10% of the cells stained at the end of the period. In both cases the total number of

cells, counted in a haemocytometer chamber, was unaltered.

The three suspensions were finally centrifuged and the clear supernatant fluid collected. The extract from the autoclaved suspension (a) was deep yellow in colour, that from the irradiated cells (b) yellow, while the extract from the control (c) was colourless. All showed a blue fluorescence in ultraviolet light, the control being only slightly fluorescent. All extracts were kept at 0° and analysed immediately, as they were, especially in the case of the extract from irradiated cells, excellent media for bacterial growth. Extract (b), which had pH 5.8, gave a positive biuret test but no precipitate on boiling or with nitric acid. It gave a precipitate with tungstic acid. Extract (c) from the control gave a negative response to the biuret test and no precipitate with tungstic acid. Extract (a) from autoclaved cells was heavily loaded with protein.

In the three extracts total N was estimated by the micro-Kjeldahl procedure, amino-N by the manometric method of Van Slyke, non-protein-N after deproteinization with tungstic acid, and nucleotide, nucleoside, and free purine-N by the method of Kerr and Blish

Table 14.

*Analyses of centrifuged extracts from autoclaved,
irradiated and control cells*

Extract from ...	(a) Autoclaved cells mg./100 ml.	(b) Irradiated cells mg./100 ml.	(c) Control cells mg./100 ml.
Dry wt. (excluding NaCl)	1705	1164	280
Total N	148.4	104.9	12.6
Non-protein-N	72.8	96.2	10.5
Protein-N (by difference)	75.6	8.7	2.1
Amino-N (non-protein)	57.4	63.3	9.0
Nucleotide-N	11.8	11.8	0.4
Nucleoside- and free purine-N	2.9	9.4	1.4

(1932) as modified by Kerr (1940).

Several separate batches of yeast were treated in this way at different times and the results of a typical experiment are shown in Table 14.

Irradiation sets free a large amount of nitrogenous material. A very small amount is in the form of protein while a high proportion is present as amino-N. Much more N than in the case of the control is present in the form of nucleotide, nucleoside and purine:

Table 14(b).

Complete destruction of the cells yields an extract with much protein. The non-protein-N is chiefly amino-N: Table 14(a).

After treating the extract from irradiated cells with 10% sulphuric acid to hydrolyse nucleic acid derivatives after the method of Jones (1920), adenine was isolated both as the picrate and the sulphate. Small amounts of guanine were also found. Thus it is probable that the nucleotide and nucleoside fractions are chiefly adenine derivatives with small amounts of guanine present.

The growth-promoting powers of the three extracts were tested by seeding Reader's medium (Reader, 1927) with a dilute suspension of yeast cells. Varying

Ordinate: number of cells per ml.
After 24 hrs. at 21°C.

Figure 10.

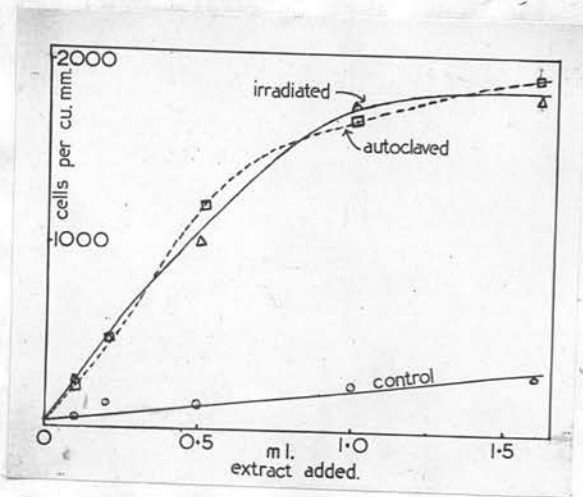

Effect of increasing amounts of cell free extracts from irradiated, autoclaved and control cells on the growth of yeast in Reader's medium. Abscissa: amount of extract added to each culture flask. Ordinate: number of cells per cu. mm. after 24 hrs. at 21°C.

Figure 11.

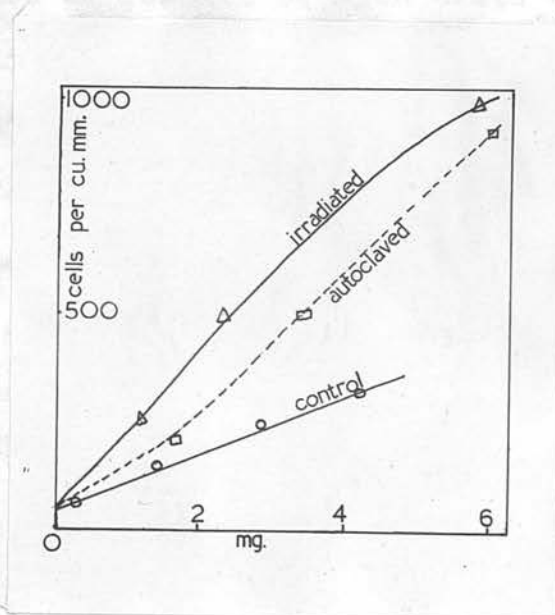

Effect of increasing amounts of material from irradiated, autoclaved and control cells on the growth of yeast in Reader's medium. Abscissa: weight of material added to each culture flask. Ordinate: number of cells per cu. mm. after 24 hrs. at 21°C.

amounts of the extracts were added to the media and the cultures grown at 21° in Erlenmeyer flasks as recommended by Williams & Saunders (1934) and by Narayanan (1930). The crop was estimated after 20 hr. by counting the cells in a haemocytometer.

Examples of results of such tests are shown in Figs. 10 and 11. When equal volumes of the extracts are compared (Fig. 10), extract (b) from irradiated cells was found to have about six times the growth promoting power of extract from the control. The irradiated suspension had six times as many cells injured as the control suggesting a correlation between cell injury and liberation of growth promoting material. The extract (a) from autoclaved cells stimulated growth as powerfully as (b). When, however, the materials in the various extracts are compared on a weight for weight basis (Fig. 11), a different picture appears. The material from irradiated cells is much more active than an equal weight of material from the control cells, and appreciably more active than the material from autoclaved cells. These results suggest that irradiation sets free growth promoting materials which are either more active or relatively more abundant, than those produced by total destruction of the cells.

A few experiments were also carried out in which small amounts of suspensions of rabbit leucocytes, obtained by the method of de Haan (1938), were irradiated at 37° with ultraviolet light in a quartz test tube provided with a magnetic stirrer. The extracts obtained were found to have a considerably greater growth promoting action on yeast cells than those of control extracts. The extracts of the irradiated leucocytes also had a higher N content and a more marked blue fluorescence in ultraviolet light than control extracts.

In view of the statement by Loofbourow and Dwyer (1939) that growth promoting substances are also produced under the action of X-rays experiments were carried out in which yeast cells were exposed to X-rays in doses up to 100,000 r. (with back scatter, unfiltered, 50 Kv., 2 m.a., 15 cm. distance from the tube). This appeared to have very little injurious effect on the cells and caused no appreciable liberation of nitrogenous materials into the surrounding medium. This medium did not stimulate yeast growth more than did the corresponding fluid from control cells. This is in agreement with the findings of Pourbaix and Kennaway (1928). According to Henshaw

and Turkowitz (1940), yeast cells are either unaffected by Röntgen rays or are killed outright, rather than injured, if the dosage is very high.

A few preliminary experiments have also been carried out in which living chick embryos were exposed to X-rays using conditions and dosage similar to those employed by Mitchell (1942) in his experiments on nucleotides in tumour tissue (see p.231). Ten day or thirteen day chick embryos were exposed to a dose of 1000 r. at 75.5 r. per minute (250 Kv., 10 m.a., F.S.D. 40 cm.). Sixteen hours later the embryos were removed from the shells. The nucleotide and nucleoside contents were the same as in control embryos and extract from them had no greater or smaller growth promoting power than extract from control embryos.

Another method was adopted for examining the effects of irradiation on living animal cells. Roller tubes (see p. 57) were constructed of quartz. In each of four such tubes twelve pieces of fresh nine day chick heart were explanted in plasma clot. Embryo extract was added and the tubes allowed to rotate in the incubator for two days. The embryo extract was then removed from the actively growing cultures which were washed with Tyrode solution, 0.5 ml. Tyrode being

left in each tube. The tubes were then transferred to a drum rotating in a thermostatically controlled (38°C.) cabinet one side of which was cut away to take the front of a "Hanovia" analytical ultraviolet lamp. Control tubes on the drum were screened by lead foil. After a suitable period of irradiation, e.g. 15 min., the fluid phase from each tube was transferred to an ordinary roller tube with six explants which had rotated for two days in Tyrode solution as for the usual tissue culture test described in Section I. After a further two days the N.P.P. was determined in the roller tubes in the usual way. There was no difference in growth promoting power of the extracts from irradiated and control cells.

These latter experiments have been only of a preliminary nature but they yield no evidence of the liberation of growth promoting factors by irradiated tissues.

Discussion.

A large number of substances can accelerate yeast growth, for example, such components of the bios group as inositol, aneurin, biotin, pantothenic acid and adermin. Other substances with similar properties are found in liver extracts (Williams et al., 1940).

Amino-acids such as leucine (Miller, 1936), alanine, aspartic acid, glutamic acid, lysine and arginine stimulate yeast growth, and mixtures of these substances have a more pronounced effect than equivalent amounts of the acids alone (Nielsen & Hartelius, 1938; 1939). Lysine and arginine are known to be plentiful in the proteins of yeast (Kraut & Schlottmann, 1937).

Such being the case, it is not surprising that rupture of yeast cells by autoclaving should liberate substances with growth-promoting properties towards yeast. Irradiation of yeast, however, yields a surprisingly potent extract without destruction of the cells. This extract has even more non-protein nitrogenous matter than the extract from autoclaved cells. The slow death of the yeast cell does seem to cause liberation of substances into the surrounding medium but it is impossible to say whether or not this is a specific response to injury and an attempt to compensate for the death of some cells by accelerated growth of others.

Among the nitrogenous materials are nucleotides and nucleosides containing adenine and it is highly probable that their presence accounts for the

spectrographic findings of Loofbourow et al. But it seems premature to conclude that these adenine nucleotide complexes are necessarily the active principles in the extract from irradiated yeast which are responsible for stimulating the growth of yeast, or that they are elaborated by the cells as a specific response to injury.

Two possibilities must be considered. The nitrogenous materials may be merely disintegration products of the dying and dead cells, liberated however, without rupture of the cell membrane, or the effect of the injury may be to alter the permeability of the cell membrane so that some of the cell contents escape. In either case the material from the irradiated cells might be expected to be qualitatively similar to that from autoclaved cells but to be less in quantity. This, however, is not the case since the organic material from irradiated cells is weight for weight more potent as a growth factor than the material from autoclaved cells, and much more so than the material from control cells. Moreover the material from irradiated yeast cells gives, in contrast to that from autoclaved cells, strongly positive tests for sulphhydryl groups. Similar positive sulphhydryl tests were

obtained by Pourbaix and Kennaway (1928) on extracts of yeast cells which had been exposed to the injurious influence of ultraviolet light, heat, grinding, freezing and thawing and certain chemical agents. The biological activity of sulphhydryl compounds is well known, and their growth promoting action has already been reviewed by Hammett (1934, 1936) and by Riley (1940) (see p. 11), but the extent to which the growth promoting power of the extracts from irradiated cells is due to -SH compounds is unknown.

It would appear to be reasonably beyond doubt that injured cells set free substances as the result of the breakdown of their own protoplasm. These substances may, under suitable circumstances, stimulate tissue growth and so aid regeneration, but whether the substances are synthesised ad hoc by the injured cells or are merely products of protein or nucleoprotein breakdown with general nutritive properties is not clear.

The liberation of protein degradation products by injured cells is a well established and hardly surprising phenomenon. It is reasonable to suppose that the intact cells with which they come into contact utilise them as food materials, but whether they provide

a more specific stimulus to growth in the sense that their effect is wholly or partially catalytic in nature is much more problematical.

The growth-promoting action of protein degradation products is, of course, well known and has already been discussed (p. 38). Moreover, among the protein split products are compounds of specific biological activity. These include for example the polypeptides gramicidin (Dubos, 1942), hypertensin (Houssay and Braun-Menendez, 1942), trypsin inhibitor (Northop, 1939), the polypeptide responsible for some of the phenomena of acute inflammation (Duthie and Chain, 1939) and, probably, the anti-anaemic principle of liver (Karrer, 1941; Subbarow, 1942). However, until the protein degradation products from injured cells can be shown to be produced as a specific response to injury and to have some specific catalytic activity as growth stimulants rather than general nutritive properties, the question of their falling into the category of true wound hormones must remain open.

SUMMARY.

1. The existence is discussed of the so-called "wound

hormones", substances produced by living cells as a specific response to injury, which have the power of stimulating the growth of uninjured cells.

2. In the case of plants such "wound hormones" exist and their chemical constitution is known.
3. There is some evidence that injured animal tissues are the source of a factor (or factors) which accelerates tissue proliferation and the healing of secondary wounds but the nature of this factor is unknown. The implications of this factor in wound healing are discussed.
4. Injured yeast cells produce nitrogenous materials containing protein degradation products and nucleic acid derivatives of the pentose nucleotide type. These substances stimulate the growth of fresh yeast cells, but whether they are produced as a specific response to injury or are merely degradation products of dead and dying cells released perhaps as the result of increased permeability is not yet certain.

THE RELATIONSHIP OF NUCLEIC ACIDS AND
THEIR DERIVATIVES TO TISSUE GROWTH.

I. REVIEW OF LITERATURE.

As a result of the pioneer work of Miescher, Kossel, Jones, Levene and others, it has been generally recognized that two types of nucleic acid exist. The

PART III.

one type, ribonucleic acid, contains the sugar ribose and uracil as one of its pyrimidine bases, whereas the

THE RELATIONSHIP OF NUCLEIC ACIDS AND

other type, deoxyribonucleic acid, contains the sugar deoxyribose and the purine base thymine in place

of uracil. It was originally thought that ribonucleic acid was characteristic of yeast cells and plant tissues generally, while deoxyribonucleic acid characterized animal cells, but this view has now been abandoned.

Recent work from Sweden (T. Caspersson), Denmark (A. Fischer) and the United States (A. Claude, A. E. Mirsky) has drawn attention to the probable importance of the nucleic acids and nucleoproteins in animal tissue particularly in connection with cellular activity, and has suggested that nucleoproteins containing pentose nucleic acids ('ribonucleoproteins') play a special role in protein synthesis and tissue growth. Although the association between the deoxyribonucleic

THE RELATIONSHIP OF NUCLEIC ACIDS AND
THEIR DERIVATIVES TO TISSUE GROWTH.

1. REVIEW OF LITERATURE.

As a result of the pioneer work of Miescher, Kossel, Jones, Levene and others, it has been generally recognised that two types of nucleic acid exist. The one type, ribonucleic acid, contains the sugar ribose and uracil as one of its pyrimidine bases, whereas the other type, desoxyribonucleic acid, contains the sugar desoxyribose and the methylated base thymine in place of uracil. It was originally thought that ribonucleic acid was characteristic of yeast cells and plant tissues generally, while desoxyribonucleic acid characterised animal cells, but this view has now been abandoned.

Recent work from Sweden (T. Caspersson), Denmark (A. Fischer) and the United States (A. Claude, A. E. Mirsky) has drawn attention to the probable importance of the nucleic acids and nucleoproteins in animal tissues particularly in connection with cellular activity, and has suggested that nucleoproteins containing pentose nucleic acids ('ribonucleoproteins') play a special role in protein synthesis and tissue growth. Although the association between the desoxyribonucleic

acid of cell nuclei and the processes of cell division has been known for a long time, attention has only recently been attracted to the nucleoproteins containing pentose nucleic acid which are now known to be constituents of many self-reproducing filterable viruses and which appear to be abundant in the rapidly growing cells of embryos, tumours and regenerating tissues. The evidence for their association with the processes of growth is reviewed here.

A. Structure of the Nucleic Acids.

The condensation product of a purine or pyrimidine base with a sugar radical and phosphoric acid forms a nucleotide (Fig. 14). According to the generally accepted view, when four such nucleotides, each containing a different base, are condensed together, the resulting tetranucleotide forms the unit out of which the nucleic acids or polynucleotides are built by a process of polymerisation. As these polymers occur not only in the nucleus, the term polynucleotide is preferable to nucleic acid. If the sugar radical is desoxyribose the produce is a desoxyribopolynucleotide or desoxyribonucleic acid (thymonucleic acid, animal nucleic acid, chromonucleic acid); if it is a pentose,

the product is a pentose polynucleotide or pentose nucleic acid (zymonucleic acid, phytonucleic acid, plasmonucleic acid, ribonucleic acid). In only one polynucleotide, that of yeast, has the pentose been conclusively proved to be ribose (Gulland and Barker, 1943). In this case alone, therefore, is the term ribonucleic acid or ribopolynucleotide fully justified. In other cases the pentose is probably also ribose, but until conclusive proof is forthcoming, it would be better to retain the more general term pentose polynucleotide.

The structure of the nucleic acids has been reviewed by Levene and Bass (1931), Gulland (1938, 1944), Allen (1941) and others.

Desoxyribopolynucleotide (desoxyribonucleic acid, thymonucleic acid) originally obtained from the thymus gland is built up from the two purine bases adenine and guanine, the two pyrimidine bases cytosine and thymine, phosphoric acid and the carbohydrate, d-2-desoxyribofuranose (Fig. 12), the bases being condensed each with one molecule of sugar and one of phosphoric acid in the form of nucleotides. Polymerisation of the nucleotides results in the formation of long fibrous molecules of molecular weight

Figure 12.

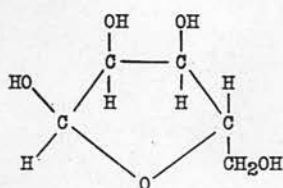

d-Ribofuranose

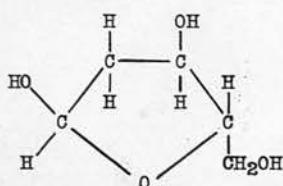

d-2-deoxyribofuranose

500,000-1,000,000 as shown by X-ray measurements (Astbury and Bell, 1938) and by measurements of viscosity and double refraction of flow (Signer, Caspersson and Hammarsten, 1938).

The biological importance of this nucleic acid has been reviewed by E. Hammarsten (1939). Its properties depend to a large extent on the method of its isolation. The older drastic methods (e.g. that of Levene and Bass, 1931) produced a very different material from that obtained by more recent and much milder procedures, e.g. that of Mirsky and Pollister (1942).

Yeast ribopolynucleotide (yeast ribonucleic acid)

is made up of similar nucleotide units in which the bases are adenine, guanine, cytosine and uracil and the carbohydrate is mainly d-ribofuranose (Fig. 12). Small amounts of l-lyxose may also be present (Gulland and Barker, 1943). The exact structure of the tetranucleotide unit formed (Figs. 13a, 13b) is still unknown (see Gulland, 1938, 1944), and the degree of polymerisation of these units in the cell is a matter of some doubt. The sum of the molecular weights of the four constituent nucleotides in 1357, a figure which agrees well with the value of 1300-1700 found

Yeast nucleic acid
 A Levene and Sim's formula.
 B Makino's formula. Hydrolytic action at the dotted lines gives Levene's formula.
 From Gulland (1938).

Figure 13b.

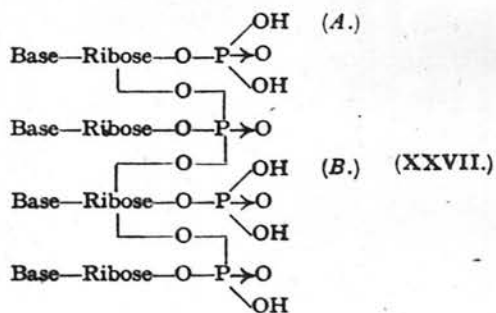
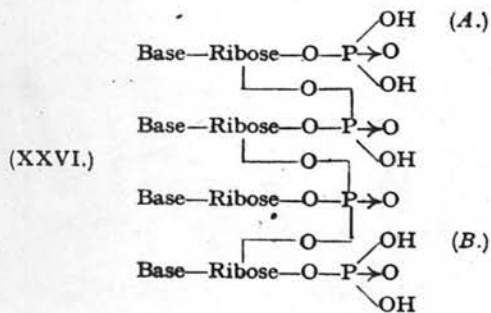
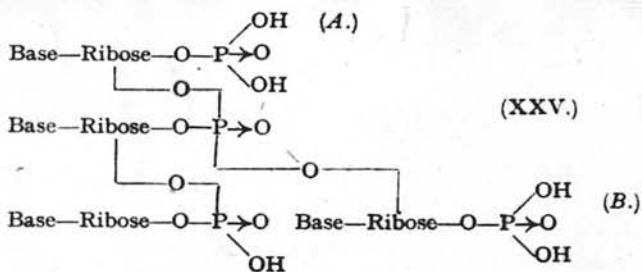

Possible structures for the tetranucleotide unit of yeast ribonucleic acid. Polymerisation to form the polytetranucleotide would occur either through group (A) or through group (B).
 (Gulland, 1944).

by Myrbäck and Jorpes (1935) for the molecular weight of isolated material. A much higher figure (10,000) was found by Fischer, Böttger and Lehmann-Echternacht (1941). Fletcher, Gulland, Jordan and Dibben (1944) found molecular weights between 10,280 and 23,250 depending on the commercial source of the nucleic acid employed. As Fischer (1942) and earlier authors, e.g. Steudel and Peiser (1922), Johnson and Harkins (1929), have pointed out, yeast ribonucleic acid, although usually prepared by alkaline extraction, is labile towards alkali, and the molecular weight and degree of polymerisation thus vary considerably according to the method of preparation. In the case of both ribo- and desoxyribonucleic acids, especially the former, some of the methods employed in the process of isolation may bring about considerable alteration in properties (Mayer and Gulick, 1942; Cohen, 1942). This is well exemplified in the case of virus ribonucleic acid (vide infra).

Yeast ribonucleic acid is attacked by a heat stable enzyme discovered by Jones (1920a), partially purified by Dubos and Thompson (1938) and crystallised by Kunitz (1940) who named it "ribonuclease". Its action has been investigated by several authors

(Kunitz, 1940; Eiler and Allen, 1941; Allen and Eiler, 1941; Loring and Carpenter, 1943) but is still imperfectly understood. It appears, however, to bring about partial breakdown of the ribonucleic acid molecule with the liberation of some mononucleotide units. It has no action on desoxyribonucleic acid, and it does not hydrolyse egg albumin, haemoglobin, peptone, mucoproteins or polysaccharides of animal plant or bacterial origin according to Dubos and Thompson (1938) though an unpublished account by Mazia quoted by Gersh and Bodian (1943) suggests that it may have some effect on fibres of denatured thymonucleohistone, egg albumin, casein and haemoglobin. It has no effect on synthetic phosphoric esters (Eiler and Schmidt, 1941).

Kunitz (1940) found that the products of its action on ribonucleic acid contained no inorganic P but were diffusible through a collodion membrane. Whereas 100% of the P in ribonucleic acid can be precipitated by a mixture of 0.25% uranyl acetate in 2.5% trichloroacetic acid after the reaction with ribonuclease has gone to completion only 40% of the P is so precipitable (see also Smolens and Sevag, 1942; Hoagland et al., 1943).

The nature of the reaction catalysed by ribonuclease is obscure. Schmidt and Levene (1938) suggested that the enzyme was a depolymerase breaking down high molecular weight tetranucleotides to those of lower molecular weight but the action is almost certainly more complex than this.

According to Eiler and Allen (1941) and Allen and Eiler (1941) its action is to liberate an acidic group in the range of a secondary phosphoric acid group dissociation (ribonucleic acid has four acidic groups in the range of the first and second dissociable phosphoric acid groups). The liberation of the fifth acidic group may indicate opening of a cyclic structure. Bolomey and Allen (1942) found that preliminary treatment of ribonucleic acid with ribonuclease increased the yield of inorganic phosphate, guanosine and adenosine when the residue was treated with a non-specific phosphatase. They suggested the possibility that guanylic acid lay at one end of a chain with adenylic acid either next to it or at the other end.

From the products of the reaction of crystalline ribonuclease on yeast ribonucleic acid Loring and Carpenter (1943) have isolated all four mononucleotides.

As the action of the enzyme therefore seems to be that of a depolymerase, even though other products of higher molecular weight than the mononucleotides may be formed as well, they suggest that the enzyme should be called "ribonucleinase".

The physical and chemical properties of crystalline ribonuclease have been described by Fankuchen (1940-41), Rothen (1940-41), and Uber and Ells (1941). It can act as an antigen (Smolens and Sevag, 1942); it inhibits certain enzyme systems (Potter and Albaum, 1942); and it reversibly inactivates tobacco mosaic virus (Loring, 1942).

The pentose polynucleotide of the pancreas. In 1894 O. Hammarsten prepared a substance from the pancreas to which the name " β -pancreas nucleoprotein" was applied. From this material Bang (1898-99, 1900-01) prepared a "guanylic acid" which could be precipitated from a solution of its salts by acetic acid, and assumed that this acid was the prosthetic group of the nucleo-protein. About the same time Levene (1901, 1902-03, 1922) also found desoxyribonucleic acid in the pancreas. Later this was shown (Steudel, 1935) to contain thymine among its bases.

The subject of the " β -pancreas nucleoprotein" was later taken up by Feulgen (1919-20), E. Hammarsten

(1920) and Hammarsten and Jorpes (1922) who concluded that the nucleic acid was a pentose polynucleotide. The suggestion that a pentose polynucleotide might be found in the pancreas was supported by the work of Berkeley (1921) who had found an adenine pentose phosphoric acid along with guanylic acid in dogfish pancreas while Jones and Perkins (1924-25) isolated crystalline guanine, adenine and cytosine pentose nucleotides from the " β -pancreas nucleoprotein" and reported that a substance resembling the guanylic acid of the pancreas occurred in spleen and liver. The suggestion that ribonucleic acids (polynucleotides) may be widespread in animal tissue dates from this time.

About the same period Jorpes (1924) isolated crystalline brucine salts of cytidine and uridine phosphoric acids from pancreas nucleic acid. The isolation and properties of the parent polynucleotide were described in a series of papers by Jorpes (1928, 1934) who supported the view that the acid was a pentanucleotide containing three molecules of purine pentose nucleotides (guanine : adenine ratio - 2 : 1) and two molecules of pyrimidine nucleotides. It is acted on by ribonuclease (Eiler and Schmidt, 1941)

Pentose polynucleotides of virus nucleoproteins.

A third source of pentose nucleic acids is to be found in certain of the highly purified filterable viruses such as tobacco mosaic virus (Loring, 1939), ring spot virus (Stanley, 1939), the Rous sarcoma virus (Claude, 1938, 1939, 1940) and the virus of equine encephalomyelitis (Taylor, Sharp, Beard and Beard, 1943). Of these the nucleic acid of tobacco mosaic virus has received most attention since its first isolation from the virus nucleoprotein by Loring (1939). From the hydrolysis products guanine, adenine, cytosine and the brucine salt of an acid similar to, and probably isomeric with, yeast uridylic acid were obtained. Like yeast ribonucleic acid it is attacked by ribonuclease when in the free state but not when bound to the native virus protein (Loring, 1939, 1942; Cohen and Stanley, 1942a). The intact virus is inactivated reversibly by the crystalline enzyme (Loring, 1942), a dissociable enzyme virus complex being formed.

The virus nucleic acid appears to be highly polymerised. When methods involving the use of alkali were avoided, Cohen and Stanley (1942b), by extraction with sodium chloride from the heat denatured virus protein, obtained a highly asymmetric nucleic acid with

Figure 14.

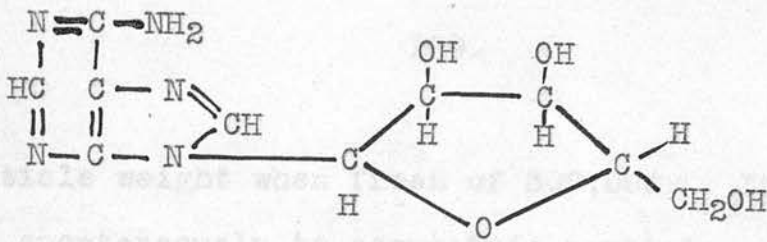

adenosine

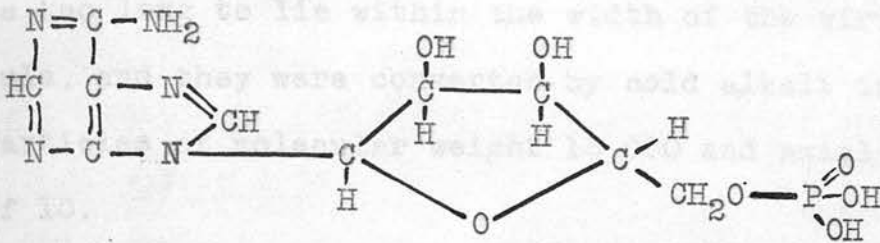

muscle adenylic acid (adenosine-5-phosphoric acid)

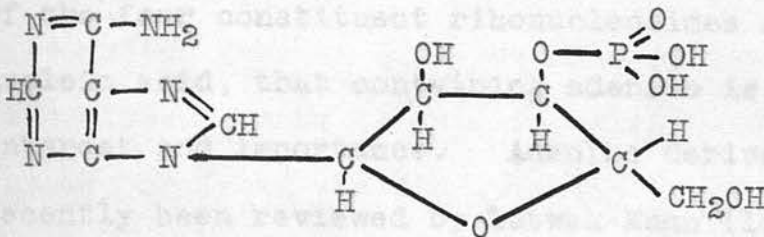

yeast adenylic acid (adenosine-3-phosphoric acid)

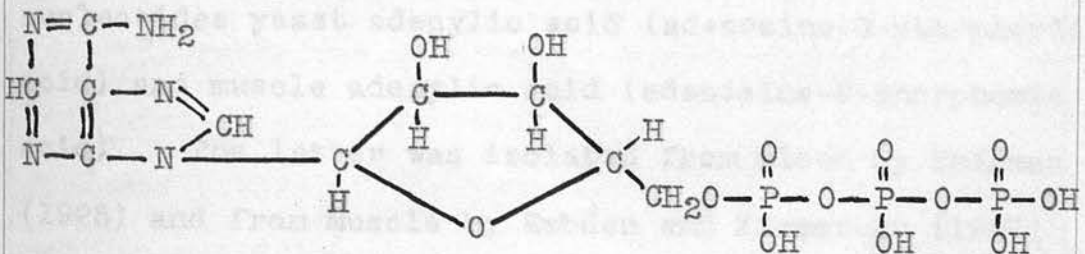

adenosine triphosphate (adenyl pyrophosphate)

disaccharide are well known for the part they play as a particle weight when fresh of 300,000. It decomposed spontaneously to asymmetric particles of particle weight 61,000. Both of these particles appeared to be too long to lie within the width of the virus molecule, and they were converted by cold alkali into particles of molecular weight 15,000 and axial ratio of 10.

Nucleotides (Fig. 14). Desoxyribomononucleotides are not known to occur in the free state in tissues. Of the four constituent ribonucleotides of yeast nucleic acid, that containing adenine is of greatest interest and importance. Adenine derivatives have recently been reviewed by Lutwak-Mann (1939). They include the nucleoside adenosine whose pharmacological action has been reviewed by Drury (1936), and the two nucleotides yeast adenylic acid (adenosine-3-phosphoric acid) and muscle adenylic acid (adenosine-5-phosphoric acid). The latter was isolated from blood by Hoffman (1925) and from muscle by Embden and Zimmerman (1927) where it is formed by the dephosphorylation of adenosinetriphosphate (adenyl pyrophosphate) (Fig. 14). This and other adenine nucleotides such as the nicotinamide nucleotides (diphosphopyridine nucleotide and triphosphopyridine nucleotide) and riboflavin-adenine

dinucleotide are well known for the part they play as co-enzymes. Their function in this capacity has been reviewed by Warburg (1938), Baumann and Stare (1929) and by Allen (1941).

B. Methods of differentiating between the two types of Nucleic Acid.

(i) Chemical methods. These methods depend upon specific tests for desoxypentoses and pentoses.

(a) Tests for desoxypentoses. Dische's (1930) test, which depends upon the reaction of desoxypentoses with diphenylamine in acid solution to form a blue colour, has been applied quantitatively by Sevag, Smolens and Lackman (1940) and by Vowles (1940).

Feulgen's test has been quantitatively applied by Widström (1928) and modified by Caspersson (1932).

(b) Tests for pentoses. Bial's orcinol test has been applied quantitatively, e.g. by Dische and Schwartz (1937), by Mejbaum (1939) and by Barrenscheen and Peham (1941a).

Most tests (e.g. those of Hoffman (1927) and of Reeves and Munro (1940)) depend upon the formation from pentoses of furfural which can be colorimetrically estimated by its reaction with such substances as

aniline acetate. been used by Schultz (1931) as differ-

(ii) Histochemical methods.

(a) The Feulgen test (Feulgen and Voit, 1924).

The reagent used in this test is fuchsin decolourised by sulphurous acid as used in the Schiff's test for aldehydes. Desoxyribonucleic acid by virtue of its desoxysugar group gives the test (brings back the purple colour of the fuchsin) after gentle hydrolysis with 0.1 N HCl. The test can be applied histologically to tissue sections. Cell nuclei stain a striking purple colour.

The interpretation of the mechanism of the test may have to be modified (Choudhuri, 1943) in the light of the work of Stedman and Stedman (1943a, b, c) on chromosomin.

(b) Ribonucleic acid can be detected histochemically in fixed tissue sections using the test described by Brachet (1940) which depends on the fact that the enzyme ribonuclease attacks specifically the ribonucleic acids digesting them out of the sections which therefore no longer show such deeply basophilic staining.

The Brachet test has been described independently by Painter and Taylor (1942) and by Gersh and Bodian

(1943), and has been used by Schultz (1941) at different pH values.

The orcinol test has been used histochemically by Mitchell (1942).

C. The Distribution of Polynucleotides in Animal and Plant Tissues.

The nucleic acids which were first isolated were ribonucleic acid from yeast and desoxyribonucleic acid (thymonucleic acid) from the thymus gland, and for a time it was considered that "there are but two nucleic acids in nature, one obtainable from the nuclei of animal cells, and the other from the nuclei of plant cells" (Jones, 1920b).

At the same time it was known that pentose derivatives in addition to the " β -pancreas nucleoprotein" already mentioned were present in animal tissues (Blumenthal, 1898; Grund, 1902; Wohlgemuth, 1903; Neuberg, 1904; Mendel and Leavenworth, 1908; Jenkinson, 1914). As well as the more recently discovered mono- and di-nucleotide coenzymes containing adenine, pentose nucleotides of other bases presumably derived from ribonucleotides have been prepared, e.g. of uracil (Levene and Mandel, 1906) from eggs of the ^{haddock} ~~xxx~~

(Gadus aeglefinus) and all four nucleotides of ribonucleic acid (Calvery, 1928) from hydrolysates of chick embryo pulp. The presence of a ribopolynucleotide acid in the mammary gland is suggested by Odenius (1900) and Mandel and Levene (1905), and both types of polynucleotide have been found in sea urchin eggs (Blanchard, 1935). As a result of this work and of the work of Jones and Perkins (1924-25) on ribonucleotides in spleen and liver and of similar observations by Thomas and Berariu (1924) doubts arose as to the validity of earlier views on the distribution of nucleic acids, e.g. "the distinction between animal and plant nucleic acid will in future not be so definitely drawn" (Jones and Perkins, 1924). About this time the suggestion (c.f. Jorpes, 1928) was made that ribonucleic acids might be widespread in animal tissues, and was supported by the subsequent histochemical observations of Brachet (1933, 1937, 1940a & b) on amphibia, of Desclin (1940) on the anterior pituitary of the growing rat and guinea pig, and of Painter and Taylor (1942) on toads' eggs.

The presence of large amounts of pentose nucleic acids as well as desoxyribonucleic acid has been demonstrated in the tissues of the embryo and adult sheep in

the present investigation (p.251).

The discovery of pentose nucleic acid in animal tissues has of course meant the abandonment of the early view that desoxyribonucleic acid alone is characteristic of animal tissues and ribonucleic acid of plant tissues. Desoxyribonucleic acid has moreover been located not only in animal cells but also in the cell nuclei of plant tissues (Feulgen and Rossenbeck, 1924; Kiesel and Belozerski, 1934; Belozerski, 1936; Belozerski and Uspenskaya, 1942, Behrens, 1938a) including yeast cells (Delaporte and Roukheldman, 1938). Both types of nucleic acid are present in bacteria (Sevag, Smolens and Lackman, 1940). From bacteria Henry and Stacey (1943) have extracted ribonucleic acid as the magnesium salt and have suggested that the Gram positive (dye retaining) material is a high molecular complex formed by combination of a reduced basic protein substrate with magnesium ribonucleate.

Recent work has also led to the view that nucleic acids are not confined to the nucleus. As long ago as 1905 Beebe and Shaffer suggested that pentose derivatives might be present in the cytoplasm of tumour cells, and such work as that of Feulgen and Rossenbeck (1924), Feulgen, Behrens and Mahdihassan (1937),

Behrens (1938), Delaporte (1939), Painter and Taylor (1942), and of Mirsky and Pollister (1942), has given rise to the conception that in both animal and plant cells desoxyribonucleic acid is characteristic of the nucleus and ribonucleic acid chiefly of the cytoplasm (Mirsky, 1943; Pollister and Mirsky, 1944).

D. Distribution of the Polynucleotides in the individual cell.

(i) The nucleus, chromosomes and genes.

The early work on the chemistry of the cell nucleus was carried out by Miescher (1897) who first described the essential nuclear materials, desoxyribonucleic acid, and the basic proteins and who suggested that they might be concerned in the mechanism of heredity. The nucleic acids were studied by Jones, by Hammersten, and by Levene and others, and the protein components of the cell nuclei, the protamines and histones, by Kossel. Our knowledge of the essential role of the nucleic acids in nuclear structure has been extended by recent work (see review by Mirsky, 1943).

Nucleoproteins can now be isolated with very little protein denaturation of the protein or alteration in chemical properties (c.f. Greenstein and Jenrette,

1940). The nucleoproteins of the cell nucleus have been prepared by Mirsky and Pollister (1942) who removed the cytoplasmic ribonucleoproteins by simple extraction of the minced tissue with physiological saline solution and treated the extracted pulp with 1M sodium chloride. The desoxyribonucleoprotein was extracted as a viscous birefringent material from which the nucleoprotein was precipitated by addition of six volumes of water. It was found to be soluble in 1 M NaCl, insoluble in 0.14 M NaCl and soluble again in 0.02 M NaCl, but at this concentration of NaCl it was less viscous and less birefringent. The nucleic acid which appears to be exclusively desoxyribonucleic acid, comprised some 51-66% of the nucleoprotein. If a solution of the nucleoprotein in 1 M NaCl was dialysed against 1 M NaCl, the protein component, which was of the protamine or histone type, slowly diffused through the cellophane sac leaving the highly polymerised nucleic acid behind. The material termed "plasmosin" by Bensley (1942) is prepared in a similar way and its relationship to these nucleohistones is discussed by Hoerr (1943) and by Mirsky and Pollister (1943).

Caspersson's (1936b, 1940a, c) use of the quartz microscope with photometric determinations of the

ultraviolet absorption in different regions of the nucleus and cytoplasm of cells is one of the most important recent developments in cytochemical technique and has yielded much information about the location of nucleic acids which show a characteristic high absorption maximum at 2600 \AA by virtue of the conjugated double bonds of the constituent pyrimidine and purine rings. The high extinction coefficient of the purines and pyrimidines (known since the time of Dhéré (1906)) distinguishes these bases from other substances known to be present in biological material. The absorption spectra themselves do not differentiate between the two types of nucleic acid but in conjunction with other tests such as the Feulgen (1924) reaction for desoxyribonucleic acid or the Brachet (1940) test for ribonucleic acids (Schultz, 1941), they have been used to indicate the site of each type of nucleic acid. In this way information has been obtained about the nucleic acid nature of the chromosome and of the gene (see also Schultz, 1941; Gulick, 1941; Darlington, 1942) and about the role of nucleic acids in cell division (Caspersson, 1937a, c, 1939, 1940a, b; Caspersson and Schultz, 1939, 1940). The deductions of Caspersson from ultraviolet absorption measurements are based on

the assumption (Caspersson, 1936) that the characteristic nucleotide absorption maximum is not affected by polymerisation of the nucleotides or by their conjugation with protein. The ultraviolet absorption spectra of the nucleoproteins are assumed to be the same as those of mixtures of nucleotides or polynucleotides and proteins. It is possible that these assumptions are not fully justified. Graff and Barth (1938) suggest that "tautomeric shifts in the constituents of nucleic acids are responsible for the alterations in the ultraviolet absorption spectra" noted by Caspersson (1937) in the chromosomes of dividing cells, and that in fact "the total amount of nucleic acid in the cell is constant".

Wyckoff, Ebeling and Ter Louw (1932) compared the ultraviolet absorption of various types of living cells with the results of the Feulgen method of staining of fixed preparations for desoxyribonucleic acid. Resting cell nuclei were found to be much less opaque to ultraviolet light than those of dividing cells, except in the Feulgen negative nucleoli and "all the gross structures brought out by Feulgen staining have been found in the living material by their intense ultraviolet absorption".

Using the large chromosomes of Stenobothrus spermatocytes and of the salivary gland of Diptera larvae, Caspersson (1935) has shown that in the ultraviolet regions of the spectrum the chromosomes show not only the characteristic absorption of the nucleic acids but also a discoidal structure of alternating light and dark bands, which are not revealed by ordinary light (Caspersson, 1937b). He therefore concluded that the chromosomes consisted of alternating nucleic acid and protein segments. These observations were later extended to the chromosomes of Drosophila and Chironomus larvae (Caspersson, 1936). The chromosomes are usually assumed on the basis of a positive Feulgen reaction to contain nucleic acid of the desoxyribose type (c.f. Gulick, 1941), and there appears to be a direct correlation between cell division and nucleic acid content. Desoxyribonucleic acid apparently increases in prophase and decreases in telophase (Caspersson, 1935a, b, 1936, 1939).

The protein content of the chromosomes has also been investigated (Caspersson, 1940a, d, 1941b). The ultraviolet absorption curve of the grasshopper chromosomes shows not only the presence of nucleic acid but also a slight rise at 2800 Å attributed to tyrosine and

tryptophane. Evidence has accumulated that the euchromatic sections contain complex proteins of the globulin type while the heterochromatic regions (and the nucleus) contain simple proteins such as the histones (c.f. Darlington, 1942). Caspersson's identification of the protein constituents of the nucleus and chromosomes has however been questioned by Mirsky (1943) who found that the ultraviolet absorption curves of histone and albumin did not show the differences described by Caspersson).

Mazia (1941) suggests that the salivary chromosome consists of a continuous framework of histone-like protein and a matrix consisting of protein containing many acidic groups. The chromatic bands contain a protamine-like substance to which the nucleic acid is attached. Such a fibrous organisation of the chromosome structure was supported by the similarity between the behaviour of chromosomes and of artificial nucleoproteins towards enzymes.

Schultz (1941) has painted a more complex picture of the structure of the chromosome as a protamine-like thread with desoxyribonucleic acid at intervals along it, the whole having a sheath or cement of ribonucleic acid or ribonucleoprotein, but the evidence he presents

is by no means conclusive.

A survey of the structure of protoplasm and cell nuclei is given by Seifriz (1942), and of the structure of the chromosomes by Darlington (1942).

It is usually assumed, mainly on the basis of the Feulgen test, that desoxyribonucleic acid is located exclusively in the nucleus (though Loo (1937) has reported in the case of Purkinje cells that desoxyribonucleoprotein may pass from nucleus to cytoplasm as age advances) and that it is the most important constituent of the chromosomes. Modern views on the structure and function of the nucleus have, until recently, centred round its desoxyribonucleic acid (e.g. Gulick, 1941), but a new conception of the chemistry of the nucleus has been introduced by recent preliminary reports by Stedman and Stedman (1943a, b, c, 1944) of the discovery of a new protein in the nucleus. Since it appears to be one of the principal components of the chromosomes its discoverers have named it "chromosomin". It possesses predominantly acidic properties being soluble in alkalis and precipitated from solution by addition of acid. It contains 9.5% arginine, 5% histidine, and 11% lysine, large amounts of glutamic acid and tryptophane, and

smaller quantities of aspartic acid and cystine (Stedman and Stedman, 1943a). Chromosomin is one of the three major constituents of the nucleus, the other two being histone and desoxyribonucleic acid. While the percentage of chromosomin in the dried lipid free nuclei is high (33-72.4%) the amount of histone is variable and is particularly low (1.6-3%) in the nuclei of cells undergoing frequent mitosis (Walker rat carcinoma, mouse carcinoma, and chick embryos). In such nuclei the chromosomin content is particularly high. Stedman and Stedman (1943c) suggest "that a high content of histone in the nucleus of a cell produces an inhibition of both the processes which lead to mitosis and those which lead to the synthesis of chromosomin necessary for the duplication of the chromosomes".

Since the chromosomes are reported to consist essentially of chromosomin the location and function of the nuclear desoxyribonucleic acid becomes a matter of some interest. Stedman and Stedman (1943a) suggest that the nucleic acid is the main component of the nuclear sap and may compose the spindle which is formed at metaphase. On this basis (1943c) it will fill the hollow interior of the compressed cylindrical spirals

formed by the metaphase chromosomes and may to this extent be regarded as a possible constituent of the chromosomes. Criticism has been made by Callan (1943), Barber and Callan (1944) and by Caspersson (1944). Full consideration of chromosomin must be deferred until complete experimental details are available.

The discovery of chromosomin has necessitated a review of the mechanism of the Feulgen reaction. Stedman and Stedman (1943a) have shown that chromosomin very readily takes up such basic dyes as haematoxylin which is very firmly held despite repeated washings. The stained chromosomin has the typical blue colour associated with nuclei stained by haematoxylin. In the case of the Feulgen stain, the reagent (decolourised basic fuchsin) reacts specifically with the hydrolysis products of desoxyribonucleic acid, forming the coloured product which is then taken up by the chromosomin. Support for this explanation has been given by Choudhuri (1943) who found that chromosomes, like chromosomin, can be stained directly with such a "developed nucleal stain". Although the Feulgen test therefore, when applied in its original form, can detect the presence of desoxyribonucleic acid, it cannot accurately locate its position, and the original

view that, because the chromosomes are stained by Feulgen's procedure, they must of necessity contain desoxyribonucleic acid ~~may have to be revised~~.

(ii) The nucleolus.

On the basis of strong absorption at 2600 \AA and a negative Feulgen test Caspersson and Schultz (1940) working with sea urchin eggs, spinach cells, and the salivary gland of Drosophila melanogaster have concluded that the nucleolus is composed of ribonucleoproteins containing varying percentages of ribonucleic acid. They believe that the activity of the nucleolus is associated with intense synthesis in the cytoplasm of ribonucleic acids which appear to be especially abundant at the nuclear membrane (see, however, Claude, 1941). It has been pointed out (c.f. Darlington, 1942), that nucleoli are proportionately largest in cells which are concerned with rapid protein production (animal egg cells, meristematic and tumour cells) and are smallest in cells where no protein is being made (e.g. leucocytes).

The presence of ribonucleic acid in the nucleolus has also been reported by Brachet (1940a & b) who observed the staining to be less pronounced after treatment with ribonuclease, by Gersh (1943) who found the

ultraviolet absorption to be diminished after treatment with ribonuclease, and by Mitchell (1942) who obtained positive histochemical tests for pentoses.

(iii) The cytoplasm.

A satisfactory but laborious method of separating cytoplasm from nuclei was achieved by Behrens (1938a, b) who suspended powdered frozen-dried tissue in columns of organic solvents of graded density. From the cytoplasm he obtained guanylic acid derived apparently from ribonucleic acid. The nuclei contained desoxyribonucleic acid (see also Mayer and Gulick, 1942; Williamson and Gulick, 1942). The other chief method for separating nuclei from cytoplasm involves the separation of the cellular components in different layers on centrifuging a tissue suspension treated with citric acid (Stoneburg, 1939; Marshak, 1941). Using a similar method Dounce (1943a, b) prepared pure desoxyribonucleic acid from isolated rat liver nuclei.

The work of Behrens and his collaborators has supported the suggestion of earlier authors, e.g. Brachet (1933), that ribonucleic acid is a cytoplasmic constituent, and this view is in agreement with the results of Delaporte (1939) and Delaporte and

Roukhelman (1938) working with yeast, and Painter and Taylor (1942) working with toads' eggs. Caspersson and Schultz (1939) found evidence of the presence of "ribonucleotides" ("ribose nucleic acids", Caspersson and Schultz, 1940) in the cytoplasm of rapidly growing plant and animal tissues but not in the homologous mature tissues. The evidence in favour of the presence of "ribonucleotides" consisted of (1) a strong absorption of 2600 Å, (2) a strong orcinol reaction for pentose, (3) a positive phosphorus test on micro-incineration, (4) a negative Feulgen test for desoxy-pentose. Ribonucleic acids or ribonucleotides have also been reported in the cytoplasm of tumour cells (Caspersson, Nyström and Santesson, 1941; Mitchell, 1942: *vide infra*).

The evidence for the presence of high concentrations of ribose nucleotides in the cytoplasm of growing cells is not altogether conclusive. The high absorption at 2600 Å is taken to indicate the presence of purines and pyrimidines but there is no conclusive evidence to show whether they are present as free purines, nucleosides, nucleotides, or polynucleotides (nucleic acids) or whether the ultraviolet absorption is modified by polymerisation or by combination with

native protein. Moreover, the evidence as to the nature of the sugar is not conclusive. A negative Feulgen reaction would appear to exclude desoxyribo-polynucleotides but does not for that reason indicate any specific pentose. The orcinol test is not very convincing when applied histochemically nor is it absolutely specific for pentoses.

F. G. Fisher (1942) points out that the tetra(desoxy)nucleotides in contrast to the polynucleotides are easily water- and acid-soluble (hence the importance of their possible formation during mobilisation of nuclear material) and therefore give neither nuclear staining nor the Feulgen reaction. Their presence might account for alterations in the chromatin, during the formation of the resting nucleus, which may be so profound as to render the chromosomes "achromatic". Similar observations have been made during oogenesis or spermatogenesis. The cytoplasmic nucleotides found during processes of growth and cell division are usually classed as ribose nucleotides on the basis of a negative Feulgen test but desoxyribo-nucleotides, which are removed during the acid hydrolysis stage of Feulgen's procedure also give no Feulgen reaction (Fischer, 1942) and cannot be excluded on this

evidence alone.

Not only are ribonucleic acids reported in the cytoplasm but they appear to occur there in part at least, in the form of particulate components, e.g. the volutin granules of yeast (c.f. Delaporte, 1939; Caspersson and Brandt, 1941). According to Menke (1938) ribonucleic acid is present in chloroplasts.

E. Phospholipin-nucleoprotein complexes.

The use of the ultracentrifuge has rendered possible the isolation of macromolecular materials in which nucleic acid exists in the form of phospholipin-nucleoprotein complexes. They may contain either ribonucleic acid or desoxyribonucleic acid. Most of those so far obtained contain the former.

From embryonic tissue a phospholipin-ribonucleoprotein complex was isolated by Claude (1940), a similar complex of different sedimentation constant was isolated by Taylor, Sharp, Beard and Beard (1942), and a heat stable particulate material containing ribonucleic acid which stimulated tissue growth was obtained in the ultracentrifuge by Tennant, Liebow and Stern (1941) and Tennant, Stern and Liebow (1942).

Taylor, Sharp and Woodhall (1943) obtained another

phospholipin-ribonucleoprotein complex from normal chick embryo brain tissue and a desoxyribonucleoprotein complex from human embryo brain.

Phospholipin-nucleoprotein complexes are also associated with infective agents. The viruses of the Rous sarcoma (Claude, 1938, 1939, 1940) and of equine encephalomyelitis (Taylor, Sharp, Beard and Beard, 1943) are phospholipin-ribonucleoprotein complexes, while similar complexes containing desoxyribonucleic acid are found in the rabbit papilloma virus (Taylor, Beard, Sharp and Beard, 1942) and in the elementary bodies of vaccine virus (Hoagland, Lavin, Smadel and Rivers, 1940).

The cytoplasmic granules prepared from liver tissue by Claude (1939, 1940, 1941) by high speed centrifugation are stated to consist chemically of phospholipid-ribonucleoprotein complexes and were at first thought (Claude, 1939, 1940) to be related to the mitochondria. Claude (1941) suggests that the accumulation of cytoplasmic ribonucleic acids described by Caspersson and Schultz (1940) in the neighbourhood of the nucleus is due in fact to the breakdown of mitochondria under the influence of the acid fixative employed. The cytoplasm of rapidly growing cells is

known to be highly basophilic and to be also rich in mitochondria (Claude, 1941). The special biochemical activity of the mitochondria has been known for a long time. Warburg (1913) investigated the respiratory activity of particles (presumably mitochondria) obtained from liver and the problem of their oxygen uptake has been taken up more recently by Lazarow and Barron (1941). The association of these particles with the mitochondria is due largely to the work of Bensley (Bensley and Hoerr, 1934; Bensley, 1937, 1942) who extracted under microscopic control "mitochondria" from the liver of the guinea pig by utilising the fact that they appeared to be insoluble in 0.85% sodium chloride solution at pH 6.0. Finely divided liver pulp suspended in 0.85% NaCl was centrifuged at low speed and low temperature to remove tissue fragments, nuclei, etc., and then at high speed to separate the required particles. They contained a large proportion of phospholipins including acetal phospholipin. The phospholipin nature of the mitochondria is known (Guilliermond, 1934).

The approach made by Claude (1940, 1941) utilised the high speed centrifuge (18,000 ^{x g.} ~~zzz~~zzz). From guinea pig liver he was able to obtain phospholipin-

ribonucleoprotein complexes which he considered to have existed in the cell as formed elements in the cytoplasm. They were of two sizes. The smaller type (Claude, 1940) termed "microsomes" (Claude, 1943a), were of diameter 50-200 $m\mu$. Some 40-50% of the whole particle consisted of phospholipins including those of the acetal or plasmal type (Feulgen and Bersin, 1939) while the protein portion contained 10-15% ribonucleic acid. These submicroscopic particles contained in guinea pig and rat liver 9.08-9.14% N and 1.62-1.69% P (although in the microsomes of embryonic tissues and of pancreas the P content may be as high as 2.1%). The microsomes appear to represent a considerable proportion of the cell, at least 10-15% of dry weight according to Claude (1943a), and are universal in distribution having been found in chicken, mouse, rat and rabbit tumours, chick, mouse and rabbit embryos, guinea pig, rat and amphibian liver, normal and leukaemic spleen, and beef and rabbit pancreas.

The larger type of particle has been termed "secretory granules" (Claude, 1941) or "zymogen granules" (Claude, 1943a). Their diameter is 0.5-2.0 μ and they contain 12.08-12.09% N and 1.25-1.26% P in the case of material from guinea pig and rat liver.

They are, in the opinion of Claude (1943a), probably similar to the Bensley granules (Bensley and Hoerr, 1934; Bensley, 1942) but their relationship to the mitochondria is not clear. Hoerr (1943) maintains that they are identical with the mitochondria.

Both of these types of particulate or granular structures contain ribonucleic acid in the form of phospholipin-ribonucleoprotein complexes. They both contain sulphur (Claude, 1943a), and inositol (Claude, 1943b) and may have a common origin, but their exact relationship is not yet clear (Claude, 1943b).

F. The Nucleoprotein content of tissues.

(a) Most methods of estimating the nucleoprotein content of tissues depend on the estimation of nucleic acid phosphorus and are based on the original procedure of Kossel (1882) which assumes that when tissues have been extracted with dilute acid to remove acid soluble phosphorus and with fat solvents to remove lipid phosphorus all the residual phosphorus is present in the form of nucleic acid phosphorus. This procedure with various modifications has been used by many authors, e.g. Plimmer and Scott (1908), Grund (1910), Masing (1911), Javillier and Allaire (1926, 1931),

Table 15.

Nucleic acid content of tissues expressed as nucleoprotein phosphorus (N.P.P.) in mg./100 g.

Tissue	From fresh tissue		From †	From #	Species	Author
	Wet wt.	Dry wt.*	residual-P Dry wt.	purine-N Dry wt.		
Adult brain	12	75	-	-	Horse	4
	99	-	-	-	Sheep	1
	-	-	-	100	"	9
	18	114	369	191	"	16
	-	116	-	-	Rabbit	12
	-	110	-	-	Rat	10
	-	156	-	-	"	12
Embryo brain	25	119	-	-	Fowl	16
	-	-	-	370	Sheep	9
	24	253	556	301	"	16
Adult gut	50	459	-	-	Fowl	16
	-	-	-	284	Sheep	9
	110	559	636	551	"	16
	-	-	370	-	Dog	6
	-	-	668	-	Rabbit	6
Embryo gut	-	-	-	-	Guinea pig	6
	-	-	-	870	Sheep	9
	78	673	958	693	"	16
Mucosa stomach	88	-	-	-	Pig	7
	97-101	-	-	-	Cat	13
	-	609	-	-	Rabbit	12
Smooth muscle (stomach)	-	105	-	-	Man	12
	-	166	-	-	Rat	12
Adult heart	-	-	-	-	Horse	4
	13	61	-	-	Sheep	9
	-	-	-	71	"	16
	29	129	219	154	"	13
	8	-	-	-	Cat	13
Embryo heart	32	161	-	-	Fowl	16
	-	-	-	307	Sheep	9
	64	492	616	484	"	16
Adult kidney	75	835	-	-	Fowl	16
	34	169	-	-	Horse	4
	90	239	-	-	Ox	1
	-	-	460	390	"	5
	-	-	-	258	Sheep	9
	80	421	442	354	"	16
	51	317	-	-	Dog	3
	-	-	329	-	"	6
	49-55	-	-	-	Cat	13
	-	-	407	-	Rabbit	6
-	290	-	-	Rat	10	
-	285	-	-	"	12	

Tissue	From fresh tissue		From #	From #	Species	Author
	Wet wt.	Dry wt*	residual-P Dry wt.	purine-N Dry wt.		
Adult testis	67	-	-	-	Bull	1
	58	427	660	553	Sheep	16
Adult thyroid	37	139	-	-	Horse	4
	25	102	166	148	Sheep	16
Embryo thyroid	78	394	682	649	Sheep	16
Thymus	249	1296	-	-	Horse	4
	-	-	2030	-	Calf	2
	-	1430	-	-	"	4
	-	-	1835	1685	"	5
	415	-	-	-	"	7
	-	-	-	2240	Sheep	9
	170	1080	2760	2385	"	16
Carotid	107	-	-	-	Ox	7
Submaxillary gland	-	561	-	-	Rat	12
Lymph node	-	842	-	-	Rat	12
	184	903	-	-	Calf	16
Adult liver	56	204	-	-	Horse	4
	123	-	400	-	Ox	1
	104	-	-	-	"	7
	-	-	-	630	Sheep	9
	70	231	384	313	"	16
	139	-	-	-	Dog	1
	80	302	-	-	"	3
	-	-	311	-	Dog(fed)	6
	-	-	459-511	-	" (fasted)	6
	74-84	-	-	-	Cat	13
	76	-	-	-	Rabbit	7
	-	-	310-462	-	Rabbit(fed)	6
	-	-	411-484	-	" (fasted)	6
	-	247	-	-	" (glycogen rich)	12
	-	330	-	-	" (normal)	12
	-	-	418	-	Guinea pig (fed)	6
	-	-	470	-	Guinea pig (fasted)	6
	-	-	318	-	Rat	8
	-	340	-	-	"	10
-	310	-	-	"	11	
110	367	-	-	Rat fed	14	
136	453	-	-	" fasted	14	
-	-	-	-	24 hrs.		
134	447	-	-	Rat fasted	14	
-	-	-	-	48 hrs.		
134	449	-	-	Rat fed	16	
152	502	-	-	" fasted	16	
242-246	-	730-742	-	Mouse (fed)	15	
267-308	-	973-1131	-	" (fasted)	15	
83	391	-	-	Fowl	3	
113	408	-	-	"	16	
85	-	-	-	Fowl (fed)	1	
161	-	318	-	" (fasted)	1	
-	280-520	-	-	Mouse	11	
155	537	-	-	"	16	

Table 15 (continued)

Tissue	From fresh tissue		From †	From #	Species	Author
	Wet wt.	Dry wt.*	residual-P Dry wt.	purine-N Dry wt.		
embryo liver	-	-	-	752	Sheep	9
	103	592	1175	1100	"	16
	95	475	-	-	Fowl	16

1. Kossel (1882)
2. Neumann (1898)
3. Grund (1910)
4. Javillier & Allaire (1925; 1926; 1927 & 1931)
5. Alders (1927)
6. Cahn & Bonot (1928)
7. Jorpes (1928 a & b)
8. Rondoni (1941)
9. Robertson & Dawbarn (1929)
10. Berenblum, Chain & Heatley (1939)
11. Dickens & Weil-Malherbe (1943)
12. Rosenthal & Drabkin (1943)
13. Teorell & Norberg (1932)
14. Kosterlitz & Cramb (1943)
15. Tichmeneff (1914)
16. Present investigation

* Calculated from N.P.P. on wet weight basis and from water content of tissue.

† Total P content of a tissue powder from which water acid soluble P and phospholipin P have been extracted.

Nucleic acid P = purine N x 0.886 (assuming N:P atomic ratio of 10:4).

authors on different species are shown in Table 15.

Comparison of the figures available for the nucleoprotein content of embryonic and adult tissues shows that the amounts in embryonic tissues particularly when expressed on a dry weight basis are higher than in the corresponding adult tissues. Such a comparison has been made in this investigation for a large series of tissues in the sheep, and isolated observations have been recorded by other workers, e.g. Kossel (1882) who records a higher figure for cattle embryo muscle than for adult muscle. Masing (1911) detected a progressive fall in the nucleoprotein content of rabbit embryos, in relation to total N, with advancing age; Le Breton and Schaeffer (1923) reported a continuous decrease in the ratio $\frac{\text{purine N}}{\text{total N} - \text{purine N}}$ during the embryonic development of the chick, pig and mouse; Graff and Barth (1938) recorded a rapid decrease in $\frac{\text{purine N}}{\text{total N}}$ during the embryonic life of the guinea pig; Robertson and Dabarn (1929) estimated nucleoprotein as guanine N both in the newborn lamb and in the adult ewe and found higher figures for the former. Both types of nucleic acid appear to participate in this increase in nucleoprotein which is evident in the embryo.

(b) Liver tissue (see also p.292). Liver tissue is of special interest, since in this case, and possibly in the case of some other tissues as well, the nucleic acid content is conditioned to some extent by the nutritional state of the animal. The results of estimations of the nucleic acid content of liver by various authors is shown in Table 15. The results obtained by different methods with different species show that the nucleic acid content does not vary greatly from species to species but may vary quite widely in different specimens from one species. Rondoni (1941) attributed such differences to variations in the age and state of nutrition of the animals used. In fasting animals the nucleic acid concentration in the liver rises as has been shown by Kossel (1882) in the fowl liver, by Tichmeneff (1914) in the mouse liver, by Cahn and Bonot (1928) in the dog, guinea pig and rabbit livers, by Rosenthal and Drabkin (1943) in rabbit liver, by Kosterlitz and Gramb (1943) by Kosterlitz (1944) and in this investigation (p.303) in rat liver. This rise is of course due in part to loss of glycogen and stored protein and is in any case relative rather than absolute. In terms of the original body weight, the liver nucleoprotein P falls

on fasting as also do the relative liver weight, the liver phospholipin P and the liver protein N (Kosterlitz and Cramb, 1943). The decrease in liver weight is due to a decrease in the volume of the individual cell rather than to a decrease in the number of cells.

If these facts are kept in mind it will be seen from Table 15 that the liver nucleic acid content of various species as estimated by a number of authors using different methods does not vary over a very wide range.

The liver of the embryo rat is rich in erythropoietic cells (Norris, Blanchard and Povolny, 1942) and in any direct comparison of the nucleic acid content of the liver of the embryo and adult the influence of this factor must be kept in mind. In the sheep and fowl (p.247) as well as in the rat (Dumm, 1943) the nucleic acid content is much higher in the embryo than in the adult. A progressive fall in liver nucleic acid content in the course of embryonic development is recorded by Dumm (1943) for the rat and by Masing (1911) for the rabbit. Robertson and Dawbarn (1929) found more nucleic acid in the liver of the newborn lamb than in that of the adult ewe.

Liver tissue is known to contain a desoxyribonucleic

acid very similar to thymus desoxyribonucleic acid (Peters, 1911; Levene, 1922; Ishiyama, 1928; Greenstein and Jenrette, 1940). From the early work of Hammarsten (1894), Wohlgemuth (1902), Jones and Perkins (1924) and Thomas and Berariu (1924), it appeared probable that liver also contains a pentose polynucleotide. Moreover the cytoplasm of liver cells has been shown to contain particulate components consisting of phospholipid-ribonucleoprotein complexes which have already been discussed. It will be shown later (p.306) that the liver does indeed contain large amounts of a pentose nucleic acid which acts as a substrate for ribonuclease and this acid has been isolated (p.266) and shown to be closely similar to yeast ribonucleic acid.

(c) The nucleoprotein content of tumours (see also p.312). It is generally assumed that tumours are rich in nucleic acids. High figures for the nucleic acid content of tumours are quoted by Wolter (1913), Enselme and Enselme (1927), Roffo and Pilone (1930), Boyland (1932), Euler and Schmidt (1934a), Edlbacher and Jucker (1936) and Berenblum, Chain and Heatley (1939). On the other hand, Wells (1912) and Wells and Long (1913) did not find high figures for the

purine N of the tumours they examined. The figures for the nucleic acid content of tumours vary greatly from one type of tumour to another and even among different samples of the same type of tumour (c.f. Stowell, 1942), and their significance can be properly assessed only in those rare cases where a direct comparison can be made between the tumour and its tissue of origin as has been done in connection with glycolysis mechanisms (Berenblum, Chain and Heatley, 1940a & b; Burk, 1942). Where comparisons of this type have been made the tumour is usually found to be richer in nucleic acid than the tissue of origin. The rat hepatoma of Fujiwara, Nakahara and Kishi (1937) had a nucleoprotein phosphorus content which was lower on a fresh weight basis and higher on a dry weight basis than that of normal rat liver. Dickens and Weil-Malherbe (1943) record higher nucleoprotein phosphorus figures for butter yellow rat liver tumours (though not for spontaneous mouse hepatomas) than for the corresponding normal liver. The nucleoprotein phosphorus of a benzpyrene rat sarcoma was five times that of normal connective tissue (Rondoni, 1941). An increase in nucleoprotein metabolism in neoplastic tissue has been observed by Kohman and Rusch (1941)

using radioactive phosphorus but a low P^{32} turnover in the nucleic acid fraction, as compared with the soluble nucleotide fraction, was found in the Jensen rat sarcoma by Hevsey and Euler (1942).

So far as the nature of the tumour nucleic acids is concerned little is known. Willheim (1925) and Stern and Willheim (1934) found a lower nitrogen content in desoxyribonucleic acid isolated from malignant tumours than in that from normal organs but this observation was not confirmed by Klein and Beck (1935), by Maver and Voegtlin (1937), by Vowles (1940) or by Euler and Petterson (1941).

The existence of pentose derivatives in tumour tissue was investigated as long ago as 1905 by Beebe and Shaffer and was commented on by Neuberg (1905). Part of this pentose, at least, may be present in the form of ribonucleic acids. Their presence in the cytoplasm of malignant cells is indicated by the work of Caspersson, Nyström and Santesson (1941), of Mitchell (1942), and is suggested in a preliminary note by McDonald (1940). Moreover, they are present in the form of phospholipin-ribonucleoprotein complexes in tumour-producing cell-free sarcoma extracts (Claude, 1940). From one of these complexes Claude

(1939) prepared a nucleic acid giving positive pentose tests, a negative Feulgen test, an absorption maximum at 2575 Å and minimum at 2400 Å. From it guanylic acid was isolated by hydrolysis but it was not further characterised.

The report by Caspersson, Nyström and Santesson (1941) of high concentrations of ribonucleic acids or ribonucleotides in the cytoplasm of some cells of rapidly growing malignant tumours is of considerable interest in view of the work of Mitchell (1941, 1942, 1943). Using optical methods similar to those of Caspersson, Mitchell has demonstrated in fixed preparations an increase in the absorption of ultraviolet radiation of wavelength 2537 Å in the cytoplasm of proliferating and differentiating cells of neoplastic and normal hyperplastic tissues exposed in vivo to therapeutic doses of X or gamma radiation. Mitchell claims that the increased ultraviolet absorption of the cytoplasm after irradiation is due to the accumulation of pentose nucleotides containing adenine and some other unidentified chromophoric groups. These nucleotides may be present in local concentration of the order of 3%.

Caspersson and Santesson (1942) maintain that

individual tumours contain cells which vary between two extreme types - the one type of cell small and rich in nuclear and cytoplasmic nucleic acid and in protein, and the other type with large nucleus poor in nucleic acid but with large nuclei rich in ribose nucleotides and with cytoplasm poor in protein and apparently free from nucleotide elements. "The type of the individual cell seems to be determined to a considerable degree by the nutritional conditions" of the tumour tissue.

Koller (1943a, b) supports the view that a high cell division rate in tumours is associated with a high concentration of desoxyribonucleic acid in the nuclei, whereas in cells of low division rate, high cytoplasmic volume and large nucleoli, ribonucleic acid is abundant as a cytoplasmic and nucleolar constituent. This view has been criticised by Dounce (1943b, c) on the grounds that the nuclei of rat hepatoma cells are no richer in desoxyribonucleic acid than are normal liver cell nuclei.

G. The Ribonucleotide Content of Tissues.

An examination of the nucleic acid content of tissues would be incomplete without concurrent estimations of the simple acid-soluble nucleotides. Few

Table 16.

Nucleotide-N, nucleoside-N and free purine-N content of tissues in mg./100 gm.
The sum of all three gives total soluble purine-N.

Tissue	Nucleotide-N	Nucleoside + free purine-N	Total soluble purine-N	Species	Author
Adult brain	15-22	3	18-25	Dog	1
	12.5-15.5	-	-	"	2
	17.7-20.7	-	-	Rabbit	2
	14.6	13.7	28.3	"	4
Adult brain grey matter	-	-	24.6-32.6	Sheep	5
white	-	-	17.5-28.0	"	5
"	-	-	19.6-23.8	"	5
Embryo brain	-	-	18.6-21.6	Sheep	5
Cartilage (embryo)	-	-	15.4-19.6	Sheep	5
Adult heart	-	-	37.5-48.3	Sheep	5
	26.0-31.0	-	-	Dog	2
	32.0-37.9	-	-	Rabbit	2
	23.4-27.6	12.0-15.4	39.6-44.5	Fowl	5
Embryo heart	-	-	20.0-30.9	Sheep	5
Adult gut	8.7-18.1	-	-	Dog	2
Adult kidney	-	-	25.3-31.5	Sheep	5
	17.6-25.5	-	-	Dog	2
	28.0-33.6	-	-	Rabbit	2
cortex	39.2	17.4	46.6	"	4
medulla	39.2	20.4	49.6	"	4
Embryo kidney	-	-	17.5-22.3	Sheep	5
Adult liver	-	-	35.9-36.4	Sheep	5
	22-31	2-4	-	Dog	1
	25.8-28.3	-	-	"	2
	46.2-49.0	-	-	Rabbit	2
	42.7	26.0	68.7	"	3
	39.2	15.3	54.5	Guinea pig	4
	21.6-30.0	13.6-23.8	33.9-50.4	Fowl	5
Embryo liver	-	-	24.4-28.6	Sheep	5
Adult lung	-	-	25.7-30.5	Sheep	5
Embryo lung	-	-	13.3-24.2	Sheep	5

Table 16 [continued]

Tissue	Nucleotide-N	Nucleoside + free purine-N	Total soluble purine-N	Species	Author	
Skeletal muscle	-	-	40.6-57.1	Sheep	5	
	23-47	-	-	Dog	1	
	46.7-56.7	-	-	"	2	
	48.2	10.5	58.7	Cat	4	
	54.1-64.4	-	-	Rabbit	2	
	red	51.6	11.2	"	4	
	white	50.9	12.9	"	4	
		52.3	11.7	64.0	Guinea pig (young)	4
		46.7	12.3	59.0	Guinea pig (old)	4
		62.2	8.9	71.1	Fowl	4
	red	44.5	7.5	52.0	"	4
	white	46.8	5.7	52.5	"	4
	red	26.3-34.6	7.3-9.1	34.0-41.9	"	5
	white	31.1-52.4	5.9-13.7	44.8-58.3	"	5
	Smooth muscle	26.1-28.8	7.7-11.3	33.8-40.1	Fowl	4
Embryo muscle	-	-	24.2-25.4	Sheep	5	
	15.8	7.0	22.8	Chick (16 day)	5	
Adult pancreas	19.2-27.7	-	-	Dog	2	
	31.9-34.3	18.0-23.2	52.3-54.1	Calf (1 month)	4	
	44.2	9.2	53.4	Rabbit	4	
Adult spleen	-	-	29.8-41.5	Sheep	5	
	21.3-24.5	-	-	Dog	2	
Embryo spleen	-	-	30.8	Sheep	5	
Thymus	32.3	31.9	64.2	Calf (1 month)	4	
Whole embryo	10.8-14.1	6.0	16.8-20.1	Chick (9 day)	5	
	11.2-12.6	5.6-7.0	16.8-19.6	Chick (10 day)	5	
	14.4-14.8	3.6-4.1	18.4-18.5	Chick (13 day)	5	
Tumours						
Rous sarcoma	7.7-11.9	7.0	14.7-18.9	Fowl	5	
	16.2	13.7	29.9	"	45	
Flexner sarcoma	8.1	17.0	25.1	Rat	45	
Jensen sarcoma	14.8	12.0	26.8	"	45	
Adenocarcinoma	12.6-22.7	14.8-16.8	27.4-39.5	Mouse	45	

1. Kerr (1940)
2. Eiler & Allen (1935)
3. Dell'Aqua (1935)
4. Barrenscheen & Peham (1941)
5. Present investigation

authors have carried out such a series of estimations but their results are summarised in Table 16.* Most authors have used the method of Kerr and Blish (1932) or its modification by Kerr (1940), in which the nucleotides are precipitated by uranyl acetate while nucleosides and free purines are left in the filtrate. The nucleotides estimated in this way include adenosine triphosphate, adenylic acid, inosinic acid, the nicotinamide nucleotides and flavin-adenine dinucleotide, but the first two account for the major part of the total nucleotide N in most tissues. The sum of the nucleotide N, nucleoside N and free purine N gives the total acid-soluble purine N.

The nucleotide content varies widely from tissue to tissue and even in different samples of the same tissue. There is also a wide species variation, rabbit tissues, for example, giving consistently higher figures than dog tissues. Muscle in all species gives the highest figure while brain is low. In muscle also the amount of nucleoside relative to nucleotide is low while in liver nucleoside and free purine constitute a much higher proportion of the total

*

The nucleotide content of blood has been discussed by a number of authors including Buell (1935, 1936), Rothman (1931), Kerr and Daoud (1935), Kerr and Antaki (1937).

acid-soluble purine N. As will be shown later, in rapidly growing tissues either from the sheep and chick embryo or from malignant tumours the nucleotide content is consistently low even when the higher water content of these rapidly growing tissues is taken into account (p.257). The strong ultraviolet absorption of the cytoplasm of such rapidly growing tissues is not therefore due to simple ribonucleotides, but more probably to acid-insoluble pentose polynucleotides.

The nucleotide content of rat liver tissue does not appear to be affected greatly by feeding or fasting (Rapoport, Lever and Guest, 1943; this investigation, p.304).

H. The Biological Importance of the Nucleic Acids in relation to Growth.

The biological function of the nucleoproteins is of particular biochemical interest in view of the resemblance between their structure and that of many of the oxidising enzymes, the "dissociating proteids" of Warburg (1938), which consist of a mono- or di-nucleotide co-enzyme or prosthetic group bound more or less loosely to a protein carrier. Ribonucleic acids may also be associated with enzyme systems (Potter and

Albaum, 1942). As in the case of the nucleotide co-enzymes, the nucleic acids appear to manifest their biological activity when they are bound to protein (e.g. in the virus nucleoproteins). The bonds between the nucleic acids and proteins vary with the type of nucleic acid. In the desoxyribonucleoproteins, e.g. the nucleohistones of the thymus, the bond is apparently salt-like whereas in the ribonucleoproteins it is non-polar (Mirsky, 1943) and differs from the polar bond in artificial protein ribonucleates formed by mixing nucleic acids and proteins (Sevag and Smolens, 1941).

The nucleoproteins compose, or are associated with, self-reproducing agents or molecules. The viruses, as exemplified by tobacco mosaic virus, itself known to be a ribonucleoprotein (Loring, 1939; Stanley and Knight, 1941; Stanley, 1942), are self-reproducing agents of this type. Another example is the gene (Schultz, 1941; Muller, 1941; Astbury, 1941).

Cytoplasmic ribonucleic acid has been suggested by Claude (1943a) to play "a fundamental role, perhaps of an enzymatic nature in the process which enables the (cytoplasmic) structure to reproduce itself".

The microsomes and secretory granules which contain

ribonucleic acid may indeed "be endowed with the property of self-duplication" (Claude, 1943a).

The discovery that the spacing between the nucleotides in an oriented desoxyribopolynucleotide is almost exactly equal to that between the successive side chains in a fully-extended polypeptide chain (Astbury and Bell, 1938) has directed attention to the physicochemical condition of the nucleoproteins. It is of interest, in view of the high water content characteristic of growing tissues, that the X-ray pattern of virus nucleoproteins is a composite one, the intermolecular part showing varying spacings as the water content is varied while the molecular part remains unchanged (Bawden, Pirie, Bernal and Fankuchen, 1936; Bernal and Fankuchen, 1937). The intermolecular arrangement of the nucleoproteins of the cell, which may be influenced by variations in electrolyte concentration, is probably intimately connected with the conditions under which nucleoprotein reproduction and cell division occur.

While the functions of the nucleic acids in tissues are still very incompletely understood, the facts which have come to light regarding their distribution in animal tissues have suggested certain probable associations between these compounds and the

processes of growth. Examination of individual cells by ultraviolet microscopy has revealed that cells of growing tissues contain high concentrations of materials with the absorption characteristics of the nucleic acids, both in the nucleus and in the cytoplasm. In Caspersson's opinion, such high concentrations in the cytoplasm are associated with cells in which rapid protein synthesis is taking place either for growth or for secretion (Caspersson, 1936b, 1941b; Caspersson and Brandt, 1941; Caspersson, Landström-Hyden and Aquilonius, 1941). The nucleus is thought by Caspersson (1941a, b) to be a site of protein formation, for which the desoxyribonucleic acids are essential in the chromosomes. Huskins (1942) points out a possible fallacy in assuming a causal connection between nucleic acid formation and gene reduplication.

To what extent these views may have to be modified in the light of the discovery of chromosomin remains to be seen, but it appears reasonably certain that before mitotic division can occur the cell builds up a "certain quantity" (Caspersson, 1936b), a "certain minimum quantity" (White, in Bourne, 1942), or a "threshold quantity" (Darlington and LaCour, 1940) of nucleic acid. The building up of such a quantity can

be followed by estimations of nucleoprotein phosphorus in tissue cultures (Willmer, 1942b; this investigation, p.131).

What interrelationship exists between the nucleic acids of the two types in the cell is not known, though Mitchell postulates a synthesis of desoxyribonucleotides from ribonucleotides and Painter and Taylor (1942) and Painter (1943) the reverse procedure. In both embryonic and adult tissues, a fairly constant proportionality of desoxyribopolynucleotides to ribopolynucleotides has been found, and some sort of equilibrium may therefore be presumed to exist, conditioned in the several cases by the protein components characteristic of each tissue. This relative constancy does not preclude the possibility that cyclic changes in nucleic acid content may occur in individual cells in the tissue. The work of Caspersson and Santesson (1942), supported by Koller (1943a, b), suggests that great variations in nucleic acid content may occur in individual cells in different regions of malignant tumours. The high concentrations of nucleic acids found by chemical methods in large aggregates of cells in rapidly growing tissues may be the expression of a high proportion of cells about to

undergo division.

The tissue growth promoting factor or factors which have been known since the early work of Carrel (1912) to be present in extracts of embryonic tissue have recently been partially purified by Fischer (1939, 1940, 1942) who maintains that the active principle is a ribonucleoprotein or is associated with the ribonucleoprotein fraction. The presence of large amounts of ribonucleic acid in such extracts is demonstrated in this investigation (p.255).

Ribonucleic acid derivatives with proliferation promoting properties have further been claimed to be released into the intercellular fluids by living cells exposed to noxious agencies such as lethal or sublethal ultraviolet irradiation (Loofbourow, 1942a, b). The subject has been reviewed earlier (p.150).

The problem of the formation of nucleic acids and nucleoproteins in the embryo has been reviewed by Needham (1942, p. 632) (see also Gulland, 1944). It is known that during the development of the echinoderm egg nucleoprotein phosphorus and purine N remain unaltered although the Feulgen reaction for desoxyribonucleic acid increases while the pentose content of the embryos decreases (Brachet, 1937). It appears

therefore that the initially abundant store of ribonucleic acid in the cytoplasm is steadily being converted into desoxyribonucleic acid in the nuclei. In amphibia this transformation may occur but there is probably some synthesis of thymonucleic acid as well while in the teleostean and selachian fishes both types of nucleic acid are synthesised from a store of purine and pyrimidine bases. In birds and reptiles complete synthesis of both types from non-cyclic precursors is thought to occur.

Evidence that nucleic acids take part in metabolic processes is supported by the work of Marshak (1941) and of Brues, Tracy and Cohn (1942) with radioactive phosphorus.

Marshak (1941) found a rapid turnover of P in the protein fraction of the isolated nuclei of lymphoma and of resting liver which he attributed to a rapid synthesis and breakdown of nucleic acids.

Brues, Tracy and Cohn (1942) precipitated the soluble proteins of liver from rats injected with P^{32} and extracted the phospholipins, leaving a "total protein" fraction from which nucleic acids were extracted by Levene's or Hammarsten's method for the preparation of desoxyribonucleic acid. The remaining

"protein residue" contained about half the total P of the "total protein" fraction. The P turnover in the nucleic acid fraction was much less than in any other P-containing fraction, while the "protein residue" had a rapid P turnover. This agrees with Hevesy and Euler (1942) (vide supra). Phospholipin turnover was more rapid still. (1942 and private communication)

In the "regenerating" liver of rats after partial hepatectomy (see p.292), the turnover rate of the "total protein" was much higher owing to an increased nucleic acid turnover rate. The increased P^{32} uptake by the nucleic acid could be accounted for by synthesis of nucleic acid in the formation of new cells while the protein residue had the same turnover rate as in resting liver. These authors suggest, without quoting evidence, that the cytoplasmic nucleic acids have a higher rate of phosphorus turnover than the nuclear nucleic acids. (the which may polymerise to ribonucleic)

All these considerations suggest that it is extremely improbable that the ribonucleic acids are mere inert structural units in the cell. The exact nature of their mode of action is not understood but it is possible that one function, at least, is to act as a store from which the simple nucleotide co-enzymes may

be drawn. In the case of yeast Ostern, Terszakowec and Hubl (1938) suggest a possible pathway for adenosine di- and tri-phosphate formation from ribonucleic acid. Such connections between the simple nucleotides and the polynucleotides are at the moment obscure but an indication of possible relationships is given by the work of Mitchell (1942 and private communication) who suggests that an accumulation of nucleotides occurs in the cytoplasm of rapidly growing cells after irradiation owing to inhibition of the conversion of ribonucleotides to desoxyribonucleotides. His view is that ribonucleotides are formed in the cell from unknown precursors and are reduced to desoxyribonucleotides which are finally polymerised and deposited as desoxyribonucleic acid. The reduction of ribonucleotide to desoxyribonucleotide is assumed to be inhibited by X- or gamma radiation with consequent accumulation of ribonucleotide which may polymerise to ribonucleic acid. The role assigned to desoxyribonucleotides in this scheme is an important one. Their formation from ribonucleotides by reduction of the sugar and by methylation of uracil to thymine, is a reaction which has not been proved to occur in vivo but it is more probable that desoxyribonucleic acid is produced by

polymerisation of desoxyribonucleotides formed in this manner than that the ribonucleotides first polymerise to ribonucleic acid, the ribose residues of which are then simultaneously reduced to the desoxy form, while at the same time uracil is methylated to thymine. If in such a reaction the reduction were to occur in stages, hybrid nucleic acids containing both types of sugar residues would be formed. The existence of such compounds has been postulated by Donovan and Woodhouse (1943) but Gulland, Barker and Jordan (1943) point out that in the absence of experimental evidence for their existence, the suggestion is at the moment mere speculation.

The biogenesis of the nucleic acids has been discussed by Gulland (1944). One view is that the pentose components originate in the hexuronic acids. If this is so, d-ribose and l-xylose might have their origin in d-glucuronic acid and d-galacturonic acid respectively, assuming that Walden inversion occurs at C₃ during the conversion of uronic acid to pentose. In this connection it is of interest that the rapidly growing tissues of both embryos and tumours are rich in uronic acid-containing materials of the mucopolysaccharide type.

The formation of d-ribose by oxidation of glucose-6-phosphate to phosphogluconic acid and so to pentose-5-phosphoric acid has also been suggested. Other possibilities include the aldol condensation of lower sugars.

The purine and pyrimidine components of the nucleic acids do not appear to arise in the bird and mammal from the purines and pyrimidines of the diet (Plentl and Schoenheimer, 1944). Experiments with isotopic nitrogen have indicated that they may be synthesised from smaller molecules, or that ready-made purines and pyrimidines may be utilised in the form of nucleosides and nucleotides (see also p.117).

growth is very rapid (Gurli, 1947). Arrangements were made to obtain the material immediately after slaughter but even so some hydrolysis by the very active tissue nucleotidases of nucleotide to nucleoside was unavoidable.

Small organs were pooled for analysis. In the case of large organs groups of specimens were analysed separately at different times. Where fetal tissues were used, they were excised from the anaesthetised bird and immediately dealt with. Chick embryos were

2. EMBRYONIC MATERIAL.

A. Experimental Methods.

An attempt has been made to establish firstly whether ribonucleic acids are indeed of widespread occurrence in animal tissues and secondly whether there is a high concentration of ribonucleic acid, and/or of ribonucleotides, in rapidly growing tissues.

As the first example of rapidly growing tissues, embryonic tissues have been employed and have been compared with the corresponding adult material.

The tissues used were obtained chiefly from the freshly killed adult and embryo sheep. The embryos used were all about 9-10 weeks old, a stage at which growth is very rapid (Gurlt, 1847). Arrangements were made to obtain the material immediately after slaughter but even so some hydrolysis by the very active tissue nucleotidases of nucleotide to nucleoside was unavoidable.

Small organs were pooled for analysis. In the case of large organs groups of specimens were analysed separately at different times. Where fowl tissues were used, they were excised from the anaesthetised bird and immediately dealt with. Chick embryos were

used immediately on removal from the egg. In some cases avian material was frozen with solid CO_2 immediately on removal from the bird, but this procedure was later found to be unnecessary.

(1) Small portions of fresh tissue were taken for histological examination when required.

(2) In the fresh tissue moisture was determined by drying weighed portions in tared beakers at 100° to constant weight.

(3) Nucleotide, nucleoside, and free purine N were determined in trichloroacetic acid extracts of the fresh tissue by the method of Kerr and Blish (1932) as modified by Kerr (1940). The sum of all three gave the total acid soluble purine N.

(4) The total nucleic acid content of the tissues was estimated on 15-25 mg. portions by making nucleoprotein phosphorus (N.P.P.) determinations by the method of Berenblum, Chain and Heatley (1939) in which lipid P is extracted with ethanol-chloroform mixture and acid soluble P is extracted with HCl and the remaining acid insoluble P, as determined by the micro-method of Berenblum and Chain (1938), is taken to be nucleic acid P. This is almost certainly not the case as will be seen later. In the results, therefore,

the figures for N.P.P. indicate rather residual acid insoluble P (the "protein-bound" P of Rosenthal and Drabkin, 1943). This fraction will, of course, include phosphoprotein P (see p.251), which appears, however, to be low in nearly all tissues, including embryonic tissue.

(5) For the separate estimation of the two types of nucleic acid, methods involving the determination of pentose and desoxypentose have been employed, but before they could be applied, the nucleic acids were extracted from the tissue. It was found desirable first to prepare an ethanol-ether powder from the fresh tissue, to submit this powder to extraction of acid soluble P and of lipoid soluble P and to dry the resulting residue containing the acid insoluble P (nucleic acid P + residual P as previously mentioned). Euler and Schmidt (1934b) claim that preliminary treatment with ethanol and ether binds some acid soluble P to the protein and renders its subsequent extraction difficult but control experiments have revealed no difference in the P content of powders prepared by Euler and Schmidt's method and the method employed here.

For the removal of both types of nucleic acid simultaneously from the denatured proteins of the

tissue residues in the extracted powder, alkali was avoided, since, although it could remove all, or nearly all, the P from the powder, it could only do so at the expense of some destruction of nucleic acid, particularly ribonucleic acid, which is much more labile to alkali than thymonucleic acid (Steudel and Feiser, 1922; Johnson and Harkins, 1929). Most methods for the isolation of desoxyribonucleic acid are sufficiently drastic to cause at least partial destruction of ribonucleic acid.

The use of proteolytic enzymes to digest away the protein leaving the nucleic acid, c.f. Caspersson (1936) and Hillary (1940), was not found satisfactory for the present purpose. A suitable reagent for the extraction of the nucleic acids was found to be 10% NaCl, c.f. Clarke and Schryver (1917); Jorpes (1928, 1934); Javillier and Allaire (1926b, 1931); Barnes and Schoenheimer (1943). From the brine extract the nucleic acids were precipitated as lanthanum salts, which have been shown by Caspersson, Hammarsten and Hammarsten (1936) and by Caspersson (1936) to be very insoluble. From 10% NaCl solution the precipitation is incomplete unless one volume of ethanol is added. In the precipitate pentose and desoxypentose were

colorimetrically estimated.

Most methods of pentose estimation depend on the liberation of furfural from the pentose by boiling with HCl and the subsequent colorimetric estimation of the furfural after reaction with some such reagent as aniline acetate. As the uronic acids of the mucopolysaccharides such as chondroitin sulphuric acid may interfere under these conditions the figures for pentose estimation may tend to be high. It is unlikely that interference from this source will be serious in the lanthanum precipitates except in the case of such a tissue as cartilage, but independent confirmation of the presence of ribonucleic acids has been sought by other and more specific methods using the enzyme ribonuclease which attacks specifically the ribonucleic acids (Kunitz, 1940). The action of ribonuclease is discussed earlier (p.183). It does not break down nucleic acid completely to the component mononucleotides, but whereas 100% of the phosphorus of ribonucleic acid is precipitable by 0.25% uranyl acetate in 2.5% trichloroacetic acid, only 40% of the P is so precipitable after the action with the enzyme has gone to completion. The extent of the reaction depends on a number of factors (Kunitz, 1940)

and for this reason, the application of the enzyme to the exact quantitative estimation of the nucleic acids is not feasible. Ribonuclease has, however, been made use of here not only to confirm the presence of ribonucleic acids but to give a semi-quantitative estimation of the amount of nucleic acid present by allowing crystalline ribonuclease in high concentration to act to completion on the NaCl extract and measuring the amount of uranyl precipitable P rendered non-precipitable by the enzyme.

Procedure. The fresh tissue is minced, dehydrated with several successive portions of ethanol, then ether, and dried. The dried material is ground to a fine powder in a mill and passed through a sieve. About 2 grams of the powder are weighed out into a stoppered centrifuge tube and are shaken for six one-hour periods with successive portions of 30-40 ml. 0.1 N HCl. This process removes acid soluble P including simple nucleotides. The residue is washed twice with ethanol and is then extracted for two successive two-hour periods at 65° under a reflux condenser with an ethanol-chloroform mixture (3:1). It is then washed with ether and dried.

(a) Total P is estimated in the extracted powder

by a modification of the method of Allen (1940).

(b) Purine N is estimated by the method of Graff and Maculla (1935).

(c) Phosphoprotein P is determined, using a method similar to that of Euler and Schmidt (1934a) making use of the fact that phosphoprotein P is split off as inorganic P when the phospho-protein is incubated at 37° for 24 hours with 0.25 N NaOH (Plimmer and Scott, 1908). After removal of protein with trichloroacetic acid inorganic P is precipitated as described by Lohmann (1928) using Mathison's (1909) reagent.

(d) For the nucleic acid extraction a suitable quantity (50-750 mg. depending on the P content) is then weighed out into a 15 ml. conical centrifuge tube and two drops triacetin added. Extraction with 10% NaCl is then carried out with five successive 3 ml. portions, (a) for four hours at 0° , (b) overnight at 0° , (c) for 30 min. at 100° , (d) for 10 min. at 100° , and (e) for 10 min. at 100° respectively.

The extracts are combined and made up to 15 ml.

(α) 1.0 ml. is taken for total P estimation.

(β) 1.5 ml. portions are taken for the ribonuclease test (vide infra).

(δ) 9 ml. are pipetted into a 25 ml. centrifuge

50 ml. eth tube and 1 ml. 2% lanthanum acetate and 10 ml. ethanol added. After one hour at 0° the precipitate is centrifuged down and washed twice with 3 ml. 0.2% lanthanum acetate. It is decomposed with 0.6 ml. 0.5 M Na_2CO_3 and 5.4 ml. water are added. The lanthanum carbonate is centrifuged down.

The supernatant is treated as follows:-

- (i) 1 ml. is taken for total P estimation.
- (ii) 1 ml. is taken for estimation of pentose by a modification of the method of Reeves and Munro (1940). This method depends upon the liberation of furfural which is trapped in xylene and allowed to react with aniline acetate.

The 1 ml. of solution is pipetted into a graduated test-tube with a B14 ground glass socket. 2 ml. 5.55 N HCl and 5 ml. xylene (purified by distillation) are added. The tube is attached to an air condenser with ground glass cone and is immersed in a briskly boiling water bath for $2\frac{1}{2}$ hours. The contents are cooled and the xylene layer made up to 7 ml. The lower aqueous layer is sucked off with a fine pipette and the xylene layer dried with anhydrous sodium acetate. When the xylene has cleared, 5 ml. is pipetted into a dry Pyrex tube and 5 ml. freshly made aniline acetate reagent (1 ml. colourless aniline is dissolved in 50 ml. AnalaR glacial acetic acid and

50 ml. ethanol) added. The tube is allowed to stand in the dark room for precisely 20 minutes and the red colour is examined in the Hilger Spekker Absorbtiometer (filter No. 6) using a calibration curve drawn up in terms of ribonucleic acid phosphorus (RNAP) and prepared from standard solutions of ribonucleic acid purified by precipitation from glacial acetic acid as described by Kunitz (1940). Yeast ribonucleic acid and liver ribonucleic acid gave similar curves.

Desoxyribonucleic acid does not interfere.

(iii) 3 ml. are taken for the colorimetric estimation of desoxypentose by the modification by Sevag, Smolens and Lackman (1940) of the diphenylamine reaction of Dische (1930).

The 3 ml. solution are pipetted into a conical graduated centrifuge tube containing 1 ml. 0.55 N HCl. The tube is heated in a boiling water bath for 15 minutes, cooled, and the volume made up to 4 ml.: 3 ml. of the supernatant are transferred to a Pyrex tube and 8 ml. freshly made diphenylamine reagent added (1 gm. diphenylamine (AnalaR, twice^{re} crystallised from ethanol) dissolved in 2 ml. H₂SO₄ (AnalaR) and 98 ml. glacial acetic acid (AnalaR)). The tube is placed in the briskly boiling water bath for three

minutes, quickly cooled and the blue colour read off in the Hilger Spekker Absorbtiometer (filter No. 1) after five minutes using a calibration curve drawn up in terms of desoxyribonucleic acid phosphorus (DNAP). Ribonucleic acid does not interfere (nor does chondroitin sulphuric acid).

Using these two methods, good recovery has been obtained from a mixture of ribo- and thymo-nucleic acids in 10% sodium chloride solution.

Both calibration curves were made with nucleic acids precipitated as La salts.

For the ribonuclease method 1.5 ml. sodium chloride extract are pipetted into each of three 15 ml. conical centrifuge tubes: 2.4 ml. veronal acetate buffer pH 6.12 (Michaelis, 1931) are added to each tube and 0.2 ml. of a solution of 5 mg. crystalline ribonuclease in 100 ml. water are added to one tube. The other two tubes are used as controls. To one of these are added immediately 4.0 ml. 0.25% uranyl acetate in 2.5% trichloroacetic acid. The remaining control tube and the tube containing enzyme are immersed in a thermostatic bath at 37° for one hour before the uranyl acetate reagent is added. Fifteen minutes after addition of the reagent the tubes are centrifuged

and the precipitate washed with 2 ml. 0.125% uranyl acetate in 1.25% trichloroacetic acid. It is then dissolved in 0.5 M sodium carbonate and the solution is transferred to a digestion flask for total phosphorus determination.

The non-incubated tube gives the amount of uranyl precipitable P originally present while the tube containing enzyme gives the amount present after ribonucleic acids have been broken down. The second control without enzyme gives a measure of the amount of spontaneous decomposition of nucleic acid in sixty minutes at 37°. In most cases it is low.

With each batch of tubes used in this determination a standard set of three tubes containing 0.1% purified ribonucleic acid in 10% NaCl is set up to check the extent of hydrolysis. Under the conditions stated about 60% of the ribonucleic acid P is rendered non-precipitable by the enzyme. Sodium chloride does not inhibit the action of the enzyme but the degree of hydrolysis of ribonucleic acid may be to some extent influenced by the quantity of thymonucleic acid simultaneously present. The enzyme has no action on thymonucleic acid.

Examination of the Method.

In using calibration curves reading directly in ribo- or desoxyribonucleic acid phosphorus, the assumption is made that the nucleic acid in the tissues contains the same relative amounts of ribose (or rather furfural yielding material, since purine and pyrimidine nucleotides yield different amounts of furfural: Levene and Jorpes, 1930) to P, or of desoxyribose to P as do the pure acids used to prepare the calibration curves. This assumption appears to be justified in the case of ribonucleic acid isolated from the liver (see p.266) which gives figures which agree well with the calibration curve prepared from yeast nucleic acid. In the case of desoxyribonucleic acid (Vowles, 1940) the sugar residues from the purine nucleotides also react in the estimation to a much larger extent than those from pyrimidine nucleotides, and the estimation of desoxyribose will only be valid if all tissue desoxyribonucleic acids contain equimolecular amounts of purine and pyrimidine. This appears to be the case (Mirsky, 1943).

Compounds of La and other metals have been shown by Bamann and Meisenheimer (1938) to be capable under certain conditions of hydrolysing organic phosphates.

The danger of interference from actions of this type in the present circumstances is negligible.

It cannot be taken for granted that the ribonucleic acids of the tissues are identical with yeast nucleic acid. They do, however, function as substrates for ribonuclease and the ribonucleic acid isolated from liver (p.266) suffers the same degree of hydrolysis as does yeast nucleic acid.

B. Results.

(a) Total nucleic acid and water content.

The results of the N.P.P. estimations are shown in Table 17. Kossel (1882) quotes only one figure for sheep tissue (brain) and his figure (99 mg. % wet weight) in this case as in the case of other tissues from other species is rather higher than that found here. The present figures are, however, very much of the same order as those of Javillier and Allaire (1926a) for the horse, Jorpes (1928) for the ox and Grund (1910) for the dog and hen (See Table 15).

The water content of the embryonic tissues is considerably higher than that of the corresponding adult tissues. It has of course been known for a long time that actively growing tissues, normal or

neoplastic, have a high water content - "the highest growth rates occur when the proteins are at their wettest" (Willmer, 1935). Neuberg (1904-1905), for example, quotes high figures for the water content of tumours while Cramer (1916) found a fall in moisture in the course of embryonic development and a high water content in carcinomata. Gortner (1930) went so far as to say that "many of the relations characteristic of living processes have more to do with the water relationships of the organism than with any other single factor".

As a result of the high water content of the embryo, the difference in N.P.P. between embryo and adult is much more marked when the comparison is made on a dry weight basis than on a fresh tissue basis.

When the figures for the embryo and the adult are compared on a dry weight basis it is found that the N.P.P. in the embryo is invariably higher than in the corresponding adult tissue. In some cases the difference is very marked, e.g. heart, muscle, cartilage and thyroid. In some tissues, on a fresh weight basis, the difference between embryo and adult is small and the figure for the adult may actually be higher, e.g. intestine, spleen, kidney medulla,

brain (white matter).

On a dry weight basis embryonic tissues are richer in nucleic acid than the corresponding adult tissues. No extensive comparison of the tissues of any one species is to be found in the literature but figures have been quoted for individual tissues. Masing (1911) has shown that the N.P.P. of whole rabbit embryo and of embryo rabbit liver diminishes progressively as the age of the embryo increases while Dumm (1943) has recorded a fall in the N.P.P. of embryo rat liver with age. Le Breton and Shaeffer (1923), using pig and mouse embryos, have found a fall in purine N concentration as gestation advances. Kossel (1882) quotes a higher figure for cattle embryo muscle than for adult muscle. Robertson and Dawbarn (1929) estimated the nucleic acid N in the tissues of two new born lambs and one adult ewe. From their tables the ratio of the percentage of nucleic acid N in the new born lamb to the percentage of nucleic acid N in the adult sheep can be calculated to be 1.4 for the small intestine, 2.6 for liver, 1.9 for lung, 4.6 for skin, 2.5 for kidney, 3.7 for cerebrum, 4.3 for heart and 5.0 for muscle. These figures obtained by quite a different method are strikingly similar to the ones

quoted here. (and this qualification appears to hold

Liver tissue is of special interest and is discussed in a later section (p.281).

The position of nervous tissue is rather striking. Not only does the white matter of the central nervous system have a higher N.P.P. than the grey matter, but even peripheral nerve has an appreciable N.P.P. content comparable indeed with muscle. Caspersson (1941) records a high ribonucleotide or ribonucleic acid content in nerve cells (see also Gersh and Bodian, 1943).

The figures for the P content of the tissues extracted in bulk are shown in the first column in Table 18. These figures are of course essentially the same as the N.P.P. figures on a dry weight basis, except that the P content is expressed in terms of a powder from which all acid soluble and lipoid material has been removed.

To investigate whether or not all this P could be taken to be nucleic acid P, purine estimations were carried out on the extracted powders. If the tissue nucleic acids have the same relative amounts of purine and P as have purified thymonucleic acid and yeast

nucleic acid (and this qualification appears to hold for the desoxyribonucleic acids of the tissues (Mirsky, 1943), the atomic ratio of purine N to P is 10:4 for tetranucleotides. (The ratio would of course be higher in the case of pentanucleotides (Jorpes, 1934)). As Table 18 shows, in many cases the figure for nucleic acid P calculated from purine N is rather less than the figure for total P. It is probable therefore that some of the P in the extracted powder is not present in the form of nucleic acid. Alders (1927) carried out estimations of both N.P.P. and total purine in thymus, kidney, pancreas and spleen. Except in the case of ox pancreas, the nucleic acid calculated from the purine content was lower than that calculated from the N.P.P. (see also Graff and Barth, 1938). In the case of liver nucleoprotein Brues, Tracy and Cohn (1942), using P^{32} found that only about 50% of the residual P after extraction of acid soluble and lipid P could be accounted for in terms of desoxyribonucleic acid. The remainder had a different turnover rate. Somewhat similar results were obtained with P^{32} by Hevesy and Ottesen (1943) who have shown that after very exhaustive extraction of muscle and other tissue of the frog with trichloroacetic acid and ethanol-ether,

Table 18.

Analyses of tissue powders remaining after extraction of acid-soluble and lipoid P, and of lanthanum salts precipitated from the NaCl extract of these powders

All tissues from the adult or 9-10 weeks embryo sheep unless otherwise stated.

Nucleic acid P = purine N \times 0.886 (assuming purine N : P atomic ratio of 10 : 4).

DNAP = desoxy^{ribo}nucleic acid P. RNAP = ribonucleic acid P.

Tissue	Extracted tissue powder				P in NaCl extract as percentage of P in extracted powder	Precipitate of La salts			
	Total P (mg./100 g.)	Purine N (mg./100 g.)	Nucleic acid P calculated from purine content (mg./100 g.)	Nucleic acid P as percentage of total P		P in La ppt. as percentage of P in NaCl extract	DNAP as percentage of P in La ppt.	RNAP as percentage of P in La ppt.	Ratio RNAP/DNAP
Adult liver	384	353	313	82	84	74	19	65	3.5
Embryo liver	1175	1241	1101	94	75	60	24	61	2.6
Adult lung	565	397	352	62	94	73	50	43	0.9
Embryo lung	1225	866	767	63	93	69	50	35	0.7
Adult gut	636	622	551	87	88	66	41	39	1.0
Embryo gut	958	782	693	72	82	83	31	35	1.1
Adult heart	219	174	154	70	56	65	19	70	3.6
Embryo heart	616	546	484	79	81	79	25	59	2.4
Adult spleen	914	974	863	95	78	67	50	27	0.5
Embryo spleen	1380	1448	1284	93	97	70	47	26	0.6
Adult kidney	442	400	355	80	74	74	29	52	1.8
Embryo kidney	923	949	840	91	79	72	49	41	0.8
Adult brain	369	215	190	52	40	67	31	65	2.1
Embryo brain	556	340	301	54	82	79	23	55	2.3
Adult muscle	147	145	129	88	55	71	19*	66	3.6*
Embryo muscle	650	572	507	78	95	70	37	53	1.4
Adult cartilage	84	85	75	89	63	40	41	—	—
Embryo cartilage	382	343	304	80	92	53	40	60	1.5
Adult thyroid	166	167	148	89	63	68	24	48	2.0
Embryo thyroid	682	732	649	95	83	69	39	41	1.1
Adult skin	135	141	125	93	68	48	32	60	1.9
Embryo skin	842	824	730	87	94	68	43	41	1.0
Adult testis	660	624	553	84	70	66	26	67	2.6
Adult ovary	484	444	394	81	87	42	39	52	1.3
Sheep placenta	655	613	543	83	83	74	33	65	2.0
Thymus (15-week sheep embryo)	2760	2696	2390	87	97	72	66	13	0.2
Whole blood (embryo sheep)	152	—	—	—	63	73	32	63	2.0
Nuclei (embryo sheep liver)	2630	2382	2110	80	86	82	75	14	0.2
Dried sheep embryo extract	192	175	155	81	82	93	11	83	7.4
Nucleoprotein fraction from embryo extract	658	746	661	101	82	80	81	10	8.0
Whole chick embryo (9 days)	1040	1017	901	87	86	74	29	58	2.0
Whole human embryo (3 months)	590	613	544	92	80	75	29	59	2.1
Ox pancreas	1670	1782	1580	95	79	87	10	82	8.0

* The total nucleic acid content of muscle is so low that the figures quoted should be regarded as provisional.

the specific activity of the residual P was much higher than that of the P in purified (desoxyribo) nucleic acid prepared from the same material. These results might be due in part to the presence of ribonucleic acids with a high specific activity.

The nature of the non-nucleic acid residual P is still in doubt. Some of it may be present as phosphoprotein but estimations show that the phosphoprotein P is in most cases negligible and in all cases is less than 5% of the total residual P except in adult brain (6.2%) and adult heart (6.7%). Euler and Schmidt (1934) found that the phosphoprotein P in most tissues is very low, and in so far as comparison is possible (Euler and Schmidt quote only for fresh tissue) the figures found here are rather lower than theirs.

(b) Ribonucleic Acids.

The percentage of P extracted by NaCl from different tissues is not uniform (Table 18). In most cases extraction is of the order of 80-90% but in certain tissues, e.g. adult heart, adult muscle and adult brain, particularly the last, the amount extracted is low, although constant for different specimens.

The amount of P in the NaCl extract which appears

in the precipitate of La salts is also variable (Table 18). Precipitation is poor in the case of cartilage, skin and ovary, all of which yield extracts containing much material of a mucopolysaccharide type. As a result the La precipitate contains in most cases 60-80% of the P of the extracted powder. As previously shown the P of the extracted powder is not entirely derived from nucleic acid. In such tissues as adult heart, brain, muscle, cartilage, skin and ovary, the percentage is much lower. It is, however, even in these cases remarkably constant for different batches of powder prepared from different animals.

Results of the analyses of the La precipitate for pentose and desoxypentose are shown in Table 18 expressed in terms of ribonucleic acid phosphorus (RNAP) and desoxyribose nucleic acid phosphorus (DNAP) as percentages of the total P. In most cases between 80 and 95% of the total P in the La precipitate can be accounted for in terms of ribo- or desoxyribonucleic acid. In the case of adult cartilage, the sum was greater than 100% due to interference in the pentose estimation by chondroitin sulphuric acid.

The relative amounts of the two types of nucleic acid found in the La precipitates are shown in the last

column of Table 18. The ratio of RNAP to DNAP varies greatly from tissue to tissue, being high in such tissues as pancreas, liver, heart, brain, testis and muscle and low in thymus, spleen and lung. These ratios are not necessarily the same as those which obtain in the original tissue, especially in those cases where precipitation and extraction are low, e.g. adult heart and adult brain.

In any given tissue the ratio of RNAP to DNAP is of the same order in the embryo as in the adult or is somewhat higher in the adult. Therefore, since the amount of total nucleic acid is higher in the embryo than in the adult, any given embryonic tissue must have a higher content not only of nuclear desoxyribonucleic acid, but also of cytoplasmic ribonucleic acid. This observation may explain Caspersson's finding of a high absorption at 2600 \AA in the cytoplasm of rapidly growing tissues.

To examine the view that desoxyribonucleic acid is found in the nuclei and ribonucleic acid in the cytoplasm, nuclei of embryo sheep liver were isolated by the citric acid method of Marshak (1941). Acid soluble and lipid P were extracted from the nuclei and the residue worked up in the usual way (Table 18).

The very low ratio (0.2) suggests that provided the nucleic acid content of the nuclei remains unaltered during the isolation process, there is indeed very little ribonucleic acid in the nuclei. The small amount found may be due in part at least to adherent cytoplasmic residues.

Dounce (1943a,b,c) has isolated the nuclei from rat liver cells and estimated their desoxyribonucleic acid content. His figure is of the order of 20% of the dry weight. This amounts to about 1.8% P. The figure shown here for extracted embryo sheep nuclei is 2.63% total P. Of this P about 75% would appear to be DNAP. Thus 1.97% of the material would be DNAP. This figure is of the same order, therefore, as that of Dounce.

On the other hand ribonucleic acid predominated in a saline extract of minced whole sheep embryo. The extract was prepared by allowing the minced embryos to stand overnight with Tyrode solution at 0°. It was then filtered through gauze and centrifuged. The extract so obtained had powerful growth promoting properties to chick heart fibroblasts in vitro (p. 80). It was dried at room temperature as recommended by Fischer (1942) and powdered. Such a saline extract

would be expected to contain mainly cytoplasmic material (c.f. Mirsky and Pollister, 1942) and the ratio obtained (7.4) is evidence in favour of the predominance of ribonucleic acids in the cytoplasm.

From such an embryo extract the "nucleoprotein" fraction which fell out at pH 4.3 was centrifuged down, washed repeatedly with very dilute acetic acid, extracted with ethanol-chloroform mixture and worked up as usual. Again the ratio was high (8.0).

Fischer (1939, 1940, 1942^a) has claimed that the growth promoting substances of embryo juice are associated with the nucleoprotein fraction and has suggested that the activity may lie in ribonucleoproteins. The results of the present investigation show that of this fraction some 80% is in fact ribonucleoprotein.

(c) Ribonuclease experiments.

In all cases the NaCl extract of the tissue contained a proportion of phosphorus which treatment with ribonuclease rendered non-precipitable by uranyl acetate reagent. The amount of P in the NaCl extract precipitable by the uranyl acetate reagent is in most cases of the same order as that precipitable by lanthanum acetate. With yeast ribonucleic acid as substrate, 60% of the phosphorus is rendered non-

Figure 15.

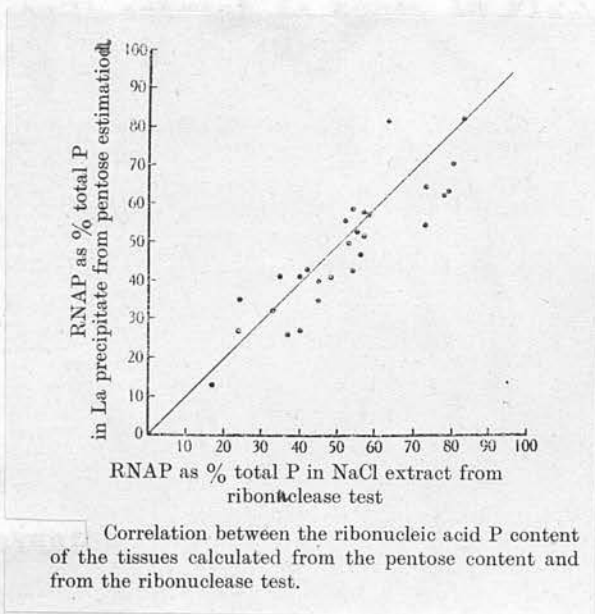

precipitable when ribonuclease has acted to completion. On the same basis the ribonucleic acid content of the NaCl tissue extract has been calculated as a percentage of the total P in the extract. The relationship between the percentage of RNAP in the La precipitate and in the NaCl extract is shown in Fig. 15. In most cases there is reasonably good correlation between the pentose content in the La precipitate and the amount of substrate for ribonuclease in the NaCl extract. This agreement gives independent confirmation of the presence of ribonucleic acids in the tissue powders.

(d) Nucleotides, nucleosides, and free purine.

An investigation of the polynucleotide content of tissues would be incomplete without a series of concurrent estimations of the simple mononucleotides which differ from the polynucleotides in being acid soluble and in appearing in a trichloroacetic acid filtrate. The purine nucleotides which are precipitated by uranyl acetate include adenosine triphosphate, adenylic acid, inosinic acid, the nicotinamide nucleotides and flavine adenine dinucleotide. Of these adenosine triphosphate accounts for the major part of the total tissue nucleotides while the last two form

Table 19.

Total acid-soluble purine N (nucleotide N + nucleoside N + free purine N) in trichloroacetic acid extracts of different samples of adult sheep and 9-10 weeks embryo sheep tissues

Tissue	Total acid-soluble purine N (mg./100 g. fresh tissue)	
	Embryo	Adult
Liver	24.4, 28.6, 28.0	35.9, 36.4
Heart	30.9, 20.0, 21.7	37.5, 48.3, 45.9, 43.8
Muscle	24.2, 25.4, 25.3	53.9, 40.6, 57.1
Spleen	30.8	41.5, 29.8, 37.8, 35.0
Brain:		
Whole	20.9, 21.6, 18.6	24.6, 32.6
Grey matter		20.0, 28.0, 17.5
White matter		23.8, 23.1, 19.6
Kidney	22.3, 17.5, 17.5	25.3, 31.5
Lung	24.2, 13.3, 15.4	30.5, 25.7
Cartilage	15.6, 19.6, 15.4	—

Table 20.

Nucleotide, nucleoside, and free purine content of the adult and embryo fowl

Adult birds fasted 24 hr. before use. All figures are in mg. N/100 g. fresh tissue.

Exp. no.	Tissue	Nucleotide N	Nucleoside N † (free purine N)	Total soluble purine N
204*	Adult liver	21.6	14.1	35.7
208	"	30.0	16.5	46.5
209	"	20.3	13.6	33.9
212	"	26.6	23.8	50.4
219	"	27.3	14.3	41.6
203*	Adult heart	27.6	12.0	39.6
207	"	29.1	15.4	44.5
210	"	23.4	15.0	38.4
201*	Adult muscle (breast)	52.4	5.9	58.3
205	"	42.3	10.2	52.5
402†	"	40.0	11.2	51.2
404†	"	31.1	13.7	44.8
406†	"	41.8	11.6	53.4
202	Adult muscle (leg)	34.6	7.3	41.9
206	"	26.3	7.7	34.0
408†	"	28.7	9.1	37.8
301*	Whole chick embryo (9 day)	14.1	6.0	20.1
308	" (9 day)	10.8	6.0	16.8
1E	" (10 day)	11.2	5.6	16.8
2E	" (10 day)	12.6	7.0	19.6
302*	" (13 day)	14.8	3.6	18.4
303*	" (13 day)	14.4	4.1	18.5
305	Chick embryo muscle (16 day)	15.8	7.0	22.8
9E	Chick embryo viscera (16 day)	16.8	9.8	26.6
8E	Chick embryo minus viscera (16 day)	17.5	7.0	24.5
401†	Rous sarcoma	11.9	7.0	18.9
403†	"	7.7	7.0	14.7

* Tissues frozen in solid CO₂.

† From birds with Rous sarcoma.

conditions of the experiments minimised the chances of hydrolysis of nucleotide to nucleoside and figures for nucleotide and nucleoside are quoted separately.

Adult muscle has the highest total nucleotide content. In muscle, however, the amount of nucleoside relative to nucleotide is low; in heart and especially in liver nucleoside and free purine form a much more significant proportion of the total acid soluble purine.

In the chick embryo both fractions are low and the total acid soluble purine N content is of the same low order as in the case of the sheep embryo.

These results are expressed in terms of fresh tissue. Owing to the higher water content of embryonic tissue, if the results are expressed in terms of dry weight, much smaller differences between embryo and adult are apparent.

There are few references in the literature to the nucleotide content of tissues for comparison, and none to sheep tissues (see p.221). The results obtained here, however, are of the same order as those quoted by Kerr (1932, 1942) for the brain, muscle and liver of the dog, by Barrenscheen and Peham (1941b) for a number of tissues from a variety of different sources

including fowl muscle, and by Euler and Allen (1935) for the dog. The figures of Dell'Aqua (1935) for rabbit liver are appreciably higher than the values for sheep or fowl liver (see also Table 16).

These results tend to show that rapidly growing tissues have in general a low concentration of total soluble purine (including nucleotides) and that the high concentration of cytoplasmic nucleotides reported by Caspersson is not due to the presence of acid soluble nucleotides.

C. Discussion.

The procedure which has been described must not be regarded as an accurate quantitative estimation of the ribonucleic acid content of tissues. It serves, however, to demonstrate the presence of ribonucleic acids in all the tissues examined and to give an indication of the relative amounts of ribo- and desoxyribonucleic acids.

If crystalline ribonuclease attacks ribonucleic acids only and if it is uncontaminated by traces of other enzymes (and there appears to be no reason to doubt the validity of these assumptions) then the NaCl extract of the tissue powder contains a substrate

for ribonuclease, presumably a ribonucleic acid. Moreover in the precipitate of lanthanum salts obtained from the NaCl extract, a certain proportion of the P present can be accounted for in terms of pentose. Finally, the amount of pentose containing material and the amount of substrate for ribonuclease show a definite correlation. There seems to be no doubt therefore that we are dealing with some type of ribonucleic acid. Whether all tissues contain the same ribonucleic acid and whether in that case it is similar to the ribonucleic acid of the pancreas or of yeast or to neither, is of course unknown, but observations on the ribonucleic acid which has been isolated from liver suggest that it is similar to yeast nucleic acid.

The ratios of RNAP to DNAP reveal that the amounts of ribonucleic acid in many tissues are high. In cases where the same organs have been examined by Jorpes (1928) there is agreement between his results and those quoted here. Jorpes estimated both N.P.P. and total pentose in the fresh tissue. In the case of thymus he found a total N.P.P. of 0.441% and a pentose content of 0.152% corresponding to 0.063% pentose nucleic acid phosphorus (if all pentose comes

from ribonucleic acid): 14.2% of the N.P.P. could therefore be accounted for as RNAP. Similarly in the case of pancreas 84.3% of the N.P.P. is RNAP. Assuming that the remainder of the N.P.P. is all DNAP these figures would give ratios RNAP/DNAP of 0.2 for thymus and 5.4 for pancreas. From Jorpes' data the ratios can similarly also be calculated to be 2.1 for ox liver, 3.2 for rabbit liver, and 0.5 for ox spleen. The ratios calculated from the results of Jorpes, therefore, are of the same order as those obtained here.

In view of these results, it is apparent that in embryonic tissues which are growing rapidly there is no high concentration of acid soluble purine nucleotides. On the other hand, the total nucleic acid of an embryonic tissue is higher than that of the corresponding adult tissue and since the ratio of ribonucleic acid to thymonucleic acid is of the same order in the embryo as in the adult, a high concentration of cytoplasmic ribopolynucleotides is to be expected in the embryonic tissue. This would explain the high absorption at 2600 \AA found by Caspersson and his colleagues in the cytoplasm of rapidly growing tissues.

It is of interest to note that Stedman and Stedman (1943b) have recently reported that the nuclei of

rapidly growing tissues such as chick embryo and mouse and rat carcinoma, are characterised by a much lower histone content than is found in non-proliferating tissues. It is probable that the high content of both desoxyribo- and ribonucleic acid in rapidly growing tissues is intimately connected with the process of cell division. As the result of experiments on tissue cultures growing in embryo extract, Willmer (1942^b) has suggested that a rise in total nucleic acid may precede cellular division by some hours and observations described earlier (p.131) support this view.

The relationship between nucleotides and nucleic acids in tissues is uncertain. Although the function of many of the nucleotides is well known, that of the nucleic acids is obscure. Ostern, Terszakowec and Hubl (1938) have brought forward evidence that in yeast ribonucleic acid may act as a reservoir from which nucleotides including adenosine triphosphate are obtained, while Brachet (1937) has claimed that in the development of the sea urchin egg ribonucleic acid is converted into desoxyribonucleic acid. The synthesis of desoxyribonucleic acid from ribonucleotides by rapidly proliferating cells is according to

Mitchell (1942) inhibited by X- and gamma radiation with consequent accumulation of cytoplasmic ribonucleotides or more probably of ribonucleic acids. Whether or not nucleotides are actively concerned in the protein synthesis of the growing cell (c.f. Needham, 1942; Loofbourow, 1942) is still an open question.

in pancreas, liver, testis, brain and heart and low in spleen. SUMMARY. thymus.

1. The total nucleic acid content of embryo and adult sheep tissues has been estimated. In most organs the embryonic tissue has a higher nucleic acid and water content than the corresponding adult tissue.
2. Ribonucleic acids as well as desoxyribonucleic acid are present in both embryonic and adult tissue. Their presence has been proved by extracting the nucleic acids with 10% sodium chloride, precipitating them as La salts, and estimating pentose and desoxypentose after decomposition of the La precipitate.
3. The presence of ribonucleic acids in the tissue extracts has been confirmed enzymatically by the use of crystalline ribonuclease.
4. The relative amounts of ribonucleic acid and

desoxyribonucleic acid have been approximately assessed. The ratio of ribonucleic acid to desoxyribonucleic acid is of the same order in the embryo as in the corresponding adult tissue or may be slightly higher in the latter, but varies widely from tissue to tissue, being high in pancreas, liver, testis, brain and heart and low in spleen, lung and thymus.

5. The results obtained support the view that desoxyribonucleic acid is located in the nucleus and ribonucleic acids mainly in the cytoplasm.
6. Rapidly growing tissues such as embryonic tissue tend therefore to be characterised by a high concentration of desoxyribonucleic acid in the nucleus and of ribonucleic acids in the cytoplasm.
7. Acid soluble purine nucleotides are present in lower concentration in embryonic tissues than in the corresponding adult tissues.

3. THE ISOLATION AND PROPERTIES OF
LIVER RIBONUCLEIC ACID.

So far, although the presence of pentose nucleic acids has been demonstrated in many biological materials, only three such acids have been isolated and characterised (see p.180). The first to be isolated was yeast ribonucleic acid whose structure has been reviewed by Gulland (1938, 1944). In addition to d-ribofuranose it contains small amounts of l-lyxose (Gulland, Barker and Jordan, 1943; Gulland and Barker, 1943) and is usually considered to be composed of tetranucleotide units in which the bases are adenine, guanine, uracil and cytosine in equimolecular proportions. The pancreas pentose nucleic acid was considered by Jorpes (1928, 1934) to be probably a pentanucleotide containing three molecules of purine (guanine : adenine ratio = 2.1) and two of pyrimidine. Jorpes (1924) isolated the crystalline brucine salts of cytidine and uridine phosphoric acids from hydrolysates of this nucleic acid, and concluded that the pyrimidines were cytosine and uracil.

The third pentose nucleic acid which has been isolated and characterised has been prepared from

tobacco mosaic virus (Loring, 1939; Cohen and Stanley, 1942b). It appears to be very similar to yeast ribonucleic acid and on hydrolysis has yielded guanine, adenine, cytosine and the brucine salt of an acid similar to and probably isomeric with, yeast uridylic acid (Loring, 1939).

Liver tissue is known to contain a desoxyribonucleic acid very similar to thymus desoxyribonucleic acid (Levene, 1922; Peters, 1911; Ishiyama, 1928; Greenstein and Jenrette, 1940). Desoxyribonucleic acid has been prepared from isolated liver cell nuclei by Dounce (1943a). From the early work of Hammarsten (1894), Wohlgemuth (1902), Jones and Perkins (1924), and Thomas and Berariu (1924) it appeared probable that liver might also contain a pentose polynucleotide as well as simple pentose mono-nucleotides. Moreover, the cytoplasm of liver cells has recently been shown to contain particulate components of at least two sizes (Claude, 1941, 1943a & b; Bensley, 1942) consisting of phospholipin nucleoprotein complexes containing a pentose nucleic acid, which has not yet been isolated and characterised.

It has previously been shown that sheep liver (among other tissues) contains appreciable amounts of

pentose nucleic acid. The evidence for the presence of such a nucleic acid, presumably a ribonucleic acid, in liver is fairly conclusive, but it has seemed desirable also that this nucleic acid should be isolated and characterised. Sheep liver tissue is very suitable for this purpose. It is easily obtained in sufficiently large amounts, it contains a high total nucleic acid content of which a high proportion (60-80%) is ribonucleic acid (p.306).

A. Experimental Methods.

Principle.

For the extraction of the nucleic acids mild methods are essential and the use of alkali has been avoided. The methods usually employed for the preparation of desoxyribonucleic acid are sufficiently drastic to break down much of the ribonucleic acid. Extraction with 10% NaCl as used by Clarke and Schryver (1917) for the preparation of yeast ribonucleic acid has proved satisfactory provided that the liver proteins were first denatured with ethanol. Extraction of fresh minced liver with 10% NaCl gave tissue extracts from which separation of the nucleic acids was difficult. From the sodium chloride solution the nucleic acids were precipitated with ethanol. The

crude pentose nucleic acid was purified through the barium salt by the method of Jorpes (1934) and was finally precipitated from glacial acetic acid.

Procedure.

Fresh sheep liver was minced, mixed well with three volumes of ethanol, and allowed to stand overnight. The ethanol was sucked off on a large Buchner funnel and the tissue suspended in two further successive portions of ethanol. After being washed with ether, it was dried in air and ground to a fine powder in a mill: 200 gram portions of this powder were suspended in 800 ml. 10% NaCl and allowed to stand overnight in the refrigerator. The suspension was then filtered through muslin and the solid residue mixed with 400 ml. 10% NaCl, heated for 30 minutes in a boiling water bath, and cooled. The mixture was again filtered through muslin and the residue washed with a further 200 ml. 10% NaCl at room temperature, and filtered. The filtrates were combined (1000 ml.) and centrifuged. A small amount of precipitate and of floating fatty material was discarded. To the slightly cloudy fluid two volumes of ethanol were slowly added with brisk stirring, and the mixture allowed to stand overnight in the refrigerator. As

much as possible of the supernatant fluid was then siphoned off and the precipitate centrifuged down, washed once with 70% ethanol, twice with absolute ethanol, dried in a vacuum desiccator, and powdered: yield 4-5 gm.

Four grams of this crude nucleic acid were ground in a mortar with 60 ml. water and centrifuged. The residue was ground with 40 ml. water and centrifuged. To the combined supernatant fluids, 0.25 vol. 20% barium acetate (pH 6.8) was added and the precipitate of Ba salts centrifuged down and washed three times with 5% barium acetate. The precipitate was then ground in an ice cold mortar with 4-5 ml. ice cold N HCl and centrifuged. The precipitate was washed with four successive 3 ml. portions of ice water, with ice-cold N NaOH added dropwise until the solution was no longer acid. Alkaline reaction was carefully avoided. The solution was made up to about 10 ml. with ice-water and made just acid with acetic acid. A small precipitate was centrifuged down and discarded. The supernatant fluid was poured into 10 volumes of glacial acetic acid with constant stirring. The precipitate was centrifuged down, washed three times with ethanol, once with ether and dried in vacuo: yield

200-250 mg.

500 mg. of this material was treated with ice-cold alkali until the mixture was no longer acid, alkaline reaction being avoided. A small amount of material remained undissolved. The solution (10 ml.) was made just acid with acetic acid and centrifuged. The supernatant fluid was poured into 10 volumes glacial acetic acid, washed twice with ethanol, once with ether, and dried in vacuo: yield 300 mg.

B. Properties of the Nucleic Acid.

The liver ribonucleic acid prepared in this way was a light brown powder, slightly soluble in water giving an acid solution, and easily soluble in dilute alkali. It gave a negative biuret test and negative tests for desoxypentoses. Tests for pentoses were strongly positive. After drying at 100° it gave N = 15.0 - 15.1%, P = 6.7 - 7.4%. Both these values are lower than the theoretical values, which, for a tetranucleotide of the yeast ribonucleic acid type, $C_{38}H_{49}O_{28}N_{15}P_4$, are N = 16.3%, P = 9.5%. It has been pointed out that the figures for P in many samples of nucleic acid tend to be low (Fletcher, Gulland, Jordan and Dibben, 1944; Fletcher, Gulland and Jordan, 1944).

A sample of yeast ribonucleic acid precipitated twice from glacial acetic acid gave N = 15.0%. P = 8.2%.

These figures suggest that the liver ribonucleic acid still contains some impurity.

The purine content was determined by hydrolysing a sample of the nucleic acid in 1.2 N sulphuric acid at 100° for one hour. The purines were precipitated with copper hydroxide and copper bisulphite as described by Kerr and Blish (1932) and Kerr (1942) and the purine N determined. It varied from 55.1-61.3% of the total N. For a tetranucleotide of the yeast nucleic acid type the figure would be 66.7%. for a pentanucleotide with three purine nucleotides, 75%, and for a hexanucleotide with four purine nucleotides, 80%.

The easily hydrolysable P, i.e. that derived from the purine nucleotides, was determined by hydrolysing a portion of the nucleic acid for 2½ hours with 5% (V./V.) H₂SO₄ at 100°. Inorganic P was then determined by the method of Allen (1940). It amounted to 54.2-54.7% of the total P. For a tetranucleotide of the yeast ribonucleic acid type the figure is 53% (Jorpes, 1934), for a pentanucleotide, 63%. for a hexanucleotide, 69%.

The pentose content of the

Figure 16.

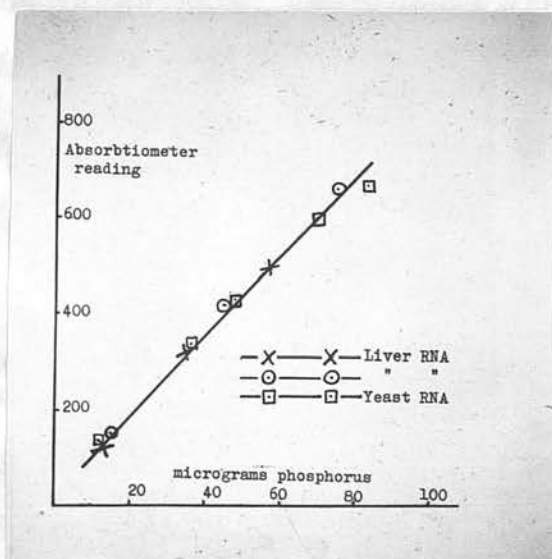

Pentose content of two samples of liver ribonucleic acid compared with that of yeast ribonucleic acid.

nucleic acid was estimated by the method of Mejsbaum (1939) the heating being continued for 30 minutes as recommended by Schlenk (1942). The greenish blue colour was examined in the Hilger Spekker Absorptiometer and the readings plotted against the phosphorus content. The results obtained with two different samples of the liver ribonucleic acid are shown in Fig. 16. The points obtained for the two samples lie on the same straight line and the points for yeast ribonucleic acid lie on the same line. Liver ribonucleic acid and yeast ribonucleic acid therefore contain the same amounts of pentose relative to the phosphorus content.

The action of crystalline ribonuclease (Kunitz, 1940) on liver ribonucleic acid was also examined. To each of three conical 15 ml. centrifuge tubes containing 1.5 ml. of a 0.1% solution of the sodium salt of liver ribonucleic acid, 2.4 ml. veronal acetate buffer pH 6.12 were added. To one tube 0.01 mg. crystalline ribonuclease was added. To one of the remaining two (control) tubes 4.0 ml. 0.25% uranyl acetate in 2.5% trichloroacetic acid were added immediately. The other control tube and the tube containing enzyme were incubated at 37° for one hour

Figure 17.

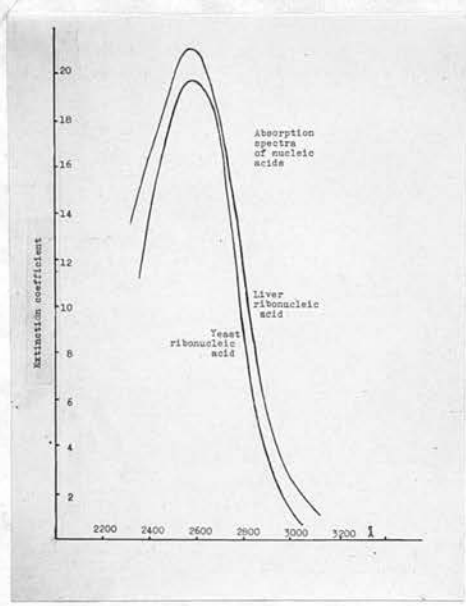

Absorption spectrum of liver ribonucleic acid and yeast ribonucleic acid as sodium salts in 0.005 M phosphate buffer pH 7.2. Concentration 0.0023% [in terms of free acid].

before receiving the uranyl acetate reagent. The precipitate produced by the reagent was centrifuged down, washed with 2 ml. 0.125% uranyl acetate in 1.25% trichloroacetic acid, dissolved in 0.5 M Na_2CO_3 and transferred to a digestion flask for total P estimation. The P content of the precipitate from the tube containing the enzyme was 39% of that of the precipitate from the control tubes, i.e. 61% of the total P has been rendered non-precipitable by the uranyl acetate reagent.

Absorption Spectrum.

The absorption spectrum of the nucleic acid was measured in a Hilger medium quartz spectrograph. Thanks are due to Dr A. Clow for carrying out these measurements.

The nucleic acid was dissolved in the minimum amount of dilute sodium hydroxide and diluted to a suitable concentration (40-160 μg . P per 100 ml.) with 0.005 M phosphate buffer pH 7.2. A sample of yeast ribonucleic acid was examined at the same time under the same conditions. The curves are shown in Fig. 17. The curve for yeast ribonucleic acid shows the typical absorption maximum in the region of 2600 Å and is similar to the curves for pentose nucleic acids shown

in the papers of Caspersson (1936) (yeast and pancreas pentose nucleic acids), Lavin, Thompson and Dubos (1938) (pneumococcal pentose nucleic acid) and Lavin, Loring and Stanley (1939) (virus pentose nucleic acid). The liver ribonucleic acid gives a curve very similar to that from yeast ribonucleic acid, the maximum being even slightly higher than with the latter.

Hydrolysis Products.

(a) The purines of liver ribonucleic acid.

200 mg. liver ribonucleic acid were heated with 10 ml. 0.1 N sulphuric acid for six hours on the boiling water bath under a reflux condenser. The mixture was centrifuged while hot and a small insoluble residue discarded. The hot supernatant fluid was made alkaline with ammonium hydroxide and the precipitate of guanine centrifuged down. The supernatant fluid was boiled to remove ammonia and a small precipitate of guanine which appeared on cooling was centrifuged down.

To the supernatant fluid 15 ml. 1% silver sulphate were added. The precipitate of silver salts was centrifuged down and washed four times with 0.1 N sulphuric acid saturated with silver sulphate and twice with 5 ml. water. It was suspended in 10 ml. water

and decomposed with H_2S . The silver sulphide was centrifuged down and the supernatant was freed from H_2S by a current of air and reduced to half its volume in a vacuum desiccator. 10 ml. 1% picric acid were added and the precipitated adenine picrate centrifuged down and washed twice with ice water. It was recrystallised twice from 25% acetic acid, washed twice with ice water and dried. M.P. $280-281^\circ$ (decomp.).

The guanine precipitate was washed with very dilute ammonium hydroxide, dissolved in 10% sulphuric acid and precipitated from the hot solution with ammonium hydroxide. The guanine was again dissolved in hot dilute sulphuric acid and precipitated with ammonium hydroxide. The free base was dissolved in 1 ml. hot 5% (w./v.) HCl. On cooling, typical crystals of guanine hydrochloride separated. They were washed twice with dilute HCl and recrystallised from 5% HCl, washed with dilute HCl and finally decomposed with ammonium hydroxide to give the free

base which was washed several times with very dilute ammonium hydroxide and dried.

(b) Other hydrolysis products.

The hydrolysis products of the nucleic acid were also investigated following the procedure of Bredereck and Richter (1938) as used by Gulland and Barker (1943). The process was first carried out with 1 gram of yeast ribonucleic acid and then with the same amount of liver ribonucleic acid.

One gram of liver ribonucleic acid was heated with 10 ml. 2% (W./V.) sulphuric acid for two hours in a flask attached to a reflux condenser and immersed in an oil bath at 105-110°. The mixture was transferred to a centrifuge tube and the concentration of sulphuric acid increased to 3.8% (W./V.) by the addition of conc. H_2SO_4 . The tube was allowed to stand overnight at room temperature. The precipitate

of guanine sulphate was centrifuged down and washed with 1 ml. of 2% sulphuric acid.

To the supernatant and washings barium hydroxide solution was added until the reaction was just neutral. The barium sulphate was centrifuged down and washed with a few drops of water. The supernatant and washings were taken down to 5 ml. in a shallow dish in a vacuum desiccator over conc. H_2SO_4 . Solid matter which separated out was centrifuged down, washed with a few drops of water and discarded, and the supernatant and washings were taken down to dryness in the vacuum desiccator. The dry residue was rubbed up with 0.5 ml. water and transferred to a centrifuge tube. Insoluble matter was centrifuged down, washed with two drops of water and discarded. To the supernatant and washings in a fresh centrifuge tube cooled in ice, 7 ml. pyridine were added with stirring. The precipitate of cytidylic acid was centrifuged down and washed twice with 1 ml. pyridine.

The supernatant and washings were taken to dryness in a vacuum desiccator over $CaCl_2$. The residue was dissolved in 2 ml. water and ethanol added until no further precipitate appeared (about 5 ml.). The precipitate was centrifuged down. The supernatant

fluid was taken to dryness in a vacuum desiccator over CaCl_2 and dissolved in 2.5 ml. water. A small insoluble residue was discarded: 0.5 ml. of a 2% alcoholic brucine solution were added and the tube set aside for five days at room temperature. The brucine salt of uridylic acid was centrifuged down.

The supernatant fluid was made alkaline with hot saturated baryta. The precipitate was discarded and the supernatant was extracted three times with chloroform to remove brucine. The aqueous layer was then centrifuged to remove a small amount of insoluble material and was exactly neutralised with 10% H_2SO_4 . The barium sulphate was centrifuged down and washed with a few drops of water. In the combined supernatant and washings pentose was determined by the method of Mejbaum (1939). The amount present was 29.1 mg. calculated as ribose.

The pentose solution was divided into two portions which were dried in vacuo in centrifuge tubes from the frozen state.

To 15 mg. pentose, 20 mg. p-bromophenylhydrazine were added followed by 0.48 ml. water and 0.1 ml. 50% acetic acid. The mixture was allowed to stand overnight at room temperature. The yellow precipitate

of the p-bromophenylhydrazone was centrifuged down, washed with a little absolute alcohol and recrystallised from 50% alcohol. It softened at 168° and melted at 169°. A mixture of this material with ribose p-bromophenylhydrazone made from pure d(-)ribose (prepared from guanosine by the method of Levene and Clark (1921)) softened at 168° and melted at 169-170°. The p-bromophenylhydrazone made from this sample of ribose softened at 169° and melted at 171-172°. The p-bromophenylhydrazone made from the pentose of yeast ribonucleic acid melted at 166°. Arabinose p-bromophenylhydrazone prepared in exactly the same way melted at 154-155°.

The guanine sulphate precipitate was stirred with hot 10% (W./V.) H_2SO_4 until no more would dissolve and was centrifuged while hot. A moderately large insoluble residue was discarded. To the hot solution excess ammonium hydroxide was added. The precipitate of free guanine was centrifuged down and washed with a little dilute ammonium hydroxide.

The supernatant and washings were boiled to remove ammonia, cooled and treated with saturated picric acid solution. On standing in the refrigerator overnight, a precipitate of adenine picrate appeared. It

was centrifuged down and recrystallised from 25% acetic acid.

The cytidylic acid fraction was dissolved with gentle heating in 2.5 ml. water. The solution was centrifuged and a small insoluble residue discarded. To the supernatant 25% lead acetate was added until no more precipitate appeared. The precipitate was centrifuged down and washed with a little dilute lead acetate solution. It was suspended in dilute acetic acid and decomposed with H_2S . The lead sulphide was removed on the centrifuge and the supernatant and washings taken to dryness. The cytidylic acid was taken up in water and precipitated with ethanol. On crystallisation from 50% ethanol a small amount of material melting at 223-224° was obtained. Cytidylic acid melts at 230°.

The brucine salts of the uridylic acid fraction were crystallised repeatedly from 35% ethanol. The final product melted at 190°. The brucine salt of uridylic acid melts at 182° (Loring, 1939), 195° (Levene & Bass, 1931), 179-181° (Gulland & Holiday, 1940).

The evidence so far obtained is not adequate for complete identification of the pyrimidine nucleotides. The amounts of material available were insufficient for further investigation.

C. Discussion.

The composition of the material under examination, the pentose content, the absence of positive tests for proteins and desoxypentose, indicate that it is a nucleic acid of the pentose nucleic acid type. Since the pentose appears to be ribose the acid can be correctly designated "liver ribonucleic acid".

The presence of ribose in liver tissue has been suggested by Levene and Jacobs (1909) who maintained that guanylic acid from liver contained d-ribose: Winter (1927) identified ribose derivatives in a mixture of goat liver and muscle.

It has been generally assumed that the sugar in pentose nucleic acids and nucleotides is d-ribose but the evidence for this has until recently not been

altogether satisfactory. Gulland and Barker (1943), using the benzimidazole method (c.f. Moore and Link, 1940; Dimler and Link, 1943) have now demonstrated conclusively that the sugar in yeast nucleic acid and its related nucleotides is d-ribose. This method of pentose identification is probably superior to any other, but it requires a larger amount of sugar than has been available in the present investigation. The p-bromophenylhydrazone method requires much less pentose and has been used by Schlenk (1942) to show that the sugar in cozymase is d-ribose. The melting points for ribose-p-bromophenylhydrazone quoted in the literature (c.f. Levene and Jacobs, 1909) vary over a wide range. In the present instance, however, the agreement between the melting points of the p-bromophenylhydrazones of ribose and the pentose of the liver nucleic acid prepared at the same time under the same conditions and recrystallised from the same solvent, together with the results of the mixed melting point, is sufficient to justify the conclusion that the pentose is ribose. The M.P. of the p-bromophenylhydrazone of arabinose is lower than that of ribose and that of the xylose derivative is lower still. The possibility of the presence of small

amounts of l-lyxose in the liver ribonucleic acid such as are present in yeast ribonucleic acid (Gulland and Barker, 1943) cannot be excluded but the amounts of nucleic acid available have been too small for any attempt to be made to detect it.

The similarity between liver ribonucleic acid and yeast ribonucleic acid is revealed by the pentose content, by the absorption spectrum, by the action of ribonuclease, and by the nature of the hydrolysis products. Moreover, the purine content and the easily hydrolysable P content suggest that the liver ribonucleic acid like yeast ribonucleic acid is composed of tetranucleotide units containing equimolecular amounts of purines and pyrimidines. It is possible therefore that liver ribonucleic acid may differ from the pentose polynucleotide of the pancreas which appears to be probably a pentanucleotide containing three purine nucleotide residues (Jorpes, 1934).

The pentose nucleic acid of tobacco mosaic virus appears to differ from yeast ribonucleic acid in its uridylic acid component (Loring, 1939). The identity of both pyrimidine nucleotides of liver ribonucleic acid has not been completely established owing to the small amount of material available. The data so far

available, however, suggest that they are very similar to, if not identical with, the corresponding materials obtained from yeast ribonucleic acid.

SUMMARY.

A method for the isolation of a ribonucleic acid from liver tissue is described. The nucleic acid is free from protein and from desoxypentose. It resembles yeast ribonucleic acid in its pentose content, in its absorption spectrum, in its action as a substrate for ribonuclease and in its content of purine and easily hydrolysable phosphorus.

Among the hydrolysis products adenine, guanine, inorganic phosphate, and d-ribose have been identified.

4. THE HISTOCHEMICAL DEMONSTRATION OF
RIBONUCLEIC ACID IN MAMMALIAN LIVER.

Ribonucleic acid has been isolated from liver tissue in which it is present in larger amounts than is desoxyribonucleic acid. It is generally considered that the distribution of the two types of nucleic acid is not between plant and animal tissues but between cell nucleus and cytoplasm, desoxyribonucleic acid being a nuclear constituent while ribonucleic acid is mainly a cytoplasmic constituent (see p.205). A distinction between the two types of nucleic acid can be made by means of the heat stable enzyme ribonuclease which can be highly purified and obtained in the crystalline state (Kunitz, 1940) and which attacks specifically the ribonucleic acids (see p.183). The enzyme can, for example, be used to digest out ribonucleic acids from tissue sections, thus removing one of the basophilic constituents of the cells which are stained with such dyes as pyronine or toluidine blue (see p.191). Such a histochemical test was first used by Brachet (1940) who incubated tissues sections from amphibia with a crude preparation of ribonuclease from boiled pancreas extract and found that some of

Plate 13.

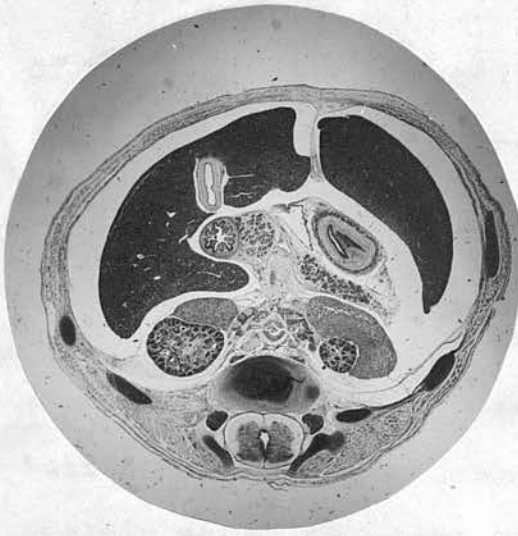

A

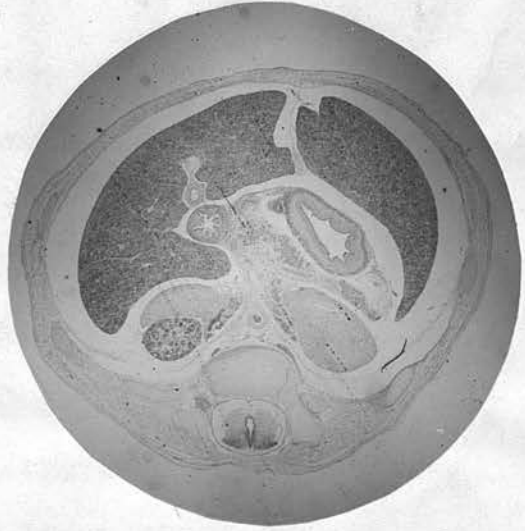

B

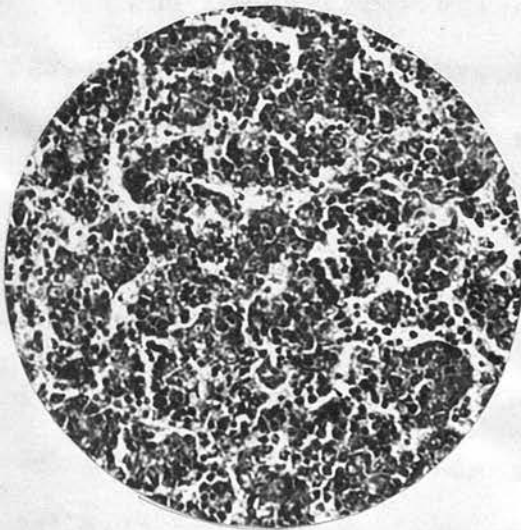

C

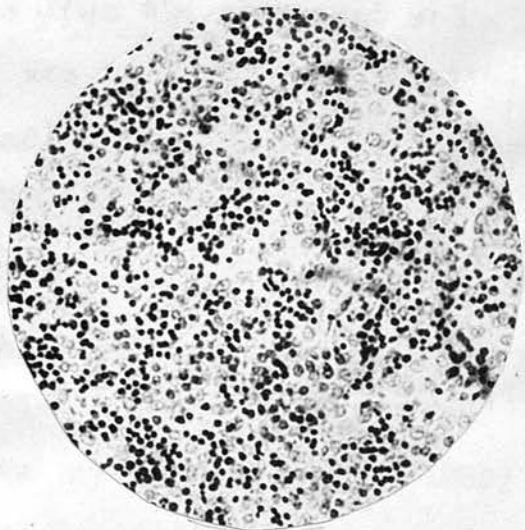

D

- A Human embryo section incubated in buffer. x 6
B Human embryo section incubated in buffer + crystalline ribonuclease. x 6
C Human embryo liver section incubated in buffer. x 110
D Human embryo liver section incubated in buffer + crystalline ribonuclease. x 110
Stained:- Toluidine blue.

of the cytoplasmic constituents no longer stained with the pyronine of Unna-Pappenheim pyronine methyl green. The test was subsequently employed by Desclin (1940) on anterior pituitary, and with crystalline ribonuclease by Painter and Taylor (1942) on toads' eggs, and Gersh and Bodian (1943) on nerve cells. Such a test is used here to demonstrate not only that ribonucleic acid is present in liver tissue but that it is present in the cytoplasm of the liver cells.

The fresh liver tissue from the adult rat and from human and rat embryos was fixed in formol saline overnight and dehydrated and embedded in paraffin in the usual way. Sections cut and mounted were taken through two changes of chloroform, down through a series of alcohols, to distilled water (three changes). The slides were then incubated for five hours at 37° in a bath of veronal acetate buffer (Michaelis, 1939) pH 6.75 containing 1 mg. crystalline ribonuclease per ml. as employed by Gersh and Bodian (1943) for nervous tissue. They were rinsed in three changes of distilled water and stained in 1% aqueous toluidine blue overnight. They were then rinsed quickly with absolute alcohol, blotted, quickly dehydrated with absolute alcohol, passed through toluene and mounted

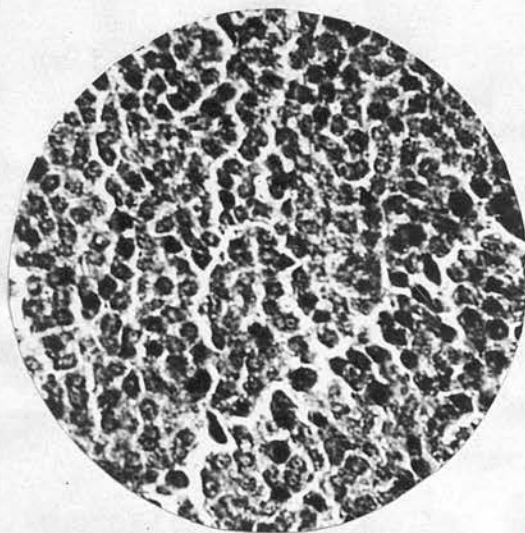

A

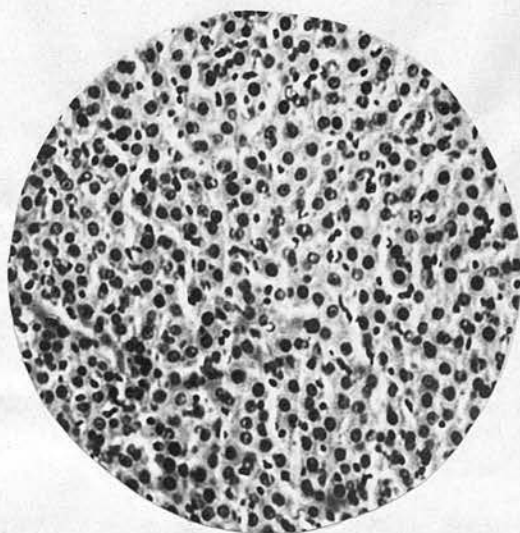

B

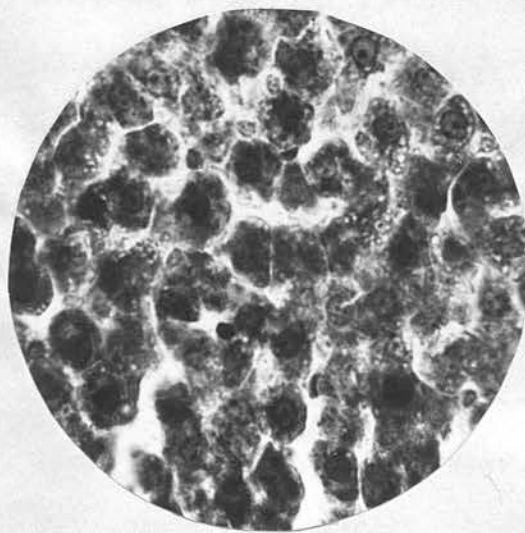

C

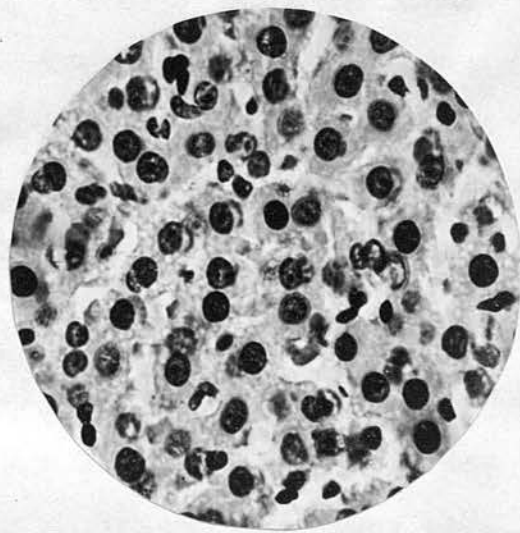

D

- A Rat liver section incubated in buffer. x 110
B Rat liver section incubated in buffer
+ crystalline ribonuclease. x 110
C as A x 540
D as B x 540
Stained:- Toluidine blue.

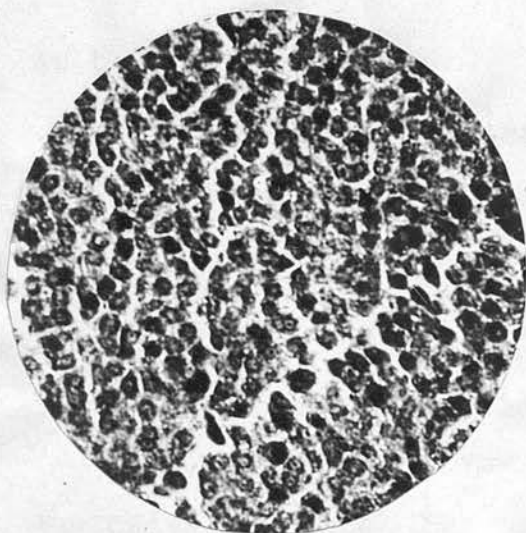

A

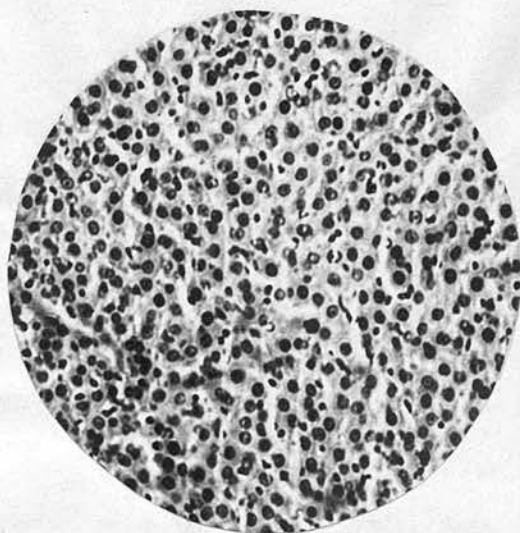

B

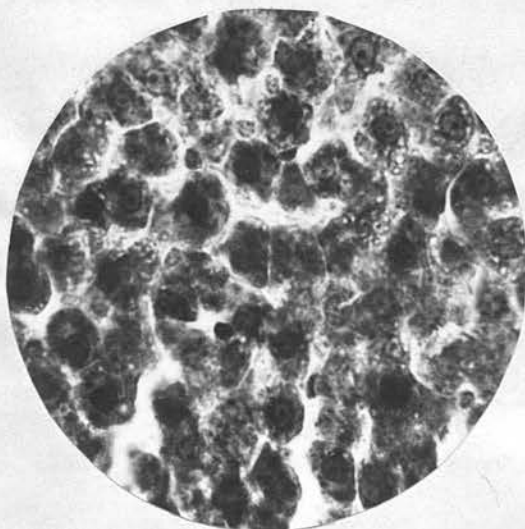

C

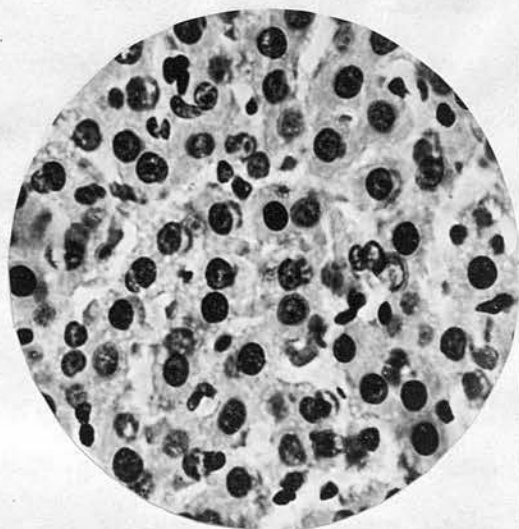

D

- A Rat liver section incubated in buffer. x 110
B Rat liver section incubated in buffer
+ crystalline ribonuclease. x 110
C as A x 540
D as B x 540
Stained:- Toluidine blue.

in balsam.

Control sections were treated in exactly the same way, being incubated in a bath of buffer without enzyme.

Sections of whole human embryo of about ten weeks were treated in exactly the same way.

The results are shown in Plates 13 and 14. The photomicrographs at low magnifications show that the amount of staining material in the control sections of the whole embryo is much greater than in the enzyme treated sections (Plate 13). The difference shows up in a striking fashion in the case of both embryo and adult liver. When the photomicrographs of the adult rat liver at high magnification are examined, it is seen that, in the control sections, not only do the nuclei stain but masses of staining material are found in the cytoplasm (Plate 14). In the sections treated with ribonuclease the nuclei stain as before but the cytoplasm no longer stains. Treatment with ribonuclease has removed the staining material which can therefore be assumed to be, or to contain, ribonucleic acid.

It would appear therefore that not only is ribonucleic acid present in liver tissue but that it is

present in large amounts in the cytoplasm.

It is obvious, of course, that this test depends on the specificity of crystalline ribonuclease (see p.184). The enzyme is known to have no action on desoxyribonucleic acid, and was found by Dubos and Thompson (1938) not to hydrolyse egg albumin, haemoglobin, peptone mucoproteins or polysaccharides of animal or bacterial origin, but an unpublished account by Mazia quoted by Gersh and Bodian (1943) suggests that it may have some unspecified effect on fibres of denatured thymonucleohistone, egg albumin, casein and haemoglobin. The ribonucleic acid isolated from liver tissue has, however, been shown to act as a substrate for ribonuclease (see p.273).

It will be noted in Plate 14 that the nucleoli of the liver cells still stain after treatment with ribonuclease. The work of Caspersson and Schultz (1940), Brachet (1940a & b), Mitchell (1942) and Gersh (1943) (see p.204) has suggested that ribonucleoproteins are present in the nucleolus, but if this be true also of the liver cell, they would appear either to be accompanied by staining material (probably desoxyribonucleic acid) which is not acted upon by ribonuclease, or to be present in some form which is not affected by the

enzyme.

It appears to be probable that the cytoplasmic ribonucleic acid is present in the form of particulate components in the cytoplasm, of the liver cell, probably in the form of phospholipin-ribonucleoprotein macromolecules (Claude, 1939, 1940, 1941, 1943a & b; Bensley, 1942; Hoerr, 1943; Lazarow, 1943) (see p. 208). Such materials were isolated by Claude (1940, 1943a & b) from liver tissue by high speed centrifugation in the form of particles of two different sizes, the smaller being termed "microsomes" and the larger "secretory granules" or "zymogen granules". The latter are probably identical with the mitochondria (Hoerr, 1943) which Bensley and Hoerr (1934) and Bensley (1937, 1942) have separated from the liver cytoplasm.

For such an examination liver tissue has many advantages. It is possible to compare normal adult liver not only with the embryonic organ but with the regenerating organ and with liver tumours produced by the administration of such agents as butter yellow, diazotylamine, or benzene. This fact has already been utilized by Park (1942) in an examination of the glycolysis mechanism in liver in different states.

5. THE NUCLEIC ACID AND NUCLEOTIDECONTENT OF LIVER TISSUE.

It has been shown previously that ribonucleic acids are widespread in animal tissues and are present in high concentrations in rapidly growing embryonic tissues, although the proportion of ribonucleic acid to desoxyribonucleic acid appears in most cases to be the same in the embryo as in the corresponding adult tissue. One such ribonucleic acid has been isolated from the liver of the sheep and its properties described. It has been demonstrated histochemically in the cytoplasm of the liver cell. It is of some interest, therefore, to examine the amount of this nucleic acid present in liver tissue and its possible variation under different circumstances. For such an examination liver tissue has many advantages. It is possible to compare normal adult liver not only with the embryonic organ but with the regenerating organ and with liver tumours produced by the administration of such agents as butter yellow, dimethylaminoazobenzene. This fact has already been utilised by Burk (1942) in an examination of the glycolysis mechanisms in liver in different states.

The total nucleic acid content of the liver may depend to some extent on the age and nutritional state of the animal and has already been discussed (p.215).

When the median and left lateral lobes (65-75% of the whole organ) of the liver of the rat are removed the remaining lobes undergo a process of rapid growth until in 28 days the liver has been restored to its original weight (Higgins and Anderson, 1931). This growth process is usually termed "regeneration" although Sulkin (1943) points out that it would more correctly be designated as a compensatory hyperplasia. The most active phase occurs about the third day after operation when mitotic figures are most numerous (Burk, 1942; Norris, Blanchard and Povolny, 1942). During the first 24 hours after partial hepatectomy the mass of the residual liver fragment increases markedly (even in starved animals) although the liver mass increases much more rapidly in fed animals (Brues, Drury and Brues, 1936). During the process of regeneration the nucleic acid metabolism of the liver is profoundly affected. Using P^{32} Brues, Tracy and Cohn (1942) have shown that while in normal rat liver the (desoxyribo)nucleic acid P has a lower turnover rate than the non-(desoxyribo)nucleic acid protein-

bound P, in the regenerating liver the turnover rate of the nucleic acid P is increased up to the level of the non-(desoxyribo)nucleic acid protein-bound P.

The liver is moreover an organ in which experimental tumours can be produced without great difficulty by feeding the dyestuff "butter yellow", p-dimethylaminoazobenzene (c.f. Sugiura and Rhoads, 1941). The process involves a "proliferation of connective tissue cells in the portal systems with degeneration of the contiguous liver cells, a typical regenerative proliferation of bile duct and liver epithelium leading ultimately to non-architectural nodular hyperplasia and a macroscopically hob-nailed liver" in which three types of tumour may arise, liver cell carcinoma, bile duct carcinoma and bile duct cystadenoma (Orr, 1940). Liver is indeed one of the few tissues in which it is possible to make a direct comparison between tumour tissue and its tissue of origin (Dickens and Weil-Malherbe, 1943). Tumour formation is associated with a rise in nucleic acid content (Fujiwara, Nakahara and Kishi, 1937; Dickens and Weil-Malherbe, 1943).

Using rat liver therefore it is possible to compare normal adult liver tissue with rapidly growing liver tissue in the case of the embryonic or

"regenerating" organ and with the cirrhotic or tumour bearing organ. This method has indeed been employed by Burk (1942) in an examination of the glycolytic mechanisms of all these types of liver tissue. He was able to show that only in malignant liver tissue was anaerobic glycolysis markedly increased (see also Dickens and Weil-Malherbe, 1943). In regenerating liver it was normal and the high values obtained for embryonic liver could be to a large extent accounted for by the amount of erythropoietic tissue present at this stage (Burk, 1942; Norris, Blanchard and Povolny, 1942).

A. Experimental Methods.

All experiments were carried out on adult hooded rats supplied by the Rowett Institute and fed, unless otherwise stated, on the stock diet described by Thomson (1936).

Pregnant animals were used one or two days before parturition was expected, in order that embryos of reasonable size might be obtained. The embryos were removed from the uterus, quickly weighed, and the livers excised, pooled and dealt with as for adult liver.

"regenerating" organ and with the cirrhotic or tumour bearing organ. This method has indeed been employed by Burk (1942) in an examination of the glycolytic mechanisms of all these types of liver tissue. He was able to show that only in malignant liver tissue was anaerobic glycolysis markedly increased (see also Dickens and Weil-Malherbe, 1943). In regenerating liver it was normal and the high values obtained for embryonic liver could be to a large extent accounted for by the amount of erythropoietic tissue present at this stage (Burk, 1942; Norris, Blanchard and Povolny, 1942).

A. Experimental Methods.

All experiments were carried out on adult hooded rats supplied by the Rowett Institute and fed, unless otherwise stated, on the stock diet described by Thomson (1936).

Pregnant animals were used one or two days before parturition was expected, in order that embryos of reasonable size might be obtained. The embryos were removed from the uterus, quickly weighed, and the livers excised, pooled and dealt with as for adult liver.

In the experiments involving regenerating liver, rats under "Nembutal" anaesthesia were partially hepatectomised by the method of Higgins and Anderson (1931). For the first 16 hours after operation the animals received only a solution of glucose in water. Subsequently they received stock diet. In a control group of animals the abdomen was opened under "Nembutal" anaesthesia and closed again without removal of hepatic tissue. The rats were killed on the third day after operation, after a 24 hour fast.

For the experiments on hepatic tumours three groups of rats were chosen. Two groups were fed on husked but unpolished rice to each kilo of which was added 25 ml. of a 3% solution of dimethyl-aminoazobenzene (B.D.H. Analar) in arachis oil. Each rat received a slice of raw carrot daily and water ad libitum, and was fasted for 24 hours before use. One of these groups was used after 100 days and the other after 150 days. The third group of rats received rice with arachis oil but without dye, and served as controls (Plate 17). Their livers were examined at the end of 100 days.

All the rats were killed by decapitation and the livers immediately excised and divided into portions

thus:- One portion was ground in ice-cold trichloroacetic acid for estimation of nucleotide and nucleoside by the method of Kerr (1940). A second portion was dried in a tared beaker at 100° to constant weight for determination of water content. A third portion was fixed for histological examination. A fourth small portion was used for determination of total nucleoprotein phosphorus or residual P by the method of Berenblum, Chain and Heatley (1939).

The remainder of the tissue was used for the estimation of the relative amounts of the two types of nucleic acid.

The tissue was minced, dehydrated with several successive portions of ethanol, washed with ether and dried. The dried material was transferred to a stoppered 50 ml. centrifuge tube and shaken for four one-hour periods with successive portions of about 40 ml. 0.1 N HCl. This process removes acid soluble P including simple nucleotides. The residue was washed twice with ethanol and was then extracted for two successive two hour periods at 65° under a reflux condenser with an ethanol-chloroform mixture (3:1). It was then washed with ether, dried, ground to a fine powder in a mechanical mortar and passed through

a sieve (120 mesh). In cases where the amount of powder available from one liver was small, material from several livers was pooled for analysis.

Total P was estimated in the extracted powder by a modification of the method of Allen (1940).

The relative amounts of ribonucleic acid phosphorus (RNAP) and desoxyribonucleic acid phosphorus (DNAP) in the extracted powder were determined by two different methods. One method involved the extraction of the nucleic acids with 10% NaCl, their precipitation as lanthanum salts, and analysis of the precipitate for pentose and desoxypentose by modifications of methods previously described. As this procedure in the case of liver tissue involved certain losses which were relatively greater for desoxyribonucleic acid than for ribonucleic acid direct estimations of pentose and desoxypentose were also undertaken on the extracted tissue powders. Such estimations yield useful information in the case of liver tissue though it is doubtful if they could be applied indiscriminately to other tissues.

(a) Direct method.

Portions of powder expected to contain 100-200 μ g. RNAP were used for pentose, and 100-300 μ g. DNAP for

desoxypentose, estimations.

Pentose estimation. Appropriate portions of powder (20 mg. in the case of liver) were weighed into each of two graduated 10 ml. centrifuge tubes. To one was added 2 ml. water and 2 ml. Mejbaum's (1939) reagent (100 mg. orcinol in 10 ml. concentrated HCl containing 0.1% $\text{FeCl}_3 \cdot 6\text{H}_2\text{O}$), and to the other 2 ml. water and 2 ml. of HCl containing 0.1% $\text{FeCl}_3 \cdot 6\text{H}_2\text{O}$ but no orcinol. Both tubes were heated with stirring in a boiling water bath for exactly ten minutes and cooled. The blue-green colour was extracted successively with 2 ml., 2 ml. and 1.5 ml. amyl alcohol. The amylalcohol layers were separated by centrifuging, combined, mixed with 1 ml. ethyl alcohol, and made up to a total volume of 8 ml. with amyl alcohol. Exactly similar extractions were carried out on the blank tube (without orcinol). The coloured solution was read against the blank in the Hilgar Spekker absorptiometer, using the Blue (No. 7) colour filter. A calibration curve was prepared from yeast ribonucleic acid, using 2 ml. portions at various concentrations (25-200 $\mu\text{g. P}$) and extracting with amyl alcohol to a total volume of 8 ml. as in the estimation.

The desoxypentose estimation was carried out by

a modification of the diphenylamine reaction employed by Sevag, Smolens and Lackman (1940) and Dische (1930). A portion of powder containing twice the amount of DNAP required for the estimation (200 mg. in the case of liver) was heated in a graduated 10 ml. centrifuge tube with 8 ml. 0.1 N HCl for 20 minutes, with frequent stirring. After cooling the volume was made up to 8 ml. and the mixture was centrifuged. A 3 ml. portion was taken and heated for exactly six minutes in a briskly boiling water bath with 8 ml. diphenylamine reagent (1 g. diphenylamine, Analar, twice recrystallised from ethanol, 2 ml. concentrated H_2SO_4 and 98 ml. glacial acetic acid, Analar). A blank was prepared from a second 3 ml. of the supernatant and 8 ml. acetic acid. The cooled solution was read against the blank in the Hilger Spekker absorptiometer, using the Red (No. 1) colour filter. A calibration curve was prepared from desoxyribonucleic acid, hydrolysing 4 ml. portions in HCl of final concentration 0.1 N, and using 3 ml. portions of the supernatant for developing the colour with 8 ml. of reagent.

(b) Method for lanthanum salts.

The nucleic acids were extracted from the tissue

powders with 10% sodium chloride and precipitated as lanthanum salts. The lanthanum precipitate was then used for the estimation of pentose and desoxypentose by a modification of the method previously employed (p.241).

For the nucleic acid extraction a suitable quantity (e.g. 400 mg.) was then weighed out into a 15 ml. conical centrifuge tube and four drops triacetin added. Extraction with 10% NaCl was then carried out with five successive portions, (a) 3 ml. overnight at 0°, (b) 2 ml. for 30 min. at 100°, (c) 2 ml. for 30 min. at 100°, (d) 2 ml. for 10 min. at 100°, and (e) 2 ml. for 10 min. at 100°, respectively.

The extracts were combined and made up to 10 ml.: 0.5 ml. was taken for total P estimation: 9 ml. were pipetted into a 25 ml. centrifuge tube and 1 ml. 2% lanthanum acetate and 10 ml. ethanol added. After one hour at 0° the precipitate was centrifuged down and washed twice with 3 ml. 0.2% lanthanum acetate. The moist precipitate was decomposed with two successive 0.25 ml. portions of 0.5 M Na₂CO₃. The lanthanum carbonate was centrifuged down and the extract made up to 5 ml.

The extract was treated as follows:-

(i) 0.5 ml. was taken for total P estimation.

(ii) 0.2-0.3 ml. was pipetted into a Pyrex tube for estimation of pentose by a modification of the method of Mejbaum (1939). The volume was made up to 2 ml. with water and 2 ml. Mejbaum's reagent were added (p.298). The tube was heated in a boiling water bath for 30 minutes as recommended by Schlenk (1943) and was then cooled: 2 ml. ethanol and 4 ml. water were added and the green colour read off in the Hilger Spekker absorptiometer (Filter No. 7), using a calibration curve drawn up in terms of RNAP and made from liver ribonucleic acid precipitated as La salt and treated as described above.

(iii) 3 ml. were taken for the colorimetric estimation of desoxypentose by the diphenylamine reaction, and were pipetted into a conical graduated centrifuge tube containing 1 ml. 0.55 N HCl. The tube was heated in a boiling water bath for 20 minutes, cooled, and the volume made up to 4 ml.: 8 ml. freshly made diphenylamine reagent were added (p.299) and the tube was placed in the briskly boiling water bath for six minutes, quickly cooled, and the blue colour read off in the Hilger Spekker absorptiometer (Filter No. 1) after five minutes, using a calibration curve drawn

Plate 15.

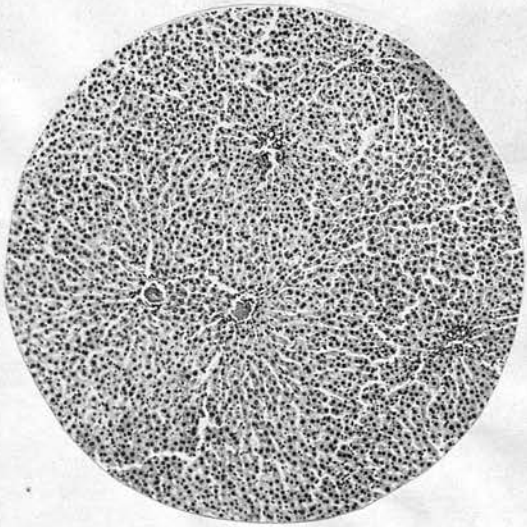

A

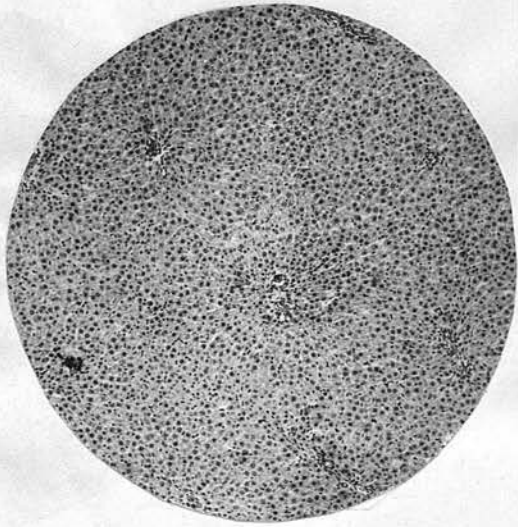

B

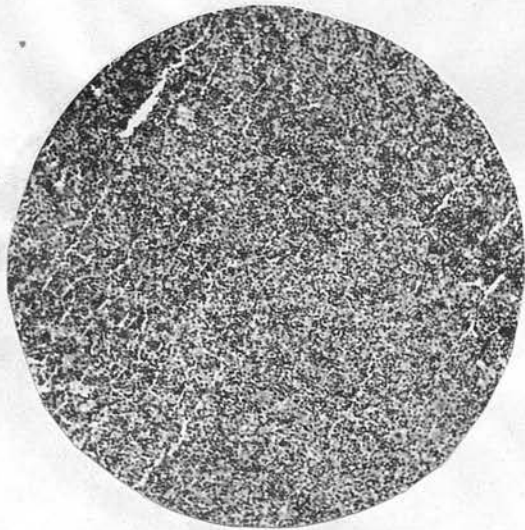

C

A Normal rat liver (fasted)
B Pregnant rat liver
C Embryo rat liver
Stained:- Haematoxylin-eosin x 70

Plate 16.

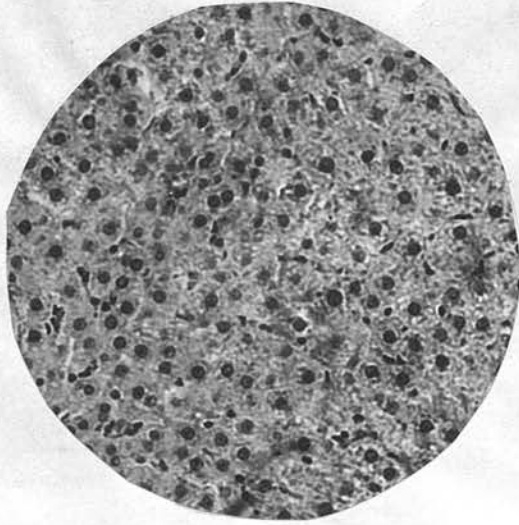

A

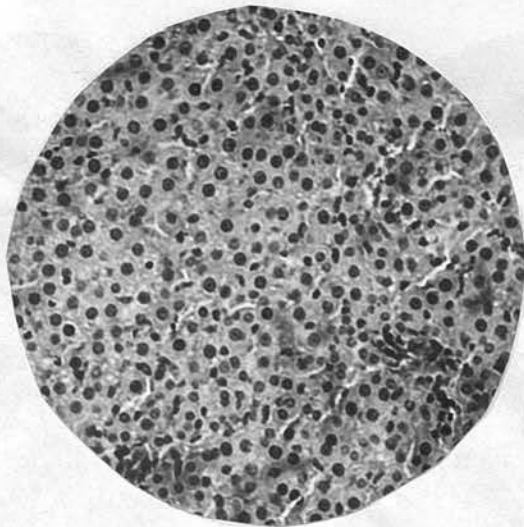

B

A Normal rat liver (fed)
B Normal rat liver (fasted)
Stained:- Haematoxylin-eosin x 110

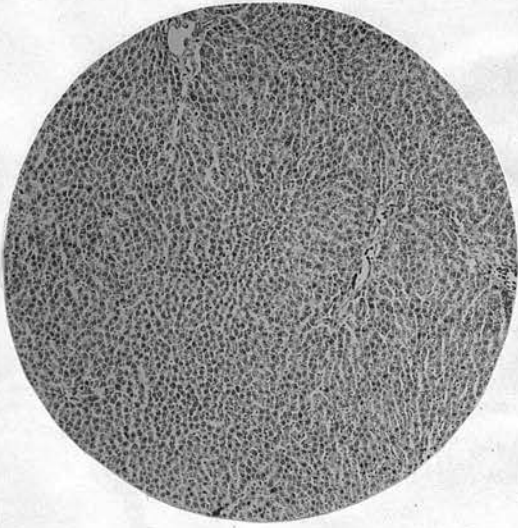

A

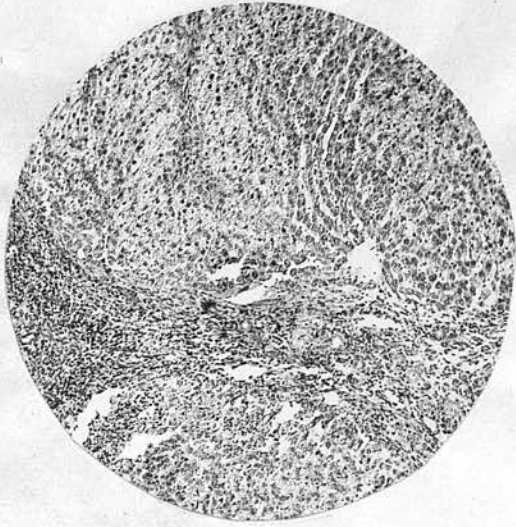

B

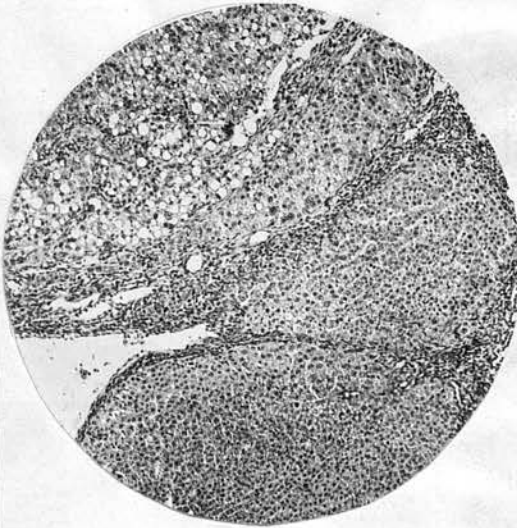

C



D

A Rat liver - control diet
B, C, D Tumour bearing livers
Stained:- Haematoxylin-eosin

x 70

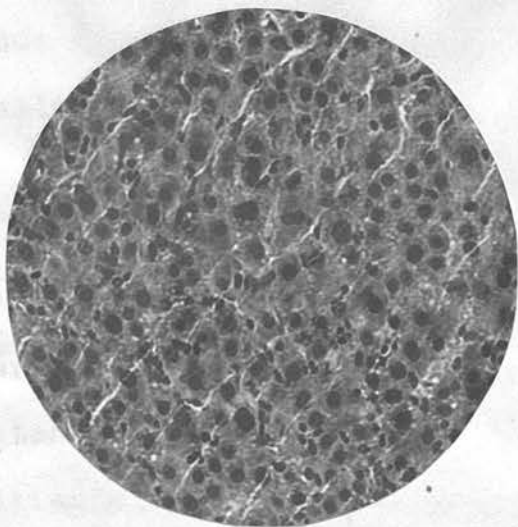

A

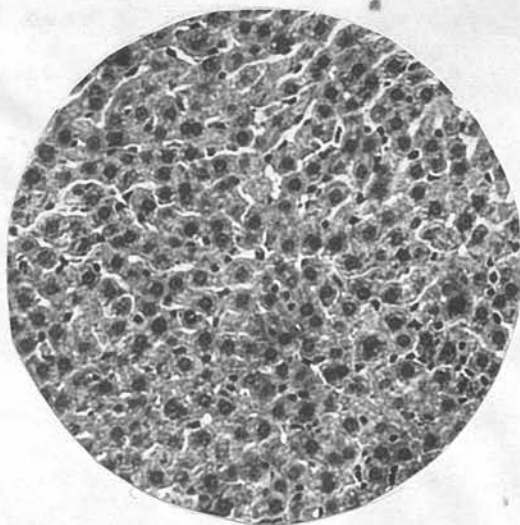

B

A Regenerating rat liver
B Rat liver - control laparotomy
Stained:- Haematoxylin-eosin X 110

up in terms of desoxyribonucleic acid phosphorus (DNAP) and made from desoxyribonucleic acid precipitated as La salt.

B. Results.

The histological appearances of the various types of liver examined are shown in the photomicrographs in Plates 15, 16, 17 and 18.

The striking difference between the histological appearance of the adult and embryo liver is shown in Plate 15. In the fasting animal the liver cells are smaller, and have a less granular cytoplasm, than is the case for the fed animal (Plate 16). The regenerating livers contain cells which vary widely in size (Plate 18). Some show mitotic figures. The livers of rats from the control laparotomy group present a normal appearance. The histological appearance of three of the tumour bearing livers is shown in Plate 17. The livers of rats on the control diet are similar to those of fasted rats.

The results of the N.P.P. and moisture estimations are shown in Table 21. The moisture content in most cases remains constant at about 70% but is higher in embryo liver and in liver tumour. The

Table 21.

Water and nucleoprotein phosphorus (N.P.P.) content of rat livers. The mean values and the standard error are shown in each case. The figures in brackets are the numbers of animals employed.

Type of liver tissue	Water content %	Nucleoprotein phosphorus (N.P.P.) mg. per 100 gm.		Weight of rats grams	Weight of livers grams	Weight of liver as % body weight
		Wet wt.	Dry wt.			
Normal male (fed)	69.9 ± 0.412 (9)	134 ± 2.56 (14)	449 ± 7.33 (14)	361 ± 16.09 (9)	10.6 ± 0.55 (6)	2.89 ± 0.10 (6)
Normal male (fasted 24 hours)	69.7 ± 0.195 (11)	152 ± 2.65 (16)	502 ± 9.84 (16)	316 ± 22.83 (8)	7.9 ± 0.54 (8)	2.51 ± 0.10 (8)
Normal female (fed)	70.0 ± 0.263 (12)	137 ± 3.74 (12)	452 ± 13.25 (12)	172 ± 5.49 (11)	7.1 ± 0.36 (7)	4.17 ± 0.15 (7)
Normal female (fasted 24 hours)	69.9 ± 0.237 (12)	142 ± 3.66 (12)	473 ± 12.81 (12)	168 ± 6.80 (10)	5.1 ± 0.22 (6)	3.39 ± 0.13 (6)
Pregnant female (fasted 24 hours)	71.0 ± 0.258 (6)	156 ± 3.64 (6)	543 ± 12.06 (6)	-	-	-
Embryo	80.6 ± 0.271	174 ± 13.27	908 ± 101.5	2.6 ± 0.24	-	-
Regenerating	70.0 ± 0.395 (9)	153 ± 3.18 (9)	512 ± 12.04 (9)	350 ± 15.12 (8)	7.3 ± 0.32 (8)	* -
Laparotomy	69.5 ± 0.229 (6)	150 ± 1.64 (8)	490 ± 5.47 (8)	353 ± 12.04 (6)	9.0 ± 0.40 (7)	-
Control diet	70.6 ± 0.111	149 ± 2.44	505 ± 6.97	224 ± 3.05	-	-
Liver tumours (100 days)	73.8 0.444 (6)	143 1.64 (6)	543 10.95 (6)	179 6.27 (6)	-	-
Liver tumours (150 days)	76.0 ± 0.731 (5)	128 ± 6.54 (5)	535 ± 40.74 (5)	163 ± 4.95 (4)	-	-

* The mean weight of liver removed three days previously at partial hepatectomy was 6.8 ± 0.46 gm.

high moisture content of the rapidly growing tissues of embryos and tumours has already been commented on (see p.247). The N.P.P. figures for the rat liver are rather higher than those quoted by other authors (Rondoni, 1941; Berenblum, Chain and Heatley, 1939; Dickens and Weil-Malherbe, 1943; Kosterlitz and Cramb, 1943) and are closer to those of Fujiwara, Nakahara and Kishi (1937). The N.P.P. rises on fasting. In the series of normal male rats (340 ± 60 gm.) the difference between the N.P.P. of livers of fed and fasted animals is statistically significant. In the series of female rats (170 ± 30 gm.) it is not significant but the difference between the total P content of the extracted powders from the livers of fed and fasted female rats is significant. The weight of the liver as a percentage of the body weight shows a significant fall in the fasted animal (male and female). The pregnant female rat liver (Plate 15) has a particularly high N.P.P. content but the highest values are found in the embryo. The weights of the embryos used varied from 3.4 - 1.5 grams and the N.P.P. values from 125-246 mg. % wet weight or 596-1440 mg. % dry weight.

The regenerating livers show slightly higher

Table 22.

Nucleotide N, nucleoside N, and free purine N of rat livers in mg. per 100 gm. The sum of all three gives total acid soluble purine. The mean and the standard error are shown in each case. The number of animals is given in brackets.

Type of liver tissue	Nucleotide N	Nucleoside N + free purine N	Total acid soluble purine N
Normal male (fed)	30.6 ± 1.01 (6)	9.7 ± 1.20 (6)	40.3 ± 0.62 (6)
Normal male (fasted 24 hours)	31.1 ± 0.68 (10)	10.2 ± 0.74 (9)	41.4 ± 0.83 (9)
Embryo	17.1 ± 0.89 (6)	7.3 ± 0.30 (6)	24.4 ± 0.79 (6)
Regenerating	36.1 ± 1.46 (8)	10.9 ± 1.41 (8)	47.0 ± 1.87 (8)
Laparotomy	32.0 ± 1.09 (8)	9.9 ± 0.59 (7)	41.1 ± 1.18 (7)
Control diet	31.4 ± 1.48 (6)	9.9 ± 0.71 (6)	44.0 ± 1.23 (6)
Tumours (100 days)	28.8 ± 0.28 (6)	10.7 ± 0.67 (6)	39.6 ± 0.92 (6)
Tumours (150 days)	17.3 ± 3.31 (5)	9.9 ± 1.24 (5)	27.3 ± 3.43 (5)

N.P.P. values than those of the controls but the difference is not statistically significant. On the other hand, the difference between the values for the 100 day liver tumours and those of the controls is significant.

The N.P.P. of the tumours is lower on a wet weight basis than in the livers of rats on the control diet but on a dry weight basis it is higher on account of the high water content of the tumours.

Results of the nucleotide, etc., estimations are shown in Table 22. There is no significant difference between the nucleotide and total soluble purine concentration in the livers of fed and fasted rats. This confirms the tentative conclusion made by Rapoport, Lever and Guest (1943). Embryo liver, like other embryonic tissues, has a particularly low nucleotide concentration. The nucleotide and total purine concentration in regenerating livers is significantly higher than that of controls. In the case of the 100 day tumours the nucleotide concentration is significantly lower on a wet weight, but not on a dry weight, basis than that of the controls.

The results of the analyses of the extracted tissue powders are shown in Table 23. The total P

Table 23.

Ribonucleic acid phosphorus (RNAP) and desoxyribonucleic acid phosphorus (DNAP) content of extracted liver powders, as estimated directly and on the precipitate of La salts. The figure in brackets shows the number of powders examined. Each powder represents, in most cases, pooled material from several animals.

€ = standard error.

Type of liver tissue	Total P in extracted powder mg. per 100 gm.	RNAP as % total P		DNAP as % total P		RNAP + DNAP as % total P		Ratio $\frac{\text{RNAP}}{\text{DNAP}}$	
		direct	from La ppta.	direct	from La ppta.	direct	from La ppta.	direct	from La ppta.
Fed €	554 ± 10.72 (10)	75.3 ±2.33 (10)	81.9 ±1.89 (10)	17.6 ±0.59 (10)	10.6 ±0.51 (10)	92.6	93.5	4.3	8.1
Fasted €	583 ± 20.46 (9)	66.0 ±2.86 (9)	75.8 ±1.82 (9)	20.2 ±0.84 (9)	13.3 ±0.52 (9)	86.7	89.1	3.1	5.8
Pregnant	774 (1)	75	77	17.7	10	93	86	4.2	7.8
Regenerating	690 (2)	72	90	18	8.5	90	98	4.0	10.9
Laparotomy	603 (2)	85	88	22.2	10.5	107	97	3.8	8.5
Control diet	716 (1)	61	85	13.7	13	75	98	4.5	6.5
Tumours	738 (2)	71	75	19.5	18.9	90.5	94	3.6	4.0
Embryo	1720 (1)	49.5	70	33.7	28	83.5	98	1.5	2.5

content runs parallel with the N.P.P. figures but is expressed here in terms of dry fat-free material. In most cases more than 90% of this total P can be accounted for in terms of ribonucleic acid phosphorus (RNAP) or desoxyribonucleic acid phosphorus (DNAP). The powders from liver of fasted animals show a higher RNAP content and a lower DNAP content than do those of fed rats and both these differences are statistically significant. The ratio RNAP/DNAP is therefore reduced by fasting. This ratio is almost the same in the regenerating as in the control livers. In the tumours it is lower than in the corresponding controls but the actual amounts of RNAP and DNAP determined in the tumour powders are both higher than those in the controls. Owing to the high total P content of pregnant rat livers the total RNAP content is particularly high. In embryonic liver the ratio is low; the extracted liver powder contains a higher RNAP content and DNAP content than does any other form of liver tissue, but the relative amount of DNAP is higher. This is due in part at least to the presence of erythropoietic cells in the embryo liver. A lower RNAP/DNAP ratio in the embryo liver than in the adult liver has already been noted in the case of the sheep (Table 18).

Neither the total P of the extracted powder nor the ratio RNAP/DNAP was appreciably altered when the fresh livers were allowed to stand overnight at room temperature.

The ratios of RNAP/DNAP obtained for various forms of rat liver tissue indicate that a large proportion (some 80%) of the total nucleic acid of rat liver tissue is present in the form of ribonucleic acid. Similar ratios have been obtained with the liver tissue of other species (sheep, pig, horse, man).

The ratios obtained for the analysis of the precipitate of lanthanum salts are in most cases considerably higher than those found on direct analysis of the liver powder. Owing to losses in extraction of the nucleic acids, in precipitation as La salts and on resolution from the La precipitate, the amount of P in the material recovered from the La precipitate is, in the case of liver tissue, only about 60% of that in the tissue powder. These losses are proportionately greater for desoxyribo- than for ribo-nucleic acid, and the RNAP/DNAP ratios are therefore high. Nevertheless the ratios obtained for various forms of liver show the same relative variations among themselves as do the ratios obtained by direct analysis.

C. Discussion.

The rise in N.P.P. concentration in liver tissue found on fasting confirms the earlier observations of other workers (Kossel, 1882; Tichmeneff, 1914; Cahn and Bonot, 1928; Rosenthal and Drabkin, 1943; Kosterlitz and Cramb, 1943). Kosterlitz (1944) has shown that fasting results in the loss of stainable material and of mitochondria in the cytoplasm of the liver cell. The particulate components of the cytoplasm are reported by Claude (1943a, b), Bensley (1942), Hoerr (1943) and Lazarow (1943) to contain a nucleic acid of the pentose type which is presumably identical with the ribonucleic acid which has been isolated from liver tissue. The fall in the RNAP/DNAP ratio on fasting would be consistent therefore with a diminution in the phospholipin-ribonucleoprotein complex content of the liver cytoplasm. The loss on fasting of liver weight as a percentage of body weight is in agreement with the results of other workers (e.g. Kosterlitz and Cramb, 1943).

Comparison of normal adult liver tissue with rapidly growing liver tissue from the embryo is rendered difficult by the peculiar cellular content of the latter (Plate 15) but such a comparison can be made

between normal and regenerating liver. The livers of rats submitted to laparotomy give figures for nucleic acid and nucleotide content which are very close to those obtained for normal male fasted rats. The regenerating livers differ appreciably only in one respect, their high simple nucleotide and total soluble purine concentration. In this they differ from other rapidly growing tissues (embryonic and neoplastic) which have characteristically low acid soluble nucleotide concentrations. Such low concentrations are found in the embryonic rat liver and to a much less pronounced extent in the liver tumours.

The N.P.P. of the 100 day liver tumours is higher than that of the control livers when the comparison is made on a dry weight basis but the difference is due largely to the increased water content of the tumours. In no case was the difference between the N.P.P. (dry weight basis) of the liver tumours and that of normal rat liver as great as that recorded by Dickens and Weil-Malherbe (1943) and by Fujiwara, Nakahara, and Kishi (1937). On a wet weight basis the N.P.P. figures are of the same order for liver tumours, livers from rats on the control diet and livers from normal fasting male rats. On the other hand the P contents of the

extracted liver powders are much higher in the case of both liver tumours and livers from rats on the control diet than in the case of normal fasted rat livers. The P content of the extracted powder from pregnant rat liver is also at the same high level.

Caspersson, Nyström and Santesson (1941) and Caspersson and Santesson (1942) have reported the presence of high concentrations of ribopolynucleotides in the cytoplasm of tumour cells. Although the concentration of RNAP in the liver tumours is higher than that of the controls the difference is in no case very great. The DNAP concentration is also raised so that the RNAP/DNAP ratio is lower than that of the controls.

It is clear that liver tissue contains ribonucleic acid, that this acid is found in the cytoplasm of the liver cell, that it is present in liver tissue in large amounts, and that the amount may vary independently of the amount of nuclear desoxyribonucleic acid.

Despite the large amounts of ribonucleic acid present in liver tissue, most of which is probably located in the cytoplasmic granules, its function is but imperfectly understood as yet. There is, however, evidence that it may be connected with the

structure of certain enzyme systems. For example, the succinoxidase system was demonstrated in mitochondria and submicroscopic particles by Lazarow and Barron (1931) and succinic dehydrogenase, cytochrome oxidase and coenzyme I-cytochrome C reductase have been shown to be inhibited by crystalline ribonuclease (Potter and Albaum, 1943). The cytoplasmic ribonucleic acid may also play an important part in the self-duplication of cytoplasmic structures (Claude, 1943a; Caspersson and Santesson, 1942).

SUMMARY.

The nucleic acid and nucleotide concentration has been examined in a series of rat livers from fed and fasting animals, in the pregnant and embryo rat, in the regenerating rat liver and in liver tumours induced by feeding butter yellow. The total nucleic acid concentration, as measured by the nucleoprotein phosphorus, rises on fasting, is high in pregnancy and very high in the embryo, is not appreciably altered in the regenerating liver, and is slightly raised in the liver tumours. The acid soluble nucleotide concentration is unaltered on fasting, is raised in regenerating livers, is low in liver tumours and very

low in embryo livers.

Of the total nucleic acid a large proportion (70-90%) is present as ribonucleic acid. On fasting, the ribonucleic acid concentration falls by about 12%, while the desoxyribonucleic acid concentration rises, both changes being statistically significant. The ratio of ribonucleic acid P to desoxyribo nucleic acid P therefore falls on fasting, is the same in regenerating as in control livers and is lower in liver tumours and in embryo livers than in the normal liver, although in both liver tumour and in the embryo, particularly the latter, the concentrations of both ribonucleic acid and desoxyribonucleic acid are higher than in the normal liver.

Tumour-bearing fowls were killed by decapitation and the blood from the carotid arteries collected in a beaker containing oxalate.

The tumour tissue was immediately excised and dealt with as follows:

(a) A small portion was fixed for histological examination.

(b) Moisture was determined by drying weighed portions in tared beakers at 100° to constant weight.

6. THE NUCLEIC ACID AND NUCLEOTIDE
CONTENT OF TUMOURS.

The nucleic acid content of tumour tissue has already been discussed (p.217).

Procedure and Methods.

The tumours used in this investigation have been mainly the Rous sarcoma and the chemically induced GRCH 15 fowl tumour (Peacock, 1940) (Plate 19). Both were obtained from fowls in which tumour growth was far advanced. A number of human tumours obtained at biopsy were also examined. After excision they were conveyed at once to the laboratory and were examined immediately by the same methods as were used for the fowl tumours.

Tumour-bearing fowls were killed by decapitation and the blood from the carotid arteries collected in a beaker containing oxalate.

The tumour tissue was immediately excised and dealt with as follows:-

- (a) A small portion was fixed for histological examination.
- (b) Moisture was determined by drying weighed portions in tared beakers at 100° to constant weight.

Plate 19.

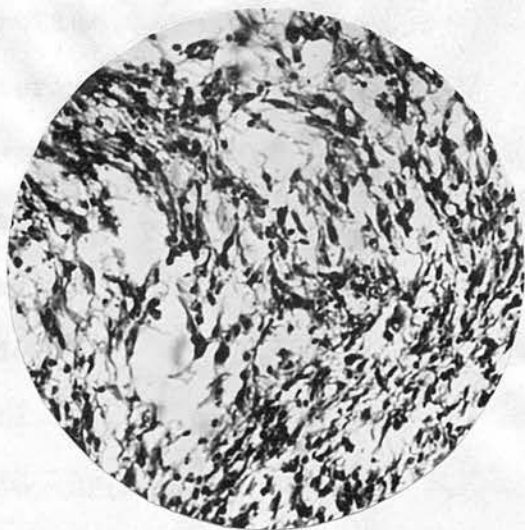

A

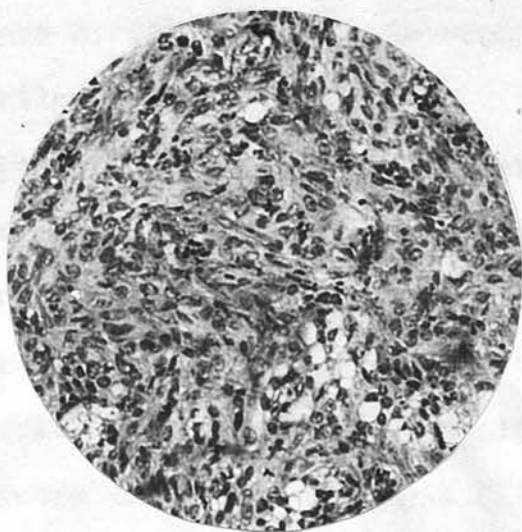

B

A Rous sarcoma

B GRCH 15

Stained:- Haematoxylin-eosin.

x 110

- (c) Nucleotide, nucleoside, and free purine N were determined in trichloroacetic acid extracts by the method of Kerr and Blish (1932) as modified by Kerr (1940). The sum of all three gave the total acid soluble purine N. Nucleotides were determined in blood by pipetting 5 ml. blood into 20 ml. 10% trichloroacetic acid, centrifuging, and following the method of Kerr (1940).
- (d) The total nucleic acid content of the tissues was estimated on 15-25 mg. portions by making nucleoprotein phosphorus (N.P.P.) determinations by the method of Berenblum, Chain and Heatley (1939).
- (e) Polypeptide estimations were carried out on tissue by a modification of the method of Burstein (1937). Portions of about 3 grams were weighed out and ground in a mortar with 5 vols. 5% trichloroacetic acid. After 15 minutes the suspension was filtered. Of the filtrate 2 ml. were taken for total N determination (micro-Kjeldahl): 5 ml. was treated with 1 ml. 5% phosphotungstic acid in 2 N HCl. After 15 minutes the precipitate was

centrifuged down, washed with 2 ml. 1% phosphotungstic acid in 0.4 N HCl and transferred to a digestion flask for total N determination (micro-Kjeldahl, modification of Ma and Zuazaga, 1942).

For blood polypeptide determinations 5 ml.

oxalated blood were pipetted into a centrifuge tube containing 5 ml. water and 5 ml. 15% trichloroacetic acid was added. The mixture was centrifuged and the supernatant fluid treated as for tissue extracts. Non-protein nitrogen (N.P.N.) was also determined on the supernatant fluid. It, of course, includes polypeptide N.

- (f) The remainder of the fresh tissue was minced, dehydrated with several successive portions of ethanol, then ether, and dried. The dried material was transferred to a stoppered 50 ml. centrifuge tube and shaken for four one-hour periods with successive portions of about 40 ml. 0.1 N HCl. This process removes acid soluble P including simple nucleotides. The residue was washed twice with ethanol and was then extracted for two successive two-hour periods

at 65° under a reflux condenser with an ethanol-chloroform mixture (3:1). It was then washed with ether, dried, ground to a fine powder in a mechanical mortar and passed through a sieve (120 mesh).

Total P was estimated in the extracted powder by a modification of the method of Allen (1940). The amounts of ribonucleic acid phosphorus (RNAP) and desoxyribonucleic acid phosphorus (DNAP) were determined in the extracted tissue powders by the indirect method previously described for liver tissue (p.299), the results again being expressed in terms of RNAP and DNAP.

The sodium chloride extract was also examined for ribonucleic acids, which acted as substrates for crystalline ribonuclease, by the method previously employed (p.243).

Results.

The results of the water and N.P.P. estimations are shown in Table 24. In nearly all cases the water content of the tumours is high. The high moisture content of rapidly growing tissues (Cramer, 1916; Willmer, 1935) such as embryonic tissue and tumour

Table 24 .

Nucleoprotein phosphorus (N.P.P.) and water content of tumours. In the case of fowl tumours the mean values and the standard error are shown and the number of tumours examined is given in brackets.

	Water content %	Nucleoprotein phosphorus (N.P.P.) mg. per 100 gm.	
		Wet weight	Dry weight
<u>Fowl tumours</u>			
GRCH 15	83.2 ± 0.56 (5)	88.8 ± 2.38 (5)	531 ± 22.6 (5)
Rous sarcoma	88.1 ± 3.10 (12)	53.1 ± 5.38 (12)	462 ± 49.5 (12)
Adjacent muscle	77.0 ± 1.26 (4)	30.5 ± 5.61 (4)	133 ± 23.9 (4)
<u>Rat tumour</u>			
Fibroadenoma of mammary gland	84	40	247
<u>Human tumours</u>			
Lymphosarcoma	85	72	490
Fibrosarcoma (thigh)	84	98	529
Sarcoma (breast)	82	72	400
Adenosarcoma (breast)	84	22	140
Carcinoma (breast)	75	63	250
Carcinoma (breast)	64	99	280
Secondary carcinoma of colon	82	25	135
Hypernephroma	81	63	335
Carcinomatosis, omentum.	88.5	27	233

tissues (c.f. Marvelli, 1930; Cavina, 1931) is of course well known (see p.247). The N.P.P. figures indicate a high nucleic acid content in the fowl tumours. This is most striking in the case of the N.P.P. values on a dry weight basis owing to the high water content of the tumours. Figures for the N.P.P. content of other fowl tissues on a dry weight basis are heart, 161, liver, 408, brain, 119, nerve, 205 mg. per 100 gm. (p.246). Muscle adjacent to the tumours gave a figure of 133 ± 23.9 .

On the other hand the figures for the N.P.P. content of human tumours vary greatly according to the type of tumour in question. Comparison with the tissue of origin is in most cases not possible but, in any case, the data presented do not justify any broad generalisation about the nucleic acid content of tumours.

The nucleotide content of the tumours is shown in Table 25. In the case of the fowl tumours, especially the Rous sarcoma, the nucleotide concentration is very low. The figures are lower than those found for all adult fowl tissues previously examined and are comparable with those for chick embryonic tissue. The nucleoside concentration and hence also the total acid soluble purine are also low.

Table 25.

Nucleotide N, nucleoside N and free purine N of tumour tissue. The sum of all three gives total acid soluble purine N. In the case of fowl tumours mean values and the standard error are given. The figure in brackets is the number of animals.

	milligrams per 100 gm. fresh tissue		
	Nucleotide N	Nucleoside N and free purine N	Total acid soluble purine N
<u>Fowl tumours</u>			
GRCH 15	19.7 ± 1.38 (4)	9.3 ± 0.45 (4)	29.0 ± 1.16 (4)
Rous sarcoma	10.4 ± 0.92 (12)	7.4 ± 0.37 (12)	17.8 ± 1.18 (12)
Adjacent muscle	43.9 ± 4.42 (8)	11.0 ± 0.51 (8)	55.0 ± 4.18 (8)
<u>Rat tumour</u>			
Fibroadenoma of mammary gland	7.0	6.3	13.3
<u>Human tumours</u>			
Lymphosarcoma	9.0	18.5	27.5
Hypernephroma	16.1	9.8	25.9
Carcinoma of colon - secondary growth	11.2	9.8	21.0
Fibrosarcoma of thigh	21.0	12.6	33.6
Carcinomatosis, omentum.	4.9	9.1	14.0

The nucleotide concentration in human tumours is variable, but in most cases it is of the same low order as that in fowl tumours.

It will be seen from Table 26 that tumour tissue, like normal tissues, contains appreciable amounts of ribonucleic acid. Of the total amount of phosphorus in the extracted tumour powder, in most cases some 50-70% is extracted with sodium chloride, precipitated in the lanthanum nucleates and recovered from the precipitate. Of this, between 90 and 100% in most tumours can be accounted for in terms of RNAP and DNAP. Although it cannot be assumed that the ratios found for the lanthanum precipitates necessarily represent the actual proportions in the original tissue, it does appear that the amount of ribonucleic acid, especially in the fowl tumours, is considerably greater than the amount of desoxyribonucleic acid. In most of the human tumours probably more than 50% of the total nucleic acid is present in the form of ribonucleic acid.

The direct estimation of pentose and desoxypentose on the extracted tissue powders, as has been done with liver, is not generally applicable to tumour tissue powders, on account of the presence in many tumours of substances which interfere with the colorimetric procedures. Where these have been carried out on the fowl tumours the RNAP/DNAP ratios obtained have been rather lower, as in the case of liver tissue, than those obtained by the indirect method.

Table 26.

Ribonucleic acid phosphorus (RNAP) and desoxyribonucleic acid phosphorus (DNAP) as a percentage of the total P recovered from the precipitate of lanthanum salts.

Type of tumour	RNAP as % total P	DNAP as % total P	RNAP + DNAP as % total P	<u>RNAP</u> <u>DNAP</u>
<u>Fowl tumours</u>				
Rous sarcoma (a)	73.2	18.3	91.5	4.0
" " (b)	73.2	14.7	87.9	4.9
" " (c)	85.2	13.4	98.6	6.4
" " (d)	77.2	20.6	99.8	3.8
GRCH 15 (a)	80.4	15.3	95.7	5.3
" (b)	75.5	15.4	91.0	4.9
" (c)	80.5	18.0	98.5	4.5
" (d)	88.5	15.5	104.0	5.7
<u>Human tumours</u>				
Lymphosarcoma	50.9	35.7	86.5	1.4
Carcinoma of cervix	58.2	31.5	90.0	1.9
Carcinoma of breast	66.4	35.0	101.4	1.9
Carcinoma of breast secondary in axillary lymph node	49.0	41.4	90.5	1.2
Sarcoma of breast	77.4	22.4	99.8	3.5
Adenosarcoma of breast	65.7	29.2	95.0	2.3

Figure 18.

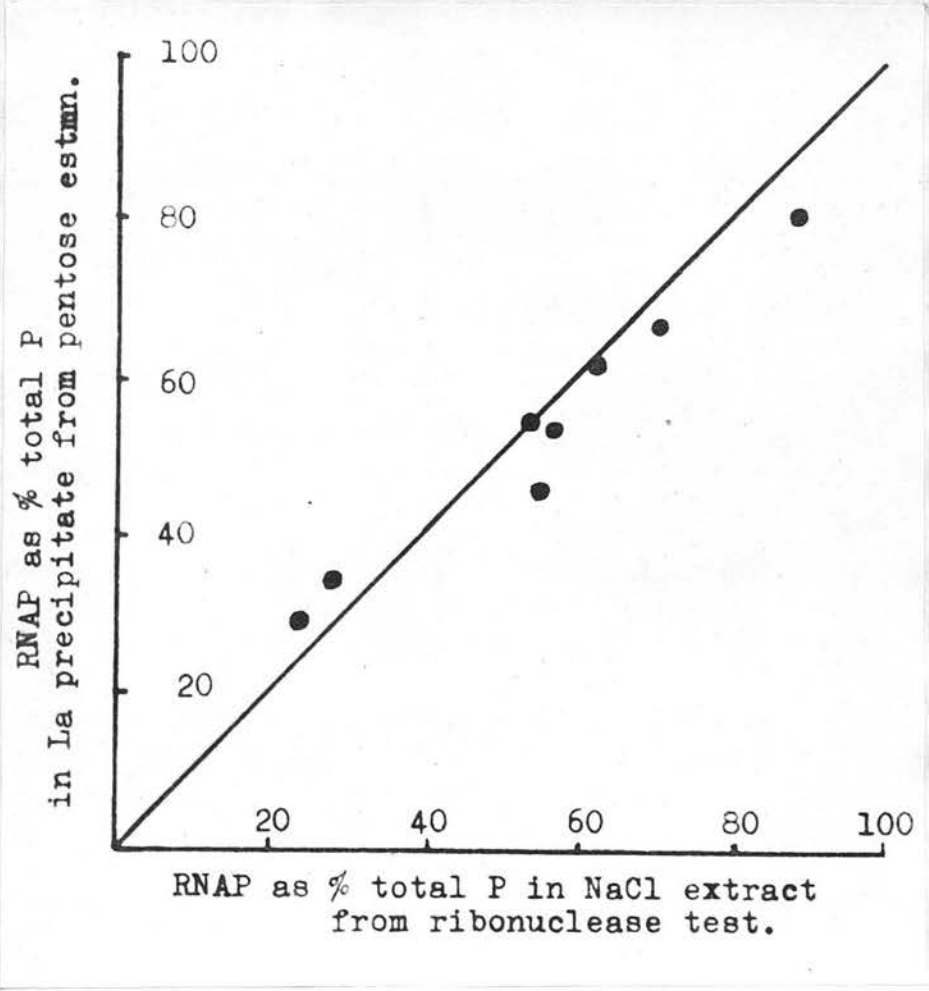

Correlation between the ribonucleic acid P content of the tumours, calculated from the pentose content and from the ribonuclease test.

The amounts of ribonucleic acid in the sodium chloride extract, measured as substrate for ribonuclease, are compared with the results of pentose estimations on the lanthanum precipitate in Fig. 18. As in the case of sheep tissues, there is good correlation between the amounts of ribonucleic acid found by the two methods.

Ribonucleic acid has been isolated from Rous sarcoma tissue by a method similar to that employed in the isolation of ribonucleic acid from liver (p. 269). The tumour tissue was dehydrated with ethanol and the nucleic acids extracted from the dry powder with 10% NaCl, precipitated with ethanol, and purified through the barium salts (Jorpes, 1934). The ribonucleic acid was finally precipitated from glacial acetic acid and washed with ethanol and ether. Reprecipitation from glacial acetic acid did not render the material completely free from desoxyribonucleic acid. It was protein free, and acted as a substrate for crystalline ribonuclease.

The results of the polypeptide estimations are shown in Table 27. The method employed is not absolutely specific for polypeptides but is a measure of the amount of nitrogenous material precipitated by phosphotungstic acid but not by trichloroacetic acid. Nucleotides and nucleosides, for which figures are quoted in the table, are not precipitated by phosphotungstic acid under the conditions employed but are included in the N.P.N. fraction.

Table 27.

Polypeptide nitrogen, non-protein nitrogen (N.P.N.), nucleotide N, nucleoside N and free purine N, and total acid soluble P of fowl blood, plasma and tissues. All figures are in milligrams per 100 ml. blood, plasma or tissue.

Bird No.	Tissue	Poly-peptide N	N.P.N.	Nucleotide N	Nucleoside and free purine N	Total acid soluble P
<u>Normal fowls</u>						
1	Whole Blood	25.2	62.0	5.3	2.8	-
2	" "	12.1	43.2	-	-	-
3	" "	13.9	49.3	-	-	-
4	" "	11.2	42.8	-	-	-
5	" "	8.9	34.0	-	-	-
6	" "	7.7	44.8	-	-	-
7	" "	9.8	47.0	-	-	-
8	" "	9.2	47.2	-	-	-
9	" "	13.6	44.3	-	-	-
10	" "	10.1	40.9	-	-	-
11	" "	13.5	59.9	-	-	-
	Mean	12.3	46.9	-	-	-
	Standard error	±1.43	-	-	-	-
<u>Fowls with Rous sarcoma</u>						
1	Whole Blood	23.5	46.2	3.4	5.5	-
2	" "	28.6	66.1	3.4	5.9	-
3	" "	16.8	42.0	1.3	5.8	-
4	" "	23.1	56.6	1.3	8.8	-
5	" "	16.0	66.6	5.3	4.6	-
6	" "	13.4	50.2	7.0	6.5	-
7	" "	19.3	57.8	6.7	3.5	-
8	" "	14.3	45.2	4.6	4.2	-
9	" "	13.4	52.5	-	-	-
10	" "	13.0	57.8	6.7	3.5	-
11	" "	16.2	54.5	5.6	5.6	-
12	" "	23.9	60.9	4.9	3.9	-
	Mean	18.5	54.9	-	-	-
	Standard error	±1.55	-	-	-	-
5	Plasma	5.5	22.1	-	-	-
7	"	6.3	26.2	-	-	-
10	"	8.4	24.2	-	-	-
1	Sarcoma	37.4	64.1	14.0	9.8	74.0
2	"	21.4	24.1	13.3	9.8	53.5
3	"	14.7	46.2	7.0	5.6	36.5
4	"	29.4	54.6	14.0	7.7	62.0
5	"	19.8	55.7	-	-	-
6	"	18.1	47.3	-	-	-
1	Muscle [breast]	29.8	137.5	35.0	13.3	154.5
2	"	81.9	254.0	58.1	10.5	201.5
3	"	81.5	261.5	58.8	9.8	185.0
4	"	14.3	56.6	58.1	9.1	183.0

The figures for the polypeptide content of the blood of both normal and tumour-bearing fowls vary over a wide range. In the case of the tumour-bearing birds the mean value is, however, higher than for normal fowls and the difference is statistically significant. Both the non-protein nitrogen and the polypeptide nitrogen of the blood of normal and tumour-bearing fowls are high in comparison with normal mammalian blood where ^{the} polypeptide content is of the order of 4 mg. polypeptide N per 100 ml. for man (Arduino, 1941) and for the dog (Burstein, 1937).

Comparison of the figures for blood and plasma polypeptide shows that the bulk of the polypeptide N is in the cells. This holds also for mammalian blood (Larizza, 1937; Arduino, 1941; Burstein, 1937; and Claudatus, 1939).

The polypeptide content of the Rous sarcoma tissue is similar to that of whole blood and is much lower than that of muscle.

In two cases fibromyomata of the uterus have been compared with the uterine tissue in which they were growing (Table 28). Such a comparison is not altogether free from objection, but in both cases the nucleic acid content is higher and the nucleotide

Table 28.

Fibromyomata of the uterus.

	Water content %	milligrams per 100 gm. tissue				
		Nucleoprotein phosphorus (N.P.P.)		Nucleotide N	Nucleoside N + free purine N	Total acid soluble purine N
		wet wt.	dry wt.			
Myometrium	79	52	250	8.8	10.5	19.3
Fibromyoma	83	57	330	8.1	6.7	14.8
Myometrium	82	55	310	10.9	10.5	21.4
Fibromyoma	71	114	390	10.0	8.8	18.8

content slightly lower, in the tumour than in the normal myometrium.

Discussion.

It is unfortunate that in the case of the fowl tumours no comparison can be made between the tumour and the tissue of origin. The Rous sarcoma is derived from connective tissue (macrophage or fibroblast, Berenblum, Chain and Heatley, 1940b) but it is not feasible to obtain large enough amounts of sufficiently pure connective tissue for reliable comparable analyses. The figures for adjacent muscle tissue are included in the tables as an example of a normal tissue in contact with the tumour but vastly different from it in chemical composition. On a dry weight basis the fowl tumour tissue has a high nucleic acid content, comparable indeed with that of normal liver. This is not surprising in view of the histological structure (Plate 19) which is densely cellular. The Jensen rat sarcoma has an even higher nucleoprotein phosphorus content, 179 mg. per 100 gm. wet weight (Boyland, 1932) or 680 mg. per 100 gm. dry weight (Berenblum, Chain and Heatley, 1937). Rondoni (1941) found figures of 350 mg. per 100 gm. (dry weight) for

rat sarcoma and 63 mg. per 100 gm. (dry weight) for rat skin and subcutaneous tissue. One of the few cases where comparison of tumour tissue with the tissue of origin is possible is liver (c.f. Burk, 1942). The rat hepatoma (induced by feeding p-dimethylaminoazobenzene) has a higher nucleic acid content than normal rat liver (see p.218). While, therefore, it may be justifiable to conclude that rapidly growing cellular tumours have, like embryonic tissues, in general a high nucleic acid content, it is obvious from the figures obtained from the human tumours that this does not hold in all cases. Where a tumour contains large amounts of fibrous tissue, for example, the nucleic acid content, as might be expected, is by no means high.

Of the total nucleic acid a considerable proportion appears to be ribonucleic acid. The results of the pentose estimations on the lanthanum precipitates indicate the presence of amounts of ribonucleic acid which are of the same order as those found in the ribonuclease test in which the amounts of substrate for ribonuclease are estimated. The evidence hitherto adduced for the presence of ribonucleic acids in tumour tissues, e.g. by Caspersson and Santesson (1942)

and by Koller (1943a, b), has been indirect, and the ribonucleic acid of the phospholipin-ribonucleoprotein complexes in the Rous sarcoma virus (Claude, 1939) has not been obtained in sufficient amounts for complete characterisation.

On the other hand, tumour tissue, like embryo tissue, is peculiar in its low acid soluble nucleotide content. Preliminary rough experiments by Saiki (1909-10) indicated the presence of only small amounts of acid soluble purine derivatives in tumour tissue. Barrenscheen and Peham (1942b) found low figures for the nucleotide content of a miscellaneous collection of tumours. The high amounts of nucleoside relative to nucleotide shown in their tables suggests that the tissues employed were not absolutely fresh. Tumour tissue contains active nucleotidases (Adler and Euler, 1940) such as are present in normal tissues (Reis, 1937), which rapidly convert nucleotides to nucleosides. For that reason all the human material used in this investigation has been freshly obtained at biopsy. Post-mortem specimens have been avoided. Of the total nucleotide, which includes adenylic acid, adenosine triphosphate, inosinic acid, the nicotinamide nucleotides and flavin adenine dinucleotide, the bulk is

present in the form of adenylic acid and adenosine triphosphate, chiefly the latter. Boyland (1932) quotes figures for the pyrophosphate content (derived from adenosine triphosphate) of the Jensen rat sarcoma and the LR 10 tumour which are considerably lower than those of normal muscle, although he concludes without apparent justification that "tumours contain practically as much" adenosine triphosphate as does normal muscle.

The total acid soluble P (Table 27), which includes nucleotide P, is also much lower in the Rous sarcoma than in fowl muscle, for which the figures are of the same order as those quoted by Boyland (1932) for frog muscle. The polypeptide level in normal fowl blood is considerably higher than in normal mammalian blood, but has been found to be significantly lower than in the blood of tumour-bearing fowls. This is of some interest in view of the statement by Winzler and Burk (1943) that the blood of tumour-bearing rats contains 20-50 mg. % proteose N (precipitable by phosphotungstic acid but not by trichloroacetic acid) whereas the figure for

normal rat blood is 3-4 mg. %. In human patients with carcinoma, high blood polypeptide levels have been reported (Larizza, 1937; Godfried, 1939; Ramond & Zizine, 1922; Hahn, 1921a, b). The nucleotide level in the blood of the tumour-bearing fowls was normal.

It can be concluded that the materials absorbing light at 2600 Å observed by Caspersson and Santesson (1942) and Caspersson, Nyström and Santesson (1941) in the cytoplasm of rapidly growing tumours and classified as "ribonucleotides", are ribopolynucleotides rather than simple acid soluble nucleotides. The material observed by Mitchell (1942, 1943) in the cytoplasm of tumour cells exposed to X- and gamma radiation would appear to be of a similar nature. While tumour tissue contains ribonucleic acid, there appears to be no reason to conclude that the ribonucleic acid content is higher than in many normal tissues, and the presence of ribonucleic acid is certainly not limited to malignant, or even to rapidly growing, tissues. Where the tumour tissue is highly cellular, the total nucleic acid content,

including ribonucleic acid, is high. In this respect, and in the low concentrations of acid soluble nucleotides, tumour tissues resemble the highly cellular tissues of the rapidly growing embryo.

SUMMARY.

Tumour tissue from the Rous sarcoma and from the GRCH 15 fowl tumour has a high water content and a high total nucleic acid content. In a series of human tumours the water content was high but the total nucleic acid content was variable. In both fowl and human tumours, the concentration of acid soluble nucleotide was lower than is found in most normal tissues.

Of the total nucleic acid a large proportion is present in the form of ribonucleic acid. Its presence has been determined both by pentose estimations on the extracted nucleic acids and by the use of crystalline ribonuclease which attacks specifically the ribonucleic acids.

In the blood of fowls with the Rous sarcoma the concentrations of polypeptide N and of non-protein N are higher than in normal fowl blood. The levels of both are high in comparison with mammalian blood.

GENERAL SUMMARY AND CONCLUSIONS.

The results of this investigation have confirmed the view that no other substances can stimulate the growth of tissues *in vitro* so successfully as do extracts of embryonic tissue. It is improbable, however, that the effects of embryo extract can be attributed to any one individual constituent. Attempts to separate any particular constituent, or group of constituents, have always resulted in loss of activity. While embryo extracts are found to be rich in ribonucleoproteins, there is no reason to suppose that their growth promoting activity is associated to any great extent with the ribonucleoprotein fraction.

Of the non-embryonic material tested, the higher protein-split-products have shown greatest growth promoting power in stimulating nucleoprotein synthesis in growing cells. The products of partial breakdown of the nucleic acids have also shown activity.

Both these types of material have been found in the products released by yeast cells injured by exposure to ultraviolet light. They may be released either as the result of increased cell permeability or as disintegration products of dead and dying cells,

and are responsible, in part at least, for the proliferation-promoting properties of extracts of irradiated yeast cells.

Ribonucleic acids have been demonstrated in all mammalian tissues tested. In many tissues the amount of cytoplasmic ribonucleic acid is greater than the amount of nuclear desoxyribonucleic acid. When adult sheep tissues are compared with the corresponding embryonic tissues, the ratio of ribonucleic acid phosphorus to desoxyribonucleic acid phosphorus for any given tissue is, in most cases, of the same order in the adult as in the embryo, although the total amount of nucleic acid in the embryonic tissue is higher than in the adult tissue.

A ribonucleic acid has been isolated from liver and shown to be similar to yeast ribonucleic acid. It is present in the cytoplasm of the liver cell. The amount present in liver tissue under various conditions has been ascertained.

Tumour tissues also contain ribonucleic acid. The total nucleic acid content of tumours is variable, but in most cases is of a high order.

Rapidly growing tissues, embryonic or neoplastic, tend to be characterized by a high water content, a

high total nucleic acid content, and a low acid soluble nucleotide content.

The work described in this paper was carried out with the financial support of the Medical Research Council and of the University of Edinburgh. The author wishes to thank Mr. J. W. Haywood for assistance in the experiments, to Mr. R. A. Wilson for valuable advice on snake venom, to Dr. H. S. Harvey of the Royal College of Pathology, Edinburgh, for the supply of snake venom, to Dr. G. R. Barker and James Brown of the University of California for a gift of pure crystalline samples of the bovine virus, to Dr. J. W. Greenwood of Manchester for a sample of crystalline ribonucleic acid, to Professor V. de Vries of London for a sample of crystalline ribonucleic acid, and to the University of Edinburgh for a sample of snake venom.

ACKNOWLEDGEMENTS.

The work described in the preceding pages was carried out with the financial support of the Medical Research Council and of the Carnegie Trust for the Universities of Scotland, to whom grateful thanks are due. The author wishes also to record his gratitude to Miss C. Waymouth for assisting in many of the experiments, to Mr E. N. Willmer of Cambridge for valuable advice on tissue culture matters, to Lt.-Col. W. F. Harvey of the Royal College of Physicians' Laboratory, Edinburgh, for histological advice, to Dr A. W. Greenwood of Edinburgh University for maintaining a supply of chick embryos, to Mr J. G. Carr of Edinburgh for supplying the tumour bearing fowls, to Dr G. R. Barker and Messrs Boots of Nottingham for supplying snake venom, to Dr H. Fraenkel-Conrat of California for a gift of pure crotoxin, to Dr M. Kunitz of the Rockefeller Institute for the gift of a sample of crystalline ribonuclease, to Dr J. Madina-veitia of Manchester for a sample of purified mucinase, to Professor V. du Vigneaud of Cornell University for a sample of crystalline biotin, to Dr Neil Campbell of Edinburgh University for a sample of pure

References.

Those marked * have been available only in the form of abstracts. In all other cases the original papers have been consulted.

- Adler, E. and von Euler, H. (1940) Arkiv. Kemi Min. Geol. 13A, No. 26.
- Akamatsu, N (1922) Virch. Arch. 240, 308.
- Alders, N. (1927) Biochem. Zeit. 181, 400.
- Allan, F. W. (1941) Ann. Rev. Biochem. 10, 221.
- Allen, F. W. and Eiler, J. J. (1941) J. Biol. Chem. 137, 757.
- Allen, F. W., Lucia, S. P. and Eiler, J. J. (1936) Proc. Soc. Exp. Biol. Med. 34, 609.
- (1936) J. Clin. Invest. 15, 157.
- Allen, R. J. L. (1940) Biochem. J. 34, 860.
- * Amorosi, C. (1931) Rev. Pat. Sper. 7, 33.
- Andai, G. (1932) Arch. Exp. Zellforsch. 12, 301, 307.
- Antopol, W., Glaubach, S., Goldman, L. M. and Katzin, E. (1943) Proc. Soc. Exp. Biol. Med. 53, 125.
- * Arduino, J. C. (1941) Rev. Fac. Cien. Quim. La Plata 16, 191.
- Arey, L. B. (1936) Physiol. Rev. 16, 327.
- (1942) J. Franklin Inst. 233, 506.
- Artom, C., Sarzana, G., Perrier, C., Santangelo, M. and Segre, E. (1937) Nature 139, 836.
- Astbury, W. T. (1941) Proc. 7th Internat. Genet. Cong. Edin. (1939) p. 47.
- Astbury, W. T. and Bell, F. O. (1938) Nature 141, 747.
- Baker, J. R. (1942) Nature 149, 611.
- Baker, L. E. (1929) J. Exp. Med. 49, 163.
- (1933) *ibid.* 57, 689.
- (1933) *ibid.* 58, 575.
- (1936) Science 83, 605.
- (1936) C.r. Soc. Biol. 121, 427.
- (1938) Proc. Soc. Exp. Biol. Med. 39, 369.
- (1939) J. Exp. Med. 69, 625.

- Baker, L. E. and Carrel, A. (1925) J. Exp. Med. 42, 143.
(1926) *ibid.* 44, 387.
(1926) *ibid.* 44, 397.
(1927) *ibid.* 45, 305.
(1928) *ibid.* 47, 353.
(1928) *ibid.* 47, 371.
(1928) *ibid.* 48, 533.
- Baker, L. E. and Ebeling, A. H. (1939) J. Exp. Med. 69, 365.
- Bamann, E. and Meisenheimer, M. (1938) *ber.* 71B, 1171, 2233.
- Bang, I. (1898-99) Z. physiol. Chem. 26, 133.
(1900-01) *ibid.* 31, 411.
(1902) *Beitr. Chem. Physiol. Path.* 1, 189.
(1904) *ibid.* 4, 115, 362; 5, 317.
- Barrenscheen, H. K. and Peham, A. (1941) Z. physiol. Chem. 272, 81.
(1941) *ibid.* 272, 87.
- Barber, H. N. and Callan, H. G. (1944) *Nature* 153, 109.
- Barker, S. B. and Summerson, W. H. (1941) J. Biol. Chem. 138, 535.
- Barnes, J. W. and Schoenheimer, R. (1943) J. Biol. Chem. 151, 123.
- Bass, L. W. (1914) *Arch. exp. Path. u. Pharmakol.* 76, 40.
- Baumann, C. A. and Stare, F. J. (1939) *Physiol. Rev.* 19, 353.
- Bawden, F. C., Pirie, N. W., Bernal, J. D. and Fankuchen, I. (1936) *Nature* 138, 105.
- Beebe, S. P. and Shaffer, B. (1905) *Amer. J. Physiol.* 14, 231.
- Beek, J. (1941) J. Amer. Chem. Soc. 63, 1483.
- Behrendt, H. (1942) *Amer. J. Dis. Child.* 64, 55.
- Behrens, M. (1938) Z. physiol. Chem. 253, 185.
(1938) *Abderhaldens Handbuch d. biol. Arbeitsmethoden* Abt. V. Teil 10, S. 1363.

- * Belozerski, A. N. (1936) *Biochimia* 1, 253.
- * Belozerski, A. N. and Tschigirev, S. D. (1936) *ibid.* 1, 134.
- * Belozerski, A. N. and Dubrovskaja, A. (1936) *ibid.* 1, 665.
- * Belozerski, A. N. and Uspenskaya, M. S. (1942) *ibid.* 7, 155.
- Bennet, D. W. and Drury, A. N. (1931) *J. Physiol.* 72, 288.
- Bensley, R. R. (1937) *Anat. Rec.* 69, 341.
 (1938) *ibid.* 72, 351.
 (1942) *Science* 96, 389.
- Bensley, R. R. and Hoerr, N. L. (1934) *Anat. Rec.* 60, 251, 449.
- Berenblum, I. and Chain, E. (1938) *Biochem. J.* 32, 295.
 (1940) 17th Ann. Rep. Brit. Emp. Can. Campaign p. 159.
- Berenblum, I., Chain, E. and Heatley, N. G. (1939) *Biochem. J.* 33, 68.
 (1940a) *Amer. J. Cancer* 38, 367.
 (1940b) *Nature* 145, 778.
- * Bergami, G. (1925) *Rendiconti d.R. Acad. (Naz.) dei Lincei* 2, 140.
- Bergman, M. and Niemann, C. (1936) *J. Biol. Chem.* 115, 77.
- Berkeley C. (1921) *J. Biol. Chem.* 45, 263.
- Bernal, J. D. and Fankuchen, I. (1937) *Nature* 139, 923.
- Berrill, N. J. (1943) *Physiol. Rev.* 23, 101.
- Bier, A. (1917) *Dtsch. med. Wschr.* 43, 833.
- Blanchard, K. C. (1935) *J. Biol. Chem.* 108, 251.
- Blumenthal, F. (1898) *Z. klin. Med.* 34, 166.
- Bolomey, R. A. and Allen, F. W. (1942) *J. Biol. Chem.* 144, 113.
- Bonner, J. and English, J. (1937) *Science* 86, 352.
 (1938) *Plant Physiol.* 13, 331.
- Borger, G. and Peters, T. (1933) *Z. Physiol. Chem.* 214, 91.
- Borger, G. and Zenker, R. (1932) *Arch. exp. Zellforsch* 12, 347.
- Bourne, G. (1942) *Cytology and Cell Physiology*, Oxford University Press.

- Boyland, E. (1932) *J. Physiol.* 75, 136.
- Boyland, E. and McClean, D. (1935) *J. Path. Bact.* 41, 553.
- Brachet, J. (1933) *Arch. Biol.* 44, 519.
 (1937) *ibid.* 48, 529.
 (1938) *C.r. Soc. Biol.* 127, 1455.
 (1940) *Arch. Biol.* 51, 151, 167.
 (1940) *C.r. Soc. Biol.* 133, 88, 90.
- Brailey, H. W. (1912) *Trans. Opht. Soc. U.K.* 4, 32, 214.
- * Brandt, K. M. (1941) *Protoplasma* 36, 77.
- Brand, K. (1942) *Biochem. Z.*, 312, 89.
- Bredereck, H. (1938) *Ergeb. Enzymforschung* 7, 105.
- Bredereck, H. and Jochmann, I. (1942) *Ber.* 75(B), 395.
- Bredereck, H. and Richter, G. (1938) *Ber.* 71(B), 718.
- Brues, A. M. and Cohen, A. (1936) *Biochem. J.* 30, 1363.
- Brues, A. M., Drury, D. R. and Brues, M. C. (1936)
Arch. Path. 22, 658.
- Brues, A. M. and Jackson, E. B. (1941) *Can. Res.* 1, 557.
- Brues, A. M., Jackson, E. B. and Aub, J. C. (1936) *Proc. Soc. Exp. Biol. Med.* 34, 270.
- Brues, A. M., SubbaRow, Y., Jackson, E. B. and Aub, J. C.
 (1940) *J. Exp. Med.* 71, 423.
- Brues, A. M., Tracy, M. M. and Cohn, W. E. (1942) *Science* 95, 558.
- Brunstig, L. S. and Simonsen, D. C. (1933) *J. Amer. Med. Assoc.* 101, 1937.
- Buell, M. V. (1935) *J. Biol. Chem.* 108, 273.
 (1936) *ibid.* 112, 523.
 (1943) *ibid.* 150, 389.
- Buell, M. V. and Perkins, M. E. (1927) *J. Biol. Chem.* 72, 745.
 (1928) *ibid.* 76, 95.
- * Bugliari, G. R. (1927) *Ann. Ital. di Chir.* 6, 729.

- Burk, D. (1942) *A Symposium on Respiratory Enzymes.*
Univ. Chicago Press, p. 235.
- Burt, A. S. (1943) *Proc. Soc. Exp. Biol. Med.* 54, 191.
- Burrows, M. T. (1925) *Amer. J. Physiol.* 72, 180.
- Burstein, M. (1937) *J. Physiol. Path. gen.* 35, 71.
- Byrom, F. B. (1929) *Brit. J. exp. Path.* 10, 10.
- Byrom, F. B. and Kay, H. D. (1927) *Brit. J. exp. Path.* 8, 429.
(1928) *ibid.* 9, 72.
- Bywaters, E. G. L. and Beall, D. (1941) *Brit. Med. J.* I, 427.
- Cahn, T. and Bonot, A. (1928) *Ann. Physiol. Physicochim.*
Biol. 4, 399, 385, 781.
- Calkins, G. N., Bullock, F. D. and Rohdenburg, G. L. (1912)
J. Infect. Dis. 10, 421.
- Callan, H. G. (1943) *Nature* 152, 503.
- Calvery, H. O. (1928) *J. Biol. Chem.* 77, 489, 497.
(1930) *ibid.* 86, 263.
- Cameron, G. (1935) *Essentials of Tissue Culture Technique.*
New York, Farrar & Rinehart.
- Carleton, H. M. and Haynes, F. (1927-28) *Arch. exp.*
Zellforsch. 5, 111.
- Carnot, P. and Carnot, M. (1927) *C.r. Soc. Biol.* 97, 694.
- Carnot, P. and Terris, E. (1926) *C.r. Soc. Biol.* 95, 655.

Carrel, A. (1911) J. Amer. Med. Assoc. 57, 1611.

(1912) J. Exp. Med. 15, 516.

(1913a) *ibid.* 17, 14.

(1913b) *ibid.* 18, 287.

(1914) *ibid.* 20, 1.

(1922a) *ibid.* 36, 385.

(1922b) *ibid.* 36, 645.

(1923a) *ibid.* 37, 759.

(1923b) *ibid.* 38, 407.

(1923c) *ibid.* 38, 521.

(1923d) C.r. Soc. Biol. 89, 1017.

(1924a) Brit. Med. J. ii, 140.

(1924b) J. Amer. Med. Assoc. 82, 255.

(1924c) C.r. Soc. Biol. 90, 29.

(1924d) Phys. Rev. 4, 1.

(1926) J. Exp. Med. 44, 285.

(1928) Arch. f. exp. Zellforsch. 6, 70.

(1930) Proc. Chicago Inst. Med. 8, 62.

Carrel, A. and Baker, L. E. (1926) J. Exp. Med. 44, 503.

Carrel, A., Baker, L. E. and Ebeling, A. H. (1927)
J. Exp. Med. 45, 215.

Carrel, A. and Burrows, A. (1911) J. Amer. Med. Assoc.
56, 32.

Carrel, A. and Ebeling, A. H. (1921a) J. Exp. Med. 34, 317.

(1921b) *ibid.* 34, 599.

(1922a) *ibid.* 35, 17.

(1922b) *ibid.* 35, 647.

(1922c) *ibid.* 36, 365.

(1922d) *ibid.* 36, 645.

(1923a) C.r. Soc. Biol. 89, 1266.

- Carrel, A. and Ebeling, A. H. (1923b) J. Exp. Med. 37, 653.
(1923c) *ibid.* 38, 419.
(1923d) *ibid.* 38, 499.
(1923e) *ibid.* 38, 513.
(1926) *ibid.* 44, 261.
- Carrel, A. and Hartmann, A. (1916) J. Exp. Med. 24, 429.
(1917) *ibid.* 26, 95.
- Carter, R. O. and Hall, J. L. (1939) Nature 144, 329.
- Caspersson, T. (1932) Biochem Zeit. 253, 97.
(1934) *ibid.* 269, 161.
(1935) Naturwiss. 23, 500, 527.
(1936a) *ibid.* 24, 108.
(1936b) Skand. Arch. Physiol. 73 Suppl. No. 8.
(1937a) Protoplasma 27, 463.
(1937b) Bull. histol. appl. physiol. path. tech. microscop. 14, 33.
(1937c) Arch. exp. Zellforsch. 19, 217.
(1938a) *ibid.* 22, 655.
(1938b) Proc. XVI Internat. Physiol. Congr. p. 265.
(1939) Chromosoma 1, 147.
(1940a) *ibid.* 1, 562.
(1940b) *ibid.* 1, 605.
(1940c) J. Roy. Microscop. Soc. 60, 8.
(1940d) Naturwiss. 28, 514.
* (1940e) Arch. exp. Zellforsch. 28, 514.
(1941a) Proc. 7th Internat. Genetical Congr. Edinburgh, 1939, Aug. 23-30, p. 85-86.
(1941b) Naturwiss. 29, 33.
* (1941c) Nord. Med. (Hygiea) 12, 3106.

- Caspersson, T. and Brandt, K. (1941) *Protoplasma* 3, 507.
- Caspersson, T., Hammarsten, E. and Hammarsten, H. (1935)
Cohan, G. (1935) *Trans. Faraday Soc.* 31, 367.
- * Caspersson, T., Landström-Hyden and Aquilonius, L. (1941)
Chromosoma 2, 111.
- Caspersson, T., Nyström, C. and Santesson, L. (1941)
Naturwiss. 29, 29.
- Caspersson, T. and Santesson, L. (1942) *Acta Radiol.*
Suppl. (1942) *Quart. Rev. Biol.* 2, 459.
- Caspersson, T. and Schultz, J. (1938) *Nature* 142, 294.
(1939) *ibid.* 143, 602.
(1940) *Proc. Nat. Acad. Sci.*
26, 507.
- * Caspersson, T. and Thorell, B. (1941a) *Chromosoma* 2, 132.
*(1941b) *Naturwiss.* 29, 363.
*(1942) *Acta Physiol. Scand.*
4, 97.
- * Cavina, C. (1931) *Tumori* II, 4, 27.
- Centanni, G. (1932) *Ber. ũ.d. wiss. Biol.* 20, 275.
- Chain, E. and Duthie, E. S. (1940) *Brit. J. Exp. Path.*
21, 324.
- Chambers, L. A., Henle, W., Lauffer, M. A. and Anderson, T. F.
(1943) *J. Exp. Med.* 77, 265.
- Choudhuri, H. C. (1943) *Nature* 152, 475.
- Christensen, L. R. (1942) *J. Lab. Clin. Med.* 27, 799.
- Chu, H. J. (1938) *Proc. Soc. Exp. Biol. Med.* 38, 99.
- Clarke, G. and Schryver, S. B. (1917) *Biochem. J.* 11, 319.
- Claudatus, I. (1939) *Mikrochem.* 26, 305.
- Claude, A. (1938) *Proc. Soc. Exp. Biol. Med.* 39, 398.
(1938) *Science* 87, 467.
(1939) *Amer. J. Cancer* 37, 59.
(1939) *Science* 90, 213.
(1940) *ibid.* 91, 77.
(1941) *Cold Spring Harbor Symp. Quant. Biol.* 9, 263.

- Claude, A. (1943a) Science 97, 451.
(1943b) Biol. Symp. 10, 111.
- Cohen, S. S. (1942) J. Biol. Chem. 146, 471.
- Cohen, S. S. and Stanley, W. M. (1942) J. Biol. Chem. 142, 863.
(1942) *ibid.* 144, 589.
- Cohn, A. E. and Murray, H. A. (1925) J. Exp. Med. 42, 275.
(1927) Quart. Rev. Biol. 2, 469.
- Conway, E. J. and Cooke, R. (1937) Biochem. J. 33, 457.
- Cook, E. S. (1939) Chem. Products 1, 65; 2, 89.
- Cook, E. S. and Cronin, A. G. (1942) Nature 150, 94.
- Cook, E. S., Cronin, A. G., Kreke, C. W. and Walsh, T. W.
(1943) Nature 152, 474.
- Cook, E. S. and Fardon, J. C. (1942) Surgery, Gynaecology and
Obstetrics 75, 220.
- Cook, E. S., Hart, M. J. and Stimson, M. M. (1940)
Biochem. J. 34, 1580.
- Coleman, L. C. (1938) Stain Technol. 13, 123.
- Cowdry, E. V. (1918) Contrib. Embryol. (Carnegie Inst. Wash.)
8, 39.
- Craciun, E. C. (1931) La culture des tissus en biologie
experimentale. Manon et Cie, Paris.
- Cramer, W. (1916) J. Physiol. 50, 322.
- Cramer, W. and Pringle, H. (1910) Proc. Roy. Soc. 82, 307.
- Cunningham, B. and Kirk, P. L. (1942) J. Cell. Comp. Physiol.
20, 343.

- Dale, H. H. (1933) Bull. Johns Hopkins Hosp. 53, 297.
- Damodaran, M. and Ramachandran, B. U. (1941) Biochem. J. 35, 122.
- Dann, L., Glücksmann, A. and Tansley, K. (1940) Brit. J. Exp. Path. 22, 1.
(1941) *ibid.* 22, 70.
(1942) Lancet i, 95.
- Darlington, C. D. (1942) Nature 148, 66.
- Darlington, C. D. and LaCour, L. F. (1940) J. Genet. 40, 185.
(1942) The Handling of Chromosomes. London, Allen & Unwin.
- Davidson, J. N. (1940) Biochem. J. 34, 1537.
(1943) Edin. Med. J. 50, 70.
- Davidson, J. N. and Findlay, J. D. (1941) Chem. and Ind. 60, 617.
- Davidson, J. N. and Waymouth, C. (1942) Proc. Biochem. Soc.
(1943) Nature 152, 47.
(1943) Biochem. J. 37, 271.
(1943) J. Physiol. 102, 8P.
(1944) Biochem. J. 38, 39.
- Dawbarn, M. C. (1932) Aust. J. Exp. Biol. Med. Sci. 9, 213.
- Delaporte, B. (1939) Rev. gen. de bot. 51, 449.
- Delaporte, B. and Roukelman, N. (1938) C.r. Acad. Sci. 206, 1399.
- Delezenne, C. and Fourneau, E. (1914) Bull. Soc. chim. Fr. 15, 421.
- Desclin, L. (1940) C.r. Soc. Biol. 133, 457.

- Dell'Acqua, G. (1935) Biochem. Zeit. 279, 403.
- Deutsch, A., Eggleton, M. S. and Eggleton, P. (1938)
Biochem. J. 32, 203.
- Dhere, C. (1906) C.r. Soc. Biol. 60, 34.
- Dickens, F. and Weil-Malherbe, H. (1943) Can. Res. 3, 73.
- Dimler, R. J. and Link, K. P. (1943) J. Biol. Chem. 150, 345.
- Dische, Z. (1930) Mikrochem. 8, 4.
(1938) Naturwiss. 26, 252.
- Dische, Z. and Schwartz, K. (1937) Mikrochim. Acta 2, 15.
- Doljanski, L. and Auerbach, E. (1944) Proc. Soc. Exp. Biol.
Med. 55, 112.
- Doljanski, L. and Hoffman, R. S. (1939) C.r. Soc. Biol.
130, 1246.
(1943) Growth 7, 67.
- Doljanski, L., Hoffman, R. S. and Tenenbaum, E. (1939)
C.r. Soc. Biol. 131, 432.
(1942) Nature 150, 23.
- Donovan, H. and Woodhouse, D. L. (1943) Nature 152, 509.
- Dounce, A. L. (1943) J. Biol. Chem. 147, 685.
(1943) *ibid.* 151, 221.
(1943) *ibid.* 151, 235.
- Drummond, J. C. (1916) Biochem. J. 10, 473.
- Drury, A. N. (1936) Physiol. Rev. 16, 292.
- Dubos, R. J. and MacLeod, C. A. (1938) J. Exp. Med. 67, 791.
- Dubos, R. J. and Thompson, R. H. S. (1938) J. Biol. Chem.
124, 501.
- Dubos, R. J. (1942) Ann. Rev. Biochem. 11, 659.
- Dumm, M. E. (1943) J. Cell. Comp. Physiol. 21, 27.
- Duthie, E. S. and Chain, E. (1939) Brit. J. Exp. Path.
20, 417.
- Dvorak, H. J. and Byram, J. W. (1941) Z. Krebsforsch. 51, 193.

Earle, W. R. and Voegtlin, C. (1938) Amer. J. Cancer
34, 373.

(1940) U.S. Public Health Rep. 55, 303.

Ebeling, A. H. (1913) J. Exp. Med. 17, 273.

(1914) *ibid.* 20, 130.

(1921) *ibid.* 34, 231.

(1922) *ibid.* 35, 657.

(1922) *ibid.* 35, 755.

(1924) C.r. Soc. Biol. 90, 31.

(1924) *ibid.* 90, 562.

Ebeling, A. H. and Fischer, A. (1922) J. Exp. Med. 36, 285.

Edlbacher, S. and Jucker, P. (1936) Z. physiol. Chem. 240, 78.

Edlbacher, S. and Kutscher, W. (1931) Z. physiol. Chem.
199, 200.

Edwards, F. R., Kay, J. and Davie, T. B. (1940) Brit. Med. J.
i, 377.

Eggleton, M. G., Richardson, K. C., Schild, H. O. and
Winton, F. R. (1942) Brit. Med. J. ii, 392.

Egorov, N. (1943) Science 97, 162.

Eiler, J. and Allen, F. W. (1935) Proc. Soc. Exp. Biol. Med.
33, 208.

(1938) J. Biol. Chem. 123, 655.

(1941) Proc. Soc. Exp. Biol. Med. 46, 436.

- Eiler, J. J. and Schmidt, G. (1941) Proc. Soc. Exp. Biol. Med. 46, 436.
- Ellis, E. L. (1934) J. Comp. Cell. Physiol. 4, 127.
- Emden, G. and Zimmermann, M. (1927) Z. physiol. Chem. 167, 137.
- Emmerie, A. (1938) Nature, 141, 416.
- English, J. (1941) J. Amer. Chem. Soc. 63, 941.
- English, J. and Bonner, J. (1937) J. Biol. Chem. 121, 791.
- English, J., Bonner, J. and HaagenSmit, A. J. (1939) Proc. Nat. Acad. Sci. 25, 323.
- (1939) Science 90, 329.
- (1939) J. Amer. Chem. Soc. 61, 3434.
- Enselme, J. and Enselme, J. (1927) C. R. Acad. Sci. 184, 1353.
- Ephrussi, B. (1931) C.r. Soc. Biol. 106, 274, 546.
- Erdos, J. (1942) Science 96, 141.
- Euler, H. v., Ahlström, L. and Högberg, B. (1942). Arkiv. Kemi. Min. Geol. 16A, No. 5.
- Euler, H. v. and Schmidt, G. (1934) Z. physiol. Chem. 223, 215.
- (1934) ibid. 225, 92.
- * Euler, H. v. and Petterson, I. (1941) Z. Krebsforsch. 51, 193.

~~Exxxxxxxxx~~

- Fankuchen, I. (1940-41) J. Gen. Physiol. 24, 315.
- Fardon, J. C., Norris, R. J., Loofbourow, J. R. and Ruddy, M. V. (1937) Nature 139, 589.
- Fardon, J. C. and Sullivan, W. A. (1938) Stud. Inst. Divi Thomae 2, 39.

- Fardon, J. C., Sullivan, W. A. and Andrus, M. B. (1938)
Stud. Inst. Divi Thomae, 2, 233.
- Fearon, W. A. (1942) Brit. Med. J. ii, 95.
- Felix, K. and Harteneck, A. (1926) Z. physiol. Chem. 157, 76.
- Feulgen, R. (1919-20) Z. physiol. Chem. 108, 147.
- Feulgen, R. and Behrens, M. (1938) *ibid.* 256, 15.
- Feulgen, R., Behrens, M. and Mahdihassan, S. (1937)
ibid. 246, 203.
- Feulgen, R. and Bersin, T. (1939) *ibid.* 260, 217.
- Feulgen, R. and Grunberg, H. (1939) *ibid.* 257, 161.
- Feulgen, R. and Rossenbeck, H. (1924) *ibid.* 135, 203.
- Feulgen, R. and Voit, K. (1924) *ibid.* 137, 272.
- Fischer, A. (1922) J. Exp. Med. 35, 367.
- (1924) *ibid.* 39, 577.
- (1925) Act. Path. Scand. 7, 1.
- (1925) Arch. f. exp. Zellforsch. 1, 122.
- (1925) *ibid.* 1, 369.
- (1925) Tissue Culture, Levin & Monksgaard,
Copenhagen.
- (1930) Gewebezuchtung, Muller & Steinicke,
Munche.
- (1930) Virchow's Arch. 279, 94.
- (1936) Protoplasma 26, 51.
- (1936) *ibid.* 26, 344.
- (1939) Nature 144, 113.
- (1940) Chem. Products 3, 79.
- (1941^a) Acta Physiol. Scand. 2, 143.
- (1941^b) *ibid.* 3, 54.
- (1942^a) *ibid.* 4, 207.
- (1942^b) Naturwiss. 30, 665.

- Fischer, A. and Astrup, T. (1939) Arch. exp. Zellforsch. 23, 77.
(1942) Pflüger's Arch. ges. Physiol. 245, 633.
- Fischer, A. and Demuth, F. (1927) Arch. exp. Zellforsch. 5, 131.
- Fischer, A. and Parker, R. C. (1929) Brit. J. Exp. Path. 10, 312.
- Fischer, F. G. (1942) Naturwiss. 30, 382.
- Fischer, F. G., Böttger, I. and Lehmann-Echternacht, H. (1941) Z. physiol. Chem. 271, 246.
- Fischer, F. G., Lehmann-Echternacht, H. and Böttger, I. (1941) J. pr. Chem. (ii), 158, 79.
- Fischer, F. G., Wehmeier, E., Lehmann, H., Jühling, L. and Hultzsck, K. (1935) Ber. dtsh. chem. Ges. 68, 1196.
- Fleischmann, W. (1939) Cold Spring Harbor Symp. Quant. Biol. 7, 290.
- Flock, E., Bollman, J. L. and Mann, F. C. (1936) J. Biol. Chem. 115, 179.
- Flosdorf, E. W. and Mudd, S. (1935) J. Immunol. 29, 389.
- Fowler, O. M. (1937) J. Exp. Zool. 76, 235.
- Friedheim, E. A. H. (1929) C.r. Soc. Biol. 101, 1039.
- Freud, J., Laqueur, E. and Myhlboch, O. (1939) Ann. Rev. Biochem. 8, 305.
- Frey, E. K., Kraut, A. and Schultz, F. (1930) Arch. exp. Bath. Pharmakol. 158, 334.
- Frey, E. K. (1932) Arch. exp. Path. Pharmakol. 167, 64.
- Fujiwara, T., Nakahara, W. and Kishi, S. (1937) Gann (Japanese Journal of Cancer Research) 31, 51.
- Fletcher, W. E., Gulland, J. M., ~~and~~ Jordan, D. O. and Dibben, H. E. (1944) J. Chem. Soc. 30.
- Fletcher, W. E., Gulland, J. M. and Jordan, D. O. (1944) *ibid.* 33.

*

Gaillard, P. J. (1932) Ber. u. d. wiss. Biol. 20, 659.

Gatty-Kostyal, M. and Tesarz, J. (1936) Wiadom. Farm. 63, 213.

Gaza, W. v. and Gissel, H. (1932) Arch. klin. Chir. 170, 3.

Gersh, I. (1932) Anat. Rec. 53, 309.

(1941) Physiol. Rev. 21, 242.

(1943) quoted by Mirsky (1943).

Gersh, I. and Bodian, D. (1943) Biol. Symp. 10, 163.

Gey, G. O. (1933) Amer. J. Cancer 17, 752.

Gey, G. O. and Gey, M. K. (1936) Amer. J. Cancer 27, 45.

Giersch, C. and Cook, E. S. (1941) Nature 148, 754.

Godfried, E. G. (1939) Biochem. J. 33, 955.

Gortner, A. (1930) Trans. Faraday Soc. 26, 678.

Graff, S. and Barth, L. G. (1938) Cold Spring Harbor Symp. 6, 103.

Graff, S. and Maculla, A. (1935) J. Biol. Chem. 110, 71.

Gralen, N. and Svedberg, T. (1938) Biochem. J. 32, 1375.

Green, H. N. (1943) Lancet ii, 147.

Green, R. D. and Black, A. (1937) J. Amer. Chem. Soc. 59, 1820.

Greenstein, J. P. (1942) J. Nat. Can. Inst. 2, 357.

(1942) *ibid.* 2, 511.

Greenstein, J. P. and Andervont, H. B. (1942) J. Nat. Can. Inst. 2, 345.

Greenstein, J. P. and Jenrette, W. V. (1940) J. Nat. Can. Inst. 1, 77.

(1940) *ibid.* 1, 91.

(1941) *ibid.* 1, 841.

(1941) *ibid.* 2, 301.

(1941) Cold Spring Harbor Symp. Quant. Biol. 9, 236.

Greenstein, J. P., Thompson, J. W. and Jenrette, W. V. (1940) J. Nat. Can. Inst. 1, 367.

Greenstein, J. P., Turner, F. C. and Jenrette, W. V. (1940) J. Nat. Can. Inst. 1, 377.

- Sachs, D. (1934) Arch. exp. Zellforsch. 15, 179.
- Saha, K. C. and Ghosh, N. C. (1941) Ann. Biochem. Exp. Med. 1, 151.
- Saiki, T. (1909-10) J. Biol. Chem. 7, 23.
- Salle, A. J. and Strechmeister, I. L. (1936) Proc. Soc. Exp. Biol. Med. 34, 603.
- Schloss, W. (1928) Arch. klin. Chir. 151, 701.
- Schlenk, F. (1942) J. Biol. Chem. 146, 619.
- Schmidt, G. and Levene, P. A. (1938) J. Biol. Chem. 126, 423.
- Schmidt, G. and Tannhauser, S. J. (1943) J. Biol. Chem. 149, 369.
- Schramm, G. (1941) Ber. 74B, 532.
- Schultz, J. (1941) Cold Spring Harbor Symp. Quant. Biol. 9, 55.
(1941) Proc. 7th Internat. Genet. Congr. Edin. 1939, Aug. 23-30, p. 257-262.
- Schultz, J. and Caspersson, T. (1938) Arch. exp. Zellforsch. 22, 650.
- Seifriz, W. (1942) A symposium on the structure of protoplasm, Ames, Iowa (Iowa State College Press).
- Semmens, C. S. (1940) Nature 146, 130.
- Sémura, S. (1931) Arch. exp. Zellforsch. 10, 329.
(1932) *ibid.* 11, 545.
- Sevag, M. G., Lackman, D. B. and Smolens, J. (1938) J. Biol. Chem. 124, 425.
- Sevag, M. G. and Smolens, J. (1941) J. Biol. Chem. 140, 833.
- Sevag, M. G., Smolens, J. and Lackman, D. B. (1940) J. Biol. Chem. 134, 523.
- Sevag, M. G., Smolens, J. and Stern, K. G. (1941) J. Biol. Chem. 139, 925.
- Shearer, C. (1922) Proc. Roy. Soc. B. 93, 213.
- Shibata, T. (1929) Arch. exp. Zellforsch. 8, 291.
- Shipp, M. E. and Hetherington, D. C. (1936-37) Proc. Soc. Exp. Biol. Med. 35, 180.
- Shukoff, R. I. (1942) Nature 150, 461.

- Signer, R., Caspersson, T. and Hammarsten, E. (1938) Nature 141, 122.
- Simms, H. S. and Stillman, N. P. (1937a) J. Gen. Physiol. 20, 603.
- (1937b) *ibid.* 20, 621.
- (1937c) *ibid.* 20, 649.
- Singer, E. and Hoder, F. (1929) Arch. exp. Zellforsch. 8, 447.
- Slotta, K. H. and Forster, W. (1938) Ber. 71B, 1082.
- Slotta, K. H., Forster, W. and Fraenkel-Conrat, H. L. (1938) Ber. 71B, 1623.
- Slotta, K. H. and Fraenkel-Conrat, H. L. (1938a) Nature 142, 213.
- (1938b) Ber. 71B, 1076.
- Slotta, K. H. and Szyszka, G. (1938) Ber. 71B, 258.
- Smolens, J. and Sevag, M. G. (1942) J. Gen. Physiol. 26, 11.
- Smyth, H. F. (1914) J. Med. Res. 31, 255.
- Sperti, G. S., Loofbourow, J. R. and Dwyer, C. M. (1937) Stud. Inst. Divi Thomae 1, 163.
- (1937) Nature 140, 643.
- Stanley, W. M. (1939) J. Biol. Chem. 129, 405.
- (1942) J. Gen. Physiol. 25, 881.
- Stanley, W. M. and Knight, C. A. (1941) Cold Spring Harbor Symp. Quant. Biol. 9, 255.
- Stedman, E. and Stedman, E. (1943a) Nature 152, 267.
- (1943b) *ibid.* 152, 503.
- (1943c) *ibid.* 152, 556.
- (1944) *ibid.* 153, 500.
- Stern, K. G. (1943) Biol. Symp. 10, 291.
- Stern, K. and Willheim, R. (1934) Biochem. Zeit. 272, 180.
- Studel, H. (1935) Z. physiol. Chem. 231, 273.
- (1936) Z. physiol. Chem. 241, 84.
- Studel, H. and Brigl, G. (1910) Z. physiol. Chem. 68, 40.
- Studel, H. and Peiser, E. (1922) Z. physiol. Chem. 120, 292.

Stiven, D. (1930) Biochem. J. 24, 172.

Stone, W. E. (1943) J. Biol. Chem. 149, 29.

Stoneburg, C. A. (1939) J. Biol. Chem. 129, 189.

Stowell, R. E. (1942) J. Nat. Can. Inst. 3, 111.

Strangeways, T. S. P. (1924) The Technique of Tissue Culture
in vitro, Cambridge, Heffer & Sons.

SubbaRow, Y. (1942) Current Sci. 11, 311.

Sugiura, K. and Rhoads, C. P. (1941) Can. Res. 1, 3.

(1942) *ibid.* 2, 453.

Sulkin, N. M. (1943) Anat. Rec. 73, 107.

Swezy, O. (1915) Biol. Bull. 28, 47.

Taylor, A. R. and Beard, J. W. (1940) Science 92, 612.

~~Taylor, A. R., Sharp, D. G., Beard, D. and Beard, J. W.
(1941)~~

Taylor, A. R., Beard, D., Sharp, D. G. and Beard, J. W.
(1942) J. Infect. Dis. 71, 110.

Taylor, A. R., Sharp, D. G., Beard, D. and Beard, J. W.
(1941) Science 94, 613.

(1942) J. Infect. Dis. 71, 115.

(1943) *ibid.* 72, 31.

Taylor, A. R., Sharp, D. G., Finkelstein, H. and Beard, J. W.
(1939) Proc. Soc. Exp. Biol. Med. 42, 462.

Taylor, A. R., Sharp, D. G. and Woodhall, B. (1943) Science
97, 226.

* Tazima, M. (1940) Tohoko J. Exp. Med. 38, 8.

Teorell, T. and Norberg, B. (1932) Biochem. Zeit. 249, 53.

Tennant, R. and Liebow, A. A. (1941) Yale J. Biol. Med. 13, 39.

(1942) *ibid.* 14, 553.

Tennant, R., Liebow, A. A. and Stern, K. G. (1941) Proc. Soc.
Exp. Biol. Med. 46, 18.

Tennant, R., Stern, K. G. and Liebow, A. A. (1942) Can. Res.
2, 218.

Thomas, P. and Berariu, C. (1924) C.R.Soc. Biol. 91, 1470.

Thomson, W. (1936) J. Hyg., Camb. 36, 24.

Tichmeneff, N. (1914) Biochem. Z. 59, 326.

* Timofeivski, A. and Benevolenskaia, A. (1927) Ber. Wiss. Biol. 5, 685.

de Tomasi, J. A. (1936) Stain Technol. 11, 137.

Törö, I. (1937) Zeit. mikr. anat. Forsch. 41, 1.

(1938-39) Arch. exp. Zellforsch. 22, 304.

Trethewie, E. R. (1942) Aust. J. Exp. Biol. Med. Sci. 20, 49.

Trowell, O. A. and Willmer, E. N. (1939) J. Exp. Biol. 16, 60.

Tuttle, L. W., Erf, L. A. and Lawrence, J. H. (1941)
J. Clin. Inves. 20, 57.

Wallach, B. (1925) G. v. Soc. Biol. 92, 1421.

Walton, A. J. (1934) J. Exp. Med. 29, 534.

Warburg, O. (1913) Pflüger's Arch. ges. Physiol. 154, 523.

(1926) Über den Stoffwechsel der Tumoren, Berlin.

Uber, F. M. and Ellis, V. R. (1941) J. Biol. Chem. 141, 229.

(1938) Ergeb. Enzymforsch. 7, 210.

Warburg, O. and Christian, W. (1938) Biochem. Zeit. 312, 152.

Warweg, E. and Stearns, S. (1935) J. Biol. Chem. 112, 507.

Wasteneys, H. and Horscock, H. (1934) J. Biol. Chem. 92, 1.

Waugh, F. G. (1940) Brit. Med. J. 1, 249.

(1941) Ibid. 11, 256.

Wahnefeld, B. (1927) Jahrb. Wiss. Bot. 35, 773.

Wells, E. G. (1912) J. Biol. Chem. 11, Proc. X.

(1925) Chemical Pathology 5th Ed. Philadelphia.
W. B. Saunders Co.

- Van Slyke, D. D. (1929) J. Biol. Chem. 83, 425.
- Verne, J. and Verne-Soubiran, A. (1939) C.r.Soc. Biol. 130, 1232.
- Voegtlin, C. (1934) Cold Spring Harbor Symp. 2, 84.
- White, A. (1937) Physiol. Rev. 17, 102.
- Vollmar, H. (1939) Arch. exp. Zellforsch. 23, 42.
- Vowles, R. B. (1940) Arkiv. Kemi. Mineral. Geol. 14B, No. 10.
- Widstrom, G. (1933) Biochem. Zeits. 268, 102.
- Wiesner, J. (1923) Biochem. Zeits. 163, 102.
- Wigglesworth, V. E. (1937) J. Exp. Med. 69, 102.
- Wilhelm, J. (1930) J. Biol. Chem. 95, 102.
- Willheim, B. (1935) Biochem. Zeits. 288, 102.
- Williamson, M. H. and G. G. (1937) Physiol. 17, 102.
- Willmer, E. H. (1932) J. Biol. Chem. 98, 102.
- (1935) J. Biol. Chem. 108, 102.
- (1938) J. Biol. Chem. 121, 102.
- Wallich, R. (1926) C.r.Soc. Biol. 95, 1481.
- Walton, A. J. (1914) J. Exp. Med. 20, 554.
- Warburg, O. (1913) Pflüger's Arch. ges. Physiol. 154, 599.
- Willmer, E. H. (1926) "Über den Stoffwechsel der Tumoren, Berlin.
- Willmer, E. H. (1938) Ergeb. Enzymforsch. 7, 210.
- Warburg, O. and Christian, W. (1938) Biochem. Zeit. 298, 150.
- Warweg, E. and Stearns, G. (1936) J. Biol. Chem. 115, 507.
- Wasteneys, H. and Borsook, H. (1924) J. Biol. Chem. 62, 1.
- Waugh, W. G. (1940) Brit. Med. J. i, 249.
- Wilson, H. (1941) *ibid.* ii, 236.
- Wehnelt, B. (1927) Jahrb. wiss. Bot. 66, 773.
- Wells, H. G. (1912) J. Biol. Chem. 11, Proc. X.
- (1925) Chemical Pathology 5th Ed. Philadelphia.
W. B. Saunders Co.

- Wells, H. G. and Long, E. R. (1913) Z. Krebsforsch. 12, 598.
- Werner, H. and Doljanski, L. (1942) Nature 150, 660.
- West, P. M. and Woglom, W. H. (1941) Science 93, 525.
(1942) Cancer Res. 2, 324.
- White, A. and Sayers, M. A. (1942) Proc. Soc. Exp. Biol. 51, 270.
- White, M. J. D. (1942) The Chromosomes (2nd Edit.) Methuen.
- Widström, G. (1928) Biochem. Zeit. 199, 298.
- Wiesner, J. (1892) Elementarstruktur, Wien, p. 102.
- Wigglesworth, V. B. (1937) J. Exp. Biol. 14, 364.
- Wilhelm, J. (1930) Jahrb. wiss. Bot. 72, 203.
- Willheim, R. (1925) Biochem. Z. 163, 489.
- Williamson, M. B. and Gulick, A. (1942) J. Cell. Comp. Physiol. 20, 116.
- Willmer, E. N. (1928) Biol. Rev. 3, 271.
(1935) Tissue Culture, London, Methuen.
(1942a) J. Exp. Biol. 18, 237.
(1942b) 19th Ann. Rep. Brit. Emp. Can. Campaign, p. 53.
(1943) 20th Ann. Rep. Brit. Emp. Can. Campaign, p. 60.
- Willmer, E. N. and Kendal, L. P. (1932) J. Exp. Biol. 9, 149.
- Willmer, E. N. and Wallersteiner, K. (1939) J. Physiol. 96, 16P.
- Williams, R. J. (1941) Biol. Rev. 16, 49.
- Williams, R. J., Eakin, R. E. and Snell, E. E. (1940) J. Amer. Chem. Soc. 62, 1204.
- Williams, R. J. and Saunders, D. H. (1934) Biochem. J. 28, 1887.
- Wilson, H., Jackson, E. B. and Brues, A. M. (1942) J. Gen. Physiol. 25, 689.
- Winter, L. B. (1927) Biochem. J. 21, 467.
- Winzler, R. J. and Burk, D. (1943) Cancer Research 3,
Wohlgemuth, J. (1902) Z. physiol. Chem. 37, 475.
(1903) Biochem. Centralblatt 1, 533.

- Wolter, B. (1913) Biochem. Zeit. 55, 260.
- Woodard, H. G. (1943) Can. Res. 3, 159.
- Wright, G. P. (1925a) J. Exp. Med. 43, 591.
(1925b) Brit. J. Exp. Path. 6, 279.
(1926) Proc. Soc. Exp. Biol. Med. 23, 603.
- Wyckoff, R. W. G., Ebeling, A. H. and Ter Louw (1932)
J. Morphol. Physiol. 53, 189.
- Wyckoff, R. W. G. and Luyet, B. J. (1931) Radiology 17, 1171.

- Young, F. G. (1938) Biochem. J. 32, 513.
(1941) Brit. Med. J. ii, 897.
(1942) J. Physiol. 100, 19P.
- Young, J. S., Fisher, J. A. and Young, M. (1941)
J. Path. Bact. 52, 225.

Zifferblatt, A. H. and Seelaus, H. C. (1931) Anat. Rec.
48, 367.

(1931) Ber. u. d. wiss. Biol. 18, 326.

Zakrzewski, Z. (1932) Arch. exp. Zellforsch. 13, 152.

THE EFFECT OF ULTRAVIOLET LIGHT
ON LIVING YEAST CELLS

BY

J. N. DAVIDSON

[FROM THE BIOCHEMICAL JOURNAL, Vol. XXXIV, No. 12, pp. 1537-1539, 1940]



CAMBRIDGE
AT THE UNIVERSITY PRESS

PRINTED IN GREAT BRITAIN



182. THE EFFECT OF ULTRAVIOLET LIGHT ON LIVING YEAST CELLS

By J. N. DAVIDSON

*From the Physiology Department, University College, Dundee,
The University of St Andrews*

(Received 11 October 1940)

IN recent communications, Loofbourow *et al.* [1938; 1939; 1940] state that living yeast cells, injured by ultraviolet light, liberate, possibly as a specific response to injury, substances which powerfully stimulate the growth of yeast. These substances they call "proliferation-promoting intercellular hormones" or wound hormones. They suggest, mainly on the basis of spectrographic evidence, that such substances are adenine-guanine nucleotide complexes.

Similar substances with the power of stimulating yeast growth were also obtained by ultraviolet irradiation of living cells of newts and of chick and rat embryos. Such substances from chick embryos are claimed to accelerate the growth of chick fibroblasts *in vitro*.

Loofbourow's conclusions concerning the chemical nature of the growth-promoting substances are based mainly on qualitative tests and on spectrographic evidence. It therefore seems desirable to carry out quantitative chemical analyses of the products released by yeast cells injured by ultraviolet irradiation.

150 g. fresh D.C.L. bakers' yeast (*Saccharomyces cerevisiae*) were washed twice on the centrifuge with 0.9% NaCl solution and were then suspended in 750 ml. of the same solution. The suspension was divided into three equal portions. One portion (*a*) was autoclaved at 120° for 20 min. Such treatment destroyed cell structure. The second portion (*b*) was exposed for 6 hr. at 13 cm. distance to ultraviolet light from a quartz mercury vapour lamp (3.5 amp., burner volts 150) by being repeatedly run through the rack of quartz tubes described by Stiven [1930] at such a rate that the temperature of the suspension never exceeded 40°. A third portion (*c*) was kept for the same time and at the same temperature as a control but without exposure to ultraviolet light.

The effect of irradiation was followed by withdrawing a drop of the suspension from time to time, treating it with methylene blue and examining microscopically. Living yeast cells are not stained by methylene blue while injured and dead cells stain deeply [Richards, 1932]. At the outset only 1% of the cells stained, but at the end of irradiation 60% stained. The cells were shrunken. In the control suspension 10% of the cells stained at the end of the period. In both cases the total number of cells, counted in a haemocytometer chamber, was unaltered.

The three suspensions were finally centrifuged and the clear supernatant fluid collected. The extract from the autoclaved suspension (*a*) was deep yellow in colour, that from the irradiated cells (*b*) yellow, while the extract from the control (*c*) was colourless. All showed a blue fluorescence in ultraviolet light, the control being only slightly fluorescent. All extracts were kept at 0° and analysed immediately, as they were, especially in the case of the extract from irradiated cells, excellent media for bacterial growth. Extract (*b*), which had pH 5.8, gave a positive biuret test but no precipitate on boiling or with nitric acid. It gave a precipitate with tungstic acid. Extract (*c*) from the control

gave a negative response to the biuret test and no precipitate with tungstic acid. Extract (a) from autoclaved cells was heavily loaded with protein.

In the three extracts total N was estimated by the micro-Kjeldahl procedure, amino-N by the manometric method of Van Slyke, non-protein-N after de-proteinization with tungstic acid, and nucleotide, nucleoside, and free purine-N by the method of Kerr & Blish [1932] as modified by Kerr [1940].

Several separate batches of yeast were treated in this way at different times and the results of a typical experiment are shown in Table 1.

Table 1. *Analyses of centrifuged extracts from autoclaved, irradiated and control cells*

Extract from ...	(a)	(b)	(c)
	Autoclaved cells mg./100 ml.	Irradiated cells mg./100 ml.	Control cells mg./100 ml.
Dry wt. (excluding NaCl)	1705	1164	280
Total N	148.4	104.9	12.6
Non-protein-N	72.8	96.2	10.5
Protein-N (by difference)	75.6	8.7	2.1
Amino-N (non-protein)	57.4	63.3	9.0
Nucleotide-N	11.8	11.8	0.4
Nucleoside- and free purine-N	2.9	9.4	1.4

Irradiation sets free a large amount of nitrogenous material. A very small amount is in the form of protein while a high proportion is present as amino-N. Much more N than in the case of the control is present in the form of nucleotide, nucleoside and purine: Table 1 (b).

Complete destruction of the cells yields an extract with much protein. The non-protein-N is chiefly amino-N: Table 1 (a).

After treating the extract from irradiated cells with 10% sulphuric acid to hydrolyse nucleic acid derivatives after the method of Jones [1920], adenine was isolated both as the picrate and the sulphate. Small amounts of guanine were also found. Thus it is probable that the nucleotide and nucleoside fractions are chiefly adenine derivatives with small amounts of guanine present.

The growth-promoting powers of the three extracts were tested by seeding Reader's medium [Reader, 1927] with a dilute suspension of yeast cells. Varying amounts of the extracts were added to the media and the cultures grown at 21° in Erlenmeyer flasks as recommended by Williams & Saunders [1934] and by Narayanan [1930]. The crop was estimated after 20 hr. by counting the cells in a haemocytometer. At all concentrations extract (b) from irradiated cells had six times the growth-promoting power of the extract from the control. The irradiated suspension had six times as many cells injured as the control, suggesting a correlation between cell injury and liberation of growth-promoting material. The extract (a) from autoclaved cells stimulated growth as powerfully as extract (b) but, since the extract from autoclaved cells contained more solid matter, weight for weight the material from the irradiated cells was more potent.

Extracts from irradiated and autoclaved cells had greater growth-promoting power than either inositol or aneurin.

DISCUSSION

A large number of substances can accelerate yeast growth, for example, such components of the bios group as inositol, aneurin, biotin, pantothenic acid and adermin. Other substances with similar properties are found in liver extracts

[Williams *et al.* 1940]. Amino-acids such as leucine [Miller, 1936], alanine, aspartic acid, glutamic acid, lysine and arginine stimulate yeast growth, and mixtures of these substances have a more pronounced effect than equivalent amounts of the acids alone [Nielsen & Hartelius, 1938; 1939]. Lysine and arginine are known to be plentiful in the proteins of yeast [Kraut & Schlottmann, 1937].

Such being the case, it is not surprising that rupture of yeast cells by autoclaving should liberate substances with growth-promoting properties towards yeast. Irradiation of yeast, however, yields a surprisingly potent extract without destruction of the cells. This extract has even more non-protein nitrogenous matter than the extract from autoclaved cells. The slow death of the yeast cell does seem to cause liberation of substances into the surrounding medium but it is impossible to say whether or not this is a specific response to injury and an attempt to compensate for the death of some cells by accelerated growth of others.

Among the nitrogenous materials are nucleotides and nucleosides containing adenine and it is highly probable that their presence accounts for the spectrographic findings of Loofbourow *et al.* But it seems premature to conclude that these adenine nucleotide complexes are necessarily the active principles in the extract from irradiated yeast which are responsible for stimulating the growth of yeast.

SUMMARY

Exposure of living yeast cells to ultraviolet light results, without disintegration of the cells, in the liberation of large amounts of nitrogenous material into the surrounding medium. This material has the property of stimulating yeast growth to a marked extent. Although the medium contains adenine nucleotide derivatives, these are not necessarily the growth-promoting principles.

I should like to express my thanks to Prof. R. C. Garry for his helpful encouragement, and to Mr B. L. Andrew and Mr J. D. Findlay for assistance in the analyses.

REFERENCES

- Jones (1920). *Nucleic acids*. London: Longmans, Green and Co.
 Kerr (1940). *J. biol. Chem.* **132**, 147.
 — & Blish (1932). *J. biol. Chem.* **98**, 193.
 Kraut & Schlottmann (1937). *Biochem. Z.* **291**, 406.
 Loofbourow, Cook & Stimson (1938). *Nature, Lond.*, **142**, 573.
 — & Lane (1939). *Arch. exp. Zellforsch.* **22**, 607.
 — Dwyer & Lane (1940). *Biochem. J.* **34**, 432.
 Miller (1936). *Trans. roy. Soc. Can.* (iii), **30**, III, 99.
 Narayanan (1930). *Biochem. J.* **24**, 6.
 Nielsen & Hartelius (1938). *Biochem. Z.* **295**, 211.
 — (1939). *Biochem. Z.* **301**, 125.
 Reader (1927). *Biochem. J.* **21**, 904.
 Richards (1932). *Arch. Protistenk.* **78**, 263.
 Stiven (1930). *Biochem. J.* **24**, 172.
 Williams, Eakin & Snell (1940). *J. Amer. chem. Soc.* **62**, 1204.
 — & Saunders (1934). *Biochem. J.* **28**, 1887.

The *Biochemical Journal* is conducted by the Biochemical Society and is published by the Cambridge University Press.

This Society has been instituted solely for the advancement of the Science of Biochemistry. Persons interested in Biochemistry are eligible for election.

Meetings are held at different centres for the communication of papers to the Society.

Members are entitled to receive a copy of the *Journal*. Further information as to the conditions of membership may be obtained on application to the Hon. Secs., Dr F. G. Young, National Institute for Medical Research, Hampstead, N.W. 3 or Dr W. T. J. Morgan, Lister Institute, Chelsea Bridge Road, S.W. 1, or to the Hon. Treas., Mr J. Addyman Gardner, 35 Bullingham Mansions, Church Street, London, W. 8, to whom subscriptions should be sent.

Papers for publication should be sent to Prof. C. R. Harington, F.R.S., University College Hospital Medical School, University Street, London, W.C. 1. Communications respecting the printing of the articles, or respecting the purchase of offprints should be addressed to the University Press, Cambridge.

The *Journal* is issued in monthly numbers and the date at which each paper is received is printed at the beginning of the paper.

All communications respecting the purchase of copies of the parts or volumes, whether current or back issues, or respecting subscriptions in the case of non-members of the Biochemical Society (£3. 10s. 0d. net per volume (post free) payable in advance) should be addressed to The Cambridge University Press, Bentley House, 200 Euston Road, London, N.W. 1, or to the Hon. Treas., Mr J. Addyman Gardner, 35 Bullingham Mansions, Church Street, London, W. 8. For prices of back numbers and volumes see list on p. 4 of Wrapper.

Quotations can be given for Buckram binding cases and for binding Subscribers' Sets.

The Cambridge University Press has appointed the University of Chicago Press agent for the sale of the *Biochemical Journal* in the United States of America.

Wound Hormones

BY

J. N. DAVIDSON, B.Sc., M.D.

Lecturer in Biochemistry, The University of Aberdeen

Reprinted from the EDINBURGH MEDICAL JOURNAL, Vol. L., p. 70, 1943



WOUND HORMONES

By J. N. DAVIDSON, B.Sc., M.D.

Lecturer in Biochemistry, The University of Aberdeen

I. Introduction

THE suggestion that injured cells liberate substances, for which the name "wound hormones" has been proposed, which stimulate cellular proliferation in the neighbourhood of the injury, has given rise to much speculation and to a considerable volume of experimental work. Although the wound hormone hypothesis was first postulated by Wiesner in 1892 in connection with plant tissues, and although the most clear-cut results in this field have been obtained with botanical material, attempts have been made to extend the hypothesis to animal tissues and to apply it to the healing of wounds in animals and in man. Of the several biologically active substances which may possibly be liberated by damaged living cells, *e.g.* histamine, thrombokinase, "leucotaxine," the permeability-promoting polypeptide discovered by Menkin (1940) in inflammatory exudates, factors responsible for or associated with impairment of renal function after crush injuries (Bywaters and Beall, 1941; Eggleton *et al.*, 1942), and the adenylyl compound produced as the result of tissue injury by trypsin (Trethewie, 1942), none can be regarded as falling into the category of wound hormones. It is undoubtedly attractive to suppose that living cells can actually elaborate as a specific response to injury an agent or agents which might play a part in initiating the early stages of wound healing by causing proliferation of intact cells. Although there is no doubt that injured cells can and do set free nitrogenous material, it is difficult to prove that this material is other than disintegration products of dying and dead cells. Much of the experimental evidence is not easy to interpret, and the conclusions must of necessity be rather speculative. An attempt is here made to examine critically from the biochemical point of view the evidence put forward in favour of the wound hormone hypothesis.

II. Plant Wound Hormones

Wiesner's original suggestion was made as the result of observations on the proliferation of plant cells in the neighbourhood of injuries, and the problem was subsequently taken up

Wound Hormones

by other workers including Haberlandt (1921, 1922) and Reiche (1924), who investigated the repair of plant wounds to which crushed plant tissues had been applied. The results of these investigations left no doubt that when plant tissues are injured substances are produced which can, under suitable circumstances, stimulate renewed growth and proliferation of uninjured mature cells in the neighbourhood (English and Bonner, 1937). These so-called "wound hormones" have the power of producing intumescence due to cell proliferation and enlargement in the parenchymatous lining of the seed chambers of young string bean pods (Wehnelt, 1927), and this fact is the basis of a method of quantitative physiological assay for wound hormones devised by Bonner and English (1937, 1938). As a measure of the wound hormone activity they use the height of intumescence produced which is known to be linearly proportional to the concentration of the wound hormone solution expressed in terms of arbitrary units. The test is not given by other substances such as vitamins, growth-promoting substances or auxins, unless they are used in sufficiently toxic concentrations to cause injury to the test cells with liberation of wound hormones themselves. For the isolation from plant tissue of the wound hormone, for which the name "traumatin" has been proposed (English and Bonner, 1937), bean pods were used as starting material, and as the result of a lengthy process involving extraction with water, acetone, ethyl acetate and chloroform, precipitation as barium salt, and the formation of a methyl ester, the wound hormone was isolated in the pure state. After hydrolysis, a crystalline dibasic acid was obtained, $C_{12}H_{20}O_4$, m.p. 165.5° - 166° , to which the name "traumatic acid" was applied (English, Bonner and Haagen-Smit, 1939). A ten-thousandth of a milligram of the pure acid can promote cell division and enlargement in the tissue of the bean mesocarp, and the activity is greatly enhanced by the presence of co-factors such as glutamic acid and sucrose, which themselves possess little or no activity. Traumatic acid also promotes wound periderm formation in the potato and inhibits germination of tomato and other seeds.

The structure of traumatic acid was elucidated by English, Bonner and Haagen-Smit (1939), who showed it to be Δ^1 -decene-1:10-dicarboxylic acid $HOOC-CH=CH-[CH_2]_8-COOH$, and confirmed its constitution by synthesis. English (1941) has recently synthesised some of its analogues, such as Δ^5 -undecene-1:11-dicarboxylic acid and $\Delta^{1,7}$ -octadiene-1:8-dicarboxylic acid,

J. N. Davidson

and demonstrated that they also have wound hormone activity as shown in the bean test.

III. Evidence from Yeast

An approach to the problem from a different angle has been made in America in a long series of papers by Loofbourow and his colleagues (1938-1942), who have exposed living yeast cells to a number of injurious agencies which, they claim, cause the cells to release into the surrounding medium factors termed "proliferation-promoting intercellular hormones" or wound hormones, which cause marked stimulation of the growth of fresh yeast cells.

The destructive effects of irradiation on cells and tissues are well known and have recently been reviewed by Laurens (1941) and by Harvey (1942). In the hands of the American workers ultraviolet irradiation of living yeast cells has formed a very convenient method of injuring the cells without either causing gross mechanical damage or adding any chemical agent which would subsequently complicate growth tests and chemical analyses. Suspensions of *Saccharomyces cerevisiae* in water or a suitable saline medium were exposed to ultraviolet light for several hours till the bulk of the cells were killed, as shown by appropriate staining reactions. Unlike bacteria, yeast cells can be injured without being killed outright by ultraviolet irradiation (Wyckoff and Luyet, 1931). Cell-free extracts from such suspensions when added to cultures of fresh uninjured yeast cells in Reader's saline medium, caused very pronounced stimulation of cell proliferation, which was much more marked than in the case of cultures to which cell-free extracts of control (non-irradiated) cells had been added (Fardon *et al.*, 1937; Sperti, Loofbourow and Dwyer, 1937). The growth-promoting factors produced by the irradiated yeast cells were stable to heat.

Similar thermostable substances were also shown to be produced as the result of injury by chemical agents, *e.g.* β -indolylacetic acid, by mechanical means, by heat and by X-rays. Moreover, ultraviolet irradiation of bacteria (Loofbourow and Morgan, 1940) and of algæ (Giersch and Cook, 1941) also resulted in the liberation of growth-promoting factors.

Evidence as to the chemical nature of the materials liberated by the cells exposed to ultraviolet light was provided by spectrographic methods. The ultraviolet absorption spectrum of the

Wound Hormones

materials showed a maximum at 2600 Å (and a minimum at 2360 Å), characteristic of purines and pyrimidines of the nucleic acid complexes. Chemical tests revealed the presence of adenine, guanine, pentose and phosphorus and the absence of protein, pyridine and sulphur, and the suggestion was therefore put forward that the proliferation-promoting factors consisted of nucleic acid-like substances of the pentose nucleotide type. In subsequent experiments an increased yield of nucleic acid-like substances was obtained from the irradiated suspensions, and photomicrographs taken with the aid of a quartz microscope revealed a progressive increase in the ultraviolet absorption of the cells during irradiation, the wavelengths employed being in the range highly absorbed by purines and pyrimidines (Loofbourow *et al.*, 1938-42).

The fact that living yeast cells exposed to ultraviolet light liberate into the surrounding medium materials which stimulate yeast growth was confirmed by Davidson (1940), who carried out analyses of cell-free extracts from irradiated yeast cells, control cells, and cells which had been destroyed by autoclaving with rupture of the cell walls and liberation of intracellular materials. It was evident that the irradiated cells liberated into the surrounding medium without rupture of the cell walls a surprisingly large amount of nitrogenous material, most of it as protein breakdown products with a high proportion of amino nitrogen. As might be expected, the material from the autoclaved cells was rather richer in nitrogen, about 50 per cent. of which was present as protein.

About 20 per cent. of the nitrogen in the material from the irradiated cells and about 10 per cent. in the material from autoclaved cells was in the form of nucleotides or nucleosides. It seems probable that the presence of these compounds could account for the spectrographic findings of Loofbourow *et al.*, but there is no direct evidence either that these compounds are responsible for the intense proliferation-promoting power, or that they are elaborated by the cells as a specific response to injury.

Two possibilities must be considered. The nitrogenous materials may be merely disintegration products of the dying and dead cells, liberated, however, without rupture of the cell membrane, or the effect of the injury may be to alter the permeability of the cell membrane so that some of the cell contents escape. In either case the material from the irradiated cells

J. N. Davidson

might be expected to be qualitatively similar to that from autoclaved cells, but to be less in quantity. This, however, is not the case. Davidson and Findlay (1940) found that the organic material from irradiated cells was weight for weight more potent as a growth factor than the material from autoclaved cells, and much more so than the material from control cells. They also found that the material from irradiated yeast cells gave, in contrast to that from autoclaved cells, strongly positive tests for sulphhydryl groups. Similar positive sulphhydryl tests were obtained by Pourbaix and Kennaway (1928) on extracts of yeast cells which had been exposed to the injurious influence of ultraviolet light, heat, grinding, freezing and thawing and certain chemical agents. The biological activity of sulphhydryl compounds is well known, and their growth-promoting action has already been reviewed by Hammett (1934, 1936) and by Riley (1940), but the extent to which the growth-promoting power of the extracts from irradiated cells is due to $-SH$ compounds is unknown.

In contrast to the results of Loofbourow *et al.*, Davidson and Findlay (1941) found that X-rays even in doses up to 100,000 r appeared to liberate no appreciable amounts of nitrogenous material from living yeast cells, nor did extracts from such cells have any greater growth-promoting power towards yeast than had extracts of control cells. This is in agreement with the findings of Pourbaix and Kennaway (1928). According to Henshaw and Turkowitz (1940), yeast cells are either unaffected by Röntgen rays or are killed outright rather than injured if the dosage is very high.

It is important to stress the fact that a large number of substances are known which stimulate the growth of yeast even in minute concentrations. These substances include amino acids (Mitchell and Williams, 1940), and the large group of compounds belonging to the bios group recently reviewed by Williams (1941). Many such substances must obviously be present in the nitrogenous material from the irradiated cells and must account in part at least for its growth-promoting activity. Cook, Hart and Stimson (1940), as the result of investigations on bios fractions obtained from yeast, suggest either that the proliferants produced as a response to injury differ in nature from proliferants of the normal bios type or that predominance of a certain fraction of proliferants results from injury. More recently Cook and Cronin (1942) have shown that when yeast is grown in a saline medium

Wound Hormones

supplemented by inositol, thiamin, pantothenic acid, biotin, pyridoxin, riboflavin, uracil, choline, acetyl choline, ethanolamine, nicotinic acid, *p*-aminobenzoic acid and twenty different amino acids, the addition of cell-free extracts from irradiated yeast cells was still able to bring about increased proliferation, and the extracts therefore appeared to contain materials differing from all the known yeast growth-promoting substances.

Some of the known components of the bios complex are undoubtedly present in the materials from irradiated yeast cells which have been shown (Loofbourow, 1942) to contain appreciable quantities of biotin, pantothenic acid, pyridoxin, nicotinic acid and folic acid, while these substances are absent from the extracts from control cells. Moreover, the addition of adenosine, muscle adenylic acid and adenylyl pyrophosphate to well supplemented media, brings about stimulation of the growth of yeast which is in some ways comparable with that produced by the material from irradiated cells.

Other adenine compounds, the diphospho- and triphosphopyridine nucleotides, have so far proved to be absent from the wound hormone preparations (Loofbourow, Webb, Loofbourow and Abramowitz, 1942) and the proliferation-promoting activity of the preparations is apparently not concerned with the effect of these nucleotides on cellular respiration. It may, however, be significant that the increased growth-promoting activity of materials from injured cells over those from control cells can only be manifested if the test cultures to which the materials are added are well aerated (Loofbourow *et al.*, 1942).

An attempt to determine whether the nitrogenous material from irradiated yeast cells is (*a*) the result of the release of dead cell disintegration products, (*b*) due to increased permeability of the cell membrane, or (*c*) synthesised as the result of a specific response to injury was made by Loofbourow, Dwyer and Cronin (1941). They found—

1. That when the cells were irradiated in such a way that 90 per cent. were killed, the yield of proliferants was proportional, within limits, to the time of exposure to the injurious influence, and the activity therefore did not depend on the number of cells killed.

2. That the yield of active material from cells irradiated while suspended in various media, was greatest when the medium contained materials useful to the cell in its metabolism, such as carbohydrate, nitrogenous substances, phosphates, etc.

3. That cells irradiated and then destroyed mechanically or by heat yielded more growth-promoting substance than cells irradiated after being destroyed. They suggest that these results favour the hypothesis that the growth-promoting factor is probably a product synthesised by the living cell.

IV. Evidence from Animal Tissues *in vitro*

Stimulation of the growth of yeast is caused not only by extracts of irradiated yeast cells but also by extracts from irradiated animal tissues. Loofbourow, Dwyer and Lane (1940) have claimed that when the cells of newt, chick and rat embryos are irradiated thermostable materials stimulating yeast growth are produced. They appear to be chemically very similar to the materials obtained from irradiated yeast cells. It has also been claimed that similar factors from irradiated chick embryonic tissue stimulate the growth of chick heart fibroblasts in tissue culture to a greater extent than do extracts from non-irradiated embryos (Loofbourow, Cueto and Lane, 1938-39). In these experiments the embryonic tissues were submitted to such severe mechanical trauma before being irradiated or used as controls that the evidence in favour of the production of wound hormones as the result of irradiation is not altogether satisfactory.

Other evidence obtained from the use of tissue cultures has been put forward by Fischer (1930), who showed that the infliction of wounds on tissue cultures caused the production of substances which accelerated growth. Cultures which were repeatedly wounded mechanically grew more quickly than controls. If the colony consisted of old, vacuolated cells, the regenerating cells at the edge of the wound were fresh and unvacuolated. When the wound healed the new young cells took on the appearance of the old cells of the original culture.

Moreover, saline extracts of wounded tissue cultures were able to revive growth in other cultures in which growth was latent from lack of embryo juice. Fischer therefore concluded that the injured cells produced a chemical growth stimulant.

Cameron (1935) states that the growth of tissue cultures can also be stimulated by extracts from inflamed tissue, while Menkin (1941) has produced evidence that injured cells liberate one or possibly several proliferation-promoting factors into inflammatory exudates. When injections of sterile inflammatory exudates

Wound Hormones

were repeatedly made into the subcutis of a rabbit's ear over a long period of time, a severe inflammatory reaction resulted. Months after cessation of the injections, marked proliferative activity characterised by hyperplasia and metaplasia of the normal epithelial layer occurred. The cartilage of the ear at the site of the injections also showed marked proliferative activity. In some cases the proliferation response was definitely neoplastic in type. The nature of the substances liberated into inflammatory exudates by injured cells is unknown.

V. Wounds in the Intact Organism

Direct evidence of the production of growth-promoting substances when the intact organism is injured locally or generally is much more difficult to obtain. As the result of observations on the healing of wounds in an insect, *Rhodnius prolixus* Hemiptera, Wigglesworth (1937) concluded that the injured cells produced chemical substances which caused "activation" or enlargement of the surrounding epidermal cells and provided a chemotactic stimulus to their migration and concentration round the wound. Information about the chemical nature of these substances is scanty, but they are believed to be protein degradation products produced by autolysis of proteins in the injured cells. The migration of activated cells is stimulated not only by these products but by proteins and especially by peptones from many sources, while amino acids and simple peptides appear to be inactive.

Carrel (1922, 1924, 1930) concluded that similar protein degradation products which he termed "trephones" are liberated by leucocytes. Cultures of leucocytes set free into the medium protein derivatives which appear to stimulate markedly the proliferation of epithelial cells and fibroblasts, and Carrel considered that leucocytic enzymes acting on the cell debris and coagulated fibrin in the neighbourhood of a wound produce growth-activating polypeptides, while in superficial wounds the damaged cells might themselves set free growth-activating protein degradation products which could play a part in initiating the healing of wounds. Similar suggestions have been put forward by Marchand (1901) and Bier (1917), and Akamatsu (1922) has shown that the plasma from a wounded animal has more growth-promoting power to tissue cultures than it had before the wounds were made.

J. N. Davidson

Interesting observations have been described by Lorin-Epstein (1927), who reported the presence of substances which accelerated wound healing, so-called "Regenerations- und Wiederherstellungs-körper," in the serum and blood of wounded animals. These substances could be transferred passively to animals of the same or other species. In his opinion their presence explained his observation that repeated wounds and fractures in man appeared to heal more quickly than primary ones. The factors which accelerated ossification in fractures were claimed to appear in the blood within five or six days and to be destroyed by heating for thirty minutes to 70° C. Apparently similar materials termed "cytopoiétines" by Carnot and Terris (1926) were extracted from regenerating skin and applied successfully to the acceleration of wound healing.

The existence of such substances is, however, still obscure, and no attempts at isolating them have succeeded.

As Young, Fisher and Young (1941) point out, "so far as wound healing in the living animal is concerned . . . these growth-promoting substances are still theoretical and highly speculative because no precise means are available of demonstrating them either chemically or biologically." If these substances exist they might be expected to be abundant at the stage of wound healing when proliferative activity is most vigorous. With this in mind, Young, Fisher and Young (1941) measured the rate of healing of both primary and secondary experimental wounds in rabbits, the secondary wounds being inflicted some ten or twelve days after the primary ones. In a statistically significant number of cases the secondary wounds healed at a greater rate than the primary wounds, and the authors suggest that the latter may be the source of a factor or factors which tend to accelerate the healing of the secondary wounds. This factor may be a chemical agent, a growth-promoting substance elaborated by the primary wound, or it may be a by-product of a general or tissue immunity, or it may act in some quite different way.

Young, Fisher and Young conclude that existing experimental methods are too crude to render possible the biological assay of wound-healing substances without the employment of very large numbers of experimental animals.

Wound Hormones

VI. Discussion

It would appear to be reasonably beyond doubt that injured cells set free chemical substances as the result of the breakdown of their own protoplasm. These substances may, under suitable circumstances, stimulate tissue growth and so aid regeneration, but whether any of them are synthesised *ad hoc* by the injured cells or whether they are merely products of protein or nucleoprotein breakdown with general nutritive properties, is not clear. They may be derived either from the proteins of the cytoplasm alone or from nuclear material as well. The evidence from yeast tends to implicate the latter, and it may be significant that some evidence has accumulated in favour of a connection between the rate of growth of a tissue and its nucleic acid content.

Two chief types of nucleic acid are known, ribonucleic acid (yeast- or pentose-nucleic acid) in which the sugar moiety is ribose, and thymonucleic acid (animal- or desoxyribo-nucleic acid) in which the sugar is desoxyribose. The old conception that ribonucleic acid was to be found exclusively in plant tissues, and thymonucleic acid in animal tissues is no longer tenable. Ribonucleic acid has been demonstrated histochemically in animal tissues (Brachet, 1940; Desclin, 1940) and has been isolated from mammalian pancreas (Jorpes, 1934), while thymonucleic acid has been reported in plant tissues (Feulgen *et al.*, 1937) and in yeast (Delaporte and Roukheldman, 1938; Delaporte, 1939). It has been suggested that thymonucleic acid is located mainly in the nucleus and ribonucleic acid in the cytoplasm. Both types of nucleic acid are present in bacteria (Sevag, Smolens and Lackman, 1940).

Ribonucleic acid appears to be especially abundant in those tissues which exhibit rapid growth, and has been demonstrated by a particularly elegant technique in such varied materials as sea-urchin eggs, the nucleolus of the root-tip periblem cell of spinach and the cells of the salivary gland of *Drosophila melanogaster* (Caspersson and Schultz, 1939, 1940) and in tumour tissue (McDonald, 1940). Attention has been drawn to the ribonucleic acids also by the work of Mitchell (1940), who has shown that exposure of tumour tissue *in vivo* to X- and gamma radiation results in a significant increase in the ultraviolet absorption of the cytoplasm. The absorbing material appears to resemble ribonucleic acid.

The rapid growth rate of embryonic tissue has resulted in

J. N. Davidson

the use of embryo extracts as a standard means of promoting the growth of tissue cultures (Carrel, 1912), and Fischer (1939) has suggested that the growth-promoting power of embryonic extracts is located in the nucleoprotein fractions, especially those containing ribonucleic acids. The presence of such substances in embryonic material has been confirmed by Davidson and Waymouth (1942), who have succeeded in demonstrating chemically the presence of ribonucleic acids in appreciable quantities in a number of tissues from the sheep embryo and also in fowl tumour tissue.

The powerful growth-promoting power of embryo extracts towards tissue cultures has led to their employment as agents in the acceleration of wound healing, *e.g.* by Schloss (1928), by Nielsen (1939), by Waugh (1940), and others who have reported favourable effects. Their methods and results have, however, been subjected to severe criticism by Young, Fisher and Young (1941).

The liberation of protein degradation products by injured cells is a well-established and hardly surprising phenomenon. It is reasonable to suppose that the intact cells with which they come into contact utilise them as food materials, but whether they provide a more specific stimulus to growth in the sense that their effect is wholly or partially catalytic in nature is much more problematical.

The growth-promoting action of protein degradation products is, of course, well known. Willmer and Kendal (1932), following up earlier observations by Carrel and Baker (1926) and Baker and Carrel (1928), have shown that proteoses can potentiate enormously the growth-promoting power of embryo extracts on tissue cultures, while peptones are reported to accelerate wound healing (Roulet, 1926; Wallich, 1926; Kiaer, 1927).

Moreover, among the protein split products are compounds of specific biological activity. These include, for example, the polypeptides hypertensin (Houssay and Braun-Menendez, 1942), trypsin inhibitor (Northrop, 1939); the polypeptide responsible for some of the phenomena of acute inflammation (Duthie and Chain, 1939) and, probably, the anti-anæmic principle of liver (Karrer, 1941). However, until the protein degradation products from injured cells can be shown to be produced as a specific response to injury and to have some specific catalytic activity as growth stimulants rather than general nutritive properties, the question of their falling into the category of true wound hormones must remain open.

Wound Hormones

VII. Summary

1. The existence is discussed of the so-called "wound hormones," substances produced by living cells as a specific response to injury which have the power of stimulating the growth of uninjured cells.

2. In the case of plants such "wound hormones" exist and their chemical constitution is known.

3. Injured yeast cells produce nitrogenous materials containing protein degradation products and nucleic acid derivatives of the pentose nucleotide type. These substances stimulate the growth of fresh yeast cells, but whether they are produced as a specific response to injury or are merely degradation products of dead and dying cells, released perhaps as the result of increased permeability, is not yet certain.

4. There is some evidence that injured animal tissues are the source of a factor (or factors) which accelerates tissue proliferation and the healing of secondary wounds, but the nature of this factor is unknown. The implications of this factor in wound healing are discussed.

REFERENCES

- Akamatsu, N., "Über Gewebekulturen von Lebergewebe," *Virch. Archiv.*, 1922, ccxl, 308. Baker, L. E., and Carrel, A., "The Effects of Digests of Pure Proteins on Cell Proliferation," *Journ. Exp. Med.*, 1928, xlvii, 353. Baker, L. E., and Carrel, A., "Nitrogen Metabolism of Normal and Sarcomatous Fibroblasts in Pure Culture," *Journ. Exp. Med.*, 1928, xlvi, 533. Bier, A., "Beobachtungen über Regeneration beim Menschen. II. Abhandlung. "Die Ursachen der Regeneration," *Dtsch. med. Wschr.*, 1917, xliii, 833, 865, 897, 925. Bonner, J., and English, J., "Purification of Traumatins, a Plant Wound Hormone," *Science*, 1937, lxxxvi, 352. Bonner, J., and English, J., "Traumatins, a Plant Wound Hormone," *Plant Physiol.*, 1938, xiii, 331. Brachet, J., "La localisation de l'acide thymonucléique pendant l'oogénèse et de la maturation chez les amphibiens," *Compt. rend. Soc. Biol.*, 1940, cxxxiii, 90. Brachet, J., "Étude histochimique des protéines au cours du développement embryonnaire des poissons, des amphibiens et des oiseaux," *Arch. Biol.*, 1940, li, 167. Bywaters, E. G. L., and Beall, D., "Crush Injuries with Impairment of Renal Function," *Brit. Med. Journ.*, 1941, i, 427. Cameron, G., *Tissue Culture Technique*, Farrar and Rinehart, New York, 1935. Carnot, P., and Terris, E., "Sur la cicatrisation de plaies cutanées par les extraits d'embryons ou de peau régénérée," *Compt. rend. Soc. Biol.*, 1926, xcv, 655. Carrel, A., "On the Permanent Life of Tissues Outside the Organism," *Journ. Exp. Med.*, 1912, xv, 516. Carrel, A., "Growth Promoting Function of Leucocytes," *Journ. Exp. Med.*, 1922, xxxvi, 385. Carrel, A., "Leukocytic Trephones," *Journ. Amer. Med. Assoc.*, 1924, lxxxii, 255. Carrel, A., "The Process of Wound

J. N. Davidson

Healing," *Proc. Chicago Inst. Med.*, 1930, viii, 62. Carrel, A., and Baker, L. E., "The Chemical Nature of Substances required for Cell Multiplication," *Journ. Exp. Med.*, 1926, xlv, 503. Caspersson, T., and Schultz, J., "Pentose Nucleotides in the Cytoplasm of Growing Tissues," *Nature*, 1939, cxliii, 602. Caspersson, T., and Schultz, J., "Ribonucleic Acids in both Nucleus and Cytoplasm; Function of Nucleolus," *Proc. Nat. Acad. Sci.*, 1940, xxvi, 507. Cook, E. S., Hart, M. J., and Stimson, M. M., "Proliferation-promoting Properties and Ultraviolet Absorption Spectra of Yeast Fractions," *Biochem. Journ.*, 1940, xxxiv, 1580. Cook, E. S., and Cronin, A. G., "Proliferation-promoting Activities of Extracts from Ultraviolet Injured Yeast Cells and of Bios Components," *Nature*, 1942, cl, 93. Davidson, J. N., "The Effect of Ultraviolet Light on Living Yeast Cells," *Biochem. Journ.*, 1940, xxxiv, 1537. Davidson, J. N., and Findlay, J. D., 1940 (unpublished results). Davidson, J. N., and Findlay, J. D., "Some Effects of Ultraviolet Light and X-rays on Living Yeast Cells," *Chem. and Ind.*, 1941, lx, 617. Davidson, J. N., and Waymouth, C., 1942 (unpublished results). Delaporte, B., "Sur les acides nucléiques des levures et leur localisation," *Rev. gen. bot.*, 1939, li, 449. Delaporte, B., and Roukheldman, N., "Sur la présence de la thymine dans l'acide nucléique extrait de la levure. Recherches cytologiques et chimiques," *Compt. rend. Acad. Sci.*, 1938, ccvi, 1399. Desclin, L., "Détection de substances pentosenucléiques dans les cellules du lobe antérieur de l'hypophyse du rat et du cobaye," *Compt. rend. Soc. Biol.*, 1940, cxxxiii, 457. Duthie, E. S., and Chain, E., "Polypeptide responsible for some of the Phenomena of Acute Inflammation," *Brit. Journ. Exp. Path.*, 1939, xx, 417. Eggleton, M. G., Richardson, K. C., Schild, H. O., and Winton, F. R., "Renal Impairment due to Crushing Limbs in Anaesthetised Dogs," *Brit. Med. Journ.*, 1942, ii, 392. English, J., "Wound Hormones of Plants. V. The Synthesis of some Analogs of Traumatic Acid," *Journ. Amer. Chem. Soc.*, 1941, lxiii, 941. English, J., and Bonner, J., "Wound Hormones of Plants. I. Traumatins; The Active Principle of the Bean Test," *Journ. Biol. Chem.*, 1937, cxxi, 791. English, J., Bonner, J., and Haagen-Smit, A. J., "The Wound Hormones of Plants. II. The Isolation of a Crystalline Active Substance," *Proc. Nat. Acad. Sci.*, 1939, xxv, 323. English, J., Bonner, J., and Haagen-Smit, A. J., "The Wound Hormones of Plants. IV. Structure and Synthesis of a Traumatins," *Journ. Amer. Chem. Soc.*, 1939, lxi, 3434. Fardon, J. C., Norris, R. J., Loofbourow, J. R., and Ruddy, M. V., "Stimulating Materials obtained from Injured and Killed Cells," *Nature*, 1937, cxxxix, 589. Feulgen, R., Behrens, M., and Mahdihassan, S., "Darstellung und Identifizierung der in den pflanzlichen Zellkernen vorkommenden Nucleinsäure," *Z. physiol. Chem.*, 1937, ccxvi, 203. Fischer, A., "Regeneration—Versuche an Gewebekulturen *in vitro*," *Virch. Archiv.*, 1930, cclxxix, 94. Fischer, A., "Nature of the Growth-accelerating Substance of Animal Tissue Cells," *Nature*, 1939, cxlv, 113. Giersch, C., and Cook, E. S., "The Production of Proliferation-promoting Factors by the Ultraviolet Irradiation of Algæ," *Nature*, 1941, cxlviii, 754. Haberlandt, G., "Wundhormone als Erregen von Zellteilungen," *Beitr. allgem. Bot.*, 1921, ii, 1. Haberlandt, G., "Zur Physiologie der Zellteilungen. 6. Mitteilung: Über Auslösung von Zellteilungen durch Wundhormone," *Sitzgsber. Preuss. Akad. Wiss.*, 1921, viii, 221. Haberlandt, G., "Über Zellteilungshormone und ihre Beziehungen zur Wundheilung, Befruchtung, Parthenogenesis und adventive Embryonie," *Biol. Zent.*, 1922, xlii, 145.

Wound Hormones

Hammett, F. S., "The Thiol Postulate for Cell Proliferation," *Protoplasma*, 1934, xxii, 489. Hammett, F. S., "Genetics, Thiol, and Cancer," *Science*, 1936, lxxxiii, 57. Harvey, W. F., "Review of Irradiation Effect on Cells and Tissues of the Skin," *Edin. Med. Journ.*, 1942, xlix, 529. Henshaw, P. S., and Turkowitz, H., "Some Effects of Roentgen Rays on *Saccharomyces Cerevisiae*," *Amer. Journ. Roentgenol.*, 1940, xliii, 93. Houssay, B. A., and Braun-Menendez, E., "The Role of Renin in Experimental Hypertension," *Brit. Med. Journ.*, 1942, ii, 179. Jorpes, E., "On the Pentose Polynucleotide of the Pancreas," *Biochem. Journ.*, 1934, xxviii, 2102. Karrer, P., "Versuche zur Reinigung des Antiperniziosa-Faktors," *Schweiz. med. Wschr.*, 1941, lxxi, 343. Kiaer, S., "Biologische Beachtung über Wundheilung. Über die Möglichkeit das Wundheilungsprozess mittels Hunerembryonalsaft und Proteosen zu Beschleunigen," *Arch. Klin. Chir.*, 1927, cxlix, 146. Laurens, H., "The Physiological Effects of Radiant Energy," *Ann. Rev. Physiol.*, 1941, iii, 21. Loofbourow, J. R., "Role of Adenine Nucleotides and Growth Factors in Increased Proliferation following Damage to Cells," *Nature*, 1942, cl, 349. Loofbourow, J. R., Cook, E. S., Dwyer, C. M., and Hart, M. J., "Production of Intercellular Hormones by Mechanical Injury," *Nature*, 1939, cxliv, 553. Loofbourow, J. R., Cook, E. S., and Stimson, M. M., "Chemical Nature of Proliferation-promoting Factors from Injured Cells," *Nature*, 1938, cxlii, 573. Loofbourow, J. R., Cueto, A. A., and Lane, M. M., "Stimulation of Tissue Culture Growth by Intercellular Wound Hormones from Injured Tissues," *Archiv. exp. Zellforsch.*, 1938-39, xxii, 607. Loofbourow, J. R., Cueto, A. A., Whalen, D., and Lane, M. M., "Local Growths in Animals produced by Injection of Intercellular Wound Hormones," *Nature*, 1939, cxliv, 939. Loofbourow, J. R., and Dwyer, C. M., "Intercellular Wound Hormones produced by Heteroauxin," *Science*, 1938, lxxxviii, 191. Loofbourow, J. R., and Dwyer, C. M., "Production of Intercellular Hormones," *Nature*, 1939, cxliii, 725. Loofbourow, J. R., and Dwyer, C. M., "Effect of the Suspending Medium on the Production of Growth Factors by Injured Cells," *Nature*, 1940, cxlv, 185. Loofbourow, J. R., Dwyer, C. M., and Cronin, A. G., "Proliferation-promoting Intercellular Hormones. 2. Evidence for their Production by Living Cells as a Response to Injury," *Biochem. Journ.*, 1941, xxxv, 603. Loofbourow, J. R., Dwyer, C. M., and Lane, M. M., "Proliferation-promoting Intercellular Hormones. 1. Quantitative Studies of Factors produced by Injured Animal Tissue Cells," *Biochem. Journ.*, 1940, xxxiv, 432. Loofbourow, J. R., Englert, M. E., and Dwyer, C. M., "Increased Yield of Nucleic Acid-like Substances from Irradiated Yeast," *Nature*, 1941, cxlviii, 113. Loofbourow, J. R., and Joyce, L., "Increased Ultra-violet Absorption of Cells following Irradiation with Ultra-violet Light," *Nature*, 1941, cxlviii, 166. Loofbourow, J. R., and Morgan, M. N., "Investigation of the Production of Growth-promoting and Growth-inhibiting Factors by Ultraviolet Irradiated Microorganisms," *Journ. Bact.*, 1940, xxxix, 437. Loofbourow, J. R., Webb, A. M., and Abramowitz, R. K., "Relation of Aeration to the Activity of Proliferation-promoting Factors from Injured Cells," *Nature*, 1942, cxlix, 272. Loofbourow, J. R., Webb, A. M., Loofbourow, D. G., and Abramowitz, R. K., "Proliferation-promoting Intercellular Hormones. 3. Relationship of Aeration to the Activity of Proliferation-promoting Factors from Injured Cells," *Biochem. Journ.*, 1942, xxxvi, 513. Loofbourow, J. R., Webb, A. M., Loofbourow, D. G., and Lisco, H., "Further Observations on the Increased Yield of Nucleic Acid

J. N. Davidson

from Irradiated Yeast," *Nature*, 1942, cxlix, 328. Lorin-Epstein, M. J., "Über allgemeine Faktoren der Wiederherstellungsprozesse und ihre Bedeutung für die chirurgische Pathologie," *Arch. Klin. Chir.*, 1927, cxliv, 632. McDonald, E., "Progress of the Biochemical Research Foundation of the Franklin Institute," *Journ. Franklin Inst.*, 1940, ccxxx, 727. Marchand, F., "Der Process der Wundheilung mit Einschluss der Transplantation," *F. Enke. Stuttgart*, 1901. Menkin, V., "Dynamics of Inflammation," Macmillan & Co., New York, 1940. Menkin, V., "Cellular Injury in Relation to Proliferative and Neoplastic Response," *Cancer Research*, 1941, i, 548. Mitchell, H. K., and Williams, R. J., "The Importance of Amino Acids as Yeast Nutrients," *Biochem. Journ.*, 1940, xxxiv, 1532. Mitchell, J. S., "Increase in Ultra-violet Absorption of Cytoplasm after Therapeutic X and Gamma Radiation," *Nature*, 1940, cxlvi, 272. Nielsen, E., "Om Virkningerne af animalske vaeststoffer paa forløbet af saarhelingen," *Ugeskr. Laeger*, 1939, xxxvii, 1071. Northrop, J. H., "Crystalline Enzymes," Macmillan & Co., New York, 1939. Pourbaix, Y., and Kennaway, E. L., "The Liberation from Yeast of Substances giving the Nitroprusside Reaction," *Biochem. Journ.*, 1928, xxii, 1112. Reiche, H., "Über Auslösung von Zellteilungen durch Injektion von Gewebesäften und Zelltrümmern," *Zeit. Botan.*, 1924, xvi, 241. Riley, J. F., "Sulphydryl Compounds and Wound Repair," *Brit. Med. Journ.*, 1940, ii, 516. Roulet, F., "Action de la peptone de Witte sur le bourgeonnement des plaies cutanées expérimentales chez le Cobaye," *Compt. rend. Soc. Biol.*, 1926, xcv, 1340. Schloss, W., "Über Beeinflussung der Wundheilung durch Embryonalgewebe," *Arch. Klin. Chir.*, 1928, cli, 701. Sevag, M. G., Smolens, J., and Lackman, D. B., "Nucleic Acid Content and Distribution in Streptococcus Pyogenes," *Journ. Biol. Chem.*, 1940, cxxxiv, 523. Sperti, G. S., Loofbourow, J. R., and Dwyer, C. M., "Proliferation-promoting Substances from Cells Injured by Ultra-violet Radiation," *Nature*, 1937, cxl, 643. Trethewie, E. R., "Tissue Injury by Trypsin," *Austral. Journ. Exp. Biol.*, 1942, xx, 49. Wallich, R., "Contribution à l'étude de la culture des tissus *in vivo* dans les phénomènes de cicatrisation des plaies superficielles," *Compt. rend. Soc. Biol.*, 1926, xcv, 1480. Waugh, W. G., "Experiments on the Acceleration of Wound Healing," *Brit. Med. Journ.*, 1940, i, 249. Wehnelt, B., "Untersuchungen über das Wundhormon der Pflanzen," *Jahrb. wiss. Botan.*, 1927, lxvi, 773. Wiesner, J., *Elementarstruktur und das Wachstum der lebenden Substanz*, 1892, p. 102, Vienna. Wigglesworth, V. B., "Wound Healing in an Insect (*Rhodnius prolixus hemiptera*)," *Journ. Exp. Biol.*, 1937, xiv, 364. Williams, R. J., "Growth-promoting Nutrilites from Yeasts," *Biol. Rev.*, 1941, xvi, 49. Willmer, E. N., and Kendal, L. P., "The Utilisation of Proteoses by Chicken Heart Fibroblasts Growing *in vitro*," *Journ. Exp. Biol.*, 1932, ix, 149. Wyckoff, R. W. G., and Luyet, B. J., "Effects of X-rays, Cathode and Ultra-violet Rays on Yeast," *Radiology*, 1931, xvii, 1171. Young, J. S., Fisher, J. A., and Young, M., "Some Observations on the Healing of Experimental Wounds in the Skin of the Rabbit," *Journ. Path. Bact.*, 1941, lii, 225.

Factors Influencing the Nucleoprotein Content of Fibroblasts Growing *in vitro*

BY J. N. DAVIDSON AND CHARITY WAYMOUTH, *From the Biochemical Laboratory,
Physiology Department, The University of Aberdeen*

(Received 21 January 1943)

Since Carrel [1912] first showed that the growth of tissue cultures *in vitro* could be stimulated by means of extracts of embryonic tissue, and that cultures could be maintained apparently indefinitely in such extracts, much speculation has arisen as to the chemical nature of the constituents of embryo juice responsible for the stimulation of cellular proliferation. Baker & Carrel [1926] came to the conclusion that activity lay in the protein fraction, and obtained active materials by precipitation of these with ethanol or CO₂. Rejecting the theory that embryo juice contained a specific hormone for cell proliferation, they later suggested [Carrel & Baker, 1926] that growth-activating substances are not preformed in embryo juice but are continuously made from its protein, perhaps in the cells of the cultures themselves, as the result of enzyme action. In support of this suggestion they pointed out that proteoses and higher protein degradation products have very potent growth-promoting properties, an observation which was confirmed and extended by Willmer & Kendal [1932]. Needham [1931] also rejected the view that any one particular factor was responsible for the growth-promoting properties of embryo juice, which he regarded as 'a special collo-

cation of the right nutrient substances probably protein break-down products', but later [Needham, 1942] he did not exclude the participation of 'some carrier substance of nucleotide type'. However, Fischer [1939; 1940] prepared a very active growth-promoting factor from beef embryos by isolating the nucleoproteins. The activity seemed to be located in the nucleoprotein fraction containing the ribonucleic acids, but repeated reprecipitation of the nucleoproteins resulted in loss of activity. In the active fractions the phosphorus content was higher than could be accounted for by the nucleic acid content. Some active fractions contained sulphur, probably derived from chondroitin or mucoitin sulphuric acid complexes precipitated with the nucleoproteins. The presence of ribonucleic acids in rapidly growing tissues is now well recognized [Caspersson & Schultz, 1939; 1940; Mitchell, 1940; Schultz, 1941], and the nucleoproteins of several different embryonic tissues have been shown to contain ribonucleic acids [Davidson & Waymouth, unpublished results].

By the term 'growth', applied to cells *in vitro*, as distinct from mere survival of the cells with or without cell migration and even cell division, is



meant cellular proliferation with the formation of new protoplasm. A number of criteria of growth have been suggested, e.g. the area of the culture [Ebeling, 1921], the mitotic index [Willmer & Kendal, 1932], the mass of the culture [Meier, 1931; Laser, 1933*b*; Wilson, Jackson & Brues, 1942], its metabolic activity [Meier, 1931; Laser, 1932; 1933*a*; Lipmann, 1932; 1933] or the nucleoprotein content [Willmer, 1942] as determined by chemical estimation of the nucleoprotein P (N.P.P.). The last has appeared to us to be most satisfactory although, as Willmer [1942] points out, it suffers from the defect that nucleic acid or nucleoprotein is a cytoplasmic constituent in some tissues [cf. Caspersson & Schultz, 1940]. Moreover, its chemical determination is based on the assumption that when a tissue has been extracted with fat solvents and with dilute acid, the residual P is all present as nucleic acid. Some may be present as phosphoprotein P [Plimmer & Scott, 1908], but the amounts of this in most tissues, including embryonic tissue, is very low [v. Euler & Schmidt, 1934], or negligible [Masing, 1911].

The work of Brues, Tracy & Cohn [1942] with radioactive P, suggests that the above assumption may not be fully justified for all tissues, but in agreement with Willmer we have found that the estimation of the 'nucleic acid phosphorus' provides a satisfactory index of growth in the case of cultures from the embryo chick heart.

MATERIALS AND METHODS

As reported in a preliminary communication [Davidson & Waymouth, 1942] we have employed the general technique described by Willmer [1942], involving the use of constricted roller tubes made of Pyrex glass.

General. All the tests have been carried out with fresh explants from the heart of the 9-day chick embryo. No experiments have been carried out on cultures maintained as a pure strain. This must be kept in mind when considering the results. Plasma was obtained from young cockerels. The Tyrode solution used had the composition described by Willmer & Kendal [1932], and was sterilized by filtration through a Berkefeld candle. Chick embryo extract was prepared by pulping 9-day chick embryos in sterile graduated centrifuge tubes with an equal volume of Tyrode solution, freezing, thawing, centrifuging, and pipetting off the supernatant fluid into sterile storage tubes. This concentrated extract (total N = 40–60 mg. %) was suitably diluted before use.

Control experiments. As the composition of plasma is variable, direct comparisons of the effects of two substances on the tissue N.P.P. are made only where control and test series are grown in plasma from the same sample at the same time. For a similar reason, when embryo extract with and without some supplement is tested, comparisons are drawn only when a single sample of extract is used throughout. The effect of any lack of uniformity, due to inherent variations in potential growth capacity between

different hearts, is reduced by using in each test pieces from a mixed sample from 6 to 8 hearts.

Preparation of explants. Each of the embryo hearts was cut up into 20–30 small and approximately uniform pieces according to the usual aseptic tissue culture technique [cf. Strangeways, 1924]. Six pieces of tissue were implanted in 0.2 ml. sterile plasma in each roller tube. The tubes were set aside until the plasma had clotted and 0.5 ml. Tyrode solution was then added. The tubes were stoppered with sterile rubber bungs, and mounted on a drum which rotated, by means of a small electric motor, in the incubator at 38° at a speed of 1 revolution/min. With each revolution the fluid washed over the growing cultures.

Six to eight of the tubes contained a plasma clot but no tissue, and served as plasma blanks. The remainder contained 6 pieces of tissue each. As the drum carried a total of 20 tubes, each test involved the use of some 70–80 pieces of tissue.

Technique of experiments. The tubes were rotated, with Tyrode solution alone as fluid phase, for 2 days to allow traces of growth-promoting substances present in the fresh tissue pieces to be used up, and to allow the cultures to be as uniform as possible before addition of test materials. The 'residual growth energy' is reported by Trowell & Willmer [1939] to be exhausted after this time. The tubes were then opened and the fluid phase (Tyrode + serum + metabolic products) sucked off. The test proper then began.

To each tube was added Tyrode, embryo extract, or test substance, or a combination of two or three of these, the total volume being 0.5 ml. As many duplicates as possible were set up. The tubes were re-stoppered and rotated for a further 3 hr. to allow the fluid to permeate the plasma clot. Some of the tubes were removed at this time (time = 0) to give figures for the initial value of N.P.P. The remainder were allowed to run for a further period of time, usually 2 days (time = *t*).

At 'time *t*' the tubes were removed. By means of a projectoscope, images of the cultures could be either outlined on paper and the areas subsequently determined with a planimeter, or recorded in silhouette on Hford Reflex Document paper, although the curvature of the roller tubes made very accurate projection impossible.

Estimation of nucleic acid phosphorus. The method of Willmer [1942] was again followed. The roller tube became a test tube, and lipid P and acid-soluble P were extracted by ethanol-chloroform and 0.1 N HCl respectively, according to the procedure of Berenblum, Chain & Heatley [1939]. The tissue remained in the plasma clot throughout this process. It was then ashed in the roller tube with 0.15 ml. 70% perchloric acid, and P was determined by the ultra-micro-method of Berenblum & Chain [1938]. As originally described, the method is time consuming, since each estimation must be done individually, but we have devised a new type of mixing vessel (Fig. 1) which saves time by allowing

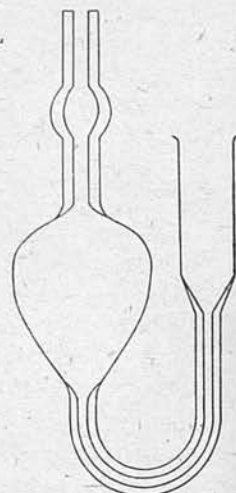

Fig. 1. Mixing vessel for phosphate estimation. $\frac{2}{3}$ actual size.

a large number of estimations to be done simultaneously. A battery of seven (or more) of these vessels is set up in a rack so that at least six estimations and one standard can be carried through at the same time. The reagents are pipetted into the cup on the short limb and are transferred to the bulb by gentle suction applied to the long limb. After mixture of the aqueous and butanol layers in the bulb, the aqueous layer settles out and can be sucked off through a capillary pipette inserted into the bottom of the cup. The blue alcoholic layer is finally poured from the cup into a small tube graduated at 1 ml., and the colour is read off either in a colorimeter against a standard prepared simultaneously, or in the Hilger Spekker Absorbtiometer with micro-cups.

The figure for the N.P.P. in the tissue alone is determined by subtracting the appropriate plasma blank from the N.P.P. figure for each tube containing tissue. The index $(100Y)/X$ gives an indication of the increase in N.P.P. relative to the amount originally present where X and Y are the figures for the N.P.P. at 'time 0' and 'time t' respectively.

RESULTS

Tyrode solution alone as fluid phase

In agreement with Willmer [1942] we find a drop in N.P.P. in the course of the experiment (Table 1). In 23 different experiments the average figure for the initial N.P.P. was 1.28 $\mu\text{g.}/\text{roller tube}$ (after subtraction of appropriate plasma blanks). After 2 days the N.P.P. had fallen to 1.13 $\mu\text{g.}$ (Table 1). No significant alteration in N.P.P. occurred in the tubes containing plasma and Tyrode without tissue.

Table 1. Changes in N.P.P. (nucleoprotein P) in roller tubes containing Tyrode solution alone as fluid phase

All tubes run for 2 days with Tyrode solution alone before test begins. Fresh Tyrode then introduced (time 0) and initial N.P.P. measurements made. Final N.P.P. estimation carried out 2 days later (time t).

	Initial N.P.P. at 'time 0' per roller tube $\mu\text{g.}$	Final N.P.P. at 'time t' per roller tube $\mu\text{g.}$	Diff.	No. of exps.
Tubes with plasma alone	0.29 ± 0.01	0.31 ± 0.02	+0.02	26
Tubes with tissue (corrected for plasma blanks)	1.28 ± 0.07	1.13 ± 0.06	-0.15	23

It is probable that this fall is due to the presence in the plasma of nucleases which break up the nucleic acid in such of the cells as die in the course of the 2 days. We have demonstrated the presence of such nucleases in cockerel plasma and serum. A mixture of 0.2 ml. cockerel plasma with 0.3 ml. veronal-acetate buffer (pH 7.6) and 0.1 ml. 2% thymonucleic acid or ribonucleic acid (as Na salts) was incubated at 37°. At suitable intervals portions were treated with an equal volume of 0.25% uranyl

acetate in 2.5% CCl_3COOH . The precipitate of unhydrolysed nucleic acid was centrifuged down, washed with 0.125% uranyl acetate in 1.25% CCl_3COOH , and dissolved in Na_2CO_3 solution. Total P was determined in this solution by a modification of the method of Allen [1940]. Some spontaneous decomposition of nucleic acids takes place at pH 7.6, which was allowed for by a control series without plasma. Both types of nucleic acid are hydrolysed by plasma to compounds no longer precipitable by the uranyl acetate reagent (Table 2), but the ribonucleic acid suffers more decomposition than the thymonucleic acid. Cockerel plasma therefore contains enzymes of the nuclease type such as ribonuclease [Kunitz, 1940], and thymonucleodepolymerase [Fischer, Böttger & Lehmann-Echter-nacht, 1941; Greenstein & Jenrette, 1941], as well as nucleotidases, phosphatases, etc.

Table 2. Influence of incubation with cockerel plasma on nucleic acids

0.1 ml. 2% nucleic-acid solution (as Na salt) incubated with 0.2 ml. cockerel plasma and 0.3 ml. veronal-acetate buffer pH 7.6 at 37°.

Time hr.	Hydrolysis (%)			
	Ribonucleic acid		Thymonucleic acid	
	With plasma	Without plasma	With plasma	Without plasma
2	12.2	6.8	0	0
6	36.0	15.0	5.3	1.4
24	74.0	20.4	20.4	7.0

A similar fall in N.P.P. occurs during the first 2 days after the cultures are set up, during which period no measurements are normally made (Fig. 2).

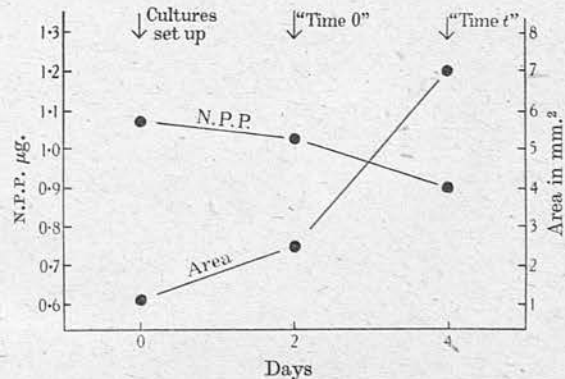

Fig. 2. Decrease in nucleoprotein P (N.P.P.) and increase in area in cultures grown in Tyrode solution alone for 4 days. N.P.P. in $\mu\text{g.}/\text{roller tube}$ (plasma blanks subtracted). Area in mm.^2 /individual culture.

Although the amount of nuclear material as measured by the N.P.P. diminishes continuously, the area of the cultures increases and may at the

Table 3. *Effect of various substances on nucleoprotein P (N.P.P.) content of tissue cultures*

All cultures grown for 2 days in Tyrode solution alone before introduction of test substance and estimation of initial N.P.P. (X). Final N.P.P. (Y) estimation 2 days later.

Material under test	Fluid phase in roller tubes	Alteration in N.P.P. $\mu\text{g./tube}$	(100Y)/X
A Tyrode solution	Tyrode solution alone	-0.15	88
B Chick embryo extract	Embryo extract	+0.31	120
	Embryo extract after exposure to heat	+0.34	124
C Crystalline ribonuclease	Tyrode solution alone	-0.14	87
	Crystalline ribonuclease in Tyrode solution (final conc. of enzyme = 9.4 mg. %)	-0.08	91
D Crystalline ribonuclease	Chick embryo extract	+0.42	137
	Chick embryo extract + crystalline ribonuclease (final conc. = 9.4 mg. %)	+0.35	148
E Crystalline ribonuclease (Dr Kunitz)	Tyrode solution alone	-0.13	76
	Chick embryo extract	+0.11	114
	Chick embryo extract + crystalline ribonuclease (final conc. = 12.5 mg. %)	+0.09	114
	Tyrode solution + crystalline ribonuclease (conc. as above)	-0.10	82
F Crystalline ribonuclease (Dr Kunitz)	Tyrode solution alone	-0.07	92
	Chick embryo extract	+0.39	143
	Chick embryo extract + crystalline ribonuclease (final conc. = 50 mg. %)	+0.32	157
G Crude ribonuclease in pancreatic extracts	Tyrode solution alone	-0.09	92
	Chick embryo extract	+0.45	136
	Chick embryo extract + preparation from pancreatin	+1.03	173
H Mucinase	Chick embryo extract	+0.44	149
	Chick embryo extract + mucinase (final conc. of mucinase = 168 mg. %)	+0.07	107
J Mucinase	Tyrode solution alone	-0.08	90
	Chick embryo extract	+0.37	143
	Chick embryo extract + mucinase (final conc. of mucinase = 160 mg. %)	+0.14	116
K Embryo cartilage extract	Tyrode solution alone	+0.06	106
	Cartilage extract	+0.35	125
L Anterior pituitary extract	Tyrode solution alone	-0.15	91
	Pituitary extract	-0.10	86

end of 4 days be as much as 6-10 times greater than it was when the cultures were first set up (Fig. 2) owing to the migration of cells from the original explant. The area of cultures from fresh explants is not, however, of great significance [Parker, 1938].

Chick embryo extract as fluid phase

(a) *The effect of normal extract.* When the Tyrode solution is replaced by embryo extract, during the second 2 days of the test (i.e. the days of the test proper), very marked growth of the tissue occurs, accompanied by a rise in N.P.P. (Table 3 B). The final area, instead of being of the order of 7.0 sq. mm., is of the order of 20 sq. mm./culture.

The rise in N.P.P. is greater as the concentration of embryo extract increases. The effects of different concentrations of embryo extract are shown in Fig. 3. In this case some of the tubes were allowed to run for a further 2 days. During this time no further rise in N.P.P. occurred—in fact a slight fall was observed (Fig. 3). All tests have subsequently been restricted to 2 days after addition of the test substances.

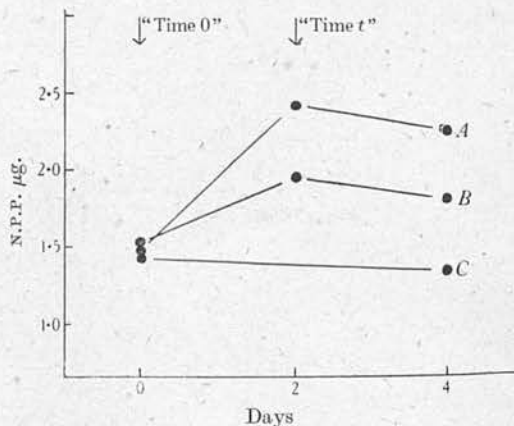

Fig. 3. Influence of different concentrations of embryo extract on the nucleoprotein P (N.P.P.) of tissue cultures. N.P.P. in $\mu\text{g./roller tube}$ (plasma blanks subtracted). All cultures grown for 2 days in Tyrode solution alone before addition of embryo extract. Curve A: fluid phase in roller tube, embryo extract 30 mg. % N (approx.). Curve B: embryo extract 10 mg. % N (approx.). Curve C: fluid phase, Tyrode solution alone. The explants used in this experiment were rather larger than usual.

(b) *Effect of heat on embryo extract.* It is usually stated that the active principles of embryo extract are easily destroyed by heat [Carrel, 1913; Lasnitzki, 1937].

We have examined the effect of heating chick embryo extract to 100° for 10 min. To minimize the pH changes due to bicarbonate decomposition, the extract, prepared by pulping the embryonic tissue with water instead of Tyrode solution, was divided into two portions, one of which was heated while the other was kept as a control. The salt concentrations (including bicarbonate) in both extracts were then adjusted by adding appropriate amounts of sterile concentrated saline medium. Tissue cultures gained as much nucleoprotein P in this heated material as in the unheated control extract (Table 3B).

(c) *The effect of ribonuclease on embryo extract.* In view of Fischer's [1939] suggestion that the growth-promoting power of embryo extract is located in the ribonucleoprotein fraction, we have examined the action of the enzyme ribonuclease on the activity of chick embryo juice. Ribonuclease, which has been prepared in the crystalline state from pancreas by Kunitz [1940], attacks specifically the ribonucleic acids bringing about partial hydrolysis. The enzyme is strikingly thermostable and aqueous solutions can be sterilized by heat.

Chick embryo extract incubated overnight at 37° with crystalline ribonuclease (prepared from cattle pancreas) was tested on the tissue cultures, and showed no diminution in activity as compared with control embryo extract incubated without enzyme (Table 3 C, D). A sample of crystalline ribonuclease kindly supplied by Dr M. Kunitz gave the same result, even when the enzyme concentration in the roller tubes was as high as 50 mg./100 ml. (Table 3 E, F).

Ribonuclease in Tyrode solution alone appeared to have no effect on the living cells (Table 3 C, E). On the other hand, crude preparations of ribonuclease, prepared by extracting commercial pancreatin with 50% acetone [cf. Dubos & Thompson, 1938], and sterilized by heating to 100° for 10 min., gave a very different response. Cultures grown in a mixture of this medium and embryo extract showed a characteristic dense type of growth with a sharply demarcated margin. Growth appeared to be abundant but cell migration was not so pronounced as in the controls grown in embryo extract alone, which had a considerably larger area. The cultures grown with the addition of the pancreatic extract showed a much greater increase in N.P.P. than did the controls (Table 3G). This increased growth is not caused by the ribonuclease in the pancreatic extracts, but is due to another factor, the nature of which is at present under investigation. It is destroyed by heating for 30 min. at 100° in feebly alkaline solution.

(d) *The effect of mucinase on embryo extract.* In view (1) of the large amount of mucin-like substances in embryonic material [cf. Baker & Carrel, 1926], (2) of the good growth-promoting power of embryonic cartilage extracts, and (3) of Fischer's [1940] suggestion that the active principle may contain S, we have tested the effect of a highly purified preparation of the enzyme mucinase [Madinaveitia, 1941] prepared from bull testicle, to see whether hydrolysis of some of the muco- or sulpho-poly-saccharides in embryo extract affected its activity. We are grateful to Dr Madinaveitia for a sample of mucinase, which besides acting as a diffusing factor with hyaluronidase activity and with the power to reduce the viscosity of some mucopolysaccharides (of synovial fluid, vitreous humour, and umbilical cord, but not of saliva and gastric mucin), also had a low glucosaminidase activity. Testicular mucinase is stated by Meyer, Chaffee, Hobby & Dawson [1941] to hydrolyse chondroitin sulphuric acid, the mucopolysaccharides of skin, and the polysaccharide (or its H₂SO₄ ester) of the cornea as well as hyaluronic acid. The enzyme was dissolved in Tyrode solution and sterilized by passage through a small Berkefeld candle. A slight loss in N content resulted but the sterile solution still retained powerful enzyme activity as measured by the diffusion test in rabbits with haemoglobin [Madinaveitia, 1938].

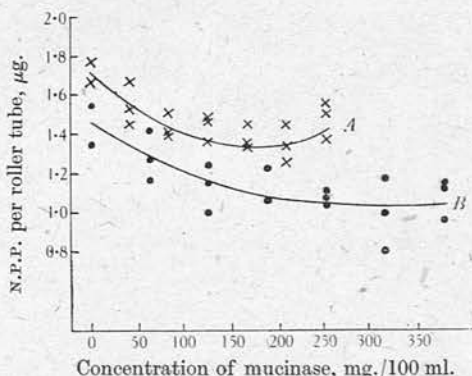

Fig. 4. The effect of increasing concentrations of mucinase on the nucleoprotein P (N.P.P.) of tissue cultures grown in embryo extract. N = 25 mg. % for embryo extract in all cases. Abscissa: N.P.P., µg./roller tube. Ordinate: final concentration of mucinase in roller tube, mg./100 ml. Embryo extract and mucinase incubated for 2½ hr. at 37° before being added to roller tubes. Curve A (test 74): cultures grown for 2 days. Curve B (test 76): cultures grown for 1 day. Plasma blanks not subtracted. All cultures grown for 2 days in Tyrode solution alone before addition of embryo extract and mucinase.

Embryo extract was mixed with the mucinase solution, and incubated at 37° for 2½ hr. before being added to the roller tubes. Embryo extract incubated at the same concentration without mu-

cinase served as a control. A slight precipitate sometimes appeared in the mucinase mixture.

The cultures grown in embryo extract plus mucinase showed a smaller increase in N.P.P. than did the controls (Table 3 H, J). As the effect seemed to vary considerably with the concentration of mucinase, experiments were carried out in which constant amounts of embryo extract were incubated with increasing concentrations of mucinase. The results are plotted in Fig. 4. It will be seen that the maximum effect was obtained when the mucinase concentrations were 170–250 mg. %. In one test (curve A) higher concentrations were rather less effective.

Extracts of cartilage from mammalian embryos

We have also employed extracts made from mammalian embryos, chiefly sheep embryos of 9–10 weeks, a stage at which growth is very rapid [Gurlt, 1847]. Cattle, pig and human embryos have also been used. As whole extracts prepared by mincing the complete embryos contained an undesirably large amount of blood, we have examined extracts from individual tissues. Embryo cartilage was found to give a very satisfactory extract.

The embryos were dissected and the cartilage of the vertebral column, skull, pelvic and shoulder girdles freed as far as possible from muscle and connective tissue. The cartilage was minced and the mince allowed to stand with an equal volume of water overnight at 0° before being filtered through muslin. The filtrate was centrifuged and treated with $\frac{1}{2}$ vol. of double strength Tyrode solution. To check the salt concentration a chloride estimation was carried out and final small adjustments of salt concentration made as required.

Embryo cartilage extract could be sterilized by filtration through a Berkefeld candle, and kept quite well at 0° or, better, at -30°.

Results obtained with cartilage extract are shown in Table 3K.

The effect of pituitary extract

In view of the well-known action of extracts of the anterior pituitary gland in stimulating the growth of young animals [cf. Young, 1941] we examined the effect of pituitary extracts on the nucleoprotein content of fibroblasts *in vitro*. Saline extracts prepared according to the method described by Marks & Young [1940] were kindly supplied by Dr F. G. Young. The salt concentrations were adjusted to that of Tyrode before the extracts were tested. In no case did the pituitary extract cause any increase in the N.P.P. of the cultures (Table 3L).

This is in agreement with the findings of Trowell & Willmer [1939] who, contrary to Semura [1931], found that pituitary extracts had no growth-promoting power on tissue *in vitro*.

DISCUSSION

It must be emphasized that all the tests have been carried out in fresh explants from the 9-day embryo chick heart and not on pure strains of fibroblasts. The term 'fibroblast' is used here in the usual tissue-culture sense of cells characterized by a network arrangement [cf. Mayer, 1939].

Willmer's [1942] results were obtained mainly with chick periosteal fibroblasts, but in a few experiments with heart fibroblasts he found a fall in N.P.P. in Tyrode solution, while the effect of embryo extract was rather to prevent the fall than to cause a definite increase. In most of our experiments embryo extract produced a definite rise in N.P.P., and this effect was not appreciably diminished with extract which had been heated to 100° for a few minutes, or at 38° overnight. Although Carrel's [1913] original emphasis on the labile nature of the cative principles has been supported by later workers, e.g. Cracium [1931], Hueper, Allen, Russell, Woodward & Platt [1933], and Lasnitzki [1937] who found a decrease in activity on incubation at 70° for 10–30 min., recent workers have reported a greater heat stability, e.g. Paterson [1938]. Tennant, Liebow & Stern [1941] prepared in the ultracentrifuge a growth-promoting fraction from embryonic tissue the activity of which was not diminished by heating at 100° for several minutes. The effect of heated embryo extract on the N.P.P. of pure strains of fibroblasts is, of course, undetermined.

Ribonuclease attacks specifically ribonucleic acids, but its precise mode of action is unknown. Its action may be modified by the presence of protein to which the nucleic acid is bound. For example, Loring [1942] found that ribonuclease was unable to split up the nucleic acid of tobacco mosaic virus—a ribonucleoprotein—so long as the nucleic acid remained attached to the protein, although it could inactivate the virus by forming an enzyme-virus complex containing 14% enzyme. This complex could subsequently be decomposed with liberation of intact and active virus. The claim of Schramm [1941] that intestinal nucleases were able to remove the nucleic acid from the virus leaving the protein intact was not confirmed by Cohen & Stanley [1942]. Although in our experiments ribonuclease even in high concentrations has not influenced the growth of cultures in embryo extract, the participation of ribonucleoproteins as growth-promoting agents cannot be completely excluded since the possibility of the reversible formation of enzyme-ribonucleoprotein complexes remains.

The nature of the factor present in a ribonuclease-containing extract of pancreatin, which causes such a marked increase in N.P.P., is not yet fully elucidated. The effect produced is not merely a quantitative one. Qualitative changes in the type of

growth produced are also found. There is some evidence that the factor may be a P-containing degradation product of protein.

The effect of mucinase is produced only when the enzyme concentration is very high. Both in this case and in the ribonuclease experiments, the enzymes remained active in the roller tubes and one cannot therefore exclude the possibility that, in the case of mucinase, the lower N.P.P. found in presence of the enzyme might be due to a direct action of the enzyme on the cells, rather than an action on the embryo extract. These experiments do, however, suggest that the muco- or sulpho-polysaccharides may be responsible for at least some part of the growth-promoting power of embryo extract.

SUMMARY

1. The effect of various substances on the nucleoprotein phosphorus content (N.P.P.) of fresh explants from the embryo chick heart growing *in vitro* in roller tubes has been examined.

2. Cultures grown in Tyrode solution alone show a fall in N.P.P. The addition of embryo extract to

the cultures causes a definite rise in N.P.P., and this rise is unaltered when the embryo extract has been heated to 100° for 5 min.

3. Crystalline ribonuclease has no effect on the growth-promoting properties of embryo extract, but crude ribonuclease preparations from pancreatin contain a factor which causes a marked stimulation of nucleoprotein synthesis in the presence of embryo extract.

4. Cultures grown in embryo extract to which mucinase has been added in high concentration show a smaller rise in N.P.P. than control cultures grown in embryo extract without mucinase.

5. Extracts of mammalian embryos cause an increase in N.P.P. Sheep embryo cartilage extract is particularly effective.

6. Anterior pituitary extracts are without effect on the N.P.P. of the cultures.

We wish to express our gratitude to Mr E. N. Willmer of Cambridge for much valuable advice on tissue culture matters. A grant for scientific assistance from the Medical Research Council and an expenses grant from the Carnegie Trust for the Universities of Scotland to one of us (J. N. D.) are gratefully acknowledged.

REFERENCES

- Allen, R. J. L. [1940]. *Biochem. J.* **34**, 860.
 Baker, L. E. & Carrel, A. [1926]. *J. exp. Med.* **44**, 387.
 Berenblum, I. & Chain, E. [1938]. *Biochem. J.* **32**, 295.
 ——— & Heatley, N. G. [1939]. *Biochem. J.* **33**, 68.
 Brues, A. M., Tracy, M. M. & Cohn, W. E. [1942]. *Science*, **95**, 558.
 Carrel, A. [1912]. *J. exp. Med.* **15**, 516.
 ——— [1913]. *J. exp. Med.* **17**, 14.
 ——— & Baker, L. E. [1926]. *J. exp. Med.* **44**, 508.
 Caspersson, T. & Schultz, J. [1939]. *Nature, Lond.*, **143**, 602.
 ——— [1940]. *Proc. nat. Acad. Sci., Wash.*, **26**, 507.
 Cohen, S. S. & Stanley, W. M. [1942]. *J. biol. Chem.* **142**, 863.
 Cracium, E. C. [1931]. *La culture des tissus en biologie expérimentale*. Paris: Masson et Cie.
 Davidson, J. N. & Waymouth, C. [1942]. *Biochem. J.* **36**, i (Nos. 3 and 4).
 Dubos, R. J. & Thompson, R. H. S. [1938]. *J. biol. Chem.* **124**, 501.
 Ebeling, A. H. [1921]. *J. exp. Med.* **34**, 231.
 v. Euler, H. & Schmidt, G. [1934]. *Hoppe-Seyl. Z.* **225**, 92.
 Fischer, A. [1939]. *Nature, Lond.*, **144**, 113.
 ——— [1940]. *Chem. Products*, **3**, 79.
 Fischer, F. G., Böttger, I. & Lehmann-Echternacht, H. [1941]. *Hoppe-Seyl. Z.* **271**, 246.
 Greenstein, J. B. & Jenrette, W. V. [1941]. *J. nat. Can. Inst.* **1**, 845.
 Gurlt, O. [1847]. Quoted by Needham [1931].
 Hueper, W. C., Allen, A., Russell, M., Woodward, G. & Platt, M. [1933]. *Amer. J. Cancer*, **17**, 74.
 Kunitz, M. [1940]. *J. gen. Physiol.* **24**, 15.
 Laser, H. [1932]. *Biochem. Z.* **251**, 2.
 ——— [1933a]. *Biochem. Z.* **264**, 72.
 ——— [1933b]. *Z. Krebsforsch.* **39**, 384.
 Lasnitzki, I. [1937]. *Skand. Arch. Physiol.* **76**, 303.
 Lipmann, F. [1932]. *Biochem. Z.* **244**, 177.
 ——— [1933]. *Biochem. Z.* **261**, 157.
 Loring, H. S. [1942]. *J. gen. Physiol.* **25**, 497.
 Madinaveitia, J. [1938]. *Biochem. J.* **32**, 1806.
 ——— [1941]. *Biochem. J.* **35**, 447.
 Marks, H. P. & Young, F. G. [1940]. *Lancet*, **1**, 493.
 Masing, E. [1911]. *Hoppe-Seyl. Z.* **75**, 135.
 Mayer, E. [1939]. *Tabul. biol., Berl.*, **19**, 65.
 Meier, R. [1931]. *Biochem. Z.* **231**, 247, 253.
 Meyer, K., Chaffee, E., Hobby, G. L. & Dawson, M. H. [1941]. *J. exp. Med.* **73**, 309.
 Mitchell, J. S. [1940]. *Nature, Lond.*, **146**, 272.
 Needham, J. [1931]. *Chemical Embryology*, p. 465. Cambridge: University Press.
 ——— [1942]. *Biochemistry and Morphogenesis*, p. 630. Cambridge: University Press.
 Parker, R. C. [1938]. *Methods of tissue culture*, p. 156. New York: Hoeber.
 Paterson, E. [1938]. *15th Annual Report Brit. Emp. Cancer Campaign*, p. 265.
 Plimmer, R. H. A. & Scott, F. H. [1908]. *J. chem. Soc.* **93**, 1699.
 Schramm, G. [1941]. *Ber. deutsch. chem. Ges.* **74B**, 532.
 Schultz, J. [1941]. *Cold Spr. Harb. Symp. quant. Biol.* **9**, 55.
 Semura, S. [1931]. *Arch. exp. Zellforsch.* **10**, 329.
 Strangeways, T. S. P. [1924]. *The Technique of Tissue Culture in vitro*. Cambridge: Heffer and Sons.
 Tennant, R., Liebow, A. A. & Stern, K. G. [1941]. *Proc. Soc. exp. Biol., N.Y.*, **46**, 18.
 Trowell, O. A. & Willmer, E. N. [1939]. *J. exp. Biol.* **16**, 60.
 Willmer, E. N. [1942]. *J. exp. Biol.* **18**, 237.
 ——— & Kendal, L. P. [1932]. *J. exp. Biol.* **9**, 149.
 Wilson, H., Jackson, E. B. & Brues, A. M. [1942]. *J. gen. Physiol.* **25**, 689.
 Young, F. G. [1941]. *Brit. med. J.* **2**, 897.

Ribonucleic Acids in Animal Tissues

THE original view that ribonucleic acids (yeast nucleic acid, phytonucleic acid) are to be found exclusively in plant tissues, and desoxyribonucleic acid (thymonucleic acid, animal nucleic acid) exclusively in animal tissues is now known to be no longer tenable.

Apart from the ribose mononucleotides and dinucleotides which are known to play an important part in the metabolism of animal cells, ribopoly-nucleotides (nucleic acids) have been detected histo-chemically in animal tissues¹, and one such ribonucleic acid has been isolated from mammalian pancreas². Moreover, desoxyribonucleic acid has been reported in yeast cells³ and in plant tissues⁴. Both types of nucleic acid are present in bacteria⁵.

Evidence is accumulating that both in the plant cell⁶ and in animal cells⁷ desoxyribonucleic acids are to be found in the nucleus and ribonucleic acids mainly in the cytoplasm. Ribonucleic acids may also form, especially in active cells, a small proportion of the nucleic acid of the nucleus⁸ where thymonucleoprotein associated with the structure of the chromosomes predominates⁹. The nucleolus is composed of ribonucleoproteins¹⁰ and is claimed to be associated actively with the synthesis of the cytoplasmic ribonucleic acids or nucleotides which are especially abundant at the nuclear membrane. These ribonucleic acids may also form part of the mitochondria¹¹, which appear to be phospholipid-ribonucleoprotein complexes. Such complexes of phospholipid with nucleoprotein containing ribonucleic acid are found in adult liver¹¹, in normal embryonic tissue¹², in embryo and adult brain¹³, in equine encephalomyelitis virus¹⁴ and in the active fraction of tumour-producing sarcoma extracts¹⁵.

The biological activity of the ribonucleic acids has also been emphasized by their presence in plant viruses such as tobacco mosaic virus¹⁶ and in the tissue growth-promoting factor of embryo juice¹⁷, and by recent reports of high concentrations of ribonucleotides in the cytoplasm of cells in which rapid protein synthesis is taking place¹⁸, including embryonic tissues, in tumour tissues¹⁸, in the cytoplasm of proliferating and differentiating cells exposed to X- and gamma-radiation¹⁹, and in the intercellular fluids from injured cells²⁰.

We have recently demonstrated, using chiefly tissues from the adult and embryo sheep, that ribonucleic acids (ribopolynucleotides) are widely



Tissue Nucleic Acids

1. RIBONUCLEIC ACIDS AND NUCLEOTIDES IN EMBRYONIC AND ADULT TISSUE

BY J. N. DAVIDSON AND CHARITY WAYMOUTH, *Biochemical Laboratory,
Physiology Department, University of Aberdeen*

(Received 10 December 1943)

Desoxyribonucleic acid (thymonucleic acid, chromonucleic acid), known for a long time to be a constituent of the nuclei of animal cells, together with histones and the recently discovered protein chromosomin (Stedman & Stedman, 1943*a*), has been found also in plant tissues (Feulgen & Rossenbeck, 1924), in bean seedlings (Kiesel & Belozerski, 1934; Belozerski, 1936), in onion bulbs (Belozerski, 1939), in the rye grain (Behrens, 1938) and in yeast cells (Delaporte & Roukheldan, 1938). At the same time evidence has accumulated that pentose nucleic acid (ribonucleic acid, yeast nucleic acid, zymonucleic acid, plasmonucleic acid, phytonucleic acid), which differs from desoxyribonucleic acid in containing *d*-ribofuranose in place of *d*-2-desoxyribofuranose and uracil in place of thymine (methyl uracil), and which was originally thought to be solely a plant constituent (cf. Jones, 1920), is present in animal tissues.

Pentose derivatives have long been known to be present in animal tissues (Blumenthal, 1898; Grund, 1902; Wohlge-

muth, 1903; Neuberg, 1904; Mendel & Leavenworth, 1908). As well as the mono- and dinucleotide coenzymes containing adenine, e.g. adenosine triphosphate, the nicotinamide nucleotides and riboflavin-adenine-dinucleotide, pentose nucleotides of other bases have been found, e.g. uridylic acid (Levene & Mandel, 1907) in shell-fish eggs, and all four nucleotides of ribonucleic acid (Calvery, 1928) in hydrolysates of chick embryo pulp. Ribopolynucleotides may also occur. The so-called β -nucleoprotein of the pancreas, originally prepared by O. Hammarsten (1894) and subsequently investigated by Bang (1898-9, 1900-1), Feulgen (1919-20), E. Hammarsten (1920), Jones & Perkins (1924-5) and Steudel (1936), was shown by Jorpes (1924, 1928, 1934) to consist essentially of a ribopolynucleotide—probably a pentanucleotide and almost certainly similar to but not identical with the ribonucleic acid of yeast. It may form as much as 10% of the weight of the pancreas, and, like yeast nucleic acid, contains uracil (Jorpes, 1924). The presence of a ribonucleic acid containing thymine in the mammary gland is suggested by Mandel & Levene (1905). As a result of this work, and of the work of Jones & Perkins (1924-5), who found that a ribonucleotide resembling the guanylic acid of the pancreas was also present in spleen and liver, and of similar observations by Thomas & Berariu



(1924), the suggestion, supported by Jorpes (1928), was made that ribonucleic acids might be widespread in animal tissue. They have more recently been demonstrated histochemically by Brachet (1933, 1937, 1940 *a, b*) in Amphibia, by Desclin (1940) in the anterior pituitary of the growing rat and guinea-pig, and by Painter & Taylor (1942) in toads' eggs. This work has also led to the view that nucleic acids are not entirely confined to the nucleus. As long ago as 1905 Beebe & Shaffer (1905) suggested that pentose derivatives might be present in the cytoplasm of tumour cells, and such work as that of Feulgen & Rossenbeck (1924), Feulgen, Behrens & Mahdihassan (1937) and of Behrens (1938) on rye embryos and yeast cells, of Delaporte (1939) on yeast, of Painter & Taylor (1942) on toads' eggs, and of Mirsky & Pollister (1942), has given rise to the conception that, while desoxyribonucleic acid is located exclusively in the nucleus (Mirsky, 1943), ribonucleic acid is chiefly a cytoplasmic constituent. It has been reported, however, in small amounts in the nucleus (Schultz, 1941) and especially in the nucleolus (Brachet, 1940 *a, b*; Caspersson & Schultz, 1940; Mitchell, 1942; Gersh, 1943).

Ribonucleic acids may occur in the form of phospholipin-ribonucleoprotein complexes in liver cells, e.g. in the mitochondria (Claude, 1941, 1943; Bensley, 1942), in normal chick embryonic tissue (Taylor, Sharp, Beard & Beard, 1942; Claude, 1940, 1941), in the embryonic chick brain (Taylor, Sharp & Woodhall, 1943), in tumour-producing fowl sarcoma extracts (Claude, 1939) and in the virus of equine encephalomyelitis (Taylor, Sharp, Beard & Beard, 1943). The importance of ribonucleic acids in biologically active material has further been emphasized by their presence in chloroplasts (Menke, 1938), in plant viruses (Loring, 1939; Stanley, 1939; Stanley & Knight, 1941), in the growth-promoting factor of embryo juice (Fischer, 1939, 1940, 1942), in some enzyme systems (Potter & Albaum, 1943) and by the presence of their derivatives in the materials liberated by injured cells (Loofbourow, 1942). Using spectrophotometric methods in conjunction with the quartz microscope, Caspersson (1936, 1940) has located materials which show powerful absorption at 2600 Å and which he claims to be ribonucleotides or ribonucleic acids (he does not distinguish clearly between mono- and polynucleotides), in the cytoplasm of rapidly proliferating cells such as sea-urchin eggs, the spinach root-tip periblem cell and the imaginal disks of larvae of *Drosophila melanogaster* (Caspersson & Schultz, 1939, 1940), in the embryo (Caspersson & Schultz, 1939; Caspersson & Thorell, 1941 *a, b*), in tumour tissues (Caspersson, Nyström & Santesson, 1941) and in the cells of actively secreting glands (Caspersson, Landström-Hydén & Aquilonius, 1941). A high concentration of similar absorbing materials, which may be ribonucleic acids, has been found in the cytoplasm of proliferating and differentiating cells exposed to X- or gamma-radiations (Mitchell, 1942). Caspersson (1941) has concluded that a high concentration of these absorbing materials (presumably ribonucleic acids or ribonucleotides) is characteristic of the cytoplasm of cells in which rapid protein synthesis is taking place (either for growth or for secretion), and is to be associated rather with protein synthesis than with metabolic activity or fermentation (Caspersson & Brandt, 1941).

We have attempted to establish first whether ribonucleic acids are indeed of widespread occurrence in animal tissues, and secondly whether there

is a high concentration of ribonucleic acid and/or of ribonucleotides in rapidly growing tissues. In a preliminary note (Davidson & Waymouth, 1943*a*), we reported that ribonucleic acids are widely distributed in animal tissues. The comparison between embryonic and adult tissues is further extended in this paper.

METHODS

Materials

We have used chiefly the tissues from the freshly killed adult and embryo sheep. The embryos were all about 9–10 weeks old, a stage at which growth is very rapid (Gurlt, 1847). Arrangements were made to obtain the material immediately after slaughter but, even so, some hydrolysis by the very active tissue nucleotidases of nucleotide to nucleoside was unavoidable.

Small organs were pooled for analysis. In the case of large organs groups of specimens were analyzed separately at different times. Where fowl tissues were used, they were excised from the anaesthetized bird and dealt with immediately. Chick embryos were used immediately on removal from the egg. In some cases avian material was frozen with solid CO₂ immediately on removal from the bird or egg, but this procedure was later found to be unnecessary.

Analytical methods

Moisture was determined by drying at 100° to constant weight.

Nucleotide, nucleoside, and free-purine N were determined in trichloroacetic acid extracts by the method of Kerr & Blish (1932) as modified by Kerr (1940). The sum of all three gave the total acid-soluble purine N.

Total nucleic acid was estimated on 15–25 mg. portions on the basis of nucleoprotein phosphorus (NPP) determinations by the method of Berenblum, Chain & Heatley (1939), in which lipid P is extracted with ethanol-chloroform mixture, and acid-soluble P is extracted with HCl and the remaining acid-insoluble P, as determined by the micromethod of Berenblum & Chain (1938), is taken to be nucleic acid P. This is almost certainly not the case, as Jorpes (1928) has suggested, and our own observations (*vide infra*) support this view. Most methods of estimating NPP in tissues, such as the original one of Kossel (1882), and the later similar ones used by Malan & Green (1928), Needham & Needham (1930), Euler & Schmidt (1934), Tuttle, Erf & Lawrence (1941) and Marshak (1940), depend upon the same principle, and estimate residual P after extraction with lipid solvents and acid. In our results, therefore, the figures for NPP indicate rather residual acid-insoluble P (the 'protein-bound P' of Rosenthal & Drabkin (1943)). This fraction

will, of course, include phosphoprotein P (Plimmer & Scott, 1908; Plimmer & Kaya, 1910; Needham & Needham, 1930; Euler & Schmidt, 1934), which appears, however, to be low in nearly all tissues, including embryonic tissue (Euler & Schmidt, 1934). The residual P would also include such ill-defined compounds as the phosphoglucoproteins and gluco-nucleoproteins mentioned by Wells (1925).

Ribonucleic acid and desoxyribonucleic acid were estimated by methods involving the determination of pentose and of desoxypentose, after extraction and precipitation of the nucleic acids.

Acid-soluble P and lipid-soluble P were extracted from ethanol-ether-dried tissue and the resulting residue, containing the acid-insoluble P (protein-bound residual P as previously mentioned) was dried in a vacuum desiccator. Euler & Schmidt (1934) claim that preliminary treatment with ethanol and ether binds some acid-soluble P to the protein and renders its subsequent extraction difficult, but we have found no difference in the P content of powders prepared by Euler & Schmidt's and our own methods.

In extracting the nucleic acids from the tissue powders the use of alkali was avoided. Most methods for the isolation of desoxyribonucleic acid are sufficiently drastic to cause at least partial destruction of ribonucleic acid, but a suitable reagent for the extraction of both nucleic acids was found to be 10% NaCl (cf. Jorpes, 1928, 1934; Javillier & Allaire, 1926*b*, 1931). From the NaCl extract the nucleic acids were precipitated as lanthanum salts, which have been shown by Caspersson, Hammarsten & Hammarsten (1935) and by Caspersson (1936) to be very insoluble. From 10% NaCl solution the precipitation is incomplete unless one volume of ethanol is added. In the precipitate pentose and desoxypentose were colorimetrically estimated. We have sought independent confirmation of the presence of ribonucleic acids by more specific methods, using the enzyme ribonuclease which attacks specifically the ribonucleic acids (Kunitz, 1940). The action of ribonuclease is not fully understood. It does not break down nucleic acid completely to the component mononucleotides, but whereas 100% of the phosphorus of ribonucleic acid is precipitable by 0.25% uranyl acetate in 2.5% trichloroacetic acid, only 40% of the P is so precipitable after the action with the enzyme has gone to completion. The extent of the reaction depends on a number of factors (Kunitz, 1940), and for this reason the application of the enzyme to the exact quantitative estimation of the nucleic acids is not feasible. We have, however, made use of ribonuclease not only to confirm the presence of ribonucleic acids but to give a semi-quantitative estimation of the amount of nucleic acid present by allowing crystalline ribonuclease in

high concentration to act to completion on the NaCl extract and by measuring the amount of uranyl precipitable P rendered non-precipitable by the enzyme.

General analytical procedure. The fresh tissue is minced, dehydrated with several successive portions of ethanol and of ether, and dried in a vacuum desiccator. The dried material is ground to a fine powder in a mill and passed through a sieve. About 2 g. of the powder are weighed out into a stoppered centrifuge tube and are shaken for six 1 hr. periods with successive portions of about 40 ml. 0.1N-HCl. This process removes acid-soluble P, including simple nucleotides. The residue is washed twice with ethanol and is then extracted for two successive 2 hr. periods at 65° under a reflux condenser with an ethanol-chloroform mixture (3:1). It is then washed with ether and dried.

Total P is estimated in the extracted powder by a modification of the method of Allen (1940) and purine N by the method of Graff & Maculla (1935). Phosphoprotein P is determined by a method similar to that of Euler & Schmidt (1934), making use of the fact that phosphoprotein P is split off as inorganic P when the phosphoprotein is incubated at 37° for 24 hr. with 0.25N-NaOH (Plimmer & Scott, 1908). After removal of protein with trichloroacetic acid, inorganic P is precipitated, as described by Lohmann (1928), with Mathison's (1909) reagent.

For the nucleic acid extraction a suitable quantity (50-750 mg., depending on the P content) is then weighed out into a 15 ml. conical centrifuge tube and 2 drops triacetin added. Extraction with 10% NaCl is then carried out with five successive 3 ml. portions, (a) for 4 hr. at 0°, (b) overnight at 0°, (c) for 30 min. at 100°, (d) for 10 min. at 100°, and (e) for 10 min. at 100° respectively.

The extracts are combined and made up to 15 ml. 1.0 ml. is taken for total P estimation. 1.5 ml. portions are taken for the ribonuclease test (*vide infra*). 9 ml. are pipetted into a 25 ml. centrifuge tube and 1 ml. 2% lanthanum acetate and 10 ml. ethanol added. After 1 hr. at 0° the precipitate is centrifuged down and washed twice with 3 ml. 0.2% lanthanum acetate. It is decomposed with 0.6 ml. 0.5M-Na₂CO₃ and 5.4 ml. water are added. The lanthanum carbonate is centrifuged down.

The supernatant is treated as follows: (i) 1 ml. is taken for total P estimation; (ii) 1 ml. is taken for estimation of pentose by a modification of the method of Reeves & Munro (1940). This method depends upon the liberation of furfural, which is trapped in xylene and allowed to react with aniline acetate. The 1 ml. of solution is pipetted into a graduated test-tube with a B 14 ground glass socket. 2 ml. 5.55N-HCl and 5 ml. xylene (purified by distillation) are added. The tube is attached to an

air condenser with ground-glass cone and is immersed in a briskly boiling water-bath for $2\frac{1}{2}$ hr. The contents are cooled and the xylene layer made up to 7 ml. The lower aqueous layer is sucked off with a fine pipette and the xylene layer dried with anhydrous sodium acetate. When the xylene has cleared, 5 ml. is pipetted into a dry pyrex tube and 5 ml. freshly made aniline acetate reagent (1 ml. colourless aniline dissolved in 50 ml. Analar glacial acetic acid and 50 ml. ethanol) added. The tube is allowed to stand in the dark room for precisely 20 min. and the red colour then examined in the Hilger Spekker Absorptiometer (filter no. 6), with a calibration curve drawn up in terms of ribonucleic acid phosphorus (RNAP) and prepared from standard solutions of ribonucleic acid purified by precipitation from glacial acetic acid as described by Kunitz (1940). Yeast ribonucleic acid and liver ribonucleic acid gave similar curves. Desoxyribonucleic acid does not interfere. (iii) 3 ml. are taken for the colorimetric estimation of desoxypentose by the modification by Sevag, Smolens & Lackman (1940) of the diphenylamine reaction of Dische (1930). The 3 ml. solution are pipetted into a conical graduated centrifuge tube containing 1 ml. 0.55N-HCl. The tube is heated in a boiling water-bath for 15 min., cooled, and the volume made up to 4 ml. 3 ml. of the supernatant are transferred to a pyrex tube and 8 ml. freshly made diphenylamine reagent added (1 g. diphenylamine (Analar, twice recrystallized from ethanol) dissolved in 2 ml. H_2SO_4 (Analar) and 98 ml. glacial acetic acid (Analar)). The tube is placed in the briskly boiling water-bath for 3 min., quickly cooled and, after 5 min., the blue colour is read in the Hilger Spekker Absorptiometer (filter no. 1) and compared with data in a calibration curve drawn up in terms of desoxyribonucleic acid phosphorus (DNAP). Ribonucleic acid does not interfere, nor does chondroitin sulphuric acid. Using these two methods, we have obtained good recovery from a mixture of ribo- and thymonucleic acids in 10% NaCl. Both calibration curves were made with nucleic acids precipitated as La salts.

For the ribonuclease method, 1.5 ml. NaCl extract are pipetted into each of three 15 ml. conical centrifuge tubes. 2.4 ml. veronal buffer pH 6.12 (Michaelis, 1931) are added to each tube and 0.2 ml. of a solution of 5 mg. crystalline ribonuclease in 100 ml. water is added to one tube. The other two tubes are used as controls. To one of these are added immediately 4.0 ml. 0.25% uranyl acetate in 2.5% trichloroacetic acid. The remaining control tube and the tube containing enzyme are immersed in a thermostatic bath at 37° for 1 hr. before the uranyl acetate reagent is added. 15 min. after addition of the reagent the tubes are centrifuged and the precipitate washed with 2 ml. 0.125% uranyl acetate

in 1.25% trichloroacetic acid. It is then dissolved in 0.5M- Na_2CO_3 and the solution is transferred to a digestion flask for total P determination. The non-incubated tube gives the amount of uranyl precipitable P originally present, while the tube containing enzyme gives the amount present after ribonucleic acids have been broken down. The second control without enzyme gives a measure of the amount of spontaneous decomposition of nucleic acid in 60 min. at 37° . In most cases it is low.

With each batch of tubes used in this determination a standard set of three tubes containing 0.1% purified ribonucleic acid in 10% NaCl is set up to check the extent of hydrolysis. Under the conditions stated, about 60% of the ribonucleic acid P is rendered non-precipitable by the enzyme. Sodium chloride does not inhibit the action of the enzyme, but the degree of hydrolysis of ribonucleic acid may be to some extent influenced by the quantity of desoxyribonucleic acid present. The enzyme has no action on desoxyribonucleic acid.

Examination of the procedure. When calibration curves reading directly in ribo- or desoxyribonucleic acid phosphorus are used, the assumption is made that the nucleic acid in the tissues contains the same amounts of ribose (or rather furfural-yielding material), since purine and pyrimidine nucleotides yield different amounts of furfural (Levene & Jorpes, 1930) relative to P, or of desoxyribose to P, as do the pure acids used to prepare the calibration curves. This assumption appears to be justified in the case of a ribonucleic acid which we have isolated from the liver and which gives figures which agree well with the calibration curve prepared from yeast nucleic acid. In the case of desoxyribonucleic acid (Vowles, 1940), the sugar residues from the purine nucleotides also react in the estimation to a much larger extent than those from pyrimidine nucleotides, and the estimation of desoxyribose will be valid only if all tissue desoxyribonucleic acids contain equimolecular amounts of purine and pyrimidine. This appears to be the case (Mirsky, 1943).

Compounds of lanthanum and other metals are capable, under certain conditions, of hydrolyzing organic phosphates (Bamann & Meisenheimer, 1938). The danger of interference from actions of this type in the present circumstances is negligible.

One object of extracting the nucleic acids and precipitating them as lanthanum salts was to reduce the possible danger of interference in the pentose estimation by furfural derived from uronic acids (e.g. of muco- and sulpho-polysaccharides).

It cannot be taken for granted that the ribonucleic acids of the tissues are identical with yeast nucleic acid. They do, however, function as substrates for ribonuclease, and the ribonucleic acid which we have isolated from liver suffers the same degree of hydrolysis as does yeast nucleic acid.

RESULTS

Total nucleic acid

The results of the NPP estimations are shown in Table 1.

The position of nervous tissue is rather striking (Table 1). Not only does the white matter of the central nervous system have a higher NPP than the grey matter, but even peripheral nerve has an appreciable NPP content comparable indeed with that of muscle. Caspersson (1941) records a high

Table 1. *Nucleoprotein phosphorus (NPP) and water contents of adult and embryonic tissues*

Sheep embryos, 9-10 weeks. Chick embryos, 16 days.

Each figure represents the mean value of several estimations from different animals.

NPP on dry-weight basis calculated from NPP on wet-weight basis and water content.

Tissue	Adult			Embryo			Ratio $\frac{\text{Embryo NPP}}{\text{Adult NPP}}$	
	Water content (%)	NPP content (mg./100 g.)		Water content (%)	NPP content (mg./100 g.)		Fresh tissue	Dry tissue
		Fresh wt.	Dry wt.		Fresh wt.	Dry wt.		
			Sheep					
Liver	69.7	70	231	82.6	103	592	1.5	2.6
Lung	79.0	88	419	89.0	84	763	1.0	1.8
Small intestine	80.3	110	559	88.4	78	673	0.7	1.2
Heart	77.7	29	129	87.0	64	492	2.2	3.8
Spleen	77.2	129	566	83.0	109	642	0.8	1.1
Kidney (cortex)	81.0	80	421	87.0	85	654	1.2	1.6
Kidney (medulla)	85.5	47	324	90.4	34	354	0.7	1.1
Brain (grey matter)	84.2	18	114	92.6	24	324	1.3	2.8
Brain (white matter)	74.2	53	206	90.5	24	253	0.5	1.2
Muscle	74.8	19	75	87.4	47	373	2.5	5.0
Cartilage	60.1	21	53	78.4	43	199	2.0	3.8
Testis	86.4	58	427	—	—	—	—	—
Ovary	81.9	101	558	—	—	—	—	—
Thyroid	75.4	25	102	80.2	78	394	3.1	3.9
Thymus*	—	—	—	84.2	170	1080	—	—
Skin	63.5	38	107	89.3	56	524	1.4	4.9
Placenta	87.8	59	484	—	—	—	—	—
Lymph node (calf)	79.6	185	925	—	—	—	—	—
			Fowl					
Heart	80.1	32	161	91.0	75	835	2.3	5.2
Liver	72.3	113	408	80.0	95	475	0.8	1.2
Brain	79.1	25	119	89.1	50	459	2.0	3.9
Nerve	71.2	59	205	—	—	—	—	—
Muscle	75.9	30	125	81.4	74	398	2.5	3.1
Rous sarcoma	88.2	61	516	—	—	—	—	—

* 15-week embryo.

The water content of the embryonic tissues is considerably higher than that of the corresponding adult tissues. As a result the difference in NPP between embryo and adult is much more marked when the comparison is made on a dry-weight basis than on a fresh-tissue basis.

When the figures for the embryo and the adult are compared on a dry-weight basis it is found that the NPP in the embryo is invariably higher than in the corresponding adult tissue. In some cases the difference is very marked, e.g. heart, muscle, cartilage and thyroid. In some tissues, on a fresh-weight basis, the difference between embryo and adult is small and the figure for the adult may actually be higher, e.g. intestine, spleen, kidney medulla, brain (white matter).

ribonucleotide or ribonucleic acid content in nerve cells.

The high water and NPP contents of Rous sarcoma (Table 1) appear to be characteristic of neoplastic tissue.

The figures for the P content of the tissues extracted in bulk (Table 2) are of course essentially the same as the NPP figures on a dry-weight basis, except that the P content is expressed in terms of a powder from which all acid-soluble and lipid material has been removed. To investigate whether or not all this P could be taken to be nucleic acid P, purine estimations were carried out on the extracted powders. If the tissue nucleic acids have the same relative amounts of purine and P as have purified thymonucleic acid and yeast nucleic acid (and this

Table 2. *Analyses of tissue powders remaining after extraction of acid-soluble and lipoid P, and of lanthanum salts precipitated from the NaCl extract of these powders*

All tissues from the adult or 9-10 weeks' embryo sheep unless otherwise stated.
Nucleic acid P = purine N \times 0.886 (assuming purine N : P atomic ratio of 10 : 4).
DNAP = deoxyribonucleic acid P. RNAP = ribonucleic acid P.

Tissue	Extracted tissue powder				P in NaCl extract as percentage of P in extracted powder	Precipitate of La salts			
	Total P (mg./100 g.)	Purine N (mg./100 g.)	Nucleic acid P calculated from purine content (mg./100 g.)	Nucleic acid P as percentage of total P		P in La ppt. as percentage of P in NaCl extract	DNAP as percentage of P in La ppt.	RNAP as percentage of P in La ppt.	Ratio RNAP/DNAP
Adult liver	384	353	313	82	84	74	19	65	3.5
Embryo liver	1175	1241	1101	94	75	60	24	61	2.6
Adult lung	565	397	352	62	94	73	50	43	0.9
Embryo lung	1225	866	767	63	93	69	50	35	0.7
Adult gut	636	622	551	87	88	66	41	39	1.0
Embryo gut	958	782	693	72	82	83	31	35	1.1
Adult heart	219	174	154	70	56	65	19	70	3.6
Embryo heart	616	546	484	79	81	79	25	59	2.4
Adult spleen	914	974	863	95	78	67	50	27	0.5
Embryo spleen	1380	1448	1284	93	97	70	47	26	0.6
Adult kidney	442	400	355	80	74	74	29	52	1.8
Embryo kidney	923	949	840	91	79	72	49	41	0.8
Adult brain	369	215	190	52	40	67	31	65	2.1
Embryo brain	556	340	301	54	82	79	23	55	2.3
Adult muscle	147	145	129	88	55	71	19*	66	3.6*
Embryo muscle	650	572	507	78	95	70	37	53	1.4
Adult cartilage	84	85	75	89	63	40	41	—	—
Embryo cartilage	382	343	304	80	92	53	40	60	1.5
Adult thyroid	166	167	148	89	63	68	24	48	2.0
Embryo thyroid	682	732	649	95	83	69	39	41	1.1
Adult skin	135	141	125	93	68	48	32	60	1.9
Embryo skin	842	824	730	87	94	68	43	41	1.0
Adult testis	660	624	553	84	70	66	26	67	2.6
Adult ovary	484	444	394	81	87	42	39	52	1.3
Sheep placenta	655	613	543	83	83	74	33	65	2.0
Thymus (15-week sheep embryo)	2760	2696	2390	87	97	72	66	13	0.2
Whole blood (embryo sheep)	152	—	—	—	63	73	32	63	2.0
Nuclei (embryo sheep liver)	2630	2382	2110	80	86	82	75	14	0.2
Dried sheep embryo extract	192	175	155	81	82	93	11	83	7.4
Nucleoprotein fraction from embryo extract	658	746	661	101	82	80	81	10	8.0
Whole chick embryo (9 days)	1040	1017	901	87	86	74	29	58	2.0
Whole human embryo (3 months)	590	613	544	92	80	75	29	59	2.1
Ox pancreas	1670	1782	1580	95	79	87	10	82	8.0

* The total nucleic acid content of muscle is so low that the figures quoted should be regarded as provisional.

qualification appears to hold for the deoxyribonucleic acids of the tissues (Mirsky, 1943), the atomic ratio of purine N to P is 10 : 4 for tetranucleotides. The ratio would, of course, be higher in the case of pentanucleotides (Jorpes, 1934). As Table 2 shows, in many cases the figure for nucleic acid P calculated from purine N is rather less than the figure for total P. It is probable therefore that

some of the P in the extracted powder is not present in the form of nucleic acid. Alders (1927) carried out estimations of both NPP and total purine in thymus, kidney, pancreas and spleen. Except in the case of ox pancreas, the nucleic acid calculated from the purine content was lower than that calculated from the NPP (see also Graff & Barth, 1938).

The nature of the non-nucleic acid residual P is still in doubt. Some of it may be present as phosphoprotein, but estimations show that the phosphoprotein P is in most cases negligible and in all cases is less than 5% of the total residual P except in adult brain (6.2%) and adult heart (6.7%). Euler & Schmidt (1934) found that the phosphoprotein P in most tissues is very low, and in so far as comparison is possible (Euler & Schmidt quote only for fresh tissue) our figures are rather lower than theirs.

Ribonucleic and desoxyribonucleic acids

The percentage of P extracted by NaCl from different tissues is not uniform (Table 2). In most cases it is of the order of 80–90%, but in certain tissues, e.g. adult heart, adult muscle and adult brain, particularly the last, the amount extracted is low, although constant for different specimens.

The amount of P in the NaCl extract, which appears in the precipitate of La salts, is also variable (Table 2). Precipitation is poor in the case of cartilage, skin and ovary, all of which yield extracts containing much material of a mucopolysaccharide type. As a result the La precipitate contains in most cases 60–80% of the P of the extracted powder. As previously shown, the P of the extracted powder is not entirely derived from nucleic acid. In such tissues as adult heart, brain, muscle, cartilage, skin and ovary, the percentage is much lower. It is, however, even in these cases remarkably constant for different batches of powder prepared from different animals.

Results of the analyses of the La precipitate for pentose and desoxypentose are shown in Table 2 expressed in terms of ribonucleic acid phosphorus (RNAP) and desoxyribose nucleic acid phosphorus (DNAP) as percentages of the total P. In most cases 80–95% of the total P in the La precipitate can be accounted for in terms of ribo- or desoxyribonucleic acid. In the case of adult cartilage, the sum was greater than 100%, on account of interference in the pentose estimation by chondroitin sulphuric acid. The RNAP/DNAP ratios for the La precipitates (Table 2) vary greatly from tissue to tissue, being high in such tissues as pancreas, liver, heart, brain, testis and muscle and low in thymus, spleen and lung. These ratios are not necessarily the same as those which obtain in the original tissue, especially in those cases where the proportion of P extracted and precipitated is relatively low, e.g. adult heart and adult brain.

In any given tissue the ratio of RNAP to DNAP is of the same order in the embryo as in the adult, or is somewhat higher in the adult. Therefore, since the amount of total nucleic acid is higher in the embryo than in the adult, any given embryonic

tissue must have a higher content not only of nuclear desoxyribonucleic acid, but also of cytoplasmic ribonucleic acid.

To examine the view that desoxyribonucleic acid is found in the nuclei and ribonucleic acid in the cytoplasm, nuclei of embryo sheep liver were isolated by the citric acid method of Marshak (1941). Acid-soluble and lipoid P were extracted from the nuclei and the residue worked up in the usual way (Table 2). The very low RNAP/DNAP ratio (0.2) suggests that, if the nucleic acid content of the nuclei remains unaltered during the isolation process, there is indeed very little ribonucleic acid in the nuclei. The small amount found may be due in part at least to adherent cytoplasmic residues. On the other hand, ribonucleic acid predominated in a saline extract of minced whole sheep embryo. The extract was prepared by allowing the minced embryos to stand overnight with Tyrode solution at 0°. It was then filtered through gauze and centrifuged. The extract so obtained had powerful growth-promoting action on chick heart fibroblasts *in vitro* (Davidson & Waymouth, 1943*b*). It was dried either in vacuum desiccators over H₂SO₄ or in the air at room temperature in the blast of an electric fan as recommended by Fischer (1942), and powdered. Such a saline extract would be expected to contain mainly cytoplasmic material (cf. Mirsky & Pollister, 1942), and the RNAP/DNAP ratio obtained (7.4) is evidence in favour of the predominance of ribonucleic acids in the cytoplasm.

From such an embryo extract the 'nucleoprotein' fraction which was precipitated by acetic acid at pH 4.3 was centrifuged down, washed repeatedly with very dilute acetic acid, extracted with ethanol-chloroform mixture and worked up as usual. Again the ratio was high (8.0).

Confirmatory evidence for the presence of ribonucleic acids by experiments with ribonuclease

In all cases the NaCl extract of the tissue contained a proportion of phosphorus which treatment with ribonuclease rendered non-precipitable by uranyl acetate reagent. The amount of P in the NaCl extract precipitable by the uranyl acetate reagent is in most cases of the same order as that precipitable by lanthanum acetate. With yeast ribonucleic acid as substrate, 60% of the P is rendered non-precipitable when ribonuclease has acted to completion. On the same basis the ribonucleic acid content of the NaCl tissue extract has been calculated as a percentage of the total P in the extract. The relationship between the percentage of RNAP in the La precipitate and in the NaCl extract is shown in Fig. 1. In most cases there is reasonably good correlation between the pentose content in the La precipitate and the amount of substrate for

ribonuclease in the NaCl extract. This agreement gives independent confirmation of the presence of ribonucleic acids in the tissue powders.

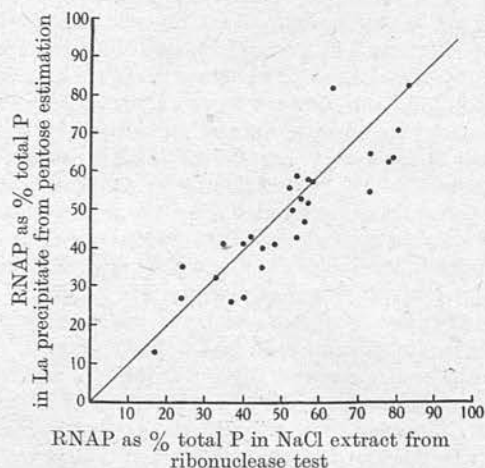

Fig. 1. Correlation between the ribonucleic acid P content of the tissues, calculated from the pentose content and from the ribonuclease test.

Nucleotides, nucleosides, and free purine

The simple mononucleotides differ from the polynucleotides in being acid-soluble and in appearing in a trichloroacetic acid filtrate. The purine nucleotides which are precipitated by uranyl acetate include adenosine triphosphate, adenylic acid, inosinic acid, the nicotinamide nucleotides and riboflavin-adenine-dinucleotide. Of these adenosine triphosphate accounts for the major part of the total tissue nucleotides, while the last two form only a very small proportion of the total. The nucleosides together with free purines are estimated separately, and the sum of these and the nucleotides gives the total acid-soluble purine N. As most tissues (particularly brain) contain an active nucleotidase which rapidly dephosphorylates nucleotides to nucleosides (Reis, 1937; Kerr, 1942), and as rapid deamination of adenine derivatives is liable to occur, the tissues must be ground in trichloroacetic acid immediately on removal from the animal. For the sheep tissues, in which some hydrolysis of nucleotide to nucleoside was unavoidable, figures for total acid-soluble purine N only are quoted (Table 3). Control experiments have shown that the loss in total acid-soluble purine under the conditions of our experiments would be very slight. By the method of analysis employed excellent agreement of duplicates was obtained, but specimens of the same tissue from different animals showed a wide range of variation. Individual figures are therefore quoted. Of the tissues examined, adult muscle gives higher figures than any other

tissue. Lower values were found for all the embryo tissues than for the corresponding adult tissues (Table 3).

Table 3. Total acid-soluble purine N (nucleotide N + nucleoside N + free purine N) in trichloroacetic acid extracts of different samples of adult sheep and 9-10 weeks' embryo sheep tissues

Tissue	Total acid-soluble purine N (mg./100 g. fresh tissue)	
	Embryo	Adult
Liver	24.4, 28.6, 28.0	35.9, 36.4
Heart	30.9, 20.0, 21.7	37.5, 48.3, 45.9, 43.8
Muscle	24.2, 25.4, 25.3	53.9, 40.6, 57.1
Spleen	30.8	41.5, 29.8, 37.8, 35.0
Brain:		
Whole	20.9, 21.6, 18.6	24.6, 32.6
Grey matter		20.0, 28.0, 17.5
White matter		23.8, 23.1, 19.6
Kidney	22.3, 17.5, 17.5	25.3, 31.5
Lung	24.2, 13.3, 15.4	30.5, 25.7
Cartilage	15.6, 19.6, 15.4	—

In the case of the fowl tissues (Table 4), the conditions of the experiments minimized the chances of hydrolysis of nucleotide to nucleoside, and figures for nucleotide and nucleoside are quoted separately. Adult muscle has the highest total nucleotide content. In muscle, however, the amount of nucleoside relative to nucleotide is low; in heart, and especially in liver, nucleoside and free purine form a much more significant proportion of the total acid-soluble purine. In the chick embryo both fractions are low and the total acid soluble purine N content is of the same low order as in the case of the sheep embryo.

Our results are expressed in terms of fresh tissue. Owing to the higher water content of embryonic tissue, much smaller differences between embryo and adult are apparent if the results are expressed in terms of dry weight.

Preliminary results on tumour tissues suggest that the total soluble purine N is low. Figures for the Rous sarcoma are shown in Table 4.

DISCUSSION

Estimations of the nucleic acid content of sheep tissues have not, as far as we are aware, been previously recorded. Kossel (1882) quotes only one figure for sheep tissue (brain) and his figure (99 mg./100 g. of fresh tissue) in this case, as in the case of other tissues from other species, is rather higher than ours. Our figures are, however, very much of the same order as those of Javillier & Allaire (1926a) for the horse, Jorpes (1928) for the ox and Grund (1910) for the dog and hen.

On a dry-weight basis embryonic tissues are richer in nucleic acid than the corresponding adult

Table 4. *Nucleotide, nucleoside, and free purine content of the adult and embryo fowl*

Adult birds fasted 24 hr. before use. All figures are in mg. N/100 g. fresh tissue.

Exp. no.	Tissue	Nucleotide N	Nucleoside N (free purine N)	Total soluble purine N
204*	Adult liver	21.6	14.1	35.7
208	"	30.0	16.5	46.5
209	"	20.3	13.6	33.9
212	"	26.6	23.8	50.4
219	"	27.3	14.3	41.6
203*	Adult heart	27.6	12.0	39.6
207	"	29.1	15.4	44.5
210	"	23.4	15.0	38.4
201*	Adult muscle (breast)	52.4	5.9	58.3
205	"	42.3	10.2	52.5
402†	"	40.0	11.2	51.2
404†	"	31.1	13.7	44.8
406†	"	41.8	11.6	53.4
202	Adult muscle (leg)	34.6	7.3	41.9
206	"	26.3	7.7	34.0
408†	"	28.7	9.1	37.8
301*	Whole chick embryo (9 day)	14.1	6.0	20.1
308	" (9 day)	10.8	6.0	16.8
1 E	" (10 day)	11.2	5.6	16.8
2 E	" (10 day)	12.6	7.0	19.6
302*	" (13 day)	14.8	3.6	18.4
303*	" (13 day)	14.4	4.1	18.5
305	Chick embryo muscle (16 day)	15.8	7.0	22.8
9 E	Chick embryo viscera (16 day)	16.8	9.8	26.6
8 E	Chick embryo minus viscera (16 day)	17.5	7.0	24.5
401†	Rous sarcoma	11.9	7.0	18.9
403†	"	7.7	7.0	14.7

* Tissues frozen in solid CO₂.

† From birds with Rous sarcoma.

tissues. No extensive comparison of the tissues of any one species is to be found in the literature, but figures have been quoted for individual tissues. Masing (1911) has shown that the NPP of whole-rabbit embryo and of embryo rabbit liver diminishes progressively as the age of the embryo increases, while Dumm (1943) has recorded a fall in the NPP of embryo rat liver with age. Le Breton & Shaeffer (1923), using pig and mouse embryos, have found a fall in purine N concentration as gestation advances. Kossel (1882) quotes a higher figure for cattle embryo muscle than for adult muscle.

Liver tissue is of special interest. Kosterlitz & Cramb (1943) have shown that in rats fasted 24-48 hr. there is a fall in liver NPP in terms of the original body weight, although the NPP/100 g. of liver rises. We have confirmed this rise in NPP in the liver of fasting rat. It would appear, therefore, that in the liver at least, the NPP is conditioned to some extent by the nutritional condition of the animal. Embryo liver differs from adult in containing numerous erythropoietic cells, and chemical comparison of embryo and adult liver must be made with this reservation in mind.

The procedure which we have described must not be regarded as an accurate quantitative estimation of the ribonucleic acid content of tissues. It serves,

however, to demonstrate the presence of ribonucleic acids in all the tissues examined and to give an indication of the relative amounts of ribo- and desoxyribonucleic acids.

If crystalline ribonuclease attacks ribonucleic acids only, and if it is uncontaminated by traces of other enzymes (and there appears to be no reason to doubt the validity of these assumptions), then the NaCl extract of the tissue powder contains a substrate for ribonuclease, presumably therefore a ribonucleic acid. Moreover, in the precipitate of lanthanum salts obtained from the NaCl extract, a certain proportion of the P present can be accounted for in terms of pentose. Finally, the amount of pentose-containing material and the amount of substrate for ribonuclease show a definite correlation. There seems to be no doubt, therefore, that we are dealing with some type of ribonucleic acid. Whether all tissues contain the same ribonucleic acid and whether in that case it is similar to the ribonucleic acid of the pancreas or of yeast or to neither, is of course unknown, but preliminary observations on the ribonucleic acid which we have isolated from liver suggest that it is similar to yeast nucleic acid.

The amounts of ribonucleic acid in many tissues are high. Where the same organs have been ex-

aminated by Jorpes (1928) there is agreement between his results and our own. Jorpes estimated both NPP and total pentose in the fresh tissue. For thymus he found a total NPP of 0.441% and a pentose content of 0.152% corresponding to 0.063% pentose nucleic acid phosphorus (if all pentose comes from ribonucleic acid). 14.2% of the NPP could therefore be accounted for as RNAP. Similarly, in pancreas 84.3% of the NPP is RNAP. If the remainder of the NPP is all DNAP these figures would give ratios RNAP/DNAP of 0.2 for thymus and 5.4 for pancreas. From Jorpes's data the ratios can similarly also be calculated to be 2.1 for ox liver, 3.2 for rabbit liver, and 0.5 for ox spleen. The ratios calculated from the results of Jorpes, therefore, are of the same order as our own.

In the case of liver nucleoprotein, Brues, Tracy & Cohn (1942), using the radioactive phosphorus isotope P^{32} , found that only about 50% of the residual P after extraction of acid-soluble and lipid P could be accounted for in terms of desoxyribonucleic acid. The remainder had a higher specific activity. These authors point out that they do not distinguish cytoplasmic from nuclear nucleic acids but that they have obtained some evidence that 'the former have a higher rate of phosphorus turnover than the latter'. Somewhat similar results were obtained with P^{32} by Hevesy & Ottesen (1943), who have shown that after very exhaustive extraction of muscle and other tissue of the frog with trichloroacetic acid and ethanol-ether, the specific activity of the residual P was much higher than that of the P in purified (desoxyribo-) nucleic acid prepared from the same material. These results might be due in part to the presence of ribonucleic acids with a high specific activity.

Fischer (1939, 1940, 1942) has claimed that the growth-promoting substances of embryo juice are associated with the nucleoprotein fraction and has suggested that the activity may lie in ribonucleoproteins. Our results show that of this fraction some 80% is in fact ribonucleoprotein, but its relationship to the growth-promoting properties of the extract is not fully established.

The acid-soluble nucleotide content varies considerably from tissue to tissue and even, in contrast to total nucleic acid, in different specimens of the same tissue. For comparison there are few references in the literature to the nucleotide content of tissues and none to sheep tissues. Our results, however, are of the same order as those quoted by Kerr (1940, 1942) for the brain, muscle and liver of the dog, and by Barrenscheen & Peham (1941) for a number of tissues from a variety of different sources including fowl muscle. The figures of Dell'Aqua (1935) for rabbit liver are appreciably higher than our values for sheep or fowl liver.

From our results it is apparent that in embryonic tissues which are growing rapidly there is no high concentration of acid-soluble purine nucleotides. On the other hand, the total nucleic acid of an embryonic tissue is higher than that of the corresponding adult tissue and since the ratio of ribonucleic acid to desoxyribonucleic acid is of the same order in the embryo as in the adult, a high concentration of cytoplasmic ribopolynucleotides is to be expected in the embryonic tissue. This might explain the high power to absorb light of wavelength 2600A found by Caspersson and his colleagues in the cytoplasm of rapidly growing tissues.

Data so far obtained from neoplasms suggest that tumour tissue resembles embryo tissue in possessing a low soluble nucleotide content and a high polynucleotide content. Barrenscheen & Peham (1941) quote figures for a number of miscellaneous tumours in which the total soluble purine is almost invariably low, while the total purine (including nucleic acids) is high.

These results tend to show that rapidly growing tissues have in general a low concentration of total soluble purine (including nucleotides) and that the high concentration of cytoplasmic 'nucleotides' reported by Caspersson is not due to the presence of acid-soluble nucleotides.

It is of interest to note that Stedman & Stedman (1943*b*) have recently reported that the nuclei of rapidly growing tissues, such as chick embryo and mouse and rat carcinoma, are characterized by a much lower histone content than is found in non-proliferating tissues. It is probable that the high content of both desoxyribo- and ribonucleic acid in rapidly growing tissues is intimately connected with the process of cell division. As the result of experiments on tissue cultures growing in embryo extract, Willmer (1942) has suggested that a rise in total nucleic acid may precede cellular division by some hours, and our own (unpublished) observations support this view.

The relationship between nucleotides and nucleic acids in tissues is uncertain. Although the function of many of the nucleotides is well known, that of the nucleic acids is obscure. Ostern, Terszakowec & Hubl (1938) have brought forward evidence that, in yeast, ribonucleic acid may act as a reservoir from which nucleotides including adenosine triphosphate are obtained, while Brachet (1937) has claimed that, in the development of the sea urchin egg, ribonucleic acid is converted into desoxyribonucleic acid. The synthesis of desoxyribonucleic acid from ribonucleotides by rapidly proliferating cells is, according to Mitchell (1942), inhibited by X- and γ -radiation, with consequent accumulation of cytoplasmic ribonucleotides or more probably of ribonucleic acids. Whether or not nucleotides are

actively concerned in the protein synthesis of the growing cell (cf. Needham, 1942; Loofbourow, 1942) is still an open question.

SUMMARY

1. The total nucleic acid content of embryo and adult sheep tissues has been estimated. In most organs the embryonic tissue has a higher nucleic acid and water content than the corresponding adult tissue.

2. Ribonucleic acids as well as desoxyribonucleic acid are present in both embryonic and adult tissue. Their presence has been proved by extracting the nucleic acids with 10% sodium chloride solution, precipitating them as lanthanum salts, and estimating pentose and desoxypentose after decomposition of the lanthanum precipitate.

3. The presence of ribonucleic acids in the tissue extracts has been confirmed enzymatically by the use of crystalline ribonuclease.

4. The relative amounts of ribonucleic acid and desoxyribonucleic acid have been approximately assessed. The ratio of ribonucleic acid to desoxyribo-

nucleic acid is of the same order in the embryo as in the corresponding adult tissue, or may be slightly higher in the latter, but varies widely from tissue to tissue, being high in pancreas, liver, testis, brain and heart and low in spleen, lung and thymus.

5. The results obtained support the view that desoxyribonucleic acid is located in the nucleus and ribonucleic acids mainly in the cytoplasm.

6. Rapidly growing tissues such as embryonic tissue tend therefore to be characterized by a high concentration of desoxyribonucleic acid in the nucleus and of ribonucleic acids in the cytoplasm.

7. Acid-soluble purine nucleotides are present in lower concentration in embryonic (and tumour) tissues than in the corresponding adult tissues.

8. These results are discussed in relation to tissue growth.

Our grateful thanks are due to Dr M. Kunitz of the Rockefeller Institute for a specimen of crystalline ribonuclease, and to Mr E. Alexander for technical assistance. A grant for scientific assistance from the Medical Research Council and an expenses grant from the Carnegie Trust for the Universities of Scotland to one of us (J. N. D.) are gratefully acknowledged.

REFERENCES

- Alders, N. (1927). *Biochem. Z.* **181**, 400.
 Allen, R. J. L. (1940). *Biochem. J.* **34**, 858.
 Bamann, E. & Meisenheimer, M. (1938). *Ber. dtsh. chem. Ges.* **71 B**, 1171, 2233.
 Bang, I. (1898-9). *Hoppe-Seyl. Z.* **26**, 133.
 — (1900-1). *Hoppe-Seyl. Z.* **31**, 411.
 Barrenscheen, H. K. & Peham, A. (1941). *Hoppe-Seyl. Z.* **272**, 87.
 Beebe, S. P. & Shaffer, B. (1905). *Amer. J. Physiol.* **14**, 231.
 Behrens, M. (1938). *Hoppe-Seyl. Z.* **253**, 185.
 Belozerski, A. N. (1936). *Biochimia*, **1**, 134.
 — (1939). *C.R. Acad. Sci. U.R.S.S.* **25**, 751.
 Bensley, R. R. (1942). *Science*, **96**, 389.
 Berenblum, I. & Chain, E. (1938). *Biochem. J.* **32**, 295.
 — & Heatley, N. G. (1939). *Biochem. J.* **33**, 68.
 Blumenthal, F. (1898). *Z. klin. Med.* **34**, 166.
 Brachet, J. (1933). *Arch. Biol.* **44**, 519.
 — (1937). *Arch. Biol.* **48**, 529.
 — (1940a). *Arch. Biol.* **51**, 151, 167.
 — (1940b). *C.R. Soc. Biol., Paris*, **133**, 88, 90.
 Brues, A. M., Tracy, M. M. & Cohn, W. E. (1942). *Science*, **95**, 558.
 Calvery, H. O. (1928). *J. biol. Chem.* **77**, 489.
 Caspersson, T. (1936). *Skand. Arch. Physiol.* **74**, Suppl. No. 8.
 — (1940). *J. R. micr. Soc.* **60**, 8.
 — (1941). *Naturwissenschaften*, **29**, 33.
 — & Brandt, K. M. (1941). *Protoplasma*, **35**, 507.
 — Hammarsten, E. & Hammarsten, H. (1935). *Trans. Faraday Soc.* **31**, 367.
 — Landström-Hydén, H. & Aquilonius, L. (1941). Quoted by Mirsky (1943).
 — Nyström, C. & Santesson, L. (1941). *Naturwissenschaften*, **29**, 29.
 Caspersson, T. & Schultz, J. (1939). *Nature, Lond.*, **143**, 602.
 — — (1940). *Proc. nat. Acad. Sci., Wash.*, **26**, 507.
 — & Thorell, B. (1941a). Quoted by Mirsky (1943).
 — — (1941b). *Naturwissenschaften*, **29**, 363.
 Claude, A. (1939). *Science*, **90**, 213.
 — (1940). *Science*, **91**, 77.
 — (1941). *Cold Spr. Harb. Symp. quant. Biol.* **9**, 263.
 — (1943). *Science*, **97**, 451.
 Davidson, J. N. & Waymouth, C. (1943a). *Nature, Lond.*, **152**, 47.
 — — (1943b). *Biochem. J.* **37**, 271.
 Delaporte, B. (1939). *Rev. gén. Bot.* **51**, 449.
 — & Roukheldman, N. (1938). *C.R. Acad. Sci., Paris*, **206**, 1399.
 Dell'Aqua, G. (1935). *Biochem. Z.* **279**, 403.
 Desclin, L. (1940). *C.R. Soc. Biol., Paris*, **133**, 457.
 Dische, Z. (1930). *Mikrochemie*, **8**, 4.
 Dumm, M. E. (1943). *J. cell. comp. Physiol.* **21**, 27.
 Euler, H. v. & Schmidt, G. (1934). *Hoppe-Seyl. Z.* **225**, 92.
 Feulgen, R. (1919-20). *Hoppe-Seyl. Z.* **108**, 147.
 — Behrens, M. & Mahdihassan, S. (1937). *Hoppe-Seyl. Z.* **246**, 203.
 — & Rossenbeck, H. (1924). *Hoppe-Seyl. Z.* **135**, 203.
 Fischer, A. (1939). *Nature, Lond.*, **144**, 113.
 — (1940). *Chem. Products*, **3**, 79.
 — (1942). *Act. physiol. scand.* **3**, 54.
 Gersh, I. (1943). Quoted by Mirsky (1943).
 Graff, S. & Barth, L. G. (1938). *Cold Spr. Harb. Symp. quant. Biol.* **6**, 103.
 — & Maculla, A. (1935). *J. biol. Chem.* **110**, 71.
 Grund, G. (1902). *Hoppe-Seyl. Z.* **35**, 111.
 — (1910). *Z. Biol.* **54**, 173.
 Gurlt, O. (1847). Quoted by Needham, J. *Chemical Embryology* (1931), p. 1647. Cambridge: University Press.

- Hammarsten, E. (1920). *Hoppe-Seyl. Z.* **109**, 141.
- Hammarsten, O. (1894). *Hoppe-Seyl. Z.* **19**, 19.
- Hevesy, G. & Ottesen, J. (1943). *Acta physiol. scand.* **5**, 237.
- Javillier, M. & Allaire, H. (1926a). *C.R. Acad. Sci., Paris*, **183**, 162.
- (1926b). *Bull. Soc. Chim. biol., Paris*, **8**, 924.
- (1931). *Bull. Soc. Chim. biol., Paris*, **13**, 678.
- Jones, W. (1920). *Nucleic Acids*, p. 9. London: Longmans Green and Co.
- Jones, W. & Perkins, M. E. (1924-5). *J. biol. Chem.* **62**, 290.
- Jorpes, E. (1924). *Biochem. Z.* **151**, 227.
- (1928). *Act. med. scand.* **68**, 253, 503.
- (1934). *Biochem. J.* **28**, 2102.
- Kerr, S. E. (1940). *J. biol. Chem.* **132**, 147.
- (1942). *J. biol. Chem.* **145**, 647.
- & Blish, M. E. (1932). *J. biol. Chem.* **98**, 193.
- Kiesel, A. & Belozerski, A. N. (1934). *Hoppe-Seyl. Z.* **229**, 160.
- Kossel, A. (1882). *Hoppe-Seyl. Z.* **7**, 7.
- Kosterlitz, H. W. & Cramb, I. (1943). *J. Physiol.* **102**, 18 P.
- Kunitz, M. (1940). *J. gen. Physiol.* **25**, 15.
- Le Breton, E. & Shaeffer, G. (1923). *Variations biochimiques du rapport nucléoplasmique au cours du développement embryonnaire*. Paris: Masson et Cie.
- Levene, P. A. & Jorpes, E. (1930). *J. biol. Chem.* **86**, 389.
- & Mandel, J. A. (1907). *Hoppe-Seyl. Z.* **49**, 262.
- Lohmann, K. (1928). *Biochem. Z.* **194**, 306.
- Loofbourow, J. R. (1942). *Biochem. J.* **36**, 631, 737.
- Loring, H. S. (1939). *J. biol. Chem.* **130**, 251.
- Malan, A. I. & Green, H. H. (1928). *J. agric. Sci.* **18**, 391.
- Mandel, J. A. & Levene, P. A. (1905). *Hoppe-Seyl. Z.* **46**, 155.
- Marshak, A. (1940). *Science*, **92**, 460.
- (1941). *J. gen. Physiol.* **25**, 275.
- Masing, E. (1911). *Hoppe-Seyl. Z.* **75**, 135.
- Mathison, G. C. (1909). *Biochem. J.* **4**, 233.
- Mendel, L. B. & Leavenworth, C. S. (1908). *Amer. J. Physiol.* **21**, 77.
- Menke, W. (1938). *Hoppe-Seyl. Z.* **257**, 43.
- Michaelis, L. (1931). *Biochem. Z.* **234**, 139.
- Mirsky, A. E. (1943). *Advances in Enzymology*, **3**, 1.
- & Pollister, A. W. (1942). *Proc. nat. Acad. Sci., Wash.*, **28**, 344.
- Mitchell, J. S. (1942). *Brit. J. exp. Path.* **23**, 285, 296, 309.
- Needham, J. (1942). *Biochemistry and Morphogenesis*, p. 631. Cambridge: University Press.
- & Needham, D. M. (1930). *J. exp. Biol.* **7**, 317.
- Neuberg, C. (1904). *Ergebn. Physiol.* **3**, 373.
- Ostern, P., Terszakowec, J. & Hubl, S. (1938). *Hoppe-Seyl. Z.* **255**, 104.
- Painter, T. S. & Taylor, A. N. (1942). *Proc. nat. Acad. Sci., Wash.*, **28**, 311.
- Plimmer, R. H. A. & Kaya, R. (1910). *J. Physiol.* **39**, 409.
- & Scott, F. H. (1908). *J. chem. Soc.* **93**, 1699.
- Potter, V. R. & Albaum, H. G. (1943). *J. gen. Physiol.* **26**, 443.
- Reeves, R. E. & Munro, J. (1940). *Industr. Engng Chem. (Anal. ed.)*, **12**, 551.
- Reis, J. (1937). *Enzymologia*, **2**, 110, 183.
- Rosenthal, O. & Drabkin, D. L. (1943). *J. biol. Chem.* **150**, 131.
- Schultz, J. (1941). *Cold Spr. Harb. Symp. quant. Biol.* **9**, 55.
- Sevag, M. G., Smolens, J. & Lackman, D. B. (1940). *J. biol. Chem.* **134**, 523.
- Stanley, W. M. (1939). *J. biol. Chem.* **129**, 405.
- & Knight, C. A. (1941). *Cold Spr. Harb. Symp. quant. Biol.* **9**, 255.
- Stedman, E. & Stedman, E. (1943a). *Nature, Lond.*, **152**, 267.
- (1943b). *Nature, Lond.*, **152**, 556.
- Steudel, H. (1936). *Hoppe-Seyl. Z.* **241**, 84.
- Taylor, A. R., Sharp, D. G., Beard, D. & Beard, J. W. (1942). *J. infect. Dis.* **71**, 115.
- (1943). *J. infect. Dis.* **72**, 31.
- & Woodhall, B. (1943). *Science*, **97**, 226.
- Thomas, P. & Berariu, C. (1924). *C.R. Soc. Biol., Paris*, **91**, 1470.
- Tuttle, L. W., Erf, L. A. & Lawrence, J. H. (1941). *J. clin. Invest.* **20**, 57.
- Vowles, R. B. (1940). *Ark. Kemi Min. Geol.* **14B**, no. 10.
- Wells, H. G. (1925). *Chemical Pathology*, 5th ed., pp. 20, 31. Philadelphia: W. B. Saunders.
- Willmer, E. N. (1942). *19th Ann. Rep. Brit. Emp. Cancer Campaign*, p. 53.
- Wohlgemuth, J. (1903). *Biochem. Zbl.* **1**, 533.