

SAVE THERE, EAT HERE:
A CULTURAL STUDY OF
LABOUR MIGRATION FROM
A PAKHTUN VILLAGE.

Francis Watkins

PhD
University of Edinburgh
February 1995



I hereby declare that this thesis has been composed by me and (save where acknowledgement is made below) is based on my own work

Francis Watkins

ABSTRACT

For at least the last century men have been leaving the village of Kohery in North West Frontier Province, Pakistan to look for work and better opportunities. In all that time migration has remained a temporary phenomenon with the men always returning to their home village. Migration has become a way of life and is deeply rooted in the experience and ideas of the people. In the 1970s the men of Kohery began to take part in labour migration to the Gulf states along with millions of other Asians. This thesis is about this migration in the 1990s, and the social and economic effects that it has had and continues to have. It is a cultural study of labour migration from Kohery to the Gulf and is divided into four parts.

Part I consists of the life histories of several men from a group of eight households where the research was carried out. The aim is to describe the experiences of a group of individuals over several decades of migration. The stories illustrate the long history of migration from the area and form a background to the rest of the thesis. The stories are also used to demonstrate the ways in which individuals use their own life histories to represent themselves as honourable men.

Part II examines households. The association of gender with space - women with houses and men with 'outside' - affects the sexual division of labour, so that men are the ones who participate in migration and who control household resources. Within households, the composition of the group and the position of individuals in the hierarchy give rise to tensions and conflicts which result in divisions. Despite considerable variations in the composition of households the differences between them are played down and the similarities are emphasised. In particular households are described as being unproductive in themselves and dependent on migration.

In Part III it is argued that, contrary to the portrayal of Pakhtun households in most ethnographic work, the people in Kohery saw their own households as highly dependent on one another. The complex ties of descent and marriage between households and the strong emphasis placed on marrying 'in' showed that the people of Kohery regarded their community as a single, extended kin group.

Part IV draws the threads of the preceding parts together and acts as a conclusion to the thesis. A model of the economic situation of households in Kohery is built around the view that saving can only take place outside the community, while spending must take place within and as part of the community. While men, as selfless individuals, work and save in the different world of work, houses as a whole spend or 'eat' in ways dictated by social and religious obligations. As a model it seeks to explain the situation which the people of Kohery find themselves in and to present ways of best dealing with it. This framework of understanding is not a static one but is one that is affected by national and international religious and political discourses. These discourses are worked out in the local setting through contests between individuals and groups for status and power.

ACKNOWLEDGEMENTS

Though this thesis has ended up with one name on the title page there are many people who have contributed a great deal to both the research and the writing. At the University of Edinburgh in the Department of Anthropology Jonathan Spencer, Tony Good and Professor A Cohen have provided constant support, encouragement and advice, all of which has been greatly valued. My colleagues among the postgraduates in the department have provided a highly stimulating academic environment and good companionship at all times. Special thanks go to the members of the writing group, Jon Mitchell, Joan Stead, Robert Gibb, John Harries, Ros Edbon, Justin Kenrick and many others and to Abdullah Yateem for his encouragement in the early days. In the wider University I owe a great deal to Toby Morris for his advice and help and to Ali Servisht for his Pakhtun perspective

None of the work would have been possible without the generous support of a number of funding bodies. These include the Carnegie Trust for the Universities of Scotland, The Tweedie Trust, The Emslie-Horniman Trust of the Royal Anthropological Institute, The Radcliffe-Brown Trust of the Royal Anthropological Institute, The Charles Wallace Trust, Pakistan and the Department of Social Anthropology.

In the United Arab Emirates it was Zahoorulhaq, Miagwal, Ghulam Wahid and many others who made me so welcome and who produced the idea for the research. Jay and Shanth Laxman made my stays and my work a great deal easier than might otherwise have been the case. John and Di Martin and Ursula Binsfeld all helped with accommodation and friendship.

In Pakistan my debts are many. First and foremost my thanks go to the people of Kohery. It is impossible to explain just how much I relied on Zahoorwahid and Wahid Gul and how much their whole family made me feel so welcome. My special thanks go to the women whom I never met but who looked after me so well. My thanks also go to Azum Khan, Noorwahid, Abdul Hadi, Abdur Rahim, Gul Halim, Abdul Halim, Sadiqullah, Ghulam Wahid and many others for their patience, good humour and hospitality. In Peshawar Abdul Haq and John Humphreys made us welcome and made our stay a bit easier and more enjoyable. In Islamabad Les Phillips of the British

Council provided encouragement and much support. There are many others along the way who have helped, to them my special thanks.

My mother and father, Twin and Trevor Watkins, and my sisters, Cath and Char, gave me help in many forms and supported me at all times. Debbie King, my wife, made it all possible and kept me going through the good and the bad. Finally I dedicate the thesis to my son Joseph Henry for whom it was all for in the end.

TABLE OF CONTENTS

| | |
|---|------|
| Abstract | ii |
| Acknowledgements | iii |
| Illustrations | vi |
| Maps | vii |
| Diagrams | vii |
| Tables | vii |
| Abbreviations | viii |
| Part I A Century of Migration..... | 1 |
| Chapter 1 Arrivals..... | 6 |
| Chapter 2 Migration before the Gulf: 1940s to 1970s..... | 32 |
| Chapter 3 Gulf Migration: 1970s to 1990s..... | 50 |
| Part II <i>Kor</i> : The Household..... | 69 |
| Chapter 4 Gender and Space | 75 |
| Chapter 5 Loyalty and Division: The Composition of Households | 88 |
| Chapter 6 Ways of Spending: The Economy of Households..... | 105 |
| Part III <i>Khpulwan</i> : The Kin Group | 133 |
| Chapter 7 <i>Khpul na Predee Keegee</i> : Your Own Don't Become Strangers..... | 134 |
| Chapter 8 We are all <i>Khpul</i> : Marriage and Marrying in..... | 171 |
| Part IV Save There, Eat Here: The Morality of Migration..... | 189 |
| Chapter 9 Saving and Eating..... | 190 |
| Chapter 10 <i>Kheyrat</i> : The Religious Feast..... | 216 |
| Chapter 11 Conclusion..... | 239 |
| Glossary | 246 |
| Bibliography | 250 |

ILLUSTRATIONS

| | | |
|-------------|--|------|
| Plate 1 | Mohamad Zahid's taxi with Gul Hamid and Wali Mohamad..... | 8 |
| Plate 2 | Remote garden in UAE..... | 8 |
| Plate 3 | Wahid Gul with Posia..... | 18 |
| Plate 4 | Zahoorwahid with Yunus..... | 18 |
| Plate 5 | Abdur Rahim with grandchildren | 19 |
| Plate 6 | Azum Khan with sons..... | 19 |
| Plate 7 | General view of Kohery and Mond Ghar..... | 23 |
| Plate 8 | View from Kohery towards Malakand and Timirgara..... | 23 |
| Plate 9 | Panoramic view of Bagh neighbourhood, Kohery | 27 |
| Plate 10 | Wahid Gul's pickup..... | 106a |
| Plate 11 | Zahoorwahid's shop..... | 106a |
| Plate 12 | Terraced fields..... | 106b |
| Plate 13 | Wahid Gul ploughing..... | 106b |
| Plate 14 | Group photograph at Ghat Akhtar..... | 143 |
| Plate 15 | Building Gul Halim's new room..... | 143 |
| Plate 16-8 | Wedding scenes..... | 177 |
| Plate 19-21 | Scenes from Mohamad Zahid's <i>kheyrat</i> | 218 |

MAPS

| | | |
|-------|---|---|
| Map 1 | Pakistan and the Gulf | 2 |
| Map 2 | Pakistan provinces..... | 3 |
| Map3 | Dir and the surrounding districts NWFP, Pakistan | 4 |
| Map 4 | Sketch map of Kohery and the surrounding villages | 5 |

DIAGRAMS

| | | |
|-----------|--|-----|
| Diagram 1 | Genealogy of Utman Khayl, tribal subsections | 26 |
| Diagram 2 | Moolian Khayl in Bagh neighbourhood, Kohery | 35 |
| Diagram 3 | Moolian Khayl in Kohery | 153 |

TABLES

| | | |
|---------|---|-----|
| Table 1 | Household survey for Bagh, Kohery | 99 |
| Table 2 | Estimated household expenses..... | 118 |
| Table 3 | Government salary scales..... | 132 |

ABBREVIATIONS

| | |
|------|-------------------------------------|
| Dh | - Dirham; currency of the UAE |
| g | - gram |
| ILO | - International Labour Organisation |
| kg | - kilogram |
| NWFP | - North West Frontier Province |
| Rs | - Rupees; currency of Pakistan |
| UAE | - United Arab Emirates |

A CENTURY OF MIGRATION

PART I

*God don't kill the traveller,
Grant their desire that their last breath be at home.*

(Pakhtun *tappa*, poem: Zahoorwahid)

Map 1 - Pakistan and the Gulf

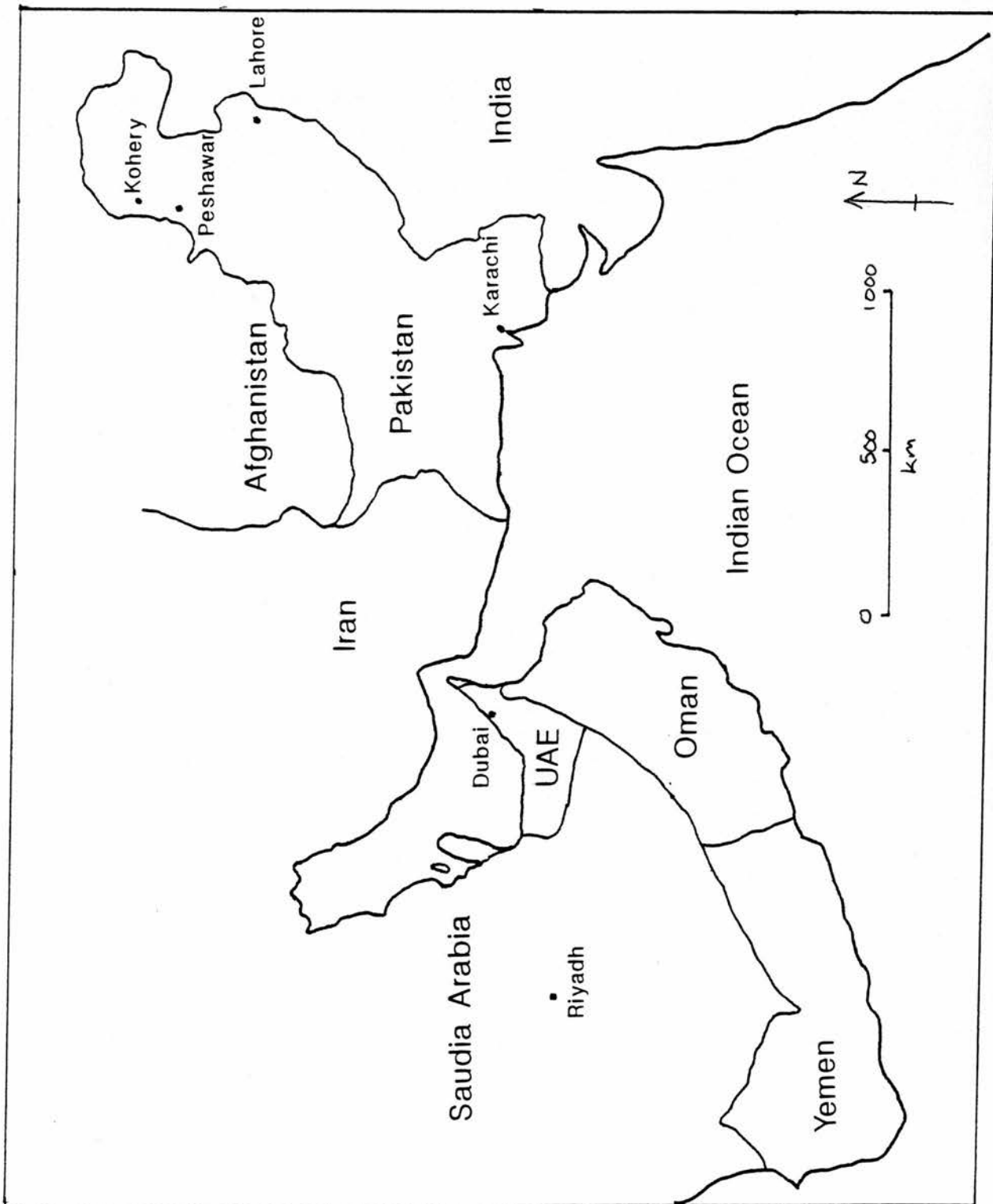

Map 2 - Pakistan provinces

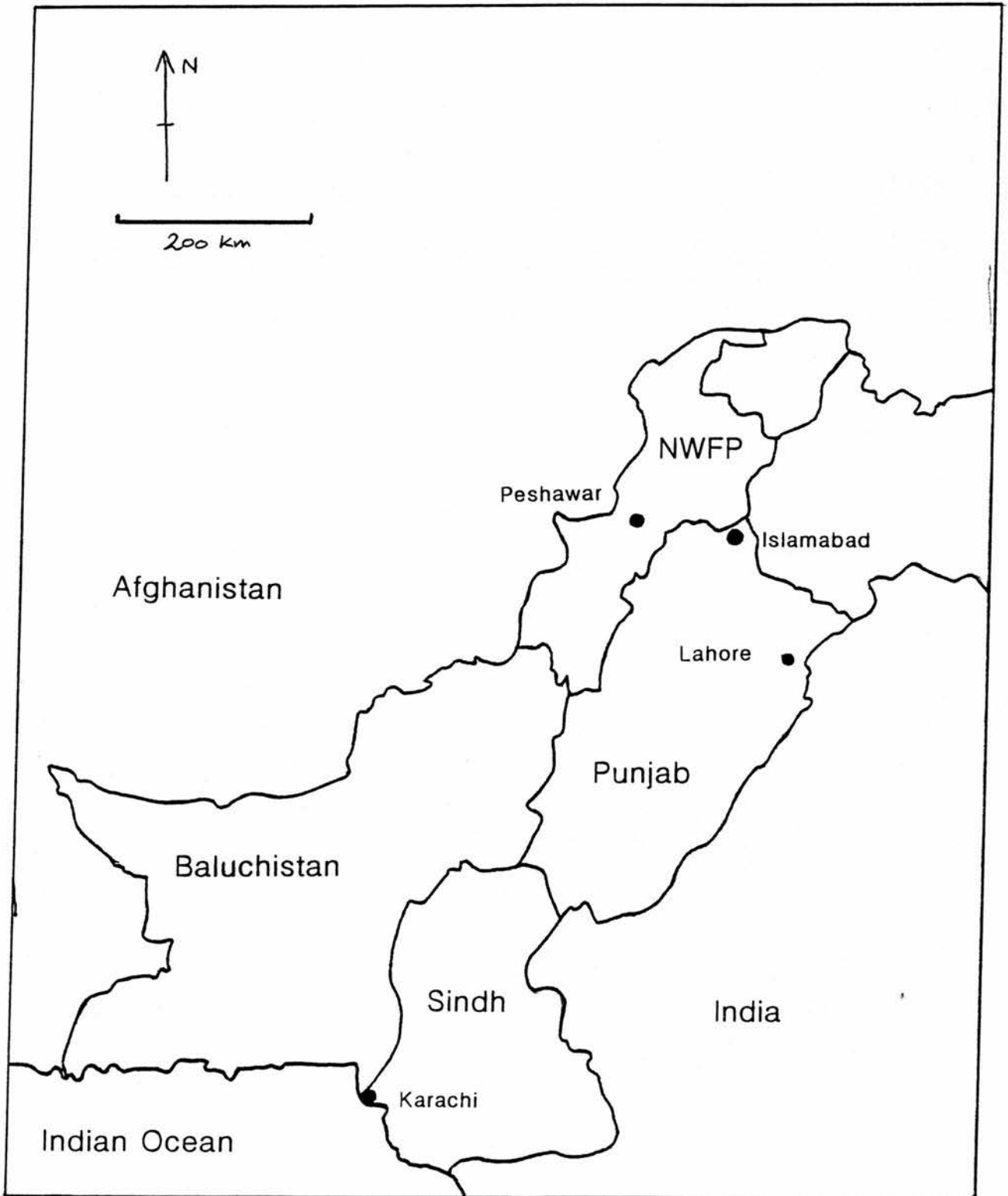

Map 3 - Dir and the surrounding districts, NWFP, Pakistan



Map 4 - Sketch map of Kohery and surrounding villages (original drawn by Wahid Gul)

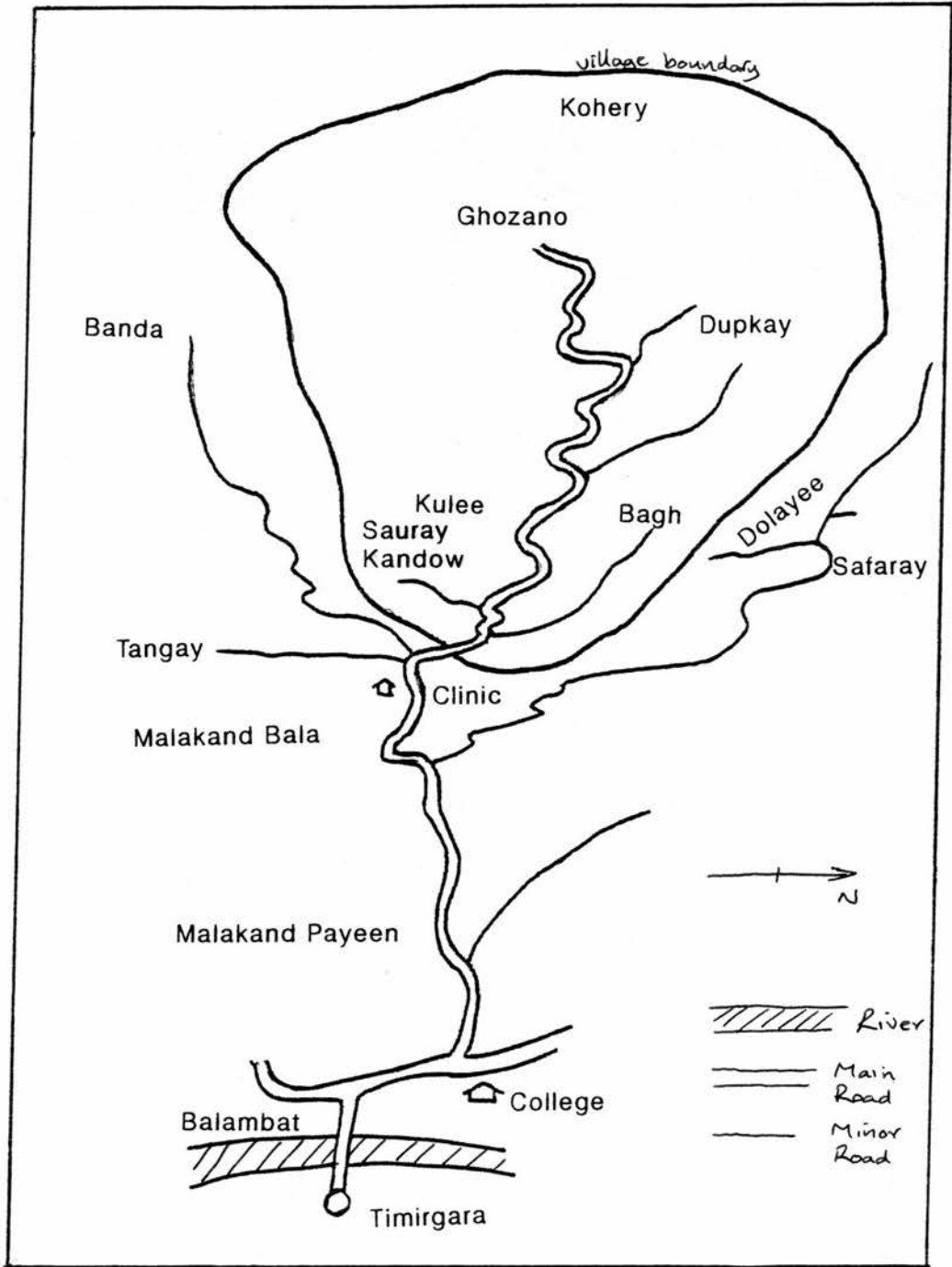

As I stepped off the plane at Dubai for the first time in 1988 I was struck by the warm wet heat and the smell of the sea. A bus carried us from the plane to the air-conditioned arrivals hall where we joined the huge queues for customs. The customs hall was obviously designed to handle large numbers and as other planes arrived the queues around us grew. The contrasts were extraordinary. As the elegantly dressed Arabs swept through their gate, we travellers stood patiently clutching our passports and papers, shuffling slowly forward. My experiences through the next five months in the United Arab Emirates (UAE) (see Map 1) confirmed this first impression of a deep division between the citizens and those who were, for whatever reason, migrants or travellers. Everywhere I went I saw and met fellow migrants from all over the world. I rarely met, and seldom even saw, the local Arabs; they kept their lives private and in public they were aloof. I became fascinated by those who, like myself, didn't belong. I endlessly asked the questions, where are you from and what are you doing here? The shared experience of working away from home, and of being outsiders, made a bond, weak though it was, between us as fellow migrants.

A series of experiences and encounters sum up what I felt and thought in my first encounter with the Gulf. The first set of experiences relate to the time that I spent working with an archaeological team in a mountain village in a valley called Wadi al Qawr. Our work involved the survey and excavation of archaeological sites along the sides of the valley system. We worked there for three months and lived in the main village in the sheikh's house. In all of our time there I met, at most, two or three local residents. Our day-to-day contacts were with the various migrants who lived and worked in this relatively remote spot. Much of the heavy labouring of the excavations was carried out by a group of Pakhtuns who came from the North West Frontier Province (NWFP) of Pakistan. Over the months we came to know them well and socialised with them in the evenings after work, drinking tea and playing cards. Despite the relative poverty of their living conditions in a gerry-built hut of waste wood and corrugated iron, we were overwhelmed by their hospitality. They complained about the local Arabs and their lack of a real sense of community. The local doctor, an Egyptian who had lived in the village for twenty years, took a different view of things. He had first come before there was any electricity and

while the people still lived in semi-subterranean houses with palm-frond roofs. The hardest times, he recalled, were the summers when the temperatures rose to 50°C and the stones became too hot to touch. People had been friendlier then, but when they moved to the cheap government housing in the 1970s they took to staying inside more. I thought that I had finally got to meet some of the local residents when the police came to join in with our impromptu volleyball games in the evenings. I was shocked to discover that they were all Baluchis from southern Pakistan or Omanis. In appearance and dress they were indistinguishable from the local Arabs but they were as much outsiders as I was.

My other memories relate to our visits to the towns and cities of the UAE. Most vivid in my memory are our regular visits to the city of Dubai. Photographs in the museum there, showed that, twenty years before, all that existed was a fort, some merchants houses at the edge of the creek and a scattering of palm houses. In the 1990s the city was a glowing testament to its success as a centre of trade and travel in the region. At night, crossing the creek was an extraordinary experience with the lines of ultra-modern tower blocks and everywhere the glow of neon advertising the world's products. The streets at night were packed with a bustling mass of people eager to spend their hard earned wages on gold, electronics and cloth. - "the flow of people with their inexplicable nationalities" (Ghosh 1986: 321). - The areas had maintained their divisions into markets or *suqs* with the cloth *suq*, the gold *suq* and the spice *suq*, supplemented with the electrical goods *suq*. My other experiences in the towns were in the offices of those who administered our archaeological projects. In Ras al Khaimah the man who helped us was Jay Laxman. He had come from Kerala and had worked for 15 years as Sheikh Sultan's assistant. It had been Jay who had developed the idea of archaeological exploration in the Emirate and who had been instrumental in setting up the museum. In the other offices as well, those who kept the administration running smoothly were Indians, Sudanese, Somalis, Egyptians and Palestinians. Usually Arabs only held prestigious figurehead jobs and few of them took any direct personal interest in what was being done.

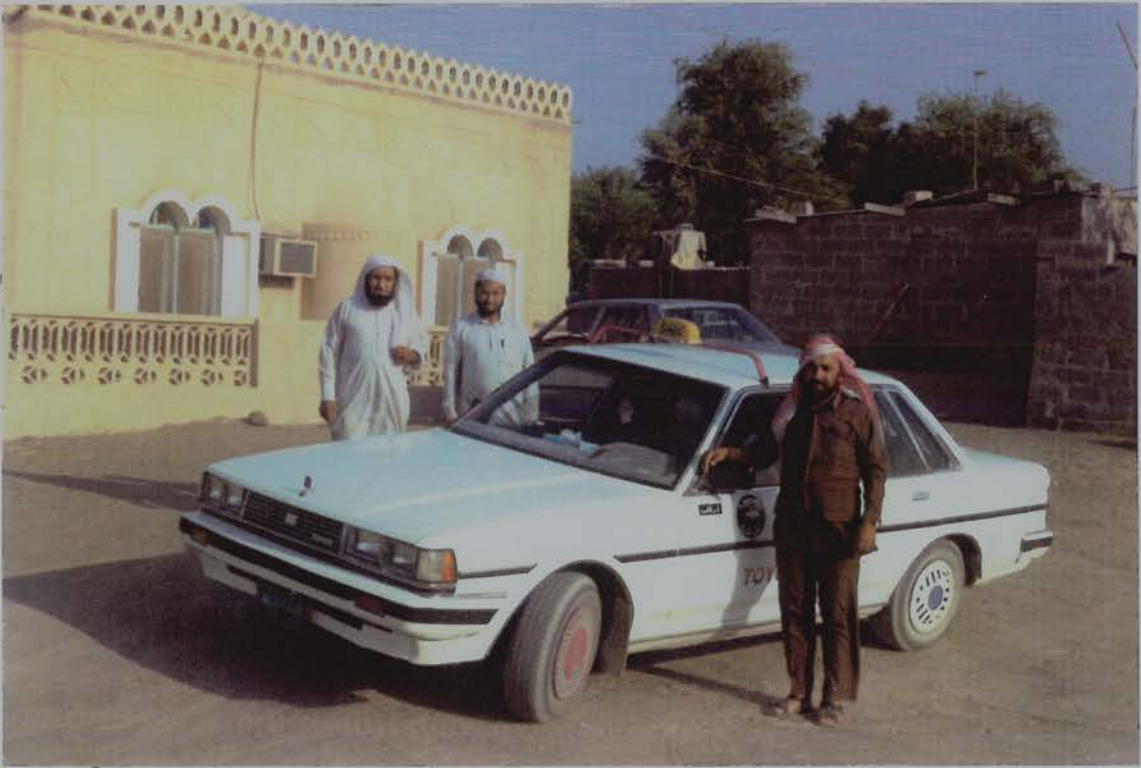

Plate 1 - Mohamad Zahid's taxi with Gul Hamid and Wali Mohamad



Plate 2 - Remote garden in the UAE

SECOND IMPRESSIONS

After my second visit to the UAE in 1989 my fascination had turned into a desire to research some aspect of Gulf migration. When I started my PhD in October 1990 I started by searching through the enormous amounts of material on the topic. I began to get a sense of the physical and economic scale of the phenomenon. At the same time, what I read jarred with my own experiences of what I had seen and what I had learned. First, though, it is necessary to convey some of the impact that these initial readings had on me; both the information they conveyed and the questions that they raised.

Gulf migration had been a source of both interest and concern for a variety of international bodies such as the United Nations (UN), the International Labour Office (ILO) and the World Bank throughout the 1970s and 1980s. Enormous numbers of surveys and papers were produced to attempt to understand what was happening. These surveys in turn generated overviews and summaries, many of which speculated about the future of the phenomenon. In general, though, there was much disagreement about the methods of data collection and the reliability of the available figures (cf. Gunatilleke 1986, Owen 1985, Feller 1991). The most reliable, or at least the most agreed-upon, figures for the 1970s come from Birks and Sinclair (1980). Their figure for the non-national work-force in the major labour-importing Middle Eastern countries was 1.79 million for 1975. The UN figures (Appleyard 1988) were 1.7 million for 1975, increasing to 2.7 million by 1980. Owen (1985), working from ILO figures estimated a total of 6 million for the early 1980s, while Feller (1991) came up with the figure of 5 million for 1983. Owen provides a welcome note of caution and emphasises the fact that accurate statistics on migrants entering and leaving the Gulf countries were not published by either the importing or exporting countries. He suggests that the information is of an impressionistic nature rather than being a precise estimation (Owen 1985: 5). Nevertheless the impression is of vast numbers of people on the move.

The figures are put in some kind of context when looking at the numbers of migrants in particular Gulf countries, such as the UAE. The UAE is, it seems, particularly reliant on imported workers and is often used as an extreme case example. Birks and Sinclair (1980) give estimates for the size of the workforce in 1975 of 45,000 nationals and 251,500 migrants; that is 84.8% of the workforce were migrants. Of

these migrants a total of 163,500, that is 51.3%, were Asians. By 1980 Owen estimates a figure of 410,000 migrants, by this time 90% of the workforce. Birks and Sinclair estimate that by 1985 the number of migrants in the UAE had made a massive jump to 1,038,800, going against many predictions of a decline in the number of migrants after initial increases in the 1970s (Feller 1991). When I was in the UAE, people's impressions were that 'nine out of ten' of the population came from outside the country. In fact, in 1992, after the Gulf War, the perception of some was that the true figures were hidden, and that the 9:1 ratio was exaggerated to favour the Arab population in order to reassure the local population.

There is general agreement that Pakistanis form a large proportion of the migrants in the Gulf. Robinson (1986), working from a variety of sources, estimates that in 1981 there were 1.8 million Pakistanis working in the Middle East, 7.5% of the total recorded work force of Pakistan. Owen (1985) makes an estimate from ILO figures, suggesting that in the early 1980s there were 1.2 million Pakistanis in Saudi Arabia alone, with a total of between 1.7 and 2.3 million in the Gulf Cooperation Council (GCC) states. Addleton (1992) provides perhaps the most comprehensive overview of the various information available for Pakistan. He estimates that in 1972 there were a total of 200,000 Pakistanis in the Middle East. By 1977 this figure had grown to 727,000, and by 1981 had further expanded to between 1.2 and 1.6 million (Addleton 1992: 56-8). In 1982, with almost 2 million Pakistanis abroad, 63% or 1.26 million were in the Middle East - 37% (740,000) in Saudi Arabia and 10% (200,000) in the UAE (Addleton 1992: 59). These figures confirmed my impressions of Pakistan where everybody I met had either been to the Gulf or had relatives there. There was something of a sense of a nation on the move.

There have been several general assessments of the national economic effects of migration to the Gulf on Pakistan (Appleyard 1988, Gunatilleke 1986, Robinson 1986, Tsakok 1982). Again Addleton's summary is the most comprehensive and is presented in two tables. To put it simply, in 1972-3 remittances to Pakistan were estimated at \$125 million. By 1978-9 they exceeded \$1 billion and, at their peak in 1982-3 they were near to \$3 billion. Despite declines in the 1980s they continued to be greater than \$2 billion a year (Addleton 1992: 113). The figures become most striking when they are compared to other significant figures relating to the country's outside earnings. Robinson calculates that in the early 1980s remittances formed 8% of Pakistan's GNP, 40% of its foreign exchange earnings, and this only records money that was sent back officially (Robinson 1986). Tsakok states that since 1977-8 remittances have exceeded disbursements of foreign assistance, and that at

the start of the 1980s they were running at a level roughly twice that of receipts from international aid (Tsakok 1982). Addleton's figures cover from 1975 to 1988 and compare remittances to both merchandise exports and foreign aid disbursements showing the extraordinary level of the former (Addleton 1993: 115).

The problems with these figures are a constant source of comment and discussion. As both Owen and Addleton point out the major problem is the level of illegal migration, which some surveys have tried to estimate while others have conveniently ignored it. For example one figure for 1981 estimates that the number of Pakistanis in the Middle East was around 1.2 million while the same group (the Pakistan Institute of Development Economics) estimated that including illegal immigrants, the figure could be as much as 1.6 million. There are similar problems with measuring the levels of remittances where the official figures include only money sent back through official banks. As Addleton notes, a significant portion of remittance income was sent back to Pakistan through the blackmarket *hundi* system (Addleton 1992: 127). In my experience all of the money earned abroad by those from Kohery was sent back by *hundi*. To the people's minds banks were inconvenient, expensive and not to be trusted. The figures, then, give some impression of the scale of the phenomenon, though they are undoubtedly an underestimate.

More worrying for me in reading this literature was that there was a lack of any real sense of the social and economic effects that migration was having, whether on a national or local scale. The main survey has been carried out by the Pakistan Institute of Development Economics in cooperation with the World Bank. Khan (1986) summarised the economic information from the survey but could give only crude estimates of how the money was spent. He concluded only that a large part of the remittance money was spent on raising current consumption and what were considered to be unproductive investments - real estate, houses and consumer durables. Gilani's (1988) conclusions on the social effects of migration are, if anything, cruder. At best he can state that "on the whole overseas Pakistanis are a fairly happy and contented group. As many as 40% claimed that they were very happy while 30% said they were happy. Only 7% said they were either unhappy or very unhappy" (Gilani 1988: 205). At worst his general assessment is that migration and economic change have only marginally affected the life-style of the family and that "on balance, labour emigration from Pakistan has brought net benefits to its economy and has caused certain welcome changes in its social structure" (Gilani 1988: 215). Conclusions such as those about the happiness of migrants were at

odds with the poor living and working conditions that I had seen for myself in the UAE. They were also strongly contradicted by much of what was said in works such as Owen's Minority Rights Group report in 1985.

Other work that I read in the initial stages of my research suggested that there were similar problems with the conclusions that Khan and Gilani had reached about the effects of migration on the Pakistan economy. Roger Ballard (1983), for example, has looked at the effects of remittance money on local economies in two geographically close areas, Jullundur in the Indian Punjab and Mirpur in Pakistan. Both were areas of high migration with over half of the British South Asian population coming from the Punjab, mainly from these two areas. He notes the very different effects of remittances in the two areas and seeks to situate these differences in their historical, economic and political contexts.

In Jullundur, he argues, migrants' remittances have brought about great economic growth. Ballard suggests that, in this area with its egalitarian agrarian structure and a tradition of local craft skills, industry and agriculture grew together. Further, since independence, India has been committed to self-sufficiency and has maintained tight import controls. The area, then, offers a fertile environment for migrant returnees and their remittances, with a wide variety of opportunities for investment.

Mirpur, according to Ballard, stands in strong contrast to Jullundur. In Mirpur remittances have led to local economic stagnation. Few opportunities exist for migrants to invest their money. In agriculture, equipment, seeds or fertilisers are either not available or are restrictively expensive. In general there is little demand for locally manufactured goods and the basic infrastructure is poor. Ballard suggests that one of the key reasons for this is that the Pakistan economy is largely run for the benefit of the urban elite. In contrast to India, there is no import embargo and most of Pakistan's imports are being paid for by migrants' remittances. As Ballard says "Mirpur's under-development is therefore best understood not so much as the outcome of the innate backwardness of Mirpuri culture, but rather as a consequence of the broader structural conditions in which Mirpuris find themselves enmeshed" (Ballard 1983: 131). Ballard's paper was important to me at the time I read it because it demonstrated how essential it was to look at the local economic and political context in assessing the effects of migration and remittance money. His conclusions were backed up by other calls for more studies on the local economic and social impact of migration (Appleyard 1988, Gunatilleke 1986, Martin 1991).

The large scale surveys and general reviews of international migration, such as Cohen (1987), can at best provide a structural background to more local studies. As Abu-Lughod (1975) and others (including Appleyard 1989) point out, studies of migration have shown that there is a much greater degree of diversity in patterns of migration than most theorists had anticipated. Certainly, detailed studies carried out on migration in Turkey (Abadan-Unat 1976, Engelbrektsson 1978), Egypt (Brink 1991, Taylor 1987), Jordan (Seccombe 1981, 1987), Yemen (Stevenson 1985, Weir 1987), India (Dandekar 1986, Oberai and Singh 1980, Osella and Osella 1994), Sri Lanka (Eelens and Speckman 1990), Bangladesh (Gardner 1995) and Pakistan (Helweg 1983, Naveed-i-Rahat 1990) show a remarkable variation in patterns of recruitment and migration as well as social and economic impacts. As Ballard (1983, 1987) and other writers have argued it is important to examine local processes of migration and other forms of change in their historical, economic and political contexts (see also Antoun and Harik 1972, Abu-Lughod 1975, Zohlberg 1989, Gardner 1995). I have already partially outlined the economic context of migration from Pakistan. In the rest of Part I I go on to look in detail at the historical context of migration from the NWFP and Kohery in particular.

WAYS OF KNOWING

My reaction to what I had read gave me a strong conviction about what I wanted to do with my own research. Two things were paramount. First, I wanted to convey in some way the experience of migration, both for the individuals involved and for their families and communities. Second I wanted to look in detail at the social and economic effects of migration in a local context. This second point is something that I will deal with in the next section of the thesis. Now, I want to look at some other influences on my own work in terms of describing and relating the experience of labour migration.

I visited Pakistan briefly in 1991 and returned for a longer period of fieldwork in 1992. The second time around I came away with a much stronger feeling that I wanted to describe the experience of migration. I thought then that one way to do this would be to tell the life stories of several individuals who had taken part in migration. In 1992 I collected the bare bones of several stories with the hope that I would be able to add some flesh to them when I returned for more fieldwork. When I did return in 1993 I worked hard at putting together a whole series of stories that focused on the lives of several individuals, but that at the same time came together to build into the story of one extended family. In this initial stage I was influenced

by several books that I had come across in my more general reading. First among these were Oscar Lewis's famous books *The Children of Sanchez* (1961) and *Five Families* (1959). Just as influential for me were Peter Matthieson's account of the Harvard-Peabody Expedition of 1961 to the New Guinea highlands in *Under the Mountain Wall* (1962), Erika Friedl's *Women of Deh Koh* (1989) and John Berger's (1979) account of an Alpine village, *Pig Earth*. All of them, in their own ways, seemed to bring an air of humanity to ethnography and to convey something of the experience of living in another culture.

Subsequently I read other, more recent works, which have further confirmed my initial convictions. Fischer and Abedi simply, but convincingly present their project as follows:

There are times, increasingly, when we need touchstones, reminders and access to the humanism of others. The following essays are intended to explore genres of access.

Their work is, they say, to make available reading material on the lives of people in the Middle East:

Lives that make narrative sense...Lives that have stories to tell, stories that open up cultural worlds, worlds of difference, worlds of experience, worlds of sense, worlds that can draw their own limits, that illuminate their limitations as well as their depths, that localize and situate their knowledge, their thresholds of change, and their paths of transformation (Fischer and Abedi 1990: xix)

Abu-Lughod (1993) explores in detail the idea of what she calls tactical humanism, a humanism that makes no radical claims to be a new form of representation but rather seeks to reform the existing idea of the ethnography (Abu-Lughod 1993: 28-9). Tactical, too, because it is an approach that recognises the political and ethical implications of the representation of 'other cultures' but seeks to find ways of dealing with these (Abu-Lughod 1993: 29). Thus, she calls for "ethnographies of the particular made up of everyday stories", which she hopes will go far in providing a "discourse of familiarity" (Abu-Lughod 1993: 28). In her own work she tries to find a balance between a reflexivity in which the ethnographer imposes herself on the text and work that results in the total erasure of the writer; between the presentation of the individual as isolated and making general statements about Bedouin culture; and between fiction and pure theory (Abu-Lughod 1993: 29-32).

In this thesis I want to start by using a series of life stories for a number of reasons. Firstly, I want to use them as a way of presenting the humanity of others and as a

way of trying to understand the experience of migration. This is important because as Abu-Lughod says "focusing on individuals encourages familiarity rather than distance and helps to break down 'otherness'" (Abu-Lughod 1993: 29). All too often in ethnographies individuals only appear in 'case studies'. Relegated in this way they become ciphers, losing any sense of identity and individuality for the convenience of representing an example for a general point or an ideal type. This process can be avoided by introducing individuals and their stories at the very start. Secondly, I want to deal with Abu-Lughod's point that telling the life histories of individuals may contribute to a sense that they exist in isolation. Therefore, the stories of several individuals will build up into the story of an extended family, consisting of six households. Even at an early stage of writing in 1992 I found it impossible to tell the stories of individuals without mentioning in detail their involvement with those around them. I found it more useful to trace their relationship and describe in detail their involvement with one another in the stories that I told.

These stories, then, are about a group of individuals who I came to know well. It was from their answers to my questions, and from what I learned from them, that I formed the analysis of migration from Kohery. In this analysis general points are situated in the context of the lives of those I knew. The 'case studies' that I present are taken from the lives and experiences of those described in the initial stories. This is also a way of situating my analysis in the specificities of the times and places of my fieldwork (see Edwards 1994 for the problems of dealing with research carried out in several different places over a long time span). In this way I want to present my own ethnography of the particular. I have tried as much as possible to avoid the use of the ethnographic present which I see as essentially problematic (see Fabian 1983, Sanjek 1991 and Hastrup 1992 for discussions). I have followed Davis' (1992) suggestion that ethnographers should use the past tense more in order to fix both the society being described, and the description itself, in a particular time. I want to make clear just how general points were arrived at and demonstrate the simplifying process of analysis. I want to try and integrate describing the particular with an analysis of the general.

As much a part of these stories is how they came to be told and how I formed them into the shape they are now. As I said, I already had ideas about the kinds of ethnographic writing that I aspired to before I arrived in Kohery. When I stayed in the village I lived with Wahid Gul, his brother Zahoorwahid and their family. I began by asking about their father, Fazal Wahid, who had spent most of his life

p. 16
follows

In Kohery storytelling was an important skill. Men who had returned from even a short trip to Peshawar could turn their journey into a two and a half hour tale. Those who returned from the Gulf after a couple of years spent the first few days just talking; giving news of relatives and friends and regaling those at home with tales of their exploits. I often felt seriously lacking in my inability to generate these stories and I disappointed those who knew me with concise summaries of my experiences. In gatherings of men, while conversations were the norm, sometimes one individual would be called on to entertain the others with a story. This was particularly the case in winter when the men sat together through the long evenings in guest rooms or at the mosque. I took advantage of this storytelling to ask those I knew about their experiences of the Gulf. I was encouraged by the storytelling skills of men like Azum Khan, Wahid Gul and Abdul Hadi to use the story format in my own work. /

Insert p. 16

away from the village. Wahid Gul enjoyed telling me tales about his father and gradually the story developed into one about the whole of their immediate family. Their father's eldest brother, Abdur Rahim, was brought in to tell me stories about his own experiences working in the Punjab and Karachi and the project grew from there. In 1993 I wanted to interview all those I knew well in detail in order to be able to write their stories. Initially I was encouraged by Wahid Gul's cousin, Azum Khan, who sat down with me one afternoon and told me stories of his experiences in the Gulf. I soon found that others either had less time for interviews and storytelling or had less skills than Azum Khan or Wahid Gul. Over the months in Kohery, then, I talked to people when I could, interviewing them at length sometimes or asking a few questions at others. As I learned more about the families I also began to hear about men I had never met. To establish their stories I would ask around, trying to build up a picture of what they had done and where they had been. In the end the whole set of stories became a composite assembled from what people had told me about themselves, what others had told me and what I saw for myself.

15a

In several cases the bulk of what I have written is a direct relation of the stories that individuals told me. This is the case in the stories of Abdul Wahid, Abdul Hadi, Azum Khan and Abdul Halim. One problem here is the point that Abu-Lughod raises, that "life histories are actually stories that people tell about themselves, texts requiring attention to the conventions of story-telling and the context of elicitation" (Abu-Lughod 1993: 30). In the final section of the thesis I want to explore the ways in which these life stories were used and the reasons why they were told to me in the way that they were. Here, though, I do not wish to use them as direct oral history. Rather, I wish to see them as stories which give some idea about what the people I knew were like and to give some idea of the things that were important to them. The stories are supplemented with information from other sources - from other ethnographies, reports, histories and novels. What I want to do with all of this information is build up a picture of what migration from Kohery was like and what it meant to those who had taken part in it.

ARRIVALS IN PAKISTAN

A year or so after working in the UAE one of my letters to a friend, Zahoorulhaq, went astray in Pakistan and ended up in the hands of another man, a Zahoorwahid from a neighbouring village. Zahoorwahid wrote to me and we became penfriends, exchanging photographs and simple letters about our families and the weather. By 1990 I had begun the first year of my PhD under the impressive title of 'The social

and economic impact of labour migration on Pakhtun communities'. In the spring of 1991 I was fortunate enough to be awarded a Tweedie exploration grant which enabled me to travel to Pakistan for the first time. My idea was to check the place out to see if I would be able to do research there and, more importantly, to see if I wanted to do research there. I travelled first back to my familiar haunts in the UAE before joining the flow of migrants east back to Pakistan.

The scenes in Dubai airport were extraordinary and I felt somehow alone in not having to pay for overweight luggage. On the plane I filled my time completing immigration forms for those around me. When I arrived in the intimidating squalor of the old Karachi International Airport I was frankly terrified. Rather than stay in the imagined horrors of Karachi I set out that afternoon on a gruelling train journey north to Peshawar. I sometimes wonder how, in my state of utter innocence, I made it. The journey lasted two nights and a day, in which time we were totally exposed to the early heat of spring, the many beggars and the insects. Most often it was through the kindness and assistance of strangers, who went out of their way to help me, that I continued with my journey safely.

As the train neared Peshawar I was adopted by a Pakhtun who was impressed with my knowledge of two or three words of Pukhto. He led me from the train station to the right bus station and, after ensuring that I was charged the correct fare, squeezed me into the 'safe' front seat of my first flying coach. From there I travelled north again, squashed against an Afghan who ate sugar cane continuously and whose pistol dug into my side. I was overawed by the scenery as we wound our way up north, over the Malakand Pass and dipping back down towards the Swat River which we finally crossed to enter Dir itself. My mind was, however, mainly preoccupied with the thought of the next stage of the journey; how I would find my way via the vague addresses that I had with me to the homes of the people who I knew. I needn't have worried as when the bus pulled into its final destination, Timirgara, I was picked out of the crowd and greeted by Zahoowahid himself. Zahoowahid was accompanied by his elder brother, Wahid Gul and their many cousins whose names I struggled to take in (see Plates 3-6). To this day I do not know how long they waited at that bus depot for me, it could quite possibly have been days. As soon as I had been introduced the hospitality began; I was fed, new sandals were bought for me to replace my unsuitable boots and I was assured that there were Pakistani clothes for me to wear in the village. The final stage of my trip was by pickup up the dirt track, past the house of my original friend, Zahoowulhaq, and on to the village of Kohery.



Plate 3 - Wahid Gul with Posia



Plate 4 - Zahoorwahid with Yunus



Plate 5 - Abdur Rahim with grandchildren

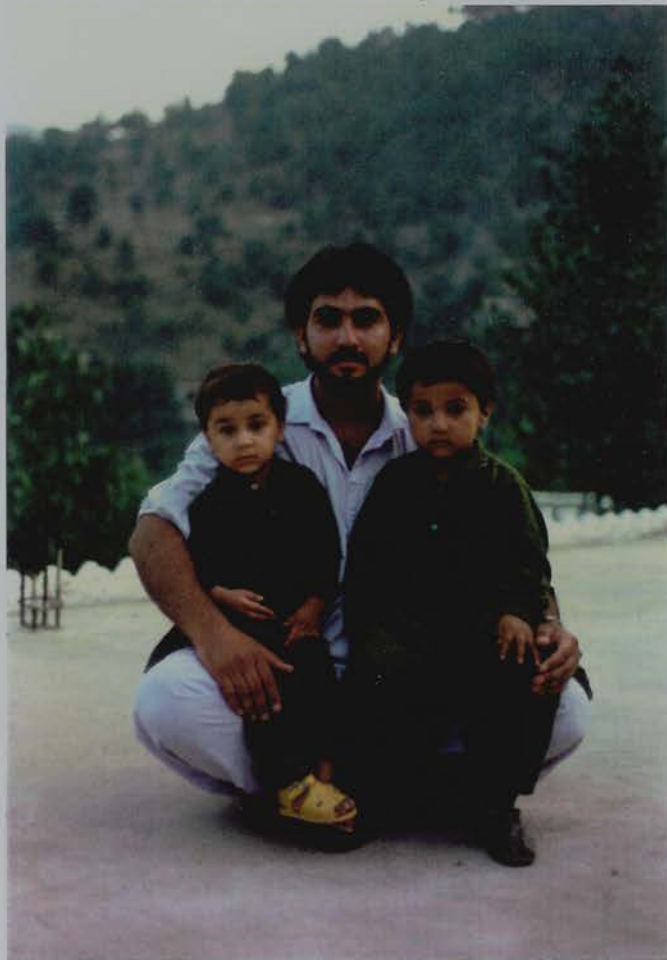

Plate 6 - Azum Khan with sons

I stayed for a week in Kohery initially. I was stunned by the scenery, overwhelmed by the hospitality and friendliness. It seemed that doing fieldwork in this place would be no problem; people were happy to answer my questions and were especially pleased that I wanted to learn Pukhto. At the end of the week I made the journey back down to Peshawar and from there I was put on the train to Karachi by Zahoor and Wahid Gul. In Karachi I met my wife, Debbie, off the plane from Britain and together we flew back up north. After a few days of acclimatisation we went back to Kohery together. For Debbie it was something of a terrifying experience, the worst kind of culture shock. Whereas I knew a few words of Pukhto, she knew none and had to rely on the occasional presence of Zahoor for translation. To meet the family she was led alone into the house where she was received by the many women and children with their incomprehensible questions and their constant staring. The women were friendly enough, it was just that many of them had never seen an *inglayzee khaza*, a foreign woman, before. One woman, who had walked all morning to get to the house, just sat and stared, open mouthed and silent. She was teased and challenged by the other women. She retorted saying that she may never have another chance to see another foreign woman again so she was making the most of this time. In all we stayed for ten days in Kohery though we were begged to stay for longer. For another ten days we toured the tourist spots of Pakistan before returning home.

FIELDWORK AND AFTER

The first eighteen months of my research were spent applying for money to pay for fees and to carry out fieldwork. During this time, and throughout the four years of research, the Carnegie Trust for the Universities of Scotland were generous in their support of me, paying fees and providing a research grant in 1992. In the spring of 1992, with money from the Carnegie Trust, the Social Anthropology Department and the Emslie Horniman Trust, I was able to embark on my first period of fieldwork. On this initial trip of six months my wife, Debbie, and I worked together in Kohery. It was a particularly difficult time for her as she suffered the claustrophobic life of a village woman, though without the support of family and relatives. Nevertheless she made close friends with the women of the house and provided the invaluable insights into household life on which this thesis is based. I spent much of the six months improving my basic Pukhto and asking the general questions of the innocent ethnographer. I filled notebooks with numerous

genealogical diagrams and with descriptions of weddings, families, graves, clothes and ploughs.

We returned to Edinburgh in September 1992 and for a long time it looked as though I would be unable to find the money to go back to Kohery and complete my fieldwork. Throughout this period my supervisors, Tony Good and Jonathan Spencer, were very supportive. They encouraged me to begin writing and showed me that I already had a wealth of material that I could draw on. They also continued to support my numerous applications for funds, correcting my applications and writing generous references. In the spring of 1993 I was thrilled to receive a letter from the British Council in Pakistan telling me that I had been awarded a Charles Wallace Trust grant to support a further eight months of fieldwork. Debbie and I left for Pakistan almost immediately. On our arrival in Peshawar Debbie set to work searching for a job and a place to live. By the end of the week she had found a job with the International Organisation for Migration (IOM) and a house to rent in the cantonment. Once I had seen her settled in I headed on the bus journey north to see my friends in Kohery.

1993 was a very different experience from 1992 for both Debbie and myself. Debbie found her work on the Afghan Repatriation Assistance Programme both challenging and rewarding. In the summer she was promoted to Pakistan co-ordinator and we moved our base to the capital, Islamabad. Away from the frontier atmosphere of Peshawar, life was much easier. Debbie also had numerous chances to travel in her work and saw Quetta in Baluchistan, Taftan on the Iranian border and the city of Herat in Afghanistan. In the meantime I continued with my fieldwork in Kohery. My Pukhto improved dramatically and I learned to read and write in the Arabic-based script. More rewarding, though, were my close relationships with Zahoorwahid and Wahid Gul and their families. I made new friendships with their uncles, Abdur Rahim and Abdul Hadi, and with their cousins, Azum Khan and Noorwahid, who spent their leave in the village over that summer. I felt my grasp of the situation in the village grow stronger over the eight months that I spent there. Some of the insights that developed in 1992 were strengthened while others were abandoned. Most of all, though, I enjoyed collecting new material, stories, biographies, proverbs and poems. Every day felt like a bonus to add to the work we had done in 1992.

We returned home for Christmas in December. On my way back I spent two weeks in the UAE visiting the various people I knew from Kohery. It was a hectic but rewarding time of socialising and exchanging news which proved a fitting end to my

fieldwork. Our intention in 1994 was to return to Islamabad for Debbie to continue with her work and for me to write my thesis. Over Christmas, however, the fighting in Afghanistan intensified and IOM's programme was cancelled, with the loss of Debbie's job. We were both deeply disappointed and worried about our prospects for the year. Eventually we managed to sort ourselves out and I realised that I now had the opportunity to write my thesis in the excellent working environment of the department. Tony Good and Jonathan Spencer continued to provide support and encouraged me to give papers at the Pakistan Studies Group in Satterthwaite and the South Asian Anthropologists' Group annual conference at the LSE. The reaction to the papers and the probing questions helped me a great deal in my formulation of themes. In addition a group of postgraduates in the department formed a writing group which ran through the summer and continues to run now. The original group of Justin Kenrick, Jon Mitchell, John Harries, Joan Stead, Ros Edbon and myself grew rapidly. The comments and discussions of this group have been of continued value throughout the period of my writing up.

THE VILLAGE OF KOHERY

The place where I carried out the fieldwork for this thesis lies in the heart of the district of Dir (see Map 3). Dir is about three hours north of Peshawar, the capital of the North West Frontier Province, over the Malakand Pass. The pass marks the beginning of the foothills which rise to form the great mountains of the Hindu Kush, Karakorum and Pamir ranges. In the areas of Dir, Swat, Bajaur and Malakand the hills are high but habitable, cut through by fast-flowing, snow fed rivers. In the main valley of Dir runs the river Panjkora which goes on to feed the Kabul River. The bulk of settlement is scattered around the valley bottom, taking advantage of the rich, irrigated land there. Previously the hills were heavily wooded with holly-oak and pines (McMahon and Ramsay 1901: 8). Gradually settlement extended to these areas, leaving most of them deforested. All up the hillsides, now, cling small settlements dotted around their terraced fields which rely on rainfall. Kohery is one of these settlements, perched precariously on Mond Ghar, one of the highest hills in the area at 2200 metres, and overlooking the administrative capital, Timirgara (see Map 4 and Plates 7, 8).

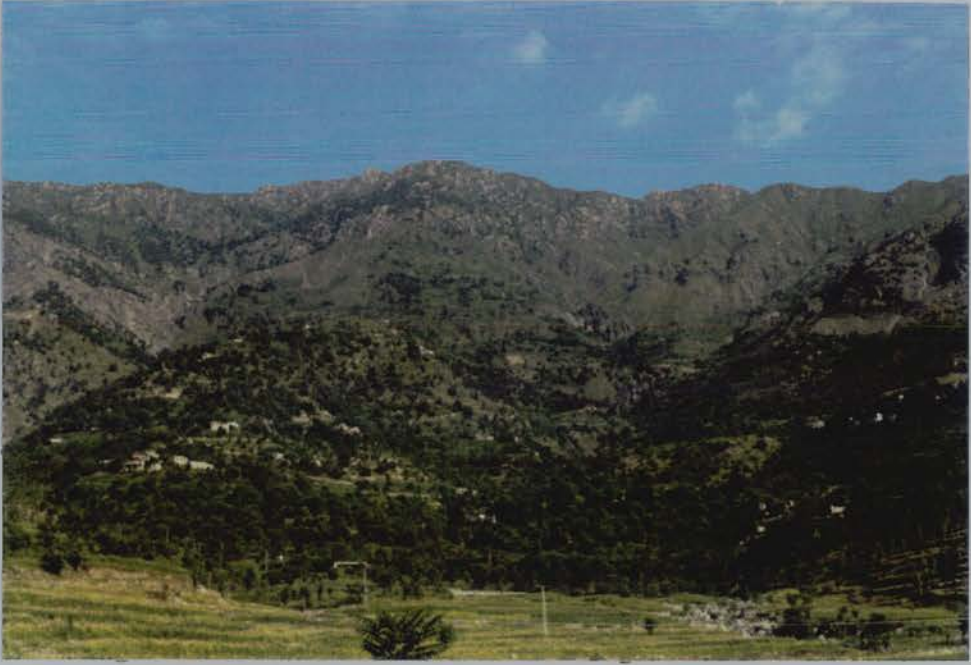

Plate 7 - General view of Kohery and Mond Ghar



Plate 8- View from Kohery towards Malakand and Timirgara

To reach the village required first taking the bus from Peshawar to Timirgara. Timirgara is an undistinguished market town and stop off point on the road north to Chitral. It lies next to the Panjkora river and also serves as the administrative centre for the district, with the district commissioners offices and main hospital. Pickups for the surrounding areas wait in the hectic and filthy bus station or tour up and down the main bazaar searching more actively for business. Twenty or more people and their belongings cram into these vehicles for gruelling journeys to villages like Kohery. The road to the village crosses the Panjkora and passes through the town of Balambat which houses the local police headquarters and the UN offices. Leaving the main road the pickups begin to slow as they encounter the start of the gradient. The journey from then on is slow as the road deteriorates and winds its way through the large villages of Malakand Payeen and Malakand Bala. Finally, after passing the turn off for Banda the road turns and climbs and arrives at Aday, the original dropping-off point for Kohery.

Kohery lies at a height of 2000 metres, spread out over the side of Mond Ghar and climbing almost to its summit. Over the ridge to the west lies the village of Banda, while to the east are Safaray, Sangolayee and Doolayee. The village is cut through by two seasonal stream beds which supply most of the water and is now linked together by a tortuous road hacked from the hillside by the people themselves. The centre of the village is called simply Kulee (village) and consists of a densely packed cluster of houses and shops with the main mosque at its centre. The rest of the village houses are scattered in small named clusters - Bagh, Dupkay, Sauray Kandow, Shokano and so on - or individual houses. Most of these houses are set at the edges of their terraced fields, occupying the least useful land. The terraces break the steep slopes into massive steps held in place by dry stone walls up to 2 metres in heights. In the early summer the village was a beautiful sight, a dense green of young crops and the surrounding trees. At the margins of the village, the fields thinned and became more stony gradually giving way to scrub and occasional areas of low forest. At the heart of the village, from Kulee to Aday, was the untended and rocky ground of the graveyard.

In all, Kohery consisted of about 400 households, with a population that I estimated at 4600 (based on an average household size of 11.5). Census data and other estimates of the population were wildly inaccurate as I was told by my friends in Kohery. Each household was based in its own separate house which ranged from a single room in a mud, wood and stone building, to a sprawling collection of brick and concrete houses and rooms. In addition every household

owned and farmed some land, be it only a couple of small fields. In some cases families owned considerable areas of land, 20 or more large fields which took two or three days to plough and sow. Because the land was so irregularly shaped and divided there were no more accurate ways of estimating land ownership. The forest land at the margins of the village was owned by particular patrilineages and the individual members had recognised access to particular trees. There was virtually no unused land within the village boundaries and most protected their own land carefully with it rarely being offered for sale. Those who wished to invest in new land had to look outside the village, to the areas around Timirgara and beyond.

The people of Kohery were all Pakhtun and belonged to the same tribe, the Utman Khayl. The word *khayl* was used to describe any kind of grouping from a living patrilineage to the Pakhtun 'tribes' which were in many senses non-existent outside of histories and folk memory. Each of the tribes of the Pakhtun is divided into segments, with the various segments tracing their genealogies back to a common ancestor. In Kohery there were six recognised *khayls*, which at this level were described by Ahmed as sub-sections, the operative sections of the tribe (Ahmed 1980: 6). The six *khayls* of Kohery were named Sauray, Boodayee, Jamalee, Saddee, Kus Kor and Moolian. To give an example of how these sub-sections recognised their ancestry I use Moolian Khayl and a tribal genealogy from McMahan and Ramsay (1901) (see Diagram 1). The members of Moolian traced themselves part of the Turi Khayl section of Mutakkai; Mutakkai being both a section of the Utman Khayl tribe and the name of their home base in the district of Bajaur. While individuals and families knew their ancestry the *khayls* as groups were rarely active in the village and were really only used for occasional political purposes.

Diagram 1 - Genealogy of Utman Khayl, tribal subsections (from McMahon and Ramsay 1901)

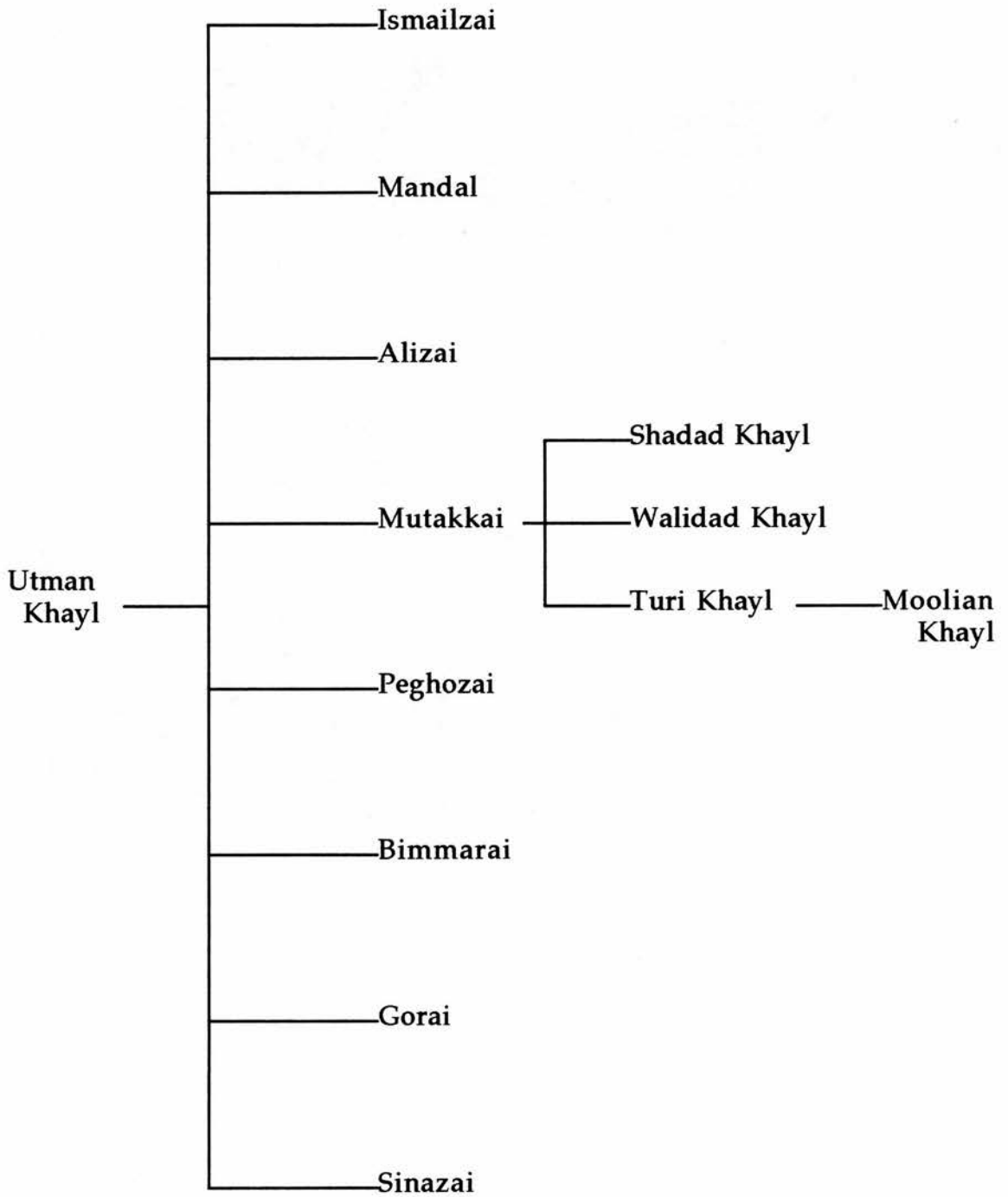



Plate 9 - Panoramic view of Bagh neighbourhood, Kohery

The other main division in the village was into neighbourhoods, called simply *koruna*, houses. Neighbourhoods were named areas of the village that contained a collection of houses and in many cases a mosque. In some cases the names referred to certain areas such as Kulee, village, and Bar Kohery, upper Kohery, while other referred to topographic features, such as Bagh, garden, which was located near to an old garden (see Plate 9). The village neighbourhoods all contained households from the various *khayls* of the village. People identified closely with the other inhabitants of the same neighbourhood in certain circumstances and cooperated closely with them in the celebration of major events such as marriages and births, particularly if the families were related by marriage. Many of the neighbourhoods in Kohery had their own local mosque. These mosques had been built by subscription, each household donating a set amount towards the initial costs and continuing to support the mosque with annual donations. Within the neighbourhoods the inhabitants saw to the upkeep of roads, paths and irrigation channels.

The village as a whole was united around the village council, the *jirga*, which saw to community matters. The council was made up of a core of elders from the village who were chosen for their wisdom and intelligence to represent all of the main sections of the village. The size of the council varied according to what was being decided. A small group of about 30 chosen elders met regularly to decide on everyday issues, from the upkeep of the village mosques, paths and roads, to settling family disputes that were brought to them. When larger issues arose, such as the siting of a Public Call Office in the village, then all those who wished to attend and make their point of view known could. Decisions were made by council consensus; if there was disagreement then discussions and arguments continued until settled. Various popular members of the council had, over the years, led the village in large projects such as the construction of a road linking the village to the valley and the piping of water to houses. The existence and strength of the village council was seen as giving testimony to the strength of the community. In turn the strength of the community was seen as being reflected in the appearance of the village. The many modern houses, the new mosques, the road, the schools, shops and even the many vehicles demonstrated the strong sense of community. Those villages that did not have a sense of community and a strong council did not have these things and looked old and run-down.

THE PEOPLE

As I have described, the people of Kohery were all Pakhtuns, all Sunni Muslims. Pakhtuns (variously known as Pathans, Pukhtuns, Pashtuns and even [unfortunately] Paxtuns) have been the subject of numerous studies, historical, ethnographic and popular (see Singer 1982 for the latter and for the best pictures of people and places). Many of these studies have focused on the Pakhtuns' status as the world's largest tribal grouping. Most of them contain complex tribal genealogies which demonstrate their inter relatedness and their descent from a common ancestor (see for example Caroe 1958: chapter 1; Barth 1959: 26; and McMahon and Ramsay 1901: 130-2). Ahmed identifies one of the key elements of the code of the Pakhtuns, *Pakhtunwali*, as the ability to trace one's ancestry from named Pakhtun ascendants (Ahmed 1980: 86). As I found to my cost, one of the key elements of studying Pakhtuns is the ability to describe the genealogy of the group under study in polite, academic company. Certainly this emphasis in the literature has meant that studies of Pakhtuns have focused on certain areas; in the main social structure, political processes and dominant male identity, as I shall discuss in detail below. When I came to search through the information available I found that little had been written on ordinary Pakhtuns, especially women and families.

In a sense it was chance that led me to that particular part of Dir, though I found that the area had numerous advantages. For a start, the hilly area was extremely attractive and the climate was good. On a more academic note, an additional attraction of the area was that it was one of those 'gaps' in the literature which researchers search so long and hard for. Extensive research had been carried out in the neighbouring district of Swat by Barth (1959, 1969, 1981), Lindholm (1982) and Grima (1993), while Ahmed had covered the tribal areas with studies in Mohmand (1980) and Waziristan (1983 [reprinted 1991] and 1986). A number of studies had been carried out in Afghanistan by Anderson (1975, 1978, 1982a, 1982b, 1983), Nancy and Richard Tapper (1980, 1989 and 1991), Christensen (1980) and Boesen (1983) among various Pakhtun groups. Dir, then, offered the attractions of being unstudied and of combining both a certain air of safety, since it was a district administered directly by the Pakistan government, and a tang of excitement, with its proximity to the tribal areas and the Afghan border and its 'wild' reputation.

Dir is a distinctive district whose inhabitants see themselves as in some way different from those around them. Part of this difference comes from the history of the area which was for many years ruled by the Nawab's family. Dir, like Swat and

Bajaur, managed to avoid direct rule by the British, and the Mughals and Sikhs before them, through terrain and general unruliness. The whole area of Dir was brought together under the rule of the original Nawab of Dir in the nineteenth century, sometimes by negotiation, more often by conquest. The Nawab subjugated the large land-owning leaders, or *khans*, of the valley areas and ruled through them. The hill areas, though, he claimed for his own. Those who wished to take land in these areas had to do so through the Nawab. Land was offered in return for service to the Nawab; the greater the amount of service, the larger the amount of land.

In 1895, at the height of the Great Game, the British advanced through Dir for the first time to relieve the besieged garrison and British Resident in Chitral (McMahon and Ramsay 1901, Caroe 1958). After that the British negotiated with the then Nawab to keep this valuable road open and secure for them. In return the British supported the Nawab and left him free to rule Dir as he wished. While the neighbouring valley of Swat flourished under the benevolent rule of Wali, the Nawab kept the Dir valley under his thumb. Even after independence, when Dir was nominally administered by the new Pakistan government, the Nawab held sway and was able to prevent the development of the district, refusing to allow schools, hospitals or even vehicles in. Only after the Nawab had been ousted by the army in 1960 could the district begin to develop. As a result Dir has always been seen as Swat's poor neighbour, with large numbers of men leaving to seek their fortunes elsewhere (Dichter 1967). Those from Dir saw themselves as more hardworking and hard-bitten than the Swatis. Even in the 1990s both Pakistanis and expatriates were puzzled as to why exactly I wanted to live and work in Dir with its reputation for lawlessness and poverty.

In my case, as I have described, where I worked and who I lived with were matters that were decided for me. As it turned out though Kohery was by far the easiest and most comfortable place for me to carry out my fieldwork. Throughout my fieldwork I lived in the guest room of Zahoor and Wahid Gul's house. I ate all of my meals at the house and spent much of my time with them. At times both Debbie and I suffered from the lack of privacy that resulted from this arrangement. Particularly in 1993, the only time that I had to myself was after everybody else had gone to bed at about 10p.m.. At the time I craved some solitude and space away from the constant presence of other people. However, reflecting back, our place in the household gave us a privileged view of Pakhtun life and has heavily influenced the shape of this research.

Much of the existing ethnographic work on Pakhtuns pays scant attention to the women and seems to follow Ahmed's opinion that "women are crammed into the interstices of tribal structure" (Ahmed 1980: 250). Pakhtun society is certainly highly segregated, at least as far as outsiders are concerned, and *pardah* is strongly maintained. This has meant that male ethnographers such as Barth, Ahmed and Lindholm had no access to the private world of the family. The same was the case for me in the early stages of my fieldwork. Despite Debbie's presence, in 1991 and 1992 I met none of the women from the house where we stayed. At times the women whom Debbie described to me and the lives that they led seemed strangely foreign and even unreal. Gradually, though, as I came to know the men better I could see the importance of their families to them. With the insights that Debbie's view gave me I could take a critical view of what the men told me and, in 1993 as well, I was able to ask more perceptive questions and read between the lines of the answers I received. The work of Boesen (1983), Tapper (1980, 1991) and Grima (1993) gave me a more general view of Pakhtun women's lives.

I was helped particularly by the fact that I had a good introduction through my friendship with Zahoor and a ready-developed network of contacts. Because Zahoor and his relatives could explain me to others the people of the village were generally friendly and lacking in suspicion about my presence and my work. For most of my fieldwork I concentrated on questioning and writing about those I knew best, the members of Zahoor's patrilineage, the Moolian of Bagh. At other times I ventured more widely, though usually my contacts were with those Zahoor and Wahid Gul knew well and could introduce me to. People everywhere were always keen to answer my questions and supply me with information and often wanted to reciprocate with questions of their own or, if I was unlucky, with religious lectures. They were always curious about my presence and rumours abounded about my belonging to the CIA. My friends in Kohery often warned me of the dangers from outsiders, suspicion, jealousy or even kidnapping. In all the time I spent there, though, they protected me from these dangers, even fending off enquiries from the district commissioner who suddenly took an interest in me. For their protection and especially their hospitality and friendship I am profoundly grateful.

MIGRATION BEFORE THE GULF: CHAPTER 2

1940s TO 1970s

When I began to collect life stories about men's experiences of migration it opened up a whole new area for me, the history of migration. There is a general tendency to see migration to the Gulf and migration generally as a new phenomenon (see Wolf 1982: 354-83). While the Gulf states may be a new destination, migration itself is certainly not an unknown phenomenon. The work of historians such as Chaudhuri (1985), contemporary administrators like Lorimer (1908), and writers like Ghosh (1992), demonstrate the long-standing and important links between the Gulf and the Indian subcontinent. Initially, I was just as guilty and started with an idea of the research as a before-and-after study looking at the impact of Gulf migration. The stories that I was told, though, were of working in Karachi before Gulf migration had even begun, of working in the Punjab before that and of travelling to Bengal at the time of the British government. Addleton's book (1992) and work by historians of India such as Kessinger (1974) confirmed that this was not just an isolated experience but that it was part of something much more widespread. It is a point that he is keen to stress, that Pakistani society has for a long time been highly mobile (Addleton 1992: 27). He argues that internal migration was an important feature of society in the western frontier of British India. After independence this tendency continued with large scale rural-to-urban and rural-to-rural migration (Selier 1988). He further states that the North West Frontier Province was a particularly important area of out-migration (Addleton 1992: 36) a point that is also noted by others (Dichter 1967, Ahmed 1980: 64).

The Pakhtun experience in general is one of movement; of mass migrations into new territories and of individual and group migrations in search of work and better opportunities. This experience is reflected in the stories of Pakhtun movements into the areas of the NWFP that they now occupy. These stories are related in detail by Caroe (1958) and referred to by Barth (1959: 7). The Utman Khayl, like those of Kohery, were said to have been one of the earliest Pakhtun groups to move into the area, before even the now dominant Yusufzai. Forced out of Kabul in Afghanistan at the end of the fifteenth century the Utman Khayl finally settled in Bajaur while the Yusufzai took the land in the valleys of Dir and Swat (McMahon and Ramsay 1901: 58-61). Those from the village related its origins in terms of a similar story of

movement. The *khayls* of Kohery described their move into the hilly areas from their original home in Bajaur in search of land to farm. They still continued to call themselves travellers, *musafaran*, despite at least two centuries of settlement.

The life that people found in the hills around Kohery was a hard one. The land that they took belonged directly to the Nawab and in return for working it they had to do service for him. In the main they were issued with guns and, when called, they would rally to fight for the Nawab. Other forms of service included bringing supplies of firewood once a year, working on the road through Dir to Chitral and taking part in the 'royal' hunts. In addition there was the seasonal tax of one tenth of the harvest produced on the Nawab's land. This system of taxation persisted into the 1960s so that the younger men could still remember the visits of the Nawab's man. The only people who were free from the Nawab's service and taxes were those on *seree* land, that is land given by the other *khayls* of the village in return for work. *Seree* land was given to those who worked in the village providing services for all of the houses there, service jobs such as the carpenter and the *mullah*, like many of those from Moolian Khayl. In addition the other *khayls* paid the taxes on this land leaving those who worked it free from service and tax. However, the area of land that was given in return for services was small. This meant that groups such as Moolian Khayl as they grew found that the land that they shared was relatively small so that they were in many ways poorer than the other *khayls*.

In general the land in Kohery was poor and the people relied on the weather and especially the rain for successful crops. When the crops were not enough or the family needed something beyond their means then their only recourse was to mortgage their land. Many, in addition to their own land, sharecropped the land of the rich khans in the Panjkora valley. The fields there were irrigated and so were richer and could be used to grow rice. Sharecropping was hard as the land was a long way from Kohery. People I knew recalled their experiences of sharecropping. They would set out before dawn driving the oxen and carrying the ploughs down the valley. As it was still dark people had to carry pine torches to see their way on the path. The journey took up to two hours after which they had to carry out a hard day's labour in the fields. They stopped only at noon to eat the bread and onion that they had brought with them. When the day's work was finished there was the tiring journey back up the hill to Kohery to be faced. For all of their hard labour they received only a small proportion of the harvest. The landowner supplied the land and the seeds for planting and for his part took two out of every three shares of the harvested grain. Those who worked the land took a scant single share, a mere third

of the harvest. Nevertheless the rice was a valuable addition to the family income and a luxurious supplement to their diet.

Many looked outside the village for better opportunities. In Kohery, as in other parts of the NWFP, there were stories of generations of travel for education or work (see for example Dichter 1967). The stories of the members of Moolian Khayl are the ones that I knew best and are illustrative of the history of migration of the rest of the village. The members of Moolian Khayl felt that they had a lot to be proud of, given their long tradition of religious education. Many of their members had travelled far from the village to gain their education and take up their traditional profession of religious leaders, *mullahs*. They had travelled out of the hills of Dir to Kohat, Baluchistan, Bengal and even as far as Burma if the stories are to be believed. Here I concentrate on the stories that were best remembered; the stories of those who were most influential and those who were still alive.

Diagram 2 - Moolian Khayl in Bagh neighbourhood, Kohery

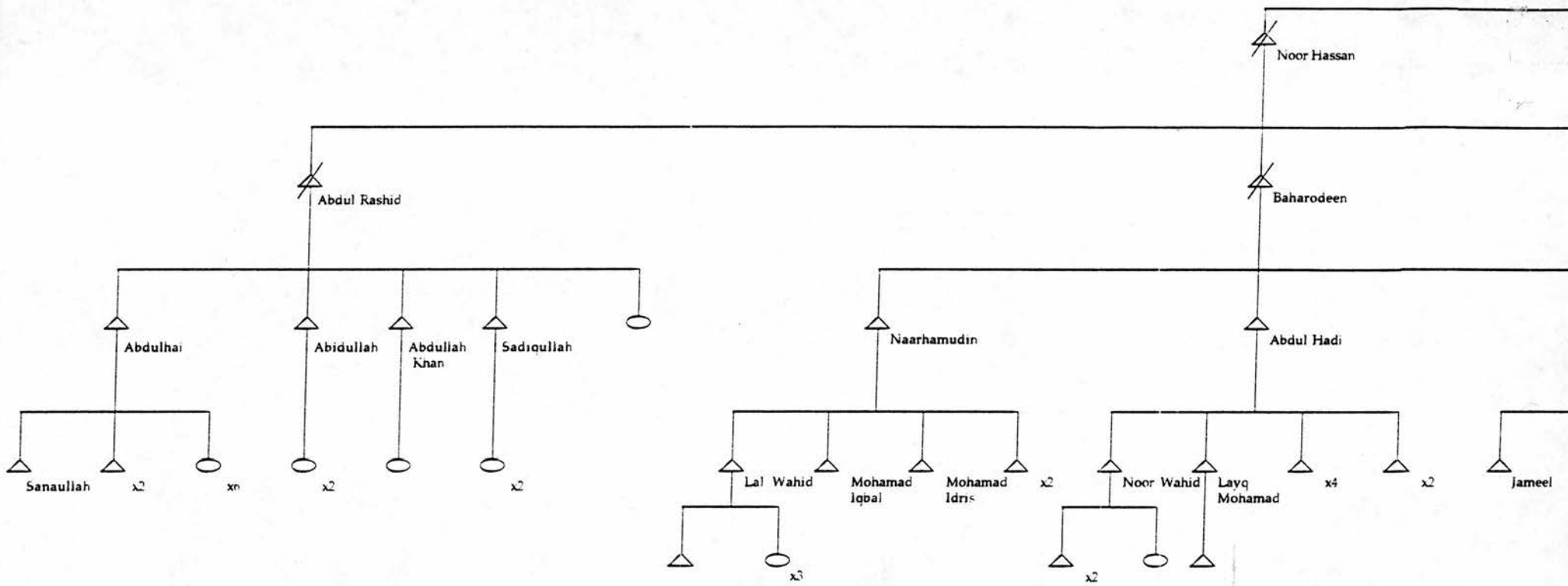

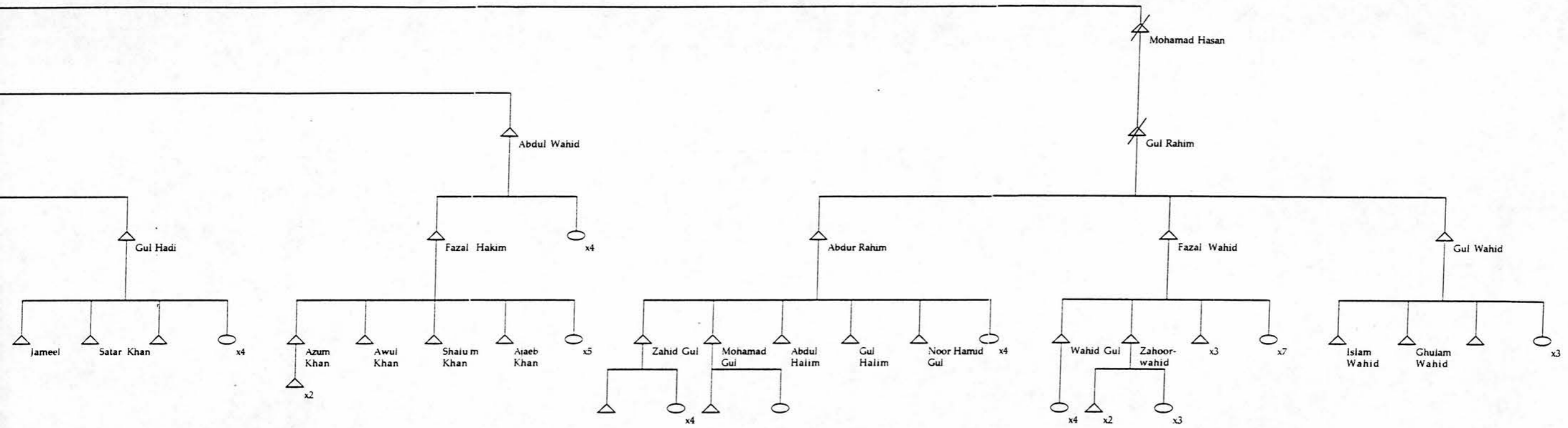

ABDUL RASHID'S STORY

In about 1925, while his father, Nooree Hassan, worked abroad in Bengal, Abdul Rashid left home to go and find his education. At the time there were no schools as can be found today in Pakistan and the only education to be had was in the mosques. Like many others at the time, Abdul Rashid would travel to a place that had a mosque with a well known *mullah* and would stay there with him to learn. The boys were known as *taleeb* and in return for being taught they would look after the *mullah*, cleaning his clothes and fetching him food. At meal times the boys would go around the village with a dish and a bag calling out to the people for donations of food. People would come out of their houses and give the boys a piece of bread here, some lentils or a piece of meat there. When the dish was full the boys would take the food back to the mosque for them all to eat. After staying for a few months learning in one place Abdul Rashid moved on to the next place with a famous *mullah* to learn from him. In this way, moving from mosque to mosque Abdul Rashid got all of his education.

When Abdul Rashid felt that he had learned enough and that he was ready to work he headed for Baluchistan where he had heard that there was work available. As he wandered from place to place looking for a position he was pointed in the direction of one village where others said that they were looking for a *mullah*. When he arrived at the place in the area of Kooloo, in the north of the province, the people of the village took a liking to Abdul Rashid and said that he should stay and act as their *mullah*. Abdul Rashid worked in Baluchistan for many years, indeed, for most of his working life. He remained for all of that time as *mullah* in the same village in the district of Kooloo. During his time there he was joined by many other members of Moolian Khayl who were also able to find work as *mullahs* in the surrounding areas. His own younger brothers, Baharodeen and Abdul Wahid, although they had only been educated in the Qur'an at home, were able to join him there.

As well as encouraging other members of Moolian Khayl to come to Baluchistan to work Abdul Rashid brought many of their sons to his mosque for their education. The Nawab still controlled all of Dir. He was suspicious of those who were educated and so forbade schools in Dir. This meant that while the rest of Pakistan after independence began to build schools and create a new education system, in Dir this was not allowed to take place. The only education that was to be had was

in the Qur'an as is was taught in the local mosques. In Baluchistan though there were government schools and so Abdul Rashid brought the boys of Moolian Khayl to live with him and to be educated there. Many benefited from his generosity including the sons of his brothers, Baharodeen and Abdul Wahid and the sons of his more distant cousin, Gul Rahim. Abdul Rashid paid for their keep and for their education and in return the boys would cook and clean. In addition he taught them to tailor, a skill that proved very useful in later years.

ABDUL WAHID'S STORY

In 1993 Abdul Rashid's last surviving brother, Abdul Wahid, was still a formidable man in age (of about 70 years of age), appearance and character. His bent back, slow gait and constant illnesses made him seem old beyond calculation. However, his quick, searing wit and sparkling eye that missed nothing were in sharp contrast to his appearance. Many were afraid of becoming the butt of his caustic comments and sharp jokes though all had to accept what he said respectfully. He continued to keep those around him in line, insisting that his grandsons prayed the obligatory five times a day and objecting loudly to any taped music that he heard. At the same time he had a wicked sense of humour and a ready mind. His story, though, was clear and simple.

In his early life in Kohery Abdul Wahid often had to leave the village to look for work although at first he did not travel as far as his elder brother, Abdul Rashid. Like many in the village the family had little land and what they had was poor. Many men would travel to the area known as Mayra during the sugar cane harvest in the late summer. Mayra is the area beyond the Malakand Pass where the plain, on which Peshawar stands, begins. The area extends from Malakand itself, down through Skhakot to Mardan and Dargayee. Abdul Wahid travelled down to Mayra with one or two others from the village for fear of thieves on the road. They would walk there carrying thick baked bread to eat on the journey and staying overnight in mosques by the road. Once in Mayra the men would find work harvesting or refining the cane. For a full day and night's work the men were paid only 4 anay. On their return to Timirgara the men could sometimes travel on the Nawab's bus, the only form of transport in the area. The fare, though, was expensive and on one occasion Abdul Wahid's brother, Baharodeen, refused to pay the 1 ana demanded and chose to walk from Batkhayla instead. For a while a number of men found work with the British contractors building the canal and tunnel that carried part of the Swat River under the Malakand Pass to irrigate the plain beyond. At first Abdul

Wahid found work as a labourer earning 12 anay a day. He was then taken on by Sadbar Khan, another man from Kohery who had work as a foreman. Abdul Wahid worked for a total of six months for him as a cook and was paid directly by him. He could remember that many of the men would add to their wages by hiding the tools with which they had been issued with and taking them home to use or to sell.

Abdul Wahid first went to join his elder brother, Abdul Rashid, in Baluchistan around 1940 when there was still a British government in Pakistan. He himself was about 25 years old and had only a small moustache and beard. He travelled down from Peshawar, through Lahore and Mianwali to Dera Ghazi Khan by train. From there he took several long bus journeys into Baluchistan to the area of Kooloo where his brother lived and worked. He was able to find work as a *mullah* in a place called Gulsalayee. This was a place close to Abdul Rashid and where there were others from his own kin group in Kohery working as *mullahs*. At first he found things hard and had to spend six months learning the local Baluchi language. The people were very ignorant and often contradictory as they would not listen to what he had to say. Many of the people there, even the older men and those who considered themselves good Muslims, did not know even the simplest prayers and Abdul Wahid had to start from scratch. Other things too made life difficult for him.

The people who Abdul Wahid was *mullah* to were nomadic, Gujar as he called them. From the start they told him that if he wanted *zakat*, the grain and animals that they would pay him with, then he had to come with them, following them from place to place. As he was not used to the life of the nomads he found being their *mullah* hard. In the winter the people moved to the lower areas to avoid the snow and in the summer they went to the hills to avoid the heat. They did not build proper houses from stone and wood but rather wove mats from reeds and made temporary houses from them. Their ideas about hospitality too were very different from those of the Pakhtuns. A visiting guest, such as Abdul Wahid, was kept away from the house, sleeping in the open. Even at night the guests were left to sleep away from the house. Abdul Wahid recalled that the people were like this at all times and even if he were ill nobody would come to ask if he needed help, something which shocked his listeners even in 1993.

However, the nomads were generous with their *zakat* and every season each household would give 15-20 kg of grain and 2-3 sheep or goats to their *mullah*. Abdul Wahid sold the animals that he was given to rich merchants and would save

the money. After two seasons he had saved a lot of money and was able to go back to Kohery to visit. The first few times that he went he was able to take back Rs-300 which was a great deal of money at the time. On the journey home he stopped at the big bazaar in Batkhela to buy gifts like clothes and tea for his family. As he said, when I returned people looked at me, they saw the money and gifts that I had brought and they knew that I was doing well.

Over the years that he worked Abdul Wahid was able to save considerable amounts of money. When he returned to Kohery he was able to buy land at the edge of the village. Abdul Wahid bought the land from a man called Khono Baba for a cost of Rs 1100. Abdul Wahid was extremely proud of his land and claimed that he would never sell it even for Rs 600,000, a huge amount of money. When he first bought the land it was bare hillside and he had to work himself to turn it into fields. Over the years he laboured and hired labourers at Rs 1.5 a day to build eight terraced fields. The land was relatively poor and stony but could still be used to produce two crops, of wheat and maize, every year. The beautifully constructed terrace walls stood as a testimony to Abdul Wahid's life of work. Others, too, did well from their years in Baluchistan. Abdul Rashid was able to buy large areas of fields in the village as well as building a large new house and setting up one of the first shops in Kohery. Land was the real key to security at the time. It enabled families to live and provided them with a surplus in some cases that they could trade for other necessities.

FAZAL WAHID AND ABDUR RAHIM'S STORY

The lives of those who remained at home seemed as secure at first. Nooree Hassan's elder brother, Mohamad Hassan, stayed in Kohery as the mullah for all of his life. He had only one son and one daughter. Gul Rahim, his son, inherited all of the land and, by working it and sharecropping land by the Panjkora, supported his family comfortably. He had a daughter and three sons, the latter named Abdur Rahim, Fazal Wahid and Gul Wahid. In the mid-1950s, when Gul Rahim was only thirty years old he, like many others in the village, contracted a disease like cholera from the dirty water by the Panjkora. He died and overnight the fortunes of the family changed dramatically.

As Gul Rahim's children were still young - his daughter was 15 years old, Abdur Rahim 13, Fazal Wahid 10 and Gul Wahid only 2 - they were unable to work the land that they had been left. This meant that, suddenly, they were very poor.

Their mother, who was still young, remarried in another village and, only four months after her husband's death she left Kohery to join her new husband. The family's relatives lived all around them and their father's cousins, Abdul Rashid, Baharodeen and Abdul Wahid, were like true uncles to them. However, they had families of their own to support and so Gul Rahim's children had to split up. The eldest daughter left Kohery to go to Matakko in Bajaur where Moolian Khayl had other relatives. Abdur Rahim went to Baluchistan to join Abdul Rashid there in order to get some education. He still remembered how beautiful the place where his uncle worked was. He talked to me about the hills and the lovely gardens in the village where many different types of fruit grew. Abdur Rahim had no real aptitude for education and after only a few months, when he was old enough, he left Baluchistan and went to look for work.

Fazal Wahid stayed closer to home at first. He went to the neighbouring village of Malakand where he worked in the house of the khan, Sadullah Khan Malik, as a servant looking after the buffalo. For his work Fazal Wahid received shelter, food and a new set of clothes each year. In addition he was able to go to the local mosque where he received a basic education. In all, Fazal Wahid worked for Sadullah Khan for five years. Fazal Wahid's uncle, Abdul Rashid, decided that the boy would be better off with him and so brought him to Baluchistan. In the meantime the family's land was mortgaged off. Fazal Wahid stayed in Baluchistan for some years and was educated up to the 6th class in school, a very high standard of education for the time. In addition he, like Abdul Hadi and others, learned to be a tailor from Abdul Rashid.

Abdul Rashid, after 20 years of working in Baluchistan, decided that he wanted to return home and brought Fazal Wahid with him. On his return to Kohery, Fazal Wahid, looking round for something to do, decided to use his education and set up the first proper school in the village. The Nawab still ruled Dir and education was discouraged, making Fazal Wahid's enterprise a risky one. Nevertheless the people of Kohery responded enthusiastically and many sent their sons to the new school which was set up in the main village mosque. Like the mullah and others in the village who provided a service, Fazal Wahid was paid in donations of grain after each harvest for his work as a teacher. Abdul Rashid, on his return, built a large new house for his family and, in a room on the ground floor, set up one of the first shops in the village. As well as teaching Fazal Wahid worked for his uncle in the shop, selling cloth and general goods.

WORK IN THE PUNJAB

In the meantime Fazal Wahid's elder brother, Abdur Rahim, had been working for a number of years in the Punjab, along with many other men from Kohery. The new government of Pakistan had begun many large projects developing the infrastructure of the country in the mid-1950s. One of the main ones was the building of large irrigation canals in the Punjab to the north and south of the city of Lahore. Much of the work was done by hand as there was little machinery around. As a result there were many opportunities for those who wanted to work as labourers. Some of the better off men in Kohery caught on early to the opportunities available and had been able to set themselves up as small-scale contractors with teams of donkeys, which were used to move earth. These contractors hired other men to work as labourers for them and in many cases they took on men from Kohery. Others in the village heard about the prospects and went to find work for themselves. In this way there were soon large numbers of men from the village working together in the Punjab.

As well as the work being hard, the men who worked on the irrigation projects sometimes faced great risks. Abdur Rahim's memory for stories was not good and so I first heard about the great flood through another man, Rasool Khan. Abdur Rahim later confirmed the story and even added a few details to the telling of it. Rasool Khan was the younger brother of one of the main Kohery contractors in the Punjab and he had himself worked there. When I met him he was an imposing village elder, with a startling red beard and a tendency to lecture me at length about why I should become a Muslim. As much as possible I tried to avoid him until I accompanied Zahoor on a trip to Kulee. Rasool Khan invited us to lunch and Zahoor accepted. After we ate Rasool Khan began to lecture. Having endured his diatribe I felt that it was my own turn and began to ask him questions about his life. Gradually the conversation turned to his experiences in the Punjab and then I first heard about the flood.

Much of the Punjab is flat with large river systems running through it which enable some of this relatively dry land to be cultivated. The Pakistan government sought to continue and expand the work of the British before them by expanding the area that could be irrigated. This meant building enormous irrigation canals to carry the water from the river to new areas. The rivers were fed by rain and melted snow, mainly from the mountains in the north of the country. During the monsoon period in the late summer, when there were often substantial amounts of rainwater in the

rivers, the plains could sometimes flood, even when there had been little rain in the actual area. Rasool Khan recalled that day there had only been light rain while they worked. Then, without warning, they heard and saw a great rush of water coming towards them. The men fled for whatever high ground they could find, leading the donkeys where they could.

Soon they were stranded on the high banks of the canal that they had been building, completely surrounded by water. There was nowhere for them to go as the country all around them was flooded and their camps had been destroyed. With the camps gone they had no food and so for several days they ate nothing. As the flood continued, however, debris from destroyed villages began to float past. The men were fortunate enough to rescue some undamaged tins of flour which they could use to make bread. One day they saw a buffalo swimming towards them in the flood waters. They captured the animal, slaughtered, cooked and ate it, thankful to have *helal* meat to eat. Abdur Rahim also recalled that the government sent planes which dropped some supplies for them. While they themselves could eat, there was nothing for the donkeys on the bare, newly built canal banks. The men improvised a raft from flotsam and used it to paddle about to collect what fodder they could for the animals. The flood lasted for over a week and the men had to wait until the waters finally receded until they could escape from their island.

After several years of working in Kohery, Fazal Wahid went to join his brother, Abdur Rahim, working in the Punjab. With his education Fazal Wahid was able to find work easily, as a kind of quantity surveyor. He worked at estimating how much earth had been removed and how much materials had been brought for construction. The earnings that the two brothers made were good and between them they were able to save enough to pay for Abdur Rahim's marriage. In addition they saved enough so that when Fazal Wahid returned to Kohery he was able to pay off the mortgage on the family's land and so take possession of it again. Fazal Wahid also set himself up in a small cloth and tailoring business. The shop was a small one and was based in Abdul Rashid's house, the latter being a partner in the business. As Fazal Wahid was the only tailor for some distance, business was good. At about this time as well the three brothers, Abdur Rahim, Fazal Wahid and Gul Wahid, set up separate houses. Wahid Gul claimed that the break-up into separate households was due to disagreements over money, though others like Abdur Rahim were less willing to make comment.

THE MOVE TO KARACHI

As the government programmes in the Punjab reached completion the contractors and labourers began to look elsewhere for work. Some of the contractors found work in the construction of the new international airport in Karachi. Soon many others were heading south to look for work in the growing city. The end of the 1960s and beginning of the 1970s was a period of great industrial expansion in Pakistan. Karachi, which had previously been the capital of the country took on a new role as the main port and industrial centre. Men from Kohery found work easily in this period of first industrial and then commercial development. One of the first to go was Abdul Hadi, the son of Baharodeen.

In 1953 Abdul Hadi accompanied his uncle, Abdul Rashid, to Baluchistan for his education. After a time he found work as a mullah in an area near his uncle's mosque. For three years Abdul Hadi worked as a *mullah* to a nomadic people though he was still a young man. One day in the early 1960s, while he was sitting outside on a bed studying his books, a man leading camels came by. The camels were loaded with tobacco and the man stopped them, sat them down and came over to speak to Abdul Hadi. Abdul Hadi asked the camel man, the *kuchay*, what he was doing. The *kuchay* replied that he was selling tobacco and asked Abdul Hadi in turn what he did. Abdul Hadi said that he was a *mullah*. The *kuchay* was surprised and asked him, how can such a young man with only the beginnings of a beard be a *mullah*, why are you doing this work? He asked again how it was that he was so young and yet he was a *mullah*, how can you give the call to prayer, he asked. He said to Abdul Hadi, you shouldn't be a *mullah*, you should be doing different work. The *kuchay* had been to Karachi and told Abdul Hadi that was the place for a young man. In Karachi there are big buildings, bazaars, cars and different work. As Abdul Hadi said to me,

After that I thought to myself, why am I a *mullah* when I am so young? I realised then that in my heart I did not want to be a *mullah* and that I should be doing different work.

After only another five months he gave up his job and a few months later he headed to Karachi to seek his fortune there.

Other men, like Abdur Rahim, followed the contractors and the work from the Punjab down to Karachi. At first most of the men lived and worked on the construction sites until the buildings were completed. Abdur Rahim worked first as a labourer and then as a night watchman in Karachi for a number of years. He

remembered working on buildings many storeys high with lifts in them, a new experience for him. They lived in temporary shelters, often just a roof covered with vegetation, which was fine in the hot weather, but when it rained the places often flooded. As the building became more complete the men moved inside to live.

Fazal Wahid gave up his business in Kohery and went to join his brother in Karachi. He soon found work, again as a quantity surveyor. He worked on a number of large projects including the construction of the Pakistan steel mills outside the city. The work paid well and Fazal Wahid was soon able to return to Kohery and pay for his own marriage. Only a few short months after the wedding he returned to Karachi, this time to work for a fellow Pakhtun from Swat, a man called Baharam who was a large contractor. All the time that Fazal Wahid was working for Baharam he was saving money so that he could start his own business in Karachi. After a number of years he was able to open up a shop in rented premises where he sold cloth and did tailoring work. Fazal Wahid had four other tailors working for him in the business, each paying him a share of their own profits towards the rental of the premises. Business was very good and after only a couple of years Fazal Wahid was able to move on and buy his own shop in a part of Karachi called Heyadaree.

Although most of the people from Kohery were scattered all over Karachi, wherever there was work, there were some places where groups of them congregated to live. In Heyadaree there was a small community of Pakhtuns, mostly from Swat, but with a number from Kohery. Fazal Wahid's brother, Gul Wahid, lived there with his wife, Abdul Hadi had a small shop there and there were others. Fazal Wahid bought his shop in Heyadaree and soon afterwards built himself a small house in the same area. In 1973 he moved his family - his wife, daughter and two sons - to Karachi to live with him. At the same time Fazal Wahid bought into partnership in a truck with Abdul Hadi and Abdul Rashid's eldest son, Abdulhai, who was working as a mullah in Karachi. It was a very poor investment as the truck was beset with problems. They made little money and often lost more than they earned, causing numerous arguments which put Fazal Wahid off sharing a business for life.

After Fazal Wahid sold his share in the truck he went back to working for himself in his own shop. Not long after those events he was severely affected by a family tragedy. One of his own *khpulwan*, who also worked in Karachi, an Abdul Maliq, was killed in a road accident. As Abdul Maliq had been crossing the road from his house to the mosque opposite he was hit by a rickshaw and killed. After a lot of

deliberation it was decided by his family that it would be too difficult to send the body of Abdul Maliq back to Kohery and so he was buried in Karachi. That Abdul Maliq was buried in Karachi and not in his home of Kohery affected Fazal Wahid quite deeply and he worried about it constantly. He thought about how unhappy the rest of the family were that the body hadn't been buried in the village but was rather buried outside. With these thoughts on his mind he decided to move his family back to Kohery.

The whole family were very happy about the idea of the move but Fazal Wahid's wife was especially pleased. For most of the time she had lived in Karachi she had been ill and even after she returned to Kohery she was troubled with illness. After seeing his family safely back home Fazal Wahid returned to Karachi, sold up his own business and took up work as the manager of a fleet of trucks. His skill and experience meant that he could command a high salary and over the years he saved considerable amounts of money. In the mid-1970s Fazal Wahid returned to Kohery himself. Back home he was able to use the money from the business and house he had sold in Karachi as well as the money he had saved to open a shop in the main part of the village, Kulee. Thanks to his years of saving he was able to open the shop independently and stock it well. The purchase of the shop marked the end of Fazal Wahid's period of working in Karachi.

MOVING AWAY FROM HOME

Over the period from independence in 1947 to the 1970s there were considerable changes in the nature of migration from Kohery. More and more men moved further away from the village to take advantage of the opportunities that were available to them as the new Pakistan began to develop. Other authors note the importance of these developments for internal migration in different areas of Pakistan (Naveed-I-Rahat 1990). Part of Addleton's (1992) thesis is that these earlier internal movements in search of labour opened the way for the enormous migration from Pakistan to the Gulf. Indeed, for the Pakhtuns in particular, he suggests that migration had become a way of life (Addleton 1992: 37). The Pakhtuns came to be seen as a way of life in parts of the Punjab, such as the city of Lahore. In Bapsi Sidhwa's novel *Ice-Candy Man*, for example, the young narrator is taken through the streets of the city:

just before we cross the Ravi bridge we rattle through the small Pathan section of town. Now I see only fierce tribesmen from the northern frontiers around the Khyber and Babusar Passes who descend to the plains in search of work. They leave their families behind in flinty impoverished valleys concealed in the arid and massive tumult of the Karakorums, the Hindu Kush and the Himalayas. They can afford to visit them only every two or three years (Sidhwa 1988: 51).

Dichter (1967), writing about the North West Frontier in the 1960s, noted widespread poverty and a reliance on migration throughout the area. In surveys of various parts of the province he recorded villages with men working in places as far afield as Peshawar, Lahore and Karachi sending home remittances. He even goes as far as to suggest that the Frontier was unable to support its population leading to temporary and permanent migration (Dichter 1967: 168).

For the people of Kohery the migrations were a natural progression. Their experience of local migration to work on the sugar cane and more distant movements within the Indian subcontinent meant that they were ready to take advantage of the opportunities that opened up after Independence. Some of the better off men were able to get in early on the irrigation projects in the Punjab. They employed some men from Kohery while others heard about the opportunities and saw the gains to be made from their fellow villagers. The same process took place when the opportunities in the Punjab declined in the 1960s and new ones in Karachi opened up. This isn't to say that this shift wasn't a massive change for the villagers. Karachi, although it is in the same country, was still a long way from Kohery; a

journey of two or three days by train and bus at that time. The departure of a man or group of men for Karachi was seen as a major event for the village as a whole. On the day that the men left everybody from the whole village would gather at the start of the path to Timirgara to see the men off. People would give letters and verbal messages to be passed on to family members in Karachi. All those present would then join in prayers for a safe journey and for the safe return of all those working away from the village. Men travelling to and from the village were seen as the only reliable means of communicating with other family members. The messages sent were brief - the children are well, the crops are good, we have plenty of rain - but they and the return news from those in Karachi were eagerly sought.

Migration was beginning to become much longer term as well. Previously migration to Bengal, and even to the Punjab, was much more seasonal, with men working away from the village during the quieter summer months and returning for the harvest and replanting in the autumn. With the shift to Karachi more men began to stay for longer. Travel was relatively easy, with a cheap train journey direct from Karachi to Peshawar and no complications of visas. The prospects in Karachi were good; there were plenty of well paid jobs to be had and now there were numerous opportunities for small businesses in the rapidly growing city. Some of the men, like Fazal Wahid, took their families to live in Karachi with them so that they needn't be separated. Life there, especially for the women, was hard, but at least they could be together and there were some other villagers around. Small communities developed in Karachi over the years though few seemed to have had the intention of settling permanently. All maintained close links with Kohery which was still very much home. As Fazal Wahid's reaction to Abdul Maliq's death in Karachi showed, the village community was seen as the most important thing.

Those who returned from Karachi to Kohery brought back a wide variety of things. The most common gifts were cloth and tea, luxuries that were still in short supply in Dir. On the practical side some brought back the springs from scrapped vehicles to be used by the village blacksmith to make tools. Many new luxury items were bought in Karachi as well. Fazal Wahid brought back one of the first watches, one made in Pakistan, that broke after only a few weeks, but it was really only for show anyway. He also brought back the first tape recorder to the village, an expensive Sony model. With few people able to read, many saw the advantages of the machine and started sending messages to their family recorded on cassette. The cassette recorder was passed from house to house for many months so that people could listen to their messages and tape their own replies. Gradually more and more

families came to own one, until by 1993 it was the most common object in every house.

Most of the money earned came back in the form of savings. The main investments were in new houses and in land. At first people continued to build houses in the old way with the simple innovation of sawn timber roof beams. Gradually, though, new building techniques and skills learned in Karachi were brought back to the village. The first buildings made in the new materials, breeze blocks and concrete, were guest rooms. The new materials increased the costs of buildings dramatically, especially as they had to be brought from Timirgara, and so they were used where they were most on display. Soon, though, houses were constructed with breeze block walls, retaining the timber and earth roofs. Eventually the roofs too were made with reinforced beams and poured concrete ceilings.

The investments in housing were matched with investments in land. With the arrest of the Nawab of Dir at the beginning of the 1960s people were able to lay claim to the land that they had always worked. Those who could afford it bought up the unused land at the edges of the village for conversion into terraced fields. The amounts of land under cultivation increased substantially and new neighbourhoods began to appear as families moved out of the cramped village centre to new houses. The increased amounts of money available from Karachi meant that families could be more self-reliant. Mortgaged land was bought back and the practice began to disappear until it was virtually unknown in the 1990s. The 1970s saw the end of share-cropping, which people welcomed as freeing them from a tremendous burden. Sharecropping was starting to be replaced with wage labour at the time when men first started to leave to work in the Punjab. As more and more men left the area to take advantage of the better opportunities outside the local demand for labour became acute. This resulted in landowners having to offer wages for labour and in the demise of the sharecropping system.

People remembered the time of migration to the Punjab and then Karachi as a good time. Obviously they saw marked improvements in their lifestyle. The money that they were earning enabled them to build new houses, to give up sharecropping, to buy luxuries and generally give their families better lives and, in some cases, to buy new land to provide for the family's future security. During that time people still helped each other a great deal. Zahoor remembered that shop-owners gave credit to everybody. Families lived on credit, but when the men returned from Karachi the first thing that they would do was discharge all of their debts immediately. People

recalled that money was far more frequently and easily given in loans. Some people thought, however, that the times were not as good as others liked to remember. Rasool Khan, one of the main village elders, took a moralistic view, and some other older men backed him up. The money that people earned then was no good, it had no blessing attached to it. To earn it, the men had to work continuously and could not stop to pray. The result was that the money that they earned was not blessed and so did them no good. This is a theme that I will return to in the last section of the thesis.

THE PIONEERS

A few men had visited the Gulf and the UAE many years before the start of full-scale migration there. One man made his way by road to Jordan in the 1960s and from there went to Saudi Arabia on Haj. Another, Gul Hamid, first went to work in the UAE before 1970. They remained lone cases, however, and it was not until 1975 that men in any sort of numbers went to work there. For them it was, like the previous move from the Punjab to Karachi, a natural progression. Similar sorts of processes operated as the companies that the men worked for expanded to take advantage of the new opportunities that were available in the Gulf states. The Gulf states were short of labour and so imported it through these companies. Many of the first men went to the Gulf on special contracts. These 'agreement contracts' limited the men who took them to working for the company and only for a given time period. However, once the men got to the UAE they saw that better opportunities existed away from these companies and left. In the early days of migration states such as the UAE were desperate for labour and so could choose to be lax in their immigration laws and ignore some of those working illegally.

Abdul Hadi remembered quite clearly the departure of the first men from Kohery for the Gulf. He was working in Karachi in about 1970 when one of his neighbours from the village, Ghasurahman, came to him and told him that he was going to work in a place called Dubai. Ghasurahman told him that a friend had got him the visa and that the price of the plane ticket was Rs 1000. Ghasurahman was one of the very first men to go to the UAE. Abdul Hadi recalled that a group of them took him to the airport to see him off even though they hardly had any idea of where he was going. A few years later, in 1975, Abdul Hadi himself went to the UAE but by that time there were already quite a few other men from Kohery there.

These first men from Kohery were like pioneers for the rest of the village. They encountered the most serious language difficulties, the problems of isolation and with their legal situation. It was these men who made it easier for those who followed them. The timing was right; there was a general decline in the work available in Karachi as the large scale industrial and private development came to

an end. This coincided almost exactly with the massive increases in opportunities in the UAE which came in the wake of 1974 OPEC oil price rises. The Gulf oil states, even small ones like the UAE, suddenly had enormous amounts of money to use and began to invest heavily in infrastructure, housing and industry. Those in Kohery, like many others in Pakistan, were beginning to look for work elsewhere and the reports from their fellow villagers in the UAE of fantastic wages and plentiful work encouraged them to make the journey themselves. In the UAE the visa system operated on a personal basis. Visas could not be obtained through agents in Pakistan but had to be negotiated with an individual sponsor in the UAE. Thus, those already there could obtain visas for the people in Kohery who wanted them. Some, like Gul Hamid and Abdulhai obtained visas on the basis of *khpulwan* and village ties. Others, like Mashooq Jan, obtained and sold visas to make money. Often those already in the UAE found not only visas but jobs and places to live for those who came to join them. Whichever way, the system encouraged the growth of networks of contacts and of communities in the UAE which continued to grow throughout the 1980s.

Addleton develops the point that for many in Pakistan and especially for the Pakhtuns of the NWFP migration had become a way of life. He argues that the move from Karachi to the Gulf states was a natural progression. As he puts it:

For the young Pathans from the NWFP who had already travelled a thousand miles and crossed several cultural frontiers in search of work in Karachi, the short journey across the Gulf to Oman or the UAE was relatively easy, involved few risks, and held the promise of extraordinary economic return. (Addleton 1992: 38).

While I would dispute that the journey was relatively easy and held few risks, many from Kohery did anticipate that they would be able to earn good money. Another interesting point that Addleton picks up from Burki (1980) is the fact that many Pakhtuns worked in construction, which in some cases helped with their moving to the Gulf. Pakhtuns formed a large part of the labour force in construction projects such as the Mangla and Tarbela Dams, and publicly funded housing and office complexes in Islamabad and Karachi. These contracts were carried out by foreign firms that themselves moved on to take part in the Middle Eastern construction boom. At the time the projects in Pakistan were coming to an end and so often these firms also took their work forces with them (Addleton 1992: 37). From Kohery, some men like Ghasurahman and Gul Hamid, went to the UAE unassisted, others went under contract with construction companies.



Abdul Hadi was among the many groups of men who headed for the UAE in 1976 and the years following. Among the group of eight men from Kohery that Abdul Hadi travelled with was Abdul Rashid's eldest son, Abdulhai. Abdulhai had been a successful and popular *mullah* in Karachi but had decided to seek his fortune in the new territory of the Gulf. There were still only a few men working there from Kohery and many of those who set off did not know what to expect. Many of them had got their first visas from Ghasurahman's younger brother, Mashooq Jan, who sent back visas to Kohery and sold them there. Abdul Hadi and the other men flew from Karachi to Dubai and from there took a taxi to Dhaid, the only place that they knew about.

At the time Dhaid was a small place with few shops, no police station and only really the Kuwaiti mosque where Gul Hamid worked. Most of the men who arrived with Abdul Hadi had to look elsewhere to find work. Abdul Hadi first went to Falaj al Moalla, a place about an hour from Dhaid. At the time there were no other shops there either, but Abdul Hadi set up a small tailoring shop. The local Arabs came to his shop but only to laugh because he did not understand anything; he couldn't speak Arabic and did not know how to make Arabic clothes. After only three months he decided to move on and cancelled his first visa. He obtained a visa for the emirate of Fujairah and moved there to a place between the towns of Fujairah and Kor Fakhn and the Indian Ocean coast. He set up another tailoring store there which was much more successful. In all he worked there for eleven years and became well known as a master tailor.

Other men experienced similar problems in getting themselves established. Abdulhai, for one, sat for a long time in Dhaid without work. He then started to travel to look for work and went first to Manama. The local sheikh there got him to lead the prayers in the mosque but could not offer him any money. Abdulhai made friends with the sheikh and the latter offered him a job as the *mullah* of a new mosque in a place called Muzeirah. Abdulhai asked everybody where Muzeirah was but nobody knew. Eventually he found a man who said that he had worked as a trader there and could take him there. Abdul Hadi heard through others about Abdulhai's new job and found out where Muzeirah was so that he could visit him. When Abdulhai saw Abdul Hadi he was very happy as all the time that he had been working in Muzeirah he had been on his own. It had been a very hard time for him in those first few months, living alone for the first time, cooking for himself and with nobody else from Kohery for company. Abdul Hadi stayed for a couple of days to keep him company and, for the first time since he had come to the UAE,

Abdulhai was happy. Abdulhai had remained in Muzeirah since that time. He had made many visas for others from Kohery so that, by 1993, Muzeirah seemed almost like an extension of the village.

Throughout the end of the 1970s and into the 1980s the numbers going from Pakistan to the UAE increased. From Kohery virtually all of the men who had previously worked in Karachi moved on to work in the Gulf. Only a few men continued to go to Karachi while some young men headed there for their first taste of what it was like to work away from home. In the 1980s more opportunities began to open up in Saudi Arabia, mainly in the capital Riyadh. The visas were more expensive and could only be obtained through an agent but the jobs were better paid and the work seemed more secure. More and more men found the money for their first visa and air ticket and headed off for the rich rewards of the Gulf. By the 1990s some in Kohery were claiming that Dir alone was sending a plane load of men to Dubai every day. Certainly business was good enough that there was a daily flight from Dubai to Peshawar and back run by PIA. As the 1980s progressed, the patterns of migration had begun to change so that more and more young men were heading for the Gulf to find work and to prove themselves. In Kohery, in the neighbourhood of Bagh alone, by 1993 67% of the adult male population was absent working somewhere in the Gulf. Below are the stories of two of them, Abdul Halim and Azum Khan.

AZUM KHAN AND NOORWAHID

Azum Khan's grandfather, Abdul Wahid, after many years of working in Baluchistan, returned to Kohery to work his fields and bring up his family. His only son, Fazal Hakim, in his turn left the village to seek better opportunities. While he was still young he joined his uncle in Baluchistan for his education. He returned to the village for a number of years to learn tailoring but soon joined the many men from Kohery who worked in Karachi. In the late 1970s Fazal Hakim moved on to the United Arab Emirates (UAE) to take advantage of the new opportunities there. With the money that he was able to earn he could easily support his growing family on his own. In 1980 Fazal Hakim cancelled his visa for the UAE and returned to Kohery to take a second wife for himself and to settle down.

Azum Khan did well at school but in 1984 after he had completed the seventh class, he decided that he wanted to go and work in the UAE. At the age of 17 he saw himself, like many boys of the same age, as a grown man who should be

earning money for his family. His father had no real work in the village other than tending the family fields so there was no money coming in. For Azum it was a matter of pride. When he went to the bazaar in Timirgara and met his friends he was embarrassed as they would suggest going for something to eat and he knew that he would not be able to go because he had no money of his own. Most of all though he thought of his father sitting at home and he knew that he should be working elsewhere and sending money home to him. Many young men expressed a similar desire to see their fathers at home resting - "eating, sleeping and praying" - while they send back enough money to support the family.

In many cases it was a source of conflict between fathers and their growing sons. While the sons, like Azum, longed for the chance to prove themselves working abroad, most fathers hoped that their sons would remain in education in order to improve their prospects that way. Few fathers wanted their sons to endure the hardships that they themselves had gone through and ordered them to remain at home in Kohery. Some young men made their own arrangements to leave in secret; Azum was one of these men. He knew that his father would not agree to him going to the UAE and so decided to make the arrangements himself. He first went to a relative, a man called Gul Zamin, to ask for a loan of Rs 1000. Gul Zamin knew that Azum would use the money to obtain a passport and was upset but felt that he could not refuse. Once Azum had the money he went straight to the nearest passport office in Swat and had an emergency passport made that day for Rs 600. A few days later somebody from the village was going to the UAE and so Azum sent his passport to his uncle's eldest son, Abdulhai, with instructions to have a visa made. Throughout all of this time his family, his father and grandfather never knew what he was intending to do.

Some time later Abdulhai sent a cassette to Azum and his family saying that the visa had been made and that the passport would be sent to him. Of course then all of Azum's family knew what he had done and all of them were very upset. Azum's grandfather cried at what the boy had done and his father was so angry that he hit Azum for the first time in many years. Fazal Hakim asked him if he knew what he was going to do out there when he was so young. Azum replied that he would be able to do labouring work and make money that way which upset his father still more. In the end though Fazal Hakim agreed to let his son go. Abdulhai paid for the cost of the first visa, Rs 24,000, and in 1985 Azum left on his own to go for the first time to the UAE.

Like most men from Kohery who have worked in the UAE, Azum found the first few months the hardest. For a start, in 1985 there were no other men of his own age from the village working there. Many of the men there were much older than he was and so he had no real companions. Then there was the problem of not knowing how to speak Arabic. Azum was anxious to learn quickly and resolved to make a great effort. He bought a copy book and wrote down every new word that he heard in it. He used to ask whoever was around in the only Arabic that he knew, *shu haatha*, what is this? In the garden where he first worked, the local children would come to play so he would sit with them and ask questions. The children used to laugh at him but his copy book was soon full. In the end, though, he found that he never had the chance to study what he had written and that it was through listening to the conversations of others that he learned the most. These problems of learning the language, coupled with the difficulties that he had in getting used to a new lifestyle of caring for himself - cooking and washing clothes - made the early months the worst.

Azum was fortunate that he found labouring work almost immediately, and though the work was hard, it paid well at 40 Dh a day, the equivalent of Rs 240. Most of the labouring work was on a day-to-day basis and so Azum was happy to take on the work that he found in a vegetable garden as it paid a regular, monthly wage. The work, though, was hard and at times seemed never-ending. There were two seasons in the garden, the tomato season in the spring and the clover season during the rest of the year. In the tomato season the work started with planting and then fertilising the tomatoes. Each plant had to be fertilised individually by digging a small hole at its base, putting in the dried fish fertiliser and then covering it up. When the tomatoes ripened, Azum and the other workers would spend all afternoon picking and packing the tomatoes in wooden crates. Each day they filled up to 300 crates which then had to be carried to the store room. Early the next morning the crates of tomatoes were loaded into a lorry and the men would take them to Dubai, Sharjah or Fujairah, all several hours away, to sell them in the markets there. Any crates that were unsold, they would bring back and take around the neighbouring villages to try to sell them there. When they returned to the garden in the afternoon, they would begin to pick tomatoes again for the next day. When one area of the garden was picked clean, they would move on to the next area that had begun ripening, and so on until the season was over.

The clover season was equally, if not more, strenuous. Each day Azum and the others would cut up to 400 bundles of clover. The clover was cut with small hand

sickles which meant having to crouch while working, so that by the time they were finished, Azum could barely stand. The bundles of clover once cut were loaded into the truck to be transported to the markets to be sold to camel owners as fresh fodder. The wage that Azum was paid was a basic 800 Dh a month which even at the time was poor. The men in the garden at one time demanded extra from the owner. In the end the owner agreed to give each man 2 crates of tomatoes or 3 bundles of clover to sell for himself each time that they harvested. This meant that in season Azum could earn an extra 20-30 Dh a day, though out of season there was no change.

After a few months, Azum moved from the vegetable garden to a date garden. The work there was especially hard as the date harvest came during the hottest months of the year, June and July, when the temperatures can reach 50 degrees Celsius. Azum's job was to cut the dates from the palms and then lay them out on mats to dry in the sun. The work that he hated most was collecting the dates to be packed as this had to be done in the mid afternoon when the sun was at its hottest and the dates were often covered in hornets which stung his fingers as he worked. While he worked in the garden Azum lived in a small shelter at the garden itself. As the garden was some way from the village there was no electricity connection and so no fans or air-conditioners. In the summer at night the temperature barely drops and so it was hard to even sleep. The only way to be at all comfortable was to soak the foam mattress with water and sleep on that. Each day Azum and the others who worked in the garden would take their mattresses in the garden dumper truck to the tank to soak them and bring them back to their room.

In all of this time Azum's only real pleasure was to watch Hindi films at the local cafes run by Indians. The colourful, exotic films became a passion for him and each night after eating with his companions at the garden he would walk on his own for an hour to get to the nearest cafe. At the cafe he would watch the latest videos and drink maybe one or two cups of tea before walking home, arriving back at midnight or one in the morning. On one night as he was walking home he was stopped by two policemen in a patrol car who wanted to know where he was going at such a late hour and where he worked. Azum explained that he had only been watching films and was returning to the place where he worked. The policemen told him that he was mad to spend so much of his time watching such an un-Islamic thing but offered to drive him back to the garden nevertheless.

In all, in his first visit to the UAE Azum stayed for 2 years and 3 months without returning home. All of this time he did nothing but save money so that he was able to pay off the price of his visa and ticket, send home Rs 24,000, and still have money to take back with him. Azum's great dream was to be able to take enough money back with him to pay for his own marriage. His father's second wife had come from Dir and it was while visiting her family that Azum had caught a glimpse of a young woman who he knew that he wanted to marry. He had told his grandmother about his secret desire to marry this woman but she had disapproved saying that Dir was too far away and he should marry a woman from his own village. Azum continued to think about the woman and thought that if he saved his own money then his family could hardly disagree. One day while working in the fields a friend brought him a letter from his father which he opened immediately. His dreams were shattered by the news from his father that they had chosen a suitable girl for him and that they would be married before he returned. Azum then had to send home the money that he had so carefully saved to marry a woman he had never even seen before.

When he returned to Kohery he was understandably nervous about seeing his new bride. It seemed that the woman herself was even more frightened for he never had a chance to see her during the first day of his return. He had to wait until nightfall when he shared his first night with her with his own grandmother for company and protection. Azum stayed with his wife in Kohery for six months before returning to the UAE to work again.

He went back to working in gardens which, once he had become used to the work, he found a lot easier. At one time Azum worked in a garden in the mountains behind the town of Hatta. The gardens there are actually in the territory of Oman and are very remote, reachable only from a dirt road. The garden that Azum worked in was a long way from the village where the man who owned it lived and the next nearest garden was over twenty minutes walk away. Although Azum was still young, he lived and worked in the garden alone, and in his time there rarely saw anybody else. The work in the garden was easy, tending the garden itself as well as looking after nine goats and a cow. What Azum found hardest was living alone as he had never experienced it before. During the day he hardly cooked for himself at all, usually only once at lunch time and never in the evening. At night though it was especially bad as he was very afraid. He knew that the garden was haunted by many spirits or *pirian* and at times he could barely sleep through fear of them.

The worst part of working in the garden, though, was the loneliness. Even the owner of the garden rarely went there and once for nine days Azum did not see or speak to another living soul. On the tenth day another man came past the garden while herding his goats. The man called out his salaam but when Azum came to reply no sound would come from his mouth. When he tried again he had to cough before he could say anything even in the weakest voice. The man came to ask him if there was anything the matter and when Azum explained why he had been unable to speak he was upset. He asked Azum if his mother and father were still alive and, if they were, then were not they upset at their son working like this. Azum could only reply that at least it was some kind of work.

The owner of the garden came to suspect that Azum was not doing his job properly and was sleeping at another place leaving the animals unattended. One night the owner tried to catch Azum out by arriving at the garden unannounced at 2 in the morning. The man left his car outside the fence and made his way up to where Azum slept with a torch. Azum had been woken by the arrival of the car and saw the man coming, so he hid himself under the mosquito netting of the bed. The owner looked around Azum's bed but could see no sign of him in the dark. As he went to lift the netting on the bed Azum leapt out waving the stick that he always kept with him. The owner was terrified and yelled out, "it's your sponsor, your sponsor" before falling backwards over a stone onto the ground. Azum kept up the pretence and picked up the owner's torch to examine his assailant. When he saw who it was he helped him up and explained that he was afraid that it might have been spirits. The shaken owner agreed with him, said that he was right to be afraid and never tried to catch him out again. Azum's cousin, Abdulhai, later found out about the incident and berated the owner for not trusting Azum, adding that he had been lucky as Azum was such a dangerous man who could easily have beaten him if he had not realised in time.

Soon after Azum had started working in the garden his father returned to work in the UAE. One of the first things that Fazal Hakim did when he returned was to go and visit his son in the garden. When Fazal Hakim and the friend who came with him saw the place where Azum was working and heard about his hardships they both wept. They agreed that Azum should go straight to his Bedu to tell him that he would be leaving immediately and that he should cancel his visa. The next day Azum packed up all that he had - a razor, some scissors, a mirror and some soap - and headed for the village of Muzeirah to see his Bedu. When he arrived at the Bedu's house he told him that he no longer wanted to work in the garden and that

he wanted his visa to be cancelled. The Bedu refused immediately so Azum handed him his identity card and repeated his demands. He added that he wanted 2 months wages and the cost of a ticket home, a total of 3000 Dh. At this the Bedu became very angry but also frightened. He knew that the laws in the UAE meant that for a sponsor to cancel a worker's visa he must provide that person with a valid ticket home, otherwise when the police checked they would refuse to cancel the visa. In addition, a person who has not received their money from their employer can report the employer to the police who will often tend to believe the worker. His boss soon realised all of this, and so instead offered to employ somebody else from Kohery to work in the garden with Azum. Azum soon found somebody from Kohery who was looking for work, a man called Saida Mohamad, and offered him the job.

Up to his fourth term in the UAE Azum had found work through his sponsor. When he returned from Kohery he decided that he wanted to be free to look for work elsewhere and so asked his sponsor to allow him to do this. His sponsor, though, was reluctant to agree and in the end demanded 3000 Dh to let him go. Under the labour laws in the UAE, a worker should remain in the area where his sponsor lives and should carry out the work nominated on their visa. In fact many workers, especially Pakhtuns, ignore these restrictive laws and look for work wherever and with whoever they can. To do this can be expensive, however, as the sponsor will often demand money as some kind of compensation, Azum's case being an example. Having a bad sponsor can be a costly business for a worker as many Arabs see sponsorship as a way of making easy money. A sponsor can demand excessive amounts of money to make a visa and then take more money to renew a visa or to allow the worker to work freely. Once free, Azum went back to garden work for a short while. He eventually decided that the work had become too much for him; getting up early every day, working all of the time until late in the evening and all for poor pay. He first found other work as a labourer with a small-scale contractor before he moved on to join his cousin, Noorwahid, who also worked as a contractor in the area.

Noorwahid was the eldest son of Abdul Hadi who had himself worked for many years in the UAE. Noorwahid, after reaching a medium level at school, left, wishing to go to the UAE. His father, however, ordered him to stay in Kohery and so he found work as an apprentice to a well known builder in Malakand. Noorwahid was an able pupil and soon picked up the skills of making the moulds for pouring concrete. After just fifteen days his teacher told him that he was ready to go off and

work on his own. For about five years, Noorwahid worked in and around Kohery building houses and guest rooms. He worked mainly with other skilled builders and over the years picked up other skills such as brick laying and plastering.

In about 1985 Abdul Hadi returned to Kohery from the UAE for good and set up a small shop in the village. After only one year the family still needed money and so it was decided that Noorwahid should go to the UAE. Abdulhai got him his first visa and also found him work with an Afghani building contractor. Noorwahid's first years were not easy ones. He knew no Arabic and the contractors that he worked for either paid him too little or cheated him out of his wages. Even when he went into business as a partner with another Afghani he had trouble. While Noorwahid was in Pakistan his partner died, leaving behind 10,000 Dh of debts which he had known nothing about. After that Noorwahid knew that he would only work for himself. In time, too, he made a success of his business. At first he had to work without a licence to build because it was so expensive. It was easy to find work without a licence but he always had to be on the lookout for the police. There was plenty of work to be had in the new villages around Muzeirah, adding rooms, bathrooms and gates to the government built houses. In time he made enough money to buy the licence: 5000 Dh for the licence itself and then at the end of two months the authorities had to be shown a further 80,000 Dh in the bank. In the spring of 1993 Noorwahid was able to bring back Rs 150,000 for his father though the money was soon used up.

I spent a great deal of time with Noorwahid and especially Azum Khan in the summer of 1993. They arrived after me in the spring and, as they were on leave, they had time for talking to me and accompanying me on the occasional trips in the village. Azum, in particular, enjoyed talking and in the time that I knew him I learned a lot. I found him good company, not merely because he did not mind answering my interminable 'anthropological' questions. His preference, though, was for telling stories and talking about his life as a migrant labourer. Noorwahid's building skills were in great demand in his time in Kohery and he spent much of his leave supervising the small scale building projects of family and friends. Azum often accompanied him but usually liked to spend time at home. He obviously enjoyed being at home and having the time to spend with his family, his mother, grandmother, grandfather and especially wife and children. However, all of the time he was on leave his enjoyment was overshadowed by the thought that at the end of the six months he would have to return to the UAE. As he told me once: "If a person has easy work over there then he is happy while he is on leave and happy to go

back to the UAE. If a person has only hard work when he is in the UAE then he spends all of his time thinking about how hard the work is there, about the heat and so is unhappy even when he is on leave." As the time for his departure drew near Azum grew more and more unhappy until the last few days when he seemed to have resolved himself about leaving again.

After I had finished my fieldwork in November 1993, I returned to Britain, stopping briefly in the UAE on the way. For about a week I stayed with Noorwahid in Muzeirah and saw Azum Khan most days. Noorwahid's work was already in full swing again and, by the time that I left, he had three projects on the go. Noorwahid and the labourers who he employed, including Azum, worked from dawn until last light with only an hour or so for lunch. As there was so much competition for work, both contractors and labourers have to work almost continuously. The work was all carried out by hand, using only basic tools - shovels, picks, buckets and trowels - and there were few of the labour-saving devices that might be seen in Britain. While skilled workmen, called *ustaaz*, were employed to carry out the work of constructing the steel reinforcing, erecting the walls and making the shuttering for the concrete, the labourers had to carry out the endless, backbreaking tasks of mixing concrete, carrying, lifting and shovelling. The relentless heat during the summer could be especially debilitating for those who were not used to it, and the summer was dreaded even by those who had lived and worked in the UAE for many years. Summer was a time when many of the men from Kohery chose to return home. Labouring work in the UAE was, in many ways, harder than garden work. As Azum himself said: "A person who does labouring work gets up early and has a shovel in his hands from the morning until he stops at night. The work is hard and by the end of the day the person's whole body is aching."

When I spoke to them in the UAE, both men talked about the problems that they faced when they returned. Azum told me about how much he was missing his family and especially his children:

The first few months are the hardest as you think about your family all of the time, your mother and father, your children. After the first three months you think about them less and less. Then whenever you get a letter or cassette from home you start thinking about them again.

Azum's father had two of his youngest daughters living with him in Muzeirah. Azum loved to play with them and the Arab children who were always wandering past the places where they worked. At times, though these children served only as a reminder of his own children and he would suddenly become sad, saying nothing.

For Noorwahid the problems were very similar. As he described it:

As soon as you arrive in Dubai, no matter how much you have wanted to go, you miss your family, mother, father and children. For the first six months it is difficult and you think about them all the time. During the days when you are busy you don't think so much about home but in the evenings you wish that you were with them. After the first six months you begin to forget a bit and it becomes easier. Whenever a cassette arrives from home, though, you start thinking about them again and missing them. When you get home after two years the first two months are the best. After those two months I start wanting to go back to Dubai.

SUFFERING AND DEPENDENCE

In the stories that men told me, those who had worked away from home all emphasised similar themes. For a start many of the stories were about the problems that they had overcome in going to work in another place. Abdul Wahid, Abdul Hadi and Azum Khan all began by telling tales of learning the language, enduring loneliness or having to search for work. Many of the stories focused on periods when the men had to endure particular hardships, an accident, illness or hard conditions. Azum Khan's story is a good example; each of his periods in the UAE was remembered through an episode of illness or an accident. His own narrative brings out another important, recurring theme, that of isolation. In many cases what made the hardships even more difficult was the lack of friends and family to help deal with it. Thus, Azum Khan's most poignant tale is of the time he worked alone in a garden; his circumstances alone were enough to reduce his father to tears and in the telling of the tale he managed to induce similar emotions in his listeners. Abdul Wahid, too, mentioned the fact that when he was ill the Baluchis he worked with never visited him. Again, Abdul Halim's story of his first few days in the UAE is made all the more moving by the fact that he was left alone in the garden where he worked. Even the men in the neighbouring gardens had fled for fear of arrest. The sense of isolation emphasises the distance that the men felt from those they knew best and had come to rely on most. Throughout these tales of hardship the underlying theme is one of selflessness. Men repeatedly emphasised the point that they worked abroad not to earn money for themselves but to save it and send it home to their families. Thus, their aim was not immediate, personal reward but was rather to endure hardships and struggle for the sake of others.

Unlike others who I met in the UAE, those from Kohery had no dreams of settling down there and there were few families living with the men. Other groups, like those from India and from the Pakistani Punjab, harboured hopes of settling

permanently, of setting themselves up in businesses, of finding a house and bringing their families to join them. The migration plans of men from Kohery were always temporary, their ultimate aim was to return home. This heartfelt desire was a theme of popular prayers and poems. A frequently used prayer ended "Bring all the travellers home in safety, God willing". There was a particular fear that those who travelled might die away from home and from their loved ones. One poignant poem dealt with this theme "God, don't kill the traveller, their only desire is for their last breath to be at home". When men died abroad every effort was made by their families and kin to ensure that the body was returned for burial in the village. Those who had left and never returned, like Mohamad Hassan, Abdul Rashid's father, were still fondly remembered.

An interesting comparison here is with the work of Benedicta Grima in her book *The Performance of Emotion among Paxtun Women: The misfortunes which have befallen me* (Grima 1993). Grima argues that for Pakhtuns there is an important aesthetic and ethic of suffering and hardship. She identifies the aesthetic of grief or sorrow, *gham*, in Islam and in the literature of the area. She even goes as far as to argue that "The 'tragic esthetic'...is deeply rooted in the Indo-Iranian perception and worldview" and that throughout this area "*gham* is taught as honorable and redemptive" (Grima 1993: 143). Using examples from her own fieldwork in Swat and Kohat, Grima develops a case for suffering being an ethic for Pakhtun women. She argues that women gain respect and status from being seen to have endured hardships and undergone much suffering. She notes that honour amongst Pakhtuns generally is judged through their observed behaviour; in other words, a person's reputation is evaluated from the ways in which they speak and behave (Grima 1993: 164). The route to women's honour is through their suffering and their silent endurance of the many hardships of their harsh lives. One of Grima's informants made this point quite explicit; as she explained "When I asked a thirty-year-old unmarried rural school teacher what gives a woman renown, she replied, 'Her hardships. How else could she prove herself?'" (Grima 1993: 126). Women's suffering is enacted and given voice in certain contexts, the main ones for Grima being the life story and visits of enquiry made during illness.

What I found most interesting about Grima's work were the similarities in the stories told by women to the tales of migration which men told me. The same emphases were there and the same themes appeared; tales of individual suffering and lives of continuous hardship. The problem is that Grima presents the case for women only, arguing that Pakhtun men and women have different evaluations of

emotions and their value (Grima 1993: 166). In arguing her case for suffering being the main Pakhtun ethic, however, she includes all of Pakhtun society. Indeed, she specifically states "*gham* not only is the salient expressive form for women but also dominates in the poetic, political, religious, and public discourse of men" (Grima 1993: 159). In Kohery suffering, *gham*, featured just as much in the lives of men as in the lives of women.

I would argue two points here. First, that contrary to what Grima says, suffering plays an important expressive role in the emotional lives of Pakhtun men. Second, following Abu-Lughod (1986), that those who are independent and those who are dependent have separate routes to honour. Abu-Lughod argues that, while there is the honour code for those who are independent, for dependants, including women, junior men and servants, there is a separate modesty code (Abu-Lughod 1986: 79). In this modesty code the route to honour for a dependent is through voluntary submission to those who have the resources to be independent (Abu-Lughod 1986: 104). My point is that the people of Kohery have always been in a position of dependence; until the 1960s to both the Nawab and the local khans. Only in the 1970s did they gain some sort of independence by being able to lay claim to their own land. It could even be argued that, where the people of Kohery were dependent on the local khans, in the 1990s they had to depend on the vagaries of the world economic system. Nevertheless, the men of Kohery in particular had no real access to the honour system of those who could count themselves as truly independent. Certainly, those who worked in the Gulf found themselves in a situation where they were treated very much as second class individuals, as dependants on local Arab sponsors and bosses and as lesser Muslims. In these situations, then, they have always used the forms of expression which could be characterised as those of the dependent.

Whichever argument is taken, it seems that the men of Kohery presented themselves as having endured hardships and suffered in much the same ways as Grima describes for Pakhtun women. The tales of the 'selfless migrants' played on and emphasised the important twin themes of suffering and hardship. Like the women whose stories Grima relates, the men of Kohery made much of the fact that they had suffered not for themselves but for others. At one point Grima asks the questions, "Why ask for and tell a life story?". The answers that she puts forward are "The request for a life story is thus a request for the newcomer to prove herself as a worthy individual, an honorable Pakhtun. The discourse, in return, is one attesting to this identity" (Grima 1993: 118). In my case, the request for life stories

was made in order to learn more about the individual experience of migration. The stories that I was told did this but, at the same time, these experiences were related in forms that defined those telling them as 'worthy' individuals and as honourable, poor Pakhtuns. They were tales of individual experiences and at the same time they represented these lives through the key themes of the honour of dependants. These enactments of honourable lives were played out for me as an outsider and as a person who was potentially going to represent them to a Western audience.

THE IMPORTANCE OF KIN

There are a number of other points to be drawn out in conclusion. The first is the importance of the involvement of families and groups of kin in migration. As the stories show, co-operation between kin was important in all areas of life. Wahid Gul, for example, commented that after his grandfather died Abdul Wahid, Baharodeen and Abdul Rashid acted like 'real uncles' to his father and brothers. Abdul Rashid was particularly important in ensuring that some of the boys of Moolian Khayl, like Fazal Wahid and Abdul Hadi, got the chances that they needed for an education. In later periods, when large numbers of men were absent in the Punjab and Karachi, then other members of their kin took over the responsibilities of caring for their families and land. Abdur Rahim, then, moved into his brother's house and took over the care of his land. Abdul Hadi's brother, Gul Hadi, was well known for his farming abilities and for the number of fields that he looked after in the days of migration to Karachi. In the 1980s and 1990s, kin networks had come to take on a special importance as every household had at least one man working in the Gulf. Co-operation between households and within groups of kin is a theme that I will develop in Sections 2 and 3.

Kin networks also acted as conduits of information. In the first instance, other members of Moolian Khayl found out about the opportunities in Baluchistan through Abdul Rashid. Later, in the 1960s, they played an important role in informing large numbers in Kohery about the jobs in the Punjab. Young men like Abdur Rahim could make the long journey to the Punjab safe in the knowledge that they would find friendly faces and a job at the end of it. The contractors from Kohery relied on these networks to find themselves an effective workforce. Throughout the various periods of migration these networks also served to maintain the vital ties between the men and their families. Messages and news were sent, first by word of mouth, and then by letters and cassettes carried by kin and fellow villagers.

The stories also offer a poignant comment on the importance of home for the migrants. The death of Abdul Rashid's father in Bengal was recounted by Abdullah Khan as a real tragedy. Such was Fazal Wahid's reaction to Abdul Maliq's death and burial in Karachi, that he decided to send his family back home. It was remarkable, too, that in all the decades of migration, those who had left the village permanently or who had died away from home could still be remembered in the 1990s. Particular sorrow was voiced about those who had, for some reason, gone missing and whose whereabouts had never been discovered.

In Karachi and later in the Gulf, kin networks came to play an especially important role. Communities of men from Kohery and other parts of the NWFP developed in Karachi. Many set up small businesses to service these communities while others brought their families to live with them. Nevertheless, life in Karachi, especially for the women and children, was harsh, as Zahoor recalled. In the shift from Karachi to the Gulf, and particularly the UAE, the networks of kin were ideally suited to take advantage of the relatively informal visa system (cf. Addleton 1992: 69). Men such as Gul Hamid and Abdulhai, were able to find willing local sponsors who would provide jobs and sometimes work for those back in Kohery. But for those who were the first to go the problems were acute. In contrast to Addleton's statement that the short journey across the Gulf was 'relatively easy' and 'involved few risks', those from Kohery saw it as a leap into unknown territory. Without the networks of support, life for the early migrants was hard. Even in the 1990s, for a man like Azum Khan, separation from family and friends in the isolation of a garden brought with it all the terrors of loneliness. The emphases of such stories confirm the importance of the networks of kin in migration.

THE LONG-TERM NATURE OF MIGRATION

An important part of the Pakhtun historical experience is of movement and migration, as Caroe's book (1958) is a testament to. The wandering Pathan also exists as a familiar figure in the memory and literature of the Indian sub-continent (see Kipling's *Kim* and Ghosh's *The Circle of Reason* [1986] for examples). Such imaginings are backed up by the analyses of the area during British rule. Addleton makes reference to the large number of migrants recorded by the British administration. He also suggests that internal migration was of great significance and that an important factor in this was the army focusing its recruitment on areas such as the Punjab and the NWFP, where the land was relatively poor (Addleton 1992: 28-31). The poverty of the land in the NWFP was a fact recognised by both

those who lived there and outsiders. Abdul Hadi made strong reference to the poor quality of the village fields and the dependence of everybody on the unpredictable rains. Dichter (1967) argued that the NWFP was incapable of supporting its population. Sidhwa (1988) gives voice to popular notions of the area in describing the 'flinty, impoverished valleys' with their 'gritty, unyielding soil'. The perception in Kohery was that the people felt that they had to look outside the village and outside Dir for better opportunities.

This long-term involvement in movements and migrations of various sorts meant that the people of Kohery were ready to take advantage of the opportunities that arose in the new Pakistan. Drawing on various sources, Addleton suggests that Pakhtuns figured prominently in migration to work on new construction projects and to the new urban areas. In the early 1970s, for example, it is estimated that between one half and one million of the population of NWFP were working in other regions in Pakistan (Addleton 1992: 36). Karim and Robinson (quoted by Addleton: 37) noted the importance of migration from NWFP to Karachi in particular. As the stories and other information show, those from Kohery, and many Pakhtuns generally, were ideally placed to take advantage of the new opportunities in the Gulf. Indeed, as Abdul Hadi told me, in the early 1970s the development of Karachi had begun to wind down and people were beginning to look elsewhere for jobs.

People in Kohery were quick to point out the benefits that money earned by migrating had brought to them and to the village. They talked about the dramatic improvements in the standard of living that had been brought about over one generation. The contrast was stark; between the crowded houses, poverty and hunger of Abdul Hadi's and Abdulhai's generation and the large new houses lit by electricity, the roads and vehicles, the smart clothes and plentiful food of Azum Khan's and Zahoor's generation. Men like Abdul Hadi remarked that the young men could not truly appreciate what they had since they had not experienced how hard things had been before. The money brought other real benefits to people, most notably allowing them to redeem their mortgaged land and free themselves from poor share-cropping agreements. A direct link was made between these improvements and migration. By working away from the village, outside Dir and taking advantage of opportunities elsewhere men were able to save money, which they could bring home to change their situation. The perceived links between 'outside' the village and money and opportunities are something that I will return to in Section 4.

Vital to the utilisation of outside opportunities were the large, extended families and the networks of kin which tied households together. In Kohery, as the stories of the large, extended family group are testimony to, the kin links and family networks were vital to the process of migration. Abdul Rashid could bring boys for education in Baluchistan and encourage others to come and seek work while at home the families helped each other in caring for the houses and fields. Abdul Hadi could work in Karachi and then the UAE for many years, knowing that his brother, Gul Hadi, would look after his land and ensure that the best interests of his family were maintained. Many men, like Azum Khan, Noorwahid and Zahoor, turned to Abdulhai when they wanted a visa for the UAE and then for a job once they arrived. Despite the many thousands of miles separating them, men stayed in close contact with their families and kin at home. Indeed, through migration itself these kin links were developed and maintained.

Overall, though, it was a sense of the importance of home that had made migration a way of life. The view that the home and the village were all-important is reflected in a number of ways. For a start, there have been few from Kohery who have permanently settled away from the village. The importance of returning, even in death, was paramount. Abdul Rashid took a great deal of persuading before he decided to leave his father's body in its final resting place in Bengal. In the 1990s as well, families would go to great expense and enormous lengths to have those who died abroad returned to the village for burial. Another important argument for this sense of place were the enormous amounts of money invested over the years in village land which most agreed was poor quality. Finally, the strength of the ties between kin and villagers that had been maintained over decades of migration was testimony to the sense of place. Migration was always seen as a temporary solution to the problem of how to maintain life in Kohery. Migration was a way of life only because it supported households and the village.

KOR: THE HOUSEHOLD

PART II

*Friend, you have become a traveller,
How will I pass my life at home*

INTRODUCTION

"foreign places are all alike in that they are not home. Nothing binds you there" (Ghosh 1986: 266).

A lot of my early readings on the ethnography of Pakhtuns focused on the dominant issues of male identity, social structure and political processes. Barth's works were the strongest influence, particularly *Political Leadership among Swat Pathans* (1959) and various essays in *Ethnic Groups and Boundaries* (1969) and *Features of Person and Society in Swat* (1981). Ahmed's work was directly concerned with Barth's theoretical ideas, from his extended criticisms of Barth's analysis of Swat in *Millennium and Charisma* (1976), to his major ethnography of the Mohmand Pukhtuns, *Pukhtun Economy and Society* (1980), which set itself out as a model of the social structure of all Pukhtun society including Swat. Lindholm's book, *Generosity and Jealousy* (1982), accepted Barth's description of the social structure in Swat and sought psychological explanations for the apparent contradictions between the importance of hospitality and friendship and a social order based on opposition. Edwards (1990), writing about Pakhtun refugees in the late 1980s, engaged with and tried to redefine Barth's notions of Pakhtun identity (see also Tapper 1989 on Afghanistan). In all of the mainstream ethnographies of Pakhtuns it had been Barth's work of the 1950s which set the agenda. Initially in my own work I too set out to deal with issues of 'Pakhtun identity in the situation of migration to the UAE'.

My fieldwork experiences in 1991 and 1992 were very different from what I had expected. The lives of the men who I knew revolved much more around families and kin than questions of identity and political process. On my return to Edinburgh,

and kin than questions of identity and political process. On my return to Edinburgh, I began to write about households and kin groups using other material from South Asia (Parry 1979, Bloch 1973, Jeffrey, Jeffrey and Lyon 1988) for inspiration and comparison. A re-examination of the literature on Pakhtuns led me to the conclusion that households and kin groups had either been ignored, or looked at only in relation to their manipulation in the political process. At the same time I read an article by Lila Abu-Lughod (1989) which developed Appadurai's useful image of 'gate-keeping concepts'. These are concepts that seem to limit anthropological theorising about an area, in the main by defining the dominant questions of interest in the region (Abu-Lughod 1989: 279). Certainly in the ethnography on Pakhtun groups much of the attention had been focused on questions of identity and politics. Other factors affected this particular approach. As Nelson points out for the Middle East, the European or American ethnographers who worked in the area had limited access to the social world of women which influenced their view of the society as a whole (Nelson 1974: 553). In the case of the Pakhtun the predominantly male ethnographers had used their limited access to the social world of women as a reason to virtually ignore them. Indeed, whole areas, such as households and the domestic domain in general, seemed to have been left untouched and unquestioned. Other work that I read subsequently (Anderson 1978 and 1982, Boesen 1983, Grima 1993, Tapper 1980 and 1991) approached these areas, though often from the standpoint of identity or politics.

I was guided in the direction of feminist writing on the household and the division between the domestic and political domains. The lessons that these writings taught were useful ones for me. The work of writers such as Rosaldo and Lamphere (1974) and Sanday (1974) broke down the 'natural' association between women and the domestic domain based on their reproductive role (Harris 1981, La Fontaine 1981, Moore 1988). Yanagisako's influential article, 'Family and Household: the analysis of domestic groups' (1979) warned that only by doing away with the assumptions that reproduction is the primary function of the family and that women are universally the basis of the reproductive unit, can domestic groups be properly analysed (Yanagisako 1979: 199). She further argued that what must be investigated are the functions of the family in each society in their own particular historical context. Taking this view enables the 'family' and the 'household' to be seen as "inherently complex, multifunctional institutions imbued with a diverse array of cultural principles and meanings" (Yanagisako 1979: 200).

The word *kor* (pl. *koruna*) was used in Kohery to describe both the building and those who inhabited it and could, therefore, be translated as both house and household. In some circumstances where two families shared the same building but lived independently they were distinguished as being two houses, *dwa koruna*. Usually those who shared a house operated as a single household. This unity was talked of in terms of cooking and eating together as one family. Within the household land was kept undivided and was farmed as a whole. Income was pooled and supplies were bought for the whole household. Those in charge of the household planned for the unit as a whole. The household, then, was the basic unit of organisation for a variety of functions. There was great variation in the size and composition of households, though there was a tendency by men to regard the large, joint household as the final shape of all households. In the thesis I look carefully at the composition, formation and development of households as well as the changing roles and attitudes of the household members.

The house was seen as the realm of women and they were particularly associated with the private space of the 'inside' of the house. Male access to this space was restricted to those directly related to the household members. Women's lives and work focused on the house and the care of its occupants. The division of labour was based on the house and women's association with it. Thus, men worked 'outside', in the fields, outside the village and increasingly further away from the village. Men's labour, because it was more easily evaluated and was often paid, was called *kar*, work, while women's labour was seen as a normal part of their lives and was generally undervalued. Men's wage labour was seen as providing the basis of household income, upon which everybody depended. This male assessment was based around the increased importance of wage labour and labour migration as a source of income.

There is a tendency in the study of gender in segregated societies to take the association of men with the public sphere and women with the private as a hard and fast separation between them. Nelson suggested that in writings on the Middle East in particular, the domestic world of women is seen as narrow and restricted. She argued that, rather than impose Western cultural categories and accept this narrow view, it was necessary to re-think notions of power, seeing it as a particular kind of social relation (Nelson 1974: 553). To do this entails looking at the various ways in which women influence men to achieve their own objectives, and seeing women as a necessary part in networks of communications, as links and mediators between groups (Nelson 1974: 553-9). While Nelson's analysis seems to accept the

world and women with the private (see also Cornwall and Lindisfarne 1994). It is tempting in any Islamic setting to see the separation as absolute and the domains as independent. In the case of the ethnography of Pakhtuns the limited view of male ethnographers was converted into a hard and fast division between the political (which was described) and the domestic (which was conveniently ignored).

Eickelman (1981) suggests that a more critical attitude to the common themes of the public/private dichotomy, economic and political roles is necessary (see also Peters 1978). Nelson's work demonstrates that it is essential to examine and describe women's participation in the public domain. Just as important is a careful examination of men's participation in the private domain. It is necessary to look at men's associations with, and place within, the private sphere of the house, to look at their changing relationships with the other members of the household and kin group, and to assess the importance of these relationships to their participation in the public sphere of the community. Men's lives focused on families and homes; supporting them was given as the main reason for them participating in labour migration. All of the money that was earned 'outside' the house was channelled back to support the family or to invest in new houses. Men subjugated themselves to the good of the household. Male loyalty to their fathers and to the household was seen as a matter of honour and morality.

However, this was very much a view of the senior men. They had a tendency to represent their own interests and desires as the honourable ideal. Taking Yanigisako's point that the institutions of family and household are imbued with 'a diverse array of cultural principles and meanings', it is useful to reflect on the ways in which these principles and meanings are utilised. Bourdieu looks at the strategic uses of rules in Kabyle society, looking at parallel-cousin marriage in particular. He warns against accepting 'native' theories of practice at face value, arguing that such theories can be advanced for strategic reasons. He suggests that those who choose to abide by the rules are at the same time choosing to honour the values of the society. Thus, they may choose to represent their actions as being in accordance with the rules in order to present themselves as obedient and honourable. It is, he says, "not sufficient to say that the rule determines practice when there is more to be gained by obeying than disobeying...conformity to the rule can bring secondary benefits such as prestige and respect" (Bourdieu 1977: 22). Elsewhere (Bourdieu 1990) he puts the case that supposedly rigid objects of study, such as genealogies, can be read in many different ways. The view most often accepted and presented by anthropologists is the male, dominant reading, which is the reading imposed in

official situations (Bourdieu 1990: 173). However, kin relationships within a genealogy are open to many different readings, depending on the context and the individuals involved; as he puts it "the genealogical relationship never completely predetermines the relationship between the individuals it unites" (Bourdieu 1990: 170). Other writers, such as Donnan (1988) and Gilsenan (1976) have used similar approaches in other areas. Donnan, looking at a Dhund village in northern Punjab, has sought to situate marriage preferences and choice in their economic and political contexts. Gilsenan looks at the strategic uses of knowledge in the achievement of status in a Lebanese village.

All of these approaches emphasise the importance of looking closely at how people describe their own situation and how they assess the behaviour of others. Donnan's analysis of marriages among the Dhund shows that each marriage emerges from a whole web of preferences in which economic and political considerations are as important as considerations of marriage rules and customs (Donnan 1988: 208-9). Marriages and other events may be re-interpreted after they have happened. The re-interpretation of events and of the actions of individuals is a process of negotiation between those directly involved and those who are observers. Gilsenan argues that for the men of Beit Ahmad achievement of social status is a process of negotiation. Social status is established through the assessment of individuals' behaviour against a code of honour. Lying is an important part of self-presentation, it is a way of manipulating what others see and the meanings that they give to perceived actions and behaviour. Individuals play an active role in their own assessment through presenting themselves and their actions in particular ways; as Gilsenan puts it "one steps forward, differentiates oneself, invites judgement, and strives to establish a significant social biography" (Gilsenan 1976: 198). These presentations of self are always open to challenges from others and so various strategies are used to confirm an individual's status and to prevent such challenges. Thus, it is possible to examine the ways in which individuals present themselves and their actions in particular contexts. In Kohery, men and women, seniors and juniors all had different interests which were influenced by their position in the household hierarchy. In this analysis I want to look at the ways in which people, and particularly men, presented themselves and their households. I also want to examine how assessments of actions and events were a source of conflict and were subject to negotiated understandings.

Part II is divided into three chapters; the first on the relations between gender, space and access to resources, the second on household composition, and the third on the utilisation of resources to form household economies. In the first chapter I describe

my own position in the community and examine the association of women with the inside of houses and men with the 'outside' generally. I argue that, although this association does not exclude women from the public sphere or men from the domestic, it does have an affect on the access of the sexes to resources. In the second chapter I describe the ways in which household groups and the structure of authority within them were presented to me. In the third chapter I look in detail at the way in which the resources available to households were assessed and the ways in which they were combined to form incomes. Finally in this chapter I examine the presentation of household economies. In the following Part III I argue that households are involved in complex webs of co-operation and interdependency through ties of kin.

THE VIEW FROM THE GUEST ROOM

Throughout my fieldwork I lived in the guest room of Wahid Gul and Zahoor's household. My status as a guest in their house and my friendship with them gave me a reason for being in the village as it was acceptable that a friend would come and stay, even for a long period. This more general acceptance gave me greater access to people, events and places; to Zahoor and Wahid Gul's family and friends, to weddings and other celebrations, and to the homes and shops of those people. At the same time I felt that my status as a guest was very restrictive for me. In Kohery, as for most Pakhtuns, hospitality, *melmastiya*, is of great importance. The way in which a guest is treated can reflect quite seriously on the honour of the family. As a guest it was expected that I should always be first, that I should be given the best food, that I should never exert myself and certainly never work, and that all my needs should be taken care of without my spending any money. The role came to feel restrictive to me as I realised that there were many activities that I could not participate in. I wanted to be treated as an equal, but as a guest this was not possible as I was always to be thought of first.

At times I came to think of the role of the guest as a way of controlling and restraining my actions and behaviour. It meant that I was always restricted to the village guest rooms or places that others considered suitable for me. I could see others who I knew entering the inner sanctum of the house while I was left alone or in the company of other outsiders. It was considered unsuitable or bad mannered to leave a guest totally alone and so I was always in the company of others. I felt that this was a way of keeping me under constant surveillance. This feeling was made worse by the fact that my movements and the people whom I could meet were restricted by what was considered suitable and safe for me as a guest.

In another way, too, the people whom I was able to meet were restricted to certain groups. In 1992 especially, I relied on Zahoor and Wahid Gul a great deal for contacts, accompanying them wherever they went. Even by 1993, when I had more confidence, I found the complex, unspoken rules of visiting and hospitality hard to follow and so tended to rely on others to go with me and assist me. This meant that my visiting was subject to the approval of those who went with me. In 1992, for

example, my old friend from the UAE, Zahoorulhaq, invited me to visit and stay in his house several times. I was keen to go and see another village and meet some new people. However, various excuses were always found by Zahoor or Wahid Gul and the visit kept being postponed. I began to suspect that they did not want me to go but I was too lacking in confidence to go alone. In the end I forced the issue and insisted that we go, arguing that I was being placed in a difficult position and that Zahoorulhaq might think that I no longer thought of him as a friend. In retrospect it seems that Zahoor and Wahid Gul thought that the house where I would stay and the people that I would meet were unsuitable and so tried to avoid the visit without making a confrontation.

While I realised that my network of contacts was restricted, those who I did know I knew intimately. Though I understood that I would never be completely accepted as part of Zahoor and Wahid Gul's kin, to them I had become more than a guest. At times I began to feel that I belonged, most often when I was asked to help out. I came to feel that I was known and trusted by Zahoor and Wahid Gul's relatives who lived close by. A strong sign of this came from Abdul Hadi who acted as elder for the group of houses. On several occasions he invited me into his house while there were women present. Only Abdul Hadi's elderly mother greeted me while the rest of the women carried on as if I were not there but nevertheless I felt that I was part of this group of *khpulwan*. My contacts extended out through this network of kin to most of the neighbourhood of Bagh and into the village beyond. Though I felt that these contacts were restricted and that I had little choice in whom I met, there were advantages. Those I did meet trusted me because of my close links with Zahoor, Wahid Gul and others. They felt more comfortable with me and could confide in me.

As a male outsider my research had a distinctly male bias to it. Because of my position as a guest I spoke only to men and often in relatively formal circumstances. The only alternative view that I was presented with came from my wife Debbie who stayed with me for the first six months of field work in 1992. Her comments were extremely valuable to me as she was able to supplement my own narrow view from the outside with her 'insiders' view. What she told me enabled me to question some of what I was being told and to ask more pertinent questions of those I knew well. As my confidence in the language increased, I was able to ask more relevant questions and, more importantly, was able to follow much of the ordinary gossip and news of the village. My analysis is, then, an analysis of the male view of households, kin groups and labour migration. It is a view which revolves around

what has traditionally been considered the domestic domain and which examines critically the position of men in and their relations to households

THE HOUSE AND OUTSIDE: GENDER AND SPACE.

As an outsider I felt the need early on to get to grips with the proper forms of avoidance between men and women. Right from the start I was made aware of the fact that as a male stranger I could meet none of the women of the house. When I approached a house, or entered one, prior warning had to be given so that any women could retire or veil themselves. Much more difficult for me was the matter of chance meetings in public spaces outside houses, most often on paths around the village. While in most circumstances it was the women who took the initiative by leaving the path well in advance or turning away from me, pulling head scarves closer and allowing me to pass, this was not always possible. I asked Wahid Gul about the etiquette of avoidance in public spaces. He said that it was up to the two parties to make the decision. In most cases the woman would defer. However, if the woman were carrying children or burdens then it was up to the man to leave the path or turn away, leaving the woman free to pass. He added that on no account should eye contact be made, both parties should avert their eyes. Eye contact, innocent though it may be, could be construed by observers as tantamount to adultery and could result in the deaths of both the man and the woman. I found that in other circumstances too, men were expected to take the initiative in ensuring avoidance. If I was approaching a house, I was advised to stop at some distance away and call out the name of the man I wished to see. This gave the women of the house a chance to hide themselves or to send out somebody to inform me of the whereabouts of those I sought. Looking back on it, these rituals of avoidance seem incredibly long-winded. In the circumstances they were very necessary.

Anderson (1982) has analysed the importance of avoidance and veiling for the Ghilzai Pakhtun of Afghanistan . He argues that the total social field is divided between those who have access to the same house, *kor*, and those who veil from each other (Anderson 1982: 400). As in Kohery it is both men and women who take part in controlling their contact with one another; the veil is just one form used by women and is "accompanied by a constellation of other behaviours which have equivalents or counterparts for men"; a man will avert his gaze and 'not notice' a woman, he will cover his face, turn to face the wall, cover his mouth and avoid eye contact (Anderson 1982: 402). It is, therefore, not simply a matter of complete avoidance, but rather of both men and women taking their part in managing

interactions. Thus, "The problem as Pakhtuns conceive of it is not so much keeping men and women apart as bringing them together or, rather, of ordered presences" (Anderson 1982: 405).

My own situation in Kohery changed, or was re-negotiated over time, as I became more of a known quantity - first as a married man, then as a regular visitor with close friends in the village. I gradually came to be admitted to some of the houses in the area where I lived. I would be seated in an out of the way position and the women would go about their business more or less as usual. I began to meet some of the older women and exchange a few words of greeting with them. In certain circumstances, younger women would pass on information to me directly, although in these situations a careful state of non-contact was maintained - no eye contact or speaking with the woman hidden from view. Over time, then, my contact with various women was re-negotiated as the particular circumstances demanded.

In general, the avoidance between, and separation of, men and women leads to the association of particular sexes with certain spaces. Most notably women were associated with the inside of houses. Boesen, in her paper on Pakhtun women, uses the famous Pakhtu proverb to graphically illustrate this point: *khadza ya po kor-ke xa-da ya po kor ke*, a woman is best either in the house or in the grave (Boesen 1983: 104). She argues from this, and other evidence, that men dominate the public sphere, while women are confined to the domestic. In Kohery, women certainly had a close association with houses and were highly restricted and controlled in public areas. Within new houses especially, most women had rooms for themselves, their husbands and their children. While the rooms belonged to married couples they were identified with the names of the women. It was the women who spent most of the time during the day in the rooms and who decorated them according to their taste. Most of the women's day was spent in and around the house, restricted as they were by domestic tasks and the care of small children. In contrast, the men tended to avoid the inside of their houses during the day. The men's presence in this women's space during the daylight hours was somewhat frowned upon by both men and women. I often heard men who had expressed the desire to go home being asked, what are you going to do there, *alta sa kay*, usually followed by some crude teasing.

Nevertheless the lines between the public and domestic were not as sharply defined as Boesen states. The boundaries between the inside of the house and outside, the private and the public were not fixed but were flexible. Spaces within the village

were subject to the same kinds of negotiation as contacts between individuals. At the very core were the most private spaces, the insides of houses. Generally while women could enter these private spaces, men's entry had to be negotiated and decided by those involved. Within the village, women moved around outside their houses with relative freedom. Women tended to wear a slightly heavier, outside cloth over the lighter, 'indoor' veil. This was something that could be used to cover up more effectively if strangers or unrelated men were encountered. Whilst out, women also took care to avoid those places where there were likely to be men, gathering places such as shops and mosques. Mostly they came and went freely between close neighbours' houses and in the fields around. Men contributed to this avoidance as well by keeping to paths that skirted around both houses and areas where women frequently worked. I could use the path that bypassed the six houses where I lived, but I seldom used the busiest path that ran between the houses even though it would often have been more convenient. At certain times of the year, like harvest, new areas became out of bounds. During the harvest there were many women working in the fields which the men, then, tended to avoid. Similarly if a group of men were hanging around outside a shop and it became obvious that a woman wanted to use it, then the men would retire to a discreet distance until the shopping was finished. When I spent time with my friend Zahoor at his shop I was often sent off 'round the corner' by the appearance of a child emissary or call from just out of sight. Thus in various ways the safe, 'private' spaces could be extended within the village. Anderson argues this point further:

Since most villages are overgrown households and feature overlaid primary bonds, the boundary of *kor* space ambiguously extends up to the physical limits of the entire settlement. Women moving outside the physical confines of the walled house...itself are thus still marginally 'in' the *kor* (Anderson 1982: 415).

In Kohery too 'inside' and 'outside' were negotiated spaces rather than fixed points.

Women travelling outside the village were, however, subject to close controls. No women would travel unaccompanied even to the nearby town. When they travelled any distance they always wore the *burqa*, a heavily restrictive garment designed to obscure any feature. This heavy veil could only be raised in places where there were no strangers present, in curtained alcoves in restaurants, special waiting rooms or segregated areas. Even while veiled, women could have no direct contact with other men so that in buses the front seats were reserved for them or male relatives sat between them and other passengers. Given the problems of organising trips women seldom if ever got the chance to move outside the village. Most women in Kohery

had only rarely left the village. A friend, Gul Halim, echoed the proverb that Boesen uses when he said that the only time that the women of the village ever left was to go to a shrine or to a hospital. Certainly the only times that most women went to the nearest town of Timirgara was to go to the hospital if they were sick or accompanying a sick child or relative.

The opposite was the case for men, some of whom went to the town almost daily, just to hang out as far as I could see. The contrast was emphasised for Debbie and myself, when I was taken on a day trip to the town of Dir while Debbie had to stay in Kohery. Debbie complained that she found the enclosed life in Kohery suffocatingly claustrophobic, particularly as there was no option for even the briefest of escapes. For me it was easier as I knew that I could get out if I wanted to. Men in general had much more freedom of movement in the public spaces of the village and beyond. Outside the village, the public spaces of Timirgara and other towns were exclusively male. Men moved freely in these spaces and relished the time in them, shopping, gossiping and meeting friends. Women in these spaces were completely anomalous and even women wearing the *burqa* tended to avoid them. Men were also associated with this space, known as *bahar*, outside. Most of the main male activities - working, shopping and politicking - took place in the space 'outside'. However, between the more female world of the house and the male world of 'outside' were other spaces within the village that were subject to redefinition as 'inside' or 'outside' depending on how they were being used.

MEN AND HOUSES: MALE PARTICIPATION IN THE PRIVATE SPHERE

For men, too great an association with the world of the house was not considered good. An extreme example of this is recounted by Barth who states that "A married man who spends his leisure time at home with his wife is jeered at" (Barth 1959: 54). Indeed in some areas of Swat, Barth suggests, the men used the local guest house as a dormitory due to "feelings of sexual shame at being associated with women" (Barth 1959: 55). While the situation in Kohery was not so exaggerated, during the day at least men tended to avoid their own houses. Men who were regarded as spending too much time in their homes were teased, but there was no real shame associated with men being at home. Indeed, men who had recently returned from the Gulf were expected to remain at home for the first few days. As Azum Khan and Noorwahid told me, it was necessary for them to stay in the confines of the house in case guests came to visit them. Both of them continued to spend as much time as possible with their families, although Noorwahid in particular was teased by his

cousins about his late starts in the morning and his general lack of energy. The attitude of both of these young men was a reflection of the more general importance given to the home, both by men who migrated and those who remained in the village.

When I visited men that I knew in the UAE, their first questions were always about their parents and children, and by implication, their wives. Men were eager for whatever news they could get that would make them feel part of their home lives again. Azum Khan and Noorwahid spoke very movingly about their feelings of being away from their families. As Noorwahid said, while they were eager for news of their families, when they did hear from them it only served to remind them of how much they missed them. The stories that the men told about their lives of migration centred on their homes. For those in the village too, their daily lives were concentrated on their homes though they claimed to be seldom in them. Their homes were the places to which they returned at the end of the day, the time at which families assembled to eat together. It was unusual for men to miss their evening meal at home and their unexplained absence was a cause for concern. Homes, then, were the pivot of men's lives, the place to which they returned at the end of the day or at the end of their period of migration.

Homes were also an important pivot of meaning for men, symbolised by their houses. Houses were the first thing that men saved for and the investments that they made in time and money were often considerable. Most houses in the village had been remodelled or rebuilt. In the time of migration to the Punjab, people introduced sawn beams for the roofs and guest houses for individual houses. In the 1970s the scale of investment in houses increased dramatically as new materials and techniques were introduced. As Wahid Gul told me, the prices of brick, reinforcing steel and concrete, as well as the substantial costs of transporting them to the village, led to vast increases in the amounts of money that were put into building new houses. In addition, people began to build substantially bigger houses. It had come to be expected that each married couple would have their own room in a house. When additional rooms were needed they were added on wherever there was space. In 1993, Nazir started to build a relatively modest three room house for his family. By the end of his stay he had spent over Rs 100,000 and still had only the shell of a house. Wahid Gul reckoned that overall the house would cost him Rs 200,000. The family of Lal Mohamad lived in their unfinished house while he went back to earn enough to finish it off. The addition of a single room to Abdur Rahim's house was reckoned to have cost at least Rs 40,000.

In order to build a new house or add to an existing one, a family also had to call on their entire network of kin and neighbourhood ties to supply additional labour. For the larger tasks, such as pouring the concrete roof, considerable amounts of labour were required. Few families could afford to pay for labourers on top of the costs of the materials and so they turned to their relatives and neighbours. Often, during the summer, the word would go out that somebody required assistance for half a day in mixing, carrying and pouring concrete for a roof. In 1992, when Abdur Rahim added a new room to their house, about 20 men turned up, including all of their closest kin from the neighbourhood. In return for the labour the family supplied a substantial meal for all those who had worked. Throughout the construction various kin turned up for a day or two to assist in whatever task was at hand. Those who participated expected that when their time came they would receive similar help. To do any kind of building, then, a family needed to call on all of their resources in terms of money and labour.

Every new house incorporated the latest innovations and fashions. In the 1970s many began to add concrete-built guest rooms to their existing houses. Those who had space built large walled courtyards which often contained bathrooms and wash areas. During my stay a number of families added bathrooms with the latest 'flush systems' in matching suites of toilet and basin. The most significant development in houses was in their scale. Up until the 1960s, most houses had consisted of a single large room for the whole family, whether nuclear or joint. When people began to have more substantial sums of money available they began to build much larger houses. By the time of my fieldwork it had become necessary to provide each married couple in the household with their own separate room. These rooms were regarded as the private domain of the couple and their children. Their private belongings were locked away there, the room was decorated according to the couple's taste and only those who were invited could freely enter. In Wahid Gul and Zahoor's case the household nominally operated as a single unit. However, although the cooking was done on a household basis, on most occasions the meals were eaten as family units in separate rooms. Thus, larger houses provided the space for individual families to have some privacy. The point was still made, though, that those who shared the same building were all part of the same household.

Investments in houses were a focus of real pride for the people of Kohery. The appearance of these houses, and of the village as a whole, was put forward as demonstrating their dedication to their families and homes. Wahid Gul and others

made disparaging comments about the neighbouring villages of Banda and Safaray where the people were more interested in money for its own sake. In those villages the houses were built of stone and wood and there was relatively little building. In Kohery, as Wahid Gul put it, people prefer to spend their money now and make their children, mothers and fathers happy. The fact that the people of Kohery preferred to spend their money and not save it in banks demonstrated both their trust in God and their love of their families. The importance of building new houses, and the amounts of money that were invested in these projects, demonstrated the real importance and centrality of families and homes to the life of the village. Nevertheless, over time men have had to move further and further from the village in order to support this home life. The increased participation in migration has also led to a greater division of labour between the sexes.

ONLY WOMEN HAVE TIME, MEN ARE ALWAYS BUSY: WOMEN'S WORK AND ACCESS TO RESOURCES.

The term *bahar*, 'outside', has been gradually extended as the male experience of the world away from the village has expanded. The term could be used to refer to spaces as diverse as areas within the village, neighbouring villages and towns, or as far away as the Gulf states. One development worker told me of the problems that he and his assistants had encountered in administering a questionnaire in the area. In several cases when they asked for the head of the household they were told merely that he was 'outside', *bahar*. It took them a while to work out that in many cases the man who was just 'outside' was in fact working somewhere in the Gulf and would not be returning for two years or more. What I would suggest is that over the decades the reference of the term 'outside' has gradually expanded in geographical area. While the space of the house that women were associated with has remained relatively unchanged, the space of 'outside' has grown. These associations of gender with space have also led to a much greater inequality in the division of labour than formerly existed.

In Kohery there was a very clear division between women's work and what men could do. Women were generally associated with child care, cleaning, food preparation and caring for animals, while men took on the heavy work in the fields, building work, repairs and all of the wage labour outside the home in small businesses or for wages. Debbie and I compared notes about what men and women did during the day and it was obvious that the women bore the heaviest burden of work. Women were engaged from 4 a.m. until 10 p.m. in a whole series of

repetitive, dull and often dirty tasks. In the morning, after preparing the morning tea and waking the children for school, they cleaned the house and courtyard. For the rest of the morning, cleaning continued along with washing clothes, fetching fodder for the animals, making the dung fuel cakes, preparing the food for lunch and caring for the small children. The tasks were divided among the women of the house with the least desirable work falling to the youngest women. There was a slight lull in the work after lunch until 3 when preparations for the evening meal began and more fodder was collected for the animals. These tasks were repeated day after day, seemingly endlessly, and the women often complained that they were fed up with having to do so much.

Men tended to describe whatever they did with the term *kar*, work, whether it was physical labour in the fields, work for wages or just visiting. The men who stayed in the village often laboured very hard in short bursts at ploughing and planting time and then again at harvest time. A lot of the time was spent sitting, talking and drinking cups of tea. Their lives were relatively free from drudgery and they had time available to indulge themselves. This contrasted with those men in the Gulf who usually worked extremely hard, especially if they were involved in some kind of manual labour. Whatever they were doing, most men seemed to regard themselves as the busy ones; they were the ones who worked 'outside' and who earned the money for the house. When I asked Wahid Gul why it was that women were the ones who owned the animals in households, he replied that it was only the women who had time to look after them, the men were always too busy working 'outside'. His statement had two important implications. The first was that the care of animals was something extra, while in fact what they produced played an important part in household income. The second, of greater interest here, was that he regarded women's lives as not being burdened with 'work'. His statement reflected a general attitude among the men that the women did not have much work, and in fact had plenty of free time, while they were the busy ones. There was some recognition by men that some of the women's tasks were less than pleasant. Those men who worked in the Gulf complained about the difficulties of cleaning clothes and cooking for themselves, and were glad to hand them back to the women when they returned. The women in their turn laughed about the difficulties that the men experienced. Yet at home no man would dare be seen helping out. Women complained to Debbie that the men did not or could not take part in the most time-consuming task of all, the care of children. The women treated it with a sense of wearied amusement that men would take their children until they became tiresome or started crying and then hand them back to their mothers.

The problem of women's work was its apparent 'naturalness' and therefore its relative invisibility. Much of the work was associated with the house, it was seen as being an ordinary part of a woman's life and was often not regarded as 'work' at all by the men. This is a common theme in studies of women's work, such as in Moore's summary (Moore 1988: 43). A particularly interesting comparison comes in a paper by Maher on women and work in Morocco (Maher 1981). Maher's list of women's work is very similar to that in Kohery - care of animals, cultivation of subsistence crops, processing and cooking of agricultural products, care of the house and its occupants (Maher 1981: 121). She argues, however, that in the estimation of both men and women it is much more difficult to separate work from women's role than it is from men's (see also Whitehead 1981). This meant that when she tried to ask women what they had been doing during the day they would often respond with puzzlement. When she pressed them by asking about specific tasks, "Since these were inseparable from her social role, perhaps the only feasible reply...would have been 'I have been being a woman all day'" (Maher 1981:122). The same problem could be said to exist in Kohery. There men were much more likely to associate their own tasks with the concept of 'work' while dismissing what women did as merely 'for women' or ordinary women's activities.

One reason for this identification of men's tasks with work is that what men did was often much more easily identifiable and quantifiable. Most of their work was associated with 'outside' the home; heavy work in the fields, time spent at a business, or working for wages. Their work could also be more readily quantified; time measured from leaving home and returning, hours spent ploughing and planting, or measured in profits made or wages earned. Over the years too while women's work has not changed a great deal in its scope, men's has. Traditionally both men and women have been involved in growing subsistence crops on village land. In addition, however, many men sharecropped land in the valley near Timirgara. Over the last five decades the 'outside', *bahar*, that men have been associated with has moved further and further from the village as they have moved gradually further into the world of wage labour. First there was seasonal work in the plains around Peshawar, then labouring in Punjab and Karachi and, in the 1980s and 1990s, working for long periods in the Gulf. This movement away has led to a greater separation from the internal life of the village which has given rise to its own hardships. I found it extraordinary to reflect on the fact that most of the women in the village had rarely if ever left the village, while most of the men had travelled extensively in Pakistan and the Gulf states.

Over the last five decades, more and more of the men from the village have become involved in wage labour as opportunities have increased. There has been a greater and greater reliance on wage labour; in the 1990s there were few households that could produce enough from their own fields to last more than a few months. Money had become the main source of income for all of the households in the village. Men had the main access to money since they were the ones who earned, saved and spent it. Nevertheless amongst men there was differential access to money. Junior men in particular were expected to obey their seniors, being told when and where to go and work and sending all of their money home. Household heads were the ones who decided how the money should be spent. In many cases even men who worked abroad had to go to their fathers to obtain large amounts of money. In fact, younger men did have some limited access to funds, but only by keeping some of their earnings or saving secretly. In contrast women's access to money was now extremely limited.

Women's access to money was mainly through the husband or directly through the household head. Money was sometimes given in the form of gifts to a woman by her own family or more rarely by her husband or household head. The problem in the latter cases was one of jealousy. As one woman said to Debbie, her husband couldn't treat her specially by giving her gifts of money but had to give all of it to the house as a whole. Some women, especially if they were older, had animals and their products which they could sell, although this was a very limited source of cash. Women carefully guarded their own possessions and kept secret the amounts of money that they had from each other. In general, though, as men have moved into the world of money, women have kept away from it, with their access to it mediated through men.

Different forms of labour migration have had different effects on household organisation, the division of labour and the position of women (Chant 1992). Some studies have suggested that the position of women has been generally improved by labour migration with increased control of resources (Naveed-i-Rahat 1990, Taylor 1987). Others have suggested that increases in family wealth have led to greater restrictions on women's lives (Pastner 1990). Abu-Lughod describes a situation similar to that in Kohery among the Bedouin of Egypt where there has been a gradual shift from subsistence to market reliance. There, she notes, "Women's work is confined to an increasingly separate and economically devalued sphere. Women have also become profoundly dependent on men" (Abu-Lughod 1986: 73). Maher also suggests that women in Morocco are in a similar situation where women's

relation to the monetary sphere is nearly always mediated by men (Maher 1981: 123). She argues that in a variety of ways women are separated from money; their labour is used as a resource by men in negotiations, few women go to the weekly markets and women have to resort to subterfuge or go through kin links to obtain money (Maher 1981: 123-5). In much the same way, women in Kohery have only indirect access to money, the main resource, and are chiefly associated with the sphere of the house and the village.

Men's association with the 'outside' sphere has, over the decades, led them to move further and further afield into the world of labour migration. While migration has given them greater access to and control over money, it has also meant that they spend more and more time away from their families. In the meantime, women's association with the inside space of the house and the village has changed very little so that their role in the domestic sphere has restricted their access to money. Men, then, are the ones who deal with money, earning, saving and spending it. Households varied considerably in size and composition and individual access to resources, for both men and women, was influenced by their position in the household. There was a strong sense of hierarchy in households where senior men and women - the household head, elder sons and their wives - had much more direct access to resources while those in a junior position were often disadvantaged. Thus, interest in the household varied according to position in the hierarchy: while seniors favoured large, joint households, for those lower in the hierarchy there were practical advantages in small, nuclear households. In the next chapter I consider questions of household composition, hierarchy and conflicts of interest in households.

LOYALTY AND DIVISION: THE COMPOSITION OF HOUSEHOLDS

CHAPTER 5

HOW IT WAS SUPPOSED TO BE : THE COMPOSITION OF HOUSEHOLDS

In this first part I have two purposes which run simultaneously. The first of these is to describe the complexities of household composition and organisation. The second is to explain the process by which I came to understand these complexities. What I write now is part of a process of understanding and interpretation. I say part because my understanding of households changed during the period of my fieldwork and continues to change now. Here I will attempt to partially reconstruct the process of understanding.

The first impressions that I gained - of what households were and what they meant to people - stayed with me for a long time. At first I was struck with an impression of harmony and togetherness, a sort of happy, united front. These first impressions were partially formed from the particular situation that I found myself in in Kohery. My experience of what a household was like came from living in one house, that of Wahid Gul and Zahoor. It was a large household consisting of the head of the house, Fazal Wahid, who was absent in Jordan, his two wives, his two elder sons and their wives and a total of 17 children, ranging from 15 years old to a newly born baby. As I later found out, it turned out to be one of the largest households in the neighbourhood. I was surprised by the general co-operation that I heard about and impressed that so many people could live in one house so peacefully. My contacts with most of the members of the household were extremely limited. I learned about the house through what my wife, Debbie, told me and through what I was told by the men of the house. My own view of the household was limited to what could be seen from the guest room which was situated outside the main courtyard of the house. As I could not see into the house directly, as it were, my view was mediated through others.

In the first few months of my fieldwork, as I learned to speak Pukhto, I relied almost exclusively on Wahid Gul, whose house I lived in. He spoke clear, simple Pukhto for my benefit and was excellent at answering my constant questions. My first, faltering attempts at ethnography stuck close to the mainstream as I asked about families and kinship. Wahid Gul was keen to answer and I was presented with a general, almost idealistic view of households in answer to my general, ethnographic questions. My method of enquiry, and my attitude, were based on the assumption that there were simple, coherent answers that supplied definitions of things such as 'the family', 'the household' and 'the kin group'. At this stage my field notes and writings were full of references to the proper composition of households, the correct structure of authority within them, how brothers should always live with their fathers and so on. My own approach, however, fitted with a general view amongst the men in Kohery that there was indeed a correct and honourable way of living and behaving. This was a view that was regularly presented by the men I spoke to and a view against which many circumstances were compared.

Wahid Gul was very clear about what a household was. This view was one that was regularly repeated both to me when I asked about households, and in general when they were discussed publicly. A household consisted of an older man, his wife or wives, his married sons, their wives and children and his younger, unmarried sons and daughters. Men remained in the same house as their father and brothers after marriage, and for at least as long as their father remained alive. Households grew when sons married and brought their wives to live in their father's house, raising their children there under the authority of their fathers. Daughters left their father's house when they married to go to live in their husband's house. Women continued to maintain close contacts with their father's house throughout their lives, visiting as frequently as circumstances allowed. After the death of the head of the household the brothers would continue to live together in the same joint house. Households composed of several brothers, their married sons, wives and children were regarded as being somehow right: as one man told me, a noisy house full of children is what we like. Those who were left to live alone, without the support of large families were to be pitied.

Wahid Gul's picture of the structure of authority in the household was as clear as his picture of the household itself. At the head of the household was the oldest man, the father. While he normally controlled the household, in his absence it was his eldest son who took over his position. Younger brothers always deferred to their elder brothers in all matters, decisions, education, marriage, migration and so on.

Men, and even boys, had authority over the women in the house. Amongst the women of the house, the hierarchy was equally rigid. The first wife of the head of the household was in charge of all the internal affairs of the house. She had control over subsequent wives and over her daughters-in-law while the wives of the elder brothers took precedence over the wives of younger brothers. The wife of the youngest brother, the most newly arrived woman in the household, had to accept the lowliest position in the hierarchy. Unmarried daughters occupied a similar position to young wives before they left to go to their husbands' houses.

It was made clear by Wahid Gul, Zahoor and their cousins that there were set roles which governed how individuals should act and their relationships with others. The head of the household was the oldest male of the house, usually the father. He was in overall, direct control of the way in which the house was run. The resources of the whole household were channelled through him and he was supposed to make all of the important decisions to do with the family and expenditure whether he was present or not. If he was absent somewhere like the Gulf then such decisions would be referred to him by telephone, cassette or letter, however long it might take. What the father said in the household went, and his sons and all others were expected to accept his word without question. As Wahid Gul put it to me, if a father does not want something then his sons should not want it either, it is only very bad sons who will disagree with their father. In 1992, for instance, Zahoor went to the UAE without his father's permission. Fazal Wahid sent two cassettes from Jordan to Zahoor in the UAE demanding that he return home immediately. After only six short months in the Gulf, and before he had even begun to pay off the expenses of the trip, Zahoor returned to Kohery.

The head of the household was expected to plan for the future of his sons and the other members of the house, hoping to make the best for them. It was he who decided what was best for the family, which of the sons would go to work abroad, which would remain behind in education, and when, if at all, they would follow their brothers. A father was supposed to balance the interests of the household as a whole with the interests of the individual members, although the former usually came first. One man that I knew had told his grown-up son that he should remain at home despite the son's desire to go to the UAE. The man knew that sending his son abroad would be expensive and that the money would be wasted because his son was a *lopa*, that is somebody who hangs around and does little or no work. Therefore, it was better that the son remain at home where at least he could look

after the family's fields. The father made it clear to me that he had taken the decision with the best interests of the whole household in mind.

Elder brothers, like Wahid Gul, considered their own role the most important in the house after their fathers. In the father's absence, or in the event of his death, it was they who took over as head of the household. The difference here was that, while the father's authority was somehow natural, that of the elder brother had to be developed and maintained in various ways. As Wahid Gul explained it to me the eldest brother was expected to order his younger brothers around. He was expected to find fault with what the younger brothers did and to be angry with them. In the face of this fault-finding and sometimes unjustified anger, younger brothers should continue to show their elders respect and should defer to them. Thus, junior brothers were expected to contribute to this relationship of authority with the same kind of deference shown to their fathers. The elder brother's wife occupied a similar position to her husband in the women's hierarchy. In the absence of the mother, it was she who would take over the main duties of the house, ensuring its smooth running and caring for guests.

In many cases the younger brothers in a household played a very subordinate role to their elders. While Zahoor deferred to Wahid Gul in some circumstances, in others he stood his ground. The three youngest brothers, Wahidullah, Mahidullah and Ershad, obeyed their elders without question: the greater the age gap the more circumspect they were expected to be. To a certain extent, being younger than Wahid Gul, I was treated by him as a younger brother. I was expected to defer to him in all matters, about where I should go, what I should do and even to his opinion in arguments. I found this role hard to adjust to, and often found myself telling Wahid Gul that he was not my elder brother and that I was in fact an elder brother in my own right. This deference to elders was something that was expected more generally. In social situations the younger men and boys were expected to defer to their elders; to huddle uncomfortably in the corner or wait, standing for orders, not talking unless directly addressed, and to refrain from smoking. The older men would dominate the room and the conversation, while their juniors often exhibited an air of embarrassment. The same was expected of younger brothers in the presence of their elders. The wives of younger brothers were also expected to defer to the elder wives in the house. They were always given the most unpleasant and dirty jobs such as the twice daily collecting of fodder and making the dung cakes for fuel.

On the other hand, even Wahid Gul agreed that relations between brothers were supposed to be more equitable. If brothers had to make a decision then, as he put it, they would hold a meeting to decide what all of them wanted. It was not considered good to do something if only one brother, say the elder, wanted it. The contradiction between equality and authority based on age was a recognised source of tension between brothers. It was seen as inevitable that when the father died and the moral bond was gone, then brothers would sooner or later want to set up their own houses. Brothers inherited equal shares of the family land when they chose to divide, and the decision to remain together had to be made jointly. While sons were held to their fathers by a moral link, brothers were supposed to be held together by more practical considerations. Sons remained with their fathers because it contributed to the family's honour. Brothers remained together mainly because it kept their land together and made it easier to work or because it meant that while one brother worked in the Gulf the other could stay at home and look after the rest of the family. Brothers divided and formed separate households when it suited their practical interests; when they could save for their own family rather than contribute to a joint household. Nevertheless any disagreement or fighting between brothers was a source of great shame and even households of brothers that had divided 'naturally' were talked about in a slightly embarrassed way. A divided house was always thought to have been the result of some kind of disagreement or fighting. Indeed, in giving reasons for the break up of many households, some reference was usually made to disagreements between the brothers. On one occasion, as we passed a field that had obviously been recently divided, my companion remarked that it made him sad to see that families divided in this way. His general comment on the inevitable friction that divided households was that it was in some way shameful.

People, then, spoke about households in the way that I felt I should be writing about them. They spoke of the way households should be, harmonious, joint houses ruled by the patriarch. They talked about a rigid hierarchy of authority where individuals knew their place and respected their elders. In situations where these things were obviously not the case - where families were arguing and houses splitting up - they were described as being, in some way, deviations from the norm. In a certain sense, people were describing an accepted norm to me in response to my general, ethnographic questions about households. This was the picture that I came back with in 1992 and the situation that I initially wrote about. However, I already had a suspicion that things were not so simple. In a sense I felt that what I was

being told was at odds with the day-to-day reality that I had sometimes seen and heard about.

CONFLICTING VIEWS OF HOUSEHOLDS

For a start, Debbie, through her closer contact with the things that actually went on in the house, gave me the key to look beyond this initial impression. It was she who suggested that the house that we were living in was in no way as harmonious as we had previously thought. At times, she said that the tensions within the household had been almost unbearable. The two wives of Fazal Wahid, the head of the household, barely spoke to each other, avoiding each other's company and playing on the loyalties of the two sons' wives. Within the confines of the courtyard, while the cooking was done as a single household, meals were eaten in the different rooms of each wife, dividing the joint household into nuclear families for every meal. The elder brother's wife chose to get on by making her separate peaces with the two elder wives. The younger brother's wife didn't fit in at all, preferring to look outside for support.

Both in Fazal Wahid's household and others, while there was talk of shared household income, there were hints that there were conflicts over who should get what. Men returning from abroad frequently joked that the money that they had brought back had been spent by other members of the household. Zahid Gul once joked with me that his money had been used to build his younger brother a new room, and buy him a pickup to drive, while he and his wife had to make do with an old room with a timber and earth roof, and he would soon have to return to Dubai to earn more money. Within the house, it was the women who were entirely responsible for bringing up their own children, using what resources they could. Despite the comforting statements about sharing household income, in most cases the women had to find their own money to send their children to school and to care for them when they were sick. The only real source of income that the women could rely on was to keep animals, mainly chickens, which they could sell if necessary.

Generally the women went through their husbands to get access to resources. Husbands returning from the Gulf would sometimes try to give their wives more than their share of gifts and money, though this had to be done in secret to avoid jealousy. The absence of a woman's husband, while he was working in the Gulf, could cause problems for her. One occasion that both Debbie and I were involved in, brought home to me some of the problems that the women faced. Zahoor's wife

became worried because her only son, Adnan (also her youngest child at the time), had been sick for some time with a stomach complaint. With her husband only recently gone to the UAE, she was feeling particularly isolated. Her relations with the other women in the house were not good and so she turned to Debbie and myself as a way out. She asked Debbie if I would be able to bring some medicine for her son as I could easily go to the chemist's shop. In the circumstances I acted rather clumsily and told her young uncle who intervened immediately. He came to the house and found the medicine she had requested in one of the other rooms. He either didn't know about, or chose to ignore the situation, and asked only why she hadn't made her request to somebody else in the house. The point here is that, because her relations with the others in the house were so bad, Zahoor's wife felt that her only choice was to turn to outsiders.

I write all of this not to try to rubbish the idea of the harmonious joint household, but rather as a prelude to showing that the situation was a lot more complex than I first understood. What I saw as simple statements about the ways things were, began to seem a lot more complicated. What I had assumed to be descriptions of what households were like now appeared to be something else. When I returned in 1993 and had the opportunity to improve my knowledge of the language, and to get to get to know people better, my views began to change. I began to understand a lot more of what was going on. Through knowing more people, and being able to follow the village news and gossip, I could see for myself what was happening on a day-to-day basis. I found ways of circumventing my own lack of contact with the inner workings of households. I could, as it were, read between the lines of what I was being told. For example I began to see that my view of the rigid hierarchy within the household was a distorting view

It was through discussions with Debbie, who spent all of her time with the women of the house, that I came to see that the situation was not as straightforward as I would like to have thought. The hierarchy was not something that existed on its own without requiring work. Rather it needed forms of control to back it up, ways of ensuring that those who had a mind to disobey could be prevented from doing so or brought back into line. For the women of the household, there were various forms of control. In the main, the elder wife controlled the other wives through her position, she was the one who decided what should be done in the house, what tasks should be carried out by whom, who should cook, what should be cooked and so on. It was the elder wife who also decided which of the women could visit their own home and when. By passing on all of the heavy and unpleasant tasks,

such as chopping wood, making dung fuel and collecting fodder for the animals, to the youngest wives, she could ensure that these juniors had no time for anything else. In addition to all of the work involved in looking after the house, the younger wives often had several young children to look after which further cut into the time that they had available. At the same time, the elder women had more direct access to resources through the head of the household, and in many cases they had resources of their own such as animals and their products. Thus in the case of Fazal Wahid's senior wife, she had several of her own goats and a cow, which were fed with fodder collected by the other women in the house. She also had the free time to sell and buy animals when the chance arose and was able to keep the money for herself. This contrasted with Zahoor's wife, the youngest wife in the house, whose access to resources was mediated entirely through others. When Zahoor went briefly to the Gulf to work, she found things very difficult as her immediate channel of communications with the rest of the house was removed.

Abu-Lughod compares the situation of women among the Bedouin in Egypt with that of the junior men, suggesting that there are inequalities of status and authority between patriarchs and their dependants, a category including both women and junior men (Abu-Lughod 1986: 80). She points out that there are similarities in the deference of junior men to their seniors and the deference of women to men in general. These observations led me to make comparisons with the behaviour of the junior men in the households in Kohery. In changing circumstances, young men who I knew well would alter their behaviour quite dramatically. Sadiqullah was a case in point. Normally an outspoken, often opinionated and humorous young man, in the presence of his eldest brother he turned into a model of junior decorum. He seldom spoke, answering only to direct questions and he took the role of servant, rarely eating at the same time as his elders. Deference was expected and received by elders from juniors. While such deference was voluntary senior men did have ways of ensuring the obedience of their juniors and controlled in much the same ways as senior women controlled their juniors.

It was household heads who decided what their sons should do, whether they should remain in education or go to work abroad. Abdur Rahim decided that his eldest son, Zahid Gul, should leave school and start by working in Karachi. The extra source of money enabled him to insist that his other sons, like Abdul Halim, should remain in school. The authority of household heads was given force by their control over resources. It was the father who made the final decision about whether land and property should be divided or not. His ultimate threat was the

dispossession of his sons. In some cases this did occur. A close friend of Zahoor's disagreed strongly with his father's remarriage and chose to leave to live with his father-in-law. His own father retaliated by disowning him and refused to give him the land that was rightfully his. In the end the elders of the village negotiated a reconciliation, although the father was still slow in deciding when and what land his son should have. Household heads also maintained tight controls over the other main resource, money. Sons were expected to give all of their earnings to their fathers while they stayed in the same house; those who did not were subject to the condemnation of the community. The ultimate decisions about large household expenditures lay in the hands of the patriarch. Thus, Zahid Gul joked that the money that he had earned had been spent on his brothers. There was little that those lower in the hierarchy could do about this control other than try to set themselves up independently.

The hierarchy of authority, whilst being accepted as a given and being reinforced by economic power, was something that was constantly rehearsed. Every social occasion was accompanied by the reiteration of the hierarchy, something which I often had to be schooled in to avoid potential embarrassment. Juniors had always to defer to their seniors, in drinking tea, in talking, in walking on a path. These situations were not simple politeness but were ways of rehearsing and redefining the hierarchy. I found these social graces hard to adapt to, particularly as they were confused by my own role as a guest. While my age, and my assumed status as a young married man without children, led me to try to adopt a role low in the hierarchy others, especially those who did not know me, tended to treat me differently. In many cases I was treated as an honoured guest which meant that I had to take the lead in often complex social exchanges. My inclination to defer to those who I saw as my elders was confused by their deference to me. Like the guest, there were other contradictions within the hierarchy that complicated what seemed at first to be a simple age ranking. There was for instance great respect for intelligence, education and strength of character or charisma. Individuals could use their personal attributes to make a special place for themselves outside of their allotted position in the hierarchy and to alter their assigned roles. In some cases a combination of factors such as the absence of figures of authority within the household and the relative strength of character of an individual allowed a strong-willed younger wife or a decisive younger brother to alter the expected pattern of relations.

Among the women, too, the rigid hierarchy could be circumvented. In Fazal Wahid's household, his second wife, through sheer strength of character, brought herself and the first wife onto a much more equal footing. She refused to bow to the considerable pressure to play the second fiddle in the household and acted as a person in her own right rather than somebody to be ordered about. The relations between men and women were also a lot more complex than the men liked to portray. While men, and even young boys, were supposed to have authority over all of the women in the house, this was often not the case. The relationships were usually open to much more negotiation than the men were willing to admit.

Within the household, there were ways to challenge and alter the accepted norm. The father son relationship was one of great respect and yet even that was open to some manipulation. In the case of Zahoor's uncle, Abdur Rahim, his own sons pronounced him as weak-willed and joked about him being mad, using that as a way to circumvent the authority which he was entitled to in the house . At the same time they placed him in the revered position of a man whose lifetime of work was over, who could now remain at home to be supported by his five sons. All he had to do now, as they so often said, was eat, sleep and pray. In this way they placed him in a position of respect but, at the same time, one that allowed them to take all of the serious decisions into their own hands. Other older patriarchs, despite their age and apparent infirmity, maintained a tight control over their sons and their affairs.

As I mentioned before, the relationship between brothers was a complex one that required constant negotiation to balance out authority and equality. In the case of two brothers whom I knew well, I was for a long time confused about their exact relationship. The younger brother, Abdul Hadi, was the elder for the Bagh neighbourhood and for Moolian Khayl in that part of the village. What I found hard to understand was how he could be such a respected elder and at the same time a younger brother. I assumed that his elder brother, Naarhamudin, because of his seniority, would have been more suitable for the position. As I was repeatedly told, however, the qualities of an elder were intelligence, wiseness and an ability to argue well, none of which Naarhamudin had. Abdul Hadi's position as an elder affected not only his status in the neighbourhood but his relationship with his brother as well. The brothers behaved much more as equals than I had seen in other such relationships. Abdul Hadi was able to use his status as a respected elder to flatten the hierarchical relationship with his brother, putting them on more equal terms.

SURVEY

What I had come to see led me to question a lot of what I was being told, or at least to take a different view of the statements that were being made. I was beginning to question the fixity of what I had previously been told. While I had taken what had been said about the household, and the hierarchy of authority within it, as descriptions of a state of affairs, I was now beginning to think of these statements as comments on the situation. At the same time that I was questioning what I had previously understood I completed a small household survey which I had started the year before. The results of the survey gave me a different perspective again through a much more concrete sense of what I was seeing. The survey covered the 25 households of the neighbourhood of Bagh where I lived. The survey results are reproduced below in Table 1.

The survey, though small, was sufficient to show that there was considerable variation in the size and composition of the households, as one would expect. The households in Bagh varied from one as big as 24 persons, to the two smallest widows' households which consisted of one person each. The average and median for the size of households were similar at 11 persons and 10 persons respectively. In a sense the figures confirmed what most people said about household composition; a great number of them were large, joint households. The figures also show that there was an equal number of smaller, nuclear households, and between these, medium sized houses that were developing from nuclear to joint. At the same time, knowing the members of the households as I did, led me to question what I had been told about the developmental cycle of the households.

Table 1: Household survey for Bagh, Kohery 1993

| Head of Household | Adult Women | Children | Composition | | Total Resident | Total including abroad |
|-------------------|-------------|----------|-------------|--|----------------|------------------------|
| | | | Adult Men | Number Abroad Men/Women and Children | | |
| Fazal Wahid | 4 | 17 | 3 | 1 | 23 | 24 |
| Abdur Rahim | 5 | 9 | 6 | 3 | 17 | 20 |
| Heemat Khan | 4 | 11 | 4 | 3 | 16 | 19 |
| Abdul Hamid Jan | 5 | 9 | 5 | 3 | 16 | 19 |
| Abdulhai | 5 | 10 | 4 | 3/9 | 7 | 19 |
| Abdul Wahid | 5 | 8 | 5 | 3/3 | 12 | 18 |
| Abdul Hadi | 4 | 10 | 3 | 2 | 15 | 17 |
| Naarhamudin | 4 | 7 | 4 | 2 | 13 | 15 |
| Amirzad Khan | 4 | 6 | 4 | 2 | 12 | 14 |
| Abdul Mateem | 3 | 6 | 3 | 1 | 11 | 12 |
| Ali Ahmed Jan | 3 | 6 | 3 | 2 | 10 | 12 |
| Salim Jan | 2 | 6 | 2 | 2 | 8 | 10 |
| Wali Mohamad | 2 | 6 | 2 | 1 | 9 | 10 |
| Gul Faraz Khan | 3 | 3 | 4 | 2 | 8 | 10 |
| Bunnair Gul | 2 | 6 | 2 | 2 | 8 | 10 |
| Gul Hadi | 1 | 6 | 2 | 2 | 7 | 9 |
| Barad Gul | 1 | 6 | 1 | 1 | 7 | 8 |
| Haista Mohamad | 2 | 5 | 1 | 1 | 7 | 8 |
| Gul Wahid | 2 | 3 | 3 | 3 | 5 | 8 |
| Lal Mohamad | 1 | 5 | 1 | 1 | 6 | 7 |
| Hadimullah | 2 | 2 | 2 | 1 | 5 | 6 |
| Nazir Mohamad | 1 | 4 | 1 | 1 | 5 | 6 |
| Halim Gul | 2 | 2 | 2 | 1 | 5 | 6 |
| Anar Gul Chacha | 1 | | | | | 1 |
| Abdul Maliq | 1 | | | | | 1 |
| Totals | 68 | 153 | 67 | 55 | 233 | 288 |
| Averages | 2.7 | 6.1 | 2.7 | 2.2 | 9.3 | 11.5 |

DEVELOPMENTAL CYCLE OF HOUSEHOLDS

What I had been told earlier might have led me to believe that households did not divide at all. The message seemed to be that households remained together and were only torn apart by the bad intentions of certain individuals. As I mentioned, divisions, at whatever stage, were talked about with an attendant sense of shame. The family of a man called Shayr was pointed out to me as how things should be, the ideal. It was a huge household, consisting of three married generations and over fifty members. I was certainly prepared to accept that households stayed together until the death of the father heading them and often even after that. The survey results, however, surprised me because there were so many small, nuclear

households. However, knowing the members of the households and having their genealogies allowed me to see something else.

Most of the larger households, of 15 members and more, did indeed consist of older men living with their married sons, wives and children. However, many of the smaller households were newly formed by men who had fathers who were still alive. In many cases the father was living with one of his sons in the original house while the other sons had built new houses near by. The heads of many of these new households were mature men with grown up sons of their own who had broken away from their elderly fathers to build new houses for themselves and to start their own households. What became apparent to me was that in the majority of cases, mature men did not wait until their fathers had died to form their own households. Indeed in most of the larger, joint households the sons who continued to live with their fathers had only young children. These men would not consider moving out to form new households until their own sons had grown up enough to be productive, or at least responsible. While there were some households that consisted of brothers still living together after their father had died (two in all), they were the exception rather than the rule.

This led me to re-examine my own ideas about the relationships within households which up to then I had regarded as relatively good. My re-examination brought up numerous tales of family strife, of fathers fighting with sons, and brothers with brothers. I only now began to see and hear about much of the troubles that marked family life. Most household divisions, though initially blamed on women, were put down to disagreements among brothers and were more often blamed on a bad, younger brother. Now, however, I could hear about the break-ups myself. I could ask the protagonists questions and I could follow the events as they happened. Both the decision to separate, and the actual division seemed, in the cases that I saw, to be marked by considerable acrimony. The initial decision to divide was in several cases made by one brother without consulting the others which in itself caused conflict. It was the shame associated with the split that caused the most problems, the fact that everybody was discussing and passing judgement on the family's problems. In many cases the actual decision and announcement was preceded by a period of tension and often argument over money.

Discussions and gossip about family disputes over money were often the first sign that a household was going to split up. For example, in the case of one household the first that I knew about their problems was that one of the younger brothers had

refused to give the money that he had brought back from the UAE to his father as would normally be the case. The refusal was followed by the announcement that he wished to use the money to build himself a large new house. The man's father and mother were very unhappy and his eldest brother sent a cassette from the UAE saying that he would come back to fight with his younger brother. What struck me immediately was that the whole thing was being carried out so openly. The mother complained bitterly to Zahoor and myself in the public space of his shop about her son. She described the arguments that had taken place in great detail, though we had already heard about them at second hand. It was almost as if, knowing that everybody else would be gossiping about their affairs, she wanted to get things out in the open. Perhaps by telling everybody how bad her son was, she was presenting her side of the case in preparation for a future division. As interesting as the case itself, were the reactions of others. Several held that the younger brother was a man with bad intentions and referred back to his lack of action in a feud that his family had been involved in. Others mentioned the fact that he was always fighting with his wife and that their arguments caused tension in the household. The man then was condemned and taken to be a bad lot for wishing to break with his father and brothers. People were in general agreement in placing the blame for the division of the household at the feet of one individual, the youngest son.

The initial refusal of the son to give money to the father was a direct and open challenge to his authority as the household head controlling the resources. It was a way of asserting the son's own interests ahead of those of the rest of the group; saying that he wanted to build himself a new house rather than relinquish control of the money. This was one way in which individuals could articulate their own interests against those of the group. At the same time, those inside and outside were looking for a single individual to blame. The joint household, and the loyalty between close kin that it represented, were so important that it was better to find a scapegoat in one individual than admit that division was an inevitable outcome. Although splits seemed to be inevitable and certainly, considering the size of some households, natural some sort of dispute between the brothers involved was used as an explanation. Large joint households, where brothers remained together, were exceptional but were regarded as being ideal. They were living representations of the triumph of group interests and loyalties over the interests of the individual.

In certain circumstances people did recognise the nuclear households did have some advantages over joint ones. Economic factors, which I discuss later, were certainly of importance. The problem was that such acrimonious splits undoubtedly caused

rifts in families the effects of which were felt for many years following. Divisions of joint households put the loyalties between close kin under great strain and exposed them to public scrutiny. An unduly unpleasant rift could even result in the complete separation of a father and his sons or of brothers. Given the moral importance of such ties it was impossible for them to be completely broken or even left under undue strain.

In *Caste and Kinship in Kangra* Parry (1979) looks at the developmental cycle of joint households. Parry sees partition of households as a normal phase in their development, "the inevitable outcome of the opposing pulls of a man's loyalty to his conjugal family on the one hand and to his father and brothers on the other" (Parry 1979: 179). However, in explaining the partition of individual households women are often used as a scapegoat; their quarrels are used as a pretext to preserve the important facade of solidarity between male agnates (Parry 1979: 177). Nancy Tapper, like Parry, suggests that the tensions between women were used as an excuse to hide the tensions between male agnates among the Maduzai Pakhtuns (Tapper 1991: 120). In Kohery, divisions of households resulted from conflicts between individual and group interests. Mature men broke away from their father's household to form their own before they are 'supposed' to, that is before their father's death, in order to advance the interests of themselves and their own maturing families. The arguments, ploys and gossip I have described can be seen as the way in which the community decided how individual divisions should be viewed. Like Parry and Tapper's cases, in retrospect divisions were often blamed on women, though, at another level of intimacy they were also blamed on younger brothers. The aim, whoever was blamed, was to preserve the ideal of household loyalty among men.

Tapper argues that there is an ideal of unity against which the characters of individual households were assessed (Tapper 1991: 102). While the people in Kohery accepted that the division of households was inevitable it was still an idea that was vigorously resisted and that was certainly never seen as normal. Large, undivided households were presented as a norm, and were in some senses seen as an ideal. Household unity was, then, something against which all households could be assessed in the public domain. A split in a household, however inevitable, was something shameful. In discussing the division of other people's households those in Kohery were seeking to establish what was acceptable and what was not. Those actually involved sought to present their own case. They attempted their own

damage management and tried to influence the way that others regarded and judged the situation that they were involved in.

The situations with which people were faced were complex and in a continuous state of change. People looked for ways to talk about these situations, to describe them to themselves and others, that would make sense of them and normalise them. In describing the situation to me as an outsider they used a general, almost idealistic interpretation of events which painted over the fissures in households and presented a normalising view. This general interpretation described households as harmonious, loyal and hierarchical. When the fissures and divisions became public then people had to have another way of talking about the situation. People had different ways of publicising the divisions in their own households, of joining in with the gossip about their problems as the examples above have shown. In some cases people tried to anticipate the division and present their case first. In others they tried to create the situation to their own advantage while in others still those involved tried to present their own side while condemning the others. Those not directly involved took their part in deciding how the divisions should be presented, more often than not looking for somebody to blame.

To fully understand the positions from which people in Kohery argued their cases it is necessary to consider that understanding of the important economic factors. Tapper argues that for the Maduzai Pakhtun, the developmental cycle is from paternal joint household to fraternal joint household. Before the brothers' sons are married these fraternal joint households are usually partitioned to form further incipient paternal joint households (Tapper 1991: 80). In Kohery the pattern is different, as households tended to divide before the death of the patriarch so that there were few fraternal joint households. Tapper suggests that the increasing importance of land as the main source of household independence meant that there were important economic advantages in keeping households together (Tapper 1991: 108). Parry similarly emphasises the importance of demographic and economic factors in maintaining joint households. He argues that the decision to divide is made within the context of demographic, economic and moral constraints (Parry, 1979: 154-5). Having considered the moral context of household division, I turn to look at the economies of households in Kohery.

Among men money was a regular topic of conversation, in the main discussing the prices of large items like vehicles and electrical equipment. This openness about money encouraged me initially as I was keen to do detailed surveys of household

economies. However, I came to find that men were far more unwilling to speak about how much money they earned and in many cases they exaggerated the amounts. They were equally unwilling to talk about household expenditure in all but the vaguest terms. I did find that household spending patterns were talked about in much more general terms that were in themselves interesting. The common theme seemed to be that household expenditure was consistently uncontrolled and uncalculated. At this point in the research I was unable to collect information on women's views of household income and expenditure to see if they were similar or not. I will go on now to describe in detail this male view of household economies and outline the ways in which this view centred around families.

THE ECONOMY OF HOUSEHOLDS

Examining the economy of the household was not a simple task. Gardner (1995) in particular points out the problem of defining households in areas of migration with a variable population. She suggests that Parry's distinction between residential and property-holding groups is problematic in a situation where households are dynamic, responsive to change and may even be said to exist across continents. Other definitions of Pakhtun households, such as Tapper's (1991) which sees marriage decisions as primarily defining the group, are unnecessarily narrow in the situation of my own fieldwork. In Kohery, households were groups who shared in a number of different areas. Practically, households were formed of those who shared the same building, who held and tended their land in common, who shared resources and who made decisions regarding all of them under the auspices of a head. As long as joint households remained together under the authority of a patriarch, the house and the land were considered to be his, although each son who would inherit knew what his share would be. Resources of the joint household were pooled and redistributed through the patriarch. The patriarch planned for the household as a single unit, making decisions about resources, labour, marriage and so on that would best benefit the group as a whole.

Smith and Wallerstein (1992), in looking at households in the world-economy, point out the importance of variable sources of income - rent, market exchanges, subsistence, etc. - to households everywhere. They suggest that "Wages must always be combined with other forms of income. These other forms of income are never negligible" (Smith and Wallerstein 1992: 254). Writers like Netting, Wilk and Arnold (1984) and Nash (1994) have also placed great emphasis on the economic adaptability of household units. In Kohery, too, there were various sources of income available to households which could be combined in any number of ways. However, in order to properly consider these sources of income it is necessary to examine the ways in which they were assessed by the people of Kohery. These assessments of resources were important in the ways in which men in particular described their own household economies. In discussions of their household



Plate 10 - Wahid Gul's pickup



Plate 11 - Zahoorwahid's shop



Plate 12 - Terraced fields



Plate 13 - Wahid Gul ploughing

incomes men gave great predominance to wage labour and generally devalued other resources.

RESOURCES AVAILABLE TO HOUSEHOLDS

One of the original purposes of my research was a 'straightforward' economic study of the village of Kohery. I had envisaged a detailed survey of household income and expenditure, coupled with an assessment of the place of migration and remittance money in the economy of the community. Following along the lines of other economic studies of Gulf migration (see for example Appleyard 1988, Khan 1986, Oberai and Singh 1980) I wanted to examine issues of 'productive' and 'unproductive' investment of remittances and levels of dependency on migration. I found that the situation that I was faced with was considerably more complex than the 'objective' ideas of such surveys could cope with.

Household expenditure was a particular problem. Although people were always quite happy to discuss prices of commodities, and even to tell me about the amounts of money that they earned or received from abroad, they were either unwilling or unable to estimate their household expenditure. It seemed curious to me that people whose conversation revolved so often around money and prices, should show such reluctance or inability to calculate, what seemed to me to be, such important figures. Some of the figures that I did get, now seem, in retrospect, wild exaggerations. Getting other figures was like extracting teeth. Men often preferred to talk in vague terms about all of the income being 'eaten' by the household and of every household being in the same financial position. One term that kept cropping up was *khrooskoo*, which was used to describe houses as being 'eating/drinking'. It seemed that, despite my best efforts, I would be unable to produce my economic survey of a representative cross-section of the community. However, the figures that I did manage to obtain, and the rhetoric that surrounded the household economy were fascinating in themselves.

A useful way forward in my predicament was presented by Gudeman in his book *Economics as Culture* (1986). The problem for Gudeman is that Western economic analyses are based on logical and mathematical schemes which are assumed to be universally applicable. Anthropologists, and others who try to apply these economic models and schemes to non-Western settings, have encountered problems. As Gudeman puts it, "We cannot simply rearrange their models and reword their categories to be derivable from ours, for it is especially in the

patterning of these categories... that cultural differences lie" (Gudeman 1986: viii). This was certainly the case in Kohery where situations that seemed inexplicable and illogical took on a whole new perspective when looked at from the point of view of people's own cultural categories.

LAND

A case in point was land. I was deeply confused by the fact that, while on some occasions men would talk about the poverty of their own land, on others they would assert that they would never sell their land for any price or would put the most astronomical figures on it. It was only when people explained the factors involved to me that I came to see the complexity of the issues and began to understand this apparent contradiction.

The land of the village surrounded the houses and clung to the hillside in enormous terraced steps (see Plates 12 and 13). The terraces had been hand-built out of dry-stone and were in some places built up to heights of 2-2.5m. The fields followed the contours of the hill and were irregularly shaped making it difficult for me to estimate the areas of land that families owned. Most of the land which had been cultivated for a long time was of a reasonable quality with a deep, rich, black loam that was fertilised with ash and other waste from the house. People categorised the land into that which could be irrigated with water from the streams and that which could not. However, as Wahid Gul pointed out, while the former was considered to be of better quality, in reality all of the land was dependent on rainfall to be effectively cultivated. Many said that their own land had never been any good and that this was because it was dependent on rainfall. As Wahid Gul put it: you can spend all of your money buying the seed to plant your land and buying fertiliser for the plants and then if it does not rain, then all of your money is gone.

It was recognised that over the decades a variety of factors had led to a decrease in the productivity of the land. McMahon and Ramsay writing about Dir in 1901, recorded that "the upper slopes of the mountains are thickly wooded" (McMahon and Ramsay 1901: 8). By the 1950s Dichter (1967) characterised the area as being denuded of its forests. The people of Kohery recognised the fact that it was their own deforestation of the hills above them throughout the century had resulted in the damage. In the 1970s year after year of heavy rainfall had led to an increase in the size of many stream beds in the village and had made it impossible to protect and restore the damaged fields. Another water related problem was that in the

1980s nearly every house had connected pipes from the streams and springs to taps inside the courtyards. This put a strain on the water supplies so that at the times when it was needed in the fields - that is when there was no rainfall - there was little or none available for irrigation. The dry season between the end of the monsoon in September and the beginning of the winter rains in December had become a time of water shortages.

Another major problem was the subdivision of the land. As Zahoor pointed out, Moolian Khayl especially had started out with little enough land and with many families to share it amongst. Thus while his grandfather, Gul Rahim had owned enough to support his own family, when it was divided amongst his three sons it left them each with very little. An additional problem was that the equitable division of the land resulted in each household owning a scattering of small fields. The area of Bagh was a patchwork of fields, each owned by a different member of the Moolian family. This was a situation that was repeated throughout the village. As the situation in Wahid Gul's household graphically illustrated, the land was coming to have less and less of a productive role in the village economy. The household, which consisted on 24 persons, had only four large fields and six smaller ones which altogether produced only enough grain to last two or three months at most. For the rest of the year Wahid Gul bought flour from the market in Timirgara. Many agreed that this was the situation for all but a few households in the village as a whole. At the same time, though, most households had shifted to wage labour as their major source of income.

Before migration, in the 1940s, most families relied almost entirely on what they could grow. The land was intensively farmed and the main annual crops were barley and maize while numerous other smaller crops - including rice, sugar cane, vegetables and fruit - were grown on small pockets of irrigated land or were sharecropped to supplement the diet and for trade. As more opportunities outside the village opened up after independence then there was a general decline in the labour available to work the land. Large numbers of men took part in seasonal migration to the Punjab and families had to rely on co-operation with their relatives and neighbours to carry on relatively intensive agriculture. As the men began to move to Karachi in the 1970s they spent longer periods away from the village and the practice of seasonal migration began to decline. The move to the Gulf at the end of the 1970s saw this trend continue and resulted in a major decline in the amounts of labour available for agriculture. Though the main crops of wheat and maize were still grown they were less well cared for and there were fewer other crops grown.

When the maize crop of 1993 failed people were upset at the amounts of labour lost. As Azum Khan put it, now we don't have to worry as we can buy flour from the market.

Nevertheless, all of the land was still used relatively intensively to produce two main crops a year and large amounts of labour were devoted to agriculture. The majority of the fields were still farmed using a wooden plough pulled by oxen since they were inaccessible by the more recently introduced tractors. In the winter the most important crop, wheat, was grown being harvested in the early summer. At the start of the summer rains the second crop, maize, was planted to be harvested in the autumn. Some fields, especially those that were small and irrigated, were used to grow clover which was used as a green fodder to feed animal kept in the house. A few small areas of land were still used to produce vegetables such as onions, tomatoes and cucumbers for family consumption. At the edges of all the fields a variety of trees were grown, every one for some purpose, whether fodder, fuel or fruit. Most of the trees were grown for green fodder, the trees being regularly pollarded and the green leaves fed to animals. In addition there were a large variety of fruit and nut trees such as apricots, mulberries, figs, oranges and walnuts.

As well as working their land relatively intensively, many considered their own land too valuable to sell and when any fields did come up for sale the price was usually well beyond the reach of most normal people. Some suggested that these enormous increases in the monetary value assigned to land in the village were due to the lack of land in the village while others reckoned that the inflated prices of land were a reflection of the inflated amounts of money available from those working abroad. However, if land in general was considered to be a highly valued asset then it was easily available elsewhere to those who wanted it. Many families owned land around Timirgara, in Bajaur and as far afield as Chakdara and Dir. It was, however, most often talked about in terms of the trouble that it caused those who owned it, generally being considered to be more trouble than it was worth. It seemed, then, that much of the high value of the land in Kohery was purely because it was in the village. Owning land in the village was important to people because it was a link to the place, it was part of the sense of belonging.

Like the desire of migrants to return home and the huge investments in building houses, the farming of land in the village and the high value placed on it were more to do with a commitment to and investment in home and family than a 'rational' or 'logical' in 'productive' investments. Although the land was relatively unproductive

and contributed little to household income it was closely guarded and heavily used, a source of great pride. Spencer's (1990) discussion of the evaluation of land in rural Sri Lanka raises a similar issue. There, he suggests, perspectives on land were influenced by the local political context and the changing economic conditions. As Gudeman (1986) suggests, it is problematic to try and understand non-Western economic conditions with Western economic models. Thus, in the terms of economic analysts such as Appleyard (1988), Khan (1986) and even Ballard (1983), the investments in houses and land in Kohery make little sense and seem unproductive. Yet, from the inside, these investments in home and family are the reason for labour migration. The low productivity of the land and its lack of reliability have meant that people have turned to other sources of income.

WAGE LABOUR AND SMALL BUSINESSES

With low land productivity most households relied on wage labour or the profits from small businesses for their main income. The opportunities for work locally were scarce and so many chose to migrate. Again, the opportunities for local investment were limited, the main areas being shops, transport businesses and construction. The way in which these opportunities were evaluated was strongly influenced by notions of expenditure and saving. In general, men said that it was impossible to control expenditure in the home environment while saving could only be effective away from home. Most households were to some extent reliant on money that had been saved abroad; the profits from work or businesses at home were not seen as reliable. Another influence on this attitude were the conditions in Pakistan as compared to those in the Gulf and elsewhere. Those who worked abroad were considerably better off than those who worked at home.

For a start there were few opportunities locally for wage labour. The main openings were to work for someone else in their small business or to find a government job. Wages in Pakistan generally were low and in 1993 they were severely affected by high national inflation. A labourer could earn Rs 55 per day at most, which, given the infrequency of work, made a monthly income of Rs 1000. A pickup driver could earn Rs 1400, while a pickup conductor earned Rs 900 per month. As Timirgara is also the regional administrative centre there was some work available in organisations such as the police and electricity company which paid about Rs 2000 per month (for comparisons of wages nationally see appendix). The other main problem was that jobs such as these were not given out on the basis of qualifications

but required recommendations from politicians or other powerful people which were not easy to come by. In all of Kohery there were only two men who worked for the police and one for the electricity company worker.

Far better opportunities for wage labour existed outside of the village, especially in the Gulf. As one man put it to me, a man with a degree from Pakistan can earn more with a shovel in his hand in Dubai. In comparison to the salaries in Pakistan, even in 1993 as wage levels were declining, the wage levels in the Gulf states were far better than anything that a man could hope to earn at home. For example in the UAE an unskilled labourer earned at least 40 Dh a day which converted to Rs 240 at 1993 levels. Working in a garden a man could earn 800 Dh a month, which came to Rs 4800. Azum Khan's father who ran his own tailoring business estimated his profits at 1000 Dh a month which meant that he was able to send home up to Rs 6000 every month to his family. Most men who worked in the Gulf were able to send home enough money to support their families, often as much as Rs 5000, and still brought back money that they had saved at the end of their two year stints. In comparison to the salaries at home (see appendix) these were considerable amounts of money by Pakistani standards. A man doing simple work in a garden in the UAE was able to earn more than a headmaster in Pakistan.

It was also suggested by the men who worked abroad that it was much easier to save when working away from home. Most men working abroad, whatever job they took, saved as much of their wages as possible. They lived in the cheapest accommodation available and often passed their money on to another trusted individual for safekeeping. The Gulf was considered to be the ideal place in which to save money. There, away from family life and from most of the restraints of kin ties men could work and save and do nothing else. In the place of work there were none of the usual drains on resources like families to feed, medicines to buy and guests to entertain. Money was not 'eaten' immediately and so could safely be saved in order to be sent home.

Those who had extra cash often chose to invest in some kind of small business to provide income at home. People were reluctant to invest in an untried business idea and there were few successful businesses other than shops and vehicles. There were a number of very general stores in the village, about 17 in 1992, though by 1993 the number had declined somewhat. These shops stocked everything from fruit and vegetables to tea and rice and were run with varying degrees of success, depending on the interest of those who ran them. Perhaps the most successful shop was run by

Zahoor, the elegantly named Diamond General Store and Radio Repairs (see plate 10). In addition there were three small tailoring establishments and three drug shops. Tailors and doctors relied to a great extent on their reputation for their success. The main transport business was pickups which made daily journeys between the village and the local town of Timirgara (see plate 11). Drivers took on whatever work they could, transporting people and goods and often had to travel long distances and work long hours to make a profit. The costs of a new pickup soared from Rs 350,000 at the start of 1992 to Rs 460,000 in June 1993. The high initial investment and the exorbitant maintenance costs meant that the numbers of vehicles in Kohery fluctuated rapidly, from as many as 10 in 1992 to as few as 3 at one point in 1993. Two other families owned tractors though much of the work for these vehicles was to be found outside the village.

The two main considerations in investing in a business were risk and the safe return of the investment, and income for the household. The rapidly fluctuating numbers of vehicles suggested that they were considered a safe investment. They were easy to come by and they could be sold quickly with a good return on the money invested. Some, like Abdur Rahim's sons, speculated in vehicles, buying them second-hand and attempting to sell them at a profit, whilst making money as a business. As Zahoor pointed out, the greatest risk was that of a crash in which case all of the money was lost since there was no form of insurance. In Zahoor's mind, the better option was a shop where a lot less could go wrong; as he put it, the worst that could happen is that the watermelons could go off. Nevertheless shops did occasionally go out of business, usually because the owners had lost interest in them.

Risk, then, was a major factor in the assessment of business opportunities. In general there was too much competition in a limited market. This was certainly the case for pickups. In 1992 the number of pickups grew to 10 and more until they were fighting for work. Drivers had to look further and further afield and take lower and lower rates in order to make ends meet. Such competition inevitably pushed some individuals out, usually those who could take the option of returning to the Gulf. Stevenson (1985) describes a similar situation in a Yemeni highland town where there were large numbers migrating to work in Saudi Arabia. There, return migrants looked for a safe investment in some type of small business. The local economy was small and relatively restricted so that by the 1970s it had become more difficult to find a gap in the market. In Kohery and the surrounding areas those individuals with a lot more capital to invest had been able to develop other

opportunities, including chicken farms and even a tree nursery and a small cloth manufacturing plant. Few others had the extra capital to take the risk with.

A complicating factor in assessing businesses was that most of them were not independent and relied to a greater or lesser extent on money from the Gulf. While Zahoor's shop made enough to keep it going on a day-to-day basis, on some occasions he had to seek out other sources of money. In the autumn of 1993, he wrote to his father in Jordan asking for Rs 20,000 in order to buy in a winter stock of shoes and cotton stuffing for quilts. The same situation operated for the pickup that Wahid Gul drove, where ordinary costs were covered by the money he made, while extraordinary expenses had to be funded from outside. Vehicles, because they were so expensive to maintain, required regular inputs of cash from outside. Abdur Rahim's family could only really afford to run a pickup because the two elder sons were working in the Gulf. Those families without a secure source of income from the Gulf could not even contemplate risking investment in a business.

Small businesses were generally set up as a way of ensuring a safe return on money saved but also as a way of generating income. Businesses like Zahoor's shop were run on a day-to-day basis with family labour. The shop stayed open for as long as Zahoor and his brothers could work there. He stocked whatever he could afford to buy with the profits from the previous day. Few could say how much their businesses made, or indeed whether they were profitable at all. I never came across any shopkeeper who took records of income or expenditure and it took a great deal of persuading to get Zahoor and Wahid Gul to record even the most basic figures for me. Most who had businesses were vague about how much they made, if they made any money at all. Even those like Ghulam Wahid, who was a flour merchant in the busy bazaar of Timirgara, claimed that his profits were 'eaten' by his household before they could be calculated. In general then, businesses were run as a direct source of day to day income rather than as a way of saving money.

However, many shops especially supported not only those who ran them, but many others as well. Shops could not be run without extending credit to those who used them. As a result they were enmeshed in a complex web of family and neighbourhood ties which made profit calculation a complex and potentially depressing task. Even Zahoor who refused credit to all but his closest kin was owed over Rs 27,000, though for a time it had been more than Rs 100,000. The largest amounts of credit had been extended to close kin who owed as much as Rs 6000 each. Since shops were run on a day-to-day basis extensive credit could be a major

problem. Usually, though, if credit was owed by close kin, when cash was needed pressure could be brought to bear to obtain some money. Many families, like Abdur Rahim's, relied on credit and the goodwill of shopkeepers who would wait until they received money from abroad to pay off their bills. Businesses like Zahoor's shop, then, supported not only those who ran them but also those who depended on their credit.

Small businesses were regarded first and foremost as safe investments for money brought from abroad. They were run as a direct source of income for the households that owned them, a part of those households rather than as independent entities. The stock of shops was used as if it were part of the households' resources while any other profits were immediately taken up or 'eaten'. At the same time most businesses relied on outside sources of income, whether remittance money or loans from other kin, in order to keep going. In addition businesses supported not only those who owned them but many others as well. The businesses were, in every sense of the phrase, 'family businesses'.

ORGANISING THE HOUSEHOLD ECONOMY

The ways in which households combined their sources of income varied considerably and depended on a wide range of factors, from family size and composition, to the resources that were available to them. All households were to some extent dependent on migration. This is shown most clearly in the figures for men absent from households in the Bagh neighbourhood. There every household had at least one man absent and working in the Gulf. Even those households with businesses relied on remittance money, as I have shown. It could be said that whatever the organisation of household income was it was always underpinned in some way by remittance money. The best way to illustrate the variety of ways in which households organised themselves is to give examples from households that I knew.

People in Kohery had a clear idea of the best ways in which to plan the household's income. To many a large joint household, especially if there were several grown up sons, was the ideal option. In a large household with several adult men available, two or three could work in the Gulf. They would be able to send back up to Rs 5000 monthly to support the family as well as saving considerable amounts. In some cases the money from abroad allowed the family to establish small businesses at home which supplied an additional source of income and acted as a form of

insurance. As Gul Halim, Zahoor's cousin put it, this was the best way to organise things, one brother in the UAE, another in Saudi Arabia, and others at home where they could take care of the family. That way if things went wrong then there were other options open, other sources of income available. For small households without the ability to make a choice the problems were very different. In almost all cases these households were entirely dependent on the money sent back from the Gulf by the household head. The main problems arose from the male head being absent from the household for much of the time. Such households relied entirely on money sent back from abroad. In addition in households where there was no adult male available, then they had to rely for assistance in agriculture and looking after the household on relatives and neighbours.

The options of households were also influenced by the land and other resources that they had in the village. Those who had substantial holdings of land had a safe base on which they could build. The remittance money could more easily be invested in more land or in local business ventures. There were several families in the village who had substantial landholdings around Timirgara and even further afield which they had bought with money saved abroad. Such families also diversified into other businesses, including rented property in Timirgara, flour merchants, visa agencies and even building contractors in the Gulf. However, it was generally stated that ownership of land was not enough, but that everybody had to take part in migration in order to get by. The new investments that had been made had been possible only because those who had land had also taken part in migration. Those families who had started with an advantage had to migrate in order to maintain that advantage. Those without the initial advantage had also been able to improve their position.

To give a specific example, Fazal Wahid's household was large with 24 members. The grain that their small amount of land produced (400 kg in 1993) lasted them for barely three to four months of the year, the rest having to be bought from the bazaar. In the main the family were dependent for their day to day income on the two businesses that Fazal Wahid's sons ran. The small general store that Zahoorwahid looked after kept them supplied with most of the essentials, which consumed the shop's profits entirely. In addition, Wahid Gul drove his wife's brother's pickup, for which he received Rs 1400 a month. These two sources of income covered all of the family's everyday needs. Fazal Wahid himself worked in Jordan running a shop in a town near Amman. The money that he saved there and in Karachi had paid for the shop in Kohery in the first place and continued to

provide for the family. Fazal Wahid had been able to save the money that he made to pay for special expenditures such as his sons' large weddings, improvements to the house and, in 1994, a pickup for Wahid Gul to drive for himself. Thus, through years of migration, Fazal Wahid had been able to substantially improve the situation of his family.

Households, then, varied considerably in the ways in which they organised their income. For smaller households there were few options and they were almost totally dependent on the remittance money sent back by their members abroad. For larger households their options varied according to their resources in the village. A household with little land had to look to other options such as sending several members to work abroad or combining work abroad with businesses at home. In households where the land provided a considerable part of their income, there was still a reliance on remittances to support other costs. Those households that had substantial holdings of land had the money to diversify and improve their economic situation still further. However, despite these considerable variations in the way that income was put together, the expenditure of this income was remarkably similar from one household to the next.

SPENDING THE MONEY

While there were some options for households in the way that they earned money, the expenditure of this money was considered to be far more of a given. Zahoor and others suggested that there was very little variation in the ordinary, day-to-day purchases of households. Most people ate the same things, the only real difference being whether or not they ate rice or bread or both. Zahoor held that there was variation between rich and poor households. He suggested that the rich ate less to save more of their money while the poor ate more of a variety of food since it was their only luxury. The main variations were of scale; in general, the larger the household, then the greater their everyday expenditure. I really have only one set of what I consider to be reliable figures for everyday expenditure although I have other information with which to make comparisons. The figures that I obtained for Fazal Wahid's household were calculated by Zahoorwahid himself. Over a period of three months he wrote down the costs of all the items taken daily from his own shop to supply the house (Table 2). The shop supplied all of the main requirements of the house and little was bought in the market.

Table 2. Estimated household expenses for Fazal Wahid's household (24 persons), 1993.

| <u>Month</u> | <u>Rupees</u> |
|--------------|---------------|
| January | 1918 |
| February | 2090 |
| March | 2690 |
| Average | 2233 |

In addition Zahoor and I estimated other outgoings of Rs 1950 per month (1400 on flour, 500 on school expenses and 50 on electricity). The total average monthly costs for a household of 24 persons came to between Rs 4000 and Rs 4500. While I do not have such precise figures from other households I do have information to show that their expenditure was roughly equivalent. For Abdul Wahid's household, for example, while their expenditure on flour was reduced because they could use their own wheat, the costs of other staples brought the money they spent in the month up to the same level as Fazal Wahid's household. Other households such as Abdul Hadi's, Abdur Rahim's and Abdulhai's also used to receive similar amounts from household members abroad to cover their monthly expenditures.

Another group of expenses that were considered harder to estimate were those that were unexpected but that nevertheless had to be taken into account. The main items here were hospitality and the treatment of illness. Hospitality could range from providing tea and biscuits for a neighbour or relative, to purchasing several chickens, meat and other special foods to host a larger meal. Hospitality was considered to be extremely important and often large amounts of money were spent. It was essential that every house have a good stock of tea and treats as people were always calling by. The women from the houses usually went calling locally at least once a day. When special guests, like relatives who visited infrequently or the odd Inghayzee anthropologist called, then it was treated as a special occasion. Enormous spreads were put on for such special guests and the household would present far more food than could possibly be eaten. In addition there was a constant round of other occasions, from small celebrations for the birth of a child or the return of a relative from the Gulf, to thanksgivings for the survival of a family member in an accident, to the purchase of a pickup. The costs of such occasions soon mounted up, though they could seldom be predicted.

Some households involved themselves in considerable amounts of entertaining. At weddings and engagement celebrations there were frequent exchanges of gifts

between the guests and their host. The women who attended especially would bring some kind of gift, most often peanuts or money. When they left, if they had brought peanuts then these would be returned and all those who had brought a gift would be given some money, Rs 50, or up to Rs 200. Considering the numbers who attended some of these celebrations the costs of such gift-giving would soon mount up. Wahid Gul's mother-in-law was renowned for her generosity with her relatives and neighbours. It was said that whenever she had guests in the house she gave them gifts of money. She always had people visiting her as she had many relatives and she frequently went out herself. Wahid Gul, who helped with some of the family finances, estimated that in one period of 11 months, the household had managed to spend almost Rs 100,000, about Rs 9000 a month for a household of 13 persons. Whilst most other households were not quite so profligate, all of them had to take into consideration the considerable but unknown costs of receiving guests and visiting.

The other main costs that had to be budgeted for, but that were often difficult to estimate, were those of dealing with illness in the household. Those with illnesses that persisted after home remedies had been tried were taken from place to place looking for a cure. The local drug dispensers, or 'small doctors' were tried first, followed by the hospital in Timirgara and the various private clinics. In all of these places the practitioners charged a fee and often prescribed four or five different types of medicine. If a child or adult became seriously ill then considerable amounts of money could be spent on these visits and the purchase of various medicines. The costs soon added up and for a less well off household could be crippling. Minor illnesses, especially among the children, were relatively common and so every household had to budget something for the costs of treatment.

Zahoor estimated for his household that, when all of these items were taken into account, then the total monthly expenditure of the household for everything came to Rs 6000. For the other households of the group the figures were similar with slight variations according to the size of households. The Moolian households in Bagh used to receive about Rs 5000 each from those working abroad to cover ordinary monthly costs. Both the amounts of money spent and what it was spent on, was remarkably similar from household to household. Most people ate the same types of food, lived in similar houses and wore the same types of clothes. Every household was expected to take part in similar displays of hospitality, receiving guests, visiting and giving and receiving gifts. The main variations were of scale; larger houses had to spend more to feed and clothe their members, richer

households were expected to be more generous in their hospitality. Households were not only expected to behave in similar ways as I shall describe in more detail later, but they were also described in similar ways, despite their considerable variations.

THE *KHROOSKOO* HOUSE

People in Kohery saw few differences in the situations of the households in the village. All of them were, in their own eyes, dependent on labour migration and remittance money. Households that were dependent were described as *khrooskoo*, which roughly translates as eating/drinking. *Khrooskoo*, as Zahoor described it to me, referred to a situation where at least one of the adult male members of the household had to work abroad in order to support the other members. The money that was sent back from abroad was used to buy ordinary household essentials such as wheat flour and rice. However much money was sent back, it was spent almost immediately. In general a *khrooskoo* household had no money saved in bank accounts and no real resources to fall back on.

People described *khrooskoo* as a recognisable pattern in the development of a household. In addition to sending money home to support his new household a man would try to save whatever money that he could. On his first return trip all of the money would go into building a new house so that by the end of his six months leave all of the money, and often more, had gone. When the man's sons and daughters began to grow up, there then came the costs of weddings which again use up years of savings. As the sons married, and the household grew, it cost more and more to support, so that any form of large expenditure became a problem. There seemed to be no real way out of this pattern of continuous consumption of the money earned.

Virtually all of the households in the village were described as being *khrooskoo* and were, in a sense, expected to be in that situation. The people of Kohery consciously compared themselves with those of other surrounding villages where they saw the situation as being different. The most common and frequent comparison was with the village of Banda which differed in appearance from Kohery quite dramatically. Where Kohery had many new houses, a number of small, newly built mosques, numerous shops and many vehicles coming and going on the tracks, Banda had few, if any, new houses, only one communal mosque, one shop and no vehicles.

Wahid Gul tried to explain the differences to me in terms of a difference in attitudes to do with money. As he put it:

In Kohery people say, why save money when you can spend it now on your family? What is the point of having a pocket full of money when your children are hungry, it is better to buy food for them? When you have saved a lot of money it is better to build a new house for your children and your mother and father. If you spend all the money today then you can always go out tomorrow to earn some more. The people of Banda are afraid to spend their money. They are afraid to spend their money today because they think, what if I have no money tomorrow. They are afraid to spend their money on a pickup because there are many feuds in their village and they think that the pickup might be destroyed in the night. The people from Banda like to keep their money in the bank. The people of Safaray (another neighbouring village) used to be the same as the people of Banda, they were afraid to spend their money and liked to save it in the bank. Now the people of Safaray have become intelligent, like the people of Banda. Now they know how cheap it would have been if they had built a house before and how expensive it is now. Now many of them prefer to spend their money now building a house rather than saving it.

It was, indeed, the case that in 1993 there was a great deal of building work going on in the village of Safaray.

The people of Kohery, then, were expected to spend the money that they earned and saved by the other members of the village. It was as if all of the households in the village were expected to be *khrooskoo*. There was a moral dimension to this expectation as those households which were not seen to be conforming to this pattern were condemned as foolish or miserly and were often publicly ridiculed. Some spoke of the way rich households saved their money, by skimping on buying food. The members of households could also be ridiculed for spending their money in a way considered too ostentatious by others or even for taking too much of an interest in money. This morality is something that I want to return to in more detail in the final section.

Khrooskoo was a description that played down the obvious differences between households and emphasised the similarities among them. It was a description that suggested that there were no real differences between households like Gul Rahim's and Abdulhai's with ample land and successful businesses at home or abroad, and those like Fazal Wahid's and Abdur Rahim's which had only a scrap of land and were entirely dependent on a single source of income. The real differences, it was suggested, were between those in Banda who saved money for its own sake, and those in Kohery who spent all of their money to benefit their families. It was a description that drew attention to the ultimate similarities amongst households in

Kohery. It drew attention to the fact that they were all, in one way or another, dependent on migration and remittance money. It also drew attention to the fact that the development of a household changed its fortunes considerably as it grew from a small, saving household to a large, 'eating' one. At the same time this emphasis on these similarities proposed that all households *should* behave in a similar way. It was a moral ideal that was in some ways a blueprint for the successful and religious household. This is something that I will return to in the final section. For now I want to pursue the issue of the persuasiveness of this particular view of households in the situation of Kohery in the 1990s.

ADVANTAGES AND DISADVANTAGES OF NUCLEAR AND JOINT HOUSEHOLDS.

While in certain circumstances people talked about households as being the same, they had very definite ideas about the advantages and disadvantages of both joint and nuclear households. It was generally acknowledged that both types of household could work and a number of points were raised in their favour and against. In a joint household, for example, resources were shared and the men could take mutual responsibilities in looking after the house and its occupants. With holdings of land becoming increasingly fragmented and small, keeping the land undivided within a household was often the only way to make it at all profitable to farm. A large household with several adult men could also afford to have several of them away working in the Gulf. The large amounts of money that they could send back would support the family and even allowed those who remained behind to invest in some local business. Individual men from the household could go away to work abroad, happy in the knowledge that their wives and children were being well looked after. The brothers who remained behind ensured the safety of the house and at the same time ensured that the interests of those who were absent were still represented in the village.

The main problems of a joint household were, firstly that it was expensive to maintain. Many men complained that all of the money that they sent back from the Gulf was consumed immediately by their houses. A large household, such as that of Fazal Wahid, consumed at least an 80 kg sack of flour a week and as much as 1 kg of sugar a day. Some younger men complained that all of their hard-earned savings were taken up by the needs of the household to which they belonged, and that they rarely saw the benefits themselves. Secondly, things were particularly problematic

for those who were low in the hierarchy. They had little say in how money should be distributed and spent and often had to take second place to their elder brothers. In Abdul Rahim's house in 1993, the two eldest brothers argued at length about where their younger brothers should be, and what they should be doing. One ordered the younger brothers to sell the pickup that they ran and to go to work in the UAE. The other countermanded this order and said that his brother was acting out of spite. In all of this, the two younger brothers were barely consulted, although the decisions would affect their lives. Thirdly, and perhaps most importantly, large households often gave rise to a great deal of conflict. In many cases the cramped conditions and the need to compete for resources created almost unbearable tensions.

Other writers [including Tapper (1991), Parry (1979), and Abu-Lughod (1986)] have discussed the economy of scale for households. All of them discuss the various advantages of the joint household and suggest that their numbers may have increased. Nancy Tapper, writing about the Ghilzai Pakhtuns of Afghanistan, argues that joint households have major economic advantages especially a flexible division of labour and undivided land (Tapper 1991:108). Parry discusses the suggestion that economic diversification may act as an incentive for individuals to remain in a joint family for longer. Men who work away from the house can leave the wives and families there, while the undivided land is an advantage as it can still be cared for (Parry 1979:153-4). Lila Abu-Lughod, writing about the Bedouin of Egypt, argues that more wealth and greater opportunities have enabled extended families to remain as co-resident groups. Within these groups there is a division of labour so that individuals specialise in certain sources of income (Abu-Lughod 1986:71). The situation is similar in Kohery. There large, joint households enable individuals to take advantage of different opportunities while their families and land are cared for at home. However, none of the writers mention the disadvantages or otherwise of smaller, nuclear households. The people of Kohery, however, saw that small households too had their advantages and problems.

In separate, smaller households the main advantages were that there were fewer members and the house did not consume as much. It was held that it was at this time that the household could actually save money. At other stages in the household's life cycle, there was always something that would consume the money. Household heads in small independent households were also free to use the resources as they wished, their money was not eaten up by the rest of the many members. The main problems, however, were that resources had been divided and

so were much smaller. In addition, for the household to survive, the man at its head usually had to go and work in the Gulf. This meant that other relatives and neighbours had to be relied upon to cultivate the land and to look after the household. This was seen to be particularly problematic for the woman of the house. As Wahid Gul put it, it was often the women who wanted separate houses, not realising that it would make great problems.

A woman wants to be the head of her own household and in a large house another woman is the head. If a man and a woman do set up a separate house then when the husband goes to the Gulf, she will be afraid and things will be difficult for her.

There were many ways around these problems as I will discuss in Part III, but nevertheless it was still considered to be difficult.

People in Kohery, then, were quite willing to recognise the relative advantages of one type of household over another in varying circumstances. They saw that the joint household, while being advantageous to the household as a whole, was disadvantageous to some individuals within the group. In many cases it was junior brothers, prompted by their wives, who initiated the process of household division. In large joint households the advantages and authority lay in the hands of the elder members of the family, fathers, elder brothers and their wives. They were the ones who controlled the resources and labour in the household and who made the major decisions. The junior members of a household could only be in full control of their own lives if they separated from their elders. In their own separate household junior brothers would no longer be obliged to fund the migration and weddings of their elder brothers' sons and could save for their own families instead.

The actual division of households seemed to allow all of the pent up and previously unexpressed tensions within the family to be released but the actual process seemed to exacerbate the situation still more. The complex process of dividing an extended and shared household in many cases led to further and even greater argument. At the point of separation the language changed from that of the uncalculating joint household to that of calculation and individual advantage. In the case of one separation of two brothers that I actually saw it was the younger brother who initiated the split. The first attempt to make a division of their common property was overseen by the elders, *masharan*, of their own family though this was subsequently not accepted by either of them. I went to the second meeting, which several elders of the village council attended, as well as the brothers themselves and other men who seemed to have no other role than as supporters. Things started

peacefully enough, but it was not long before the arguments started, as the brothers explained their objections to the previous agreement. The biggest problems stemmed from the fact that the affairs of the two brothers had become inextricably intertwined in their many years of belonging to the same household. The only way to deal with things that the elders could find was to go right back to the beginning and make estimates of the costs of everything that they owned or had paid out for, and try to divide them as evenly as possible.

At every step, the brothers and their supporters disputed the estimated costs, or took the opportunity to press their own case, emphasising the unfairness of their own positions. Everything was drawn in, the costs of the house and its additions, including a new gate, the elder brother's son's recent marriage and then his visa for the UAE, the cost of the woodworking shop that the younger brother had built up, the money that the family owed and the money that was owed to them. I became lost in the endless lists of figures and the complex additions and subtractions of assets, debts and credit, attended as they were by the constant reiterations of the brothers' cases. The meeting ended undecided and the division continued for many weeks after.

Having a household split was obviously a painful process, and to have the division carried out so publicly made it more painful still. While the tensions and fault lines within the household had previously been concealed in a joint household, or talked about in terms of women fighting, now they were revealed to all. The two brothers took their part in this public discussion of their own differences. They saw that the one way to deal with things was to argue at every step and condemn someone who had previously been an ally and was now an antagonist. The arguments were made in terms of individual advantage and fairness, and the only way to separate their affairs was to deal in minute calculation. The only way that they could see of dealing with the situation was to look for somebody to blame, trying to make sure that others would accept their version of events.

In situations where households were dividing or experiencing internal conflict the language was of calculation and individual advantage. Once the divisions between close kin had been made public, then individuals sought to create an advantageous situation for themselves. They attempted, like these two brothers, to make sure that they got what was theirs and that at the same time they came out in the best possible light. In other circumstances, however, the language used was the opposite, one which emphasised non-calculation and group advantage. *Khrooskoo*,

in particular, spoke of uncontrolled spending and resources consumed, literally eaten and drunk. This said a great deal more about the ways in which the people of Kohery saw and described their own situation. The term emphasised what was important to them and demonstrated the ways in which they dealt with a complex and risky situation.

KHROOSKOO HOUSEHOLD AS A RHETORICAL DEVICE

Over several decades the men of Kohery have moved further and further away from the village in pursuit of better work opportunities. Throughout this time they have remained strongly attached to their houses and families. The bulk of the money they have earned has been invested in the maintenance of families, in new houses and in land in the village. These investments, while they appeared puzzling or even unproductive from the outsider's point of view, make a great deal of sense when examined from the inside. In Gudeman's (1986) terms, it is essential to see things through people's own cultural categories and to analyse the patterns in these categories. Men from Kohery took part in migration, not for their own individual gain, but so as to be better able to support their families. Money from migration has enabled them to improve their lives immensely; to provide better food more reliably, to build larger and more comfortable houses and to provide security for following generations through investments in land. Over the decades the profits from migration have been eaten and drunk by households but it is these *khrooskoo*, eating/drinking households that provide the justification for migration in the first place.

The image of the *khrooskoo* household, however, was ultimately a negative one. It was an image of a household as unproductive, entirely dependent on remittance money and at risk from changes in the outside that were beyond the control of individuals. As I have described in detail, it was recognised that households could seek income in a variety of ways. However, all households were to some extent dependent on migration to support themselves and their other enterprises. This situation was recognised in the way that all households were described as *khrooskoo*. The term, eating/drinking, played on their lack of real productivity; they were seen as being unable to produce and only able to consume. The image of the *khrooskoo* household encapsulated and highlighted the real dangers that the people of Kohery faced. The main problem was that they were all dependent on a single source of income and had no other resources to fall back. All households, whatever their

position in the developmental cycle, were at risk, whether from internal problems or from changes in the national or international situation.

The small, nuclear household was seen as economic and in certain senses productive in that it was able to save money. Younger men with their own maturing families, and especially those who were juniors, saw the advantages to themselves of heading their own families. Their wives saw the opportunity to escape from the authority of others and to be in charge of their own households. The overall aim, though, was to form the basis of a new joint household. The risks in the early stages of a growing household were obvious and recognised. Nuclear households were entirely dependent on one individual. If he could not find work or became sick then the household lost its entire income. Even while the household head was saving abroad the rest of his family was left in the hands of relatives and neighbours for support and safety. In certain circumstances people did emphasise the potential advantages to the individual and his family. In the main, though, people like Wahid Gul played on what they saw as the real risks and disadvantages to those in nuclear households.

The joint household, while it was described as an ideal, was not immune to problems. The real advantages in such large households lay in the hands of those who had the authority and controlled the resources, the household head, his wife and his elder sons. Younger brothers and their wives often felt that their earnings and labour benefited their elders' families rather than the household as a whole. As Fazal Wahid's household showed, the outer appearance of harmony and co-operation could conceal the tensions that existed between the different parts of the household. The design of new houses, with a room for each married couple, emphasised the fault lines in joint families along which they would inevitably divide. Joint households were expensive to maintain and were often fraught with tensions. The language of the *khrooskoo* household, of non-calculation and co-operation, disguised these problems. When households divided the contrasting language of individual advantage and calculation brought them to the public eye.

To cope with the dangers and unpredictability of the international world, households had to work out strategies that spread their risks as much as possible. The joint household could be seen as one of these strategies. As Gul Halim and others emphasised, the joint household with several working sons was the ideal solution. The aim of most households could, then, be said to be to spread risks so that if things went wrong it would not be a total disaster. Of course, for some small

households such risk spreading was not an option, as the family was often reliant on a single source of income. Where they could, households tried to save money or sought alternative sources of income to protect themselves. Investments were made in businesses that were easily sold so that cash would quickly be available in any kind of emergency. However, even joint households which were as fortunately endowed with sons as Abdur Rahim's were not totally immune to changes

In Pakistan in 1992 and 1993, there were enormous increases in prices of vehicles and especially pickups, the main form of transport in the hill areas of Dir. These prices resulted from changes in government policy in line with what was being demanded by the international banking community, in this case the abolition of the free port in Karachi. These changes had an immediate effect on Abdur Rahim's household, which had invested in a number of pickups over the years, buying and selling them in order to make a profit. In 1992 a relatively new pickup cost Rs 350,000 although the price was already beginning to rise. The abolition of the free port in Karachi resulted in a shortage of vehicles, and in 1993 prices rose to over Rs 400,000. As the year went on it became more and more difficult for the family to invest the amount necessary in a new pickup. At the beginning of June 1993 they bought an eight-month-old vehicle for Rs 460,000 and just eight days later had to sell it again. The purchase of the vehicle had taken up too much of the family's available cash and they were forced to sell. For several months the family had to wait with the two brothers idle at home until prices began to fall again.

Households were equally at risk from changes in international demand for labour. The changes in the Middle East were a constant topic of conversation throughout my stay in Kohery. In the late 1980s, more and more migrants from Bangladesh and the Far East had begun to arrive in the Gulf states. As the men of Kohery saw it, these new migrants were willing to accept much lower wages and so the labour markets began to change. There was far greater competition for work and what work there was paid far less. Abdur Rahim's family were again affected by these changes. In 1992 Abdul Halim cancelled his visa for the UAE and returned home because he could no longer find work. He remained at home throughout 1993, sometimes working but often not, thinking about what he should do next. In the summer of 1993 the family had sent the fifth and youngest brother, Noor Hamid Gul, to Saudi Arabia to work there. For months he, too, sat idle in Riyadh, unable to find work in a declining market. It was only because the two other brothers had successful businesses in the UAE and Saudi Arabia that the family was able to continue at all.

Spreading risks was not always enough when households were so dependent on labour migration. The *khrooskoo* household could be seen as a way of portraying households at risk with no resources to fall back on in times of crisis. As the people themselves recognised, changes or crises, whether in the international situation or in the house itself with the death or illness of an earning man, could be potentially disastrous for their households. Unable to effectively produce and support themselves they were forced to expose themselves to risk by taking part in international labour migration. All of the households in the village saw themselves being in the same economic position, regardless of their wealth or poverty. Gardner (1993 and 1995) describes a similar economic model which was used by the people of Sylhet, Bangladesh. There *desh*, the home, was seen as a source of spiritual power, while *bidesh*, away, was a source of economic and political power which home was dependent on (Gardner 1993: 7-8). In Kohery, while households were the reason for migration, they were seen as unproductive and dependent on the resources earned and saved abroad. The joint household particularly was a model for dealing with a certain set of circumstances, similar in approach to the house model described by Gudeman and Rivera (1990). While it was in itself unproductive, unable to save, it was flexible and provided security.

The joint household represented one way of dealing with an insecure and rapidly changing situation. As the example of Abdur Rahim's household showed, it was a highly successful strategy for dealing with a variety of unpredictable circumstances. Over 1992 and 1993 his household was able to cope with a series of dramatic changes without being severely affected. Smaller households, while they had their own advantages were far more vulnerable and the effects of changes could be devastating. As the example of Fazal Wahid and Abdur Rahim's father in Section I showed the only real solution to the loss of a household head was for the members to separate. Joint households, then represented relative security and flexibility. In Gul Halim's own words, if you have one brother in Dubai, one in Saudi Arabia and another at home, then if one has problems you still have the other two.

A successful joint household of married sons living with their father, or married brothers sharing one house represented an ideal of patrilineal loyalty and at the same time represented an ideal solution to a complex and rapidly changing situation. The security and flexibility of such a household combined with ideal notions of patrilineal loyalty to present a compelling and persuasive picture. At the same time the image of the joint household coincided with the preferences of the senior men and women who controlled much of the authority in the community.

For these senior figures the joint household represented the ideal towards which they had worked all of their lives. For them it stood for comfort and security in their old age as well as giving them the chance to control resources and prestige. As one older man put it to me when asking why I had no children yet;

If you have children now, then, when you are old they can save while you eat, you can just sit at home.

COMPARISONS

There is a tendency in many anthropological studies of work and labour to see the economic strategies of households and small communities in terms of the operation of the world system; in other words to take the outsider's point of view. Nash in a recent article (1994) , for example, sees the various economic strategies of communities in Bolivia, Mexico and the USA as responses to threats from world capitalism to their subsistence (Nash 1994: 7). Such responses are reactions to 'subsistence insecurity'; Nash's choice of words says it all "subsistence activities are on the increase as households throughout the world resort to them for survival" (Nash 1994: 22). Those who live in subsistence economies only react to the changes in the world system. Migration, too, is often explained in terms of the workings of the capitalist world system (see for example Kearney 1986, Eades 1987, Meillassoux 1981). Cohen describes post-1945 migrant workers as the historical descendants of slaves and indentured labourers before them (Cohen 1987: 29). Migrants in this system are inexorably drawn to wherever world capital needs to fill its next labour deficit. Little attention is drawn to the strategies of the migrants, households and communities involved.

Mascarenhas-Keyes opposes this approach in her study of migration strategies of Catholic Goans; as she puts it the assumption in many migration studies is "that migrations result from a passive reaction to changes in the political economy" (1987: 84). She favours seeing migrants as proactive, that is anticipating events and planning for them. In the case of Catholic Goans, she suggests that they invested heavily in education and the use of western languages in order to better exploit labour markets wherever they arose. She develops Mitchell's (1969) analysis of social networks to describe the ways in which information and assistance is mobilised in the migration process. Mascarenhas-Keyes' work is most helpful in drawing attention to the long-term strategies involved in migration and to the fact

that migrants actively plan for their futures and exploit opportunities of their choosing.

Marx's work on the Bedouin of Sinai (1987) recognises that they fully understand the precarious economic and political situation that they work in and actively plan to deal with it. Rather than seeing their strategies as some kind of reaction for survival as Nash does, Marx describes the ways in which the Bedouin actively invest in an economically and socially secure home base. They are aware that they cannot rely on labour migration and so maintain their tribal links, their rights to resources and a basic economy at home that can quickly be revived should they be forced to return there. In another paper Marx (1984) suggests that their investments should be understood in similar terms. Money from migration is invested in polygynous marriages, jewellery and vehicles, all of which protect their owners against political and economic change (Marx 1984: 6). As Marx suggests, the overall aim of the Bedouin's strategies and investment is long-term security, although they recognise that security is an elusive goal (Marx 1987: 163).

The people of Kohery also saw themselves as actively seeking out new opportunities to improve the lives of their families rather than passively reacting to a changing situation. Over the decades ever increasing numbers of them have sought out new opportunities to exploit: as labourers for the British, as mullahs in Baluchistan, on construction sites in Punjab and then Karachi and most recently in the Gulf. During this time they have planned for the future, investing in education, first in Baluchistan and then locally, learning new building skills and taking advantage of any business opportunities that existed. At the same time they have been aware of the relative precariousness of their situation and have sought to minimise the risks that they faced. Large, joint households have meant that several individuals could take advantage of a variety of opportunities abroad while others maintained a secure, and at times developing, home base.

Marx's analysis of the investment strategies of the Bedouin shows that they have to be understood from the inside; that is it is important to understand the aims behind these investments. Ballard takes an outsider's view of the situation when he pronounces the Mirpur economy as 'stagnant' (Ballard 1983). He sees the investment in the area in outsider's terms only and does not consider what the insiders' view or views may be. Stevenson in his work on a Yemeni Highlands settlement (1985) gives a more detailed analysis of investment in a limited economy. Early investment in the 1960s was in small businesses that could be run by

individuals, such as general stores and taxis, bringing with it a change in attitude towards commerce, previously considered low status. With a relatively undiversified economy there were few investment outlets and many were soon filled up. As a result in the mid-1970s those with money to invest had to look for new ideas, such as cement block factories. The development of new economic sectors also brought a shift in the evaluation of land. Agricultural land came to be regarded as relatively less valuable, while land that could be rented to build shops or houses was seen as more valuable. Thus, being a landlord became a way to increase an individual's status since it provided a secure source of income (Stevenson 1985: 119). The situation as Stevenson describes it is far more complex and changing than Ballard's relatively simplistic assessment of Mirpur.

APPENDIX

As a comparison for these figures I reproduce below a table printed in the popular Urdu daily newspaper Jang that shows the government salary scales as they have changed over the last decade (Table 3).

Table 3 Government monthly salary scales for the last decade in rupees (source, Jang newspaper, 28.05.93)

| Wage Scale/Year | 1981-2 | 1983-4 | 1992-3 |
|-----------------|--------|--------|--------|
| 1 | 250 | 440 | 920 |
| 7 | 335 | 560 | 1095 |
| 14 | 520 | 850 | 1530 |
| 17 | 900 | 1600 | 2870 |
| 21 | 3000 | 4200 | 7535 |

To give some examples a teacher just starting out would be on grade 1, while one with several years experience would be on grade 7 and a headmaster would be on grade 17.

**KHPULWAN:
THE KIN GROUP**

PART III

*My love is going and not staying,
God grant me my wish that I may go with him*

(Pakhtun *tappa*, poem: Zahoorwahid)

Part of the anthropological project, initiated by writers such as Asad (1973), Said (1978, 1989) and Clifford and Marcus (1986), is the close examination of the contexts of production of ethnographic writing and theorising. Fardon's book *Localizing Strategies* (1990) brings together a number of such examinations in different ethnographic regions. Brian Street in his paper 'Orientalist Discourses in the Anthropology of Iran, Afghanistan and Pakistan' develops ideas similar to those of Abu-Lughod's 'gate-keeping concepts'. He looks in detail at the role of individuals and institutions in constructing and controlling what he calls 'appropriate discourse' in the ethnography of regions. He draws attention to one particularly significant factor in the ethnography of the area he deals with; who the anthropologists spoke to and whose views they represented. He quotes Eickelman's suggestion that many ethnographers working in tribal societies in Iran tended to live with, and talk to, socially and politically dominant individuals. The anthropologists in their writings had a tendency to represent the views and notions of these individuals as the views and notions of the tribe as a whole. Street gives the example of Barth who "spent perhaps 11 months with the Basseri, mostly with M. Zarghami the leader, or khan, and provided an account of which Zarghami was proud" (Street 1990: 248). Indeed, when Street visited the leader in 1967, he "recalled Barth's visit clearly and referred to his book *Nomads of South Persia* as the story of 'my family'" (ibid.). While Barth (1992) has pointed out that he had little contact with Zarghami and his family during his fieldwork he does not deal directly with the issue of whose view he was representing. Street (1992) has in his turn suggested that, despite his arguments, Barth projected the views of one part of the group onto the group as a whole.

Street goes on to suggest that Barth's analysis of Swat Pakhtuns was a similar 'khan's eye view' (Street 1990: 251). Ahmed, who is so critical of much of Barth's approach and analysis, is himself subject to the same criticisms. Street quotes a review of Ahmed's book *Millennium and Charisma amongst Pathans* as saying that the account is as biased as Barth's in emphasising the power of the ruler of Swat. Ahmed's later, detailed ethnography of the Mohmand Pakhtuns takes a similar

view of their society; from the top looking down. In the introduction to his work, Ahmed describes himself as a 'local officer' (1980: 22); before his fieldwork he worked as the Registrar of the Co-operative Societies, NWFP and afterwards he went on to be the Political Agent of the Orakzai Agency (1980: 13). His main contacts during his fieldwork were with *maliks*, the petty chiefs of the area. The same kind of criticisms can be made of other work on Pakhtuns. Nancy Tapper makes explicit reference to those who she and her husband worked with. Their host during fieldwork was "Hajj Ibrahim, leader of Lineage C, the headman of Sinjit village and the principal rival (not enemy) of Maduzai Khan" (1991: 5). Hajj Ibrahim's main reason for taking on the Tappers as guests was a strategy "to enhance his own prestige and reveal the Khan as weak and fearful" (1991: 5). Such strategising emphasises the position of those who were the Tappers' main informants. Lindholm is another who refers to his main informant as "a real khan or noble" (1982: xiv). The man's position was undoubtedly a great influence on Lindholm's view of Swat society, not the least since "Zaman's own respected position rubbed off on me, and his allies and relatives were always most helpful" (1982: xxii). With informants such as these, it is little wonder that much of the ethnography of Pakhtuns focuses on the concerns of the ruling groups, on lineage competition and the political process.

Most writers on Pakhtuns (Barth 1959, Ahmed 1980, Lindholm 1982, Edwards 1990 and Tapper 1991) have stated that Pakhtun identity revolves around the notion of belonging to a distinct patrilineage with a genealogy that binds all the lineages together as Pakhtuns. They have tended to describe Pakhtun tribal society as a classic example of the segmentary lineage system in which individuals and lineages are regarded as equal and compete for position and status, which in itself is problematic (see Holy 1979, Caton 1987). Many have placed particular emphasis on the notion of *tarboorwali*, competition between close agnatic kin, and particularly patrilineal cousins, for the inheritance of land and for political position (Barth 1959: 111, Ahmed 1980: 91, Lindholm 1982: 111). Within this basic social structure individuals and households place great value on autonomy and compete with one another in marriage (Tapper 1991), for political position (Barth 1959) and for honour (Ahmed 1980). However, these were the concerns of the leaders in Pakhtun society, those who had the resources to compete with and the land to inherit. They were the concerns of those who ethnographers such as Barth, Ahmed, Lindholm and Tapper talked to; the leaders, the *khans* and the *maliks*.

Ethnographers, then, have tended to project the ideals of one powerful section of society onto the whole of Pakhtun society. In Barth's analysis of Swat society, he makes reference to the non-landowning castes who cannot make claim to the title of Pakhtun (Barth 1959: 3), a point which Asad (1972) bases his re-analysis on. Barth never makes it completely clear what the differences between Pakhtuns and non-Pakhtuns are. In general the interests and values of the landowning groups have been taken to be the interests of every other group. This has particularly affected the writing on households and kin groups. Ahmed asserts that in all cases households amongst the Mohmand are separate and distinct units, with budgets organised strictly within their boundaries (1980: 228). This assumes that all households have the resources to enable them to remain separate and distinct. Tapper plays down the role of both agnatic and affinal kin (1991: 48-9, 50) in her analysis which emphasises the importance of household autonomy and competition (1991: 102). However, her analysis is of groups who can afford to be autonomous and to compete. Little reference is made to those groups and households with little or no land and few resources. In Bourdieu's terms they have all projected the ideological, 'official' kinship of the ruling groups onto the whole of Pakhtun society (1977: 34).

In Kohery I was shown a contrasting view of those who had nothing to gain from competing with their agnatic kin, and, indeed, a view of those who relied on their kin for survival. Those in Kohery were quite clear about their own status at the bottom of the social scale. They spoke of themselves as recent incomers and talked without shame about their former subordinate position to the Nawab and the local khans. Those I knew from Moolian Khayl made no attempt to hide their ancestry, as the lineage of a wandering religious man who had been given land for the services that he provided. The emphasis in the village was on what Bourdieu called 'practical kin', those with whom there was day-to-day interaction. While on certain occasions men talked in terms of the independence of households, there was no discussion of overt competition between them. Rather, there was a recognition of the importance of close kin co-operation and household interdependence. The people of Kohery emphasised the necessity of forming close kin links and of utilising them to their best advantage. They pointed out the importance of marrying within their community and saw their community as a group of close kin. Part III of the thesis is a detailed description of the importance of kin groups to the people of Kohery.

TERMS OF EXCLUSION AND INCLUSION: *PRADAY* TO *KHPULWAN*

Throughout my time in Kohery I always felt like the outsider that I was. At best I was Zahoor's friend or the man who stayed in Zahoor's house as his guest. Usually to most I was the *Inglayz*, the western foreigner who stayed in the village. I was easily identifiable and yet I was anonymous, a mere representative of an entire group of outsiders. To most, the title 'Zahoor's friend' was enough to identify me. Within the close knit community of Kohery, being an outsider meant exclusion from all that was most important in village life. It meant that I was restricted to only certain areas in the village; the public areas outside shops, the larger paths and the guest rooms of houses. Most importantly, as an outsider, I could not meet or speak to any of the women. Even as I came to know people better there was no relaxation of this general exclusion. I felt a certain sense of resentment when, at social occasions, those who I knew left me with the other guests, while they entered the inside of the house.

On the times when I accompanied friends from Kohery on trips away from the village, I was struck by the limited circles in which they moved. In Peshawar they would usually stay in the same hotels and eat in the same restaurants, places where they knew the staff or owners. By going to the hotel where the owner was a man from Timirgara, or the restaurant where the waiters recognised them, they created for themselves an island of familiarity in a sea of strangers. In the reverse situation, when strangers entered the village people attempted to place them, to link them to somebody within the community. The presence of somebody new and unknown seldom went undetected for long. On days when I sat with Zahoor and the others who gathered outside his shop, we watched as the occasional car entered the village on the only road. Everybody in the vehicle was identified and questions would be passed back and forward as people tried to locate an unfamiliar face. One day as I sat with Abdul Hadi in Kulee he shouted out to a stranger, 'Where are you going?' disguising his question as a helpful gesture in giving directions. The stranger, *praday*, was seen as somebody problematic, somebody who had to be controlled by being linked to a fellow villager as a guest.

Like me, strangers in the village were given a temporary identity as so-and-so's guest or 'what's-his-name's' friend; some way in which they could be recognised and included. Once a stranger had become attached as a guest of a particular individual in the community, then the hosts became responsible for both their well-being and safety. The way in which a family treated a guest was taken as one measure of the

family's standing. I was often asked in excruciating detail about my living arrangements and the way in which I was treated at Zahoor's house. That I insisted on sleeping in a room on my own was a source of great curiosity as guests should never be left without company or unprotected. As other writers have noted (Ahmed 1980: 90) the host takes responsibility for the protection of his guest, even to the extent of having to revenge a guest who is attacked or murdered. In my own experience, Zahoor and his family took my safety very seriously, providing a Kalashnikov for my protection at night. Zahoor's uncle, Abdur Rahim - a born worrier - always insisted that I should never travel alone, even in the village. Their protection extended beyond a concern with just my physical safety. I was once snubbed by a local *mullah* at a wedding that I attended. Abdur Rahim was particularly incensed and claimed that the insult to me was an insult to the whole family. At the same time that Zahoor's family were responsible for my safety, they also had to take responsibility for my actions in the village. They made sure that I could greet and respond to people properly, that I knew how to accept hospitality and eat and drink properly. In short they tried to ensure that my behaviour and actions in social situations measured up to the standards set by the community.

As I stayed longer and became better known in Kohery I came to be regarded by many as Zahoor and Wahid Gul's friend, their *doest*. A visiting male friend was treated as a special guest, but a guest nevertheless. As Lindholm has discussed (1982) friendship is of particular importance to Pakhtun men. In my own experience, friendships were formed quickly yet they were expected to last. As many men remarked to me, when a Pakhtun says that he is your friend then he is your friend for life. Proven friendships brought with them obligations. For example if a friend requests help of whatever sort, then the other must respond without question. A visiting friend was, however, as limited and restricted in who they could meet and where they could go as the guest who was a stranger. Friends were, then, problematic; they were as close as kin in many ways and yet as excluded and restricted as absolute strangers.

One way that the relationship could be changed and marked as important was for friends to arrange a marriage between their children. In a community that seemed to place such value on intra-village marriage, I found this a curious yet fairly common anomaly. The main aim of marriages between the children of friends seemed to be to make the ties of friendship more concrete. Often young friends of mine, such as Zahoor, Sadiqullah and Gul Halim would describe what they saw as an ideal future for me and Debbie. We would become Muslims, build a house and settle in the

village, our children would marry their children and we would live in Kohery from then on. As my relationship with Abdul Hadi developed, he joked with his youngest son that I would be his father-in-law when he married my daughter. By changing us from friends into kin or family we could have the full relationship that they wanted. Marriage was thus a way of creating strong and lasting ties between friends; of turning strangers into family, *khpulwan*.

THOSE YOU CAN TURN TO: *KHPULWAN*.

The term *praday*, that I translated as 'stranger' could in another sense be used to make reference to something belonging to another, so that *da praday day* meant, 'that is somebody else's', 'that belongs to another'. The opposite of the term *praday* was *khpul* which could be variously translated as, 'our', 'belonging to us', or 'us'. 'Our' was an expanding term which could refer to a group as small as the household to one as large as the whole village; in letters I have received from Zahoor he has referred to *zamsung khpul kor*, 'our house', and to vehicles from the village as *khpul galay*, 'our vehicles'. *Khpul* was also used as an adjective to refer to groups to whom a person belonged; so that *khpul gawandeean* was 'our neighbours' and *khpul kuleewallah* was 'our villagers'. It was a term used, then, to distinguish those who were known or who belonged to the group from those who were strangers or outsiders. It was a term of inclusion, those who belonged, and of exclusion, to distinguish those who were strangers.

The term *khpulwan* is the plural of *khpul*, but was used much more specifically to refer to those with whom some relationship of descent or marriage could be traced. *Khpulwan* could thus be distinguished from those with whom there was no specific relationship, strangers, guests, friends or those who were merely fellow villagers. *Khpulwan* was also used to refer to groups of people related to an individual or to all the members of a household. In some circumstances *khpulwan* referred to a particular group of people, most notably the patrician. In others the use of the term could have been seen as a way of setting the relationship apart, of emphasising the relatedness of particular people. Recognising another as *khpulwan* always carried with it a set of important implications. It is to these implications, the meaning of what it is to be *khpulwan*, that I want to turn first.

Azum Khan defined *khpulwan* to me as being all those who can enter your house. This statement is important here, as the inside of the house is the most private of spaces; entry into this space was strictly controlled and could be a source of

conflict and dispute. For example at one wedding that I attended, many were unhappy that one young man who was not closely related to the house, who was not *khpulwan*, was allowed to serve food to the women as this involved him in frequently entering the house during the day and having close contact with the many women assembled there. In all of the time that I was in Kohery I only ever went into the courtyard of Zahoor and Wahid Gul's house a few times, and properly perhaps only twice. Inside the walls of the courtyard was the place where the women spent most of their time. Entry into the house meant entry into this private space and, more importantly, access to the women there, to meet and to talk with them. In social situations where there were many male guests those who could leave the public space of the guest room and enter the house were, to my eyes and to all those present, marked out as belonging to that house. Therefore giving somebody who was not a member of a household free entry into the house was demonstrating a relationship of great trust.

As explained in Part II, men and women made conscious efforts to ensure that the distance between unrelated males and females was maintained. Men took part in avoiding direct contact by turning away and lowering the gaze. Thus where there was contact between men and women - when men could enter private areas and women met, greeted and talked freely to them - then their relatedness was being emphasised. An example of this was the way that unmarried couples avoided one another and members of their respective families. This situation contrasted sharply with that after marriage where women were expected to have contact with all the men of their husbands' household as well as his male *khpulwan*, while men had free entry into their wives' families' houses and all of the women there. Marriage brought with it an expansion of the limits of the households involved to include all of the members of the two families. Marriage was thus an expansion of 'us'; from the members of one household to *khpulwan*, the members of several households.

In the way that people talked about *khpulwan* there was a particular emphasis on the strength of the relationship. Zahoor, for example, used two proverbs to explain the importance of the relationship to me. The first went, *khpul na pradee keegee*, which I translated as, 'your own don't become strangers'. Zahoor's explanation of this proverb was that although you may fight with your *khpulwan* the link with them is never broken, they still remain related to you. In other words the link is a permanent one, one that can withstand setbacks and that can be relied on. There is also the implication in the proverb that even if the relationship is not wanted it is still there. Another closely related proverb was , *ubo pa daug na beleegee*, 'a stick

doesn't make a hole in water'. This was explained to me as meaning that if you hit a pool of water with a stick there is, for a short time, a hole. However, the water quickly comes back and there is no hole again. The same is true of *khpulwan*, it was asserted, the link may be broken briefly by a fight but the break is only temporary and the link is always there. The point that was being emphasised was that the relationship of *khpulwan* between people always exists, it is almost a fact of nature and it can never be broken by petty squabbling. It is as if what is being said is that the relationship is stronger and more important than those people that it is formed between.

As a result of the strength of this tie, people frequently emphasised that they could always depend upon their *khpulwan*. Wahid Gul, in discussing the borrowing of money with me, said that, *khpulwan* are the first ones that we turn to. For a start it was stated that *khpulwan* are always there, that the bonds of kinship cannot be broken: as the proverb says, your own cannot become strangers. Secondly, the demands of *khpulwan* are demands that cannot be turned down. Zahoor, in discussing the problems of credit in his shop, said that the solution had been to refuse to extend any more credit. However, he still gave considerable amounts of credit to his own *khpulwan*; as he remarked, I can't refuse credit to my own *khpulwan*, if they ask I have to give it to them, they expect it. In the case of Azum Khan's story (in Section I), when he asked his relative for money to make his passport, although the man was unhappy about how the money would be used, he could not refuse the boy. Not only were the bonds of kinship unbreakable, but the demands that could be made by kin could not be refused, they carried important moral weight.

People in Kohery spoke in similar terms to Fortes (1969) and Bloch (1973) in emphasising the moral nature of kin relations. Like Zahoor's proverbs, Fortes comments on the unbreakable nature of kin ties when he says, "Kinship is binding; it creates inescapable moral claims and obligations" (Fortes 1969: 242). People in Kohery talked about the claims that were made on them by *khpulwan* that could not be turned down, such as in Zahoor's comments on credit and Azum's own claims for money. Bloch argues that the moral nature of kin relations makes them long-term and dependable. He suggests that the moral nature of the relationship brings with it a great tolerance of imbalance, such as in Zahoor's willingness to continue to extend long-term credit to his kin. As Bloch says "the crucial effect of morality is long-term reciprocity and...the long-term effect is achieved because it is not reciprocity which is the motive but morality" (Bloch 1973:76). Thus, the closeness of the links makes

them moral and dependable so that great demands can be made on those who are close kin. Before examining the obligations of kin, it is first of all necessary to look in detail at the variety of relationships in kin groups and at the importance of these kin.

GHAT AKHTAR: A CELEBRATION OF FAMILY

I have a group photograph taken on the morning of Ghat Akhtar that brings back a lot of memories for me (see Plate 14). Ghat Akhtar is the big Islamic festival that takes place during the Haj season celebrating Ibrahim's willingness to sacrifice his son. On the first day of the celebrations in 1993 the men gathered outside my room early in the morning. There was an air of nervous excitement that reminded me of Christmas. The men greeted each other, complimented each other on their new outfits and chatted, waiting to depart for the main mosque. I asked if I could take a group photograph as there were so many of my friends there. One of the pictures that I took captures the atmosphere of the day for me perfectly. The picture shows the group of cousins - Gul Halim, Zahoor, Abdul Halim, Azum Khan, Noorwahid, Wahid Gul, Mahidullah, Jameel, Shalum Khan and Wahid Gul's two daughters, Zakia and Poeseea - standing formally and unsmiling as in so many of my posed pictures. Yet in this one several of the faces betray a faint smile, hinting at the happiness of the day. All of the clothes are brand new and many still bear the tailor's carefully ironed creases. The two little girls and their clothes are clean and their hair is oiled ready for the visit to their grandmother's house.

After I took the picture, the girls went off with their mother while I joined the men on the start of the journey up through the village to the mosque. Along the way we were joined by other neighbours; first Abdul Hadi and Naarhamudin from next door and then Sadiqullah and Abidullah. We kept stopping as we met other groups of men all heading for the same place. When we arrived, I was left to sit outside under a huge chinar tree while my companions went to join in the communal prayers. As I sat alone, I was able to reflect quietly on what I could see and hear. I looked at the piles of sandals outside and tried to assess the number of men and boys packed inside the mosque, overflowing onto the veranda. Almost the whole village must have been represented that day. I made comparisons with my own



Plate 14 - Group photograph at Ghat Akhtar: back row, left to right, Gul Halim, Zahoorewahid, Abdul Halim, Azum Khan, Noorwahid, Wahid Gul; front row, Mahidullah, Sataar Khan, Shalum Khan, Zakia, Posia



Plate 15 - Building Gul Halim's new room: top to bottom, Abdul Halim, Wahid Gul, Ghulam Wahid, Amir Gul, Gul Halim

experiences of Christmas at home and in church. I felt sad that I was so far away from home on this festival that was so much about family, and I felt sad that I was not able to fully participate in what was going on. As the prayers finished and the men began to flood out of the mosque, I forgot my thoughts and concentrated on greeting people in the way I had been taught the year before - a hug, a handshake and a quick, *Akhtar day mubaraksha*. My feelings of loneliness and isolation disappeared, as people greeted me with genuine warmth and I realised that I was not so alone.

With the prayers over, we returned back home to begin the real celebrations. Starting in Abdur Rahim's house we sat on the veranda around a large mat while the dishes of rice were brought. To the piles of rice pieces of chicken were added and over this warm milk and melted ghee were poured. The previous year I had been unaware of what was going on and at the first house I ate my fill. I was then horrified to discover that this was only the start as we moved on to the next house to be presented with the same meal again. This year I knew to eat only a little, though my mistake was brought up again as a joke to tease me with. From Abdur Rahim's house we went on to Gul Wahid's, then ours, entering the courtyard to eat on the veranda for my first time that year. We carried on to Gul Hadi's, Abdul Hadi's and finally Naarhamudin's houses, always eating the same things and always moving on after a few polite handfuls. At the time the things that struck me were that I was inside the houses, many for the first time, and that the women were around. Most of the women had left early in the morning, taking their children back to their mothers' and fathers' houses. A few remained, the older women and those who belonged to the house. The women preceded the men on the rounds of the houses, lingering briefly to greet the men with '*Akhtar day mubaraksha*' as they arrived and to help serve the food before they moved on.

The atmosphere in the morning was one of happiness and togetherness as the men and women jokingly argued about whose house they should go to next. Having eaten at six houses, the liveliness diminished slightly and the men turned to the main focus of ritual activity, the slaughter of the Akhtar animal, a goat, sheep or calf. Once that was completed, often in a very matter of fact way, people were free to do what they wanted. Many of the children rushed to the makeshift fair - a couple of roundabouts and some small stalls - to spend their Akhtar money and grubby their new clothes. Later in the afternoon was a time reserved for men to visit their mothers-in-law, paying their respects to the family, perhaps bringing them a gift of sweets and wishing them the best for the day. Once again I felt isolated from

the celebrations, especially now as I had been unable to meet and greet any of the women. In the evening, the eating restarted as we moved to a wider circle of houses to start on the sacrificial meat served with bread. That first evening we went to Sadiqullah's house, then to Wali Mohamad's and last next door to Gul Mohamad's.

The next day the rounds of eating continued and the arguing began as the order of houses to be visited was discussed. The food was the same as on the first day, rice and chicken in the morning, meat and bread in the evening. There were a number of aims in the constant visiting and the special meals. The first was a religious one, that the meat that had been sacrificed should be shared out and should be consumed as quickly as possible. All over Pakistan a similar process was taking place and sacrificed meat was even flown in from Mecca in Saudi Arabia to be shared out with the Muslim brothers in the Afghan refugee camps. The second aim was a family one, that by the end of the three days of Akhtar celebrations the family should have eaten at least one morning and one evening meal in the houses of all their closest neighbours. A third aim was that families should visit as many of their relations as possible. Everybody wanted to be given the chance to greet their *khpulwan* at this time. This was especially true of the women who had to wait in their houses for a chance to greet their male relatives.

OUR HOUSE IS LIKE ONE HOUSE: CLOSE PATRILINEAL KIN

The main focus of the celebrations at Akhtar were those at the heart of the family's *khpulwan*, the members of the six houses that were visited on the first morning of the festival. In those six houses lived Wahid Gul and Zahoor's uncles, their father's two brothers, Abdur Rahim and Gul Wahid, and their uncles by extension, their great grandfather's son's sons, Naarhamudin, Abdul Hadi and Gul Hadi. When Abdur Rahim, Fazal Wahid and Gul Wahid were young, their father died and Abdul Hadi's father and uncles had looked after them and treated them as if they were their own uncles. The families still lived together in a group of houses known as a *gawand*, a round. They referred to each other either as *khpulwan* or *gawandeean*, neighbours, using the two terms interchangeably. A short walk from Abdul Hadi's house lived their uncle, Abdul Wahid whose house had once been at the very centre of the cluster. Towards the dry stream bed lived their other closest *khpulwan*, the sons of Abdul Rashid. This was a situation that was repeated throughout the village, where groups of brothers and cousins tended to build their houses close together in small clusters. People thus lived surrounded by their close *khpulwan* and refer to them as their neighbours as well. For men their main significance was that

they were related as *khpulwan*, for women that they were close neighbours, those with whom they interacted daily.

As Azum Khan once said, 'Our house is like one house'. At the time he was making reference to the fact that as the guest of one house I was the guest of them all. Having become the close friend of Zahoor and Wahid Gul I was now, he said, the friend of all of the members of the seven houses. As I came to see, though, his simple statement meant a great deal more. In many other senses the houses of that group were as one house. The women of the seven houses visited each other daily and with no ceremony. Borrowing between the houses was common, if one house ran out of sugar then a child was sent next door to borrow a cup to keep them going. When one house cooked a special dish of meat they would often send round a plateful, especially if there were guests in the other house. When Debbie lived in Kohery, she accompanied the women in the mid-afternoon when there was a slight slackening of the day's hectic pace and there was time for visiting. The women would gather with their youngest children at one of the houses to sit, chat, embroider and drink tea. Even Debbie had to take her turn in entertaining her friends in our temporary home in the guest room. The men for their part came and went in any of the houses without fear of disturbing the privacy of the women. Often as one of them was passing they would be called in to assist in the house; fixing some wiring or putting up a new piece of embroidery. Children were sent to and fro with messages to the other houses or to bring back hot water or ice from those houses with heaters or fridges. With the new fridge situated in the room that I used, it became my afternoon's task to pass out blocks of ice to the children who came round. In the morning or late afternoon only one bread oven, *tanoor*, was lit and the women from the houses would gather to bake their bread there. In this way they were able to save on relatively scarce fuel. In these various ways the houses lived as if they were one house. For the members of the houses the walls around the courtyards ceased to exist and they came and went as if they were all one. Only when those inside chose to close the gates would the house become a private domain again.

On the evening of the first day of Akhtar, the visiting circle had widened to take in the houses of other close kin and neighbours who lived in the same neighbourhood of Bagh. Although this larger group of houses was not so close, they co-operated and visited a great deal. Between them, Wali Mohamad, Lal Mohamad and Gul Mohamad's houses had only one adult male present, Wali Mohamad's son Meraj. As Meraj had so much to attend to in looking after three households as well as

attending college, Wahid Gul and his cousins often helped out in the houses particularly when there were guests to be entertained. Within this wider circle of houses over the summer of 1993 there were a number of small meals given for the families' immediate *khpulwan*. As it was explained to me by various people, the idea was that each house should give a small celebration for those who had returned from the Gulf that summer. By the end everybody would be equal and all the households would have shared in the expense of entertaining. For a long time as well, the men discussed having a joint meal to celebrate the births of all the newborn children in the *gawand*. The idea was that each man who had a new child would give Rs 100 so that with the money they could buy several chickens for a large celebratory meal. In the end nobody found the time to organise the event but the discussions went on enthusiastically for several months. Nevertheless, the enthusiasm that the idea of the event generated demonstrated the closeness of this group of kin and their importance to each other.

Outside of the group of close *khpulwan*, were others who were also referred to as neighbours, with whom there were links of marriage or sometimes neighbourliness alone. Neighbours visited each other, attended each other's weddings and religious feasts and sometimes helped each other. However, there was not the close co-operation that took place between *khpulwan*. Barth in his book on Swat describes neighbourhood co-operation in associations called *taltole*. However, in Swat the members of these associations were often not related: as Barth describes it, the association "is multi-caste in membership, and thus unites persons most of whom are not related by kinship ties of any kind" (Barth 1959: 32). This differed from the situation in Kohery where people were doubly linked by their *khpulwan* relations and by their ties of neighbourliness. The ties of kinship and co-operation extended beyond the boundaries of the neighbourhood and of agnatic kin to include those who were linked affinally.

IN DESCENDING ORDER OF IMPORTANCE: WOMEN'S KIN TIES.

When I was once discussing the importance of *khpulwan* ties with Sadiquallah he said something which I turned over in my mind for a long time. He said;

We have three important relations; the most important are our father's brother's sons, *tarbooroona* (sing. *tarboor*), then there are our mother's brother's sons, *mamazaman* (sing. *mamazooaway*), and third there are our father's sister's sons, *trorzaman* (sing. *trorzooway*).

What is significant here is that he placed the three relationships together. The importance of the father's brother's son relationship is noted by most writers on Pakhtuns (Ahmed 1980: 140, Barth 1959: 109). Few make anything other than a passing reference to the relative importance of any other relationships. Tapper makes a brief reference to the term *khpalwan*, which she suggests refers to the effective kinship circle (1991: 50). However, she goes on to argue that "agnation and affinity of themselves impose few specific rights and obligations" (1991: 51). In Kohery, however, there was a great deal of importance placed on these other relationships. Following Nelson's argument, women who marry into their husbands' families should be seen as links and mediators between two groups (1974: 554-5). Certainly, in Kohery, women retained close links with their families after marriage and in many cases these links were important to their husbands as well.

For women the significance given to the ties was somewhat different. On the morning of Akhtar, for instance, the women of the house returned to their mothers and fathers' houses to celebrate with their own *khpulwan*. In more normal circumstances, the women in the house where we stayed often told Debbie about the importance of their relations with their own families. A visit home was eagerly anticipated by a woman and her children, even if the journey was not a particularly long one. Both Wahid Gul's and Zahoor's wives visited home regularly. Their parents' houses were relatively close and yet they always spent the night if they went, enhancing the holiday atmosphere of the visit. For the women a visit home was an escape from the daily drudgery of home and a chance to be treated like a special guest. Debbie went on several visits, at least once with each of the wives. The families were happy to see the women and their children, they bought in special food and made sure that they did not have to do anything. Most of the days were spent sitting around talking and catching up on all of the news. Women carefully followed events in their own families; to keep up with news of their own was just as important as following the day-to-day happenings of their husbands' houses.

The point here is that, while women were said by men - usually their husbands - to belong to their husbands' *khpulwan*, their allegiance lay with the *khpulwan* of their fathers and brothers. Women retained strong links with their father's house, visiting as often as possible and especially on important occasions such as Akhtar and weddings. In the case of women such as Wahid Gul's sister, Wahida, marriage with her father's brother's son allowed these links to be stronger still. Such marriages with parallel cousins were common and were particularly approved of by mothers as it allowed them to keep their daughters close to them. Close links with the

women of the *khpulwan* were important not only to mothers but also to the men. Wahid Gul and Zahoor, for example, maintained close relations with the family of their grandfather's sister, visiting frequently and helping the family where they could. Abdur Rahim kept in close contact with his eldest married daughter though she lived at some distance from Bagh. When her child died in 1993, he and his sons attended throughout the funeral and mourning, acting as they would with any other close *khpulwan*. Tapper writing about the Maduzai Pakhtun of Afghanistan also suggests that men may continue to feel responsible for and take an interest in their married daughters (Tapper 1991: 107). The links between women and their fathers' and brothers' families were of great importance to both them and their husbands.

The male view of women's primary loyalties was very clear and tended to play down the official importance of women's existing links. As Sadiqullah once put it to me:

When a woman marries then she becomes part of her husband's *khayl*. If she is Joomalee Khayl and she marries a man from Moolian Khayl then she becomes one of us, she becomes Moolian.

At the same time all men recognised that their wives had at least some nominal right to keep in touch with their fathers' families, with at least one visit per year. They certainly expected that the women of their own *khayl*, their sisters and daughters, could visit home whenever they pleased. Those men who did not allow their wives to maintain contact with their families were regarded as unnecessarily cruel. Women's strong links with their own families were culturally recognised in a number of ways. An important part of the marriage ritual was the bride's return to her father's house after three days. After that, women were expected to return home at least at Ghat Akhtar. At other times during the year, if a woman stayed away from her husband's home for more than three nights, then she was expected to bring back gifts for her husband, such as specially baked pastries called *ghunzakay*. After a woman's death it was her own family who decided where she should be buried. In many cases she was brought back to her home village to be buried next to 'her own'. Both Barth and Tapper mention this latter custom which Tapper goes on to describe as "puzzling" (Tapper 1991: 53). She takes refuge in social structural arguments to solve the puzzle and suggests that for the Durrani "though the practical importance of the agnatic ties of a woman is minimised after her marriage, the notion of patrilineal descent remains unambiguous and ascriptive and women, like men, are born and die members of a named agnatic group" (Tapper 1991: 53). Tapper's 'puzzlement' comes from her emphasis on the male,

'official' explanation and her interest in playing down the importance of women's links. In Kohery, it is clear, both agnatic and affinal kin played an important role in the life of households; the father's sister's sons were seen as just as important as the mother's brother's sons.

Women's loyalties to their husband's household could be said to shift over time. The easiest way to illustrate this is to compare the situations of the women in Fazal Wahid's household, his own two wives, and the wives of his two eldest sons. Zahoor's wife, the youngest wife in the house, had very poor relations with the other women. In normal circumstances she mediated her relations through Zahoor, getting him to ask for the things that she wanted or make complaints on her behalf. When Zahoor went away to work in the Gulf she was very upset, she missed him dreadfully and found it almost impossible to communicate directly with the other women. Wahid Gul's wife was in much more of an established position as the wife of the elder brother. She was careful to balance her relations with the other women and tried to avoid situations of conflict. Fazal Wahid's second wife was in the uncomfortable position of being her husband's favourite and yet had no real authority in the house. In her husband's absence, she maintained her own independent position and yet hardly communicated with Fazal Wahid's first wife. To all of these women their own families were of great importance and they visited as often as they could. They were fortunate in that their own homes were close so that they could go fairly frequently. Fazal Wahid's first wife was the female head of the household and she ruled with an iron rod. Though she still had contact with her family, they lived at some distance and she rarely visited, staying in Kohery even at Ghat Akhtar. Her position as the head of the household meant that her loyalties lay much more closely with the house where she lived.

A few general points can be extracted from these particular cases. To start with, younger women who were lower in the household hierarchy had mixed loyalties. In their husband's household their loyalties were directed more towards individuals, in most cases their husbands, rather than to the household as a whole. At the same time they maintained strong loyalties to their fathers' houses. Older women who had become matriarchs shifted their loyalties much more to their husbands' houses. With their position of control and with younger wives to work for them their interests lay much more with the place where they lived. While they still maintained an interest in their fathers' houses these links had over time diminished in importance.

Nevertheless, men tended to continue to give great importance to their mother's brothers, their *mamagan*. The term *mama* was applied specifically to the mother's brother, while *mamagan* was used to cover the whole of the mother's own family, including her brothers, brothers sons and so on. The importance of the relationship was underlined for me by Wahid Gul's statement that, whatever the *mama* asks for has to be given straight away, whatever it is. In many cases that I saw, it seemed to be marked with a certain air of formality. While the actual importance of the *mamagan* varied from family to family, it was always a relationship that was marked in some way. In Wahid Gul and Zahoor's case, they had little regular contact with their mother's family as they lived in a village some distance away. However, whenever their mother's brothers visited they were warmly welcomed. In 1993 Wahid Gul went a considerable distance to take a pickup load of maize stalks that his *mamagan* had offered to him. In the case of Sadiquallah's family, there were much closer ties. The marriage links had been repeated over three generations with Abidullah marrying his mother's brother's daughter and Abdulhai's daughter marrying his mother's brother's son. The families were closely linked in business as well, acting as partners in businesses in the UAE and at home. As Sadiquallah was himself only young he was also helped by his mother's brother in looking after his family's extensive land.

THE PAKHTUN TRIBE IN A VILLAGE SETTING.

As the Akhtar celebrations progressed the circle of houses visited widened to include other *khpulwan* who lived in the neighbourhood. In Zahoor and Wahid Gul's case those visited on the following days included those *khpulwan* who were closely related and those who lived in close proximity: Sadiquallah and his elder brother, Abidullah, and the three brothers, Wali Mohamad, Lal Mohamad and Haista Mohamad. All of these men were related patrilineally and shared a common genealogy. Within the neighbourhood of Bagh there were others who could be traced on the same genealogy and who Zahoor and Wahid Gul recognised as *khpulwan*, though they thought of them as less close relatives. All of them recognised their membership to the same patrilineage or *khayl* called Moolian *khayl*. While at times the details of the genealogy were hazy the important thing for those in Bagh was that they all knew that they belonged to Moolian *khayl*. There were five other patrilineages in Kohery - Sauray, Boodayee, Jamalee, Saddee, Kus Kor - all belonging to the same Pakhtun tribe, Utman *Khayl*.

Within the village everybody knew which *khayl* they belonged to, which Ahmed describes as sub-sections, or the operative segments of tribes (Ahmed 1980: 6). In my early, enthusiastic, Barth and Ahmed-driven days I took a great interest in the social structure of Pakhtun tribes. I pestered Wahid Gul and others endlessly about their tribal affiliations, although my enthusiasm declined as I found them less than forthcoming with the information that I wanted. In most cases, people did not know their tribal lineages and could barely remember their own family genealogy much beyond the living generations around them. However, people did know their tribal affiliations and could place themselves and their own *khayl* in relation to other *khayls* and tribes. Moolian *Khayl*, Wahid Gul told me, was part of Utman *Khayl*, most of which lived in the neighbouring district of Bajaur. He knew the village where the Moolian *nika* originally came from and he spoke of having relatives still living there. As he once put it, if I went to that village I would have no trouble and people there would help me. Some used these links to their own advantage. In 1993 Sadiqullah used his family's link with their ancestral village in applying for a place at university by obtaining a domicile certificate for Bajaur. The tribal areas, such as Bajaur, had a larger number of allotted places at national universities and thus by showing his residence there Sadiqullah much improved his chances of acceptance. In most cases such links were of little daily importance.

Diagram 3 - Moolian Khayl in Kohery

Moolian Khayl

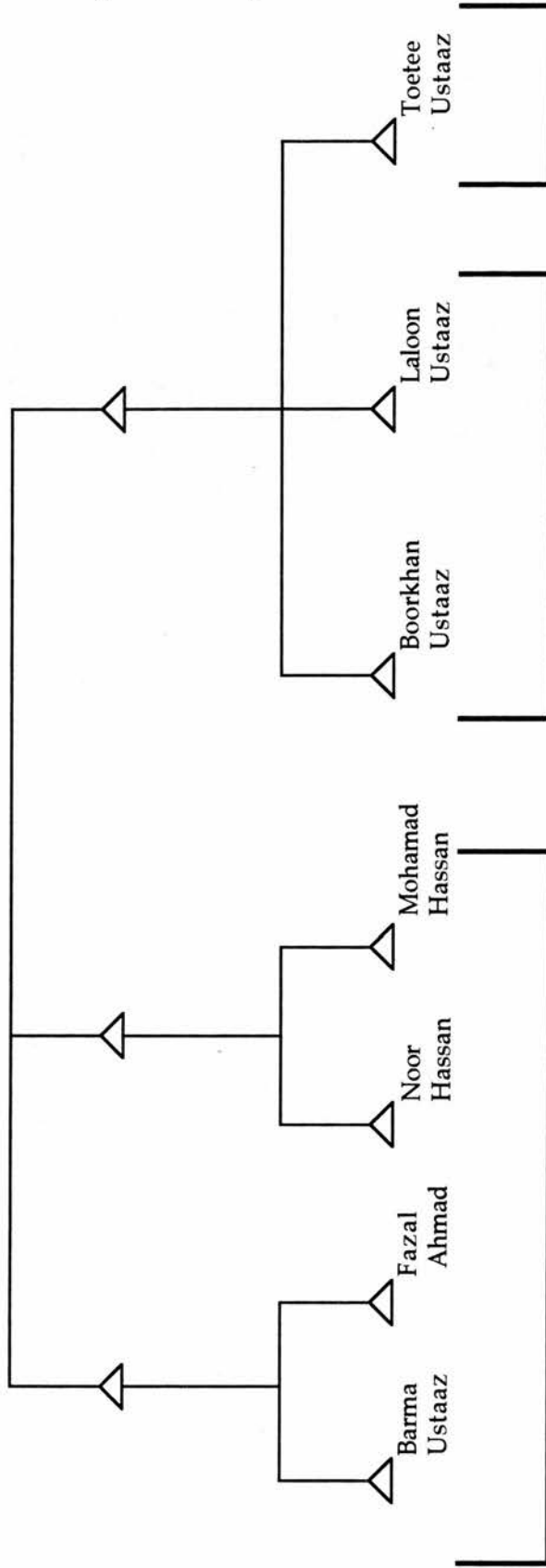

Moolian - Bagh

Moolian - Kulee

Moolian - Dupkay

On a village level, membership of a patrilineage meant a number of things. In the case of Moolian *khayl* there were members throughout the village divided into three groups; descended from three brothers and now living in separate neighbourhoods (see Diagram 3). In fact, as few could trace their own genealogies back more than three generations, I could not find any way of linking the three branches up. I was told that the Moolian ancestor had three sons from whom the whole *khayl* was descended. It seemed that this was some kind of convenient invention along the lines of the missing generations recorded by other writers on segmentary lineage systems (see for example Evans-Pritchard 1940 and Peters 1959) . For the members of Moolian *khayl* like Zahoor and Wahid Gul, the important thing was that there was some link between the different groups and that they could be recognised as some kind of *khpulwan*. While all of the other members of Moolian *khayl* were regarded by Zahoor and Wahid Gul as *khpulwan* they described them as *larayee khpulwan*, distant relatives rather than *khas khpulwan*, special relatives. The distinction was between *larayee*, those recognised as relatives but with whom there were no special relations, and *khas*, those with whom there was a link and relations on a day-to-day or more regular basis. *Larayee khpulwan* could thus be said to be potential kin, those with whom some kind of useful relationship could be formed should needs require it.

On a day-to-day basis the important relations for households were those with close or special *khpulwan* as I have described. Patrilineage relationships were important in certain rather more limited circumstances. On occasion membership of a patrilineage influenced political affiliation. Mashooq Jan was head of Boodayee *khayl* in Kohery and in his political career he had often relied on the other members of the patrilineage as a reliable bloc of support. On many other occasions individuals preferred to follow their own political judgement rather than be dictated to by those who they felt should be representing them. The six patrilineages were all represented on the village council by their own elders. In some cases the patrilineages tried to deal internally with problems such as household divisions and family disputes over land. More often those involved took their cases to the village council for judgement. As Keesing points out, networks of kinship and systems of descent can be seen as separate and parallel systems (1975: 22). In the ethnography of Pakhtuns there has been a tendency to regard the patrilineage as the full extent of important kin relations. In Kohery, patrilineage loyalty was just one minor influence among many for individuals and households. Far more important

for the people of Kohery were the kin ties of *khpulwan* which they invested heavily in and relied on daily.

The picture for Kohery seems in marked contrast with that presented by other ethnographers writing on Pakhtuns. It is, however, more a matter of emphasis than a radically different situation. Kohery, like all of the hill villages in the area, has always been poor in comparison to the villages in the valley around Timirgara. The people of the village own little land and what they have is of poor quality. The other main difference is that in Kohery everybody owns some land and there are no large landowning families. The villagers formed patron-client relationships with large landowners outside the village; with the Nawab in Dir and with the *khans* and *maliks* of the valley area. The people of Kohery may be compared to the lower castes in Swat described by Barth (1959: 16-22), the shopkeepers, carpenters and agricultural labourers. Unlike the situation described by Ahmed (1980) in Mohmand people in Kohery had little opportunity to assert the autonomy of their households or compete with one another over land inheritance. While the Ghilzai Pakhtuns played down the importance of agnatic and affinal ties, the people of Kohery made the most of them. Those Pakhtuns with large areas of land and plentiful resources could concentrate on autonomy and lineage rivalry while those with little land and few resources had to rely on their kin for support.

KHAS AND LARAYEE KHPULWAN: A WIDENING CIRCLE OF KIN.

On the first day of Akhtar most women went home to their parents' house to celebrate with their own *khpulwan*. The afternoon of the first day of Akhtar was set aside as a time when men would visit their wife's family's house. For men the relationship with their wives' families was of particular significance. While it was fathers who arranged marriages it was up to the sons to develop and maintain the relations with their new *khpulwan*. However, while a man's wife's family were regarded as part of the *khpulwan* of the whole family they were of especial importance to the man himself. For example while Wahid Gul and Zahoor took some part in visiting the family of their father's second wife they preferred to keep them at arms length most of the time. It was only when Fazal Wahid himself came back from Jordan that he took up the links properly and visited more frequently. The links between families were more formalised, generally involving exchanges of labour and visiting. Attending the major ceremonies of affinal kin was particularly important for maintaining links between the families.

However, the link was of greater significance to those directly involved, the woman, her husband and her family. In Wahid Gul's own case, his wife's family were of particular significance and he had a close relationship with his wife's brother. Wahid Gul farmed his wife's father's extensive land mostly on his own, though he was sometimes helped by his cousin, Abdul Halim, who was married to his wife's sister. In 1993, Wahid Gul worked driving the pickup that his wife's brother bought on his return from the UAE. Wahid Gul was so conscientious in the running of the business and in his care of the vehicle that for a long time I assumed that he took all of the profits. I later found out, to my surprise, that he was actually paid the standard wage of Rs 1500 per month. Zahoor's wife's father also played a significant role in his life. In 1992 he obtained Zahoor a visa for the UAE and work there, against Fazal Wahid's wishes. In some ways, however, Zahoor resented his father-in-law's control of his life and in 1993 he turned down Abdulhai's offer to set up a shop for him in Timirgara. At the time Zahoor said to me that he did not wish to be beholden to anybody, though I suspect that he was referring specifically to Abdulhai.

Like the *larayee khpulwan* in the patriclan, some people chose to recognise more distant relations among their married kin. In most cases it was only the immediate family of the spouse who were thought of as *khpulwan*. In some cases, however, individuals could choose to emphasise those more distantly related as *khpulwan*. Wahid Gul, for example, thought of his wife's father's father's brother's sons as *khpulwan*, describing them as *larayee khpulwan*. The family were well off and influential in the village, the head of the household being an important member of the village council. Wahid Gul acted towards the family as he did with other *khpulwan*, attending major celebrations at their house and often assisting in the running of the events. In this way he emphasised their relatedness, distant though the link was, and confirmed his relationship with them as *khpulwan*.

Bloch remarks that the kinship relationship is not a unique one and that there may be other types of relationship that individuals can utilise. He suggests that kinship could be seen as one end of a continuum of relationships and that there may be many types of kinship (Bloch 1973: 77). He describes from his own work the situation of the Merina in Madagascar where individuals concentrate on manipulating short term links of what he calls 'artificial' kinsmen in order to build up a pool of potential labourers. The 'real' kinsmen can always be relied on in the long term and so need less attention (Bloch 1973: 77). Parallels can be drawn here with the situation in Kohery. There individuals such as Wahid Gul actively

developed good relations with those he was more tentatively linked to, those he described as *larayee khpulwan*. Such relations may have been useful in the past, could be so again and were therefore worth maintaining. However, in Kohery people were in many ways dependent on their *khas khpulwan* because of the situation in which they worked. Therefore relationships with these 'real' relations could not be left to chance but had to be worked at just as hard.

The term *khpulwan* was, then, used in a variety of ways. It was used to cover relationships with agnatic and affinal kin where there were sets of real and unavoidable obligations. It was also used to cover relationships where the link was less clear but where there was some potential use. The real significance of the term was that it referred to those 'practical' kin with whom individuals and families had important day-to-day relations, especially those who were seen as close or special kin. The importance of these kin links can only really be seen by looking at the ways in which they were maintained and utilised. Important kin links were maintained by constant visiting and gift-giving. They were utilised in complex networks of loans and labour co-operation that tied households together in a web of interdependence, as I will now describe.

PEOPLE WOULD BE VERY UNHAPPY IF WE DIDN'T GO: VISITING AND GIFT-GIVING.

A few months after Debbie and I had arrived in Pakistan in 1993, I was told that Wahid Gul and Zahoor's cousins, Azum Khan and Noorwahid, were arriving home from the UAE for six months leave. I planned to spend a weekend with Debbie in Peshawar and suggested that I should meet the welcoming party from Kohery at the airport. Representatives from the whole extended family had come down the day before and stayed overnight so that they could meet the early flight from Dubai. By the time that I turned up at the airport before 5 a.m. some of the others had been there for a while already. Gul Halim and Saheb Gul had arrived early to bring the pickup for the luggage and so had managed to get inside the airport building. I had been to the airport before and I knew that the arrival of a flight from the Gulf was an extraordinary sight. There is one flight a day from Dubai alone and it is always full, both with passengers and with luggage. This time, though, I felt like I was part of it and I caught the mood of intense excitement from the others waiting around me as they saw the first men appear through customs wheeling trolleys piled high with trunks, suitcases, boxes and 'Samsonite' *chootee* cases. It was an emotional scene as

Azum and Noorwahid greeted their relatives and friends, many of whom they had not seen for two years or more. Outside the airport gates the scene was repeated as Abdulhadi, Wahid Gul, Shalum Khan and Satara found us. In the confusion of new arrivals, their families and the hordes of persistent beggars, somebody had managed to find a small, 'flying' coach to take us home. With Azum, Noorwahid and the others who had travelled with them, we easily filled the twenty cramped seats in the coach and the piles of luggage swamped the pickup.

After the early start I struggled to stay awake and take in all that was going on; the exchanges of news, currency exchange slips, letters and cassettes. As we made our way up the Malakand Pass, Noorwahid commented on the scenery and the cool wind blowing in through the windows; *khpul yachnee hawa*, our own cool breeze. At Timirgara we transferred into pickups for the final leg of the journey up the track to Kohery. When we finally came in sight of the houses, the children ran out to greet their fathers. In many ways I felt it was a sad scene as the older children had to introduce their younger siblings to their own fathers. Often the smaller children were embarrassed or even scared. I was not there to see Azum and Noorwahid entering their own houses but I had seen the many women, dressed in their finest and brightest clothes, standing out on the roofs, watching and waiting eagerly. Their houses were full that day as many of the families' *khpulwan* had arrived to greet Azum and Noorwahid on their return. The buzz of excitement continued throughout the rest of the day with family and relatives constantly coming and going.

For the first three days after their arrival, I hardly saw Azum and Noorwahid. For most of the time they stayed at home, enjoying the company of their families and receiving the many visitors. I saw Noorwahid briefly on the morning of the first day and he explained that he could not wander far as he might be called back at any time when somebody new arrived. On the first day it was *khpulwan* from the village, and as the news spread relatives from further afield made their way to greet the new arrivals. The visits were accompanied with exchanges of news, messages, cassettes, letters and gifts. Most of the enormous piles of luggage that the men had brought back were gifts. In the main there were gifts for the house and family. In addition, though, they had brought back something for all of their *khpulwan*: watches and cloth for the men, cloth, creams, soaps, perfumes and jewellery for the women. Even those who did not receive specific items were given small presents of money. The women arrived with bundles of peanuts which they were handed back on their departure with a Rs 20 or Rs 50 note stuffed in for good measure.

Another occasion the year before was brought to mind by the events following Azum and Noorwahid's return. One morning after breakfast, Zahoor had proudly announced the birth of his first son, Adnan, during the night. That day there was a constant stream of visitors at the house, coming to see the new child and congratulate the parents. I had been unable to see the proceedings, but between Zahoor and Debbie I was kept up to date on who had come and what had been brought. *Khpulwan* came from far and wide as soon as they heard the news. All of them brought gifts of some sort; sandals, cloth, combs and mirrors for the child, money for the mother. The parallels with the return of Azum Khan and Noorwahid that came to mind were general ones; the importance given to the physical presence of those who came, and the significance of the gifts that they brought. In the first case it was necessary for each household to send at least one representative. In the second, the gifts further marked the visit, and in the case of the returning men, the gifts of peanuts were returned unused with money added.

The obligations of visiting were something that were taken very seriously indeed and visiting was spoken about as being a great responsibility. It was the responsibility of all households to be represented by at least one of their members at every occasion of celebration and crisis of their own *khpulwan*. When I asked Wahid Gul in 1993 when I first arrived what he was now doing with his time he spoke of his full time work being to represent his family at weddings, feasts and funerals. Between them, Wahid Gul and Zahoor ensured that one or both were present at all of their *khpulwan*'s significant occasions. When I asked why visiting was so important, I was told that if even one member of the *khpulwan* did not attend then the host family would be very unhappy. Both men and women took part in visiting for most occasions though if the event took place at some distance from the house, then only those women who were closely related would attend.

As people in Kohery came to know me better, I was also expected to take part in this visiting, especially among the local neighbours. I was often uncertain about my own responsibilities and relied on others to tell me where to go and what to do. Two particular occasions stand out for me as showing the importance of visiting. In one case, I was severely reprimanded for failing to attend a funeral which I was not even sure had taken place. My arguments that I did not fully understand the local customs, were not enough, the main problem was that I had missed the actual occasion of the funeral and so had caused distress both to those I stayed with and to the bereaved family. On another occasion, when Abdul Hadi, who I knew well, was ill, I was reluctant to visit as I knew that it would mean actually entering his

house and I also felt (in a very British way) that I should leave the family to it. When I was finally taken to the house, I was teased about my lack of concern and my ignorance of my own responsibilities.

At certain times of the year, such as during the summer, the occasions for visiting seemed never-ending. The list of significant occasions grew all the time that I was in Kohery as I discovered new ones: birth, cutting the baby's hair for the first time, circumcision of a boy, the first complete reading of the Qur'an, engagement, marriage, departing to work abroad, returning, sickness, religious feasts, and death. Events such as the birth of a child, sickness, death, departure and return from abroad were occasions when *khpulwan* visited without specific invitations. People were expected to come to the house to show some measure of support for the family. They often brought small gifts (except in the case of death), or, if they were closely related, food or flasks of tea to help the family entertain their other guests. There were many small occasions such as the circumcision of a boy or *shukrana* where the family gave a small meal of meat and rice to their close neighbours. *Shukrana* were occasions where the family wanted to give thanks to God for something like the survival of a family member in an accident or their recovery from illness. There were many times when I was diverted on my way home by a message to go to another house or to the local mosque for a special meal. Invitations were given at short notice and attendance was more voluntary. The largest and most significant occasions were the celebration of engagements, weddings and *kheyrats*. *Khpulwan* were expected to take part in all aspects of the preparations and to play an important role in their running as I shall discuss in greater detail below. The presence of *khpulwan* was therefore very important.

Despite the similarities, each occasion was significant in its own right and they were all marked in very different ways. Births were occasions of great joy and excitement. Visitors brought small gifts for the child and money for the mother but stayed only briefly. Sickness was a time when people showed their real concern for the individual and their household. The main reason for visiting was to check on the welfare of the sick person, so visitors would stop only to drink tea and chat. The departure of a man for abroad was a time for mixed feelings, sorrow on the part of those being left behind, excitement if it was a young man leaving for Dubai for the first time. The man departing was often asked on a round of meals by relatives and friends beforehand. On the night before the departure, people would eat at the house and many would stay overnight. Men and women went on the following night to sit and chat with the family. Death was a time of sorrow for all concerned and

the mourning was marked with great solemnity and sometimes anguish. Another house would prepare food and tea for those who came to mourn with the family. Other *khpulwan* would bring more tea to help out. In cases of departure and death there were some striking similarities in the visiting. In both cases, those who came to be with the family often stayed overnight. On the second night, when *khpulwan* came to be with the family of a man who had just left for the Gulf, it was almost as if they were mourning his loss or comforting those left behind. Both forms of departure were accompanied with numerous prayers.

Most visiting was accompanied by some form of gift-giving which was usually done by the women. The gifts that were brought varied according to the occasion of the visit. For many celebratory occasions, peanuts were considered suitable. Often gifts of peanuts were symbolic in the sense that they were returned untouched as the guest left, often with the addition of some money. Werbner in her book on Pakistanis in Manchester (Werbner 1990) takes as her inspiration Eglar's work on the gift economy in a Punjabi village in Pakistan (Eglar 1960). Werbner particularly emphasises that gift exchange plays a major part in the formation of social relationships and hierarchies. As she says "Among Pakistanis in Britain relationships between friends and kinsmen are objectified through elaborated transactions" (Werbner 1990: 206). Both Werbner and Eglar suggest that the transactions include not just gift exchange but a whole range of other goods and services (Eglar 1960: 106, Werbner 1990: 204). However, they emphasise the overall importance of gift exchanges as the main ways in which relationships between families can be read both by the families themselves (Eglar 1960: 122, Werbner 1990: 221) and by outsiders (Eglar 1960: 111, Werbner 1990: 205). I would agree here that gift exchange has to be seen as part of a whole range of other goods and services. However, I would emphasise that in Kohery, gifts were less significant in themselves. The most important thing was the relationship itself, so that visiting and the actual presence of the individual was the supreme measure of the relationship. Gifts were a lesser part of that overall relationship.

People in Kohery were very conscious of their responsibilities to visit their *khpulwan* on significant occasions. As several individuals said to me in different circumstances, people would be very unhappy if we didn't go. Barth, writing about Swat, noted that non-attendance at a *rite de passage* was not simply a matter of having no time or forgetting but was taken as a statement that the relationship was in trouble. Barth emphasised particularly the political significance of participating in occasions; for an individual "the ceremonies offer an occasion for the expression

of friendly feelings, disapproval or enmity in terms of one's presence or absence" (Barth 1959: 35). The individual that Barth writes about is the khan, the political leader or pretender, involved in building up followings and outmanoeuvring opponents. The situation that I have emphasised for Kohery is very different. There individuals were far more concerned with the importance of their *khpulwan* relations and in maintaining those relations. Therefore attendance at occasions and ceremonies was a necessity in maintaining feelings of amity. Non-attendance was not even a serious possibility where people were so dependent on their *khpulwan*.

Barth's comments are useful here in reasserting the temporal nature of kin relations, something that Bourdieu discusses in detail (Bourdieu 1977). More generally Bourdieu argues that time should be reintroduced into all theoretical representations of practice (Bourdieu 1977: 8). This is particularly the case in the analysis of kin relations which have so often been seen as something static. For example, Bloch and Fortes describe the ways in which non-kin or 'artificial' kin relations can be manipulated to advantage. However, they characterise 'real' kin relations as long-term, dependable and somehow static. I have argued that 'real' kin require just as much work to be maintained. Bourdieu suggests that practical groups exist only for the particular functions for which they are effectively mobilised. These groups continue to exist only through use and maintenance (Bourdieu 1977: 35). So it was with groups of *khpulwan* in Kohery; the ties, while they were strong had to be continually remade and reconfirmed in order to remain strong and effective. By calling on and assembling *khpulwan* the existence of the groups was constantly emphasised and the members were reassured of their existence. While kin were tolerant of imbalances in relations at a certain economic level, they were less tolerant at other levels of relationship. As both Gul Halim and Sadiqullah said to me independently, we go now because we will need them to come in the future.

LABOUR, LOANS AND MIGRATION: NETWORKS OF DEPENDENCE BETWEEN HOUSEHOLDS.

Visiting and gift-giving helped to maintain important kin ties which were used in a variety of ways. Significant exchanges of labour and money in the form of loans took place among networks of kin. It was these exchanges that enabled migration to the Gulf to take place on such a large scale. Exchanges of labour were particularly important to households. Wahid Gul, for example, as well as farming his family's own land, put considerable energy into looking after the numerous fields of his

wife's father. While he could plough his own land in less than a day, it took him at least three days to work his father-in-law's land. This was partly because the fields were spread all over the village although the main reason was that the land was so extensive; while Wahid Gul's family had 4 large fields (*balay*) and 6 small fields (*ghwagay*), his father-in-law had 21 large fields and 19 smaller ones. When I first learned of the amount of work that Wahid Gul did I immediately assumed that there was some kind of immediate reciprocal arrangement, either that Wahid Gul was paid for his work or received a portion of the crops at harvest time. In fact the only form of immediate arrangement was that Wahid Gul used his father-in-law's oxen to plough his own land. When I asked Wahid Gul why he farmed all of this land for no obvious reward he seemed surprised at the question. When I pressed him for an answer he suggested that his reward might lie rather in the long term; something along the lines of, if I work on his land today, then when I need his help tomorrow he will help me. Such arrangements were not new. Abdul Hadi's younger brother, Gul Hadi was described to me as a very good farmer who had cared for all the fields of his *khpulwan* while they were away in Karachi. In 1993 the arrangement was common to most households as almost all of them had men absent in the Gulf. Abdul Hadi and Sadiquallah's family were partners in a pair of oxen which they used on their own land co-operatively. In addition Abdul Hadi farmed the land of his two brothers, his son's father-in-law's extensive field as well as helping out occasionally on Abdul Wahid's land. Such arrangements were important as they allowed many households to keep their land under cultivation even while their men were absent.

Although many of the households in the Bagh neighbourhood and throughout the village had only small areas of land, they relied on the co-operation of others to work it. Most often, while a household had its own plough, they had no oxen to pull it and so had to borrow from other *khpulwan*. Most of the work repairing terrace walls, ploughing, planting and re-ploughing was carried out by one man from the household or by another male *khpulwan* member. At the busier times of the year, like harvesting and threshing, then larger groups of *khpulwan* would co-operate in working together in order to finish the work as quickly as possible. Men, women and some of the older children would work together cutting the wheat or maize with sickles and gathering the crop for threshing. Tractor-driven threshing machines were brought in from outside and worked day and night for several weeks after the harvest. The work was extremely unpleasant and the whole village was filled with a noxious mixture of dust and small pieces of straw. Groups of

khpulwan, mostly men with a few women, followed the tractor from field to field, often working for 10 to 12 hours at a stretch to get the work done. After threshing came the equally laborious task, which was mainly carried out by the women, of carrying the straw to be stored in the houses as fodder.

For other tasks such as building new houses families relied extensively on the help of their *khpulwan*. Both Noorwahid and Azum Khan seldom had a free moment to spend with their families throughout their 6 months of leave. Every day there was a new call from some other relative to help out with building a new house, adding a new room or animal shed and even refurbishing a grave. Their building skills were well known and so they were always in demand. In building work different groups, both large and small, were assembled to deal with different tasks. Over the summer of 1992 I watched Gul Halim and his family add a new room to their house. In the initial stages Zahid Gul's father- and brother-in-law came for several days to help clear out the space for the room. I have a picture of Gul Halim and several of his cousins at a later stage, working on the walls and concrete pillars (see Plate 15). During this work Wahid Gul was particularly in demand as he was an experienced mason. For the difficult job of preparing the reinforcing and shuttering for the beams and roof Gul Halim hired an *ustaaaz*, a skilled craftsman, for several days. On the day when the beams and roof were to be poured a group of between 15-20 relatives and friends assembled to mix the cement, then carry and pour it while the *ustaaaz* supervised. This group were given a large meal of meat in the evening once the job was completed. Finally Gul Halim and Abdul Halim worked alongside a plasterer who they hired for several days to finish the room off. Without *khpulwan* to assist in the laborious work, the costs of hiring workmen would have been considerable.

Because they were trusted and could be depended on, people turned to their *khpulwan* first when they needed money. Money loans could take the form of regular credit in a shop such as Zahoor's. As he explained, credit was seen by *khpulwan* as a right, something that he could not refuse. The amounts may have been small but they could mount up considerably over time, sometimes causing those running the businesses serious problems. In Zahoor's shop the credit in 1993 amounted to over Rs 20,000, the bulk of it owed by close *khpulwan*. Although Zahoor complained about the problems that credit caused him, he took it for granted that should he need the money it would be repaid in cash or kind. Credit was not always restricted to *khpulwan* and was often extended to all of the customers who frequented particular shops and it was here that the problems lay. I

was told by Zahoor and other shopkeepers, that previously, when most men worked in Karachi, there were fewer problems and families honoured their debts. At that time, when men had returned from Karachi every year, the first thing that they would do with the money that they had brought back was pay off their credit at the shops, giving the businesses a regular and welcome boost of cash. Now, the shopkeepers complained, the last thing on people's minds was paying off their debts. One way to deal with this was, like Zahoor, to limit credit to *khpulwan*. In this way, at least, they could have some way of retrieving the money should they need it.

In raising money, people in Kohery seldom had to look outside their circle of relations. When I first arrived and began to take an interest in the mechanics of migration I assumed that the large amounts of money needed for visas and plane tickets were raised through bank loans. Wahid Gul's assumptions were entirely opposite to mine. As he explained:

Banks are no good. If a person needs money then they will go to their *khpulwan* to ask for it. If one person doesn't have enough then they will go around asking until they have enough.

Such loans between *khpulwan* are treated as long-term and fully negotiable though they are frequently a source of irritation and sometimes conflict. Younger men especially tended to ignore their responsibilities to those who had helped them in the first place. Often they became carried away in enjoying the good life in the Gulf or in purchasing consumer goods, forgetting their obligations to others. The irritation on the part of the loaners was less that they were not receiving the money due to them, more that the young men were not saving 'properly' or sending money home as they should be. In other words there was a great deal of tolerance of the imbalances between *khpulwan*, but intolerance of the ways some young men chose to use their money 'selfishly'. The advantage in such cases was that pressure could be brought to bear on *khpulwan* from a variety of angles. In the same way that loans of money and credit, both known as *qaras*, could not be refused, so there was an equal pressure to repay the money when finally requested to do so. In this way a loan was like a gift, something that had to be reciprocated and on the basis of which greater demands could be made. Thus, loans reinforced ties between individuals. While the link existed before the request for a loan, it was made into an active tie while the loan was extended.

Another form of loan, very different from *qaras*, was described by the term *amanat*, an Arabic loan word with a very specific meaning in Pukhto. *Amanat* referred to something that was passed from one person to another. The person to whom the thing was loaned could use it in whatever way they wished. However, should the loaner request its return then it had to be given back immediately and in the same state in which it was loaned. I was told by Zahoor that it was considered a great sin not to be able to return the object immediately or not to be able to return it in its original state. In Kohery *amanat* always took the form of money which was given on the desire of the owner to a consenting borrower to be used as the latter wished. The money was basically given into the safe-keeping of another and had to be returned on request. Although the money could be used in whatever way the taker of the money wished, it nevertheless placed a considerable burden on them. *Amanat* was particularly widespread among men working in the Gulf. Among the men I knew, most of them passed on their weekly wages to Abidullah who ran a successful shop in Muzeirah. The men regarded him as trustworthy and they knew that he would be able to use the money in the short term. When I spoke to Abidullah about the money given to him, he described it as a considerable burden; it's like being a bank, he said. Both *qaras* and *amanat* together ensure a free flow of money between kin and friends, emphasising and reinforcing the ties between them.

One of the most important elements of Islam is *zakat*, the giving of a portion of income annually to support the poor of the community. In Pakistan attempts had been made to collect *zakat* as a kind of charitable tax which could be distributed nationally. People in Kohery resisted this idea and argued that *zakat* was an individual and community responsibility where those involved should decide how much to give and to whom it should be given. *Zakat* was mainly given at the end of Rojeh, the month of fasting, known in Arabic as Ramadhan. On the first day of the celebrations, called Warkotay Akhtar, families would give gifts of money, clothes and food to those in the village who were considered less fortunate. In most cases gifts were given to other households in the immediate neighbourhood. While *zakat* was given once a year there were numerous other ways in which those who were less well off were helped out. Households would pass on work where it was available, paying either wages or in meals. Wahid Gul's mother-in-law was well known for her excessive generosity and gave numerous gifts of money to *khpulwan* at weddings and other celebrations. Gifts of money and food were frequent between all related households. In these ways and other it was ensured that all the households in the neighbourhood were well cared for. As Wahid Gul and several

others said to me, nobody in our neighbourhood is poor. A noticeably poor household would have been a source of shame to all of those around them, a visible indictment of their lack of concern as a community.

It was the co-operation between households for labour and the free flows of money between families that allowed so many of them to take part in migration to the Gulf. Throughout the village, virtually every household had at least one adult male working somewhere in the Gulf. At every stage of the migratory process individuals turned to their *khpulwan* for assistance and support. The stories of those involved in migration show the importance of the various networks of co-operation. Right from the start the decisions of many individuals were influenced by those around them. In the cases of the younger men like Azum Khan and Zahoor it was peer pressure that persuaded them that the Gulf was the place to be. In the case of an older man such as Fazal Wahid he was persuaded by his second wife's family that the attractions of the place, and the opportunities there, made Jordan the right choice. Once persuaded, people turned to their *khpulwan* for both financial and organisational support. As Wahid Gul said, if a man needs money he turns first to his *khpulwan*, to those who will not refuse him even if they have qualms, as in the case of Azum Khan. The cost of a visa and ticket for Saudi Arabia from one of the many agents in Timirgara was prohibitively high in 1993, about Rs 70,000. This meant that, unless the family already had somebody working to supply the money, they would be unable to manage the costs without assistance. In the case of the UAE, visas were unobtainable through agents in Pakistan. Those wishing to go had to be able to contact somebody in the UAE who could obtain the visa for them and send it back to Pakistan. In most cases it was the person in the UAE who footed the initial cost of the visa, treating it as a long term loan to be paid off over the first two years of work.

Men rarely travelled alone to the Gulf. Usually small groups of 2-6 men would try to co-ordinate with one another so that they could help each other out if any problems arose along the way. This was particularly the case with men on their first trip as the emigration and immigration authorities often made life difficult for those who did not know exactly what to do. On the night before departure large numbers of friends and *khpulwan* assembled at the houses of those who were leaving for a farewell meal. At the end of the evening many prayers were said for those about to leave and for all travellers, asking God for their safe return with their hands full. Early the next morning, all along the road to Timirgara people gathered to pass on letters, cassettes and messages to those in the Gulf. I was told that when men first

started to go to Karachi the whole village would turn out to see them off and to pray for their safe return. Often several friends and relatives would join those leaving as far as Peshawar or Islamabad to wish them final farewells and see them off at the airport. At the other end, in Dubai or Riyadh, a few *khpulwan* usually turned up to welcome the new arrivals and take them back to where they lived. It was an exciting time for those away from home as they eagerly looked forward to the letters, cassettes and presents that the new arrivals brought. Times like these only emphasised to those who had just arrived how far away from home they were. In Kohery, at the same time, *khpulwan* gathered at the houses the men had left to console those left behind and to distract them with talk.

For new arrivals, the first few months were always the most problematic and were a time when they relied most heavily on *khpulwan*. In many cases, it took them several months to find suitable work, and until that time they were dependent on those they knew for a place to live and money to live with. They also had a lot to learn, most importantly Arabic, but also many other things like washing clothes, ironing, making tea and cooking. As Azum Khan's story shows, the first 3-4 months as the most difficult to get through. For finding work as well, they were reliant on those they knew to help find them something that paid well and where the boss would be reasonable. Many men I knew had had many problems with bosses who made unreasonable demands, or who refused to pay for work done, so that finding a good boss was a high priority. Often groups of men lived and worked together in a large garden or by some construction work. By living together, they could share the costs of the accommodation and food, as well as sharing the cooking and having constant company. Working together meant that they could deal with problems as a group and so bring more pressure to bear. The men from Kohery who worked in the UAE lived mainly in two places, Dhaid where Gul Hamid had first gone to work and Muzeirah where Abdulhai was the mullah of the main mosque. Both of these men had found their *khpulwan* and fellow villagers sponsors, visas and subsequently a place to work. In these two places the groups of men had resumed their community relations in full, re-establishing their village networks. Fridays were particularly important times when men had a chance to visit each other, exchanging news and giving and receiving hospitality. In Saudi Arabia all of the men from Kohery lived and worked in the capital Riyadh. The situation there was similar to that in the UAE with most of them living together in two large buildings where they rented most of the rooms.

Throughout the year there was a constant flow of men to and from the Gulf carrying cassettes, letters, money, gifts and messages. Although men were away from their families for two years or more, they were able to keep in touch with what was going on at home and in the village. In 1992, when Debbie and I left Pakistan to return to Scotland, we announced that we would be stopping in Dubai to visit some friends there. The day before we left, the cassettes and letters started to arrive until we had one bag full of them alone. Friends mainly exchanged letters, but cassettes were for families. Each member of the family got their chance to speak, relaying their news and passing on their blessings and prayers. Greetings were sent to all of the men's work companions, *handeewalan*, even though they had never been met. People usually only sent small gifts: new trouser ties from the women, religious charms, *taweez*, perhaps a new pair of sandals and sometimes some special fruit or nuts, most ridiculously in our case, a fresh coconut from Wahid Gul to Zahoor. Letters and cassettes were sent in equal numbers back from the Gulf, often accompanied by money. Urgent messages could occasionally be phoned through, most often to Ghulam Wahid's shop in Timirgara, which became my 'home base'. On the day before Akhtar, the celebration at the end of the month of fasting, Roja, there were a flurry of calls back wishing everybody special greetings. Thus men and their families managed to keep in close touch even though they were so far apart.

Migration, then, is a particularly good example of the importance of the kin ties between households. Numerous other studies have given testimony to the importance of networks in migration (Epstein 1969, Mascarenhas-Keyes 1987, Boyd 1989, Kressel 1991) In Kohery the closeness of *khpulwan* meant that households separated by thousands of miles could keep in close touch. Just as importantly such ties enabled these extended households to continue to operate. Exchanges of labour and money along networks of kin ensured that all households were well looked after, whether they had adult men present or not. Such exchanges also reinforced the important *khpulwan* ties and created complex networks of dependence between households. Thus, while Azum Khan's statement that, 'We are all one house', referred directly to a notion of patrilineal loyalty, indirectly it referred to these networks of dependence.

WE ARE ALL ONE HOUSE: NETWORKS OF INTERDEPENDENCE

Khpulwan played a significant role in the life of all households. People in Kohery recognised the fact that they were unable to stand alone and needed the support of their kin. As one proverb put it, in a bad place a bad cousin is necessary. Kin were

those who were tied together morally by a bond that could not be broken, they were those who could be turned to, those who could be relied upon. The real significance of the ties of kinship was demonstrated on a day-to-day basis in the ways that they were maintained and utilised. Visiting and gift-giving represented ways of valuing and reinforcing the ties. Flows of money and co-operation in labour at home and in migration followed these ties and bound households together. People tolerated and honoured the often excessive demands made on them by their *khpulwan* as they knew that in the future their own demands would be reciprocated. As I described in Part II the similarities between households were constantly emphasised; they were all *khrooskoo*, eating / drinking, households at risk. This emphasis made the point all the more clearly that households were dependent on one another for survival.

This presents a strong contrast with the emphasis in the work of Ahmed, and especially Tapper, where households are portrayed as fiercely independent and competitive. It is significant that they were both representing the views of the elite, for whom household autonomy was a major factor in their claims to prestige (Ahmed 1980: 25; Tapper 1991: 103). In Kohery, too, in certain circumstances, individuals made claims to relative household autonomy. However, in the main people themselves pointed out their own dependence on others. Few were in the position to take part in overt economic competition with other households. Most relied on their kin to such an extent that aggressive behaviour would have been senseless. People in Kohery operated at the level of day-to-day necessity and practical kinship, rather than at a level of competition for status and official kinship.

Considerations of the importance of *khpulwan* also influenced marriage strategies and the choice of partners. Tapper suggests that for the Maduzai Pakhtuns whom she describes, the primary considerations in marriages were political ones (1991: 56). In Kohery, marriage strategies were influenced as much by practical considerations as by political ones. The choice of partner was affected by mundane, everyday factors and by individuals within the household rather than by long-term, lineage strategising. In contrast to the situation described by Tapper, few in Kohery had the resources or the opportunities to plan marriage strategies according to purely political considerations. There was a far greater emphasis given to the importance of marrying in and the benefits that this brought. This in turn gave great prominence to the view that all those in the community were related, were all *khpul* as I will now describe.

MAKING *KHPULWAN*: CHOOSING A PARTNER

Choosing a suitable marriage partner for a girl or a boy was a decision made by various members of the household in consultation. It was usually held that the final decision rested with the head of the household. However, to avoid disagreement and potential strife a variety of conflicting interests had to be taken into account. For household heads their wider, outside interests led them to look for a good match, that is a marriage that would bring with it *khpulwan* who would be useful in some way and possibly even prestige. If they were making a match for their daughters then the distance of the groom's house was less of a consideration than making a good link with a friend or somebody influential. Young men had a conflict between loyalty to their family's, and in particular their father's, wishes and their own desires for what they called a 'love marriage'. For the women of the house, there were very different considerations. If a new woman was to be brought into the house as the wife of one of the sons, then each woman looked for somebody who might potentially be an ally, a woman of their own house or from their *khpulwan* who would help to cement the ties with her own family. For mothers their main concern was for their daughters to marry a family close by so that they could see them often. Young girls hoped for similar things to their mothers, to be married close by into a family that they knew and had contact with. All of the family wanted the same thing, a marriage with a good family, that is a family that did not fight and that was reasonably well off.

There were other, more general considerations that were taken into account when seeking a partner for marriage. These I would term family and community considerations. Like Donnan, however, I would add that many of these considerations were specifically male ones. My situation was like Donnan's in that the women's role in decision-making was less visible to me, while the men had ample opportunity to exaggerate their own roles and emphasise their concerns (Donnan 1988: 84). Wahid Gul, early on in my fieldwork, described the process of finding a suitable partner which mainly involved finding a suitable family. The way

that he described it was that before the marriage both families like to know as much about each other as possible. It is as much a concern that the families are compatible, as ensuring that the couple like each other. Ideally both families involved in marriage negotiations should be able to convince themselves that the other is reasonably well off and peaceful. Within the village the internal affairs of all households were common knowledge and so it did not take much to find out if there were any problems or faults. If a family was seeking a partner from outside the village then obtaining information about the family was more difficult. Overall the women of the bride's family were much happier if the bride married close by, so that she could stay within her own community. A woman married outside the village was much more isolated and potentially vulnerable.

Wahid Gul went on to emphasise that the people of Kohery preferred to marry within the village. One of the main reasons that he gave was that the marriage customs in the village were 'good'. In this case he was referring specifically to the Pakhtun custom of giving bride price, in the form of jewellery given to the bride and money given to her father. This custom, though it is recognised as un-Islamic, was recorded among other Pakhtun groups by both Barth (1959: 37) and Ahmed (1980: 248). In Kohery in the mid-1980s, the village council had acted to try to limit the inflated amounts of both the jewellery for the bride and the money for her father. While I was there, I was told that the groom's family were supposed to give at most 30g of gold jewellery and perhaps only Rs 5000 to the bride's father, all of which was supposed to be given to the bride in the form of wedding gifts and money. The stated aim of these limits was to protect the poorer families in the village. Outside Kohery, in villages such as Malakand, there were no such limits and the amounts of jewellery and money had become wildly inflated over the years. In 1993 women's families were demanding and getting as much as 80g of jewellery and Rs 20,000, most of which the woman's father kept. Ahmed, describing the situation in Mohmand in the mid-1970s, talks of a similar inflation in the sums asked for women (Ahmed 1980: 248). In Kohery there was general condemnation of the scale of weddings in the villages around them and of the amounts of money involved. I was witness to a public display of this when the mullah of a Malakand mosque took the occasion of an engagement party in Malakand as an opportunity to condemn such conspicuous displays of wealth as un-Islamic. While the hosts were understandably outraged by the mullah's behaviour, those guests from Kohery spoke afterwards in strong support of the mullah's actions and words.

As a result of the customs in Kohery and the generally good reputation of the community, Wahid Gul argued, people from outside were keen to give their women in marriage. The reverse was true for those in Kohery who were reluctant both to give their women out and to bring women in. For a woman going from Kohery it meant isolation from her family, while for a family bringing in it meant involvement in an expensive and possibly problematic marriage. More generally, it was held that the villagers were reluctant to leave the village at all. Wahid Gul used a local proverb to support his case: *Kohery na laywanay spay hoom bahar to nowzee*, which translates as, even the mad dog won't leave Kohery. He explained this as meaning that a mad dog, even though it is badly treated, is afraid to leave the village as it may find no food outside or have stones thrown at it. Similarly, he argued, the people of Kohery are afraid to leave, to go outside the village. The village people were also reluctant to allow their women to leave as was shown by a custom that had fallen into disuse. Formerly when a man came to collect a Kohery bride the young men and boys of the village demanded money from him and threatened to beat or stone him. Wahid Gul also claimed that the people of Kohery gave out only the worst women in marriage, those who were ugly or who had a bad nature. While Wahid Gul's account of the factors influencing marriage was prone to exaggeration, what he said reflected more general attitudes towards marriage in the village.

WE ARE ALL KHPULWAN: MARRYING IN AND MARRYING OUT.

Marriages within patrilineages, *khayls*, were fairly common. In the group of houses where I lived there were a number of such marriages. The closest was that between Zahoor and Wahid Gul's sister, Wahida and their paternal cousin, Gul Halim, their father's brother's son. Wahida and Gul Halim were known to like each other, and after their marriage this affection flourished into a close, loving relationship. Other marriages were less close but were obviously advantageous for the families involved. Zahoor, for instance, was married to Abdulhai's daughter, his FFFBSSD, and the two families enjoyed a very close relationship. These links once made or established, were often repeated over several generations, such as in the case of the marriages between Abdulhai's family and Naarhamudin's. Naarhamudin's eldest son Lal Wahid initially married Abdulhai's sister. In 1992 the links between the families were further solidified when Naarhamudin's second son Mohamad Iqbal was married to Abdulhai's own daughter. The marriage links were not confined to one part of the family as, in the summer of 1994, Abdulhai's eldest son Sanaullah married the daughter of Gul Hadi, Naarhamudin's younger brother. These

numerous intermarriages often resulted in a complex web of ties within groups of *khpulwan*.

For those involved, such marriages were well regarded. For a start they were 'safe' in that the families involved already had well-established relations and knew in detail about each other's circumstances. In addition, the couples often knew each other beforehand and, indeed, had the opportunity to meet and even form relationships before marriage, as in the case of Gul Halim and Wahida. Donnan, writing about marriage preferences for the Dhund, suggests that they themselves give similar reasons. The Dhund, he says "point out that a union between paternal cousins not only avoids the trauma of marriage to someone entirely unknown, but that since the bride and groom are already well known to each other, this contributes to the likelihood of their being happy together" (Donnan 1988: 127). Tapper also mentions that the Maduzai considered marriages between those who were already linked as being much safer (1991: 94). Not all such close marriages were necessarily happy but at least they had a reasonable chance.

Within Kohery, the *khayls* were also tied together with an intricate network of marriage links. As Wahid Gul once said to me, everybody in Kohery is *khpulwan*, there is not even one outsider, *praday*, here, we are all related by marriage ties, *rishtay*. Most families thought it important to have ties with the other *khayls* in the village. The patterns of inter-*khayl* marriage were very similar to those within *khayls*. For a start, ties once made were often repeated over the generations. In Abdulhai's family, their relations with their mother's brother's family were particularly important. Abdulhai's brother, Abidullah, was married to his mother's brother's daughter, while Abdulhai had married his daughter to his mother's brother's son. The links that were made were in some cases followed by marriage with other branches of the family. Wahid Gul and Abdul Halim were *sandoo*, that is men married to sisters, Abdul Halim being married to Wahid Gul's wife's younger sister. Marriages between *khayls* in the village were favoured by men because, as Wahid Gul's comments suggest, they generated a sense of community solidarity: we are all *khpulwan*. They were still considered to be safe as individual household affairs were well known within the village. This was particularly the case if the families were already linked by ties of marriage. Donnan records the Dhund women's point of view that "Marriage nearby is...felt to make things easier for the bride since she can make or receive regular visits" (Donnan 1988: 137). In Kohery similar reasons were suggested by men, but especially by women, for why marriage within the village was good.

Marriage ties formed with those outside the village were considered a lot more risky although the benefits could be just as great. Such marriages were formed with much more of an eye towards the advantages to be gained for the families involved, and so they were more frequently arranged around male interests. Fazal Wahid had arranged his own first marriage to a woman from a family at some distance from Kohery. There were no obvious benefits other than the usefulness of close family in another village and the contacts that this brought. For his second marriage, Fazal Wahid looked slightly closer to home, although still outside the village. Soon after this marriage, his new father-in-law was able to help Fazal Wahid obtain a visa and passage to Jordan. Once he was there, various other in-laws helped him to find work and then to set up a small shop which had been very successful over the years. More often in Kohery, it was those families who were already well-off and had existing ties outside the village who were able to form prestigious marriage links with outsiders. This was the case in the marriage of Ghulam Nabi with a woman from an influential family in Bar Malakand. Both the bride-price and the scale of the celebrations were enormous, though the link was one that was to be remembered by the community for a long time. Such a view is echoed in a statement made by one of Donnan's informants, that "Poor families will marry father's brother's daughters but wealthy families will look elsewhere, as they have enough money to look further afield" (Donnan 1988: 145). Richer families, then, had the resources available that enabled them to increase the scale of prestige involved in their marriages.

In more general terms, men emphasised the advantages of marriages in. To a certain extent this was reflected in the prevalence of marriages within patrilineages and between the patrilineages in the village, in other words within the community. It was further reflected in the relative importance given to the celebration of such marriages. Bourdieu suggests that there is a distinction between ordinary marriages arranged between practical kin which are celebrated on a less grand scale and extraordinary marriages arranged by men outside the area of practical kinship and which are celebrated with solemn ceremonies (Bourdieu 1977: 53). In Kohery, there was little distinction made between the types of marriage. The main determinant of the scale of the ceremony was the economic position of the families involved. Weddings arranged to celebrate marriages between close, practical kin could be given just as much significance as those arranged to celebrate prestigious, 'extraordinary' marriages. This goes some way to demonstrating the relative importance of such 'ordinary' marriages to the people of Kohery. The differences in the scale and style of wedding were a matter of negotiation with families. How such

weddings were viewed was sometimes a matter of argument and debate as I saw for myself in 1992 and 1993.

TWO WEDDINGS

Weddings in Kohery are something that I now find difficult to think dispassionately about (see Plates 16-8). They were the main social events in Kohery, and even at the smallest several hundred people would attend. They seemed at the time impossible to avoid so that I often went to several a week, and sometimes two a day in the high season. Even modest households put on an immense show. As a constant guest, however, I found it hard to really appreciate the effort involved. On the day before, or in the early morning of the wedding day, I would receive my oral invitation; somebody also wanted the *Inglayz* to go to their wedding. I would then find somebody to accompany me and show me the way and together we would set off. Usually by the time that the rest of the guests and I arrived, the main part of the celebration, the fetching of the bride, was over. When I arrived, I was usually greeted by members of the groom's family and would be led to the guest room or to a seat in a shaded place to be served with sherbet if the day was hot. The food was served almost immediately, a huge plate of rice cooked with spices, raisins and chickpeas with a few choice pieces of boiled meat placed on top. Like most of the other guests I would eat my fill and leave straight away, or stay for a while to talk to the other guests. I became so ill after so many of these visits that I came to dread them. After the first month, they became a matter of routine and in my mind weddings subsided into a single, general category.

My interest was only reawakened when I had the chance to see a wedding from the other side. When I had seen the view of the house organising it I began to appreciate the enormous amounts of money and organisation that they required. Over the two years that I was in Kohery, I saw several weddings from the insider's point of view. I never ceased to be impressed by the amounts spent, the time it took to organise, the numbers of people involved and the amounts of material that they had to muster. A single household alone could not possibly have coped, and all of their *khpulwan* had to be called upon. What I want to focus on here is what these events meant to those involved. To give some idea of what was involved, of the scale and complexity of things, I will describe two weddings. The first was the marriage of Abdul Mateem's son, Amir Nawab, which I will call Nawab's wedding. Abdul Mateem was absent in the UAE at the time of the wedding and many of the members of Moolian Khayl were actively involved in the arrangements under the

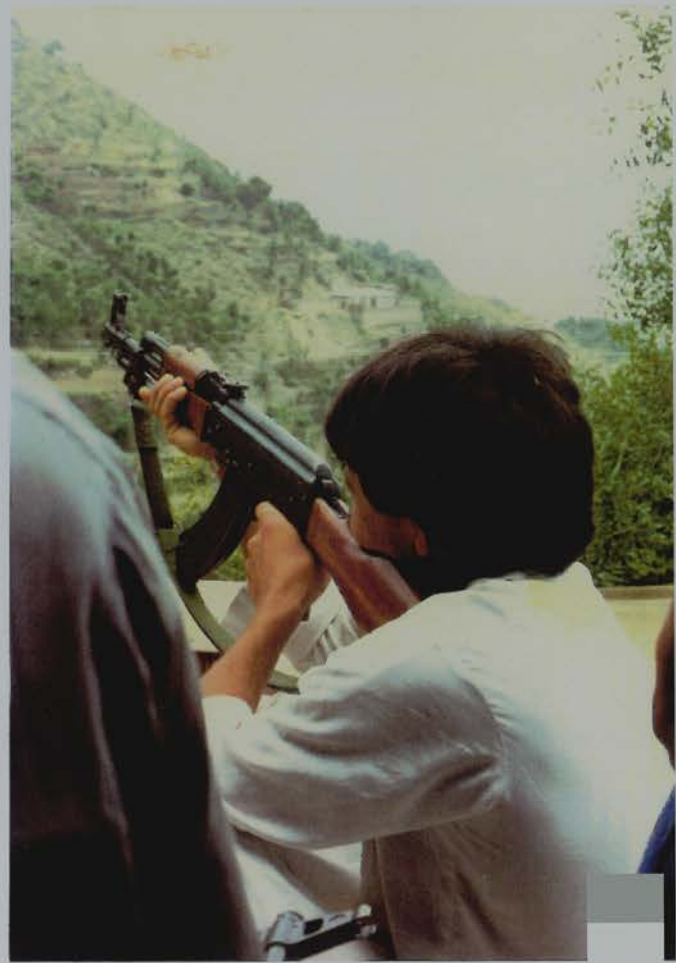

Plates 16-8 - Wedding scenes

nominal organisation of Naarhamudin. The second wedding was arranged to celebrate the marriage between Abdulhai's daughter and Naarhamudin's son. It was part of an on-going series of weddings between the families which would tie them together still more closely. The wedding was a double one with two of Naarhamudin's sons marrying on the same day. The event was timed to coincide with Abdulhai's return from the UAE with his daughter and the rest of the family. The timing did, however, mean that Naarhamudin's son was not himself present as he had only recently gone to work in Saudi Arabia. The absence of male members of the family, including the groom, was a fairly common occurrence and it certainly did not inhibit the scale of the celebrations.

In both the bride and groom's houses the families relied heavily on their *khpulwan* for assistance. The cook for the day had to be booked as at that time of the year he had a wedding a day. In the groom's house the preparations were on an enormous scale and were usually supervised by a cook hired for the day. Previously the family had organised things themselves but by the 1990s the scale of celebrations were such that it had become almost inconceivable to have a wedding without a cook unless the family was very poor. Nevertheless the mundane preparations had to be seen to by the family themselves. To carry out these tasks they began to call on their immediate *khpulwan*, those who were their neighbours. For days before, the women of the surrounding houses visited to help sort and clean the sacks of rice and chick-peas for the enormous pilau. The buffalo that would provide the meat was bought and kept in the house to be slaughtered just before the actual wedding. On the afternoon before the big day, the call went out to all of the family's *khpulwan* to come and assist with the final stages of preparation.

The work of slaughtering the buffalo was overseen by the cook but the actual butchery was carried out by the twenty or so men who had answered the call. At the same time other *khpulwan* began to arrive bringing with them everything necessary to serve several hundred guests: floor mats, dishes, knives, water coolers, jugs, cups and thermos flasks. As the light of day faded, most of the work was finished and those who had helped were served with a meal of cooked liver and kidney with fresh bread. A few self-nominated individuals worked on into the night with the cook, building the temporary fireplaces for the enormous copper cauldrons. The fires were lit and the cooking of the meat began. While the involvement of *khpulwan* in the preparations for both weddings were very similar, the actual styles of celebration were markedly different.

Nawab's wedding was remarkably similar to many other weddings that I had attended in Kohery. In the mid-morning a straggling procession of women and children, followed at a safe distance by the few men present, made their way to the bride's house in the main part of the village. After a great deal of argument about how the wedding gifts were to be carried back, the procession began its return journey. At the head of the women's procession went two of the groom's friends armed with Kalashnikovs. Accompanying the men were a young man with a Kalashnikov and another man with an aged Chinese rifle. All along the way these men took whatever opportunities they could find to fire at impromptu targets and to blast haphazardly into the air. Even some of the men began to complain about the shooting, mainly because it looked so dangerous. The firing continued, however, and as first the bride and then the gifts arrived at the groom's house, they were celebrated with prolonged bursts of aerial shooting. Even after things had settled down a bit, the relative quiet was shattered with deafening explosions of gunfire as other friends of the groom took their turns at congratulating him. Fortunately that day there were no injuries, but on other occasions some guests were injured in shooting accidents. Shooting, though, was taken to be a wedding custom and was generally tolerated unless it got too much out of hand.

The second wedding was very different and the arrangements for the actual day of the wedding had provoked intense debate for many days beforehand. Abdulhai and Naarhamudin together had decided that it was to be a good, Islamic wedding. It was to be relatively small and quiet, male guests were discouraged from bringing guns and there was to be no shooting. Following Abdulhai's guidance on Islamic precedents, there was to be a minimum of display. In this case, in contrast to the large, daytime displays of other weddings, the procession took place before dawn. The numbers who were allowed to go were severely limited to keep the scale of the display down. By the time that Debbie and I woke up, an hour after dawn, it was all over bar the celebrating. The bulk of the guests had already eaten and many had left again. At eight o'clock I reluctantly sat down to eat a few token handfuls of congealing, greasy rice though I refused any meat. For the remainder of the day small and large parties of guests arrived from near and far to celebrate. Members of the families' *khpulwan* took it in turns to help serve those who arrived. Most were served with food as soon as they arrived, some left immediately afterwards while others relaxed, sitting on beds and chatted to the family and other guests.

In the afternoon a small group of men assembled with Abdulhai for the wedding vows; only one of the grooms and neither of the brides were present. With the

wedding procession long over, and with the ban on shooting, the male side of the celebration had no real focus. By the evening most of the male guests had left. A few close *khpulwan* remained, mostly those who had helped through the day with the serving. They stayed on to eat with the men of the groom's family and left soon afterwards. The women, however, did not wish to be so restrained and wanted to enjoy the celebrations to the utmost. Debbie later described to me how the presence of an old bangle-seller had caused arguments. The bangle-seller came to most weddings and the women looked forward to the opportunity of being able to purchase something for themselves. Naarhamudin was outraged when he found her selling things in his house, and shouted at the old woman to leave, finally reducing her to tears. The women were themselves outraged by his behaviour and reacted defiantly by locking the gates to the house, thus keeping all of the men outside. This meant that they could carry on with their celebrations undisturbed for the rest of the day. The first part of the entertainment involved dramas in which the young women and girls parodied the wedding celebrations and especially the men. Later the women encouraged them to start the dancing to taped music. The celebrations continued long into the night so that I was long asleep by the time that Debbie returned.

Despite the arguments, the women enjoyed themselves at the wedding. As far as Abdulhai and Naarhamudin were concerned, they had shown the village what a good Muslim wedding should be like. To me they had managed to remove any enjoyment that the men might have got out of the wedding at all. Other men joked that the wedding had been 'hot', implying that it was exactly the opposite. Nawab's wedding had been a run-of-the-mill affair, hardly distinguishable from any other wedding in the village. The wedding of Abdulhai's and Naarhamudin's children was an influential one in so far as a number of subsequent weddings had early morning wedding processions to collect the bride. More to the point it was set out deliberately to influence others in the village. However, the arguments over guns and shooting raged on. In some cases it sounded as if war had broken out in the village, in others a few perfunctory shots were fired before the perpetrators could be caught. To understand fully what was at stake in these arguments it is necessary to look first at what marriages meant and then at the ways in which they had changed.

A GOOD WEDDING

An important part of the prestige of marriage came from the way that it was celebrated. Werbner, too, suggests that weddings are the main occasion on which

families seek to establish their claims to honour and status (Werbner 1990: 200). In Kohery there were a number of ways in which the success of a marriage was measured. The first, most obvious measure was the scale of the celebrations that the groom's family mounted. If I went to a wedding without Zahoor, then I was always expected to report back to him when I returned. He would ask afterwards, what was it like, or more specifically, what was the food like. A successful wedding was one where all of the guests were adequately catered for at whatever time they arrived. A specific measure of this was how much meat was served to the various guests as this was generally the first thing that ran out. The family had to accurately estimate how many guests would come through the day and try to provide enough for them. I was at one wedding where the meat ran out in the mid-morning. There was a panic as people were sent off into Timirgara to buy beef to feed the late arrivals and avoid the shame of not having catered properly for all of the guests.

To a certain extent, the family could control the number of guests through the written and verbal invitations that they gave out. However, weddings were open to all those in the village who had heard about them, nobody was not invited. Those who wished to enjoy the family's hospitality were free to come; those whose presence the family had to ensure were sent a formal, written invitation. The number of guests who did turn up to celebrate a wedding was also a measure of success. It was not numbers alone that counted, but who the guests were, where they came from and their relations with the family that counted. Weddings where a large number of guests came from outside the village, especially if the guests were influential people related to the family, were talked about for many months and were considered successful. As an easily recognisable, 'prestigious' *Inglayz* guest I also became the target for numerous wedding invitations from those I met. Nothing was required of me at these occasions, the fact that I could come, sit and eat was enough. The scale of the celebrations, their success, the number of guests who attended and their importance became a visible measure of the family's own prestige.

The scale of the celebration of a marriage was something that was decided by the bride and groom's families together. The bride's family had the most say in the numbers who would come to collect the bride while the groom's family decided the size of the celebration on the return to the groom's house. Particularly in the latter celebration the family had to make two important estimates. Firstly, they had to work out the resources that were available to them, through themselves and through their *khpulwan*. Secondly they had to assess the number of guests who

would come to support and celebrate with them. If their estimates fitted with everybody else's estimates of how they should celebrate in their circumstances then the wedding was judged to have been a success. For a family with few resources a small celebration was not necessarily a source of disgrace. Zahoor and I attended a wedding of a relatively poor family who lived near to Zahoor's shop. The family had done all of the cooking themselves and had slaughtered a ram for meat instead of the customary buffalo. The celebrations were relatively low key but on our return to the shop Zahoor talked at length about how enjoyable they had been. He made particular comparisons with the quality of the food cooked by the family and that cooked at other weddings. He said that the delicious unspiced rice and bread that we had eaten reminded him of how good weddings used to be. However, in most cases families celebrating weddings stretched their own resources to the absolute limit and relied heavily on their *khpulwan* to take on some of the burden. *Khpulwan* were particularly important in ensuring that the family put on a good show for the outside guests who came.

In putting on a good show at a wedding there were some aspects that were widely accepted while others were a matter for debate and even dispute. It was generally accepted that in order to put on a good show the family's *khpulwan* had to be well represented. The *khpulwan* played an important logistical role in supplying the materials necessary for a large celebration as well as ensuring the smooth running of the occasion. Just as importantly, they represented the family in a good light in the procession to collect the bride. As Gul Halim told me, various members of the *khpulwan* help out by engaging pickups for the procession and by attending so that both the family and the group of *khpulwan* will look good. At one wedding in Bagh that I went to, I heard discussions about the procession going on. The groom's father was arguing that they needed to find more men so that there would be both a good procession and a good party to remain at the house and receive the bride's family when they arrived. Previously the procession had been very much a show of strength on the part of the groom's family. Every man who attended was expected to be armed and they all took part in the competitions and celebratory shooting. Up until the late 1980s, it had been the custom to organise a special shooting competition at the bride's house. The bride's family would set up a distant target of iron which the members of the groom's party attempted to hit. Some even claimed that if the target was not hit the bride's father would not allow the groom to take the bride at all. During my fieldwork, fewer men carried guns at weddings, though most of those who did had automatic weapons, mostly Kalashnikovs. At most weddings that I went to, there was some kind of shooting though there was not

always a target competition. There were other elements in weddings that had changed over the years and that had become a source of dispute.

Generally there seemed to be two recognised influences on the way that weddings were celebrated, the secular and the religious. The first set, the secular influences, were to do with the ways in which wedding celebrations had become elaborated. There was a chain of influence extending from Kohery to the valley areas around Timirgara, and from there to the Peshawar plain and to the Punjab. People from the village heard about or saw innovations in the ways weddings were celebrated, and in some cases introduced these innovations to Kohery. Those in Timirgara were influenced by weddings in Mardan and Peshawar, who were in turn influenced by weddings in the urban areas of the Punjab. So, for instance, Gul Hamid introduced the innovation of having a cook to supervise the food at his son's wedding. Within ten years, every wedding in the village used a cook. Similarly there had been changes in what was served at weddings, from bread to rice and fat to meat. Another fairly recent innovation in village weddings was displays of fireworks and the firing of tracer bullets.

At a wedding in Bar Malakand in 1991, I saw some other innovations that those from Kohery were more reluctant to adopt. There the groom's procession was enormous and on their return the bride was carried in a covered and decorated litter called a *dolai* (see also Ahmed writing about Mohmand in the mid-1970s, 1980: 249). In Dir, however, this was taken as being a fairly recent introduction from the Punjab. Some people in Kohery were highly critical of this practice. Other innovations seemed to have been just as controversial. Zahoor once went to the wedding of a doctor acquaintance of his who was influential in the local organisation of the Jamaat-i-Islami. He complained that everybody there was a doctor or a teacher, and especially that the meal had been a *Inglayz* programme. Zahoor and his friends had had to wait for the food which was then put out on a self-service basis. As Zahoor said, those who were shy took only a little while those who were not took what they wanted and left nothing for the others. By the time Zahoor managed to fight his way to the table all the meat had gone and there was only rice left. Not all innovations worked as well as each other or were as popular as some.

In many cases, these secular influences on the style of weddings resulted only in increasing the scale of the ceremonies. Weddings, such as that of Zahoor's doctor friend, were explicitly modelled on the 'Western-style' ceremonies held by middle

class families in Peshawar and other cities. Such new styles were adopted by the rich of Dir in order to further set themselves apart from those they lived among. These styles of celebration were the realm of those who could afford to adopt such innovations in order to maintain the distinctions between themselves and those they wished to be set apart from. Others in the lower economic groups strove to save the resources to enable them to adopt such innovations. Some, like Zahoor, Abdulhai and members of the Kohery village council, were critical of the changes. They saw them as unnecessarily conspicuous displays of wealth. The main influences on their views were religious.

This second set of religious influences were concerned mainly with making restrictions on how weddings should be celebrated. These influences were seen as being specifically to do with making weddings more 'Islamic' in the way that this was interpreted by certain groups. By the 1990s, there had already been a number of changes in the ways that marriages were celebrated that had been influenced by the village council. Wahid Gul recalled his own wedding as one of the last big, 'traditional' weddings to be celebrated in the village. The whole thing had gone on for at least three days and had included musicians and even a female dancer brought from Swat. In the intervening period, between Wahid Gul's and Zahoor's weddings, the village council decided that musicians, and particularly women dancing for men, were un-Islamic and so moved to ban them, imposing a system of fines for those who ignored the ban. At Zahoor's wedding his father, Fazal Wahid, had been keen to celebrate on the same scale as for Wahid Gul. After some argument he was persuaded by the council members that a more Islamic wedding was the best thing. The celebrations lasted for only one day and there was no music and little shooting. The changes were adopted by the whole community and by the 1990s, the only music to be heard came from pre-recorded cassettes played on tape players in the women's celebrations.

Some in the village sought to influence even more reforms, and in the summers of 1992 and 1993 other elements of wedding celebrations came under attack. In 1993, when Abdulhai married his daughter to Naarhamudin's son, they used the occasion to demonstrate what a truly Islamic wedding was like. They were not alone in their efforts, as the mullah of Malakand had previously spoken out very openly against the scale of weddings in the area, condemning them as un-Islamic. Other laws had been passed by the village council in Kohery to limit the amounts of money spent on wedding gifts although, as Nawab's wedding showed, the style and the scale of celebrations had been left up to the families involved. Abdulhai and Naarhamudin

set out to demonstrate that the wedding of their children was small and simple. Through their example they sought to establish modest, 'Islamic' weddings as something prestigious and worthy of imitation. Thus, they tried to alter both the way in which weddings were celebrated and the way they were seen.

Many spoke of the former laws to limit the size of wedding gifts in terms of being fair to those in the village with little money. The laws meant that within the village marriage choice was not limited by considerations of family wealth. Thus, while Abdulhai's family had a comfortably established position, Naarhamudin's was less well off. Again, although Wahid Gul's family had little capital, he was married to a woman from one of the richer families in the village. As I have suggested above, however, families could be judged on the scale of celebration that they could put on. In general, the bigger weddings in the village were the more memorable ones. Over the years, with the introduction of various innovations, weddings had become more and more elaborate until some families were spending up to Rs 100,000 on them. As Zahoor's comments on the small wedding that he attended suggested, though, large did not necessarily have to mean good. This was a point that Abdulhai and Naarhamudin sought to elaborate through the wedding that they put on. In their, 'Islamic' terms, small and simple was prestigious and good. They also emphasised the point that such a view of weddings was fair to all. However, not everybody in the village agreed with all that Abdulhai and others were trying to do. One particular focus of the dispute was the issue of shooting at weddings.

SEEKING TO CONTROL: GOOD WEDDINGS AND SHOOTING

For many in Kohery, being armed and being able to shoot well, was an important tradition which demonstrated the independence of the men (see also Ahmed 1980: 267). Every house had some sort of gun and boys from an early age were taught how to use them. Weapons were never carried openly in normal circumstances, and so weddings were an excellent opportunity to give the guns an airing. Added to this, the shooting competitions and firing in the air were probably the most enjoyable part of the men's celebrations. Nevertheless certain factions in the village opposed both the carrying of guns and their use at weddings.

I first encountered the dispute when I began to ask questions about the importance of guns at weddings. Initially I was told by Wahid Gul that shooting at weddings had been forbidden by the village council. I was therefore very surprised when a shooting competition took place at a wedding not long afterwards. When I asked

Sadiqullah and Wahid Gul about what was going on, they told me that the ban covered the families involved but that they could do nothing to prevent their guests using their guns. I remained confused and unconvinced. Soon afterwards a very public dispute took place at a large wedding. At the bride's house a target was set up and the shooting began. Just after I had had my turn, the bride's father intervened and said that the shooting should stop because there was a sick person in the house and the women were frightened. An argument took place, in which Wahid Gul and Mohamad Zahid took part, though eventually all agreed to stop shooting. When we returned to the groom's house, one man walked out onto a nearby roof and let fly, surprising everybody with a full clip of bullets fired into the air. Mohamad Zahid was quite obviously part of the family and so subject to the ban. Sadiqullah explained that there were no real leaders in the village who could enforce the ban and so people did as they wished. I realised that I was being told different things as the circumstances suited.

It was true that the village council had instituted a ban on shooting. However, instituting a ban and enforcing it were two different matters. A number of ways were used to try and influence people's behaviour. For example, at various times the matter of safety was raised. In 1993 in particular, there was a series of accidents which the village council members and others tried to use as examples of why shooting should be stopped. At one wedding, the main power line was cut by a stray bullet, while in Malakand a man was killed by a falling bullet. Then in Kohery, during a night of particularly spectacular shooting, a house high in the village was hit while the family were sleeping outside. For a short time afterwards, this seemed to discourage at least uncontrolled celebratory shooting. Others tried to influence behaviour by example. At the wedding of Abdulhai's daughter, guests were told that they should not bring weapons and that shooting was banned. It became fairly common at that time to see a note at the bottom of printed invitations telling those who were invited not to bring guns. When I left in November 1993 the argument raged on unresolved. One of the problems was that the argument was not between two factions in the village. In many cases, those like Wahid Gul, who argued against shooting at one wedding would be pressing forward for their turn at the next. It was rather an argument over who should decide how weddings should be celebrated and who people decided to agree with. It was also an argument about what weddings represented or what they were supposed to represent.

In Kohery the religious elements within the community had, over the years, fought a successful campaign against certain traditional practices in Pakhtun weddings.

The elders of the village council, together with certain charismatic figures such as Haji Hakim Zada and Abdulhai, had condemned a series of traditions as un-Islamic and banned them - namely live music, dancing and large bride-price. More importantly, though, they had got the people of Kohery to come to a consensus on these matters. They had persuaded the community as a whole to abandon these practices as un-Islamic so that the ban was successfully observed. What Wahid Gul told me about his father demonstrates this point. Fazal Wahid was initially keen to celebrate Zahoor's wedding in traditional style until persuaded, presumably by Abdulhai the father of the bride, to do otherwise and to celebrate the wedding in the new 'traditional' way. What I saw, and have described here represented the continuation of this debate over what a good, Islamic wedding should be. The Malakand mullah was attempting to fight against the increasing size of weddings and to persuade others of his own view. Abdulhai was in a better position to persuade others through his own actions. He thus used his daughter's wedding as a demonstration of what he thought a truly Islamic wedding was like. There were, however, other elements in Kohery and other villages who were not persuaded by these arguments. Thus the Malakand mullah was replaced, and was even condemned as being more interested in money than religion. In Kohery too the debate over guns and shooting was enacted publicly with arguments over safety and people choosing to ignore the council's bans.

In most matters, the women had been very much on the receiving end of attempts to control weddings so that, for instance, there was no longer live music at weddings. However, as the events at Naarhamudin's house demonstrated, the women had their own view of what weddings were about which the men found difficult to control. Generally, for women, weddings were very significant events and were a major source of entertainment. They were often very enjoyable, especially for guests, and they were a rare opportunity for groups of women from a wide area to meet with each other. It was usually only those women directly related to either family who could go, so that there was an additional reason to celebrate. The women were, therefore, keen to preserve weddings as special occasions for themselves, and to continue to enjoy the dancing, music and dramas that went on at them. At Naarhamudin's house, they showed that they also had the ways and means of resisting the pressures brought to bear on them. When Naarhamudin threw the bangle seller out and shouted at the women for encouraging dancing, the women of the house retaliated by locking the gates of the house to exclude all the men. They also carried on regardless of the arguments, and indeed it seemed as if the evening's entertainment was all the more enjoyable because of what had

happened. While many of the women had a strong interest in religious matters and were as pious as the men, they were still relatively unaffected by the arguments of people like Naarhamudin and Abdulhai.

The disputes and arguments over weddings were very much a matter of control. They were to do with matters of who could exert authority and over whom, of who could define how something should be and of who would accept that definition. While many in the village had accepted what the elders of the council had decided about the scale of wedding gifts and music at celebrations, some were more reluctant to accept other changes. As I have described, in some cases, the secular influences on weddings were as powerful as the religious ones. However, these arguments also tied in with the ways in which the community saw itself and wished to represent itself to outsiders. As Wahid Gul said, the whole community was 'us', there were no outsiders living there. They saw themselves, in certain circumstances, as a single community acting as a group of kin. To outsiders - whether other villagers or anthropologists - they wished to represent themselves as better Muslims than those in the villages around them. They did this with explicit reference to the modest wedding customs of their village that the whole community had agreed on. In the next section I will address the issues of how the community represented itself to others and of how this view affected how people understood their situation and behaved. I will also look in more detail at the arguments and disagreements over these representations of community.

Marriages were in the main about establishing and maintaining ties between households, about creating groups of kin. Marriage ties and the ties of the patrilineage were of great importance to individual households. Such ties were maintained with constant visits and gift-giving and were utilised with exchanges of labour and money. These various exchanges in their turn created complex webs of inter-household dependency. As the example of migration to the Gulf so clearly illustrates, no single household could participate without the aid of this network, both at home and in the place of work. This network was constantly being expanded and reinforced through marriage ties which established new groups of *khpulwan*. Men and women placed the greatest emphasis on the value of marrying in, drawing attention both to the importance of inter-household ties and to their notions of their own community. In Part IV I turn to look at these notions of community and at the new religious ideas that these and the styles of marriage are based around.

SAVE THERE, EAT HERE: PART IV
THE MORALITY
OF MIGRATION.

*How will things be for the travellers,
Will they be hungry or will they eat dogs*

(Pakhtun *tappa*, poem: Zahoorwahid)

In this thesis I have taken a cultural approach to migration from Kohery to the Gulf. Part I looked at how migration from the village was described and at the ways in which individuals represented their own lives of migration to me. Part II examined the way individuals saw themselves as subsumed to family groups in households and the representation of these households by their members. In Part III, I described the ways that households were represented as dependent on one another and, through the notion of marrying 'in', the community of Kohery was represented as a single group of related households. In the final section I want to make a single, coherent whole of these representations. I want to show that at a level of analytical abstraction these representations make sense together. This is my own model of how the community was described to me by its inhabitants. No one individual made the various interconnections for me or suggested that the ideas came together in a single whole. It was only by looking at all the statements that people made, by comparing all of the stories, proverbs and information that I had gathered that I was able to see the patterns that they contained.

In this process of analysis I found several works particularly useful. The main ones were Gudeman's *Economics as Culture* (1986), Gudeman and Rivera's (1990) *Conversations in Colombia*, Appadurai's *The Social Life of Things* (1986) and Parry and Bloch's *Money and the Morality of Exchange* (1989). All of them argue from a similar position, that it is impossible to understand economic processes outside of their particular cultural context. Gudeman makes the point that Western economists and anthropologists have made the common mistake of trying to use their own models of economic patterns to assess the models of others. He argues that to do so is mistaken since it is in the details of these models and in the metaphors around which they are constructed that cultural differences lie (Gudeman 1986: vii-viii). The works of anthropologists such as Nash (1979) and Taussig (1980) have taken a similar approach to the understanding of local models of economic processes. Appadurai and Bloch and Parry look at specific economic processes with a similar cultural perspective. Bloch and Parry look at exchange and particularly the role of money in such transactions. They argue that "in order to understand the way in

which money is viewed it is vitally important to understand the cultural matrix into which it is incorporated" (Parry and Bloch 1989: 1). The papers in Appadurai (for example Kopytoff 1986), take a similar approach to the understanding of commodities and the values they are assigned in a number of cultures. The point is the same for all of them, in order to fully understand local economic processes it is necessary to see them in their cultural context.

Basic though this point may seem to be, analyses of migration have tended to ignore it. As Gardner suggests, most models of migration have focused on the 'macro' processes - the national and international impacts, flows of labour and so on - leaving the migrants and their communities mute (1995: 12). Reviews of anthropological approaches to migration place great emphasis on the value of such 'macro' processes (Kearney 1986, Eades 1987); though some of the papers in Eades' volume suggest the value of more culturally specific approaches. Meillassoux's examination of the economy of colonial West Africa (1981), is a prime example of the problems that a model of migration that focuses on 'macro' processes has. His analysis subsumes all local meanings of structures and processes to the marxist model that he uses. As Gardner puts it, the problem of studying migration is that it functions at different levels and can be viewed equally effectively from both an individual and a structural perspective (1995: 3). Most studies, especially of Gulf migration, have tended to take the structural view.

Studies, such as those of Quibria (1986), Appleyard (1988), Stahl (1988), Gunatilleke (1986) and even Ballard (1983, 1987), have been particularly guilty, not only of taking a purely structural view but of using only Western economic models to evaluate the impact of migration on sending communities. Such studies talk in terms of 'productive' and 'unproductive' investments (Stahl 1988), or of local economic 'transformations', 'underdevelopment' and 'stagnation' (Ballard 1983). To find work that is influenced by concerns similar to those of Gudeman and Bloch and Parry, it is necessary to turn to studies in eastern and southern Africa. There the work of writers such as Parkin (1979), Murray (1979) and Comaroff and Comaroff (1987), examines migration in its cultural context. Much of the work on Gulf migration has tended to focus on particular aspects of the process, such as the role of networks (Mascarenhas-Keyes 1987). It is only recently that more

comprehensive studies of the cultural significance of Gulf migration have begun to emerge in the work of Gardner (1993, 1994 and 1995) and Osella and Osella (1994).

My own analysis has taken a cultural approach to migration from Kohery. The first three sections of the thesis have elaborated some elements of the cultural context of migration and work generally in this Pakhtun village. I now want to turn to look specifically at the cultural evaluations of the economic processes that the people of Kohery saw themselves as being involved in. First, I will look at how men talk about the effective saving of money. Second, I will examine the consumption of this money in households and the moral influences on, and evaluations of, spending behaviour. To draw out some of the salient features of this model I will make comparisons to other work on the moral evaluation of labour and consumption. Third, I want to suggest that this model of migration, labour and consumption is not a static one but is subject to constant re-negotiation and re-evaluation. To illustrate this point I look at some of the different interpretations of the 'correct' ways to spend money and at the influence of authority on the negotiation of these interpretations. The argument focuses on religious feasts and other religious uses of money and on the changing roles of authority in the community.

WAYS OF SAVING

The situation as the men of Kohery saw it was summed up by a proverb that Wahid Gul invented for me; *alta gatee, dalta ookhree*, saving there, eating here. In other words the only place that money could effectively be made, that is saved, was 'there', away from the house. 'Here', at home in the house, the money could only be 'eaten'. Men made the point that saving could only be done away from the home, 'there' in the distant 'outside' of the Gulf. The only way of effectively saving money was for men to get away from the home environment and to remove themselves to another place. 'There' in the Gulf, away from the social environment of the village, away from the context of continuous, necessary consumption, men could save money. In this other, 'outside' environment the rules of acceptable behaviour changed. In this different world of work, away from houses, there was a different kind of sociality where consumption was kept to a minimum. The circumstances that men lived in were extremely frugal. Most men had few possessions, at most their work clothes, a mattress and bedding, and some toiletries. As Azum Khan put

it in his story, when he moved from the garden he took with him all he had, a comb, a mirror and a piece of soap. Men saw that there was little point in accumulating things while they were working. Most of them lived transient lives, moving to find new work or better pay and conditions as they chose. Few established themselves permanently anywhere unless they found a steady job. Everybody recognised the precariousness of their situation; they could be sent home at any time and so there was little point in setting themselves up comfortably. Men's real attention was focused on their homes.

The different sociality of men's lives in the Gulf was emphasised by the reversals in normal behaviour from that of the home environment. Whereas the calculation of funds and resources was avoided at home, it was made into a virtue in the Gulf. Men were careful about what they spent and kept their day-to-day expenses to the absolute minimum. Most men talked about the importance of self-restraint in the Gulf, of hard work and saving. More indirectly the tales that they told me of life there played on the hard conditions that they endured and the difficulties that they had overcome. It was rare to find a man in the UAE who spent all of the money that he earned and sent none home. Those few who did so were usually unmarried. Most men saved all the money that they could, and generally lived very frugally in the place where they worked. Accommodation and food was shared with as many companions as possible to keep the expenses down. The rest of their money went as savings or was sent home monthly.

Older men especially, talked about the problems of young men in the Gulf. Many fathers were reluctant to allow their sons to leave home and travel to find work. They argued that the costs of paying for the visa and the travel would be wasted. A young man who did not work at home, whilst a problem there, became a liability when in the Gulf, using more resources than he created. A prime example of what could go wrong was a man who I knew who had spent nine years in the UAE without returning. In all that time he had never once sent money home and had never contacted his family even though the woman he was engaged to was living in his father's house. He never had employment for long and he spent all that he had earned. Other young men seemed to aspire to a life of ease in the Gulf; they hoped for an easy job in an air-conditioned shop or office and dreamed of spending their money as they chose with their friends in the city going to the cinema, to

restaurants and to cricket matches. The reality was usually very different but their dreams emphasised their relative lack of responsibility and maturity. Those young men who were more conscientious recognised the dangers to them of living in the city where the expense made it almost impossible to save. They knew that it was better to labour in the rural, mountainous areas where there was nothing to do other than work and save.

The ideal type was the frugal, almost miserly man who worked hard at a regular job and who sent money home every month. Those who lacked a sense of responsibility through lack of maturity were condemned as wasteful and a burden for spending rather than saving. Outside of the normal social sphere of the home and the village, spending money became problematic. Indeed, even for the frugal man, saving and not spending was something that had to be worked at. Azum Khan, like other men, talked about his inability to deal with money and his unreliability in saving it. As a solution he handed over his savings to Abdulhai's brother, Abidullah, whom he trusted implicitly, and let him look after them. This took the worry away and meant that just before he went home he could collect what he had accumulated without having to deal with a bank. This was a system that many men from Kohery used. The informal saving system was seen as highly effective and reliable. Money was saved by one whilst being used by another. At the same time, those who considered themselves as irresponsible could pass on the burden of restraint to another whom they could trust.

As much as possible, men tried to recreate their lives at home, basing their lives in the Gulf around existing family ties. However, there was very little emphasis on visiting and hospitality other than the bare essentials. Men visited each other only when time and their circumstances allowed, usually Fridays and religious holidays. In emergencies such as illness, groups of kin gathered to offer emotional and financial support. Other than these events, there was none of the usual round of constant visiting that marked village life. In the main there were few opportunities because the work was so hard, but there was also a conscious attempt to keep spending to a minimum. Only a very few individuals in the UAE involved themselves in large-scale hospitality and feast-giving. Abdulhai for one held occasional *kheyrats* and organised celebrations at Akhtar and other religious feasts. He, however, had brought his family to the UAE, and had two of his brothers there

with him as well. A large part of his family life was based in the Gulf and so it made sense for him to continue his life much as normal there. In addition he was the focus of many village networks and so men from all parts of Kohery visited him regularly in the UAE.

As I discussed in Part I, in their stories of migration men presented themselves as honourable. Their main claims to honourable status were having endured hardship and having suffered, not for themselves but for the sake of their families. This selfless devotion to home and family justified the interest in money that they needed to have in order to save. It was only because the resources that they acquired were destined for the use of families that they could give so much attention to this activity. The questionable activity of saving was also made safe by the fact that it took place in the different social world of 'outside'. Once the money was returned to the social world for consumption a different set of values took over. In the village the spending of remittance money was not an individual activity but one that was organised by social groups, in particular the household.

MEN SAVE BUT HOUSES EAT

While it was individuals that saved, it was houses that ate. The money that men saved, then, was brought back home to Kohery where it was pooled within households to be spent jointly. Money was sent back to the head of the household where it was expected to be used for the good of all of its members. Money was used to buy essential items like flour, rice, tea and ghee. Smaller households that could save some additional funds, put the money aside to build a new house or to marry off the children of the house. Men tended to emphasise the point that they were saving and spending not for themselves, but for their families. Thus Wahid Gul emphasised that the money is spent for 'your children' and 'for your children and your mother and father'. Even when men brought back single, luxury items like televisions and VCRs, they were said to be for the house, although in some cases they might end up in one man's room. Those men who kept money back for themselves, or who refused to pass on funds to the household head, were condemned as bad by the community. Many household break-ups were blamed on one member - usually a younger brother - who had withheld funds from the others. As the women emphasised to Debbie, even their own husbands could not single

them out with special gifts but would give all of their money to the house. Money and other resources were to be used jointly and equally by all of the family members. In this way it was houses and not individuals that ate. Indeed, houses could be said in some ways to be seen as social actors. Only houses and not individuals were described as *khrooskoo*, eating/drinking, and it was the houses themselves that were described as saving or eating.

Houses had their own recognisable life cycle; growing from small, saving households to large, eating ones. People described the cycle of development into a *khrooskoo* household as a recognisable pattern. Small, new households formed when mature men broke away from their fathers and brothers. Because they were small, these households were able to save money though the man heading the house had to work abroad to do this. Whilst working abroad they would send some money home while saving whatever they could to build new houses for their families. On the first return trip after two years, they would start the construction of a brick and concrete house. By the end of the six months leave, all the money was gone and they would be forced to return to earn more. Thus the initial savings would be taken up by house building. As sons and daughters began to grow up there then came the costs of weddings, each one of which could use up years of savings. As the sons married and the family grew into a joint household, it would cost more and more to support, until all of the earnings were being eaten or consumed and no money could be saved. Thus households grew from small, nuclear households that could save to large joint households that could only eat or consume.

This household life cycle depended entirely on the consumption of resources brought from outside, from the Gulf. Whatever resources there were in the household were consumed immediately. Saving was seen to be impossible at home as houses would continuously consume everything that was produced or given to them. This was certainly true of the profits of small businesses in the village. Those who ran shops or transport businesses professed not to be able to work out their profits since they were 'eaten' immediately by their households. As much as business owners were unable to keep up with the needs of their households, they often made little attempt to keep any records of their income or outgoings. It was equally true of money sent or brought back from the Gulf. As soon as it arrived it was gone, I was often told, eaten by the house. Regardless of where the money

came from men said that houses consumed all of the resources that were given to them.

Men recognised the fact that they were the ones who were involved in spending or eating the money saved. When there was talk of uncontrolled spending, it was usually the men who were doing the actual spending. A friend, Azum Khan, often used to say that it was impossible for him to go to Timirgara, or even to the local shop without spending all of the money in his pocket: I see fresh vegetables and I buy them for the house, then I see a toy and I buy it for my son, the money is soon gone. More generally there was an attitude amongst men that money at home was there to be spent. Wahid Gul gave voice to this attitude when he said:

If you have a pocket full of money and you are hungry, then what good is it. If you save all of your money and don't build a house for your children, then it is no good. It is better to have a full stomach and a new house for your children and have no money.

The points being made were, firstly, that what mattered was the present. It was better to use the money now for the good of the family and not worry about the future, which could be assumed to take care of itself. The second point is best illustrated by comments that Zahoor made in another context when he explained to me why *khrooskoo* houses were a good thing. As he put it: "What are you going to do with the money if you die tomorrow. For a rich person, on judgement day there will be a lot to be judged". Too great an interest in money was seen, then, as being a bad thing. Therefore, men, in the way that they talked at least, tried to demonstrate a lack of interest in money. They talked in 'easy come, easy go' terms. The rhetoric was of continuous, uncontrolled spending and the attitude was, if we need more then God will provide.

WAYS OF EATING

The spending of money was described as uncalculated and uncontrolled in the sense that it was used up as soon as it arrived and could not be kept or saved. Men spoke in this way to deliberately mark their lack of interest in the accumulation of money. When I tried to ask questions about the expenditure of individual households, people were confusingly vague. While much of the everyday conversation revolved around prices and money sent home from the Gulf, when it

came to what they spent, people were either unwilling or unable to make even rough estimates. Those who did show too great an interest in money were likely to be ridiculed and labelled as misers. The ways in which money was spent were, however, subject to much greater controls. In Kohery, people expected each other to take part in similar patterns of household expenditure. People tried to conform to the notion of continuous consumption of resources.

All households in the village engaged in very similar patterns of expenditure and there was often little to tell the rich and the poor apart. There was, for instance, little variation in diet. Most families ate bread, yoghurt, and a dish of vegetables cooked in a sauce. A few had switched to eating rice, or a mixture of bread and rice, though this was more a matter of taste than wealth. Nobody ate meat every day, usually the most people had was a chicken cooked for the visit of a guest. Some, like Zahoor, reckoned that the less well off had a better diet than those with more money. As he put it, the poor had few pleasures other than food, while the rich loved money too much and tried to save more by giving their families only bread, yoghurt and raw onions. In terms of appearance, too, there was little to mark people apart as far as their clothing went. Only a very few families could not afford new clothes and they were often helped out by their relatives and neighbours. Men's styles of clothing were all very similar and the colours that they wore were restricted to dull greys, blues and browns. White clothing had become something of a sign of status and piety, though it was almost universally worn. Women wore a dazzling array of synthetic fabrics in every colour and liked to have new outfits for special occasions. Much of the fabric was brought back as gifts from the Gulf where a much greater selection was available. New fashions were soon copied by others and were not seen as a sign of affluence or position.

There was some variation in the household items that people owned, the main ones being cassette players, televisions, VCRs, fridges, electric fans and latterly satellite dishes. Those who had the money bought them and many men brought items back with them from the Gulf. As so many households had men working in the Gulf all of them had access to these things which were regarded as luxuries. There seemed to be little prestige attached to owning them and certainly there was no stigma to being unable to afford them. Indeed, in many cases it seemed to be more a matter of personal choice about whether a family owned luxury items or not. Other, even

more expensive items, such as air conditioners, washing machines and saloon cars were regarded as desirable but essentially of little use in the village. They were talked about as being purely luxurious but they could quite easily be done without. In fact, on various occasions people pointed out that the difficulties involved in actually using them made them not worth having. Thus, an air conditioner would have made some days more bearable but it was not strictly necessary in the cool of the hills and was expensive to run; a washing machine would be impossible to plumb in and, besides, women had plenty of free time already; and a saloon car might look good but it would soon be wrecked on the rough tracks and in the meantime you could not even transport anything in it. For some items, like televisions and VCRs, there was a certain amount of status attached to not owning one. Televisions were said by the grimmer fundamentalists to encourage staring at women and so it was better not to have one. When Layq Mohamad brought a new television back from Saudi Arabia his father, Naarhamudin, made him sell it immediately to keep the family in Abdulhai's favour.

Almost every house in the village was new, built from bricks, breeze blocks and concrete. There were few of the old style wood and stone houses left inhabited and they were mainly in places like the centre of the village where it was difficult to rebuild. Every household had either built a new house, aspired to building one, or was actively saving towards it. In some places families had built houses in the 1970s in the new style but using old materials. Many of them were saving, planning to start rebuilding again. Each year, in the spring, there was a new spate of building as men returned home with saved money for a new house or additions to an existing one. In the summer of 1993 alone in the Bagh neighbourhood of just 25 households, two new houses were built and two others had major additions. The costs of building had inflated enormously, especially when people started using new building materials. Wahid Gul explained to me that when people built stone and wood houses most of the materials were available locally. With the advent of the brick and concrete house, the materials - brick, cement, sand and reinforcing steel - cost a lot to buy and to transport. In addition to the materials, came the costs of skilled labour in pouring concrete roofs and plastering. One man I knew, who built himself a relatively simple three roomed house, reckoned that he had spent about Rs 200,000 in all. Households, then, put years of their savings into building a new house. The houses, though, were very similar in style and the main variations were

in scale and innovations such as en-suite bathrooms with 'flush systems'. There was a tendency for families to build houses with a room for each married couple so that people did not really compete in terms of scale. Ostentatious houses were not really appreciated, they were seen as being an unnecessary waste of money and the owners were generally ridiculed.

Even large expenditures like weddings had little to mark them apart other than details. Whatever the financial status of a household, it was expected to put on a large celebration, often incurring crippling expenses. A wedding could cost the groom's family anything up to Rs 100,000. Celebrations were all remarkably similar and what had been innovations - serving rice and the use of a cook - were quickly adopted by everybody. The main signs of difference were the scale of the feasting and the number and status of the guests who attended. The community, in the form of the village council, had taken steps to limit the amounts spent on weddings. They had introduced measures to limit the amounts given as bride gifts and bride wealth and also the scale of the celebrations. These new rules were regarded as necessary and good and so everybody in the village followed them. When it came to poorer families, who could not afford to celebrate on such a grand scale there were many who went to great pains to point out that a small wedding was not necessarily a bad thing. Zahoor, for example, went on at great length about a wedding that he had attended where the family had made all of the preparations, including the cooking themselves. He talked about how much he had enjoyed the plain food that was like people used to eat. He also made disparaging remarks about the spicy food that the local cook prepared and the filthy conditions that he worked in. In this case he was actively trying to play down the importance of the differences that were so obviously there.

While spending was carefully uncontrolled, what the money was spent on was equally carefully controlled. The emphasis of a lack of control over resources was the same throughout the community, everybody spent all that they had. At the same time, there were only certain areas where the money could be acceptably spent; food, housing and weddings being the main ones. Expenditure in these areas was expected and encouraged, but equally to spend too much on the wrong things was something that was discouraged and even condemned. The realms of taste and the limits of consumerism were decided by the group. Those who took too eagerly

to the newly available consumer world were restrained by the condemnatory comments of others in the community. These could be said to be ways of socially managing desire. The community as a whole found ways of establishing new rules of consumption, deciding what counted as acceptable expenditure and what was unacceptable.

THE MISER AND THE SPENDTHRIFT: MORAL TALES AND THE MANAGEMENT OF DESIRE.

The ways in which others spent money was a matter for continuous public evaluation and judgement. The terms in which these judgements were made and the tales that were told around them were in themselves interesting. They give an idea of the moral evaluations that were being made of others. The most obvious is the contrast drawn between the miser and the spendthrift. The word most often used for miser was *shoom*, which literally means a sip or a small amount. The word, used to describe a miser, had both good and bad connotations. At its worst to call somebody a *shoom* was to imply that they had too great an interest in money. According to Zahoor a *shoom*, though he was rich, would make his family eat only bread and raw onions all year round. He has plenty of money but he will not pay off his credit and will take as much as he can get. On the positive side, a *shoom* is a person who is careful with their money, who saves it for a rainy day. The evaluation, good or bad, depended very much on the intentions of the person; whether the person was interested only in money for its own sake or was interested in money to help their family. A far worse term for miser was *kanjoos*, which I was warned against using as it would have been taken as extremely insulting. *Kanjoos* had only the bad connotations of one who loved money for its own sake and was used as a condemnation of an individual.

The word for greed, *hayras*, could also be used as a term of abuse. To call somebody greedy was to say that they were only interested in themselves and wanted to keep their money and possessions away from others. Grima, in her analysis of Pukhtu emotion concepts, singles greed out as particularly bad. She compares the concepts of greed and envy and argues that "Both greed and envy are considered destructive and antisocial, but envy is tolerated as inevitable, while accusations of greed are often used to denigrate and harm people" (Grima 1993: 35). The real damage, then,

comes from a lack of concern for others or too great an interest in money or things. Thus, a person who is miserly out of concern for others is acceptable and even amusing. On the other hand those who are greedy or miserly out of love for money in itself, are to be condemned as potentially dangerous. The *kanjoos* is capable of ignoring the needs of others in order to follow their quest for money; they will make their family eat only bread and onions or even go hungry in order to satisfy their own desire for greater wealth.

At the other end of the scale is the spendthrift, the *sakhee*. Zahoor characterised himself as a *sakhee*. He described a *sakhee* as a person who gives money freely away to others in charity, who lends money to those who ask and buys things for those in their own household without stopping to calculate or to worry about their own future needs. Because they use their money to benefit others and not themselves, it is thought that, however much they give away, when they themselves need money it will come to them. They are in some way especially blessed by God for their unthinking generosity. The *sakhee*, then, contrasts with the miser in two ways. For a start the *sakhee* uses money without really stopping to consider or calculate; they are demonstrably uninterested in money. In addition, though, what interest they may be thought to show comes from their wish to use it for the benefit of others; in other words, to use it only in social ways. The danger that the people of Kohery are aware of is that too great an interest in money can lead to the exclusion of social relations. The *sakhee* is seen as the perfect person, using money unthinkingly, trusting in God and using money only for social purposes. The real danger lies in the greed of the true miser. For the miser an interest in money replaces a proper interest in social relations and money is saved for its own sake betraying a lack of trust in God.

Just as dangerous, though, are those who used money incorrectly. Again money is seen to have the potential to disrupt normal social relations. The fear of this is reflected in the notion of blessing, *barakat*, which is closely linked to the idea of the miser and the spendthrift. In certain cases it was held that people were unable to profit from what they produced because of a lack of blessing, *barakat*. The term is derived from religious sources and was explained to me using examples. As Zahoor put it, if there are only two glasses of water for a large group of people and a prayer is said over the glasses, then the water will satisfy the thirst of all those who are there because there is *barakat*, blessing. On the other hand, if there is a lot of water

but few people and no prayer is said, then the water will not satisfy their thirst because there is no *barakat*. In a similar way, it was explained to me, there is no profit to be made from money or anything else that is obtained dishonestly. Money made by those who have bad intentions has no *barakat* and is used up quickly without profiting the person. Various stories were told to back up these claims. For example, Wahid Gul told me about one man in Kohery whose brother had died. The man quickly took over his brother's fields and gave nothing to his widow, refusing even to help her as he was expected to do. As a result, although he had a great deal of land, the grain that it produced was quickly used up and he had to buy flour from the bazaar. Another man, who worked in Saudi Arabia, used to cheat the owner of the shop where he worked and so was able to bring home large amounts of money. The last time that the man came back to Kohery, however, the money that he brought back was finished so quickly that he had to borrow money to buy his ticket back to Saudi.

Similar tales were told of those who spent their money with little thought for others and with only their own position in mind. Such people were described as *loowee*, a term used about those with new-found wealth who looked down upon the poor. As Wahid Gul put it, such people, *lar ta na gooree, asman ta gooree*, don't look at the path but look only at the sky. The disapproval of those who ignored their roots was evident in the moralistic stories told about them. One family in Kohery was formerly very poor and never even had enough food in the house. However, they managed to send two brothers to Saudi Arabia and another to the UAE. They became very rich, but at the same time people said that they had become *loowee*. They would no longer speak to and socialise with their neighbours and so they were no longer liked. They were then affected by a run of bad luck. First one brother in Saudi Arabia was involved in a car accident and had to pay out the crippling amount of 100, 000 Riyals in compensation to the Arab involved. At almost the same time, the brother in the UAE was involved in a similar incident, and to cap it all they had their pickup in Kohery stolen. All of this bad luck reduced the family to relative poverty again but, as a result, many said that they became better people.

In another case, a man from Malakand got a job working in the army in Saudi Arabia. He became very rich and at the same time many considered him to have

become *loowee*. One sign of this change was that he built the biggest (and possibly the ugliest) house in the village at a cost of Rs 800,000. Most people considered that he had done this merely to show off his new found wealth. Just as he had finished the house he received a letter from Saudi telling him that he had lost his job and that he should not return. The moral of the story was that he had invested all of his money in the house and had nothing to live on. Those who are judged to be *loowee* are thought to show too great an interest in what money can bring. They also believe that their wealth can alter their former social relations and improve their standing in the community. The moral tales told about them demonstrate quite graphically the dangers of such misguided thinking and warn others away from trying to replace proper social relations with wealth.

The comments and judgements that I heard drew attention to two types of 'deviant' behaviour; not spending money at all and spending money on the wrong things. When it came to not spending money, there were two models of behaviour, one deviant and one ideal. They were, respectively: the miser, or greedy person who ignored their social responsibilities in the interests of money; and the spendthrift who ignored money in the interests of their social responsibilities. The moralistic stories about those who spent their money on the wrong things substantiated this view. They portrayed the individuals concerned as deviants whose incorrect behaviour was ultimately doomed. Those who were called *loowee* were judged to have allowed money to come between them and their social responsibilities. Such tales, and the moral ideas that surrounded them, were an effort towards the management of desire. They defined the safe limits of desire for money and material goods and emphasised the overarching importance of social relations. This was something that was further emphasised in the contrasts that were drawn between Kohery and the surrounding villages.

PEOPLE IN KOHERY HAVE GOD: SIMILARITIES AND DIFFERENCES

In comparison with some other studies of communities of migration (see for example Gardner 1995 and Osella and Osella 1994) there was a remarkable lack of internal differentiation in Kohery. Gardner describes the situation in the Bangladeshi community of Talukpur, where involvement in international migration had led to increased economic and social polarisation. Those who had access to the

resource of migration were able to transform their economic circumstances which set them apart from those who did not have access to this resource (Gardner 1993, 1995). In Kohery the situation differed in that almost every household was involved in migration so that they were all in a similar position. That is not to say that there were not substantial differences in the economic positions of households. Those who had substantial land holdings were in a much better position to use their remittances to develop new enterprises, while those with little land were wholly dependent on their remittances. Nevertheless, all households in Kohery were to some extent dependent on migration. As Cohen suggests, what is important "is a commonality of forms (ways of behaving) whose content (meaning) may vary considerably" (1985: 20). What is interesting is that people in Kohery played down the differences between households and emphasised the similarities.

People drew attention to the various ways in which they, as members of the same community, were similar. In describing their arrival in the area they emphasised their shared status as incomers and as dependants of the Nawab and local khans. Talking about the past, they drew attention to their common poverty. As Abdul Hadi put it, everybody's land was no good, we all relied on the rain, if there was no rain then we all went hungry. People described their situation in the 1990s in much the same ways. All households were described as *khrooskoo*, they were all in the same financial position, reliant on money from migration to eat and drink. At the same time, most households lived in the same ways, they lived in similar houses, wore the same clothes and ate similar food. Again, people tended to emphasise the point that there was little variation in spending between households. What differences there were, they played down in these descriptions of community history and life. In Kohery people seemed to agree with Cohen's suggestion that community is an aggregating device, a way of creating commonality (1985: 20). The main differences were to be found in comparisons with other communities.

Those in Kohery frequently compared their community with the villages that surrounded them. Banda was in a sense used as a counter example for Kohery; it was seen as a place where the sense of community had broken down completely. Feuding was very prevalent in the village and intense jealousy of the success of certain families had led to cases of theft and the destruction of property. In the summer of 1993 a particularly ugly feud broke out in which several children were among the victims. The deaths were a source of continuous discussion for many weeks and seemed to cast a pall of depression over the whole area. The root causes of the Banda's problems were seen to lie in the people's attitudes towards money. Too great an interest in money for its own sake at an individual level had resulted in the breakdown of social relations between households which was reflected in the lack of a real community.

In other ways, too, self-interest had led to further breakdowns of the village fabric. Pride and jealousy among the families of Banda had meant that the village council had ceased to operate, since nobody was willing to listen to them or obey what they said. As those in Kohery pointed out, the people of Banda took no pride in their community and could not even agree to build and maintain a new mosque. Safaray,

on the other hand, was held to be an intermediary example since they had taken the example of Kohery, they had become 'intelligent', *hookhyar*. They were said to have put aside an interest in money for its own sake and had begun to see its real value by investing it socially. In other words, they had realised that money was only there for the good of families and the community. Thus, the people of Safaray had begun to build houses for themselves and had in the process begun to develop proper social relations. The social investment of money had in turn led to the development of many businesses in the village and to a growth of interest in community symbols like the main mosque.

The appearance of the community was seen as an expression of the behaviour of the members of that community and their beliefs. The new houses of Kohery, the well-kept mosques and many businesses and vehicles were living testimony, not only of the strong sense of community, but of the fact that the people valued social relations over money. The poor houses of Banda, the single, run-down mosque and the absence of vehicles and businesses was taken as an outward sign of the fact that people were interested in money for its own sake, which resulted in jealousies and the breakdown of the community. Safaray was on the road to reform. Previously the people had, like those in Banda, been interested in money for its own sake. They had, however, changed their attitudes to ones similar to Kohery and the rapid improvements in the appearance of their community were an expression of this. The people of Kohery used these differences in appearance to draw attention to both the differences in behaviour between the communities and the similarities in behaviour within their own community.

The problem of styles of consumption is a theme that Stirrat addresses in his description of a fishing community in Sri Lanka (Stirrat 1989). There money was seen as dirty and there was a recognised danger that it could upset the normal and correct order of life (Stirrat 1989: 98, 99-100). Stirrat identifies two spheres of consumption (Stirrat 1989: 108). In the first, which is concerned with the reproduction of households, variations in income had little effect on life-style. Similar living conditions and a shared life style were regarded as part of the community identity. Indeed, "To live differently was essentially to say that one wasn't really a fisherman but was trying to be something else" (Stirrat 1989: 103). The second sphere of consumption was concerned with high value status objects

and was one of competition between households. Stirrat argues that this sphere was part of a cultural struggle with the Sinhalese middle classes over the value and meaning of marker goods (Stirrat 1989: 109). This leads him to identify the problem of money and its use. As he puts it "The two styles of consumption effectively demonstrated the ambiguity of commodity exchanges: on the one hand it creates collective identities...and on the other it creates isolation, particularism and competition between what are so often seen as the 'natural units' of society" (Stirrat 1989: 108). The latter effects were something that those in Kohery tried to play down by emphasising the similarities of their circumstances.

As I have argued, in Kohery the living conditions and life styles of households were very similar. To paraphrase Stirrat, it could be said that, in Kohery, to live differently was essentially to say that one was not part of the community. There people used the examples of the miser and the *loowe* to demonstrate the point that to live differently was to break effective relations with kin and neighbours. However, unlike the situation described by Stirrat, in Kohery the importance of the second sphere of consumption, in high value goods, was suppressed by the same sense of community solidarity. Competition was seen as less between households and more between communities. Thus, people played down the differences between households within the community on all levels of consumption and emphasised the differences between communities in styles of consumption. The people of Kohery sought to outspend their neighbours in Banda and Safaray, the better to emphasise their own correct attitudes to money, and their own trust in God. This ambiguity between community solidarity and competition is an issue dealt with by Gell (1986).

Gell, in his description of the Muria Gonds, suggests ways in which this basic ambiguity of consumption can be solved (Gell 1986). The financial circumstances of the Muria Gonds have improved dramatically over the last decades and their new wealth has given them the opportunity to engage in consumerism for the first time. However, even among the wealthiest families consumption is severely restrained and there is little competition between individuals or households. In the Muria understanding, collective identity is paramount so that consumption is subsumed to the need to display commitment to the village. Items for consumption are singled out and incorporated into a collective style which all Muria try to approximate to as

best they can (Gell 1986: 122-3). Consumption, then, is not associated with competition, rather, the emphasis is on collective style. As Gell rather neatly puts it "The Muria are dedicated followers of fashion, followers being the operative word" (Gell 1986: 123). Where existing notions define what should be purchased and how these items should be used and displayed, the process of consumerism becomes a creative rather than a destructive one.

In similar ways to those described by Gell for the Muria Gonds, the people of Kohery emphasised a collective style of consumption. Daily expenditure and life styles were remarkably alike, but the similarities did not end there. As people pointed out, households grew in the same way and their major expenditures were the same; first the new house, then came the weddings of its children. The appearance of the houses was the same and their contents varied little; innovations were quickly adopted by others. Every household strove to put on the best display it could for a wedding, and, at the same time, the community through the village council attempted to restrain the overdevelopment of these celebrations. The main contrast was with neighbouring communities. Consumption was used to create an identity as the members of a particular village. The contrasts were made to emphasise that Kohery's style of consumption was the correct one. Nevertheless, there was still a feeling of unease about money generally.

THE PROBLEM OF MONEY

There was an underlying feeling that it was money that was essentially problematic. This feeling was most obvious in the way that people compared the situation two or three generations ago with that of the 1990s. People recognised the fact that things were much harder at the time of their grandparents. They talked about the poverty then and knew that people were often hungry. And yet, everybody agreed that their grandparents were much happier than people now. As Azum Khan commented to me, although people have all that they need now, they are unhappy; in their hearts they are unhappy, *zla ki khpa day*. Abdul Hadi, who had experienced both poverty and the comfort of money, elaborated. This unhappiness of the heart came from a constant desire, *arman*, for more than what they have now. When a person has money they always want more money, when they have things, such as a house or a car, then they always want more things. Abdul Hadi even went

so far as to link this unhappy desire to the coming of money. Others, like Azum Khan and Wahid Gul disagreed, and suggested that it was the desire itself that was wrong and not the money. The problem that money presented was that it almost inevitably led to the desire for more money or for the things that money could buy. These desires, if not properly channelled, could replace a concern for social relations which, in turn, could lead to their breakdown. People in Kohery, however, saw that there were various ways in which these problems could be resolved.

The main problem was that the act of saving money was a suspect activity that suggested too great an interest in money. A solution to this was to say that the activity of saving was only possible in a place outside the community. Thus, saving could only be successful 'outside', in the place of work, in an antisocial world where normal attitudes could be reversed without harmful side effects. In the UAE and Saudi Arabia, then, the social world was incomplete and was deliberately kept that way since the important world lay at home. As a result careful calculation of resources and the accumulation of savings became normal and acceptable activities since they could not result in the damaging of social relations. At the same time, this 'over-interest' in money was justified as being only for others, for the family. These justifications were evident in the tales of the 'selfless migrants', those who had endured hardships and overcome problems in order to ensure the better life of those they loved. Without families at home, working and saving became a pointless exercise. Throughout all of this was the constantly reiterated desire to return home, to the social world.

Men drew, not on a single view of masculinity, but on a variety of images of how they should and should not behave in different circumstances (see Loizos 1994, Osella and Osella 1994 for comparisons). In the home environment uncontrolled and uncalculated expenditure of resources was seen as the norm. There, in the village, the miser was dangerous because of his greed and his antisocial nature. In many senses the perfect example was the spendthrift, a person who spent all their money on others, without thinking of themselves and trusting in God for more. In the work environment, where saving was the norm the images were almost totally reversed. In the Gulf the calculating, 'miserly' behaviour of the saving man seemed reasonable and made sense. The reverse was true of those who spent, the prime example being the *lopa*, a young man, unaware of his responsibilities, who spent all

of the money he earned on himself and sent none home. Out of the home context, where there was no family to spend money on, then the act of spending became unreasonable and antisocial. At the same time, even in the 'outside' world of work, the act of saving still indicated at too much of an interest in money. Therefore, money was passed on to another trusted individual who could act as a restraining influence. Men such as Azum Khan presented themselves in this way as being unable to properly deal with money and having to rely on others to help them act with restraint.

At home the reverse situation was true and men had to demonstrate to others that their interest in money was not for its own sake. Thus, individuals tried to demonstrate their real lack of interest in money for its own sake by describing their households as *khrooskoo*, as continuously eating and drinking, as consuming without stopping to calculate. Only in situations where the normal social relations had already broken down, where members of households were already arguing and a breakup was threatening, did people resort to the language of careful calculation. In these situations, when relations were bad anyway, people abandoned the usual rhetoric of sharing and non-calculation and reverted to the necessary language of 'that belongs to me and it was my money that bought that'.

In normal circumstances, however, most households took part in continuous consumption and circumscribed spending. In these ways money was invested socially and at the same time the differences between households were reduced. Each household invested heavily in its own reproduction and yet, because consumption was similar and circumscribed, there was little to mark them apart. The success of these strategies was made evident in comparisons with other villages. In Banda too great an interest in money was perceived to have led to a deterioration in social relations and the virtual collapse of the community. In Safaray the people, by changing their ways, had started to recreate their social network and had breathed life into their community again. The external appearances of the three villages was taken as a reflection of individual and household attitudes to money. Banda was old with few businesses and only one, uncared-for mosque. Safaray showed signs of redevelopment, while Kohery, with its new houses and numerous businesses and mosques, was the most successful of all.

While men saved in the Gulf under conditions of great self-restraint, they spent at home, as part of households, with a marked lack of restraint. Unrestrained and uncalculated spending became both necessary and inevitable. It was necessary in order for individuals to appear like spendthrifts, unconcerned with the accumulation of wealth and trusting in God for more resources. It was necessary also to use the money socially as part of a household and as part of a community. Spending was, at the same time, inevitable; it was houses, because of their size, their voracity and their unproductiveness, that 'ate' all of the resources that they were given. This inevitability detached individual men from the responsibility of spending money and, in a sense, detached them from the acts of spending. Men described themselves as having no real choice in the matter, houses 'ate' what they were given, thus detaching themselves from the responsibility of how the money should be spent. Agency was therefore displaced from men (and women) onto 'houses' as collective actors. Decisions about how money was spent were seen as more a matter of inevitability in properly supporting a growing household. The fact that it was houses and not individuals that 'ate' the money detached the men from the act of spending.

Men, then, denied the importance of themselves; they saved for others in conditions of great restraint and discomfort, they only took part in spending as part of a household. Men saw that they and the money that they earned were only really viable as part of households and communities. They solved the problem of how to bring 'dangerous' money into the social sphere, and themselves with it, by seeing themselves as an integral part of their households. The money was socialised by spending it entirely on households and the community, thus neutralising it and making it safe. In all of these processes, they did their best to detach themselves from the substance of money itself and the acts of accumulating and spending it. The identity of a truly mature man was based almost entirely on his responsibilities, firstly to a household and its members and secondly to a community consisting of related kin.

COMPARISONS

The problematic nature of the separation of the world of work from home life is something that anthropologists working on African labour migration have dealt

with. The Comaroffs, writing about the Tshidi of southern Africa, note that the words 'work' and 'labour' are contrasted (Comaroff and Comaroff 1987). 'Work' is a vernacular term used to describe work for the self, done at home; it "is the positive aspect of human activity, and is expressed in the making of the self and others in the course of everyday life" (Comaroff and Comaroff 1987: 163). In contrast, the term 'labour' has been adopted to describe work for wages carried out for whites. While it is regarded as necessary in order to earn enough money to support families, it has a generally negative evaluation because, "As rural Tswana have long said, migrant workers are 'outside' in forced exile to the realm of whites, they are external to the creative life of the community" (Comaroff and Comaroff 1987: 168). Murray, writing again about southern Africa, describes a much greater separation of the spheres of production and reproduction (Murray 1979). In the rural areas there is little employment and the predominantly female-headed households are dependent on the earnings of migrants, over which they have little control. The way that the two spheres are linked, though, is through the 'works' of the ancestors, that is through expensive investments in custom by migrant workers in their home community (Murray 1979: 339). Through this investment in custom, Murray argues, the social relationships broken by the economic situation are reconstituted (Murray 1979: 348). The problem that both the Comaroffs and Murray address is how to deal with this separation of spheres of production and reproduction, the world of work from the world of the home.

For the people of Kohery, the problem that they faced was the same as that in southern Africa: in order to support their home lives men had to work abroad. However, the focus of the problem for them was not on contrasting definitions of 'work' and 'labour' but rather on the role of money. In order to earn sufficient money to support their households, men had to move further and further from their homes. This exile from home life was seen as something positive in that it enabled the men of the community to take part in the potentially corrupting activity of obtaining money outside the home environment. In the anti-social world of 'outside', men could justify activities that would have been condemned at home. 'Outside' they could calculate, save and ignore their social obligations with impunity. The problem then became one of how to reintroduce saved money into the home environment, of how to safely link the two spheres of production and

reproduction without corrupting the latter. A solution to this process was the socialisation of money through its consumption in households.

Carsten describes the process by which money is socialised as a moral one (Carsten 1989). In the Malay fishing community where she carried out her research, the men earn money working as fishermen while the women work in the rice fields. Men bring the money to their houses where it is transferred to the women who manage household expenditure (Carsten 1989: 132). In spending money to reproduce the household "women create an association of households, a community, through the circulation of money for the purposes of the household, in other words, of domestic consumption" (Carsten 1989: 135-6). Women, in creating a community, are seen, therefore to have the ability to socialise money, to invest it with values and morality (Carsten 1989: 136). Women, through using money for domestic consumption have the ability to transform it into something moral.

In the situation described by Gardner, money was seen as transformative (1995). It was used by households to improve their economic and social status. In Kohery the situation was more similar to that described by Carsten, in that, through its consumption for households and by households, money was transformed into something social. The process of consumption was itself seen as something social because it was not individuals who used the money, but households that ate it. At the same time consumption was socially creative in the ways that Gell and Stirrat described. Particular styles of consumption were used to further enhance a sense of community. Consumption was circumscribed, so that what and how much was bought became expressions of that community. Money used otherwise or used incorrectly was seen as problematic and essentially destructive.

Parry and Bloch, reflecting more generally on the symbolic representation of money and the morality of exchange, suggest that there is a general pattern to be found in the totality of exchanges in various cultures (Bloch and Parry 1989: 1). They argue that there are two related but separate transactional orders. One is a 'sphere' of short-term transactions which is concerned with individual competition and the acquisition of resources. The other order is concerned with the reproduction of the long-term social and cosmic order (Bloch and Parry 1989: 24). Goods which are acquired in the short-term order are converted in the long-term order by a variety

of processes, described in various contexts as 'drinking', 'cooking' and 'digesting' (Bloch and Parry 1989: 25). Bloch and Parry suggest that it is important that the two orders be kept separate but that, at the same time, they must be related. Thus, while the long-term order is dependent on the acquisition of resources by individuals, the short-term order must be subordinated to the long-term (Bloch and Parry 1989: 26). The long-term order is always evaluated as morally positive while the short-term order is only evaluated as such when the resources obtained in it are converted to serve in the reproduction of the long-term cycle. The relationship between the two orders, then "forms the basis for a symbolic resolution of the problem posed by the fact that transcendental social and symbolic structures must both depend on, and negate, the transient individual" (Bloch and Parry 1989: 25).

The men of Kohery articulated many of the same concerns and theories as those suggested by Bloch and Parry. The world for them was very clearly divided into the 'here' of the village and the 'there' of the work environment. In this different social world of work, men could safely engage in the individual, acquisitive transactions associated with wage labour. The resources obtained there were brought back home and were there converted by being 'eaten' into the long-term cycle of reproduction of households. Resources obtained for this purpose and converted in this way thus became safe and social. However,

there is always the opposite possibility - and this evokes the strongest censure - the possibility that individual involvement in the short-term cycle will become an end in itself which is no longer subordinated to the reproduction of the larger cycle; or, more horrifying still, that grasping individuals will divert the resources of the long-term cycle for their own short-term transactions (Bloch and Parry 1989: 26-7).

In Kohery, the main area of concern was the corrupting potential of money on the individual. Thus, to accuse another of greed was a strong form of condemnation and the title 'miser' was a severe censure. To be greedy was to divert funds away from the social and towards one's own ends. To be a miser was to make the acquisition and saving of money an end in itself. The problem of money was that it diverted the attention of the individual away from their social ties and responsibilities, away from their role of providing for the social group and continuing the long-term cycle.

CLEANSING WEALTH: CHARITY AND RELIGIOUS DONATIONS

In talking about the socialization of money, the people of Kohery drew not just on local discourses of household and community reproduction but on wider discourses from Islam as well. For the people of Kohery, as for all Muslims, the Qur'an sets out a basic moral framework for living which covers all aspects of life. At the heart of this framework are the two opposing notions of *halal* and *haram*; *halal* is that which God has ordained and *haram* that which is forbidden. By following that which is ordained, *halal* and avoiding what is *haram* at all times, a person can live a life of servitude to God, of continuous worship or *'ibadat*, as Maudoodi puts it (Maudoodi 1976: 9). The Prophet Mohamad was himself, during the first part of his life, a successful merchant and so the Qur'an contains detailed instructions about the ways in which money should be earned, saved and spent. Again money and ways of making a living are covered by the notions of *halal* and *haram*. As Maudoodi describes it in his lectures to fellow Muslims:

For instance, you go out to earn your livelihood. In this pursuit, many opportunities arise for you to acquire forbidden (*Haram*) money easily. If, for fear of God, you abstain from that money and earn only *Halal* livelihood, the time spent in the latter endeavour is all counted as *'Ibadat*. And the bread you brought home, ate yourself and fed it with your wife and children and also fed those who are deserving of it as prescribed by God - for all these acts you become worthy of reward and blessings of Allah (Maudoodi 1976: 9).

To earn a living in a *halal* way, then, a person should avoid *haram* practices such as stealing, cheating and usury. The Qur'an and other related religious texts such as the Hadith particularly urge Muslims to avoid greed, to seek only to make enough money for their own immediate use and for their own future. To seek to earn more is not considered good, though those who are rich are not condemned outright. Indeed, those who have wealth beyond their needs are required to give a portion of this money annually in the form of charity, called *zakat*, so that they may keep the rest of their money with a clear conscience. Maudoodi explains that "*Zakat* means purity and

cleanliness. A proportion set apart in your wealth and for the needy and poor is called *zakat* because in this manner a man's wealth and along with it his own *nafs* (self) becomes purified" (Maudoodi 1976: 81). In the Qur'an itself the faithful are exhorted to "Take alms of their wealth and make them pure and clean" (Sura 9: 103). There are other ways in which excess wealth can be used virtuously, such as the giving of loans to those who need them which is considered to be similar to *zakat*. In these, and many other more direct ways, Muslims are given guidelines as to how they should earn their living and spend what they earn.

This moralistic framework was translated into everyday life in Kohery in ways that both fitted directly and others that developed the underlying notions. People emphasised the point that by going abroad to work they were choosing a *halal* way of making a living. As several people suggested to me, it would be much simpler for a person to make money in a *haram* way at home: it would be easy to take the gun from the house and go out at night and steal more than enough money. Instead, many men said, they go to work in the UAE or Saudi Arabia, often under difficult circumstances, in order to earn a living for their families. The emphasis was very much on the choice of a more difficult form of life. Men expressed two parallel ideas. Firstly, in line with Bloch and Parry's (1989) argument, they subordinated themselves and their activities to the reproduction of households and the wider community, to the reproduction of the long-term order. Secondly, in Islamic terms, they saw their subordinated lives as expressions of *'ibadat*, of continuous worship.

There were, however, differences in the ways that people drew on these and other Islamic discourses. In looking at weddings in Part III, I described the development of conflicts over traditional customs used in the celebrations. The conflicts were over individual elements of custom, such as music and the use of weapons, and the arguments were about the interpretation of these customs. Those in support of them argued that they were traditional Pakhtun customs, a position firmly based on the belief that a good Pakhtun was by definition a good Muslim. Those who fought against them sometimes described them as 'Hindu' customs and drew on a reformist vision of an ideal Islamic society. Their vision was of a universal Islam and was one that was used by national political parties in Pakistan such as the Jamaat-i-Islami and by international movements such as Tableegh. What I want to focus on now is the use of these wider discourses of traditional and reformist Islam in Kohery. To do this I will



Plates 19-21 - Scenes from
Mohamad Zahid's *kheyrat*

look at another area of major expenditure in the village, religious feasts or *kheyrats*. I will first describe what these feasts involved and the different ways in which they were discussed. To demonstrate the different uses that these feasts were put to I will concentrate on several individuals, all of whom made some claim to authority in the community.

KHEYRAT DESCRIPTION

Kheyrats were large feasts organised by a single household to which anybody was welcome to come. They were popular events and attracted large numbers of guests. Many households held them despite their obvious cost. By the 1990s *kheyrats* had become large-scale affairs, similar in the level of organisation needed, and the amounts of money spent, to weddings. In most cases a cook was taken on to oversee the food and all of the family's available *khpulwan* were drafted in to supply materials and assistance. The food was the same as at weddings, spiced rice and enormous quantities of meat, usually buffalo or cow. As at weddings, guests were invited in from outside to enhance the prestige of the event. The main difference between a wedding and a *kheyrat* was that at the latter anyone could attend, invited or not, and the hosts would serve them in the same way as anybody else. I had attended weddings when those around me muttered complaints about the treatment that they received. They compared the food that they were served with that being given to more favoured guests; a pile of rice with a few dry bones as compared to a great mound of rice covered with pieces of well cooked meat. At a *kheyrat* this was not permissible. All who came had to be treated equally as guests and served with the same. Certainly at the *kheyrats* that I attended, everybody ate together and nobody was set apart. Men and boys were served together and the meat was rationed evenly between them all. *Kheyrats* were particularly enjoyed by young boys who were sent in their droves to fill up on rice and to pick out a choice piece of meat. For those who could not attend - women, girls and men who could not leave their businesses - plates, bowls and bags of food were sent home. This was part of the overall importance of *kheyrats*; this equal treatment fitted with the message that they were given in the name of God.

Mohamad Zahid's *kheyrat*, arranged to celebrate his return from Haj, gave me the chance to see the organisation and costs that went into such an event. As Mohamad Zahid's closest friend, Wahid Gul played the role of one of the prime movers in the

arrangements. It was he who took on the cook, which in its turn decided which day the *kheyrat* would be held on. He also bought the printed invitations and, with Mohamad Zahid, wrote them, deciding on some of the more important guests. A whole range of other *khpulwan* were called on to assist in the various stages of organisation. About ten men and myself went one Friday after prayers to choose and chop down one of the family's trees on the hillside above the village, thus making a substantial saving on the purchase of firewood. The chopped wood was rolled downhill to the nearest point on the road where Mohamad Zahid's cousin, Ghulam Wahid, was waiting with a pickup to transport it back home. The costs soon added up, with the buffalo alone costing Rs 9000. After a wedding, a *kheyrat* was often the largest expenditure that a family involved itself in. The pictures that I have of Mohamad Zahid's *kheyrat* give some idea of the scale of things. The first photographs show the slaughtering and butchering of the buffalo and show the numbers of *khpulwan* who were involved. That afternoon, Mohamad Zahid's uncles and their families were there along with his mother's brother's family and a substantial number of his brothers-in-law's *khpulwan*. The later pictures show the cooking in progress, with a row of enormous copper cauldrons being used to prepare the meat and rice. The cooking and other preparations went on through the night ready for an early start the next day.

Having been very ill the night before, I arrived late in the morning to find things well under way. From dawn on, guests had been arriving to be served straight away from the enormous tub of rice and meat. Wahid Gul and Abdul Halim worked without break keeping up with the steady stream of food to be served. At times they berated those carrying the trays back and forth and urged them to hurry up. Mohamad Zahid hung around, wandering between the servers and his guests with an anxious expression on his face. The picture I have shows him posed by a group of happy eaters with a frown of perpetual anxiety instead of the customary solemn grimace. A great deal was at stake for him that day and he had to worry both about circumstances that were under his control and those that were not. For the *kheyrat* to be judged successful it was essential that all those who arrived were well fed with large quantities of rice and meat. Even those who came late in the day had to be adequately provided for, which meant careful consideration of how the food was served throughout the day.

INTERPRETATIONS - GIVEN IN GOD'S NAME

When I first came across the *kheyrat* I searched for a secular interpretation of these large and costly events. Whenever I asked, though, I was given religious interpretations of what they were supposed to mean. Wahid Gul and Sadiqullah told me quite straightforwardly that they were feasts 'given in the name of God,' that is given for the better glory of God's name. They stuck to this definition despite my attempts to give the events a more earthly meaning. As Wahid Gul and Sadiqullah said, and as many would have agreed, *kheyrats* were given not in the name of those who paid for them but rather they were given selflessly, 'in the name of God'. *Kheyrats* were held on various occasions, the most important ones being death anniversaries, the return of an individual from Haj, and the circumcision of a son. The first of these was the most common. If a family chose to and had the means, then on the first anniversary of a family member's death a *kheyrat* was held to commemorate them. Such a commemoration, I was told, helped that person and other dead souls in the eyes of God. In other words such *kheyrats* were selflessly given by those on earth to aid and commemorate those who had died.

People gave similar explanations for *kheyrats* held on the more celebratory occasions such as a return from Haj or a circumcision. The feasts were given without thought for the host but as a thanks to God. In discussing these feasts with me, people emphasised the public and charitable side of these events. Looked at from the point of view of poorer individuals in the community, *kheyrats* were a great opportunity to fill up on rice and meat with little or no returns. Those who attended may have felt some obligations to those who provided the food although the scale of the events and the religious interpretations given to them played down these obligations. While some guests attended mainly in order to eat, others came for social reasons, and still others came to make their allegiances public. Whatever their intentions or their individual status, all guests were treated in the same manner. *Kheyrats* were the purest form of public, charitable event; anyone and everyone came to them and all were served without question. Unlike weddings, there was no exchange between guests and hosts, *kheyrats* were purely a matter of giving on the part of the hosts. The reward for the hosts lay at one remove; by selflessly hosting such charitable feasts they hoped to find their reward from God.

The form of the *kheyrat* was of overarching importance. At one point Mohamad Zahid declared that he did not like buffalo meat but preferred chicken. He suggested, half in seriousness, half in jest, that he would prefer to buy one hundred chickens and feed his guests on them instead. People joked in turn that they would give him the nickname of the 'chicken haji,' unless he agreed to go along with the traditional food. The suggestion was quickly dropped though the point had been made. Although the whole episode had been treated as a joke, I think that the point being made was a serious one. People were concerned that the proper forms were maintained, that the *kheyrats* in the village all followed the same formula. Unlike weddings, *kheyrats* were not subject to innovation, the important thing was that they were all the same. Their sameness emphasised their role as charitable, ritualistic events rather than conspicuous displays and celebrations. At the same time only those who had extra resources could afford to take part in this feasting.

These public forms of charity were necessary for those with money to establish their personal and household status. Like *zakat*, *kheyrats* were used by those who were rich to cleanse their wealth. As Zahoor put it, for a rich person, on judgement day there will be a lot to be judged. The charitable, religious feast gave the rich a chance to demonstrate their generosity to the whole community. This could be seen particularly in relation to *kheyrats* held for those returning from Haj. It was suggested to me that without the *kheyrat* the person would not be entitled to the appellation *haji*; as Wahid Gul said, if you come back from Haj and do not have a *kheyrat* then nobody will call you *haji*. Thus, in Mohamad Zahid's case, the *kheyrat* became almost as important as his own Haj. It was as if his individual experience of Haj had to be marked and verified publicly in the form of a public feast in Kohery. Having matched the money spent on an individual Haj with a public act of charity, Mohamad Zahid was entitled to the appellation 'haji'.

An interesting comparison is with Anderson's description of leadership among Pakhtuns in Afghanistan (1978). Anderson, like Barth (1959) and Azoy (1982), argues that *khans* and other leaders achieve and maintain their position in part through offering hospitality to those who would follow them. In Afghanistan *khans* are said to 'feed the people', that is, they use patronage to develop a following. *Khans* use their own surplus to convert into social relations; offering followers employment, hospitality and other forms of favours (Anderson 1978: 169). Thus, to achieve position potential leaders have to be able to demonstrate that they have something to offer in return. As

Anderson puts it, *khans* are seen as creditors rather than 'lords' (Anderson 1978: 169). Those who are leaders are those with the ability to provide, whether it be representation, a visa for the Gulf or the occasional meal. By extension it could be argued that the same goes for titles like '*haji*'. In Kohery, people would not recognise the claims of rich individuals to such titles unless they could publicly demonstrate their religious generosity. In Mohamad Zahid's case, by demonstrating both his religious faith and his generosity, earned himself the title.

TOURNAMENTS OF CHARITABLE GENEROSITY

Those with excess wealth competed to prove their generosity and to earn their status as people of influence from the community. *Kheyrats* were the most public form of competitive charity but there were others that were thought of as being more secret, in the sense that the donor made no public announcement of their intentions. Nevertheless work usually got out and these forms of private donation brought with them public acclaim. Many of the smaller local mosques in the neighbourhoods of Kohery had been built through subscription, each family donating a set sum. In many cases individual families gave much larger sums, sometimes enough to build a whole mosque. After the mosques had been built people continued to donate large sums towards particular items or projects, such as a loudspeaker system, carpeting, a new roof or decoration inside. As all of the mosques in Kohery were well maintained through the efforts of their local communities, some individuals turned their public efforts to the villages around them. Gul Hamid, Mohamad Zahid's father, had, for example, donated enough money to build a large new mosque in the village of Safaray. Mashooq Jan, a local political figure, gave money for the loudspeaker system of the main mosque in Banda. Others looked further afield still and took on even greater commitments. It was well known that Abdulhai gave money for the monthly upkeep of a small *madrassa* or religious college in the valley below the village. The things that were stressed about these other donations were, firstly, that they were secret and, secondly, that they were given to benefit the community as a whole.

The first thing about these donations was that they were given in secret, the donor was not supposed to mention it to others and they did not have the full publicity of a *kheyrat*. Anybody who might have given such a donation in full view of the public would have been condemned as self-seeking much in the same way as some were

branded as *loowee*. Charitable donations given without seeking public attention proved both the individuals' generosity and their sincerity. Much as there was a form to the *kheyrat*, there was a form to other donations which emphasised their privacy and hence the individual's genuine generosity. The second point was that they were for the religious benefit of the community. Families did not build personal mosques or set up private schools or *madrassas*, such money would have been considered ill-spent. Rather they gave money for community mosques, either in their own village or, like Gul Hamid and Mashooq Jan, in a neighbouring village. Families, like that of Abdulhai, helped with the upkeep of local *madrassas* for the benefit of all the surrounding communities. Despite their secrecy, people knew about these donations and information about them, their frequency and the amounts involved was public knowledge.

To develop Appadurai's idea (1986), those who sought status and influence in the community engaged in tournaments of charitable generosity. Wealth and traditional position in the village were not enough, individuals and families had to develop and maintain their authority by seeking support and forming a body of influence. One way in which individuals could gain support was through establishing themselves as persons of generosity and faith. This they could do through religious feasts and donations. By giving feasts and donating money to alleviate poverty and enhance the community they established themselves as good Muslims in the eyes of that community. They used their wealth not to benefit themselves but to the benefit of the religious community to which they belonged. Thus in Gell's terms, the competitive uses of excess wealth were incorporated into the collective style (1986: 122-3). Those who saved their money rather than spend it on their family could be condemned as misers, while those who spent it on conspicuous, personal displays were called *loowee*. In the same ways, the rich who kept their money to themselves and didn't use their excess wealth to the benefit of the community were thought of as antisocial and had little influence or support.

Kheyrats and donations were measured one against the other and those involved were subject to the judgements of the whole community. The motives of the feast givers and donors were interpreted in the light of their other activities and judgement was passed accordingly. It was in these judgements that differences in the way that people drew on wider discourses could be read. Thus, some saw the possibilities of using *kheyrats* in a

more directly political way. The potential dangers of this strategy were illustrated in the events in Kohery of 1993. The events showed further that there had been a shift in nature of authority and leadership which reflected wider national shifts.

TWO FIGURES FROM KOHERY: THE RANGE OF PUBLIC POSITION

To look in more detail at what these various uses of money meant to the people of Kohery I want to take two figures from the village and examine their positions in the community. The two figures are Mashooq Jan and Abdulhai. For the benefit of a logical argument they could be placed at either end of a continuum with Mashooq Jan on one side as the most secular and overtly political and Abdulhai at the other as the most religious. What I want to look at is the way in which these individuals used both similar and entirely different methods to achieve their aims. In the case of Mashooq Jan it was entirely open and obvious what his aims were; he wanted to achieve and maintain political position in the village. In the case of Abdulhai his aims were, to me at least, less clear and here I want to make some suggestions as to what exactly he was up to.

Mashooq Jan was a severe, grim-faced man of about forty who was very aware of his position. Even at this age he was the head of Boodayee Khayl, the largest and most influential grouping in the village. He used this position and his place on the village council to influence a group of political followers, though this was not large enough in itself to keep him in power. Mashooq Jan was one of the earliest men to go to the UAE, following his brother Ghasurahman there in the early 1970s. Once he had established himself there he began a lucrative trade in obtaining and selling work visas to other men back in Kohery. Over the years he made a great deal of money which he invested at home in a variety of enterprises, including an official visa agency in the town of Timirgara. He also began to invest in political enterprises. As Abdul Hadi, a one time political ally of Mashooq Jan's, told me, over the years he had spent all of his money on rice and meat to bring him political supporters. What he meant was that he had sponsored numerous political meetings in order to attract support to himself and to the party that he belonged to. Mashooq Jan's political career had followed that of the national parties as he moved to follow whoever was in power in the government; first the PPP, then the Jamaat-i-Islami (JI) and latterly the Muslim League. As a member of the JI he was chosen as the consensus candidate for Kohery and was elected as the local

councillor for Kohery and Safaray. By 1993 he had lost his official political position but continued to invest heavily in maintaining himself as an influential figure in the village.

Abdulhai was a figure of influence of a very different order, keeping himself mostly to religious matters. He was an imposing figure of a man, both in physical appearance and in presence. He was part of Moolian Khayl, the religious family in Kohery, and he had followed the tradition of the family and the path of his father in becoming a mullah. After obtaining his education he first took up his profession in Karachi where he was highly successful, obtaining a large and devoted religious following. In the mid-1970s, he moved to the UAE, having heard that mullahs were in great demand there. After several months of struggling to find work, he was appointed head of a large, new mosque in a rural village called Masfut. As the town grew, he brought many of his fellow-villagers to the area, finding them visas and work in the businesses and gardens around the village. Though he never profited financially from obtaining visas, his influence among those from Kohery working in the area grew.

Unlike most from Kohery, Abdulhai invested a great deal in his life in the UAE. He brought his family to live with him, raised his children there and put money into a number of businesses in Masfut including a shop and several vehicles. More importantly, though, he was one of the few who held large scale events in the UAE, organising *kheyrats* and Akhtar celebrations. At the same time he invested heavily in Kohery, developing both his financial and personal position. He built the family a large house, bought land and invested in a tractor that was run as a business. Whenever he returned to Kohery - usually once a year - he held a large *kheyrat* that was usually well attended. In addition he donated money regularly to a local *madrassa* and to other religious causes. Despite his absence for most of the year Abdulhai retained a strong position in the village as a religious leader. Although he was not a mullah in Kohery, his ideas, edicts and example were highly influential in the village council and in the community as a whole.

At the two ends of the spectrum, then, Mashooq Jan and Abdulhai demonstrated different approaches to developing a body of support and creating a position of influence in the community. To deal first with Mashooq Jan, he utilised what were more traditional approaches to finding himself a position of political leadership. Initially I wanted to find a direct link between the process of obtaining Gulf visas for

others and developing political patronage. Abdul Hadi told me that Mashooq Jan had sold visas to others who wanted to work in the Gulf. Put in simple terms, men from Kohery wanted Gulf visas, these were obtained by Mashooq Jan who took money for them in return and thus a contract was concluded. At that point, as Abdul Hadi emphasised, the relationship was ended, there were no further obligations on either side and there was no more to the contract. The route to political position was a much more indirect one than I had first assumed. Mashooq Jan took the money back to Kohery where he invested it in the traditional political pathways. The money was put into attracting supporters to Mashooq Jan and the party that he belonged to through political meetings and feasts; as Abdul Hadi said, he spent all of his money on rice and meat. He put himself forward as a political leader, giving food and hospitality and offering representation and potential patronage. At the same time he utilised his position as head of Boodayee Khayl as a way to influence a political bloc that could, to a certain extent, be relied on. Where Mashooq Jan led, the other members of his *khayl* would follow, at least if they saw that it was to their advantage. Thus, I describe Mashooq Jan as a traditional political leader because he actively sought position and established himself through building up a body of support.

In 1993, however, Mashooq Jan came under a certain amount of criticism for his political manoeuvring. It became a running joke that you never knew from one day to another what party he was going to belong to next. The criticisms even came from those who were counted as his closest supporters, those who belonged to his *khayl*. Those who followed Mashooq Jan wanted a reliable leader and not somebody who so obviously tried to gauge the political fortunes of the national parties and merely tried to follow them. This in part reflected on his move from the JI to the Muslim League just before the 1993 elections. Mashooq Jan was reacting to the general disenchantment that many felt with the religious parties such as the JI and was trying to disassociate himself from them. These parties, it was argued, had used religious positions for political gain at the last elections and had no real or abiding interest in the issues that they had raised. Abdul Hadi spoke in proverbial terms when he told me:

Before the last election the leaders of JI shouted out that if they were the government then they would bring Sharia Law to Pakistan. When they were in the government after the election they didn't shout but only whispered, 'We want Sharia Law'.

In other words, having obtained positions of power they went back on their former promises. It was a dangerous game to play and in 1993 the religious parties paid the price and lost heavily in the elections. Mashooq Jan, too, paid the price for his political expediency. His shift from the JI to the Muslim League made it obvious to many that he had little to offer them in return for his political position. His support base foundered and his credibility in the community was severely shaken.

The contrast with Abdulhai, at the other end of the spectrum, becomes much more apparent when his methods are compared with those of Mashooq Jan. For a start, Abdulhai never sought to profit financially from obtaining visas for others from Kohery. And yet he worked hard in finding both sponsors and jobs for a large number of fellow villagers. Despite the claims that he gave the visas for nothing other than the repayment of the actual costs, it remained the case that Abdulhai would have formed an open-ended contract with those he helped. These men and their families would inevitably have felt a sense of continuing obligation to the man who had aided them in the first place. Abdulhai may not have sought to benefit financially but he would have known that he stood to gain in terms of influence. Thus, while Abdulhai did not actively seek to find position like Mashooq Jan, position would have come to him indirectly, through his influence.

In terms of influence, Abdulhai could be said to have had a head start, given his reputation as a charismatic figure. Some individuals were particularly effective at persuading others to agree with their point of view and follow their lead. A few of the elders on the village council, like Abdul Hadi, were admired for their abilities to argue and persuade. They were seen as having the wisdom of years but also of possessing the important ability to keep a cool head in an argument. On another level altogether were individuals like Haji Hakim Zada and Abdulhai, both of whom were highly persuasive and influential in the village. Both of them were said to possess the special quality of *roab*, which Zahoor described in detail. To have *roab*, he said, is to be respected and obeyed, though not through the use of force. Those who have *roab*, rather, inspire others to listen to what they say and to do what they want through fear of their anger or displeasure. Few have this quality. Haji Hakim Zada, who died in 1988, was still remembered for his influence over village affairs and for all that he was able to achieve. Abdulhai, while he was absent for most of the year in the UAE, was influential both in the village and among those working abroad.

Looked at carefully, Abdulhai's reputation had been built up over his career as a mullah. In part the foundations of this reputation were Abdulhai's ancestry as part of Moolian Khayl. In particular there was the family founder, the Moolian nika, about whom tales emphasising his religious piety were told. The family tradition was one of education and piety, a tradition that Abdulhai had followed zealously. Indeed, within Moolian Khayl, Abdulhai's father and Abdulhai himself were the leading figures in maintaining the family tradition and name. While other members of the *khayl* had become mullahs, they were, for the most part, workaday figures with little education to speak of (as Abdulhai's brothers would have had me believe). Abdulhai built on this family reputation by acting the part of the pious cleric. His appearance said it all; the large but well-trimmed beard, the solemn expression that seldom turned to laughter, and the crisp, white Arab robe and skullcap. His demeanour, too, demanded reverence; he seldom spoke other than on religious matters: when he spoke he dominated the conversation and his bearing was that of a man who expected deference and respect. Abdulhai further built on his reputation through his work in Karachi as a successful mullah with a large following. He also turned to the new Islamic revival, supporting its calls for Sharia Law in Pakistan and for a return to true Islamic values.

As a final example, I use another figure from the village, Gul Hamid, a close cousin of Haji Hakim Zada. Gul Hamid was a more indeterminate figure with some religious pretensions. He was a short, jovial man with a well-deserved reputation for his hospitality. He was part of the rich and influential Sauray Khayl family, one of whom was the head of the village council. Gul Hamid was the very first man from Kohery to go to the UAE; he went first in 1968 and had worked there ever since. In his time there he had obtained a huge number of visas for others from Kohery and a large community had developed in the town of Dhaid and around. Like Abdulhai he had never profited from finding visas, although he had also never sought much influence with those who lived around him. For a long time he had worked as the *azan*, the man who gives the call to prayer, in what had formerly been the only mosque in Dhaid, though it had since been superseded. The position of *azan* was somewhat unusual as it was semi-religious though it required no real education. Gul Hamid was, however, well paid and well treated with a month's paid leave annually. In Kohery he donated generously to the village mosques and, in 1992, gave enough to build a large new mosque in Safaray. The family also held large *kheyrats*, such as that of his son Mohamad Zahid. When in Kohery he tended to adopt certain signs of religious piety, such as white, Arab dress,

though he never held forth on religious matters. His main aim seemed to be to maintain his family's position in the changing climate of the village.

Gul Hamid and his family participated to a remarkable extent in religious spending without ever really seeking to be figures of influence. They held *kheyrats*, donated more than generously to large scale projects such as mosques and they involved themselves in numerous charitable acts. Indeed, it was said by Wahid Gul and others that the family's charitable donations were almost crippling to their household finances. However much as Gul Hamid and his son, Mohamad Zahid, sent home, the money was gone by the end of the month and more had to be sent for. At the same time, Gul Hamid played up what was a rather ambiguous religious position to the utmost. At times there was an air of tension between Abdulhai and Gul Hamid, as if the latter's claims to piety and position were rather too much. However, Gul Hamid was buying into the prevailing religious discourse more to maintain the family's position in the village than to attempt to influence. For others, it was less a matter of choice and more a matter of necessity. Mashooq Jan, for example, had to participate in a certain amount of religious spending in order to maintain his position as a serious political figure. The risks of buying into the religious discourse for political ends became apparent in 1993. By that time proving real devotion to religious causes and demonstrating one's piety had become part of the game.

These figures and their actions are comparable with the situation described by Appadurai as tournaments of value (1986: 21). Appadurai refers to these tournaments as status contests between those who hold power in society. In these contests the actors seek to redefine the cultural value of items and tokens to their own advantage. The contestants, through their strategic skills in diverting or subverting the "culturally conventionalized paths for the flow of things" (1986: 21), attempt to win status, rank, fame, or reputation. In Kohery both Mashooq Jan and Abdulhai participated in the same rounds of patronage and generosity, as was expected of any wealthy family. Both obtained visas for their fellow villagers, both took part in major public feasts at weddings and *kheyrats*, both gave religious donations to the community. Yet, their aims in doing so were entirely different. Mashooq Jan was an openly political figure who participated in order to gain influence and position. Abdulhai played a very different game. Through his actions he attempted to create a tournament of charity or generosity. He tried, through his words and example, to divert the cultural value of

weddings, *kheyrats*, and donations. He sought to redefine them as displays of piety rather than displays of conspicuous wealth. He foregrounded the religious meaning of such actions, which in turn affected their political meaning. While Abdulhai gained in his reputation as a charismatic, pious man, Mashooq Jan lost out as a man who used a religious posture for purely political ends. These individuals cannot, however, be seen as isolated cases, but have to be looked at in a wider context of change.

THE KHAN AND THE MULLAH: CHANGING STYLES OF LEADERSHIP

It is useful at this point to consider how other writers have analysed Pakhtun notions of leadership and to compare these to the situation in Kohery. The consensus in writing on Pakhtuns seems to be that the ideal notion of the Pakhtun leader is the khan, a man who achieves status through what he can offer to those willing to follow. Barth, in his analysis of politics in Swat, emphasised that the political system was built around individual choice (Barth 1959: 2). He argued that potential leaders built up bodies of supporters by manipulating contractual relationships with a whole series of supporters. Individuals were free to choose whichever leader they thought could offer them the most (Barth 1959: 2-3). In Kohery men tended to articulate their relationship with leaders, whether local or national, in similar contractual terms. Even the decision about how to vote in the national elections was talked about in terms of a contract, an exchange between the voter and the candidate. Anderson goes into even greater detail in examining notions of leadership in Afghanistan. Among the Ghilzai Pakhtun, khans were said to 'feed the people', that is they used their own surplus to convert into social relations through hospitality, employment and other forms of patronage (Anderson 1978: 169). At the same time they were said to 'tie the knot of the people', acting as self-financed public servants. Thus, their role as leaders was not totally self-serving, to maintain their position they had to be able to offer something in return. Like 'Big Men' in other parts of the world, khans had to tread the fine line between position and representation (Anderson 1978: 170). In Kohery, too, those who sought position had to have something to offer to their potential followers, whether it was good official representation, access to a Gulf visa, association with a good name or the occasional meal. Those who overstepped the mark and tried to force their ideas on those they led soon found that their position crumbled.

Analyses of the changing place and reputation of religious men in Pakhtun society give some context to an examination of the figure of Abdulhai. At a local, village level, the only real role for religious men was an ambivalent and rather lowly one, as the mullah. Mullahs occupy an ambiguous position among Pakhtuns, provoking a mixed reaction of respect and disdain. While the mullah was generally listened to in the mosque, outside in the community, to call somebody the son of a mullah was an insult. Ahmed, for example, described the village mullah's role as 'institutional', 'functional' and 'humdrum' and suggested that they were respected but not held in awe (Ahmed 1976: 53). The mullah's position was that of somebody paid to provide a service but with no real say in the community and no place on the village council. Edwards suggests that mullahs have a subordinate place in Pakhtun society and are considered as clients rather than equals (Edwards 1990: 91). Malakand in 1993 provided an example of this ambiguity when the village dismissed the mullah of the main mosque who was considered to have overstepped the mark in his criticisms of the community and its leaders. The message was clear, the mullah was considered as a functionary and was easily replaced. On a slightly higher level were those families who claimed descent from the Prophet, the *sayyids*. As Barth described them in Swat they occupied a marginal position in Pakhtun society. They often acted, quite literally, as buffers between rival Pakhtun leaders. They acted as mediators in their disputes (Barth 1959: 57), a role for which they received marginal land on the edges of communities or between them (Barth 1959: 11).

Finally there are the charismatic religious leaders who were said to arise periodically in times of crisis. Ahmed, in his criticisms of Barth's analysis, suggested that Barth had confused the distinct roles of mullahs, *sayyids* and charismatic leaders into the single role of the Saint. Ahmed argued that "Religious leaders, whether 'mullahs' or Saints, only emerge as natural leaders in times of great religious crises and usually against non-Islamic forces" (Ahmed 1976: 53). Edwards makes a very similar point in examining changes in leadership amongst Pakhtun refugees in Pakistan (Edwards 1990). He, too, argues that, while in normal circumstances religious men are regarded as clients, in times of threat and *jihad* or religious war, they may take on the role of leaders (Edwards 1990: 91). Edwards goes on to suggest that religious leaders played an important role in the initial resistance to the Communist regime in Afghanistan. However, as the war went on the situation began to change: so that, "Where the present situation differs from past conflicts is that a temporary condition became in

essence a permanent one, and the role of Islam has begun to change in the society" (Edwards 1990: 92). Part of this change has been the continuing and growing influence of religious leaders amongst Afghan refugees. Edwards goes on to describe this new influence and "the new status and authority of religious leaders who have come to occupy positions of power both in the religious parties and the camps and who, in the process, have sometimes relegated traditional leaders to a subservient role" (Edwards 1990: 93). I think, however, that the processes that Edwards describes as being particular to the situation of Afghan refugees are much more general to the area of Afghanistan and Pakistan.

General Ziaulhaq, during his long period of military rule, did much to increase the role of Islam in state discourse. Following his demise and the revival of full democracy in Pakistan, Islam had an important, if not dominant, place in the political rhetoric of almost every major political party. In particular, the message of Islamic reform was given a political face by the JI party which promised to introduce Sharia law to the country if they formed a government. Under Nawaz Sharif, and supposedly with the backing of the military establishment, a coalition of religious and secular political parties came to power. Religious issues and religious rhetoric came to dominate the political process. The level of political debate deteriorated, until by the time of the elections in 1993, it had become sufficient to label the opposition as un-Islamic to destroy the credibility of their policies and arguments. During the election campaign, the interim government found it necessary to ban political candidates from describing their opposition as infidels. The return of the PPP under Benazir Bhutto in 1993 was widely heralded by the media and middle classes as a victory over the religious parties and their ideas. Indeed, it seemed as if they had fallen entirely from favour, as parties such as JI managed to retain only two seats in the entire country.

However, the national discourse on Islam was not confined only to the state. Other organisations, like the Tableeghee Jama'at, operated on a national level spreading the message of reformist, universal Islam (see Metcalf 1993 on the Tableegh in India). Tableegh was particularly popular in many areas of the NWFP. Many men, and even some women, from Kohery regularly took part in its activities. Gardner also suggests that migration generally may have an effect, giving rise to a greater sense of 'being a Muslim' (1995: 243). These influences had obviously had a strong effect in areas like Dir, which was one of the districts which retained its JI candidate. The sense that the

1993 election was a victory over the forces of reformist Islam that had come to dominate the political arena has to be called into question by the events in Malakand in 1994. Even during the election campaign many in Kohery expressed their disappointment in the religious parties who had failed to bring Sharia law to Pakistan. In 1994 it was reported in the international media that the people of the Malakand Agency had enforced a blockade and strike to force Bhutto's government to allow the imposition of Sharia law in the area. In letters, Zahoor told me that he and others had joined the blockade and that there was general support for the call for Sharia law. Thus, while the 1993 elections illustrated a general disillusionment with the religious parties it did not reflect on interest in the ideas that they had used.

THE BATTLE WITH TRADITION

A similar trajectory of Islam in national and regional discourse can be traced in the local political process of Kohery. There was first an upsurge of interest in the ideas of Islamic reform, led by certain individuals. Often, when I asked about changes in the village, I was told that they had taken place at the time of Haji Hakim Zada. Many seemed to attribute the successes of the village to his charismatic leadership. Others put down the problems in Kohery since his time - the internal fighting and the lack of obedience to village rules - to the fact that there was no big leader, *ghat mashar*, like Haji Hakim Zada. Haji Hakim Zada seemed to have been highly regarded throughout the area and even though he died in 1988 he was still fondly remembered. He was a popular man, said to possess *roab*, charisma; that is to persuade and lead, to get others to accept his word through admiration and fear. In Kohery he was particularly admired for his skills as the head of the village council, when he was a mixture of mediator, organiser and authoritarian. As a mediator he was attributed with having had the ability to resolve even the largest of disputes, something which enabled him to bring together the various factions in the village. He was best remembered as an organiser and it was in his time that people said most had been achieved in the village. It was under his influence that the people of the village were organised into building roads that linked the various parts of the village and connected them to the villages in the valley below. As the local union council member, Haji Hakim Zada was credited with bringing three new schools to the area, had the village connected to the electricity supply and brought money to have water piped to every house. He managed to avoid the disputes that later resources, such as telephone connections, provoked.

Perhaps the lack of disputes was attributable in part to Haji Hakim Zada's reputation as a strongly authoritarian figure. He was a zealous member of the JI and, though he was an unaffiliated member of the union council, he passed measures in Kohery banning membership of any other parties. Wahid Gul remembered this particularly as he was a member of the secular Awami National Party at the time. Haji Hakim Zada was also influential at the time in gaining support for a whole series of measures to change customs in Kohery, making them more Islamic. The bans and fines that brought about these changes were instituted by the village council as a whole but it was Haji Hakim Zada who was credited with having organised and influenced them. The most notable changes were in the ways that weddings were celebrated. Wahid Gul's wedding was held before the new rules and the celebrations were held over three days. In the memory of Wahid Gul at least, it was the last of the great traditional weddings with shooting, drumming, music and even a dancing girl from Swat. Zahoor's wedding came soon after the new rules and was, in contrast, something of a staid affair. The celebrations were held over one day and, although they were as large in scale, there was no shooting or music and there were certainly no dancing girls. While Zahoor claimed to support the changes, I thought that there was a note of regret in the way that he compared his own wedding with that of his elder brother.

There were numerous other small changes in customs that had taken place, many of which could be traced back to the time of Haji Hakim Zada. With my natural curiosity about things 'traditional', I regularly asked questions about old festivals and customs. All too often I was told, we used to do that, but now we do not because we know that it is no good. For example, in the past, before Akhtar, people soaked bundles of rags in oil and then tied them into balls. On the night when the new moon announcing Akhtar was spotted, these balls would be set alight and hurled into the air. Both this, and the lighting of bonfires that same night, were stopped and condemned as Hindu customs, left behind after the Pakhtuns invaded in the seventeenth century. I also asked about women's funeral laments which Grima describes in detail in Swat in the 1980s (Grima 1993: 58-61). Again, I was told, our women used to do that, but they have stopped because it was not good, people realised that it was a sin. As Zahoor explained it to me, the women were discouraged from performing laments at funerals because in the Qur'an it says that it is not good to show too much grief at funerals. He specifically mentioned the customs of the Bedu in the UAE where nobody shows any grief at funerals, rather they celebrate because the person has gone to join God. The changes in

wedding customs also brought about the demise of the trade of village barber, the man who carried out the celebratory drumming at weddings. The old barber who worked in Kohery and the surrounding villages was the last to follow his profession and his son went off to Karachi to earn his fortune there. The common theme in all of these changes was that they were customs condemned as being 'un-Islamic'. The elders, under the leadership of Haji Hakim Zada, were moved to ban them in order to improve the image of the village.

REDEFINING THE RULES OF ENGAGEMENT: NEW LEADERSHIP, NEW RULES.

A number of writers on Islam have suggested that there is not one single version of Islam representing a 'Great Tradition' against which local, 'Little Traditions' may be compared (Cantwell Smith 1962, 1981, Gilsenan 1982, Eickelman 1983, Robinson 1983). Rather than a single unified tradition of 'Islam' (el-Zein 1977), Asad has suggested that there are socially and historically situated traditions of Islam which consist of discourses "that seek to instruct practitioners regarding the correct form and purpose of a given practice" (1986: 14). Gilsenan suggests in a similar vein that local practices and forms of Islam need to be examined in their own cultural, political and historical settings (1982: 11, see also Ahmed 1988). Several studies have begun to carry out the task of examining how local traditions of Islam have developed and how they continue to develop (see for example Antoun 1980, Lambek 1990, Messick 1986). The process in Kohery was a similar development as various individuals and factions sought to establish the correct form of Islam and with it their own claims to position.

Various groups within the village tried to claim exclusive credit for having brought about the changes in customs and for having restored the village to 'true' Islam. Members of Moolian Khayl regularly asserted that, as a religious family, they had always been opposed to the un-Islamic customs, but that they had been ignored. Various important and pious elders in their turn tried to establish their credentials as men of wisdom and influence. Most agreed, however, that Haji Hakim Zada had been the prime mover in the village. He was singled out as an individual who had successfully combined the characteristics of both a political and religious leader. As the union council member he had organised the various groups in the village into working together and had brought valuable resources from outside through his political

contacts. At the same time he was recognised as a skilful mediator and as a charismatic man able to influence others on religious matters. Abdulhai, while he had no pretensions as a man of politics, was considered by many as being as, if not more, successful than his predecessor. His influence over matters religious was not backed up by official position and yet many listened to him and followed his example. Haji Hakim Zada was identified as being something of a turning point, a figure of change. He was recognised as important because he was seen as one of the first to introduce religious discourses into what had previously been purely political processes.

What Haji Hakim Zada had managed to do before, and what Abdulhai was still trying to do in 1993, went beyond simply killing off a few un-Islamic customs. It was part of a much wider process that involved changes in the style of leadership. On both a national and local level religious discourses had come to dominate the political process. In politics, and in academic circles, everything was argued in terms of Islam. At the local level as well, especially in Dir with its fundamentalist reputation, the religious elements had come to be more and more influential. The changing discourse had been used to influence styles of leadership so that religious figures who had previously been ignored had come to power. The changes in discourse also had a marked effect on the way that people expressed themselves and behaved.

Zahoor put the various changes in customs in context for me. As he told me

Before people were poor, they were often hungry and they had to work hard to get enough to eat. People at that time didn't know much about the Qur'an. Before, even the elders weren't educated. It was only a few mullahs who travelled who were educated. Now things have become much easier for people, they have more free time. They have time to read the Qur'an. Now many more people know about the Qur'an.

The next day, talking about old Akhtar customs and funeral laments, Zahoor talked about the changed attitudes to these customs,

Before, Moolian always said that these customs were no good. People said, they are only Moolian, what do they know, these are good customs. Now people have become wise or intelligent - *hookhyar shuway day*. They have read the Qur'an for themselves, they know what is right. They have education or knowledge - *taleem* - from school, from *tableegh*, from translations of the Qur'an, they know that the old customs are no good.

What Zahoor said illustrates two things. Firstly, that through the changed circumstances in the village - and in particular, improved conditions and education -

people have much greater access to religious texts and ideas. Secondly, Zahoor's statement that, "Before Moolian Khayl always said that these customs were no good," gives some indication of the changed status of religious groups and Islam more generally. Whereas before their ideas had been dismissed, in more recent years they were listened to. It had become obvious how important religious leaders and what they had to say had become.

Looked at from a wider context these changes can be seen as the local development of a wider process of change. In Pakistan and, indeed, in the Islamic world as a whole, Islam has come to once again play an increasingly important role in all areas of life, and particularly in politics. This increased awareness of the political role of Islam has been fuelled by organisations such as Tableegh and the various forms of Jamaat-i-Islami, as well as by reactions to the West. Gardner (1995) and Eickelman and Piscatori (1990: 5) have also suggested that international migration has played a role in this heightening of Islamic awareness. As Gardner puts it:

migrants to Britain and the Middle East have moved from an Islam based around localized cults and moulded to the culture and geography of the homelands, to foreign countries where Muslim migrants from many different countries and cultures have together created an international version of Islam (1995: 242).

Certainly in Kohery, those who have been most influential in the community's religious reforms, such as Haji Hakim Zada and Abdulhai, started after working in the UAE. While the investigation of the links between migration and religious reform will have to be left for another thesis, I would suggest here that there is some kind of connection. Those who have migrated returned with the resources at least to realise some of their ambitions. As Zahoor's statements suggest, the improved circumstances of all in the community have enabled many to turn their attentions to religious ideas and activities. At the same time, religious ideas have acted as a framework for understanding the rapidly changing circumstances of life in Kohery and the Gulf. They have enabled the people to deal with the new opportunities and to frame their responses. Thus, the words 'Save There, Eat Here', not only describe the situation that people find themselves in, but also outline the basis for dealing with it.

The men of Kohery, NWFP, Pakistan have been leaving their village to look for work and better opportunities since at least the beginning of the century. Thus, migration to the Gulf states in the 1990s is best understood as part of their way of life rather than an adaptation to radically new circumstances. The life histories of the men of Kohery that I related in Part I of the thesis served a number of purposes. Firstly, they acted as an introduction to the history of migration from Kohery. In local contexts such as the one described, the history of migration is the history of individuals and families who were involved in that migration. The life histories that I used demonstrate how these individuals and families influenced the patterns of migration that developed and the numbers who came to be involved. To paraphrase Gardner (1995: 36), the global and local conditions created the opportunities, but it was the responses and initiative of individuals and families from Kohery who created the local history of migration. As other anthropological studies of migration, such as those by Mascarenhas-Keyes (1987), Marx (1984, 1987), Gardner (1993, 1994) and Osella and Osella (1994), have shown, analyses of migration in specific local contexts give a much clearer picture of the processes at work and the patterns of development than macro-studies have so far managed to do.

The second purpose in using the life histories of migrants was to give a better sense of their experience of migration. In many macro-studies of national and international migration those actually involved become mere numbers responding to demands for labour. This thesis is, in part, a response to Gardner's claim that many models of migration leave the migrants and their communities mute (1995: 12). It is a response, too, to the work of Abu-Lughod (1993) and Fischer and Abedi (1990) who in their own ways call for a more humanist anthropological approach which focuses on the lives of individuals and on their concerns. In many cases in ethnographies individuals become ciphers, representing general points in an analysis. This thesis starts with the particular stories of individuals and families, providing a context for the more general analysis that follows.

The third purpose in Part I of the thesis was to show that migration from Kohery is a way of life. The majority of the men of all generations in the village had been involved in migration at some point in their lives. Many travelled to Bengal and

other parts of British India before Independence. After 1947, as more opportunities opened up, larger and larger numbers of men went to work, first in the Punjab and then in Karachi. Over the decades more and more families became dependent on money earned outside the village. By the 1990s there were no households in Kohery that were not to some extent reliant on remittance money. Migration was, however, not just a major part of the economy of households but it was also an important part of the local culture. To fully understand migration from Kohery it is necessary to take a cultural approach. It is necessary to look at the way migration is understood in its local context, to look at the ideas that form this understanding and to see how these ideas influence behaviour.

Parts II and III of the thesis detail the cultural context of migration from Kohery. The people of Kohery have always been poor, farming small areas of poor quality land in the hills with few extra resources. They have also been dependants, working for the ruling Nawab of Dir and for the landowning *khans* in the valley areas. Their lives, therefore, provide a different perspective from most other ethnographic work on Pakhtuns which has focused on the concerns of the ruling groups (Barth 1959, Ahmed 1980, Lindholm 1982, Tapper 1991). This focus on ruling groups has been translated into the gate-keeping concepts (Abu-Lughod 1989), or dominant themes of Pakhtun ethnography; namely male identity, social structure and the patrilineage and the political process. Much of this ethnography either ignores, or pays scant attention to the main concerns of the people of Kohery, to households and kin groups. The people of Kohery were ordinary Pakhtuns without any real stake in lineage politics and with few opportunities to assert individual or household autonomy. Their economic position meant that they had to rely much more on close kin for aid and support.

As the stories in Part I made clear, the main purpose of migration has always been seen by the people of Kohery to be to support households and improve the lives of their members. Men, who are associated with the 'outside' world of wage labour, have moved further from their homes, following the opportunities as they arose. Long-term migration to the Gulf has meant that they were often physically absent from their home for long periods. However, their lives have continued to be based around their families and households, concerned with earning and saving money to send back to them. Men's devotion to their homes was evident in the way they talked with pride about the many improvements their work had brought to their families' lives; improvements in diet, living conditions and health. It was also evident in the enormous amounts of money that were invested in building new

houses and filling them with electric fans, fridges, stoves, televisions and other new goods.

The household groups that families lived in varied considerably in size and composition, from small nuclear households of 6 members, consisting of a man, a woman and their children, to large joint households of over 20 members, formed of an older man and his wife or wives, his married sons, with their wives and children. People recognised both types of household had their own particular advantages, though joint households were often presented as an ideal. The position of individuals within the household hierarchy influenced their interests in and ultimately affected their loyalties towards the other members of the household. Senior men and women, who had greater authority and access to resources and who made the decisions that affected the whole household, favoured joint households which brought them position and security. Joint households were, however, expensive to maintain and provided little space for individual interests. Those who were junior in the hierarchy favoured small, nuclear households in which they could more easily look after their own interests and make decisions about the use of resources. The main perceived advantage of large, joint households was that they were more secure, with several sources of income while nuclear households were potentially more at risk through their dependency on a single source of income.

Households in Kohery did not exist in isolation but were part of a complex network of inter-dependency. Much of the ethnography of Pakhtuns has tended to play down the importance of kin ties (Tapper 1991: 48-50) and emphasise the conflicts between close kin (Ahmed 1980: 74). The people of Kohery, with few resources to fall back on, relied much more heavily on both agnatic and affinal kin links. They invested time and resources in forming and maintaining these links; investing in large weddings, in visiting and gift-giving and in exchanges of labour and money. The inter-locking links formed a complex network of inter-dependent households which enabled large numbers of men to migrate from all parts of the village. Household marriage strategies were particularly concerned with the importance of repeating existing marriage within patrilineages and between the patrilineages within the village. Men and women valued marrying in as a way of confirming and consolidating the existing links on which they relied. Through marrying in groups of patrikin were seen as single, extended households, while the community as a whole was seen as a single, extended group of kin.

This cultural context of the importance of households and kin groups is the background against which the economic processes of migration can be assessed. The real value of a cultural approach to the study of migration and local economic processes in general is that, as Gudeman suggests, it seeks to understand local models of these processes (1986: vii). In the case of Kohery, it is possible to come to a better understanding of investments of remittance money considered 'unproductive' by some analysts (Khan 1986: 82, Appleyard 1988: 103). Investments in supporting households, in village land, in building new houses and in filling them with consumer durables when seen from the insider's point of view are investments in the reasons for migration in the first place. Investments in hospitality and gifts, in weddings, in charitable donations and feasts are investments in kin groups and community upon which individual households are dependent in order to continue with migration.

Local models of the economy also frame people's understanding of migration and influence their actions and behaviour. The acquisition of money is seen as basically problematic. As Bloch and Parry suggest, money acquisition takes place on an individual basis and is potentially socially disruptive (1989: 24). The solution for the men of Kohery is that this process takes place away from homes, in the 'outside' world of work. In the different social world of the Gulf, men can show an interest in money, they can pay less attention to their normal social ties and as a result they can effectively save money. At the same time in the stories that men told about their experiences of labour migration they emphasised the hardships that they had been through and the suffering that they had endured, thus presenting themselves as worthy individuals and honourable Pakhtuns. Men also laid great stress on the fact that they migrated not for personal gain or for the money itself, but for the sake of their families, households and future generations.

The problem then became one of how to bring the corrupting commodity of money back into the community. While it was individual men who saved, it was houses as social actors in themselves that spent. Houses ate and drank the money that was brought back by men in a way similar to that described by Bloch and Parry (1989: 25). The consumption of resources by houses rather than individuals served as a way of socialising money, converting it into the long-term cycle of household reproduction (Bloch and Parry 1989: 25-6). Houses were described as *khrooskoo*, eating/drinking, meaning they consumed all of the resources available in an uncontrolled fashion. Most households in the village took part in very similar patterns of spending and there was little to distinguish the rich from the poor in

terms of lifestyle and house contents. By taking part in this form of uncontrolled and similar spending, individuals and households displayed their lack of interest in money for its own sake, in contrast to the world of 'outside'. In the environment of the community the miser was condemned for taking too great an interest in money and ignoring their social responsibilities while the ideal spendthrift spent uncontrollably in the interests of these social responsibilities.

There was a general tendency to play down the differences between households in the village and to describe them all in the same terms as *khrooskoo*, despite obvious differences in size and resources. This description of all households as *khrooskoo* showed that uncontrolled spending and a lack of interest in money for its own sake was part of the way that the community represented itself to others. As Stirrat (1989) and Gell (1986) suggest, the people of Kohery used their patterns of consumption to create a collective identity for themselves. The people of Kohery drew attention to the similarities in their lifestyles, in the ways their households developed and in their major expenditures. They drew contrasts with the neighbouring villages where the people were said to have more of an interest in money for its own sake. The moral message of the contrasts that they drew was that the people of Kohery were better Muslims than their neighbours, they spent without thought for tomorrow and trusted in God to provide for them.

The *khrooskoo* household was also an economic model, like that described by Gudeman and Rivera (1990). It was a model of dependency, like that described by Gardner (1993, 1995) in which households were seen as essentially unproductive and reliant on resources from outside. As people often pointed out everybody in Kohery was in the same economic position, dependent on money earned through labour migration to continue. There was a recognition of the fact that all households, whether big or small, with resources at home or without, were dependent on one or more of their members working abroad to support the rest. Small households ran the greatest risk in relying on a single source of income though they could rely on their kin for support and aid in times of crisis. Joint households, while they were more secure, relied heavily on remittances from several sources and were just as much at risk from changes in the national and international political and economic situation.

This model of the economic situation in Kohery was not a static one and many of its features owed a great deal to the new Islamic ideas made popular by organisations such as Tableeghee Jama'at and the Jamaat-i-Islami. The people of Kohery themselves suggested that greater literacy, education, a better lifestyle and

participation in *tableegh* had given them greater access to the bases of Islam through the Q'ran and other newer sources of religious ideas. Others such as Gardner (1995) have argued that international migration has had an influence on the development of a greater awareness of Islam. Influential writers such as Maudoodi (1976) call for a return to what they see as a truly Islamic society, modelled on the original community of Muslims. They argue that the life of a Muslim should be a life of continuous worship where every action should be in line with the word of the Q'ran. The men of Kohery drew on such ideas when they suggested that their lives as migrants were being lived out not for themselves but for their families. Their lack of interest in money for its own sake and their uncontrolled spending at home they saw as demonstrating their piety and trust in God.

The popularity of reformist Islam was the background against which religious leaders had come to greater prominence in Pakhtun society generally (see for example Edwards 1990, Ahmed 1983). Religious leaders in Kohery had, over the years, used their influence to introduce reforms to traditional customs. They tried, through the village council and their own example, to influence customs in the celebration of weddings, trying to encourage an interest in smaller, more 'Islamic' celebrations. In some cases these attempts at reform created conflict as not all in the village were willing to accept the word of mere *mullahs*. Some of the customs that came under attack were, like the use of guns and shooting at weddings, long-standing traditions of great importance to people and their sense of being Pakhtuns. Other, secular influences had introduced new customs, such as large processions to take the bride to the groom's house, which quickly became popular. Many in Kohery and the surrounding villages still held an ambivalent attitude towards religious leaders and the ideas that they attempted to introduce, which made them reluctant to accept their reforms without question.

The conflicts that developed over reforms were conflicts over authority within communities. In other areas the religious reformists in Kohery were more successful in influencing actions and attitudes. Those with the resources engaged in large scale expenditures on religious feasts and donations, which were forms of public charity. These forms of charity fitted in with long-established notions of Pakhtun leadership. Traditional Pakhtun leaders achieved their status in part through their generous hospitality and their ability to act as patrons and representatives to the community (Barth 1959, Anderson 1978). Thus, traditional leaders in the community could use religious feasts in order to establish and maintain their political position. Religious feasts and donations were, however, also seen as a

necessary way for those with excess resources to cleanse their wealth, to use it for the benefit of others. A shift had come about as those with influence sought to establish their status as men of piety and generosity. They engaged in tournaments of charitable generosity (a notion developed from Appadurai 1986) in which they attempted to redefine feasts and donations in purely religious terms and establish themselves as men of faith. Those who used religious feasts for overtly political ends became subject to criticism and lost support. Feasts and donations came to be seen as displays of faith and piety rather than displays of conspicuous wealth.

Conflicts over the importance of religious feasts and weddings in Kohery demonstrate that cultural values are not static. People were continuously and actively engaged in defining and redefining meanings and values. The men of Kohery represented their own lives both as lives of honourable suffering as worthy Pakhtuns and as self-less lives lived out for their families as the continuous worship of a good Muslims. A whole range of ideas were drawn on to help the people of Kohery deal with their rapidly changing circumstances. Their *khrooskoo* households were simultaneously a demonstration of their faith in God, a collective style of consumption and a model of their state of dependency. Individuals used meanings and redefinition to challenge others so that religious leaders drew on popular notions of international, reformist Islam in order to develop their position. Throughout this the only constant is the economic position of the people of Kohery which forces them to save there and eat here.

GLOSSARY

| | |
|----------------------------|---|
| Akhtar | -feast at the end of the Muslim month of fasting, Ramadan |
| amanat | -loan |
| arman | -desire |
| azan | -person who gives the call to prayer at a mosque |
| bahar | -outside |
| balay | -large field |
| barakat | -blessing, blessed by God |
| burqa | -heavy veil worn by women in purdah |
| doest | -friend |
| gawand | -round, neighbourhood |
| gawandeean | -neighbours |
| ghat | -large, big |
| gham | -grief, sorrow |
| ghwagay | -small field |
| haji | -a person who has performed the pilgrimage to Mecca |
| handeewal, pl. handeewalan | -work companion |
| haram | -that which is forbidden in the Qur'an |
| hayras | -greed |

| | |
|-----------------|---|
| helal | -that which is allowed in the Qur'an |
| hookhyar | -intelligent, wise |
| hundi | -blackmarket exchange system |
| 'ibadat | -continuous worship |
| Inglayz(ee) | -British or generally Western or foreign |
| jihad | -religious war |
| jirga | -village council |
| kanjoos | -miser |
| kar | -work |
| khan | -Pakhtun landowner and leader |
| khayl | -patrilineage |
| khas | -special |
| khaza | -woman |
| kheyrat | -religious feast |
| khpul | -own, one's own, belonging to one |
| khpulwan | -kin group of agnatic and affinal kin |
| khrooskoo | -eating/drinking; used with reference to households that consume all the resources they receive |
| kor, pl. koruna | -house, household |
| kuchay | -camel driver |
| larayee | -distant |
| lopa | -a person who does not work and ignores their responsibilities |

| | |
|----------------------------|---|
| loowee | -person with new money who ignores their former friends |
| madrassa | -religious school or college |
| malik | -tribal or village leader |
| mama, pl. mamagan | -mother's brother, more generally mother's family |
| mamazoo-way, pl. mamazaman | -mother's brother's son |
| mashar, pl. masharan | -elder |
| melmastiya | -hospitality |
| mullah | -leader of religious community |
| musafar, pl. musafaran | -traveller |
| nika | -grandfather, ancestor |
| pir, pl. pirian | -spirit |
| praday, pl. pradee | -other, stranger, belonging to another |
| qaras | -credit, loan |
| quam | -tribe |
| rishtay | -marriage ties |
| roab | -charisma |
| sakhee | -spendthrift |
| sayyid | -person claiming descent from the Prophet Mohamad |
| seree | -land given in exchange for services provided |

| | |
|---------------------------|---|
| shoom | -one who is careful with their money, miser |
| shukrana | -feast given to celebrate special occasion and give thanks |
| suq | -Arabic market |
| tableegh | -religious pilgrimage with the Tableegh organisation |
| taleeb | -student |
| taleem | -education, particularly religious education |
| tarboor, pl. tarbooroona | -father's brother's son |
| taweez | -religious charm |
| tror | -father's sister |
| trorzooway, pl. trorzaman | -father's sister's son |
| ustaaz | -teacher, somebody skilled at a particular job |
| zakat | -annual donation given by all Muslims to support the poor of their community |

BIBLIOGRAPHY

- Abadan-Unat, N (ed) (1976) *Turkish Workers in Europe 1960-75: A Socio-economic Reappraisal* Leiden: E J Brill
- Abu-Lughod, Janet (1975) 'Comments: The end of the age of innocence in migration theory' in DuToit, B and Safa, H (eds) *Migration and Urbanization: Models and adaptive strategies* The Hague: Mouton
- Abu-Lughod, Lila (1986) *Veiled Sentiments: Honor and poetry in a Bedouin society* Los Angeles: University of California Press
- Abu-Lughod, Lila (1989) 'Zones of Theory in the Anthropology of the Arab World' *Annual Review of Anthropology* 18: 267-306
- Abu-Lughod, Lila (1993) *Writing Women's Worlds: Bedouin Stories* Berkeley, California: University of California Press
- Addleton, Jonathan (1992) *Undermining the Centre: Gulf migration and Pakistan* Karachi: Oxford University Press
- Ahmed, A S (1976) *Millennium and Charisma among Pathans: A critical essay in social anthropology* London: Routledge and Kegan Paul
- Ahmed, A S (1980) *Pukhtun Economy and Society: Traditional structure and economic development in a tribal society* London: Routledge and Kegan Paul
- Ahmed, A S (1983) *Religion and Politics in Muslim Society* Cambridge: Cambridge University Press
- Ahmed, A S (1986) *Islam, Ethnicity and Leadership in South Asia* Karachi: Oxford University Press
- Ahmed, A S (1988) *Discovering Islam: Making sense of Muslim history and society* London: Routledge and Kegan Paul

- Ahmed, A S (1991) *Resistance and Control in Pakistan* previously published as (1983) *Religion and Politics in Muslim Society* Cambridge: Cambridge University Press London: Routledge
- Anderson, Jon W (1975) 'Tribe and Community among the Ghilzai Pashtun' *Anthropos* 70: 575-601
- Anderson, Jon W (1978) 'There are no Khans anymore: economic development and social change in Afghanistan' *Middle East Journal* 32: 167-83
- Anderson, Jon W (1982a) 'Social Structure and the Veil: comportment and the composition of interaction in Afghanistan' *Anthropos* 77: 397-420
- Anderson, Jon W (1982b) 'Cousin Marriage in Context: Constructing Social Relations in Afghanistan' *Folk* 24: 6-28
- Anderson, Jon W (1983) 'Khan and Khel: Dialectics of Pakhtun Tribalism' in Tapper, R (ed) *The Conflict of Tribe and State in Iran and Afghanistan* London: Croom Helm
- Antoun, Richard (1980) 'The Islamic Judge, The Islamic Court, and the Accomodation of Traditions: A Jordanian case study' *International Journal of Middle East Studies* 12: 455-67
- Antoun, R and Harik, I (eds) (1972) *Rural Politics and Social Change in the Middle East* London: Indiana University Press
- Appadurai, Arjun (ed) (1986) *The Social Life of Things: Commodities in cultural perspective* Cambridge: Cambridge University Press
- Appleyard, R T (ed) (1988) *International Migration Today. Volume I: Trends and Prospects* Paris: UNESCO
- Appleyard, R (1989) 'Migration and Development: Myths and reality' *International Migration Review* 23 (2): 486-99
- Asad, Talal (1972) 'Market Model, Class Structure and Consent: A reconsideration of Swat political organisation' *Man* 7: 74-94
- Asad, Talal (ed) (1973) *Anthropology and the Colonial Encounter* New York: Ithaca Press

- Asad, Talal (1986) *The Idea of an Anthropology of Islam* Occasional Papers Series
Center for Contemporary Arab Studies Washington DC: Georgetown
University Press
- Azoy, G Whitney (1982) *Buzkashi: Game and power in Afghanistan* Philadelphia:
University of Pennsylvania Press
- Ballard, Roger (1983) 'The Contexts and Consequences of Migration: Jullundur and
Mirpur compared' *New Community* XI (1/2): 117-36
- Ballard, Roger (1987) 'The Political Economy of Migration: Pakistan, Britain and
the Middle East' in Eades, J (ed) *Migrants, Workers and the Social Order*
ASA Monographs 26 London: Tavistock Publications
- Barth, Fredrik (1959) *Political Leadership among Swat Pathans* LSE Monograph
London: Athlone Press
- Barth, Fredrik (1961) *Nomads of South Persia: The Basseri Tribe of the Khamseh
Confederacy* London: George Allen and Unwin
- Barth, Fredrik (ed) (1969) *Ethnic Groups and Boundaries* Boston: Little Brown and
Company
- Barth, Fredrik (1981) *Features of Person and Society in Swat* London: Routledge and
Kegan Paul
- Barth, Fredrik (1992) 'Method in our Critique of Anthropology' *Man* 27: 175-7
- Berger, John (1979) *Pig Earth* London: Hogarth Press
- Birks, J S and Sinclair, C A (1980) *International Migration and Development in the
Arab Region* Geneva: International Labour Office
- Birks, J S and Sinclair, C A (1989) *Manpower and Population Evolution in the Gulf
Cooperation Council and the Libyan Arab Jamahiriya* World Employment
Programme Working Paper Geneva: International Labour Office
- Bloch, Maurice (1973) 'The Long Term and the Short Term: the economic and
political significance of the morality of kinship' in Goody, J (ed) *The
Character of Kinship* Cambridge: Cambridge University Press

- Boesen, I (1983) 'Conflicts of Solidarity in Pakhtun Women's Lives' in Utas, B (ed) *Women in Islamic Societies* London: Curzon Press
- Bourdieu, P (1977) *Outline of a Theory of Practice* Cambridge: Cambridge University Press
- Bourdieu, P (1990) *The Logic of Practice* Cambridge: Polity Press
- Boyd, M (1989) 'Family and Personal Networks in International Migration: recent developments and new agendas' *International Migration Review* 23 (2): 638-70
- Brink, J (1991) 'The Effect of Emigration of Husbands on the Status of Wives: an Egyptian case' *International Journal of Middle East Studies* 23: 201-11
- Burki, S J (1980) 'What Migration to the Middle East may mean for Pakistan' *Journal of South Asian and Middle Eastern Studies* 3 (3): 47-66
- Cantwell Smith, W (1962) *The Meaning and End of Religion* New York: Mentor Books
- Cantwell Smith, W (1981) *On Understanding Islam: Selected Studies* The Hague: Mouton
- Caroe, O (1958) *The Pathans 550 BC -AD 1957* Karachi: Oxford University Press
- Carsten, J (1989) 'Cooking Money: Gender and the Symbolic Transformation of Means of Exchange in a Malay Fishing Community' in Parry, J and M Bloch (eds) *Money and the Morality of Exchange* Cambridge: Cambridge University Press
- Caton, S (1987) 'Power, Persuasion and Language: A Critique of the Segmentary Model in the Middle East' *International Journal of Middle East Studies* 19: 77-102
- Chant, S (ed) (1992) *Gender and Migration in Developing Countries* London: Belhaven Press
- Chaudhuri, K N (1985) *Trade and Civilization in the Indian Ocean: An Economic History from the Rise of Islam to 1750* Cambridge: Cambridge University Press

- Choueiri, Y M (1990) *Islamic Fundamentalism* London: Pinter Publishers
- Christensen, A (1980) 'The Pashtuns of Kunar: Tribe, Class and Community Organization' *Afghanistan Journal* 9 (3): 79-91
- Clifford, J and G Marcus (eds) (1986) *Writing Culture: The Poetics and Politics of Ethnography* Berkeley, Calif.: University of California Press
- Cohen, A P (1985) *The Symbolic Construction of Community* London: Tavistock Publications
- Cohen, R (1987) *The New Helots: Migrants in the International Division of Labour* Avebury: Gower Publishing Company
- Comaroff, J and J Comaroff (1987) 'The Madman and the Migrant: Work and Labour in the Historical Consciousness of a South African People' *American Ethnologist* 14: 191-209
- Cornwall, A and N Lindisfarne (eds) (1994) *Dislocating Masculinity: Comparative Ethnographies* London: Routledge
- Dandekar, H C (1986) *Men to Bombay, Women at Home: Urban Influences on Sugao Village, Deccan Maharashtra, India* Michigan: University of Michigan
- Das, V (ed) (1990) *Mirrors of Violence: Communities, Riots and Survivors in South Asia* Delhi: Oxford University Press
- Davis, J (1992) 'Tense in Ethnography: Some Practical Considerations' in Okely, J and H Callaway (eds) *Anthropology and Autobiography* ASA Monograph 29 London: Routledge
- Dichter, D (1967) *The North West Frontier of West Pakistan* Oxford: Clarendon Press
- Donnan, H (1988) *Marriage among Muslims: Preference and Choice in Northern Pakistan* Leiden: E J Brill
- Du Toit, B (1975) 'A Decision-making Model for the Study of Migration' in Du Toit, B and H Safa (eds) *Migration and Urbanization: Models and Adaptive Strategies* The Hague: Mouton

- Du Toit, B (1990) 'People on the Move: Rural-urban Migration with Special Reference to the Third World: Theoretical and Empirical Perspectives' *Human Organisation* 49: 305-19
- Eades, J (ed) (1987) *Migrants, Workers and the Social Order* ASA Monograph 26 London: Tavistock Publications
- Edwards, D B (1990) 'Frontiers, Boundaries and Frames: The Marginal Identity of Afghan Refugees' in Ahmed, A S (ed) *Pakistan: The Social Sciences' Perspective* Karachi: Oxford University Press
- Edwards, D B (1994) 'Afghanistan, Ethnography, and the New World Order' *Cultural Anthropology* 9 (3): 345-60
- Eelens, F and Speckmann, J D (1990) 'Recruitment of Labour Migrants for the Middle East: The Sri Lankan Case' *International Migration Review* 24 (2): 297-322
- Eglar, Z (1960) *A Punjabi Village in Pakistan* New York: Columbia University Press
- Eickelman, D (1981) *The Middle East: An Anthropological Approach* New Jersey: Prentice-Hall
- Eickelman, D (1983) 'The Study of Islam in Local Contexts' *Contributions to Asian Studies* 17: 1-16
- Eickelman, D and Piscatori, J (eds) (1990) *Muslim Travellers: Pilgrimage, Migration and the Religious Imagination* London: Routledge
- el-Zein, A H (1977) 'Beyond Ideology and Theology: The Search for the Anthropology of Islam' *Annual Review of Anthropology* 6: 227-54
- Engelbrektsson, U (1978) *The Force of Tradition: Turkish Migrants at Home and Abroad* Gothenburg: Acta Universitatis Gothenburgensis
- Epstein, A L (1969) 'The Network and Urban Social Organization' in Mitchell, J C (ed) *Social Networks in Urban Situations* Manchester: Manchester University Press
- Evans-Pritchard, E E (1940) *The Nuer: A Description of the Modes of Livelihood and Political Institutions of a Nilotic People* Oxford: Oxford University Press

- Fabian, J (1983) *Time and the Other: How Anthropology Makes its Object New* New York: Columbia University Press
- Fardon, M (ed) (1990) *Localizing Strategies: Regional Traditions of Ethnographic Writing* Edinburgh: Scottish Academic Press
- Feller, G (1991) 'Migration and Recession: Arab Labour Mobility in the Middle East, 1982-9' *Population and Development Review* 17 (1): 134-55
- Fischer, M M J and M Abedi (1990) *Debating Muslims: Cultural Dialogues in Postmodernity and Tradition* Madison, Wisconsin: Univ of Wisconsin Press
- Fortes, M (1969) *Kinship and the Social Order* London: Routledge and Kegan Paul
- Friedl, E (1989) *Women of Deh Koh: Lives in an Iranian Village* Washington DC: Smithsonian Institution Press
- Gardner, K (1993) 'Desh-bidesh: Sylheti Images of Home and Away' *Man* 28(1): 1:15
- Gardner, K (1994) 'Women and Islamic Revivalism in a Bangladeshi Migrant Community' conference paper given at the South Asian Anthropologists' Group annual conference, LSE
- Gardner, K (1995) *Global Migrants, Local Lives: Travels and Transformation in Rural Bangladesh* Oxford: Clarendon Press
- Gell, A (1986) 'Newcomers to the World of Goods: Consumption among the Muria Gonds' in Appadurai, A (ed) *The Social Life of Things* Cambridge: Cambridge University Press
- Ghosh, A (1986) *The Circle of Reason* London: Hamish Hamilton
- Ghosh, A (1992) *In An Antique Land* London: Granta Books
- Gilani, I S (1988) 'Effects of Emigration and Return on Sending Countries: The Case of Pakistan' In C Stahl (ed) *International Migration Today, Vol 2: Emerging Issues* Paris: UNESCO
- Gilsenan, M (1976) 'Lying, Honour and Contradiction' in B Kapferer (ed) *Transaction and Meaning* Philadelphia: Inst. for the Study of Human Issues

- Gilsenan, M (1982) *Recognizing Islam* London: Croom Helm
- Grima, B (1993) *The Performance of Emotion among Paxtun Women: The Misfortunes which have Befallen Me* Karachi: Oxford University Press
- Gudeman, S (1986) *Economics as Culture: Models and Metaphors of Livelihood* London: Routledge and Kegan Paul
- Gudeman, S and A Rivera (1990) *Conversations in Columbia: The Domestic Economy in Life and Text* Cambridge: Cambridge University Press
- Gunatilleke, G (ed) (1986) *Migration of Workers to the Arab World* Japan: United Nations University
- Harris, O (1981) 'Households as Natural Units' in Young, K, C Wolkowitz and R McCullagh (eds) *Of Marriage and the Market* London: Routledge and Kegan Paul
- Hastrup, K (1992) 'Writing Ethnography: State of the Art' in Okely, J and H Callaway (eds) *Autobiography and Anthropology* ASA Monograph 29 London: Routledge
- Helweg, A (1983) 'Emigrant Remittances: Their Nature and Impact on a Punjabi Village' *New Community* 10 (3): 435-43
- Holy, L (1979) 'The Segmentary lineage Structure and its Existential Status' in Holy, L (ed) *Segmentary Lineage Systems Reconsidered* Belfast: Queen's University of Belfast
- Jeffrey, P, R Jeffrey and A Lyon (1988) *Labour Pains and Labour Power* London: Zed Books
- Kearney, M (1986) 'From the Invisible Hand to Visible Feet: Anthropological Studies of Migration and Development' *Annual Review of Anthropology* 15: 331-61
- Keesing, R (1975) *Kin Groups and Social Structure* New York: Holt, Rinehart and Winston
- Kessinger, T G (1974) *Vilyatpur 1848-1968: social and Economic Change in a North Indian Village* Berkeley, California: University of California Press

- Khan, M F (1986) 'Pakistan' in G Gunatilleke (ed) *Migration of Asian Workers to the Arab World* Japan: United Nations University
- Kipling, R (1901, 1908 edition) *Kim* London: Macmillan
- Kopytoff, I (1986) 'The Cultural Biography of Things: Commoditization as Process' in Appadurai, A (ed) *The Social Life of Things: Commodities in Cultural Perspective* Cambridge: Cambridge University Press
- Kressel, G (1991) 'Continuity and Endurance of Patrilineage in Towns' *Middle Eastern Studies* 27: 79-93
- La Fontaine, J S (1981) 'Domestication of the Savage Male' *Man* 16: 333-49
- Lambek, M (1990) 'Certain Knowledge, Contestable Authority: Power and Practice on the Islamic Periphery' *American Ethnologist* 17: 23-40
- Lawless, R (ed) (1987) *The Middle Eastern Village: Changing Economic and Social Relations* London: Croom Helm
- Lewis, O (1959) *Five Families: Mexican Case Studies in the Culture of Poverty* New York: Basic Books
- Lewis, O (1961) *The Children of Sanchez: Autobiography of a Mexican Family* London: Secker and Warburg
- Lindholm, C (1982) *Generosity and Jealousy: The Swat Pukhtun of Northern Pakistan* New York: Columbia University Press
- Loizos, P (1994) 'A Broken Mirror: Masculine Sexuality in Greek Ethnography' in Cornwall, A and N Lindisfarne (eds) *Dislocating Masculinity: Comparative Ethnographies* London: Routledge
- Lorimer, J G (1908) *Gazetteer of the Persian Gulf, Oman and Central Arabia* Calcutta: Superintendent Government Printing, India
- McMahon, A H and A D G Ramsay (1901) *Tribes of Dir, Swat and Bajour Together with the Utman-Khel and Sam Ranizai* reprinted Peshawar: Saeed Book Bank

- Maher, V (1981) 'Work, Consumption and Authority within the Household: A Moroccan Case' in K Young, C Wolkowitz and R McCullagh (eds) *Of Marriage and the Market* London: Routledge and Kegan Paul
- Martin, P L (1991) 'Conference Report on Labour Migration in Asia' *International Migration Review* 25 (1): 176-93
- Marx, E (1984) 'Economic Change among Pastoral Nomads in the Middle East' in Marx, E and A Shmueli (eds) *The Changing Bedouin* New Jersey: Transaction
- Marx, E (1987) 'Labour Migrants with a Secure Base' in Eades, J (ed) *Migrants, Workers and the Social Order* ASA Monograph 26 London: Tavistock Publications
- Mascarenhas-Keyes, S (1987) 'Death Notices and Dispersal: International Migration among Catholic Goans' Eades, J (ed) *Migrants, Workers and the Social Order* ASA Monograph 26 London: Tavistock Publications
- Matthiessen, P (1962) *Under the Mountain Wall: A Chronicle of Two Seasons in Stone Age New Guinea* New York: Viking Press
- Maudoodi, Sayyid Abul A'ala (1976) *Fundamentals of Islam* Lahore: Idarar Tarjuman-ul-Quran
- Meillassoux, C (1981) *Maidens, Meal and Money: Capitalism and the Domestic Community* Cambridge: Cambridge University Press
- Messick, B (1986) 'The Mufti, the Text and the World: Legal Interpretation in Yemen' *Man* 21: 102-19
- Metcalf, B (1993) 'Living Hadith in the Tablighi Jama'at' *The Journal of Asian Studies* 52 (3): 584-608
- Mitchell, J C (ed) (1969) *Social Networks in Urban Situations* Manchester: Manchester University Press
- Moore, H (1988) *Feminism and Anthropology* Cambridge: Polity Press

- Murray, C (1979) 'The Work of Men, Women and the Ancestors: Social Reproduction in the Periphery of Southern Africa' in Wallman, S (ed) *Social Anthropology of Work* ASA Monograph 19 London: Academic Press
- Nash, J (1979) *We Eat the Mines and the Mines Eat Us* New York: Columbia University Press
- Nash, J (1994) 'Global Integration and Subsistence Insecurity' *American Anthropologist* 96 (1): 7-30
- Naveed-i-Rahat (1990) *Male Outmigration and Matri-weighted Households* Delhi: Hindustan Publishing Corp
- Nelson, C (1974) 'Public and Private Politics: Women in the Middle Eastern World' *American Ethnologist* 1 (3): 551-63
- Netting, R, Wilk, R and E Arnould (eds) (1984) *Households: Comparative and Historical Studies of the Domestic Group* Berkeley, Calif.: University of California Press
- Oberai, A S and H K M Singh (1980) 'Migration Remittance and Rural Development: Findings of a Case Study in the Indian Punjab' *International Labour Review* 69 (2): 229-41
- Osella, F and C Osella (1994) 'Migration and Masculinity in Kerala' conference paper given at the South Asian Anthropologists' Group annual conference, LSE
- Owen, R (1985) *Migrant Workers in the Gulf* Report No 68 London: Minority Rights Group
- Parkin, D (1979) 'The Categorization of Work: Cases from Coastal Kenya' in Wallman, S (ed) *Social Anthropology of Work* ASA Monograph 19 London: Academic Press
- Parry, J P (1979) *Caste and Kinship in Kangra* London: Routledge and Kegan Paul
- Parry, J P and M Bloch (eds) (1989) *Money and the Morality of Exchange* Cambridge: Cambridge University Press

- Pastner, C M (1990) 'A Social Structural and Historical Analysis of Honour, Shame and Purdah in Baluchistan' in Ahmed, A S (ed) *Pakistan: The Social Sciences' Perspective* Karachi: Oxford University Press
- Pehrson, R (1966) *The Social Organisation of the Marri Baluch* Chicago: Aldine Publishing Company
- Peters, E (1959) 'The Proliferation of Segments in the Lineage of the Bedouin of Cyrenica' Curl Bequest Prize Essay
- Peters, E (1978) 'The Status of Women in Four Middle Eastern Communities' in Beck, L and N Keddi (eds) *Women in the Muslim World* Cambridge: Harvard University Press
- Quibria, M G (1986) 'Migrant Workers and Remittances: Issues for Asian Developing Countries' *Asian Development Review* 4 (1): 78-99
- Robinson, F (1983) 'Islam and Muslim Society in South Asia' *Contributions to Indian Sociology* 17 (2): 185-203
- Robinson, V (1986) 'Bridging the Gulf: The Economic Significance of South Asian Migration to and from the Middle East' in King, R (ed) *Return Migration and Regional Economic Problems* London: Croom Helm
- M Rosaldo and L Lamphere (eds) (1974) *Women, Culture and Society* Stanford: Stanford University Press
- Said, E (1978) *Orientalism* London: Routledge and Kegan Paul
- Said, E (1989) 'Representing the Colonized: Anthropologies Interlocuters' *Critical Inquiry* 15: 205-25
- Sanday, P (1974) 'Female Status in the Public Domain' in M Rosaldo and L Lamphere (eds) *Women, Culture and Society* Stanford: Stanford University Press
- Sanday, P R and R G Goodenough (eds) (1990) *Beyond the Second Sex: New Directions in the Anthropology of Gender* Philadelphia: University of Pennsylvania Press
- Sanjek, R (1991) 'The Ethnographic Present' *Man* 26: 609-28

- Secombe, I (1981) *Manpower and Migration: The Effects of International Labour Migration on Agricultural Development in the East Jordan Valley 1973-80* Durham: Centre for Middle Eastern and Islamic Studies
- Secombe, I (1987) 'Labour Migration and the Transformation of a Village Economy: A Case Study from North-west Jordan' in Lawless, R (ed) *The Middle Eastern Village: Changing Economic and Social Relations* London: Croom Helm
- Selier, F (1988) *Rural-urban Migration in Pakistan: The Case of Karachi* Lahore: Vanguard
- Shaheed, F (1990) 'The Pathan-Muhajir conflicts, 1985-6: A National Perspective' in Das, V (ed) *Mirrors of Violence* Delhi: Oxford University Press
- Sidhwa, B (1988) *Ice-Candy-Man* New Delhi: Penguin Books
- Singer, A (1982) *Guardians of the North-West Frontier: The Pathans* Time Life Books
- Smith, J and I Wallerstein (eds) (1992) *Creating and Transforming Households: The Constraints of the World-economy* Cambridge: Cambridge University Press and Maison des Sciences de l'Homme
- Spencer, J (1990) *A Sinhala Village in a Time of Trouble: Politics and Change in Rural Sri Lanka* Delhi: Oxford University Press
- Stahl, C (1988) *International Migration Today, Volume 2: Emerging Issues* Paris: UNESCO
- Stevenson, T (1985) *Social Change in a Yemeni Highlands Town* Salt Lake City: University of Utah Press
- Stirrat, R L (1989) 'Money, Men and Women' in Parry, J and M Bloch (eds) *Money and the Morality of Exchange* Cambridge: Cambridge University Press
- Street, B (1990) 'Orientalist Discourses in the Anthropology of Iran, Afghanistan and Pakistan' in M Fardon (ed) *Localizing Strategies: Regional Traditions of Ethnographic Writing* Edinburgh: Scottish Academic Press
- Street, B (1992) Reply to Barth's 'Method in our Critique of Anthropology' *Man* 27: 177-9

- Tapper, N (1980) 'Matrons and Mistresses: Women and Boundaries in Two Middle Eastern Tribal Societies' *Archives Europeennes de Sociologie* 21 (1): 59-79
- Tapper, N (1991) *Bartered Brides: Politics, Gender and Marriage in an Afghan Tribal Society* Cambridge: Cambridge University Press
- Tapper, R (1989) 'Ethnic Identities and Social Categories in Iran and Afghanistan' in Tonkin, E et al (eds) *History and Ethnicity* ASA Monograph 27 London: Routledge
- Taussig, M (1980) *The Devil and Commodity Fetishism in South America* North Carolina: University of North Carolina Press
- Taylor, E (1987) 'Egyptian Migration and Peasant Wives' in Lawless, R (ed) *The Middle Eastern Village: Changing Economic and Social Relations* London: Croom Helm
- Tsakok, I (1982) 'The Export of Manpower from Pakistan to the Middle East 1975-85' *World Development* 10: 319-25
- Tsing, A L and S J Yanagisako (eds) (1983) 'Feminism and Kinship Theory' *Current Anthropology* 24 (4): 511-6
- Weir, S (1987) 'Labour Migration and Key Aspects of its Economic and Social Impact on a Yemeni Highland Community' in Lawless, R (ed) *The Middle Eastern Village: Changing Economic and Social Relations* London: Croom Helm
- Werbner, P (1990) *The Migration Process: Capital, Gifts and Offerings among British Pakistanis* Oxford: Berg
- Whitehead, A (1981) 'I'm Hungry Mum: The Politics of Domestic Budgeting' in Young, K, C Wolkowitz and R McCullagh (eds) *Of Marriage and the Market* London: Routledge and Kegan Paul
- Wolf, E (1982) *Europe and the People without History* Berkeley, Calif.: University of California Press
- Yanagisako, S J (1979) 'Family and Household: The Analysis of Domestic Groups' *Annual Review of Anthropology* 8: 161-205

Young, K, C Wolkowitz and R McCullagh (eds) (1981) *Of Marriage and the Market*
London: Routledge and Kegan Paul

Zolberg, A R (1989) 'The Next Waves: Migration Theory for a Changing World'
International Migration Review 23 (2): 403-30