

THE BEST USE OF BIOMASS? GREENHOUSE GAS LIFE CYCLE ANALYSIS OF PREDICTED PYROLYSIS BIOCHAR SYSTEMS

James A R Hammond

I assert my right to be identified as the author of this work in accordance with section 78 of the
Copyright Designs and Patents Act 1988

A dissertation presented for the degree of Master of Science

University of Edinburgh, 2009



Acknowledgements

Many thanks to my supervisor, Simon Shackley, whose enthusiasm and personability brought this project to life.

Many thanks to my parents, without whose support this Masters course would not have been possible.

Abstract

Life cycle analysis is carried out for 11 predicted configurations of pyrolysis biochar systems to determine greenhouse gas balance, using an original spreadsheet model. System parameters reflect deployment in Scotland, and results demonstrate that all major crop and forestry feedstocks offer greater GHG abatement than other bioenergy technologies, regardless of system configuration.

Sensitivity analysis determines the relative importance of uncertain variables in the model and optimistic to pessimistic scenarios are used for system operation. Slow pyrolysis is compared to fast pyrolysis and biomass co-firing for GHG abatement and electricity production, using various scenarios for availability of indigenous Scottish feedstocks.

Contents

Chapter 1: Introduction	13
I. Background	13
A. What are Pyrolysis Biochar Systems?	13
B. Gaps in the Knowledge: Justification for the dissertation	15
II. Project Goals	15
Chapter 2: Literature Review	17
I. LCA	17
A. Biochar LCAs.....	17
B. Other Bioenergy LCAs	18
C. LCAs: Methodological Papers.....	20
II. Scenarios.....	21
III. Feedstocks.....	22
A. Defining the Feedstocks.....	22
B. Quantifying the Feedstocks	26
C. Obtaining GHG Balances for the feedstocks.....	27
IV. Pyrolysis Technology.....	28
A. Pyrolysis Process Data.....	28
B. Building the Pyrolysis Plant.....	29
V. Soil Effects.....	29
VI. Other Research methods	30
A. Expert Interviews	30
B. Email Enquiries.....	30
Chapter 3: Methodology.....	32
I. Creating the Case studies.....	32

A.	Scenarios	33
B.	Case Study Families.....	34
C.	Locating the Case Studies	35
D.	Case by Case Narrative.....	37
II.	Modelling the Case Studies.....	40
A.	The Spreadsheet	41
III.	Methodology for Calculations.....	42
A.	Key assumptions	42
B.	Feedstock Production	43
C.	Transport of Feedstocks to Pyrolysis Plant	43
D.	Handling Losses.....	44
E.	Pyrolysis	44
F.	Transport of Char from Pyrolysis to Farm.....	46
G.	Transport of Char from Farm to Field	47
H.	Application of Char to Soils.....	47
I.	Soil Effects of Biochar	49
J.	Carbon Sequestration in the Soil	53
Chapter 4:	Results	55
I.	Part One: Case Study Analysis.....	57
A.	Absolute Abatement	57
B.	Success is Relative: Normalising System Performance	59
II.	Part Two: Analysis of Life Cycle Stage.....	63
A.	Analysis of Case Studies – Proportional System Components.....	63
B.	Sensitivity Analysis – determining important uncertainties	64
III.	Part Three: Pyrolysis Scenarios	84
A.	Slow Pyrolysis: Reducing Uncertainty, Removing Benefits.....	84
B.	Alternatives to Slow Pyrolysis	90
C.	Estimated Maximum Potential in Scotland from PBS.....	97

D. Combining the scenarios.....	102
Chapter 5: Discussion.....	103
I. Optimal system configuration.....	103
II. Comparisons to the literature.....	104
A. Other Bioenergy Systems.....	104
B. Other biochar LCAs.	104
III. Electricity or Soil? The best use of our biomass	105
Chapter 6: Conclusions	107
Reference List.....	108
Appendix 1: Change Over Time Modelling	115
I. Comparing the Change over Time Model	116
II. Energy Reference System Changes	116
Appendix 2: Default Case Study Assumptions	118
I. Default Assumptions used in all case studies	118
II. Default Assumptions: case study specific	119
Appendix 3: General Assumptions for calculations	121
Appendix 4: Default Results.....	123
Appendix 5: Results of Pyrolysis Scenarios	126
Appendix 6: Results of Alternatives to Slow Pyrolysis	128
Appendix 7: Notes from Interviews	130
I. Notes From Meeting with Patricia Thornley, Simon Shackley, Pete Brownsort and Jim Hammond on 15/6/09 at Swan Institute, Newcastle.	130
II. Interview with Dr Saran Sohi	135
III. Interview with Jason Cook	136
IV. Interview with Dr Ondrej Masek.....	137

LIST OF FIGURES

Figure 1 The benefits of biochar (UKBRC, 2009).....	13
Figure 2: The basic biochar system (Lehmann, 2007).....	14
Figure 3 Shell diagram 1.....	33
Figure 4 Shell diagram 2.....	33
Figure 5 Shell diagrams populated with imaginary case studies	34
Figure 6 The location of Lothian (5) and Borders (2) in Scotland (Map, 2009).....	36
Figure 7 SRC suitability map (Andersen et al., 2005).....	36
Figure 8. Land cover in Scotland. Yellow is arable crops, while maroon is woodland (Towers et al., 2006).	36
Figure 9 Life Cycle Flow Chart for PBS	37
Figure 10 Spreadsheet model used in study.....	41
Figure 11 Char application on a windy day (Husk, 2009).....	48
Figure 12 GHG emissions by life cycle stage	57
Figure 13 Feedstock input with GHG emissions	58
Figure 14 Feedstock input plotted against GHG emissions	59
Figure 15 Relative GHG emissions	60
Figure 16 Relative Electricity Production.....	60
Figure 17 PBS - Absolute and Relative indicators	62
Figure 18. Proportional contribution to GHG emission by life cycle stage.....	63
Figure 19 Transport Distance.....	65
Figure 20 Char Application Vehicle Volume	66
Figure 21 Handling loss - in transit.....	67
Figure 22 Handling loss - application to fields	68
Figure 23 Various Pyrolysis Types: Yields.....	69
Figure 24 Slow Pyrolysis Yields	70
Figure 25 Electrical Conversion Efficiency	71
Figure 26 Electricity Offset.....	72
Figure 27 Heat Use.....	73
Figure 28 All Soil Effects.....	74
Figure 29 Initial SOC.....	75
Figure 30 Change in Input	75
Figure 31 SOC - Changes in Decay Rate	76
Figure 32 SOC - Changes in Input and Decay Rate.....	76

Figure 33 Fertiliser Requirement Change	77
Figure 34 Calculating N ₂ O Soil Emissions	78
Figure 35 Suppression of N ₂ O Soil Emissions, at 1% of Applied N	78
Figure 36 Suppression of N ₂ O Soil Emissions, at 3% of Applied N	79
Figure 37 Labile Fraction of Char	80
Figure 38 Mean Residence Time, Horizon 100 yrs.....	81
Figure 39 Mean Residence Time, Horizon 200 yrs.....	81
Figure 40 Mean Residence Time, Horizon 500 yrs.....	82
Figure 41 Emissions for Pyrolysis Scenarios.....	85
Figure 42 Default case: pyrolysis scenarios absolute and relative emissions indicators.....	86
Figure 43 Optimistic case: pyrolysis scenarios absolute and relative emissions indicators	87
Figure 44 No soil no heat case: pyrolysis scenarios absolute and relative emissions indicators	88
Figure 45 Pessimistic case: pyrolysis scenarios absolute and relative emissions indicators	89
Figure 46 Extremely pessimistic case: pyrolysis scenarios absolute and relative emissions indicators	90
Figure 47 Slow Pyrolysis.....	92
Figure 48 Slow pyrolysis, no soil no heat	92
Figure 49 Slow pyrolysis, char combustion.....	92
Figure 50 Fast Pyrolysis.....	93
Figure 51 Fast Pyrolysis, no soil no heat	93
Figure 52 Fast Pyrolysis char combustion.....	93
Figure 53 Biomass Combustion.....	94
Figure 54 Comparison of Pyrolysis Alternatives	94
Figure 55 Slow Pyrolysis, grid average 2030.....	95
Figure 56 Fast Pyrolysis, grid average 2030.....	95
Figure 57 Combustion, grid average 2030.....	96
Figure 58 Comparison of pyrolysis alternatives when electrical reference system is varied	96
Figure 59 GHG abatement in potential Scotland from PBS, by feedstock.....	99
Figure 60 Electricity production potential Scotland from PBS, by feedstock	100
Figure 61 GHG emissions and Electricity produced from PBS for feedstock scenarios.....	101
Figure 62 GHG and electricity by Case study for Scotland Optimistic and Pessimistic Scenarios	101
Figure 63 Scotland Optimistic feedstock assumptions, pyrolysis scenarios and alternatives compared using SRC.....	102

LIST OF TABLES

Table 1. Resource Assessment phase 1: Feasibility.	23
Table 2 Resource Assessment phase 2: Availability for the period 2015 to 2025	27
Table 3 Sawmill co-products	31
Table 4 Case study families	35
Table 5 case study name and number	56
Table 6 case study GHG emissions and feedstock consumption	58
Table 7 Representative yields from pyrolysis alternatives (Bridgewater, 2007)	69
Table 8 Results of sensitivity analysis: relative importance of life cycle stage variation on GHG emissions.....	83
Table 9 Pyrolysis Scenario assumptions.....	84
Table 10 Feedstock availability scenarios	97
Table 11 GHG abatement possible using PBS for feedstock availability scenarios	98
Table 12 Electricity production possible using PBS for feedstock availability scenarios	98

LIST OF ABBREVIATIONS

CO ₂ eq	Carbon Dioxide equivalent
FRs	Forestry Residues
GWP	Global Warming Potential
LCA	Life Cycle Analysis
MWh e	Mega watt hours of electricity
MWh th	Mega watt hours of thermal energy
NPP	Net Primary Productivity
PBS	Pyrolysis Biochar Systems
SOC	Soil Organic Carbon
SRC	Short Rotation Coppice
SRF	Short Rotation Forestry
SRW	Small Round Wood
UKBRC	UK Biochar Research Centre

Chapter 1: Introduction

I. Background

Biochar systems are hoped to offer the multiple benefits of carbon sequestration and reduction, energy production, soil enhancement, and in some cases, waste disposal. The scale of these desired benefits is not yet proven. Biochar is a new concept, or at least an old concept which has been updated and is now being investigated. This dissertation forms part of the investigation into the potential of biochar systems.

Much is unknown or uncertain in this new field of research, and this dissertation has sometimes had to rely upon data which has a low level of certainty attached. Biochar systems are at the research stage, not yet the commercial demonstration or deployment stage; so there have been no real world cases available for study. This document is an investigation into how Pyrolysis Biochar Systems (PBS) may evolve.

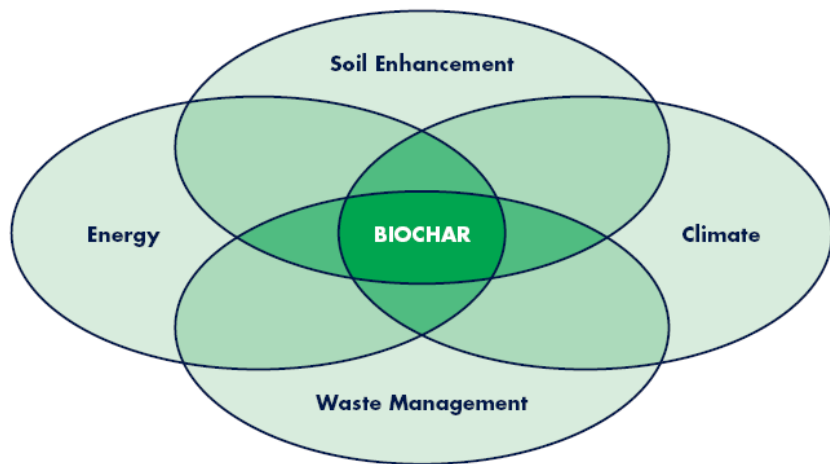

Figure 1 The benefits of biochar (UKBRC, 2009)

A. What are Pyrolysis Biochar Systems?

The heating of natural organic material in an oxygen limited environment is called pyrolysis. Pyrolysis yields three products: a solid product called char, or biochar; a liquid product called pyrolysis oil and a gaseous product called syngas (Lehmann, 2007). The carbon content and energy content of each product depends on the conditions of pyrolysis: the temperature, the length of time in the kiln and oxygen availability are three most important factors (Sohi, 2009b). Each product may be combusted, releasing the energy to be converted to electricity or used as heat (Bridgewater, 2007, Brown, 2009).

PBS however, use the char as soil amendment (Joseph and Lehmann, 2009). A proportion¹ of carbon in the char is highly stable, probably on a millennial time scale and almost certainly on the century time scale, permitting long term carbon storage (Lehmann et al., 2008, Liang et al., 2008). Soil organic carbon stocks have been observed to increase with biochar additions, further enhancing soil carbon sequestration (Liang et al., Forthcoming, Steiner et al., 2008). Biochar enhances soils through water retention, increased retention and availability of nutrients, and other less well understood mechanisms (Chan and Xu, 2009, Steiner et al., 2008, Warnock et al., 2007, Liang et al., 2006); in many cases increasing crop growth (Chan et al., 2008, Chan et al., 2007, Steiner et al., 2007, Sohi, 2009b, Glaser et al., 2002).

The biochar system requires biomass feedstock as the 'fuel' or input. This can come from many sources, including wastes, such as demolition wood or sewage sludge; crop residues such as straw or brush; or purpose grown energy crops such as miscanthus or short rotation coppice (SRC). This project does not examine waste sources, for lack of time. The feedstock is pyrolysed, the energy product sold or used, the char added to soils and the cycle restarts. This system is represented in figure 2 below.

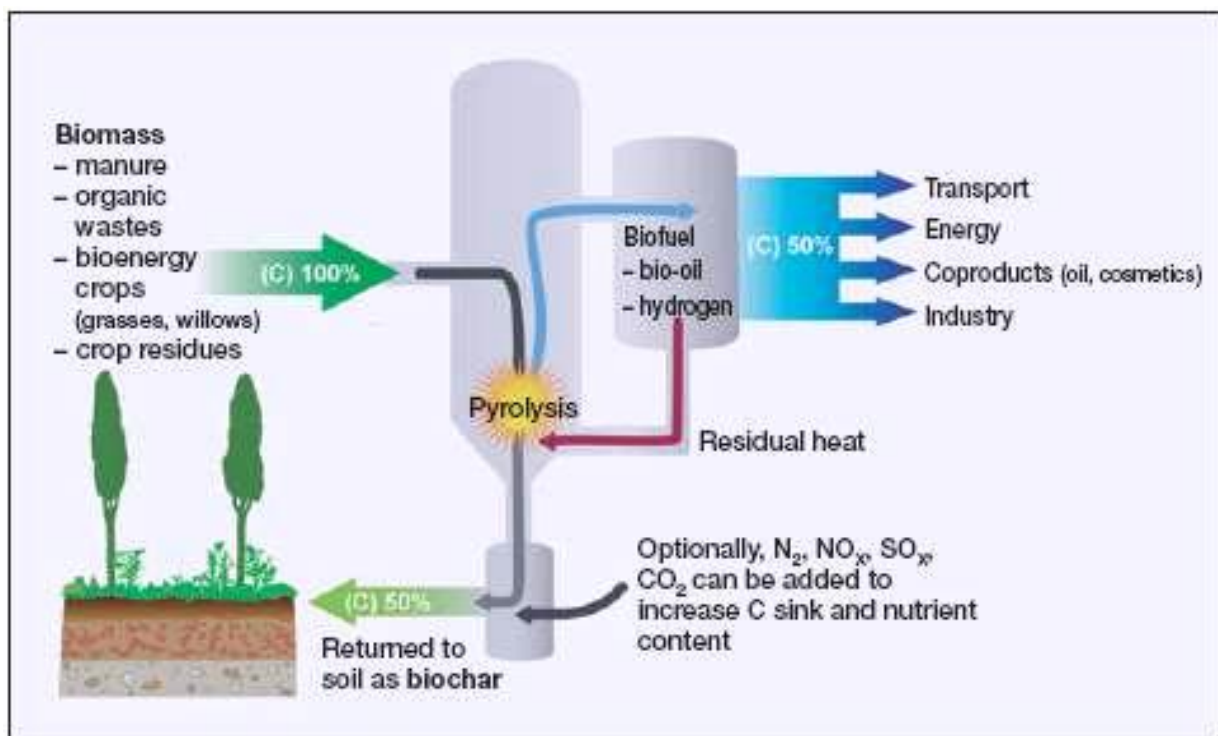

Figure 2: The basic biochar system (Lehmann, 2007)

¹ The proportion varies depending on feedstock and pyrolysis conditions, and may be between 10 and 90% (Lehmann et al., 2009); but by following good practice typical values of 70% or higher can be consistently achieved (Antal and Gronli, 2003).

B. Gaps in the Knowledge: Justification for the dissertation

Biochar holds the potential to decrease global concentrations of CO₂ (Lehmann, 2007), although whether it may be considered 'carbon negative' depends on the details of any specific project and the assumptions made for comparison in life cycle analysis (Bruun and Luxhøi, 2008). It is predicted that globally biochar could sequester up to 1GtC/yr using only waste biomass (Woolf, 2009) by 2050, or between 5 and 9 GtC /yr if specifically grown crops were used (Lehmann, 2006). These preliminary predictions have not yet been corroborated elsewhere.

Individual benefits of biochar have been researched, in particular the unique elements of soil-char interactions, long term char stability, and effect upon crop yields. Crop studies have focussed on tropical countries² because soils are poorer and biomass resources more quickly replenished, thus offering greater potential benefits (Lehmann, 2006). Research into the functioning of entire biochar *systems* has been much more limited. Only two life cycle analyses (LCAs) have so far been published for PBS, covering limited permutations of potential systems and producing divergent results (Gaunt and Lehmann, 2008, McCarl et al., 2009). Whilst it is correct to research important uncertainties regarding system components, it is also important to attempt to understand the whole system, using current knowledge and understanding. Such analysis can help to target future research, allow comparison between other competing systems (such as biomass combustion), and provide inspiration for the future development of biochar systems.

II. Project Goals

This study has produced a spreadsheet tool for assessing the green house gas (GHG) balance of PBS. It would be useful to consider also energy balance, and economic and social feasibility, but it was not possible within the scope of this exercise. The spreadsheet tool is easily modified and these assessments could be integrated in the future. The spreadsheet has been included as an electronic appendix, on a CD at the back of this document.

The goals of this project are listed here:

1. To compare different configurations of PBS

Factors to consider:

- Small or large scale
- Origin and type of feedstock

² See (Sohi, 2009b, Chan and Xu, 2009) for details.

- Pyrolysis technology used
 - Electricity and heat use
2. To determine the important variables in PBS determining GHG abatement
 3. To generate data useful to the ongoing discussion regarding the best use of biomass, with specific reference to Scotland.

Chapter 2: Literature Review

This literature review details the relevant fields of enquiry pursued for this project. The sections are as follows: LCA literature, cases and methodological; scenario development; a resource assessment for Scotland; pyrolysis production technology and biochar soil effects. Also conducted were four expert interviews and an email enquiry to local sawmills.

I. LCA

A. Biochar LCAs

Two full LCAs have so far been published focussing specifically on Biochar systems, each offering rather different results (Gaunt and Lehmann, 2008, McCarl et al., 2009). In addition Gaunt and Cowie outline a possible methodology and provide partial examples of how to conduct a GHG audit of a pyrolysis biochar system (Gaunt and Cowie, 2009).

John Gaunt and Johannes Lehmann (Gaunt and Lehmann, 2008) compared slow pyrolysis optimised for char production to slow pyrolysis optimised for energy production with input of 16,000 t/yr dry matter using both purpose grown bioenergy crops and arable crop wastes, assuming the reference land use to be growth of winter wheat. They make the case that optimising slow pyrolysis for char output and adding the char to agricultural soils would save 2 to 3 times more carbon than if the process were optimised for energy production. They perform a limited economic analysis and conclude that biochar must retail at US \$47/t to replace the profits which could have been made from the extra energy generation if the process had not been optimised for char, a fee which the authors claim could be covered by sale of carbon credits. The LCA is based upon a number of uncertainties: the exact details of the pyrolysis process and expected outputs are not known or given; no distribution or deployment emissions are accounted for after the char is produced; the effects of the char upon the soils are based on a limited number of studies using soil types and crops different from those in the LCA; and, most importantly, this is a false comparison because slow pyrolysis is not good for energy production and so would not be used if the system was optimised for energy yield – the comparison should be between slow pyrolysis optimised for char and fast pyrolysis, gasification or combustion.

Bruce McCarl et al focus more heavily on the economics of biochar production, and compare two large pyrolysis facilities, each processing 70,000t/year feedstock. Slow pyrolysis optimised for char

and fast pyrolysis optimised for energy production are compared, using maize residues as the feedstock (McCarl et al., 2009). McCarl et al account for more steps in the life cycle and use more conservative estimates when faced with uncertain data. They find biochar from slow pyrolysis stands to make a loss of \$70/t when accounting for all possible sources of revenue. Fast pyrolysis optimised for energy stands to make a \$40/t loss. The differing results between this and Gaunt and Lehmann's 2008 study serve to highlight the uncertainties in biochar systems rather than to give any definite answers. There are variations in assumptions are on energy reference systems, energy conversion efficiency, degree of soil effects, longevity of char, and application rate of char to soil. There is little discussion of the feasibility of obtaining large quantities of biomass or the application of the resultant char to soils.

B. Other Bioenergy LCAs

Many more LCAs have been published on other types of bioenergy systems. The recent and thorough study by Thornley et al. presents the findings from the first phase of the Supergen project³ assessing 25 different configurations of bioenergy power generation options (Thornley et al., 2009). Gasification, fast pyrolysis, combustion and co-firing are considered, using purpose grown energy crops. Green house gas balance, energy balance, air pollution, economic viability, social acceptability and technological novelty are all assessed. Pyrolysis, optimised for energy with no char used as soil amendment performs poorly in relation to all other technologies. It is worth noting that pyrolysis is also considered the most novel technology.

The Environment Agency report *Minimising GHG emissions from biomass energy generation* (Bates et al., 2009) uses the publically available Beat2 model (Biomass Energy Centre, 2009a) to calculate the carbon intensity of various biomass feedstocks likely to be used in the UK, considering best, good and worst practice scenarios. Important factors are found to be the direct or indirect land use change from energy crop cultivation, energy used in drying the feedstock, use of nitrogenous fertilisers and distances transported for imported feedstocks. The use of waste stream wood feedstocks is found to have the lowest carbon intensity (this result is repeated in Mortimer et al., 2009). The report recommends that energy conversion from biomass to heat or electricity should be as efficient as possible, carbon debts incurred from land use change should be avoided, and that incentives should be created for good practice.

The now defunct Scottish Executive Environment and Rural Affairs Department (SEERAD) commissioned a very useful report from a 13 strong expert team headed by David Galbraith at

³ The Supergen biomass and bioenergy consortium is a research partnership between various academic institutions and selected members of industry based in the UK (Supergen, 2009)

Aberdeen University (Galbraith et al., 2006). The report consists of a literature review of all LCAs relevant to biomass energy production in Scotland considering GHGs, air pollutants and economics and an evaluation of the potential and actual availability of the main indigenous feedstocks. The point is made that LCAs are specific to local conditions and supply chains, and whilst studies can be extrapolated to make estimates for the Scottish case, specific LCAs must be performed to permit proper analysis.

In a report for the Department of Trade and Industry Sustainable Energy Program, Elsayed et al. assess the carbon and energy balances for 23 bioenergy options (Elsayed et al., 2003). The paper relies on literature review to gather data on the production of feedstocks and the operating of the plants to generate energy, and presents this literature in a clear and coherent way. Flow charts are provided for each feedstock and each technology type, accompanied by data for each step of the process. Woodchips from large scale forest residues, small scale woodland management, and SRC are covered, alongside straw and miscanthus. Fast pyrolysis with woodchip is assessed, as well as gasification and combustion.

Heeding the call for more localised specific lifecycle work, Gabrielle and Gagnaire report an LCA on using straw for CHP generation in a bioethanol plant in three specific locations in Northern France (Gabrielle and Gagnaire, 2008). Biophysical modelling is used to understand the impacts of increased straw removal upon soil organic matter and nutrient retention, and to understand the impacts of increased NPK fertiliser deployment to counteract those effects. Findings are that straw removal and combustion GHG benefits outweigh the negative effects; and that straw left in the field contributes only 5-10% of its carbon to SOC, over a period of 30 years. It would be interesting to repeat this LCA with a pyrolysis system in place of the CHP boiler, generating energy and facilitating a much greater proportion of the carbon in straw to remain stable in the soil.

Stephenson et al. produced a simple but clear and coherent GHG and energy balance LCA comparing large scale and small scale biodiesel from OSR production in the UK, with some discussion of allocation procedures and uncertainty regarding N₂O soil emissions (Stephenson et al., 2008). Data were gathered directly from producers and refinery operators. The two case studies are compared at every stage of the process in a detailed table. An interesting observation made is that if rape meal were combusted for energy and fertiliser requirements could be lessened for the crops, the process would give more desirable energy and GHG outcomes. PBS could potentially offer these two solutions.

Various possible configurations of liquid biofuel systems are explored in the paper from Dunnett et al and the report from North Energy Associates (Dunnett et al., 2008, Mortimer et al., 2009). Dunnett et al. model different spatial and technological configurations of feedstocks, processing facilities and demand for products in both a current and a future scenario. This is done using grids of various sizes, producing diagrammatic representations of each case study.

Mortimer et al. present a more typical LCA based on generic British feedstocks and averaged transport distances, examining the GHG balance and economic viability of biomass to liquid biofuel schemes. The possibilities of densifying feedstocks through pelletisation, torrefaction and pyrolysis are examined, along with conversion of untreated feedstock. Through sensitivity analyses various factors are assessed, including: scale of plants, conversion efficiencies, transport distances, feedstock prices, and the carbon credit awarded to the char output. The point is made (as it is elsewhere e.g. Stephenson et al., 2008) that because of low energy density of biomass feedstocks, transport distances can have a large effect upon overall energy efficiency and green house gas balance. However, densification technologies become increasingly viable over a distance of 290-1000km (depending on feedstock) and are therefore not generally important when considering UK feedstocks for national consumption. It is also found that the substitution credit awarded to char can have a strong influence upon total GHG balance⁴. The results are presented very clearly in a series of graphs showing the sensitivity analyses. Also assessed are different allocation methods: by mass, market value, energy content or substitution credit. It is found that mass, market price and energy content give similar GHG balances, but using the substitution credit system, GHG savings are always higher. Finally, the spreadsheets used for calculating this LCA have been made available by the authors, and appear robust and appropriate for modification to be used for my research project. The authors of this report also developed the BEAT2 model, and are key figures in the field of biomass LCA. Using their spreadsheets and data is therefore a defensible choice.

Additionally, an LCA of ten of the main agricultural products in the UK gives good data on many aspects of British agricultural systems, providing useful data for the agricultural aspects of a biochar LCA (Williams et al., 2006).

C. LCAs: Methodological Papers

Francesco Cherubini et al. review biofuel and bioenergy LCAs and suggest methodological good practice to follow (Cherubini et al., 2009). The case and location specific nature of LCAs is raised as a

⁴ The difference is between 40 and 100% for different feedstocks, where the credit is between 0 and 3 t CO₂e per ton of char (Mortimer et al., 2009). It credit is awarded for combustion of the char, and the upper limit of 3t CO₂e is if char combustion offset coal combustion.

key issue limiting generalisability, along with the use of uncertain data in LCAs. Components of life cycles often vary in energy cost, GHG output or financial cost depending on case specific factors: this should be conveyed by using data ranges rather than single values, and presenting results as a range alongside mean averages. Methodological standardisation is recommended for the following factors: the biomass carbon cycle, including carbon stock changes in biomass and soil over time; inclusion of nitrous oxide and methane emissions from agricultural activities; selection of the appropriate fossil fuel reference system; homogeneity of the input parameters in Life Cycle Inventories; influence of the allocation procedure when multiple products are involved; accounting for land use change and indirect land use change; and finally system boundaries.

Matthew Brander et al. from the consultancy Ecometrica have produced a technical paper advising on system boundary delineation for biofuel emission based LCAs (Brander et al., 2008). The distinction between 'consequential LCAs' and 'attributional LCAs' is drawn, where attributional LCAs (ALCAs) attribute emissions to the direct processes and material flows in each stage of the life cycle, where as consequential LCAs examine the consequences of marginal change in the cycle of a product, and the indirect emissions resulting from market or socio-politico-economic system effects that this may cause. ALCAs are more robust, but may miss important issues if they are the only tool used for assessment – an example of these wider system effects is the change in global grain prices due to the US' liquid biofuel policy, and the resulting land use change to accommodate more agricultural land (Searchinger et al., 2008). Brander et al. make the point that the two LCA types answer different questions, and what is important is not to mix the methods. For my project, the ALCA methodology is more appropriate, although Brander et al. state that ALCAs should include direct land use change, but not indirect land use change, which contradicts to the advice of Cherubini et al (2009).

Journal papers using integrated assessment models highlight the benefits this approach can bring (Thornley et al., 2009, Styles and Jones, 2008, Holman et al., 2008). Combining LCA with economic, environmental or other analyses gives a much greater understanding of the overall viability of a project. Unfortunately this approach will be too time and labour intensive for this MSc dissertation.

II. Scenarios

Scenarios are used to predict future outcomes for a given situation, where the outcomes are uncertain. Multiple scenarios give a range of possible outcomes, depending on the input parameters. These scenarios may then aid the decision making processes (Audsley et al., 2006). Scenarios can be used in large projects such as the IPCC SRES scenarios (IPCC, 2007) or in the ACCELERATES project predicting land use change in Europe (Abildtrup et al., 2006); but can also be used in national

projects (Mander et al., 2008, Anderson et al., 2008) and regional scale projects (Upham et al., 2007, Upham and Speakman, 2007, Shackley and Deanwood, 2003).

Offering general advice on scenario development methodology, the EEA published a literature review on the topic and warn against using flawed methodologies (Lempert et al., 2009); in a similar study Bishop et al. review literature, categorise scenario types and explain the advantages and disadvantages and mechanisms of the different methods (Bishop et al., 2007); van Notten et al. review literature and suggest a typology of scenarios methods focussing on the purpose of different scenario types (van Notten et al., 2003).

Studies from the Tyndal centre (e.g. Shackley and Deanwood, 2003, Upham and Shackley, 2005) use scenarios to explore stakeholder preferences. Shackley and Deanwood (2003) developed socio-economic scenarios using the Shell method where autonomy/interdependence and consumerism/community are the variables. The method is useful, although these variables are not appropriate for the goals of my project. Upham and Shackley (2005) describe their scenarios clearly through both narrative and data tables.

III. Feedstocks

A. Defining the Feedstocks

As many feedstocks as possible were considered for selection, drawn from a variety of sources (Thornley et al., 2009, Bates et al., 2009, Elsayed et al., 2003, Galbraith et al., 2006, TSEC, 2009, Biomass Energy Centre, 2009a, McKay, 2003). The initial list and results may be seen in table 1 below.

These feedstocks were assessed on three criteria: the quantity of the resource in Scotland now and by 2025; whether competing markets for the resource would render it unattainable to biochar systems and whether the resource would be suitable for pyrolysis.

Table 1. Resource Assessment phase 1: Feasibility.

Note: One tick means that it is feasible, two ticks means it looks good. These are qualitative not quantitative judgements.

Feedstock	Quantity Generated in Scotland	Availability after Competing Uses	Appropriate for Pyrolysis	References
SRC	✓✓	✓✓	✓✓	(Andersen et al., 2005, McKay, 2003, Aylott et al., 2008, Forest Research, 2003)
Short Rotation Forestry	✓	✓	✓✓	(Forest Research, 2009b, Biomass Energy Centre, 2009a, Mitchell et al., 1999)
Miscanthus	FAIL	✓	✓	(Price et al., 2004, Agricultural Census, 2008, Galbraith et al., 2006, Riche, 2006, Defra, 2007, Lovett et al., 2009)
Reed Canary Grass	FAIL	✓	✓	(Galbraith et al., 2006, Riche, 2006)
Switchgrass	FAIL	✓	✓	(Riche, 2006, Galbraith et al., 2006)
Corn Stover	FAIL	✓	✓	(Agricultural Census, 2008)
Wheat Straw	✓	FAIL	✓	(Agricultural Census, 2008, Galbraith et al., 2006, Gabrielle and Gagnaire, 2008)
Barley Straw	✓	✓	✓	(Agricultural Census, 2008, Galbraith et al., 2006, Gabrielle and Gagnaire, 2008)
Oilseed Rape Straw	✓	✓✓	✓	(Agricultural Census, 2008, Galbraith et al., 2006, Stephenson et al., 2008, Newman, 2003)
Other Cereal Straw	FAIL	FAIL	✓	(Agricultural Census, 2008)
Small Round Wood	✓✓	✓	✓✓	(McKay, 2003, Scottish Executive, 2007, Galbraith et al., 2006)
Forestry Residues	✓	✓✓	✓✓	(McKay, 2003, Andersen et al., 2005, Scottish Executive, 2007, Galbraith et al., 2006, Mistry et al., 2008, Forest Research, 2009a)
Arboricultural Arisings	FAIL	✓	✓✓	(McKay, 2003, Levy et al., 2006)

Sawmill residues	✓	✓	✓✓	(McKay, 2003, Forestry Commission, 2008)
Manure	✓	✓	FAIL	(Smith and Frost, 2000, Galbraith et al., 2006, Mistry and Misselbrook, 2005, Smith et al., 2000a)
Slurry	✓	✓	FAIL	(Smith and Frost, 2000, Galbraith et al., 2006, Mistry and Misselbrook, 2005, Smith et al., 2000a)
Chicken Litter	✓	FAIL	✓	(Galbraith et al., 2006, Thornley, 2009a, Smith et al., 2000a, Chan et al., 2008)
OSR Meal	✓	FAIL	✓	(Stephenson et al., 2008, Galbraith et al., 2006, Mortimer and Elsayed, 2006, Onay and Kockar, 2003)
Palm Kernel Expeller	FAIL	✓	✓	(Woods et al., 2006, Perry and Rosillo-Calle, 2006, Thornley, 2009a, Yang et al., 2006)
Olive Cake	FAIL	FAIL	✓	(Vigouroux, 2001, Perry and Rosillo-Calle, 2006, Alguacila et al., 2008, Alkhamis and Kablan, 1999)
Jatropha Residues	FAIL	✓	✓	(Thornley, 2009a)
Imported Forestry Residues	FAIL	✓✓	✓✓	(Perry and Rosillo-Calle, 2006, Perry and Rosillo-Calle, 2007, Thornley, 2009a)

The most promising are indigenous forestry resources; small round wood and forest residues. Quantities available can be seen in table 2 below. Small round wood is any part of the stem or branchwood which is harvested but less than 14cm in diameter. These pieces of wood are not suitable as timber and frequently end up as firewood or are left to decompose (McKay, 2003). Forest residues, or brash may be harvested following stem extraction. Machines have recently been developed which can harvest fallen branches, sticks and twigs, compressing them into bales (Forest Research, 2009a). These residues currently remain mostly uncollected and offer a new resource of biomass, although care must be taken not to cause any soil nutrient degradation by over removal (as may occur too with straw – see (Gabrielle and Gagnaire, 2008)).

Sawmill residues constitute a centralised stock of woody biomass some of which has no market but most of which is used in compressed wood board manufacture (Forestry Commission, 2008). Depending on market dynamics, there may be more or less of this resource available to bioenergy. Projects which use residues on site, to provide power for milling and other operations, are particularly promising – for example the 2.7MWe plant in Eniskillin, Northern Ireland (Unknown, 2005) or the planned 5MWe plant at Invergorden, Scotland (Balcas, 2009). Both are owned by Balcas, a large wood processing company, and power the sawmill and wood pellet factory.

Woody energy crops grow better in Scotland than perennial grasses (Defra, 2007, Riche, 2006, Andersen et al., 2005). Indeed, farmers have not chosen to grow any grass energy crops, but some SRC is in place (Agricultural Census, 2008). Scotland has a large potential for woody energy crops (Andersen et al., 2005), presently SRC is more advanced but it may be that SRF will be planted increasingly as trials progress (Forest Research, 2009b). Pyrolysis systems will have to compete with other bioenergy systems for this resource, but there will be in competition with other markets, such as animal feed.

Woody feedstocks are better suited to pyrolysis than those which contain high quantities of cellulose such as cereal straw, although straw feedstocks can be used (Lehmann and Joseph, 2009, Yang et al., 2007). Scotland grows mainly wheat and barley, but also grows a significant quantity of oilseed rape; other cereals (including corn) are not grown in sufficient quantity to be worth considering as a feedstock at this stage (Agricultural Census, 2008). Wheat straw is used very commonly as animal feed and bedding, indeed the demand is much higher than it is in England where the climate is warmer (Galbraith et al., 2006). Barley straw is used to a lesser degree as a bedding material (Galbraith et al., 2006), and OSR straw is generally ploughed back into the soil as it is inappropriate as a feed or bedding material (Newman, 2003, Cook, 2009).

Animal manures and slurries, although available in large quantities are generally inappropriate for combustion, gasification or pyrolysis without extensive drying because of their very high moisture content. These feedstocks are better suited to anaerobic digestion (Galbraith et al., 2006). Although it may be possible to use excess process heat to dry the feedstocks, it is an extra complication which need not be investigated until simpler avenues have been investigated. For this reason manures and slurries will not be considered further here.

Chicken litter has proved a useful soil amendment once pyrolysed, having a high nutrient content, but a short residence time (Chan et al., 2008). However almost all of the available chicken litter is already combusted in a power plant at Westfield in Fife, Scotland, so chicken litter will not be considered further.

The remains of oil crops (OSR, olives, oil palm) which have had the oil extracted are commonly combusted in cofiring plants, and sometimes used as animal feed (Perry and Rosillo-Calle, 2006). The increase in OSR cropping in the UK is likely to come to an end as the Renewable Transport Fuel Obligation has been put on hold at present, which means that there will be no extra rape meal for biochar systems. The high oil content also means that the feed is very energy rich and therefore suited to combustion. Alternatively, it may be that pyrolysis is a good way to extract the remaining oil, if in the future the oil product attracts a high price.

Imported feedstocks, including both the remains of oil crops and forestry residues are generally available in large quantities (with the exception of olive cake, which mainly remains in the Mediterranean) (Perry and Rosillo-Calle, 2006, Alguacila et al., 2008, Thornley, 2009a). The sustainability of removing very large quantities of biomass from often nutrient poor areas and shipping the biomass many thousands of kilometres is low (Thornley et al., Forthcoming) and therefore it was decided to consider only imported forestry residues from Canada, where the resource is large and well managed, and transport to the UK is by ship (Thornley, 2009a).

B. Quantifying the Feedstocks

The maximum quantities of each resource are shown in the table 2 below. In some cases this value has been worked out from average yield statistics and data on the area planted, and in some cases it has been obtained from the literature. It has been arbitrarily assumed that 50% of the total available biomass could go to biochar systems if the only competitors for the resource are other bioenergy systems, and that 25% of the biomass could be obtained by PBS if there are other competing markets, such as animal feed or chipboard manufacture. Where no specific information can be obtained on the Lothian and Borders region, it is assumed that 15% of the national resource may be

obtained. This is also arbitrary, but justified in the case of sawmill residues and SRC because large sawmills are in the area (Forestry Research, 2009) and the land is well suited to SRC (Andersen et al., 2005).

Table 2 Resource Assessment phase 2: Availability for the period 2015 to 2025

Feedstock	Max available in Lothian and Borders odt/yr	Max available in Scotland odt/yr	Likely max in L&B assuming competition odt/yr	Assumptions	References
Barley Straw	109695	699074	27500	5.6/4.1 t/ha yield at 50%mc (winter/spring barley)	(SAC, 2009, Agricultural Census, 2008)
OSR Straw	23495	84056	11748	yield of 2.5 t/ha	(Agricultural Census, 2008, Galbraith et al., 2006)
Sawmill Residues	No Data	388526	29139		(Forestry Research, 2009) ⁵
SRC	No Data	700000	52500	5% of biological potential in Scotland is exploited	(Andersen et al., 2005, Galbraith et al., 2006)
Short Rotation Forestry	No Data				
Small Round Wood	94807	327519	47000		(Forestry Research, 2009)
Forestry Residues	68011	319126	34000		(Forestry Research, 2009)
Imported Forestry Residues	100000+	1000000+	100000+		(Thornley, 2009a)

C. Obtaining GHG Balances for the feedstocks

A number of published LCA papers (Williams et al., 2006, Mortimer et al., 2009) and the BEAT2 and Biomass to Liquids LCA spreadsheets available in the public domain (Biomass Energy Centre, 2009a, Mortimer et al., 2009) contained all the information necessary for my study. Further data from Patricia Thornley submitted to the UKBRC as part of an ongoing project contracted by Defra served

⁵ (Forestry Commission, 2008) gives higher values, but do not take into account competing uses of the biomass.

to check the accuracy of the data acquired, and Nigel Mortimer kindly agreed to process a number of modifications through his private spreadsheets for me at no charge.

The useful internet database Phyllis (Phyllis, 2009) contained information on the energy and carbon content of certain feedstocks.

IV. Pyrolysis Technology

A. Pyrolysis Process Data

The important things to know about a pyrolysis system from a green house gas point of view are the relative outputs of char, gas and liquids, and the carbon and the energy content of each. The energy in those fractions which are combusted is converted into electricity and heat, and the efficiency of this process depends on the type of technology used. A certain amount of the energy is lost, and a certain amount is used within the process to sustain itself. All the carbon contained in those elements combusted is emitted as carbon dioxide. The carbon remaining in the char is sequestered in the soil, where it remains for as long as the char survives (Lehmann and Joseph, 2009, Masek, 2009).

The LCA papers on biochar (McCarl et al., 2009, Gaunt and Lehmann, 2008) provide some information on biochar systems, but using their data would risk producing the same results.

Bridgewater has a useful table demonstrating general yields at different temperatures (Bridgewater, 2007).

Pete Brownsort, a fellow MSc student, is conducting his dissertation on the variation of pyrolysis systems, with a focus on biochar. He has provided me with a summary of the most complete data available on pyrolysis systems; as there are many incomplete data sets, this has been very useful. Data on the operation of slow pyrolysis at 400°C is the most comprehensive, although it is not the most efficient temperature for producing char⁶. It may be assumed therefore that it is possible to produce more energy from slow pyrolysis whilst maintaining the same soil and carbon sequestration benefits that occur in this study. For straw feedstocks, most of the data are taken from the Haloclean system, and the rest has been interpreted by Brownsort (Hornung et al., Unpublished, Brownsort, 2009). For wood feeds, information from Dynamotive has been synthesised with Holoclean data and

⁶ Char produced at a lower temperature tends to have the same absolute amount of fixed carbon, i.e. that which does not degrade or degrades very slowly, but less volatile carbon. If this volatile carbon is removed and tapped of as gas or liquid it can be combusted generating useful energy, and the amount of fixed carbon in the soil remains the same (Antal and Groenli, 2004, Ryu et al., 2007).

gaps again filled by Brownsort (Dynamotive, 2000). The data sets appear comparable to those in other literature sources (e.g. DEMÇIRBAS and ARIN, 2002, Ryu et al., 2007, Bridgewater, 2007). For fast pyrolysis, the data set from Best energies has been used (Downie et al., 2007) which is the same process that McCarl based his study upon (McCarl et al., 2009).

B. Building the Pyrolysis Plant

Elsayed and Mortimer have made estimates on the emissions from building a 20MWe power only pyrolysis plant (Elsayed and Mortimer, 2001), Mortimer et al. have then used these figures to determine emissions on a per MWe installed capacity basis (Mortimer et al., 2009). McCarl estimates that a 70,000 t input per year pyrolysis plant may cost US\$23.7m to build, which equates to US\$340 per ton of feedstock input (McCarl et al., 2009). Lehmann and Joseph estimate US\$15m, plus \$0.5m per year costs for 100,000 t input per year, equating to US\$250/t input⁷ (Lehmann and Joseph, 2009).

V. Soil Effects

The soil effects are perhaps the most uncertain of all the stages in the biochar lifecycle. Review papers (Sohi, 2009b, Woolf, 2009) provide an overview of the basic mechanisms and much of the recent and comprehensive publication *Biochar for Environmental Management* (Joseph and Lehmann, 2009) considers the effects of biochar upon soils. Different types of biochar affect different types of soil in different climates in different ways, and the effects vary for different crops. Nevertheless, some generalisations can be made.

Char generally increases crop growth, and more so on weathered or poor soils (Lehmann, 2006, Glaser et al., 2002). Biochar enhances the water retention of soils, thus improving dry or sandy soils and reducing irrigation requirements; biochar enhances cation exchange capacity (CEC) stabilising and making available more nutrient ions in the soil, which can lead to lower fertiliser requirements (Liang et al., 2006). It appears that CEC increases over time (Chan and Xu, 2009, Hammes and Schmidt, 2009) probably at an inverse exponential rate, over a period of ten years (Sohi, 2009a). Strong clay soils require more energy for field operations (such as ploughing), and biochar may lessen this by reducing soil strength, but the effect is still unknown (Gaunt and Cowie, 2009). Biochar decreases soil nitrous oxide and methane emissions through a variety of mechanisms (VanZweiten et al., 2009), probably by around 25% (Sohi, 2009a) although different experiments have produced a range of results varying from 15% to 90% reductions and indeed, in some cases, an increase in emissions (Yanai et al., 2007, Rondon et al., 2007, Sohi, 2009b). Biochar is generally of alkaline pH

⁷ These calculations take the total cost of the plant, and in Lehmann and Joseph's case also the operating costs, and divide by the number of t of feedstock input per year.

and so may alter soil pH in a favourable direction for most crops (Chan and Xu, 2009), thus offsetting the need for agricultural liming. Soil organic matter increases because of more input due to increased productivity of the plants, and the char also slows down the rate of decay of soil organic matter (Thies and Rillig, 2009). There is considerable uncertainty, so I have relied upon on the advice of Dr Saran Sohi in making conservative estimates of the likely magnitude of these effects (Sohi, 2009a), while also comparing his estimates to the literature.

VI. Other Research methods

A. Expert Interviews

To supplement the literature review I conducted a number of expert interviews on specific topics for further clarification. These interviews were conducted in an informal manner, with notes made throughout. The notes from these interviews may be found in Appendix 8.

1 Dr Patricia Thornley

Dr Patricia Thornley is an engineer by training and a key member of the Supergen research project (Supergen, 2009). Dr Simon Shackley, Pete Brownsort and I spent a day talking with her about the viability of a range of feedstocks and pyrolysis technology options; Dr Thornley then provided us with detailed information, both published and unpublished, and a range of carbon balances for the provision of different feedstocks.

2 Members of the UKBRC

Dr Ondrej Masek is the engineer of the UKBRC team, and helped me to understand the variety of pyrolysis and biomass conversion technologies which exist. Dr Saran Sohi also of the UKBRC is a soil scientist and provided advice on modelling soil effects and estimating the degree of those effects. Jason Cook is a PhD student with the UKBRC currently conducting field trials and told me about the methods and practical difficulties encountered when deploying biochar on a Scottish farm, as well as provided information on farming practice and constraints.

B. Email Enquiries

1 Sawmills

I emailed ten sawmills based in and around the Lothian and Borders region, asking for specific information on the quantity of wood chip, sawdust and bark produced each year. The results of this inquiry are in the table 3 below.

Table 3 Sawmill co-products

Company	Wood Chips	Sawdust	Bark
Perthshire Timber	4670	1648	780
James Callender and Son Ltd	38000	6000	5000
A & J Scott Ltd	75000	25000	5000

Chapter 3: Methodology

This chapter outlines how the case studies and spreadsheet model were generated. Part I explains how the case studies were arrived at, and explains each one. Part II explains the spreadsheet model, and Part III details the calculations within the model.

I. Creating the Case studies

Good LCAs are located in a specific place, and all details are based in reality, limiting generalisability, but maximising accuracy (Cherubini et al., 2009). This is especially true for biomass systems because biomass is bulky and inefficient to transport and usually grown near to the place of consumption (Upham and Speakman, 2007). People often feel attached to their biomass stocks (Upham et al., 2007).

Unfortunately there are no working biochar systems in Scotland, or indeed anywhere: real world cases cannot yet be studied. Realistic and representative cases have had to be constructed, which required the creation of likely scenarios. From these scenarios, two families of case studies were created. Each case study is located in a representative region, although due to time constraints these are theoretical locations. Scale of pyrolysis plant has been determined by feedstock availability, in the light of likely (but not quantitatively assessed) economic and financial constraints.

A. Scenarios

Shell diagrams can help with envisaging possible configurations of future systems (Bishop et al., 2007). Using the shell diagrams in figures 3 and 4, a number of different scenarios for PBS can be imagined, operating on micro or macro scales – from a single small pyrolysis kiln to a network of large pyrolysis plants.

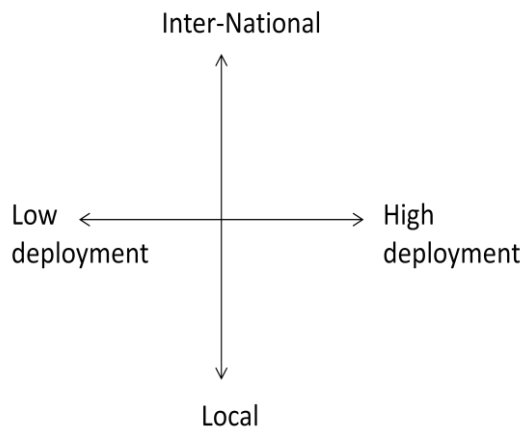

Figure 3 Shell diagram 1

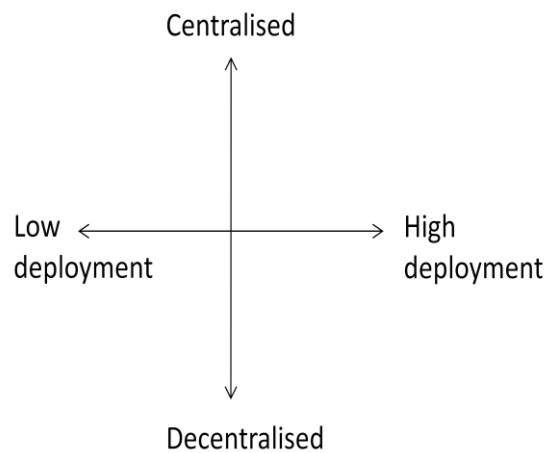

Figure 4 Shell diagram 2

The low to high deployment axis on both diagrams refers to the quantity of char produced for mixing with soil. The international to local axis (figure 3) could refer to sourcing of feedstocks, location of kilns or location of char deployment. Although the deployment of biochar holds much promise in tropical countries with poor soils (Lehmann, 2006), this study will only consider PBS on Scottish soil. This axis will therefore only refer to the sourcing of feedstocks. The centralised-decentralised axis (figure 4) refers to how much government or large businesses are involved in planning the system. More centralised planning is assumed to lead to larger and more complex systems, requiring greater investments and more linking components

Figure 5 illustrates how the shell diagram can be populated and used.

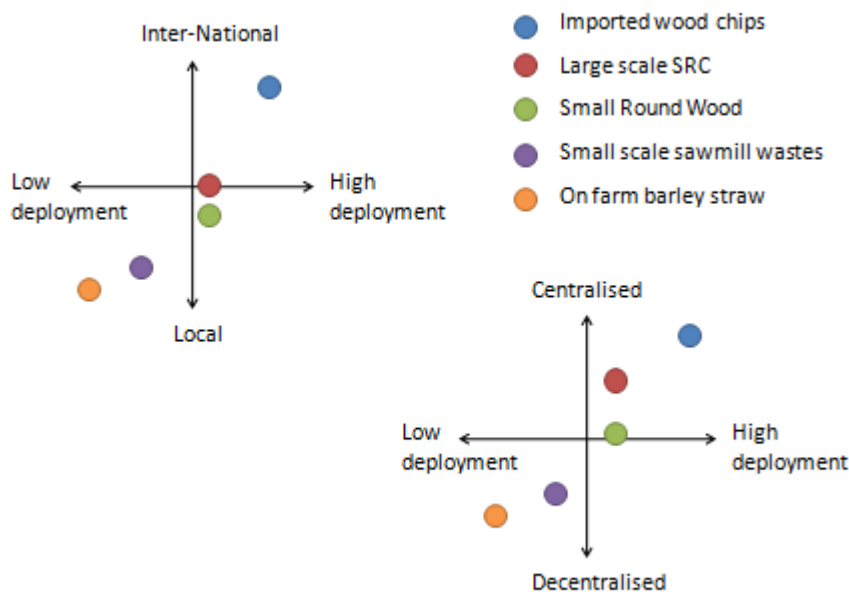

Figure 5 Shell diagrams populated with imaginary case studies

It is assumed the degree of centralisation also correlates with the origin of feedstock, and centralised systems result in higher deployment of char. This may change if farm scale PBS became very popular; then decentralised systems would result in high deployment. Conversely, if small scale pyrolysis were subsidised by government as a rural village scale power source and soil enhancement mechanism, using SRC as a feedstock, then such a system would become a low deployment centralised one.

B. Case Study Families

A number of factors will determine whether case studies occur: the state of the technology, the availability of feedstocks, and the investor and agricultural confidence in PBS. ‘Off-the-shelf’ pyrolysis systems are not yet available, and have not been trialled on a large scale (Brown, 2009). The present assumes smaller systems will be available by 2015, and larger systems by 2020. Pyrolysis plants will not be built without investor confidence and char will not be added to soils without agricultural confidence. Research and demonstration trials must provide the basis for this confidence.

When these practical constraints are considered, case study families emerge: “Small, Decentralised, Soon” and “Large, Commercial, Later” (see table 4 below). The “Soon” case studies would begin operation in 2015 and run for 15 years. The “Later” family would run from 2020 to 2040. These time periods are typical for studies of pyrolysis systems (McCarl et al., 2009, Mortimer et al., 2009).

Table 4 Case study families

Small, Decentralised, Soon	Large, Commercial, Later
<p>On-farm:</p> <ul style="list-style-type: none"> • Barley Straw • OSR Straw • Short Rotation Coppice <p>Saw Mill</p> <ul style="list-style-type: none"> • Small 	<p>Saw Mill</p> <ul style="list-style-type: none"> • Large <p>Energy Crops</p> <ul style="list-style-type: none"> • Short Rotation Coppice • Short Rotation Forestry • Small Round Wood • Scottish Forestry Residues <p>Imported</p> <ul style="list-style-type: none"> • Canadian Forestry Residue Wood Chips • Canadian Forestry residue Wood Pellets

C. Locating the Case Studies

Lothian and Borders was chosen as a representative area of Scotland in which to base this study because of high feedstock availability, large amounts of arable land for deployment of crops, relatively large populations for use of energy products and good transport links.

The maps below illustrate these points (figures 6, 7 and 8).

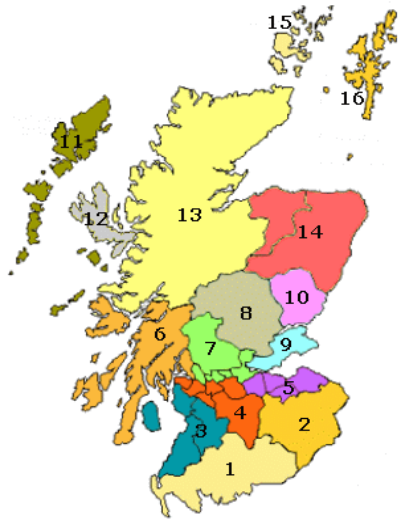

Figure 6 The location of Lothian (5) and Borders (2) in Scotland (Map, 2009)

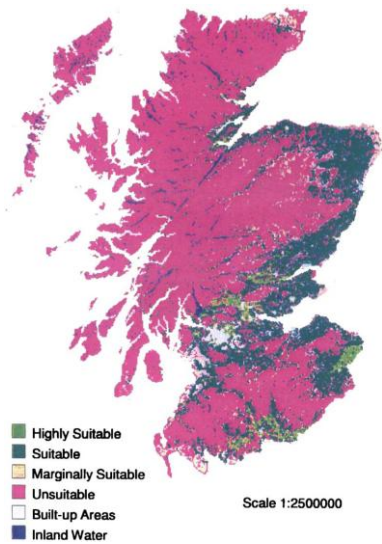

Figure 7 SRC suitability map (Andersen et al., 2005)

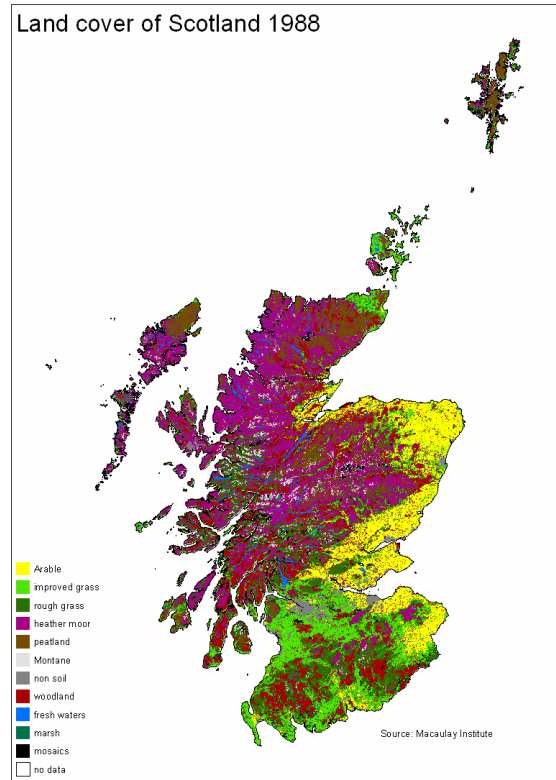

Figure 8. Land cover in Scotland. Yellow is arable crops, while maroon is woodland (Towers et al., 2006).

D. Case by Case Narrative

All the cases follow the same lifecycle stages, but have variations in scale, pyrolysis output, efficiency of energy conversion, use of heat, transport methods and distances. All cases model slow pyrolysis as the default, char is assumed to be applied to wheat crops, each char has the same effects upon the crop and the soils and the same decay rate; pyrolysis oils are converted to electricity by diesel engines. The lifecycle stages are represented in figure 9 and described in detail in section III below. For a more detailed life cycle flow chart, see appendix 1.

Each case study is briefly described here, with numerical data for all assumptions given in tables

appendix 3. In all cases except SRC, feedstock emission data is from Mortimer et al. (2009).

Life Cycle Stages

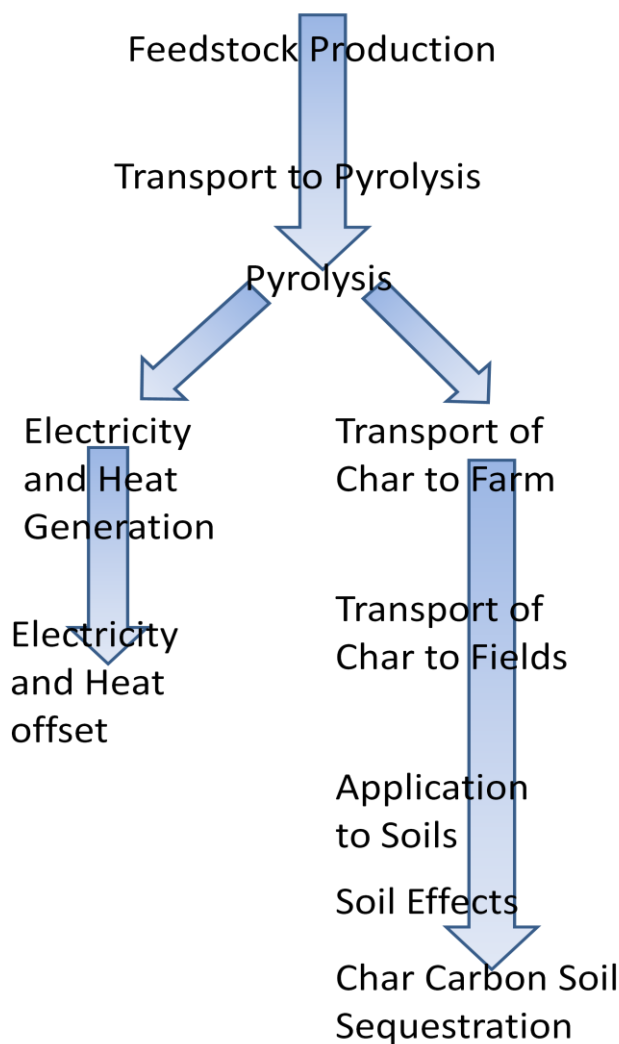

1 Barley Straw

Barely straw is collected from fields and used to as a feedstock for a local on-farm pyrolysis unit, rated 100kWe. Char is used on this and surrounding farms.

The average farm in Lothian and Borders growing barley harvests 342t barley straw per year, assuming a yield of 5.6 t/ha for winter Barley and 4.1 t/ha for spring barley (SAC, 2009, Agricultural Census, 2008). Assuming that half of this is available to PBS, and the produce of ten farms collected, 1710 t/yr would be available⁸. This is a low quantity for a continuous operation system (Morgan, 2009).

Syngas is used as a heat source for

Figure 9 Life Cycle Flow Chart for PBS

mc.

II pyrolysis calculations are performed at 0%

drying grain, offsetting propane. Syngas could also be used in household heating, vegetable tunnel heating and livestock shed heating.

2 Oil Seed Rape Straw

OSR straw is collected and used to fuel on-farm batch pyrolysis system, rated 170kWe. Char is used on this and surrounding farms.

OSR straw is not currently ploughed back into the soil (Mortimer and Elsayed, 2006). Ideally, the emission factor for OSR straw collection would account for replacement of nutrients lost due to straw removal (e.g. Gabrielle and Gagnaire, 2008), but in the absence of better data the emission factor has been used from wheat straw (Mortimer et al., 2009). Yields are 1.5-2.5 t/ha (Newman, 2003, Galbraith et al., 2006), with the higher value chosen here because the Galbraith study is Scotland specific. The average farm grows 51 ha of OSR per year (Agricultural Census, 2008), yielding 128 t straw/yr. Ten farms would yield 1280 t/yr, which is appropriate for a batch pyrolysis unit (Brown, 2009), assuming batch pyrolysis operates under the same parameters as continuous pyrolysis. Gas is used for grain drying and offsets propane.

3 Farm Scale Short Rotation Coppice

SRC is grown on marginal land without fertilisers, yielding 7odt/ha (Forest Research, 2003), providing a low input low cost fuel. Feedstock emissions data is from Thornley (2009b). To allow comparisons, the system is assumed to be on the same scale as for barley straw . To grow 180 ha of SRC would require more than one farm unless it was very large⁹, so some wood chip would have to be purchased. Excess heat would be used as in the straw examples.

4 Small Scale Sawmill Residues

A pyrolysis system is assumed to consume 25% of a fictional mill's woodchip output (5,000 t/yr)¹⁰, providing electricity and heat for wood drying. It is assumed that the wood would otherwise dry naturally, so there is no GHG benefit to the heat usage. Char would be sold to farmers, and gas converted to electricity with a gas engine, the rating of the pyrolysis unit 500kWe.

The emission factor has been modified from Mortimer et al (2009), who assumed the feedstock would otherwise go to landfill with energy capture. This leads to a high negative value for methane per ton of feedstock – methane emissions avoided by using the feedstock for pyrolysis. According to the annual sawmill survey however (Forestry Commission, 2008) less than 0.5% of soft wood sawmill

⁹ As may be found among the land owning elite in Scotland, a demographic group not considered here.

¹⁰ Data provided by James Callender and Son Ltd, see Literature Review chapter, section VII.B.

residues are sold as firewood or disposed of as waste, and according to the Woodfuel Resource report (McKay, 2003), no sawmill residues go to landfill..

5 Large Scale Sawmill Residues

A pyrolysis system appropriate for the size of the sawmill at Eniskillin, Northern Ireland (Unknown, 2005), or A&J Scott's sawmill in Northumberland, would be a 2.6MWe pyrolysis unit consuming 30,000 t/yr feedstock; 40% of A&J Scott's woodchip. The CHP plant at Eniskillin uses heat to dry sawdust which is then converted into wood pellets for sale – a similar process is assumed in this case.

Char is sold to local farmers, electricity is converted from gas and diesel engines. The above uncertainties about sawmill residues as waste apply here too.

6 Forestry Residue Wood Chip

20,000 t per year of forestry residues (FRs) are pyrolysed in a 1.7 MWe facility, feeding electricity into the national grid. Pyrolysis oil and gases are converted to electricity in engines and the char is sold to local farmers. No heat offset use is assumed. These parameters are assumed for plant operation for the following four forestry cases. These four wood resources are of comparable size, so comparing their use in similar technological systems allows assessment of which feedstock, or other factors, gives the most efficient system.

Emission factors (Mortimer et al. 2009) assume that forest residues would otherwise decay aerobically, thus use in bioenergy avoids this methane emission. The assumption has been maintained in the present study. It is unclear whether potential changes in soil carbon due to the removal of forest residues were included in the emission factor (Forest Research, 2009a).

7 Small Round Wood Chips

Small round wood means harvested stem or branchwood below 14cm in diameter. Often converted to chips, it is plentiful and changes to woodland management or supply chains are not required. In contrast FR collection would require changes to be made as they are not presently collected. The costs of FR collection are not known, but in Beat2 (Biomass Energy Centre, 2009a) they are assumed to account for only 7.4% of the sales value of wood/ha; whereas SRW accounts for 56% of the sales value. These figures may be skewed because most FRs are not collected and sold, therefore do not have value. In the absence of better data, these figures are used for allocation.

8 Large Scale Short Rotation Coppice

Coppice is assumed to be grown on grade 3 or 4 agricultural land, with sewage sludge used as a fertiliser, yielding 10 odt/ha (Thornley, 2009c).

Mortimer et al. (2009) assume electric fan drying of the wood chips for SRC and SRF. As they state, this is probably impractical when economic costs are considered. Results are therefore presented without this assumption, to illustrate the difference. If fast drying is required, heat from combustion of pyrolysis products could be used, but is assumed to offset natural drying.

9 Large Scale Short Rotation Forestry

Short rotation forestry is still under investigation as a feasible energy crop. It has been included here for study, but it is unclear to what degree the crop will be planted.

10 Canadian Forestry Residue Wood Chips

A large pyrolysis system is assumed for imported feedstocks: 100,000t/yr input and an electrical output of 8.3MWe. Large quantities of feedstock must be imported for a contract to be economically viable (Thornley, 2009b), and the facility should be near a port to minimise transport. The facility should also be near to heavy industry that requires heat, such as cement production. It is assumed that 50% of the available heat offsets natural gas.

A 14,000 km round trip by ship is assumed for importation. Due to necessity owing to the tool used for calculation (Biomass Energy Centre, 2009a), the emissions from the ship journey have been included in the feedstock emissions section of the life cycle and not in the transport section.

Transport in this model therefore only refers to in country transit.

11 Canadian Forestry Residue Wood Pellets

A pyrolysis facility of 100,000 t/yr is assumed, giving 12.2MWe because the higher calorific content of wood pellets yield more electricity. This may be an overestimate, as pyrolysis experiments have not yet been undertaken with wood pellets it has been assumed that the energy content of all pyrolysis products is increased by the same ratio as the energy content of the feedstocks “Canadian Forestry Residue Wood Chips” to “Canadian Forestry Residue Wood Pellets”.

Wood pellets have been assessed here because it is more economic to densify the feedstock before transporting it long distances. Imported wood pellets may be cheaper than imported wood chips because of the reduced transport costs.

II. Modelling the Case Studies

All calculations were all undertaken in Excel on a spreadsheet created for this project. Inspiration for the format of the spreadsheets was drawn from Beat2 (Biomass Energy Centre, 2009a) and the North East Biomass to Liquids Project (Mortimer et al., 2009).

The spreadsheet assesses each case study over one year periods, attributing all char soil benefits and decay within the time horizon immediately, and assumes that char will be deployed on virgin land every time. Modelling of the change over time (COT) was attempted but not feasible within the scope of the project. Initial results for modelling over time are presented in appendix 2, and show

that the yearly model gives higher net benefits than the COT model, but the effect does not undermine the validity of the yearly model.

A. The Spreadsheet

The spreadsheet uses a flow chart format, with each lifecycle stage or component having a separate box. The sheet flows from top to bottom, exactly as in figure 10. Supporting spreadsheets contain various numerical data for the calculations, but all case study variables can be entered into the flow chart. Blue boxes are variables to be entered, and red boxes give the results of calculations. The layout can be seen in figure 10 and the electronic appendix contains the entire workbook.

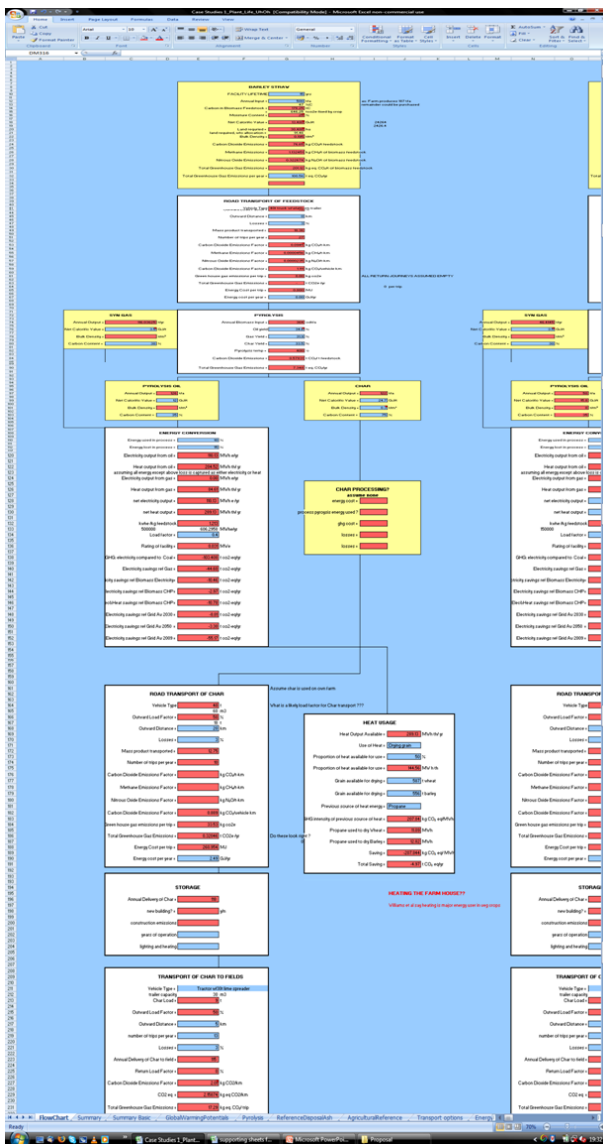

Figure 10 Spreadsheet model used in study

1 Outputs

The main data output of the spreadsheet is quantity of CO₂e for each stage in the lifecycle process, as well as MWh of electricity and heat energy produced.

Results are presented as total GHG emissions per case study, tCO₂e/MWh e, tCO₂e/odt feedstock, tCO₂e/ha. Energy product can be expressed as MWh/odt feedstock or MWh/ha for electrical, thermal or combined energy output.

The relative proportions of emissions from different lifecycle stages were compared, and sensitivity analyses performed, to determine the relative importance of particular variables.

2 Flexibility and Limitations

Reference systems can be changed to explore different system configurations. The easily modified systems include electricity offset, heat offset and the agricultural regime to which biochar is applied.

Limitations

The model only considers GHG emissions or saving. Costs, energy balance, environmental impact or social acceptability are not considered. Although potentially useful, it was not possible to allow customisation of variables affecting the emission factors of feedstock production or emissions avoided from use of waste feedstocks.

The reference scenarios for agricultural deployment of char are limited only to arable crops, thus excluding other horticultural uses. Indirect land use change has not been addressed as an issue for energy crops which may entail the conversion of land from other uses. Omissions of other processes¹¹ is explained and justified in the appropriate sections below.

3 Balance Checks

Two checks were undertaken to ensure the spreadsheet's internal consistency. First, a balance check on total CO₂ inputs from feedstocks and total CO₂ outputs from syngas and pyrolysis oil combustion, handling losses of feedstocks and char in transit, and char decay in soil revealed in discrepancies of between 0.4 and 0.51% from different case studies.

Secondly, emissions from combustion of syngas and pyrolysis oil have been checked against the values generated by a specific pyrolysis spreadsheet model (Brownsort, 2009), resulted in 0 to 1% discrepancy, depending on the case study.

III. Methodology for Calculations

A. Key assumptions

Key constant assumptions are listed in appendix 4. Multiplication of Carbon mass by 44/12 is used to calculate mass of CO₂. All global warming potentials (GWPs) of non-CO₂ gasses are taken from IPCC 4AR and are over a 100 year time horizon (IPCC, 2007). Soil N emissions are taken as 1% of applied N fertiliser (IPCC, 2006). Multiplication of Nitrogen mass by 44/28 is used to calculate mass N₂O. Diesel, propane and methane calorific values and carbon contents are listed in the appendix.

¹¹ Omissions are liming effect of char, irrigation and soil strength effects and start up fuel used in processes.

B. Feedstock Production

The quantity of feedstocks is estimated in each case according to the size of the desired system, local availability of the resource (including average farm output for barley and OSR straw), and comparison to other bioenergy systems (Thornley et al., 2009).

The emissions resulting from production of the feedstocks, or in the case of waste products the emissions saved compared to disposal of the feed, are from Mortimer et al. (2009), and from unpublished work submitted to the UKBRC by Thornley (Thornley, 2009c).

When determining land requirement for feedstocks, yield was multiplied by the quantity needed, to determine area required. The area was then divided by the ratio of price of feedstock product: price of all products obtained from land. This form of financial allocation was used throughout, with prices drawn from Beat2 (Biomass Energy Centre, 2009a), and yield data from (Mortimer et al., 2009, Thornley, 2009c). For example, sales of wheat straw generate £87.5/ha.yr, sales of wheat grain £552/ha.yr. If the total sales revenue equals 100%, then the sales of wheat straw give $87.5/(552 + 87.5) = 13.7\%$ of the total revenue. Therefore 13.7% of the land requirement is allocated to straw, whilst the remaining 86.3% is allocated to the grain. The same allocation method is used within Beat2 and Mortimer et al. (2009) when allocating emissions from agricultural operations such as planting or fertiliser applications.

C. Transport of Feedstocks to Pyrolysis Plant

1 Emission Factors

In Defra's guidelines for Green House Gas reporting (Defra, 2008) CO₂ emission factors expressed as kg CO₂/vehicle km are given for all vehicles representative of the British fleet. Emission factors for HGVs are given for 0, 50, 100 % cargo load, and for UK average load.

Defra's statistics gives greater flexibility than those of Mortimer et al. (2009) because they provide a greater range of vehicle classes and return load factors. Defra however do not provide data on N₂O or CH₄ emissions or information on the vehicles' capacity in m³ or the maximum cargo weight.

To account for N₂O and CH₄ emissions the relative fraction of total GHG emissions due to N₂O and CH₄ was calculated from Mortimer et al. (2009), using the equation

$$(N_2O \text{ emissions} \times GWP) + (CH_4 \text{ emissions} \times GWP) / \text{total GHG emissions}$$

N₂O and CH₄ account for between 6.8% and 7.4% of total vehicle emissions during transport, calculated for trucks operating at 100% load capacity and at 25% load capacity respectively. This

percentage of emissions was added to the Defra data to account for N₂O and CH₄. The higher value of 7.4% is used to increase all CO₂ emissions factors for vehicles where N₂O and CH₄ have not been accounted for.

For all cases except straw, transport emissions are based on using 60m³ trucks with a maximum load weight of 25.5 t and a total weight of 40t. For straw a platform trailer is attached to the same cab, offering 120m³ carrying capacity, but the same weight limits (Mortimer et al., 2009, Thornley, 2007). For all feedstocks an outward load factor of 50% is assumed, in line with values from other studies (Defra, 2008, Mortimer et al., 2009, Biomass Energy Centre, 2009a), because of the low bulk density of the materials, Return journeys are at 0% load factor.

All journey distances are estimated according to reference literature (Mortimer and Elsayed, 2006, Thornley et al., 2009, McCarl et al., 2009). Sensitivity analysis performed on journey distance vindicates this inaccurate approach(see Results chapter).

D. Handling Losses

At each stage of transport or storage some loss of feedstock or char is assumed. 1% loss has been estimated for all transport stages - lower than the 3% assumed by Mortimer et al (2009), but higher than the total 1% losses assumed by Thornley (Thornley, 2009c). These values are explored in sensitivity analysis.

Losses are presumed during transport of feedstock to pyrolysis plant, transport of char to farm, transport of char from farm to field and application to soil. A 3% loss is assumed for application to soil because of char dispersal by rain or wind. Where no journey is made, no loss has been assumed (e.g. in on-farm pyrolysis systems).

E. Pyrolysis

1 Pyrolysis

During pyrolysis, all gaseous emissions are contained and stored as part of the syngas. Liquids are tapped off and the char product remains. The process is endothermic up to 280°C but exothermic above this, and so requires variable amounts of energy(Antal and Gronli, 2003). Stored syngas, liquids or char may be combusted to supply the start up energy (e.g. McCarl et al., 2009), except for the first time the reaction is started. It is assumed that 10% of total energy available for conversion to electricity is required in the process, and that a further 10 to 15% is lost in the process, partially accounting for start up fossil fuel (Brownsort, 2009). The products of pyrolysis may all be combusted for electricity or heat, or the char may be used as a soil amendment. As all emissions from pyrolysis

are contained in the syngas, the total carbon in the gas, liquid and char equals the total carbon in the feedstocks going into the kiln.

Emissions for the construction of the pyrolysis plant are accounted for by the ratio 0.22 tCO₂eq/ odt feedstock input per year (Elsayed and Mortimer, 2001). Total emissions due to construction are then divided equally over the plant life span measured in years.

Load factors have been estimated for each size of pyrolysis unit, but do not make a difference to GHG emissions in this study, and so can be omitted. Were fossil fuel start-ups considered, the load factor would become more important.

2 Electricity and Heat Generation

i Pyrolysis Oil and Syngas

All pyrolysis oil and syngas is converted to electricity in diesel or gas engines. Diesel engines are assumed to have conversion efficiency between 35 and 40%, increasing with size, up to 200MWe. Gas engines are not available in such large sizes, up to only 5MWe with conversion efficiency between 35 and 38% for syngas¹². Smaller systems are assumed to use only a diesel engine, but larger systems are assumed to use both diesel and gas engines. Start up fuel has not been accounted for in the engines.

All carbon in syngas or pyrolysis oil is assumed to be combusted to CO₂. These emissions are not included in the lifecycle analysis because it is assumed that the biomass crops will re-grow and therefore remove the equivalent amount of carbon from the atmosphere¹³. This is common practice for biomass LCAs (Cherubini et al., 2009, McCarl et al., 2009).

ii Combustion of Biochar

Char can also be combusted to produce electricity. This alternative use is explored in the results chapter. Conversion to electricity is assumed to be in co-combustion (Masek, 2009), giving an efficiency of 40 to 45%(Perry and Rosillo-Calle, 2006).

3 Electricity and Heat Offset

i Electricity Offset

The CO₂eq emissions per MWh e for various power generation options were obtained from the literature (DUKES, 2008, Bates et al., 2009). For Bioenergy systems where the fuel is carbon neutral,

¹² Both types of engine are available in smaller sizes.

¹³ The char added to the soil is however counted as part of the life cycle emissions, because it is carbon being taken out of circulation - it is not being released back to the atmosphere; it is being stored in the ground, where growing crops cannot access the carbon and convert it into lignin or cellulose.

the total emissions come from crop productions, transport and infrastructure; this is reflected in low typical values of 95 kgCO₂eq/MWh e (Bates et al., 2009). Gas or coal fuels are not carbon neutral, reflected in much higher values of 405 and 939 kgCO₂eq/MWh e respectively (DUKES, 2008). The grid average figures for 2008 are 501 kgCO₂eq/MWh e (DUKES, 2008); for 2030 are 80 kgCO₂eq/MWh e and for 2050 are 30 kgCO₂eq/MWh e (Bates et al., 2009).

For each MWh e generated by PBS, it is assumed that 1 MWh e is not being generated by the reference system. The default reference system is typically the grid average 2008, and this is varied in the results and discussion chapters.

ii Heat Offset

Heat is more difficult to use effectively than electricity. Local District heating systems have not progressed well in Britain, and heat cannot be transported efficiently. Maximum conversion of energy to electricity was therefore assumed. In those cases where heat is used on site, the quantity of heat energy has been calculated and presumed to offset the previous method of generating heat.

For example, on-farm pyrolysis heat is assumed to offset grain drying, where the average grain yield per farm gives the quantity of grain to be dried (Agricultural Census, 2008). The energy requirement is 68 MJ/t for wheat and 83MJ/t for barley (Williams et al., 2006). Propane is the typical fuel used in Lothain and Borders (Cook, 2009), with a heating value of 51950.5 MJ/t and CO₂eq emissions of 3 t/t propane combusted (Phyllis, 2009). This equates to 207 kgCO₂eq/MWh th from propane. Each MWh th used from the pyrolysis process is assumed to offset one MWh th previously from propane.

The same methodology is used where the pyrolysis heat offsets natural gas (Phyllis, 2009), or electric fans used for drying woodchips (Biomass Energy Centre, 2009a).

F. Transport of Char from Pyrolysis to Farm

Transport of char from pyrolysis facility to farm uses 40t trucks and assumes a 50% load factor. A 50% load factor assumes that 12.75 t of char could be carried at any one time. A completely full 60m³ truck would carry 18t of char, assuming bulk density of 3 t.m³ (Cook, 2009, Blackwell et al., 2009). A 50% load factor is more realistic because it accounts for when the trucks are not completely packed, and will slightly overestimate rather than underestimate emissions.

Transport distances are again estimated.

G. Transport of Char from Farm to Field

Feedstocks and products are assumed to be transported around the farm by tractor, towing a load of 18t wet char in a lime spreader. This is discussed further below (subheading 1.3.6.2).

Lindgren and Hansson give fuel use for a 81kW tractor carrying a 12 t load on the back of a trailer (Lindgren and Hansson, 2002). Assuming that 1 litre of diesel fuel combusted emits 2.63 kg CO₂ (Defra, 2008), 0.95 kg CO₂ per vehicle km are emitted. The emission factor for a 17t rigid HGV at 100% capacity is 0.864 kg CO₂ per vehicle km (Defra, 2008). Although the HGV is more efficient, the result for the tractor is (surprisingly) only slightly less efficient.

A Czech study on tractors with 50, 63 and 114 kW engines towing a 10.2 t load both up and down hill gives higher results (Jílek et al., 2008). Travelling uphill, the range was 1.53-2.01 kg CO₂/vehicle km and travelling downhill the range was 0.99-1.5 kg CO₂/vehicle km. In all cases, nitrous oxide and methane emissions are assumed to follow the same ratio as from HGVs as calculated from the North Energy (Mortimer et al., 2009) data, thus accounting for total CO₂eq.

The higher emission values of Jílek's study are chosen here for three reasons: Lothian and Borders is a hilly region, tractors are likely to be more powerful than those studied and thus consume more fuel (173kW reported by Cook, 2009), and the load transported (18t) is heavier than those in the studies by Jílek et al. and Lindgren and Hansson. Therefore the largest tractor available, 114kW, is considered, using the uphill figure for the outward journey and the downhill figure for the return journey. The emissions from tractor transport may still be underestimated.

H. Application of Char to Soils

1 Quantity and Regularity of Char Applications

The optimal quantity of char added to soils for either agricultural benefits or cost effectiveness has not yet been established. Studies suggest from 0.5 t/ha application to 135 t/ha, and resulting changes in crop yields are not linear (Sohi, 2009b). There are no published studies about the addition of char to soils and crops of the types in Scotland; most studies focus on degraded tropical soils (Blackwell et al., 2009).

The present model assumes an application rate 30t/ha, with a top-up application of 5 t/ha every 5 years to maintain the same level of beneficial soil effects. These applications should give favourable agricultural effects even on relatively productive Scottish soils (Sohi, 2009a). Lower rates of char application are considered in the discussion chapter. Alternatively char can be applied to soil 'little and often' perhaps 5t/ha every year (e.g. McCarl et al., 2009). This would be easier to integrate into

existing farming practices but soil effects would take longer to accrue. The total yield benefits might be greater because a greater area could be covered. This option has not been explored because of the limitations of the COT model.

In all cases, char is assumed to be spread onto wheat crops. Wheat accounts for 41,651 ha of arable land, enough for 1,249,530 t of biochar, at 30t/ha. Spring Barley accounts for 36,584 ha, space for another 1,097,520 t biochar (Agricultural Census, 2008). These areas of land are sufficient for the present study, and much more land remains for future biochar deployment.

2 Spreading the Char

Spreading 30t/ha of char presents significant logistical difficulties. The amount of char carried to field in each load should be maximised to reduce the number of trips and limit GHG emissions from fuel, as well as time and

financial costs. The low bulk density of char means that, even in a large volume trailer, only a low mass of char can be transported. The char is often fine and 'dusty', blowing away during application if there is wind (see figure 11) (Husk, 2009).

To counteract this char should be wetted with water before application to soil (Cook, 2009).



Figure 11 Char application on a windy day (Husk, 2009)

Agricultural lime spreaders are the best farm machines for spreading biochar (Husk, 2009, Blackwell et al., 2009), being larger than seed or fertiliser broadcasters. The largest agricultural lime spreaders available are 30 m³ (e.g. Continental, 2009), carrying a maximum of 35t. Assuming a biochar bulk density of 0.3t/m³ this gives 9t per load, or 3.3 loads per hectare. Wetting the biochar before application doubles mass to transport (Cook, 2009), increasing fuel costs.

Deploying large quantities of biochar by tractor and trailer is inefficient for the farmer. It is likely that outside contractors will invest in specially designed machinery appropriate to the task. A tractor towing a lime spreader has been assumed here however, even for the largest cases.

3 Mixing the Char with the Soil

After spreading biochar over the soil, it may be turned to facilitate mixing of the char and top layer of soil. It is most efficient to integrate the turning into the normal agricultural timetable: by spreading the char immediately before a ploughing, harrowing, disking or seed drill operation is planned (Blackwell et al., 2009). This way the turning of the soil will incur no further costs in terms of man hours or GHG emissions.

4 Methodology of Calculations

Typical liming operations deploy 8 to 15 t/ha (RothLime, 2009), while char deployment will require 30 t/ha. This is assumed to take two runs, so the typical energy requirement of lime spreading (Williams et al., 2006) has been doubled.

I. Soil Effects of Biochar

All assumptions about soil effects have come from discussions with Dr Saran Sohi and from relevant literature. Soil effects change over time: both the degree and the rates at which they change are uncertain. It has been assumed that all soil effects accrue immediately, and all char which will decay within the time horizon decays instantly. Estimations of the effects over time are in appendix 2.

Char types will not produce the same effects in all soils, (Blackwell et al., 2009). However, a uniform effect has been assumed here because there are no data on the interactions between the char types studied and the soil types in the region.

A net primary productivity (NPP) increase of 10% and a crop yield increase of 10% have been assumed. This is lower than most results from the literature (Sohi, 2009b, Blackwell et al., 2009), because published studies concern degraded soils with low yields, and therefore greater scope for improvement.

Wheat crops use more fertiliser than Barley crops, thus offer greater potential savings from fertiliser reductions. Low till agriculture methods also facilitate char incorporation when using combined seed drills and diskers (Cook, 2009). Whilst horticultural crops potentially offer larger economic returns and GHG abatement/ha (Gaunt and Cowie, 2009), the variety of agricultural practices and crops introduce a level of complexity beyond the scope of this project.

1 Increased Soil Organic Carbon Accumulation

Soil Organic carbon (SOC) is the largest carbon pool in the UK, and Scotland's soils account for 70% of total terrestrial carbon stored in Britain (Towers et al., 2006). Thus even a few per cent change over a small area provides a large total change. The argument for soil carbon management to fight climate change has been made (Lal, 2004).

Biochar increases SOC through two mechanisms: by increasing input of plant matter, through enhanced NPP; and by slowing the rate of SOC breakdown by microbes (Thies and Rillig, 2009). It is assumed that the increase of organic matter input due to NPP occurs in the first year, and is equal to that NPP change, as a percentage. SOC breakdown processes are assumed to increase SOC by a maximum of 10%, over a period of 20 years, assumed to be a linear rate in the absence of experimental data (Sohi, 2009b). In the S spreadsheet model this total benefit is attributed to each char addition (assuming that each char addition is on previously untreated land) when in reality it would take 20 years to occur.

Accounting for both increased input and decreased decay rate, a change of 21% is assumed. Whilst large, this is comparable to studies of the effects of reduced tillage agriculture, which decreases decay rate (Smith et al., 1998) and estimates for total potential of soil carbon sequestration (Smith et al., 2000b). There is also initial evidence on the degree that biochar increases the stabilisation of organic carbon (Liang et al., 2008, Liang et al., Forthcoming). It has been found that the terra preta soils of the north east Amazon (long treated with charcoal) contain three times the SOC than do neighbouring soils (Glaser, 2007). Whilst it would be unfounded to assume this effect everywhere, it does suggest that considerable SOC increases may occur.

i Calculating SOC Increases

Soil organic carbon figures do not exist for Scotland. The MacAulay Institute report supplies some relevant facts, but lacked the resources to gather information on soil bulk density around the country (Towers et al., 2006). Instead, they provide information on the % content of SOC, and estimate bulk density of agricultural soils to be 1.31 t/m³. The range of bulk density of English and Welsh soils is typically 1.3-1.6 t/m³ (Sohi, 2009a).

SOC is determined by the following formula:

$$\text{Length of land area} \times \text{Width} \times \text{Depth} \times \text{Bulk Density of soil} \times \% \text{SOC}$$

There are two types of soils in the region under study: brown earths and mineral podzols, with SOC contents of 1.5-3% and <1.5% respectively (Towers et al., 2006). Assuming (arbitrarily) that the range of <1.5 % extends from 0.8 to 1.5%, it is calculated that mineral podzols' carbon content ranges between 23.92 tC/ha (minimum) and 55.2 tC/ha (maximum). The minimum and maximum for brown earth soils are 44.85 and 110.4 tC/ha. As the distribution of brown earths and mineral podzols is fairly equal over the study area, and the char is not planned for any one specific site, a middle value of 50tC/ha has been chosen.

Estimates for English and Welsh SOC range from 20 to 60tC/ha (Sohi, 2009a), somewhat lower than for Scottish soils. This concurs with other research on Scottish soils: "Compared with soils in England and Wales, even the mineral soils have higher levels of organic carbon than their counterparts south of the border (Bradley et al., 2005)" in Towers et al. (2006).

2 Increased Fertiliser Use Efficiency

Biochars enhance nutrient properties of soils both directly and indirectly (Chan and Xu, 2009). Direct effects come from the nutrients contained in the char itself (available N, P, K or other trace minerals). Indirectly char enhances the long term nutrient availability of soils and decreases the need for fertiliser¹⁴ through increased cation exchange capacity, or the liming effect of the alkaline char on the soils (Chan and Xu, 2009).

i Direct Effects

Data from a current experiment show that eucalyptus char contains 7.5 kg soluble N/t char (Sohi, 2009a). Lehmann et al (2003b in Chan and Xu, 2009) found 10.9 kg N/t wood char. Deploying 30 t/ha, this would provide 225 and 327 kg N per ha – more than the usual 200kgN/ha added to wheat crops in Scotland (SAC, 2009). A similar result is found for P, but not for K (Lehmann et al., 2003b in Chan and Xu, 2009). The effect lasts only one cycle of crops because the nutrients are quickly released. This effect has not been included in the Smodel; it is assumed instead that the boost in nutrients will increase the crop yield. In the COT model it is assumed that no N or P fertilisers are applied to the land after the first application of biochar.

ii Indirect Effects

The cation exchange capacity is assumed to increase over a period of 20 years to its maximum, at an inverse exponential rate (Sohi, 2009a). This is modelled in the COT spreadsheet, but the maximum

¹⁴ It would also be possible to keep adding the same quantity of fertiliser and perhaps receive an even greater yield or NPP benefit.

effect has been assumed for the static model. It is assumed that the maximum cation exchange capacity gives a 10% reduction in N-fertiliser necessity and 5% reductions for P and K fertilisers (Sohi, 2009a). This is explored in the sensitivity analysis.

Biochar pH effects would offset the need for agricultural liming, but this has not been included here because of the difficulty in comparing pH and Neutralising Value, the unit of measurement of agricultural lime (requires lab testing), and because of the wide range of Biochar pH values: from 4 to 12 (Lehmann, 2007).

iii Calculating Fertiliser Reductions

The average fertiliser rates for wheat in Scotland were taken from the literature (SAC, 2009). Fertiliser energy requirement in production and resultant GHG emissions were taken from Beat2 (Biomass Energy Centre, 2009a). The relative saving of fertiliser was then calculated as a saving of CO₂eq.

3 Suppression of Soil Nitrous Oxide Emissions

Biochar has been found to suppress N₂O emissions from soils, in some cases by 90% (Yanai et al., 2007) using 150t/ha char; but 50, 15 and 0% suppression has been reported, for lower applications and other soil types (Gaunt and Lehmann, 2008, Sohi, 2009b). The mechanisms are not well understood and accurate predictions cannot be made (VanZweiten et al., 2009). It has been assumed that 30t/ha char may offer a 25% reduction in N₂O release from soils. This is explored further in sensitivity analysis.

The IPCC recommend calculating soil N₂O emissions as a function of the quantity of N fertiliser applied¹⁵ (1% of N applied is oxidised and released) (IPCC, 2006). There has been debate about whether this is the best procedure to follow, Cherubini et al. (2009) recommending 1.325%, whilst Crutzen et al recommend 3% be used (Crutzen et al., 2007). These options are explored in the results and discussion chapter.

4 Irrigation Requirement and Soil Strength

Biochar helps soils hold moisture (VanZweiten et al., 2009), minimising harm in drought years and lowering irrigation requirements. Neither are relevant to case studies in Lothian and Borders, so are not considered further here.

Mixing biochar with high density soils lowers soil strength, decreasing diesel usage in soil operations such as ploughing (Gaunt and Cowie, 2009). This has not been considered here because the amount

¹⁵ Char additions also decrease the quantity of N applied, therefore also reducing N₂O emissions by reducing input.

of char needed to achieve this is unknown, and data on soil strength in Scotland are poor (Towers et al., 2006)¹⁶

J. Carbon Sequestration in the Soil

1 Char Longevity in Soil

The carbon stored in char is mostly inert, and remains in the ground for a long time. How long is unknown and varies with the char and soil interactions. Studies have estimated char mean residence times from 293 years (Hammes et al., 2008) to 9259 years (Lehmann et al., 2008), with most studies suggesting some thousands of years (Lehmann et al., 2009). To err on the side of caution, a 500 year mean residence time (MRT) for all char types has been assumed here, . Chars produced at 400°C rather than 550°C may have shorter MRT¹⁷ (Joseph et al., 2009). Selection of a lower mean residence time is therefore appropriate since the present study models pyrolysis at 400°C, so.

2 Super Labile and Labile Fractions

Char also contains labile and super labile, or soluble, fractions. These vary according to char type and production technique, but assumptions of 10% labile and 5% super labile (Sohi, 2009a, Lehmann et al., 2009, Joseph et al., 2009) are used here. Labile and super labile fractions are emitted on annual to decadal timescales (Lehmann et al., 2009); in this study they are assumed to be emitted within the first year.

3 Calculating Char Carbon in the Soil

The carbon content of char is assumed to be 75% (Brownsort, 2009). The time horizon for assessing char remaining in soil is taken to be 100 years, the MRT 500 years and a linear decay rate is assumed (Sohi, 2009a) after the labile fractions have decayed. Carbon remaining in the soil is calculated by the following formula in the static model:

$$\text{Total Char applied to soil} \times \text{Carbon Content} \times (100\% - \text{Labile and Super Labile Fraction loss}) \times (100\% - (\text{Time horizon}/\text{MRT}))$$

¹⁶ It could be assumed that diesel for agricultural soil operations was reduced by a factor relative to the quantity of char added and relative to the starting soil density.

¹⁷Or, it may also be that lower temperature produced chars have the same stable char content, but higher labile char content, therefore initial losses appear greater, but these will diminish over time leaving the same absolute quantity of stable carbon (Antal and Gronli, 2003)

The summary the calculations is complete. It is possible to run the model on a variety of different assumptions, generating different results. These results are presented in the following chapter.

Chapter 4: Results

The original project goals provide the framework for this chapter:

- To compare different configurations of PBS
- To determine the important variables in PBS determining GHG abatement
- To generate data useful to the ongoing discussion regarding the best use of biomass, with specific reference to Scotland.

This chapter is split into three parts, addressing each question in order. Part 1 deals with absolute abatement levels from each case, and examines each case through normalised units (eg CO₂eq/MWh e). Part 2 looks at the relative part played in total GHG emissions by each life cycle stage. Sensitivity analysis determines the effect of changing certain variables on total GHG emissions for a sample of four case studies; the variables and the degree of effect are summarised in table 4. Part 3 runs the pyrolysis model on three different scenario groups: PBS extremely pessimistic to optimistic assumptions; alternatives to PBS (including fast pyrolysis and combustion); and deployment scenarios using optimistic to pessimistic assumptions for Scottish feedstock availability. Selected examples from the three scenario groups are then combined.

Results are presented graphically, and all supporting data tables may be found in Appendices 5 to 7.

IMPORTANT NOTE: In all cases, negative GHG emission values indicate GHG reductions. Positive values indicate emissions. In some cases the axes have been inverted.

Each case study is either identified by name or by number, as shown in table 5.

Table 5 case study name and number

Number	Case
1	Barley Straw
2	OSR Straw
3	Small Scale SRC
4	Small Scale Sawmill Residues
5	Large Scale Sawmill Residues
6	Scottish Forestry Residue Chips
7	Scottish Small Round Wood
8	Large Scale SRC
9	Short Rotation Forestry
10	Imported Forestry Residue Chips
11	Imported Forestry Residue Pellets

I. Part One: Case Study Analysis

A. Absolute Abatement

1 Case study Comparisons

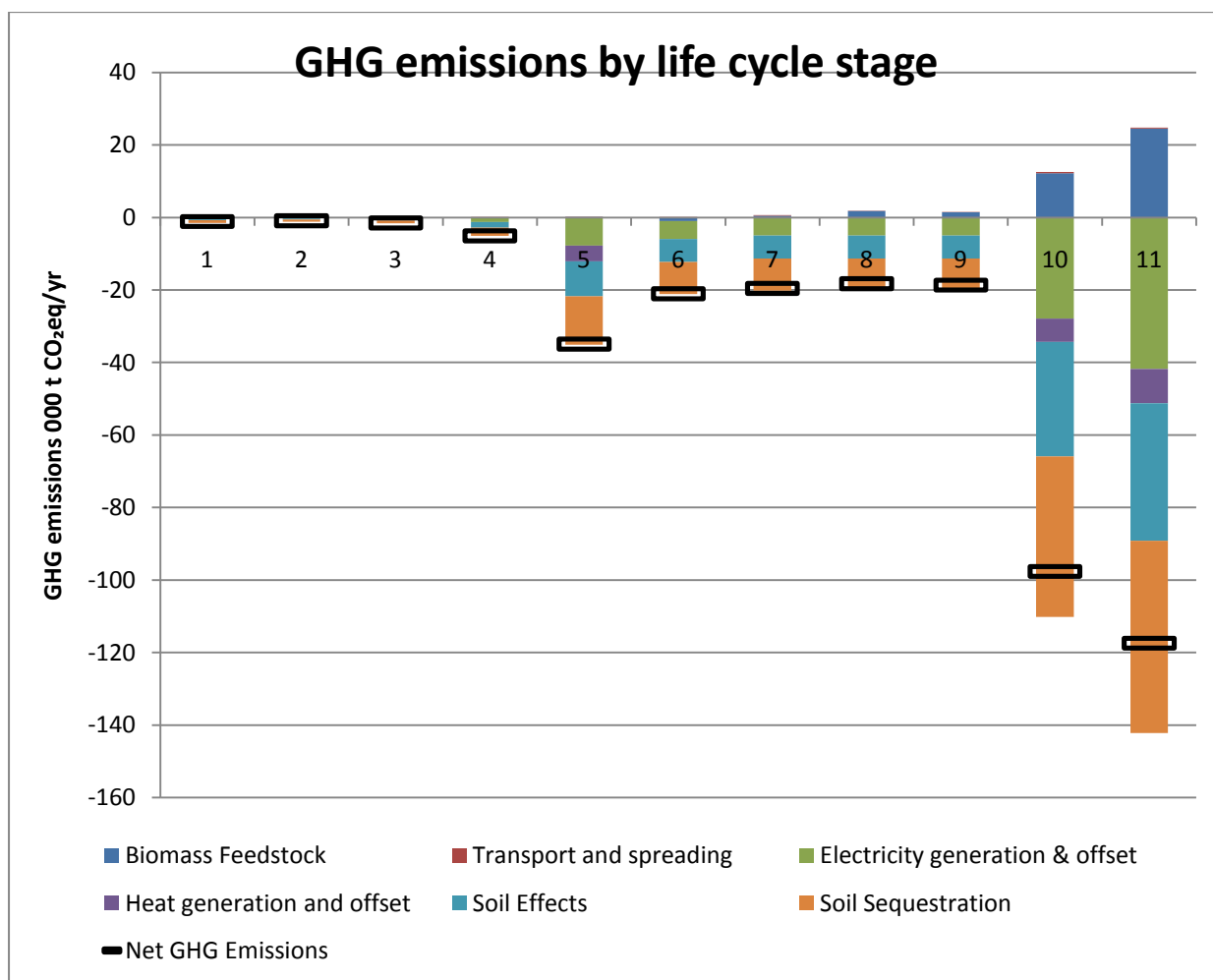

Figure 12 GHG emissions by life cycle stage

The most striking finding here is the difference in GHG abatement between the cases. This is due mainly to variations in scale, not in efficiency¹⁸.

The next observation is that every system results in a net reduction of GHG concentrations in the atmosphere. This is not unique in bioenergy systems, and is explored further in part 3 and the discussion chapter.

¹⁸ See the following section I.A.2

Finally, the contributions of each stage of the life cycle can be observed. This is explored further in part 2.

2 Explaining Variation: The importance of feedstock.

The relationship between GHG emissions and quantity of feedstock consumed per year is presented in table 2 and figures 2 and 3.

Table 6 case study GHG emissions and feedstock consumption

Case Study	1	2	3	4	5	6
GHG Emissions tCO ₂ eq/yr	-1133	-894	-1487	-5053	-34957	-21040
Feedstock input t/yr	1710	1280	1710	5000	30000	20000
Case Study	7	8	9	10	11	
GHG Emissions tCO ₂ eq/yr	-19545	-18271	-18642	-97650	-117432	
Feedstock input t/yr	20000	20000	20000	100000	100000	

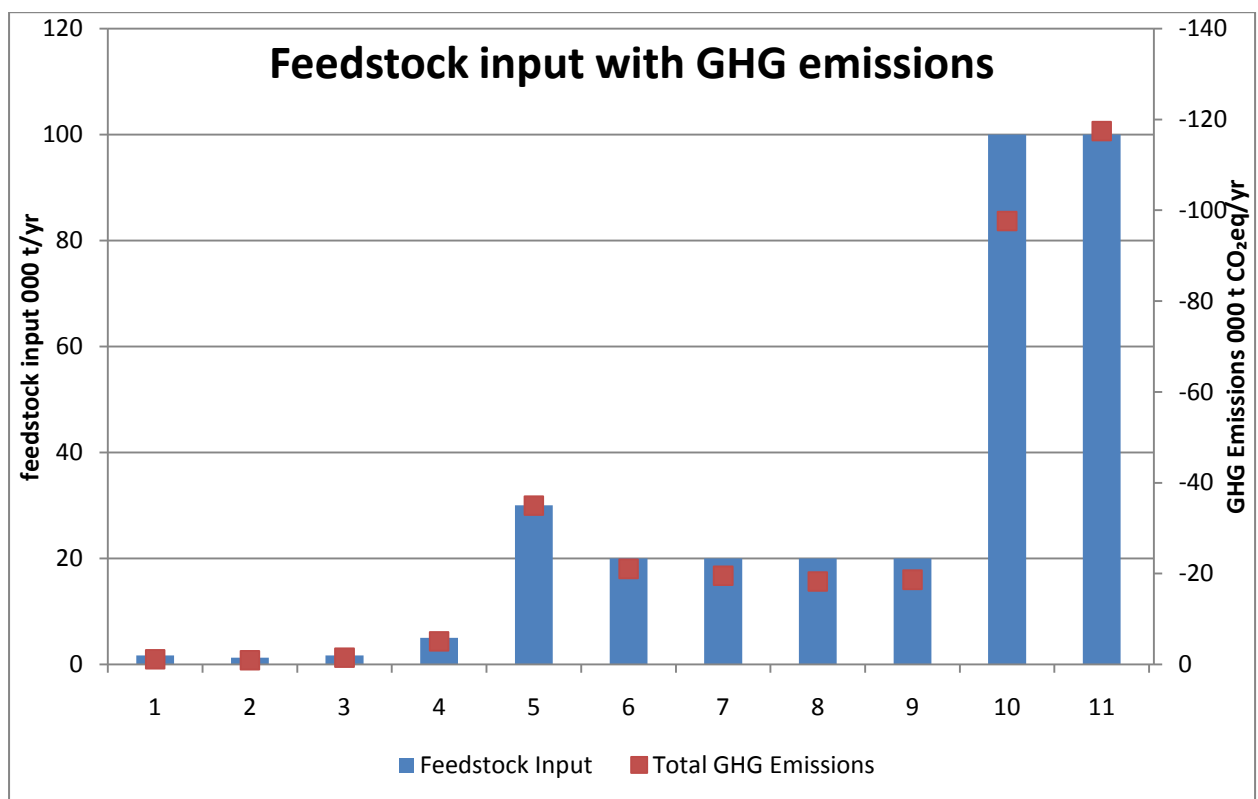

Figure 13 Feedstock input with GHG emissions

There is a linear relationship between feedstock input and variation in GHG emissions, as shown in figure 3.

The difference between imported wood chips (10) and imported pellets (11) is explained by the differences in feedstock. Wood pellets entail higher emissions to produce, but have greater energy content than woodchips, thus generating more electricity and heat. The lower moisture content also means that per t of feedstock more char is produced.

Other variations between cases are explained by feedstock variation, use of heat or electrical conversion efficiencies.

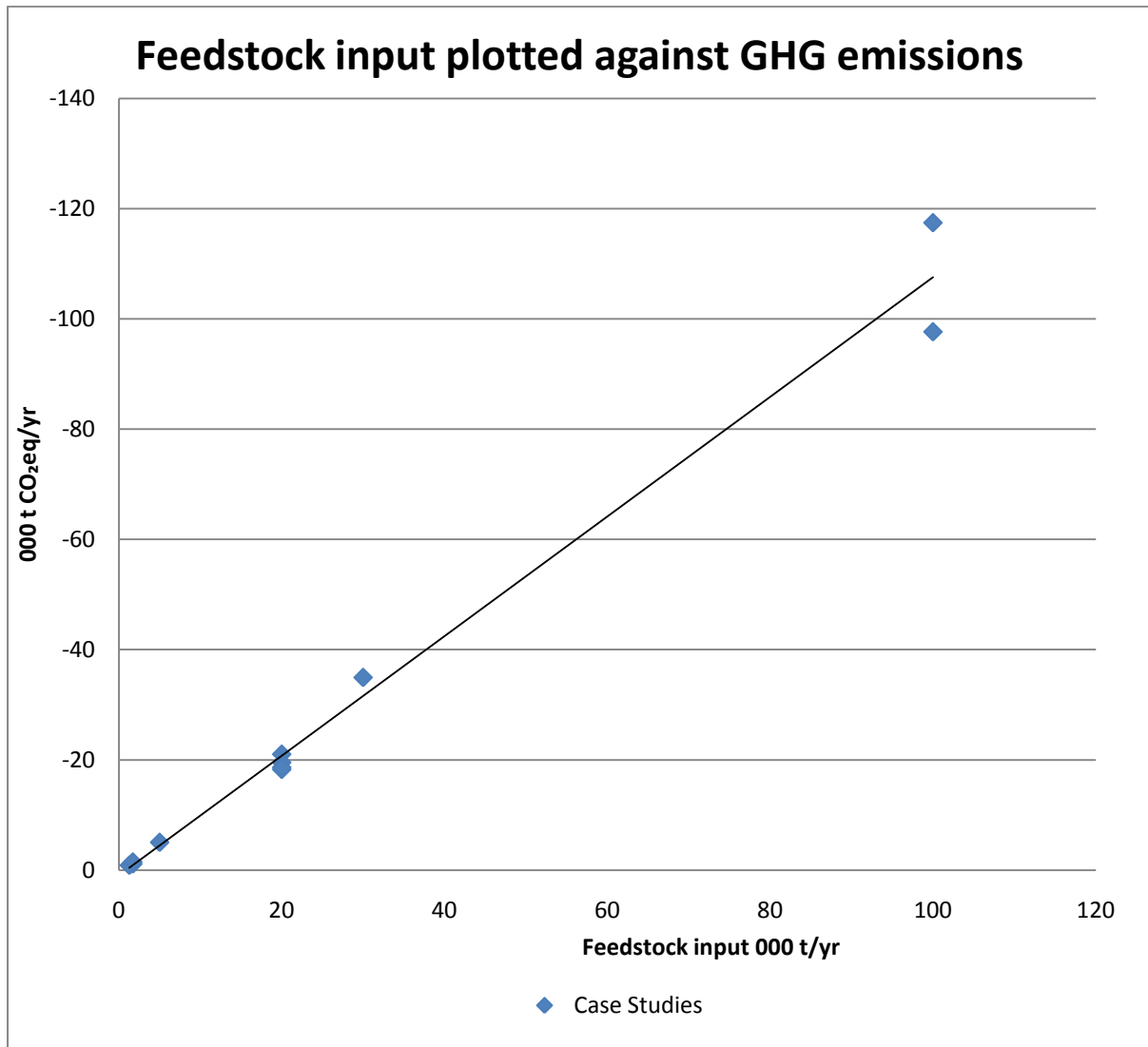

Figure 14 Feedstock input plotted against GHG emissions

B. Success is Relative: Normalising System Performance

Normalised data must be used to compare the case studies. Units considered here are tCO₂/MWh e, tCO₂/odt feedstock, tCO₂/ha. Electricity production has been assessed using MWh e/odt feedstock and MWh e/ha. Each is discussed below, and are plotted in figures 4 and 5 below. To facilitate use of

the same axes, per ha has been converted to per 0.1 ha. Outcomes are plotted on figures 4 and 5 below.

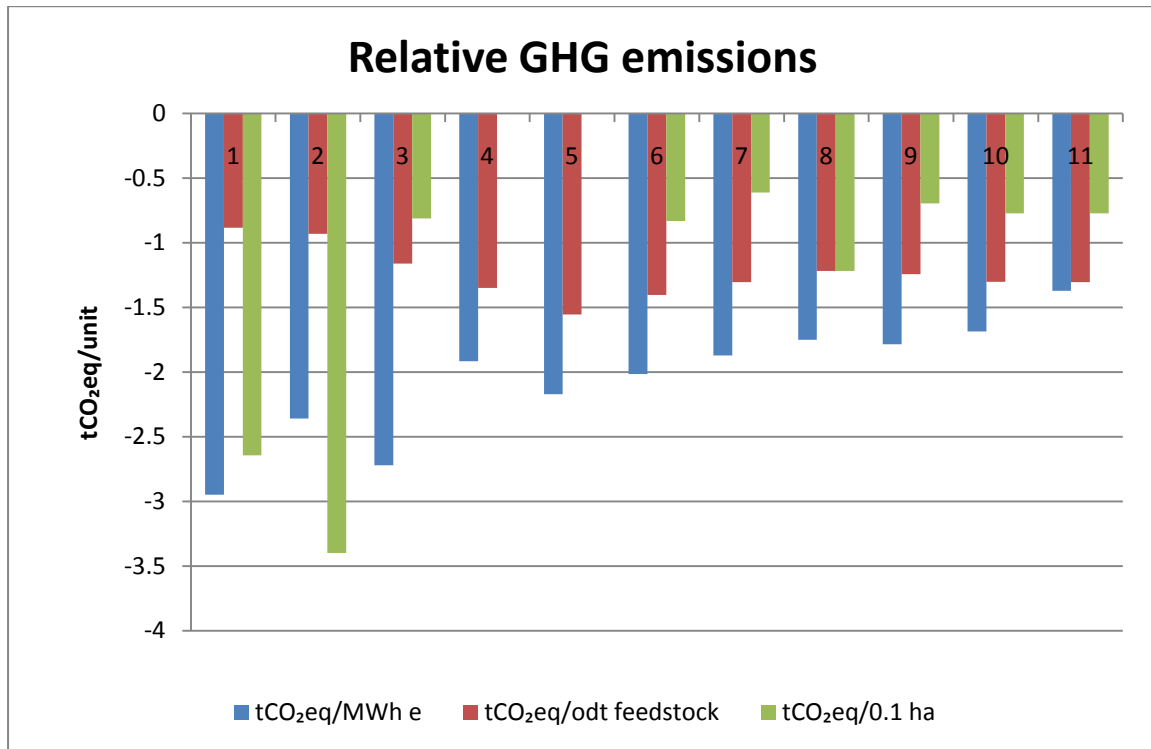

Figure 15 Relative GHG emissions

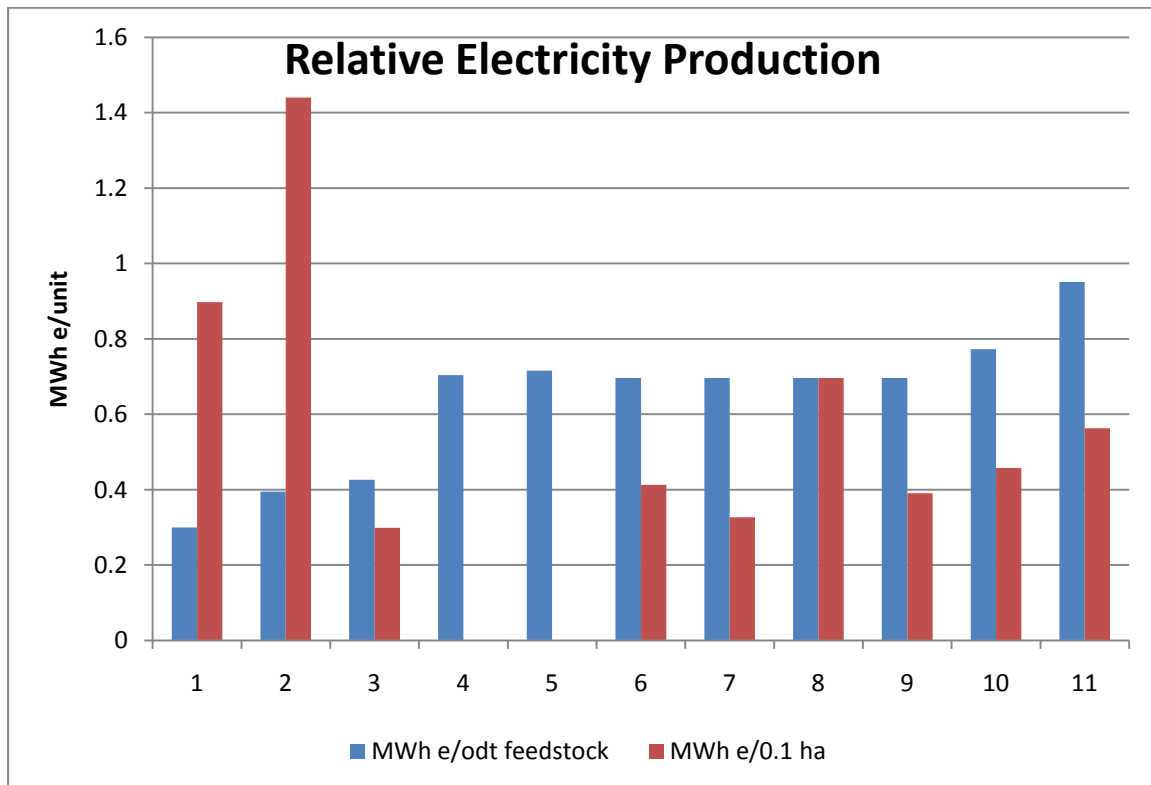

Figure 16 Relative Electricity Production

1 CO₂ per MWh e

Surprisingly, the smaller cases have considerably higher abatement/MWh e efficiency than the larger cases. This is counter intuitive to the notion of economies of scale. The larger cases produce more electricity, both in absolute terms (see section III.B) and in relative terms (see figure 5 above). A large part of the total GHG abatement is not due to energy production (see figures 1 or 11), therefore the relationship between electricity product and GHG abatement is not 1:1. Systems with more electricity product have more units to divide the GHG abatement by. CO₂eq/MWh is not an appropriate unit for comparison of PBS systems.

2 CO₂ per odt feedstock

Abatement efficiency is higher for the wood feedstocks which yield pyrolysis oil of greater calorific value for conversion to electricity. Of those, forestry residues perform best, because of the benefit inherent in the feedstock – the avoided methane emissions from natural decomposition. Further variation is explained by feedstock production emissions and gains in electrical efficiency from larger systems, as well as heat use.

3 CO₂ per ha

Land uptake for feedstock production has been calculated using financial allocation as described in the Methodology chapter. Allocation and yield are the key factors in determining land take. Yield is site and climate specific, and allocation procedures vary according to the reference base: financial allocation, market fluctuations or other changes alter the allocation rate. Per hectare analysis, although useful in defining land use efficiency, must be used with caution, especially where yield and allocation assumptions are not clear.

Sawmill residue cases have not been plotted on per ha evaluations because the feed is a not directly related to land area.

Straw out-performs all other cases, because of high yields and low land take. This outcome is only valid while straw is considered a co-product and worth less, therefore deserving of lower allocation. If market rates were to change or straw were to be grown as an energy crop the outcome would be different.

SRC does well, because of high yields, and SRW does badly, because of high allocation assumptions. This is an example of a resource which, although a co-product has a high market value, appears worse on a /ha metric.

4 MWh e/odt

Larger cases perform better, reflecting higher electricity conversion efficiencies. The smallest three cases (1,2 and 3) perform worst, because only pyrolysis oil is converted to electricity (gas is flared or used for heat). The larger systems all perform comparably, with the higher outputs of imported pellets reflecting the higher energy content of the feed.

5 MWh e/ha

The same cases perform well as do when measured CO₂eq/ha is measured¹⁹, suggesting that yield and allocation play a more important role than the case study parameters.

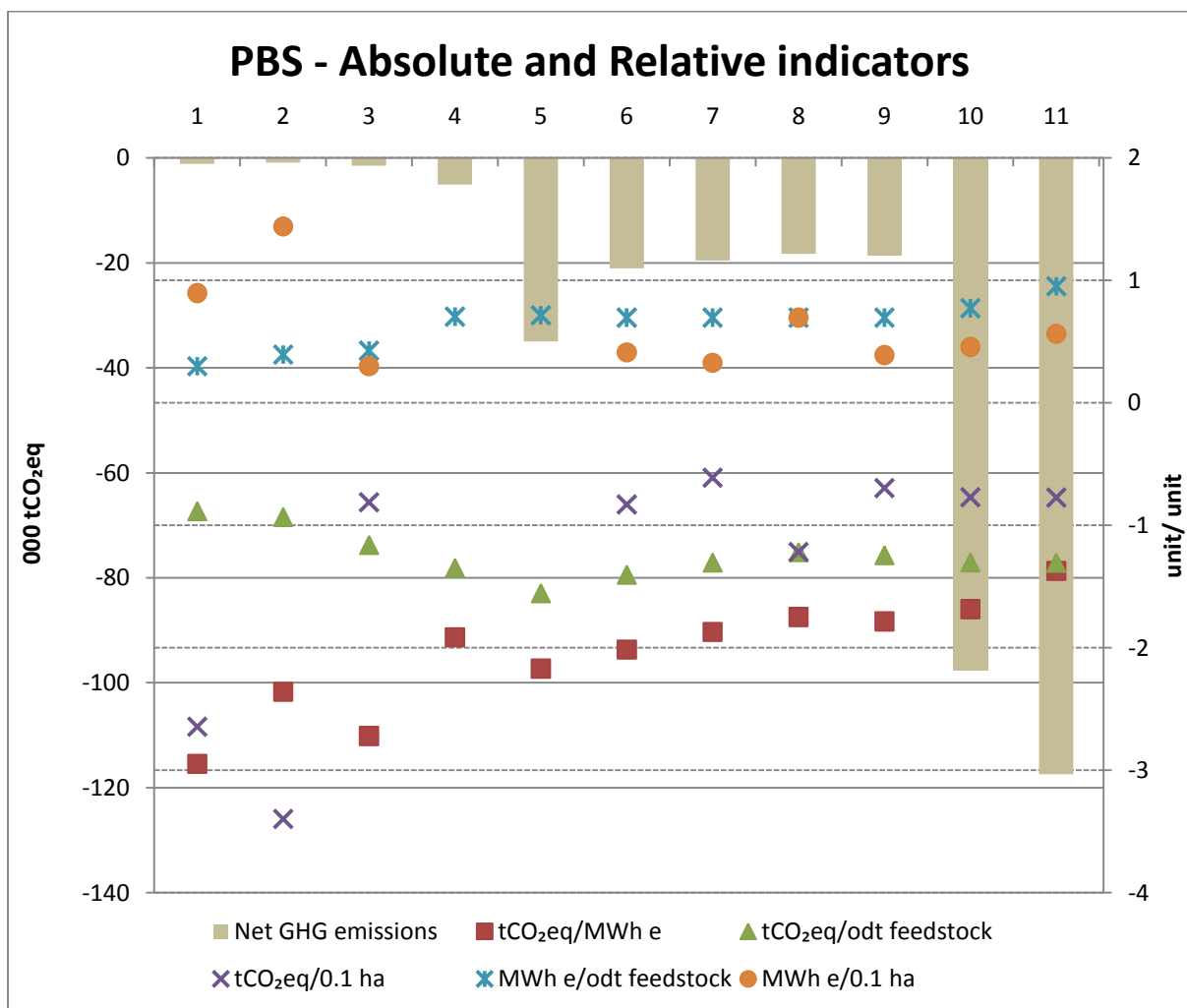

Figure 17 PBS - Absolute and Relative indicators

Figure 6 plots total GHG abatement per case study, and each indicator, as discussed above.

¹⁹ With the exception of imported pellets, which again must be due to the higher energy content of the feed.

II. Part Two: Analysis of Life Cycle Stage

Quantification of the relative importance of life cycle stages in PBS is useful for a number of reasons:

- To evaluate whether uncertainties in assumptions used in the model are important to final outcomes.
- To evaluate which life cycle stages are more important for good practice to be observed in real world deployment.
- To evaluate which unknowns are more important and should be the subject of targeted research.

A. Analysis of Case Studies – Proportional System Components

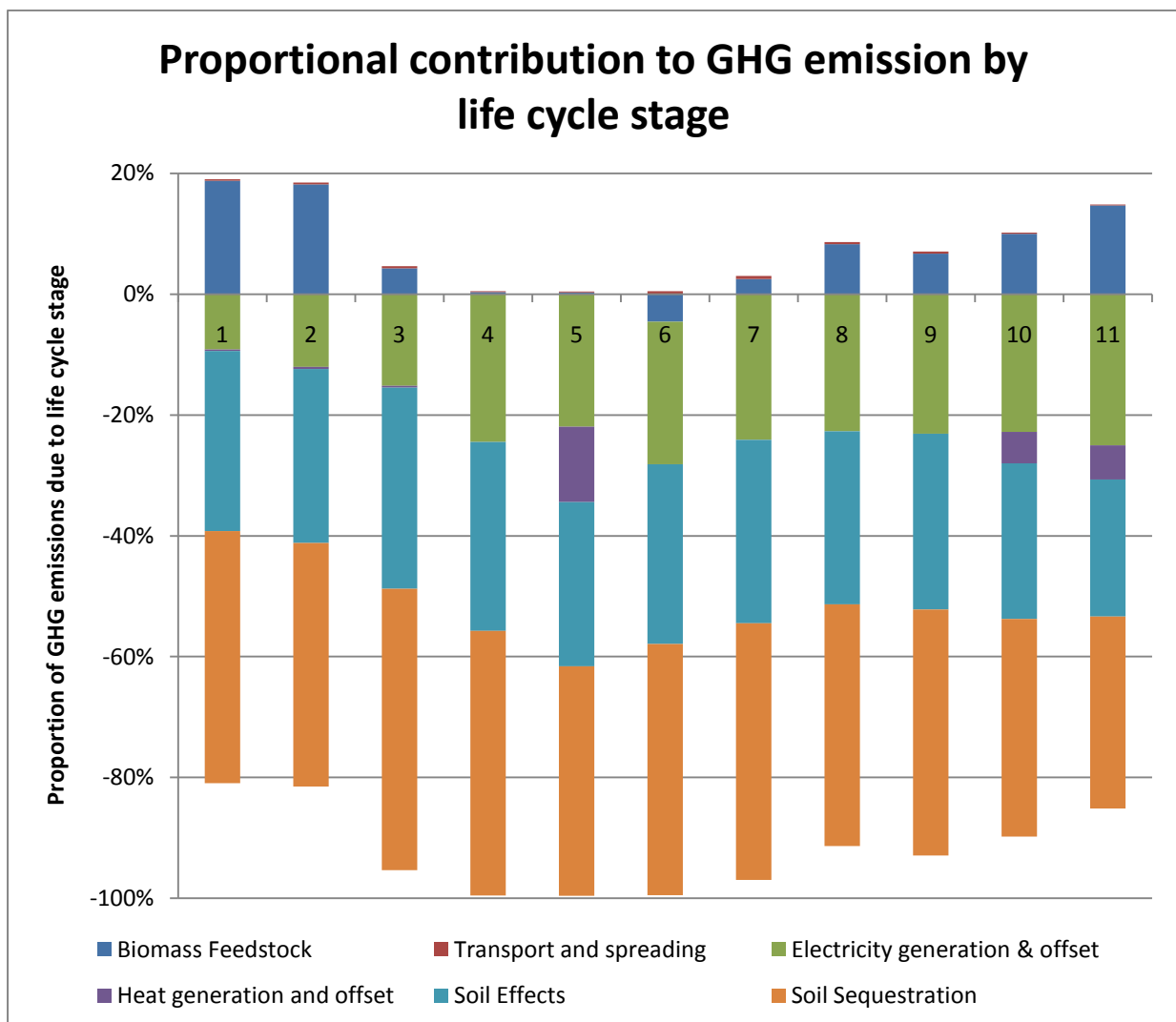

Figure 18. Proportional contribution to GHG emission by life cycle stage.

Figure 7 shows the relative GHG emissions due to each life cycle stage. The total emissions have all been normalised to 100%. Values above zero indicate emissions, negative values indicate savings.

In every case, sequestration of char carbon in soil accounts for the largest proportion of the GHG change. Next are soil effects of the char; 99% of this is due to increase in soil organic carbon (according to the assumptions used in this project). Char both stimulates plant growth and reduces decay rates of organic carbon, although the degree of certainty around this effect is still low and so these estimates must be viewed with caution.

Different biomass feedstocks account for different proportional contributions. With the straw examples, the crops require more chemical and mechanical assistance than others; for the imported forestry residue feeds, it is due to long transport distances and the energy required in pellet manufacture. The differences between large scale SRC and small scale are due to large scale using sewage sludge as a fertiliser, but small scale not using fertiliser. The Scottish forestry residue chips are assumed to decay naturally, releasing CO₂ and CH₄, were they not collected and pyrolysed. The use of this feedstock therefore offers a net reduction in GHG emissions.

In all cases, transport emissions account for very little of the overall emissions. In those cases which are optimised for heat usage, the heat offset is notable, but where heat use is not optimised (the on-farm cases) the heat offset is barely noticeable. In all cases Electricity offset is important in all cases, more so where more electricity is produced.

B. Sensitivity Analysis – determining important uncertainties

Four of the 11 case studies have been chosen for sensitivity analysis: barley straw, large scale sawmill residues, small round wood and imported forestry residue chips. Each of these case studies represents a different system configuration, although the SWR and imported forestry residue chips produce very similar results, reflecting the similarity between the two cases²⁰. In these cases, the imported forestry residue line has been dashed, to show the small round wood line beneath.

Sensitivity analysis has been performed on uncertain variables (e.g. soil-char effects), upon estimated values (such as transport distances) and upon certain system variables which may affect the design of biochar systems (such as heat use).

Results are presented in terms of percentage change of total case study GHG emissions, compared to default assumptions. In all cases, positive percentage change means greater emissions; negative percentage change means greater GHG savings.

²⁰ It is fair to say that SWR represents a medium centralised facility and the imported woodchip a large centralised facility. The main differences are in electrical conversion efficiency, heat use and transport distances.

Many of the horizontal axes do not follow linear scale; care should be taken when interpreting trends. This makes it appear that some of the relationships are not linear when in fact they are. This has been done to facilitate the inclusion of extreme or particular values. Where the trend line crosses the horizontal axis is the default value used in the study.

Realistic modification of factors which result in a less than 1% change in total GHG emissions are considered to have a low effect. One to 10% changes are considered to have a medium effect, and higher than 10% changes are considered a high effect.

1 Transport distances

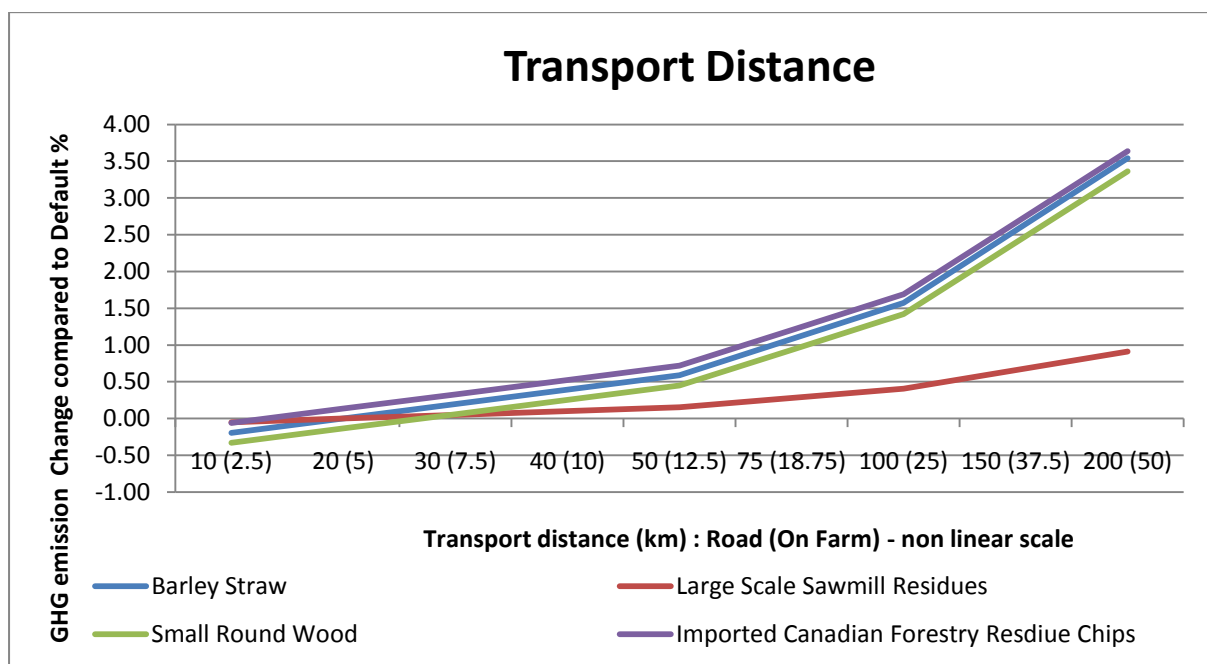

Figure 19 Transport Distance

Transport distance for each road trip and for on-farm tractor transport was varied from the default values. The maximum GHG emission change was 3.64%, for 200 km road trips and 50km trips by tractor. These journey distances would not occur in a small study area like Lothian and Borders. Providing transport distances are kept below 50km for road transport and 12.5km for tractor trips, the total change is less than 1%.

Differences between case study configurations are illustrated by the different outcomes. In the case of sawmill residues, the feedstock does not need to be transported from production site to pyrolysis site and so there is one less travel component in the life cycle. On-farm systems do not require transport of char from pyrolysis facility to farm, but the influence on the result here is less marked. This is because char is much less bulky to transport than feedstock, so it is more beneficial to minimise feedstock transport distance than char transport distance.

2 Volume of Vehicle Applying Char to Soil

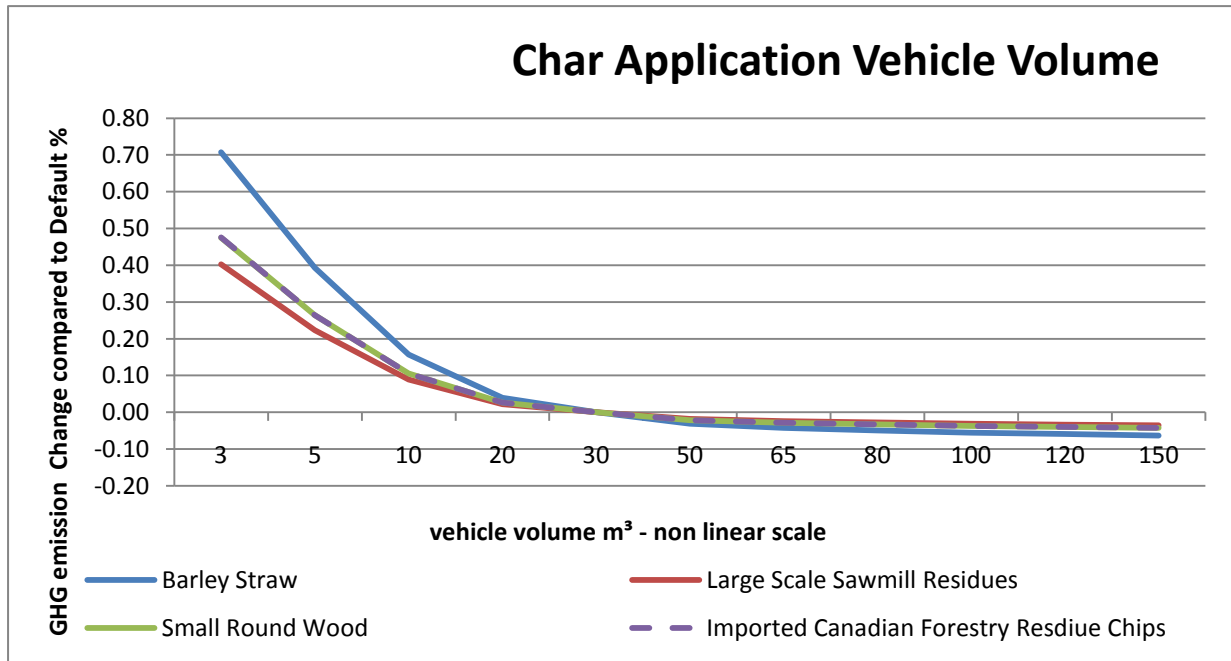

Figure 20 Char Application Vehicle Volume

The volume of the vehicle or trailer which transports char from farm to field was varied, from the size of a standard seed broadcaster (Cook, 2009) to the size of a very large articulated lorry (Thornley, 2007). The effect upon total emissions is very small, varying less than 0.2% between volumes of 20 and 150m³.

A larger volume vehicle has to make fewer trips between the farm and the field. Whilst this is insignificant in GHG terms, it may be very significant in the number of hours spend deploying char.

3 Handling Losses

i In Transit

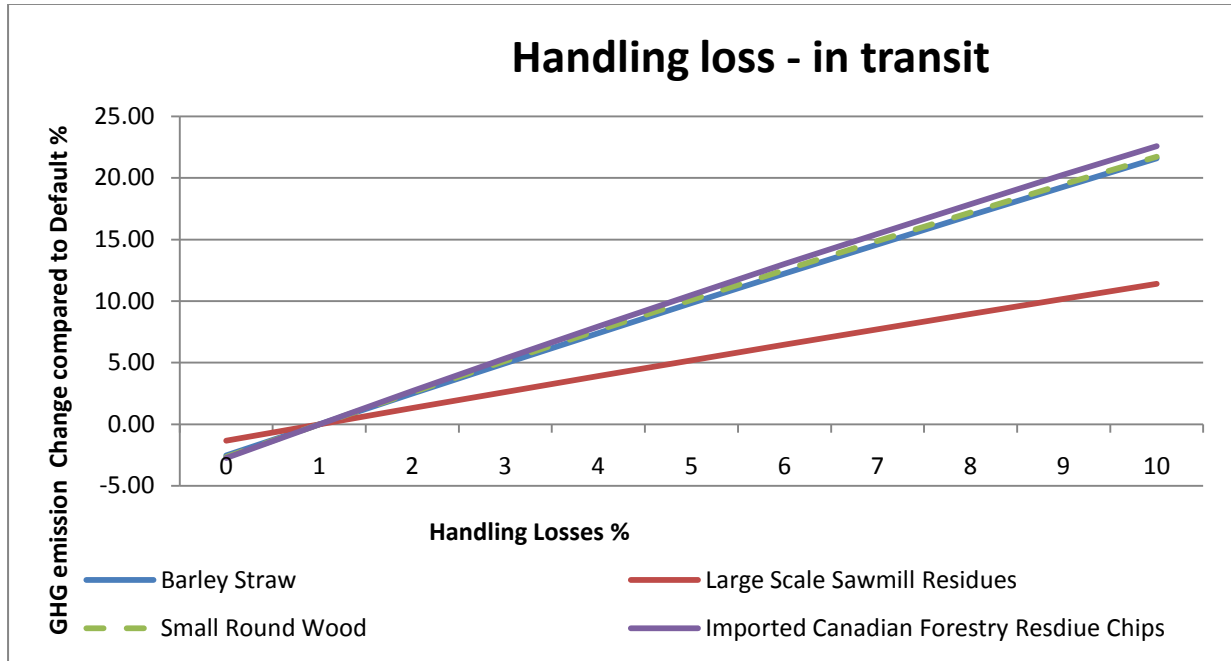

Figure 21 Handling loss - in transit

Handling losses at each stage of transport were varied. The default is 1% at each stage, but higher and lower values may be found in the literature: 3% at each stage (Mortimer et al., 2009); 1% total losses (Thornley, 2009c). Handling losses can have a high influence upon total GHG emissions.

ii *During Soil Applications*

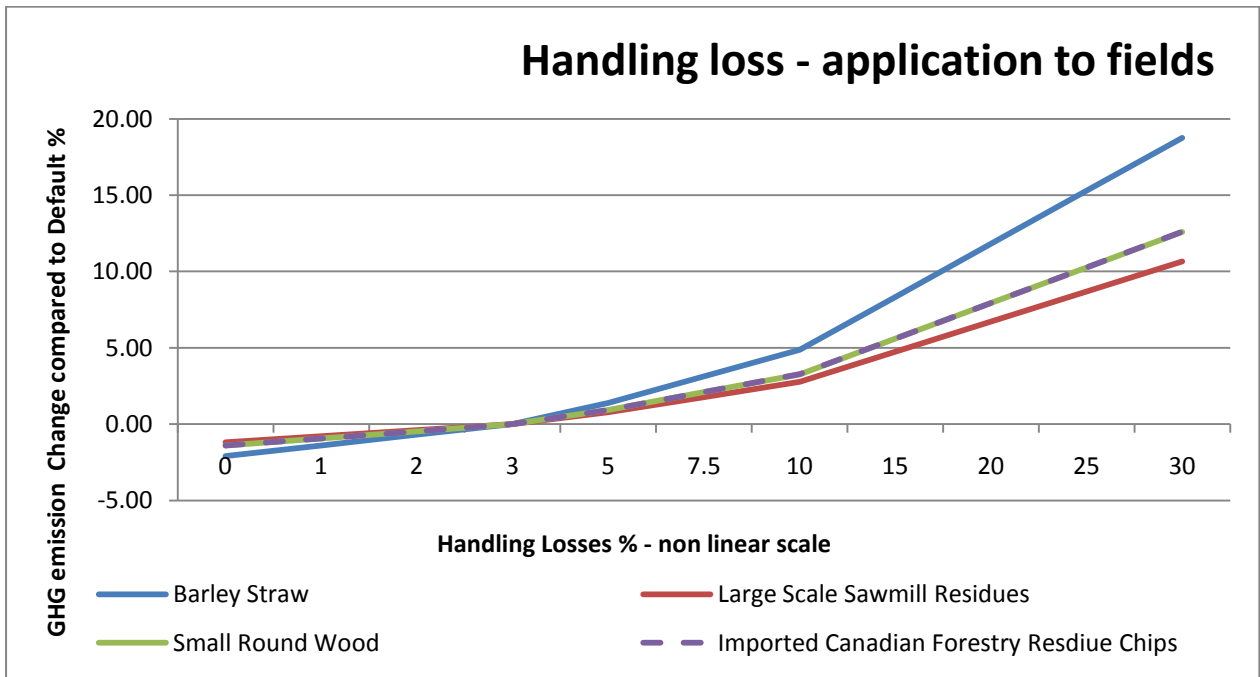

Figure 22 Handling loss - application to fields

The application of char to fields must be well managed or large losses can occur: one field trial lost 25% of char applied due to wind (Husk, 2009). Losses of char to field can have a high influence on total GHG emissions.

4 Pyrolysis Yields

i Comparing Gasification, Fast, Moderate, and Slow Pyrolysis

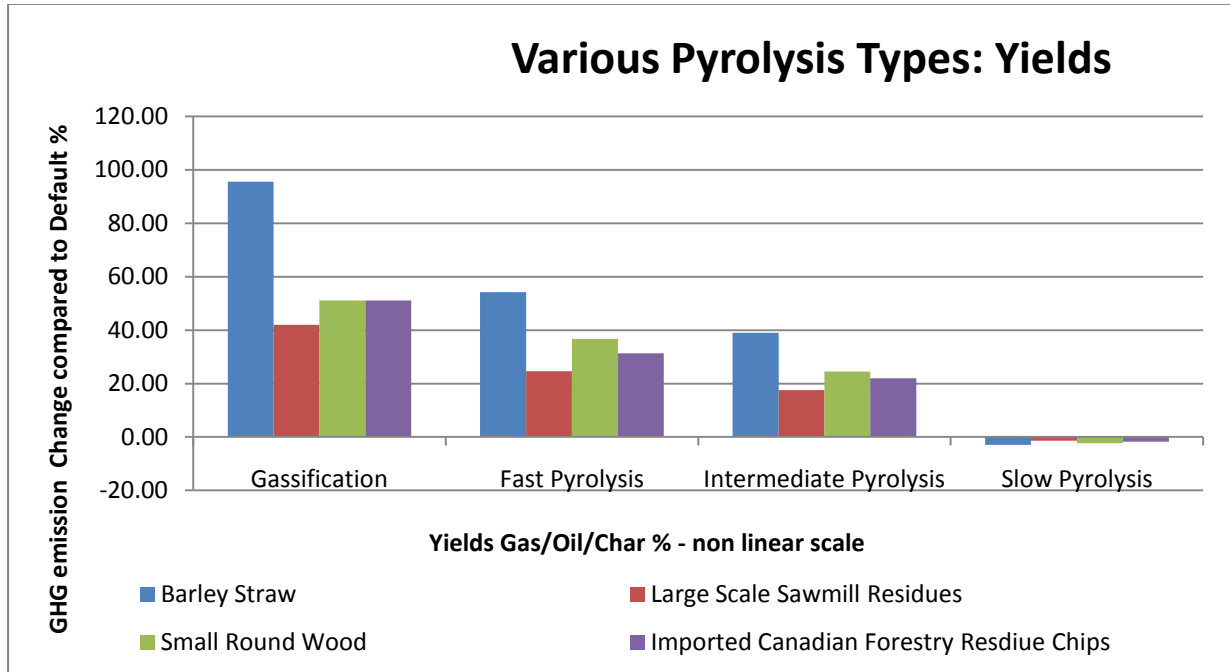

Figure 23 Various Pyrolysis Types: Yields

Typical yields were modelled for fast pyrolysis, moderate pyrolysis, slow pyrolysis and gasification, respectively (Bridgewater, 2007 - see table 7 below). The energy contents of the different outputs were not altered however, so the results here are indicative only. Further details are explored in section III below.

All systems except slow pyrolysis generate GHG emission increases, suggesting slow pyrolysis is best suited to biochar systems. This is intuitively correct, because slow pyrolysis offers the greatest char yields, and char effects account for much of the total GHG benefit (see figure 7).

The proportion of GHG benefit due to the char is greater in those case studies which generate less electricity and use less heat. In the sensitivity analysis, this is represented by barley straw.

Alterations which decrease the char available for application to soils have a greater effect upon barley straw total emissions, as shown in Figures 12 and 13.

Table 7 Representative yields from pyrolysis alternatives (Bridgewater, 2007)

	gasification	fast pyrolysis	intermediate pyrolysis	slow pyrolysis
gas yield %	85	13	30	35
oil yield %	5	75	50	30
char yield %	10	12	20	35

ii Comparing Slow Pyrolysis Yields

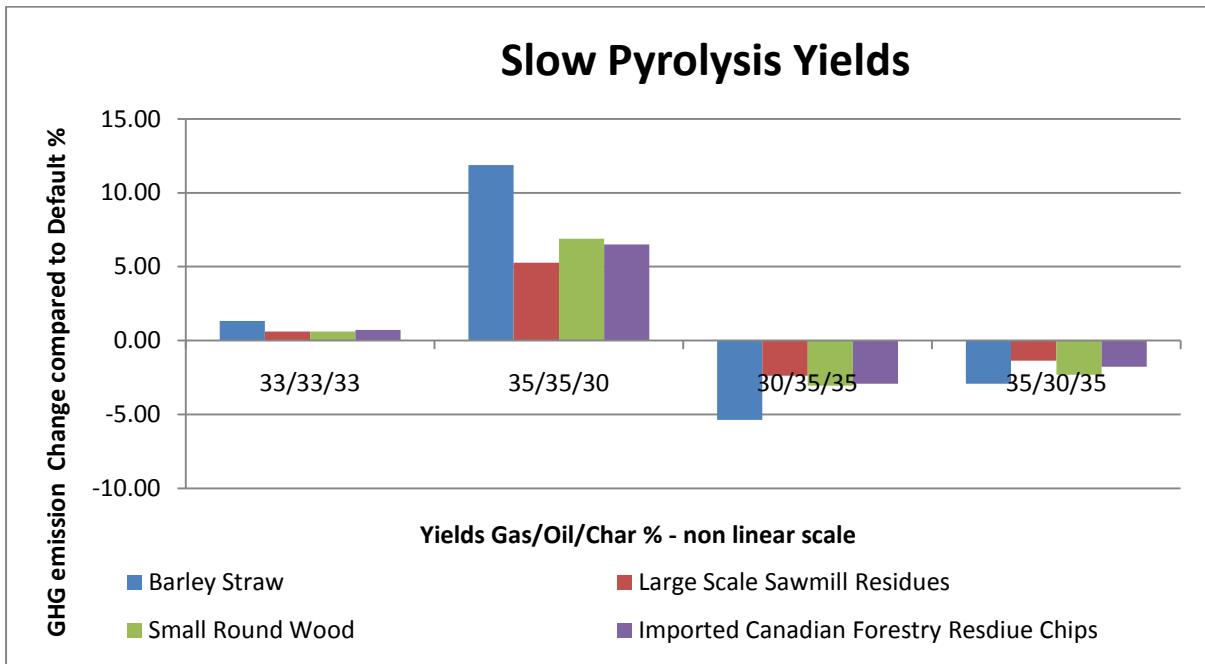

Figure 24 Slow Pyrolysis Yields

There is variation in the yields gas, oil and char within slow pyrolysis. Decreases in char yields have the greatest effect, and the effect is magnified in smaller systems which produce and use less electricity and heat.

Char yields of 20 to 60% have been reported for slow pyrolysis, which would have much greater effects (Antal and Gronli, 2003) (Peacock and Bridgewater 2000); but higher char yields may contain higher labile fractions however so are not necessarily better (Brownsort, 2009, Antal and Gronli, 2003). For percentage changes in yield between 30 and 35%, the effect is still worth consideration.

5 Electricity

i Conversion Efficiency

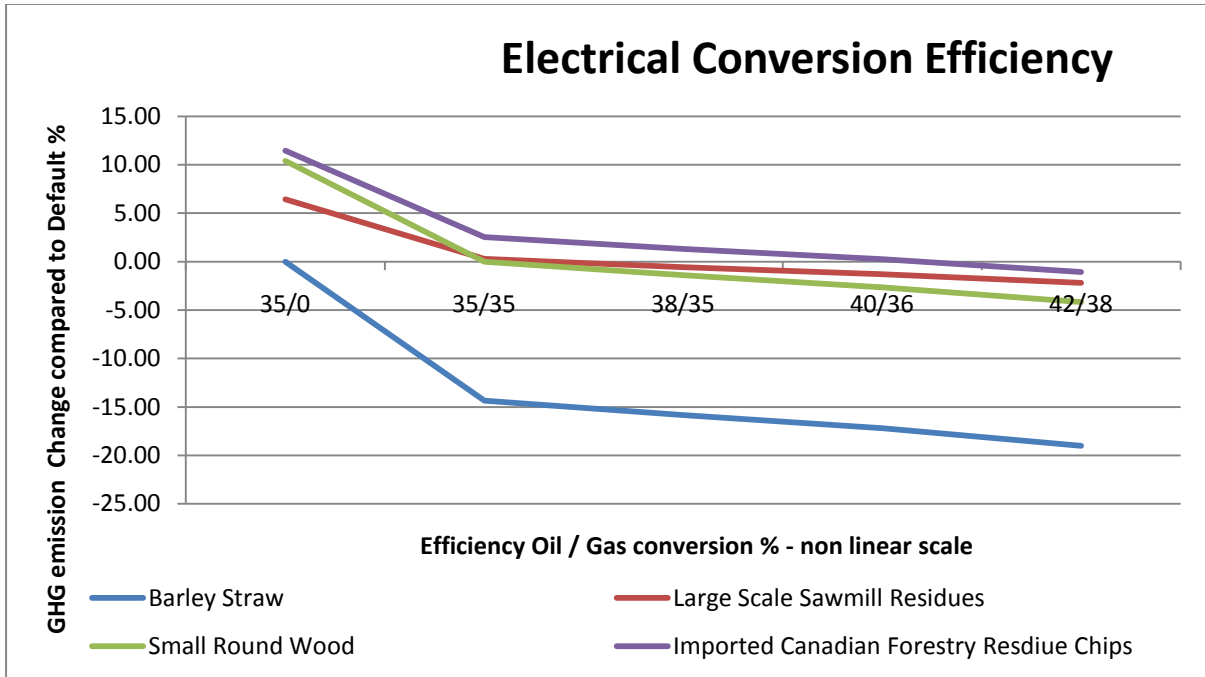

Figure 25 Electrical Conversion Efficiency

It is assumed that smaller PBS configurations do not convert both syngas and pyrolysis oil into electricity: this graph highlights the 10 to 15% benefit that converting both products brings. The effect is greatest in the barley straw example, which makes the least use of energy products either electricity or heat, and least in the case of sawmill residues, which makes very high use of heat. It may be concluded that converting maximum energy into electricity is important unless the heat product can be used effectively.

Once both gas and oil streams are converted into electricity, the relative GHG emission savings from increases in conversion efficiency is less, but still worth noting.

ii Reference Case for Electricity Offset

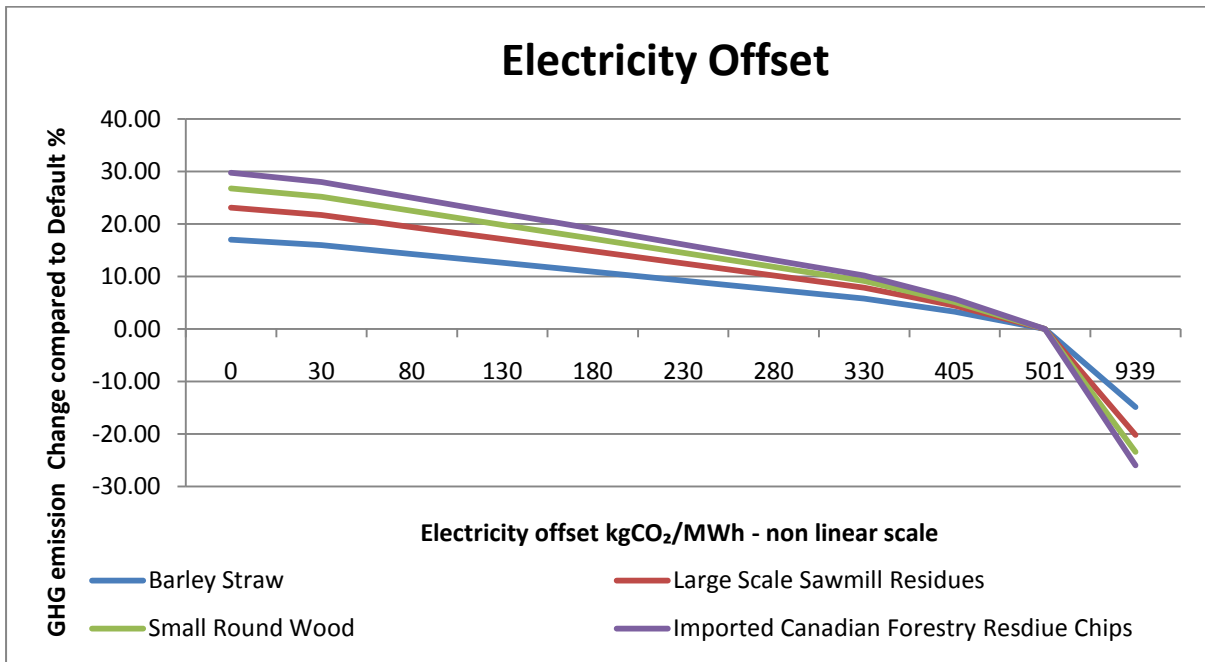

Figure 26 Electricity Offset

The reference case offset by electricity generation varies. The horizontal axis is not linear; the values correspond to different electricity generation reference cases. 501 kgCO₂/MWh is the 2008 grid average in the UK, and the default value used in this study (DUKES, 2008). 405 and 939 are the emissions produced by gas and coal combustion, respectively (DUKES, 2008). 30 and 80 are the predicted values for grid averages in 2050 and 2030 respectively (Bates et al., 2009).

The changing of the reference system has a high effect on total GHG emissions. The effect is greater on systems which produce more electricity (forestry residue imports), or on systems which electricity generation is accounts for a larger proportion. Although the sawmill residue case produces more electricity than the small round wood case, the effect is greater for small round wood. This is because the sawmill case uses a lot of heat energy, thus decreasing the proportion of GHG benefit due to electricity (see figure 7).

Extending this argument, other systems which rely even more heavily on electricity production to provide GHG savings (such as biomass combustion) will be affected even more by reductions in reference system values. By 2030, if decarbonisation plans are followed, technologies such as combustion will not appear as favourable as they do today.

6 Heat Usage

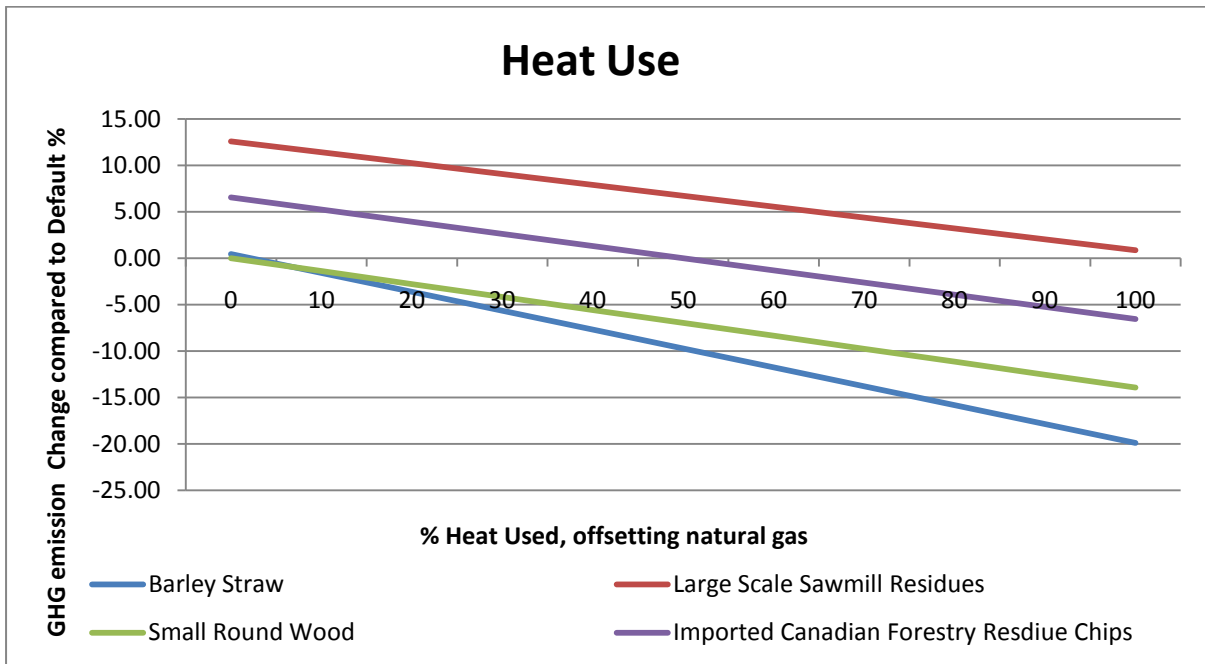

Figure 27 Heat Use

The default assumption for each case was that 75% of the heat generated was available for use, and the proportion of available heat used varies from case to case. This analysis varies the available heat used, assuming offsetting of natural gas. Heat used for heating homes is likely to be required less often in summer than in winter, but higher heat uses may be obtained from use in industry or large public buildings.

Heat usage could potentially have a high impact on PBS GHG emissions.

7 Soil Effects

i Total Soil Effects

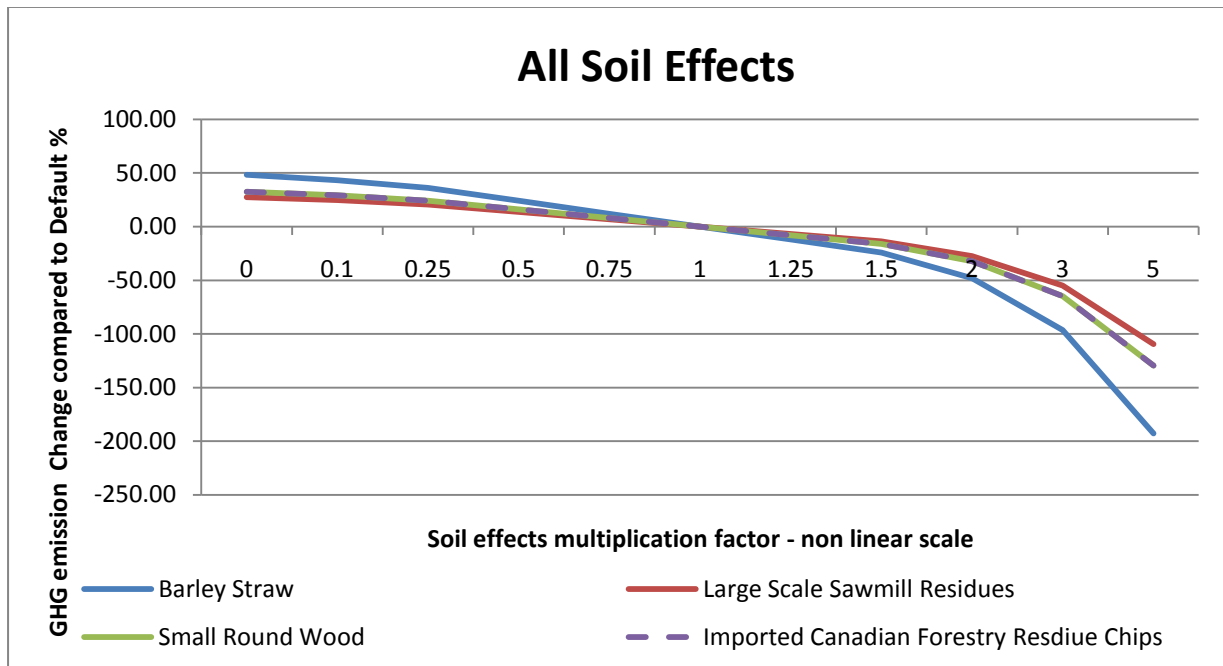

Figure 28 All Soil Effects

Soil effects account for the second largest GHG emission reduction, after char sequestration in soil. It therefore follows that change in soil effects has a very large effect on total GHG emissions.

In the above sensitivity analysis (figure 17), the total soil effects have been multiplied by the stated factor – multiplication by 1 gives the default value. Complete negation of soil effects results in a 25 to 50 % increase in emissions. Conversely, doubling soil effects further enhances GHG savings by the same factor.

ii Soil Organic Carbon

SOC accounts for 99% of GHG savings due to soil effects. There are three factors which influence SOC change: the amount of organic material input (assumed to be equal to NPP change); the decay rate of organic material; and the initial SOC content of the soil, as changes are worked out as percentages – a ten percent increase will be greater in a soil which starts with a higher SOC content.

Each factor is investigated separately below. Increased input and decreased decay rate have been combined in figure 21.

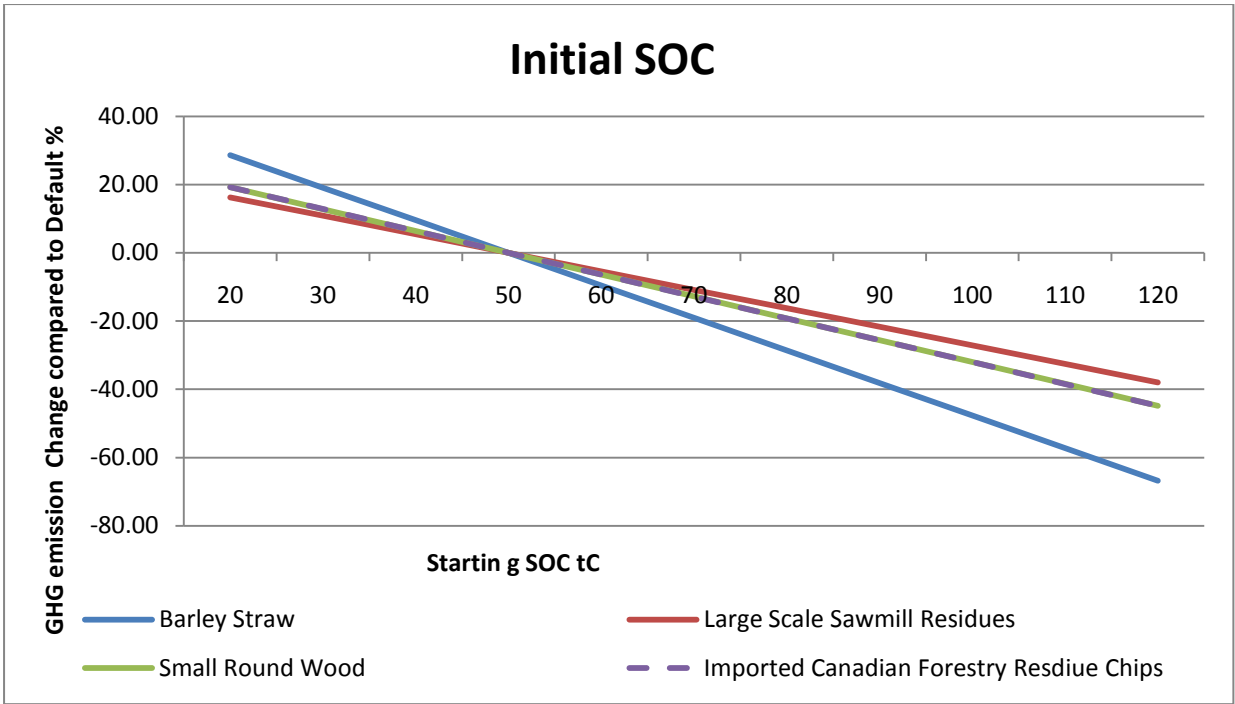

Figure 29 Initial SOC

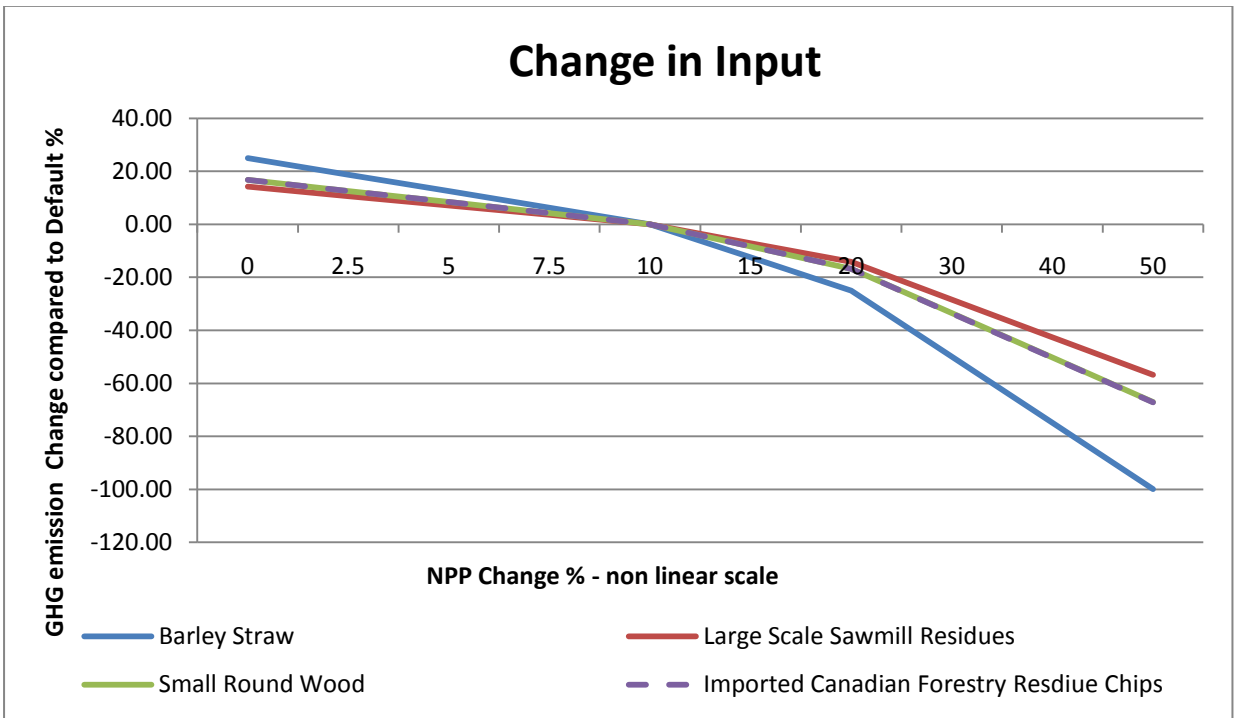

Figure 30 Change in Input

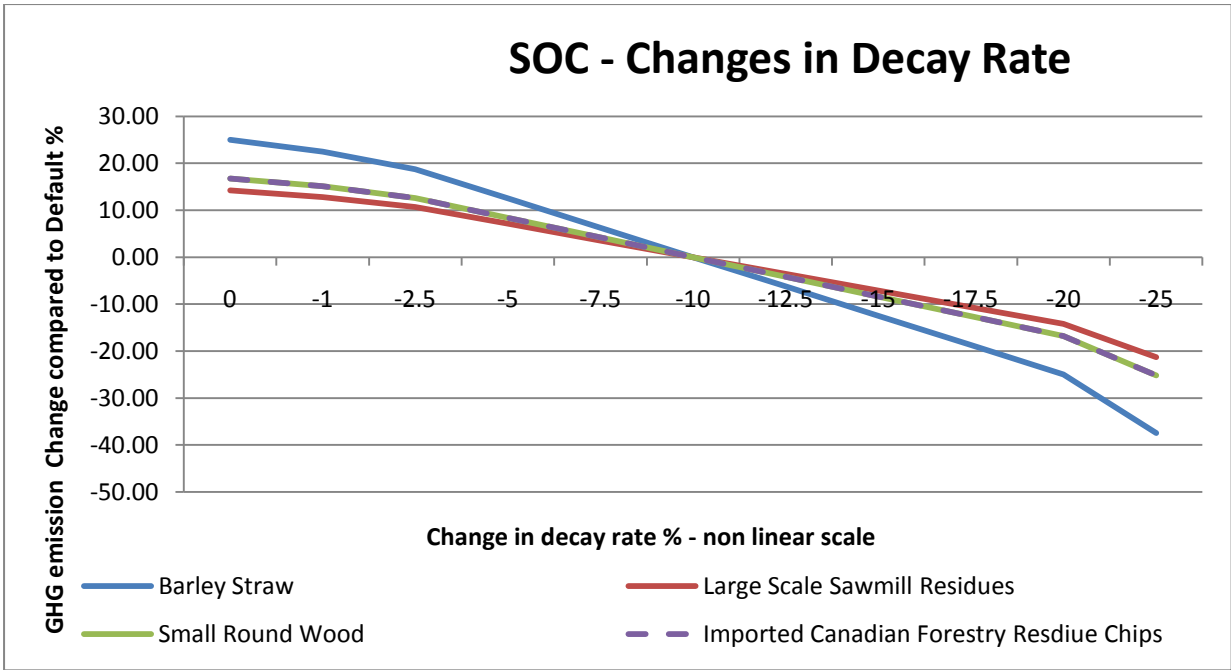

Figure 31 SOC - Changes in Decay Rate

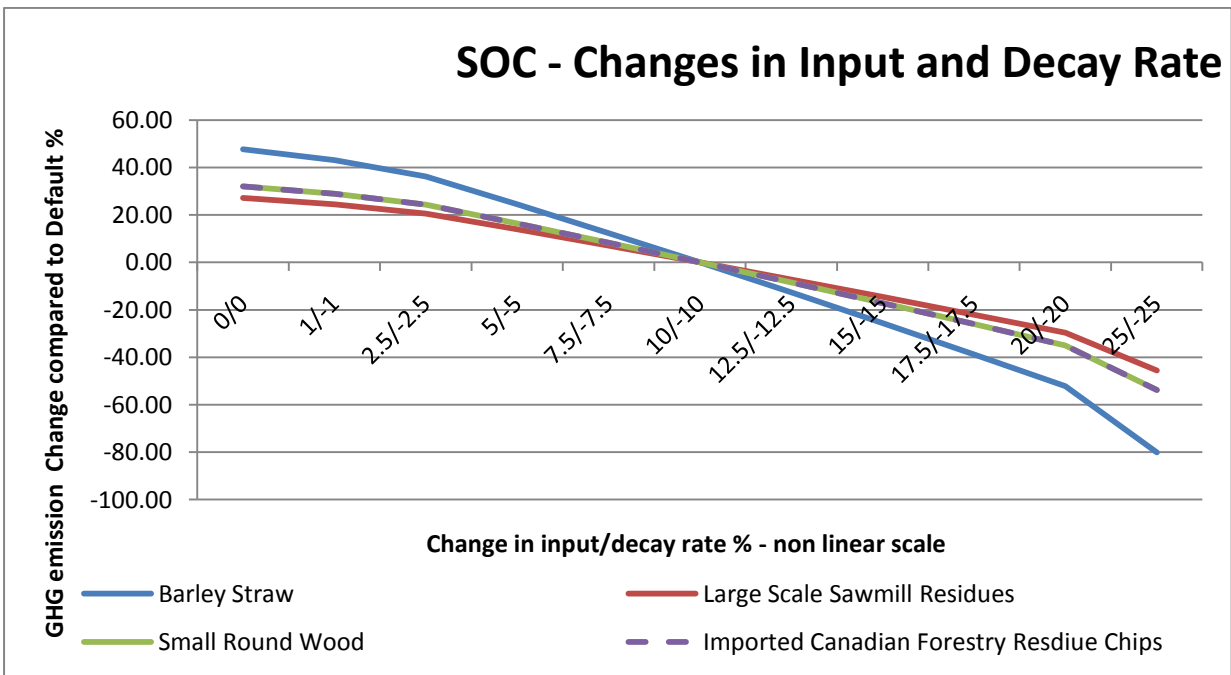

Figure 32 SOC - Changes in Input and Decay Rate

iii Fertiliser

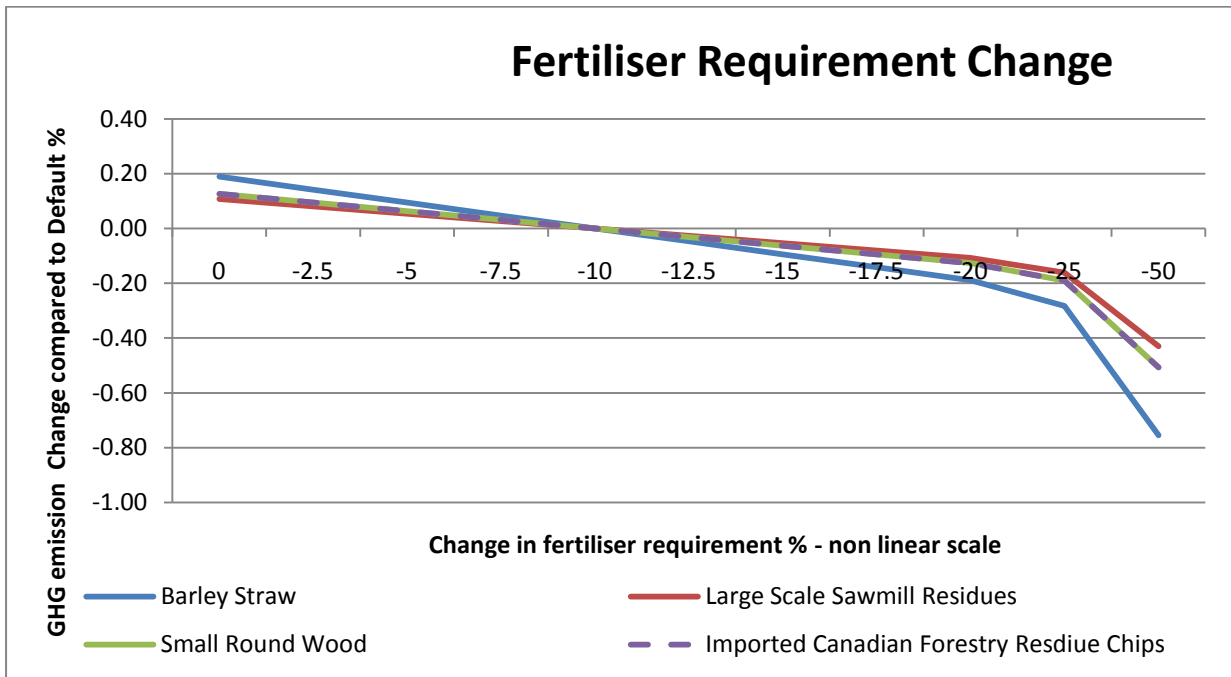

Figure 33 Fertiliser Requirement Change

Even drastic changes in the requirement of fertilisers makes less than 1% difference to total GHG emissions. The difference to the total costs of the system may attract farmers to biochar because of lower fertiliser costs.

This may seem surprising when compared to the high emissions attributed to production of some fertiliser intensive feedstocks (such as straw), but the biochar is applied to an area of land much smaller than the area which was required to grow the feedstock, thus the effect is not comparable to the production emissions.

iv Char effect upon soil N₂O Emissions

There is uncertainty regarding how best to calculate soil N₂O emissions, and uncertainty regarding the effect biochar may have. These factors have been modelled separately and together.

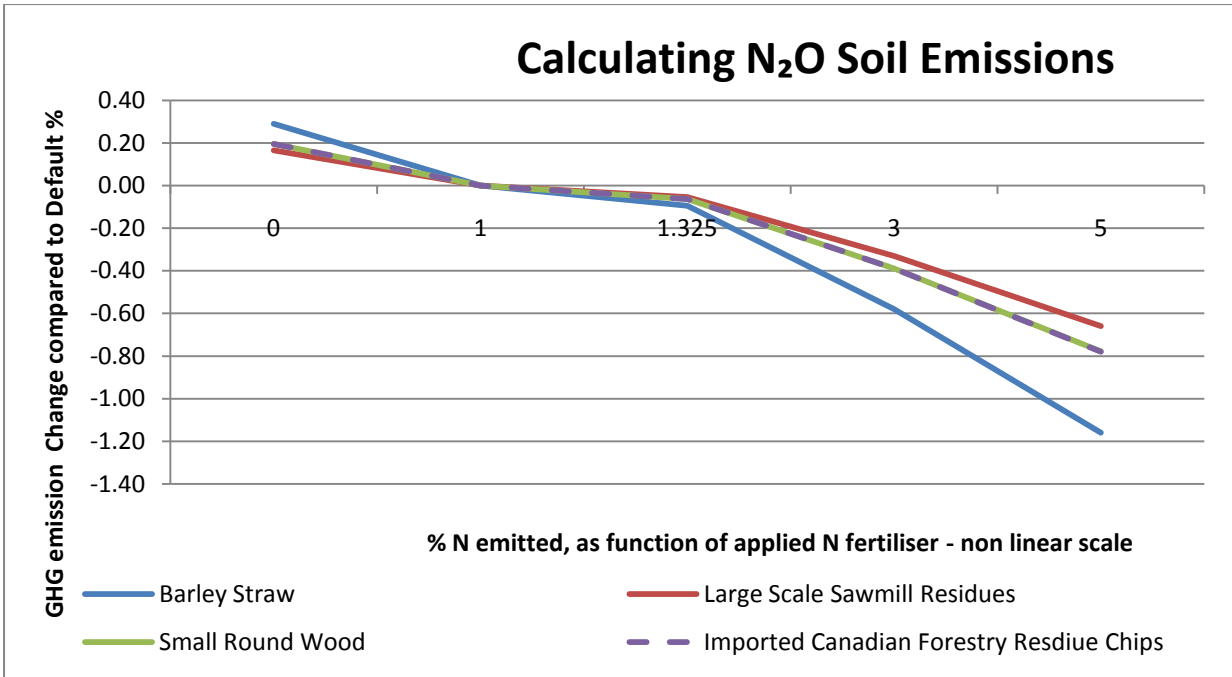

Figure 34 Calculating N₂O Soil Emissions

The debate over how best to calculate soil N₂O emissions suggests optimum values between 1 and 3 % (IPCC, 2006, Crutzen et al., 2007, Cherubini et al., 2009), with 0 and 5% included as illustrative extremes.

Assuming the default that biochar suppresses 25% of N₂O emissions, the total effect is low.

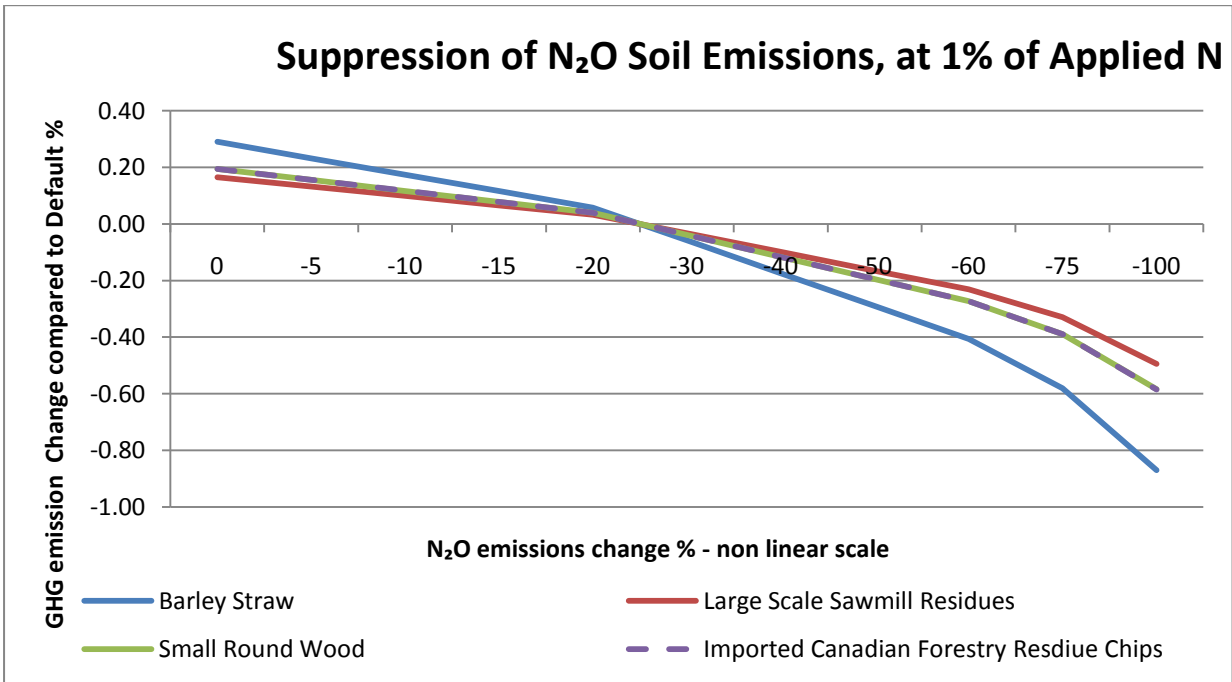

Figure 35 Suppression of N₂O Soil Emissions, at 1% of Applied N

Assuming 1% of applied N is emitted for conversion to N₂O, the suppression of soil nitrous oxide emissions makes little difference to total GHG balance, even in extreme cases of total or zero suppression.

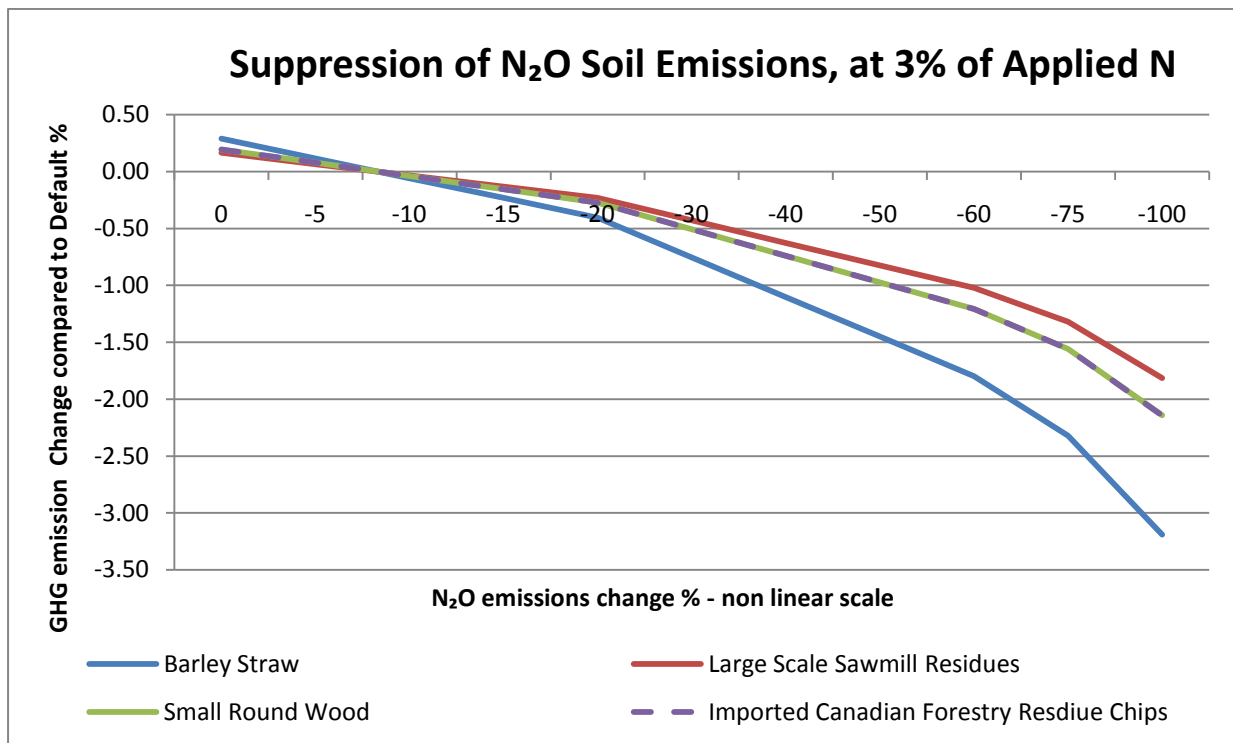

Figure 36 Suppression of N₂O Soil Emissions, at 3% of Applied N

Assuming 3% of applied N is emitted, biochar N₂O suppression becomes more important.

8 Char Decay

Char carbon sequestration in soils accounts for the greatest proportion of total GHG benefits in every case studied. It has already been shown that alterations to the life cycle which result in less char reaching the soil, whether through decreased char production or increased char losses, have dramatic impacts upon total GHG balance

The quantity of char lost from soils has similar dramatic effects.

i Labile Fractions

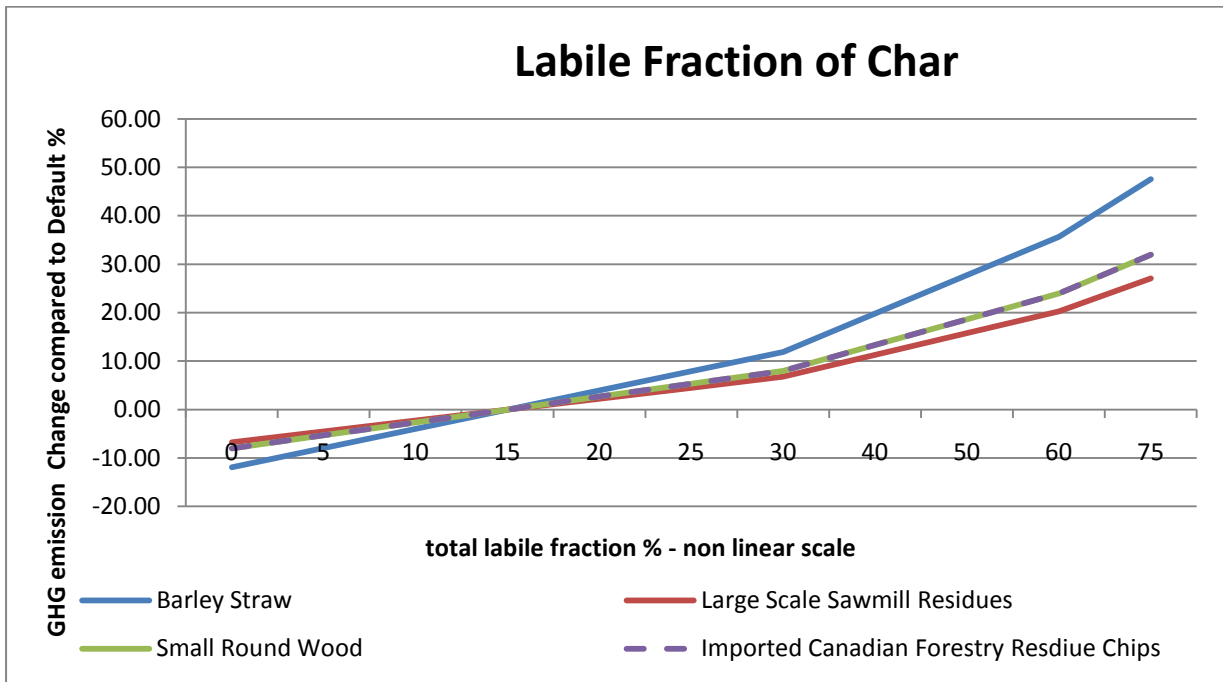

Figure 37 Labile Fraction of Char

In the present study, labile fractions are assumed to be emitted as CO₂ within one year. Thus the greater the labile fraction, the less carbon sequestered in the soils. The effect is greater on case studies which receive smaller benefits from electricity or heat use.

ii Mean residence Time

MRT can have effect upon total GHG balance. The time horizon is the point at which the char remaining in the soil is measured; if a lot of char has decayed by the end of the time horizon, char sequestration in soil is low. Conversely, if little char has decayed by the end of the time period, char soil sequestration will be much larger. The outcome is an interaction between time horizon and MRT. From results here, it appears that as long as the MRT is approximately three times greater than the time horizon, the effect is small.

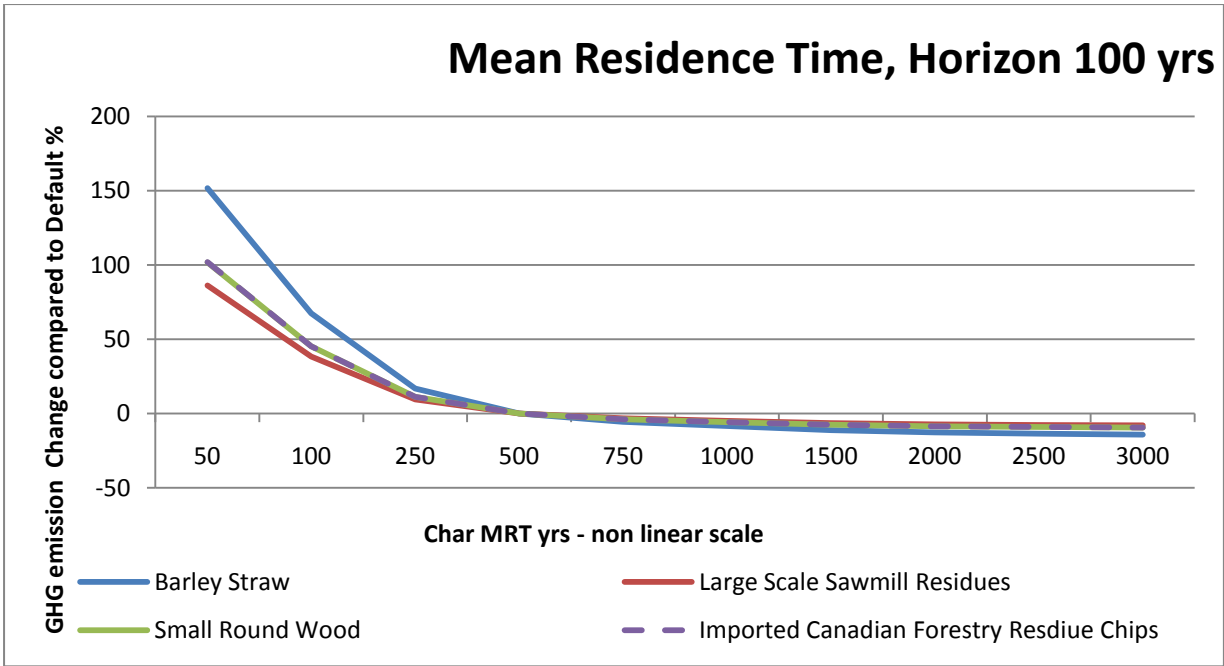

Figure 38 Mean Residence Time, Horizon 100 yrs

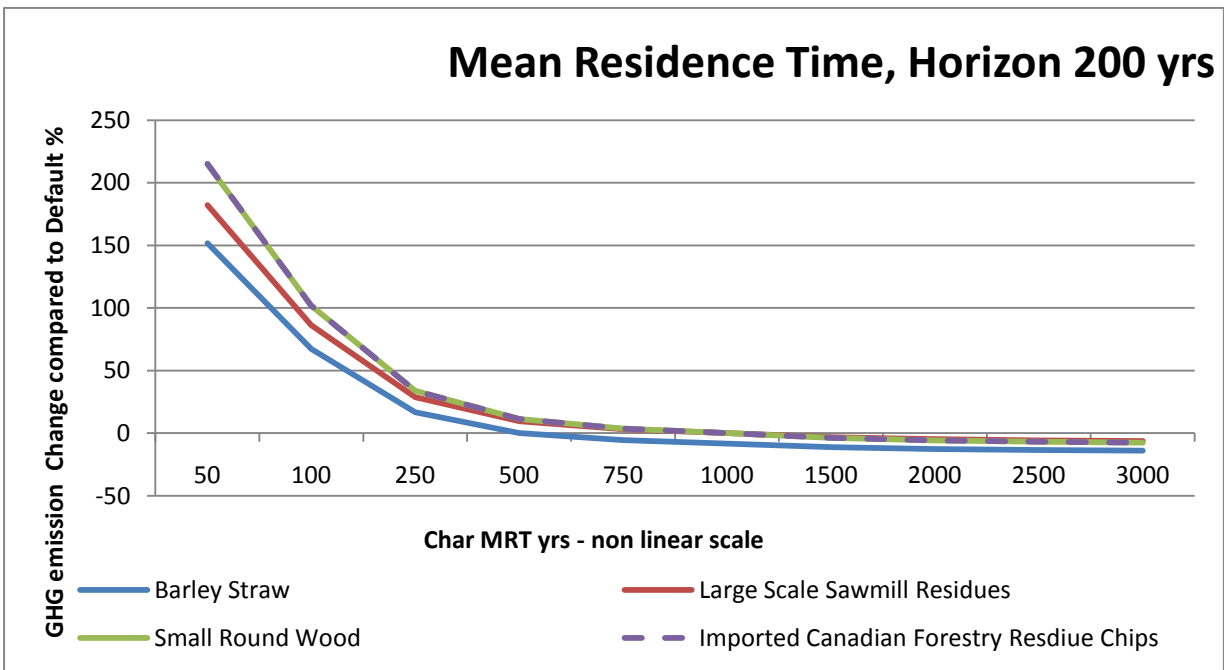

Figure 39 Mean Residence Time, Horizon 200 yrs

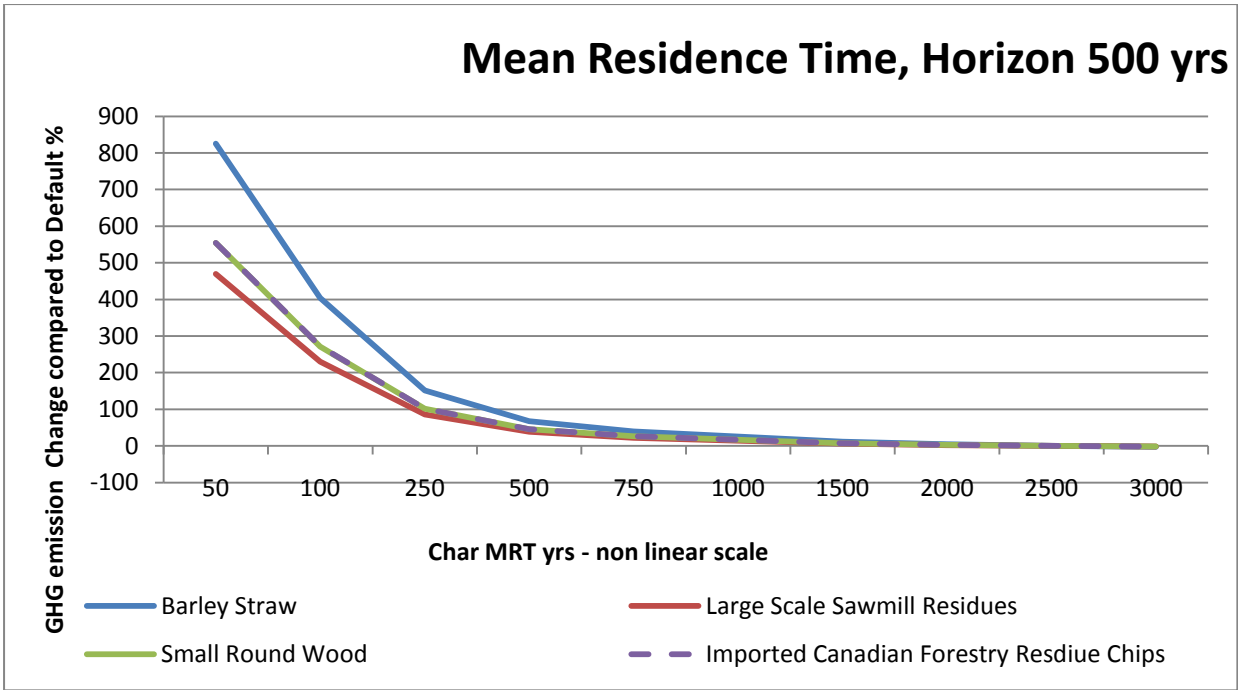

Figure 40 Mean Residence Time, Horizon 500 yrs

9 Conclusions from Sensitivity Analysis

Table 8 Results of sensitivity analysis: relative importance of life cycle stage variation on GHG emissions

Factor	Effect	Level of certainty regarding default values
Transport Distance	Low	Medium
Char Application Vehicle Volume	Low	Medium
Handling Losses in Transit	High	Medium
Handling Losses - char to soil application	High	Medium
Pyrolysis System	High	Medium
Slow Pyrolysis yields	Medium	Medium
Converting both oil and gas to electricity	High	Medium
Improving electrical conversion efficiency	Medium	Medium
Electricity offset	High	High
Heat Use	High	Low
All Soil effects	High	Low
SOC: initial quantity	High	Low
SOC: input changes	High	Low
SOC: decreased decay rate	High	Low
SOC Input and decay rate changes	High	Low
Fertiliser requirement	Low	Low
Char effect upon soil N ₂ O emissions	Low	Low
Calculating N ₂ O emissions	Low	Low
Labile fraction of char	High	Low
MRT / time horizon	High	Medium

Energy products – electricity and heat – decrease the severity of changes which decrease char sequestration or soil effects, but are more susceptible to changes in the energy reference system.

Conversion of both oil and gas to electricity offers greater benefits than increasing the efficiency of one stream alone. Use of heat product lessens the benefit of increasing electricity output.

Some parameters have little influence on GHG balance but may be important in other ways to the deployment of biochar. Farmers may value fertiliser requirement decreases because of financial benefits, and may value using a high volume vehicle to deploy char because of the time saved, even though. Road transport may have little influence on GHG balance, but may be a factor in social acceptability – many deliveries can displease local residents (Upham and Shackley, 2005). Higher energy product yields may not offer such large GHG abatement, but may make projects more financially viable. An integrated socio-economic assessment could take this further.

III. Part Three: Pyrolysis Scenarios

To aid understanding of uncertain future systems, various scenarios have been created. Slow pyrolysis is modelled making extremely pessimistic to optimistic assumptions about variables in each life cycle stage.

Alternatives to PBS are modelled: slow pyrolysis with char combustion, fast pyrolysis, fast pyrolysis with char combustion, and biomass combustion. All combustion is assumed to occur in co-firing conditions which offer maximum efficiency of electrical conversion, providing the most stringent comparison to PBS. Co-firing is however of limited benefit to decarbonisation because fossil fuels must be burned along with the biomass.

GHG benefits and electricity production offered by PBS are modelled for Scotland using pessimistic to very optimistic assumptions for feedstock availability. The contribution of each feedstock is demonstrated.

Finally, the potential for PBS in Scotland is compared to the other scenarios for pyrolysis or alternatives to pyrolysis, as outlined above.

A. Slow Pyrolysis: Reducing Uncertainty, Removing Benefits.

Scenarios for the operation of slow pyrolysis biochar systems are outlined below in table 4. Important variables, as isolated in sensitivity analysis above, have been changed to allow for bad practice in PBS implementation and to allow for uncertainty in assumptions about the degree of biochar effects on soils or the use of heat energy product. The No Soil No Heat scenario assumes good practice but no char soil effects and no use of heat product.

Table 9 Pyrolysis Scenario assumptions

	unit	Extremely Pessimistic	Pessimistic	Default	Optimistic	No Soil No Heat
Transport handling losses	%	5	3	1	0	1
Application handling losses	%	25	10	3	0	3
Heat Offset	%	0	0	Default	50	0
Soil Effects	%	0	25		200	0
Electricity offset	kg CO2/MWh	80	200	501	501	501
Labile Fractions	%	25	15	15	10	15
MRT/Time horizon	yrs	300/100	500/100	500/100	2000/100	500/100

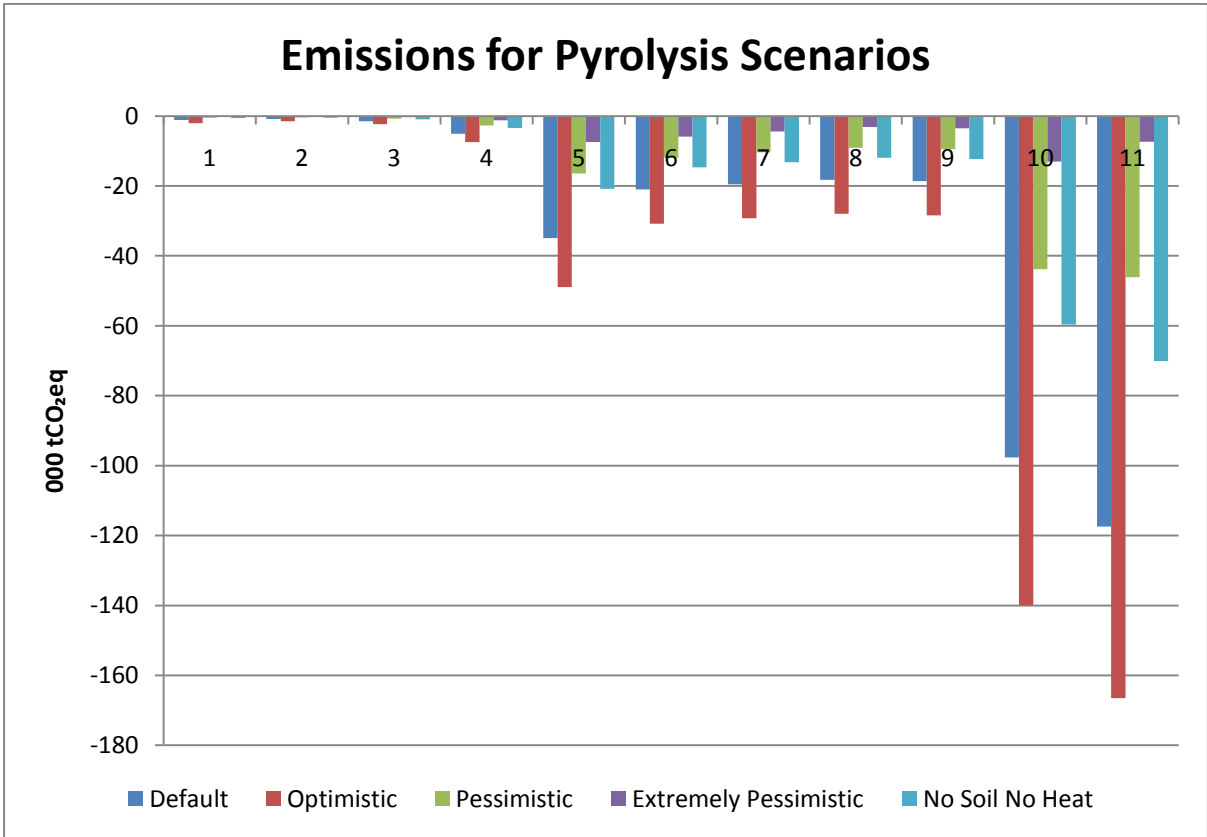

Figure 41 Emissions for Pyrolysis Scenarios

The outcomes from running the PBS spreadsheet for the above scenarios are plotted on figure 30. Under all scenarios, net emissions remain negative, although massively decreased by the extremely pessimistic scenario. The No Soil No Heat scenario offers more than 50% of the reductions offered in the default assumptions.

Each of the scenarios is plotted in detail below on figures 31 to 35, with net GHG emissions and normalised emission indicators (tCO₂/unit). Normalised indicators for efficiency of electricity production have not been included because they do not change in these scenarios. The scales on the axes are maintained, to permit visual comparison of each scenario.

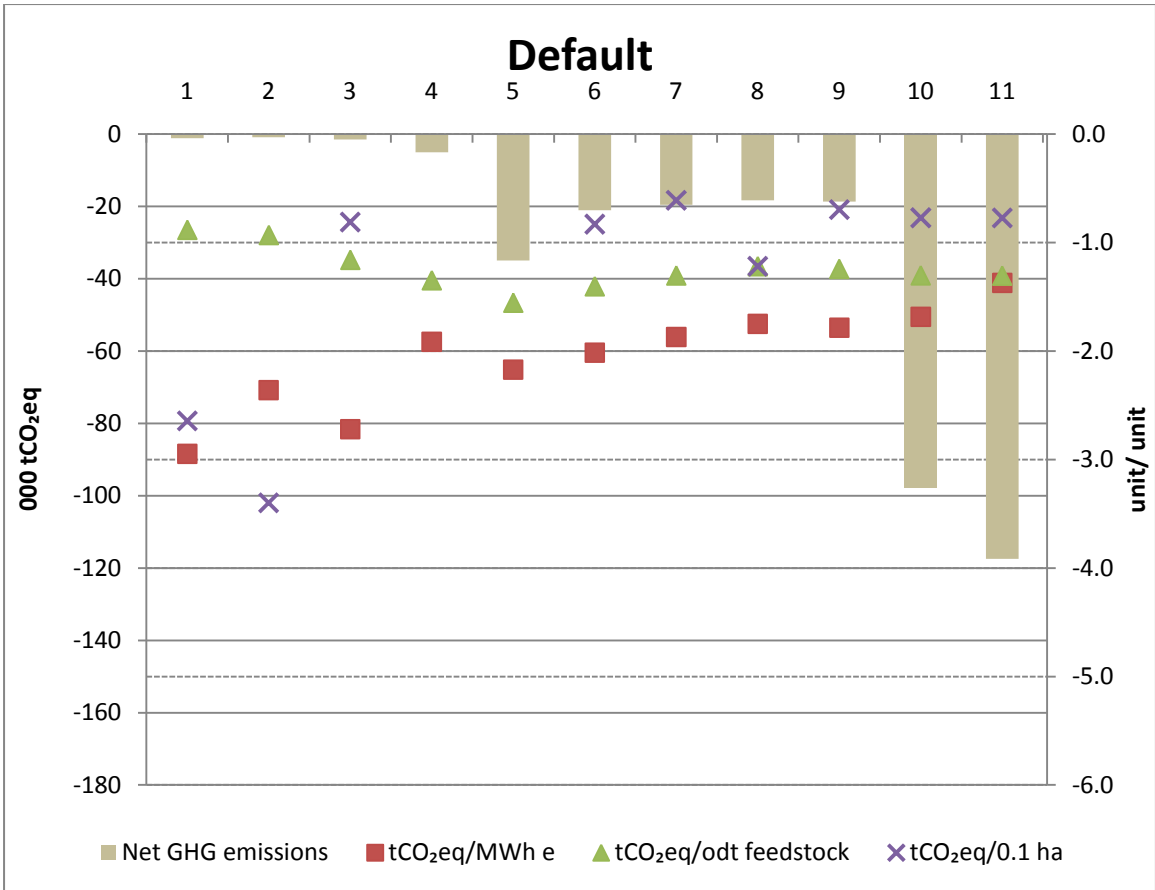

Figure 42 Default case: pyrolysis scenarios absolute and relative emissions indicators

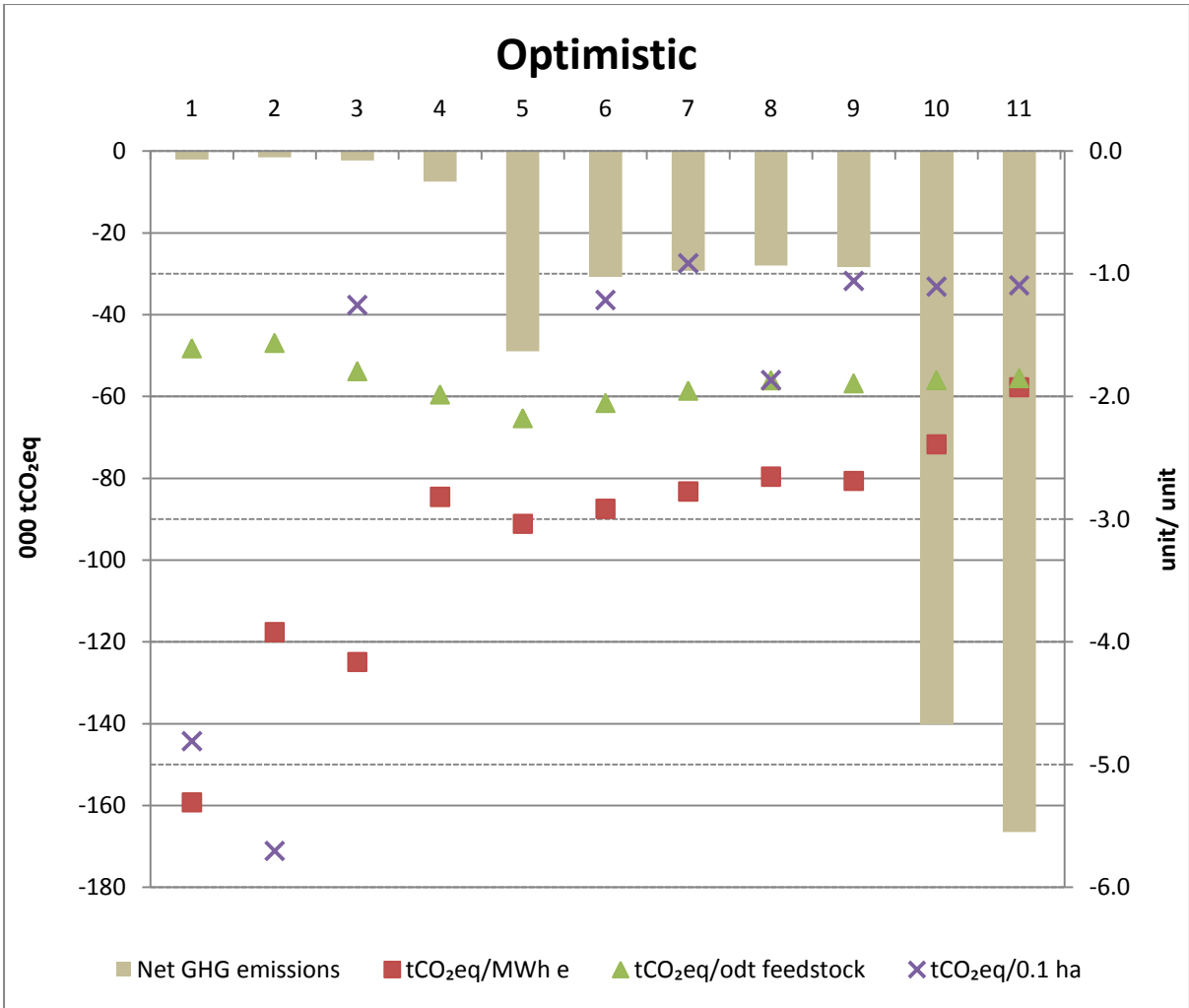

Figure 43 Optimistic case: pyrolysis scenarios absolute and relative emissions indicators

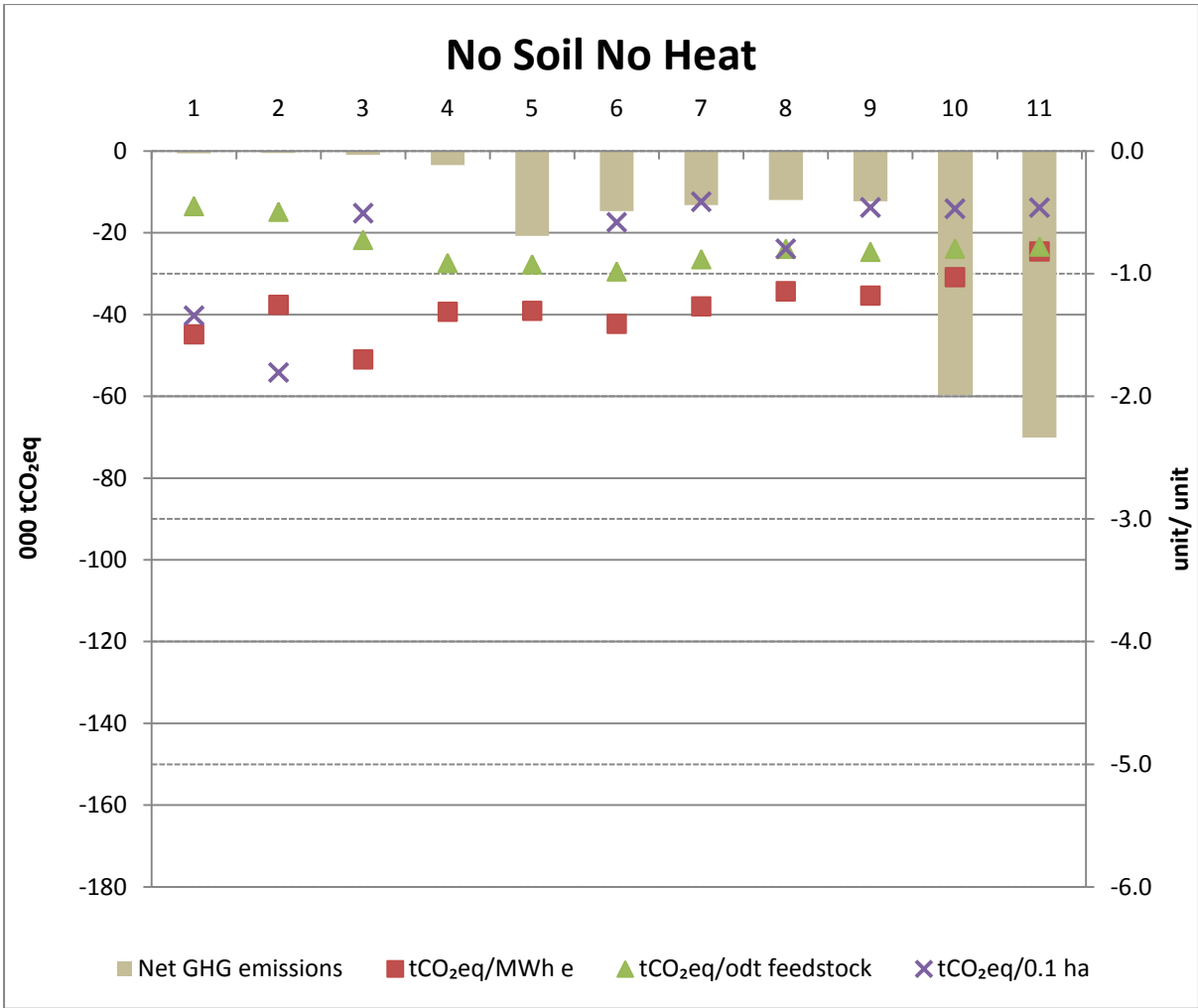

Figure 44 No soil no heat case: pyrolysis scenarios absolute and relative emissions indicators

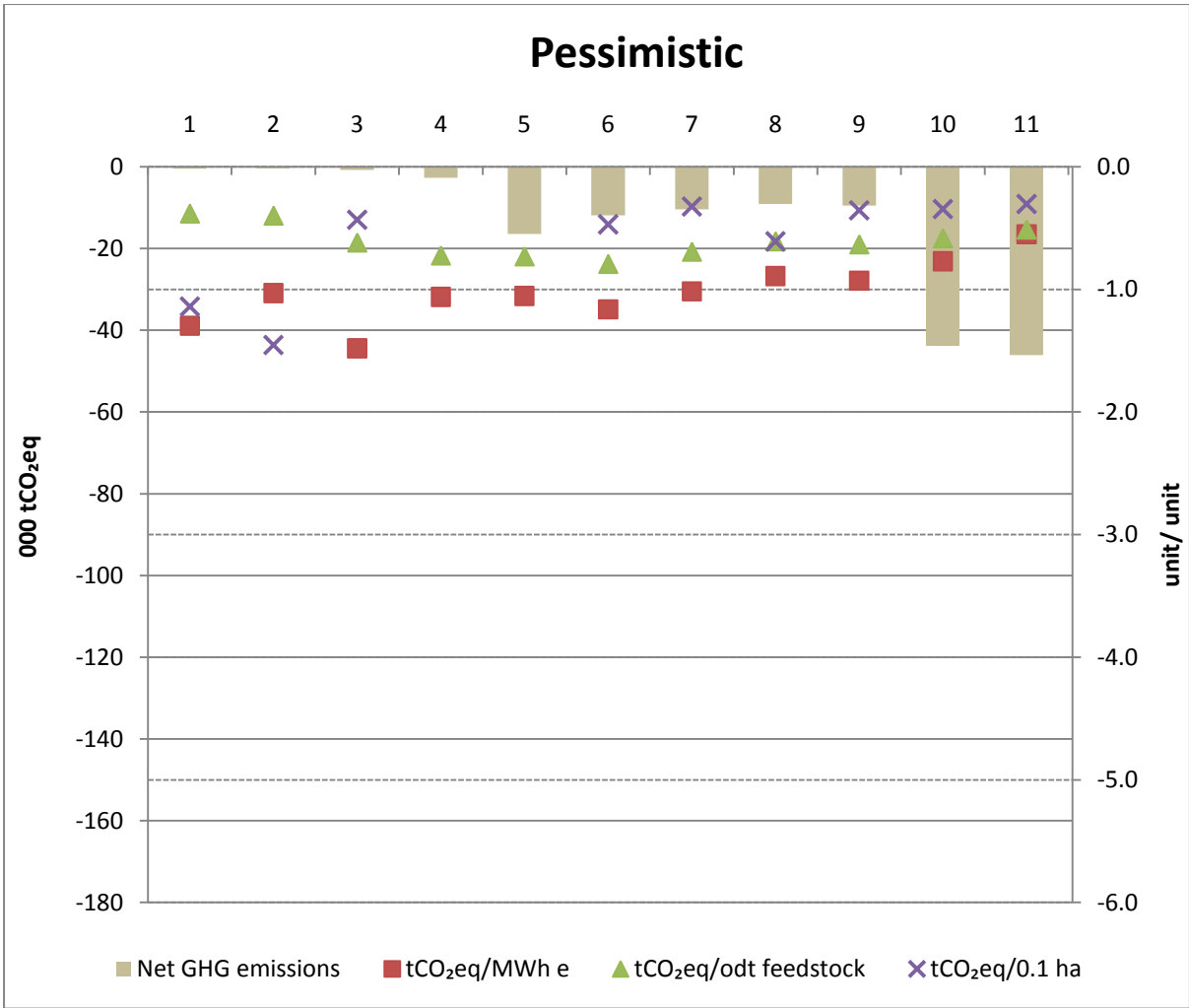

Figure 45 Pessimistic case: pyrolysis scenarios absolute and relative emissions indicators

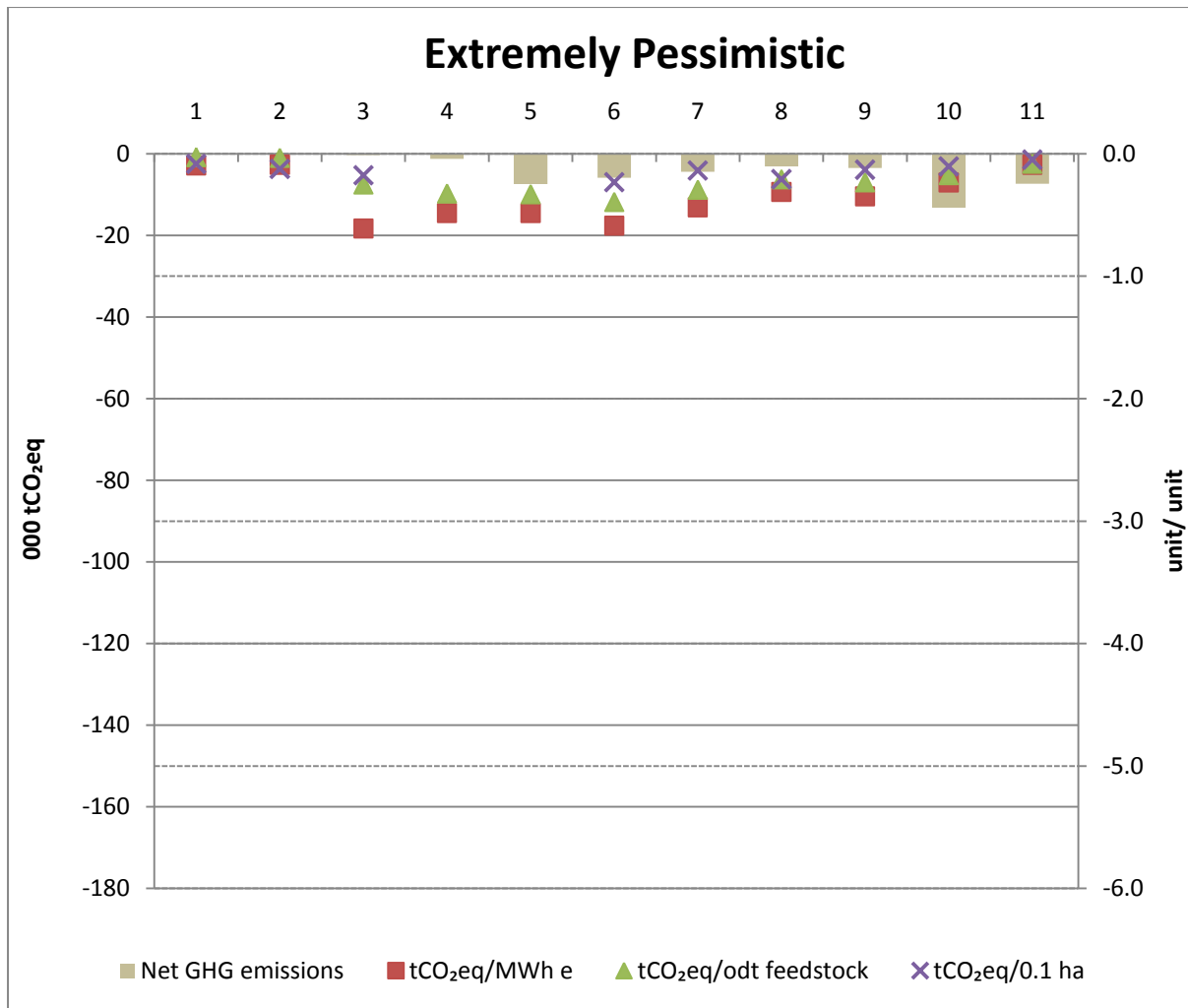

Figure 46 Extremely pessimistic case: pyrolysis scenarios absolute and relative emissions indicators

Net GHG abatement decreases progressively from optimistic through default, no soil no heat, and pessimistic to extremely pessimistic assumptions, as do abatement efficiency indicators. Changes in normalised indicators are more marked in the smaller cases (1 to 3, not 4), reflecting the reliance on char sequestration and soil effects for GHG benefits. The /MWh e and /ha units vary the most for small systems, whereas /odt feedstock is more consistent. This may suggest that /odt is a more reliable measure of PBS efficiency when dealing with uncertain system variables.

Even in the worst case scenario abatement continues (GHG emissions remain negative). Whether PBS is worthwhile in bad or worst case scenarios must be judged in comparison to other uses of the biomass.

B. Alternatives to Slow Pyrolysis

Biomass is a limited resource, and it would be prudent to use it as efficiently as possible. Depending on the goal, biomass may be used in many different ways. Assuming the goal is GHG reduction,

biomass may be grown, harvested, used and regrown. This can be used in many ways, not only for slow pyrolysis biochar systems. Modelled here are slow pyrolysis biochar (char to soil); slow pyrolysis assuming no heat use or soil effects; slow pyrolysis char combusted; fast pyrolysis biochar; fast pyrolysis assuming no heat use or soil effects; fast pyrolysis char combusted; and combustion. All combustion is assumed to occur in a co-firing plant, where 42% of the energy content is converted to electricity (Thornley et al., 2009). Fast pyrolysis yields have been taken from Dynamotive (Brownsort, 2009, Dynamotive, 2000) . Other life cycle emissions are assumed to be the same remain constant. Assumptions and data output are in appendix 6

The outcomes are plotted on the following figures 47 to 53, with a summary in figure 54.

1 Slow Pyrolysis

Slow pyrolysis biochar systems have the greatest GHG abatement, but the least electricity production. If there were no soil or heat effects, it would not make sense to sequester the char; more GHG could be offset by combusting the char, with the added bonus of more electricity being produced. Char combustion offers approximately 75% of the GHG abatement, but more than doubles the electricity output. However, when compared to combustion of the biomass, greater GHG abatement and electricity production is obtained. Combustion also requires less investment and is already being used; therefore it makes no sense to produce and then combust char.

2 Fast Pyrolysis

The difference in electricity production between the fast pyrolysis scenarios are less marked than in slow pyrolysis. Fast pyrolysis with default soil effects and heat use offers the best outputs, and the difference is not so great between fast pyrolysis no heat no soil and fast pyrolysis char combustion. This implies that where there may be soil/heat effects, of whatever size, it would be safer to use fast pyrolysis than slow.

3 Combustion

Combustion delivers less GHG abatement than would slow pyrolysis biochar, is soil effects and heat were to occur. Fast pyrolysis delivers slightly greater GHG abatement than would combustion. Without soil and heat effects, combustion appears superior in both GHG abatement and electricity production.

Combustion delivers much more electricity than any of the other options considered here, and so considering the demand for electricity, and the need to decarbonise our electricity sector, it is not surprising that combustion is a more widely used technology than fast, or slow, pyrolysis at present.

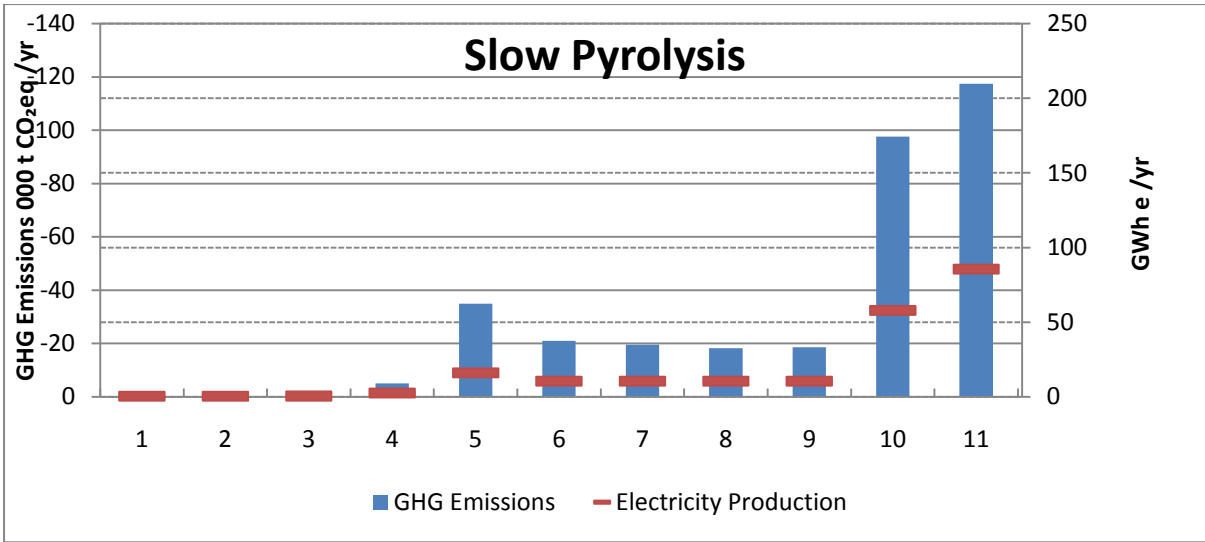

Figure 47 Slow Pyrolysis

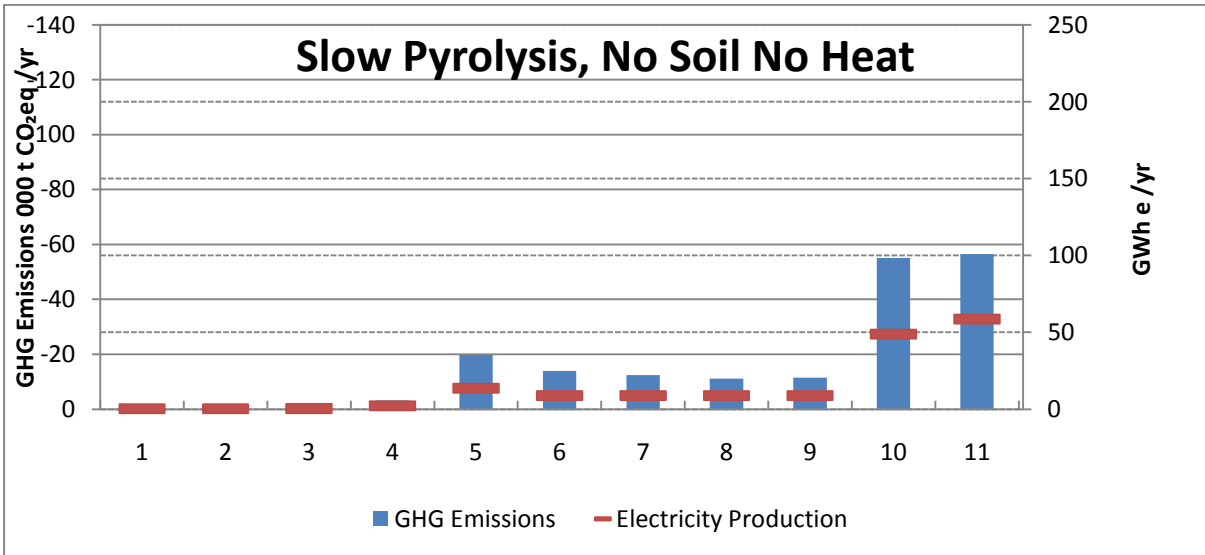

Figure 48 Slow pyrolysis, no soil no heat

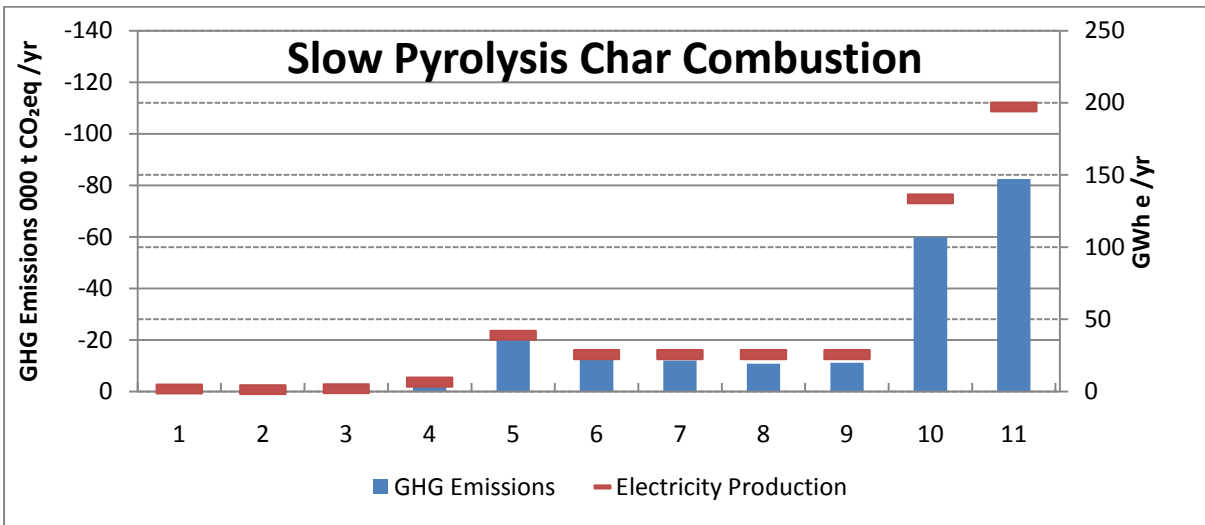

Figure 49 Slow pyrolysis, char combustion.

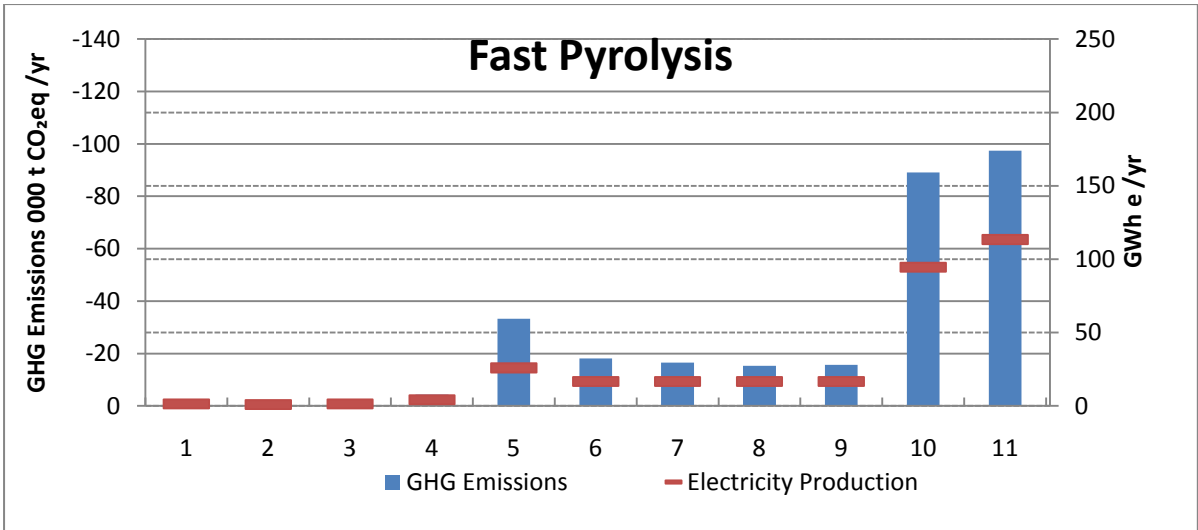

Figure 50 Fast Pyrolysis

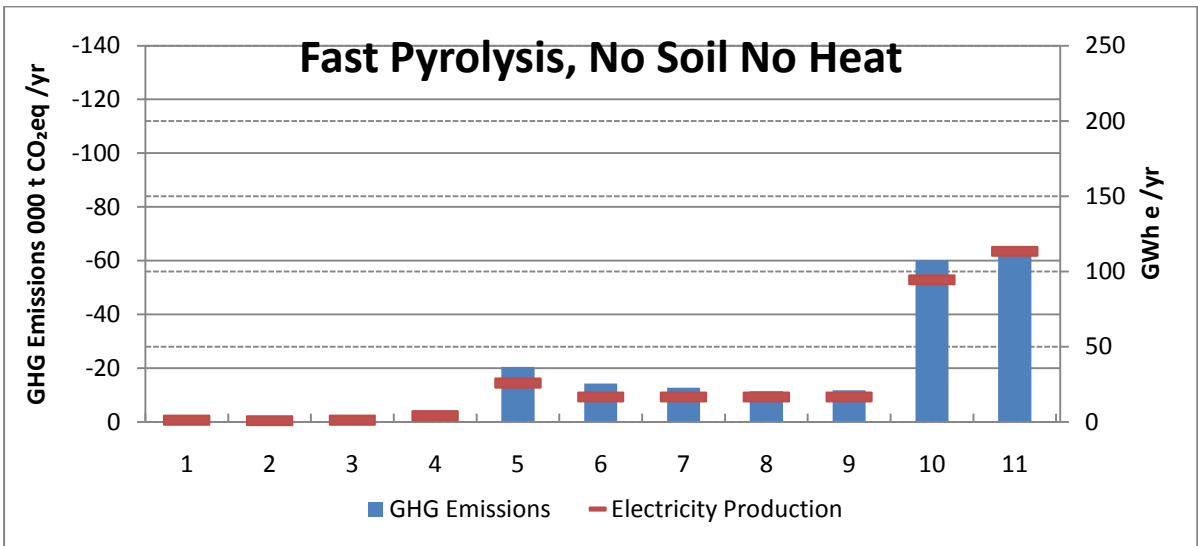

Figure 51 Fast Pyrolysis, no soil no heat

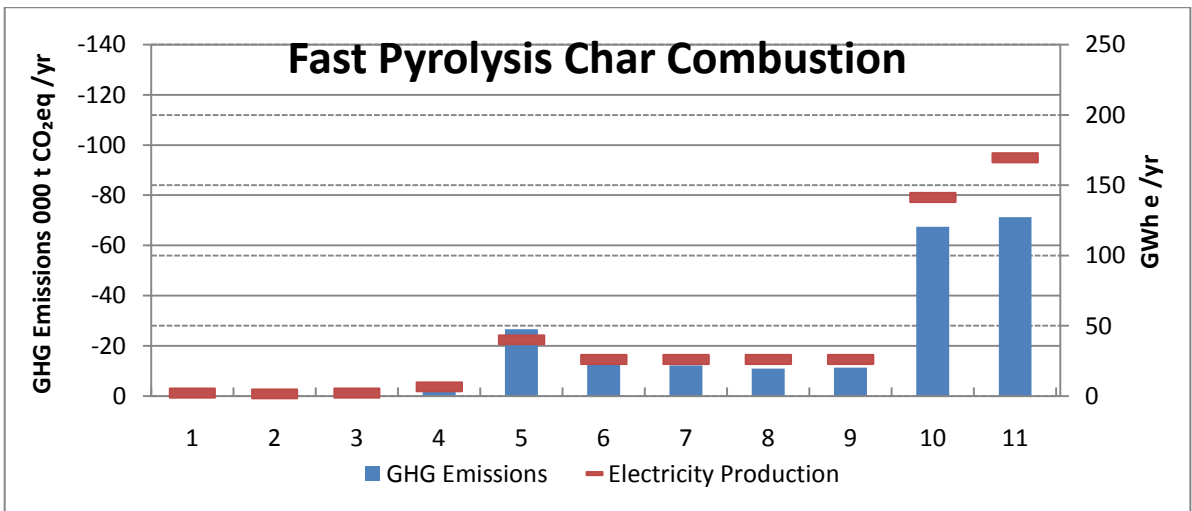

Figure 52 Fast Pyrolysis char combustion

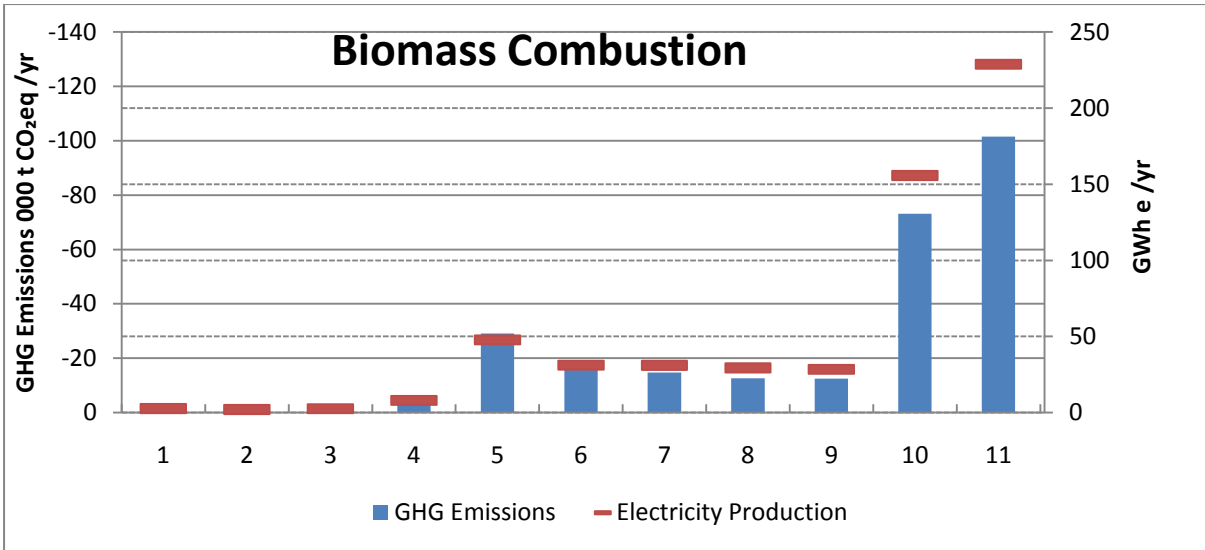

Figure 53 Biomass Combustion

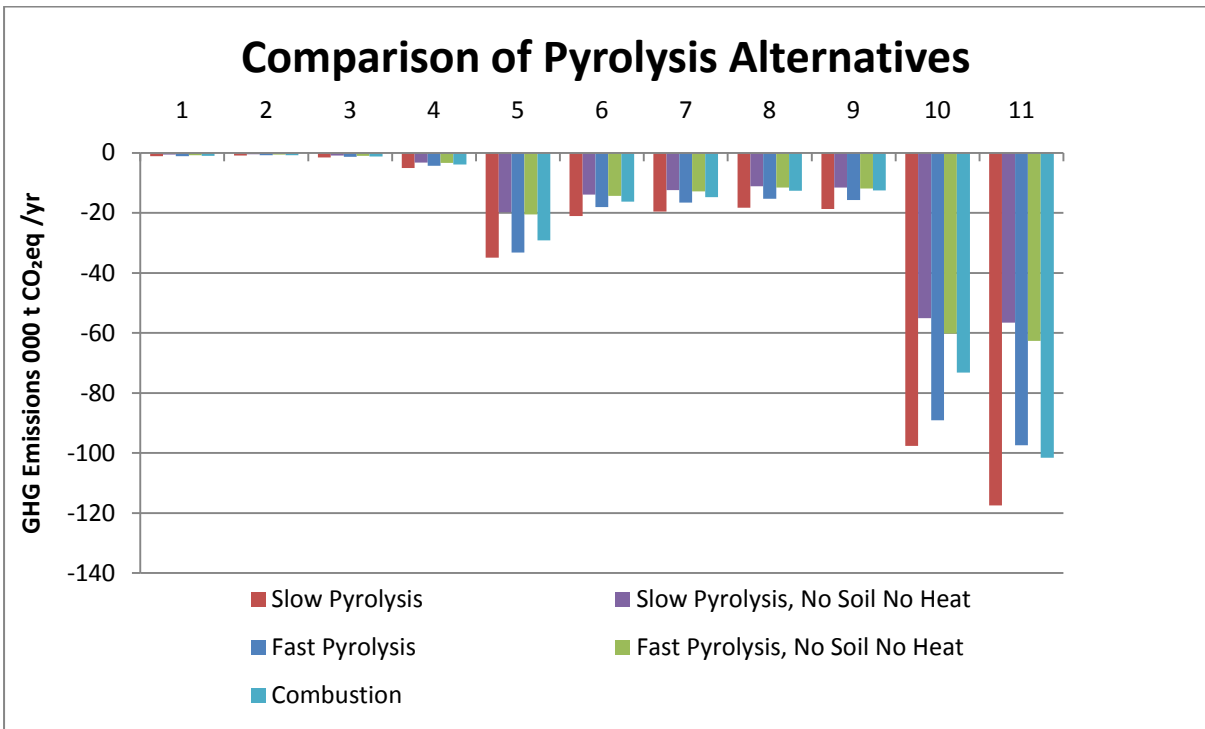

Figure 54 Comparison of Pyrolysis Alternatives

4 Changing the Electrical Reference System

Electricity production and GHG abatement are considered to determine the choice of use of biomass. If decarbonisation of the electricity sector occurs, the GHG abatement due to electricity production will also decrease. At present the average grid intensity is 501kgCO₂eq/MWh, and any electricity produced offsets that. If decarbonisation is achieved as planned (e.g. CCC, 2008), by 2030 the grid average will be 80 kgCO₂eq/MWh. Electricity produced will then appear to deliver less benefit. If such a future occurs and there is available biomass, then pyrolysis becomes far more

appealing than combustion, continuing to offer carbon sequestration and electricity. This is represented in figures 45, 46 and 47 below.

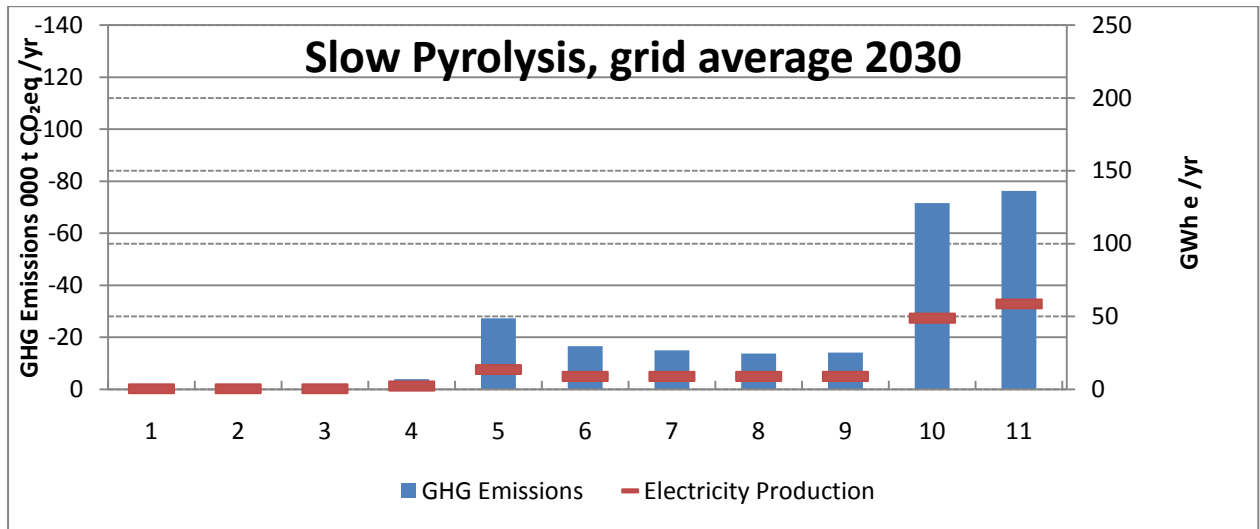

Figure 55 Slow Pyrolysis, grid average 2030

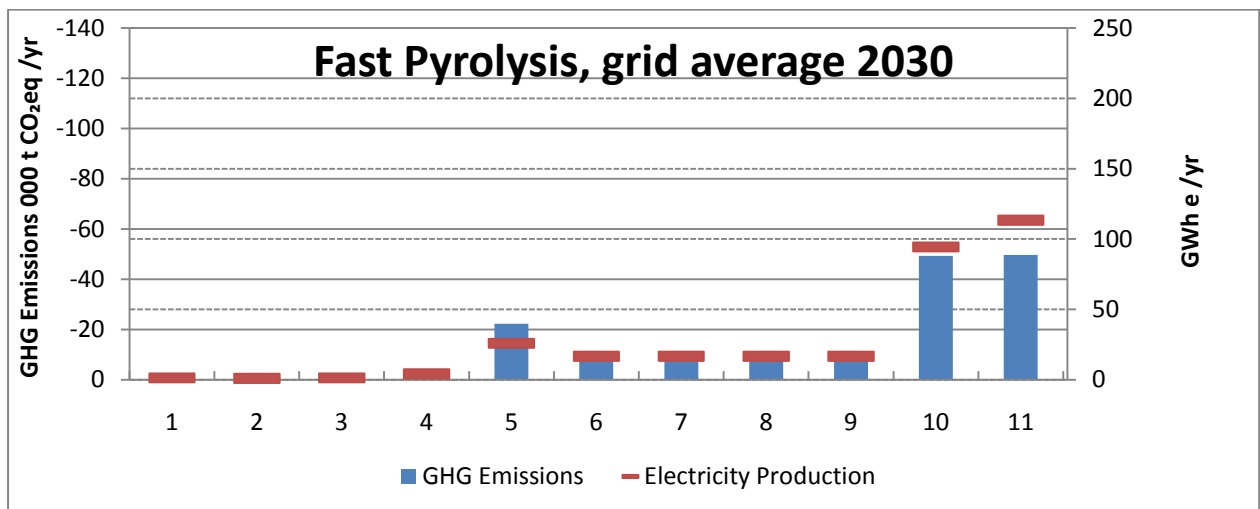

Figure 56 Fast Pyrolysis, grid average 2030

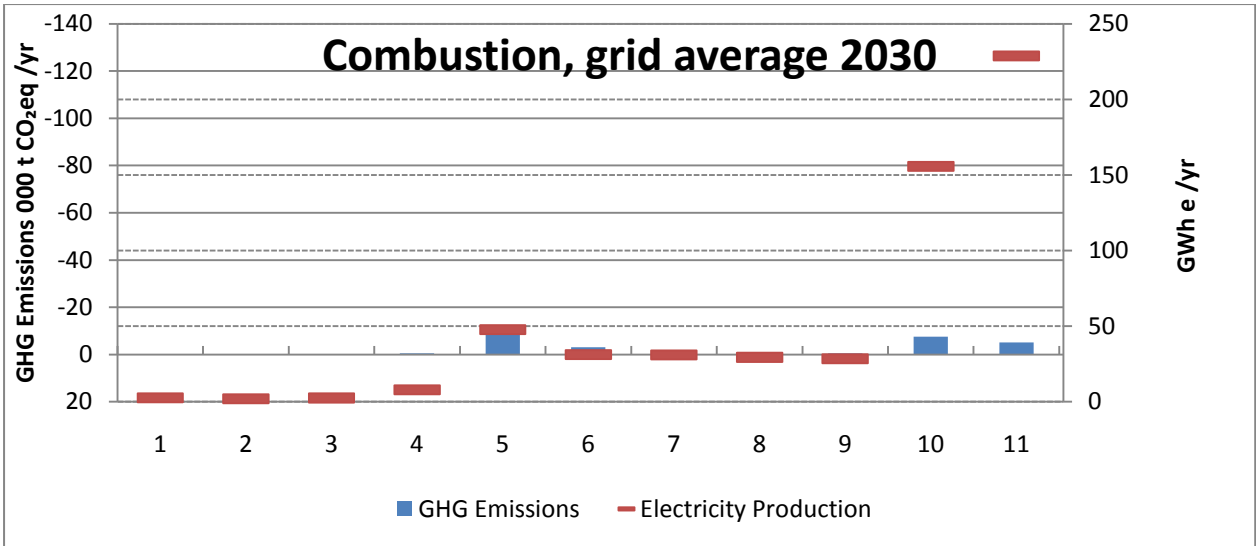

Figure 57 Combustion, grid average 2030

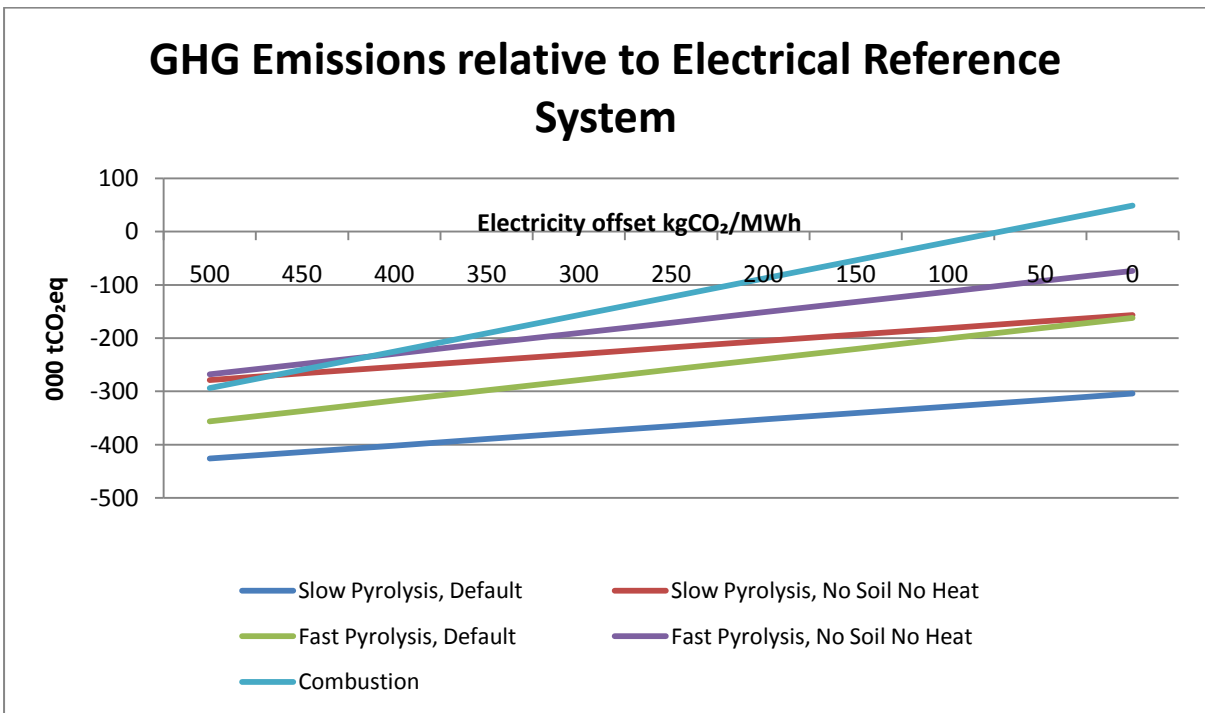

Figure 58 Comparison of pyrolysis alternatives when electrical reference system is varied

Figure 58 above shows the point at which the different bioenergy technologies appear to offer greater GHG abatement, as the average intensity of the national grid changes. It may be an impossible comparison, if biomass combustion is required to decrease the average grid intensity. This concept is examined in more detail in the discussions chapter.

C. Estimated Maximum Potential in Scotland from PBS.

Using the data from the resource assessment outlined in the Literature Review chapter (see tables 1 and 2), it is possible to estimate maximum GHG abatement and electricity production in Lothian and Borders and in Scotland. Pessimistic, optimistic and very optimistic assumptions are applied to maximum available feedstocks to determine how much may be available to PBS.

Optimistic assumptions are that 50% will be available assuming no competition except from other bioenergy systems, and 25% available when facing other competing markets. Pessimistic assumptions are that 25 and 10% will be available, very optimistic assumes 100 and 50% availability. Only ingenious feedstocks are assessed and imported forestry residues excluded. Imported feedstocks dwarf those available in Scotland, and so could potentially offer very large GHG abatement and electricity production. Data is insufficient on short rotation forestry to make an estimate. Table 10 below presents the feedstock availability, tables 11 and 12 GHG abatement and electricity product.

The very optimistic scenario for Scotland would deploy 620546 t char per year. Assuming a rate of 30t/ha with 5t/ha top up every 5 years, 17730 ha would be required per year for char deployment. Scotland has 1,545,000 ha of cereal, combine harvested and tilled crops (Agricultural Census, 2008). At this rate, there is enough land for 87 years of char additions to virgin farmland. The land constraint is therefore not a problem.

Table 10 Feedstock availability scenarios

Feedstock odt/yr	Max available in L&B	Max available in Scotland	L&B: Very optimistic	L&B: Optimistic	L&B: Pessimistic	Scotland: Very optimistic	Scotland: Optimistic	Scotland: Pessimistic
Barley Straw	109695	699074	54846	27424	10970	349537	174769	69907
OSR Straw	23495	84056	23495	11748	5874	23495	42028	21014
Sawmill Residues	120000 (own estimate)	388526	60000	30000	12000	194263	97131	38853
SRC	60000 (own estimate)	700000	60000	30000	15000	700000	350000	175000
Small Round Wood	94807	327519	94807	47404	23702	327519	163760	81880
Forestry Residues	68011	319126	68011	34006	17003	319126	159563	79782

Table 11 GHG abatement possible using PBS for feedstock availability scenarios

	L&B very optimistic	L&B Optimistic	L&B Pessimistic	Scotland Very Optimistic	Scotland Optimistic	Scotland Pessimistic
t CO ₂ eq /yr						
Barley Straw	-48254	-24130	-9655	-307496	-153751	-61503
OSR Straw	-21762	-10884	-5445	-21762	-38924	-19465
Large Scale Sawmill Residues	-93218	-46609	-18644	-301814	-150906	-60363
Scottish Forestry Residue Chips	-95395	-47698	-23849	-447621	-223811	-111906
Scottish Small Round Wood	-123534	-61768	-30884	-426758	-213380	-106690
Large Scale SRC	-73084	-36542	-18271	-852650	-426325	-213162
Total	-455247	-227631	-106748	-2358101	-1207097	-573089

Table 12 Electricity production possible using PBS for feedstock availability scenarios

	L&B very optimistic	L&B Optimistic	L&B Pessimistic	Scotland Very Optimistic	Scotland Optimistic	Scotland Pessimistic
MWh e /yr						
Barley Straw	16439	8220	3288	104764	52382	20953
OSR Straw	9272	4636	2318	9272	16586	8293
Large Scale Sawmill Residues	42948	21474	8590	139054	69527	27811
Scottish Forestry Residue Chips	47367	23684	11842	222260	111130	55565
Scottish Small Round Wood	66030	33015	16508	228106	114053	57027
Large Scale SRC	41788	20894	10447	487526	243763	121881
Total	223844	111923	52992	1190981	607440	291530

1 Potential from PBS

GHG abatement and electricity production are plotted in figures 48 and 49 below for each scenario of feedstock availability. Findings are summarised in figures 50 and 51. It is assumed that the case study parameters stay the same, but the quantity of feedstock increases, with many systems of each case study running simultaneously. Where cases compete for resources, it has been assumed estimated that 25% of sawmill products used are in small systems, and that 1/6th of SRC is used in small systems.

SRC offers the greatest potential; it is also the largest resource. Size of resource is the determining factor. The relative contribution of barley straw and sawmill residues to electricity is less than it is to GHG abatement; this is explained by the lower electrical conversion efficiency of the smaller systems.

The emission reductions estimated for Scotland range from 0.5 to almost 2.5 MtCO₂eq/yr. Total emissions in 2006 were 59 MtCO₂eq (Scottish Government, 2009). Total electricity requirement in Scotland was 28,962.4 GWh .in 2007 (DECC, 2008), production here ranges from 300 to 1200 GWh.

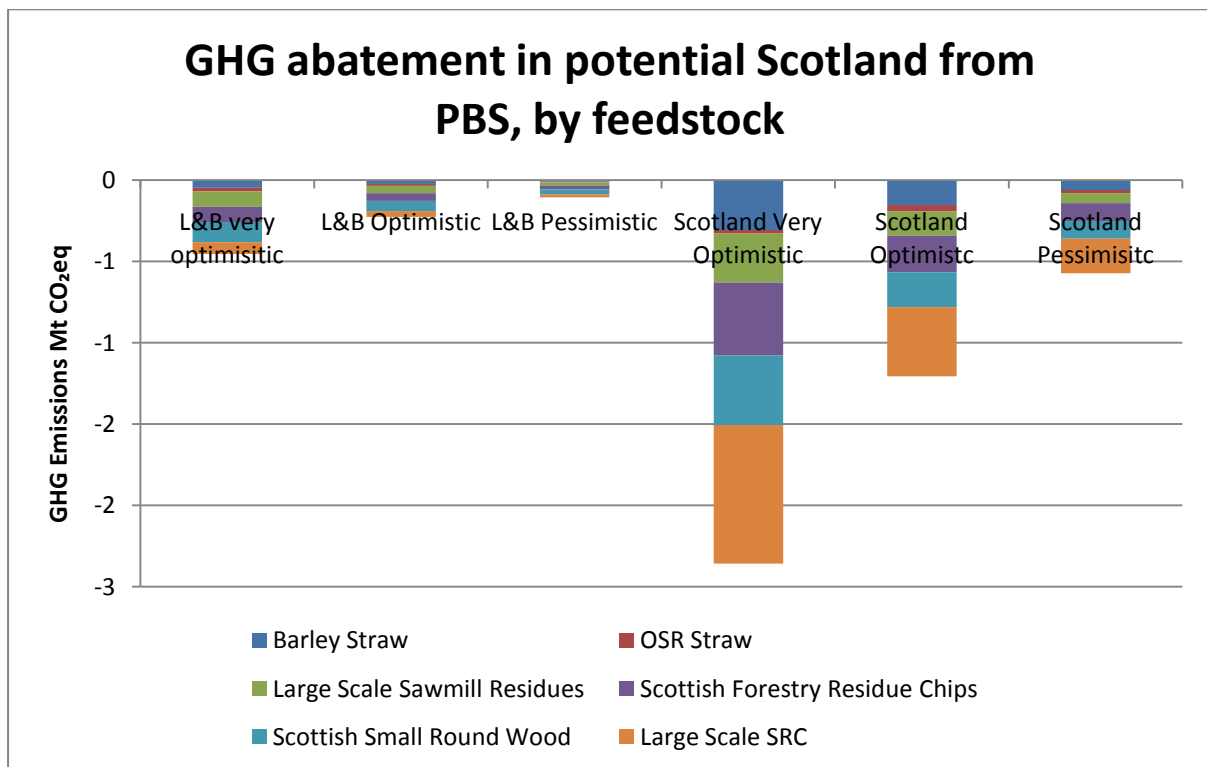

Figure 59 GHG abatement in potential Scotland from PBS, by feedstock

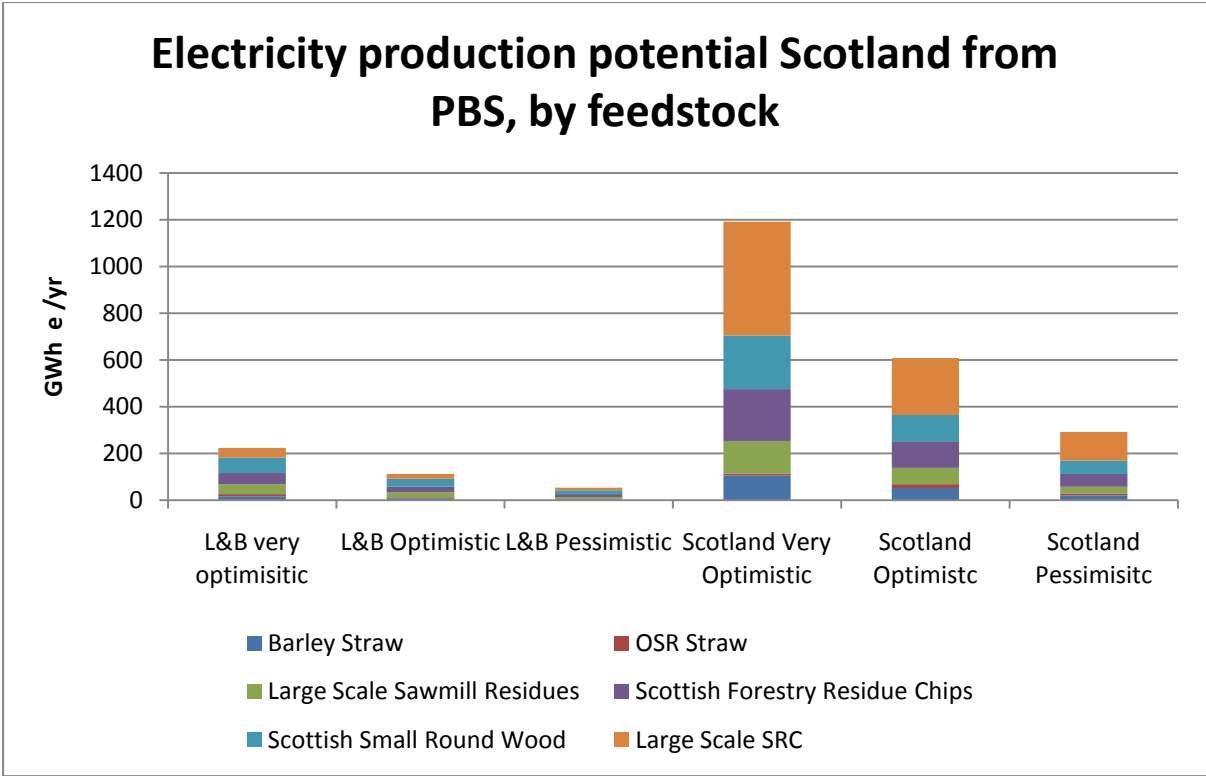

Figure 60 Electricity production potential Scotland from PBS, by feedstock

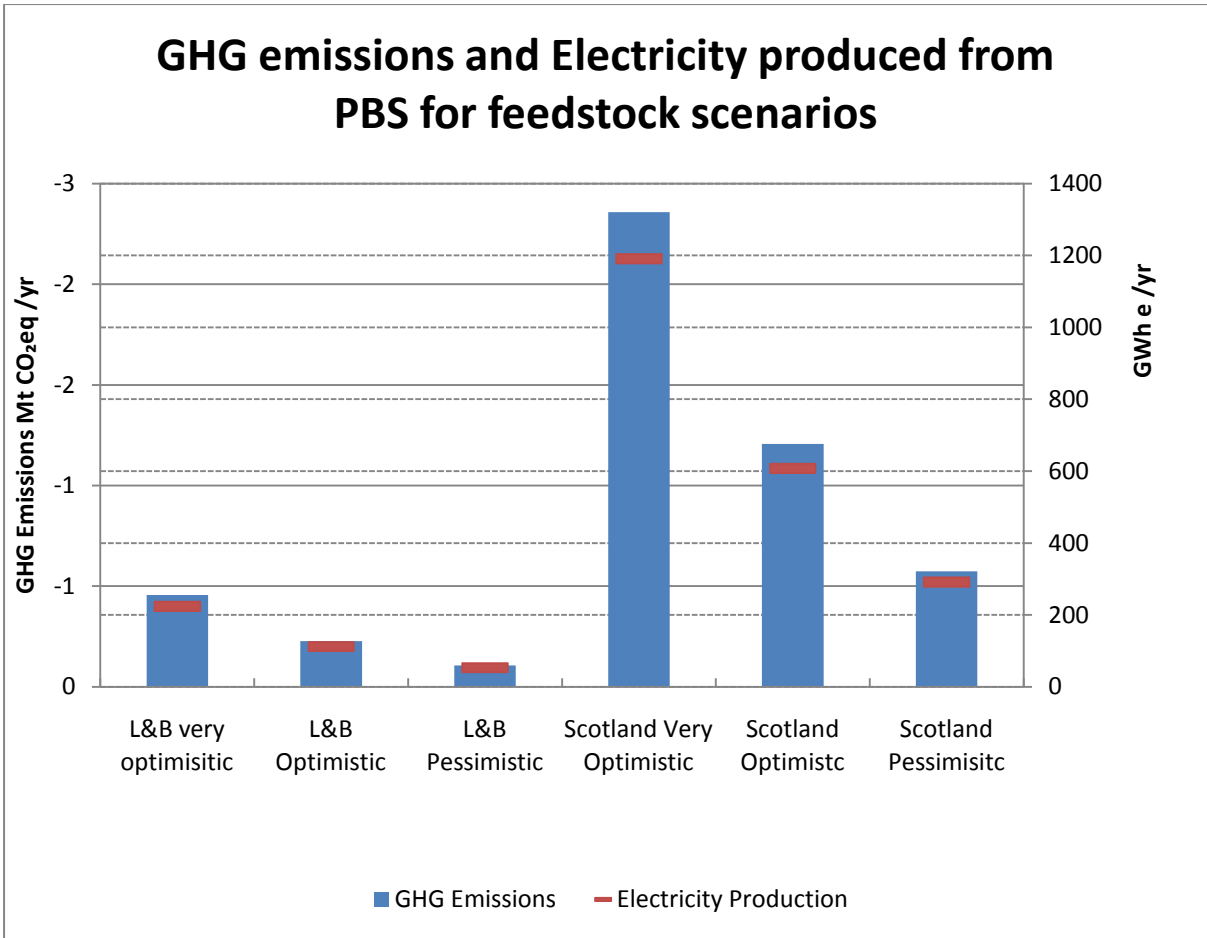

Figure 61 GHG emissions and Electricity produced from PBS for feedstock scenarios

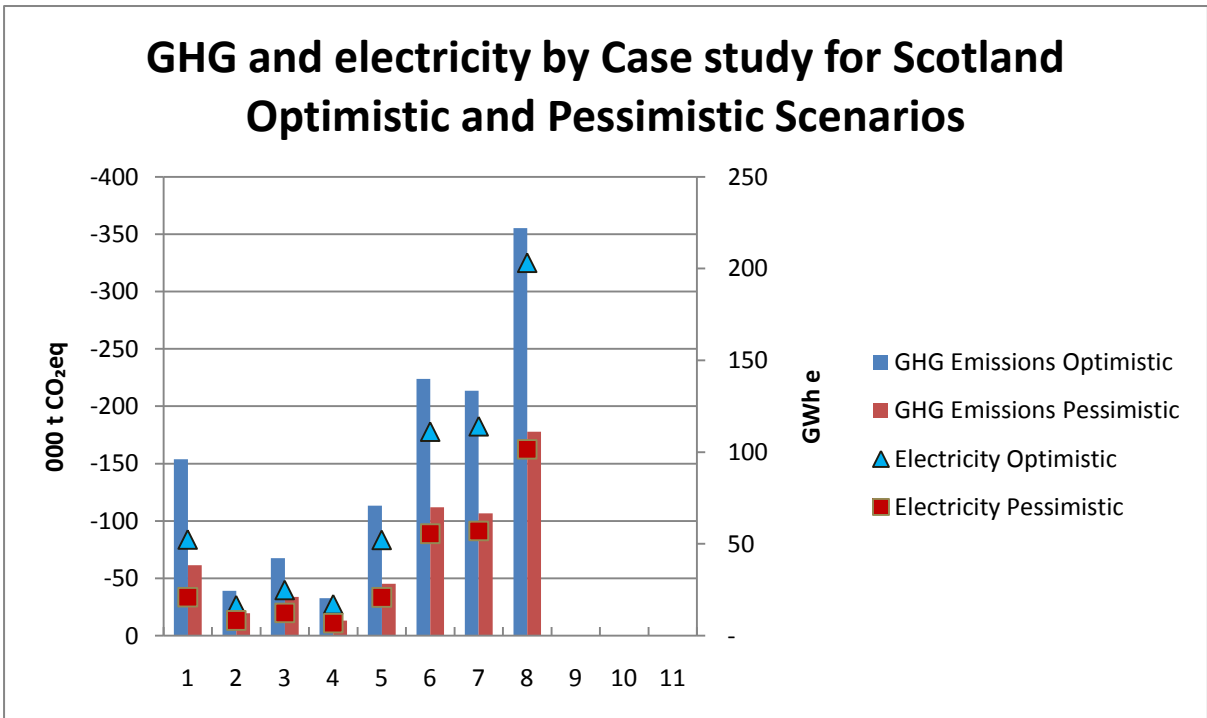

Figure 62 GHG and electricity by Case study for Scotland Optimistic and Pessimistic Scenarios

D. Combining the scenarios

The optimistic assumptions for national availability of feedstocks are chosen, and the abatement potential and electricity product are shown for slow and fast pyrolysis assuming default and no heat no soil scenarios, and combustion. All are referenced against the average grid intensity 2008 and the predicted average grid intensity 2030.

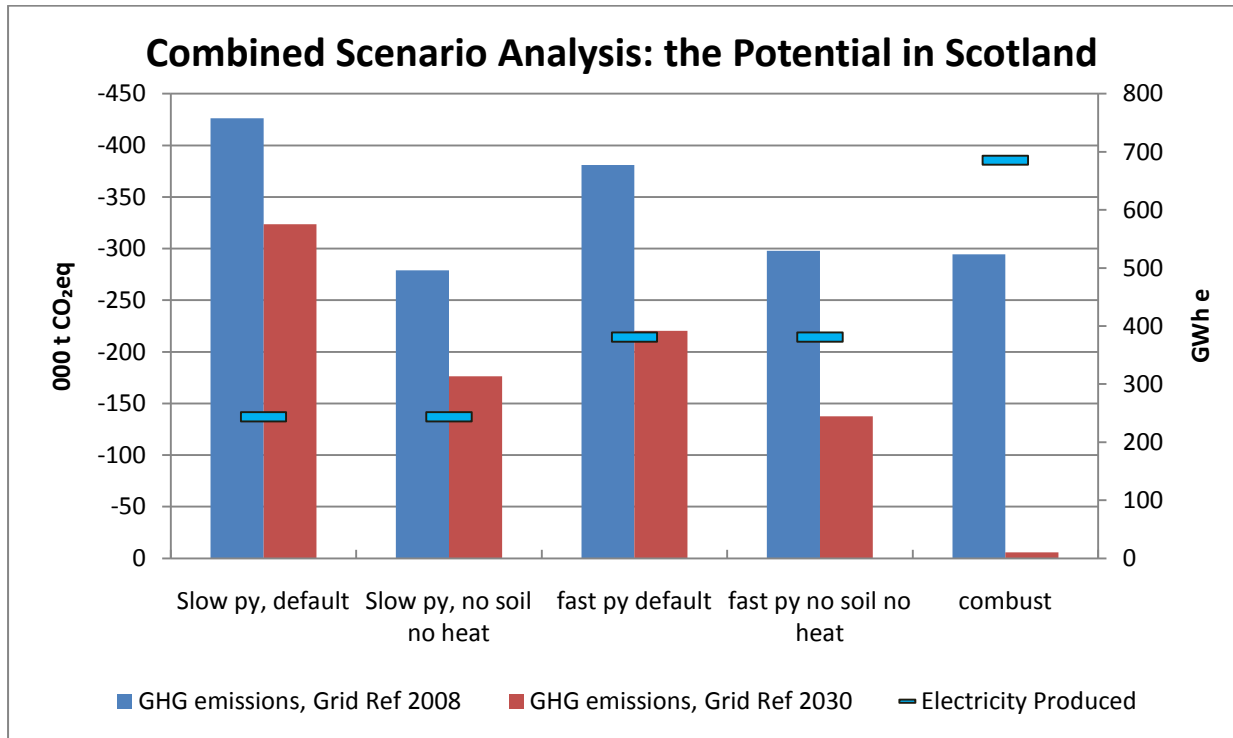

Figure 63 Scotland Optimistic feedstock assumptions, pyrolysis scenarios and alternatives compared using SRC

The choices between slow pyrolysis, fast pyrolysis and combustion all depend on the demand for biomass generated electricity. Pyrolysis will appear more favourable *if* the electrical system has been decarbonised and biomass remains available as a resource.

Chapter 5: Discussion

Three topics are raised for discussion: which, if any, configuration of biochar systems is the best; comparisons between this study and others in the literature; and the debate between using biomass for electricity or for maximum GHG abatement through PBS.

I. Optimal system configuration

When comparing PBS configurations through the 11 different case studies, the most important factor is the quantity of feedstock being processed. More feedstock results in more GHG abatement and more energy product.

When abatement is measured per odt feedstock or per ha, all the wood fuel case studies perform comparably. Imported wood pellets produce greater abatement and greater electricity, which is appropriate for a higher grade fuel. SRC performs well on a per ha basis, validating its designation as an energy crop. Forest residues and SRW perform slightly better than other on a per odt basis, due to the low emissions generated in feedstock production. The extra emissions due to transport of feedstock from Canada appear to be compensated for by gains in the efficiency provided by a large facility.

Straw performs extremely well on a per ha basis, reflecting the good yields and low allocation values, but performs poorly on a per odt basis, because of high emissions due to cultivation.

Electricity production per odt feedstock is similar for all wood cases except small scale SRC, reflecting the loss in electricity due to non-conversion of syngas in the smaller cases (which also occurs with barley and OSR straw). The systems that have higher heat use also tend to generate greater emissions reductions. MWh e/ha are again higher for straw, reflecting low allocation and SRC, reflecting high yields.

All the case studies assessed therefore appear viable and promising. Maximum use of energy products and electrical conversion efficiency should be attempted, but is not essential to the success of PBS. Data from the 'pessimistic' and 'extremely pessimistic' scenarios show that bad practice or very low char stability and soil enhancement can lead PBS systems to very low relative abatement factors. The low electricity production combined with low abatement factors would not make an attractive or worthwhile investment. However, the 'no soil no heat' scenario for PBS shows that all

cases are still viable, and that SRC and straw still perform well. Forestry residues appear more attractive, because using this feedstock avoids methane emissions. Assuming good management of the PBS processes, the complete removal of char-soil enhancement and heat use benefits does not prevent biochar systems being successful.

II. Comparisons to the literature

A. Other Bioenergy Systems

In the assessment of various bioenergy systems using the Beat2 model (Bates et al., 2009), performance is expressed as kg CO₂eq/MWh e. The technologies modelled are co-firing, biomass power plant and domestic biomass boiler; all return positive values (when electricity offset was not been counted). All biochar systems modelled in the present study return negative values, ranging from -2.4 to -0.6 tCO₂eq/MWh, indicating that the systems modelled do offer carbon negative power. Each MWh of electricity produced *decreases* atmospheric GHG concentrations. What is not stated is that the total quantity of electricity produced is much less for biochar systems.

Thornley et al. find a 5MWe pyrolysis system using an engine for electricity generation to have an overall electrical efficiency of 30% (Thornley et al., 2009). The lower result generated in the present study (15% efficient for an 8MWe pyrolysis system – case 10) is accounted for the large amount of energy which remains in the char. If all the char were to be combusted, the total electrical efficiency rises to 34%. The corresponding carbon abatement is 40kgCO₂eq/ha, where the best performing system is CHP using miscanthus, at 225 kgCO₂eq/ha (Thornley et al., 2009). Case 10, under default assumptions, abates 7706kgCO₂/ha. These values are hugely different. It may be that Thornley et al. have not used an allocation system for land take, a theory supported by straw performing badly when judged by this metric in their study²¹. Assuming no allocation, case 10 abates 570kgCO₂eq/ha. This value seems to be comparable to that of Thornley et al.; and shows that PBS achieves greater abatement efficiencies. However, case 10 is one of the worst performing by this metric; SRC abates 12000kgCO₂eq/ha. It is difficult to assess whether comparisons between the two studies are valid without access to their assumptions. If the comparisons are valid, it may be concluded that PBS offers much greater carbon abatement per hectare than bioenergy options.

B. Other biochar LCAs.

In their biochar LCA, Gaunt and Lehmann (2006) find abatement efficiencies of 12 .5 to 15.3t CO₂eq/ha, for switchgrass and miscanthus. These results are comparable to those here. Gaunt and

²¹ This confusion reinforces the point made earlier about the problem of using abatement/ha as a unit, when assumptions have not been made clear.

Lehmann also find that 41 to 63% of GHG abatement is due to char sequestration in soils, which is comparable to the 38 to 67% found in this study. The greater variation may be due to the greater variety of systems studied. Gaunt and Lehmann do however find that suppression of soil N₂O emissions and decrease in fertiliser requirement can count for between 20 and 50% of total avoided emissions. The present study finds that a maximum of 4.5% difference may occur between zero and maximum suppression of N₂O and fertiliser requirement decrease.

McCarl et al. estimate GHG abatement at -1.113 tCO₂eq/t feedstock²² for slow pyrolysis and -0.823 tCO₂eq/t feedstock for fast pyrolysis. Results from the present study range from -0.886 to -1.553 tCO₂eq/odt feedstock for slow pyrolysis and -0.617 to -1.107 tCO₂eq/odt.

III. Electricity or Soil? The best use of our biomass

From the present study it appears that PBS offers greater GHG abatement than any other use of biomass, but produces less electricity. This is clearly illustrated in figure 64 above.

Fast or slow pyrolysis offer greater GHG abatement than biomass combustion, if default assumptions prove correct, and comparable abatement if the 'no heat no soil' scenario proves correct. Electricity production is 36% for slow pyrolysis and 54% for fast, compared to combustion, when averaged across all case studies. This is the definitive choice that must be made: to use biomass for electricity or to use biomass for GHG abatement.

Soil and crop benefits of biochar may help to swing the balance, but must be demonstrated convincingly. As long as the effects remain uncertain they will not influence decision makers or biochar users. It is farmers who will have to agree to mix biochar with their soils, and if it proves beneficial, it is farmers who will provide the market for the char and indeed, it may be farmers who decide to start producing char first, on a small scale, if they are convinced of its benefits and the incentives are right.

While PBS may offer greater carbon abatement, that carbon abatement presently has no market value in the UK; it cannot be sold like electricity can be sold. At present, char also has no or very little market potential. Electricity on the other hand has a huge market in the UK. The ROCs scheme at present incentivises emergent technologies including pyrolysis and gasification, but payment is issued per MWh e (Biomass Energy Centre, 2009b). This is not a useful incentive for systems that produce less electricity, but greater GHG abatement²³. If the purpose of decarbonising the electricity

²² Presumably oven dry, but moisture contents are not stated.

²³ An omission from this project has been analysis of gasification – a bioenergy technology which is highly efficient in producing electricity and also produces a small amount of char.

sector is to decrease GHG emissions, but that goal could be met a more efficient way without decarbonising the electricity sector (PBS), it makes sense to pursue the most efficient method. The argument is not against decarbonising electricity but for the greatest GHG abatement.

The question to answer is what contribution biomass can make to generating electricity, and if this is really necessary to ensure that demand is met²⁴. A question important to the development of biochar systems is whether we need to generate low carbon electricity from biomass, or whether we can generate our electricity from other sustainable technologies, and use biomass for the most efficient GHG abatement available.

²⁴ Demand for electricity must also be reduced if sustainability constraints are taken seriously.

Chapter 6: Conclusions

Conclusions drawn from this research project are presented below, followed by suggestions for further research.

- PBS offers greater GHG abatement than any other use of biomass.
 - PBS offers less electricity per unit of biomass than many other uses of biomass.
 - PBS is viable for all major non-waste stream feedstocks in Scotland
 - PBS is theoretically viable at very small to very large scale
-
- GHG abatement or electricity production is best measured per odt feedstock for PBS, and should be used as a standard unit for bioenergy LCAs.
-
- SOC accumulation is important to GHG balance, and requires further research
 - Char yields and char stability are important to GHG balance
 - Good practice regarding handling losses is important to PBS GHG balance
 - Maximising energy product output and usage improves GHG balance, and moderates the negative impact of lower char stability on soil effects
 - Fertiliser and N₂O emissions are less important than found in other studies.

Further research is necessary to increase the level of certainty regarding soil and crop effects, and pyrolysis yields. An integrated LCA analysing socio-economic factors would be an ideal progression for the present project. An analysis of whether biomass should be used for electricity or GHG abatement would be useful to the progression of PBS.

Reference List

- Abildtrup, J., Audsley, E., Fekete-Farkas, M., Giupponi, C., Gylling, M., Rosato, P. & Rounsevell, M. (2006) Socio-economic scenario development for the assessment of climate change impacts on agricultural land use: a pairwise comparison approach. *Environmental Science & Policy*, 9, 101-115.<Go to ISI>://000236511100002
- Agricultural Census (2008) Final Results of the Agricultural Census National Statistics Office, Scottish Government <http://www.scotland.gov.uk/Publications/2008/10/agriccensus2008>
- Alguacila, M. M., Caravaca, F., Azcon, R. & Roldan, A. (2008) Changes in biological activity of a degraded Mediterranean soil after using microbially-treated dry olive cake as a biosolid amendment and arbuscular mycorrhizal fungi. *European journal of soil biology*, 40, 347–354
- Alkhamis, T. M. & Kablan, M. M. (1999) Olive cake as an energy source and catalyst for oil shale production of energy and its impact on the environment. *Energy Conversion & Management* 40, 1863±1870
- Andersen, R. S., Towers, W. & Smith, P. (2005) Assessing the potential for biomass energy to contribute to Scotland's renewable energy needs. *Biomass & Bioenergy*, 29, 73-82.<Go to ISI>://WOS:000230541400001
- Anderson, K. L., Mander, S. L., Bows, A., Shackley, S., Agnolucci, P. & Ekins, P. (2008) The Tyndall decarbonisation scenarios-Part II: Scenarios for a 60% CO₂ reduction in the UK. *Energy Policy*, 36, 3764-3773.<Go to ISI>://000260561400014
- Antal, M. J. & Gronli, M. (2003) The art, science, and technology of charcoal production. *Industrial & Engineering Chemistry Research*, 42, 1619-1640.<Go to ISI>://WOS:000182226500012
- Audsley, E., Pearn, K. R., Simota, C., Cojocar, G., Koutsidou, E., Rousevell, M. D. A., Trnka, M. & Alexandrov, V. (2006) What can scenario modelling tell us about future European scale agricultural land use, and what not? *Environmental Science & Policy*, 9, 148-162.<Go to ISI>://000236511100005
- Aylott, M. J., Casella, E., Tubby, I., Street, N. R., Smith, P. & Taylor, G. (2008) Yield and spatial supply of bioenergy poplar and willow short-rotation coppice in the UK. *New Phytologist*, 178, 358–370
- Balcas (2009) Brites Wood Pellets Webpage 18/08/09 <http://www.brites.eu/>
- Bates, J., Edberg, O. & Nuttall, C. (2009) Minimising greenhouse gas emissions from biomass energy generation Environment Agency http://www.environment-agency.gov.uk/static/documents/Research/Minimising_greenhouse_gas_emissions_from_biomass_energy_generation.pdf
- Biomass Energy Centre (2009a) BEAT.2 Webpage http://www.biomassenergycentre.org.uk/portal/page?_pageid=74,153193&_dad=portal&_schema=PORTAL
- Biomass Energy Centre (2009b) Renewables Obligation Certificates Webpage 20 August http://www.biomassenergycentre.org.uk/portal/page?_pageid=77,20190&_dad=portal&_schema=PORTAL
- Bishop, P., Hines, A. & Collins, T. (2007) The Current State of Scenario Development: An Overview of Techniques. *Foresight*, 9, 5-25. <http://www.emeraldinsight.com/Insight/ViewContentServlet?Filename=/published/emeraldfulltextarticle/pdf/2730090101.pdf>
- Blackwell, P., Riethmuller, G. & Collins, M. (2009) Biochar Applications to Soil. IN Joseph, S. & Lehmann, J. (Eds.) *Biochar for Environmental Management*. London, Earthscan.

- Brander, M., Tipper, R., Hutchison, C. & Davis, G. (2008) Consequential and Attributional Approaches to LCA: a Guide to Policy Makers with Specific Reference to Greenhouse Gas LCA of Biofuels
Ecometrica
- Bridgewater, A. (2007) IEA Energy Update 27: Biomass Pyrolysis. *Biomass and Bioenergy*, 31, 1-5
- Brown, R. (2009) Biochar Production Technologies. IN Joseph, S. & Lehmann, J. (Eds.) *Biochar for Environmental Management*. London, Earthscan.
- Brownsort, P. (2009) Unpublished MSc Dissertation. University of Edinburgh.
- Bruun, S. & Luxhoi, J. (2008) Is biochar production really carbon-negative? *Environmental Science & Technology*, 42, 1388-1388.<Go to ISI>://WOS:000253521300001
- CCC (2008) Building a low-carbon economy – the UK’s contribution to tackling climate change
Committee on Climate Change <http://www.theccc.org.uk/reports/>
- Chan, K. Y., Van Zwieten, L., Meszaros, I., Downie, A. & Joseph, S. (2007) Agronomic values of greenwaste biochar as a soil amendment. *Australian Journal of Soil Research*, 45, 629-634.<Go to ISI>://WOS:000251427900008
- Chan, K. Y., Van Zwieten, L., Meszaros, I., Downie, A. & Joseph, S. (2008) Using poultry litter biochars as soil amendments. *Australian Journal of Soil Research*, 46, 437-444.<Go to ISI>://WOS:000258823800004
- Chan, K. Y. & Xu, Z. (2009) Nutrient Properties and Their Enhancement. IN Joseph, S. & Lehmann, J. (Eds.) *Biochar for Environmental Management*. London, Earthscan.
- Cherubini, F., Bird, N. D., Cowie, A., Jungmeier, G., Schlamadinger, B. & Woess-Gallasch, S. (2009) Energy- and greenhouse gas-based LCA of biofuel and bioenergy systems: Key issues, ranges and recommendations. *Resources, Conservation and Recycling*, In Press
- Continental (2009) Continental SteuMaster Range of Lime Spreaders
<http://www.continentalsoiltechnology.com/binder%20spreaders.htm>
- Cook, J. (2009) Interview - see appendix 7.
- Crutzen, P., Mosier, A., Smith, K. & Winiwarter, W. (2007) N₂O release from agro-biofuel production negates globalwarming reduction by replacing fossil fuels. *Atmos. Chem Phys Discuss*, 7, 11191–11205
- DECC (2008) Electricity Consumption Data at Regional and Local Authority Level Department of Energy and Climate Change <http://www.berr.gov.uk/energy/statistics/regional/regional-local-electricity/page36213.html>
- Defra (2007) Planting and Growing Miscanthus
Best Practice Guidelines
http://www.biomassenergycentre.org.uk/pls/portal/docs/PAGE/BEC_TECHNICAL/SOURCES%20OF%20BIOMASS/ENERGY%20CROPS/GRASSES%20AND%20NON-WOODY%20ENERGY%20CROPS/MISCANTHUS/MISCANTHUS-GUIDE.PDF
- Defra (2008) Guidelines to Defra's GHG Conversion Factors: Annexes updated April 2008
<http://www.defra.gov.uk/environment/business/reporting/conversion-factors.htm>
- DEMÇIRBAS, A. & ARIN, G. (2002) An Overview of Biomass Pyrolysis. *Energy Sources*, 24, 471-482
- Downie, A., Klatt, P., Downie, R. & Munroe, P. (2007) SLOW PYROLYSIS: AUSTRALIAN DEMONSTRATION PLANT SUCCESSFUL ON MULTI-FEEDSTOCK’S. *BIOENERGY 2007 CONFERENCE IN FINLAND*.
- DUKES (2008) Digest of UK Energy Statistics
<http://www.berr.gov.uk/energy/statistics/publications/dukes/page45537.html>
- Dunnett, A. J., Adjiman, C. S. & Shah, N. (2008) A spatially explicit whole-system model of the lignocellulosic bioethanol supply chain: an assessment of decentralised processing potential. *Biotechnol Biofuels*, 1, 13.<Go to ISI>://MEDLINE:18662392
- Dynamotive (2000) Fast Pyrolysis of Biomass for Green Power Generation DynaMotive Energy Systems Corporation <http://www.biooil.ru/docs/2000SevilleBiomassPaper.pdf>

- Elsayed, M. A., Matthews, R. & Mortimer, N. D. (2003) Carbon and Energy Balance for a range of Biofuel Options DTI Sustainable Energies Program
- Elsayed, M. A. & Mortimer, N. D. (2001) Carbon and Energy Modelling of Biomass Systems: Conversion Plant and Data Updates DTI
- Forest Research (2003) Preliminary Yield Estimates for Energy Coppice of Poplar and Willow
- Forest Research (2009a) Guidance on site selection for brush removal
- Forest Research (2009b) Short Rotation Forestry Trial in England – Overview January 2009
<http://www.forestry.gov.uk/srf>
- Forestry Commission (2008) Forestry Statistics
- Forestry Research (2009) Woodfuel Resource On-line
<http://www.eforestry.gov.uk/woodfuel/pages/home.jsp>
- Gabrielle, B. & Gagnaire, N. (2008) Life-cycle assessment of straw use in bio-ethanol production: A case study based on biophysical modelling. *Biomass & Bioenergy*, 32, 431-441.<Go to ISI>://WOS:000256654900006
- Galbraith, D., Smith, P., Mortimer, N., Stewart, R., Hobson, M., McPherson, G., Matthews, R., Mitchell, P., Nijnik, M., Norris, J., Skiba, U., Smith, J. & Towers, W. (2006) Review of Greenhouse Gas Life Cycle Emissions, Air Pollution Impacts and Economics of Biomass Production and Consumption in Scotland Scottish Executive Environment and Rural Affairs Department (SEERAD) www.scotland.gov.uk/publications
- Gaunt, J. & Cowie, A. (2009) Biochar, Greenhouse Gas Accounting and Emissions Trading. IN Joseph, S. & Lehmann, J. (Eds.) *Biochar for Environmental Management*. London, Earthscan.
- Gaunt, J. L. & Lehmann, J. (2008) Energy balance and emissions associated with biochar sequestration and pyrolysis bioenergy production. *Environmental Science & Technology*, 42, 4152-4158.<Go to ISI>://WOS:000256274300042
- Glaser, B. (2007) Prehistorically modified soils of central Amazonia: a model for sustainable agriculture in the twenty-first century. *Philosophical Transactions of the Royal Society B-Biological Sciences*, 362, 187-196.<Go to ISI>://WOS:000243976000003
- Glaser, B., Lehmann, J. & Zech, W. (2002) Ameliorating physical and chemical properties of highly weathered soils in the tropics with charcoal - a review. *Biology and Fertility of Soils* 35
- Hammes, K. & Schmidt, M. W. I. (2009) Changes of Biochar in Soil. IN Joseph, S. & Lehmann, J. (Eds.) *Biochar for Environmental Management*. London, Earthscan.
- Hammes, K., Torn, M., Lapenas, A. & MWI, S. (2008) Centennial black carbon turnover observed in a Russian steppe soil. *Biogeosciences Discussion*, 5, 661-683
- Holman, I. P., Rounsevell, M. D. A., Cojocar, G., Shackley, S., McLachlan, C., Audsley, E., Berry, P. M., Fontaine, C., Harrison, P. A., Henriques, C., Mokrech, M., Nicholls, R. J., Pearn, K. R. & Richards, J. A. (2008) The concepts and development of a participatory regional integrated assessment tool. *Climatic Change*, 90, 5-30.<Go to ISI>://000258528700002
- Hornung, A., Apfelbacher, A., Koch, W., Linek, A., Sagi, S., Schöner, J., Stöhr, J. & Seifert, H. (Unpublished) THERMO-CHEMICAL CONVERSION OF STRAW – HALOCLEAN® - INTERMEDIATE PYROLYSIS.
- Husk, B. (2009) Preliminary Evaluation of Biochar in a Commercial Farming Operation in Canada Blue Leaf http://www.blue-leaf.ca/main-en/report_a3.php
- IPCC (2006) *IPCC Guidelines for National Greenhouse Gas Inventories*.
- IPCC (2007) The Physical Science Basis IPCC <http://www.ipcc.ch/pdf/assessment-report/ar4/>
- Jílek, L., Pražan, R., Podpěra, V. & Gerndtová, I. (2008) The effect of the tractor engine rated power on diesel fuel consumption during material transport. *Resource Agricultural Engineering*, 54, 1-8
- Joseph, S. & Lehmann, J. (2009) *Biochar for Environmental Management*, London, Earthscan.
- Joseph, S., P Munroe, Zweiten, L. v., A. Cowie, Krull, E., Singh, B. & Downie, A. (2009) Unpublished Presentation: BIOCHAR FOR SOIL FERTILITY AND

- CARBON SEQUESTRATION - A Review of current understanding. Australia and New Zealand Biochar Researchers Network.
- Lal, R. (2004) Soil carbon sequestration to mitigate climate change. *Geoderma*, Vol. 123, 1-22
- Lehmann, J. (2007) Bio-energy in the black. *Frontiers in Ecology and the Environment*, 5, 381-387.<Go to ISI>://WOS:000249192100020
- Lehmann, J., Czimczik, C., Laird, D. & Sohi, S. (2009) Stability of Biochar in the Soil. IN Lehmann, J. & Joseph, S. (Eds.) *Biochar for Environmental Management*.
- Lehmann, J. & Joseph, S. (2009) Biochar Systems. IN Joseph, S. & Lehmann, J. (Eds.) *Biochar for Environmental Management*. London, Earthscan.
- Lehmann, J., Skjemstad, J., Sohi, S., Carter, J., Barson, M., Falloon, P., Coleman, K., Woodbury, P. & Krull, E. (2008) Australian climate-carbon cycle feedback reduced by soil black carbon. *Nature Geoscience*, 1, 832-835.<Go to ISI>://WOS:000261278700013
- Lehmann, J. G., J;Rondon,M (2006) BIO-CHAR SEQUESTRATION IN TERRESTRIAL ECOSYSTEMS – A REVIEW. *Mitigation and Adaptation Strategies for Global Change* 11, 403–427
- Lempert, R., Hallsworth, M., Hoorens, S. & Ling, T. (2009) Looking back on looking forward: a review of evaluative scenario literature European Environment Agency
- Levy, S., Blandford, N., Mayhead, G. & Fowles, M. (2006) Of Chips and Logs... Making the most of Local Authority Arboricultural Arisings in the Mersey Belt Forestry Commission North West England Conservancy
- Liang, B., Lehmann, J., Sohi, S. P., Thies, J. E., O'Neill, B., Trujillo, L., Gaunt, J., Solomon, D., Neves, E. G. & Luizão, F. J. (Forthcoming) BLACK CARBON AFFECTS THE CYCLING OF NON-BLACK CARBON WITHOUT PRIMING OF AGED BLACK CARBON IN SOIL.
- Liang, B., Lehmann, J., Solomon, D., Kinyangi, J., Grossman, J., O'Neill, B., Skemjstad, J., Thies, J., Luizao, F., Petersen, J. & Neves, E. (2006) Black Carbon Increases Cation Exchange Capacity in Soils. *Soil Science Society of America Journal*, 70, 1719-1730
- Liang, B., Lehmann, J., Solomon, D., Sohi, S., Thies, J. E., Skjemstad, J. O., Luizao, F. J., Engelhard, M. H., Neves, E. G. & Wirick, S. (2008) Stability of biomass-derived black carbon in soils. *Geochimica Et Cosmochimica Acta*, 72, 6069-6078.<Go to ISI>://000261914200017
- Lindgren, M. & Hansson, P. A. (2002) Effects of Engine Control Strategies and Transmission Characteristics on the Exhaust Gas Emissions from an Agricultural Tractor. *Biosystems Engineering* 83, 55-65.<http://www.idealibrary.com>
- Lovett, A. A., Sünnenberg, G. M., Richter, G. M., Dailey, A. G., Riche, A. B. & Karp, A. (2009) Land Use Implications of Increased Biomass Production Identified by GIS-Based Suitability and Yield Mapping for Miscanthus in England. *Bioenergy Resources*, 2, 17–28
- Mander, S. L., Bows, A., Anderson, K. L., Shackley, S., Agnolucci, P. & Ekins, P. (2008) The Tyndall decarbonisation scenarios-Part I: Development of a backcasting methodology with stakeholder participation. *Energy Policy*, 36, 3754-3763.<Go to ISI>://000260561400013
- Masek, O. (2009) Interview - see appendix 7.
- McCarl, B. A., Peacocke, C., Chrisman, R., Kung, C. & Sands, D. (2009) Economics of Biochar production, utilization and greenhouse gas offsets. IN Lehmann, J. J., S. (Ed.) *Biochar for Environmental Management*. London, Earthscan.
- McKay, H. (2003) Woodfuel Resource in Britain <http://www.eforestry.gov.uk/woodfuel/>
- Mistry, P. & Misselbrook, T. (2005) Assessment of Methane Management and Recovery Options for Livestock Manures and Slurries Defra
- Mistry, P., Mouat, A., Campbell, K. & Howes, P. (2008) The Evaluation of Energy from Biowaste Arisings and Forest Residues in Scotland SEPA
- Mitchell, C. P., Stevens, E. A. & Watters, M. P. (1999) Short-rotation forestry - operations, productivity and costs based on experience gained in the UK. *Forest Ecology and Management*, 121, 123-136
- Morgan, D. (2009) Personal Communication: Details of Reactor Technologies Pyrolysis Plant.

- Mortimer, N. D. & Elsayed, M. A. (2006) NORTH EAST BIOFUEL SUPPLY CHAIN CARBON INTENSITY ASSESSMENT Northeast Bio-fuels Ltd
- Mortimer, N. D., Evans, A., Shaw, V. L. & Hunter, A. J. (2009) Life Cycle and Techno-Economic Assessment of the North East Biomass to Liquids Project North Energy Associates Limited http://www.nnfcc.co.uk/metadot/index.pl?id=9055;isa=DBRow;op=show;dbview_id=2539
- Newman, R. (2003) A TRIAL BURN OF RAPE STRAW AND WHOLE CROPS HARVESTED FOR ENERGY USE TO ASSESS EFFICIENCY IMPLICATIONS DTI
- Onay, O. & Kockar, M. (2003) Slow, fast and flash pyrolysis of rapeseed *Renewable Energy* 28 2417–2433
- Perry, M. & Rosillo-Calle, F. (2006) Co-firing Report- United Kingdom
- Perry, M. & Rosillo-Calle, F. (2007) Country Report for United Kingdom Imperial College, IEA
- Phyllis (2009) Energy Research Centre of the Netherlands <http://www.ecn.nl/phyllis/>
- Price, L., Bullard, M., Lyons, H., Anthony, S. & Nixon, P. (2004) Identifying the yield potential of *Miscanthus x giganteus*: an assessment of the spatial and temporal variability of *M. x giganteus* biomass productivity across England and Wales. *Biomass and Bioenergy* 26, 3 – 13
- Riche, A. B. (2006) A Trial of the Suitability of Switchgrass and Reed Canary Grass as Biofuel Crops Under UK Conditions Rothamsted Research
- Rondon, M. A., Lehmann, J., Ramirez, J. & Hurtado, M. (2007) Biological nitrogen fixation by common beans (*Phaseolus vulgaris* L.) increases with bio-char additions. *Biology and Fertility of Soils*, 43, 699-708.<Go to ISI>://WOS:000247999500009
- RothLime (2009) Rothamsted Agricultural Liming Model. <http://www.rothamsted.bbsrc.ac.uk/aen/rothlime/>
- Ryu, C., Sharifiz, V. N. & Swithenbank, J. (2007) Waste pyrolysis and generation of storable char. *INTERNATIONAL JOURNAL OF ENERGY RESEARCH*, 31, 177-191
- SAC (2009) *SAC Farm Management Handbook*, SAC.
- Scottish Executive (2007) A BIOMASS ACTION PLAN FOR SCOTLAND www.scotland.gov.uk
- Scottish Government (2009) CLIMATE CHANGE IN SCOTLAND ANNUAL REPORT 2008-09 <http://www.scotland.gov.uk/Resource/Doc/276140/0082901.pdf>
- Searchinger, T., Heimlich, R., Houghton, R. A., Dong, F. X., Elobeid, A., Fabiosa, J., Tokgoz, S., Hayes, D. & Yu, T. H. (2008) Use of US croplands for biofuels increases greenhouse gases through emissions from land-use change. *Science*, 319, 1238-1240.<Go to ISI>://WOS:000253530600042
- Shackley, S. & Deanwood, R. (2003) Constructing social futures for climate-change impacts and response studies: building qualitative and quantitative scenarios with the participation of stakeholders. *Climate Research*, 24, 71-90.<Go to ISI>://WOS:000186448400008
- Smith, K. A., Charles, D. R. & Moorhouse, D. (2000a) Nitrogen excretion by farm livestock with respect to land spreading requirements and controlling nitrogen losses to ground and surface waters. Part 2: pigs and poultry. *Bioresource Technology* 71, 183±194
- Smith, K. A. & Frost, J. P. (2000) Nitrogen excretion by farm livestock with respect to land spreading requirements and controlling nitrogen losses to ground and surface waters. Part 1: cattle and sheep. *Bioresource Technology*, 71, 173±181
- Smith, P., Milne, R., Powlson, D. S., Smith, J. U., Falloon, P. & Coleman, K. (2000b) Revised estimates of the carbon mitigation potential of UK agricultural land. *Soil Use and Management*, 16, 293-295.<Go to ISI>://WOS:000167168400009
- Smith, P., Powlson, D. S., Glendining, M. J. & Smith, J. U. (1998) Preliminary estimates of the potential for carbon mitigation in European soils through no-till farming. *Global Change Biology*, 4, 679-685.<Go to ISI>://000075290900009
- Sohi, S. (2009a) Interview - see appendix 7.
- Sohi, S. L.-C., E;Krull,E;Bol,R (2009b) Biochar, climate change and soil: A review to guide future research CSIRO <http://www.csiro.au/files/files/poei.pdf>

- Steiner, C., Glaser, B., Teixeira, W. G., Lehmann, J., Blum, W. E. H. & Zech, W. (2008) Nitrogen retention and plant uptake on a highly weathered central Amazonian Ferralsol amended with compost and charcoal. *Journal of Plant Nutrition and Soil Science-Zeitschrift Fur Pflanzenernahrung Und Bodenkunde*, 171, 893-899.<Go to ISI>://WOS:000261899200010
- Steiner, C., Teixeira, W. G., Lehmann, J., Nehls, T., de Macedo, J. L. V., Blum, W. E. H. & Zech, W. (2007) Long term effects of manure, charcoal and mineral fertilization on crop production and fertility on a highly weathered Central Amazonian upland soil. *Plant and Soil*, 291, 275-290.<Go to ISI>://WOS:000245299700022
- Stephenson, A. L., Dennis, J. S. & Scott, S. A. (2008) Improving the sustainability of the production of biodiesel from oilseed rape in the UK. *Process Safety and Environmental Protection*, 86, 427-440.<Go to ISI>://WOS:000261289500004
- Styles, D. & Jones, M. B. (2008) Life-cycle environmental and economic impacts of energy-crop fuel-chains: an integrated assessment of potential GHG avoidance in Ireland. *Environmental Science & Policy*, 11, 294-306.<Go to ISI>://000257013400002
- Supergen (2009) SUPERGEN Biomass and Bioenergy Consortium <http://www.supergen-bioenergy.net/>
- Thies, J. E. & Rillig, M. C. (2009) Characteristics of Biochar: Biological Properties. IN Joseph, S. & Lehmann, J. (Eds.) *Biochar for Environmental Management*. London, Earthscan.
- Thornley, P. (2007) Life Cycle Assessment of Bioenergy Systems Supergen [http://www.supergen-bioenergy.net/Resources/user/Research%20Output/LCA%20Report%20\(P%20Thornley\)%20-%20SG%20Research%20Output.pdf](http://www.supergen-bioenergy.net/Resources/user/Research%20Output/LCA%20Report%20(P%20Thornley)%20-%20SG%20Research%20Output.pdf)
- Thornley, P. (2009a) Interview - see appendix.
- Thornley, P. (2009b) Interview - see appendix 7.
- Thornley, P. (2009c) Unpublished Work - Carbon Balances of Short Rotation Coppice.
- Thornley, P., Upham, P., Huang, Y., Rezvani, S., Brammer, J. & Rogers, J. (2009) Integrated assessment of bioelectricity technology options. *Energy Policy*, 37, 890-903.<Go to ISI>://WOS:000263942700014
- Thornley, P., Upham, P. & Tomei, J. (Forthcoming) Sustainability constraints on UK bioenergy development. *Energy Policy*,
- Towers, W., Grieve, I. C., Hudson, G., Campbell, C. D., A.Lilly, Davidson, D. A., Bacon, J. R., Langan, S. J. & Hopkins, D. A. (2006) SCOTLAND'S SOIL RESOURCE – CURRENT STATE AND THREATS Scottish Executive, Environment and Rural Affairs Department <http://www.scotland.gov.uk/Resource/Doc/149337/0039742.pdf>
- TSEC (2009) TSEC-Biosys: A whole systems approach to bioenergy demand and supply <http://www.tsec-biosys.ac.uk/>
- UKBRC (2009) Biochar Factsheet <http://www.geos.ed.ac.uk/sccs/biochar/Publications.html>
- Unknown (2005) ExCo56 Study Tour. *IEA Bioenergy News*.
- Upham, P. & Shackley, S. (2005) Indicative 2030 Bioenergy Scenarios for Yorkshire and Humber. Tyndall Centre/Manchester Business School, The University of Manchester
- Upham, P., Shackley, S. & Waterman, H. (2007) Public and stakeholder perceptions of 2030 bioenergy scenarios for the Yorkshire and Humber region. *Energy Policy*, 35, 4403-4412.<Go to ISI>://WOS:000249741900001
- Upham, P. & Speakman, D. (2007) Stakeholder opinion on constrained 2030 bioenergy scenarios for North West England. *Energy Policy*, 35, 5549-5561.<Go to ISI>://WOS:000250545300030
- van Notten, P. W. F., Rotmans, J., van Asselt, M. B. A. & Rothman, D. S. (2003) An updated scenario typology. *Futures*, 35, 423-443.<Go to ISI>://WOS:000182314600001
- VanZweiten, L., Singh, B., Joseph, S., Kimber, S., Cowie, A. & Chan, K. Y. (2009) Biochar and Emissions of Non-CO2 Greenhouse Gases from Soil. IN Joseph, S. & Lehmann, J. (Eds.) *Biochar for Environmental Management*. London, Earthscan.
- Vigouroux, R. Z. (2001) Pyrolysis of Biomass. *Royal Institute of Technology*. Stockholm.

- Warnock, D. D., Lehmann, J., Kuyper, T. W. & Rillig, M. C. (2007) Mycorrhizal responses to biochar in soil - concepts and mechanisms. *Plant and Soil*, 300, 9-20.<Go to ISI>://WOS:000250582500002
- Williams, A. G., Audsley, E. & Sandars, D. L. (2006) Determining the environmental burdens and resource use in the production of agricultural and horticultural commodities. Main Report. Cranfield University and Defra
<http://randd.defra.gov.uk/Default.aspx?Menu=Menu&Module=More&Location=None&Completed=0&ProjectID=11442>
- Woods, J., Tipper, R., Brown, G., Diaz-Chavez, R., Lovell, J. & Groot, P. d. (2006) Evaluating the Sustainability of Co-firing in the UK DTI
- Woolf, D. (2009) Biochar as a soil amendment: A review of the environmental implications. University of Swansea
http://www.orgprints.org/13268/01/Biochar_as_a_soil_amendment_-_a_review.pdf
- Yanai, Y., Toyota, K. & Okazaki, M. (2007) Effects of charcoal addition on N₂O emissions from soil resulting from rewetting air-dried soil in short-term laboratory experiments. *Soil Science and Plant Nutrition*, 53, 181-188
- Yang, H., Yan, R., Chaen, H. & Lee, D. (2007) Characteristics of hemicellulose, cellulose and lignin pyrolysis. *Fuel*, 86, 1781-1788
- Yang, H., Yan, R., Chen, H., Lee, D. H., Liang, D. T. & Zheng, C. (2006) Mechanism of Palm Oil Waste Pyrolysis in a Packed Bed. *Energy & Fuels*, 20, 1321-1328

Appendix 1: Detailed Life Cycle Flow Chart

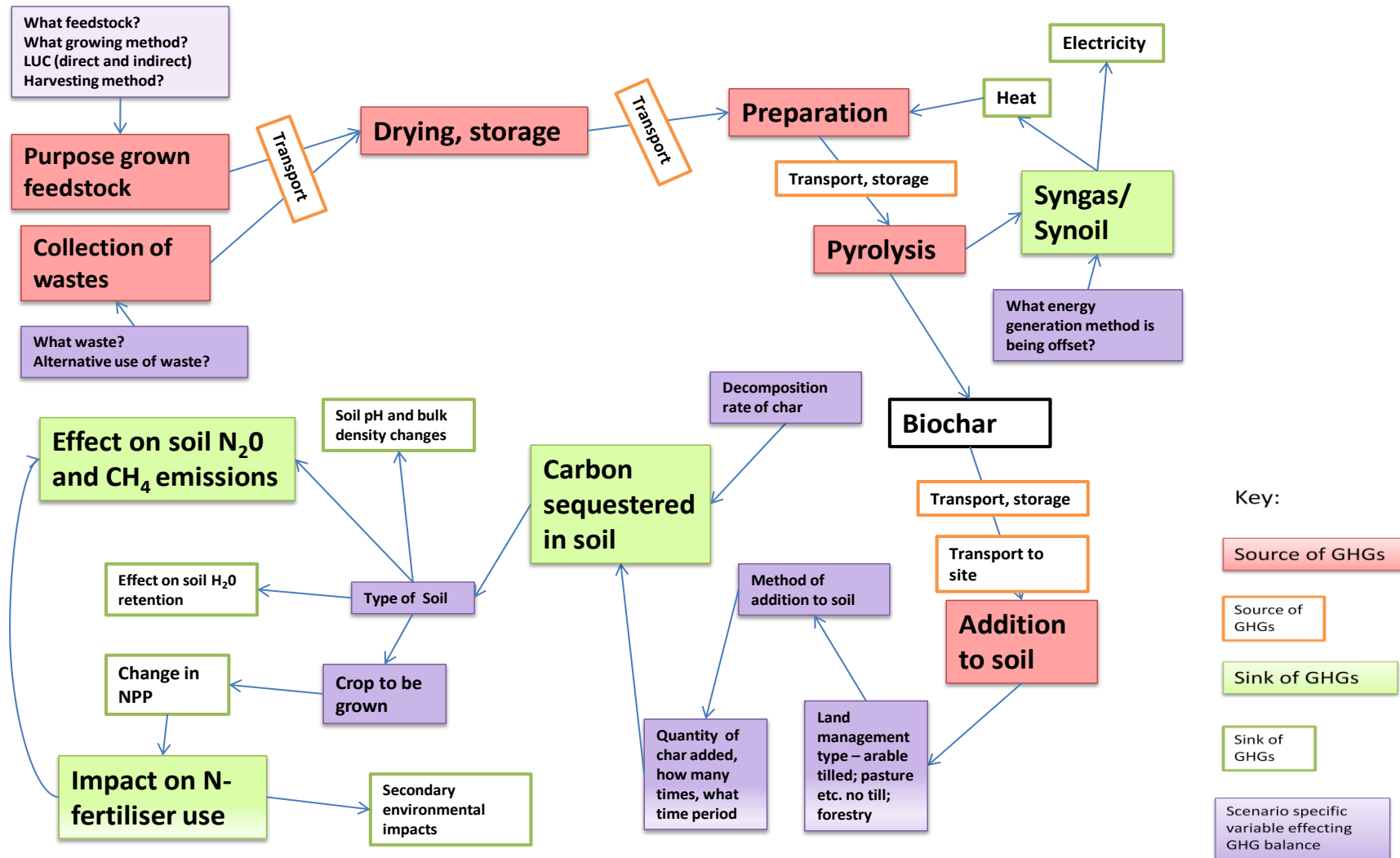

Appendix 2: Change Over Time Modelling

Spreadsheets modelling changing processes over time were created, but ultimately were not flexible enough to warrant full inclusion in the project. Initial results show that despite the possible over estimation of soil-char effects as instantaneous, yearly model matches the model over time reasonably well.

I. Comparing the Change over Time Model

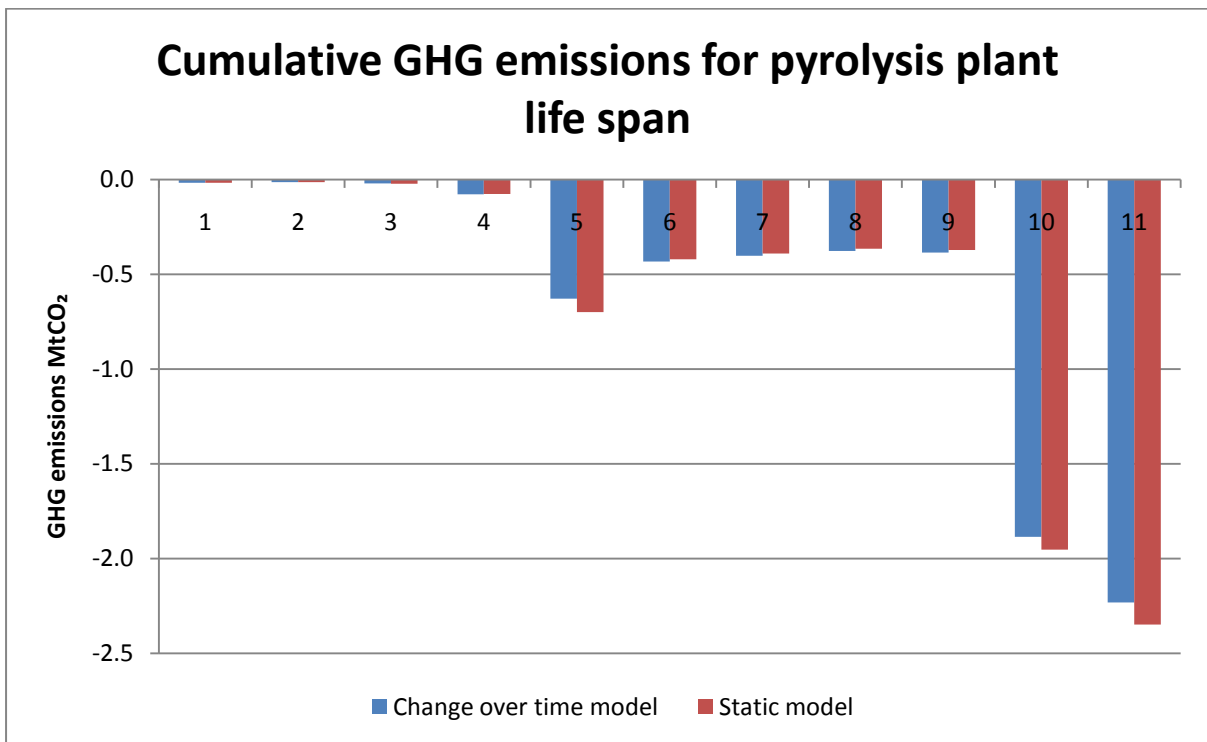

Figure A

II. Energy Reference System Changes

Changes to the electrical reference system during the life span of the pyrolysis facility are also modelled, and compared to the results of the yearly spreadsheet.

year	2015	2020	2025	2030
kgCO ₂ e /MWh	450	300	200	80

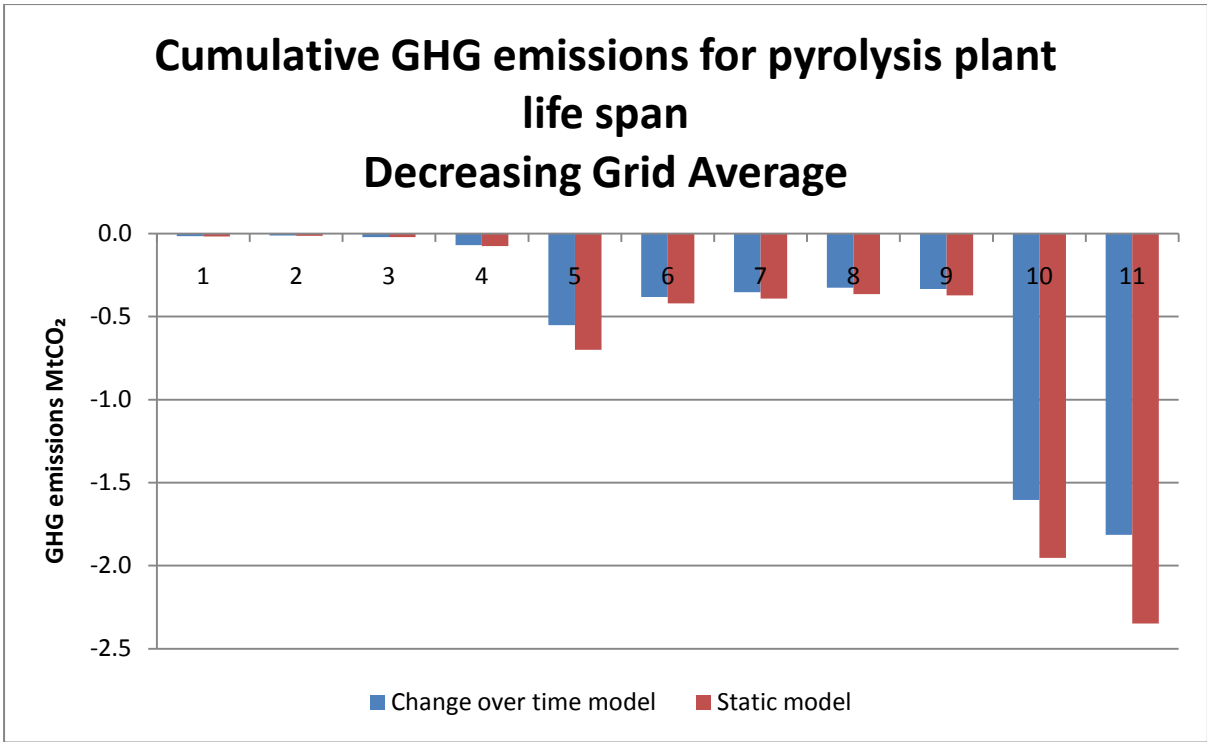

Figure B

It can be seen that a steadily decreasing electrical reference system does not undermine the outcomes of the static model.

Appendix 3: Default Case Study Assumptions

I. Default Assumptions used in all case studies

General			
		Unit	Source
Transport Vehicle	60m ³ capacity truck		Mortimer et al. 2009
Load Factor	50	%	
Emissions Factor	0.995	kgCO ₂ /km	Defra 2008
Emissions from Construction of Pyrolysis Plant	0.22	tCO ₂ /odt feedstock	Elsayed and Mortimer, 2001
Pyolysis Energy Requirement	10	%	Brownsort 2009
Pyrolysis Energy Loss	15	%	Brownsort 2009
Char to Farm Transport Vehicle	60m ³ capacity truck		Mortimer et al. 2009
Farm to Field Distance	5	km	
Farm to Field Vehicle	114 kW tractor with 30m ³ lime spreader		Jílek et al. 2008
Application to Soil emissions /ha	32	kgCO ₂ /ha	Williams et al. 2006
Char to electricity conversion efficiency	42	%	Masek 2009, Perry and Rosillo-Calle 2006
Crop for char application	Wheat		
Fertiliser applications N/P/K	200/70/70	kg/ha	SAC 2009
Max N fertiliser reduction	10	%	Sohi 2009a
Max P fertiliser reduction	5	%	Sohi 2009a
Max K fertiliser reduction	5	%	Sohi 2009a
SOC	50	tC/ha	calculation from Towers et al 2006
Max SOC increase	20	%	Sohi 2009a
N emissions from soils, of N applied	1	%	IPPC 2007
Effect upon N ₂ O emissions	-25	%	Sohi 2009a
Labile fraction of char	10	%	Sohi 2009a
Super Labile fraction of char	5	%	Sohi 2009a
Char MRT	500		Lehmann et al 2009
Char Yield from Pyrolysis	33.5	%	Hornung
Syngas Yield from Pyrolysis	31.9	%	Hornung
Pyrolysis Oil Yield from Pyrolysis	34.6	%	Hornung
Syngas Carbon Content	30	%	Brownsort 2009
Syngas Calofic Value	11	MJ/t	Hornung
Pyrolysis Oil Carbon Content (from straw)	35	%	Hornung

Pyrolysis Oil Carbon Content (from wood)	45	%	Dynamotive
Pyrolysis Oil Calofic Value (from straw)	12	MJ/t	Hornung
Pyrolysis Oil Calofic Value (from wood)	16	MJ/t	Dynamotive
Char Carbon Content	75	%	Hornung
Char Calofic Value (from straw)	24.6	MJ/t	Hornung
Char Calofic Value (from wood)	26	MJ/t	Best
Initial char deployment	30	t/ha	
Top up char deployment	5	t/ha	
Frequency of char top ups	5	yrs	

II. Default Assumptions: case study specific

Case Specific	Barley Straw	OSR Straw	Small Scale SRC	Small Scale Sawmill Residues
Quantity feedstock t at 25%mc	1710	1280	1710	5000
Feedstock emissions factor kg eq. CO2/t feed	201	201	41.15	3.46
Yield odt/ha	4.10	2.50	7.00	
Allocation ratio for land take	0.137	0.0685	1	
Transport Distance: feedstock to pyrolysis	20	20	20	0
Transport Distance: char to farm	0	0	0	20
Transport Distance: farm to field	5	5	5	5
Process energy required	10	10	10	10
Energy loss	15	15	10	10
Pyrolysis Oil conversion efficiency to electricity	35	35	35	35
Syn Gas conversion efficiency to electricity	0	0	0	35
Total Electical Efficiency	6	8	9	14
Load Factor of Pyrolysis kiln	0.4	0.2	0.4	0.6
Rating of Pyrolysis Plant	109 kW	216kW	156kW	0.5MW
Use of heat	grain drying	grain drying	grain drying	wood drying
Heat source displaced	propane	propane	propane	none
Proportion of heat used	2%	2%	2%	

Case Specific	Large Scale Sawmill Residues	Scottish Forestry Residue Chips	Scottish Small Round Wood	Large Scale SRC	Short Rotation Forestry	Imported Canadian Forestry Residue Chips	Imported Canadian Forestry Residue Pellets
Quantity feedstock t at 25%mc	30000	20000	20000	20000	20000	100000	100000
Feedstock emissions factor kg eq. CO2/t feed	3.46	-48.5	26.4	91.25	72.69	122.34	245.54
Yield odt/ha		0.438	2.0625	10	5.6	0.438	0.438
Allocation ratio for land take		0.074	0.56	1	1	0.074	0.074
Transport Distance: feedstock to pyrolysis	0	30	30	20	20	10	10
Transport Distance: char to farm	20	20	20	20	20	20	20
Transport Distance: farm to field	5	5	5	5	5	5	5
Process energy required	10	10	10	10	10	10	10
Energy loss	10	10	10	10	10	10	10
Pyrolysis Oil conversion efficiency to electricity	36	35	35	35	35	40	40
Syn Gas conversion efficiency to electricity	35	35	35	35	35	37	37
Total Electrical Efficiency	14	14	14	14	14	15	15
Load Factor of Pyrolysis kiln	0.7	0.7	0.7	0.7	0.7	0.8	0.8
Rating of Pyrolysis Plant	2.6MW	1.7MW	1.7MW	1.7MW	1.7MW	8.3MW	8.3MW
Use of heat	wood drying for pellets	none	none	none	none	heating	heating
Heat source displaced	electric fans					methane	methane
Proportion of heat used	100%					50%	50%

Appendix 4: General Assumptions for calculations

Conversion factor C to CO ₂		C to CO ₂		44/12		
GWP	CH ₄	kgCO ₂ eq/kg CH ₄	25 IPCC 4AR			
GWP	N ₂ O	kgCO ₂ eq/kg N ₂ O	298 IPCC 4AR			
Conversion factor N to N ₂ O		44/28				
Applied N emitted		1 IPCC 2006				
Electrical offsets		kg CO ₂ /MWh e				
	Coal	939 Dukes 2008				
	Gas	405 Dukes 2008				
	Grid Average	501 Dukes 2008				
	Grid Av 2030	80 Energy Agency Bates 2009				
	Grid Av 2050	30 Energy Agency Bates 2009				
Total kg CO ₂ -eq GHG emissions/kg of fertiliser						
		6.9831 N Fertiliser				
		1.859724 P Fertiliser				
		1.767996 K Fertiliser				
Heat used for Drying						
	substance to be dried	Method	MJ/t	kgCO ₂ e/t feed to be dried	kg CO ₂ e/MWh	source
	Sawdust for Pellets	Electrical Fans	1226.58	68.4946	201.031	Beat 2
	Wheat	Propane	68	3.91	207.844	
	Barley	Propane	83	4.77	207.844	

CO2/l diesel	2.6304			
MJ/l diesel	38.6 (SAC handbook)			
	MJ/t	kg CO2/MWh	C Content %wt	Source
Propane:	51950.5	207.844	81.8	Phyllis
Methane	52918.5	187.0801	75	Phyllis

Appendix 5: Default Results

Table 1 Default Results GHG emissions by life cycle stage

	Barley Straw	OSR Straw	Small Scale SRC	Small Scale Sawmill Residues	Large Scale Sawmill Residues	Scottish Forestry Residue Chips	Scottish Small Round Wood	Large Scale SRC	Short Rotation Forestry	Imported Forestry Residue Chips	Imported Forestry Residue Pellets
	t eq. CO ₂ /a	t eq. CO ₂ /a	t eq. CO ₂ /a	t eq. CO ₂ /a	t eq. CO ₂ /a	t eq. CO ₂ /a	t eq. CO ₂ /a	t eq. CO ₂ /a	t eq. CO ₂ /a	t eq. CO ₂ /a	t eq. CO ₂ /a
Provision of Biomass Feedstock	343.91	257.43	70.36	17.32	103.91	-969.94	524.72	1825	1453.88	12234.3	24554.5
Transport of Biomass to Pyrolysis Plants	3.57	3.84	4.5	-	-	78.89	78.89	52.6	52.6	131.49	71.87
Pyrolysis Process	25.13	18.81	25.13	73.48	330.67	220.44	220.44	220.44	220.44	1102.22	1102.22
Electricity	-192.58	-189.8	-273.89	-1321.7	-8068.88	-5233.93	-5233.93	-5233.93	-5233.93	-29037.98	-42890.48
Heat	-4.97	-4.97	-4.97	0	-4390.43	0	0	0	0	-6403.93	-9458.9
Char Transport to Farm	0	0	0	3.3	19.82	13.08	13.08	13.08	13.08	65.41	78.5
Char Transport to Fields	0.90	0.70	0.90	2.60	15.60	10.30	10.30	10.30	10.30	51.60	61.90
Application to Soils	0.50	0.40	0.50	1.40	8.50	5.60	5.60	5.60	5.60	28.00	33.60
Agricultural Impacts	-546	-409	-546	-1596	-9576	-6320	-6320	-6320	-6320	-31600	-37920
Carbon stored in Soil as Char	-764	-572	-764	-2233	-13400	-8844	-8844	-8844	-8844	-44221	-53065
Net GHG emissions	-1133	-894	-1487	-5053	-34957	-21040	-19545	-18271	-18642	-97650	-117432

Table 2 Default Results, break down by life cycle stage type and relative contribution to emissions

Process Stage	1	2	3	4	5	6	7	8	9	10	11
	Total GHG	Total GHG	Total GHG	Total GHG	Total GHG	Total GHG	Total GHG	Total GHG	Total GHG	Total GHG	Total GHG
	tCO ₂ eq/yr	tCO ₂ eq/yr	tCO ₂ eq/yr	tCO ₂ eq/yr	tCO ₂ eq/yr	tCO ₂ eq/yr	tCO ₂ eq/yr	tCO ₂ eq/yr	tCO ₂ eq/yr	tCO ₂ eq/yr	tCO ₂ eq/yr
Biomass Feedstock	343.91	257.43	70.36	17.32	103.91	-969.94	524.72	1825	1453.88	12234.3	24554.5
Transport and spreading	4.94	4.87	5.87	7.32	43.93	107.89	107.89	81.59	81.59	276.45	245.83
Electricity generation & offset	-167.45	-170.99	-248.76	-1248.22	-7738.21	-5013.49	-5013.49	-5013.49	-5013.49	-27935.76	-41788.26
Heat generation and offset	-4.97	-4.97	-4.97	0	-4390.43	0	0	0	0	-6403.93	-9458.9
Soil Effects	-545.82	-408.57	-545.82	-1595.97	-9575.81	-6320.03	-6320.03	-6320.03	-6320.03	-31600.16	-37920.19
Soil Sequestration	-764	-572	-764	-2233	-13400	-8844	-8844	-8844	-8844	-44221	-53065
TOTALS	-1133	-894	-1487	-5053	-34957	-21040	-19545	-18271	-18642	-97650	-117432
Relative Proportion of total GHG emissions, %											
Biomass Feedstock	-30.35	-28.8	-4.73	-0.34	-0.3	4.61	-2.68	-9.99	-7.8	-12.53	-20.91
Transport and spreading	-0.44	-0.55	-0.39	-0.14	-0.13	-0.51	-0.55	-0.45	-0.44	-0.28	-0.21
Electricity generation & offset	14.78	19.13	16.73	24.7	22.14	23.83	25.65	27.44	26.89	28.61	35.59
Heat generation and offset	0.44	0.56	0.33	0	12.56	0	0	0	0	6.56	8.05
Agricultural Impacts	48.17	45.7	36.7	31.59	27.39	30.04	32.34	34.59	33.9	32.36	32.29
Soil Sequestration	67.4	63.96	51.36	44.2	38.33	42.04	45.25	48.41	47.44	45.28	45.19
Total	100	100	100	100	100	100	100	100	100	100	100
Feedstock input t/yr	1,710	1,280	1,710	5,000	30,000	20,000	20,000	20,000	20,000	100,000	100,000
Electricity Production MWh/yr	384.39	378.85	546.69	2,638.13	16,105.55	10,446.98	10,446.98	10,446.98	10,446.98	57,960.05	85,609.74

Default Results,
Normalised

Table 3

Total tCO ₂ e w/o energy reference	-939.2	-697.0	-1207.9	-3731.2	-22497.5	-15805.8	-14258.5	-13037.1	-13408.2	-62273.6	-65118.3
Total tCO ₂ e, energy referenceGrid avg 2030	-970.0	-727.3	-1251.7	-3942.3	-23785.9	-16641.5	-15094.3	-13872.9	-14244.0	-66910.4	-71967.1
kgCO ₂ e/MWh e no energy ref	-2443.4	-1839.9	-2209.5	-1414.3	-1396.9	-1513.0	-1364.8	-1247.9	-1283.5	-1074.4	-760.6
kgCO ₂ e/MWh e energy ref grid avg	-2957.3	-2354.0	-2710.5	-1915.3	-2170.5	-2014.0	-1865.8	-1748.9	-2044.5	-1685.9	-1372.1
kgCO ₂ e/MWh e energy ref grid avg 2030	-2523.4	-1919.9	-2289.5	-1494.3	-1476.9	-1593.0	-1444.8	-1327.9	-1363.5	-1154.4	-840.6
kgCO ₂ e/MJ feedstock at 25%mc, no energy ref	-40.7	-40.3	-55.5	-54.7	-55.0	-58.6	-53.1	-51.2	-54.5	-46.2	-39.4
kgCO ₂ e/MJ feedstock at 25%mc, energy ref grid avg	-49.3	-51.5	-68.1	-74.1	-85.4	-78.0	-72.5	-71.8	-86.8	-72.5	-71.2
kgCO ₂ e/odt feedstock, no energy ref	-732.3	-726.1	-941.9	-995.0	-999.9	-1053.7	-950.6	-869.1	-893.9	-830.3	-723.5
kgCO ₂ e/odt feedstock, energy ref grid av	-886.4	-929.0	-1155.4	-1347.4	-1553.6	-1402.6	-1299.5	-1218.1	-1423.9	-1302.9	-1305.2
kgCO ₂ e/odt feedstock, energy ref grid av 2030	-756.3	-757.7	-976.0	-1051.3	-1057.2	-1109.4	-1006.3	-924.9	-949.6	-892.1	-799.6
MWh e/odt feedstock	0.30	0.39	0.43	0.70	0.72	0.70	0.70	0.70	0.70	0.77	0.95
MWh e/ha	8.97	14.40	2.98			4.12	3.26	6.96	3.90	4.57	5.63
tCO ₂ e/ha no energy ref	-21.92	-26.50	-6.59			-6.24	-4.46	-8.69	-5.01	-4.91	-4.28
tCO ₂ e/ha energy ref grid av 2009	-26.53	-33.90	-8.09			-8.30	-6.09	-12.18	-7.97	-7.71	-7.73
tCO ₂ e/ha energy ref grid av 2030	-22.63	-27.65	-6.83			-6.57	-4.72	-9.25	-5.32	-5.28	-4.73
tCO ₂ e/ha no allocation	-3.63	-2.32	-8.09			-0.61	-2.68	-12.18	-7.97	-0.57	-0.57
t feed/MWh e	4.45	3.38	3.13	1.90	1.86	1.91	1.91	1.91	1.91	1.73	1.17
t char/MWh e	1.11	0.84	0.78	0.48	0.47	0.48	0.48	0.48	0.48	0.43	0.35

Appendix 6: Results of Pyrolysis Scenarios

Assumptions for Pyrolysis Scenarios

	unit	Extremely Pessimistic	Pessimistic	Default	Optimistic	No Soil No Heat
Transport handling losses	%	5	3	1	0	1
Application handling losses	%	25	10	3	0	3
Heat Offset	%	0	0	normal	50	normal
Soil Effects	%	0	25		200	
Electricity offset	kg CO2/MWh	80	200	501	501	501
Labile Fractions	%	25	15	15	10	15
MRT/Time horizon	yrs	300/100	500/100	500/100	2000/100	500/100

Case study 1 2 3 4 5 6 7 8 9 10 11

Default

total ghg	-1133	-894	-1487	-5053	-34957	-21040	-19545	-18271	-18642	-97650	-117432
kgCO ₂ eq/MWh e	-2948	-2360	-2720	-1915	-2170	-2014	-1871	-1749	-1784	-1685	-1372
kgCO ₂ eq/odt feedstock	-884	-931	-1160	-1347	-1554	-1403	-1303	-1218	-1243	-1302	-1305
kgCO ₂ eq/ha	-26443	-33986	-8117			-8302	-6108	-12181	-6960	-7706	-7723
MWh e/odt feedstock	300	395	426	704	716	696	696	696	696	773	951
MWh e/ha	8.97	14.40	2.98	0.00	0.00	4.12	3.26	6.96	3.90	4.57	5.63

Optimistic

total ghg	-2061	-1500	-2299	-7434	-48939	-30770	-29275	-28001	-28372	-139926	-166470
kgCO ₂ eq/MWh e	-5308	-3921	-4164	-2818	-3039	-2916	-2774	-2654	-2689	-2390	-1925
kgCO ₂ eq/odt	-1607	-1563	-1793	-1982	-2175	-2051	-1952	-1867	-1891	-1866	-1850

kgCO ₂ eq/ha	-48090	-57044	-12550			-12142	-9149	-18668	-10592	-11043	-10948
MWh e/odt	303	399	431	704	716	704	704	704	704	781	961
MWh e/ha	9.06	14.55	3.01	0.00	0.00	4.16	3.30	7.04	3.94	4.62	5.69

Pessimistic

total ghg	-488	-382	-793	-2715	-16455	-11895	-10400	-9126	-9497	-43773	-46108
kgCO ₂ eq/MWh e	-1297	-1030	-1480	-1061	-1053	-1162	-1016	-892	-928	-771	-550
kgCO ₂ eq/odt	-381	-398	-618	-724	-731	-793	-693	-608	-633	-584	-512
kgCO ₂ eq/ha	-11397	-14533	-4327			-4694	-3250	-6084	-3546	-3455	-3032
MWh e/odt	294	387	418	682	694	682	682	682	682	757	932
MWh e/ha	8.79	14.11	2.92	0.00	0.00	4.04	3.20	6.82	3.82	4.48	5.52

Extremely Pessimistic

total ghg	-36	-32	-321	-1214	-7413	-5889	-4394	-3120	-3491	-13061	-7339
kgCO ₂ eq/MWh e	-96	-89	-611	-484	-485	-587	-438	-311	-348	-235	-89
kgCO ₂ eq/odt	-28	-34	-250	-324	-329	-393	-293	-208	-233	-174	-82
kgCO ₂ eq/ha	-829	-1232	-1750			-2324	-1373	-2080	-1303	-1031	-483
MWh e/odt	288	379	409	668	680	668	668	668	668	742	913
MWh e/ha	8.61	13.82	2.86	0.00	0.00	3.96	3.13	6.68	3.74	4.39	5.40

No Soil No Heat

total ghg	-575	-475	-929	-3421	-20776	-14720	-13225	-11951	-12322	-59646	-70053
kgCO ₂ eq/MWh e	-1495	-1253	-1699	-1310	-1303	-1409	-1266	-1144	-1179	-1029	-818
kgCO ₂ eq/odt	-448	-495	-724	-912	-923	-981	-882	-797	-821	-795	-778
kgCO ₂ eq/ha	-13413	-18047	-5069			-5808	-4133	-7967	-4600	-4707	-4607
MWh e/odt	300	395	426	696	709	696	696	696	696	773	951
MWh e/ha	9	14	3	0	0	4	3	7	4	5	6

Appendix 7: Results of Alternatives to Slow Pyrolysis

slow py default	GHG	-1133	-894	-1487	-5053	-34957	-21040	-19545	-18271	-18642	-97650	-117432
	MWH E	384	379	547	2638	16106	10447	10447	10447	10447	57960	85610
Slow py No soil No Heat	GHG	-582	-435	-868	-3255	-19742	-13919	-12424	-11150	-11521	-55069	-56516
	MWH E	384	288	410	2234	13614	8848	8848	8848	8848	48826	58591
slow, ch combust	GHG	-439	-374	-825	-3140	-23479	-13465	-11970	-10696	-11067	-59775	-82454
	MWH E	1610	1296	1837	6449	38969	25537	25537	25537	25537	133410	197054
fast py	GHG	-1055	-790	-1328	-4299	-33201	-18054	-16560	-15286	-15657	-89124	-97382
	MWH E	1281	959	1281	4208	25895	16663	16663	16663	16663	94497	113396
Fast Py, No Soil No Heat	GHG	-725	-541	-997	-3346	-20513	-14281	-12787	-11513	-11884	-60189	-62659
	MWH E	1281	959	1281	4208	25895	16663	16663	16663	16663	94497	113396
fast py char combust	GHG	-675	-505	-948	-3201	-26612	-13706	-12211	-10937	-11308	-67380	-71289
	MWH E	2081	1558	2081	6570	40070	26018	26018	26018	26018	141274	169529
combustion	GHG	-966	-726	-1164	-3897	-29152	-16277	-14727	-12624	-12510	-73149	-101513
	MWH E	2662	1999	2512	7960	47761	31150	31039	29386	28418	155752	228801
fast py, 2030	GHG	-185	-137	-458	-1575	-9611	-7266	-5772	-4498	-4869	-20406	-14920
	MWH E	1281	959	1281	4208	25895	16663	16663	16663	16663	94497	113396
slow, grid ref 2030	GHG	-971	-727	-1246	-3910	-27309	-16514	-15019	-13745	-14116	-71557	-76301
	MWH E	384	288	410	2234	13614	8848	8848	8848	8848	48826	58591
fast, grid ref 2030	GHG	-516	-386	-789	-2528	-22299	-11040	-9545	-8271	-8642	-49341	-49643
	MWH E	1281	959	1281	4208	25895	16663	16663	16663	16663	94497	113396
combustion, grid ref 2030	GHG	155	115	-106	-546	-9044	-3163	-1659	-253	-546	-7577	-5187
	MWH E	2662	1999	2512	7960	47761	31150	31039	29386	28418	155752	228801

Assumptions			
combustion: total electrical efficiency 42 %			
Char combusted in co firing, 42% efficient			
Fast Pyrolysis	yield %	MJ/t	C content %
oil	71	17	45
gas	9	15	35
char	20	27	75
process energy	13%		
energy loss	1%		

Appendix 8: Notes from Interviews

I. Notes From Meeting with Patricia Thornley, Simon Shackley, Pete Brownsort and Jim Hammond on 15/6/09 at Swan Institute, Newcastle.

Defining the limits of the LCA

A brief discussion outlining the primary and secondary impacts with which we are concerned.

To include growth of the feedstock, and any land use change and indirect land use change resulting from this. In the case of waste collection, to include any alternative use of the waste as reference cases against which comparisons can be made. In the case of a cultivated feedstock which has an alternative use (e.g. rape meal as feed) the impacts of substituting an alternative product must be considered. At the other end of the process, the resulting soil effects of reduced fertilizer usage, reduced N₂O soil emissions, higher NPP (and subsequent higher rate of soil organic matter accumulation), reduced fuel use for field operations and lower water usage will all be accounted for.

The time scale of the LCA was not discussed, but I suggest that 2020 may be used if we wish to look into the future.

Feedstocks

Most Viable Feedstocks

- * Short Rotation Coppice (Willow)
- * Miscanthus
- * Barley and OSR straw
- * Small Round wood chips/pellets
- * Forestry Residues chips/pellets. Bales possible.
- * Imported Forestry Residues (chipped) – Probably Canadian/North American.
- * Chicken Litter – likely to be opportunity for one more plant in England

Discussions of the viability of different feedstocks took up a lot of the meeting.

PT showed a pie chart detailing relative quantities of biomass feedstock available to the UK limited by sustainability constraints relevant to each feedstock. PT offered to send this over. The major feedstock we had not examined was Jatropha.

Jatropha

PT recommended that we include examination of potentials for pyrolysis of a foreign energy crop such as Palm Kernel Expeller (PKE), Olive Cake or Jatropha, with Jatropha being the most highly available. Jatropha produces oil, oil cake and wood, although yields are uncertain. These feedstocks would be pyrolysed in the country of origin and the char spread over the plantation from which the biomass was taken. This approach may yield high GHG benefits for low financial cost compared to Britain, but SS felt that it was outside the scope of the Defra study. Concerns over data availability were raised.

Agricultural Wastes

Straw

Wheat straw is produced in high quantities but already has various markets in feed and animal bedding, as well as for combustion in co-firing power stations. Wheat straw availability in Scotland is very low, but may be higher in some parts of England. Material handling is better than Barley or OSR straw, but may still pose challenges for smaller pyrolysis units.

Barley straw and Oil Seed Rape (OSR) straw is produced in lower but significant quantities, and is not generally used for biomass combustion due to higher sodium/potassium levels giving problems of 'slagging' and materials corrosion in high temp combustion (>600-800°C). The fusion temperature for potassium and sodium is about 800°C. Barley straw is used in animal bedding and feed, but OSR straw is not. (Animals are not that fond of eating barley or OSR straw). OSR straw is difficult to work with, shattering when cut. Barley is also hard to cut up compared to wheat. It is unlikely that domestic OSR production will increase in UK because the RTFO has been put on hold. (The GHG balance for OSR is not especially promising). Barley and OSR straws may be more available to pyrolysis, but some material handling difficulties will have to be overcome. Straws could, ideally, be cut up and blown into the pyrolyser, but this would be difficult for barley and OSR straw.

ISPRA have produced a new study on how much straw to remove each year to maintain soil health – in the order of 50% per year should be retained. Similar results are found for forestry (this has been published). ISPRA have also produced a GIS map of straw crop densities of Europe.

Chicken Litter

Chicken litter available may be 1 to 3 Mt/a, with sufficient feedstock densities for 2x 200,000t/a plants in England. Locations suggested Suffolk, Powys, North Lincolnshire, possibly East Yorkshire (PT).

Scottish plant at Westfield (125,000 t/y) monopolises resource, there is no more scope in Scotland. (Contact for Westfield is Bill Livingstone, Mitsui Babcock).

Chicken Litter char may be less stable in terms of C sequestration in soils than other types of biochar (SS).

Manure and Slurry are considered too wet for pyrolysis.

Energy Crops:

Miscanthus and Short Rotation Coppice

More Miscanthus is being planted in Britain than Short Rotation Coppice (SRC) by a ratio of 5:1.

Miscanthus being grown on managed grasslands comes at a lower GHG cost than SRC being grown on previously unmanaged grasslands.

PT will sent data on SRC and Misc, e.g. regarding present and expected harvests, supply chain, GHG and energy balances.

There are currently 350,000 ha of grade 3 or 4 agricultural land which may be termed surplus and could be used for the growth of energy crops without affecting the food system (Lovett et al 2009 – PT to sent reference?). PT warned that growth on unproductive lands or with low input will produce low yields. This may still be attractive to farmers, but will give lower yields.

Short Rotation Forestry (SRF)

Was raised as a possibility, but is still under investigation. It is unlikely that this would be commercially productive by 2020. Poplar is used for SRF with a 10-year cycle. It can also be used in SRC at a 5-year cycle. Southern beech and eucalyptus are other possible species. Worth considering [PT]

Wood Sources

Wood may in fact make up a large part of the LCA work, as it appears to be a highly viable feedstock for a number of reasons. There are a number of streams of wood feedstocks, but because the pyrolysis unit would have to be attuned to one specific stream, this poses certain logistical issues. A pyrolyser could take only one feedstock, and this feedstock would have to be transported to them. Economically, this may mean that only the largest feedstock in an area is worth considering, although the other feedstocks could be transported elsewhere. Another configuration would be a number of smaller pyrolysers, each processing a different feedstock.

PT identified the Woodfuel Resource study (by Forest Research) as a key source. Talk to Helen McKay or Jeff Hogan for advice or help.

Lockerbie Power Station contact to discuss feedstocks used at the plant: Mike Colchin

It may be worth investigating the pellets vs. chips, as producing pellets may be a use of the low grade heat/steam, and may improve material handling and pyrolysis efficiency.

Small Roundwood

Refers to round logs cut in cross section which are 7 to 14 cm in diameter. Also branch wood may be included in this category. Generally this wood is not suitable for commercial purposes and is sold as firewood or to be chipped. It may be available to bioenergy systems in large quantities.

PT to send references by Tubby and Matthews on how to calculate LCA for timber.

Brash, or Forestry Residues (FR)

Currently an unused but abundant resource, Sweden leads the way in mechanized collection of FRs, and also leads the debate on how much it is safe to remove without damaging soil vitality. Removal is expensive, and may also damage soil structure or carbon stocks due to heavy machinery. A recent study put the costs at over \$100 per tonne of brash wood.

Sawmill Co-products (or wastes?): Bark

Bark is not used in bioenergy combustion systems because of the irregularity of the combustion profile. (It has higher levels of certain metals I think – SS). It may produce good char however (SS), and this should be investigated. There is little competition for this feedstock, as its main use is chipping as mulch, however it is a limited feedstock (100,000 t/a in UK).

Saw Mill Co-products (or wastes?): Woodchip and Sawdust

Not such a good option as supply is not huge (<1Mt) and there is a lot of competition with chipboard manufacturers. However, there is a 7 MW facility which generated power from these feedstocks in Northern Ireland owned by a large sawmill in Eniskillin, Balcas (7MWe / 5 MWt CHP plant). This type of project may become more viable with double ROCs for biomass combustion. There is a proposed similar project in Scotland (PB). David Kidney is the contact for the Eniskillin project.

Arboricultural Arisings

Felt to be too small a feedstock to be worth considering (<100,000 t/yr). Gathering feedstock may not be a problem however as it is generally taken to a municipal waste facility. SEEDA have a workshop coming up on this topic. (Several local authorities have indicated their interest in utilizing arboricultural arisings and green waste for biochar production – SS).

Imported Forestry Residues

Almost infinite quantities of wood chip from forestry residues would be available from Canada, North America and Scandinavia. These could be pelletized at source to make for higher density of feedstock and therefore lower travel costs. In order for contracts to be made, a high demand for the feedstock is essential.

This feedstock will be highly sensitive to transport costs and emissions. Shipping is better than haulage by road. Ralf Sims, Sweden has calculated that FR imports may cost €100/t (PT to send reference?)

Matthews has a study on North American chip imports. (PT to send reference?)

Doug Bradley is a contact of PT's in the Canadian Forestry Institute (CANBIO)

David Layzell is a contact of SS's at Queens University (Kingston, Ontario).

IEA Bioenergy task 40 is focused on the international trade of bioenergy crops and biomass.

Oil Crop Residue Cakes

The remains after pressing and extracting all available oil from oil crops such as OSR, Oil Palm, Olives, Soya Beans etc.

OSR Meal

High competition as animal feed, especially considering growing Chinese market for cattle.

PKE

PKE is produced in extremely large quantities (20Mt/a), may or may not be used as a feed and is currently used in co-firing in Britain (~1Mt/a). PT to send quantifications on PKE.

Olive Cake

Unknown quantity produced (~1Mt/a?), almost entirely in the Mediterranean region. May be used as feed, local fuel or mulch. PT to send quantifications.

Wastes

The most important thing to consider when conducting LCA for wastes is the appropriate reference case.

Also important will be the time setting of the LCA: if it is in the future (eg 2020) then estimates of future waste output will be needed – this may be difficult. (Would need to assume how well the requirements of the EU Landfill Directive have been met).

PT spoke of a model by the Environment Agency (EA) called something like WRATE used for to conduct LCAs on waste streams. There is also an EA document which gives benchmarks and carbon footprints for each waste treatment method. PT to send references?

National Household Waste Classification cited as a key source – a national survey of what is thrown away in every part of the country, performed every 2-5 years. (PT)

Env. Agency has a tool called WRATE for looking at waste mgt. options. This was based upon BPEO – benchmarking for all incinerators.

Construction and Demolition Wastes (C&D)

PT believed that there would be a proportion (potentially large) which would require little 'cleaning up' and therefore be economically viable as biomass feedstock. As demand for biomass increases and price of biomass increases, proportion of recoverable C&D will increase. PT to send reference?

Industrial and Commercial wastes (I&C)

Was much said about this ?

Sewage Sludge

High moisture content. Potential reference cases: Combustion, 40MW facility at Shell Green (fluidized bed); Gasifier (pelletized) at Seal Sands (ENTEC); AD facilities; spread on land after treatment (thermal stabilization of sewage sludge). (ROCs available at present for these plants – but this may be changing in the future).

Green Wastes

Not kitchen/food wastes

MSW

Was this discussed?

MBT MSW

A large feedstock according to PT's pie chart. Can be applied directly on to land, but there are some problems with that (not always a stable material). It would make an interesting comparison with pyrolysing the MSW directly. (SS)

Pyrolysis Technology

Energy Policy Paper

Process used for data in Energy Policy paper was Aston's ablative plate rig. PT to send some data used for that report. Also a Carbon Trust report on high grade process steam from biomass entitled "Operational Realities of Heat" . PT mentioned the Ensyn/RTP process as the most established pyrolysis technology (but only oil as product).

PT thinks we should limit comparison for power generation to use of (large) gas engines.

I haven't thought this through yet but guess she means comparing biochar option with excess energy converted through gas to power vs complete gasification and power conversion.

SS: I think what we meant is that it would be better to generate electricity from a gas engine (e.g. Jenbacher type) than to have a gas turbine which is more temperamental.

Heat Output

She views heat output as likely to be un-marketable; sceptical of district heating potential in UK (cost, planning problems, load factor, necessity of standby system) and limited scope for industrial CHP; and anyway that most heat is likely to be re-used within pyrolysis process - eg drying. She thinks pyrolysis processes are likely to have higher internal heat use/recycle than usually quoted, i.e. less efficient than quoted and that this may be a key issue for pyrolysis.

There is something particularly synergistic about combining pyrolysis, heat and syn-gas with cement kiln. (ref PT?). New tyre pyrolysis plant planned at Dunbar to link up to Cement Factory. Old pyrolysis plant/cement kiln at Blue Circle in the Wear.

Was PT suggesting that electrical output would also be minimal for slow pyrolysis, or did I misunderstand?

Data Robustness/ Process Variability

On pyrolysis process robustness/variability she had no particular view, other than she thinks data is likely to be very limited at commercial/production level. She suggested Anja Oasmaa of VTT, PyNe state of the art reports and Cordner Peacocke as most likely sources.

PT's intuitions/ predictions

Biochar vs complete Combustion, still needs to be proven: Large scale/centralised facilities likely to be most efficient overall; that UK-only scope likely to be limited; that imported forest waste with port-side treatment may be worthwhile (but presumably only if sufficient UK market/sink for biochar); that developing country treatment of fuel crop residue (eg jatropha) may have biggest scope to be useful.

II. Interview with Dr Saran Sohi

Highest likely effect on GHGs will be high value crops (veg/fruit) on sandy soils.

Highest N and water efficiency improvements.

Addition of biochar to clay soils will give greater decrease in soil bulk density/soil strength, making the soil easier to work.

A 10% reduction in N-fertiliser requirements is a good place to start, and perhaps half that for P and K. The reduction in P and K requirement is less well understood than the N effects and appears to be less. There are two effects going on: the improvement in cation exchange capacity (ie the efficiency with which nutrients may be taken up from the soil and are retained in the soil) and the direct substitution value of the nutrients in the char. In Saran's Woburn experiments Eucalyptus char contained 7.5 kg/t soluble N. Thus at a 20t/ha application rate, 150 kg/ha N were applied.

Assuming a large initial application, Saran recommended not topping up with char every year but on a 5 to 10 year timescale, and topping up perhaps half the original application, without allowing the total soil carbon to double the original concentration. This is more akin to liming operations. The investment would be recovered over a period of years as crop yields remain improved, and then the application repeated when the soil effects begin to wear off.

On soil effects: also to be considered are pH effect – offsetting the need for liming, and increased root health and resistance to disease translating into a yield or NPP benefit. The labile fraction of

char decomposes over a period of months, releasing nutrient benefits normally associated with organic matter decomposition. The super-labile or soluble fraction is released in a shorter period and makes mineral nutrients available to the soil. The soluble fraction is made up of the ash content of the char. Improvements to soil bulk density decreasing soil strength are likely to diminish over time, as char particles are ground down and fill natural crevices in soil, thus creating no new spaces and the effect becoming diminished. Water retention in soils will increase, which will bring consistent yearly benefits for irrigated crops and occasional benefits for crops which suffer drought years.

Cation exchange capacity is likely to improve over time thus decreasing the fertiliser requirement over time. Saran estimates believes that a likely maximum is 10% fertiliser reduction which may be reached over 20 years, at an inverse exponential rate.

Soil N₂O emissions are considered by the IPCC to be 1% of applied N, although this is challenged by some scientists to be higher – in the region of 3 to 5%. 1% will be the initial default value and other values may be tested through sensitivity analysis. De-nitrification impact of char is not certain – see review paper.

SOC changes slowly over time but evidence from terra preta soils (work that Saran did with Cornell) suggests that over time concentrations can build up. There are two mechanisms for this: enhanced plant productivity leads to more plant matter entering the soil and char may reduce the rate at which SOC is decomposed. The first is in direct and linear relation to NPP change, the second is a function of the quantity and type of char in the soil, and is not yet well understood. Saran suggests a 0.5 to 1% increase in SOC per year from the latter effect, to a maximum of 10% original SOM. Assuming NPP increase of 10%, this would lead to a maximum increase of 121% ($100 \times 1.1 = 110$, $110 \times 1.1 = 121$). Agricultural soils typically contain 40 to 60 t C/ha.

When adding char, usually only the top 30cm are being discussed. Char below this may be less subject to decomposition etc but will provide less crop benefits.

The effect of char upon soil N₂O emissions may change over time, depending on the mechanism by which char has this effect. If it is related to cation exchange, then the effect will increase over time. It could be due to char hydrophobia however, which lessens over time meaning that the effect would decrease over time. For now, it is best to assume a constant impact. The effect is something in the region of 20 to 25%.

The forthcoming Woburn field trials added 20t/ha of eucalyptus char to agricultural land. The char was found to have 7.5 t/ha available N.

III. Interview with Jason Cook

Soil Application Actions

10t/ha were applied, on a low till system growing barley.

Used seed spreader “KRM Brendel” to spread char.

Max capacity 1.5 odt.

Jason wetted char to stop it blowing away upon application, before loading onto seed spreader.

Char particles mainly 3x3x1 cm or less.

Seed spreader loaded on farm using forklift, then driven to field.

With max output setting, 10t/ha equivalent could be applied on a single pass.

Fields were then sown with barley seed using a seed drill, turning the soil to a depth of 15cm.

Jason believes that much of the char has percolated down into the soil, with only the larger particles at the surface. Initially, much black matter was visible on top of the soil, now only large particles are visible.

Tractor on farm – John Deere 7820 : 173kW

Crop ha 80 - 180 wheat / barley. 50 - 100 OSR

Jason's Thoughts

It would be more cost effective, and therefore more attractive to farmers, to integrate biochar applications into normal farming operations. There is scope for biochar spreading to be integrated with NPK fertiliser applications.

To if the seed trailer has a max capacity of 1.5 t, then to apply 30 t/ha, 20 loads would be necessary. If seed trailer loading cannot be done at the field, each load would have to be driven from the farmyard.

To facilitate loading of trailer at field, a large trailer of char with a small crane or JCB attachment would be necessary.

To apply large quantities of char, dedicated machinery must be used to make the process efficient. This would potentially entail a very large outlay for the farmer (or an outlay for an entrepreneur starting up a biochar deployment business).

IV. Interview with Dr Ondrej Masek

Diesel Engines: 35-40% efficient. Up to even 200MW in size.

Gas Engines: 35-38% efficient. 42% with natural gas. Up to only 4 or 5 MW in size.

Smaller system would have only one type of engine – perhaps diesel and use the gas for producing heat, for drying, process etc.

Larger systems may have more than one type of engine when there is too much gas to use the heat, it may prove more efficient to convert it to electricity.

It is also possible to convert the liquid to gas. Would it be possible to use this in a large Combined Cycle Gas Turbine? CCGT may operate at 30 to 40 % efficiency, at MW plus.

The efficiency of gassifying synoil would be a conservative 85%.

On smaller systems the liquid could be converted and a single gas engine could make use of all the energy.

If combusting char, the best use would be to co-fire it with coal in existing large scale plants, as that would give the highest efficiency.

