

**The English Spinnet**  
**with particular reference to**  
**The Schools of Keene and Hitchcock**

A Dissertation Submitted for the Degree of

**Doctor of Philosophy**

by

**Peter Geoffrey Mole MA MPhil**

**The University of Edinburgh**

**2009**

*For my mother -*

*go not out and still at the crease*

## DECLARATION

I declare that this dissertation has been composed by me and that the work reported in it is my own. I further declare that the work has not been submitted for any other degree or professional qualification.

A handwritten signature in black ink, appearing to read 'Z. Male'.

1st September 2009

## **Abstract**

Organological inspections of a representative sample of English spinets made during the period 1680-1740 have been performed. The sample includes instruments made by Stephen Keene and his co-workers, by the Hitchcock family firm, and by selected other makers. Analysis of the Keene instruments allows them to be classified into four groups reflecting their development in size and compass over time. In contrast, little development is discernible in spinets from the Hitchcock workshop: rather, the instruments can be seen to have existed as two basic models – a mitred tail model and a serpentine tail one. Some variations and hybrids are recognisable in both models.

The commonly held view that the spinet was merely a cheap and compact substitute for the harpsichord, even during the late-Stuart and early-Georgian period, is refuted by reference to archival and iconographic evidence of the status in society of those who bought the instruments.

# Table of Contents

Title Page	
Dedication	i
Declaration	ii
Abstract	iii
Table of Contents	iv
Acknowledgements	xii
<b>1. Introduction</b>	
1. The Research	1
2. The Research Methodology	4
3. Conventions	7
4. The Argument	9
5. The Literature	11
6. The Structure of the Dissertation	12
7. Published Material	16
<b>2. Late-Stuart England</b>	
1. Introduction	19
a. The Economy & Immigrant Workers	21
b. Politics and Religion	24
c. The Influence of the Royal Court	25
d. The Great Fire of 1666	28
2. Education, Apprenticeship and the Craft Companies	30
a. Education	31
b. Apprenticeship	32
c. The Joiners and Haberdashers Companies	34
d. Business Activities	37
3. Summary	41
<b>3. The Spinnet in Late-Stuart and Early-Georgian England</b>	
1. The Origins of the Design	43
2. The Spinnet in English Musical Culture	54

a.	Spinnet and Harpsichord Ownership	54
b.	Early Owners	57
c.	Music. Music Publishing, and Keyboard Players	65
3.	Summary	72

#### **4. The School of Keene**

1.	Introduction	74
2.	Stephen Keene	75
3.	Edward Blunt	82
4.	Thomas Barton	86
5.	Charles Brackley	88
6.	The Keene Workshop	89
7.	Keene's Competitors	93
a.	Charles Haward	93
b.	John Player	95
c.	Benjamin Sison	97
d.	Benjamin Slade	98
e.	Keene's Former Apprentices	99
8.	Summary	100

#### **5. Spinets from the School of Keene**

1.	Introduction	103
2.	The 'Standard' Instruments	112
a.	The Keene spinet of 1707	112
b.	Other Standard Instruments	121
c.	The Standard Instruments – General Characteristics	124
3.	The Early Instruments	129
a.	The Keene spinet at the Royal College of Music	129
b.	The Keene spinet at Hall i' th' Wood, Bolton	139
c.	The Early Spinets – General Characteristics	150

4.	The Transitional Instruments	152
	a. The Keene spinet of 1711	152
	b. Other Transitional Instruments	160
5.	The Five-Octave Spinets	163
6.	Summary, and the Proposed Classification	169
<b>6.</b>	<b>The School of Hitchcock</b>	
1.	Introduction	173
2.	The Hitchcock Family	175
	a. Thomas Hitchcock the Elder	178
	b. ‘Thomas Hitchcock Free 1701’	184
	c. Thomas Hitchcock the Younger	187
	d. John Hitchcock	189
3.	The Hitchcock Workshop	192
	a. Establishment	192
	b. Hitchcock Workers	194
4.	Summary	205
<b>7.</b>	<b>Spinets from the School of Hitchcock</b>	
1.	Introduction	207
2.	Production from the Hitchcock Workshop	207
	a. Hitchcock Inscriptions	212
	b. The Serial Number/Date Correlation	215
3.	The Two Models of Hitchcock Spinet	223
	a. Plan Form	223
	b. Veneering	226
	c. Stands	231
	d. The Mitred-Tail Model	235
	e. The Serpentine-Tail Model	242
4.	Model Development	248
	a. Case Size	248
	b. Special Decorative Features	251
	c. Special Features affecting Musical Performance	254

5.	The Influence of Slade	260
6.	The Hitchcocks' Competitors	262
7.	Summary	264

## **8. Design Features**

1.	Introduction	266
2.	Case Size and Plan Form	267
3.	The Register	277
4.	Compass	280
	a. Pre-1710 Spinets	283
	b. Transitional Spinets (1711-1718)	286
	c. Post-1720 Spinets	287
	d. Compass and Published Music	290
5.	Pitch	294
6.	Stringing	301
	a. The String-Band and Case Design	301
	b. Scaling and Design Note	304
	c. Stringing Material	307
	d. Plucking Point	309
7.	Summary	311

## **9. Decoration**

1.	Introduction	314
2.	Raw Materials	314
	a. Walnut	315
	b. Ebony	316
	c. Brass	317
	d. Ivory	319
3.	Veneers and Marquetry Cartouches	320
4.	Brass Furniture	332
5.	Keyboards	341
	a. Late-Stuart Spinets	341
	b. Early-Georgian Spinets	346
6.	Stands	349

7.	Summary	354
----	---------	-----

## **10. Conclusions and Suggestions for Further Research**

1.	Introduction and Re-capitulation of the Objectives	357
2.	The Spinet's Place in English Musical Culture	359
3.	Organological Characterisation and Comparison	365
a.	The School of Keene	365
b.	The Development of Spinets from the School of Keene	367
c.	The School of Hitchcock	371
d.	The Hitchcocks' Two Models	374
4.	Design and Decoration in Context	377
5.	Methodological Conclusions	380
6.	Further Research	381

## Volume II

### Appendix 1

- |    |                                     |     |
|----|-------------------------------------|-----|
| 1. | The Parts of an English Spinet      | 383 |
| 2. | Details of the Research Methodology | 388 |

### Appendix 2

- |  |   |     |
|--|---|-----|
|  | Apprenticeship Relationships of Spinet Makers | 392 |
|--|---|-----|

### Appendix 3

- |  |  |     |
|--|--|-----|
|  | The John Player chinoiserie-painted spinet | 393 |
|--|--|-----|

### Appendix 4

- |  |  |     |
|--|--|-----|
|  | The Grant of Probate to the Will of Stephen Keene                                  | 394 |
|  | Transcript of the Grant  | 395 |
|  | The Family Tree of the Keenes  | 397 |
|  | Images of the Records relating to Stephen Keene                                    | 398 |
|  | The Anonymous Seventeenth-Century Spinet at<br>the Royal Northern College of Music | 399 |
|  | The Slade Spinet at the Red Lodge Museum, Bristol                                  | 406 |
|  | The Slade Spinet at the Bate Collection, University of Oxford                      | 411 |
|  | The Slade Spinet sold at Bonhams   | 417 |
|  | The Slade Spinet sold at Christies   | 419 |

### Appendix 5

- |  |  |     |
|--|--|-----|
|  | The 1700 Keene Spinet at Colonial Williamsburg                         | 420 |
|  | The Undated Keene & Blunt Spinet privately owned in Lancaster          | 427 |
|  | The 1703 Edward Blunt Spinet   | 431 |
|  | The 1704 Keene Spinet at the University of Edinburgh                   | 432 |
|  | The Keene Spinet<br>at the Cantos Musical Foundation, Calgary, Alberta | 441 |
|  | The Keene Spinet<br>at the Musical Instrument Museum, Phoenix, Arizona | 443 |

The Keene & Brackley Spinet	448
The Charles Brackley Spinet privately owned in Philadelphia	457
The 1724 Thomas Barton Spinet	463
The Anonymous 1708 Spinet at the Royal College of Music	466

## **Appendix 6**

Images of the Records of the Joiners and Haberdashers Companies	472
---	-----

## **Appendix 7**

1. Thomas Hitchcock Spinet Serial No. 471	473
2. Thomas Hitchcock Spinet Serial No. 1007	478
3. Thomas Hitchcock Spinet Serial No. 1075	481
4. Thomas Hitchcock Spinet Serial No. 1143	482
5. Thomas Hitchcock Spinet Serial No. 1193	484
6. Thomas Hitchcock Spinet Serial No. 1228	486
7. Thomas Hitchcock Spinet Serial No. 1243	488
8. Thomas Hitchcock Spinet Serial No. 1287	492
9. Thomas Hitchcock Spinet Serial No. 1289	494
10. Thomas Hitchcock Spinet Serial No. 1335	495
11. Thomas Hitchcock Spinet Serial No. 1396	501
12. Thomas Hitchcock Spinet Serial No. 1460	505
13. Thomas Hitchcock Spinet Serial No. 1518	507
14. John Hitchcock Spinet Serial No. 1520	509
15. Thomas Hitchcock Spinet Serial No. 1547	512
16. John Hitchcock Spinet Serial No. 1570	514
17. John Hitchcock Spinet Serial No. 1630	516
18. John Hitchcock Spinet Serial No. 1676	517
19. The John Hitchcock Spinet at the Musikhistorisk Museum Copenhagen	523
20. The John Hitchcock Spinet at Yale University	525

## Appendix Eight

- |    |  |     |
|----|--|-----|
| 1. | The John Player Spinet at York Castle    | 527 |
| 2. | The John Player Spinet at Sizergh Castle | 534 |

## Extracts from the Long Forms

### Keene Spinets - Case Measurements

- |   |     |
|---|-----|
| LFSKHW, LFSKRCM, LFK&Bl and LFSK1700CW  | 536 |
| LFSK1704, LFSK1707, LFSK1711 and LFK&Br | 537 |

### Keene Spinets - Keyboard and Stringing

- |            |     |
|------------|-----|
| LFSKHW     | 538 |
| LFSKRCM    | 539 |
| LFSK1700CW | 540 |
| LFSK1704   | 541 |
| LFSK1707   | 542 |
| LFSK1711   | 543 |
| LFK&Br     | 544 |

### Hitchcock Spinets - Case Measurements

- |                                     |     |
|-------------------------------------|-----|
| LFTH471, LFTH616, LF1241 and LF1243 | 545 |
| LFTH1335 and LFJH1676               | 546 |

### Hitchcock Spinets - Keyboards and Stringing

- |          |     |
|----------|-----|
| LFTH471  | 547 |
| LFTH616  | 548 |
| LFTH1241 | 549 |
| LFTH1243 | 550 |
| LFTH1335 | 551 |
| LFJH1676 | 552 |

### Accession Numbers of Museum Spinets

### Bibliography

## Acknowledgements

The author wishes to thank all those who have helped him during this research project. Foremost of these are Dr Darryl Martin who has supervised this research. He has responded promptly to any queries, has made comments on portions of early draft texts and has read this dissertation with a critical eye. Dr John Kitchen has given musicological input on many occasions and just as importantly, has given encouragement. Thirdly is of course Maureen Mole, who has been involved in this project from its inception to finality: she has had to temper criticism with tact and praise with circumspection. The support, enthusiasm and knowledge of these three persons have been indispensable.

There are many others who have helped. These include, but are not confined to, Emily Azis, Peter Bavington, Peter Barnes, Sheila Barnes, Wendy Barnes, Ture Bergstrom, Colin Booth, Susana Caldeira, Michael Fleming, Miles Hellon, Graham Gadd, Andrew Garrett, David Hitchin, Andy Lamb, David Law, Olaf Kirsch, Darcy Kuronen, Sarah Maultby, Denis McCaldin, Jesse Moffatt, Stephen Morris, Charles Mould, Jenny Nex, Chris Nobbs, Nick Orman, Sandra Penketh, John Raymond, Albert Rice, Malcolm Rose, Daniel Smith, Eleanor Smith, Paul Simmonds, Philip Scott, Tim Thorpe, Graham Wells, The Rt. Hon. The Baroness Willoughby de Eresby, John Watson, Lance Whitehead, John Weston, Anna Wright and Paula Woods. I am most grateful to them for allowing me to use their time, knowledge and experience.

# Chapter One - Introduction

## 1. The Research

The research reported in this dissertation is primarily an organological study of the English spinet. Its main focus is the output of spinets from the two most significant spinet-making schools of the late-Stuart and early-Georgian periods, those of Stephen Keene and of the Hitchcocks: these two schools dominated the production of spinets during the period under study (1660–1740). Also, and to a limited extent, the research studies the culture of the England from which the English spinet emerged.

The two main objectives of the research are:-

First, to ‘place’ the spinet in the musical culture of Britain during the period 1660-1740 and in doing so to question whether the soubriquet of ‘the poor man’s harpsichord’ withstands examination;

Secondly to provide an organological characterisation of representative spinets from the Keene and Hitchcock schools. The purpose of that characterisation is to investigate whether lines of development can be discerned which connect the design of spinets made early in the period with that of those made later. Within that task it seeks to answer long-standing open questions about the lives and output of members of the two schools, and to determine whether dates accorded in the literature to some of their instruments are consistent with the genealogical facts.

It would be as well to state at the outset what is meant by the term 'English spinet'. The etymology of the 'spinet' is reviewed by Ripin, revised by Whitehead.<sup>1</sup> They note that the Italian term 'spinetta' was originally used in renaissance Italy to denote a rectangular virginal, and that the French 'epinette' was a term which was applied indiscriminately in France until the seventeenth century to any plucked keyboard instrument. But those usages were quite different from the meaning of the equivalent term 'spinet' in English: the term 'spinet' in English was used narrowly to denote a small, generally triangular, plucked keyboard instrument.

In this dissertation an instrument is considered as an English<sup>2</sup> spinet if it has all of the following characteristics:-

1. a generally triangular shape with the main case wall to the right of the keyboard being arcuate or serpentine rather than rectilinear;
2. a string-band running substantially parallel to the spine of the instrument with the longer (bass) strings being adjacent the spine and away from the player;
3. a single bridge on free soundboard with the nut attached to the wrestplank;
4. an eight foot sounding pitch.

Many instruments which are described in museum catalogues as spinets, particularly Italian instruments, are more properly termed virginals or octave virginals as will be apparent from the brief etymological history outlined above.

---

<sup>1</sup> Edwin M. Ripin/Lance Whitehead ; 'Spinet', *Grove Music Online* ed L.Macy (accessed 7<sup>th</sup> November 2008), <<http://www.grovemusic.com>>

<sup>2</sup> The term 'English' spinet is used to denote a style or design, not a geographical origin: there are Scottish spinets which fall within the definition.

The spinet was the most common keyboard instrument in Britain for more than a hundred years, from the final demise of the virginal about 1680 until the unequivocal establishment of the square piano by about 1780.<sup>3</sup> Several thousand spinets were made during their long period of popularity and large numbers of them, perhaps as many as four hundred, have survived to the present day. Many of these are in publicly accessible collections in Britain and in the United States, the remainder being mostly in private hands. Despite this ready accessibility the spinet has attracted little attention from scholars, perhaps because it has been regarded as a 'poor man's harpsichord' - a small, low-cost substitute for the instrument of primary interest.

The large number of surviving spinets has necessitated a restriction to the scope of the research project. The spinet developed very significantly as a musical instrument from its adoption in England in the late 1660s to its obsolescence some 120 years later and instruments at opposite ends of this temporal scale are similar only in their general features. An attempt to characterise all of the surviving spinets, or even to characterise a sample instrument from each of the makers represented by surviving instruments, would have been to produce a superficial study. So the research described here is confined largely, though not exclusively, to spinets from two 'schools' of spinet making - to Stephen Keene and those of his apprentices who became important makers in their own right, Edward Blunt, Thomas Barton and Charles Brackley, and to the large Hitchcock family firm.

---

<sup>3</sup> The first surviving square pianos, by Johann Zumpe date from 1766. Zumpe's design rapidly became fashionable and similar pianos were made by other makers, including Beyer, Pohlmann, Ganer and importantly, Broadwood, see generally Cole 1998.

Despite this relatively close focus, the study adopts a broad interpretation of the task of the organologist, including within its scope an enquiry into the economic, religious, political, and aesthetic attitudes of the society from which the English spinet emerged and within which it became popular. It seeks to characterise the structural details of the instruments themselves, but also, as an aid to that characterisation, to illuminate the lives of the makers on whom the dissertation is primarily focussed. Consequently it touches upon the institutions within which spinet makers worked, the lives of those who bought spinets, and of those who produced music for them. It is therefore a contextual study.

## **2. The Research Methodology**

The core of the dissertation is an empirical study. The methodology of the study was a simple one: suitable instruments for inspection were located, using Boalch (1995) as a guide, and were inspected at their locations. The instruments which were inspected are shown in Table 101.<sup>4</sup> In addition, three spinets not included in Table 101 were viewed in their display locations without detailed inspection - the Keene spinet at the Museum of Fine Arts, Boston, the Thomas Hitchcock spinet Serial No 1193 at Packwood House, Warwickshire, and the Thomas Hitchcock spinet Serial No.1289 at Haddon Hall, Derbyshire. Though a substantially full survey of most of the instruments of Table 101 was performed, there was some variation in the level of detail which was obtainable due to the varying circumstances of inspection.

---

<sup>4</sup> In some of the diagrams and tables which appear later, it has been necessary for presentational reasons to refer to some of these spinets by means of a shorthand code. The code used is shown in the right hand column of Table 101.

<b>Table 101 - Spinets Inspected During the Research</b>		
	<b>Keene Spinets</b>	<b>Code</b>
1	Hall i' th' Wood, Bolton	SKHW
2	Royal College of Music, London	SKRCM
3	Keene & Blunt, privately owned, Lancaster	K&BI
4	Colonial Williamsburg (1700)	SK1700CW
5	St. Cecilia's Hall, Edinburgh (1704)	SK1704
6	Grimsthorpe Castle, Lincolnshire (1707)	SK1707
7	Westwood Manor, Wiltshire (1711)	SK1711
8	Keene & Brackley, owned by the author	K&Br
	<b>Hitchcock Spinets</b>	
9	Colonial Williamsburg, Serial No. 471	TH471
10	Bate Collection, Oxford, Serial No. 616	TH616
11	St. Cecilia's Hall, Edinburgh, Serial No. 1241	TH1241
12	Serial No.1243, Offered for sale, Bonhams Oct. 2006	TH1243
13	Sulgrave Manor, Oxfordshire, Serial No. 1335	TH1335
14	King's Lynn Museum, Serial No. 1396	TH1396
15	Serial No.1460, Offered for sale, Sotheby's Nov. 2005	TH1460
16	Royal College of Music, London, Serial No 1676	JH1676
	<b>Spinets by Other Makers</b>	
17	Benjamin Slade, Bate Collection, Oxford	BSBC
18	Benjamin Slade, Red Lodge Museum, Bristol	BSRL
19	Benjamin Sison, Lady Lever Art Gallery, Wirral	BSLLG
20	Richard Horsborough, St. Cecilia's Hall, Edinburgh	RH1786
21	John Player, York Castle Museum	JPYC
22	Cawton Aston, Colonial Williamsburg (1726)	CA1726
	<b>Anonymous Spinets</b>	
23	Royal College of Music, London (1708)	RCM1708
24	St.Cecilia's Hall, Edinburgh	RCAnon
25	Royal Northern College of Music	RNCM

The survey methodology consisted of measuring the instruments directly with basic measuring equipment and transferring the results to a computer spreadsheet in Microsoft Excel™. Diagrams of the plan forms were then produced from the recorded data using IMSIDesign TurboCAD 14 Deluxe™, a computer-aided design

application. In order to ensure a systematic approach to measurement, a *pro forma*, the 'Long Form' was developed. This form was used as the survey record during the surveying process. Extracts from the Long Forms are included in the appendices<sup>5</sup> for the majority of spinets from the Keene and Hitchcock schools which were inspected.

The content of the Long Form was determined by two main considerations:- First, that the recorded data should be sufficient to allow subsequent characterisation of the instrument in terms of the design and the workshop practice of the maker - the Long Form was not intended to provide a basis for preparation of a detailed plan of the instrument, (though it is thought that an experienced instrument maker could make a very close copy of the instrument from the data which the Long Form contains and from photographs of the instrument).

Secondly, the Long Form was confined to those items which it was thought could be obtained by the author during a survey of the instrument lasting only one day. Some of the instruments surveyed belong either to private individuals or to museums, or were temporarily present at the premises of auction houses or restorers. It is not appropriate to undertake surveys whose duration is more than a few hours in many of these environments. Further details of the methodology adopted for the inspection of the spinets studied are included in Appendix One.

---

<sup>5</sup> In the instances of the Keene & Blunt spinet, and of Thomas Hitchcock spinets Serial Nos. 1396 and 1460, the practical difficulty of making the necessary measurements in the time and space made available was too severe for Long Forms to be produced.

The knowledge base which informs the conclusions of this dissertation was not confined to evidence from the primary source of surviving spinets. Details of many other spinets have been obtained from secondary sources. These details are reported in the appendices.

Initial investigations of the dates of birth, marriage, and death of persons referred to in this dissertation were made using on-line archival resources including [www.familysearch.org](http://www.familysearch.org), which hosts the genealogical search facility of The Church of Jesus Christ of Latter Day Saints and two commercial resources, [www.ancestry.co.uk](http://www.ancestry.co.uk) and [www.britishorigins.com](http://www.britishorigins.com). Subsequent investigations were made using the microfilm versions of the parish registers of the London churches kept in the Guildhall Library, London. Civic records, including the registers of what were originally the Guilds of the City of London, and the Land Tax Assessments, which are not available electronically, were inspected at the Guildhall Library. Wills adjudicated by the Prerogative Court of Canterbury (PCC) are kept in the National Archive at Kew, Middlesex but the indices are searchable on-line and copies of the Probate of Wills were obtained electronically. Indices to Letters of Administration granted by the PCC are also available but are not yet searchable on-line.

### **3. Conventions**

The Gregorian calendar, in which the year starts on January 1<sup>st</sup>, was not adopted until 1752 in Britain and before then the first day of the calendar year was Lady Day, 25<sup>th</sup> March. When a date is quoted which is in the period January 1<sup>st</sup> – 24<sup>th</sup> March, the

year designation used includes both the Julian and the Gregorian year. Thus Brackley's Freedom of the Joiners' Company in January 1710 is designated 1710/11.

The organisations which began life as the Guilds and became Worshipful Companies and then Livery Companies are termed 'Craft Companies'. Footnotes to the text beginning with the designation 'MS' are references to the manuscript numbers of documents in the Guildhall Library, London. Similarly, references beginning with the designation 'PROB' are to documents in the National Archive, Kew.

Throughout the dissertation comments are made about the dates of particular spinets. Where a spinet is not dated but good evidence is available to enable attribution of a date, the date is quoted as 'c.1712'. Where only a general attribution of date can be given a range is quoted.

The pitch notation system used here is a modification of that of Helmholtz<sup>6</sup> which is used by Oxford University Press. The Helmholtz system describes an octave as a series of notes starting with the note name **c** with different octaves being distinguished by the use of upper and lower case and superscript primes.

---

<sup>6</sup> See <http://www.dolmetsch.com/musictheory1.htm#helmholtz>, accessed 18<sup>th</sup> March 2009.

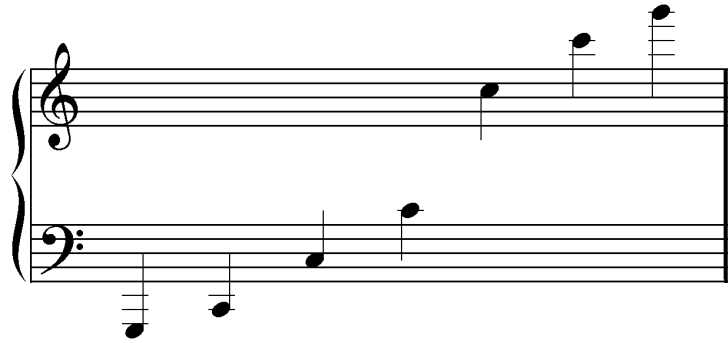

Modified Helmholtz	GG	C	c	c'	c''	c'''	g'''
USA Standard	G <sub>1</sub>	C <sub>2</sub>	C <sub>3</sub>	C <sub>4</sub>	C <sub>5</sub>	C <sub>6</sub>	G <sub>6</sub>

**Figure 101**

The note ‘middle c’ shown here one ledger line above the bass staff is referred to as c’ in this system, with additional primes being added in subsequent upper octaves. Below C, two ledger lines below the bass staff, three notes are found in spinets and here these notes are designated using the doubled upper case, GG, AA and BB as indicated in Figure 101, in which the equivalent ‘USA standard system’ notation, see Campbell, Greated & Myers (2004: 16), is set out by way of concordance. A five-octave spinet is therefore designated as having a compass of GG-g''' (G<sub>1</sub>-G<sub>6</sub>). Pitch levels are quoted in hertz (Hz) at the note a'. The designation a'~ 403Hz denotes a pitch in which the note a' has a sounding pitch centred on 403 Hz.

#### **4. The Argument**

It has been suggested, for example in the article in Grove Music Online by Ripin/Whitehead already referred to, that it is likely that the bent-side spinet was introduced into England from Italy by Zenti and it will be shown why this is thought to be so. It will be argued that the spinet's initial acceptance was due to more than one factor: its

small size and its stylish appearance distanced the instrument from the rectangular virginal, its immediate predecessor, which displayed a renaissance style of decoration evoking its origins in a much-disliked Catholic culture. It will be said that the end of the Puritan period, the reopening of the theatres and the opportunity which that provided for music publishing also contributed to the spinet's initial popularity, and that it soon became the keyboard instrument of choice for amateur players.

The first English spinets were made by virginal makers – Haward, Player and Keene in particular. By 1700 Player and Keene had ceased to produce virginals (and Haward had died)<sup>7</sup> and were producing spinets. Their instruments became extremely fashionable and were highly sort after. Brackley, Barton and the Hitchcocks developed their spinets in compass and therefore in size after about 1710. This development seems to have been driven as much by the desire of customers to have 'the latest thing' as being a response to notated music of increasing range. Though the earliest surviving spinet of five octaves may be by Barton, the Hitchcocks brought the spinet to maturity as a five-octave instrument and by developing their manufacturing operations dominated the market until Thomas Hitchcock the Younger died in 1737. That date marks the temporal end of the primary focus of this dissertation.

It is nevertheless appropriate to note that spinet makers working after about 1735 had to sell their product in the face of increasing competition from the 'factory' harpsichord workshops of Shudi and Kirkman. They did this by adopting the

---

<sup>7</sup> Charles Haward died in 1689: National Archive, London, PROB/11/396.

decorative style of these large harpsichords and further increasing the size of their instruments to provide a more powerful tone in the bass. But by the 1760s spinets had indeed become the 'poor man's harpsichord'. Later instruments were produced by out-sourcing manufacture: Thomas Culliford supplied John Hitchcock, as will be shown in Chapter Six, and music shops such as Longman & Broderip (see, for example, Boalch 1995: 486): Andrew Rothead supplied Neil Stewart in Edinburgh (Boalch 1995: 646). The square piano began to supersede the spinet in the 1770s. Culliford and Rothead (Clinkscale 1995: 81 & 226) in particular turned their attentions to this new instrument and made both square pianos and spinets for a time. Spinets were obsolescent by 1780. Boalch (1995: 542) suggests that latest spinet known to have survived may be the one by Rothead in private ownership in Pennsylvania, to which a date of 1795 has been attributed.

## **5. The Literature**

The literature on the bent-side spinet is both sparse and widely scattered. With two exceptions no textbook, monograph, article or dissertation dealing exclusively with the English spinet has been found. Works which do deal in part with it fall into three categories:-

1. Classic and now rather outdated textbooks including James (1930), Hipkins (last re-printed 1945), Hubbard (1965) and Russell (1959). A more modern textbook is Kottick (2003), but only a few pages are devoted to the English spinet.

2. Catalogues detailing the collections of major museums, which include Russell (1959 & 1968), Libin (1989), Schott (1998), Koster (1994), Beurmann (2000), Wells (2000) and Waitzman (2003).
3. Standard reference works, the two most important of which are the three editions of Boalch (1956, 1974 & 1995) and the article by Ripin/Whitehead in *Grove Music Online* which has already been referred to.

Occasional information about specific instruments also appears in the catalogues of the major auction houses and in commentaries on the subsequent sales, notably by Montagu.<sup>8</sup> Martin (2003: I: 224-242) discusses the reasons for the demise of the virginal, attributing this mainly to the comparative ease of manufacture of the bentside spinet, but also pointing to the spinet's stylistic sympathy with the new fashions of the Restoration, as well as its practicality in the domestic sphere.

The exceptions referred to at the outset of this brief survey of the literature are Morris (1983)<sup>9</sup> and Barnes (1985). Morris's work was aimed in part at a general objective addressed in this dissertation, the characterisation of late-Stuart and early-Georgian spinets. However its nature allowed only a comparatively superficial study. There is no original archival research on the makers discussed and much of the historical material presented has been garnered from Boalch (1974). Little more than a page is devoted to each of the spinets listed, though it seems that seven of them were actually inspected, since plan drawings are provided.

---

<sup>8</sup> A large number of short articles by Montagu reporting sales by auction appear in *Early Music*. Because of their frequency, these have not been referenced individually.

<sup>9</sup> Strictly speaking, Morris's work is a Personal Communication of June 2007, since no copy of his dissertation is available for inspection in a publicly-accessible library.

Barnes (1985), the second of the exceptions to the general statement above, is a monograph intended to help the first-time maker of a spinet to produce a satisfactory instrument after the Keene & Brackley spinet then owned by Barnes but now in the author's possession. It is a key document for understanding the process by which a particular spinet, and by extension other spinets, were originally made.

## **6. The Structure of the Dissertation**

The substantive chapters of the dissertation begin in Chapter Two with an exposition of the economic, political, religious, social and artistic culture of late-Stuart England, the culture from which the English bentside spinet emerged. This background is central to an understanding of why the spinet developed to become the domestic keyboard instrument of choice at that time. The chapter continues with a general account of the lives of artisan craftsmen of the seventeenth century and of the institutions within which they worked. Within the present context those institutions were the Worshipful Company of Joiners and Ceilers (referred to hereafter as the Joiners Company) and the Worshipful Company of Haberdashers (the Haberdashers Company). The chapter continues by describing ways in which spinet makers would have earned their living, which it is suggested was not solely by making spinets.

Chapter Three is concerned with two essentially separate matters: - the mechanism by which the spinet was introduced into England, and its rise to popularity. In the first part it examines the evidence for treating Zenti as the originator of the spinet and suggests some additional routes by which it might have arrived. In the second part,

the chapter seeks to displace the assumption made by scholars that the bentside spinet was a 'second choice' instrument. It begins that task by examining the evidence for the distribution of harpsichords in late-Stuart England and proceeds to investigate the typical customer for a spinet. Lastly, it identifies some considerations from the sphere of music publishing which, it is argued, would have had the effect of stimulating interest in the spinet.

Chapters Four and Five, and Chapters Six and Seven parallel each other and set out the major findings of this study. The first pair, Chapters Four and Five, focuses on the School of Keene and Chapters Six and Seven focus on the Hitchcocks.

Chapter Four details the lives of the four late-Stuart spinet makers who, it is suggested, should be considered as forming the School of Keene - Stephen Keene himself, Edward Blunt, Thomas Barton and Charles Brackley. It sets out the results of research designed to establish precisely *when* these makers lived. This knowledge is important in providing an explanation for the variety of makers' inscriptions which appear on surviving spinets from the school. New information, in particular about the dates of death of Keene and of Brackley provides insights into the likely dates of otherwise undated instruments. The chapter proceeds to consider the staffing of the Keene workshop and Keene's attempts to ensure that his business was passed on as a going concern to a successor. It also identifies those whom Keene must have considered as his competitors, despite his earlier close relationship with many of them.

Chapter Five seeks to identify and characterise the surviving instruments from the Keene school. The starting point for this examination is the entry for Keene's instruments which appears in Boalch (1995: 414-419) but it is suggested that this entry over-states the number of surviving spinets. A detailed characterisation of four particularly significant instruments and a suggested classification of the surviving *oeuvre* follow. The research findings for this chapter are extensive and much of the descriptive material appears as Appendix 5 in order to keep the dissertation within its permitted word-count.

Chapter Six parallels Chapter Four and provides a detailed description of the lives of members of the Hitchcock family firm. The persons who worked either in or for the Hitchcock workshop, whose initials and names appear on some of the surviving instruments, are identified in this chapter. Archival research on these persons has allowed suggestions to be made about the way in which the Hitchcock workshop was organised. It has also enabled a long-standing problem to be addressed and in part solved, namely the relationship of the serial numbers found on surviving instruments to their date.

Chapter Seven parallels Chapter Five and seeks to identify, characterise and classify the surviving spinets from the Hitchcock workshop. It provides a detailed characterisation of two typical Hitchcock spinets, one with a mitred tail and one with a serpentine bentside without a separate tail. It draws attention, through a comparison of two pairs of instruments which, from their serial numbers, would have been expected to be similar, to various 'options' which seem to have been available

to Hitchcock customers. Like Chapter Five, much of the supporting material for this chapter has had to be included in its appendix, Appendix Seven.

Chapter Eight is a summary chapter. It draws together the observations made from inspections of the instruments listed in Table 101 and additional information from the literature to provide a holistic picture of the design of late-Stuart and early-Georgian spinets. It points to some general conclusions about design which are relevant to spinets from both the Keene and Hitchcock schools and to spinets from other makers working in the period.

Chapter Nine is also a summary chapter. It reviews the styles of decoration which are found on spinets in the period under study and is particularly concerned with the use of new raw materials and with the style of decorative items which were bought-in by spinet makers from the general furniture trade rather than being made in-house. Such items include veneer and marquetry cartouches, brass furniture and the stands for spinets. The chapter also analyses the decorative aspects of late-Stuart and early-Georgian keyboards.

Chapter Ten summarises the conclusions of the research and makes suggestions for the direction of future work.

Chapters One to Eight are each provided with an appendix numbered to correspond with the chapter number. The appendices comprise additional material which

supports the arguments and conclusions of the dissertation. This material is detailed in the Table of Contents.

## 7. Published Material

The University of Edinburgh's Postgraduate (Research) Regulations 2008/9, 3.1.11 advise that copies of articles by the author which have been published in academic journals and which refer to the research reported should be included in the Appendix. However, here the publications are extensive and their inclusion, in the author's view, would unnecessarily add to the bulk of the Appendix. The articles are nevertheless listed below:-

- Mole, P G., 2007 'The Hitchcock Spinet Makers - A New Analysis',  
*The Galpin Society Journal*, LX, 45-61.
- 2008 a 'Two Spinets in the Collection of Viscount Leverhulme',  
*The Galpin Society Journal*, LXI, 325-331.
- 2008 b 'On the Trail of Purcell's Spinet',  
*Early Music*, 36, 409-414.
- 2008 c 'The Bentside Spinets of Stephen Keene and his School',  
*Journal of the American Musical Instrument Society*,  
XXXIV, (2008) 5-25.

In addition to these four articles, other material in the dissertation has been published in the form of papers read at seminars and symposia. The papers in question are:-

'The English Spinet - not so unassuming after all',  
University of Edinburgh Research Seminar, February 2007

'Designing a Spinet - an Apprentice's Work Book',  
University of Edinburgh Music Postgraduate Seminar, June 2007

'The Bentside Spinets of Stephen Keene and his School',  
American Musical Instrument Society Meeting at Yale University, June 2007

‘The Parrot, the Tulip and the Frenchman – Some Decorative Aspects of the Late-Stuart Spinet’,  
University of Edinburgh Early Keyboard Symposium, October 2008

Appendix One contains a generalised description of a typical English bentside spinet. This description is primarily intended for those who are unfamiliar with the spinet, but it also facilitates understanding of the measurements recorded in the Long Forms.

In those sections of Chapters Five and Seven which provide detailed descriptions of instruments, the decision has been taken to include some points of discussion amongst the descriptive matter. The rigorous separation of description and discussion which is the norm in academic dissertations was found to be too cumbersome for the reader in these sections, which rely significantly on pictorial representation.

## Chapter Two – Late-Stuart England

### 1. Introduction

The first part of this chapter begins the task of addressing the first of the objectives set out in Chapter One, that of placing the English spinet within its musical culture. It does so by drawing attention to some significant aspects of the culture of late-Stuart England, the culture from which the spinet emerged. The second part of the chapter outlines the typical education and training process undertaken by those who made spinets, as a contribution to the task of characterising the spinets under study. It also points to ways in which those who became Freemen were able to earn their living.

Before proceeding, it is worthwhile to ask why such material is of value. The answer is given by Dawe (2003: 237).

‘Musical instruments are formed, structured, and carved out of personal and social experience as much as they are built up from a great variety of natural and synthetic materials. They exist at an intersection of material, social, and cultural worlds where they are as much constructed and fashioned by the force of minds, cultures, societies, and histories as axes, saws, drills, chisels, machines, and the ecology of wood.’

But, as Pinch and Bijsterveld (2003: 537) point out, it is not always altogether clear precisely where the intersection identified by Dawe lies,

‘Throughout history, new instruments and instrument components drawing upon the technological possibilities of the day have often incited debates as to their legitimacy and place within musical culture. The arrival of the pianoforte into a musical culture that revered the harpsichord was for some an unwarranted intrusion by a mechanical device.’

Some thought is therefore needed about the emergence and development of the spinet before the cultural influence of the period can be properly understood, and a prerequisite of that is to fix the time-frame within which that process took place.

The earliest English spinets appeared in the 1660s during the reign of King Charles II, though so far as is known, none of these very early instruments have survived.<sup>1</sup> Nevertheless the existence of a spinet in London as early as 1664 is evidenced by the diary entry of Samuel Pepys:-

*'1st July 1664, to the Change and thence home to dinner: and so to my office, busy till the evening: and then by agreement came Mr Hill and Andrew and one Cheswyke, a maister who plays very well upon the spinette...'*<sup>2</sup>

It is possible of course that this 'spinette' was an imported one and if so then it seems likely that it would have been imported from France, but by 1668 Pepys was able to consider the commission of a locally made spinet from Charles Haward:-

*'4 April, 1668. 'Up betimes, and by coach towards White Hall, and took Aldgate Street in my way and there called on one Haward that makes virginalls, and there did like of a little espinette, and will have him finish it for me: for I had a mind to a small harpsicon, but this takes up less room and will do my business as to finding out of chords ...' (Le Gallienne 2003: 266).'*

Charles Haward, for of the several Hawards who may have been harpsichord makers it is Charles Haward to whom Pepys was referring, was the earliest documented spinet maker in England. Several keyboard instruments made by him, including some spinets, have survived. Amongst these are the spinets at the National Music Museum

---

<sup>1</sup> Chapter Six suggests that the reports in Boalch (1995: 386) of spinets by Thomas Hitchcock the Elder dated 1660 and 1664 are the results of faulty scholarship. In 2008 Messrs Bonhams sold a Charles Haward spinet dated by the auction house to 1668. That dating seems to be based on nothing more than the passage in the diary of Samuel Pepys quoted above.

<sup>2</sup> 'The Change' was the Royal Exchange. This extract was accessed on 17<sup>th</sup> July 2008 through <http://www.pepysdiary.com/archive/1664/07/>

at Vermillion, South Dakota, at Mellerstain House close to Kelso in the Scottish Borders and at Leipzig University. It is clear therefore that by the early part of the reign of King Charles II, spinets were being made in London.

So what were the characteristics of Dawe's 'material, social and cultural worlds' which were to influence the emergence and development of the spinet in England during the late-Stuart and early-Georgian periods?

#### a. The Economy and Immigrant Workers

The England of the late-Stuart period was an essentially agricultural economy: technology was primitive. Until the invention of the steam engine by Thomas Newcomen in 1712<sup>3</sup> there was little possibility of using power to assist in any agricultural or manufacturing process unless running water was available. Those goods which were manufactured were produced in the home by manual labour occasionally assisted by wind- or horse power. But it was only in London that there was any significant market for manufactured goods. The population elsewhere was too low, and too immobile, to support a sophisticated market.<sup>4</sup> To put a journey into context, the coach from London to Edinburgh took about 12 days even in the summer, the only alternative – and it was of course not a real alternative for journeys to many destinations – being the hazardous passage by sea. This was not a propitious economic environment for the development of new manufactured articles.

---

<sup>3</sup> This engine was intended for pumping water from mines and did not readily lend itself to other uses.

<sup>4</sup> A population of 4.9 million for the year 1681 has been calculated from the numbers of births, marriages, and deaths recorded in surviving parish registers. This figure rose only slowly to 5.7 million in 1751 (Wrigley & Schofield 1981: 528).

The shortages of essential materials caused by the Civil War began to ease from about 1680 and personal incomes began to rise. The income rise was mostly a consequence of a rise in population which, though slow at the beginning of the period, began to accelerate from about 1710 as a result of greater fertility (itself a consequence of women marrying at an earlier age) and of static mortality rates.<sup>5</sup> Wrigley (1983; 121-150) argues that English society was peculiar in having what he calls a 'low pressure demography' in which there is a low dependency ratio in families, with the opportunity for women to enter the workforce. This, though still producing an economy in which it is difficult to produce much change in domestic output, is likely to produce higher equilibrium income levels than in 'high pressure demographies' where both birth and death rates are high. Voth (2003: 224) agrees. Though writing about the middle of the long eighteenth century and therefore in a context which is somewhat later in date than the present one, he summarises the position in this way:-

'More populous than the equally wealthy Dutch and much richer than more populous France, by 1750, England probably did have the greatest market size for those goods whose production subsequently became more efficient.'

The ground for that competitiveness was already being laid in the late-Stuart period.

Since the middle ages, immigrant workers had been arriving in England in significant numbers from both the German states, from the Protestant areas of France and from the Low Countries. This influx rose sharply in the late 1670s as a result of the increasing harassment of French Protestants (Huguenots) by Louis XIV culminating

---

<sup>5</sup> Laslett (2005; 108) shows average birth rates over the decades from 1541 to 1871. The rate was at a low in 1661 and rose only slowly. It did not reach a rate similar to that of modern developing countries until about 1810.

in 1685 in the revocation of the Edict of Nantes. Gwynn (2000: 30) estimates that some 40-50,000 refugees came to England from Louis XIV's France alone. But a second factor was the rising wealth of London, which attracted economic migrants regardless of their religious persuasion.

Most of these immigrants were urban artisans, and the impact they had on English culture was through the many new craft and trade practices which they introduced, chief of which was in clothing and textile manufacture. (Gwynn 2000: 74ff) More relevant for the present context were furniture and cabinet-making, including marquetry, and crafts dependent upon mining, including general metal working, silversmithing, wire-drawing and the making of needles and pins.

Huguenot immigrants, being largely of French origin, produced artefacts in a markedly French style. It is in the field of silverware, where the regulation of marking allows precise identification of the maker and date of an article, that this is most easily observed. Banister (1965: 23ff) sets out the Huguenot design tradition in this field – one of sturdiness, simplicity and of formality of line but with meticulous attention to detail in a decorative tradition based on natural forms. It is suggested that this approach to design is reflected in the elaborate cast brass hinges which begin to appear on English spinets about 1680. It may be, indeed, that they are of Huguenot manufacture. More is said about this in Chapter Nine.

## b. Politics and Religion

The social and political structure of late-Stuart England was hierarchical, parochial, and conservative (Miller 1977: 27ff.). Though the Civil War was over, the religious and constitutional strife which was at its heart had left a legacy. The country gentry had disliked the absolutism of Charles I, but they had disliked even more the military regime which followed it. Their social position and their administrative status had been usurped, as they saw it, by men of lesser social rank – soldiers. They did not admire soldiers and they certainly did not like paying for them, so when the Restoration came in 1660, it was welcomed. But it was a conditional welcome, the condition being that the monarch should be a Protestant. Stuart England was resolutely anti-Catholic, associating Catholicism with absolutism, with intolerance, and with cruelty. Louis XIV's predatory approach to international diplomacy did little to dispel that distrust, though with hindsight, the English prejudice seems to have been considerably over-done.

Charles II was acceptable to the country because he presented himself as a Protestant,<sup>6</sup> which his brother James, Duke of York did not, but he was a Protestant who was a stranger to English culture. Charles had fled to France in 1646 when he was 16 years old and had lived there with his mother, Henrietta Maria, who was in exile at the French royal court. With only a brief interruption in the Netherlands, Charles remained in France until he gained the English throne in 1660. When he did so at the age of 30, it was as a young man whose tastes and experiences were French.

---

<sup>6</sup> He converted to Catholicism on his death bed, though possibly as a result of the opportunism of his brother.

### c. The Influence of the Royal Court

The cultural and artistic environment of England which greeted Charles on his return was very different from that of France. Immediately after the English Reformation, cultural contacts and trading links between England and the Italian city-states diminished, whereas France as a Catholic country maintained a close cultural relationship with Italy and felt the full influence of her artistic renaissance. In England, the reigns of Elizabeth and James I were ones in which English literature and English music rose to high points, but thereafter came a period of artistic stagnation. During the Civil War, many of England's mediaeval and renaissance treasures were desecrated or destroyed. What remained – a puritanical asceticism and a dislike of ornament, which was associated with 'Popish Foppery' – must have seemed old-fashioned to Charles on his return.

The relief generally felt at the Restoration, reinforced by Charles's personable character, allowed him considerable freedoms. Charles was an eclectic person and in two fields, his personal influence shows itself strongly. The first of these is his fascination with the 'natural philosophy' of the physical sciences. Charles was keenly interested in science and particularly in navigation. In 1673 he had founded the School of Mathematics at Christ's Hospital to instruct boys in both mathematics and in navigation. His personal accounts contain many items relating to the purchase of clocks and he was obsessed with the idea of having a lunar globe depicting the visible features of the moon. (Fraser 1979: 195) It was with his encouragement that the Royal Society was founded by Sir Isaac Newton, Robert Boyle and Robert

Hooke amongst others and at his instigation that Sir Christopher Wren designed both The Royal Hospital and The Royal Observatory at Greenwich. His enthusiasm for technical development was contagious. In that respect, if in no other, he was a natural leader of Restoration society.

The second field of Charles' influence is that of fashion. Right from the outset of his reign, Charles began to introduce French dress fashions and French artistic values into the English Court. From the musical standpoint, it was in the Eucharist and in the dance that this became most obvious. John Evelyn (1620-1706), who regarded himself as something of a chronicler of his times, notes retrospectively and not without some regret in his diary,

'21 December 1662: (One) of His Majesties Chaplaines preachd: after which instead of the antient, grave and solemn wind music accompanying the Organ was introduced a Consort of 24 Violins between every pause, after the French fantastical light way, better suiting a Tavern or Play-house than a Church; This was the first time of change, and now we hear no more of the Cornet which gave life to the organ, that instrument quite left off in which the English were so skilfull;..' (de la Bédoyère 1995: 132)

And Pepys remarks in the entry in his Diary for 15th November 1666, the Queen's birthday,

'Presently after the King was come in, he took the Queene, and about fourteen more couple there was, and begun the Bransles.<sup>7</sup> After the Bransles then to a Corant, and now and then a French dance: but that so rare that the Corants grew tiresome, that I wished it done. Only Mrs Stewart danced mightily finely, and many French dances, specially one the King called the New Dance,<sup>8</sup> which was very pretty;'

---

<sup>7</sup> The Bransles or more properly, *Branles* was a French dance which was popularised by the publication of Arbeau's *Orchesography* in 1589. It remained popular until about 1725.

<sup>8</sup> The 'New Dance' was probably the Minuet, originating from Poitou and popular in Paris from about 1650.

Charles was especially interested in the French instrumental music which he would have heard while in exile (Fraser 1979: 332). On his return to England, many musicians who had served King Charles I were reappointed, and since there was no new music, and there were no new types of instruments in England at that time, the inevitable conclusion is that the consort music which was popular before the Civil War was what was played, and that the instruments used were the traditional English instruments – viol, cornett, recorder, shawm and sackbut. But this seems to have been a stop-gap measure until sufficient resources could be assembled to provide a band in the French style: that style included the use of French instruments. The ‘four and twenty violins’ are well enough known, but Haynes (2002: 125), relying on Talbot and Roger North, states that a number of French wind players arrived in England in 1673, lead by Robert Cambert, and that they brought their French wind instruments, which included the new French ‘hautbois’, with them. These instruments would of course have been at French pitch, a consideration which is dealt with in detail in Chapter Eight.

Charles’ interest in French music was sufficient to cause him to despatch one of the choristers of the Chapel Royal, Pelham Humfrey, to Paris to learn more about it, possibly from Lully. Pepys encountered him several times on his return and notes on November 15, 1667,

‘Home, and there find, as I expected, Mr. Casar and little Pelham Humphrey, lately returned from France, and is an absolute Monsieur, so full of form, and confidence, and vanity, and disparages everything, and everybody's skill but his own.’

In 1672, Humfrey succeeded his old pupil master as Master of the Children of the Chapel Royal. One of the choristers was the young Henry Purcell. His contribution to late-Stuart musical culture is described in Chapter Three.

#### d. The Great Fire of 1666

The Great Fire of London in 1666 might be thought hardly to qualify as a cultural influence: indeed, following a severe outbreak of the plague in the previous year it might be thought that it was nothing short of a disaster. Nevertheless, it must be assumed to have had a significant effect on the manufacture of keyboard instruments. It is clear from the entry for 2<sup>nd</sup> September 1666 in Pepys's diary that a great many instruments were saved from the fire but a great many more must have been destroyed.

'River full of lighters and boats taking in goods and good goods (sic) swimming in the water, and only I observed that hardly one lighter or boat in three that had the goods of a house in, but that there was a pair of virginalls in it.' (Le Gallienne 2003:188).

Since it is known that at least three major makers of 'pairs of virginalls', Player, Haward and Keene had premises within the City, it would be somewhat surprising if all three were completely unaffected by the fire. It must be presumed that at least one, and possibly all of them will have suffered loss of or damage to premises and/or stock. If that stock included stocks of oak of furniture-making quality, then that may have acted as a catalyst to change and to re-stocking with the more fashionable walnut, from which nearly all early English spinets were made.

Just as far-reaching were the measures which were put in place to prevent a repetition of the fire, the chief of these being The Rebuilding Act of 1667<sup>9</sup> which governed the size and design of domestic buildings. These regulations had the effect of standardising the design of houses, which not only made the re-building process more efficient but also produced houses having standard-sized rooms.<sup>10</sup> A case of particular relevance to the present dissertation is that of Haberdashers Hall, the Headquarters of the Haberdashers Company, of which the Hitchcocks were members. The original Hall, a drawing of which is shown in Plate 201, stood at the corner of Staining Lane and Maiden Lane (now Gresham Street).



**Plate 201**  
**The Mediaeval Haberdashers Hall**



**Plate 202**  
**Haberdashers Hall in 1671**

Despite the crudeness of the image it is clear that this was a timbered house to a Tudor design. It burnt down in the Great Fire and was replaced in 1671 by the ashlar

---

<sup>9</sup> 19 Charles II, Chapter III.

<sup>10</sup> It seems likely that re-building of the mediaeval city will also have had some effect in preventing a repetition of the disastrous outbreak of the plague which had taken place in 1665: this will have helped to stabilise the London population.

faced Hall shown in Plate 202 which is typical of London houses built in accordance with the Act.<sup>11</sup>

The standardisation of room sizes in newly built houses allowed furniture to be made speculatively to standard sizes. (Bowett 2002: 26). A boom in furniture making was the result, and the furniture which was made was based on designs which were essentially French.

In summary, it can be seen that the late-Stuart period was one in which new opportunities arose in the economic and artistic spheres. But it is undoubted that these were dominated by the wish to follow in the footsteps of the French.

## **2. Education, Apprenticeship and the Craft Companies**

The second section of this chapter outlines the educational process, the apprenticeship system, and the business and earnings opportunities available to those who became Freemen of the two craft companies which are most relevant here, the Joiners Company and the Haberdashers Company. It provides a background to the account of the lives of those spinet makers studied during this research project which appears in Chapters Four and Six.

---

<sup>11</sup> <http://www.haberdashers.co.uk/public/publicWrapper.php?t=1&p=hallHistory> accessed 8<sup>th</sup> November 2008. This hall burnt down as a result of enemy action in 1940. A parallel cycle of construction and destruction applies to Joiners Hall, which stood in what is now Upper Thames Street.

## a. Education

Early education in artisan families was often left to a family member and some written materials were produced to assist with this (Grassby 1995: 189). But ‘petty’ or ‘dame’ schools were established in most large villages, supervised by some local person of learning, possibly the parish priest. Children went to school from the ages of 6-7 years in the country areas (Brinsley 1612: 9, quoted in Cressy 1975: 71) and earlier in London. Of the ‘three Rs’, reading and writing were taught sequentially but arithmetic often not at all. Many sons and daughters of artisans were self-taught at the secondary level, or they were taught by their masters’ families during their apprenticeships.

By the time of the Stuarts, the commercial advantages of an education were beginning to be appreciated (Wase 1678: 33/4). Laslett (2005: 229ff) points to literacy as being the factor determining whether a person could enter the political world of the English state or whether he would remain an outsider. So literacy was valued and was reasonably widely distributed, with about a third of the population being able to read and write. A survey of ecclesiastical court records in five English dioceses showed that in the years 1580-1700, London had the highest percentage of tradesmen and craftsmen able to sign their names, at 72% out of a sample of 391 persons (Laslett 2005: 231).

It is reasonable to assume that in a craft as complex as musical instrument making, the makers were literate. This placed these men in a special social position in their communities. To anticipate a discussion in Chapter Four, it is certain that Stephen

Keene was both fully literate and numerate since many of the tax returns made in his own hand have survived: a receipt made out by him has also survived and is reproduced in Chapter Three. It is equally certain that the Hitchcocks were literate: John Hitchcock even became a local councillor in the London ward of Farringdon Without (see Chapter Six).

## b. Apprenticeship

For those who were not born 'gentlemen' or better, life was to a large extent pre-ordained in the seventeenth century. Under the Statute of Artificers of 1563<sup>12</sup> any unmarried person, and any married person under the age of 30 years having an income of less than forty shillings per year and not already employed, was obliged to become a yearly servant or to take a trade. That stricture applied to women as much as to men: everyone was compelled to work, either in domestic service or in a trade, since labour was scarce. Householders were authorized to take the otherwise unemployed who were under twenty-one years of age as apprentices for a term of at least seven years. In those households whose head was a Freeman of one of the merchant or craft Companies, apprentices were taken on under the regulations of the Company concerned.

For a family to place one of its sons as an apprentice terms had to be agreed with the Master and a premium paid. Premia varied considerably, both with the prestige of the Company and with the conditions which the parents wished to secure for their offspring: the premium for the Joiners in London seems typically to have been six to

---

<sup>12</sup> 5 Eliz.C.4. See generally, Woodward (1980) and <http://www3.uakron.edu/lawrev/quigley1.html>, accessed 18th November 2005.

eight pounds. In the seventeenth and eighteenth centuries even that was a considerable sum, but *premia* in more prestigious occupations were very much higher.<sup>13</sup>

In effect, the master stood *in loco parentis* and was responsible for the child - for such he was - from the date of his binding at the age of twelve to sixteen years until maturity. That responsibility covered the provision of food, clothing and shelter, education and training in the craft skills. Apprentices lived in the households of their masters as members of the family and worked for six days per week as a minimum. Some would not have seen their parents again until they had become Freemen, and might not have had any communication with them until that time unless their parents were literate. They were bound for seven or more usually eight years, but received no pay and no holiday either, except that on Sundays they were not expected to work. Inevitably, some apprentices were treated little better than servants,<sup>14</sup> particularly in the early years of the apprenticeship before much could be done which was of value to the master's business.

Many spinet makers were born and brought up in the countryside, not in London. For example, the record of John Player's binding as an apprentice to Gabriel Townsend in June 1650 describes him as a son of Giles Player, shepherd, of Longborough, Gloucestershire.<sup>15</sup> Stephen Keene came from Sydenham in

---

<sup>13</sup> When Thomas Hitchcock the Younger's eldest son was apprenticed in 1728 to John Forrest, a Clerk at the Kings Bench, the premium was £70 guineas. That would have been well beyond the means of most families. The *premia* are quoted in *London Apprentice Abstracts 1442-1850* available electronically to subscribers through <http://www.ancestry.com/>

<sup>14</sup> *London Inhabitants Within the Walls*, an index of the inhabitants of the City of London in 1695 made under the Act of 6 & 7 Wm. & Mary, c. 6, actually designates Edward Blunt as a servant, <http://www.british-history.ac.uk/report.aspx?compid=8477> accessed 18<sup>th</sup> December 2008.

<sup>15</sup> London Guildhall MS 8052/1

Oxfordshire and Charles Brackley from a village near Swindon, Wiltshire (see Chapter Four). Thomas Culliford, who worked for John Hitchcock and for several square piano makers, seems to have died at Compton near Winchester<sup>16</sup> and though he worked in London, he presumably went back to his Hampshire village towards the end of his life. How the necessary arrangements were made by country people to apprentice their sons (and sometimes daughters) to London craftsmen is not certain, but it can be assumed that there was an effective network provided by the Companies. For example, Sydenham, Keene's village, is close to High Wycombe, the centre of furniture-making in England. There must have been many members of the Joiners Company and the Turners Company working there.

### c. The Joiners and the Haberdashers Companies

The medieval guilds, forerunners of the late-Stuart craft Companies, originated as associations of craftsmen and merchants who gathered for worship at a particular church. The craft of musical instrument making, which was heavily focussed on London, had no craft guild of its own, but most workers in this field were members of the Joiners Company.<sup>17</sup>

The Joiners Company began life as the Guild of St James, Garlickhythe, a church which still stands in the form in which it was rebuilt by Wren after the Great Fire on the corner of Upper Thames Street and Garlick Hill.<sup>18</sup> The Haberdashers Company had similar but much more prestigious origins: their original members were persons

---

<sup>16</sup> National Archives, PROB 11/1639

<sup>17</sup> Except for the Hitchcocks, who were Haberdashers.

<sup>18</sup> <http://www.stjamesgarlickhythe.org.uk/hist.asp> accessed 8th November 2008

who worshipped at St. Paul's Cathedral.<sup>19</sup> The Order of Precedence of the City Companies, set by the Court of Aldermen in 1515, places the Haberdashers at number eight. It is thus one of the 'Great Twelve' companies and it is even today considerably more prestigious to be a Freeman of the Haberdashers than of the Joiners Company, which is placed at number forty-one.<sup>20</sup> Though these Companies were involved in charitable care in the community, their primary concern was the exercise of control over the trade monopolies granted to them by Royal Charter in order to restrict competition. The Companies also acted as a means for disseminating proven trade or craft practices through their apprenticeship system. This ensured a high standard of service and of workmanship in manufactured goods.

It might be thought that there was little need for institutionalising the dissemination of craft practices in a craft culture which was effectively a closed shop. Those who were members of the Companies were closely inter-related in craft terms and, in addition, were often related by marriage. That is no more evident than in the example of the Joiner, Gabriel Townsend (born c.1604, died c.1662).<sup>21</sup> Gabriel Townsend was a virginal maker.<sup>22</sup> He was apprenticed to the eldest Thomas White of the White family of virginal makers. It is thought that he married Elizabeth Hasard (or Hazard), the daughter of John Hazard the harpsichord maker who is represented by a surviving instrument at Knole Park, Kent (Boalch 1995: 194). He died before any record exists of a spinet having been made in England, but his

---

<sup>19</sup> <http://www.haberdashers.co.uk/public/publicWrapper.php?t=1&p=companyHistory> accessed 12<sup>th</sup> November 2008.

<sup>20</sup> This may explain why Thomas Hitchcock the Younger chose to become a Haberdasher, despite being qualified to become a Joiner (see Chapter Six).

<sup>21</sup> Boalch (1995: 194)

<sup>22</sup> A virginal by Townsend dated 1641 survives (Martin, 2003: II: 221).

significance here lies in this: - two of his apprentices were John Player and Stephen Keene, both of whom were spinet makers. Keene's sister, Philadelphia, became Philadelphia White on her marriage, and it seems possible that she married into the White virginal making family, though that has not been researched. Player and Keene became Freemen of the Joiners Company and later Masters of that Company, as Townsend himself had been before them. The Townsend craft influence is traceable to the mid-eighteenth century through the Hitchcocks and Thomas Barton.

Entry to the freedom of a Company, which was a pre-requisite to working as a craftsman,<sup>23</sup> was strictly limited.<sup>24</sup> There were three routes to entry - through apprenticeship, by patrimony where the prospective entrant's father was a Freeman, and by redemption (purchase of freedom), the latter being discouraged by the levying of high entry fees.<sup>25</sup> Both the Joiners and the Haberdashers Companies still exist today as City livery companies and their archives are available for inspection at the Guildhall Library, London.<sup>26</sup>

It has already been said that the craft companies constituted a close-knit community. It is clear that those who were making musical instruments and who were members of the Joiners Company must have known each other fairly well. Many of the makers considered in this dissertation worked geographically close to each other in the Bishopsgate area of London, and some who had once lived as apprentices with their masters later found themselves as his competitors as proprietors of their own

---

<sup>23</sup> Strictly, the jurisdiction of the London Companies subsisted only within the City boundaries and it was therefore open to unqualified craftsmen to work in Southwark or Westminster.

<sup>24</sup> The Worshipful Company of Joiners still restricts its numbers to 320

<sup>25</sup> The Worshipful Company of Haberdashers charged £20 for redemption until 1699 with an additional payment of £20 to the City of London (Grassby 1995: 66).

<sup>26</sup> <http://www.joinersandceilers.co.uk> and <http://www.haberdashers.co.uk/public/publicWrapper.php>

businesses. From the dates of their binding to Gabriel Townsend it is clear that both John Player and Stephen Keene would have lived and worked together in the same house for two years: they would have known each other well. Later, Thomas Barton will have lived with Keene and will no doubt have known Player and his apprentices too, since the Player and Keene establishments were only minutes away from each other in walking time in their respective parishes of St Martin, Outwich and St Benet Fink. More is said about these relationships in Chapter Four.

In view of the similarities between some components of spinets from different makers of late-Stuart London – raw materials such as walnut, ebony and ivory and manufactured items such as brass hinges, wire strings and marquetry cartouches in particular – it is likely that one or more central sources of supply were used for such items. That circumstance implies a degree of co-operation between the makers as to precisely what is sought to be supplied. For this reason alone it is suggested that the ‘competition’ implicit between makers in what was a growing market for spinets will have been of a relatively low-key nature.<sup>27</sup>

#### d. Business Activities

Freedom of the Company could be taken after the indentures had been discharged, as long as the master was satisfied with the standard of workmanship displayed. But as in the conditions of apprenticeship, opportunities for abuse lay there. Upon becoming a Freeman, most Companies, including the Joiners, insisted that the man work as a journeyman for a period before being allowed to establish himself as a

---

<sup>27</sup> Then as now.

master and to take on apprentices of his own. Many journeymen remained employed for the whole of their working lives.

By the time they had served their time and become Freeman, most men would have been between the ages of twenty two and twenty six. Unsurprisingly, the records show that many married almost immediately they were able.<sup>28</sup> Edward Blunt married in 1701 after becoming free in 1700 and John Hitchcock married in 1752 after taking freedom by patrimony in 1750. Children were often born quickly afterwards and perhaps surprisingly from a modern perspective, illegitimacy rates were low.<sup>29</sup> The fact that marriage was late and that most children were born in wedlock accounts for the slow growth of the population. The apprenticeship system, which was initially intended as a measure for increasing the size of the working population, can therefore be seen as in part responsible for the shortage of craft labour.

How did spinet-makers earn their money? Not just by making spinets: some of those thought of now as spinet makers also made virginals and harpsichords, though surviving instruments are rare. A virginal dated 1664 survives from John Player (it is now in the Cobbe Collection at Hatchlands Park, Surrey, (Boalch 1995: 525 and Martin 2003: II: 179) and there is a reference in Boalch (1995: 147) to a Player harpsichord having been inspected by a Mr Thomas Day on 10<sup>th</sup> June 1712 though

---

<sup>28</sup> It was not lawful for apprentices to marry. But marriage would have been totally impractical since they had no income.

<sup>29</sup> Nevertheless a large number of 'foundling' children, including many babies who may have been either illegitimate or orphaned at birth appear in the birth registers of the London parishes.

no Player harpsichord survives.<sup>30</sup> There are two surviving virginals from Stephen Keene, one dated 1668 and the other 1675, the former being at St. Cecilia's Hall, University of Edinburgh. A harpsichord by Benjamin Slade survives as does one by Thomas Barton. Both of these are part of the Rodger Mirrey Collection now at St. Cecilia's Hall, University of Edinburgh. Lastly, two Hitchcock harpsichords survive, one by Thomas Hitchcock the Younger in the Victoria & Albert Museum, London and one by John Hitchcock at Lyme Park, Cheshire. Nevertheless, judging from the surviving numbers of instruments, it was the manufacture of spinets, not harpsichords, which was the mainstream of the business of makers in the late-Stuart and early-Georgian periods.

Obviously enough from what has been said, the newly-freed spinet makers were paid a wage while they were working as journeymen, making instruments in the workshop of the master. Many Freemen remained employed as journeymen all their working lives. But those who had been prudent or lucky enough to be able to set up in business on their own account apparently had several options for earning open to them:-

Milhous & Price (1990) review the activities revealed by the surviving papers from a lawsuit brought by Stephen Heming, a harpsichord- and spinet-maker against Christopher Rich, the manager of the Theatre Royal, Drury Lane. Though no instruments by Heming are known to have survived, Milhous & Price (1990: 39) record a reference to 'a spinnet by Heming' in an inventory to a Will, and an account

---

<sup>30</sup> Though the biographical entry for John Player in Boalch (1995: 147) suggests that a sighting of a harpsichord by Player is recorded in the mid-eighteenth century, this is an error. The entries in question refer to a rare double-strung spinet; see generally Mole 2008 (b).

survives by Heming himself of a sale in 1704 to Henry Purcell's brother Daniel of a spinet for use in the Theatre Royal Company's two theatres. It is clear that Heming supplied harpsichords and spinets to four London theatres from about 1697 to 1715. But it is the account of work done for the Theatre Royal from 1706-1708 which is of most interest. During the 1706-7 season, Heming tuned harpsichords and spinets for each operatic performance at the theatre, charging two shillings and sixpence for tuning a spinet and five shillings for a harpsichord. He also leased two spinets to Rich for eight shillings per month from 16<sup>th</sup> December 1706 to 17<sup>th</sup> April 1707 and a third one from 14<sup>th</sup> November to 20<sup>th</sup> December 1706 (Milhous & Price (1990: 41)).

Gratton Flood (1914) sets out the accounts of Ferdinand Weber,<sup>31</sup> an immigrant from Meissen who worked in Dublin as a spinet and harpsichord maker in the second half of the eighteenth century. This is a somewhat later era than the focus of this dissertation, but there is no reason to think that qualitative changes took place in the way that income was earned between the time under consideration here and that described by Gratton Flood.

Inspection of Weber's accounts shows that he was only in part a maker of spinets and harpsichords. He was also, like Heming, a dealer, repairer, tuner and hirer of instruments and he operated an import business.<sup>32</sup> For example, in November 1775 the Bishop of Ferns paid £34 2s 6d for a new harpsichord, though he seems to have traded in an old spinet and a harpsichord in part-payment, receiving part-exchange allowances of £5 13s 9d on each instrument. In 1782 a Miss Broadstreet, the daughter of the Recorder of Dublin, was charged 11s 4½d for 'new cloathing it being

---

<sup>31</sup> Boalch (1995: 677/8) lists four harpsichords, two clavicytheria and a spinet by Weber.

<sup>32</sup> For a fuller account of his activities see Nex & Whitehead (2000)

all moatheaten, tuning, quilling, etc' (sic). The Honourable Mrs Herbert hired a spinet for six months in 1773 and was charged £1 12s 6d which included tuning.<sup>33</sup> Weber also worked repairing organs including one belonging to the Earl of Ely and one to Sir Luscious (sic) O'Brien.

The impression which emerges, both from the accounts of Heming and of Weber, is one of artisan entrepreneurs rather than of craftsmen single-mindedly making spinets. It is suggested that this was quite typical of the trade which spinet makers were able to set up, and by the end of the period under investigation it was quite clearly a prosperous trade.

### **3. Summary**

This chapter opened by providing a brief but wide-ranging study of late-Stuart England as background to the task identified in Chapter One, that of placing the spinet in its musical culture. It identified two prominent discontinuities, first in the economic area and secondly in the field of fashion, which were conducive to the emergence of the spinet. Special attention was drawn to the surprising vibrancy of the economy, fuelled in part by the arrival of economic migrants and religious refugees who introduced new skills to England, especially in the metalwork and furniture making trades. As regards fashion, it was noted that there was a dislike of Catholicism and a wish to distance the artistic culture of England from its influence.

This generated a paradox, in that the lead given by King Charles II, who had been

---

<sup>33</sup> Many of the periods of hire are quite short. This may be because there was a definite 'season' in the country houses around Dublin or, as suggested elsewhere in this thesis, because the young girls who played these instruments did not adhere to their task for very long.

brought up in France during the interregnum, was to the adoption of French fashions. Attention was drawn to the influence of Charles in introducing French music, musical instruments and even French pitch to England. Attention was also drawn to the influence of the Rebuilding Acts following the Great Fire, which introduced a degree of standardisation to the design of houses. This enabled similar standardisation in furniture design which in turn allowed furniture, including the larger musical instruments, to be made speculatively.

The second part of the chapter described the life pattern of a typical spinet maker from childhood through adolescence and apprenticeship to maturity and adulthood as a Freeman, probably of the Joiners Company. Some pointers were also given to the opportunities which makers found for earnings outside their primary occupation as spinet makers.

## **Chapter Three – The Spinet in late-Stuart and early-Georgian England**

This chapter is in two parts: - in the first part the evidence for the origin of the design of the spinet either in Italy or France is discussed in detail. In the second part, the place of the spinet in the musical culture of late-Stuart and early-Georgian England is established. The chapter concludes with a summary.

### **1. Origins of the Design**

Until the restoration of Charles II and even for some years afterwards, the common domestic keyboard instrument in England was the rectangular virginal. Twenty-two examples of these instruments dating from 1580-1684 are known to have survived and these instruments are from a number of makers.<sup>1</sup> It is significant that three of these makers, Charles Haward, John Player and Stephen Keene also produced spinets at later dates, many of which have survived<sup>2</sup> and it is self-evident that a change-over period must have existed during which rectangular virginals and spinets were being made side-by-side in their workshops. But how did the design of the spinet emerge? There is very little evidence available on that point, but a discussion of that which there is follows:-

In a recent article, Koster (2008: 3-78) has drawn attention to the possibility that the early traditions of harpsichord-making in Europe were related. He describes the

---

<sup>1</sup> See generally, Martin 2003

<sup>2</sup> And in the case of Haward, a harpsichord also, though no virginal.

evolution of what he refers to as an ‘international style’ which had developed by 1500 from an earlier and ‘archaic’ school in northern Europe, exemplified by the designs in the well-known treatise of Arnaut de Zwolle and by the clavicytherium at the museum of the Royal College of Music, London. This ‘international style’ produced both the school of harpsichord making which is generally referred to as ‘Italian’ and the instruments of the ‘Ruckers’ type whose production was centred in Antwerp (Koster 2008: 5). Viewed in that context, there is little doubt that the earliest surviving spinets, which are thin-walled with heavy mouldings and a box-guide register, belong to the Italian tradition.

The earliest dated spinet known to have survived is by Girolamo Zenti. It is in the *Muziekinstrumentenmuseum* (MIM) in Brussels and is shown in Plate 301 which is reproduced here by kind permission of the Museum.



**Plate 301**  
**The Zenti Spinet – MIM, Brussels**

The spinet is inscribed on the face of the nameboard with what Ripin describes as a ‘garbled tag from Psalm 150’ which he attributes to Leopoldo Franciolini<sup>3</sup> but on the

---

<sup>3</sup> Franciolini was a late-nineteenth century musical instrument dealer and forger.

reverse, which judging from Plate 301 may once have been the face, it bears the inscription *Hieronimus de Zentis Viterbiensis faciebat 1637* (Ripin 1973: 75 & 76, where the inscription is illustrated). That date of 1637 is considerably earlier than the earliest date of any surviving or documented English spinet and so, subject to the comments below, this must be taken as the earliest example. It is of course unlikely that this surviving instrument is the earliest to have been made, and it is not the only early survivor of its type: a similar but anonymous and undated instrument is in the National Museum of Music and Musical Instruments at Ringve, Trondheim, Norway.<sup>4</sup> It may well be that this instrument is earlier than the Zenti one, but it is unlikely that a proof of that could now be established.

It is clear from the inventory of the instruments belonging to Ferdinando de Medici, prepared in 1700, that Girolamo Zenti (born c. 1609, Viterbo, died c. 1666-68, Paris) was a very prominent keyboard instrument maker since six of his instruments are listed there, including four described as *cembali*, two as *spinetti*, and one as a *spinettina*. Ripin comments that Zenti was a man who ‘[...] is known to have worked in several different styles, [...]’ (1973: 74) which adds to the impression of him, formed from accounts of his travels, that he was an eclectic person to whom it would be not unreasonable to attribute innovative capacity. That was certainly the retrospective impression of him formed by one of his contemporaries, Giovanni Andrea Bontempi (1624-1705) a famous *castrato*, who in his *Historia Musica..* (Perugia, 1695) states that ‘The most modern [harpsichords] were invented by

---

<sup>4</sup> A working drawing of this instrument by Darryl Martin is available from St. Cecilia’s Hall, University of Edinburgh.

Girolamo Zenti, made in the form of a not quite equilateral triangle' (quoted in Ripin 1973: 77).

The existence of the two early spinets and of the documentary evidence referred to above make it likely that the first school of spinet making was founded in Italy around 1630, probably by Girolamo Zenti, and if not by him, then at least developed by him. For that reason, and in the absence of any contradictory evidence, Zenti is now generally understood to have been the originator of the design of the spinet.

Earlier instruments variously described as virginals or spinets, which were polygonal in form, and at eight foot pitch, had been made in apparently quite large numbers in the city states of the Italian peninsula during the sixteenth century. These instruments seem almost invariably to be virginals in the present terms - that is to say they have their longest strings closest to the player and their short treble ones at the rear, together with two bridges on freely suspended soundboard - despite often being described as spinets. Many of these survive.<sup>5</sup> It is reasonable to assume that the polygonal form of these instruments was derived from a rectangle by excising those parts, particularly the corners, which were thought to serve no useful purpose but which added both weight and cost. But there is no such simple modification of the polygonal virginal which would arrive at the English spinet.

Martin has drawn attention to the design of the generally triangular 'octave virginal', an instrument which, paradoxically, is normally constructed as a spinet, with the

---

<sup>5</sup> See generally Wraight 1997.

longer strings at the rear and one of the bridges on the wrest plank, as in the instance of the example shown below in Plate 302, which depicts the c.1650 instrument in the Museum für Kunst und Gewerbe, Hamburg. The plate appears in the Museum catalogue (Beurmann 2000: 56) and is reproduced by permission. Other instruments of this type but dated earlier than the Zenti spinet of 1637 have survived, including one made in Rome by Albana dated 1617 now in the Tagliavini Collection, Bologna.



**Plate 302**  
**An Octave Spinet c.1650**  
**Museum für Kunst und Gewerbe, Hamburg**

It was common practice amongst harpsichord makers to provide a bentside which closely followed the line of the bridge. Martin points out that if it were decided to build a spinet of this type at eight foot pitch, then the opportunity would arise of allowing the side adjacent the bridge to follow the bridge's curve also, a design feature which it is difficult to adopt in the octave because of its small overall size.<sup>6</sup> This may indeed have been the source of the idea which has traditionally been attributed to Zenti. Nevertheless, there is a great deal more to the design of the spinet than the shape of the instrument. Another feature which was common practice

---

<sup>6</sup> Personal communication, September 2008

in harpsichord manufacture in Italy<sup>7</sup> was the use of a register in the form of a box guide attached to the case, rather than to the soundboard. This feature also appears in the Zenti and Ringve spinets. It seems that members of this first Italian school of spinet making adopted some of the features of the indigenous harpsichord making tradition with which they were familiar, rather than providing an entirely disjunctive innovation. However it is the combination of these more common features with the unusual geometry, perhaps derived from the octave spinet as already discussed, which is responsible for the success of the design. The monolithic wrestplank above the keyboard and the attachment of the register to it, provide a markedly enhanced structural rigidity to the instrument as compared with the virginal. The reversal of the usual arrangement of the string band so that the longer strings are at the rear aids the mechanical reliability of the instrument by allowing plucking of the bass strings close to the nut.<sup>8</sup> The amplitude of vibration of the bass strings in this arrangement is markedly reduced as compared with the virginal. This and the ability to provide a register which is fixed rather than vibrating with the soundboard avoids the problems of lack of repetition in the bass to which virginals are subject. These innovations also provide an instrument with a unique tone, an aspect of the design which is discussed in Chapter Eight.

The spinet was clearly associated with Italy for a considerable period, since in the inventory of Jean Denis (II) of 1686 quoted in Hubbard (1965: 107) we find:-

---

<sup>7</sup> Whether it *originated* in Italy is moot: some authors suggest it was German in origin.

<sup>8</sup> Though it is possible to achieve this in virginals, it implies a design in which the left bridge is close to the register (with consequent shortening of the sounding length), or a string-band which is pronouncedly displaced to the right hand of the instrument, which may adversely affect the size of free soundboard in the treble.

*'quatre corps d'Epinettes l'un à l'Italienne et les trois autres quarré don't deux a deux coffrets et l'un qui n'a que le clavier, les petites sont garnys de leur tables, et celle a l'Italienne aussy.'*<sup>9</sup>

In his discussion of this entry, Hubbard points to the fact that since two of the square instruments had 'two cases' and were therefore recognisably 'inner-outer' instruments something else must have been meant by '*à l'Italienne*'. Hubbard believed that what was meant was that the spinet described was of the bentside form and that the appellation recognised the contribution of Italian makers in general and of Zenti in particular to this design. If that is so, and it is difficult to gainsay it, then it is probably fruitless to ask whether the spinet might have originated in Italy and France more or less simultaneously but independently: it seems it did not.

Nevertheless the possibility of concurrent development has been tentatively suggested by Wraight (1997: 151), based upon an entry in Boalch (1995: 510) for a spinet dated 1632 by Jean Montazeau, although it is not stated whether this is a bentside spinet or perhaps a triangular one. The location of this instrument is unknown. Clearly the maker's name is of French origin, though whether he was active in France, or whether he worked in Italy, or was associated in some way with Zenti is also unknown. Apart from that reference, the earliest surviving French spinets known to the author are listed in Table 301 below, which has been assembled from the data in Boalch (1995: 549, 291, 243, 538 & 540 respectively).<sup>10</sup>

---

<sup>9</sup> Four spinet cases, one in the Italian style and the three others squared, of which two have two cases and one which has only a keyboard, the small ones provided with their soundboards, and the one in the Italian style also (Hubbard's translation).

<sup>10</sup> The 1667 spinet by Jean Denis (III) exhibited in Varzy, Nièvre and listed by Boalch (1995: 291) is an octave spinet (Germann 1981: 192).

<b>Table 301</b>		
<b>Surviving Early French Spinets</b>		
<b>Date</b>	<b>Maker</b>	<b>Collection</b>
1680	Rozet	Musée des Beaux-Arts et d'Archologie, Besançon
1681	Louis Denis	Tagliavini, Bologna
1686	Nicolas Blanchet	Charleston Museum, South Carolina
1689	Honoré Rastoin	Not known
1690	Michel Richard	Musée de la Musique, Paris

Apart from these five surviving instruments, the remaining French spinets appear to be eighteenth century examples. The dates of these surviving instruments are considerably later than that of the Zenti and, by extension, most probably later than the similar Ringve instrument and unless evidence comes to light showing earlier existence of spinets in France, the conclusion to be drawn is that both the English and the French schools of spinet making owed their origin to the Italian school.<sup>11</sup> Indeed there is some circumstantial documentary evidence to support the idea that Zenti himself brought his design to England:-

Reference was made earlier to the apparent eclecticism of Girolamo Zenti: he worked at the courts of Queen Christina of Sweden in Rome and afterwards in Stockholm between about 1652 and 1654, and of Louis XIV in Paris from about 1660 to 1662 before coming to London.<sup>12</sup> He was clearly in London in 1663, attached to the English Court as a harpsichord maker, since on 29<sup>th</sup> January 1663/4 a pass was issued to him to travel to Italy (Ashbee & Lasocki (1998: 1186)). On 27<sup>th</sup>

---

<sup>11</sup> Germann suggests (1980: 435) that the use of ebony natural plates and 'solid bone sharps which slant downhill at the back' is of French origin. That is probably so, but it is not inconsistent with the design of the spinet being Italian.

<sup>12</sup> Ripin comments that the date of Zenti's arrival in London does not emerge from the English state papers. A possible explanation for that is that Zenti was of insufficient status, as a mere harpsichord maker, to be recorded individually, as in the case of his arrival in Stockholm, but that he arrived as a member of a group of Italian musicians who came to London in late 1662. (Ripin 1973: 71 & 72).

January 1664/5 ‘a payment order was issued by Charles II granting Zenti the sum of £50 a year as “Serv<sup>t</sup> in Ord<sup>y</sup> in y<sup>e</sup> place & quality of Our Virginall-maker”’ (Ripin 1973: 72). Ripin believed that this indicated that the payment order was for past services rendered by Zenti, presumably between late-1662 and 1664/5. A further reference to Zenti appears in 1668 when his employee – Andrea Testa – petitioned the King for a pension,

‘.. your Majestie about foure years since was pleased to give a pencion to Seignior Gerolamo Zenti, Harpsecall-maker, who in short time after obtained leave to goe beyond Sea, and sent your Petitioner (as one fitly qualified) to supply his place. The said Zenti since dieing at Parris in the French Kings service, and your Petitioner having in all this time only had a small sum of money for ordering and repairing your Majesty's Harpsicalls, being in great want and acquainting your Majestie therewith, your Majesty was graciously pleased to declare that your Petitioner should have a petition allowed him.’<sup>13</sup>.

The above accounts provide persuasive evidence of a connection between Zenti and the English court at a date at which we know from a surviving instrument that Zenti had already built at least one spinet, probably in Rome or Viterbo. It is consistent with a theory of the origination of the spinet in Italy and introduction of it into England shortly after the Restoration and subsequent introduction into France.

Despite the above, it is thought that the English spinet is more French in style than Italian. The use of walnut rather than oak as a construction timber, of marquetry decoration rather than gilded papers, and of pierced brass hinges rather than gothic iron ones, distances the treatment of the spinet stylistically from the rectangular virginal. This decorative treatment, which is essentially French, is a direct consequence of the cultural discontinuities which were identified in Chapter Two. So

---

<sup>13</sup> Mabbett (1986: 246, referring to National Archives, SP29/233, folio 143): she notes that another hand has filled in the dates of Zenti's pension and passport as, respectively, 27 and 29 January 1664/5.

though the basic design of the English spinet may well have been Italian, the stylistic influences on English makers were French.

Nevertheless, it is noticeable that some French spinets and some English ones also, adopt decorative features which are Italian. Spinets by both Cawton Aston and by Benjamin Slade have been found with Italianate scrolls on the inside of the keywell cheeks, in imitation of the scrolled cheeks found in Italian inner-outer instruments.<sup>14</sup>

The Blanchet spinet at Charleston Museum, South Carolina also has this feature as does the 1709 Thomas Barton harpsichord in St.Cecilia's Hall.

The objection might be raised here that Table 301 indicates that the earliest surviving French spinets date only from the 1680s, while it is clear from the diary entries of Samuel Pepys referred to in Chapter Two that spinets were being made in London at least by 1668. Though that is true, it should not be overlooked that the earliest surviving English spinets also date only from the 1680s: the earliest instruments to have survived, from both England and from France, are therefore closely contemporary.<sup>15</sup> A further objection might be that French spinets are generally painted, rather than being in bare timber. That is so, but it is not clear that these decorations are original.<sup>16</sup>

If the design of the English spinet is French with Italian origins, how did the English virginal makers – Haward, Player and Keene – become aware of it in the mid-1660s?

It has been suggested that John Player was a supplier to the English Court at this

---

<sup>14</sup> The Zenti spinet is such an instrument and its case survives.

<sup>15</sup> There are in any case very few surviving French harpsichords of any type, owing to destruction of a large number of them during the Revolution.

<sup>16</sup> It is not only French spinets which are suspected of having been painted some time after manufacture. A spinet by John Player offered for sale at Messrs Bonhams on 4<sup>th</sup> November 2008 has also been painted with *chinoiserie*. This instrument is briefly described in Appendix Three.

time, since his virginal dated 1664, now in the Cobbe Collection at Hatchlands Park, Surrey bears the branding ‘WP’ on the left face-board. This is thought to indicate that the instrument was supplied to Whitehall Palace (Cobbe 1992, referred to in Boalch 1995: 525). If that is the position, then it may be that Player saw a spinet by Zenti at the Palace and perhaps even while Zenti was there, though that is speculation.

It is also clear that Charles Haward was working at the Court, since in 1674 a record of a payment appears in the Lord Chamberlain’s accounts,

‘To Mr Charles Haward for mending the harpsicords and pedalls at the Great Hall in the Privy Lodgings and for the private musick, for two whole years - £6 10s 0d.’

and again in 1675,

‘To Mr Haward the virginnall maker, for mending the harpsichords – £2 0s 0d’ (Lafontaine 1909: 299 & 300).<sup>17</sup>

The excerpts in Chapter Two from the diary of Samuel Pepys, describing his visits to Charles Haward in 1668 and eventual purchase of a spinet, also establish that Haward was making spinets by that time, and that he was making them speculatively.

There are several possible inferences from these facts but it seems most likely that one or both of Haward and Player saw a spinet at Court, or in the house of a person prominent at Court – either a French instrument which was copied directly,<sup>18</sup> or an

---

<sup>17</sup> Lafontaine refers to the Lord Chamberlain’s Accounts Vol. 745, 345-355 for 7<sup>th</sup> February 1675/6. It is thought these papers are now catalogued as National Archives, LC 9-11 in date order. These references to Haward are not included in Ashbee & Lasocki (1998).

<sup>18</sup> The Denis spinet of 1681 referred to in Table 30 exhibits characteristics also found in Haward spinets, including a serpentine bentside, a rose and a soundboard register. The same features are exhibited in the anonymous instrument illustrated in Plate 44 of Russell (1959).

Italian one which was copied but produced in a French style.<sup>19</sup> One of those scenarios seems the most likely account of the emergence of the spinet in England. Alternative scenarios would necessitate the notion of independent conception of the bentside design by an English maker. While independent and substantially simultaneous generation of an idea by two persons is not unknown in the history of technical development, it is very rare: direct copying is much the more usual circumstance. For that reason, an hypothesis of the emergence of the English spinet based on independent origination is rejected as being improbable.

## **2. The Spinet in English Musical Culture**

### **a. Spinet and Harpsichord Ownership**

The general understanding about spinet ownership in the seventeenth and eighteenth century has been that the spinet was an instrument which was acquired by a person who would have preferred a harpsichord, but who either could not afford one or who had insufficient space for one. What little has been written about the instrument by scholars tends to caricature the spinet as just a ‘poor man’s harpsichord’. That is the designation accorded to it by James (1930: 32):-

‘Those who could not afford or who had not room for a harpsichord would buy a spinet, but although they were being made as late as 1785 they were by that time obsolete [...] Apart from these considerations of cost and size – to which may be added its undoubted charm as a piece of furniture – the spinet is essentially the inferior instrument, for its tone is often harsh and inevitably monotonous owing to the lack of stops.’

---

<sup>19</sup> At this date, the concept of property was only just beginning to emerge, largely influenced by John Locke’s labour theory. Copying did not carry the moral approbation which it does today.

That somewhat pejorative characterisation has persisted. The Catalogue of the Victoria and Albert Museum (Russell 1968: 21) comments that

‘The spinet became a popular instrument in England in the eighteenth century, and was no doubt generally used in circumstances in which the upright piano forte would make its appearance today’,

and in the definition of ‘spinet’ in their article in *Grove Music Online*<sup>20</sup> Ripin/Whitehead comments,

‘More affordable than a harpsichord [...] the spinet is essentially a domestic instrument, which cannot be said to have a repertory of its own distinct from that of the harpsichord. However, much of the music printed in such collections as *Musick’s Handmaid* (1663, 1689), *The Harpsichord Miscellany* (2 vols., c1763) and *The Harpsichord Master* (1697–1734) was doubtless intended for use by the amateur performer who had no larger instrument at his disposal.’

The overall implication of these comments is clear: the spinet was an inferior instrument which does not compare well with the harpsichord.

That may be fair comment for the later spinets built from about 1740 to 1780, during which period they had to stand comparison with large multi-register harpsichords. By that time Shudi and Kirckman had started to produce harpsichords in great numbers using trade suppliers to produce specialist items, and as a result the availability of harpsichords had risen and their cost fallen in relative terms. But the pejorative characterisation of the spinet is much less fitting for the early instruments considered here.

If the numbers of surviving English harpsichords built before 1740 is juxtaposed with the numbers of surviving spinets, it is difficult to avoid the conclusion that the

---

<sup>20</sup> Ripin E M & Whitehead L., ‘Spinet’ in *Grove Music Online* ed. L.Macy accessed 21<sup>st</sup> January 2008.<<http://www.grovemusic.com>>

harpsichord was quite a rare instrument in the late-Stuart and Early-Georgian periods,<sup>21</sup> although populations of surviving instruments are not necessarily accurate indicators of original populations – survival rates could be affected by physical stability differences, for example. Nevertheless, taking only the signed instruments (ie those listed in Boalch 1995) it is found that there are only fifteen surviving harpsichords from the period – those by Haward, Tisseran, Barton, Hancock, possibly three by Shudi, by Smith, Tabel, Slade, Coston, Hitchcock, Wilbrook, and two by Mahoon. Furthermore, the makers listed are predominantly spinet makers, only Smith and Tabel being un-represented by surviving signed spinets.<sup>22</sup> It is difficult to be certain what the equivalent figure is for the signed spinets surviving from the same period, since the present research has shown that there is much double-counting in Boalch 1995. However, an analysis undertaken by the author in 2007<sup>23</sup> indicated that the number is well over ninety, including about ten spinets listed as being by Haward, and a similar number by Player, in addition to the forty-six spinets identified in Chapter Five as belonging to the school of Keene and the thirty-two identified in Chapter Six as being by Hitchcock and probably falling within the temporal period.

It is a general principle of human behaviour that those things which are most valued (and most valuable) are those which are most carefully kept. On that basis it could be expected that a harpsichord would be more carefully kept than a spinet and would

---

<sup>21</sup> Milhous & Price (1990: 39) note that before 1700, the harpsichord was an unusual instrument even in the London theatres, an environment where its power might be expected to have made it an essential component of the English theatre band. It did not become common even in this environment until the introduction of Italian opera to the London stage in the first decade of the eighteenth century.

<sup>22</sup> A spinet jointly signed by Slade and Tisseran survives

<sup>23</sup> This was undertaken for his paper 'The English Spinet – not so unassuming after all', presented at the University of Edinburgh Research Seminar, February 2007

have been more likely to have survived. So if, contrary to the argument here, there were more harpsichords than spinets in late-Stuart and early-Georgian England, then it could be expected that the number of harpsichords which would have survived to the present day would be very much greater than the number of spinets. But the opposite is true. Since that is the case, it may well be that the number of spinets made during the period in question exceeded the number of harpsichords by an even greater ratio than the approximately seven to one ratio indicated by the analysis just undertaken.

#### b. Early Owners

The purchase of a Charles Haward spinet by Samuel Pepys has already been referred to several times. Pepys was an official in the naval administration and was well-connected socially - he was the nephew Edward Montagu, 1st Earl of Sandwich and the First Sea Lord at the time when the Duke of York, later to be King James II, was Lord High Admiral. Pepys' skill as an administrator and his personal enthusiasm gained him considerable influence in Restoration London. He knew the Duke of York personally and as a musical person, Pepys may have exerted some influence on purchasing patterns of those at Court – it is easy to imagine his enthusiastic personality extolling the virtues of his newly purchased 'little espinette'.

Though Pepys is the most prominent early owner of a spinet there are other well-documented sources retrievable from the iconography of the instrument and from archival sources. The iconography of the spinet comprises two well-known portraits. The first portrait shows Master Garton Orme (1695-1758) seated at the spinet: it is

reproduced below as Plate 303, by kind permission of The Trustees of the Holburne Museum, Bath.<sup>24</sup>



**Plate 303**  
**A Portrait of Garton Orme**

Although it displays several interesting features of the instrument the main point of the portrait is the sitter. Master Orme, a child of about nine years, is dressed in extremely expensive-looking clothing complete with a ceremonial sword: the obvious conclusion is that the portrait depicts him on some important occasion - a birthday perhaps. The portrait has been attributed to Jonathan Richardson the Elder

---

<sup>24</sup> The Ormes were a wealthy family with estates at Graffham near Midhurst in Sussex. The museum acquired the portrait from Sir Orme Sargent in 1962. The painting was attributed to Jonathan Richardson the Elder in 1988 by Sir Oliver Millar (then Surveyor of H.M. the Queen's Pictures); that attribution was confirmed by Malcolm Rogers. The work was previously attributed to Thomas Hill, and before that to Sir Godfrey Kneller.

and dated to about 1707. As a comment from the Museum staff states, ‘it is difficult to be certain whether the portrait reflects the wealthy background of the child or whether it is more aspirational.’ But either way, the inclusion of the spinet indicates the desirability of the instrument to someone from a wealthy background.<sup>25</sup> The spinet in the portrait can be seen to have a compass with a GG/BB broken octave with two split sharps in the bass. It appears to rise to only c''' in the extreme treble, so in this respect, and also from the absence of a nameboard inscription, it can be said that some artistic licence has been taken. The nameboard is veneered in a light-coloured timber with inlaid stringing typical of a late-Stuart spinet. From the existence of a front stretcher near the sitter’s feet, the instrument appears to be placed on a table with barley-twist legs rather than on a stand.

A second well-known portrait which includes a spinet is that of Teresa Blount, which is reproduced below as Plate 304 by kind permission of the Virginia Historical Society. The Blounts of Mapledurham House near Reading were a prominent royalist family of Norman descent. Teresa Blount was for a time courted by the poet Alexander Pope. The portrait is thought to be from the school of Sir Godfrey Kneller and to date from 1709-1715 (Price & Rasmussen 1996: 74). It is clear from the triangular key-well cheeks that the instrument shown in the portrait is a spinet and not a harpsichord. Though it is not well drawn, it is also apparent that it has at least one split sharp in the bass and though it is not legible in the reproduction in Plate 304, Price and Rasmussen (1996: 70) report that the keyboard inscription reads

---

<sup>25</sup> The information in note 24 and the comment were Personal Communications from Amina Wright, Curator of Fine Art, The Holbourne Museum, University of Bath, July 2008.

*Franciscus Coston Londini fecit.* No signed spinets by Francis Coston are known to have survived,<sup>26</sup> though a harpsichord by him is now at St Cecilia's Hall.



**Plate 304**  
**A Portrait of Teresa Blount**

Though the spinet itself, like the sheet of music held by Miss Blount, may merely be a studio prop, it may equally be designed to show the sitter's musical prowess.

The presence in these two portraits of a spinet demonstrates the desirability of the spinet in late-Stuart England, but they are not the only pieces of evidence for that: it

---

<sup>26</sup> An unsigned spinet attributed by the auctioneers to Francis Coston appeared in the salerooms of Messrs Malletts in June 2005.

is clear that Henry Purcell owned at least two spinets. In the Will<sup>27</sup> of his wife Frances, who died in 1706, she reports that,

‘According to her husband's desire she had given her deare son a good education, and she alsoe did give him all the Bookes of Musicke in generall, the Organ, the double spinett, the single spinett, a silver tankard, a silver watch, two pair of gold buttons, a hair ring, a mourning ring of Dr. Busby's, a Larum clock, Mr. Edward Purcell's picture, handsome furniture for a room...’.

A double-strung spinet, perhaps the type of instrument referred to in this extract, has survived. It is by John Player and is in a private collection in Wiltshire (Boalch 1995: 525 and Mole (2008 b)).

A piece of primary evidence on the question of early ownership is a receipt for a spinet by Stephen Keene which has survived. It is dated 4<sup>th</sup> February 1689 and is made out to Lady Catherine Brudenell, Countess of Middleton. It is reproduced below as Plate 305.

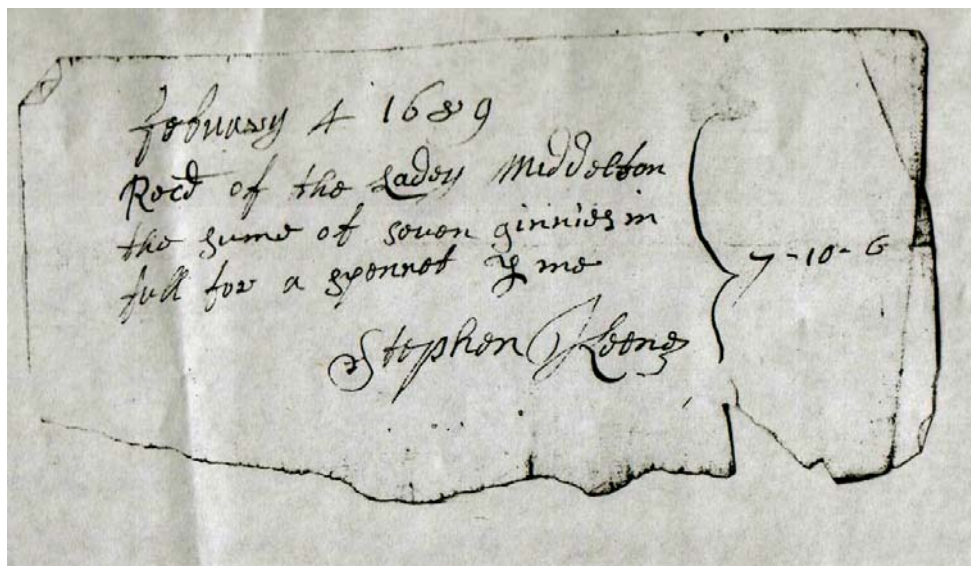

**Plate 305**  
**A Receipt of Payment for a Spinet by Stephen Keene**

<sup>27</sup> National Archive PROB11/489

The spinet is now lost, or at least it cannot be identified. Two mezzotints of Lady Middleton are held in the National Portrait Gallery, London.<sup>28</sup>

Other aristocrats also bought spinets: one such person who has left a record is Lady Grisell Baillie, Countess of Haddington, of Mellerstain House, Kelso, Scotland. The following passage appears in her household accounts for 1707 recording the routine which she set for 'Grisie', one of her two daughters, then aged fourteen:-

'To rise by seven a clock and goe about her duty of reading etc etc and be drest and come to breakfast at nine, to play of the spinet till eleven, from eleven till twelve to write and read French, at two a clock to sew her seam till four, at four learn arithmetic, after that dance and play herself until supper and be in bed at nine'.

It sounds a strict regime and one unlikely, one would think, to generate much enthusiasm for 'playing of the spinet'.<sup>29</sup> But it does establish that daily activity as one which was expected of a young gentlewoman at this time.

Lastly, it seems highly probable that the Keene spinet now owned by Lady Willoughby de Eresby (see Chapter Five) was first purchased in 1707 by her ancestor, Lady Jean Drummond, 2<sup>nd</sup> Duchess of Perth. The spinet has been included in the Willoughby de Eresby family inventories since the eighteenth century and has been kept until recent times at the family's private home Drummond Castle,

---

<sup>28</sup> National Portrait Gallery, London D5255/6.

<sup>29</sup> Mellerstaine House, the home of the present Lord and Lady Bailie, Earl and Countess of Haddington, contains a spinet by Charles Haward, though it is probably not the spinet upon which 'Grisie' was made to play. <http://www.archive.org/details/householdbookofl00bailrich> accessed 13<sup>th</sup> August 2008.

Perthshire, once the home of the 2<sup>nd</sup> Duchess. On the death of the present Lady Willoughby's father in 1983 it was moved to Grimsthorpe Castle, Lincolnshire.<sup>30</sup>

The persons exemplified in the documentary and iconographic sources listed above include some of the most aristocratic members of the society of late-Stuart England and Scotland, a senior and influential administrator, and the foremost composer of his day. These people cannot be regarded as being unable to afford a harpsichord or unable to find room for one: such a suggestion taxes the credulity. On the contrary, the iconography even suggests that possession of a spinet may have added to such a person's status. This evidence is admittedly small in quantity, but it is sufficient, in the authors view, to justify a rejection of the indiscriminate "poor man's harpsichord" characterisation of the spinet by James and later commentators: it is inconsistent with the evidence, at least for the late-Stuart spinet.

By the middle of the eighteenth century the place of the spinet conformed more closely to the modern stereotype characterisation of it as a poor-man's harpsichord. This can be seen from *The Accounts of Thomas Green* (Sheldrick 1992). Green (1719-1791) was an instrument-tuner, music teacher, and drawing master. In the course of his work he visited the houses of several aristocrats and almost four hundred more ordinary families, within a radius of about eight miles from his homes, first in Cheshunt, Hertfordshire and later in Hertford itself. His accounts provide a detailed insight into the musical instruments which belonged to those families in the

---

<sup>30</sup> Personal communication, Lady Willoughby de Eresby, March 2007. One of Lady Willoughby's ancestors is the Tudor soldier 'Lord Willobie' for whom William Byrd wrote *Lord Willobie's Welcome Home*. Possibly the Willoughbys were a musical family.

mid- to late-eighteenth century, sometimes with particulars of makers, of musical dispositions, of how often the instruments were serviced and to whom they passed over time.

It is clear that by the time that Green was working, the aristocracy and gentry owned harpsichords and not spinets. The Countess of Salisbury at Hatfield, Lady St John at Goldings, the Marchioness of Exeter, then living at Bell Bar and Lady Herbert, Dowager Countess of Pembroke at Panshanger all owned harpsichords which Green tuned, but there is no mention of his tuning spinets specifically for those great personages.<sup>31</sup> But analysis shows that those houses sometimes held spinets too. Green tuned a spinet for a Miss Aldersley at Hatfield in 1766-7 and for a Miss Spooner at Goldings in 1755. These women may have been governesses or housekeepers.

Further down the social scale in the 1750s the spinet was ubiquitous. In addition to the persons already mentioned who owned both spinets and harpsichords, there were another seventy-nine people within the small area of Hertfordshire who owned spinets but not harpsichords. Green himself owned at least five different spinets at various times. Several of the spinets which he tuned are identified by maker and it is noteworthy that many of these instruments were of considerable age by the 1750s – a testament to their robust construction. Of makers working in the period 1680-1740 there is one spinet by Cawton Aston, four by Thomas Barton, two by Hitchcock, two

---

<sup>31</sup> The material in Sheldrick 1992 consists of little more than a series of lists reproduced from account books. The individual entries are numerous and are not referenced here separately.

by Joseph Mahoon, one by John Player and two by Benjamin Slade. That is quite a list and some of the instruments referred to deserve comment:-

Only two instruments definitely attributable to Cawton Aston have survived, one spinet by Aston himself dated 1726 and one by Aston and Barton dated 1709, although a third which bears the initials CA may also be by him (Boalch 1995: 225). There are no surviving instruments known to be by Samuel Blumer, though he is documented as a maker. The reference to the Player spinet belonging to Mrs Morgan at Warlies and identified in 1746 as 'double' is especially interesting. Since John Player died in 1707 (see Chapter Four) it seems that Mrs Morgan's double-strung spinet was at least forty, and more probably about seventy years old when Green encountered it last in 1753 (see generally Mole 2008 b).

### c. Music, Music Publishing, and Keyboard Players

Shortly before the emergence of the spinet in England, English music began to change. By 1628, all of the celebrated virginalist composers, William Byrd (d.1623), Orlando Gibbons (d.1625), John Bull (d.1628), and Peter Phillips (d.1628) had died: of those who composed in the virginalist tradition only Thomas Tomkins remained. Tomkins continued to compose pavan and galliard pairs, *In nomines*, and *miseres* until his death in 1656 (Caldwell 1973: 141-150), but others began to introduce continental styles into English music, chief of whom was William Lawes (1602-1645).<sup>32</sup> Lawes did not write for the keyboard, but his consort music contains the prototype of the keyboard suite – a slower alman and corant than those of the

---

<sup>32</sup> Lawes was killed fighting in the royalist cause in the Battle of Rowton Heath near Chester.

virginalists,<sup>33</sup> together with a sarabande. Dances arranged in this order were indicative of French influence (Caldwell 1973: 152). Transcriptions for keyboard of Lawes' consort music together with pieces in a similar French style by Albertus Bryne, Benjamin Rogers, Mathew Locke and others were included in the first edition of John Playford's *Musick's Hand-maid* in 1663.

The publication of *Musick's Hand-maid* was a watershed: - though some liturgical music had been published in England before the seventeenth century,<sup>34</sup> no keyboard music was printed in England until the publication of *Parthenia*<sup>35</sup> in 1612/3 (Brown, in Silbiger 2004: 28). *Parthenia*, which was re-published in 1646, 1651, and 1655, contained pieces by Byrd, Bull, and Gibbons, but the pieces included were not ones which were genuinely accessible to the amateur player. The music of the virginalists is intellectual, contrapuntal, often in four or more parts, and many of the pieces are long in comparison with later *genres*. This is music for professional keyboard players – those associated with a cathedral or a university college chapel for example – but it is not within the competence of girls and young women who have been playing for only a few months, which was the main amateur market in late-Stuart England. *Parthenia* was followed in 1624 or 1625 by *Parthenia In-Violata* which, though no longer focussed on Tudor formats, can still be considered only as a link between the keyboard music of the sixteenth century and that of the Carolean and Restoration periods.

---

<sup>33</sup> Caldwell (1973: 152) infers a slower tempo from the change of time signature from one which was related to the *saltarello* (6/2:3/1) to one which was related to the saraband (simple triple time)

<sup>34</sup> Notably by William Byrd (c.1543-1623) who together with Thomas Tallis published the *Cantiones Sacrae* in 1575

<sup>35</sup> The full title is *Parthenia or the Maydenhead of the first musicke that ever was printed for the Virginalls*

In *Musick's Hand-maid*, for the first time a collection of pieces for the keyboard which was graded in technical difficulty was available in print. It quickly sold out and was subsequently re-published, with a second part appearing in 1689. In contrast to *Parthenia*, it is an extremely accessible collection. It consists largely of melodic pieces to be decorated in the French style, with simple harmonisation in the left hand. The first piece in it, a simple prelude based on one by John Bull, would be approachable by someone after only a few weeks of tuition on the keyboard, and the whole volume proceeds no further in technical difficulty than could be reached within three or four years at the most. It set a pattern for printed keyboard music which continues to the present day.<sup>36</sup>

Pieces by Henry Purcell appeared in the second part of *Musicke's Hand-maid*, which used his name in its promotional introduction, but Purcell's main contribution to the keyboard repertoire was his posthumously published *Choice Collection of Lessons for the Harpsichord or Spinet* (London, 1696). As noted by Holman et al. in their article on Purcell in *Grove Music Online*,<sup>37</sup> this has the double distinction of being not only the first keyboard collection printed in England which was devoted to a single composer, but is also the first to acknowledge the importance of the spinet, and of those who played it to sales of keyboard music by including the name of the instrument in the title.

---

<sup>36</sup> For example, the *Easy Keyboard Pieces* of the Associated board of the Royal Schools of Music, London and the *Leichte Klaviermusik* series of G Henle Verlag, Munich.

<sup>37</sup> Holman, P., Thompson, R., and Humphreys, M., 'Purcell' *Grove Music Online* ed L. Macy (accessed 4<sup>th</sup> September 2005) <<http://www.grovemusic.com>>

We cannot of course know what Purcell's intention was for the choice of keyboard instrument on which to play his relatively small output of keyboard pieces. They could have been intended for the virginal, the harpsichord or the spinet. However, 'the frequency with which the term 'spinet' arises in connection with Purcell certainly makes the spinet a likely choice'.<sup>38</sup> 'Mr Henry Purcell the spinet master' as he was referred to by Rhoda Cartwright,<sup>39</sup> very probably played these pieces on the spinet himself.

Prior to the publication of *Parthenia*, music had been published by manuscript copying or by letterpress printing. Letterpress printing was suitable only for the simplest music with the result that its use was largely restricted to liturgical settings,<sup>40</sup> and professionally-produced manuscript copies were beyond the means of all but the wealthiest. As a result, if less wealthy persons were to own sheet music at all, then it was most likely to have been owned as a home-made manuscript copy. The routine adoption of copper-plate engraving by John Playford as the preferred process for publishing music had a marked effect in reducing its price, opening up published music to a wider group of players.

In the discussion above, some comments are made about the likely level of technical competence achieved by early- to mid-seventeenth century keyboard players. An insight into the probable level of achievement has been provided by Bailey (2008)

---

<sup>38</sup> Christopher Hogwood, speaking at the Purcell Society's Study Day at the British Library, 4<sup>th</sup> October, 2008

<sup>39</sup> Rhoda (or Rhodia) Cartwright of Aynho, Northamptonshire, married Lord Henry Cavendish, second son of the Duke of Newcastle. She is the dedicatee of Purcell's posthumously published 1697 trio sonatas and herself studied the spinet with Purcell (Keates 1996: 190)

<sup>40</sup> See the notes to Thurston Dart's undated edition of *Musick's Hand-maid* (Stainer & Bell Ltd.)

who examined collections of manuscript keyboard music belonging to contemporary players. Bailey contrasts two early seventeenth century virginal books, those of Priscilla Bunbury and Lady Jean Cambell, both dating from the late 1630s, with that of Elizabeth Rogers (c.1657). She points to the extreme simplicity of the pieces collected by or for Priscilla Bunbury and Lady Jean Cambell, listing such items as masque tunes, settings of popular songs, and fashionable dances. She characterises the pieces as requiring ‘extremely modest technical proficiency’ (Bailey 2008: 510). Elizabeth Rogers’ virginal book is more demanding: it too contains old-fashioned repertoire in the form of masque tunes but also more contemporary pieces, some derived from foreign sources. The latter include pieces by La Barre, Jean Mercure and Jacques Champion de Chambonnières. But Bailey concludes that Elizabeth Rogers’ technique was unusual, probably the result of special teaching in composition and ornamentation ‘beyond the simple performance requirements we have assumed were necessary for marriageability’ (Bailey 2008: 542).

These ‘simple performance requirements’ emerge also from *The Accounts of Thomas Green* (Sheldrick 1992).<sup>41</sup> Most of Green’s clients were female: of the one hundred and twelve clients listed in Sheldrick (1992) for whom Green tuned spinets, only twenty-nine of those were male. Not only was the playing of keyboard instruments a women’s accomplishment, it was one mostly for young women. Women like Green’s client Lady Caroline Seymour (née Cowper) who were committed players throughout their lives were unusual. The normal pattern was that a girl would begin lessons at the age of about eight to ten years and would have given up playing by the

---

<sup>41</sup> These accounts were compiled in the mid- to late-eighteenth century and were therefore later in date than the prime temporal focus here.

time she had reached the age of sixteen. This pattern can be recognised in Green's accounts. In about 1780 Green compiled a detailed '*List of scholars and the time, when they begun, and left off,*' to which he later added (Sheldrick 1992: 133). The list opens with 'Miss Letitia Cartright begun in the year 1743 and learnt till the year 1746' and continues in a similar vein with about seventy-five entries for private pupils whom Green taught from 1738 to 1782: most of the periods of teaching are very short, some being as little as from July to October the same year and many being for less than a year.

The account for another pupil, who may just possibly have been an adult, Miss Hadley of Ware Priory, gives an insight into the level of proficiency which Green's pupils sometimes reached. 'Miss Hadley', who seems to have had a sister who also played, was taught from May 1782 to January 1787. Green's accounts include the following items which he purchased for her:-

'1783	Bach's Sonatas Op 16 dedicated to Miss Greenlands <sup>42</sup> .	10s 6d
1784	A Lesson, Arnold and Bach's Sonatas	1gn
1785	Handel's Organ Concerto	5s
1786	Nicholai's Sonatas	10s 6d
1786	Handel's Overtures 6 of them	3s'

The occasional example noted by Thomas Green of what would now be regarded as a modest level of keyboard attainment should not disguise the fact that most eighteenth century young women were not especially competent players. At this period they generally played the accompaniment to popular songs derived from the theatre, perhaps accompanying themselves on the vocal line. The keyboard accompaniment in these strophic songs was by definition repetitive and was therefore

---

<sup>42</sup> The reference is, of course, to Johann Christian Bach

ideally suited to a player who is a beginner but perhaps unlikely to be a 'continuer' and who may not be particularly interested in playing in the first place!

In summary, the evidence in Bailey 2008 from the seventeenth century, and in Sheldrick 1992 from the eighteenth, shows the average amateur keyboard player not to have achieved a high level of technical competence. The combination of the circumstance of players struggling to play through inadequate technique, the introduction into English music of more modern and less technically taxing pieces, and the publication by Playford of a relatively inexpensive volume of these works, will undoubtedly have stimulated interest in keyboard playing. It is no coincidence that the spinet, the new instrument then, gained popularity in the late seventeenth century.

It is appropriate to say something here about the practice of transposition at the keyboard, since it has a bearing on the question of pitch, which is considered in Chapter Eight. Particularly at the beginning of the period under discussion it would not have been unusual to transpose the notated music to whatever pitch was required. Haynes (2002: 90) suggests that before the Restoration, transposition by a major second or a minor third would have been routinely necessary in England to enable ensemble playing.<sup>43</sup> After the Restoration new instruments, and especially new wind instruments, were being imported into England from France, pitched about one and a half semitones below modern pitch of a' ~ 440Hz. (See Haynes (2002: 124ff and Chapter Eight). Those who still possessed the instruments pitched at the

---

<sup>43</sup> The implication there is that would have been ensemble playing by professionals.

old quire pitch of about  $a' \sim 473\text{Hz}$ . would have been in some difficulty unless they had a facility with transposition. Those who accompanied them on the keyboard would have faced the same difficulty. That suggests a level of competence at the keyboard which would be unusual today, but that may give a false impression. It seems likely that as a consequence of the use of moveable clefs in notated music, keyboard pupils would have been taught to be much more conscious of musical intervals and less conscious of notated pitch than are their modern counterparts.

### **3. Summary**

This chapter began with an evaluation of the probable route by which the spinet was introduced to England. The evidence of surviving instruments points to the development of the design in Italy about 1630 by a school which included, but was not necessarily confined to Girolamo Zenti. It is thought either that Zenti introduced his design to England directly during his visit to the Court, or that it was introduced indirectly through from France, probably by importation of one or more instruments. It was suggested that the most likely mechanism by which the spinet became first known and later copied in England was through visits to the Court to repair instruments by native craftsmen including Charles Haward and John Player. It is clear from archival evidence and from the numbers of surviving instruments that the spinet quickly became popular in the latter part of the reign of King Charles II, from 1680 onwards, maintaining its popularity at least until the mid 1750s. However, although the design was probably Italian in origin the manner in which it was adopted to English taste followed French fashions.

In its second part, the chapter criticises the common view that the spinet can be thought of as 'a poor man's harpsichord' as inconsistent with the evidence at this early phase of its life, though that may well be an accurate epithet for later instruments. It seems more likely that in the late-Stuart period, it was a highly sought-after instrument which was bought by persons at the upper end of English society.

In the final part of the chapter, evidence of the ownership and use of spinets and of patterns of instruction was examined. It suggests that in both of the centuries considered, most keyboard players were women who learnt for only a short time and were therefore unlikely to acquire a high level of competence as keyboard players. That observation will be true, whether the instrument played was the virginal the harpsichord or the spinet.

## Chapter Four – The School of Keene

This chapter provides salient details of the lives of those who can be thought of as forming the Keene school of spinet makers - Stephen Keene himself and his former apprentices and co-workers, Edward Blunt, Thomas Barton and Charles Brackley. It is based on information about these men which is contained in Boalch 1995, but has been supplemented by searches through the Apprenticeship and Freedom Registers<sup>1</sup> of the Joiners Company, and through the parish registers of the churches at which they worshipped held in the Guildhall Library, London. Further information has been derived from the Probate Records of the Canterbury Prerogative Court (PCC) held in the National Archives, Kew, Middlesex. An image of Keene's Will from those records is included in Appendix Four together with a transcript.

Some deductions are then made about the organisation of the Keene workshop. These deductions are used in Chapter Five for analysis of spinets from the School of Keene. The chapter also includes comments on some of those craftsmen whom Keene would have regarded as his competitors in business.

The Chapter concludes with a summary.

---

<sup>1</sup> London Guildhall MSs 8052 and 8051 respectively

## 1. Stephen Keene

Although a number of instruments bearing an inscription containing the name of Stephen Keene have survived, little is known about Keene himself. The records of the Joiners Company contain an entry for Keene's binding as an apprentice to Gabriel Townsend on 6<sup>th</sup> August 1655. The record reads,

‘Stephen Keen Sonn of Richard Keen late of Sydenham in the County of Oxford, ybound app. Gabriel Townsend Joyner for 7yrs from ye date 6 day’ (sic).

Adopting the assumption that when Keene became bound to Gabriel Townsend he was about the age of 16 years, his date of birth was therefore about 1639. From the record, it seems that he was probably born in the village of Sydenham, near Thame in Oxfordshire. However, the baptism records of St Mary, Sydenham have survived only from 1662<sup>2</sup> – many parishes lost their records during the Interregnum – so it seems unlikely that it will be possible to determine Keene's date of birth with precision.

The most informative document about Stephen Keene's family is his Will. The original Will<sup>3</sup> which is dated 4<sup>th</sup> December 1712, has survived:<sup>4</sup> it is not a holograph

---

<sup>2</sup> <http://www.oxfordshire.gov.uk/wps/portal/publicsite> accessed 19 February 2007. Since all of the children of the Richard Keene referred to in the Joiners Company's apprentice binding records will have been born well before 1662, the absence of parish records earlier than that date precludes precision about the number of children whom Richard Keene fathered: but the point is of minor importance here.

<sup>3</sup> National Archives, London, Barnes Quire Numbers 223-262: PROB 11/530

<sup>4</sup> Wills and their Grants of Probate (proofs) are bound separately in the National Archives

and there is no signature on it. Additionally, the Grant of Probate of the Will is in the records of the Canterbury Prerogative Court (PCC).<sup>5</sup>

Keene appointed his wife, Sarah, and his 'kinsman' Christopher Keene as his joint executors. There is no mention in the Will of virginals, spinets or indeed of any of his chattels but that is not unusual in Wills of this period – the normal practice (and indeed it was a legal requirement) was to prepare an inventory, but in this case if an inventory was prepared, it is missing from the records. Clearly, by the date of his death Keene was a person of some substance since he refers to 'all my freehold houses situated in York Buildings'<sup>6</sup> which he Wills to Christopher Keene, and to 'all that my freehold Estate in Grace St', (now Gracechurch Street), which he Wills to Christopher Keene and to Christopher's brothers, William and Stephen. Keene left a 'moiety'<sup>7</sup> of his personal property to his wife, Sarah, but there are other specific bequests, including one to his sister, Philadelphia White.

From the persons named, using the archival records at the Guildhall Library and the Wills of two of the persons to whom Keene refers, his wife Sarah and William Keene, it has been possible to construct a family tree of the Keenes, a shortened version of which appears below as Figure 401: a fuller version is in Appendix Four.

Keene specifically says that he and his wife were childless.

---

<sup>5</sup> Before 1858 wills were proved in any one of about 300 local ecclesiastical courts. The main court was the Prerogative Court of Canterbury which during the second half of the 17<sup>th</sup> century had national jurisdiction in certain circumstances.

<sup>6</sup> York Buildings, in Buckingham Street, which leads down to the river from The Strand, was the home of the diarist Samuel Pepys (it is illustrated on the rear cover of the dust jacket of de la Bedoyere 1995). It is therefore possible that Pepys and Keene knew each other.

<sup>7</sup> A 'moiety' in this context has the meaning of a half share: the other half was willed to Christopher Keene.

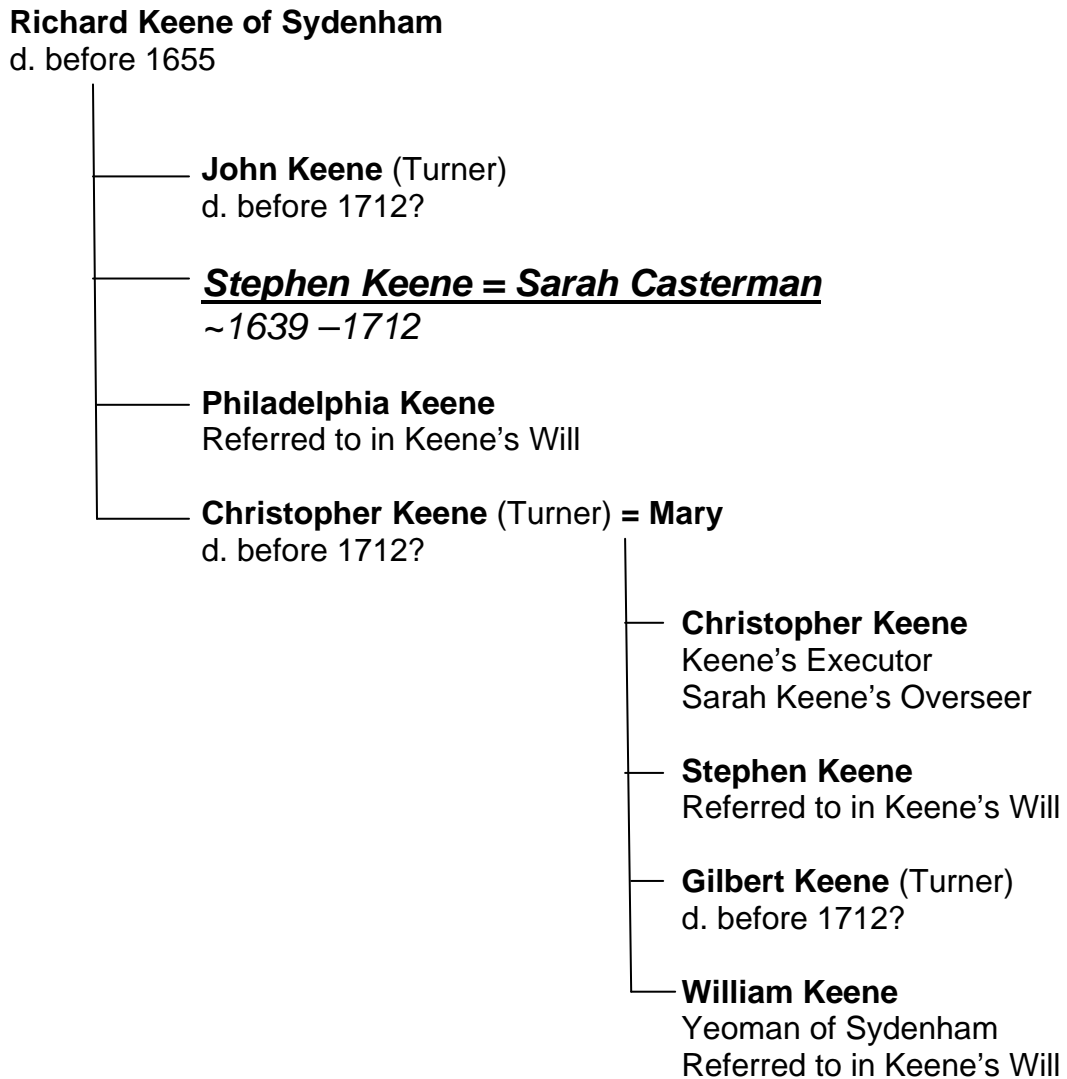
**Figure 401 – The Family Tree of Stephen Keene**

As is apparent from Figure 401, Keene had at least two brothers and a sister. From the fact that neither brother is mentioned in his Will, it is assumed here that both had died before Keene himself died in 1712. However, the apprenticeship records of the

Turners Company<sup>8</sup> show that John Keene was apprenticed as a turner in 1652 and Christopher Keene in 1660, also as a turner, so it seems that Stephen Keene was the middle brother.<sup>9</sup> Keene also had a sister, Philadelphia, who as noted in Chapter Three became Philadelphia White,<sup>10</sup> and possibly other siblings who did not survive to adulthood.

The village of Sydenham in Oxfordshire, from which Keene's father came, lies close to High Wycombe, which for centuries has been a centre of furniture-making in England on account of the large number of beech trees growing in that area. It is therefore unsurprising to find three brothers associated with woodworking crafts in that location: that fact may account for the otherwise difficult point of how it might be that Stephen Keene found himself apprenticed to a London virginal maker.

Keene's father, Richard Keene, is described in Keene's binding as 'of Sydenham' and in the Will of his nephew, William Keene he describes himself as 'of Sydenham in the county of Oxford, Yeoman'. So the family were probably farmers and that the farm property passed from Richard Keene to William Keene, Richard Keene's second oldest child.

---

<sup>8</sup> London Guildhall MS 3302/1

<sup>9</sup> It is said in Chapter Nine that it would have been unlawful for Joiners to make turned items because of the legal monopoly enjoyed by members of the Turners Company. Keene was clearly well-placed to commission turned items such as the legs of stands for his instruments.

<sup>10</sup> The possibility that she married into the family of Mrs Gabriel Townsend, who was a daughter of one of the White family of virginal makers has also been noted.

Keene was admitted to freedom of the Joiners Company on 3<sup>rd</sup> of November 1662.<sup>11</sup>

Like Townsend and Player before him, he became Master of the Joiners' Company, in 1704/5.<sup>12</sup>

Keene's Will was dated 4<sup>th</sup> December 1712 and he must have died a few days later, since the Grant of Probate, which is in Latin, was dated the 17<sup>th</sup> of the same month (see Appendix Four). This date is some seven years earlier than the date of death which appears in the literature. Although Boalch (1995: 102) gives Stephen Keene's death as 'after 1719', this is based upon the following extremely brief comment in Hipkins (1945: XXII).

'It is proved that Keene was long in business by a name-board which is in my possession dated 1719. Indeed, longer than the period occupied by Thomas Hitchcock, whose autograph occurs in spinets from 1664 and 1703.'<sup>13</sup>

The present whereabouts of that name-board is unknown. Furthermore, there is not a single surviving spinet by Keene which is dated on the name-board. Where Keene spinets are dated, the date is either inscribed on the jack-rail or is hand-written on a key-lever or on a jack. For that reason and because of the discovery of Keene's Will it is suggested that if this date was correctly read by Hipkins then it was a forgery.

A date of death for Keene of 1712 is fully consistent with the present-day absence of an instrument by Keene bearing a date later than 1711, and it provides a *terminus*

---

<sup>11</sup> MS 8051/1. The record, which is partly in Latin, indicates that by that time, Gabriel Townsend had died, since he was admitted on the recommendation of John Player, who had also been a Townsend apprentice.

<sup>12</sup> London Guildhall MS 8051/2. In 1661 one Gilbert Keene, possibly a relative of Stephen became Upper Warden of the Joiners Company (MS 8051/1).

<sup>13</sup> This comment must be taken in context. Hipkins (1945) is not a scholarly work. As argued elsewhere, the reference to Thomas Hitchcock is erroneous and it is suggested that Hipkins must have been mistaken about the name-board too.

*ante quem* for the date of the Keene & Brackley spinet, Keene's last surviving instrument.

The Grant of Probate of the Will of Keene's wife Sarah dated 8<sup>th</sup> September 1720 is also in the records of the Canterbury Prerogative Court.<sup>14</sup> Interestingly, looking at the persons named as beneficiaries, it is difficult to avoid the conclusion that Sarah Keene was related to Edward Blunt in some way. Sarah Keene appointed her 'Loving Cousin Christopher Keene' as Overseer of her Will and her 'Nephew Stephen Blunt' as her Executor. She names in her Will her 'late nephew'<sup>15</sup> Edward Blunt, which confirms the note in Boalch<sup>16</sup> that Blunt died 'before December 1718'. But additionally and significantly, Sarah Keene included Edward Blunt's still-infant daughter Mary as a beneficiary. Though this is not certain, it is therefore likely that the relationship between Stephen Keene and Edward Blunt was not only one of master and apprentice but also one of family.

It should be said that when Sarah married Stephen Keene her name was given as 'Casterman', but that is not necessarily inconsistent with her nephew being a Blunt, she might have had a sister who married a Blunt, and there are other possible explanations.

---

<sup>14</sup> National Archives, London, PROB 11/580

<sup>15</sup> Use of the terms 'cousin' and 'nephew' at this date need not necessarily indicate a blood relationship – they were often used as terms of endearment - but here they probably do show a family connection. Christopher Keene was not Sarah's cousin, but her nephew by marriage.

<sup>16</sup> Boalch (1995: 19)

The inscription ‘*Keene & Blunt*’ on two surviving spinets<sup>17</sup> are therefore significant:- Keene’s normal practice was for his name to be applied as a name-board inscription and for the apprentice or journeyman to initial a key or jack – this pattern is found both on earlier and on later Keene spinets which appear, for example, with the initials ‘JH’ (John Harris), ‘EB’ (Edward Blunt), ‘TB’ (Thomas Barton), and ‘CB’ (Charles Brackley). The existence of the two instruments with the joint inscription probably evidences a close business relationship amounting to *de facto* partnership. The persons referred to in both Wills are shown in the family tree in Appendix 4.

In 1693/4 what in effect was a wealth tax – the ‘Four Shilling in the Pound Tax’ was levied in England to fund the wars of William III (William of Orange) against Louis XIV. The returns from that levy have survived<sup>18</sup> and have been published in a volume entitled *London Inhabitants within the Walls*, the alphabetical index of which is available electronically.<sup>19</sup> Under the letter ‘K’ Stephen Keene and his wife Sarah are found.

A tax assessor was appointed for each parish and Keene was appointed assessor for the parish of St. Benet Fink.<sup>20</sup> He quotes himself as having with his wife Sarah personal wealth of £600. This was the maximum amount which was required to be

---

<sup>17</sup> These spinets are included in the discussion in Chapter Five. One is at Dumfries House, Ayr, Scotland and the other in private ownership in Lancaster.

<sup>18</sup> London Guildhall MS 11316/21

<sup>19</sup> An index of London inhabitants within the city walls in 1695. Based on assessments for 80 parishes made under the Act of 6 & 7 Wm. & Mary, c. 6, <http://www.british-history.ac.uk/source.aspx?pubid=31> accessed 28 January 2009.

<sup>20</sup> This church, whose strange name is accounted for by the fact that it was built by a family called Fink or Finke, stood in Threadneedle Street as shown in Plate 401. The original church was destroyed in the Great Fire and after being re-built by Wren, was again demolished in 1844 to make way for building of the present Royal Exchange.

declared and many such declarations would have hidden greater resources. Clearly Keene's virginals and spinets had made him a very wealthy man.<sup>21</sup>

Keene was the best known and most prestigious maker of his day and was patronised by some leading figures in society, some of whom have been identified in Chapter Three. The receipt made out to Lady Middleton referred to in Chapter Three bears Keene's signature: this signature matches that found on the tax records just referred to. Those facts prompt an additional comment. It is extremely unlikely that the Joiners Company would have elected as their Master someone who was not fully literate. Equally, it is extremely unlikely that Keene would have been appointed Tax Assessor for the Parish of St Benet Fink if he could not write fluently. That is the basis for the assertion made in Chapter Two that Stephen Keene was fully literate.

## **2. Edward Blunt**

From the binding registers of the Joiners Company, it is known that Edward Blunt was bound to Stephen Keene from 5<sup>th</sup> September 1693 for seven years. Again on the assumption that Blunt was about 16 years old when bound, he must have been born about 1677. His father, also called Edward, was a freeman of the Weavers Company.<sup>22</sup> Edward Blunt junior became a freeman of the Joiners in December 1700.<sup>23</sup> Blunt married Anne Beezley on 13<sup>th</sup> June 1702 at St James' Westminster and their daughter Anne was christened at St Botolph, Bishopsgate on 18 April

---

<sup>21</sup> John Player's name also appears in another parish, but with only £200 declared.

<sup>22</sup> London Guildhall MS 8051/2

<sup>23</sup> London Guildhall MS 8051/2

1703.<sup>24</sup> A son Edward, born 19<sup>th</sup> September 1704 was christened at St Benet Fink on 6<sup>th</sup> October 1704.<sup>25</sup> A spinet bearing the inscription *Stephanus Keene Edwardus Blunt Londini fecerunt* and bearing the date of 1702 has survived (Boalch 1995: 418), so it is clear that Keene regarded Blunt as his partner by this time. It seems likely that the period 1700 to 1702 was that during which Blunt was working for or with Keene in Keene's premises 'in Threadneedle Street at the sign of the virginals'.

A spinet dated 1703 bearing the inscription of Edward Blunt alone has survived. It was sold at Sotheby's on 24<sup>th</sup> November 2004 as Lot 261.<sup>26</sup> The catalogue entry for the lot noted that the spinet is inscribed *Edward Blunt Londini fecit*. After a short *résumé* including a description of the name-board as being of sycamore inlaid in a darker wood with a central crown flanked by two exotic birds, it stated that the uppermost jack is inscribed *Thomas Hitchcock 1703* and that the uppermost key lever is also inscribed *T.H.1703*.<sup>27</sup> This is a most significant instrument, since it provides the basis for two important inferences: - first that a Thomas Hitchcock was working for Edward Blunt in 1703. As will be shown in Chapter Six, the Thomas Hitchcock in question was the Thomas Hitchcock (of several of that name) who became a freeman of the Haberdashers Company in 1701.

The existence of the spinet also establishes that Edward Blunt was working on his own account by 1703, just possibly still in Keene's premises, but as a maker who

---

<sup>24</sup> London Guildhall MS 4516/2

<sup>25</sup> London Guildhall MS 4098

<sup>26</sup> [http://www.sothebys.com/app/live/lot/LotDetail.jsp?lot\\_id=4B5MS](http://www.sothebys.com/app/live/lot/LotDetail.jsp?lot_id=4B5MS), accessed 13<sup>th</sup> July 2007. An image from the catalogue appears in Appendix Six.

<sup>27</sup> The entry in Boalch (1995: 246) gives the date as 1705, but the author prefers the earlier reading as being more consistent with other evidence of Hitchcock activities.

presented himself to his customers as an independent proprietor. The latter inference is also supported by evidence from both the apprenticeship binding records of the Joiners Company and from the Land Tax Assessment Records for the Ward of Farringdon Without.<sup>28</sup> The records of the Joiners Company show the binding to Blunt of an apprentice, Nicholas Mitchell in 1704<sup>29</sup> and Abraham Saintcleer was bound to him in 1707.<sup>30</sup>

The question of the premises from which Blunt was working is clarified by the Land Tax Assessment records. It is clear that by 1706 he was in his own premises in the parish of St Benet Fink since a separate entry appears for him in that year. At some time between the Land Tax Assessment dates in 1707 and 1708 Blunt moved into John Player's former premises in the neighbouring parish of St. Martin Outwich,<sup>31</sup> Player having died in June 1707 (see page 95). These premises are recorded as being occupied by 'Widow Player' in 1707 and by Edward Blunt in 1708.<sup>32</sup>

It is not clear what prompted Blunt to move home. Perhaps he felt the need for more space because on 30<sup>th</sup> March 1708, a second daughter, Mary, was christened at St.

---

<sup>28</sup> London Guildhall MS 11316/21

<sup>29</sup> London Guildhall MS 8052/3. This fits very nicely with the date of Thomas Hitchcock Free 1701 leaving Blunt's employ, see Chapter 6.

<sup>30</sup> London Guildhall MS 8052/3

<sup>31</sup> London Guildhall MS 11316/27

<sup>32</sup> London Guildhall MS 1131624 & MS 11316/27. This discovery is somewhat surprising. It is likely that Player's premises were those of Gabriel Townsend before him, and that they had therefore been used for making keyboard instruments for about seventy five years when Player died. The advantage to Blunt of taking over well-known business premises is evident. However, (Morris 1986: 21) suggests that Cawton Aston became Player's successor in business, an assertion which is supported by the fact that Player's last two apprentices, Gabriel Pelly and Thomas Higgins were bound over to Aston in 1708 (Boalch 1995: 715/6). These Land Tax Assessment Records shows that if Aston regarded himself as the successor to Player's as proprietor of the Player business, then he carried it out in new premises.

Martin, Outwich.<sup>33</sup> John Bancks was bound to him as apprentice in 1709 (Boalch 1995: 715). St. Martin Outwich and St Bennet Fink stood very close to each other at the Bishopsgate end of Threadneedle Street, and St Botolph Bishopsgate was not far away, opposite the junction of Bishopsgate and Houndsditch (see Plate 401 on page 90 below). So the pattern of christenings does not imply that Blunt was living in a variety of lodgings at this stage. On the contrary, it implies a fairly static domestic arrangement.

Blunt's second daughter Mary died in April 1709. There must therefore have been a further child named Mary, since in the Will of Sarah Keene referred to above and dated 1720, a daughter of Edward Blunt named Mary is specifically referred to as still being a juvenile. But since none of the other children is mentioned in the Will, it is possible that none but this second Mary survived infancy. Boalch (1995: 19) states that Edward Blunt was dead by December 1718, without quoting the evidence for that, but the Land Tax Assessments provide clarification – in the year 1711 the Blunt (and former Player premises) were empty and in 1712 they were occupied by a James Anselm.<sup>34</sup> So either Blunt had died or he and his family had moved away. Since no further record of Blunt has survived, it seems likely that he died in 1711.

From the archival evidence referred to earlier, it seems likely that Blunt was Keene's nephew by marriage and that it was Keene's intention to leave his business to Blunt. Perhaps Keene helped Blunt to set up on his own with the intention of establishing

---

<sup>33</sup> London Guildhall MS 6837

<sup>34</sup> London Guildhall MS 11316/33 & 11316/36

Blunt's reputation before retiring from building instruments. If so, that plan may have been negated by Blunt's untimely death in his late 30s. Barton had by that time moved away and only Brackley was still working in Keene's premises. So Brackley became Keene's successor. This is hypothesis, but it is hypothesis which fits the known facts.

### **3. Thomas Barton**

Thomas Barton was baptised at St. Leonard, Shoreditch on 1<sup>st</sup> January 1685<sup>35</sup>. From the apprentice binding records of the Joiners Company<sup>36</sup> it can be seen that he was apprenticed to Stephen Keene, as Keene's penultimate apprentice on 1<sup>st</sup> August 1699. The record gives the trade of his father, also named Thomas, to have been that of a butcher. Barton became a Freeman of the Joiners Company in August 1706.<sup>37</sup>

Though it seems that Barton worked with Keene as a journeyman, unlike Blunt he does not seem to have worked as a freeman in partnership with Keene. Inspection of the Land Tax Assessment records shows that Barton had moved into his own premises in Keene's neighbouring parish of St. Martin Outwich by 1708.<sup>38</sup> He must have married his wife Mary between 1706 and 1708 since the parish records<sup>39</sup> record the birth of several children, including the birth of a son, Thomas in 1708, a daughter

---

<sup>35</sup> London Guildhall MS 7495

<sup>36</sup> London Guildhall MS 8052/3

<sup>37</sup> London Guildhall 8051/2

<sup>38</sup> London Guildhall MS 11316/27

<sup>39</sup> London Guildhall MS 6837

Mary in 1711, Richard in 1714, William in 1715<sup>40</sup>, another Thomas in 1717 who died almost immediately, and Susanna in 1720. Since the entry in Boalch (1995: 11) refers to Barton living ‘at The Crown, near the South Seas House’, that would be consistent with his worshipping at St. Martin Outwich since the South Seas House was directly opposite the church in Threadneedle Street. It is therefore suggested that that is where his work place was. An extract from Strype’s 1720 edition of John Stow’s Survey of London and Westminster, showing the South Seas House is reproduced below as Plate 401 on page 90.

It might be wondered why Barton was apparently not taken into partnership by Keene when he became free of his binding to Stephen Keene in August 1706. That question becomes the more pertinent given that as established above, Edward Blunt, was no longer in partnership with Keene and was in all probability working on his own account and certainly from separate premises close by.<sup>41</sup> One answer is that Barton joined with Cawton Aston in business rather than with Keene. Evidence for that is the survival of a spinet dated 1709 and inscribed on the wrest plank *Aston & Barton Londini FF*, said by Boalch (1995: 225) to be in the Museum of Fine Arts, Boston, although it has not been possible to confirm that. But if these two men worked together, then it seems that it was only for a short period, since spinets

---

<sup>40</sup> Boalch (1995:12) refers to British Patent No 525 dated 1730 which relates to the use of metal plectra in plucked instruments. The proprietor’s name is apparently William Barton. Boalch suggests that this William Barton was a son of Thomas Barton. That seems unlikely to the case, since the William who was Thomas Barton’s son would have been only 15 years old at the time of the patent grant. This matter has not been researched since no instruments by William Barton are known to have survived.

<sup>41</sup> London Guildhall MS 11316/21

inscribed with their names separately have survived. The surviving spinets by Barton are considered in Chapter Five.

#### 4. Charles Brackley

The record of Charles Brackley's binding<sup>42</sup> to Stephen Keene is dated 2 November 1703. It reads 'Charles Brackley son of John Brackley of Roughton in the County of Wilts Clerke putts to Stephen Keene Citizen and Joyner of London for 7 yeares date as above'. Again using the assumption that he would have been apprenticed at the age of about sixteen years, Charles Brackley would therefore have been born about 1687. Roughton (now Wroughton) lies between Swindon and Devizes in Wiltshire. John Brackley, Charles's father, was appointed Perpetual Vicar of Roughton, a sinecure, in 1682 and it can be presumed that the Reverend Brackley and his wife Sarah (nee Stilwell) lived in the vicarage, a house which is still standing.<sup>43</sup> Charles Brackley became a freeman of the Joiners Company in January 1710.<sup>44</sup>

On 2<sup>nd</sup> September 1711, Brackley married Elizabeth Langwill or Longueville at St. Benet Fink. A son, Samuel, was baptised at St Benet on 21st June 1713, and a daughter, Sarah, named after Brackley's mother, on 12<sup>th</sup> April 1715, but the baby survived only until July 1718. A further daughter, Elizabeth, was baptised on 23<sup>rd</sup> August 1717 but died later that year.

---

<sup>42</sup> London Guildhall MS 8052/3

<sup>43</sup> It is now called Ivery House (Personal Communication, Nick Orman, July 2007)

<sup>44</sup> London Guildhall MS 8051/3. The freedom record appears not to have been written out correctly by the Company's registrar, since it is incomplete. Nevertheless, there is no doubt that it refers to Brackley.

The entries in the parish register of St Benet Fink for the year 1718 are significant. The record notes the birth of Charles Brackley, ‘son of Charles and Elizabeth Brackley’, on 12th January 1718 and his baptism the following day. But a further entry records the burial of a Charles Brackley on 2<sup>nd</sup> October 1718. The Gregorian calendar, in which the year changes at the 1<sup>st</sup> January, was not adopted in England until 1752. Before that, and consequently in 1718, the Julian calendar was used in which the year changes at 26<sup>th</sup> March. It follows that October 2<sup>nd</sup> is earlier in the year 1718 than is January 12<sup>th</sup> and the inescapable conclusion therefore is that Charles Brackley the spinet maker died in October 1718, before the birth of his son later that year. That is consistent with the fact that no further record of him or of his family has been found and it is not known what became of the family.<sup>45</sup>

## 5. The Keene Workshop

Two Stephen Keene virginals dated 1668 and 1675 survive, so Keene’s workshop must have been established by 1668 at least. That is confirmed by an advertisement which appears in the sixth edition of Playford’s *Introduction to the Skill of Music* (1672):-

‘Mister Stephen Keen, Maker of Harpsicons and Virginals, dwelleth now in Threadneedle Street at the sign of the Virginal, who maketh them exactly good both for sound and substance.’

The word ‘now’ is interesting, indicating that Keene had recently moved to Threadneedle Street, perhaps into new premises after the devastation caused by the Great Fire in 1666. Threadneedle Street is shown in Plate 401, which is an extract

---

<sup>45</sup> All of the otherwise un-referenced archival information referred to under this heading can be found in London Guildhall MSs 4097 & 4098, the parish registers of St Benet Fink.

from Strype's 1720 edition of John Stow's Survey of London and Westminster. The octagonal church of St Benet Fink, where Keene worshipped, the church of St. Martin, Outwich, the South Seas House opposite St. Martins, and Birchin Lane are all highlighted in red as being of significance for those makers discussed in this chapter.

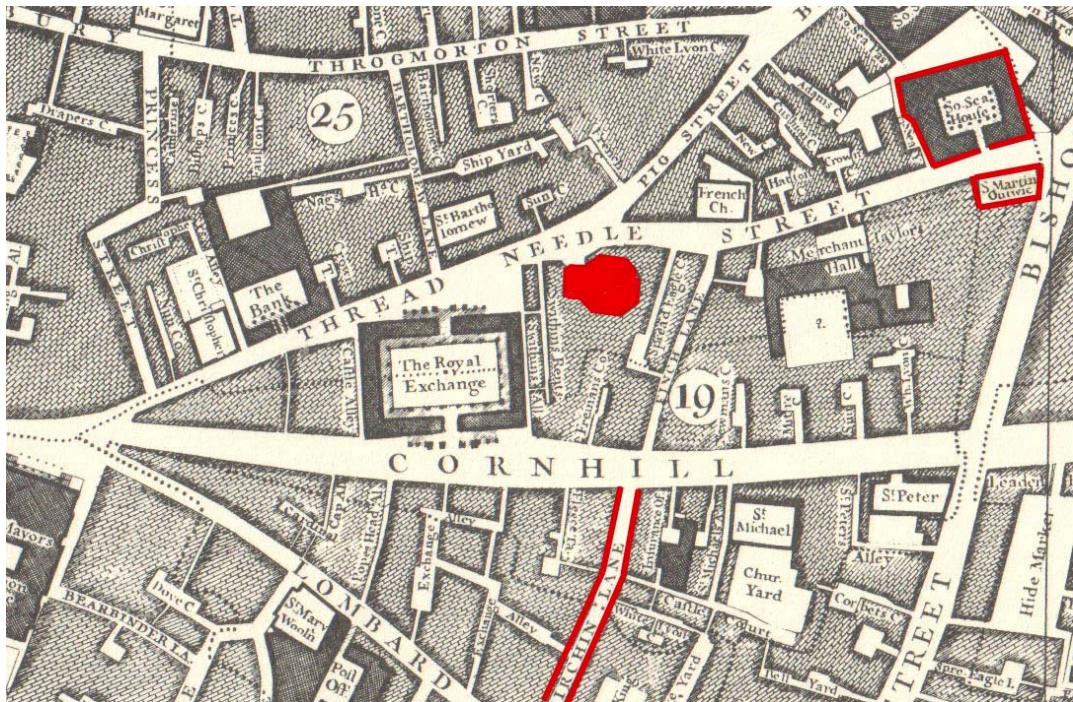

**Plate 401**

**An extract from Strype's 1720 Edition of John Stow's Survey of London**

The Joiners' Company records indicate that Keene nearly always had an apprentice under training as shown in Table 401. One name in Table 401, that of Richard Vesey may need further comment since Boalch (1995: 672) lists a spinet by him as 'c1800'. However, the 1974 edition of Boalch contains a photograph of the same spinet by Vesey at Plate 15a, which is referred to as being in the Pro Musica Museum, Annapolis, Maryland. The name-board bears the inscription '*Ricardus*

*Vesey Ebor fecit* and has a marquetry-work central cartouche of flowers and birds. From that, and the fact that the compass appears to be GG/BB-d''' with a split octave in the bass, it is clear that the photograph is of a seventeenth-century or very early eighteenth-century spinet. It is possible that Vesey may have moved to York after completing his apprenticeship with Keene but before becoming a freeman. He would in those circumstances have had to become a freeman in York by the payment of a fee to that city's governing body.

<b>Binding</b>		<b>Freeman</b>
1664	Abraham Richardson	1671
1670	Robert Smith	—
1675	John Harris	1685
1682	Leonard Dutton	—
1687	Richard Vesey	see text
1693	Edward Blunt	1700
1699	Thomas Barton	1706
1703	Charles Brackley	1711

Some comments about the business activities of Blunt and Barton have already been made when setting out the significant events in their lives, but to summarise, the names of both Blunt and Brackley, but not of Barton, appear with that of Keene on surviving spinets (see Chapter Five) and it has been assumed that both were partners in Keene's business (Boalch 1995: 102). But there are also surviving spinets which bear the names of Edward Blunt and Charles Brackley only without reference to

Keene. Barton set up in business on his own account as already noted and trained John Ladyman as a spinet-maker, who in turn trained Henry Hill. Like Townsend before him, the Keene craft influences were handed down through several generations.

It is not easy to be certain how productive the Keene workshop was. Very few of his instruments have survived, which is hardly surprising since he was almost at the end of his life nearly three hundred years ago. But there is some evidence on production rates:- The Keene spinet now at Westwood Manor bears an inscription on the top key lever which may shed some light on production numbers.



**Plate 402**

**Inscription on the key lever of the 1707 Keene Spinet**

The inscription, which is shown in Plate 402, is thought to read

$$\begin{array}{r} \underline{56} \\ \underline{CB} \\ \underline{1711} \\ \underline{18} \end{array}$$

the number 56 being the number of the key in the AA,GG – d'', e''' compass, the initials CB being those of Charles Brackley and the year being 1711. There is perhaps another letter or figure below the figure 18, but it is illegible. A similar inscription is reported by Beurmann (200): 128) as appearing on the 1705 Keene spinet at the Museum für Kunst und Gewerbe, Hamburg. In that instance the inscription reads '54 CB 1705 6'. It is thought that the number 18 indicates that this was the eighteenth spinet made by Charles Brackley, or by the Keene workshop, in 1711: similarly, it is thought that the number 6 indicates the sixth spinet to be made in 1705. That would indicate a production rate of between six and eighteen spinets per year as a minimum. A maximum of eighteen spinets seems not unreasonable for a small workshop containing only the master, a journeyman and an apprentice, so it is possible that the 1711 spinet was made quite close to the year end, in March 1711.

## **6. Keene's Competitors**

It was said in Chapter Three that the spinet was extremely popular in Restoration England and of course, Keene's was not the only workshop making spinets, even before some of his former apprentices had decided to leave him and set up in business on their own. Some comments about these makers follow:-

### **a. Charles Haward**

Charles Haward was probably the first instrument maker to start production of spinets, and though no Haward instrument dated earlier than the 1680s has survived (Boalch 1995: 377-379), it is clear that Haward was making spinets by the mid 1660s

(see Chapter Three). Boalch lists nine spinets inscribed by Haward as having survived and two attributed instruments.<sup>46</sup> Haward was probably older than Keene – he was admitted to the Joiners Company by patrimony in 1660 (Boalch 1995: 84), two years before Keene - and though as noted above Keene must have been in business by 1668, it is likely that the Haward business was established much earlier, since a John Haward was admitted to freedom of the Joiners Company in 1652 and a Thomas Haward in 1657. It seems likely that these three men, Charles, John and Thomas were brothers and that their entitlement to gain freedom of the Joiners Company by patrimony derived from Thomas Haward senior, a virginal maker living in the parish of St. Giles Cripplegate in 1663 (Boalch 1995: 85).<sup>47</sup> Charles Haward died in 1689.<sup>48</sup>

It is difficult to judge what impact Keene's early spinets would have made in a market which had been developed and probably dominated by Haward.

---

<sup>46</sup> The author has inspected one of the attributed instruments – that at the Royal Northern College of Music, Manchester, England. It is described in Appendix Four. It seems unlikely to be by Haward, though the author has not otherwise researched Haward spinets.

<sup>47</sup> Residence in the parish of St Giles Cripplegate would have been consistent with a business in *Aldersgate* but not in *Aldgate*, which is the location Pepys refers to. *Aldgate* is in the East of the City but it is not in the parish of St. Giles. It is possible that Pepys meant *Aldersgate* as his destination. But the point does not seem of sufficient importance, since regardless of its location, the Haward business was certainly in competition with that of Keene at least in the late 1660s.

<sup>48</sup> National Archive, London, PROB/11/396.

## b. John Player

John Player was the son of a shepherd, Giles Player, of Longborough, near Stow-on-the-Wold, Gloucestershire. He was born in 1636<sup>49</sup> and was apprenticed to Gabriel Townsend for 7 years from 24th June 1650. He became a freeman of the Joiners Company in June 1658<sup>50</sup> and on the 29<sup>th</sup> April 1662 he married Elizabeth Slough (or Sloe) of Bishopsgate at St Mary Aldermary.<sup>51</sup> The couple are recorded as living in the parish of St. Martin Outwich in 1691 in *London Inhabitants within the Walls*<sup>52</sup> In 1693/4 they were still there<sup>53</sup> - Player was required to pay £5 4s in tax. His property was valued at £200. Player became Master of the Joiners Company in 1684: he died and was buried at St. Martin Outwich on 16<sup>th</sup> June 1707: Elizabeth Player died in 1713. So far as it has been possible to discover, the couple were childless.

Several of Player's instruments survive, though the usual difficulty pertains of knowing *exactly* how many owing to the problem of distinguishing one instrument from another without an accurate identification or account of provenance. On the face of the information in Boalch (1974: 121) and Boalch (1995: 525-527) it seems that the surviving *oeuvre* comprises a virginal and possibly eleven spinets.

---

<sup>49</sup> Boyd's *Inhabitants of London*, accessed through <http://www.originsnetwork.com/BritishOrigins>, March 2007

<sup>50</sup> Boalch (1995:147)

<sup>51</sup> [www.familysearch.org](http://www.familysearch.org), Call no 6903683, accessed 20<sup>th</sup> February 2007

<sup>52</sup> 'Surnames beginning 'P'', *London Inhabitants within the Walls 1695* (1966), pp. 220-41. URL: <http://www.british-history.ac.uk/report.asp?compid=2442>, accessed: 20 February 2007.

<sup>53</sup> 'Four Shillings In The Pound Aid 1693-1694: City of London, Broad Street Ward, St. Martin Outwich', *Four Shillings In The Pound Aid 1693/4: The City of London, the City of Westminster, and Metropolitan Middlesex* (1992). URL: <http://www.british-history.ac.uk/report.asp?compid=19727&strquery=Player>. Date accessed: 20 February 2007.

John Player is an especially interesting example of the close relationship – both of friendship and rivalry – which must have existed between spinet makers, since the periods of Player's and Keene's apprenticeships overlapped: they will have lived together in the Townsend house and will have known each other well. It is even possible that Keene worked as Player's journeyman, since when Keene was admitted to freedom of the Joiners Company, it was on the relation of Player (see Appendix Four). John Player began his training with Gabriel Townsend before Keene and it seems likely that he set up his workshop before Keene too, possibly on Townsend's former premises. He lived until five years from Keene's own death and so would have been a competitor in the market both for spinets and virginals for the majority of Keene's working life. It is difficult to be certain how effective a competitor he was, but to judge from the tax returns in 1693/4, and the absence of a PCC Will, it seems that he was not as successful as Keene in acquiring wealth. Nor was he as successful in bringing his apprentices through to success themselves as freemen.<sup>54</sup> Additionally, looking at the output of his workshop, it is striking that several of his spinets have been altered to up-date them in compass.<sup>55</sup> This may be an indication that Player was more conservative than Keene and less inclined to follow the lead of the market. But it may also be that the surviving instruments are unrepresentative of his later work, or that his instruments were so highly prized by their owners that they

---

<sup>54</sup> It is not clear that any spinet makers saw that as an objective: but of the seven apprentices of John Player recorded in the binding registers of the Joiners Company, only Cawton Aston is known to have set up a spinet making business of his own.

<sup>55</sup> A full account of John Player's life and of his output of instruments is outside the scope of this dissertation, but the author has inspected a number of Player spinets and has gathered information about some others. Those at York Castle Museum, at the University of Witwatersrand, Johannesburg, the double-strung spinet described in Mole (2008 II), and the spinet offered for sale by Bonham's on 4<sup>th</sup> November 2008 (Lot 29) have all been extended in keyboard compass. The anonymous instrument at St. Cecilia's Hall, University of Edinburgh, which is attributed to Player, has also been altered.

thought it worth going to the trouble of having them extended in compass rather than buying a new one. Nevertheless, to the modern eye, Player's instruments seem less stylish than Keene's. This may add support to the evidence of sales to aristocratic customers that Keene was the maker of choice in the late-Stuart period.

### c. Benjamin Sison

The entry for Benjamin Sison in Boalch (1995: 179) states that he was apprenticed to John Needler, Joiner, on 10<sup>th</sup> October 1673. It is possible therefore that it was he who was born 1658, the son of Henry Sison and Susanna and baptised on 17<sup>th</sup> February of that year. He married Anne Nuton at St Katherine By The Tower on 20<sup>th</sup> February 1689.<sup>56</sup> A son, John was born, but no further details have emerged from the archives. This son was apprenticed to John Harris, one of Keene's apprentices (Boalch 1995: 179). Sison was buried at St. Michael, Cornhill on 12<sup>th</sup> November 1710.

Boalch states that Sison was principally a furniture manufacturer. He worked in Birchin Lane (see Plate 401 on page 90) Three spinets by him survive, one of which has been inspected by the author and is described in Mole (2008, I).

---

<sup>56</sup> [www.familysearch.org](http://www.familysearch.org), accessed 19<sup>th</sup> February, 2007

#### d. Benjamin Slade

Benjamin Slade must have been born about 1668 since he was apprenticed to James Aland, a freeman of the Haberdashers' Company, in September 1684.<sup>57</sup> He must have been intended by his father to have become a Haberdasher, but he did not complete his time with Aland – it is not known why – but was turned over to George Castleman, a Joiner, and became a freeman of the Joiners' Company in March 1698. Nevertheless, he was clearly well-known amongst Haberdashers, since Thomas Hitchcock the Younger, whose family had been freemen of the Haberdashers for generations, was apprenticed to him in 1715.<sup>58</sup> Slade is recorded in the Lord Chamberlaine's Appointment Books 3/64 as 'harpsichord maker in ordinary' on 21 August 1727.<sup>59</sup>

Slade had four children. His eldest son, also called Benjamin, who was baptised on 9<sup>th</sup> August 1711, survived to maturity and became apprenticed to John Westley of the Coachmakers' and Coach Harness Makers Company in 1725 for a Premium of twenty-five pounds. Benjamin Slade the elder was stated in the binding record to be of St. Martin in the Fields.<sup>60</sup> Slade died in 1729 and was buried at St Luke, Chelsea.<sup>61</sup> Boalch (1995: 632-633) lists eight surviving spinets and a single-manual harpsichord by Slade. Two of the spinets have been inspected by the author. Both

---

<sup>57</sup> Boalch (1995: 179 ) contains a typographical error in the entry for Slade

<sup>58</sup> Nevertheless, Hitchcock took freedom of the Haberdashers Company, by patrimony.

<sup>59</sup> Boalch (1995: 179)

<sup>60</sup> London Apprenticeship Abstracts 1442-1850, , [www.originsnetwork/BritishOrigins](http://www.originsnetwork/BritishOrigins), accessed 16<sup>th</sup> August 2006

<sup>61</sup> Boyd's London Burial Records, [www.originsnetwork/BritishOrigins](http://www.originsnetwork/BritishOrigins), accessed 16<sup>th</sup> August 2006

are especially well-constructed instruments which can stand full comparison with Keene's spinets. Descriptions of these two spinets appear in Appendix Four.

#### e. Keene's Former Apprentices

Reverting to the opening remark of the section of this chapter relating to Keene's competitors, several of Keene's former apprentices set themselves up in business on their own account during his lifetime. These include John Harris (Boalch 1995: 80), Richard Vesey, Edward Blunt, and Thomas Barton. Very few instruments from these makers have survived, but both Vesey and Blunt seem to have made spinets very similar to those which they had been taught to make when working with Keene, though Blunt's instruments were probably decorated in a more up-to-date style (see Appendix Five). It is suggested that if Blunt was a real competitor, and not just operating as an off-shoot of Keene's workshop, then he will have been a formidable one, first since the instrument of his which the author has inspected is of high quality and secondly because towards the end of his life he occupied premises which were well-known as a place where keyboard instruments could be bought, owing to their previous use by John Player and probably Gabriel Townsend. But Blunt did not live long it seems, as already explained.

Boalch (1995: 225) suggests that a spinet inscribed on the wrestplank *Aston & Barton Londini FF* and dated 1709 was once in the collection of E. M Ripin and that it might now be in the Museum of Fine Arts, Boston. However the present Curator

of Musical Instruments at the Museum has no knowledge of such an instrument.<sup>62</sup> If that entry in Boalch is correct and such a spinet does exist, then the implication is that Barton joined with Cawton Aston, John Player's last apprentice and journeyman, for a period before setting up in business by himself. If that is so, then it may well be that the two men worked together from 1707, when John Player died, possibly for as long as seven years, when a spinet inscribed with Barton's name alone and dated 1714 appears. Judging by the stylishness of the spinet by Cawton Aston dated 1726 at Colonial Williamsburg, Cawton Aston seems to have been a craftsman of great skill, and a firm constituted by him and by Barton would have been a significant competitor to the Keene firm in the period 1709 to 1712.

Surviving instruments by Barton indicate that he was one of the first makers to extend the keyboard compass of the spinet to five octaves. But that will have been done after the date of Keene's death. The firm set up by Thomas Barton is therefore more properly seen as a competitor to the Hitchcocks than to Keene.

## **8. Summary**

This chapter focuses on the results of archival research directed to the salient features of the lives Stephen Keene, Edward Blunt, Thomas Barton and Charles Brackley who together constitute the school of Keene. It also reports details of the lives of some of Keene's competitors, though these persons have been less deeply

---

<sup>62</sup> Personal Communication, Darcy Kuronen, October 2008.

researched. From the binding and freedom registers of the Joiners Company, and from the discovery of Keene's Will, it has been possible to construct a family tree for the Keenes. Keene's appointment as tax assessor for his parish, and the detail of his tax returns evidence his ability as an administrator and show hitherto unsuspected wealth. Keene was a man of some substance.

Keene's Will shows that the accepted date of 1719 for his death is incorrect: he died in December 1712. This newly established date provides a *terminus ante quem* for his output of spinets, but in particular for his last and undated spinet, the Keene & Brackley, which can now be said to date from c.1712.

Details of Keene's Will and of that of his wife Sarah point to a close family relationship with Edward Blunt, his penultimate apprentice. They also demonstrate that the Keenes were a childless couple. The archival records of Blunt, particularly the details of the baptisms of his children and the Land Tax Assessment records, suggest that after leaving Keene, Blunt initially worked close to Keene's workshop in Threadneedle Street while making spinets inscribed only with his name. He then moved into the premises vacated by John Player on the latter's death in June 1707. It is suggested that Blunt was Keene's intended heir to his business: but there is strong evidence that Blunt died in 1711 and so did not survive to inherit it.

By 1711, Thomas Barton had moved into his own premises, probably in the South Seas House further down Threadneedle Street, but in any event away from the Keene workshop and set up in business either on his own or with Cawton Aston. Because

of that and because it seems that by that time Blunt died, Charles Brackley became the successor to Keene's business. Brackley himself died in 1718.

In the final part of the chapter, some details of those with whom Keene competed in the market for spinets are provided, together with some comments about their likely effectiveness as competitors. Inevitably, these comments are somewhat speculative. The Keene workshop was established at least by 1668 and continued in production uninterrupted until 1718 (under Brackley), a period of half a century. It is suggested that during the later part of this period the workshop may have been producing a spinet as frequently as one every three weeks. If that is so, then a very small proportion of the total output has survived. These surviving instruments are analysed in the next chapter.

## Chapter Five - Spinets from the School of Keene

### 1. Introduction

In this chapter the surviving spinets from the school of Keene are described and their similarities and differences are analysed. The school is taken to comprise the four makers identified in Chapter Four, Stephen Keene himself, Edward Blunt, Thomas Barton, and Charles Brackley. A characterisation of the 'standard' instruments produced by the school leads to an identification of a first group in a proposed classification. The characteristics of those instruments which do not exhibit these standard features and are thus exceptions lead to the identification of three further groups and to a proposed classification into four groups. The proposed classification scheme is set out in the penultimate part of the chapter which includes a summary. Further descriptions of those spinets not described in detail here appear in Appendix Five. The appendix also includes the 'Long Forms', tables of measurements taken from those spinets which the author has inspected personally.

Boalch (1995: 414-418) lists twenty-seven surviving spinets inscribed with Keene's name alone and one anonymous instrument which has been attributed to Keene by some authors. Additionally two spinets inscribed *Stephanus Keene Edwardus Blunt fecerunt* and one inscribed *Stephanus Keene Carolus Brackley fecerunt* are listed by Boalch. This listing is summarised in Table 501.

<b>Table 501</b>		
<b>Spinets Inscribed by Keene and Listed in Boalch 1995</b>		
<b>No.</b>	<b>Date</b>	<b>Owner or Location</b>
<b>Keene</b>		
1	1685	E R Hawkings
2	1685(A) <sup>1</sup>	Private Collection, England
3	1690	Not known
4	1700	Museum of Fine Arts, Boston
5	1700	Colonial Williamsburg Foundation
6	1700(A)	Royal College of Music, London
7	1701(A)	R Mickleburgh, Bristol
8	1704	Dr Percival Agnew, Ayr
9	1705	Private Collection
10	1705	Dr Andreas Beurmann, Hamburg
11	1706	Not known
12	1711	Westwood Manor, Bradford-on-Avon
13		Christopher Lloyd, Great Dixter
14		Hugh Gough, New York
15		Memorial Hall Museum, Deerfield, Mass
16		Connell Collection, Melbourne, Victoria
17		Kenneth G Fiske Museum, Claremont, California
18		Red Lodge Museum, Bristol
19	1707	Grimsthorpe Castle
20		City of Hammamatsu, Japan
21		Not known
22		Not known
23		Not known
24		Hall i' th' Wood, Bolton
25		Not known
26		Not known
27		Dr B E Juel-Jensen, Oxford
28 (A)	1708	Royal College of Music, London
<b>Keene &amp; Blunt</b>		
29	1702	The Marquess of Bute
30		Prof D McCaldin, University of Lancaster
<b>Keene &amp; Brackley</b>		
31		John Barnes, Edinburgh

<sup>1</sup> In Table 501 and in other tables in this chapter, the designation (A) means that the instrument or the date is attributed. No 28 (A) is therefore not inscribed by Keene. The locations given for the spinets listed are 1995 locations, not current ones.

In addition to the spinets listed in Boalch (1995) as being Keene instruments, fourteen instruments by Thomas Barton are listed together with one attributed instrument (Boalch 1995: 231-233). These are shown in Table 502 below.

<b>Table 502</b>	
<b>Instruments by Barton listed in Boalch (1995)</b>	
<b>Date</b>	<b>Owner/Location</b>
1709	St. Cecilia's Hall (a harpsichord)
1709	Formerly in the Collection of E. M. Ripin <sup>2</sup>
1714	Not known
1719	Ex Mrs Brackenbury, sold at Sotheby's 22 November 1990 <sup>3</sup>
1720?	Capt A F Matheson, Invergordon
1723	Ex the late Prof. Christiane Jacottet, Geneva
1724	Ex Dartington Hall
1724?	Ex Blickling Hall, Norfolk
1725	Sotheby's, 31 July 1953, withdrawn
1727	Auctioned at Sotheby's 11 March 1960
1729	Auctioned at Sothebys 26 November 1992
1730	Smithsonian Institution, Washington
1731	Stated in Boalch (1974) to be Roger Yates, Michaelstowe
1740	Once in the Taphouse Collection
(A)	Private Collection, Buckinghamshire

Boalch (1995: 246) lists two spinets by Edward Blunt, one bearing both his inscription and the date of 1705 (sic). It is thought that this is the instrument sold at Sothebys in November 2004 which was referred to in Chapter Four. The other spinet listed in Boalch as being by Blunt is stated in the entry to be the Keene spinet at Colonial Williamsburg (Number 6 of Table 501). The entry in Boalch 1995 seems to have been included under the heading of Blunt because of the presence of Edward Blunt's initials on the instrument. Finally, Boalch (1995: 254) lists a spinet by Charles Brackley as being in the ownership of a Mrs Diana Colville of Launceston, Cornwall. It is described in Appendix Five.

<sup>2</sup> This instrument as listed as being inscribed by Aston & Barton.

<sup>3</sup> This instrument was formerly on display at St. Cecilia's Hall

To summarise the position therefore, Boalch (1995) lists the following numbers of instruments as ostensibly belonging to the school of Keene as defined in this dissertation: -

Inscribed by Keene	27
Anonymous but attributed to Keene	1
Inscribed by Keene and Blunt	2
Inscribed by Keene & Brackley	1
Inscribed by Barton	13
Anonymous but attributed to Barton	1
Inscribed by Blunt	2 <sup>4</sup>
Inscribed by Brackley	1
<b>Total</b>	<b>46</b>

The author has been unable to confirm the existence of so many surviving spinets from the school. Considering first the spinets with inscriptions which include the name of Stephen Keene, despite enquiries both in the United States of America and in Britain, only sixteen Keene spinets, including the three jointly inscribed instruments, have been located. These are listed in Table 503, together with anonymous the instrument at the Royal College of Music, London, which is has been attributed by some scholars to Keene.

---

<sup>4</sup> Though listed under the heading of Blunt, one of these is included in the figure of 27 for the number of Keene spinets.

<b>Table 503 Identifiable Spinets By Keene</b>		
<b>No.</b>	<b>Date</b>	<b>Owner or Location</b>
<b>Stephen Keene</b>		
4	1700	Museum of Fine Arts, Boston, MA
5	1700	Colonial Williamsburg Foundation, VA
6	1700(A) <sup>5</sup>	Royal College of Music, London
7	1701(A)	Cantos Musical Foundation, Calgary, Alberta
8	1704	University of Edinburgh
10	1705	MKG Hamburg
12	1711	Westwood Manor, Bradford-on-Avon
15		Memorial Hall Museum, Deerfield, MA
17		Musical Instrument Museum, Phoenix, AZ
19	1707	Grimsthorpe Castle, Bourne, Lincs
20		City of Hammamatsu, Japan
24		Hall i' th' Wood, Bolton
28(A)	1708	Royal College of Music, London
<b>Keene &amp; Blunt</b>		
29	1702	The Marquess of Bute
30		Prof D McCaldin, University of Lancaster
<b>Keene &amp; Brackley</b>		
31	1715(A)	P G Mole, Shropshire, England

The disparity between Tables 501 and 503 requires comment. First, it is clear that the listing in Boalch (1995) relies heavily on the listing in Boalch (1974: 81-83), which in turn relies on the original listing in Boalch (1956: 58 & 59). Some of the data is therefore very old and the passage of time has reduced its accuracy. But the age of the data alone is not sufficient to account for the disparity. Of those spinets listed in Boalch (1995), Number 18 of Table 501, that at the Red Lodge Museum, Bristol is by Benjamin Slade and not by Keene.<sup>6</sup> Though spinet Number 27, listed as belonging to Dr Bernt Juel-Jensen, has a genuine Keene nameboard, it is not by Keene but most likely by John Player or possibly Cawton Aston: a brief description and some discussion of it appears in Chapter Eight of this dissertation. Several of the

<sup>5</sup> The descriptor (A) denotes that the date is that ascribed to the instrument in Boalch 1995.

<sup>6</sup> The Bristol Museums hold two spinets, one by Slade and one by William Harris, but have never held a Keene spinet (Personal Communication, Karin Walton, Curator, April 2007)

private owners listed in Boalch have died since assembly of the third edition in 1995. These include Mr R Mickleburgh, whose spinet is now at the Cantos Musical Foundation in Calgary, Alberta, Dr Percival Agnew, whose spinet dated 1704 is now at St. Cecilia's Hall, Hugh Gough, and Dr Juel-Jensen the last of whom in any case sold his spinet some years before he died.<sup>7</sup> It has not been possible to locate two other spinets listed in Boalch with details of their owners - those listed as belonging to Mr E R Hawkings and Mr Christopher Lloyd of Great Dixter.<sup>8</sup> The instrument listed as being at the Connell Collection, Melbourne, Australia is no longer there. The identification of many of the other spinets listed would be difficult without details of dates or provenance and the author suspects that many are duplicate entries for spinets which appear elsewhere in the listings.

The present location and/or ownership of the sole surviving Blunt spinet is unknown, though clearly since it was sold quite recently at Sotheby's (see Appendix Five), it is still probably in existence. On the other hand, the location of the sole surviving Brackley instrument is known – it is in Philadelphia in private ownership.

Turning to the Barton instruments, with the exception of the instrument listed as being at the Smithsonian Institution, Washington, it has not been possible to locate *any* of these instruments. That failure is exacerbated by the fact that through most of the period of this study, the National Museum of American History at the

---

<sup>7</sup> Personal communication Charles Mould, July 2007. Mould said that the spinet was sold in Oxford for about £2000 well before the owner's death in 2006.

<sup>8</sup> A telephoned enquiry in 2006 confirmed that this spinet is no longer at Great Dixter. The file of the anonymous 1708 spinet held by the Royal College of Music contains an undated newspaper clipping reporting the sale of the Great Dixter spinet at an auction in Sussex.

Smithsonian Institution has been closed for renovation<sup>9</sup> and the musical instruments exhibited there have been in store and were not available for inspection. The consequence is that the only details which it has been possible to obtain for the spinets of Thomas Barton are derived from secondary sources. The details of these sources are as follows:-

- a drawing included in an advertisement for sale of a spinet by Barton dated 1714,<sup>10</sup>
- Photographs taken during the restoration by Messrs Garrett & Campbell of the 1724 spinet formerly at Blickling Hall,<sup>11</sup>
- Photographs supplied by the Smithsonian Institution, Washington D.C. of the 1730 spinet in their collection.

To summarise therefore, it has been possible to locate only sixteen spinets by Keene (including the attributed one), one by Barton, and one by Brackley – eighteen spinets in total. These surviving instruments represent a very small fraction - probably less than 5% - of the total output of the school.

Of the surviving spinets, nine bearing a Keene inscription have been inspected during this research project:-

- No. 3, the undated instrument at the Royal College of Music, London,
- No. 4, the instrument dated 1700 at the Museum of Fine Arts, Boston<sup>12</sup>

---

<sup>9</sup> It reopened on 21<sup>st</sup> November 2008.

<sup>10</sup> This drawing is reproduced later in this chapter.

<sup>11</sup> The author is indebted to Andrew Garrett for the supply of these photographs. This instrument was once on loan to the National Trust and was displayed at Blickling Hall: it may be the same instrument which was once at Dartington Hall, Totnes, Devon, but the National Trust has no records relating to it (Personal Communication, Andrew Garrett, December, 2007).

<sup>12</sup> This instrument is fully described in the Museum catalogue: it has been inspected only briefly by the author in its display location in the Museum.

- No. 6, the instrument dated 1700 at Colonial Williamsburg, Virginia,
- No.8, the instrument dated 1704 at St.Cecilia's Hall,
- No 12, the instrument dated 1707 belonging to Lady Willoughby de Eresby, formerly at Grimsthorpe Castle, Lincolnshire<sup>13</sup> and now at Drummond Castle, Perthshire,
- No 13, the instrument dated 1711 at Westwood Manor, Wiltshire,
- No 23, the undated instrument at Hall i' th' Wood, Bolton,
- No.30, the undated instrument by Keene and Blunt belonging to Professor McAldin,
- No 31, the undated instrument by Keene and Brackley now in the author's possession.

The attributed instrument, No 28 of Table 501 has also been inspected.

Some details of other spinets from the school have been gathered from secondary sources, either from museum catalogues, catalogues of auction houses, reference books and websites, or by inspections by others on the author's behalf. Referring to Table 501 where appropriate, these instruments are:-

- The instrument by Edward Blunt sold at Sotheby's in November 2004,
- No 7, the Keene instrument dated 1700 at the Cantos Music Foundation, Calgary, Alberta, Canada,
- No 10, the Keene instrument dated 1705 at the Museum für Kunst und Gewerbe, Hamburg,

---

<sup>13</sup> Grimsthorpe Castle is not in Scotland as stated by Boalch (1995:417) but near Bourne, Lincolnshire.

- No 15, the undated Keene instrument at Deerfield Memorial Hall, Mass.,
- No 18, the undated Keene instrument on loan to The Musical Instrument Museum, Phoenix, Arizona,
- The 1714 instrument by Barton which appeared in an advertisement in the 1930s,
- The 1724 instrument by Barton formerly at Blickling Hall, Norfolk,
- The 1730 instrument by Barton at the Smithsonian Institution, Washington.

This source material is summarised in the Table 504 below. The discussion which follows is based on information derived from all of these sources, where doubt arises, greater weight being placed on conclusions derived from the author's personal inspections. It is thought that this data is fully representative of the surviving spinets made by Keene and his school while Keene was still alive, in that it covers nearly two thirds of the probable surviving output, but it is much less representative for instruments made later.

<b>Table 504 - Keene Spinets</b>		
<b>Sources of information</b>		
<b>Maker</b>	<b>Inspected</b>	<b>Secondary Source</b>
Keene	9*	5
Keene & Blunt	1	
Keene & Brackley	1	
Barton		3
Blunt		1
Brackley		1

\*including the attributed instrument

## 2. The 'Standard' Instruments

The surviving spinets from Stephen Keene and his school include a large number of what are referred to here as 'standard' instruments – spinets with a keyboard compass of 54 notes GG/BB–d<sup>'''</sup>, and a box-guide register. Thirteen instruments have been identified as belonging to this group together with one, by Edward Blunt, which has not been seen since 2004 when it was sold at Sotheby's. A typical spinet, the 1707 instrument belonging to Lady Willoughby de Eresby of Grimsthorpe Castle, is described in detail below. This description is intended to establish the norm for spinets built between about 1690 and 1710 as a basis for classification.

### a. The Keene Spinet of 1707



**Plate 501 - The Keene Spinet of 1707**

This spinet, Number 19 in Table 501, is shown in Plate 501 above. It bears the inscription *Stephanus Keene Londini Fecit* on the nameboard, the initials ‘CB’ (the initials of Charles Brackley) and the date ‘1707’ on the uppermost key lever and on one of the original jacks. The spinet is the property of Lady Willoughby de Eresby and in April 2007 it was on display to the public at Grimsthorpe Castle, near Bourne, Lincolnshire but it is believed that it has now been moved back to Drummond Castle, Perthshire, where it has spent most of its life. The instrument is in good condition but is not at present playable since it is unstrung. The measurements made during the inspection are recorded in Long Form LFSK1707 in the Appendix and an outline plan of the instrument is shown in Figure 501.

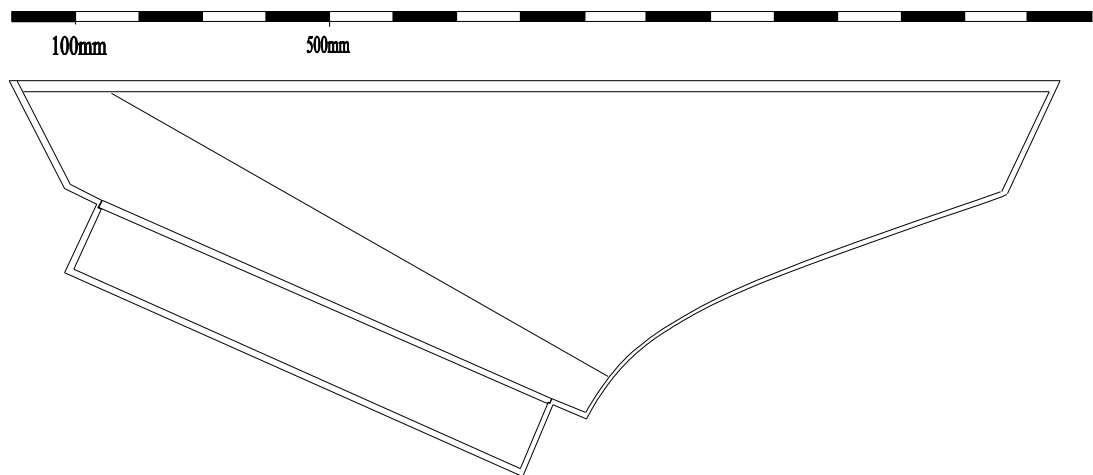

**Figure 501 - Plan Form of the Keene Spinet of 1707**

The instrument was restored by Clayson and Garrett in 1980<sup>14</sup>. It is recorded in Boalch (1995: 417), which incorrectly identifies Grimsthorpe Castle as being in

<sup>14</sup> Andrew Garrett, Personal Communication, 12<sup>th</sup> March 2007

Scotland, but in neither of the two previous editions of Boalch does the instrument appear.

The decorative treatment of the case is characteristic of the work of Keene and other Restoration makers with triple stringing of contrasting light and dark veneer inlaid on the nameboard and aligning with similar lines of stringing on the keywell cheeks to form triangular panels. The nameboard, which incorporates a central marquetry cartouche and the maker's inscription in ink, is shown in Plate 502 and the detail of the central cartouche in Plate 503.



**Plate 502 - The Nameboard of the Keene Spinnet of 1707**



**Plate 503 - The Marquetry Cartouche of the Keene Spinnet of 1707**

The spinnet has a full set of brass furniture which appears to be original – three lid hinges, one long and two short, three matching flap hinges, a lock and hasp and a lid closure - though it is thought that the lock may be the modern item produced for

reproduction spinets,<sup>15</sup> since the tarnishing on the lock-plate exhibits a patina different from that of the other brass items. Two items from the brass furniture are shown in Plates 504 and 505, the first being a long lid hinge and the second one of the flap hinges.



**Plate 504**



**Plate 505**

**A Lid Hinge and a Flap Hinge from the Keene Spinet of 1707**

The compass of the instrument is GG/BB–d''' (54 notes) with a broken octave in the bass. The inscriptions referred to above can be seen from Plate 506. The key lever also bears the number of the key, No.54. The construction of the key levers forming part of the broken octave, that part containing the lowest four keys, is shown in Plate 507

---

<sup>15</sup> By David Law, Long Compton, Warwickshire



**Plate 506**



**Plate 507**

**The Inscription and the Construction of the Broken Octave  
of the Keene Spinet of 1707**

Plate 508 shows the black-painted paper arcades of the traditional trefoil design at the proximal ends of the natural keys. The natural keys have touch plates of ebony

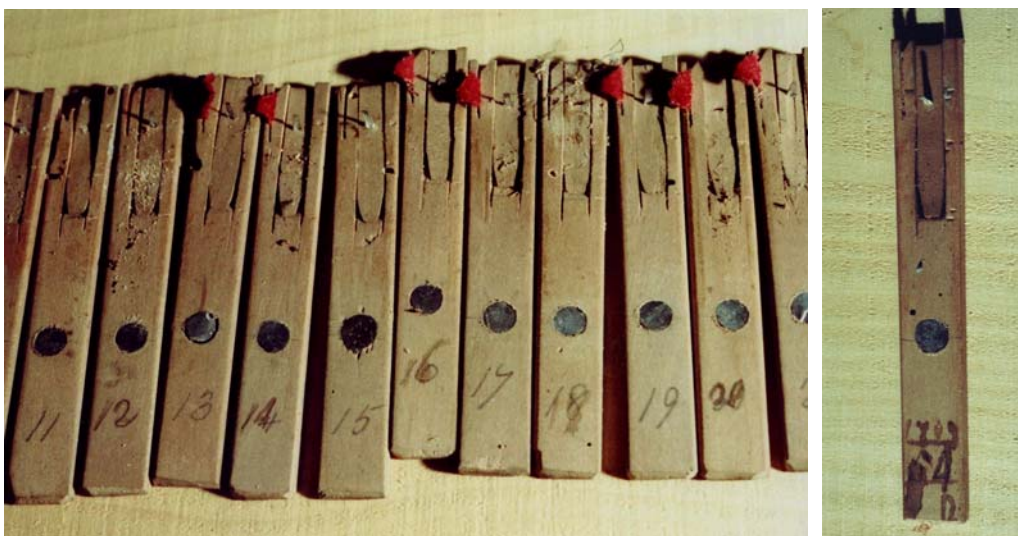

**Plate 508**

**The Trefoil Arcades of the Keene Spinet of 1707**

and the sharp blocks are of ivory. The sharp blocks slope downwardly away from the player.

The original jacks survived at least until 1980. Though they do not appear to have been retained with the instrument they were photographed by Clayson and Garrett during their restoration. Plates 509 and 510<sup>16</sup> show, respectively, a representative selection of the original jacks, and jack No. 54, bearing the inscription *1707 54 CB*.



**Plate 509**

**Plate 510**

**Jacks from the Keene Spinet of 1707, showing the inscriptions**

Plate 511 below shows the keyframe with four of its keys having been removed. Some new work is visible but the rack is original, the light colour being attributable to lack of actinic degradation in an environment which is substantially that of darkness. Plate 512 shows the complete keyframe assembly as removed from the instrument.

---

<sup>16</sup> The photographs are by Andrew Garrett and are reproduced by kind permission.



**Plate 511**

**The Rack and Guidance System of the Keene Spinet of 1707**



**Plate 512**

**The Keyboard of the Keene Spinet of 1707**

The soundboard, which is original, is of coniferous material arranged in the instrument with the grain running parallel to the spine. During the 1980 restoration

it was necessary to fabricate new sections for the bridge, the original being beyond repair due to worm damage.<sup>17</sup> These new sections are at the treble end and carry pins for the twenty one uppermost notes. They can be seen in Plate 513, which also shows that the soundboard has been removed from the instrument and replaced at a lower level so that box-guide register and wrestplank stand proud. This is not an original feature of the standard instruments. The design and construction of the registers found on spinets referred to in this dissertation is discussed in detail in Chapter Eight.



**Plate 513**

**The Treble End of the Soundboard of the Keene Spinet of 1707**

The instrument was re-strung in steel during the restoration in 1980. The scaling at  $c''$  is 255mm (See Form LFSK1707) and although that is unlikely to be original, because of the repairs made to the bridge, it is typical of the standard instruments at

---

<sup>17</sup> Personal communication, Andrew Garrett, February 2007.

this date. Observations about the likely intentions of the maker for the stringing material and pitch are included in Chapter Eight.

The stand with this spinet is of stained hardwood, possibly elm, and is based on a leg section of 46mm square and will therefore have been made from two inch square sawn timber. Plate 514 shows the leg profile used.



**Plate 514**

**The Stand of the Keene Spinet of 1707**

Since it is thought that this instrument has been in the continuous ownership of one family since it was new, it may well be that the stand is also original and that it was originally intended for this instrument.

This 1707 spinet is typical of the standard instruments produced by members of the School of Keene between about 1690 and 1710. It is probably unique in having been bought new and having remained in the ownership of one family throughout its life.

## b. Other Standard Instruments

Descriptions of other instruments of a similar design and construction to the Keene spinet of 1707 which have been inspected, or for which data has been gathered are described in Appendix Five, where the measurements taken are also set out in the Long Forms. The instruments belonging to this group consists entirely of spinets which are very similar to each other in design and appearance and, the author suggests, in musical performance. However, there are detailed differences in the plan forms of the cases which, it is suggested, arise from the method of manufacture and in particular from the difficulty of producing bentsides of consistent curvature. The minor variations in case size and shape can be seen in Figure 502 which is a comparison of the plan forms of four spinets in the group which have been subjected to detailed inspection - the Keene & Blunt spinet, No 30 of Table 501, the Keene spinet at St. Cecilia's Hall, University of Edinburgh, No. 8 of Table 501, the 1707 Keene instrument just described and one instrument which has been inspected on the author's behalf,<sup>18</sup> a spinet now part of the collection to be displayed at the Musical Instrument Museum, Phoenix, Arizona, No. 17 of Table 501.

---

<sup>18</sup> By Albert (Al) Rice, to whom thanks are due.

Keene & Blunt in blue  
 Keene at Phoenix in red  
 1704 Keene in green  
 1707 Keene in black

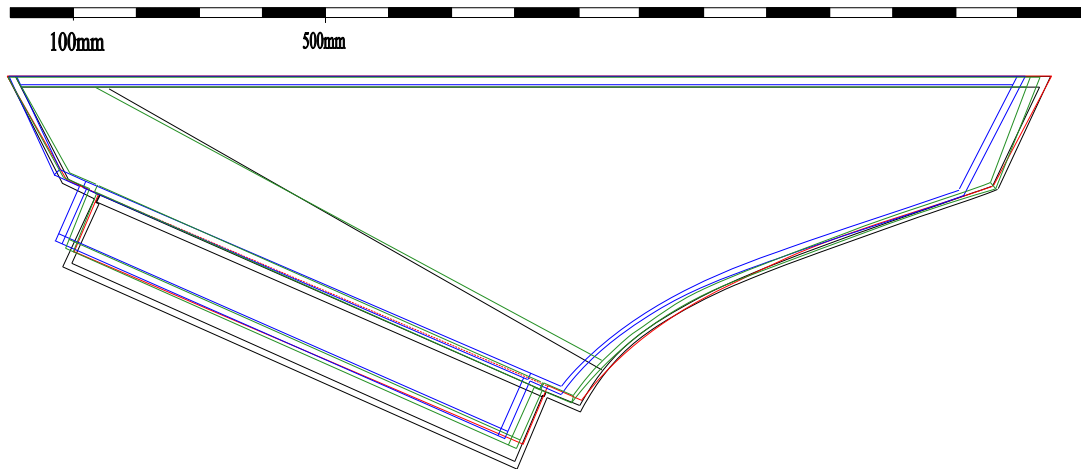

**Figure 502 - Plan Forms of Four Keene Spinets**

It can be seen from Figure 502 how close in plan form the four instruments are. In particular, the Figure shows the consistency in the included angle between the spine and the keyboard, which at the bass end is  $23.5^\circ$  on average.<sup>19</sup> Indeed merely by inspection and without undertaking careful measurement, it would be difficult to distinguish between the instruments except for their marquetry cartouches, all of which are unique and which are shown in Appendix Five and discussed in Chapter Nine. It can be seen that the Keene and Blunt instrument, that thought to be the earliest in this representation, is also the smallest. However the differences are not great: the spine lengths of the four spinets are set out below. The very close concordance in plan form between the 1707 spinet (in black) and the undated instrument now in Phoenix (in red) must point to their being similar in date, it is thought, since no example from the school of Keene has been found of a larger spinet

<sup>19</sup> The error in measurement due to distortion of the cases is more significant than any designed difference.

being of earlier date than a smaller one, or a smaller one being of later date than a larger one.

Keene and Blunt	1615mm
Keene 1704	1638mm
Keene Phoenix	1657mm
Keene 1707	1656mm

That is said despite the fact that the Phoenix instrument displays two decorative features which might be thought to indicate an earlier date – a stand with ‘barley twist’ legs and unique marquetry cartouche, shown in Plate 515, which is in an abstract style reminiscent of the ‘seaweed’ designs of marquetry of the William and Mary period (1689-1702).



**Plate 515**

**The Marquetry Cartouche of the Keene Spinnet now in Phoenix**

However as can be seen in the Plate, this cartouche shows signs of being quite crudely made and there must be some doubt whether it is original, though there is no *a priori* reason why a reserve of seaweed marquetry should not have been incorporated into an artefact such as a spinnet at any time from about 1685 to 1715.

### c. The Standard Instruments – General Characteristics

The foregoing description of the 1707 spinet and other similar instruments allows the establishment of a first group in the classification proposed here: spinets of the group are characterised by:-

1. a 54 note keyboard of compass GG/BB-d''' with a broken octave including split sharps in the bass,
2. a box-guide register made up from individual trapezoidal blocks in the manner of Italian instruments.

These characteristics are described and depicted above in relation to the 1707 Keene spinet.

The confusion about the identity of individual instruments which was summarised in the introduction to this chapter is produced by the fact that they are all very similar in design and construction. But though very similar, they are not identical. Indeed, given the method by which they were made, which adopted the 'must fit' approach to assembly described in Barnes (1985: 2), they are extremely unlikely to be identical, since the first major step is to produce a blank for the bentside which is tapered by a process of hand planing. This is then bent over a former. Inevitably, because of differing bending characteristics of the blanks, this produces some variations in the curvature of the bentside produced which may carry forward in to the length and width of the instrument.

The spinets are of extremely similar appearance: they are mitre-tailed with a nameboard having a central marquetry cartouche flanked by the maker's inscription(s). The keyboards have natural key-plates of ebony and the sharp blocks are of ivory,<sup>20</sup> The keys are flanked by key blocks which are made by gluing thin leaves of contrasting woods between thicker leaves of walnut to form a 'sandwich' and cutting the scrolled profile shown in Plate 512 above.

The brass furniture items found on the 1707 spinet and described above are normally present on all examples of this group of spinets. However they are not uniquely characteristic of instruments of the Keene school – brass items of identical design have been found on the Slade spinet at the Red Lodge Museum Bristol also. It is probable that the brassware is characteristic of spinets built between about 1690 and 1712. The manufacture and aesthetics of the brassware is discussed in Chapter Nine.

Many of these spinets are either initialled, or dated, or both, on the treble-most key and it is suggested on the basis of these dates that 1690-1710 is an approximate date range for production of these standard instruments. The spinets which have been located and which can be placed in this standard group are shown in Table 505.

---

<sup>20</sup> Garrett (Personal Communication April 2007) has suggested that the ivory is walrus ivory, though that cannot be confirmed, and other evidence shows that large quantities of elephant ivory were being imported into London in the late seventeenth century. This is detailed in Chapter Nine.

<b>Table 505</b>			
<b>Standard Instruments from the School of Keene</b>			
<b>Boalch No.</b>	<b>Inscription</b>	<b>Date</b>	<b>Owner/Location</b>
4	Keene	1700	Museum of Fine Arts, Boston, MA
5	Keene	1700	Colonial Williamsburg Foundation, VA
7	Keene	Undated	Cantos Musical Foundation, Calgary, Alberta
8	Keene	1704	University of Edinburgh
10	Keene	1705	MKG Hamburg
12	Keene	1711	Westwood Manor, Bradford-on-Avon
15	Keene	Undated	Memorial Hall Museum, Deerfield, MA
17	Keene	Undated	Musical Instrument Museum, Phoenix, AZ
19	Keene	1707	Grimsthorpe Castle, Bourne, Lincs
20	Keene	Undated	City of Hammamatsu, Japan
28(A)	Attributed	1708	The Royal College of Music
29	Keene & Blunt	1702	Dumfries House, Ayrshire
30	Keene & Blunt	Undated	Prof D McCaldin, University of Lancaster
-	Blunt	1703	Sold at Sotheby's 2004

It is inevitable that when dealing with keyboard instruments whose sizes and shapes are so closely similar, and whose keyboard compass is identical, the string-bands will be closely similar too, since the only variables available in these circumstances are the curvature and position of the bridge on the soundboard and the precise position of the nut-pins and bridge-pins. The string-bands have indeed been found to be very similar as shown by the three examples in Table 506 and Figure 503. The instrument dated 1700, which is somewhat shorter than the other two in spine length, has noticeably fore-shortened stringing in the bass, but otherwise the string lengths are close. The scalings at  $c''$  of 270.0mm, 260.5 and 255.0mm (somewhat over 10 inches) allow the instruments to be strung throughout in brass if a pitch of about  $a' = 408\text{Hz}$  is taken as the designed pitch. The designed pitch of the late-Stuart spinet is discussed in Chapter Eight

<b>Note</b>	<b>SK1700</b>	<b>SK1704</b>	<b>SK1707</b>
<b>GG</b>	1380.0	1412.0	1407.0
<b>C</b>	1248.5	1380.5	1381.0
<b>F</b>	1196.0	1155.0	1235.0
<b>c</b>	946.5	955.5	977.5
<b>f</b>	775.0	745.5	822.0
<b>c'</b>	519.0	526.5	511.0
<b>f'</b>	407.0	400.0	389.0
<b>c''</b>	270.0	260.5	255.0
<b>f''</b>	214.0	206.5	200.0
<b>c'''</b>	135.0	133.0	129.0
<b>d'''</b>	131.0	120.5	106.0

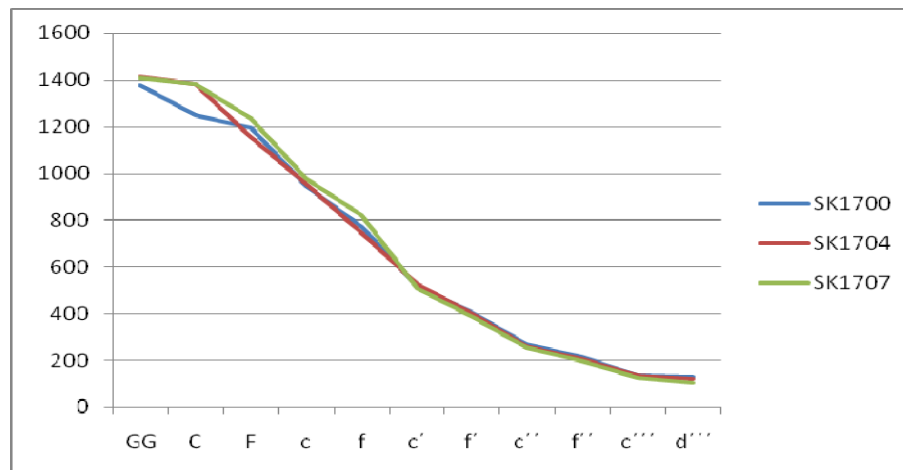
**Figure 503**

**Plot of C and F String Lengths against Sounding Note  
for three Keene Spinets from the Standard group**

A comparison of the rack of the 1707 Keene spinet shown in Plate 511 with that of the Keene spinet dated 1700 at Colonial Williamsburg, Virginia is instructive. From Plate 516<sup>21</sup> below it can be seen that the rack of the 1700 spinet is fitted with a rear upper touch-rail presumably designed to stop the key travel.

<sup>21</sup> This photograph was taken by John Watson who has kindly agreed to its reproduction.



**Plate 516**

**The Rack and Stop-Rail of the Keene Spinet at Colonial Williamsburg**

The 1707 instrument does not have this feature, nor does the 1704 Keene at St. Cecilia's Hall, and so far as is known the feature does not re-appear in later spinets of the Keene school.<sup>22</sup> It seems that at some time after 1700 but before 1704, Keene decided that this touch-rail was unnecessary and that a better arrangement would be to stop the key travel at the jack rail, in the manner of a French harpsichord. However, it seems that this innovation on Keene's part did not find favour with players, since on the 1707 spinet a front touch-rail has been added, presumably to provide an easier method of adjustment of the key travel. The rail on the 1707 spinet can be seen in Plate 513.

---

<sup>22</sup> Because of this it is tempting to say that the feature is not original: however it is present on the two early spinets discussed below, both of which have upper touch cloths fixed to the rail using heavy thread at long spacing. Accordingly the presence of this rail is thought to be an early feature rather than a non-original one.

Claims are often made by museums that their spinets rest on their original stands. The author has found no firm evidence that spinets in this group of instruments were generally supplied with a stand, though as noted, it is probable that the stand of the 1707 Keene spinet described above is original. The design of spinet stands is discussed in Chapter Nine.

### **3. The Early Instruments**

Only three inscribed instruments belonging to the class of early instruments are listed in Boalch (1995), those at the Royal College of Music (RCM), No.3 in Table 501 above, at Hall i' th' Wood, Bolton (No.24) and one (No.1) in private ownership: the last of these has not been seen for about 50 years. In addition, an anonymous instrument at the Royal Northern College of Music, Manchester, and (RNCM) bears some features which might point to an attribution to Keene, though other makers and particularly Tisseran or Slade are also a possibility. The first two of these spinets, which are quite different in design, are described below. The anonymous RNCM spinet is described in Appendix Four.

#### **a. The Keene Spinet at the Royal College of Music, London**

In comparison with the 'standard' late-Stuart spinet with a fifty-four note compass and a box-guide register, this spinet, which is shown in Plate 517, has a number of unusual features: -

- It has a soundboard register,
- The soundboard includes a rose,
- It has the inscription on the jack rail,
- It has a serpentine bentside without a separate tail.
- It is veneered with so-called 'oyster' veneers but without a cartouche on the nameboard,
- It has a short octave compass without split sharps,
- It has 'skunk-tail' sharp blocks,
- It has long string scaling,



**Plate 517 - The Keene Spinet at the Royal College of Music, London**

With the exception of the long string scaling, which is discussed later in this chapter, these unusual features will be discussed in turn:-

The upper member of the register is shown in Plate 518 below: it is thought to be non-original. It consists of a strip of beech or similar hardwood formed with the requisite number of jack-guides, which has been applied to the top surface of the soundboard. However, it can be seen that the apertures in the strip have elliptical clearance holes for the jack-tongues, quite atypical of those found in other early keyboard instruments. Furthermore, the scribe lines marking out these apertures are still very clear. These two features suggest that the timber is a repair of the original upper part of the jack-guide, which would have been of leather and would have had plain rectangular apertures for the jacks.



**Plate 518**

**The Soundboard Register of the Royal College of Music Spinet**

The soundboard is unusual in two other respects: - first it extends over the wrestplank to the front of the instrument, the nut being applied to the upper surface of the soundboard and being secured through it to the wrestplank. The holes for the tuning pins are drilled through the soundboard into the wrestplank. Secondly it contains a rose as shown in Plate 519.



**Plate 519 - The Rose of the Royal College of Music Spinet**

The rose is also shown in Wells (2000: 41) where it is suggested that its pattern is similar to one of the four roses found on the Keene virginal of 1668, now at St. Cecilia's Hall, University of Edinburgh. The presence of both the soundboard register and the rose are more characteristic of virginal-making practice than of spinet-making. Their presence in this spinet is the most obvious indications which lead to the conclusion that it is early in date.

As can be seen in Plate 520, the spinet bears the inscription *Stephanus Keene Londini Fecit* on the jack rail.



**Plate 520 - The Jack Rail of the Royal College of Music Spinet**

The veneering of the jack rail and the presence of some vestigial characters indicate that the inscription once included a date, which has been removed and is no longer legible. Two points arise: - first, the placing of the inscription on the jack rail is in accordance with Keene's virginal practice: for example, the Keene virginal of 1668 is inscribed on the jack rail (see Martin 2005: II: 118 for another example); secondly, the removal of the date points to the conclusion that the date which was proclaimed was uncomfortably early for the owner. The importance which was attached to having 'the latest thing' in the late-Stuart period will explain why it was removed – it was removed to disguise the instrument's antiquity. A plan view of the instrument is shown in Figure 502, from which it can be seen that though the instrument has a serpentine-tail design, it has a mitred left tail.

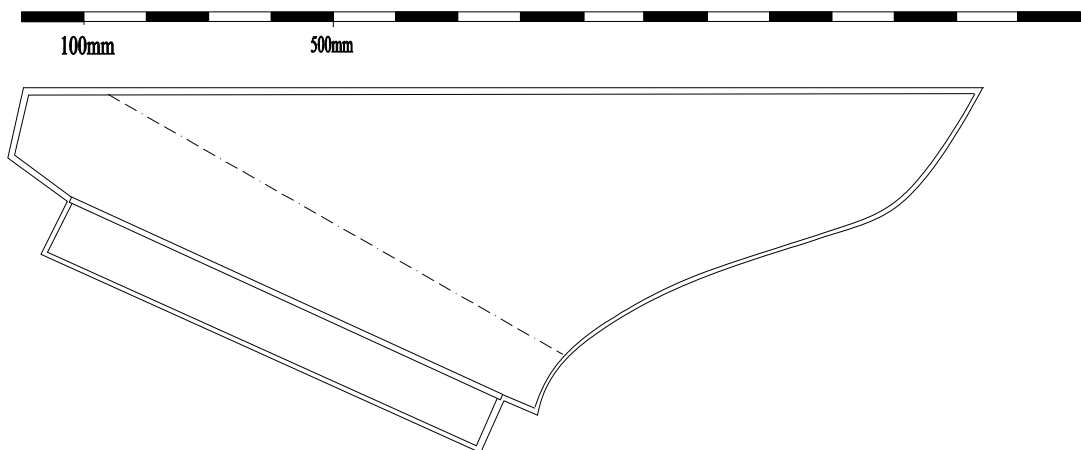

**Figure 504 - The Plan Form of the Royal College of Music Spinnet**

The plan form shown in Figure 504 is unique amongst surviving Keene spinets, though spinets by Charles Haward including that dated 1687 at Leipzig University and that dated 1689 at the University of South Dakota also have serpentine bentsides. This feature is therefore not unusual in itself, though it is a feature which had died

out by 1690 in favour of bentsides having single arc and a mitred tail. The serpentine-tail design was not re-introduced until about 1715-20, the 1714 Barton instrument referred to above being the earliest known to the author amongst the eighteenth-century examples.

The oyster veneering which is shown in Plates 517 above and 521 below *is* unique in spinets so far as is known. Bowett (2002: 55) suggests that oyster veneering in cocus or princeswood was popular between about 1660 and 1675, and he illustrates a chest of drawers veneered in this way to which he attributes the date range c.1670–1700 (Bowett 2002: 51). Cocus and princeswood oysters were used in the earlier part of the date range quoted and olive and walnut at the later dates.<sup>23</sup> Though no microscopic examination has been carried out on this spinet, the present oysters are thought to be walnut. The veneer of the nameboard is divided into panels which give the impression of having been prepared for the application of standard-shaped reserves of veneer<sup>24</sup> though they are indistinct in the printed version here.<sup>25</sup> One such panel can be seen by careful inspection of Plate 520 below. It shows as a lighter coloured line describing (in part) an arc, beginning on the left under the letter ‘A’ of the word *Stephanus* in the jack rail inscription and ending between the letters ‘N’ and ‘D’ of the word *Londini*.

---

<sup>23</sup> Fine examples of oyster veneered furniture can be seen at Ham House, Richmond, Surrey, and at Powis Castle (sic), Welshpool, Powys.

<sup>24</sup> At the Early Keyboard Symposium held at the University of Edinburgh in October 2008, the author presented a paper entitled ‘The Parrot, The Tulip and The Frenchman – Some Decorative Aspects of the Late-Stuart Spinet’. During the presentation he referred to case furniture decorated with veneer reserves of the shape found in this spinet. Some of these items are illustrated in Bowett (2002: 57 & 58)

<sup>25</sup> They are more easily seen on an electronic version of the image.



**Plate 520 - The Nameboard of the Royal College of Music Spinet**

It is suggested in Chapter Nine that in later spinets, the reason for providing panels for reserves such as cartouches is that such panels were normally bought in from the furniture trade. Yet here the oysters appear to be applied continuously across the panels. It is not clear why this approach to veneering would have been taken.

The compass of the keyboard is GG/BB-d''' (52 notes) with a short octave in the bass. This compass appears to be original. A short octave disposition is highly unusual in spinets and is indicative of an early date of manufacture. As can be seen from Plate 520, the sharp blocks are skunk-tailed in an ivory-ebony-ivory sandwich. This spinet is the only surviving one by Keene to have skunk-tail sharps and though this is not an unusual feature in spinets, it is normally found in instruments of a date later than about 1715 and again is an indication of early manufacture.

The ebony of the natural touch-plates is heavily scored with four lines, providing guidance for the chamfering at the plate edges and for the saw cuts to be made to accommodate the front of the sharp blocks, as can be seen in Plate 521. It can also be seen that this touch-plate – that of key d''' - has a longitudinal join in the ebony.

That is a not-unusual feature of Keene spinets: its presence indicates that the cost of ebony was sufficiently significant in Keene's pricing structure for waste to be significant (Barnes 1985: 17). These two features indicate the difference in attitude to the visible presence of constructional features between the late-Stuart period and the present time. Though a join of this sort and the presence of constructional lines on the natural key-plates would not be acceptable today, it seems to have been acceptable in the late-Stuart period. Indeed, the presence of score lines where only two are necessary indicates that functional embellishment was to be enjoyed rather than avoided.

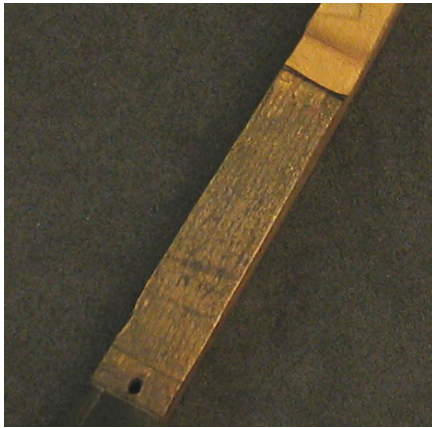

**Plate 521**

**A Natural Key-plate from the Royal College of Music Spinet**

Both Boalch (1995: 414) and Wells (2000: 40) refer to a very indistinct inscription on the d''' key lever. This inscription is shown in Plate 522 below. After electronic manipulation in Adobe Photoshop™ as described in Appendix One this inscription can be made legible: it reads '52', the number of the key, and the initials beneath

this number read 'JH'. This can be seen most readily by examining the digital files of this dissertation on the attached DVD in Adobe® Photoshop using a liquid crystal computer monitor. In Plate 523 the upper part of the inscription, but not the remaining part, which cannot be deciphered, has been hand-enhanced.



**Plate 522**



**Plate 523**

**The Initials Inscribed on the d''' Key Lever  
of the Royal College of Music Spinet**

The initials 'JH' are likely to be those of John Harris, who was apprenticed to Keene in 1675 and became a freeman of the Joiners Company in 1685 (Boalch 1995: 80).<sup>26</sup>

It is therefore probable that the instrument was made after 1675 and probably after 1678; it seems unlikely that an apprentice with less than three years experience would be allowed to initial the instruments on which he worked. It is also likely, from the combination of early features which the instrument exhibits, that 1685 is the

---

<sup>26</sup> According to Boalch (1995: 80) Harris took on John Sison, son of Benjamin Sison, as an apprentice, so he may well have been in business on his own account by that date. However, the *London Apprentice Abstracts 1442-1850* available electronically on subscription through [www.ancestry.com](http://www.ancestry.com) do not confirm that. On the contrary, they contain an entry in the year 1696 for the apprenticeship of John Sison, son of Benjamin Sison, Citizen and Joiner to George Clarke, a vintner. Since Benjamin Sison was himself not apprenticed until 1673, the later date for the apprenticeship of his son seems to be the correct one, though the John Sison apprenticed to Harris may have been a relative of Benjamin Sison.

latest date and so on that basis this instrument has tentatively been attributed the date c.1682. In addition to the initials, the treble-most key lever bears two lines, probably location lines and some additional illegible material.

The spinet is fitted with three brass lid hinges, of similar pattern but differing sizes, three substantially identical flap hinges, a lock and hasp and two lid closure fittings. It is thought that with the exception of the lock, the brassware is original. This spinet is the only one which has been inspected by the author on which there are two lid closure fittings, so this feature is highly unusual if not unique. The hasp is to a design which has not been found elsewhere but apart from that the design of the brassware is common to all Keene spinets, and to several late-Stuart spinets by other makers. One of the lid-hinges has fractured, probably due to movement of the lid across the grain. The brass furniture of spinets is discussed in Chapter Nine. Details of the stringing of this spinet are provided in the Long Form in Appendix Five and are discussed below.

## b. The Keene Spinet at Hall i' th' Wood, Bolton

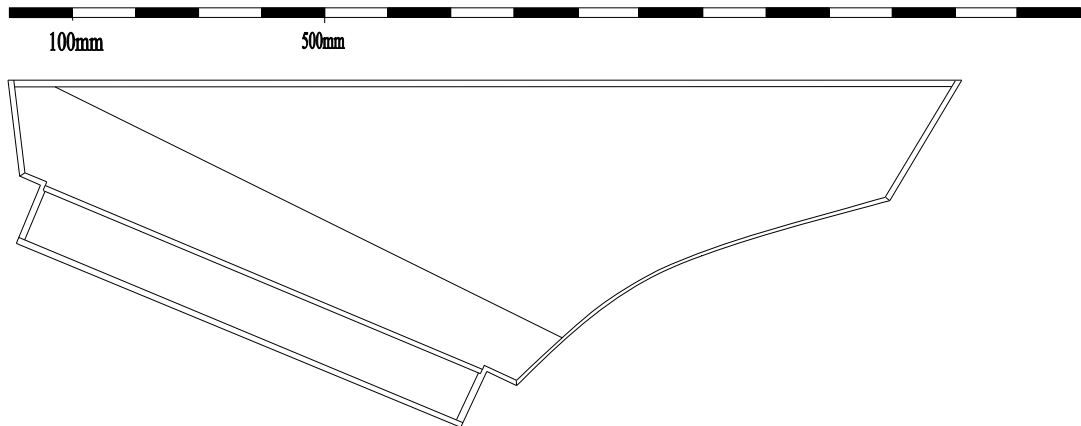

**Plate 524 - The Keene Spinet at Hall i' th' Wood**

This spinet exhibits some, but not all of the unusual features exhibited by the instrument discussed above. It has a soundboard register and a rose, and long string scaling, but the keyboard compass is GG/BB-d''' broken octave and the treatment of the veneering is relatively conventional. A general view of the spinet is shown in Plate 524 and a plan of the case form in Figure 504, from which it can be seen that the instrument has a mitred tail design. The left tail forms an unusually obtuse angle with the spine, producing a low spine length. Further details of the instrument appear in Appendix Five and it is in part the subject of Mole 2008 (a).

The nameboard is veneered in simple style, using walnut with single stringing of holly, box or sycamore, defining a rectangle and a central reserve for a cartouche, which is of unusual length for a Keene spinet. However, no cartouche is present and it must be assumed that at the date of manufacture the marquetry cartouche had not

yet come into fashion. This very plain decorative style of the spinet points to an early date of manufacture.



**Figure 503**

**Plan Form of the Keene Spinet at Hall i' th' Wood**

The nameboard reserve contains an inscription in ink. The scribe-lines for the inscription are clearly visible. The inscription reads *Stephanus* ◇ *Keene* ◇ *Fecit* ◇ *Londini*. The word order of this inscription is unique except for a spinet recorded in Boalch (1995: 414) as belonging to Mr E R Hawkins and dated 1685.<sup>27</sup> That may be significant: other Keene spinets, and the two surviving Keene virginals of 1668 and 1675, have an inscription in which the words *Fecit* and *Londini*, where they are both present, are reversed. It is possible that Keene was persuaded for a period to adopt the word order found here and that the word order found here indicates a date similar to that of the Hawkins spinet, and so of c.1685. However there is a possible alternative explanation:-

<sup>27</sup> The present location of this spinet is unknown.

The jack rail of the spinet, which is not shown in Plate 524, is not original. It may be that like the spinet at the Royal College of Music discussed above, the original jack rail bore an inscription and that as a result of damage it had to be replaced. It is possible that at that time, the restorer opted to place an inscription on the nameboard, in accordance with later practice, which may explain both the unusual word order and the fact that the inscription is not placed centrally in the reserve, as can be seen from Plate 524. It is not possible to say that one or other of these explanations is correct.

The register is of the 'soundboard' design normally found in north European virginals and is shown in Plate 525.



**Plate 525 - The Register of the Keene Spinet at Hall i' th' Wood**

The upper guides of the register consist of clearance holes for the jacks cut into the soundboard. A thin strip of leather, attached to the soundboard by gluing, provides the guide surfaces for the jacks. Some repairs to the register have been made. Apart from its manner of construction, the register is also unusual in that it consists of twenty-six pairs of guides and two singletons, rather than twenty-seven pairs of guides, to accommodate the 54 note compass. Martin<sup>28</sup> has suggested that this arrangement may have been adopted to allow Keene to use the virginal templates with which he would have been familiar to lay out the string-band. In both the virginal and the spinet, the strings run in pairs separated by a pair of jacks. Because of the geometry of the instruments and in particular because of the need to provide room for the jacks and their action, those strings which are on the player's side of their jacks are longer than their theoretical lengths, and those that are on the spine side of their jacks are shorter than their theoretical lengths. Martin's suggestion is that Keene may have arranged the register so that, for example, all the 'c' strings were 'long' in this context though that suggestion is speculative.

Like the Royal College instrument, the soundboard of this spinet incorporates a rose, the design of which is shown in Plate 526 below. The design is similar to but not identical with that incorporated in the soundboard of Keene's 1675 virginal shown in Plate 527 below. It seems likely that these 'honeysuckle' style roses might well have been made by the same craftsman. But if so, then he must have produced the

---

<sup>28</sup> Personal communication, March 2006

same design over a relatively long period, since it is not thought that this spinet dates from so early a date as 1675, though that cannot be entirely ruled out.<sup>29</sup>



**Plate 526 - The Rose of the Keene Spinet at Hall i' th' Wood**



**Plate 527 - The Rose of the 1675 Keene Virginal<sup>30</sup>**

---

<sup>29</sup> The rose of the Royal College spinet discussed immediately above is similar to that of the 1668 Keene virginal, so too close a reliance on the design of the rose would force an attribution of c.1668 to that instrument. Yet as stated, it is thought that spinet cannot be earlier than 1675 because of the craftsman's initials which it carries.

<sup>30</sup> This image is by Darryl Martin and is reproduced here by kind permission

The bridge of the spinet is formed with a heavily scribed line at its crest as shown in Plate 528. It has been suggested by several authors, including Barnes (1985), that a line of this sort this may have been intended to contain a wire running along the crest, but there is no evidence to support such a suggestion in this instrument and it seems more likely that the groove is a construction line to guide sawing-out of the bridge. As can be seen, the bridge has a split in it at the treble end. It is possible that this split runs along the line of a glue joint where two boards have been shot together to form a blank for the bridge.<sup>31</sup>



**Plate 528 - The Bridge of the Keene Spinet at Hall i' th' Wood**

---

<sup>31</sup> Several Keene spinets, including the author's Keene & Brackley instrument, have bridges made from two boards in this way.

The keyboard compass of the spinet is GG/BB-d''' with split sharps in the bass (54 notes). A general view of the keyboard, removed from the instrument, is shown in Plate 529. The natural key-plates are of ebony, heavily chamfered and the proximal ends of the natural levers bear paper arcades with a trefoil design. Unusually, the sharp blocks are of walnut with an ivory slip. The walnut has been painted black in a crude way.



**Plate 529 - The Keyboard of the Keene Spinet at Hall i' th' Wood**

It can be seen from Plate 529 that the right hand key block is unusually narrow: it is some 7.5 mm narrower at the front and 9mm at the rear than the left hand block (see Form LFSKHW of Appendix Five). The probable explanation for that is that the key lever of the d''' key is cracked at the distal end and so that end of it is now somewhat wider than it originally was. It is thought likely that the key block has been trimmed to compensate for that. The alternative explanation is that the compass has been altered. However, neither the rack nor the balance rail shows any evidence of that nor does it appear that any non-original balance pins are present: they are all original and they all match.

Plate 530 is an enlargement of Plate 529 showing the bass end of the keyboard. Just visible is a scribed diagonal line, emphasised in yellow in Plate 530, serving as an aid to replacement of the keys in their correct order, though the keys are also numbered.<sup>32</sup>

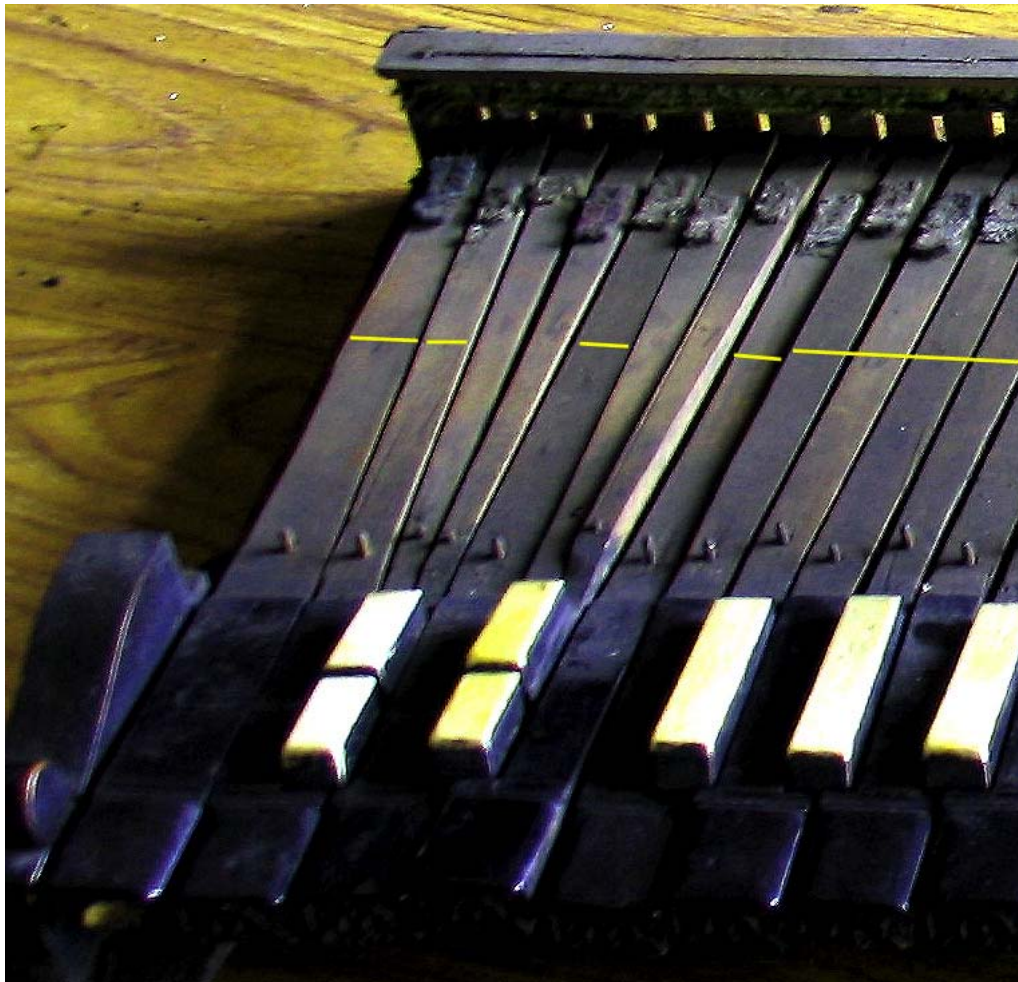

**Plate 530 - Numbering and Scribing of the Keys  
of the Keene Spinnet at Hall i' th' Wood**

The scribed line introduces some uncertainties about the originality of the compass in the bass octave, despite the statement just made about the originality of the balance

---

<sup>32</sup> The author suggests that Keene may have used both aids for the benefit of those who were not numerate.

pins: - as can be seen in Plate 530, the line is missing on key lever numbers 3, 4 6 and 7, the key levers for the split sharps. However all the key levers are numbered consecutively. How can these facts be explained?

Three possibilities arise: - the first is that the split sharps were not in the instrument when it was built, but were added soon afterwards, in which case it has to be assumed that the numbering of the keys was done at this time. But that seems unlikely since inspection of the rack shows that it is unaltered. The second possibility is that the split sharps were there originally, but they became damaged and had to be replaced, and that when that was done the present numbers were scribed. Thirdly, it also possible that both scenarios are correct – the keys were not there originally, but were added and then deteriorated, and what we see now are replacements for non-original key levers. On balance the author considers it more likely that that the spinet was originally built with its present keyboard configuration and compass and that the present split sharp levers are replacement for damaged originals. The conclusion consequently is that the keyboard compass of 54 notes, GG/BB-d''' is original. That conclusion probably indicates a date somewhat later than that of the Royal College Keene spinet.

The spinet has been re-strung in steel. It has a long scaling (see Long Form LF SKHW in the Appendix) in which c'' is 304mm, very close to the metric equivalent of 12 inches (~304.8mm). In Table 507 below the string lengths of the Royal College spinet (SKRCM) and the Hall i' th' Wood spinet (SKHW) are compared with those of the two surviving Keene virginals dated 1668 (SKV1668) and 1675

(SKV1675) which were referred to during the discussion. The string lengths quoted for the virginals are those provided by Martin (2003: II: 110 & 123). As can be seen from Table 507, the Hall i' th' Wood spinet is very much closer in string length at its treble end<sup>33</sup> to that of the virginal of 1675 than it is to that of the Royal College of Music spinet. The latter in turn more closely resembles SKV1668.

	SKHW	SKRCM	SKV 1675	SKV 1668
<b>GG</b>	1325	1361	1589.5	1536
<b>C</b>	1276	1344	1478	1361
<b>F</b>	1212	1212	1231	1142
<b>c</b>	968	977	979.5	912
<b>f</b>	848	840	786	732
<b>c'</b>	595	595	573	535
<b>f'</b>	474	460	429	395
<b>c''</b>	304	288	307.5	287
<b>f''</b>	222	227	225	215
<b>c'''</b>	161	152	158	151
<b>d'''</b>	149	142	142	131

---

<sup>33</sup> Inevitably, any similarities between the spinets and the virginals disappear when considering the bass strings, because of the much shorter casework of the two spinets.

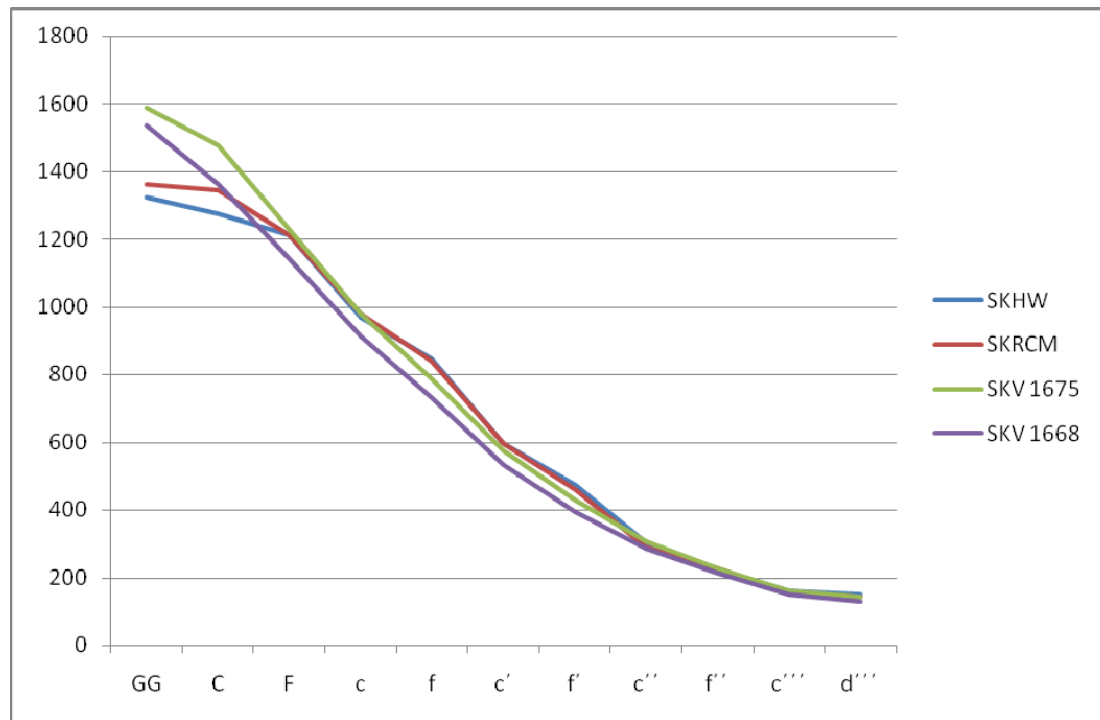

**Figure 504**  
**Plot of C and F String Lengths against Sounding Note**  
**For the Instruments of Table 507**

Martin concludes (2003: I: 69/70 & 231/232) that there is evidence that early spinets by Keene were either strung in iron in the treble, or that they were strung in brass and tuned to a much lower pitch than  $a \sim 415\text{Hz}$ . This conclusion was largely based on data obtained from the Keene spinet at the Royal College of Music and includes a deduction that both it and Keene's 1668 virginal have scaling based on a design note of  $c'''$ . Table 507 provides further evidence in support of Martin's general conclusions. A full discussion of the stringing of spinets appears in Chapter Eight.

To summarise, though the Hall i' th' Wood spinet is undated, it has a number of features which point to an early date: - its extremely small size, its plain decorative style, the word order, placing, and style of its inscription, its long scaling, and in

particular its soundboard register: these features point to a date of from 1680-1685. Because of its 54 note compass it is thought to be later in date than the Royal College instrument, and probably c.1685.

### c. The Early Spinets – General Characteristics

Very few of the early spinets by Stephen Keene have survived. The two described in detail here and another enigmatically identified in Boalch (1995: 414) as belonging to a Mr E R Hawkings seem to be the only ones. A comparison of the plan forms of the two early Keene spinets described above is shown in Figure 505 below. The obtuse angle which the left tail forms with the spine in the Hall ‘i th’ Wood spinet, commented upon earlier, is very evident.

**Keene Hall i’ th’ Wood in black**  
**Keene Royal College of Music in red**

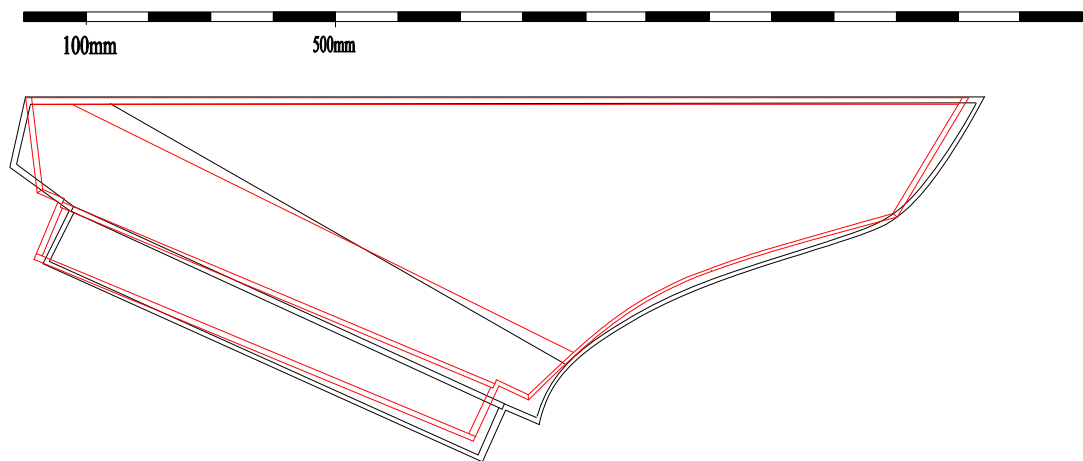

**Figure 505**  
**Comparison of the Plan Forms of two early Keene Spinets**

A further interesting comparison is with an anonymous seventeenth-century spinet at the Royal Northern College of Music, Manchester. This instrument is described in Appendix Four. Although the spinet has been attributed to Charles Haward (Boddington & Pyne 1888, No VIII) that attribution seems most unlikely since the characteristic plan form of the Haward spinet with a sharply curved serpentine tail and single case wall at the bass end is absent. No firm attribution of this spinet can be made, but the possibility that it is a fourth example of an early spinet from the school of Keene cannot entirely be ruled out.

It is tempting to suggest that all of these spinets are very early indeed and that they date from before 1675, the date of the later of the two Keene virginals, since it is self-evident that production of virginals in the Keene workshop must have tailed off and that of spinets accelerated - there would not have been an abrupt change of product. But the evidence for such an early date is tenuous – in both of the Keene spinets there are some features which make a definite dating difficult. Nevertheless, the presence of the virginal characteristics – the soundboard registers, the soundboard roses, the long string scaling, and the absence of a marquetry cartouche on the nameboard distinguish the two instruments clearly from those in the standard group discussed earlier. These four features are characteristic of this small group.

## 4. The Transitional Instruments

The group of 'transitional' instruments from the school of Keene – those instruments which have a compass greater than the 54 note keyboard of the standard group, but of less than five octaves, consists of only three surviving instruments so far as is known:-

- The Keene spinet dated 1711 at Westwood Manor, Somerset,
- The Keene & Brackley spinet formerly belonging to the late Mr John Barnes and now in the author's possession, and
- A spinet by Charles Brackley, now in private ownership in Philadelphia.

The first two of these instruments have been inspected by the author and some details of the Philadelphia instruments have also been kindly supplied by John Watson. Descriptions of the 1711 spinet and of the undated Keene & Brackley spinet appear in Appendix Five, together with briefer details of the Philadelphia instrument. What follows is a brief account of the 1711 spinet to allow discussion of some general points of difference between instruments of this group and those of the previous one.

### a. The Keene spinet of 1711

This spinet, which is shown in Plate 531, is on public display at Westwood Manor, Bradford on Avon, Wiltshire, a National Trust property. The National Trust was not willing to agree to a full inspection being carried out, but the author was greatly assisted by the supply of information and photographs taken during restoration of the spinet by Messrs Clayson and Garrett in 1983. Much of the following report relies

on that documentation, which is reproduced here by kind permission of Andrew Garrett.



**Plate 531 – The 1711 Keene Spinet at Westwood Manor**

Figure 506 shows the plan form of the instrument from which it be clear that in essence, the spinet is a larger version of the standard instruments described in the earlier part of this chapter. The spinet is supported on a stand which is likely to be of some age but is probably not original.

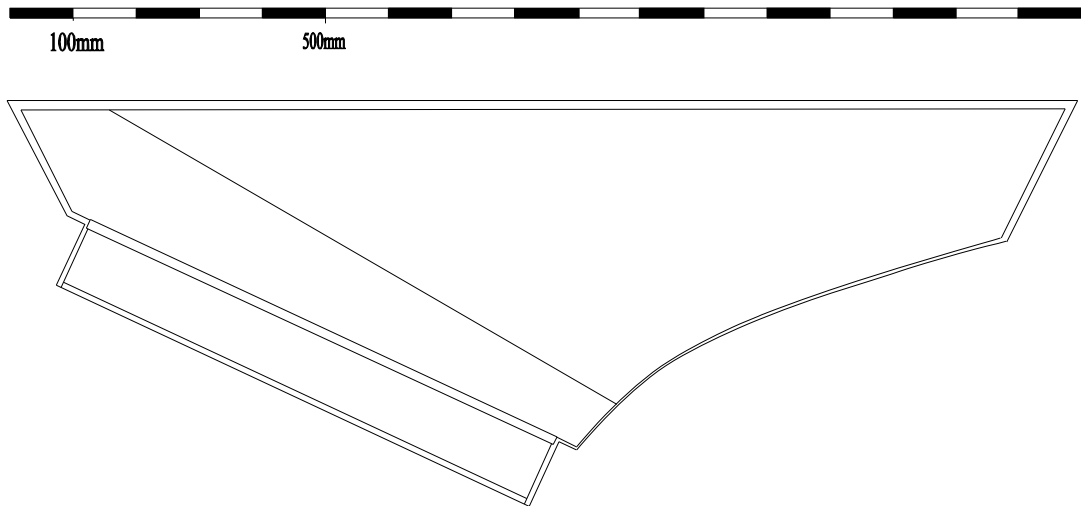

**Figure 506 – The Plan Form of the Keene Spinet at Westwood Manor**

The spinet bears the inscription *Stephanus Keene Londini Fecit* on the nameboard and on the uppermost key lever, further inscriptions shown in Plate 532 below. Those inscriptions read ‘56 CB 1711 18’ with an undecipherable mark, perhaps an ‘*m*’. The numerals ‘56’ refer to the number of the key lever in the compass, the letters ‘CB’ are the initials of Charles Brackley, Keene’s last apprentice, and ‘1711’ is clearly the date. The numerals ‘18’<sup>34</sup> are thought to refer to the number in a production run, probably the number of spinets made in the Keene workshop in the year 1711.

<sup>34</sup> Boalch (1995: 416) refers to these figures as ‘13’, incorrectly in the author’s view. Beurmann (2000: 128) suggests by implication that the figures refer to a sequence of the spinets made by Brackley, but that seems unlikely given that Brackley had by 1711 been working for Keene for eight years.



**Plate 532**

**The inscriptions on the d''' key of the Keene Spinet at Westwood Manor**

The nameboard includes an elaborate marquetry cartouche of birds and flowers, including tulips, as shown in Plate 533. Though the impression is of a very intricate piece of marquetry, much of the detailing is added in ink upon a relatively simple marquetry base.



**Plate 533**

**The Marquetry Cartouche of the Keene Spinet at Westwood Manor**

The brassware is extremely old but it is not original. It seems that the spinet must have undergone a fairly substantial refurbishment at some time in the late-eighteenth or nineteenth century, since the brassware now present, which consists of three lid

hinges, three flap hinges, a lock and hasp and an S-shaped hook lid closure are of a gothic pattern reminiscent of that found on Hitchcock spinets, as can be seen from Plates 534 and 535, though these items are not chased, as early eighteenth century brassware would have been. One of the lid hinges is a modern copy of these replacements. Vestiges of the fastening holes for the original lid closures can be seen on the bentside and elsewhere.



**Plate 534**

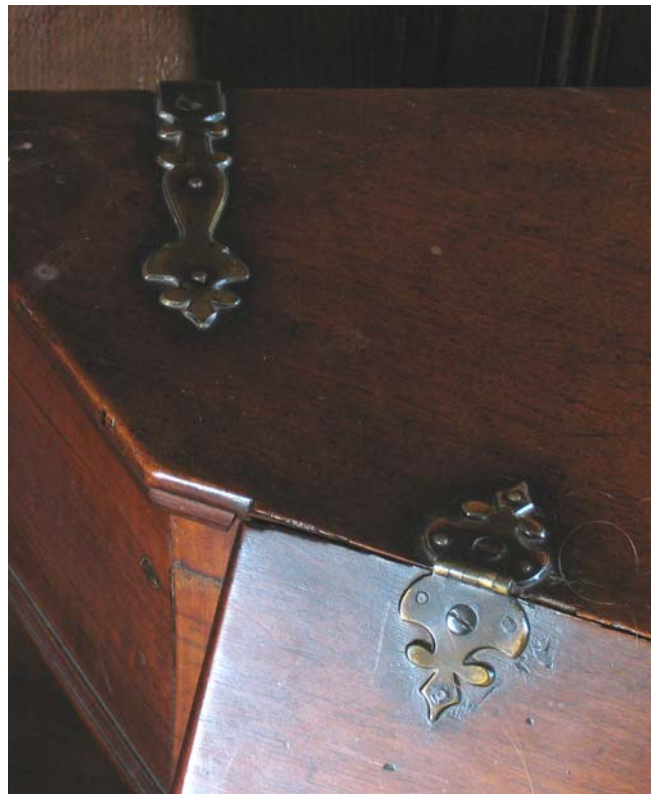

**Plate 535**

**Lid and Flap Hinges of the Keene Spinet at Westwood Manor**

Only a single key was permitted to be removed from the instrument, so inspection of the keyframe was not possible. But photographs supplied by Garrett and on file with the author show that the key levers are guided in accordance with the normal practice of the Keene school by slips of beech inserted into their distal ends, co-operating

with a rack. As with the 1707 spinet detailed earlier, there is no rear touch-rail. The key travel is stopped by means of a front touch rail, added after initial manufacture. It is thought that the travel was originally stopped at the jack rail.

The keyboard has the compass GG, AA – d''', e''', (GG - e''' without GG # and d#''') and is therefore of 56 notes. A general view of the keywell and keyboard is shown in Plate 536.



**Plate 536 – The Keyboard of the Keene Spinet at Westwood Manor**

The absence of the two accidentals is noteworthy and can be accounted for in two ways: - either, as some commentators have suggested <sup>35</sup> it is the result of the wish to provide an appearance which was, as nearly as could be achieved, symmetrical. The alternative explanation, and in the author's view the more likely one, is that it was recognised that GG# and d#''' would add cost to the instrument without adding greatly to the capability of the instrument in musical terms. More is said about keyboard compass in Chapter Eight.

<sup>35</sup> For example, Malcolm Rose, speaking at the University of Edinburgh Early Keyboard Symposium in October, 2008.

Garrett reports that all but four of the jacks are original, though they have all had additional weights added to them since manufacture. One jack, No 44, has the damper on the opposite side to the others. Garrett believes that this was originally made in this way in error.

The soundboard of the spinet has undergone considerable repair at various stages of its life, but is still in good structural and acoustic condition.<sup>36</sup> The nut is original though the bridge is not. Garrett reports that when he first inspected the spinet in 1981 it was furnished with a bridge of a section appropriate for a piano, so he made a replacement which is now in the instrument. Because the original bridge has been lost, it is unlikely that the scaling of the stringing exactly replicates the original. Garrett based his bridge pin positions on his knowledge of other Keene spinets and upon the principle of endeavouring to equalise the lengths of the jack quills. This produced the present stringing lengths, reported in Long Form LFSK1711, which have been extrapolated from Garrett's figures, which were measured in imperial units.

The major point of difference between the 1711 spinet and those of the standard group considered earlier, apart from the compass, is that the grain of the soundboard, which is of coniferous material, runs substantially parallel to the register rather than parallel to the spine. This difference is shared by the other two surviving instruments in the group (see Appendix Five). This significant change in practice requires some comment, since it seems to have been adopted not only by Brackley, but also by the Hitchcocks and indeed most subsequent makers. The change may have been

---

<sup>36</sup> The instrument is in playable condition.

engendered by some pragmatic factor or by a sophisticated acoustical consideration. It is tempting, with the benefit of the hindsight given by modern physics, to think that the laying of the individual planks of the soundboard with the grain running parallel with the register was a deliberate choice made to improve the tone of the instrument. The flexibility of timber varies markedly with the direction of the grain, especially in timber as thin as a soundboard (typically 3mm): it bends readily across the grain but is stiffer longitudinally. The effect of the alteration to the use of angled grain would be to stiffen the soundboard in a direction perpendicular to the spine - see generally, Benade (1990: 124-148). The result would be an increase in the impedance of the soundboard in that direction, raising its characteristic frequency and favouring a stronger tone and greater attack in the treble, (but possibly also adversely increasing the rate of decay, which is already short because of the small size and weight of the soundboard and bridge).<sup>37</sup>

A possible objection to this explanation is that it relies too heavily on modern understanding derived from the nineteenth century work of Rayleigh<sup>38</sup> and others: seventeenth-century spinet makers would not have had sufficient knowledge of acoustics for such a sophisticated analysis and craft response. However, reference to the author's article Mole 2008 (b) demonstrates that though acoustical knowledge may have been derived empirically rather than theoretically, it *was* available to spinet makers to a considerable degree, since the soundboard of the John Player spinet

---

<sup>37</sup> It is not known what the original soundboard thickness was. However Barnes's technical drawing of the Keene & Brackley spinet, which is closely similar, show the soundboard to be between 1.55 and 1.91 mm. thick, which is an unusually low thickness in a spinet. It may therefore be that the choice of grain direction was a result of the choice of a very thin soundboard.

<sup>38</sup> Lord Rayleigh, *The Theory of Sound* (1894)

described in the article was found to be loaded with a mass, presumably to increase the period of vibration and favour the fundamentals in the bass. A complex system of barring was also present, presumably to ensure that the soundboard vibrated as a single body.

## b. Other Transitional Instruments

As indicated earlier, only two other spinets of this group have survived, the author's own instrument being one. Comparison of this Keene & Brackley spinet with the Keene of 1711 shows that the two instruments are similar, which is not surprising since as explained in Chapter Four earlier, the Keene & Brackley cannot be dated later than 1712 and the two are therefore close in date. Figure 507 shows a comparison of the plan forms of the two spinets:-

As can be seen from the Figure 507 the Keene & Brackley spinet is marginally larger than the 1711 instrument, despite their having the same keyboard compass, the two spine lengths being 1754mm and 1693mm respectively. This might be explained by assuming that Brackley wished to provide a more powerful instrument generally by providing for a larger soundboard and for longer strings in the bass. Unfortunately the bridge position of the 1711 instrument is unlikely to be original, so no meaningful comparisons of stringing can be made.<sup>39</sup>

---

<sup>39</sup> Though the Keene & Brackley spinet suffered complete collapse of the soundboard, this has been restored and the bridge returned to its original position in the instrument. It has been re-strung using the original bridge and nut pins, so this instrument accurately reflects its state as built, see LFK&Br in the Appendix.

**Keene & Brackley in black**  
**Keene 1711 in red**

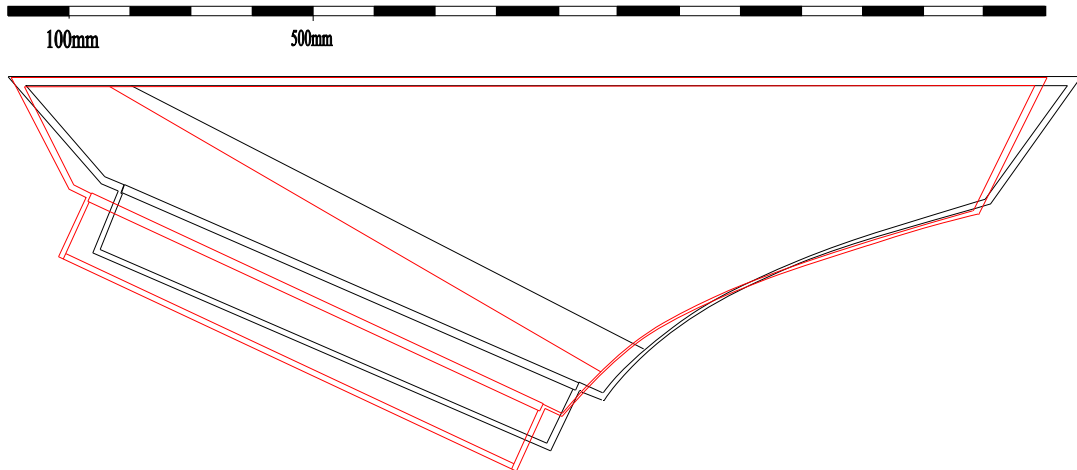

**Figure 507 - Comparison of the Plan Forms of Two Transitional Spinets**

Returning to the discussion of soundboard construction, when Barnes measured the thickness of the sound board of the Keene & Brackley spinet he noted with some surprise that it was less than 2mm thick in places<sup>40</sup> – less than the thickness of many veneers. Though no such measurements are available for the 1711 spinet, Garrett reported<sup>41</sup> that some considerable repair had been carried out to the soundboard before he restored it. Again, the question arises of whether the production of such a thin soundboard was deliberate, or whether it was due to error or to some other and now lost consideration. A general reduction in thickness of the soundboard will result in a general increase in flexibility, favouring the lower notes by emphasising the fundamental vibration. It is possible to postulate that this was done deliberately in conjunction with the change in grain direction to obtain the both an emphasis on the fundamental in the bass and an increase in impedance in the treble. Equally, it

<sup>40</sup> The thickness at various locations is shown on the scale drawing prepared by John Barnes, available from Mrs Sheila Barnes of Edinburgh

<sup>41</sup> Personal communication, April, 2007

could have been considered necessary to align the grain in the way described in order to strengthen the soundboard, given that it had been decided to plane it to such a low thickness: the precise rationale is likely to remain obscure.

The surviving spinet by Brackley is described in Appendix Five. Because it includes no reference in the inscription to Keene, it must be accorded a date between of 1712 and 1718, the window after Keene's death during which Brackley was still alive (see Chapter Four). It is notable that the style of the nameboard, shown in Plate 537 has moved away from that of the two earlier instruments. It includes feathered stringing characteristic of the early Georgian period and the cartouche, though still present, is more abstract and includes images of what have been identified as hoopoes (*Upupa epops*)<sup>42</sup> and a crown.<sup>43</sup>



**Plate 537**

**The Keyboard and Nameboard of the Brackley Spinet**

<sup>42</sup> The author is grateful to Simon Evans of the Department of Zoology, University of Oxford for this identification.

<sup>43</sup> The image of a 'crown with two boyes' (*putti*) is frequently encountered on late-Stuart furniture, see for example Bowett (2002: 98).

It is also notable that the instrument's compass includes GG# and d#''' and is therefore of 58 notes as shown in part in Plate 537. This is believed to be the original compass.

## **5. The Five-Octave Spinets**

So far as is known the entire output of five-octave spinets from the school of Keene are by Thomas Barton. The surviving spinets by Barton are shown in Table 508, which has been assembled from data in Boalch (1995: 231-233) updated where new information has become available. In addition, a harpsichord by Thomas Barton dated 1709 is at St. Cecilia's Hall. It is unfortunate that no Barton spinet was on public exhibition at the time that this dissertation was in preparation and that as a consequence what little information is available has been gathered has been from secondary sources. Nevertheless, it is important to include the spinets of Thomas Barton in this discussion, since Barton, as a Keene apprentice, is clearly a member of the Keene school.

It can be seen from Table 508 that several of the spinets were once in private ownership. However, several of the owners identified by Boalch 1995 have since died, including Professor Christiane Jaccottet (d.1999) and it is thought, Captain Matheson. The attribution of the 1731 spinet is from Boalch 1974, some thirty five years ago and it is not known whether the spinet is still in the same ownership. The 1724 spinet which was once on loan to the National Trust and on display at Blickling Hall, Norfolk, but it has been returned to its owners of whom the National Trust has

no record.<sup>44</sup> A similar circumstance surrounds the 1719 spinet once on display at St. Cecilia's Hall, which has since appeared in Sotheby's sale room. The instrument at the Smithsonian Institute in Washington at the time of preparation of this dissertation was in store and was inaccessible pending restoration of the Museum of American History.

<b>Table 508</b>	
<b>Surviving Instruments by Thomas Barton</b>	
<b>Date</b>	<b>Owner/Location</b>
1709	Formerly E. M. Ripin
1714	Not known
1719	Ex St. Cecilia's Hall, sold at Sotheby's 22 November 1990
1720	Capt A F Matheson, Invergordon
1723	Formerly the late Prof Christiane Jacottet, Geneva
1724	Ex Dartington Hall
1724	Ex Blickling Hall, Norfolk
1725	Sotheby's, 31 July 1953, withdrawn
1727	Auctioned at Sotheby's 11 March 1960
1729	Auctioned at Sothebys 26 November 1992
1730	Smithsonian Institute
1731	Stated in Boalch (1974: 9) to be Roger Yates, Michaelstowe
1740	Once in the Taphouse Collection

The result is that no Barton spinet has been inspected by the author. Nevertheless, some details of Barton spinets have been found:- An advertisement which appeared in the *Antique Collector* 1937 which shows a Barton spinet said to be dated 1714 was found during inspection of the correspondence file relating to the spinet by Benjamin Sison, now in the Lady Lever Art Gallery, Port Sunlight, Wirral, Merseyside.<sup>45</sup> The advertisement is reproduced below as Plate 538.

<sup>44</sup> Personal Communication, Andrew Garrett, December 2007.

<sup>45</sup> This spinet is described in Mole (2008 (a))



**Plate 538**

**A 1937 Advertisement for a Thomas Barton Spinet**

It is unfortunate that the lid of the spinet is shut, since judging by the general proportion, this instrument may well have a keyboard compass of five octaves, in which case it is the earliest five-octave spinet known to the author to have survived into modern times.<sup>46</sup> The simple turned stand appears to have ‘hoof’ or ‘scroll’ feet, similar to the feet found on the stands of some Hitchcock spinets. No further details of this instrument have been found.

Although the Thomas Barton 1730 spinet held by the Smithsonian Institution, Washington D.C was not available for inspection, two photographs of the instrument were provided. Both of these are reproduced below by kind permission as Plates 539 and 540.

<sup>46</sup> Another instrument for which this claim has been made is the FF-f'' Thomas Hitchcock spinet at the Museum für Kunst und Gewerbe, Hamburg. This claim is repudiated in Chapter Eight

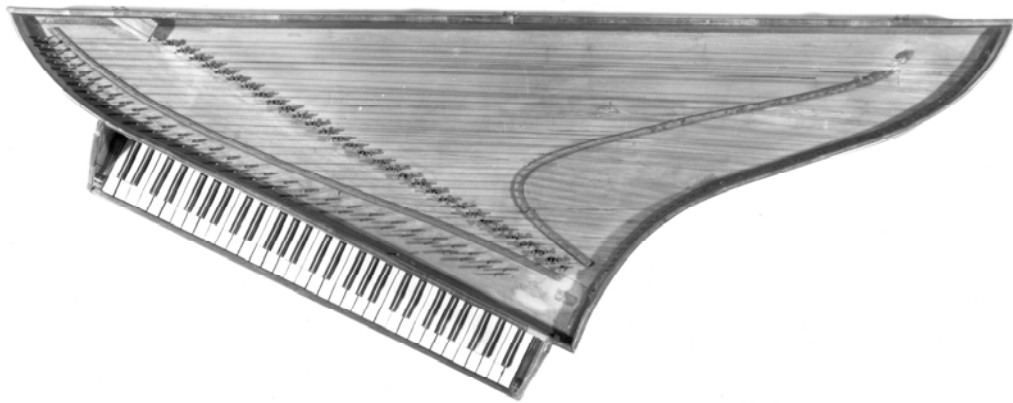

**Plate 539**

**A plan view of the 1730 Barton Spinet at the Smithsonian Institution**

As can be seen from Plate 539, the spinet has a serpentine tail of the type which by this date was commonly used by the Hitchcocks and an arcuate left tail. As noted earlier, use of a serpentine tail is not unique to Barton amongst the spinets of the Keene school, though the author believes that all Barton spinets are to this pattern. This construction was probably adopted by Barton purely for stylistic reasons, though it is possible that a serpentine tail was found easier to manufacture than a mitred one. There seems to be no significant acoustic advantage to the format.

Several other points of interest arise from the image in Plate 539, the first being that from what appears to be cracking of the soundboard, it seems that the planking and therefore probably the grain of the timber runs parallel to the spine of the instrument. It is possibly relevant in this regard that though Keene changed his practice during the time of Brackley's apprenticeship as noted in the previous section, Barton had left Keene's employ by then: he may merely have continued with the practice which he had been taught by Keene.

The instrument has skunk-tail sharp blocks as shown in Plate 539. Once again, though this is not unique to Barton – the early Keene spinet at the Royal College of Music has skunk-tail sharps, as does the Hancock harpsichord at St. Cecilia’s Hall – it is thought that this style was adopted by Barton to provide a more up-market appearance and to provide more effective competition to the Hitchcocks, whose spinets also had skunk-tail sharps.

Lastly, it is noticeable in Plate 539 that the nut, rather than being straight, has a pronounced curvature which is convex to the player. A curved nut is not found in other spinets of the Keene school but is not unusual in later spinets, again including those of the Hitchcocks. The effect of providing a nut which is curved in this way is to move the plucking point of the bass strings towards their centre. This will produce a vibration with a higher proportion of the fundamental and a more ‘flutey’ and less nasal tone.

An elevation of the Smithsonian Institution’s Barton spinet is shown in Plate 540. A further point of interest, and a further point of distinction with other spinets of the Keene school can be seen in the plate - the spinet has no removable nameboard: rather, it has a removable batten to allow access to the keys and keyframe for maintenance.<sup>47</sup> Though this is a feature which harks back to virginal practice, it came to be adopted increasingly as an alternative to a removable nameboard during the second half of the eighteenth century. Of many examples, the Richard Horsburgh spinet of 1786 in St.Cecilia’s Hall exhibits this form of construction. The feature is

---

<sup>47</sup> For this reason the nameboard inscription is at a higher level than in the spinets described thus far.

also exhibited by the 1724 Thomas Barton spinet formerly at Blickling Hall (see Appendix Five). It is likely to have produced a marginally stronger instrument than the earlier form of construction using a completely removable nameboard.



**Plate 540**

**An elevation of the 1730 Barton Spinet at the Smithsonian Institution**

In addition to the spinet shown in Plates 539 and 540, some details of the Barton spinet dated 1724 once displayed at Blickling Hall have been made available by Andrew Garrett, the National Trust's advisor on early keyboard instruments. These are reproduced in Appendix Five.

## **6. Summary, and the Proposed Classification**

In this chapter the spinets of Stephen Keene, of Edward Blunt, of Thomas Barton, and of Charles Brackley have been treated as a continuous output from a single school of spinet-making during a period of over forty years stretching from about 1680 to 1720. Though the spinets in question were made in several different workshops, all of these were within a few hundred yards of each other in the area around Bishopsgate and Threadneedle Street, and the craft traditions of the school, reinforced by the geographical proximity of its members show through strongly. Attention has been drawn to significant changes in the design of the spinets over time. These changes include an increase in keyboard compass and consequent general increase in size, the adoption of a box-guide register in place of a register integral with the sound board, the adoption of a more elaborate decorative scheme including a marquetry cartouche on the nameboard, a change to the orientation of the grain in the soundboard, and a construction method which eliminated the removable nameboard. Comments on the likely motivation for, and effect of, these changes are included.

The classification proposed for the surviving spinets of the school of Keene emerges from the foregoing description and the discussion of typical instruments. Two features have been identified as providing clear points of characterisation of these spinets – the construction of the register, and the keyboard compass. Using these characteristics and arranging the classification chronologically, the instruments can be seen to fall into four groups below:-

1. The early instruments having a soundboard register and probably produced at the same time as virginals were being made in the Keene workshop, or shortly after virginal production had ceased. Only two instruments having these characteristics have been definitively identified, with the possibility that there are two more.
2. The 'standard' GG/BB-d''' spinets of 54 notes with a broken octave and split sharps in the bass and an Italian style box-guide register, produced between about 1690 and 1710. The large majority of Keene spinets, together with those inscribed jointly by Keene and Blunt and those made by Blunt alone, fall into this group.
3. The 'transitional' spinets made by Brackley both while Keene was still alive and after his death in 1712, having an extended compass, but not reaching five octaves. Only three instruments have been identified as belonging to this group. Thomas Barton may also have made instruments of this type, though none have been identified during the research.
4. Five-octave spinets made by Barton. Though only one of these has been definitively located, it is clear from the literature that a number of these have survived, perhaps even as many as ten.

Adopting this classification, the surviving instruments which have been located or for which details have been obtained from secondary sources are set out in Table 509 below in their respective groups:-

<b>Table 509</b>			
<b>Proposed Grouping of Spinets from the School of Keene</b>			
<b>Boalch No.</b>	<b>Maker</b>	<b>Date</b>	<b>Owner/Location</b>
<b>Group 1</b>			
6	Keene	Undated	Royal College of Music, London
24	Keene	Undated	Hall i' th' Wood, Bolton, England
<b>Group 2</b>			
4	Keene	1700	Museum of Fine Arts, Boston, MA
5	Keene	1700	Colonial Williamsburg Foundation
7	Keene	Undated	Cantos Musical Foundation, Calgary, Alberta
8	Keene	1704	University of Edinburgh
10	Keene	1705	MKG, Hamburg
12	Keene	1711	Westwood Manor, Bradford-on-Avon
15	Keene	Undated	Memorial Hall Museum, Deerfield, MA
17	Keene	Undated	Musical Instrument Museum, Phoenix, AZ
19	Keene	1707	Grimsthorpe Castle, Bourne, Lincs
20	Keene	Undated	City of Hammamatsu, Japan
28(A)	Attributed	1708	Royal College of Music, London
29	Keene & Blunt	1702	Dumfries House, Ayrshire
30	Keene & Blunt	Undated	Private Owner, Lancaster
	Blunt	1703	Sold at Sotheby's 2004
<b>Group 3</b>			
31	Keene & Brackley Brackley		P G Mole, Shropshire, England Private Owner, Philadelphia
<b>Group 4</b>			
	Barton	1724	Formerly Blickling Hall, Norfolk
	Barton	1730	Smithsonian Institution, Washington D.C.

One last point must be made: - a classification which relies to a large extent upon keyboard compass might be misleading if the compass of an instrument had been extended after manufacture. But a striking feature of spinets of the Keene school is that in no instance has clear evidence emerged of the keyboard compass having been

altered. That stands in stark contrast to the position for the instruments made by some of Keene's competitors, Player and Sison for instance, which in many cases exhibit evidence of alteration. It seems likely that the reason why no Keene spinet seems to have been altered is that Keene was active in developing the compass of his spinets to take account of a changing market.

The development of keyboard compass and configuration is discussed holistically in Chapter Eight. The dissertation now turns to the School of Hitchcock.

## Chapter Six - The School of Hitchcock

### 1. Introduction

This chapter focuses on the lives and on the organisation of the workshop of the most significant spinet-making family of the early Georgian period, the Hitchcocks. It relies significantly on information garnered from genealogical websites. The following chapter, Chapter Seven, describes and discusses the spinets of the Hitchcocks.

Boalch (1995) lists at pages 386-396 the surviving spinets signed by or attributed to members of the Hitchcock family and identifies three individuals as spinet makers – Thomas Hitchcock the Elder, Thomas Hitchcock the Younger, and John Hitchcock. At pages 91 and 92 it sets out the understanding which subsisted in 1995 of the relationship between individual members of the Hitchcock family. In doing so it draws heavily on the two earlier editions of Boalch (1956 & 1974) as source material. That understanding was that the relationship between the three Hitchcocks who made spinets was that of grandfather, father and son. No research work dealing with the Hitchcocks was published between the appearance of Boalch (1995) and the publication of Mole (2007) referred to in Chapter One.

The discussion which follows seeks to answer two perplexing questions. First, how is it, if the general understanding set out in Boalch (1995) is correct, that a spinet dated 1703 (see Chapter Four, pages 75-76) which carries the inscription of Edward Blunt

on the nameboard additionally bears an informal inscription of the name and initials of a Thomas Hitchcock? The force of this question is not readily apparent until it is realised that Thomas Hitchcock the Elder was dead by 1699 and that Thomas Hitchcock the Younger did not begin his apprenticeship until 1700, and that he was bound apprentice to Benjamin Slade, not to Edward Blunt: and that he did not take his freedom until 1715.

The second question arises out of the serendipitous re-discovery of the year in which Thomas the Younger died, which has been lost for many decades.<sup>1</sup> Who took over Thomas the Younger's business on his death? The immediate answer – that it was his son, John Hitchcock – is suspect if it cannot be shown that Thomas had a son called John, which despite rigorous searching it has not been possible to show. Put another way, who was John Hitchcock?

It is clear that Mould, the editor of Boalch (1995), had realised that the entry for the Hitchcocks in his work is not completely coherent, since it contains this passage:-

‘The study of the Hitchcock family is still to be dealt with in detail and would be rewarding work [...] It is interesting to note that if Thomas Hitchcock the Elder died in 1700 and Thomas the Younger was apprenticed to Slade for eight years in that year, it would seem likely that there was no member of the Hitchcock family who could have been making instruments signed with this name in the period at least from 1700 to 1708 [...] This suggests that either the name was used under licence or that there was a fourth, as yet unidentified member of the family.’<sup>2</sup>

---

<sup>1</sup> Now known to be 1737, *qv*.

<sup>2</sup> Boalch (1995: 91/2) and Hubbard (1967: 138)

In what follows, the evidence for treating Thomas the Elder, Thomas the Younger and John Hitchcock as spinet makers is examined. Mould's 'fourth member of the family' – one who almost certainly made spinets – is then identified, which enables an identification of John Hitchcock. Last, organological evidence from the surviving spinets is combined with genealogical data in order to work towards a better understanding of the Hitchcock business.

## **2. The Hitchcock Family**

A difficulty in researching the Hitchcocks, which is no doubt in part responsible for the present unsatisfactory state of knowledge, is that the surname Hitchcock was quite common in London in the eighteenth century. There were two main groups of Hitchcocks – those centred on the parish of St. Dunstan's, Stepney in the East End of London and those in the more prosperous area of Holborn and the Barbican.<sup>3</sup> Apart from the large numbers in the extended family, a further difficulty is that it was a generally popular practice at that time to name the eldest son after the father and the eldest daughter after the mother. So not only were there a large number of people with the surname Hitchcock living in London, there were also considerable numbers of Thomas Hitchcocks and John Hitchcocks, the names which are inscribed on surviving spinets. Just considering what is thought to be the spinet maker's family, there were four consecutive generations with the name Thomas Hitchcock. These factors lead to some uncertainty, but if progress is to be made it is necessary to make

---

<sup>3</sup> This can be seen by conducting a general search for persons named Hitchcock who lived in London using the facilities of [www.familysearch.org](http://www.familysearch.org), the genealogical website of the Church of Jesus Christ of Latter Day Saints.

some assumptions. Here the assumptions adopted are that unless there is clear evidence to the contrary, boys were put into apprenticeship at the age of about 14 to 16 years; that they took freedom of their craft companies after seven or eight years of apprenticeship; and that they married as soon as they were both legally permitted and financially able to do so, at the age of about 24 years.

The spinet-making Hitchcocks were members of the Haberdashers' Company. Table 601 summarises the persons with the surname Hitchcock, highly likely to be related to some degree, who have been found in the Haberdashers Company's records in the Guildhall Library, London. From Figures 601 and 602 below it can be seen that there were actually two groups of Hitchcocks concerned with spinet-making, the group of Figure 601, which shows the father and son relationship of Thomas the Elder and Thomas the Younger, and that of Figure 602, which shows the relationship of John Hitchcock to the person shown in Table 601 as the Thomas who became a Freeman of the Haberdashers Company in 1701.

<b>Table 601</b>		
<b>Hitchcocks who were Freemen of the Haberdashers Company</b>		
	<b>Year of Freedom</b>	<b>Route</b>
Robert	1647	Apprenticeship to Ralph Wingfield
Hugh	1653	Apprenticeship to Ralph Wingfield
<b>Thomas (The Elder)</b>	1653	Apprenticeship to William Truelove
William	1693	Apprenticeship to George Wayloft
Timothy	1698	Apprenticeship to Thomas Overbury
<b>Thomas</b>	1701	Apprenticeship to Thomas Overbury
<b>Thomas (The Younger)</b>	1715	By Patrimony
<b>John</b>	1750	By Patrimony
<b>Samuel</b>	1782	By Patrimony

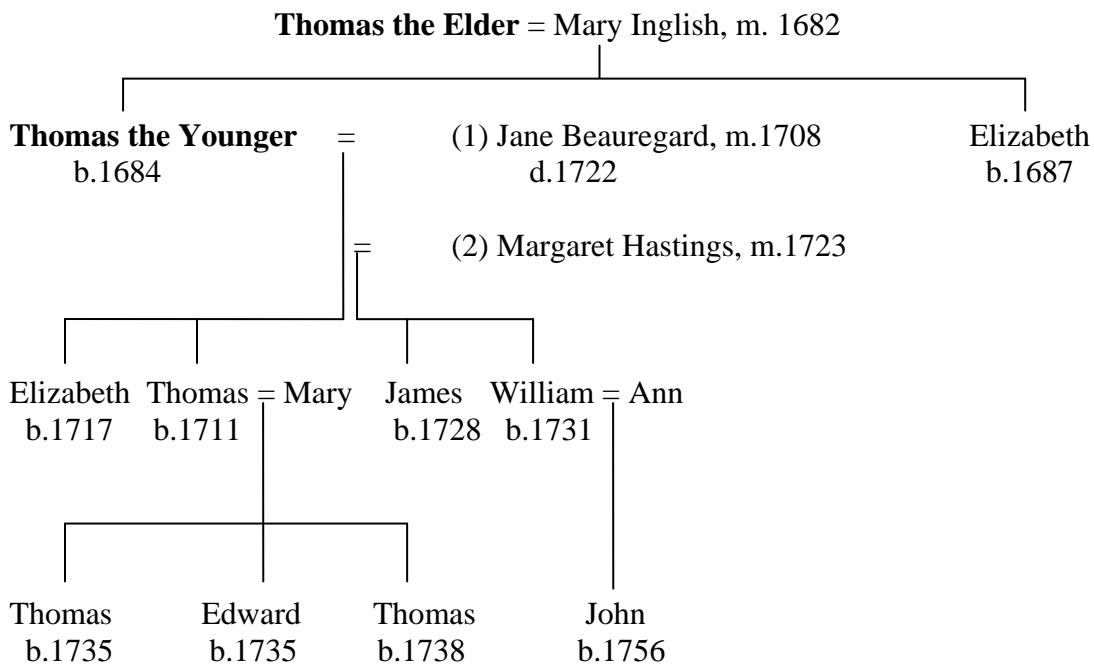

**Figure 601**  
**The Family Tree of Thomas the Younger**

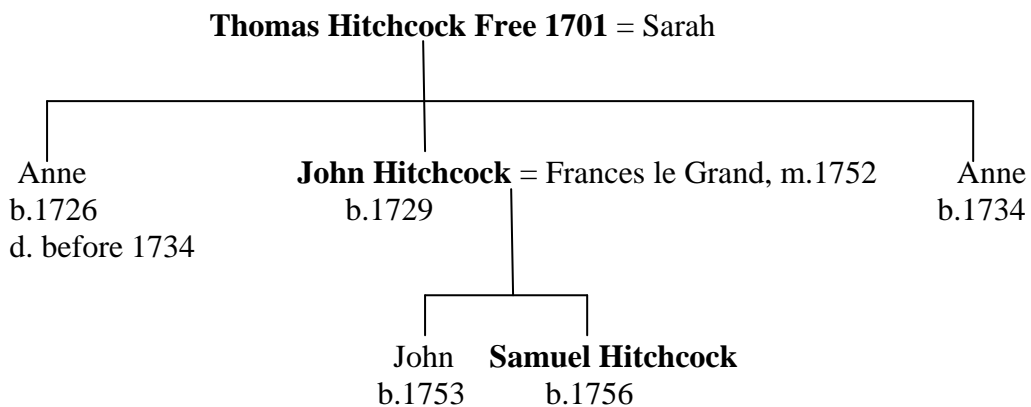

**Figure 602**  
**The Family Tree of John Hitchcock**

In order to distinguish this person from the two other persons named Thomas Hitchcock, he will now be referred to as ‘Thomas Hitchcock Free 1701’. It is unclear how Thomas Hitchcock the Elder was related to Thomas Hitchcock Free 1701. As mentioned in Chapter Four in relation to Stephen Keene, the parish records of some churches are incomplete for the period which includes the Civil War and the Interregnum. Whether a lack of completeness at St. Andrews, Holborn (the Hitchcocks’ parish church) is responsible for this is uncertain too, but no clear indication about the relationship between the two men has emerged from the archives.

The family trees in Figures 601 and 602 have been set out at an early stage in this chapter to aid understanding of the genealogical argument, which is complex. In what follows, the individuals whose names are emboldened in Table 601 will be considered in detail as a means of establishing that the trees are correct:-

#### a. Thomas Hitchcock the Elder

The entry in successive editions of Boalch for the person referred to as ‘Thomas the Elder’ (Boalch 1995: 91) is brief. It merely says: - ‘Dates ascertained, 1660-1700. He died before February 1700. He was a Freeman of the Haberdashers’ Company.’ It seems very likely that this person was the Thomas Hitchcock who married Mary English (or English) at St. James, Duke Place, London on 27 August 1682.<sup>4</sup>

---

<sup>4</sup> St. James, Duke Place was a notorious parish in Restoration London where clandestine marriages, without ban or licence were performed (Picard 1997: 226). Whether this marriage was of that sort it is impossible to tell. The date of marriage was ascertained from [www.familysearch.org](http://www.familysearch.org), accessed September 2005.

The date of 1660 in the phrase ‘Dates ascertained 1660-1700’ should not be taken as Thomas’s likely date of birth. It is based upon the belief that a spinet dated 1660 exists and that it is by Thomas Hitchcock the Elder. It is therefore a date by which it is thought that Thomas the Elder became active as a spinet maker. As will become apparent, that is almost certainly incorrect. However, it *is* correct that Thomas the Elder died before 1700. We know this from the record of the binding as apprentice of his son, whom Boalch consistently refers to as ‘Thomas the Younger’, to Benjamin Slade since the record describes Thomas the Younger as the ‘son of Thomas Hitchcock deceased’.<sup>5</sup> It is also correct that Thomas the Elder was a Freeman of the Haberdashers’ Company – he is the person shown in Table 601 who gained his freedom in 1653. From this it can be assumed that Thomas the Elder was apprenticed about 1645, when he would have been about 14 to 16 years old, so he would have been born around 1631. From the pattern of the birth of his children it is known that he lived until 1686 at least.

The marriage of Thomas to Mary English referred to earlier may indicate that Thomas’s first wife had died, since in 1682 Thomas would have been 51 years old on the present assumptions, which is very late for the birth of a first child. On the other hand, the birth of a son, christened Thomas at St. Andrew, Holborn on 10<sup>th</sup> October 1684, to a Thomas Hitchcock and his wife Mary living in Onslow Street<sup>6</sup> may suggest the opposite, since from the choice of Christian name it may be assumed that this child was the first-born son. That does not however, preclude the possibility that

---

<sup>5</sup> London Guildhall MS 15860/7

<sup>6</sup> Onslow Street ran into Vine Street, see Plate 601.

children by one or more earlier marriages may have been girls or that one or more boys named Thomas may have died. A sister for Thomas followed, stated to be born in Vine Street<sup>7</sup> but probably in the same house in Onslow Street, since Vine Street and Onslow Street intersected. She was christened Elizabeth at St. Andrew on 1 May 1687.

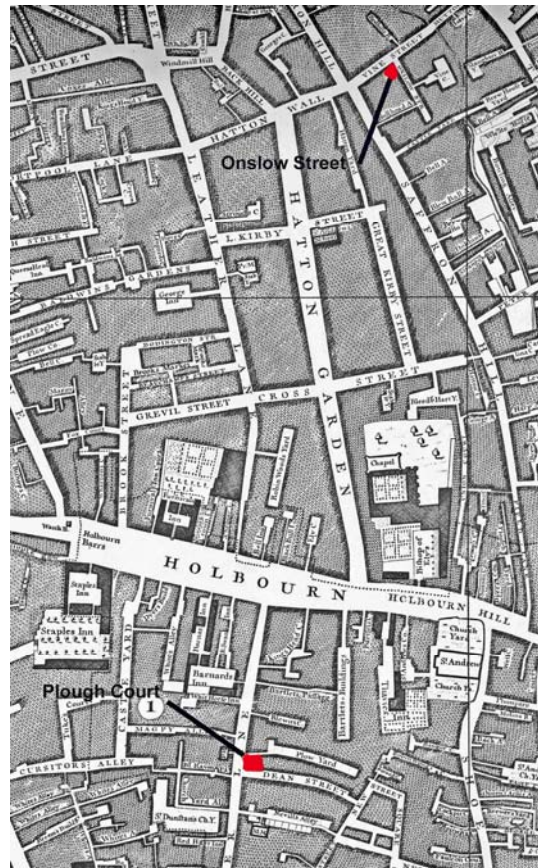

**Plate 601 - Hitchcock's London**

Plate 601 shows the part of John Rocque's 'Plan of the Cities of London and Westminster and Borough of Southwark' where the Hitchcock residences are thought to have been. The Hitchcock house at the corner of Vine Street and Onslow Street is shown, as is the workshop premises at Plough Court in Fetter Lane, between Plough

<sup>7</sup> Vine Street ran in an East-West direction across the top of Hatton Garden. It ran approximately along what is now Theobald's Road.

(or Plow) Yard and Dean Street.<sup>8</sup> Though the publication date of this street map is 1747, the street layout shows a good deal of stability over a long period. Many of the streets shown are still there today.

A hypothesis that postulates a man living in the seventeenth century marrying a young wife and becoming a father (again?) at the age of 52 may sound rather improbable, but it has two merits: - first it is biologically possible, and second, it is fully consistent with the archival evidence of Thomas Hitchcock the Younger becoming bound to Benjamin Slade after his father had died. That death unusually early in the young son's life might imply a father who was older than normal.

Boalch (1995: 386/7) refers to three spinets as possibly being by Thomas Hitchcock the Elder, but that attribution now seems unlikely. The spinets referred to are listed as dating from 1660, 1664 and 1700. It is clear that the data given in Boalch (1995: 386 to 396) has been reproduced from Boalch (1974: 71). Boalch (1974), in turn relies on James, first published in 1930 and re-printed in 1970 and also on Boalch (1956: 51) in respect of the first two spinets. James contains the following passage, relating to the admission by patrimony to the Haberdashers' Company of the younger Hitchcocks, Thomas and John, in 1715 and 1750 respectively.

‘They could have been admitted in any year after obtaining their majority and Thomas's signature on the key of an instrument dated 1703 suggests that some years elapsed before his admission.’

A footnote to that comment is provided,

---

<sup>8</sup> It seems likely that these premises were established in 1710 or early 1711 (see page 196).

‘A similar signature on a spinet by Blunt dated 1664 either must be a forgery or must signify the existence of a second and older Thomas Hitchcock (James 1970: 31).

It is believed that it is these two passages which are the source of the reference in all three editions of Boalch to Thomas Hitchcock the Elder as a spinet- and harpsichord-maker.

The advice of Mould, that the dates of these three spinets should be treated with caution, is well founded. The most immediate concern arises out of the footnote quoted above. There are two surviving spinets by Edward Blunt, one of which was sold as Lot 261 at Sotheby’s in November 2004. This spinet is believed to be the one referred to by James and by Boalch (1995: 387) as being from 1703, and it has already been referred to in Chapter Four and is briefly described in Appendix Four. According to the Sotheby’s 2004 catalogue, it bears the nameboard inscription *Edwardus Blunt Londini fecit*. The top jack bears the inscription *Thomas Hitchcock 1703* and the top key bears the initials *T.H.1703*. The style of the spinet is very similar to that of several spinets by Stephen Keene, which is unsurprising since as will be apparent from Chapter Four, Edward Blunt was apprenticed to Stephen Keene and eventually became a partner in Keene’s business. But Edward Blunt was not apprenticed to Keene until 1693. He would therefore not have been born until about 1678. So although it is likely that Blunt was responsible for the 1703 spinet, he cannot possibly have been active in 1664 as implied by the footnote in James (1970 reprint: 31). To understand that footnote another Edward Blunt who also made spinets must be postulated, perhaps the father of the well-known maker. Yet it is

clear from the records of Blunt's binding to Keene that Blunt's father was a Freeman of the Weavers Company.<sup>9</sup>

This notorious footnote from James, which is almost certainly erroneous, seems to have led some to deduce the existence of an earlier Edward Blunt who made spinets. Further, and worse, that deduction has been used to support a conclusion that Thomas Hitchcock the Elder was a spinet maker.

In general, although some Hitchcock spinets are dated, most are identified by a serial number rather than by a date. The serial numbers found on surviving Hitchcock instruments range from number 471 to 2018. It is immediately clear that an uninformed person could easily mistake a serial number such as 1660, 1664 or 1700 for a date. Cole, quoted in Boalch (1995: 386) comes to the view that this is exactly what has happened. Martin (2003: 224) agrees with Mould that caution is needed in accepting the attribution of these instruments.

None of these three early spinets have been seen for more than a century. If the reported dates are genuine, then it is curious that their locations are not known, since the two dated 1660<sup>10</sup> and 1664 would be the two earliest English spinets to have survived. In these circumstances, a mere signature on a jack or initials on a key – and particularly the signature or initials of a Thomas Hitchcock (said to be the 'The Elder') which is a signature which could equally be that of another Thomas Hitchcock – is insufficient to establish the existence of a maker who is otherwise unrepresented.

---

<sup>9</sup> London, Guildhall MS 8052

<sup>10</sup> It is also significant that no documentary evidence has been found of a spinet appearing in England which is earlier than 1664, see Chapter Three.

But there is a second important piece of evidence on the question of Thomas the Elder being a spinet maker: - the record of the christening at St. Andrew, Holborn of Thomas the Younger's sister, Elizabeth, in May 1687 describes Thomas the Elder as a chair maker.<sup>11</sup>

The new archival discoveries, the fact that James's reference to Edward Blunt seems to ignore established chronology, that there is no explanation for the disappearance of the three earliest English spinets which are key to establishing Thomas the Elder's activity as a maker, and that there are alternative explanations for the alleged signatures on those '1660s' Hitchcock spinets force the author a conclusion beyond that of Cole and of Martin - that the evidence pointing to Thomas the Elder as being an instrument maker is unreliable. He was probably principally a chair maker, if indeed he made any instruments at all.

#### b. 'Thomas Hitchcock Free 1701'

If Thomas the Elder was dead by 1703 and his son Thomas the Younger was still an apprentice in that year, then who was the Thomas Hitchcock whose name appears on the Blunt spinet? The answer is that there was a Thomas Hitchcock who was a Freeman of the Haberdashers Company in 1703 and who was almost certainly a spinet maker. That person is the Thomas Hitchcock listed in Table 601 who took freedom of the Haberdashers Company in 1701. This person, Thomas Hitchcock Free 1701, is Mould's 'fourth member of the family', this author suggests.

---

<sup>11</sup> London Guildhall MS 6667/5

What is the evidence for that? There is no reference to Thomas Hitchcock Free 1701 in any of the editions of Boalch or indeed in any of the musicological literature. However, the fact that John Hitchcock is known to have taken freedom of the Haberdashers' Company *by patrimony* in 1750 begs this question – from whom did he derive his claim? The answer provided by successive contributors to Boalch (1995) is that John claimed through his father, who has been assumed to have been Thomas Hitchcock the Younger. But as noted, it has not been possible to show that Thomas the Younger had a son named John. John Hitchcock derived the right to enter the Haberdashers' Company by patrimony from his father, who was Thomas Hitchcock Free 1701.

What can be deduced about the life of Thomas Hitchcock Free 1701? First, that since he became a Freeman after an apprenticeship, then he will have been a minimum of 21 years old in 1701 and that he would therefore have been born about 1680. He was therefore a little older than Thomas the Younger, but not much. His wife Sarah bore him a son, John, in 1729 but the date of their marriage and Sarah's maiden name are unknown. Marriages normally took place in the bride's parish, and without knowledge of which parish is the relevant one, a searcher would have to investigate all the parishes in the country.<sup>12</sup> Nothing further has been discovered so far about the life of Thomas Free 1701.

---

<sup>12</sup> For this the on-line facilities are inadequate. The electronic databases were prepared from microfilms of original parish registers. It is known that these are incomplete, but it is not known in what respect!

Once it has been accepted that Thomas Free 1701 was a spinet maker the problem over the Blunt spinet disappears. The signature and the initials are his. Probably he became Edward Blunt's journeyman after completing his apprenticeship with Thomas Overbury.

James (1970 reprint: 65) considers the possibility that since Thomas the Younger was three years into his apprenticeship with Benjamin Slade in 1703, he might have done some work informally for Edward Blunt. In view of the discovery of the existence of Thomas Free 1701, that now seems unlikely. But might it be that Thomas Hitchcock Free 1701 was the father of Thomas Hitchcock the Younger and therefore that Thomas the Elder and Thomas Free 1701 are one and the same person? That cannot be the case since as already noted, Thomas the Younger's father was described in the records of the Joiners' Company as deceased in 1699.

It has not been possible to determine unequivocally how Thomas Free 1701 was related to Thomas the Elder (and so to Thomas the Younger). What little information is available seems to indicate that the father of Thomas Free 1701 was Richard Hitchcock born either 1623 or 1628. This Richard may have been Thomas the Elder's older brother. If those birth dates are correct, then Richard would have been in his 50's when Thomas Free 1701 was born.

### c. Thomas Hitchcock the Younger

On 10 October, 1684 St. Andrew Holborn hosted the christening of: ‘Thomas ye Sonne of Thomas Hitchcock and Mary his wife in Onslow Street on Saffron Hill’.<sup>13</sup>

A sister to Thomas was born three years later, but nothing more is known of Thomas Hitchcock the Younger until he was bound as an apprentice to Benjamin Slade on 17 February 1699/1700.<sup>14</sup> An eight year apprenticeship with Slade would have allowed Thomas to become a Freeman of the Joiners Company in 1708. But he did not do so. He chose instead to become free of the Haberdashers by patrimony in 1715. Why he made that choice can only be the subject of speculation, but the Hitchcock family had been Haberdashers for some considerable time. It is likely therefore that it was done both for family reasons and for prestige.<sup>15</sup> Whatever the reasons for Thomas’s choice, there is no doubt that Thomas the Younger was able to run a successful business making spinets and the occasional harpsichord without being a Freeman of the Joiners Company. It seems likely that he was doing that at least by 1715 and perhaps earlier.

On 25 November 1708, presumably after being discharged from his bond to Slade, Thomas married Jane Beauregard at St. Martin in the Fields.<sup>16</sup> A son, Thomas, was born and was christened at St. Andrew on 18 November 1711 but no more children from this marriage followed and the Parish Register of St. Andrew records the burial

---

<sup>13</sup> London Guildhall MS 6667/5.

<sup>14</sup> London Guildhall MS 15860/7

<sup>15</sup> The Haberdashers, as a merchant Company were higher in the order of precedence of the City Companies than the Joiners, see Chapter Two.

<sup>16</sup> www.familysearch.org, Source Call No 0374352, accessed August 2006.

of 'Jane Hitchcock of Fetter Lane' on 4 October 1722.<sup>17</sup> In 1723 Thomas married again. His bride, from Wantage, Oxfordshire<sup>18</sup> was Margaret Hastings. Thomas and Margaret had two sons, James, born 1728 and William born 1731.

Thomas the Younger died in 1737. The following announcement appears in *The Gentleman's Magazine* of June 1737<sup>19</sup> under the heading, 'A list of Deaths, for the Year 1737':-

'Mr. Hitchcock, an eminent Harpsichord-Maker kill'd by being overturn'd in a Chaise'<sup>20</sup>

The date of death is given as 8 June 1737. Thomas the Younger was therefore 52 years of age when he died. The burials section of the parish register of St. Andrew, Holborn shows an entry for 'Thomas Hitchcock, Fetter Lane' on 12 June 1737.<sup>21</sup>

The Guild Church of St. Andrew, which is where the spinet-making Hitchcocks worshipped, survived the Great Fire, but was re-built by Wren. It was partly destroyed by enemy action in 1941, but though it has been restored, there is now no grave-yard. During redevelopment of the area surrounding the church and re-building

---

<sup>17</sup> London Guildhall MS 6673/8. The on-line resources are poor at recording deaths and burials.

<sup>18</sup> There are many persons in the archives with the name Hitchcock living in Wantage and it may be that the London Hitchcocks originally came from there. Margaret Hastings may therefore have been a distant relative.

<sup>19</sup> Frustratingly, the June issue of *The Gentleman's Magazine* for 1737 contains a printing error which is carried forward into the version of the magazine available electronically through <http://www.bodley.ox.ac.uk/ilej>. The error is referred to in the contemporary index, but what is said does not completely clarify the position. For the avoidance of difficulty, the notice of Thomas Hitchcock the Younger's death is on the second of two non-identical pages which are both numbered 371 in a series from 376 to 400 which appears twice. This page is not available electronically. The existence of this death notice was discovered through an anonymous hand-written note inserted into the author's copy of Boalch (1974).

<sup>20</sup> Coaching accidents were very common in Georgian England.

<sup>21</sup> London Guildhall MS 6673/9.

of the crypt in recent times, 14,700 bodies were removed to Manor Park Cemetery, Ilford.<sup>22</sup> So no spinet makers lie at St. Andrew now.

Thomas Hitchcock the Younger died intestate. A grant of Letters of Administration by the Prerogative Court of Canterbury (5 July 1737) confirms the absence of a Will:

‘Administration of the goods, chattels and credits of Thomas Hitchcock, late of the parish of St. Andrew Holborn, London, deceased, was granted to Margaret Hitchcock, widow, the relict of the said deceased, being first sworn duly to administer.’<sup>23</sup>

That the person who died in this accident was ‘Thomas Hitchcock the Younger’ and not ‘Thomas Hitchcock Free 1701’ is settled by these Letters of Administration. The Christian name of the wife of Thomas Hitchcock Free 1701 was Sarah, not Margaret.

#### d. John Hitchcock

Although Boalch (1995: 91) claims that John Hitchcock is ‘almost certainly’ the son of Thomas Hitchcock the Younger, rigorous searching, using both the on-line records and the microfilms of parish registers in the Guildhall Library, London, has not confirmed that. Thomas Hitchcock the Younger had sons named Thomas, William and James, but no son named John has been found. The assumption that John Hitchcock merely took over the Hitchcock workshop on the death of his father Thomas the Younger is therefore simply wrong. But the discussion about Thomas Free 1701 above shows that there is no need to find a John Hitchcock who was

---

<sup>22</sup> <http://www.standrewholborn.org.uk>, accessed December 2005.

<sup>23</sup> London, National Archives PROB 6/113.

mature enough to take over the spinet-making firm on the sudden death of Thomas the Younger. Though Martin<sup>24</sup> has queried whether this may have been a case of a newly-widowed woman (Margaret Hitchcock) taking over their late husband's business until a suitable successor could be found, this now seems unlikely, particularly since Margaret seems not to have had a son called John. It seems much more likely that on Thomas the Younger's death in 1737, Thomas Free 1701 merely continued to supervise the production of spinets (and harpsichords too, perhaps) and that his son John Hitchcock became a partner once his freedom was granted in 1750. So in 1737, the firm lost one of its partners, but continued trading under the same name.

There is a John Hitchcock, possibly 'our' John Hitchcock, in which case he would have been a performer as well as (eventually) a maker, who appears in the list of subscribers to William Boyce's *Solomon* in published in 1743, to William Hayes' *Six Cantatas set to Musick* published in 1748, to Thomas Bowman's *Collection of English Odes* published in 1749, and to Richard Langdon's *Ten Songs and a Cantata* dated 1754. The dates of these subscriptions are not inconsistent with a birth date of 1729, but to accept them as referring to John Hitchcock the spinet maker would require postulating that at this early stage in his life he already had a private income.

In 1750 John became a Freeman of the Haberdashers' Company by patrimony as shown in Table 601 and in 1752 he married Frances le Grand at St. Andrew,

---

<sup>24</sup> Personal Communication, December 2005, drawing a parallel with the famous example of Kirkman marrying his former master Tabel's widow and carrying on his harpsichord business.

Holborn. A son, christened John, was born in 1753 and another son christened Samuel in 1756. John Hitchcock is listed in Thomas Mortimer's *The Universal Director* as at Fetter Lane in 1763 and in 1769 he appeared at the Old Bailey as a witness. Here is his evidence against John Lane, one of his workmen, who was charged with (and convicted of) stealing three planes, an iron vice and two screw-plates from him:-

'I live in Fetter-lane. I am a harpsichord and spinnet maker. The prisoner worked with me about thirteen or fourteen months. The beginning of last February he absconded from his business, which gave me some suspicion of him. I searched, to see if any thing was missing, and I missed the things mentioned in the indictment..... '

The wife of another worker of Hitchcock's, Hannah Sherman gave corroboration:-

'I am wife to William Sherman, who works with Mr. Hitchcock. The prisoner's wife brought the tools to me the day after he was before the Justice.' <sup>25</sup>

John Hitchcock died in 1774. James (1970 re-print: 31) notes the following announcement in the *General Evening Post*,

'On the 23<sup>rd</sup>. Nov. 1774 died Mr. Hitchcock, organ builder in Fetter Lane, and one of the Common Councilmen of Farringdon Without.'

Letters of Administration were granted to his widow, Frances Hitchcock, by the Prerogative Court of Canterbury on 16 December 1774,<sup>26</sup> so it seems that like Thomas Hitchcock the Younger, John Hitchcock died intestate. It has not been possible to determine the cause of death. Though the death notice describes him as an organ maker that is possibly just journalistic inaccuracy since a recent edition of

---

<sup>25</sup> [http://www.oldbaileyonline.org/html\\_sessions/T17690405.html](http://www.oldbaileyonline.org/html_sessions/T17690405.html), accessed May 2006.

<sup>26</sup> London, National Archives, PROB 6/150

the *Journal of the British Institute of Organ Studies* notes that there are no surviving organs in London by anyone named Hitchcock.<sup>27</sup>

The point has now been reached where it is possible to identify someone who was alive and qualified to conduct the Hitchcock workshop throughout the period from which Hitchcock bent-side spinets have survived. The discussion now turns to consider the organisation, and particularly the staffing of the Hitchcock workshop.

### 3. The Hitchcock Workshop

#### a. Establishment

It is not known precisely when the Hitchcock workshop first started production. The implication in Boalch (1995: 91) is that it was early in the reign of King Charles II, but for the reasons given above, such an early start is now considered unlikely. So when could the workshop have started, theoretically? One answer is 1704, by when Thomas Free 1701 would have served three years as a journeyman, possibly all of that time with Edward Blunt, and there would be no legal impediment to his beginning to work on his own account as a master craftsman making spinets and perhaps other artefacts. If he did that, he must have left Blunt's employ, since though Blunt did not live long, he was alive in 1707 as shown by the birth of his daughter Mary in 1708<sup>28</sup> (see Chapter Four). By that time Thomas Free 1701 would have been aware that Thomas the Younger was making progress with his apprenticeship

---

<sup>27</sup> *Bios Reporter*, July 2003, Vol XXVII, No 3, available electronically through <http://npor.emma.cam.ac.uk/Reporter/jul03/h703.htm>, accessed February 2006

<sup>28</sup> [www.familysearch.org](http://www.familysearch.org) call no 6903696, accessed August 2006, and London Guildhall MS 6387.

with Benjamin Slade, and a not-so-distant prospect was of his freedom, either of the Joiners Company by virtue of his apprenticeship, or of the Haberdashers Company by patrimony – a potential partner within the family.

Where in London was the Hitchcock workshop first established? Again that is uncertain. If Thomas Free 1701 set up in business in 1704, then it was not in the Fetter Lane premises which became the main Hitchcock workshop. Inspection of the Land Tax Assessments for the Ward of Farringdon Without record a Thomas Hitchcock at Plough Court, Fetter Lane<sup>29</sup> (See Plate 601) in 1712-1713 but he was not there in 1710-1711 nor in earlier years.<sup>30</sup> The assumption here is that this Thomas was Thomas the Younger, who though not a Freeman of the Haberdashers Company at that time had served his apprenticeship with Benjamin Slade and had married Jane Beauregard in 1708. Jane had her first son, also called Thomas, in 1711 in Fetter Lane.

There is no compelling evidence, disregarding for a moment the Blunt spinet referred to earlier, to force a conclusion that the Hitchcocks started production of spinets any earlier than about 1715, the date attributed to the earliest Hitchcock spinet to have survived, No 471. However, it is unlikely that the earliest spinet to have survived is also the first to have been made (and that if it were, that it would have been numbered 471) and so it seems that the workshop was established some years earlier

---

<sup>29</sup> Though Fetter Lane (EC4) and a street named Plough Place still exist, the area was badly bombed in World War II and Plough Court has disappeared.

<sup>30</sup> London Guildhall MS 11316/44.

and perhaps in late 1711 when, it seems, Thomas Hitchcock the Younger and Jane set up home together in Fetter Lane.

It is suggested that Thomas the Younger would have been unlikely to have set up in business on his own account without having first taken the step of becoming a Freeman. It is possible therefore that he worked under the proprietorship of Thomas Free 1701, who may have been working elsewhere, but close by, in the parish of St. Andrew, Holborn.<sup>31</sup>

## b. Hitchcock Workers

Many Hitchcock spinets carry the names or initials of Hitchcock workers. The surviving spinets listed in Boalch (1995: 386-396) have been reviewed and are tabulated in Table 602 below with their serial numbers.<sup>32</sup> A full justification for this tabulation appears in Chapter Seven, but here, the list is presented without justification in order to set out the variety of workers' names and initials which appear. Unless otherwise referenced, this information has been compiled from Boalch (1995: 386 & 396) and from inspections carried out by the author, or by others on the author's behalf. The identity of the workers is discussed on the subsequent pages.

---

<sup>31</sup> Beurmann (2000: 135) suggests that one of the four Hitchcock spinets formerly in his collection and now in the Museum für Kunst und Gewerbe, Hamburg may date from 1703. That seems unlikely to the author both since the suggestion is made merely on the basis the number '18' inscribed informally on the reverse of the nameboard, and because the instrument in question is a five-octave spinet: a date of 1703 would be astonishingly early for a five-octave spinet (see Chapter Eight).

<sup>32</sup> Some instruments which do not carry serial numbers or workers' initials are presented here for consistency with Table 701 of the next chapter.

Table 602 - Hitchcock Workers' Incriptions		
No.	Serial No	Name or initial
1	471	
2	511	JJ
3	-	
4	616	James Steffkin
5	-	18, J.L. 15.18
6	1007	
7	1060	James is 2
8	1075	James is 9
9	1093	
10	1102	
11	1143	
12	1193	Harris 29
13	1228	
14	1241	William Hilliar 7
15	1243	Harris 19 Will Hilliar GW
16	1279	Tho No 20
17	1287	
18	1289	<b>Tho 21</b>
19	1335	Tho 8
20	1379	Tho 65
21	1390	
22	1396	Tho 8
23	1425	Tho 9, William Hilliar
24	1442	James is 9
25	1444	James's No 10
26	1455	James 16/ 1540
27	1460	Thomas 18/ James 18
28	1484	James is No 4
29	1518	Emmanuel No 2
30	1519	
31	1520	
32	1547	
33	1570	Sam's No 12
34	1625	
35	1630	Sam's No 21
36	1676	Sam No 2
37	1677	Sam 28
38	2012	Backus No 8
39	2018	
40	-	
41	-	
42	-	Culliford No 12
43	-	Culliford No 10

James



Hilliar



Thomas



Sam



**'James'**

Reference to Table 602 shows that Hitchcock spinets bearing Serial Nos. 1060, 1075, 1442, 1444, 1455, 1460 and 1484 all bear the name 'James'. Additionally, examination of spinet Serial Number 616 by the author revealed a craftsman's inscription on the baseboard. This is shown as Plate 602.

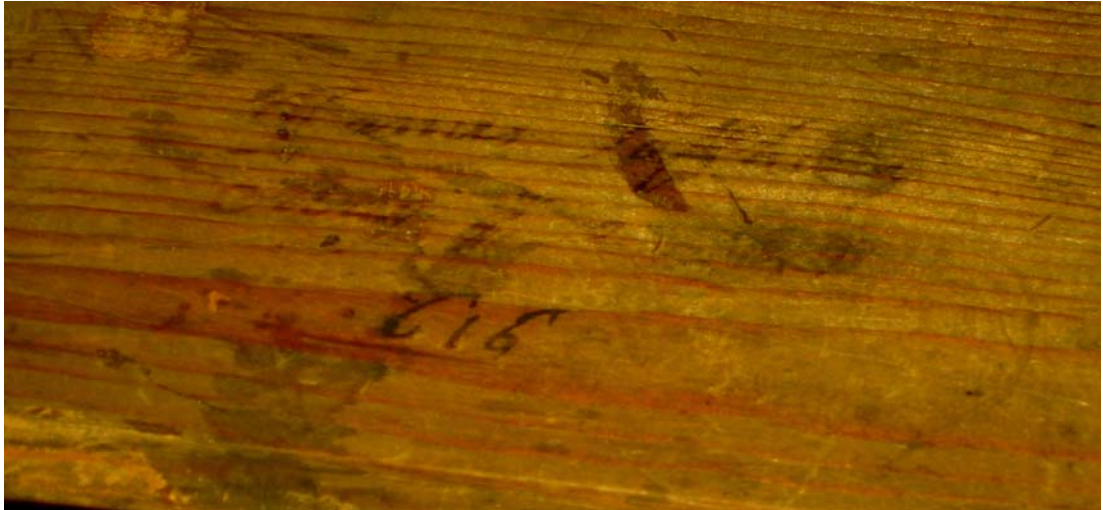

**Plate 602**

**The inscription on Hitchcock Spinet Serial No. 616**

The inscription is indistinct: it was initially thought to read *James Lufkin May 7<sup>th</sup> 1723 616*, but no James Lufkin living in London was found in the archival records. The Haberdashers Company's' binding records were therefore examined to identify someone with the name of James who was bound to one of the Thomas Hitchcocks.<sup>33</sup> A binding dated 8<sup>th</sup> July 1715 was found:

'James Steffkin Son of Frederick Steffkin late of Bazinghall street  
Musick Master bound to Thomas Hitchcock for eight years from [the  
date] Fetter Lane Musicall Instrumentmaker'

---

<sup>33</sup> This can be done even when the surname is not known, by searching the indices which list apprentices alphabetically. The entry for James Steffkin was found in London Guildhall MS 15864/3

It seems likely that it was James Steffkin who made all of the spinets in question. Furthermore, it seems likely that the initials 'JJ' reported as being on spinet Serial no. 511 and 'J.L.' reported as being on the spinet at the MKG, Hamburg (No.5 of Table 602) are mis-readings of the initials 'JS'.<sup>34</sup>

The name Steffkin must not pass without comment. The Steffkins, variously spelled, were a family of musicians intimately connected with the Court (Ashbee & Lasocki 1998: 1048-1052). Dietrich Steffkin, who would have been James's grandfather, had served the English Court from 1629, at first as one of Queen Henrietta Maria's musicians, until the outbreak of the Civil War in 1642.<sup>35</sup> Frederick Steffkin, James's father, was a viol player for the Private Music of William and Mary, as was his brother Christian. James Steffkin, Frederick Steffkin's last known child, was baptised on 16<sup>th</sup> October 1699 at St. Michael, Bassishaw,<sup>36</sup> so the binding referred to above can be seen to have taken place when he was almost sixteen years old.

There may be more significance in this choice of apprentice than at first sight appears. Was the success of the Hitchcocks in developing the market for the spinet due to a connection with royalty, perhaps through the Steffkin family acquaintance?

---

<sup>34</sup> A mis-reading of this sort is understandable: the author initially made the same error because of the unfamiliar calligraphy before the apprentice binding records established the correct reading.

<sup>35</sup> The author is indebted to Paula Woods for pointing this out to him.

<sup>36</sup> A church which lay immediately to the north of the Guildhall: The Barbican complex now extends over the site.

That may very well be so, but no evidence has been found to support such speculation.<sup>37</sup>

Spinets Nos 1060 and 1075 bear the inscriptions ‘James is 2’ and ‘James is 9’. At first sight there is no direct relationship between the two arithmetical series 1060 and 1075 on the one hand and 2 and 9 on the other. However, reference to Table 603 below shows that there is a relationship.

<b>Serial Numbers</b>	<b>James</b>	<b>Colleague</b>	<b>Surviving</b>
<b>1060</b>	<b>2</b>		<b>James is No 2</b>
1061		2	
1062	3		
1063		3	
1064	4		
1065		4	
1066	5		
1067		5	
1068	6		
1069		6	
1070	7		
1071		7	
1072	8		
1073		8	
1074		9	
<b>1075</b>	<b>9</b>		<b>James is No 9</b>

It seems very likely that James Steffkin made or finished eight spinets during a particular period and that a co-worker made or finished the other eight instruments in the series. Who that co-worker was, and whether ‘James’ worked in a partnership

---

<sup>37</sup> A further possible connection with the royal household would be via Benjamin Slade, who was recorded as ‘harpichord maker in ordinary’ in 1727 Boalch (1995: 179, quoting London Lord Chamberlain Appointments Books 3/64, 21 August 1727).

with a single person is unclear. Probably 'James' would have been a journeyman by this period (1720s). 'James numbers' appear on other spinets by Thomas Hitchcock, as shown in Table 602. Serial Nos. 1442, 1444, 1455 and 1460 bear the notations 'James's No 9', 'James's No 10', 'James 16' and 'James 18' respectively. Since there was a 'James is No 9' in the series just discussed, the notation found on spinet No. 1442 must be in a different series. The two possibilities which seem most likely are that 'James' numbered his spinets in a different series for each year, or for some other temporal interval, or that the 'James' who made spinet No.1442 is not the same 'James' as the one who made spinet No.1075. It is not possible to decide from the evidence at present available whether these two 'James' are in fact one person. There may also be other explanations of the evidence.

### **'Harris'**

Two spinets, Serial Nos 1193 and 1243, have the name 'Harris' inscribed on them. Harris is a common name in keyboard instrument making – Boalch (1995: 80-81) lists five persons with the name of Harris. Almost any of them, or an entirely unrecorded person named Harris, could have been the person who wrote his name on these instruments.

### **'Thomas'**

It cannot be said who 'Thomas' was. The most likely explanation is that he was one of the Thomas Hitchcocks, though he could have been almost anyone with that forename.

## **Edward Sparks**

No spinet carrying the name 'Edward' has survived. However the binding records of the Haberdashers Company record the binding of 'Edward Sparks Son of John Sparks, Glover, late of Little Morefield to Thomas Hitchcock on the 3<sup>rd</sup> May 1717 for seven years.'<sup>38</sup>

## **'William Hilliar'**

The name of William Hilliar occurs on three surviving Hitchcock spinets, Serial Nos. 1241, 1243 and 1425. The first pair is especially important since as will be shown in Chapter Seven, No 1241 is of a serpentine-tail design and No 1243 has a mitred tail. The closeness of the two serial numbers indicates that these two spinets would have been in the Hitchcock workshop at the same time, which is confirmed by the fact that they are signed by the same workman.<sup>39</sup> There was a William Hilliar who married a Sarah Thompson at St. Martin in the Fields on 16 October 1704 and this person may well have been the Hitchcock workman.<sup>40</sup>

## **'Emmanuel'**

There is one surviving Hitchcock spinet, No 1518, which bears the name 'Emmanuel'. This was Emmanuel Rosey, son of Thomas Rosey who interestingly is described as 'late of the island of Antigua' in the record of the binding for seven years of Emmanuel to Thomas Hitchcock on 14<sup>th</sup> January 1725.<sup>41</sup> Nothing more is

---

<sup>38</sup> London Guildhall MS 15860/8

<sup>39</sup> Paula Woods (Personal Communication, October 2006) has asked whether the Hitchcocks could have had two workshops, but this evidence shows it to be unlikely.

<sup>40</sup> [www.familysearch.org](http://www.familysearch.org), Call no. 6901259, accessed October 2006.

<sup>41</sup> London Guildhall MS 15860/8

known about Emmanuel, but his binding gives some further tentative information about the date of this one surviving instrument bearing his name. It seems unlikely that Emmanuel would have been allowed to sign his name on a spinet until well into his apprenticeship and perhaps not even then. 'His' spinet must be presumed to be a later instrument than Nos 1289 of 1730 and 1425 of 1733.

### **'Sam'**

The identity of 'Sam', whose name appears on four spinets bearing the John Hitchcock inscription, is not at all clear. Craske (1999: 187-216) discusses in general terms the tendency of proprietors of successful businesses in mid-eighteenth century England, like John Hitchcock, to function as 'upholders'.

'The basic function of the upholder was to insulate the polite gentleman from dealing with the range of rough-mannered mechanics who actually made the luxury products which were the physical expression of taste.'

Consistent with that it has been suggested that 'Sam' was Samuel Blumer (Boalch 1995: 395). If that is so, then the thought that Blumer was working on contract remotely must be implied since it is unlikely that Samuel Blumer was actually working in John Hitchcock's workshop for any extended period, as is shown by three items of evidence: - First, a photograph of a trade card of Blumer's firm, which can be dated stylistically to the 1740's. This is shown in Heal (1925) and was reproduced in James (1970 re-print: Plate XLIX (b)). Secondly, a harpsichord belonging to Lord and Lady Cowper of Cole Green, Hertfordshire was tuned by Thomas Green at various dates from 1742 to 1746, and when Green began to identify in his accounts the makers of the instruments which he tuned, he identified the Cowper's instrument as by Blumer (Sheldrick 1992: 92). Lastly, a bill-head from Blumer's firm dated

22nd August 1753 survived until recent times (James 1970 re-print: caption to Plate XLIX), and in 1765 Green tuned a spinet by Blumer at Lemsted Mill, Hertfordshire (Sheldrick 1992: 108). So, far from working in Hitchcock's workshop, the evidence suggests that Blumer worked on his own account from the 1740s until 1753 at least. Prior to that he worked for Shudi (James 1970 re-print: Caption to Plate XLIX), but it also seems possible that Blumer supplied Hitchcock.

A second possibility for the identity of 'Sam', largely on the basis of his name, is that he was Samuel Weaver. Weaver was a legatee of John Ladyman (1693-1742), the spinet maker, described in his will<sup>42</sup> as 'my friend Samuel Weaver of London, Musical Instrument Maker'. Thomas Barton took Ladyman into apprenticeship in 1708 (Boalch 1995: 113) and a spinet which is probably by him survives (Boalch 1995: 786). If Weaver was working with Ladyman when the latter died, then the date of 1742 at which he would suddenly have found himself in need of new employment fits reasonably well with the date at which it can be estimated that a 'Sam' was working for Hitchcock, though Weaver would have been old by then.

A final possibility for 'Sam', but a remote one, is that he was none other than John Hitchcock's own son Samuel, who was born in 1756. On John Hitchcock's death in 1774 Samuel would have been 18 years old and might well have been working as an apprentice in the workshop from the age of 15 or so and therefore from 1772 onwards. As already noted, Samuel took Freedom of the Haberdashers by patrimony in 1782

---

<sup>42</sup> London, National Archives PROB 11/722

Does the relationship of serial number and worker's number found when analysing the spinets made by 'James' hold for 'Sam' too? The answer is that it does not. Serial No. 1570 bears the artisan inscription 'Sam's No 12', but it is not until Serial No. 1630 that 'Sam's No 21' is reached. Had the previous pattern held, 'Sam's No 21' would have been expected at about Serial No. 1588. The pattern only re-emerges if it is assumed that five or perhaps six other people were making spinets at the same rate as 'Sam' in or more likely, *for* the Hitchcock workshops. The Old Bailey evidence referred to above establishes that in 1769 there were at least three people working in the John Hitchcock workshop – John Hitchcock himself, William Sherman and John Lane, but there may also have been an apprentice and/or others. Nex and Whitehead (2005: 251) refer to Thomas Young who, after having been educated at Christ's Hospital school, in 1756 was “discharged into the hands of John Hitchcock...by trade a spinet & harpsichord maker living in Fetter Lane whom is to provide for him...”<sup>43</sup>

### **Culliford and 'Backus'**

While John Hitchcock may not have been adopting an upholder *rôle* while the run of spinets which bear Serial Nos 1519–1677 were being manufactured, the inscriptions 'Culliford No 10' and Culliford No 12' make it certain that he was doing so for those manufactured later. Thomas Culliford (c.1750-1821) is well known to have been in the business of supplying to what would now be referred to as the 'Own Label' trade. A number of square pianos bearing the name of Longman & Broderip on the name-

---

<sup>43</sup> I am grateful to Jenny Nex for drawing this to my attention. Young was bound under the regulation of the Haberdashers' Company on 7th October 1757, although it is not clear how long he remained at the Hitchcock business.

boards are signed discreetly by Culliford elsewhere. Clinkscale (1993: 81) suggests that Culliford worked with John Hitchcock, but the evidence for this seems to be no more than that at present under discussion. Both of Culliford's workshops in Cheapside and later in the Strand were within an easy walk of that of Hitchcock in Fetter Lane, and it seems most likely that Culliford merely made spinets to Hitchcock's design and inscribed them with John Hitchcock's name.

The same comment can be made about the inscription 'Backus' No. 8' which appears on the Hitchcock spinet Serial No. 2012. Boalch (1995: 395) suggests that 'Backus' was Americus Backers, a Dutch *émigré* who came to London about 1763 and died in January 1788. A harpsichord by Backers inscribed *Americus Backers me fecit 1766* survives, as do two grand pianos, one of which dated 1772 is at the University of Edinburgh. It seems unlikely that Backers, having set up in business on his own account, would suddenly give up to work with Hitchcock and then start up on his own again later, though the vagaries of commerce make that just possible. But if 'Backus' and Backers are one and the same, then the two most likely scenarios are either that spinet No. 2012 dates from the period before Backers set up his business in Jermyn Street – in which case it is certainly from 1763 - or it was supplied to Hitchcock by Backers at a later date. The second of those seems much the more likely of the two.

## 4. Summary

This chapter begins by re-analysing the general understanding of the relationships within the Hitchcock family of spinet makers in the light of new information obtained from archival sources. This suggests that Thomas Hitchcock the Elder was probably not a spinet maker, as has been assumed, but was almost certainly a chair-maker: that he made any instruments at all is open to serious question. The father-son relationship of Thomas the Elder to Thomas the Younger has been confirmed, but no son of Thomas Hitchcock the Younger named John Hitchcock has been found. This provokes a question as to who John Hitchcock was, given that he was able to take freedom of the Haberdashers Company by patrimony.

The search for a person who provided John Hitchcock with that entitlement and the existence of a spinet ostensibly by Edward Blunt dated 1703 which bears the initials and name of a Thomas Hitchcock has led to the identification of a hitherto unknown member of the Hitchcock family, 'Thomas Hitchcock Free 1701'. This person, it is suggested, was both the father of John Hitchcock and the author of the inscriptions on the Blunt spinet.

The identification of Thomas Hitchcock Free 1701 provides a new understanding of the chain of proprietorship of the Hitchcock spinet-making firm. Although it is suggested that the firm could theoretically have started in business as early as 1704, it is thought more likely that it began some time after 1703 and before 1715 and probably about 1711. The firm then passed from the sole proprietorship of the hitherto unknown Thomas Free 1701 to a partnership that included Thomas the

Younger. Some time after the latter's death in 1737 it passed to John Hitchcock and probably subsisted for only a short period after his death in 1774.

The chapter provides identifications of many of the artisan craftsmen who worked for the Hitchcocks. An explanation has been given of how the firm's production run was managed during the proprietorship of John Hitchcock from about the mid 1750s until his death. This explanation identifies some makers who were independent suppliers to the Hitchcock business.

## **Chapter Seven - Spinets from the School of Hitchcock**

### **1. Introduction**

This chapter, in conjunction with Appendix Seven, provides an organological characterisation of the spinets from the School of Hitchcock, that is to say the family firm whose proprietors and workers were described in Chapter Six. As would be expected from a family firm which was in business for a period of at least sixty years, variations and developments can be observed in the spinets which the Hitchcocks produced. These variations relate to the plan forms of the instruments, to their decorative treatment, to the design of their stands – for unlike the Keene spinets considered in Chapter Five it is clear that the Hitchcocks provided stands with some, at least, of their spinets – and to aspects which more directly affect the musical performance of the instruments, including compass, string scaling, and plucking points. It will be shown that the Hitchcocks produced two different ‘models’ of spinet, though some variations seem to have been available to special order.

### **2. Production from the Hitchcock Workshop**

The surviving bentside spinets thought to be made by or for the Hitchcocks are shown in Table 701 below. As can be seen, there are thought to be forty-three surviving spinets, including four instruments which have been attributed to Hitchcock. Table 701 is based upon the information in Boalch (1995: 386-396), updated where new information has become available since 1995. Most Hitchcock

spinets are undated although most carry a serial number, as shown in the table.<sup>1</sup> The ten spinets highlighted in pink in the table have been seen by the author to degrees ranging from a sighting of an instrument in its display location to a full organological inspection: they are described later in this chapter or in Appendix Seven. The eleven spinets highlighted in blue have not been seen, but some information about them has been gathered from other sources and this is reproduced in Appendix Seven. In addition, some spinets are characterised in major and readily accessible catalogues to the extent that it is thought unnecessary to include details of the instruments here or in Appendix Seven. The spinets which fall into this category are the four at the Museum für Kunst und Gewerbe, Hamburg which are fully described in the Museum Catalogue (Beurmann 2000) and that at the Victoria & Albert Museum (Schott (1998), reprinted as Wilk & Yorke (2002)): these five spinets are highlighted in purple in Table 701. No information has been forthcoming about the spinets which remain without highlighting.

It can be seen therefore that of the forty-two<sup>2</sup> surviving Hitchcock spinets, it has been possible to gather information about twenty-seven of them, either through inspection or other means. It is thought impractical to attempt to inspect all the surviving Hitchcock spinets within the timeframe of this research project.

---

<sup>1</sup> It is thought likely that all of them contain a serial number somewhere on the instrument, but not always on the nameboard.

<sup>2</sup> That is the forty-three listed in Table 701, less the one destroyed in the Dearborn fire.

<b>Table 701 - Surviving Hitchcock Spinets</b>		
<b>No.</b>	<b>Serial No.</b>	<b>Location or Owner</b>
1	471	Botetourt Historical Society, Fincastle, VA
2	511	Not Known.
3	—	MKG Hamburg
4	616	Bate Collection, University of Oxford
5	—	MKG Hamburg
6	1007	Offered for Sale, Ewbanks, Woking, 2006
7	1060	William Benz, Eastbourne?
8	1075	Sold Sotheby's 12 December 1985
9	1093	Sir Fitzroy Maclean, Strachur
10	1102	Private Collection, USA
11	1143	Tryon Palace, North Carolina
12	1193	Packwood House, Warwickshire
13	1228	Smithsonian Institution
14	1241	St. Cecilia's Hall, University of Edinburgh
15	1243	Offered for sale Bonhams 2006
16	1279	MKG Hamburg
17	1287	Smithsonian Institution
18	1289	Haddon Hall, Derbyshire
19	1335	Sulgrave Manor, Banbury
20	1379	MKG Hamburg
21	1390	Not Known
22	1396	Kings Lynn Museum
23	1425	Ambassador Middendorf, The Hague?
24	1442	Leigh County Historical Society, PA
25	1444	F R Rubens
26	1455	Concord, MA
27	1460	Offered for Sale, Sotheby's, 2005
28	1484	V & A, London
29	1518	Metropolitan Museum, New York
30	1519	Not Known
31	1520	Winterthur Museum, Delaware
32	1547	Dr Neil Black, Birmingham?
33	1570	Stratford Hall, Richmond, VA
34	1625	Private Collection, Tokyo
35	1630	Not Known
36	1676	RCM, London
37	1677	Destroyed in the 1970 Ford Museum Fire
38	2012	Elizabeth Elder, Amherst, MA
39	2018	J R Redman, London
40	—	Richard Jaffe, Coral Gables, FA
41	—	Musikhistorisk Museum, Copenhagen
42	—	D Rowland, Andover, MA
43	—	Yale University

Table 701 requires considerable comment: - The first four Hitchcock spinets listed in Boalch (1995: 386) are not included in the table. The reasons for that are first, as explained in Chapter Six, the instruments dated 1660 and 1664 are considered to be spurious entries in Boalch. Secondly, the spinet dated 1700 in the list has not been seen for a century or more and is probably also a spurious entry.<sup>3</sup> The fourth spinet listed in Boalch (1995) is by Edward Blunt and not by Hitchcock.

Table 701 therefore begins with the fifth entry in Boalch, Serial No. 471, a spinet which belongs to a museum in Fincastle, near Roanoke, Virginia. At the time of writing the spinet is at the Conservation Laboratory at Colonial Williamsburg. The location of the second spinet in Table 701 is not known, though since the serial number is quoted in Boalch (1995) it seems reasonable to include it in the list of identifiable spinets. The table then contains three entries which are not in the order presented in Boalch (1995) before it proceeds to list Serial Nos. 1007 – 1518, which appear in the same order as in Boalch. The three spinets which appear as numbers 3, 4 and 5 in Table 701 are two of the four Hitchcock spinets now in the Museum für Kunst und Gewerbe, Hamburg (formerly in the Andreas Beurmann Collection), and the spinet at the Bate Collection, University of Oxford. The latter is listed in Boalch (1995: 393) but without its serial number, 616, which was discovered by the author during an inspection, so it is listed in Table 701 in its probable correct serial number order.

---

<sup>3</sup> If these spinets are genuine entries in Boalch (1995: 394), then it would have been expected according to the understanding at the time, that these three instruments would have been inscribed with John Hitchcock's name, see Table 702 below.

One of the Hamburg instruments, number 3 in Table 701 – that with an FF-f'' – compass is stated by Beurmann (2000: 134) to be missing from the listing in Boalch 1995, but the author believes it to be the instrument listed as belonging to Tony Bingham and recorded as having an altered compass at Boalch (1995: 393).<sup>4</sup> The second of the Hamburg instruments, number 5 in Table 701, is that referred to in Beurmann (2000: 137) as carrying the workman's inscription 'J.L.15 18'. It is thought to be the instrument referred in Boalch (1995: 393) as having been sold at Sotheby's on 26<sup>th</sup> November, 1992. It is also referred to in the Errata and Addenda in Boalch (1995: 784)

In addition Boalch (1995: 393) carries listings of two spinets which are not identified sufficiently to allow them to be included in Table 701 – these are the spinets referred to as having been sold at Christie's on 14 May 1936, and as once having been in the Steinert Collection, respectively.

The instruments with Serial No.1519 and those below it in Table 701 generally follow the listing in Boalch 1995 with the exception of that listed as belonging to Richard Jaffe, which because of the uncertainty about the inscription and the absence of a serial number is listed at number 40 in Table 701. Serial No. 1677, the instrument listed in Boalch (1995: 395) as being at the Henry Ford Museum in

---

<sup>4</sup> Beurmann (2002: 133) confirms that the compass has been altered. A footnote about this instrument is included in Chapter Eight under the heading 'Compass'. However the instrument is listed at Boalch (1995: 393) as having black sharps, whereas that illustrated in Beurmann (2002: 130) has skunk-tail sharps. Some doubt about the identification therefore remains, though the Bingham instrument is not listed again in Table 701

Dearborn, Michigan was destroyed in the fire at the museum in 1970,<sup>5</sup> but is included in Table 701 since some details of it have been recorded and they assist the analysis set out below. An unidentified instrument listed in Boalch (1995: 396) has been omitted as being likely to be a duplicate of one of the other entries. The attributed instrument at Yale University listed in Boalch (1995: 396) as containing the inscription ‘Culliford No 10’ has been included, but the two last attributed spinets have not been, again because it is thought likely that they are already included.

#### a. Hitchcock Inscriptions

Whether or not the serial number is recorded, all of the spinets listed in Table 701 between Serial Nos. 471 and 1518 are believed to carry an inscription referring to Thomas Hitchcock. The entry in Boalch (1995: 394) relating to spinet Serial No. 1519 is unclear about the inscription on this spinet, the location of which is unknown. Numbers 1, 3, 4 and 5 (and presumably number 2 also) of the spinets in Table 701 are inscribed *Thomas Hitchcock Londini fecit*. Serial No. 1007 is the first of the surviving spinets to have an inscription in the format *Thomas Hitchcock Londini fecit No. Ixxx*. This format carries through to Serial No. 1518<sup>6</sup> and possibly also to Serial No. 1519.

---

<sup>5</sup> Personal Communication, CarolAnn Missant, Access Service, Benson Ford Research Centre, 6<sup>th</sup> March 2006)

<sup>6</sup> The nameboard inscriptions of those spinets of which the author has photographs are included in Appendix Seven. Details of the remaining inscriptions have been taken from the entries in Boalch (1995).

Serial No.1520, number 32 in Table 701, is reported in Boalch (1995: 394) as carrying the inscription *Johannes Hitchcock fecit Londini 1520* on the nameboard and it would be tempting to assume that all Hitchcock spinets with a higher serial number than 1520 would carry the inscription *Johannes Hitchcock fecit Londini xxxx*. However, Morris (1986: 85) shows a photograph of the inscription on Serial No. 1547 which reads *Thomas Hitchcock Londini fecit No. 1547* (see Appendix Seven). However, this appears to be the sole exception in the series of serial numbers from 1520 to 1677.

The spinets belonging to Mr. D Rowland of Andover, Massachusetts, number 42 in Table 701, and that at the Musikhistorisk Museum, Copenhagen also have John Hitchcock's inscription on the nameboard (Boalch 1995: 396 and Appendix Seven respectively), but information is missing about the other spinets, numbers 38-40 and 43 of Table 701. The various inscriptions found on the surviving instruments are summarised in Table 702 below.

<b>No.</b>	<b>Serial No.</b>	<b>Nameboard Inscription</b>
1	471	Thomas Hitchcock Londini fecit
2	511	Not known
3	—	Thomas Hitchcock Londini fecit
4	616	Thomas Hitchcock Londini fecit
5	—	Thomas Hitchcock Londini fecit
6	1007	Thomas Hitchcock Londini fecit No 1007
7	1060	Thomas Hitchcock Londini fecit No 1060
8	1075	Thomas Hitchcock Londini fecit No 1075
9	1093	Thomas Hitchcock Londini fecit No 1093
10	1102	Thomas Hitchcock Londini fecit No 1102
11	1143	Thomas Hitchcock Londini fecit No 1143
12	1193	Thomas Hitchcock Londini fecit No 1193
13	1228	Thomas Hitchcock Londini fecit No 1228
14	1241	Thomas Hitchcock Londini fecit No 1241
15	1243	Thomas Hitchcock Londini fecit No 1243
16	1279	Thomas Hitchcock Londini fecit No 1279
17	1287	Thomas Hitchcock Londini fecit No 1287
18	1289	Thomas Hitchcock Londini fecit No 1289
19	1335	Thomas Hitchcock Londini fecit No 1335
20	1379	Thomas Hitchcock Londini fecit No 1379
21	1390	Not known
22	1396	Thomas Hitchcock Londini fecit No 1396
23	1425	Not known
24	1442	Thomas Hitchcock Londini fecit No 1442
25	1444	Not known
26	1455	Thomas Hitchcock Londini fecit No 1455
27	1460	Thomas Hitchcock Londini fecit No 1460
28	1484	Thomas Hitchcock Londini fecit No 1484
29	1518	Thomas Hitchcock Londini fecit No 1518
30	1519	Not known
31	1520	Johannes Hitchcock fecit Londini 1520
32	1547	Thomas Hitchcock Londini fecit no 1547
33	1570	Johannes Hitchcock me fecit Londini 1570
34	1625	Johannes Hitchcock fecit Londini 1625
35	1630	Johannes Hitchcock fecit Londini 1630
36	1676	Johannes Hitchcock fecit Londini 1676
37	1677	Johannes Hitchcock fecit Londini 1677
38	2012	Not known
39	2018	Not known
40	—	Not known
41	—	Johannes Hitchcock Londini fecit
42	—	Not known
43	—	Johannes Hitchcock Londini fecit

## b. The Serial Number/Date Correlation

A small number of Hitchcock spinets have been reported to bear dates. These are shown in Table 703 below. Several scholars, including Cole,<sup>7</sup> Garrett,<sup>8</sup> Morris (1986) and Mould (in Boalch 1995: 92) have attempted to correlate the serial numbers of Hitchcock spinets with their dates, though with the exception of Mould's, none of these correlations have been published. The author's article in the Galpin Society Journal 2007 (Mole 2007) included a correlation based upon some, though not all, of the information presented here.

<b>No.</b>	<b>Date</b>	<b>Serial No.</b>	<b>Nameboard Inscription</b>
3	1715 <sup>9</sup>	—	Thomas Hitchcock Londini fecit
4	1723 <sup>10</sup>	616	Thomas Hitchcock Londini fecit
6	1722 <sup>11</sup>	1007	Thomas Hitchcock Londini fecit No 1007
16	1729 <sup>12</sup>	1279	Thomas Hitchcock Londini fecit No 1279
18	1730 <sup>13</sup>	1289	Thomas Hitchcock Londini fecit No 1289
23	1733 <sup>14</sup>	1425	Not known

The first question to be answered in attempting to construct a correlation is whether the serial numbers found on surviving spinets, which range from 471 to 2018, constitute a single arithmetical series. That they did so was taken as axiomatic in Mole (2007). However, the author now believes that there are in fact three separate arithmetical series. Three factors point to that:-

---

<sup>7</sup> Personal communication June 2007

<sup>8</sup> Personal communication June 2007

<sup>9</sup> Beurmann (2000:134)

<sup>10</sup> Inspection by the author

<sup>11</sup> Morris (1986) reporting Robertson, who restored the instrument

<sup>12</sup> Beurmann (2000: 139)

<sup>13</sup> Personal Communication, John Raymond, October 2005 and Boalch (1995: 390)

<sup>14</sup> Boalch (1995: 391)

First, the serial number distribution of surviving instruments is unusual as is shown in Figure 701 below, in which the serial number of the surviving spinets of Table 701 is plotted against their sequence number, also in Table 701.<sup>15</sup>

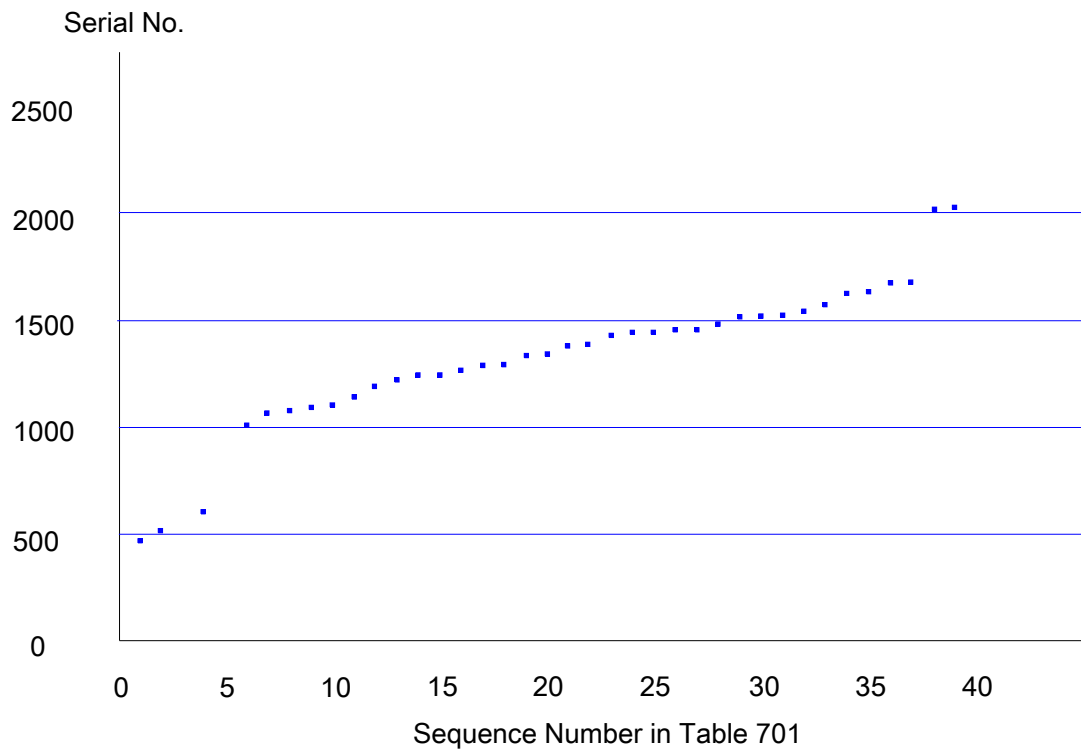

**Figure 701- Serial Numbers and Sequence Numbers  
of Surviving Hitchcock Spinets**

Of the spinets which are known to have the plain inscription *Thomas Hitchcock Londini fecit*,<sup>16</sup> in two instances (Serial Nos. 471 and 616) the serial number was written informally inside the instrument. From inspections and published accounts, all of the spinets which do not have a nameboard inscription which includes a serial number give the impression of being early instruments and it seems likely that these instruments belong to a separate arithmetical series from those whose serial numbers

<sup>15</sup> I am grateful to David Hitchin, former Lecturer in Statistics at the University of Sussex, who assisted me with this analysis.

<sup>16</sup> It seems likely that Serial No. 511 has the same inscription.

are inscribed on the nameboard and which probably begin at Serial No. 1000 or 1001 (though the earliest to have survived is Serial No. 1007).

Only five spinets (and only three of known serial number) with the earlier style of inscription have survived of the nine hundred and ninety-nine which would have to be postulated for the single series hypothesis, whereas thirty-two have survived of those having serial numbers between 1000 and 1677. If that were a real difference in respective survival rates it is a very extreme one which would need a special explanation.<sup>17</sup> But a further discontinuity exists: - of the thirty-five surviving spinets having serial numbers 1000-2018, all but two are in the range 1000 to 1677. It seems likely that not only was there a discontinuity somewhere between serial numbers 616 and 1000, there was also one at a number between serial numbers 1677 and 2000, and that the surviving spinets are in three separate but incomplete arithmetical series, 1-999, 1000-1999, and 2000 and above.

It follows that it is not possible to say how many Hitchcock spinets were made. All that can be said with a degree of certainty is that the Hitchcocks made at least 146 spinets in the series 471-616, 670 spinets in the series 1007-1677, and eight others which have survived, making an output of 824. It is difficult to know how far to extend this calculation, but it would be surprising if the total output reached 1200. Since the Hitchcocks were in business from about 1711 until about 1774, at least,

---

<sup>17</sup> Though Serial No. 471 (and presumably also any spinets which had been constructed having serial numbers from 1 to 470) has a keyboard compass of less than five octaves, No. 616 (and presumably any spinet having a serial number from 617 to 999) is a five-octave spinet. Though there is a remote possibility that a large number of spinets in the first of these groups were discarded as being old-fashioned, that cannot have been the position for the second group.

these figures would equate to an average production of about 13 to 19 spinets per year – a not unreasonable average expectation given the resources which the Hitchcock firm had at its disposal, at least during part of its existence.<sup>18</sup>

A second factor in support of the three series hypothesis is that the spinet with Serial No. 616 carries the date 1723, yet Serial No. 1007, which would be expected to be a later instrument than No 616, is reported to carry the date 1722.

A third factor pointing to the existence of at least two separate series is the sheer number of spinets which are implicit in the single series hypothesis. Even if the Hitchcock firm had indeed started in business as early as 1704, over 2000 spinets would have had to be made in a period of only 70 years, taking the death of John Hitchcock in 1774 as marking the effective end of the business. A *consistent* output of one spinet every other week over such a long period seems unlikely. More likely is that the firm started with a relatively slow production rate, rising to a peak and then tailing off as (1) the disruption of Thomas the Younger's sudden and unexpected death was felt in the business and (2) the popularity of the spinet diminished with the introduction of the square piano in the late 1760s. The author now strongly prefers a hypothesis in which the correlation of serial number and date assumes three different arithmetical series. Figure 702 below adopts that hypothesis.

---

<sup>18</sup> A production of 824 spinets over 64 years equates to an average annual production of about 13 spinets per year: similarly if the total output is taken as 1200, the average annual production is 19 spinets per year. As shown later, there seem to have been considerable variations round these averages.

Key

- James Steffkin's Apprenticeship
- Emmanuel Rosey's Apprenticeship
- Period of Change-over from Nameboards inscribed 'Thomas' to those inscribed 'Johannes'

Serial No.

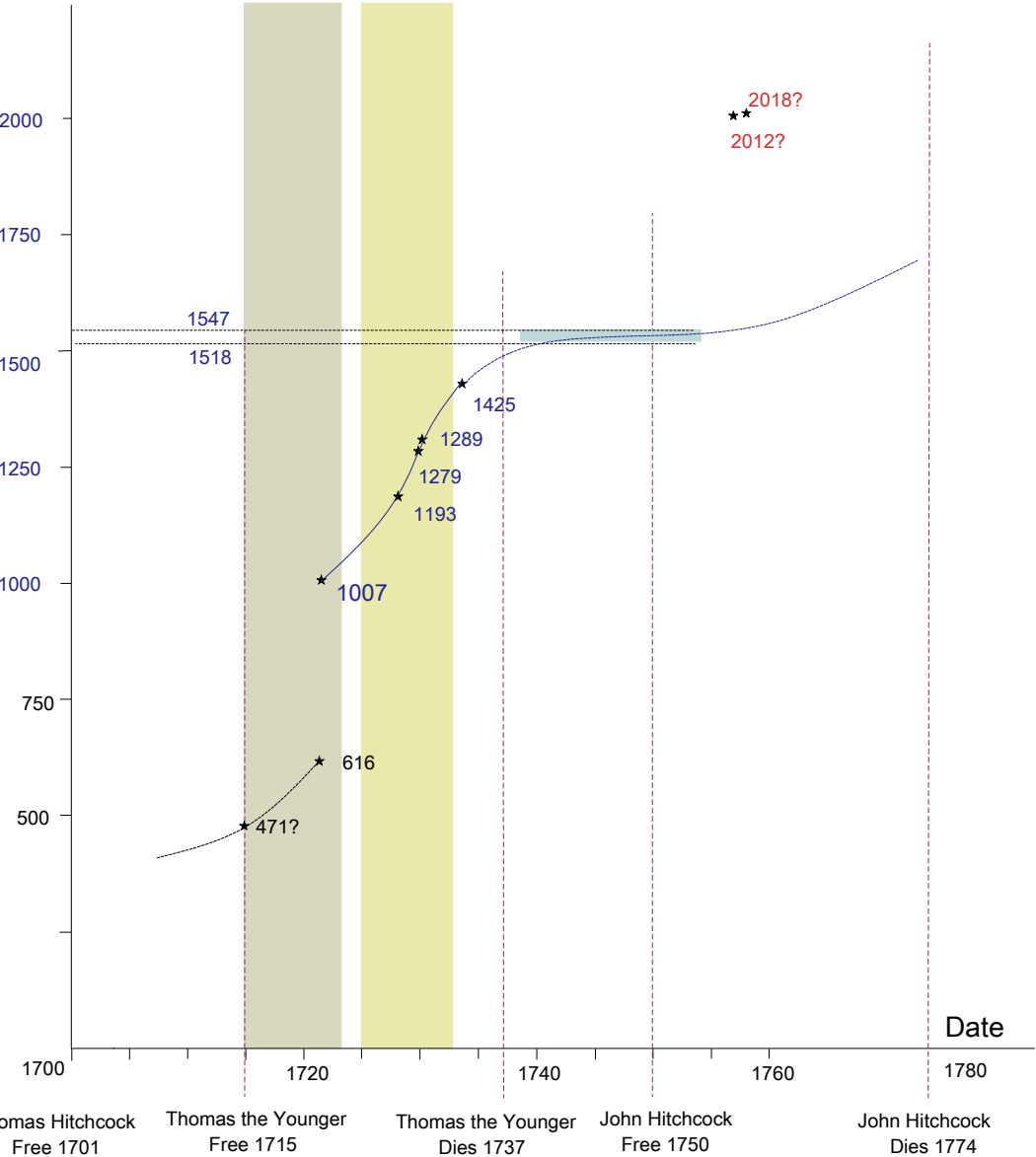

Figure 702 - Serial Number/Date Correlation of Hitchcock Spinets

In Figure 702, data points have been marked for those instruments which have so far been discovered to bear both serial numbers and dates, Serial Nos. 616, 1007, 1279, 1289 and 1425. Some data lines (though not points) can be derived from the events chronicled earlier - the freedoms of the three Hitchcocks, Thomas in 1701, Thomas the Younger in 1715, and John in 1750 are shown. Additionally, the deaths in 1737 of Thomas the Younger and of John Hitchcock in 1774 are shown as dotted vertical lines coloured maroon

It can be seen from Figure 702 above, and adopting the 'three series' hypothesis, that it is scarcely possible to draw any curve which represents the relationship between serial number and date owing to the paucity of data points. The exception to that general statement is for the spinets carrying serial numbers in the range 1007 to 1425. The curve representing the serial number/date relationship in question is the solid blue line. This is extended as a dotted line through an indeterminate area shown as a blue rectangle during which the changeover of inscriptions from that of Thomas Hitchcock to John Hitchcock occurred.

The date line denoting the death of Thomas the Younger prompts this question; is it likely that the inscription applied to the instruments changed immediately after on Thomas's death from '*Thomas Hitchcock*' to '*Johannes Hitchcock*'? Because if it is, then that date could be used together with the recorded change-over of the inscriptions between Serial Nos. 1518 and 1520 to provide another valuable datum point. Unfortunately, such an immediate change is unlikely. Although Thomas the Younger died in an accident rather than as a result of sickness (and there is therefore

no presumption that before his death he was inhibited by illness from being an active maker) the position is complicated. In the first place, it seems that Thomas Free 1701 was still alive and working when Thomas the Younger died, and as has already been said, his son John was still a minor in 1737. Additionally, it is probable that the Hitchcock workshop contained partially finished instruments when Thomas the Younger was killed. This may account for the fact, noted earlier, that Serial No. 1547 bears the inscription of Thomas Hitchcock.

Judging from the surviving serial numbers, only about one hundred and fifty spinets were made in-house during the time that John Hitchcock was the proprietor of the Hitchcock business, and it is suggested that thereafter the manufacture of spinets was out-sourced. This suggestion is shown in Figure 702 by labelling the approximate data point for spinets Nos. 2012 and 2018 in red.

Two early spinets, Serial Nos. 471 and 616 are also shown in Figure 702. Though No. 616 can be accurately placed on the graph, the data point for Serial No. 471 is an estimated based on its keyboard compass (GG-e'''). From knowledge of the date of spinets of similar compass it is thought that it must date from about 1715. Though it seems likely that at this early stage of the firm, the rate of production of spinets was increasing, the shape of the curve in the lower part of Figure 702 is speculative. It has already been said that it now seems unlikely to the author that the series of numbers including spinet Nos. 471 and 611 (and 511) began at No. 1, since that would imply a high rate of production of spinets from the inception of manufacture. That is thought unrealistic.

Although a significant number of Hitchcock spinets has been inspected during the course of this research, only one of them was found to have a previously unreported date. It would be a major task to inspect, or to re-inspect, all the surviving Hitchcock spinets and it is thought that further information allowing a more accurate serial number/date correlation to be made is likely to emerge only over a relatively long period.

From the analysis above it is clear that the Hitchcock workshop became busy quite soon after its inauguration by Thomas Free 1701. Though in theory this could have been as early as 1703 or 1704, such an early beginning would imply the existence of spinets having a compass characteristic of that period, typically fifty-four notes of GG/BB-d''' with a broken octave. If such instruments were made, none is known to have survived. Clearly the firm was in production by 1715 and probably by 1711. As shown in the previous chapter, by 1715 there were several men working together – at first the two Thomas Hitchcocks and James Steffkin, who were joined later by Edward Sparks and Emmanuel Rosey, by William Hilliar and by a person called 'Harris'.<sup>19</sup>

By the time John Hitchcock took over the Hitchcock firm, probably some time after 1750, it had become very successful and had made the Hitchcock family very wealthy.<sup>20</sup> It seems that John had a smaller workshop, with perhaps only one

---

<sup>19</sup> This *cadre* of workmen could easily have made 20 spinets per year, and probably many more – but it is not clear that all continued to work with the Hitchcock firm for an extended period.

<sup>20</sup> The premium paid in 1728 by Thomas the Younger for his son's apprenticeship to an attorney (70 guineas = £73 10s.) was a huge sum by Georgian standards and demonstrates the proprietors' prosperity.

journeyman, a labourer and an apprentice. He was able to become involved in local politics while some at least of the spinets which he sold under his name were made in the workshops of others. The two late John Hitchcock spinets shown as numbers 41 and 43 in Table 701, those at the Musikhistorisk Museum, Copenhagen and at Yale University respectively, are very different in design from those of Serial Nos. 1520 and 1570 to 1676, as shown in Appendix Seven. It may well be that Thomas Culliford made both instruments<sup>21</sup> to his own design, merely adding the name of John Hitchcock to the nameboard, as he did with other spinets for other suppliers.<sup>22</sup> John Hitchcock may also have realised, by about 1770, that the days of the spinet were numbered. No compelling evidence has so far been discovered that shows either of his sons continuing with the business beyond John Hitchcock's death in 1774.

### **3. The Two Models of Hitchcock Spinet**

#### **a. Plan Form**

All of the surviving Hitchcock spinets conform to two fundamental plan forms, those with a simple curve to the bentside having a separate mitred tail as shown in Figure 703 and those with a serpentine bentside and no separate tail component as shown in Figure 704. These will be referred to as 'mitred-tail' and 'serpentine-tail'

---

<sup>21</sup> His inscription on the Yale instrument makes it close to certain that Culliford made it.

<sup>22</sup> The alternative, that these spinets were deliberately mis-represented as by John Hitchcock seems unlikely in view of Culliford's known activity in producing spinets and harpsichords for Longman & Broderip.

instruments respectively. The mitred tail instruments have a straight tail to the left of the keyboard and the serpentine ones have a left tail made from two components but designed to be of curved form, though considerable variation in the curvature has been observed from one instrument to another.

In many instances it has been possible to determine the plan form of Hitchcock spinets without inspection, by use of images derived from textbooks, from the internet, from museum data, or from other researchers. The results of this determination are shown in Table 704 below.

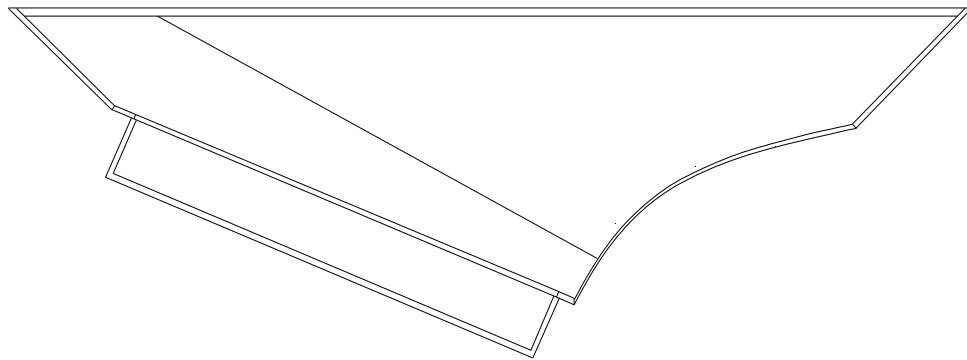

**Figure 703**

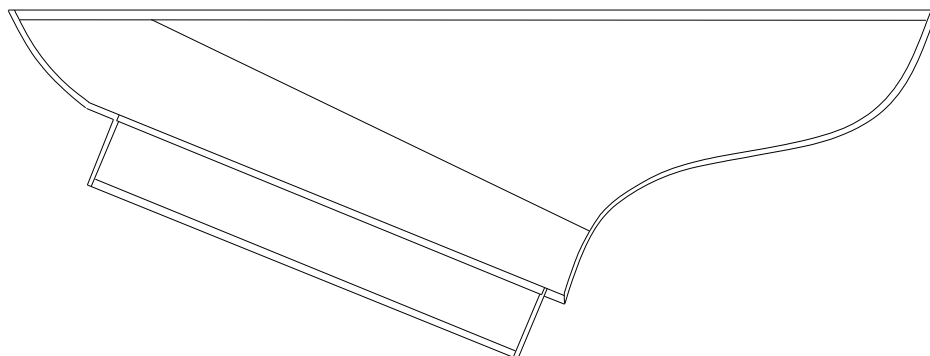

**Figure 704**

<b>No.</b>	<b>Serial No.</b>	<b>Tail</b>
1	471	Mitred
2	511	
3	—	Mitred
4	616	Mitred
5	—	Serpentine
6	1007	Serpentine
7	1060	
8	1075	Mitred
9	1093	
10	1102	
11	1143	Serpentine
12	1193	Mitred
13	1228	Mitred
14	1241	Serpentine
15	1243	Mitred
16	1279	Serpentine
17	1287	Mitred
18	1289	Mitred
19	1335	Serpentine
20	1379	Serpentine
21	1390	
22	1396	Serpentine
23	1425	
24	1442	
25	1444	
26	1455	
27	1460	Serpentine
28	1484	Serpentine
29	1518	Serpentine
30	1519	
31	1520	Serpentine
32	1547	Mitred
33	1570	Serpentine
34	1625	
35	1630	Mitred
36	1676	Serpentine
37	1677	
38	2012	Mitred
39	2018	Serpentine
40	—	
41	—	Mitred
42	—	
43	—	Mitred

Support for the description of the plan forms summarised in Table 704 is provided in Appendix Seven in the form of descriptions and photographs of the instruments. It can be seen from Table 704 that both mitred-tail spinets and serpentine-tail ones occur randomly through the production run. It is thought that this indicates that both types were being produced simultaneously in the Hitchcock workshop. A number of researchers and restorers have noted that Hitchcock spinets exist in two plan forms<sup>23</sup> but the more general conclusion that both forms were made throughout the production run is one which seems to have been reached prior to the publication of Mole 2007 only by Morris (1986: 72). Morris relied on only eight observations but it is suggested that a great deal more evidential support than that is needed before the general conclusion can be drawn with confidence.

## b. Veneering

Individual Hitchcock spinets demonstrate a second striking lack of conformity: two styles of veneering are found – a style with plain veneer in a light coloured timber, probably sycamore, with triple linear stringing in a dark/light/dark arrangement as shown in Plate 701 – and a style using a figured veneer of walnut and feathered stringing as shown in Plate 702. The nameboards of Hitchcock spinets are veneered so that their appearance matches that of the insides of the instrument case, with the maker's inscription inscribed in ink often within an inlaid cartouche. Examples of the two commonly found styles are shown in Plates 703 and 704.

---

<sup>23</sup> From personal communications at various times during this research, Darryl Martin, the author's supervisor, certainly seems to have been aware of it, as do Michael Cole, Andrew Garrett, and David Law.



Plate 701 - Plain Veneer with triple stringing on No. 616



Plate 702 - Figured Veneer with banding on No. 1335



Plate 703 – Plain Nameboard on No. 616



Plate 704 – Figured Veneer and Ogee Cartouche on No. 1335

It is thought that the nameboard shown in Plate 703 would have been relatively easily made in-house by the Hitchcock workshop, but that the nameboards with the central cartouche were bought in. It can be seen from Plate 704 that the numbers '1335' inscribed in the cartouche do not align correctly with the remainder of the inscription. That is frequently observed phenomenon in Hitchcock spinets and one of two possible explanations emerge - it is thought that either the legend '*Thomas Hitchcock Londini fecit 1...*' was inscribed on the nameboard by its maker, and the remaining three figures of the serial number were added in the Hitchcock workshop on completion of the instrument, or that the whole inscription was added in the workshop to a bought-in nameboard by means of a stencil. The placing of the inscription on the nameboard of Thomas Hitchcock spinet Serial No. 1396, an

instrument which is described in Appendix Seven, is misaligned vertically and cramps the serial number at the right-hand extremity. It therefore shows signs of having been produced in the second way by means of a stencil. The cartouche is shown in Plate 705 below.



Plate 705 – Misaligned Lettering on the Nameboard of No. 1396

While it may be thought that the plain veneer with triple stringing might be the earlier style and that the figured veneer and feathered stringing superseded it, inspection of Table 705 below shows that to be true only in part. Though there is a preponderance of the simpler style of veneering shown in Plate 701 amongst the instruments with lower serial numbers, it seems that like the plan form variation, both styles of veneering were produced right through the production run.

It will be seen from Table 705 that for the most part, those spinets which have a serpentine tail also have the figured veneer with feathered banding and those that have a mitred tail have the plainer style. This leads to the conclusion that the Hitchcocks offered two ‘models’ of spinet – the mitred-tail instrument with plain veneer and triple stringing and the serpentine-tail instrument with figured veneer and feathered banding. It is thought that this observation had not been made before the publication of Mole 2007.

<b>Table 705 Veneering of Hitchcock Spinets</b>			
<b>No.</b>	<b>Serial No.</b>	<b>Tail</b>	<b>Veneering</b>
1	471	Mitred	Plain/Triple Stringing
2	511		
3	—	Mitred	Plain/Triple Stringing
4	616	Mitred	Plain/Triple Stringing
5	—	Serpentine	Plain/Triple Stringing
6	1007	Serpentine	Plain/Triple Stringing
7	1060		
8	1075	Mitred	Plain/Triple Stringing
9	1093		
10	1102		
11	1143	Serpentine	Figured/Feathered Stringing
12	1193	Mitred	Plain/Triple Stringing
13	1228	Mitred	Plain/Triple Stringing
14	1241	Serpentine	Figured/Feathered Stringing
15	1243	Mitred	Plain/Triple Stringing
16	1279	Serpentine	Figured/Feathered Stringing
17	1287	Mitred	Plain/Triple Stringing
18	1289	Mitred	Plain/Triple Stringing
19	1335	Serpentine	Figured/Feathered Stringing
20	1379	Serpentine	Figured/Feathered Stringing
21	1390		
22	1396	Serpentine	Figured/Feathered Stringing
23	1425		
24	1442		
25	1444		
26	1455		
27	1460	Serpentine	Figured/Feathered Stringing
28	1484	Serpentine	Figured/Feathered Stringing
29	1518	Serpentine	Plain/Triple Stringing
30	1519		
31	1520	Serpentine	Figured/Feathered Stringing
32	1547	Mitred	Plain/Triple Stringing
33	1570	Serpentine	Figured/Feathered Stringing
34	1625		Figured/Feathered Stringing
35	1630	Mitred	Plain/Triple Stringing
36	1676	Serpentine	Plain/Feathered Stringing
37	1677		
38	2012	Mitred	
39	2018	Serpentine	Figured/Feathered Stringing
40	—		
41	—	Mitred	Plain Stringing
42	—		
43	—	Mitred	Plain Stringing

However, there are exceptions to the rule – Serial No. 1007 is a serpentine-tail spinet but has the simpler style of stringing and both the serpentine-tail John Hitchcock spinet Serial No. 1676 at the Royal College of Music, London and the mitred-tail one at in Copenhagen<sup>24</sup> have decorative styles which do not conform to the norms. But Table 705 does not show mitred tail spinets with figured veneer and feathered stringing.

### c. Stands

A final general variation found in Hitchcock spinets is in the stands. Though some spinets have either lost their stands or may not have been supplied with one originally, many have stands which conform to one of two patterns – simple turned stands having turned feet, and turned stands with more elaborate moulded feet. The distribution of the different types, so far as it is known, is shown in Table 706 below.

---

<sup>24</sup> The appearance of this spinet, which is illustrated in Appendix Seven, is highly unusual for a Hitchcock instrument and there must be considerable doubt whether it is genuinely a Hitchcock.

<b>Table 706 Stands of Hitchcock Spinets</b>				
<b>No.</b>	<b>Serial No.</b>	<b>Tail</b>	<b>Veneering</b>	<b>Stand</b>
1	471	Mitred	Plain/Triple Stringing	None
2	511			
3	—	Mitred	Plain/Triple Stringing	Turned Foot
4	616	Mitred	Plain/Triple Stringing	Turned Foot
5	—	Serpentine	Plain/Triple Stringing	Non-Original
6	1007	Serpentine	Plain/Triple Stringing	Turned Foot
7	1060			
8	1075	Mitred	Plain/Triple Stringing	
9	1093			
10	1102			
11	1143	Serpentine	Figured/Feathered Stringing	Turned Foot
12	1193	Mitred	Plain/Triple Stringing	Turned Foot
13	1228	Mitred	Plain/Triple Stringing	Non-Original
14	1241	Serpentine	Figured/Feathered Stringing	Scroll Foot
15	1243	Mitred	Plain/Triple Stringing	Turned Foot
16	1279	Serpentine	Figured/Feathered Stringing	Scroll Foot
17	1287	Mitred	Plain/Triple Stringing	Scroll Foot
18	1289	Mitred	Plain/Triple Stringing	Scroll Foot
19	1335	Serpentine	Figured/Feathered Stringing	Scroll Foot
20	1379	Serpentine	Figured/Feathered Stringing	Turned Foot
21	1390			
22	1396	Serpentine	Figured/Feathered Stringing	Scroll Foot
23	1425			
24	1442			
25	1444			
26	1455			
27	1460	Serpentine	Figured/Feathered Stringing	Scroll Foot
28	1484	Serpentine	Figured/Feathered Stringing	Non-Original
29	1518	Serpentine	Plain/Triple Stringing	Turned Foot
30	1519			
31	1520	Serpentine	Figured/Feathered Stringing	Scroll Foot
32	1547	Mitred	Plain/Triple Stringing	
33	1570	Serpentine	Figured/Feathered Stringing	Non-Original
34	1625		Figured/Feathered Stringing	
35	1630	Mitred	Plain/Triple Stringing	
36	1676	Serpentine	Plain/Feathered Stringing	Non-Original
37	1677			
38	2012	Mitred		
39	2018	Serpentine	Figured/Feathered Stringing	
40	—			
41	—	Mitred	Plain Stringing	Triangular
42	—			
43	—	Mitred		Non-Original

A turned stand, that which belongs to spinet Serial No. 616, is shown in Plate 706. Turned stands of this type employ standard architectural profiles in various simple combinations, which may suggest that these stands were made locally for the purchaser and were therefore not, or not necessarily, made by the Hitchcocks.



Plate 706 - The Stand of No. 616



Plate 707 – A Scroll Foot

The second type of stand with a scroll foot is of a consistent pattern and it is therefore thought that stands of this type were made by or for the Hitchcocks and supplied with their spinets when new. The stands are of similar construction to that shown in Plate 706 but all four feet are moulded in a form referred to in the furniture trade as a ‘scroll foot’, a ‘hoof foot’ or sometimes as a ‘Braganza foot’ (Bowett 2002: 254-258). The moulding is shown in Plate 707. This type of foot appears mostly on chair furniture of 1715 and later and it must surely be significant in this

context that Thomas Hitchcock the Elder, and his widow Mary after his death, have been shown to be chair makers (see Chapter Six).<sup>25</sup>

Referring to Table 706 it can be seen that most of the serpentine-tail instruments which have retained their original stands have stands of the scrolled foot pattern. These are highlighted in the Table. Because of the frequency of occurrence of spinets having a serpentine tail, a figured veneer with feathered stringing, and a stand having scrolled feet it is thought that the Hitchcocks sold this combination as their more expensive model and that mitred tail spinets with plain veneer, linear stringing and a turned stand, or even no stand at all, were sold at a lower price.

A spinet typical of each model will now be described in detail. Less detailed descriptions of other Hitchcocks spinets for which details have been obtained appear in Appendix Seven.

---

<sup>25</sup> As already noted, strictly, it was unlawful to make turned articles unless the maker was a Freeman of the Turner's Company. It is possible therefore that Thomas Hitchcock the Elder employed a Turner and that this person made stands for the Hitchcocks after Thomas the Elder's death. That possibility has not been researched.

#### d. The Mitred-Tail Model

The spinet chosen for exemplification of the mitred tail model is Serial No. 616 at the Bate Collection, University of Oxford. A general view of the instrument is shown in Plate 708.



Plate 708 – The Mitred-Tail Spinet No. 616

With the exception of the spine and base, which are of deal, the case is of walnut. The interior veneering of the instrument can be seen in Plate 708: it is of sycamore with plain linear stringing using thin alternating black/white/black lines of veneer. The spine is inlaid with two parallel lines of triple stringing which are carried round the interior of the case and along the jack rail.



Plate 709 – The Nameboard of the Mitred-Tail Spinet No. 616

There is no central cartouche on the nameboard, the inscription *Thomas Hitchcock Londini fecit* being scribed ink, within a rectangular panel defined by stringing on the nameboard as shown in Plate 709. The bottom of the nameboard carries a batten, in walnut, cut out in way of the sharp blocks. Construction lines for the inlaid stringing have been left on the instrument. In addition to the maker's inscription, a workman's inscription in an eighteenth century round hand was found on the baseboard of the instrument under the keyframe. This was illustrated in Chapter Six.

The brassware is fixed with clenches, probably of a high copper alloy. It consists of three lid hinges, three flap hinges, a lock and hasp, and a lid closure fitting. Though the lid and flap hinges, which are of the pattern shown in Plate 710 below, match each other, they are of a different pattern from the lock and hasp and the lid closure, which are not shown but which are thought not to be original.



Plate 710 – Lid Hinge of the Mitred-Tail Spinet No. 616<sup>26</sup>

---

<sup>26</sup> Substantially identical hinges appear on the Bate Collection's Slade Spinet.

A general view of the keyframe as removed from the instrument is shown in Plate 711 below. As can be seen, it is roughly constructed from deal. All of the timber components are thought to be original. The balance rail, which is of walnut, has replacement pins and balance cloths, but it is thought that some of the touch cloths under the upper touch-rail above the rack are original. The lower touch cloth is a replacement.

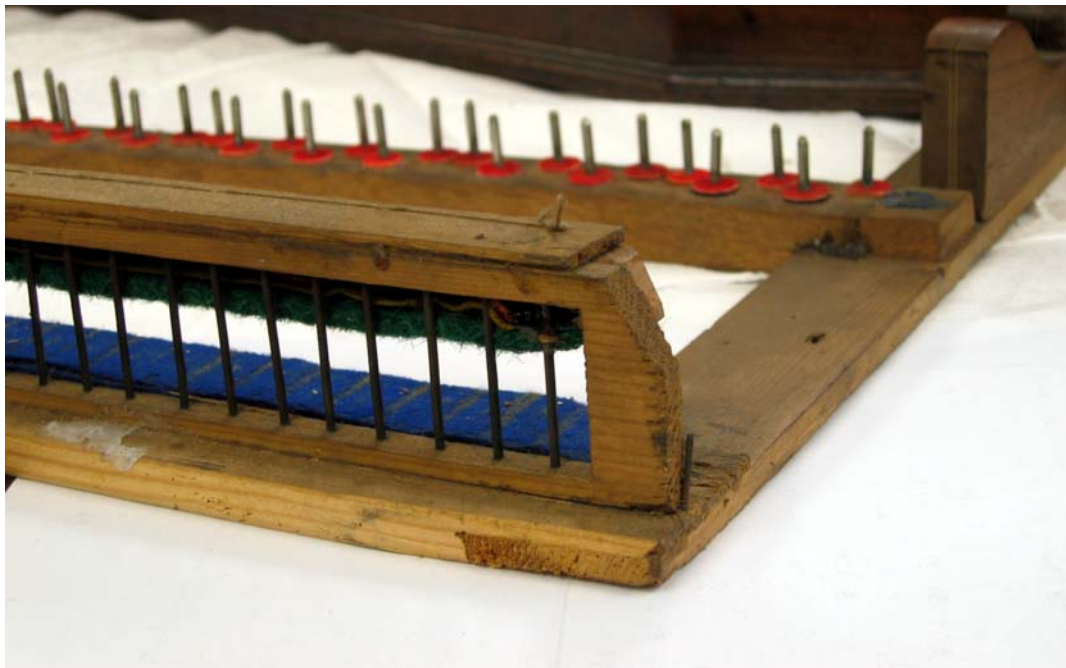

Plate 711 – Keyframe of the Mitred-Tail Spinet No. 616

As can be seen in Plate 711 the rack is constructed from a framework fitted with guidance wires running vertically to engage slots in the key levers. Except for the rack of Serial No. 471, which is of the design adopted by the Keene school having slips of timber in the distal ends of the key levers moving in vertical slots, all Hitchcock spinets which have been inspected have this design of rack. The rear of one of the key blocks can be seen to the right of the Plate 711.

The compass of the instrument is five octaves, GG-g''' and is fully chromatic (61 notes). The key levers are of pine and show evidence of multiple repairs and additions of lead weights. The natural key-plates are of ivory with ivory arcades and the sharps have skunk-tail blocks of an ebony/ivory/ebony sandwich construction. These decorative features are shown in Plates 713 to 716. On the uppermost key lever (No.61), the inscription '*James made (it?)*' appears. This inscription has been covered in modern times with a leather pad which was removed for this inspection. This key lever is shown in Plate 712.



Plate 712 – Key Lever 61 of Mitred-Tail Spinet No. 616



Plate 713 – Keyboard of the Mitred-Tail Spinet No. 616



Plate 714 – Keyboard of the Mitred Tail-Spinet No. 616



Plate 715 – Sharp Block of Mitred-Tail Spinet No. 616

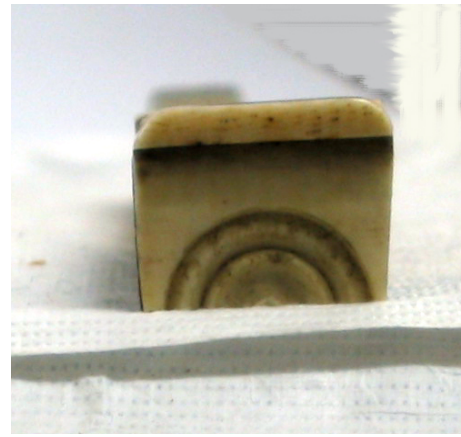

Plate 716 – Arcade of Mitred-Tail Spinet No. 616

The register is of the box-guide type made from rhomboids of walnut glued together (see Chapter Eight). The individual jack guides formed by the rebates in the rhomboids can be seen in Plate 717.

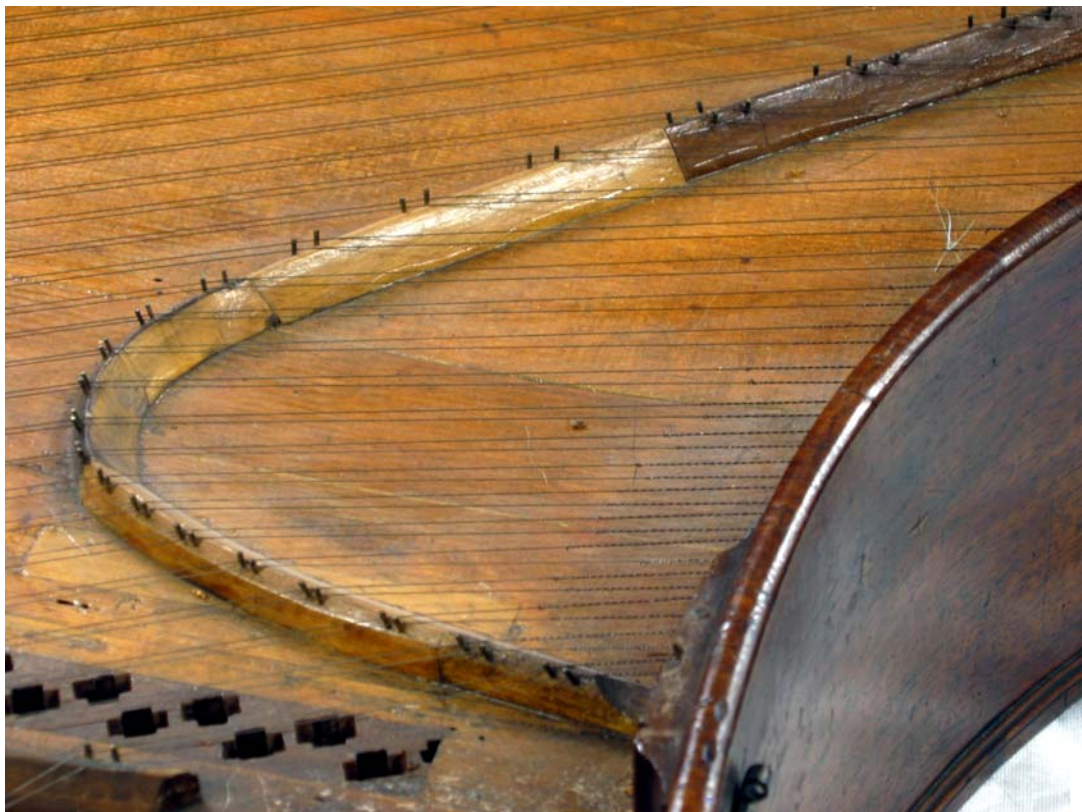

Plate 717 – Register of Mitred-Tail Spinet No. 616

The jacks are modern replacements, probably provided during a restoration which took place in 1954. The soundboard, visible in Plate 717, is original with some recent repairs. It is of coniferous material, with the grain running parallel to the register. The bridge, which is of beech, has been repaired in several places and replacement parts have been inserted. At the treble end those replacements are so close to treble end of the hitchpin rail and to the register that the vibrational freedom of the soundboard must be compromised in this area, though it is not known whether that was also the original position.

From their external diameter of 5mm, the tuning pins can be identified as replacements of the pattern used in early square pianos. The speaking length of the string at c'' is 273mm which probably indicates that the instrument was intended to be strung in brass in the treble. The strings are non-original mainly in modern steel wire, but of brass in the bass. There are no indications of string gauges on the instrument. The string lengths and plucking points are recorded in Long Form LFTH616.

The stand, which seems to be original, has already been depicted in Plate 706. It has legs of a simple turned pattern. Each pair of legs is united by upper and lower rails, with a single lower stretcher between them.

e. The Serpentine-Tail Model

The spinet chosen for exemplification of the serpentine tail model is Serial No. 1241 held in St. Cecilia's Hall, University of Edinburgh, Accession No. 4310. A general perspective view of the instrument is shown in Plate 718.



Plate 718 – The Serpentine-Tail Spinet No. 1241

The significant dimensions of the instrument are recorded in Long Form LFTH1241. A full scale drawing is also available from the Friends of St. Cecilia's Hall. With exception of the base and the spine, which are of deal, the case, lid and flap are of walnut. It seems likely that the lock-board is a replacement, since though a brass hasp is present on the flap, there is no corresponding lock. It is possible that the lock

was missing and that at the time of the restoration in 1967 it was decided to improve the spinet's appearance by replacing the lock-board.

The interior of the case, the name board and the jack rail are elaborately veneered in figured walnut, where appropriate in 'book-match' configuration, inlaid with feather pattern banding. The spine is inlaid with two parallel bands which are carried round the interior of the case and on the jack rail. The general decorative scheme is shown in Plate 719.



Plate 719 – Decorative Scheme of the Serpentine-Tail Spinet No. 1241

The nameboard inscription, which reads *Thomas Hitchcock Londini fecit No. 1241*, is in ink within an ogee cartouche within a panel of rectangular banding. As in the mitred-tail spinet described above, the bottom of the nameboard carries a batten cut out in way of the sharp blocks. The keywell sides are banded with a self-contained triangular device similar to that already shown in Plate 702. There are manufacturing advantages associated with the provision of veneer banding in the form of a self-contained rectangle or triangular device, since there is no necessity to

ensure exact alignment of the inlay on the keywell sides with that on the nameboard, as there is with the decoration found on the Keene spinets considered in Chapter Five.

The lid of the spinet carries three ornamental hinges of the same size and of the design shown in Plate 720. The lid-flap is also hinged with three substantially identical ornamental hinges: one of these is shown in Plate 724. The lid closure fitting is not original and is not shown.



Plate 720 - Lid Hinge



Plate 721 - Flap Hinge

Hinges of Serpentine-Tail Spinet No. 1241

The keyframe and keyboard of this spinet are substantially the same as that in the mitred tail model Serial No. 616 described immediately above. Interestingly, the decoration of the key block, which is shown in Plate 702 above, does not seek to

copy that found on the rest of the instrument, confirming that the technical challenge of inlaying a block of such tight curvature with veneer is too great.



Plate 722 – Keys of Serpentine-Tail Spinet No. 1241

As in Serial No. 616 the compass is a full five octaves, GG-g''' (61 notes). The natural key-plates, as shown in Plate 722 are of ivory with heavy scoring in two lines, one to denote the position of the cuts to be made in way of the sharps, the other, on the player's side of this line, denoting the limit of the chamfer. The sharp blocks are 'skunk-tailed' and the proximal ends of the natural key levers carry ivory arcades: these were most probably made with an auger to form a circular pattern in an ivory slip, which was then cut into two pieces with a fine-tooth saw.

The extreme bass key lever (GG) bears the inscription *Wm Hilliar Harris H 7*, see Plate 723 and the treble-most one (g''') bears another inscription which possibly reads '*Haris 7*' and the inscription *Hilliar* see Plate 724. The key levers are in pine.



Plate 723 - Inscription on the GG Key Lever  
of Serpentine-Tail Spinet No. 1241

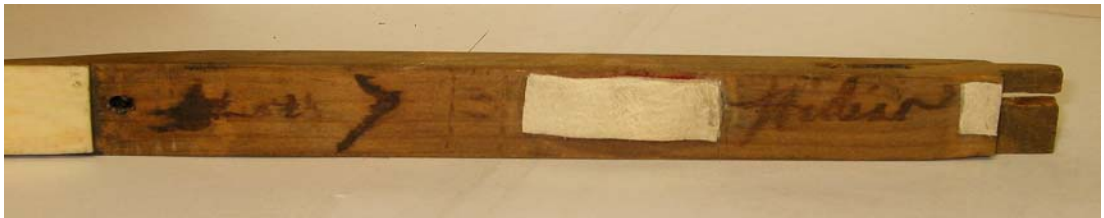

Plate 724 – Inscription on the g''' Key Lever  
of Serpentine-Tail Spinet No. 1241

The register of this instrument is of the box-guide type described above in relation to spinet Serial No. 616. Many of the jacks in the instrument are original; including jack number 9, which is an original jack but which has been repaired, which is shown in is shown in Plates 725 and 726 and in Figure 703 below.



Plate 725



Plate 726

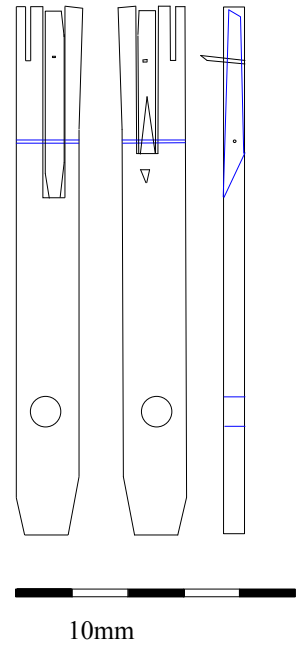

Figure 703

### A Typical Jack from Serpentine-Tail Spinet No. 1241

The soundboard is of a coniferous material, with grain running parallel to the register. The bridge is of beech. There are no indications of string gauges on the instrument. It was re-strung in 1990, using wire from Malcolm Rose of Lewes, Sussex.

## 4. Model Development

### a. Case Size

Although two models of Hitchcock spinet can be identified, the mitred-tail models did not remain entirely static in design: some changes can be observed over time, later instruments being somewhat larger than early ones. That can be seen in the comparison of two Thomas Hitchcock mitred tail spinets, Serial Nos. 616 and 1243 shown in Figure 704 in which the plan forms of the two instruments are drawn to the same scale and super-imposed upon each other.

Hitchcock Spinet No.1243 in red  
Hitchcock Spinet no 616 in black

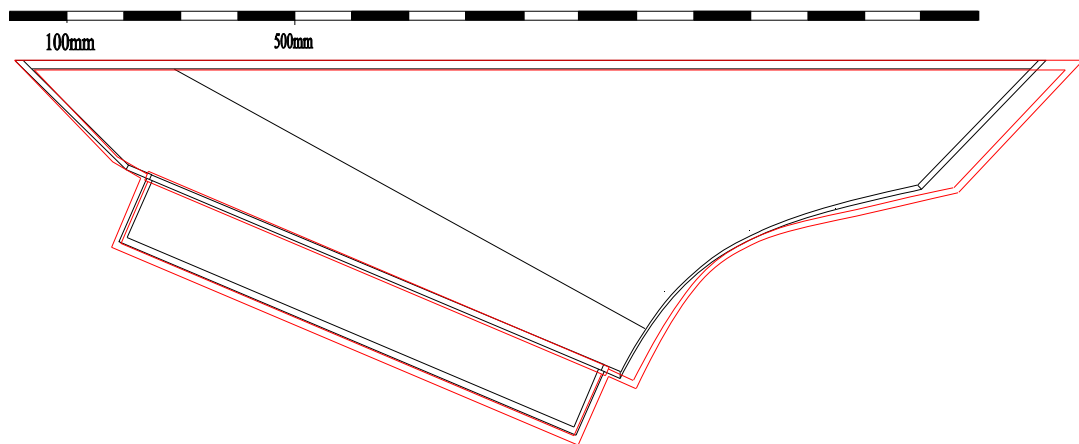

Figure 704 – Plan Form Comparison of Two Mitred-Tail Hitchcock Spinets

The two spinets in this comparison are thought to date from 1723 and 1729 respectively. It can be seen that the later instrument, in red, is somewhat larger than the earlier one and that the keyboard of the later one also protrudes from the case marginally further. The differences are not great, the respective spine lengths being 1809mm and 1874mm, and the lengths of the keywell ends being 121mm and

130mm respectively. But these differences are too great to have been random: they must have been intentional. They indicate the tendency for spinets to become larger as time proceeded, independently of the necessity of their becoming so because of increasing keyboard compass. It is likely that this tendency was driven by the desire for a more powerful instrument, having longer strings and a larger soundboard.

A different conclusion can be drawn from a comparison of two Hitchcock spinets with close serial numbers but of different plan forms. Figure 705 shows the plan forms of Serial Numbers 1241, a serpentine tail instrument, and 1243, a mitred tail one. It can be seen again that though they are quite similar, the serpentine tail allows spinet No 1241 to be somewhat shorter than No 1243, the spine lengths being 1774.5mm and 1874mm respectively.

Hitchcock Spinet No.1241 in red  
Hitchcock Spinet No.1243 in black

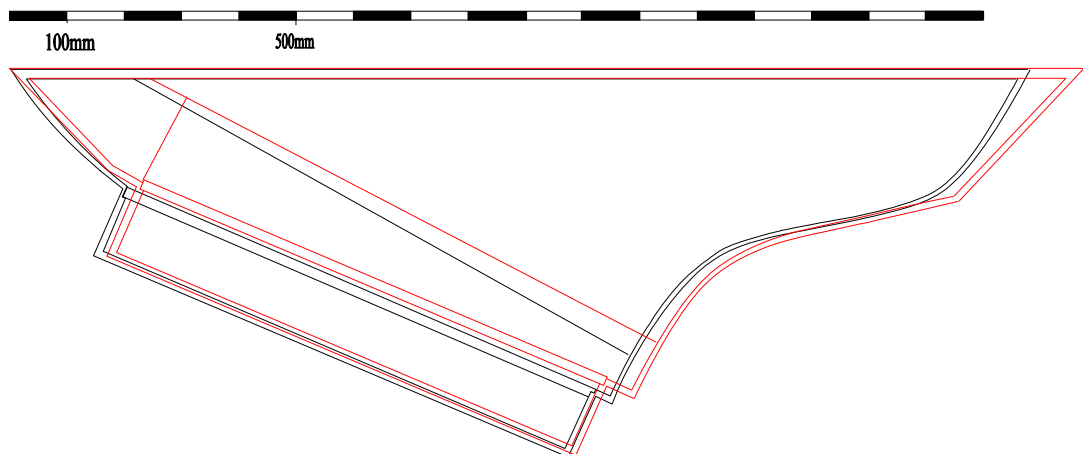

Figure 705 - Comparison of Two Hitchcock Spinets with Differing Plan Forms

It seems likely, in view of their close numbers, that the two spinets Shown in Figure 705 were in the Hitchcock workshops simultaneously. Indeed, Serial Number 1241 bears the inscription *Will Hilliar Harris No 7* on a key, and Number 1243 has a similar inscription, *Harris 19 Will Hilliar*. It is difficult to say whether the latter inscription is properly read *Harris No 9*. Despite the obvious arithmetical attractions of that, the author believes that ‘19’ is the correct figure. But whether the figure is ‘9’ or ‘19’, its presence is a strong indication that the two spinets have keyboards, at least, which were made by the same person or persons at very much the same time, that is to say, some time during 1729.

The final comparison under the heading of case size is that of two serpentine-tail spinets, Serial No. 1241, the instrument at St. Cecilia’s Hall, University of Edinburgh used in the previous comparison and Serial No. 1335 which is held at Sulgrave Manor, nr Banbury, Oxfordshire and is thought to date from about 1732. It can be seen from Figure 706 below that the cases of the two spinets are substantially identical. It is noteworthy in this respect that the catalogue of the Museum für Kunst und Gewerbe, Hamburg (Beurmann 2000: 140) reports that the two serpentine-tailed Thomas Hitchcock spinets in the museum, Serial Numbers 1279 and 1379 are ‘in principle in build and configuration identical’.<sup>27</sup> One of these two Hamburg instruments, Serial No. 1279 is dated 1729 and the other, Serial No. 1379 probably dates from 1732.<sup>28</sup> From this evidence and from the author’s own investigations, it

---

<sup>27</sup> Dieses Instrument (Serial No 1379) ist im Prinzip in Aufbau und Ausstattung mit Nr 37 ( Serial No. 1279) identisch.

<sup>28</sup> Which implies that during this period production of spinets was proceeding at about 30 per year.

therefore seems that the serpentine-tail instruments were substantially identical in plan form, at least from 1729 to 1732 and perhaps beyond. It is not clear why the mitred-tail instruments would have been developed in size but the serpentine-tail ones left undeveloped, unless the Hitchcocks believed that their serpentine design had reached its development limits.

Hitchcock Spinet Serial No. 1335 in red

Hitchcock Spinet No. 1241 in black

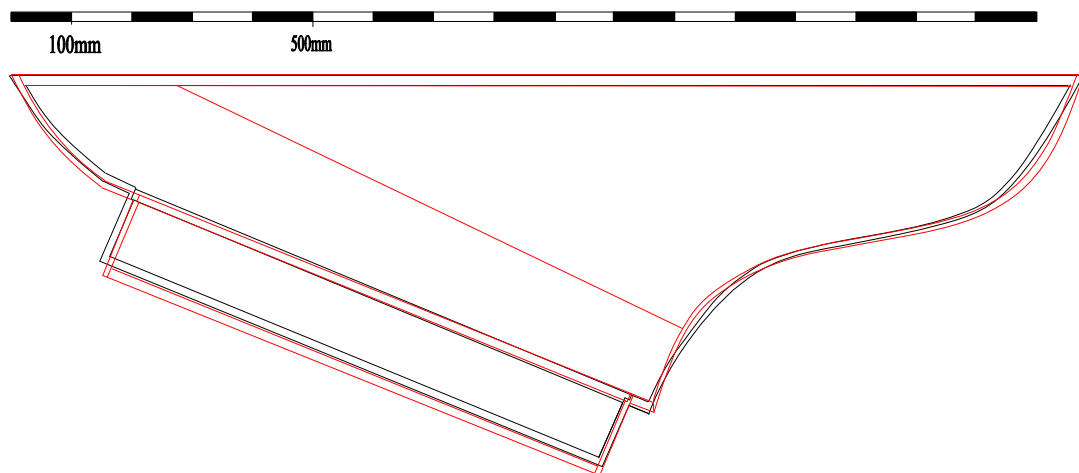

Figure 706 – Plan Form Comparison of Two Serpentine Tail Spinets

## b. Special Decorative Features

Table 707 below tabulates features found in some Hitchcock spinets which depart from the standard decorative schemes of the two models in one or more respects. It is surmised that as a consequence of their substantial operation, the Hitchcocks were able to offer instruments to special order which were variations on the two mainstream products described in detail above.

<b>Table 707</b>		
<b>Serial Nos. of Hitchcock Spinets with Special Decorative Features</b>		
	<b>Serpentine Tail</b>	<b>Mitred Tail</b>
Plain veneer/triple stringing	1676	616, 1193, 1228
Turned foot	1007, 1143	
Ebony natural plates		1193, 1228, 1289, 1518, 1547, 1630

As can be seen from the Table 707, Spinet Serial No. 1676, a serpentine tail spinet by John Hitchcock, has the plainer style of veneering normally found on the mitred tail instruments, though it has feathered banding. This spinet also has rectangular key blocks with a corner chamfered. This is shown in Plate 727.



Plate 727 – Plain Veneer on Spinet No. 1676

It would of course have been a simple matter to veneer an instrument in a different way if the prospective owner wanted that. But it is difficult to think that an owner opting for the model which is presumed to have been the more expensive would also

have opted for delivery with a simple turned stand or with no stand at all, and it is therefore thought that the turned stands shown in Table 707 as present with Serial Nos. 1143 and 1007 are replacements.

Table 707 shows the existence of at least six spinets with ebony natural plates. That occurrence might be thought surprising since ebony natural plates might be presumed to have looked somewhat old-fashioned by their dates of approximately 1726-1755. However the position is not so simple: both a spinet by Mahoon dated 1753 in the Smithsonian Institution, Washington and some early square pianos, including the Zumpe instrument of 1766 now at Emmanuel College, Cambridge (Maunder 1989: 78) have ebony natural plates and it seems that this feature did not disappear until the last decades of the eighteenth century.

Plate 728 shows one of the Thomas Hitchcock spinets, Serial No.1518, which is held at the Metropolitan Museum, New York. This has ebony natural plates and consequently the skunk-tailing of the sharp blocks is reversed from the normal pattern so that the ivory components are adjacent the ebony naturals.<sup>29</sup> Appendix Seven illustrates the five other spinets so far found to have the same decorative style of keyboard, Serial Nos. 1193, 1228, 1289, 1547 and 1630

---

<sup>29</sup> The author is grateful to Susana Caldeira who kindly photographed the instrument on his behalf and allowed him to reproduce her image here.



Plate 728 – The Keyboard of Hitchcock Spinet No. 1518

It is noteworthy that all the Hitchcock spinets with ebony naturals are the mitred-tail model. A possible explanation for that is the Hitchcocks wanted to maintain an up-market image for their serpentine tail spinets and that the exclusive use of ivory was seen as consistent with that.

### c. Special Features affecting Musical Performance

Most Hitchcock spinets have a nut which is straight, with a short section in the bass which is mitred towards the spine. The mitred-tail instruments Serial Nos. 616, 1228 and 1287 have this arrangement as do the serpentine-tail instruments Serial Nos. 1241, 1335 and 1520. The nut of Serial No. 1520, a spinet by John Hitchcock, is

typical of this arrangement and is shown in a view from the bentside towards the bass in Plate 729 which is reproduced here by kind permission of John Watson. It is thought that this is by far the most common arrangement. However inspection of Hitchcock spinet Serial No. 471 revealed that in this instrument the nut was pronouncedly convex towards the player. Subsequently, it was discovered that some other Hitchcock spinets show the same feature, including Serial Nos. 1143, 1279 and 1484. Plate 730 is a view along the nut in spinet Serial No. 471. The curve of the nut is very evident.



Plate 729



Plate 730

Nuts of Hitchcock Spinets No. 1520 (left) and No. 471 (right)

Mitring, or in the alternative bending the nut, affects the string-band in two ways:- first it ensures that the strings in the tenor and bass regions are as long as they can be while still being accommodated within the confines of the case of the instrument. This has the effect of reducing the inevitable foreshortening of the tenor and bass

strings in relation to the treble ones. It therefore makes for a spinet with a bass which is likely to produce a greater proportion of the fundamental vibration, and a possibility of a greater vibrational amplitude, than one in which the nut is straight throughout its length. This will produce more power in the bass octave. Secondly, by varying the angle of the dog-leg, or of the degree of curvature of the nut, the plucking point of the strings can be varied, which again affects the tone of the note produced, a closer plucking producing a more nasal tone.

From the pattern of serial numbers of the spinets referred to, it seems that both approaches to the design and construction of the nut were being adopted by the Hitchcocks simultaneously, at least until the 1750s. Although the use of a pre-bent nut cannot be entirely ruled out, it seems likely that the curved nuts were produced *in situ* on the instrument. Close inspection of Serial No. 471 shows the presence on the upper surface of the wrestplank of a scored guide-line, and of retaining pin-holes, presumably used to force a straight nut component into the desired curve during gluing.<sup>30</sup>

The reason for the subsistence of the two methods is also unclear, but one possibility is that the design of the nut may have been a result of the practice taught to the maker responsible for the instrument within the Hitchcock operation during his apprenticeship, and could be evidence of a particular craft tradition. Plate 731 below is a view along the nut of the Benjamin Slade spinet at The Bate Collection,

---

<sup>30</sup> The author is grateful to John Watson who assisted with this inspection.

University of Oxford.<sup>31</sup> Since Thomas Hitchcock the Younger was apprenticed to Benjamin Slade, it is possible that he was responsible for the spinets with the curved nut. By the same token, if it is a craft tradition which is at play here, then one might expect Thomas Free 1701 and his son John Hitchcock to produce spinets with a straight but dog-legged nut, since the present thesis is that Thomas Free 1701 worked with Edward Blunt, whose spinets exhibit nuts of that design. A second possibility, but again one which might have arisen from differing craft traditions within the workshop, is that the instruments were deliberately made so that they exhibited different tonal characteristics. This consideration is a sophisticated one and it is thought that choice of tone is unlikely to have been a choice which would have been offered to the Hitchcocks' potential customers.



Plate 731 – Nut of the Slade Spinet  
Bate Collection, University of Oxford

---

<sup>31</sup> The c.1702 Slade spinet at the Red Lodge Museum, Bristol also has a curved nut, though in this example the curvature is concave to the player with a dog-leg

Nevertheless, analysis of the string lengths and the plucking points of a pair of spinets, Serial Nos. 471 and 1279, which have curved nuts and a pair, Serial Nos. 616 and 1241 which have dog-leg nuts lends considerable support to the idea of there being two different Hitchcock sounds. In Table 708 below the string lengths and plucking points of the two pairs of spinets are tabulated, and in the graph of Figure 707 the percentage plucking points from GG up to c''' are plotted against the key note.

<b>Table 708</b>												
<b>Comparison of String Lengths and Plucking Points</b>												
<b>of two pairs of Hitchcock Spinets</b>												
	<b>471</b>			<b>616</b>			<b>1279</b>			<b>1241</b>		
<b>Note</b>	<b>L</b>	<b>Pluck</b>	<b>%</b>	<b>L</b>	<b>Pluck</b>	<b>%</b>	<b>L</b>	<b>Pluck</b>	<b>%</b>	<b>L</b>	<b>Pluck</b>	<b>%</b>
<b>GG</b>	1478	201	13.6	1455.5	193	13.3	1510	200	13.2	1510	177	11.7
<b>C</b>	1389	215	15.5	1381	214	15.5	1421	213	15.0	1437	209	14.5
<b>F</b>	1292	231	17.9	1279	200.5	15.7	1314	229	17.4	1310	198.5	15.2
<b>c</b>	1020	234.5	23.0	992	175.5	17.7	1012	236	23.3	1017	173	17.0
<b>f</b>	840	239	28.5	820	166.5	20.3	814	233	28.6	834.5	161.5	19.4
<b>c'</b>	548	217	39.6	543.5	139.5	25.7	529	215	40.6	548	131	23.9
<b>f'</b>	419	199.5	47.6	423	128.5	30.4	405	187	46.2	387	124	32.0
<b>c''</b>	267	132.5	49.6	276	105.5	38.2	270	130	48.1	275	102	37.1
<b>f''</b>	215	110.5	51.4	215.5	96	44.5	210	107	51.0	215	90.5	42.1
<b>c'''</b>	136	66	48.5	135.5	67	49.4	135	66	48.9	136.5	76	55.7
<b>e'''</b>	103	52.5	51.0									
<b>f'''</b>				97.5	51	52.3	108	54	50.0	107	53	49.5
<b>g'''</b>				96	54	56.3	93	46	49.5			

It can be seen particularly from the graph of Figure 707 that when plucking point is used as the criteria for classification, the instruments fall into two pairs, the instruments with the curved nut, Serial Nos. 471 and 1279 producing plucking points which are closer to the centre of the string than the other pair with dog-legged nuts, Serial Nos. 616 and 1241. Other things being equal, a plucking point close to the centre of the string produces a greater proportion of the fundamental frequency and a

more ‘flutey’ sound than one close to the nut. Serial Nos. 471 and 1279 can therefore be expected to have sounded more ‘flutey’ than Serial Nos. 616 and 1241.

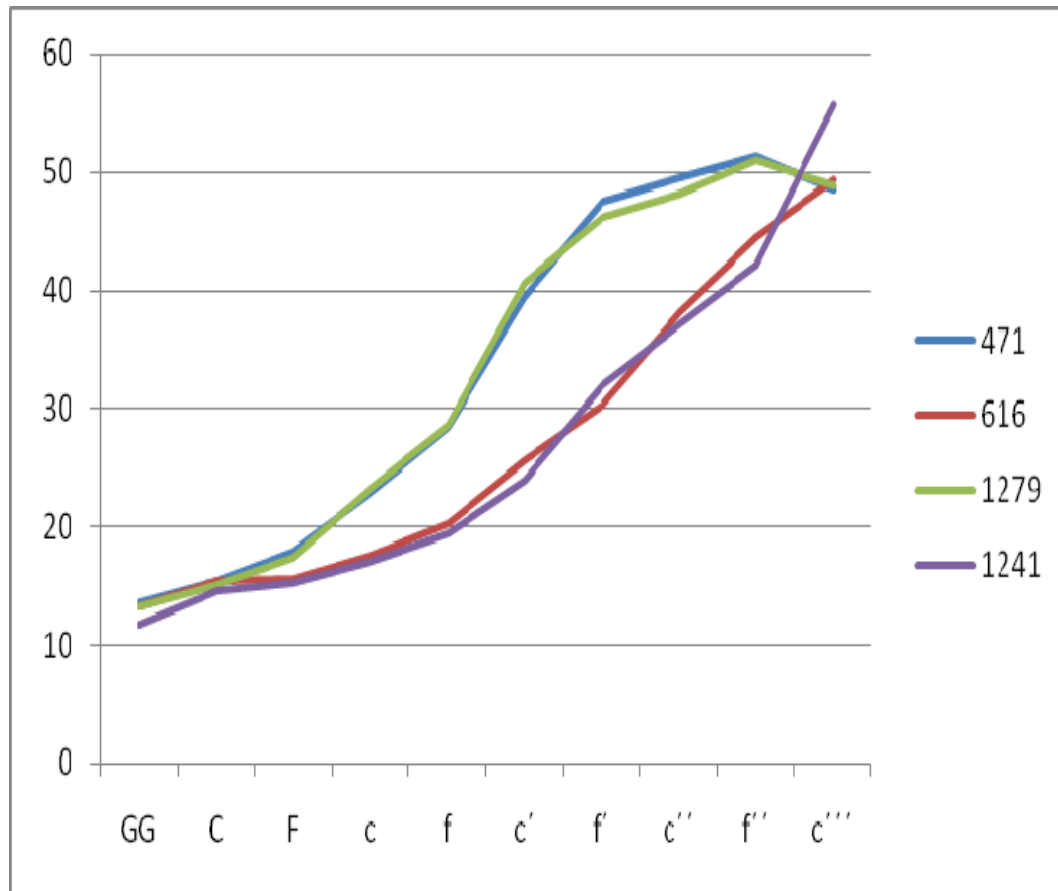

Figure 707 - Plucking Points at C and F plotted against Note Sounded for the spinets of Table 708

Fortunately, recordings are available of Serial Nos. 1241 and 1279. The difference in the sound produced sound can readily be heard.<sup>32</sup>

<sup>32</sup> Serial No. 1241 can be heard played by John Kitchen on the CD *Instruments from the Russell Collection*, Delphian Records, DCD34001 (2001) and Serial No. 1279 can be heard played by Hannelore Unruh on the CD *Historische Tasteninstrumenten in Museum für Kunst und Gewerbe Hamburg*, available from the museum shop.

## 5. The Influence of Slade

It was noted in Chapter Four that spinet makers had inevitably to cope with the fact that their apprentices might one day establish a competing spinet and harpsichord making business. The previous part of this chapter has also referred to the fact that Thomas Hitchcock the Younger was apprenticed to Benjamin Slade and the possibility that Slade's craft traditions might be visible in the instruments built by Thomas the Younger. This part of the chapter enquires whether other aspects of Slade's practices are visible.<sup>33</sup> A difficulty here is that it is not easy to say which of the forty-three Hitchcock spinets which are thought to have survived were made by Thomas the Younger and which by Thomas Free 1701: certainly the inscriptions will not help directly in this respect. Nevertheless, some influences may be discernible:-

Boalch (1995: 632 - 633) lists seven spinets and one harpsichord by Benjamin Slade. The harpsichord is part of the Rodger Mirrey Collection recently donated to the University of Edinburgh and though it is not yet present in St. Cecilia's Hall at the time of writing, a brief description of it is available.<sup>34</sup> It is stated to be dated 1720 to 1725. It is clear from the small photograph on the website that it has a serpentine bentside. The single surviving harpsichord by Thomas the Younger (Boalch 1995: 392 and Yorke 1998: 69) is of similar date and also has a serpentine bentside. A serpentine bentside was quite an unusual feature in an English harpsichord, as noted by Yorke (1998: 70) though the 1683 harpsichord by Charles Haward, and Haward's spinets also have this feature.

---

<sup>33</sup> Four Slade spinets are described in Appendix Four.

<sup>34</sup><http://www.music.ed.ac.uk/euchmi/uck/uckd4480.html> accessed 8th January 2009

It would be difficult to state either that Thomas the Younger was influenced by Slade to produce his harpsichord(s?) with a serpentine bentside, or that Slade was influenced by Thomas the Younger to produce his, even ignoring the possibility that the harpsichords may have been made by Thomas Free 1701, but the re-appearance of this unusual feature in two instruments which are close in date seems likely to be more than a coincidence.<sup>35</sup> Furthermore, the use of this feature in harpsichords seems to reflect, or possibly to drive, an increasing tendency for spinets to be made in the serpentine bentside format. The serpentine-tail Hitchcock spinet with the lowest serial number, Serial No. 1007, is undated, but a reference to a Barton spinet with a serpentine tail has been found as early as 1714, with two others dated 1724 and 1730, and the spinet at Colonial Williamsburg by Cawton Aston and dated 1726 also has a serpentine tail. Again, it is difficult to say whether Barton and Aston influenced the Hitchcocks or *vice versa*, though the author believes that the size of the Hitchcock business is likely to have made their influence greater than that of either Barton or Aston.

This discussion leads to the following tentative conclusion: - in any attempt to allocate the responsibility for production<sup>36</sup> of spinets between Thomas the Younger and Thomas Free 1701, it seems to the author more likely that Thomas the Younger would have been responsible for the serpentine tail instruments, on the basis of the known involvement of Benjamin Slade in producing an instrument of that type. In so

---

<sup>35</sup> Thomas the Younger had of course been discharged from his binding to Slade many years previously, but that is not to say that the two men were no longer in contact.

<sup>36</sup> There is no assumption here that either Hitchcock actually made spinets as such, though they may have done – merely that they each would have been responsible for certain elements of the workshop production.

far as Thomas Free 1701 was subject to any craft influence in spinet making, then his is likely to have derived from Edward Blunt, who is not known to have made serpentine-tail spinets.

## **6. The Hitchcocks' Competitors**

The large number of surviving spinets by the Hitchcocks evidences their success. Significant numbers of Hitchcock spinets probably began to be built towards the end of the second decade of the eighteenth century. Milhous & Price (1990) suggest that at this time harpsichords were being built in greater numbers than had been the case in earlier decades. Nevertheless the harpsichord was still quite unusual in England: it was not until later in the century that serious production started in the major 'factory' harpsichord workshops of Shudi and Kirkman. The earliest of Shudi's harpsichords to have survived is that of 1729 (Mould 1976: 124) but Mould estimates that at this early stage Shudi was producing only nine instruments per year, a figure which rose to thirty-six per year during the period 1770-1780. The earliest of Jacob Kirkman's harpsichords is dated 1744 (Boalch 1995: 424). So in the period under consideration, the effect which output from the Shudi and Kirkman operations had on the saleability of Hitchcock spinets was relatively minor. Indeed, the fact the Hitchcocks had produced several hundred spinets – the precise number is uncertain - before 1740 is a clear demonstration of their desirability in the market place in the first half of the eighteenth century.

Nevertheless the Hitchcocks had competitors, two of whom, Slade and Barton were introduced in Chapter Four: Cawton Aston was also a prominent maker, as the successor to John Player's business. From inspection of only two Slade spinets and of only a single Aston instrument, the author has formed the view that these makers were fine craftsmen who produced up-market instruments which would have provided strong competition to the Hitchcocks' serpentine tail spinet. But it would have been competition on a relatively small scale. No Barton spinet has been inspected, but the impression formed from photographs is that the Barton instruments were less elaborate and were probably cheaper than those of the Hitchcocks. Francis Coston may have been a fourth competitor, though as noted on in Chapter Three, none of his spinets is known to have survived:<sup>37</sup> he was probably principally a harpsichord maker in a small business environment.

Though these competitors will have deprived the Hitchcocks of some sales, the author believes that they will have been less troubled by competition from other spinet makers than by the increasing popularity and affordability of the harpsichord in the third and fourth decades of the eighteenth century. Later, John Hitchcock will have experienced competition from the introduction by Zumpe of the square piano and indeed this would eventually render the spinet obsolete.

---

<sup>37</sup> The attribution to Francis Coston by the Mallett auction house of a spinet offered for sale in their New York rooms in 2005 (Stock No. F2D0209) seems to the author to be entirely speculative. See <http://www.mallettantiques.com/Public/Stock/View.aspx?ref=F2D0209> accessed 25<sup>th</sup> April 2009.

## 7. Summary

This chapter and its associated appendix, Appendix Seven, has provided an organological characterisation of the Hitchcock spinet. The chapter began by identifying the surviving spinets, of which there are thought to be forty-three – several of the greater number listed in Boalch (1995) being thought to be erroneous entries or duplicates. From the inscriptions on surviving instruments, from dates found or reported on a limited number of spinets, and from salient dates in the lives of those who worked for in the Hitchcock business which were described in Chapter Six, it is possible to produce a date/serial number correlation. The correlation presented here recognises the probability that the serial numbers on surviving instruments are not in a single arithmetical series, but in three incomplete series.

With the exceptions of Serial No. 471, which has the compass GG - e''' and one instrument which has been altered, all of the surviving spinets have a five-octave compass of 61 notes GG - g'''. The distribution amongst the instruments of two plan forms, one with a mitred tail and one with a serpentine tail, of two patterns of veneering, one using plain veneer and linear stringing and the other using figured veneer and feathered banding, and of two designs of stand, one with a plain turned foot and the other with a scroll foot leads, to an unusual conclusion: that the Hitchcocks produced two models of spinet simultaneously throughout the production run. A detailed characterisation of a representative spinet of each model was presented.

Some development, in particular in case size and so in the musical power of the instruments is observable. That was described using superimposed scale plans of significant pairs of instruments. Other variations which have been observed are explicable if it is assumed that because of the size of the Hitchcocks' business, they were able to accept special orders for unusual decorative schemes or for unusual technical features. Chief of the variations is the occasional use of ebony instead of ivory for the natural plates of the keyboard, and the use of a nut curved convexly toward the player. Analysis of the plucking points of instruments displaying each design and reconciliation of the plucking point curves with recordings of the instruments on compact disc shows that the spinets with a convex nut exhibit a 'flutier' tone in all but the extreme bass and extreme treble.

It was suggested that John Hitchcock out-sourced his later production of spinets to third-party manufacturers, including Thomas Culliford. Some comments are included in the Chapter on the likely craft influences applied to Thomas Hitchcock the Younger as a result of his apprenticeship with Slade. Attention is also drawn to the possible influence of Edward Blunt on Thomas free 1701. Additionally and finally, comments are included on the probable effectiveness of the Hitchcocks' competitors. Chief of these, it was thought, were the Kirkman and Shudi harpsichord-making firms, though Slade, Barton and Aston will all have added to the competition.

## Chapter Eight – Design Features

### 1. Introduction

This chapter is concerned with the way in which certain features of spinets were designed and to some extent with the way in which they were constructed.

Barnes (1985) provides a detailed exposition of how he believed one spinet, the Keene & Brackley instrument, was made in the Keene workshop. His monograph is intended to instruct the first time maker in producing a spinet by traditional methods and it is thought first, that it is an extremely competent account of how a spinet was made and secondly that it is unnecessary to repeat any of its contents. Rather, in this chapter, some general observations made during inspection of spinets from the schools of Keene and Hitchcock, and of spinets from other makers, are drawn together to provide an holistic picture of the design of the English spinet during the period under study. The chapter begins with a consideration of the size and plan form of the spinet case, in particular comparing Keene and Hitchcock instruments with spinets of other makers. The design and construction of spinet registers and the relationship of these registers to the jacks is then considered. This is followed by a comparison of the development of keyboard compass and of the development of range in published music. The chapter then discusses the pitch for which spinets were designed, basing the discussion largely on historical evidence of pitch. Lastly, the design of the string-band is analysed, including the choice of design note, scaling and plucking points. The Chapter concludes with a summary.

## 2. Case Size and Plan Form

One of the most obvious characteristics of the spinet is that the major axis of the keyboard lies at an angle to the spine, resulting in an essentially triangular shape. This triangular shape introduces some complexities. In a spinet, pairs of jacks lie in a staggered back-to-back pattern between substantially parallel pairs of strings. The fundamental criterion for the instrument is that each of the jacks can be brought into plucking engagement with a single string without fouling any other string. There must therefore be sufficient space between the spine of the instrument and the right-hand corner of the case, marked 'D' in the Figure 801, to accommodate a band of say, 54 strings as a minimum, whilst meeting this criterion. For this reason, the wrestplank of a spinet tapers towards the treble as shown in Figure 801.

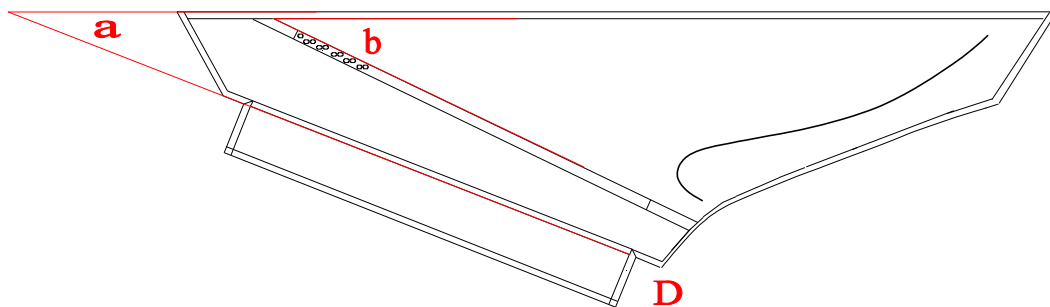

**Figure 801 – Plan form of a typical Spinet  
showing the included angle 'a'**

The taper brings the register further forward in the case at the treble end, allowing a shorter string length in the treble (which makes the string less likely to break) and providing sufficient working depth for the string-band. The included angle 'b' of Figure 801 between the axis of the register and the spine can be interpolated from the

majority of the plan diagrams in this dissertation<sup>1</sup>. On the Keene & Brackley spinet it measures 27°, producing a 3.5° taper on the wrest plank. The characteristic angle of the triangular shape of the spinet, the included angle 'a' shown in red in Figure 801, can also be interpolated from the plan diagrams of instruments presented in the appendices to this dissertation. If the angle is tabulated for a number of instruments, it can be seen that there is a considerable degree of conformity in its size. This has been done in Table 801.

<b>Table 801</b> <b>Angle 'a' of Figure 801</b>	
<b>Instrument</b>	<b>Angle a</b>
Sison, Lady Lever Art Gallery, Wirral	15½
Anon., Attributed to Player, St. Cecilia's Hall	19½
Keene, Hall i' th' Wood	21½
Keene 1700, Colonial Williamsburg	23
Keene 1704, St. Cecilia's Hall	24
Anon. 1708, Royal College of Music	24
Keene & Brackley, the author	23½
Thomas Hitchcock S/No.616, Bate Collection, Oxford University	23
Thomas Hitchcock S/No.1241, St. Cecilia's Hall	23
Thomas Hitchcock S/No.1243, Bonhams	23
Thomas Hitchcock S/No.1335, Sulgrave Manor	22
John Hitchcock S/No.1676, Royal College of Music	25

The figures appear to be clustered around an angle of 23°, with the exceptions being the John Hitchcock spinet Serial No. 1676, which is clearly a larger instrument than the others, and the early instruments which are somewhat narrower, but only marginally so. It is difficult to state categorically whether the designed angle was 23° or possibly some other quite close angle. The angle 22.5° may have had some

---

<sup>1</sup> Except in the instances of instruments having a soundboard register.

philosophical attractions in the seventeenth century, since it is one quarter of a right angle, but whatever the precise angle intended, it is important to note this: the tabulated angle is constructed - it cannot be measured directly because it is not present on the instrument. Angles which *are* on the instrument have been measured to the nearest degree but experience has shown that even this is probably an optimistic accuracy to aim at owing to distortion of the case over time, resulting in case walls which are neither rectilinear nor vertical. In these circumstances it is difficult to know what was the angle which was originally constructed, let alone what was originally intended by the craftsman. The Benjamin Sison spinet has an unusually narrow angle.<sup>2</sup>

Barnes (1985: 2 & 6) believed that the Keene & Brackley spinet was laid out using basic measuring equipment and that the fundamental triangular shape of the instrument was obtained by measurement. That is possible. Equally, it is possible that it was obtained by constructive geometry as postulated by Birkett & Jurgenson (2001 & 2002). Though it is not suggested that trigonometry was part of the formal acquired knowledge base of historic spinet makers, the practical use of trigonometry had been given a fillip in 1650 by publication of Rudd's treatise (Rudd 1650, referred to in Birkett & Jurgenson 2001: 8).

---

<sup>2</sup> The use of such a narrow angle in the design of that instrument is unsatisfactory, since it produces very short treble key levers which will be difficult for a player to control. However, detailed consideration of the Sison instrument is outside the strict context of this dissertation.

It was said in Chapter Two that one of the reasons why the spinet became popular was its small case size. Inspection has shown that spinets having early features such as a short keyboard compass, a rose, and a soundboard register are generally smaller than later instruments with a longer compass and with a box-guide register. But care needs to be taken when using the spine lengths of the spinets instruments as a comparator: spine lengths can be misleading since different plan forms can produce markedly different spine lengths in spinets which are of substantially similar size. The author considers that the Keene spinets at Hall i' th' Wood and at The Royal College of Music, London are the two earliest Keene spinets to have survived. But other spinets are of comparably small size: - Figure 802 below shows a comparison of the two Keene instruments with the John Player spinet at York Castle<sup>3</sup> described in Appendix Eight.

**York Castle Player in black**  
**Hall i' th' Wood Keene in red**  
**Royal College Keene in blue**

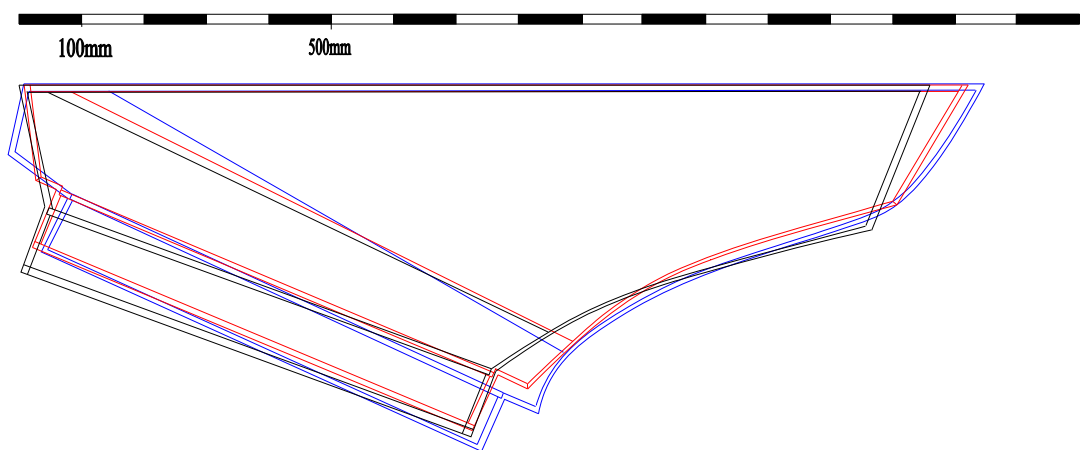

**Figure 802**

---

<sup>3</sup> The John Player spinet at Sizergh Castle, Cumbria is very similar to the one at York Castle. The Sizergh instrument has not been inspected, but Morris (1986) includes a sketch of it which is included in Appendix Eight by kind permission.

Though the spines of the Keene spinets are longer than that of the Player, at 1515mm and 1540mm compared with 1457mm for the Player, there is very little difference in usable space inside the instruments owing to the slightly greater depth of the pentagonal Player instrument. All three spinets are undated, though as was explained in Chapter Five a date of c.1682 has been attributed to the Royal College of Music Keene spinet and the other two instruments are likely to be of similar date.

Figure 803 below shows a comparison of two spinets in St. Cecilia's Hall, the anonymous spinet attributed to Player<sup>4</sup> and the 1704 Keene spinet. The spine length of the anonymous spinet is only 1497mm as compared with 1638mm for the Keene, but there is much less difference in the interior area of the instruments.

**St. Cecilia's Hall Anonymous in red**  
**Keene 1704 in black**

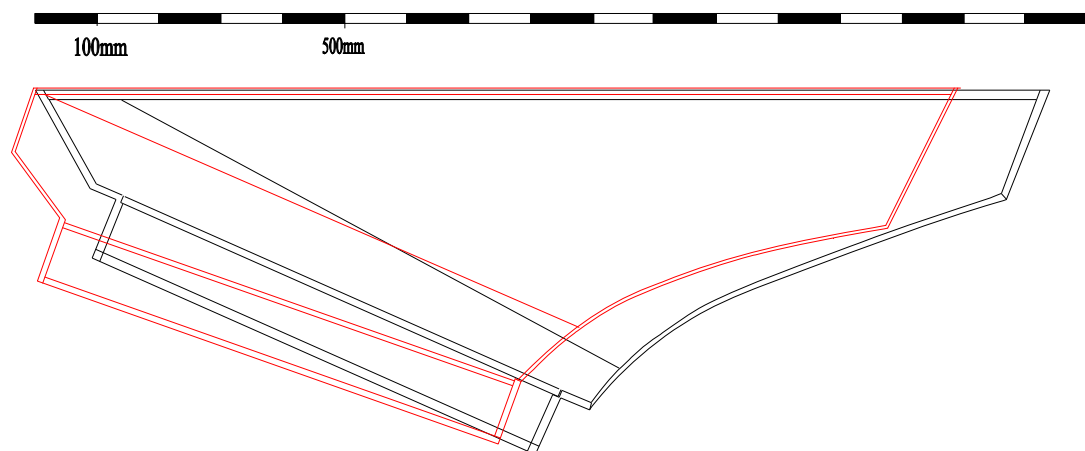

**Figure 803**

---

<sup>4</sup> A comparison of the plan form of this spinet with that of the Player spinet at the Victoria and Albert Museum, London, and a comparison with photographs of the Player spinets at the University of Witwatersrand and at Helmingham Hall, supports Martin's provisional attribution of this instrument to John Player. But a full justification for this attribution is outside the scope of this dissertation.

The shorter original keyboard (GG/BB-c''') of the anonymous instrument is placed further towards the bass end of the instrument than in the Keene, in a deeper part of the instrument.

The comparison of Figure 803 is included here since it provides a justification for the exclusion from Table 501 of the Keene spinet numbered 27 in the Table, the spinet formerly belonging to the late Dr B E Juel-Jensen shown in Plate 801 below. The plate is reproduced by kind permission of Messrs Mallams, who sold the instrument in 2004. Even though the view in Plate 801 is a perspective, it can be seen that the spinet has the plan form of the St. Cecilia's Hall anonymous spinet shown in red in Figure 803 – the bentside is joined directly to the right hand keywell cheek and the left tail meets the spine at an obtuse angle rather than at an acute angle as in authentic Keene spinets. Though it appears to have a genuine Keene nameboard, the spinet has a keyboard which is similar to that of an eighteenth century square piano.

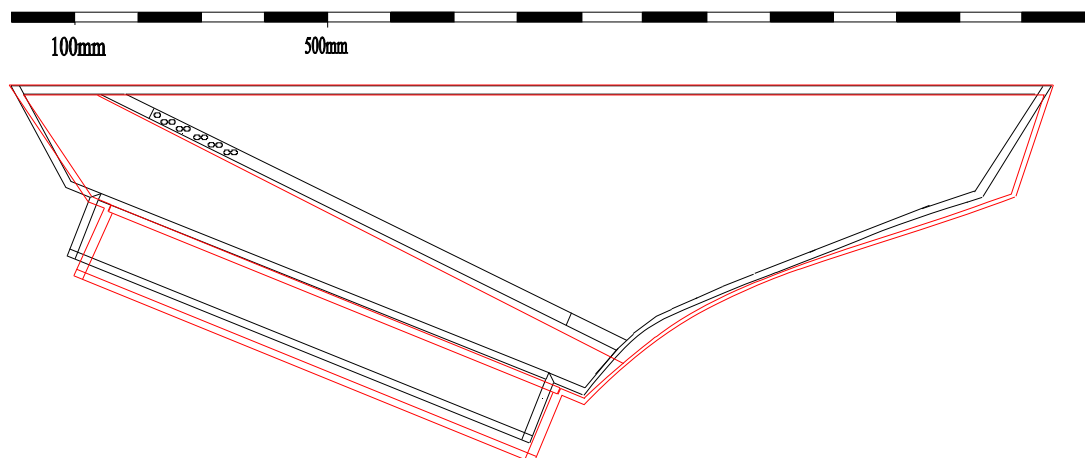

**Plate 801 – Spinet No 27 of Table 501**

The inside of the keywell cheeks are formed with an Italianate moulding similar to that of the anonymous instrument at Finchcocks which has been attributed to Cawton Aston.<sup>5</sup> It is thought that the spinet shown in Plate 801 has been assembled from a spinet by Player or by Aston using a nameboard from a derelict Keene spinet.

The plan form of the two spinets shown in Figure 804, the Keene spinet at St. Cecilia's Hall and the Benjamin Slade spinet at the Red Lodge Museum, Bristol are believed to represent the standard Queen Anne instrument made before 1710.

**Red Lodge Museum Slade in red**  
**1704 Keene in black**



**Figure 804**

The Keene spinet is dated 1704 and it is thought from documentary evidence in the file of the Slade instrument in the Red Lodge Museum that it may bear the date of 1702, which has been covered up by jack cloths during a modern restoration. It is striking how close in size and plan form these two spinets are, despite their having

<sup>5</sup> See Burnett (2004: 15) where that instrument is illustrated.

been made by different makers. That similarity is in part a consequence of the compass of spinets of this period becoming standardised at GG/BB – d''.

Very few of the spinets identified as 'transitional' in Chapters Five and Seven have survived so opportunities for comparison of their plan forms are limited. But a comparison of the plans of three of these spinets, the Benjamin Slade spinet at the Bate Collection, University of Oxford, the Keene and Brackley instrument which belongs to the author, and Thomas Hitchcock Serial No. 471 is shown below as Figure 805.

**Keene & Brackley in black**  
**Bate Collection Slade in red**  
**Hitchcock Serial No. 471 in blue**

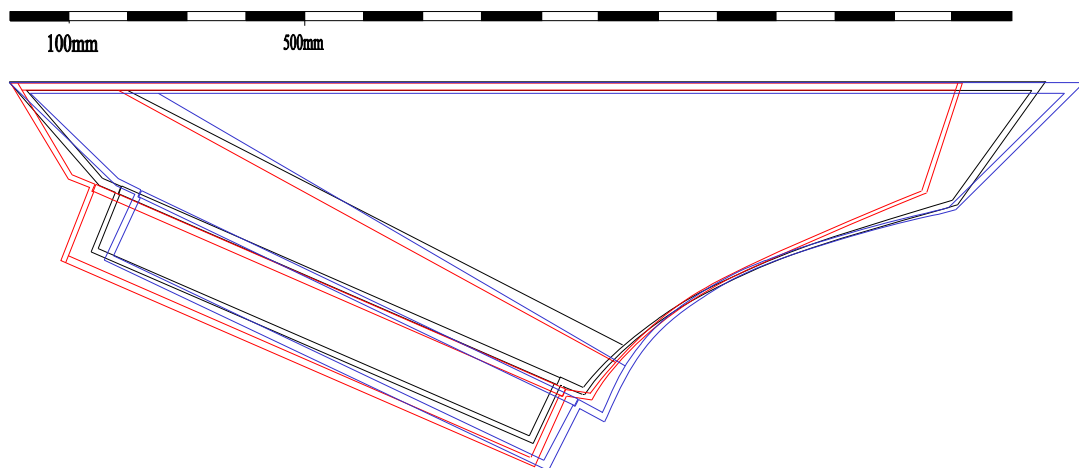

**Figure 805**

It can be seen that the Slade instrument is considerably shorter than the Keene & Brackley, despite having the same number of keys, and despite having a larger keyboard. Inevitably, such a small instrument for such a relatively wide keyboard compass will result in sub-optimal compression of the bass string lengths. The Hitchcock is longer in the spine than the Keene & Brackley and considerably longer

than the Slade. It could be expected that it will be a somewhat more powerful instrument than either,<sup>6</sup> reflecting a probable later date of about 1718 as compared with a latest date for the Keene & Brackley of 1712 and a likely date for the Slade of 1716.<sup>7</sup>

It is not possible to be precise about the year in which the five-octave spinet became 'state of the art', since it is not certain that those early five-octave instruments which have survived are the earliest of that configuration. Probably, the process was one in which more and more five-octave instruments came onto the market and the popularity of instruments with a shorter compass quickly diminished. It is likely that this will have happened in the period 1715-1720. But the five-octave instrument had become the norm by 1720. It seems that the dominance of the Hitchcocks in the market, and particularly the success of their serpentine tail instrument set the standard, since an instrument by Cawton Aston adopts a quite similar size and plan form, as can be seen from Figure 806 below.

---

<sup>6</sup> The speaking length of the GG string in the Keene & Brackley spinet is 1472mm, compared with 1373mm in the Slade instrument, resulting in a difference of 101mm or some 6-7½%. The GG string of the Hitchcock is 1478mm.

<sup>7</sup> Rose & Law (1991: 102) report a spinet having the compass GG-e''' as bearing the inscription *Benjamin Slade Londini fecit 1716*. This may be the instrument shown in Appendix Seven. It is thought that the Bate Collection Slade spinet is of similar date, though it is not the instrument referred to by Rose.

**Aston 1726 in black**

**Hitchcock Serial No. 1241 in red**

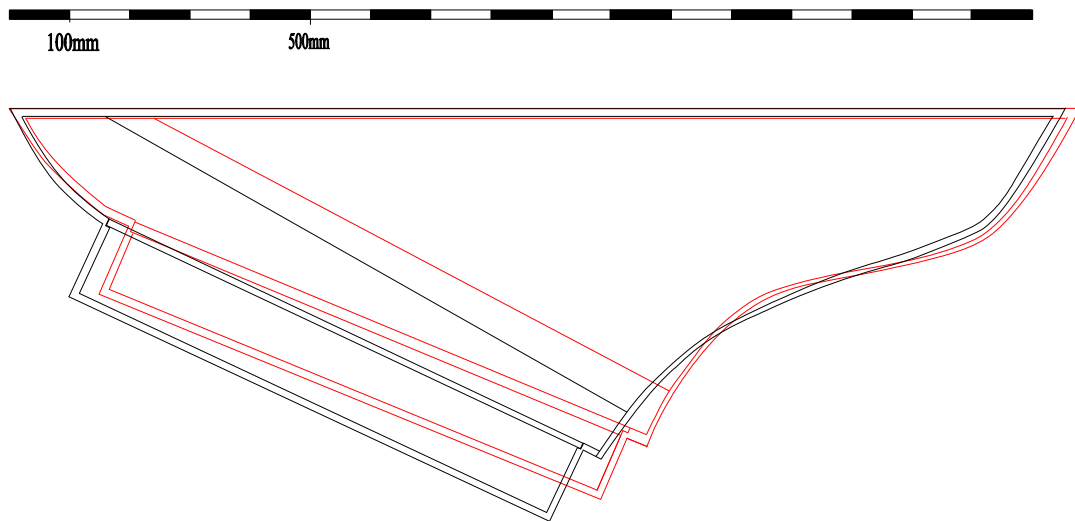

**Figure 806**

From inspection of the Long Forms in the Appendices and of Table 802 below it can be seen that there is some variation in the height of the case of English spinets.

<b>Table 802</b>	
<b>Case Height Variation</b>	
<b>Instrument</b>	<b>Height (mm)</b>
Player, Victoria & Albert Museum	162.0
Anon., Attributed to Player, St. Cecilia's Hall	166.0
Keene, Royal College of Music	171.0
Keene, Hall i' th' Wood	161.0
Sison, Lady Lever Art Gallery, Wirral	164.5
Keene 1704, St. Cecilia's Hall	165.5
Keene & Brackley, the author	176.0
Slade, Bate Collection, Oxford University	174.0
Thomas Hitchcock S/No.616	163.5
Thomas Hitchcock S/No.1241	171.0
Thomas Hitchcock S/No.1243	174.0
Thomas Hitchcock S/No.1335	172.0
John Hitchcock S/No.1676	187.0

There is a minimum practical case-height which is required to accommodate the components of the action and the tuning pins. Table 802 indicates that height to be about 165mm, a nominal 6½ to 7 inches. Although some spinets have a considerably greater case-height – notably the anonymous late 18<sup>th</sup> century instrument at Fenton House, London which has a height of 230mm including the cap moulding (Waitzman 2003: 57), and the Crang spinet in the Victoria and Albert Museum, which measures 247mm (Schott 1998: 81) – the additional height serves no structural or mechanical purpose, though it may possibly add to the resonance of the instrument. It has also been suggested to the author that it is there merely to add ‘presence’.<sup>8</sup>

The size and shape of the case of a spinet is a strong indicator of its date, the smaller cases of pentagonal<sup>9</sup> plan form, or rare forms such as those of the Royal Northern College anonymous spinet (see Appendix Four), being earlier than the larger spinets which became of settled hexagonal plan form by about 1690. Larger spinets with serpentine tails are characteristic of the Georgian period from about 1720 onwards.

### **3. The Register**

Two general forms of register were found in the spinets which have been inspected, a soundboard register, and a box-guide register. The individual jack guides found in spinets with a soundboard register are normally parallel sided without a recess for the

---

<sup>8</sup> Personal communication, Paula Woods, November 2005.

<sup>9</sup> The terms ‘pentagonal’ and ‘hexagonal’ are used here as a short-hand. Taking the York Castle Player spinet shown in black in Figure 802 as an example, and ignoring the keyboard, the body of the instrument is approximately pentagonal, accepting that one of the sides of the resultant pentagon is curved. Similarly, later spinets, which have an additional component in the case, are approximately hexagonal.

jack tongue. This allows the use of jacks of the Italian type in which the tongues are able to pivot within the relatively thick body of the jack, without the necessity for separate additional clearance apertures in the register.

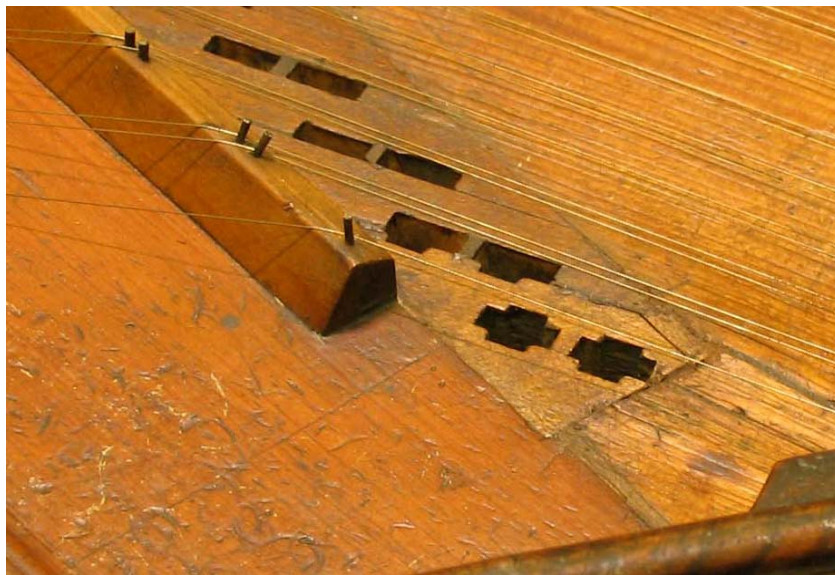

**Plate 802 - The Soundboard Register of the Keene Spinet  
at Hall i' th' Wood**

The upper element of the register of the Stephen Keene spinet at Hall i' th' Wood, Bolton, which is of this type, is shown in Plate 802. This type of register, which is found in the English virginal, derives from the practice of Ruckers and other north European virginal workshops. Its design and construction is described in detail in Martin (2003: I: 116-7). Those surviving spinets known to the author as having this form of register are the Charles Haward instruments, the two early Keene spinets described in Chapter Five, the John Player spinet at Sizergh Castle and the

anonymous spinet at the Royal Northern College of Music. Apart from those instruments, the other spinets from the period under study have box-guide registers.

Box-guide registers have been found in two forms, one in which the guide slots for the jacks are parallel-sided like those in a soundboard register and those in which they are of cruciform shape. Conveniently, both of the two forms (and two hybrids) are present in the register of the anonymous spinet attributed to Player at St. Cecilia's Hall, as shown in Plate 803 below. The cruciform jack guides are a non-original addition in this spinet, which has been modified by insertion of two additional guides during an extension to the keyboard compass.



**Plate 803 – The Register of the Anonymous Spinet,  
St. Cecilia's Hall, Edinburgh**

The type of register found, and the shape of the jack guides found in box-guide registers, appears to be an indicator of the age of a spinet. Soundboard registers are found in English spinets which follow the virginal-making tradition: these are of very early date, probably before about 1690. Box-guide registers with parallel sided jack-

guides indicate a date of in the last decade of the seventeenth century and cruciform jack guides in a box-guide register indicate a later date still, probably about 1700 and later.

#### **4. Compass**

Keyboard compass is the main factor in determining the size of a spinet since the keyboard occupies most of the interior of the instrument. Though there is some space in a spinet under the soundboard at the treble end, there is very little towards the bass, and so a short compass with a correspondingly short keyboard allows the instrument itself to be small.

The length of a keyboard is determined by a number of factors:-

1. the number of natural keys,
2. the width of the natural plates,
3. the clearance between them,
4. the width of the key blocks, and
5. the key block clearances.

Keyboard width is conventionally stated as the '3-octave span', which is the overall width of twenty-one natural key-plates and the gaps between them. The keywell span and the 3-octave span as quoted in the Long Forms in the appendices are tabulated for selected instruments in Table 803.

<b>Table 803</b>			
<b>Variation of Keywell Span with Compass</b>			
<b>Instrument</b>	<b>Naturals</b>	<b>Keywell Span</b>	<b>3-Octave Span</b>
Keene, Royal College of Music	30	736.5	468
Keene, Hall i' th' Wood	31	738	477
Anon.1708, Royal College of Music	31	745	466
Attributed to Player, St. Cecilia's Hall	30	747	476
Keene 1704	31	763	477
Sison, Lady Lever Art Gallery, Wirral	31	789	492
Keene & Brackley, the author	34	795	479
Slade, Bate Collection, Oxford University	34	848	496
Thomas Hitchcock S/No.616	36	854	472
Thomas Hitchcock S/No.1676	36	861.5	476
Thomas Hitchcock S/No.1335	36	862.5	482
John Hitchcock S/No.1241	36	872	482

It can be seen from Table 803, in which the instruments are ordered in increasing keywell span that the dominant factor in keywell span is the number of natural keys: the 3-octave span is less significant.

It would be straightforward if it could be stated that the earliest spinets had the shortest compasses, and that this compass expanded systematically as time progressed. Unfortunately, very few spinets are dated, so it is difficult to make that statement categorically. Table 804 below lists twenty-one spinets representative of the variety of compasses found, but only six of these spinets bear dates. A further problem for the analysis here is that the dating accorded in previous chapters to some spinets has relied on the compass of the instrument. There is a danger of creating a logical solecism if an analysis of compass were to rely on a date which had itself been determined in part by compass. Nevertheless, that difficulty has to be faced in a showing of the development of spinet compass over time. In Table 804 the spinets detailed have been allocated to three temporal classes - Pre-1710 Spinets,

Transitional Spinets (1711-1718), and Post-1720 Spinets. This allocation has been done so far as is possible by relying on features of construction and decoration other than compass.

<b>Table 804 - Development of Compass</b>			
	<b>Designed Compass</b>	<b>Naturals</b>	<b>Notes</b>
<b>Pre-1710 Spinets</b>			
Player, York Castle	GG/BB – c <sup>'''</sup>	30	50
Anon., Attributed to Player, St. Cecilia's Hall	GG/BB – c <sup>'''</sup>	30	52
Player, Victoria & Albert Museum	GG/BB – c <sup>'''</sup>	30	52
Keene, Royal College of Music	GG/BB – d <sup>'''</sup>	31	52
Sison, Lady Lever Art Gallery, Wirral	GG/BB – c <sup>'''</sup> , d <sup>'''</sup>	31	53
Keene, Hall i' th' Wood	GG/BB – d <sup>'''</sup>	31	54
Haward 1687	GG/BB – d <sup>'''</sup>	31	53
Haward 1689	GG/BB – d <sup>'''</sup>	31	53
Slade, Red Lodge Museum, Bristol	GG/BB – d <sup>'''</sup>	31	54
Keene 1704, St. Cecilia's Hall	GG/BB – d <sup>'''</sup>	31	54
Anon. 1708, Royal College of Music	GG/BB – d <sup>'''</sup>	31	54
<b>Transitional Spinets (1711-18)</b>			
Keene 1711	GG, AA – d <sup>'''</sup> , e <sup>'''</sup>	34	56
Keene & Brackley, the author	GG, AA – d <sup>'''</sup> , e <sup>'''</sup>	34	56
Brackley, Philadelphia	GG – e <sup>'''</sup>	34	58
Thomas Hitchcock S/No. 471	GG – e <sup>'''</sup>	34	58
<b>Post-1720 Spinets</b>			
Thomas Hitchcock S/No.616	GG – g <sup>'''</sup>	36	61
Thomas Hitchcock S/No.1241	GG – g <sup>'''</sup>	36	61
Thomas Hitchcock S/No.1243	GG – g <sup>'''</sup>	36	61
Thomas Hitchcock S/No.1335	GG – g <sup>'''</sup>	36	61
Anon. 1742, Fenton House	GG – g <sup>'''</sup>	36	61
John Hitchcock S/No.1676	GG – g <sup>'''</sup>	36	61
Longman & Broderip 1780	FF/GG – f <sup>'''</sup>	36	60

### a. Pre-1710 Spinets

Of the spinets in Table 804 grouped in this period, that is to say those dating from about 1680 to about 1710, only the instruments by Charles Haward, the Keene spinet of 1704 at St.Cecilia's Hall, and the anonymous instrument at the Royal College of Music bear dates, though since John Player died in 1707 (see Chapter Four), all Player spinets must be early than that date. But the characteristics of these dated spinets allow a judgement to be made of the likely period of the undated ones without undue reliance on compass. Dates were allocated to the two undated Keene spinets in Chapter Five. These and the Hawards have soundboard roses. They also have soundboard registers of the early design derived from that of the English virginal and/or from other North European instruments. The Hawards, the Player instruments, and the anonymous spinet at St. Cecilia's Hall all have early plan forms and the Sison instrument has the inscription on the jack rail, a virginal feature.<sup>10</sup> These features allow the spinets to be placed in an approximate order of date. This has been done in Table 804. Examination of the compass then demonstrates the development which took place during the period under consideration.

The two earliest surviving spinets pentagonal spinets by John Player, now at York Castle Museum and Sizergh Castle, originally had a fifty note compass of GG/BB - c''' with a short octave in the bass in which the apparent BB was tuned to GG. A third instrument with a short octave in the bass is the serpentine-tail Keene spinet at

---

<sup>10</sup> It is believed that the anonymous spinet at St. Cecilia's Hall also originally had its inscription on the jack rail by analogy with the very similar instrument at the University of Witwatersrand, but the original jack rail is lost. The present jack rail is of mahogany, whereas the original would have been of a veneered soft wood.

the Royal College of Music, which has a keyboard with two additional notes in the treble which are original. The compass of this spinet is therefore of fifty-two notes, GG/BB-d'''. The extension to the treble was also applied to the anonymous spinet at St. Cecilia's Hall, but after it had been manufactured. Some other seventeenth-century spinets also show the same post-manufacture upgrading, notably the John Player instrument at York Castle Museum. The two Haward instruments have a compass which is different again – they have the two additional notes in the treble, but only one of the bass sharps is split (D sharp), giving a fifty-three note compass with the apparent BB tuned to GG, C sharp tuned to AA, and BB flat becoming available through the proximal part of the split D sharp key.

Can this variation in the compass be used to assist in arriving at a chronological ordering of these spinets? It is believed that it can. The argument here relies on the probability that it was in part the small physical size of the spinet which contributed to its attractiveness and its competitiveness with the much larger rectangular virginal.<sup>11</sup> As already noted, size is closely proportional to compass. The addition of natural keys either in the treble or in the bass, or the replacement of notes available through the use of split sharps by natural keys, will inevitably increase the length of the keyboard and therefore of the keywell span unless the key blocks are commensurately reduced in width. At some point, a longer keywell will necessitate a spinet of longer spine length. It is suggested therefore that the earliest spinets are

---

<sup>11</sup> The relative size of the spinet and the virginal is evident from a visual inspection. But to emphasise the point, the smallest spinet in Table 804, that at the Victoria and Albert Museum, is reported by Schott (1998: 66) as having a maximum length of only 1302mm and the largest, the Stephen Keene instrument at the Royal College of Music has a spine measurement of 1546mm. In contrast, the Stephen Keene virginal of 1675 has a spine length of 1773mm. Martin (2003: II: 119)

those which have the smallest size and narrowest compass and that as soon as the instrument became established as a class, pressures developed to expand the compass, accepting that size would increase also, albeit marginally. On that basis it is possible to say that the York Castle Player fifty-note spinet is earlier than the fifty-two note instruments. This places it a date prior to c.1682 and probably at 1675-80.

The 1704 Stephen Keene instrument at the Russell Collection, the Slade spinet at the Red Lodge Museum, Bristol and the anonymous spinet at the Royal College of Music, London are typical of spinets from the first decade of the eighteenth century in that they exhibit a compass of fifty-four notes, GG/BB-d''' with a broken octave including two split sharps. This had become the standard compass for spinets by 1700 and is very common in spinets made after 1690 and before 1710. Boalch 1995 lists one by Cawton Aston (p.225), one by Edward Blunt (p.246), two by Benjamin Slade (p.632/3), and about ten by Stephen Keene.

The configuration of the bass octave in these early spinets reflects the underlying construction of the music which was played on them, which had become tonal by the time that the first spinets had been made.<sup>12</sup>

---

<sup>12</sup> The bass short octave is a feature which is derived from renaissance virginals and harpsichords, though in these instruments the short octave arrangement is normally based upon an apparent E, tuned to C and the notes F, F sharp, G and G sharp being tuned to F, D, G and E respectively. This configuration provides notes in the bass octave for music written in the common 'ecclesiastical' modes, whilst dispensing with notes not commonly found in such music (F sharp, G sharp) (Taylor 1991: 239).

## b. Transitional Spinets (1711-1718)

Four of the instruments in Table 804 show a compass which is transitional between the fifty-four note keyboard and the sixty-one note five-octave keyboard which was to become standard by about 1720. The first two of these are fifty-six note spinets which have an incomplete octave in both the bass and the treble. The compass can be envisaged as being GG-e''' with both GG# and d#''' missing.<sup>13</sup> One of the Keene spinets from this period is dated 1711, that at Westwood Manor, Bradford-on-Avon. As stated in Chapter Four, Stephen Keene died in 1712 so no instrument which is genuinely by him can be dated later than that year and it is likely that the Keene & Brackley instrument was made in late 1711 or in 1712. Brackley himself died in 1718, so the spinet by him now in Philadelphia cannot be later than 1718. The surviving Hitchcock instrument with the lowest serial number, Serial No. 471, can also be dated to about 1715, see Chapter Seven. This instrument is the only Hitchcock spinet with fewer than five-octaves known to have survived.<sup>14</sup>

---

<sup>13</sup> Boalch (1995: 415) refers to a second 'transitional' spinet by Keene being in the collection of Dr Andreas Beurmann, Hamburg, but inspection of the Catalogue of the Museum für Kunst und Gewerbe, Hamburg (MKG) (Beurmann 2000: 130) shows this to be an error. The 1705 spinet by Stephen Keene pictured there has a standard GG/BB - d''' broken octave compass of fifty-four notes.

<sup>14</sup> Beurman (2000: 131) reports the mitred-tail five-octave FF-f''' Thomas Hitchcock spinet now at the MKG to be dated 1715. The style of the brass furniture found on this spinet is consistent with that date (see Chapter Nine) and in particular, the lock-plate is of the same pattern as that found on Hitchcock's Serial No. 471 – a transitional instrument. But Beurmann (2000: 133, *Anmerkungen* 1) states that the keyboard configuration of the Hamburg spinet has been altered from GG-g'''. He concludes that the original GG key which bears the date 1715 has been converted to FF and that two new keys, FF# and GG have been inserted, as shown both by the different appearance of the key levers and by the absence of the original Hitchcock numbering on these keys. The subsequent keys, GG# to e''' are numbered 2-58 in Hitchcock's manner. The original g''' key, bearing the Hitchcock number 61 follows e''' as the present f''' key, Beurmann suggests. It seems likely to the present author that this alteration coincided with a three-note extension to the compass, since Beurmann (2000: 134: Plate 35.8) shows both that the final two strings in the treble of this spinet have a greater side-draught to the hitchpin rail than the other treble strings, and that the present FF string is a singleton, spaced at a greater distance from the present GG than would be expected if it were original. It seems likely therefore, that this instrument has been provided with three new jack guides, one in the bass and two in the treble and that it was originally built as a transitional fifty-eight note instrument of compass GG-e'''.

So even within the narrow time-frame of this group of 1711 to 1718 it is possible to demonstrate some compass development – from the fifty-six note compass omitting the two sharps in the extreme bass and treble, to a fully chromatic keyboard of fifty-eight notes and possibly even to a full five-octave spinet of sixty-one notes. As noted in Chapter Five, the 1714 Barton spinet may have this compass, though that is uncertain.<sup>15</sup>

### c. Post -1720 Spinets

The earliest dated five-octave spinet which can be identified positively is one by Thomas Barton. Boalch (1995: 231) lists this spinet as being loaned to the University of Edinburgh, as being dated 1719, and being of five-octave compass.<sup>16</sup>

This is confirmed by Raymond and by Martin, but the instrument was peremptorily removed and its present location is unknown.<sup>17</sup> However, the inference is that earlier five-octave spinets exist. Thomas Hitchcock Serial No. 511 is listed in Boalch (1995: 387) as being in an unidentified private collection in England and it may be that this instrument is both of five-octaves and of earlier date than 1719. However, it

---

<sup>15</sup> The Thomas Hancock harpsichord dated 1720 at St. Cecilia's Hall (Boalch 1995: 350) has a fifty-eight note compass GG-e'''. This provides further evidence that the five-octave keyboard was not fully established in English-built instruments at that date. An anonymous and undated spinet privately owned in London has a serpentine tail. Like the Barton serpentine-tail instruments referred to at pages 170-171 it is constructed with a fixed nameboard and a removable, virginal-style name batten. The author believes it is probably by Barton. But the keyboard has a compass of only GG, AA-d'', so the five-octave compass for this early Barton of 1714 is by no means a foregone conclusion.

<sup>16</sup> Beurmann (2000: 135-137) suggests that one of the five-octave Thomas Hitchcock spinets now at the MKG may date from either 1703 or from 1718. Both dates seem to be suggested because of the presence of the number 18 inscribed behind the nameboard and on the lowest key lever, which is said to bear the inscription 'J.L. 15 18'. A similar inscription which Beurmann reads differently appears on the uppermost key lever. Like the spinet discussed in footnote 14 above, this spinet has brass furniture of a style characteristic of the transitional period 1711-1718. It is therefore possible that this spinet does indeed date from 1718 (though not from 1703, a suggestion which seems to have been made on the basis that '18' is the instrument's serial number).

<sup>17</sup> Personal communications February 2008

seems unlikely that the 1709 Aston & Barton instrument is in fact a five-octave instrument, despite the statement to that effect in Boalch (1995: 225). The present location of that instrument is not known, but the date of 1709 seems very early for a five-octave spinet. It is significant in this connection that the Barton harpsichord now in St.Cecilia's Hall and also dated 1709 has a compass of only GG/BB-d''' with a broken octave in the bass: even the harpsichord had not arrived at a five-octave compass by 1709. The earliest five-octave harpsichord known to the author is the 1711 double manual Donzelague referred to in Boalch (1995: 48 & 298): another by the same maker and dated 1716 is in the Musée Lyonnais des Arts Decoratifs. It would therefore be mildly surprising if a spinet by an English maker had pre-empted this development as early as 1709.

Though there are many surviving eighteenth century five-octave spinets, not all have a compass of GG - g''', or have sixty-one notes. With the one surviving exception already referred to in the footnote above, all those of the Hitchcocks do, as do at least some instruments by Joseph Mahoon (Boalch 1995: 499) and Joseph Harris (Boalch 1995: 358) but as shown in Table 804, a Longman and Broderip spinet of 1780 has a compass of FF-f''' omitting FF sharp and is therefore of sixty notes. This appears to have been a common modification to the five-octave compass, since spinets by Baker Harris (Boalch 1995: 351-356), John Kemys (Boalch 1995: 419), Jacob Kirkman (Boalch 1995: 424), John Kirshaw (Boalch 1995: 460) and James Scouler (Boalch 1995: 612) all have this compass. A very late spinet by Andrew Rothead, an Edinburgh maker, is stated to have the harpsichord five-octave compass of FF-f''' and sixty-one notes (Boalch 1995: 543). This instrument has not been inspected.

The first of the spinets listed in Table 804 in the present group of post-1720 instruments is Thomas Hitchcock Serial No. 616. It is signed internally 'James Steffkin' and it also bears a date, though some extrapolation has to be employed to de-cipher it (see Mole 2007: 57 and Chapter Seven). The most probably reading is thought to be *May ye 17<sup>th</sup> 1723*, though the last figure is frustratingly indistinct. This is a five-octave instrument and at present, this instrument is the earliest dated five-octave spinet to have been located. It should also be said that so far as is known to the author, all spinets built after Hitchcock Serial No. 616, that is to say after 1723, are of substantially five octaves (either sixty or sixty-one notes).

It is striking that though most five-octave harpsichords have a compass of FF-f'', the five-octave spinets are commonly GG-g'''. Since it is not possible to say that the spinet has a musical repertoire which is separate from that of the harpsichord, it cannot be the case that this difference in compass is a musical requirement. It seems much more likely that it is a consequence of the separate manufacturing traditions of those workshops which made spinets and those which made harpsichords. Spinet keyboard compass began at GG with a short octave from the very early days of the instrument<sup>18</sup> and expanded to become GG-g'''. Spinet makers who occasionally made harpsichords seem to have followed their own traditions and provided keyboards which begin at GG. In addition to the 1709 single-manual harpsichord by Thomas Barton referred to above, the double-manual Thomas Hitchcock instrument at the Victoria and Albert Museum has a sixty-one note compass of GG-g''' (Schott 1998: 69), as does the Benjamin Slade harpsichord now in St. Cecilia's Hall, (Boalch

---

<sup>18</sup> This was just a continuation of the compass of the English virginal (Martin 2003: 271-273)

1995: 633). Conversely, those who were primarily harpsichord makers continued with their accustomed workshop procedures and provided keyboards having the compass FF-f''' when they made the occasional spinet. Examples of this are the spinet by Kirkman, already noted, and some spinets sold by Longman and Broderip but made by others on the firm's behalf including Culliford, who also made five-octave harpsichords of FF-f''' for Longman and Broderip (Boalch 1995: 485). The slight difference in compass between five-octave English bentside spinets and contemporary English harpsichord is therefore best understood as a consequence of a separate manufacturing tradition, rather than as a response to any musical demand.

From what has been said, it can be seen that when considering the development of keyboard compass in the spinet there are two especially interesting periods – the early period before 1690 (since a good understanding of the pressures for extension of the compass may allow the surviving instruments to be dated more reliably) and the transitional period between about 1710 and 1718. Though very few spinets survive from this second period, the pressures to develop keyboard compass which were being felt then will be applied to the harpsichord too and again, a proper understanding may allow more accurate dating of all the contemporary instruments to take place.

#### d. Compass and Published Music

Though some composers may have felt willing to compose music whose range stepped outside the compass of the average keyboard instrument, it must be close to

certain that publishers, who in the sixteenth- and seventeenth centuries stood most of the financial risk, would not be willing to include such works in their editions. To do so would have been to further limit the market for a product which was already only accessible to the more wealthy members of society. Since all the evidence suggests that keyboard music published in England in the late-seventeenth century was almost exclusively English (see Chapter Three), the published music of this period can be seen as a direct reflection of the minimum compass of the contemporary English keyboard instrument.

Before turning to that, it is appropriate to re-orientate something which was said in Chapter Three about the practice of transposition at the keyboard. The discussion there focussed on the question of pitch, but transposition practice is also relevant to the question of compass. Martin has suggested that a possible explanation for the presence of notes outside the range of printed music,  $f''$  for example in the compass of some English virginals, may be that it was common practice for players to transpose upwardly from notated music when accompanying other performers.<sup>19</sup> That is possible, though an upward transition by as much as a fourth would be quite an extreme one. It is thought therefore that other factors must be introduced if the disconformity between observed compass and published music is to be explained. The author considers it more likely that even at the period under consideration, notated music was the exception in a culture which still placed great value on improvisation, and that the presence of notes which are absent from published music

---

<sup>19</sup> Personal communication, February 2006. It is of course only when accompanying others that transposition would be necessary: solo playing would have occurred either in the notated key or *extempore*.

can be explained by reference to that practice. That no early spinets have a compass reaching f''', whereas some English virginals do, may show that improvisation practice was changing to a more restrained style, possibly one influenced by French taste.

So what does the music published in the sixteenth- and seventeenth centuries say about compass?<sup>20</sup> It can be shown that until the publication of the first part of *Musick's Handmaid* in 1663, all music printed in England could be played on a keyboard no wider than AA-a''.<sup>21</sup> *The Golden Grove* (No. 45) by William Lawes in *Musick's Handmaid* requires c''' as does an Alman by Mathew Locke (No.64). It is not until the second part of *Musick's Handmaid* was published in 1689 that a requirement for d''' arises, in *Mortlack's Ground* by John Blow. Given the popularity of *Musick's Handmaid* (Brown in Silbiger 2004: 68 & 74) it seems unlikely that any instrument would have been built after about 1690 whose treble range ended below d'''. On this basis, 1690 is likely to be the *latest* date for instruments which rise in the treble only to c''' and so the three spinets in Table 804 whose compass is GG/BB-c''' must therefore presumably be accorded an earlier date.

Inspection of the compasses of surviving English virginals shows that all instruments built after the Restoration have compasses extending at least to GG/BB in the bass and rising to d''' in the treble, and that some rise to f''' (Martin 2003: 271-273).

---

<sup>20</sup> A comprehensive analysis of the range of renaissance music and therefore of the compass required of an instrument has been carried out by Kinsela (2001).

<sup>21</sup> Strictly, such a keyboard would probably have had the disposition C-a'' with a short bass octave in which the C# would have been tuned to AA.

The last surviving English virginal which extends only to  $c'''$  is the James White instrument of 1656 belonging to the Museum of London. This wide compass in relation to printed music remains problematical. However, the adoption of too parochial approach may be misleading. The arrival of printed English keyboard music in *Parthenia* in 1612 was significantly predated by several collections printed in Venice. As early as 1523, Marc'Antonio Cavazzoni's *Recherchari motetti canzoni* had appeared in print. This was followed by an anonymous set of dances in 1551 published by Gardane<sup>22</sup> and volumes by Facoli (1588) and Radino (1592). Some of Cavazanni's *recherchari* rise to  $f'''$  in the treble (Judd in Silbiger 2004: 253-264). These latter pieces should probably be understood as reductions to notated form of contemporary *extempore* performances. It seems likely that their high reach provides an explanation for the existence in some harpsichords and polygonal virginals from the Italian renaissance of a compass rising to  $f'''$ . Venice was the major centre in Europe both for music printing and musical instrument making in the sixteenth century and the dominance of the Venetian music trade may have resulted in  $f'''$  becoming a norm for the upper note of keyboard instruments throughout Europe at least in the mid- to late-sixteenth century.

Turning to the other end of the compass, there seems to a much greater conformity between the range of printed keyboard music and keyboard compass. The use of GG is not at all unusual in the keyboard music of Restoration England. For example, Purcell's G minor suite, Z661 uses GG at the end of three of its movements, and the

---

<sup>22</sup> Although these are of restricted range.

G major suite Z662 uses it in the prelude and in the corant. Similarly the A minor suite Z663 uses AA. However, and in contrast, no FF appears in the F major suite Z 669: the cadential chords of all four movements use F. The first appearance of FF in printed music occurs in measure 84 of Rameau's *Les Cyclopes*, which is part of his *Premier Livre des Pieces de Clavecin of 1706* (Rampe 2004: xiv & 54). Thereafter FF does not re-appear until the transcriptions for harpsichord by Jean-Baptiste-Antoine Forqueray's of his father's viol suites, which did not appear until 1747.<sup>23</sup> Even then Forqueray remarked that 'some of the pieces may seem a little low [..]' (Sherman 1996: 120). Rampe (2004: xiv) notes that the earliest surviving French harpsichords with a compass extending to FF are those of Friedrich Ring (1666-1701), built in 1701<sup>24</sup> and Nicholas Dumont (c1650-1710) built in 1707. As noted earlier, the oldest five-octave French harpsichord to have survived including FF is the 1711 Donzelague. It seems therefore that sixteenth- and seventeenth-century keyboard instrument makers were accustomed to providing keyboard compasses which were wider by some margin than was strictly necessary for playing the printed music of their time. English spinet makers were no exception to that general practice.

## 5. Pitch

The question of the pitch for which a keyboard instrument was designed is one which generates considerable controversy. Some scholars believe that by making certain assumptions, it is possible to derive the probable pitch of a strung keyboard

---

<sup>23</sup> I am grateful to John Kitchen for drawing these suites to my attention (Personal communication June 2008)

<sup>24</sup> Martin, (Personal communication April 2009) believes there is some doubt whether this instrument was built in France, despite the (non-contemporary) plate which it bears stating that it was built in Strasbourg in 1700 (Boalch 1995: 542).

instrument organologically, from a consideration of its string lengths: others believe that an historical enquiry directed to a comparison with fixed pitch wind instruments is a more fruitful approach. It is fair to summarise the present state of affairs as being one in which there are strongly held but conflicting views.

It is not theoretically possible to determine the pitch originally intended for a stringed keyboard instrument by simple inspection of its string lengths. The reason for that is that the pitch or frequency of vibration of a vibrating string is proportional not only to its length but also to the tension to which it is subjected, to its diameter and to the density of the material from which it is drawn in accordance with the formula:-

$$F = \sqrt{\frac{9.81 T}{L^2 D^2 \rho \pi}}$$

where F is the frequency in Hertz, L and D are the string length and diameter respectively in metres and  $\rho$  is the density of the string material in kilograms per cubic centimetre. Strictly there are three unknowns in this equation, though it is possible to make fairly accurate estimates of the likely values of D and  $\rho$ . But that still leaves both F and T as unknowns. All that can be done is to determine the relative pitches of two or more instruments.

The tension applied to a plucked keyboard instrument string can be varied from a point just below its breaking point to a point at which either the tone produced becomes aesthetically unacceptable or the plucking action fails to repeat reliably. Within these tension- and therefore pitch limitations, substantial tonal differences can

be observed when pitch is raised or lowered. Rose<sup>25</sup> suggests that acceptable tone to the modern ear can be obtained if a string is tensioned to between 65% and 80% of its limiting tension. However, it is not known what tonal characteristics were sought in the seventeenth and eighteenth centuries, although from the presence of such devices as the *arpichordium* stop on some Flemish muselaar virginals the indications are that the *desiderata* may have been very different from those of today.

O'Brien (1990), Wraight (1997) and Martin (2003) have suggested that strung keyboard instruments were designed so that the strings were very close to their breaking points at working pitch. If that is so, and if it is accepted that in practice the length at which a string breaks is independent of its diameter,<sup>26</sup> then a comparison of string lengths on a series of instruments should yield information about their relative pitches, though not their absolute pitches. O'Brien (1990: 223-225) undertakes this comparison in very considerable detail in relation to the instruments with which he was concerned, Ruckers harpsichords and virginals. He postulates two families of instruments, each family being a tone apart in pitch and each member of a single family being separated by intervals of a fourth or a fifth. He designates a reference pitch R and characterises the two families as consisting of instruments at R-5, R, R+4, & R+8, and R-4, R+2, R+5 & R+9 respectively (O'Brien 1990: 223/4). He overcomes the theoretical difficulty referred to above by reliance on an historic measurement of the pitch (409Hz) of a tuning fork which is thought to have belonged

---

<sup>25</sup> Personal communication, February 2009.

<sup>26</sup> This counter-intuitive proposition, which is referred to by Wraight (1997: 164) has sound theoretical justification, since the increase in strength of a larger diameter wire is offset by the higher tension to which it must be drawn to reach a given pitch: in the present author's experience it holds roughly true for iron and brass wires.

to Pascal Taskin (O'Brien 1990: 62, quoting Helmholtz 1855: 495).<sup>27</sup> He then compares the scaling of the Ruckers instruments with those of Taskin, deriving a pitch (presumably the reference pitch R, though this is not specifically stated) of 419Hz for iron-strung notes and 413Hz for brass strung ones. A weakness of this analysis, which O'Brien himself acknowledges (O'Brien 1990: 225), is that no explanation is available of the relevance of these pitches to the musical culture of the sixteenth- and seventeenth centuries. Nevertheless, O'Brien's specific analysis of the Ruckers family system of pitches and scalings has generally been accepted by the majority of current authorities. The same authorities have also accepted the more general conclusion that historical stringed-instrument makers designed their instruments so that at working pitch, the treble strings, whether of iron or brass, were stressed to a point close to that at which they would break, with a reasonable margin built in for reliability. It seems likely that Keene, Hitchcock and other contemporary makers would have adhered to that design concept.

It is not appropriate in this dissertation to provide a full account of the development of musical pitch in England – a comprehensive account has in any case been provided by Haynes (2002), who cautions (2002: xli) that when considering the pitch of a piece of music,

‘four kinds of information are relevant: the city where it was played, the period in question, the genre and function of the music, and which instruments were involved’

---

<sup>27</sup> Haynes (2002: 31) criticises the use of tuning forks as a reference for pitch determination, placing such use under the heading ‘Unreliable Evidence’ on the basis that the forks are usually encountered without musical context.

So what can be said about the pitch at which music would have been played on the spinet in late-Stuart and early-Georgian London? First, that its likely use would have been secular. In that environment it would have been used both as a solo instrument, for which no precise pitch would be required, and to accompany either a vocal line or a treble instrument such as a violin, a recorder, oboe, or other wind instrument. In the instance of vocal accompaniment, music for the voice tends to lie mostly within the *tessitura* of the voice in question, but it is difficult to extrapolate any information about pitch from such considerations. But the position is more promising when considering the evidence from wind instruments.

It was said in Chapter Two that prior to the Restoration, instrumental music in England was played in the traditional consort format using traditional instruments, principally the viol, and wind instruments such as the cornett, the shawm and the sackbut. Haynes (2002: 124) believes that during this period ‘the principle instrumental pitch at court had probably been Q-1 (448) [...]’.<sup>28</sup> Shortly after the Restoration, King Charles II began to introduce French music to England, and either to introduce, or to accept the introduction by Louis XIV, of French musicians with their French instruments, into England.<sup>29</sup> These instruments, which included the flute<sup>30</sup> and the then new ‘hautbois’ were at French pitch. It seems from Haynes’s

---

<sup>28</sup> ‘Q’ is used by Haynes to denote an organ pitch, *Quire pitch*, to which he assigns the frequency  $a' \sim 473\text{Hz}$ . Q-1 refers to a pitch a semitone lower than quire pitch (Haynes 2002: 90).

<sup>29</sup> On 29<sup>th</sup> July 1676 Honoré Courtin, the French Amabassador in London wrote to King Louis XIV that ‘*Cambert accompagne les voix sur son clavessin et on y joindra les flustres: il y a ici deux françois qui en jouient parfaitement bien;*’ (Cambert accompanies the singers with his harpsichord, and with flutes as well: there are two Frenchmen here who play perfectly;) (Buttrey 1995: 200). A similar letter from Courtin referring to ‘five or six’ flautists is quoted by Buttrey at p. 205). Buttrey states that Cambert was almost certainly sent by Louis to spy on Charles II.

<sup>30</sup> The flute here was what is now called the recorder.

analysis (2002: lii & 122) that this pitch will have been *Ton de la Chambre du Roy*, which he places at a' ~ 398–408Hz. and an average of 403Hz. Haynes (2002: 94/5 & 124) dates the downward change in pitch to the mid 1670s.

Haynes (2002: 127) also notes that the pitches of forty eight English recorders (flutes) from the period 1670-1700 are known: thirty three of them range from a' ~ 395–405Hz., with an average of 402Hz. and the remainder range from a' ~ 408–418Hz. with an average of 411Hz. He attributes the first of these average pitches to *Consort-pitch*, to which he assigns the designation 'Q-3', that is to say a pitch of a minor third below quire pitch. To the second group of instruments he assigns the pitch designation 'A-1', a pitch 5 commas below the modern level of a' ~ 440Hz. Haynes then equates *Ton de la Chambre du Roy* with *Consort pitch*.

This analysis suggests that spinets made immediately after the pitch change-over period of the mid-1670s would have been made so that they could be tuned to a range of pitches which would have included *Consort pitch* at a' ~ 403Hz so that they could accompany the new French-inspired wind instruments when needed.

The orchestra of the Queen's Theatre in Haymarket was still at a' ~ 403Hz in January 1712, as shown by an order for two bassoons from the French maker Rippert (Haynes 2002: 175). An analysis of the pitch and key relationship of the *andante* from the *Chandos Anthem* - an oboe solo - show that a' ~ 403Hz was still prevalent when Handel was working at the Duke of Chandos' country seat, Cannons, from 1717-1720 ( Haynes 2002: 176). Thereafter pitch began to rise.-

Haynes (2002: 176 & Graphs 15c & 15d) suggests, using the evidence from historic recorders already referred to, that ‘at some point between 1700 and 1730’, the use of a higher pitch than  $a' \sim 403\text{Hz}$ . began to be more common, reaching A-1, an average of  $a' \sim 413$  by the early 1720s and  $a' \sim 423\text{Hz}$ ., which Haynes terms ‘new consort pitch’, by 1746.<sup>31</sup> It is not entirely clear from Haynes analysis, which suffers from the difficulty of dating woodwind instruments, whether this is to be understood as suggesting that as new wind instruments were made, they were made to progressively higher pitches or whether a tipping-point was reached at which the majority of woodwinds were found to be at ‘new consort pitch’ probably at some time after 1730 and that as a consequence, the use of this pitch became more and more common.<sup>32</sup> The second model seems the more likely, but in either case it seems likely that spinets built at in the period 1725-1740 were designed so that they could be tuned to the higher pitch which was in general use as well as to the earlier lower pitches, albeit with some sacrifice in tonal quality at those levels.

In summary therefore, the author considers that the earliest spinets to have survived, those built in the 1680s, are likely to have been designed to allow some flexibility in tuning to allow them to comply with the pitch standards which were in use at the time. It is clear that no matter what the design intentions, spinet owners were free to adopt a pitch which was convenient for them and were free to re-string their spinets as they pleased. Makers may have chosen certain scalings because they could

---

<sup>31</sup> 423Hz is the pitch of the tuning fork claimed to have been left by Handel at the Foundling Hospital in Dublin after a performance of *Messiah* in 1751. This claim is clearly a contextual reference to evidence from tuning forks. See also Haynes (2002: 289-291)

<sup>32</sup> The alternative, that wind players were expected to raise the pitch at which they played by as much as a semitone seems an unlikely interpretation of Haynes.

accommodate various practical contingencies, which may have resulted in instruments straying, to a greater or lesser degree, from the presumed principles of scaling design. Indeed it is clear from the tables in the next part of this chapter that the string lengths of spinets became shorter as time progressed. For example, though the two early Keene spinets discussed in Chapter Five have c'' string lengths close to 12 inches,<sup>33</sup> later instruments from the Queen Anne and early-Georgian periods generally show shorter scaling, typically about 10 inches at c''. The adoption of shorter scaling was probably a reaction to the rising level of *Consort pitch*. It would have allowed the use of brass stringing throughout the compass in a spinet, or at least a move of the crossover point from brass to iron at a higher point in the compass.

From the design point of view, the instrument would have fulfilled its purpose if it were able to play at the pitch required by the customer.

## 6. Stringing

### a. The String-Band and Case Size

As indicated in the opening part of this chapter, the design of the string-band in a spinet must accommodate several conflicting requirements – the strings must fit into the case of the instrument, and must fit with the geometry of the layout to allow each string to be plucked. For a given size of case, the shorter the bass strings and the

---

<sup>33</sup> Rose has recently re-strung the serpentine-tail Keene spinet at the Royal College of Music. He reports that it cannot be strung in brass at a' ~ 415 owing to string tensions in the top four notes exceeding their working limits (Personal communication, February, 2009). The author suggests that this instrument should probably be strung in iron in the treble and pitched at about 403Hz.

fewer notes in the compass, the more easily this can be achieved. In attempting an analysis of the design process, it is difficult to be certain whether early makers set out with the idea of building a spinet of a specific compass and case length, and then adapted the string-band to the designed case, or whether they designed the string-band first and made a case to fit round it. But the resultant tone of the instrument must have been an important factor. Since a shorter string vibrates as if it were stiffer than a longer one, unduly short strings in relation to the intended pitch will produce an unacceptable tone, especially in the bass. Quite where the tone deteriorated to the point where it was thought, in the period under study, to be unacceptable is indeterminate, but Barnes (1985: 40) notes that in the Keene & Brackley spinet, the length of the GG string, the longest in that instrument, is only 52% of the theoretical Pythagorean value based on the length of the string at c''. He describes the sound at GG as 'passable'. That judgement of course adopts a modern aesthetic.

A further consideration affecting the design of the string-band is the position and design of the bridge. If the bridge is to be effective in transmitting the vibrations of the strings to the soundboard, there must be a sufficient area of freely suspended soundboard around it. This factor also limits the lengths of the strings both in the treble and in the bass and adds to the restrictions imposed by the case-size.

A third general consideration which is common to all stringed instruments is that the materials chosen for the strings must be sufficiently strong to withstand the tensions placed upon them. In the spinet, this consideration is most pertinent in the treble,

since it is here that the strings are close to their limiting working tensions. To sound at a particular pitch, a longer string will need to be under a higher tension than a shorter one and so will be more likely to break. This consideration affects the choice of brass or iron strings in the treble region of the compass.

Table 805 below lists, in string length order, the length of the longest bass strings (L max) of ten representative spinets including three from Keene and four from Hitchcock. As has been seen, demands for a larger compass resulted in a longer case which gave the opportunity for longer bass strings. This is apparent in Table 805.

<b>Table 805</b>		
<b>Length of Longest Bass Strings</b>		
<b>Spinet</b>	<b>Compass</b>	<b>L max</b>
Anon., Attributed to Player, St. Cecilia's Hall	GG/BB-c'''	1308.0
Keene, Hall i' th' Wood	GG/BB-d'''	1325.0
Sison, Lady Lever Art Gallery, Wirral	GG/BB-c''', d'''	1348.0
Keene, Royal College of Music	GG/BB-c'''	1361.0
Slade, Bate Collection, Oxford University	GG,AA-d''', e'''	1373.0
Keene 1704, St. Cecilia's Hall	GG/BB- d'''	1412.0
Hitchcock S/No.616	GG-g'''	1455.0
Hitchcock S/No.1241	GG-g'''	1510.0
Hitchcock S/No.1335	GG-g'''	1500.5
Hitchcock S/No.1676	GG-g'''	1494.0

The string lengths tabulated are considerably shorter than the length of the longer 8ft GG string in the c. 1725 harpsichord by Thomas Hitchcock at the Victoria & Albert Museum, London, which measures of 1731mm (Yorke 2002, 70). On the assumption that the intended pitches of the Hitchcock spinets on the one hand and the harpsichord on the other are close, the implication of these relatively short strings for the tone of the bass notes in a spinet are self-evident.

## b. Scaling and Design Note

The design considerations outlined above result in the maker choosing a ‘scaling’ – that is a string-length for a particular note in the compass – which he considers will best accommodate the conflicting design requirements. He then designs the string-band based on that choice, accepting some deviation from the theoretical Pythagorean relationship of a doubling of string length from one octave to the octave below.

It is quite common for museum catalogues to assume that  $c''$  is the design note of keyboard instruments and to report only the length of the  $c''$  string as an indication of the scaling chosen. Koster (1994: xiv) identifies two cultural traditions of scaling, the Italian one, in which the string length at  $c''$  was about 270-320 mm and the Flemish one in which the same note had a string length of about 360mm. Using that analysis the English spinet belongs firmly to the Italian tradition, with lengths at  $c''$  typically of 250mm. Though some instruments have longer scalings, none approach a value of 360mm. There is some justification for the adoption of a general standard of scaling comparison using  $c''$ , but other notes were also used as the design note:-

Martin (2003: I: 48) investigates the likely design note of twenty-one English virginals. His methodology involves making the assumption that early makers would have been unlikely to have used a multiple of any measurement less than one quarter of an inch to produce their scaling lengths. That assumption is thought to be correct

and to hold for the spinet makers too.<sup>34</sup> He then inspects a table of string lengths, concentrating on the treble end of the compass, determining the design note as that note which has a length close to an integral number of quarter inches. He finds that 'c3 (c'') is used for the scaling-design note, unless the compass extends to f3 (f''), in which case that note is used.' (Martin 2003: I: 50) and concludes that only the 1679 Charles Rewallin instrument can be said to have c'' as the design note. However, in spinets, which have a generally shorter scaling than English virginals, if deviations from the expected Pythagorean relationship of string lengths subsist, then measurement inaccuracies and the effect of distortions and repairs seem to mask them and it does not appear to be possible to determine the design note when Martin's methodology is used. Because of the absence of a satisfactory methodology, it is assumed here that c'' is the design note.

The choice of design note is relevant to the *process* of designing a string-band, but is much less relevant to the design of the resultant string-band, which is heavily influenced by the absolute value of the scaling chosen at the design note. But a meaningful comparison of string-band design can only be made by considering the scaling at a single note. Table 806, below shows the scaling at c'' of those English spinets for which it has been possible to record a meaningful observation during this research.<sup>35</sup> The scalings are shown in ascending order. The table seems to indicate that the two early Keene instruments, the one at the Royal College of Music and that at Hall i' th' Wood, with scalings of 288.0mm and 304.0mm respectively, may have

---

<sup>34</sup> The workshops of Haward, Keene, Player and Slade probably constructed both virginals and spinets simultaneously for a time.

<sup>35</sup> Some spinets have been so altered or damaged that this was not always possible.

been designed using a scaling of close to twelve inches (304.8mm) at c<sup>''</sup>. All of the other instruments could be said to have a scaling of between ten inches (254.0mm) and eleven inches (279.4mm) at c<sup>''</sup> except for the Hitchcock Serial No. 1335, which has a c<sup>''</sup> scaling of thirteen inches (330.0mm).

<b>Instrument</b>	<b>c<sup>''</sup> length (mm)</b>
Player, York Castle	249.5
Player, Sizergh Castle	251.0
Keene, 1707	255.0
Keene, 1711	257.0
Anonymous, St. Cecilia's Hall	259.0
Keene & Blunt	259.0
Keene, 1704	260.5
Keene & Brackley	261.0
Sison, Lady Lever Art Gallery	262.0
Hitchcock, Serial No. 471	267.0
Keene, 1700, Colonial Williamsburg	270.0
Hitchcock, Serial No. 1676	270.5
Slade, Bate Collection	273.0
Hitchcock, Serial No. 1241	275.0
Hitchcock, Serial No. 616	276.0
Hitchcock, Serial No. 1243	282.0
Keene, Royal College of Music	288.0
Aston 1726	291.0
Keene, Hall i' th' Wood	304.0
Hitchcock, Serial No. 1335	329.0

Considering the relationship of scaling to designed pitch, the instrument which seems to stand out in Table 806 is Hitchcock Serial No 1335, highlighted in yellow, with its long scaling of 329mm. This is a relatively late instrument (c.1732), by which time, as explained in the previous part of this chapter, pitch would have risen, perhaps to as

<sup>36</sup> There is no implication in this table that the stringing materials used are the same.

much as 423Hz. The two Keene instruments highlighted in pink also have long scaling, though not as long as the Hitchcock, but since they are earlier instruments, a lower pitch close to 403Hz. will have been intended. At the other end of the scale, the two very early Player spinets highlighted in green have short scaling. These two spinets would also have been designed for a pitch close to 403Hz. (*Consort pitch* at their probable date of 1675-80). There then follows a virtual continuum of spinets with scalings gradually increasing in length until Hitchcock Serial No. 1243 is reached with c'' at 282mm. The Aston spinet, which is at Colonial Williamsburg, Virginia, is not strung at present but its long scaling of 291mm at c'' might dictate the need for need iron wire in the treble at a pitch close to 423Hz.. The question of stringing material is discussed below.

### c. Stringing Material

With the exception of one spinet, the Hitchcock spinet Serial No. 471, which had the remnants of coils of wire on some tuning pins, none of the spinets inspected retained their original stringing. Even in the case of the Hitchcock, it can not be said with any force that the vestigial coils are from the original strings. Some spinets, including the Hitchcock just referred to but also the Keene spinet of 1704 at St. Cecilia's Hall, and the Keene of 1711 at Westwood Manor, Bradford on Avon have gauge numbers written on the nut which are just legible, but there is no guarantee that these numbers are those of the maker and for that reason they have not been given close attention. Rose (1991) reports details of three spinets which are either said to have some remnants of original stringing, or have gauge numbers written on the nut: - a Benjamin Slade spinet dated 1716 (Rose 1991: 102), a spinet by John Ladyman from

the second quarter of the eighteenth century (Rose 1991: 103), and a spinet by John Kemys from the third quarter of the eighteenth century (Rose 1991: 104). In addition a spinet in private ownership in London and probably dating from about 1730 has survived with what is said to be its original stringing, which is brass from GG to B and iron thereafter,<sup>37</sup> (Rose 1991: 15).

It is difficult to extrapolate the original stringing materials from experience with their modern equivalents. However, modern 'Rose' wire and wire from other modern makers is produced to be an acceptable equivalent of the wire which was available to historic makers. It is of course more consistent in quality both in its metallurgy and in the uniformity of its cross-section than historic music wire would have been, and it is therefore probably stronger than the original material. That said, a rule of thumb derived from current experience<sup>38</sup> is that spinets with a scaling at  $c''$  of more than about 290mm would need to have been strung in iron in the treble if pitched between  $a'' \sim 403$  and 423 Hz. if reliability were not to be compromised by frequent breakages. Spinets with shorter scaling than this were probably strung in brass throughout. Consequently it is thought that the spinets of Table 806 with a scaling less than that of the Keene at the Royal College of Music were probably designed to be strung in brass throughout. Any problems with reliability in particular instruments in this group could have been solved by replacing those brass strings which had a tendency to break with iron. Martin (2003: 69/70 & 231/232) concluded that early

---

<sup>37</sup> This spinet has a nameboard bearing the inscription 'Will Strolger', which Rose describes as 'doubtful'. The name Strolger is not known as a spinet maker and it may be the owner's, rather than the maker's name.

<sup>38</sup> Experience with the Keene & Brackley spinet is that strings break mostly in the tenor; it is thought that this is due to the very pronounced turn over the bridge pins caused by the back-pinning on that instrument.

spinets by Keene were either strung in iron in the treble, or that they were strung in brass and tuned to a much lower pitch than a'~415Hz. His judgement is that they were strung in iron at a pitch of about 450Hz. Table 806 provides further evidence in support of those conclusions.

#### d. Plucking Point

Table 708 and the associated plot of Figure 707 in Chapter Seven provided an analysis of some observed differences in the plucking points of four Hitchcock spinets. Table 807 presents a similar comparison, but with different instruments to provide context. The plucking points are expressed as percentages of string length.

	<b>Leversidge Virginal (1670)<sup>39</sup></b>	<b>Hitchcock S/No. 1241</b>	<b>Hitchcock S/No. 1335</b>	<b>Anon. St. Cecilia's Hall</b>	<b>Keene Hall i' th' Wood</b>	<b>Keene 1707</b>
<b>GG</b>	11.8	11.7	12.5	8.3	10.9	9.9
<b>C</b>	11.4	14.5	14.5	8.0	11.6	10.7
<b>F</b>	12.8	15.2	15.4	8.6	12.6	13.7
<b>c</b>	13.3	17.0	17.0	9.7	11.7	14.6
<b>f</b>	16.4	19.4	19.0	11.3	13.7	16.9
<b>c'</b>	18.3	23.9	24.0	14.3	14.1	21.9
<b>f'</b>	23.3	32.0	27.1	18.0	18.8	27.5
<b>c''</b>	26.6	37.1	32.2	26.8	20.1	33.3
<b>f''</b>	33.7	42.1	37.3	28.4	23.4	38.5
<b>c'''</b>	31.4	44.3 <sup>40</sup>	43.7	38.5	30.4	42.6

<sup>39</sup> This instrument has been chosen because a recording of it being played by Martin Souter (CCL CD832) is available from the Ashmolean Museum, Oxford and it is therefore possible to make a judgement of its tone.

<sup>40</sup> What is being evaluated here is the degree to which the plucking point departs from a central position, so to make the graph more comprehensible, the point plotted for TH1241 at c''' is the complement of the calculated value.

The instruments are the Leversidge English virginal of 1670, two Hitchcock spinets, one of which, Serial No. 1241, was included in Table 708 and Figure 707, the anonymous spinet attributed to Player at St. Cecilia's Hall, and two of the Keene spinets described in Chapter Five. Except for the virginal, for which the observations are those of Martin (2003: II: 154), the plucking points were calculated from the observations in the Long Forms in the Appendices. The six instruments are compared in Figure 807 which is a graph of the plucking points, expressed as a percentage of the overall string lengths, plotted against the notes sounded. It can be seen that the anonymous spinet at St. Cecilia's Hall, the virginal of 1670, and the Keene Spinet at Hall i' th' Wood are designed so that the plucking point is much closer to the nut than in the two Hitchcock spinets and the Keene spinet of 1707.

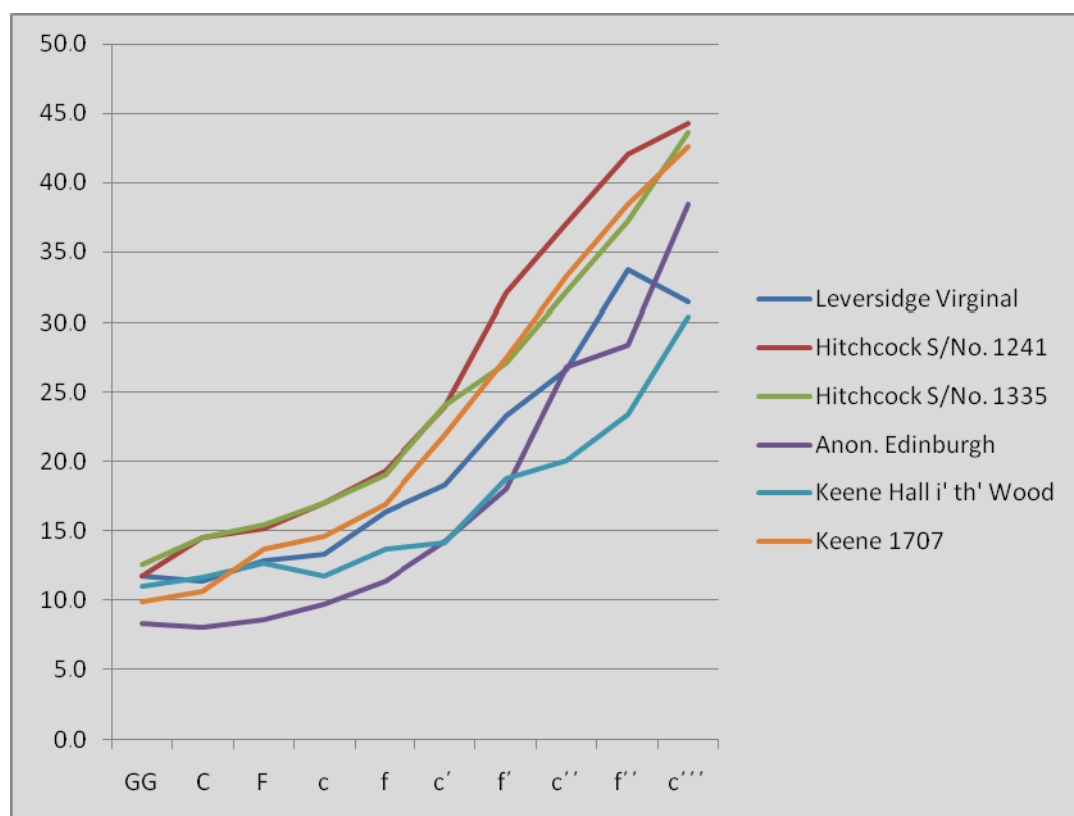

**Figure 807**

**Plucking Point Comparisons at the notes C and F**

Campbell, Greated & Myers (2004: 33ff) discuss the timbre of musical sounds, pointing to the relative amplitudes of the harmonics present and the degree to which the structure of the instruments allow these harmonics to resonate as being major factors which determine timbre. It seems that this subject is as yet imperfectly understood (Campbell *et al.* 2004: 37), but it also seems highly likely that the flutier timbre of the Hitchcock and later Keene spinets, particularly in the treble, is a consequence of the strings being plucked more substantially centrally, exciting greater proportions of the fundamental than in the earlier instruments which have plucking points with a greater element of offset from the central position. The anonymous spinet from St. Cecilia's Hall is particularly extreme in this respect and its tone is markedly nasal. The discussion in Chapter Seven points to instances where the Hitchcocks seem deliberately to have produced versions of their spinets with two different timbres.

## **7. Summary**

In this chapter representative spinets from the schools of Keene and Hitchcock were compared and contrasted both with each other and with spinets of other makers. This comparison set in context the lines of development and the settled characteristics established in earlier chapters for the spinets from these schools.

The chapter began by comparing the size and plan form of selected spinets from three temporal periods. It is thought that a comparison of plan form provides a more informative comparison of the overall design than a mere comparison of spine length. It is shown that early spinets by Keene, like those of Player, were made to

differing plan forms but that their sizes were generally comparable. In the first decade of the eighteenth century the size and plan form became remarkably standardised. The Keene 1704 spinet and the Benjamin Slade spinet at the Red Lodge Museum, Bristol are typical of what was termed the 'standard' Queen Anne spinet. Later instruments, dating from 1711 to 1718 such as the Thomas Hitchcock spinet Serial No. 471 and the 1711 Keene at Westwood Manor show essentially the same plan form as the 'standard' instruments but are larger, the Hitchcock considerably so. A standardisation similar to that of the Queen Anne spinets can be seen in the five-octave serpentine-tail spinets of the Hitchcocks and of Aston from the post-1720 period. Though case height variations have been observed, it is not thought that these assist organological classification of the spinet.

The two different designs of register which have been found in the spinets inspected were characterised. Attention was drawn to the different designs of individual jack-guides, the guides with parallel sides being thought to derive from virginal-making practice and the cruciform guides being from a later practice.

The classification of spinets into three temporal periods is reinforced by an analysis of changes in keyboard compass. Early spinets typically have a keyboard compass of fifty, fifty-two or fifty-three notes, though the precise disposition varies from instrument to instrument. The standard spinets made between about 1690 and 1710 have fifty-four notes with a compass GG/BB-d''' with two split sharps in the bass octave. Later instruments built after 1710 have a wider compass approaching, though not reaching five octaves. The two surviving Keene instruments have

keyboards in which the two extreme sharps, GG sharp and d''' sharps are missing. The five-octave spinet was established by 1720. Except for Serial No 471, and one of the instruments at the Museum für Kunst und Gewerbe, Hamburg, all Hitchcock spinets have five-octave compasses so far as is known and a configuration of sixty-one notes, GG-g'''. Some spinets from other makers have only sixty notes, omitting a sharp in the bass.

The pitch and the design of the string-band in a keyboard instrument are related. The conflicting views of scholars about the pitch at which spinets were intended to be tuned were resolved by referring to cultural changes at the Restoration and to evidence from surviving contemporary recorders which point to a pitch of a''~403Hz. for the early spinets, with a tendency for this pitch to rise towards 423Hz. by 1740. The string lengths found in spinets is consistent with this pitch even, in most cases, if the instrument is strung in brass throughout the compass. It is in only in the very early Keene spinets, and in the long-scaled Hitchcock and Aston instruments that it would have been necessary to resort to iron stringing at this pitch.

It has been shown that like the virginal, and unlike the harpsichord, the geometry of the spinet allows timbre to be varied by variations in the plucking point of the strings. A graph of sounding note against the percentage plucking point of the strings shows the resemblance of the timbre of the early spinets to the 1670 Leversidge virginal. The flutier timbre of two Hitchcock spinets and the 1707 Keene can also be recognised from the graph provided.

## Chapter Nine - Decoration

### 1. Introduction

This Chapter reviews the decorative characteristics of typical spinets from the period under study, focusing on the spinets from the Keene and Hitchcock schools, but including spinets from other makers. The purpose of the chapter, like that of Chapter Eight is to provide context, as a means to understanding the decorative treatment which was adopted. The chapter begins with a consideration of the availability of the raw materials which were used in the manufacture of spinets up to about 1740 – that is to say walnut, ebony, brass and ivory, and with the decorative style of components of the spinet which were manufactured separately and sourced by spinet makers from specialist craftsmen. Those components are principally the marquetry cartouches and similar veneer items, brass furniture and the stands for spinets. It then considers the decorative treatment of spinet keyboards, dividing the discussion into two parts – the keyboards of late-Stuart spinets and those of early-Georgian ones.

### 2. Raw Materials

The raw materials used in the construction of the English spinet represented a departure from previous practice in the construction of keyboard instruments. Oak had been the traditional timber for furniture making in England during the Tudor and Jacobean periods, the better quality pieces being of imported Continental oak (Bowett 2002: 310) and keyboard instruments had followed that tradition by using a combination of oak and of softwood which is referred to here generically as ‘deal’.

Apart from the 1641 Gabriel Townsend instrument and the 1679 Charles Rewallin instruments, all of the surviving English virginals are made from oak (see generally Martin 2003), as is the Lodewijk Theewes clavierorganum at the Victoria and Albert Museum (Wilk & Yorke 2002: 40) and the Hasard harpsichord at Knole Park (Boalch 1995: 364). In contrast, except in one example, that of the John Player spinet at the Victoria and Albert Museum, early English spinets were made in walnut and later ones in mahogany.

#### a. Walnut

Walnut is a timber which is typical of French furniture of the mid-seventeenth century and it remained the timber of choice for sophisticated furniture until about 1735, with a gradual change to mahogany thereafter. The walnut wood most highly prized in England was that imported from France (Bowett 2002: 312). Some walnut trees (*Juglans regia*) were grown in the south of England, though the prime purpose of that was for the nut. But the disastrously severe winter of 1709 in Europe killed many of the walnut trees and caused importers to look for other sources of supply, and in particular to Virginia where a darker "black" walnut wood (*Juglans nigra*) was to be found.<sup>1</sup>

A second factor in the choice of walnut rather than oak for spinet making was pragmatic: - oak was the timber of prime choice for ship building and for the construction of houses and even before the Restoration it had been in short supply.

---

<sup>1</sup> Though it is not clear that any English spinets were built from this material

In 1662 John Evelyn, the diarist, had read a paper<sup>2</sup> at the newly inaugurated Royal Society reporting the conclusions of his enquiry into the supply of timber and on the re-planting and management of forests in England. This enquiry had been instigated by the Board of the Royal Navy, which had expressed concern following the over-felling and neglect of forests during the Civil War (de la Bédoyère 1995: 136). The use of walnut rather than oak for the case of spinets discussed here, and its later replacement with mahogany as this became increasingly available, may therefore be seen as a change in part made for stylistic reasons, but also as one driven by anxieties about the supply of oak as a raw material.

## b. Ebony

The term 'ebony' has been used in the furniture and musical instrument making trades in a loose way without being species-specific (Zadro 1975: 250). The true ebonies are one of the species of *Diospyrus* – either *Diospyrus ebenus* from what is now Sri Lanka, *Diospyrus melanoylon* and *Diospyrus tomentosa*, both from India, and *Diospyrus crassiflora* from West Africa. These woods are believed to have been introduced into Southern Europe in the first half of the sixteenth century. By the mid-1600s, the British East India Company had established more than twenty 'factories' (trading posts) in India including several in the Bay of Bengal, which would have placed them in a good position to secure *Diospyrus* species. The Dutch East India Company, though principally trading with the 'spice islands' (modern Indonesia), were similarly well-placed (Stein 1998: 203-206).

---

<sup>2</sup> This was subsequently published in 1664 as *Sylva*, Evelyn's most influential book.

These eastern ebonies were very expensive and cheaper substitutes, nevertheless still referred to as 'ebony', were frequently used. Pear wood (*Pyrus communis*) was one possible substitute and cocus wood (*Byra ebenus*) another (Bowett 2002: 308). Both could be dyed to produce (or to increase) the depth of the black colour, possibly using printers' ink (Zadro 1975: 249). Bowett suggests (2002: 307) that much of what is now taken to be ebony in seventeenth century furniture is in fact cocus:-

'Cocus wood was exported from Jamaica in large quantities from 1660 onwards and was widely used by English cabinet makers both as a veneer and in the solid. It was most typically used for oyster veneering, and is characteristic of early cabinets made between 1660 and 1675.'

No microscopic investigation has been carried out on any of the instruments inspected during this research project and it is therefore not known whether what appears to be ebony in the keyboards of spinets is the true *Diospyrus* ebony or whether it is a cheaper substitute. However, the observation that in some Keene spinets the ebony natural key plates are joined in the middle to avoid waste suggests that the cost of timber was a significant factor, and therefore that it is the true ebony which was being used.

### c. Brass

A further major departure from earlier practice in the use of raw materials is the adoption of brass, both for the elaborate hinges used on the spinets of the period, and for the string band (at least in part). English virginals invariably had iron hinges and it is thought that they were intended to be strung using iron wire (see generally Martin 2003). Gentle (1975) reviews the early history of brass-making in England. It proved problematical from the technical standpoint. Despite the identification of

brass and bronze as being strategically important to England in Tudor times, it was not until the turn of the seventeenth century that good quality brass alloy was being made (in Bristol). Prior to that, though English brass was available, it was not of good quality, and many metalworkers rejected it in favour of brass imported from Sweden (Gentle 1975: 32). The alloy was converted into artefacts such as hinges in small smelting works centred on the Port of London where the alloy was off-loaded. Gentle (1975:34) suggests that most metal workers were recent immigrants from Germany and the Low Countries, and Huguenots, many of whom had been button and buckle-makers in their home countries. They would have been well used to making small items of intricate design, possibly supplementing their stocks of imported brass by 'shruff', a brass alloy which had been produced by smelting scrap articles. By 1720, good quality brass was in plentiful supply, but that is too late a date to account for the production of hinges for late-Stuart spinets.

The main driving force for the production of wire was the wool trade. Until 1748, fleeces were 'carded' (brushed to align the fibres) by hand using wooden brushes having wire teeth. In the middle ages, iron wire was used for the teeth, but the rust-resistance of brass obviously had advantages and attempts were made to produce suitable wire in England. But for the reasons related above this did not succeed and it was not until about 1720 that brass wire of a satisfactory quality was being made domestically, first in Esher, Surrey and almost simultaneously in Cheadle near Manchester (Gentle 1975: 35 & 39). It seems therefore that early spinets strung in brass wire must have used imported material, at least at the date of manufacture,

though early-Georgian music masters would have had access to a supply of suitable domestic material after about 1720.

#### d. Ivory

The use of ivory rather than hardwood for the sharp blocks of late-Stuart spinets and its subsequent adoption in the early-Georgian period for natural key-plates for almost all keyboard instruments is due not to perceived shortages of ebony, but on the contrary to a good supply of ivory arriving from West Africa as a result of the trading activities of the Dutch and English East India Companies and of the Royal African Company. It has been estimated that a minimum of five million pounds weight of ivory left West African ports for Europe between 1699 and 1725 (Feinberg & Johnson 1982: 451).<sup>3</sup> Ivory was seen as a luxury material and its use will have added to the desirability of the spinet. But it is clear that its cost was a considerable factor in the price of an instrument, since many of the sharp blocks from the Keene spinets described in Chapter Five and Appendix Five have been found to include shims of timber intended to reduce the amount of ivory used.<sup>4</sup>

---

<sup>3</sup> It has been suggested that walrus ivory was used for the sharp blocks of spinets (Personal communication, Andrew Garrett, April 2007). This may be true, though the author has seen no evidence in support of that, and since whaling and related activities were carried out from the northern ports of Britain, it is thought that it is much more likely that the ivory used by London spinet makers will have been the material shipped directly to the Port of London.

<sup>4</sup> The Benjamin Slade spinet at the Red Lodge Museum, Bristol also exhibits this feature.

### 3. Veneers and Marquetry Cartouches

With very few exceptions the spinets which have been inspected during this research project were of walnut, which was left plain externally and polished to a gloss finish. No spinet from the period under study has been found with any original external embellishment of the case, though one instrument, the Player instrument illustrated in Appendix Three, has a chinoiserie-painted case which is thought to have been applied well after the date of manufacture.<sup>5</sup> However, the use of ornamental brassware and of highly-ornamental nameboards including marquetry cartouches is ubiquitous. Internally, without exception the cases were veneered. That was necessary to provide a uniform internal appearance, since the spine was invariably of deal. Furthermore, Barnes (1985: 30) suggests that some makers warmed the soundboard liners of their instruments by burning shavings inside the case, which he reports as being shown by soot marks on some spinets. These would need a veneer covering. On the late-Stuart spinets the common practice was to veneer the interior faces of the case so as to replicate the appearance of the nameboard. This can be seen in Plate 901, in which the elaborate oyster veneer of the Stephen Keene spinet at the Royal College of Music, London is carried round the insides of the case.

Inspection of the construction of the spine of Hitchcock spinet Serial No. 471 showed that the veneer is joined about half way along the spine. In places on this spinet the spine capping is missing and it was possible to see that the veneer,

---

<sup>5</sup> The anonymous spinet at the Royal Northern College of Music shown in Appendix Four is very elaborately decorated internally. The spine veneer is thought to be contemporary, and there are indications that this veneer was once carried right around the instrument above the soundboard. One of the Benjamin Slade spinets shown in Appendix Four also has elaborate marquetry on the inside of the spine.

complete with stringing, was attached to a softwood backing which was in turn attached to the spine.<sup>6</sup> This, coupled with the facts that the stringing was joined at the same place as the sheet veneer, and that the two separate runs of stringing were not quite in line leads to the conclusion that sheets of veneer on a backing complete with stringing, were bought in rather than the veneer being laid and in-laid *in situ*.



**Plate 901 – Internal Veneering of the Keene Spinet  
at the Royal College of Music**

It is the nameboard which dominates the decoration of the English spinet. It is also characteristic of the period to which the spinet belongs, although some must be exercised before allocating a date to a spinet on the basis of the style of the cartouche. That is said because one of the results of Charles II's great interest in

---

<sup>6</sup> Martin (personal communication March 2009) reports that the Haward harpsichord shows the same form of construction.

fashion and technology was that in late-Stuart England it was 'smart' to own the latest designs. This was most evident in the desire for fashionable clothing, but furniture – and a spinet was a piece of furniture as well as a musical instrument – was not excluded from that tendency. Several of the spinets inspected show signs of having been 'modernised' quite soon after their manufacture. The anonymous spinet at St. Cecilia's Hall, University of Edinburgh is a particularly clear example of that and the Benjamin Sison instrument is another. The date has been removed from the jack-rail of the Keene spinet at the Royal College of Music, possibly early in its life as a measure to disguise its true age and it is clear that the top two notes of the John Player spinet at York Castle Museum were added after manufacture. It is believed that these modifications were driven by a desire to be seen to be 'up-to-date' just as much as by a musical need for a wider compass, as discussed in the previous chapter. There is also the point that since at this period the nameboard of the spinet is separate from the instrument<sup>7</sup> and slides into the case as a push fit, it is one of the easiest components to modify. An extreme example of that was referred to in Chapter Eight in relation to the Player/Aston spinet which has a Keene nameboard.

The nameboards of early spinets were very plain. That of the John Player spinet at the Victoria and Albert Museum is in cedar with the maker's inscription within a central rectangular panel delineated by a relief moulding. Makers normally provided for a central cartouche, but by not all of them exploited the decorative opportunities of that. The exuberant marquetry cartouches which appear on later spinets did not

---

<sup>7</sup> Except in Barton spinets.

come into fashion until the late 1680s. It is thought that these simple early nameboards were made in the maker's own workshop. However, and in contrast, it is thought that the marquetry cartouches which appear on later nameboards were bought-in from one or more specialist suppliers, though no attempt has been made to identify that supplier.

An early surviving dated example of a spinet with a nameboard including a marquetry cartouche is the Keene spinet of 1700 at Colonial Williamsburg. The way in which the cartouche is set into the nameboard, which is shown in Plate 902, became typical. The nameboard is veneered in walnut with triple white/black/white stringing. The maker's name, which is in ink, is elaborately inscribed within a rectangular panel of stringing. The stringing meets that of the keywell ends to form a triangular shape and is also incorporated into the key-blocks



**Plate 902 – The Nameboard of the 1700 Keene Spinet  
at Colonial Williamsburg**

Analysis of the marquetry cartouches found on spinets shows four basic patterns of design – seaweed designs, floral designs, designs with exotic birds, and designs with both naturalistic exotic birds and flora. On the following pages some representative cartouches from each class are reproduced as monochrome images.<sup>8</sup>

---

<sup>8</sup> Reproduction in monochrome avoids attention being drawn to different tonal characteristics caused by lighting differences or differences in actinic degradation of the veneers: it therefore emphasises similarities in design.

## Seaweed Designs



**Keene, Phoenix, Arizona<sup>9</sup>**



**Sison, Lady Lever Art Gallery**

## Floral Designs



**1700 Keene, Colonial Williamsburg<sup>10</sup>**

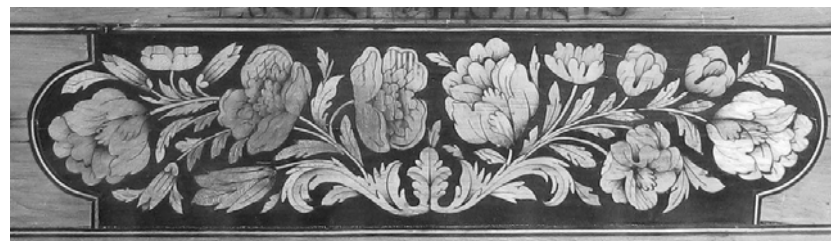

**Keene & Blunt, Privately Owned, Lancaster**

---

<sup>9</sup>The author is obliged to Albert Rice who supplied this photograph and granted permission for its reproduction here.

<sup>10</sup> The author is obliged to John Watson who supplied this photograph and granted permission for its reproduction here.

### Stylised Exotic Bird Designs



**RCM London, 1708 Anonymous**



**Brackley c. 1718, Privately Owned, Philadelphia<sup>11</sup>**

### Floral Designs with Naturalistic Birds



**Anonymous Spinnet, attributed to Player at St. Cecilia's Hall**

---

<sup>11</sup> The author is obliged to John Watson who supplied this photograph and granted permission for its reproduction here. The general similarity of these two cartouches is striking, but for reasons already given, the instruments which contain them must be at least four years apart in date and probably considerably more, as indicated in the captions.



**Benjamin Slade, Red Lodge, Bristol**



**Keene 1707, Lady Willoughby de Eresby**



**Keene 1711, Westwood Manor**



**Keene & Brackley c. 1712, the Author**

In addition to those cartouches which are illustrated, it has been possible to gather other images, of insufficient resolution for reproduction here, which allow the following allocations to be made:-

**1. Seaweed**

Sison, Lady Lever Art Gallery

Keene, Phoenix

**2. Floral**

Keene 1700, Colonial Williamsburg

Keene, Calgary

Keene, 1700, MFA Boston

Keene &amp; Blunt, Lancaster

Keene, Deerfield, Mass

Player Double, Wiltshire

**3. Stylised Exotic Birds**

Keene, 1705, MFG Hamburg

Anonymous, RCM London

Brackley c. 1718, Philadelphia

Blunt, 1703

Slade, 1705, sold Bonhams Nov.04

**4. Floral with Naturalistic Birds**

Anonymous, St.Cecilia's Hall.

Player, University of Witwatersrand

Slade, Red Lodge, Bristol

Keene 1707, Lady Willoughby

Keene, 1711, Westwood Manor

Keene &amp; Brackley, the Author

The marquetry cartouche has a French origin but almost certainly the cartouches found on English spinets are of English manufacture. The fashion for floral marquetry in France was begun by Pierre Gole, who supplied marquetry furniture to Louis XIV from about 1661 onwards (Bowett 2002: 55-62). It has been suggested that similar marquetry work was being made in England as early as 1664, but the evidence for that is slight. A more reliable first date for English manufacture is 1670, since John Evelyn's *Sylva* (1670: 200) contains a detailed description of the way in which individual veneer components of the marquetry design were coloured,

using hot sand. By 1679 extremely sophisticated marquetry furniture was being produced, some of which, formerly belonging to the Duke of Lauderdale, has survived at Ham House, Richmond, Surrey (Bowett 2002: 58 & 59). In the period 1685 to 1700 the technique of producing marquetry had become widely known and pieces of quite ordinary quality were being applied to furniture of modest price, including English spinets.

It is suggested that the cartouches found on late-Stuart spinets were standard artefacts bought in from the furniture trade, since Bowett (2002: 57 & 58) illustrates two cabinets having drawer fronts veneered with cartouches which are very similar to those illustrated above. To that extent the choice of design will probably have been dictated by what was fashionable, and therefore available, at the time of manufacture.

The manufacture of floral marquetry pieces began by making a paper pattern, which was glued to a sheet of veneer. A 'packet' of about five further veneers was then assembled behind the top one and the packet cut out in one operation using a jigsaw. If a colour was required in the overall design one method of achieving that was to use veneers of differing woods. The veneers were then temporarily assembled onto a ground, often of ebony or ebonised wood, the pattern was pricked out onto the ground and sawn out. The ground was then glued to a piece of stout paper and the individual components were glued into position. The cartouche was applied to the nameboard with the paper side uppermost, the paper subsequently being removed by soaking.



**Plate 903 – Cartouche of the Slade Spinet  
Red Lodge Museum, Bristol**

Much of what appears to be detail in the marquetry was added by scribing the veneers and colouring them with inks. Colours could be applied using hot sand as described by Evelyn. Plate 903 shows a cartouche from the Slade spinet at the Red Lodge Museum, Bristol in which the colouration is clearly visible.

The marquetry cartouche continues to appear on spinets even up to the early years of the Georgian period. The latest surviving instrument to carry one, so far as is known, is the Brackley spinet, dated by the author to no later than 1718 now in private ownership in Philadelphia. The cartouche is shown in monochrome above.

With only two exceptions amongst the instruments referred to in this dissertation, the cartouches depict either flowers or exotic birds or both. Though many of the representations are stylised, many of the birds seem to be, or are intended to be, parrots or parakeets. It is thought that many of the flowers are tulips. The images of the parrot and the tulip were allusions to possessions which were affordable only by those at the upper end of seventeenth-century society. Goldgar (2007: 12 & 73-77) points to the sixteenth century's fascination with the interaction between nature and

art, inherent in the cultivation of exotic tulips, and to an obsession with material wealth as accounting for the high prices commanded by tulip bulbs in early modern Holland and elsewhere.<sup>12</sup> Verdi (2007:13) identifies the artistic theme of the ‘woman with a parrot’, but most striking is the c.1619 portrait of Elizabeth, Countess of Kelly, attributed to Paul van Somer which is now in the Paul Mellon Collection at Yale University (Verdi 2007: 23). The notes available to this painting in the Centre for British Art at Yale refer specifically to the parrot in this portrait as denoting great wealth. These images of tulips and exotic birds were therefore highly aspirational and probably appeared in the cartouches of these instruments, and other furniture which contained them, as a deliberate sales ploy.

A second form of cartouche bearing marquetry of a different style generally referred to as ‘seaweed’ marquetry also appears on late-Stuart spinets including the one by Stephen Keene which is now at the Musical Instrument Museum in Phoenix, Arizona, and one by Benjamin Sison at the Lady Lever Art Gallery, Port Sunlight, Merseyside referred to earlier in this chapter. These two cartouches are shown in Plates 904 and 905 below.

---

<sup>12</sup> Tulips were aspirational flowers in the seventeenth century. Following their introduction from Turkey, prices for tulip bulbs in the Low Countries reached astronomic heights, see generally, *Extraordinary Popular Delusions and the Madness of Crowds*, by Charles Mackay, London 1841.



**Plate 904 – Cartouche of the Keene Spinnet  
Musical Instrument Museum, Phoenix**



**Plate 905 – Cartouche of the Benjamin Sison Spinnet  
Lady Lever Art Gallery**

Seaweed cartouches were made in a different way from the floral ones because of the complexity of the shapes needing to be formed. The general procedure was to lay two veneers of contrasting colours together and to cut the pattern through both of them simultaneously with a knife. Two cartouches of identical design would be produced by this method, one being the ‘negative’ of the other.<sup>13</sup> Though these abstract designs are generally characteristic of a later period than the floral ones, according to Bowett (2002: 199), it is not thought that either the Sison spinnet or the

---

<sup>13</sup> The 1755 double-manual Kirkman harpsichord in St. Cecilia’s Hall is decorated in seaweed marquetry. Burnett (2004: 25) suggests that the 1756 Kirkman at Finchcocks, Goudhurst, Kent, is the ‘negative’ of the St.Cecilia’s Hall instrument.

Keene one are late instruments: both may exhibit cartouches which have been introduced after manufacture. In this connection it is worth noting that marquetry cartouches are easily damaged, particularly by high temperatures and low humidity, causing the veneers to become loose. The Keene spinet of 1704 at St. Cecilia's Hall has a central cartouche of a willow pattern design which is clearly a replacement. The same can be said of the image of a cat which appears on the Keene spinet at the Museum of Fine Arts, Boston (Koster 1994: 79). This image seems to be of a nineteenth-century style and it is thought that it replaces some earlier veneers which have been lost. For these reasons and those mentioned earlier, the dating of a spinet is best done holistically, by reference to all of its features, not just to the cartouche. That said, the quality of the marquetry on spinet cartouches and on other marquetry furniture diminishes over time. This tendency is visible in the monochrome plates above, in which the two 1700 Keene instruments show much more sophisticated marquetry than the Keene & Brackley of c. 1712, for example.

#### **4. Brass Furniture**

Those spinets which have retained their original brassware carry a matching set of furniture consisting of one long and two short strap-hinges for the lid, three equally-sized flap hinges, a lock and hasp, and a lid closure fitting.<sup>14</sup> Many of these brass fittings are illustrated in the descriptions of spinets in Chapters Five and Seven and in their appendices. The fact that sets of brassware to an identical design have been found on spinets from different makers suggests that those sets must have been made

---

<sup>14</sup> The Keene spinet at the Royal College of Music carries two identical lid closure fittings.

in the same forge, but it has not been possible to establish that directly. Despite that, it is not thought that these items were bespoke – they seem to be pieces which were common to the furniture trade, as shown by some crude adaptations presumably made in the spinet maker's workshop. For example, the lock-plate shown in Plate 913, that from Hitchcock spinet Serial No. 471, shows an alteration made in the top left-hand corner to accept the staple on the hasp: this lock plate was clearly intended only for a mortise lock. This alteration is commonly found: a similar one is shown in Plate 914.

The Player spinet at York Castle Museum does not retain all of its original furniture, but those pieces which it does retain – three flap hinges – are in an early style characteristic of the reign of King Charles I or of the Interregnum. A representative hinge from this spinet is shown in Plate 906. The Russell Collection anonymous spinet has similar flap hinges.



**Plate 906 – Flap Hinge  
Player Spinet, York Castle**

Plates 907 to 910 show lid hinges from four late-Stuart spinets. Despite the fact that these spinets span a time period of about 30 years, and that one of them is by Slade whereas the other three are by Keene, it is clear that the hinges are of the same pattern.<sup>15</sup>



**Plate 907 - Keene Spinnet, Royal College of Music**



**Plate 908 - Keene Spinnet, 1704**

---

<sup>15</sup> It cannot be said that they are from the same mould since these hinges were made by sand casting. David Law, (Personal Communication, September 2006) states that he has measured a series of historic hinges and can detect a gradual increase in size over time, confirming the casting technique.



**Plate 909 - Slade Spinnet, Red Lodge Museum, Bristol**

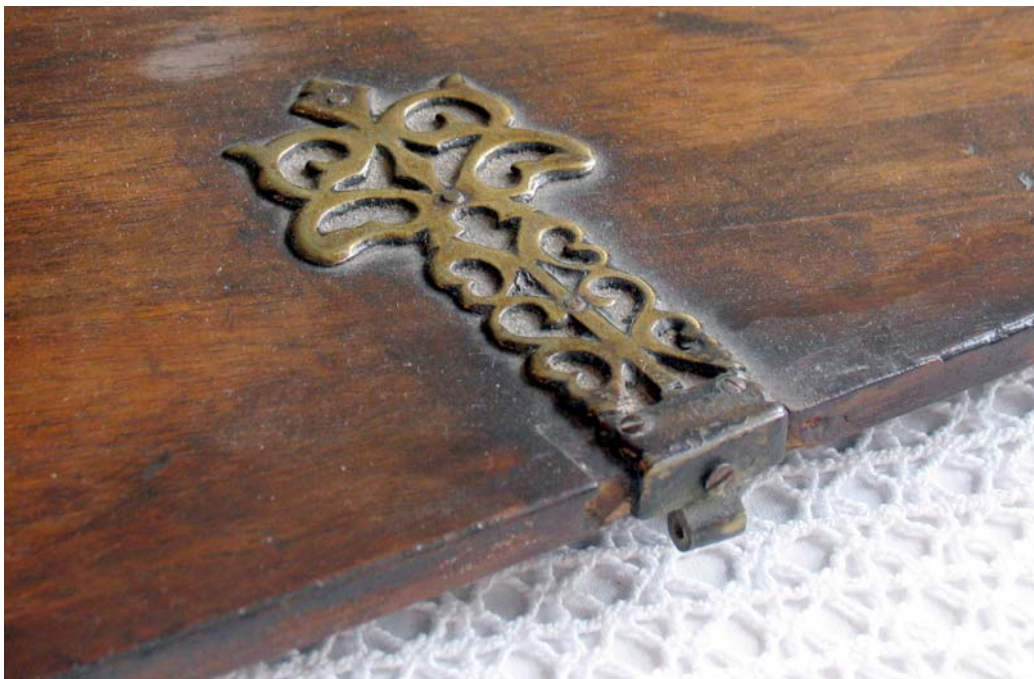

**Plate 910 - Keene & Brackley Spinnet**

Several spinets carry brassware which can be seen as intermediate between the cast and pierced hinges of the late-Stuart instruments shown above and the lighter styles which became established on Hitchcock spinets of the mid-1720s. Amongst these spinets are the Slade spinet at the Bate Collection, Oxford, which is thought to date from about 1716, and the early Hitchcock instrument Serial No. 616, also at the Bate Collection, which carries a date of 1723. All of these spinets have brassware which is heavily cast but which is also decorated by chasing. As is shown in Plates 911 and 912 these sets of brassware are similar in style, but are not identical.



**Plate 911 – Slade Spinet, Bate Collection, Oxford**



**Plate 912 - Hitchcock Spinet Serial No. 616**

A similar design appears in the lock-plate of Hitchcock spinet Serial No. 471 shown in Plate 913. Bowett (2002: 229, Plates 7:82 and 7:83) suggests that designs of this type have an Oriental inspiration, intended to be appropriate for japanned cabinets which were fashionable between 1700 and 1730. It is conceivable that these items are of Bristol-made English brass rather than the imported material, though no chemical analysis has been carried out to determine that.



**Plate 913 - Hitchcock Serial No.471**

Hitchcock spinets from the mid-1720s onwards bear sets of brassware in which the casting is less elaborate than that illustrated above, but with more elaborate chasing applied after casting. The items shown in Plates 914, a lock-plate from Hitchcock spinet Serial No.1335 at Sulgrave Manor, in Plate 915, a flap hinge from the St. Cecilia's Hall Hitchcock Serial No.1241, in Plate 916, a lid hinge from the John Hitchcock spinet at the Royal College of Music Serial No. 1676 and Plate 917, a lid closure from Hitchcock spinet Serial No. 1243 are typical, though differences are found on individual instruments<sup>16</sup> and several instruments appear to be furnished with items which do not match, as is apparent from Chapter Seven and its Appendix.



**Plate 914 - Hitchcock Spinet Serial No. 1335**



**Plate 915 - Hitchcock Spinet Serial No. 1241**

---

<sup>16</sup> For example, Hitchcock spinet Serial No. 1241 has a 'swan-neck' lid closure, a pattern which appears quite frequently also.



**Plate 916 - Hitchcock Spinet Serial No. 1676**



**Plate 917 - Hitchcock Spinet Serial No. 1243**

From comments made by Gentle (1975: 102) about the distribution of brass foundries in eighteenth-century England, it seems likely that the brass furniture for Hitchcock and later spinets was made in the Birmingham/Wolverhampton area and

that the items were bought-in by the Hitchcocks and other makers from a factor. Following the re-opening of the Cornish copper mines in 1719, brass began to be made in Cheadle, near Warrington, Cheshire, and large quantities of it were sent to Birmingham for forming into domestic items, which would undoubtedly have included hinges. Loose-leaf pattern books for many eighteenth-century brass items have survived and are stored at the Victoria and Albert Museum, but they are unsigned and undated (Gentle 1975: 62), so it was not thought valuable to search through them.

The style of brassware found on a spinet is indicative of its age. The cast, stamped and pierced hinges of identical pattern found on late-Stuart spinets and illustrated above were used at least from 1682, the date attributed to the Keene spinet at the Royal College of Music, London until 1712, the date attributed to the author's Keene & Brackley spinet. Those few Player spinets which have retained their original brass furniture appear with items of a different style which appears much older, but otherwise, no late-Stuart spinet has been found with any other design, so unless modern replacement hinges have been used, this pattern can be used to date a spinet within this admittedly wide range of thirty years.

The somewhat more 'gothic' looking patterns illustrated in Plates 911 and 912 are found between 1712 and about 1723, after which the cast and chased designs found on the Hitchcock spinets and illustrated in Plates 914 to 917 become the norm until at least the mid-1750s.

## 5. Keyboards

### a. Late-Stuart Spinets

The keyboards of late-Stuart spinets present a remarkably uniform appearance typified that of the Keene & Blunt spinet of c. 1702 shown in Plate 918. The edges of the natural key-plates, which are of ebony, are heavily chamfered and the paper arcades applied to the proximal ends of the key-levers are formed with a decorative moulding of the trefoil design in Plate 919, which shows the proximal ends of three naturals from the 1707 Keene spinet.<sup>17</sup>



**Plate 918 – Keyboard of the Keene & Blunt Spinet**



**Plate 919 – Arcades of the 1707 Keene Spinet**

---

<sup>17</sup> These arcades are available today newly manufactured and it is therefore difficult to determine whether a particular arcade is original or a replacement to the original pattern. But because they are protected in their normal position within the spinet by the lock-board, they are durable items.

Though there is the occasional exception, sharp blocks are normally of solid ivory, tapered downwardly in height towards the nameboard. In instruments which have remained unaltered in compass, key-blocks fabricated from veneers of walnut/ebony/box/ebony/walnut and having a scroll profile are found at either end of the keyboard.

The natural plates are heavily scored as can be seen in Plate 920 which shows the bass end of the keyboard of the anonymous spinet at St. Cecilia's Hall. The general construction of the two keys having split sharps and one of the scrolled key blocks can also be seen in Plate 920.

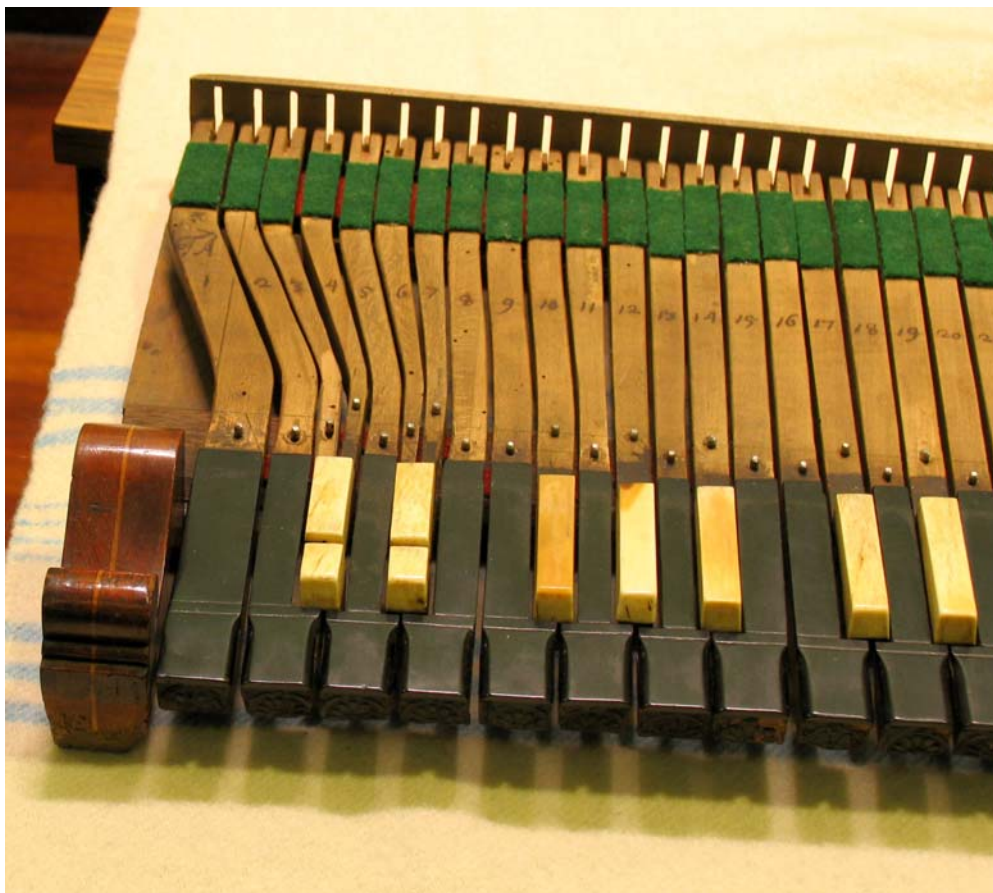

**Plate 920 – Keyboard of the Anonymous Spinet  
St. Cecilia's Hall**

Though the scorings are construction lines – the nearer one showing the limit of the chamfer and the far one the limit of the excision for the sharp blocks - they are thought to have been regarded as decorative in the seventeenth century. Evidence for this is that in one instrument – the serpentine-tailed Keene spinet at the Royal College of Music, London – two additional score lines have been added, as shown in Plate 921. The additional scorings have no constructional purpose, leaving little doubt that they are decorative.



**Plate 921 – Score Lines on a Key of the Keene Spinet  
Royal College of Music**

The ebony key plate shown in Plate 921 exhibits a longitudinal join. Barnes (1985: 17) notes that two other Keene instruments incorporate key plates which show joins – the 1668 virginal and the Keene & Brackley spinet – attributing this practice to economising on the use of expensive timber. That the practice would not be acceptable today demonstrates a significant change in aesthetic attitudes over the three centuries since the Royal College of Music spinet was made.

The Royal College of Music Keene spinet also exhibits a further decorative distinction in the treatment of its keyboard – namely the provision of skunk-tail sharp blocks as shown in Plate 921. Since the other early Keene spinet described in Chapter Five also exhibits an uncommon treatment of the sharp blocks – using hardwood blocks with an ivory capping, see Plate 922, it is possible that Keene had not yet adopted a settled decorative practice at this early date, although both of his virginals have solid sharp blocks.

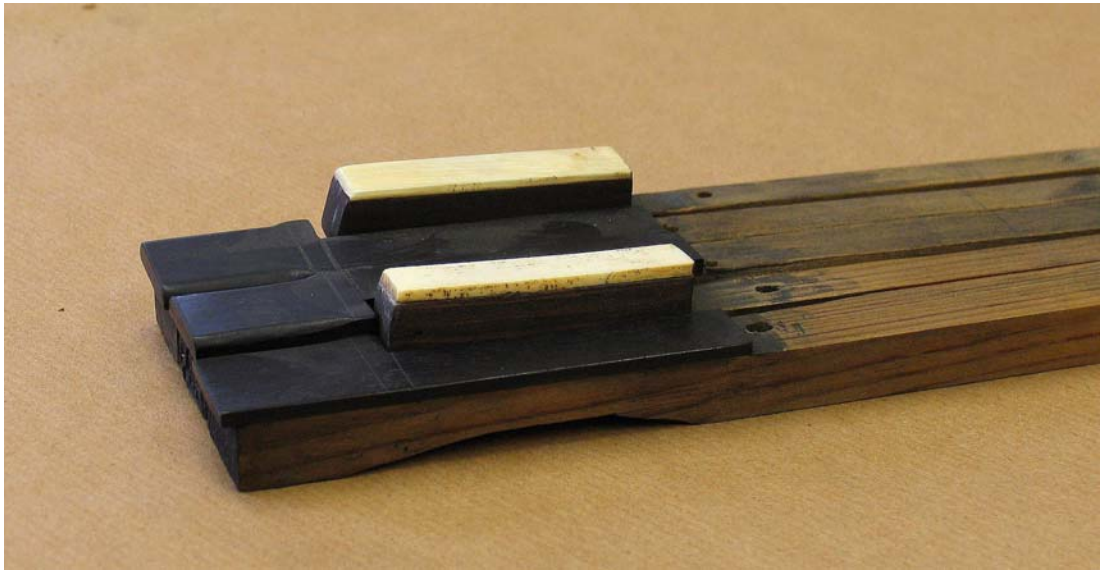

**Plate 922 – Skunk-tail Sharp Blocks  
Keene Spinet, Royal College of Music**



**Plate 923 – Ivory Capped Sharp Blocks  
Keene Spinet, Hall i' th' Wood**

The John Player spinet at York Castle Museum also has sharp blocks of hardwood capped with ivory, see Plate 924.



**Plate 924 – Ivory Capped Sharp Blocks  
Player Spinet, York Castle**

The plates and the discussion above have referred to four instruments by Keene, one by Player and one anonymous instrument which is attributed to Player. But the decorative scheme applied to the spinets of these makers is quite general - other makers, including Haward, Slade and Sison also adopted it for their keyboards.

It was said in Chapter Three that the influence on decorative schemes adopted by spinet makers was a French one. A feature of the keyboard's decorative scheme which is decidedly French is one to which attention has already been drawn – the use of solid ivory (or sometimes bone) sharp blocks which are tapered in height away

from the player. This feature appears, for example, in the anonymous French harpsichord of 1667 in the Museum of Fine Arts, Boston (Koster 1994: 43).<sup>18</sup>

## b. Early-Georgian Spinets

Surviving spinets with natural key plates of ebony become uncommon at about the same date as the five-octave spinet became established, that is from about 1720. Thereafter, ivory naturals are normally found as shown in Plate 925 which shows part of the keyboard of Serial No.1241.



**Plate 925 – Keyboard of Hitchcock Spinet Serial No. 1241**

---

<sup>18</sup> The author is grateful to John Koster who drew this to his attention during the Early Keyboard Symposium, University of Edinburgh, October 2008.

Hitchcock spinet No. 471, which is not a five-octave spinet, has natural key plates of ivory with moulded wooden arcades, and skunk-tailed sharps, though little of the keyboard has survived. Most subsequent Hitchcock spinets have the decorative treatment shown in Plate 925 with ivory arcades to the naturals consisting of a slip of ivory which has been profiled with semicircular rings, presumably using an auger to produce a circle and cutting the result in half. This is the standard decorative treatment for Hitchcock keyboards, regardless of which model of spinet is under consideration.



**Plate 926 – Keyboard of the 1726 Aston Spinet**

It has already been said that the Hitchcocks set the norms in the market for spinets after about 1720, and spinets by other makers adopt the decorative used by them. The 1726 Aston spinet at Colonial Williamsburg, Virginia has a keyboard of very similar appearance to a Hitchcock spinet, as shown in Plate 926, although in this instrument the natural plates carry three lines of scoring rather than two and there is a

difference in the profile of the key blocks, which are hooked in the Aston rather than convex as in the Hitchcock. This seems to be a feature introduced to facilitate removal of the keyboard assembly from the instrument.

Some Hitchcock instruments have natural plates of ebony as noted in Chapter Seven, and these instruments have reverse skunk-tail sharp blocks but retain the ivory arcades. The keyboard of one of these, Thomas Hitchcock Serial No.1518, is shown in Plate 927



**Plate 927 – Keyboard of Hitchcock Spinet Serial No. 1518<sup>19</sup>**

A spinet at the Musical Instrument Museum, Copenhagen which bears the plain inscription *Johannes Hitchcock Londini Fecit*, without a serial number, has a keyboard with ivory naturals but with solid ebony sharps. This instrument has not been inspected, but from a photograph supplied by the museum it can be seen to be a

---

<sup>19</sup> The photograph in this plate was taken by Susana Caldeira who has kindly agreed to its reproduction here.

mitred-tail instrument which has an unusually high case height. There must be considerable doubt whether this is a genuine John Hitchcock spinet.

Although it is likely that the re-appearance of spinets with ebony natural plates in the second half of the eighteenth century can be accounted for by treating them as special orders, it is also possible that the late instruments, such as the spinet in Copenhagen, were made with ebony naturals in an attempt to mimic the newly introduced square pianos. A square piano by Zumpe, now at the Cantos Musical Foundation, Calgary, Alberta having ebony naturals and dated 1766 is illustrated in Cole (1998: Plate 1).

## **6. Stands**

The stands of late-Stuart spinets do not conform to a standard pattern. It is thought that there are several reasons for that: - in the first place, it is not clear that these instruments were originally supplied with stands. Provision of a stand may well have been the exception rather than the rule and many customers will merely have placed the instrument on a table or chest. The portrait of Master Garton Orme (see Plate 303) shows him seated at a late-Stuart spinet placed on what appears to be a small table with barley-twist legs. The table has a front stretcher and he is seated somewhat sideways in the manner of a virginal player, though this may actually be an artifice required for the portrait. Also, it may be significant that the single surviving receipt for a late-Stuart spinet, made out to Lady Middleton, makes no mention of a stand. Secondly the monopoly of the Joiners Company did not extend

to the craft of wood turning, for which a separate craft company existed<sup>20</sup> and so strictly, it was unlawful for a Joiner to produce a stand for a spinet by turning. The legs, at least, for any stand intended for a late-Stuart spinets would have to have been made by a Freeman of the Turners Company. The requirement to involve another craftsman in the production of such a simple item may explain why some variation is found in the stands which have survived. Thirdly, it is invariably the case that a genuine stand was made of a cheaper timber - frequently elm - than that of the instrument and was stained to provide a colour match. Several of the spinets inspected had stands of that type. A result of that is that many such stands have deteriorated either from rot or from insect attack and have not survived. A good example of that is the stand of the Sison spinet at the Lady Lever Art Gallery, Port Sunlight, which originally had a stained elm stand, many of the original components of which have had to be replaced. Last, as has been noted frequently, many of these early spinets have been modernised to make them appear more up-to-date than they actually were. One of the ways of enhancing that impression would have been to provide a fashionable stand where none had previously existed, or to replace one which had become outmoded. For all these reasons there is considerable difficulty in knowing whether a given instrument has an original stand. A survey of a large number of early spinet stands shows considerable variation in pattern. The oak spinet by John Player at the Victoria and Albert Museum has a stand, said by the Museum to be original (Yorke 2002: 67), having four turned legs and turned stretchers; the Charles Haward spinet at the University of South Dakota has a four-

---

<sup>20</sup> The Worshipful Company of Turners still exists; see <http://www.turnersco.com> accessed 16<sup>th</sup> January 2009.

legged rectangular stand with barley-twist legs and plain stretchers,<sup>21</sup> and the stand of the Slade spinet at the Red Lodge Museum, Bristol has a stand with turned legs and moulded stretchers. These three spinets will probably be close in date, but whether their stands are original is moot.

A common form of stand found with late Stuart spinets is that with four turned legs and moulded lower stretchers, of generally trapezoidal plan form. A stand of this general type, from the 1707 Stephen Keene spinet at Grimsthorpe Castle, is shown in Plate 928.



**Plate 928 – Stand of the 1707 Keene Spinet**

---

<sup>21</sup> <http://www.usd.edu/smm/Keyboards/HawardSpinet/HawardSpinet.html> accessed 28th March 2007

Because of the provenance of this instrument it is thought that it is the one most likely to be with its original stand.<sup>22</sup> Perhaps because the upper stretchers are invisible when the instrument is in place, they are generally only roughly finished. No stand has been found with a top rail. The reason for that must be economic, since though the stands are made so that they can be collapsed for easy transport, it would be a simple matter to arrange the same facility for a stand comprising a top rail. The absence of a top rail considerably weakens the structure. Though the turned legs of this stand are typical in being made up from standard architectural features, no two instruments from the late Stuart period have been found with identical leg profiles.

Though the comments made about late-Stuart instruments apply to those spinets made before about 1715, a more consistent pattern of stand emerges in later years. The stand which appears with Thomas Hitchcock spinet Serial No.1335 at Sulgrave Manor, illustrated in Plate 929 below, is typical of those Hitchcock spinets having a serpentine tail. The distribution of hoof-footed stands amongst Hitchcock spinets was set out in Chapter Seven, but in addition a 'hoof' foot has been seen on the Thomas Barton spinet said to be dated 1714, which was advertised in the *Antique Collector* of September 1937. The hoof foot is said by Germann (1980: 436) to be of French origin and to date from the *régence* period.<sup>23</sup> The upstanding pegs visible on the stand co-operate with holes drilled into the base of the spinet.

---

<sup>22</sup> Unfortunately, the photograph does not show the profiling of the lower stretchers, since it was inadvertently taken from the rear, an error which was not noticed at the time of the inspection.

<sup>23</sup> By '*régence*' Germann is presumably referring to the regency of the Phillippe, Duc d' Orleans, which began on the death of Louis XIV in 1715, his heir, Louis XV then being only five years old.

They are intended to locate the instrument securely and are an original feature found on several Hitchcock spinets.



**Plate 929 – Stand of Hitchcock Spinet Serial No. 1335**

Germann (1980: 436) refers to the practice of French harpsichord makers of turning to the specialist furniture trade to provide the more complex stands for their instruments and it seems very likely that this practice was adopted by the Hitchcocks too. It was said in Chapter Five that Thomas Hitchcock the Elder was a chair maker. This business was continued by Thomas the Elder's widow Mary after his death:- Mary Hitchcock, who was then living in St Brides Lane, took her daughter, also called Mary, into apprenticeship as a cane chair maker in 1712.<sup>24</sup> It seems probable that the widow continued to make stands for the spinets made by the two younger Hitchcocks and that they were therefore willing to offer a choice of styles. Support

---

<sup>24</sup> London Guildhall MS 15864/3. An Elizabeth Taylor was also bound.

for that lies in the fact that while many serpentine-tailed Hitchcock spinets have the more elaborate stand, some do not. Because of the uncertainties about originality it is not thought that the style of stand found with a spinet is of great assistance in forming a judgement of the date of the instrument.

## **7. Summary**

This chapter is concerned with the decorative detail found in spinets from the Keene and Hitchcock schools and in spinets of other makers. The first part of the chapter details changes which took place in late-Stuart England in the availability of raw-materials necessary for making keyboard instruments. Though concern had begun to be expressed about supplies of oak, the move to walnut for building spinets was driven largely by the adoption of French styles of furniture making. There were some uncertainties over the supply of walnut as a result of a cold winter in 1709.

Early brass making in England was not successful and as a consequence, workers who produced brass items usually relied on importation for their raw material. It is thought that the brass furniture of late-Stuart spinets were made in small forges close in the Port of London where metal was off-loaded. By 1720, good quality domestically produced brass was being produced. Much of the material was sent to Birmingham for conversion into domestic items. It is thought likely that the brass items which appear on early-Georgian spinets were produced in the Birmingham/Wolverhampton area. Brass wire was being made by 1720 initially in

Esher, close to London. Ivory was being imported into London from West Africa in large tonnages by 1700.

The similarities in the designs of marquetry cartouches, of brass furniture and of the stands found in spinets from different makers suggest that these items were sourced from specialist suppliers. Analysis of the marquetry cartouches shows that they fall into four distinct groups – seaweed designs, floral designs, designs with stylised exotic birds, and designs containing both naturalistic images of both exotic birds and flowers. There is a marked deterioration in the quality of the marquetry work in these cartouches in the later instruments. Some information about date can be derived from the style of the cartouche.

The brass furniture found on spinets also provides information about its date. The commonly found brass furniture on late-Stuart spinets is to a single pattern. Later instruments (1715-1723) have a different style of furniture which has been found in more than one pattern, and the Hitchcock spinets, and instruments from other makers of instruments from post-1725, have furniture of a lighter casting which is chased.

Stands for late-Stuart spinets are made using legs which have been turned to standard architectural profiles, but they do not appear in a consistent pattern. Reasons for that are suggested, the most important of which is that the legal monopoly of the Tuners Company prohibited the making of turned items by persons who were not Freemen of that Company. This necessitated a variety of third-party contractors supplying spinet stands, if stands were required. Stands of early-Georgian spinets occur more

frequently in a consistent pattern and often exhibit the scroll foot. It is thought that stands of Hitchcock and other serpentine-tail spinets which are of similar design may have been made by the Hitchcock chair-making firm.

# Chapter Ten – Conclusions and Suggestions for Further Research

## 1. Introduction and Re-capitulation of the Objectives

This chapter summarises the conclusions, both substantive and methodological, drawn from the research described in this dissertation and adds some suggestions for further work. In the previous chapters, care has been taken to preface conclusions with appropriate terms of academic caution. But here that approach would result in innumerable repetitions of the words ‘probably’ and ‘it is likely’. The events which are summarised here occurred about three hundred and fifty years ago, and some of the instruments from which conclusions have been derived are nearly as old. There can be no certainties in such circumstances, but to avoid an unduly hedged account of the research conclusions, the author asks that in this final chapter proper academic cautions are taken as read.

The research reported here had two main objectives:-

First, to ‘place’ the spinet in the musical culture of Britain during the period 1660-1740 and in doing so to question whether the soubriquet of ‘the poor man’s harpsichord’ withstands examination;

Secondly to provide an organological characterisation of representative spinets from the Keene and Hitchcock schools. The purpose of that characterisation was to investigate whether lines of development could be discerned which connect the

design of spinets made early in the period with that of those made later. Within that task it sought to answer long-standing open questions about the lives and output of members of the two schools, and to determine whether dates accorded in the literature to some of their instruments are consistent with the historical facts.

The research process has involved the gathering of data on English spinets not only from the schools of Keene and of Hitchcock but from several other makers. The data has been acquired from a number of different sources. The main source was empirical, the organological inspection of twenty-five spinets in the collections of museums, of universities and of private individuals. The results of these inspections are set out in part in the text and in part in the appendices. Those results consist of textual descriptions, photographs, tabulated numerical data, and in most cases, scale drawings produced by CAD techniques of the outlines of the instruments. A secondary source, which can be characterised generally as archival, was the published catalogues of major collections, which in some instances served to supplement the empirical data and in other instances was the only source of data. In addition, three organologists have assisted the author by taking measurements and in one instance by tracing an outline of an instrument on the author's behalf. The internet has also provided some information, particularly on spinets sold in the rooms of the major auction houses.

The conclusions of the research will now be considered under the headings of the two objectives set out above:-

## 2. The Spinet's Place in English Musical Culture

Two prominent discontinuities in the culture of late-Stuart England were conducive to the emergence of the bentside spinet. The first of these lay in the surprising vibrancy of the economy and in its swift recovery after the Civil War. That recovery was particularly marked in London, despite the setbacks caused by a severe outbreak of the plague in 1665 and by the Great Fire in the following year.

Economic growth was in part a consequence of a halting of the decline in the population, and then the beginnings of a slow increase by about 1710. The population numbers were fuelled by the arrival of large numbers of economic migrants and religious refugees, largely from Germany, the Low Countries and France, who introduced new craft skills to England. The Huguenots were especially influential in introducing new techniques, and more importantly new styles, in the metalworking and furniture-making trades.

One response to the Great Fire, enactment of the Rebuilding Acts, was especially significant since it introduced a degree of standardisation into the design of houses in London. This enabled similar standardisation in furniture design which in turn allowed furniture, including the larger musical instruments, to be made speculatively. This speculative activity was one to which the newly-arrived workers were well-placed to contribute.

The second discontinuity was in the field of fashion and popular taste. The Restoration of the Monarchy in 1660 was generally welcomed, largely because King Charles II presented himself as a Protestant: Catholicism, which was associated with

absolutism, intolerance and cruelty, was rejected. That rejection included Catholicism's essentially renaissance aesthetic. This generated a cultural paradox, in that the lead given by King Charles II, who had been brought up in Catholic France during the *Interregnum*, was to the adoption of French fashions: but that lead was enthusiastically followed, in the visual arts, in music, and the dance. Charles introduced to his court French musicians, who brought with them not only French music but their French musical instruments tuned to French pitch, the *Ton de la Chambre du Roy*. Additionally, because the Huguenots were largely of French origin, the styles which they introduced to manufactured items were French.

Restoration Britain, then, had a growing economy and a *quasi*-French aesthetic. It was into this environment that the spinet was introduced. The evidence of surviving instruments points to the development of the design of the spinet in Italy about 1630 by a school which included Giralomo Zenti. Whether Zenti introduced his design to England directly during his visit to the Court, or it was introduced indirectly from France by importation of one or more instruments is unknown. The most likely mechanism by which the bent-side spinet became first known and later copied in England was through visits to the Court to repair instruments by native craftsmen including Charles Haward and John Player. It is clear from archival evidence and from the numbers of surviving instruments that the spinet quickly became popular in the latter part of the reign of King Charles II, from about 1675 onwards, maintaining its popularity at least until the mid-1750s.

Although the design shows Italian origin, the manner in which it was adapted to English taste followed French fashions. The use of walnut rather than oak as a

construction timber, the adoption of marquetry decoration in the keywell rather than gilded papers, and the presence of pierced brass hinges rather than gothic iron ones were essentially French adaptations. They distanced the stylistic treatment of the spinet from the rectangular virginal which preceded it, reflecting the cultural distancing from Catholicism.

The shape of the spinet is its most characteristic feature: nevertheless there was a great deal more to the design than just the shape. The monolithic wrestplank above the keyboard and the use of a register in the form of box-guide attached to it, provided a markedly enhanced structural rigidity to the instrument compared with the English and Flemish Virginals. The reversal of the earlier arrangement of the string-band, so that the longer strings were at the rear, improved the consistency of the pluck by plucking the bass strings close to the nut where vibrational amplitudes are low. These innovations produced an instrument with better repetition in the bass and greater tuning stability than the virginal. It also produced an instrument with a new sound, at once lighter and more tonally varied through the compass.

The general understanding about spinet ownership in the seventeenth- and eighteenth century has been that the spinet was an instrument acquired by a person who would have preferred a harpsichord, but who either could not afford one or who had insufficient space for one. This understanding may reflect the position once the 'factory' harpsichords of Shudi and Kirckman had begun to be made in increasingly large numbers after about 1740, but it is incorrect when applied to spinets made during the period 1660-1740. On the contrary, during this earlier period, the spinet

was the instrument of choice and the harpsichord was seldom encountered in late-Stuart England.

A simple numerical enquiry is supportive of the harpsichord's rarity: - If the numbers of surviving English harpsichords built before 1740 is juxtaposed with the numbers of surviving spinets, and counting only the signed instruments, it is found that there are only fifteen surviving harpsichords from the period – those by Haward, Tisseran, Barton, Hancock, possibly three by Shudi, by Smith, Tabel, Slade, Coston, Hitchcock, Wilbrook and two by Mahoon<sup>1</sup> – as compared with ninety or more spinets. Furthermore, the makers listed are predominantly spinet makers, only Smith, Tabel and Tisseran being un-represented by surviving signed spinets. Only three harpsichords have survived from the late-Stuart period (1660-1714), those by Haward, Tisseran and Barton.

It is a general principle of human behaviour that those things which are most valued are those things which are most carefully kept. On that basis it can be expected that a harpsichord would have been more carefully kept than a spinet and would be the more likely to have survived. So if, contrary to the numerical result above, there were more harpsichords than spinets in late-Stuart and early-Georgian England, then it could be expected that the number of harpsichords surviving to the present day would be very much greater than the number of spinets. But the opposite is true. Since that is the case, the number of spinets made during the period in question is

---

<sup>1</sup> One of the surviving Mahoon harpsichords is stated by Boalch (1995: 499) to be dated 1742, which strictly, is outside the temporal period under consideration here, but it is not stated whether that date actually appears on the instrument.

likely to have exceeded the number of harpsichords by an even greater ratio than the seven to one ratio shown by the analysis above.

That conclusion – that the spinet was relatively common and the harpsichord comparatively rare in late-Stuart England – forms one component of the general conclusion made here about the place of the spinet in English musical culture from 1660-1740. But there is a second conclusion, which is concerned with the pattern of ownership and purchase of spinets:-

The evidence of ownership and purchase of spinets begins with references to the entries in the *Diary of Samuel Pepys* about his eventual purchase of a spinet from Charles Haward. It was followed by a reproduction of the receipt issued in 1685 to Lady Katherine Brudenell, Countess of Middleton for a spinet ordered from Stephen Keene; the portrait (c.1707) of a young man from a prosperous family, Master Garton Orme seated at spinet is reproduced in Chapter Three; from 1707 is the account by Lady Grisell Baillie, Countess of Haddington, of the regime she set for her daughter which included ‘to play of the spinet’; a later portrait, (1709-1715) of Lady Teresa Blount seated at a spinet by Francis Coston follows; the inventories of the ancestors of Lady Willoughby de Eresby are believed to show that her Keene spinet of 1707 has been in her family since it was bought new by Lady Jean Drummond, 2<sup>nd</sup> Duchess of Perth; and last, the evidence from the Will of Frances Purcell, wife of Henry Purcell, shows that Purcell owned two spinets and an organ (but no harpsichord) and other evidence shows that he taught keyboard skills to Lady Rhoda Cavendish on the spinet.

This is not evidence of the spinet being confined to those who could not afford a harpsichord or who could not find room for one: on the contrary it shows that the spinet was the keyboard instrument chosen by some of the most aristocratic members and influential members of British society, including perhaps the greatest composer of his time, Henry Purcell. No doubt persons who were of a lower status and influence bought spinets too, but the fact that they may have done so does not demonstrate that the spinet was a 'poor man's harpsichord'. Because of the large numbers of surviving spinets in comparison with harpsichords and because of the status of the early purchasers, the 'poor man's harpsichord' characterisation of the late-Stuart and early-Georgian spinet is rejected as being inconsistent with the available evidence.

But to say what the spinet was *not*, is not the same thing as placing it in its musical culture. The technical advantages offered by the spinet have already been summarised but in addition, it must be recognised that the spinet was a fashion item: - the finish of the case, the use of stylish and elaborate brass furniture, the adoption, about 1690-1700, of the marquetry cartouche on the nameboard and the use of ivory for the sharp keys all contributed to the French allusions which were so sought-after in late-Stuart England. The floral design of the hinges and the use of highly aspirational images – tulips and exotic birds – in the cartouche reflected in part the new interest taken by the late Stuarts in the natural world, and added to the instruments desirability. The re-opening of the theatres and the new lighter and more accessible style of music which was brought to them by composers such as Purcell,

Locke, and Croft, together with the increasing use of the technique of engraving for publishing music also stimulated interest in the spinet.

In summary, it is thought that the spinet was the first choice keyboard instrument for amateur players in late-Stuart England, at least in the domestic environment, and that it remained so at least until about 1730. At the heart of that conclusion, almost inevitably, is an evaluative judgement, but it is a judgement which is fully consistent with the available evidence. The *soubriquet* of the ‘poor man’s harpsichord’ is appropriate, if at all, only at a period considerably later than the prime focus here.

That conclusion clearly has implications for historically-informed performance practice. If it were to become widely accepted, then performance of the music of the late-Stuart period on a seventeenth- or early-eighteenth century spinet, or on a copy of one, should become the norm rather than the exception which it is today.

### **3. Organological Characterisation and Comparison**

#### **a. The School of Keene**

The second objective of the research was to provide an organological characterisation of representative spinets from the schools of Keene and Hitchcock. The School of Keene has four main members, Stephen Keene himself, Edward Blunt, Thomas Barton and Charles Brackley.

From the binding and freedom registers of the Joiners Company, and from the discovery of Keene's Will, a family tree for the Keenes was constructed. Keene came from farming stock and may have been introduced to his London apprentice-master, Gabriel Townsend, through contacts in the furniture trade in High Wycombe made through his brothers, who were freemen of the Turners Company. Keene's freedom of the Joiners Company was granted in 1662. His workshop was set up at least by 1668 and initially made virginals but continued in production, making spinets, uninterrupted until 1718 (under Brackley), a period of half a century. During the later part of this period the workshop may have been producing a spinet as frequently as one every three weeks. If that is so, then a very small proportion of the total output has survived, Keene became Master of the Joiners Company in 1704/5.

Keene's workshop always had at least one apprentice working in it: those apprentices who worked on spinets include John Harris, Edward Blunt, Thomas Barton and Charles Brackley. The Keenes had no children, but some details of Keene's Will, and of that of his wife Sarah point to a close family relationship with Edward Blunt and it is suggested that Blunt was Keene's intended heir to his business. But the archival records of Blunt, particularly the details of the baptisms of his children and the Land Tax Assessment records, show that Blunt left Keene and set up in business on his own close to Keene's workshop in Threadneedle Street while making spinets inscribed only with his name. He then moved into the premises vacated by John Player on the latter's death in June 1707. No records of Blunt later than 1711 have been found and he probably died that year.

By 1711, Thomas Barton, the apprentice who followed Blunt, had also moved into his own premises, probably in the South Seas House in Threadneedle Street, but away from the Keene workshop and set up in business either on his own or with Cawton Aston, Player's last apprentice. Because of that and because it seems that by that time Blunt had died, Charles Brackley became the successor to Keene's business. Brackley himself died in 1718.

Keene's Will shows that the accepted date of 1719 for his death is incorrect: he died in December 1712. This newly established date provides a *terminus ante quem* for his output of spinets, but in particular for his last and undated spinet, the Keene & Brackley, which can now be said to date from c. 1712. Similarly, it provides a *terminus post quem* for the sole surviving Brackley spinet, which can now be dated 1712-1718. Keene's appointment as tax assessor for his parish in the 1690s, the hitherto unsuspected wealth detailed in his own tax returns, and his Mastership of the Joiners Company evince his ability as an administrator and show his prominence in his local community: Keene was clearly a man of substance.

#### b. The Development of Spinets from the Keene School

The spinets of Stephen Keene, of Edward Blunt, of Thomas Barton, and of Charles Brackley were treated as a continuous output from a single school of spinet-making during a period of over 40 years stretching from about 1680 to 1720 and beyond. Attention was drawn to significant changes in the design of these spinets with time. These changes include an increase in keyboard compass and consequent general increase in size, the adoption of a box-guide register in place of a register integral

with the soundboard, the adoption of a more elaborate decorative scheme including a marquetry cartouche on the name-board, a change to the orientation of the grain in the soundboard, and a construction method which eliminated the removable name-board.

The classification proposed for these surviving spinets of the School of Keene emerges from this analysis. Two features from those listed immediately above were identified as providing clear points of characterisation – the construction of the register, and the keyboard compass. Using these characteristics and arranging the classification chronologically, the instruments can be seen to fall into four groups forming a line of development:-

1. The early instruments having a soundboard register and probably produced at the same time as virginals were being made in the Keene workshop, or shortly after virginal production had ceased. Only two instruments having these characteristics have been definitively identified:- one, to which a date c. 1682 has been attributed is held at the Royal College of Music, and one at Hall i' th' Wood, near Bolton, Lancashire which has is thought to date from c. 1685. There is a possibility that there are two more early Keene spinets, the anonymous instrument at the Royal Northern College of Music, which may be by Keene, and the Keene spinet listed in Table 501 as belonging to a Mr E R Hawkins.
2. A group of later instruments made either by Keene himself, or under his guidance by one of his apprentices, or co-signed by Edward Blunt, with a 54

note keyboard compass of GG/BB-d''' and a box-guide register similar to that found on Italian and early-English harpsichords. At least thirteen of these 'standard' instruments from the School of Keene are thought to have survived, and there may be several more. Two of the instruments in this category bear inscriptions indicating that they were made during the time that Edward Blunt and Keene were in partnership. All were produced between about 1690 and 1710. Many are dated, but the work reported allows an additional attribution, that of the date c.1707 for the spinet formerly at the Kenneth G Fiske Museum in Claremont, California.

3. The 'transitional' spinets made by Brackley, both while Keene was still alive and after his death in 1712, having an extended keyboard compass. Only three instruments have been identified as belonging to this group. One instrument is dated 1711, but in addition the Keene & Brackley spinet can now be said to date from c.1712, and the Brackley instrument, which has a fully chromatic compass GG-e''' of 58 notes from 1712-1718. Thomas Barton may also have made instruments of this type, though none have been identified during the research.
  
4. Five-octave spinets made by Barton. Though only one of these has been definitively located, it is clear from the literature that a number of these have survived, perhaps even as many as ten.

Adopting this classification, the surviving instruments which have been located or for which details have been obtained from secondary sources are set out in Table 1001 below in their respective groups. A number of these instruments are undated

but in Table 1001 date attributions, based on analysis of the data gathered during the research have been added. These dates are in an emboldened font.

<b>Table 1001</b>			
<b>Proposed Grouping of Spinets from the School of Keene</b>			
<b>Boalch No.</b>	<b>Maker</b>	<b>Date</b>	<b>Owner/Location</b>
<b>Group 1</b>			
6	Keene	<b>c.1682</b>	Royal College of Music, London
24	Keene	<b>c.1685</b>	Hall i' th' Wood, Bolton, England
<b>Group 2</b>			
4	Keene	1700	Museum of Fine Arts, Boston
5	Keene	1700	Colonial Williamsburg Foundation
7	Keene	Undated	Cantos Musical Foundation, Calgary
8	Keene	1704	University of Edinburgh
10	Keene	1705/6	MKG, Hamburg
12	Keene	1711	Westwood Manor, Bradford-on-Avon
15	Keene	Undated	Memorial Hall Museum, Deerfield, Mass
17	Keene	<b>c.1707</b>	Musical Instrument Museum, Phoenix, Az
19	Keene	1707	Grimsthorpe Castle, Bourne, Lincs
20	Keene	Undated	City of Hammamatsu, Japan
28(A)	Attributed	1708	Royal College of Music, London
29	Keene & Blunt	1702	Dumfries House
30	Keene & Blunt	<b>c.1702</b>	Private Owner, Lancaster
	Blunt	1703	Sold at Sotheby's 2004
<b>Group 3</b>			
31	Keene & Brackley Brackley	<b>c.1712</b> <b>1712-1718</b>	P G Mole, Shropshire, England Private Owner, Philadelphia
<b>Group 4</b>			
	Barton	1724	Formerly Blickling Hall, Norfolk
	Barton	1730	Smithsonian Institution, Washington D.C.

A striking feature of spinets from the School of Keene is that in no instance has clear evidence emerged of the keyboard compass having been altered. That stands in contrast to the position for the instruments made by some of Keene's competitors, Player and Sison for instance. It seems likely that the reason why no Keene spinet has been altered is that he had learned to take account of a changing market and that

he taught his apprentices to do the same. Therein, probably, lies the source of his unusual wealth.

### c. The School of Hitchcock

Research on the school of Hitchcock began with an investigation of the relationships within the Hitchcock family, which scholars have struggled to understand for decades. The establishment of the dates of salient events in the lives of the Hitchcocks is a *sine qua non* of a proper understanding of the relationships between their instruments. The conclusions of James, first published in 1930, have proved particularly influential, but in the light of new information obtained from archival sources during this research, they have been shown to be mistaken. Thomas Hitchcock the Elder, who has been assumed in the past to have been a spinet maker was a chair maker, and his widow Mary continued with his chair-making business long after his death: that Thomas the Elder made any instruments at all is open to serious question. The father-son relationship of Thomas the Elder to Thomas the Younger has been confirmed, but no similar relationship of Thomas the Younger and John Hitchcock has been found. Though Thomas the Younger had several children from two marriages, no son named John has emerged from the records.

The search for a person who provided John Hitchcock with the entitlement to take freedom of the Haberdashers Company by patrimony, and the existence of a spinet by Edward Blunt and dated 1703, which bears the initials and name of a Thomas Hitchcock, has lead to the identification of a hitherto unknown member of the Hitchcock family, 'Thomas Hitchcock Free 1701'. This person was both the father of John Hitchcock and the author of the inscriptions on the Blunt spinet.

The identification of Thomas Hitchcock Free 1701 provides a new understanding of the chain of proprietorship of the Hitchcock spinet-making firm. Although the firm could theoretically have been started as early as 1703 by the hitherto unknown Thomas Free 1701, it is thought more likely that it began between 1703 and 1715 and probably, judging from evidence from property taxation, about 1711. No reliable documentation of a surviving instrument forces a conclusion of an earlier date of commencement. The firm then passed from the sole proprietorship of Thomas Free 1701 to a partnership that included Thomas the Younger. The date of death of Thomas the Younger, which had been lost for decades, has been re-discovered: he died suddenly in 1737 as a result of a coaching accident. At his death, Thomas Free 1701 again became sole proprietor of the Hitchcock business, but thereafter it passed to John Hitchcock, presumably after the death of Thomas Free 1701, the date of which is unknown. The business probably subsisted for only a short period after John Hitchcock's death in 1774, since by then the popularity of the square piano had rendered the spinet obsolete.

Many of the artisan craftsmen who worked for the Hitchcocks and who left names or initials on Hitchcock spinets have been identified. That identification leads to an explanation of how the firm's production run was managed during the proprietorship of John Hitchcock from about the mid 1750s until his death. It is suggested that John Hitchcock was acting as an 'upholder' by the mid 1760s – that is to say he adopted a role in which he acted as the interface between the customer and the craftsman who actually made the instruments. He adopted the modern practice of out-sourcing the

production of his instruments from independent makers such as Thomas Culliford and Americus Backers.

The earliest surviving Hitchcock spinet, Serial No. 471, has a 58 note keyboard compass (GG-e<sup>'''</sup>). In the terms of Chapter Five it is therefore a 'transitional' instrument: it is thought to date from about 1715. The surviving instruments which are later in date than No 471, those which are dated or which bear higher serial numbers than 471, are five-octave instruments. With one exception, which has a keyboard compass of FF-f<sup>''</sup>, and which is stated in the literature to have been altered, all these five-octave instruments have a GG-g<sup>'''</sup> compass. The Hitchcocks, with Barton and some other makers were responsible for bringing the spinet to its maturity as a five-octave instrument.

Analysis of the serial numbers of surviving Hitchcock spinets shows that they exist not in a single numerical series as has been previously presumed but in three incomplete series – those below 999, those from 1000 to 1999, and those of 2000 and above. Within these series only three instruments are known to have survived from the group numbered up to 999, the highest serial number found being 616: of those numbered from 1000 to 1999 thirty-three spinets are known to have survived with the highest number being No. 1677; and of those numbered above 2000, there are only two. There are six other spinets for which the serial number is unknown, making a probable total of forty-three which survived to modern times, though one was lost in a fire in the 1970s. The assumption that the Hitchcocks made over 2000

spinets, which the author and other scholars have made until now,<sup>2</sup> is therefore almost certainly unfounded.

To start a numbering system at No. 471 or to omit certain numbers on a random basis would be very eccentric, but that cannot be ruled out. All that can be said with a degree of certainty is that the Hitchcocks made at least 146 spinets in the series 471-616, 670 spinets in the series 1007-1677, and eight others which have survived, making a likely minimum output of 824. It is difficult to know how far to extend this calculation, but it would be surprising if the total output reached 1200. Since the Hitchcocks were in business from about 1711 until about 1774, at least, these figures would equate to an average production of about 13 to 20 spinets per year – a not unreasonable expectation given the resources of the Hitchcock firm. It should be added that these average figures will have been subject to considerable variations.

Not many Hitchcock spinets are dated and this has lead scholars, including the author, to attempt to establish a serial number/date correlation. However, all the earlier analyses have taken it as axiomatic that the serial numbers are in a single series. A consequence is that the earlier correlations are in error. A new serial number/date correlation curve is provided as Figure 702 of Chapter Seven.

#### d. The Hitchcocks' Two Models

The organological analysis of surviving Hitchcock spinets focused on their plan form, the style of their veneering, and the design of their stands, since these features

---

<sup>2</sup> Mole 2007

provided points of distinction. Two basic case forms appear, those with a mitred tail and those in which the bentside has a serpentine shape, obviating the necessity for a separate tail. Similarly, the spinets are found with two styles of veneering, a simple style in which the interior of the case and the nameboard are veneered in plain sycamore or perhaps later, satinwood, with a triple stringing inlay, and a more elaborate style using figured walnut veneer, feathered banding inlay and an ogee cartouche for the inscription on the nameboard. Two designs of stand have also been found, a plain design in which the legs and feet are turned, and a more elaborate design including a 'hoof' or 'scroll' foot. The results of this analysis have led to the identification of two 'models' of spinet – a basic instrument having a mitred tail, simple veneer and a turned stand and a superior model having a serpentine tail, figured walnut veneer and a stand with a scroll foot. These two models were made side-by-side in the Hitchcock workshop right through the production run.

It follows that unlike the School of Keene, which produced spinets which can be shown to stand in a line of development, the spinets from the School of Hitchcock were settled in their design at an early stage and then existed as two models. The mitred-tail spinets were developed in size initially, but the serpentine ones appear to be substantially identical in case size and plan form.

The Hitchcock workshop was substantial and was able to accommodate special orders. There are examples of instruments which are 'hybrids' in the treatment of their veneers and several instruments with ebony natural plates have been identified. In addition to those spinets which are seen as special by virtue of their decorative

treatment, there are surviving instruments which are structurally distinct from the Hitchcocks' standard products. Several spinets have a nut which is convex towards the player, which is shown to alter the timbre of the instrument in the tenor especially to make it more 'flutey' than the standard spinet with a dog-leg nut. The tonal difference can be heard on tracks of commercially available compact disc recordings.

An intriguing question is whether it is possible to determine which of the two Thomas Hitchcocks – Thomas Free 1701 or Thomas the Younger – made the instruments which have survived. That has not been possible to determine with certainty, unless it can be said that the craft influences of Benjamin Slade and Edward Blunt, exerted on their former apprentices, can be seen to carry through into the two different models of Hitchcock spinet. If that is the position, then it can be said that Thomas the Younger will be the man more likely to have made the serpentine spinets (because Slade is known to have made serpentine-tailed instruments also) and Thomas Free 1701 the more likely to have made the mitred-tail spinets (because Blunt is not known to have made spinets in anything but the mitred-tail form).

The Hitchcocks were able to establish the spinet as an instrument of choice in early-Georgian England to the point that it is difficult to define any significant competitor until Shudi and Kirkman began to make harpsichords by equally efficient manufacturing processes. Though Hitchcock products were undoubtedly of very high quality, in retrospect it is possible to characterise the main contribution of the Hitchcocks to musical instrument making as being a marketing innovation - the offer

of standard instruments with a list of 'options'. This approach became standard practice once the larger factory instrument workshops became established at the end of the eighteenth century.

#### **4. Design and Decoration in Context**

The lines of development and the settled characteristics established in earlier chapters for the spinets from the schools of Keene and Hitchcock need to be set in context. This task was approached by comparing and contrasting spinets from each school both with each other and with spinets from other makers. By comparing the size and plan form of selected spinets from three temporal periods it is shown that early spinets by Keene and by Player were made to different plan forms but that the overall size of their spinets was generally comparable. In the first decade of the eighteenth century the size and plan form of spinets became remarkably standardised. The Keene 1704 spinet and the Benjamin Slade spinet at the Red Lodge Museum, Bristol are typical of what was termed the 'standard' Queen Anne spinet. Later instruments dating from 1711 to 1718 such as the Thomas Hitchcock spinet Serial No. 471 show essentially the same plan form as the 'standard' instruments but are larger, the Hitchcock considerably so. A standardisation similar to that of the Queen Anne spinets can be seen in the five-octave serpentine-tail spinets of the Hitchcocks and of Aston from the post-1720 period. Though case height variations have been observed, it is not thought that these assist organological classification of the spinet.

Two different designs of register have been found in the spinets inspected, the soundboard register and the box-guide register. Attention was drawn to the different designs of individual jack guides, the ones with parallel sides being thought redolent of virginal making and the cruciform ones being from a later practice.

The classification of spinets into three temporal periods is reinforced by an analysis of changes in keyboard compass. Early spinets typically have a keyboard compass of fifty, fifty-two or fifty-three notes, though the precise disposition varies from instrument to instrument. The standard spinets made between about 1690 and 1710 have fifty-four notes with a compass GG/BB-d''' with two split sharps in the bass octave. Later 'transitional' instruments built after 1710 have a wider compass approaching, though not reaching five octaves. The two surviving transitional Keene instruments have keyboards in which the two extreme sharps, GG# and d#''' are missing. The five-octave spinet was established by 1720. Except for Serial No 471, all Hitchcock spinets have five-octave compasses so far as is known and nearly all five-octave spinets have a configuration of 61 notes, GG-g'', though there are exceptions which have only 60 notes, omitting a sharp in the bass.

The pitch and the design of the string-band in a keyboard instrument are related. The conflicting views of scholars about the pitch at which spinets were intended to be tuned were resolved by referring to cultural changes at the Restoration and to evidence from surviving contemporary recorders which point to a pitch of a''~403Hz. for the early spinets, with a tendency for this pitch to rise, reaching 420Hz. by 1740. The string lengths found in spinets is consistent with this pitch even, in

most cases, if the instrument is strung in brass throughout the compass. It is in only in the very early Keene spinets that it would have been necessary to resort to iron stringing at this pitch, and then only in the extreme treble. It has been shown that like the virginal, and unlike the harpsichord, the geometry of the spinet allows timbre to be varied by variations in the plucking point of the strings.

Attention was drawn to changes which took place in late-seventeenth century England in the availability of raw materials for making keyboard instruments. The initial move to the use of walnut for building spinets was driven largely by the adoption of French styles of furniture making and walnut continued to be used until the mid-1730s. Early brass making in England was not successful and as a consequence, workers who produced brass items in the 1680s usually relied on importation for their raw material. By 1720, good quality domestically produced brass was being produced. Brass wire was being made by 1720 initially in Esher, close to London. Ivory was being imported into London from West Africa in large tonnages by 1700.

The similarities in the designs of marquetry cartouches, of brass furniture and of the stands found in spinets from different makers suggest that these items were sourced from specialist suppliers. Analysis of the marquetry cartouches shows that they fall into four distinct groups – seaweed designs, floral designs, designs with stylised exotic birds and designs containing both naturalistic images of both exotic birds and flowers. Some information about date can be derived from the style and

workmanship of the cartouche: there is a marked deterioration in the quality of the marquetry work in cartouches in the later instruments.

The brass furniture found on spinets also provides information about its date. The commonly found brass furniture on late-Stuart spinets is to a single pattern and it is thought that these items were made in small forges close to the Port of London where the metal alloy was off-loaded. Later instruments (1715-1723) have a different style of furniture which has been found in more than one pattern, and the Hitchcock spinets and instruments from other makers of instruments from post-1725 have brass furniture of a lighter casting which is chased. It is thought that the brass items which appear on these early-Georgian spinets were produced in Birmingham or Wolverhampton.

Stands for late-Stuart spinets are made using legs which have been turned to standard architectural profiles, but they do not appear in a consistent pattern. Reasons for that are suggested, the most important of which is that the craft monopoly of the Tuners Company prohibited the making of turned items by persons who were not Freemen of that Company. This necessitated a variety of third-party contractors supplying spinet stands, if stands were required. Stands of early-Georgian spinets occur more frequently in a consistent pattern and often exhibit the scroll foot. It is thought that stands of Hitchcock and other serpentine-tail spinets which are of similar design may have been made by the Hitchcock chair-making firm.

## **5. Methodological Conclusions**

This summary has set out the substantive conclusions of the research, but it is also important to note the methodological conclusions. The research reported here relies on empirical data derived from physical inspection of a large number of spinets, but it also relies significantly on investigation of archival sources. These sources have illuminated the lives of the spinet makers which have been studied: in several instances new evidence has provided missing items of historical data – the dates of death of Stephen Keene, of Charles Brackley, and of Thomas Hitchcock the Younger being examples – which allow dates to be attributed to some spinets with a new confidence. The archival resources for English makers are exceptionally rich and much of the data which they contain has become accessible electronically in recent years. In the author's view, the research methodology used here, a combination of physical inspection of instruments and searches in the archival sources has been shown to be so powerful that it would be difficult to justify a study of English-made musical instruments now without reliance on both techniques.

## **6. Further Research**

The research on which this dissertation is based is inevitably incomplete. The English spinet of the late-Stuart and early-Georgian periods enjoyed considerable popularity. Large numbers of these and later instruments have survived and some are still emerging from sources hitherto unknown, even in the early years of the twenty-first century. There is therefore ample opportunity for further studies to be

carried out to provide greater understanding. Three of these opportunities are set out below:-

1. One opportunity stems from the limited time-frame of the present study. Spinets continued to be produced until they were made obsolete by the square piano by about 1785 and a substantial number of instruments from the years 1740 onwards have survived. It is thought that these instruments, which have been included here by exception, could provide the focus of one or more major research projects.
2. A more limited opportunity would be to investigate the Harris family and their output of keyboard instruments. One member of the family, John Harris, emigrated to Boston, Massachusetts. The author has encountered considerable interest in the family from American organologists.
3. In the choice of the scope for this research, which is the first comprehensive major study of the English spinet, one major maker, Charles Haward, did not receive any significant attention. A research project directed to Haward's instruments would be valuable, though there are some practical difficulties inherent in this since the instruments are widely spread geographically.

- END -