

Investigating the Role of the Hippocampal Formation in Episodic and Spatial Memory

Cassie Hayley Stevenson



Doctor of Philosophy
Biomedical Sciences
School of Medicine and Veterinary Medicine
University of Edinburgh
2011

Abstract

This thesis aims to explore the two dominant functional roles of the hippocampal formation, in the relational encoding of episodic memory and the neural representation of allocentric space, using a combination of pharmaceutical manipulations and single-unit recording techniques in rodents. The first part of this thesis focuses on episodic-like memory, defined by the original episodic memory triad: ‘what-where-when’ (Tulving 1972), which enables the behavioural aspects of episodic memory to be tested in non-human animals. Permanent neurotoxic lesions of the hippocampus and its subregions were induced to assess their role in a putative episodic-like memory task developed by Eacott and Norman (2004). In view of the difficulties encountered in successfully demonstrating the temporal component of episodic-like memory in rats, this task tested integrated memory for ‘what-where-which’, where the temporal component (when) was replaced with another event specifier: context (on ‘which’ occasion). Disruption of the hippocampal circuitry led to a specific impairment in the integration of all three event components, whereas the associative recognition of any combination of these features in isolation was left intact. These results confirm the hippocampal dependence of this episodic-like memory task and further reveals the necessity of both CA3 and CA1, hypothetically due to the underlying autoassociative role of CA3 with CA1 functioning as the vital output pathway for this associated information and/or as a mismatch detector. There has been much debate over the inclusion of the temporal component and sceptics may argue that any such interpretations of task-dependence on episodic-like memory processing are invalid considering the requirement for temporal processing is absent. Due to the proposal that a temporal framework necessarily provides the foundation on which episodic memories are built, the second chapter focuses on the development of a suitable protocol in which integrated memory for the original ‘what-where-when’ episodic memory triad can be reliably tested.

The other main function attributed to the hippocampus was brought to light by the fascinating revelation that its neurons selectively fire in different regions of an environment, termed ‘place cells’ (O’Keefe and Dostrovsky 1971). From the numerous publications resulting from this discovery it has emerged that place cells not only respond to the spatial features of the environment but are also sensitive to a multitude of non-spatial features. These characteristics support the logical assumption that the primary firing patterns of the hippocampus should underlie its main purported roles, leading to speculations that they reflect episodic memory processes. The second part of this thesis aims to examine the relationship between hippocampal cells and behaviour by extending the work of Ainge et al. (2007a), in which a subset of hippocampal place cells were found to encode both current and intended destination in a double Y-maze ‘win-stay’ task. The development of these ‘goal-sensitive’ cells were initially investigated during the learning phase of this task. An exciting pattern of results showed a strong positive correlation between the emergence of goal-sensitive firing and behavioural performance on the task, tempting speculations that these firing patterns may underlie spatial learning and future planning, necessary to support per-

formance. To ensure these firing patterns were not a mere reflection of greater experience on the maze, a second study was conducted in which the task demands changed over set periods of days. A significant increase in the proportion of cells demonstrating goal-sensitive firing was revealed when the protocol shifted to incorporate the spatial memory demands of the 'win-stay' task, with all other parameters of the protocol remaining constant. These results support the theory that goal-sensitive firing patterns are specifically related to the learning and memory demands of the spatial task, not a result of increased exploration of the maze. The last of this series of studies assessed hippocampal-dependence of this task and revealed that bilateral hippocampal lesions induced an impairment in spatial 'win-stay' performance. Collectively, these experiments demonstrate that goal-sensitive firing of hippocampal cells emerge in line with behavioural performance in a hippocampal-dependent task and the emergence of these firing patterns are specific to the learning and memory demands of a spatial 'win-stay' protocol.

The functional role of the hippocampus in allocentric spatial processing may thus underpin its function in episodic memory and potentially in the imagining and planning of future events, whereby the hippocampus provides a 'space' in which retrieved information can be integrated in a coherent context to support the fluent and flexible use of information. This hippocampal function would necessarily require visual information to be accessed, concerning the arrangement of landmarks and cues within the environment, in association with information regarding internal orientation and direction and this leads to the question assessed in the final part of this thesis of where this integration occurs. Based on anatomical evidence and the current literature, the postsubiculum, an input structure to the hippocampus, emerged as a potential site for the convergence of sensory cues into the internally generated head direction cell and place cell networks to enable hippocampal-dependent spatial processing. Thus, the effects of temporary pharmacological blockade of AMPARs and NMDARs in the postsubiculum were assessed on the encoding of spatial memory in an object recognition paradigm. The impairment revealed in the ability to recognise novel object-place configurations demonstrates a key role for NMDAR-dependent plasticity within the postsubiculum itself in the formation of allocentric spatial memory.

In summary, the experimental results reported in this thesis further elucidate the critical role the hippocampal formation plays in spatial and episodic memory by combining evidence from cellular physiology and neuroanatomy to the behaving animal and extends these findings to discuss a more general role for the hippocampus in imagining both past and future events, in order to successfully navigate, learn and enable past experience to influence our intended future plans and decisions.

Acknowledgements

First and foremost, I would like to thank my family for all the tolerance, understanding and encouragement they have relentlessly shown over the course of my PhD, in particular to my parents, Rick Hosburn and Tatiana Shuttleworth, for their constant support throughout the entire course of my studies and also to my husband Simon, whose exceptional patience and faithful support has pulled me through the final stages of my PhD and to whom this thesis is dedicated.

Many thanks for the generous help, tolerance and support of my colleagues, namely: Steven Huang, Dave Bett, Mike Smith, Ros Langston, Jane Tulloch, Kate Shires, Brittany Davis, Dorothy Tse, Ingrid Bethus, Roger Redondo and Steph Daumas, for going out of their way to help with numerous projects, offering advice and also, most importantly, providing a great place to work and for always being there in my many hours of need! Paul Dudchenko has also endured hours of discussions, offered countless experimental ideas and suggestions, and his infectious positivity and enthusiasm regardless of the nature of the experiments being discussed, has been greatly appreciated.

Finally, a huge thank you to my supervisor Emma Wood for providing invaluable, friendly support throughout the entire course of this PhD and without whom this thesis certainly would not exist!

Declaration

I declare that this thesis was composed by myself, that the work contained herein is my own except where explicitly stated otherwise in the text, and that this work has not been submitted for any other degree or professional qualification except as specified.

(Cassie Hayley Stevenson)

To Simon Adrian Stevenson

Table of Contents

I	Introduction	1
0.1	Learning and Memory	2
0.1.1	Classification of Memory	2
0.1.2	Synaptic Modification Model of Learning and Memory	3
0.2	The Hippocampal Formation	4
0.2.1	Investigative Techniques for Exploring Hippocampal Functions	6
0.2.2	The Rat Hippocampus	7
0.3	The Hippocampus in Episodic Memory	16
0.3.1	Episodic Memory	16
0.3.2	Episodic-like Memory	19
0.3.3	Planning, Decision Making and Imagination	32
0.4	The Hippocampus in Spatial Memory	34
0.4.1	Place Cells	36
0.4.2	Neural Networks in Navigation	45
0.5	Aims of this Thesis	50
II	Experiments	52
1	The Role of Hippocampal Subregions in Object-Place-Context Recognition	53
1.1	Introduction	53
1.2	Materials & Methods	58
1.2.1	Subjects	58
1.2.2	Lesion Surgery	59
1.2.3	Apparatus	59
1.2.4	Behavioural Testing	62
1.2.5	Histological Procedures	66
1.2.6	Data Analysis	66
1.3	Results	67
1.3.1	Histological Data	67

1.3.2	Behavioural Data	69
1.4	Conclusions & Discussion	71
2	Integrated Memory in an Object-Place-Temporal order Recognition Task	78
2.1	Introduction	78
2.2	Materials & Methods	82
2.2.1	Subjects	82
2.2.2	Apparatus	82
2.2.3	Behavioural Testing	83
2.2.4	Data Analysis	88
2.3	Results	88
2.4	Conclusions & Discussion	92
3	The Development of Goal-Sensitive Cells on a Double Y-Maze ‘Win-Stay’ Task	96
3.1	Introduction	96
3.2	Materials & Methods	101
3.2.1	Subjects	101
3.2.2	Single-Unit Recording Implants	101
3.2.3	Single-Unit Recording Implant Surgery	102
3.2.4	Single Unit Activity: Screening and Recording	102
3.2.5	Apparatus	103
3.2.6	Behavioural Testing	104
3.2.7	Histological Procedures	104
3.2.8	Data Analysis	105
3.3	Results	107
3.3.1	Histological Data	107
3.3.2	Behavioural Data	107
3.3.3	Single-Unit Recording Data	109
3.3.4	Behavioural Performance and Goal-Sensitive Firing Relationship	112
3.4	Conclusions & Discussion	114
4	The Development of Goal-Sensitive Cells across Double Y-Maze Paradigms	118
4.1	Introduction	118
4.2	Materials & Methods	120
4.2.1	Subjects	120
4.2.2	Single-Unit Recording Implants and Surgery	120
4.2.3	Single-Unit Recording System and Activity Screening	121
4.2.4	Behavioural Testing	121

4.2.5	Histological Procedures	122
4.2.6	Data Analysis	123
4.3	Results	125
4.3.1	Histological Data	125
4.3.2	Behavioural Data	125
4.3.3	Single-Unit Recording Data	131
4.3.4	Behavioural Performance and Goal-Sensitive Firing Relationship	136
4.4	Conclusions & Discussion	137
5	The Role of the Hippocampus across Double Y-Maze Paradigms	141
5.1	Introduction	141
5.2	Materials & Methods	146
5.2.1	Subjects	146
5.2.2	Lesion Surgery	146
5.2.3	Behavioural Testing	148
5.2.4	Histological Procedures	150
5.2.5	Data Analysis	150
5.3	Results	153
5.3.1	Histological Data	153
5.3.2	Behavioural Data	153
5.4	Conclusions & Discussion	183
6	The Role of the Postsubiculum in Spatial & Non-Spatial Recognition Memory	189
6.1	Introduction	189
6.2	Materials & Methods	195
6.2.1	Subjects	195
6.2.2	Bilateral Cannulae Implant Surgery	195
6.2.3	Apparatus	196
6.2.4	Preliminary Testing of the Behavioural Protocol	197
6.2.5	Habituation	198
6.2.6	Behavioural Testing	198
6.2.7	Infusion Protocol	201
6.2.8	Histological Procedures	203
6.2.9	Data Analysis	203
6.3	Results	204
6.3.1	Histological Data	204
6.3.2	Behavioural Data	205
6.4	Conclusions & Discussion	207

III	Concluding Remarks	213
6.5	Concluding Remarks	214
6.5.1	Associative Object Recognition: The Role of the Hippocampus	215
6.5.2	The Role of Place Cell Firing on Navigational Decisions	217
6.5.3	The Role of the Postsubiculum in Object-Place Recognition	218
6.6	Future Extensions	221
6.6.1	Associative Object Recognition: The Role of the Hippocampus	221
6.6.2	The Role of Place Cell Firing on Navigational Decisions	222
6.6.3	The Role of the Postsubiculum in Object-Place Recognition	223
A	Additional Data	224
	Bibliography	228

Abbreviations

AMPAR	alpha-amino-3-hydroxy-5-methyl-4-isoxazolepropionic acid receptor
AP5	D(-)-2-amino-5-phosphonopentanoic acid
CA	cornu ammonis
CNQX	6-cyano-7-nitroquinoxaline-2,3-dione
CNS	central nervous system
CSF	cerebrospinal fluid
EPSP	excitatory postsynaptic potential
ERP	event-related potential
fMRI	functional magnetic resonance imaging
LTD	long-term depression
LTP	long-term potentiation
NMDAR	N-methyl-D-aspartate receptor
PET	positron emission tomography
REM	rapid eye movement
SEM	standard error of the mean

Part I

Introduction

0.1 Learning and Memory

Postulations regarding how the mind works have been proposed since the days of Aristotle and remain an area of keen debate across the fields of philosophy to medicine to molecular biology. The mechanisms underlying one of the most fascinating cognitive processes, memory, remains to be elucidated. Memory represents the ability to store, retain and retrieve information; the critical role it plays in our lives, in many cases defining who we are, is highlighted, like many things, by its absence. Alzheimer's disease erases an entire lifetime of memories having a devastating impact on its victims and their families. Cases in which memory is disrupted either through disease or physical trauma provide essential insights into the neural networks and/or processes underlying these functions, progressing our understanding and enabling putative therapeutics to be developed.

0.1.1 Classification of Memory

The categorisation of memory based on anatomical functions was mainly driven through investigative studies stemming from the patient Henry Gustav Molaison (H.M.), who underwent radical bilateral surgical removal of parts of the medial temporal lobe, a region which encompasses the hippocampus, entorhinal cortex, perirhinal cortex and parahippocampal cortex (homologue of the rat's postrhinal cortex). This resulted in 50% of the anterior hippocampus and parts of the amygdala and olfactory cortex and the parahippocampal gyri (Corkin et al. 1997) being removed in an attempt to relieve his epileptic seizures. H.M. became the most studied individual in the history of neuroscience (Squire 2009), providing fascinating insights into the workings of memory and the organisation of the medial temporal lobe for five decades, until his death in December 2008. Intellectual and perceptual abilities were unaffected by the surgery and he was able to retain information for as long as he was able to rehearse it, actively maintaining the immediate memory but this information was rapidly forgotten if distraction interfered with the process of rehearsal, supporting an anatomical distinction from the ability to successfully encode and retrieve information in long-term memory (Corkin 2002). Furthermore, H.M. was capable of learning skill-like tasks, such as the ability to mirror draw, despite lacking the conscious knowledge that learning or even the task itself had taken place. Such findings have led to a division of long-term memory between declarative (information about facts and events which can be clearly communicated, e.g. the ability to recall the events of 9/11) and non-declarative memory (expressed through performance, which is hard to describe, e.g. the ability to ride a bicycle) (Squire and Zola 1996). Since this time further sub-classifications have been made under the non-declarative umbrella to include classical conditioning, priming, procedural (skill) learning and non-associative learning. These non-declarative memories remained intact in H.M. whereas declarative memory was largely impaired, suggesting a specific role for the medial temporal lobe in processing declarative memory. Like non-declarative

memory, declarative memory can be further divided into semantic and episodic memory (Tulving and Markowitsch 1998) (see figure 1 for an overview of long-term memory categorisation). Semantic memories consist of general facts about the world which are recalled without the additional contextual information which were associated with the initial learning of the fact, for example ‘Paula Radcliffe is the current world record holder in the women’s marathon’. Episodic memory refers to the context-rich recollection of unique personal experiences, for example ‘the birth of your first child’.

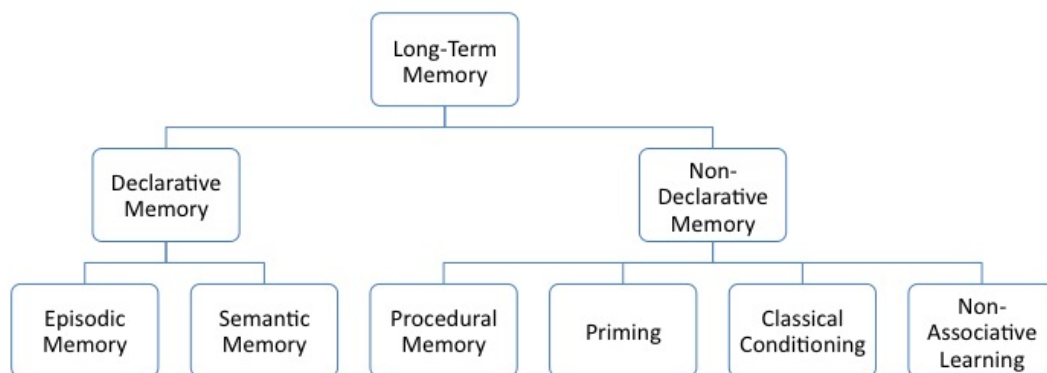

Figure 1: Taxonomy of long-term memory. Declarative memory includes both episodic (recollection) and semantic (familiarity) memory, whilst non-declarative memory includes procedural memory (skills), priming effects, simple classical conditioning and non-associative memory. Figure adapted from Squire and Zola (1996).

0.1.2 Synaptic Modification Model of Learning and Memory

More than 35 years ago the phenomenon of LTP was revealed by Bliss and Lomo (1973) as an activity dependent enhancement of synaptic strength in the hippocampus, now widely believed to underlie the cellular basis of learning and memory. The main focus of the colossal volume of research resulting from this discovery has centred on NMDAR-dependent LTP, the underlying biochemical events of which are beyond the scope of this thesis (see Izquierdo and Medina 1997 for a comprehensive review). Briefly, glutamate released pre-synaptically binds to the AMPARs (responsible for the majority of fast excitatory synaptic transmission throughout the CNS) on the post-synaptic membrane, resulting in an influx of sodium ions, which depolarises the post-synaptic cell to produce an EPSP, the magnitude of which determines whether LTP will occur. In NMDAR-dependent LTP, a sufficient depolarisation will unblock the NMDAR by releasing the magnesium ion enabling a large influx of calcium ions, triggering biochemical mechanisms which modify synaptic strength. A specific antagonist of NMDARs, AP5, has been shown to block the induction of LTP in CA1 (Collingridge et al. 1983) and impair the acquisition of hippocampal-dependent tasks (Morris et al. 1986), demonstrating a necessity for NMDAR-dependent plasticity

in learning (for review see Nakazawa et al. 2004). Furthermore, LTP is induced by the acquisition of hippocampal-dependent memory (Whitlock et al. 2006), its saturation occludes new spatial learning (Moser and Moser 1998) and similarly, its enhancement improves spatial memory (Tang et al. 1999). Collectively, these studies provide strong support that LTP is the synaptic model of memory; however, despite accumulating evidence of its necessity for learning and memory its sufficiency is yet to be convincingly demonstrated.

0.2 The Hippocampal Formation

The hippocampus, a heterogeneous structure which lies within the medial temporal lobe, has attracted huge interest from a variety of fields from neurophysiologists through to computational neuroscientists to psychologists and medics, where the question of its function has been hotly debated. Proposed roles for the hippocampal region range from olfaction to anxiety; however, its important contribution to the formation of declarative memory was highlighted in the case of H.M. (Scoville and Milner 1957). Although H.M. did not have a complete selective lesion of the hippocampus, having only 50% removed, the remaining hippocampal tissue would have been rendered unfunctional due to the removal of the entorhinal cortex (resulting in deafferentation of the remaining hippocampal tissue) and the fact that the memory impairments observed in H.M. were not apparent in the investigations of patients with similar levels of hippocampal damage occurring unilaterally or those suffering damage to the amygdalar or olfactory cortex, support a specific role of the hippocampus in declarative memory. Furthermore, patients with selective hippocampal damage appear to acquire a normal level of semantic knowledge whereas episodic memory is effectively eradicated (Vargha-Khadem et al. 1997), focussing hippocampal research on episodic memory (Vargha-Khadem et al. 2001).

Theories regarding a time-limited role of the medial temporal lobe in episodic memory (Alvarez and Squire 1994; Morris 2006) soon emerged as a result of H.M.'s apparent ability to recall autobiographical memories from before surgery, as the retrograde, unlike his anterograde, amnesia was only partial, occurring only three years prior to surgery (Milner et al. 1968). It was therefore proposed that the memory trace is consolidated over time, where the hippocampus stores an index of the multiple cortical regions across which the memory trace is distributed, where repeated reactivations of the memory trace through retrieval strengthens the neocortical connections such that retrieval of factual information can be extracted from the episode in which it was initially experienced, ultimately allowing the information to be supported independently of the hippocampus (Teyler and DiScenna 1986). In the multiple trace theory of memory it is stated that hippocampal independence through consolidation could only be achieved for semantic and not episodic memories, which are hypothesised to require an index relating to the memory to remain within the hippocampus indefinitely, enabling the associated recall of the previous event (Nadel

and Moscovitch 1997; Nadel et al. 2000). The multiple trace theory offers an explanation for the retrograde amnesia evident in patients suffering hippocampal damage, as more remote information is repeated across many episodes, resulting in the formation of multiple indexes, which are argued to allow these memory to be retrieved, based upon the minimal tissue left undamaged. Indeed, re-examinations of H.M. suggested that the remote 'episodic' memories were semanticised such that H.M. was unable to describe any given event with the specific time and place in which it occurred, supporting the theory that episodic memory depends upon the intact functioning of the hippocampus indefinitely (Corkin 2002; Steinworth et al. 2005).

Imaging studies have enabled hippocampal activity to be recorded from healthy individuals performing specific behavioural tasks and have revealed that activity recorded during encoding correlates with performance levels during subsequent retrieval tasks (Davachi and Wagner 2002; Eldridge et al. 2005; Hannula and Ranganath 2008), providing support for the hippocampus' role in mnemonic processing in the 'normal' human brain. The problem with such imaging studies is that they only provide correlational results and thus can not demonstrate causality nor structural dependence and there are often many confounding factors, such as small sample sizes and difficulties due to poor spatial or temporal resolution. Likewise, whilst clinical studies of patients suffering damage to the hippocampal region are invaluable, the sample sizes are very small and there are many uncontrolled variables and damage is usually incomplete or non-specific to a given region. As the general architecture of the hippocampal region is well preserved across species (Amaral and Witter 1989), the rodent hippocampus has emerged as an ideal model for studying memory systems and provides a vital contribution in the quest to elucidate the functional role(s) of the hippocampal system, enabling the precise neural pathways, receptors and subregions to be investigated in large controlled sample sizes using a variety of tasks.

Neuronal recordings from rodent studies revealed the now characteristic spatially-tuned activity patterns of the hippocampal region (O'Keefe and Dostrovsky 1971). The discovery of these spatial correlates fuelled research into the emerging spatial learning and memory function of the hippocampus, in turn leading to the discovery of spatial activity patterns in the human hippocampus (Ekstrom et al. 2003). In more recent times, it has become apparent through single-unit recording studies in rats, that the principal cells of the hippocampal formation encode more than just the rats' present location, where activity has been found to reflect a variety of features such as: past, present and future spatial destinations; goal location; task demands; motivation; head direction; velocity; landmarks; odours and geometric features in the environment (for further information see section 0.4.1). These revelations have drawn the two main theories of hippocampal function together, where the overlapping hippocampal processes involved in the formation of episodic and spatial memory have received growing attention. Through a range of lesioning, recording and imaging techniques the hippocampus has been shown to provide an essential associative mismatch detector function, between current sensory input and recalled memories from similar previ-

ous events, in both rats (Fyhn et al. 2002; Honey et al. 1998) and humans (Kumaran and Maguire 2006, 2007). It is hypothesised that this mismatch detector function, alongside the hippocampus' ability to rapidly encode associated stimuli during unique events (Rudy and O'Reilly 2001) and form an allocentric (environment-centred) representation of space, underlies its critical role in the formation of episodic memory.

0.2.1 Investigative Techniques for Exploring Hippocampal Functions

The development in our knowledge of hippocampal processes and resulting behavioural functions has arisen from advances in investigative tools and techniques available. It has been over 25 years since subregion-specific neurotoxic-induced lesions were first tested on cognitive task performance (Sutherland et al. 1983), which have had a substantial impact in our ability to test hypotheses of functions arising from more complex, widespread, individual human cases. Reversible pharmacological interventions provide another avenue of research, the essential contribution of which, for example led Morris et al. (1986) to uncover the role of NMDARs in spatial learning, through infusions of the NMDAR antagonist AP5, which has subsequently been shown to effectively block LTP induction in CA1 and spatial learning with a similar dose-response characteristic (Steele and Morris 1999). Drug infusions have the advantage over lesioning techniques in the sense that they allow temporal control and enable a powerful within-subjects approach to be implemented; however, their cerebral distribution is often difficult to control, both spatially and temporally and necessarily requires surgery and the stressful process of infusions. More recently, gene targeting techniques have been utilised to assess the functional contribution of specific proteins in learning and memory (Lathé and Morris 1994; Mayford et al. 1995; Wilson and Tonegawa 1997), enabling complete and specific deletions which can be targeted through the Cre/loxP system to specific brain areas or cell types (Tsien et al. 1996a), where subjects do not have to undergo invasive surgical procedures. The production of the NMDAR1 gene specific 'knockout' in CA1 (Tsien et al. 1996b), combined with multiple electrode recording techniques in freely behaving mice (McHugh et al. 1996), have revealed that NMDAR-mediated synaptic plasticity is required to enable the acquisition of spatial memories and for 'normal' spatial representation in CA1 (McHugh et al. 1996; Tsien et al. 1996b). One drawback of such genetic manipulations was that the absence of function during development complicates the interpretation of any observed behavioural effects. This limitation was overcome by the emergence of inducible gene-targeting techniques (e.g. Mayford et al. 1995), although the effectiveness of these depends upon how rapid and effective the promoter is and also this technique is currently limited to mice, which are not as appropriate as rats are for examining behaviour in more complex and demanding tasks. Finally, the single-unit recording techniques allows 'normal' function to be assessed 'on-line' in the behaving animal and provides a direct link between the neural activity in the region of interest and behavioural performance (e.g. Wood et al. 2000); however, these studies presently only offer

correlational results and the relationship between neural activity patterns and behaviour is often difficult to interpret conclusively. The techniques briefly discussed are just a handful of those commonly used to probe the behavioural functions of the hippocampal system but highlight the importance of using a combination of techniques and subjects (humans, rats, mice, etc.) to yield the advantages of each in order to maximise our understanding of the important functions of the hippocampus.

0.2.2 The Rat Hippocampus

The hippocampal complex is a term often used to refer to the dentate gyrus, CA3, CA2, CA1, subiculum, presubiculum, parasubiculum and entorhinal cortex (Amaral and Witter 1995). For the purpose of this thesis the term hippocampus will only be used to refer to the CA fields and the dentate gyrus and lesions of the hippocampus will aim to target just these subfields. The subiculum is often included when referring to the hippocampus and in hippocampal lesions; however, the subiculum receives inputs from the entorhinal cortex which do not pass through CA1 and this pathway has been hypothesised to have an important role in spatial learning and memory, therefore the subiculum will be treated as distinct from the hippocampus in this thesis. The rodent hippocampus is located within the medial temporal lobe and is connected with cortical and sub-cortical structures, with input received from multiple modalities across various sensory cortices which potentially enables the multiple types of stimuli involved in relational/episodic memory to be processed. Whilst the anatomical connections between medial temporal lobe structures are well documented (Amaral and Witter 1995; Witter et al. 2000), the question of their behavioural functions is still largely debated.

There are two main pathways in which information can pass through the hippocampus, known as the monosynaptic and the trisynaptic loops (see figure 2). The monosynaptic loop (direct pathway) defines the connections from layer III of the entorhinal cortex to CA1 via the temporoammonic pathway. The trisynaptic loop (indirect pathway) describes the connections from layer II of the entorhinal cortex to the dentate gyrus granule cells which pass information through mossy fibres to the pyramidal CA3 cells, which in turn sends both ipsilateral projections (via the schaffer collaterals) and contralateral connections (via the hippocampal commissure) to CA1. The output from CA1 pyramidal cells travels back to the deep layers of the entorhinal cortex directly and indirectly via the subiculum to complete both loops. Information generally flows unidirectionally through the hippocampus; however, CA3 has a large number of recurrent collaterals through which information can circulate. In addition, the hippocampal output, received by the deep layers of the entorhinal cortex (layers IV-VI), can also be fed back into the hippocampal system by modifying the superficial entorhinal cortex layers (layers I-III), which provide the majority of hippocampal input. The superficial layers of the entorhinal cortex also receive input from the presubiculum (to layer III) and the parasubiculum (layer II, indirectly via the dentate gyrus/CA3) and the ol-

factory cortex. In addition to the hippocampal output, the deep layers of the entorhinal cortex receive inputs from the amygdala, the anterior thalamic nuclei, the retrosplenial cortex, the pre- and infra-limbic cortices, the anterior cingulate cortex and the orbitofrontal cortex.

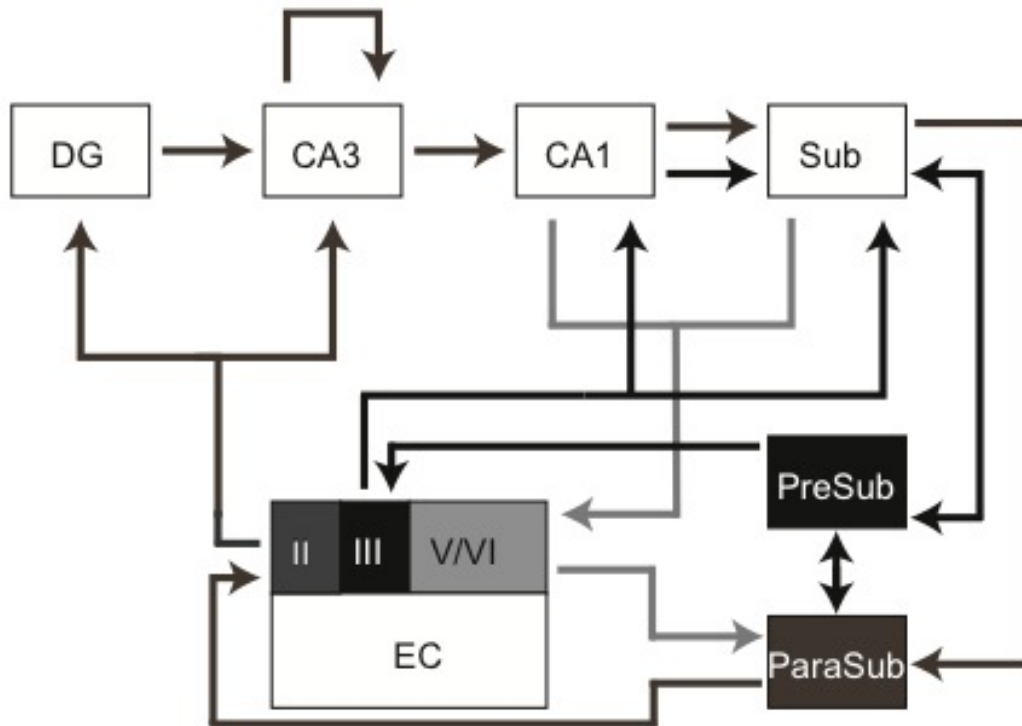

Figure 2: This figure depicts the connectivity within the hippocampal region. The trisynaptic circuit is the main excitatory pathway consisting of the layer II stellate cells of the entorhinal cortex (EC) which connect to the dentate gyrus (DG) granule cells which in turn connect to the pyramidal CA3 cells along the mossy fibres. CA3 pyramidal cells then send inputs to the CA1 pyramidal cells via the schaffer collaterals, with the CA1 pyramidal cells sending inputs back to the deep layers of the entorhinal cortex. The perforant path describes the connection from the stellate cells of layer II of the entorhinal cortex to the dentate gyrus and CA3. The temporoammonic pathway defines the connection from the pyramidal cells of layer III of the entorhinal cortex directly to CA1. The hippocampal connections with the subiculum (sub), presubiculum (presub) and parasubiculum (parasub) are also displayed.

CA1 provides the main route of hippocampal output via the subiculum, which has many connections with cortical and subcortical structures, such as: retrosplenial cortex; perirhinal cortex; postrhinal cortex; septum; nucleus accumbens; mammillary nuclei and hypothalamus. CA3 efferents, however, also project to the septum (Amaral and Witter 1995; Gaykema et al. 1991; Risold and Swanson 1997) which in turn projects to the subiculum and the entorhinal cortex (Amaral and Witter 1995), potentially providing hippocampal output independently of CA1. This enables the separate functions of CA3 and CA1 to be specifically assessed through examination of the effects of lesions on task performance.

Differentiation of Hippocampal Subregions

Traditionally, the hippocampus was thought to provide a serial processing pathway of information from the entorhinal cortex through the trisynaptic loop; however, the parallel entorhinal projection to CA1 alongside the distinct cytoarchitectonic organisation of the hippocampus is suggestive of a differentiation of function amongst the hippocampal subregions. In particular, CA3 has an extensive recurrent collateral system, which provides the largest input to this region (Amaral and Witter 1995, 1989), which has led to theories regarding an associator role (Hasselmo et al. 1995; Levy 1996; Lisman 1999; Marr 1971). In contrast, the feed-forward network of CA1, which has almost no intrinsic excitatory connections, is ideally suited to support a role in matching CA3 output with input from the entorhinal cortex, putatively providing a mismatch detector function between the recall of stored experiences (in CA3) and the current sensory input (in the entorhinal cortex) (Eichenbaum et al. 1990; Hasselmo and Wyble 1997; Lisman 1999; Lisman and Otmakhova 2001). In terms of supporting the hippocampus' role in episodic memory, the individual features of an event were proposed to be represented by a unique ensemble of CA3 cells linked together by autoassociation, supported by the extensive excitatory recurrent connections of this region (Ishizuka et al. 1990; Marr 1971). As CA1 contains a greater number of neurons than CA3 (Boss et al. 1987), with individual CA3 cells projecting to numerous CA1 cells (Ishizuka et al. 1990), it is hypothesised that CA1 cells individually respond to simultaneous activity across multiple CA3 ensembles, enabling the integration of information from CA3, resulting in a more conjunctive representation of an event presented in the CA1 cells (Rolls 1996).

The CA3 recurrent collaterals are thought to act as an attractor network to enable the rapid formation of arbitrary associations, thought to underlie the hippocampus' functional role in associative memory (Marr 1971; McNaughton and Morris 1987; Rolls et al. 1987) and in pattern completion (Gold and Kesner 2005), where input from partial elements of the original event stimulates a subset of the neurons originally active during learning, which in turn re-activates the entire neural network supporting the memory through the autoassociative network of cells in this region, resulting in the retrieval of the complete memory representation.

Gold and Kesner (2005) investigated the hypothesised pattern completion role of CA3 in a study where rats were trained to displace a sample-phase object in order to receive a reward, which could appear in one of five possible locations on a maze surrounded by four extra-maze cues. After a 30-second delay rats were required to locate the sample-phase food well, which was no longer cued by an object, in order to gain a reward. After pre-training, rats received CA3 lesions. The behavioural task was altered post-training such that a subset of the extra-maze cues, available during the sample-phase, were removed. In this task CA3-lesioned rats were impaired relative to controls and this impairment substantially increased as the number of cues available during the test-phase decreased, providing behavioural support for the contribution of CA3 in the pattern completion process (Gold and Kesner 2005). Additional support was obtained in the study

by Vazdarjanova and Guzowski (2004), where the activation levels of CA3 and CA1 were investigated using immediate-early gene imaging (Arc/H1a catFISH) when rats were placed in distinct environments. This study revealed that neuronal ensembles in CA3 displayed greater overlap in their activity between similar environments, relative to those in CA1, which may reflect a pattern completion process within the CA3 region, whereby the familiar features encountered in the second environment, induced the representation of the first environment to be retrieved. Furthermore, Lee et al. (2004b) found higher levels of internal consistency in CA3 place cells than those in CA1 in response to environmental changes, suggesting that CA3, not CA1, is likely to provide a pattern completion role, which is in line with the autoassociative structure of this region which would facilitate this function. Moreover, Nakazawa et al. (2002) found that blocking CA3 NMDAR-plasticity in mice, by 'knocking-out' the NR1 gene, resulted in impaired navigation in the water maze when only a subset of the previously learned cues were available, suggesting that CA3 NMDARs are specifically required for performance in tasks involving pattern completion. CA3 NMDARs are also required for the rapid acquisition of one-trial novel spatial information, but not for incremental spatial learning nor for spatial reference memory acquisition, which relied upon CA1 NMDARs (Nakazawa et al. 2002). Further support of this functional role of CA3 was provided in a study by Nakashiba et al. (2008) in which blocking CA3 output, via a reversible tetanus toxin, impaired rapid context learning and also recollection from a subset of the previously presented cue set. It therefore appears that NMDAR-mediated rapid plastic changes in CA3 are required for the encoding of novel associations of a spatial nature and their subsequent associative retrieval induced by only a subset of cues, where recall is putatively supported by CA1 via back-projections to the neocortex enabling the neural activity patterns from the previously experienced event to be replayed (Rolls and Kesner 2006).

The theoretical role of CA3 in the rapid encoding of trial-unique associations was studied by Kesner et al. (2008) in an object recognition task. In the first sample phase object A is presented in location X, then in the second sample phase object B is presented in location Y, where rats were rewarded for displacing each sample-phase object. In the subsequent test phase, rats were provided with an object cue from one of the sample phases (e.g. A) prior to entering the test arena, in which two identical copies of a familiar non-sample phase object (C) are presented in locations X and Y and the rat is only rewarded for displacing the object positioned in the location that the cued object had previously been positioned in the sample phase (in this example displacing the object in location X would yield rewards). An additional set of trials were performed in which spatial location was used as a cue. In these trials there is a pre-test phase where the familiar object (C) is presented at one of the locations used for object presentation in the sample phase (e.g. location Y) and again the rat is rewarded for displacing the object. Subsequently, the rat is released into the arena where an object from each sample phase (A and B) is located in a new positions (not X or Y) in the arena and the rat is rewarded for displacing the object which was previously

located (in the sample phase) in the position cued by object C (in this case rewards would be obtained for displacing object B). The location upon which objects were presented differed across trials, enabling trial unique associations to be formed. After a period of pre-training, surgery was performed to lesion dorsal CA3 which resulted in significant impairments in performance levels relative to both controls and also to pre-surgery performance. Lesioned rats were, however, able to acquire the task when incremental learning was made possible, albeit at a slower rate of learning relative to controls, with object-location pairs remaining stable across multiple trials and days (Kesner et al. 2008). These results support the hypothesised role of CA3 in the encoding of trial unique, rapidly acquired, spatial associations.

The functional role of CA3 was further investigated in a spontaneous object exploration task in both mice and rats using a complex protocol in which object-place recognition and object recognition could be tested. The task consisted of seven six-minute sessions, each separated by three-minute delays. No objects were presented in session one. In sessions two to four, five different objects (A-D) were presented at distinct locations on the maze. In session five object E displaced object D, which was moved to a novel location, the set of objects and locations then remained stable for session six. In the final session object A was replaced with a novel object (F). Object-place memory was tested by comparing object exploration in sessions five and six with that shown in sessions three and four, whilst object recognition was tested by comparing exploration levels of object F compared with the other four objects in session seven. Lesions of the dorsal hippocampus resulted in a deficit in object-place but not object recognition memory, relative to controls, although lesioned rats did demonstrate a preference to explore displaced relative to the stable objects in sessions five and six (Save et al. 1992). Increased exploration of the novel object-place configuration in sessions five and six were not shown by rats with dentate gyrus, CA3 or CA1 lesions, although all lesion groups displayed a similar preference for novel object exploration in session seven (Lee et al. 2005a). Whereas CA1-lesioned rats had similar exploration levels in sessions five and six, rats with lesions of the dentate gyrus or CA3 did not seem able to distinguish the change in object location pairing as exploration decreased across these sessions suggesting that habituation had taken place. Thus, Lee et al. (2005a) proposed that the dentate gyrus and the CA3 region were necessarily required for novel object-location associations to form, with object and place information being associated within the trisynaptic loop. This suggests a role for CA3 in novelty detection, however, the lack of impairment following lesions of CA1 contrasts with previous literature which support a specific role for CA1 in mismatch detection, based on current sensory input from the entorhinal cortex and recalled previous experiences from CA3 (Eichenbaum et al. 1990; Hasselmo and Wyble 1997; Lisman and Otmakhova 2001). One explanation for these seemingly conflicting data is that rather than showing an important role for CA3 in mismatch detection, these results may be simply highlighting the necessity of CA3 for the associated retrieval of prior memory which necessarily provides information for CA1 to compare with current

sensory inputs. Although this would imply that both CA3 and CA1 are equally important for task performance, the lesser impairments observed in CA1-lesioned rats may have arisen as a result of partial sparing of tissue which would enable some mismatch detection to still occur. The results presented were also not clear-cut as there were subtle differences in the groups responses to novelty, where exploration levels of control rats were not increased as a result of object displacement across sessions five and six, but were increased relative to sessions three and four (an opposite pattern of behavioural responses to that exhibited by the hippocampal-lesioned rats).

Stupien et al. (2003) conducted a similar study, using the same task, in which the effects of temporally controlled inactivation of dorsal CA3 was tested on performance in mice, where activity in synapses between mossy fibres from the dentate gyrus and the CA3 pyramidal cell dendrites was blocked by injecting diethylthiocarbamate (DDC) into CA3. The inhibition of activity across sessions one to five was found to impair reaction to spatial novelty, which remained the case if activity was blocked after session four, with session five occurring after a 24-hour delay; however, if the activity was blocked after this 24-hour delay, i.e. before session five, then object-place exploratory preferences of the treated and control mice were indistinguishable (Stupien et al. 2003). The dentate gyrus to CA3 pathway therefore appears necessary for the early-phase consolidation of object-place memory but does not appear to be required for the subsequent retrieval of this information. Gilbert and Kesner (2003) extended this study to examine the functional role of dorsal CA3 using a similar protocol in which odour-place recognition was additionally assessed alongside object-place associations. For each trial only one odour/object was present in one of the two possible locations, with performance relying upon rats digging in the sand (odour trials) or displacing the object (object trials), if it was positioned at the rewarded location, to obtain the reward. Lesioned rats were significantly impaired at forming odour-place associations and displayed retarded learning of object-place associations relative to controls, whereas dentate gyrus- and CA1-lesioned rats were unimpaired on both tasks. Gilbert and Kesner (2003) therefore concluded that CA3 plays an important role in the association of information only when a spatial element is involved and suggested that this ability may depend upon on the direct projection from the entorhinal cortex to CA3 via the perforant path.

In contrast to the role of CA3, the dentate gyrus is involved in the process of spatial pattern separation of related memories, necessary to enhance the differences between representations (Kesner 2007; Lassalle et al. 2000; Rolls and Kesner 2006). Support for this theoretical role was provided by McHugh et al. (2007) in a dentate gyrus NMDAR 'knock-out' study in mice, in which mutant mice lacked the gene for NR1, a necessary subunit of the NMDAR, specifically in dentate gyrus granule cells. In this study, rate remapping across different geometrical arena shapes was found to be significantly reduced in the CA3 region of the mutant mice, and through fear conditioning, where only one of the two contexts was paired with a footshock, an impairment in the ability to distinguish two similar contexts was revealed, where mutant mice exhibited increased

freezing in the shock-free context, despite demonstrating ‘normal’ contextual fear conditioning in a single context. These results suggest that whilst the mice were able to encode and retrieve context-related information they were unable to distinguish a new, rapidly acquired, contextual representation from similar previously experienced contexts, indicating that the dentate gyrus is necessary for pattern separation. In addition, it is proposed that the large number of dentate gyrus projections, relative to CA3 and the entorhinal cortex, provide an extensive capacity for detecting novelty (Amaral et al. 1990) and that the strong, specific information from the dentate gyrus is then projected to CA3, putatively enabling the orthogonalisation of incoming activity patterns. In summary, the dentate gyrus is considered to provide the first step in the processing of information from the entorhinal cortex, where its unique neuroanatomy alongside results of behavioural investigations has implicated this region in spatial pattern separation, the associational encoding of multiple sensory inputs (Kesner 2007) and the facilitation of spatial encoding, through its outputs to CA3. Whilst only briefly mentioned in this thesis, the dentate gyrus has received substantial attention in an array of fields and has been well reviewed elsewhere (see Kesner 2007 for further information).

CA1 putatively enables the integrative novelty detection of objects in context (O’Reilly and Rudy 2001), where its direct entorhinal input regarding current events is thought to be compared with stored information received from CA3, supporting a role in mismatch detection (Lisman and Otmakhova 2001). Unlike CA3, CA1 is not normally required for item association unless temporal processing is required to associate features of an event across time (Rolls and Kesner 2006; Wallenstein et al. 1998).

Kesner et al. (2005) revealed that the entorhinal pathway to CA1 is necessary to associate non-spatial items (object-odour) over a time delay in an object recognition study. In the object-odour association task rats explored either object A or B before the object was removed. Ten seconds after the object was removed, the rat was placed into the other half of the testing box which contained a pot of sand scented with odour X or Y, an odour which was associated with an object-cued reward contingency (e.g. object A cued that digging in X-scented sand yielded rewards, whereas object B indicated that only Y-scented sand would be rewarded). CA1-lesioned rats were significantly impaired, relative to controls, in preferentially digging in the object-cued odour-rewarded sand (Kesner et al. 2005). Hunsaker et al. (2006) adapted this protocol to include a spatial requirement, where rats were required to displace a block if it was located at X only if object A had been presented whereas object B cued the rats to displace the block located at Y. When this protocol was employed no evidence of learning was found for either CA3- or CA1-lesioned rats, supporting a specific role for CA1 when information must be associated across a delay period, and for CA3 specifically when information to be associated involves a spatial element.

The functional contribution of CA1 and CA3 was specifically examined in an object-temporal order recognition test by Hoge and Kesner (2007). In this task two objects were presented in

the same two location for each phase of the experiment. Two identical objects were initially presented over a set five-minute period in the first sample phase, after which a three-minute delay was imposed. This was repeated with a new set of objects in the second sample phase and likewise for the third sample phase. After a three-minute delay object-temporal order preference was tested by presenting rats with a copy of one object from the first sample phase, and one object from the third sample phase. Additionally memory for the object presented in the first sample-phase was tested in an identical fashion with the exception that in the test phase one object from the first sample phase was paired with an entirely novel object, to ensure intact memory of items from the first sample phase. Control and dorsal CA3-lesioned rats were reported to demonstrate a preference to explore remote objects (presented 19 minutes prior to the test phase) as opposed to the more recently seen objects (presented three minutes prior to testing) indicating memory for the relative recency of object presentation. In contrast, this preference was reversed for the dorsal CA1-lesioned rats which preferentially explored the recently seen object, despite all rats demonstrating a novel object preference in the control task (Hoge and Kesner 2007). Thus the CA1 lesion-induced reversal of exploratory preference was specific to the processing of temporal information, not a consequence of impaired memory for items in the first sample phase.

Hunsaker et al. (2008a) obtained a similar pattern of exploration in a subsequent spatial location temporal order memory study. The task involved different locations being marked out by the same object across three sample phases. In the test phase two copies of the same object were presented, one located in a position from the first sample phase and the other in a position from the third sample phase. Control and dentate gyrus-lesioned rats preferentially explored the most remote object-place pair, CA3-lesioned rats demonstrated no significant preference whereas CA1-lesioned rats preferentially explored the most recent object-place pair. Importantly, all lesion and control groups performed similarly in the control test, where the object-place from the first sample phase was presented with an identical object located in a completely novel location. These results support a specific role for CA1 in the temporal processing of visual object information. The reversal of preference induced by CA1 lesions was proposed by Hoge and Kesner (2007) to be due to an impairment in consolidation with objects presented in the first sample phase being remembered less well than objects presented most recently, where the preference of control and CA3-lesioned rats to explore the most remote object was suggested to result from the longer consolidation period enabling the remote object to be remembered better inducing greater levels of exploration. This theory, however, does not fit in with rats' natural tendency to explore the most novel aspects of the environment, which has been demonstrated in numerous studies (e.g. Eacott and Norman 2004; Ennaceur and Delacour 1988; Good et al. 2007; Langston and Wood 2009). Hunsaker et al. (2008a) proposed a more plausible explanation for these results, that in the absence of a functioning CA1, a compensatory mechanism mediated by the perirhinal cortex could provide a temporal processing function which produces an increased exploration of the most recently presented ob-

ject, thus resulting in the reported reversal of exploration preference when CA1 is lesioned. This would not be due to an inability to temporally process events, as this would have resulted in no significant preference, but that the mechanism by which this occurs is altered to an extra-hippocampal process. This fits better with current theories of object recognition but still does not explain why no preference for remote or recent objects is shown after complete hippocampal lesions (Good et al. 2007) or after dorsal CA3 lesions (Hunsaker et al. 2008a). Furthermore, Gilbert et al. (2001) demonstrated that dorsal CA1, but not dorsal dentate gyrus lesions, induced significant impairments in performance on a spatial location sequence in the radial arm maze, supporting a specific role for CA1 in temporal separation of events in time; however, Kesner et al. (2010) found that dorsal CA1 lesions did not impair temporal order memory for odour sequences, which was instead found to depend upon ventral CA1. This collection of results provides an insight into the complex challenge of elucidating the specific differential functions of the hippocampal subregions which, although difficult to interpret, do generally support a differentiation of function between the hippocampal subregions, where CA1 appears more critical than CA3 in the temporal processing of visual object information.

Studies such as that described by Kesner et al. (2010) also imply a differentiation of hippocampal function along the dorsal-ventral gradient which, whilst beyond the scope of this thesis, is important to outline. The dorsal hippocampus receives inputs from the perirhinal, postrhinal, frontal and insular cortices and is thought to be required for spatial navigation (Steffenach et al. 2005), with studies showing that lesions of the dorsal, but not ventral, hippocampus impair spatial learning (Ferbinteanu and McDonald 2001; Moser et al. 1995; Pothuizen et al. 2004, but see Ferbinteanu et al. 2003). In addition to lesion studies the greater density of place fields in the dorsal relative to ventral hippocampus (Jung et al. 1994) also implies a specific role for the dorsal hippocampus in the processing of spatial information and this is consistent with imaging studies in the human literature (Maguire et al. 1997). The intermediate hippocampus receives inputs from the cingulate cortex and the pre/para-subiculum and is thought to be involved in the translation of cognitive and spatial information into motivation and action (Bast 2007; Bast et al. 2009). The ventral hippocampus receives the majority of its inputs from the amygdala and olfactory cortices and lesion studies have demonstrated an important role for the ventral, but not dorsal, hippocampus in anxiety-related behaviours (Henke 1990; Kjelstrup et al. 2002; Steffenach et al. 2005). In addition, fear conditioning experiments, such as that by Hunsaker et al. (2007a,b) have revealed differentiation of function along the dorsal-ventral axis with regard to the phase of memory processing, where dorsal CA3 contributed to encoding whereas ventral CA3 supported retrieval, and dorsal CA1 was involved in both encoding and retrieval but ventral CA1 mediated retention. The different streams of hippocampal input can also be distinguished with regards to spatial and non-spatial functions, where the perirhinal cortex (projecting mainly to the lateral entorhinal cortex) is thought to process non-associative 'what' features of an event whereas parahippocampal cortex

(projecting mainly to the medial entorhinal cortex) processes the spatial ‘where’ elements of an event (Burwell et al. 1995; Suzuki and Amaral 1994). This theory is supported by a range of studies such, as that by Hargreaves et al. (2005) in which the neurons of the medial entorhinal cortex were found to have more spatially selected firing patterns than those in the lateral entorhinal cortex, which fired based on non-spatial object information. The lateral entorhinal cortex and medial entorhinal cortex send separate projections to the hippocampus, where information from the two areas are only combined on the same neurons in the dentate gyrus and CA3 but input to separate neurons in the CA1 (Witter et al. 2000). This likely underlies the different pattern separation and completion processes of these areas (discussed above) and, the fact that these two pathways mainly converge in the hippocampus, suggests that the hippocampus (specifically the dentate gyrus and CA3) is ideally situated to integrate spatial and non-spatial features of an event, necessary for episodic memory.

Overall, the accumulation of studies investigating the functional roles of the hippocampal subregions have induced a shift in the perceived relationship between these regions, from the traditional view that they operate in series, as part of a feed-forward processing system, to that of a heterogeneous complex with dissociable functions where parallel streams enable differential roles for the subregions in some tasks whilst other tasks require the interaction between CA3 and CA1.

0.3 The Hippocampus in Episodic Memory

0.3.1 Episodic Memory

Episodic memory defines memory for unique, personally experienced events, containing ‘what’, ‘where’ and ‘when’ information, which inherently involves phenomenological aspects such as a ‘subjective sense of time’ and an ‘autonoetic awareness’ to be incorporated in the recollection of the memory (Tulving 2001). This type of memory is particularly sensitive to the effects of ageing (Mitchell et al. 1990), disease (Graham et al. 2004) and brain trauma (Aggleton and Brown 1999) and therefore it is imperative that the neural networks supporting this process are elucidated in order to develop a better understanding and potential therapies to offer treatments for such conditions. Episodic and semantic memory are the subcomponents of the declarative memory system, which were traditionally thought to form a unitary memory system reliant upon the medial temporal lobe (Cipolotti and Bird 2006; Knowlton and Squire 1995; Squire et al. 2004; Squire 1987; Squire and Zola 1998). Although there is obviously an overlap between these two forms of memory, as learning any semantic knowledge must initially occur as part of an event before being extracted for semantic representation, the view that distinct neural systems underlies the two forms of declarative memory has received considerable support in recent times (Aggleton and Brown 1999; Brown and Aggleton 2001; Vann et al. 2009, but see Kirwan et al. 2010).

There is evidently overlap between semantic and episodic memories as each semantic memory

must necessarily be encoded in a unique context with which one experiences the information at a specific time; however, this additional information is not necessarily encoded and recollection of these details are not required when answering semantic questions. Likewise, when encoding episodic events there are semantic elements which are involved. It has even been contested as to whether declarative memory should be sub-divided at all (Humphreys and Pike 1989) but evidence supporting the distinction between the memory systems has arisen from a number of studies involving a range of techniques including, fMRI (Eldridge et al. 2000), ERP's (Duezal et al. 1997), receiver operating characteristic (ROC) curve analysis (Yonelinas and Levy 2002) as well as anatomical distinction of function based on human clinical studies (Vann et al. 2009) and lesion studies in the rat (Eacott and Gaffan 2005).

Episodic memory is usually tested in humans through recognition tests, for example using the 'remember-know' paradigm, in which participants must state whether they have seen an item before (generally testing declarative memory). Participants are then requested to make a judgement as to whether they can recollect specific details (remember) or are just familiar (know) with the stimulus, where 'know' responses are thought to represent semantic familiarity-based recognition whereas 'remember' responses reveal a recollection of the event in which the learning took place (Eldridge et al. 2005; Yonelinas and Levy 2002). Analysis of receiver operating characteristics (ROCs) provides a different approach to examine familiarity and recollection separately (Yonelinas et al. 1996). The proportion of true positive responses identified (participants correctly respond that they have seen the familiar stimulus before) is plotted against the fraction of false positives (incorrect responses where participants state they have seen a novel stimulus before) at different confidence intervals, using a confidence rating scale. Purely recollection-based responses yield an asymmetric, linear function whereas familiarity gives rise to a curvilinear, symmetric function. Thus, 'normal' human recognition involves both processes and is expected to result in an asymmetric, curvilinear function. Patients suffering from specific hippocampal damage, due to hypoxia, are reported to have symmetrical, curvilinear ROC curves suggestive of a specific deficit in recollection but not familiarity, whereas patients with damage extending into the parahippocampal region have deficits in both types of declarative memory (Aggleton et al. 2005; Yonelinas et al. 1998; Yonelinas and Levy 2002, but see Wais et al. 2006), implying that the hippocampus has a specific role in recollection. In contrast, familiarity appears to depend on extra-hippocampal cortical areas such as the perirhinal and postrhinal cortices (Aggleton and Brown 2006; Diana et al. 2010; Eacott and Gaffan 2005; Haskins et al. 2008). Participants tend to report 'remember' responses with much higher levels of accuracy than 'know' responses leading to the alternative interpretation that 'know' responses merely reflect a weaker memory than 'remember' responses suggesting the memory strength is being tested rather than different underlying processes (Donaldson 1996; Glanzer et al. 1999; Wais et al. 2010; Wixted and Squire 2010).

It is more difficult to differentiate 'remember/know' responses in rats; however, task demands

and rewards have been manipulated in order to assess confidence levels. ROC curve analysis of an odour recognition task was designed based on this principle and demonstrated that rats show a similar dual process of recollection and familiarity to human declarative memory (Yonelinas 2001) and that the recollective component depends upon the hippocampus (Fortin et al. 2004). Furthermore, Sauvage et al. (2008) demonstrated that in an odour association task using ROC curve analysis hippocampal-lesioned rats were impaired in recollection, whereas familiarity was enhanced, strongly arguing against the memory strength hypothesis. Manipulations of memory demands can remove the recollection component whilst sparing familiarity and also remove the contribution of familiarity whilst maintaining recollection (Sauvage et al. 2010). These results highlight the similarities in memory from rats to humans and also provides further support for the dual process hypothesis of declarative memory, as opposed to the memory strength argument, whereby familiarity represents just a weaker memory trace than recollection.

The hippocampus is involved in episodic aspects of declarative memory in both rats (Eacott and Gaffan 2005; Fortin et al. 2004) and humans (Aggleton et al. 2004; Corkin 2002; Ranganath et al. 2004; Scoville and Milner 1957; Tulving and Markowitsch 1998; Vargha-Khadem et al. 1997; Yonelinas et al. 2005). The hippocampus has been shown to be selectively involved in the retrieval of contextual features of an event and their associations in human fMRI studies (Burgess et al. 2001; Davachi et al. 2003; Davachi and Wagner 2002; Dobbins et al. 2003) and similarly in lesion studies in the rat (Kennedy and Shapiro 2004). It has been suggested that over time the re-experiencing of similar events, through both repetitive recall and the experience of similar events, results in a shift from episodic towards semantic memory (Conway et al. 1997), which would explain the standard theory that the medial temporal lobe is involved in storing and retrieving declarative memory for only a limited period of time, based mainly on findings that patients with damage to the medial temporal lobes report temporally graded retrograde amnesia. Imaging studies of healthy participants; however, suggest a permanent role of the hippocampus in episodic memory retrieval regardless of remoteness and reports context-rich recollection of remote episodes in participants (Piolino et al. 2009). Furthermore, although the temporally graded impairment in memory shown in patients suffering damage to the medial temporal lobe appears to support the standard theory, the intact remote memories appear to be semanticised, suggesting only a temporally-graded amnesia of semantic declarative memory and a complete absence of episodic memory (Piolino et al. 2009), which would support the multiple trace theory. The multiple trace theory states that only semantic, not episodic, memory becomes independent of the medial temporal lobe over time as it is consolidated to cortical regions, but that the cortex only enables context-free information to be stored so episodic memories always require the hippocampus to provide the spatial and temporal context to support episodic memory retrieval regardless of how old the memory is.

In summary, patients with damage restricted to the hippocampal region are reported to be pre-

dominantly impaired in the process of recollection whereas familiarity remains largely intact; in contrast, patients suffering more widespread damage to the medial temporal lobe are impaired in both recollection and familiarity (Eichenbaum et al. 2007 but see Squire et al. 2004). Moreover, fMRI data suggests that, in the healthy human brain, the hippocampus is selectively involved in recollection and association of information whereas the perirhinal cortex is activated primarily for familiarity and non-associative processing (Davachi et al. 2003; Eichenbaum et al. 2007). Similarly, the rat hippocampus has been shown to be specifically involved in retrieval based on recollection as opposed to familiarity (Day et al. 2003; Easton et al. 2009; Fortin et al. 2004). These data provide strong support for an anatomical distinction of function within the medial temporal lobe region with regards to the two subcomponents of declarative memory, where the hippocampus is thought to critically underlie the processing of episodic memory.

0.3.2 Episodic-like Memory

Human studies have enabled investigations into the neuroanatomical and cognitive features of episodic memory but due to the inevitable restrictions involved in human studies, the underlying neural mechanisms of episodic memory remain to be elucidated. It is therefore critical that animal models which are amenable to neurophysiological investigation are developed. In non-verbal animals, however, it is almost impossible to demonstrate the subjective experiences involved in episodic memory recall, such as mentally travelling back in time to personally re-experience the event, although elaborate methods have been proposed (Suddendorf and Busby 2003), leaving many to argue that episodic memory is a uniquely human trait (Roberts and Shapiro 2002; Suddendorf and Corballis 1997; Tulving 1983, 2002; Tulving and Markowitsch 1998). To avoid the inherent difficulties in demonstrating these phenomenological aspects of episodic memory, investigations into the neural basis of episodic memory in non-human animals have focussed on the behavioural features, originally defined by Tulving (1972) as the hallmark triad of 'what-where-when' components of a unique, previously experienced event; the integrated recall of which have been demonstrated behaviourally non-verbal animals (Babb and Crystal 2006; Clayton and Dickinson 1998; Eacott et al. 2005; Eacott and Norman 2004; Good et al. 2007; Kart-Teke et al. 2006). As these behavioural studies do not necessitate the incorporation of the phenomenological features of episodic memory, such as demonstrations of auto-noetic consciousness (Tulving 1983) and the flexible use of information, as opposed to being directly elicited by stimuli (Tulving 2001), these models of episodic memory have been termed 'episodic-like' memory. Testing episodic-like memory does not aim to cover all of the features of human episodic memory but allows components of episodic memory to be explored in animal models, enabling the neurobiological mechanisms which may contribute to episodic memory processing in humans to be identified.

Some have argued that non-human animals only possess awareness of the immediate present with behaviour arising purely from their current motivational states (Roberts and Shapiro 2002;

Suddendorf and Corballis 1997). Whilst it is possible that higher cognitive processes, such as episodic memory, developed at a later stage of evolution, it seems more logical that at least a basic form of episodic memory should exist in non-human animals, as it would provide huge benefits to the survival of a species. Furthermore, through observation of natural behaviour it appears that some form of episodic memory is available to non-human animals. The existence of food-caching animals that are able to re-locate previously stored food suggests a memory for the caching event in addition to the fact that when the food was initially stored the animals must have been at least at some level planning for a future time in which their motivational state would change. Also, the ability to remember previous encounters with either poisonous food or predators and the location in which this occurred obviously offers a huge evolutionary advantage. At a higher level, pinyon jays behaviour has been reported to change as a result of observing the dominant member of their social group being defeated by an unfamiliar jay from an outside group, where their subsequent behaviour towards this new jay was submissive from their first encounters (Paz-Y-Mio et al. 2004), suggesting the experience of observing past social interactions inform their later behaviours.

The ability to mentally travel back in time and re-experience an event is considered one of the central features of human episodic memory (Tulving 2002). Assemblies of hippocampal cells were shown to fire during slow wave and REM sleep in the same sequence as they had previously fired in the awake behaving rat (Louie and Wilson 2001), suggesting that these experiences were 'replayed' during sleep. Furthermore, the sequence of place cell activations recorded as rats ran laps on a maze was reactivated in reverse immediately after the behavioural event in the awake rat (Foster and Wilson 2006). Thus, despite the difficulties in demonstrating whether rats are able to perform such cognitive tasks in the absence of language, the concept of reactivation demonstrates that at least on a neural level events can be replayed.

An ethological method of assessing episodic-like memory was developed by Clayton and Dickinson (1998) utilising the natural caching behaviour of scrub-jays. In this protocol the three components of the behavioural episodic memory triad were assessed using food-type (what), cached location (where) and time since caching (when), based on learned knowledge of decay. Figure 3 illustrates the protocol employed by Clayton and Dickinson (1998), where the birds were allowed to cache the degradable but preferred food (wax worms) in different locations on one side of an ice cube tray, which was filled with sand enabling food to be buried. The birds were subsequently allowed to bury the second food-type, non-degradable peanuts, on the other side of the ice cube tray, with the first side covered and inaccessible. The food was then retrieved by the birds following either a short or a long delay. After the short four-hour delay the birds preferentially retrieved their preferred food-type (wax worms), but following a longer 124-hour delay the birds preferentially retrieved the peanuts, demonstrating that they had learnt that after this longer delay period the worms would have decayed and thus the peanuts would be the most palatable option. If the order of food caching was reversed the birds' preference changed accordingly, such that

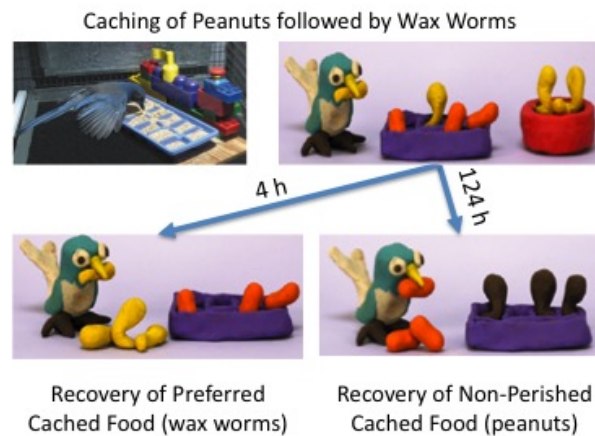

Figure 3: The figure depicts the protocol employed by Clayton and Dickinson (1998) to test episodic-like memory. The caching phase is shown in the top panel, where Scrub-jays hid two types of food, non-perishable peanuts followed by perishable worms, in trays. On the top-left, a photo shows the bird caching the food in trays filled with sand, where the Lego sculpture behind the trays provides trial unique visual cues of the spatial locations. In the top right-hand panel a cartoon is used to depict this caching phase where fresh worms are represented in yellow and peanuts are shown in orange. The lower panel shows the retrieval phase of the experiment, which occurred after either a 4-hour delay (shown on the left) or a longer 124-hour delay (shown on the right). Following a short delay birds are shown to recover the preferred food-type (worms). After the longer delay birds are shown to retrieve the non-perished peanuts, with the perished worms shown in brown. Figure adapted from Clayton et al. (2003a).

the wax worms were retrieved on both the short and the long delay periods as they would not have decayed in either condition. The birds retrieval preference remained even when the food was removed prior to retrieval demonstrating that performance was not based on odour cues. Additionally, the ice cube tray was placed in front of a Lego structure which enabled spatial cues to be trial-unique, where food was cached in different locations and the relation of the caching sites with the cues changed across days. It was not tested, however, whether the birds were using this visuospatial cue during caching and retrieval and it would be interesting to investigate the effect of changing the cue configuration to determine whether the preferred food-type could still be retrieved or whether the trial unique spatial cues were necessary for retrieval. An additional control group, which were not taught that worms decayed did enable the influence of decay learning to be tested. Under these conditions the birds retrieved the preferred food-type (wax worms) in both delay conditions, suggesting that the reversal of retrieval preference seen after the longer delay in the decay condition was due to a specific knowledge of the condition of the worms, not just a lack of memory for the initial caching event. Additionally, the birds demonstrated the ability to discriminate episodes in which the same food type was cached in different locations and at different times, which was considered to provide evidence that the memories of the caching episodes involved integrated ‘what-where-when’ information (Clayton et al. 2001b). Furthermore, the birds were found to switch their preferences, from worms to nuts, during retrieval of previously cached food when they experienced more rapid degradation to occur, than expected, in a separate tray, although

they maintained their preference to retrieve worms if they had been cached recently (Clayton et al. 2003b). These results suggest that the memory for the cached events could be used flexibly in situations other than those for which it was previously trained, whereby new information was used in combination with the memory of the caching event to inform behaviour. It was therefore argued that the birds were capable of forming and flexibly utilising episodic-like memories, as they were able to integrate memory of what type of food was cached in which location and if it should be retrieved depending on whether the food would have perished, which relied upon knowledge of the time since caching.

As the functional anatomy of scrub-jays is relatively unknown and there are far fewer techniques of investigation available to these species, relative to that of rodents, the work by Clayton and Dickinson (1998) re-focused researchers to find a similar suitable task to test episodic-like memory in rodents. A similar protocol of food caching, as described in the episodic-like memory task for scrub-jays, was attempted with rats using the radial arm maze, where although rats were able to demonstrate ‘what-where’ information to retrieve the preferred food-type, they were unable to learn the temporal component of the task (Bird et al. 2003). It was suggested that this may be due to the fact that, unlike scrub-jays, rats do not naturally cache food for subsequent retrieval and thus it is not an ethologically valid paradigm for the rat, which may explain the difficulty in learning the decay condition of cached food over time. Despite these difficulties, Babb and Crystal (2005) designed a protocol to test episodic-like memory in rats, again using the radial arm maze and found that rats could learn to obtain different types of food using a short/long delay interval to determine which arm to return to. The authors argued that this demonstrated that rats could remember ‘what-where-when’ information; however, it did not provide evidence that these three components were necessarily being integrated, performance levels were relatively low, and, due to the substantial training required, were not trial-unique.

In a subsequent study, Babb and Crystal (2006) conducted a similar protocol, in which slightly longer delay periods, to those previously reported by Babb and Crystal (2005), were more successfully used to demonstrate rats’ ability to remember what food was located where using temporal information, suggesting that rats were able to remember the content of episodic-like memories. The task was again conducted in the radial arm maze which had four of the possible eight arms available and rewarded in the sample phase, two of which contained distinct, preferred flavoured pellets and the remaining two contained chow-flavoured pellets. In the short one-hour delay condition all eight of the radial arm maze arms were available, but only those not previously available during the sample phase were baited with basic chow-flavoured rewards, inducing a delayed-non-match-to-sample search behaviour to yield rewards. In the long six-hour delay, all eight arms of the radial arm maze were also available, with the four not available in the sample phase again being rewarded with chow-flavoured pellets but in addition the two locations rewarded with the preferred flavoured pellets in the sample-phase were rewarded again with the same flavours. One of the two

flavoured pellets, however, was paired with subsequent lithium chloride injections, to induce an aversion to one of the two preferred flavoured pellets from the sample phase. This resulted in a preference for the rats to choose the untreated preferred flavour, suggesting that what and where information had been integrated across the long delay. One criticism of this interpretation is that performance relied upon rats entering one of the flavoured arms within its first four choices in the test phase of the task. Since there were only four arms from the sample phase available during the test phase, it is possible that the rats could obtain the performance criteria based on chance alone, if they learnt to adopt a match-to-sample strategy for tests occurring after long delays. In addition, although it could be argued that rats were able to remember where to find the rewards depending on how much time had passed since the sample phase, and also separately demonstrated memory for the location of food type (rats preferentially retrieved flavoured rewards which were not treated with lithium chloride), this ‘what-where’ memory was only shown in the long delay condition. Therefore, although the task is testing the rats’ ability to remember ‘what-where-when’ it does not test the integration of the temporal component. To fully show integrated memory for ‘what-where-when’ information, the short delay condition could have been conducted in an identical manner to the test phase but without the lithium chloride treatment, and without the need to open the four arms not available during the sample phase nor the need to include the unflavoured chow rewards, but with the other preferred flavour being the unflavoured chow. It could have then simply tested whether the rats’ could remember whether the preferred food-type would have been unpalatable due to treatment with lithium chloride and thus to retrieve the less preferred chow reward or whether it had been a shorter delay and thus the flavoured food would not have been treated and so should be preferentially retrieved.

These types of episodic-like memory models have been criticised for using food rewards and repeated training as they are likely to induce a more semantic strategy to be employed in order to obtain successful performance (Zentall et al. 2001). These criticisms have led researchers to adopt object recognition memory paradigms in which one-trial learning of entirely novel objects can be tested where performance relies upon spontaneous behaviour rather than being reward-driven.

Object-Place-Temporal order Recognition Tasks

The spontaneous novelty recognition paradigm has been developed to test integrated ‘what-where-when’ memory. This paradigm is based on the rats’ innate preference to explore the most novel aspects of the environment (Ennaceur and Delacour 1988), and is ideal for adapting to test episodic-like memory because it requires no training nor reward-based motivation, as it is based on spontaneous exploration. Additionally, objects used can be trial unique, meeting the one-trial learning requirements of episodic memory. Habituation to the testing environment induces familiarity with the arena and locations in which objects will be presented, such that attention is directed at the objects involved in the study. In the basic tasks, object recognition typically involves the presenta-

tion of two identical copies of an object for a set period of time, after which memory is assessed in a subsequent test-phase, where a copy of one of the previously seen objects from the sample phase is presented alongside an entirely novel object. Object exploration times in the test phase are then used to provide a measure of memory for the sample-phase objects, where successful recognition is expected to induce an increased exploratory preference for the novel, relative to the familiar, object. Different elements of episodic-like memory can be tested through slight alterations to this basic protocol.

The protocol has been adapted to test the ability to detect the most novel ‘object-place’ configuration, in order to assess rats’ ability to integrate spatial and object identity information (‘what-where’). An example of an ‘object-place’ recognition task would involve two different objects being presented in the sample phase followed by two identical copies of one of these objects being presented in the test phase, where one the familiar objects is located in a new position, with the other remaining in a stable position. The ability to detect the most novel object-position configuration has been successfully demonstrated in a number of paradigms (Barker et al. 2007; Dix and Aggleton 1999; Eacott and Norman 2004; Ennaceur and Aggleton 1994; Ennaceur et al. 1997; Good et al. 2007; Kart-Teke et al. 2006; Mumby et al. 2002; Save et al. 1992). Temporal order memory has also been assessed using the relative recency of the objects presented (‘what-when’). An example of an ‘object-temporal order’ recognition task would involve two sample phases, in which two identical objects are used in one sample phase, and two different identical objects are used in a second sample phase. An object from each sample phase is then presented in the test phase, such that to identify the most novel configuration the type of object presented the most remotely must be identified. This type of protocol has been used to successfully demonstrate that rats have memory for temporal order (Barker et al. 2007; Good et al. 2007; Kart-Teke et al. 2006; Mitchell and Laiacona 1998). Object recognition tasks have also been adapted to test contextual features of the environment (‘what-which’), such as texture, shape, colour, etc.; which are also key components of the episodic representation (Dix and Aggleton 1999; Mumby et al. 2002; Norman and Eacott 2005).

In order to test episodic-like memory in rats, Kart-Teke et al. (2006) examined integrated memory for ‘what-where-when’ in a further adaptation of the object recognition paradigm (see figure 4). The task involved two five-minute sample phases, separated by a fifty-minute delay period, over which two different sets of four identical objects were presented. The test-phase commenced fifty minutes after the second sample phase and again was of a five minute duration. In the test phase, a different set of four objects was presented, in which two copies of the objects from each sample phase were presented, with the location of one of each object pair being switched, such that the test-phase set of object configurations presented were of differing relative familiarities. One would hypothesise that the most recently presented object (seen 50 minutes prior to test) located in the same position to that in which it was previously presented would be explored the least (as it is

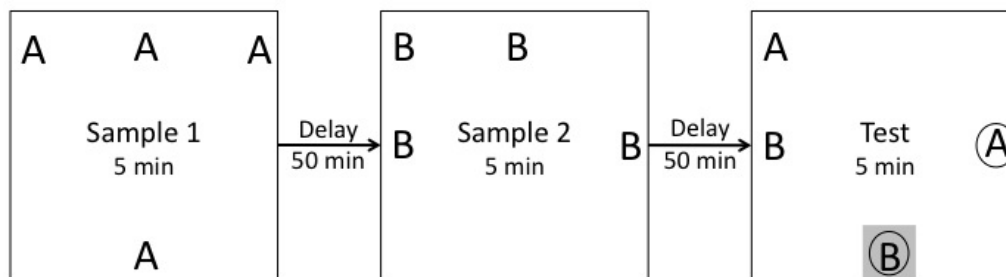

Figure 4: A schematic of the experimental design employed by Kart-Teke et al. (2006). The objects used in sample one and two are represented by the letters A and B respectively. In the test phase the objects which are positioned in a new location relative to the sample phase are circled and the grey box indicates the location which was only used for object presentation in the first sample phase. Figure adapted from Kart-Teke et al. (2006).

the least novel configuration of ‘what-where-when’ information) and the object from the first sample phase (seen 105 minutes prior to test) which had been located to a ‘new’ position would induce the most exploration (as it would be the most novel configuration of the ‘what-where-when’ information). As expected, the rats preferentially explored the displaced relative to the stable object from the second sample phase and had a preference to explore the most remote object when the object’s location remained stable; however, surprisingly rats preferentially explored the stationary over the displaced object from the first sample phase. Kart-Teke et al. (2006) interpreted this reversal of object-place exploratory preference, from the recent to the remotely tested conditions, as a reflection of an integrated temporal-spatial representation of the event components, rather than that expected based on relative familiarity of event features in isolation. This explanation does not fit logically with rats’ natural tendency to explore the most novel aspects of the environment, which is unlikely to be altered as a result of the development of an integrated representation of event information. An alternative explanation for the difference in preference for the displaced or stationary objects depending on the remoteness of the sample phase may be due to the fact that the objects from the first sample phase were located in positions that had been explored more recently and/or the displaced object from the second sample phase was located in a less recently used location to that of the stationary object from sample phase two. This, however, would imply that the location in which the objects are presented is more salient than the identity of the object and furthermore, would indicate that the rats were not integrating object identity with the spatial location in which it is presented but instead were remembering the features of the sampling event separately. Additionally, if location was directing novelty preference it would only explain why the re-located object from the second sample phase was preferentially explored, it would not explain why the stable object from the first sample phase induced higher levels of exploration given that the location in which the object was presented had been used the most frequently of all the test-phase locations. One could argue that the fact that two different types of objects were presented in the same locations across the sample phase may have contributed to the higher level of

exploration in the test phase, based on mismatch detection. A more plausible explanation as to why a preference was demonstrated for the stationary relative to the re-located object only in the remote task, is that these results reflect a weaker memory for the object-place configurations from the first sample phase such that, although object identity could still be recognised the location in which it was presented can not be retrieved. Thus the preference for the stationary object merely arises from the fact that one of the objects from the first sample phase has replaced an object from the second sample phase, with the mismatch in expectation of object-position configuration inducing the preference to explore the stationary object from the first sample phase, independently of the relative positions of the two sample-phase objects. In order to tackle the potentially confounding factors involved in this experimental protocol, one could use the sample locations for object presentation in each phase of the task and test the effects on preferential exploration, additionally one could also explore the impact of reducing the inter-phase delay intervals.

The role of CA3 in episodic-like memory was specifically examined using the protocol developed by Kart-Teke et al. (2006), in which control rats displayed a similar pattern of object preferences to that previously obtained and described above, whereas rats with bilateral electrolytic lesions of CA3 demonstrated a preference to explore the most novel aspects of the environment under all conditions, which was interpreted as evidence that CA3 is necessary for the integration of the spatial and temporal aspects of events, supporting the proposed role for CA3 in episodic memory (Li and Chao 2008). Rather than reflecting a specific deficit in the association of event components to form an integrated object-place-temporal order memory, the exploratory preference of the CA3-lesioned rats could be argued to be what one would expect, based on rats natural tendency to explore the most novel aspects of the environment (Ennaceur et al. 1997), leading to the alternative conclusion that the CA3-lesioned rats were the only subjects able to successfully encode object, place and temporal order information to induce a preferential exploration of the most novel aspects of the environment in the test-phase. There were a number of features of the study which complicate the interpretation of the results (in addition to those previously described above), such as the fact that the untreated and sham-operated rats' exploration patterns varied substantially, with only marginal differences in exploration expressed between the object configurations. Additionally, the electrolytic lesions were not quantified so the extent of damage was unclear. Furthermore, the control test of the spatial component of the episodic-like memory task was conducted in a completely different manner to that required in the main task, where instead of being tested in the open field, spatial memory was assessed using a radial-arm maze. Therefore it is not clear whether the results obtained in the integrated object-place-temporal order task were an indirect reflection of a more basic impairment in object-place processing over such a long delay period.

Good et al. (2007) tested episodic-like memory in a similar object recognition protocol to that described by Kart-Teke et al. (2006); however, recognition was tested using a much shorter delay

between the sample and the test phases, and the configuration of the objects differed (see figure 5). In the first sample phase two different objects were presented in the two top corners of the arena for a set period of five minutes. The second sample phase followed after a two minute delay and involved the presentation of a further two different objects, presented in the bottom two corners of the arena. Two minutes after the second sample phase the test phase commenced, in which four copies of the objects, previously used in the sample phase were presented in the four corners of the arena, such that one of the two object pairs presented in the sample phase were positioned in the same positions in which they were previously seen, whereas the remaining object pair from each sample phase had their positions switched such that they created novel object-place configurations. The most novel object configuration is the object which was presented the longest time ago (nine minutes) and in a new position relative to the sample phase, which, as expected, was explored preferentially by the sham-operated controls (Good et al. 2007). In contrast to the controls, the hippocampal-lesioned rats were impaired in the integrated object-recognition paradigm, where no significant exploratory preference for any of the four objects presented in the test phase was observed in the integrated object-place-temporal order task. This indicates that the hippocampus is required for performance in this episodic-like memory task. Hippocampal-lesioned rats, however, were also significantly impaired in object-place recognition. Therefore it could be argued that any lesion-induced detriment in integrated object-place-temporal order recognition may simply be reflecting an impairment in memory for the object-place configurations. Object-temporal order recognition scores were also low for both the hippocampal-lesioned and the sham-operated rats, most likely due to the fact that there was only a seven minute difference in time since exposure to the objects in two sample phases which may be too short to significantly bias exploratory preference in favour of the most remote object. These impairments in the control tasks (object-place recognition and object-temporal order recognition) involved in this episodic-like memory study complicate the interpretation of the main results.

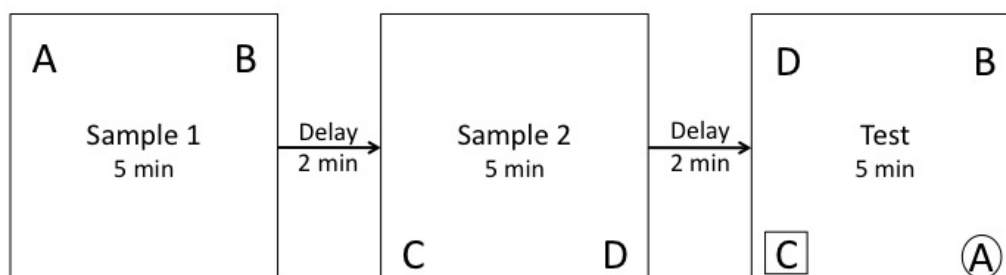

Figure 5: A schematic of the experimental design employed by Good et al. (2007). The objects used in sample one are represented by the letters A and B, and those used in sample two are represented by C and D. The most novel object configuration in the test phase is highlighted by the circle, whereas the least novel object configuration is indicated by the square. Figure adapted from Good et al. (2007).

The preceding discussion of the experiments in which the basic requirements of episodic-like memory (‘what’, ‘where’ and ‘when’) were tested demonstrates the multitude of difficulties in

developing suitable protocols in which episodic-like memory can be tested in rats, in which any impairments due to experimental manipulations can be easily interpreted as reflecting deficits in episodic-like memory processing.

The Element of Time in Episodic-Like Memory

Multiple theories have been proposed to explain how the temporal component of human episodic memory is recalled. The distance theory states that elapsed time from when the event occurred is used to determine the time at which the event occurred (Anisfeld and Knapp 1968; Brown et al. 1985; Glenberg et al. 1983; Hinrichs and Buschke 1968). According to this theory the memory is changed through intrinsic mechanisms such that it correlates with the elapsed time since initial encoding, which is linked to the strength of the memory and the amount of associated contextual cues that can be recalled about the event. This fits with the general notion that one has a vague sense of how long ago an event occurred; however, the continuous updating of each memory over time would be inefficient. The location theory provides a more reasonable explanation, that temporal information is based on information encoded at the time at which the event originally occurred, rather than the passage of time since its occurrence (Glenberg and Swanson 1986; Yntema 1963) although this does not explain why, unlike information regarding what happened, or the event location or its context, the timing of an event is such a poor retrieval cue for episodic memories (Jones 1976). The most plausible theory is therefore the reconstructive view, which proposes that this temporal tag is not necessary; instead contextual elements of the event in combination semantic knowledge regarding the passage of time are sufficient to estimate the time at which the event took place (Brown et al. 1985; Friedman and Wilkins 1985). This would explain our generalised notion of the timing of previous events, unless they happen to coincide with a specific date or time of interest such as 'Christmas dinner'. An overall comparison between these theories and the available literature from human research predominantly supports the idea that encoding contextual information at the time of the event enables retrieval of associated information for the episodic memory to be used in order to ascertain the time at which the event occurred; however, this comparison also revealed that temporal information may not necessarily form part of the episodic memory (Friedman 1993). Although some still argue that the temporal component is one of the crucial defining features of episodic memory, overall it appears that as long as the event is temporally organised enabling one to seamlessly link sequential episodes to provide a coherent clip of the event, the temporal component is either insignificant (Zentall et al. 2001), or provides an aspect of the event which can be used as an occasion-specifier to distinguish similar events. The sequential organisation of information is thought to occur in the hippocampus and is what some refer to as the temporal processing of the event, which is generally accepted to be necessary for the formation of episodic memory.

Thus, as long as events are retrieved in the same sequence in which they were encoded and

there is a generalized sense of how long ago the event occurred, which could be a combination of memory strength and contextual cues, memory for the precise timing of an event may not be a necessary feature of episodic memory, especially as no unique event can ever occur at the same time as another event and therefore it would be unnecessary/unhelpful to distinguish similar events based on temporal information. Friedman (1993) also argued that humans do not naturally store events and their associated details in a temporal code chronologically in memory (Brown and Aggleton 2001; Friedman 1993, 2001), for example the majority of people would not be able to precisely recall the time that something happened, such as losing one's first tooth, or precisely how long ago the event occurred. Temporal details of episodic memories are therefore inferred, by using other contextual cues from the associated recollection alongside general knowledge regarding the passage of time, for example 'I was at in my second year at school so it must have been a week day, I was eating an apple so I imagine it was during lunchtime, etc.'

Object-Place-Context Recognition Task

In the preceding section the temporal component of episodic-like memory was proposed to act like any other distinguishing feature of an event and thus may be substituted for other event features (such as 'context') which would also enable similar experiences to be distinguished based upon the occasion in which the event took place. In combination with the difficulties encountered in testing 'what-where-when' memories in rats, this concept led to the development of a novel episodic-like memory task based on an alternative set of event components - 'what-where-which', where the temporal component was replaced by another event specifier - 'context' (Eacott and Norman 2004).

The 'object-place-context' task is based on integrated recognition of these event features where 'what' refers to the presented object-type, 'where' refers to the object's position and 'which' refers to the arena configuration in which the object is presented (made up of different colour walls and floor). As in the object-place-temporal order studies described, this task required no training as it relies upon the spontaneous innate behaviour of rats to explore novel aspects of their environment and involves the trial-unique presentation of objects - akin to human episodic memory. The main integrated task involves two sample phases which are conducted in the two different contexts (set-up in the same arena) in which identical copies of a pair of different trial unique objects are presented but the locations of the object pairs are switched between sample phases (see figure 6). In the test phase two identical copies of one of the objects used in the sample phases are presented in one of the previously used contexts. Therefore, both test-phase objects have been seen in both of the available locations and have both been presented in the test-phase context before, thus successful performance relies upon the rat identifying that one of the object configurations is novel because that object has not been presented in that location before in the current context, requiring the integration of the 'what-where-which' components of the sampling event. In the task

there are only two possible locations in which the objects are presented and these remain stable throughout all experimental phases and sessions, thus performance is not affected by differing familiarity levels of the locations used.

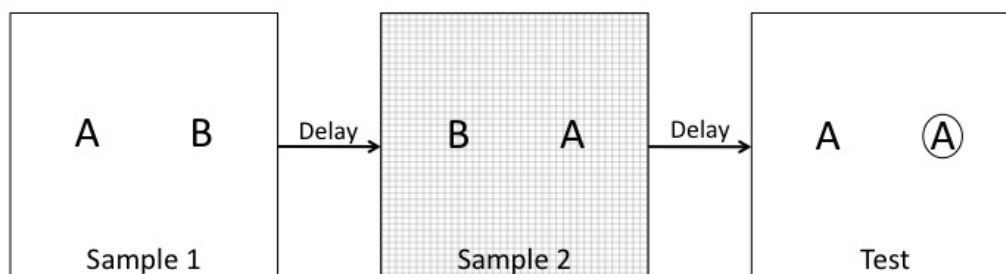

Figure 6: A schematic of the experimental design employed by Eacott and Norman (2004). The two objects presented in each sample phase are represented by the letters A and B. The positions of these objects are switched between the two sample phases. One context is presented in the first sample phase (represented by the white background) and a second context is presented in the second sample phase (represented by the grid background). In the test phase, two copies of one of the previously seen objects are presented in one of the two contexts. The novel object-place-context configuration in the test phase is highlighted by the circle. Figure adapted from Eacott and Norman (2004).

Studies which have investigated the neural basis of the integrated object-place-context recognition have revealed that rats with either fornix (bundles of fibres providing input and output from the hippocampus and its associated structures) lesions (Eacott and Norman 2004) or complete hippocampal lesions (Langston and Wood 2009) were impaired at recognising the novel ‘what-where-which’ configuration but performance in control tasks, testing components of the integrated task, were unimpaired. Thus, unlike the object-place-temporal order tasks described earlier, performance levels in the individual elements of the task do not explain the impairments in object-place-context performance when the hippocampal processing is disrupted, suggesting that the hippocampus has a specific role in recognition memory only when the ‘what-where-which’ features of the event must be recalled in an integrated manner to support performance.

Although human episodic memory has been shown to rely upon recollection (Tulving 1983, 2002), it is unclear as to whether a recollective strategy is utilised by the rats to support performance in these tasks of episodic-like memory, as a recollective strategy was not enforced in these tasks. Therefore, it is possible, but unlikely, that the rats were using a complex relative familiarity approach to determine the most novel object-place-context configuration. To address this issue Eacott et al. (2005) adapted the object-place-context task to enable testing of recollection and familiarity independently (see figure 7). An E-shaped maze was used for all testing, where rats started at the bottom of the central arm and had one choice point at the top of the arm where, in the sample phases the two objects were visible on emerging from the central arm, placed at the top of the two outer arms, with their positions and the context in which they were presented being swapped between sample phases. After the second sample phase, rats were put in a holding cage for an eight-minute period in which they were allowed to freely explore a copy of one of the

previously presented objects, resulting in habituation to this object. The test phase then ensued in one of two contexts, with the two objects positioned in the same arms to that in which they were previously presented in this context, but were placed at the bottom rather than the top of the outer arms, such that they were not visible at the choice point and so to locate the most novel (non-habituated) object, the rats must recall the arm in which this object had been previously presented in the current context in the sample phase. Furthermore, after the recollective decision was made the rats were free to explore both objects in the maze, where the accumulated exploration time for each object provides a second performance score based on familiarity, but as neither object configuration is entirely unique (as the set up is identical to one of the sample phases), this measure of familiarity is purely based on preference to explore the non-habituated object and thus does not require an episodic-like representation to be formed. Fornix-lesioned rats were significantly impaired at recollection-based performance but were unimpaired in familiarity-based performance (Easton et al. 2009). The finding that only performance based on recollection, not familiarity, in this episodic-like memory task is hippocampus-dependent suggests that performance in the previously described object-place-context task in the open field is likely to have necessitated a recollective strategy to support performance as the hippocampus was shown to be essential for successful integrated recognition of the novel object-place-context configuration. Furthermore, as recollection is thought to be an integral component of episodic memory (Clayton and Dickinson 1998; Tulving 1983), it further validates this task as a suitable model of episodic memory.

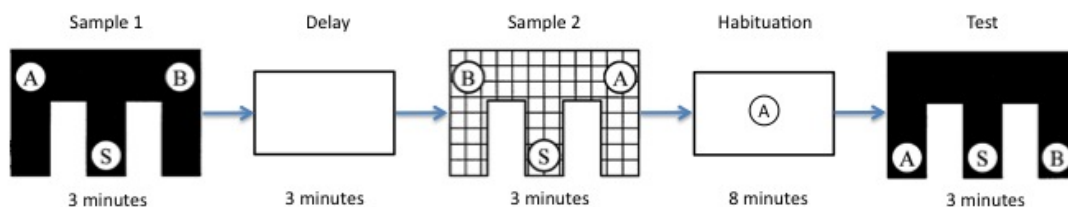

Figure 7: An example of the apparatus and protocol employed by Eacott et al. (2005) which enables recollection of 'what-where-which' memory to be tested specifically. The rat is placed into the maze at the start (S) of the middle arm, and freely explores the objects (denoted by 'A' and 'B'), visible from the end of the start arm, in the sample phases. The two three-minute sample phases are conducted in two different contexts (represented by black and a grid pattern) across which the objects positions are reversed. The rat is placed in a holding cage for both the delay and the habituation session, with a copy of a sample-phase object (in this example object 'A') presented only in the latter. The rat is subsequently placed back into one of the two contexts for the test phase, which is set up as in the sample phase with the exception that the objects are located at the bottom of the outer arms, where they are not visible when the rat emerges from the start arm. Performance is determined by which object the rat initially explores. Figure adapted from Eacott et al. (2005).

Recently, using a similar protocol to that described by Eacott and Norman (2004), mice were found to demonstrate episodic-like memory through the successful recognition of the novel object-place-context configuration and furthermore, 3xTgAD mice (model of Alzheimer's disease) were significantly impaired on this integrated task, performing at chance levels (Davis et al. 2010).

Thus, the object-place-context recognition task can be successfully and unambiguously performed by both rats and mice, where a significant preference for the most novel configuration is demonstrated and recognition of the integrated object-place-context configuration has been specifically shown to depend on the hippocampus and moreover, appears suitable for examining disease-induced episodic memory deficits in humans, as task performance is sensitive to the impairments induced in a model of Alzheimer's disease.

0.3.3 Planning, Decision Making and Imagination

Patients with hippocampal damage present not only with specific deficits in the ability to recall episodic memories of past events but also demonstrate a significant difficulty to imagine future events, where they are only able to provide brief accounts with large generalisations and show a severe reduction in the imagined detail of previously recollected events (Andelman et al. 2010; Hassabis et al. 2007; Klein et al. 2002; Tulving 1985). Indeed, patient H.M. could not imagine any personal future events and, when pushed to do so, recalled only memory from the distant past. Overall, studies show that patients with hippocampal damage possess disjointed imaginations with an absence of a unified spatial context, which is not attributable to a simple loss in general imagery, as this ability remains intact (Rosenbaum et al. 2004). Moreover, the deficits in the ability to retrieve past episodic memories and imagine future events in amnesic patient D.B. was shown to be specific to D.B.'s personal past or future, with the ability to imagine more general public events still accessible, such as upcoming political events (Klein et al. 2002). Furthermore, both the ability to report previous events and to predict future events emerges at the same stage in development in children, normally between 3-5 years (Suddendorf and Busby 2005) and have been shown, through PET and fMRI studies, to share a similar functional anatomy, both critically involving the hippocampal-cortical system (Addis and Schacter 2008; Addis et al. 2007; Botzung et al. 2008; Okuda et al. 2003; Szpunar et al. 2007).

The necessary role of memory in imagination is highlighted by its limitations, for example one can not imagine a new colour that is not based on a combination of previously experienced colours. The importance of the hippocampus in imagination is not only due to retrieval of past events, as patients suffering hippocampal damage report a lack of spatial structure in their imagined episodes where individual fragments can not be combined into a coherent spatial context. Thus, the contribution of the hippocampus in imagining future scenarios may at least in part be due to its role in the flexible recall of previously experienced elements and their incorporation into a coherent spatiotemporal context. The hippocampus' role in the formation of allocentric spatial memory (discussed in more detail in section 0.4) may therefore underlie a common mechanism in the construction of past and potential events, providing a congruent context in which specific elements of different memory systems can be integrated and manipulated to meet the current demands of the subject.

The hippocampal system is therefore not only necessary to provide a link to the past, but also connects the present with the future. In terms of successful survival, our ability to recall specific personal events from the past would offer no evolutionary advantage if it could not be flexibly used to evaluate future outcomes, anticipate future needs or shape our future behaviours. One could argue that episodic memory itself is not a distinct type of memory, but a method of recalling memory to provide a faster, more coherent recall of important events which run seamlessly like that of a film. Episodic memories themselves are composed of many distinct items of information which can be semantically recalled in isolation and episodic memories are not reliable reports of unique personal experiences, instead they are reconstructions of fragments of information sewn together to provide flexible coherent accounts of previous events. It is common knowledge from lawyers, to magicians, to psychotherapists that episodic memory is liable to suggestion, expectancy, prospective and retrospective interference and that false memory can be easily acquired, which results in the same activity within neural networks underlying episodic memory as real previous experiences (Okado and Stark 2005). Thus, episodic memory may require the hippocampal machinery to provide this illusion of travelling through time to re-experience an event in a coherent, sequential, context-rich manner and this role of the hippocampus, in combining the many different types of information and manipulating them into this coherent scene, may also explain its role in imagining and forward planning. In support of this theory, the hippocampus is thought to provide an important contribution to the process of dreaming, where the dreams of hippocampal-damaged patients are reported to be infrequent and brief, lacking contextual detail and are often unemotional and repetitive/stereotyped in nature (Torda 1969).

A reasonable assumption based on this evidence is that the encoding of information functions to support our future planning and decision making, which is not necessarily known at the time of encoding, where the hippocampal-cortical system may enable predictions and decisions to be made regarding the future. Furthermore, forward planning may be the most important function of the hippocampal system as it enables us to assess the possible consequences of our behaviour, allowing predictions to be formed based on experience and used to our advantage, enhancing our survival and reproductive chances. The hippocampal structure contains the necessary flexibility to enable memories to be manipulated in order to aid decision making and problem solving processes as well as our imagination and future planning. Retrieval would therefore not only enable the flexible reconstruction of past events but also the construction of imagined future events, facilitating mental time travel both into our pasts as well as into our imagined future, where downstream processes may enable the the consequence of various options and reward contingencies to be evaluated in order to deduce the most cost effective decision. In support of this theory, the firing patterns of the ventral striatum, a downstream projection from the hippocampus, emulates the hippocampal neural activity (Martin 2001) and ventral striatal neural firing correlates with, and is predictive of, reward (Carelli 2002; Martin and Ono 2000; Yun et al. 2004). Similarly, the neural firing of the

orbitofrontal cortex in anticipation of odours, in an odour sequence memory task, depends upon the hippocampus (Ramus et al. 2007).

Demonstrations of forward planning have been shown in several non-human animals (Correia et al. 2007; Emery and Clayton 2001; McKenzie et al. 2004; Mulcahy and Call 2006; Raby et al. 2007). Emery and Clayton (2001) investigated the future planning of scrub-jays in an adapted protocol to that previously used in their earlier studies (Clayton and Dickinson 1998, described in section 0.3.2). In this protocol the birds were observed by another scrub-jay (potential stealer) during the caching phase of the experiment. The subsequent retrieval phase, which occurred in private, was found to be affected by whether the bird retrieving the food had previously stolen another scrub-jays' cached food or not. Those which had previously been thieves themselves re-hid their food in new sites during the retrieval phase but only when they had been observed in the caching phase, whereas birds with no previous experience of stealing did not re-hide their food even when their caching behaviour had been observed. Emery and Clayton (2001) argued that the birds' experience of having been observed during caching, alongside their previous experience of stealing, is used flexibly to direct their future behaviour, i.e. re-caching the food to prevent a loss of food. Demonstrations of forward planning such as this have not been successful in studies involving rats (Naqshbandi et al. 2006); however, multiple single-unit recording studies have reported hippocampal cell firing patterns which are thought to relate to forward planning and predictions, where context-specific firing of hippocampal pyramidal neurons may modulate down-stream structures in order to recall the appropriate memory and initiate the necessary behavioural responses required for the given context (for further information see section 0.4.1). A more rudimentary demonstration was shown behaviourally over 64 years ago, where rats were found to navigate using shortcuts (Tolman et al. 1946), a process which requires the flexible use of past experience from multiple events to produce novel combinations of intended future destination and route planning. More recently, a transitive interference paradigm was used to show that this is a hippocampal-dependent process in both humans (Smith and Squire 2005) and rats (Dusek and Eichenbaum 1997). In this type of task the subjects learn a series of rules, e.g. always chose A over B, chose B over C and chose C over D, then the critical test presents an unconditioned pair such as B and D and tests whether they are able to correctly infer that they should choose B over D.

0.4 The Hippocampus in Spatial Memory

The formation of an allocentric spatial representation may enable different configurations of event stimuli to be constructed into a scene/clip, where retrieval of the components from within this scene enables similar events to be distinguished.

The ground breaking discovery that cells within the hippocampus have spatially-related firing

(O'Keefe and Dostrovsky 1971) emphasised the special role of the hippocampal region in spatial memory and navigation, which had been evidenced in the wealth of literature documenting the behavioural abnormalities resulting from hippocampal damage. It appears that the size of the human hippocampus may vary depending on the amount of spatial information stored and the frequency that this information is used in a similar manner to reports of food storing birds, which were found to have seasonal changes in their hippocampal volume relating to spatial memory demands (Smulders et al. 1995, 2000). The average size of a given London taxi driver's posterior hippocampus was found to be significantly larger than that of non-taxi driving controls and the accumulated time spent driving taxis positively correlated with the size of their posterior hippocampus (Maguire et al. 2000). Similarly, birds with high spatial demands, e.g. food-caching birds have larger hippocampal volume to size ratios (Lee et al. 1998). In support of these correlational results, patients suffering hippocampal damage are reportedly impaired in a range of spatial learning and memory tasks (Bohbot et al. 1998; Pigott and Milner 1993; Smith and Milner 1989; Spiers et al. 2001; Worsley et al. 2001) and likewise hippocampal lesions in rats result in impaired spatial learning (Morris et al. 1982, 1986; Pearce et al. 1998). Furthermore, fMRI studies have revealed that in the 'normal' human brain, the hippocampal activity is significantly increased as participants navigate through complex virtual environments (Maguire et al. 1996b, 1997) and spatially modulated cells have even been identified in human single-unit recording studies, performed during necessary neurosurgery (Ekstrom et al. 2003).

Spatial learning/navigation is not considered to be a homogeneous process, being sub-divided based on either egocentric (body centred) or allocentric (centred on environmental landmarks) representations. In a similar manner to the differential behavioural effects of hippocampal damage on declarative memory, only spatial processing of an allocentric nature appears to be affected by disruption of the hippocampal circuit (e.g. Morris et al. 1982; Packard and McGaugh 1996), whereas damage to the parietal lobe disrupts performance requiring egocentric processing (Weniger et al. 2009). These behavioural results suggest that the hippocampus plays an important role in the formation of an allocentric representation of space, which is consistent with the spatial properties of its principle neurons, which fire with respect to environmental landmarks, providing a neural representation of allocentric space within the hippocampal network.

The contribution of the discovery of hippocampal place cells, alongside the spatial and episodic memory impairments resulting from damage to this region, led to the development of the 'cognitive map theory' in which a role for the hippocampus in memory requiring spatial context was laid out, with the implication that this defines its role in episodic memory (O'Keefe and Nadel 1978). This theory is more sensible if one considers that episodic memory defines the associative retrieval of a specific collection of memories rather than being a different form of memory, as after all memory is just a store of knowledge, but how this knowledge is recollected; i.e., in its pure form (semantic) or within a contextual frame/image (episodic) may give rise to the different types

of memory categorised. Thus, memories are encoded as an event (requiring the hippocampus) but the information can be recalled semantically in the absence of the context in which it was originally encoded. Indeed memories may lose their context dependence becoming more semantic over time or as a consequence of experiencing a multitude of similar events, allowing us to generalise information across contexts that share common components, with multiple memory traces operating in parallel during the encoding phase (Cermak 1984; Piolino et al. 2009). Hence the role of the hippocampus may be to provide a spatial scaffold upon which the individual features of an event, stored outside of the hippocampus, are related to one another (O'Keefe and Nadel 1978), such that the retrieval of the individual components of an event can occur in the absence of a functional hippocampus, but the recollection of the event in a congruent manner critically requires the hippocampus to spatially relate the individual features, providing us with the illusion of a scene/clip. This theory draws together the hippocampus' purported roles in navigation, spatial learning, episodic memory, planning, imagining and dreaming, as the same process necessary for the construction of a spatio-temporal representation, based on previously acquired knowledge, is required, where the spatial and temporal dynamics of the hippocampal place cell network, alongside their context-based firing characteristics, provides a tantalizingly good model of the neural basis for this construction process.

0.4.1 Place Cells

It has been almost 40 years since the landmark paper by O'Keefe and Dostrovsky (1971) was published, in which the firing patterns of certain hippocampal cells, termed 'place cells', were found to encode space (see figure 8 for an example of a place cell). In the decades of subsequent single-unit recording studies a multitude of additional types of neurons exhibiting distinct spatial firing properties have been discovered (see section 0.4.2) and are considered essential for successful navigation. Additionally, many non-spatial properties of place cell firing have been revealed (see the 'Features of Place Cell Activity' subsection below), calling into question the functional role of hippocampal place cells to behaviour. As discussed through the remaining introduction, the growing body of literature strongly suggests that the hippocampal place cell network simultaneously acts to map spatial location and to process episodic memories; however, conclusive evidence remains elusive.

Within a given familiar environment the firing fields of place cells remain constant across repeated exposures, but place cells can have different place fields across a range of environments. Place is therefore represented, by the activity of a network of place cells rather than the activity of any given place cell (Wilson and McNaughton 1993). Whilst still an area of debate, it is widely believed that there is no topographical organisation of place cells, i.e., any given place cell is as likely to have adjacent firing fields with cells physiologically adjacent as with cells more widely distributed within the hippocampus (Knierim et al. 1998; Muller et al. 1987; Muller and Kubie

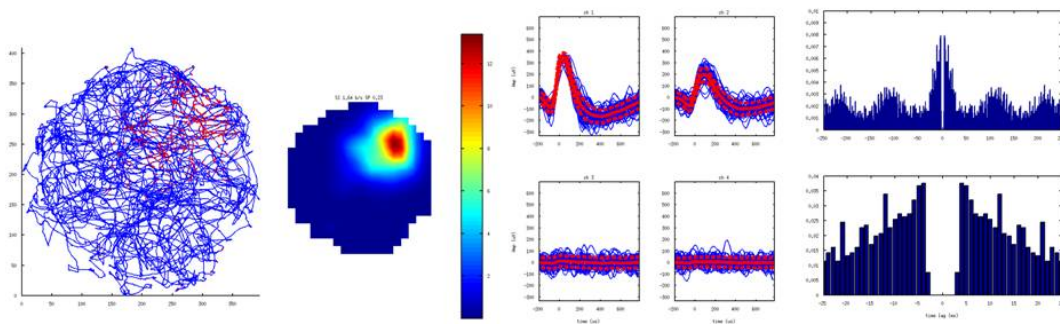

Figure 8: An example of a place cell. The left panel is a trajectory plot in which the rat trajectory is plotted in blue with red dots used to indicate the location of the rats when action potentials were fired. The middle left panel shows a colour-coded spatial firing rate map of the recorded cell, where the adjacent bar reveals the firing rate (Hz) that each colour corresponds to. On the middle-right panel waveforms of the pyramidal cell are shown across the four recording channels. The right panel displays the time autocorrelogram for the cell, where the theta modulation can be seen in the top autocorrelogram (500 ms scale) and the refractory period of the lower autocorrelogram (50 ms scale) can clearly be seen.

1989; O'Keefe 1976; Redish et al. 2001; Tanila et al. 1997; Thompson and Best 1989; Wilson and McNaughton 1993). A few studies have, however, described a clustering organisation of hippocampal place cells (Deadwyler et al. 1996; Eichenbaum et al. 1989; Hampson et al. 1999b, 2002) and have proposed that the contrasting results obtained are due to the inherent difficulty of the single-unit recording technique in recording from more than a few neurons at any given time, explaining why potential cluster-type organisations may not have been detected in other studies. Additionally, Nakamura et al. (2010) claimed that recording tetrodes could deform and damage neural tissue which may affect the ability to detect clustering of cells and, given the limited number of cells that can be recorded from in single-unit recording studies, suggested that new methods should be used to enable the entire hippocampal place cell population to be sampled. It seemed that an end had been put to this debate when Redish et al. (2001) published a study in which no topographical organisation was identified (no evidence of clustering) in a sample of more than 3000 hippocampal neurons, using both ensemble recording and direct cellular imaging of activity traces. A contrasting report, however, was recently published by Nakamura et al. (2010), in which the results obtained using immediate early genes (IEGs) to mark neuronal activation revealed that re-exposure to a given environment produced a tighter clustering of active nearby hippocampal cells, suggesting that small clusters of approximately four hippocampal place cells encode specific environments. Nakamura et al. (2010) proposed that the discrepancy between the two studies could be due to a much larger maze having been employed in the study by Redish et al. (2001) and/or due to a greater percentage of active CA1 pyramidal cells reported in this study which could potentially obscure the functional organisation of the hippocampus in the clustering of cells.

Within the active hippocampal network, place cells' field locations are quickly established,

identifiable from the initial exposure to an environment (Hill 1978) but only usually stabilise after 10-20 minutes of exploration and/or upon repeated exposure to the same environment (Wilson and McNaughton 1993). Once stable, the preferred firing field for any given place cell is generally maintained across re-exposure to the same environment, in some cases over periods of months (Thompson and Best 1990, 1989) and the place field's stability and selectivity correlates to spatial navigation performance levels (Liu et al. 2003). Furthermore, treatments which prevent the formation of stable place fields also result in impaired spatial learning (Rosenzweig et al. 2003) and place cells in aged rats seem unable to remap in new environments, which was found to be predictive of spatial memory impairments (Wilson et al. 2006). These results signify an important functional role for place cells in spatial memory and navigation. Kentros et al. (1998) demonstrated that the stability of hippocampal place cells' field locations over repeated exposure to the same environment can be disrupted by infusions of NMDAR antagonists, revealing a role for NMDAR-mediated plasticity in the stabilisation of place fields; however, due to the systematic application of the NMDAR antagonist it remains unclear as to where in the brain this plasticity is occurring.

The firing fields of place cells have been shown to depend on visual cue location, whereby the rotation of cues in a familiar environment result in the rotation of their place fields, with respect to the cues, only when the cue rotations are not detectable by the rat, due to either the rats' absence or by rotations made below the detection level of the vestibular system (Rotenberg and Muller 1997; Sharp et al. 1995). Although visual cues seem to be the primary determinant of place cell firing, place cells have been shown to maintain their firing field specificity in the dark (Markus et al. 1994; O'Keefe 1976; Sharp et al. 1995) and place cells have been reported in blind rats (Save et al. 1998). This demonstrates that visual input is not necessary to develop firing patterns, leading to the natural conclusion that other features of the environment, such as odour and texture, can support spatial representations within the hippocampal network. Place cells' firing fields can also be manipulated by varying the rats' egocentric movements (Gavrilov et al. 1998; Knierim et al. 1995, 1998; Markus et al. 1994; McNaughton et al. 1983; Wiener et al. 1995) which make it possible for place cells to maintain location-specific firing in the absence of cues, where factors such as velocity, distance travelled from previously known position, etc., can be used to calculate the present location, thought to be derived from neural circuitry involving head direction cells (discussed below) in a process termed path integration (Etienne and Jeffery 2004). The combination of these results with the wealth of literature regarding the 'off-line' replay of the spatio-temporal pattern of place field during subsequent sleep (for review see Diekelmann and Born 2010) and studies in which place cells, which initially required visual input to stabilise, persist in the face of environmental change (Mizumori et al. 1999), suggests that the place cell firing network is not purely a stimulus driven spatial navigation tool but is guided by past experience and potentially may enable mental representations of experience to be played in the mind's eye.

Whilst a discussion of theta rhythms is outside the scope of this thesis, their essential role in enabling distributed cell ensembles to be linked during episodic learning and spatial navigation make them worth briefly mentioning. Recently these theta rhythms have been found to originate within the hippocampus and it appears that CA3 and CA1 have independent theta generators (Colgin and Moser 2009). The spike firing changes relative to the current theta oscillations in the EEG as the rat moves through the place field of a given cell, whereby the initial spike occurs progressively earlier in the theta, termed ‘phase precession’ (O’Keefe and Recce 1993). This mechanism is believed to support the temporal coding of place fields, which could combine with the cells’ spatial firing properties to form the spatiotemporal framework thought to underlie episodic memory (see Nyhus and Curran 2010 for a review).

Place cells’ firing fields tend to exhibit either a completely different place field or no firing at all when put into a different environment, a phenomenon referred to as ‘remapping’. The identification of remapping emphasises the multi-representational character of the hippocampal neurons, which would be essential for episodic memory storage in order to enable similar events to be distinguished. Whether or not remapping takes place depends upon the level of variation between environments (Fyhn et al. 2007), previous experience (Quirk et al. 1990; Wills et al. 2005) and the behavioural context (Frank et al. 2000; Wood et al. 2000), where place fields require experience to be able to differentiate features within a similar environment, e.g. two different geometrical arenas within the same curtained arena (Lever et al. 2002).

Exposure to changes within the environment, such as altering the colour/shape of the recording arena, can also result in place cells remapping based on changes in firing, rather than location, and this is referred to as ‘rate remapping’ (Leutgeb et al. 2005b), putatively enabling simultaneous encoding of both spatial and contextual features of an event. Global remapping defines the case where both the firing rate and location of the place field are altered.

Partial remapping, the phenomena in which some place cells maintain their initial place fields whereas others remap in response to a new environment (Skaggs and McNaughton 1998), enables place fields to represent both the similarities and differences across environments. Partial remapping has been documented in response to changes in the odour and colour of an environment, with some cells responding to the changes in odour and others responded to changes in colour (Jeffery et al. 2004). This suggests that different cells within the hippocampus may be driven by the inputs of different environmental features, rather than responding to overall context as a cohesive network. Furthermore, Anderson et al. (2006) recorded from rats in an open field environment in which an unmarked location was rewarded and found evidence of partial remapping when the colour of the arena was switched. The authors also observed a partial remapping in behaviour, with rats exhibiting thigmotaxis, in which anxious rats maintain proximity to the arena walls to avoid the open field, indicating that the novelty of the arena had been acknowledged yet navigation was unimpaired, in relation to the ability to locate the rewarded goal area. Further evidence

that the hippocampal place cell network does not necessarily function cohesively comes from a study in which local and distal cues were rotated in opposite directions resulting in the shifting of some place cells in line with the local cue rotations, whereas others shifted with the distal cues and some split their place fields, such that one field agreed with the distal and the other agreed with the local cues (Knierim 2002). In an analogous experiment by Lee et al. (2004b), recordings were made simultaneously from CA3 and CA1 whilst rats ran around a circular arena, then, after much training, the arena and the distal cues located on the surrounding curtains were rotated in opposite directions. As a result, the majority of CA3 cells maintained their place fields and rotated as a coherent ensemble in line with one set of cues, usually the local cues. In contrast CA1 place fields were divided, with equivalent numbers rotating with each set of cues and a large proportion remapping (Lee et al. 2004b). These results support the autoassociative functions of the CA3 network (Rolls 1996), required for pattern completion, as well as the proposed function of CA1 in pattern separation which may be based on the different inputs to CA1 from CA3, dentate gyrus and the entorhinal cortex, where the entorhinal cortex inputs are sufficient for normal CA1 place field activity (Brun et al. 2002; McNaughton et al. 1989), where the partial reorganisation of the hippocampal network supports its hypothesised function as a mismatch detector.

Place cells can be found throughout the hippocampus, having been identified in CA1, CA3 and the dentate gyrus (Jung and McNaughton 1993), with the population of place cells in these areas expressing differing characteristics. Dentate gyrus place cells, unlike the CA1 and CA3 pyramidal cells, are granule cells and appear to have a role in distinguishing similar environments. Leutgeb et al. (2007) recorded place cell activity in an open arena which gradually morphed from a square to a circular environment. In contrast to CA1 and CA3 place cells, dentate gyrus place cells' firing field location changed in response to minor alterations in arena shape. Furthermore, dentate gyrus place cells have been found to express multiple place fields on linear tracks (Jung and McNaughton 1993) as well as in the open field (Leutgeb et al. 2007), suggesting that the signal may not be as helpful for accurately determining location within the environment. It appears that CA1 place cells may be primarily driven by poorly tuned entorhinal cortex place cell activity which is then rapidly refined, over a matter of minutes, by the highly tuned inputs from CA3 as when exposed to a novel environment CA1 place fields become enlarged in CA3 NMDAR 'knock-out' mice (Nakazawa et al. 2004). Re-exposure of the mice to the environment the following day resulted in recordings of refined, 'normal', CA1 place fields, suggesting that an 'off-line' refinement process had occurred, indicating that CA3 NMDARs are only involved in the rapid refinement of CA1 place fields, whereas a slower refinement process appears to occur independently of CA3 and was postulated to arise via synaptic plasticity within the temporoammonic pathway (Nakazawa et al. 2004).

Hippocampal place cell coding is not only affected by changes in environmental context, both geometrical (Mizumori et al. 1999; O'Keefe and Burgess 1996) and non-geometrical, such as

colour and odour (Anderson and Jeffery 2003; Hayman et al. 2003), but are also sensitive to non-environmental features such as motivational state (Kennedy and Shapiro 2004), mnemonic and behavioural task demands (Markus et al. 1995; Smith and Mizumori 2006a) as well as the strategy employed (Yeshenko et al. 2004). Additionally, experiences such as fear conditioning within an environment can change the representation of that environment through partial remapping (Moita et al. 2004). Cognitive processes therefore appear to influence cellular behaviour, with place fields, for example, becoming more defined with higher spatial tuning in a constant arena when rats shift from freely roaming an environment to navigating in a task which demands cues to be attended to (Zinyuk et al. 2000), further suggesting that the place cell network is not simply a reflection of an automatically produced spatial map of the environment. The modulation of place fields' firing by non-spatial features, such as the passing of time (Manns et al. 2007), signifies that at the very least, the integrated encoding of the location, content and temporal context of the event is reflected within the place cells' firing properties.

Features of Place Cell Activity

Place cells encode more than just current location within the environment. They have been reported to encode non-spatial aspects of the environment which define the event, such as auditory features (Sakurai 1994), reward location (Breese et al. 1989; Hok et al. 2007; Kobayashi et al. 1997), odour (Anderson and Jeffery 2003; Young et al. 1994) and visual cues (Anderson and Jeffery 2003; Bostock et al. 1991; Hayman et al. 2003; Jeffery et al. 2003) and exhibit direction-dependent firing on linear tracks (Gothard et al. 1996; Markus et al. 1994; McNaughton et al. 1983), although this trait is not observed in the open field (Muller et al. 1994). A proportion of recorded place cells, termed 'goal sensitive cells', have been reported to fire differentially on the common part of a maze depending on the final goal destination. The types of studies that have investigated this characteristic of place cells tend to involve a common pathway leading to multiple possible goal locations, whereby the rat's choice of location determines whether the rat is rewarded or not, in both 'win-stay' (return trials to the rewarded destination are reinforced) and 'win-shift' (rewards are obtained by not returning to the currently rewarded goal location) protocols (Ainge et al. 2007a,b; Bower et al. 2005; Dayawansa et al. 2006; Ferbinteanu and Shapiro 2003; Frank et al. 2000; Ji and Wilson 2008; Lipton et al. 2007; Smith and Mizumori 2006b; Wood et al. 2000). Place cells were reported to fire differentially, across trials on a common path, when the rat was performing a spatial alternation task depending on the current route the rat was running, despite the location of the rat not changing between paths (Frank et al. 2000; Wood et al. 2000). The differential activity reported by Wood et al. (2000) was recorded from CA1 place cells as rats ran around a modified T-maze (shown in figure 9a), in which rats returned to the start area after each choice point enabling a continuous, unidirectional, alternating running pattern to be implemented. The task required rats to run along the common central stem of the T-maze, turn right/left to ob-

tain a sucrose reward (if the rat correctly alternated their choice relative to the preceding trial) and return to the base of the central stem to start the next lap. Wood et al. (2000) reported that the majority of place fields recorded in the central stem displayed differential firing patterns depending on the current sequence of actions the rat was at (for examples see figure 9b and 9c), which were not due to differing running speeds nor direction. These findings were replicated in a similar continuous T-maze task (Lee et al. 2006) but further investigations suggested that this firing was not necessary for task performance, as lesions of the hippocampus (performed after pre-training to criterion) did not impair overall performance (Ainge et al. 2007b).

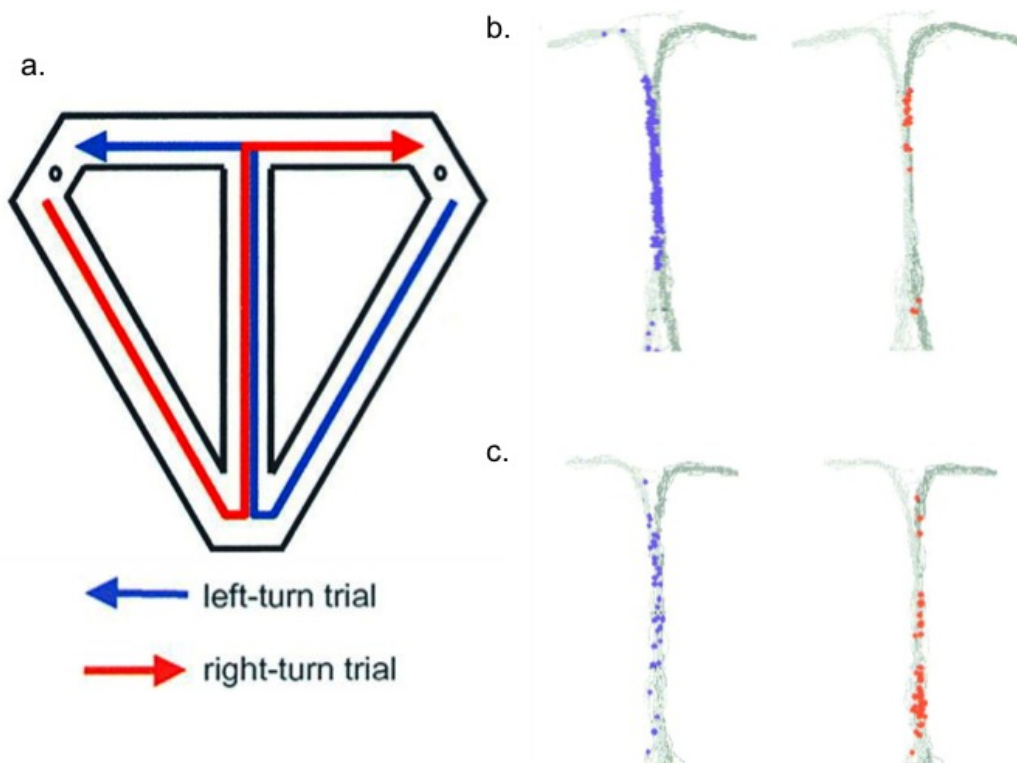

Figure 9: Differential hippocampal place cell firing on a spatial alternation task on the continuous T-maze. **(a)** A schematic of the continuous T-maze is displayed with the two alternating pathways displayed in red (to the right) and blue (to the left) goal positions (represented by a circle). In the panel on the right the rats trajectory during the task is represented by grey lines (dark grey for right turns, light grey for left turns), with individual action potentials shown as dots (red for right turns, blue for left turns). **(b)** An example of the differential firing of one cell which had significantly higher firing rate for left turns than right turns. **(c)** An example of a cell which shows a different pattern of activity depending on whether the rat is making a left or a right turn on the maze, this cell is demonstrating a higher firing frequency for turns to the right at the beginning of the common pathway, whereas on turns to the left the firing rate is much higher further along the common trajectory. Figure adapted from Wood et al. (2000).

Hippocampal place cells have been reported to demonstrate firing based on previous locations (retrospective) as well as on intended future destination (prospective) (Ferbinteanu and Shapiro 2003; Frank et al. 2000; Ji and Wilson 2008), with a general tendency to transfer from prospective to retrospective encoding with accumulated experience in the maze and an overall preference

towards retrospective encoding (Ji and Wilson 2008). To directly examine prospective and retrospective differential activity, Ferbinteanu and Shapiro (2003) designed an experiment on the plus maze where two different (opposite) start arms could be used on any given trial to one of the two adjacent goal arms. The rewarded goal arm was kept constant until the rat reliably returned to the rewarded arm for nine out of ten consecutive trials, after which the reward switched to the opposite arm for the subsequent block, with the initial start arm chosen pseudo-randomly. Importantly a 10-15 second delay was enforced after the reward was obtained before the next trial commenced. Differential firing patterns were revealed on the common trajectories depending on current journey, with both retrospective and prospective firing patterns being identified in the same ensemble on any given journey (Ferbinteanu and Shapiro 2003). Furthermore, performance of pre-trained rats was significantly impaired as a result of lesioning the fornix, and on 'error' trials (unrewarded goal box was visited first) differential activity was reduced (Ferbinteanu and Shapiro 2003). Smith and Mizumori (2006b) employed a similar protocol, but with a set number of 15 trials comprising each block and again both retrospective and prospective firing were identified with temporal inactivation of the dorsal hippocampus (performed prior to training) also found to impair performance. These results demonstrate the ability of place cells to be modulated by the previous and future behaviour of the rat and show that the hippocampus is necessary for performance; however, no attempt was made in these studies to correlate the firing patterns with performance levels. Multiple single-unit recordings of the hippocampal region were made whilst rats performed an alternating figure-of-eight task where an active delay period was enforced on the running wheel between laps. The recordings obtained from this hippocampal-dependent task revealed that several units active during the delay period were predictive of the rats future sequence of turns and were also related to error trials (Pastalkova et al. 2008).

A logical assumption is that the goal sensitive cell firing described in these tasks supports behavioural performance; however, understanding the functional role of the differential firing is complicated by studies such as that by Ainge et al. (2007b), in which goal sensitive cells were identified in a non-delay alternating T-maze task where lesions of the hippocampus were not found to impair performance. Furthermore, good behavioural performance has been found in tasks where differential activity of place cells has not been observed along common pathways to different destinations (Berke et al. 2009; Holscher et al. 2004; Lenck-Santini et al. 2001). Although unlikely, this may be due to the small sample of cells recorded in each subject. It is more likely, however, to be due to subtle differences in task demands, training and goal locations. Lenck-Santini et al. (2001) suggested that the absence of this differential activity in a continuous alternation Y-maze task may be a consequence of rats running in both directions in the maze in contrast to other studies, such as the modified continuous T-maze used by Wood et al. (2000) where rats always ran in the same direction. In the study by Frank et al. (2000), however, differential activity was recorded as rats ran in both directions along linear tracks in a similar protocol to that employed by Lenck-Santini et al.

(2001), but on a W-shaped rather than Y-shaped maze. Additionally, Holscher et al. (2004) failed to identify differential activity when recording in a comparable continuous alternation T-maze task to that used by Wood et al. (2000). Thus, in similar mazes in which similar behaviour has been performed, curiously different results have been obtained. Bower et al. (2002) suggested the differing training techniques employed across studies may explain the discrepancy by influencing the type of strategy underlying successful performance, where unlike allocentric strategies, procedural egocentric-based performance is unlikely to depend upon hippocampal processing (McDonald and White 1994; Packard and Knowlton 2002).

In humans, goal-sensitive cells were reported to fire in different places whilst the participant explored a virtual town, aiming to reach specific destinations (Ekstrom et al. 2003). The prospective firing recorded suggests that a proportion of human hippocampal place cells also respond not only to current location but also to intended destination. One could even conceive that the role of place cell hippocampal activity may be in forward planning, predicting and decision making, based on recall of previous experience (retrospective firing), rather than just route planning. In support of this argument, neural ensemble recordings from CA3 in rats on a multiple junction T-maze revealed a tendency for the neural representations of location to sweep forward, ahead of the rat's physical location, down each possible exit pathway at decision points and this facilitated decision making at the choice points (Johnson and Redish 2007). Thus, it is plausible that the imagining of possible future destinations and their consequence could be aiding the decision process to plan future trajectories; however, the link between the cell's activity and the behavioural decision of the rat was not assessed. Gelbard-Sagiv et al. (2008) recorded from human hippocampal cells whilst subjects watched short video clips containing recognisable characters, such as Harry Potter, after which the participants were asked to recall these clips and give a verbal account of what they were imagining during this process. Analysis of these recordings revealed that units which were originally active during the initial viewing of the video clip were reactivated when these scenes were subsequently recalled.

In summary, the retrospective and prospective firing properties of hippocampal place cells may be involved in episodic-like memory and planning for the future and may even play a role in imagination, based on previous experience. Current studies combining the physiological and behavioural evidence for the combined role of the hippocampus may reveal how patients suffering hippocampal damage present with a specific range of deficits in episodic memory, navigation and the imagining of future events. Studies relating place cell activity to behavioural performance, however, are currently still correlational, which does not imply causality and there remain conflicting reports regarding the necessity of hippocampal-dependent activity for behavioural performance. Consequently the relation, and indeed the function, of the neural correlates remains controversial and the underlying networks involved in the generation of these differential firing patterns remains to be discovered.

0.4.2 Neural Networks in Navigation

The hippocampus has a specific role in spatial memory of an allocentric rather than egocentric nature. Allocentric space is independent of the rat's location, instead relying on the relationships between landmarks within an environment. In contrast egocentric spatial navigation is based on the relationship between the current position of the rat and landmarks in the surrounding environment and thus needs to be constantly updated as the rat moves through the environment. The following subsections focus on the putative circuitry underlying the formation of allocentric space.

Non-Hippocampal Spatial Firing Correlates

Global remapping of hippocampal place fields appears to be a direct result of changes in the firing locations of grid cells in the medial entorhinal cortex (Fyhn et al. 2007). There are a large number of different cell types whose firing patterns relate to different aspects of the environment; cells which fire in response to the borders of an environment have even been identified in the entorhinal cortex, termed 'border cells' (Solstad et al. 2008). The range of features that these cells respond to could all contribute to successful navigation, based on an internal representation of the environment, but where these features are integrated and how they are processed remains unclear.

Grid cells, first discovered five years ago in the medial entorhinal cortex (Fyhn et al. 2004), are cells which have spatially modulated firing fields, such that their firing fields form a hexagonal pattern across the whole environment, with cells firing when rats cross the vertices of a triangular grid, the spacing and field size of which is larger in cells that are located more ventrolaterally in the medial entorhinal cortex (Hafting et al. 2005). The discovery of grid cells and head direction cells (described below) alongside the multitude of non-spatial aspects of the environment and higher cognitive functions that the hippocampal place cells respond to, suggest that the spatial properties represented by place cells are unlikely to originate in the hippocampus itself. Instead, the fundamental spatial code for successful navigation may occur extra-hippocampally to provide the spatial scaffold upon which non-spatial information can be incorporated in the hippocampus. This is supported by the fact that, unlike grid cells, hippocampal place cells can remap across different environments, due to sensory inputs changing or as a result of a pattern separation process of similar inputs (Anderson and Jeffery 2003; Knierim and Rao 2003; Muller et al. 1987), which enables context-specific representations to be formed. These context-specific representations can be used, for example, to distinguish behavioural contingencies occurring in different behavioural contexts in the same environment. In addition, individual features and events that occur in each environment can be incorporated into this context-specific representation, which is presumably required to support episodic memory. However, Lipton et al. (2007) employed a similar protocol to that described by Wood et al. (2000) and found dorsomedial entorhinal cortex grid cells showed comparable trial-type specific differential firing, suggesting this theory is over simplistic. Additionally, the prefrontal cortex, which is known to be involved in short-term memory (Floresco et al.

1997; Kesner et al. 1996), has also been shown to contain cells which fire differentially in similar spatial alternation tasks to those in which CA1 differential activity has been identified and these differential patterns have similar elements (Baeg et al. 2003; Jones and Wilson 2005; Jung et al. 1998). As the prefrontal cortex projects to the entorhinal cortex it is possible that the differential firing patterns may originate in the prefrontal cortex and then be processed through the entorhinal and hippocampal circuits, but likewise activity from the CA1 may be influencing that of the prefrontal cortex via a backprojection.

Although immensely complex and still poorly understood, it seems logical, given that the hippocampal representation of space, in terms of place cell firing, is affected by a number of non-spatial characteristics of an experience and that extra-hippocampal regions also demonstrate spatial firing through a range of cells and structures, that the subicular regions and the entorhinal cortex are responsible for constructing the spatial layout of the environment; with the hippocampus functioning to enrich this spatial framework with context-rich features of an experience, combined across a spatial-temporal time frame, to support episodic types of processes.

Postsubiculum

The postsubiculum, also known as the dorsal presubiculum, projects to the hippocampus via the entorhinal cortex and is an important component of the neural network underlying spatial memory, although it has received little attention in terms of its behavioural function. Of the few experimental findings that have been published, regarding the effects of postsubicular damage, impairments in a range of spatial memory tasks have emerged. Excitotoxic lesions of the postsubiculum have been found to impair the acquisition and performance of a working memory task in the radial arm maze (Taube et al. 1992) and combined lesions of the parasubiculum and presubiculum (which include the postsubiculum) were reported to impair a variety of spatial memory tasks, mainly in the water maze, but did not disrupt non-spatial tasks (Davidson and Jarrard 2004; Jarrard et al. 2004; Kesner and Giles 1998; Taube et al. 1992, but see Liu et al. 2001). Moreover, pre- and para-subicular lesions not only induce deficits in reference and working memory performance in the water maze but also significantly enhance working memory performance in the water maze when non-spatial cues were used (Jarrard et al. 2004), most likely due to a loss of a competing spatial strategy, providing further support for a specific and important role for this region in the processing of allocentric spatial learning and memory.

The main focus of interest in the postsubiculum lies in another type of fascinating cells, the head direction cells, which were originally discovered in the postsubiculum itself (Ranck 1973). The firing rate of head direction cells is maximal when the rat faces a given cell's preferred firing direction, reducing to almost silent levels when the rat's head rotates out of its preferred firing direction, where, in any given brain region, the preferred firing direction of the head direction cells always maintain a constant angle apart from one other (in register) (Taube et al. 1990). Unlike

place cells, the firing rates of head direction cells are not affected by the rats' location in an environment, its behaviour or locomotor activity levels and therefore provide the purest allocentric signal in the neural network of spatial navigation. The head direction cell's firing directions result from learned associations with environmental cues, becoming stable across repeated visits to the same environment and demonstrating cue control (rotating with cue card rotations within an environment), where place cell and head direction cell rotations are coupled in response to the cue card rotations (Hargreaves et al. 2007; Knierim et al. 1995). This implies that place field orientation is based upon inputs from the head direction cell network. A range of theories have been postulated regarding the development and interactions between head direction, grid and place cell networks and the functional connectivity between these neural representations, this subject; however, is far too vast to do justice to in this thesis. The most salient and relevant points are briefly discussed in relation to the role of the postsubiculum in the neural network underlying hippocampal-dependent spatial memory.

A combination of lesion studies and firing latencies of the head direction cells, relative to the current head direction of the rat, provides an insight into the development of the firing (see figure 10 for a summary of the head direction and place cell networks across the the postsubiculum, entorhinal cortex, hippocampus and associated structures). Lesions of the lateral mammillary nuclei, which contains head direction cells (Stackman and Taube 1998), abolished the directional firing preferences of head direction cell firing in the anterodorsal thalamic nuclei and the postsubiculum (Blair et al. 1999) and lesions of the anterodorsal thalamic nuclei were found to abolish head direction cell firing within the postsubiculum (Goodridge and Taube 1997). Also, the head direction cells of the anterodorsal thalamic nuclei encode future head direction by 25 ms whereas the head direction cells in the postsubiculum encode the present, or slightly past, head direction. The lateral mammillary nuclei is therefore the proposed site at which the head direction signal is generated, based on the integration of angular velocity cells from the dorsal tegmental nuclei. The head direction signal appears to then pass from the lateral mammillary nuclei to the anterodorsal thalamic nuclei before reaching the postsubiculum, which would subsequently transmit the signal to the medial entorhinal cortex and onto the hippocampus.

Calton et al. (2003) examined the cue control of place fields in rats which had received postsubicular lesions and found that place fields from the lesioned rats shifted unpredictably when cue cards were rotated and did not re-establish themselves upon counter-rotation of the cue card. In contrast lesions of the anterodorsal thalamic nuclei did not disrupt the ability of the place fields to follow cue rotations but did reduce the information load of CA1 place cells. In addition, although CA1 place fields can be established independently of the postsubiculum, the postsubiculum has been shown to play an important role in helping to maintain the specificity of place field firing in the hippocampus (Liu et al. 2004). The postsubiculum projects back to the anterodorsal thalamic nuclei and the lateral mammillary nuclei (see figure 10) and postsubicular lesions prevent

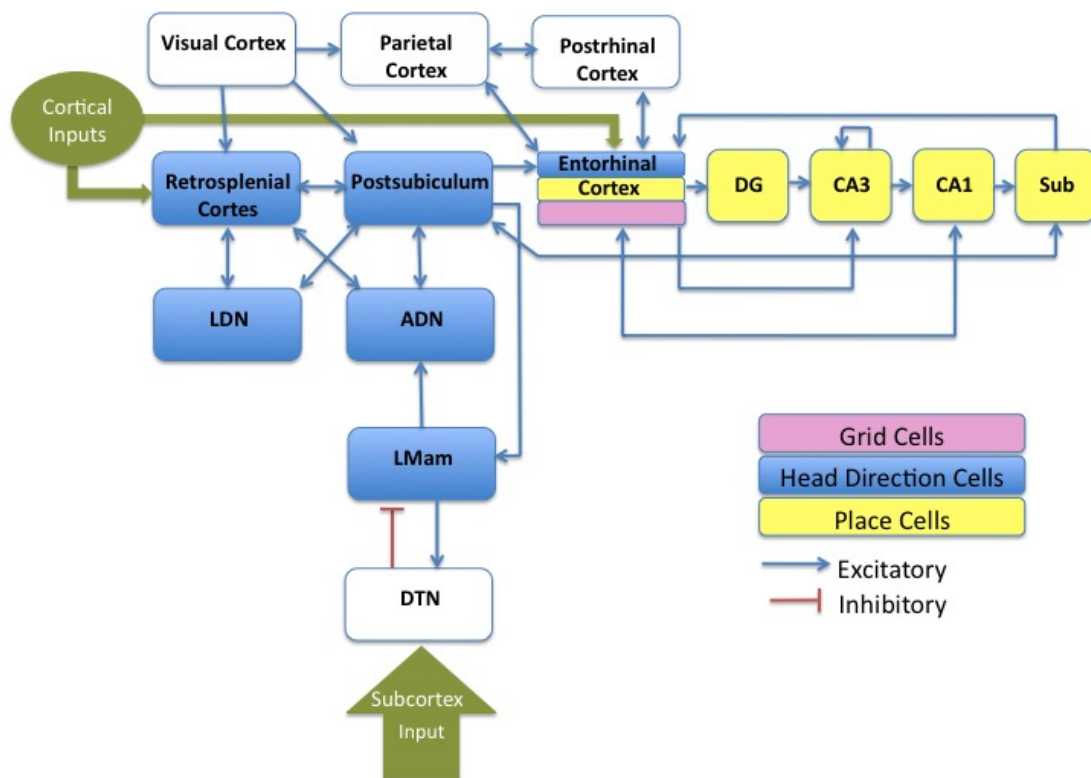

Figure 10: A depiction of a simplified model of the head direction and place cell networks. The reported results of lesion and recording studies suggests that head direction information passes from the dorsal tegmental nuclei to the lateral mammillary nuclei to the anterodorsal thalamic nuclei to the postsubiculum which then projects this information to the entorhinal cortex and into the hippocampal system. Abbreviations: ADN, anterior nucleus of the thalamus; DG, dentate gyrus; DTN, dorsal tegmental nucleus of Gudden; LDN, lateral dorsal thalamic nucleus; LMam, lateral mammillary bodies; Sub, subiculum. Figure adapted from Taube (2007) and Nakashiba et al. (2008).

cue card control being established in the head direction system of the anterodorsal thalamic nuclei (Goodridge and Taube 1997). These results indicate that the postsubiculum is required for place cell stability in relation to environmental landmarks, potentially integrating external visual cue information into the place cell network. Accordingly, hippocampal lesions have little effect on the postsubicular head direction cells, where the ability of head direction cells to establish cue control is not disrupted (Golob and Taube 1997, 1999). The discovery of ‘place by head direction’ cells in the postsubiculum, which are modulated by both place and head direction (Cacucci et al. 2004), support the hypothesised role for the postsubiculum in the integration of hippocampal ‘place’ representation with head direction information. It is possible that the postsubiculum receives visual inputs from the laterodorsal thalamic nuclei and the retrosplenial cortex, which contains head direction cells (Chen et al. 1994), as the hippocampal place cells become mildly unstable when either of these structures are inactivated (Cooper and Mizumori 2001; Mizumori et al. 1994); however, the postsubiculum also receives visual input directly from the visual cortex, which may independently enable external visual information to be incorporated into the signal. Overall, these results suggest that the head direction signal is not merely relayed but is slowly refined from dorsal tegmental nuclei to the anterodorsal thalamic nuclei, with spatial information potentially being integrated into this signal in the postsubiculum. The head direction signal may then be integrated with the grid cell network at the level of the entorhinal cortex, supported by the identification of ‘grid by head direction cells’ in the entorhinal cortex (Sargolini et al. 2006), prior to hippocampal processing.

In summary, the current literature regarding the neuroanatomical connectivity of the hippocampal region, the non-spatial features of place cell firing and the evident role that the hippocampus plays in spatial and episodic memory suggests that rather than providing a specific role in the computation of space, the hippocampus’ contribution to spatial mapping most likely arises from its function as an associator. This would enable the construction of a spatio-temporal scaffold, necessary for the sequential and context-rich information of an event to be related, combining the hippocampus’ purported roles in both spatial and episodic processing.

0.5 Aims of this Thesis

It is widely known that patients suffering hippocampal damage have impaired episodic memory (Aggleton and Brown 1999; Cipolotti and Bird 2006; Scoville and Milner 1957), but impairments in spatial learning and navigation resulting from hippocampal damage have also been documented throughout the human and non-human animal literature (Maguire et al. 1996a,b; Morris et al. 1982). The development of neuroimaging and intra-hippocampal cell recording techniques have enabled further investigation of normal hippocampal function and have found support for both these functional roles. The question then arises as to whether the hippocampus fulfils these functions independently or whether, as it is argued in this thesis, these functional roles are linked by a more general role; in which the hippocampus processes multiple inputs and relates them in a meaningful manner to provide a context-rich flow of information along a suitable spatial-temporal axis. This processed information can then be manipulated to support both the recollection of episodic memories and also the ability to imagine, plan and re-experience events coherently. In order to explore these hypothesised roles of the hippocampal formation a series of different types of experiments will be conducted in which a range of techniques, such as temporally limited blockade of glutamatergic receptors, lesions and single-unit recordings will be employed to investigate episodic-like memory, spatial memory and future planning and the neural circuitry underlying these functions. The thesis is divided into three main sections:

1. This first part assesses the hippocampus' role in a theorised model of the behavioural aspects of episodic memory through examination of the effects of complete hippocampal and subregion specific lesions on performance. The nature of the task employed enables the functional contributions of these regions to be examined in the absence of confounding experimental demands such as allocentric or temporal processing. This study is then extended to develop a suitable protocol in which the neurobiological basis of the originally defined episodic memory triad can be deduced.
2. The second part examines the hippocampus' role in spatial learning and future planning by assessing the development of goal-sensitive firing patterns of hippocampal place cells in relation to learning in a spatial 'win-stay' task. Further experimentation aims to distinguish whether experience navigating the maze or the mnemonic and spatial demands of the task underlies the emergence of these firing patterns and investigates the necessity of the hippocampal region for successful task performance. The focus of this part of the thesis is to further elucidate the relationship between the primary firing patterns and the main behavioural functions of the hippocampus.
3. The final part of this thesis aims to investigate the neural circuitry which gives rise to hippocampal-dependent allocentric processing, which is theorised to underpin its contri-

bution to episodic memory, spatial learning and navigation, planning, imagining and decision making. Examination of the effects of temporally limited blockade of postsubicular glutamatergic receptors on performance in a spatial object recognition task will enable assessment of its putative role in the integration of internally and externally generated visual cues, a process necessary in the formation of allocentric space.

Part II

Experiments

Chapter 1

The Role of Hippocampal Subregions in Object-Place-Context Recognition

1.1 Introduction

Memory, the process by which information is stored and retrieved, plays a central role in life, where episodic memory enables the recollection of personal events which uniquely define our lives, and underlies the essence of our sense of self. The term ‘episodic memory’ was formally proposed to involve the recollection of unique past personal experiences incorporating what happened, where and when (Tulving 1972). This definition has subsequently been updated to include a requirement for autonoetic consciousness during recollection of an event (Tulving 1983), a component difficult to examine in non-animals, due to the absence of language. The development of valid models of episodic memory are necessary to unravel the neural circuitry underlying episodic memory, not only to gain further insight into our understanding of how the brain performs this complex feature of human cognition, but it is also imperative in determining the underlying aetiology of neurodegenerative diseases, such as Alzheimer’s disease, where episodic memory impairments are an early symptom (Desgranges et al. 1996). Furthermore, tasks in which non-human animal models of episodic memory can be tested are essential for examining the efficacies of putative therapeutics for such memory disorders.

A variety of techniques have been used to investigate the possible brain systems mediating episodic memory in humans, including the following: case studies of amnesics with medial temporal lobe damage, which have reported episodic memory impairments (Corkin 2002; Scoville and Milner 1957; Spiers et al. 2001; Tulving and Markowitsch 1998; Vargha-Khadem et al. 1997); and fMRI studies of healthy patients performing episodic memory tasks, which have also reported hippocampal involvement (Burgess et al. 2002; Eldridge et al. 2000) with hippocampal activity during encoding found to be predictive of subsequent performance (Davachi and Wagner 2002; Eldridge et al. 2005; Hannula and Ranganath 2008). The variations in pathology presented clini-

cally, and the numerous confounding factors involved in studying small groups of human subjects and ethical issues involved, alongside the difficulties in proving correlations between neural activity and psychological functions in fMRI studies, highlights some of the limitations of this type of research. Thus, whilst human studies are a vital component of episodic memory research, alone they are insufficient to determine the specific functional role of the hippocampus in episodic memory, nor the underlying subregional circuitry required and so the development of non-human animal models of episodic memory are crucial.

Clayton and Dickinson (1998) designed an elegant study (described in detail in the introduction, section 0.3.2) in which they tested the behavioural features of episodic memory based on the original 'episodic memory triad', consisting of 'what-where-when' (Tulving 1972), and provided the first evidence of integrated 'what-where-when' memory in non-human animals. Since this criteria demands none of the phenomenological aspects of episodic memory to be demonstrated, the term 'episodic-like' memory was created to refer to this ability which can be behaviourally tested in non-human animals. The original episodic-like memory task was designed for scrub jays, based on their natural caching behaviour. There is; however, less available neuroanatomical understanding and experimental tools available for birds compared to rodents. Subsequent studies aimed at examining episodic-like memory in rats have been challenging due to a difficulty in demonstrating and subsequently manipulating the temporal component, although a number of tasks have been developed (see chapter 2, for further discussion).

The necessity of the temporal component in episodic memory has been debated, where instead of experiences involving an innate temporal code, it has been suggested that the temporal context of memory may be inferred, with time merely acting as an occasion-setter to distinguish similar experiences (Friedman 1993). On this premise, Eacott and Norman (2004) developed a novel method to test episodic-like memory in rats where the temporal component (when) of Tulving's (1972) definition was replaced with another occasion setter- context- which was also unique to a particular event. This episodic-like memory task (described in detail in the introduction, section 0.3.2) examined rats' ability to remember trial-unique configurations of objects (what), their locations (where) and the context in which they were presented (which), using a recognition memory protocol. In this paradigm, the rats' memory for the trial unique objects presented in the sample-phase is indirectly measured through the analysis of test-phase object exploration preferences, for novel relative to familiar object configurations. As the task exploits rats' natural tendency to explore novel aspects of a familiar environment (Ennaceur and Delacour 1988) no training is required - akin to human episodic memory, in which unique events experienced only once are remembered. In the integrated 'what-where-which' task rats are exposed to two different contexts consecutively. The first context contains two different novel objects, whose locations are reversed in the second context. Following a two-minute delay, the rat is returned to one of the familiar contexts, containing two copies of one of the sample-phase objects. All individual components

of the task (objects, contexts and locations) are equally familiar and only one configuration of 'object-place-context' is novel. Performance in this task relies on the rats' ability to identify this novel configuration. Previously, both fornix (bundles of axons which provide reciprocal connections to the hippocampus and its numerous connected structures) (Eacott and Norman 2004) and hippocampal (Langston and Wood 2009) lesions have resulted in impaired performance in this integrated task. Conversely, performance remained intact for recognition of distinct 'what-where' or 'what-which' components (Langston and Wood 2009). The nature of hippocampal involvement and the neural mechanisms underlying processing of the task, remain elusive.

Object recognition based on the retrieval of object identity alone does not appear to rely upon hippocampal processing (Forwood et al. 2005; Gaskin et al. 2003; Good et al. 2007; Mumby et al. 2002, 2005; Winters et al. 2004, but see Broadbent et al. 2004; Clark et al. 2000; Gould et al. 2002), but hippocampal dependence emerges when the position in which the object was presented must also be retrieved to determine which object has been displaced in the object-place recognition test (Mumby et al. 2002; Save et al. 1992). These object-place recognition tests in which hippocampal dependence was documented, all involve the rat being placed into the arena at different locations across trials, which encourages the use of an allocentric (environment-centred reference frame) strategy, necessitating hippocampal involvement (Morris et al. 1982) and that may underlie the performance impairments resulting from hippocampus disruptions. In contrast to many published object-place recognition tasks, an important feature of the object-place recognition task used in this protocol is that an egocentric (body-centred reference frame) strategy is sufficient to identify the novel object-place configuration. This was achieved by always placing the rat into the experimental arena at the same location, facing the same direction with large extra-maze cues in close proximity to the test objects. Langston and Wood (2009) demonstrated that in a similar paradigm hippocampal lesions did not impair object-place recognition when this protocol was employed, but reduced object-place recognition levels to chance when rat was placed into the arena at different locations, requiring an allocentric strategy to be engaged to determine the relative positions of the objects. The experimental design therefore allows the role of the hippocampus and its subregions to be examined in an episodic-like memory task without a confounding requirement for allocentric space to be used, as the hippocampus is not required for egocentric spatial memory (Eichenbaum et al. 1990). Furthermore, the inclusion of a separate object-place recognition task in this study allows one to clarify whether any deficit observed in the integrated object-place-context task is also seen in the object-place task which would determine whether deficits were due to a specific role in association or a more general spatial role.

Studies have also reported hippocampal-dependence in tasks requiring the encoding and retrieval of contextual information, for example Nakashiba et al. (2008) report that the rapid acquisition of context was impaired when CA3 output was blocked in mice using a fear conditioning task. The term 'context' was used here to describe two entirely different environments which in-

volve a combination of different odour, arena size, lighting, texture and were located in different testing rooms. The use of the term ‘context’ in the current study; however, merely refers to the distinct circular floor and wall which are inserted into the experimental environment to produce the arena. The two different contexts were of the same shape and size and occupied the same position within the testing environment, surrounded by the same cues. This simple distinction between contexts is likely to be encoded as any other item in the testing environment, such as object identity. This is another important aspect of the experimental design, as tasks in which ‘context’ is used to refer testing environments located in different rooms (e.g. Mumby et al. 2002) are likely to have involved features of the testing environment, such as odours, light levels, auditory cues, etc., to be associated and the ability to relate multiple items of information itself is likely to require the hippocampus, inducing a confounding variable to object-context recognition testing in this manner. This issue is avoided in the object-place-context task, described by Eacott and Norman (2004) and employed in the current study, as successful recognition of contextual change in this protocol only requires rats to encode an individual item such as colour/texture of the context.

In this chapter an investigation into the functional roles of the hippocampus and its subregions is reported in an associative model of episodic-like memory that does not require either allocentric space nor temporal processing and in which contextual information is not dependent on the association of multiple uncontrolled items but merely provides another event specifier such as object identity. This protocol enables the function of the hippocampal subregions to specifically be tested in the integration of three defining features of an event ‘what-where-which’, a putative model of episodic memory.

The hippocampus was previously assumed to function in a serial manner, where any disruption to the circuit would prevent function. There are, however, multiple pathways within the system where, even in the absence of CA1, partial output may be mediated from CA3 via the lateral septum, which projects to the subiculum. This connection is relatively small and is likely to provide a modulatory role due to connections back to the hippocampus (Rolls and Kesner 2006); however, it may provide a behaviour-influencing pathway in the absence of a functional CA1 region. Consequently, investigations of the hippocampal subregions began and numerous studies have investigated the roles of CA3 and CA1 in spatial, temporal and associative memory, with functional dissociations between structures discovered (which are described in detail in the introduction, section 0.2.2).

The CA1 region is currently thought to: decorrelate CA3 output temporarily (Gilbert et al. 2001; Lee et al. 2005b; Rolls and Kesner 2006), compute mismatch by acting as a novelty detector comparing CA3 output with direct cortical input (Lisman and Otmakhova 2001), and relay information from CA3 to the neocortex (McClelland and Goddard 1996). In contrast, the CA3 region is proposed to mediate allocentric space associations such as those with objects (Kesner et al. 2004) and odour (Gilbert and Kesner 2003). Contextual fear conditioning- a proposed model of episodic

memory- is also impaired by CA3 disruption. The separate components of the task, memory of the contexts and expression of fear, remain intact, but the rat displays equal fear for both shocked and unshocked contexts, indicating an inability to associate the event (shock) with the context in which it occurred (Lee and Kesner 2004). This suggests CA3 is integral to association, a function supported by the large number of recurrent collaterals in this region, putatively involved in encoding and retrieval of associations between information. The connectivity of cells within the CA3 region provide the potential to support pattern completion (O'Reilly and Rudy 2001), where input from partial cues stimulates a subset of the neurons originally active during learning, which in turn re-activates the entire neural network supporting the memory through the autoassociative network of cells in this region, resulting in the retrieval of the complete memory.

Episodic memories require encoding of context-rich information to occur rapidly in a single exposure (Eichenbaum 2001). This may relate to the plasticity and autoassociative network in CA3, proposed to support one-trial learning (Nakazawa et al. 2003) and the rapid acquisition of information (Lee et al. 2004a). These autoassociative properties are not evident in CA1, and association studies in the rat have found CA1 disruption to result in lesser impairments in performance than CA3 disruption, unless information is required to be associated over an interval (Hunsaker et al. 2006). The majority of episodic memory focus has consequently been placed on CA3, with CA1 thought to provide a supportive role in mediating CA3 output. Support for a role of CA3 in one-trial memory has been provided by research from a number of lesion studies (Gilbert and Kesner 2003; Hunsaker et al. 2007a, 2006; Kesner et al. 2005), pharmacological studies (Daumas et al. 2005), genetic studies (Nakazawa et al. 2002, 2003), electrophysiological studies (Brun et al. 2002; Leutgeb et al. 2004; Mizumori et al. 1999), and computational models (Hasselmo 2005; Rolls and Kesner 2006); however, almost all of these studies have required elements of allocentric navigation. There may; however, be a specific role for the CA1 region in recollection as CA1 is hypothesised to process information from CA3 back to its original cortical signal and create an associatively learned backprojection to the neocortex, where object identity is presented, which allows the retrieved episode to be 're-lived' (Rolls and Kesner 2006). This theory is supported anatomically, as NMDARs are located on the cortical pyramidal cells right back to their apical dendrites, enabling the necessary modifications to occur during learning at the synapses between the backprojecting axons originating from the active hippocampal neurons and the apical dendrites of the active cortical pyramidal neurons, which would allow the specific set of cortical neurons, active during the initial learning, to be reactivated during recall. It is plausible based on this research that the integration of object, place and contextual information would specifically require the entire hippocampal region, with the CA3 enabling rapid association of the sample-phase components and pattern completion, based on object identity presented in the test-phase supporting retrieval of sample-phase representations; and the CA1 region enabling behaviour influencing pathways to the cortex potentially supporting recollection and providing a mismatch detector role based on the

retrieved sample-phase representations from CA3 and current sensory inputs from the entorhinal cortex. The nature of the protocol employed suggests that the individual components of the integrated object-place-context task, tested in the simpler object-place and object-context tasks, would not depend on either structure (for the reasons discussed above) and would therefore enable the potential associative role of the CA3 region to be investigated in a model of episodic-like memory without the confounding factor of allocentric spatial processing, clarifying the results obtained in previous studies.

In summary, in order to gain further insight into the hippocampal networks involved in object-place-context recognition this chapter will extend the work of Eacott and Norman (2004) and of Langston and Wood (2009) to investigate effects of excitotoxic lesions of the hippocampal subregions- CA1 and CA3-, enabling the extent of their differential involvement in this putative model of episodic-like memory to be determined. It would be expected that all rats should accomplish the individual components of the task, which were not previously found to be disrupted by hippocampal lesions (Langston and Wood 2009). In contrast to controls; however, hippocampal-lesioned rats are expected to be impaired on the integrated 'what-where-which' task, as previously reported (Langston and Wood 2009). The current literature discussed would predict a role for CA3 in the encoding of associations between items and their location and context. In the test phase it is likely that the familiar context and objects would induce retrieval of context-rich sample-phase information, which may recruit the CA1 region to compare retrieved information with new sensory associations, due to its putative role in the associative mismatch process and its role as the major output structure of the hippocampus (Lisman 1999).

1.2 Materials & Methods

1.2.1 Subjects

The study involved 48 male Lister-Hooded rats (Charles River, UK), housed in groups in diurnal conditions. Handling began four days prior to surgery, which was performed on rats weighing 265-375 g. Rats were kept under 12 hour light/dark cycle and were housed in group cages. All experiments were conducted in the light phase of the cycle. Rats were given *ad libitum* access to water and were food restricted, to maintain rats at at least 90% free-feeding bodyweight, two weeks after surgery. All procedures are performed in compliance with national (Animals [Scientific Procedures] Act, 1986) and international (European Communities Council Directive of 24 November 1986 [86/609/EEC]) legislation governing the maintenance of laboratory animals and their use in scientific experiments.

1.2.2 Lesion Surgery

Surgery was performed on all rats; sixteen received bilateral CA1 lesions (CA1-), sixteen received bilateral CA3 lesions (CA3-), eight received bilateral hippocampal lesions (H-) and eight received sham operations (controls). The rats were randomly assigned to these surgical groups and the behavioural testing was conducted with the experimenter blind to these experimental groups. Rats were housed in group cages, containing a mixture of lesion groups within the cage.

Prior to surgery, rats were anaesthetised with halothane (Merial Animal Health, UK), placed on an isothermal heating pad and positioned into a stereotaxic frame (Kopf, CA). Craniotomy was performed to expose the dura above the hippocampus, bilaterally. Small focal injections of the axon sparing neurotoxin ibotenic acid hydrate (Biotechnology, CA), dissolved in phosphate buffered saline (pH 7.4) at 10 mg/ml, were used for all lesions, as previously described (Ainge et al. 2006). For lesion surgeries the ibotenic acid was injected manually (0.1 μ l/min) at the specified coordinate sites, modified from (Jarrard 1989) according to (de Hoz et al. 2003) (see table 1.1 for lesion coordinates), 30 seconds after lowering the syringe. The syringe remained in place for either a one-minute period (hippocampal lesions) or two-minute period (subregion-specific surgeries) after infusion, allowing time for proper diffusion of the acid, before being gradually raised. For bilateral hippocampal surgeries a 25 Ga bevelled 1 μ l syringe (SGE, UK) was used to inject the ibotenic acid, whereas a smaller diameter 33 Ga cannula (Plastics One, Bilaney Consultants, UK), inserted into a blunt, non-bevelled 2 μ l syringe (SGE, UK), was used to allow localised acid infusion required to perform the specific subregional lesions with accuracy. For sham surgeries a 23 Ga needle was used to penetrate the dura, causing mechanical damage comparable to that induced by the syringe in other lesions.

Once all injections were completed, or the dura had been pierced for the sham surgery, gelatin sponge (Spongostan Dental, Johnson & Johnson, NJ) was applied to areas in which the bone had been removed, skin was sutured and a subcutaneous injection of 0.05 ml/kg analgesic (Small Animal Rimadyl, Pfizer, UK) in 2 ml saline was administered. Rats were returned to their heated home cages for recovery. Analgesia (Large Animal Rimadyl, Pfizer, UK) was available in the rats's water from 24 hours before to 48 hours after surgery.

1.2.3 Apparatus

All trials were conducted in a circular arena (76 cm diameter with 40 cm high walls), positioned in a square wooden box (100 cm x 100 cm x 70 cm). Black cotton curtains (200 cm long) enclosed the east, south and west sides and a yellow plastic curtain contained the north side. Large three-dimensional visual cues (such as a multi-coloured feather duster and an orange bucket) were hung on the inside of the curtains at specific locations. Through a slit in black-cotton material, which enclosed the top of the arena, a centrally placed light and video camera were mounted.

a. H-				b. CA3-				c. CA1-			
AP (-)	ML (+/-)	DV (-)	μ L	AP (-)	ML (+/-)	DV (-)	μ L	AP (-)	ML (+/-)	DV (-)	μ L
2.40	1.0	3.0	0.05	1.80	1.2	3.0	0.04	3.12	0.8	2.8	0.04
3.00	3.0	2.7	0.10	2.92	3.6	3.1	0.04	3.96	0.8	3.5	0.04
3.00	1.4	2.1	0.05	3.84	4.2	3.7	0.04	3.96	2.5	1.6	0.04
3.00	1.4	2.9	0.05	4.52	3.6	7.3	0.06	5.04	5.8	7.3	0.04
4.00	3.7	2.7	0.05	4.92	4.6	4.3	0.04	5.04	5.4	4.3	0.04
4.00	2.6	1.8	0.05	4.92	3.8	7.1	0.04	5.04	3.0	1.9	0.04
4.00	2.6	2.8	0.05	5.76	4.4	4.1	0.04	6.24	4.5	2.6	0.04
4.30	4.0	7.0	0.05	5.76	4.4	6.0	0.04	6.24	6.0	5.5	0.04
4.90	3.9	3.5	0.05								
4.90	3.9	7.0	0.10								
5.90	5.1	4.5	0.08								
5.90	5.1	5.3	0.08								
5.90	4.3	3.9	0.10								

Table 1.1: Stereotaxic coordinate sites of ibotenic acid infusions for: **(a)** hippocampal lesions (H-), **(b)** CA3 lesions (CA3-) and **(c)** CA1 lesions (CA1-). The infusion sites were calculated using the values indicated for distance along the anterior-posterior (AP) and medial-lateral (ML) axis, from bregma, and the dorsal-ventral (DV) axis coordinates, from dura, in the appropriate direction (symbolised by \pm). The volumes of ibotenic acid infused at each site are stated in column headed ' μ L'.

The enclosure was kept in a constant position, to standardise external cues (experimenter, computer, radio, and home cage). Locations on which objects were presented remained constant and rats always placed into and removed from the arena from the same location, facing the same direction (from the south side, indicated by the white arrow in figure 1.1). This protocol enabled examination of episodic-like memory alone without confounding factors such as impaired spatial awareness as rats could perform all tasks using egocentric space which, unlike allocentric space, is not thought to rely on the hippocampus (DeCoteau and Kesner 2000). An opaque holding bucket (diameter: 30 cm, height: 31 cm), containing 2 cm of sawdust, was used to transfer each rat from its home cage, in the holding room, to the experimental arena, and for holding the rat during the delay periods, between each phase of any given trial.

The circular floor and the walls were interchangeable, providing two distinct contexts (see figure 1.2). Context 1 was composed of a black-painted wooden floor insert with brown, wood-effect sticky-backed plastic wall covering over a wire mesh frame. Context 2 consisted of white sticky-back plastic wall covering over a wire mesh frame, with a white plastic floor insert studded with circular holes (2 cm diameter), under which the black-painted wooden floor could be seen. Each floor insert contained two Dual-Lock (3M, UK) pieces, 10 cm from the wall in the north-east and north-west positions, 30 cm apart, on which the objects were always attached. Examples of objects used include cups, bottles, toys and ornaments. To ensure paired objects induced equal interest, preliminary preference tests were used to pair objects with which rats spent equal time exploring upon first exposure. Across the study rats were only exposed to each object once.

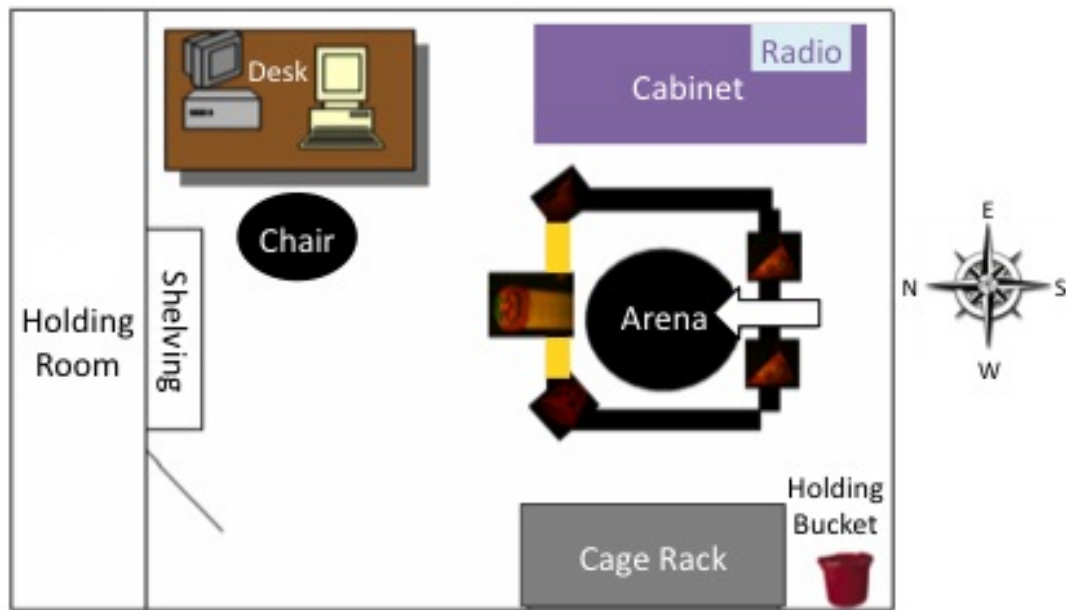

Figure 1.1: A schematic of the testing room layout. The curtains surrounding the arena are represented the three black and the one yellow lines, with square boxes indicating the available visual cue locations, hung on the curtains. The experimenter always sat at the chair opposite the computer screen, on which the rats' behaviour could be monitored, and the radio was always switched on during all habituation and behavioural testing sessions, providing additional cues which could be used for spatial orientation. The rats were removed from their home cages in the holding room and were transferred in the holding bucket into the adjacent testing room where they were placed into the arena from the south side, facing the south. The door to the holding room was closed for the duration of each session and the holding bucket was always placed to the south of the arena when not in use, to keep any potential olfactory cues in a constant location.



Figure 1.2: Photographs of the two contexts used in the task. **(a)** Context 1 composed of a black-painted wooden floor and removable wire mesh walls, covered with wood-effect wall paper. **(b)** Context 2, composed of a removable white plastic floor insert, into which circular holes have been drilled such that the black-painted wooden floor of context 1 is visible underneath the floor insert, and a circular removable wire mesh wall covered in white wall paper. In both contexts the locations on which the objects were presented on can be seen as the rectangular pieces of Dual-Lock. The blue-painted wooden box in which the contexts were positioned are also shown with some cues visible in the top corners of each photo.

1.2.4 Behavioural Testing

Behavioural testing commenced 14 days following surgery enabling all rats to regain at least their pre-surgery weights before food was restricted to sustain the rats at approximately 90% of their free-feeding body weight for the duration of the experiment. Prior to recognition memory testing eight habituation sessions were performed. Recognition memory testing consisted of four trials of four different object recognition tasks: object recognition; object-place recognition; object-context recognition and object-place-context recognition. This enabled any recency/primacy effects of the objects/contexts/location to be counterbalanced between rats (see figure 1.3 for a timeline of behavioural testing). This is important in the object-context and object-place-context tasks (see figure 1.4c-d), which include two sample phases, as a strong preference can be induced if one object is presented less recently than another equally familiar object (Kart-Teke et al. 2006). In all habituation sessions and recognition memory tasks rats were placed into the arena from the south, facing the south wall. All objects used in behavioural testing were cleaned with baby wipes (Tushies UK) before being affixed to the arena floors.

Upon sample-phase completion, the rat was retrieved from the south side of the arena and placed into the holding bucket for a two-minute period whilst the context was removed, cleaned and replaced/exchanged, and a novel object and/or duplicates of the sample objects were cleaned and positioned in the arena. The use of duplicate objects eliminated odour cues from indicating previous exposure to the object. In the test phase, the rat was placed back into the arena for three minutes, during which time all object exploration was recorded. The rat was then returned to its home cage.

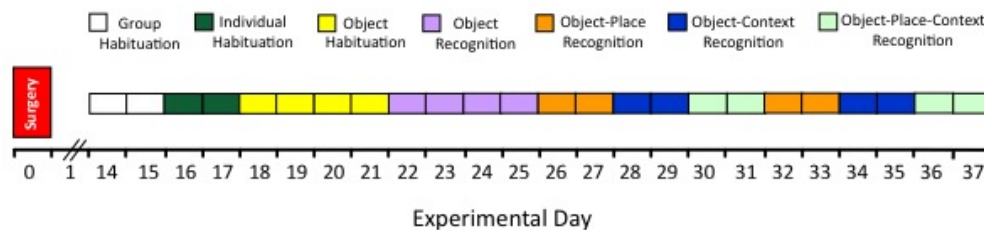

Figure 1.3: Experimental schedule from surgery until the end of behavioural testing, with each type of trial represented by a different colour block.

Habituation

Eight habituation sessions were conducted on consecutive days, familiarising the rats to the arena, and the types and locations of objects within it. In the first habituation session, each cage group of rats were allowed 30 minutes to explore context A, in the absence of any objects; this was repeated the following day in context B, where context A and B refer to the counterbalanced

exposure to context 1 or 2. The procedure was replicated over the following two sessions, except rats were placed into the arena singly for 10-minute periods, with subsequent 10-minute periods in the adjacent holding bucket. Rats then underwent four sessions, where they were put into the arena singly and allowed to explore two different novel objects, affixed to the Dual-lock pieces on the arena floor, for five minutes, before being placed back into the holding bucket for five minutes. These sessions habituated rats to the locations and types of objects used in the object recognition tasks. In a similar fashion to context presentation, the objects presented were counterbalanced between rats across the sessions.

Object Recognition Task

This task was run to ensure rats were able to demonstrate a natural preference for exploring novel objects as opposed to familiar objects and could encode and retrieve object identity. The task required one sample and one test phase which were conducted in the same context, with two sessions in context 1 and two sessions in context 2. Initially the rat was exposed to, and allowed to freely explore, two identical objects until at least 15 seconds of exploration of each object had been accumulated, within a two-five minute period (defined by the time taken to accumulate 15 seconds of exploration of each object). After a two-minute delay, the test phase was conducted, in which a duplicate of the sample-phase object was presented alongside a new object (as shown in figure 1.4a) for a three-minute period. The location of the novel object, object identity and context were counterbalanced across the four sessions between the rats.

Object-Place task

The task required one sample and one test phase which were conducted in the same context, separated by a two-minute interval, with two sessions in context 1 and two sessions in context 2. Two different objects were presented in the sample phase for a two-five minute period (defined by the time taken to accumulate 15 seconds of exploration of each object) before being replaced by identical copies of one of these objects in the three-minute test phase (as shown in figure 1.4b). Thus one of the test-phase objects was positioned in a location previously occupied by a different object in the sample phase, creating a novel object-place configuration (highlighted in figure 1.4b). The location of the novel object-place configuration, object identity and context were counterbalanced across the four sessions between the rats.

Object-Context Task

The task involved two sample phases and one three-minute test phase, where each phase of a given trial was separated by a two-minute interval. In both sample phases, rats were required to explore each object for at least 15 seconds over a two-five minute period. Two identical objects were

encountered in the first sample phase. For the second sample phase the context was changed and two different identical objects were positioned in the arena. In two of the four sessions context 1 was used in the first sample phase, whereas context 2 was used in the first sample phase for the other two sessions; counterbalanced between rats across days. In the test phase the rat was presented with two different objects, one from each sample phase, in one of the contexts (as shown in figure 1.4c), with the test-phase context matching the first sample-phase context for two of the four sessions and matching the second sample-phase for two sessions, in a counterbalanced fashion between rats across days. Therefore one of the test-phase objects was presented in a different context to that it was in when previously encountered in the sample-phase (highlighted in figure 1.4c). Over the four sessions, the location of the novel object-context configuration was counterbalanced such that the novel configuration was presented on both sides of the arena in each of the test-phase contexts.

Object-Place-Context Task

The task involved two sample phases and one three-minute test phase, where each phase of a given trial was separated by a two-minute interval. In both sample phases, rats were required to explore each object for at least 15 seconds over a two-five minute period. The two sample phases were conducted in different contexts, with two sessions involving context 1 in the first sample and two sessions with context 2 being presented in the first sample, counterbalanced between rats across days. Two different objects were presented in the first sample phase, duplicates of these objects were presented in the second sample phase, but the positions of the objects were reversed. In the test phase, the rats returned to one of the contexts, in which two identical objects from the sample phase were presented. The test-phase context matched the first sample-phase context for two of the four sessions and matched the second sample-phase for the remaining two sessions, in a counterbalanced fashion between rats across days. Although both objects had been previously encountered in the test-phase context and in the test-phase position, one of the objects was in a novel position in relation to the contexts (highlighted in figure 1.4d). Over the four sessions, the location of the novel object-place-context configuration was counterbalanced such that the novel configuration was presented on both sides of the arena in each of the test-phase contexts.

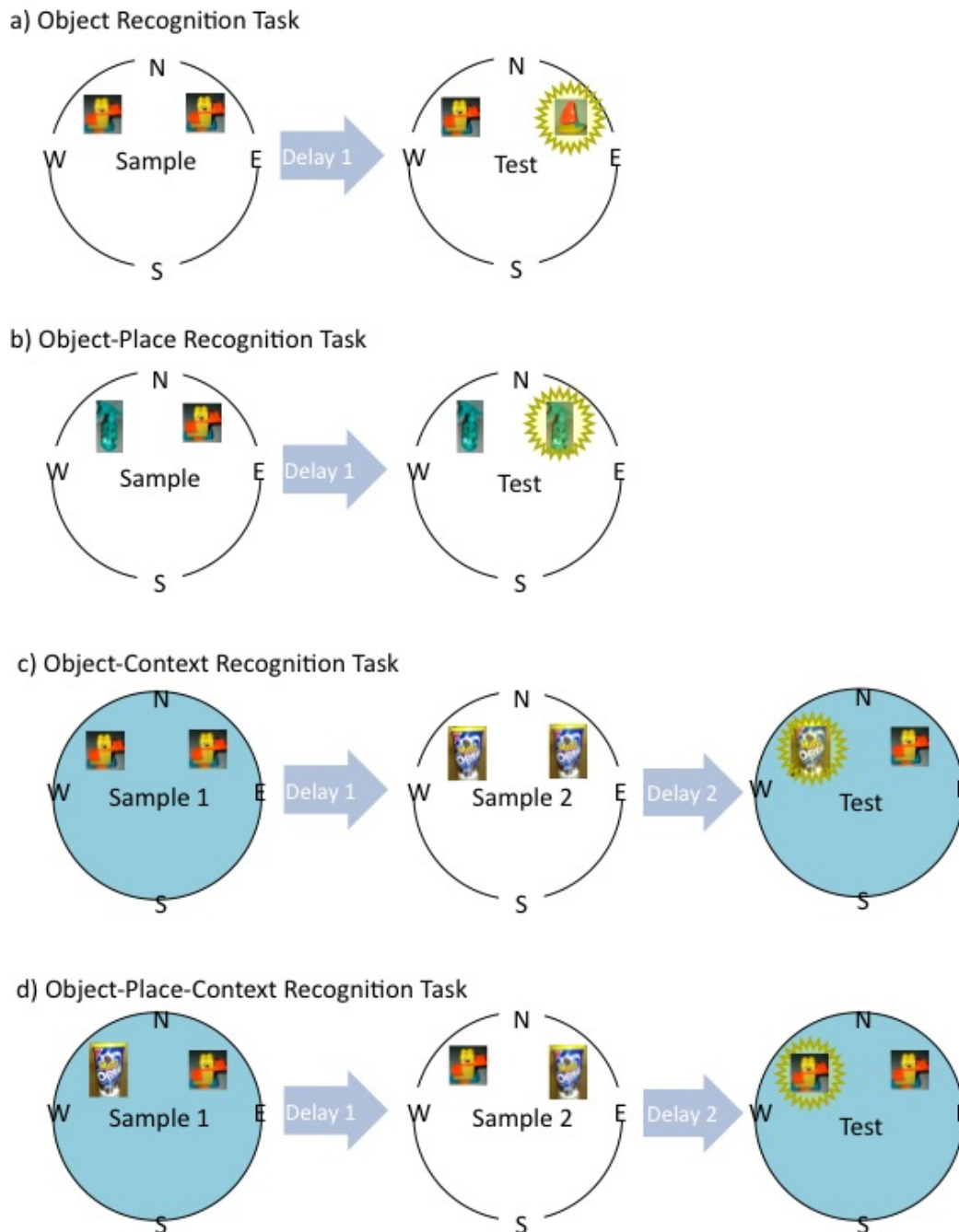

Figure 1.4: Schematic representations of object configurations for the sample and test phases of each behavioural task, **(a)** object recognition, **(b)** object-place recognition, **(c)** object-context recognition and **(d)** object-place-context recognition. The most novel object configurations are highlighted in yellow in the test phases for each task type. Circles represent the experimental arena, which was either configured for context 1 (white) or context 2 (blue). The object photos represent the objects used in the trials; however, in this study all objects were trial unique, with rats never being exposed to any given object in more than one trial.

1.2.5 Histological Procedures

Once all behavioural testing was complete, rats were terminally anaesthetised with an overdose of 1 ml/1.4kg bodyweight sodium pentobarbitol (Euthatal, Merial Animal Health, UK) and then were perfused intracardinally with 0.9% saline followed by 4% formalin. Extracted brains were stored in 4% formalin for at least 24 hours. Brains were then egg embedded and incubated for 24 hours at 37°C in 4% formalin before being removed and placed back into jars containing 4% formalin solution. A cyrostat was used cut 30 μ m coronal sections, with one in three sections mounted on gelatine-coated slides and stained with 0.1% cresyl violet acetate and coverslipped using DPX.

Images of the sections were taken using a video camera (Leica) mounted on a microscope (Wild M420, Switzerland) and were then subsequently analysed using ImageJ (NIH) in which the lengths of the hippocampal cell layers were measured. Sections from sham-operated rats were used to provide a value of 100% sparing for the hippocampus and each subregion, enabling the cell layer in the lesioned rats to be calculated as a proportion of the intact brains producing a value of percentage spared for each subregion and for the entire hippocampal region.

1.2.6 Data Analysis

The rats' movements in the arena were monitored using an overhead black and white camera (Panasonic, UK) connected to the TV monitor. Object exploration, for each object within an exposure phase, was manually recorded on-line using an in-house timing computer programme (National Instruments, LabView), where key presses activated timers which differentially timed exploration of each object, based on the rats' behaviour observable via the TV monitor. The experimenter was blind to the experimental groups to which the rats belonged for the duration of behavioural testing.

A minimum object exploration criteria was employed such that rats were required to spend at least 15 seconds exploring each object in the sample phase and a minimum total exploration time of 10 seconds for the test-phase objects. Exploration required the rat to be within a 2 cm radius of the object, with its nose directed at the object and be involved in sniffing/whisking behaviour.

Raw exploration times were collected as time in seconds before test-phase exploration for each trial was converted into a discrimination index (DI), calculated using the following formula below:

$$\sum \frac{(\text{Novel Object Configuration Exploration} - \text{Familiar Object Configuration Exploration})}{\text{Total Object Exploration Time}}$$

The influence of variability in exploration times of individual rats in each task phase was minimised by using the discrimination score for test-phase preference. The mean discrimination scores, obtained from the discrimination ratios for the four trials on each task, were calculated for each rat and subsequently analysed in SPSS. Raw test-phase exploration times were; however, analysed to determine whether hippocampal lesions affected exploration levels. A univariate ANOVA was employed to compare the experimental groups' total exploration times in the

object recognition task and a repeated-measures ANOVA was used to determine the effects of group (between-subjects factor) on test-phase exploration times across the three associative tasks (within-subjects factor).

In order to test the effect of experimental group on performance across tasks a repeated-measures ANOVA was performed, with the Greenhouse-Geisser corrections for sphericity used where necessary and Bonferroni corrections employed to account for multiple comparisons. The object recognition task was analysed using a one-way ANOVA to compare the experimental groups' performance, which were then individually compared to chance levels (zero) using one-sample t-tests. Performance of each experimental group was then tested across the associative recognition tasks using a repeated-measures ANOVA with simple main effects, and again one-sample t-tests were used to test the performance of each experimental group, with that expected by chance, for each task. Total object exploration times in the sample and test phases of each task were assessed using independent samples t-tests (2-tailed).

1.3 Results

1.3.1 Histological Data

As a result of perioperative complications, four of the CA1 and two of the CA3 lesion group died. The amount of sparing in the hippocampal lesion group ranged from 2-40%, relative to the dentate gyrus, CA3, CA2 and CA1 cell layers of the sham-operated controls, with extra-hippocampal damage occurring in the subiculum. The extent of the CA3 lesions varied with some sparing and some additional damage to the CA2, CA1 and dentate gyrus. There was also variation across the extent of CA1 lesions with variable additional damage to the dentate gyrus, CA3 and CA2 regions. Representative histological results obtained for each experimental group is shown in figure 1.5. In order to pursue further analysis of lesion effect on behavioural performance, an inclusion criteria was imposed for rats in the CA1 and CA3 lesion groups such that rats were only included if there was less than 50% sparing of the targetted structure and less than 30% of the remaining hippocampal regions were damaged. As a consequence the behavioural results were analysed for eight hippocampal-lesioned rats, eight CA3-leioned rats, five CA1-lesioned rats and eight sham-operated rats (for a summary of the percentage lesion size of each hippocampal subregion for the lesion groups see table 1.2, additionally a table detailing the extent of damage of each structure in the individual subjects is available in the appendix, table A.1).

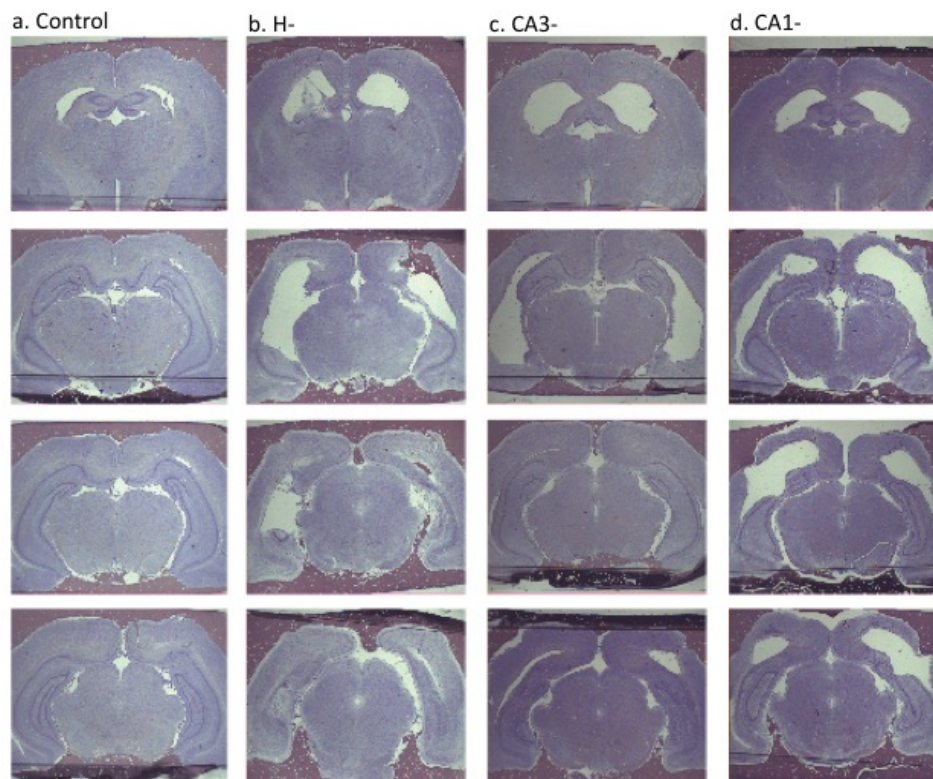

Figure 1.5: Photomicrographs of representative cresyl violet stained coronal sections for each group of rats: (a) sham lesions (controls), (b) complete hippocampal lesions (H-), (c) complete CA3 lesions (CA3-) and (d) complete CA1 lesions (CA1-). Sections within groups are organised in columns from anterior to posterior locations through the hippocampus.

	DG	CA3	CA2	CA1	Total
H-	76.8 +/- 6.9	85.0 +/- 4.7	93.2 +/- 3.3	90.4 +/- 4.3	85 +/- 4.8
CA3-	20.1 +/- 3.2	61.3 +/- 2.6	50.2 +/- 4.5	20.8 +/- 2.5	31.1 +/- 1.7
CA1-	15.5 +/- 1.0	10.4 +/- 3.0	45.8 +/- 7.5	72.8 +/- 3.4	35.1 +/- 1.5

Table 1.2: A quantified summary of the extent of lesions across groups. The lesion size was calculated as a percentage of the mean region in the sham-lesioned brains for each region. The mean percentage lesion size is reported for each lesion group (\pm SEM), calculated from the mean size in appropriate regions of the sham-lesioned brains, with numbers in bold representing the target area for each lesion group.

1.3.2 Behavioural Data

The object recognition task is the only task in which rats were purely tested on the ability to detect novelty, as objects in other tasks were all familiar, with only the configuration of the object, with respect to the position/context it was presented, providing novelty. Task performance is shown in figure 1.6a as the mean discrimination scores for each of the four groups. All groups demonstrated a similar preference for the novel object in the object recognition test, with no significant differences across the groups ($F_{(3,25)}=0.36$; $p<0.05$) and with discrimination scores significantly above chance levels (zero) for a each group: controls ($t=5.95$; d.f.=7; $p<0.001$); H- ($t=7.69$; d.f.=7; $p<0.001$); CA3- ($t=6.30$; d.f.=7; $p<0.001$) and CA1- ($t=4.79$; d.f.=4; $p<0.01$). These results demonstrate that neither complete nor subregional hippocampal lesions affected the process of object recognition.

The ability to recognise familiar object associations was tested in the object-place, object-context and object-place-context tasks (presented in figure 1.6b-d). A repeated-measures ANOVA was conducted to determine the effects of group (between-subjects factor) on performance (discrimination scores) across these associative tasks (within-subjects factor). A significant effect of group ($F_{(2,25)}=6.12$; $p<0.01$) and a significant task x group interaction ($F_{(6,50)}=2.61$; $p<0.05$) was revealed but with no significant effect of task ($F_{(2,38)}=1.86$; $p=0.166$). Bonferroni corrected pairwise comparisons between groups revealed that all the lesion groups significantly differed from controls, but not each other, only in the object-place-context task ($p<0.01$); performance between groups did not significantly differ in any of the other tasks. One-sample t-tests were performed on the mean discrimination scores, against chance levels (zero), for each experimental group in each task. Results demonstrated that all groups had a significant preference for the novel object-place configuration: controls ($t=3.44$; d.f.=7; $p<0.05$); H- ($t=3.55$; d.f.=7; $p<0.01$); CA3- ($t=3.60$; d.f.=7; $p<0.01$) and CA1- ($t=3.81$; d.f.=4; $p<0.05$), as well as the object-context configuration: controls ($t=3.65$; d.f.=7; $p<0.01$); H- ($t=3.73$; d.f.=7; $p<0.01$); CA3- ($t=2.72$; d.f.=7; $p<0.05$) and CA1- ($t=3.12$; d.f.=4; $p<0.05$); but only controls and CA1 lesions demonstrated a significant preference for the most novel object-place-context configuration: controls ($t=7.57$; d.f.=7; $p<0.001$); H- ($t=0.976$; d.f.=7; $p=0.362$); CA3- ($t=1.67$; d.f.=7; $p=0.14$); CA1- ($t=3.76$; d.f.=4; $p<0.05$).

Previously, variable object exploration times during the sample phase have affected whether hippocampal lesions impair object-recognition task performance (Ainge et al. 2006), due to hippocampal lesion-induced reduction in object exploration. This is normally only apparent when sample phases exceed five minutes, which is not the case in this study. Despite this, additional analyses were conducted to ensure that hippocampal-lesioning was not impairing integrated object-place-context recognition indirectly by inducing hyperactive behaviour and thus reducing object exploration. A univariate ANOVA revealed no significant effect of surgical group on raw exploration times in the object recognition test phase ($F_{(3,25)}=0.99$; $p=0.96$). Furthermore, a repeated-measures ANOVA performed on the experimental groups' test-phase exploration times, across the

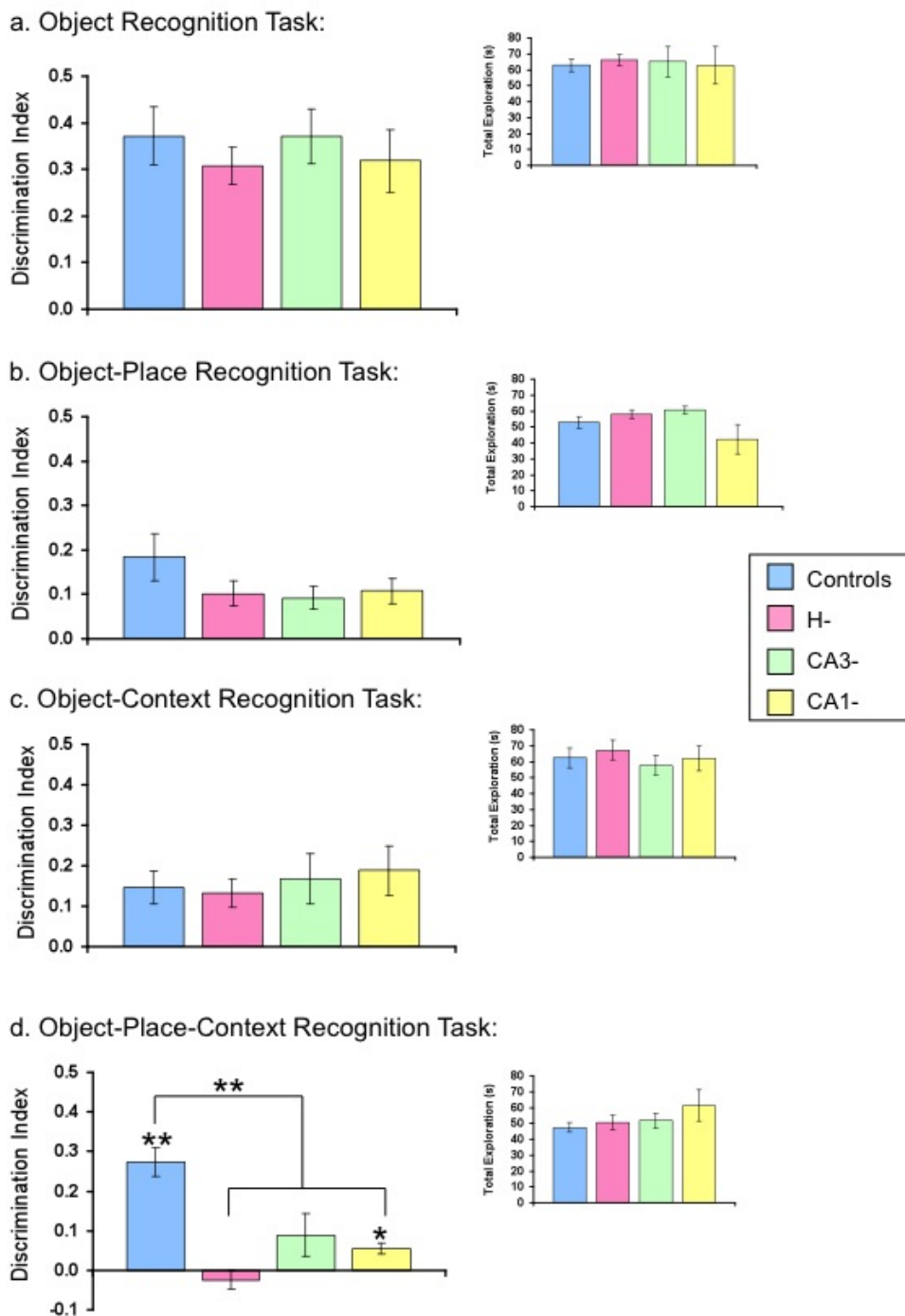

Figure 1.6: Graphical representations of performance, displayed as discrimination index (\pm SEM), of the rats in each experimental group (sham-operated rats (controls), hippocampal lesioned rats (H-), CA3 lesioned rats (CA3-) and CA1-lesioned rats (CA1)) across the four tasks: **(a)** Object Recognition, **(b)** Object-Place Recognition, **(c)** Object-Context Recognition and **(d)** Object-Place-Context Recognition. A discrimination index score of zero indicates no preference for either object configuration, positive values indicate a preference to explore the novel object configuration and negative values occur when the majority of exploration was of the familiar object configuration. Graphical representations of the mean raw exploration times (in seconds) for total test-phase object exploration for each group is displayed on the right-hand side for each task. Data is displayed as mean values \pm SEM, (*) $p < 0.05$, (**) $p < 0.001$.

associative tasks, revealed no significant effect of group ($F_{(3,25)}=0.47$; $p=0.705$) nor task x group interaction ($F_{(5,45)}=9.57$; $p=0.459$), although there was a significant effect of task ($F_{(2,45)}=3.89$; $p<0.05$), where the exploration in the object-context and the object-place-context tasks differed significantly ($p<0.05$). Thus, object exploration times did not differ between groups in the test-phases of any of the four tasks involved in this study (see figure 1.6 for test-phase exploration times) and is therefore not a contributable factor to the lesion-induced deficits in object-place-context task performance.

The results clearly show that both complete hippocampal lesions and specific subregional hippocampal lesions of CA3 and CA1 significantly impair performance only when all three components (object, place and context) must be associated in order to support associated recognition memory. Object, object-place and object-context recognition task performance was unaffected by surgical intervention. Although task performance did not significantly differ between the lesion groups, CA1-lesioned rats demonstrated a significant preference for the novel object-place-context configuration, which indicates some sparing of function relative to CA3- and hippocampal-lesioned rats who performed at chance levels.

Overall, these results indicate that both complete and subregional hippocampal-lesioned rats were selectively impaired in the object-place-context task, not in object-place nor object-context associational tasks, relative to sham-operated controls. There was no significant difference in performance across lesion groups in any of the experimental tasks; however, unlike CA3- and hippocampal-lesioned rats, CA1-lesioned rats explored the most novel object-place-context configuration significantly more than expected by chance. This suggests that CA1-lesioned rats may have some sparing of function in this domain; although, they were still significantly impaired relative to control.

1.4 Conclusions & Discussion

The present data support previous findings that the hippocampus is specifically required when object, place and context must be integrated to support recognition memory (Eacott and Norman 2004; Langston and Wood 2009) and further reveals that CA3 and CA1 lesions result in similar detriments to that of hippocampal lesions, in associative recognition of object-place-context configurations. To exclude the possibility that impairments are indirectly induced by deficits in the individual components of the object-place-context task, the rats' ability to detect novelty in these components was tested separately in object recognition, object-place recognition and object-context recognition tasks. The lack of impairment shown by any of the lesion groups in these control tasks suggest that the impairment of the lesioned rats can not be attributed to deficits in associative recognition of any of the features of the object-place-context recognition task.

In contrast to our results, previous studies have reported the hippocampus to be necessary

in object-place tasks (Kesner et al. 2004; Mumby et al. 2002). This discrepancy is likely due to a requirement for allocentric space (Langston and Wood 2009), which was not required in this study, especially as the results reported herein recapitulate those previously reported using identical protocols (Eacott and Norman 2004; Langston and Wood 2009).

The lack of impairment of the lesioned rats in object-context recognition also appears inconsistent with studies reporting a requirement for the hippocampus to support context-rich memory (e.g. Mumby et al. 2002). Furthermore, impaired object-recognition was reported after hippocampal lesioning, when there was contextual mismatch between sample and test phases (O'Brien et al. 2006). Based on these results the lesioned rats, unlike controls, should not be able to identify both test-phase objects as familiar with only one presented in a novel object-context configuration, instead the lesioned rats should not recognise the object presented in a different context and thus this object should appear entirely novel. The findings of O'Brien et al. (2006) would therefore predict that hippocampal-lesioned rats should perform better than controls in the object-context recognition task described in this study, as an object perceived as novel is expected to induce greater exploration levels than that of a familiar object in a novel context. In contrast to what might be predicted based on the current literature, the rats' performance in the object-context recognition task in this study was neither impaired nor enhanced; however, 'context' in these tasks can be encoded as specific features of the environment, such as the colour/texture of the arena, and this would be sufficient to support recognition performance (as described in the introduction to this chapter). This may explain the lack of impairment seen in the lesion groups, as hippocampal involvement in contextual processing is likely due to a requirement for the relational representation of multiple features of an event. The results obtained are consistent with previous tests of hippocampal-dependence in object-context recognition when equivalent protocols are used (Eacott and Norman 2004; Langston and Wood 2009).

The results of this study reveal a role for CA3 and CA1 in the association of event features, which do not require allocentric nor temporal information to be processed. This is seemingly contradictory to the current literature discussed in the introduction to this chapter.

Previous studies have reported that the CA3 region only becomes necessary for performance when the association of items involves a spatial element (Gilbert and Kesner 2002, 2003; Kesner et al. 2005). These results were based on experiments in which only dorsal CA3 was lesioned, believed to be primarily concerned with spatial learning (Moser et al. 1995) and the deficits obtained are likely a result of allocentric processing, explaining why CA3-lesioned rats were unimpaired on the egocentric object-place recognition task involved in this study. Also, these experiments involved incremental learning of the associated pairs and current literature suggests a unique role for the hippocampus in the association of trial-unique information, such as in episodic memory. This is supported by a more recent study, in which Hunsaker et al. (2008b) demonstrated that lesioning CA3 or CA1 in pre-trained rats impaired only the purported episodic recall of trial-unique

sequences of spatial locations and not performance on a fixed sequence, non-episodic version of the task. Thus, it is plausible that the CA3 subregion has a specific role in the rapid association of event features for trial-unique information and also has a specific function in processing allocentric space. Alternatively, the deficit in integrated object-place-context recognition of CA3-lesioned rats may be due to an impairment in retrieval, based on its proposed role in pattern completion, whereby sensory information of familiar components in the test phase induces associated retrieval through a pattern completion process of the previously experienced sample events. This associated retrieval would enable the sensory and retrieved information to be compared/contrasted, not only to detect novelty, but also for recollection of further contextual features of an episode from only a partial sensory cue.

The revelation that object-place-context recognition is impaired by lesions to the CA1 region contrasts with the current literature which found no role of the CA1 region in performance requiring association of spatial or non-spatial items (Gilbert and Kesner 2003; Lee and Kesner 2002), unless performance requires the processing of temporal information (Gilbert et al. 2001; Hunsaker et al. 2006; Kesner et al. 2005). Based on the anatomical structure of CA1 and the results from previous studies, its requirement for object-place-context recognition task performance is unlikely to involve the associative element of episodic memory encoding. The CA1 region is; however, the main output structure of the hippocampus and therefore as the ventral as well as the dorsal portions of the CA1 region were lesioned, the impairment reported herein could be due to the inability to output essential processing from elsewhere in the hippocampal circuit, such as in CA3, which is independent of CA1 function. This explanation seems likely as CA1-lesioned rats were able to perform the object-place-context recognition task significantly better than chance, suggesting the smaller hippocampal output available via the lateral septum may enable performance albeit at a significantly lower level than controls. Alternatively, it could be argued that the significant impairment of CA1-lesioned rats, relative to controls, is due to a mismatch detection function for the CA1 region in the test-phase of the object-place-context recognition task, comparing current input, from the entorhinal cortex, with stored sample-phase inputs from CA3; a function ascribed to the CA1 region in a number of studies (Anderson et al. 2006; Lisman and Otmakhova 2001; Witter 1993). This proposed function is anatomically justified since CA1 receives the majority of synapses from CA3 and approximately one sixth of synapses from direct perforant path projections from the entorhinal cortex (Amaral et al. 1990), which therefore provides the necessary circuitry to support the associative mismatch detection between current sensory input and expectation based on associative recall of previous events (Honey et al. 1998). In addition, fMRI data support a specific role for the hippocampus in associative mismatch detection in human subjects, with the extra-hippocampal cortical regions involved in rapid encoding of novel trial unique stimuli (Kumaran and Maguire 2006).

On a different note, one could argue that the similarity of the impairments across lesion groups

is due to incomplete lesions which were not entirely exclusive to the hippocampal subregion targeted; however, this is unlikely due to the pattern of results reported herein. If the performance had been affected by an incomplete lesion of the targeted structure than one would expect an impairment in the object-place-context recognition task to be reduced, whereas the performance reported shows significant impairments of all surgical groups relative to controls. Also, neither dorsal CA1 nor CA3 lesions would predict the results reported, based on the current research, and therefore it is unlikely due to just damage to one of these structures.

These results demonstrate that the combination of object, place and context in recognition memory relies on intact hippocampal circuitry, whereas associative recognition of any of the elements of this task can occur in the absence of a functioning hippocampus. It therefore appears that there is something special about the integration and retrieval of the objects' identity, its location and the context in which it was presented that necessitates hippocampal processing. It is possible that either the hippocampus is the site of convergence for all three components or that the complex nature of the associative recognition of the 'what-where-which' features of the sample phase requires a hippocampal dependent strategy. It is unlikely that the necessity of the hippocampus is due to the increased number of stimuli which must be associated in the object-place-context task, as previously rats have shown the ability to learn and retain multiple items of information across different modalities independently of the hippocampus (Dudchenko et al. 2000; Gaffan and Eacott 1997; McDonald et al. 1997). Also, it appears that the perirhinal cortex is required for object and object-object recognition (Norman and Eacott 2005) and the postrhinal cortex has been reported to support object-context recognition (Eacott and Norman 2004), but neither structure is required for object-place-context associative recognition (Eacott and Norman 2004), therefore the individual associative aspects of the object-place-context recognition task are unlikely to be supported by extra-hippocampal regions. Thus the hippocampal-dependence of this task is unlikely due to a role in the mere convergence of information. Recognition memory involves two distinct processes, recollection and familiarity (Aggleton and Brown 1999; Yonelinas 1994), of which only the recollective component is thought to necessitate the hippocampus in order to support the recall of the contextual features the event (Aggleton et al. 2005; Bowles et al. 2007; Brown and Aggleton 2001; Eichenbaum et al. 2007; Fortin et al. 2004; Ranganath et al. 2004; Sauvage et al. 2008; Yonelinas and Levy 2002). Therefore, a more plausible explanation, given the specific deficits induced by hippocampal damage in episodic memory, recollection, spatial-contextual memory and imagination (as previously discussed in the introduction to this thesis), would seem to be that when all three elements of the sampling event must be recalled to support complex associative recognition, a recollective rather than a familiarity-based strategy is employed and it is this type of strategy which results in the hippocampal dependence of the task.

It should not be possible to solve the task using relative familiarity alone, as all components of the task; object, place and context, are equally familiar. The impairment is also not a result

of the association of any two of the components of the task as neither the ‘object-place’ nor the ‘object-context’ task revealed any hippocampal impairment in the task and the spatial and contextual information-processing during exploration of these control recognition tasks is thought to occur in the neocortex (Gaskin et al. 2005), with recognition of novel object identity requiring the perirhinal cortex (Winters and Bussey 2005). It is conceivable therefore, to speculate that these control tasks involve familiarity-based recognition and rely on extra-hippocampal cortical regions, which are reciprocally connected to the hippocampus, whereas the integrated object-place-context recognition task involves context-rich recognition, requiring the hippocampus to incorporate individual components of the task to form an episodic-like representation. Only controls would be able to employ an episodic-like memory of the position and context in which the object was presented in the sample phases, with familiar objects and/or contexts inducing context-rich retrieval of sample-phase configurations which manifests in the preference for the most novel configuration to be explored. Sensory input could therefore be compared/contrasted with context-rich sample-phase information enabling mismatch detection. These results and conclusions are in line with the dual-process model of memory (Aggleton and Brown 1999), but the protocol employed in this study does not enable an examination of the type of recognition memory (familiarity or recollection) used in the object-place-context recognition task; however, the specific involvement of the hippocampus in recollective rather than familiarity based recognition would support the current research in both rats and humans (Aggleton and Brown 2006; Eichenbaum et al. 2007; Fortin et al. 2004; Kumaran and Maguire 2007; Norman and O’Reilly 2003; Sauvage et al. 2008), although these findings are still controversial and other theories have been proposed (Squire et al. 2007).

It could be argued, however, that the novel object-place-context configuration may subtly alter appearance, inducing preference for the novel configuration, which does not necessarily depend on the recollection of the sample-phases, although the task appears too complex to be solved by relative familiarity alone and the hippocampal-lesioned rats were performing at chance levels, not impaired as might be expected if both recollection and familiarity processes were involved. To combat this criticism the effects of hippocampal, CA3 and CA1 lesions would need to be tested in a protocol which specifically tests recollection, such as that described by Eacott et al. (2005). In this specific test of recollection object preference is assessed in an E-maze (described in the introduction, section 0.3.2) where the objects are placed at the ends of the outer arms in the test phase, so neither is visible. The rat must therefore decide which direction to turn to locate the novel object, based solely on recollection of where the object was positioned in that particular context during the sample phase (Eacott et al. 2005).

It is possible that the involvement of the hippocampal subregions in the integrated object-place-context study could be further clarified by comparing the effects of subregion-specific manipulations during the encoding and the retrieval phases separately. It is tempting to speculate that the impairment is more likely due to a retrieval-specific mechanism as the hypothesised roles

of CA3 and CA1 in allocentric and temporal encoding respectively, are not required in this task and therefore a plausible explanation of the CA3 and CA1 lesion-induced deficits in object-place-context recognition may represent their proposed functions in pattern completion and mismatch detection. In this model, the proposed mismatch function of CA1 works in tandem with the entorhinal cortex and the CA3 region to compare current environmental input, from the entorhinal cortex, with stored information from the sample-phase obtained by pattern completion, through a CA3-dependent process, explaining the deficits obtained in object-place-context recognition. This ability to rapidly compare sensory input with associated retrieval may represent the unique role of the hippocampus in episodic memory formation. In order to test this prediction, reversible inactivation could be induced prior to sample-phases or prior to testing, to block encoding or retrieval respectively, to determine whether the impaired object-place-context recognition performance present in the lesion groups is specifically due to a failure in encoding or retrieval.

As discussed briefly in the introduction, some have suggested a differentiation of function along the dorsoventral axis of the hippocampus. The majority of visceral, gustatory and olfactory inputs are received by the ventral hippocampus, whereas the visuospatial inputs are predominantly received by dorsal regions. Temporal and spatial information are thought to be processed by the dorsal hippocampus (Gilbert et al. 2001; Hunsaker et al. 2006; Kesner et al. 2005) whereas contextual processing is hypothesised to occur within the ventral regions (Hunsaker et al. 2008a; Kesner et al. 2010). It is therefore plausible to suggest that as the lesion-induced impairments observed in this experiment were specific to object-place-context recognition, which do not require temporal nor spatial processing, that impairments were mainly due to damage to the more ventral hippocampal regions which may be required to support the association of objects with their egocentric locations and background context. This would explain why previous studies have only found impairments in performance after dorsal CA3 and CA1 lesions in tasks that required the associations involving allocentric space and temporal processing, respectively. To investigate these theories the series of tasks used in this experiment would need to be performed on rats with specific lesions of the dorsal, intermediate and ventral portions of CA1 and CA3.

The majority of previous studies which have attempted to differentiate intra-hippocampal function have done so using electrophysiological techniques (Lee et al. 2004a; Leutgeb et al. 2005a). Recording place cells enable normal functional activity from within CA1 and CA3 to be studied, providing further insight into episodic memory formation (Leutgeb et al. 2006). An interesting extension of this work would be to perform electrophysiological recordings in the hippocampal subregions of intact rats performing the object-place-context recognition task, to detect normal activity and compare results with the present lesion study. The results from the object recognition paradigms presented herein indicate that the hippocampus has a unique functional role where it is necessary only when all three components are combined (object-place-context), however, the neural activity which supports this memory formation can not be ascertained in these types of tasks.

To further elucidate the neural network and mechanisms involved it would be necessary to pursue a single-unit recording study based around the object-place-context recognition protocol used in the current study. Accurate characterisation of neural encoding; however, requires consistent behavioural sampling on many trials and the neural activity is affected by the rats' location, movement, direction and speed (McNaughton et al. 1983) as well as the different types and locations of intra-maze cues. It would therefore be a formidable challenge to characterise a relationship between neural activity within the hippocampus and performance in these types of one-trial learning tasks. Not only could any change in the neural patterns be interpreted as learning the spatial layout, or the effects of new objects in re-setting spatial maps, but also there is a high degree of variation between trials, which are also too short to allow an adequate set of single-unit recording data to be obtained. To overcome these difficulties, aspects of episodic-like memory can be tested in a different type of task which lends itself to single-unit recording, enabling the neural activity theorised to underlie performance to be monitored on-line in 'normal' behaving animals (see chapter 3).

In summary, the results reported in this chapter replicate the previous findings of Eacott and Norman (2004) and Langston and Wood (2009) that bilateral hippocampal lesions result in specific deficits in the ability to recognise integrated object-place-contexts configurations and further demonstrates that selective bilateral lesions the hippocampal subregions - CA3 and CA1 - each produce similar impairments in performance, which are restricted to the object-place-context recognition task. The results obtained support theories which suggest the CA3 region provides an autoassociative role with the CA1 region providing the main output pathway for this processed information and/or functioning as a mismatch detector between stored representations from CA3 and the current sensory input available via the entorhinal cortex. The protocol employed in this chapter enabled the functional role of the hippocampus and its subregions to be explored in a putative model of episodic-like memory, without the confounding impact induced when allocentric or temporal processes are required, and revealed a necessity for each region in the processing of integrated 'what-where-which' memory.

Chapter 2

Integrated Memory in an Object-Place-Temporal order Recognition Task

2.1 Introduction

Episodic memory impairments occur in a range of different neurological conditions, as well as a result of brain trauma, and there are no current treatments available, mainly due to a lack of knowledge of the processes underlying these memories and the unavailability of valid animal models in which potential therapeutics can be tested. Animal models of episodic memory are therefore necessary to enable the use of investigative tools and pharmacological interventions which are not available to human studies. Due to the inherent difficulties involved in demonstrating the subjective components of episodic memory in the absence of language, non-human animal models have largely focused on the behavioural aspects of episodic memory, as originally defined by Tulving (1972): the ‘what’, ‘where’ and ‘when’ components of an event. This model of episodic memory, termed episodic-like memory, was originally described by Clayton and Dickinson (1998), in which, as previously described (see section 0.3.2), scrub-jays were successfully shown to form integrated ‘what-where-when’ memories in a food-caching task; a study which has sparked great interest and debate in a wide variety of fields, resulting in a surge of topical publications. One focus of this research aimed to develop a model which can be used to test episodic-like memory in rats, which are more amenable to investigations of the underlying neural processes involved and for which a greater number of experimental tools are available. The development of such a model; however, has been hampered by a difficulty in successfully demonstrating the integrated temporal component of episodic-like memory in rats, with studies reporting mixed success and controversial results (Babb and Crystal 2005, 2006; Bird et al. 2003; Bowles et al. 2007; Good et al. 2007; Kart-Teke et al. 2006; Naqshbandi et al. 2007). Eacott and Norman (2004) suggested

an alternative method for testing episodic-like memory in which the temporal aspect was replaced by another occasion-setter: context, thereby circumventing these problematic issues. The resulting task developed, based on this alternative episodic-like memory model, and the validity of this task to modelling episodic memory is discussed in chapter 1. Despite the possibilities created by this approach, arguments still exist that the inability to demonstrate the integrated ‘what-where-when’ memory in trial unique manner in rats reflects an absence of this cognitive function, as the temporal framework is purported to provide the necessary foundation of episodic memory. The focus of this chapter lies in developing a suitable model to test whether rats can convincingly be shown to possess episodic-like memory, based on the original ‘what-where-when’ triad, and in doing so provide a protocol in which the neural circuitry underlying this can be tested.

The concept of mental time travel in episodic memory is entwined with the idea of self consciousness and an ability to mentally travel back in time and personally re-experience the event. It is still strongly debated as to whether non-human animals have a ‘sense of self’ or if they can personally travel backwards and forwards in imagined time and even if this was proved to be the case it would be almost impossible to demonstrate that non-verbal animals were doing this in order to perform episodic memory tasks. A number of studies have examined whether this ability to mentally travel back in time is a uniquely human trait or whether it can be demonstrated in animals (for discussion see Zentall 2006), and it has been argued that this cognitive feature should be distinguished from an animal’s ability to determine how long ago an event occurred (Roberts and Feeney 2009). The difficulties in demonstrating the ability of non-human animals to travel back in time has resulted in many studies focussing on temporal order memory, although some argue this can be based purely on ‘relative familiarity’ rather than the explicit retrieval of recency information (Aggleton and Brown 1999; Clayton et al. 2001a). For the purpose of the current chapter, temporal order memory will be tested as a main component of integrated episodic-like memory where it is thought to provide unique temporal tags for events which enable memories to be sequenced and distinguished along a spatio-temporal framework.

In a test of temporal order memory Mitchell and Laiacona (1998) found that if rats were presented with two identical objects (A) in sample phase one and then two different identical objects (B) in sample phase two (one hour later) they demonstrated a natural preference to explore the most remote object (object A) in the subsequent test phase (one hour after sample phase two), in which one duplicate object from each sample phase was presented. This type of task has been extended in a similar manner to that described by Eacott and Norman (2004), where integrated ‘object-place-temporal order’ recognition memory was tested using a 50-minute delay between exposure to the objects and the test phase (Kart-Teke et al. 2006), described in detail in the introduction, section 0.3.2. The results surprisingly revealed a reversal of exploratory preference when object-place recognition was tested in the remote condition, where a preference was shown for the stationary, rather than the displaced, object. This suggests that the ability to detect and

direct exploration to the most novel object-place configuration is only demonstrated across the shorter time delay in this protocol. Whilst it was previously shown that rats could remember object identity over similarly long delay periods to enable exploration to be preferentially directed at the novel object (Mitchell and Laiacona 1998), it appears that the delay period between the remote sample phase and the test phase (125 minutes) is too long for the positions in which the objects were previously experienced to be recalled to support object-place recognition from the remote sample phase. Although, if this was the case, one would have expected no net preference to have been observed in the remote object-place recognition test, rather than a preference for the stable object, which rats demonstrated in this condition, this may; however, have arisen due to other confounding variables discussed below. The interpretation of the results, in terms of weakening associative memory over the long delay, fits with the cone structure of episodic memory, proposed by Roberts and Feeney (2009), in which the sensory clarity and detail of the recalled event reduce as time since the event was experienced passes. Kart-Teke et al. (2006) argue that the reversal of object-place exploratory preference from the recent to the remotely tested conditions is not an indication of degraded memory but rather reflects an integration of the temporal and spatial components of the event which results in a different preference pattern being displayed than that expected by relative familiarity alone. The protocol employed was also not ideal, as discussed in-depth in section 0.3.2 of the introduction, and this may have also been an influential factor in the unexpected pattern of exploratory preferences obtained. In brief, the locations in which the objects were presented could have affected the results, as in the test phase some objects were presented in the same position as they had previously been seen, others were re-positioned in a location in which the rat had only experienced another object type being located, and some objects were positioned in entirely new locations, relative to the sample phases, which would have induced greater exploration levels regardless of the object which was located there. Also, for each sample phase four objects were presented, but two of their locations were the same across sample phases and the other two were different, a factor which is likely not only to induce increased familiarisation of two of the six possible locations but is also likely to result in a different level of interference between the object-place pairs in the same locations as opposed to those in different locations across the sample phases. Finally, of the four locations used in the test phase, two locations are the same as those only presented in sample two, one location has been paired with objects on both the previous sample phases and the remaining location was only used previously in the first sample phase. Thus, this protocol may have resulted not only in different levels of interference of specific sample-phase pairs, but also may have resulted in temporal information being attached to the locations which would influence test-phase exploration, especially as rats were only tested on the task once. As the paper only provides one example of a typical object-place-temporal order task it remains unclear whether or not these issues would have been confounding factors in the experimental results published.

The study by Kart-Teke et al. (2006) was extended, based on their interpretation of the results, to investigate the role of dorsal CA3 in an object-place-temporal order study, using electrolytic lesions. The control and sham-lesioned rats performed as previously reported, with an overall preference to explore remotely presented objects preferentially explored the displaced objects and the displaced objects from the recent sample phase but stable objects from the remote sample phase. The CA3-lesioned rats demonstrated a preference to explore the most remotely presented objects and also the displaced objects presented in the recent as well as the remote sample phase (Li and Chao 2008). Li and Chao (2008) proposed that these results reflect a specific deficit in dorsally lesioned CA3 rats' ability to associate all three components to form an integrated object-place-temporal order memory which supports subsequent recognition, as their exploration patterns were simply based on relative recency for the individual components of the task. It could be argued; however, that the pattern of exploratory preference demonstrated by CA3-lesioned rats are what one would expect, based on rats natural tendency to explore the most novel aspects of the environment (Ennaceur et al. 1997), and therefore the CA3-lesioned rats were the only subjects able to successfully encode object, place and temporal order information to enable exploration to be directed at the most novel aspects of the environment in the test-phase. The validity of the unlesioned rats performance may also be questioned as the exploration patterns vary substantially between the untreated and sham-operated rats, and, particularly in the untreated group, the differences in exploration between the object configurations is relatively small. Additionally, unlike the separate tests of temporal order memory and object recognition memory which were conducted in the same open field arena as the integrated object recognition task, spatial memory was tested in a completely different manner using a radial-arm maze. Thus, it is not clear whether the results obtained in the integrated object-place-temporal order task were an indirect reflection of a more basic impairment in object-place processing over such a long delay period. Additionally the undesirable features of the experimental design (discussed above and in detail in section 0.3.2 of the introduction) may well have affected exploratory patterns and, as the effects of this were not examined within the study, the extent of the effect on results is unclear. Furthermore, the electrolytic lesions performed were not quantified and so it is unclear as to the extent of the lesions induced.

More recently, Good et al. (2007) tested integrated object-place-temporal order memory in rats with a shorter, nine-minute, delay interposed between the first sample and test phase, and demonstrated that rats had a greater preference to explore the most novel object-place-temporal order combination, and additionally demonstrated impaired performance of hippocampal-lesioned rats. The protocol used in this task ensure that test-phase object locations were equally familiar as two of the four possible locations were used to present objects in the first sample phase and the remaining two were used for object presentation in the second sample phase, with the test phase utilising all four object locations. The study also tested the components of the integrated object-place-temporal order task separately using similar protocols within the same arena, creating

a more reliable manner in which to ensure any impairment in the integrated task was not due to an impairment in its simpler features. Results presented in these control tasks; however, revealed poor temporal order memory in both control and lesioned rats, which suggests that this time delay was too short to distinguish 'remote' and 'recent' situations (Morris et al. 1990). Also, subtleties in the experimental design, such as entering rats into the arena from random locations, would require rats to employ an allocentric strategy which would explain why lesioned rats were unable to detect object displacement, which may have been the underlying factor resulting in the deficit in integrated object-place-temporal order performance, observed in the hippocampal-lesioned rats.

In light of these factors in the previously tested integrated object-place-temporal order studies, the current chapter will describe the results from a new protocol developed to test integrated object-place-temporal order recognition memory. Based on the issues discussed regarding the time delays employed by Good et al. (2007) and Kart-Teke et al. (2006), this protocol imposed a 12-minute delay between the end of the first sample phase and the start of the test phase. In addition, all task types involve two sample phases which each contain four objects positioned in the same four locations, in order to standardise conditions across the control and test phases such that each exposure to the arena appears the same (with the exception of the type of object presented) across tasks and across the sample and test phases. This protocol therefore enables fair comparisons of object exploration preferences across tasks.

2.2 Materials & Methods

2.2.1 Subjects

Eight naïve male Lister-hooded rats weighing approximately 300-350 g, at the start of behavioural testing, were involved in the study. Rats were given *ad libitum* access to food and water and were housed in cages of four and kept on a 12 hour light/dark cycle; with all testing taking place in the light phase of the cycle.

2.2.2 Apparatus

All behavioural testing was conducted in a blue-painted, square, wooden box (1 m x 1 m x 0.7 m), which was enclosed by white cotton curtains along the east, south and west sides, stretching 2 m from the base of the box and covering the roof of the enclosure, with a black cotton curtain along the north side. The enclosure was kept in a constant position to standardise external cues and rats always entered and left the arena from the south side, facing the south. Large 3D visual cues, such as a rainbow-coloured feather duster and large plastic flower, were attached to the inside of the curtain, hanging over the testing arena. Pieces of Dual-Lock (3M, UK) were placed onto each corner of the arena floor, 15 cm away from the walls, onto which the objects used in the study were attached. Examples of objects used include cups, bottles, toys and ornaments. Preliminary

preference tests were used to pair objects with which animals spent an equal amount of time exploring, upon first exposure. Rats were only exposed to each object once during the study.

2.2.3 Behavioural Testing

Prior to recognition memory testing, five habituation sessions were conducted to habituate the rats to the experimental arena and the types of objects that would be involved in the study. Recognition memory testing consisted of four trials of four different object recognition tasks: object recognition; object-place recognition; object-temporal order recognition and object-place-temporal order recognition (see figure 2.1 for a timeline of behavioural testing). The four trials for each task enabled any order effects or natural preferences of object-type/location to be counterbalanced between rats and across trials. To ensure all object locations were equally familiar and that sample phases appeared the same across tasks, each trial type consisted of two sample phases, in which four objects were presented (for details see figure 2.3).

All objects used in behavioural testing were cleaned with baby wipes (Tushies, UK) before being affixed to the arena floors and the arena was cleaned with warm soapy water prior to each exposure. In addition, duplicate objects were used for each phase of any given trial to further minimise the use of odour cues influencing exploration.

Upon sample-phase completion, the rat was retrieved from the south side of the arena and placed into the holding bucket for either a five-minute or a two-minute period, for the first and second delay respectively (see figure 2.2 for an outline of the temporal structure of a session). During delay periods the arena was cleaned and a novel object and/or duplicates of the sample objects were cleaned and positioned in the arena. In the test phase the rat re-entered the arena for five minutes, during which time all object exploration was recorded; the rat was then returned to its home cage in the adjacent holding room.

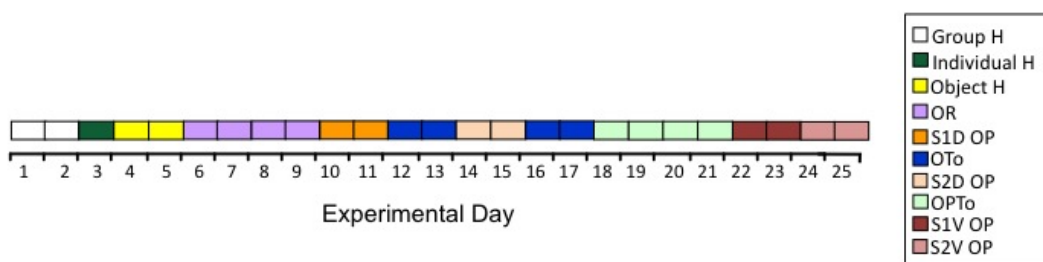

Figure 2.1: The diagram provides an overview of the experimental schedule for the duration of behavioural testing which includes: group habituation (Group H), individual habituation (Individual H) object habituation (object H), object recognition (OR), remote object-place recognition resulting from a diagonal swap (S1D OP), object-temporal order recognition (OTo), recent object-place recognition resulting from a diagonal swap (S2D OP), object-place-temporal order recognition (OPTo), remote object-place recognition resulting from a vertical swap (S1V OP) and recent object-place recognition resulting from a vertical swap (S2V OP).



Figure 2.2: The figure depicts the overall structure of any given session (constant across trial types) and above the schedule the elapsed times since object exposure from the remote (12 minutes) and recent (2 minutes) sample phases are shown.

Habituation

Habituation to the arena and holding bucket took place over three consecutive sessions. A further two habituation sessions were run to habituate the rats to the types of objects which would be used in the study and the locations in which these objects would be presented. In the first two habituation sessions, a cage group of rats were entered into the arena together for a 30-minute period in which they were free to explore the arena, in the absence of any objects. The third habituation session involved each rat having an individual 10-minute exposure to the arena, again with no objects present, the rat was then placed into the adjacent opaque holding bucket (30 cm diameter), which contained 2 cm of sawdust, for a further 10-minute period before being returned to the home cage. In the remaining two habituation sessions, rats were required to enter the arena singly, for a five-minute period, and allowed to explore four different novel objects, affixed to the Dual-lock pieces on the arena floor, before being placed back into the holding bucket for five minutes. These sessions habituated rats to the locations and types of objects used in the object recognition tasks.

Object Recognition Task

This task was run to ensure all rats were able to demonstrate a natural preference for exploring novel objects, as opposed to familiar objects, and could encode and retrieve object identity. Initially rats were exposed to two different pairs of identical objects. After a five-minute delay, a further two different pairs were presented. In the following test phase duplicates of one of the first sample-phase pairs were presented, in the same location in which it had previously been seen, alongside a novel pair of objects (highlighted in figure 2.3a).

Object-Place Task

Two different pairs of identical objects are presented in the first sample, followed by a further two different pairs in the second sample phase. In the test phase, duplicate copies of the objects from the first sample phase were presented, but one of each of the object pairs locations are swapped along the diagonal axis, such that the most novel configuration would be the objects located in a new position relative to the sample phase (highlighted in figure 2.3b). There were four different

types of object-place task conducted. In two of the initial four trials, the test-phase objects were duplicates of those previously presented in the second (recent) sample phase (see the top panel in figure 2.3b), whereas in the other two trials, the test-phase objects were duplicates of those presented in the first (remote) sample phase (see the lower panel in figure 2.3b). This protocol ensured that rats' object-place preference was stable across the short (2-minute) as well as the long (12-minute) elapsed periods since initial object exposure. The test-phase novelty of object-place configurations may have been affected by the fact that the novel object configurations could be construed as a 90° rotation, relative to the sample phase, rather than by identifying that one object in each object pair was swapping places, with respect to the remaining object in each pair, staying in a stable location. This interpretation of the test-phase object configurations is highly unlikely given the large visual, auditory and olfactory cues present alongside the constant position and direction in which the rat is entered into the maze. To eliminate the possibility that this may have affected the results; however, a further four trials were conducted using the same protocol, as described above, but with one of each object pair being swapped along a vertical, rather than diagonal axis, to avoid the confounding factor of rotation (see figure 2.4).

Object-Temporal order Task

Two different pairs of identical objects are presented in the first sample, followed by a further two different pairs in the second sample phase. In the test phase the rat was presented with duplicates of two pairs of objects, one pair from each sample phase, which were presented in the same locations in which they had previously been seen. The test-phase objects which had been presented in the first sample-phase were more remote and therefore comprised the most novel test-phase configurations (highlighted in figure 2.3c). The delays from the sample-phase object exposures to the test-phase were two and twelve minutes for the recent and the remotely presented objects respectively (see figure 2.2 for an outline of the timings for each session).

Object-Place-Temporal order Task

Two different pairs of identical objects are presented in the first sample, followed by a further two different pairs in the second sample phase. In the test phase rats were presented with one object from each of the pairs previously presented in the sample phases, where one object from each of the sample phases was in a different position relative to the sample phase (see figure 2.3d). Based on the concept of relative familiarity, rats were expected to spend the most time exploring the displaced object from the first sample phase, and the least time exploring the object from the second sample phase which was presented in a constant location.

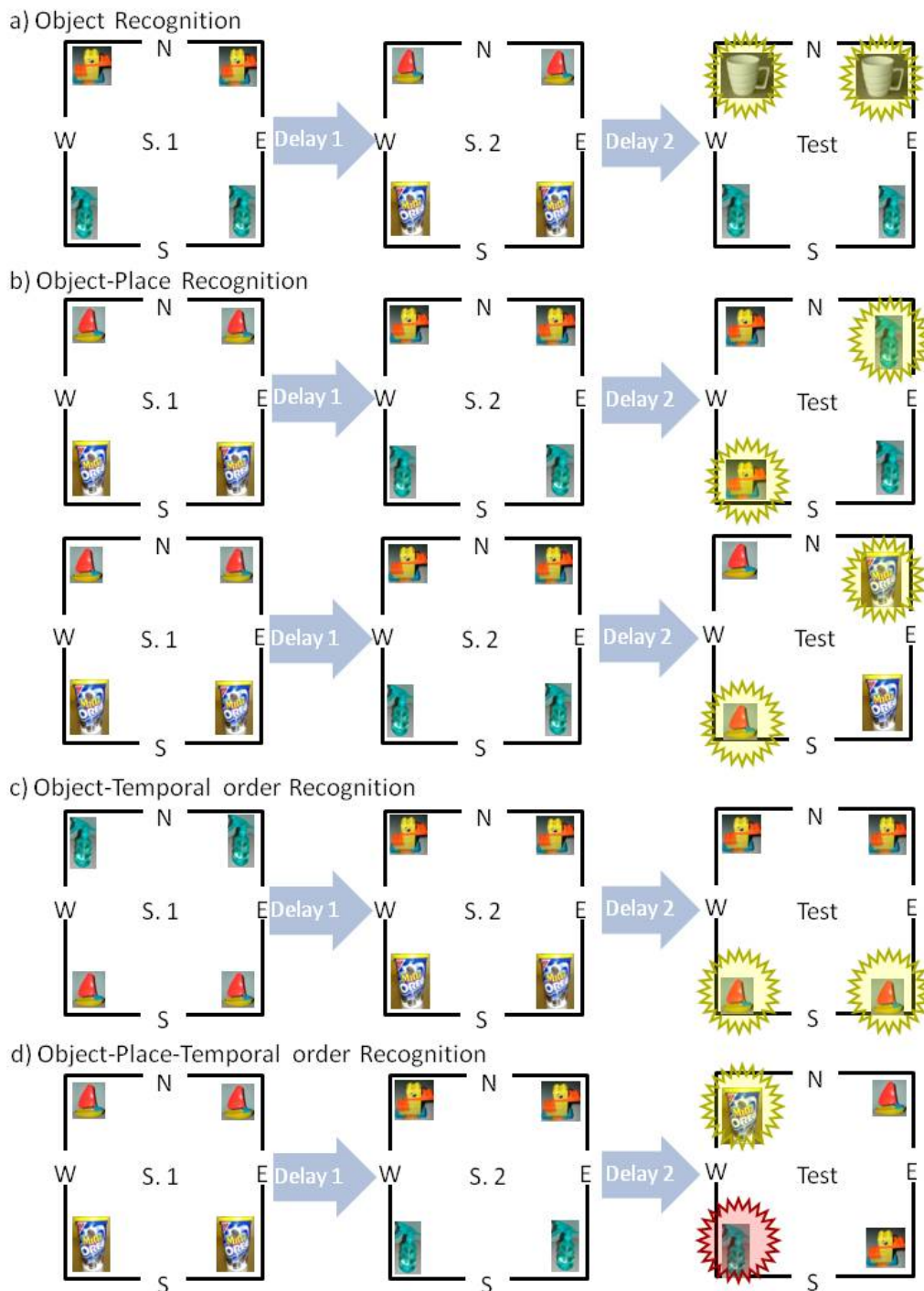

Figure 2.3: Diagrammatic examples of each recognition task: **(a)** object recognition task, **(b)** object-place (recent in the panel above the remote trial types) **(c)** object temporal order and **(d)** object-place temporal order. The most novel configurations are highlighted by yellow stars and the least novel configuration in the object-place-temporal order task is highlighted with a red star shape. In all tasks rats enter and are removed from the arena facing the south side and are placed into the bucket during delay periods. All sample (S.) and test phases were set to a 5-minute duration. Here for ease of presentation the same objects are shown for each trial type, however in the experiments objects were only used once (one set for each session).

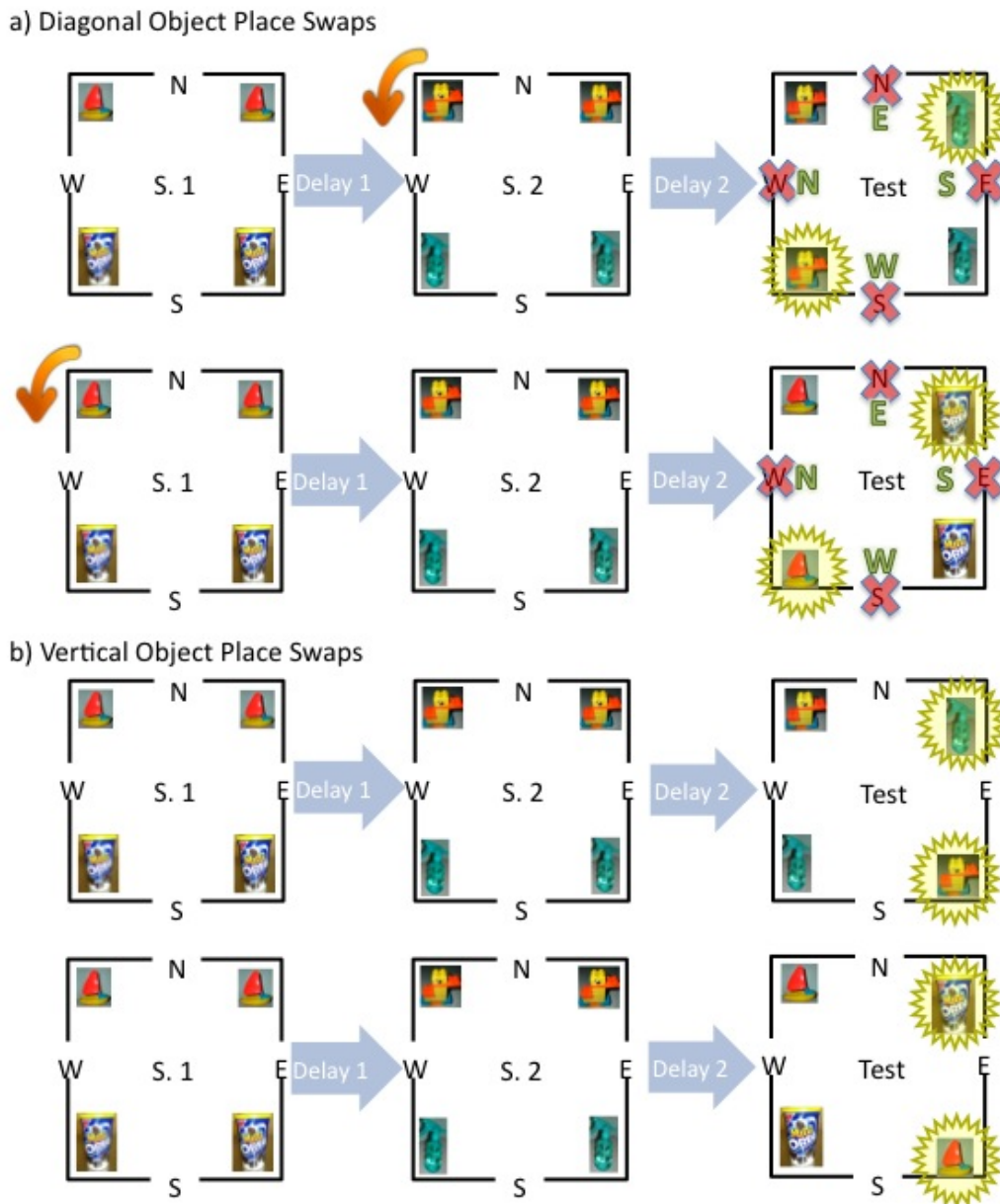

Figure 2.4: Diagrammatic examples of each object-place recognition task conducted in this study. **(a)** Diagonal swap condition for the two different trial types (recent above, remote below) for object-place recognition condition, the orange arrows show how the sample-phase objects could be rotated in order that all the objects would appear equally familiar in the test phase if the rat thought the arena had been rotated (represented by re-labelling the cardinal directions). **(b)** Vertical swap condition for the two different trial types (recent above, remote below) for object-place recognition condition, where novelty of the object-place configurations can be detected regardless of assumed cardinal direction.

2.2.4 Data Analysis

The rats' movements in the arena were monitored by an overhead camera (Panasonic, UK) connected to the TV monitor. Object exploration, for each object within an exposure phase, was manually recorded on-line using an in-house timing computer programme (National Instruments, LabView), where key presses activated timers which differentially timed exploration of each object, based on the rats' behaviour observable via the TV monitor.

For each sample phase, in all tasks, the rat was required to explore each object for at least 15 seconds, over a set period of 5 minutes. Exploration required the rat to be within a 2 cm radius of the object, with its nose directed at the object and be involved in sniffing/whisking behaviour.

Raw exploration times were collected as time in seconds before test-phase exploration for each trial was converted into a discrimination index (DI), calculated using the following formula below.

$$\sum \frac{(\text{Novel Object Configuration Exploration} - \text{Familiar Object Configuration Exploration})}{\text{Total Object Exploration Time}}$$

The influence of variability in exploration times of individual rats in each task phase was minimised by using the discrimination score for test-phase preference. The mean discrimination scores, obtained from the mean discrimination ratios for the four trials on each task, were calculated for each rat and subsequently analysed in SPSS to test whether rats demonstrated exploratory preferences for the most novel configurations of the objects in the recognition tasks. Performance of the rats for the object, object-place (for remote and recent exposures as well as for diagonal and vertical swap conditions) and object-temporal order tasks were tested against chance levels (zero) using one-sample t-tests. A one-way ANOVA was used to test whether there was an effect on object-place recognition performance between diagonal and vertical swap conditions.

For analysis of the object-place-temporal order task a calculation of the proportion of exploration time was altered due to the presentation of four differing levels of familiarity presented by the object configurations presented in the test-phase. Exploratory preferences for each object configuration were calculated based on the proportion of total object exploration time in which the rat explored each object configuration. These proportions of exploration for each test-phase object configuration were then analysed using a univariate ANOVA with Bonferroni corrected pair-wise comparisons.

2.3 Results

In figure 2.5 it can be seen that rats display a general tendency to explore the most novel features of the environment. For each of these tasks, in which the individual components of the integrated object-place-temporal order task are tested, one-sample t-tests were performed on the mean discrimination scores against chance levels (zero). Results revealed that rats displayed a significant preference to explore: the novel object in object recognition trials ($t=5.04$; $d.f.=7$;

$p < 0.001$); the displaced object in both the ‘remote’ and the ‘recent’ object-place recognition trials ($t = 4.18$; $d.f. = 7$; $p < 0.001$) and ($t = 7.70$; $d.f. = 7$; $p < 0.001$) respectively, and the remote object in object-temporal order tasks ($t = 5.13$; $d.f. = 7$; $p < 0.001$). These results confirm that rats were able to encode/retrieve object identity, that they were able to distinguish between displaced and stable objects, with a preference for the displaced object; and that the time delay used was sufficient for rats to distinguish the two sample events to result in an object preference temporally, with increased exploration for the most remotely presented objects.

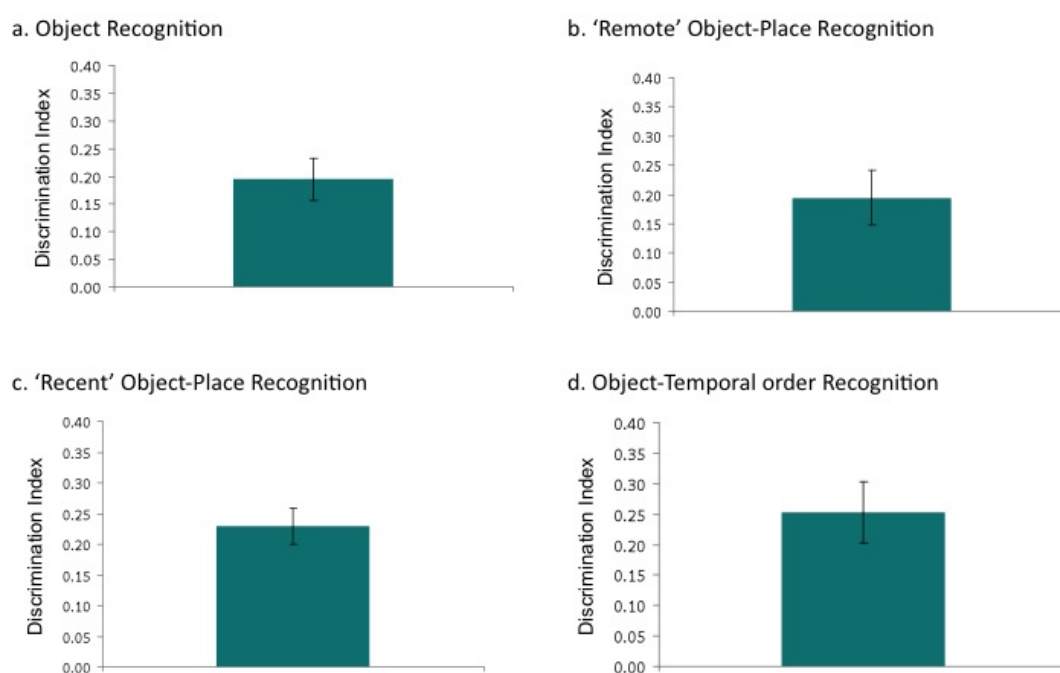

Figure 2.5: Graphical representations of performance across: (a) object recognition; (b) ‘remote’ object-place recognition; (c) ‘recent’ object-place recognition and (d) object-temporal order recognition tasks. From the results presented, rats can clearly be seen to demonstrate an exploratory preference for the most novel object configuration in each task. Data is displayed as the mean discrimination index (\pm SEM).

A second set of object-place trials were set up in which objects were swapped along the vertical, rather than diagonal, axis, to ensure that rats were identifying a displacement of objects as opposed to a rotation of objects within the arena. In the vertical object-place task, shown in figure 2.6, rats still showed a significantly greater exploration of the displaced compared to the stable object ($t = 10.15$; $d.f. = 7$; $p < 0.001$), with the results of a one-way ANOVA revealing no significant differences in performance between these two types of object-place tasks ($F_{(1,14)} = 0.34$; $p = 0.57$). These results suggest that rats performance in the diagonal displacement condition was based on detection of object-place novelty rather than being influenced by an appearance of rotation.

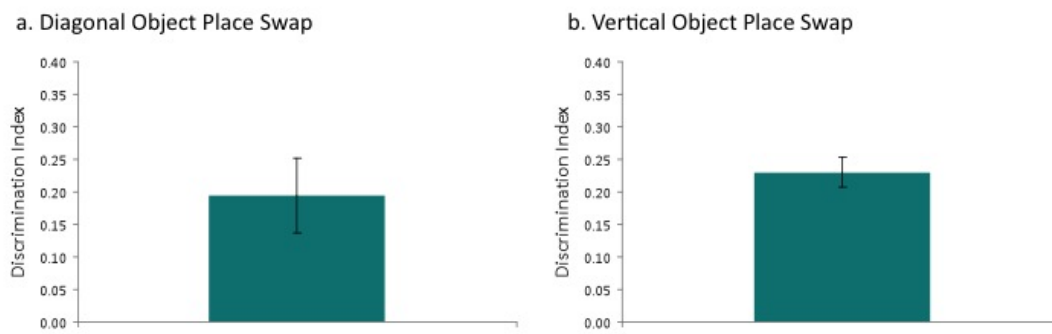

Figure 2.6: Graphical representations of object-place recognition performance for: **(a)** diagonal object-place recognition and **(b)** vertical object-place recognition; in which a similar exploratory preference is apparent for the displaced object in both swap conditions. Data is displayed as the mean discrimination index (\pm SEM)

The pattern of exploration in the object-place-temporal order task can be seen in figure 2.7. As expected, the most novel object configuration ('remote-displaced') resulted in the majority of exploration, whereas the least novel configuration ('recent-stationary') resulted in the lowest level of exploration (shown in 2.7a). Overall, the rats demonstrated a strong preference to explore the displaced objects over the stationary objects (shown in 2.7b) and explored the remote objects substantially more than the recent objects (shown in 2.7c). This indicates that in the object-place-temporal order task, rats were preferentially exploring the most novel aspects of the environment and through an additive affect this resulted in the most exploration being directed at the most novel object configuration and similarly the least novel object configuration being explored the least, rather preferences arising from a complex interaction between recency and spatial displacement factors, as proposed in the study by Kart-Teke et al. (2006). Statistical analysis of these results using a univariate ANOVA confirms a significant effect of configurational novelty on exploration ($F_{(2,12)}=9.80$; $p<0.001$). Bonferroni corrected pair-wise comparisons between exploration of the object configurations further reveals that rats demonstrated a preference for the displaced object in both remote and recent conditions ($p<0.01$) and had a significant preference for the more remotely displaced object than the recently displaced object ($p<0.05$), but there was no significant difference in preference between the remote stationary and recent stationary objects ($p=0.23$). Additionally, rats explored the most novel object configuration ('remote-displaced') significantly more than the least novel configuration ('recent-stationary') ($p<0.001$) but demonstrated no significant preference between the equally novel, recently presented displaced and the remotely presented stationary, objects ($p=0.30$).

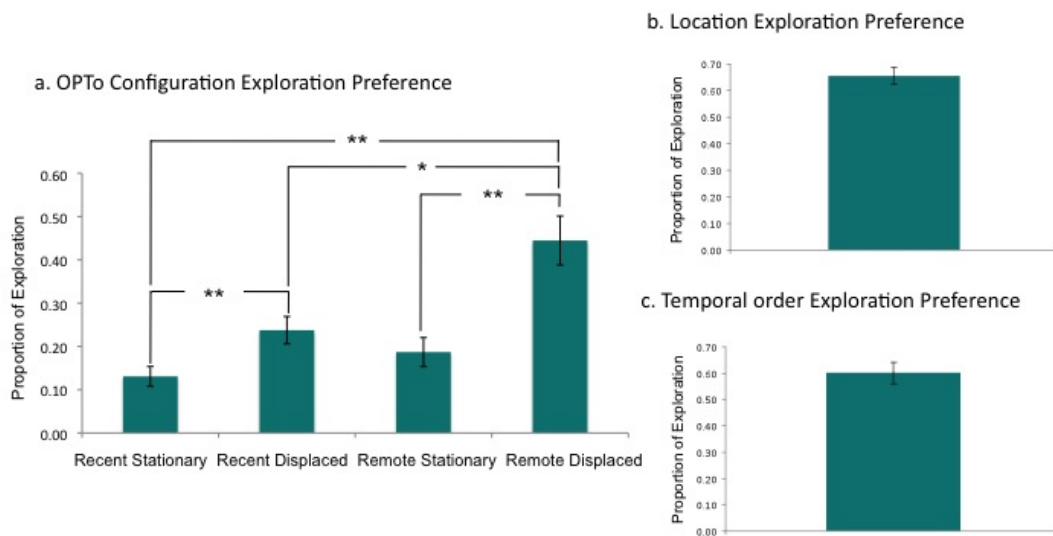

Figure 2.7: Graphical representations of: **(a)** overall object-place-temporal order (OPTo) performance, displayed as proportion of time spent exploring each object configuration out of the total test-phase object exploration; **(b)** location exploration preference within the object-place-temporal order task, displayed as preference for the two displaced objects relative to the two stable objects across the object-place-temporal order test-phase; **(c)** temporal order exploration preference within the object-place-temporal order task, displayed as preference for the two remote objects from sample-phase 1 relative to the two recent objects from sample-phase 2, across the object-place-temporal order test-phase. Rats can be seen to present an exploratory preference for the most novel aspects of the environment in a similar manner to that detected in the control tests of the component features of the integrated task. Data is displayed as mean values SEM, (*) $p < 0.05$, (**) $p < 0.001$.

Overall, rats demonstrated a greater preference to explore the most novel object configurations, with greater exploration of displaced rather than stationary objects, of remote rather than recently presented objects and displayed a preference for the most novel object-place-temporal order configuration, in both the integrated object-place-temporal order task, and also in the separate control tasks, for the different components tested in the main integrated task.

2.4 Conclusions & Discussion

The object recognition task was performed to a comparable level to that presented previously in chapter 1 and demonstrates that rats are able to retain object identity information in the current protocol to support the detection of novelty in the test phases of these tasks. The performance levels obtained in the object-temporal order task, in which the ability to demonstrate an object configuration preference was based on relative recency alone, were in line with previous research (Good et al. 2007; Hannesson et al. 2004; Hotte et al. 2005; Kart-Teke et al. 2006; Mitchell and Laiacina 1998), in that naïve rats displayed an exploratory preference for objects presented the longest time ago (from the first rather than the recent sample phases), when all other factors were equal, suggesting that the temporal delay employed in the current protocol was sufficient for rats to retain object identity over and to induce a preference based on relative familiarity. More importantly the tests of object-place preference revealed that the naïve rats are able to successfully detect the displacement of an object in the current protocol and this ability was shown both over the shorter and the longer delay periods since sample-phase exposure. The finding that control rats have a natural preference for the displaced relative to the stable object from the remote sample phase supports results reported by Good et al. (2007) and agrees with the general finding that rats have a natural tendency to explore the most novel aspects of the environment (Ennaceur et al. 1997), but contrast with the results obtained by Kart-Teke et al. (2006). The differing result is likely due to the inability of rats to discriminate whether objects had been displaced or remained in a stable position across the longer 105-minute delay used in the study by Kart-Teke et al. (2006) or possibly due to the confounding effects of their testing protocol, previously discussed (see section 0.3.2).

In the integrated object-place-temporal order task described in this study it was shown that naïve rats were capable of complex recognition based on the integration of the critical features of episodic memory, defined by Tulving (1972) as ‘what’, ‘where’, ‘when’, with significant exploratory preference to explore the most novel object configuration (‘remote-displaced’) and the least exploration directed at the least novel object configuration (‘recent-stable’). This pattern of exploratory preference support those previously found on a similar task (Good et al. 2007), but the preference to explore objects presented from the remote sample phase, relative to those of the recent sample phase, is stronger in the current study, which is most likely a result of longer time delays being employed in the current study, making discriminations based on temporal order

easier. In the present study, the control tasks were designed to test the individual features of the integrated object-place-temporal order task in as similar a manner as possible to be able to make valid comparisons across tasks and also to ensure that if the current protocol was employed to test structure dependence, for example, that any specific deficits in performance of the integrated task could be reliably interpreted as a deficit in the integration of the three hallmarks of episodic memory ('what', 'where' and 'when') and could not be argued to be a result of any minor differences in protocol between the tasks, as could be the case in the protocol described by Good et al. (2007).

The aim of this chapter was to present a new protocol for testing episodic-like memory reliably in rats based on its core features, 'what', 'where' and 'when', to enable further investigation of the neural networks supporting episodic memory, and also to provide a task in which models of neurological conditions which manifest themselves in episodic memory impairments, such as Alzheimer's disease, can be tested for validity and also may enable potential treatments for such conditions to be tested. Whilst it could be argued that the ability to detect novelty in the integrated object-place-temporal order task may still be based on relative novelty rather than the recollection of the integrated object-place-temporal order representations from the sample phase, it is unlikely, due to the complex nature of the task and the fact that each component and even each pairwise configuration of 'object-place' and 'object-temporal order' are equally familiar.

Although this criticism has been avoided in other models of episodic-like memory, such as in the task described by (Clayton et al. 2001b), these raise other issues. The advantage of the current study over that described by Clayton et al. (2001b) is that the main feature of the event, 'what', is trial unique and also the task does not require training nor reward and therefore is less likely to evoke elements of semantic memory.

The functional role of the hippocampus and its subregions were examined previously, in chapter 1, in an alternative model of episodic-like memory which tested the integrated object-place-context recognition, based on the protocol first described by Eacott and Norman (2004). A natural progression of the current study would be to examine the role of subregion-specific lesions of the hippocampus on performance, especially as the functional roles of these regions have previously been found to be differentiated with respect to the relational processing of spatial and temporal information for the CA3 and the CA1 region respectively, as discussed in the introduction, section 0.2.2. Whilst reports of the importance of the hippocampus in temporal information processing has been well documented (Levy 1996; Lisman 1999; Rolls and Kesner 2006), where it is thought to be involved in both spatio-temporal memory (Chiba et al. 1994) as well as non-spatial sequential memory (Fortin et al. 2002; Kesner et al. 2002), it has been difficult to exclusively examine the functional role of the hippocampus and its subregions in episodic-like memory due to the lack of a suitable protocol in which the effects of region-specific lesions can be tested. Although Li and Chao (2008) demonstrated that electrolytic lesions of the dorsal CA3 region resulted in a different pattern of object exploration relative controls when object-place-temporal order memory

was tested in the same manner as that described by Kart-Teke et al. (2006), the unexpected pattern of exploratory preferences of the controls in this study combined with the possible confounding effects of the protocol, previously discussed, makes these differences in CA3-lesioned rats difficult to interpret. The protocol employed by Good et al. (2007) yielded a more expected pattern of results in the control groups exploratory preferences and was used to test the hippocampal dependence of the integrated object-place-temporal order task. The resulting impairment in ability to detect the most novel object-place-temporal order configuration does not; however, necessarily lead to the conclusion that this form of episodic-like memory depends upon the hippocampal structure, as the hippocampal-lesioned rats were also unable to detect the displacement of objects which, as previously described (in section 1.1), suggests that an allocentric strategy was required to support object-place recognition, which would necessitate the involvement of the hippocampus. The increased number of objects involved in the object-place recognition task may also have required relational processing in a hippocampal-dependent manner. If the object-place-temporal order task had required allocentric spatial processing then any impairment seen in hippocampal-lesioned rats could be a result of an impairment in the hippocampal-dependent allocentric spatial processing. Alternatively, if the incorporation of four items in the sample phase induced the need for hippocampal-dependent processing then the impairment of the hippocampal-lesioned rats in the object-place-temporal order task is unlikely due to a spatial encoding problem as the sample phases in the object-place-temporal order task only involved two objects and similar object-place recognition tasks involving two objects in the sample phase have previously been found to be independent of the hippocampus unless allocentric spatial processing is required (Eacott and Norman 2004; Langston and Wood 2009). The protocol described in this current chapter has been designed to avoid the issues outlined in the previous studies and therefore any lesion study conducted using this protocol should clarify previous results to determine the functional role of the hippocampus and its subregions in episodic-like memory.

In terms of further elucidating the neural circuitry supporting episodic memory processing, one could also examine the potentially differential roles of the medial and lateral entorhinal cortices (defined by the medial and lateral perforant pathways to the hippocampus) in this model of episodic-like memory. Current research supports a role for the medial entorhinal cortex in the processing of spatial information (Cauter et al. 2008; Fyhn et al. 2004). The majority of the inputs to the medial entorhinal cortex originates from the postrhinal cortices, which is thought to be critically involved in the development of spatial processing, contributing to the well defined and stable hippocampal place fields, and is necessary for spatial memory tasks (Burwell and Hafeman 2003; Liu and Bilkey 2002). In contrast, the lateral entorhinal cortex receives the majority of its inputs from the perirhinal region, required for object recognition (Brown and Aggleton 2001; Ennaceur et al. 1996), and is hypothesised to have a non-spatial function (Hargreaves et al. 2005). It would be possible to distinguish the functional roles these two inputs to the hippocampus, based on their

differing plasticity (Do et al. 2002) or immunoreactivity (Fredens et al. 1984), using the current object-place-temporal order task to start to understand the larger network of structures which necessarily support the essential role of the hippocampus in episodic memory.

As standardised, specific hippocampal lesions do not naturally occur and are not ethical to induce in humans, the formation of a valid model of episodic memory in non-human animals is essential for study of the underlying neurocircuitry supporting this process. The current chapter has presented a suitable protocol for testing episodic-like memory based on the original triad of the episodic memory attributes ('what', 'where' and 'when') (Tulving 1983). Unlike the initial episodic-like memory task developed by Clayton and Dickinson (1998), the protocol outlined in this chapter is suitable to be tested in rats, which are amenable to a wealth of experimental tools enabling the examination of specific structures, receptors and pharmaceuticals on episodic-like memory. Indeed, the integrated object-place-context paradigm, first described by Eacott and Norman (2004), has already been used by Cozannet et al. (2010) to investigate the episodic memory impairment in schizophrenia, using a rat model. This could potentially lead to new pharmacological treatments for episodic memory impairments suffered by schizophrenic patients, where a combination of the object-place-context and object-place-temporal order tasks would provide a very powerful means of testing such models and therapeutics in rodents in the future.

Chapter 3

The Development of Goal-Sensitive Cells on a Double Y-Maze ‘Win-Stay’ Task

3.1 Introduction

Almost 40 years ago, O’Keefe and Dostrovsky (1971) revealed the fascinating firing properties of hippocampal pyramidal cells, which were found to correlate with the rats’ position, where each ‘place cell’ preferentially fires in localised regions of an environment, termed the cell’s ‘place field’ (O’Keefe and Nadel 1978). As these principle hippocampal neurons encode space (e.g. Muller et al. 1996; O’Keefe and Nadel 1978) and as lesions of the hippocampus are commonly known to impair performance in spatial tasks (e.g. Becker et al. 1980; Morris et al. 1982), it seems a reasonable assumption that the two are related. Furthermore, it has become increasingly apparent in the literature that place cells not only represent spatial location but are also modulated by the non-spatial aspects of the environment, such as goal-location, intended future destination, past locations, sequences of events and task demands, amongst others (Ferbinteanu and Shapiro 2003; Frank et al. 2000; Hok et al. 2007; Ji and Wilson 2008; Kobayashi et al. 1997, 2003; Lee et al. 2006; Manns et al. 2007; Smith and Mizumori 2006b; Wood et al. 2000). Additionally, they have been shown to encode combinations of stimuli from an event independently of spatial location suggesting that they could reflect neural records of unique episodic experiences (Wood et al. 1999). These characteristics of place cells support a role in processing both spatial and episodic elements of an event, which are similarly impaired as a result of hippocampal disruption (see Burgess et al. 2002 for a review). Although there is accumulating support for a functional role of place cells in learning and memory, it is currently unclear as to how these neural patterns of hippocampal activity link to the learning and memory functions of this region. Whilst the results of hippocampal damage in humans and rats has enabled the putative functions of hippocampal

processing to emerge based on the behaviours expressed in abnormally functioning subjects, one can only postulate as to the neurophysiological mechanisms of these cognitive processes. The development of single-unit recording techniques has enabled hippocampal cells to be monitored in 'normal' subjects during behavioural tasks providing the opportunity to examine the underlying circuitry purported to support these functions on-line.

Previously, in chapter 1, permanent neurotoxic lesions of the hippocampus and its subregions were found to specifically impair the integration of all three event components, 'what-where-which', but left the associative recognition of any combination of these features in isolation intact. In order to investigate the normal functional activity in these areas one would ideally record the neural activity from the hippocampus in 'normal' behaving animals performing the object-place-context recognition task; however, for the reasons outlined in chapter 1 this would not be feasible. This chapter therefore aims to explore the relationship between hippocampal activity and behavioural performance in a task more amenable to single-unit recording in which aspects of episodic memory are tested.

Many studies which have examined the relationship between neural firing patterns and behaviour have been conducted in mazes composed of interlinked linear tracks leading to a potentially rewarded location, enabling the trajectories of the rats to be restricted to ensure that the same paths are run on multiple occasions, with a segment of the journey common to multiple routes. This allows the effects of position on the firing properties of place cells to be controlled for assessing the influence of planned route, goal destination, etc., on their firing properties. Typically, reward contingencies are based upon either a 'win-stay' or a 'win-shift' rule which, in their simplest terms, require the rat to return to a constant destination or continuously switch locations, respectively. One of the first studies in which goal-sensitive firing was observed was conducted by Wood et al. (2000), where differential firing patterns of CA1 place cells were observed in the common segment of a modified T-maze as rats performed a continuous alternation task (shown in the introduction, figure 9). The firing patterns of many cells with place fields in the central stem significantly differed depending on whether the rat was about to make a left or a right turn. Due to the nature of this alternation protocol it was not possible to determine whether the differential firing patterns were based on trajectory travelled in the preceding trial (retrospective firing) or the intended destination of the current trial (prospective firing). This issue was investigated by Frank et al. (2000) in which rats were trained on an alternation task in a W-maze, in which they were required to run in a set sequence (centre, left, centre, right, centre, etc.) to obtain rewards. It was therefore possible to classify the differential firing based on whether it related to the arm the rat had come from or the arm it was travelling towards. This analysis revealed evidence of both retrospective and prospective firing. Furthermore, Ferbinteanu and Shapiro (2003) investigated the differential firing patterns observed as rats navigated a plus maze in a serial reversal win-stay task (one of two arms was rewarded in any given block) in which the start arm was

pseudo-randomly changed between two possible arms, enabling prospective and retrospective firing to be distinguished. Again both retrospective and prospective firing patterns were identified within ensembles over any given journey. Consistent with these findings, Smith and Mizumori (2006b) obtained a similar pattern of results in an analogous study. Collectively, these studies suggest that the rat is recalling both the previously visited destination (retrospective firing) and also planning the route to the next intended destination and/or simulating the available choices to determine the most lucrative decision (prospective firing).

It would seem logical to employ both retrospective and prospective firing in order to successfully locate the current goal destination, as this requires information to be retrieved about where the rat has just come from and whether the reward was obtained there and also what the reward contingencies of the task are, based on generalising past experience of the patterns of routes taken and whether rewards were received. This information could then be flexibly used to determine the destination of the current trial and what route would need to be taken to get there. These types of task have been proposed to test aspects of episodic-like memory as they require planning and decision making to be based on previous knowledge of whether food rewards were obtained when a given goal destination was navigated to, alongside information regarding how long ago this occurred. Thus, single-unit recording of hippocampus cells during performance in these types of cognitive tasks enables the neural processes theorised to underlie these behaviours to be assessed on-line in 'normal' behaving animals.

The differential firing of hippocampal place cells is not simply based on a binary process, as Ainge et al. (2007a) reported goal-sensitive firing related to individual goal destinations, from a number of alternatives, suggesting this represents the encoding of current and intended destination, on a spatial 'win-stay' task in the double Y-maze (Ainge et al. 2007a). Furthermore, in a multiple T-maze task, Johnson and Redish (2007) found that when rats pause at important decision points on the maze neural ensembles from CA3 transiently switched from representing the current location of the rat to reflecting activity based on locations along one and then the other available arm. This sweeping activity along potential future paths at decision points is suggestive of a role for place cell activity in forward planning, by considering the possibilities in order to determine which path to take to reach the intended goal destination.

The firing patterns of place cells, however, are not always predictive of behaviour (Frank et al. 2006; Jeffery et al. 2003). Lenck-Santini et al. (2001) employed a similar spatial alternation task to the W-maze described by Frank et al. (2000), but where rats ran along arms of a Y-maze in which rewards were obtained (on the central arm only) for performing a set sequence of arm visits (left-middle-right-middle-left). In contrast to the previous reports, Lenck-Santini et al. (2001) found no evidence of differential firing patterns despite successful performance. Subsequent studies have also failed to observe differential firing patterns. For example, in a comparable continuous alternation T-maze task to that used by Wood et al. (2000), Holscher et al. (2004) showed very little

differential activity, and in a win-stay task in the plus maze Berke et al. (2009) found no evidence of differential activity. Thus, in similar mazes where comparable protocols have been employed strikingly contrasting results have been obtained. Bower et al. (2002) suggested this may be due to the different training techniques employed across studies, which is logical, as modifying the way in which the rats learn tasks is likely to influence whether a procedural egocentric-based strategy is employed, which would not necessitate hippocampal processing (McDonald and White 1994; Packard and Knowlton 2002), or whether a hippocampal-dependent strategy is enforced, in which the memory of past locations would be used to influence current goal-destination, requiring allocentric spatial navigation to obtain rewards. Another explanation for the contrasting results obtained in similar studies may be whether the recording took place in the learning phase or in well-trained rats. In support of this theory, Kim and Frank (2009) found spatial alternation performance of hippocampal-lesioned rats was specifically impaired in the learning phase of the W-maze task, with performance of the lesioned and control rats comparable by the end of the 10-day study. These results suggest that extra-hippocampal structures, such as the basal ganglia, were able to compensate in the absence of a functional hippocampus, but that the acquisition of performance based upon the hippocampal-independent process takes longer to acquire and is likely based on a procedural strategy (Packard and McGaugh 1996). Furthermore, it has been reported that the hippocampus becomes active in human participants as they navigate through a virtual town (Groen et al. 2000; Maguire et al. 1998); however, this activation is greatest when participants are planning routes and learning spatial associations between cues within the virtual environment, than when correctly identifying these learned relationships or when accurately navigating previously learned routes (Spiers and Maguire 2006; Wolbers and Buechel 2005). This supports a vital role for the hippocampus in learning the spatial context for behavioural performance, rather than being required for accurate performance of a well learned task.

Surprisingly, there have been studies in which minimal/no differential firing has been identified in the common trajectory of rats performing hippocampal-dependent tasks (Ainge et al. 2007b; Bower et al. 2005). The behavioural performance of rats in the study by Ainge et al. (2007b) was disrupted however, at the start of the common segment during which a delay period was enforced. Subsequent analysis of cell firing during this delay period revealed that a large proportion of cells fired differentially based on subsequent direction of turn, which is in line with studies in humans which have found hippocampal activity to increase when planning rather than when implementing navigational routes (Spiers and Maguire 2008). Additionally, in the study by Bower et al. (2005) an open maze was used which has been shown to hugely affect the firing properties of place cells (Muller et al. 1994). In this task rats were trained to run eight paths in sequence and the authors argue that it is likely to be hippocampal-dependent as rotation of paths in relation to the intra- and extra-maze cues disrupted performance, suggesting an allocentric hippocampal-dependent strategy was being employed; however, the necessity of the hippocampus for task performance was not

actually tested.

When testing the hippocampal dependence of these task types, the majority of studies have found hippocampal lesions to impair performance both in win-shift (Ainge et al. 2007b; Becker et al. 1980; Higgs et al. 2001; Kim and Frank 2009; Olton and Feustle 1981; Packard et al. 1989) and win-stay paradigms (Ferbinteanu and Shapiro 2003; Kesner et al. 1993; Smith and Mizumori 2006b); however, other studies have found no impairments resulting from hippocampal lesions in either win-shift (Ainge et al. 2007b) or win-stay tasks (Ainge et al. 2007a; Packard et al. 1989). Thus, tasks in which differential activity of the hippocampal neurons are observed do not necessarily imply hippocampal-dependence. This surprising finding and the possible reasons underlying these results are discussed in detail in chapter 5. Briefly, the studies which report a lack of impairment of hippocampal lesions employ relatively simple tasks in which it is possible that a procedural strategy may suffice to support performance, which is not possible in more complex forms of the tasks, such as that conducted by Ferbinteanu and Shapiro (2003) in which performance was found to be impaired by disruptions to the hippocampus when implemented either prior to training (Smith and Mizumori 2006b) or in pre-trained rats (Ferbinteanu and Shapiro 2003). This explanation is supported by the finding that hippocampal lesions only impaired performance on the alternating T-maze task when a delay was imposed between trials (Ainge et al. 2007b), suggesting that the delay disrupted the ability to solve the task using a procedural strategy alone, especially as hippocampal-lesioned rats preferentially adopt procedural strategies where available (Packard and McGaugh 1996). The double Y-maze 'win-stay' task protocol however, involves rats being removed from the maze and replaced into the start box for a delay period at the beginning of each trial which should prevent a procedural strategy from being used. Thus, the lack of overall impairment resulting from hippocampal lesions on this 'win-stay' task may be explained instead by the fact that these rats were extensively trained before surgery and therefore all learning took place when the hippocampus was intact, during which time performance may have become independent of hippocampal processing either due to consolidation of the learned elements of the task or by a slower learned procedural strategy, which would enable compensation by other structures in the absence of a functioning hippocampus. In addition, testing the involvement of the hippocampus only in well trained rats would mask any specific function that the hippocampus has in the rapid acquisition of the task from being identified as the slower learned hippocampal-independent procedural strategy could support performance concealing any hippocampal contribution.

In summary, these results demonstrate the ability of place cells to be modulated by the previous and future behaviour of the rat which, if convincingly shown to be necessary for and correlated to task performance, would logically suggest that differential place cell activity patterns underlies the hippocampal system's involvement in episodic memory. This may explain how patients suffering hippocampal damage present with a specific range of deficits in episodic memory, navigation and the imagining of future events. Currently, it is still unknown as to how these neural patterns

develop and whether this translates to successful behavioural performance. In order to further investigate how the neural activity supports memory formation, this chapter examines the development of CA1 place fields during the learning phase of a spatial 'win-stay' task in an identical maze to that reported by Ainge et al. (2007a). If goal-sensitive firing of the CA1 cells is necessary for performance, one would expect that either they should be present prior to task learning or if a more direct link exists, that they should develop in line with the behavioural acquisition of the task; whereas if it is not necessary for performance, then one would expect the firing patterns to be present prior to learning or equally, they may develop after learning. Thus, the present chapter aims to further examine the relationship between place cell firing and behavioural performance during the acquisition of a spatial 'win-stay' task in the double Y-maze.

3.2 Materials & Methods

3.2.1 Subjects

Seven adult male Lister-Hooded rats, weighing 250-350 g at the time of surgery, were individually housed and were kept under 12 hour light/dark cycle. All experiments were conducted in the light phase of the cycle. Rats were given *ad libitum* access to water and were food restricted to 85% free-feeding weights after two weeks of post-surgery recovery. All procedures were performed in compliance with national (Animals [Scientific Procedures] Act, 1986) and international (European Communities Council Directive of 24 November 1986 [86/609/EEC]) legislation governing the maintenance of laboratory animals and their use in scientific experiments.

3.2.2 Single-Unit Recording Implants

Tetrodes were constructed from four HML-coated 17 μm wires (90% platinum and 10% iridium; California Fine Wire, Grover Beach, CA) twisted together and heat annealed for 10 seconds using 170°C heat gun (GHG660LCD, Bosch). Eight tetrodes were then inserted into a stainless steel cannula (27 Ga Hypo Tube, Small Parts Inc, Miramar, FL), which was soldered onto a pin from a Mill-Max plug (Mill-Max, Oyster Bay, NY), to protect the tetrodes from mechanical damage, leaving only 7 mm of the tetrode tips exposed for implanting into CA1. Super Glue (Super Glue, Hankel Loctite Ltd.) was applied at each end of the cannula to secure the tetrodes in place. The Mill-Max pin was inserted into the middle of a nine-pin Mill-Max plug. Subsequently, the insulation from the tips of each tetrode wire was removed using a lighter. Individual wires from the tetrodes were then wrapped around each Mill-Max pin, such that the exposed tip of the wire made electrical contact with just one individual pin. Silver conductive paint (Electrolube, Derbyshire, UK) secured each wire to its pin. The insulation from the tips of a piece of copper ground wire was also removed and the wire was soldered onto the middle pin of the Mill-Max plug.

Three drive screws were used to secure the implant and enable the tetrodes to be advanced into CA1 post-surgery (during screening). The three screw drives (80 thread per inch; Small Parts Inc, Miramar, FL) were each inserted through a nut and into a tapped plastic socket (Amphenol, Wallingford, CT), with Super Glue used to secure the nut. The screws were then arranged around the two pre-wired pieces of Mill-Max (as described above) and were cemented together using dental acrylic (Simplex Rapid Acrylic Denture Polymer, Kemdent), with Vaseline (Vaseline, Lever Faberge Ltd., London) used to protect the Mill-Max holes and the top and the sides of the screws from being fixed with cement.

An outer metal cannula (18 Ga Hypo Tube, Small Parts Inc, Miramar, FL) was placed over the tetrode tips and inner cannula, providing protection. In order to enhance the sensitivity of the tetrodes' signal, each wire was gold plated prior to surgery, to reduce impedance to 200-300 k Ω in a saline solution.

3.2.3 Single-Unit Recording Implant Surgery

The surgical implantation of the single-unit recording implants was performed by Steven Huang. Isoflurane (Abbott Laboratories Ltd., Maidenhead) was used to induce anaesthesia. The rats' head was then secured in a stereotaxic frame (Kopf, CA), the skull was exposed and a small circular hole was created in the skull to expose the dura above CA1 (3.5 mm posterior to bregma and \pm 2.7 mm lateral of the midline). Several screw holes were then drilled into the skull enabling self-tapping screws to be inserted into the skull. The dura was pierced and the electrode was lowered to 1.5-1.7 mm below dura, bilaterally, with only the tetrodes entering the brain surface. The ground wire was then wrapped around one of the skull screws and fixed with the application of silver paint. Protective sterilised Vaseline was applied around the outer cannula and onto the exposed dura before dental cement (Simplex Rapid Acrylic Denture Polymer, Kemdent) was used to fix the implant to the skull screws. Analgesic (Small Animal Rimadyl, Pfizer, UK) was then injected intraperitoneally and rats were placed in their heated home cage to recover. All rats received at least two weeks recovery time prior to screening and experimentation.

3.2.4 Single Unit Activity: Screening and Recording

Rats were plugged into an Axona 32-channel recording system (St. Albans, UK) for all recording and screening sessions, at the Mill-Max plug, and were allowed to freely roam around a 30 cm diameter elevated circular arena in an open environment. The detected signals were amplified (1000 fold) before being relayed into the recording system where further amplification took place (10-40 times). These signals were then examined on-screen using an Oscilloscope in the DACQ program to determine whether the activity should be recorded. If no complex spike activity was identified during screening, the rat was unplugged and the tetrodes were advanced by approximately 40 μ m before returning rats to their home cage. Once complex spike activity was discovered tetrodes

were only advanced by approximately 15 μm until a sufficient number of pyramidal cells were obtained with place cell activity. Screening for cells took place up to twice a day, but never less than six hours apart, to ensure the tetrodes were settled in their deeper positions before screening. Recordings were made in one millisecond time slots during the recording session. Data was only collected if the amplitude of one or more channels on tetrode surpassed the predefined amplitude threshold, in which case one millisecond of data for all four channels of the tetrode were collected. The rats' position was also monitored with an overhead monochrome CCD camera which detected the signals from the infra-red light-emitting diodes (LEDs), which were soldered to the Mill-Max plug attached to the lower (rat) end of the recording cable. The tracked LED position data was automatically recorded, time-stamped and associated with the recorded signals, which exceeded the manually pre-set amplitude threshold at these time-stamps, for further analysis. The recordings were analysed focusing on the waveforms, frequency modulation and other characteristics of the recorded data to determine whether the activity originated from pyramidal neurons from CA1. Once pyramidal neurons from CA1 were identified which exhibited place cell activity, behavioural experimentation commenced.

3.2.5 Apparatus

The maze was constructed of eight wooden octagonal boxes connected with wooden tracks (25 cm x 8 cm x 10 cm), painted black and positioned on stools, raising the maze 64 cm above the ground (see figure 3.1). The octagonal boxes provided the starting box (with only one exit track leading to the first choice point), the common first choice point (with an entrance and two exit tracks, leading to the second choice points), the two second choice points (each with an entrance and two exit tracks leading to the goal boxes) and the four goal boxes (with only one entrance track each). Within each octagonal goal box there was an object (metal wine glass, plastic bottle, metal block or a metal retort stand) and a perspex wall cue, provided to help distinguish the four goal boxes. There was also a piece of Velcro in the centre of each goal box which enabled the ceramic food bowl to be fixed. The ceramic bowl in the rewarded goal box was filled with multiple chocolate Weetos (Weetabix, Kettering, UK), which were cut into quarters, and only one goal box was rewarded at any one time with the remaining three ceramic bowls being left empty.

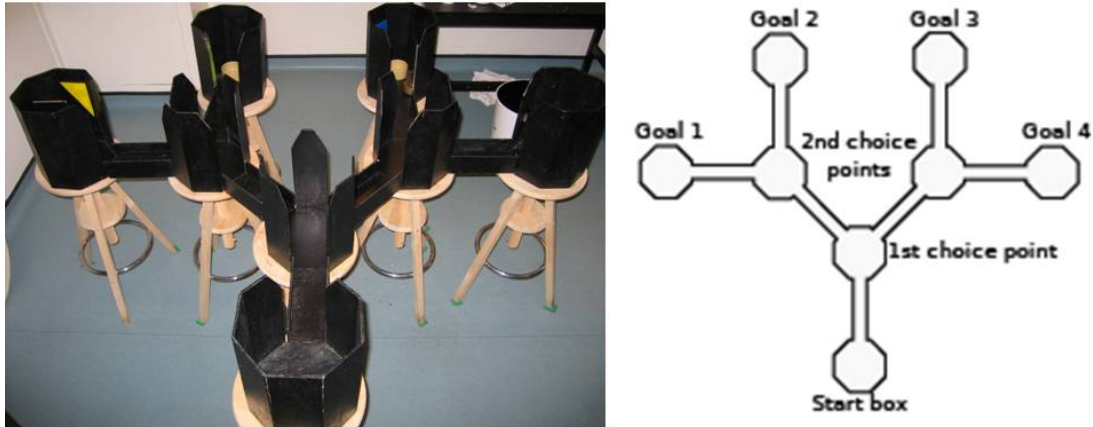

Figure 3.1: The double y-maze is presented photographically on the left, where the cues in the goal boxes can be seen. The diagram on the right provides an illustration of the maze, with the start box, goal boxes and the two decision points clearly indicated.

3.2.6 Behavioural Testing

Each rat was tested over 14 consecutive days, with one session conducted per day. A session involved four blocks of trials with a different goal box being baited for each block of trials in a pseudo-random order such that all goal boxes were baited once during each session, with one session per rat being carried out each day. The rat was placed into the start box at the beginning of each trial and a barrier (black-painted wood) was used to keep the rat in the start box for 10 seconds whilst the maze was wiped clean with warm soapy water. The barrier was then removed and the rat was free to run to any of the four goal boxes, although the barrier was used when necessary to ensure rats did not retrace their steps during a trial. Once the rat entered one of the four goal boxes, the barrier was placed behind the rat, blocking the rat in the chosen goal box for 10 seconds, during this period the rat was free to eat the chocolate Weetos if the correct goal box had been identified. The rat was replaced back in the start box for a further 10 seconds before the next trial commenced, during which time the maze was wiped clean with warm soapy water masking any odour cues along the trajectory. Following the first trial to the correct goal arm, a further nine trials were run with the rewarded goal box remaining in the same location before the block was completed. The block was terminated nine trials after the rat first entered the correct goal box and therefore the number of trials per block varied upwards from 10. A different goal box was rewarded for each of the four blocks run in a session, and the order of rewarded goal boxes was counterbalanced across rats and days.

3.2.7 Histological Procedures

Rats were terminally anaesthetised with sodium pentobarbital (Euthatal, Merial Animal Health, UK) after the behavioural experiments were successfully completed, before being perfused with 0.9% saline followed by 4% formalin. The brains were then removed and stored in 4% formalin

in glass jars until they were coronally sectioned on a cryostat (30 μm) and mounted onto gelatine-coated slides, before being stained with 0.1% cresyl violet and coverslipped. Examination of the electrode tract location was achieved using a light microscope (Wild M420, Switzerland), under 20-fold magnification.

3.2.8 Data Analysis

Single-Unit Processing

All the recorded activity from the behavioural experiments were saved for off-line analysis in which recorded data was processed using a series of custom written Matlab scripts (Steven Huang, University of Edinburgh, UK). For each isolated unit a firing rate map was calculated as described by Leutgeb et al. (2007), where the total number of spikes in each 5 cm x 5 cm bin in the recording environment was divided by the total amount of exploration time within that bin. Initially the data was automatically clustered with KlustaKwik 1.5 (K. Harris, Klustakwik.sourceforge.net), these clusters were then manually checked and corrected using the Klusters Programme (L. Hazan, Buzsaki lab, Rutgers, Newark, NJ; klusters.sourceforge.net).

The custom-written Matlab scripts ensured potential place cells were only included if: the average firing rates across the session lay between 0.1 - 5 Hz; the average peak amplitude exceeded 80 μV ; the largest waveform width exceeded 250 μS and Skaggs spatial information exceeded 0.5 for at least one session. If these conditions were not met the unit was either classified as silent or as an interneuron, depending on the characteristics which were unfulfilled and were not included in further analysis.

Identification of Goal-Sensitive Firing

The double Y-maze was divided into four areas of interest (see figure 3.2) in which the activity of pyramidal cells were examined. At least five pyramidal cells were required to be active in one of the four areas to be included in the analysis. The average firing rates in each area was then calculated as the number of spikes of a given unit in a given area divided by the total time spent in the area. These trial by trial average firing rates for each unit were tested to determine if they differed significantly between the destination goal box visited (independent factor) of the trials using a univariate unbalanced ANOVA. A pyramidal cell was classified as goal-sensitive if the significance value was less than 0.05 (this was adjusted to account for cells active in more than one area and tested for goal-sensitive firing more than once). All activity recorded was subsequently analysed based on the end goal destination of each trial.



Figure 3.2: A schematic of the four areas defined on the double Y-maze which were used to assess the recording patterns of recorded place cells to determine whether there were significant differences in firing rates of cells within any one of these areas depending on goal destination for each trial. The start box defines area 1, the first common trajectory from the start box up to and including the first choice point, defines area 2, and areas 3 and 4 are defined as the common trajectories from the first up to and including the second choice points on the maze for initial left-hand and right-hand turns respectively.

Statistical Analysis

There were two measures of behavioural performance in the 'win-stay' task, firstly the average percentage of trials made to the rewarded goal box in each block of the session (overall performance) and secondly the average percentage of correct trials after finding the rewarded goal box in each block of the session (post-goal performance). Overall performance reflects the efficiency in switching strategy when the previously rewarded goal box is no longer rewarded (the 'lose-shift' component) as well as the ability to perform within a block based upon a win-stay rule. Post-goal performance is a reflection of learning the win-stay strategy which avoids the element of chance in initially locating the rewarded goal box at the beginning of each block and therefore was used to assess the relationship between behaviour and hippocampal firing patterns. Initially, however, both post-reward performance and overall performance were assessed to ensure there was no significant differences in performance levels or learning rates across the two types of analyses due to the 'lose-shift' element of the task.

A within-subjects univariate ANOVA was used to test whether the rats' performance significantly improved across sessions, with the Greenhouse-Geisser corrections for sphericity used where necessary and Bonferroni corrections employed to account for multiple comparisons. The average performance level for each session was then individually compared to chance levels (25%) using one-sample t-tests.

In order to test the relationship between the rats' post-goal performance and the proportion

of pyramidal cells displaying goal-sensitive activity, a linear regression was performed firstly to include all data (each session of the task) and then to assess the relationship during each phase of learning as necessary.

3.3 Results

3.3.1 Histological Data

Inspection of each sectioned brain's electrode tract revealed that the tetrode wires either passed through, or terminated in, CA1 in all of the rats (for an example of tetrode placement refer to figure 3.3, additionally the electrode tip placements for each subject included in the study are detailed in the appendix, figure A.1).

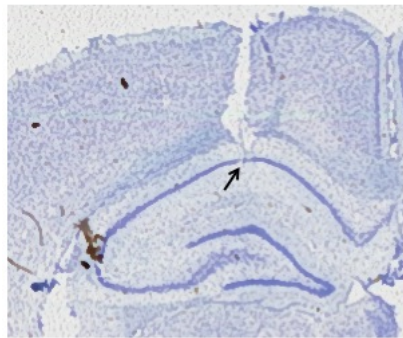

Figure 3.3: An example histological section with the electrode tract present. The black arrow points to the placement of the electrode tip in the CA1 region of the dorsal hippocampus, marked by the microlesion induced by the electrode.

3.3.2 Behavioural Data

All rats learned to return to the correct goal box, within a given block, for at least 75% of subsequent trials on the double Y-maze by session three. The rats rapidly learned the task with performance greater than that expected by chance (25%) from the first session ($t=3.62$; d.f.=6; $p<0.01$) and remaining above chance for the remainder of sessions ($t=44.55$; d.f.=88; $p<0.001$). In figure 3.4a, overall performance can clearly be seen to improve over the first three sessions, before plateauing. A univariate ANOVA revealed that performance differed significantly across days ($F_{(13,82)}=10.91$; $p<0.001$) and *post hoc* analysis with Bonferroni corrections for multiple comparisons found session one to be significantly different from all subsequent sessions ($p<0.001$) except session two ($p>1.00$), session two was also significantly different from all subsequent sessions ($p<0.01$) and session three was not significantly different from any subsequent session ($p>1.00$). The same pattern of results was obtained when a univariate ANOVA was performed on performance of trials only after the rewarded goal box had been identified, i.e., in the last nine trials

of each block, shown in figure 3.4b, where a significant difference in performance across sessions was revealed ($F_{(13,82)}=11.13$; $p<0.001$), and again *post hoc* analysis confirmed that performance plateaued from day three onwards, with post-goal performances shown to be significantly above that expected by chance from the first session ($p<0.01$) and remaining above chance for the remainder of sessions ($p<0.001$).

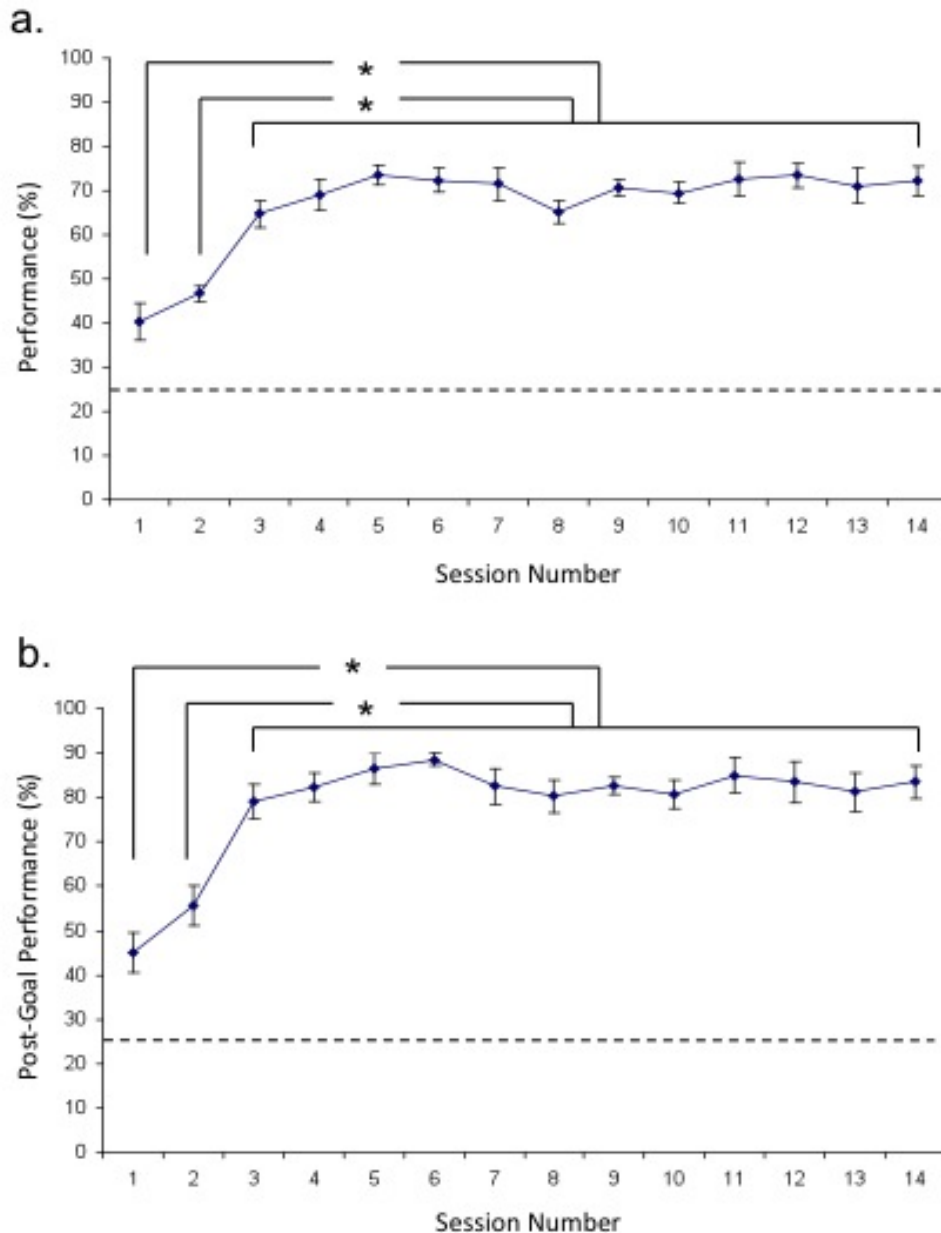

Figure 3.4: The rats' average behavioural performance across experimental sessions is plotted for: (a) the whole session and (b) the trials after the goal was identified in each block of each session. The graphs show rats' performance to be above chance levels (represented by the dashed line) from the first session, with performance rapidly increasing across the first three sessions after which performance plateaus. Data is displayed as mean values \pm SEM, (*) $p < 0.01$.

3.3.3 Single-Unit Recording Data

Pre-test screening ensured that recording electrodes were optimally positioned to enhance the number of cells recorded at the beginning of testing, consequently the number of recorded cells fluctuated between days with an overall gradual reduction over the duration of the experiment. No attempt was made to determine whether the same cells were recorded across experimental days. Overall, 675 cells fulfilled the place cell inclusion criteria (defined above, in section 3.2.8) and were active in at least one of the four areas of interest; of these cells, 228 (34%) displayed goal-sensitive activity (as defined in section 3.2.8), examples of the non-differential and goal-sensitive firing patterns can be seen in figure 3.5.

In figure 3.6 it can be seen that the percentage of pyramidal cells demonstrating goal-sensitive firing increases over the first three experimental days, from $\approx 10\%$ to $\approx 50\%$, before plateauing at $\approx 45\%$, the approximate level reported by Ainge et al. (2007a) in overtrained rats, around which the proportion of goal-sensitive cells fluctuates for the remainder of behavioural testing. It can also be seen that in figure 3.6b the number of pyramidal cells recorded generally reduces from session six onwards.

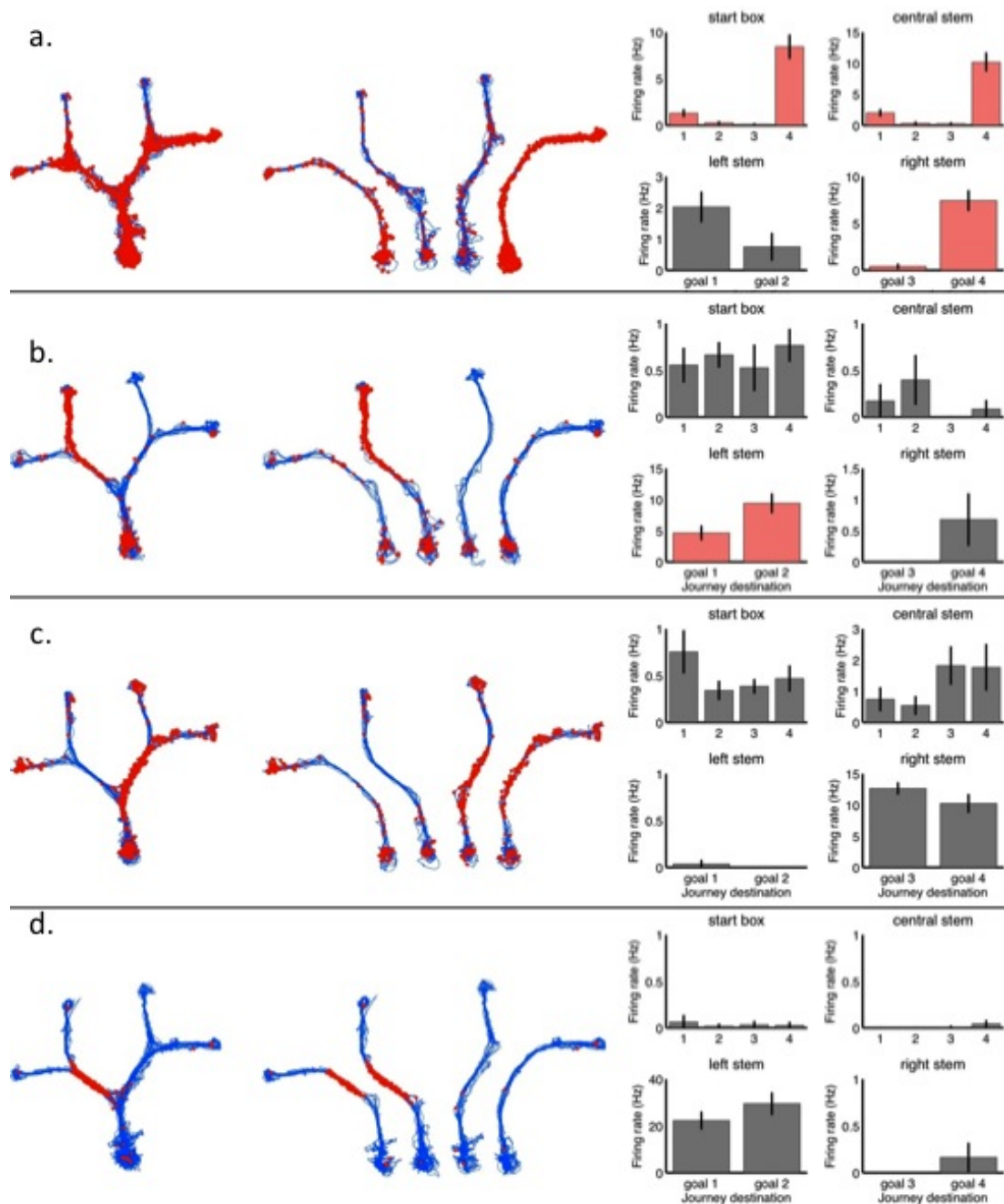

Figure 3.5: Examples of goal-sensitive and non-differential CA1 cell firing patterns. The left-hand panel displays the rat's trajectory (blue) on all trials within a given session, with red dots indicating cell firing locations. These trajectories are separated into trials to each goal box in the middle panel. The right panel graphically represents the relationship between mean firing rate (Hz) and journey destination (goal destination, 1-4), with each maze area plotted separately. Grey and pink bars show the firing rates across journey type, pink bars highlight those which reach significance ($p < 0.05$). Examples of goal-sensitive firing is displayed for: **(a)** a cell firing significantly more on journeys specifically to goal box 4 in the start, central and right areas of the maze; and **(b)** a cell with similar firing in the start and central areas for all journeys but with significantly higher firing rates on the left arm of the maze for journeys to goal box 2 relative to goal box 1. Examples of non-differential firing is displayed for: **(c)** a cell firing predominantly in the start, central and right areas of the maze which does not significantly differ across journey types; and **(d)** a cell firing predominantly on the left arm of the maze with similar firing rates for journeys to goal box 1 and 2.

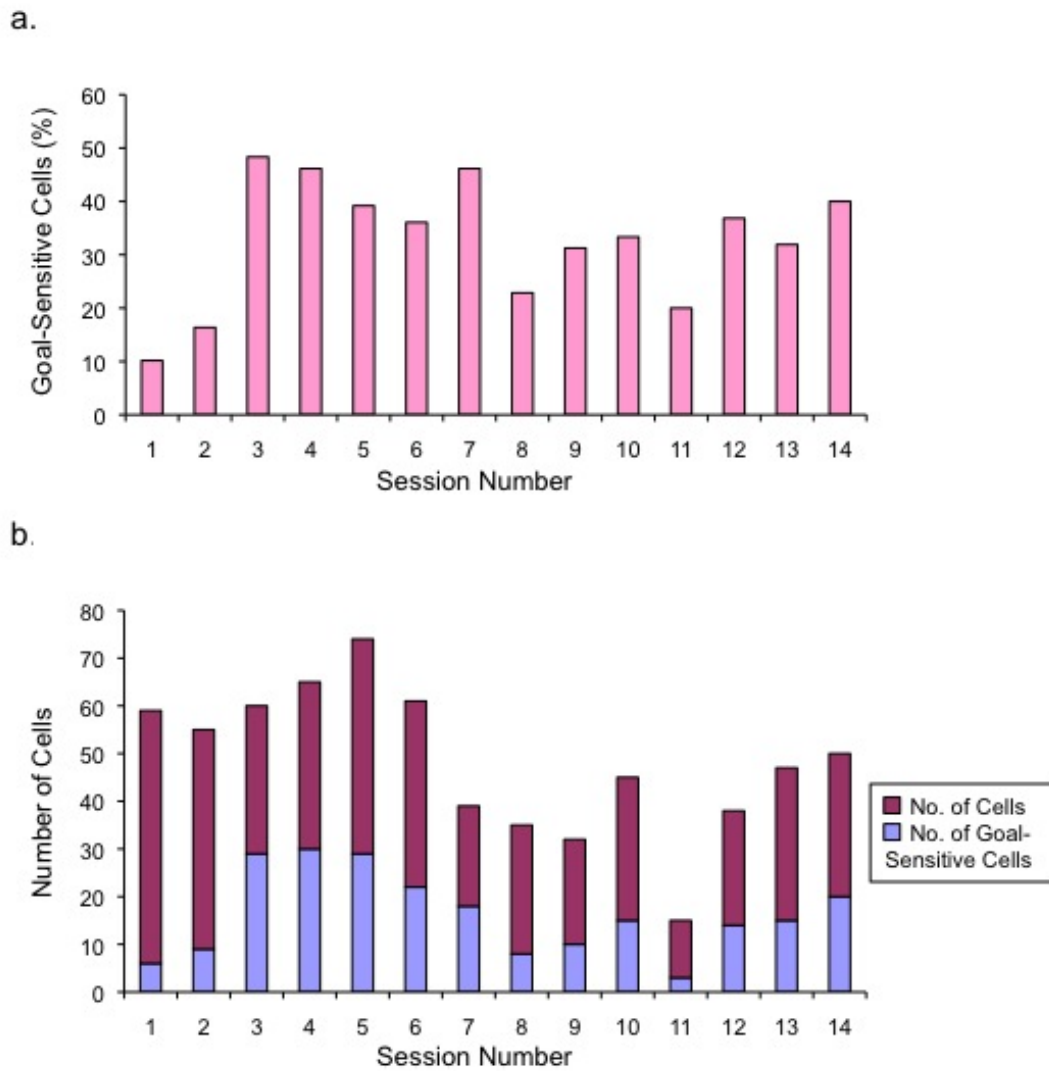

Figure 3.6: The proportion of pyramidal cells displaying goal-sensitive firing across the experimental sessions is graphically displayed. **(a)** The percentage of pyramidal cells displaying goal-sensitive firing is shown for each experimental session, where the percentage of goal-sensitive cells can be seen to dramatically increase across the first three sessions, after which the proportion fluctuates around approximately 40%. **(b)** The number of goal-sensitive cells identified on each session is displayed in combination with the total number of pyramidal cells recorded in the same session.

3.3.4 Behavioural Performance and Goal-Sensitive Firing Relationship

In figure 3.7 the proportion of pyramidal cells displaying goal-sensitive firing is plotted with respect to the rats' behavioural performance. A linear regression revealed a positive linear relationship between behavioural performance and the proportion of pyramidal cells displaying goal-sensitive firing recorded during each session over the 14 experimental days ($R^2=0.236$; $p<0.001$). In figure 3.8a it can clearly be seen that the relationship between the two variables is stronger when only the first six sessions are examined ($R^2=0.501$; $p<0.001$). The relationship, between the proportion of pyramidal cells displaying goal-sensitive firing and the behavioural performance, is strongest; however, during the first three sessions ($R^2=0.676$; $p<0.001$), in which behavioural performance rapidly improved (see figure 3.8c). In the three day period immediately after asymptotic behavioural performance was reached (from sessions three to six) no significant correlation was found between the proportion of pyramidal cells displaying goal-sensitive firing and the behavioural performance of the rats ($R^2=0.145$; $p=0.131$, shown in figure 3.8d). After behavioural performance had plateaued and remained constant, for the last eight sessions of the experiment, the correlation between the two variables remained insignificant ($R^2=0.045$; $p=0.213$, see figure 3.8b).

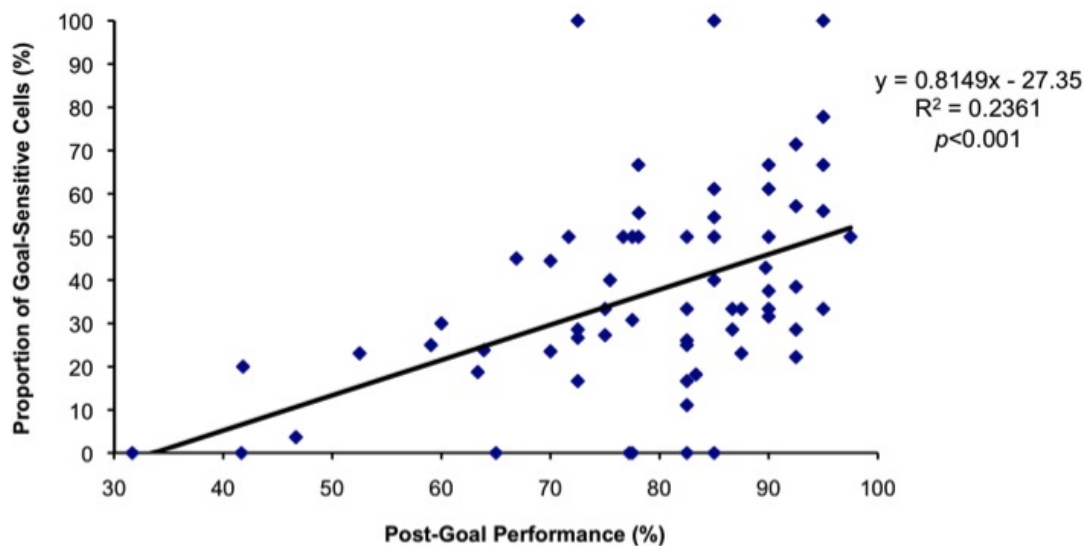

Figure 3.7: The percentage of the individual rats' pyramidal cells showing goal-sensitive firing patterns on each session is plotted against the individual rats' performance within the same session, once the rewarded goal box had been identified in each block of trials. Linear regression, used to plot the line of best fit, reveals a strong correlation between behavioural performance and the proportion of pyramidal cells demonstrating goal-sensitive firing ($R^2=0.236$; $p<0.001$).

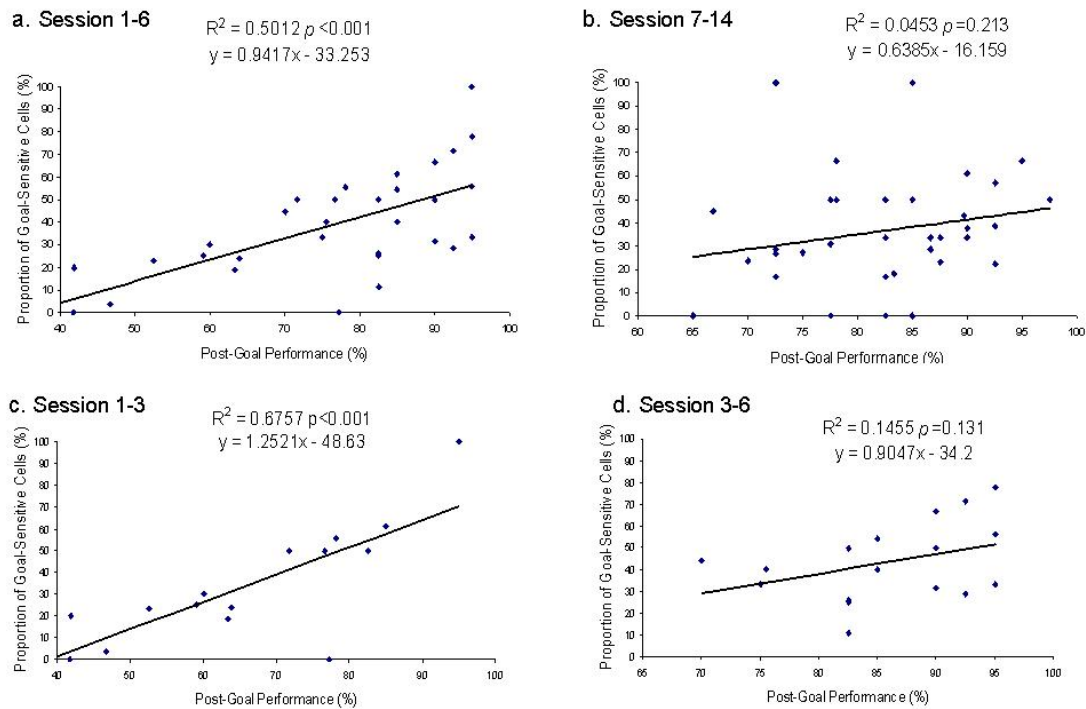

Figure 3.8: The correlation between the individual rats' pyramidal cells demonstrating goal-sensitive firing patterns and the individual rats' performance within the same session, once the rewarded goal box had been identified for each block, is shown separately for: **(a)** the first six experimental sessions; **(b)** the last eight sessions; **(c)** for the first three sessions; **(d)** for sessions three, four, five and six. Linear regression, used to plot the line of best fit, reveals a highly significant relationship between behavioural performance and the proportion goal sensitive cells across the first six sessions ($R^2=0.501$; $p<0.001$, see graph **(a)**), and this correlation is stronger still when rapid learning is taking place, across the first three sessions ($R^2=0.676$; $p<0.001$, see graph **(c)**). Linear regression, however, failed to detect a linear relationship between the levels of performance and goal-sensitive cells when tested for the last eight days of the experiment ($R^2=0.045$; $p=0.213$, see **(b)**) or for the period immediately after performance levels reached asymptotic levels, in sessions 3-6 ($R^2=0.145$; $p=0.131$, see graph **(d)**).

These results clearly demonstrate that goal-sensitive firing patterns of CA1 neurons emerge over the first few days of learning in the double Y-maze 'win-stay' task and furthermore this increase in the proportion of cells demonstrating goal-sensitive firing is positively correlated with behavioural improvements in task performance.

3.4 Conclusions & Discussion

The present study was implemented to specifically investigate the development of goal-sensitive firing patterns in CA1 pyramidal cells during the learning phase of a spatial 'win-stay' task in the double Y-maze as rats acquired and used their memory to guide their behaviour.

The rats rapidly learned the 'win-stay' task, performing above the level expected by chance from the first session. Performance levels continued to significantly increase over the first three sessions before reaching asymptotic levels with rats' returning to the rewarded goal-box (post-goal performance) for 85% of trials. Goal-sensitive firing was observed in a proportion of hippocampal pyramidal cells in the common segments of the maze which was predictive of the rats' intended destinations, supporting the previous findings by Ainge et al. (2007a). The proportion of CA1 pyramidal cells with goal-sensitive firing rose from approximately 10% to 50% over the first three 'win-stay' sessions, after which time the proportion fluctuated around 45%. Thus, the time taken for the proportion of goal-sensitive cells to reach plateau levels corresponded to when rats reached optimal performance levels. A significant linear relationship was revealed between the proportion of CA1 pyramidal cells demonstrating goal-sensitive activity and level of task performance. As performance levels increased, the proportion of pyramidal cells with goal-sensitive firing patterns increased and this relationship was strongest across the first three days in which the rapid acquisition of task learning took place. These results further support a role for the neural firing properties CA1 pyramidal cells in the learning and execution of spatial 'win-stay' task performance.

There was a slight reduction in the proportion of goal-sensitive cells recorded after asymptotic behavioural performance was achieved, where no significant linear relationship was observed between behavioural performance and the percentage of pyramidal cells demonstrating goal-sensitive firing immediately after the learning phase (sessions 3-6) or in the overtraining period (sessions 7-14). This may indicate that the hippocampus is more critically involved in the acquisition phase of the 'win-stay' task, which may explain why only minor impairments in performance were reported on this task in well trained rats following hippocampal lesions, which were found to be specifically related to the 'lose-shift' component of the task (Ainge et al. 2007a). This theory is also consistent with previous findings where hippocampal-lesions only retarded the learning but not the eventual post-acquisition performance of rats on the W-maze task (Kim and Frank 2009). In addition, Packard and McGaugh (1996) showed that overtraining results in a

shift from a hippocampal-dependent to a striatal-dependent strategy, where a procedural method is employed to solve the win-stay task. The general reduction in the number of pyramidal cells recorded after day five may be attributable to a decrease in the number of CA1 cells active after this time as Karlsson and Frank (2008) found that the overall CA1 population rate and the number of active cells declines as the rats become familiar with the environment and the demands of the task. Alternatively, the fluctuations and slight decline in the number of pyramidal cells recorded and the proportion of these displaying goal-sensitive firing after optimal performance levels were reached, could possibly be due to the small movements in electrode tips, which is unfortunately inevitable across testing days. It is technically very difficult to identify and isolate a constant set of cells in single-unit recording across multiple days which is one limitation of single-unit recording in experiments which are conducted over a long period of time, such as this. Without further technological advances this issue can not be ruled out; however, it is possible to test whether the hippocampus is more critically involved in the learning phase of this task as opposed to its minimal role previously revealed in the post-learning phase (Ainge et al. 2007a). The involvement of the hippocampus in the rapid-acquisition of the 'win-stay' task is documented in chapter 5, where hippocampal lesions were conducted prior to any pre-training and their effects on learning were examined.

Goal-sensitive firing patterns of CA1 cells may contribute to successful behavioural performance through the retrospective encoding of previous successful and unsuccessful pathways which can be used flexibly to plan the most fruitful trajectory for the current trial, based on semantically learned task rules, where this intended destination may be reflected through prospective firing patterns. These processes presumably involve some form of mental time travel are likely to require similar trials involving overlapping trajectories to be distinguished, supporting a theoretical role for CA1 in mismatch detection (discussed in the introduction, section 0.2.2).

The pattern of the results reported in this chapter may alternatively arise from goal-directed behaviours which are not involved in task solving itself but arise from repeated exposure to the maze. Previously, Frank et al. (2004) found that place fields changed over the first few days before stabilising by the third day and others have reported similar time courses for the stabilisation of neural representations of new environments (Bostock et al. 1991; Hayman et al. 2003; Lever et al. 2002). The increase in goal-sensitive firing obtained in the present study, over the first three days of the task may therefore merely reflect a stabilisation period of neural firing patterns, as the rats became habituated to the maze environment, the spatial relationships between intra-maze and extra-maze cues and the multiple possible reward locations, or equally it could result from running direct trajectories along arms to gain rewards, as opposed to the more tentative behaviour observed in the first few sessions. Since the rats were only exposed to the maze in the first 'win-stay' session it is not possible to distinguish whether the development of these goal-sensitive firing patterns is reflecting the learning and mnemonic task demands, or whether they are simply the

result of increased experience of navigating the maze, using the protocol employed herein. This issue is investigated in chapter 4, where the emergence of goal-sensitive firing is examined over a five-day period in which the rat was allowed to gain experience navigating the maze and running direct trajectories to each goal box, obtaining rewards at specific locations and developing a stable representation of the environment in the absence of any task-specific learning or memory demands before the 'win-stay' protocol was employed.

A further interpretation of the results is that experience of the four 'win-stay' blocks induces four different contexts to be encoded which are each defined by the series of turns necessary to yield rewards, with the change in rewarded goal box inducing a remapping effect. This switch in behaviour between blocks is likely to result in perfect post-goal performance within a block, as the set of decisions would be pre-mediated and the 'remapping' of the cell network to a new context/block would only occur after finding the rewarded goal location of the block to be empty. This was not the case in this study, where curiosity led rats to 'check' other non-rewarded locations within a block to pre-empt the shift in reward location. Also, previous findings in which differential firing patterns have not been identified in rats performing sequential tasks where two different behavioural contexts could theoretically be encoded to support performance (Bower et al. 2005; Lenck-Santini et al. 2001), further refute this theory. Even if the rats' were performing this task based on having encoded separate contexts for each reward location, in which the correct series of turns are automatically implemented, the result would still be fascinating to explore, as it would present a similar phenomenon to the concept of schemas, which are widely reported in the human literature, where they provide a set of information which can be applied to ensure the correct response is yielded, based on the generalisations of a multitude of episodic events.

In this study goal-sensitive firing has been shown in a task in which successful performance is based upon the ability to remember which goal arm was visited in the most recent trial and whether rewards were obtained, a process which may occur through the utilisation of some form of episodic memory of the individual trials of the session. Episodic memory encoding would predict some differences between trials to the same goal box. Therefore, whilst the future planning and decision making would be the same for successful trials to any given goal box within a block, one would expect additional differences between these trials. It is difficult to assess any potential differences in firing patterns between the trials to the same goal box with any reliability as, by their nature they would only occur once and are likely to be encoded in the spurious firing of cells outside of their place fields, which are often treated as 'noise' and largely ignored in further analysis. Unfortunately identification of unique firing patterns would present an arduous challenge with many experimental difficulties.

In summary, the results reported in this chapter replicate the previous findings of Ainge et al. (2007a) that the firing patterns of CA1 pyramidal cells reflect intended destination on a 'win-stay' task in the double Y-maze and further demonstrates that this goal-sensitive firing emerges

in line with behavioural performance. A strong positive correlation was revealed between the development of goal-sensitive firing patterns and successful behavioural performance during the rapid acquisition of the task, providing strong support for the role for the goal-sensitive firing of CA1 neurons in spatial 'win-stay' task performance. Although the protocol employed in this study does not enable investigations into the causality of this relationship, the neural correlates of task performance may underlie the hippocampus' role in the processes of spatial planning and decision making based on the flexible retrieval of previous experience.

Chapter 4

The Development of Goal-Sensitive Cells across Double Y-Maze Paradigms

4.1 Introduction

Previously, in chapter 3, a clear correlation between the emergence of goal-sensitive firing of CA1 cells and the acquisition of a spatial ‘win-stay’ task was revealed. The interpretation of this result, with respect to the mnemonic functions of the hippocampus was troubled, however, by the possibility that the development of this differential place cell activity could arise from the basic features of the study, such as becoming habituated to the testing environment through increased exploration of the double Y-maze, learning the possible locations in which food rewards can be obtained and behavioural aspects (i.e., running direct trajectories), rather than the specific learning and memory demands of the task. This possibility was highlighted by previous studies which have shown place cell firing patterns to develop over a similar time course to that in which goal-sensitive firing was previously found to emerge, when rats are exposed to novel environments (Bostock et al. 1991; Frank et al. 2004; Hayman et al. 2003; Lever et al. 2002).

It is widely accepted that the hippocampus plays a vital role in a host of cognitive processes, such as episodic memory, spatial learning, forward planning and imagination (discussed fully in the introduction to this thesis), which are all likely to contribute to successful performance in the double Y-maze ‘win-stay’ task. It is logical to assume, therefore, that the goal-sensitive firing which emerged in line with the acquisition of this task (reported in chapter 3) is supporting behavioural performance, especially as neural population level distributions of CA1 firing rates have been found to correlate with behavioural changes in spatial alternation performance in a separate task (Karlsson and Frank 2008). Unfortunately, the protocols employed in both of these tasks prevents one from determining whether the changes in neural activity are linked to the learning and memory demands of the tasks themselves or result from accumulated experience navigating the maze. Some insight was provided in the study by Smith and Mizumori (2006b), who recorded

activity from CA1 neurons whilst rats performed two different types of task in a plus maze. In a preliminary training session a ‘random’ task was conducted over two blocks of 10 trials (separated by 30 seconds of darkness), in which the goal arm was randomly located for each trial, preventing a successful strategy from developing. After the ‘random’ task session, a daily ‘win-stay’ task was enforced. In the ‘win-stay’ protocol, rats obtained rewards for returning to the previously rewarded arm for a period of 15 trials, after which the goal location was shifted and the rats were required to locate and return to the second goal position over the course of next 15 trials. For both task types the start arm was always randomly determined from the three unrewarded arms. The neuronal activity obtained revealed that goal-sensitive activity emerged only in the ‘win-stay’ task sessions and not in the ‘random’ task session; however, as the ‘random’ task was only conducted once in preliminary testing, it is not clear whether the goal-sensitive activity recorded relates specifically to the planning and mnemonic task demands or whether it emerges as a result of increased experience navigating the maze. Furthermore, the relationship between the development of these goal-sensitive firing patterns and behavioural performance was not assessed and therefore it is difficult to interpret how it relates to the learning and memory functions of the hippocampus. Thus, the present chapter aims to distinguish whether the behaviourally-correlated emergence of goal-sensitive activity, previously reported in chapter 3, is a result of the cognitive task demands or due to increased navigational experience and familiarisation of the maze. This is explored through the recording of CA1 pyramidal cells during the learning phases of three separate tasks within the same double Y-maze.

In all three tasks the behavioural conditions remain constant, with only the reward contingencies changing between task types. The first of the three tasks was a ‘random’ foraging task, in which rats were exposed to the basic task features, such as running through the maze, receiving food rewards etc., but no spatial strategy nor any memory demands were enforced. This ‘random’ task was run for five sessions to ensure any emergence of goal-sensitive activity resulting from increased exploration of the maze was captured, as previously the development of goal-sensitive firing patterns occurred over the first three double Y-maze sessions. The utilisation of the ‘random’ task provides a control in which environmental habituation can be dissociated from the learning and memory demands necessary for spatial ‘win-stay’ performance in the analysis of the CA1 cell firing patterns. After the ‘random’ task sessions, the previously described ‘win-stay’ task was implemented for a further six sessions. This time-scale was chosen to ensure the entire learning-phase was covered, again based on the results obtained in chapter 3, in which learning was found to rapidly occur across the first three sessions, after which performance levels plateaued and were no longer correlated with the emergence of goal-sensitive activity. As lesions of the hippocampus were only previously reported to induce minor deficits on ‘win-stay’ task performance in the double Y-maze (Ainge et al. 2007a), a spatial ‘win-shift’ task was conducted which is likely to depend on the hippocampus (Ainge et al. 2007a,b; Becker et al. 1980; Higgs et al. 2001; Kim and

Frank 2009; Olton and Feustle 1981; Packard et al. 1989), at least in the acquisition phase. If the previously reported emergence of goal-sensitive was merely due to greater experience on the maze, enabling stabilisation of the neural representations, then a similar proportion of cells with goal-sensitive activity should develop during ‘random’ task performance and this should remain at a set level for the duration of the ‘win-stay’ task. The ‘win-shift’ task would then allow a second question, of whether further goal-sensitive firing is expressed when the hippocampus becomes specifically required for task performance.

In summary, this chapter aims to examine whether the emergence of goal-sensitive activity of CA1 cells is related to increased experience and familiarisation with the maze or whether it is due to the employment of specific task strategies which have mnemonic demands and involve spatial learning. To distinguish these possibilities, CA1 place cells were recorded during training on three different tasks within the same double Y-maze: a ‘random’ task, requiring no strategy nor memory demand; a ‘win-stay’ task, involving spatial learning and memory demands, and a ‘win-shift’ task, requiring spatial memory and learning of an alternating strategy. To the extent that the goal-sensitive firing identified in chapter 3 is related to the learning and memory demands of the ‘win-stay’ task, the expectation would be to observe cells that demonstrate goal-sensitive activity in line with performance only when the ‘win-stay’ task contingencies are enforced. Conversely, to the extent that the goal-sensitive firing developed simply as a result of increased navigation in the maze and learning of reward location, one would expect goal-sensitive firing to emerge across the first few days of the ‘random’ task in line with accumulated exploration of the maze.

4.2 Materials & Methods

4.2.1 Subjects

Six adult male Lister-Hooded rats weighing 250-350 g at the time of surgery were used. Rats were kept under a 12 hour light/dark cycle and were housed in individual cages after surgery. All experiments were carried out during the light phase of the cycle. Rats were given *ad libitum* access to water and were food restricted to 85% of their free-feeding weights after one week of post-surgery recovery. All procedures were performed in compliance with national (Animals [Scientific Procedures] Act, 1986) and international (European Communities Council Directive of 24 November 1986 [86/609/EEC]) legislation governing the maintenance of laboratory animals and their use in scientific experiments.

4.2.2 Single-Unit Recording Implants and Surgery

Individual single-unit recording implants were manufactured, in an identical fashion to that reported in section 3.2.2, and were implanted into the CA1 region for each rat, using the procedure described in section 3.2.3.

4.2.3 Single-Unit Recording System and Activity Screening

Implanted rats were connected to the recording system and allowed to freely roam on a circular platform to enable neural activity to be screened for CA1 pyramidal cells, in a procedure identical to that described in section 3.2.4. Once pyramidal cell activity from CA1 displayed place cell firing patterns the behavioural testing commenced (as described in section 4.2.4) and continued for 17 consecutive days, with recordings made during each testing session. In two of the six rats initially implanted, no pyramidal cells were identified and therefore no behavioural experimentation nor recordings were performed on these subjects.

4.2.4 Behavioural Testing

The same double Y-maze to that described previously (in section 3.2.5) was used for all three tasks conducted in this study (see figure 4.1 for the experimental schedule).

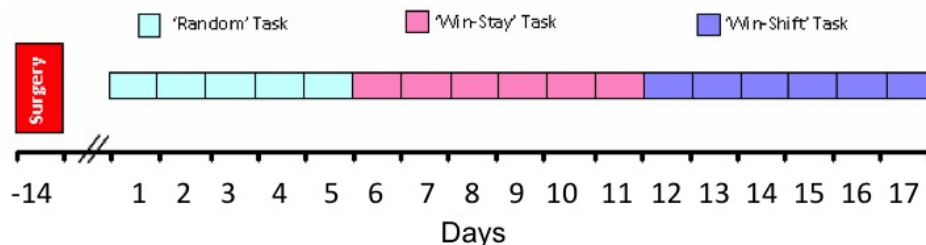

Figure 4.1: The order of behavioural testing of the three tasks; 'random', 'win-stay' and 'win-shift', is shown relative to the experimental days.

'Random Task' protocol

At the start of each session all four ceramic bowls, one located in each goal box, were filled with chocolate Weetos (Chocolate Weetos, Weetabix, Kettering, UK), cut into quarters, such that the amount in each goal box exceeded the amount that could be consumed in any one session. The rat was removed from its home cage and placed into a holding bucket (30 cm diameter, containing 2 cm of sawdust) and carried through to the experiment room. The rat was then removed from the holding bucket and placed into the start box at the beginning of each trial. A black-painted wooden barrier was used to keep the rat in the start box for 10 seconds whilst the maze was wiped clean with warm soapy water. The barrier was then removed and the rat was free to run to any of the four goal boxes, although the barrier was used when necessary to ensure rats did not retrace their steps. Once the rat entered a goal arm, the barrier was used to block the rat in the chosen goal box for a 10-second delay, during which time the rat was free to eat the rewards. The rat was then placed back in to the start box for 10 seconds, in which the maze was wiped clean with warm soapy water to mask any odour cues along the trajectory. The barrier was then removed and the next trial commenced using the same protocol. Each session consisted of one block of 40 trials

(or until the 60-minute time limit was reached). Following the last trial of the session the rat was placed back into the holding bucket and returned to its home cage.

'Win-Stay' Task protocol

The protocol for the win-stay task was identical to that described in section 3.2.6, with the exception that this experimental phase was conducted for six, as opposed to 14, consecutive sessions, for reasons previously validated in the introduction to this chapter.

'Win-Shift' Task protocol

The rats were run on the win-shift protocol for six sessions, each consisting of eight blocks of trials. At the start of a block of trials, each of the four goal boxes was baited with one quarter of a chocolate Weeto. The rat was placed into the start box, with the barrier in place. The rat was then released to run freely in the maze, although the barrier was used where necessary to ensure that the rat ran only in a unidirectional manner. Once the rat entered a goal box the barrier was placed at the end of the goal arm, blocking the rat in the chosen arm. The rat was allowed to fully consume the reward in the goal box, before being returned to the start box, where it was blocked with the barrier for 10 seconds during which time the maze was wiped with warm soapy water. The rat was then released from the start box, marking the beginning of the next trial, where it was allowed to run towards a goal box, in which, if a rewarded goal box (i.e. a previously unvisited goal box) had been chosen, the reward could be consumed. If the rat returned to a previously chosen goal box within the block (error trial), no food reward was available, as the reward had already been consumed by the rat on an earlier trial. On these error trials the rat was blocked in the chosen arm for a 10-second period, before being placed back into the start box. The number of trials within a block varied from four upwards, depending on behaviour, where, within a given block of trials, the goal boxes were not replenished and thus the location of the available rewards depended upon which arms the rat had visited within the block. Once the rat obtained all the rewards, one from each of the four possible goal boxes, the block of trials was terminated. The rat was removed from the maze and placed on an elevated pedestal for a one-minute period, during which time the maze was cleaned and one quarter of a chocolate Weeto was placed into each of the four goal boxes. The rat was then replaced in the start box and the next block of trials ensued, as previously described. Each session consisted of eight blocks of trials.

4.2.5 Histological Procedures

All perfusion and histological procedures were performed in an identical manner to those described in section 3.2.7.

4.2.6 Data Analysis

Single-Unit Processing and Identification of Goal-Sensitive Firing

A similar analysis of recording data to that described in section 3.2.8 was implemented; however, due to the fewer number of rats involved in this study, pyramidal cells were analysed if the average peak amplitude exceeded $60 \mu\text{V}$, to increase the yield of cells assessed. A second independent analysis was performed using the previous average peak amplitude threshold of $80 \mu\text{V}$, to ensure the same pattern of cellular behaviour was present at more conservative criteria thresholds.

Statistical Analysis

Behaviour in the 'random' task was assessed by determining whether the rats were performing based on a win-stay, a win-shift or a genuinely random strategy. Thus, the number of trials in which the rat returned to the goal box visited on the preceding trial ('repeat' trials) and the number of trials in which the rat entered a different goal box to that visited on the preceding trial ('shift' trials) were calculated for each rat in each session. A univariate ANOVA was then performed to determine whether the average ratio of 'repeat' and 'shift' trials varied across the sessions.

The behavioural strategies employed over the five sessions were additionally tested by determining the average number of trials that each rat took to complete a 'win-shift' block, where a 'win-shift' block required each of the four goal boxes to be visited at least once. If a random strategy is employed then the rat should enter a previously unvisited arm on the first trial by definition, on the next trial only three of the four arms remain unvisited so rats should take on average 1.33 trials to enter an unvisited arm, leaving only half the arms are unvisited, thus the rat is likely to take 2 trials to locate one of these and therefore as only one unvisited arm remains, the number of trials taken to randomly to enter this would be 4. These summate to a value of 8.33, providing the average number of trials one would expect the rats to take to visit all four goal boxes based on chance alone. If an alternating strategy is employed then the rat will visit an unvisited arm on it's first trial, on the second trial the rat should visit an unvisited arm as the rat would alternate from the previously visited arm, on the third trial two of the three potential arms remain unvisited, as the rat could alternate back to the originally visited arm, therefore it should take an average of 1.5 trials to enter an unvisited arm and on the final trial only one of a possible three arms remain to be visited, which would take an average of 3 trials to locate. Thus, the summation of these gives a value of 6.5, providing the average number of trials one would expect the rats to take to visit all four goal boxes at least once, based on chance, when an alternating strategy is employed. The higher the number of trials to complete a 'win-shift' block, the more likely the rat is to be employing a win-stay strategy, as if a purely win-stay strategy was employed then the number of trials to complete a 'win-shift' block would be infinite. The average number of trials the rats took to complete a 'win-shift' block in the 'random' task were compared with that expected by a purely

random (8.33) or a perfect alternation (6.5) strategy using one-sample t-tests.

Behavioural performance in the 'win-stay' task was defined as the average percentage of trials made to the rewarded goal box in each block of the session. The 'win-stay' analysis was performed twice firstly on all the data collected (overall performance), enabling both the learning of the 'win-stay' as well as the 'lose-shift' elements of the task to be assessed and then independently on trials only after the rewarded goal box had been located for each block (post-goal performance), which removes the element of chance in initially locating the goal box and allows the learning purely of the 'win-stay' element of the task to be assessed.

A univariate ANOVA was used to test whether the rats' average performance significantly improved across sessions, with Bonferroni corrections employed to account for multiple comparisons. The average performance level for each session was then individually compared to chance levels (25%) using one-sample t-tests. Performance across blocks within the first session was then assessed using a univariate ANOVA.

The acquisition of the 'lose-shift' element of the 'win-stay' task was also assessed by calculating the number of trials in which the rats returned to an unrewarded goal box prior to locating the rewarded goal box at the start of each block. A univariate ANOVA tested whether this number of 'pre-goal' errors significantly reduced across sessions as the rats learned the task.

Performance in the 'win-shift' task was calculated as the percentage of trials in each session in which the rat obtained rewards. The rats average performance for each session was then analysed using a univariate ANOVA to test whether performance significantly improved across sessions, with Bonferroni corrections employed to account for multiple comparisons.

In order to test the relationship between the rats' post-goal performance in the 'win-stay' task and the proportion of pyramidal cells displaying goal-sensitive activity, a linear regression was performed.

4.3 Results

4.3.1 Histological Data

Analysis of each sectioned brain's electrode tract revealed that the tetrode wires passed either through, or targeted, CA1 in all of the rats, indicating that recorded place cells from behavioural experimentation originated from CA1 cells (for examples of tetrode placements refer to figure 4.2, additionally the electrode tip placements for each subject included in the study are detailed in the appendix, figure A.2).

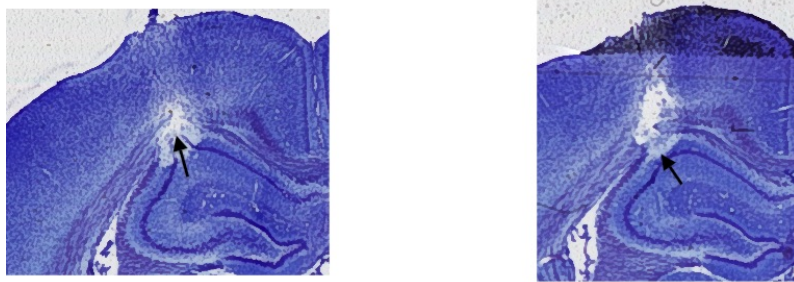

Figure 4.2: Example histological sections displaying the electrode tract. Black arrows points to the placement of the electrode tip in the CA1 region of the dorsal hippocampus in each section, marked by the microlesion induced by the electrode.

4.3.2 Behavioural Data

'Random' Task

In figure 4.3a, the number of trials completed within the session can be seen to increase, from 13 to the required 40 trials, across the first three sessions as rats become familiarised with the maze and the reward locations. It appears from figure 4.3a that the 'repeat': 'shift' ratio changes across sessions, with a general increase in the proportion of 'repeats', suggesting the rats switched from a win-shift to a more win-stay strategy over the sessions. This trend; however, was not found to be significant ($F_{(4,15)}=2.97$; $p=0.054$).

The type of strategy utilised by the rats was also tested by analysing the average number of trials required to complete a 'win-shift' block, which gives an indication of the type of strategy employed, the fewer average trials taken indicates a greater tendency to alternate/shift between trials and a higher number of trials indicates an increased dominance of a win-stay/repetitive strategy. In figure 4.3b it appears that the rats' behaviour tends to move towards a more win-stay strategy, from an alternation strategy implemented initially, across the first three sessions; however, overall the rats behaviour was not found to significantly differ from that expected by either the random ($t=0.20$; d.f.=4; $p<0.850$) or the perfect alternation ($t=1.15$; d.f.=4; $p<0.315$) strategy.

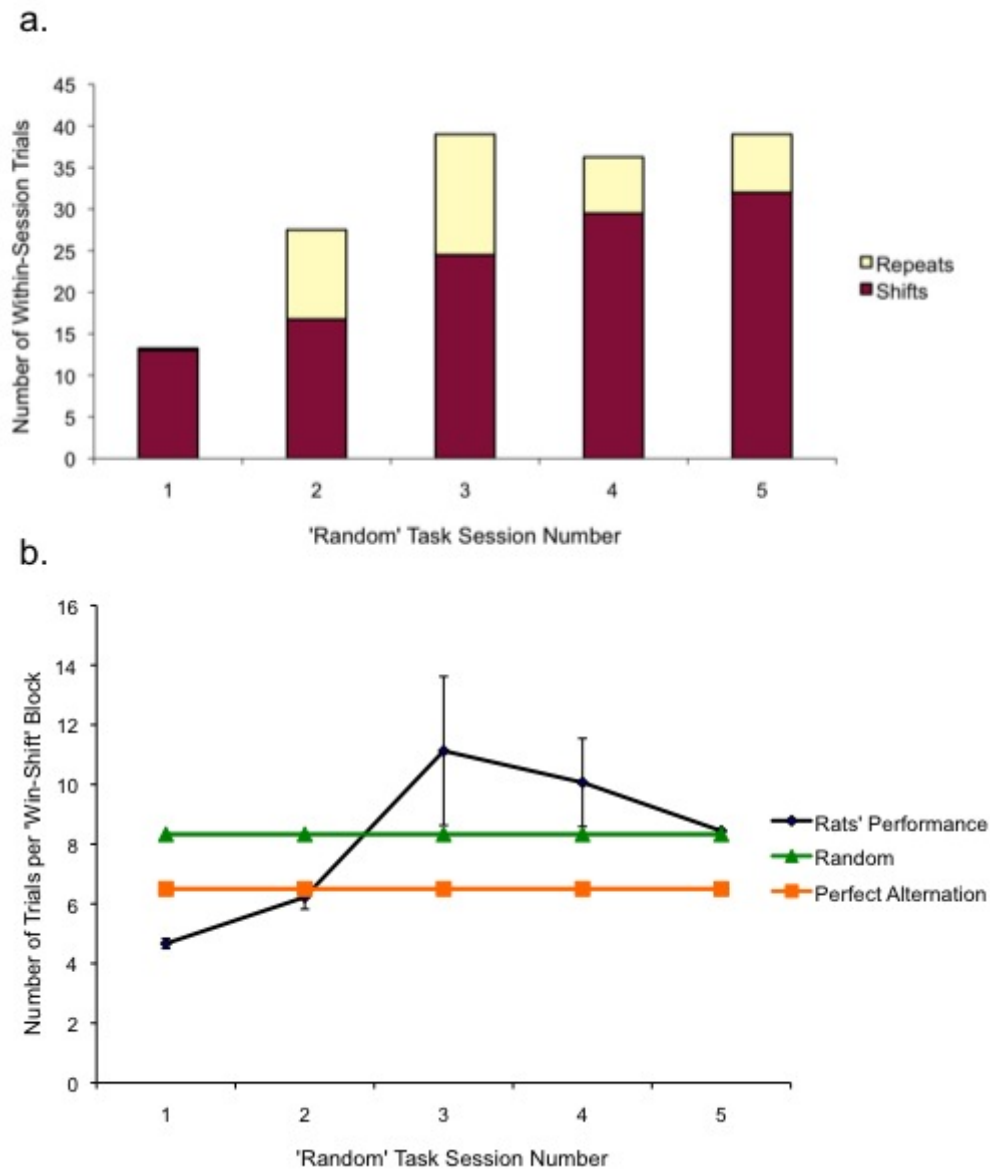

Figure 4.3: The type of strategy employed in the 'random' task across sessions is displayed. **(a)** The numbers of 'repeat' and 'shift' trials are shown for each session, where 'repeat' trials are defined as trials back to the previously visited goal, and 'shift' trials refer to trials in which the rat has entered a different goal box relative to the preceding trial. It can be seen that an alternating strategy clearly dominates with elements of win-stay behaviour slowly emerging from the second session. **(b)** The average number of trials to complete a 'win-shift' block is plotted across the experimental sessions. A 'win-shift' block is defined as visiting each goal once, such that the lowest number of trials to complete a 'win-shift' block would be four. The orange and the green horizontal lines plot the expected number of trials to complete a 'win-shift' block based on a perfect alternation strategy and based on an entirely random strategy, respectively. Perfect win-stay performance would result in an infinite number of trials required to complete a win-shift block as the rat would never visit all four goal boxes, and for this reason it is not plotted. The fewer number of trials required to complete a 'win-shift' block, the more shifting behaviour the rat is showing, whereas a greater number of trials indicates a tendency to exhibit win-stay behaviour. The tendency to alternate is again evident on the first few days, shifting towards a more win-stay strategy on the third session and in the last two sessions of the task behaviour appears to be governed by a purely random strategy.

'Win-Stay' Task

The rats rapidly learned the task with performance levels exceeding those expected by chance (25%) from the first session ($p < 0.01$) and remaining above chance for the remainder of sessions ($p < 0.001$). In figure 4.4a, overall performance levels can be seen to gradually improve over the sessions and this was shown to be significant, using univariate ANOVA analysis ($F_{(5,18)} = 4.40$; $p < 0.01$). Bonferroni pairwise comparisons revealed a significant difference only when session one was compared with sessions four, five and six ($p < 0.05$). As can be seen in figure 4.5a, no significant improvement was found in performance across the blocks of session one ($F_{(3,11)} = 0.60$; $p = 0.631$). This is probably due to the fact that the rats learn to win-stay in the first block and perform quite well, but it is only after this block that the rat must learn the 'lose-shift' component of the task and so performance would be expected to be a lot lower in the second block as a result. Furthermore, as more blocks are completed, more goal-locations are presented and therefore there is a greater level of interference induced across blocks which is likely to impair performance as the rat learns the rules of the task. This impact of shifting the block location on performance levels is clearly shown in figure 4.5c as the number of pre-goal errors increases almost linearly over the session.

Overall performance levels can be influenced by chance, due to the fact that they include the trials at the start of a new block, when the rat is unaware of the new location of the rewarded goal box. In a well trained rat, one would expect the rat to make an error in the first trial (to the rewarded goal box of the previous block of trials) before demonstrating an effective searching strategy visiting each unrewarded goal-box only once until the newly rewarded goal-box is located. Whilst this 'lose-shift' element is interesting and shows a type of learning, it is also subject to chance, where a well trained rat could find the newly rewarded goal box on the second trial of the block or on the fourth trial of the block without any difference in the numbers of errors made and likewise it could be located by chance on the first trial of the block. For this reason post-goal performance on the 'win-stay' task was investigated. Figure 4.4b shows that post-goal performance reveals a very similar pattern to that of the overall performance levels (shown in figure 4.4a), although the rapid learning phase across the first two sessions is more apparent with a more stable plateau phase occurring over the last four sessions of the task, unlike overall performance. Univariate ANOVA found no significant effect of session on post-goal performance ($F_{(5,18)} = 1.91$; $p = 0.143$). This lack of significance is likely due to the more stable plateau phase across the later sessions of the task, where 'win-stay' performance is likely to have been acquired mainly within the first two sessions before plateauing; however, again univariate ANOVA revealed no significant improvement in post-goal performance across the four blocks of session one ($F_{(3,11)} = 1.18$; $p = 0.910$). This is probably due to a similar impact of the shifting goal location across the blocks masking any improvements or learning over the session. The increased interference due to experiencing the goal location shifting to multiple different destinations is likely to reduce confidence in the win-stay

strategy until the rat learns that the goal location is stable for a set period of time before shifting for the next block. This rule seems more difficult to acquire than the simple ‘win-stay’ rule within a block and probably underlies the increased performance levels seen in the second session.

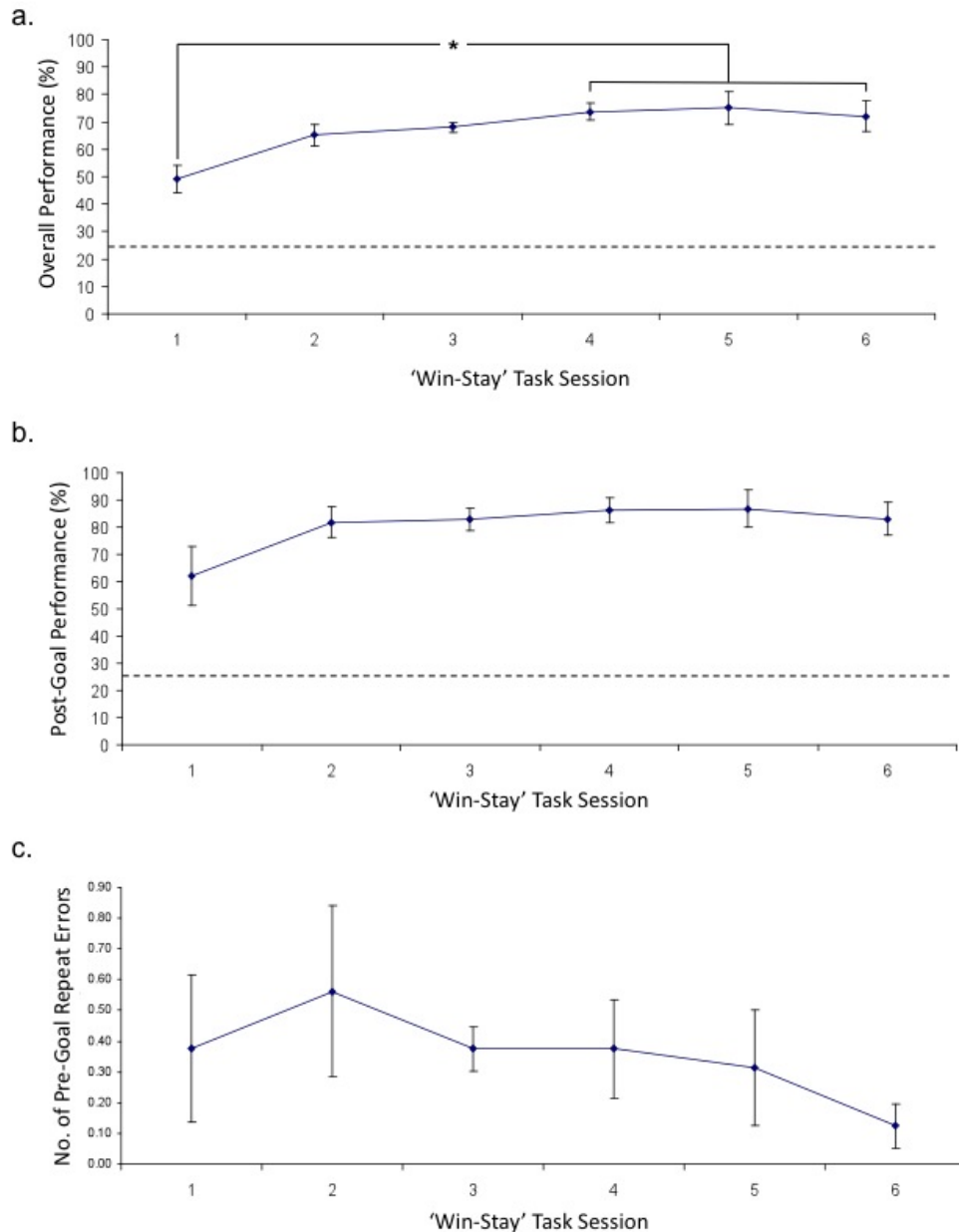

Figure 4.4: The average performance of the rats in the ‘win-stay’ task is presented graphically for: **(a)** overall performance, in which the rapid acquisition of the ‘win-stay’ task is evident, with above chance-level performance (represented by the dashed line) present from the first session and performance levels steadily increasing thereafter before plateauing from the fourth session; **(b)** post-goal performance, in which a similar pattern of performance as seen in the overall analysis is shown but where performance levels plateau earlier, by session two after which they remain stable; and **(c)** the ‘lose-shift’ component of the task, where the number of errors generally decreases over the entire duration of the task, which may explain why the overall performance did not plateau in as stable a manner as post-goal performance. Data is displayed as mean values \pm SEM, (*) $p < 0.05$.

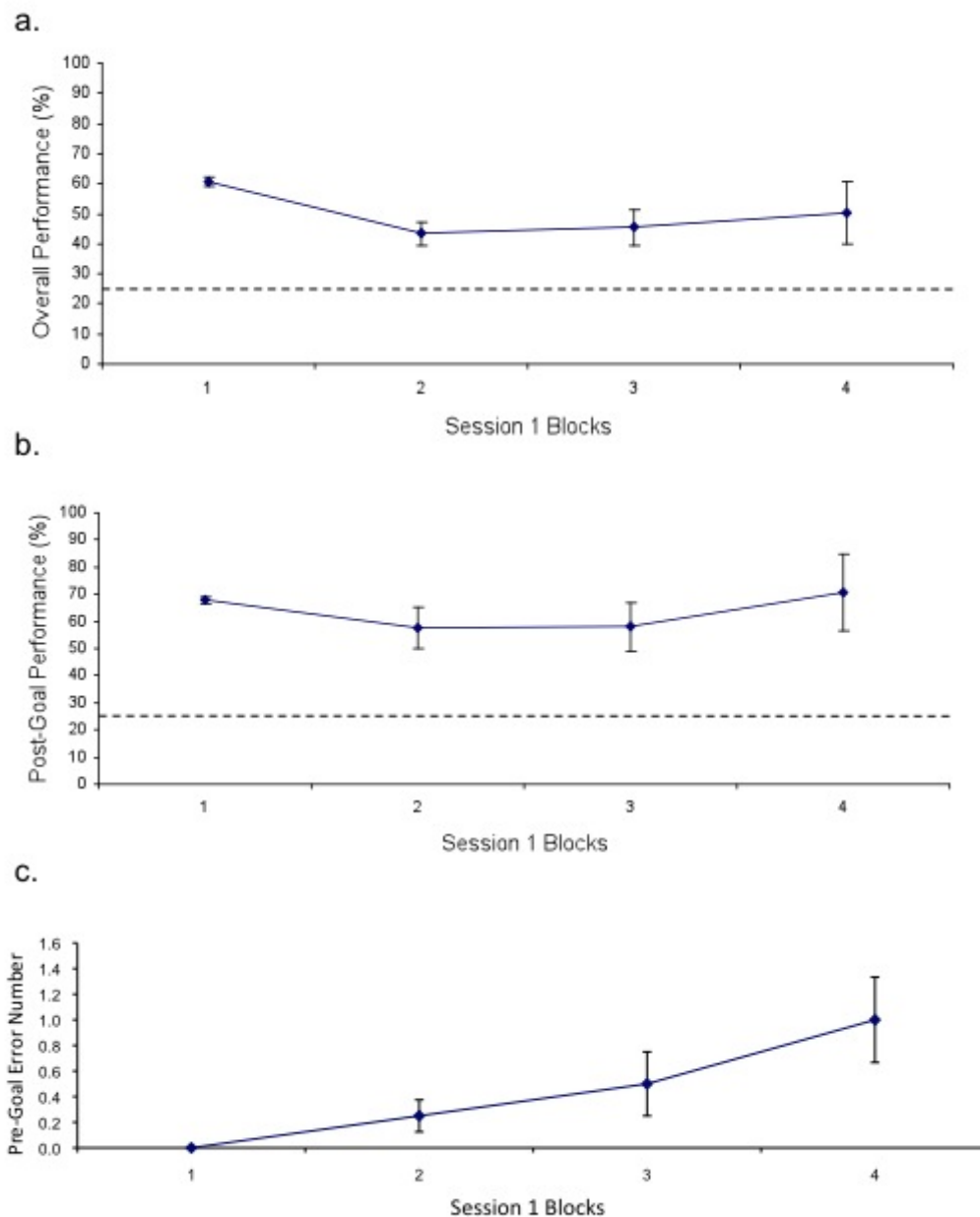

Figure 4.5: Behavioural performance across the four blocks of the first 'win-stay' session. **(a)** Overall performance is plotted and can be seen to be above the level expected by chance (represented by the dashed line) for the whole of the first session, although performance decreases after reward is shifted for the first time to a different goal box. **(b)** Post-goal performance is plotted and although it is clear that post-goal performance levels reduce after the reward location is shifted for the first time, it clearly remains above the level expected by chance (represented by the dashed line) for the whole of the first session and in block four post-goal performance levels start to increase again; however, there is large variation in performance. **(c)** The 'lose-shift' component of the task is plotted, where the number of pre-goal errors can be seen to steadily increase across the four blocks of session one, likely due to the increasing number of previously rewarded goal locations. All data is displayed as mean values \pm SEM.

The rapid improvement in performance is comparable to that reported in chapter 3; however, previously rats' performance was found to improve across the first three sessions, from 45%, before plateauing at approximately 80%, whereas the rats exposed to the 'random' task prior to the 'win-stay' task appeared to learn more rapidly across two days, from approximately 55%, before performance plateaued at a similar level. Performance levels in the first 'win-stay' session of the rats pre-exposed to the double Y-maze (through 'random' task sessions) were very similar to those reported in naïve rats from the second session onwards (see chapter 3, figure 3.4). This may be explained by a reduction in anxiety and the result of learning where the potential goal boxes were located across the 'random' task sessions, which would aid motivation.

Finally, the 'lose-shift' component of the task was assessed by comparing the number of trials in which the rats returned to an un-rewarded goal box at the beginning of each block of trials before the rewarded goal box was identified. A clear reduction in 'lose-shift' errors can be seen in figure 4.4c over sessions two to six, as the number of trials in which the rat repeated the previous error to an unrewarded goal box is dramatically reduced. Univariate ANOVA analysis; however, finds no significant reduction in this number of repeat errors before the rewarded goal box is identified ($F_{(5,18)}=0.58$; $p=0.717$). Furthermore, univariate ANOVA found no significant reduction in the number of repeat errors, before the rewarded goal box was visited, across the four blocks of session one ($F_{(3,11)}=1.18$; $p=3.62$), shown in figure 4.5c. This is likely due to large variation between rats and also the slight increase in the number of repeat errors shown on session two relative to session one.

'Win-Shift' Task

The rats can be seen to rapidly acquire the 'win-shift' task in figure 4.6, with performance (percentage of successful session trials) steadily improving across the first three sessions before plateauing. Analysis with univariate ANOVA found this improvement in performance across sessions to be significant ($F_{(5,18)}=7.07$; $p<0.001$). Bonferroni corrected pair-wise comparisons further revealed that performance was significantly different for session one relative to sessions three, four, five and six ($p<0.05$).

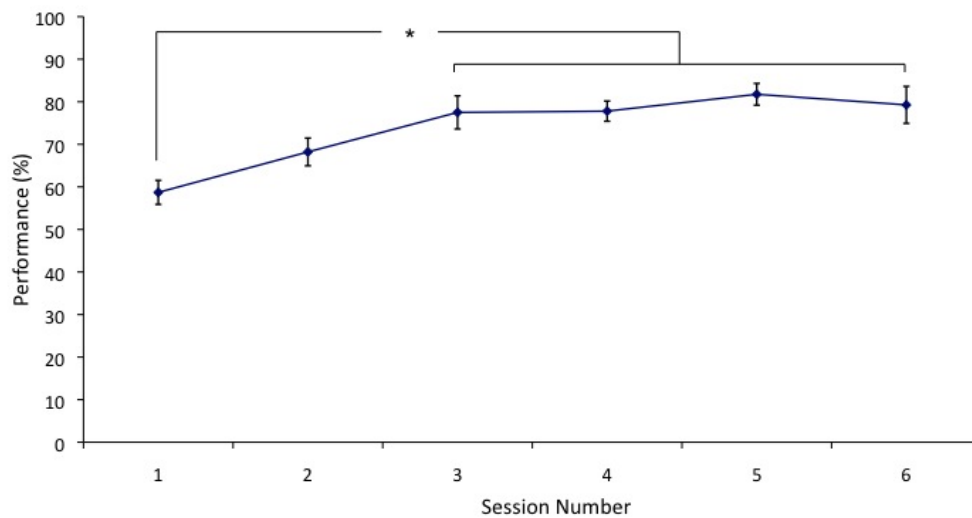

Figure 4.6: Behavioural performance over the 'win-shift' task, where performance is measured as the average percentage of visits to rewarded goal boxes across each session. The rapid learning is evident across the first three sessions, before performance plateaus at approximately 80%. Data is displayed as mean values \pm SEM, (*) $p < 0.05$.

4.3.3 Single-Unit Recording Data

Overall 172 cells fulfilled the place cell inclusion criteria (defined above see section 3.2.8) and were active in at least one of the four areas of interest; of these cells, 48 (30%) displayed goal-sensitive activity (as defined in section 3.2.8). As a number of cells were just below the average peak amplitude threshold, a second set of analysis was performed using the same place cell inclusion criteria with the exception of a less stringent peak amplitude of $60 \mu\text{V}$ being implemented. This resulted in 231 cells being included in the second set of analyses, of which 69 (30%) displayed goal-sensitive activity (as defined in section 3.2.8). Examples of the non-differential and goal-sensitive firing patterns identified in the three tasks can be seen in figure 4.7.

Figure 4.8a shows how the proportion of pyramidal cells demonstrating goal-sensitive firing change over the three types of task, in the larger cohort of pyramidal cells (with a peak amplitude of $60 \mu\text{V}$). Analysis with univariate ANOVA revealed that this difference in the proportion of pyramidal cells demonstrating goal-sensitive firing changed significantly across task type ($F_{(2,13)}=12.04$; $p < 0.001$). Bonferroni corrected pair-wise comparisons confirmed that the proportion of cells with goal-sensitive activity significantly differed in the 'win-stay' task relative to both the 'random' and the 'win-shift' tasks ($p < 0.01$) but that there was no significant difference between the 'random' and the 'win-shift' tasks ($p > 0.5$).

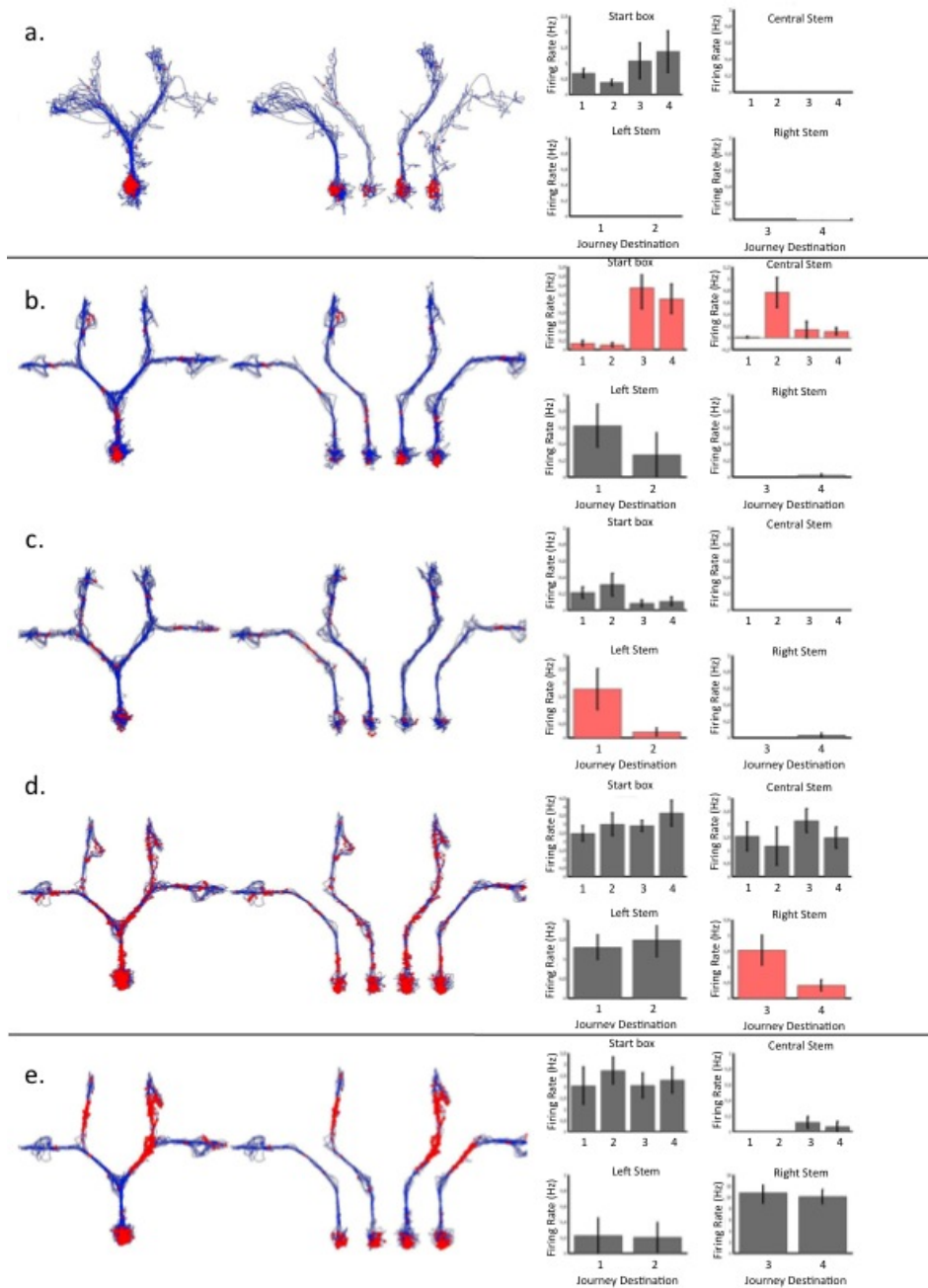

Figure 4.7: Examples of goal-sensitive and non-differential CA1 cell firing patterns identified across task types in the double Y-maze task. The left-hand panel displays the rats trajectory (blue) on all trials within a given session, with the locations at which the cell fired (represented by red dots). Trials to the four different goal boxes are displayed separately in the middle panel. The right panel graphically represents the relationship between mean firing rate (Hz) and journey type (goal destination, 1-4) for the cell and this is plotted in separate graphs for each of the four overlapping areas on the maze. Grey bars represent no significant differences in firing rates across journey type, whereas pink bars are used to indicate significance ($p < 0.05$). **(a)** An example of non-differential firing recorded in the 'random' task, where the cell can be seen to be firing predominantly in the start area regardless of final destination. Examples of the goal-sensitive firing patterns identified in the 'win-stay' task are displayed for: **(b)** a cell demonstrating differential activity in the start area and the central stem, with significantly greater firing in the start arm on journeys to goal boxes 3 and 4, than 1 and 2, and a significantly higher firing rate in the central stem for journeys to goal box 2; **(c)** a cell with differential activity in the left stem with significantly higher firing rates on journeys to goal box 1 relative to goal box 2; and **(d)** a cell with differential activity in the right side of the maze, with significantly higher firing rates for journeys to goal box 3, relative to goal box 4. **(e)** An example of non-differential firing recorded in the 'win-shift' task, where the cell can be seen to be firing predominantly in the start area and right stem of the maze regardless of the final destination.

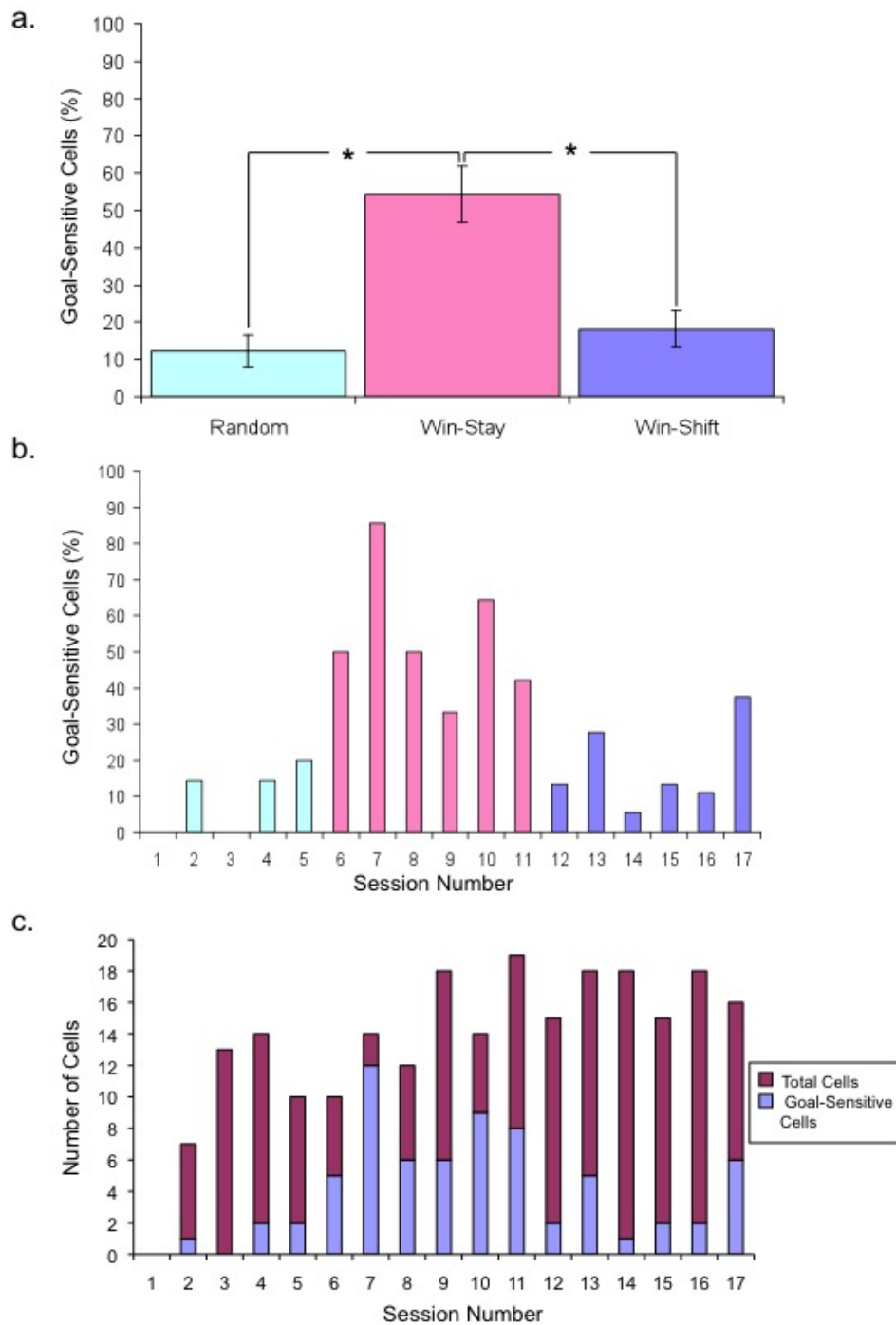

Figure 4.8: A graphical representation of the number of pyramidal cells recorded (with a peak amplitude greater than $60 \mu\text{V}$) with goal-sensitive firing over the three tasks ('random', 'win-stay' and 'win-shift'). **(a)** The percentage of the pyramidal cells recorded which demonstrate goal-sensitive firing is displayed as an average across sessions for each task, with data displayed as mean values \pm SEM. The percentage of goal-sensitive cells significantly increased when the 'win-stay' task was enforced, (*) $p < 0.01$. **(b)** The percentage of the pyramidal cells recorded which demonstrate goal-sensitive firing is displayed for each of the 17 experimental sessions, with the sessions in each of the three tasks, 'random', 'win-stay' and 'win-shift' displayed in blue, pink and lilac respectively. Again, it is clear that the percentage of goal-sensitive cells dramatically increases over 'win-stay' sessions, peaking on the second session of the task. **(c)** The number of the pyramidal cells recorded which demonstrate goal-sensitive firing (lilac) is displayed against the number of pyramidal cells which do not show goal-sensitive firing (plum), for each of the 17 experimental sessions.

The same pattern of results can be seen in figure 4.9, which shows how the proportion of pyramidal cells demonstrating goal-sensitive firing change over the three types of task when the peak amplitude is increased to the more conservative criteria of $80 \mu\text{V}$. Again analysis with univariate ANOVA revealed that the difference in the proportion of pyramidal cells demonstrating goal-sensitive firing significantly changed across task type ($F_{(2,13)}=13.85$; $p<0.001$). The Bonferroni corrected pair-wise comparisons also confirmed that the proportion of cells with goal-sensitive activity significantly differed in the 'win-stay' task relative to both the 'random' and the 'win-shift' tasks ($p<0.01$) but that there was no significant difference between the 'random' and the 'win-shift' tasks ($p>1$).

The overall pattern of results for both the larger cohort of pyramidal cells and the smaller cohort of pyramidal cells recorded using the more conservative peak amplitude threshold were the same, with the proportion of recorded pyramidal cells demonstrating goal-sensitive firing significantly increasing for sessions where the 'win-stay' task protocol was employed. Unfortunately, on the first day of the 'random' task not all the four goal boxes were visited by the rats and thus the cells could not be analysed for goal-sensitive firing as the sampling criteria for analysis was not met. In the following four days of the 'random' task, however, the rats gained sufficient exploration of the four goal boxes and subsequent analysis revealed little or no goal-sensitive activity present ($\approx 7\%$) during the course of this task. The proportion of CA1 cells demonstrating goal-sensitive activity then rapidly increased from the first day that the 'win-stay' protocol was implemented and this significantly higher level ($\approx 55\%$) of goal-sensitive cells was maintained over the duration of 'win-stay' sessions. Once the 'win-shift' task was enforced, the proportion of goal-sensitive cells significantly decreased with approximately 15-20% of CA1 cells showing goal-sensitive firing patterns.

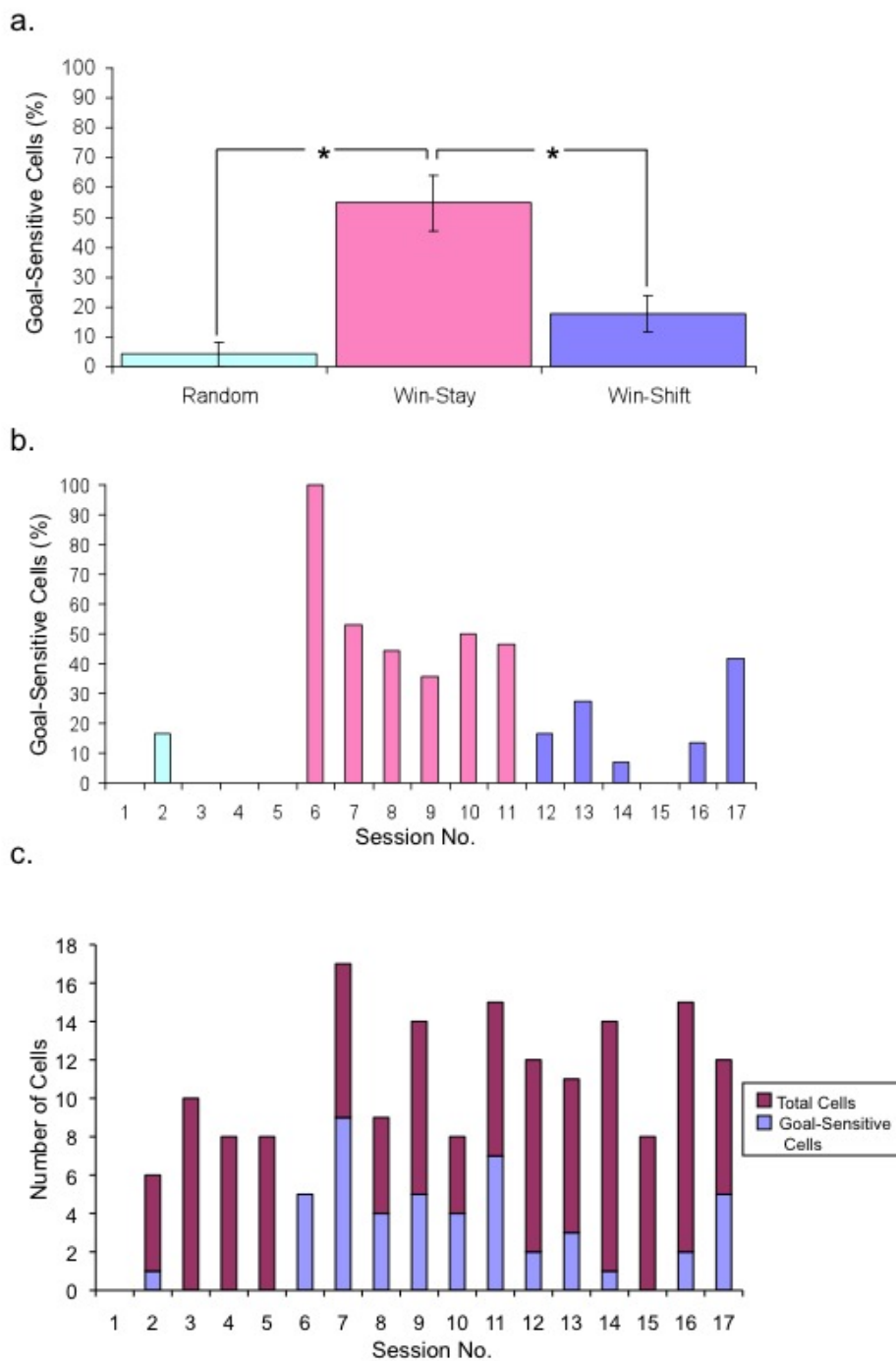

Figure 4.9: A graphical representation of the number of pyramidal cells recorded (with a peak amplitude greater than $80 \mu V$) with goal-sensitive firing over the three tasks ('random', 'win-stay' and 'win-shift'). **(a)** The percentage of the pyramidal cells recorded which demonstrate goal-sensitive firing is displayed as an average across sessions for each task, with data displayed as mean values \pm SEM. The percentage of goal-sensitive cells significantly increases when a 'win-stay' strategy is enforced, (*) $p < 0.01$, and appears to be lowest when only a 'random' strategy is required. **(b)** The percentage of the pyramidal cells recorded which demonstrate goal-sensitive firing is displayed for each of the 17 experimental sessions, with the sessions in each of the three tasks, 'random', 'win-stay' and 'win-shift' displayed in blue, pink and lilac respectively. Again, it is clear that minimal/no goal-sensitive cells were identified in the random task, whereas from the first session of the 'win-stay' task over half the recorded cells were goal-sensitive, peaking in the first session. In the 'win-shift' task the proportion of goal-sensitive cells can be seen to fluctuate at approximately 25%. **(c)** The number of the pyramidal cells recorded which demonstrate goal-sensitive firing (lilac) is displayed against the number of pyramidal cells which do not show goal-sensitive firing (plum), for each of the 17 experimental sessions.

4.3.4 Behavioural Performance and Goal-Sensitive Firing Relationship

In figure 4.10 the proportion of pyramidal cells displaying goal-sensitive firing is plotted with respect to the rats' behavioural performance in the 'win-stay' task. A linear regression revealed a positive linear relationship between behavioural performance and the proportion of pyramidal cells displaying goal-sensitive firing recorded during each session over the six experimental days ($R^2=0.512$; $p<0.01$). The relationship is comparable to that demonstrated across the first six days of the 'win-stay' task in chapter 3 ($R^2=0.501$; $p<0.001$).

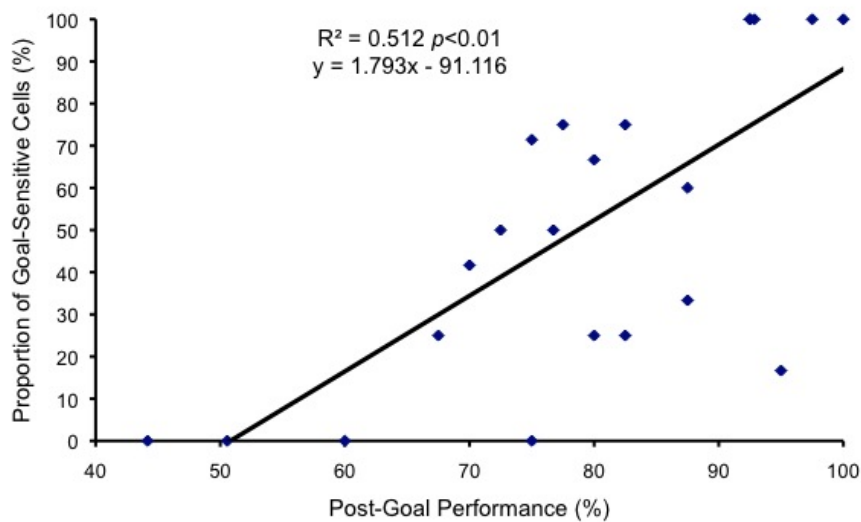

Figure 4.10: The percentage of the individual rats' pyramidal cells showing goal-sensitive firing patterns on each session is plotted against the individual rats' 'win-stay' task performance within the same session, once the rewarded goal box had been identified in each block of trials. Linear regression, used to plot the line of best fit, reveals a significant positive correlation between behavioural performance and the proportion of pyramidal cells demonstrating goal-sensitive firing ($R^2=0.512$; $p<0.01$).

This data therefore supports the finding of the previous chapter that the goal-sensitive firing patterns of CA1 neurons emerge in line with behavioural improvements in the first few days of learning the double Y-maze 'win-stay' task. Furthermore, the sparsity of goal-sensitive firing identified across the five sessions of exploration in the 'random' task suggests that this development of goal-sensitive firing is not merely a consequence of repeated exposure to the double Y-maze, but arises due to the behavioural and mnemonic demands of the 'win-stay' task.

4.4 Conclusions & Discussion

The focus of this chapter was to clarify whether the relationship between spatial ‘win-stay’ task performance and the emergence of goal-sensitive activity, previously reported in chapter 3, was due to increased experience on the maze or a specific result of the cognitive ‘win-stay’ task demands. In order to distinguish these possibilities a ‘random’ task was employed across five sessions enabling rats to become familiar with the spatial lay out of the maze, the possible reward locations and the basic features of the ‘win-stay’ task, such as running from the start box to goal boxes to obtain rewards; however, no specific strategy was enforced and no mnemonic demand was required to gain rewards.

The behaviour of rats in the initial ‘random’ task sessions suggest a tendency to alternate between arms with more random performance found to emerge across the five sessions of the task, during which time little/no goal-sensitive activity was recorded. This is in line with the previous findings that goal-sensitive firing only develops when the hippocampus becomes necessary for successful performance (Smith and Mizumori 2006b). The few cells which did show goal-sensitive firing were possibly due to a self-imposed strategy and/or recall of previous trials; however, this is merely speculative as the task did not impose any such demands nor did it allow any such theory to be tested. Overall, the minimal, fluctuating goal-sensitive firing observed across the five ‘random’ sessions does not explain the rapid emergence of goal-sensitive firing previously recorded over the first three sessions of the ‘win-stay’ task, despite similar behaviour being enforced, with direct trajectories, latencies and trial number comparable across the tasks. These results suggest that the development of the differential firing patterns is not merely due to greater exploration and experience in the maze.

In the ‘win-stay’ task behavioural performance rapidly improved, with above chance performance present from the first session. The pattern of behavioural results obtained are comparable to performance levels previously reported from session two onwards in chapter 3, indicating that the experience in the ‘random’ task accelerated the learning of the ‘win-stay’ task, probably due enhanced incentive provided by the learning of the possible reward locations and a reduction in anxiety levels resulting from an increased familiarisation with the maze. Interestingly, the ‘lose-shift’ element of task performance took longer to acquire, with the number of pre-goal errors steadily decreasing over the six session task period. Consistent with previous reports (Ainge et al. 2007a; Ferbinteanu and Shapiro 2003; Smith and Mizumori 2006b) and the results obtained in chapter 3, goal-sensitive activity was identified in CA1 cells across the ‘win-stay’ task, with a rapid emergence apparent over the first two sessions, in which the majority of learning appeared to take place, settling to approximately 50% thereafter, comparable to the level of goal-sensitive cells previously obtained in chapter 3, when levels plateaued over sessions 3-6. This significant increase in the emergence of goal-sensitive firing which developed when the spatial ‘win-stay’ strategy was enforced, suggests that it is specifically related to the learning, planning and memory

processes required for successful performance based on the spatial ‘win-stay’ task contingencies and the rats’ recent within-block behaviour, as in the ‘random’ task, which involves no cognitive demands, very little or no goal-sensitive activity was identified.

The win-shift task was also quickly learned, with performance levels steadily increasing over the first three sessions before plateauing at approximately 80%. Goal-sensitive firing of CA1 cells was observed across the ‘win-shift’ task in accordance with previous reports from other alternation tasks (Frank et al. 2000; Wood et al. 2000); however, the level of goal-sensitive cells was significantly lower than in the ‘win-stay’ task and varied over the sessions in a behaviourally uncorrelated manner. These results are surprising, as given the critical role the hippocampus has been shown to have in delayed spatial alternation tasks such as this (Aggleton et al. 1986; Ainge et al. 2007b; Dudchenko et al. 2000; Karlsson and Frank 2008; Olton and Papas 1979), one would expect a similar level of goal-sensitive firing to be apparent as in the ‘win-stay’ task and/or to reflect behavioural performance in the task. It is possible that the results obtained are due to interference from the previous tasks. This could be tested by repeating the current study but where the order of the tasks presented were reversed such that the ‘win-stay’ task would follow the ‘win-shift’ task. An alternative explanation of the results is that the increased experience on the maze resulted in a shift in activity from more prospective to more retrospective firing, which has previously been documented to occur as a consequence of greater spatial learning and exploration (Ji and Wilson 2008). If greater experience on the maze does lead to a shift towards more retrospective firing then this would not be detectable in the ‘win-stay’ task, as the previously visited goal box and the intended destination are usually the same. In the ‘win-shift’ task, however, the location visited in the preceding trial and the current intended destination should be different. Thus, if the rat is recalling its previous location and planning its next journey, as would be expected based on previous studies which have recorded retrospective and prospective firing patterns simultaneously (Ferbinteanu and Shapiro 2003; Frank et al. 2000; Ji and Wilson 2008), then the firing patterns of the two different locations would obscure the detection of goal-sensitive cells and would likewise prevent the detection of ‘preceding goal-sensitive’ cells from being identified. This is not a problem in other alternation tasks where differential firing patterns have been observed, such as that described by (Wood et al. 2000), where both the intended goal of the current trial and the preceding goal location visited remain paired throughout the task, therefore it would not affect the differential activity patterns whether prospective, retrospective or a combination of both types of firing were being employed. If the differential firing patterns are based on the final destination of the current/previous journey, as opposed to the trajectory, then the development of differential firing patterns during alternation behaviour in a maze with multiple locations could be tested for by maintaining the same goal location but requiring the rats to locate the pre-defined start box, which alternated in a pre-set sequence, after consuming the reward in the goal box.

The collection of results reported herein suggest that the behaviourally correlated goal-sensitive

activity reported previously in chapter 3 is not merely the consequence of repeated exposure to the double Y-maze, as in the ‘random’ task few/no goal-sensitive cells were identified over five sessions of maze exploration, but arises due to the behavioural and mnemonic demands of the ‘win-stay’ task, as the goal-sensitive firing only emerged when the task-related reward contingencies were enforced. As CA1 is thought to play an important role in the process of pattern separation (for discussion see introduction section 0.2.2 and chapter 1) and as it is logical for the neural firing of a region to relate to its main function, a plausible role of this goal-sensitive activity could be to allow similar trials to be distinguished, which would importantly prevent the interference between highly similar trials where only one of the event features changes (presence of reward (‘what’), goal box visited (‘where’) and whether the trial occurred in the present block (‘when’)).

It is important to emphasise that one of the limitations of single-unit recording studies, such as this, is that the results obtained are only correlational, not causative, therefore although it seems unlikely given the hypothesised roles of the hippocampus in learning and memory, it is conceivable that the patterns of activity recorded in the hippocampus, which correlate with behavioural performance, may not be processed in the hippocampus at all but may merely reflect neural processes elsewhere. In addition even if the neural correlates of behaviour do reflect hippocampal processes necessary for task performance, they may not necessarily be generated within the hippocampal circuit but may reflect task-related information received from extra-hippocampal structures. Indeed, behavioural performance has been found to be affected by the concurrent activity of multiple memory systems (McDonald and Hong 2004; McDonald et al. 2004; White and McDonald 2002) and so whilst a correlation between the neural activity in the hippocampus and behavioural performance has been reported in the current and previous chapter, this activity is unlikely to be independently supporting the rats’ behavioural performance. A further complication in the analysis of the current data is that the necessity of the goal-sensitive firing to behavioural performance is unclear. It is quite possible that the hippocampus could automatically encode experiences which have the potential to be used where necessary to guide behaviour but are not critical for successful performance (Yeshenko et al. 2004), a theory which would explain why goal-sensitive firing has been shown in tasks known not to require the hippocampus (Ainge et al. 2007b; Bower et al. 2005). The necessity of the goal-sensitive firing identified in this study can be assessed by testing the learning of hippocampal-lesioned rats, relative to controls, in the current ‘win-stay’ task (see chapter 5).

The hippocampus plays an important role in many facets of our lives, enabling us to access and relive a lifetime of personal experiences, successfully navigate around our environments and imagine and plan for our future. The on-line monitoring of hippocampal cells during tasks such as this provides a powerful insight into the neural circuitry which gives rise to these cognitive functions; however, as discussed in the current and previous chapter, convincingly relating these firing patterns to behaviour remains a formidable challenge. The present results add further support

to the theory that the goal-sensitive firing properties of CA1 pyramidal neurons are specifically related to the mnemonic demands of a spatial task and are not merely a consequence of increased exploration of the maze. Thus, the data reported in the current and previous chapter provide further insight into the neural activity thought to support the process in which decision making, based on the retrieval of previous trials within the block, is used to guide behaviour through the implementation of the necessary motor programmes, based on the anticipation of future events.

Chapter 5

The Role of the Hippocampus across Double Y-Maze Paradigms

5.1 Introduction

In the previous two chapters (chapters 3 and 4) goal-dependent firing was reported to occur in hippocampal place cells during the learning phase of a ‘win-stay’ task in the double Y-maze. This development in the proportion of goal-dependent firing was not merely reflective of experience in the maze nor did it arise as a result of running different routes through the maze to obtain rewards; instead, it appears to be specifically related to the learning and subsequent performance of a spatial ‘win-stay’ task. The results obtained in the previous two chapters are only correlational however, and thus the significance of the neural correlates to the learning and memory demands of the task remain unclear. In order to determine whether the neuronal firing patterns of the hippocampal place cells are necessary for behavioural performance in the double Y-maze task, the current chapter explores the effects of hippocampal lesions on task performance.

Hippocampal lesions/inactivations provide a complimentary approach to the single-unit recording technique, enabling the necessity of the task-relevant firing patterns, identified in ‘normal’ behaving rats, to be examined. This information is essential in determining the function of these behavioural neural correlates and progresses our understanding of the possible networks underlying these behaviours. As discussed previously in chapter 3, the presence of task-relevant differential activity in hippocampal neurons does not necessarily imply that the task is hippocampal-dependent. Previously, performance in both win-shift (Ainge et al. 2007b) and win-stay tasks (Ainge et al. 2007a; Packard et al. 1989), in which differential firing patterns have been reported (Ainge et al. 2007a,b; Wood et al. 2000), was not found to be impaired by hippocampal lesions. Pertinently, the type of spatial ‘win-stay’ performance reported in the previous two chapters was not found to depend upon intact hippocampal circuitry, when bilateral hippocampal lesions were performed following training to criterion (Ainge et al. 2007a). This somewhat surprising finding

may suggest that the goal-sensitive neural coding reported does not support task performance, although the inevitable questions then arise as to why it develops in line with behaviour and what its purpose is. More perplexing perhaps is the fact that hippocampal lesions have resulted in impairments to both spatial win-shift performance (Ainge et al. 2007b; Becker et al. 1980; Higgs et al. 2001; Kim and Frank 2009; Olton and Feustle 1981; Packard et al. 1989) and win-stay performance (Ferbinteanu and Shapiro 2003; Kesner et al. 1993; Smith and Mizumori 2006b) in similar tasks in which differential activity had also been observed. These contradictory results are likely due to differences in experimental protocols and settings employed in the tasks.

The lack of impairment resulting from hippocampal lesions in tasks in which differential firing patterns have been observed may arise as a result of a number of different factors. Firstly, in behavioural testing there are normally multiple ways in which a task can be completed. It appears that there are parallel spatial learning processes, one based on the flexible integration of contextual cues to provide an allocentric representation of space, thought to be dependent upon the hippocampal system (Morris et al. 1982; Tsien et al. 1996b) and another inflexible, response-based egocentric strategy dependent upon the neostriatum (Cook and Kesner 1988; Packard and Knowlton 2002; Yin and Knowlton 2006). Disruption of either structure has been shown to result in compensatory action of the intact system, where possible (Packard and Knowlton 2002). These results suggest that the task may not necessarily be hippocampal dependent, i.e. other structures or strategies may be recruited in the absence of the hippocampus. The dual processes underlying spatial performance have also been reported in human studies, where patients with hippocampal damage were found to be impaired in allocentric spatial learning but are able to learn striatal-dependent procedural skills (Eldridge et al. 2002; Knowlton et al. 1996). Furthermore, imaging studies in humans have revealed an inverse relationship between hippocampal and striatal activation during spatial learning tasks (Hartley et al. 2003; Poldrack et al. 2001). The two strategies appear to act in competition, where disruption of the striatal system impairs cued learning but enhances spatial learning, whilst hippocampal lesions impair spatial learning but enhance non-spatial cued learning (Lee 2008).

An important feature of the study by Ainge et al. (2007a) is that the rats were trained on the 'win-stay' task prior to surgery, where they were required to reach a criterion of 90% correct for the final six trials of the first block for two consecutive days. Previous studies have found that if unenforced, rats primarily adopt a spatial strategy to solve the task but after repeated training a more stereotyped cue-response strategy develops and starts to dominate (Devan and White 1999; Packard and McGaugh 1996). In the study conducted by Smith and Mizumori (2006b), described previously in chapter 4, the goal-sensitive firing observed was shown to depend on the hippocampus, where temporal inactivations of the dorsal hippocampus resulted in repetitive behavioural strategies, supporting previous reports that the loss of hippocampal processing leads to procedural strategies being adopted (Buckmaster et al. 2004; Bunsey and Eichenbaum 1996; Eichenbaum

et al. 1990; Whishaw and Tomie 1997). Furthermore, hippocampal lesions (performed prior to task training) were found to significantly impair the learning phase of a spatial alternation task in the W-maze (Kim and Frank 2009), a task in which differential hippocampal activity had previously been reported (Frank et al. 2000), as rats ran pre-set arm alternation sequences, 'left-central-right-central-left', to receive rewards, obtained at the end of each arm. Half of the hippocampal-lesioned rats were however, able to learn the task by the end of the 10-day study (with task acquisition ranging from 6-9 days), suggesting that extra-hippocampal regions can support performance, although the extra-hippocampal learning of these lesioned rats was retarded relative to controls (Kim and Frank 2009). Therefore, even when the hippocampus is required for learning, given sufficient experience of the maze and task, other brain areas may be able to support learning and fluent performance. The authors suggest, based on previous studies of compensation over similar time-scales of slower learning (Packard and McGaugh 1996), that performance of the hippocampal-lesioned rats in this study is likely to be mediated by a basal ganglia-dependent strategy. Overall, these results are suggestive of a functional role for the differential task-relevant activity in the rapid acquisition of this spatial alternation task but imply that it is not essential for subsequent performance. Indeed overtraining has been shown to shift rats preference from a hippocampal- to a striatal-dependent strategy, involved in stimulus-response learning (Packard and McGaugh 1996). Similar results have arisen in different studies, such as that by Jarrard et al. (2004), where hippocampal lesioned rats were impaired in rapidly learning to switch responses from previously visited and reinforced arms in a non-spatial water maze task but, as with the study by Kim and Frank (2009), performance rose to control levels with further training. This may explain why (Ainge et al. 2007a) found that the performance of rats which were trained to criterion prior to surgery was not impaired by hippocampal lesions in a task in which differential hippocampal firing patterns had been previously observed, as by the time of surgery performance may have become independent of the hippocampus. The fact that the task relevant patterns of hippocampal activity can be identified beyond the time frame of hippocampal-dependence of task performance may occur as the alteration in system dominance over time does not represent a loss of the hippocampal-mediated strategy, as this re-emerges upon striatal system disruption (Packard and McGaugh 1996). Thus, the firing patterns would still be present but may not be necessary for performance if the striatal system can support performance.

It therefore seems that the hippocampus may be necessary for the rapid acquisition of these tasks but that performance can be mediated by extra-hippocampal structures in the absence of hippocampal processing, either when lesions are performed after training to criterion (hippocampal processing available throughout the learning process) or when lesions are performed prior to surgery, if training occurs over a sufficiently long period for the slower extra-hippocampal learning processes to acquire the task to support performance (where retarded learning is observed if the hippocampus is not present during the learning process). The dorsal-striatal strategy can, however,

only support performance in tasks that can be simply solved by developing a conditioned response, for example to a cued location in order to navigate to a reward, rather than requiring memory of recent behaviour or allocentric processing; furthermore in these simple tasks hippocampal lesions have been found to actually enhance performance (McDonald and White 1993; Packard et al. 1989). The hippocampus (but not the dorsal striatum) becomes necessary for complex versions of win-stay tasks which require allocentric processing, and in win-shift tasks which require spatial alternation based upon memory of the previously visited arms (Becker et al. 1980; McDonald and White 1993). For example, the alternation task in the continuous T-maze (win-shift performance) only becomes hippocampal-dependent when a 10-second delay is introduced between laps (Ainge et al. 2007b), as this time delay is likely to disrupt the egocentric strategy from being employed and in the absence of the hippocampus the allocentric strategy is not available, thus resulting in a specific impairment in performance of the hippocampal-lesioned rats, relative to controls, only when the time delay is imposed.

In contrast to the double Y-maze study reported by Ainge et al. (2007a), performance of a similar win-stay task in the plus maze was shown to be impaired by fornix lesions (Ferbinteanu and Shapiro 2003). In this win-stay task, differential firing of hippocampal cells was identified whilst the rats ran from either the north or the south arm to either the east or west arm, with rewards obtained for demonstrating win-stay behaviour within a block of trials, to one of the east or west sides (Ferbinteanu and Shapiro 2003). The complete bilateral hippocampal lesions performed on well-trained rats in the study by Ainge et al. (2007a) did not, however, impair overall performance in the 'win-stay' double Y-maze task, but did induce a significant impairment specifically in the ability to switch to find the new goal box at the beginning of a new block of trials, i.e. in the 'lose-shift' element. It seems likely therefore that the lesioned rats in the study by Ainge et al. (2007a) were able to employ a stereotyped motor sequence (procedural strategy) which could be executed to obtain rewards within a current block, supporting the purely win-stay aspect of the task, which, as discussed, would not require hippocampal processing as performance could be mediated by the striatum (McDonald and White 1994; Packard and Knowlton 2002). The main difference between these two tasks was the fact that in the plus maze the starting arm was changed in a pseudo-random fashion within each block of trials to enforce the use of a place-based (allocentric) strategy. This suggests that the lack of impairment found in the double Y-maze task may be due to the rats adopting a body-turn strategy to find the food from the fixed start location, such that an egocentric representation of the environment would suffice to support behavioural performance, especially as in the absence of hippocampal processing rats have an enhanced preference to adopt an egocentric strategy (Packard and McGaugh 1996; Smith and Mizumori 2006b). Intra- and extra-maze cues were, however, used in the double Y-maze study and there was a delay between trials, which, as discussed, can be a critical factor as to whether the task is dependent on the hippocampus (Ainge et al. 2007b; Hampson et al. 1999a), and rats were removed from the maze and replaced into the

start box at the start each trial, which should all encourage the use of allocentric space, although this was not enforced. The lack of impairment resulting from the post-training hippocampal lesions in the within block win-stay performance in this task indicates that an extra-hippocampal procedural strategy was sufficient to support performance. As the procedural strategy is acquired over a longer period than the hippocampal-dependent strategy, exploration of the effects of hippocampal lesions in the learning phase of this task may further elucidate the precise role of the hippocampus in 'normal' double Y-maze task performance, and consequentially the role of the goal-sensitive firing patterns of the hippocampal neurons, reported to emerge in line with learning in the previous chapters.

Despite the lack of impairment in overall 'win-stay' performance following post-training bilateral hippocampal lesions in the previous study by Ainge et al. (2007a), the hippocampal-lesioned rats were found to be significantly impaired, relative to controls, when just the second block of trials were examined, after the reward location had been switched. Lesioned rats were retarded in the ability to shift goal arms to the newly baited arm at the start of each block (Ainge et al. 2007a). This 'lose-shift' element of the task, unlike the 'win-stay' component cannot be solved by a non-spatial procedural strategy, as it requires information regarding which arms have been previously visited, whether the goal box contained food and how long ago this was (whether it was within the same block/session) in order to successfully navigate to the rewarded goal box in the least number of trials as possible. This element of the task is therefore likely to require hippocampal-dependent processing which may explain why this component alone was impaired in the hippocampal-lesioned rats. In addition, Kim and Frank (2009) suggest that the impairments in performance of the hippocampal-lesioned rats in the W-maze task early in training were due to an increase in perseverative errors, in a similar manner to those observed in the study by Ainge et al. (2007a). These results support previous reports that the hippocampus is necessary for the suppression of conditioned behavioural responses when reward location is shifted (Ainge et al. 2007a; Chan et al. 2001; Jarrard et al. 2004; Schmelzeis and Mittleman 1996; Whishaw and Tomie 1997), an important component of the double Y-maze task.

The results obtained in the previous two chapters have revealed that goal-sensitive firing of hippocampal neurons develop in line with behavioural performance and are specifically related to the learning and memory demands of the 'win-stay' task; however, the interpretation of these results is complicated by previous findings that the hippocampus is not necessary for overall fluent performance (Ainge et al. 2007a). A number of possible reasons for this somewhat surprising finding has been discussed, where it appears that any role the hippocampus plays in the acquisition of the task would have been masked by performing lesions only after rats had been trained to criterion. Thus, to further examine the contribution of the goal-sensitive hippocampal activity, reported in chapters 3 and 4, to task performance and the learning and memory functions of the hippocampus, a lesion study using a similar double Y-maze protocol to that employed in the previous two

chapters, was conducted in which the hippocampus was lesioned prior to any training on the maze, enabling the role of the hippocampus to be explored across the learning phase of this task. If the goal-sensitive firing of the hippocampal neurons is necessary for the acquisition of 'win-stay' task performance on the double Y-maze, then one would expect that hippocampal-lesioned rats' performance would be significantly impaired relative to controls. If the neural firing relates purely to the rapid learning of the task, which can also be mediated extra-hippocampally by the striatal system for example, then one would expect that only the learning phase of the task would be retarded but given sufficient training the lesioned rats should acquire a comparable level of performance as controls. Finally, if the hippocampal firing is not necessary for either learning or to support fluent performance on the task then one would expect no difference in performance levels between the hippocampal-lesioned rats and the controls throughout the duration of the task. Thus, the aim of the current chapter is to further elucidate the functional role of these neural correlates by assessing the hippocampus' contribution to the acquisition and subsequent fluent performance of the spatial 'win-stay' double Y-maze task.

5.2 Materials & Methods

5.2.1 Subjects

The subjects were sixteen male adult Lister-Hooded rats, weighing 250-350 g at the time of surgery. Rats were kept on a 12 hour light/dark cycle, with all experiments conducted during the light phase of the cycle. Throughout behavioural testing, rats were given *ad libitum* access to water and were food restricted to maintain 85-90% of their free-feeding bodyweight two weeks following surgery, by which time rats had surpassed their pre-surgery weights. All procedures were performed in compliance with national (Animals [Scientific Procedures] Act, 1986) and international (European Communities Council Directive of 24 November 1986 [86/609/EEC]) legislation governing the maintenance of laboratory animals and their use in scientific experiments.

5.2.2 Lesion Surgery

Surgery was performed on all rats, where ten received bilateral hippocampal lesions and six received sham surgery. The rats were randomly assigned to these surgical groups and were housed in group cages, containing a mixture of surgical groups within the cage. All behavioural testing was conducted with the experimenter blind to these surgical groups.

Prior to surgery, rats were anaesthetised with isoflurane (Abbott Laboratories Ltd.), placed on an isothermal heating pad and positioned into a stereotaxic frame (Kopf, CA). Craniotomy was performed to expose the dura above the hippocampus, bilaterally. Small focal injections of the axon sparing neurotoxin ibotenic acid hydrate (Biotechnology, CA), dissolved in phosphate buffered saline (pH 7.4) at 10 mg/ml, were used for all lesions, as previously described (Ainge

et al. 2006). For the hippocampal lesion surgeries, a 25 Ga, bevelled, 1 μl syringe (SGE, UK) was used to inject ibotenic acid manually (0.1 $\mu\text{l}/\text{min}$) at the specified coordinate sites, reported in table 5.1, 30 seconds after lowering the syringe. The syringe remained in place for one minute after infusion, to allow time for the proper diffusion of the acid, before being gradually raised. For sham surgeries a 23 Ga needle was used to penetrate the dura, causing mechanical damage comparable to that induced by the syringe in the lesion surgery.

AP (-)	ML (+/-)	DV(-)	μL
2.40	1.0	3.0	0.05
3.00	3.0	2.7	0.10
3.00	1.4	2.1	0.05
3.00	1.4	2.9	0.05
4.00	3.7	2.7	0.05
4.00	2.6	1.8	0.05
4.00	2.6	2.8	0.05
4.30	4.0	7.0	0.05
4.90	3.9	3.5	0.05
4.90	3.9	7.0	0.10
5.90	5.1	4.5	0.08
5.90	5.1	5.3	0.08
5.90	4.3	3.9	0.10

Table 5.1: Stereotaxic coordinate sites of ibotenic acid infusions for complete bilateral hippocampal lesions. The infusion sites were calculated using the values indicated for distance along the anterior-posterior (AP) and medial-lateral (ML) axis, from bregma, and the dorsal-ventral (DV) axis coordinates, from dura, in the appropriate direction (symbolised by +/-). The volumes of ibotenic acid infused at each site are stated in the column headed ' μL '.

Once all injections were completed, or the dura had been pierced for sham surgeries, gelatin sponge (Johnson & Johnson, UK) was applied to areas in which the bone had been removed, skin was sutured and a subcutaneous injection of analgesic (Small Animal Rimadyl, Pfizer, UK) in 5 ml saline was administered. Rats were then returned to their heated home cages for recovery. All rats received at least two weeks recovery time prior to experimentation, during which they were regularly handled and their weights were monitored.

5.2.3 Behavioural Testing

The same double Y-maze to that described previously (in section 3.2.5) was used for each task in this experiment (see figure 5.1 for the experimental schedule). A similar protocol as described in chapter 4, section 4.2.4, was implemented, to allow comparisons across the experiments; however, a few alterations in the protocol were necessary for this experiment and these are described in the following sections.

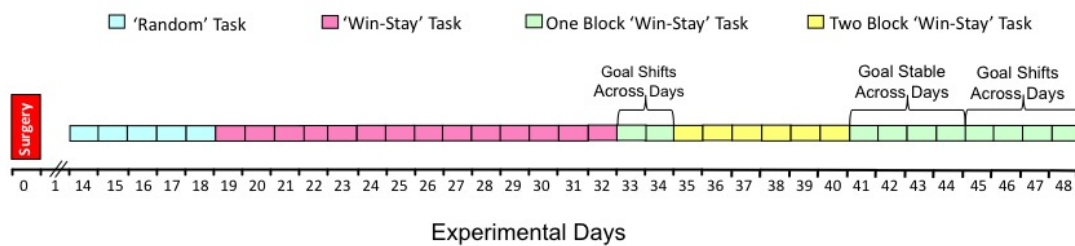

Figure 5.1: The experimental schedule from surgery until the end of behavioural testing, with each session represented by a block, the colour of which refers to the task type: 'random', 'win-stay' or the variations of the 'win-stay' task - one block 'win-stay' and two block 'win-stay'. The one block 'win-stay' tasks are further labelled as to whether the goal location shifted (experimental days 33-34 and 45-48) or remained stable (experimental days 41-44) across sessions.

'Random' Task Protocol

At the start of each session all four ceramic bowls, located in the four possible goal boxes, were filled with chocolate Weetos (Chocolate Weetos, Weetabix, Kettering, UK), cut into quarters, such that the quantity in each goal box exceeded the amount that could be consumed in any one session. The rat was removed from its home cage and placed into a holding bucket (diameter: 30 cm, height: 31 cm), containing 2 cm of sawdust and carried through to the experiment room. The rat was then removed from the holding bucket and placed into the start box, where a black-painted wooden barrier ensured that the rat remained in the start box for 10 seconds, whilst the maze was wiped clean with warm soapy water. The barrier was then removed and the rat was free to run to any of the four goal boxes, although the barrier was used when necessary to ensure rats did not retrace their steps during a trial. Once the rat entered a goal arm the barrier was placed behind the rat, blocking the rat in the chosen goal box for 10 seconds, during which time the rat was free to eat the rewards. The rat was then placed back into the start box with the barrier in place for 10 seconds, where again the maze was wiped clean with warm soapy water to mask any odour cues along the trajectory. The barrier was then removed and the next trial ensued, following the same protocol. Each session consisted of one block of 40 trials (or until the 60-minute time limit was reached); following the last trial of the session the rat was placed back into the holding bucket and

returned to its home cage.

This protocol was run for at least five sessions for each rat, in which the rat was required to have completed all 40 trials in at least three of these sessions, with no more than one session occurring in a 24-hour period.

'Win-Stay' Task Protocol

In this task only one of the four goal boxes was rewarded at any given time, with the remaining three ceramic bowls containing just a scattering of powdered reward to control for odour. The ceramic bowl in the rewarded goal box was filled with chocolate Weetos (Chocolate Weetos, Weetabix, Kettering, UK), which were cut into quarters. A session involved four blocks of trials with a different goal box being baited for each block in a pseudo-random order, such that each goal box was baited once during each session, with no more than one session conducted per day for any given rat. For each session, the rat was removed from its home cage and transferred to the experiment room in the holding bucket. The rat was then removed from the holding bucket and placed into the start box, with the barrier in place, for a 10-second period, in which the maze was wiped clean with warm soapy water. The barrier was then removed and the rat was free to run to any of the four goal boxes, although the barrier was used when necessary to ensure that rats did not retrace their steps during a trial. Once the rat entered the goal arm, the barrier was placed behind the rat, blocking the rat in the chosen goal box for 10 seconds, during which the rat was free to eat the rewards if the correct goal box was identified. After this period, the rat was placed back into the start box for a further 10 seconds, whilst the maze was wiped clean with warm soapy water masking any odour cues along the trajectory, before the rat was released for the next trial. Once the rewarded goal arm had been visited during a block of trials, a further nine trials were run before the rewarded goal location was switched, in a pseudo-random fashion. This marked the start of the next block of trials. Following the last trial of the session the rat was placed back into the holding bucket and returned to its home cage.

This protocol, which involves both a win-stay (following goal-identification, within a block of trials) and a lose-shift (prior to goal box identification, at the start of each block) element, was implemented on 14 consecutive sessions.

One Block 'Win-Stay' Task Protocol

This task was conducted as described above for the 'win-stay' protocol, but as opposed to each session consisting of four blocks of 'win-stay' trials, this task required only 40 trials to be run in any given session with the rewarded goal box location remaining constant. The task was either conducted with the rewarded goal box shifting location across sessions or with the location of the rewarded goal-box being maintained across sessions, for any given rat (see figure 5.1 for the order and number of sessions of each task type). The goal box to be rewarded was pseudo-randomly

assigned, such that the goal boxes were evenly rewarded across rats within the surgical groups. These tasks enabled the ability to perform purely based on a win-stay strategy to be tested across experimental groups and allowed any interference between rewarded locations across sessions to be assessed.

Two Block 'Win-Stay' Task Protocol

This task was carried out as described above for the 'win-stay' protocol, but as opposed to each session containing four blocks of 'win-stay' trials, this task required two blocks of 20 trials to be completed in any given session, with the goal box switching locations after the first 20 trials regardless of behaviour. Again, for any given rat, the rewarded goal box pseudo-randomly shifted across blocks and across sessions, such that for each of the four goal boxes were evenly rewarded across the six sessions. Additionally, the assignment of the rewarded goal box ensured that each rewarded location was evenly represented across rats within the surgical groups on each experimental day. This protocol was conducted to assess whether the hippocampus is necessary to perform a basic serial reversal task where the rewarded location shifts only once in any given session.

5.2.4 Histological Procedures

The histological procedures used in this task were identical to that described in section 1.2.5. A video camera (Leica) mounted on a microscope (Wild M420, Switzerland) was used to collect images of the sections obtained. These were subsequently analysed using ImageJ (NIH), in which the lengths of the hippocampal cell layers were measured. Sections from sham-operated rats were used to provide a mean value of 100% sparing for the hippocampal region, enabling the percentage sparing of hippocampal tissue in the lesioned rats to be calculated, as a proportion of the intact brains.

5.2.5 Data Analysis

Behaviour in the 'random' task was assessed by determining whether the rats were performing based on a win-stay, a win-shift or a genuinely random strategy. Thus, the number of trials in which the rat returned to the goal box visited on the preceding trial ('repeat' trials) and the number of trials in which the rat entered a different goal box to that visited on the preceding trial ('shift' trials) were calculated for each rat in each session. In order to determine whether the proportion of 'repeat' trials for each experimental group varied across the sessions, a repeated-measures ANOVA was performed with Bonferroni corrections for multiple analysis.

The behavioural strategies employed over the five sessions were additionally tested by determining the average number of trials that each rat took to complete a 'win-shift' block, where a

‘win-shift’ block required each of the four goal boxes to be visited at least once. If a random strategy is employed then the rat should enter a previously unvisited arm on the first trial by definition, on the next trial only three of the four arms remain unvisited so rats should take on average 1.33 trials to enter an unvisited arm, leaving only half the arms unvisited, thus the rat is likely to take 2 trials to locate one of these and therefore as only one unvisited arm remains, the number of trials taken to randomly enter this would be 4. These summate to a value of 8.33, providing the average number of trials one would expect the rats to take to visit all four goal boxes based on chance alone. If an alternating strategy is employed then the rat will visit an unvisited arm on its first trial, on the second trial the rat should visit an unvisited arm as the rat would alternate from the previously visited arm, on the third trial two of the three potential arms remain unvisited, as the rat could alternate back to the originally visited arm, therefore it should take an average of 1.5 trials to enter an unvisited arm and on the final trial only one of a possible three arms remain to be visited, which would take an average of 3 trials to locate. Thus, the summation of these gives a value of 6.5, providing the average number of trials one would expect the rats to take to visit all four goal boxes at least once, based on chance, when an alternating strategy is employed. The higher the number of trials to complete a ‘win-shift’ block, the more likely the rat is to be employing a win-stay strategy, as if a purely win-stay strategy was employed then the number of trials to complete a ‘win-shift’ block would be infinite. The average number of trials the rats took to complete a ‘win-shift’ block in the ‘random’ task were compared with that expected by a purely random (8.33) or a perfect alternation (6.5) strategy using one-sample t-tests. A repeated-measures ANOVA, with Bonferroni corrections for multiple analysis, was also used to compare the average number of trials taken to complete a ‘win-shift’ block across experimental groups.

Behavioural performance in the ‘win-stay’ task was defined as the average percentage of trials made to the rewarded goal box in each block of the session. The ‘win-stay’ analysis was performed twice, firstly on all the data collected (overall performance), enabling both the learning of the ‘win-stay’ as well as the ‘lose-shift’ elements of the task to be assessed and then independently on trials only after the rewarded goal box had been located for each block (post-goal performance), which removes the element of chance in initially locating the goal box and allows the learning purely of the ‘win-stay’ element of the task to be assessed.

In each set of analysis a repeated-measures ANOVA was performed to determine whether lesioning the hippocampus had a significant effect on performance across sessions, with Bonferroni corrections employed to account for multiple comparisons. The average performance level for each session was then individually compared to chance levels (25%) using one-sample t-tests and the average ‘win-stay’ task performance for each rat across the 14 sessions was compared for lesioned and control rats using a one-way ANOVA.

Performance across blocks within the first session was also examined to assess any difference in learning between the lesion and control groups in the initial session using a one-way ANOVA.

The acquisition of the 'lose-shift' element of the 'win-stay' task was then separately assessed by calculating the number of trials in which the rats returned to an unrewarded goal box ('error' trials) prior to locating the rewarded goal box at the start of each block. A repeated-measures ANOVA tested whether the number of 'pre-goal' errors significantly differed across experimental groups and/or over sessions as the rats learnt the task.

As hippocampal lesions can induce an inability to suppress previously learned behaviours (Ainge et al. 2007a; Kim and Frank 2009) the data was analysed further to determine whether perseveration had a specific detrimental effect on hippocampal-lesioned rats' performance levels. Errors made were classified either as 'perseverative', if the goal box rewarded in the preceding block was incorrectly visited, or as 'random' if one of the other two unrewarded goal boxes was visited. For fair comparison of the type of errors made by each experimental group, the 'perseverative' errors were compared to the mean 'random' errors made across sessions using a repeated-measures ANOVA with Bonferroni corrections.

Previously, hippocampal lesions have been shown to induce locomotor hyperactivity (Bannerman et al. 1999; Godsil et al. 2005; Good and Honey 1997), therefore to determine whether the hippocampal-lesioned rats' performance in this study was affected by running speed, trial times were compared across surgical groups using one-way ANOVAs, for both the 'random' and the 'win-stay' tasks.

In the one block and two block versions of the 'win-stay' task the overall and post-goal performances of the hippocampal-lesioned and sham-operated rats across sessions were compared with repeated-measures ANOVAs followed by *post hoc* pairwise comparisons with Bonferroni corrections for multiple analysis for each task type separately. The average performance of the two groups across sessions was also compared with one-way ANOVAs for each task type and one-way t-tests were used to compare the performance of each group to that expected by chance (25%) on each session of each task type. Additional analysis of the types of error made were performed on the one block 'win-stay' task where the rewarded goal box shifted across days and on the two block 'win-stay' task. The number of errors made were assessed between experimental groups and across sessions using Bonferroni-corrected repeated measures analysis. The number of 'repeat' errors, defined as errors made to the same unrewarded goal box over consecutive sessions, were then specifically compared across sessions for the experimental groups with Bonferroni-corrected repeated-measures ANOVA analysis. In the two block 'win-stay' task the number of errors made by the lesioned and control rats in each block was assessed over the sessions using a repeated-measures ANOVA with *post hoc* pairwise comparisons with Bonferroni corrections for multiple analysis. Finally, the type of error made, 'mean random' or 'perseverative', in the second block of trials on the two block 'win-stay' task was analysed with a Bonferroni-corrected repeated-measures ANOVA to determine whether there was a significant difference in the type of errors being made by the lesioned relative to control rats across the sessions.

5.3 Results

5.3.1 Histological Data

The amount of spared hippocampal tissue in the lesion group ranged from 16% to 54% (mean sparing = 34.6%, SEM = 4.5), relative to the mean combined length of the dentate gyrus, CA3, CA2 and CA1 cell layers of the sham-operated controls, with extra-hippocampal damage occurring in the subiculum. Representative histological results obtained for the sham and hippocampal-lesioned rats are shown in figure 5.2, and a table detailing the percentage of hippocampal tissue spared in each lesioned subject is available in the appendix, table A.2.

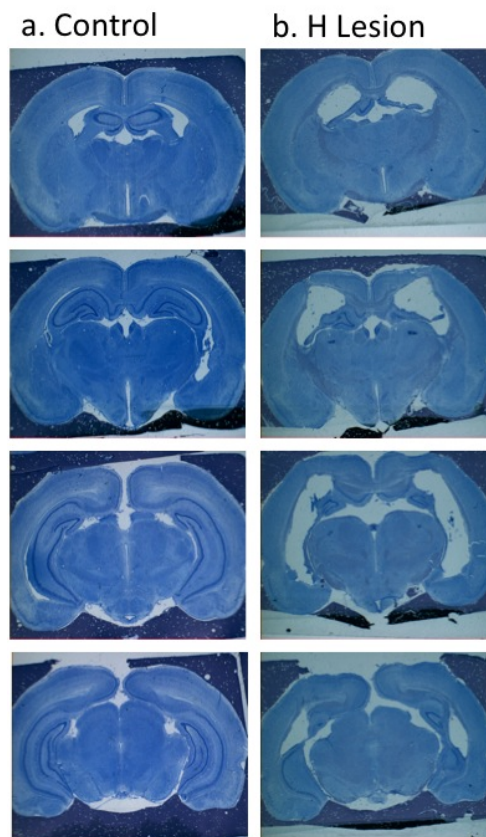

Figure 5.2: Photomicrographs of representative cresyl-violet stained coronal sections for: **(a)** sham lesions (Controls) and **(b)** complete hippocampal lesions (H Lesion). Sections are organised in columns from anterior to posterior locations through the hippocampus.

5.3.2 Behavioural Data

5.3.2.1 'Random' Task

In figure 5.3a the number of 'repeat' (trials in which the rat returned to the goal box visited on the preceding trial) and 'shift' (trials in which the rat entered a different goal box relative to the preceding trial) trials are displayed for each group of rats over the five sessions of the 'random'

task. It can be seen that the two groups perform similarly with a greater number of 'repeat' trials occurring in later sessions of the task. A repeated-measures ANOVA was performed on the proportion of 'repeat' trials for the two groups of rats (between-subjects factor) across the sessions (within-subjects factor) and revealed a significant effect of session ($F_{(2,32)}=6.55$; $p<0.01$) and group ($F_{(1,14)}=6.01$; $p<0.05$), but no session x group interaction ($F_{(2,32)}=0.16$; $p=0.88$) was found. Bonferroni corrected pair-wise comparisons revealed that the experimental groups only differed on session three ($p<0.05$), in which the lesioned rats performed a greater proportion of 'repeat' trials than shams.

In figure 5.3b the average number of trials to complete a 'win-shift' block is displayed for the two experimental groups across task sessions. A 'win-shift' block was defined as visiting each goal box once. This provides an additional measure of the type of strategy utilised by the rats where the fewer average trials taken indicates a greater tendency to alternate/shift between trials and a higher number of trials indicates an increased dominance of a win-stay/repetitive strategy. It can be seen in figure 4.3b that both groups perform similarly with a slight shift in strategy to reveal a stronger influence of win-stay behaviour across sessions. To determine whether there was a significant effect of group (between-subjects factor) or session (within-subjects factor) on the number of trials to complete a 'win-shift' block, a repeated-measures ANOVA was performed. The results of the test reported no significant effect of session ($F_{(3,37)}=1.00$; $p=0.396$), nor group ($F_{(1,14)}=0.37$; $p=0.555$), nor session x group interaction ($F_{(3,37)}=0.83$; $p=0.473$), indicating that the two groups utilised similar strategies across the sessions.

The type of strategy utilised by the rats was also analysed by comparing the average number of trials required to complete a 'win-shift' block for each group with the average number of trials expected to complete a 'win-shift' block if either a perfect alternation or a purely random strategy was employed. In figure 5.3b it appears that the rats behaviour tends to move towards a more win-stay strategy, from an alternation strategy implemented initially, in both experimental groups. Analysis with one-sample t-tests revealed that the performance of the sham-operated rats did not differ to either that expected by a random ($t=1.62$; d.f.=5; $p=0.167$) or a perfect alternation strategy ($t=4.22$; d.f.=5; $p=0.08$), whereas the hippocampal-lesioned rats' performance significantly differed from both that expected by a random ($t=2.91$; d.f.=9; $p<0.05$) and that expected by a perfect alternation strategy ($t=4.80$; d.f.=9; $p<0.01$). These results indicate that overall there was no significant difference between the strategy employed by the two groups but that the hippocampal-lesioned rats demonstrated more win-stay behaviour than the controls.

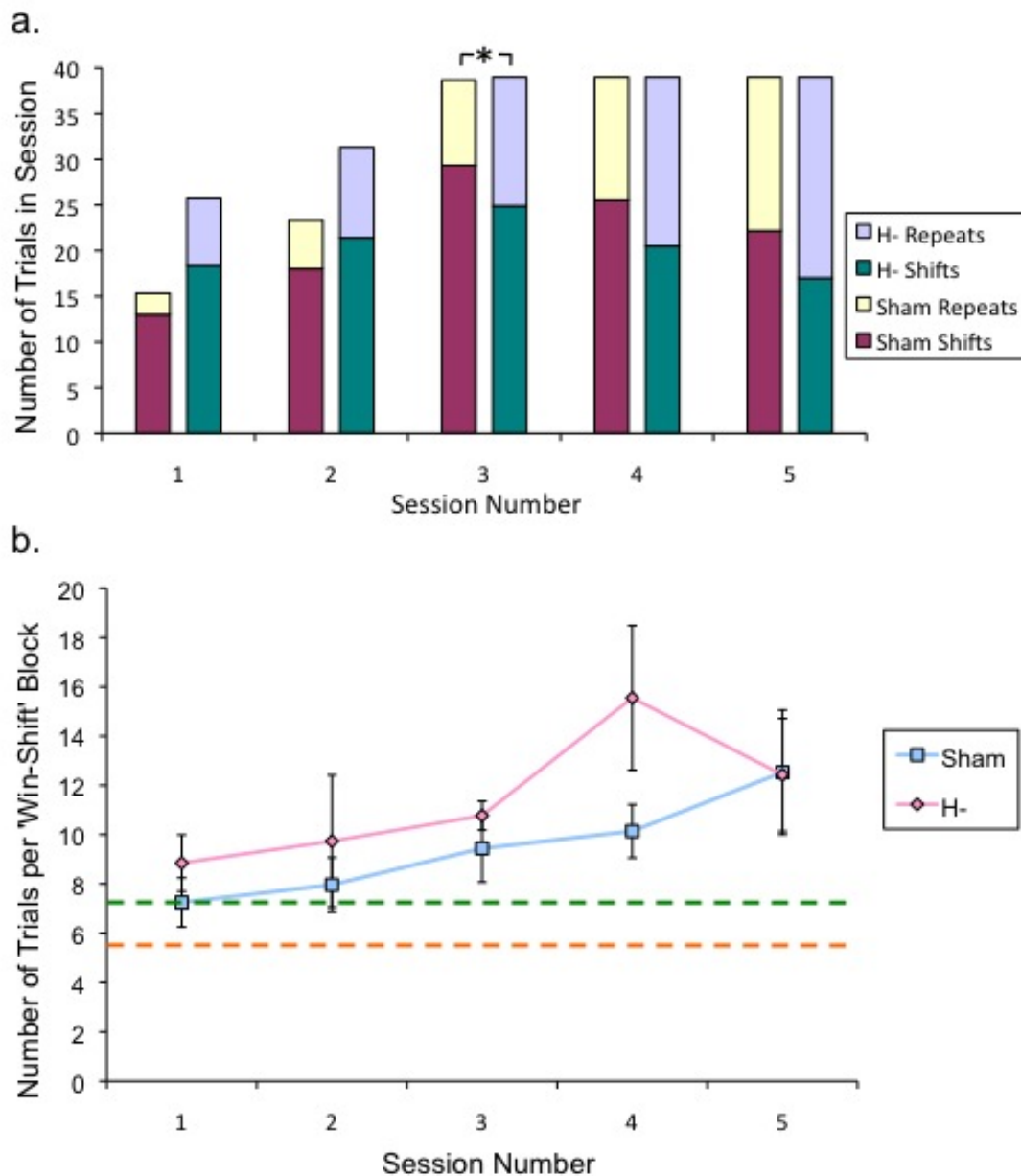

Figure 5.3: The average behavioural 'random' task performance of the sham (blue) and hippocampal-lesioned (pink) rats is displayed to compare strategies employed across the five sessions. **(a)** The numbers of 'repeat' and 'shift' trials performed in each session, where 'repeat' trials are defined as trials back to the previously visited goal, and 'shift' trials refer to trials in which the rat has entered a different goal box relative to the preceding trial. A similar pattern can be seen in both groups, where an alternating strategy initially dominates with elements of win-stay behaviour slowly emerging across the first three sessions, with approximately equal proportions of 'repeat' and 'shift' trials in the final sessions of the task. **(b)** The average number of trials to complete a 'win-shift' block for each experimental group is displayed across task sessions. A 'win-shift' block is defined as visiting each goal box once, such that the lowest number of trials to complete a 'win-shift' block would be four. The orange and the green horizontal dashed lines plot the expected number of trials to complete a 'win-shift' block based on a perfect alternation strategy and based on an entirely random strategy, respectively. Perfect win-stay performance would result in an infinite number of trials required to complete a win-shift block as the rat would never visit all four goal boxes, and for this reason it is not plotted. The fewer number of trials required to complete a 'win-shift' block, the more alternating behaviour the rat is showing, whereas a greater number of trials indicates a tendency to exhibit win-stay behaviour. The type of strategy employed by both groups is similar, where the tendency to alternate is again evident initially, with win-stay behaviour emerging across sessions, with hippocampal-lesioned rats tending to demonstrate more win-stay behaviour overall than shams. All data is displayed as mean values \pm SEM, (*) $p < 0.05$ between the proportion of 'repeat' trials for each experimental group.

'Win-Stay' Task

The performance of the hippocampal-lesioned and control rats over the 14 sessions of the 'win-stay' task, grouped into blocks of two sessions for clarity, is plotted in figure 5.4a. The sham-operated rats' pattern of performance across the 'win-stay' sessions is comparable to those previously reported in chapter 4 for intact rats run on the same protocol (see figure 4.4), with performance levels at approximately 70%, whereas hippocampal-lesioned rats performed at a consistently lower level across all 14 sessions. A repeated-measures ANOVA was conducted to determine the effects of experimental group (between-subjects factor) on 'win-stay' task performance across the 14 sessions (within-subjects factor). A significant effect of session ($F_{(6,87)}=14.29$; $p<0.001$), group ($F_{(1,14)}=25.39$; $p<0.001$) and session x group interaction ($F_{(6,87)}=10.52$; $p<0.001$) was revealed. Bonferroni corrected pair-wise comparisons reported no significant difference across sessions within each experimental group ($p>0.05$) but the two groups were significantly different to each other on each session of the 'win-stay' task ($p<0.05$). Overall, the average 'win-stay' task performance for the hippocampal-lesioned rats, across the 14 sessions, can be seen (in figure 5.4b) to be impaired, relative to the control rats, and this impairment was shown to be significant using a one-way ANOVA ($F_{(1,14)}=25.39$; $p<0.001$). Although hippocampal-lesioned rats were impaired throughout the task, the results of one-sample t-tests comparing performance levels to that expected by chance (25%) revealed that both the hippocampal-lesioned and sham-operated controls performed significantly above chance levels in all 14 'win-stay' sessions ($p<0.05$).

In figure 5.4a it seems that the controls are performing the 'win-stay' task significantly better than the hippocampal-lesioned rats from the first trial. To determine whether this effect of experimental group was due to rapid learning of the control rats, the performance of the two groups of rats was examined across the four blocks of session one (shown in figure 5.4c), where hippocampal-lesioned rats' performance appears to become impaired, relative to controls, across these four blocks. A repeated-measures ANOVA of performance of the experimental groups (between-subjects factor) across the four blocks of session one (within-subjects factor) revealed only a significant effect of group ($F_{(1,14)}=21.59$; $p<0.001$) but no significance was shown for block ($F_{(2,27)}=1.08$; $p=0.351$) and the interaction between block and group was not found to be significant ($F_{(2,27)}=0.96$; $p=0.393$). Bonferroni corrected pair-wise comparisons revealed that the hippocampal-lesioned rats were not significantly impaired relative to controls in the first two blocks of trials ($p>0.1$) but performance of the two groups significantly differed by the third and fourth blocks of the first session ($p<0.01$). Further analysis of performance in the first session with one-sample t-tests revealed that sham-operated rats performed significantly better than that expected by chance for all four blocks of the first session ($p<0.01$) whereas the hippocampal-lesioned rats performed significantly better than that expected by chance only in the first two blocks of session one ($p<0.05$), with blocks three and four being performed at chance levels ($p>0.05$). The reduction in performance between the second and third blocks of the first session

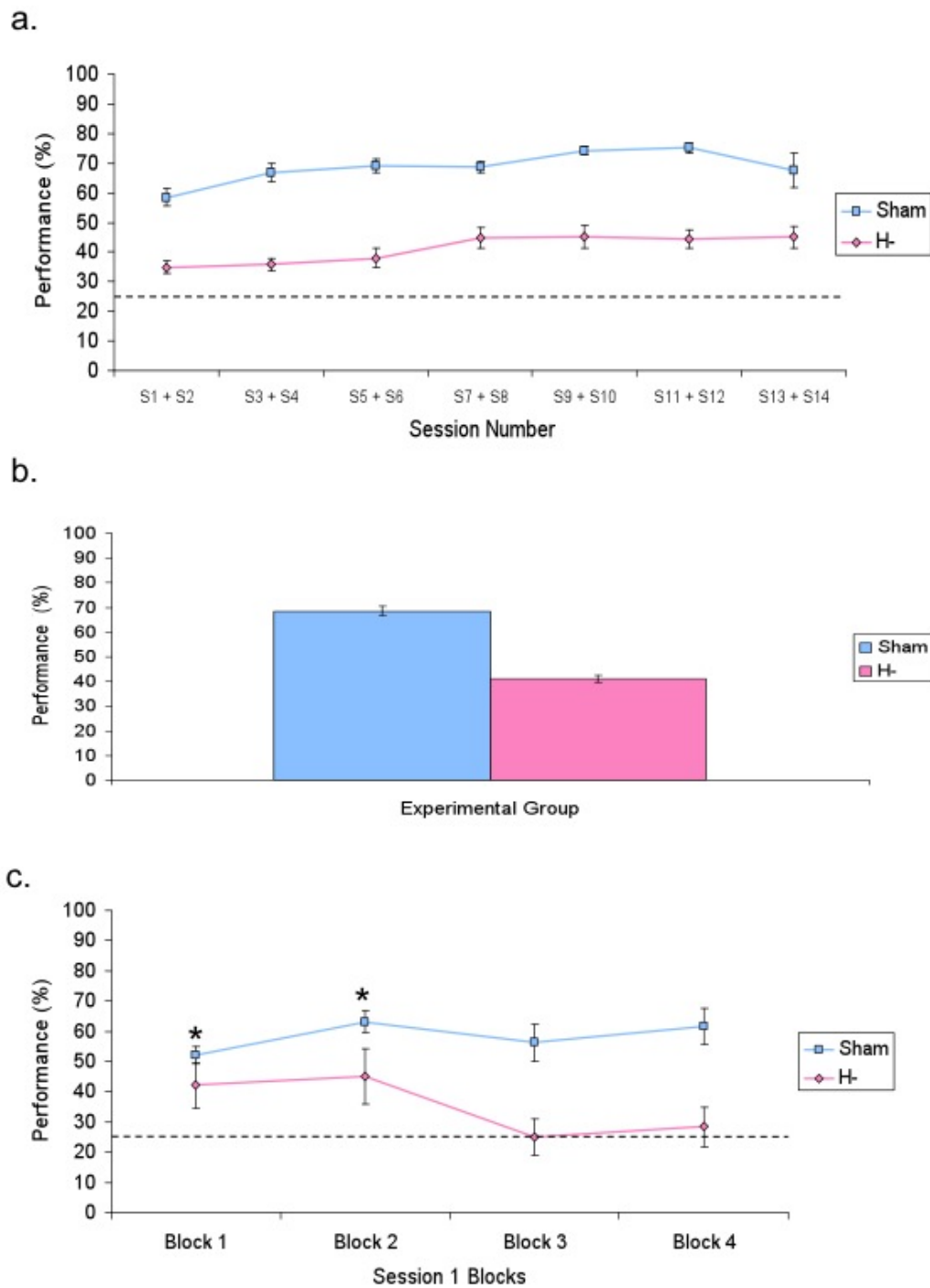

Figure 5.4: The average behavioural 'win-stay' task performance of the sham (blue) and hippocampal-lesioned (pink) rats is plotted for: **(a)** all 14 sessions of the 'win-stay' task, presented in groups of two sessions (S) for clarity; **(b)** the overall average performances of the experimental groups in the 'win-stay' task; and **(c)** the average performance of the two experimental groups across the four blocks of trials within the first 'win-stay' session. All data is displayed as mean values \pm SEM, (*) indicates the non-significant ($p > 0.05$) comparison between the sham and hippocampal-lesioned rats.

are likely due to the increasing level of interference across the blocks due to previous reward locations; although this affects both groups, the impact is more prominent in the hippocampal-lesioned group, where performance drops to chance levels. Thus, although the two groups began the 'win-stay' task with similar levels of performance, in contrast to control rats, the hippocampal-lesioned rats were unable to demonstrate the rapid within-session learning of a new goal box location, such that by the end of session one, the hippocampal-lesioned rats' were significantly impaired, relative to the controls' level of performance. The two experimental groups' performance remain significantly different for the subsequent 13 sessions.

In order to test specifically whether the hippocampal-lesion rats were impaired relative to controls in the purely win-stay element of the task; performance based on the percentage of trials to the rewarded goal box in each block only after the rewarded goal-box had been visited was separately examined. Analysis of this post-goal performance removed the effect of any impairment in the hippocampal-lesioned rats' ability to locate the newly rewarded goal box in each block (the 'lose-shift' component of task) on task performance, which may be induced in the hippocampal-lesioned rats due to an inability to suppress conditioned responses.

Figure 5.5a shows that the post-goal performance of hippocampal-lesioned rats is still impaired relative to controls for the 14 sessions of the 'win-stay' task, where for clarity the data is presented in two session blocks. From the graphically presented results, it appears that the controls' post-goal performance improved across the first six sessions, whereas a later learning phase seems apparent in the last eight days for the hippocampal-lesioned group of rats, although performance levels of the hippocampal-lesioned rats remains impaired, relative to controls, throughout the task. A repeated-measures ANOVA was conducted to determine the effects of experimental group (between-subjects factor) on post-goal 'win-stay' task performance across the 14 sessions (within-subjects factor). A significant effect of session ($F_{(5,72)}=3.03$; $p<0.01$) and group ($F_{(1,14)}=25.72$; $p<0.001$) was revealed, but there was no significant session x group interaction ($F_{(5,72)}=0.85$; $p=0.521$). Bonferroni corrected pair-wise comparisons reported significant differences between the two experimental groups across all sessions ($p<0.05$). Overall, the average post-goal 'win-stay' task performance for the hippocampal-lesioned group across the 14 sessions (shown in figure 5.5b) can clearly be seen to be impaired, relative to the control rats and this impairment was shown to be significant using a one-way ANOVA ($F_{(1,14)}=25.73$; $p<0.001$). Despite the hippocampal-lesioned rats' post-goal performance remaining consistently below the controls throughout the task, the results of one-sample t-tests comparing the post-goal performance of the experimental groups to that expected by chance (25%) revealed that both groups' post-goal performance was significantly greater than chance levels in all 14 win-stay sessions ($p<0.05$).

To ensure that the controls were not significantly better than the hippocampal-lesioned rats from the start of 'win-stay' task testing, the post-goal performance was analysed across blocks for the first session. Figure 5.5c shows the post-goal performance of the two groups of rats to

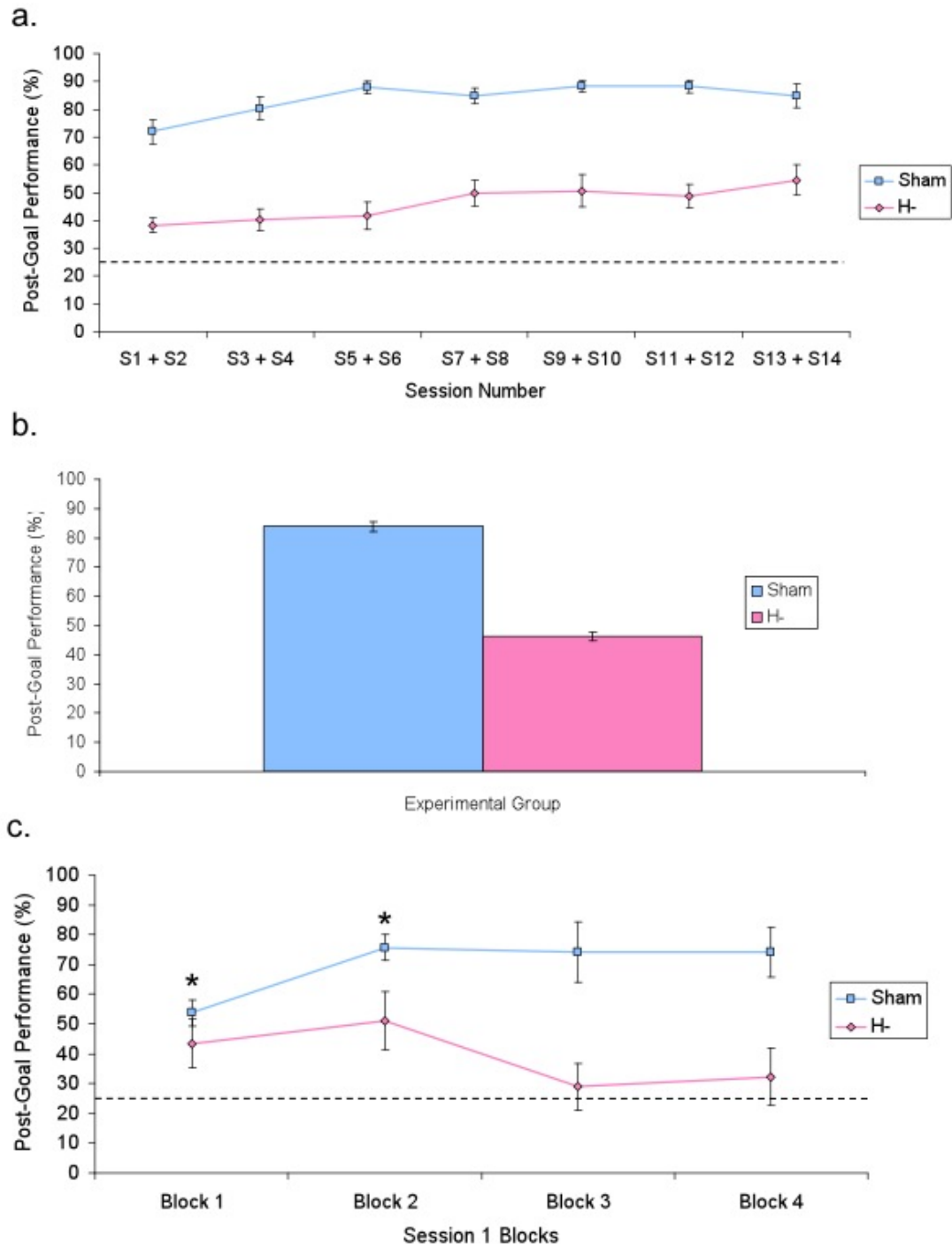

Figure 5.5: The average behavioural ‘win-stay’ task post-goal performance of the sham (blue) and hippocampal-lesioned (pink) rats is plotted for: **(a)** all 14 sessions of the ‘win-stay’ task presented in groups of two sessions (S) for clarity; **(b)** the overall average performances of the experimental groups in the ‘win-stay’ task; and **(c)** the average performance of the two experimental groups across the four blocks of trials within the first ‘win-stay’ session. All data is displayed as mean values \pm SEM, (*) indicates non-significant ($p > 0.05$) comparisons between the sham and hippocampal-lesioned rats.

be similar for the first block of trials, with the control rats' performance dramatically improving across the first two blocks. In contrast, the hippocampal-lesioned rats post-goal performance appears to reduce to chance levels for the last two blocks of the session, thus by the end of session one the hippocampal-lesioned rats' were significantly impaired, relative to the control-level of performance. A repeated-measures ANOVA of the post-goal performance of the experimental groups (between-subjects factor) across the four blocks of session one (within-subjects factor) revealed a significant effect of group ($F_{(1,14)}=18.88$; $p<0.001$), but no significant effect of block ($F_{(2,33)}=1.08$; $p=0.360$) nor block x group interaction ($F_{(2,33)}=1.52$; $p=0.233$). Bonferroni corrected pair-wise comparisons revealed that the hippocampal-lesioned rats were not significantly impaired relative to controls in the first two blocks of trials ($p>0.05$), in which both controls' and hippocampal-lesioned rats' post-goal performance was significantly above chance levels ($p<0.01$ and $p<0.05$ respectively) but the post-goal performance of the two groups significantly differed in the third and fourth blocks of the first session ($p<0.01$), where only the controls performed significantly better than chance ($p<0.01$), with performance in the hippocampal-lesioned group reduced to chance levels ($p>0.05$).

It seems that the same pattern of results can be obtained when looking at the overall task performance of the two groups of rats as when examining only post-goal performance, with the two groups demonstrating similar post-goal performance levels in the 'win-stay' task in the initial two blocks of session one, but the impairment induced by hippocampal lesions becomes apparent thereafter as controls, unlike hippocampal-lesioned rats, rapidly learn the 'win-stay' task within the first session and the performance of the two groups remain significantly different from each other for the remainder of the task.

The number and type of pre-goal errors made in the 'win-stay' task can be compared for the lesion and control rats in figure 5.6. Overall, the number of errors made prior to goal-identification appears to decrease across sessions in both groups, with the hippocampal-lesioned rats making more errors overall (see figure 5.6a). The results of a repeated-measures ANOVA, performed to determine the effects of experimental group (between-subjects factor) on the number of pre-goal errors made across blocked sessions (within-subjects factor), revealed a significant effect of session ($F_{(3,84)}=2.81$; $p<0.05$) and group ($F_{(1,14)}=14.54$; $p<0.01$), but there was no significant session x group interaction ($F_{(3,84)}=0.89$; $p=0.464$). Bonferroni corrected pair-wise comparisons reported significant differences between the two experimental groups in blocked sessions two, five and seven ($p<0.05$) and between blocked sessions two and five for the lesioned rats ($p<0.05$). The type of pre-goal error was further investigated to determine whether the hippocampal-lesioned rats were specifically impaired in inhibiting visits to the rewarded goal box from the previous block ('perseverative' errors) relative to mean random errors ('random') to the other two unrewarded boxes (see figure 5.6b). A repeated-measures ANOVA was performed to test the effect of experimental group (between-subjects factor) on the average number of each type of pre-goal error

made in the 'win-stay' task (within-subjects factor). The results report a significant effect of group ($F_{(1,14)}=14.58$; $p<0.05$) but no significant effect of error type ($F_{(1,14)}=3.94$; $p=0.067$) nor error type x group interaction ($F_{(1,14)}=1.39$; $p=0.258$). Bonferroni corrected pair-wise comparisons revealed that the number of 'random' pre-goal errors made between the lesioned and sham-operated rats significantly differed ($p<0.01$) but there was no significant difference in the number of 'perseverative' errors made between groups ($p>0.05$). These results imply that the impaired 'win-stay' performance of the hippocampal-lesioned rats is not due to a specific deficit in inhibiting previously reinforced behaviour from the preceding block of trials within a given session. In order to further investigate the nature of this impairment, overall trial times and performance on the different win-stay protocols were investigated.

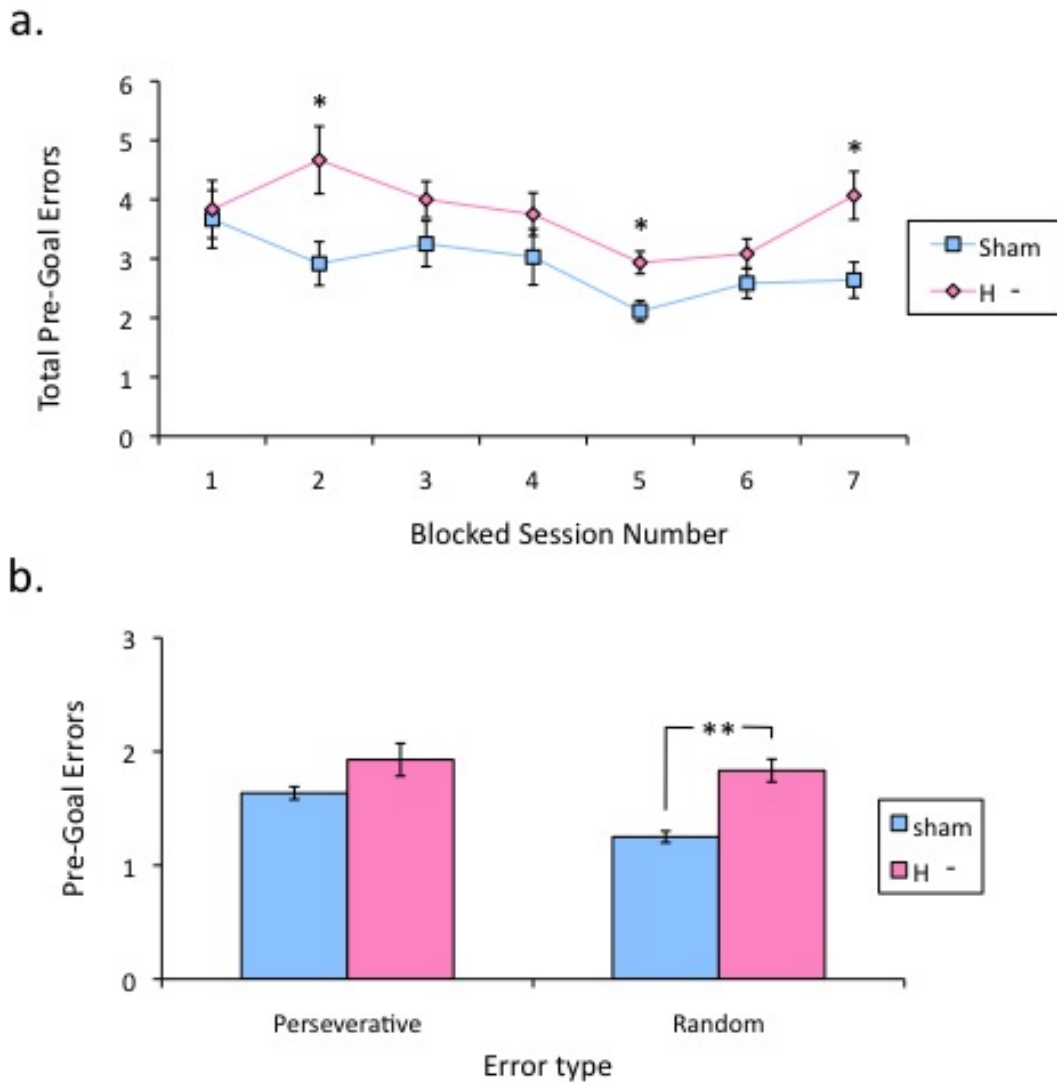

Figure 5.6: The average number of pre-goal errors made by the sham (blue) and hippocampal-lesioned (pink) rats in the 'win-stay' task is plotted for: **(a)** all 14 sessions of the 'win-stay' task, presented in two session blocks for clarity; and **(b)** the overall average number 'perseverative' and 'random' pre-goal errors made by the experimental groups in the 'win-stay' task, where errors to the previously rewarded goal box from the immediately preceding block of the session are labelled 'perseverative' and errors made to the other two unrewarded goal boxes are averaged and labelled 'random'. Overall, the hippocampal-lesioned rats can be seen to make more pre-errors across the sessions, relative to controls, with a specific increase in the tendency to make 'random' pre-goal errors. All data is displayed as mean values \pm SEM, (* or **) indicates a significant ($p < 0.05$ or $p < 0.01$ respectively) comparison between the sham and hippocampal-lesioned rats.

Trial Times

In order to ascertain whether running speed was affected by lesioning the hippocampus, a one-way ANOVA was performed to compare the average trial times across sessions for the 'random' and the 'win-stay' task for the lesioned relative to the sham-operated rats (see figures 5.7a and 5.7b respectively). The analysis revealed no significant effects of experimental group on average trial times in either the 'random' ($F_{(1,14)}=2.14$; $p=0.165$) or the 'win-stay' task ($F_{(1,14)}=1.07$; $p=0.317$). Thus, the impairments in performance of the hippocampal-lesioned rats in the 'win-stay' task are not secondary to an effect on running speed.

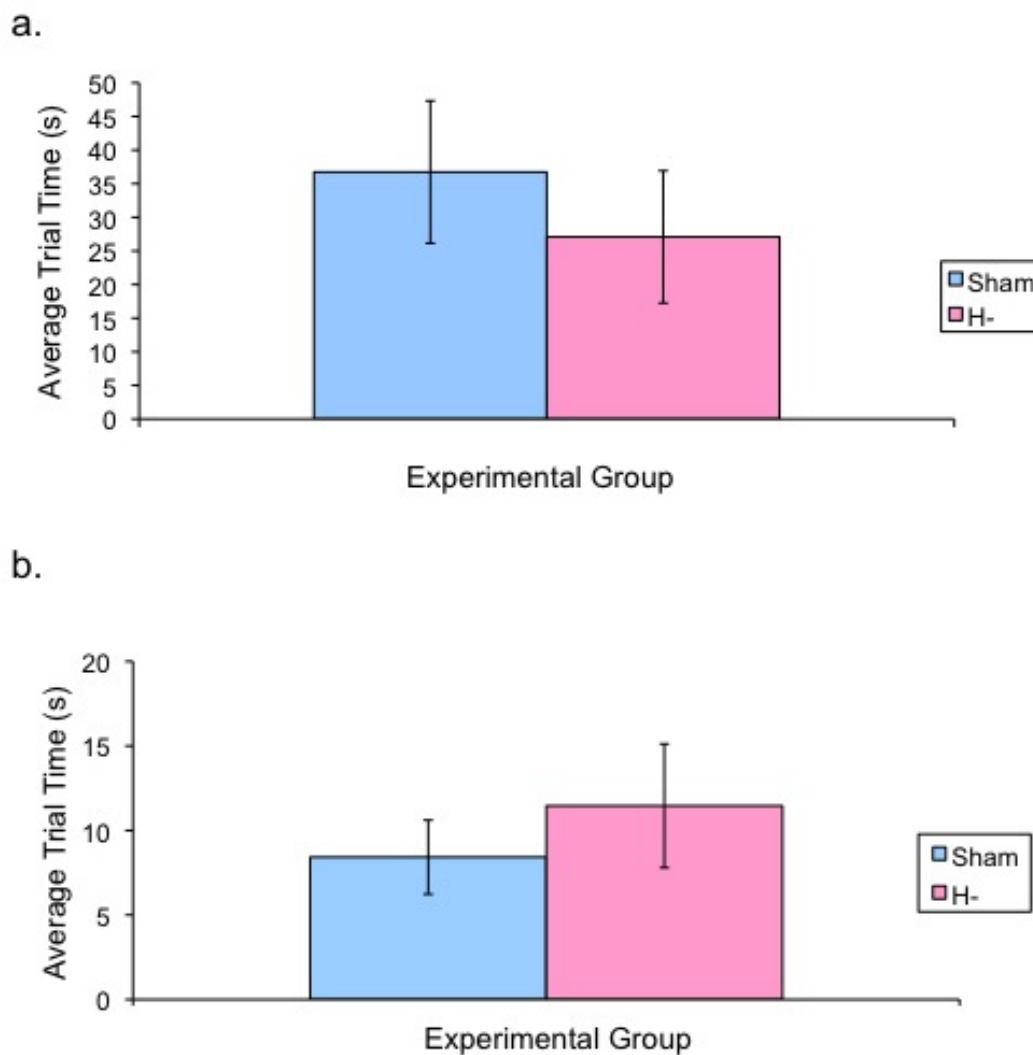

Figure 5.7: The average time taken to complete each trial is displayed for the sham (blue) and hippocampal-lesioned (pink) rats for: **(a)** the average trial times in the five sessions of the 'random' task, and **(b)** the average trial times for the 14 'win-stay' task sessions. It can be seen that the average trial times for the two groups do not differ significantly in either task type. All data is displayed as mean values \pm SEM.

One Block 'Win-Stay' Task

The one block 'win-stay' task was conducted to determine whether the hippocampal-lesioned rats could learn to perform based upon a win-stay strategy, when the goal box rewarded remained constant over the 40 trials of the first session before the reward location shifted to a different goal box for the 40 trials of the second session. The performance of the hippocampal-lesioned and control rats over the two sessions of this one block 'win-stay' task is displayed in figure 5.8a. In this graph the hippocampal-lesioned rats appear to be performing at a comparable level to controls in the first session, but unlike the performance of the sham-operated rats, the performance of the lesioned rats drops across the two sessions, although the performance of both the lesion and control groups remained significantly above chance across the two sessions ($p < 0.05$ and $p < 0.001$ respectively). A repeated-measures ANOVA was performed to determine the effects of experimental group (between-subjects factor) on performance across the two sessions (within-subjects factor) and revealed a significant effect of group ($F_{(1,14)}=6.21$; $p < 0.05$) but no significant effect of session ($F_{(1,14)}=2.57$; $p=0.131$) nor session x group interaction ($F_{(1,14)}=2.75$; $p=0.120$). Bonferroni corrected pair-wise comparisons subsequently confirmed only performance in session two significantly differed across the experimental groups ($p < 0.05$). The average performance of each experimental group across the two sessions is shown in figure 5.8b, where the hippocampal-lesioned rats' performance can be seen to be impaired relative to that of the sham group, a finding confirmed through one-way ANOVA analysis ($F_{(1,30)}=5.80$; $p < 0.05$).

The post-goal performance of the hippocampal-lesioned and control rats over the two sessions of the one block 'win-stay' task is displayed in figure 5.9a. In this graph the hippocampal-lesioned rats appear to be performing at a comparable level to controls, but like overall performance, the post-goal performance of the hippocampal-lesioned rats appears to decrease across the two sessions, whereas the post-goal performance of controls remains constant. The performance of both the lesion and control groups can be seen to be significantly above chance levels across the two sessions, which was confirmed with one-sample t-tests ($p < 0.01$ and $p < 0.001$). Further analysis with a repeated-measures ANOVA, performed to determine the effects of experimental group (between-subjects factor) on post-goal performance across the two sessions (within-subjects factor), revealed no significant effect of session ($F_{(1,14)}=0.76$; $p=0.399$), group ($F_{(1,14)}=3.50$; $p=0.083$) nor session x group interaction ($F_{(1,14)}=0.40$; $p=0.537$). Furthermore, although the average post-goal performance of the hippocampal-lesioned rats appears slightly below that of the sham group (shown in figure 5.8b), analysis with one-way ANOVA reported no significance in this comparison ($F_{(1,30)}=2.69$; $p=0.111$).

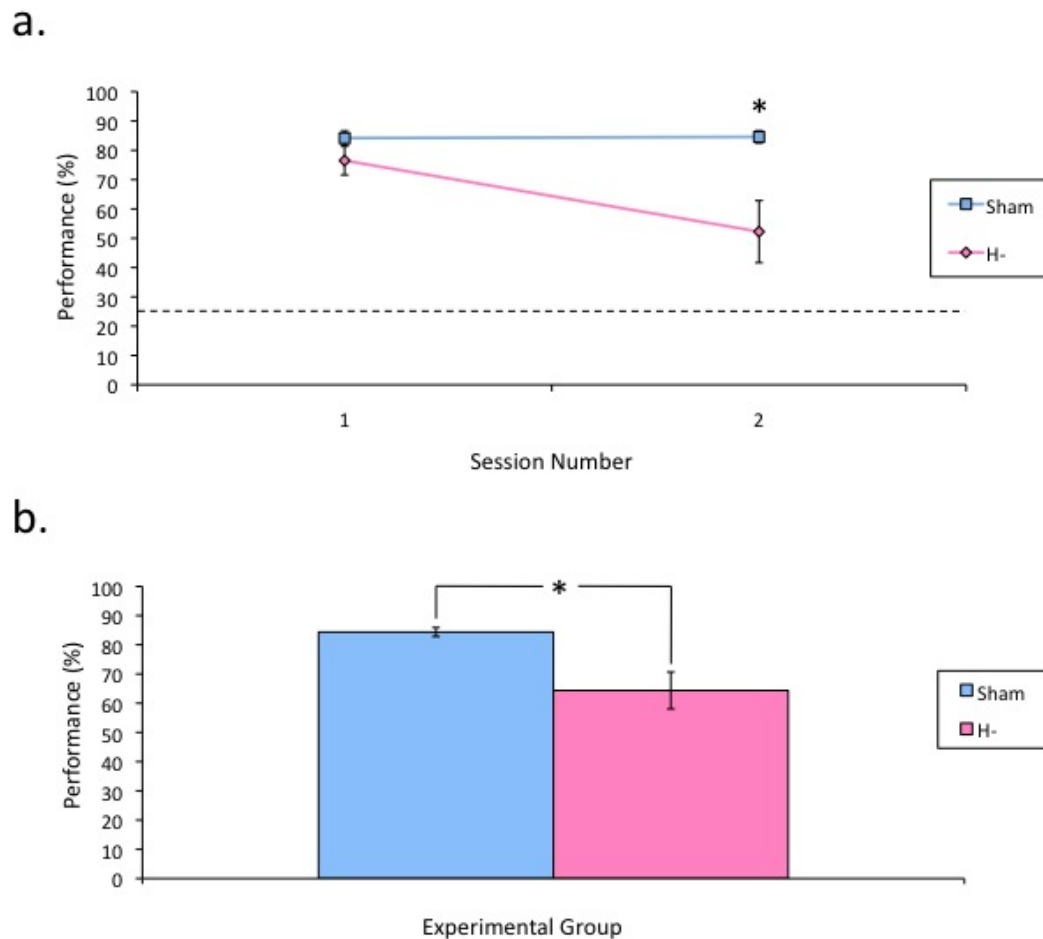

Figure 5.8: The average behavioural one block 'win-stay' task performance of the sham (blue) and hippocampal-lesioned (pink) rats is plotted for: **(a)** both sessions of the one block 'win-stay' task individually, with both groups demonstrating above chance-level performance (represented by the dashed line) throughout the sessions; and **(b)** the overall average performances of the experimental groups across the two sessions of the one block 'win-stay' task. All data is displayed as mean values \pm SEM, (*) $p < 0.05$ between experimental groups.

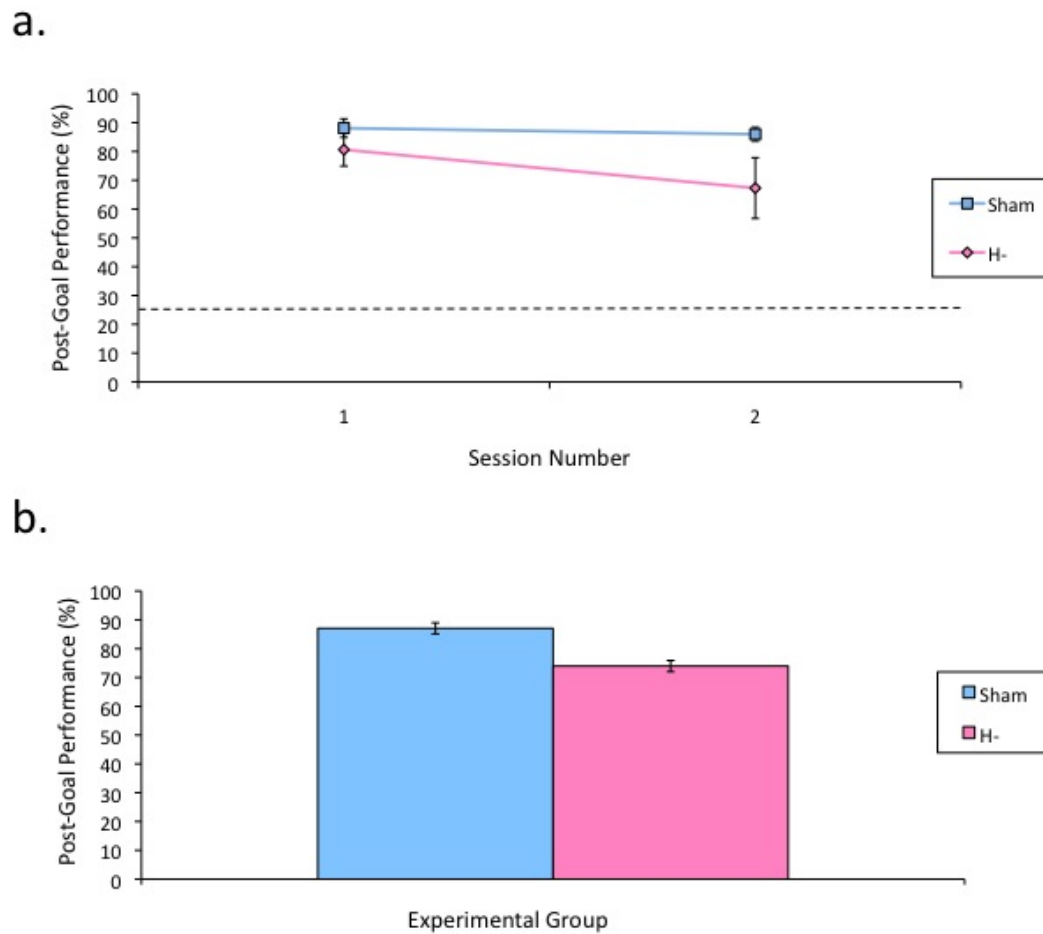

Figure 5.9: The average behavioural one block 'win-stay' task post-goal performance of the sham (blue) and hippocampal-lesioned (pink) rats is plotted for: **(a)** both sessions of the one block 'win-stay' task individually, with both groups demonstrating above chance-level performance (represented by the dashed line) throughout the sessions; and **(b)** the overall average post-goal performances of the experimental groups across the two sessions of the one block 'win-stay' task. All data is displayed as mean values \pm SEM.

These results indicate that hippocampal-lesioned rats are unimpaired in purely win-stay performance when the rewarded response is consistent within a single session, although even the switching of the reward location over the two sessions impairs performance, due to an inability of the hippocampal-lesioned rats to locate the newly rewarded goal box, however once the goal box to be rewarded in the second session is located, the hippocampal-lesioned rats perform at a comparable level to controls.

In order to confirm that the hippocampal-lesioned rats could indeed perform a purely win-stay task with no impairments if the rewarded goal box remained consistent over sessions, a further variation of the one block 'win-stay' task was implemented, where the rewarded goal box remained in the same location for any given rat across four sessions. In figure 5.10 the experimental groups can be seen to perform at comparable levels throughout the task, with performance levels again significantly above that expected by chance for both groups ($p < 0.001$). A repeated-measures ANOVA was conducted to examine any effects of experimental group (between-subjects factor) on win-stay task performance across the four sessions (within-subjects factor). A significant effect of session ($F_{(2,24)} = 5.25$; $p < 0.05$) and session x group interaction ($F_{(2,24)} = 3.60$; $p < 0.05$) was revealed but there was no overall effect of group ($F_{(1,14)} = 0.42$; $p = 0.528$). Bonferroni corrected pair-wise comparisons reported no significant difference across sessions within the sham group ($p > 0.05$) but the hippocampal-lesioned group did differ significantly when performance in session one was compared to sessions two and three ($p < 0.05$, $p < 0.001$). Furthermore, the results of a one-way ANOVA again revealed no effect of group when average one block 'win-stay' task performance for each rat, across the four sessions, was compared for the hippocampal-lesioned rats relative to the control rats ($F_{(1,62)} = 0.43$; $p = 0.517$), shown in figure 5.10b.

A similar pattern of results was obtained when only post-goal performance was analysed for the same data set, shown in figure 5.11a, where the experimental groups can be seen to be performing at comparable levels, with performance levels significantly above that expected by chance for both groups ($p < 0.001$) throughout the task. A repeated-measures ANOVA was conducted to examine any effects of experimental group (between-subjects factor) on post-goal performance across the four sessions (within-subjects factor). A significant effect of session ($F_{(1,20)} = 3.87$; $p < 0.01$) and session x group interaction ($F_{(1,20)} = 3.22$; $p < 0.01$) was revealed but again there was no overall effect of group ($F_{(1,14)} = 0.63$; $p = 0.44$). Bonferroni corrected pair-wise comparisons reported no significant difference across sessions within the sham group ($p > 0.05$) but the hippocampal-lesioned group did differ significantly when performance in session one was compared to sessions two and three ($p < 0.05$, $p < 0.001$ respectively). The results of a one-way ANOVA again revealed no effect of group when average post-goal performance for each rat, across the four sessions, was compared for the hippocampal-lesioned rats relative to the control rats ($F_{(1,62)} = 0.66$; $p = 0.418$), shown in figure 5.11b.

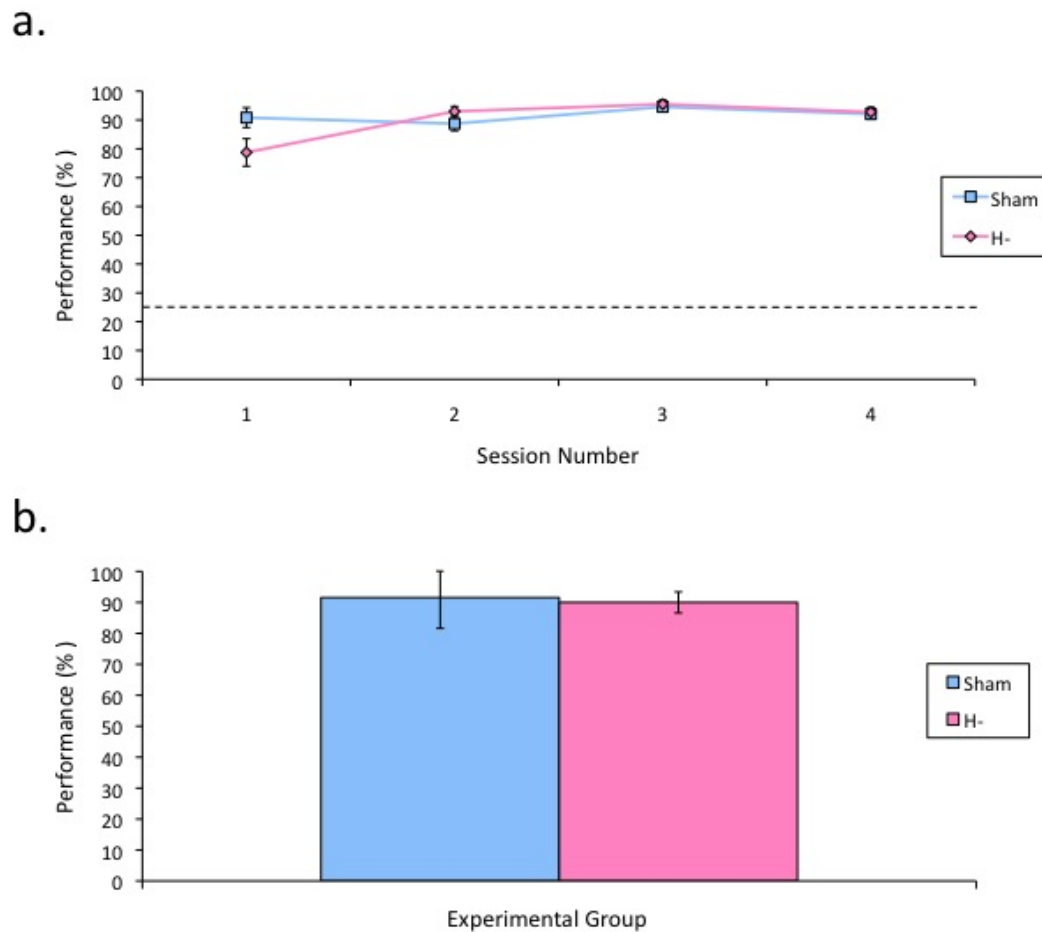

Figure 5.10: The average behavioural one block 'win-stay' task performance of the sham (blue) and hippocampal-lesioned (pink) rats is plotted for sessions across which the rewarded goal-box remained in the same location. **(a)** The graph displays performance of the two groups in all four sessions of the one block 'win-stay' task, with both groups demonstrating above chance-level performance (represented by the dashed line) throughout the sessions. The two groups can be seen to be performing similarly across the four sessions at a constant level with only the hippocampal-lesioned rats showing a slight improvement across the first two sessions. **(b)** The overall average performances of the experimental groups in the one block 'win-stay' task is presented for each experimental group where they can be seen to be performing at a similar level. All data is displayed as mean values \pm SEM.

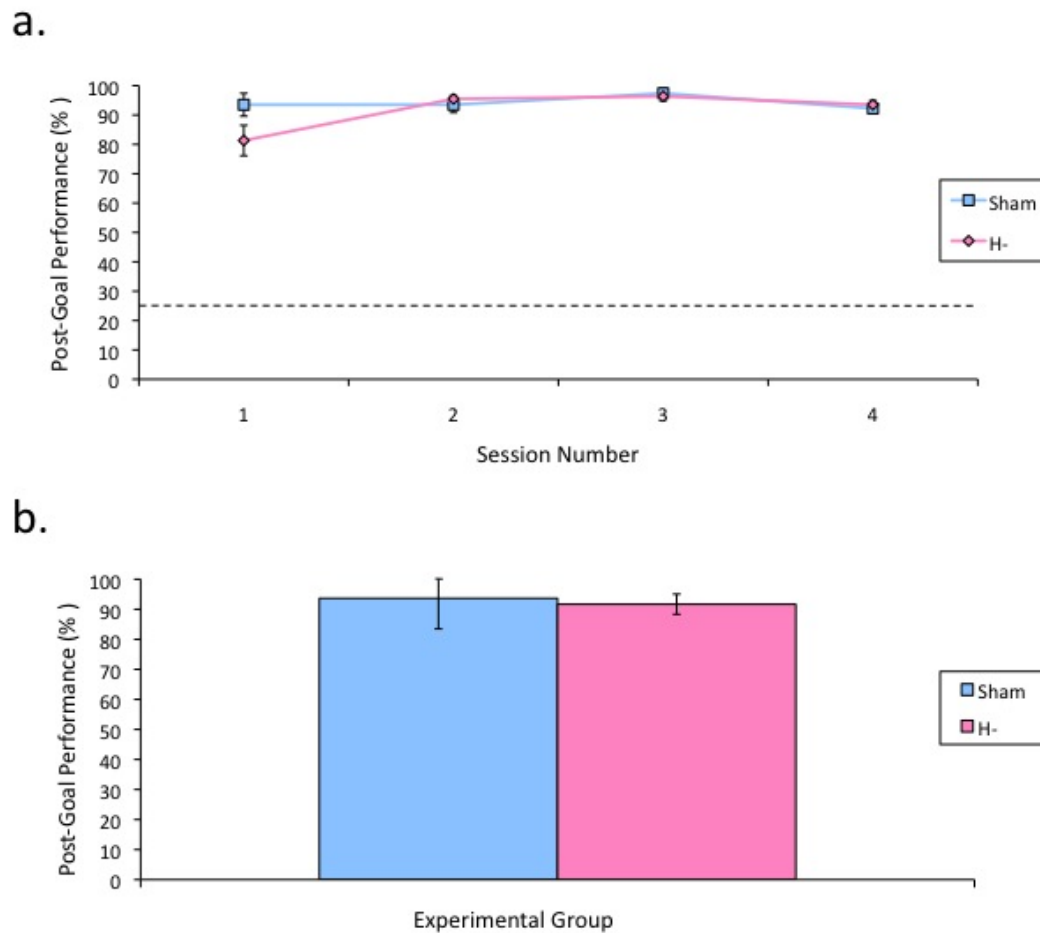

Figure 5.11: The average behavioural one block 'win-stay' task post-goal performance of the sham (blue) and hippocampal-lesioned (pink) rats is plotted for sessions across which the rewarded goal-box remained in the same location. **(a)** Post-goal performance is presented across the four sessions of the one block 'win-stay' task, where both groups can be seen to be demonstrating comparable above chance-level performance (represented by the dashed line) throughout the sessions. **(b)** The overall average post-goal performances of the experimental groups in the one block 'win-stay' task is displayed, where both groups can be seen to be performing at a similar level. All data is displayed as mean values \pm SEM.

These results confirm that the hippocampal-lesioned rats are not impaired in the ability to adopt a win-stay strategy. The slight improvement which is apparent across the first two sessions is likely due to interference from the previous task in which the hippocampal-lesioned rats performance dropped (below that of the controls) when the goal-box location shifted across sessions. In the two day one-block 'win-stay' task the location of the goal box remained constant within a session but changed between sessions. In order to assess whether the disruption seen in performance across this task was due to an inability of the hippocampal-lesioned rats to inhibit the previously reinforced behaviour, of returning to the goal box rewarded on the preceding day, and if so, whether the lesioned rats would be capable of learning a win-stay task in which the reward location shifted across sessions, if a sufficient number of sessions were performed; a further one block win-stay task was conducted, in which the rewarded goal box remained in the same location for the 40 trials of a session but shifted pseudo-randomly between each of the four sessions.

In figure 5.12a it can be seen that although performance levels across sessions are above chance levels for both groups; the hippocampal-lesioned rats' performance is lower than the performance of the sham-operated rats for the first two sessions but gradually improves such that performance across groups is comparable in the third and fourth session. A repeated-measures ANOVA was conducted to determine the effects of experimental group (between-subjects factor) on one block 'win-stay' task performance when the rewarded goal box switched location across the four sessions (within-subjects factor). A significant effect of session ($F_{(2,27)}=5.76$; $p<0.01$) and session x group interaction ($F_{(2,27)}=3.59$; $p<0.05$) was revealed but there was no significant effect of experimental group ($F_{(1,14)}=3.78$; $p=0.072$). Bonferroni corrected pair-wise comparisons reported no significant difference between groups across any of the four sessions ($p>0.05$) nor any differences across sessions for the sham-operated rats' performance ($p>0.05$), but the hippocampal-lesioned rats' performance was significantly different in sessions three and four relative to session one ($p<0.05$ and $p<0.01$ respectively). Results of the one-sample t-test confirmed that both the hippocampal-lesioned and sham rats' performances were significantly better than that expected by chance (25%) on all sessions ($p<0.05$ and $p<0.01$ respectively). Although there was no significant difference between groups across sessions, the average one block 'win-stay' task performance, across the four sessions, can be seen to be impaired in the hippocampal-lesioned relative to the sham-operated rats in figure 5.12b, and analysis with one-way ANOVA reported this to be significant ($F_{(1,62)}=9.20$; $p<0.01$).

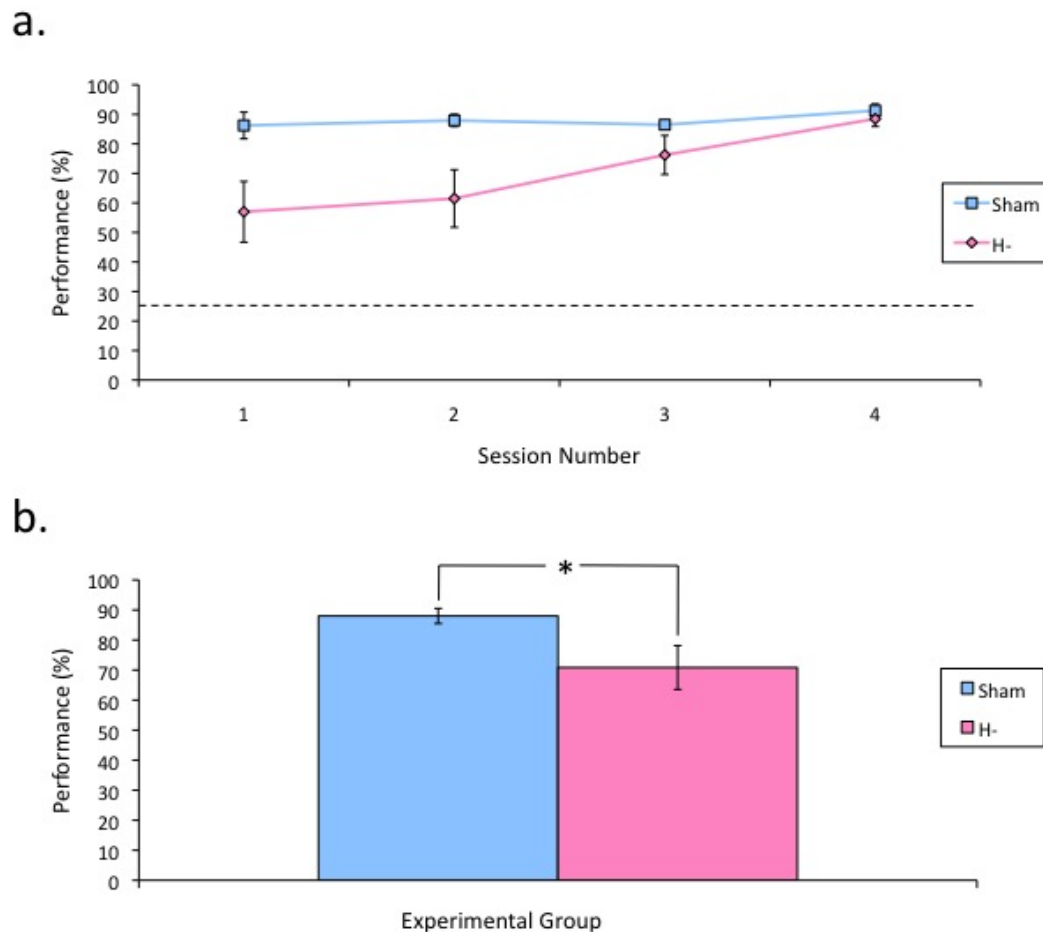

Figure 5.12: The average behavioural one block 'win-stay' task performance of the sham (blue) and hippocampal-lesioned (pink) rats is plotted for sessions across which the rewarded goal-box shifted. The shams can be seen to be performing at a consistently high level across sessions whereas the hippocampal-lesioned rats performance is initially impaired in the first two sessions but increases to reach control levels in sessions three and four. **(a)** Performance levels are displayed across the four sessions of the one block 'win-stay' task, with both groups demonstrating above chance-level performance (represented by the dashed line) throughout the sessions. **(b)** The overall average performances of the experimental groups in the one block 'win-stay' task is presented, where the sham group are shown to be performing significantly better than hippocampal-lesioned rats overall. All data is displayed as mean values \pm SEM, (*) $p < 0.01$.

To assess whether the impairment seen in the hippocampal-lesioned rats' performance across the first two sessions of this task was due to an inability to inhibit the previously reinforced behaviour of returning to the goal box rewarded on the preceding day, post-goal one block 'win-stay' performance was compared between experimental groups across the four sessions, for which the goal-location changed. In figure 5.13a it can be seen that although post-goal performance levels across sessions are above chance levels for both groups ($p < 0.01$), the hippocampal-lesioned rats' performance is lower than the performance of the sham-operated rats for the first two sessions but gradually improves such that performance across groups is comparable in the third and fourth session. A repeated-measures ANOVA was conducted to determine the effects of experimental group (between-subjects factor) on post-goal one block 'win-stay' task performance when the rewarded goal box switched location across the four sessions (within-subjects factor). A significant effect of session ($F_{(2,30)}=4.24$; $p < 0.05$), group ($F_{(1,14)}=4.59$; $p < 0.05$) and session x group interaction ($F_{(2,30)}=4.10$; $p < 0.05$) was revealed. Bonferroni corrected pair-wise comparisons reported no significant difference across sessions for the sham-operated rats' performance ($p > 0.05$), but the hippocampal-lesioned rats' performance was significantly different in sessions three and four relative to session one ($p < 0.05$ and $p < 0.01$ respectively) and the experimental groups' performance was found to significantly differ only on sessions one and two ($p < 0.05$). The average post-goal one block 'win-stay' task performance, across the four sessions, can be seen to be impaired in the hippocampal-lesioned relative to the sham-operated rats in figure 5.13b, and analysis with one-way ANOVA reported this to be significant ($F_{(1,62)}=12.16$; $p < 0.001$).

These results indicate the hippocampal-lesioned rats are capable of performing a purely win-stay task when the reward location shifts between sessions if a sufficient number of sessions are experienced such that the rats can learn the rule that the rewarded location remains stable within but not across sessions and this learning appears to take place between sessions two and three. The impaired performance present in the hippocampal-lesioned group was present in the first two sessions when overall and post-goal performance was assessed indicating that the impairment was not just due to an inability to shift from the previously rewarded goal box (of the preceding session) in order to locate the rewarded goal box of the current session. Although the impaired performance was not solely due to inability to locate the rewarded goal box of the current session, the rats did make more repetitive errors (repeatedly visiting unrewarded goal boxes) throughout the session indicating an inability to suppress previously rewarded behaviours of preceding sessions. Thus, further analysis focussed on the number and type of errors made by the two experimental groups across the sessions of this task.

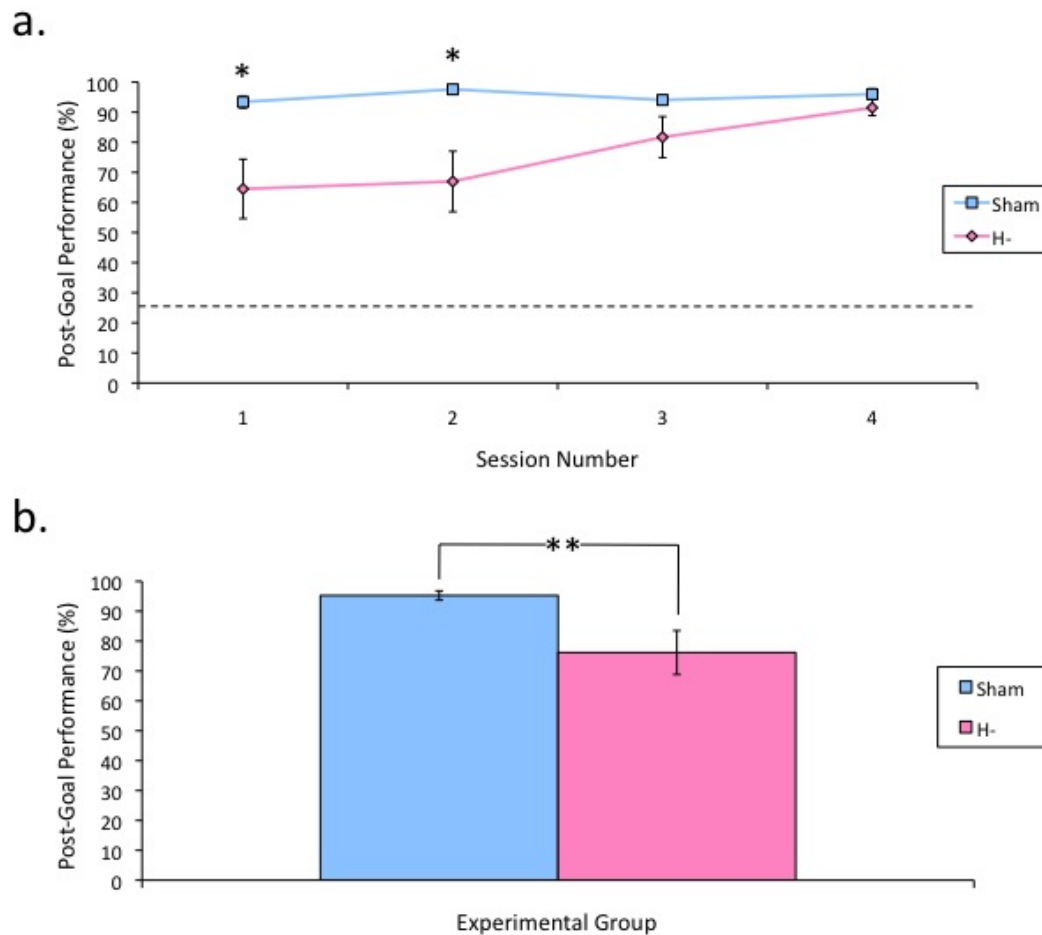

Figure 5.13: The average behavioural one block 'win-stay' task post-goal performance of the sham (blue) and hippocampal-lesioned (pink) rats is plotted for sessions across which the rewarded goal-box shifted. **(a)** Post-goal performance across all four sessions of the one block 'win-stay' task is displayed, with both groups demonstrating above chance-level performance (represented by the dashed line) throughout the sessions. The sham's performance remains at a consistently high level throughout the sessions whereas the hippocampal-lesioned rats are initially impaired in the first two sessions before post-goal performance levels improve to control levels over sessions three and four. **(b)** The overall average post-goal performances of the experimental groups in the one block 'win-stay' task is presented where the hippocampal-lesioned rats can be seen to be impaired in overall post-goal performance relative to controls. All data is displayed as mean values \pm SEM; for comparisons between groups: (*) $p < 0.05$, (**) $p < 0.001$.

The total number of pre-goal errors made in the 'win-stay' task can be compared for the lesion and control rats in figure 5.14a where the high number of pre-goal errors made by the hippocampal-lesioned rats (relative to controls) in the first session reduces to control levels across the remainder of the task. The results of a repeated-measures ANOVA, performed to determine the effects of experimental group (between-subjects factor) on the number of pre-goal errors made across sessions (within-subjects factor), revealed no significant effect of session ($F_{(1,20)}=2.68$; $p=0.107$), group ($F_{(1,14)}=1.11$; $p=0.311$), nor session x group interaction ($F_{(1,20)}=1.83$; $p=0.192$). The number of 'repeat' errors was then examined, where these were defined to occur when the rat incorrectly returned to an unrewarded goal-box on consecutive trials. It can be seen in figure 5.14b that hippocampal-lesioned rats make consistently more 'repeat' errors compared to shams but the number of repeat errors decrease across the sessions. The results of a repeated-measures ANOVA report only a significant effect of session ($F_{(1,18)}=5.31$; $p<0.05$), with no significant effect of group ($F_{(1,14)}=4.10$; $p=0.062$) nor session x group interaction ($F_{(1,18)}=3.68$; $p=0.063$). These results are likely to be a consequence of the high level of variation in the hippocampal-lesioned rats performance, with similar numbers of repeat errors as shams in the final two sessions and due to the fact that both groups displayed an overall reduction in the numbers of errors made across sessions. Bonferroni corrected pair-wise comparisons reported a significant difference in the number of 'repeat' errors only in the lesioned rats when session one was compared to sessions two, three and four ($p<0.05$) and when session two was compared to session four ($p<0.05$).

Further analysis of the goal box choices made in the one block 'win-stay' task were then performed. The trial type was further broken down into correct responses, visits made to the previously repeatedly reinforced goal box of the stable one block 'win-stay' task, visits to the previously rewarded goal-boxes of other sessions of the shifting one block 'win-stay' task, or random errors to goal-boxes which had not yet been rewarded in the one block 'win-stay' task. In figure 5.14c the hippocampal-lesioned rats can again be seen to be making more errors overall relative to shams on the first two sessions but this appears to be the result of a general performance deficit, rather than the result of any specific inhibition deficit.

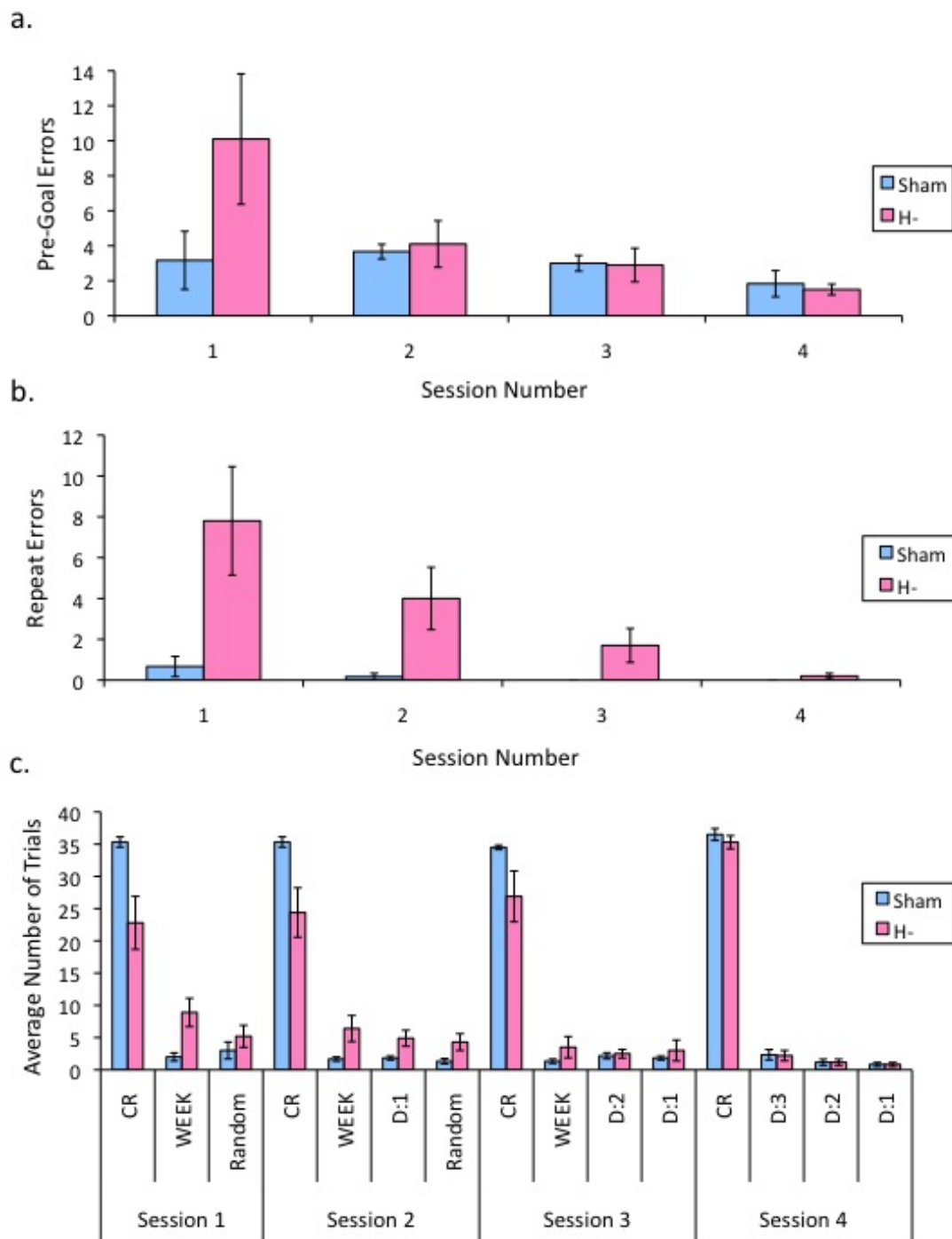

Figure 5.14: The average number of errors that the sham (blue) and hippocampal-lesioned (pink) rats made in the one block 'win-stay' task is plotted for sessions across which the rewarded goal-box shifted. **(a)** The average number of errors made before the goal location was identified are displayed across the four sessions. **(b)** The average number of 'repeat' errors made across each of the four sessions are displayed. The number of consecutive trials to the same unrewarded goal box ('repeat' errors) can be seen to decrease in both experimental groups across sessions, with the hippocampal-lesioned group making more 'repeat' errors than shams overall. **(c)** The average number of trials to the rewarded goal box (CR), the previously rewarded box from the stable one block 'win-stay' task (WEEK), the previously rewarded box from the first, second or third session (D:1-D:3) or a random goal-box (RAN) is presented for each experimental group, across the four sessions. All data is displayed as mean values \pm SEM.

Two Block 'Win-Stay' Task

In order to further examine the specific deficits underlying the impairments obtained in 'win-stay' performance of the hippocampal-lesioned rats relative to controls, the ability to perform the task with rewarded location shifting just once across the session was examined. In figure 5.15a performance on this task can be seen to be clearly impaired in the hippocampal-lesioned group with no signs of improvement across the six sessions, although performance levels in both the hippocampal-lesioned and sham group was maintained at above chance levels throughout ($p < 0.01$ and $p < 0.001$ respectively). A repeated-measures ANOVA was performed to determine the significance of experimental group (between-subjects factor) on two block 'win-stay' task performance across the six sessions (within-subjects factor). Analysis revealed only a significant effect of experimental group ($F_{(1,14)}=9.50$; $p < 0.01$) but not significant effect of session ($F_{(2,23)}=0.73$; $p=0.468$) nor session x group interaction ($F_{(2,23)}=0.41$; $p=0.625$). Bonferroni corrected pair-wise comparisons reported that the two experimental groups only significantly differed in sessions one and five ($p < 0.01$). The hippocampal-lesioned rats' average two block 'win-stay' task performance, across the four sessions, can be seen to be clearly impaired, relative to the shams, in figure 5.15b and analysis with one-way ANOVA reported this to be highly significant ($F_{(1,94)}=26.46$; $p < 0.001$).

Post-goal performance on this task was assessed separately to determine whether the impairment was purely due to the 'lose-shift' component of the task or whether a similar pattern would be seen in the purely 'win-stay' component. In figure 5.16a, post-goal performance again appears to be impaired overall in the hippocampal-lesioned group, with no clear signs of learning across the six sessions, with a greater level of variability in the lesioned group's post-goal performance levels across sessions. Similarly to overall performance, both experimental groups maintained significantly above chance levels of post-goal performance throughout the task ($p < 0.001$). A repeated-measures ANOVA was performed to determine the significance of experimental group (between-subjects factor) on post-goal two block 'win-stay' task performance across the six sessions (within-subjects factor). Analysis again revealed only a significant effect of experimental group ($F_{(1,14)}=6.81$; $p < 0.01$), with no significant effect of session ($F_{(1,20)}=0.79$; $p=0.427$) nor session x group interaction ($F_{(1,20)}=0.72$; $p=0.454$). Bonferroni corrected pair-wise comparisons reported that the two experimental groups only significantly differed in sessions one and five ($p < 0.01$). The overall average post-goal two block 'win-stay' task performance, across the four sessions, is once again clearly impaired in the hippocampal-lesioned relative to the sham-operated rats (shown in figure 5.16b) and analysis with one-way ANOVA reported this to be highly significant ($F_{(1,94)}=15.76$; $p < 0.001$).

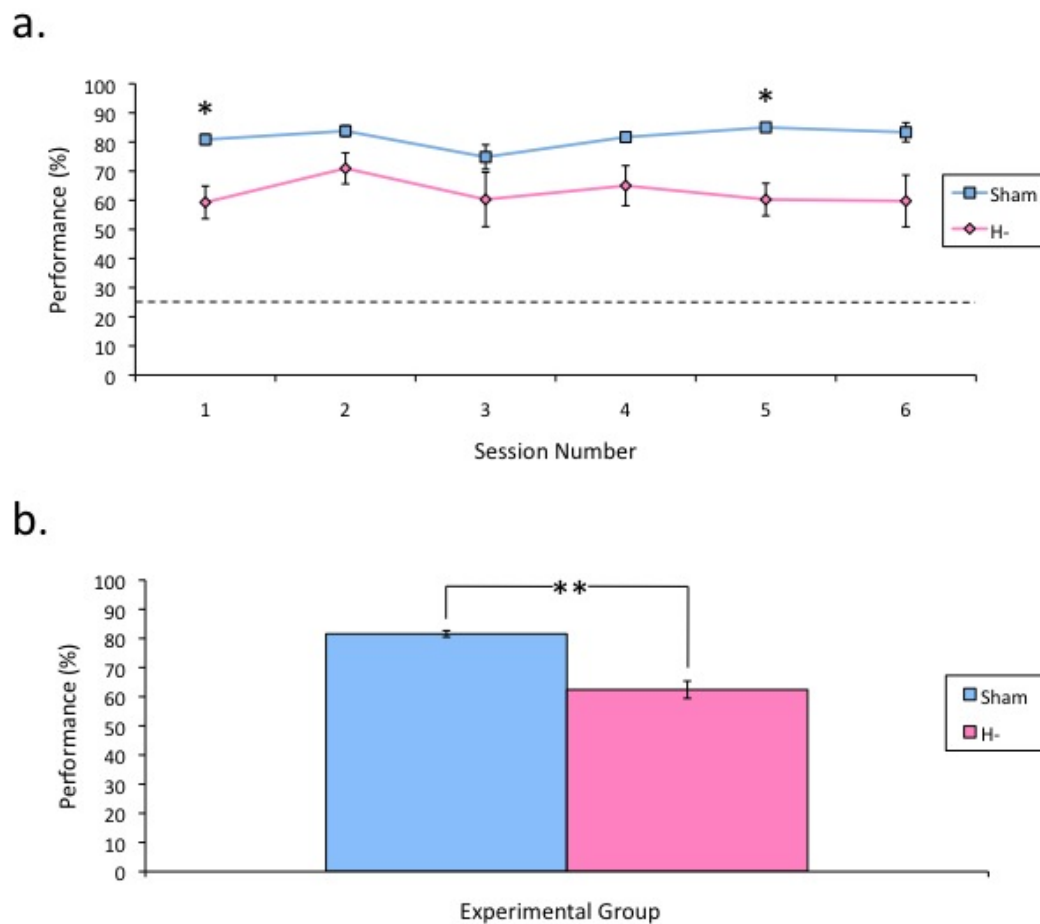

Figure 5.15: The average behavioural two block ‘win-stay’ task performance of the sham (blue) and hippocampal-lesioned (pink) rats is plotted for: **(a)** all six sessions of the two block ‘win-stay’ task, where both groups can be seen to be demonstrating above chance-level performance (represented by the dashed line) throughout the sessions, and **(b)** the overall average performances of the experimental groups in the two block ‘win-stay’ task. From both graphs the hippocampal-lesioned rats can be clearly seen to be impaired in performance of this task relative to controls. All data is displayed as mean values \pm SEM; for comparisons between groups: (*) $p < 0.01$, (**) $p < 0.001$.

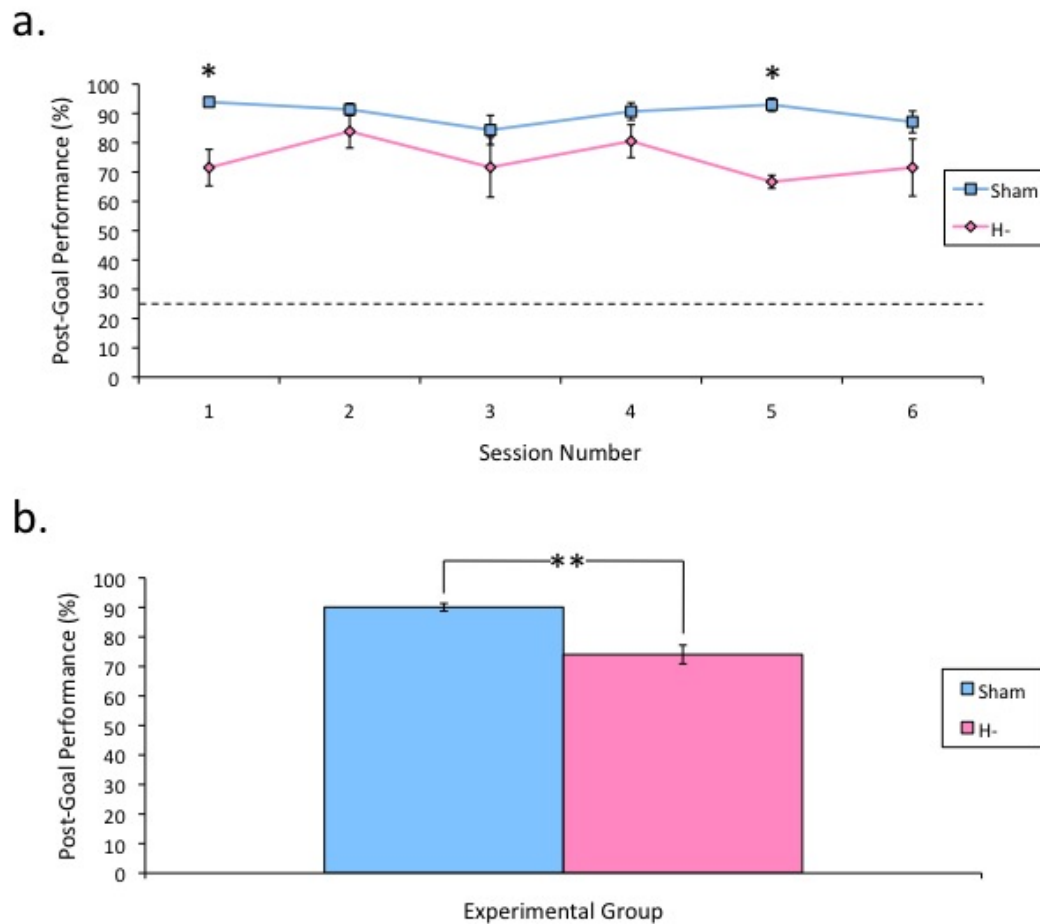

Figure 5.16: The average behavioural two block ‘win-stay’ task post-goal performance of the sham (blue) and hippocampal-lesioned (pink) rats is plotted for: **(a)** all six sessions of the two block ‘win-stay’ task, where both groups can be seen to be demonstrating above chance-level performance (represented by the dashed line) throughout the sessions, and **(b)** the overall average post-goal performances of the experimental groups in the two block ‘win-stay’ task. The post-goal performance of the hippocampal-lesioned rats can be clearly seen to be impaired relative to control levels throughout the task. All data is displayed as mean values \pm SEM; for comparisons between groups: (*) $p < 0.01$, (**) $p < 0.001$.

These results indicate that the impaired performance of the hippocampal-lesioned rats in this task is not solely due to an inability to locate the rewarded goal box at the start of each block. To further identify the source of impairment induced by hippocampal lesioning in the two block 'win-stay' task, the type of errors made were further examined. In figure 5.17a the hippocampal-lesioned rats can be seen to be making consistently more errors than controls throughout the sessions of the two block 'win-stay' task. Analysis with repeated-measures ANOVA reported only a significant effect of experimental group ($F_{(1,14)}=11.74$; $p<0.01$), with no significant effect of session ($F_{(2,24)}=0.79$; $p=0.483$) nor session x group interaction ($F_{(2,24)}=0.29$; $p=0.717$) on the total number of errors made. Bonferroni corrected pair-wise comparisons reported that the two experimental groups only significantly differed in sessions one and five ($p<0.01$), with the average total number of errors made across the two block 'win-stay' sessions significantly differing across experimental groups ($F_{(1,94)}=28.2$; $p<0.001$). The number of 'repeat' errors were then separately assessed to determine whether these were the underlying cause of the deficits observed in the hippocampal-lesioned rats' performance. In figure 5.17b the number of 'repeat' errors made by both groups can be seen to be clearly higher across all sessions in the lesion compared to sham group. A repeated-measures ANOVA again revealed only a significant effect of experimental group ($F_{(1,14)}=10.18$; $p<0.01$), with no significant effect of session ($F_{(5,70)}=0.61$; $p=0.693$) nor session x group interaction ($F_{(5,70)}=0.72$; $p=0.61$) on the number of 'repeat' errors made. Bonferroni corrected pair-wise comparisons reported that the two experimental groups only significantly differed in sessions four, five and six ($p<0.01$), with results from a one-way ANOVA revealing a significant effect of experimental group on the average number of 'repeat' errors made across the sessions ($F_{(1,94)}=19.03$; $p<0.001$).

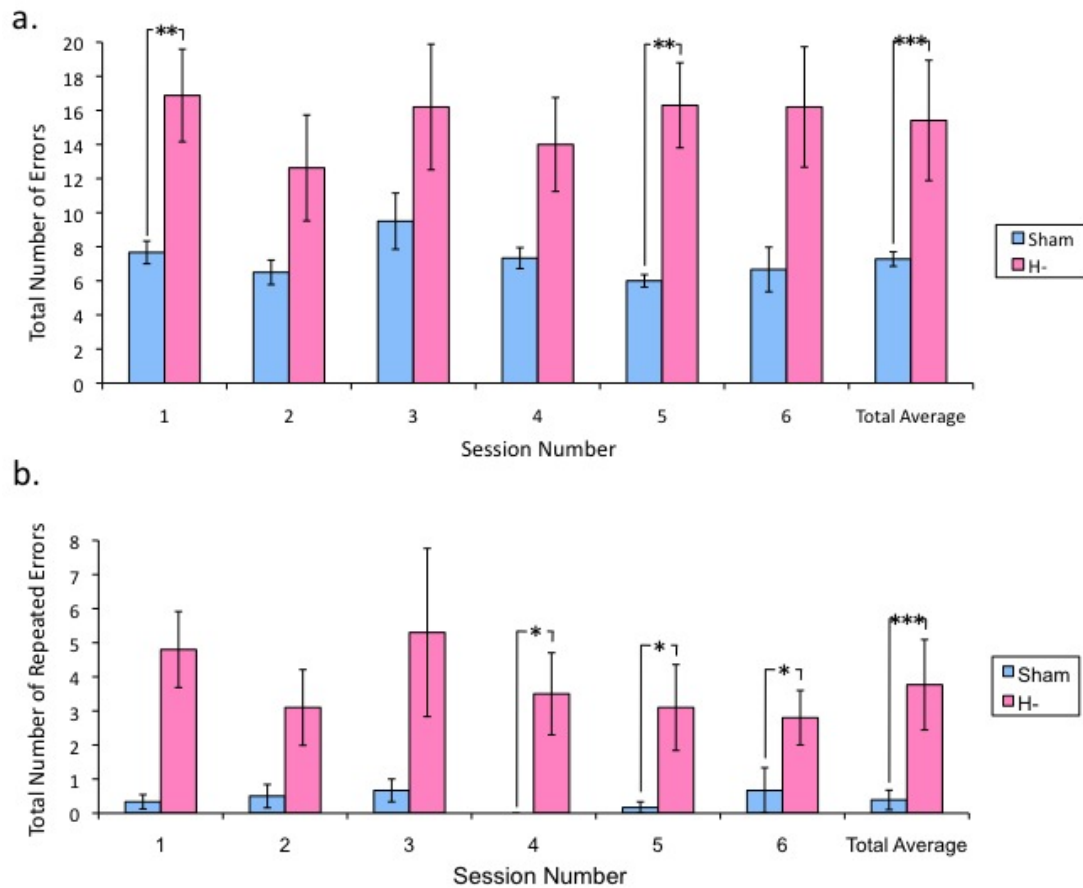

Figure 5.17: The average number of errors made in the two block ‘win-stay’ task is displayed for the sham (blue) and hippocampal-lesioned (pink) rats. **(a)** The total number of errors is plotted for each group across the six sessions, with the total average number of errors for each group across the task displayed. Hippocampal-lesioned rats can clearly be seen to make more errors throughout the duration of the task relative to controls. **(b)** The total number of ‘repeat’ errors made by each group are shown across the six sessions and as an average across the task, where ‘repeat’ errors refer to those in which an incorrect goal box is re-visited on the subsequent trial. Hippocampal-lesioned rats are shown to make a greater number of ‘repeat’ errors throughout the task sessions. All data is displayed as mean values \pm SEM; for comparisons between groups: (*) $p < 0.05$, (**) $p < 0.01$, and (***) $p < 0.001$.

The errors made by the groups were then compared across the two blocks of each session separately to assess whether the switching of reward within the session had a detrimental effect on the hippocampal-lesioned rats' performance. In figure 5.18a it can be seen that the hippocampal-lesioned group makes significantly more errors in both blocks, relative to controls, with an overall increase in the number of errors made in block two relative to block one. In contrast there appears no discernible difference in the number of errors made by the controls across the two blocks. A repeated-measures ANOVA was used to assess whether the experimental group (between-subjects factor) or the block (within-subjects factor) had a significant effect on the number of errors made within the session (within-subjects factor). The results revealed a significant effect of group only ($F_{(1,14)}=11.74$; $p<0.01$), with no significant overall effect of session ($F_{(2,24)}=0.48$; $p=0.591$), block ($F_{(1,14)}=3.89$; $p=0.069$), session x block interaction ($F_{(4,53)}=0.52$; $p=0.711$), session x group interaction ($F_{(2,24)}=0.29$; $p=0.717$), block x group interaction ($F_{(1,14)}=2.82$; $p=0.115$) nor session x block x group interaction ($F_{(4,53)}=0.95$; $p=0.439$). Bonferroni corrected pair-wise comparisons reported that the two experimental groups only significantly differed in sessions one and five ($p<0.01$), with sessions one and two significantly differing only in the hippocampal-lesioned group ($p<0.05$). Furthermore, the effect of block was only found to be significant on the errors made by the hippocampal-lesioned group ($p<0.01$), with no effect of block reported in the control group ($p>0.05$). Therefore, throughout the sessions hippocampal-lesioned rats made more errors than controls but whereas controls made a comparable number of errors across the two blocks of the sessions, the hippocampal-lesioned rats made significantly more errors in the second block of each session, indicating that the within-session shift of reward location contributed to the overall impaired performance of the hippocampal-lesioned rats.

To examine whether the lesioned rats were specifically impaired in extinguishing previously reinforced behaviours, the number of errors made by the groups in block two were then compared for 'mean random' or 'perseverative' errors separately across each session. For the trials in block two of this task, the rats could either correctly run to the rewarded goal box or they could return to the goal box rewarded in the first block of trials of that session (termed a 'perseverative' error) or they could run to one of the other two unrewarded arms ('random' error). As there were two 'randomly' incorrect goal boxes the mean number of 'random' errors were used to enable fair comparisons to be made. In figure 5.18b it can be seen that both groups make more 'perseverative' than 'random' errors across the task sessions, with the hippocampal-lesioned group making significantly more errors overall, relative to controls. A repeated-measures ANOVA was used to assess whether the experimental group (between-subjects factor) or the type of error (within-subjects factor) had a significant effect on the number of errors made within the session (within-subjects factor). The results revealed a significant effect of group ($F_{(1,14)}=18.43$; $p<0.001$) and type of error ($F_{(1,14)}=14.60$; $p<0.01$) but no significant effect of session ($F_{(5,70)}=0.39$; $p=0.854$), session x group interaction ($F_{(5,70)}=0.82$; $p=0.502$), type of error x group interaction ($F_{(1,14)}=0.09$;

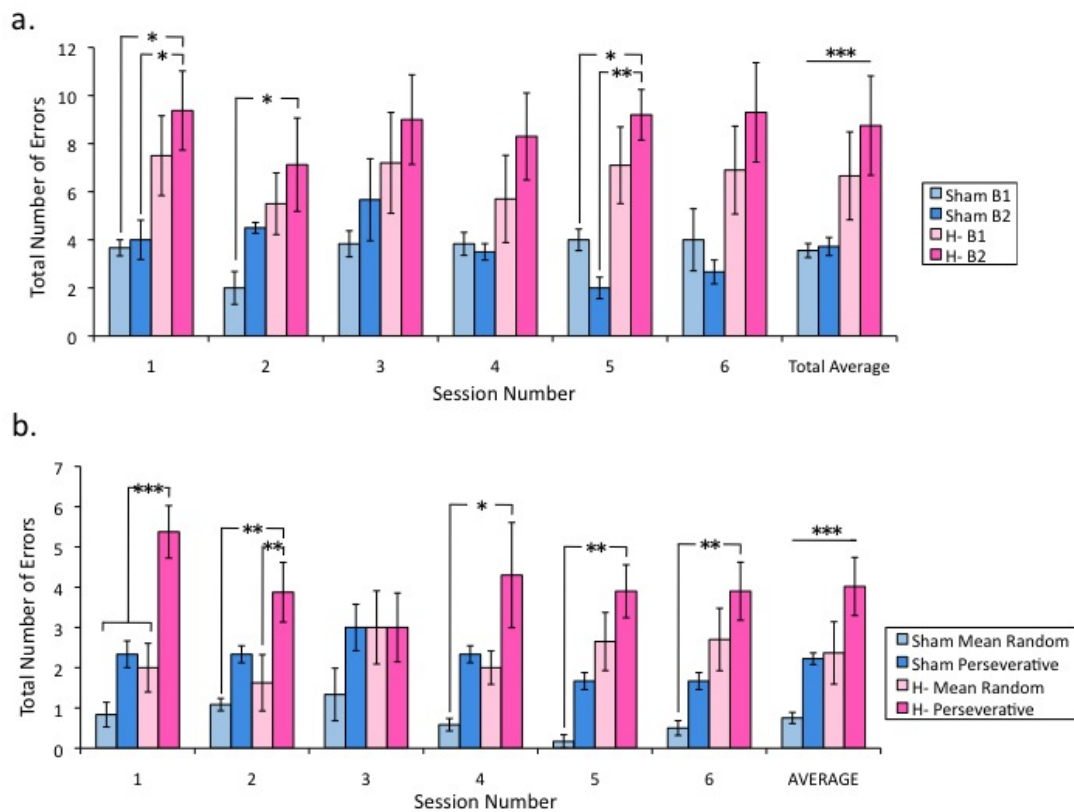

Figure 5.18: The average total number of errors made in the two block 'win-stay' task by the sham (blue) and hippocampal-lesioned (pink) rats is plotted across the six sessions with the overall task average displayed. **(a)** The total number of errors made by the groups in each block of the sessions is shown where the lighter shades represent the first block of trials and the darker shades represent the second block of trials for each group. The hippocampal-lesioned rats appear to make more errors in block two relative to block one and demonstrate a higher error rate overall than the errors made by the control group, which do not seem to differ across blocks of the sessions. **(b)** The graph displays the type of errors made by each group in block 2, where errors to the previously rewarded goal box from the first block of the session are labelled 'perseverative' and are represented by darker shades and errors made to the other two unrewarded goal boxes are averaged and labelled 'mean random'; and are displayed in the lighter shades for each experimental group. From the graph both groups appear to make more 'perseverative' than 'mean random' errors, with hippocampal-lesioned rats making more errors overall. All data is displayed as mean values \pm SEM; for comparisons between groups: (*) $p < 0.05$, (**) $p < 0.01$, and (***) $p < 0.001$.

$p=0.764$), session \times type of error interaction ($F_{(5,70)}=1.09$; $p=0.376$) nor session \times error \times group interaction ($F_{(1,14)}=18.43$; $p=0.344$). Bonferroni corrected pair-wise comparisons reported that the two experimental groups only significantly differed in sessions one ($p < 0.01$), five ($p < 0.01$) and six ($p < 0.05$). Furthermore, the greater number of 'perseverative', opposed to 'random', errors was found to be significant for both the sham-operated controls ($p < 0.05$) and also the hippocampal-lesioned rats ($p < 0.01$).

5.4 Conclusions & Discussion

The experiments in this chapter were designed to investigate the functional significance of the goal-sensitive firing patterns which were previously shown to develop alongside performance in a spatial ‘win-stay’ task (see chapter 4). Despite neural activity being altered by behavioural events during learning, it does not necessarily follow that the structure in which the neural correlates were identified is required to support behavioural performance and indeed, as previously discussed, some tasks which revealed hippocampal activity related to behaviour have not been found to depend on the hippocampus and likewise hippocampal-dependent tasks do not always result in task-related firing of hippocampal cells. Thus, in this chapter the effect of lesioning the hippocampus was investigated on behavioural task performance in a similar protocol to that in which goal-sensitive firing of hippocampal place cells was previously found to emerge in line with the spatial task performance.

The results obtained in this study revealed that the behaviour of both the hippocampal-lesioned and sham-operated rats in the initial ‘random’ task sessions was similar, with both groups showing a tendency to adopt a win-shift strategy initially, with win-stay behaviour emerging across the task sessions. Once the ‘win-stay’ task was introduced, a significant impairment in the hippocampal-lesioned group’s performance quickly emerged, with deficits present from the first session. Despite performance levels improving across sessions five to eight, the hippocampal-lesioned rats’ performance failed to reach control levels across the 14 sessions over which the task was conducted, although performance was above chance levels from the first session. To determine whether this deficit was due to a specific inability to learn the ‘lose-shift’ component of the task, post-reward behaviour was separately examined, in which only win-stay behaviour was required. The hippocampal-lesioned rats remained significantly impaired, relative to controls, when only post-reward behaviour was examined and again performance levels did not reach control levels over the 14 sessions in which the task was conducted. Furthermore, these impairments were not contributed to by lesion-induced alterations in running speed, as the two experimental groups demonstrated comparable trial times in both the ‘random’ and ‘win-stay’ tasks. The results obtained thus demonstrate the dependence of ‘normal’ acquisition and performance of the ‘win-stay’ double Y-maze task on the hippocampus, where the hippocampus appears necessary for rats to successfully learn the task to support fluent performance.

Unlike the results obtained herein, Ainge et al. (2007a) found that hippocampal-lesioned rats were only impaired in the second block of trials after the rewarded location had been reversed, but were unimpaired in overall performance, where the lesioned rats were able to return to the rewarded goal-box, once it’s location had been identified (post-goal performance). There were some key differences between the protocol employed across the studies which may account for these differences. Firstly, and most importantly, rats in this study were naïve to both the maze and the task before training commenced, whereas previously Ainge et al. (2007a) studied rats which

were pre-trained prior to surgery. Therefore, it could be that the hippocampus is only necessary during the learning phase of the task (in which the goal-sensitive firing was previously shown to develop) but following task acquisition, performance may be supported by extra-hippocampal structures and thus the impact of hippocampal lesions following training would be diminished. Additionally, the protocol employed by Ainge et al. (2007a) was subtly different to the 'win-stay' task conducted in this thesis. The 'win-stay' task described by Ainge et al. (2007a) involved only two blocks of 10 trials in which two goal locations were rewarded at any one time, the combination of which differed across sessions, which were switched following the first block of trials. Thus, the chance of the rats obtaining rewards by chance was increased two-fold and the number of times the reward contingencies changed within a given session was reduced by two thirds relative to the task employed herein. This not only reduces the mnemonic demands of the task but as the rats are more likely to enter the rewarded goal boxes by chance, the lesioned rats are more likely to receive reinforcements of correct behaviour thus enhancing learning of the win-stay rule. Furthermore, to enable direct comparison across studies, the same protocol was employed in the present chapter as in chapter 4 and therefore, unlike the study of Ainge et al. (2007a), the rats experienced the 'random' task prior to the training of the spatial 'win-stay' task. Although the 'random' task did not require learning of any spatial strategies, its inclusion may have led rats to adopt differing strategies which could have had an impact on the results obtained. This is unlikely; however, due to the fact that both the lesioned and control rats performed similarly on this task and that the control rats acquired the 'win-stay' task across a similar time-scale to that previously reported when only the 'win-stay' task was employed (see chapter 3), and performed the task to comparable levels to those reported by Ainge et al. (2007a).

In order to ascertain the specific ability in which the hippocampal-lesioned rats were impaired in the 'win-stay' task employed in the current study, a further set of experiments were conducted. The results obtained demonstrate that the hippocampal-lesioned rats were able to successfully adopt a win-stay strategy under conditions in which the rewarded goal box does not shift within the session and although performance was initially impaired when the goal location shifted between sessions, the hippocampal-lesioned rats quickly learnt to perform the one-block win-stay task when the reward location remained stable within the session but shifted across sessions. This demonstrates that the impairment in the four-block 'win-stay' task was not due to an inability to learn a basic win-stay rule, which is consistent with previous studies in which simplistic win-stay tasks were not found to be hippocampal dependent (McDonald and White 1993; Packard et al. 1989), where performance is likely to be supported by the development of a conditioned response (egocentric strategy), thought to depend on the striatal system (McDonald and White 1993; Packard et al. 1989).

A simplified version of the main 'win-stay' task was then implemented in which the rewarded goal box shifted across two blocks within each session, with 20 trials performed prior to the reward

location changing. Performance levels of the hippocampal-lesioned rats in this task were shown to be significantly impaired relative to controls and no improvements were observed in performance levels over the six sessions in which the task was conducted. The results from this task therefore demonstrate that switching the rewarded goal box once within the session is sufficient to reveal an impairment within hippocampal-lesioned rats.

The fact that the hippocampal-lesioned rats' performance levels did not reach that of the controls in the 14 sessions over which the 'win-stay' task was conducted implies that the more slowly acquired hippocampal-independent strategy is not sufficient for fluent performance to be obtained in this task, as opposed to studies such as that by Kim and Frank (2009) where only the rapid learning of spatial alternation was impaired when hippocampal lesions were performed prior to training. In the study by Kim and Frank (2009) the task only required the rats to learn a pre-defined sequence of turns to support alternation performance such that the rats visited the three arms of the W-maze in the following order: left-central-right-central-left. This type of performance, unlike that required in the main 'win-stay' task reported in the present chapter, could be supported by a simple procedural strategy based on a series of egocentric turns, reliant upon the striatum. It is likely that a hippocampal-independent procedural strategy was adopted by the hippocampal-lesioned rats in the present study to support the above chance level ability to return to the rewarded goal box within blocks. It is also likely that this procedural strategy enabled fluent performance in the one-block 'win-stay' tasks; however, as these tasks were performed after both the 'random' and the main 'win-stay' task, any retardation in learning the 'win-stay' rule in the hippocampal-lesioned rats relative to controls (for which the rapidly acquired hippocampal-strategy could have been utilised) is likely to have been masked.

As opposed to the ability to return to a rewarded goal box within a simplified one-block 'win-stay' session, the ability to perform the two- and four-block 'win-stay' tasks, where the reward location shifts within the session, therefore appears to depend upon hippocampal processing. This replicates the previous findings by Ainge et al. (2007a) that the hippocampal-lesioned rats have an impaired ability to respond to changes in spatial reinforcement. The results are also consistent with the theory that the hippocampal-lesioned rats adopted a procedural strategy in order to perform the one block 'win-stay' task, as this would yield no deficits in purely win-stay behaviour but when there is a shift in reward location within the session, performance based on a procedural strategy would be impaired relative to one based on a more complex allocentric strategy, thought to depend on the hippocampal system (Becker et al. 1980; McDonald and White 1993). This impairment would be induced in the two or four block 'win-stay' tasks as the pattern of motor sequences which led to reward in the previous block would need to be inhibited and then once the rewarded goal box of the current block had been identified the rat would need to visit it over a sufficient number of times such that the sequence of egocentric turns leading to the rewarded goal box could be reinforced to support performance. As the hippocampus is thought to be necessary for inhibit-

ing previously reinforced behaviours (Ainge et al. 2007a; Chan et al. 2001; Holland et al. 1999; Jarrard et al. 2004; Kimble 1968; Schmelzeis and Mittleman 1996; Whishaw and Tomie 1997) it is likely that the hippocampal-lesioned rats would be more affected from interference occurring across the blocks of each experiment and as more errors are made, there are less reinforced trials before the rewarded goal location is switched again making it very difficult to acquire the rules of the task. This effect is apparent in the results presented as the lesioned, but not the control, rats made significantly more errors in the second block of trials after the rewarded location had shifted than in the first block of trials. One would have expected the perseverative errors to have comprised a greater proportion of the errors performed by the hippocampal-lesioned rats, relative to the controls, as was found previously (Ainge et al. 2007a), due to an inability to suppress previously rewarded behaviour; however, this was not the case in the current study. This may have been due to an inability of the hippocampal-lesioned rats to inhibit behaviour not only from the immediately preceding block of trials but also from rewarded goal boxes from other previous blocks, especially in the main task where all four goal boxes are rewarded once for each block of the session. As previously discussed, this affect of multiple types of errors arising from each block of the trial would not have impacted the results obtained by Ainge et al. (2007a) as each session only consisted of two blocks of trials. The hippocampal-lesioned rats in this study did make a greater proportion of 'repeat' errors than controls, in which an unrewarded goal box was visited over consecutive trials, signifying some inability to inhibit previously unsuccessful performance. Additionally, in some of the blocks the hippocampal-lesioned rats only visited the rewarded goal box on a few occasions such that behavioural responses to the correct goal box was not sufficiently rewarded for the rats to be able to learn the reward contingencies of the task. In contrast, the control rats are likely to have been adopting a hippocampal-dependent allocentric strategy in which the rat would be able to recall which goal boxes had been visited, whether the reward had been located there and when this occurred (within the current block of trials or not). Thus, previously rewarded behaviour would quickly be inhibited once the rat found the reward location to be empty and a hippocampal-dependent search strategy using the 'lose-shift' rule could be adopted to efficiently identify the reward location at the start of the next block of trials, enabling successful performance to be achieved.

The findings reported in the current chapter therefore support the theory that the hippocampus is necessary for the flexible use of context-rich information to guide decision making and planning but when hippocampal processes are unavailable a habit-based procedural strategy can be adopted. Previously, in a conditional T-maze task, where rewarded location (left or right) was cued with distinct tones, differential firing was identified in striatal neurons during the learning phase of the task (Barnes et al. 2005; Jog et al. 1999). It would be interesting to record striatal neurons to investigate any developments of goal-sensitive firing patterns during the learning and overtraining periods of the different 'win-stay' task protocols employed in the present study and

these could then be compared with the development of goal-sensitive cells in the hippocampus. This could also be extended to explore structure dependence in a lesion study, in order to further investigate any interactions between these regions in spatial ‘win-stay’ task performance on the double Y-maze. Although there is no direct connection between the striatum and CA1 there is an indirect pathway through the global pallidus and temporal cortical structures and striatal activity can influence hippocampal activity, as inactivation of the dorsal striatum was found to disrupt the hippocampal EEG (Gengler et al. 2005). There is however, no evidence to date that has found striatal activity to affect activity in CA1.

The habit-based egocentric strategy was found to be sufficient for lesioned rats to obtain rewards in the ‘purely win-stay’ task but in the two- and four-block ‘win-stay’ tasks where the reward location shifts too frequently for the lesioned rats to decipher the successful trajectory to make, the procedural strategy is inefficient resulting in impaired performance of the lesioned, relative to control, rats. It seems that hippocampal-independent processes are able to compensate to enable slower learning in some protocols, but protocols which require association of one-trial complex associations, such as ‘what-where-when/which’, or necessarily require allocentric space to be used, can not be compensated for by extra-hippocampal processes. In the double Y-maze task, the purely ‘win-stay’ element was not found to be impaired in rats which had received much experience on the maze. This is not surprising as this appetitive behaviour which can be slowly learnt using an egocentric strategy is likely to be supported by structures such as the striatum. The consistent impairment seen in the double Y-maze ‘win-stay’ task for hippocampal-lesioned rats, relative to controls, demonstrates that even after many weeks of training the rats still can not learn in a hippocampal-independent manner, suggesting that the combination of the win-stay and lose-shift elements across the four blocks in each session necessitates either the use of allocentric space, or requires an episodic-like recollection of previous trials and future planning, which can not be supported by extra-hippocampal regions. For successful ‘win-stay’ task performance, the rat must recall ‘where’ (which goal box) and ‘when’ (to distinguish whether the event occurred within the current block of trials) and ‘what’ happened (whether the reward was obtained) from the previous trials experienced, and use this information flexibly to direct the current behaviour to increase the chances of successfully returning to/finding the rewarded goal box on the current trial. It is possible that a combination of retrospective and prospective firing of goal-sensitive place cells are involved in this process, with retrospective encoding of the trajectory which led to the currently rewarded/unrewarded goal box (integrating the within-trial event features, ‘what-where-when’) used to inform the next trial, and prospective encoding used to plan the trajectory which is most likely to lead to the rewarded goal-box being located, based on the recall of information from previous trials alongside the semantically learnt rules of the task.

Whilst these results provide further support for the functional role of the goal-sensitive hippocampal place cell firing, which was found to emerge during the learning phase of the ‘win-stay’

task (reported in chapter 3), they do not demonstrate a requirement for this specific place cell behaviour in task performance, as in this study the whole of the hippocampus was lesioned, not just the goal-sensitive cells previously recorded in CA1. In order for this to be demonstrated it would be necessary to record from the whole hippocampal region, identifying all cells with goal-sensitive firing patterns during behavioural performance and then specifically ablating these cells and subsequently testing the rats' behavioural performance on the task. The technology currently available; however, does not allow for such designs to be implemented and thus one can only speculate across lesion and recording studies at the present time.

The on-line monitoring of hippocampal cells during cognitive tasks provides a powerful insight into the neural circuitry which gives rise to the hippocampus' behavioural functions; however, relating these firing patterns to behaviour convincingly, remains a formidable challenge, made more challenging by the possibility that hippocampal processing may occur automatically and continuously regardless of the hippocampal-dependence of the task (Yeshenko et al. 2004). In the current chapter the functional role of the neural correlates of 'win-stay' performance in the double Y-maze, previously reported in chapters 3 and 4, were investigated by performing complete bilateral hippocampal lesions prior to training. The hippocampal-lesioned rats were found to be severely impaired in the 'win-stay' task suggesting that the goal-sensitive activity, which develops specifically in line with spatial 'win-stay' performance, is necessary for task performance. Furthermore results obtained from additional testing suggest that this impairment is due to the complex nature of this 'win-stay' task, which requires flexible responses to be made based on which locations had been visited, when and whether rewards had been obtained. Overall, the results reported over the last three chapters demonstrate that goal-sensitive firing of hippocampal cells emerge in line with behavioural performance in a hippocampal-dependent task and the emergence of these firing patterns are specific to the learning and memory demands of a spatial 'win-stay' protocol. Investigations such as these bring us tantalisingly close to bridging the gap between the neural coding of the principle hippocampal cells and the learning and memory functions of the hippocampus.

Chapter 6

The Role of the Postsubiculum in Spatial & Non-Spatial Recognition Memory

6.1 Introduction

One of the main roles of the hippocampus is believed to be in the spatial processing of allocentric information. Ordinarily the hippocampus is found to be necessary to support spatial object recognition (Mumby et al. 2002; Save et al. 1992), although, as previously reported in chapter 1, the dependence of performance on the hippocampus is only apparent when the object-place recognition protocol involves allocentric processing of the spatial information. As previously demonstrated in this thesis (chapters 1 and 2) and reported in numerous studies (Forwood et al. 2005; Gaskin et al. 2003; Good et al. 2007; Mumby et al. 2002, 2005; Winters et al. 2004), the hippocampus is not required for non-spatial object recognition, thus the hippocampus must become involved specifically to support the association of the object with the allocentrically-coded location in which it was presented. The aim of this chapter is to further investigate the neural circuitry supporting this spatial component of episodic memory.

It would seem logical that the primary firing patterns of the hippocampus should underlie the main purported role of this region in the spatial processing of episodic memory. As the most conspicuous firing pattern of hippocampal neurons exists within place cells, investigation of the neurocircuitry which gives rise to the spatial properties of these cells provides a natural starting point to unravelling the neural circuitry involved in this important hippocampal function. Environmental information can exert 'control' over the activity of place cells (Sharp et al. 1995), grid cells (Hafting et al. 2005) and head direction cells (Goodridge et al. 1998), whereby rotations of a cue card within an environment results in a comparable rotation of the firing field of these neurons. Therefore, at each stage in the neural circuit, information regarding environmental cues is

capable of influencing the polarisation of cell firing. The spatial firing of place cells is partially dependent on inputs from the head direction cell network (Jeffery et al. 1997; Yoganarasimha and Knierim 2005), where the ability of hippocampal place cells to form a stable representation of the environment, based on available cues, is disrupted by lesions of the postsubiculum (Calton et al. 2003). It would appear, therefore, that the integration of environmental cues into the head direction cell network, and subsequently into the place cell representations, happens prior to hippocampal processing, thus the question of where this occurs, arises. Kentros et al. (1998) demonstrated that the ability of rats to maintain stable hippocampal place field representations of the environment was prevented by the application of NMDAR antagonists; however, the NMDAR antagonists were administered systemically and it is therefore unclear as to which structure(s) necessarily require(s) NMDAR-dependent plasticity to enable stable place field representations of the environment to be formed, in relation to the available environmental cues. A potential candidate is the postsubiculum, an input structure to the hippocampus and an important component of the spatial processing circuitry, which is ideally located to integrate information from cortical and sub-cortical areas. The postsubiculum also provides visual input to the hippocampus, via the entorhinal cortex, which is vital as the hippocampal place cell network is highly modulated by visual input (Bostock et al. 1991; Muller et al. 1987; O'Keefe and Nadel 1978; Shapiro et al. 1997; Tanila et al. 1997; Young et al. 1994), and is therefore likely to play an essential role in spatial processing. The postsubiculum contains head direction cells as well as place-by-head direction cells, and is reciprocally connected with area 28b of the visual cortex, the laterodorsal thalamic nuclei, which is involved in the transmission of visual information, and the retrosplenial cortex (van Groen and Wyss 1990). Thus the postsubiculum is an ideal candidate for the site of visual input integration into the internally generated head direction signal, which can in turn be processed by the hippocampal place cells to support allocentric spatial memory processing. One could argue that direct connections from the retrosplenial cortex to the entorhinal cortex may also be a potential candidate, especially as this region receives strong visual inputs and has also been found to contain head direction cells (Chen et al. 1994; Cho and Sharp 2001); however, specific lesions of the retrosplenial cortex have little effect on spatial learning (Aggleton et al. 1995; Warburton et al. 1998) and therefore it is unlikely to support the hippocampus' role in these tasks. Furthermore, the postsubiculum is necessary for head direction cell networks (in the anterodorsal thalamic nuclei) and place cell networks to fire in a stable manner with respect to the available visual landmarks within the environment (Calton et al. 2003; Goodridge and Taube 1997). Neither lesions immediately upstream of the postsubicular head direction signal (at the level of the anterodorsal thalamic nuclei), nor downstream of the postsubicular head direction signal (at the hippocampus) impair the stability of the head direction cell firing patterns, with respect to visual cues (Golob and Taube 1997). Moreover, lesions of the postsubiculum have been reported to induce deficits in spatial behavioural performance (Taube et al. 1992), as discussed below. It is therefore conceivable that the postsubiculum is necessary to

provide the hippocampus with a stable representation of the available environmental landmarks. In regard to the hippocampus' role in object-place recognition, this representation would enable the position of the objects to be represented, with respect to the environmental scaffold, which could support a subsequent mismatch detection when an object is re-located, relative to the sample phase, inducing greater exploration levels of the novel object-place representation.

As previously discussed in the introduction (section 0.4.2), there has been much interest in the cells of the postsubiculum, but the behavioural function of the postsubiculum has received little attention. From the few behavioural investigations which have been carried out on the postsubiculum, a potential role in spatial memory has emerged. The behavioural effects of lesions to the postsubiculum were tested by Taube et al. (1992) in a range of spatial and non-spatial memory tasks, in which performance was found to be impaired only in tasks requiring spatial processing. Of the tasks conducted, two tested spatial memory and two tested learning in non-spatial paradigms. The water maze was used to test the ability of the rats to locate a hidden platform which was either cued (non-spatial condition) or uncued (spatial condition). In the spatial version of the task, rats were placed into the pool at one of four possible entry points, with the platform position remaining stable in regard to the experimental room across sessions, and would therefore be likely to require a hippocampal-dependent allocentric spatial strategy to be employed in order to determine the location of the platform, and subsequently escape. Postsubicular lesions impaired performance, relative to controls, only in the uncued spatial version of the task, suggesting a role for the postsubiculum in the processing of allocentric spatial information. The lesioned rats were also impaired in the spatial radial arm maze task, in which rats were required to visit each arm of the maze once in order to retrieve the water rewards initially available, but not replenished, at the end of each arm. Hippocampal-lesioned rats were also impaired on this task (Olton and Papas 1979), despite the fact that the task could be solved by employing an egocentric strategy, such as always turning right when exiting an arm. The necessity of the postsubiculum and the hippocampus in this task may occur due to the employment of an allocentric spatial strategy (despite this not being necessarily required) and/or the nature of the task, which requires the rat to alternate choices on successive trials without returning to a previously visited arm, which therefore taxes working memory, as rats must keep track of which arms had been visited, which could necessitate the postsubiculum and hippocampus. The postsubicular lesions did not induce a general learning deficit as performance on both the cued version of the water maze and also a conditioned taste aversion task were unimpaired (Taube et al. 1992).

Lesions of the pre-/para-subiculum (which includes the postsubiculum) have been reported to disrupt the spatial resolution of hippocampal place fields (Liu et al. 2004), supporting a role for this region in the preservation spatial firing specificity in the hippocampal place cell network, which is likely to underlie the performance impairments induced by pre-/para-subicular lesions (Jarrard et al. 2004; Kesner and Giles 1998; Liu et al. 2001). Kesner and Giles (1998) revealed

that bilateral lesions of the pre-/para-subiculum impair rats' performance in a continuous spatial recognition task in the radial arm maze. Furthermore, Liu et al. (2001) found that rats with pre-/para-subicular lesions were impaired in a range of spatial memory tasks, including: a delayed non-match to place task in the T-maze; reference and working memory tasks in the water maze; and spatial object recognition memory; but they were not impaired in the non-spatial cued versions of the water maze task. Surprisingly, Liu et al. (2001) reported an impairment in non-spatial object recognition performance of the lesioned rats (discussed below). More recently, Jarrard et al. (2004) tested the effects of specifically lesioning different regions of the medial temporal lobe on performance in spatial and non-spatial versions of the radial arm maze and found similar deficits in rats with pre-/para-subicular lesions relative to those observed in the hippocampal-lesioned group, specifically in spatial memory tasks. In the non-spatial working memory task on the radial arm maze pre-/para-subicular lesions were found to enhance performance, presumably resulting from a loss of the competing spatial strategy. Hippocampal lesions, however, did not enhance performance and actually resulted in an impairment in early in training, which is likely due to the role of the hippocampus in inhibition rather than spatial processing (Chan et al. 2001).

Overall, these studies suggest a role for the postsubiculum in supporting hippocampal-dependent spatial memory, with the exception of the impaired non-spatial object recognition performance resulting from pre-/para-subicular lesions, reported by Liu et al. (2001). The results of this non-spatial object recognition task are shown in figure 6.1a, where it can be clearly seen that object novelty induced significantly greater levels of exploration in both the lesioned and control rats, suggesting that the pre-/para-subiculum is not necessary to support non-spatial detection of novelty. Liu et al. (2001) focus on the significant difference between the levels of exploration of the novel object between the lesioned and control rats; however, this may simply be due to an overall reduction in exploration levels (shown in figure 6.1b), and the authors report a significant lesion-induced reduction in exploration levels even in habituation sessions. The protocol employed is also not ideal for purely testing non-spatial object-recognition memory, as the ability to determine the novel object was examined in a series of object recognition tasks in which the same objects and positions were used across task-type. The series of object recognition tasks involved four objects being presented to the rats in a testing box over a five-minute period (phase one), after which the rats were exposed to the testing arena again for a five-minute period completing the second exposure phase of the day. On the first two days the objects and locations were fixed for both sample phases, whereas on day three two of the objects switched locations (the object displacement test), relative to those presented in the first sample phase and on days one and two. Object recognition testing took place in the second sample phase on days three and four, where one object was replaced by an entirely new object. Finally the reaction to object dislocation was tested in the second phase on days six and seven, with one of the objects positions shifting towards (day six) or away (day seven) from the other objects presented. The first phase of each day was identical,

with the same objects being presented to the rat in the same locations. This may well have had an undesired impact on the ability to detect object novelty as the repeated exposure to the same objects in constant locations may have resulted in the rats encoding the objects as intra-maze cues, especially as there were no visual cues present in the testing arena, and odour cues and auditory cues were eliminated through the use of alcohol wipes and white noise respectively. Also, the ability to detect object novelty was tested after the rats had experienced the displacement task which may have also affected the relative novelty of the objects and locations in which the objects were presented.

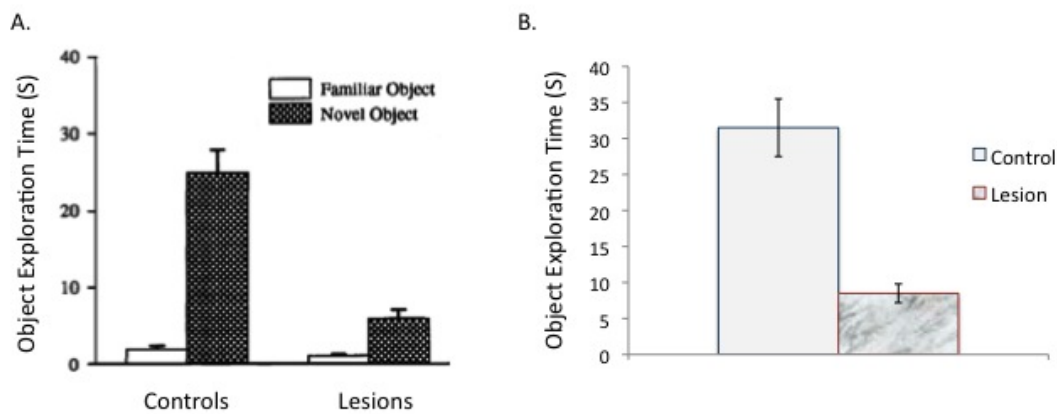

Figure 6.1: Graphical representations of the results obtained in the non-spatial object recognition task described by Liu et al. (2001). **(a)** The raw test-phase exploration times for the novel and familiar objects are shown for the control and the pre-/para-subicular lesioned rats. The lesioned rats have significantly lower levels of exploration of the novel object but both control and lesioned rats have a significant preference to explore the novel object. **(b)** The raw object exploration times in the test-phase are shown for the lesioned and the control rats, where pre-/para-subicular lesioned rats were found to significantly reduce test-phase exploration. Figure adapted from Liu et al. (2001).

As opposed to the series of object recognition tasks conducted by Liu et al. (2001), an object displacement task was employed in isolation by Larkin et al. (2008) to investigate the role of NMDARs in spatial learning. In this study four objects were presented in the formation of a square in a circular arena over three six-minute periods, separated by three-minute delay periods. Recognition testing then occurred after a 24-hour delay, where one of the four objects was moved into a new location, with the other three objects presented in the positions in which they were previously seen in the sample phases. The rats' exploratory preferences for displaced and stationary objects were then examined in three six-minute test phases, again interspersed by three-minute delay periods. The role of NMDARs in this task was assessed by examining whether an intraperitoneal injection of an NMDAR antagonist either prior to the sample phases or prior to the test phases impaired performance. Larkin et al. (2008) report that spatial object-place recognition was only impaired when the NMDAR antagonist was injected before the sample phases commenced. This demonstrates a role for NMDARs in the acquisition of spatial memory; however, as the NMDAR antagonist was administered intraperitoneally, the region(s) in which these NMDARs are necessary remains

unclear.

The effects of postsubicular lesions on both behavioural performance in spatial tasks and on the stability of the place cell and head direction cell networks could potentially be due to a specific role of the postsubiculum in integrating environmental landmarks with spatial representations in the neural networks. Alternatively, it is possible that the deficits observed both in the recording and lesion studies following postsubicular disruption arise as a result of an indirect postsubicular role in the transmission of this integrated spatial information. In this case, the postsubiculum would merely act as a relay between the structure involved in the generation of the integrated spatial representation and the hippocampus.

This study aimed to test the effects of blocking postsubicular plasticity on performance in an allocentric object-place cue-controlled task, where AP5 (to block NMDAR-dependent plasticity) and CNQX (to block AMPAR-mediated fast synaptic transmission) were used to determine whether the postsubiculum is necessary for object-place recognition, and, if so, whether it acts simply as a relay for the object location information or whether postsubicular plasticity itself is required. These antagonists were chosen as CNQX should block glutamatergic transmission, as previously it has been shown to eliminate postsubicular EPSPs *in vitro* (Funahashi and Stewart 1997) and *in vivo* (Shires et al. 2008). Additionally, NMDARs have been identified in the postsubiculum (Maragos et al. 1988) and NMDAR-mediated postsubicular responses were shown to be blocked by the application of an NMDAR antagonist *in vitro* (Funahashi and Stewart 1997). Additionally, hippocampal infusions of AP5 have been reported to induce impairments in spatial tasks, demonstrating a necessity for hippocampal NMDARs in spatial learning (Morris et al. 1986). If the necessary plasticity required to associate environmental features with the head direction network, to enable the hippocampus to form stable cue-based representations in the place cells network, is within the postsubiculum, then the application of AP5 into the postsubiculum should prevent this association of cues with the head direction system. This would result in an inability to encode the location of the sample-phase objects, in relation to the cue card and would therefore result in a lack of preference in test phase object-place combinations in the object-place recognition task. In contrast, if the postsubiculum merely acts as a relay for the head direction signal then novelty-induced exploratory preference in the object-place recognition tasks should be unaffected by AP5 infusions, but should be abolished following CNQX infusions. Thus, only if the postsubiculum is the site of convergence for visual cue information into the head direction and place cell networks, will the postsubicular plasticity be required, and therefore the AP5 infusions disrupt, the rats' ability to use the cue card to detect the displaced, and therefore least familiar, object.

In summary, this chapter focuses on elucidating the neural network involved in hippocampal-dependent spatial processing by investigating the role of the postsubiculum in the encoding of novel object-place configurations. As discussed throughout this thesis, the hippocampus is es-

sential for allocentric spatial memory, a function which necessarily requires visual information to be accessed, concerning the arrangement of landmarks and cues within the environment, in association with information regarding internal orientation and direction. Based on the current literature reviewed and the anatomical evidence, the postsubiculum emerges as a likely candidate for the incorporation of sensory cues into the internally generated head direction cell and place cell networks to enable this form of hippocampal-dependent spatial processing. This hypothesised function will be tested by comparing the effects of postsubicular infusions of AP5 or CNQX, antagonists of the NMDAR and AMPAR respectively, on object-place recognition (which requires object-place associations to be formed) and on object recognition (in which spatial associations are not required). Furthermore, the protocol employed enables any emergent role for the postsubiculum to be defined, where it either merely acts as a relay for head direction information to be transmitted to the hippocampus, or where NMDAR-mediated plasticity within the postsubiculum itself is necessary to support spatial object recognition memory.

6.2 Materials & Methods

6.2.1 Subjects

Thirty-four male adult Lister-Hooded rats (Charles River, UK) weighing 250-350 g at the time of surgery were used. Rats were housed in group cages and kept under 12 hour light/dark cycle, with all experimental procedures carried out in the light phase of the cycle. Rats were given *ad libitum* access to water and were food restricted, to 90% free-feeding body weight, two weeks after surgery. All procedures were performed in compliance with national (Animals [Scientific Procedures] Act, 1986) and international (European Communities Council Directive of 24 November 1986 [86/609/EEC]) legislation governing the maintenance of laboratory animals and their use in scientific experiments.

6.2.2 Bilateral Cannulae Implant Surgery

Prior to surgery all animals were anaesthetised with isoflurane (Abbott Laboratories Ltd.), placed on an isothermal heating pad and positioned into a stereotaxic frame (Kopf, CA). The skin was retracted to expose the skull. Small burr holes were made bilaterally into the skull, above the postsubiculum. Further burr holes were drilled at various positions and small stainless steel jewellers screws (Fine Science Tools GmbH, Heidelberg, Germany) were inserted, to ensure the dental cement fixed onto the skull securely. 26 Ga stainless steel guide cannulae (Plastics One, Bilaney, UK) were then lowered bilaterally to 3 mm below dura, at the postsubiculum (7.5 mm posterior to bregma and ± 5 mm lateral of the midline), at an angle of 20°. Dental cement (Simplex Rapid Acrylic Denture Polymer, Kemdent) was then placed around the cannulae and over the screws to ensure that the cannulae maintained their position. 33 Ga dummy cannulae were then inserted into

the guide cannulae, which protruded 0.5 mm from the end of the guide cannulae. The dummy cannulae were the same depth and diameter as the injection cannulae used for the experimental drug infusions (described in section 6.2.7), and were used to prevent infection or blockage of the guide cannulae.

A subcutaneous injection of 0.05 ml/kg analgesic (Small Animal Rimadyl, Pfizer, UK) in 2 ml saline was administered following surgery, at which time rats were returned to home cages for recovery. Analgesia (Large Animal Rimadyl, Pfizer, UK) was available in the rats' water, from 24 hours before until 48 hours, after surgery. All rats were given 14 days recovery from surgery and had surpassed their pre-surgery weights before the start of behavioural testing.

6.2.3 Apparatus

Object-Recognition Arena

All object recognition trials were conducted in a circular arena (76 cm diameter with 40 cm high walls), placed within a square wooden box (1 m x 1 m x 0.7 m). The black-painted wooden circular floor was surrounded by brown, wood-effect, sticky-backed plastic wall covering over a wire mesh frame. Two Dual-Lock (3M, UK) pieces were fixed to the floor of the arena 10 cm from away from the circular wall in the north-east and north-west positions, 23 cm apart. Objects were always attached at these positions onto the pieces of Dual-Lock. The arena was enclosed by white cotton curtains along the east, south and west sides, stretching 2 m from the base of the box and covering the roof of the enclosure, with a black cotton curtain along the north side and large 3D visual cues, such as a rainbow-coloured feather duster and a large plastic flower, were attached to the inside of the curtain, hanging over the testing arena. The arena was kept in a constant position, relative to the holding room, computer monitor, experimenter, etc., to standardise external cues and rats were always placed into and removed from the arena from the south side, facing the south. An overhead black and white camera (Panasonic, UK) was fixed centrally above the arena through a slit in the curtain enclosing the roof of the enclosure.

Object-Place Arena

All object-place recognition trials were conducted in a grey-painted, plastic, cylindrical arena (68 cm diameter with 50 cm high walls), with a white cue card placed in a fixed position extending from the base to the top of the walls (21 cm x 50 cm) and six pieces of Dual-Lock (3M, UK) fixed onto the cylinder base at equal locations around the perimeter (10 cm away from the walls), onto which objects could be positioned. The arena was enclosed by black curtains, which stretched 2 m from under the base of the box to over the top of the arena, preventing all light and external visual information from being detected inside the arena. There were three possible entry points available to the arena via slits in these curtains (depicted in figure 6.2). The arena was kept in a constant

position, relative to the holding room, computer monitor, experimenter, etc., to standardise external cues and a radio emitting white noise was attached centrally to the ceiling above the arena. A black and white camera (Panasonic, UK) and a light bulb were also attached alongside the radio in a central position above the arena, around which the curtains were hung.

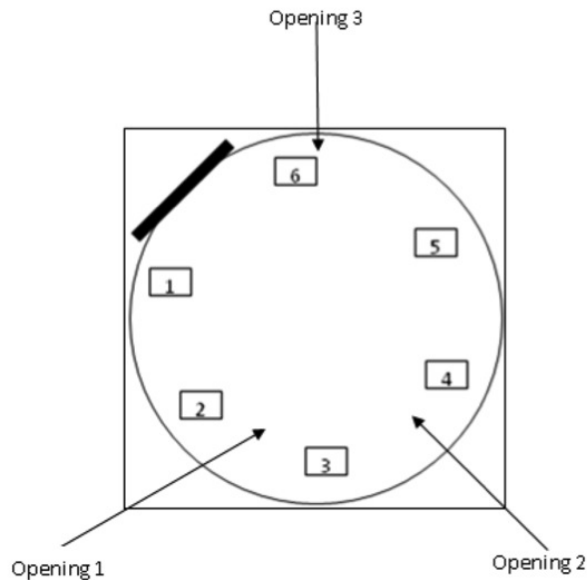

Figure 6.2: A schematic representation of the object-place recognition task testing arena (circle) with the Dual-Lock (3M, UK) pieces affixed to the base of the arena, in which the objects could be located, represented by rectangular boxes labelled 1-6, the square surrounding the circle symbolizes the black curtains, with the three potential openings where the rat could be placed into the arena, and a thick diagonal black line used to represent the white cue card, which is affixed inside the circular arena.

All objects used in behavioural testing were trial-unique and were presented in pairs, where object pairing was based upon pilot exploration data, such that they evoked similar levels of exploratory interest. Examples of objects used include: cups, bottles, toys and ornaments.

6.2.4 Preliminary Testing of the Behavioural Protocol

In order to develop the behavioural testing protocol outlined below, a subset of the rats involved in this study underwent a series of pre-surgery testing (data not shown) in which the duration of the recognition memory, the effects of alternating two different tasks on exploration, and also the effects of arena rotation were examined. The results of the preliminary tests of memory duration demonstrated that rats had a preference to explore the novel object-place configuration in the object-place recognition task and also the novel object in an object recognition task over a short three minute delay and, by repeating the sample phase across three identical five-minute exposures, this ability to detect novelty was maintained when rats were tested after a 24-hour delay. This longer delay is necessary in the main study to ensure that behaviour during testing was not affected by the infusions performed prior to encoding. The preliminary data also revealed that alternating

the two recognition tasks did not affect object exploration times nor the ability to detect the novel object. This enabled a more powerful integrated approach to be implemented in the main study, such that exploration of the two tasks could be tested in the same rats, under identical infusion conditions concurrently. Finally, the object-place recognition task employed in this study was designed to be allocentric, therefore to ensure that rats were not using any undetected cues within the environment, which could enable performance to be supported using an egocentric strategy, preliminary trials were conducted in which the effects of arena rotation on performance were tested. The exploratory preference for the novel object-configuration was not found to differ in 'rotation' trials, in which the object-place arena was rotated 120° between each sample phase, relative to 'stable' trials, in which the arena remained in a constant position throughout the object-place sessions, suggesting that rats were not using any extra-maze cues to support the detection of the re-located object.

6.2.5 Habituation

Prior to recognition memory testing four habituation sessions were performed in order to familiarise the rats to the two testing arenas. For the first habituation session rats were placed into the object-place arena with their cage mates, where they were allowed to freely explore the arena in the absence of objects for a 30-minute period before being placed in the holding bucket and transferred into the object recognition arena (located opposite the object-place arena) for another 30-minute period of free exploration. The following three habituation sessions were run in a similar manner with the exception that the rats were placed into the arena individually for 10-minute periods. Rats were disoriented by being placed into the object-place arena through a different opening, pseudo-randomly designated, in each of the three individual habituation sessions. Following the 10-minute exploration period in the object recognition arena the rat was placed back into the holding bucket for a further 10-minute period. After each habituation session the arena was wiped clean using warm soapy water and the rat was returned to the home cage in the adjacent holding room. The video camera relayed the rats movements onto the computer screen at which the experimenter was situated for all habituation and behavioural testing sessions, ensuring any extra-maze cues were kept constant.

6.2.6 Behavioural Testing

Recognition memory testing consisted of nine trials of the object-place recognition and the object recognition tasks, which were run concurrently in an alternating fashion (see figure 6.3 for an illustration of the experimental design, which are described in detail below). As described in section 6.2.4, the results of preliminary testing suggested that running object-place recognition and object recognition trials concurrently did not affect behavioural performance, therefore it was decided that the two tasks should be conducted in this alternating manner as it enables spatial and

non-spatial recognition memory to be tested simultaneously, in the same subjects, under identical conditions, strengthening the reliability of comparisons in performance levels across tasks.

Of the nine trials conducted, the first two trials were implemented prior to any infusion to ensure rats could demonstrate a preference for the most novel object and most novel configuration of object and location over a 24-hour period. These pre-infusion trials were followed by one mock infusion trial (described in section 6.2.7), which was run to ensure the stress induced by the infusion protocol did not significantly impair performance levels. The remaining six trials comprised the three drug infusion and three non-infusion trials, which were conducted alternately. The non-infusion trials were conducted using an identical behavioural protocol to that employed on infusion trials, with the exception that rats were transferred directly from their home cages to the testing room, rather than being taken to the infusion room and receiving drug infusions. Non-infusion trials were included in the experimental design to ensure that rats maintained a preference to explore the most novel object or object-place configuration after each infusion trial.

For both the sample and the test phase the rat was collected from either the infusion room (infusion trials) or from the rat's home cage in the holding room (non-infusion trials) and carried into the experimental room in the holding bucket and was then immediately placed into the experimental arena for the start of the first sample phase. In order to be transferred between the two experimental arenas between sample phases, and between test phases, the rat was placed back into the holding bucket. The experimental arenas and the objects were cleaned and the objects were positioned within each arena before both the sample/test phase commenced. For the three-minute test phase of the experiment, duplicate objects were used to ensure odour cues from the sample phase were not affecting exploration preferences. Following the termination of the object recognition test phase, the rat was returned to its home cage.

For each sample phase, in all tasks, the rat was allowed to freely explore the objects over a five-minute period. The objects used in behavioural testing were cleaned with baby wipes (Tushies UK) before being affixed to the arena floors. Object identity, position within the environment, object-place novelty, as well as infusion conditions were counterbalanced across rats to minimise the effects of natural preferences for locations and object types as well as the effects of repeated testing and infusions. Each object pair involved in the task were also chosen to be of relatively similar interest levels, based on preference testing of object exploration with a previous cohort of rats. Across the study, rats were only exposed to each object once.

Object Recognition Task

The non-spatial object recognition task was implemented in order to determine whether the rats were able to successfully encode and retrieve object identity from the sample phase to recognise a previously seen object as novel, and thus direct exploration to the novel object, measured by increased exploration of the novel relative to the familiar object. The task consisted of three iden-

tical sample phases, in which the rat was exposed to two identical objects, separated by three five-minute object-place task sample phases (see section 6.2.6 for task details). The test phase commenced 24 hours after the last sample phase. In the test phase, one duplicate of the sample-phase object was presented alongside a novel object (highlighted in figure 6.3), these were positioned in the two locations previously occupied by the sample phase objects.

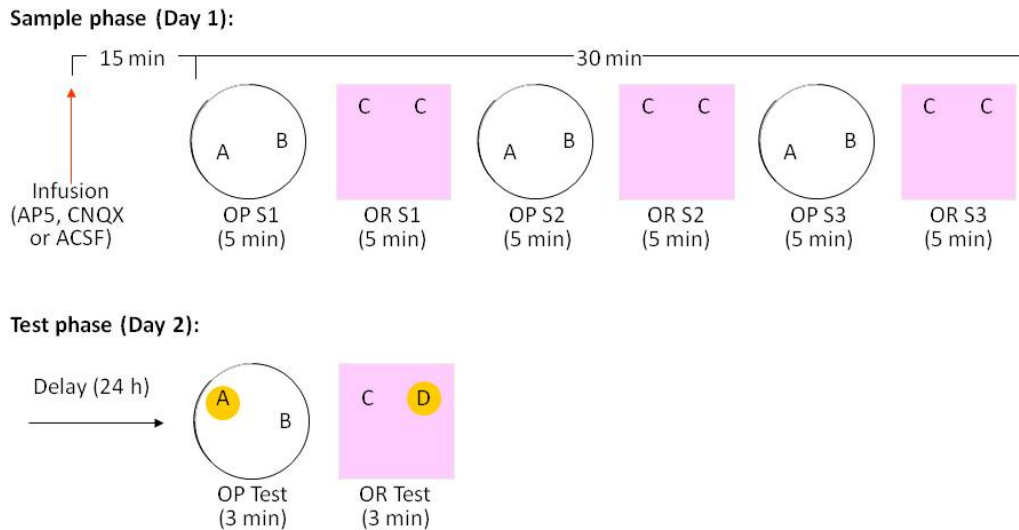

Figure 6.3: This is an illustrative diagram of the experiment protocol. Infusion sessions required the infusion (represented by the red arrow) to take place 15 minutes prior to the first sample phase (S1), for non-infusion trials this process was unnecessary and the rat was taken directly from their home cage to the testing room for the start of the first sample phase (S1). The object-place (OP) arena is displayed as a black circle with the grey arc representing the location of the cue card. The object recognition (OR) arena is represented by the pink square. The duration of the three five-minute sample phases (S1-3) totals 30 minutes, after which there was a 24 hour delay before the three-minute test phases commence. The letters A-D represent different objects, with test-phase novelty highlighted in yellow.

Spatial Object-Place Recognition Task

In order to investigate the role of the postsubiculum specifically in spatial association memory, between the objects and the cue card, the rats were exposed to two different objects in three identical five-minute sample phases (see figure 6.3). The objects were presented at two of the six possible locations around the cylindrical arena (see figure 6.2) and the objects positions remained stable across the three sample phases, which were separated by the five-minute object-recognition task sample phases. At the start of a trial the holding bucket, containing the rat, was placed into the centre of the arena from different locations (120° apart) for each sample phase, which were counterbalanced between rats and across trials. The lid was removed and the rat was placed into the arena facing the cue card. The bucket was then removed from the arena and the recording was initiated. Once the trial was complete the rat was placed back into the bucket and removed from the arena via the same opening point from which the rat was previously entered. Following a

24-hour delay, in which they were returned to the animal house in their home cages, the rats were placed back into the testing arena through one of the three possible openings, which was pseudo-randomly allocated, and were presented with identical copies of the sample-phase objects, where one object was located in the position in which it occupied in the sample phases, but the other familiar object occupied a novel location, creating a novel object-place configuration (highlighted in figure 6.3). The locations used in both the sample and the test phases were counterbalanced between rats and across trials such that each object location was equally familiar as was the spatial relationship between the object pairs and the distance an object was displaced in the test phase.

The use of a hippocampal dependent allocentric strategy was enforced by placing the rats into the arena at different locations and by minimising the detection of extra-maze orienting cues (Langston and Wood 2009), preventing the novel object-place configuration from being recognised using an egocentric strategy. The preliminary testing, described in section 6.2.4, further suggests that rats were not using an egocentric strategy to support performance in the object-place recognition task, as rotations of the experimental arena, relative to the testing room, between exposure did not affect performance levels.

6.2.7 Infusion Protocol

Mock infusions were performed prior to any drug infusions to allow the rats to become habituated to the infusion process and to minimise the effects of infusion-induced stress on performance in the recognition tasks. All infusions were conducted in a designated infusion-room, separate from the holding and testing rooms. A within-subjects design was employed for the experiment such that each rat was tested once under each infusion condition (ACSF, AP5 or CNQX), which alternated with three non-infusion tests (see figure 6.4 for the experimental schedule), in a pseudo-randomly assigned order for each rat. Infusions were made directly into the postsubiculum prior to the sample phases of the two tasks (see figure 6.3 for the experimental protocol).

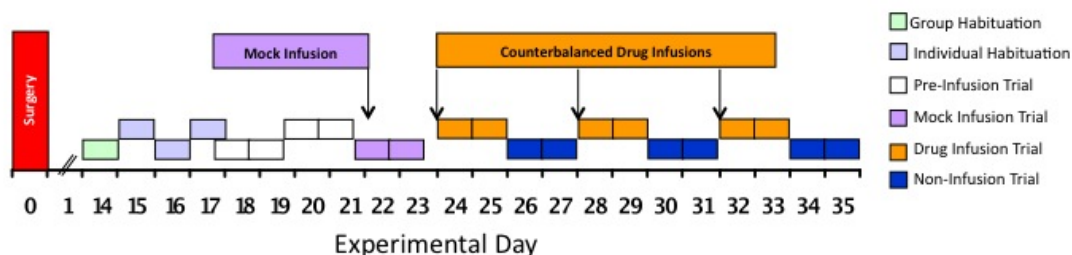

Figure 6.4: The experimental schedule is depicted in the diagram across experimental days 0-35. For each experimental trial two blocks are used to represent the sample and the test phase which were conducted across two days. The counterbalanced drug infusions (shown in orange) represent the trials in which the rats were infused with ACSF, AP5 or CNQX prior to the first sample phase.

6.2.7.1 Drug Preparation

Phosphate-buffered artificial CSF (ACSF) was used as a control infusion condition and as a vehicle for the drug infusions. Solutions of 5.9 mg/ml (30 mM) AP5 (Tocris, UK) and 0.89 mg/ml (3 mM) CNQX (Tocris, UK) were prepared and dissolved with ACSF. The pH of the drug solutions were adjusted using 1 M NaOH, for AP5, or concentrated phosphoric acid, for CNQX, to a value of 7.2, that of the ACSF solution. A sufficient quantity of the three infusion solutions (ACSF, AP5 and CNQX) was prepared, ensuring the same batch of drugs were used throughout the study, and this was then divided into smaller 1 ml aliquots, and frozen at -20°C until use.

For the mock, ACSF, AP5 and CNQX infusions, the rat was taken from the home cage in the holding room to the infusion room in the holding bucket. The rat was then placed onto the lap of the experimenter and the two dummies, protecting the postsubicular guide cannula, were removed and cleaned and an injector was inserted into each guide cannula. These injectors were attached to flexible polyvinyl chloride tubing (PKG Tubing PE20, Plastics One, Bilaney, UK), which connected them to the SGE microsyringes in a microinfusion pump (Sp200i syringe pump, World Precision Instruments, USA). Two syringes were set up in the infusion pump. The drug and mock infusions were conducted in an identical manner with the exception that for the mock infusions the syringe was not depressed and therefore no infusion was made into the postsubiculum. The rat was connected to the infusion pump and then, for the drug infusions, 1 μ l of either ACSF, AP5 (30 mM) or CNQX (3 mM) was simultaneously infused bilaterally through the two cannulae, directly into the postsubiculum, over a five-minute period, at a rate of 0.2 μ l/min. After the infusion, the injectors remained in place for a further two minutes to ensure proper diffusion of the substance into the surrounding tissue and to avoid back-flow. The injectors were then removed and cleaned and the rats' protective dummies were replaced into the cannulae. The rat was then placed back into the bucket until 15 minutes had elapsed from when the syringe was first depressed, at which time the rat was taken into the testing room, in the holding bucket, and placed into the object-place arena for the first sample phase.

Each test phase commenced 24 hours after the last sample phase of the trial, by which time the drugs were no longer active. The timings of these infusions are based on those described in Bast et al. (2005) in which it was suggested that they are maximally effective in the 10-60 minute period following the start of infusion, based on hippocampal infusions. Additionally, when CNQX was infused into the postsubiculum (using the same coordinates as reported in the present study), it was shown to be maximally active in the 50-minute period following the infusion, after which pre-infusion levels were gradually approached, with a return to baseline occurring after just over two hours after infusion (Shires et al. 2008).

6.2.8 Histological Procedures

Once all behavioural testing was complete, rats were terminally anaesthetised with an overdose of 1 ml/1.4 kg bodyweight sodium pentobarbital (Euthatal, Merial Animal Health, UK) and then were perfused intracardially with 0.9% saline followed by 4% formalin. Extracted brains were stored in 4% formalin for at least 24 hours. Brains were then egg embedded and incubated for 24 hours at 37°C in 4% formalin before being removed and placed back into jars containing 4% formalin solution. A cyrostat was used to cut 30 μ m coronal sections, with one in two sections mounted on gelatine-coated slides and stained with 0.1% cresyl violet acetate and coverslipped using DPX. The sections were examined using a light microscope (Wild M420, Switzerland), under 20-fold magnification, to verify cannula placements.

6.2.9 Data Analysis

The rats' movements in the arena were monitored, for all sample and test phases, by an overhead camera (Panasonic, UK) connected to the TV monitor. Object exploration was manually recorded on-line on an in-house timing computer programme (National Instruments, LabView), where key presses activated timers which differentially timed exploration of each object, based on the rats' behaviour, observable via the TV monitor. The experimenter was blind to the experimental condition to which the rats belonged for the duration of behavioural testing.

Raw test-phase exploration times were collected as time in seconds for each trial. These test-phase exploration times were subsequently converted into a discrimination index (DI), calculated using the following formula below.

$$\sum \frac{(\text{Novel Object Configuration Exploration} - \text{Familiar Object Configuration Exploration})}{\text{Total Object Exploration Time}}$$

The influence of variability in exploration times of individual rats in each task phase was minimised by using the discrimination score for test-phase object configuration preference, and in addition any trials in which less than 15 seconds was spent exploring each object in the sample phase, or in which total object exploration time in the test-phase was less than 10 seconds, were excluded from analysis. Exploration required the rat to be within a 2 cm radius of the object, with its nose directed at the object and be involved in sniffing/whisking behaviour.

The discrimination scores were calculated for each rat and subsequently analysed in SPSS. Rats' performance under each infusion condition was tested across both the spatial object-place and non-spatial object recognition tasks using a within-subjects repeated-measures ANOVA. This was followed by a separate analysis of each task using one-way ANOVAs with *post hoc* pairwise comparisons of the effects of experimental conditions on performance.

To determine whether rats could discriminate between test-phase objects under the different experimental conditions, one-sample t-tests were performed to compare the rats' discrimination

scores with those expected by chance, for each task. In addition the rats behaviour was also analysed to assess whether any differences in the discrimination scores could be attributed to changes in exploration levels induced by the postsubicular infusions. The mean raw object-exploration times were analysed using a within-subjects repeated-measures ANOVA, followed by *post hoc* pairwise comparisons with Bonferroni corrections for multiple analysis.

6.3 Results

6.3.1 Histological Data

Nine of the initial 34 rats lost their cannulae implants before completing the behavioural testing and were therefore removed before processing the behavioural data. Furthermore, histological analysis revealed that the cannulae tips were accurately located, bilaterally, within the postsubiculum (for cannulae tip placements see figure 6.5) for all but three of the rats which were also removed from the final data. Thus, behavioural analysis was performed on the remaining 22 rats' discrimination scores, under the four infusion conditions, in the two recognition tasks.

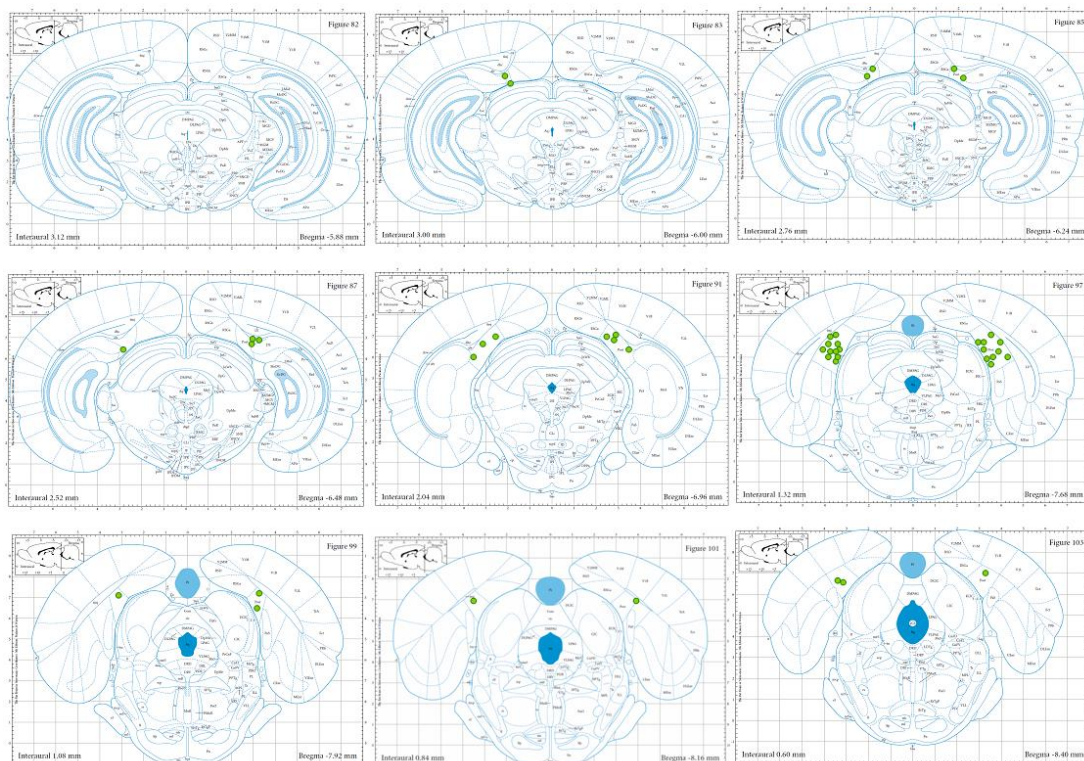

Figure 6.5: The figure represents the cannulae placement for each rat included in the results of this study. The position of the cannulae tips, revealed by examination of the stained brain sections using a light microscope, were drawn onto plates from the atlas of Paxinos and Watson (1998), and are represented as green circles in the brain atlas sections.

6.3.2 Behavioural Data

Figure 6.6 shows the object discrimination levels across the four experimental conditions (non-infusion, ACSF, AP5 and CNQX) for the object recognition and object-place recognition tasks. A repeated-measures ANOVA was conducted to determine the effects of experimental group (within-subjects factor) on performance (discrimination scores) across the spatial and non-spatial object recognition tasks (within-subjects factor), and found a significant effect of experimental group ($F_{(3,63)}=7.077$; $p<0.001$; $\eta^2=0.252$) and task-type ($F_{(1,21)}=24.62$; $p<0.001$; $\eta^2=0.540$) on performance, but there was no significant group x task interaction ($F_{(3,63)}=0.80$; $p=0.50$; $\eta^2=0.036$). A subsequent one-way ANOVA analysis of the object recognition task revealed a significant effect of experimental group on performance ($F_{(3,63)}=3.192$; $p<0.05$) where *post hoc* pairwise comparisons revealed that only ACSF infusions were significantly different to CNQX infusions and non-infusion conditions ($p<0.01$ and $p<0.05$ respectively), otherwise groups performance did not differ. One-way ANOVA analysis again reported a significant effect of experimental group on performance in the object-place recognition task but in this spatial version of the task the *post hoc* pairwise comparisons revealed that performance of ACSF-infused rats significantly differed to performance under both AP5 or CNQX infusion conditions ($p<0.05$ and $p<0.01$ respectively).

In figure 6.6a all rats can be seen to be preferentially exploring the novel object under all experimental conditions. To test whether these discrimination indexes differed from that expected by chance (zero) one sample t-tests were performed. These confirmed that the rats explored the novel object significantly more than expected by chance in all infusion conditions: non-infusion- ($t=5.66$; d.f.=21; $p<0.001$); ACSF ($t=8.95$; d.f.=21; $p<0.001$); AP5 ($t=2.82$; d.f.=21; $p<0.01$), and CNQX- ($t=2.47$; d.f.=21; $p<0.05$).

In figure 6.6b identification of the novel object-place configuration appears only apparent in the control conditions (non-infusion and ACSF). The one-sample t-tests, performed against chance levels (zero), revealed that rats' explored the novel object-place configuration significantly more than expected by chance under control conditions: non-infusion- ($t=4.51$; d.f.=21; $p<0.001$) and ACSF ($t=5.12$; d.f.=21; $p<0.001$); but that object-place recognition was significantly impaired by disruption of postsubicular activity, with mean discrimination scores of AP5- or CNQX-infused rats found to be at chance levels: AP5 ($t=1.11$; d.f.=21; $p=0.28$), and CNQX- ($t=0.46$; d.f.=21; $p=0.65$).

These results demonstrate that rats explored the novel object significantly more than the familiar object in the object recognition task under all experimental conditions, whereas in the object-place recognition task, only the rats in the non-infusion and ACSF infusion conditions preferentially explored the novel object-place configuration. Although rats receiving postsubicular infusions of AP5/CNQX were able to detect the novel object in the object recognition task, they demonstrated no significant preference in the object-place recognition task.

To test whether infusion-induced differences in the object-place discrimination scores were

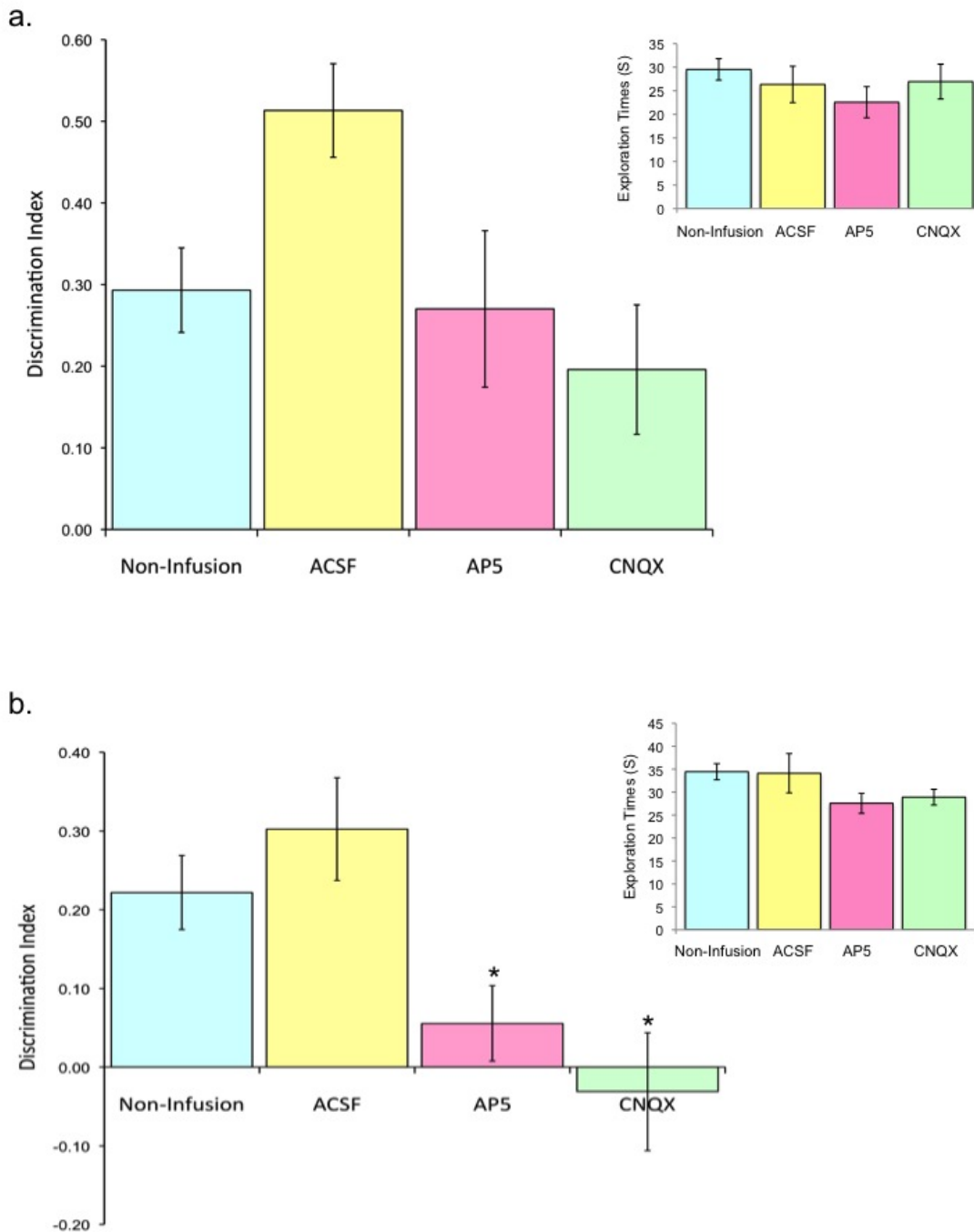

Figure 6.6: The average discrimination index is displayed for the four infusion conditions for: **(a)** the non-spatial object recognition task test-phase, in which the discrimination index for all four conditions are significantly better than that expected by chance (zero), $p < 0.05$; and **(b)** the object-place recognition task test-phase, in which the discrimination index under control non-infusion and ACSF infusion conditions are significantly better than that expected by chance (zero), but performance is at chance levels for the AP5 or CNQX infusion conditions. Graphical representations of the mean raw exploration times (in seconds) for total test-phase object exploration for each experimental condition (non-infusion, ACSF, AP5 and CNQX) is displayed on the right-hand side of each of the recognition task performance graphs. Data is displayed as mean values \pm SEM, (*) $p > 0.05$, relative to chance.

an indirect result of an affect of inactivation of the postsubiculum on object exploration levels, the raw object exploration times were analysed. The rats' raw object exploration levels under the four experimental conditions are displayed beside their recognition performance levels in the test phase of each recognition task in figure 6.6. A within-subjects repeated-measures ANOVA revealed no significant effect of group ($F_{(3,54)}=2.78$; $p=0.058$), task ($F_{(1,21)}=0.57$; $p=0.459$), nor group x task interaction ($F_{(2,40)}=0.62$; $p=0.538$) on discrimination scores. Thus AP5- and CNQX-induced impairments in object-place recognition is not attributable to an indirect effect on object exploration levels.

6.4 Conclusions & Discussion

The current chapter aimed to test whether the postsubiculum is the site of integration for sensory environmental cues with the internally generated head direction signal, necessary to support hippocampal-dependent spatial memory. To test this purported role, the effects of postsubicular infusions of AP5 or CNQX were examined in a spatial and a non-spatial object recognition task, enabling one not only to ascertain whether the postsubiculum is involved in this spatial processing pathway, but also whether NMDAR-dependent plasticity within the postsubiculum itself supports this function.

In the non-spatial object recognition study a preference to explore the novel object was demonstrated under all experimental conditions, implying that neither plasticity in, nor transmission through, the postsubiculum is necessary during the encoding of object identity to induce familiarity, enabling novelty detection in the subsequent test-phase. In this task the non-infusion, AP5 and CNQX groups all performed similarly but the ACSF group had a significantly higher exploratory preference for the novel object relative to the CNQX and non-infusion groups. In the spatial object-place recognition task rats only demonstrated an exploratory preference for the novel object-place configuration under control (non-infusion and ACSF-infusion) conditions, where no significant preference was observed following either AP5 or CNQX infusions. Furthermore, pairwise comparisons between groups revealed that only the exploratory preference following AP5 or CNQX infusions were significantly different to that obtained following ACSF infusions. These results indicate that postsubicular AMPARs and NMDARs are specifically required for the encoding of object-place associations to support 24-hour recognition performance in this cue-controlled allocentric task, but are not necessary for the encoding of non-spatial object identity to support subsequent object recognition performance. Alternatively, if one interprets this data based on the similar pattern of performance shown between experimental groups across the recognition tasks, postsubicular infusions of AP5 and CNQX could be construed as having a similar detrimental effect in both the non-spatial object recognition and the spatial object-place recognition tasks. This interpretation contrasts; however, with the comparisons of the experimental groups' perfor-

mance relative to chance, where in the non-spatial object recognition task all groups are exploring the novel object significantly more than expected by chance, whereas in the spatial object-place recognition task only the control groups demonstrate a preference to explore the novel object-place configuration, with AP5 and CNQX infusions reducing performance to chance levels.

The appearance of the enhanced preference to explore novelty in both recognition tasks following ACSF infusions complicates the interpretation of the between conditions analysis. This affect is particularly evident in the object recognition task, where preferential exploration of the novel object-place configuration is significantly higher when rats received ACSF infusions opposed to when no infusions took place and the ACSF group were the only experimental group to significantly differ from the others, with all groups performing significantly better than chance. One interpretation of these results is that the stressful infusion procedure resulted in an enhancement in memory which was only apparent in the ACSF condition, as the detrimental affects of AP5 and CNQX countered any such enhancements. This interpretation seems unlikely; however, as previous studies have not found the postsubiculum to be necessary for non-spatial tasks such as the object recognition task and do not generally report any enhancement of memory following ACSF infusions, additionally in the spatial object-place recognition task, this speculative infusion-induced enhancement in performance did not seem apparent with the two control conditions not differing significantly and the AP5 and CNQX infusions resulting in chance level performance. Despite the objects being paired for equal preference and the novel object being pseudo-randomly assigned, it is possible that the seemingly enhanced preference for novelty under ACSF conditions is simply the result of the rats' natural preference for the novel object in the object pairing which has skewed the result. Further testing with larger sample sizes would be necessary to determine whether this was the case.

The fact that rats in the ACSF-infusion condition demonstrated a much greater preference to explore novelty in the object recognition task than in the object-place task, relative to the non-infusion control group, and rats in both the AP5 and CNQX groups performed similarly, detecting the novel object in the object recognition task but having reduced discrimination scores in the object-place task (performing at chance levels), resulted in a similar ratio between the three infusion groups across the two tasks. Thus, even though the AP5 and CNQX groups were performing above chance and at a comparable level to the non-infusion controls in the non-spatial object recognition task but unlike the controls, were reduced to chanced levels in the spatial object-place recognition task, the effect of the ACSF group resulted in the repeated-measures ANOVA reporting no task x experimental group interaction. As the two control groups significantly differ in object recognition performance it makes interpretation based on comparison between experimental groups difficult. One could argue that performance in a recognition task is 'all or nothing' in that either novelty is recognised, resulting in a significant exploratory bias towards the novel feature, or it is not, and objects are explored equally. On this premise and in light on the difficulties

in comparing experimental groups, due to the enhanced novelty preference in the ACSF group, the interpretation of the data obtained in this study is based on comparisons of the experimental groups' performance relative to chance.

In terms of the ability to detect novelty, the bilateral postsubicular AP5/CNQX infusions, made prior to encoding, specifically impaired rats' performance in the object-place recognition task, with rats demonstrating no net preference to explore either object-place configuration, despite the fact that their ability to retrieve object identity alone was unaffected by these infusions, shown by their preferential exploration of the novel object in the object recognition task. The results reported in this study therefore support a role for the postsubiculum in spatial behaviour, which requires object location to be associated with available landmark information, as pharmacological disruption of both transmission through, and plasticity within, the postsubiculum resulted in an impairment in object-place recognition, but not in the non-spatial object recognition task. Thus, the postsubiculum appears to be specifically necessary when the location of the object within the environment must be processed in order to support performance. These findings support previous research in which lesions of the postsubiculum, and larger lesions of the pre-/para-subiculum, were shown to specifically impair performance on tasks requiring spatial processing (Jarrard et al. 2004; Kesner and Giles 1998; Taube et al. 1992). Additionally, the utilisation of reversible pharmacological manipulations of the postsubiculum enabled individual rats' spatial and non-spatial memory to be tested when fast-excitatory transmission through the postsubiculum was blocked as well as when NMDAR-dependent synaptic plasticity within the postsubiculum blocked, which could then be compared to performance levels under control conditions within the same subject. The results presented in this chapter therefore clarify those previously obtained, by showing that the spatial memory impairments induced by postsubicular damage are not merely due to a disruption in the transmission of information, but that NMDAR-dependent processes within the postsubiculum itself are necessary to support spatial memory processing.

In contrast to impairments previously described by Liu et al. (2001), no impairments were found in rats' ability to detect the novel object in the non-spatial object recognition paradigm after inactivation of the postsubiculum; however, the lesioned rats in the study by Liu et al. (2001) still demonstrated a significant preference to explore the novel object, as found in the current study, with the impairment being observed as a difference between lesioned and control rats' raw exploration times for the novel object (as previously discussed in section 6.1). This suggests that the impairment in object recognition induced by the lesions may, at least in part, be secondary to a lesion-induced reduction in overall exploratory levels, especially as in the current study, where the exploration levels did not significantly differ between infusion conditions, no impairment in object novelty detection was identified. The difference in exploration levels resulting from inactivation of the postsubiculum, in the current study, relative to those resulting from pre-/para-subicular lesions may be due to the fact that only the postsubiculum rather than the entire pre-/para-subiculum was

targeted, or could be a result of a number of differences in the protocols used (as previously discussed, see section 6.1). The impairments in rats' performance following bilateral postsubicular infusions of AP5 or CNQX were not attributable to differences in exploratory behaviour in the current study and were not a result of a more general impairment in learning or encoding object identity, as performance in the same rats, tested at the same time, under the same infusion conditions, were not impaired in the non-spatial object recognition memory task. The results obtained therefore support a specific role for NMDAR-dependent postsubicular plasticity in the encoding of object location information with respect to the environment (cue card).

The reversible pharmacological interventions utilised in this study enabled a powerful within-subjects approach to be implemented; however, unlike permanent lesions, the extent of their inactivation (CNQX) or NMDAR blockade (AP5) in the postsubiculum and how restricted their actions are to this region are difficult to ascertain. As performance in the object-place recognition task was reduced to chance levels as a result of CNQX/AP5 infusions, it appears that the extent of their actions is sufficient, although it is possible that the infusion-induced impairments on performance was contributed to by damage to other structures surrounding the postsubiculum. Although there have been no published studies investigating the diffusion of these drugs in the postsubiculum, previous autoradiographic experiments in the hippocampus have demonstrated that the diffusion of the AP5 was mainly restricted to the hippocampus, with only slight diffusion into surrounding tissue (Morris et al. 1989). Thus, based on these results it would seem that any extra-postsubicular damage resulting from the infusions performed in the current study are unlikely to have had a significant impact on the results obtained.

One of the advantages of the experimental design implemented in the current study is that it provides the opportunity to examine the role of the postsubiculum in encoding and retrieval processes separately. Investigation into the effects of AP5 and CNQX on the encoding and retrieval of spatial memory have been successfully conducted in the hippocampus by Bast et al. (2005), where rats tested in a one-trial allocentric place memory task were found to require hippocampal NMDAR-dependent synaptic plasticity for the encoding phase only, but AMPAR-mediated fast, excitatory hippocampal transmission was required for subsequent retrieval, tested 20 minutes after encoding. Additionally, Larkin et al. (2008) found intraperitoneal administration of an NMDAR antagonist impaired performance in an object displacement task when administered before, but not after training, which, taken together, support a role of NMDAR in the acquisition but not the consolidation nor retrieval of spatial memory. These results suggest that AP5 would be unlikely to disrupt spatial memory if it was infused into the postsubiculum prior to retrieval in the current object-place recognition task, but whether CNQX would result in impairments in performance would be of interest, in terms of further elucidating the neural circuitry involved in retrieval of allocentric space, and this requires further investigation. Whilst it would be valuable to determine the role of the postsubiculum in object-place recognition memory retrieval as well as encoding,

it is difficult to easily distinguish the two processes. In these object recognition tasks, the test phase involves a presentation of a familiar object-location configuration in the presence of a novel configuration. The presence of novelty during memory retrieval results in a destabilisation of the memory being retrieved which then must be reconsolidated in order to persist, and this process induces changes in synaptic efficacy (Clarke et al. 2010). Thus it is possible that infusions of AP5 or CNQX into the postsubiculum prior to testing may also disrupt memory due to difficulties in the reconsolidation of memory, rather than a retrieval problem, and it would therefore be difficult to resolve this issue using pre-test infusions.

As the postsubiculum is necessary for stable head direction and place cell representations in relation to visual cues/landmarks within the environment (Calton et al. 2003; Goodridge and Taube 1997), it would seem that the deficits reported in the spatial object-place recognition task in this chapter are likely due to an inability to integrate the objects locations within an allocentric framework, where the postsubiculum acts as the site of convergence for visual input with the internally generated head direction signal enabling the allocentric representation of space to be produced. The non-spatial information regarding object identity is likely to arise from the perirhinal cortex, a region required for object recognition (Buffalo et al. 2006; Mumby and Pinel 1994), which is not involved in spatial memory processing (Aggleton et al. 2005, 2004; Ennaceur et al. 1997, 1996). Thus, to support the detection of object-place novelty, information regarding object identity from the perirhinal cortex could be incorporated within the hippocampal, allocentric, representation of space, which is speculatively constructed from postsubicular input regarding the objects' locations in respect to the available cue card. Allocentric spatial processing is likely to be required to relate and configure individual features of an event into a coherent representation enabling the context-rich retrieval of episodic memories, as well as providing the necessary scaffold for future events to be imagined.

The anatomical connectivity of the postsubiculum indicates that the function of the postsubiculum described, for the integration of cues into the spatial processing networks, may be limited to information in the visual domain. Although the postsubiculum receives inputs from the laterodorsal thalamic nuclei and retrosplenial cortex which may provide auditory, somatosensory and olfactory information in addition to that of a spatial nature, the postsubiculum has direct inputs from the visual cortex (areas 17 and 18) which suggest a specialised role for the postsubiculum in integrating spatial information of a visual nature (van Groen and Wyss 1990). Further investigation is necessary to determine whether the role of the postsubiculum in spatial recognition is indeed limited to visual stimuli, or whether similar impairments would be seen following inactivation of the postsubiculum if non-visual cues were required to associate locations, for example in a odour-place recognition study.

Recently there has been a shift in the focus of behavioural neuroscientific research from attempts to identify the specific brain region underlying each psychological function, to attempting

to elucidate the processing functions of each region, and the nature of their connections with associated structures, in order to reveal the circuitry which gives rise to the specific behavioural functions of interest. This chapter has focussed on investigating the neural circuitry underlying the hippocampus' role in spatial cognition, and in doing so has highlighted an important role for the postsubiculum, which is likely due to the NMDAR-dependent integration of visual information with the internally generated head direction signal to support hippocampal-dependent allocentric spatial memory.

Part III

Concluding Remarks

6.5 Concluding Remarks

The aim of this thesis was to explore the two dominant functional roles of the hippocampal formation, in the relational encoding of episodic memory and the neural representation of allocentric space, using a combination of pharmaceutical manipulations and single-unit recording techniques in non-human animal models.

In the first part of this thesis the necessity of the hippocampus was investigated in an integrative model of episodic-like memory based on the novel associative recognition of the three event features: 'what-where-which'. Permanent neurotoxic lesions of the hippocampus and its subregions were found to be specifically required only when novelty recognition demanded all three event components to be integrated, confirming the hippocampal dependence of this episodic-like memory task and additionally revealing the necessity of its subregions - CA3 and CA1. These results support theories which suggest that the CA3 region provides an autoassociative role in the formation of episodic memories, with the CA1 region providing the main output pathway for this processed information and/or functioning as a mismatch detector between stored representations from CA3 and the current sensory input available via the entorhinal cortex. Unfortunately, the nature of novelty recognition paradigms do not lend themselves to single-unit recording, which would be required in order to further investigate the hippocampal activity supporting this episodic-like memory task performance. The second part of this thesis therefore explored the neural activity of the hippocampus on-line in 'normal' behaving animals performing a different task in which aspects of episodic memory could be tested. Through a series of recording and lesion experiments, goal-sensitive firing of hippocampal place cells was found to emerge in line with behavioural performance in a hippocampal-dependent task, furthermore these firing patterns were found to emerge specifically when the learning and memory demands of a spatial 'win-stay' task protocol were enforced. This task not only tests aspects of episodic memory but is also thought to tax the allocentric spatial memory network, which is also critically dependent upon the hippocampal formation. The principle cells of the hippocampus were found to relate to both the animals' position and journey type only when the mnemonic demands of the spatial 'win-stay' task were enforced. Furthermore, the goal-sensitive firing of these cells developed in line with behavioural performance. These results suggest that the purported functional roles of the hippocampus in allocentric spatial processing and episodic memory may be linked by a more general role in which the hippocampus processes multiple inputs and relates them in a meaningful manner, providing a context-rich flow of information along a suitable spatiotemporal axis which can be manipulated to support the recollection of episodic memories and the ability to plan, imagine and re-experience events coherently. In order to further examine the neural circuitry underlying these functions, the final part of this thesis focussed on investigating the neural network which gives rise to allocentric spatial processing, as this may underpin the hippocampus' role in episodic memory, and potentially in imagining and planning future events, by providing a 'space' in which retrieved information can be integrated

into a coherent context to support the fluent and flexible use of information. Allocentric spatial processing necessarily requires visual information to be accessed concerning landmarks and cues in the environment with orientation and direction information generated internally. Based on the current literature and anatomical evidence, a region upstream of the hippocampus, known as the postsubiculum, arose as a potential convergence site. Thus, the effects of temporary blockade of the postsubicular glutamatergic receptors were examined in an allocentric spatial object recognition task. The pharmacological blockade of these postsubicular glutamatergic receptors was found to impair object recognition only when it was necessary to recall the spatial relationship between the objects and the environment, suggesting a key role for NMDAR-dependent plasticity within the postsubiculum for the formation of allocentric spatial memory. The results obtained in each part of this thesis are discussed in detail in the following sections.

6.5.1 Associative Object Recognition: The Role of the Hippocampus

Non-human animal models of episodic memory have focussed on the original episodic memory triad: 'what-where-when' (Tulving 1972), which enables the behavioural aspects of episodic memory to be tested; however, due to the absence of the phenomenological aspects necessary for human episodic memory it has been termed episodic-like memory. There has been much controversy over the temporal component of this episodic memory model and in light of the many difficulties encountered in successfully demonstrating that temporal information was incorporated into event memory in the rat, Eacott and Norman (2004) developed a task in which integrated memory for 'what-where-which' was tested, where the temporal component ('when') was replaced with another event specifier: context ('which'). Based on this task, the functional contributions of the hippocampus, and specifically of the CA3 and CA1 subregions, were assessed on the ability to form an integrated representation of three features of the sampling event, 'object-place-context', in a trial unique manner to support subsequent configural recognition of novelty. The results obtained revealed a specific hippocampal lesion-induced impairment in the integration of all three event components, whereas the associative recognition of any combination of these features in isolation was left intact, successfully replicating previous published findings (Eacott and Norman 2004; Langston and Wood 2009) and further revealing a similar pattern of results induced by both CA3 and CA1 lesions. As performance for the individual features of the integrated 'object-place-context' task were left intact, in all lesion groups, the lesion-induced impairments cannot be attributed to an indirect effect of the procedural difficulty in recognition nor due to a lack of memory for the individual task components. It is also unlikely that the increased number of associated features necessarily requires hippocampal processing as previously rats were shown to successfully learn and retain multiple items of information independently of the hippocampus (Dudchenko et al. 2000; Gaffan and Eacott 1997; McDonald et al. 1997). Whilst this task does not demand a recollective strategy to be employed to support performance, it is unlikely that controls

are utilising a familiarity approach, as all the individual components, as well as their paired associations, involved in the integrated object-place-context task are equally familiar and therefore any familiarity-based recognition would be highly complex, based on the relative familiarity levels of the object-place-context configurations. Additionally, if a familiarity-based approach could be employed for successful performance, one would expect the hippocampal-lesioned rats to be performing above chance levels, given the wealth of literature which supports a specific role for the hippocampus in recollection (for discussion see Eichenbaum et al. 2007), although there remains considerable debate from those holding the opposing view that the hippocampus provides an important contribution to both recollection and familiarity (Wixted and Squire 2010). A plausible interpretation of the specific requirement for the hippocampus and its subregions only when the integration of all three event features are necessary to support successful recognition, is that it is due to the specialised role of the hippocampal formation in the process of recollection, necessary for episodic memory retrieval. This interpretation is supported by the finding that fornix-lesioned rats were specifically impaired in object recognition performance based upon recollection, but not familiarity, of associated object, place and context information in the E-maze task, which enables the dissociation of these retrieval processes (Easton et al. 2009). The deficits in object-place-context recognition arising from CA3 and CA1 lesions reveals a specific function for these regions in this putative model of episodic memory, independently of their hypothesised roles in allocentric space and temporal order processing, supporting an autoassociative role for CA3, with CA1 functioning as the vital output pathway for this associated information and/or as a mismatch detector.

In spite of the justifications discussed in this thesis for using contextual elements of an event as an alternative to demonstrating temporally-mediated 'what-where' memories, arguments still exist that the inability to demonstrate the integrated 'what-where-when' memory in rats reflects an absence of this cognitive process, as the temporal framework is purported to provide the necessary foundation of episodic memory. Therefore, in chapter 2 an alternative integrated object-recognition paradigm was developed in which naïve rats convincingly demonstrated the ability to form episodic-like memory, defined by the original 'what-where-when' triad, based on their significant preference to explore the novel object-place-temporal order configuration. Similarly to the object-place-context task employed in chapter 1, this task does not require training, reducing the impact of semantic rule learning affecting the results and event memory is tested in a trial-unique manner - akin to human episodic memory. The results obtained yielded a similar pattern to those described by Good et al. (2007), where naïve rats were shown to preferentially explore the most remote and displaced objects in the test-phases, agreeing with the general finding that rats have a natural tendency to explore the most novel aspects of the environment (Ennaceur et al. 1997). The findings reported by Kart-Teke et al. (2006), however, contrast with those obtained in chapter 2 in that they previously found naïve rats to reverse their preference for the displaced over the stable

object when the time elapsed since sampling the object-place configurations extended from 50 minutes to 105 minutes, after which rats demonstrated a surprising preference for the stationary object. The differing result is likely due to the inability of rats to discriminate whether objects had been displaced or remained in a stable position across the longer 105-minute delay used in the study by Kart-Teke et al. (2006) or possibly due to the confounding effects of their testing protocol, discussed in the introduction, section 0.3.2. In the task published by Good et al. (2007), the time delays were much shorter, with recent and remote objects being presented only two and nine minutes prior to the test phase respectively. The preference for the more remotely presented object in the protocol developed in chapter 2 was stronger than that published by Good et al. (2007), suggesting that the two- and twelve-minute delay periods used for the recent and remote objects enabled a stronger preference to be established for the remotely presented object without affecting the memory strength of the initial sampling event, to the extent that the memory of the objects' position was in jeopardy. In addition, unlike the protocol described by Good et al. (2007) in which hippocampal lesions were found to impair performance, it is unlikely that the object-place recognition employed in the protocol developed in chapter 2 is hippocampal-dependent as similar measures were taken to those described in chapter 1 to encourage an egocentric strategy to be employed, in which hippocampal processing was not shown to be necessary to support performance. The integrated object-place-temporal order task described in chapter 2 therefore provides a suitable protocol in which the neural circuitry underlying episodic-like memory can be tested.

6.5.2 The Role of Place Cell Firing on Navigational Decisions

The second part of this thesis utilised the single-unit recording technique in order to directly examine the neural activity of the hippocampus and assess its 'normal' function during behavioural tasks. The principle cells of the hippocampus (place cells) have been shown to respond not only to the spatial features of the environment, but also to a multitude of non-spatial features, and since it is logical to assume that the primary firing patterns of a region should underlie its main functional roles; the second part of this thesis focussed on elucidating the relationship between hippocampal activity and behavioural performance.

Data published by Ainge et al. (2007a) identified goal-sensitive firing in a proportion of hippocampal pyramidal neurons in well-trained rats on a double Y-maze 'win-stay' task; however, the relevance of this firing to behavioural performance was unclear, especially as removal of this goal-sensitive firing through complete hippocampal lesions had only a subtle impact on performance levels. The data obtained in chapters 3, 4 and 5 extend from these initial findings by providing an in-depth analysis of the development of these cells, their relationship with the mnemonic task demands as well as their necessity for successful behavioural performance.

In chapter 3 the emergence of goal-sensitive firing was clearly shown to correlate with performance on a spatial 'win-stay' task; however, it remained unclear as to whether this relationship was

due to the learning and memory demands of the task itself or due to increased experience in navigating the maze. This issue was tackled in chapter 4, where goal-sensitive firing was shown to significantly increase only when the spatial ‘win-stay’ task was enforced, not as a result of increased experience of navigating the maze and learning reward locations. The necessity of this firing was then investigated in chapter 5 by testing behavioural performance in the absence of a functional hippocampus. The hippocampal-lesioned rats were found to be clearly impaired on the spatial ‘win-stay’ task. Collectively, these results convincingly demonstrate that the goal-sensitive firing of hippocampal cells develop in line with behavioural performance in a hippocampal-dependent task and that the emergence of these firing patterns are specific to the learning and memory demands of a spatial ‘win-stay’ protocol. The results of the experiments described, regarding the role of the hippocampus in the double Y-maze task, suggest that hippocampal place cells could form part of a system in which each unique past experience of spatial route (‘where’) is recalled in combination with whether food rewards were obtained (‘what’) and whether this occurred within the current block of trials (‘when’), manipulating this stored information, based on the previously encoded semantic information regarding the rules of the task, in order to plan the spatial route which is most probable to result in the food reward being obtained. This flexible use of prior knowledge happens rapidly, in well trained rats, and is perhaps computed at a sub-conscious, automatic level. Efficient performance relies upon combining information from temporally distinct events in which repeated trials run along the same trajectory must be distinguished to determine whether the goal box was rewarded on that particular trajectory, and if so, whether it was rewarded on the most recent visit, thus it requires a recombination of unique past experiences to determine the most fruitful decision based on prediction of both the task rules and previous within session experience. The fact that goal-sensitive firing only emerged with behavioural performance on this task and was not merely a result of experience of spatial navigation and the association of the cues, food rewards and goal boxes, suggests that these specific firing patterns reflect specific task-related processes occurring within the hippocampal region. The impaired performance resulting from hippocampal lesions, specifically in the ability to perform this spatial ‘win-stay’ task in the double Y-maze further support the functional role of the goal-sensitive firing of the hippocampal place cells.

6.5.3 The Role of the Postsubiculum in Object-Place Recognition

An important role of the hippocampus is believed to be in the spatial processing of allocentric information, which is theorised to underlie its contribution to the functions examined in the first two parts of this thesis, namely: episodic memory; spatial learning and navigation; and speculatively, planning; imagining; and decision making. Thus, the final part of this thesis focused on investigating the neural circuitry which gives rise to the hippocampal-dependent allocentric representation of space.

In order for the hippocampus to create an allocentric representation of space, hypothesised to underlie both its role in spatial learning and episodic memory, it necessarily requires sensory input, regarding the arrangement of landmarks within the environment, in combination with information regarding internal orientation and direction. From the current literature discussed, the postsubiculum emerged as a potential candidate for the site of convergence of visual cues from the environment with the internally generated head direction cell and place cell networks which would enable hippocampal-dependent spatial processing. Through investigations of the effects of temporary pharmacological inactivations of the postsubiculum in an object recognition paradigm, the ability to specifically recognise novel object-place configurations was found to depend upon the postsubiculum itself, strongly supporting its hypothesised role as the site of integration of sensory visual cues and internally generated orientation and direction signals. Crucially, the ability to retrieve object identity was unaffected by the postsubicular infusions which significantly impaired object-place recognition, implying that memory for the sample event objects was not disrupted but that the ability to integrate the objects with the location in which they were presented specifically necessitated postsubicular-dependent processing. These results are in line with previous reports that lesions of the postsubiculum, and larger lesions of the pre-/para-subiculum, specifically impair performance which requires spatial processing (Jarrard et al. 2004; Kesner and Giles 1998; Taube et al. 1992). Through examination of the effects of bilateral CNQX and AP5 infusions into the postsubiculum prior to encoding, to pharmacologically disrupt AMPAR-mediated fast synaptic transmission through and NMDAR-dependent plasticity within the postsubiculum respectively, the impairments reported could be clarified. Thus, the results obtained herein extends those reported in the current literature to show that these impairments are not merely due to a disruption in the transmission of information but that NMDAR-dependent processes within the postsubiculum itself are necessary to support spatial memory processing, as both CNQX and AP5 infusions resulted in a similar impairment in spatial object recognition.

The aim of this thesis was to explore the two dominant functional roles of the hippocampal formation in the relational encoding of episodic memory and the neural representation of allocentric space; however, as discussed in the introduction to this thesis, patients with damage to the hippocampal system also demonstrate an impaired ability to imagine future events (Klein et al. 2002; Rosenbaum et al. 2004) and imaging studies have revealed that the circuitry underlying the prediction of future events share a similar functional anatomy to that supporting episodic memory recall (Addis and Schacter 2008; Addis et al. 2007; Botzung et al. 2008; Okuda et al. 2003; Szpunar et al. 2007). These findings, in combination with the results reported in the experimental chapters of this thesis, suggest that the hippocampus functions to enable the flexible recall of previous events and incorporates them into a coherent spatiotemporal context, where the hippocampus' role in the formation of allocentric spatial memory underlies a common mechanism in the reconstruction of

past events and the construction of potential future events by providing a congruent context into which elements of previous experience can be integrated and manipulated to enable current demands to be met. This is most clearly evidenced in the middle section of this thesis where the principle cells of the hippocampus were found to respond not only to the spatial location of the animal but also to its intended destination. This goal-sensitive neural activity only emerged as the animals learnt the reward contingencies of a spatial task that required the integrative recall of the events of previous within-block trials, regarding which goal areas had been previously visited and which of these contained food rewards, to be used flexibly in order to determine the most fruitful trajectory to take. Furthermore, not only did this complex neural activity emerge in line with behavioural performance but the task performance of the hippocampal-lesioned animals was impaired. Additionally, in the first part of this thesis the hippocampus and its subregions were found to be specifically required only when all three event features had to be integrated to support novelty recognition. The complexity of this integrated recognition is most likely to necessitate the hippocampus to recall and configure the event components into a coherent reconstruction of the sampling event to enable the current and previous events to be compared and contrasted allowing associative mismatch detection of configural novelty. In order for the hippocampus to bind elements of experience into a spatiotemporal framework to support episodic memory processing, it would require information regarding the spatial layout of the environment in relation to its position and movement within the environment, hypothesised to occur extra-hippocampally. In the final part of this thesis the integration of the internally and externally generated spatial input was reported to require NMDAR-dependent processing within the postsubiculum, further revealing the neural processes involved in developing a unified representation of the environment, which is essential to enable the hippocampus to relate multiple pieces of information into a coherent spatiotemporal context.

In summary, this thesis has provided a thorough investigation into the functional roles of the hippocampal system and in doing so has revealed further insight into the neurobiological processes underlying the ability to recall unique, personal episodes from the past, successfully navigate the present environment, and plan, make decisions and imagine future events based on previous experiences. Overall, this thesis finds support for a role of the hippocampus in providing the context-rich spatiotemporal scaffolding necessary for episodic memory.

6.6 Future Extensions

6.6.1 Associative Object Recognition: The Role of the Hippocampus

The impairments resulting from CA3- and CA1-specific lesions in the integrated object-place-context task supports the purported roles both in the process of encoding, where CA3 provides an autoassociative role, with CA1 functioning as the vital output pathway for this associated information and also in the retrieval process, for pattern completion and mismatch detection, respectively. The nature of studies such as this, in which the effects of permanent neurotoxic lesions are investigated, prevents one from distinguishing whether the necessity of these regions lies in the encoding or the retrieval phase. In order to ascertain the specific contributions of these subregions in episodic-like memory, a similar study would need to be set up in which AP5 and CNQX could be infused bilaterally into the CA3 or CA1 regions directly prior to the encoding phase or the retrieval phase, although the time delays between sampling and testing would need to be adjusted to ensure that infusions made prior to encoding were no longer active by the time of the test phase. The adjustments in the timing of the protocol necessary to enable this technique to be employed however, are likely to have a negative impact on performance levels across the experimental groups, which may reduce the performance of controls to chance levels in complex associative recognition, such as is required in the object-place-context task, hindering investigation of the role of the hippocampal subregions in task performance. A more fruitful line of inquiry may therefore be to employ the rapidly developing optogenetic technique, in which selected neuronal populations can be manipulated via light-sensitive ion channels (Boyden et al. 2005; Deisseroth et al. 2006). Through the use of the light-driven chloride ion pump, halorhodopsin, brief pulses of yellow light could be used to inhibit neurons in the CA3 and CA1 subregions, effectively silencing these neurons over a millisecond time-scale (Zhao et al. 2008), enabling the specific contributions of these hippocampal subregions, in the encoding and retrieval of episodic-like memory to be elucidated using the protocol employed in chapter 1.

Although there seems ample evidence to suggest that the impairments resulting from lesions to the hippocampus and its subregions are due to the hippocampus' role in recollection, the protocol employed in this study did not require rats to adopt a recollective strategy. Unlike humans, rats tend to rely on familiarity based judgements to support performance where possible (Aggleton and Brown 1999; Eichenbaum et al. 2007); therefore, in order to convincingly show that the recollective process is inducing this hippocampal-dependence in the integrated object-place-context task, one would need to test the effects of these complete bilateral lesions of the hippocampus, CA3 and CA1 regions in a task which necessarily requires recollection to support performance. Thus, the roles of these subregions could further be clarified by testing in a similar task which does require recall by design, such as that described by Eacott et al. (2005).

The development of the object-place-temporal order task has provided a suitable protocol in

which one could test the role of CA3 and CA1 to determine whether their specific contributions to object-place-context recognition are due to a role in episodic-like memory, or are a consequence of the encoding and retrieving of the contextual information in association with the objects' locations. One could also utilise the protocol developed to further elucidate the circuitry underlying episodic-like memory by examining the roles of the medial and lateral entorhinal cortices which are proposed to be involved in the development of spatial processing (Burwell and Hafeman 2003; Liu and Bilkey 2002) and non-spatial object recognition processing (Brown and Aggleton 2001; Ennaceur et al. 1996) respectively.

6.6.2 The Role of Place Cell Firing on Navigational Decisions

Currently, experiments are being conducted to investigate whether the goal-sensitive firing identified in the double Y-maze is specific to the trajectory travelled or whether it was a more general reflection of the journey to a given goal-box. To achieve this, the double Y-maze apparatus has been adapted to enable one to ascertain whether goal-sensitive activity would emerge when the preceding paths to the goal box are different or whether the same trajectory must be travelled to a given goal box for goal-sensitive firing to develop. In addition to this, further experiments are planned to investigate the neural circuitry underlying this goal-sensitive firing and to attempt to determine where this signal originates. The differential activity reported in hippocampal place cells is not necessarily generated within the hippocampal circuitry but may result from projections from extra-hippocampal regions, which might explain the hippocampal independence of some tasks in which differential firing has been reported (Ainge et al. 2007a,b). Equally, it is possible that intra-hippocampal circuitry underlies the generation of differential activity under certain conditions but when these conditions are not necessary for successful task performance then differential activity can be generated in extra-hippocampal regions such as the prefrontal cortex or striatum, which then project this information towards the hippocampus. This theory would explain why differential activity has been demonstrated in hippocampal-independent tasks and is supported by reports that differential firing patterns have been identified in the striatum (Barnes et al. 2005; Jog et al. 1999). In order to distinguish between these hypotheses and determine the source of the differential firing patterns one would need to investigate the effects of lesioning the prefrontal cortex, striatum, entorhinal cortex and the hippocampus on spatial 'win-stay' task performance and investigate the effects of these lesions on neuronal recording in the unlesioned regions. If the differential activity is generated independently of the hippocampus, the question arises as to why these firing patterns are projected to the hippocampus and what the functional role of the hippocampal circuitry may be if it is not required for the generation of the hippocampal signal and is not always necessary for task performance. In support of the investigations presented in this report, alongside many of the reports discussed from current literature, one answer could be that the differential firing patterns are indeed originally generated extra-hippocampally and are manipulated by the hippocampal cir-

cuitry to enable a context-rich representation of the event to be constructed, and it is only when the context-rich recall of this information is required for task performance that hippocampal-lesioned rats are impaired on the task. In contrast, if it is not required it can still be used but is not essential for performance to be achieved, explaining the lack of impairments reported in less complex tasks, in which differential activity is still reported.

As research progresses the importance of the connections between structures and the circuitry underlying behaviours is becoming increasingly apparent, leading to new emerging fields of research such as that of connectomics (Lichtman and Sanes 2008), which hopes to yield a host of exciting and useful results to elucidate the underlying processes which support episodic memory for example. Until such resources become available, however, the circuitry underpinning cognitive functions can be explored through a combination of neural recordings and lesions based on anatomically mapped connections.

6.6.3 The Role of the Postsubiculum in Object-Place Recognition

As previously discussed, the anatomical connectivity of the postsubiculum suggests that its role in the integration of cues into spatial processing networks may be limited to sensory information of a visual nature, as assessed in this thesis. To determine the extent of the postsubiculum's contribution to the formation of allocentric space across sensory domains, further investigation is necessary to see whether a similar impairment would emerge following the inactivation of the postsubiculum if non-visual cues were required to associate locations, for example in an odour-place recognition study.

Based upon previous findings in which the postsubiculum was found to be necessary for stable head direction and place cell representations to form relative to the available visual cues/landmarks within the environment (Calton et al. 2003; Goodridge and Taube 1997), it appears that the impairments reported in the spatial object-place recognition task in chapter 6 arose from an inability to integrate the objects' locations within the internally generated head direction signal, preventing the hippocampal-dependent allocentric representation of space from being produced. In order to test this theory, one could investigate the effects of infusing AP5 and CNQX bilaterally into the hippocampus prior to the sample phase of the object recognition protocols, whereby a specific impairment in performance of the AP5- and CNQX-infused rats on the object-place recognition task would support the theory that the deficits induced by the inactivation of the postsubiculum were due to a disruption in the generation of the hippocampus' allocentric representation of space. Additional experiments could be performed, employing a similar protocol to explore the role of other regions of interest, to further elucidate the neural circuitry underlying the hippocampal-dependent allocentric processing of spatial memory.

Appendix A

Additional Data

Subjects	Group	DG	CA3	CA2	CA1	Total
E3003	H-	83.0	84.1	82.0	93.6	87.6
E3007	H-	94.3	95.4	96.3	92.0	94.2
E3009	H-	53.7	64.4	76.4	83.7	69.6
E3015	H-	89.4	92.5	100.0	98.2	94.1
E3020	H-	85.1	96.6	100.0	96.3	92.8
E3023	H-	94.8	100.0	100.0	100.0	98.2
E3025	H-	72.4	73.9	100.0	96.5	83.7
E3029	H-	41.5	73.2	91.0	62.6	60.1
E3004	CA3-	22.0	65.6	74.8	26.6	35.6
E3006	CA3-	13.6	62.9	42.1	14.3	27.4
E3011	CA3-	24.5	49.6	44.3	27.8	31.6
E3022	CA3-	17.1	58.5	57.4	18.3	28.0
E3031	CA3-	11.6	75.7	38.7	11.6	27.1
E3033	CA3-	13.9	57.3	50.8	25.8	28.7
E3036	CA3-	39.4	59.6	36.4	28.2	40.6
E3039	CA3-	18.4	61.1	57.4	14.1	29.8
E3002	CA1-	17.1	13.3	63.6	73.8	36.4
E3016	CA1-	16.6	19.7	36.7	71.2	36.3
E3030	CA1-	13.3	9.8	63.0	76.8	35.4
E3034	CA1-	13.0	7.6	26.0	60.9	29.4
E3040	CA1-	17.5	1.7	39.7	81.2	37.8

Table A.1: A quantified summary of the extent of lesions across groups. The percentage lesion size is reported for the individual subjects in each lesion group included in the Object-Place-Context Recognition study reported in chapter 1. The percentage lesion size displayed is calculated as a percentage of the mean size in appropriate regions of the sham-operated controls, with numbers in bold representing the target area for each lesion group.

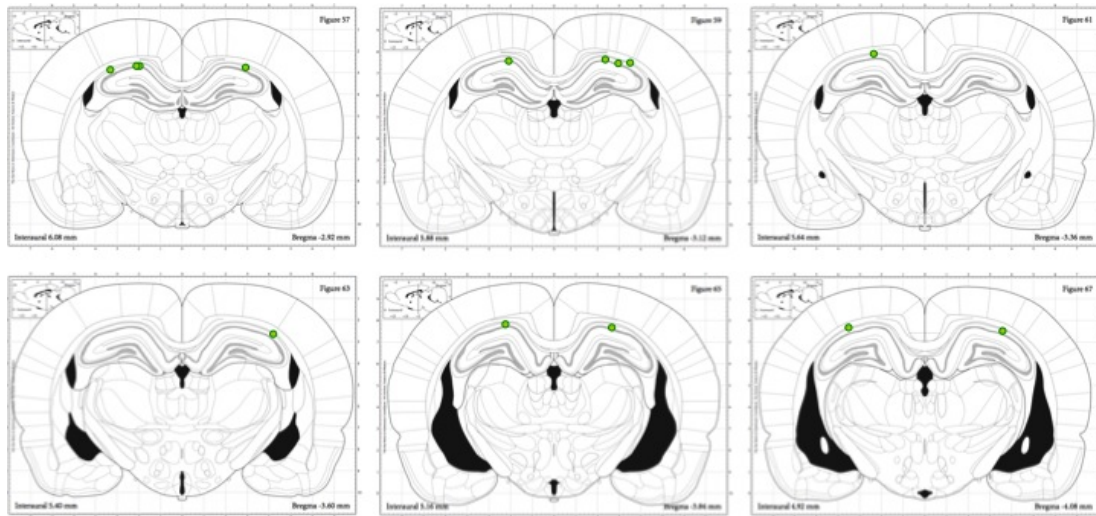

Figure A.1: The figure represents the electrode placement for each rat included in the double Y-maze study reported in chapter 3. The position of the electrode tips, revealed by examination of the stained brain sections using a light microscope, were drawn onto plates from the atlas of Paxinos and Watson (1998), and are represented as green circles in the brain atlas sections.

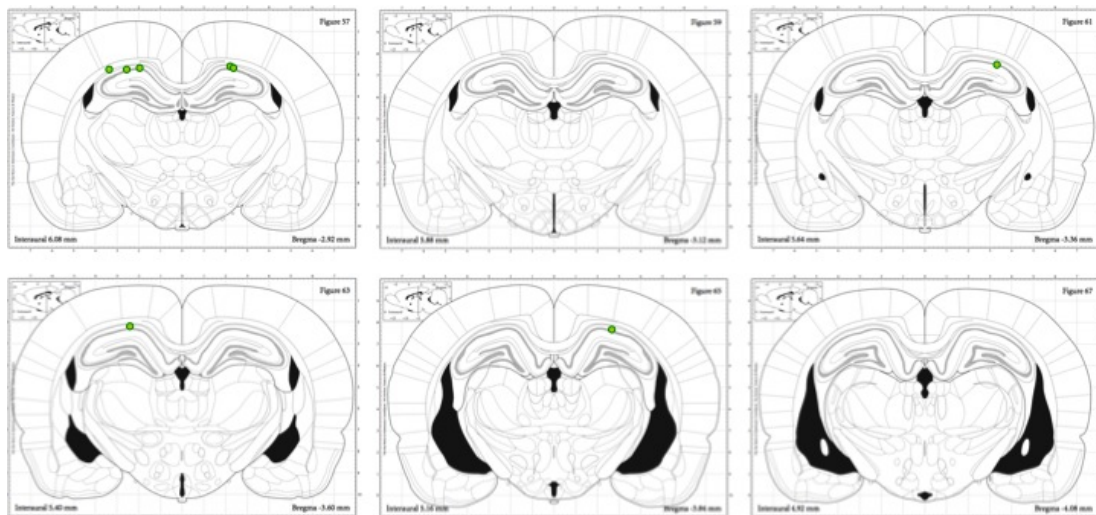

Figure A.2: The figure represents the electrode placement for each rat included in the results reported in chapter 4. The position of the electrode tips, revealed by examination of the stained brain sections using a light microscope, were drawn onto plates from the atlas of Paxinos and Watson (1998), and are represented as green circles in the brain atlas sections.

Lesion Group Subjects	Spared Hippocampal Tissue (%)
F2501	54.6
F2504	51.1
F2505	18.0
F2508	16.3
F2509	28.0
F2510	48.6
F2512	36.2
F2513	18.5
F2514	42.9
F2516	31.9
Average	34.6 +/- 4.5

Table A.2: A quantified summary of the extent of hippocampal lesions for each lesioned subject included in the double Y-maze lesion study reported in chapter 5. The percentage of spared hippocampal tissue is displayed for each subject in the lesion group, calculated from the mean combined length of the dentate gyrus, CA3, CA2 and CA1 cell layers of the sham-operated controls. The mean percentage sparing of the hippocampal lesioned group (\pm SEM) is shown in bold at the bottom of the table.

Bibliography

- Addis, D. R. and Schacter, D. L. (2008). Constructive episodic simulation: temporal distance and detail of past and future events modulate hippocampal engagement. *Hippocampus*, 18(2):227–237.
- Addis, D. R., Wong, A. T., and Schacter, D. L. (2007). Remembering the past and imagining the future: common and distinct neural substrates during event construction and elaboration. *Neuropsychologia*, 45(7):1363–1377.
- Aggleton, J., Vann, S., Denby, C., Dix, S., Mayes, A., Roberts, N., and Yonelinas, A. (2005). Sparing of the familiarity component of recognition memory in a patient with hippocampal pathology. *Neuropsychologia*, 43(12):1810–1823.
- Aggleton, J. P. and Brown, M. W. (1999). Episodic memory, amnesia, and the hippocampal-anterior thalamic axis. *Behav Brain Sci*, 22(3):425–44; discussion 444–89.
- Aggleton, J. P. and Brown, M. W. (2006). Interleaving brain systems for episodic and recognition memory. *Trends Cogn Sci*, 10(10):455–463.
- Aggleton, J. P., Hunt, P. R., and Rawlins, J. N. (1986). The effects of hippocampal lesions upon spatial and non-spatial tests of working memory. *Behav Brain Res*, 19(2):133–146.
- Aggleton, J. P., Kyd, R. J., and Bilkey, D. K. (2004). When is the perirhinal cortex necessary for the performance of spatial memory tasks? *Neurosci Biobehav Rev*, 28(6):611–624.
- Aggleton, J. P., Neave, N., Nagle, S., and Sahgal, A. (1995). A comparison of the effects of medial prefrontal, cingulate cortex, and cingulum bundle lesions on tests of spatial memory: evidence of a double dissociation between frontal and cingulum bundle contributions. *J Neurosci*, 15(11):7270–7281.
- Ainge, J., Heron-Maxwell, C., Theofilas, P., Wright, P., de Hoz, L., and Wood, E. (2006). The role of the hippocampus in object recognition in rats: Examination of the influence of task parameters and lesion size. *Behavioural Brain Research*, 167(1):183–195.
- Ainge, J. A., Tamosiunaite, M., Woergoetter, F., and Dudchenko, P. A. (2007a). Hippocampal ca1 place cells encode intended destination on a maze with multiple choice points. *J Neurosci*, 27(36):9769–9779.
- Ainge, J. A., van der Meer, M. A. A., Langston, R. F., and Wood, E. R. (2007b). Exploring the role of context-dependent hippocampal activity in spatial alternation behavior. *Hippocampus*, 17(10):988–1002.
- Alvarez, P. and Squire, L. (1994). Memory consolidation and the medial temporal lobe: a simple network model. *Proc. Natl. Acad. Sci. U. S. A.*, 91(15):7041–7045.
- Amaral, D. and Witter, M. (1995). *Hippocampal Formation*. Paxinos C, ed.
- Amaral, D. G., Ishizuka, N., and Claiborne, B. (1990). Neurons, numbers and the hippocampal network. *Prog Brain Res*, 83:1–11.

- Amaral, D. G. and Witter, M. P. (1989). The three dimensional organization of the hippocampal formation: a review of anatomical data. *Neuroscience*, 31:571–591.
- Andelman, F., Hoofien, D., Goldberg, I., Aizenstein, O., and Neufeld, M. Y. (2010). Bilateral hippocampal lesion and a selective impairment of the ability for mental time travel. *Neurocase*, pages 1–10.
- Anderson, M. I. and Jeffery, K. J. (2003). Heterogeneous modulation of place cell firing by changes in context. *J Neurosci*, 23(26):8827–8835.
- Anderson, M. I., Killing, S., Morris, C., O'Donoghue, A., Onyiahga, D., Stevenson, R., Verriotis, M., and Jeffery, K. J. (2006). Behavioral correlates of the distributed coding of spatial context. *Hippocampus*, 16(9):730–742.
- Anisfeld, M. and Knapp, M. (1968). Association, synonymity, and directionality in false recognition. *Journal of Experimental Psychology*, 77(2):171–179.
- Babb, S. and Crystal, J. (2005). Discrimination of what, when and where: Implications for episodic-like memory in rats. *Learning and Motivation*, 36:177–189.
- Babb, S. and Crystal, J. (2006). Episodic-like memory in the rat. *Current Biology*, 16(13):1317–1321.
- Baeg, E. H., Kim, Y. B., Huh, K., Mook-Jung, I., Kim, H. T., and Jung, M. W. (2003). Dynamics of population code for working memory in the prefrontal cortex. *Neuron*, 40(1):177–188.
- Bannerman, D. M., Yee, B. K., Good, M. A., Heupel, M. J., Iversen, S. D., and Rawlins, J. N. (1999). Double dissociation of function within the hippocampus: a comparison of dorsal, ventral, and complete hippocampal cytotoxic lesions. *Behav Neurosci*, 113(6):1170–1188.
- Barker, G. R. I., Bird, F., Alexander, V., and Warburton, E. C. (2007). Recognition memory for objects, place, and temporal order: a disconnection analysis of the role of the medial prefrontal cortex and perirhinal cortex. *J Neurosci*, 27(11):2948–2957.
- Barnes, T. D., Kubota, Y., Hu, D., Jin, D. Z., and Graybiel, A. M. (2005). Activity of striatal neurons reflects dynamic encoding and recoding of procedural memories. *Nature*, 437(7062):1158–1161.
- Bast, T. (2007). Toward an integrative perspective on hippocampal function: from the rapid encoding of experience to adaptive behavior. *Rev Neurosci*, 18(3-4):253–281.
- Bast, T., da Silva, B. M., and Morris, R. G. M. (2005). Distinct contributions of hippocampal NMDA and AMPA receptors to encoding and retrieval of one-trial place memory. *J Neurosci*, 25(25):5845–5856.
- Bast, T., Wilson, I. A., Witter, M. P., and Morris, R. G. M. (2009). From rapid place learning to behavioral performance: a key role for the intermediate hippocampus. *PLoS Biol*, 7(4):e1000089.
- Becker, J. T., Walker, J. A., and Olton, D. S. (1980). Neuroanatomical bases of spatial memory. *Brain Res*, 200(2):307–320.
- Berke, J. D., Breck, J. T., and Eichenbaum, H. (2009). Striatal versus hippocampal representations during win-stay maze performance. *J Neurophysiol*, 101(3):1575–1587.
- Bird, L., Roberts, W., Abroms, B., Kit, K., and Crupi, C. (2003). Spatial memory for food hidden by rats (*rattus norvegicus*) on the radial maze: Studies of memory for where, what, and when. *J. Comp. Psychol.*, 117:176–187.
- Blair, H. T., Cho, J., and Sharp, P. E. (1999). The anterior thalamic head-direction signal is abolished by bilateral but not unilateral lesions of the lateral mammillary nucleus. *J Neurosci*,

- 19(15):6673–6683.
- Bliss, T. V. and Lomo, T. (1973). Long-lasting potentiation of synaptic transmission in the dentate area of the anaesthetized rabbit following stimulation of the perforant path. *J Physiol*, 232(2):331–356.
- Bohbot, V. D., Kalina, M., Stepankova, K., Spackova, N., Petrides, M., and Nadel, L. (1998). Spatial memory deficits in patients with lesions to the right hippocampus and to the right parahippocampal cortex. *Neuropsychologia*, 36(11):1217–1238.
- Boss, B. D., Turlejski, K., Stanfield, B. B., and Cowan, W. M. (1987). On the numbers of neurons in fields ca1 and ca3 of the hippocampus of sprague-dawley and wistar rats. *Brain Res*, 406(1-2):280–287.
- Bostock, E., Muller, R. U., and Kubie, J. L. (1991). Experience-dependent modifications of hippocampal place cell firing. *Hippocampus*, 1(2):193–205.
- Botzung, A., Denkova, E., and Manning, L. (2008). Experiencing past and future personal events: functional neuroimaging evidence on the neural bases of mental time travel. *Brain Cogn*, 66(2):202–212.
- Bower, M., Euston, D., Roop, R., Gebara, N., and McNaughton, B. (2002). How an ambiguous sequence is learned determines how the hippocampus encodes it. In *Soc. Neurosci. Abstr.*, volume 678.13.
- Bower, M. R., Euston, D. R., and McNaughton, B. L. (2005). Sequential-context-dependent hippocampal activity is not necessary to learn sequences with repeated elements. *J Neurosci*, 25(6):1313–1323.
- Bowles, B., Crupi, C., Mirsattari, S. M., Pigott, S. E., Parrent, A. G., Pruessner, J. C., Yonelinas, A. P., and Khler, S. (2007). Impaired familiarity with preserved recollection after anterior temporal-lobe resection that spares the hippocampus. *Proc Natl Acad Sci U S A*, 104(41):16382–16387.
- Boyden, E. S., Zhang, F., Bamberg, E., Nagel, G., and Deisseroth, K. (2005). Millisecond-timescale, genetically targeted optical control of neural activity. *Nat Neurosci*, 8(9):1263–1268.
- Breese, C. R., Hampson, R. E., and Deadwyler, S. A. (1989). Hippocampal place cells: stereotypy and plasticity. *J Neurosci*, 9(4):1097–1111.
- Broadbent, N., Squire, L., and Clark, R. (2004). Spatial memory, recognition memory, and the hippocampus. *Proceedings of the National Academy of Sciences USA*, 101(40):14515–14520.
- Brown, M. W. and Aggleton, J. P. (2001). Recognition memory: what are the roles of the perirhinal cortex and hippocampus? *Nat Rev Neurosci*, 2(1):51–61.
- Brown, N., Rips, L., and Shevell, S. (1985). The subjective dates of natural events in very-long-term memory. *Cognitive Psychology*, 17(2):139–177.
- Brun, V. H., Otnass, M. K., Molden, S., Steffenach, H.-A., Witter, M. P., Moser, M.-B., and Moser, E. I. (2002). Place cells and place recognition maintained by direct entorhinal-hippocampal circuitry. *Science*, 296(5576):2243–2246.
- Buckmaster, C., Eichenbaum, H., Amaral, D., Suzuki, W., and Rapp, P. (2004). Entorhinal cortex lesions disrupt the relational organization of memory in monkeys. *J Neurosci*, 24(44):9811–25.
- Buffalo, E. A., Bellgowan, P. S. F., and Martin, A. (2006). Distinct roles for medial temporal lobe structures in memory for objects and their locations. *Learn Mem*, 13(5):638–643.
- Bunsey, M. and Eichenbaum, H. (1996). Conservation of hippocampal memory function in rats

- and humans. *Nature*, 379(6562):255–257.
- Burgess, N., Becker, S., King, J., and O'Keefe, J. (2001). Memory for events and their spatial context: Models and experiments. *Philosophical Transactions of the Royal Society of London Series B Biological Sciences*, 356:1493–1503.
- Burgess, N., Maguire, E., and O'Keefe, J. (2002). The human hippocampus and spatial and episodic memory. *Neuron*, 35(4):625–41.
- Burwell, R. D. and Hafeman, D. M. (2003). Positional firing properties of postrhinal cortex neurons. *Neuroscience*, 119(2):577–588.
- Burwell, R. D., Witter, M. P., and Amaral, D. G. (1995). Perirhinal and postrhinal cortices of the rat: a review of the neuroanatomical literature and comparison with findings from the monkey brain. *Hippocampus*, 5(5):390–408.
- Cacucci, F., Lever, C., Wills, T. J., Burgess, N., and O'Keefe, J. (2004). Theta-modulated place-by-direction cells in the hippocampal formation in the rat. *J Neurosci*, 24(38):8265–8277.
- Calton, J. L., Stackman, R. W., Goodridge, J. P., Archey, W. B., Dudchenko, P. A., and Taube, J. S. (2003). Hippocampal place cell instability after lesions of the head direction cell network. *J Neurosci*, 23(30):9719–9731.
- Carelli, R. M. (2002). Nucleus accumbens cell firing during goal-directed behaviors for cocaine vs. 'natural' reinforcement. *Physiol Behav*, 76(3):379–387.
- Cauter, T. V., Poucet, B., and Save, E. (2008). Unstable cal place cell representation in rats with entorhinal cortex lesions. *Eur J Neurosci*, 27(8):1933–1946.
- Cermak, L. (1984). *The episodic-semantic distinction in amnesia*. In: L.R. Squire and N. Butters, Editors., *Neuropsychology of memory*. Guilford Press, New York.
- Chan, K. H., Morell, J. R., Jarrard, L. E., and Davidson, T. L. (2001). Reconsideration of the role of the hippocampus in learned inhibition. *Behav Brain Res*, 119(2):111–130.
- Chen, L. L., Lin, L. H., Green, E. J., Barnes, C. A., and McNaughton, B. L. (1994). Head-direction cells in the rat posterior cortex. i. anatomical distribution and behavioral modulation. *Exp Brain Res*, 101(1):8–23.
- Chiba, A. A., Kesner, R. P., and Reynolds, A. M. (1994). Memory for spatial location as a function of temporal lag in rats: role of hippocampus and medial prefrontal cortex. *Behav Neural Biol*, 61(2):123–131.
- Cho, J. and Sharp, P. E. (2001). Head direction, place, and movement correlates for cells in the rat retrosplenial cortex. *Behav Neurosci*, 115(1):3–25.
- Cipolotti, L. and Bird, C. M. (2006). Amnesia and the hippocampus. *Curr Opin Neurol*, 19(6):593–598.
- Clark, R., Zola, S., and Squire, L. (2000). Impaired recognition memory in rats after damage to the hippocampus. *Journal of Neuroscience*, 20(23):8853–8860.
- Clarke, J. R., Cammarota, M., Gruart, A., Izquierdo, I., and Delgado-García, J. M. (2010). Plastic modifications induced by object recognition memory processing. *Proc Natl Acad Sci U S A*, 107(6):2652–2657.
- Clayton, N., Griffiths, D., Emery, N., and Dickinson, A. (2001a). Elements of episodic-like memory in animals. *Philosophical Transactions of the Royal Society of London Series B*, 356:1483–1491.
- Clayton, N. S., Bussey, T. J., and Dickinson, A. (2003a). Can animals recall the past and plan for

- the future? *Nature Reviews Neuroscience*, 4:685–691.
- Clayton, N. S. and Dickinson, A. (1998). Episodic-like memory during cache recovery by scrub-jays. *Nature*, 395:272–278.
- Clayton, N. S., Yu, K. S., and Dickinson, A. (2001b). Scrub-jays (*aphelocoma coerulescens*) form integrated memories of the multiple features of caching episodes. *Journal of Experimental Psychology: Animal Behavior Processes*, 27:17–29.
- Clayton, N. S., Yu, K. S., and Dickinson, A. (2003b). Interacting cache memories: evidence of flexible memory use by scrub jays. *Journal of Experimental Psychology: Animal Behavior Processes*, 29:14–22.
- Colgin, L. L. and Moser, E. I. (2009). Hippocampal theta rhythms follow the beat of their own drum. *Nat Neurosci*, 12(12):1483–1484.
- Collingridge, G. L., Kehl, S. J., and McLennan, H. (1983). The antagonism of amino acid-induced excitations of rat hippocampal ca1 neurones in vitro. *J Physiol*, 334:19–31.
- Conway, M. A., Gardiner, J. M., Perfect, T. J., Anderson, S. J., and Cohen, G. M. (1997). Changes in memory awareness during learning: the acquisition of knowledge by psychology undergraduates. *J Exp Psychol Gen*, 126(4):393–413.
- Cook, D. and Kesner, R. P. (1988). Caudate nucleus and memory for egocentric localization. *Behav Neural Biol*, 49(3):332–343.
- Cooper, B. and Mizumori, S. (2001). Temporary inactivation of the retrosplenial cortex causes a transient reorganization of spatial coding in the hippocampus. *J Neurosci*, 21(11):3986–4001.
- Corkin, S. (2002). What's new with the amnesic patient h.m.? *Nat Rev Neurosci*, 3(2):153–160.
- Corkin, S., Amaral, D. G., Gonzalez, R. G., Johnson, K. A., and Hyman, B. T. (1997). H. m.'s medial temporal lobe lesion: findings from magnetic resonance imaging. *J Neurosci*, 17(10):3964–3979.
- Correia, S. P. C., Dickinson, A., and Clayton, N. S. (2007). Western scrub-jays anticipate future needs independently of their current motivational state. *Curr Biol*, 17(10):856–861.
- Cozannet, R. L., Fone, K. C. F., and Moran, P. M. (2010). Phencyclidine withdrawal disrupts episodic-like memory in rats: reversal by donepezil but not clozapine. *Int J Neuropsychopharmacol*, pages 1–10.
- Daumas, S., Halley, H., Francs, B., and Lassalle, J.-M. (2005). Encoding, consolidation, and retrieval of contextual memory: differential involvement of dorsal ca3 and ca1 hippocampal subregions. *Learn Mem*, 12(4):375–382.
- Davachi, L., Mitchell, J. P., and Wagner, A. D. (2003). Multiple routes to memory: distinct medial temporal lobe processes build item and source memories. *Proc Natl Acad Sci U S A*, 100(4):2157–2162.
- Davachi, L. and Wagner, A. D. (2002). Hippocampal contributions to episodic encoding: insights from relational and item-based learning. *J Neurophysiol*, 88(2):982–990.
- Davidson, T. L. and Jarrard, L. E. (2004). The hippocampus and inhibitory learning: a 'gray' area? *Neurosci Biobehav Rev*, 28(3):261–271.
- Davis, K., Easton, A., Eacott, M., and Gigg, J. (2010). Episodic memory for what, where and which remain intact in the 3xtgad mouse model of alzheimer's disease. In *FENS Abstr.*, volume 5, 115.31.
- Day, M., Langston, R., and Morris, R. (2003). Glutamate-receptor-mediated encoding and retrieval

- of paired-associate learning. *Nature*, 424(6945):205–209.
- Dayawansa, S., Kobayashi, T., Hori, E., Umeno, K., Tazumi, T., Ono, T., and Nishijo, H. (2006). Conjunctive effects of reward and behavioral episodes on hippocampal place-differential neurons of rats on a mobile treadmill. *Hippocampus*, 16(7):586–595.
- de Hoz, L., Knox, J., and Morris, R. (2003). Longitudinal axis of the hippocampus: Both septal and temporal poles of the hippocampus support water maze spatial learning depending on the training protocol. *Hippocampus*, 13(5):587–603.
- Deadwyler, S. A., Bunn, T., and Hampson, R. E. (1996). Hippocampal ensemble activity during spatial delayed-nonmatch-to-sample performance in rats. *J Neurosci*, 16(1):354–372.
- DeCoteau, W. E. and Kesner, R. P. (2000). A double dissociation between the rat hippocampus and medial caudoputamen in processing two forms of knowledge. *Behav Neurosci*, 114(6):1096–1108.
- Deisseroth, K., Feng, G., Majewska, A. K., Miesenbck, G., Ting, A., and Schnitzer, M. J. (2006). Next-generation optical technologies for illuminating genetically targeted brain circuits. *J Neurosci*, 26(41):10380–10386.
- Desgranges, B., Eustache, F., Rioux, P., de La Sayette, V., and Lechevalier, B. (1996). Memory disorders in alzheimer’s disease and the organization of human memory. *Cortex*, 32(3):387–412.
- Devan, B. D. and White, N. M. (1999). Parallel information processing in the dorsal striatum: relation to hippocampal function. *J Neurosci*, 19(7):2789–2798.
- Diana, R. A., Yonelinas, A. P., and Ranganath, C. (2010). Medial temporal lobe activity during source retrieval reflects information type, not memory strength. *J Cogn Neurosci*, 22(8):1808–1818.
- Diekelmann, S. and Born, J. (2010). The memory function of sleep. *Nat Rev Neurosci*, 11(2):114–126.
- Dix, S. and Aggleton, J. (1999). Extending the spontaneous preference test of recognition: evidence of object-location and object-context recognition. *Behavioral Brain Research*, 99(2):191–200.
- Do, V. H., Martinez, C. O., Martinez, J. L., and Derrick, B. E. (2002). Long-term potentiation in direct perforant path projections to the hippocampal ca3 region in vivo. *J Neurophysiol*, 87(2):669–678.
- Dobbins, I. G., Rice, H. J., Wagner, A. D., and Schacter, D. L. (2003). Memory orientation and success: separable neurocognitive components underlying episodic recognition. *Neuropsychologia*, 41(3):318–333.
- Donaldson, W. (1996). The role of decision processes in remembering and knowing. *Mem Cognit*, 24(4):523–533.
- Dudchenko, P., Wood, E., and Eichenbaum, H. (2000). Neurotoxic hippocampal lesions have no effect on odor span and little effect on odor recognition memory but produce significant impairments on spatial span, recognition, and alternation. *J Neurosci*, 20(8):2964–77.
- Duezel, E., Yonelinas, A. P., Mangun, G. R., Heinze, H. J., and Tulving, E. (1997). Event-related brain potential correlates of two states of conscious awareness in memory. *Proc Natl Acad Sci U S A*, 94(11):5973–5978.
- Dusek, J. A. and Eichenbaum, H. (1997). The hippocampus and memory for orderly stimulus

- relations. *Proc Natl Acad Sci U S A*, 94(13):7109–7114.
- Eacott, M., Easton, A., and Zinkivskay, A. (2005). Recollection in an episodic-like memory task in the rat. *Learning and Memory*, 12(3):221–223.
- Eacott, M. and Gaffan, E. (2005). The roles of perirhinal cortex, postrhinal cortex, and the fornix in memory for objects, contexts, and events in the rat. *Quarterly Journal of Experimental Psychology Series B*, 58(3-4):202–217.
- Eacott, M. and Norman, G. (2004). Integrated memory for object, place, and context in rats: a possible model of episodic-like memory? *Journal of Neuroscience*, 24(8):1948–1953.
- Easton, A., Zinkivskay, A., and Eacott, M. J. (2009). Recollection is impaired, but familiarity remains intact in rats with lesions of the fornix. *Hippocampus*, 19(9):837–843.
- Eichenbaum, H. (2001). The hippocampus and declarative memory: cognitive mechanisms and neural codes. *Behav Brain Res*, 127(1-2):199–207.
- Eichenbaum, H., Stewart, C., and Morris, R. (1990). Hippocampal representation in place learning. *Journal of Neuroscience*, 10(11):3531–3542.
- Eichenbaum, H., Wiener, S. I., Shapiro, M. L., and Cohen, N. J. (1989). The organization of spatial coding in the hippocampus: a study of neural ensemble activity. *J Neurosci*, 9(8):2764–2775.
- Eichenbaum, H., Yonelinas, A. P., and Ranganath, C. (2007). The medial temporal lobe and recognition memory. *Annu Rev Neurosci*, 30:123–152.
- Ekstrom, A., Kahana, M., Caplan, J., Fields, T., Isham, E., Newman, E., and Fried, I. (2003). Cellular networks underlying human spatial navigation. *Nature*, 425(6954):184–188.
- Eldridge, L. L., Engel, S. A., Zeineh, M. M., Bookheimer, S. Y., and Knowlton, B. J. (2005). A dissociation of encoding and retrieval processes in the human hippocampus. *J Neurosci*, 25(13):3280–3286.
- Eldridge, L. L., Knowlton, B. J., Furmanski, C. S., Bookheimer, S. Y., and Engel, S. A. (2000). Remembering episodes: a selective role for the hippocampus during retrieval. *Nat Neurosci*, 3(11):1149–1152.
- Eldridge, L. L., Masterman, D., and Knowlton, B. J. (2002). Intact implicit habit learning in alzheimer's disease. *Behav Neurosci*, 116(4):722–726.
- Emery, N. J. and Clayton, N. S. (2001). Effects of experience and social context on prospective caching strategies by scrub jays. *Nature*, 414(6862):443–446.
- Ennaceur, A. and Aggleton, J. (1994). Spontaneous recognition of object configurations in rats: effects of fornix lesions. *Experimental Brain Research*, 100(1):85–92.
- Ennaceur, A. and Delacour, J. (1988). A new one-trial test for neurobiological studies of memory in rats. 1: Behavioral data. *Behavioral Brain Research*, 31(1):47–59.
- Ennaceur, A., Neave, N., and Aggleton, J. (1997). Spontaneous object recognition and object location memory in rats: the effects of lesions in the cingulate cortices, the medial prefrontal cortex, the cingulum bundle and the fornix. *Experimental Brain Research*, 113(3):509–519.
- Ennaceur, A., Neave, N., and Aggleton, J. P. (1996). Neurotoxic lesions of the perirhinal cortex do not mimic the behavioural effects of fornix transection in the rat. *Behav Brain Res*, 80(1-2):9–25.
- Etienne, A. S. and Jeffery, K. J. (2004). Path integration in mammals. *Hippocampus*, 14(2):180–192.

- Ferbinteanu, J. and McDonald, R. J. (2001). Dorsal/ventral hippocampus, fornix, and conditioned place preference. *Hippocampus*, 11(2):187–200.
- Ferbinteanu, J., Ray, C., and McDonald, R. J. (2003). Both dorsal and ventral hippocampus contribute to spatial learning in long-evans rats. *Neurosci Lett*, 345(2):131–135.
- Ferbinteanu, J. and Shapiro, M. L. (2003). Prospective and retrospective memory coding in the hippocampus. *Neuron*, 40(6):1227–1239.
- Floresco, S. B., Seamans, J. K., and Phillips, A. G. (1997). Selective roles for hippocampal, prefrontal cortical, and ventral striatal circuits in radial-arm maze tasks with or without a delay. *J Neurosci*, 17(5):1880–1890.
- Fortin, N., Agster, K., and Eichenbaum, H. (2002). Critical role of the hippocampus in memory for sequences of events. *Nature Neuroscience*, 5:458–462.
- Fortin, N., Wright, S., and Eichenbaum, H. (2004). Recollection-like memory retrieval in rats is dependent on the hippocampus. *Nature*, 431:188–191.
- Forwood, S. E., Winters, B. D., and Bussey, T. J. (2005). Hippocampal lesions that abolish spatial maze performance spare object recognition memory at delays of up to 48 hours. *Hippocampus*, 15(3):347–355.
- Foster, D. J. and Wilson, M. A. (2006). Reverse replay of behavioural sequences in hippocampal place cells during the awake state. *Nature*, 440(7084):680–683.
- Frank, L. M., Brown, E. N., and Stanley, G. B. (2006). Hippocampal and cortical place cell plasticity: implications for episodic memory. *Hippocampus*, 16(9):775–784.
- Frank, L. M., Brown, E. N., and Wilson, M. (2000). Trajectory encoding in the hippocampus and entorhinal cortex. *Neuron*, 27(1):169–178.
- Frank, L. M., Stanley, G. B., and Brown, E. N. (2004). Hippocampal plasticity across multiple days of exposure to novel environments. *J Neurosci*, 24(35):7681–7689.
- Fredens, K., Stengaard-Pedersen, K., and Larsson, L. I. (1984). Localization of enkephalin and cholecystokinin immunoreactivities in the perforant path terminal fields of the rat hippocampal formation. *Brain Res*, 304(2):255–263.
- Friedman, W. (1993). Memory for the time of past events. *Psychological Bulletin*, 113(1):44–66.
- Friedman, W. (2001). *Memory processes underlying humans chronological sense of the past*. In: C. Hoerl and T. McCormack, Editors, *Time and memory: Issues in philosophy and psychology*. Oxford University Press.
- Friedman, W. and Wilkins, A. (1985). Scale effects in memory for the time of events. *Memory and Cognition*, 13(2):168–175.
- Funahashi, M. and Stewart, M. (1997). Presubicular and parasubicular cortical neurons of the rat: functional separation of deep and superficial neurons in vitro. *J Physiol*, 501 (Pt 2):387–403.
- Fyhn, M., Hafting, T., Treves, A., Moser, M.-B., and Moser, E. I. (2007). Hippocampal remapping and grid realignment in entorhinal cortex. *Nature*, 446(7132):190–194.
- Fyhn, M., Molden, S., Hollup, S., Moser, M.-B., and Moser, E. (2002). Hippocampal neurons responding to first-time dislocation of a target object. *Neuron*, 35(3):555–566.
- Fyhn, M., Molden, S., Witter, M., Moser, E., and Moser, M. (2004). Spatial representation in the entorhinal cortex. *Science*, 305(5688):1258–64.
- Gaffan, E. and Eacott, M. (1997). Spatial memory impairment in rats with fornix transection is not

- accompanied by a simple encoding deficit for directions of objects in visual space. *Behavioral Neuroscience*, 111(5):937–954.
- Gaskin, S., Chai, S.-C., and White, N. M. (2005). Inactivation of the dorsal hippocampus does not affect learning during exploration of a novel environment. *Hippocampus*, 15(8):1085–1093.
- Gaskin, S., Tremblay, A., and Mumby, D. (2003). Retrograde and anterograde object recognition in rats with hippocampal lesions. *Hippocampus*, 13(8):962–969.
- Gavrilov, V. V., Wiener, S. I., and Berthoz, A. (1998). Discharge correlates of hippocampal complex spike neurons in behaving rats passively displaced on a mobile robot. *Hippocampus*, 8(5):475–490.
- Gaykema, R. P., van der Kuil, J., Hersh, L. B., and Luiten, P. G. (1991). Patterns of direct projections from the hippocampus to the medial septum-diagonal band complex: anterograde tracing with phaseolus vulgaris leucoagglutinin combined with immunohistochemistry of choline acetyltransferase. *Neuroscience*, 43(2-3):349–360.
- Gelbard-Sagiv, H., Mukamel, R., Harel, M., Malach, R., and Fried, I. (2008). Internally generated reactivation of single neurons in human hippocampus during free recall. *Science*, 322(5898):96–101.
- Gengler, S., Mallot, H. A., and Hlscher, C. (2005). Inactivation of the rat dorsal striatum impairs performance in spatial tasks and alters hippocampal theta in the freely moving rat. *Behav Brain Res*, 164(1):73–82.
- Gilbert, P. E. and Kesner, R. P. (2002). Role of the rodent hippocampus in paired-associate learning involving associations between a stimulus and a spatial location. *Behav Neurosci*, 116(1):63–71.
- Gilbert, P. E. and Kesner, R. P. (2003). Localization of function within the dorsal hippocampus: the role of the CA3 subregion in paired-associate learning. *Behav Neurosci*, 117(6):1385–1394.
- Gilbert, P. E., Kesner, R. P., and Lee, I. (2001). Dissociating hippocampal subregions: double dissociation between dentate gyrus and ca1. *Hippocampus*, 11(6):626–636.
- Glanzer, M., Kim, K., Hilford, A., and Adams, J. K. (1999). Slope of the receiver-operating characteristic in recognition memory. *Journal of Experimental Psychology: Learning, Memory, and Cognition*, 25(2):500 – 513.
- Glenberg, A. and Swanson, N. (1986). A temporal distinctiveness theory of recency and modality effects. *Journal of Experimental Psychology: Learning Memory and Cognition, Memory and Cognition*, 12(1):3–15.
- Glenberg, A. M., Bradley, M. M., Kraus, T. A., and Renzaglia, G. J. (1983). Studies of the long-term recency effect: Support for the contextually guided retrieval hypothesis. *Journal of Experimental Psychology: Learning, Memory, and Cognition*, 9:231–255.
- Godsil, B. P., Stefanacci, L., and Fanselow, M. S. (2005). Bright light suppresses hyperactivity induced by excitotoxic dorsal hippocampus lesions in the rat. *Behav Neurosci*, 119(5):1339–1352.
- Gold, A. E. and Kesner, R. P. (2005). The role of the ca3 subregion of the dorsal hippocampus in spatial pattern completion in the rat. *Hippocampus*, 15(6):808–814.
- Golob, E. J. and Taube, J. S. (1997). Head direction cells and episodic spatial information in rats without a hippocampus. *Proc Natl Acad Sci U S A*, 94(14):7645–7650.
- Golob, E. J. and Taube, J. S. (1999). Head direction cells in rats with hippocampal or overlying neocortical lesions: evidence for impaired angular path integration. *J Neurosci*, 19(16):7198–

7211.

- Good, M. and Honey, R. C. (1997). Dissociable effects of selective lesions to hippocampal sub-systems on exploratory behavior, contextual learning, and spatial learning. *Behav Neurosci*, 111(3):487–493.
- Good, M. A., Barnes, P., Staal, V., McGregor, A., and Honey, R. C. (2007). Context- but not familiarity-dependent forms of object recognition are impaired following excitotoxic hippocampal lesions in rats. *Behav Neurosci*, 121(1):218–223.
- Goodridge, J. P., Dudchenko, P. A., Worboys, K. A., Golob, E. J., and Taube, J. S. (1998). Cue control and head direction cells. *Behav Neurosci*, 112(4):749–761.
- Goodridge, J. P. and Taube, J. S. (1997). Interaction between the postsubiculum and anterior thalamus in the generation of head direction cell activity. *J Neurosci*, 17(23):9315–9330.
- Gothard, K. M., Skaggs, W. E., Moore, K. M., and McNaughton, B. L. (1996). Binding of hippocampal CA1 neural activity to multiple reference frames in a landmark-based navigation task. *J Neurosci*, 16(2):823–835.
- Gould, T. J., Rowe, W. B., Heman, K. L., Mesches, M. H., Young, D. A., Rose, G. M., and Bickford, P. C. (2002). Effects of hippocampal lesions on patterned motor learning in the rat. *Brain Res Bull*, 58(6):581–586.
- Graham, N. L., Emery, T., and Hodges, J. R. (2004). Distinctive cognitive profiles in alzheimer's disease and subcortical vascular dementia. *J Neurol Neurosurg Psychiatry*, 75(1):61–71.
- Groen, G., Wunderlich, A. P., Spitzer, M., Tomczak, R., and Riepe, M. W. (2000). Brain activation during human navigation: gender-different neural networks as substrate of performance. *Nat Neurosci*, 3(4):404–408.
- Hafting, T., Fyhn, M., Molden, S., Moser, M.-B., and Moser, E. (2005). Microstructure of a spatial map in the entorhinal cortex. *Nature*, 436(7052):801–806.
- Hampson, R. E., Jarrard, L. E., and Deadwyler, S. A. (1999a). Effects of ibotenate hippocampal and extrahippocampal destruction on delayed-match and -nonmatch-to-sample behavior in rats. *J Neurosci*, 19(4):1492–1507.
- Hampson, R. E., Simeral, J. D., and Deadwyler, S. A. (1999b). Distribution of spatial and nonspatial information in dorsal hippocampus. *Nature*, 402(6762):610–614.
- Hampson, R. E., Simeral, J. D., and Deadwyler, S. A. (2002). "keeping on track": firing of hippocampal neurons during delayed-nonmatch-to-sample performance. *J Neurosci*, 22(2):RC198.
- Hannesson, D. K., Howland, J. G., and Phillips, A. G. (2004). Interaction between perirhinal and medial prefrontal cortex is required for temporal order but not recognition memory for objects in rats. *J Neurosci*, 24(19):4596–4604.
- Hannula, D. E. and Ranganath, C. (2008). Medial temporal lobe activity predicts successful relational memory binding. *J Neurosci*, 28(1):116–124.
- Hargreaves, E., Rao, G., Lee, I., and Knierim, J. (2005). Major dissociation between medial and lateral entorhinal input to dorsal hippocampus. *Science*, 308(5729):1792–4.
- Hargreaves, E. L., Yoganarasimha, D., and Knierim, J. J. (2007). Cohesiveness of spatial and directional representations recorded from neural ensembles in the anterior thalamus, parasubiculum, medial entorhinal cortex, and hippocampus. *Hippocampus*, 17(9):826–841.
- Hartley, T., Maguire, E. A., Spiers, H. J., and Burgess, N. (2003). The well-worn route and the path less traveled: distinct neural bases of route following and wayfinding in humans. *Neuron*,

- 37(5):877–888.
- Haskins, A. L., Yonelinas, A. P., Quamme, J. R., and Ranganath, C. (2008). Perirhinal cortex supports encoding and familiarity-based recognition of novel associations. *Neuron*, 59(4):554–560.
- Hassabis, D., Kumaran, D., Vann, S. D., and Maguire, E. A. (2007). Patients with hippocampal amnesia cannot imagine new experiences. *Proc Natl Acad Sci U S A*, 104(5):1726–1731.
- Hasselmo, M. E. (2005). The role of hippocampal regions ca3 and ca1 in matching entorhinal input with retrieval of associations between objects and context: theoretical comment on lee et al. (2005). *Behav Neurosci*, 119(1):342–345.
- Hasselmo, M. E., Schnell, E., and Barkai, E. (1995). Dynamics of learning and recall at excitatory recurrent synapses and cholinergic modulation in rat hippocampal region ca3. *J Neurosci*, 15(7 Pt 2):5249–5262.
- Hasselmo, M. E. and Wyble, B. P. (1997). Free recall and recognition in a network model of the hippocampus: simulating effects of scopolamine on human memory function. *Behav Brain Res*, 89(1-2):1–34.
- Hayman, R. M. A., Chakraborty, S., Anderson, M. I., and Jeffery, K. J. (2003). Context-specific acquisition of location discrimination by hippocampal place cells. *Eur J Neurosci*, 18(10):2825–2834.
- Henke, P. G. (1990). Hippocampal pathway to the amygdala and stress ulcer development. *Brain Res Bull*, 25(5):691–695.
- Higgs, S., Bannerman, D. M., and Rawlins, J. N. (2001). The effect of cytotoxic lesions of the hippocampus on recognition memory in the rat: effects of stimulus size. *Behav Neurosci*, 115(6):1193–1203.
- Hill, A. J. (1978). First occurrence of hippocampal spatial firing in a new environment. *Exp Neurol*, 62(2):282–297.
- Hinrichs, J. and Buschke, H. (1968). Judgment of recency under steady-state conditions. *Journal of Experimental Psychology*, 78(4):574–579.
- Hoge, J. and Kesner, R. P. (2007). Role of ca3 and ca1 subregions of the dorsal hippocampus on temporal processing of objects. *Neurobiol Learn Mem*, 88(2):225–231.
- Hok, V., Lenck-Santini, P.-P., Roux, S., Save, E., Muller, R. U., and Poucet, B. (2007). Goal-related activity in hippocampal place cells. *J Neurosci*, 27(3):472–482.
- Holland, P. C., Lamoureux, J. A., Han, J. S., and Gallagher, M. (1999). Hippocampal lesions interfere with pavlovian negative occasion setting. *Hippocampus*, 9(2):143–157.
- Holscher, C., Jacob, W., and Mallot, H. (2004). Learned association of allocentric and egocentric information in the hippocampus. *Exp Brain Res*, 158(2):233–40.
- Honey, R. C., Watt, A., and Good, M. (1998). Hippocampal lesions disrupt an associative mismatch process. *J Neurosci*, 18(6):2226–2230.
- Hotte, M., Naudon, L., and Jay, T. M. (2005). Modulation of recognition and temporal order memory retrieval by dopamine d1 receptor in rats. *Neurobiol Learn Mem*, 84(2):85–92.
- Humphreys, M., I. B. and Pike, R. (1989). Different ways to cue a coherent memory system: a theory for episodic, semantic and procedural tasks. *Psychological Review*, 96:208233.
- Hunsaker, M. R., Allan, K. D., and Kesner, R. P. (2007a). Role of dca3 efferents via the fimbria in the acquisition of a delay nonmatch to place task. *Hippocampus*, published online ahead of

print.

- Hunsaker, M. R., Fieldsted, P. M., Rosenberg, J. S., and Kesner, R. P. (2008a). Dissociating the roles of dorsal and ventral ca1 for the temporal processing of spatial locations, visual objects, and odors. *Behav Neurosci*, 122(3):643–650.
- Hunsaker, M. R., Lee, B., and Kesner, R. P. (2008b). Evaluating the temporal context of episodic memory: the role of ca3 and ca1. *Behav Brain Res*, 188(2):310–315.
- Hunsaker, M. R., Rogers, J. L., and Kesner, R. P. (2007b). Behavioral characterization of a transection of dorsal ca3 subcortical efferents: Comparison with scopolamine and physostigmine infusions into dorsal ca3. *Neurobiol Learn Mem*, published online ahead of print.
- Hunsaker, M. R., Thorup, J. A., Welch, T., and Kesner, R. P. (2006). The role of CA3 and CA1 in the acquisition of an object-trace-place paired-associate task. *Behav Neurosci*, 120(6):1252–1256.
- Ishizuka, N., Weber, J., and Amaral, D. G. (1990). Organization of intrahippocampal projections originating from ca3 pyramidal cells in the rat. *J Comp Neurol*, 295(4):580–623.
- Izquierdo, I. and Medina, J. H. (1997). Memory formation: the sequence of biochemical events in the hippocampus and its connection to activity in other brain structures. *Neurobiol Learn Mem*, 68(3):285–316.
- Jarrard, L. (1989). On the use of ibotenic acid to lesion selectively different components of the hippocampal formation. *Journal of Neuroscience Methods*, 29(3):251–259.
- Jarrard, L. E., Davidson, T. L., and Bowring, B. (2004). Functional differentiation within the medial temporal lobe in the rat. *Hippocampus*, 14(4):434–449.
- Jeffery, K. J., Anderson, M. I., Hayman, R., and Chakraborty, S. (2004). A proposed architecture for the neural representation of spatial context. *Neurosci Biobehav Rev*, 28(2):201–218.
- Jeffery, K. J., Donnett, J. G., Burgess, N., and O’Keefe, J. M. (1997). Directional control of hippocampal place fields. *Exp Brain Res*, 117(1):131–142.
- Jeffery, K. J., Gilbert, A., Burton, S., and Strudwick, A. (2003). Preserved performance in a hippocampal-dependent spatial task despite complete place cell remapping. *Hippocampus*, 13(2):175–189.
- Ji, D. and Wilson, M. A. (2008). Firing rate dynamics in the hippocampus induced by trajectory learning. *J Neurosci*, 28(18):4679–4689.
- Jog, M. S., Kubota, Y., Connolly, C. I., Hillegaart, V., and Graybiel, A. M. (1999). Building neural representations of habits. *Science*, 286(5445):1745–1749.
- Johnson, A. and Redish, A. D. (2007). Neural ensembles in ca3 transiently encode paths forward of the animal at a decision point. *J Neurosci*, 27(45):12176–12189.
- Jones, G. (1976). A fragmentation hypothesis of memory: cued recall of pictures and sequential position. *J. Exp. Psychol. Gen.*, 105:277–293.
- Jones, M. W. and Wilson, M. A. (2005). Theta rhythms coordinate hippocampal-prefrontal interactions in a spatial memory task. *PLoS Biol*, 3(12):e402.
- Jung, M. W. and McNaughton, B. L. (1993). Spatial selectivity of unit activity in the hippocampal granular layer. *Hippocampus*, 3(2):165–182.
- Jung, M. W., Qin, Y., McNaughton, B. L., and Barnes, C. A. (1998). Firing characteristics of deep layer neurons in prefrontal cortex in rats performing spatial working memory tasks. *Cereb Cortex*, 8(5):437–450.

- Jung, M. W., Wiener, S. I., and McNaughton, B. L. (1994). Comparison of spatial firing characteristics of units in dorsal and ventral hippocampus of the rat. *J Neurosci*, 14(12):7347–7356.
- Karlsson, M. P. and Frank, L. M. (2008). Network dynamics underlying the formation of sparse, informative representations in the hippocampus. *J Neurosci*, 28(52):14271–14281.
- Kart-Teke, E., De Souza Silva, M., Huston, J., and Dere, E. (2006). Wistar rats show episodic-like memory for unique experiences. *Neurobiology of Learning and Memory*, 85(2):173–182.
- Kennedy, P. J. and Shapiro, M. L. (2004). Retrieving memories via internal context requires the hippocampus. *J Neurosci*, 24(31):6979–6985.
- Kentros, C., Hargreaves, E., Hawkins, R. D., Kandel, E. R., Shapiro, M., and Muller, R. V. (1998). Abolition of long-term stability of new hippocampal place cell maps by nmda receptor blockade. *Science*, 280(5372):2121–2126.
- Kesner, R. P. (2007). A behavioral analysis of dentate gyrus function. *Prog Brain Res*, 163:567–576.
- Kesner, R. P., Bolland, B. L., and Dakis, M. (1993). Memory for spatial locations, motor responses, and objects: triple dissociation among the hippocampus, caudate nucleus, and extrastriate visual cortex. *Exp Brain Res*, 93(3):462–470.
- Kesner, R. P., Gilbert, P. E., and Barua, L. A. (2002). The role of the hippocampus in memory for the temporal order of a sequence of odors. *Behav Neurosci*, 116(2):286–290.
- Kesner, R. P. and Giles, R. (1998). Neural circuit analysis of spatial working memory: role of pre- and parasubiculum, medial and lateral entorhinal cortex. *Hippocampus*, 8(4):416–423.
- Kesner, R. P., Hunsaker, M. R., and Gilbert, P. E. (2005). The role of CA1 in the acquisition of an object-trace-odor paired associate task. *Behav Neurosci*, 119(3):781–786.
- Kesner, R. P., Hunsaker, M. R., and Warthen, M. W. (2008). The ca3 subregion of the hippocampus is critical for episodic memory processing by means of relational encoding in rats. *Behav Neurosci*, 122(6):1217–1225.
- Kesner, R. P., Hunsaker, M. R., and Ziegler, W. (2010). The role of the dorsal ca1 and ventral ca1 in memory for the temporal order of a sequence of odors. *Neurobiol Learn Mem*, 93(1):111–116.
- Kesner, R. P., Hunt, M. E., Williams, J. M., and Long, J. M. (1996). Prefrontal cortex and working memory for spatial response, spatial location, and visual object information in the rat. *Cereb Cortex*, 6(2):311–318.
- Kesner, R. P., Lee, I., and Gilbert, P. (2004). A behavioral assessment of hippocampal function based on a subregional analysis. *Rev Neurosci*, 15(5):333–351.
- Kim, S. M. and Frank, L. M. (2009). Hippocampal lesions impair rapid learning of a continuous spatial alternation task. *PLoS One*, 4(5):e5494.
- Kimble, D. P. (1968). Hippocampus and internal inhibition. *Psychol Bull*, 70(5):285–295.
- Kirwan, C. B., Wixted, J. T., and Squire, L. R. (2010). A demonstration that the hippocampus supports both recollection and familiarity. *Proc Natl Acad Sci U S A*, 107(1):344–348.
- Kjelstrup, K. G., Tuvnes, F. A., Steffenach, H.-A., Murison, R., Moser, E. I., and Moser, M.-B. (2002). Reduced fear expression after lesions of the ventral hippocampus. *Proc Natl Acad Sci U S A*, 99(16):10825–10830.
- Klein, S. B., Cosmides, L., Tooby, J., and Chance, S. (2002). Decisions and the evolution of memory: multiple systems, multiple functions. *Psychol Rev*, 109(2):306–329.

- Knierim, J. J. (2002). Dynamic interactions between local surface cues, distal landmarks, and intrinsic circuitry in hippocampal place cells. *J Neurosci*, 22(14):6254–6264.
- Knierim, J. J., Kudrimoti, H. S., and McNaughton, B. L. (1995). Place cells, head direction cells, and the learning of landmark stability. *J Neurosci*, 15(3 Pt 1):1648–1659.
- Knierim, J. J., Kudrimoti, H. S., and McNaughton, B. L. (1998). Interactions between idiothetic cues and external landmarks in the control of place cells and head direction cells. *J Neurophysiol*, 80(1):425–446.
- Knierim, J. J. and Rao, G. (2003). Distal landmarks and hippocampal place cells: effects of relative translation versus rotation. *Hippocampus*, 13(5):604–617.
- Knowlton, B. and Squire, L. (1995). Remembering and knowing: two different expressions of declarative memory. *Journal of Experimental Psychology: Learning, Memory and Cognition*, 21(3):699–710.
- Knowlton, B. J., Mangels, J. A., and Squire, L. R. (1996). A neostriatal habit learning system in humans. *Science*, 273(5280):1399–1402.
- Kobayashi, T., Nishijo, H., Fukuda, M., Bures, J., and Ono, T. (1997). Task-dependent representations in rat hippocampal place neurons. *J Neurophysiol*, 78(2):597–613.
- Kobayashi, T., Tran, A. H., Nishijo, H., Ono, T., and Matsumoto, G. (2003). Contribution of hippocampal place cell activity to learning and formation of goal-directed navigation in rats. *Neuroscience*, 117(4):1025–1035.
- Kumaran, D. and Maguire, E. A. (2006). An unexpected sequence of events: mismatch detection in the human hippocampus. *PLoS Biol*, 4(12):e424.
- Kumaran, D. and Maguire, E. A. (2007). Match mismatch processes underlie human hippocampal responses to associative novelty. *J Neurosci*, 27(32):8517–8524.
- Langston, R. F. and Wood, E. R. (2009). Associative recognition and the hippocampus: Differential effects of hippocampal lesions on object-place, object-context and object-place-context memory. *Hippocampus*.
- Larkin, A. E., Fahey, B., Gobbo, O., Callaghan, C. K., Cahill, E., O'Mara, S. M., and Kelly, A. M. (2008). Blockade of nmda receptors pre-training, but not post-training, impairs object displacement learning in the rat. *Brain Res*, 1199:126–132.
- Lassalle, J. M., Bataille, T., and Halley, H. (2000). Reversible inactivation of the hippocampal mossy fiber synapses in mice impairs spatial learning, but neither consolidation nor memory retrieval, in the morris navigation task. *Neurobiol Learn Mem*, 73(3):243–257.
- Lathe, R. and Morris, R. G. (1994). Analysing brain function and dysfunction in transgenic animals. *Neuropathol Appl Neurobiol*, 20(4):350–358.
- Lee, D. W., Miyasato, L. E., and Clayton, N. S. (1998). Neurobiological bases of spatial learning in the natural environment: neurogenesis and growth in the avian and mammalian hippocampus. *Neuroreport*, 9(7):R15–R27.
- Lee, I., Griffin, A. L., Zilli, E. A., Eichenbaum, H., and Hasselmo, M. E. (2006). Gradual translocation of spatial correlates of neuronal firing in the hippocampus toward prospective reward locations. *Neuron*, 51(5):639–650.
- Lee, I., Hunsaker, M. R., and Kesner, R. P. (2005a). The role of hippocampal subregions in detecting spatial novelty. *Behav Neurosci*, 119(1):145–153.
- Lee, I., Jerman, T. S., and Kesner, R. P. (2005b). Disruption of delayed memory for a sequence

- of spatial locations following ca1- or ca3-lesions of the dorsal hippocampus. *Neurobiol Learn Mem*, 84(2):138–147.
- Lee, I. and Kesner, R. P. (2002). Differential contribution of nmda receptors in hippocampal subregions to spatial working memory. *Nat Neurosci*, 5(2):162–168.
- Lee, I. and Kesner, R. P. (2004). Differential contributions of dorsal hippocampal subregions to memory acquisition and retrieval in contextual fear-conditioning. *Hippocampus*, 14(3):301–310.
- Lee, I., Rao, G., and Knierim, J. (2004a). A double dissociation between hippocampal subfields: differential time course of CA3 and CA1 place cells for processing changed environments. *Neuron*, 42(5):803–15.
- Lee, I., Yoganarasimha, D., Rao, G., and Knierim, J. J. (2004b). Comparison of population coherence of place cells in hippocampal subfields CA1 and CA3. *Nature*, 430(6998):456–459.
- Lee, J. L. C. (2008). Memory reconsolidation mediates the strengthening of memories by additional learning. *Nat Neurosci*, 11(11):1264–1266.
- Lenck-Santini, P., Save, E., and Poucet, B. (2001). Place-cell firing does not depend on the direction of turn in a Y-maze alternation task. *Eur J Neurosci*, 13(5):1055–8.
- Leutgeb, J. K., Leutgeb, S., Moser, M.-B., and Moser, E. I. (2007). Pattern separation in the dentate gyrus and ca3 of the hippocampus. *Science*, 315(5814):961–966.
- Leutgeb, J. K., Leutgeb, S., Treves, A., Meyer, R., Barnes, C. A., McNaughton, B. L., Moser, M.-B., and Moser, E. I. (2005a). Progressive transformation of hippocampal neuronal representations in "morphed" environments. *Neuron*, 48(2):345–358.
- Leutgeb, S., Leutgeb, J., Barnes, C., Moser, E., McNaughton, B., and Moser, M. (2005b). Independent codes for spatial and episodic memory in hippocampal neuronal ensembles. *Science*, 309(5734):619–23.
- Leutgeb, S., Leutgeb, J. K., Moser, E. I., and Moser, M.-B. (2006). Fast rate coding in hippocampal ca3 cell ensembles. *Hippocampus*, 16(9):765–774.
- Leutgeb, S., Leutgeb, J. K., Treves, A., Moser, M.-B., and Moser, E. I. (2004). Distinct ensemble codes in hippocampal areas ca3 and ca1. *Science*, 305(5688):1295–1298.
- Lever, C., Wills, T., Cacucci, F., Burgess, N., and O'Keefe, J. (2002). Long-term plasticity in hippocampal place-cell representation of environmental geometry. *Nature*, 416(6876):90–94.
- Levy, W. B. (1996). A sequence predicting ca3 is a flexible associator that learns and uses context to solve hippocampal-like tasks. *Hippocampus*, 6(6):579–590.
- Li, J.-S. and Chao, Y.-S. (2008). Electrolytic lesions of dorsal ca3 impair episodic-like memory in rats. *Neurobiol Learn Mem*, 89(2):192–198.
- Lichtman, J. W. and Sanes, J. R. (2008). Ome sweet ome: what can the genome tell us about the connectome? *Curr Opin Neurobiol*.
- Lipton, P. A., White, J. A., and Eichenbaum, H. (2007). Disambiguation of overlapping experiences by neurons in the medial entorhinal cortex. *J Neurosci*, 27(21):5787–5795.
- Lisman, J. E. (1999). Relating hippocampal circuitry to function: recall of memory sequences by reciprocal dentate-ca3 interactions. *Neuron*, 22(2):233–242.
- Lisman, J. E. and Otmakhova, N. A. (2001). Storage, recall, and novelty detection of sequences by the hippocampus: elaborating on the socratic model to account for normal and aberrant effects of dopamine. *Hippocampus*, 11(5):551–568.

- Liu, P. and Bilkey, D. K. (2002). The effects of nmda lesions centered on the postrhinal cortex on spatial memory tasks in the rat. *Behav Neurosci*, 116(5):860–873.
- Liu, P., Jarrard, L. E., and Bilkey, D. K. (2001). Excitotoxic lesions of the pre- and parasubiculum disrupt object recognition and spatial memory processes. *Behav Neurosci*, 115(1):112–124.
- Liu, P., Jarrard, L. E., and Bilkey, D. K. (2004). Excitotoxic lesions of the pre- and parasubiculum disrupt the place fields of hippocampal pyramidal cells. *Hippocampus*, 14(1):107–116.
- Liu, X., Muller, R. U., Huang, L.-T., Kubie, J. L., Rotenberg, A., Rivard, B., Cilio, M. R., and Holmes, G. L. (2003). Seizure-induced changes in place cell physiology: relationship to spatial memory. *J Neurosci*, 23(37):11505–11515.
- Louie, K. and Wilson, M. A. (2001). Temporally structured replay of awake hippocampal ensemble activity during rapid eye movement sleep. *Neuron*, 29(1):145–156.
- Maguire, E. A., Burgess, N., Donnett, J. G., Frackowiak, R. S., Frith, C. D., and O’Keefe, J. (1998). Knowing where and getting there: a human navigation network. *Science*, 280(5365):921–924.
- Maguire, E. A., Burke, T., Phillips, J., and Staunton, H. (1996a). Topographical disorientation following unilateral temporal lobe lesions in humans. *Neuropsychologia*, 34(10):993–1001.
- Maguire, E. A., Frackowiak, R. S., and Frith, C. D. (1996b). Learning to find your way: a role for the human hippocampal formation. *Proc Biol Sci*, 263(1377):1745–1750.
- Maguire, E. A., Frackowiak, R. S., and Frith, C. D. (1997). Recalling routes around london: activation of the right hippocampus in taxi drivers. *J Neurosci*, 17(18):7103–7110.
- Maguire, E. A., Gadian, D. G., Johnsrude, I. S., Good, C. D., Ashburner, J., Frackowiak, R. S., and Frith, C. D. (2000). Navigation-related structural change in the hippocampi of taxi drivers. *Proc Natl Acad Sci U S A*, 97(8):4398–4403.
- Manns, J. R., Howard, M. W., and Eichenbaum, H. (2007). Gradual changes in hippocampal activity support remembering the order of events. *Neuron*, 56(3):530–540.
- Maragos, W. F., Penney, J. B., and Young, A. B. (1988). Anatomic correlation of nmda and 3h-tcp-labeled receptors in rat brain. *J Neurosci*, 8(2):493–501.
- Markus, E. J., Barnes, C. A., McNaughton, B. L., Gladden, V. L., and Skaggs, W. E. (1994). Spatial information content and reliability of hippocampal CA1 neurons: effects of visual input. *Hippocampus*, 4(4):410–421.
- Markus, E. J., Qin, Y. L., Leonard, B., Skaggs, W. E., McNaughton, B. L., and Barnes, C. A. (1995). Interactions between location and task affect the spatial and directional firing of hippocampal neurons. *J Neurosci*, 15(11):7079–7094.
- Marr, D. (1971). Simple memory: a theory for archicortex. *Philos Trans R Soc Lond B Biol Sci*, 262(841):23–81.
- Martin, P. D. (2001). Locomotion towards a goal alters the synchronous firing of neurons recorded simultaneously in the subiculum and nucleus accumbens of rats. *Behav Brain Res*, 124(1):19–28.
- Martin, P. D. and Ono, T. (2000). Effects of reward anticipation, reward presentation, and spatial parameters on the firing of single neurons recorded in the subiculum and nucleus accumbens of freely moving rats. *Behav Brain Res*, 116(1):23–38.
- Mayford, M., Abel, T., and Kandel, E. R. (1995). Transgenic approaches to cognition. *Curr Opin Neurobiol*, 5(2):141–148.

- McClelland, J. L. and Goddard, N. H. (1996). Considerations arising from a complementary learning systems perspective on hippocampus and neocortex. *Hippocampus*, 6(6):654–665.
- McDonald, R. J. and Hong, N. S. (2004). A dissociation of dorso-lateral striatum and amygdala function on the same stimulus-response habit task. *Neuroscience*, 124(3):507–513.
- McDonald, R. J., Hong, N. S., and Devan, B. D. (2004). The challenges of understanding mammalian cognition and memory-based behaviours: an interactive learning and memory systems approach. *Neurosci Biobehav Rev*, 28(7):719–745.
- McDonald, R. J., Murphy, R. A., Guarraci, F. A., Gortler, J. R., White, N. M., and Baker, A. G. (1997). Systematic comparison of the effects of hippocampal and fornix-fimbria lesions on acquisition of three configural discriminations. *Hippocampus*, 7(4):371–388.
- McDonald, R. J. and White, N. M. (1993). A triple dissociation of memory systems: hippocampus, amygdala, and dorsal striatum. *Behav Neurosci*, 107(1):3–22.
- McDonald, R. J. and White, N. M. (1994). Parallel information processing in the water maze: evidence for independent memory systems involving dorsal striatum and hippocampus. *Behav Neural Biol*, 61(3):260–270.
- McHugh, T. J., Blum, K. I., Tsien, J. Z., Tonegawa, S., and Wilson, M. A. (1996). Impaired hippocampal representation of space in *ca1*-specific *nmdar1* knockout mice. *Cell*, 87(7):1339–1349.
- McHugh, T. J., Jones, M. W., Quinn, J. J., Balthasar, N., Coppari, R., Elmquist, J. K., Lowell, B. B., Fanselow, M. S., Wilson, M. A., and Tonegawa, S. (2007). Dentate gyrus *nmda* receptors mediate rapid pattern separation in the hippocampal network. *Science*, 317(5834):94–99.
- McKenzie, T., Cherman, T., Bird, L. R., Naqshbandi, M., and Roberts, W. A. (2004). Can squirrel monkeys (*saimiri sciureus*) plan for the future? studies of temporal myopia in food choice. *Learn Behav*, 32(4):377–390.
- McNaughton, B. and Morris, R. (1987). Hippocampal synaptic enhancement and information storage within a distributed memory system. *Trends Neurosci.*, 10:408–415.
- McNaughton, B. L., Barnes, C. A., Meltzer, J., and Sutherland, R. J. (1989). Hippocampal granule cells are necessary for normal spatial learning but not for spatially-selective pyramidal cell discharge. *Exp Brain Res*, 76(3):485–496.
- McNaughton, B. L., Barnes, C. A., and O'Keefe, J. (1983). The contributions of position, direction, and velocity to single unit activity in the hippocampus of freely-moving rats. *Exp Brain Res*, 52(1):41–49.
- Milner, B., Taylor, L., and Sperry, R. W. (1968). Lateralized suppression of dichotically presented digits after commissural section in man. *Science*, 161(837):184–186.
- Mitchell, D. B., Brown, A. S., and Murphy, D. R. (1990). Dissociations between procedural and episodic memory: effects of time and aging. *Psychol Aging*, 5(2):264–276.
- Mitchell, J. and Laiacona, J. (1998). The medial frontal cortex and temporal memory: tests using spontaneous exploratory behaviour in the rat. *Behavioural Brain Research*, 97:107113.
- Mizumori, S. J., Miya, D. Y., and Ward, K. E. (1994). Reversible inactivation of the lateral dorsal thalamus disrupts hippocampal place representation and impairs spatial learning. *Brain Res*, 644(1):168–174.
- Mizumori, S. J., Ragozzino, K. E., Cooper, B. G., and Leutgeb, S. (1999). Hippocampal representational organization and spatial context. *Hippocampus*, 9(4):444–451.

- Moita, M. A. P., Rosis, S., Zhou, Y., LeDoux, J. E., and Blair, H. T. (2004). Putting fear in its place: remapping of hippocampal place cells during fear conditioning. *J Neurosci*, 24(31):7015–7023.
- Morris, R., Garrud, P., Rawlins, J., and O'Keefe, J. (1982). Place navigation impaired in rats with hippocampal lesions. *Nature*, 297(5868):681–3.
- Morris, R. G., Anderson, E., Lynch, G. S., and Baudry, M. (1986). Selective impairment of learning and blockade of long-term potentiation by an n-methyl-d-aspartate receptor antagonist, ap5. *Nature*, 319(6056):774–776.
- Morris, R. G., Halliwell, R. F., and Bowery, N. (1989). Synaptic plasticity and learning. II: Do different kinds of plasticity underlie different kinds of learning? *Neuropsychologia*, 27(1):41–59.
- Morris, R. G. M. (2006). Elements of a neurobiological theory of hippocampal function: the role of synaptic plasticity, synaptic tagging and schemas. *Eur J Neurosci*, 23(11):2829–2846.
- Morris, R. G. M., Schenk, F., Tweedie, F., and Jarrard, L. E. (1990). Ibotenate lesions of hippocampus and/or subiculum: Dissociating components of allocentric spatial learning. *Eur J Neurosci*, 2(12):1016–1028.
- Moser, M. B. and Moser, E. I. (1998). Distributed encoding and retrieval of spatial memory in the hippocampus. *J Neurosci*, 18(18):7535–7542.
- Moser, M. B., Moser, E. I., Forrest, E., Andersen, P., and Morris, R. G. (1995). Spatial learning with a minislab in the dorsal hippocampus. *Proc Natl Acad Sci U S A*, 92(21):9697–9701.
- Mulcahy, N. J. and Call, J. (2006). Apes save tools for future use. *Science*, 312(5776):1038–1040.
- Muller, R., Kubie, J., and Ranck, Jr, J. (1987). Spatial firing patterns of hippocampal complex-spike cells in a fixed environment. *J Neurosci*, 7(7):1935–50.
- Muller, R. U., Bostock, E., Taube, J. S., and Kubie, J. L. (1994). On the directional firing properties of hippocampal place cells. *J Neurosci*, 14(12):7235–7251.
- Muller, R. U. and Kubie, J. L. (1989). The firing of hippocampal place cells predicts the future position of freely moving rats. *J Neurosci*, 9(12):4101–4110.
- Muller, R. U., Ranck, J. B., and Taube, J. S. (1996). Head direction cells: properties and functional significance. *Curr Opin Neurobiol*, 6(2):196–206.
- Mumby, D., Gaskin, S., Glenn, M., Schramek, T., and Lehmann, H. (2002). Hippocampal damage and exploratory preferences in rats: memory for objects, places, and contexts. *Learning and Memory*, 9(2):49–57.
- Mumby, D., Tremblay, A., Lecluse, V., and Lehmann, H. (2005). Hippocampal damage and anterograde object-recognition in rats after long retention intervals. *Hippocampus*, 15(8):1050–1056.
- Mumby, D. G. and Pinel, J. P. (1994). Rhinal cortex lesions and object recognition in rats. *Behav Neurosci*, 108(1):11–18.
- Nadel, L. and Moscovitch, M. (1997). Memory consolidation, retrograde amnesia and the hippocampal complex. *Curr Opin Neurobiol*, 7(2):217–227.
- Nadel, L., Samsonovich, A., Ryan, L., and Moscovitch, M. (2000). Multiple trace theory of human memory: computational, neuroimaging, and neuropsychological results. *Hippocampus*, 10(4):352–368.
- Nakamura, N. H., Fukunaga, M., Akama, K. T., Soga, T., Ogawa, S., and Pavlides, C. (2010). Hippocampal cells encode places by forming small anatomical clusters. *Neuroscience*, 166(3):994–

1007.

- Nakashiba, T., Young, J. Z., McHugh, T. J., Buhl, D. L., and Tonegawa, S. (2008). Transgenic inhibition of synaptic transmission reveals role of ca3 output in hippocampal learning. *Science*, 319(5867):1260–1264.
- Nakazawa, K., McHugh, T., Wilson, M., and Tonegawa, S. (2004). Nmda receptors, place cells and hippocampal spatial memory. *Nat Rev Neurosci*, 5(5):361–72.
- Nakazawa, K., Quirk, M. C., Chitwood, R. A., Watanabe, M., Yeckel, M. F., Sun, L. D., Kato, A., Carr, C. A., Johnston, D., Wilson, M. A., and Tonegawa, S. (2002). Requirement for hippocampal ca3 nmda receptors in associative memory recall. *Science*, 297(5579):211–218.
- Nakazawa, K., Sun, L. D., Quirk, M. C., Rondi-Reig, L., Wilson, M. A., and Tonegawa, S. (2003). Hippocampal ca3 nmda receptors are crucial for memory acquisition of one-time experience. *Neuron*, 38(2):305–315.
- Naqshbandi, M., Feeney, M., McKenzie, T., and Roberts, W. (2006). Testing for episodic-like memory in rats in the absence of time of day cues: Replication of babb and crystal. *Behavioral Processes*.
- Naqshbandi, M., Feeney, M. C., McKenzie, T. L. B., and Roberts, W. A. (2007). Testing for episodic-like memory in rats in the absence of time of day cues: replication of babb and crystal. *Behav Processes*, 74(2):217–225.
- Norman, G. and Eacott, M. (2005). Dissociable effects of lesions to the perirhinal cortex and the postrhinal cortex on memory for context and objects in rats. *Behavioral Neuroscience*, 119(2):557–566.
- Norman, K. A. and O'Reilly, R. C. (2003). Modeling hippocampal and neocortical contributions to recognition memory: a complementary-learning-systems approach. *Psychol Rev*, 110(4):611–646.
- Nyhus, E. and Curran, T. (2010). Functional role of gamma and theta oscillations in episodic memory. *Neurosci Biobehav Rev*, 34(7):1023–1035.
- O'Brien, N., Lehmann, H., Lecluse, V., and Mumby, D. (2006). Enhanced context-dependency of object recognition in rats with hippocampal lesions. *Behavioral Brain Research*, 170(1):156–162.
- Okado, Y. and Stark, C. E. L. (2005). Neural activity during encoding predicts false memories created by misinformation. *Learn Mem*, 12(1):3–11.
- O'Keefe, J. (1976). Place units in the hippocampus of the freely moving rat. *Exp Neurol*, 51(1):78–109.
- O'Keefe, J. and Burgess, N. (1996). Geometric determinants of the place fields of hippocampal neurons. *Nature*, 381(6581):425–428.
- O'Keefe, J. and Dostrovsky, J. (1971). The hippocampus as a spatial map: Preliminary evidence from unit activity in the freely-moving rat. *Brain Research*, 34(1):171–175.
- O'Keefe, J. and Nadel, L. (1978). *The Hippocampus as a Cognitive Map*. Oxford University Press.
- O'Keefe, J. and Recce, M. L. (1993). Phase relationship between hippocampal place units and the eeg theta rhythm. *Hippocampus*, 3(3):317–330.
- Okuda, J., Fujii, T., Ohtake, H., Tsukiura, T., Tanji, K., Suzuki, K., Kawashima, R., Fukuda, H., Itoh, M., and Yamadori, A. (2003). Thinking of the future and past: the roles of the frontal pole

- and the medial temporal lobes. *Neuroimage*, 19(4):1369–1380.
- Olton, D. and Feustle, W. (1981). Hippocampal function required for nonspatial working memory. *Experimental Brain Research*, 41(3-4):380–389.
- Olton, D. S. and Papas, B. C. (1979). Spatial memory and hippocampal function. *Neuropsychologia*, 17(6):669–682.
- O'Reilly, R. C. and Rudy, J. W. (2001). Conjunctive representations in learning and memory: principles of cortical and hippocampal function. *Psychol Rev*, 108(2):311–345.
- Packard, M. G., Hirsh, R., and White, N. M. (1989). Differential effects of fornix and caudate nucleus lesions on two radial maze tasks: evidence for multiple memory systems. *J Neurosci*, 9(5):1465–1472.
- Packard, M. G. and Knowlton, B. J. (2002). Learning and memory functions of the basal ganglia. *Annu Rev Neurosci*, 25:563–593.
- Packard, M. G. and McGaugh, J. L. (1996). Inactivation of hippocampus or caudate nucleus with lidocaine differentially affects expression of place and response learning. *Neurobiol Learn Mem*, 65(1):65–72.
- Pastalkova, E., Itskov, V., Amarasingham, A., and Buzski, G. (2008). Internally generated cell assembly sequences in the rat hippocampus. *Science*, 321(5894):1322–1327.
- Paz-Y-Mio, Y., Bond, A., Kamil, A., and Balda, R. (2004). Pinyon jays use transitive inference to predict social dominance. *Nature*, 430(7001):778–781.
- Pearce, J. M., Roberts, A. D., and Good, M. (1998). Hippocampal lesions disrupt navigation based on cognitive maps but not heading vectors. *Nature*, 396(6706):75–77.
- Pigott, S. and Milner, B. (1993). Memory for different aspects of complex visual scenes after unilateral temporal- or frontal-lobe resection. *Neuropsychologia*, 31(1):1–15.
- Piolino, P., Desgranges, B., and Eustache, F. (2009). Episodic autobiographical memories over the course of time: cognitive, neuropsychological and neuroimaging findings. *Neuropsychologia*, 47(11):2314–2329.
- Poldrack, R. A., Clark, J., Par-Blagoev, E. J., Shohamy, D., Moyano, J. C., Myers, C., and Gluck, M. A. (2001). Interactive memory systems in the human brain. *Nature*, 414(6863):546–550.
- Pothuizen, H. H. J., Zhang, W.-N., Jongen-Rillo, A. L., Feldon, J., and Yee, B. K. (2004). Dissociation of function between the dorsal and the ventral hippocampus in spatial learning abilities of the rat: a within-subject, within-task comparison of reference and working spatial memory. *Eur J Neurosci*, 19(3):705–712.
- Quirk, G. J., Muller, R. U., and Kubie, J. L. (1990). The firing of hippocampal place cells in the dark depends on the rat's recent experience. *J Neurosci*, 10(6):2008–2017.
- Raby, C. R., Alexis, D. M., Dickinson, A., and Clayton, N. S. (2007). Planning for the future by western scrub-jays. *Nature*, 445(7130):919–921.
- Ramus, S. J., Davis, J. B., Donahue, R. J., Discenza, C. B., and Waite, A. A. (2007). Interactions between the orbitofrontal cortex and the hippocampal memory system during the storage of long-term memory. *Ann N Y Acad Sci*, 1121:216–231.
- Ranck, J. B. (1973). Studies on single neurons in dorsal hippocampal formation and septum in unrestrained rats. i. behavioral correlates and firing repertoires. *Exp Neurol*, 41(2):461–531.
- Ranganath, C., Yonelinas, A. P., Cohen, M. X., Dy, C. J., Tom, S. M., and D'Esposito, M. (2004). Dissociable correlates of recollection and familiarity within the medial temporal lobes. *Neu-*

- ropsychologia*, 42(1):2–13.
- Redish, A. D., Battaglia, F. P., Chawla, M. K., Ekstrom, A. D., Gerrard, J. L., Lipa, P., Rosenzweig, E. S., Worley, P. F., Guzowski, J. F., McNaughton, B. L., and Barnes, C. A. (2001). Independence of firing correlates of anatomically proximate hippocampal pyramidal cells. *J Neurosci*, 21(5):RC134.
- Risold, P. Y. and Swanson, L. W. (1997). Connections of the rat lateral septal complex. *Brain Res Brain Res Rev*, 24(2-3):115–195.
- Roberts, M. and Shapiro, M. (2002). Nmda receptor antagonists impair memory for nonspatial, socially transmitted food preference. *Behav Neurosci*, 116(6):1059–1069.
- Roberts, W. A. and Feeney, M. C. (2009). The comparative study of mental time travel. *Trends Cogn Sci*, 13(6):271–277.
- Rolls, E. T. (1996). A theory of hippocampal function in memory. *Hippocampus*, 6(6):601–620.
- Rolls, E. T., Baylis, G. C., and Hasselmo, M. E. (1987). The responses of neurons in the cortex in the superior temporal sulcus of the monkey to band-pass spatial frequency filtered faces. *Vision Res*, 27(3):311–326.
- Rolls, E. T. and Kesner, R. P. (2006). A computational theory of hippocampal function, and empirical tests of the theory. *Prog Neurobiol*, 79(1):1–48.
- Rosenbaum, R. S., Ziegler, M., Winocur, G., Grady, C. L., and Moscovitch, M. (2004). "i have often walked down this street before": fmri studies on the hippocampus and other structures during mental navigation of an old environment. *Hippocampus*, 14(7):826–835.
- Rosenzweig, E. S., Redish, A. D., McNaughton, B. L., and Barnes, C. A. (2003). Hippocampal map realignment and spatial learning. *Nat Neurosci*, 6(6):609–615.
- Rotenberg, A. and Muller, R. U. (1997). Variable place-cell coupling to a continuously viewed stimulus: evidence that the hippocampus acts as a perceptual system. *Philos Trans R Soc Lond B Biol Sci*, 352(1360):1505–1513.
- Rudy, J. W. and O'Reilly, R. C. (2001). Conjunctive representations, the hippocampus, and contextual fear conditioning. *Cogn Affect Behav Neurosci*, 1(1):66–82.
- Sakurai, Y. (1994). Involvement of auditory cortical and hippocampal neurons in auditory working memory and reference memory in the rat. *J Neurosci*, 14(5 Pt 1):2606–2623.
- Sargolini, F., Fyhn, M., Hafting, T., McNaughton, B. L., Witter, M. P., Moser, M.-B., and Moser, E. I. (2006). Conjunctive representation of position, direction, and velocity in entorhinal cortex. *Science*, 312(5774):758–762.
- Sauvage, M. M., Beer, Z., and Eichenbaum, H. (2010). Recognition memory: adding a response deadline eliminates recollection but spares familiarity. *Learn Mem*, 17(2):104–108.
- Sauvage, M. M., Fortin, N. J., Owens, C. B., Yonelinas, A. P., and Eichenbaum, H. (2008). Recognition memory: opposite effects of hippocampal damage on recollection and familiarity. *Nat Neurosci*, 11(1):16–18.
- Save, E., Cressant, A., Thinus-Blanc, C., and Poucet, B. (1998). Spatial firing of hippocampal place cells in blind rats. *J Neurosci*, 18(5):1818–1826.
- Save, E., Poucet, B., Foreman, N., and Buhot, M.-C. (1992). Object exploration and reactions to spatial and nonspatial changes in hooded rats following damage to parietal cortex or hippocampal formation. *Behavioral Neuroscience*, 106(3):447–456.
- Schmelzeis, M. C. and Mittleman, G. (1996). The hippocampus and reward: effects of hippocam-

- pal lesions on progressive-ratio responding. *Behav Neurosci*, 110(5):1049–1066.
- Scoville, W. B. and Milner, B. (1957). Loss of recent memory after bilateral hippocampal lesions. *J Neurol Neurosurg Psychiatry*, 20(1):11–21.
- Shapiro, M. L., Tanila, H., and Eichenbaum, H. (1997). Cues that hippocampal place cells encode: dynamic and hierarchical representation of local and distal stimuli. *Hippocampus*, 7(6):624–642.
- Sharp, P. E., Blair, H. T., Etkin, D., and Tzannes, D. B. (1995). Influences of vestibular and visual motion information on the spatial firing patterns of hippocampal place cells. *J Neurosci*, 15(1 Pt 1):173–189.
- Shires, K. L., Martin, S., Hawthorne, J. P., A.M.J., H., Dudchenko, P., and Wood, E. (2008). Functional connectivity between the thalamus and the postsubiculum in the rat: analysis of evoked responses elicited by stimulation of the laterodorsal thalamic nucleus. In *Soc. Neurosci. Abstr.*, volume 879.4.
- Skaggs, W. E. and McNaughton, B. L. (1998). Spatial firing properties of hippocampal CA1 populations in an environment containing two visually identical regions. *J Neurosci*, 18(20):8455–8466.
- Smith, C. and Squire, L. R. (2005). Declarative memory, awareness, and transitive inference. *J Neurosci*, 25(44):10138–10146.
- Smith, D. M. and Mizumori, S. J. Y. (2006a). Hippocampal place cells, context, and episodic memory. *Hippocampus*, 16(9):716–729.
- Smith, D. M. and Mizumori, S. J. Y. (2006b). Learning-related development of context-specific neuronal responses to places and events: the hippocampal role in context processing. *J Neurosci*, 26(12):3154–3163.
- Smith, M. L. and Milner, B. (1989). Right hippocampal impairment in the recall of spatial location: encoding deficit or rapid forgetting? *Neuropsychologia*, 27(1):71–81.
- Smulders, T. V., Sasson, A. D., and DeVoogd, T. J. (1995). Seasonal variation in hippocampal volume in a food-storing bird, the black-capped chickadee. *J Neurobiol*, 27(1):15–25.
- Smulders, T. V., Shiflett, M. W., Sperling, A. J., and DeVoogd, T. J. (2000). Seasonal changes in neuron numbers in the hippocampal formation of a food-hoarding bird: the black-capped chickadee. *J Neurobiol*, 44(4):414–422.
- Solstad, T., Boccara, C. N., Kropff, E., Moser, M.-B., and Moser, E. I. (2008). Representation of geometric borders in the entorhinal cortex. *Science*, 322(5909):1865–1868.
- Spiers, H. J. and Maguire, E. A. (2006). Thoughts, behaviour, and brain dynamics during navigation in the real world. *Neuroimage*, 31(4):1826–1840.
- Spiers, H. J. and Maguire, E. A. (2008). The dynamic nature of cognition during wayfinding. *J Environ Psychol*, 28(3):232–249.
- Spiers, H. J., Maguire, E. A., and Burgess, N. (2001). Hippocampal amnesia. *Neurocase*, 7(5):357–382.
- Squire, L., Stark, C., and Clark, R. (2004). The medial temporal lobe. *Annual Reviews in Neuroscience*, 27:279–306.
- Squire, L. R. (1987). The organization and neural substrates of human memory. *Int J Neurol*, 21-22:218–222.
- Squire, L. R. (2009). The legacy of patient h.m. for neuroscience. *Neuron*, 61(1):6–9.

- Squire, L. R., Zola-Morgan, J. T., and Clark, R. E. (2007). Recognition memory and the medial temporal lobe: a new perspective. *Nat Rev Neurosci*, 8(11):872–883.
- Squire, L. R. and Zola, S. M. (1996). Structure and function of declarative and nondeclarative memory systems. *Proc Natl Acad Sci U S A*, 93(24):13515–13522.
- Squire, L. R. and Zola, S. M. (1998). Episodic memory, semantic memory, and amnesia. *Hippocampus*, 8(3):205–211.
- Stackman, R. W. and Taube, J. S. (1998). Firing properties of rat lateral mammillary single units: head direction, head pitch, and angular head velocity. *J Neurosci*, 18(21):9020–9037.
- Steele, R. J. and Morris, R. G. (1999). Delay-dependent impairment of a matching-to-place task with chronic and intrahippocampal infusion of the NMDA-antagonist D-AP5. *Hippocampus*, 9(2):118–136.
- Steffenach, H.-A., Witter, M., Moser, M.-B., and Moser, E. I. (2005). Spatial memory in the rat requires the dorsolateral band of the entorhinal cortex. *Neuron*, 45(2):301–313.
- Steinvorth, S., Levine, B., and Corkin, S. (2005). Medial temporal lobe structures are needed to re-experience remote autobiographical memories: evidence from h.m. and w.r. *Neuropsychologia*, 43(4):479–496.
- Stupien, G., Florian, C., and Rouillet, P. (2003). Involvement of the hippocampal ca3-region in acquisition and in memory consolidation of spatial but not in object information in mice. *Neurobiol Learn Mem*, 80(1):32–41.
- Suddendorf, T. and Busby, J. (2003). Mental time travel in animals? *Trends in Cognitive Sciences*, 7(9):391–396.
- Suddendorf, T. and Busby, J. (2005). Making decisions with the future in mind: Developmental and comparative identification of mental time travel. *Learning and Motivation*, 36(2):110–125.
- Suddendorf, T. and Corballis, M. (1997). Mental time travel and the evolution of the human mind. *Genet. Soc. Gen. Psychol. Monogr.*, 123(2):133–67.
- Sutherland, R. J., Wishaw, I. Q., and Kolb, B. (1983). A behavioural analysis of spatial localization following electrolytic, kainate- or colchicine-induced damage to the hippocampal formation in the rat. *Behav Brain Res*, 7(2):133–153.
- Suzuki, W. A. and Amaral, D. G. (1994). Perirhinal and parahippocampal cortices of the macaque monkey: cortical afferents. *J Comp Neurol*, 350(4):497–533.
- Szpunar, K. K., Watson, J. M., and McDermott, K. B. (2007). Neural substrates of envisioning the future. *Proc Natl Acad Sci U S A*, 104(2):642–647.
- Tang, Y. P., Shimizu, E., Dube, G. R., Rampon, C., Kerchner, G. A., Zhuo, M., Liu, G., and Tsien, J. Z. (1999). Genetic enhancement of learning and memory in mice. *Nature*, 401(6748):63–69.
- Tanila, H., Shapiro, M. L., and Eichenbaum, H. (1997). Discordance of spatial representation in ensembles of hippocampal place cells. *Hippocampus*, 7(6):613–623.
- Taube, J., Kesslak, J., and Cotman, C. (1992). Lesions of the rat postsubiculum impair performance on spatial tasks. *Behav Neural Biol*, 57(2):131–43.
- Taube, J., Muller, R., and Ranck, Jr, J. (1990). Head-direction cells recorded from the postsubiculum in freely moving rats. II. Effects of environmental manipulations. *J Neurosci*, 10(2):436–47.
- Taube, J. S. (2007). The head direction signal: origins and sensory-motor integration. *Annu Rev Neurosci*, 30:181–207.

- Teyler, T. J. and DiScenna, P. (1986). The hippocampal memory indexing theory. *Behav Neurosci*, 100(2):147–154.
- Thompson, L. and Best, P. (1990). Long-term stability of the place-field activity of single units recorded from the dorsal hippocampus of freely behaving rats. *Brain Res*, 509(2):299–308.
- Thompson, L. T. and Best, P. J. (1989). Place cells and silent cells in the hippocampus of freely-behaving rats. *J Neurosci*, 9(7):2382–2390.
- Tolman, E., Ritchie, B., and Kalish, D. (1946). Studies in spatial learning. ii: Place learning versus response learning. *Journal of Experimental Psychology*, 3:221–229.
- Torda, C. (1969). Dreams of subjects with bilateral hippocampal lesions. *Acta Psychiatr Scand*, 45(3):277–288.
- Tsien, J. Z., Chen, D. F., Gerber, D., Tom, C., Mercer, E. H., Anderson, D. J., Mayford, M., Kandel, E. R., and Tonegawa, S. (1996a). Subregion- and cell type-restricted gene knockout in mouse brain. *Cell*, 87(7):1317–1326.
- Tsien, J. Z., Huerta, P. T., and Tonegawa, S. (1996b). The essential role of hippocampal ca1 nmda receptor-dependent synaptic plasticity in spatial memory. *Cell*, 87(7):1327–1338.
- Tulving, E. (1972). *Organization of memory*. New York: Academic Press.
- Tulving, E. (1983). *Elements of Episodic Memory*. Oxford: Clarendon Press.
- Tulving, E. (1985). Memory and consciousness. *Canadian Psychologist*, 25:1–12.
- Tulving, E. (2001). Episodic memory and common sense: how far apart? *Philos Trans R Soc Lond B Biol Sci*, 356(1413):1505–1515.
- Tulving, E. (2002). Episodic memory: from mind to brain. *Annu Rev Psychol*, 53:1–25.
- Tulving, E. and Markowitsch, H. J. (1998). Episodic and declarative memory: role of the hippocampus. *Hippocampus*, 8(3):198–204.
- van Groen, T. and Wyss, J. M. (1990). The postsubicular cortex in the rat: characterization of the fourth region of the subicular cortex and its connections. *Brain Res*, 529(1-2):165–177.
- Vann, S. D., Tsivilis, D., Denby, C. E., Quamme, J. R., Yonelinas, A. P., Aggleton, J. P., Montaldi, D., and Mayes, A. R. (2009). Impaired recollection but spared familiarity in patients with extended hippocampal system damage revealed by 3 convergent methods. *Proc Natl Acad Sci U S A*, 106(13):5442–5447.
- Vargha-Khadem, F., Gadian, D. G., and Mishkin, M. (2001). Dissociations in cognitive memory: the syndrome of developmental amnesia. *Philos Trans R Soc Lond B Biol Sci*, 356(1413):1435–1440.
- Vargha-Khadem, F., Gadian, D. G., Watkins, K. E., Connelly, A., Paesschen, W. V., and Mishkin, M. (1997). Differential effects of early hippocampal pathology on episodic and semantic memory. *Science*, 277(5324):376–380.
- Vazdarjanova, A. and Guzowski, J. F. (2004). Differences in hippocampal neuronal population responses to modifications of an environmental context: evidence for distinct, yet complementary, functions of CA3 and CA1 ensembles. *J Neurosci*, 24(29):6489–6496.
- Wais, P., Wixted, T., Hopkins, R., and Squire, L. (2006). The hippocampus supports both the recollection and the familiarity components of recognition memory. *Neuron*, 49(3):459–466.
- Wais, P. E., Squire, L. R., and Wixted, J. T. (2010). In search of recollection and familiarity signals in the hippocampus. *J Cogn Neurosci*, 22(1):109–123.

- Wallenstein, G., Eichenbaum, H., and Hasselmo, M. (1998). The hippocampus as an associator of discontinuous events. *Trends Neurosci*, 21(8):317–23.
- Warburton, E. C., Aggleton, J. P., and Muir, J. L. (1998). Comparing the effects of selective cingulate cortex lesions and cingulum bundle lesions on water maze performance by rats. *Eur J Neurosci*, 10(2):622–634.
- Weniger, G., Ruhleder, M., Wolf, S., Lange, C., and Irle, E. (2009). Egocentric memory impaired and allocentric memory intact as assessed by virtual reality in subjects with unilateral parietal cortex lesions. *Neuropsychologia*, 47(1):59–69.
- Whishaw, I. Q. and Tomie, J. (1997). Perseveration on place reversals in spatial swimming pool tasks: further evidence for place learning in hippocampal rats. *Hippocampus*, 7(4):361–370.
- White, N. and McDonald, R. (2002). Multiple parallel memory systems in the brain of the rat. *Neurobiology of Learning and Memory*, 77(2):125–184.
- Whitlock, J. R., Heynen, A. J., Shuler, M. G., and Bear, M. F. (2006). Learning induces long-term potentiation in the hippocampus. *Science*, 313(5790):1093–1097.
- Wiener, S. I., Korshunov, V. A., Garcia, R., and Berthoz, A. (1995). Inertial, substratal and landmark cue control of hippocampal CA1 place cell activity. *Eur J Neurosci*, 7(11):2206–2219.
- Wills, T., Lever, C., Cacucci, F., Burgess, N., and O’Keefe, J. (2005). Attractor dynamics in the hippocampal representation of the local environment. *Science*, 308(5723):873–6.
- Wilson, I. A., Gallagher, M., Eichenbaum, H., and Tanila, H. (2006). Neurocognitive aging: prior memories hinder new hippocampal encoding. *Trends Neurosci*, 29(12):662–670.
- Wilson, M. A. and McNaughton, B. L. (1993). Dynamics of the hippocampal ensemble code for space. *Science*, 261(5124):1055–1058.
- Wilson, M. A. and Tonegawa, S. (1997). Synaptic plasticity, place cells and spatial memory: study with second generation knockouts. *Trends Neurosci*, 20(3):102–106.
- Winters, B. D. and Bussey, T. J. (2005). Transient inactivation of perirhinal cortex disrupts encoding, retrieval, and consolidation of object recognition memory. *J Neurosci*, 25(1):52–61.
- Winters, B. D., Forwood, S. E., Cowell, R. A., Saksida, L. M., and Bussey, T. J. (2004). Double dissociation between the effects of peri-postrhinal cortex and hippocampal lesions on tests of object recognition and spatial memory: heterogeneity of function within the temporal lobe. *J Neurosci*, 24(26):5901–5908.
- Witter, M., Wouterlood, F., Naber, P., and Van Haeften, T. (2000). Anatomical organization of the parahippocampal-hippocampal network. *Annals of the New York Academy of Science*, 911:1–24.
- Witter, M. P. (1993). Organization of the entorhinal-hippocampal system: a review of current anatomical data. *Hippocampus*, 3 Spec No:33–44.
- Wixted, J. T. and Squire, L. R. (2010). The role of the human hippocampus in familiarity-based and recollection-based recognition memory. *Behav Brain Res*.
- Wolbers, T. and Buechel, C. (2005). Dissociable retrosplenial and hippocampal contributions to successful formation of survey representations. *J Neurosci*, 25(13):3333–3340.
- Wood, E., Dudchenko, P., and Eichenbaum, H. (1999). The global record of memory in hippocampal neuronal activity. *Nature*, 397(6720):613–6.
- Wood, E. R., Dudchenko, P. A., Robitsek, R. J., and Eichenbaum, H. (2000). Hippocampal neurons

- encode information about different types of memory episodes occurring in the same location. *Neuron*, 27(3):623–633.
- Worsley, C. L., Recce, M., Spiers, H. J., Marley, J., Polkey, C. E., and Morris, R. G. (2001). Path integration following temporal lobectomy in humans. *Neuropsychologia*, 39(5):452–464.
- Yeshenko, O., Guazzelli, A., and Mizumori, S. J. Y. (2004). Context-dependent reorganization of spatial and movement representations by simultaneously recorded hippocampal and striatal neurons during performance of allocentric and egocentric tasks. *Behav Neurosci*, 118(4):751–769.
- Yin, H. H. and Knowlton, B. J. (2006). The role of the basal ganglia in habit formation. *Nat Rev Neurosci*, 7(6):464–476.
- Yntema, D. (1963). Keeping track of several things at once. *Human Factors*, 5:7–17.
- Yoganasimha, D. and Knierim, J. J. (2005). Coupling between place cells and head direction cells during relative translations and rotations of distal landmarks. *Exp Brain Res*, 160(3):344–359.
- Yonelinas, A. P. (1994). Receiver-operating characteristics in recognition memory: evidence for a dual-process model. *J Exp Psychol Learn Mem Cogn*, 20(6):1341–1354.
- Yonelinas, A. P. (2001). Components of episodic memory: the contribution of recollection and familiarity. *Philos Trans R Soc Lond B Biol Sci*, 356(1413):1363–1374.
- Yonelinas, A. P., Dobbins, I., Szymanski, M. D., Dhaliwal, H. S., and King, L. (1996). Signal-detection, threshold, and dual-process models of recognition memory: Rocs and conscious recollection. *Conscious Cogn*, 5(4):418–441.
- Yonelinas, A. P., Kroll, N. E., Dobbins, I., Lazzara, M., and Knight, R. T. (1998). Recollection and familiarity deficits in amnesia: convergence of remember-know, process dissociation, and receiver operating characteristic data. *Neuropsychology*, 12(3):323–339.
- Yonelinas, A. P. and Levy, B. J. (2002). Dissociating familiarity from recollection in human recognition memory: different rates of forgetting over short retention intervals. *Psychon Bull Rev*, 9(3):575–582.
- Yonelinas, A. P., Otten, L. J., Shaw, K. N., and Rugg, M. D. (2005). Separating the brain regions involved in recollection and familiarity in recognition memory. *J Neurosci*, 25(11):3002–3008.
- Young, B. J., Fox, G. D., and Eichenbaum, H. (1994). Correlates of hippocampal complex-spike cell activity in rats performing a nonspatial radial maze task. *J Neurosci*, 14(11 Pt 1):6553–6563.
- Yun, I. A., Wakabayashi, K. T., Fields, H. L., and Nicola, S. M. (2004). The ventral tegmental area is required for the behavioral and nucleus accumbens neuronal firing responses to incentive cues. *J Neurosci*, 24(12):2923–2933.
- Zentall, T. R. (2006). Mental time travel in animals: a challenging question. *Behav Processes*, 72(2):173–183.
- Zentall, T. R., Clement, T. S., Bhatt, R. S., and Allen, J. (2001). Episodic-like memory in pigeons. *Psychon Bull Rev*, 8(4):685–690.
- Zhao, S., Cunha, C., Zhang, F., Liu, Q., Gloss, B., Deisseroth, K., Augustine, G. J., and Feng, G. (2008). Improved expression of halorhodopsin for light-induced silencing of neuronal activity. *Brain Cell Biol*, 36(1-4):141–154.
- Zinyuk, L., Kubik, S., Kaminsky, Y., Fenton, A. A., and Bures, J. (2000). Understanding hip-

hippocampal activity by using purposeful behavior: place navigation induces place cell discharge in both task-relevant and task-irrelevant spatial reference frames. *Proc Natl Acad Sci U S A*, 97(7):3771–3776.