

AN ACCOUNT
of
THE SANITATION OF A BATTALION
with
THE BRITISH SALONIKA EXPEDITIONARY FORCE.

Thesis for the Degree of M.D.

by

CAPTAIN H. D. ROBB,

M.B., Ch.B., D.P.H., R.A.M.C.



The following thesis is an account of the method and appliances I employed in connection with the sanitation of a unit of which I was medical officer in the British Salonika Expeditionary Force in 1915-1916.

The unit to which I was then attached was among the first to land at Salonika.

For the first months there were, except for air raids few hostilities and the troops were largely engaged in making defence works, trenches, redoubts, gun-positions, and the like. There was therefore little movement among the various units so that the sanitary arrangements had to be of a semi-permanent nature, more elaborate than when on the march, and not so substantial as in a fixed camp. As it was a matter of urgency that the available material should be used as much as possible for the extensive and various defence works being erected, the amount of material available for the various sanitary fittings was distinctly limited, and this thesis gives the details of my efforts at making the semi-permanent sanitary fittings as efficient as possible out of what might be called the "by-products" of the camp, i.e./

i.e. the boxes, tins, etc., in which our rations, supplies, and forage were brought to us at our camp. I shall also give an account of the other measures I employed to keep the men under my medical charge in as healthy, and as fit a condition as possible.

My unit was broken up into four companies, and we were at first encamped among the hills about eight miles inland.

I endeavoured to make the sanitary arrangements in each camp ultimately conform to a standard pattern which I found from personal experience to give the best sanitary results under the conditions in which we found ourselves placed.

NATURE OF THE CAMPING GROUND.

My camps were situated among high hills with bare, stony slopes and here and there patches of small dwarf gorse as vegetation.

The soil seemed to be of a boulder clay that made soakage difficult.

CLIMATIC CONDITIONS

The winter months were cold and wet, with often sleet and snow-storms.

For two months in the spring the weather was comparable/

FIG. 1.

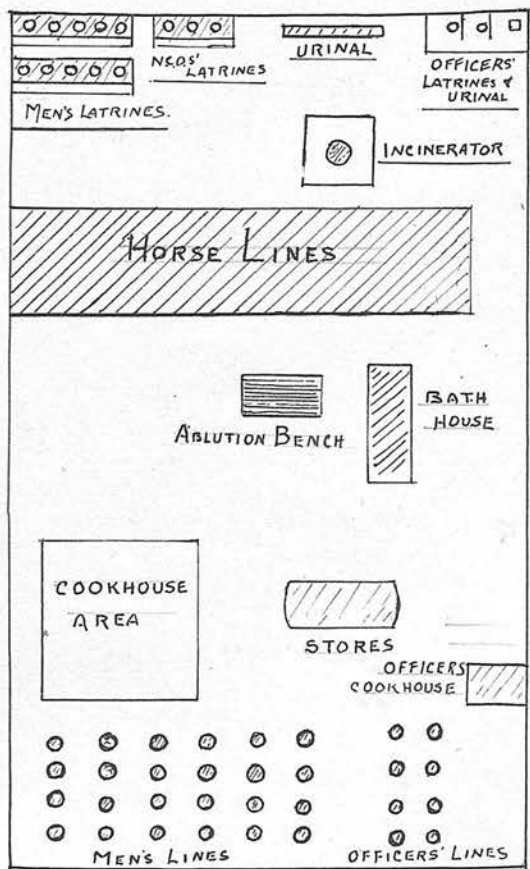

SANITARY
AREA

STANDARD PLAN
of
SEMI-PERMANENT CAMP

comparable to our best summer months, warm and dry, without being oppressive and with gentle winds.

The summer months were intensely and oppressively hot and the absence of any kind of shade made it very trying.

PLAN OF THE CAMPS.

The camps were laid out as far as the lie of the ground at each site would permit, in accordance with the usual plan as laid down in the various military hand-books on sanitation, i.e. at one end of the camp was the "sanitary area" by that I mean the area in which were the Latrines, Urinals and Incinerator. Next to this came the Transport Lines, and then came the area containing the ablution benches - Drying tent, cook-house area, men's lines and officers' lines, etc. (See figure I.)

L A T R I N E S.

In the case of a battalion on the march a common method of latrine is the "shallow trench latrine".

According to the various military hand-books on Sanitation, such as The Manual of Military Hygiene 1912, this consists of a series of short trenches in parallel, across which the soldier straddles, and solid and/

Fig. 2.

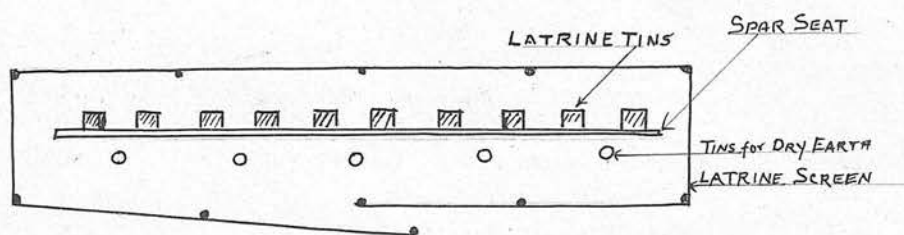

PLAN
of
SPARG SEAT LATRINE

and liquid excreta are easily directed into the hole with very little fouling or soaking of the edges.

The shallow trenches in this system are 3 feet long, $2\frac{1}{2}$ feet deep, 1 foot wide, and the space between the trenches $2\frac{1}{2}$ to 3 feet wide.

The usual allowance of trenches is 5 per cent for numbers below 500 but 3 per cent for numbers above 500.

Each trench lasts only one day.

In the interspaces on the second day, the secondary trenches are dug and the first day's trenches are well covered with earth and sods well beaten down.

As can readily be realized this is an extravagant and wasteful method as regards available space - a large amount of ground being quickly used up and fouled.

This method was of course unsuitable in our semi-permanent camps, as our available ground would have quickly become fouled, - another method was therefore necessary.

The first latrine we erected consisted of the tins in which the biscuits, or tea, or other dry rations were delivered in camp and were placed below a supported horizontal wooden spar of 3" x 2" scantling. The tins acted as buckets and the spar was the seat. (See figure 2.)

The/

The tins were provided with handles made from the bands of hoop-iron which bound the forage bundles together.

The handles were made with a big enough arch to fall behind the tin, so that they were not fouled. The tins were supplied on a 5 per cent basis. Dry earth was provided so that the men could cover up immediately their excreta. The dry earth was provided in biscuit tins - one tin in front of the seat between two latrine biscuit tins.

A scoop for the earth was made by taking a diagonal slice off a jam tin and inserting a wooden handle in the base of the tin - one scoop for each tin. The whole was enclosed by canvas latrine screens nailed to stakes, and on the stakes bundles of latrine paper were hung.

The following notice was fixed to the screen facing the men

<p style="text-align: center;">TWO SCOOPFULS OF EARTH TO BE EMPTIED INTO LATRINE TIN AFTER USE.</p>

A deep pit, 6 feet deep by 4 feet square was dug near the latrines and into this pit the latrine tins were emptied three times daily, - after breakfast, in the afternoon, and again in the evening - and the excreta/

Fig. 3.

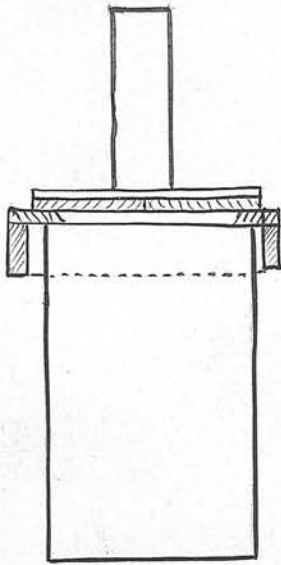

SECTION

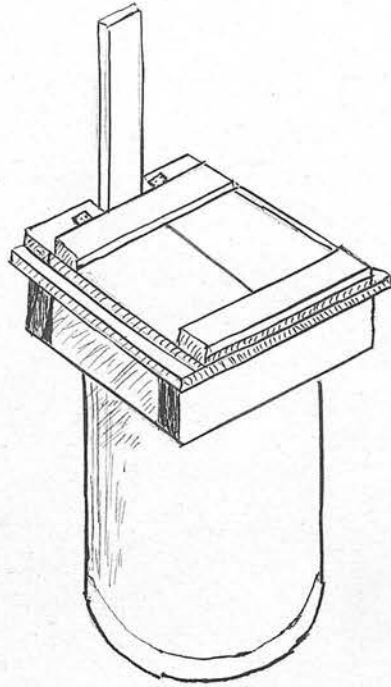

PERSPECTIVE VIEW

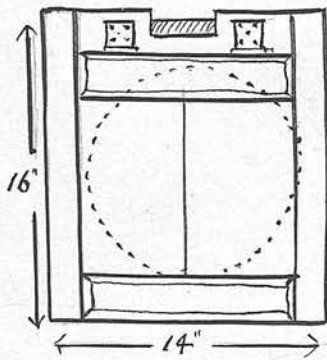

PLAN

FLY-PROOF CRESOL DRUM LATRINE
with self-closing lid

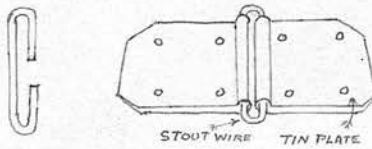

DETAILS of HINGE for "DRUM" LATRINE

excreta was immediately well covered with earth. In this way the exposure of the excreta to the outside air was reduced as much as possible. The tins after being emptied were washed out with a $2\frac{1}{2}\%$ cresol solution, a good layer of dry earth put on the bottom, and replaced below the seat.

The horizontal spar seat was wiped down twice daily with cresol solution.

Empty jam tins, beaten into the earth bottom upwards, formed an efficient hard floor which did not get sodden.

This system was of course only of a temporary nature; the tin buckets, seats, and screens were put up and the pit dug ready for use during the day of arrival, and it served the purpose till more elaborate arrangements were made.

It is obvious that in this system the latrines were far from fly proof, and although the danger of fly borne infection was almost nil when we first arrived, as the cold weather had started, it was not a satisfactory state of affairs. A fly proof latrine had to be arrived at.

Fly Proof Latrines.

Fly proof latrines for officers (see figure 3) were easily made by cutting out the top of a stout oil drum. A wooden seat was made from packing case wood, /

Fig. 7.

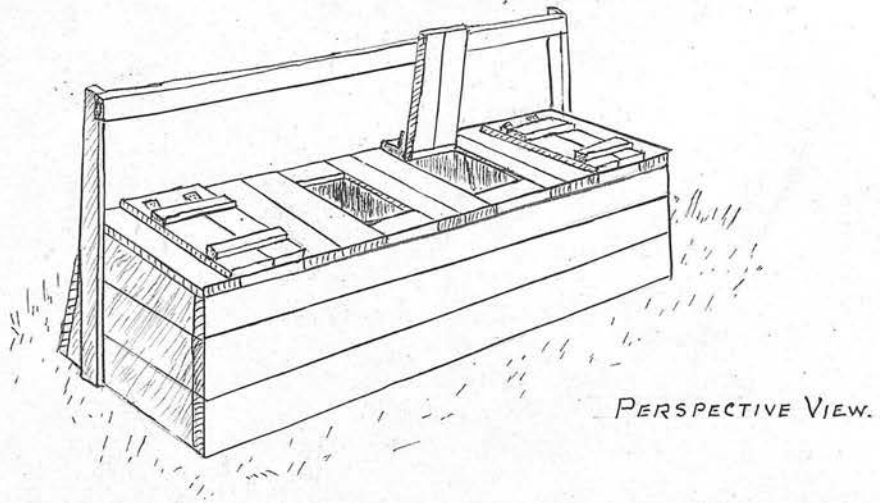

PERSPECTIVE VIEW.

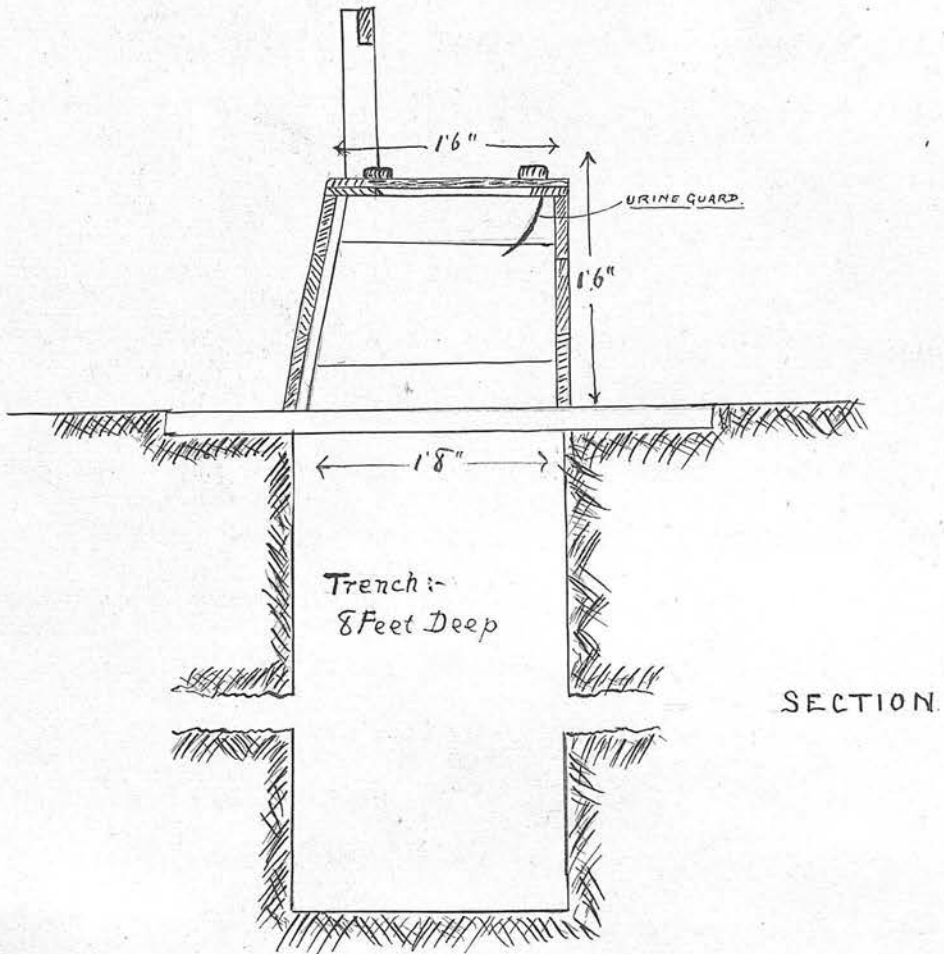

SECTION.

FLY PROOF DEEP TRENCH LATRINE

wood, fitting closely round the top of the drum. The hole in the seat was closed by an automatically closing lid - this latter was made from a square piece of wood attached behind by hinges (easily made by means of a stout wire and two pieces of tin from the biscuit tins (see figure 3) to the seat - the automatic closing being obtained by nailing on an upright strut behind, which prevented the lid from attaining the perpendicular.

For the men a different plan was adopted. This consisted essentially of a deep trench 8 to 9 feet deep and 1 foot 8 inches wide and about 9 feet long. Over this trench was placed a long box seat with no crack or holes in it except of course the seat holes, which were closed on the same automatic principle as in the officers latrine. A glance at figure 4 will show the construction of this latrine - a piece of tin inside the framework in front of each seat hole protected the wooden framework in front from being soaked with urine, with subsequent warping.

Any chance of flies getting in under the box seat where it rested on the ground was prevented by claying up this part of the box seat all round.

These latrines were inspected every day to see that there was no warping of the wood and opening up of/

of the joints, and to see that the seat lids continued to close automatically. By means of this supervision these box seats even in the hot weather when there was much warping of wood, were maintained at a constant fly proof efficiency.

Chloride of lime was daily dusted into the trench through each seat hole, and there was no unpleasant smell from these latrines even in hot weather. The seats also each day were washed down with weak cresol solution.

The latrines were of course screened off by canvas, and tin boxes for latrine paper, 3 to each box seat were attached to the screen stakes. The floor was paved with empty jam tins knocked into the ground, giving a hard flooring, easily swept clean.

Two of these latrines, each accommodating six men, were established in each company and I found them to be fly-proof, cleanly and practically odourless.

Each deep trench lasted for about two months to three months.

These latrines reduced the area of fouled ground to a minimum. I endeavoured however to do away with the fouling of the ground altogether, though this is much less necessary in Macedonia than in France, as the/

the mountainous district in which the British Salonika Force were at first encamped was very sparsely populated; a few wandering bands of comatadgi in the early days, who gave us a wide berth, and occasional shepherds at the head of their flocks of goats and sheep, being the only inhabitants of the hills we came across.

I endeavoured to get excreta burning incinerators established at each of the companies' camps, but owing to there being no sawdust available to mix with the excreta and so make it fairly combustible, I found that my first attempt to get excreta burning incinerators going were not crowned with much success.

However with the advent of the hot dry weather I found a good substitute for the sawdust that we can get in France, in the shape of the little dwarf gorse shrub on the hillsides, which became dry and withered owing to the heat; this when chopped up provided the necessary dry combustible matrix for the excreta.

I will describe the excreta burning incinerators and this method of excreta disposal when I deal with the subject of Incinerators.

U R I N A L S.

The disposal of urine presented a much simpler problem than the disposal of the faeces, yet none the less some difficulty was experienced, as the soil in our area consisted of a kind of boulder-clay through which soakage was often very slow and difficult.

The standard unit of 1000 men produces, according to Lelean, about 300 gallons of urine per diem. My unit was divided into 4 companies, so that in each company there were about 75 gallons to be disposed of daily.

The only method of urine disposal in a camp situated such as those under my care was of course by soakage and one had to find out which was the most sanitary and efficient method of disposal by soakage.

Quoting from Klinger, Lelean in his "Sanitation in War" says that "about 2 per cent of true enteric cases who have recovered from the acute disease remain "carriers" for an average of 4 years, while some continue to be infective for the rest of their lives, and that "contact carriers" - persons who appear to have had no disease corresponding to typical enteric fever and who are apparently in perfect health - exist in the proportion of from .03 per mille (Germany) to 3 per mille (United States)."

From/

From the statistics just stated, and when we remember that in the urine of a Typhoid case there may be 1000 million Bacilli Typhosus per c.c. of urine, and that 25 per cent of cases actually suffering from Typhoid Fever excrete the Bacillus in their urine, it is obvious that great care must be taken in the matter of soakage disposal of urine.

To quote again from the above authority "It has been mentioned that the best technique does not enable us to recover B. Typhosus from bacilluric urine after the third or fourth day, and this fact - although it does not prove that enteric organisms are absent - proves that they have been reduced in number at a rate which justifies the belief that few, if any, could survive several days' contact with soil teeming with more vigorous saprophytes which are known to outgrow and destroy them. It is satisfactory to know that, if every care be exercised, the soakage method of urine disposal in the field is certainly reasonably safe."

The positions of the urinals in my camps were very carefully sited, so that there should be no possibility of contamination of the camp or other water supply - they were placed so that the natural fall of the land was from the water supply to the sanitary area in which they, along with the latrines were placed.

Fig. 5.

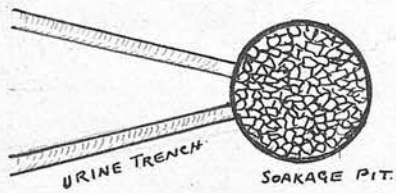

PLAN

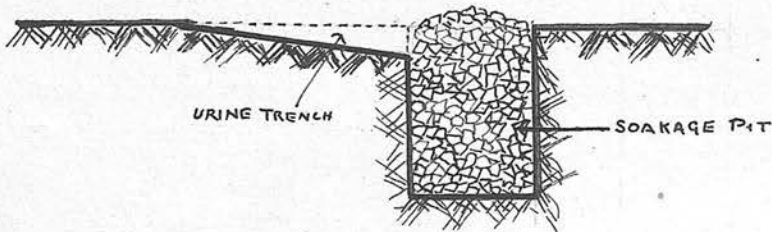

SECTION

CAMP URINAL

From
MANUAL OF MILITARY HYGIENE

The water supply of two of my camps was about a mile away from the camps and on a different water shed, so that there was no possibility of water contamination from the sanitary arrangements in these camps.

The type of urinal recommended in the Manual of Military Hygiene is one which takes the form of two shallow trenches 2 feet wide leading into a pit filled with large stones. (See figure 5).

This type of urinal I did not adopt as it is unsatisfactory in many ways. The men are not always successful in their attempts to direct their urine into the trench. As a consequence the sides of the trench and ground adjacent get sodden with urine and the men bring back on their feet urine-sodden earth to the camp. The urine also drains slowly down the trenches, hence there is a large surface of urine and urine sodden ground to which flies are attracted, with the consequent danger of food infection from the feet of those flies.

The type of urinal that I found to be satisfactory was made as a V-shaped trough (see figure 6a) the material from which it was made was wood from the boxes containing our rations. To prevent soakage of urine into the wood, the inside surface of the V trough was lined with tin from biscuit or tea tins. The side/

Fig. 6.

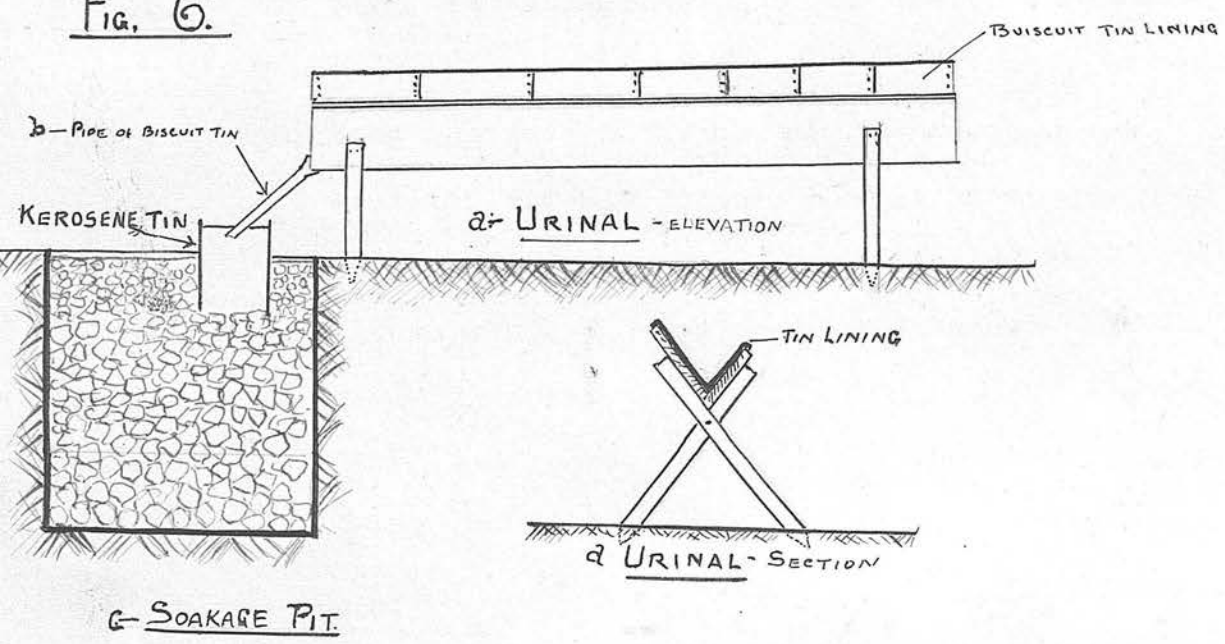

URINAL (TIN LINED), and SOAKAGE PIT

side of the V opposite to that on which the men stood when urinating was higher than the other, acting as a sort of splash board, preventing splashing over the far edge of the urinal.

This V-shaped trough was supported on two trestles, the trestle in front being shorter, so that the trough was canted at a sloping angle, causing the urine to run away quickly.

The lower end of the trough discharged the urine into a pipe made from sheets of biscuit box tin (see figure 6b) and this discharged into a soakage pit.

This soakage pit (see figure 6c) was made as follows.-

A pit was dug about 4 feet square and 5 feet deep, the soil at the bottom and sides being well loosened with picks.

This pit was filled with stones from the hill-sides, - placed on the top of the stones was a Kerosene tin with one end cut away - this open end resting on the stones.

The stones were covered with sheets of tin (from the tea-tins) to prevent the covering earth getting into the pit.

The pit was then covered in with the surface sods, leaving the Kerosene tin projecting up from the ground.

Fig. 7.

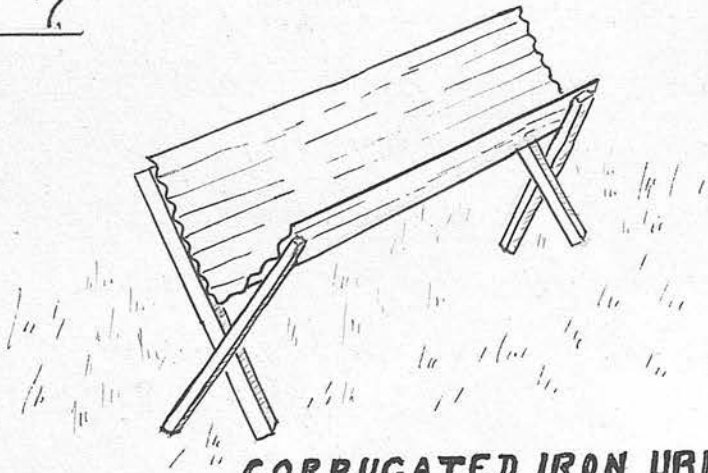

CORRUGATED IRON URINAL

A hole was made in the top of the Kerosene tin, and the discharge pipe from the urine trough fitted into this hole.

The urine pit was thus fly-proof and the urine was only exposed to the air during its passage along the urine trough, which was, of course, of short duration.

A hard platform for the men to stand on, and to prevent any soaking of the ground from spilling, was made by empty jam tins let into the ground. The urinal was flushed with cresol solution thrice daily and cresol solution sprinkled around the urinal.

The soakage in the boulder clay however was slow, and a second relief pit made on the same principle as the first had to be dug. The one pit resting and recovering soakage power while the other was in use - by means of alternating these two pits the urine in the camp was successfully disposed of.

Later when sheets of corrugated iron were available the making of this type of urinal was much simplified. Instead of having to construct the V trough out of wood from boxes and lining it with tin, the corrugated iron sheet was simply bent with one long side and one short side as before and nailed to the trestles. (See figure 7).

FIG. 8.

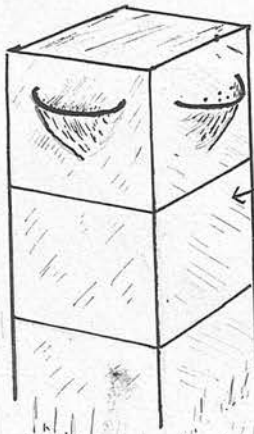

PERSPECTIVE VIEW.

BISCUIT
OR TEA TINS

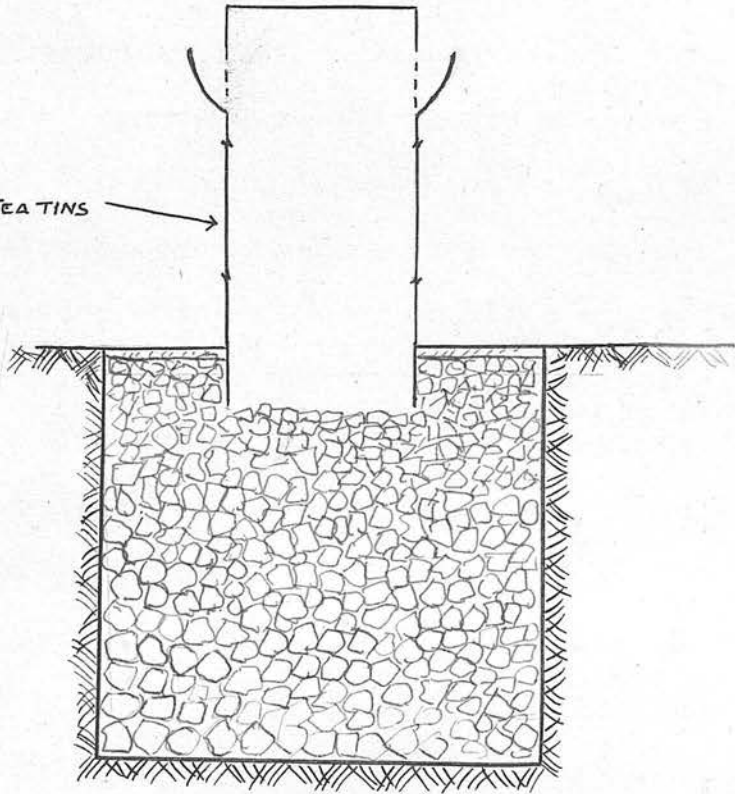

SECTION, SHEWING SOAKAGE PIT

PILLAR URINAL

I tried another form of urinal to minimise the exposure of the urine during its passage down the urinal. A urinal I had made as follows in the form of a pillar. (See figure 8).

Three biscuit or tea tins were required.

The first with both ends removed was placed over a soakage pit in the same manner as the Kerosene tin in the Trough Urinal.

The second tin,(both ends removed) was let into the first tin by bevelling the bottom, and slightly splaying the top of the first tin.

The third tin was let into the second tin, the top of this tin however was not removed.

Holes for the urine were perforated in the sides of this top tin about 6 inches from the top, and a half-basin of tin soldered on round these holes - this received the urine and directed it through the holes, and it then ran down the inside of the tin pillar into the soakage pit.

This urinal could accommodate 4 men at one time and the urine was directed at once under cover out of the reach of flies.

One other point remains to be mentioned as regards the disposal of urine.

The/

The weather in winter was cold and often wet, and to expect a man desirous of making water during the night to leave his warm tent and walk down on a cold wet night to the urinal, was to expect a state of sanitary conscientiousness rarely found among the troops. The easy insanitary thing to do is to urinate just outside the tent.

To obviate this insanitary practice, night-urine tubs, made out of the ever useful biscuit or tea tins, were placed at the door of the tents at night.

These night tubs were raised to a convenient height on a mound of stones to prevent erratic splashing, and the tins and stones were lime washed white so that their position could be made out in the dark.

In the morning the sanitary orderly, whose duty it was to look after the urinals, emptied these tins down the urinal and swilled the insides with cresol to keep away flies. The night urine tubs were kept down at the urinal during the day and only taken to the men's lines at night.

I N C I N E R A T O R S.

The daily waste products of a camp, apart from excreta and urine, are considerable. They consist largely of cook-house refuse, such as vegetable and animal refuse, tea leaves, potato parings, empty bully beef and other preserved ration tins - in other words the contents of the swill tubs; then there is also the remains from the men's meals, and the contents of the camp rubbish and waste paper tins.

All this rubbish was taken daily to the incinerator and there burnt.

As this refuse is highly attractive to flies its speedy destruction is essential, and the incinerator must therefore be able to burn this rubbish up quickly. If it does not fulfil this requirement there will be rubbish lying at the incinerator most of the day before it is all burnt, in which case there is little practical difference from the insanitary method of digging a hole in the ground and dumping the rubbish therein.

Site.

In each of the camps the incinerators were placed in the "Sanitary Area", as far as was possible to leeward of the prevailing wind, which in winter was from the Serbian mountains to the sea.

The/

The "incinerator area" was railed off by means of stakes and ropes, and the incinerator man was made responsible for the cleanliness and tidiness of the incinerator area.

He had to see that the ground in this area was levelled and kept beaten hard, and kept scrupulously clean by sweeping, and disinfected by sprinkling with cresol solution.

To prevent the ground, where the refuse to be burnt was dumped, becoming sodden, empty jam tins were let into the ground, bottom upwards and flush with the surface, to form an area 4 feet by 2 feet, along three sides of this a low parapet of stones was built, thus forming a small bay to contain the refuse and prevent it scattering, and the hard tin floor preventing soakage.

When the refuse for the day was all burnt this bay was swept out clean and sprinkled with cresol solution.

The refuse while in the bay was kept covered with sacking soaked with cresol, there was therefore little or no attraction provided for flies by the incinerator area.

The incinerated refuse, which consisted mainly of burnt tins and small cinders, was carefully stacked. It was raked over, and any greasy meaty tin or bit of organic refuse not properly burnt, was returned to the/

FIG. 9.

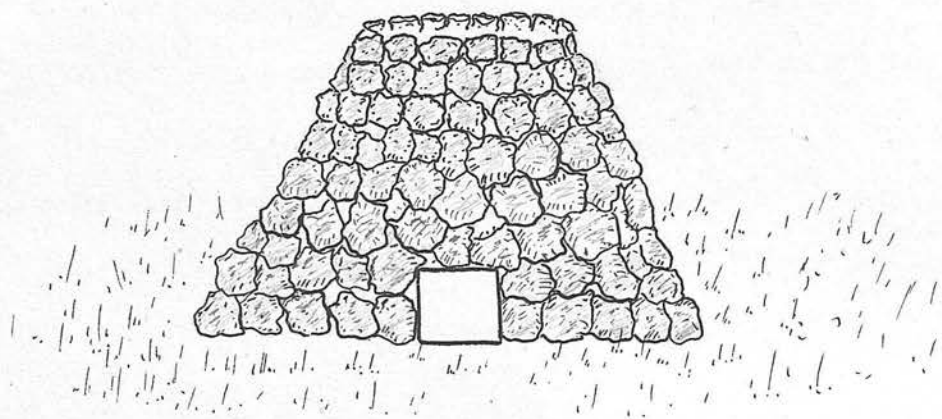

INCINERATOR, of BOULDERS

the incinerator.

The burnt refuse was kept stacked until sufficient had accumulated to fill a good sized pit. This pit was then, and not till then, dug and at once covered in again. I did not allow a pit to be dug and then gradually filled in from day to day with the burnt out refuse, because the presence of an open pit is a temptation, apparently irresistible, to the average soldier to fling something into it, and the presence of a pit near the incinerator would have meant, that besides the burnt out refuse, there would have been also flung into the pit by casual soldiers, tea leaves, vegetable refuse and other organic debris, and flies thereby attracted to the camp.

Types of Incinerators used in the Camp.

On arrival at our camping ground an incinerator had to be at once constructed, which was of necessity a simple one, pending the construction of the better and more elaborate type which I had made in all my camps.

The temporary incinerator (see figure 9) was built of large boulders which were abundant on the hillsides.

They were built up on the principle of a dry stone dyke in the form of a stone circle, about 4 feet high, broader at the base to give stability and tapering/

tapering at the top to give a circle of about 3 feet in diameter.

A large square tea tin with both ends knocked out was let in at the base, thus providing a hole through which the burnt out debris could be raked.

Other types of simply constructed incinerators are mentioned in the Manual of Field Sanitation and the Royal Army Medical Corps Training none of which I adopted, as they all, including the temporary one I erected, presented several objectionable features.

These objectionable features are obvious and common to all incinerators of the open type. They are.-

1. Rain can get directly into the incinerator on to the burning mass of refuse and will, if continuous, put out the fire.

This was an objection of some practical importance in Macedonia for the winter was wet and rainy.

2. In windy weather the lighter contents of an open incinerator, such as paper and straw, get blown out of the incinerator and get scattered over the camp, making it difficult to keep tidy and clean.
3. The starting of the fire in these incinerators is often difficult.
4. There is not a good strong draught so that combustion is slow and often incomplete.

The closed type of incinerator on the other hand has no such objectionable features and I proceeded at once to have constructed closed incinerators in all the camps.

The incinerators that I got erected were in every way satisfactory and simple in construction. They had a good draught and burned the rubbish quickly and effectively, the lighter contents could not be blown out by the wind and the burning refuse was protected from the rain.

The type of incinerator that I built was of a closed beehive shape with 4 draught holes at the base facing the four points of the compass - a raking out hole, a feed hole and a chimney. I did not require to get any material from the Engineers store to construct these incinerators; boulders, clay, empty kerosene and biscuit tins, and the bands of hoop iron from the bundles of forage, were the only materials used.

Construction of the Incinerators (See figure 10.)

The base of the incinerator was formed by a foundation circle of large boulders.

It was one and a half feet thick, and having an inside diameter of four feet. These boulders were cemented together with clay smoothed off on outside and inside.

FIG. 10.

"BEEHIVE" INCINERATOR

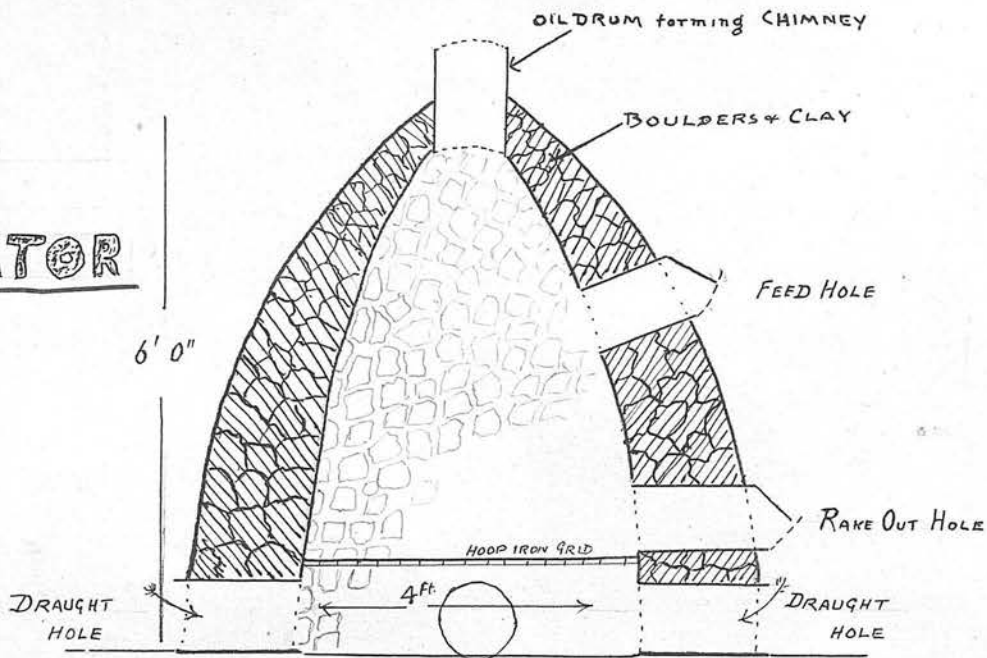

SECTION

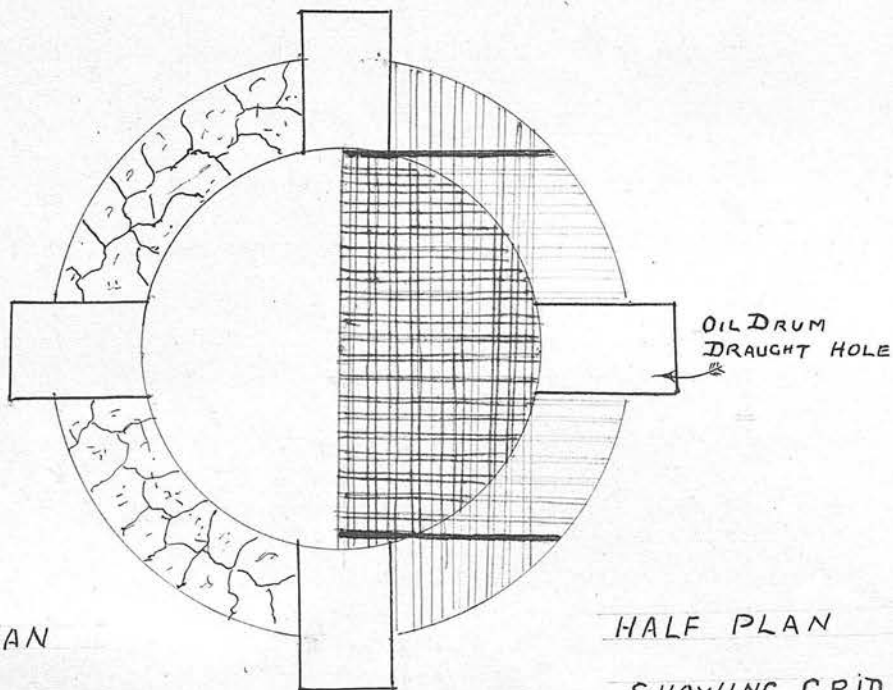

HALF PLAN
BELOW GRID

HALF PLAN
SHOWING GRID

4 Kerosene oil drums with both ends cut out and resting on the ground were let into this wall at 4 opposite points forming draught holes into the incinerator.

This foundation circle was built to about 15 inches high and then a grid, to act as fire bars, made from interwoven hoop iron from the forage bundles was laid down. (See figure 10)

The strands of the hoop iron were interwoven, and the ends left long enough to project beyond the wall of the incinerator, and the projecting ends bent over so that the grid was firmly fixed and could not sag in the centre from the weight of the refuse.

The wall of the incinerator was then built up with stones cemented together by clay, the clay being smoothed all over the outside and inside surfaces, and converged to an internal diameter of one foot at a height of six feet. Into the small opening at the top was inserted a Kerosene oil drum, which acted as a good chimney. Just above the grid a raking out hole was made by letting into the wall of the incinerator a square biscuit or tea tin with both ends removed.

A hinged lid on the outside closed this hole during the burning of the refuse.

Above/

Above the raking out hole another square hole, similarly constructed, acted as a feed hole and this also was provided with an outside hinged lid to close it during the burning of the incinerator.

The incinerator was started by first putting in a layer of straw, paper, and sticks, and sprinkling with paraffin, and then on top some of the drier refuse, this was lighted through the raking out hole and when well alight, the rest of the refuse was gradually added, the raking out and feed holes being kept closed when not being used and the incinerator very soon was in full blast.

When there was a wind a good forced draught could be obtained by closing the draught hole on the leeward side and providing wind-scoops to the lateral draught holes by placing a sheet of tin behind, and projecting beyond, the outer end of each.

The moisture of the wet refuse was got rid of as far as possible before being brought down from the cookhouse; tea leaves were put in a special tin perforated at the bottom and lower part of the sides, and the tea squeezed out of the leaves over the grease trap; and similarly the greasy water in any of the other refuse tins was decanted off down the grease trap/

trap before the refuse was brought to the incinerator.

In each of my camps I had incinerators built as I have described and they worked perfectly.

INCINERATION OF FAECES.

The problem of the incineration of faeces in Salonika was at first not so easy a problem for the Medical Officer as it is out here in France.

In France, incinerators can be indented for already constructed by the Engineers to burn efficiently the excreta and a plentiful supply of sawdust which so greatly aids in its successful burning can always be obtained.

In Salonika, incinerators had to be improvised and there was no sawdust obtainable.

My first efforts were not very successful but later on with the advent of the hot weather, the withered grass and dwarf gorse on the hillsides provided me with a substitute for sawdust and this proved to be a fairly good combustible matrix for mixing with the faeces.

The essential feature of the faeces-burning incinerator that we made, consisted of a hot plate in the incinerator for a preliminary drying of the excreta which had been previously mixed with the withered gorse and grass.

The/

Fig. 11.

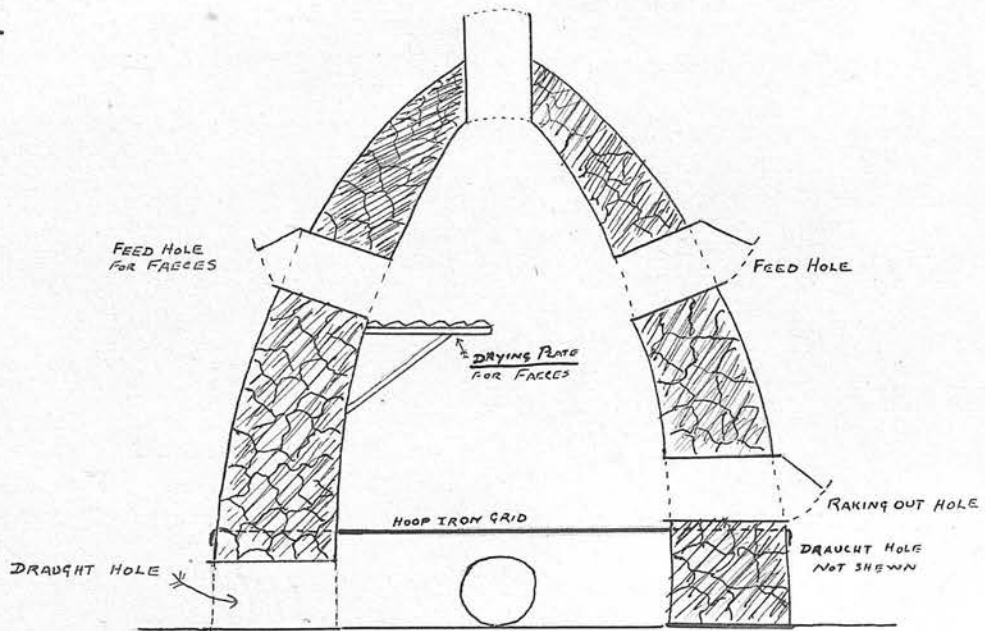

SECTION

"BEEHIVE" INCINERATOR ADAPTED FOR BURNING FÆCES

The excreta, so mixed, was first put upon this hot plate and to a certain extent dried by the heat from the burning refuse in the incinerator below the plate; when the excreta was sufficiently dried it was pushed off the hot plate on to the burning refuse below, and so consumed.

The necessary modifications for making the original Beehive incinerator into an excreta burning incinerator were not difficult (see figure 11) and consist of building in at a suitable height above the iron grid and on the side opposite to the feed hole, a drying hot plate projecting into the incinerator. This plate was a piece of corrugated iron supported by a stanchion below. A feed hole, through which the faeces were placed on to the hot plate was made as before by building into the wall of the incinerator a square tin with both ends knocked out, a hinged flap closed this on the outside.

A modification of the latrine was necessary, but this was simply accomplished.

A fly proof box seat, made as before, was placed over latrine tins made, as in the first instance, from large tea tins and provided with a folding down carrying handle.

The back panel of the box seat was made moveable and hinged so that it could be lifted up and the tins extracted/

extracted, and emptied at the incinerator.

Before the excreta was taken down to the incinerator to be mixed with the gorse and grass, the latrine man decanted off the urine in the latrine tins down into a special soakage pit, constructed on the same lines as the urinal soakage pit.

To lessen the amount of urine in the latrine tins the following notice was put up in front of the latrine

URINATE INTO THE URINAL BEFORE USING THE LATRINE.

and to a fairly large extent the men observed this notice and reduced the amount of urine in the latrine tins.

A fatigue of men cut the gorse and grass and kept a good supply at the incinerator, where the incinerator man mixed it with the faeces on a sheet of corrugated iron, - which was cleaned down daily with cresol after the faeces had been put into the incinerator.

After mixing, the faeces were put on the hot plate, dried, and subsequently burned as described.

By means of these excreta burning incinerators in the camps, all the excreta from the latrines in each was disposed of daily in a satisfactory and sanitary manner.

DISPOSAL OF HORSE LITTER.

The disposal of horse litter was a very important problem, as researches into the habits of the common house fly - *Musca Domestica* - the greatest food fouler and disease carrier that we have to contend with in a climate such as we get in the late spring and summer in Macedonia, have shown that the place of election for breeding purposes for flies is horse-droppings. It has been shown says Austen (Entomology Department, British Museum) that in 90 per cent of cases stable litter is the medium chosen by the female fly in which to deposit her ova, and one pound of horse litter has produced 455 larvae.

Leleán says "as 150 ova are laid every 10 days of the six weeks of adult female life, each female might possibly live to see 2500 of her progeny. If, further, we take the number of generations in a normal season to be nine, a single fly might conceivably produce a number represented by five followed by twenty-nine noughts (5×10^{29th})".

A knowledge of these facts should therefore make the Medical Officer of a unit in the field very desirous of disposing of the horse litter in his unit as quickly and as satisfactorily as possible.

Owing to the hilly and mountainous nature of the country in Macedonia our horse transport had to be greatly/

greatly increased.

The ordinary general-service waggon was unsuitable for a unit such as mine, situated up among the hills, and only to be reached by improvised roads and sometimes only by mule tracks.

The ordinary transport therefore was replaced by pack mules to a large extent, and the number of transport animals was increased to at least four or five times the ordinary number.

As a consequence we had daily a large amount of litter from the transport lines to be got rid of.

There were obviously two methods of getting rid of this litter, namely, by Burying or Burning.

(a) Burying.

When we realise the power that the larva of the fly has of burrowing and that the young imago can work its way up to the surface through six inches of loose soil and a much greater depth of loose sand, it will be obvious that getting rid of horse litter in which the ova of the *Musca Domestica* must have been deposited, by burying, is a method that leaves much to be desired. Besides, the amount of labour required to bury to a good depth the daily amount of litter from the transport lines was no inconsiderable item.

Burial/

Burial, therefore, was a last resort, to be adopted only when the horse litter could not be burned, for example, after heavy and continuous rain when it was hopeless to expect to get rid of more than a very small amount by burning.

To bury the horse manure a sufficiently large pit was dug and sprinkled with cresol solution, the manure was then flung in and packed down as tightly as possible, sprayed with cresol, and then covered with a minimum of 8 inches of earth tightly packed and the surface then soaked with cresol solution.

(b) Burning of Horse Litter.

This proved to be a difficult problem, and it was only after a great many trials of different methods and types of incinerators that I finally made up my mind as to what was the best method.

From its nature horse manure does not burn readily. It is moist and fairly compact, and smoulders to a very fine ash, rather than burns.

I thought at first that a large iron cage (See figure 12) made from forage bundle hoop iron, about 4 feet square and supported at 2 feet from the ground on angle iron - the mesh being about 3 inches square, would have proved to be a good manure incinerator as the manure was well exposed to the air/

Fig. 12.

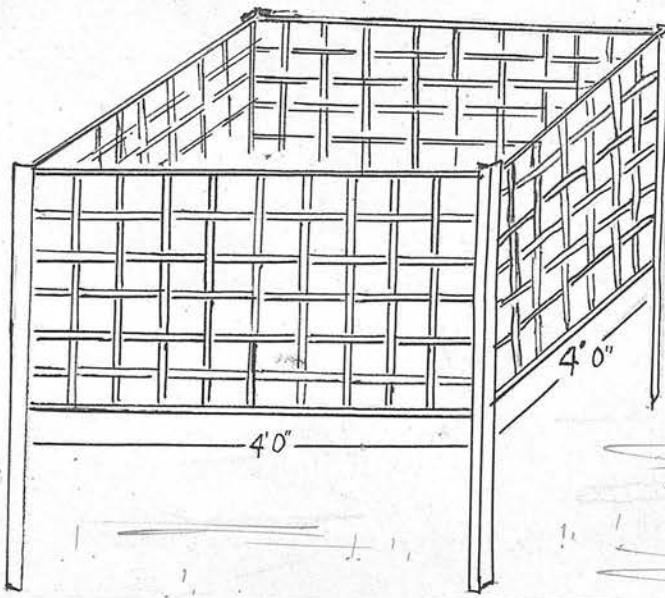

"CAGE" MANURE INCINERATOR

Fig. 13.

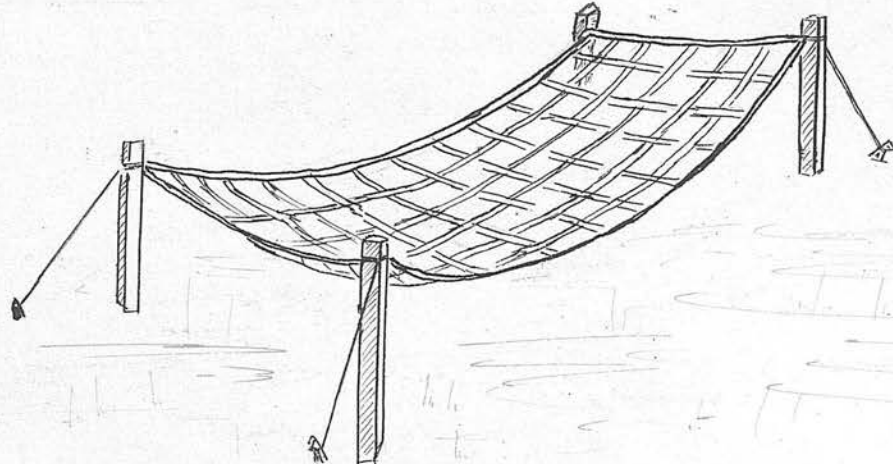

"HAMMOCK" MANURE INCINERATOR

Fig. 14.

"LIME-KILN"
MANURE INCINERATOR
(SECTION)

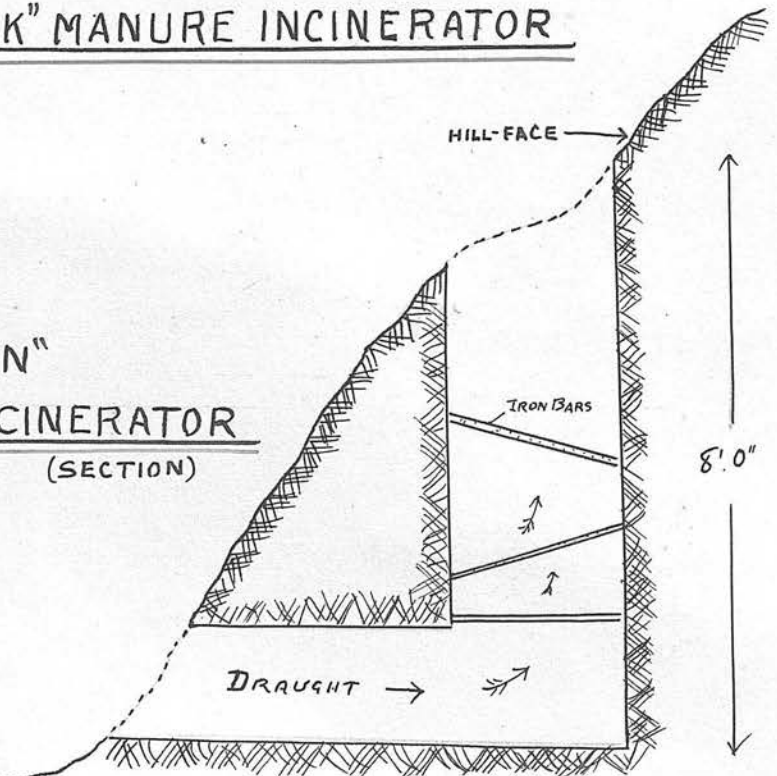

air on all sides as well as from below. This incinerator however proved to be unsatisfactory.

Next I tried square hammocks (See figure 13) about 5 feet square with a 3 inch mesh, supported about 2 feet from the ground on 4 posts - these however, though better than the square cages, did not work to my satisfaction either.

Next, taking advantage of the steep hillsides, I got dug out at a suitable face on the side of the hill, an incinerator on the principle of a lime-kiln. (See figure 14) A shaft, about 10 feet deep, and 3 feet diameter was sunk perpendicularly in the side of the hill at a steep face, at the foot of the shaft a short raking out shaft met it at right angles for raking out the burnt ash. Bars of angle iron were set across the foot of the perpendicular shaft to act as fire bars, and one or two put across up in the shaft to prevent self-packing of the manure. A fire was started with wood below, and the manure fed gradually from the top, a long iron rod was procured for raking out purposes and stirring up the manure - this method was not to my satisfaction either.

The method I found to work best and the one I adopted in all the camps consisted simply of burning the manure in conical heaps on the ground but with special/

FIG. 15.

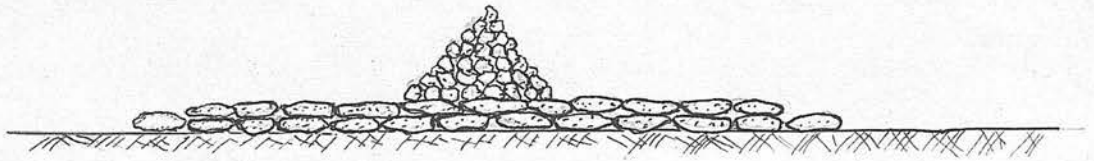

"AMERICAN" INCINERATOR for Manure

special precautions taken, and upon the careful and conscientious observance of these precautions depended the success of this method.

The heaps can be burnt on the bare ground but preferably upon a circular base made of flat stones, (See figure 15) somewhat in the style of what is known as the "American" Incinerator.

The stones help to retain the heat, which was an important point.

The circle should be about 6 to 10 feet in diameter and in the centre a small cone of stones can be built, but I found that even without this central cone of stones this method worked well if carried out according to directions.

In some of the heaps I tried a central air vent made from a sheet of corrugated iron rolled into the form of a chimney, with perforations, but I could not be sure that there was much, if any advantage in this.

At least 4 or 5 burning heaps, to get the necessary burning surface, were required to dispose of the daily stable litter in each company.

The windiest sites near the camps were chosen for the manure burning, - usually a projecting spur of the hillside adjacent to the camp.

The heaps were placed in echelon so that they should not screen each other from the wind, no matter from/

from which quarter it blew.

A heap was started by making and lighting a central core of sticks and straw sprinkled with paraffin, and on this burning core a layer of manure was laid, the driest part of the litter being put on first. When this was got properly alight, the secret of the success of this method lay in the way in which the burning heaps were subsequently fed with manure.

As the underlying smouldering fire began to shew signs of burning through the top layer of the manure another thin layer was added. It had to be added thinly and loosely, not flung on in lumps, but carefully and evenly distributed over the heap, more being added where the manure was burning more briskly, and then as this layer began to burn through another thin layer was laid on in like manner, and so the heap got gradually bigger and ultimately consisted of a central core of burnt ashes in which the heat was retained, a burning or smouldering layer, and a thin layer of fresh manure.

As the heap grew bigger the amount of heat retained in the central ash core was considerable and helped to dry the thin layers of manure that were being constantly added.

In patches where it was not burning so well, it had to be helped by making air vents by poking a stick through/

through the layer of manure into the ash core inside.

Burnt out ash had to be periodically removed at the base of the heap, to improve the draught into the heap, but not too much as heat would be lost; experience soon taught one to know how much to remove to get the best effect.

A thicker layer was put on at the last stoking at night so that the heap was still burning and ready for the next layer next morning.

A special manure burning man was detailed off, whose sole duty it was to look after the manure burning heaps. He soon became an expert and learnt just how much to put on, where to make ventilation holes, how much ash to take away at one time - in other words how to get the best burning capacity out of each heap.

I daily visited the manure heaps and made a careful inspection to see that he was carrying out his duties intelligently.

In course of time a heap would get too big to be worked easily, when it was allowed to burn completely out, the ashes taken away and buried, and a new heap started in its place.

In this way a good incinerator man by careful feeding of the heaps and intelligent working could burn the whole day's stable litter successfully.

If/

If these above precautions were not taken, and the man was allowed to get careless or lazy, for example, feeding the heaps too thickly and quickly, this method was no more successful than the others I tried.

I ultimately got the right man for the job in each company and always managed, except in cases of continuous and heavy rain, to have all the stable litter burned each day.

Owing to the heat retaining properties of the central core, it was wonderful what a lot of rain these heaps would stand before becoming extinguished.

In the spring time when we had dry sunny weather combined with briskly blowing breezes, the manure was easily thus disposed of.

The smoke from the burning kept the flies away from the heaps, and the manure waiting to be burnt was sprinkled with cresol.

I am of opinion, that for a Unit situated such as mine was, this was the best method of burning the horse droppings and stable litter.

C O O K - H O U S E S .

The cook-house is a highly important department of a camp, and it required constant and very careful supervision to ensure that it was kept in a cleanly, sanitary, and efficient state and that the cooks did their best to provide as varied, and as interesting a menu for the men as was possible with the rations at their disposal.

Site of the Cook-houses.

They were all placed at the other end of the camp from the "Sanitary Area".

They were handy to, but not too near, the men's tents.

Construction of Cook-house and plan of Cook-house Area.

On first arrival at our camping ground the cooking had of course to be done on the usual long shallow trench, in which the fire was laid and across which were placed the camp kettles.

Variety in the menu, which was my constant aim, was hardly obtainable and proper cook-houses were at once got under way.

The following plan (see figure 16) shows the arrangement of the cook-house area which I adopted in each camp.

I shall first describe the general plan of the cook-house/

Fig. 16

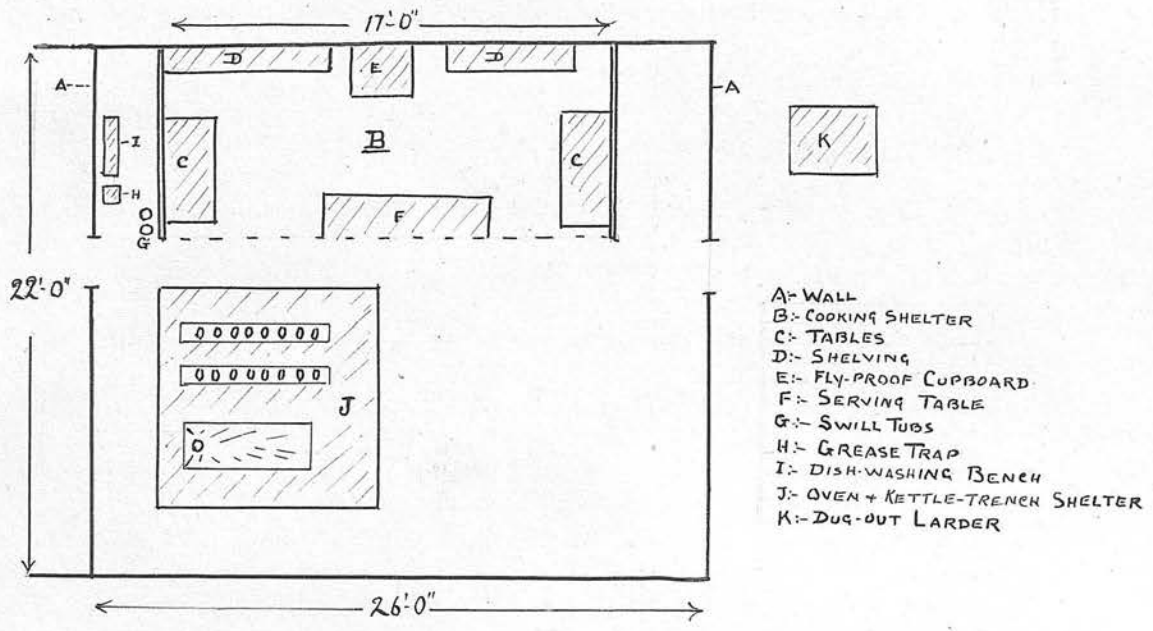

PLAN OF COOKHOUSE AREA.

cook-house area, and then describe how the various fittings were improvised.

A square area, sides 22 feet in length, was railed off by a low wall (A) of stones and turf with entrances on two sides.

No men, except cooks and cook-house fatigue men, were allowed in here except when the meals were being issued to the men.

The cooking shelter (B) was constructed of a wooden frame-work with corrugated iron roof and sides. It had a frontage of 17 feet, a depth of 8 feet and a height of 8 feet in front sloping to 7 feet behind. It was open in front and had windows at the sides and back to ensure through ventilation.

Two tables (C) for cutting up meat and preparing the food for cooking were situated on either side.

Shelving (D) was provided for holding the tea, sugar, salt, rice, raisin, oatmeal tins, etc.

A fly-proof cupboard (E) was placed in the cook-house to contain cold meats, dripping, etc.

Hooks were provided along the walls on which to hang the various cooking utensils.

No food or rations - except the dry rations such as tea, sugar, rice, etc. - were allowed to be kept in the cook-house except such as were being used for the meals of the day.

A long serving Table (F) was placed at the front of/

of the cooking shelter for serving out the meals to the men in winter time, when they had to take their meals in their tents.

The floor of the cook-house was levelled and beaten hard to facilitate sweeping up.

The inside was whitewashed when lime was available, giving a clean appearance to the cook-house, and it also served to show up any approach at dirtiness more easily.

Outside the cook-house were situated the Swill Tubs (G) and fly-proof grease trap (H) and a washing up bench (I) for kitchen utensils, the greasy water from it discharging into the fly-proof grease trap.

At (J) outside the cook-house were placed the ovens and the camp kettle trench.

They were roofed over for protection from rain by a head covering of galvanised iron on four posts.

The ovens and the camp kettle trench were placed in this position outside the cook-house so that the cook-house was kept clean and free from smoke, and the vapour and steaminess of cooking food.

Handy to the cook-house I had a dug-out meat larder constructed (K) after the hot weather started. This was dug down into the ground like an ordinary trench "dug out", and well ventilated with wind scoops so that even in the hot weather there was always a comparatively/

Fig. 17

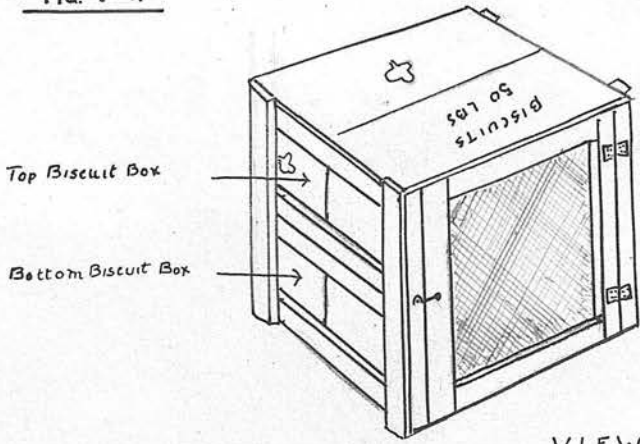

VIEW

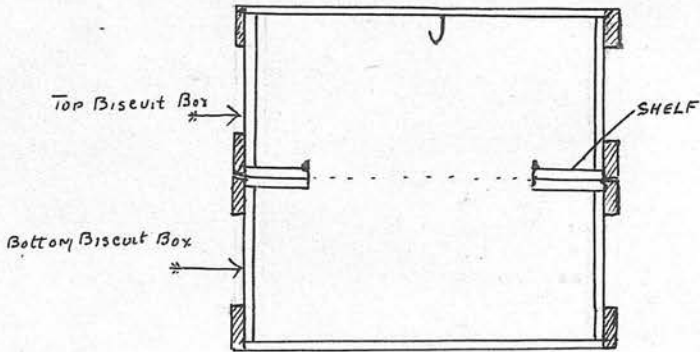

SECTION

FLY-PROOF CUPBOARD

MADE FROM

BISCUIT-BOXES

comparatively cool place to keep the meat in.

This then, was the general plan I adopted for the cook-house areas in my camp.

I shall now describe how the various ovens, grease traps, and other fittings mentioned above were improvised; the only material that we required to get from the Engineers Store being the corrugated iron for the ovens.

The Fly Proof Kitchen Cupboard.

(See figure 17.) This is very easily and efficiently made from two biscuit boxes.

The two boxes are laid one on top of the other and joined together by wooden battens from other biscuit boxes.

The shelf formed where the side of the top box rests on the side of the bottom box can either be left as a shelf dividing the safe into a top and bottom compartment, or as in the plan of the cupboard, cut away leaving a narrow shelf running round the safe and making one large compartment of the safe, thus leaving enough room to hang a small joint, etc. from hooks fastened into the roof of the safe. The shelves were lined with tin and the bottom provided with a removable tin tray made from biscuit tins. This tin lining/

lining prevented any soakage into the wood from meat, etc., and facilitated cleaning.

The door was made from a framework of wood strips across which was nailed a sheet of tin well perforated, keeping the cupboard fly-proof and well ventilated.

The Grease Trap.

Before attempting to get rid of the greasy water from the cook-house by soakage, it was absolutely essential that it should be freed as far as possible from the grease that it contained.

If this precaution is not taken the grease will be deposited on the sides and bottom of the pit, forming an impermeable layer, when further soakage ceases from that pit, and a new one will require to be dug, with the same result.

This greasy deposit will decompose giving rise to an evil smelling effluvium through the mouth of the soakage pit.

In order to remove the grease from the water, it is necessary that the water should first of all be put through some form of efficient grease trap.

Merely passing greasy water through a perforated tin containing hay or gorse, as is so often done, with the idea that the grease will be removed from the water by being entangled on the hay is a quite insufficient/

Fig. 18.

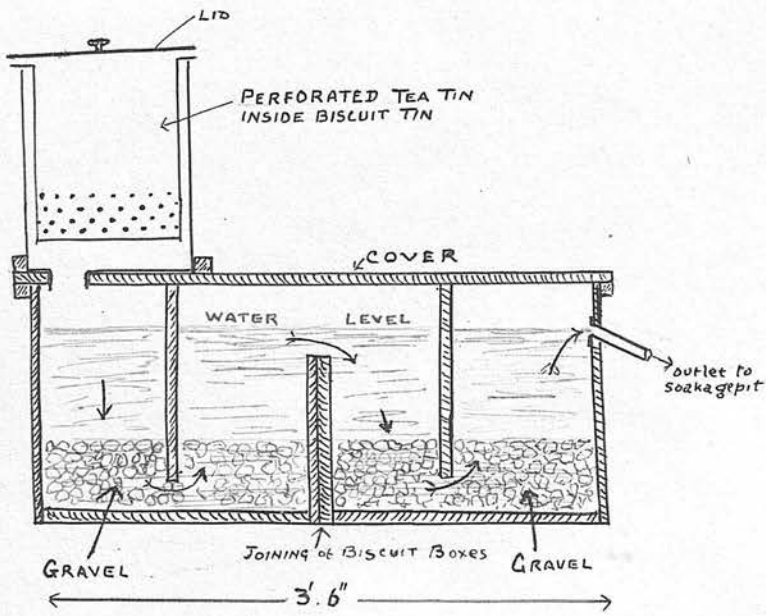

LONGITUDINAL SECTION

GREASE TRAP OF BISCUIT BOXES

insufficient and inadequate arrangement.

The hay or gorse will ensnare the grosser particles of organic matter, but that is about as much as it will do and it should be used only for that purpose.

The type of grease trap that I used in my camps was easily constructed as follows (See figure 18).

A long box about $3\frac{1}{2}$ feet long by one foot in breadth is required; two biscuit boxes nailed together end to end and made water-tight will do nicely.

The two compartments thus formed have a few inches of fine gravel placed in them and each compartment is divided into two by wooden baffles which dip into the gravel and reach to about $1\frac{1}{2}$ inches from the bottom of the boxes.

An inch and a half is taken off the height of the middle partition formed by the joining of the two boxes, thus allowing the water to flow from one box to the other and keeping the water below the level of the top edge of the box.

A glance at the diagram will show that the sullage water coming in at one end has to flow through the gravel, and under the baffle in the first box; then over the middle partition, down through the gravel and under the baffle in the second box and the/

the clean effluent flows out of the grease trap through a spout at the end of the last compartment and a little below the top edge of the box. This effluent is led by a pipe into a soakage pit in precisely the same way as I described under "Urinals".

The grease floats to the top of the water in the compartment and is periodically skimmed off.

Before the sullage water entered the grease trap it went through a biscuit tin perforated at the bottom and containing hay or gorse.

This acted as a strainer for the grosser particles in the water and was contained in an outer tin which served to direct the water into the grease trap.

This hay or gorse filter was renewed each day and the fouled hay or gorse burned.

The gravel was periodically removed and replaced by fresh gravel to prevent clogging with grease.

A lid fitted over the grease trap and one over the filter tin, making the whole fly-proof.

Washing Bench for Kitchen Utensils.

A washing bench for the greasy dishes, camp kettles, etc., was erected close to the grease trap. Its construction was precisely the same as the ablution benches which will be described fully under that heading. The flat surface of the bench was lined with tin, and the greasy water from the utensils drained/

drained off into the grease trap.

This bench prevented the ground outside the cook-house from becoming soaked from the washing and scouring of the various pots and other cooking dishes.

Swill Tubs.

Two large boxes made from biscuit boxes and lined with tin formed the swill tubs.

These were provided with tightly fitting lids making them fly-proof.

One was labelled "DRY SWILL" the other "WET SWILL". Any liquid in the wet swill tub was poured off down the grease trap before the swill tub was taken and emptied at the incinerator.

These tubs were emptied into the refuse bay at the incinerator, where the contents were burned, and after being emptied were swilled out with cresol. A hard stance for them was made by paving a suitable space with empty jam tins. Special instructions were given that the lids were always to be kept on, that they were to be emptied before they became full, so that there should be no spilling over of refuse, and that after emptying they were to be thoroughly washed out, otherwise they would become very foul from old refuse sticking to the sides of the tin.

Dug Out Meat Larder.

This was made behind the cook-house on the ordinary principle of a "dug-out" or "funk-hole" in the trenches - about 5 feet square and 6 feet high. It was well ventilated by means of wind scoops going up through the roof. The door was merely a framework across which some wire gauze which we managed to get was nailed. It was thus fly-proof, well ventilated and cool. I had this constructed because with the advent of the very hot weather this dug out larder always was sheltered and cool and kept the meat ration in good condition.

The Field Oven.

I made it a special endeavour that the men got as varied and interesting a diet as possible from the rations at our disposal, and for this an oven was absolutely essential, so I at once on the arrival of the companies at their camping ground got ovens constructed.

(a) Aldershot Oven.

I had oven constructed after this type at once, pending the construction of a more elaborate type, as they can be put up very rapidly and are simple of construction.

I used these only as a temporary measure for the Aldershot/

Fig. 19.

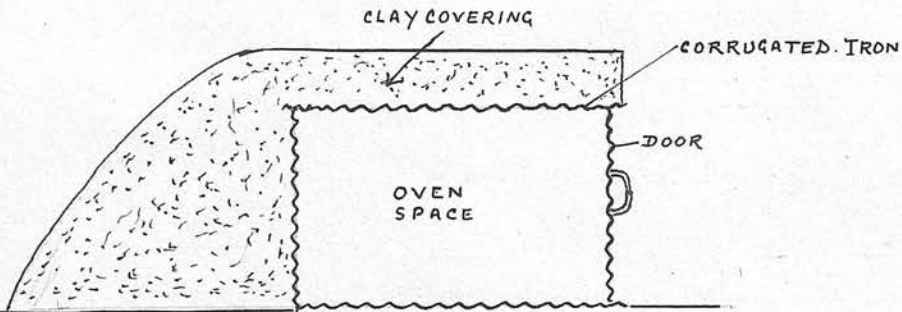

LONGITUDINAL SECTION

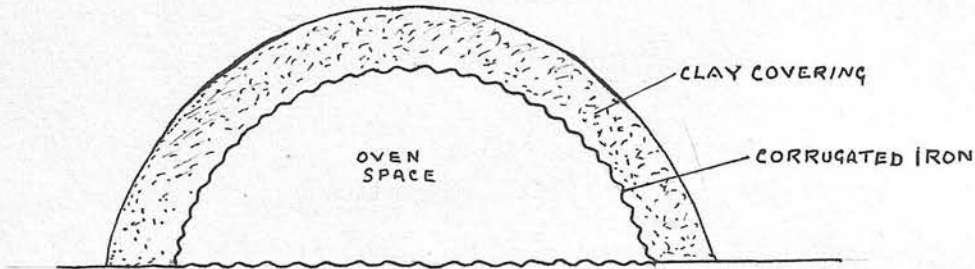

TRANSVERSE SECTION

"ALDRESHOT" OVEN.

Aldershot oven has its drawbacks; firstly, it is extravagant of fuel, secondly, it is not very convenient for the cooks.

Construction. (See figure 19).

A piece of ground about 6 feet square was levelled and a sheet of corrugated iron bent into a half circle was placed on this levelled area forming the curved sides and roof of the oven.

The front is left open, the back is closed by placing against it a piece of corrugated iron roughly cut to shape. It is then thickly covered with clay, except in front, the clay being tailed off over the back, keeping the back sheet of corrugated iron in position.

A minimum thickness of 6 inches of clay is required. The floor was covered with another sheet of corrugated iron.

The oven is then dried by burning a wood fire inside the oven, this dries and bakes the clay and it is then ready for use.

To use the Oven.

A wood fire of sticks and small logs is burned inside the oven - the door being left open, and when the oven is sufficiently heated, in about $1\frac{1}{2}$ hours, the fire is raked out, the joints of meat on trays made/

Fig. 20.

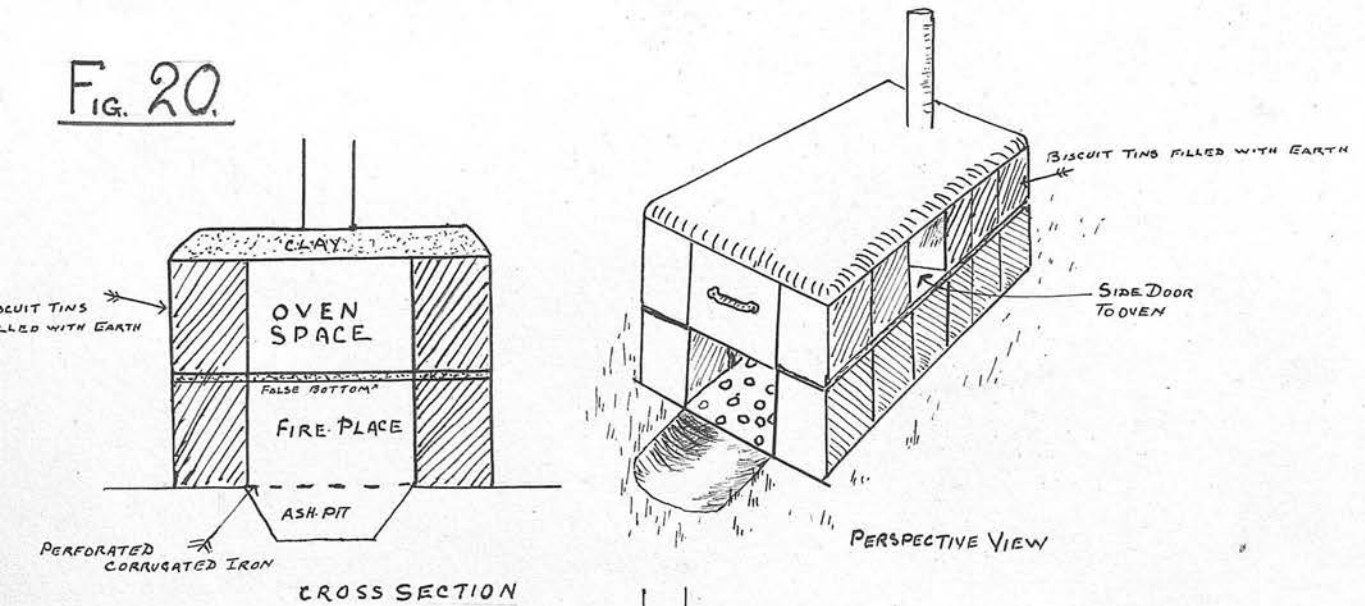

CROSS SECTION

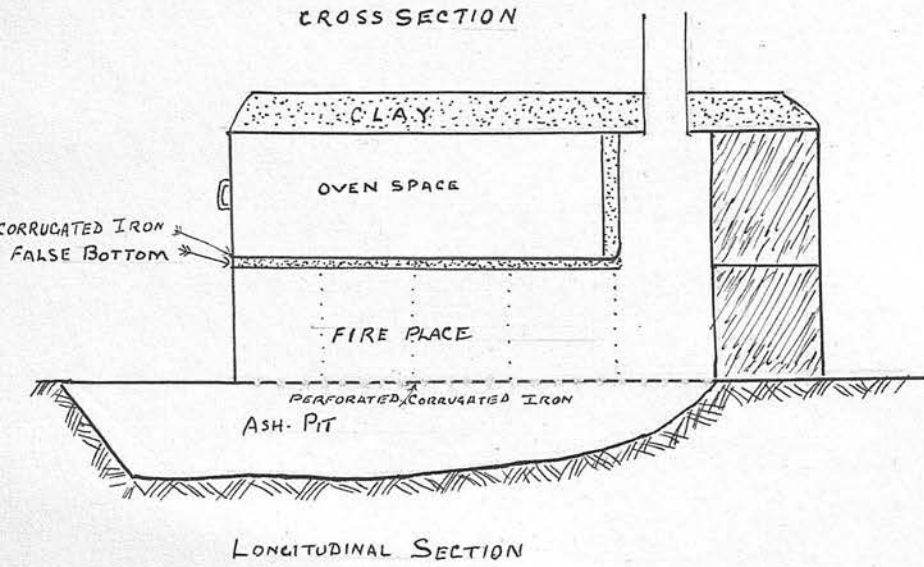

LONGITUDINAL SECTION

FIELD OVEN

of

BISCUIT TINS & CORRUGATED IRON

made from tea tins, are put in, the sheet of iron forming the door is closed against the oven and sealed all round with clay.

The thick clay covering retains the heat and moisture sufficiently to thoroughly roast the joints.

(b) Biscuit Tin Oven.

A very good and efficient type of oven and a very easily made oven was made out of 28 biscuit tins, 4 sheets of corrugated iron and a kerosene oil drum - and these ovens were continuously used after we had them constructed.

Construction. (See figure 20)

Two parallel rows of six biscuit tins filled with earth was laid down, each tin tight up against the other and the two rows less than the breadth of a sheet of corrugated iron apart.

The earth is scooped out to form a shallow trench between the two rows. Over this a sheet of corrugated iron, well perforated, is placed, the edges projecting below the biscuit tins. This sheet acts as fire bars and the trench beneath as an ashpit.

A piece of corrugated iron cut short so that it only reaches to about the middle of the fifth biscuit tin is laid upon the two rows of biscuit tins. The space below the sheet of iron forms the fire place.

A thin layer of clay is laid upon this sheet of corrugated iron and upon the surface of the clay is laid another sheet of corrugated iron,- the last 10 or 12 inches of which are bent up at right angles - to form the back of the oven space. The compartment thus formed when covered in forms the oven space and the clay layer below forms a false bottom to prevent the oven being burnt through. The false bottom can be supported by 4 iron bars laid across the tins. Other two rows of biscuit tins are placed upon the first two rows, forming the sides of the oven space, and beyond the end of the oven space, the sides of the flue.

The roof is formed by placing a full length sheet of corrugated iron on the top of the second row of biscuit tins, a hole being made in the end of this sheet over the flue at the back of the oven space for a chimney.

The joint where the bent up piece of sheeting forming the back end of the oven space meets the roof sheet, is made smoke tight by clay.

The back of the flue is build up by 4 biscuit tins, or stones and clay will do. A kerosene tin is placed over the hole in the top sheet forming a chimney and the whole structure roofed over with clay.

Spaces between the tins can be clayed up.

A sliding or flap door is easily made for the front of the oven. One of the biscuit tins forming the side of the oven space can be removed and replaced by a sliding panel, forming a side door into the oven space facilitating the placing in and removing of joints, etc., from the back part of the oven space.

An oven of this size can roast meat for about 250 men.

An oven of this type was built in each camp and also one about half the size for baking purposes.

Camp Kettle Trench.

In order to make stews, boiled meat, dumplings, tea, etc., a camp kettle trench is necessary. This was placed under the shelter beside the ovens. A common form of fire-plate or fire trench for the camp kettles is simply a narrow trench dug in the ground, or two low turf or stone parallel parapets sufficiently long to contain the number of camp kettles required, which are placed across the trench or the low parapet. The fire is laid beneath the kettles and burns up and around them.

Both of these methods had in my opinion two faults. Firstly, they were very extravagant of fuel, which was none too plentiful when we were out in Macedonia at first. Secondly, the smoke from the fire blew about anyhow and made it unpleasant work for/

FIG. 21.

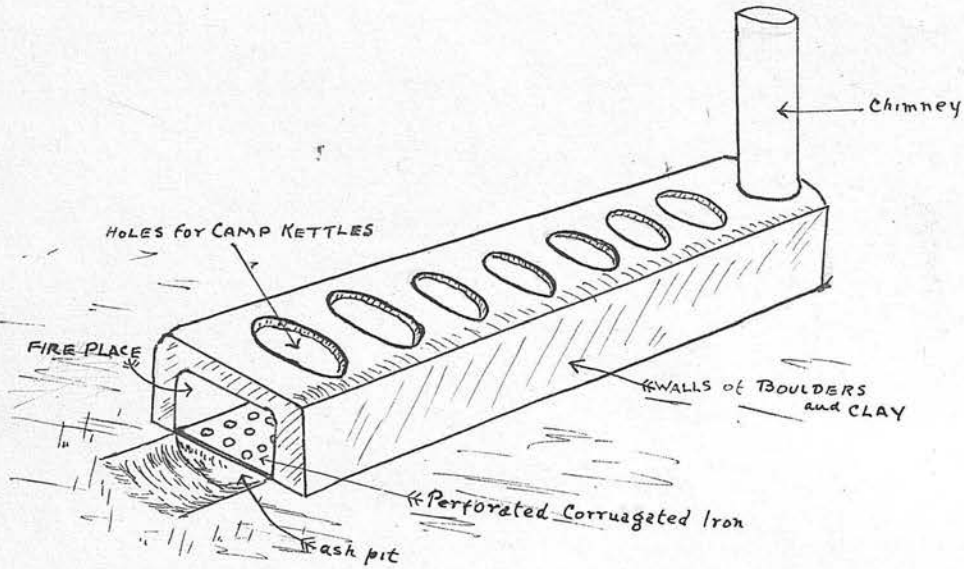

CAMP-KETTLE TRENCH

for the cooks.

These faults were obviated by making a covered in trench with holes into which the kettles fitted, and a chimney at the end to form a draught and carry off the smoke.

One fifth of the fuel used for the open trench is required in the covered in trench, which is a great saving.

It is simply constructed. (See figure 21.)

A narrow trench six inches deep and as long as required is scooped out, this forms the ashpit and across it is laid a grid of forage bundle hoop iron, or corrugated iron well perforated to act as fire bars.

Two parallel walls about 10 inches high are built along the edges of this trench. This is then covered in with turfs and clay, oval spaces being left for the camp kettles. This covering was supported by strips of forage-bundle hoop iron placed across between the holes for the kettles - one end is closed up and a chimney built in. This form of kettle trench is both economical in fuel and cleanly.

A further economy of fuel was made later by making the same fire which boiled the kettles in the camp kettle trench also heat the oven.

This was done by joining up the camp kettle trench/

trench to the oven in front of the oven fire place so that the fire from the camp kettle trench continued on into the oven fire place and so up the oven flue.

By means of these ovens and camp kettle trenches a good variety of interesting and appetising dishes were made for the men from their rations alone.

I inspected the Cook-house Area every day and insisted on a very high standard of cleanliness, as even in a clean cook-house in the summer months flies were numerous, and are much more so in a dirty one.

No person was allowed to be in the cook-house who had had a history of Typhoid Fever in case he might have been a "carrier".

Below is a copy of instructions to the cooks that I had written out and placed in the cook-house, and which by daily inspection I saw were strictly carried out.

INSTRUCTIONS TO BE STRICTLY OBSERVED by Cooks.

1. ABSOLUTE CLEANLINESS IN EVERYTHING, IN AND AROUND THE COOKHOUSE IS ESSENTIAL.
2. ALL MEAT BOARDS AND CHOPPING BLOCKS TO BE DAILY SCRUBBED DOWN WITH HOT WATER, SOAP, AND SODA, AND THEN SCRAPED AFTER USE.

3./

3. ALL SPOONS, FORKS, KNIVES AND OTHER UTENSILS IF NOT BEING USED, TO BE CLEANED AND HUNG UP ON THE HOOKS PROVIDED FOR THE PURPOSE.
4. ONLY THE DAYS MEAT RATION TO BE IN THE COOKHOUSE. THIS MEAT TO BE KEPT IN THE DUG OUT LARDER WHILE NOT BEING PREPARED FOR COOKING.
5. THE FLOOR OF THE COOKHOUSE TO BE SWEEPED OUT AND KEPT ALWAYS CLEAN AND TIDY.
6. SWILL TUBS (a) LIDS ALWAYS TO BE ON.
(b) SWILL TO BE CAREFULLY PUT IN AND NONE SPILLED ON THE GROUND.
(c) MOIST AND DRY SWILL PUT INTO THEIR SEPARATE TUBS.
(d) TEA LEAVES TO BE DRAINED BEFORE BEING PUT INTO SWILL TUB.
7. ALL GREASY WATER TO BE PUT DOWN THE GREASE TRAP. LID OF GREASE TRAP ALWAYS TO BE REPLACED AFTER USE.
8. ALL DIRTY DISHES AND UTENSILS TO BE WASHED AT THE DISH WASHING BENCH.
9. NO TUNICS OR TOWELS TO BE HUNG UP IN THE COOKHOUSE.
10. EVERYTHING TO BE READY FOR MEDICAL OFFICER'S INSPECTION BY 10.30 A.M.
11. THE CORPORAL COOK IS RESPONSIBLE FOR SEEING THAT THESE INSTRUCTIONS ARE STRICTLY CARRIED OUT.

I shall now pass on to the important subject of the feeding of the men and describe how an interesting and varied diet was maintained from the ordinary army rations with which we were issued.

D I E T.

It was my constant endeavour to get the men's diet as attractive and as varied as possible, because situated as we were, there was very little amusement or diversion for the men, little or nothing to relieve the sameness of the life they had to lead, no prospect at that time of any leave for the men, and under these circumstances their meals became nearly the main point of interest in their daily life, and if their meals are not appetising and varied, if the easily made "stew" is served up monotonously day after day, it makes the soldiers life under those circumstances a weary one indeed.

I therefore did all that I possibly could to see that the cooks made as many different dishes as possible out of the rations supplied to us.

And apart from the pleasure that it gave the men to know that there would be something different for dinner every day, the extra trouble taken with the food repaid itself in that the men worked better, were/

were more cheerful, and, I am fully persuaded, were healthier and of better morale.

On first arrival the rations consisted of bully beef or other preserved meat rations and the usual tea, sugar, jam and tinned milk. Later, as supplies became properly established, full rations were available and they consisted of the following:-

Bacon

Meat { Frozen
or
Tinned (Bully Beef or Maconochie, i.e. Preserved Meat and Vegetable ration)

Vegetables { Potatoes
or
Dried mixed vegetables.
Onions frequently.

Bread - sometimes in lieu of bread, a flour issue could be drawn.

Biscuits.

Sugar.

Tea.

Condensed Milk.

Jam.

Cheese.

Salt.

Pepper.

The following extra rations were also frequently provided from time to time.

Dried Fruits:- Raisins, Dates, Figs.

Oatmeal.

Rice.

Butter or Margarine.

Rabbits.

If interest is not taken in the cooking and the cooks allowed to get slack, a monotonous diet will be the inevitable result. The cook will not trouble to make porridge with the oatmeal ration, the dinner will invariably consist day after day of "Stew" and no attempt will be made to make puddings. There will never be any little extra "snack" added at tea time and no soup will be provided on cold nights.

In a camp where the cooking is not carefully supervised, such a state of things will very frequently result.

There are three things that are essential in addition to the ordinary cooking equipment if variety is to be obtained in field cooking, namely, an oven, a mincing machine, and a stock pot.

The Oven I have already described.

The Mincing Machine.

By means of the mincing machine a great variety of puddings can be made from the unwieldy army biscuit, the dough for the various puddings being provided by putting biscuits, soaked overnight in water, through the mincer.

From/

From the somewhat monotonous bully beef can be made appetising rissoles and a very tasty meat paste by means of the mincer.

The Maconochie Preserved Meat and Vegetable Ration can be transformed into an appetising Cottage Pie and wonders can be worked with the cheese ration by its means.

The Stock Pot.

A well-kept stock pot provides a ready means of improving all meat dishes, providing gravy, thickening the stew, making brawn, and providing soup for the men at nights. We used two ordinary camp kettles as the stock pot, except in one company where we managed to get a Sawyer's Stove which consists of a small cauldron fixed over a stove fire.

Each day all bones from the ration meat were chopped up, together with any scraps of meat, and the rind from the sides of bacon, and put into cold water and then simmered for several hours, a little salt being added, which caused the "scum" to rise to the surface and this was removed.

The fat was skimmed off from time to time and used as "second-class" fat. Each night the stock was strained off into clean receptacles.

I will now give a list of the various dishes that were provided for the men and which were made from what used to be looked upon as the dreariest part of the rations, namely the Bully Beef, Biscuits and Cheese. These can be made into many very appetising and tasty dishes with a little extra trouble on the part of the cooks. It is the preserved rations that are so often neglected and handed out of the cookhouse just as they are received from the Army Service Corps and no attempt made to cook them or serve them up in an appetising way.

The following is merely a list of the dishes made from the various rations - the recipes for making these dishes I have written out in detail in the appendix.

A copy of the various recipes was written out, given to the cooks and hung up in the cook-house for handy reference.

Dishes made from Bully Beef.

1. Rissoles.

These were prepared in the afternoon and served up hot for breakfast, when the bacon ration was short- or they made a good supper dish.

2. "Salonika" Meat Paste.

This was very simply made and was most appetising and could be easily given as a little "snack" at tea time.

3. Galantine of Beef.

This was a good cold ration for working parties to take out with them for a mid-day meal.

4. Fish Paste.

This was a modification of the Salonika Meat Paste, by the addition of Sardines when these were issued.

Dishes made from the Maconachie or Meat and Vegetable Tinned Ration.

1. Shepherd's Pie.

This made a very good hot dinner on cold days.

2. Maconochie Croquettes.

These were somewhat similar to the Bully Beef Rissoles.

Puddings made from Biscuits.

A good variety of Puddings can be made from Army Biscuits. The foundation of all these puddings is the Biscuit Dough, made by passing biscuits which have been soaked over night through the mincer and adding a sufficiency of salt and dripping.

1. Jam Roll.2. Date Pudding.3. Fig Pudding.4. Raisin Dumpling.5. "Dundee" Pudding - a marmalade pudding.

6./

6. Jam Tarts.
7. Queen Pudding.

Dishes made from Cheese.

1. Savory Cheese Biscuits.
2. Welsh Rarebit.

It will be seen from the above list that a good varied menu is obtainable even with improvised field cooking methods.

I saw that the cooks were familiar with the making of these dishes and I impressed upon them the necessity of doing their best to keep up a variety.

Each company cook had to keep a diet sheet of what the men had for food each day.

Below is a typical diet sheet for a week when everything had been going in proper order, and there is no reason why every unit situated as mine was, should not have as varied a menu.

D I E T S H E E T /

D I E T S H E E T

	SUNDAY	MONDAY	TUESDAY	WEDNESDAY	THURSDAY	FRIDAY	SATURDAY.
<u>BREAKFAST</u>	Fried Bacon Tea Bread Jam	Porridge Fried Bacon Tea Bread	Rissoles Tea Bread Jam	Porridge Fried Bacon Tea Bread	Fried Bacon Tea Bread Jam	Croquettes Tea Bread Jam	Porridge Fried Bacon Tea Bread.
1st Half Company	Roast Beef Potatoes Dundee Pudding	Brown Stew Date Pudding	Cottage Pie Rice & Raisin Pudding	Boiled Beef Preserv- ed Vege- tables Potatoes Jam Roll	Curried Stew Queen Pudding	Roast Mutton Boiled Onions Potatoes Jam Tart	Cottage Pie Fig Pudding.
<u>DINNER</u>							
2nd Half Company	Brown Stew Dundee Pudding	Roast Beef Potatoes Date Pudding	Boiled Beef Preserv- ed Vege- tables Potatoes Raisin Pudding	Cottage Pie Jam Roll	Roast Beef Potatoes Queen Pudding	Curried Stew Jam Tarts.	Roast Mutton Boiled Onions Fig Pudding.
<u>TEA.</u>	Tea Bread Butter Jam	Tea Bread Meat Paste	Tea Bread Drip- ping	Tea Bread Butter Jam.	Tea Bread Butter	Tea Bread Butter Jam	Tea Bread Butter Meat Paste.
<u>SUPPER</u>	Soup Biscuits	—	Cheese Biscuits	Galan- tine of Beef, Biscuits	Fish Paste, Biscuits	—	Soup, Biscuits.

In one company where I had a very capable cook we tried for a time making each day for dinner as far as rations would allow, three dishes, usually Roast Beef, Boiled Beef, Stew, each dish sufficient to do one third of the company, and two puddings, each sufficient to do one half of the company, and each man/

FIG. 22.

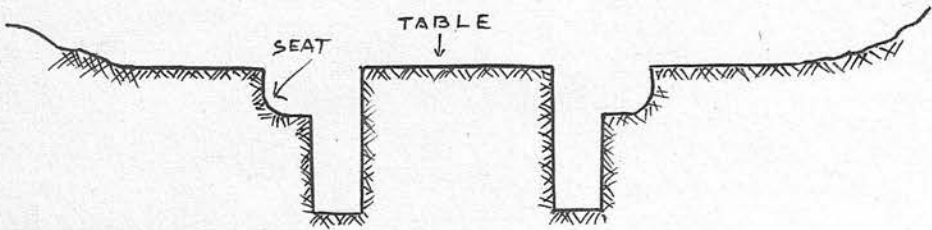

OPEN AIR "TRENCH" DINING TABLE

man was allowed to choose for himself from the menu what he would have for dinner.

The usual routine, when we gave them roast, was to do roast for one half company and stew for the other, for there was usually hardly enough meat to provide roast for the whole company. The next day the half company which had had the roast, got stew, and the other half got the roast.

D I N I N G R O O M S .

In the winter time the men had to take their food in their tents, which is never an ideal arrangement as the tents are so apt to get littered with debris of food. It was not possible to erect a large enough shelter to act as a dining room for 250 men.

When the warmer and dry weather began I took advantage of this to have open air dining room tables which were of simple construction, which could accommodate all the men of the company at one time, and thus did away with any food being taken into the tents.

Construction of Dining Tables. (See figure 22)

Two parallel trenches were dug about 3 feet apart, each trench 3 feet deep and of sufficient breadth/

breadth to let a man get his legs in comfortably.

The ground between the trenches was beaten hard and formed the long dining table.

A ledge was cut on the outer wall of the trenches, to a depth of one foot below the level of the table and this formed the seat for the men. Enough of these "tables" were dug to seat the whole company.

After each meal the whole place was swept clean and the debris taken to the incinerator.

In this way no food was left about after meals, as is always the case to a greater or less extent when the men take their food in the tents.

WASHING AND BATHING.

To keep the health of the men up to the best possible standard, to prevent the outbreak of mild forms of Dermatitis, Scabies and the like, it was essential that in the camps there should be proper facilities for washing and that each man should have a hot bath regularly.

Facilities for washing were provided by erecting Ablution Benches in each camp. Figure 23 shows the construction of the ablution benches. Two shelves 8 feet long by $1\frac{1}{2}$ feet broad, made from planking, sloping gently to each other and meeting in the centre were supported on a wooden frame work.

The/

FIG. 23.

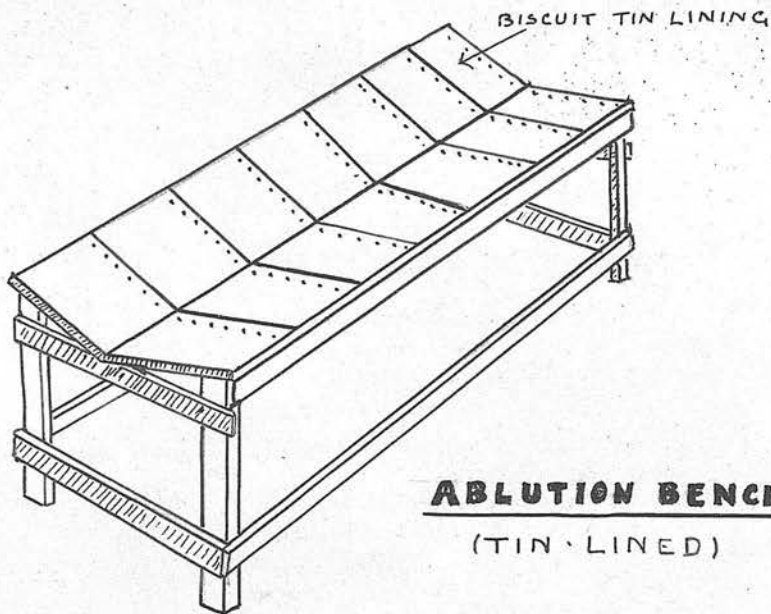
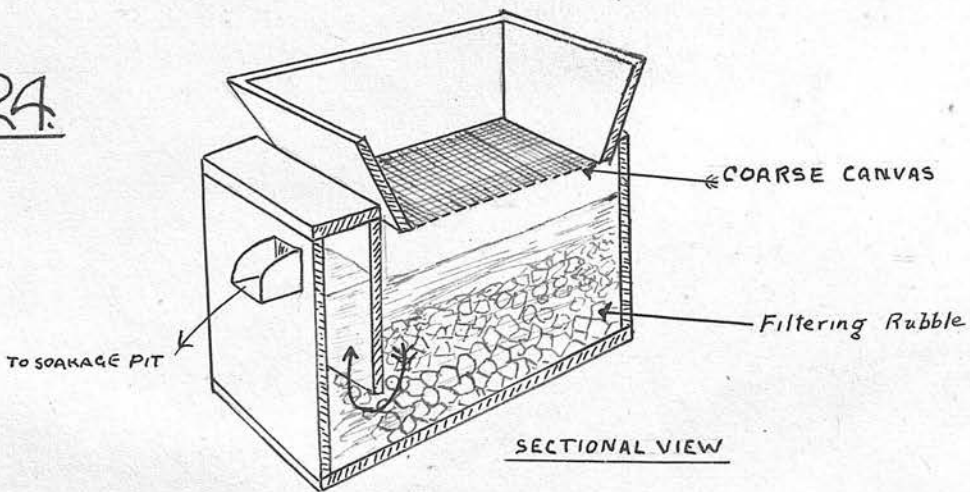

FIG. 24.



SOAP-FILTER BOX

*made from
Biscuit Box*

The surface of the bench was covered with tin sheeting from biscuit tins, to prevent soapy water dripping through and soaking the ground, and the whole was canted at a slight angle.

Washing basins for the men were provided by cutting biscuit tins in half and each half acting as a basin.

After washing, the men emptied the basin and left them turned upside down on the bench.

The soapy water discharged from the bench through a pipe made from biscuit tin into a soap-filter box, and thence into a soakage pit. This soap-filter box can be constructed in exactly the same way as the grease trap already described, or as shewn in figure 24.

It was necessary to put the soapy water through some form of soap filter otherwise the soapy scum would have been deposited on to the sides of the soakage pit into which the washing water discharged and soon would have rendered the pit useless.

In two of the camps however, the water after going through the soap-filter box was led into a small stream that ran near each of the camps thus doing without the necessity of a soakage pit.

These benches provided for the ordinary washing of the men and were also used as benches on which the men could wash their clothes.

Hot Baths.

I aimed at giving a hot bath to each man regularly. Some time after we had been established at Salonika, Divisional Baths were erected; these were at Divisional Headquarters, and as this was a good many miles back over the hills from us, they were too far away to be of practical use to my unit and our turn for the baths did not come round frequently enough to please me, so I endeavoured to establish small bath houses of our own in each camp.

This was not an easy matter ; a supply of hot water being very limited as fuel was by no means plentiful, and proper wooden tubs could not be got or made, and the men could only be bathed after "working hours".

I had small corrugated iron shelters put up in each camp to serve as bath houses, all the holes or spaces being clayed up so as to preserve the "steaminess" of the bath house as much as possible.

The bath house was paved with jam tins, on which were placed rows of duck-boarding to act as wooden battening for the men to stand on.

Two biscuit boxes nailed together, the partition formed by their joined sides cut away, and all joints covered over on the inside with strips of tin, and wooden battens on the outside made improvised tubs sufficiently watertight to serve the purpose.

Large/

Large galvanised water tanks were indented for. These were placed on two low parapets and provided with false bottoms made of clay and a sheet of corrugated iron.

A fire was lit below the tank and we managed to get on the average sufficient hot water to bathe about 25 men an evening - this worked out so that each man got a hot bath once in about 10 days.

Five men could bath in the bath house at one time. The improvised tubs were filled with hot water and each man was provided with soap and a rough flesh glove in the shape of a folded sand-bag.

They stood either in or beside the tubs and scrubbed themselves down with hot water and soap. Each man assisted his neighbour by scrubbing down the more un-get-at-able portions of his neighbour's back. About quarter of an hour was allowed to each batch of five men.

This bath was made compulsory and a roll kept to see that each man had his bath regularly. The hot baths were much appreciated by the men. Though they were more in the nature of a hot "scrubbing down" than a hot bath, they served the purpose well for which they were intended, for I never had any skin troubles among my men that could be attributed to want of proper washing.

In the hot weather bathing the men presented no difficulty at all. Three of the camps each had a small stream in its vicinity; a dam of sand bags was thrown across the streams making small bathing pools of from 4 to 5 feet in depth, and every evening there were bathing parades at these pools so that each man got a good bath once a week officially, and every evening if he liked, unofficially. At the fourth camp there was only a very small stream of water, but this was made to provide a shower-spray bath for the men.

The water of this small stream was diverted by means of a wooden chute into two biscuit tins with perforated bottoms. The stream had steep high banks and these tins were placed on stanchions driven into the perpendicular face of one of the banks about seven feet above the level of the bed of the stream. The diverted water ran into the biscuit tin and fell through in the form of sprays, and underneath the men had spray baths, in the manner of the spray room at a swimming bath.

WATER SUPPLY.

We were fortunate in the positions of our camps as regards drinking water for there were springs near each of the camps. I did not allow any drinking or cooking/

cooking water to be drawn from any of the streams, as with troops in their vicinity contamination of the streams from their banks was more than probable.

Two "water-duty" men were attached to each company whose sole duty was to supply the company with water by means of the water cart and they were responsible that the water cart was kept thoroughly clean and in good working order.

I tested the water in those springs by means of the Water Testing Case which was a part of each Medical Officer's equipment, and found that in each case the water was chemically pure.

A bacteriological laboratory was later established at Army Headquarters, the water from the springs was submitted to the bacteriologist who pronounced the water fit for use from a bacteriological point of view, but in order that there should be no risk I had the water in the carts always sterilized by bleaching powder before being issued for use.

DRAINAGE OF THE CAMP.

During the wet weather the camps became muddy and water-logged, owing to the clay subsoil, and some system of drainage was required to make the ground less sodden underfoot and to keep the interior of the/

the tents dry.

A circular ditch was cut round each tent about 8 inches broad and 8 inches deep, this prevented water getting in under the curtain of the tent- the turfs so cut, were laid round the outer edge of the trench.

These tent trenches all drained into a central ditch running down in the middle of the space between two lines of tents.

These central trenches drained into one larger trench running at right angles to the line of tents, and the surface water was thus led out of the tent lines. Similar trenches or drains were made throughout the camp and helped to make the camp a little drier than it otherwise would have been.

These open drains were loosely filled with large stones to prevent their sides being trodden in and to prevent people tripping in the dark.

Dry paths were also made along each row of tents and also from the tent lines to the cook-house and bath house, ablution benches and the latrines, urinals and incinerator.

Good dry paths were made by laying down two parallel rows of large boulders 2 feet apart and the intervening 2 feet was filled up with loose shingle, the edging of large boulders keeping the shingle together./

together.

Boulders were whitewashed at intervals to indicate the paths in the dark.

At the door of each tent were placed foot scrapers, made of a small piece of corrugated iron stuck in the ground; these appreciably helped to keep the interior of the tents free from mud.

MEASURES TAKEN AGAINST FLIES.

It is now a well established fact, which does not need elaborating, that the common fly plays a most important rôle in the spreading of disease among troops under active service conditions; it may be considered as one of the chief agents by which food is infected with disease producing organisms. *Bacillus Typhosus*, *Spirillum Cholerae*, *Bacillus Tuberculosis* have been demonstrated on the feet and in the crop of the common house fly. Lelean says "The crop of a fly may contain some 200 million organisms. By the ratio of 4000 to 1, that mass of bacteria may contain 5000 enteric bacilli or probably a similar number of other intestinal infective organisms. A large part of the crop contents may be regurgitated on to the surface of human food within a few minutes of ingestion."

All possible anti-fly precautions were therefore taken, some of these have already been indicated and the/

the methods I employed are now summarized below.-

1. The food was protected as far as possible. All rations that would attract flies were kept under cover except when being prepared or issued.

Sugar, raisins, and similar dry rations were kept in boxes with tightly fitting lids.

Meat, bacon, dripping, etc., were kept either in the fly-proof cupboard in the cook-house or in the fly-proof meat larder.

No food was allowed to be kept in the tents except such as came in parcels from home and that had to be kept under cover in a box.

2. Flies were kept off faeces and urine by means of the fly-proof latrines and the fly-proof urine soakage pit, and the faeces were incinerated.

3. The manure was burnt so that the favourite breeding place of the fly was daily destroyed. The flies were kept off the manure waiting to be burned by occasional sprinkling with cresol.

4. The cook-house refuse was kept under cover in swill tubs with tightly fitting lids till it was burned at the incinerator. When dumped at the incinerator it was covered in the refuse bay by sacking soaked in cresol.

5. A high standard of cleanliness was insisted upon in all departments.

The whole camp was patrolled morning and afternoon by two of the Sanitary section, whose duty it was to pick up all refuse that might be lying about and take it down to the incinerator.

The precautions to ensure cleanliness in the cookhouse have already been detailed. There is a marked difference in the number of flies in a clean cookhouse and an only moderately clean cook-house.

6. Killing of adult flies.

Fly papers were indented for and hung up in the cookhouse, but the supply of these was very limited.

The formalin fly-killing solution as officially recommended was used.

This consisted of

Formalin	2	tablespoonfuls
Sugar	1	dessert spoonful.
Water	to	1 pint.

The addition of a little beer seemed to make this solution more attractive.

This solution has the advantage of being non-toxic to human beings and animals.

Pieces/

Pieces of blotting paper were soaked in this solution and placed on plates and exposed in the cook-house and other places attractive to flies.

At night the flies used to accumulate inside the men's tents, clustering together at the top.

By making a large flare-torch with burning newspaper and passing it rapidly round the top of the tent below the masses of flies, a large number of flies could be killed in each tent - some care of course had to be exercised in using this method.

ANTI-MALARIAL MEASURES.

Malaria is very prevalent in Macedonia but during the time we were in these camps, we were fortunately stationed well up in the hills and anopheline mosquitoes were not prevalent near us.

Though I did not have any cases of malaria while we were there, anti-malarial measures were instituted. The district round the camps was inspected when the hot weather started. All rank vegetation in any neighbouring marshes - though these were few - was cut down and the marshy area drained by ditches. All pools of stagnant water were drained, and where they could not be drained a man was detailed to constantly keep a film of cresol on the surface of these pools.

No pools of water were allowed to form in the camp. Any receptacle containing water in the camp was provided with a lid.

A small "mosquito pool" was made near the camp in order to ascertain what kind of mosquitoes were in our area, but it was only occasionally that Anopheline pupae were discovered.

One or two more items of a general routine nature remain to be mentioned.

1. Inoculation.

The officers, and all the men, with the exception of a few stubborn "conscientious objectors" were kept "fully protected" against Typhoid, Para-typhoid (a), and Para-typhoid (b) by regular re-inoculation with the T.A.B. vaccine.

Nominal rolls of their men were submitted to me by the company commanders, with the dates of their last inoculation, and each man was re-inoculated at the end of 12 months after the date of his previous inoculation.

I also inoculated all the officers and men at the commencement of the hot weather, with anti-cholera vaccine.

2. Weekly Health Inspection.

A weekly health inspection of the men was made. The men were lined up, with tunics off, shirt sleeves rolled up, bare feet, and trousers loosened.

As I passed down the ranks, trousers were let down and shirts pulled up so that I viewed the whole body.

In this way any skin disease was discovered in its incipient stages and promptly got under treatment. The condition of the men's feet was kept under constant surveillance, and the cleanliness of the men was noted.

It was very rarely that any man was found to have lice upon him, but the few cases that occurred were discovered at this weekly inspection and they at once got a clean change of underclothing and the old garments were sent to the Divisional Steam Disinfector.

3. General Cleanliness of the Camp.

The Men's lines. A "Tent orderly" was appointed in each tent.

It was his duty to see that the tent was cleaned up each morning and that all refuse and rubbish was put into the sand-bag provided for the purpose, which was hung outside each tent; this was all collected and taken down to the incinerator by one of the sanitary section.

He was also responsible for the cleanliness of the/

the ground in the immediate vicinity of his tent.

He had also to see that the tent bottom curtain was tied up and the door tied open (except in wet weather) so that the tent was well flushed out with fresh air.

During the fine dry weather he had to see that each man took his blankets out and spread them on the ground, in this way all the men's blankets were well aired and in addition got a good sun-bath during the hot weather.

The rest of the Camp was kept clean by two of the Sanitary Section. Each patrolled his area once in the forenoon and once in the afternoon picking up all pieces of paper and other refuse and taking them down to the incinerator.

PERSONNEL OF THE SANITARY SECTION AND THEIR DUTIES.

In each company I had 5 men for sanitary duties and two water duty men.

One man looked after the latrines and urinals. He had to take the latrine buckets to the incinerator and empty them there.

He had to see that the latrines and urinals were kept in a proper sanitary condition and in good working order.

He also had to place the night urine tubs in the men's/

men's lines and empty them in the morning.

One man looked after the incinerator.

One man attended to the burning of the manure.

Two general duty men; they attended to the taking of the swill tubs to the incinerator from the cook-house - they looked after the grease traps and soap-filter box and saw that the soakage pits were working properly, and they, by morning and afternoon patrols were responsible for the general cleanliness of the camp.

The water duty men attended solely to the water supply of their camps and did no other sanitary work.

I made a daily sanitary inspection of all the camps and saw that these men carried out their duties in a satisfactory manner.

These methods of Sanitation and arrangements for the health and comfort of the men, under careful supervision, worked well and smoothly.

The general health of the men may partially reflect the efficacy of one's methods of sanitation; there were no cases of Typhoid Fever or Para-typhoid fever; two cases of Dysentery were the only cases of recognised Infectious Disease that occurred during the ten months I was with this unit in Macedonia.

References./

References.

- (1) The Manual of Military Hygiene - War Office.
- (2) Royal Army Medical Corps Training - War Office.
- (3) Sanitation in War - Major P.S. Lelean, F.R.C.S.,
D.P.H., R.A.M.C.
- (4) The House Fly as a Danger to Health -
Ernest F. Austin,
Entomological Department,
British Museum.
- (5) Fourth Army Standing Orders.

*

A P P E N D I X .

A P P E N D I X.

Recipes for making various dishes from Army Rations.

A. Dishes made from Bully Beef.(1) Rissoles.

Take equal parts of Bully Beef and biscuits (which have been soaked in water over-night) and pass them through the mincer together. Boil and chop up onions, add some pepper, mix well and roll into balls. These can either be baked in the oven or fried in boiling fat.

(2) Salonika Meat Paste.

This is extremely simple to make and is most appetising.

Bully beef is passed three times (it should not be less than three) through the mincer and some pepper kneaded well into it.

This should be pressed well down into a dish (the top of a camp kettle will do) and a little melted dripping or margarine poured over the top to put a finish on it. Cut into suitable portions and serve out to the men.

(3) Galantine of Beef.

Bully Beef, Biscuits, and Bacon are put through the mincer in the proportions of two parts/

parts Bully to one part biscuit and one part Bacon. This is mixed with stock from the stock pot. Shape into a roll, put in some pickles if on issue, tie into a pudding cloth and boil for 2 hours, then place it still in the cloth on a board and press it by a weight on the top.

Let it stand till it is cold and set and cut into portions.

(4) Fish Paste.

When sardines are on issue proceed as in (2) Meat Paste, but add sardines in the proportion of 8 tins of Bully to 4 of Sardines.

B. Dishes made from the Maconochie or Meat and Vegetable Tinned Ration.

(1) Shepherd's Pie.

The Maconochie tin should be opened cold and the gross fat removed as it is from this fat that most of the "preservative" taste comes.

Pass the meat portion of the ration through the mincer and place in the bottom of a cooking dish with some stock from the stock pot.

Then pass the vegetable part of the Maconochie ration through the mincer and make a layer of those minced vegetables above the meat. Then above this layer put a good thick layer/

layer of mashed potatoes, or if those are not available put some soaked biscuits through the mincer and use this dough instead.

Dust over the top some dry biscuit powder.

Bake in a moderate oven for at least $\frac{1}{2}$ hour.

(2) Croquettes.

Remove the fat from the tin as above and pass the contents of the tin through the mincer, add pepper, salt, biscuit dust, or flour if available. Shape into croquettes, roll in biscuit dust, fry in boiling fat till brown and serve with some hot stock from the stock pot as gravy.

C. Puddings made from Biscuits.

A good variety of puddings can be made from the ordinary army biscuit. The foundation of all these puddings is the Biscuit Dough. This is made by passing biscuits which have been soaked overnight in water through the mincer. Add to this a little salt and some dripping in the proportion of about 4 parts of dough to 1 part of dripping. Mix them well together and this forms the dough from which the following puddings are made.

Baking powder need not be used as biscuit dough will not rise with baking powder.

(1) Jam Roll.

Roll out the biscuit dough (a bottle makes a good rolling pin), spread with a good thick layer of jam, roll up and tie it into a pudding cloth (good pudding cloths are available in the shape of sand bags that have been boiled - in soda if available - and then thoroughly washed), then boil in a camp kettle for $2\frac{1}{2}$ hours.

Or it can be baked by placing it in a greased camp-kettle lid and baked in a moderate oven for $\frac{3}{4}$ hour.

(2) Date Pudding.

Stoned dates should be passed through the mincer along with the biscuit dough - make into a roll - tie up in a pudding cloth and boil for $2\frac{1}{2}$ hours - or bake for $\frac{3}{4}$ hour.

(3) Fig Pudding.

Chop up the figs - mix them with the dough - make it into a roll - tie into a pudding cloth and boil for $2\frac{1}{2}$ hours or bake for $\frac{3}{4}$ hour.

(4) Raisin Pudding. as for fig pudding using raisins instead of figs.(5) "Dundee" Pudding.

Mix in marmalade with the biscuit dough and

a/

a little condensed milk should be added - a little baking powder can with advantage be added to this pudding. Knead into a stout dough and tie tightly into a pudding cloth.

Boil for $2\frac{1}{2}$ hours and after taking it out let it remain for 10 minutes in the oven or over the fire.

Make a sauce by mixing some hot water with marmalade and serve with the pudding.

(6) Jam Tart.

Roll out the biscuit dough, and line a well greased camp kettle lid with it. Bake in an oven. The jam should be heated separately and added after the Tart is baked as it makes the biscuit dough sodden if placed in the tart before baking.

(7) Queen Pudding.

Cook six pounds of rice and sweeten.

Pass 12 lbs of soaked biscuits through the mincer. Grease camp-kettle lid and put in a layer of rice, a layer of jam and a layer of biscuits.

Barely cover each pudding with milk and place in a moderate oven till the milk is absorbed and the pudding is brown. Cut into portions and serve to the men.

D. Dishes made from Cheese.

(1) Cheese Biscuits.

Dry biscuits well powdered, and cheese, about half and half of each to be passed through the mincer.

Add a little pepper, mould together and roll out and cut into suitable shapes - an empty bully beef tin will do for this - place the biscuits so made on to a piece of well greased tin and bake in a moderate oven for about 10 minutes.

(2) Welsh Rarebit.

Pass cheese through the mincer, add a little pepper and mustard, dripping, milk and chopped boiled onion. Mix well together, place in a camp-kettle lid and bake for $\frac{1}{2}$ hour in the oven.

E. From the stock pot an excellent Brawn can be made by scraping the bones after they have been well simmered and this meat, along with any bacon rinds and other scraps of meat which have also been simmering in the stock pot, should be passed through the mincer - some pepper added. Strain some/

some stock through a piece of cloth, mix the whole well together, simmer for an hour and then pour into a dish and set aside till cold and firm.

This is a good ration to give as a mid-day lunch to a working party - or as a supper dish.