

Towards the Selective Synthesis of
Heparan Sulfate Fragments

Mark T. P. Davis

A thesis submitted for the degree of Doctor of Philosophy

University of Edinburgh

2002



This thesis is submitted in part fulfilment of the requirements for the degree of Doctor of Philosophy at the University of Edinburgh. Unless otherwise stated, the work described within is original and has not been previously submitted in whole or in part for any degree at this or at any other university.

To My Parents

Acknowledgements

I thank Sabine Flitsch for her help and supervision. Thanks to Mike Paton for his encouragement and advice. Thanks to Greg Watt for his help in the early stages. Thanks to Ian, John, Wesley, Alan and Sally for spectra. Thanks to Raymond, Kenny, Derek and Tim in Stores. Thanks to all of the members of our group past and present. Thanks to ECPT for funding.

Special thanks to Siobhan for all of her support and help over the past few years. Thanks to Alan for a much needed sofa bed for a couple of weeks! Thanks to Mike Stevenson to whom I am much indebted. Finally, thanks to my family Carol, Terry and Aoife.

Abbreviations

ABD	Antithrombin-binding domain
Ac	acetyl
All	allyl
Alloc	allyloxycarbonyl
AT-III	antithrombin III
bFGF	basic fibroblast growth factor
Bn	benzyl
CAN	ceric ammonium nitrate
COSY	correlated spectroscopy
CS	chondroitin sulfate
δ	chemical shift
d	day(s)
Da	Daltons
DCC	dicyclohexylcarbodiimide
DCM	dichloromethane
DIBAL	diisobutylaluminium hydride

DMAP	4- <i>N,N</i> -dimethylaminopyridine
DMF	<i>N,N</i> -dimethylformamide
DMSO	dimethylsulfoxide
DMT	4,4'-dimethoxytrityl
dppp	propane-1,3-diylbis (diphenylphosphane)
DS	dermatan sulfate
EA	ethyl acetate
ECM	extracellular matrix
eq	equivalents
ES ⁺	electrospray (positive ion)
ES ⁻	electrospray (negative ion)
Et	ethyl
<i>EXT</i>	<i>hereditary multiple exostoses gene</i>
<i>EXTL</i>	<i>EXT-like gene</i>
FGF	fibroblast growth factor
g	gram(s)
GAG	glycosaminoglycan
Gal	galactose
GalNAc	2-deoxy-2-acetamido-D-galactopyranose
GalT	galactosyltransferase
GlcA	glucuronic acid
GlcAT	glucuronyltransferase
GlcNAc	2-deoxy-2-acetamido-D-glucopyranose
GlcNSO ₃	2-deoxy-2-sulfamido-D-glucopyranose
h	hour(s)
HA	hyaluronic acid
HCl	hydrochloric acid
Hep	heparin
HS	heparan sulphate
HSPG	heparan sulphate proteoglycan
Hz	hertz
IdoA	iduronic acid

IR	infra-red
J	coupling constant
kDa	kilo Daltons
KS	keratin sulfate
LAH	lithium aluminium hydride
Lev	levulinoyl
lit	literature value
M	moles per litre
MCA	monochloro acetyl
Me	methyl
MeOH	methanol
mg	milligram(s)
MHz	megahertz
min	minute(s)
ml	millilitre(s)
mol	mole(s)
MP	melting point
MS	mass spectrometry
Ms	mesyl
ms	molecular sieves
m/z	mass to charge ratio
NBS	<i>N</i> -bromosuccinimide
NDST	<i>N</i> -deacetylase- <i>N</i> -sulfotransferase
NMR	nuclear magnetic resonance
PCC	pyridinium chlorochromate
PDCA	pyridinium dichromate
PE	petroleum ether, boiling at 40-60°C
PG	proteoglycan
Ph	phenyl
Piv	pivaloyl
Ppm	parts per million
PTSA	<i>p</i> -toluenesulfonic acid

Py	pyridine
RP	reverse phase
RT	room temperature
SAR	structure-activity relationships
TBACl	tetrabutylammonium chloride
TBAF	tetrabutylammonium fluoride
TBAI	tetrabutylammonium iodide
TBD	thrombin-binding domain
TBDMS	<i>t</i> -butyldimethylsilyl
TBDPS	<i>t</i> -butyldiphenylsilyl
TEMPO	2,2,6,6-tetramethyl-1-piperidinyloxy
Tf	trifluoromethane sulfonate
TFA	trifluoroacetic acid
THF	tetrahydrofuran
TLC	thin layer chromatography
TMS	trimethylsilyl
Tr	trityl
Ts	tosyl
Xyl	xylose
XylT	xylosyltransferase
Z	benzyloxycarbonyl

Abstract

The orthogonally protected trisaccharide benzyl 4-*O*-[4'-*O*-(2'',3'',4'',6''-tetra-*O*-acetyl- β -D-glucopyranosyl)-2',3'-di-*O*-allyl-6'-*O*-benzyl- α -D-glucopyranosyl]-2,3,6-tri-*O*-allyl- β -D-glucopyranoside (114) has been synthesised from maltose (123) and 1,2,3,4,6-penta-*O*-acetyl- β -D-glucopyranoside (132) in 8 linear steps with an average yield of 77% and on gram scale. Allyl ether protection could not be removed successfully so another target was designed. An alternative orthogonally protected trisaccharide pent-4-enyl 2,3,6-tri-*O*-benzyl-4-*O*-{2',3'-di-*O*-benzyl-4'-*O*-(2'',3'',4'',6''-tetra-*O*-acetyl- β -D-glucopyranosyl)-6'-*O*-pivaloyl- α -D-glucopyranosyl}- β -D-glucopyranoside (149) was synthesised on gram scale from maltose (123) and 1,2,3,4,6-penta-*O*-acetyl- β -D-glucopyranoside (132) in 9 linear steps with an average yield of 85%.

The trisaccharide (149) was deprotected in order to generate six partially protected analogues. Each of these analogues was oxidised selectively using the catalytic nitroxyl radical 2,2,6,6-tetramethylpiperidin-1-oxyl (TEMPO) (171) and the oxidant(s) sodium chlorite and/or sodium hypochlorite to form six anionic trisaccharides.

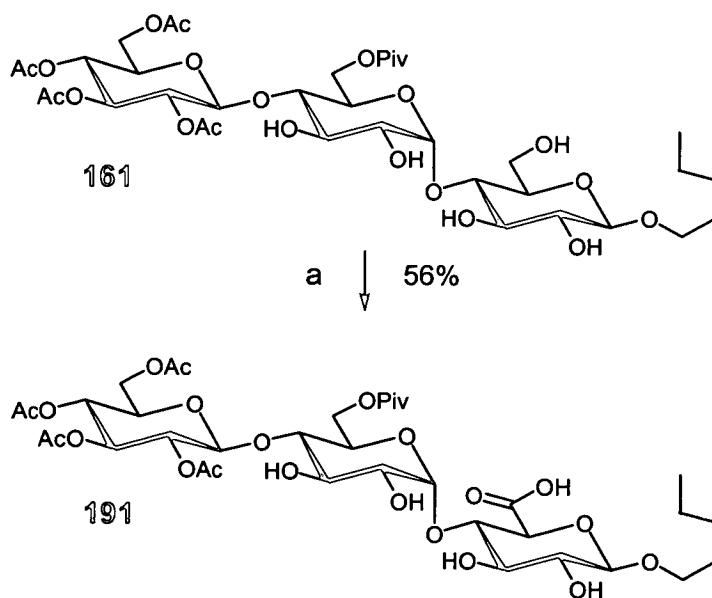

(a) TEMPO, NaO₂Cl, NaOCl, phosphate buffer pH 6.7, MeCN

Scheme (i): The nitroxyl radical-mediated oxidation of a partially protected trisaccharide.

Contents

Chapter 1: Introduction	1
1.1 Glycosaminoglycans	1
1.2 Heparan Sulfate Proteoglycans	3
1.2.1 The Structure of HS	4
1.2.2 The Biosynthesis of HS	6
1.2.3 The Physical Properties of HS	8
1.2.4 The Biological Functions of HSPGs	9
1.3 Basic Fibroblast Growth Factor	11
1.4 The Interaction Between bFGF and HS	11
1.5 The Chemical Synthesis of Fragments of Heparin and HS	13
1.5.1 The Total Synthesis of the Pentasaccharide Sequence of Heparin that Binds to Antithrombin III	14
1.5.2 The Synthesis of Related Heparin Fragments	21
1.5.3 The Synthesis of the Putative Pentasaccharide bFGF Binding Site of HS	24
1.5.4 The Use of Natural Disaccharides as Starting Materials	26
1.5.5 The Synthesis of Alternative Sequences	29
1.5.6 The Modular Approach to Heparin Fragments	30
1.5.7 The Synthetic Approach Within this Group	31
1.6 Aims of this Project	32
Chapter 2: Synthesis of an Orthogonally Protected Trisaccharide	35
2.1 Strategy in the Synthesis of Trisaccharide (114)	35
2.2 Synthesis of Acceptor (130)	35
2.2.1 The Per-Acetylation of Maltose	35
2.2.2 Activation of C-1 by Glacial HBr	37
2.2.3 The Koenigs-Knorr Reaction	37
2.2.4 Glycosylation with Benzyl Alcohol	38
2.2.5 Deacetylation	39
2.2.6 Acetal Formation	40
2.2.7 Allylation	40

2.2.8 Reductive Ring-Opening of Benzyldine Acetals	41
2.2.9 Regioselective Reductive Ring-Opening to Acceptor (130)	42
2.3 Synthesis of the Glucosyl Donor (134)	43
2.3.1 The Removal of the Anomeric Acetate	43
2.3.2 Synthesis of the Trichloroacetimidate (134)	44
2.3.3 Advantages of the Trichloroacetimidate Method	44
2.4 The Coupling Reaction	45
2.5 Deacetylation of Trisaccharide (114)	46
2.6 Allyl Ether Removal	46
2.6.1 Model Compound De-Allylation Studies	48
2.6.2 The Allyl Ether in Carbohydrate Chemistry	49
2.7 Conclusions	50
Chapter 3. Design and Synthesis of an Alternative Target Trisaccharide	51
3.1 Strategy	51
3.2 Formation of the Disaccharide Acceptor (155)	53
3.2.1 Glycosylation. Introduction of the Pent-4-enyl Group	53
3.2.2 Deacetylation	54
3.2.3 Two Routes from (151) to (154)	54
3.2.3.1 Acetal Synthesis	54
3.2.3.1.1 <i>p</i> -Methoxybenzylidene Acetal (158)	55
3.2.3.1.2 Benzyldine Acetal (152)	56
3.2.3.2 Benzylations	57
3.2.3.2.1 Benzylation of the <i>p</i> -Methoxybenzylidene Acetal (158)	57
3.2.3.2.2 Benzylation of the Benzyldine Acetal (152)	57
3.2.3.3 Acetal Cleavage	58
3.2.3.3.1 Oxidative Removal of the <i>p</i> -Methoxybenzylidene Acetal	58
3.2.3.3.2 Acid Hydrolysis of the Benzyldine Acetal	59
3.2.4 Selective Introduction of the Pivaloyl Group	59
3.3 The Coupling Step	60
3.4 Conclusions	61

Chapter 4. Selective Deblockings and Oxidations	64
4.1. General	64
4.2 Acetate Removal from (149)	64
4.3 Benzyl Removal from (149)	65
4.4 Removal of Acyl protection from (149)	66
4.5 Acetate removal from Compound (161)	67
4.6 Acetal formation on Compound (167)	68
4.7 Formation of Pentyl Trisaccharide (170)	69
4.8 The Selective Oxoammonium ion-Catalysed Oxidation of Primary Alcohols	70
4.8.1 Nitroxyl Radicals	71
4.8.2 REDOX reactions	71
4.8.3 Mechanism of Oxidation	71
4.8.4 Products of the Reaction of Primary Alcohols	73
4.8.5 <i>In Situ</i> Regeneration of the Oxoammonium Salt by a Primary Oxidant	73
4.8.6 Homogeneous Oxidation in Aqueous Solution	74
4.8.7 Organic-Aqueous Conditions	75
4.9 Development of an Oxidation Method for this Project	76
4.9.1 Development of a homogenous aqueous solution nitroxyl radical-mediated oxidation for hydrophilic substrates	77
4.9.2 Development of a nitroxyl radical mediated oxidation for the oxidation of less polar substrates	79
4.10 Results from the use of Nitroxyl Radical Mediated Oxidation in this Project	81
4.10.1 Preparation of Compound (190)	81
4.10.1.1 Comment	82
4.10.2 Preparation of compound (191)	82
4.10.2.1 Comment	83
4.10.3 Preparation of compound (192)	84
4.10.3.1 Comment	84
4.10.4 Preparation of compound (193)	85
4.10.5 Preparation of compound (194)	86

4.10.5.1 Comment	87
4.10.6 Preparation of compound (195)	87
4.10.6.1 Comment	88
4.11 The advantages of the nitroxyl radical-mediated oxidation on oligosaccharides relative to traditional methodology	88
4.12 Future Work	89
4.13 Conclusions	90
4.14 Overall Conclusions	90
Chapter 5. Experimental	91
5.1. General Experimental	91
5.1.1. Instrumentation	91
5.1.2. Chromatography	91
5.1.3. Solvents and Reagents	91
5.1.4. High Performance Liquid Chromatography (HPLC)	92
5.2 Experimental for Chapter 2	92
5.3 Experimental for Chapter 3	104
5.4 Experimental for Chapter 4	116
References	132
Appendix	

Chapter 1: Introduction

1.1 Glycosaminoglycans

The glycosaminoglycans (GAGs) are a family of structurally diverse anionic polysaccharides that are widely distributed throughout the tissues of animals.¹ These macromolecules are usually covalently bound to core protein and are hence described as proteoglycans (PG's), figure 1.1. Unlike glycoproteins, the protein component of a PG is not the major constituent. The polysaccharide moieties will constitute between 50 and 95% of the overall molecular weight, with the remainder consisting of oligosaccharide chains and protein.¹

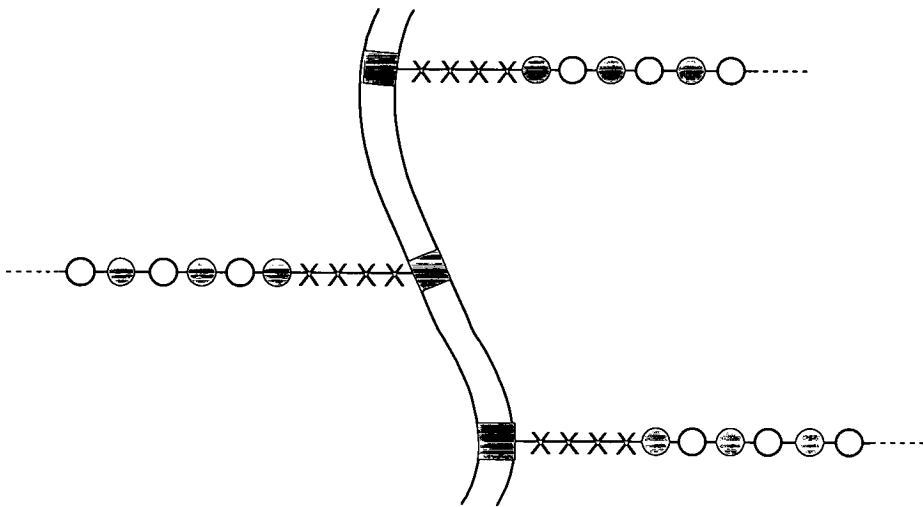
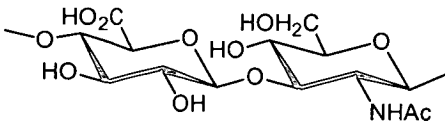

Figure 1.1; A general representation of a proteoglycan. — , region of the protein chain not involved in glycopeptide linkage; ■ , amino acid residue involved in the glycopeptide linkage; X, monosaccharide unit of the linkage region; ⊙ and ○ , monosaccharide units of the repeating disaccharide sequence of the glycosaminoglycan chain.

The extracellular spaces of connective tissue such as cartilage, tendon, skin and blood vessel walls consists of collagen and elastin fibres embedded in a gel-like matrix known as ground substance.² Ground substance is particularly rich in GAG composition. GAGs are also found on cell-surface membranes, endosomes and lysosomes.³ The biological roles of GAGs are diverse, ranging from mechanical

support to subtle and complex biochemical interactions with a wide variety of protein factors.⁴

There are eight distinct GAGs: chondroitin, chondroitin 4-sulfate, chondroitin 6-sulfate, dermatan sulfate, heparin, heparan sulfate, hyaluronic acid and keratan sulfate. Their trivial names arise from the common sources of these molecules: hyaloid (vitreous), chondros (Greek for cartilage), derm (skin), hepar (Greek for liver) and keras (Greek for horn).¹



1 hyaluronic acid

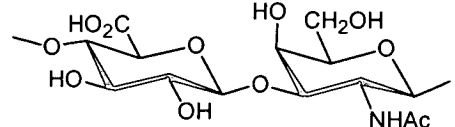

2 chondroitin

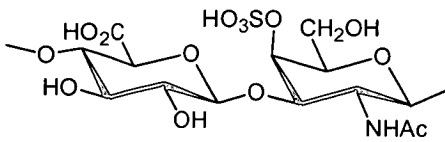

3 chondroitin 4-sulfate

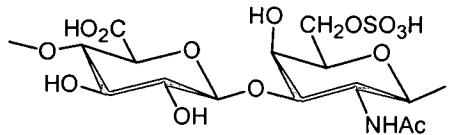

4 chondroitin 6-sulfate

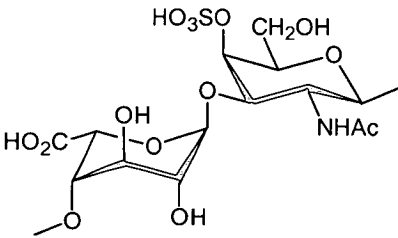

5 dermatan sulfate

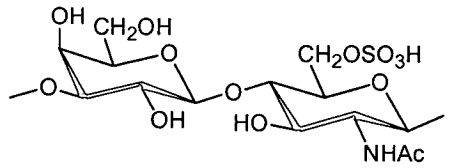

6 keratan sulfate

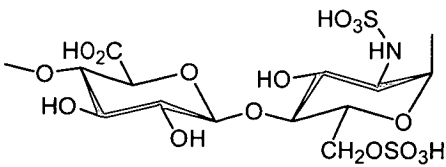

7 heparan sulfate and heparin

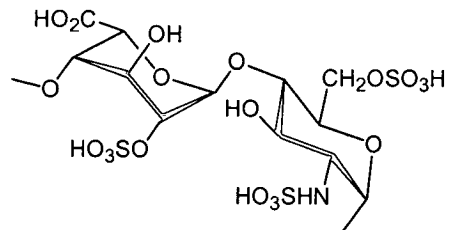

8

Figure 1.2: The repeating sequences of the common glycosaminoglycans.

The structure of a GAG polysaccharide chain is often complex and irregular. In simplistic terms the polysaccharides can be described in terms of their repeating

disaccharide units (1)-(8), figure 1.2, that form linear chains in the polymer. It is stressed that such a description is incomplete, because in reality there are irregularities in the structure as will be seen in the detailed description of heparan sulfate in section 1.2.1. The degree of deviation from the regular repeating sequence depends both upon which GAG is being discussed and upon the cell of origin.⁵

The composition of heparin is complex, even when simplifications are applied. The polysaccharide consists of a repeating unit of L-iduronic acid (L-IdoA) or D-glucuronic acid (D-GlcA) together with a glucosamine derivative. Many of the hydroxyl and amino groups are sulfated, the overall content lies in the region of 2-3 moles of sulfate per mole of disaccharide repeating unit. Heparin is principally a mixture of the blocks $[\rightarrow 4)\text{-O-(}\beta\text{-D-GlcA)-(1}\rightarrow 4)\text{-O-(2-deoxy-2-sulfamido-}\alpha\text{-D-glucopyranosyl 6-sulfate)-(1}\rightarrow]$ (7) and $[\rightarrow 4)\text{-O-(}\alpha\text{-L-IdoA 2-sulfate)-(1}\rightarrow 4)\text{-O-(2-deoxy-2-sulfamido-}\alpha\text{-D-glucopyranosyl 6-sulfate)-(1}\rightarrow]$ (8), figure 1.2.¹ Within the polysaccharide different segments or domains exist that consist of one or several disaccharides of either type; up to 90% of the uronic acid can be L-IdoA. Typically the chain will be 50-150 disaccharides in length.⁶ Heparin is the most heavily sulfated GAG.¹

Heparan sulfate (HS) is structurally similar but is far less sulfated and contains a higher *N*-acetate content. Heparin is only found in the granules of the mast cells, but HS is the most ubiquitous GAG and is distributed widely in the tissues at the cell surface and in the extracellular matrix (ECM). The structure, functions and chemical synthesis of these GAGs shall be discussed in more detail in the following sections.

1.2 Heparan Sulfate Proteoglycans

Heparan sulfate proteoglycans (HSPGs) are an important member of the GAG family. HS is found on a limited number of core proteins associated with the cell surface (the syndecan and glypican families and an isoform of CD44) or in the ECM (perlecan, agrin and collagen XVIII).⁷ HS-GAGs are complex molecules both in terms of their structural and biological properties.

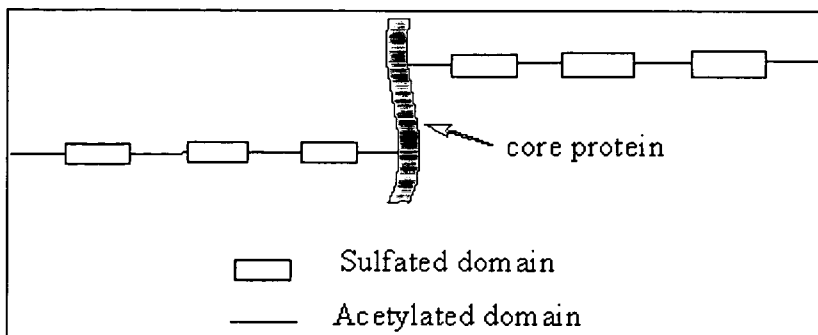

Figure 1.4: The domain structure of HS.

The S-domains are also the areas in which the major focus of polymeric modification occurs during biosynthesis.¹⁰ It is in these areas that C-5 epimerisation of D-GlcA to L-IdoA and *O*-sulfation at C-2 of IdoA and C-6 of 2-deoxy-2-sulfamido- α -D-glucopyranose (GlcNSO₃) primarily occur (although C-6 sulfation also occurs in amino sugars in the mixed sequences).¹¹ Most of the uronate residues in the S-domains are of the L-IdoA configuration and so the disaccharide [\rightarrow 4)-*O*-(α -L-IdoA 2-sulfate)-(1 \rightarrow 4)-*O*-(α -D-GlcNSO₃)-(1 \rightarrow)] (12), figure 1.5, can be considered to be a repeating sequence in these regions.¹²

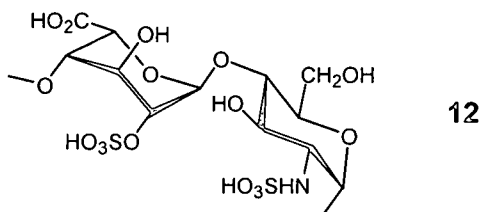

Figure 1.5: The repeating unit of HS in the S-domains.

The degree of 6-*O*-sulfation of the S-domains and the mixed sequences is variable and S-domains devoid of 6-*O*-sulfation are fairly common.¹¹⁻¹³ The rare polymer modifications of *O*-sulfation at C-3 of GlcNSO₃ and the deacetylation of 2-deoxy-2-acetamido- α -D-glucopyranose (GlcNAc) to yield an *N*-unsubstituted glucosamine also occur in the S-domain and mixed sequences of HS.¹⁴ The low frequency of these modifications belies their potential significance in creating highly specific protein-binding sequences (e.g. the antithrombin binding region).

1.2.2 The Biosynthesis of HS

The biosynthesis of HS-GAGs occurs in the Golgi apparatus and begins with the attachment of a linkage region of four monosaccharides to the core protein.¹⁰ Some PGs contain a mixture of different GAG chains on the same core protein. The process of recognition between the enzymes responsible for synthesising the linkage sequence and the protein is not fully understood. One theory is that the protein cores contain molecular “addresses” that direct them to specific polysaccharide assembly systems.¹⁵ A common feature of the attachment areas of the proteins is the presence of serine-glycine sequences. The serine (Ser) is substituted with the linkage region and the glycine is small enough to accommodate the large polysaccharides chain. HS chains are formed at sequence motifs of short Ser-Gly repeats flanked by hydrophobic and acidic domains that favour the synthesis of HS rather than chondroitin sulfate.¹⁵ Usually two or three HS chains are found in close proximity along the PG core protein, suggesting that the GAG chains act in a concerted manner in controlling cell behaviour.⁸

The linkage region consists of a tetrasaccharide sequence that is conserved in the GAGs chondroitin sulfate, dermatan sulfate and heparin, i.e. [\rightarrow 4)-*O*-(β -D-GlcA)-(1 \rightarrow 3)-*O*-(β -D-Gal)-(1 \rightarrow 3)-*O*-(β -D-Gal)-(1 \rightarrow 4)-*O*-(β -D-Xyl-(1 \rightarrow), figure 1.6.⁴

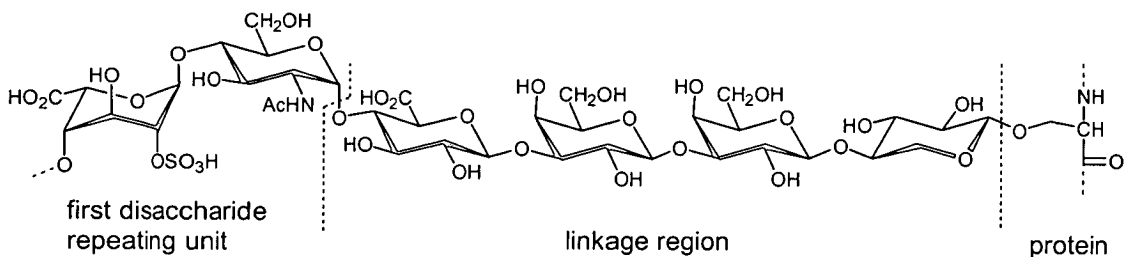
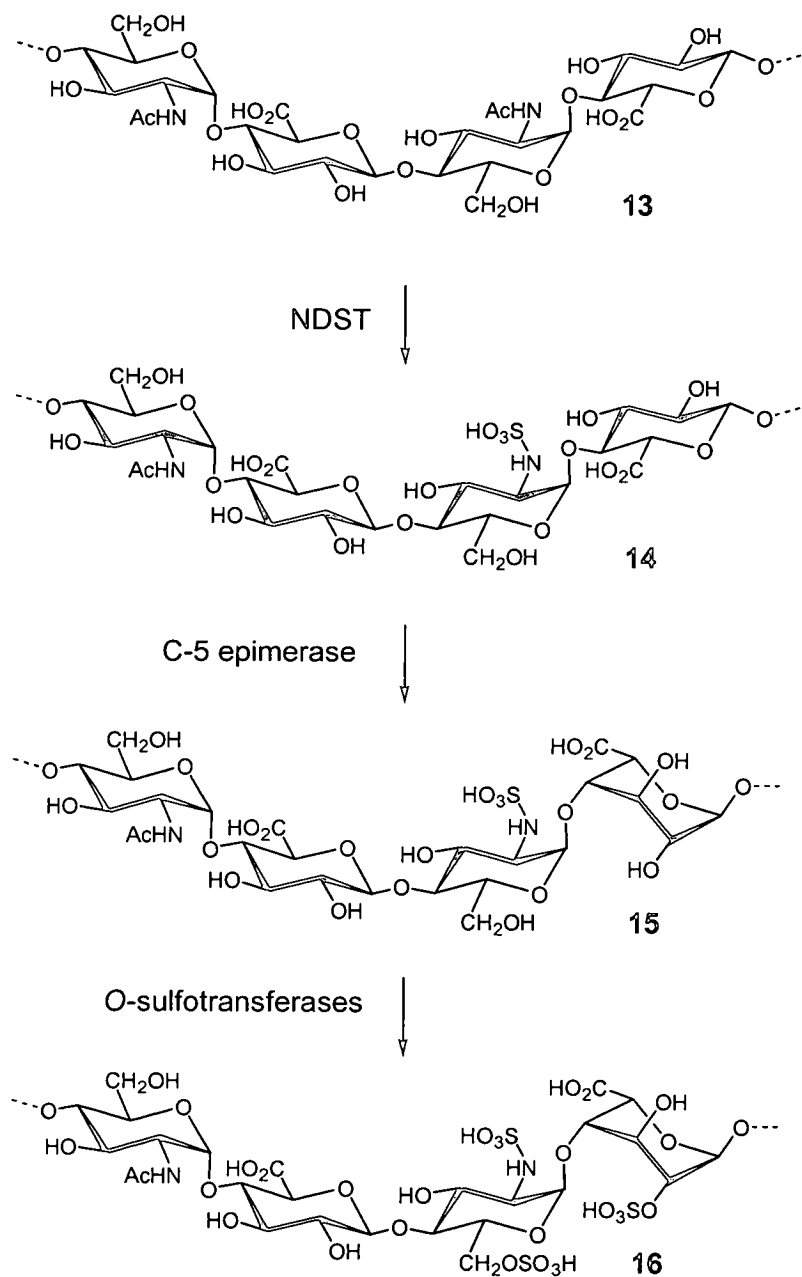

Figure 1.6: The tetrasaccharide linkage sequence in HS.

At the reducing end the linkage sequence is bound to serine in the protein, at the non-reducing end it is attached to the first of the repeating disaccharide building blocks of the polysaccharide. Linkage region synthesis is initiated by the addition of xylose to serine, followed by the addition of two Gal residues and is completed by the addition of GlcA.⁴ Each reaction is catalysed by the action of a specific glycosyltransferase:

xylosyltransferase (XylT), galactosyltransferase I (GalT-I), galactosyltransferase II (GalT-II) and glucuronyltransferase I (GlcAT-I) respectively.



Scheme 1.1: The enzymatic modification of heparan to heparan sulfate during biosynthesis.

The chain is then extended by the addition of disaccharides of (α -D-GlcNAc)-(1 \rightarrow 4)-O-(β -D-GlcA) by two glucosyl transferase enzymes *EXT1* and *EXT2*, that form a stable heterodimeric complex in the Golgi.¹⁶⁻¹⁸ The resultant molecule is a polymer of [\rightarrow 4)-O-(α -D-GlcNAc)-(1 \rightarrow 4)-O-(β -D-GlcA)-(1 \rightarrow)] (13) known as

heparan, scheme 1.1, which is common to HS and heparin prior to enzymatic changes.

The nascent chain is modified either concomitantly or independently and sequentially by a series of enzymes: *N*-deacetylase-*N*-sulfotransferase (NDST), hexuronyl C5-epimerase and the 2-*O*, 3-*O* and 6-*O* sulfotransferases, scheme 1.1.¹⁹ Like the glycosyltransferases, it is probable that these modifying enzymes also form heterooligomeric complexes within the Golgi, resulting in concomitant modification of several saccharides at the same time. Perhaps the recognition motif is not at the single enzyme level, but at the multimeric complex level.¹⁰ Several tissue-specific isoforms of the biosynthetic enzymes have been identified and it may be that the production of cell or tissue-specific HS may be the result of the specific expression of certain enzyme isoforms.²⁰

1.2.3 Physical Properties of HS

The ability of HSPGs to fulfil so many diverse and fundamental biological roles has been a long-standing enigma. The versatility in conformation and orientation of functional groups displayed by these polysaccharides may permit them to employ different modes of binding with any given protein or protein complex. Although the physical properties of HS have not been studied extensively, those of heparin have been thoroughly investigated. Heparin is an analogue of the S-domains of HS, as it consists mainly of sequences of trisulfated disaccharides of the structure $[\rightarrow 4)\text{-}O\text{-}(\alpha\text{-L-IdoA } 2\text{-sulfate})\text{-}(1\rightarrow 4)\text{-}O\text{-}(2\text{-deoxy-2-sulfamido-}\alpha\text{-D-glucopyranosyl } 6\text{-sulfate})\text{-}(1\rightarrow)]$ (8), figure 1.2. A helical conformation is adopted, whose helical rotation places clusters of sulfate groups at regular intervals of about 17Å on either side of the helical axis,²¹ a distance that approximates the spacing between groups of positively charged amino acid residues in several heparin-binding proteins. This bilateral arrangement of sulfate clusters creates a double sided polymer that can bind growth factors in trans-binary complexes with enhanced biological activity. It is probable that the S-domains of HS form similar helical structures but with a lower and more varied level of sulfation.

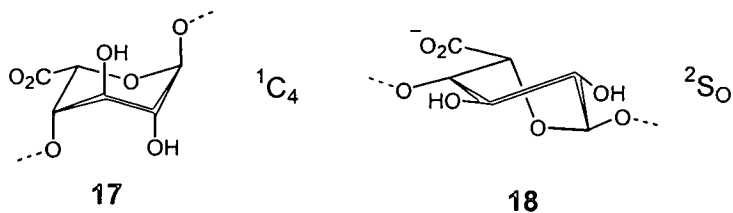

Figure 1.7: The conformations of L-IdoA in heparin.

The IdoA residues in heparin exhibit a remarkable conformational plasticity in comparison with other pyranose rings, oscillating between the 1C_4 (17) and 2S_0 (18, skew boat) forms, figure 1.7, with little change in linkage geometry to adjacent sugars.²² The importance of this flexibility has been revealed in x-ray crystallographic studies of heparin segments complexed with bFGF, where the two IdoA residues were locked in different conformations that increased the area of contact with the protein surface.²³

There is a sparsity of information about the physical properties of the *N*-acetylated sequences that form the low-sulfated regions of HS. Comparisons with model compounds suggest that these segments will be flexible,²² a property which may enable the S-domains to explore a wide variety of orientations as they combine with various proteins. Perhaps the flexibility of the *N*-acetylated regions allows the simultaneous interaction of two S-domains with dimeric proteins such as IFN- γ ,²⁴ TGF- β ²⁵ and IL-8²⁶ that have separate binding sites on each subunit.

The overall characteristic of HS is therefore that of a highly accommodating polymeric structure, that is capable of adopting various binding configurations on the large and small scale to meet the requirements of protein recognition.

1.2.4 Biological Functions of HSPGs

HSPGs are known to be involved in a wide variety of biological processes. These range from mechanical functions that are necessary for the maintenance of certain connective tissues to the dynamic and complex processes of cell adhesion, cell differentiation and morphogenesis.^{27,28} HS is known to interact with a large number of proteins including growth factors, cytokines, extracellular matrix (ECM) proteins, enzymes and protease inhibitors.¹⁰ Such behaviour indicates their involvement in

cell-cell and cell-ECM communication. The biological role of any individual HSPG will depend upon the properties of the core protein, the GAG chain and its location. HSPGs are known to be involved in neuronal development,²⁹ cellular adhesion,³⁰ cancer metastasis,^{31,32} basement-membrane permeability³⁰ and cell growth.³⁰

The growth and differentiation of cells into organs and tissues is brought about by the concerted actions of the ECM and certain “effector” proteins in the pericellular spaces.⁸ Cells respond to instructions from their microenvironments by means of specialised plasma membrane receptors, which produce intracellular signals when activated by cognate ECM or soluble peptide ligands.

In many receptor systems, the ligand first binds to an abundant low-affinity receptor. This draws the ligand into the cell surface and then transfers it to a second high-affinity receptor that transduces the appropriate signal into the cell.³³ The most common and widely acting low-affinity receptors are the HSPGs. The process is exemplified in figure 1.8: (1) bFGF is exported to the ECM by the cell and is sequestered as a complex with HSPGs. (2) bFGF is made available to cell surface HSPG low-affinity receptors. (3) Cell surface HSPGs deliver bFGF to the high-affinity receptors. (4) The signal is transduced into the cell and initiates the response.

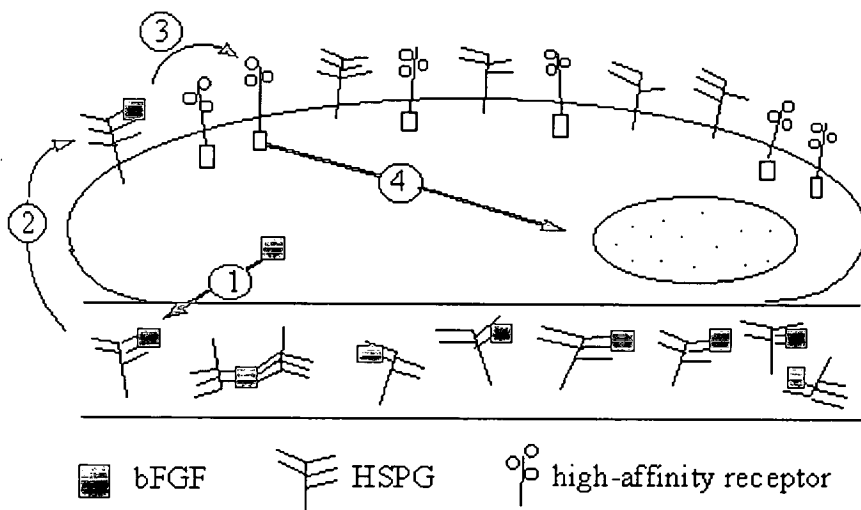

Figure 1.8: The binding of bFGF to the extracellular domain of HSPGs and high-affinity receptors.

1.3 Basic Fibroblast Growth Factor

Basic fibroblast growth factor (bFGF, or FGF-2) is a potent mitogen that stimulates proliferation, migration and differentiation of cells of mesenchymal and neuroectodermal origin.³⁴⁻³⁶ It participates as an autocrine modulator of cell growth and transformation and is a powerful stimulator of angiogenesis,³⁷ wound repair,³⁸ embryonic development³⁹ and tumour growth.³⁹ It was first isolated from the bovine pituitary gland as a polypeptide of 146 amino acids.⁴⁰ The secondary structure is comprised almost entirely of β -sheets, arranged in antiparallel strands that are organised into a folding pattern with approximately 3-fold internal symmetry.⁴¹

As mentioned in the previous section, bFGF has two types of cell-surface receptor, low-affinity but high-capacity HSPGs ($K_d = 2 \times 10^{-9}$ M) and high-affinity glycosylated proteins ($K^d = 2-20 \times 10^{-11}$ M) figure 1.8.⁴² These proteins possess intrinsic tyrosine kinase activity: on binding of bFGF to its receptor intracellular phosphorylation is rapidly induced and the bFGF ligand is subsequently internalised.⁴³ Degradation of bFGF after internalisation is slower than for other growth factors and the fate of the resulting fragments is unclear.

1.4 The Interaction Between bFGF and HS

Basic fibroblast growth factor can be displaced from HSPGs by the addition of heparin or HS, but not by the addition of other sulfated GAGs such as chondroitin sulfate.⁴⁴ This indicates a marked degree of specificity in the interaction. Furthermore, the binding of bFGF to HSPGs is a necessary prerequisite for the subsequent binding of the growth factor to its high-affinity receptor.^{43,45} Chinese hamster ovary cells that expressed high-affinity receptors, but lacked HSPGs did not bind bFGF unless exogenous heparin or HS was added. Other experiments have shown that HS protects bFGF from proteolysis and thermal degradation.⁴⁶

The question of minimal binding sequences is an important issue. Are definitive sequences in HS necessary for its interactions with protein, or are these processes accommodated by the flexible nature of the *N*-acetylated regions that arrange themselves into the appropriate conformation for a given protein?⁸ The most famous

example of a specific sequence is that of the antithrombin III-binding domain (ABD) of heparin, where many of the answers to these questions were answered by chemical synthesis and biological assay.⁴⁷ Does HS also contain such specific domains for protein interaction?

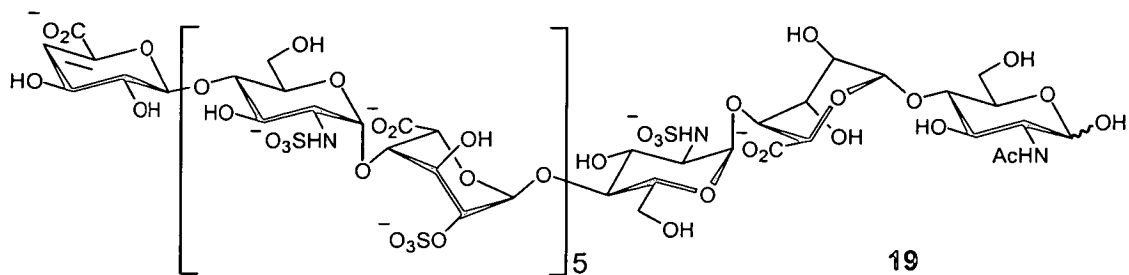

Figure 1.9: A tetradecasaccharide sequence of HS that binds to and activates bFGF.

Through chemical (nitrous acid) and enzymatic (heparinase) degradation, various oligosaccharides have been isolated that fulfil binding and activation criteria for bFGF. In the tetradecasaccharide (19), figure 1.9, which is a partial structure of HS, it was found that the 2-*O*-sulfate and *N*-sulfate groups were essential for binding.⁴⁸ Other studies revealed that the minimum requirement for activation was a dodecasaccharide,⁴⁹ but that smaller fragments were capable of binding bFGF without mitogenic activity. A pentasaccharide sequence (20), figure 1.10, was the minimal length required for binding bFGF.⁵⁰ The identity of the non-reducing and central uronate residues A and C could not be determined by the structural methods used, so they could be either D-GlcA or L-IdoA. Later synthetic investigations revealed that the analogue containing three L-IdoA residues was the most potent.^{51,52} Low-sulfated octasaccharides also bound bFGF.

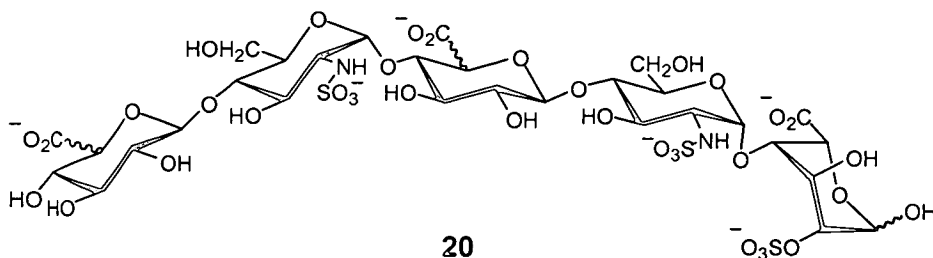

Figure 1.10: A pentasaccharide sequence that binds to bFGF.

Because pentasaccharide (20) could bind to bFGF, but dodecasaccharides were required for activation, it was proposed that native HS-GAGs might bridge both the growth factor and the high-affinity binding receptor, figure 1.11.⁴⁹

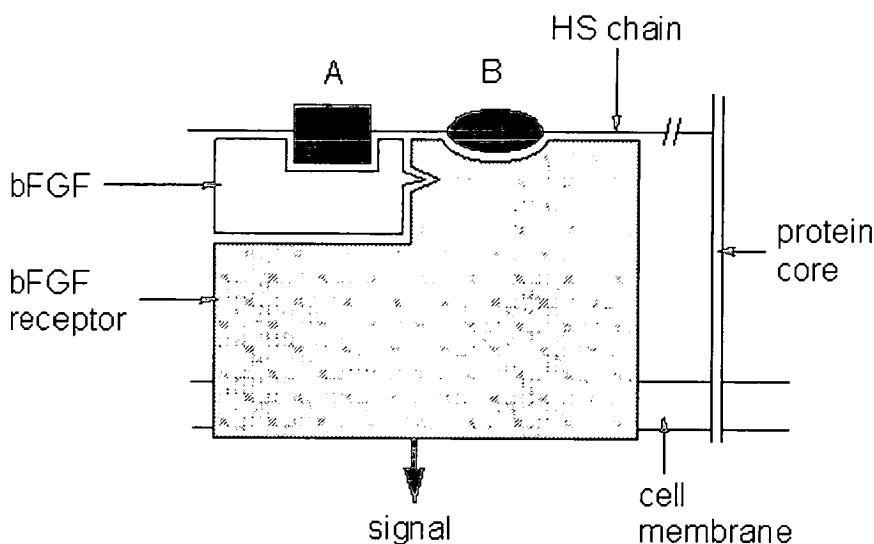

Figure 1.11: The proposed interaction between bFGF, HS and the high-affinity receptor.

It was suggested that the chains would contain both the pentasaccharide sequence (site A) which was required for bFGF binding and also a second domain that would bind to the receptor (site B). The requirement of both 2-*O* and 6-*O*-sulfation for mitogenic activity suggested that these functionalities must be present at site B.

There has been one recent report by Ornitz *et al.*⁵³ of di- and trisaccharides that are capable of binding to and activating bFGF at concentrations similar to that of HS. This observation apparently contradicts much of the work described above and is discussed in more detail towards the end of this chapter.

1.5 The Chemical Synthesis of Fragments of Heparin and HS

The structure of HS is closely related to that of heparin and therefore the methods used for the synthesis of heparin fragments can also be applied to the synthesis of HS fragments. The synthesis of these fragments is a problem of oligosaccharide synthesis that requires the formation of interglycosidic bonds between uronic acid and glucosamine residues. The problem is complicated by the presence of functional

groups on specific positions in the target molecule, such as hydroxyl, carboxyl, *O*-sulfate, *N*-sulfate and *N*-acetate. Several protection groups are therefore required during the course of the synthesis.

The choice of starting materials, activating groups and protecting groups are key decisions for the syntheses. Both monosaccharides (usually L-idose or D-glucose) and natural disaccharides (cellobiose or maltose) have been employed as starting materials. Trichloroacetimidates, halides and orthoesters have been the most popular activating groups and the use of block synthesis has generally been favoured over stepwise synthesis *en route* to the targets. The use of benzyl ethers for permanent protection and acetates for semi-permanent protection has been the most common strategy for the controlled introduction of sulfation. It has also been possible to reverse this order, or to use both groups as semi-permanent protection in conjunction with methyl ethers. The use of methyl ethers and pseudo-repeating units in the production of biologically active “non-glycosamino” glycan fragments of heparin has greatly shortened the number of synthetic steps necessary relative to the natural fragments. This has enabled the production of larger sequences that exhibit the full anticoagulant properties of the polysaccharide. These issues will be described in greater detail in the remainder of this chapter.

1.5.1 The Total Synthesis of the Pentasaccharide Sequence of Heparin that binds to Antithrombin III^{47,54-56}

Heparin inhibits blood coagulation through activation of antithrombin III (AT-III), a physiological inhibitor of coagulation. AT-III forms tight associations with several blood coagulation factors such as Xa and IIa (also called thrombin) that are thereby inactivated.⁵⁷ The rate of inactivation is increased by several orders of magnitude when AT-III is bound to heparin. Studies have revealed that a pentasaccharide sequence DEFGH (21), figure 1.12, was the smallest fragment capable of binding AT-III.⁴⁷ The synthetic strategy to (21) was to first prepare a fully protected pentasaccharide that could then be unblocked and sulfated.

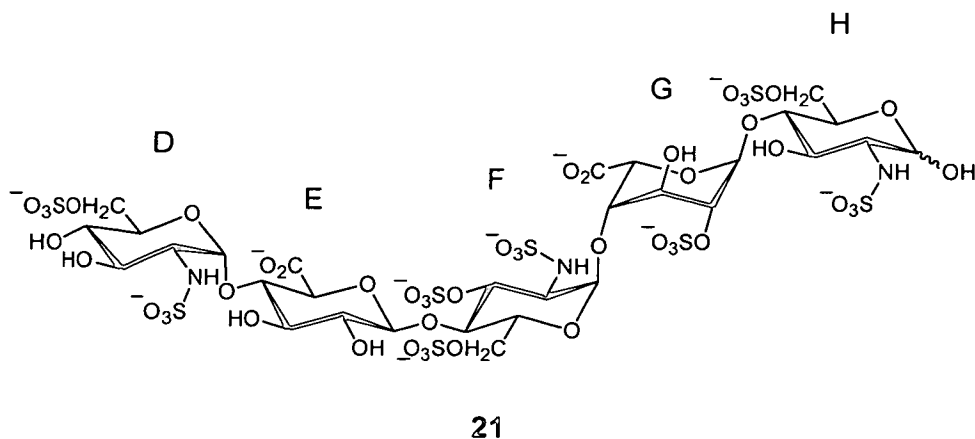
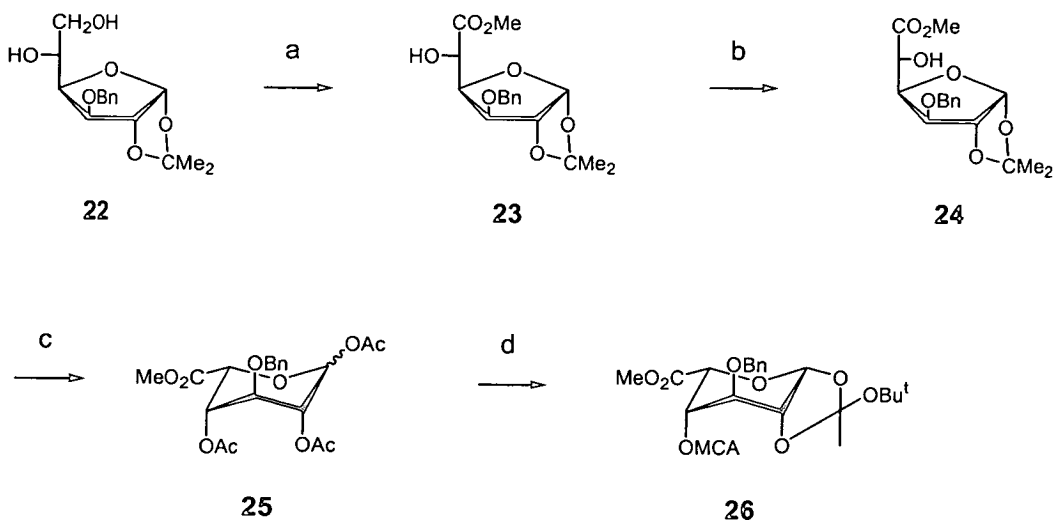

Figure 1.12: The AT-III-binding pentasaccharide of heparin.

In the earliest synthesis of (21), reported by Sinaÿ *et al.*,⁴⁷ disaccharide building blocks related to EF and GH were obtained by condensing suitably protected glucuronic acid and iduronic acid derivatives with glucosamine precursors. Protected derivatives of these disaccharides would then be coupled to form a tetrasaccharide, which would then be coupled with a monosaccharides donor to form a protected precursor of (21).

The L-IdoA, 2-sulfate (G) residue of (21) was derived from the orthoacetate (26), which was prepared from 3-*O*-benzyl-1,2-*O*-isopropylidene- α -D-glucofuranose (22) as illustrated in scheme 1.2. The glucosamine (H) portion was derived from the precursor (29), which was formed in four steps from 2-(benzyloxycarbonyl)amino-2-deoxy- α -D-glucopyranoside (27), as shown in scheme 1.3. Condensation of (26) with (29) in refluxing chlorobenzene containing 2,6-dimethylpyridinium perchlorate gave, after selective *O*-dechloroacetylation, the disaccharide derivative (30), a precursor of the GH disaccharide unit of pentasaccharide (21), scheme 1.4.⁴⁷



(a) TrCl -pyridine; Ac_2O -pyridine; CrO_3 - H_2SO_4 ; CH_2N_2 ; (b) $(\text{CF}_3\text{SO}_2)_2\text{O}$ -DCM-pyridine, -10°C , 1 h; $\text{CF}_3\text{CO}_2\text{Na}$ -DMF, 80°C , 12 h; (c) $\text{CF}_3\text{CO}_2\text{H}$ - H_2O (9:1), RT, 15 min; Ac_2O -pyridine, RT, 5 h; (d) TiBr_4 -DCM-ethyl acetate, RT, 24 h; Bu^tOH -2,4,6-trimethylpyridine-DCM, RT, 15 h; K_2CO_3 -MeOH, -20°C , 5 h; CH_2ClCOCl -DCM-pyridine, -20°C , 20 min.

Scheme 1.2: The synthesis of unit G of pentasaccharide (21).

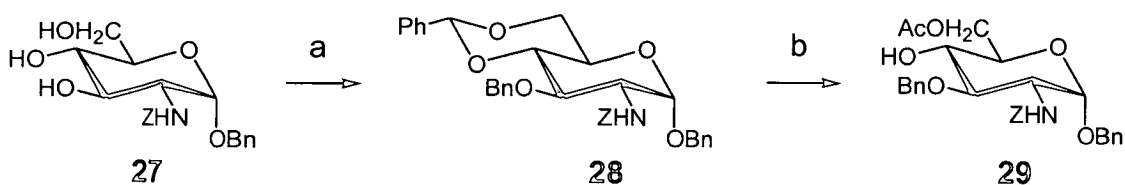

(a) PhCHO - ZnCl_2 ; BnBr - KOH ; (b) AcOH - H_2O ; *N*-acetylimidazole-DCM, reflux, 30 h.

Scheme 1.3: The synthesis of unit H of pentasaccharide (21).

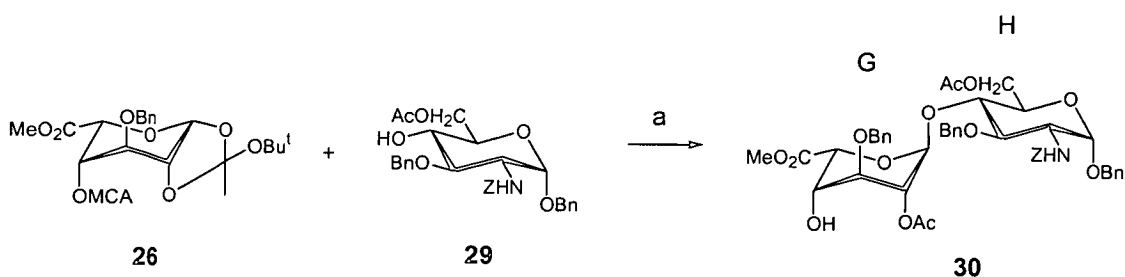

(a) 2,6-dimethylpyridinium perchlorate-chlorobenzene, reflux, 15 min; thiourea-pyridine-MeOH, 100°C , 30 min.

Scheme 1.4: The synthesis of GH disaccharide unit (30).

The synthesis of the bromide (**37**) corresponding to the EF portion of the pentasaccharide was as follows: allyl 4,6-*O*-benzylidene- α -D-glucopyranoside (**31**) was converted into the donor (**33**) as shown in scheme 1.5.⁴⁷

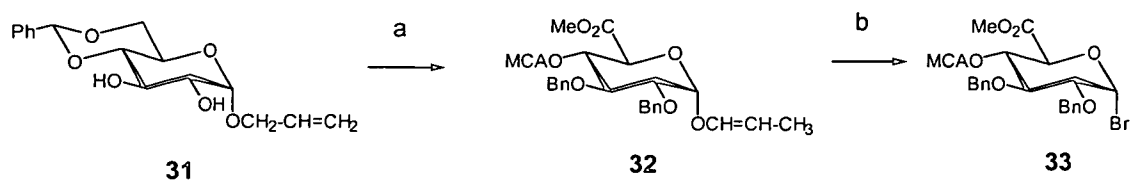

(a) PhCH_2Br -NaH-DMF, RT, 3 h; *p*-TsOH-MeOH- H_2O , 80 °C, 2 h; TrCl-pyridine; Ac_2O -pyridine; AcOH- H_2O , RT, 12 h; CrO_3 - H_2SO_4 ; NaOH-MeOH; CH_2N_2 -ether; EtOH- H_2O -PhH-(PPh_3) $_3$ Rh(I)Cl-1,4-diazabicyclo[2.2.2]octane, reflux, 4 h; CH_2ClCOCl -pyridine, RT, 30 min; (b) acetone- H_2O - HgCl_2 , RT, 5 min; DCM-[$\text{Me}_2\text{N}^+\text{CHBr}$] Br^- , 0 °C, 5 h.

Scheme 1.5: The formation of unit E of (**21**).

The alcohol (**35**), scheme 1.6, was prepared in three steps from 1,6:2,3-dianhydro-4-*O*-(tetrahydropyran-2-yl)- β -D-mannopyranose (**34**). Reaction of (**33**) and (**35**) using Ag_2CO_3 gave the disaccharide derivative (**36**), which was converted into the bromide (**37**), a precursor of the EF section of pentasaccharide (**21**), by acetolysis and bromination, scheme 1.6.⁴⁷

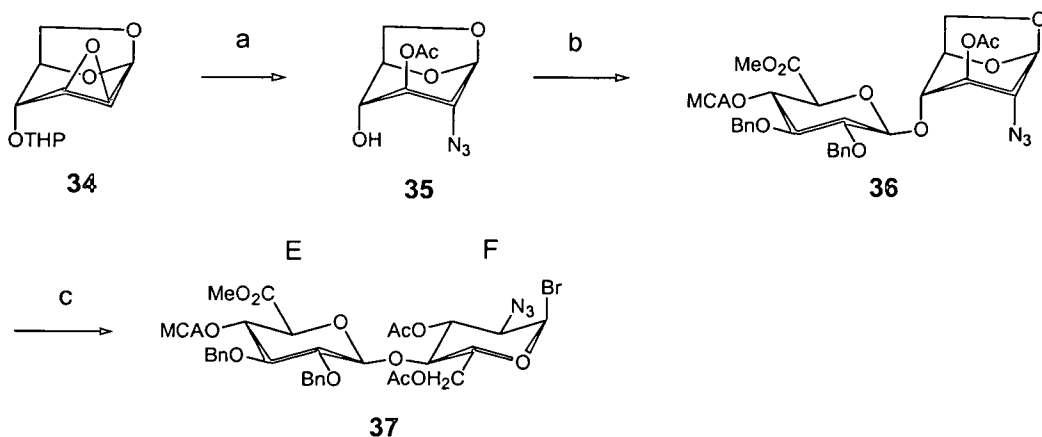

(a) NaN_3 -DMF, 110 °C, 12 h; Ac_2O , pyridine; *p*-TsOH-MeOH, RT, 3 h; (b) (**33**)- Ag_2CO_3 , DCM, ms, RT, 6 d; (c) Ac_2O - $\text{CF}_3\text{CO}_2\text{H}$, 18 °C, 18 h; TiBr_4 -DCM-EtOAc, 17 °C, 20 h.

Scheme 1.6: The preparation of unit F and subsequent coupling with unit E to give disaccharide (**37**).

Now that the disaccharide building blocks had been made, it was simply required to couple these two blocks together and add the final monosaccharides onto the non-

reducing end. Coupling of the disaccharides (**30**) and (**37**) and selective *O*-dechloroacetylation gave the EFGH tetrasaccharide (**38**), scheme 1.7. Synthesis of the bromide (**41**) was carried out in four steps from 1,6:2,3-dianhydro- β -D-mannopyranose (**39**), as shown in scheme 1.8. Monosaccharide donor (**41**) and tetrasaccharide acceptor (**38**) were then coupled in the presence of AgOTf to afford the fully protected pentasaccharide (**42**), scheme 1.9.

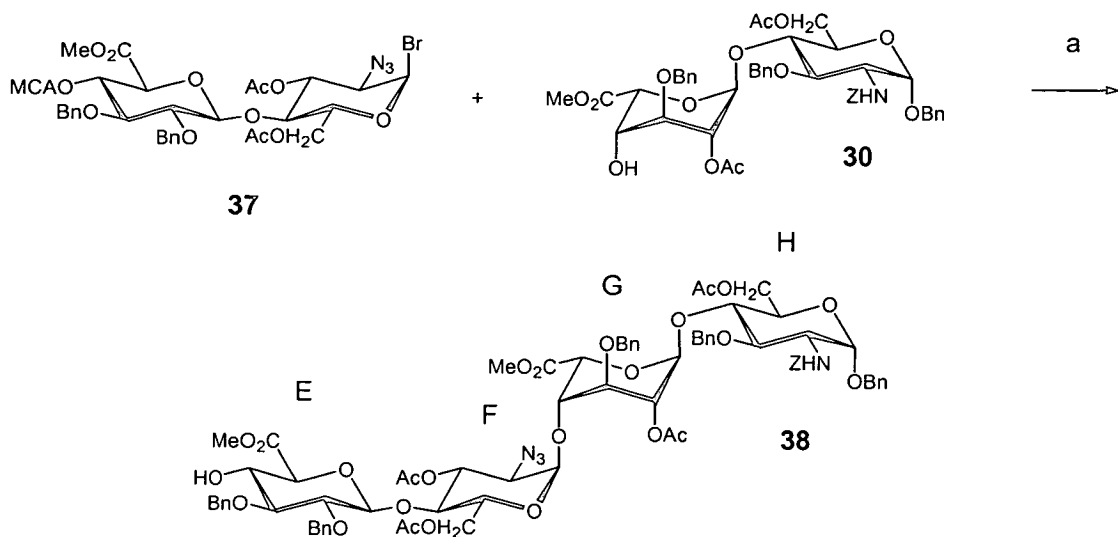

(a) AgOTf, 2,4,6-trimethylpyridine, 1,2-dichloroethane, -20°C to RT, 18 h; thiourea-pyridine-MeOH, 100°C , 30 min.

Scheme 1.7: The synthesis of EFGH tetrasaccharide (**38**).

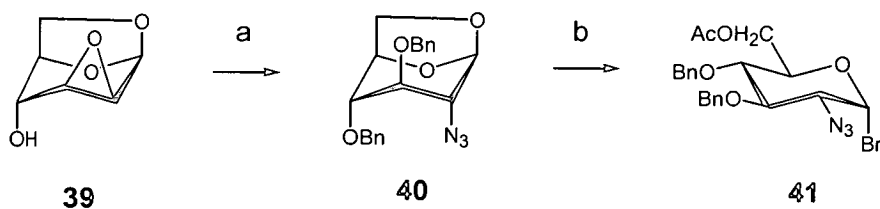

(a) NaN_3 -DMF; NaH, BnBr, DMF; (b) Ac_2O , H_2SO_4 , DMF; HBr-AcOH

Scheme 1.8: The synthesis of bromide (**41**), fragment D.

Deprotection and selective *O*- and *N*-sulfation produced the sodium salt of pentasaccharide (**21**). This compound was found to bind AT-III with an association constant in the same order of magnitude as heparin.⁴⁷

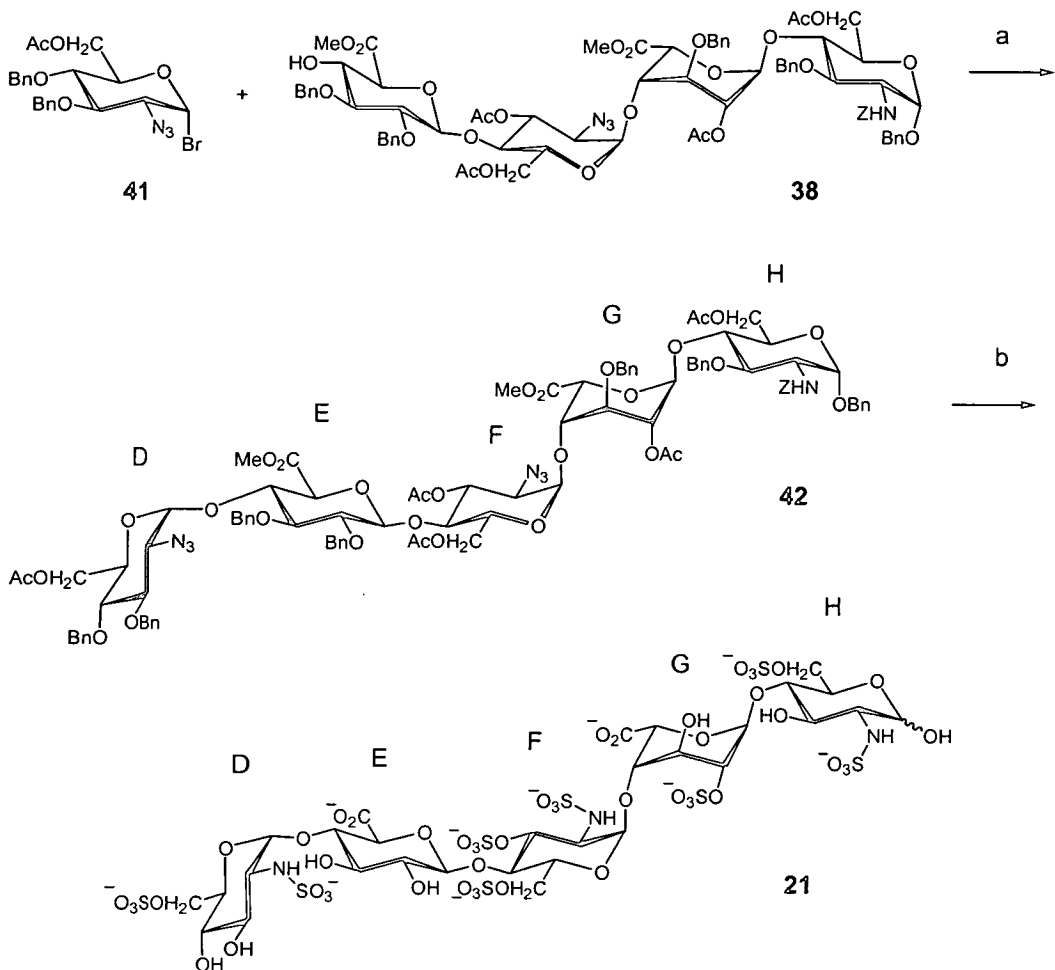

(a) AgOTf, 2,4,6-trimethylpyridine, 1,2-dichloroethane, $-20\text{ }^{\circ}\text{C}$ to RT, 12 h; (b) NaOH, DMF, MeOH, $0\text{ }^{\circ}\text{C}$, 6 h; HCl; CH_2N_2 , ether; $\text{SO}_3\cdot\text{NMe}_3\text{-DMF}$, $50\text{ }^{\circ}\text{C}$, 20 h; $\text{H}_2/\text{Pd/C}$, MeOH, H_2O , RT, 36 h; $\text{SO}_3\cdot\text{NMe}_3$, NaOH, pH 9, RT, 48 h; NaOH (0.5 M), 2 h.

Scheme 1.9: The synthesis of the fully protected pentasaccharide (**42**) and its subsequent deprotection and sulfation to give pentasaccharide (**21**).

The approach of van Boeckel *et al.*⁵⁸ to the same pentasaccharide sequence was to perform the difficult coupling reactions at an earlier stage with simpler building blocks and to carry out oxidation at the disaccharide stage. Again the protecting group strategy was to form sulfates from acetates, free hydroxyls from benzyl ethers, *N*-sulfates from azido groups and carboxylic acids from carboxymethyl esters.

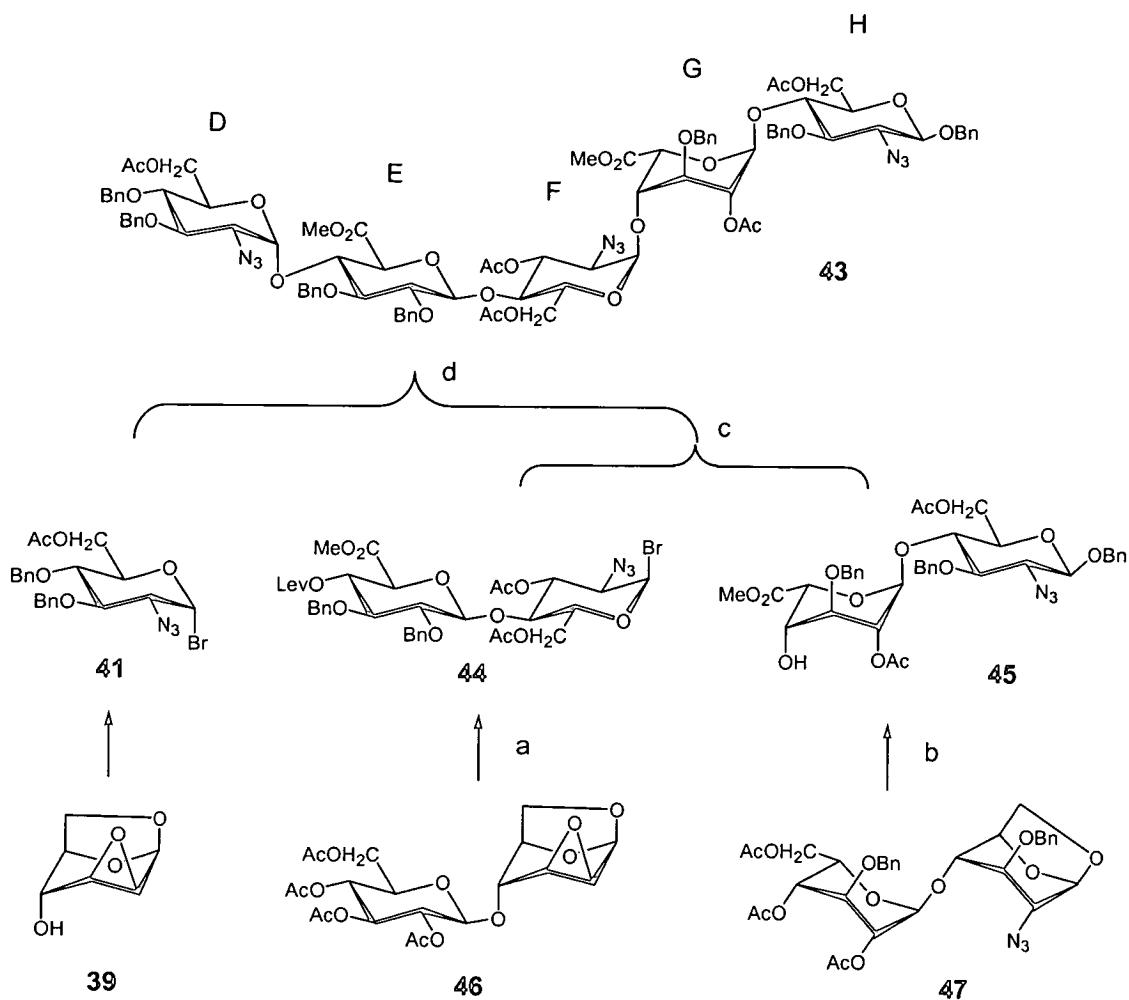

(a) KOBU^t , DMF; 2,2-dimethoxypropane, *p*-TsOH, DMF; BnBr, THF, Bu_4NI ; LiN_3 , DMF; Ac_2O , DMAP, pyridine; AcOH, H_2O ; DMTCl, pyridine; $(\text{Lev})_2\text{O}$, DMAP, pyridine; AcOH, H_2O ; CrO_3 , acetone, H_2SO_4 ; CH_2N_2 , DCM; Ac_2O , TFA; piperidine, THF; oxalyl bromide, CHCl_3 , DMF; (b) NaOMe, MeOH; 2,2-dimethoxypropane, *p*-TsOH, DMF; Ac_2O , DMAP, pyridine; AcOH, H_2O ; DMTCl, pyridine; $(\text{Lev})_2\text{O}$, DMAP, pyridine; AcOH, H_2O ; CrO_3 , acetone, H_2SO_4 ; CH_2N_2 , DCM; Ac_2O , TFA; piperidine, THF; oxalyl bromide, CHCl_3 , DMF; BnOH, silver silicate, DCM, PhCH_3 ; NH_2NH_2 , AcOH; (c) AgOTf , ms, 1,2-dichloroethane; NH_2NH_2 , AcOH; (d) AgOTf , 2,4,6-collidine, ms, 1,2-dichloroethane.

Scheme 1.10: The route to (43), a precursor of (21), taken by van Boeckel *et al.*⁵⁸

The three glucosamine units (41), (44) and (45) were derived from the 1,6-anhydro derivatives (39), (46) and (47) respectively, which on acetolysis afforded the 6-*O*-acetyl compounds, scheme 1.10. Coupling of saccharides (44) and (45), followed by *O*-dechloroacetylation and coupling of (41) yielded the protected pentasaccharide

groups were permanently blocked, so both benzyl and acetyl groups could be used to protect positions that became sulfated. Secondly, no α -configured glucosamine residues were present, which had required elaborate synthetic routes towards azide-containing building blocks. Finally, selective *N*-sulfation was not required at the end of the synthesis.

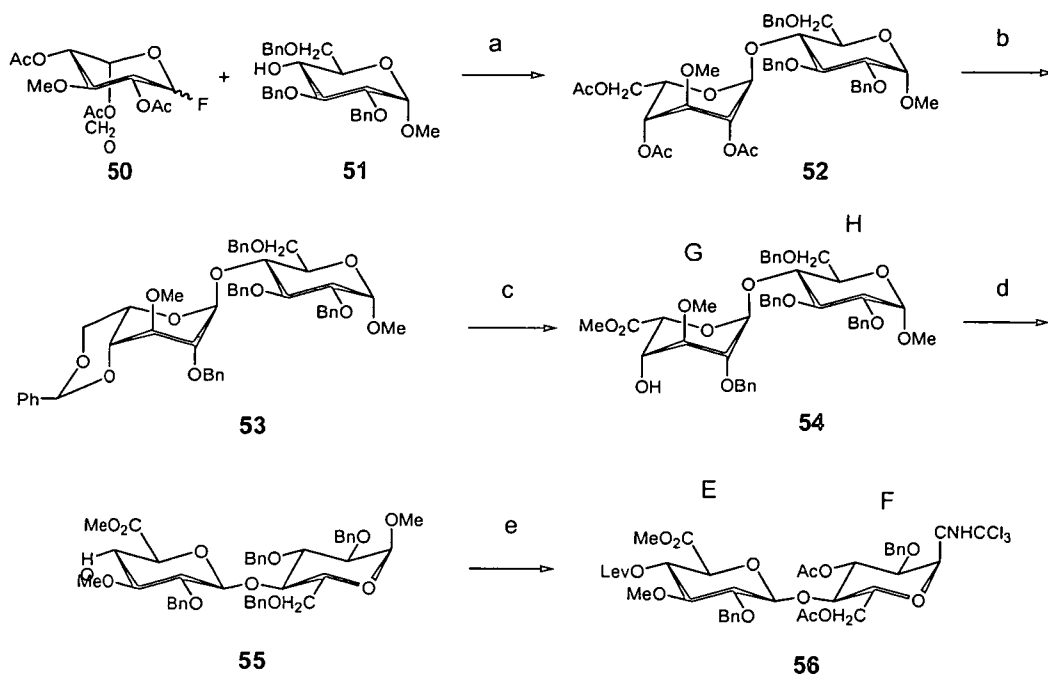

(a) $\text{BF}_3 \cdot \text{OEt}_2$, DCM, ms, 0 °C, 1 h; (b) KOBu^t , MeOH, dioxane, RT, 1 h; $\text{PhCH}(\text{OMe})_2$, *p*-TsOH, RT, 1.5 h; BnBr , NaH, DMF, RT, 2 h; (c) TFA, DCM, RT, 1 h; TBDMSCl, pyridine, RT, 16 h; levulinic acid, DCC, dioxane, DMAP, RT, 2 h; CrO_3 , H_2O , H_2SO_4 , acetone, RT, 6 min; (d) NaOMe, MeOH, reflux, 16 h; KHCO_3 , MeI, DMF, ms, RT, 3 h; (e) levulinic acid, DCC, dioxane, DMAP, RT, 2 h; AcOH, Ac_2O , TFA, RT, 2 d; piperidine, THF, RT, 16 h; Cs_2CO_3 , NCCCl_3 , DCM, RT, 30 min.

Scheme, 1.11: The synthesis of an EF fragment (56) by epimerisation of a GH fragment (54).

These results prompted studies towards even shorter syntheses. The analogue (49), figure 1.13, contained a pseudo-alternating sequence.⁶¹ Because of the introduction of the 2-*O*-sulfate group on unit E, the disaccharide fragments EF and GH have the same substitution pattern. The only remaining difference is the configuration at C-5 of the two uronic acid moieties. A synthetic route was developed in which the disaccharide fragment EF (56) was obtained by epimerisation of GH (54), scheme 1.11.⁶¹ The acetolysis of the locked anomeric centre of (55) was also a key step in the transformation. Because of this economy, the synthesis of (49) was achieved in far

fewer steps than that of (21) and the “non-glycosamino” glycan displayed a strong affinity for AT-III.

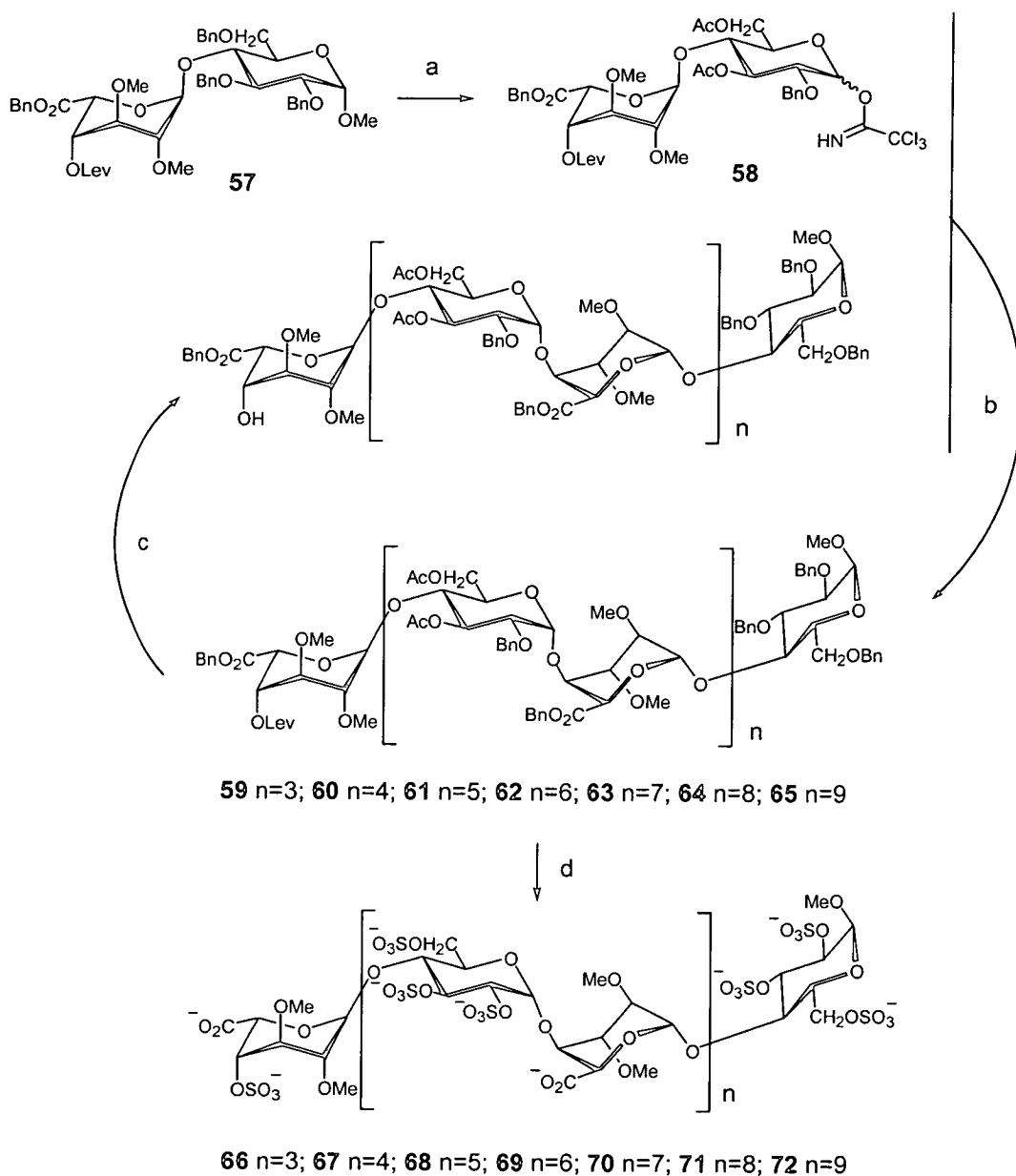

(a) TFA, Ac₂O, AcOH, 60 °C, 4 h; HOCH₂CH₂NH₂, THF, RT; CCl₃CN, K₂CO₃, DCM, RT, 1.5 h;
 (b) TMSOTf, PhCH₃, ms, -20 °C, 30 min; (c) NH₂NH₂, H₂O, pyridine, AcOH, 15 min; (d) H₂, Pd/C, MeOH, 24 h; (e) NaOH (0.5 M), 5 h; (e) pyridine.SO₃, DMF, 55 °C, 24 h.

Scheme 1.12: A route to larger heparin oligosaccharides.

Because of the success of these approaches, it became practical to synthesise larger fragments of heparin, which not only bound and activated AT-III, but also factor IIa (thrombin). In contrast to the highly specific interaction with AT-III, the interaction

of thrombin with heparin results from electrostatic attractions only. Therefore it was reasoned that an extension of the antithrombin-binding domain (ABD) would also function as a thrombin-binding domain (TBD).

To make the synthesis of such fragments more feasible, it was hoped that a single disaccharide precursor (**57**), scheme 1.12, could be used to form the large oligosaccharides.⁶² If a single disaccharide precursor was used, an ABD had to be made which did not contain both iduronic acid and glucuronic acid moieties. Studies had shown that a hexasaccharide containing three GlcA residues was inactive against AT-III, but that one containing three IdoA residues had good activity.⁶² The compound was synthesised according to the procedure laid out in scheme 1.12.

The imidate donor (**58**) was used to add disaccharide units to the glycosyl acceptor resulting from cleavage of the levulinoyl group from the previous step. The process was reiterated until the eicosamer (**72**) was obtained. The oligosaccharides obtained were deprotected and sulfated in the usual way and then tested for biological activity. The octa-, deca-, dodeca- and tetradecasaccharides were inactive in the thrombin inhibition assay, but the activity of the hexadeca-, octadeca- and eicosasaccharides increased with size. The first synthetic carbohydrates with the full anticoagulant properties of heparin had been prepared.⁶²

1.5.3 The Synthesis of the Putative Pentasaccharide bFGF Binding site of HS

The binding of HS to bFGF is another example of a specific GAG-protein interaction. A putative pentasaccharide sequence was identified (**20**), figure 1.10, which was known to contain the residues hexuronic acid-GlcNSO₃-hexuronic acid-GlcNSO₃-IdoA, 2-*O*-sulfate.⁵⁰ It was not known whether the two uronic acid residues were of the L-IdoA or D-GlcA configuration. Sinaÿ and Petitou have recently reported the total synthesis of all four isomers and found that the isomer containing only L-IdoA residues (**73**), figure 1.14, had the greatest biological activity.^{51,52}

In the synthesis of (**73**) the use of acetates for semi-permanent protection and benzyl ethers for permanent protection was unsuitable because (a) the absence of directing substituents at positions 2-A and 2-C would lead to anomeric mixtures during coupling and (b) the synthesis of unit A was shorter using acetate groups instead of

benzyl groups.⁵² Therefore both acetate and benzyl groups were used as permanent protecting groups for the targeted hydroxyl positions. Another element was needed for the temporary protection of the position to be *O*-sulfated (E-2), which could be selectively cleaved during the first step of the deprotection/functionalisation sequence and so the allyl group was chosen.

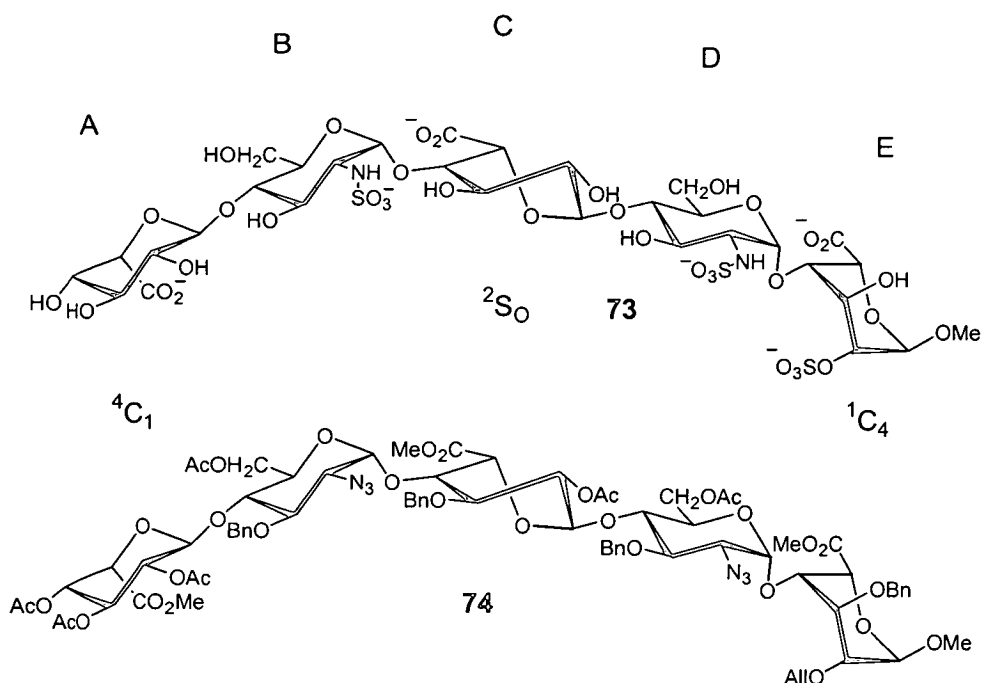
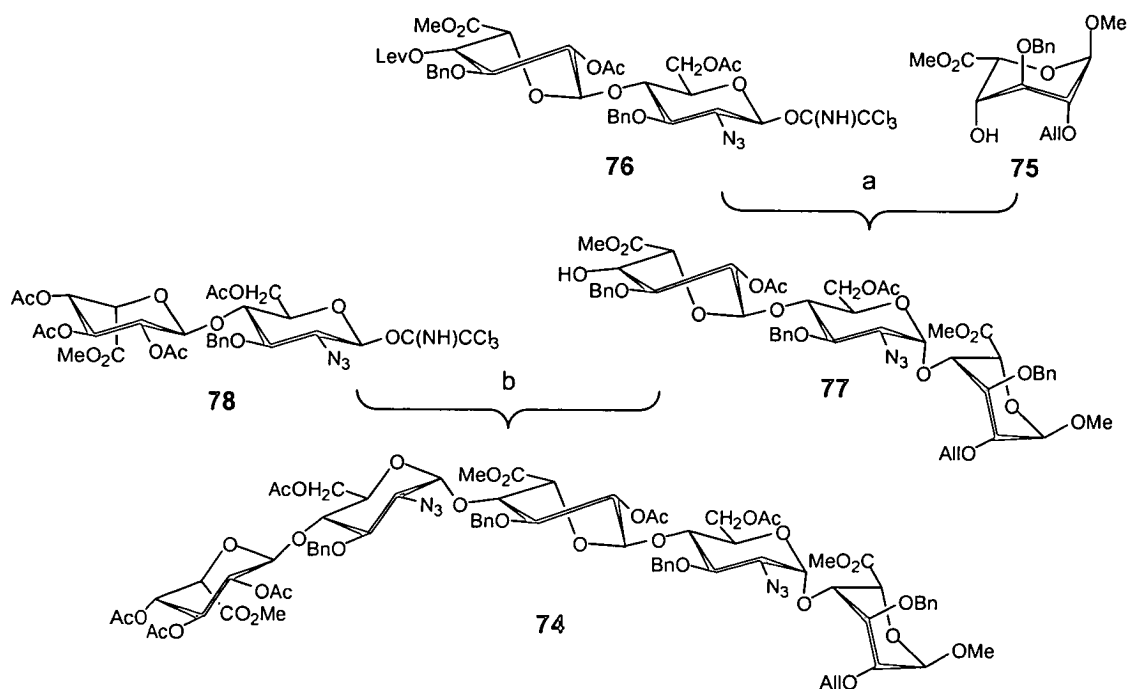

Figure 1.14: A bFGF-binding pentasaccharide and its synthetic precursor.

Condensation of the alcohol (75) with trichloroacetimidate (76) in toluene in the presence of TBDMSOTf gave trisaccharide (77) after removal of the levulinate ester. Condensation with trichloroacetimidate disaccharide (78) under similar conditions gave the protected pentasaccharide (74). The deprotection sequence consisted of allyl isomerisation (iridium catalyst, THF), hydrolysis of the propenyl ether (acetone, H₂O, HgO, HgCl₂) and *O*-sulfation of the resultant hydroxyl group (SO₃.NEt₃, DMF). This was followed by saponification (LiOH, H₂O₂, NaOH, MeOH, THF), hydrogenolysis (H₂, Pd/C, Bu^tOH, H₂O) and *N*-sulfation (SO₃.pyridine, H₂O, pH 9.8) to yield the target pentasaccharide (73) as the hexasodium salt. This compound displayed strong biological activity towards bFGF and was far more potent the GlcA-containing isomers.⁵¹



(a) TBDMSOTf, PhCH₃, -20 °C; NH₂NH₂, AcOH, pyridine; (b) TBDMSOTf, PhCH₃, -20 °C

Scheme 1.13: The synthesis of (74).

1.5.4 The Use of Natural Disaccharide Starting Materials

An alternative approach to complex fragments of heparin has been reported by Ichikawa *et al.*⁶³ They used cellobiose as a starting material in the total synthesis of the pentasaccharide AT-III binding domain.

The key intermediates (80) and (82) were derived from disaccharide (79), which was in turn synthesised from cellobiose. Preparation of the L-IdoA-containing disaccharide (82) required a method for distinguishing between the 2'- and 3'-hydroxyl groups of (79) and a method for epimerising the C-5' position. Selective benzylation of 3'-OH was achieved *via* a dibutylstannylene acetal intermediate. The configurational inversion was achieved by hydroboration of the alkene intermediate (81), which was formed by elimination from the preceding 6'-iodo compound.⁶³

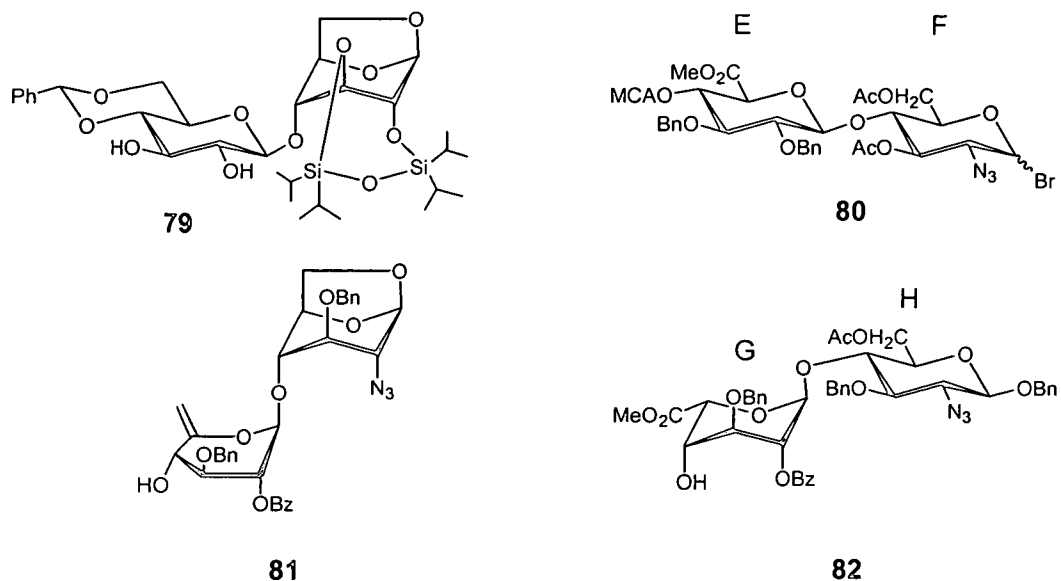
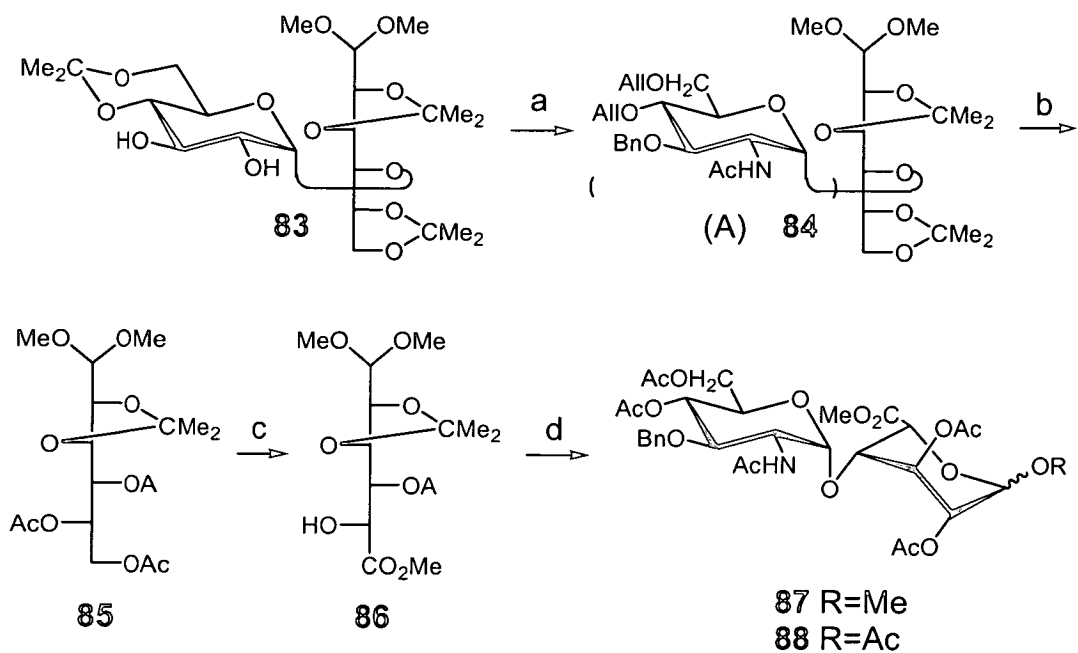

Figure 1.15: Intermediates derived from cellobiose.

Maltose has also been used as a natural disaccharide starting material in the synthesis of heparin/HS fragments by Glushka and Perlin.⁶⁴ The synthesis relied on the fact that the 4',6'-ketal group of (**83**), scheme 1.14, was more acid-labile than the 5,6-ketal, which was in turn far less stable than the 2,3-ketal.

The introduction of the aminodeoxy function was achieved using the sequence alcohol→ketone→imine→amine, scheme 1.14. Formation of the L-IdoA residue involved selective hydrolysis of the 5,6-*O*-isopropylidene group of (**84**), conversion to the dimesylate and treatment with KOAc. Subsequent protection and oxidation steps, followed by cyclisation on hydrolysis of the 2,3-*O*-isopropylidene group, gave a mixture of the methyl α - and β -pyranosides and the α - and β -pyranoses, which were isolated after acetylation, (**87**) and (**88**) respectively.⁶⁴



(a) TBDMSCl, DMF; PCC, KOAc, C₆H₆; NH₂OH, NaOAc, MeOH, H₂O; MeI, NaH, THF; LAH, THF; Ac₂O, MeOH; BnBr, NaH, THF, NBu₄Br; PTSA, MeOH; AlIBr, NaH, THF; (b) AcOH, H₂O, 40 °C; MsCl, pyridine, DCM; KOAc, Ac₂O, 120 °C; (c) NaOMe, MeOH; *p*-MeOPh(Ph)₂CCl, DMAP, pyridine, DCM; LevOH, DCC, DMAP, THF; AcOH, H₂O; methyl sulfoxide, DCC, pyridinium trifluoroacetate; NaO₂Cl, pH 3, 1,4-dioxane; CH₂N₂, DCM; NH₂NH₂, pyridine, AcOH; (d) TFA, H₂O; Ac₂O, pyridine.

Scheme 1.14: Heparin fragments from maltose, Glushka *et al.*⁶⁴

Westman and Nilsson⁶⁵ have recently reported the use of maltose and glucuronic acid derivatives in the synthesis of “non-glucosamino” glucans related to heparin/HS. Methyl 4',6'-*O*-benzylidene-β-D-maltopyranoside (**89**) was transformed into the acceptor (**90**) as shown in scheme 1.15. Glycosylation with methyl (2,3,4-tri-*O*-acetyl-α-D-glucopyranosyl bromide) uronate (**91**) in DCM containing AgOTf gave the trisaccharide (**92**). Deprotection of this compound afforded a “non-glucosamino” glucan (**93**) related to HS/heparin in a relatively short synthetic sequence.

The oligosaccharides produced contained glucose residues rather than glucosamine residues and were not sulfated. These simplifications in structure allowed for a reduced number of synthetic steps and an increased overall yield.

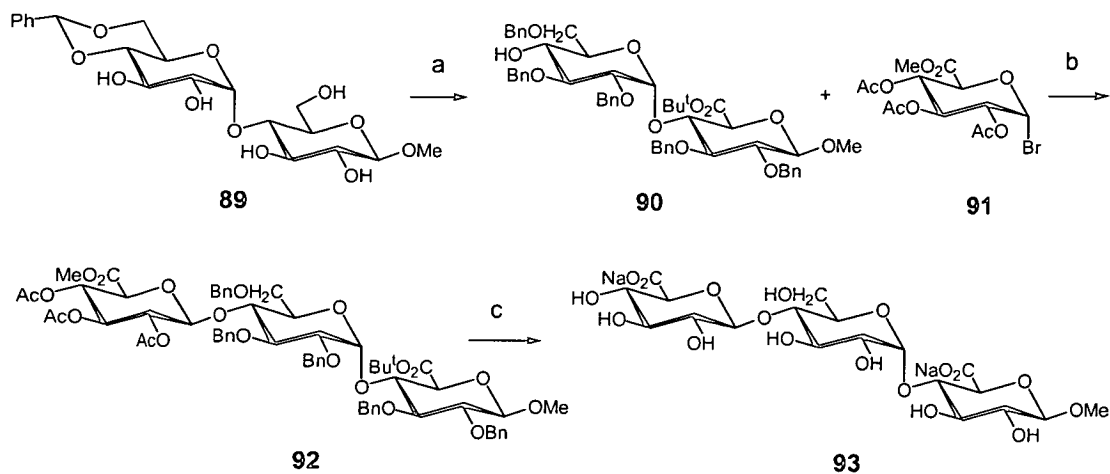

(a) TBDMSCl, imidazole, DMF; BnBr, NaH, DMF; TBAF, THF; PDCA, Bu^tOH, DCM; NaCNBH₃, HCl, Et₂O; (b) AgOTf, ms, DCM, -15 °C, 1 h; (c) TFA, DCM; NaOH (2 M), THF; H₂/Pd/C, EtOH, H₂O.

Scheme 1.15: Heparin fragments from maltose, Westman *et al.*⁶⁵

Maltose was also used by Wessel *et al.*^{66,67} for the preparation of disaccharide donors and acceptors used in the synthesis of α,β -(1→4)-glucan oligosaccharides.

1.5.5 The Synthesis of Alternative Sequences

La Ferla *et al.*⁶⁸ have reported the synthesis of a new series of heparin-related disaccharides containing the unusual sequence GlcN-IdoA. Heparin fragments are generally obtained from the native polysaccharide through deaminative cleavage with nitrous acid or enzymatic digestion. Both procedures invariably give oligosaccharides having an uronic acid at the non-reducing end. Most of the fragments prepared by chemical synthesis also contain this arrangement of the monomers.

The synthesis of the alternative arrangement of these monomers involved the formation of an acceptor (95) and a donor (97), which were coupled in toluene in the presence of TBDMSOTf to give the disaccharide (98), scheme 1.16. Deprotection, oxidation and sulfation afforded (99). Such fragments are of interest because they may exhibit different electrostatic, conformational and binding properties to those with the more standard arrangement of components.

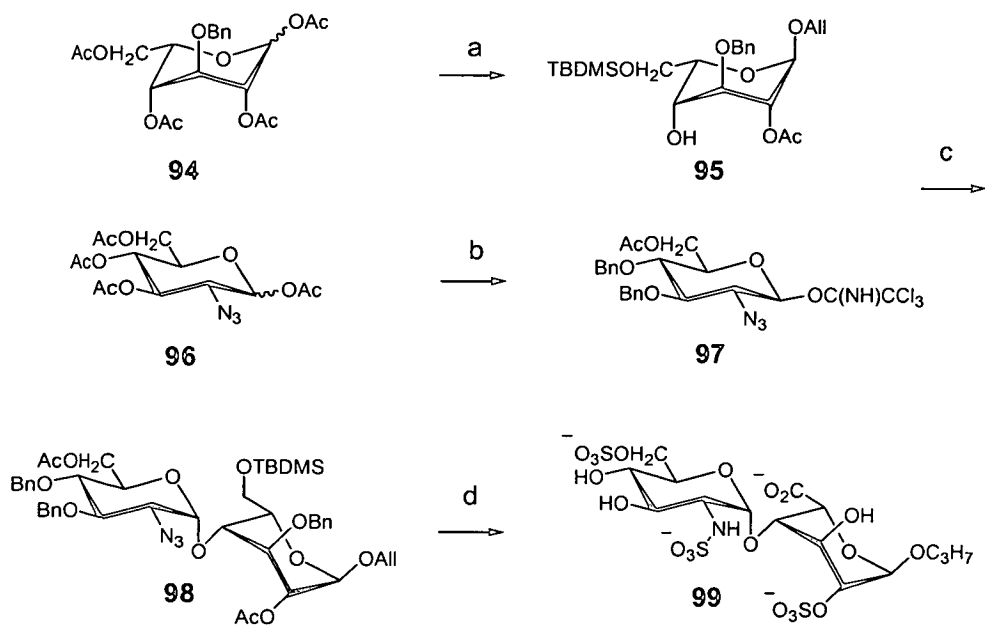

(a) TiBr_4 , DCM, EtOAc; MeOH, sym-collidine; NaOMe, MeOH; TDSCI, TEA, DMAP, DCM; AlIOH, ms, TBDMSOTf, DCM; (b) gaseous NH_3 , THF, MeOH; TBDMSCl, imidazole, DMF; MeONa, MeOH; BnBr, NaH, DMF; Ac_2O , AcOH, ZnCl_2 ; TBAF, AcOH, THF; CNCCl_3 , K_2CO_3 , DCM; (c) TBDMSOTf, PhCH_3 , $-20\text{ }^\circ\text{C}$; (d) CrO_3 , H_2SO_4 , acetone; CH_2N_2 , MeOH; NaOMe, MeOH; $\text{SO}_3\cdot\text{NMe}_3$, DMF; NaOH (2.5 M), MeOH; $\text{H}_2/\text{Pd}(\text{OH})_2/\text{C}$, MeOH, H_2O , AcOH; $\text{SO}_3\cdot\text{NMe}_3$, sat. aq. NaHCO_3 .

Scheme 1.16: The synthesis of GlcN-IldoA disaccharides.

1.5.6 The Modular Approach to Heparin Fragments

Another route to heparin fragments was the modular approach, reported recently by Boons *et al.*⁶⁹ In this strategy, suitably protected glucose derivatives (100) and (101) and glucosamine derivatives (103) were coupled together to form the trisaccharide (104), scheme 1.17. Deprotection was followed by selective oxidation of the primary hydroxyl groups to carboxylic acids using TEMPO-mediated oxidation to afford trisaccharide (105). The key nitroxyl radical-mediated oxidation allowed for the transformation of primary hydroxyl groups whilst the secondary hydroxyl groups remained unchanged. In this way glucuronic acid moieties were introduced at a late stage in the synthesis.

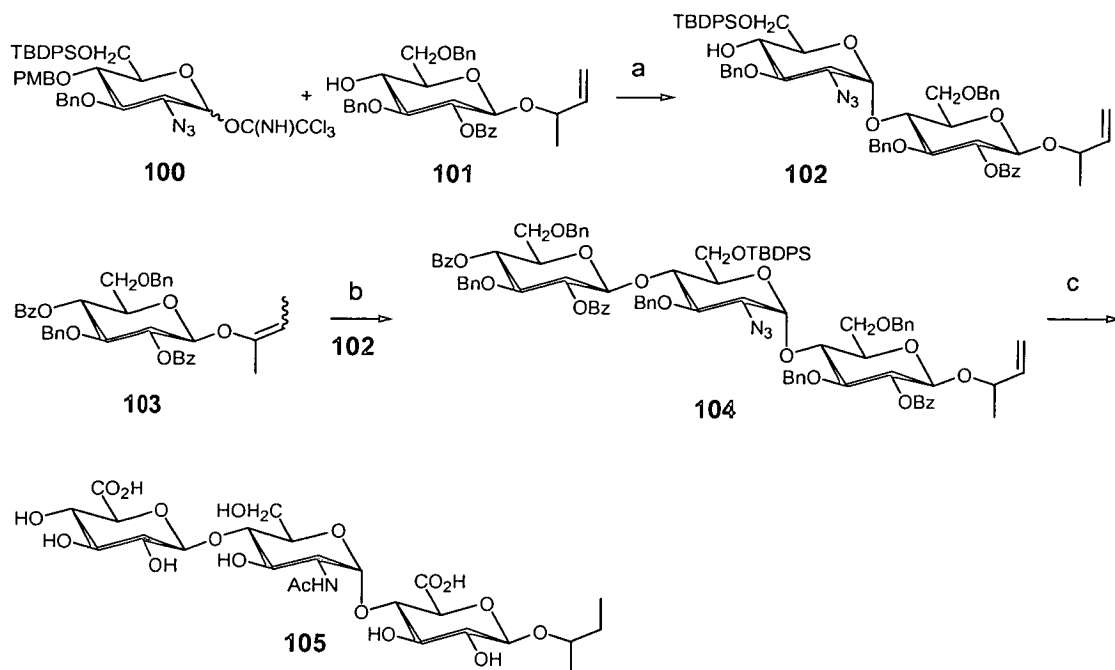

(a) TMSOTf, ms, Et₂O, DCM, 0 °C, 15 min; TFA, DCM; (b) TMSOTf, ms, DCM, -20 °C, 3.5 h; (c) K₂CO₃, MeOH; AcSH, pyridine; H₂/Pd(OAc)₂/EtOH; TEMPO, NaOCl, NaOH, NaBr, H₂O; HF.pyridine, MeCN, H₂O.

Scheme 1.17: The modular approach to heparin fragments.

1.5.7 The Synthetic Approach Within this Group

The use of nitroxyl radical-mediated oxidation to introduce uronic acid moieties was adopted to carbohydrate chemistry by Davis and Flitsch (this group).⁷⁰⁻⁷² The key oxidation step was performed on the monosaccharide level. In a reversal of the usual strategy, benzyl ethers were used as semi-permanent protection and acetates were used as permanent protection for the hydroxyl groups.⁷² A series of disaccharides such as (111) were synthesised by coupling the appropriately protected monosaccharides, followed by deprotection and sulfation, scheme 1.18. The disaccharides produced were fragments of the HS tetradecasaccharide (19), figure 1.9, which binds to and activates bFGF.

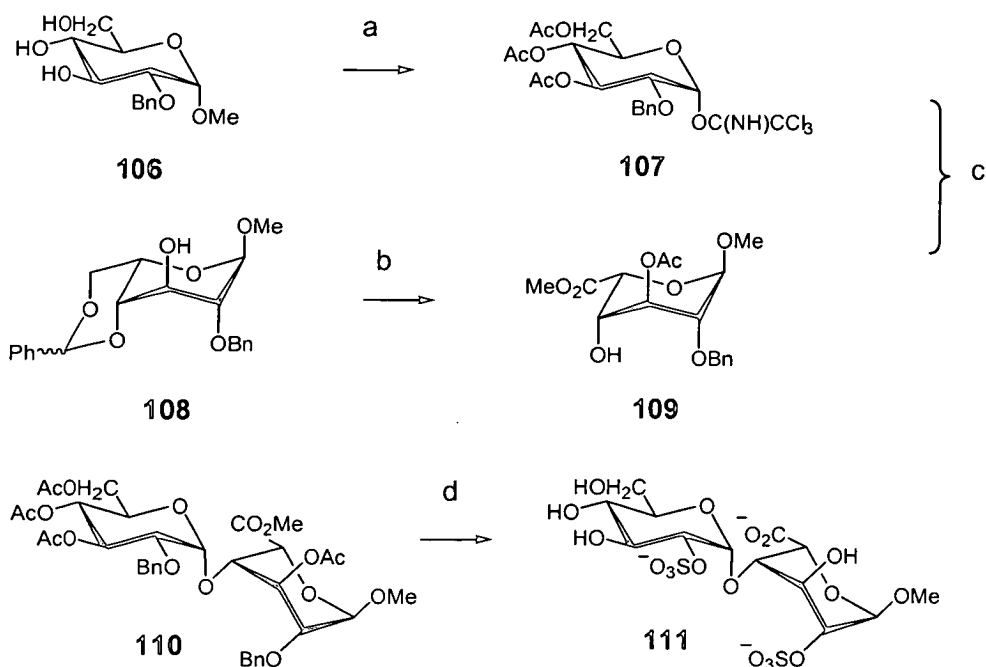

(a) Ac₂O, pyridine; Ac₂O, AcOH, H₂SO₄; NH₂NH₂, AcOH, DMF; CCl₃CN, K₂CO₃; (b) Ac₂O, pyridine; PTSA, MeOH, DCM; TEMPO, KBr, Bu₄NCl, NaHCO₃, NaOCl; DOWEX 50H⁺, MeOH; (c) TMSOTf, ms, DCM, -20 °C, 20 min; (d) H₂/Pd/C, MeOH; SO₃.NEt₃, DMF; NaOH, H₂O, THF.

Scheme 1.18: The approach of Davis and Flitsch to HS fragments.⁷²

1.6 Aims of this Project

In lengthy synthetic routes such as those necessary for HS fragments, the use of regioselective reactions such as the TEMPO-mediated oxidation is a useful way of reducing the overall number of steps. Unfortunately the disaccharide fragments synthesised by Davis did not bind to bFGF, perhaps because they were too small.⁷² The purpose of this project was to apply the selective oxidation to the synthesis of larger fragments that may be active against bFGF.

Ornitz *et al.*⁵³ have reported bFGF binding and receptor activation by synthetic di- and trisaccharides related to HS. Such findings were contradictory to the putative pentasaccharide minimum binding site (**20**), figure 1.10 and (**73**), figure 1.14,

described previously.⁵⁰ The trisaccharides (112) and (113), figure 1.16, were found to be active at concentrations similar to heparin and therefore formed the basis for the synthetic targets of the project.

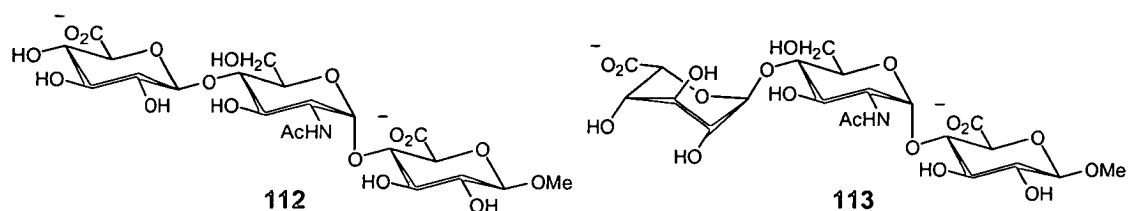

Figure 1.16: bFGF active trisaccharides.

The aim was to synthesise suitably protected carbohydrate building blocks that could be coupled together and easily modified to give the desired targets. In the synthesis of biologically active targets, the ability to produce a series of structurally related molecules from a single common precursor was desirable. It was hoped that such an approach would allow the nature and position of uronic acid moieties and sulfate esters to be decided at a late stage in the synthesis. A range of structural analogues could be produced that might provide SAR information upon biological assay.

With these ideas in mind the protected trisaccharide (114) was designed, figure 1.17. Three orthogonal protecting groups, acetate, benzyl ether and allyl ether were chosen. These could then be strategically removed to allow for oxidation or sulfation to occur specifically in a pre-determined position. For instance, treatment with sodium methoxide in methanol, followed by TEMPO-mediated oxidation and further deprotection would lead to the trisaccharide (117), figure 1.18, which was only oxidised at the C-6'' position.

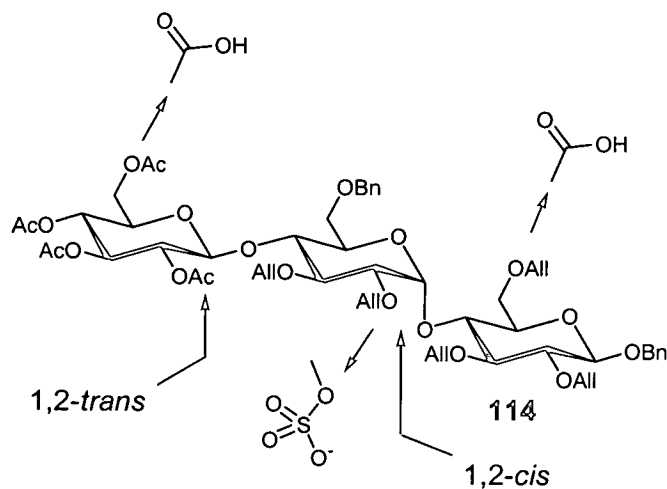

Figure 1.17: Synthetic target (114).

By altering the deprotection and oxidation/sulfation sequence, the range of analogues depicted in figure 1.18 could be synthesised. The analogues obtained were to be assayed for their ability to bind to and activate bFGF.

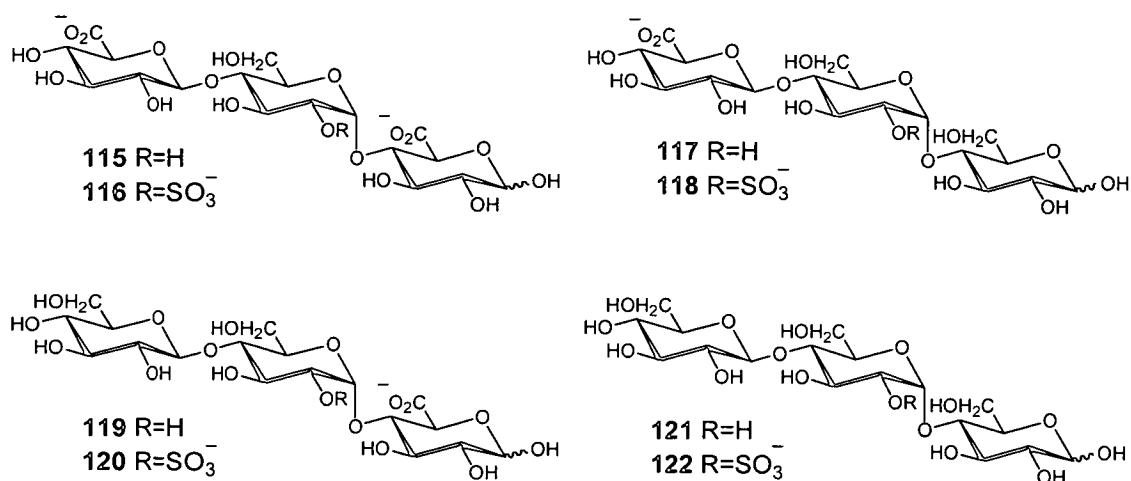

Figure 1.18: A range of analogues that could be produced from (114).

The synthesis of the fully protected trisaccharide (114) is reported in chapter 2. The compound was originally synthesised in this group by Underwood⁷³ and chapter 2 is essentially repetition of this work with some improvements, which are mentioned where relevant.

Chapter 2: Synthesis of an Orthogonally Protected Trisaccharide

2.1 Strategy in the Synthesis of Trisaccharide (114)

The initial target of the project (114) was formed by a convergent block synthesis, scheme 2.1. The natural disaccharide maltose (123) was chosen as the key starting material because it was inexpensive, readily available, provided a substantial portion of the structure of (114) and also contained the internal α -linkage. In general 1,2-*cis*-linkages are more difficult to form synthetically than 1,2-*trans*-linkages, so maltose was preferred to cellobiose as the starting material.⁷⁴

Benzyl ethers were chosen as permanent protection whereas allyl ethers and acetyl esters were used as semi-permanent protecting groups. The benzyl and allyl ethers were used to provide vital electron density for the coupling step. This was particularly important because the 4-OH is the least nucleophilic hydroxyl in a glucosyl ring.⁷⁵ The acetyl esters were used to ensure the geometry of the 1,2-*trans*-linkage formed during the coupling step.⁷⁴ All of these protecting groups were orthogonal to each other to enable their selective removal for the generation of the required targets, figure 1.18.

2.2 Synthesis of Acceptor (130)

2.2.1 The Per-Acetylation of Maltose

Maltose (123) was acetylated using the standard conditions of acetic anhydride and DMAP in pyridine, scheme 2.2.⁷⁶ At the first attempt the reaction did not go fully to completion and it was clear from mass spectrometry that partially acetylated species had been formed along with (124). Distillation of the pyridine before use solved this problem and quantitative yields of product were then obtained.

DMAP is a highly effective acylation catalyst that is approximately 10^4 times more active than pyridine alone.⁷⁶ The catalytic effect is due to the formation of *N*-

acylpyridinium salts that are present in solution as loosely-bound highly reactive ion pairs.

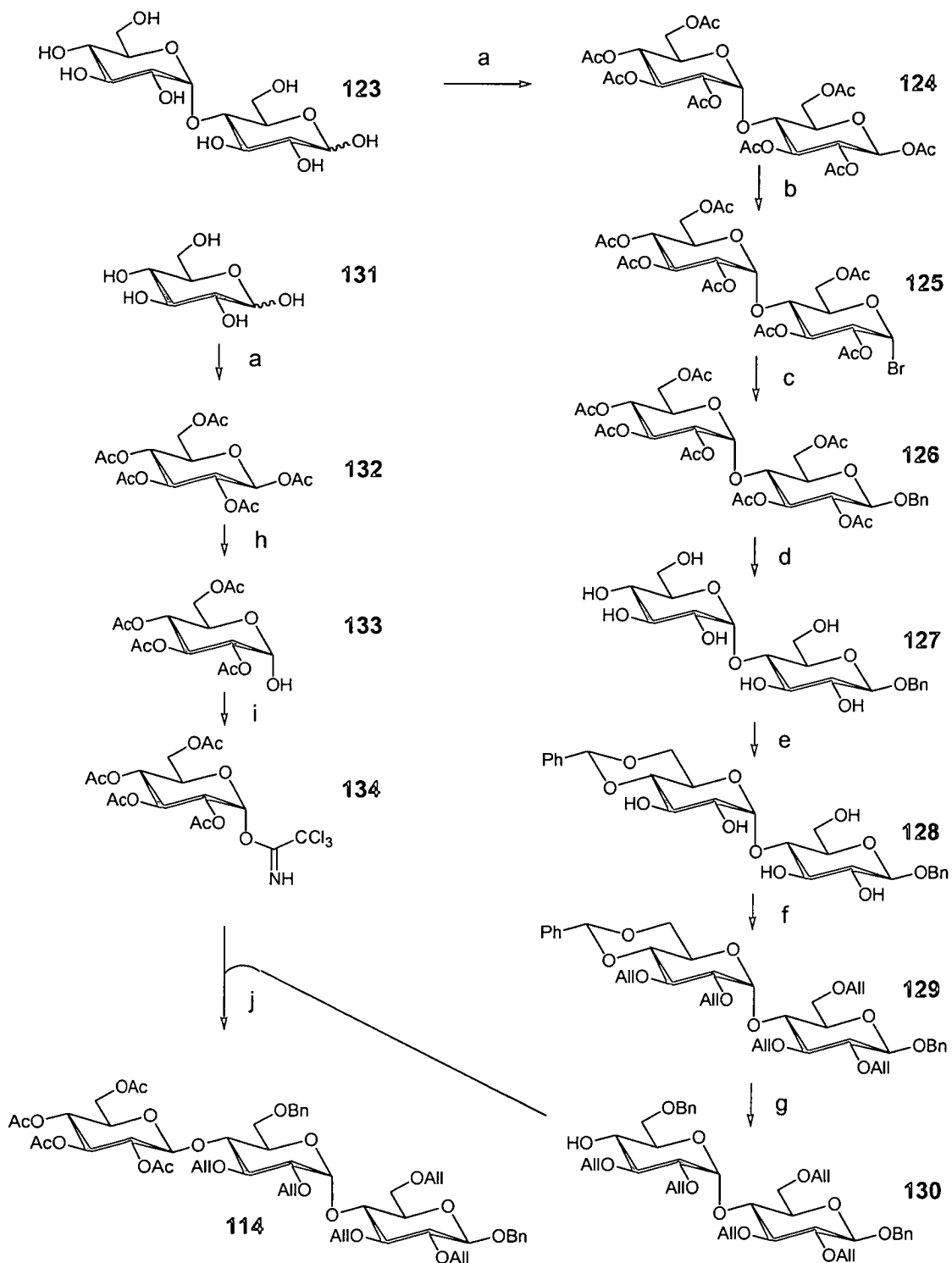

(a) Ac_2O , DMAP, pyridine; (b) HBr, AcOH; (c) BnOH, Ag_2O , Et_2O ; (d) NaOMe, MeOH; (e) PhCHO, ZnCl_2 ; (f) AlIBr, NaH, DMF; (g) Et_3SiH , TFA, $(\text{CF}_3\text{CO})_2\text{O}$, DCM; (h) ammonium carbonate, DMF; (i) Cl_3CCN , NaH, DCM; (j) $\text{BF}_3 \cdot \text{OEt}_2$, DCM.

Scheme 2.1.

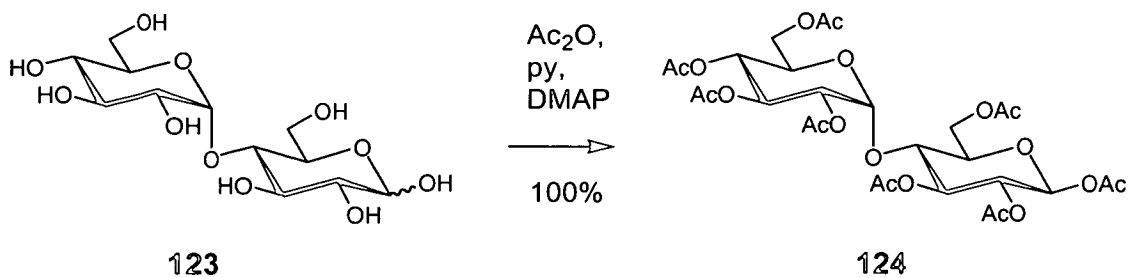

Scheme 2.2: The per-acetylation of maltose.

The data obtained compared well with that reported previously.⁷⁷⁻⁷⁹

2.2.2 Activation of C-1 by Glacial HBr

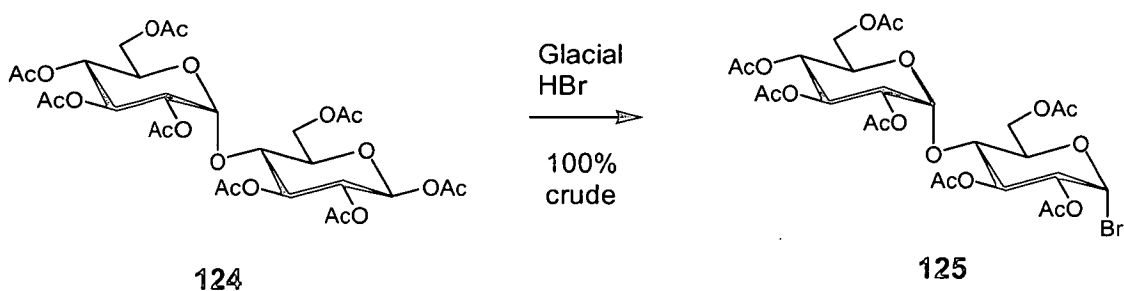

Scheme 2.3: Anomeric bromination.

The anomeric acetate of (124) was displaced with glacial HBr as prepared by Fischer and Kogl.⁸⁰ Because the HBr tended to fume vigorously it was necessary to add the solution quickly using a glass funnel and then to protect the system from the atmosphere using a drying tube. Calcium chloride that had been dried overnight in an oven (150 °C) was an appropriate desiccant.

The reaction proceeded reliably in quantitative crude yield. Chromatographic purification (using diethyl ether as eluent) was possible but telescoping was preferred, because the bromide was exposed to the atmosphere for less time.

The data obtained compared well to that reported previously.^{77,80,81}

2.2.3 The Koenigs-Knorr Reaction

The Koenigs-Knorr glycosylation is the earliest method that was widely used in the synthesis of glycosidic linkages.⁸² Chlorides and bromides can be selectively

introduced at the anomeric position of glycosides from the corresponding acetate or hemiacetal compound. Halide formation is generally the last step to be carried out prior to glycosylation as the halides are too unstable to survive reaction conditions such as protecting group manipulation. Therefore this reaction is often used in stepwise syntheses starting from the reducing end, but is relatively less useful for block syntheses. Reactions usually proceed in the presence of halophilic activators, typically silver or mercury salts.

2.2.4 Glycosylation with Benzyl Alcohol

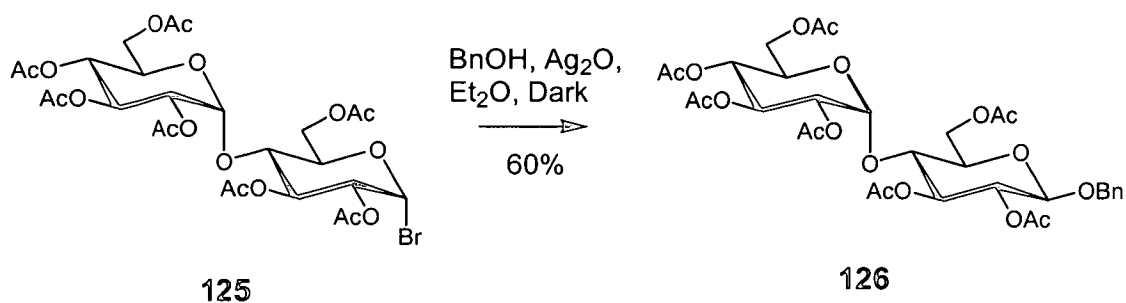

Scheme 2.4: Formation of benzyl maltoside (126).

This reaction had caused problems for Dr. Underwood⁷³ who isolated a significant quantity (27%) of the orthoester (135), figure 2.1, from the reaction mixture, leading to a reduced product yield (42%). The Ag_2CO_3 catalyst had been used, which was the same method that had been employed in the first reported synthesis of this compound by Fischer and Kögl in 1923.⁸⁰

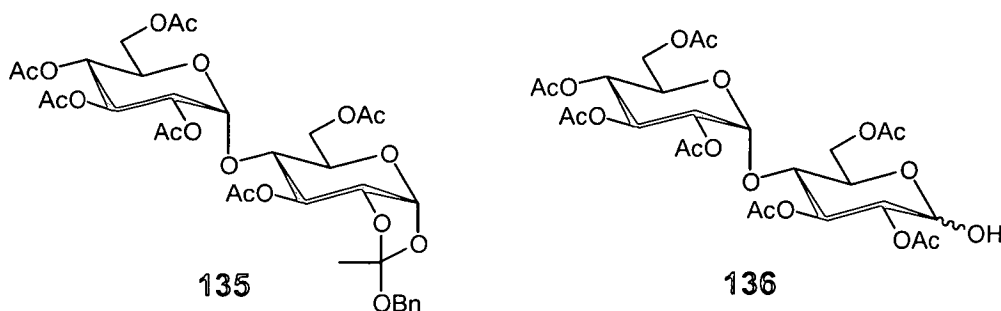

Figure 2.1: Orthoester (135) and hemiacetal (136).

In order to avoid these problems a series of catalysts, promoters and reagents were explored. The first set of conditions investigated was BnOH/AgOTf/2,6-

lutidine/DCM/-18 °C.⁸³ The reaction mixture comprised of (126) (19%), hemiacetal (136) (57%), figure 2.1, and another unidentified glycosidic by-product (3%). The second method attempted was BnOH/Ag₂CO₃/AgOTf/RT/DCM.⁸⁴ This gave another low yield of the product (22%). Repetition of this reaction under more rigorously anhydrous conditions gave another unsatisfactory yield (31%). The third method employed was Ag₂O/BnOH/Et₂O⁸⁵ which was a significant improvement on the previous reactions and gave a good yield (60%). Obviously Ag₂O was a more suitable catalyst for this particular glycosylation. The increase in yield (of 18%)⁷³ was also probably related to the purity and nature of the solvent.

The data obtained was in good agreement with that previously reported.^{80,86,87} The new bond formed was exclusively 1,2-*trans* in geometry as illustrated by the coupling constant ($J_{1,2}$ 7.9 Hz). The ¹H- and ¹³C-NMR spectra clearly showed that one benzyl group had been incorporated into the molecule.

2.2.5 Deacetylation

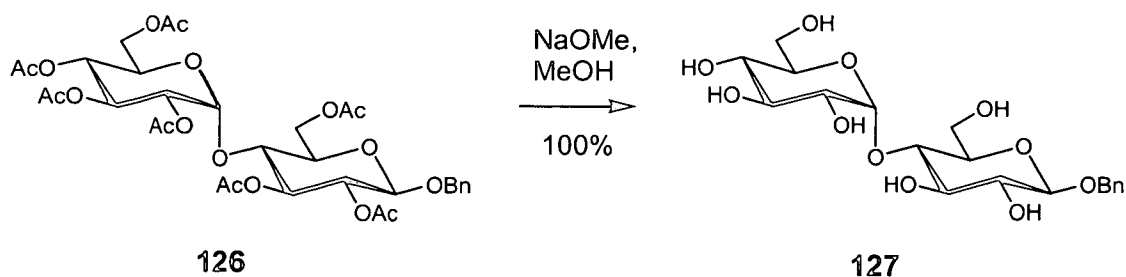

Scheme 2.5: Deacetylation.

The reaction was reliably deacetylated using the Zemplén conditions in quantitative yields.⁸⁸ The acetylated starting material was dissolved in dry methanol, sodium methoxide was added as a methanolic solution and quenched by the addition of H-form ion exchange resin after an hour. It was sometimes necessary to force the reaction to completion after the hour, this was easily achieved by a second addition of methoxide and another 30 min reaction time.

The data compared well with that previously reported.^{80,87} There was no sign of any acetyl signals in the NMR spectra.

2.2.6 Acetal Formation

The maltoside (127) was dissolved in benzaldehyde and anhydrous zinc chloride catalyst was added according to the standard Fruedenberg procedure.⁸⁹ After three hours stirring at room temperature the reaction mixture had not changed significantly and so the reaction was quenched by the addition of a quantity of warm saturated aqueous sodium hydrogen carbonate. The quenching with bicarbonate had to be carried out with very vigorous stirring so as to mix the layers as fully as possible.

Other methods for the formation of benzyldine acetal (128) were also explored, such as the formation of the acetal *via* an acetal-exchange reaction.⁹⁰ Whilst this reaction gave high yields on small scale, on larger scale it produced complex mixtures that were difficult to resolve. For this reason the ZnCl₂ procedure was favoured.

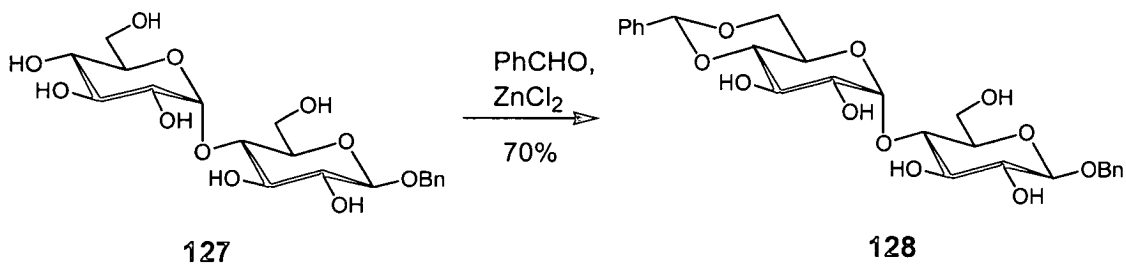

Scheme 2.6: Benzyldine acetal synthesis.

The data compared well to that reported previously.⁹¹⁻⁹³ The new benzylic singlet at 5.56 ppm and the integration of 10H in the aromatic region of the ¹H-NMR were good evidence that the acetal had been formed.

2.2.7. Allylation

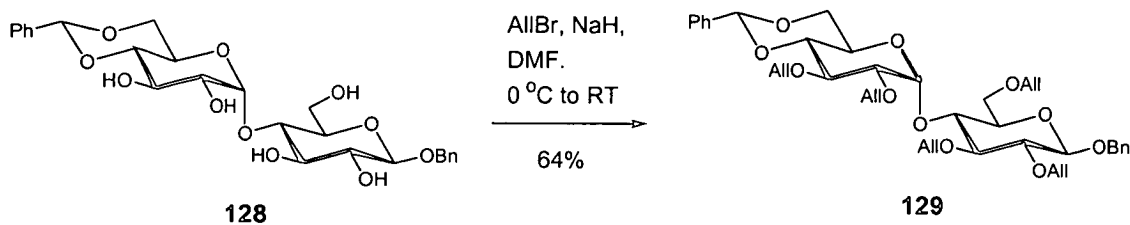

Scheme 2.7: Allylation.

The remaining free hydroxyl groups were protected as allyl ethers using the standard conditions for alkylation.⁹⁴ This gave the disaccharide (129) in reasonable yield (64%).

The data compared well to that previously reported.⁷³ The appropriate number of allylic signals in the NMR spectra indicated that all five hydroxyl groups had been allylated.

2.2.8 Reductive Ring-Opening of Benzylidene Acetals^{95,96}

Reductive opening of benzylidene acetals (137) involves activation of one of the two oxygen atoms in the dioxolane ring followed by nucleophilic attack of hydride at the benzylic carbon atom, scheme 2.8. Depending upon the nature of the acid that is used for activation, benzylidene acetals of carbohydrates can be opened onto either the C-4 or the C-6 positions. A possible mechanism for the selectivity displayed in these reactions has been postulated by Garegg *et al.*⁹⁶ Lewis acid conditions (e.g. LiAlH₄-AlCl₃) direct the opening along pathway (a) *via* intermediate (140), due to their greater steric demand relative to a proton. This is particularly the case when the O-4 substituent is bulky. In reductions that contain a Brønsted acid (e.g. NaCNBH₃-HCl) the steric requirement for the electrophile is far smaller and so the reaction proceeds along pathway (b) *via* intermediate (138), governed by the relative acidities of O-4 and O-6. The hydroxyl at C-4 is richer in electron density as it is a secondary, rather than a primary carbon atom (C-6).

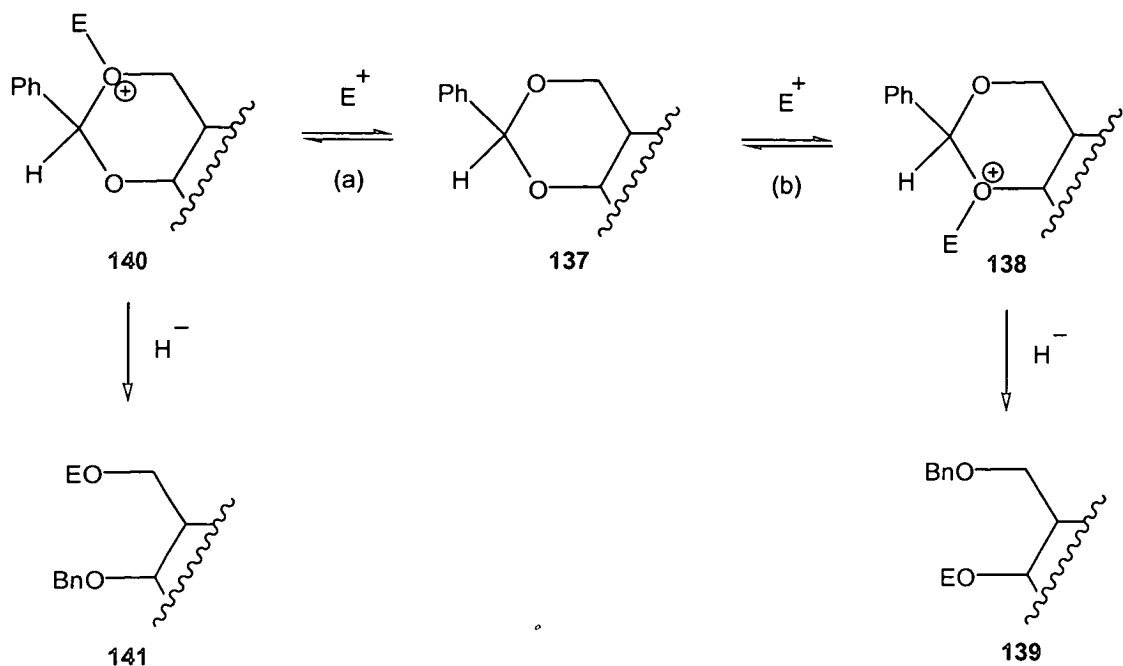

Scheme 2.8: Regioselectivity in the opening of benzylidene acetals.

2.2.9 Regioselective Reductive Ring-Opening to Acceptor (130)⁹⁶

In this case the acetal (129) was opened onto C-6' in a regiospecific reaction catalysed by protic acid (TFA). The 4'-OH acceptor (130) was formed in good yield (60%) by the treatment of (129) with $\text{Et}_3\text{SiH}/\text{TFA}/(\text{CF}_3\text{CO})_2\text{O}$ ⁹⁶ in DCM, where the triethyl silane acts as a hydride source, TFA was the proton source and the anhydride was used as a scavenger for water. Compound (130) was well activated or "armed" for use as an acceptor in the coupling step, due to the seven ether groups that were arranged around the molecule. Because of the low reactivity of 4'-OH it was particularly important that electron donating groups were used.

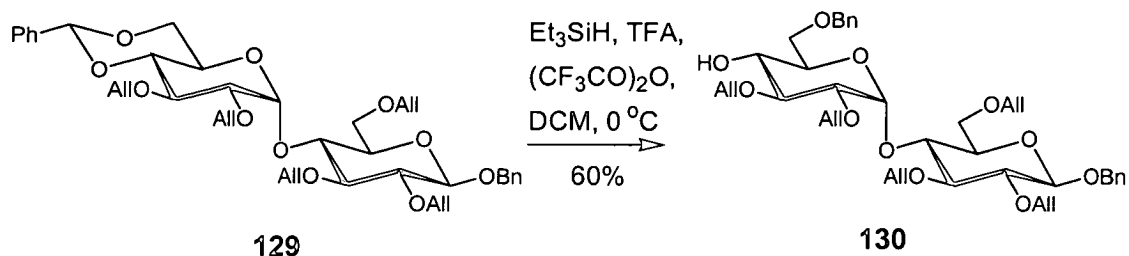

Scheme 2.9: Reductive ring opening.

Alternative strategies in Heparin and HS synthesis have involved the use of other temporary protecting groups (see introduction) such as MCA (monochloroacetyl) and Lev (levulinoyl), but the major disadvantage to this strategy was the large number of protecting group steps and hence the low overall yields.⁵⁷ The regioselective opening of a benzylidene acetal had the advantage of placing a permanent protecting group on the 6'-O position and simultaneously freeing up the 4'-OH for nucleophilic attack during the subsequent glycosylation reaction.

The data compared well to that previously reported.⁷³ In the ¹H-NMR there was an upfield shift of 0.62 ppm in the signal corresponding to the H-4' proton [from 4.29 ppm in the acetal (129) to 3.65-3.69 ppm in the acceptor (130)] so clearly the benzyl group has formed at the C-6' position. There was no more sign of the singlet that was characteristic of the benzylidene acetal and there were now four benzylic doublets in the ¹H-NMR spectrum.

2.3 Synthesis of the Glucosyl Donor (134)

The trichloroacetimidate (134) was synthesised from penta-*O*-acetyl-β-D-glucopyranoside (132) in two synthetic steps.

2.3.1 The Removal of the Anomeric Acetate

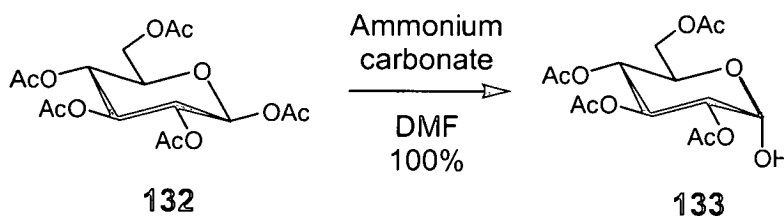

Scheme 2.10: Removal of the anomeric acetate.

The deacetylation of compound (132), which was commercially available, to afford (133) was achieved in quantitative yield using ammonium carbonate in DMF, scheme 2.10. Because the anomeric acetate was more reactive than the other positions it could be selectively removed by nucleophilic amine reagents. Often these deprotections are achieved by using hydrazine acetate, but ammonium carbonate was a milder reagent that has been reported to deliver excellent yields.⁹⁷

The data compared well to that previously reported.⁹⁷⁻¹⁰⁰ All of the data indicated that only the anomeric acetate had been removed. The coupling constant ($J_{1,2}$ 3.7 Hz) in the $^1\text{H-NMR}$ spectrum revealed that only the α -product was present, as would be expected due to the anomeric effect.

2.3.2 Synthesis of the Trichloroacetimidate (134)

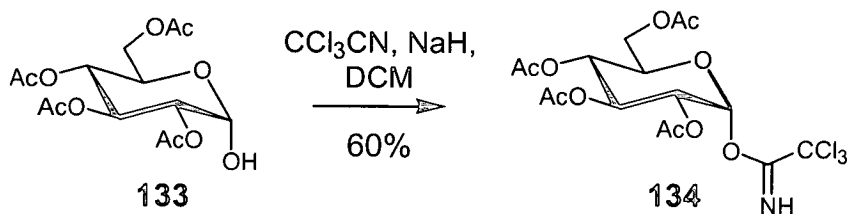

Scheme 2.11: Synthesis of the trichloroacetimidate (134).

The trichloroacetimidate (134) was made from the hemiacetal (133) by the standard method developed by Richard Schmidt and co-workers, scheme 2.11.⁷⁵ The hemiacetal hydroxyl was converted into the alkoxide by treatment with sodium hydride in DCM and trichloroacetonitrile was added. The alkoxide attacked the electrophile to form (134), the reaction was complete in approximately 30 min. The yields of the reaction were usually good (50-55%) and higher yields were attainable (60%). The donor could be stored in the freezer for long periods of time (months) without decomposition.

The data compared well with that previously reported.^{101,102} Only the α -trichloroacetimidate was present as indicated by the coupling constant ($J_{1,2} = 3.7$ Hz) in the $^1\text{H-nmr}$ spectrum. The singlet at high field strength (8.68 ppm) corresponded to the imine proton.

2.3.3 Advantages of the Trichloroacetimidate Method

The trichloroacetimidate method is a special case of direct 1-*O* alkylation and has been developed primarily by Schmidt and co-workers.¹⁰³ There are a number of advantages that this method has over classical Koenigs-Knorr reactions.⁷⁵ The Koenigs-Knorr procedure requires relatively harsh conditions for the generation of the glycosyl halide. Glycosyl halides exhibit low thermal stability and often the

correct anomer may only be generated *in situ* and at low temperatures. The compounds used are then often sterically non-homogenous and sometimes impure. The glycosyl halides are also highly susceptible to hydrolysis. The heavy metal salt catalysts are expensive and often highly toxic, particularly on larger scale. In contrast the trichloroacetimidate method requires milder conditions for the generation of the active species and their subsequent activation.¹⁰³

2.4 The Coupling Reaction

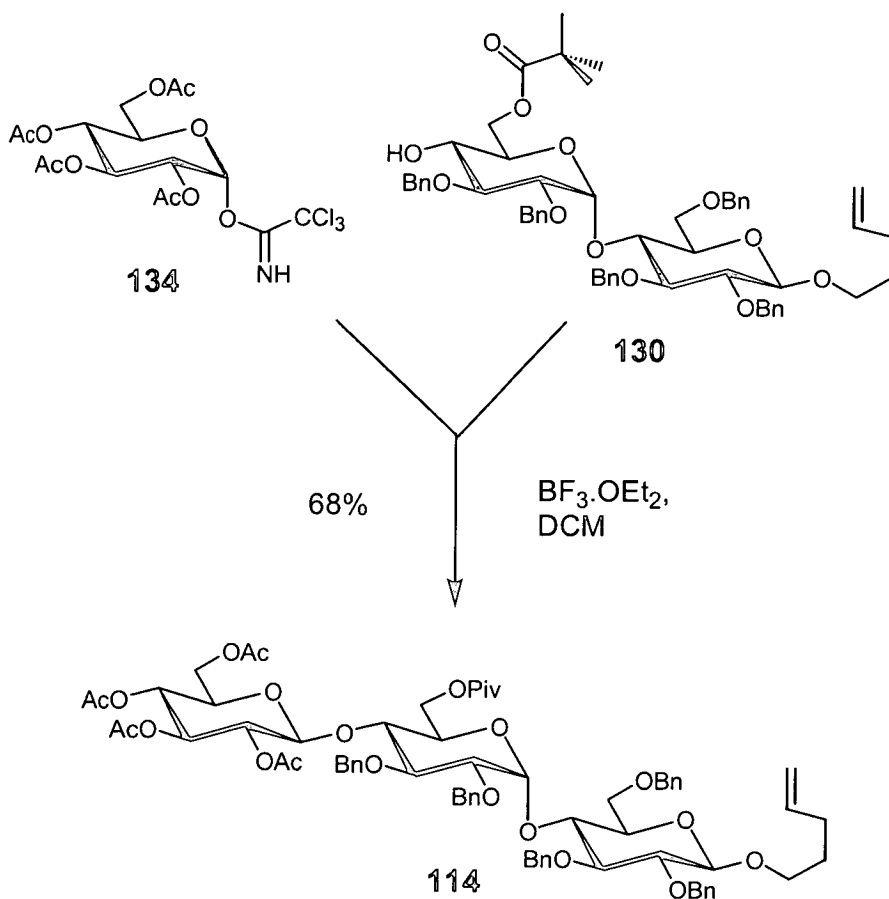

Scheme 2.12: The coupling reaction.

The thioglycoside method had been found by Underwood to give very low yields upon scale-up so the trichloroacetimidate method was used in its place.⁷³ The donor (**134**) and acceptor (**130**) were coupled together in DCM using $\text{BF}_3 \cdot \text{OEt}_2$ as catalyst in good yield (68%), scheme 2.12. The reaction was complete after 2 h between -25°C and -35°C .

The data compared well to that previously reported.⁷³ All three anomeric doublets were clearly present in the ¹H-NMR spectrum and the coupling constant ($J_{1',2'}$, 7.8 Hz) showed that the new glycosidic linkage was exclusively β in configuration.

2.5 Deacetylation of Trisaccharide (114)

Deacetylation of trisaccharide (114) was carried out in quantitative crude yield according to the standard Zemplén procedure to give compound (142), scheme 2.13.⁸⁸

The data compared well with that previously reported.⁷³ The NMR spectra revealed that a complete deacetylation had occurred, as no acetyl peaks were present.

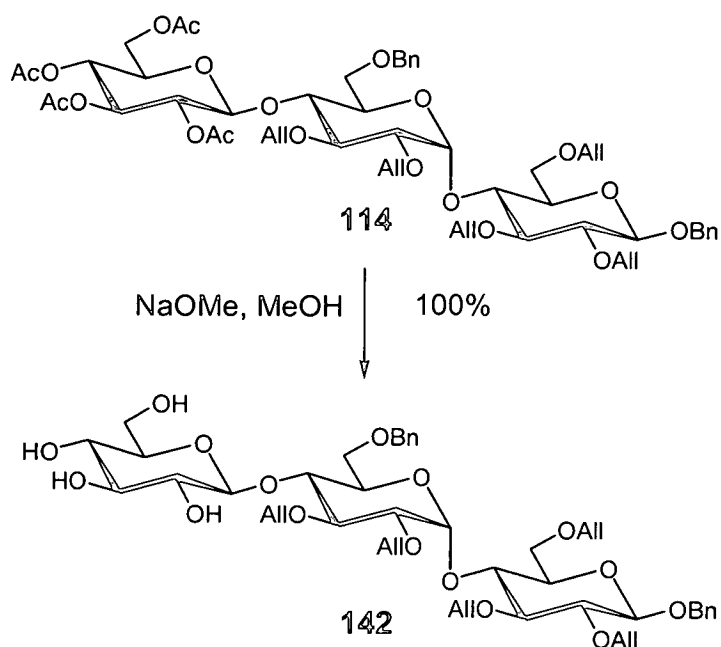

Scheme 2.13: The deacetylation of trisaccharide (114).

2.6 Allyl Ether Removal

The allyl ether group is a popular group in carbohydrate chemistry, commonly used for semi-permanent protection in the presence of permanent benzyl ethers.^{104,105} The removal of five allyl ethers from compound (114) was reported by Dr. Underwood⁷³ who used a mild one-pot removal: Pd(PPh₃)₄/glacial AcOH.¹⁰⁶ The method gave the de-allylated material (143) in good yield (57%) but with palladium contaminants. Attempts to repeat this reaction are described beneath.

The removal conditions used were Pd(PPh₃)₄/glacial AcOH/80 °C/16 h, scheme 2.14. The first attempt yielded a different result to that reported - a complex mixture with six components that were difficult to separate and isolate. Perhaps hydrolysis of the anomeric linkages was occurring. A milder second method was attempted in which the solvent was changed to ethanol: Pd(PPh₃)₄/EtOH/glacial AcOH (catalytic)/80 °C. After 24 h reaction time the mixture was found to contain only starting material and so the reaction was abandoned. The original Pd(PPh₃)₄/glacial AcOH/80 °C/16 h method was repeated on several occasions using purified, distilled and de-oxygenated glacial acetic acid and a rigorously anhydrous apparatus, but the complex mixture was always obtained. The components were extremely difficult to isolate due to their similar polarities and the small scale of the reactions [11.7 μmol of (114)]. A sample of (114) was refluxed in glacial AcOH for 16 h to see whether these conditions were causing hydrolysis, but the resultant mixture revealed no trace of hydrolysis by mass spectrometric analysis. Another palladium method attempted was palladium on activated charcoal/TsOH/dioxane/water¹⁰⁷ but this set of conditions produced no reaction. Several other methods including model studies were investigated.

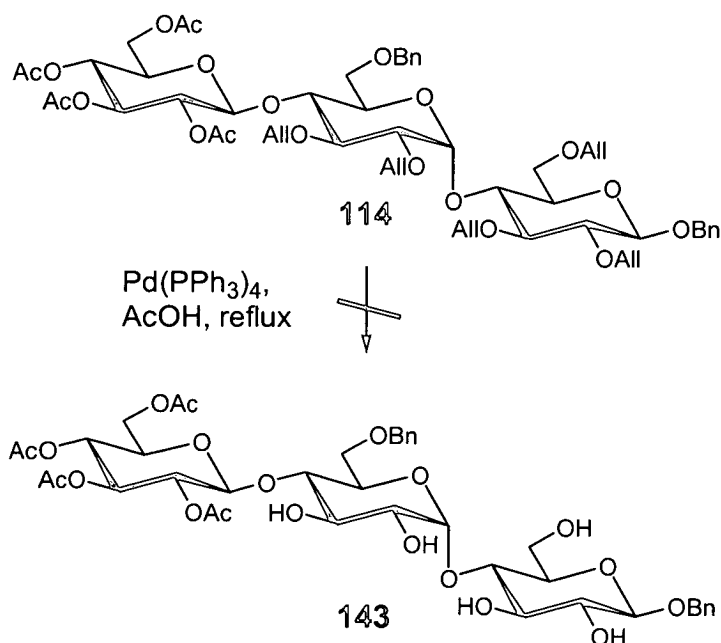

Scheme 2.14: Attempts to remove the allyl ether groups.

2.6.1 Model Compound De-Allylation Studies

A series of standard allyl-removal techniques were attempted on the model compound (144),¹⁰⁸ scheme 2.15. The use of a mild nickel-catalysed cleavage was reported by Ogasawara *et al.*¹⁰⁹ Using DIBAL/NiCl₂(dppp)/Et₂O/0 °C to RT the allyl group was successfully removed from the 3-*O* position of compound (144) to form the corresponding 3-OH compound (145). This method worked on the model compound, but on trisaccharide (114) gave mostly starting material. There was also a compatibility problem with DIBAL and acetates, so a milder hydride source was employed.

Using NaBH₄/NiCl₂(dppp)/THF/EtOH/0 °C to RT the allyl group was successfully removed from (144) when an extra additions of reagents was made in order to shift the equilibrium of the reaction to completion.¹⁰⁹ When applied to compound (114) the reaction generated a multicomponent complex mixture that was not easily shifted to completion. Mass spectrometric analysis of this mixture revealed a “staircase effect” whereby the strongest signal corresponded to compound (114), the next signal was found approximately 40 mass units down and was of lower intensity, the next peak was weaker still and also 40 mass units down and this pattern was continued to a weak peak which represented the fully deallylated product (143). Perhaps this was evidence for a sequential removal of allyl ethers from the trisaccharide. Despite this encouraging observation it proved to be very difficult to shift the equilibrium of this reaction toward compound (143). Eventually this method was also abandoned. A similar method using the mild hydride reagent Li(*t*-BuO)₃AlH gave no reaction on the model compound (144).¹⁰⁹

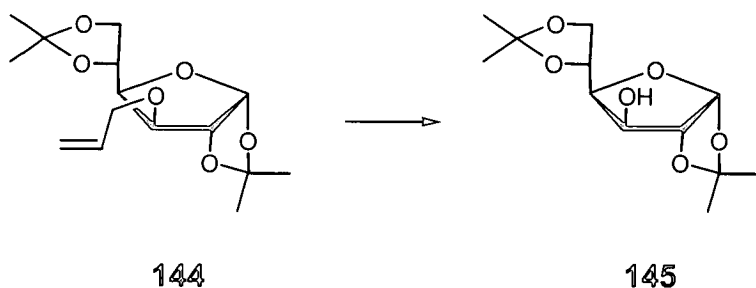

Scheme 2.15: Model de-allylation studies.

A two step procedure involving isomerisation to enol ether using Wilkinson's catalyst, followed by mercuric salt cleavage was attempted: (i) $\text{RhCl}(\text{PPh}_3)_3/\text{DABCO}/\text{EtOH}/\text{C}_6\text{H}_6/\text{H}_2\text{O}$; (ii) $\text{HgCl}_2/\text{HgO}/\text{acetone}/\text{H}_2\text{O}$.¹¹⁰ This protocol worked on model compound (144) but failed on trisaccharide (114).

The model deallylation compound (144) contained acetal and ketal linkages and an allyl ether group. In hindsight it was not a particularly useful group to choose, because there were no interglycosidic linkages, acetates nor benzyl ether groups.

2.6.2 The Allyl Ether in Carbohydrate Chemistry

The first appearance of allylic protection was reported by Stevens and Watanabe in 1950 when they used the allyloxycarbonyl (Alloc) group for amino acid protection.¹¹¹ The real starting point for the use of allyl ethers occurred in the 1960s when they were used for the protection of oligosaccharides by Roy Gigg.¹¹² The deprotection strategy was based upon an initial isomerisation from prop-2-enyl (146) to prop-1-enyl (147) followed by an oxidative cleavage of the resultant enol ether under mild conditions, scheme 2.16, route (B). The first step of this two-step relay-deprotection strategy was usually achieved with a transition metal catalyst such as $\text{RhCl}(\text{PPh}_3)_3$, $\text{Pd}(\text{PPh}_3)_4$, Pd/C , HgCl_2 , $\text{H}_2\text{Ru}(\text{PPh}_3)_4$ or iridium catalyst.¹⁰⁴ The second step was a hydrolysis in acid (e.g. TsOH) or Lewis acid (HgO) conditions.¹⁰⁴

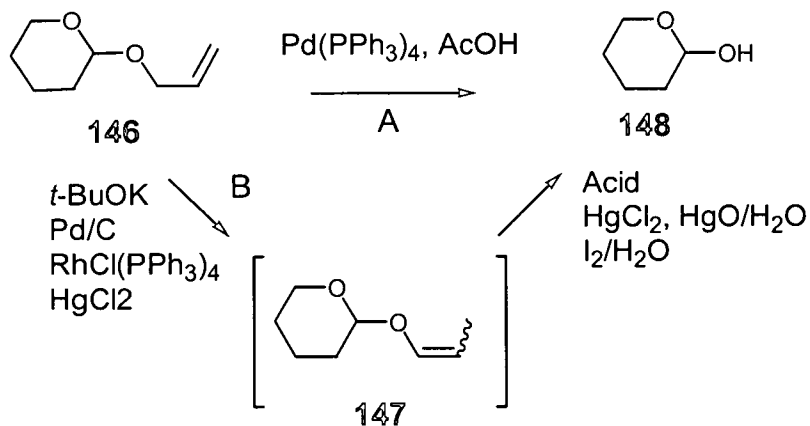

Scheme 2.16: General methods for allyl ether removal.

The introduction of catalytic palladium π -allyl chemistry for the direct cleavage of allylic protection was introduced in the 1980s, scheme 2.16 route (A).¹⁰⁵ Together

with cleavage protocols that involve stoichiometric amounts of palladium salts, these two deprotection methods are now the most common procedures for allylic removal. The specificity and the mildness (in most cases) of the removal conditions make allyl ethers highly tolerant of other functional groups present in the molecule.

Limitations include incompatibility with reagents that attack the olefinic bond, including many oxidising and reducing agents. Although hydrogenolytic procedures can be problematic allyl ethers have become very important in carbohydrate chemistry, particularly when used as semi-permanent protecting groups in the presence of permanent benzyl ether protection.

2.7 Conclusions

The orthogonally protected trisaccharide (114) has been synthesised on gram scale from maltose (123) and penta-*O*-acetyl- β -D-glucopyranose (132) in eight linear steps. The overall yield for the synthesis was 10.6% from maltose (123) and 40.8% from (132), the average yield was 78%.

Removal of acetates from trisaccharide (114) was achieved in quantitative yield, but removal of the allyl ether groups was very difficult. Evidence of a sequential removal of allyl ether groups was obtained, but the reaction equilibrium could not be shifted to completion. The problem may have been the number of groups that were present on the trisaccharide and the fact that the positions that they occupied were not particularly reactive. There are many examples of the allyl group being removed from oligosaccharides in the literature, but usually one or two at a time.^{104,105}

Chapter 3. Design and Synthesis of an Alternative Target Trisaccharide

3.1 Strategy

After the failure of the allyl removal reaction on trisaccharide (114), a new target trisaccharide (149) was designed, scheme 3.1. Benzyl groups were chosen to replace allyl ethers, as they should be far easier to remove and also would provide the electron density required in the coupling step.¹¹³ They also provided useful chromophores for analysis of the compound by HPLC.

A new group was required for permanent protection. The pivaloyl group, a hindered *t*-butyl ester, was chosen for 6-*O* protection where it was selectively introduced.¹¹⁴ Because of the steric bulk, it was far less susceptible to hydrolysis by saponification than acetates and therefore was orthogonal to all of the protection elements present in (149).

The anomeric position was protected with a pent-4-enyl group. This group, developed specifically for anomeric protection by Fraser-Reid and co-workers¹¹⁵ was chosen because it was removable under very mild conditions, but was stable to a wide variety of reagents. It also contained a double bond that could allow for further manipulation and possible solid-phase attachment.

The acetyl group was chosen again for protection of the non-reducing glucosyl unit.¹¹³ The acetates had been introduced and removed quantitatively in the synthesis of (114) and were also necessary for the stereospecific introduction of the synthetic β -glycosidic linkage.

In other areas the strategy for the synthesis of (149) was similar to that for the synthesis of (114). The same procedure was used in the synthesis of the donor (134). Maltose (123) was again used as the starting material in the synthesis of the disaccharide acceptor (155).

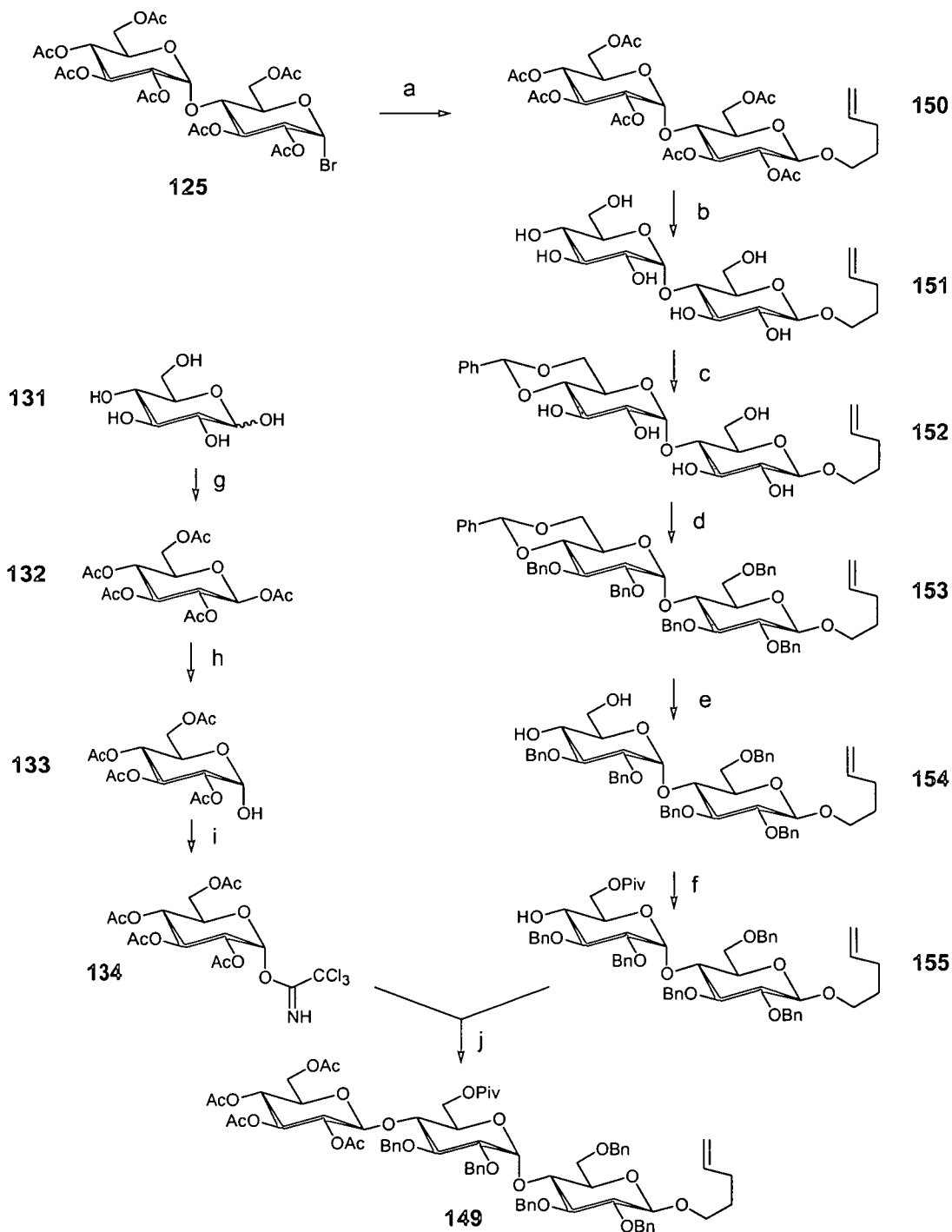

(a) Pent-4-enyl alcohol, Ag_2CO_3 , I_2 , DCM; (b) NaOMe, MeOH; (c) PhCHO, ZnCl_2 ; (d) BnBr, NBu_4I , NaH, DMF; (e) AcOH, H_2O ; (f) PivCl, DMAP, pyridine; (g) Ac_2O , pyridine, DMAP; (h) ammonium carbonate, DMF; (i) CCl_3CN , NaH, DCM; (j) $\text{BF}_3\cdot\text{OEt}_2$, DCM.

Scheme 3.1: The route to (149).

3.2 Formation of the Disaccharide Acceptor (155)

3.2.1 Glycosylation. Introduction of the Pent-4-enyl Group

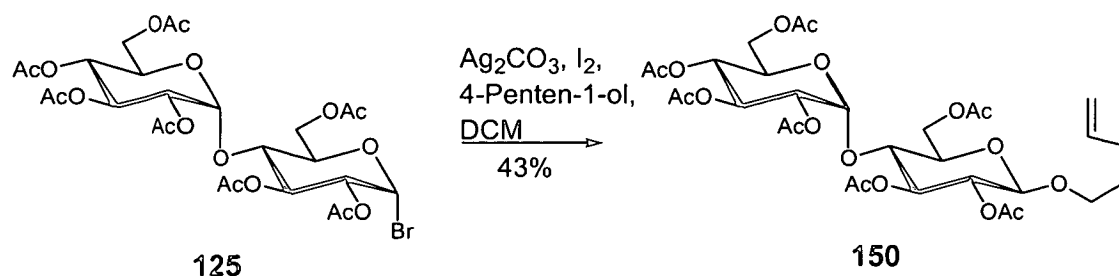

Scheme 3.2: Introduction of the pent-4-enyl group by Koenigs-Knorr reaction.

The bromide (125) was treated with 4-penten-1-ol in the presence of Ag_2CO_3 according to the Koenigs-Knorr procedure.¹¹⁶ The bromide (125) and catalyst were dried overnight in a vacuum desiccator over P_2O_5 and the DCM was freshly distilled. This gave the product (150) in moderate yields after chromatography (43%). The bromide (125) was commercially available and easy to synthesise in two high-yielding steps from maltose (123) (chapter 2). The method used was adapted from that described by Stick *et al.*¹¹⁶ for the glycosylation of the isomeric cellobiose-based bromide (156) with 4-penten-1-ol.

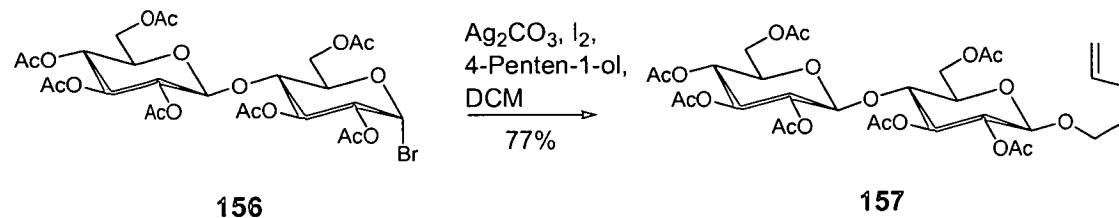

Scheme 3.3: Glycosylation of (156) by Stick *et al.*¹¹⁶

The data obtained was in good agreement with the proposed structure. The characteristic alkene signals in the NMR spectra indicated that the pent-4-enyl group had been incorporated into the molecule. The coupling constant ($J_{1,2}$ 8.0 Hz) in the ^1H -NMR spectrum showed that only the β -anomer had been formed. In the high-resolution mass spectrum the protonated adduct was found within 0.71 ppm of the theoretically calculated value.

3.2.2 Deacetylation

Deacetylation was achieved using the classic Zemplén procedure.⁸⁸ The acetylated starting material was pre-dried in a vacuum desiccator over P₂O₅ prior to reaction. Sometimes it was necessary to drive the reaction to completion by an extra addition of methoxide solution and a further 30 min reaction time. The reaction was quenched by addition of an H-form ion-exchange resin.

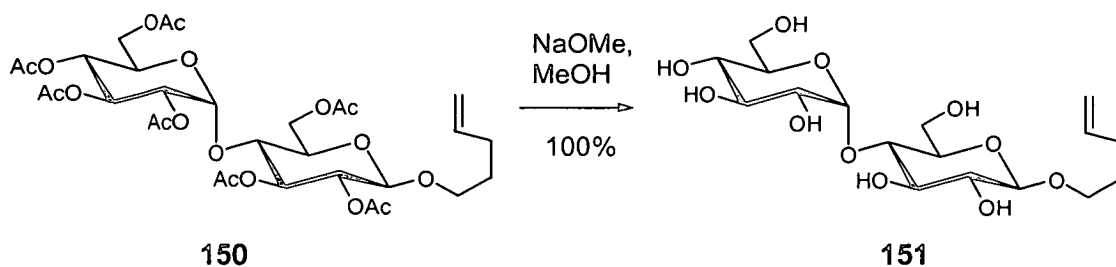

Scheme 3.4: Deacetylation.

The data recorded was in good agreement with the proposed structure. No acetyl signals were observed in the NMR spectra and the sodium adduct was present in the high-resolution mass spectrum within 2.3 ppm of the theoretically calculated value.

3.2.3 Two Routes from (151) to (154)

Two avenues were taken from the pent-4-enyl maltoside (151) to the diol (154). One route went *via* a *p*-methoxybenzylidene acetal (158) that was subsequently benzylated then hydrolysed. The other went *via* a benzylidene acetal (152) that was also benzylated and hydrolysed. Both methods gave the diol (154).

3.2.3.1 Acetal Synthesis

Synthesis of the *p*-methoxybenzylidene acetal (158) was problematic, but synthesis of the benzylidene acetal (152) was comparatively easy.

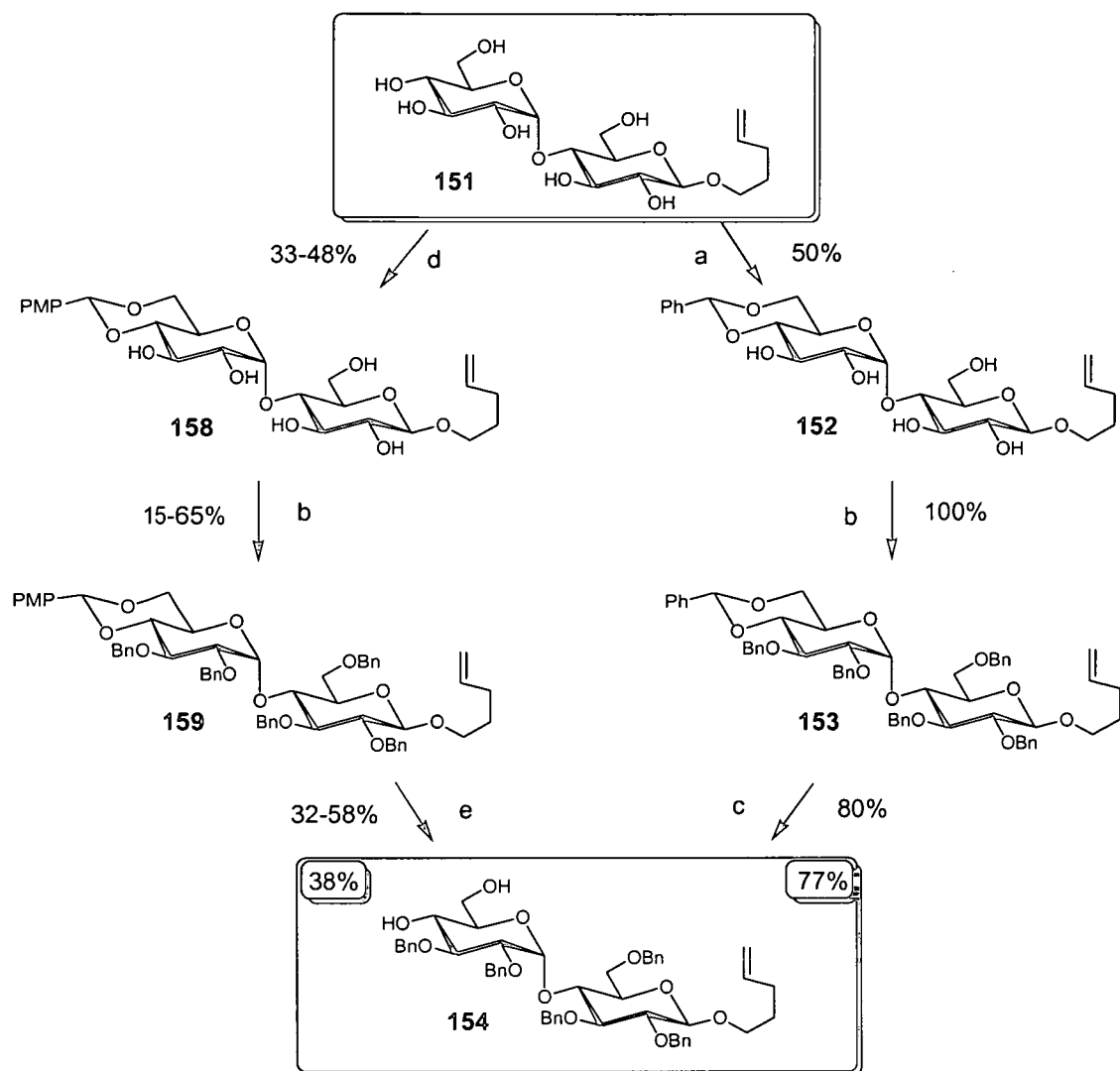

(a) PhCHO, ZnCl₂; (b) BnBr, Bu₄Ni, NaH, DMF; (c) AcOH, H₂O; (d) MeOPhCHO, ZnCl₂; (e) CAN, MeCN, H₂O.

Scheme 3.5: The two routes from maltoside (151) to diol (154), including average yields.

3.2.3.1.1 *p*-Methoxybenzylidene Acetal (158)

The *p*-methoxybenzylidene acetal (158) was difficult to introduce by both methods used and it did not form a stable intermediate. The first method attempted (PMPCH(OMe)₂/PTSA/DMF/50 °C/30 mBar/2 h)⁹⁰ was unsuccessful. The second method was anisaldehyde/ZnCl₂,⁸⁹ which worked with reasonable yield (2.55 g, 49%) but was not repeatable. The work-up involved distillation (0.035 mBar, 42 °C) of anisaldehyde (B.P. 248 °C), followed by chromatography of the resultant residue

and led to poor yields of product. The major problem was the instability of (158), which decomposed back to starting material and anisaldehyde after isolation. Coupled with this was a lack of stability of (158) to the ensuing alkylation conditions.

The data recorded was in good agreement with the proposed structure. The aromatic doublets, the benzylic singlet and the methoxy singlet were all clearly visible in the $^1\text{H-NMR}$ spectrum. The sodium adduct was the base peak in the electrospray nominal mass spectrum. In conclusion, the acetal had been formed, but did not fulfill the requirements for a good protecting group. Because of the low yields and lack of stability another route *via* the benzylidene acetal (152) was chosen.

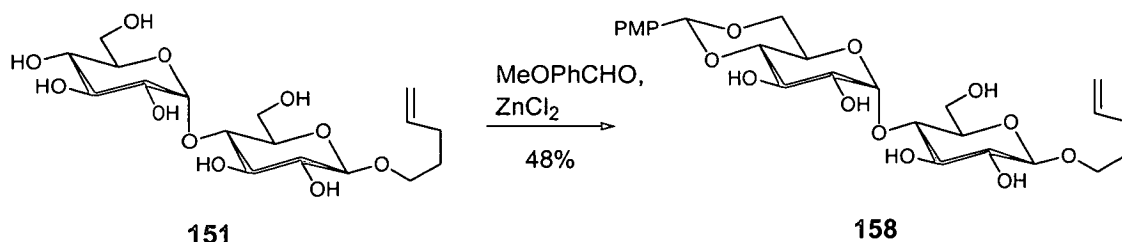

Scheme 3.6: PMB acetal (158) synthesis.

3.2.3.1.2 Benzylidene Acetal (152)

The acetal transfer reaction ($\text{PhCH}(\text{OMe})_2/\text{PTSA}/\text{DMF}/50\text{ }^\circ\text{C}/30\text{ mBar}/2\text{ h}$)⁹⁰ was successful on small-scale (100 mg, 2.51 mmol) and gave good yields of product (81 mg, 67%) after chromatography. When the reaction was attempted on a larger scale (1 g, 25.1 mmol), a complex mixture of seven components (all of significant intensity) appeared in the analytical TLC. Because the chemicals and proportions used were unchanged it was likely that the discrepancy was due to a scale-up issue such as heat-exchange characteristics.

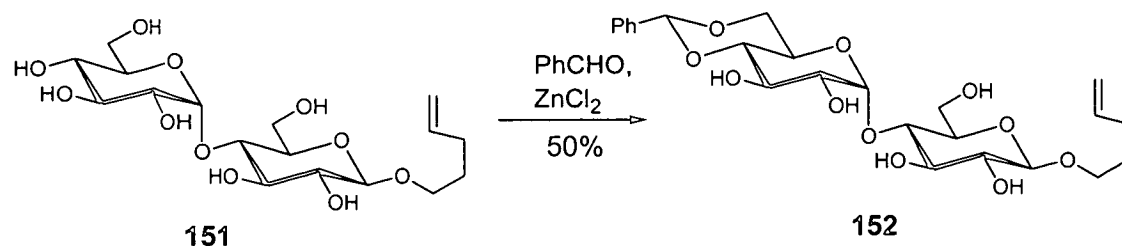

Scheme 3.7: Benzylidene acetal synthesis.

The other method was direct from benzaldehyde with zinc chloride catalysis (PhCHO/ZnCl₂).^{89,117} The zinc chloride was purchased as the anhydrous grade and was further dried by repeated heating under vacuum. The starting material was dried in a vacuum desiccator over P₂O₅ prior to use and the benzaldehyde was freshly distilled. The yields obtained were moderate but consistent (50%).

The data recorded was in good agreement with the proposed structure. The benzylic singlet was present in the ¹H-NMR spectrum and the aromatic signals were present in both NMR spectra. The protonated adduct was found to be within 1.4 ppm of the theoretically calculated value in the high-resolution mass spectrum.

3.2.3.2 Benzylations

3.2.3.2.1 Benzylation of the *p*-Methoxybenzylidene Acetal (158)

The benzylation was carried out using the standard conditions for alkylation, NaH/BnBr/DMF.⁹⁴ The mixture was stirred overnight and a good yield (65%) of acetal (159) was obtained, but the reaction was not repeatable. The problem was rooted in the instability of the PMB acetal (158). Some very low yields were obtained (15%).

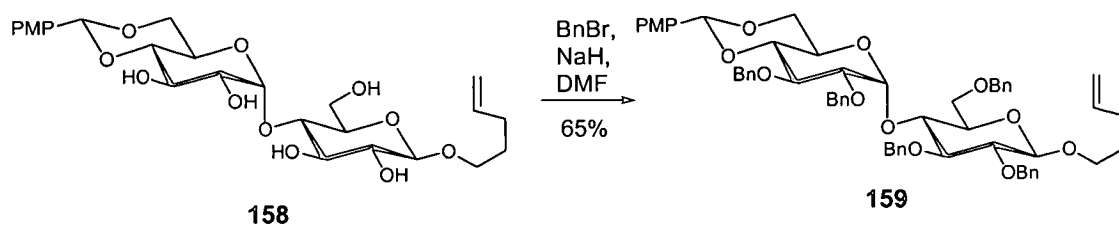

Scheme 3.8: Benzylation of PMB acetal (158).

The data recorded was in good agreement with the proposed structure. The NMR spectra indicated that five benzyl groups had been incorporated into the molecule.

3.2.3.2.2 Benzylation of the Benzylidene Acetal (152)

The benzylation of (152) was carried out according to the standard alkylation procedure and was quantitatively yielding and repeatable.⁹⁴ Benzyl bromide and

DMF were freshly distilled just before use. Tetrabutylammonium iodide was used in catalytic quantity as an *in situ* source of benzyl iodide. Sodium hydride was used directly without any attempt to remove the mineral oil (which can introduce moisture to the system). The oil was later removed during chromatography.

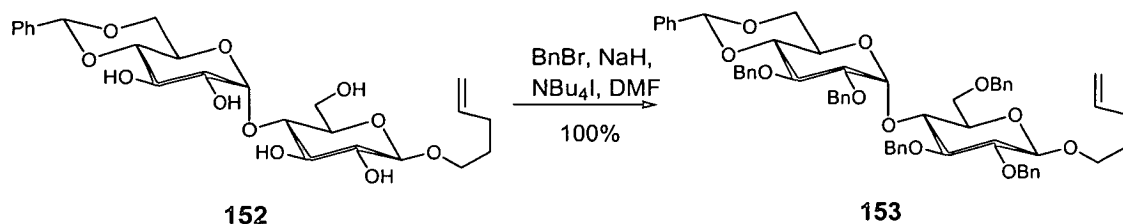

Scheme 3.9: Benzylation of benzylidene acetal (**152**).

The data recorded was in good agreement with the proposed structure. The NMR spectra showed that five benzyl groups had been incorporated into the molecule. The high-resolution mass spectrum contained the protonated adduct at m/z 949.4527 ($C_{59}H_{64}O_{11}.H^+$ requires 949.4527).

In conclusion benzylation was a very favourable reaction, repeatedly achieved in quantitative yield. The Freshness and purity of reagents were responsible for the favourable result.

3.2.3.3 Acetal Cleavage

3.2.3.3.1 Oxidative Removal of the *p*-Methoxybenzylidene Acetal

The *p*-methoxybenzylidene acetal (**159**) was removed with ceric ammonium nitrate (CAN) in acetonitrile and water to give the diol (**154**) in reasonable yield (58%), scheme 3.10.¹¹⁸

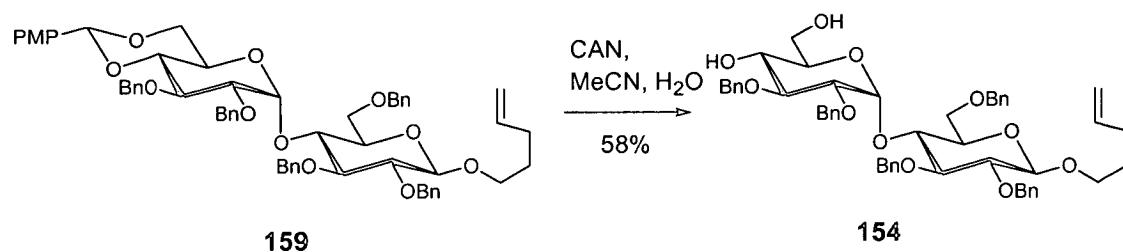

Scheme 3.10: PMB acetal cleavage.

3.2.3.3.2 Acid Hydrolysis of the Benzylidene Acetal

The benzylidene acetal (**153**) was cleaved by either using TFA¹¹⁹ or aqueous AcOH.¹²⁰ The TFA removal was carried out in DCM and gave lower yields than the AcOH method, which was far milder. The AcOH cleavage produced no side products and gave very high yields (up to 96%). Occasionally starting material was recovered from the reaction mixture by flash column chromatography, but the yield of product was still high (typically 80%) and approached quantitative yield based on recovery of starting material.

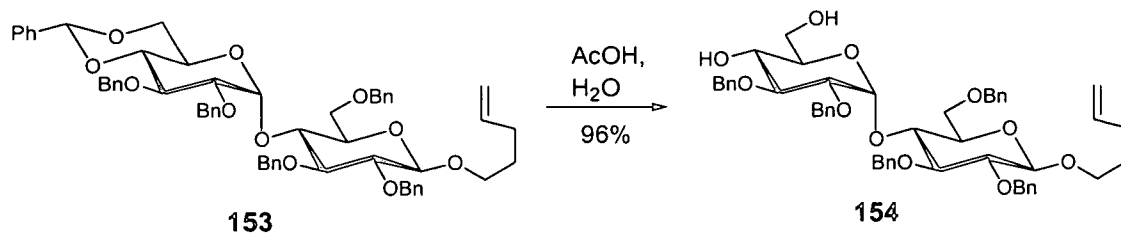

Scheme 3.11: Benzylidene acetal removal.

The IR spectrum showed the –OH stretch as a strong signal. The NMR spectra showed no benzylic singlet, there were five fewer protons in the aromatic region (¹H-NMR) and six fewer aromatic carbons (¹³C-NMR) compared to compound (**153**). The protonated adduct was found to be within 0.69 ppm of the theoretically calculated value in the high-resolution mass spectrum.

3.2.4 Selective Introduction of the Pivaloyl Group

The acceptor (**155**) was formed by treating the diol (**154**) with pivaloyl chloride DMAP and pyridine.^{114,121} Both the pivaloyl chloride and pyridine were freshly distilled. Superb yields (96%) were obtained. Occasionally the reaction did not go to completion, but on these occasions the yields based on recovery of starting material (**154**) approached quantitative yield.

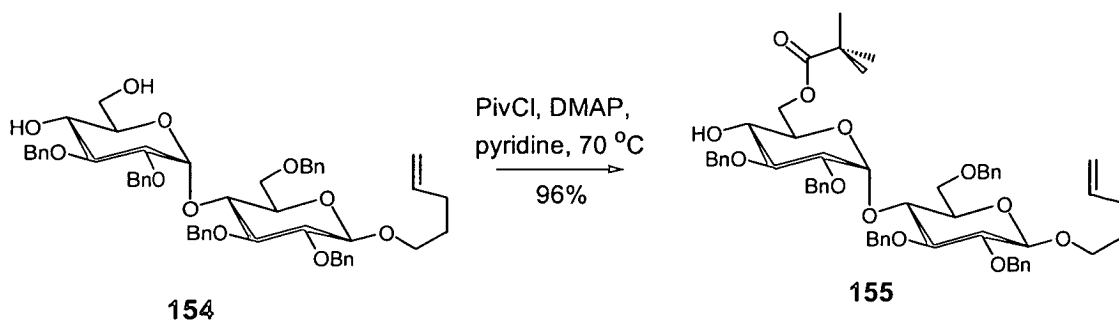

Scheme 3.12: Pivaloyl introduction.

The data recorded was in good agreement with the proposed structure. The presence of the new ester at C-6' was confirmed by the downfield shift for the H-6' protons in the $^1\text{H-NMR}$ spectrum. The protonated adduct was present in the high-resolution mass spectrum within 0.11 ppm of the theoretically calculated value.

3.3 The Coupling Step

The trichloroacetimidate protocol was used because it had produced such consistently good yields in the previous synthesis.^{75,103} The reaction was manageable and repeatable and the mildness of the method generally led to few side-products. The yields for the reaction were consistently good (65%) although one very high yield was obtained (92%).

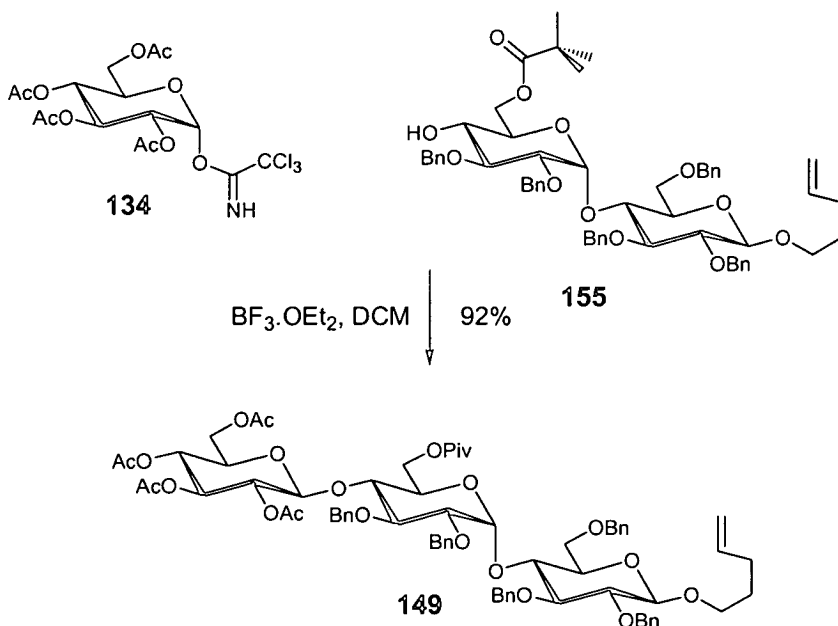

Scheme 3.13: Coupling to form trisaccharide (**149**).

The fully protected trisaccharide (149) was synthesised on gram scale (2.6 g) and was characterised by optical rotation, IR, $^1\text{H-NMR}$ (including $^1\text{H-COSY}$), $^{13}\text{C-NMR}$ (including $3\pi/2$), nominal ES-MS and accurate FAB-MS. All of these analyses were consistent with the proposed structure of compound (149). The coupling constant for the new linkage indicated the β configuration had been synthesised exclusively ($J_{1'',2''}$ 7.9 Hz). A discussion of the removal of protection from compound (149) and subsequent oxidations is found in Chapter 4.

3.4 Conclusions

Scheme 3.14 shows the yields for the synthesis of trisaccharide (149). An overall yield of 15.2% from maltose (123) and 55.2% from glucose (131) was obtained. The average yield of the synthesis was 84.5% and 2.6 g of trisaccharide (149) was synthesised in 9 linear steps.

Scheme 3.15 shows the yields for the synthesis of trisaccharide (114). An overall yield of 10.6% from maltose (123) and 40.8% from glucose (131) was obtained. The average yield of the synthesis was 78% and 1.0 g of trisaccharide (114) was synthesised in 8 linear steps.

The synthesis of (149) was an improvement upon the synthesis of (114). The route to (149) was high-yielding, repeatable and the intermediates were stable. The formation of diol (154) from compound (151) was higher yielding through benzyldine acetal intermediates (152) and (153) than *p*-methoxybenzyldine acetal intermediates (158) and (159).

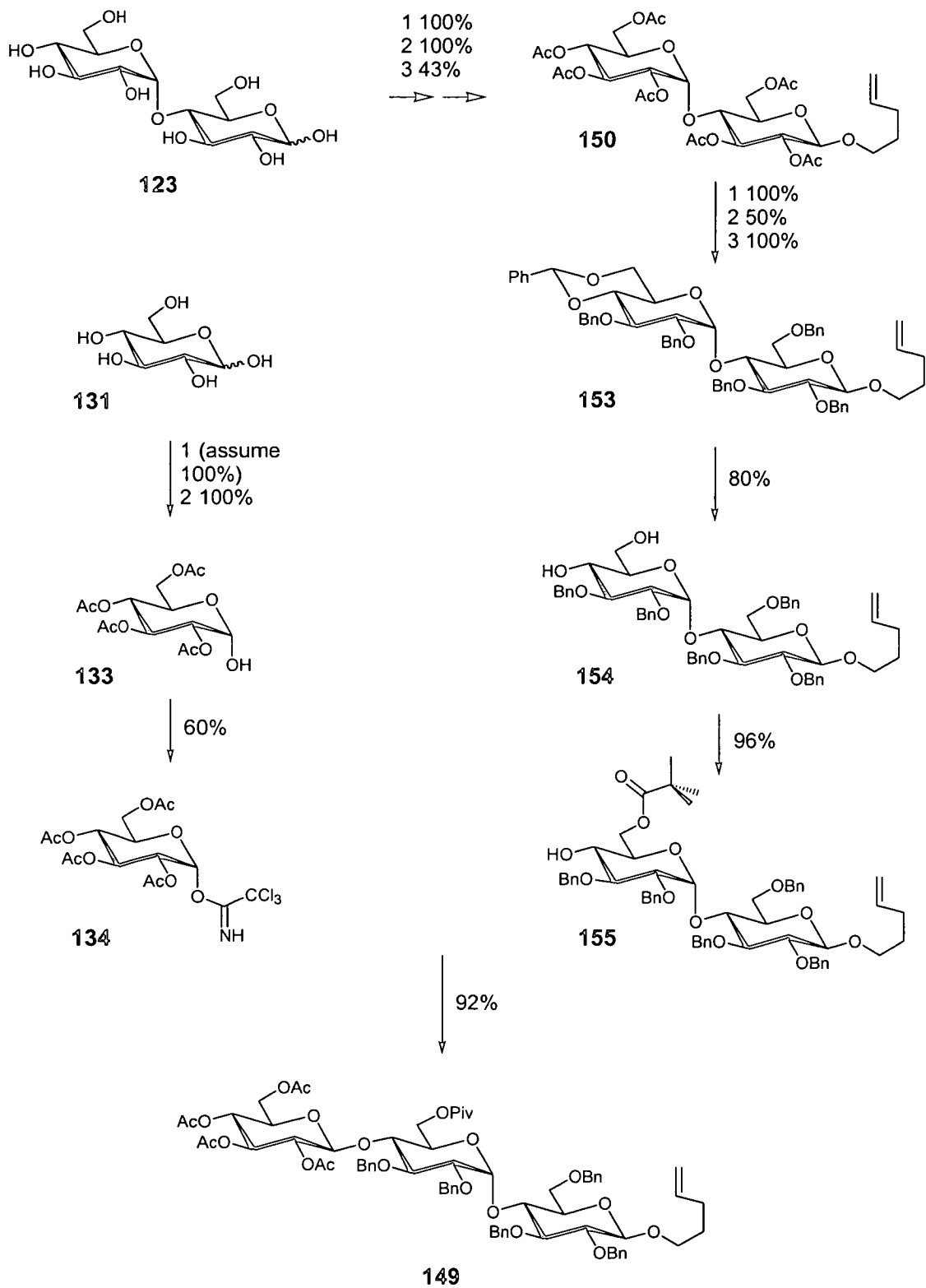

Scheme 3.14: Yields in the synthesis of trisaccharide (**149**).

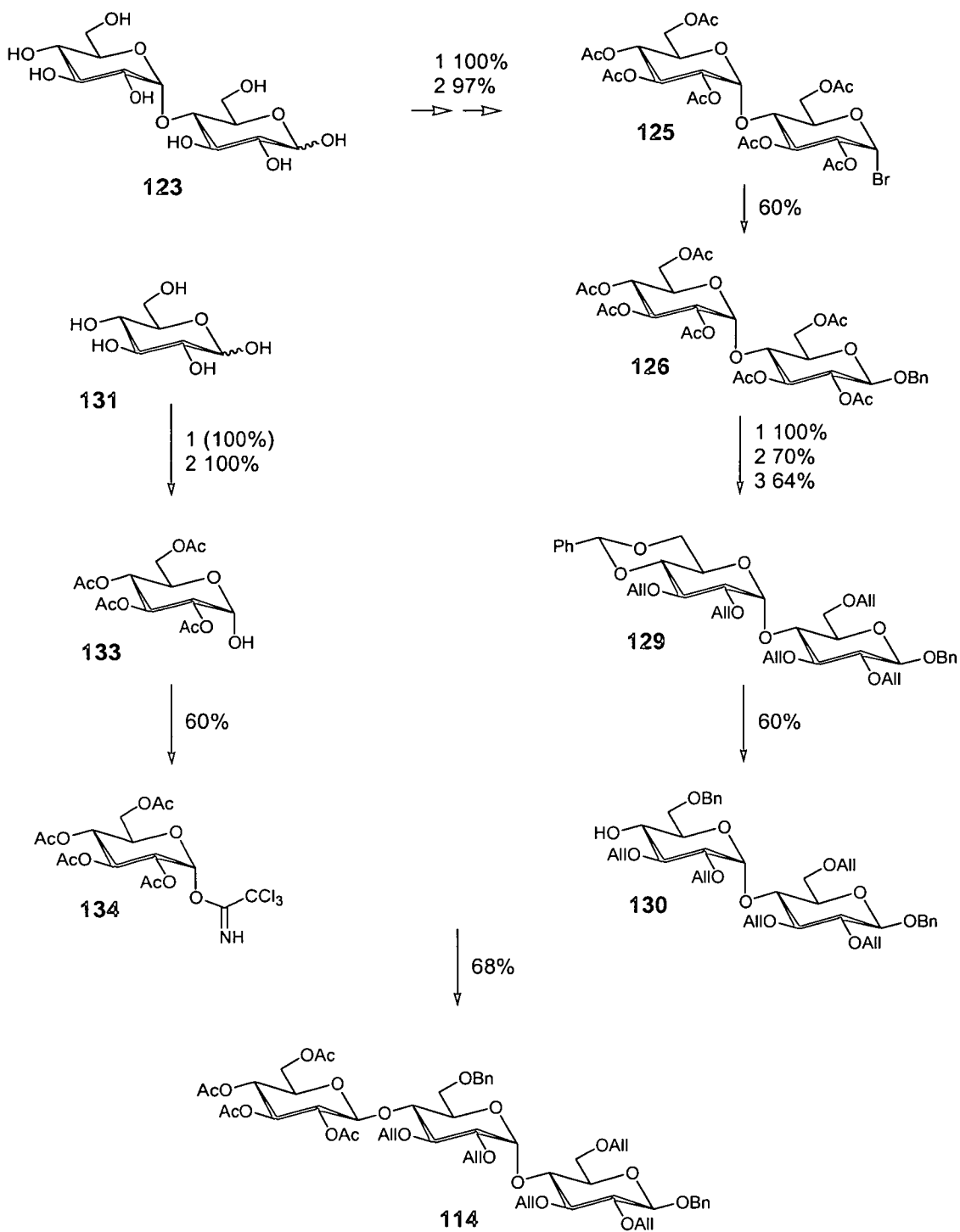

Scheme 3.15: Yields in the synthesis of trisaccharide (114).

Chapter 4. Selective Deblockings and Oxidations

4.1. General

The purpose of the synthetic work was to generate a series of partially protected trisaccharides from one common precursor. Each of the deprotected compounds formed could be oxidised and/or sulfated to generate the required targets, figure 1.18. The strategy was to deprotect trisaccharide (149) to form the partially protected substrates. In this chapter the removal of the protection groups and the development of a reliable selective oxidation method is discussed.

4.2 Acetate Removal from (149)

Guanidine is a mild reagent that is nucleophilic enough to remove the acetyl esters, but not the sterically bulky pivaloyl group.¹²² Guanidine was purchased as the hydrochloride salt and converted to its basic form by the addition of one equivalent of sodium methoxide before being added to a solution of (149) in DCM. After purification the deacetylated compound (160) was obtained in reasonable yield (51%) as a colourless oil.

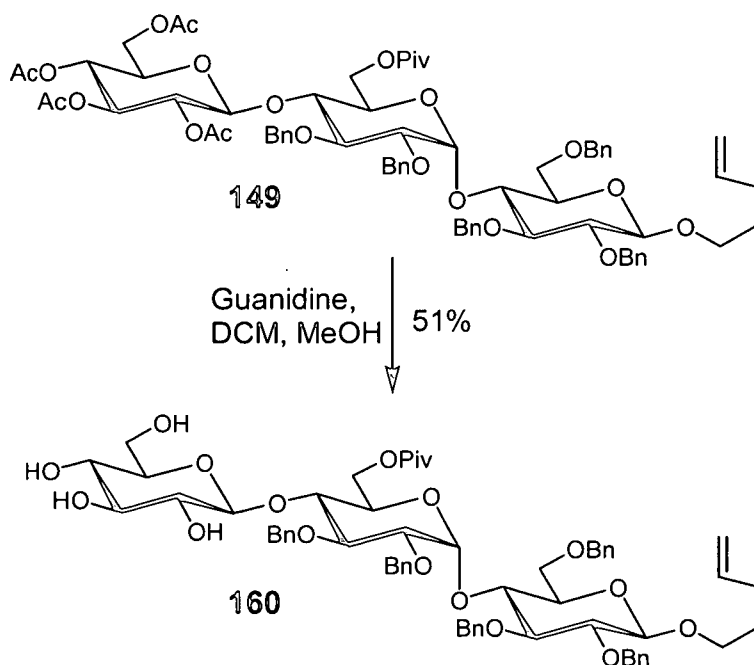

Scheme 4.1: Deacetylation.

The data recorded was in good agreement with the proposed structure. No acetyl signals were observed in the NMR spectra, but pivaloyl signals were clearly visible. A broad signal in the $^1\text{H-NMR}$ that integrated as 4H was attributed to the free hydroxyl protons. Both the sodium and ammonium adducts were present as strong signals in the nominal mass spectrum.

4.3 Benzyl Removal from (149)

The mild removal of benzylic ethers using ferric chloride has been reported to be compatible with a variety of protecting groups and with sensitive glycosidic linkages.^{123,124} Attempts to debenzylate trisaccharide (149) with FeCl_3 failed however, perhaps because the conditions were not sufficiently anhydrous.

The use of sodium in liquid ammonia for debenylation of carbohydrates containing olefinic groups has also been reported.^{125,126} Attempts at reproducing this result on compound (149) were also unsuccessful, perhaps because the acyl groups were more reactive than the benzyl ethers.

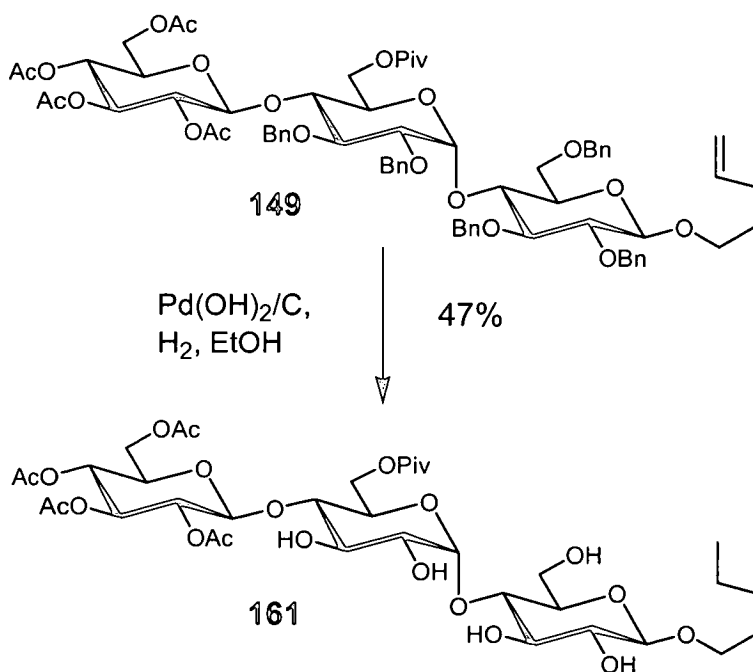

Scheme 4.2: Hydrogenolysis.

Removal of the benzyl groups was eventually achieved in reasonable yield (47%) by hydrogenolysis of (149) with Pd(OH)₂/C, H₂ in ethanol,¹²⁷ but this also caused the reduction of the double bond.

The data was in good agreement with the proposed structure. No aromatic signals were found in the NMR spectra. The sodium adduct was present in the high-resolution mass spectrum within 1.1 ppm of the theoretically calculated value.

The olefinic bond was a necessary functionality for the removal of the pent-4-enyl group from the anomeric position. Electrophilic halide sources such as NBS are used to form a halonium ion (163) that is attacked by the exocyclic anomeric oxygen resulting in the elimination of the bromo furanosyl ring. Attack of water on the resultant oxocarbenium species (165) produces the hemiacetal (166).¹²⁸ Having such a mild removal method for the anomeric protecting group was desirable and so it was regrettable that the reduction had occurred, although this did not affect reactions later in the synthesis.

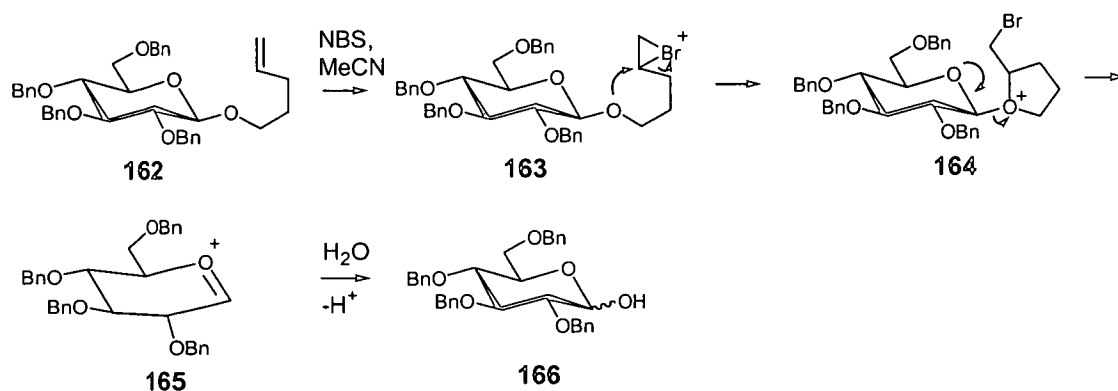

Scheme 4.3: Hydrolysis of the pent-4-enyl group.

In future syntheses there are some alternative strategies that could be used for the removal of the benzyl ethers, including transfer hydrogenation.¹²⁹ It might also be possible to protect the pent-4-enyl group by addition of bromine which can be removed by either Bu₄Ni/Zn dust or NaI.¹³⁰

4.4 Removal of Acyl protection from (149)

Removal of the acetate and pivaloyl esters from (149) was achieved in one step by using sodium methoxide in methanol.⁸⁸ The yield of (167) was modest (35%) but

perhaps could be improved by tuning the concentration of methoxide and the reaction time. A sufficient quantity of the product was obtained (190 mg) for characterisation and further reaction. This compound was either oxidised directly, or converted into the benzylidene acetal derivative (169) in order to oxidise only the C-6' position.

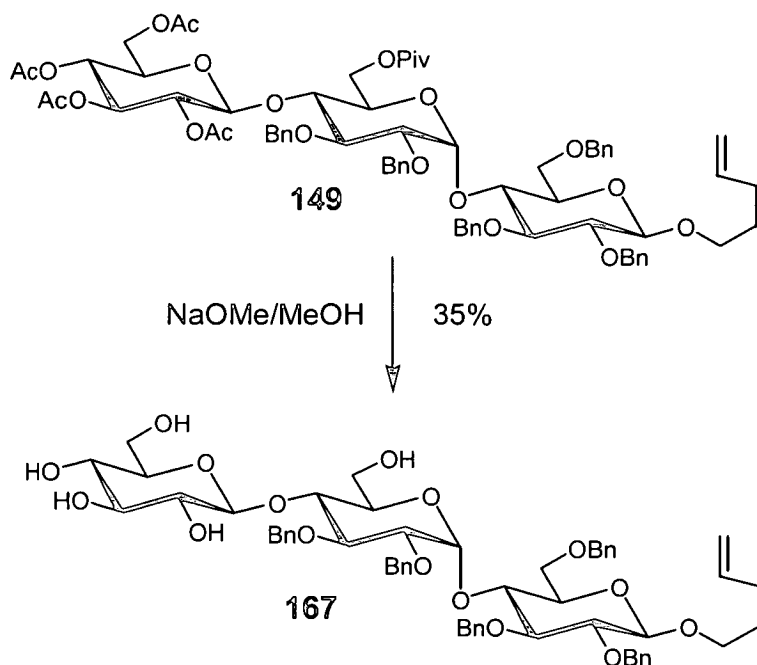

Scheme 4.4: Deacylation.

The data was in good agreement with the proposed structure. The infra-red spectrum revealed no carbonyl stretch but a strong hydroxyl stretch was clearly visible (3375 cm^{-1}). An integration of 5H was noted in the $^1\text{H-NMR}$ for the hydroxyl protons and no acyl signals were present. The protonated adduct was present in the high-resolution mass spectrum within 2.9 ppm of the theoretical value.

4.5 Acetate removal from Compound (161)

Compound (161) was treated with guanidine to remove the acetyl groups, resulting in a good yield (82%) of the hydrophilic sugar (168).¹²² Methanol was used as the solvent, which may be responsible for the higher yield in comparison to the deacetylation of compound (149), which was carried out in a DCM/MeOH mixture.

The data recorded was in good agreement with the proposed structure. No acetyl signals were present in the NMR spectra. The protonated adduct was found to be within 0.59 ppm of the theoretically calculated value in the high-resolution mass spectrum.

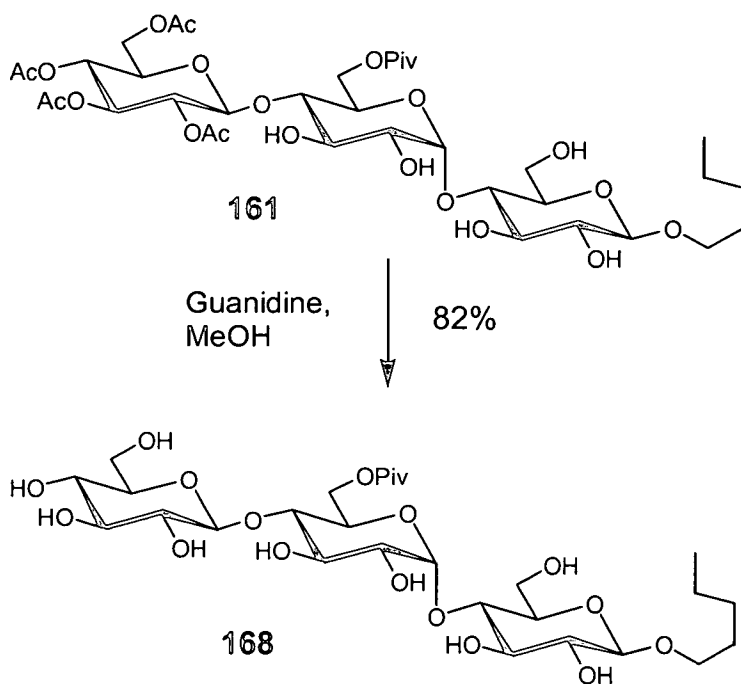

Scheme 4.5: Deacetylation of (161).

4.6 Acetal formation on Compound (167)

On small scale the use of acetal transfer reactions was found to be the method of choice for formation of benzylidene acetal compounds.⁹⁰ Compound (167) (0.154 mmol) was taken up in DMF and treated with PhCH(OMe)₂ in the presence of PTSA. The acetal was added in good yield (65%) to form (169). The benzylidene acetal portion of compound (169) was prone to hydrolysis upon standing, so benzaldehyde had to be removed from the compound (by chromatography) prior to oxidation.

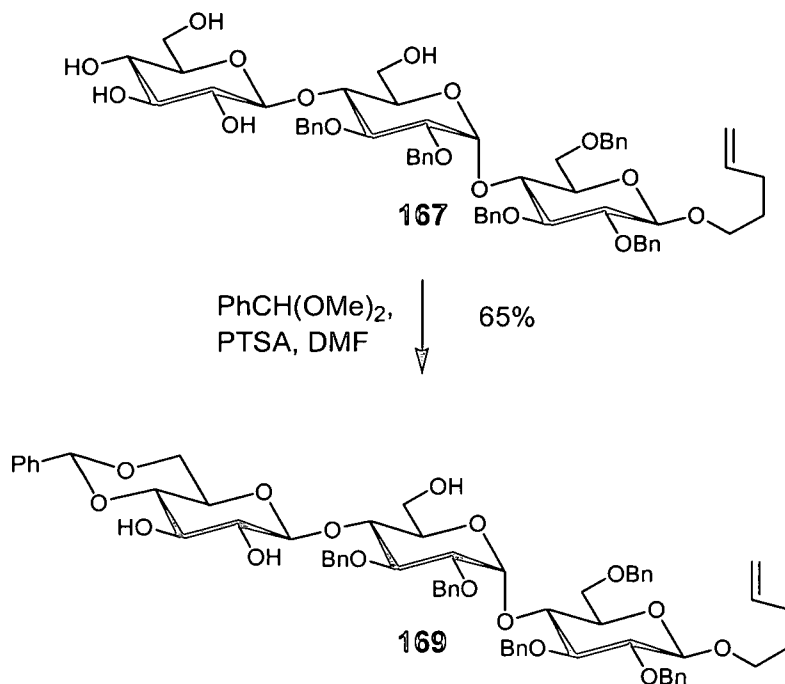

Scheme 4.6: Acetal formation.

4.7 Formation of Pentyl Trisaccharide (170)

The pentyl trisaccharide (170), scheme 4.7, was obtained from a reaction involving a mixture of the benzylidene acetal (169) and the benzyl ether compound (167). They were mixed due to a cross-contamination during handling. Nevertheless treatment with $\text{Pd(OH)}_2/\text{C}$, H_2 in ethanol¹²⁷ provided compound (170) in excellent yield (99%). The material was taken to the oxidation step without further purification.

The data was in good agreement with the proposed structure. No aromatic signals were present in the NMR spectra. The sodium adduct was present in the high-resolution mass spectrum within 1.8 ppm of the theoretically calculated value.

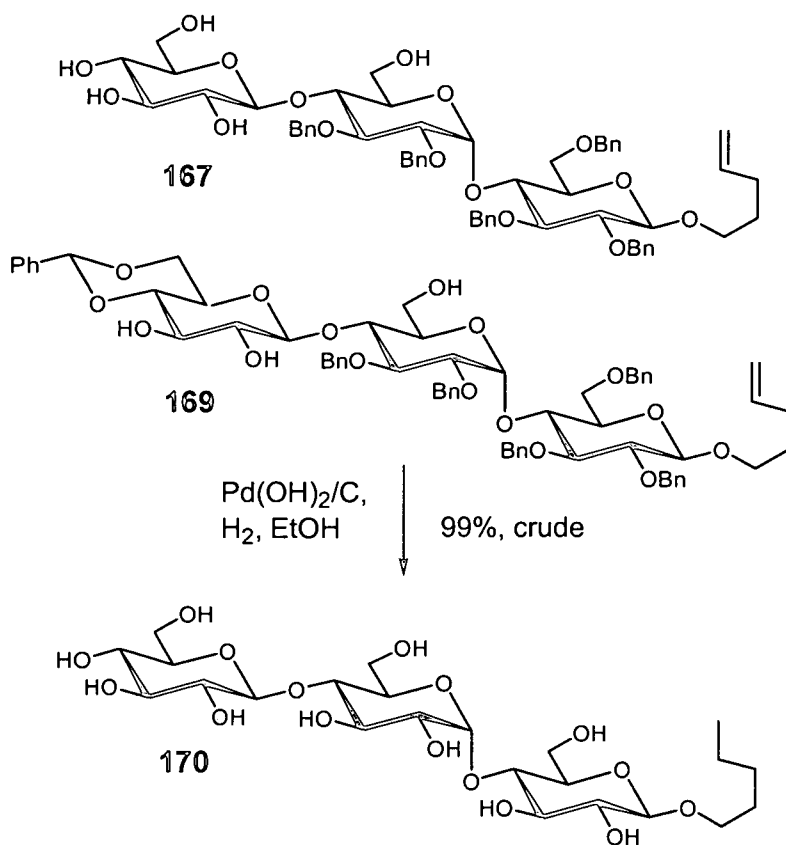

Scheme 4.7: Hydrogenolysis of (167) and (169) to give (170).

4.8 The Selective Oxoammonium ion-Catalysed Oxidation of Primary Alcohols

The conversion of alcohols to carbonyl derivatives is one of the fundamental transformations of organic chemistry. The most usual reagents for these transformations include chromium (VI) oxides,⁵⁹ dipyridine chromium (VI) oxide,¹³¹ pyridinium chlorochromate¹³² and pyridinium dichromate.¹³³ More selective reagents that have been developed include activated dimethyl sulfoxide reagents,¹³⁴ Dess-Martin periodinate¹³⁵ and tetrapropylammonium perruthenate.¹³⁶ The selective oxidation of one alcohol group in the presence of another, particularly of a primary in the presence of a secondary, is a difficult conversion in organic synthesis. It is also desirable to use catalytic methods in the presence of environmentally benign primary oxidants such as oxygen, hydrogen peroxide or hypochlorite.

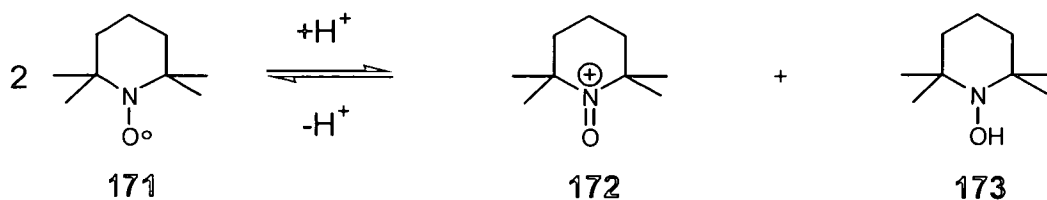

Scheme 4.9.

Below pH 2 an acid catalysed disproportionation of the nitroxyl radical (171) becomes favourable.¹⁴¹ If a catalytic amount is used, the nitroxyl radical has to be regenerated from the hydroxylamine in a one-electron reaction by a primary oxidant. Above pH 3 a rapid syn proportionation occurs between (172) and (173) to give two nitroxyl radicals (171), i.e. the reverse reaction.¹⁴¹ It is generally assumed that the oxidising oxoammonium salt (172) in the catalytic cycle is formed by a radical oxidation of the nitroxyl radical by a primary oxidant, but a direct two-electron oxidation of the hydroxylamine may also be possible, depending on the nature of the primary oxidant.

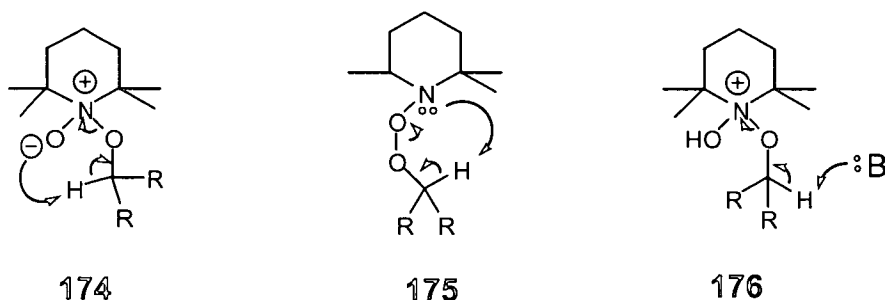
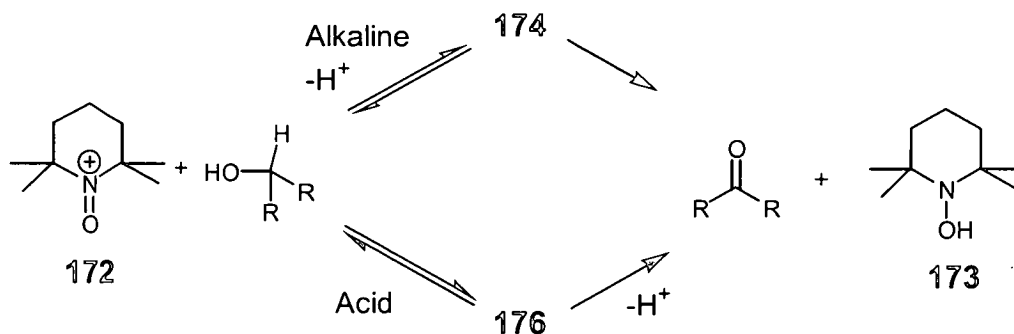

Figure 4.1.

The mechanism of reaction between (172) and the alcohol is still unclear. Perhaps the adduct (174) is formed, figure 4.1, which undergoes a Cope-like cyclic elimination to produce the carbonyl species and the hydroxylamine (173).^{141,142} Semmelhack *et al.*¹⁴³ have excluded the possibilities of a radical mechanism or a hydride abstraction. They favoured adduct (174) although adduct (175) could not be excluded. Ma and Bobbitt¹⁴⁴ proposed adduct (176) that could undergo a concerted acyclic elimination, based upon the fact that they found, unlike Sammelhack *et al.*, that there were few steric effects in the concerted oxidation of alcohols. de Nooy *et al.*¹⁴⁵ noted that under alkaline conditions steric effects became far more important, whereas in acid conditions comparable rates were found for primary and secondary

alcohols. On the basis of these observations they postulated that the reaction pathways might go through the sterically demanding cyclic reaction mechanism (174) under alkaline conditions but through the acyclic reaction mechanism (176) under acidic conditions, scheme 4.10.



Scheme 4.10.

4.8.4 Products of the Reaction of Primary Alcohols

The product of primary alcohol oxidation is the aldehyde when the reaction is carried out in an organic solvent. This implies that the oxoammonium ion itself does not oxidise the aldehyde to the carboxylic acid. It has been observed that under two phase (organic-aqueous) conditions, hydrophobic substrates were over-oxidised to carboxylic acids.¹⁴⁶ When the oxidation is carried out in aqueous solution the product is exclusively the carboxylic acid.¹⁴⁵ The intermediate aldehyde was detected and it was concluded that the aldehyde is oxidised in its hydrated form in the same manner as for the alcohol.

4.8.5 *In Situ* Regeneration of the Oxoammonium Salt by a Primary Oxidant

The vast majority of work has relied upon a primary oxidant to regenerate the oxoammonium species from the hydroxylamine. The disadvantage is that the primary oxidant must be present in solution but the advantages are that the method is generally milder than the acid-catalysed disproportionation and that an environmentally clean primary oxidant may be used (e.g. O₂/Cu in organic solvents, hypochlorite). A very high selectivity for primary alcohols in the presence of secondary ones can be obtained. This selectivity is found with only a few other

reagents (e.g. some ruthenium,¹⁴⁷ zirconium¹⁴⁸ and nickel¹⁴⁹ complexes, silver (I) carbonate on celite,¹⁵⁰ Pt/O₂¹⁵¹ and N₂O₄¹⁵²). For the oxidation of primary and secondary alcohol-containing polyols the use of the mild nitroxyl radical oxidation is preferable, however. For example the β-elimination of substrates has not been observed despite the use of alkaline conditions, probably due to the mildness of the procedures that have been developed. In a comparative study of the TEMPO and Pt/O₂ oxidation methods, oxidation of methyl 4-*O*-methyl-α-D-glucopyranoside (177), the TEMPO oxidation gave a far higher yield of methyl 4-*O*-methyl-α-D-glucopyranosiduronic acid (178) (90%) than the latter method (50%).¹⁵³ This has also been observed with the oxidation of carbohydrate polymers, which barely react with Pt/O₂ perhaps because of the heterogenous nature of the oxidant.¹⁵⁴

4.8.6 Homogeneous Oxidation in Aqueous Solution

Despite the instability of oxoammonium ions in water, particularly at high pH, nitroxyl radical mediated oxidation has been successfully carried out, probably because the reaction of oxoammonium ions is more rapid with alcohols than with hydroxide ion, scheme 4.11.

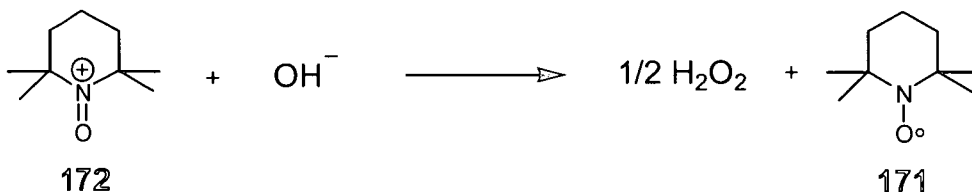

Scheme 4.11: Decomposition of (172) in aqueous solution.

For hydrophilic carbohydrates aqueous solution is probably the method of choice for nitroxyl radical mediated oxidation. Water has environmental advantages over organic solvents. de Nooy and co-workers¹⁴⁵ have developed a method using hypochlorite as the primary oxidant with about 0.01 equivalents of TEMPO in an homogenous aqueous solution, whereby primary alcohols of various carbohydrates can be oxidised. A pH of 10 was found to give the highest oxidation rate and carboxylic acids were found, as expected, to be the products.

Györgydeak and Thiem¹⁵⁵ used this procedure on glycopyranosyl azides, which were oxidised with high selectivity. The resulting carboxylic acid was then methylated using methyl iodide and acetylated using acetic anhydride and DMAP to give the fully protected glucuronyl azides in good yields (45-82%). This was attractive because it avoided difficulties in work-up and was more amenable to small-scale reaction than the procedures developed by de Nooy.¹⁴⁵ An adaptation of Györgydeak and Thiem's procedure is described in the experimental section.

Haller and Boons⁶⁹ have used the aqueous method to form the partially protected trisaccharide (105), scheme 1.17, in very good yield (89%). The oxidation occurred in the presence of TBDPS, *N*-acetyl and *iso*-butyl protecting groups. In a separate series of experiments involving disaccharides they found that the oxidation procedure was compatible with the presence of sulfate esters.

4.8.7 Organic-Aqueous Conditions

Anelli and co-workers^{156,157} found a convenient method for oxidation of alcohols under two-phase conditions (DCM-water) using the cheap and relatively clean primary oxidant sodium hypochlorite. The use of bromide as a co-catalyst increased the rate and the system was buffered at pH 8.5-9.5 with NaHCO₃. Bromide was converted into hypobromite, a stronger oxidant under these conditions. Aldehyde oxidation was found to be slow but the rate was increased by the addition of a quaternary ammonium salt (phase transfer catalysis). Nitroxyl radical mediated oxidations are, in general, very rapid when the primary oxidant is hypochlorite-bromide, even with only 0.01 equivalents of nitroxyl radical the reaction is over in a few minutes.¹⁵⁷ It seems that the rate-limiting step in systems with other primary oxidants is therefore the oxidation of the hydroxylamine back to the oxoammonium salt. Primary alcohols reacted substantially faster than secondary alcohols. Davis and Flitsch⁷⁰⁻⁷² oxidised several partially protected monosaccharide derivatives to obtain uronic acids, scheme 1.18. The partially protected monosaccharides were hydrophilic and were therefore drawn into the aqueous layer and oxidised to the carboxylic acid (which was difficult to isolate). Workup was achieved by methylation of the carboxylic acid prior to extraction into an organic solvent.

4.9 Development of an Oxidation Method for this Project

A number of problems had been encountered during the nitroxyl-radical mediated oxidation of partially protected oligosaccharides attempted by Dr. Underwood.⁷³ For example the oxidation of partially protected trisaccharide (**142**) failed under the standard two-phase conditions developed by Anelli and co-workers, scheme 4.12.^{156,157}

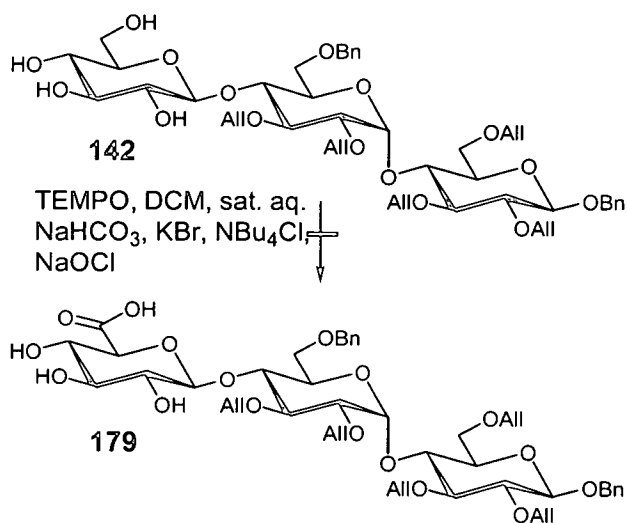

Scheme 4.12.

The oxidation of the more polar trisaccharide (**180**) by the homogenous aqueous method,¹⁴⁵ scheme 4.13, was the only successful example of a nitroxyl-radical mediated oxidation on an oligosaccharide reported by Dr. Underwood. The failure of the other oligosaccharides to oxidise was attributed to solubility issues.

In an effort to overcome the solubility problems described above, model compound studies were undertaken in this project prior to nitroxyl radical mediated oxidation of precious late-stage trisaccharides. The monosaccharide model compounds of interest were methyl α -D-glucopyranoside (MGP) (**182**) and phenyl β -D-glucopyranoside (**183**). Both two-phase (organic-aqueous) and homogenous (aqueous) methods were investigated.

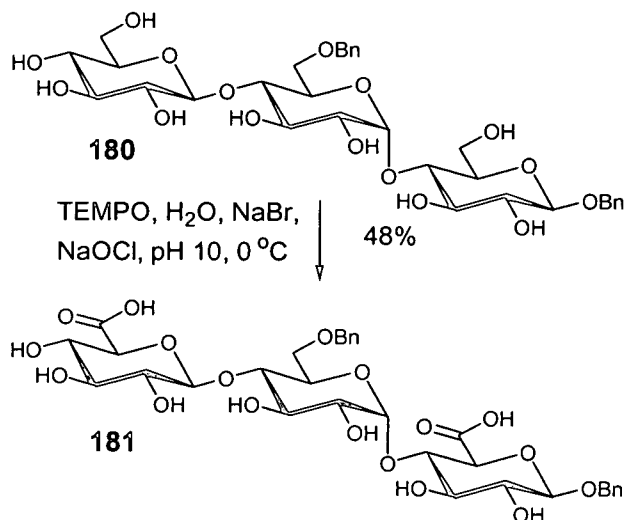

Scheme 4.13.

4.9.1 Development of a homogenous aqueous solution nitroxyl radical-mediated oxidation for hydrophilic substrates

The method developed by de Nooy and co-workers¹⁴⁵ was used, table 4.1 method 1. To a solution of (182) or (183) in water was added a small quantity of sodium bromide and a catalytic portion of TEMPO. Hypochlorite (0.7 M) was adjusted to a pH of 10 with HCl and then added. The reaction mixture was maintained at pH 10 by addition of sodium hydroxide. The reaction had reached completion once there was no appreciable change in pH, i.e. uronic acid was no longer being formed and this usually occurred within half an hour. The reaction was quenched by stirring in the presence of ethanol for an hour and then concentrated. Comparison with commercially available samples of methyl α -D-glucopyranosiduronic acid (184) and phenyl β -D-glucopyranosiduronic acid (185) was positive, so the issue was then how to purify the compounds. Salts were present in large quantities that could not be removed by dialysis, size-exclusion chromatography or a de-salting column, because the uronic acids produced were too small. An ion-exchange column was unsuitable because the HCl generated in the eluent would probably hydrolyse the saccharides. An alternative to direct purification was to chemically modify the products prior to isolation (schemes 4.14 and 4.15). It was decided to convert the acids into the methyl esters and the hydroxyls to acetates. At first introduction of the methyl ester was

attempted using diazomethane¹⁵⁸ (explosive), but this procedure did not produce reliable results.

Investigation of a method that used methyl iodide was more fruitful. The method was adapted from the procedure described by Györgydeak and Thiem.¹⁵⁵ The dry material containing the acid (184) or (185) and salts from the oxidation reaction was desiccated over P₂O₅ overnight in a strong vacuum then dissolved in anhydrous DMF, schemes 4.14 and 4.15. Addition of methyl iodide and 24 h reaction time converted the acid to the methyl ester (186) and (187). Next acetic anhydride and DMAP were added and the reaction mixture was stirred overnight then worked up to yield the fully protected products (188) and (189) in a good overall yield (70% and 85% respectively).

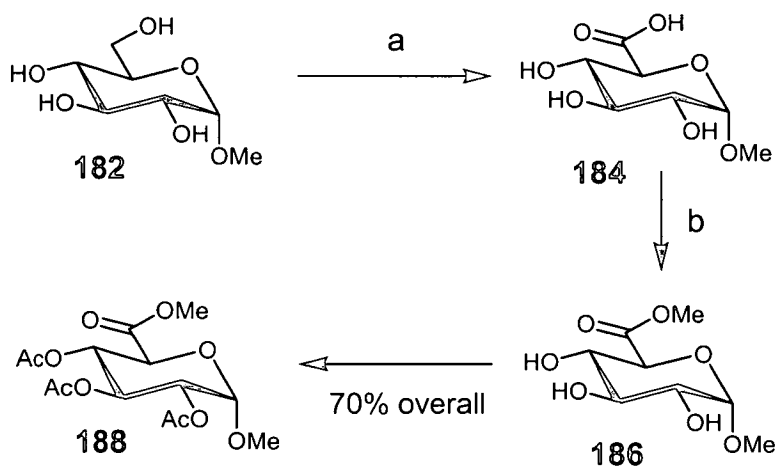

(a) TEMPO, NaOCl, NaBr, H₂O, pH 10, 0 °C; (b) MeI, DMF, then Ac₂O, DMAP

Scheme 4.14: MGP oxidation and protection.

The data for both compounds compared well with that previously reported.¹⁵⁹⁻¹⁶²

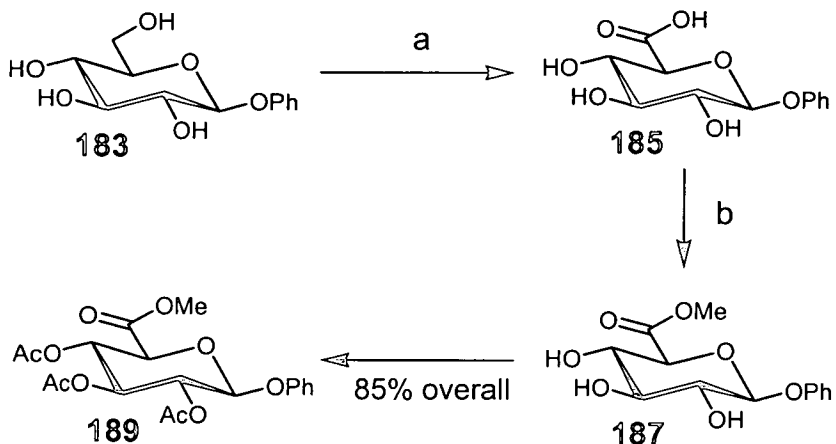

(a) TEMPO, NaOCl, NaBr, H₂O, pH 10, 0 °C; (b) MeI, DMF, then Ac₂O, DMAP

Scheme 4.15: Oxidation and protection of (183).

4.9.2 Development of a nitroxyl radical mediated oxidation for the oxidation of less polar substrates

Anelli *et al.*^{156,157} developed an organic-aqueous method that was adapted by Davis and Flitsch⁷⁰⁻⁷² in their oxidation of partially protected monosaccharides, scheme 1.18. Davis and Flitsch found the uronic acid product at the interface between the DCM and aqueous layers and used DOWEX 50H⁺ in methanol to form the methyl ester that could be isolated. There have been reports of the failure of this procedure, however, so in order to investigate other methods for the oxidation of carbohydrates the monosaccharide model compounds (182) and in particular (183) were studied. Phenyl β-D-glucopyranoside (183) contained a useful chromophore that enabled the reaction to be monitored by RP-HPLC. Table 4.1 lists the methods that were investigated.

Method 1 was the homogenous oxidation in aqueous solution, derived from the procedure developed by de Nooy *et al.*¹⁴⁵ Bleach was used as the primary oxidant with bromide as co-catalyst. The method was adapted successfully and is discussed in section 4.9.1 above (it is included in this section for the sake of completeness).

Method	Substrate	Solvent	Oxidant	Catalyst	Other	Result
1	(182)	water	NaOCl	NaBr		Product
2	(183)	MeCN/ Buffer	NaO ₂ Cl	NaOCl	35°C	Product & starting material
3	(183)	DCM/aq. NaHCO ₃	NaOCl	NBu ₄ Cl	KBr	5 peaks
4	(183)	DCM/aq. NaHCO ₃	NaOCl	Aliquat 336	KBr	5 peaks
5	(183)	DCM/aq. NaHCO ₃	NCS	NBu ₄ Cl	K ₂ CO ₃	No Reaction
6	(183)	MeCN	CuCl ₂		CaH ₂	No Reaction

Table 4.1, TEMPO radical mediated oxidation under a variety of conditions.

Method 2 was a two solvent system derived from the method developed by Zhao *et al.*,¹⁶³ using acetonitrile and aqueous phosphate buffer. Sodium chlorite was the primary oxidant with a catalytic amount of co-oxidant sodium hypochlorite, that catalysed the formation of hypochlorite from chlorite. Acetonitrile and water were miscible, but the high concentration of phosphate buffer in the aqueous layer led to decreased mixing of the layers. Vigorous stirring of the solution was required to ensure the maximum homogeneity of the system.

The reaction produced a mixture of the starting material and the uronic acid with no other peaks present by HPLC. By increasing the proportions of the oxidants and buffer in method 2 it was possible to drive the reaction to completion so that only phenyl β -D-glucopyranosiduronic acid (185) was observed in the HPLC chromatogram.

Method 3 was a biphasic organic-aqueous oxidation, derived from the method developed by Anelli *et al.*^{156,157} Dichloromethane, an aqueous bicarbonate phase and tetrabutylammonium chloride (TBACl) as the phase transfer reagent were used. The

analysis of the reaction mixture revealed five peaks that included starting material and uronic acid along with other side products that probably included the aldehyde and the hydrated aldehyde.

Method 4 was similar to method 3 but with Aliquat 336 rather than TBACl as phase transfer catalyst. A similar result to method 3 was obtained.

Method 5 was another derivation of method 3 and employed *N*-chlorosuccinimide as oxidant and potassium carbonate as base. Under these conditions no reaction was observed.

Method 6 was a homogenous organic system, derived from the method developed by Semmelhack and co-workers.¹⁶⁴ Cupric chloride was used in a stoichiometric amount as the primary oxidant and calcium hydride was used to neutralise the HCl formed during the reaction. No reaction was observed under these conditions.

4.10 Results from the use of Nitroxyl Radical Mediated Oxidation in this Project

Methods 1 and 2 were chosen for the oxidation of the partially protected trisaccharides. Compounds (160), (161), (167) and (169) were oxidised by method 2 as they contained a number of hydrophobic protecting groups. Compounds (168) and (170) were oxidised by method 1 as they contained very little protection and were therefore hydrophilic.

4.10.1 Preparation of Compound (190)

(160) was oxidised to (190) as described above (method 2) and the reaction mixture was concentrated and then purified by RP-HPLC, scheme 4.16. Despite the loss of a significant amount of material during workup (due to a bumping of solution during concentration) 2.8 mg (12%) of material was obtained after preparative HPLC.

The data recorded was in good agreement with the proposed structure. The NMR spectra of (190) were very clean (see appendix). A comparison of the chemical shift and coupling values for H-5'' clearly showed that this position had been oxidised, scheme 4.16. The sodium adduct in the high-resolution mass spectrum was within 1.6 ppm of the theoretically calculated value.

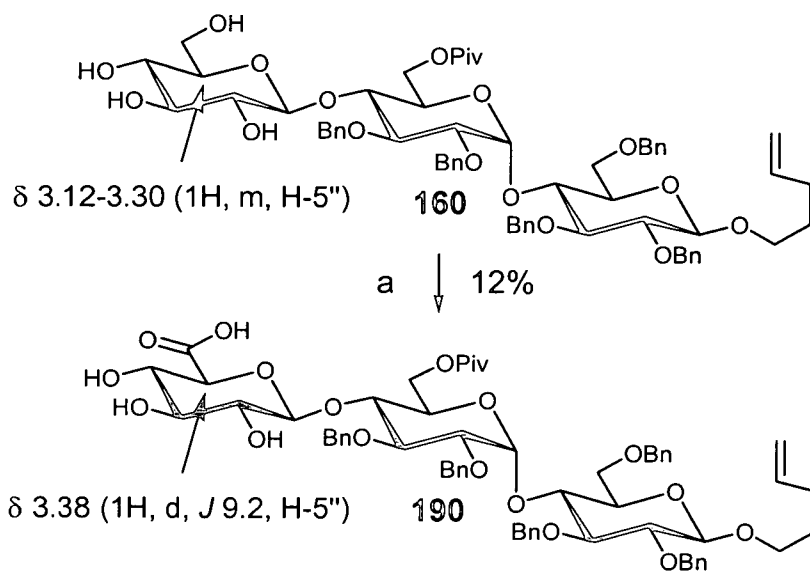

(a) TEMPO, NaO₂Cl, NaOCl, phosphate buffer pH 6.7, MeCN

Scheme 4.16: Oxidation at C-6'' altered the NMR signals.

4.10.1.1 Comment

This was the first example of the successful application of the nitroxyl radical-mediated oxidation to a partially protected oligosaccharide in this project. The solubility problems had been overcome to an extent, but the reaction was still low yielding (12%). This was probably due to material loss, but the experiment was not repeated to verify this because of a lack of sufficient material.

In compound (160) the non-reducing end of the molecule had an entirely different polarity to the central ring and the reducing end as both of these rings were heavily masked in benzyl ethers, a *t*-butyl ester and a pent-4-enyl group. Such molecules had unusual solubility properties and perhaps were not suited to Anelli's method of TEMPO-mediated oxidation (method 3).^{156,157} Acetonitrile, a water-miscible organic solvent, was more suited to dissolving these carbohydrates and the necessary oxidants.

4.10.2 Preparation of compound (191)

The de-benzylated trisaccharide (161) was oxidised by method 2 in reasonable yield (8.8 mg, 56%), scheme 4.17.

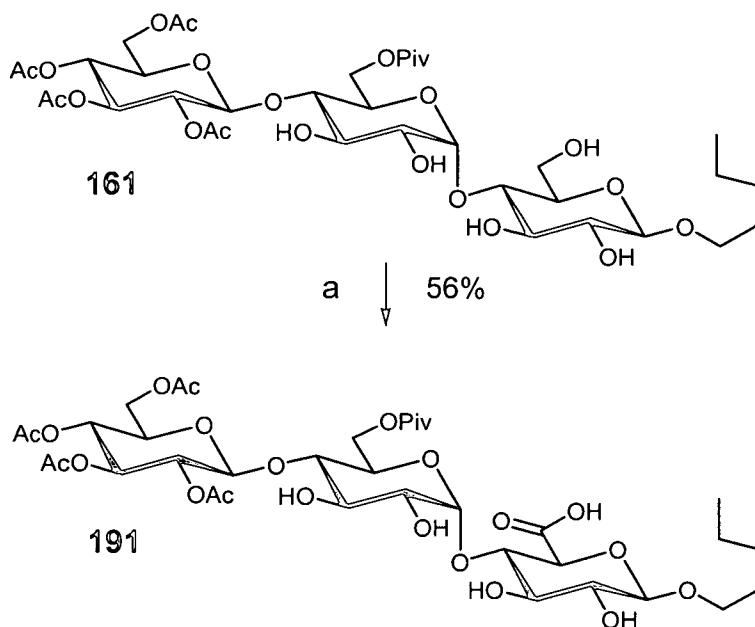

(a) TEMPO, NaO₂Cl, NaOCl, phosphate buffer pH 6.7, MeCN

Figure 4.17: Oxidation in ring 1.

The data recorded was in good agreement with the proposed structure. The NMR spectra were very clean (see appendix). The downfield shift for H-5 in the ¹H-NMR spectrum was small, but the change in multiplicity from multiplet to doublet indicated that oxidation had occurred at C-6. The sodium adduct was found to be within 0.58 ppm of the theoretically calculated value in the high-resolution mass spectrum.

4.10.2.1 Comment

This result showed that a reasonable yield (56%) was attainable from these oxidations, even on very small amounts (18.8 μmol) of partially protected trisaccharides. Although compound (**161**) had no benzyl ethers, it still contained the hydrophobic pent-4-enyl group, the pivaloyl group and the acetyl groups. Compound (**161**) was considerably more polar than compound (**160**) and this may have been a factor in the higher yield for the oxidation steps.

4.10.3 Preparation of compound (192)

Oxidation method 2 was used to form (192) from (167) in reasonable yield (12.8 mg, 52%), scheme 4.18. Because there were two primary hydroxyl groups to be oxidised the quantity of reagents was doubled as was the volume of the liquid components. In this way the concentration of the reagents was not varied and so a more direct comparison between the oxidation reactions could be made.

The data recorded was in good agreement with the proposed structure. Comparison of the H-5' and H-5'' chemical shifts and coupling constants in the ¹H-NMR with those of the starting material showed that oxidation had occurred at C-6' and C-6''. As a result of HPLC purification the spectra were clean (see appendix). The sodium adduct was found in the high-resolution mass spectrum to be within 0.75 ppm of the theoretically calculated value.

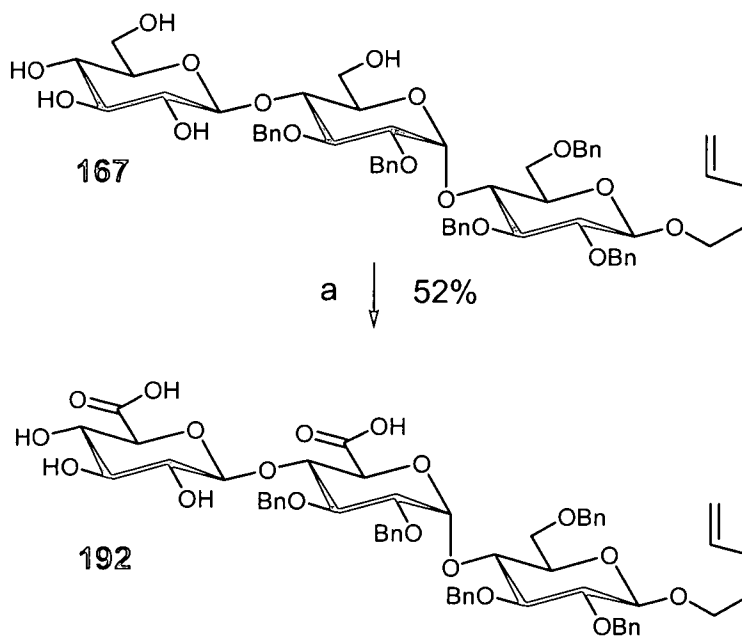

(a) TEMPO, NaO₂Cl, NaOCl, phosphate buffer pH 6.7, MeCN

Scheme 4.18: Oxidation in rings 2 and 3.

4.10.3.1 Comment

The yields for the oxidation of compound (161) (56%) and (167) (52%) are very similar. Perhaps there was a relationship between solubility and yield as both trisaccharides contained five free hydroxyl groups. The difference between

trisaccharides contained five free hydroxyl groups. The difference between compounds (167) and (160) was the presence of the bulky pivaloyl group. Trisaccharide (167) was more polar and this could have been a factor in the larger yield of (192) (52%) relative to (190) (12%). The situation was not straightforward however and a series of experiments under controlled conditions should be carried out in order to investigate what factors affect the yields of these oxidations.

4.10.4 Preparation of compound (193)

Finally the oxidation of compound (169) was achieved according to method 2, scheme 4.19. The molecular ion was present in the nominal mass spectrum, which was recorded in negative ion mode. Unfortunately (193) was unstable and broke down before a proper analysis could be recorded.

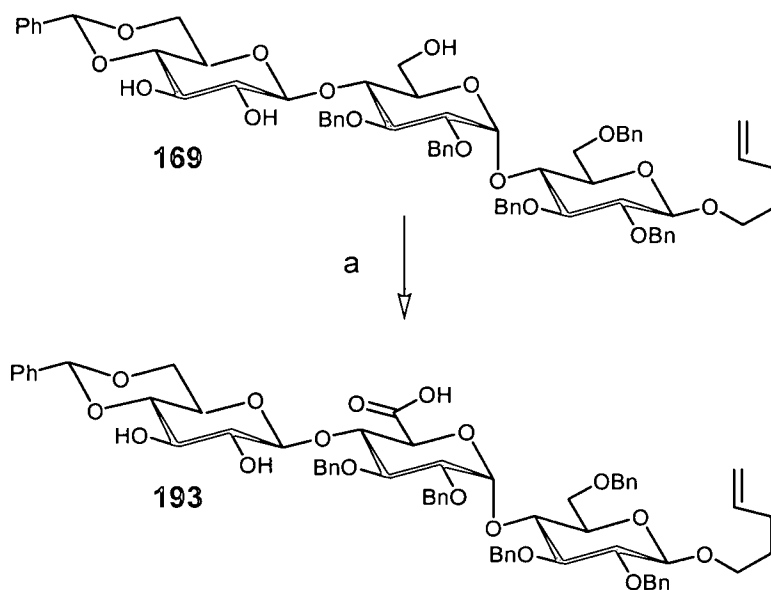

(a) TEMPO, NaO₂Cl, NaOCl, phosphate buffer pH 6.7, MeCN

Scheme 4.19: Oxidation in ring 2.

4.10.5 Preparation of compound (194)

The oxidation of compound (168) did not proceed by method 2, but because there was no side reaction it was possible to recover the starting material. Compound (168) was oxidised by method 1 on a small scale (16.2 mg, 24.6 μmol), scheme 4.20.

Isolation of (194) was difficult due to the large quantity of salt produced under the reaction conditions. RP-HPLC was unsuccessful because the product was so polar that it eluted with the salt. Trisaccharide (194) was also too small to be separated from salts by size exclusion chromatography or dialysis. Ion-exchange chromatography was unsuitable because the HCl generated might hydrolyse the anomeric linkages. Chemical modification¹⁵⁵ similar to that described in section 4.9.1 was attempted, but was unsuccessful on this occasion for unknown reasons. Finally compound (194) was isolated as the di-sodium salt in quantitative yield, by filtration through a small plug of silica (elution was with methanol). This removed substantial quantities of salt, but may also have introduced dissolved silica impurities.

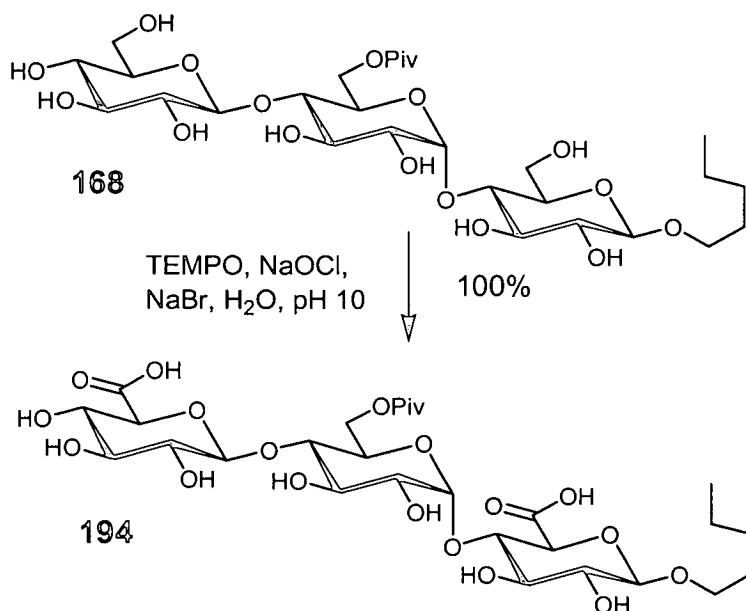

Scheme 4.20: Oxidation in rings 1 and 3.

The data obtained was in good agreement with the proposed structure. Comparison of positions H-5 and H-5'' in the ¹H-NMR spectra of starting material and product indicated that oxidation had occurred at C-6 and C-6''. The sodium adduct of the di-

sodium salt of (194) was found in the high-resolution mass spectrum ($m/z = 753.2170$), which was precisely the theoretically calculated value.

4.10.5.1 Comment

Although compound (168) was soluble in the acetonitrile-aqueous phosphate buffer system (method 2), the polarity was certainly a factor in its failure to be oxidised under those conditions.

Although the homogenous aqueous oxidation (method 1) afforded the desired product, it was necessary to develop methods for the isolation of the products of this reaction. Alternatively another set of homogenous aqueous conditions could be developed. Perhaps the monophasic oxidation could be carried out in a buffered system, if the buffer was ammonium acetate, which is volatile, there would be no need to remove the salts by other methods.

4.10.6 Preparation of compound (195)

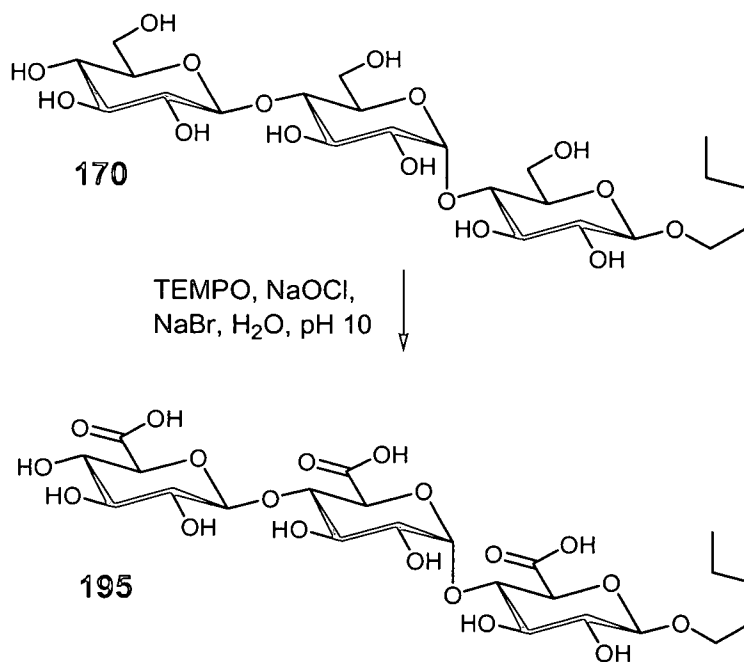

Scheme 4.21: Oxidation in all three rings.

The oxidation of trisaccharide (170), which was only protected at the anomeric position, was unlikely to be successful using the acetonitrile and sodium chlorite

oxidation (method 2) as it is even less likely to dissolve in the acetonitrile layer than the previous analogue (168), which also contained a bulky pivaloyl ester. The reaction was attempted in order to investigate whether the previous result was down to polarity issues. Only starting material was observed after overnight reaction, so (170) was recovered and oxidised according to method 1 instead. A lowering of the pH indicated that acid was being formed.

Purification was even more difficult than for compound (194) because compound (195) was only soluble in water, not in methanol.

Neither a yield nor NMR data could be obtained because of the salt impurities. The nominal mass spectrum was recorded in negative ion mode and indicated the molecular ion ($204 = M^{3-}/3$) as base peak.

4.10.6.1 Comment

The use of method 1 for the oxidation of trisaccharides bearing little or no protecting groups and method 2 for the oxidation of partially protected trisaccharides was a powerful strategy in the reduction of synthetic steps for the synthesis of anionic carbohydrates. A method for the purification of the highly polar trisaccharides (194) and (195) from inorganic salts is required.

4.11 The advantages of the nitroxyl radical-mediated oxidation on oligosaccharides relative to traditional methodology

The advantages of nitroxyl radical-mediated oxidation for the selective oxidation of the primary alcohols present in carbohydrate derivatives are indicated in Scheme 4.22. The oxidation of trisaccharide (168) (pathway A) to uronate derivative (194) was achieved using the TEMPO-mediated oxidation with a relatively environmentally friendly primary oxidant ($\text{NaO}_2\text{Cl}-\text{NaOCl}$) and is described in the experimental section, scheme 4.20. In traditional non-selective protection and oxidation strategy this would have required five steps (pathway B) instead of one.

Few other reagents are known for the oxidation of primary alcohol groups over secondary ones (section 4.8.5) and from a synthetic point of view, nitroxyl radical-mediated oxidation has been shown to be superior to these methods for the selective oxidation of carbohydrates.

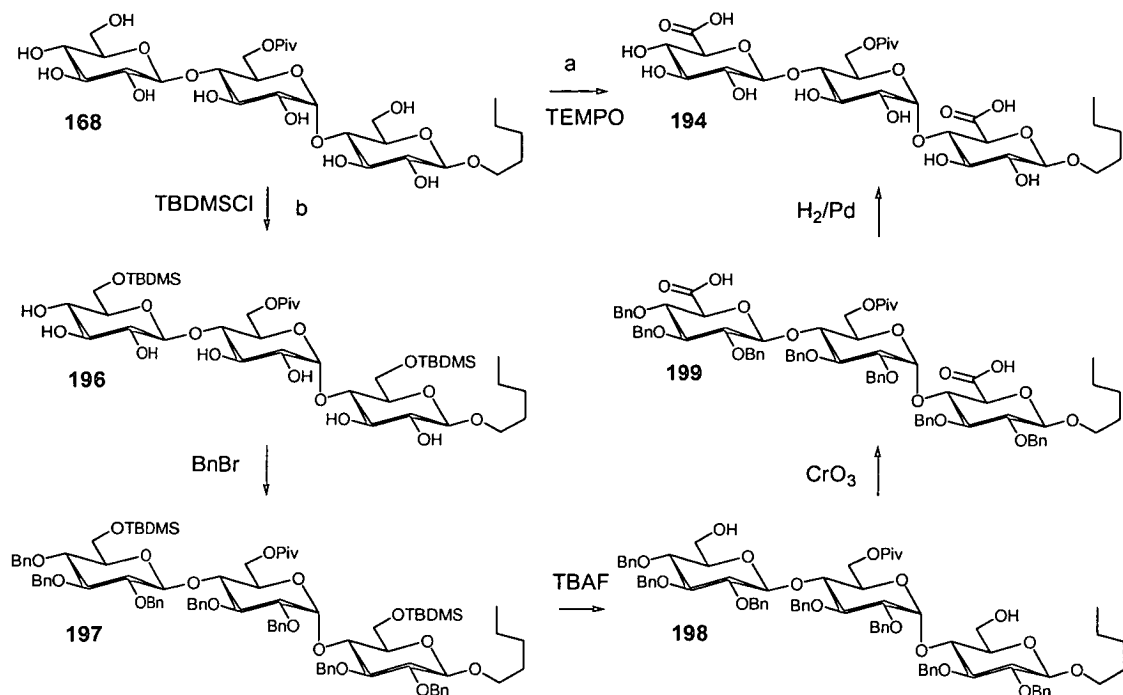

Scheme 4.22: The use of TEMPO oxidation can make a huge difference to the number of synthetic steps.

4.12 Future Work

In order to investigate the nitroxyl-mediated oxidation of partially protected carbohydrates by method 2 a series of experiments on a suitable model compounds could be carried out. The study of model compounds of differing polarities such as intermediates (160) and (170) would be particularly useful. The effects of temperature, reaction time, reagent concentration, buffer pH, etc. would give an insight into how best to approach the oxidation. This knowledge would be particularly useful for the selective oxidation of partially protected oligosaccharides which were not water soluble.

Purification of the products from homogenous aqueous oxidation from the inorganic salts is required. Alternatively the presence of a bulkier substituent such as TBDPS

for permanent protection of the C-6' position would make purification by RP-HPLC more favourable.⁶⁹

Selective sulfation reactions such as those involving stannylene acetal intermediates would be useful in generating HS substructures such as compound (116), figure 1.18.

4.13 Conclusions

Nitroxyl radical mediated oxidations are powerful methods for the selective preparation of uronic acid derivatives from partially protected trisaccharides that allow for a considerable reduction in the number of synthetic steps involved in the synthesis. The use of an organic-aqueous oxidation system was suitable for the oxidation of partially protected saccharides, whereas homogenous aqueous conditions were suited to hydrophilic saccharides.

4.14 Overall Conclusions

The concept of accessing highly anionic oligosaccharides through the introduction of functionality at a late stage in the synthesis has been shown to be feasible. The careful construction of a protecting group array is absolutely vital for a successful synthesis. The removal of five allyl ether protecting groups from trisaccharide (114) was extremely difficult. Comparatively, the removal of benzyl ethers from trisaccharide (149) was easy.

Methods for carrying out selective nitroxyl radical-mediated oxidation reactions on oligosaccharides with different degrees of protection and hence different polarities have been developed. Further development is required for the isolation of products from the homogenous aqueous oxidation.

The nature of the synthesis was efficient, versatile, convergent, repeatable, high-yielding and a vast improvement on the traditional approaches in the area of heparan sulfate and heparin fragment synthesis, which are inherently low yielding. There is scope for extending the library of compounds produced from trisaccharide (149).

Chapter 5. Experimental

5.1. General Experimental

5.1.1. Instrumentation

¹H-NMR and ¹³C-NMR spectra were recorded on Bruker AC 200, Bruker AC 250, Bruker WH 360, Varian Gemini 200 and Varian Inova 600 instruments. Electrospray (ES) mass spectrometry was performed using a Micromass platform II instrument. Fast Atom Bombardment (FAB) mass spectrometry was performed using a Kratos MS50TC instrument. Infrared spectroscopy was performed using a Perkin Elmer Paragon 1000 FT-IR spectrometer. Optical rotations were measured on an Optical Activity AA-1000 polarimeter (sodium 589 nm detection). Melting points were recorded on a Gallenkamp melting point apparatus and were uncorrected. Regulation of pH for the aqueous oxoammonium-ion catalysed oxidation reaction was achieved using a Metrohm 718 STAT Titrino.

5.1.2. Chromatography

Analytical thin layer chromatography (TLC) was performed using aluminium-backed plates coated with silica gel 60F₂₅₄ (Merck: layer thickness of 0.2 mm). Identification was carried out using U.V. fluorescence (254 nm), *p*-anisaldehyde, ammonium molybdate, potassium permanganate and ninhydrin dips. Flash column chromatography was carried out with a variety of columns using BDH silica gel (40-63 μm) and Biotage pre-packed cartridge systems.

5.1.3. Solvents and Reagents

All solvents and reagents were standard laboratory grade unless otherwise stated. Dry solvents were purchased from Aldrich or Acros and used directly. All purifications were carried out according to standard procedures.¹⁶⁵

5.1.4. High Performance Liquid Chromatography (HPLC)

The reverse phase HPLC system was comprised of a tuneable Waters 486 Absorbance Detector, a Waters 600E pump and controller and a Waters 717 plus autosampler. These were managed by the Waters Millennium Chromatography software package. For analytical work the Phenomenex Sphereclone 5 μ ODS(2) column was used, for preparative work the Anachem S5ODS2 column was employed.

The Dionex HPLC system consisted of an ED40 electrochemical detector, a GP40 pump, a PA100 column and the PeakNet software package.

5.2 Experimental for Chapter 2

Acetyl 4-*O*-(2',3',4',6'-tetra-*O*-acetyl- α -D-glucopyranosyl)-2,3,6-tri-*O*-acetyl- β -D-glucopyranoside (124)⁷⁷

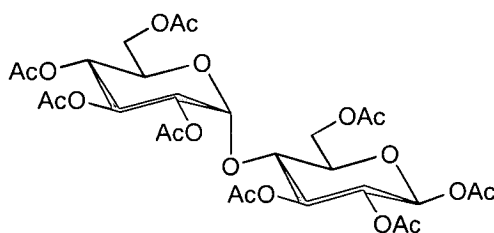

Maltose (123) (20.0 g, 58.5 mmol) and dimethylaminopyridine (0.63 g, 5.16 mmol) were dissolved in freshly distilled pyridine (60 ml) and cooled in an ice bath. Acetic anhydride (180 ml, 1.90 mol) was added and the solution was stirred under an argon atmosphere for 1 h, and then diluted with chloroform (160 ml). It was then washed with hydrochloric acid (1 M, 2 x 250 ml), saturated aqueous sodium hydrogen carbonate (160 ml) and water (2 x 160 ml). The organic washings were dried (magnesium sulfate) filtered and concentrated to yield (124) as a white solid (38.7 g, 97%). The data obtained was in good agreement with that previously reported.⁷⁷⁻⁷⁹

R_f 0.30 (EtOAc-PE 1:1); m.p. 153-156 $^{\circ}$ C (CHCl_3); lit.⁷⁷ m.p. 159-160 $^{\circ}$ C (CHCl_3); $[\alpha]_D^{23} +65.9$ (c 1.0, CHCl_3), lit.⁷⁷ $[\alpha]_D^{20} +62.9$ (c 1.0, CHCl_3); ν_{\max} ($\text{CHCl}_3/\text{cm}^{-1}$) 3000 (CH), 1750 (C=O); δ_H (200 MHz, CDCl_3): 2.00, 2.01, 2.01, 2.02, 2.04, 2.10,

2.10 and 2.13 (24H, 8s, 8 x -C(O)CH₃), 3.78-3.88 (1H, m, H-5), 3.88-3.98 (1H, m, H-5'), 3.98-4.08 (2H, m, H-4 and H-6'), 4.18-4.28 (2H, m, H-6 and H-6'), 4.45 (1H, dd, *J* 2.6 and 12.3, H-6), 4.85 (1H, dd, *J* 4.0 and 10.5, H-2'), 4.97 (1H, dd, *J* 8.1 and 9.4, H-2), 5.05 (1H, dd, *J* 9.6 and 9.9, H-4'), 5.29 (1H, dd, *J* 8.8 and 9.4, H-3), 5.33 (1H, dd, *J* 9.6 and 10.5, H-3'), 5.40 (1H, d, *J* 4.0, H-1'), 5.74 (1H, d, *J* 8.1, H-1); lit.⁷⁹ δ_{H} (250 MHz, CDCl₃): 1.93-2.07 (24H, m, 8 x C(O)CH₃), 3.75-3.81 (1H, m, H-5), 3.85-3.90 (1H, m, H-5'), 3.95-4.03 (2H, m, H-4 and H-6'), 4.13-4.24 (2H, m, H-6 and H-6'), 4.37 (1H, dd, *J* 2.0, 12.0, H-6), 4.80 (1H, dd, *J* 4.0, 10.0, H-2'), 4.91 (1H, dd, *J* 8.0, 9.0, H-2), 5.01 (1H, t, *J* 10.0, H-4'), 5.20-5.28 (2H, m, H-3, H-3'), 5.30 (1H, d, *J* 4.0, H-1'), 5.68 (1H, d, *J* 8.0, H-1); δ_{C} (63 MHz, CDCl₃) 20.3, 20.3, 20.3, 20.4, 20.4, 20.6, 20.6, 20.7 (8xC(O)CH₃), 61.2, 62.3, 67.7, 68.4, 69.0, 69.8, 70.7, 72.2, 72.7, 75.0 (C-2, C-3, C-4, C-5, C-6, C-2', C-3', C-4', C-5' and C-6'), 91.0 (C-1'), 95.5 (C-1), 168.6, 169.2, 169.7, 169.7, 169.8, 170.2, 170.3, 170.4 (8xC(O)CH₃); *m/z* (ES⁺, acetonitrile-water) 701 (MNa⁺, 100%), 696 (MNH₄⁺, 65%).

4-*O*-(2',3',4',6'-tetra-*O*-acetyl- α -D-glucopyranosyl)-2,3,6-tri-*O*-acetyl- α -D-glucopyranosyl bromide (**125**)⁷⁷

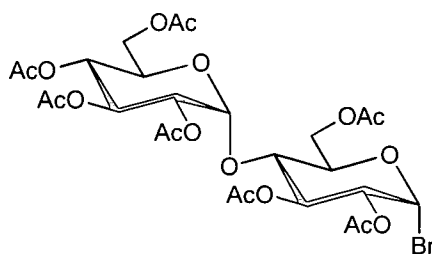

Glacial hydrogen bromide (30%, 100 ml, 0.502 mol) was added to (**124**) (10.0 g, 14.7 mmol) at 0 °C and stirred for 4 h using a calcium chloride drying tube to exclude moisture. The mixture was diluted with dichloromethane (200 ml), washed with saturated aqueous sodium hydrogen carbonate (250 ml) and water (200 ml). The water was extracted with dichloromethane and the combined organic extracts were dried (magnesium sulfate), filtered and concentrated to yield (**125**) as a white solid (10.3 g, 100%). The data was in good agreement with that reported previously.^{77,81} The crude bromide was taken on to the next step without further purification.

R_f 0.30 (EtOAc-PE 1:1); m.p. 76-78 °C (CHCl₃); lit.⁷⁷ m.p. 80-83 °C (CHCl₃); $[\alpha]_D^{25}$ +183.0 (*c* 1.0, CHCl₃); lit.⁷⁷ $[\alpha]_D^{20}$ +180.2 (*c* 1.0, CHCl₃); ν_{\max} (CHCl₃/cm⁻¹) 3000 (CH), 1750 (C=O); δ_H (200 MHz, CDCl₃): 2.01, 2.03, 2.04, 2.07, 2.08, 2.10 and 2.15 (21H, 7s, 7 x -C(O)CH₃), 3.90-3.99 (1H, m, H-5'), 4.01-4.12 (2H, m, H-4 and H-6'), 4.20-4.31 (3H, m, H-5, H-6 and H-6'), 4.50-4.55 (1H, m, H-6), 4.71 (1H, dd, *J* 4.0 and 9.9, H-2'), 4.86 (1H, dd, *J* 4.0 and 10.6, H-2), 5.08 (1H, dd, *J* 9.9 and 9.9, H-4'), 5.35 (1H, m, H-3), 5.42 (1H, d, *J* 4.0, H-1'), 5.61 (1H, dd, *J* 9.9 and 9.9, H-3'), 6.50 (1H, d, *J* 4.0, H-1); δ_C (63 MHz, CDCl₃): 20.4, 20.4, 20.4, 20.5, 20.5, 20.6, 20.7 (7xC(O)CH₃), 61.1, 61.5, 67.6, 68.4, 69.0, 69.7, 70.8, 71.2, 72.3, 85.8 (C-2, C-3, C-4, C-5, C-6, C-2', C-3', C-4', C-5' and C-6'), 95.5 (C-1), 95.5 (C-1'), 169.2, 169.3, 169.3, 169.9, 170.1, 170.3, 170.5 (7xC(O)CH₃); *m/z* (ES⁺, acetonitrile-water) 722 (MNa⁺, 100%), 717 (MNH₄⁺, 63%), 605 (44), 498 (34), 304 (44).

Benzyl 4-*O*-(2',3',4',6'-tetra-*O*-acetyl- α -D-glucopyranosyl)-2,3,6-tri-*O*-acetyl- β -D-glucopyranoside (126)^{86,87,166}

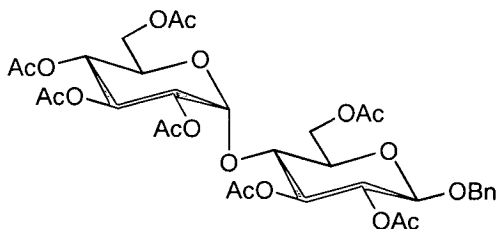

Compound (125) (1.02 g, 1.45 mmol) and silver oxide (365 mg, 1.57 mmol) were placed in a flask to which freshly distilled diethyl ether (15 ml) and benzyl alcohol (3.00 ml, 29.0 mmol) were added. The reaction was left to stir overnight, in the dark (using tinfoil) under positive pressure of argon. The next day the precipitate was allowed to settle and the mixture was filtered through a Celite pad. The filtrate was concentrated and column chromatography [gradient elution, EtOAc-PE (1:3) one column volume \rightarrow (1:1)] yielded (126) as a white solid (623 mg, 60%). The data was in good agreement with that previously reported.⁸⁷

R_f 0.30 (EtOAc-PE 1:1); m.p. 118-120 °C (aq. MeOH); lit.⁸⁶ m.p. 121-123 °C (aq. MeOH); $[\alpha]_D^{22}$ +30.0 (*c* 1.0, CHCl₃); lit.⁸⁷ $[\alpha]_D^{25}$ +28.0 (*c* 1.0, CHCl₃); ν_{\max}

(CHCl₃/cm¹) 1750 (C=O), 1045 (C-O); δ_{H} (250 MHz, CDCl₃): 1.96, 1.97, 1.98, 2.00, 2.00, 2.08 and 2.14 (21H, 7s, 7 x -C(O)CH₃), 3.61-3.67 (1H, m, H-5), 3.91-4.14 (3H, m, H-4, H-5' and H-6'), 4.19-4.27 (2H, m, H-6 and H-6'), 4.49 (1H, dd, *J* 2.8 and 12.1, H-6), 4.55 (1H, d, *J* 7.9, H-1), 4.59 (1H, d, *J* 12.5, -CH₂Ph), 4.83 (1H, dd, *J* 4.0 and 10.5, H-2'), 4.85 (1H, d, *J* 12.5, -CH₂Ph), 4.88 (1H, dd, *J* 7.9 and 9.5, H-2), 5.03 (1H, dd, *J* 9.5 and 10.1, H-4'), 5.20 (1H, dd, *J* 8.8 and 9.5, H-3), 5.33 (1H, dd, *J* 9.5 and 10.5, H-3'), 5.39 (1H, d, *J* 4.0, H-1'), 7.24-7.36 (5H, m, Ph); δ_{C} (63 MHz, CDCl₃): 20.4, 20.4, 20.4, 20.5, 20.5, 20.7 and 20.7 (7 x -C(O)CH₃), 61.4 (C-6), 62.7 (C-6'), 67.9 (C-5'), 68.3 (C-4'), 69.2 (C-2'), 69.9 (C-2), 70.6 (-CH₂Ph), 72.0, 72.0 (C-5, C-3'), 72.6 (C-3), 75.3 (C-4), 95.4 (C-1'), 98.6 (C-1), 127.7, 127.7, 127.9, 128.3 and 128.3 (Ph), 136.4 (q-Ph); 169.3, 169.5, 169.8, 170.1, 170.4, 170.4 and 170.4 (-C(O)CH₃); *m/z* (ES⁺, acetonitrile-water) 749 (MNa⁺, 59%), 744 (MNH₄⁺, 100%), 657 (23), 589 (45), 304 (22).

Benzyl 4-*O*-(α -D-glucopyranosyl)- β -D-glucopyranoside (127)⁸⁰

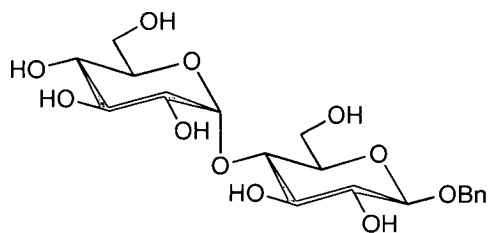

Compound (126) (2.61 g, 3.61 mmol) was dissolved in anhydrous methanol (12.5 ml) and sodium methoxide in methanol (0.5 M, 0.70 ml, 0.35 mmol) was added. The mixture was stirred under argon for 1h then neutralised by ion-exchange resin (hydrogen form, 0.7 g), filtered and concentrated to give (127) as a white solid (1.62 g, 100%). The data was in good agreement with that previously reported.^{80,87} The material was taken through to the next step without further purification.

R_f Baseline (dichloromethane-methanol 9:1); m.p. 141-144 °C (MeOH, EtOAc); lit.⁸⁰ m.p. 147-148 °C (MeOH, EtOAc); $[\alpha]_{\text{D}}^{23}$ +43.3 (*c* 1.0, H₂O); lit.⁸⁰ $[\alpha]_{\text{D}}^{17}$ +47.6 (*c* 5.0, H₂O); δ_{H} (250 MHz, CD₃OD): 3.31-3.49 (4H, m, H-2, H-6, H-4' and H-6'), 3.53 (1H, dd, *J* 3.7 and 9.6, H-2'), 3.60-3.79 (4H, m, H-3, H-5, H-3' and H-5'), 3.88-4.04

(3H, m, H-4, H-6 and H-6'), 4.47 (1H, d, J 7.8, H-1), 4.74 (1H, d, J 11.8, $-CH_2Ph$), 5.01 (1H, m, $-CH_2Ph$), 5.26 (1H, d, J 3.7, H-1'), 7.35-7.52 (5H, m, Ph); δ_C (63MHz, CD_3OD): 62.1, 62.7, 71.4, 71.7, 74.1, 74.6, 74.6, 75.0, 76.6, 77.7, 81.3 (C-2, C-3, C-4, C-5, C-6, C-2', C-3', C-4', C-5', C-6' and CH_2Ph), 102.8 (C-1'), 103.2 (C-1), 128.6, 129.1, 129.2 (Ph), 138.9 (q-Ph); m/z (ES^+ , acetonitrile-water) 455 (MNa^+ , 100%), 230 (43).

Benzyl 4-*O*-(4',6'-*O*-benzylidene- α -D-glucopyranosyl)- β -D-glucopyranoside (128)^{91,93}

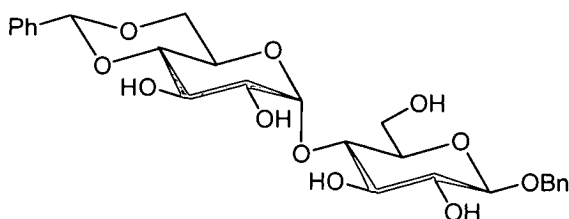

Anhydrous zinc chloride (161 mg, 1.18 mmol) was added to a solution of (127) (0.503 g, 1.16 mmol) in benzaldehyde (4.10 ml, 40.2 mmol) and the mixture was stirred under argon at RT for 3 h. It was then quenched and neutralised using warm saturated aqueous sodium bicarbonate (40 °C), filtered and concentrated. Column chromatography [dichloromethane-methanol (90:1)] gave (128) as a white solid (420 mg, 70%). The data was in good agreement with that previously reported.^{91,93}

R_f 0.37 (dichloromethane-methanol 9:1); $m.p.$ 110-113 °C (MeOH); *lit.*⁹¹ $m.p.$ 110-116 °C (EtOH, PE); $[\alpha]_D^{25} +17.2$ (c 1.1, MeOH); *lit.*⁹³ $[\alpha]_D^{20} +27.3$ (c 1.0, pyridine); δ_H (200 MHz, CD_3OD): 3.34-3.95 (11H, m, H-2, H-3, H-4, H-5, H-6, H-6, H-2', H-3', H-4', H-5' and H-6'), 4.23 (1H, dd, J 4.0 and 9.5, H-6'), 4.39 (1H, d, J 7.7, H-1), 4.66 (1H, d, J 11.7, $-CH_2Ph$), 4.92 (1H, d, J 11.7, $-CH_2Ph$), 5.20 (1H, d, J 3.7, H-1'), 5.56 (1H, s, $-CHPh$), 7.22-7.60 (10H, m, Ph); δ_C (63 MHz, CD_3OD): 61.1, 63.6, 68.6, 70.6, 71.2, 73.0, 73.1, 74.5, 75.7, 80.0, 80.5 (C-2, C-3, C-4, C-5, C-6, C-2', C-3', C-4', C-5', C-6' and CH_2Ph), 101.6 (C-1), 101.6 ($CHPh$), 102.0 (C-1'), 126.3, 127.9, 128.1, 128.2, 128.4, 129.1 (Ph), 137.0, 137.1 (2xq-Ph); m/z (ES^+ , acetonitrile-water) 543 (MNa^+ , 73%), 538 (MNH_4^+ , 71%), 436 (32), 365 (100), 242 (33).

Benzyl 4-*O*-(4',6'-*O*-benzylidene-2',3'-di-*O*-allyl- α -D-glucopyranosyl)-2,3,6-tri-*O*-allyl- β -D-glucopyranoside (**129**)⁷³

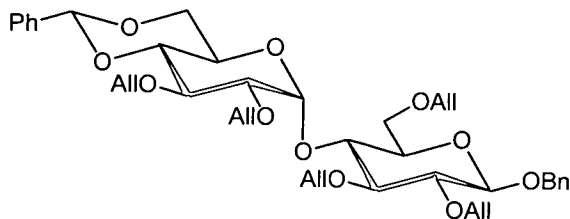

Compound (**128**) (2.50 g, 4.80 mmol) was dissolved in anhydrous dimethylformamide (50 ml) and added to sodium hydride (1.61 g, 67.0 mmol). The suspension was stirred under argon at 0 °C for 30 min. Allyl bromide (3.31 ml, 38.2 mmol) was then added and stirring was continued for a further 30 min at 0 °C then at RT for 2 h. Excess reagents were quenched using anhydrous methanol (30 ml) and the mixture was diluted with ethyl acetate (120 ml). The resultant solution was washed with brine (4 x 100 ml) and water (100 ml) then dried (magnesium sulfate), filtered and concentrated. Column chromatography [EtOAc-PE 1:1] afforded (**129**) as a solid (2.20 g, 64%). The data was in good agreement with that previously reported.⁷³

R_f 0.51 (EtOAc-PE 3:7); m.p. 90-92 °C (EtOAc); lit.⁷³ m.p. 80-82 °C; $[\alpha]_D^{23} +20.2^\circ$ (c 1.0, CHCl_3); lit.⁷³ $[\alpha]_D^{23} +17.8^\circ$ (c 2.0, CHCl_3); ν_{\max} ($\text{CHCl}_3/\text{cm}^{-1}$) 3000, 2935, 2850 (CH), 1210, 1070 (C-O); δ_H (200 MHz, CDCl_3): 3.33 (1H, m, H-2), 3.43 (1H, m, H-2'), 3.48-3.51 (1H, m, H-5), 3.56 (1H, dd, J 4.6 and 13.5, H-6), 3.63 (1H, dd, m, H-3), 3.64-3.68 (1H, m, H-5'), 3.70-3.74 (2H, m, H-6 and H-6'), 3.75-3.82 (1H, m, H-6'), 3.80 (1H, dd, J 8.8 and 9.2, H-3'), 3.93 (1H, dd, J 8.8 and 9.9, H-4), 4.04-4.50 (10H, m, 5 x $-\text{OCH}_2\text{CH}=\text{CH}_2$), 4.29 (1H, m, H-4'), 4.39 (1H, d, J 7.7, H-1), 4.62 (1H, d, J 11.7, $-\text{CH}_2\text{Ph}$), 4.92 (1H, d, J 11.7, $-\text{CH}_2\text{Ph}$), 5.10-5.35 (10H, m, 5 x $-\text{CH}=\text{CH}_2$), 5.32 (1H, s, $-\text{CHPh}$), 5.67 (1H, d, J 3.5, H-1'), 5.75-6.04 (5H, m, 5 x $-\text{CH}=\text{CH}_2$), 7.25-7.57 (10H, m, 2 x Ph); δ_C (50 MHz, CDCl_3) 62.9, 68.7, 68.8, 70.8, 71.7, 72.4, 73.1, 73.3, 73.5, 73.8, 73.9, 78.2, 78.6, 81.9, 82.1 and 84.6 (C-2, C-3, C-4, C-5, C-6, C-2', C-3', C-4', C-5', C-6', $-\text{CH}_2\text{Ph}$ and $-\text{CH}_2\text{CH}=\text{CH}_2$), 97.3 (C-1'), 101.1 ($-\text{CHPh}$), 102.2 (C-1), 115.5, 116.4, 116.7, 116.9 and 117.5 ($-\text{CH}=\text{CH}_2$), 125.9, 125.9, 127.5, 127.6, 127.6, 128.0, 128.0, 128.2, 128.2 and 128.6 (Ph), 134.5, 134.6,

134.8, 135.0 and 135.1 (-CH=CH₂), 135.1 and 137.4 (q-Ph); m/z (ES⁺ acetonitrile-water) 743 (M.Na⁺, 79%), 738 (M.NH₄⁺, 100%).

Benzyl 4-*O*-(2',3'-di-*O*-allyl-6'-*O*-benzyl- α -D-glucopyranosyl)-2,3,6-tri-*O*-allyl- β -D-glucopyranoside (**130**)⁷³

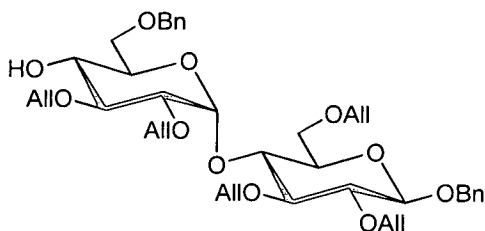

Triethyl silane (0.150 ml, 1.74 mmol) and trifluoroacetic anhydride (0.150 ml, 1.05 mmol) were added to a cooled (0 °C) solution of (**129**) (250 mg, 347 μ mol) in freshly distilled dichloromethane (1.5 ml), under argon. Trifluoroacetic acid (0.130 ml, 1.71 mmol) was added dropwise over 5 min and the reaction was stirred for a further 5 h. The mixture was diluted with ethyl acetate (10 ml), washed with saturated aqueous sodium hydrogen carbonate (15 ml), brine (15 ml) and water (15 ml). The organic washings were combined, dried (magnesium sulfate), filtered and concentrated. Column chromatography [EtOAc-PE 3:7] gave (**130**) as an oil (150 mg, 60%). The data was in good agreement with that previously reported.⁷³

R_f 0.33 [EtOAc-PE 3:7]; [α]_D²⁴ +30.1 (*c* 1.2, CHCl₃); lit.⁷³ [α]_D¹⁹ +27.4 (*c* 1.0, CHCl₃); ν_{\max} (CHCl₃/cm⁻¹) 3010, 2980 (CH), 1210 (C-O); δ_{H} (200 MHz, CDCl₃): 2.67 (1H, s, OH), 3.35 (2H, m, H-2 and H-2'), 3.44-3.53 (1H, m, H-5), 3.57-3.61 (2H, m, H-3 and H-3'), 3.65-3.69 (1H, m, H-4'), 3.67-3.77 (5H, m, H-6, H-6, H-5', H-6' and H-6'), 3.89 (1H, t, *J* 9.5, H-4), 3.98-4.49 (10H, m, 5 x -OCH₂CH=CH₂), 4.39 (1H, d, *J* 7.7, H-1), 4.52 (1H, d, *J* 12.1, -CH₂Ph), 4.61 (1H, d, *J* 12.1, -CH₂Ph), 4.62 (1H, d, *J* 12.1, -CH₂Ph), 4.91 (1H, d, *J* 12.1, -CH₂Ph), 5.08-5.33 (10H, m, 5 x -CH=CH₂), 5.63 (1H, d, *J* 3.7, H-1'), 5.78-6.04 (5H, m, 5 x -CH=CH₂), 7.28-7.38 (10H, m, 2 x Ph); δ_{C} (50 MHz, CDCl₃): 69.0, 69.9, 70.3, 70.8, 71.4, 72.2, 72.3, 72.7, 73.1, 73.3, 73.6, 74.0, 74.2, 78.8, 80.8, 81.8, 84.5 (C-2, C-3, C-4, C-5, C-6, C-2', C-3', C-4', C-5', C-6', 2xCH₂Ph, 5xOCH₂CH=CH₂), 96.6 (C-1'), 102.1 (C-1), 115.5,

116.6, 116.6, 116.6, 117.3 (5xCH=CH₂), 127.6, 127.6, 128.2, 128.2 (Ph), 134.5, 134.7, 134.9, 135.1, 135.1 (5xCH=CH₂), 137.4, 137.8 (q-Ph); m/z (ES⁺, acetonitrile-water) 745 (MNa⁺, 53%), 740 (MNH₄⁺, 100%), 670 (52), 426 (54).

2,3,4,6-Tetra-*O*-acetyl- α -D-glucopyranoside (**133**)⁹⁷⁻¹⁰⁰

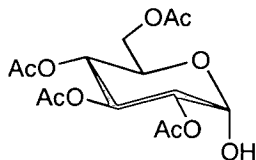

Ammonium carbonate (1.25 g, 13.0 mmol) was added to a solution of (**132**) (2.50 g, 6.40 mmol) in anhydrous dimethylformamide (15 ml). The reaction was stirred for 24 h under argon and then diluted with chloroform (40 ml). The resultant solution was then added with vigorous stirring to ice cold hydrochloric acid (1 M, 40 ml). The organic layer was separated and the aqueous layer further extracted with chloroform (3 x 40 ml). The combined organic washings were then washed with saturated aqueous sodium hydrogen carbonate (40 ml), brine (40 ml) and water (40 ml) and then dried (magnesium sulfate), filtered and concentrated. Column chromatography [EtOAc-PE 1:1] gave (**133**) as a white solid (2.25 g, 100%). The data was in good agreement with that previously reported.⁹⁷⁻¹⁰⁰

R_f 0.51 (EtOAc); m.p. 96-98 °C (Et₂O, PE); lit.⁹⁷ m.p. 99-100 °C (Et₂O, PE); [α]_D²³ +129 (*c* 1.0, CHCl₃); lit.⁹⁹ [α]_D +139 (*c* 2.0, CHCl₃); δ _H (200 MHz, CDCl₃): 1.90, 1.92, 1.96 and 1.97 (12H, 4s, 4 x -COCH₃), 3.95-4.18 (3H, m, H-5, H-6 and H-6), 4.76 (1H, dd, *J* 3.7 and 10.0, H-2), 4.96 (1H, dd, *J* 9.5 and 9.9, H-4), 5.31 (1H, d, *J* 3.7, H-1), 5.43 (1H, dd, *J* 9.5 and 10.0, H-3); lit.⁹⁸ δ _H (400 MHz, CDCl₃): 1.97, 1.99, 2.04, 2.05 (12H, 4s, 4 x C(O)CH₃), 4.1-4.15 (2H, m), 4.15-4.30 (1H, m), 4.83 (1H, dd, *J* 3.6, 10.2), 5.04 (1H, t, *J* 9.7), 5.41 (1H, m, H-1), 5.50 (1H, t, *J* 9.8); δ _C (50 MHz, CDCl₃): 20.5, 20.6, 20.6, 20.7 (4xC(O)CH₃), 61.9, 67.2, 68.4, 69.8, 71.0 (C-2, C-3, C-4, C-5 and C-6), 90.1 (C-1), 169.6, 169.7, 170.1, 170.7 (4xC(O)CH₃); m/z (ES⁺, acetonitrile-water) 371 (MNa⁺, 100%), 366 (MNH₄⁺, 25%).

1-*O*-(2,3,4,6-Tetra-*O*-acetyl- α -D-glucopyranosyl) trichloroacetimidate (**134**)^{98,101,102}

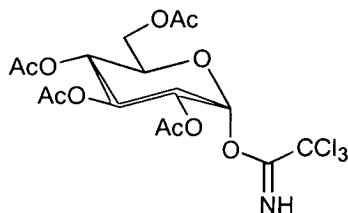

Trichloroacetonitrile (6.03 ml, 60.3 mmol) and sodium hydride (181 mg, 7.55 mmol) were added to a solution of (**133**) (2.07 g, 5.95 mmol) in freshly distilled, anhydrous dichloromethane (28 ml). The mixture was stirred under argon for 30 min, filtered through Celite and concentrated. Column chromatography [ether] gave (**134**) as an oil (1.73 g, 60%). The data was in good agreement with that previously reported.^{98,101,102}

R_f 0.65 (ether); $[\alpha]_D^{24} +57.2$ (c 1.0, CHCl_3); lit.¹⁰¹ $[\alpha]_D^{25} +53.0$ (c 1.0, CHCl_3); δ_H (200 MHz, CDCl_3): 1.99, 2.01, 2.02 and 2.05 (12H, 4s, 4 x COCH_3), 4.07-4.29 (3H, m, H-5, H-6 and H-6), 5.10 (1H, dd, J 3.7 and 9.9, H-2), 5.15 (1H, dd, J 9.5 and 9.9, H-4), 5.54 (1H, dd, J 9.5 and 9.9, H-3), 6.53 (1H, d, J 3.7, H-1), 8.68 (1H, s, NH); lit.⁹⁸ δ_H (500 MHz, CDCl_3): 2.01, 2.03, 2.03, 2.04 (12H, 4s, C(O)CH_3), 4.12 (1H, dd, J 2.0, 12.5), 4.2-4.22 (1H, m), 4.27 (1H, dd, J 4.0, 12.5), 5.12 (1H, dd, J 3.5, 10.0), 5.18 (1H, t, J 10.0), 5.56 (1H, t, J 10.0), 6.56 (1H, d, J 4.0), 8.69 (1H, s); δ_C (63 MHz, CDCl_3): 20.3, 20.4, 20.5, 20.6 (4x C(O)CH_3), 61.3, 67.7, 69.7, 69.8, 69.9 (C-2, C-3, C-4, C-5 and C-6), 90.6 (CCl_3), 92.8 (C-1), 160.7 (C=N).

Benzyl 4-*O*-[4'-*O*-(2'',3'',4'',6''-tetra-*O*-acetyl- β -D-glucopyranosyl)-2',3'-di-*O*-allyl-6'-*O*-benzyl- α -D-glucopyranosyl]-2,3,6-tri-*O*-allyl- β -D-glucopyranoside (**114**)⁷³

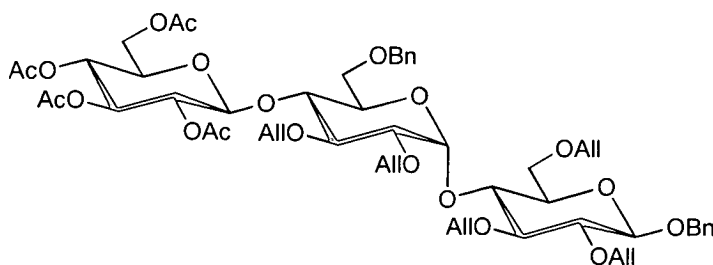

Compounds (130) (1.00 g, 1.39 mmol) and (134) (1.50 g, 3.05 mmol) were dissolved in freshly distilled dichloromethane (5 ml) and cooled to $-30\text{ }^{\circ}\text{C}$ under argon. Boron trifluoride diethyl etherate (42.0 μl , 0.342 mmol) was then added dropwise and the mixture was stirred for 2 h. The reaction was quenched by the addition of sodium hydrogen carbonate (0.692 g, 8.24 mmol) and saturated aqueous sodium hydrogen carbonate (25 ml). The mixture was diluted with dichloromethane (30 ml) and the organic layer was washed with saturated aqueous sodium hydrogen carbonate (30 ml) and water (30 ml), before being dried (magnesium sulfate), filtered and concentrated. Column chromatography [EtOAc-PE 1:1] afforded (114) as an oil (1.00 g, 68%). The data was in good agreement with that previously reported.⁷³

R_f 0.56 (EtOAc-PE 1:1); $[\alpha]_D^{25} +28.0$ (c 1.0, CHCl_3); lit.⁷³ $[\alpha]_D^{23} +25.4$ (c 1.0, CHCl_3); ν_{max} ($\text{CHCl}_3/\text{cm}^{-1}$) 3010 (CH), 1750 (C=O), 1220 (C-O); δ_{H} (250 MHz, CDCl_3): 1.88, 1.96, 2.01 and 2.04 (12H, 4s, 4 x COCH_3), 3.26-3.34 (2H, m, H-2 and H-2'), 3.39-3.44 (2H, m, H-5 and H-5''), 3.51-3.65 (7H, m, H-3, H-6, H-6, H-3', H-5', H-6' and H-6'), 3.78 (1H, dd, J 8.6 and 10.9, H-4'), 3.86 (1H, dd, J 8.8 and 9.6, H-4), 3.86-4.47 (10H, m, 5 x $-\text{OCH}_2\text{CH}=\text{CH}_2$), 3.98-4.05 (1H, m, H-6''), 4.21-4.33 (1H, m, H-6''), 4.36 (1H, d, J 7.8, H-1), 4.39 (1H, d, J 11.9, $-\text{CH}_2\text{Ph}$), 4.45 (1H, d, J 7.8, H-1''), 4.61 (1H, d, J 12.0, $-\text{CH}_2\text{Ph}$), 4.75 (1H, d, J 12.0, $-\text{CH}_2\text{Ph}$), 4.85 (1H, m, H-2''), 4.87 (1H, d, J 11.9, $-\text{CH}_2\text{Ph}$), 4.96-5.28 (12H, m, H-3'' and H-4'', 5 x $-\text{CH}=\text{CH}_2$), 5.62 (1H, d, J 3.8, H-1'), 5.75-5.93 (5H, m, 5 x $-\text{CH}=\text{CH}_2$), 7.25-7.40 (10H, m, 2 x Ph); δ_{C} (63 MHz, CDCl_3): 20.5, 20.5, 20.5, 20.6 ($\text{C}(\text{O})\text{CH}_3$), 61.6, 67.2, 68.0, 68.4, 70.2, 70.8, 71.1, 71.5, 71.7, 72.3, 73.1, 73.2, 73.2, 73.4, 73.6, 73.9, 74.1, 77.3, 78.3, 79.4, 81.8, 84.5 (C-2, C-3, C-4, C-5, C-6, C-2', C-3', C-4', C-5', C-6', C-2'', C-3'', C-4'', C-5'', C-6'', 2x CH_2Ph , 5x $\text{OCH}_2\text{CH}=\text{CH}_2$), 96.4 (C-1'), 100.0 (C-1''), 102.2 (C-1), 115.4, 115.7, 116.7, 117.0, 117.4 (5x $\text{CH}=\text{CH}_2$), 127.5, 127.6, 128.0, 128.1, 128.2, 128.5 (Ph), 134.5, 134.6, 134.8, 134.9, 135.5 (5x $\text{CH}=\text{CH}_2$), 137.3, 137.6 (q-Ph), 168.9, 169.3, 170.1, 170.6 (C=O); m/z (ES^+ acetonitrile-water) 1075 (MNa^+ , 88%), 1070 (MNH_4^+ , 100%), 709 (45).

Benzyl 4-*O*-[4'-*O*-(β-D-glucopyranosyl)-2',3'-di-*O*-allyl-6'-*O*-benzyl-α-D-glucopyranosyl]-2,3,6-tri-*O*-allyl-β-D-glucopyranoside (142)⁷³

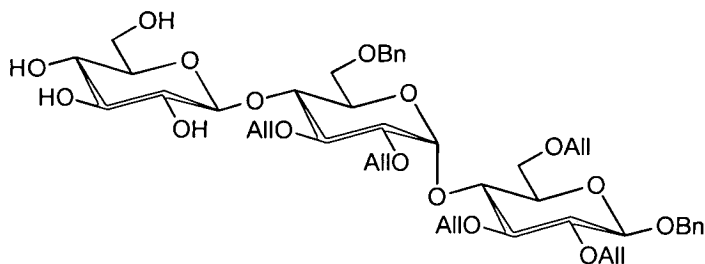

The fully protected trisaccharide (114) (110 mg, 104 μmol) was taken up in anhydrous methanol (1 ml) and a solution of sodium methoxide in methanol (37.0 μl, 0.5 M, 19.2 μmol) was added. After 1 h 30 min the reaction had not gone to completion so an extra addition of methoxide solution (30.0 μl, 15.1 μmol) was made. In another hour the reaction had gone to completion and so the mixture was neutralised using ion-exchange resin (80 mg), filtered and washed with methanol. Concentration gave the title compound as an oil (95.1 mg, 100%). The data compared well to that reported previously.⁷³

R_f 0.46 (dichloromethane-methanol 9:1); $[\alpha]_D^{23} +19.5$ (c 1.1, CHCl_3); lit.⁷³ $[\alpha]_D^{20} +21.3$ (c 1.0, CHCl_3); δ_H (250 MHz, CD_3OD): 3.27-3.60 (7H, m, H-2, H-5, H-2', H-2'', H-3'', H-4'', H-5''), 3.56 (1H, t, J 8.9, H-3), 3.66-3.81 (6H, m, H-6, H-6, H-3', H-5', H-6', H-6''), 3.87-4.05 (4H, m, H-4, H-4', H-6', H-6''), 4.05-4.49 (10H, m, 5 x $\text{OCH}_2\text{CH}=\text{CH}_2$), 4.44 (1H, d, J 7.8, H-1), 4.55 (1H, d, J 7.8, H-1''), 4.60 (1H, d, J 11.9, CH_2Ph), 4.67 (1H, d, J 12.0, CH_2Ph), 4.71 (1H, d, J 11.9, CH_2Ph), 4.94 (1H, d, J 12.0, CH_2Ph), 5.16-5.35 (10H, m, 5x $\text{CH}=\text{CH}_2$), 5.65 (1H, d, J 3.7, H-1'), 5.86-6.01 (5H, m, 5 x $\text{CH}=\text{CH}_2$), 7.31-7.41 (10H, m, Ph); δ_C (91 MHz, CD_3OD) 62.2, 68.5, 69.1, 70.9, 71.1, 71.4, 72.4, 72.9, 73.3, 73.4, 73.4, 74.4, 74.6, 74.8, 76.2, 77.1, 77.5, 78.5, 79.0, 80.4, 82.2 and 84.8 (C-2, C-3, C-4, C-5, C-6, C-2', C-3', C-4', C-5', C-6', C-2'', C-3'', C-4'', C-5'', C-6'', 2 x $-\text{OCH}_2\text{Ph}$ and 5 x $-\text{OCH}_2\text{CH}=\text{CH}_2$), 96.9 (C-1'), 102.6 (C-1''), 102.8 (C-1), 115.1, 115.9, 116.4, 116.4 and 116.8 ($-\text{CH}=\text{CH}_2$), 127.8, 127.8, 128.0, 128.0, 128.1, 128.1, 128.4, 128.4, 128.5 and 128.5 (Ph), 135.1, 135.1, 135.4, 135.7 and 135.7 ($-\text{CH}=\text{CH}_2$), 138.0 and 138.5 (q-Ph); m/z (ES^+

acetonitrile-water) 907 (MNa⁺, 90%), 902 (MNH₄⁺, 75%), 890 (67), 667 (100), 357 (99).

1,2;5,6-Di-*O*-isopropylidene- α -D-glucofuranose (145)¹⁶⁷

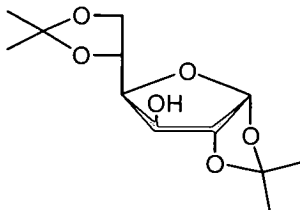

Method 1:¹⁰⁹ DIBAL (300 μ l, 20% in toluene, 0.503 mmol) was added dropwise to a stirring solution of (144) (100 mg, 0.330 mmol) and NiCl₂(dppp) (2.0 mg, 3.7 μ mol) in diethyl ether (2 ml) at 0 °C. The mixture was brought up to RT and stirred for 3.5 h then diluted with diethyl ether (3 ml) and quenched with water (600 μ l). The mixture was dried (magnesium sulfate), filtered (through a Celite pad) and concentrated. Chromatography (EtOAc/PE 1:1) gave the product as a white solid (56.2 mg, 65%).

Method 2:¹⁰⁹ NaBH₄ (250 mg, 6.61 mmol) was added to a stirring solution of (144) (50 mg, 0.17 mmol) and NiCl₂(dppp) (4.0 mg, 7.4 μ mol) in THF-EtOH (4:1, 1 ml) at 0 °C. The solution was brought to RT and stirred for 2 h. At this time TLC indicated that the reaction was not complete, so a further addition of materials was made: NiCl₂(dppp) (4.0 mg, 7.4 μ mol), NaBH₄ (250 mg, 6.62 mmol) and THF-EtOH (4:1, 1 ml) and the reaction was stirred for a further hour then diluted with THF (3 ml) and quenched with water (300 μ l). The mixture was dried (MgSO₄), filtered (through a Celite pad) and concentrated. Chromatography (EtOAc-PE 1:1) gave the product as a white solid (27 mg, 61%).

Method 3:¹¹⁰ Compound (144) (100 mg, 0.330 mmol) was dissolved in ethanol-benzene-water (7:3:1, 11 ml) and RhCl(PPh₃)₃ (43.1 mg, 47.2 μ mol) and DABCO (16.0 mg, 0.144 mmol) were added. The reaction was refluxed overnight, cooled and evaporated to dryness. The residue was dissolved in acetone-water (9:1, 10 ml), HgCl₂ (600 mg, 2.20 mmol) and HgO (5.0 mg, 23 μ mol) were added and the mixture was stirred for 4 h. The mixture was concentrated and the residue was taken up in

DCM (25 ml) and then washed with sat. aq. KI (3 x 25 ml), water (2 x 30 ml) and brine (30 ml). The organic layer was concentrated to give a residue that was purified by chromatography (EtOAc-PE 1:1) to afford the product as a white solid (57.2 mg, 67%). The data recorded was in good agreement with that reported previously.^{167,168}

R_f 0.19 (EtOAc-PE 1:1); m.p. 105-108 °C (PE); lit.¹⁶⁸ m.p. 110.5 °C (PE); $[\alpha]_D^{23}$ -25.3 (c 1.0, H₂O); lit.¹⁶⁷ $[\alpha]_D^{20}$ -18.4 (c 1.0, H₂O); δ_H (200 MHz, CDCl₃) 1.24, 1.36, 1.44, 1.51 (12 H, 4 s, 4 x CH₃), 3.05 (1H, s, OH), 3.95-4.17 (5H, m, H-3, H-4, H-5, H-6, H-6), 4.53 (1H, dd, J 3.6, 9.8, H-2), 5.83 (1H, d, J 3.6, H-1); lit.¹⁶⁷ δ_H (300 MHz, CDCl₃) 1.30-1.57 (12H, 4s, 4 x CH₃), 2.91 (1H, s, OH), 4.00-4.21 (5H, m, 3-H, 4-H, 5-H, 6H, 6H), 4.58 (1H, dd, J 3.7, 9.7, H-2), 5.90 (1H, d, J 3.7, H-1); δ_C (50 MHz, CDCl₃) 25.3, 25.6, 26.0, 26.7 (4 x CH₃), 67.6, 73.1, 74.8, 81.3, 84.9 (C-2, C-3, C-4, C-5, C-6), 105.2 (C-1), 109.6, 111.8 (OCOMe₂); m/z (ES⁺, acetonitrile-water) 283 (MNa⁺, 88%), 172 (100), 134 (45).

5.3 Experimental for Chapter 3

Pent-4-enyl 2,3,6-tri-*O*-acetyl-4-*O*-(2',3',4',6'-tetra-*O*-acetyl- α -D-glucopyranosyl)- β -D-glucopyranoside (**150**)

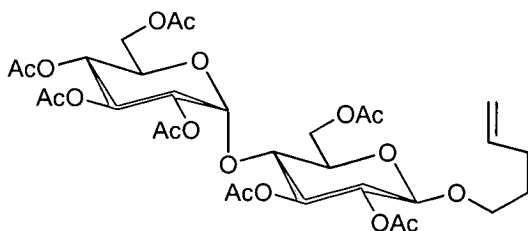

Freshly crushed Drierite (10.0 g, 10-20 mesh), silver carbonate (7.81 g, 28.3 mmol), iodine (a few crystals) and 4-penten-1-ol (7.20 ml, 70.4 mmol) were placed in a flask that was surrounded by aluminium foil. Freshly distilled dichloromethane (50 ml) was added and the green heterogenous mixture was stirred under argon at RT for 30 min after which the bromide starting material (**125**) (10.0 g, 14.3 mmol) was added. Stirring continued overnight and the next day the mixture was filtered through Celite with successive ethanol washes. The concentrated material was purified by

chromatography [hexane-EtOAc 3:2] to give the title compound as a white solid (4.28 g, 43%).

R_f 0.22 (EtOAc-hexane 2:3); m.p. 38-39 °C (aq. MeOH), $[\alpha]_D^{25} +48.9$ (c 1.1, DCM); ν_{\max} (neat/cm⁻¹) 2950 (CH), 1750 (C=O), 1435 (CH₃), 1370 (CH₃), 1235 (C-O), 1040 (C-O); δ_H (600 MHz; CD₃OD) 1.63 (2H, m, -CH₂CH₂CH=CH₂), 1.98, 1.98, 1.99, 2.00, 2.02, 2.06, 2.11 (21H, 7s, COCH₃), 2.08 (2H, m, -CH₂CH=CH₂), 3.53 (1H, m, -CH₂CH₂CH₂CH=CH₂), 3.83 (2H, m, -CH₂CH₂CH₂CH=CH₂ and H-5), 3.98 (1H, dd, J 9.0 and 9.5, H-4), 4.06 (1H, ddd, J 2.6, 4.4 and 10.1, H-5'), 4.11 (1H, dd, J 2.6, 12.4, H-6'), 4.23 (1H, dd, J 4.4, 12.4, H-6'), 4.27 (1H, dd, J 4.4, 12.2, H-6), 4.51 (1H, dd, J 2.6 and 12.2, H-6), 4.65 (1H, d, J 8.0, H-1), 4.76 (1H, dd, J , 8.0, 9.4, H-2), 4.85 (1H, dd, J 4.0 and 10.5, H-2'), 4.95 (1H, m, -CH=CH₂), 5.00 (1H, m, -CH=CH₂), 5.04 (1H, dd, J 9.6 and 10.1, H-4'), 5.30 (1H, dd, J 9.0 and 9.4, H-3), 5.35 (1H, dd, J 9.6 and 10.5, H-3'), 5.38 (1H, d, J 4.0, H-1'), 5.81 (1H, m, -CH=CH₂); δ_C (50 MHz; CD₃OD) 18.7, 18.7, 18.8, 18.8, 18.9, 18.9 and 19.3 (COCH₃), 28.0 (-CH₂CH₂CH=CH₂), 29.1 (-CH₂CH J 2.6 and 12.4, H-6'), 61.2 (C-6'), 62.4 (C-6), 67.8 (C-4'), 67.9 (C-5'), 68.2 (-O-CH₂CH₂CH₂CH=CH₂), 68.8 (C-3'), 69.7 (C-2'), 71.4 (C-5), 71.8 (C-2), 73.1 (C-4), 74.7 (C-3), 95.2 (C-1'), 99.5 (C-1), 113.6 (-CH=CH₂), 137.3 (-CH=CH₂), 169.2, 169.4, 169.6, 169.8, 170.0, 170.3 and 170.3 (C=O); m/z (ES⁺, acetonitrile-water) 727 (MNa⁺, 100%), 722 (MNH₄⁺, 28%), 641 (7), 619 (12), 560 (7), 559 (18), 477 (9), 354 (8), 335 (19), 331 (92), 312 (8); (Found (FAB⁺, matrix): MH⁺, 705.2611. C₃₁H₄₄O₁₈.H⁺ requires 705.2606).

Pent-4-enyl 4-*O*-(α -D-glucopyranosyl)- β -D-glucopyranoside (**151**)

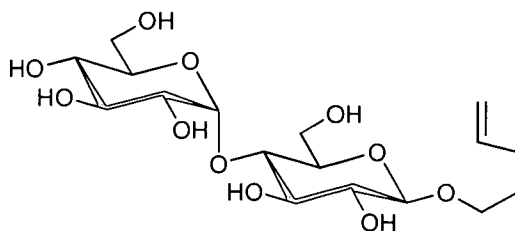

Compound (**150**) (4.09 g, 5.81 mmol) was dissolved in anhydrous methanol (20.5 ml) and reacted with sodium methoxide (1.23 ml, 0.5 M, 0.620 mmol) for 1 h 10 min

in an argon atmosphere. After this time TLC did not indicate completion and so a further addition of sodium methoxide (0.10 ml, 50 μmol) was made. After 45 min the reaction was complete and ion exchange resin (1.35 g, AG 50W-X2, H form) was added to quench the remaining methoxide. The mixture was stirred for 30 min, then filtered and concentrated to yield compound (**151**) as a white solid (2.37 g, 99%).

R_f 0.51 (dichloromethane-methanol 3:2); m.p. 70-72 $^{\circ}\text{C}$ (MeOH, EtOAc); $[\alpha]_D^{25} +55.5$ (c 1.0, MeOH); ν_{max} (nujol/ cm^{-1}) 2930 and 2860 (CH, CH_2), 1465 and 1370 (CH, CH_2); δ_{H} (600 MHz, CD_3OD) 1.70 (2H, m, $-\text{CH}_2\text{CH}_2\text{CH}=\text{CH}_2$), 2.14 (2H, m, $-\text{CH}_2\text{CH}=\text{CH}_2$), 3.22 (1H, dd, J 7.9 and 9.4, H-4'), 3.26 (1H, t, J 9.3, H-4), 3.35 (1H, m, H-5), 3.44 (1H, dd, J 3.7 and 9.7, H-2'), 3.59 (5H, m, H-2, H-3', H-6', H-6' and $-\text{OCH}_2\text{CH}_2\text{CH}_2\text{CH}=\text{CH}_2$), 3.81 (2H, m, H-3 and H-6), 3.88 (3H, m, H-5', H-6 and $-\text{OCH}_2\text{CH}_2\text{CH}_2\text{CH}=\text{CH}_2$), 4.26 (1H, d, J 7.8, H-1), 4.93 (1H, m, $-\text{CH}=\text{CH}_2$), 5.03 (1H, m, $-\text{CH}=\text{CH}_2$), 5.15 (1H, d, J 3.7, H-1'), 5.84 (1H, m, $-\text{CH}=\text{CH}_2$); δ_{C} (60 MHz, CD_3OD) 28.1 and 29.3 ($-\text{CH}_2\text{CH}_2\text{CH}=\text{CH}_2$ and $-\text{CH}_2\text{CH}=\text{CH}_2$), 60.2 and 60.8 (C-6 and C-6'), 68.3 ($-\text{O}-\text{CH}_2\text{CH}_2\text{CH}_2\text{CH}=\text{CH}_2$), 69.5, 72.2, 72.8, 72.8, 73.1, 74.6, 75.9 and 79.3 (C-2, C-3, C-4, C-5, C-2', C-3', C-4' and C-5'), 100.9 (C-1'), 102.4 (C-1), 113.3 ($-\text{CH}=\text{CH}_2$), 137.6 ($-\text{CH}=\text{CH}_2$); m/z (ES^+ , acetonitrile-water) 843 (MMNa^+ , 17%), 758 (9), 687 (11), 474 (68), 433 (MNa^+ , 100), 428 (MNH_4^+ , 25); (Found (FAB^+ , matrix): MNa^+ 433.1696, $\text{C}_{17}\text{H}_{30}\text{O}_{11} \cdot \text{Na}^+$ requires 433.1686).

Pent-4-enyl 4-*O*-(4',6'-*O*-benzylidene- α -D-glucopyranosyl)- β -D-glucopyranoside (**152**)

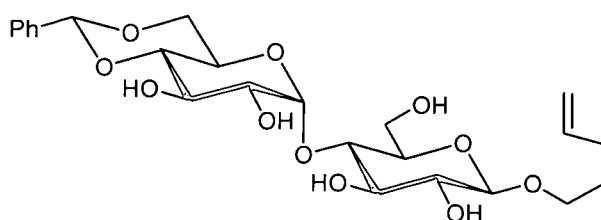

Method 1

To a solution of the pre-dried starting material (**151**) (100 mg, 0.244 mmol) and *p*-tuenesulfonic acid (5.0 mg, 26 μmol) in freshly distilled dimethylformamide (0.8

ml) was added freshly distilled dimethoxybenzylidene acetal (75 μ l, 0.50 mmol). The reaction mixture was turned on a rotary evaporator (28-30 mBar at 50 °C for 2 h) then neutralised by the addition of triethylamine (8.0 μ l, 58 μ mol). The dimethylformamide was removed with the aid of an adaptor for high boiling solvents and residual traces were evaporated as an azeotrope with toluene (2 x 1 ml). The concentrate was purified by column chromatography [gradient elution, dichloromethane-methanol 20:1 \rightarrow 15:1 \rightarrow 9:1] to give a clear oil (81.1 mg, 67%).

Method 2

The maltoside (**151**) (1.03 g, 2.51 mmol) was dried overnight in a vacuum desiccator over phosphorous pentoxide before being dissolved in freshly distilled benzaldehyde (8.20 ml). Anhydrous zinc chloride (0.351 g, 2.53 mmol) was further dried by heating under vacuum, then cooled under nitrogen before being added to the reaction mixture. After 2 h 20 min stirring under nitrogen the reaction was quenched by addition of warm (40 °C) saturated aqueous sodium hydrogen carbonate with vigorous stirring until neutralisation had occurred. The reaction mixture was filtered through a pad of Celite to remove the zinc hydroxide precipitate, and the pad was washed sequentially with dichloromethane. The filtrate was concentrated on a rotary evaporator, with the help of an adaptor used for the removal of higher boiling solvents (i.e. benzaldehyde). The residue was purified by chromatography [gradient elution, dichloromethane-methanol 20:1 \rightarrow 9:1] to give a white solid (0.632 g, 50%).

R_f 0.25 (dichloromethane-methanol 9:1); m.p. 62-64 °C (MeOH, EtOAc); $[\alpha]_D^{25} +32.1$ (c 1.0, DCM); ν_{max} (neat/ cm^{-1}) 3398 (OH, vs), 3064 (Ph and $-CH=CH_2$), 2928 and 2873 (CH), 1640 (Ph and $-CH=CH_2$); δ_H (200 MHz, $CDCl_3$) 1.63-1.76 (2H, m, $-CH_2CH_2CH=CH_2$), 2.03-2.13 (2H, m, $-CH_2CH=CH_2$), 3.22-3.97 (13H, m, H-2, H-3, H-4, H-5, H-6, H-6, H-2', H-3', H-4', H-5', H-6', $-O-CH_2CH_2CH_2CH=CH_2$), 4.20-4.25 (2H, m, H-1, H-6'), 4.94-5.06 (2H, m, $-CH=CH_2$), 5.11 (1H, d, J 3.8, H-1'), 5.47 (1H, s, $-CHPh$), 5.78 (1H, m, $-CH=CH_2$), 7.32-7.50 (5H, m, Ph); δ_C (91 MHz, $CDCl_3$) 29.1 ($-CH_2CH_2CH=CH_2$), 30.4 ($-CH_2CH=CH_2$), 61.7 (C-6), 69.1 ($-O-CH_2CH_2CH_2CH=CH_2$), 70.1 (C-6'), 71.2, 73.5, 73.7, 75.0, 76.4, 77.7, 80.5 and 81.0 (C-2, C-3, C-4, C-5, C-2', C-3', C-4' and C-5'), 102.2 (C-1'), 102.6 ($CHPh$),

103.1 (C-1), 115.6 (-CH=CH₂), 126.8, 128.7, 129.6 (Ph), 137.6 (q-Ph), 138.4 (-CH=CH₂); m/z (FAB⁺, matrix) 499 (MH⁺, 20%), 498 (M⁺, 1), 413 (14), 251 (53), 217 (15), 127 (38), 107 (97), 91 (100), 73 (60), 69 (80), 57 (50); (Found (FAB⁺, matrix): MH⁺ 499.2186, C₂₄H₃₄O₁₁.H⁺ requires 499.2179).

Pent-4-enyl 4-*O*-(4',6'-*O*-*p*-methoxybenzylidene- α -D-glucopyranosyl)- β -D-glucopyranoside (158)

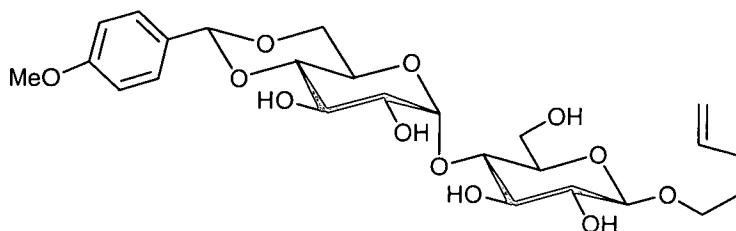

To a solution of the starting material (151) (4.05 g, 9.88 mmol) dissolved in freshly distilled anisaldehyde (40.7 ml) was added anhydrous zinc chloride (1.35 g, 9.93 mmol). The solution was stirred at RT for 2 h under argon and neutralised with vigorous stirring by warm (40 °C) saturated aqueous sodium hydrogen carbonate. The mixture was filtered through a Celite pad with successive methanol washes and concentrated by vacuum distillation. The residue was purified by column chromatography [dichloromethane-methanol 9:1] to give an oil (2.55 g, 49%).

R_f 0.28 (EtOAc-hexane 1:3); [α]_D²² +36.2 (*c* 1.0, CHCl₃); δ _H (200 MHz, CD₃OD) 1.63-1.77 (2H, m, -CH₂CH₂CH=CH₂), 2.10-2.20 (2H, m, -CH₂CH=CH₂), 3.19-3.97 (16H, m, H-2, H-3, H-4, H-5, H-6, H-6, H-2', H-3', H-4', H-5', H-6', -OCH₃ and -OCH₂CH₂CH₂CH=CH₂), 4.20 (1H, dd, *J* 4.1 and 9.5, H-6'); 4.28 (1H, d, *J* 7.6, H-1), 4.94 (1H, m, -CH=CH₂), 5.07 (1H, m, -CH=CH₂), 5.19 (1H, d, 3.8, H-1'), 5.51 (1H, s, -CHPh), 5.74-5.91 (1H, m, -CH=CH₂), 6.88 (2H, d, *J* 8.9, CH_{Ar}), 7.41 (2H, d, *J* 8.6, CH_{Ar}); δ _C (63 MHz, CDCl₃) 28.6 (-CH₂CH₂CH=CH₂), 29.9 (-CH₂CH=CH₂), 54.9 (-OCH₃), 61.2 (C-6), 68.6 (-O-CH₂CH₂CH₂CH=CH₂), 69.6 (C-6'), 69.7, 73.0, 73.2, 74.5, 76.0, 77.2, 80.0 and 80.5 (C-2, C-3, C-4, C-5, C-2', C-3', C-4' and C-5'), 101.7 (C-1'), 102.1 (CHPh), 102.8 (C-1), 115.1 (-CH=CH₂), 128.2, 129.1 (Ph), 137.6 (q-Ph), 138.4 (-CH=CH₂), 159.6 (MeOC_{Ar}); m/z (ES⁺, acetonitrile-water): 551 (MNa⁺, 100%), 529 (MH⁺, 5), 366 (12), 350 (10).

Pent-4-enyl 2,3,6-tri-*O*-benzyl-4-*O*-(2',3'-di-*O*-benzyl-4',6'-*O*-benzylidene- α -D-glucopyranosyl)- β -D-glucopyranoside (153)

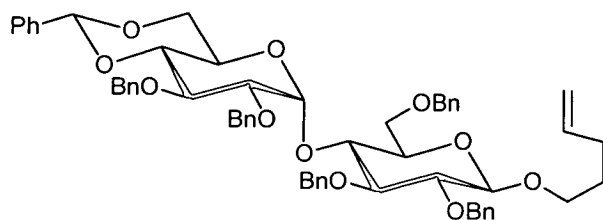

The acetal (152) (1.36 g, 2.72 mmol) was dissolved in freshly distilled dimethylformamide (26.5 ml) and the solution was cooled to 0 °C under an argon atmosphere. Sodium hydride (1.36 g, 343 mmol, 60% dispersion in mineral oil) was added carefully in portions and the mixture was stirred at 0 °C for 30 min, then at RT for 15 min at which time a muddy brown appearance was observed. The mixture was then cooled to 0 °C and a catalytic amount of tetrabutylammonium iodide was added, followed by a dropwise addition of freshly distilled benzyl bromide (6.50 ml, 55.2 mmol, over 20 min) at which time a pale yellow colour was observed. After 30 min the mixture was warmed to RT and stirred for 5 h before being cooled again to 0 °C and quenched by the dropwise addition of dry methanol (10 ml, over 20 min). The mixture was then brought up to RT and stirred for 1 h in order to destroy any residual benzyl bromide. The mixture was diluted with dichloromethane (90 ml) and washed with saturated aqueous ammonium chloride (70 ml), water (70 ml), saturated aqueous sodium hydrogen carbonate (70 ml) and again with water (70 ml). The dichloromethane layer was dried (magnesium sulfate), filtered and concentrated after which the residue collected was purified by column chromatography [EtOAc-hexane 1:4] to yield the title compound as a clear oil (2.58 g, 100%).

R_f 0.29 (EtOAc-hexane 1:4); $[\alpha]_D^{25}$ +45.2 (c 1.0, CHCl_3); ν_{max} (neat/ cm^{-1}) 3030 (=CH), 2867 (CH_2) 1462, 1453, 1367, 1080, 735, 696; δ_{H} (600 MHz, CDCl_3) 1.74-1.80 (2H, m, $-\text{CH}_2\text{CH}_2\text{CH}=\text{CH}_2$), 2.16-2.20 (2H, m, $-\text{CH}_2\text{CH}=\text{CH}_2$), 3.51 (1H, dd, J 3.8 and 9.5, H-2'), 3.52 (1H, dd, J 7.7 and 8.5, H-2), 3.56-3.66 (4H, m, H-5, H-4', H-5' and $-\text{OCH}_2\text{CH}_2\text{CH}_2\text{CH}=\text{CH}_2$), 3.76-3.90 (4H, m, H-3, H-6, H-6 and H-6'), 3.93-4.01 (2H, m, H-3' and $-\text{OCH}_2\text{CH}_2\text{CH}_2\text{CH}=\text{CH}_2$), 4.12 (1H, dd, J 9.0 and 9.2, H-4), 4.18 (1H, dd, J 4.7 and 10.1, H-6'), 4.43 (1H, d, J 7.7, H-1), 4.56 (1H, d, J 11.9,

-CH₂Ph), 4.60 (1H, d, *J* 12.4, -CH₂Ph), 4.63 (1H, d, *J* 10.9, -CH₂Ph), 4.67 (1H, d, *J* 11.9, -CH₂Ph), 4.70 (1H, d, *J* 12.4, -CH₂Ph), 4.73 (1H, d, *J* 11.4, -CH₂Ph), 4.75 (1H, d, *J* 11.1, -CH₂Ph), 4.90 (1H, d, *J* 11.1, -CH₂Ph), 4.93 (1H, d, *J* 10.9, -CH₂Ph), 4.97 (1H, d, *J* 11.4, -CH₂Ph), 4.98-5.00 (1H, m, -CH=CH₂), 5.03-5.06 (1H, m, -CH=CH₂), 5.54 (1H, s, -CHPh), 5.72 (1H, d, *J* 3.8, H-1'), 5.81-5.88 (1H, m, -CH=CH₂), 7.14-7.52 (30H, m, Ph); δ_C (63 MHz, CDCl₃) 28.8 (-CH₂CH₂CH=CH₂) 30.0 (-CH₂CH=CH₂) 63.0, 68.5, 68.7, 68.9, 71.6, 73.1, 73.5, 73.5, 73.9, 74.4, 75.0, 78.4, 78.5, 82.0, 82.0, 84.7 (C-2, C-3, C-4, C-5, C-6, C-2', C-3', C-4', C-5', C-6', 5 x -CH₂Ph and -OCH₂CH₂CH₂CH=CH₂), 97.0 (C-1'), 100.8 (CHPh), 103.3 (C-1), 114.8 (CH=CH₂), 125.8, 126.3, 126.9, 127.2, 127.3, 127.4, 127.6, 127.7, 127.9, 128.0, 128.1, 128.3, 128.6, 128.7 (Ph), 137.3, 137.6 (q-Ph), 137.8 (-CH₂=CH₂), 138.0, 138.0, 138.4 and 138.5 (q-Ph); *m/z* (ES⁺, acetonitrile- water) 971 (MNa⁺, 38%) 966 (MNH₄⁺, 100), 864 (12), 756 (12), 727 (14), 559 (9), 523 (39); (Found (FAB⁺, matrix): 949.4527, C₅₉H₆₄O₁₁·H⁺ requires 949.4527).

Pent-4-enyl 2,3,6-tri-*O*-benzyl-4-*O*-(2',3'-di-*O*-benzyl-4',6'-*O*-*p*-methoxybenzylidene-α-*D*-glucopyranosyl)-β-*D*-glucopyranoside (**159**)

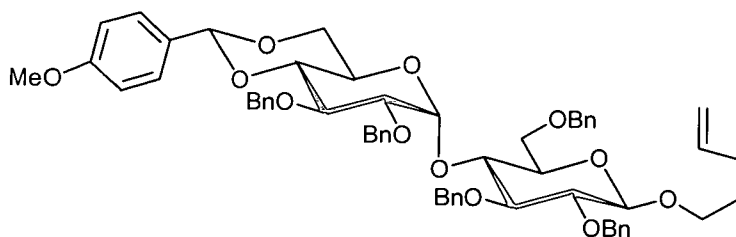

Sodium hydride (786 mg, 19.6 mmol, 60% dispersion) was added to a solution of the starting material (**158**) (835 mg, 1.58 mmol) in dry dimethylformamide (27 ml) and stirred for 30 min at RT under argon. The mixture was cooled to 0 °C and benzyl bromide (7.80 ml, 65.6 mmol) was added dropwise. The reaction was stirred overnight at RT and then quenched with methanol (7.8 ml). The resulting mixture was concentrated then taken up in chloroform and washed successively with brine and water, then dried (magnesium sulfate), filtered and concentrated. Chromatography [hexane-EtOAc 3:1] of the crude material yielded the title compound as a pale yellow oil (1.01 g, 65%).

R_f 0.71 (EtOAc-hexane 1:1); $[\alpha]_D^{22} +33.7$ (c 1.0, CHCl_3); δ_H (600 MHz, CDCl_3) 1.74-1.79 (2H, m, $-\text{CH}_2\text{CH}_2\text{CH}=\text{CH}_2$), 2.16-2.20 (2H, m, $-\text{CH}_2\text{CH}=\text{CH}_2$), 3.48 (1H, dd, J 3.9 and 9.5, H-2'), 3.50 (1H, dd, J 7.9 and 8.0, H-2), 3.55-3.63 (4H, m, H-5, H-4', H-5' and $-\text{OCH}_2\text{CH}_2\text{CH}_2\text{CH}=\text{CH}_2$), 3.82 (3H, s, $-\text{OCH}_3$), 3.54-3.87 (4H, m, H-3, H-6 and H-6'), 3.93-3.98 (2H, m, H-3' and $-\text{OCH}_2\text{CH}_2\text{CH}_2\text{CH}=\text{CH}_2$), 4.09 (1H, dd, J 8.8 and 9.5, H-4), 4.15 (1H, dd, J 4.9 and 10.3, H-6'), 4.41 (1H, d, J 7.9, H-1), 4.54 (1H, d, J 11.8, $-\text{CH}_2\text{Ph}$), 4.59 (1H, d, J 12.4, $-\text{CH}_2\text{Ph}$), 4.61 (1H, d, J 11.0, $-\text{CH}_2\text{Ph}$), 4.65 (1H, d, J 11.8, $-\text{CH}_2\text{Ph}$), 4.69 (1H, d, J 12.4, $-\text{CH}_2\text{Ph}$), 4.72 (1H, d, J 11.7, $-\text{CH}_2\text{Ph}$), 4.73 (1H, d, J 11.2, $-\text{CH}_2\text{Ph}$), 4.87 (1H, d, J 11.2, $-\text{CH}_2\text{Ph}$), 4.91 (1H, d, J 11.0, $-\text{CH}_2\text{Ph}$), 4.95 (1H, d, J 11.7, $-\text{CH}_2\text{Ph}$), 4.97-4.99 (1H, m, $-\text{CH}=\text{CH}_2$), 5.49 (1H, s, $-\text{CHPh}$), 5.70 (1H, d, J 3.9, H-1'), 5.70-5.87 (1H, m, $-\text{CH}=\text{CH}_2$), 6.90 (2H, d, J 8.8, CH_{Ar}), 7.14-7.38 (25H, m, Ph), 7.41 (2H, d, J 8.6, CH_{Ar}); δ_C (50 MHz, CDCl_3) 28.4 ($\text{CH}_2\text{CH}_2\text{CH}=\text{CH}_2$), 29.7 ($\text{CH}_2\text{CH}=\text{CH}_2$), 54.7 ($-\text{OCH}_3$), 62.7, 68.3, 68.3, 68.6, 71.3, 72.8, 73.1, 73.1, 73.6, 74.1, 74.6, 78.1, 78.1, 81.6, 81.7 and 84.3 (C-2, C-3, C-4, C-5, C-6, C-2', C-3', C-4', C-5', C-6', 5 x $-\text{CH}_2\text{Ph}$ and $-\text{OCH}_2\text{CH}_2\text{CH}_2\text{CH}=\text{CH}_2$), 96.7 (C-1'), 100.6 (CHPh), 102.9 (C-1), 114.4 ($-\text{CH}=\text{CH}_2$), 126.0, 126.4, 126.6, 126.8, 126.9, 127.1, 127.3, 127.4, 127.7 and 128.0 (Ph), 129.5, 137.3, 137.5, 137.8, 138.1 and 138.2 (q-Ph, $\text{CH}=\text{CH}_2$), 159.4 (MeOC_{Ar}); m/z (ES^+ , acetonitrile-water) 1001 (MNa^+ , 46%), 721 (21), 697 (51), 661 (16), 614 (20), 592 (26), 591 (100), 541 (29).

Pent-4-enyl 2,3,6-tri-*O*-benzyl-4-*O*-(2',3'-di-*O*-benzyl- α -D-glucopyranosyl)- β -D-glucopyranoside (154)

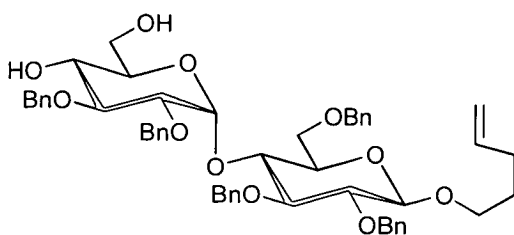

Method 1 (from benzylidene acetal (153))

The fully protected starting material (153) (492 mg, 0.518 mmol) was placed in a flask and water (5.2 ml) and freshly distilled acetic acid (12 ml) were added. The reaction was refluxed at 100 °C for 40 min. The mixture was concentrated and anhydrous toluene (3 x 2 ml) was evaporated from the resultant residue.

Chromatography [hexane-EtOAc 1:1] gave the product as a clear gum (356 mg, 80%).

Method 2 (from *p*-methoxybenzylidene acetal (**159**))

To a solution of the fully protected starting material (**159**) (147 mg, 150 μ mol) in acetonitrile and water (0.73 ml, acetonitrile-water 9:1) was added ceric ammonium nitrate (165 mg, 300 μ mol). The reaction was stirred for 45 min and then diluted with chloroform. The resulting solution was washed with saturated aqueous sodium hydrogen carbonate and the aqueous layer was extracted with chloroform. The combined organic layers were dried (magnesium sulfate), filtered and concentrated. The residue was purified by chromatography [EtOAc-hexane 2:3] giving the title compound as a clear gum (75.2 mg, 58%).

(Found: C, 72.89; H, 7.01. $C_{52}H_{60}O_{11}$ requires C, 72.54; H 7.02%); R_f 0.44 (toluene-EtOAc 1:1), $[\alpha]_D^{25} +20.3$ (c 1.1, $CHCl_3$), ν_{max} (neat/ cm^{-1}) 3425 (OH), 3064 and 3031 (=CH), 2925 and 2872 (-CH), 1497, 1454, 1363, 1089, 1057, 1028, 735, 698; δ_H (360 MHz, $CDCl_3$) 1.73-1.81 (2H, m, $-CH_2CH_2CH=CH_2$), 2.08-2.21 (4H, m, 2 x -OH and $-CH_2CH=CH_2$), 3.38 (1H, dd, J 3.7 and 9.7, H-2'), 3.45-3.79 (11H, m, H-2, H-3, H-5, H-6, H-6, H-3', H-4', H-5', H-6', H-6' and $-OCH_2CH_2CH_2CH=CH_2$), 3.82-3.99 (1H, m, $-OCH_2CH_2CH_2CH=CH_2$), 4.06 (1H, dd, J 8.2 and 9.6, H-4), 4.41 (1H, d, J 7.8, H-1), 4.49 (1H, d, J 12.1, $-CH_2Ph$), 4.53 (1H, d, J 12.0, $-CH_2Ph$), 4.58 (1H, d, J 12.5, $-CH_2Ph$), 4.62 (1H, d, J 10.9, $-CH_2Ph$), 4.62 (1H, d, J 12.1, $-CH_2Ph$), 4.63 (1H, d, J 11.5, $-CH_2Ph$), 4.72 (1H, d, J 12.0, $-CH_2Ph$), 4.91 (1H, d, J 11.5, $-CH_2Ph$), 4.92 (1H, d, J 10.9, $-CH_2Ph$), 4.96-5.06 (2H, m, $-CH=CH_2$), 4.98 (1H, d, J 12.5, $-CH_2Ph$), 5.65 (1H, d, J 3.7, H-1'), 5.83 (1H, ddt, J 6.6, 6.6, 10.1 and 16.8, $-CH=CH_2$), 7.14-7.36 (25H, m, Ph); δ_H (63 MHz, $CDCl_3$) 28.9 ($CH_2CH_2CH=CH_2$), 30.2 ($CH_2CH_2CH=CH_2$), 62.0, 68.5 and 69.1 (C-6, C-6' and $-OCH_2CH_2CH_2CH=CH_2$), 70.2, 71.8, 72.1, 72.9, 73.4, 73.7, 74.3, 74.5, 75.1, 79.0, 81.0, 82.1 and 84.7 (C-2, C-3, C-4, C-5, C-2', C-3', C-4', C-5' and 5 x $-CH_2Ph$), 96.3 (C-1'), 103.4 (C-1), 114.9 ($-CH=CH_2$), 126.5, 127.1, 127.5, 127.6, 127.7, 128.1, 128.2, 128.3 and 128.5 (Ph), 137.5 and 137.9 (q-Ph), 138.0 ($-CH=CH_2$), 138.1, 138.4 and 138.5 (q-Ph); m/z (ES^+ , acetonitrile-water) 883 (MNa^+ , 70%), 878 (MNH_4^+ , 35),

505 (22), 500 (24), 491 (80), 483 (27), 447 (20), 389 (18), 380 (20), 342 (11), 317 (100); (Found (FAB⁺, matrix) : 861.4208, C₅₂H₆₀O₁₁.H⁺ requires 861.4214).

Pent-4-enyl 2,3,6-tri-*O*-benzyl-4-*O*-(2',3'-di-*O*-benzyl-6'-*O*-pivaloyl- α -D-glucopyranosyl)- β -D-glucopyranoside (155)

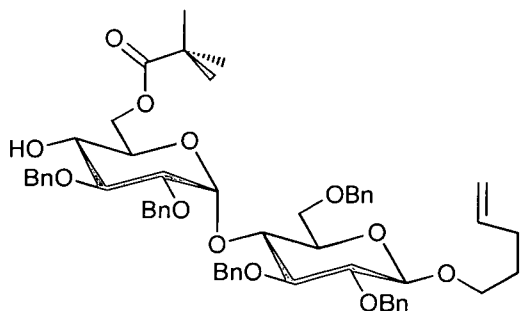

To a solution of the diol (154) (485 mg, 0.563 mmol) in dry pyridine (0.7 ml) was added a catalytic amount of dimethylaminopyridine. Pivaloyl chloride (69.5 μ l, 0.564 mmol) was added dropwise and the mixture was refluxed overnight at 70 °C. Chromatography [hexane-EtOAc 3:1] of the concentrated residue gave the product as a clear oil (513 mg, 96%).

R_f 0.49 (EtOAc-hexane 2:3); [α]_D²⁵ +15.4 (*c* 1.05 in chloroform); ν_{\max} (neat/cm⁻¹) 3494 (-OH), 3065 and 3031 (=CH), 2911 and 2872 (CH) 1730 (C=O), 1497, 1480, 1455, 1398, 1365, 1286, 1209, 1152, 1058, 1029, 911, 734, 698, 648; δ_{H} (600 MHz, CDCl₃) 1.20 (9H, s, -C(CH₃)₃), 1.76-1.79 (2H, m, -CH₂CH₂CH=CH₂), 2.17-2.19 (2H, m, -CH₂CH=CH₂), 3.34 (2H, m, H-2' and H-4'), 3.50 (1H, dd, *J* 8.0 and 8.8, H-2), 3.57-3.60 (2H, m, H-5 and -OCH₂CH₂CH₂CH=CH₂), 3.74 (1H, dd, *J* 8.8 and 9.6, H-3'), 3.77-3.82 (4H, m, H-3, H-6, H-6 and H-5'), 3.97 (1H, m, -OCH₂CH₂CH₂CH=CH₂), 4.04 (1H, t, *J* 8.8 and 8.8, H-4), 4.11 (1H, m, H-6'), 4.31 (1H, dd, *J* 4.4 and 12.3, H-6'), 4.43 (1H, d, *J* 8.0, H-1), 4.52 (1H, d, *J* 11.4, -CH₂Ph), 4.55 (1H, d, *J* 12.3, -CH₂Ph), 4.58 (1H, d, *J* 12.3, -CH₂Ph), 4.63 (1H, d, *J* 11.4, -CH₂Ph), 4.63 (1H, d, *J* 11.4, -CH₂Ph), 4.72 (1H, d, *J* 11.4, -CH₂Ph), 4.74 (1H, d, *J* 11.4, -CH₂Ph), 4.88 (1H, d, *J* 11.4, -CH₂Ph), 4.93 (1H, d, *J* 11.4, -CH₂Ph), 4.95 (1H, d, *J* 11.4, -CH₂Ph), 4.99 (1H, m, -CH=CH₂), 5.04 (1H, m, -CH=CH₂), 5.64 (1H, d, *J* 3.5, H-1'), 5.83-5.84 (1H, m, -CH=CH₂), 7.18-7.37 (25H, m, Ph); δ_{C} (63 MHz,

CDCl₃) 27.0 (-C(CH₃)₃), 28.8 (CH₂CH₂CH=CH₂), 30.1 (CH₂CH₂CH=CH₂), 38.7 (-C(CH₃)₃), 62.9, 68.9 and 69.0 (C-6, C-6' and -OCH₂CH₂CH₂CH=CH₂), 70.0, 70.3, 72.2, 72.8, 73.2, 73.4, 74.3, 74.4, 75.3, 79.0, 80.6, 81.9 and 84.5 (C-2, C-3, C-4, C-5, C-2', C-3', C-4', C-5' and 5 x -CH₂Ph), 95.9 (C-1'), 103.3 (C-1), 114.8 (-CH=CH₂), 126.4, 126.9, 127.4, 127.5, 127.5, 127.6, 127.8, 128.0, 128.0, 128.1 and 128.3 (Ph), 137.6 and 137.8 (q-Ph), 138.0 (-CH=CH₂), 138.0, 138.3 and 138.6 (q-Ph), 178.9 (C=O); m/z (ES⁺, acetonitrile-water) 967 (MNa⁺, 100%), 962 (MNH₄⁺, 7%), 555 (28), 537 (27); (Found (FAB⁺, matrix) : 945.4790, C₅₇H₆₈O₁₂.H⁺ requires 945.4789).

Pent-4-enyl 2,3,6-tri-*O*-benzyl-4-*O*-[2',3'-di-*O*-benzyl-4'-*O*-(2'',3'',4'',6'')-tetra-*O*-acetyl-β-D-glucopyranosyl]-6'-*O*-pivaloyl-α-D-glucopyranosyl]-β-D-glucopyranoside (149)

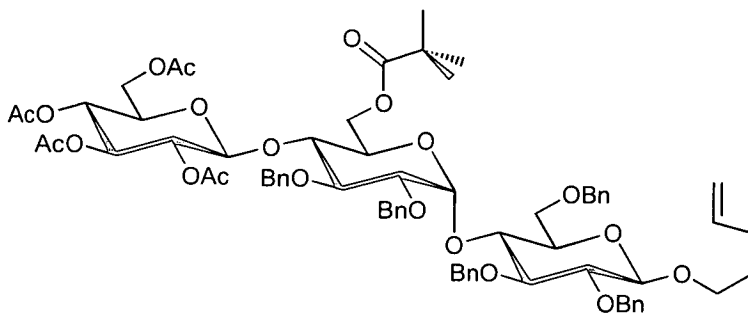

The acceptor (155) (400 mg, 0.423 mmol) and donor (134) (494 mg, 1.01 mmol) were taken up in freshly distilled dichloromethane and cooled under argon to -30°C with an acetone and dry-ice bath. Boron trifluoride diethyl etherate (35.5 μl, 0.280 mmol) was added dropwise and the mixture was stirred at -30 °C for 2 h 10 min, before being quenched with sodium hydrogen carbonate (560 mg, 6.67 mmol) and saturated aqueous sodium hydrogen carbonate (10 ml). The mixture was diluted with dichloromethane (10 ml) and washed with saturated aqueous sodium hydrogen carbonate and water. The organic layer was concentrated and purified by chromatography [hexane-EtOAc 3:2] to give the trisaccharide (149) as an oil (496 mg, 92%).

R_f 0.24 (EtOAc-hexane 2:3); [α]_D²⁵ +13.3 (*c* 1.0 in chloroform); ν_{max} (neat/cm⁻¹) 3064 and 3030 (=CH), 2935 and 2872 (CH), 1731 (C=O), 1599, 1454, 1366, 1229,

1038, 910, 826 754, 698 and 666; δ_{H} (600 MHz, CDCl_3) 1.20 (9H, s, $-\text{C}(\text{CH}_3)_3$), 1.72-1.78 (2H, m, $-\text{CH}_2\text{CH}_2\text{CH}=\text{CH}_2$), 1.92, 1.96, 1.96 and 1.97 (12H, 4s, $\text{C}(\text{O})\text{CH}_3$), 2.14-2.18 (2H, m, $-\text{CH}_2\text{CH}=\text{CH}_2$), 3.32 (1H, dd, J 3.7 and 9.5, H-2'), 3.41 (1H, ddd, J 2.4, 3.5 and 9.6, H-5''), 3.45 (1H, dd, J 7.9 and 8.9, H-2), 3.51 (1H, ddd, J 2.2, 4.3 and 9.6, H-5), 3.55 (1H, ddd, J 6.7, 6.8 and 9.5, $-\text{OCH}_2\text{CH}_2\text{CH}_2\text{CH}=\text{CH}_2$), 3.65 (1H, dd, J 8.8 and 10.0, H-4'), 3.73 (1H, dd, J 8.9 and 9.0, H-3), 3.74-3.79 (3H, m, H-6, H-6 and H-6''), 3.84 (1H, dd, J 8.8 and 9.5, H-3'), 3.87 (1H, ddd, J 1.8, 4.9 and 10.0, H-5'), 3.93 (1H, ddd, J 6.3, 6.5 and 9.5, $-\text{OCH}_2\text{CH}_2\text{CH}_2\text{CH}=\text{CH}_2$), 4.00 (1H, dd, J 9.0 and 9.6, H-4), 4.01 (1H, dd, J 4.9 and 12.0, H-6'), 4.07 (1H, dd, J 3.5 and 12.4, H-6''), 4.35 (1H, dd, J 1.8 and 12.0, H-6'), 4.39 (1H, d, J 7.9, H-1), 4.43 (1H, d, J 11.8, $-\text{CH}_2\text{Ph}$), 4.46 (1H, d, J 11.8, $-\text{CH}_2\text{Ph}$), 4.56 (1H, d, J 12.0, $-\text{CH}_2\text{Ph}$), 4.58 (1H, d, J 12.0, $-\text{CH}_2\text{Ph}$), 4.60 (1H, d, J 10.9, $-\text{CH}_2\text{Ph}$), 4.67 (1H, d, J 7.9, H-1''), 4.71 (1H, d, J 11.6, $-\text{CH}_2\text{Ph}$), 4.75 (1H, d, J 11.4, $-\text{CH}_2\text{Ph}$), 4.91 (1H, d, J 11.6, $-\text{CH}_2\text{Ph}$), 4.89 (1H, d, J 10.9, $-\text{CH}_2\text{Ph}$), 4.92 (1H, d, J 11.4, $-\text{CH}_2\text{Ph}$), 4.95-4.98 (1H, m, $-\text{CH}=\text{CH}_2$), 4.96 (1H, dd, J 7.9 and 9.2, H-2''), 5.00-5.04 (1H, m, $-\text{CH}=\text{CH}_2$), 5.05 (1H, dd, J 8.1 and 9.6, H-4''), 5.08 (1H, dd, J 8.1 and 9.2, H-3''), 5.53 (1H, d, J 3.7, H-1'), 5.82 (1H, dddd, J 6.7, 6.8, 10.2 and 16.9, $-\text{CH}=\text{CH}_2$), 7.04-7.34 (25H, m, Ph); δ_{C} (63MHz, CDCl_3) 20.3 (4 x COCH_3), 27.1 ($-\text{C}(\text{CH}_3)_3$), 28.7 ($-\text{CH}_2\text{CH}_2\text{CH}=\text{CH}_2$), 30.0 ($-\text{CH}_2\text{CH}=\text{CH}_2$), 38.6 ($-\text{C}(\text{CH}_3)_3$), 61.2 ($-\text{OCH}_2\text{CH}_2\text{CH}_2\text{CH}=\text{CH}_2$), 62.1 (C-6), 67.1, 67.6, 68.6, 68.9, 69.1, 71.6, 71.8, 72.5, 72.9, 73.1, 73.5, 74.3, 74.4, 74.5, 78.6, 78.6, 79.2, 81.8 and 84.3 (C-2, C-3, C-4, C-5, C-2', C-3', C-4', C-5', C-6', C-2'', C-3'', C-4'', C-5'', C-6'' and 5 x $-\text{CH}_2\text{Ph}$), 95.5 (C-1'), 100.8 (C-1''), 103.2 (C-1), 114.7 ($-\text{CH}=\text{CH}_2$), 126.4, 126.5, 127.0, 127.4, 127.5, 127.9, 128.0, 128.1 and 128.1 (Ph), 137.4 (q-Ph), 137.7 ($-\text{CH}=\text{CH}_2$), 137.8, 138.0, 138.5 and 138.8 (q-Ph), 163.4, 170.0, 170.3 and 171.0 (4 x $-\text{COCH}_3$), 177.6 ($-\text{COBu}^{\dagger}$); m/z (ES^+ , acetonitrile-water) 1297 (MNa^+ , 29%), 968 (13), 757 (8), 658 (100), 649 (27); (Found: MNa^+ , 1297.5534; $\text{C}_{71}\text{H}_{86}\text{O}_{21}\cdot\text{Na}^+$ requires 1297.5559).

5.4 Experimental for Chapter 4

Pent-4-enyl 2,3,6-tri-*O*-benzyl-4-*O*-[2',3'-di-*O*-benzyl-4'-*O*-(β -D-glucopyranosyl)-6'-*O*-pivaloyl- α -D-glucopyranosyl]- β -D-glucopyranoside (160)

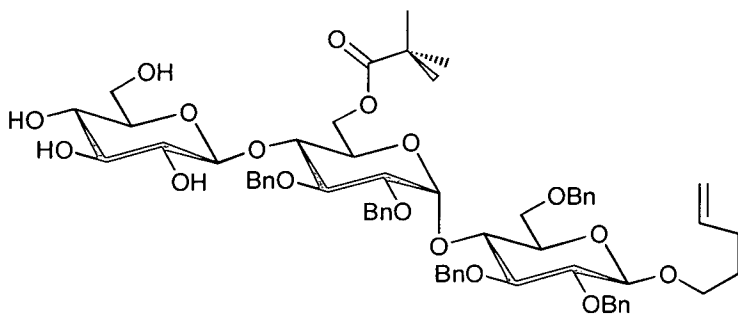

The fully protected trisaccharide (149) (54.5 mg, 42.7 μ mol) was taken up in freshly distilled dichloromethane (0.5 ml). Guanidine hydrochloride (4.1 mg, 43 μ mol) was taken up in dry methanol (0.5 ml) and converted to its basic form by addition of sodium methoxide (85.5 μ l, 42.7 μ mol). This guanidine solution was then added to the reaction mixture and allowed to stir under argon for 1 h 45 min. The mixture was concentrated and purified by chromatography [dichloromethane-methanol 20:1] to give the title compound as a clear colourless oil (24.1 mg, 51%).

R_f 0.12 (dichloromethane-methanol 19:1); $[\alpha]_D^{23} +24.9^\circ$ (c 1.0, CHCl_3); δ_H (600 MHz, CDCl_3) 1.19 (9H, s, $-\text{C}(\text{CH}_3)_3$), 1.74-1.79 (2H, m, $-\text{CH}_2\text{CH}_2\text{CH}=\text{CH}_2$), 2.16-2.20 (2H, m, $-\text{CH}_2\text{CH}=\text{CH}_2$), 3.00-3.30 (4H, br, -OH), 3.12-3.30 (1H, m, H-5''), 3.31 (1H, dd, J 8.0 and 8.3, H-2''), 3.38 (1H, dd, J 3.6 and 9.5, H-2'), 3.40-3.44 (2H, m, H-3'' and H-4''), 3.46-3.50 (2H, m, H-2 and H-6''), 3.54-3.57 (2H, m, H-5 and $-\text{OCH}_2\text{CH}_2\text{CH}_2\text{CH}=\text{CH}_2$), 3.58-3.60 (1H, m, H-6''), 3.62 (1H, dd, J 9.2 and 9.7, H-4'), 3.75 (1H, dd, J 8.7 and 8.9, H-3), 3.77-3.82 (2H, m, H-6 and H-6), 3.85 (1H, dd, J 9.2 and 9.5, H-3'), 3.93-3.98 (2H, m, H-5' and $-\text{OCH}_2\text{CH}_2\text{CH}_2\text{CH}=\text{CH}_2$), 4.00 (1H, dd, J 8.7 and 9.4, H-4), 4.15 (1H, dd, J 5.2 and 12.1, H-6'), 4.39 (1H, d, J 8.0, H-1''), 4.41 (1H, d, J 7.8, H-1), 4.40-4.44 (1H, m, H-6'), 4.49 (1H, d, J 11.8, $-\text{CH}_2\text{Ph}$), 4.51 (1H, d, J 11.8, $-\text{CH}_2\text{Ph}$), 4.58 (1H, d, J 12.2, $-\text{CH}_2\text{Ph}$), 4.61 (1H, d, J 12.2, $-\text{CH}_2\text{Ph}$), 4.62 (1H, d, J 11.0, $-\text{CH}_2\text{Ph}$), 4.72 (1H, d, J 11.5, $-\text{CH}_2\text{Ph}$), 4.81 (1H, d, J 11.5, $-\text{CH}_2\text{Ph}$), 4.84 (1H, d, J 11.0, $-\text{CH}_2\text{Ph}$), 4.91 (1H, d, J 11.1, $-\text{CH}_2\text{Ph}$), 4.91 (1H, d, J

11.1, $-\text{CH}_2\text{Ph}$), 4.97-4.99 (1H, m, $-\text{CH}=\text{CH}_2$), 5.01-5.05 (1H, m, $-\text{CH}=\text{CH}_2$), 5.55 (1H, d, J 3.6, H-1'), 5.80-5.87 (1H, m, $-\text{CH}=\text{CH}_2$), 7.12-7.35 (25H, m, Ph); δ_{C} (91 MHz, CDCl_3) 27.7 ($-\text{C}(\text{CH}_3)_3$), 29.4 ($-\text{CH}_2\text{CH}_2\text{CH}=\text{CH}_2$), 30.7 ($-\text{CH}_2\text{CH}=\text{CH}_2$), 39.4 ($-\text{C}(\text{CH}_3)_3$), 62.3, 64.0, 69.7, 69.7, 70.0, 70.4, 73.5, 73.6, 73.8, 73.8, 74.1, 75.0, 75.1, 75.6, 76.3, 77.0, 77.7, 79.6, 79.9, 82.4 and 84.9 (C-2, C-3, C-4, C-5, C-6, C-2', C-3', C-4', C-5', C-6', C-2'', C-3'', C-4'', C-5'', C-6'', $-\text{OCH}_2\text{CH}_2\text{CH}_2\text{CH}=\text{CH}_2$ and 5 x $-\text{CH}_2\text{Ph}$), 96.2 (C-1'), 103.2 (C-1), 103.9 (C-1''), 115.4 ($-\text{CH}=\text{CH}_2$), 127.1, 127.6, 128.1, 128.1, 128.1, 128.2, 128.6, 128.6 and 128.8 (Ph), 138.1, 138.5, 138.6, 138.7, 138.9 and 139.2 ($-\text{CH}=\text{CH}_2$ and q-Ph), 179.5 (C=O); m/z (ES^+ , acetonitrile-water) 1129 (MNa^+ , 100%), 1124 (MNH_4^+ , 35), 1043 (17), 1032 (23), 993 (11), 969 (12), 908 (10), 880 (17), 840 (18), 804 (20), 738 (13), 688 (23), 686 (22), 663 (41), 582 (18), 545 (32), 544 (74), 540 (28), 518 (18).

Pentyl 4-*O*-[4'-*O*-(2'',3'',4'',6''-tetra-*O*-acetyl- β -D-glucopyranosyl)-6'-*O*-pivaloyl- α -D-glucopyranosyl]- β -D-glucopyranoside (161)

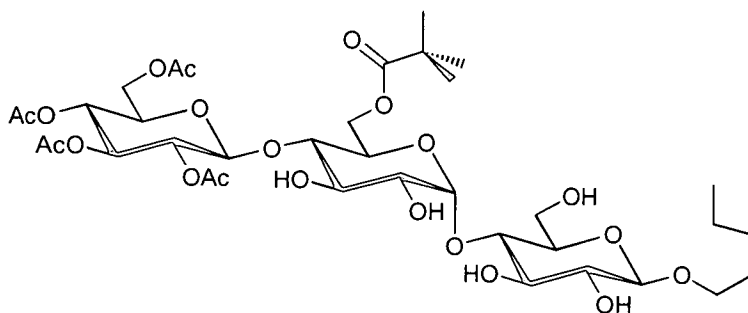

The fully protected trisaccharide (149) (51.9 mg, 40.7 μmol) was dissolved in a slurry of palladium hydroxide on activated charcoal (51 mg, 20%) in ethanol (1 ml). The reaction was stirred under an atmosphere of hydrogen for 2 h. The mixture was filtered through Celite and concentrated. Chromatography of the residue [dichloromethane-methanol 40:3] yielded the product (161) as a white solid (15.6 mg, 47%).

R_f 0.28 (dichloromethane-propan-2-ol 9:1); m.p. 172-174 $^\circ\text{C}$ (MeOH, EtOAc); $[\alpha]_{\text{D}}^{25}$ +25.0 (c 1.0 in chloroform); ν_{max} (neat/ cm^{-1}) 3435 (OH), 2934 (CH), 1754 (C=O), 1668, 1370, 1226, 1036, 905 and 755; δ_{H} (600 MHz, CDCl_3) 0.87 (3H, dd, J 6.9 and

7.1, $-\text{CH}_2\text{CH}_3$), 1.19 (9H, s, $-\text{C}(\text{CH}_3)_3$), 1.28-1.31 (4H, m, $-\text{CH}_2\text{CH}_2\text{CH}_3$ and $-\text{CH}_2\text{CH}_3$), 1.57-1.62 (2H, m, $-\text{CH}_2\text{CH}_2\text{CH}_2\text{CH}_3$), 1.96 (3H, s, $\text{C}(\text{O})\text{CH}_3$), 1.98 (3H, s, $\text{C}(\text{O})\text{CH}_3$), 2.01 (3H, s, $\text{C}(\text{O})\text{CH}_3$), 2.08 (3H, s, $\text{C}(\text{O})\text{CH}_3$), 3.31-3.38 (3H, m, H-2, H-2' and H-5''), 3.51 (1H, ddd, J 6.9, 7.1 and 14.0, $-\text{OCH}_2\text{CH}_2\text{CH}_2\text{CH}_2\text{CH}_3$), 3.57 (1H, dd, J 9.5 and 9.6, H-4'), 3.57-3.59 (1H, m, H-5), 3.65 (1H, dd, J 9.1 and 9.2, H-3), 3.76-3.86 (5H, m, H-6, H-6, H-3', H-5' and H-6''), 3.92-3.98 (2H, m, H-4 and $-\text{OCH}_2\text{CH}_2\text{CH}_2\text{CH}_2\text{CH}_3$), 4.09 (1H, dd, J 6.0 and 12.5, H-6'), 4.21 (1H, d, J 10.5, H-6''), 4.28 (1H, d, J 7.7, H-1), 4.27-4.29 (1H, m, H-6'), 4.55 (1H, d, J 8.1, H-1''), 4.98 (1H, dd, J 8.1 and 9.7, H-2''), 5.03 (1H, dd, J 9.5 and 9.8, H-4''), 5.08 (1H, d, J 3.7, H-1'), 5.15 (1H, dd, J 9.5 and 9.7, H-3''); δ_{C} (63 MHz, CDCl_3) 13.9, 20.4, 20.4, 20.5, 22.3 and 22.4 ($-\text{CH}_3$, $-\text{CH}_2\text{CH}_3$ and 4 x $-\text{COCH}_3$), 27.0 ($-\text{C}(\text{CH}_3)_3$), 27.8 ($-\text{CH}_2\text{CH}_2\text{CH}_3$), 29.1 ($-\text{CH}_2\text{CH}_2\text{CH}_2\text{CH}_3$), 38.6 ($-\text{C}(\text{CH}_3)_3$), 61.4, 61.5, 63.0, 67.8, 68.7, 70.2, 71.0, 71.7, 71.9, 72.0, 72.5, 73.0, 74.5, 75.8, 80.9 and 82.0 (C-2, C-3, C-4, C-5, C-6, C-2', C-3', C-4', C-5', C-6', C-2'', C-3'', C-4'', C-5'', C-6'' and $-\text{OCH}_2\text{CH}_2\text{CH}_2\text{CH}_2\text{CH}_3$), 101.1 (C-1'), 101.2 (C-1''), 102.5 (C-1), 169.2, 169.4, 169.9 and 170.7 ($-\text{COCH}_3$), 178.1 ($-\text{COC}(\text{CH}_3)_3$); m/z (ES^+ , acetonitrile-water) 849 (MNa^+ , 9%), 649 (42), 648 (99), 526 (21), 524 (33), 523 (100); (Found (FAB^+ , matrix): 849.3359, $\text{C}_{36}\text{H}_{58}\text{O}_{21}\cdot\text{Na}^+$ requires 849.3368).

Pent-4-enyl 2,3,6-tri-*O*-benzyl-4-*O*-[2',3'-di-*O*-benzyl-4'-*O*-(β -D-glucopyranosyl)- α -D-glucopyranosyl]- β -D-glucopyranoside (167)

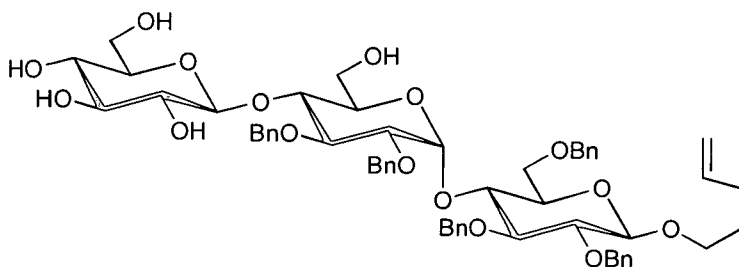

The fully protected trisaccharide (149) (668 mg, 0.524 mmol) was taken up in freshly distilled tetrahydrofuran (3.5 ml) and cooled to 0 °C under an argon atmosphere. Sodium methoxide (1.71 ml, 0.852 mmol, 0.5 M) was added dropwise and the mixture was stirred at RT overnight before being quenched with ion exchange resin (1.7 g, hydrogen form). The mixture was then filtered and concentrated before

chromatography [dichloromethane-methanol 40:3] gave the product as a clear colourless oil (190 mg, 35%).

R_f 0.19 (dichloromethane-methanol 19:1); $[\alpha]_D^{25} +24.7$ (c 0.9, CHCl_3); ν_{\max} ($\text{neat}/\text{cm}^{-1}$) 3376 (-OH), 2924 (-CH), 1454, 1028 (-OH), 735 and 697; δ_H (600 MHz, CDCl_3) 1.74-1.79 (2H, m, $-\text{CH}_2\text{CH}_2\text{CH}=\text{CH}_2$), 2.16-2.20 (2H, m, $-\text{CH}_2\text{CH}=\text{CH}_2$), 3.02-3.03 (1H, m, H-5''), 3.30 (1H, dd, J 7.6 and 7.7, H-2''), 3.39-3.59 (9H, m, H-2, H-5, H-2', H-4', H-3'', H-4'', H-6'', H-6'' and $-\text{OCH}_2\text{CH}_2\text{CH}_2\text{CH}_2\text{CH}_3$), 3.69-3.87 (12H, m, H-3, H-6, H-6, H-3', H-5', H-6', H-6' and 5 x -OH), 3.94 (1H, ddd, J 6.4, 6.5 and 12.9, $-\text{OCH}_2\text{CH}_2\text{CH}_2\text{CH}_2\text{CH}_3$), 4.02 (1H, t, J 9.0, H-4), 4.40 (1H, d, J 7.7, H-1''), 4.45 (2H, s, $-\text{CH}_2\text{Ph}$), 4.54-4.58 (2H, m, H-1 and $-\text{CH}_2\text{Ph}$), 4.58 (1H, d, J 12.0, $-\text{CH}_2\text{Ph}$), 4.61 (1H, d, J 11.0, $-\text{CH}_2\text{Ph}$), 4.71 (1H, d, J 12.0, $-\text{CH}_2\text{Ph}$), 4.81 (1H, d, J 11.4, $-\text{CH}_2\text{Ph}$), 4.87 (1H, d, J 11.4, $-\text{CH}_2\text{Ph}$), 4.92 (1H, d, J 11.0, $-\text{CH}_2\text{Ph}$), 4.94 (1H, d, J 12.0, $-\text{CH}_2\text{Ph}$), 4.97-5.02 (1H, m, $-\text{CH}=\text{CH}_2$), 5.02-5.05 (1H, m, $-\text{CH}=\text{CH}_2$), 5.61 (1H, d, J 3.3, H-1'), 5.80-5.87 (1H, m, $-\text{CH}=\text{CH}_2$), 7.08-7.33 (25H, m, Ph); δ_C (63 MHz, CDCl_3) 20.8 ($-\text{CH}_2\text{CH}_2\text{CH}=\text{CH}_2$), 30.0 ($-\text{CH}_2\text{CH}=\text{CH}_2$), 60.5, 60.9, 68.3, 68.9, 68.9, 71.1, 72.5, 72.9, 73.0, 73.7, 73.7, 74.2, 74.4, 74.7, 75.6, 75.8, 75.9, 78.9, 80.2, 81.9 and 84.5 (C-2, C-3, C-4, C-5, C-6, C-2', C-3', C-4', C-5', C-6', C-2'', C-3'', C-4'', C-5'', C-6'', $-\text{OCH}_2\text{CH}_2\text{CH}_2\text{CH}_2\text{CH}_3$ and 5 x $-\text{CH}_2\text{Ph}$), 96.2 (C-1'), 102.9 (C-1''), 103.2 (C-1'), 114.8 ($-\text{CH}=\text{CH}_2$) 126.4, 126.7, 126.9, 127.5, 127.9, 128.0 and 128.1 (Ph), 137.4, 137.8, 137.9, 138.0, 138.3 and 138.5 ($-\text{CH}=\text{CH}_2$ and q-Ph); m/z (ES^+ , acetonitrile-water) 1045 (MNa^+ , 93%), 1040 (MNH_4^+ , 9), 735 (14), 684 (21), 546 (83), 527 (100); (Found (FAB^+ , matrix): 1023.4712, $\text{C}_{58}\text{H}_{70}\text{O}_{16}\cdot\text{H}^+$ requires 1023.4742).

Pentyl 4-*O*-[4'-*O*-(β -D-glucopyranosyl)-6'-*O*-pivaloyl- α -D-glucopyranosyl]- β -D-glucopyranoside (168)

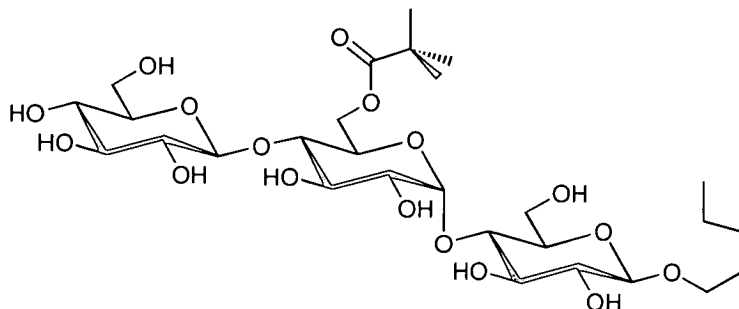

The partially protected trisaccharide (161) (37.7 mg, 45.6 μ mol) was taken up in dry methanol (0.5 ml). The hydrochloric salt of guanidine (6.5 mg, 69 μ mol) was also dissolved in dry methanol (0.5 ml) and converted to its basic form by the addition of a solution of sodium methoxide (137 μ l, 0.5 M, 68.5 μ mol). The guanidine solution was then added to that of the saccharide and stirred at RT under argon. After 1 h 30 min the solution was neutralised by addition of ion-exchange resin (50 mg, hydrogen form), filtered and washed with methanol. Concentration and purification by flash chromatography [EtOAc-methanol 17:3] gave the title compound as a white solid (24.7 mg, 82%).

R_f 0.49 (EtOAc-methanol 3:2); m.p. 168-170 $^{\circ}$ C (MeOH, PE); $[\alpha]_D^{25}$ +48.4 (c 1.2, MeOH); δ_H (600 MHz, CD_3OD) 0.91 (3H, dd, J 7.1 and 7.2, $-CH_3$), 1.22 (9H, s, $-C(CH_3)_3$), 1.34-1.37 (4H, m, $-CH_2CH_3$ and $-CH_2CH_2CH_3$), 1.61-1.63 (2H, m, $-CH_2CH_2CH_2CH_3$), 3.21 (1H, dd, J 7.8 and 9.3, H-2''), 3.21 (1H, dd, J 7.9 and 9.0, H-2), 3.25-3.34 (3H, m, H-3, H-4 and H-5''), 3.34-3.37 (1H, m, H-5), 3.49 (1H, dd, J 3.7 and 9.6, H-2'), 3.51-3.55 (3H, m, H-4', H-4'' and $-OCH_2CH_2CH_2CH_2CH_3$), 3.61 (1H, dd, J 9.0 and 9.2, H-3''), 3.64 (1H, dd, J 6.0 and 11.8, H-6''), 3.74 (1H, dd, J 8.9 and 9.6, H-3'), 3.76 (1H, dd, J 5.0 and 12.1, H-6), 3.85-3.90 (3H, m, H-6, H-6'' and $-OCH_2CH_2CH_2CH_2CH_3$), 4.00-4.03 (1H, m, H-5'), 4.26 (1H, d, J 7.8, H-1''), 4.29 (1H, d, J 7.9, H-1), 4.30 (1H, dd, J 4.5 and 12.1, H-6'), 4.48 (1H, 1.8 and 12.1, H-6'), 5.19 (1H, d, J 3.7, H-1'); m/z (ES^+ , acetonitrile-water) 681 (MNa^+ , 77%), 571 (10), 482 (34), 481 (100), 454 (20), 413 (12), 365 (12), 342 (45), 301 (40); (Found (FAB^+ , matrix): MNa^+ 681.2942, $C_{28}H_{50}O_{17} \cdot Na^+$ requires 681.2946).

Pent-4-enyl 2,3,6-tri-*O*-benzyl-4-*O*-[2',3'-di-*O*-benzyl-4'-*O*-(4'',6''-*O*-benzylidene- β -D-glucopyranosyl)- α -D-glucopyranosyl]- β -D-glucopyranoside (169)

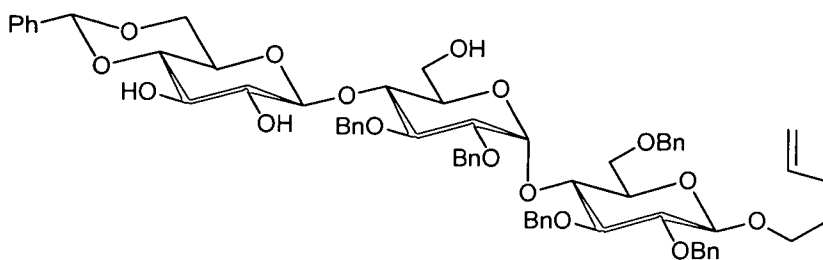

The deacylated starting material (167) (158 mg, 0.154 mmol) was dried in a flask over phosphorous pentoxide overnight in a vacuum desiccator. *p*-Toluenesulfonic acid (3.0 mg, 16 μ mol), dry dimethylformamide (0.5 ml) and freshly distilled benzylidene dimethyl acetal (46.4 μ l, 0.308 mmol) were added. The mixture was turned on a rotary evaporator (28-30 mBar) at 50 °C for 3 h 30 min and then quenched by the addition of triethylamine (8.0 μ l, 57 μ mol). The mixture was concentrated as far as possible with the aid of an attachment for the removal of high boiling solvents. Anhydrous toluene was evaporated from the resultant residue, which was then purified by chromatography [dichloromethane-methanol 400:13] yielding the product as an amorphous white solid (112 mg, 65%).

R_f 0.64 (dichloromethane-methanol 20:1); m.p. 135-137 °C (EtOAc); $[\alpha]_D^{25} +20.5$ (c 1.1, CHCl_3), ν_{max} (neat/ cm^{-1}) 3397 (OH), 3031 (=CH), 2872 (-CH), 1496, 1454, 1363, 1208, 1091 (-OH and C-O-C), 914, 734 and 697; δ_{H} (200 MHz, CDCl_3) 1.62-1.75 (2H, m, $-\text{CH}_2\text{CH}_2\text{CH}=\text{CH}_2$), 2.06-2.15 (2H, m, $-\text{CH}_2\text{CH}=\text{CH}_2$), 2.75-4.00 (23H, m, H-2, H-3, H-4, H-5, H-6, H-6, H-2', H-3', H-4', H-5', H-6', H-6', H-2'', H-3'', H-4'', H-5'', H-6'', H-6'', $-\text{OCH}_2\text{CH}_2\text{CH}_2\text{CH}=\text{CH}_2$ and 3 x -OH), 4.33 (1H, d, J 7.3, H-1''), 4.39-5.15 (12H, m, $-\text{CH}=\text{CH}_2$ and $-\text{CH}_2\text{Ph}$), 4.62 (1H, d, J 7.3, H-1), 5.30 (1H, s, $-\text{CHPh}$), 5.58 (1H, d, J 3.3, H-1'), 7.01-7.34 (30H, m, Ph); δ_{C} (63 MHz, CDCl_3) 28.8 ($-\text{CH}_2\text{CH}_2\text{CH}=\text{CH}_2$), 30.1 ($-\text{CH}_2\text{CH}=\text{CH}_2$), 61.1, 66.4, 68.2, 68.2, 69.0, 70.7, 71.9, 73.0, 73.1, 73.3, 73.7, 74.3, 74.5, 74.5, 75.8, 77.1, 79.0, 80.0, 80.9, 82.1 and 84.6 (C-2, C-3, C-4, C-5, C-6, C-2', C-3', C-4', C-5', C-6', C-2'', C-3'', C-4'', C-5'', C-6'', $-\text{CH}_2\text{Ph}$ and $-\text{OCH}_2\text{CH}_2\text{CH}_2\text{CH}=\text{CH}_2$), 96.2 (C-1'), 101.6 (CHPh), 103.3 (C-1), 104.3 (C-1''), 114.8 ($-\text{CH}=\text{CH}_2$), 126.1, 126.1, 126.4, 126.8, 127.0,

127.1, 127.5, 127.6, 127.6, 127.7, 128.0, 128.1, 128.2, 128.8, 129.0 and 129.6 (Ph), 136.8 and 137.3 (q-Ph), 137.8 (-CH=CH₂), 137.8, 138.0, 138.5 and 138.8 (q-Ph); m/z (ES⁺, acetonitrile-water) 1133 (MNa⁺, 4%), 865 (4), 762 (16), 711 (35), 710 (100), 678 (17), 644 (13), 609 (11), 589 (18), 577 (33), 540 (17), 539 (96), 537 (28); (Found (FAB⁺, matrix): MNa⁺ 1133.4861, C₆₅H₇₄O₁₆.Na⁺ requires 1133.4875).

Pentyl 4-*O*-[4'-*O*-(β-D-glucopyranosyl)-α-D-glucopyranosyl]-β-D-glucopyranoside (170)

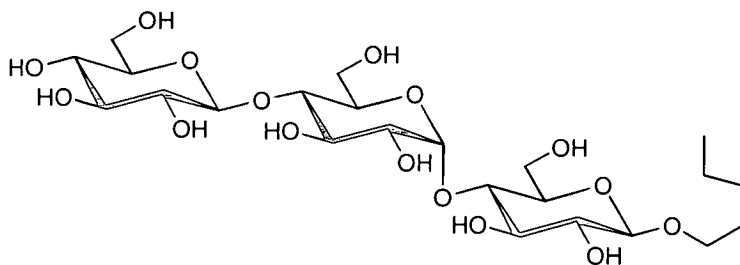

The deacylated trisaccharide (167) (53.8 mg, 52.6 μmol) and the benzylidene acetal analogue (169) (30.8 mg, 27.7 μmol) were dissolved in ethanol (3 ml). Palladium (II) hydroxide on activated charcoal (85 mg, 20%) was added as an ethanol slurry. The mixture was stirred for 2 h under an atmosphere of hydrogen and was then filtered and concentrated to give a white solid (46.2 mg, 99%). The material was taken on to the next reaction without further purification.

R_f 0.26 (EtOAc-methanol 3:2), m.p. 257-258 °C (MeOH, EtOAc); [α]_D²⁵ +54.1 (*c* 1.0, MeOH); δ_H (360 MHz, CD₃OD) 0.95 (3H, dd, *J* 7.0 and 7.2, -CH₃), 1.36-1.42 (4H, m, -CH₂CH₃ and -CH₂CH₂CH₃), 1.62-1.70 (2H, m, -CH₂CH₂CH₂CH₃) 3.25 (1H, dd, *J* 7.8 and 9.1, H-2''), 3.25 (1H, dd, *J* 7.8 and 8.1, H-2), 3.32-3.42 (4H, m, H-3, H-4, H-5 and H-5''), 3.52-3.60 (3H, m, H-4', H-4'' and -OCH₂CH₂CH₂CH₂CH₃), 3.54 (1H, dd, *J* 3.9 and 9.5, H-2'), 3.65 (1H, dd, *J* 9.0 and 9.1, H-3''), 3.68 (1H, dd, *J* 5.3 and 11.9, H-6), 3.77 (1H, dd, *J* 9.1 and 9.5, H-3'), 3.77-3.96 (7H, m, H-6, H-5', H-6', H-6'', H-6''' and -OCH₂CH₂CH₂CH₂CH₃), 4.30 (1H, d, *J* 7.8, H-1''), 4.42 (1H, d, *J* 7.8, H-1) 5.21 (1H, d, *J* 3.9, H-1'); m/z (FAB⁺, matrix) 1149 (MMH⁺, 6%), 789 (14), 683 (10), 597 (MNa⁺, 20), 575 (MH⁺, 100), 487 (24), 433 (35), 413 (75); (Found: MNa⁺ 597.2382, C₂₃H₄₂O₁₆.Na⁺ requires 597.2371).

Methyl (methyl 2,3,4-tri-*O*-acetyl- α -D-glucopyranosid)-uronate (**188**)

Method 1, aqueous conditions.^{145,155}

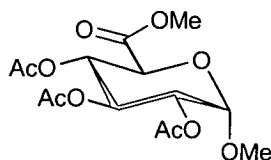

To a solution of methyl α -D-glucopyranoside (**182**) (100 mg, 0.515 mmol), sodium bromide (10.0 mg, 97.1 μ mol) and TEMPO (1.0 mg, 6.4 μ mol) in water (7 ml) was added sodium hypochlorite (2.00 ml, 0.7 M, 1.41 mmol, acidified to pH 9.7 with hydrochloric acid [2 M]) with stirring. The pH was monitored during the course of the reaction and maintained at pH 10 by addition of sodium hydroxide (0.5 M). The reaction was complete after 2 h when no more sodium hydroxide was needed. It was then quenched by the addition of ethanol (10 ml) and stirred for 1 h. The mixture was acidified to pH 4.2 with hydrochloric acid (2 M) and concentrated to give crude product and salts as a white solid (814 mg). The crude material was dried overnight over phosphorous pentoxide in a vacuum desiccator then taken up in dry dimethylformamide (3.5 ml). Methyl iodide (40 μ l, 0.64 mmol) was added and the mixture was stirred under argon for 2 d. Dimethylaminopyridine (1.0 mg, 8.2 μ mol) and acetic anhydride (245 μ l, 2.59 mmol) were added and the mixture was stirred under argon overnight, then quenched by the addition of water (10 ml). The mixture was diluted with ethyl acetate (30 ml) and the organic layer was separated and washed with saturated aqueous ammonium chloride (30ml), saturated aqueous sodium hydrogen carbonate (30ml) and then water (30ml). The organic layer was concentrated to a yellow gum that was purified by chromatography [hexane-EtOAc 1:1] to give the product as a yellow oil (125 mg, 70%). The data was in good agreement with that previously reported.^{161,162}

m.p. 152-153 $^{\circ}$ C (EtOH); lit.¹⁶² 153-155 $^{\circ}$ C (EtOH); $[\alpha]_{\text{D}}^{23}$ +116.3 (*c* 1.0, CHCl₃); lit.¹⁶¹ $[\alpha]_{\text{D}}^{25}$ +109.6 (*c* 1.2, CHCl₃); δ_{H} (200 MHz, CDCl₃) 1.94, 1.94 and 1.95 (12H, 3s, C(O)CH₃), 3.37 (3H, s, -C₁OCH₃), 3.68 (3H, s, -CO₂CH₃), 4.21 (1H, d, *J* 9.9, H-5), 4.82 (1H, dd, *J* 3.0 and 10.2, H-2), 4.96 (1H, d, *J* 3.0, H-1), 5.09 (1H, dd, *J* 9.5

and 9.9, H-4), 5.44 (1H, dd, J 9.5 and 10.2, H-3); m/z (ES^+ acetonitrile-water) 371 ($M.Na^+$, 70%), 155 (100).

Methyl (phenyl 2,3,4-tri-*O*-acetyl- β -D-glucopyranosid)-uronate (**189**)

Method 1, aqueous conditions:^{145,155}

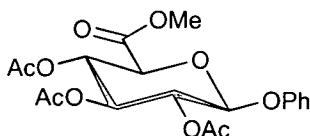

Phenyl β -D-glucopyranoside (**183**) (100 mg, 0.391 mmol) was treated in the same way as in the previous example, producing the title compound as a clear, colourless oil (136 mg, 85%). The data recorded was in good agreement with that previously reported.^{159,160}

m.p. 122-124 °C (EtOH); lit.¹⁵⁹ 126-127 °C (EtOH); $[\alpha]_D^{22}$ -28.2 (c 1.1, $CHCl_3$); lit.¹⁶⁰ $[\alpha]_D^{25}$ -35.5 (c 1.0, $CHCl_3$); δ_H (200 MHz, $CDCl_3$) 1.99, 2.00 and 2.01 (9H, 3s, $-C(O)CH_3$), 3.68 (3H, s, $-CO_2CH_3$), 4.15 (1H, dd, J 4.6 and 9.0, H-2), 5.10 (1H, dd, J 7.7 and 8.4, H-4), 5.20-5.32 (3H, m, H-1, H-3 and H-5), 6.83-7.37 (5H, m, Ph).

Phenyl β -D-glucopyranosiduronic acid (**185**)¹⁶⁰

Method 2, organic-aqueous conditions:¹⁶³

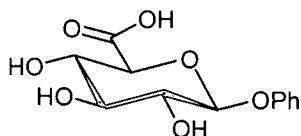

To a solution of the starting material (**183**) (100 mg, 0.391 mmol) in acetonitrile (2 ml) was added phosphate buffer (1.5 ml, 0.67 M, pH 6.7) and TEMPO (4.4 mg, 29 μ mol). The mixture was warmed to 35 °C and the oxidants sodium chlorite (0.40 ml, 2 M, 0.80 mmol) and sodium hypochlorite (0.20 ml, 0.7 M, 0.14 mmol) were added over 2 h with vigorous stirring, during which time a rusty brown colour developed. The mixture was stirred at 35 °C overnight and then purified by HPLC. The HPLC conditions used were as follows: the Dionex system, mobile phase 100 mM

NaOAc/100 mM NaOH, flow rate 1 ml min⁻¹. The retention time of the starting material was 10.4 min, that of the product (**185**) was 2.9 min. The reaction mixture consisted of starting material, product and no other peaks (47% product by integration). The results were checked by running an authentic sample of the product with the reaction mixture, which co-eluted with the product peak.

Phenyl β -D-glucopyranosiduronic acid (**185**)¹⁶⁰

Oxidation Method 2, organic-aqueous conditions on small scale:^{160,163}

To a solution of the starting material (**183**) (5.0 mg, 20 μ mol) in acetonitrile (100 μ l) was added phosphate buffer (75 μ l, 0.67 M, pH 6.7) and TEMPO (0.22 mg, 1.4 μ mol). The mixture was brought to 35 °C and the oxidants sodium chlorite (7.2 mg, 80 μ mol, in 40 μ l water) and sodium hypochlorite (2.2 μ l, 0.7 M, 1.6 μ mol, in 30 μ l water) were added over 2 h. The mixture was stirred overnight, and the next day HPLC showed that the reaction had gone to completion, with the presence of only one peak (100% product by integration). The data compared well with that previously reported.¹⁶⁰

m.p. 159-161 °C (MeOH, EtOAc), lit.¹⁶⁰ m.p. 163-164 °C (MeOH, EtOAc); $[\alpha]_D^{22}$ -85.4 (*c* 1.0, H₂O); lit.¹⁶⁰ $[\alpha]_D^{25}$ -90.0 (*c* 1.0, H₂O); *m/z* (ES⁻ acetonitrile-water) 269 (M⁻, 78%), 267 (49), 211 (23), 209 (21), 175 (39), 151 (22), 127 (23), 113 (46), 95 (47), 93 (100), 83 (49), 67 (73), 51 (61).

Pent-4-enyl
 2,3,6-tri-*O*-benzyl-4-*O*-[2',3'-di-*O*-benzyl-4'-*O*-(β-D-glucopyranosiduronic acid)-6'-*O*-pivaloyl-α-D-glucopyranosyl]-β-D-glucopyranoside (**190**)

Organic-Aqueous Conditions (Method 2):¹⁶³

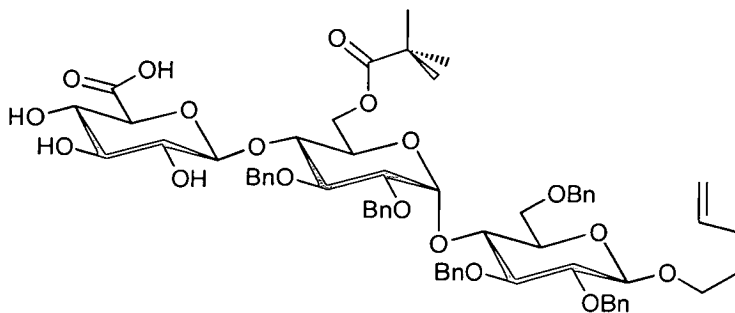

Phosphate buffer (75 μl, 0.67 M, pH 6.7) was added to a solution of the deacetylated trisaccharide (**160**) (22.5 mg, 20.0 μmol) and TEMPO (0.22 mg, 1.4 μmol) in acetonitrile (100 μl). The mixture was warmed to 35 °C and the oxidants sodium chlorite (7.2 mg, 80 μmol, in 40 μl water) and sodium hypochlorite (2.2 μl, 0.7 M, 1.6 μmol, in 30 μl water) were added over 2 h. The mixture was stirred vigorously overnight and then concentrated and purified by preparative scale reverse phase HPLC. The HPLC conditions were as follows: mobile phase acetonitrile-water 70:30, flow rate 8 ml min⁻¹, retention time of the product was 26 min. The product was obtained as a white solid (2.8 mg, 12%; a significant quantity of material was lost during handling).

m.p. 210-213 °C (MeOH, EtOAc); $[\alpha]_D^{24} +79.0$ (*c* 0.1, MeOH); δ_H (600 MHz, CD₃OD) 1.17 (9H, s, -C(CH₃)₃), 1.71-1.75 (2H, m, -CH₂CH₂CH=CH₂), 2.14-2.17 (2H, m, -CH₂CH=CH₂), 3.23 (1H, dd, *J* 7.6 and 9.5, H-2''), 3.31 (1H, dd, *J* 8.4 and 9.2, H-4''), 3.38 (1H, dd, *J* 7.8 and 8.9, H-2), 3.38 (1H, d, *J* 9.2, H-5''), 3.39 (1H, dd, *J* 3.5 and 9.2, H-2'), 3.44 (1H, dd, *J* 8.4 and 9.5, H-3''), 3.57-3.61 (2H, m, H-5 and -OCH₂CH₂CH₂CH=CH₂), 3.69 (1H, dd, *J* 8.7 and 8.9, H-3), 3.80 (1H, dd, *J* 2.0 and 11.0, H-6), 3.83 (1H, dd, *J* 8.0 and 9.6, H-4'), 3.88 (1H, dd, *J* 4.5 and 11.0, H-6), 4.00 (1H, dd, *J* 8.0 and 9.2, H-3'), 4.03 (1H, ddd, *J* 2.0, 4.5 and 9.6, H-5'), 4.33 (1H, dd, *J* 5.0 and 11.9, H-6'), 4.42-4.44 (1H, m, H-6'), 4.46 (1H, d, *J* 11.1, -CH₂Ph), 4.47 (1H, d, *J* 7.8, H-1), 4.47 (1H, d, *J* 10.6, -CH₂Ph), 4.49 (1H, d, *J* 7.6, H-1''), 4.56 (1H,

d, J 11.9, $-CH_2Ph$), 4.60 (1H, d, J 12.1, $-CH_2Ph$), 4.61 (1H, d, J 11.3, $-CH_2Ph$), 4.68 (1H, d, J 11.5, $-CH_2Ph$), 4.72 (1H, d, J 11.2, $-CH_2Ph$), 4.80 (1H, d, J 11.5, $-CH_2Ph$), 4.89 (1H, d, J 11.1, $-CH_2Ph$), 4.92-4.95 (1H, m, $-CH=CH_2$), 5.00 (1H, dddd, J 1.5, 1.6, 3.6 and 17.0, $-CH=CH_2$), 5.09 (1H, d, J 11.4, $-CH_2Ph$), 5.44 (1H, d, J 3.5, H-1'), 5.83 (1H, ddt, J 6.7, 10.2 and 17.0, $-CH=CH_2$), 7.14-7.39 (25H, m, Ph); m/z (ES⁻, acetonitrile-water) 1120 (M⁻, 63%), 550 (100); (Found (FAB⁺, matrix): MNa⁺ 1143.4911, C₆₃H₇₆O₁₈.Na⁺ requires 1143.4929).

Pentyl 4-*O*-[4'-*O*-(2'',3'',4'',6''-tetra-*O*-acetyl-β-D-glucopyranosyl)-6'-*O*-pivaloyl-α-D-glucopyranosyl]-β-D-glucopyranosiduronic acid (191)

Organic-Aqueous Conditions (Method 2):¹⁶³

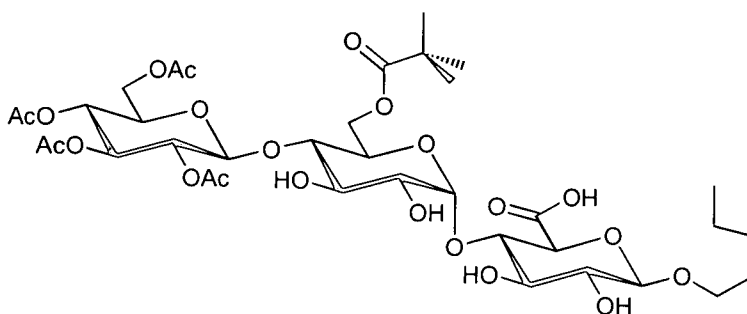

Phosphate buffer (75 μl, 0.67 M, pH 0.67) was added to a solution of the debenzylated starting material (161) (15.6 mg, 18.8 μmol) and TEMPO (0.21 mg, 1.3 μmol) in acetonitrile (100 μl). The mixture was warmed to 35 °C and the oxidants sodium chlorite (7.0 mg, 77 μmol, in 40 μl water) and sodium hypochlorite (2.2 μl, 0.7 M, 1.6 μmol, in 30 μl water) were added over 2 h. The mixture was stirred vigorously overnight and then concentrated and purified by preparative scale reverse phase HPLC. The HPLC conditions were as follows: mobile phase acetonitrile-water 80:20, flow rate 8 ml min⁻¹, retention time of the product was 28 min. The product was obtained as a white solid (8.8 mg, 56%).

m.p. 167-169 °C (MeOH, EtOAc); $[\alpha]_D^{25}$ +45.3 (c 0.2, MeOH); δ_H (600 MHz, CD₃OD) 0.89 (3H, dd, J 6.9 and 7.3, $-CH_3$), 1.23 (9H, s, $-C(CH_3)_3$), 1.31-1.35 (4H, m, $-CH_2CH_2CH_3$ and $-CH_2CH_3$), 1.57-1.62 (2H, m, $-CH_2CH_2CH_2CH_3$), 1.94 (3H, s, $-COCH_3$), 2.00 (3H, s, $COCH_3$), 2.02 (3H, s, $COCH_3$), 2.08 (3H, s, $COCH_3$), 3.26

m.p. 180-182 °C (MeOH); $[\alpha]_D^{23} +65.2$ (c 0.5, MeOH); δ_H (600 MHz, CD₃OD) 1.70-1.72 (2H, m, -CH₂CH₂CH=CH₂), 2.13-2.16 (2H, m, -CH₂CH=CH₂), 3.24 (1H, dd, J 7.8 and 9.0, H-2''), 3.37 (1H, dd, J 8.7 and 9.0, H-3''), 3.39 (1H, dd, J 8.0 and 8.9, H-2), 3.41 (1H, dd, J 8.7 and 9.7, H-4''), 3.45 (1H, d, J 9.7, H-5''), 3.49 (1H, dd, J 3.4 and 9.0, H-2'), 3.55-3.61 (2H, m, H-5 and -OCH₂CH₂CH₂CH=CH₂), 3.68 (1H, dd, J 8.8 and 8.9, H-3), 3.88-3.93 (4H, m, H-6, H-6, H-4' and -OCH₂CH₂CH₂CH=CH₂), 3.93 (1H, dd, J 8.8 and 9.6, H-4), 3.98 (1H, dd, J 8.2 and 9.0, H-3'), 4.18 (1H, d, J 9.0, H-5'), 4.45 (1H, d, J 8.0, H-1), 4.46 (1H, d, J 12.0, -CH₂Ph), 4.52 (1H, d, J 12.0, -CH₂Ph), 4.53 (1H, d, J 11.9, -CH₂Ph), 4.59 (1H, d, J 7.8, H-1''), 4.60 (1H, d, J 11.2, -CH₂Ph), 4.63 (1H, d, J 11.9, -CH₂Ph), 4.72 (1H, d, J 11.2, -CH₂Ph), 4.75 (1H, d, J 11.4, -CH₂Ph), 4.80 (1H, d, J 11.4, -CH₂Ph), 4.87 (1H, d, J 11.2, -CH₂Ph), 4.92-4.94 (1H, m, -CH=CH₂), 4.93 (1H, d, J 11.2, -CH₂Ph), 4.99 (1H, dddd, J 1.6, 1.7, 3.5, and 17.1, -CH=CH₂), 5.48 (1H, d, J 3.4, H-1'), 5.81 (1H, ddt, J 6.7, 10.2 and 16.9, -CH=CH₂), 7.16-7.39 (25H, m, Ph); m/z (ES⁻, acetonitrile-water) 1050 ((M-H)⁻, 4%) 525 (55), 524 (M²⁻, 100); (Found (FAB⁺, matrix): 1073.4155, C₅₈H₆₆O₁₈.Na⁺ requires 1073.4147).

Pentyl [4-*O*-[4'-*O*-(β-D-glucopyranosid)-uronate-6'-*O*-pivaloyl-α-D-glucopyranosyl]-β-D-glucopyranosid] uronate, disodium salt (194)

Aqueous Conditions (Method 1):¹⁴⁵

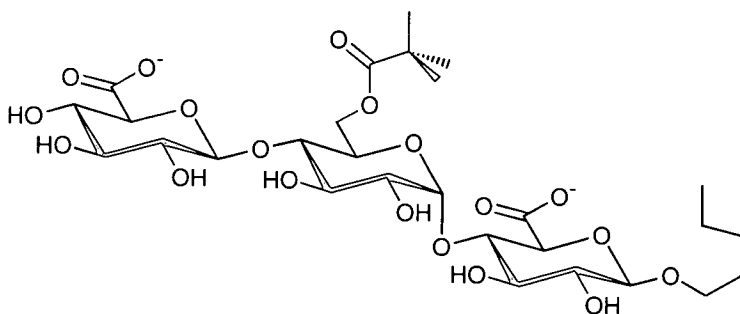

The trisaccharide (168) (16.2 mg, 24.6 μmol), sodium bromide (1.3 mg, 13 μmol) and TEMPO (0.13 mg, 0.83 μmol) were dissolved in water (1 ml). Sodium hypochlorite (250 μl, 0.7 M, 0.175 mmol) was acidified to pH 10 with hydrochloric acid (2 M) and added to the reaction mixture with stirring. The pH was monitored during the course of the reaction and maintained at pH 10 using sodium hydroxide

(0.05 M). The reaction was complete when no more sodium hydroxide was needed. It was then quenched by the addition of ethanol (0.5 ml) stirred for 1 h and concentrated to give the title compound, impurities and a mixture of salts. Purification of (194) was difficult but was eventually achieved by filtration through a plug of silica eluting with methanol (18.0 mg, 100%).

m.p. 140-142 °C (H₂O); δ_{H} (600 MHz, CD₃OD) 0.89-0.93 (3H, m, -CH₃), 1.20 (9H, s, -C(CH₃)₃), 1.28-1.34 (4H, m, -CH₂CH₃ and -CH₂CH₂CH₃), 1.57-1.63 (2H, m, -CH₂CH₂CH₂CH₃), 3.25-3.94 (13H, m, H-2, H-3, H-4, H-5, H-2', H-3', H-4', H-2'', H-3'', H-4'', H-5'' and -OCH₂CH₂CH₂CH₂CH₃), 4.07-4.09 (1H, m, H-5'), 4.27 (1H, d, *J* 7.7, H-1), 4.36-4.38 (1H, m, H-1''), 4.40-4.42 (1H, m, H-6'), 4.52-4.54 (1H, m, H-6'), 5.35 (1H, d, *J* 3.6, H-1'); m/z (ES⁻, acetonitrile-water) 707 ([M-Na]⁻, 8%), 685 ([M-2Na+H]⁻, 4), 441 (8), 439 (22), 379 (19), 362 (26), 361 (100), 335 (35); (Found (FAB⁺, matrix and NaCl) : 753.2170; C₂₈H₄₄O₁₉.Na₃⁺ requires 753.2170).

Pentyl [4-*O*-[4'-*O*-(β -D-glucopyranosid)-uronate- α -D-glucopyranosid]-uronate- β -D-glucopyranosid] uronate, trisodium salt (195)

Aqueous Conditions (Method 1):¹⁴⁵

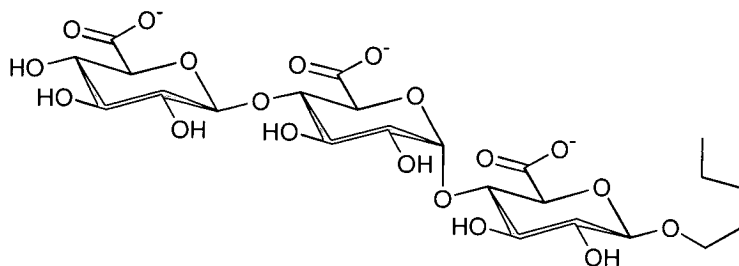

The trisaccharide (170) (23.0 mg, 40.1 μ mol), sodium bromide (2.0 mg, 20 μ mol) and TEMPO (0.21 mg, 1.3 μ mol) were dissolved in water (1 ml). Sodium hypochlorite (407 μ l, 0.7 M, 285 μ mol) was acidified to pH 10 with hydrochloric acid (2 M) and added to the reaction mixture with stirring. The pH was monitored during the course of the reaction and maintained at pH 10 using sodium hydroxide (0.05 M). The reaction was complete when no more sodium hydroxide was needed. It was then quenched by the addition of ethanol (0.5 ml) stirred for 1 h and concentrated to give the title compound and a mixture of salts.

m/z (ES⁻ acetonitrile-water) 318 ([M-2Na]²⁻, 44%), 307 ([M-3Na+H]²⁻, 47), 262 (11), 227 (31), 204 ([M-3Na]³⁻, 100), 193 (16), 184 (22).

References

- (1) Kennedy, J. F.; White, C. A.; Ch. 8, The Glycosaminoglycans and Proteoglycans, In *Carbohydrate Chemistry*; Kennedy, J. F., Ed.; Oxford University Press: Oxford, 1988, 303.
- (2) Lindhorst, T. K.; Ch. 2, Structure of Saccharides, In *Essentials of Carbohydrate Chemistry and Biochemistry*; Wiley-VCH: Weinheim, 2000, 31.
- (3) Lindahl, U.; Hook, M. *Ann. Rev. Biochem.* **1978**, *47*, 385.
- (4) Sugahara, K.; Kitagawa, H. *Curr. Opin. Struc. Biol.* **2000**, *10*, 518.
- (5) Gallacher, J. T.; Lyon, M.; Ch. 8, Molecular Organisation and Functions of Heparan Sulfate, In *Heparin*; Lindahl, U., Ed.; Edward Arnold: London, 1989, 135.
- (6) Turnbull, J. E.; Hopwood, J. J.; Gallacher, J. T. *Proc. Nat. Acad. Sci. USA.* **1999**, *96*, 2698.
- (7) Perrimon, N.; Bernfield, M. *Nature* **2000**, *404*, 725.
- (8) Gallacher, J. T. *J. Clin. Invest.* **2001**, *108*, 357.
- (9) Turnbull, J. E.; Gallacher, J. T. *Biochem. J.* **1991**, *273*, 553.
- (10) Sasisekharan, R.; Venkataraman, G. *Curr. Opin. Chem. Biol.* **2000**, *4*, 626.
- (11) Maccarana, M.; Sakura, Y.; Tawada, A.; Yoshida, K.; Lindahl, U. *J. Biol. Chem.* **1996**, *271*, 17804.
- (12) Merry, C. L.; Lyon, M.; Deakin, J. A.; Hopwood, J. J.; Gallacher, J. T. *J. Biol. Chem.* **1999**, *274*, 18455.
- (13) Safaiyan, F.; Lindahl, U.; Salmivirta, M. *Biochemistry* **2000**, *39*, 10823.
- (14) Liu, J.; Shriver, Z.; Blaiklock, P.; Yoshida, K.; Sasisekharan, R.; Rosenberg, R. D. *J. Biol. Chem.* **1999**, *274*, 38155.
- (15) Zhang, L.; Esko, J. D. *J. Biol. Chem.* **1994**, *269*, 19295.
- (16) Kobayashi, S.; Morimoto, K.; Shimizu, T.; Takashi, M.; Kurosawa, H.; Shirasawa, T. *Biochem. Biophys. Res. Commun.* **2000**, *268*, 860.
- (17) McCormick, C.; Duncan, G.; Goutsos, K. T.; Tufaro, F. *Proc. Natl. Acad. Sci. USA.* **2000**, *97*, 668.

- (18) Wei, G.; Bai, X.; Bame, K. J.; Koshy, T. I.; Spear, P. G.; Esko, J. D. *J. Biol. Chem.* **2000**, *275*, 27733.
- (19) Lindahl, U.; Kusche-Gullberg, M.; Kjellen, L. *J. Biol. Chem.* **1998**, *273*, 269.
- (20) Habaguchi, O. *Biochim. Biophys. Acta* **2000**, *1474*, 115.
- (21) Mulloy, B.; Forster, M. J.; Jones, C.; Davies, D. B. *Biochem. J.* **1993**, *293*, 849.
- (22) Mulloy, B.; Forster, M. J. *Glycobiology* **2000**, *10*, 1147.
- (23) Faham, S.; Hileman, R. E.; Fromm, J. R.; Linhardt, R. J.; Rees, D. C. *Science* **1996**, *271*, 1116.
- (24) Lortat-Jacob, H.; Turnbull, J. E.; Grimaud, J. A. *Biochem. J.* **1995**, *310*, 497.
- (25) Lyon, M.; Rushton, G. R.; Gallacher, J. T. *J. Biol. Chem.* **1997**, *272*, 18000.
- (26) Spillmann, D.; Witt, D.; Lindahl, U. *J. Biol. Chem.* **1998**, *273*, 15487.
- (27) Bernfield, M.; Gotte, M.; Park, P. W.; Reizes, O.; Fitzgerald, M. L.; Lincecum, J.; Zako, M. *Ann. Rev. Biochem.* **1999**, *68*, 729.
- (28) Bernfield, M.; Kokenyesi, R.; Kato, M.; Hinkes, M. T.; Spring, J.; Gallo, R. L.; Lose, E. J. *Ann. Rev. Cell Biol.* **1992**, *8*, 365.
- (29) Fransson, L. A.; Ch. 7, Heparan Sulfate Proteoglycans: Structure and Properties, In *Heparin*; Lindahl, U., Ed.; Edward Arnold: London, 1989, 115.
- (30) Gallagher, J. T.; Lyon, M.; Steward, W. P. *Biochem. J.* **1986**, *236*, 313.
- (31) Vlodavsky, I.; Fuks, Z.; Bar-Ner, M.; Ariav, Y.; Schirmacher, V. *Cancer Research* **1983**, *43*, 2704.
- (32) Kramer, R. H.; Vogel, K. G.; Nicolson, G. L. *J. Biol. Chem.* **1982**, *257*, 2678.
- (33) Klagsbrun, M.; Baird, A. *Cell* **1991**, *67*, 229.
- (34) Basilico, C.; Moscatelli, D. *Adv. Cancer Res.* **1992**, *59*, 115.
- (35) Heath, J. K. *Growth Factors*; Oxford University Press: Oxford, 1993.
- (36) Burgess, W. H.; Maciag, T. *Ann. Rev. Biochem.* **1989**, *58*, 575.
- (37) Folkman, J.; Klagsbrun, M. *Science* **1987**, *235*, 442.
- (38) Klagsbrun, M. *Progr. Growth Factor Res.* **1989**, *1*, 207.
- (39) Kimelman, D.; Abraham, J. A.; Haaparanta, T.; Palisi, T. M.; Kirschner, M. W. *Science* **1988**, *242*, 1053.

- (40) Esch, F.; Baird, A.; Ling, N.; Ueno, N.; Hil, I. F.; Denoroy, L.; Klepper, R.; Gospodarowicz, D.; Bohlen, P.; Guillemin, R. *Proc. Nat. Acad. Sci.* **1985**, *88*, 3441.
- (41) Zhu, X.; Komiya, H.; Chirino, A.; Faham, S.; Fox, G. M.; Arakawa, T.; Hsu, B. T.; Rees, D. C. *Science* **1991**, *251*, 90.
- (42) Yayon, A.; Klagsbrun, M.; Esko, J. D.; Leder, P.; Ornitz, D. M. *Cell* **1991**, *64*, 841.
- (43) Yanagishita, M.; Hascall, V. C. *J. Biol. Chem.* **1992**, *267*, 9451.
- (44) Presta, M.; Maier, J. A. M.; Rusnati, M.; Ragnotti, G. *J. Cell. Physiol.* **1989**, *140*, 68.
- (45) Rapraeger, A. C.; Krufka, A.; Olwin, B. B. *Science* **1991**, *252*, 1705.
- (46) Klagsbrun, M. *Curr. Opin. Cell. Biol.* **1990**, *2*, 857.
- (47) Sinaÿ, P.; Jacquinet, J. C.; Petitou, M.; Duchaussoy, P.; Lederman, I.; Choay, J.; Torri, G. *Carbohydr. Res.* **1984**, *132*, C5.
- (48) Turnbull, J. E.; Fernig, D. G.; Ke, Y. Q.; Wilkinson, M. C.; Gallagher, J. T. *J. Biol. Chem.* **1992**, *267*, 10337.
- (49) Guimond, S.; Maccarana, M.; Olwin, B. B.; Lindahl, U.; Rapraeger, A. C. *J. Biol. Chem.* **1993**, *268*, 23906.
- (50) Maccarana, M.; Casu, B.; Lindahl, U. *J. Biol. Chem.* **1993**, *268*, 23898.
- (51) Kovensky, J.; Duchaussoy, P.; Bono, F.; Salmivirta, M.; Sizun, P.; Herbert, J.-M.; Petitou, M.; Sinaÿ, P. *Bioorg. Med. Chem.* **1999**, *7*, 1567.
- (52) Kovensky, J.; Duchaussoy, P.; Petitou, M.; Sinaÿ, P. *Tetrahedron: Asymmetry* **1996**, *7*, 3119.
- (53) Ornitz, D. M.; Herr, A. B.; Nilsson, M.; Westman, J.; Svahn, C.-M.; Waksman, G. *Science* **1995**, *268*, 432.
- (54) Sinaÿ, P. *Pure App. Chem.* **1987**, *59*, 445.
- (55) Petitou, M.; Duchaussoy, P.; Lederman, I.; Choay, J.; Jacquinet, J. C.; Sinaÿ, P.; Torri, G. *Carbohydr. Res.* **1987**, *167*, 67.
- (56) Jacquinet, J. C.; Petitou, M.; Duchaussoy, P.; Lederman, I.; Choay, J.; Torri, G.; Sinaÿ, P. *Carbohydr. Res.* **1984**, *130*, 221.
- (57) van Boeckel, C. A. A.; Petitou, M. *Angew. Chem. Int. Ed. Engl.* **1993**, *32*, 1671.

- (58) van Boeckel, C. A. A.; Beetz, T.; Vos, J. N.; de Jong, A. J. M.; van Aelst, S. F.; van den Bosch, R. H.; Mertens, J. M. R.; van der Vlugt, F. A. J. *Carbohydr. Chem.* **1985**, *4*, 293.
- (59) Fieser, L. F.; Fieser, M.; In *Reagents for Organic Synthesis*; Wiley: New York, 1967; Vol. 1, 142.
- (60) Basten, J.; Jaurand, G.; Olde-Hanter, B.; Duchaussoy, P.; Petitou, M.; van Boeckel, C. A. A. *Bioorg. Med. Chem. Lett.* **1992**, *2*, 905.
- (61) Lucas, H.; Basten, J.; Konradsson, P.; van Boeckel, C. A. A. *Angew. Chem. Int. Ed. Engl.* **1993**, *32*, 434.
- (62) Petitou, M.; Duchaussoy, P.; Driguez, P.-A.; Jaurand, G.; Herault, J.-P.; Lormeau, J.-C.; van Boeckel, C. A. A.; Herbert, J.-M. *Angew. Chem. Int. Ed. Engl.* **1998**, *37*, 3009.
- (63) Ichikawa, Y.; Monden, R.; Kuzuhara, H. *Tetrahedron Lett.* **1986**, *27*, 611.
- (64) Glushka, J. N.; Perlin, A. S. *Carbohydr. Res.* **1990**, *205*, 305.
- (65) Westman, J.; Nilsson, M. J. *Carbohydr. Chem.* **1995**, *14*, 949.
- (66) Wessel, H. P.; Minder, R.; Englert, G. J. *Carbohydr. Chem.* **1995**, *14*, 1101.
- (67) Wessel, H. P.; Minder, R.; Englert, G. J. *Carbohydr. Chem.* **1996**, *15*, 201.
- (68) La Ferla, B.; Lay, L.; Guerrini, M.; Poletti, L.; Panza, L.; Russo, G. *Tetrahedron* **1999**, *55*, 9867.
- (69) Haller, M.; Boons, G.-J. *J. Chem. Soc., Perkin Trans. 1* **2001**, 814.
- (70) Davis, N. J. D. Phil, Oxford, 1994.
- (71) Davis, N. J.; Flitsch, S. L. *Tetrahedron Lett.* **1993**, *34*, 1181.
- (72) Davis, N. J.; Flitsch, S. L. *J. Chem. Soc., Perkin Trans. 1* **1994**, 359.
- (73) Underwood, M. D. Phil., Oxford, 1996.
- (74) Paulsen, H. *Angew. Chem. Int. Ed. Engl.* **1982**, *21*, 155.
- (75) Schmidt, R. R. *Angew. Chem. Int. Ed. Engl.* **1986**, *25*, 212.
- (76) Höfle, G.; Steglich, W.; Vorbrüggen, H. *Angew. Chem. Int. Ed. Engl.* **1978**, *17*, 569.
- (77) Brauns, D. H. *J. Am. Chem. Soc.* **1929**, *51*, 1820.
- (78) Gagnaire, D. Y.; Tavel, F. R.; Vignon, M. R. *Carbohydr. Res.* **1976**, *51*, 157.

- (79) Gebbie, S. J.; Gosney, I.; Harrison, P. R.; Lacan, I. F.; Sanderson, W. R.; Sankey, J. P. *Carbohydr. Res.* **1998**, *308*, 345.
- (80) Fischer, H.; Kögl, F. *Justus Liebigs Ann. Chem.* **1923**, *436*, 219.
- (81) Montero, J.-L.; Winum, J.-Y.; Leydt, A.; Kamal, M.; Pavia, A. A.; Roque, J.-P. *Carbohydr. Res.* **1997**, *297*, 175.
- (82) Flitsch, S. L.; Watt, G. M.; Ch. 4, Chemical Synthesis of Glycoprotein Glycans, In *Glycopeptides and Related Compounds*; Warren, C. D., Ed.; Marcel Dekker: New York, 1997, 207.
- (83) Garegg, P. J.; Konradsson, P.; Kvarnstrom, I.; Norberg, T.; Svensson, S. C. T.; Wigilius, B. *Acta Chem. Scand., Ser. B* **1985**, *B39*, 569.
- (84) Petrakova, E.; Glaudemans, C. P. J. *Carbohydr. Res.* **1995**, *268*, 35.
- (85) Wallace, J. E.; Schroeder, L. R. *J. Chem. Soc., Perkin Trans. 1* **1976**, 1938.
- (86) Helferich; Speicher *Justus Liebigs Ann. Chem.* **1953**, *579*, 106.
- (87) Lee, E. E.; Wood, J. O. *Carbohydr. Res.* **1979**, *75*, 317.
- (88) Zemplén, G. *Ber. Dtsch. Chem. Ges.* **1927**, *60*, 1555.
- (89) van Cleve, J. W. *Carbohydr. Res.* **1971**, *17*, 461.
- (90) Bissett, F. H.; Evans, M. E.; Parrish, F. W. *Carbohydr. Res.* **1967**, *5*, 184.
- (91) Hess *Chem. Ber.* **1937**, *70*, 1134.
- (92) Hirooka; Motoko; Koto; Shinkiti *Bull. Chem. Soc. Jpn.* **1998**, *71*, 2893.
- (93) Klemer, A. *Chem. Ber.* **1959**, *92*, 218.
- (94) Brimacombe, J. S.; In *Methods in Carbohydrate Chemistry*; Bemiller, J. N., Ed.; Academic Press: London, 1972; Vol. 6, 376.
- (95) Guindon, Y.; Guiard, Y.; Berthiaume, S.; Gorys, V.; Lemieux, R.; Yoakim, C. *Can. J. Chem.* **1990**, *68*, 1989.
- (96) Garegg, P. J.; Hultberg, H.; Wallin, S. *Carbohydr. Res.* **1982**, *108*, 97.
- (97) Mikamo, M. *Carbohydr. Res.* **1989**, *191*, 150.
- (98) Cook, B.; Bhakta, S.; Biegel, T.; Bowman, K.; Armstrong, J.; Hemmerick, S.; Bertozzi, C. *J. Am. Chem. Soc.* **2000**, *122*, 8612.
- (99) Schmidt, O. T.; Herok, J. *Justus Liebigs Ann. Chem.* **1954**, *587*, 63.
- (100) Weygand, F.; Ziemann, H.; Bestmann, H. J. *Chem. Ber.* **1958**, *91*, 2534.
- (101) Schmidt, R. R.; Stumpff, M. *Liebigs Ann. Chem.* **1983**, 1249.

- (102) Matsuo, I.; Isomura, M.; Miyazaki, T.; Sakakibara, T.; Ajisaka, K. *Carbohydr. Res.* **1997**, *305*, 401.
- (103) Schmidt, R. R.; Ch 2, The Anomeric *O*-Alkylation and the Trichloroacetimidate Method - Versatile Strategies for Glycosidic Bond Formation, In *Modern Methods in Carbohydrate Synthesis*; O'Neill, R. A., Ed.; Harwood Academic Publishers: Foster City, 1996; Vol. 1, 20.
- (104) Guibe, F. *Tetrahedron* **1997**, *53*, 13509.
- (105) Guibe, F. *Tetrahedron* **1998**, *54*, 2967.
- (106) Nakayama, K.; Uoto, K.; Higashi, K.; Soga, T.; Kusama, T. *Chem. Pharm. Bull.* **1992**, *40*, 1718.
- (107) Boss, R.; Scheffold, R. *Angew. Chem.* **1976**, *88*, 578.
- (108) Smith, A. B.; Rivero, R. A.; Hale, K. J.; Vaccaro, H. *J. Am. Chem. Soc.* **1991**, *113*, 2092.
- (109) Taniguchi, T.; Ogasawara, K. *Angew. Chem. Int. Ed. Engl.* **1998**, *37*, 1136.
- (110) Corey, E. J. *J. Org. Chem.* **1973**, *38*, 3224.
- (111) Stevens, C. M.; Watanabe, R. *J. Am. Chem. Soc.* **1950**, *72*, 725.
- (112) Gigg, R.; Cunningham, J.; Warren, C. D. *Tetrahedron Lett.* **1964**, *19*, 1191.
- (113) Grindley, T. B.; Ch 10, Protecting Groups in Oligosaccharide Synthesis, In *Modern Methods in Carbohydrate Synthesis*; O'Neill, R. A., Ed.; Harwood Academic Publishers: Foster City, 1996; Vol. 1, 225.
- (114) Card, P. J.; Reddy, G. S. *J. Org. Chem.* **1983**, 4734.
- (115) Fraser-Reid, B.; Udodong, U. E.; Wu, Z. F.; Ottosson, H.; Merritt, J. R.; Rao, C. S.; Roberts, C.; Madsen, R. *Synlett* **1992**, 927.
- (116) Rodriguez, E. B.; Stick, R. V. *Aust. J. Chem.* **1990**, *43*, 665.
- (117) Takeo; Shimimitsu *Carbohydr. Res.* **1984**, *133*, 135.
- (118) Johansson, R.; Samuelsson, B. *J. Chem. Soc., Perkin Trans. 1* **1984**, 2371.
- (119) Li, Z. J.; Huang, H. Q.; Cai, M. S. *Carbohydr. Res.* **1994**, *265*, 227.
- (120) Smith, M.; Rammler, D. H.; Goldberg, I. H.; Khorana, H. G. *J. Am. Chem. Soc.* **1962**, *84*, 460.
- (121) Nakano, T.; Ito, Y.; Ogawa, T. *Carbohydr. Res.* **1993**, *243*, 43.
- (122) Kunesch, N.; Miet, C.; Poisson, J. *Tetrahedron Lett.* **1987**, *28*, 3569.
- (123) Park, M. H.; Takeda, R.; Nakanishi, K. *Tetrahedron Lett.* **1987**, *28*, 3823.

- (124) Rodebaugh, R.; Debenham, J. S.; Fraser-Reid, B. *Tetrahedron Lett.* **1996**, *37*, 5477.
- (125) Philips, K. D.; Zemlicka, Z.; Horowitz, J. *Carbohydr. Res.* **1973**, *30*, 281.
- (126) Holick, S. A.; Anderson, L. *Carbohydr. Res.* **1974**, *34*, 208.
- (127) Seif, L. S.; Partyka, K. M.; Hengeveld, J. E. *Chem. Ind.* **1990**, *40*, 197.
- (128) Mootoo, D.; Date, V.; Fraser-Reid, B. *J. Am. Chem. Soc.* **1987**, *110*, 2662.
- (129) Entwistle, I. D.; Johnstone, R. A. W.; Whitby, A. H. *Chem. Rev.* **1985**, *85*, 129.
- (130) Arasappan, A.; Fraser-Reid, B. *J. Org. Chem.* **1996**, *61*, 2401.
- (131) Poos, G. I.; Arth, G. E.; Beyler, R. E.; Sarlett, L. H. *J. Am. Chem. Soc.* **1953**, *75*, 422.
- (132) Piancatelli, G.; Scettri, A.; D'Auria, M. *Synthesis* **1982**, 245.
- (133) Coates, W. M.; Corrigan, J. R. *Chem. Ind.* **1969**, *44*, 1594.
- (134) Mancuso, A. J.; Swern, D. *Synthesis* **1981**, 161.
- (135) Dess, D. B.; Martin, J. C. *J. Org. Chem.* **1983**, *48*, 4155.
- (136) Ley, S. V.; Norman, J.; Griffith, W. P.; Marsden, S. P. *Synthesis* **1994**, 639.
- (137) Bowman, D. F.; Gillan, T.; Ingold, K. U. *J. Am. Chem. Soc.* **1971**, *93*, 6555.
- (138) Keana, J. F. W. *Chem. Rev.* **1978**, *78*, 37.
- (139) Bobbitt, J. M.; Flores, C. L. *Heterocycles* **1988**, *27*, 509.
- (140) Yamaguchi, M.; Miyazawa, T.; Takata, T.; Endo, T. *Pure Appl. Chem.* **1990**, *62*, 217.
- (141) Golubev, V. A.; Sen', V. D.; Kulyk, I. V.; Aleksanderov, A. L. *Izv. Akad. Nauk SSSR, Ser. Khim.* **1975**, 2235.
- (142) Ganem, B. *J. Org. Chem.* **1975**, *40*, 1998.
- (143) Semmelhack, M. F.; Schmid, C. R.; Cortes, D. A. *Tetrahedron Lett.* **1986**, *27*, 1119.
- (144) Ma, Z.; Bobbitt, J. M. *J. Org. Chem.* **1991**, *56*, 6110.
- (145) de Nooy, A. E. J.; Besemer, A. C.; van Bekkum, H. *Tetrahedron* **1995**, *51*, 8023.
- (146) Siedlecka, R.; Skazewski, J.; Mlochowski, J. *Tetrahedron Lett.* **1990**, *31*, 2177.

- (147) Tomioka, H.; Taki, K.; Oshima, K.; Nozaki, H. *Tetrahedron Lett.* **1981**, *22*, 1605.
- (148) Kaneda, K.; Kawanishi, Y.; Teranishi, S. *Chem. Lett.* **1984**, 1481.
- (149) Doyle, M. P.; Bagheri, V. *J. Org. Chem.* **1981**, *46*, 4806.
- (150) Fetison, M.; Golfier, M.; Louis, J.-M. **1975**, *31*, 171.
- (151) Heyns, K.; Paulsen, H. *Angew. Chem.* **1957**, *69*, 600.
- (152) Yackel, E. C.; Kenyon, W. O. *J. Am. Chem. Soc.* **1942**, *64*, 121.
- (153) Li, K.; Helm, R. F. *Carbohydr. Res.* **1995**, *273*, 249.
- (154) Aspinall, G. O.; Nicolson, A. *J. Chem. Soc.* **1960**, 2503.
- (155) Györgydeak, Z.; Thiem, J. *Carbohydr. Res.* **1995**, *268*, 85.
- (156) Anelli, P. L.; Banfi, S.; Montanari, F.; Quici, S. *J. Org. Chem.* **1989**, *54*, 2970.
- (157) Anelli, P. L.; Biffi, C.; Montanari, F.; Quici, S. *J. Org. Chem.* **1987**, *52*, 2559.
- (158) Inoue, Y.; Nagasawa, K. *Carbohydr. Res.* **1986**, *146*, 271.
- (159) Helferich, B.; Berger, A. *Chem. Ber.* **1957**, *90*, 2492.
- (160) Bollenback, G. N.; Long, J. W.; Benjamin, D. G.; Lindquist, J. A. *J. Am. Chem. Soc.* **1955**, *77*, 3310.
- (161) Iwamoto, M.; Okabe, H.; Yamauchi, T. *Chem. Pharm. Bull.* **1985**, *33*, 1.
- (162) Timell, T. E.; Enterman, W.; Spencer, F.; Soltes, E. J. *Can. J. Chem.* **1965**, *43*, 2296.
- (163) Zhao, M.; Li, J.; Mano, E.; Song, Z.; Tschaen, D. A.; Grabowski, E. J. J.; Reider, P. J. *J. Org. Chem.* **1999**, *64*, 2564.
- (164) Semmelhack, M. F.; Schmid, C. R.; Cortes, D. A. *J. Am. Chem. Soc.* **1984**, *106*, 3374.
- (165) Perrin, D. D.; Armarego, W. L. F. *Purification of Laboratory Chemicals*; Pergamon Press: New York, 1988.
- (166) Gi, C. T.; Ishihara, H.; Tejima, S. *Chem. Pharm. Bull.* **1978**, *26*, 1570.
- (167) Chen, F.-E.; Ling, X.-H.; He, Y.-P.; Peng, X.-H. *Synthesis* **2001**, *12*, 1772.
- (168) Fischer, H. O. L.; Taube, C. *Chem. Ber.* **1927**, *60*, 485.

HD9/42 1H NMR Spectrum at 600 MHz
 I3740 14.12.00

exp3 presat

SAMPLE		SATURATION	
data	Doc 14 2000	sspul	n
solvent	CD3OD	satpwr	3
file	/export/hose/	satfrq	-213.6
vmr1/vmrsys	FLIT	satdly	3.000
SCH	2000/trpfg.HD9	satcode	nnn
-42.1H.sp.I3740.14		composit	n

ACQUISITION		DEC. & VT	
sfreq	500.811	dn	H1
tn	H1	sof	-213.6
at	4.000	sb	nnn
np	48000	ccc	ccc
sw	6000.2	dpwr	11896
fb	3000	temp	4
bs	4	temp	25.0

PROCESSING			
tpwr	02	sb	-2.860
pw	6.0	sbs	-2.230
d1	0	wtfile	
tof	-220.0	proc	ft
nt	32	fn	131072
ct	32	math	f

FLAGS		TERR	
ll	n	temp	
in	n	ws	ft
dp	y	tnt	
hs	nnn		

DISPLAY			
sp		299.0	
wp		4798.4	
vs		5000	
sc		0	
ec		250	
h2		10.10	
is		738038.99	
rfl		217.6	
rtp		0	
th		10	
ins		40.000	
al	ph		

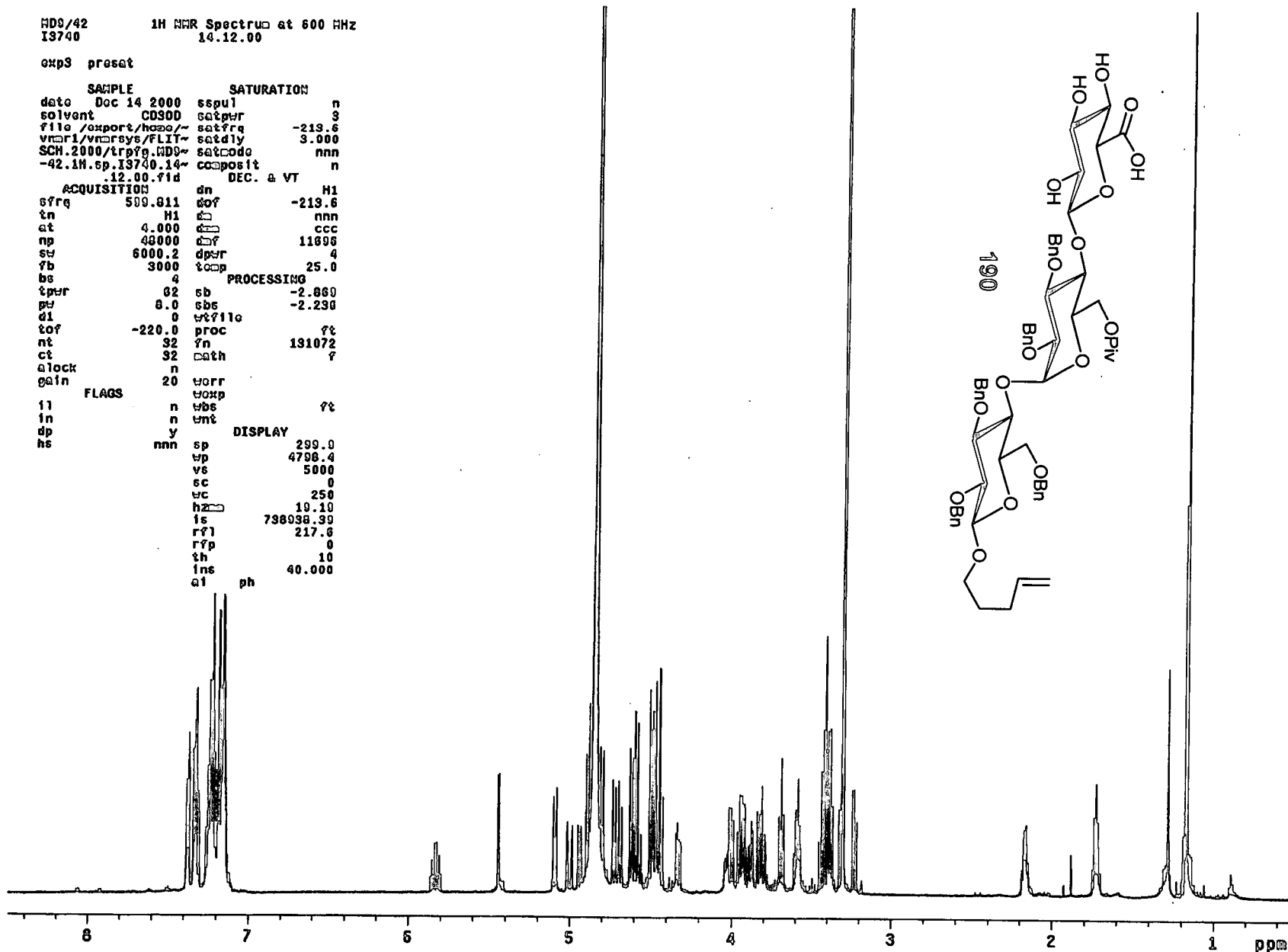

Appendix

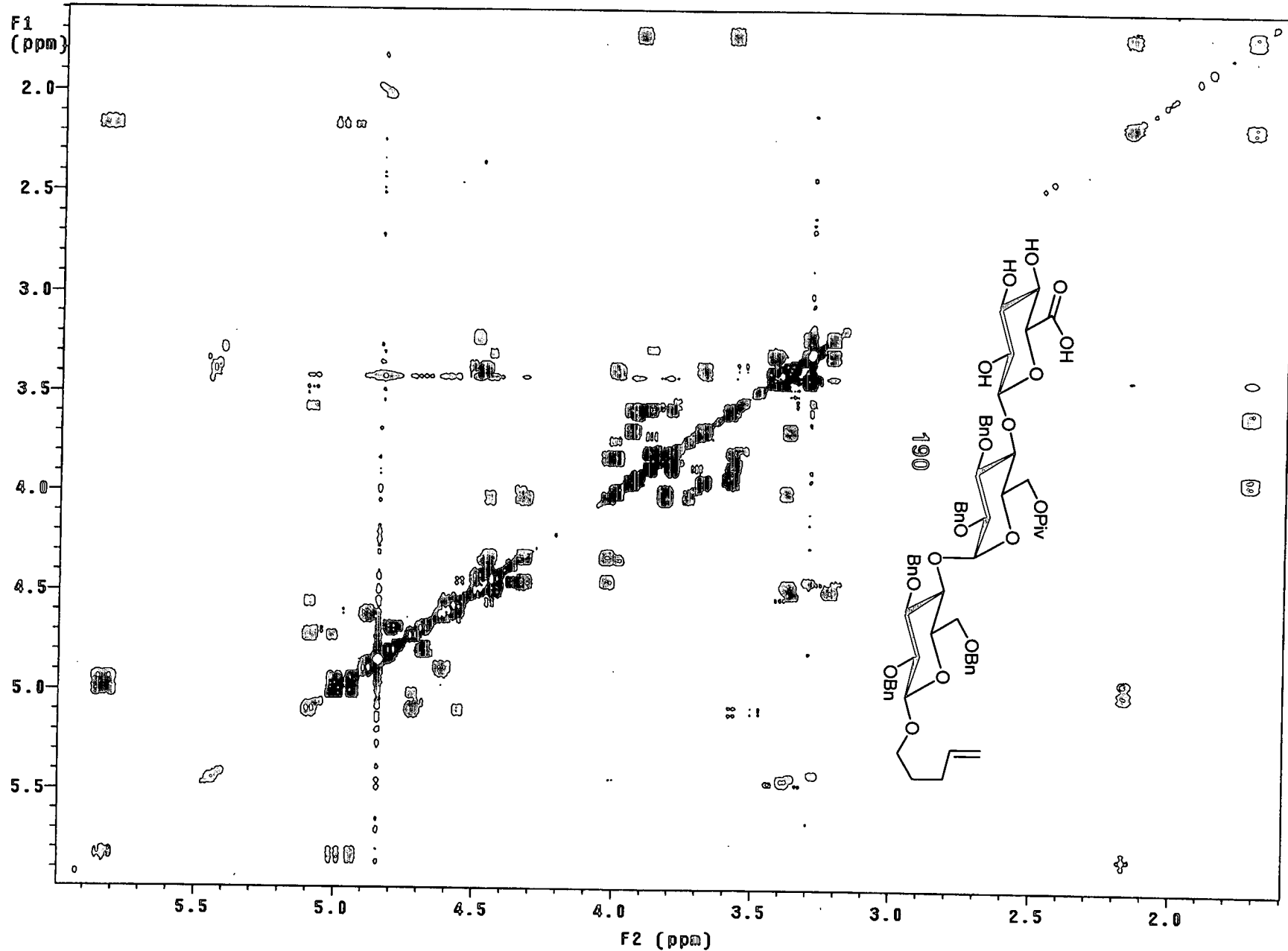

exp1 presat

SAMPLE		SATURATION	
date	Jan 23 2001	sspul	n
solvent	CD3OD	satpr	3
file	exp	satfrq	-213.8
ACQUISITION		satdy	3.000
sfrq	500.811	satcdo	nnn
tn	H1	ccposit	n
at	4.000	DEC. & VT	n
np	48000	dn	H1
sw	6000.2	dof	-213.6
fb	3000	d	nnn
bs	4	ccc	ccc
sc	2	dof	11600
tpwr	02	dpr	25.4
pv	8.5	temp	25.0
d1	2.000	PROCESSING	
tof	-220.0	sb	not used
nt	128	sbs	not used
ct	128	wtfllo	
alock	n	proc	ft
gain	20	fn	131072

FLAGS

tl	n
in	n
dp	nnn
hs	nnn

DISPLAY	
sp	-00.1
tp	4078.4
vs	0000
sc	0
tc	230
hwd	21.65
ls	8010.75
rfl	217.5
rpf	0
th	10
ins	40.000
al	ph

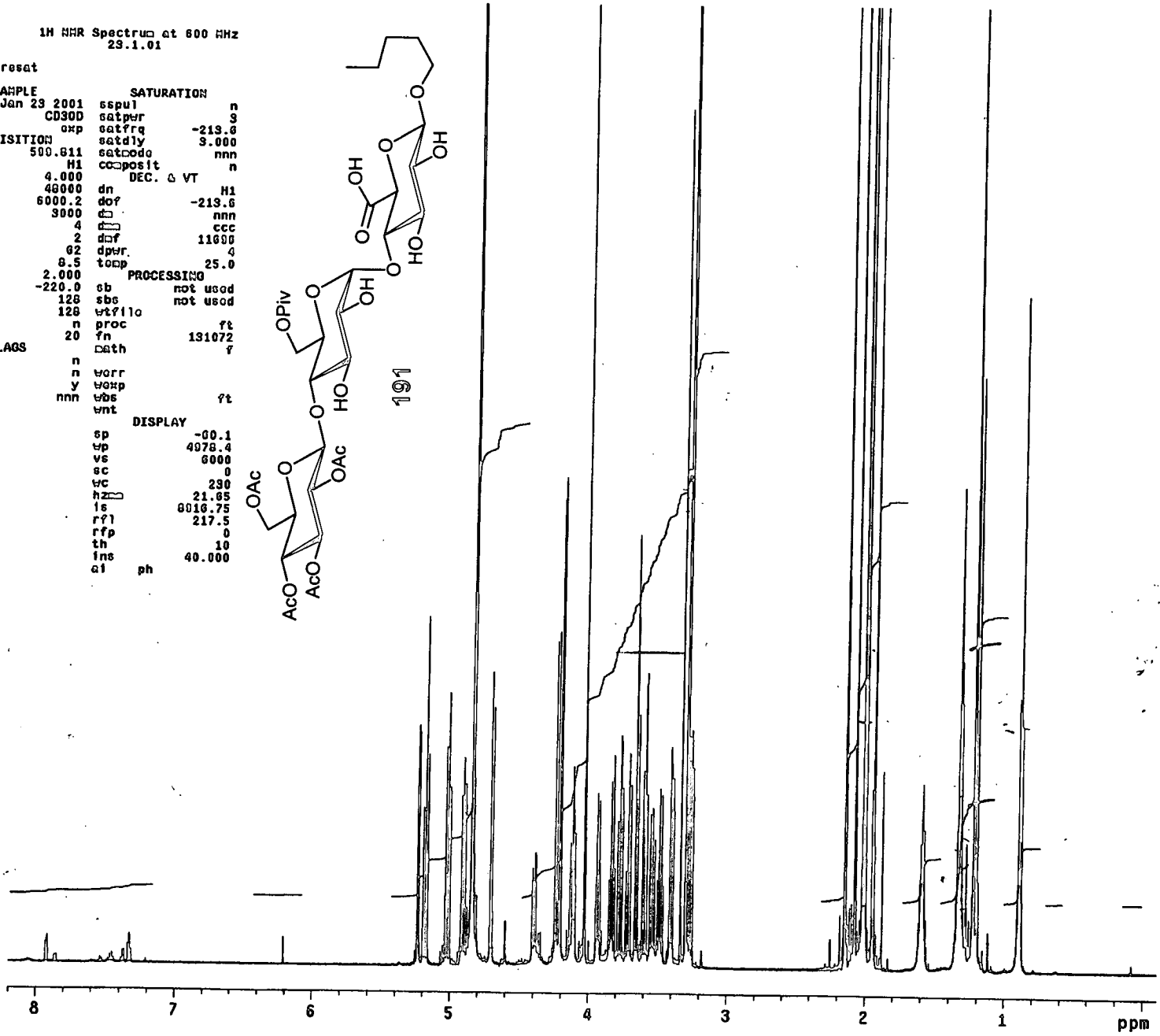
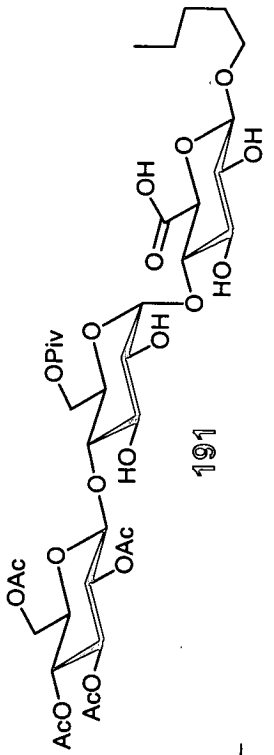

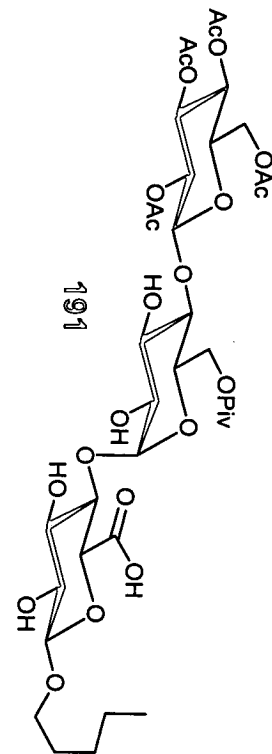
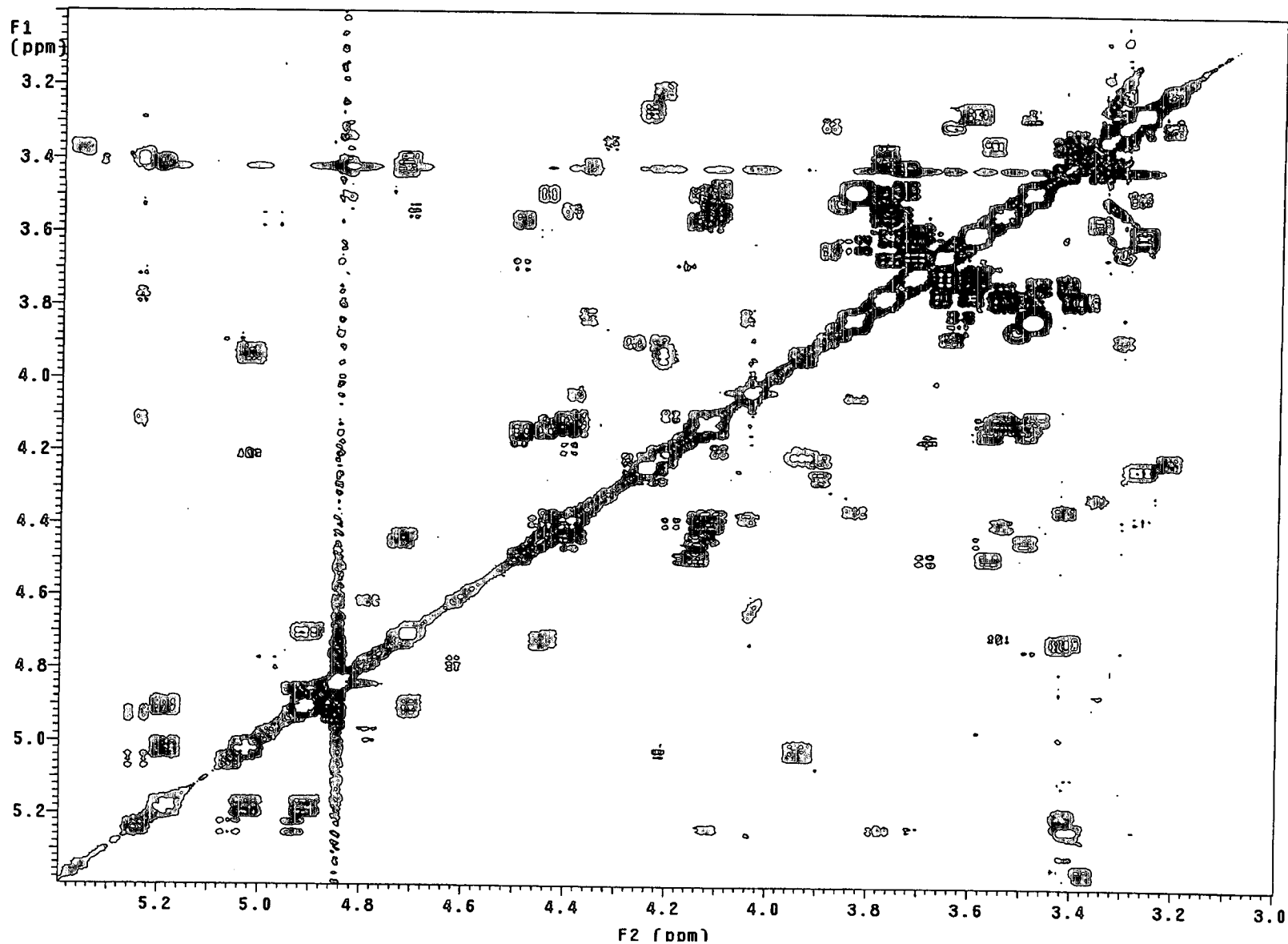

HD9/43 1H NMR Spectrum at 600 MHz
 I3781 9.1.01

expt presat

SAMPLE SATURATION
 date Jan 9 2001 ssp01 n
 solvent CD3OD sat/yr 3
 file /export/home/~ sat/yr -213.6
 vnr1/vnr2sys/FLIT sat/yr 3.000
 SCH.2000/trpfg.HDC sat/yr nnn
 -43.1H.sp.I3781.9 coapdet n
 1-01.fid DEC. & VT

ACQUISITION dn H1
 s/rq 500.811 dof -213.6
 tn H1 nnn
 at 4.000 ccc
 np 48000 daf 11696
 st 6000.2 dpt 4
 fb 3000 to 25.0

PROCESSING
 bs 4 sb -1.926
 ss 2 sb -1.621
 ipur 62 sb
 pt 8.5 wt
 d1 2.000 pro
 tof -220.0 fn 131072
 nt 128 dat
 ct 128

alock n wor
 gain 20 woc
 FLAGS n wnt
 n n
 in y
 dp nnn
 hs

DISPLAY
 sp 200.0
 up 4798.4
 vs 1500
 sc 0
 uc 250
 hze 10.10
 lg 5013.96
 rf 2196.0
 rfg 1070.4
 th 10
 fno 40.000
 ph

