

---

# Increasing the Capacity of Distributed Generation in Electricity Networks by Intelligent Generator Control

---

*Aristides E. Kiprakis*



A thesis submitted for the degree of Doctor of Philosophy.  
The University of Edinburgh.  
October 2005



---

# Abstract

---

The rise of environmental awareness as well as the unstable global fossil fuel market has brought about government initiatives to increase electricity generation from renewable energy sources. These resources tend to be geographically and electrically remote from load centres. Consequently many Distributed Generators (DGs) are expected to be connected to the existing Distribution Networks (DNs), which have high impedance and low X/R ratios.

Intermittence and unpredictability of the various types of renewable energy sources can be of time scales of days (hydro) down to seconds (wind, wave). As the time scale becomes smaller, the output of the DG becomes more difficult to accommodate in the DN. With the DGs operating in constant power factor mode, intermittence of the output of the generator combined with the high impedance and low X/R ratios of the DN will cause voltage variations above the statutory limits for quality of supply. This is traditionally mitigated by accepting increased operation of automated network control or network reinforcement. However, due to the distributed nature of RES, automating or reinforcing the DN can be expensive and difficult solutions to implement. The Thesis proposed was that new methods of controlling DG voltage could enable the connection of increased capacities of plant to existing DNs without the need for network management or reinforcement.

The work reported here discusses the implications of the increasing capacity of DG in rural distribution networks on steady-state voltage profiles. Two methods of voltage compensation are proposed. The first is a deterministic system that uses a set of rules to intelligently switch between voltage and power factor control modes. This new control algorithm is shown to be able to respond well to slow voltage variations due to load or generation changes. The second method is a fuzzy inference system that adjusts the setpoint of the power factor controller in response to the local voltage. This system can be set to respond to any steady-state voltage variations that will be experienced. Further, control of real power is developed as a supplementary means for voltage regulation in weak rural networks. The algorithms developed in the study are shown to operate with any synchronous or asynchronous generation wherein real and reactive power can be separately controlled. Extensive simulations of typical and real rural systems using synchronous generators (small hydro) and doubly-fed induction generators (wind turbines) have verified that the proposed approaches improve the voltage profile of the distribution network. This demonstrated that the original Thesis was true and that the techniques proposed allow wider operation of greater capacities of DG within the statutory voltage limits.

---

# Acknowledgments

---

I have to admit that this page was the most difficult to compose from the whole Thesis, for it is not an easy task to thank all the people who have offered me help throughout these years, and at the same time make it sound as true and honest as it feels by avoiding commonalities. Especially when I write in English. I will try my best.

First of all, I would like to thank my supervisor, Dr Robin Wallace, for being a caring mentor, for his endless support, encouragement, trust and epic patience.

I also owe many thanks to my second supervisor, Dr Ewen Macpherson for being there every time I needed him, and for providing his valuable advice, especially during my writing-up stage.

My sincere thanks also go to Dr Gareth Harrison, for being an ideal collaborator within the RNET project, a good friend and a valuable "unofficial" but always willing advisor.

Lots of thanks to the whole IES community for being a pleasant group of people and a pleasure to work with. However, I have to put Simon (lately known as "Doctor Forrest") one step above, for being such a good friend and for making sure that during my studies in Edinburgh, I received the full Scottish education. Including whisky. And beer. And sambuca on fire. Sifis, a flask of tsikoudia is always waiting for us in Crete.

I owe many thanks to my parents Manolis and Sofia, my brother Dimitrios and my sister Irene for their everlasting love, patience and support in multiple ways (some of which required the assistance of EATA and Royal Mail). Folks, I promise: I am done with my studies.

Finally, It was my family that made it possible for me to engage in this PhD study. It was somebody else's support that assisted me to complete it. Vasso, I am eternally indebted to you.

---

# Contents

---

Abstract . . . . .	ii
Declaration of Originality . . . . .	iii
Acknowledgments . . . . .	iv
Contents . . . . .	v
List of figures . . . . .	viii
List of tables . . . . .	xii
Acronyms and abbreviations . . . . .	xiii
<b>1 Introduction</b>	<b>1</b>
1.1 Research Background . . . . .	1
1.2 Basic Definitions . . . . .	2
1.3 Sustainable Electricity Systems . . . . .	3
1.4 Renewable Energy Sources in the UK Power System . . . . .	5
1.5 The RNET Project . . . . .	8
1.6 Project Objectives and Scope . . . . .	9
1.7 Thesis . . . . .	10
1.8 Contribution to Knowledge and Deliverables . . . . .	10
1.9 Thesis Outline . . . . .	11
<b>2 Embedded and Renewable Generation in the Distribution Network</b>	<b>12</b>
2.1 Introduction . . . . .	12
2.2 UK Regulations on Voltage Variation in DNs . . . . .	12
2.3 Distribution Network Structure . . . . .	13
2.3.1 Conductor Sizing and Spacing . . . . .	15
2.3.2 Selection of Distribution Network Operating Voltage . . . . .	18
2.4 Power Flows and Voltages in a Two-Bus System . . . . .	19
2.4.1 Illustration of the Effects of Conductor Sizing . . . . .	22
2.4.2 Illustration of the Effects of Voltage Level . . . . .	25
2.5 Voltage Variation in the Distribution Network . . . . .	26
2.6 Voltage Control in the Distribution Network . . . . .	29
2.7 Further Effects of Increased Generating Capacity within the Distribution Network . . . . .	30
2.8 Summary . . . . .	32
<b>3 Modelling of Hydro Generation within the Distribution Network</b>	<b>34</b>
3.1 Introduction . . . . .	34
3.2 Modelling of Distributed Generation . . . . .	34
3.3 Small Scale Hydro Power Generation . . . . .	37
3.3.1 Hydro Turbine Selection and Modelling . . . . .	38

3.3.2	Electric Generators for SHGs . . . . .	39
3.3.3	Turbine - Generator Control . . . . .	40
3.4	Hydraulic Governor Model . . . . .	41
3.5	Synchronous Generator Model . . . . .	43
3.5.1	Electrical Subsystem . . . . .	44
3.5.2	Mechanical Subsystem . . . . .	46
3.6	Operation and Control of the Synchronous Generator . . . . .	48
3.6.1	Exciter & Excitation Control . . . . .	49
3.6.2	Automatic Power Factor Controller . . . . .	51
3.7	Voltage Regulation Using Transformers with On-Line Tap Changers . .	52
3.8	The Synchronous Generator in a Distribution Network and its Operational Limitations . . . . .	55
3.9	Power System Modelling . . . . .	58
3.10	Simulation of the Developed SHG Model . . . . .	60
3.11	Simulation of the OLTC in a Network with Varying Loads . . . . .	62
3.11.1	Simulating the OLTC in AVC Mode . . . . .	62
3.11.2	Simulating the OLTC in LDRC Mode . . . . .	63
3.12	Summary . . . . .	66
<b>4</b>	<b>Modelling of Wind Energy Conversion Systems</b>	<b>69</b>
4.1	Introduction . . . . .	69
4.2	Wind Energy Conversion System Modelling . . . . .	69
4.2.1	Wind Modelling . . . . .	73
4.2.2	Dynamic Model of a Variable Pitch Wind Turbine . . . . .	78
4.2.3	Electric Generators for WECSs . . . . .	81
4.2.4	Dynamic Model of the Doubly Fed Induction Generator . . . . .	83
4.2.5	Blade Pitch Angle Controller . . . . .	85
4.2.6	Speed Controller . . . . .	86
4.2.7	Voltage / Reactive Power Controller . . . . .	88
4.3	Simulation of Wind Turbine Operation in a Distribution Network . . .	90
4.3.1	WT Operating at Constant Power Factor . . . . .	91
4.3.2	WT Operating at Constant Voltage . . . . .	95
4.4	Steady State Model of the DFIG . . . . .	97
4.5	Summary . . . . .	98
<b>5</b>	<b>Intelligent Control of Distributed Generation</b>	<b>100</b>
5.1	Introduction . . . . .	100
5.2	The Need for Intelligent Control . . . . .	100
5.2.1	Universal Power Circle Diagram . . . . .	102
5.3	Artificially Intelligent Controllers . . . . .	107
5.3.1	AI Controllers Based on Expert Systems . . . . .	107
5.3.2	Fuzzy Logic Controllers . . . . .	108
5.4	Hybrid Voltage / Power Factor Controller . . . . .	108
5.4.1	Determination of AVPFC mode selection rule set . . . . .	111

5.4.2	Performance of a Synchronous Machine Based DG under AVPFC control . . . . .	112
5.5	Fuzzy Logic Power Factor Controller (FLPFC) . . . . .	115
5.5.1	Formulation of the problem . . . . .	115
5.5.2	Design of the Fuzzy Logic Power Factor Controller . . . . .	117
5.5.3	Performance of the DG under FLPFC control . . . . .	118
5.6	AVPFC and FLPFC controlled DG under real-time varying load conditions	121
5.7	Application of the FLPFC to Wind Turbines with Doubly Fed Induction Generators . . . . .	125
5.8	Combining Intelligent Voltage Control at Generators and OLTCs . . . . .	127
5.9	Summary . . . . .	136
<b>6</b>	<b>Case Study: Integrating New Generation in the Scottish DN</b>	<b>137</b>
6.1	Introduction . . . . .	137
6.2	Description of the Test System . . . . .	137
6.3	Operation of the Test System Without Use of OLTCs . . . . .	139
6.3.1	Generators on the 11kV System . . . . .	140
6.3.2	Generators on the 33kV System . . . . .	144
6.4	Intelligent Generator Control and OLTCs in the Test System . . . . .	149
6.4.1	Connection of a Small-Hydro Scheme with Synchronous Generator	150
6.4.2	Wind Generation in the Test System . . . . .	154
6.5	Comparison of Intelligent Generator Control with Central "Active" Network Management . . . . .	159
6.6	Summary . . . . .	162
<b>7</b>	<b>Discussion and Conclusions</b>	<b>164</b>
7.1	Thesis Summary . . . . .	164
7.2	Areas of Activity . . . . .	166
7.3	Discussion of the Research Outcomes . . . . .	167
7.3.1	Distributed Generation and Network Modelling . . . . .	167
7.3.2	Intelligent Generation Control Algorithm Development . . . . .	167
7.4	Contribution to Knowledge, Novelty and Potential Impact of Study . . . . .	169
7.5	Beneficiaries of this Work . . . . .	170
7.6	Suggestions and Further Improvements . . . . .	171
7.7	Overall Conclusions . . . . .	172
7.8	Thesis Statement . . . . .	174
	<b>References</b>	<b>175</b>
<b>A</b>	<b>Publications</b>	<b>183</b>
A.1	Journal Papers . . . . .	183
A.2	Conference Publications . . . . .	184
A.3	Seminar Lectures . . . . .	184

---

# List of figures

---

1.1	Contribution to $CO_2$ emissions by various sources in the UK, 2002 . . .	3
1.2	Capacity per plant type in the UK from 1996 to 2002, DUKES 2002 . .	6
1.3	Contribution of each generation type to the total UK capacity, DUKES 2002 . . . . .	7
2.1	A section of a common distribution network consisting of a tapered radial feeder with loads . . . . .	14
2.2	Three-phase line with symmetrical spacing . . . . .	16
2.3	In-line configuration of conductors of a three-phase line (left) and conductor transposition (right) . . . . .	17
2.4	A simple two-bus system . . . . .	19
2.5	Vector diagram of the two-bus system . . . . .	21
2.6	Voltage drop due to load increase on the two-bus system . . . . .	23
2.7	Voltage effect of increasing generation on the two-bus system . . . . .	24
2.8	Power losses on the line for the two-bus system . . . . .	25
2.9	Voltage variation at the load bus of the two-bus system for type ACSR54/9 conductor and for three operating voltage levels . . . . .	26
2.10	Power losses on the line for three operating voltage levels . . . . .	27
2.11	Voltage profile of the six-bus system of Figure 2.1 with no embedded generation . . . . .	27
2.12	Voltage profile of the six-bus system of Figure 2.1 with 2 MVA of embedded generation on bus 6 . . . . .	28
2.13	Voltage profile of the six-bus system of Figure 2.1 modified to accommodate 2 MVA of embedded generation on bus 6 (transformer 1:1)	29
3.1	Source-to-electricity block diagram of a power conversion scheme. Blue arrows represent energy flow and red arrows represent control signals. .	35
3.2	Diagram of a Small Hydro Generator Installation. . . . .	38
3.3	Top-level block diagram of the developed model for the small-hydro plant	41
3.4	Block diagram of the hydraulic governor . . . . .	42
3.5	Steady state equivalent circuit of the synchronous generator (left) and terminal voltage/current vector diagram . . . . .	47
3.6	Basic steady state equivalent circuit of the synchronous generator with saliency neglected . . . . .	48
3.7	Basic functional diagram of excitation system of a synchronous machine	49
3.8	Block diagram of the simplified ST1A excitation system model . . . . .	50
3.9	Automatic power factor controller block diagram . . . . .	52
3.10	Flow chart of the operation of an On-Line Tap Changing mechanism .	53

3.11	Simulink block diagram of the OLTC mechanism . . . . .	55
3.12	Capability diagram of the synchronous generator . . . . .	56
3.13	Combined voltage surface and 3-dimensional capability diagram for a synchronous generator . . . . .	57
3.14	Synchronous generator loading up in APFC (a) and response to a load step change in AVC mode (b) . . . . .	61
3.15	The simulated 4-bus system with the OLTC . . . . .	62
3.16	24-hour varying load used in OLTC simulations . . . . .	63
3.18	Transformer primary and load bus voltage for the 24-hour simulation (AVC) . . . . .	64
3.17	OLTC tap position for the 24-hour simulation (AVC) . . . . .	65
3.20	Transformer primary and load bus voltage for the 24-hour simulation (LDRC) . . . . .	65
3.19	OLTC tap position for the 24-hour simulation (LDRC) . . . . .	66
3.21	Top-level block diagram of the Simulink small hydro scheme model . . . . .	68
4.1	Diagram of a 3-blade, horizontal axis wind turbine, image courtesy of Vestas . . . . .	70
4.2	Functional diagram and power transfer in a Wind Energy Conversion System . . . . .	72
4.3	Probability density function for a wind speed time series with $k=2.3$ and $c=9.033$ . . . . .	74
4.4	Wind speed time series sampled at 1 Hz (blue) and 30 min. average (red) . . . . .	76
4.5	A 3-minute zoom of the wind speed time series . . . . .	77
4.6	Power coefficient versus tip speed ratio for various values of blade pitch angle. Regenerated after Slootweg <i>et al.</i> , 2001 . . . . .	80
4.7	Power capture versus rotor speed for various wind speeds . . . . .	80
4.8	Most common generator topologies of wind energy conversion systems . . . . .	82
4.9	Blade pitch controller for the wind turbine . . . . .	86
4.10	Speed control characteristic for the DFIG . . . . .	87
4.11	Speed controller for the wind turbine . . . . .	88
4.12	Voltage / reactive power controller for the DFIG . . . . .	89
4.13	120 second wind speed time series used for the simulations . . . . .	90
4.14	Diagrams of the most significant blocks of the dynamic WECS model in Simulink. From (a) to (h): Top level diagram, WECS, wind turbine, DFIG and converter, pitch angle controller, power electronic converter, reactive power controller and real power controller. In (g) the $Q_s$ controller has been set up to perform power factor control. . . . .	92
4.15	Real power export, rotor speed and blade pitch angle for the DFIG in constant power factor operation . . . . .	93
4.16	Power factor and terminal voltage for the DFIG in constant power factor mode . . . . .	94
4.17	Power factor and terminal voltage for the DFIG in constant voltage mode of operation . . . . .	96

4.18	Steady-state equivalent circuit for a DFIG and corresponding phasor diagram . . . . .	98
5.1	Basic 2 bus system . . . . .	102
5.2	Universal power circle diagram for a short distribution line . . . . .	103
5.3	Composite universal power circle diagram . . . . .	104
5.4	Dynamic capability diagram for $P_{load} = 0.6$ pu, $PF = 0.8$ . . . . .	105
5.5	Dynamic capability diagram for $P_{load} = 0.45$ pu, $PF = 0.8$ . . . . .	106
5.6	Voltage vector diagram for the two-bus system of Figure 5.1 . . . . .	109
5.7	AVPFC controlled synchronous generator block diagram . . . . .	109
5.8	The flow chart of the automatic voltage/power factor control algorithm . . . . .	110
5.9	DG loading-up under AVC, APFC and AVPFC control. Legend applies to all subfigures. . . . .	114
5.10	Block diagram of a DG with a Fuzzy Logic Power Factor Controller . . . . .	116
5.11	Input membership functions of the Fuzzy Power Factor Controller . . . . .	119
5.12	Overall response of the Fuzzy Power Factor Controller . . . . .	119
5.13	DG loading-up under AVC, APFC and FLPFC control . . . . .	120
5.14	24-hour, 80% domestic 20% industrial load profile . . . . .	122
5.15	Response of APFC to a varying load . . . . .	123
5.16	AVPFC response to 24-hour varying load . . . . .	124
5.17	FLPFC response to 24-hour varying load . . . . .	125
5.18	A set of three $V - Q$ curves for the FLPFC . . . . .	127
5.19	Responses of three different fuzzy controllers and the classic power factor control . . . . .	128
5.20	A radial feeder with an OLTC transformer and distributed generation . . . . .	129
5.21	Voltage profile for the APFC controlled wind farm . . . . .	131
5.22	Voltage profile for the AVPFC controlled WECS . . . . .	131
5.23	Voltage profile for the APFC controlled WECS with line drop / rise compensation . . . . .	132
5.24	Voltage profile for the AVPFC controlled WECS with line drop / rise compensation . . . . .	132
5.25	Reactive power exchange from one AVPFC controlled WECS . . . . .	134
5.26	Reactive power exchange from one AVPFC controlled WECS with line drop / rise compensation . . . . .	134
5.27	OLTC tap position during the 24-hour simulation with the APFC controlled WECS . . . . .	135
5.28	OLTC tap position during the 24-hour simulation with the AVPFC controlled WECS . . . . .	135
6.1	The section of the Scottish distribution network used as a test system. The names of the buses are concealed. . . . .	138
6.2	Demand profile in the simulated network . . . . .	139

6.3	Voltage profiles of buses HERS3, HERS5 and GOUV5 after the connection of a 2MW generator at GOUV5 operating in power factor control mode . . . . .	140
6.4	Effect of operating the generator at GOUV5 in AVPFC mode on the voltage profiles of buses HERS3, HERS5 and GOUV5 . . . . .	141
6.5	Power factor of generator at GOUV5 operating in AVPFC mode . . . . .	142
6.6	Voltage range on all 20 buses with a 2.4MW generator connected to bus GOUV5 . . . . .	143
6.7	Voltage ranges with the generator controlled by the fuzzy controller . . . . .	143
6.8	Volt- $\tan(\phi)$ characteristic of the FLPFC . . . . .	144
6.9	Voltage ranges with a 4.2MW generator under fuzzy control on bus GOUV5	145
6.10	Voltage profiles of buses HERS3, HERS5 and GOUV5 after the connection of a 8MW generator at HERS3 operating in APFC mode . . . . .	146
6.11	Effect of operating the generator at HERS3 in AVPFC mode on the voltage profiles of buses HERS3, HERS5 and GOUV5 . . . . .	146
6.12	Power factor of generator at HERS3 operating in AVPFC mode . . . . .	147
6.13	Voltage range on all 20 buses with a 14MW generator connected to bus HERS3 . . . . .	148
6.14	Voltage ranges with the generator controlled by the fuzzy controller . . . . .	148
6.15	Voltage ranges with a 36MW generator under fuzzy control on bus HERS3	149
6.16	Voltage profile of buses GOUV5, HERS5 and HERS3 with a 2MW synchronous generator at GOUV5 and LDRC operation . . . . .	151
6.17	Tap transitions of the OLTC transformer . . . . .	151
6.18	Voltage profiles for combined AVPFC and LDRC operation . . . . .	152
6.19	Tap transitions of the OLTC transformer with the generator under AVPFC control . . . . .	153
6.20	Reactive power exchange of the generator under AVPFC control . . . . .	153
6.21	24-hour voltage profile with the wind turbine operating in APFC . . . . .	154
6.22	24-hour voltage profile with the wind turbine operating under AVPFC control . . . . .	155
6.23	Reactive power exchange of the wind turbine operating under AVPFC control . . . . .	155
6.24	24-hour voltage profile with the wind turbine in APFC mode assisted by line drop/rise compensation . . . . .	156
6.25	Tap changes throughout the 24-hour period with the generator in APFC mode . . . . .	156
6.26	24-hour voltage profile with the wind turbine operating under AVPFC control combined with LDRC . . . . .	157
6.27	Reactive power exchange of the wind turbine operating under AVPFC control combined with LDRC . . . . .	157
6.28	Tap changes throughout the 24-hour period with the generator in AVPFC mode . . . . .	158
6.29	The distribution network used in the OPF simulations . . . . .	161

---

# List of tables

---

2.1	Typical conductor sizes and their characteristics. Data taken from [1]. .	18
2.2	Relative characteristics of overhead lines in the distribution network. From [1]. . . . .	19
2.3	Electrical data of the network of Figure 2.1 . . . . .	28
3.1	Possible applications of dispersed generator models in the three time frames	36
3.2	Types of hydro turbines and their head ranges . . . . .	40
3.3	A typical set of parameters for an OLTC mechanism . . . . .	54
3.4	Parameters for the simulation of the OLTC operating in AVC and LDRC mode . . . . .	64
4.1	Wind turbine characteristics . . . . .	91
4.2	DFIG characteristics . . . . .	91
5.1	AVPFC mode selection rules set . . . . .	112
5.2	Test system data . . . . .	113
5.3	Fuzzy Logic Power Factor Controller data . . . . .	119
5.4	Test system data . . . . .	122
5.5	Parameters of the system in Figure 5.20 . . . . .	130
6.1	AVPFC settings . . . . .	141
6.2	OLTC settings . . . . .	150
6.3	AVPFC settings . . . . .	154
6.4	Line and transformer characteristics for the network in Figure 6.29 . . .	162
6.5	Capacity allocation from the optimal power flow for APFC, IntelliGens and CVC with the fault level constraints considered . . . . .	162

---

# Acronyms and abbreviations

---

APFC	Automatic Power Factor Controller
AVPFC	Automatic Voltage / Power Factor Controller
AVR	Automatic Voltage Regulator
BSP	Bulk Supply Point
BWEA	British Wind Energy Association
CCGT	Combined Cycle Gas Turbine
CHP	Combined Heat and Power
GHG	Greenhouse Gases
DG	Distributed / Dispersed Generation
DFIG	Doubly Fed Induction Generator
DN	Distribution Network
EG	Embedded Generation
EHV	Extra High Voltage (400 kV and 275 kV)
EPSRC	Engineering and Physical Sciences Research Council
FLPFC	Fuzzy Logic Power Factor Controller
HG	Hydro Generator
HV	High Voltage (132 kV)
IG	Induction Generator
IM	Induction Machine
LDRC	Line Drop / Rise Compensation
LUT	Look Up Table
LV	Low Voltage (400 V and 230 V)
mHG	Mini-Hydro Generator
$\mu$ HG	Micro-Hydro Generator
MV	Medium Voltage (11 kV and 33 kV)
OLTC	Online Tap Changer
PEC	Power Electronic Converter

PV	Photo-Voltaic panel
RES	Renewable Energy Sources
RNET	Renewable and New Energy Technologies
ROC	Renewables Obligation Certificate
SCIG	Squirrel Cage Induction Generator
SG	Synchronous Generator
SHG	Small Hydro Generator
SM	Synchronous Machine
UK	United Kingdom
WECS	Wind Energy Conversion System
WT	Wind Turbine

---

Contend with the powers of nature, force them to the yoke of superior purpose. Free that spirit which struggles within them and longs to mingle with that spirit which struggles within you. When a man fighting with chaos subdues a series of phenomena to the laws of his mind and strictly confines these laws within the boundaries of reason, then the world breathes, the voices are ranged in order, the future becomes clarified, and all the dark and endless quantities of numbers are freed by submitting to mystical quality.

Nikos Kazantzakis, "*Ascetic Life (Salvatores Dei)*"

---

# Chapter 1

## Introduction

---

### 1.1 Research Background

Increased environmental awareness has generated a number of directives both in the UK and internationally in order to motivate development of Renewable Energy Sources (RES) and Combined Heat and Power (CHP) plants. The EU Renewables Directive, the UK Renewables Obligation and revisions to energy trading agreements aim to significantly increase the European and UK capacity of Distributed Generators that will not operate in response to central dispatch. Most of the Renewable Energy Sources are located at remote ends of the Distribution Network (wind, marine, mini-hydro). The Renewables Obligation sets a target that by 2010 10%, and by 2020 20%, of total electricity supplied should be from RES plant. The government has also set a target of connecting 10 GW of fossil fuelled but very efficient Combined Heat and Power plants. In absolute terms this implies connection of around 2000 MW of new Distributed Generation (DG) plant *every year* [2]. A great amount of this new generation (especially from RES) is typically found in remote rural areas where the loads are low, the Distribution Network (DN) is medium or even low voltage and designed for a unidirectional, downstream flow of energy [3]. The steady-state, slow and transient variations of voltage levels related to the connection of a DG can lead to undesired operation of voltage control equipment on transformers at the primary substations of the network. A net reversal or increase of power flow in lines due to the presence or the loss respectively of a DG, can cause unacceptable voltage variations, and the Distribution Network Operator (DNO) will likely then require that the DG be disconnected [4]. The resulting loss of revenue can be a barrier for the development of DG towards the 2010 targets. It is therefore clear that a technology and an operational framework has to be developed that will mitigate these adverse effects.

## 1.2 Basic Definitions

The following terms will be used in this document as described here:

**Renewable Energy Source** is any energy source that is replenished by natural processes at least as fast as it is used and its overall environmental impact during its life cycle (emergence/consumption) is negligible. Examples are wind, hydro (small only), solar, biomass, geothermal, wave and tidal current.

**Transmission Network** is the part of the electric power system that is used to interconnect large power stations and ship large quantities of energy from generators to bulk supply points. Its operation is actively managed and its voltage levels in the UK are 400 kV and 275 kV. Furthermore, in Scotland the 132 kV sub-system is also operated and considered as "sub-transmission" network.

**Distribution Network** is the part of the electric power system that is used to deliver energy to end customers (loads). Currently there are only a few active means of control over its function, such as transformers with online tap changing mechanisms. The voltage levels in the UK Distribution Network are 132 kV (England & Wales), 33 kV, 11 kV and low voltage (400 V and 230 V).

**Distributed or Dispersed Generation** is generation that is connected to the Distribution Network and not 'dispatched' *i.e.* not controlled by the power system operator. There is no formal definition of its capacity, but for this document this will be considered as less than 20 MW. The terms 'distributed' and 'dispersed' will be used interchangeably.

**Embedded Generation** is considered by many as equivalent to Distributed or Dispersed Generation. In this document an Embedded Generator is defined as a Distributed Generator that is physically attached to the same busbar as a load and its output is governed by the load requirements. An example of an Embedded Generator is a Combined Heat and Power plant that provides electricity as a by-product after serving a specific heat load.

### 1.3 Sustainable Electricity Systems

It is now understood that anthropogenic pollution of the atmosphere, mainly through burning of fossil fuels, makes a large contribution to climate change. The last century saw an increase of the global temperatures of  $0.6^{\circ}\text{C}$ , while the Intergovernmental Panel on Climate Change (IPCC) has predicted that global temperatures will rise during the 21st Century by between  $1.4^{\circ}\text{C}$  and  $5.8^{\circ}\text{C}$  and that sea levels will rise by between 0.09 and 0.88 metres [5]. Energy production and consumption do more environmental damage in the world than any other human activity. Global energy demand is expected to increase 57% over the next two decades [6]. The result will be a further 60% increase in the emission of carbon dioxide ( $\text{CO}_2$ ) and other Greenhouse Gases (GHG) [7], when the present concentration of  $\text{CO}_2$  in the atmosphere is the highest for three million years. In the UK, electric power stations currently contribute 29% of the total  $\text{CO}_2$  emissions. The breakdown of the contribution to GHG emissions by each source in the UK for 2002 is shown in Figure 1.1 [8].

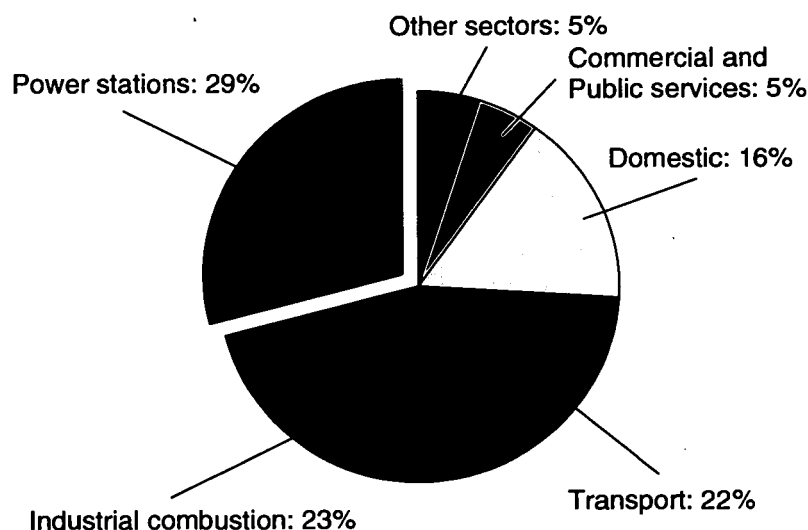

**Figure 1.1:** Contribution to  $\text{CO}_2$  emissions by various sources in the UK, 2002

At Kyoto, the member states of the European Union (EU) agreed jointly to undertake an 8% reduction of six key greenhouse gases from 1990 to 2008-2012 [9]. The UK reduction target under EU burden sharing arrangements was 12.5%, but the UK government has committed itself to a 20% reduction of carbon dioxide emissions by 2010 and has set

an ambitious target for a 60% reduction from the 1990 levels by 2050 [10].

Reduction of  $CO_2$  emissions is not the only challenge for tomorrow's electricity generation system. Fuel poverty and depletion of conventional fuels in the next few decades are also threats that cannot be ignored. Energy consumption is correlated with the per capita income and is distributed inequitably around the world. It is estimated that one third of the world's population has no access to electricity [11]. At the same time, oil and all the other fossil fuels are finite resources. World oil production is expected to peak during the next few decades and then decline. Oil prices will therefore rise rapidly unless alternative fuels can be exploited [12].

To mitigate these problems there is a need for *Sustainable Energy Development* by utilising a policy, which will aim to reduce the need for energy by improving the effectiveness of its use (*Energy Efficiency*) and motivate use of energy from a source that does not result in the depletion of the earth's resources, whether this is from a central or local source (*Renewable Energy Supply*). The criteria that need to be satisfied in order for the operation of the electric power system to qualify as sustainable are:

- provision of electricity necessary to maintain and improve quality of life to all, both in physical and economic terms;
- constraint of pollutants within healthy levels;
- minimisation of the risk of future environmental or economic impact by limiting greenhouse gases, radioactive wastes and other long-lived toxins;
- development and promotion of cheap and environment-friendly technologies for electricity generation; and
- electricity pricing that reflects the actual costs of electricity provision, including environmental and other external costs.

An exact definition of energy technologies that meet the above criteria does not exist; but when observed from the electric power point of view, sustainability resides in two

large thematic areas: increased power system efficiency and development of Renewable Energy Sources (RESs).

## 1.4 Renewable Energy Sources in the UK Power System

Electricity generated from Renewable Energy Sources is considered as "green" because it has negligible emissions of greenhouse gases and other pollutants. Commercial interest in RES started in the mid-1970s shortly after the first oil shock and was driven mainly by the goal of minimising the dependence of the western countries on oil. Then, since the late 1990s a series of incidents occurred and this led to a radical change to the UK energy market:

- $CO_2$  emissions slowed down due to the decline of coal usage;
- oil (and consequently gas) prices rose from approximately \$10 to \$60 per barrel;
- wholesale prices fell and undermined future investment in the energy sector;
- the US energy colossus Enron collapsed along with its trading model;
- the UK became a net gas importer through the Interconnector and thus gas prices were linked to those of mainland Europe.

It is therefore clear that the UK (as most of the industrialised countries) has two growing concerns: the need for an improved environmental policy and the fact that it is already an importer of gas, and through gas, of electricity too, as gas is becoming the dominant fuel source for electricity [13]. As a consequence, the UK Renewables Obligation was introduced by the UK government (and the Renewables Directive in the rest of EU) in order to motivate and stimulate development of RES. The former sets a target that by 2010 a 10% (and 20% by 2020) of total electricity supplied in the UK should be from RE plant. Further, the Renewables Obligation aims to increase installed capacity of CHP

generation to 10 GW. With the current legislation, method of operation of the power system and initiatives (or lack thereof), these targets are now proving very difficult to meet. Figure 1.2 shows the generating capacity per plant type in the UK from 1996 to 2002 [14]. The total generating capacity at the end of 2002 was 76.6 GW.

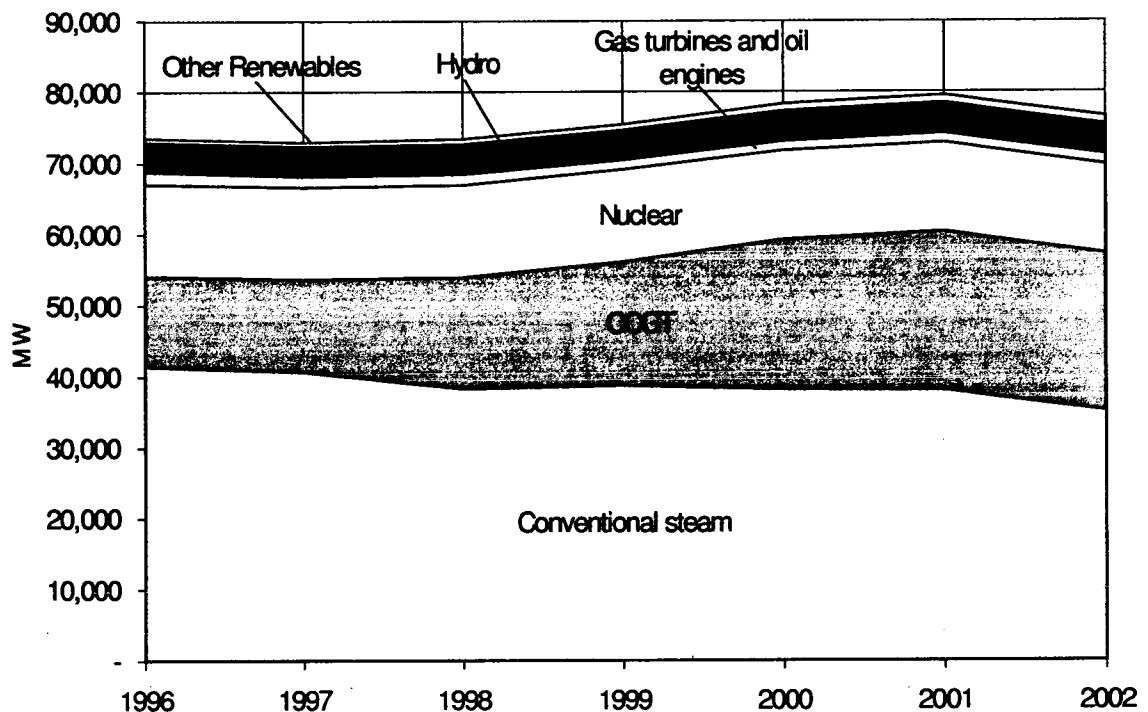

**Figure 1.2:** Capacity per plant type in the UK from 1996 to 2002, DUKES 2002

Although still small, Renewable Energy stations' capacity has been increased by 123% in these 6 years to reach the 2002 capacity of 1.13 GW. The non-renewable but highly efficient Combined Cycle Gas Turbine (CCGT) plant capacity has also been significantly increased by 74% during the same period (22.1 GW in total). On the contrary, all the non-sustainable plants have seen a decrease in their capacity, with most significant the conventional steam plants (15.2%). This is partially due to the UK non-fossil commitment, but was further assisted by the fact that some of the coal-fired plants were already at the end of their life cycles. Finally the capacity of the large hydro-electric plants (including pumped storage) has been increased by 1.24% up to 4.25 GW over these six years, although during 2002 there was a decline due to the reduction of

the output of some stations in order for them to conform to (and benefit from) the pro- Distributed Generation regulations that apply to RES plants with capacity under 20 MW. The contribution of each technology to the total generation capacity at the end of 2002 is shown in Figure 1.3.

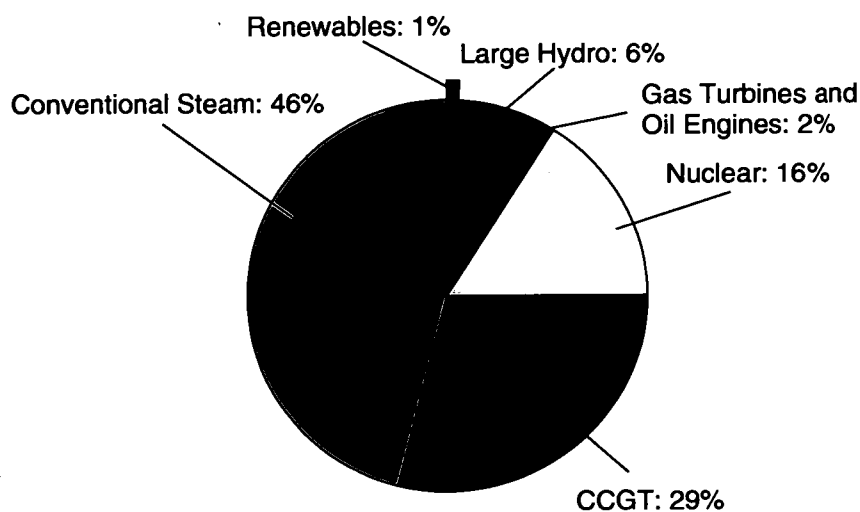

**Figure 1.3:** Contribution of each generation type to the total UK capacity, DUKES 2002

In the effort to achieve the 2010 and 2020 targets, management of a power system with such a high RES penetration is expected to impose major challenges to the network operators. The Royal Commission on Environmental Pollution in its report "Energy - The Changing Climate", published in 2000, proposes that these challenges may be overcome by installing large capacities of conventional fossil fuelled generating plants that will be used only for short intervals when the RES output does not suffice [10]. It is easy to understand that such a strategy would have an extremely high capital cost. Additionally, each renewable energy technology has its own characteristic impact on the environment and the power system and has to be assessed on an individual basis. The RE technologies that already are developed, or expected to develop, in the UK distribution systems are:

- wind (on-, near- and offshore);
- small hydro;

- biomass;
- solar photovoltaic; and
- marine (wave, tidal current).

Large hydro-electricity plants are not categorised among the RESs despite their zero-emission operation. The reasons are their high capital cost and their adverse environmental effects both upstream (large area flood and significant impacts to the habitat) and downstream (quality and quantity of water flow). Also, they are usually connected to the transmission rather than the distribution network through dedicated power lines. The above list should also contain the Combined Heat and Power (CHP) plants because, although they are not fed by a RES, they are highly efficient and therefore qualify as sustainable generation by reducing the need for conventional, inefficient steam power plant. Wind Energy Conversion Systems and Small Hydro Generators are discussed in the following sections as they are the main types of generation studied in this research.

## **1.5 The RNET Project**

The work reported here was a part of a research project funded by the UK Engineering and Physical Sciences Research Council (EPSRC) that emerged in response to the EPSRC's Renewable and New Energy Technologies (RNET) programme (Ref. RNET1/084). The title of the project was "Maximising the Integration of Embedded Renewable and New Generation into Existing Distribution Networks" and it was carried out by the Institute for Energy Systems at the University of Edinburgh (led by Dr Robin Wallace) with the collaboration of the Manchester Centre For Electrical Energy at the University of Manchester, Institute of Science and Technology (led by Prof. Goran Strbac). The project was supported by a number of industrial collaborators including SP Power Systems, East of Scotland Water, IPSA Power Engineering and others. Work was initiated in October 2000 and ended in September 2003 and involved 4 academic staff, 2 research associates and this PhD studentship.

The objective of the whole RNET project, as stated in the project proposal, was to develop a body of knowledge and software simulation toolset that would:

1. Determine the amount of Embedded, Renewable and new Generation (ERG) that can be connected to distribution networks subject to existing and revised system restrictions;
2. Embody stochastic energy production and load demand as time-series data;
3. Apply probabilistic analysis techniques to optimise ERG production, distribution system optimal power flow and voltage profiles;
4. Identify and validate possible changes to network operation and configuration to integrate a greater capacity of ERG ;
5. Quantify the economic interaction between the ERG and the network;
6. Investigate local and regional voltage reprofiling - both static and dynamic - to optimise capacity and energy production of ERG;
7. Investigate active and reactive power control techniques of, or at, the ERG that will maximise production and reduce impact on the distribution system.

These tasks were shared among the collaborators, and this report is on work mainly concerned with task 7.

## **1.6 Project Objectives and Scope**

In this work the main objective was to explore the possibility of alternative control and dispatch of Distributed Generators, in order to maximise production with minimum impact on the power system. This was implemented through a number of tasks. It modelled power and voltage influenced excitation and governor control of Synchronous Generators and studied the dispatch of active and reactive power from Doubly Fed Induction Generators by rotor voltage control. Further, DG control algorithms were

developed to maximise production, ensuring at the same time that the generator will operate within pre-defined voltage and reactive power generation limits.

## **1.7 Thesis**

The thesis of the work was that: Intelligent voltage and reactive power control algorithms of small-scale generators, which are connected to weak distribution networks, can allow increase of their capacity before the statutory voltage limits for quality of supply are violated. Particularly, novel control schemes of:

- i. Distributed Generators featuring Synchronous Machines and,
- ii. Wind Energy Conversion Systems (WECS) based on Doubly Fed Induction Generators (DFIGs),

can mitigate the adverse effects of increased generation capacity on Distribution Network voltage quality.

## **1.8 Contribution to Knowledge and Deliverables**

This study contributed to knowledge by creation of appropriate control algorithms to assist developers and network operators to increase penetration of distributed generation. Furthermore, this research generated a set of models for power systems simulation that focuses on control of distributed generation. This allowed evaluation of the impact that smart DG controllers introduce to the system, as well as the development of algorithms and methods for maximising power production and injection into a weak network. Finally, it established a set of rules that may be used to define when and which technology should be utilised, in order to achieve the most efficient generation and transport of power, taking into account the technical and economic issues in each case.

There are three main deliverables from this research:

- the establishment of combined generation, control and network models for detailed investigation of novel control algorithms for DGs connected to weak distribution networks;
- a set of novel control algorithms for Synchronous and Doubly Fed Induction Generators that will assist injection of power generated by DGs; and
- an assessment on the application of these algorithms on machines and devices connected to a (simulated) existing DN.

## **1.9 Thesis Outline**

This chapter was the introduction of this thesis. Chapter 2 explains the issues related to increased penetration of Renewable and Embedded Generation in the Distribution Network. Then Chapter 3 describes modelling of distribution networks as well as generation plants based on synchronous machines such as Small-Hydroelectric Generators (SHGs). Chapter 4 presents the modelling of wind energy conversion systems and builds a full wind-to-wire dynamic model of a variable speed wind turbine including a doubly fed induction generator. Chapter 5 presents the developed control algorithms for Distributed Generators that improve steady-state voltages. Chapter 6 presents the performance of the developed algorithms through a case study that considers connection of various DGs in a part of the Scottish Distribution Network, and then it discusses the findings. Finally, Chapter 7 makes the conclusions of this work and summarises the thesis.

---

# Chapter 2

## Embedded and Renewable Generation in the Distribution Network

---

### 2.1 Introduction

This chapter provides a background on Electricity Distribution Networks and explains the problems related to increased penetration of Renewable and Embedded Generation in the MV grid and in particular in weak rural networks. The characteristics of a typical distribution system are shown and then the obstacles for the connection of Renewable and Embedded Generation to it are presented. The most important of these is the alteration of voltage profiles throughout the distribution network due to the addition of DG, and therefore this is further discussed. The power flow between two buses is derived and used as an example to depict the voltage rise problem. The effects of different conductor sizes and voltage levels on voltage rise are presented through a series of simulations and finally the structure of voltage control within a distribution system is presented.

### 2.2 UK Regulations on Voltage Variation in DNs

The Distribution Network Operators (DNOs) are obliged to provide electricity that complies with statutory levels for quality of supply. Voltage fluctuation is one of the monitored indices. Electricity Supply Regulations 1988 (Regulation 30) requires that the voltage variation at a consumers supply terminals at a voltage less than 132 kV should not exceed 6% above or below the declared nominal voltage. The 1994 amendment of Regulation 30 (passed in order to make it compliant with the

European Standard EN50160:1994), sets the permissible voltage variation at a low voltage consumers supply terminals between 10% above or 6% below nominal.

The Electricity Supply Regulations 1988 was replaced by the Electricity Safety, Quality and Continuity Regulations 2002. As defined in Regulation 27, the voltage limits for the distribution and transmission networks in the UK are:

- 10% above or 6% below the declared voltage at the declared frequency for voltage levels between 50V and 1kV,
- 6% above or below the declared voltage at the declared frequency for voltage levels below 132kV, and
- 10% above or below the declared voltage at the declared frequency for voltage levels above 132kV (transmission level).

Traditionally in the distribution networks these limits are preserved through use of transformers with fixed taps and by using on-line tap changers on transformers at some of the bulk supply points. However, with the introduction of distributed generation these measures may not be sufficient to maintain an acceptable voltage profile throughout the network. However it should be noted that DNOs may operate well within the ones defined above in order to enhance security and quality of supply.

## **2.3 Distribution Network Structure**

Historically, Distribution Networks (DNs) were designed to convey electrical energy from the central power stations that were connected to the High-Voltage (HV) Transmission Network (TN), to consumers connected to medium (MV) and low (LV) voltage circuits [15]. The most common topology of DN in rural areas is long radial feeders. Particularly in Scotland, the DN is characterised by long overhead line circuits at 132, 33 and 11kV. Depending on the area, there may be some interconnection at 132kV, but this can be sparse at 33kV and non-existent at 11kV. Overall impedance that has increased with circuit length is not reduced by parallel circuit combination

as it would be at transmission level. The reduced loads typically found in rural areas allowed the network to be extended radially from the bulk supply points. While the fixed geometry of the conductors of 33 and 11kV overhead lines bring about a nearly uniform reactance, increasingly tapered circuits see the resistance rise with reduced conductor cross-sectional area towards the edges of the network. The diagram of a typical radial network is shown in Figure 2.1.

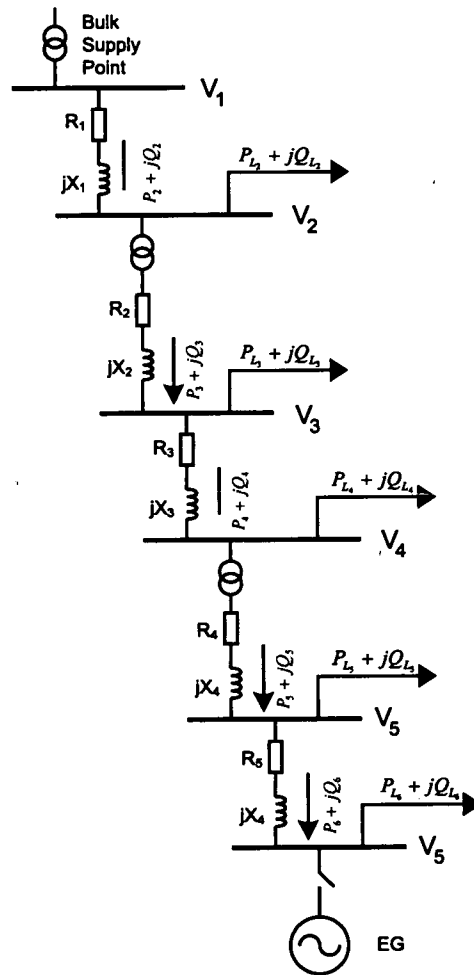

**Figure 2.1:** *A section of a common distribution network consisting of a tapered radial feeder with loads*

The distribution system was designed on the basis that power flows were unidirectional; real and reactive power were flowing from the Bulk Supply Point to the loads [16]. In addition, consumer load patterns (and therefore network power flows) were to a

great extent predictable, with periodic patterns lasting from days to seasons. Voltage profiles were established by a radially tapered conductor system, and off-load voltages (and on-load profiles) were set by initial adjustment of fixed off-load taps in the LV transformers at 11000:430V. It was operated in a passive fit-and-forget manner and was maintained on a planned routine basis. At the most remote ends of the 11kV network, voltage was passively controlled by means of transformers with fixed taps adjusted to set the on-load voltage within statutory limits. Transformers at the Bulk Supply Points (11:33kV or 33:132kV) were equipped with On-Line Tap Changers (OLTCs), which operated actively in response to voltage change with power flow [17]. Statutory voltage limits were set in order to maintain quality of supply ( $\pm 6\%$  for MV in the UK) and to ensure this, DNOs often planned and operated their networks in a  $\pm 3\%$  voltage envelope [18].

### 2.3.1 Conductor Sizing and Spacing

Typically, population density and demand for electricity tends to reduce along the feeder and towards its rural edge. This fact allows the DNOs to reduce their development costs by reducing the capacity of the feeder as it approaches its remote end. This is usually done by reducing the cross-sectional area of the conductors. However, this means that the network resistance  $R_{km}$  per kilometer increases, as:

$$R_{km} = \rho \frac{l}{\pi r^2} \quad \text{ohm/km} \quad (2.1)$$

where:  $\rho$  = resistivity,  
 $l$  = conductor length (m),  
and  $r$  = conductor radius (m).

In the simplest case of balanced currents and a three-phase line with its conductors symmetrically spaced in a triangular configuration as shown in Figure 2.2, the line inductance per phase per kilometer length is shown in by Equation 2.2 [19].

$$L_{km} = 0.2 \ln \frac{d}{r e^{-\frac{1}{4}}} \quad \text{mH/km} \quad (2.2)$$

where:  $d$  = conductor spacing (m).

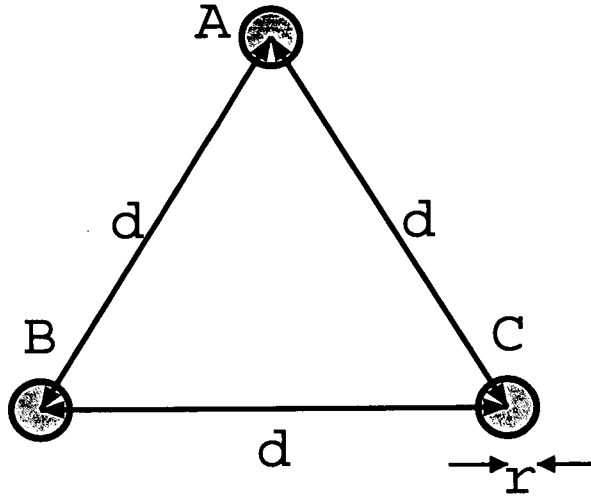

**Figure 2.2:** *Three-phase line with symmetrical spacing*

The most commonly used conductor setup in distribution systems is the in-line configuration depicted in Figure 2.3 (left). Being asymmetric, the line inductance in this setup differs from phase to phase. One way to regain symmetry in good measure is to use conductor transposition as shown in Figure 2.3 (right). However this technique is not very common in distribution levels.

It can be shown that in this case the inductance per phase per kilometre length for a solid round conductor is

$$L_{km} = 0.2 \ln \frac{GMD}{r e^{-\frac{1}{4}}} \quad \text{mH/km} \quad (2.3)$$

where GMD is the geometric mean distance and equals to

$$GMD = \sqrt[3]{D_{AB} D_{BC} D_{AC}} \quad (2.4)$$

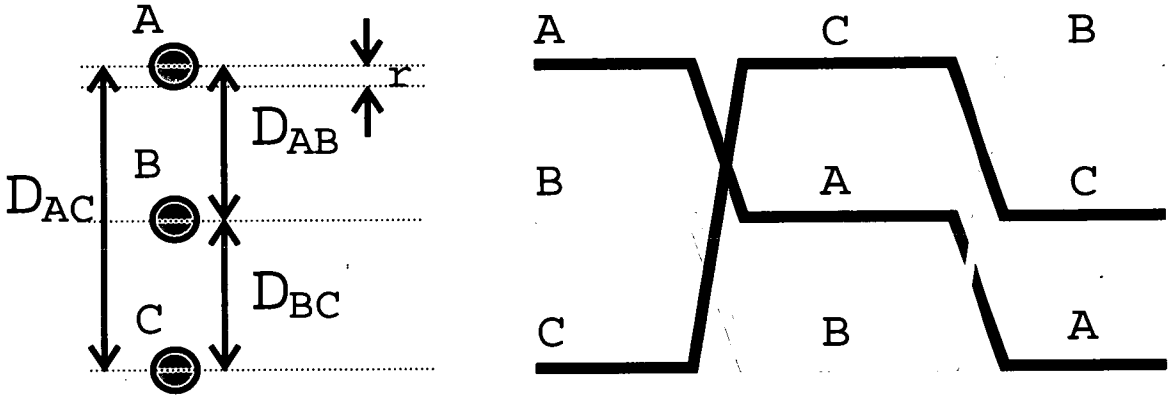

**Figure 2.3:** In-line configuration of conductors of a three-phase line (left) and conductor transposition (right)

In the case of a stranded conductor with  $n$  strands, Equation 2.3 is modified by replacing the term  $re^{-\frac{1}{4}}$  with the Geometric Mean Radius (GMR):

$$GMR = \sqrt[n^2]{(D_{aa}D_{ab} \cdots D_{an}) \cdots (D_{na}D_{nb} \cdots D_{nn})}, \quad (2.5)$$

where  $D_{aa} = D_{bb} = \cdots = D_{nn}$  are the radii of each strand and  $D_{ij}$  for  $i, j \in [1, n]$  and  $i \neq j$  are the distances between the centres of the strands. Line reactance  $X_{km}$  per kilometre is:

$$X_{km} = L \times 2\pi f \quad \text{ohm/km} \quad (2.6)$$

where  $f$  = network frequency (Hz)

In all cases equations 2.1 through 2.6 show that  $r$  is a significantly more important factor in  $R$  than in  $X$ . Line inductance is mainly geometry dependent. However, the geometry of the lines tends not to change much, hence  $X$  remains largely constant and therefore the  $X : R$  ratio decreases rapidly with reduction of the conductor cross-sectional area. This has serious implications on the development of DG projects located close to the remote ends of the DN as the increased  $R$  will exaggerate the variation of voltage due to generated real power export. It should be noted here that for other conductor topologies, line reactance  $X$  differs from the value given by Equations 2.6 and 2.3 but the effect of  $r$  on it is of the same magnitude. A set of typical conductor sizes and their characteristics is shown in Table 2.1.

Conductor type	Resistance $R$ $\Omega/km$	Reactance $X$ $\Omega/km$ (50Hz)	Thermal limit $MVA$	Investment costs $\pounds/km$
ACSR 34/6	0.848	0.4	7.4	7,870
ACSR 54/9	0.536	0.4	9.9	9,200
AAC 132	0.219	0.4	17.5	11,470

**Table 2.1:** *Typical conductor sizes and their characteristics. Data taken from [1].*

The three conductors presented in Table 2.1 are named after their size and type. Hence, the first represents a conductor with  $34mm^2$  of aluminum wire strands and a  $6mm^2$  steel core reinforcement, the second with  $54mm^2$  of aluminum wire strands and a  $9mm^2$  steel core, and the third with  $132mm^2$  of aluminum wire strands and no core. It is shown that although the reactance remains practically constant, the resistance varies widely with changing cross-sectional area, with high values for small areas and vice-versa. The thermal limit of the line is increasing with the cross-sectional area (which means that more power can be shipped through the line) and finally the investment cost also rises for heavier conductors as expected.

### 2.3.2 Selection of Distribution Network Operating Voltage

The capital cost of a distribution system can also be lowered by using lower voltage levels in low demand areas. This is done by installing step-down transformers. Table 2.2 shows the relative capital cost per kilometre, the maximum possible feeder length due to overvoltage constraints and the power losses per km for four nominal DN voltages (under the same loading conditions). It should be noted that the 6.6 and 20kV levels are not used in the UK, but are shown for comparison.

For all three parameters the 11kV voltage level is taken as reference. It is seen that the capital cost for a 33kV overhead line can be over 30% higher than for an 11kV for the same feeder length. However, the table shows that a 33kV operating voltage will allow the feeder length to be increased 9 times before voltage violations become a problem as the reduced resistance will cause less voltage rise/drop. Additionally, the power losses for the same distance will be reduced to one tenth [1]. Switchgear,

Voltage kV	Capital Cost/km %	Feeder Length %	Power Losses/km %
6.6	93	41	278
11	100	100	100
20	112	331	30
33	131	900	11

**Table 2.2:** *Relative characteristics of overhead lines in the distribution network. From [1].*

protection and transformer costs will also rise with operating voltage, but on the other hand the number of substations will be reduced due to the reduced voltage rise/drop. Hence, the decision of the operating voltage can only be made on an individual basis, also considering the long-term development projection of the covered area.

## 2.4 Power Flows and Voltages in a Two-Bus System

The simplest case of a power system consists of two buses connected by a single line. One of the buses is considered as the infinite bus, *i.e.* a bus that is assumed to have fixed voltage magnitude and angle, while the second bus hosts a load. Such a system is depicted in Figure 2.4.

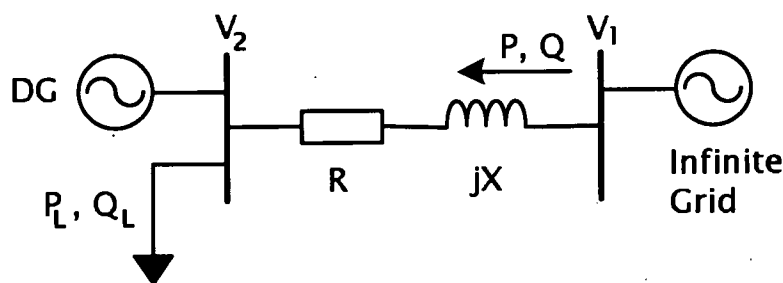

**Figure 2.4:** *A simple two-bus system*

In this system a distributed generator is connected to the load bus and therefore the real and reactive power  $P_B$  and  $Q_B$  that the load bus exchanges with the network is the difference between the  $P_G$  and  $Q_G$  of the generator and the  $P_L$  and  $Q_L$  of the load.

The complex power exchanged between the infinite bus and the rest of the system  $S$  depends on the bus voltage and the line current and is defined by:

$$\bar{S} = P + jQ = \bar{V}_1 \times \bar{I}^* \quad (2.7)$$

By solving Equation 2.7 for  $\bar{I}$  we get:

$$\bar{I} = \frac{P - jQ}{\bar{V}_1^*} \quad (2.8)$$

Application of Kirchoff's voltage law on the two-bus system gives:

$$\bar{V}_2 = \bar{V}_1 - (R + jX) \times \bar{I}, \quad (2.9)$$

where  $R$  and  $X$  are the line's resistance and reactance respectively. Using the above expression for the current and by combining it with Kirchoff's voltage law it is possible to derive the voltage on the load bus:

$$\bar{V}_2 = \bar{V}_1 - (R + jX) \frac{P - jQ}{\bar{V}_1^*} \quad (2.10)$$

Equation 2.10 calculates the voltage on the load bus for a given state of infinite bus power and voltage. This equation can be further simplified by choosing the infinite bus voltage as phase reference, (therefore  $\bar{V}_1 = \bar{V}_1^* = V_1 \angle 0^\circ = V_1$ ), allowing Equation 2.10 to be rewritten as:

$$\bar{V}_2 = V_1 - \frac{RP + XQ}{V_1} - j \frac{XP - RQ}{V_1} \quad (2.11)$$

It can be shown that if the values of  $P_L$ ,  $Q_L$ ,  $P_G$ ,  $Q_G$  and  $V_2$  were given instead, the same process would give:

$$\bar{V}_1 = V_2 - \frac{RP_B + XQ_B}{V_2} - j \frac{XP_B - RQ_B}{V_2}, \quad (2.12)$$

where  $P_B = P_L - P_G$  and  $Q_B = Q_L - Q_G$ .

In real life however, it is the voltage on the infinite bus and the power demands on the load bus that are given. Therefore it is not possible to solve Equation 2.12 algebraically,

as there is a nonlinear relationship between  $V_2$  and powers  $P_B$  and  $Q_B$ . It should be noted here that the power that the load bus exchanges with the line does not equal the power the latter exchanges with the infinite bus, as there are the real and reactive power losses on the line due to the resistance and reactance respectively. Equation 2.12 is the simplest case of a *load flow* problem that is typically solved using classic iterative algorithms such as Newton-Raphson, Gauss-Seidel and their variations.

The voltage rise  $\bar{D}V$  on the line can be calculated from Equation 2.12:

$$\bar{D}V = V_2 - \bar{V}_1 = \frac{RP_B + XQ_B}{V_2} + j\frac{XP_B - RQ_B}{V_2} \quad (2.13)$$

Equation 2.13 describes the voltage vector diagram of the system that is shown in Figure 2.5.

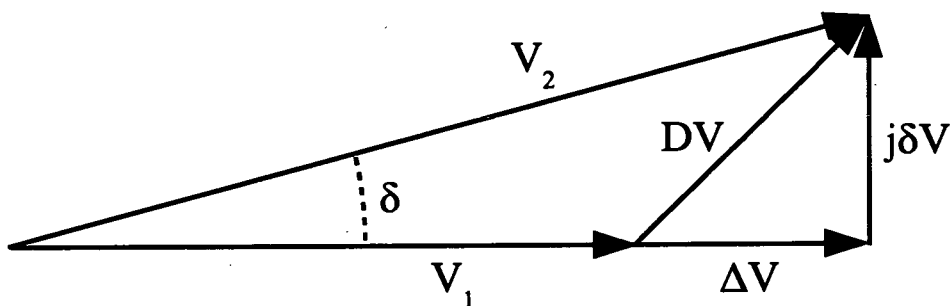

**Figure 2.5:** *Vector diagram of the two-bus system*

According to (2.13), the real and imaginary parts of the voltage rise in this figure  $\Delta V$  and  $j\delta V$  respectively are given by:

$$\Delta V = \frac{RP_B + XQ_B}{V_2}, \quad (2.14)$$

and

$$\delta V = \frac{XP_B - RQ_B}{V_2}. \quad (2.15)$$

The imaginary component of the voltage rise  $j\delta V$  in this diagram has been exaggerated

as it is normally very small relative to the real part  $\Delta V$ . This is because in distribution networks  $R$  is high (and comparable to  $X$ ). For the same reason Equation 2.13 is often simplified to:

$$DV = \Delta V = \frac{RP_B + XQ_B}{V_2} \quad (2.16)$$

In weak distribution systems, the high  $X/R$  ratios typical in the transmission network are replaced with  $X/R$  ratios dominated by resistance. Therefore the DNs are more vulnerable to  $RP/V$  than to  $XQ/V$  terms in the voltage rise, and this has commercial implications as the voltage limits are easily reached with small increases of the generator's output.

### 2.4.1 Illustration of the Effects of Conductor Sizing

The voltage response on the load bus of the two-bus system of Figure 2.4 to increasing load is shown in Figure 2.6. In this example the line has been modelled as a  $1km$  long feeder consisting of the three alternative conductor types presented in Table 2.1. The load is increased from zero to  $10MVA$  at 0.9 power factor and there is no generation.

The effect of different conductor sizing is apparent in this graph. This example shows that selection of the smaller conductor type (ACSR 34/6) would clearly lead to undervoltages well below the  $-6\%$  statutory limit, while the next size (ACSR 54/9) would just reside within the limit. It should be noted that in reality none of these two types would be selected as both of them have lower power transfer capacity, with a thermal limit of  $7.4MVA$  and  $9.9MVA$  respectively. Use of conductor type AAC 132 would give acceptable voltage results and would also be able to cope with the higher power transfer.

Figure 2.7 shows the effects on local voltage of adding a distributed generator on the load bus of the same two-bus system. In this example the local load was held constant at  $10MVA$ , 0.9 power factor and the generation increased from zero to  $25MVA$  ( $PF = 0.9$ ).

While generation was below the local demand, voltage remained below  $1.0pu$ . With

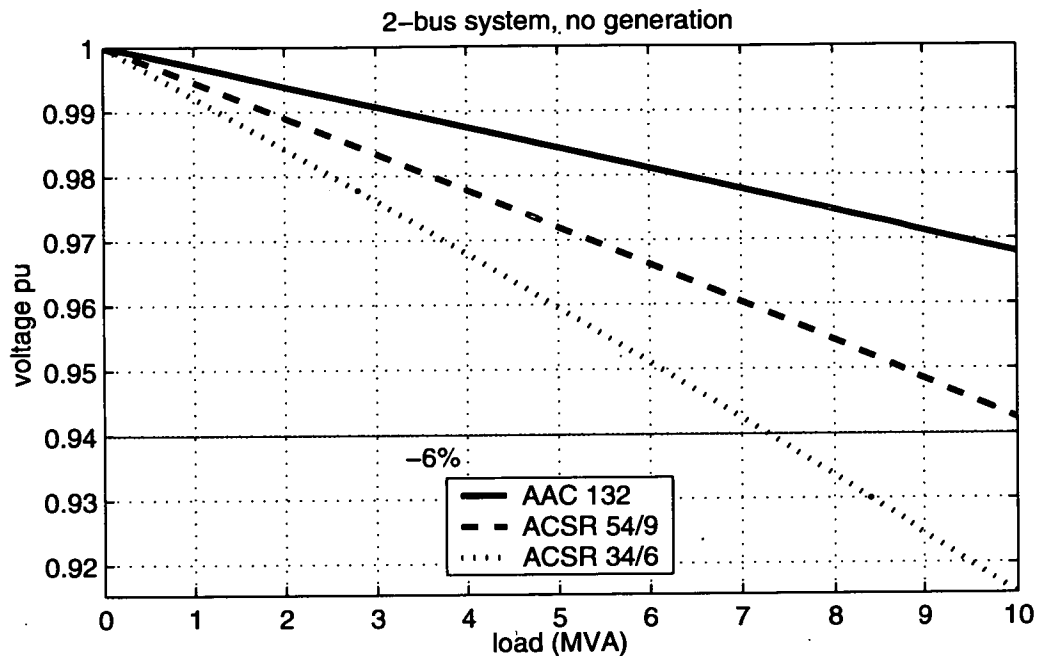

Figure 2.6: Voltage drop due to load increase on the two-bus system

the reversal of power transfer ( $S_G > S_L$ ) voltage crossed unity for all three conductor types. However, an important observation is that the weaker the line is (i.e higher resistance - lower X/R ratio), the wider the fluctuation becomes. This results in a lower power output from the generator before the statutory limit is violated. With the ACSR 34/6 type the +6% limit was reached at 18MVA (28% below rated DG output), while ACSR 54/9 allowed generation of (22MVA 13% below rated DG output). Type AAC 132 resulted in a voltage well below 1.06pu even for 25MVA generation. The financial implications of this difference are significant. With the current UK wholesale price of approximately 2 pence/kWh for DG, the 28% reduction of output in the case of ACSR 34/6 would incur a reduction in revenue of £3,360 per day for the 25MW generator. Respectively, the loss in the case of ACSR 54/9 would be £1,440/day.

The effects of distributed generation on power losses on the network are depicted in Figure 2.8. As expected, it can be seen that for generation up to the level of local demand the power losses on the line are reduced, to become zero when generation matches the load on the bus.

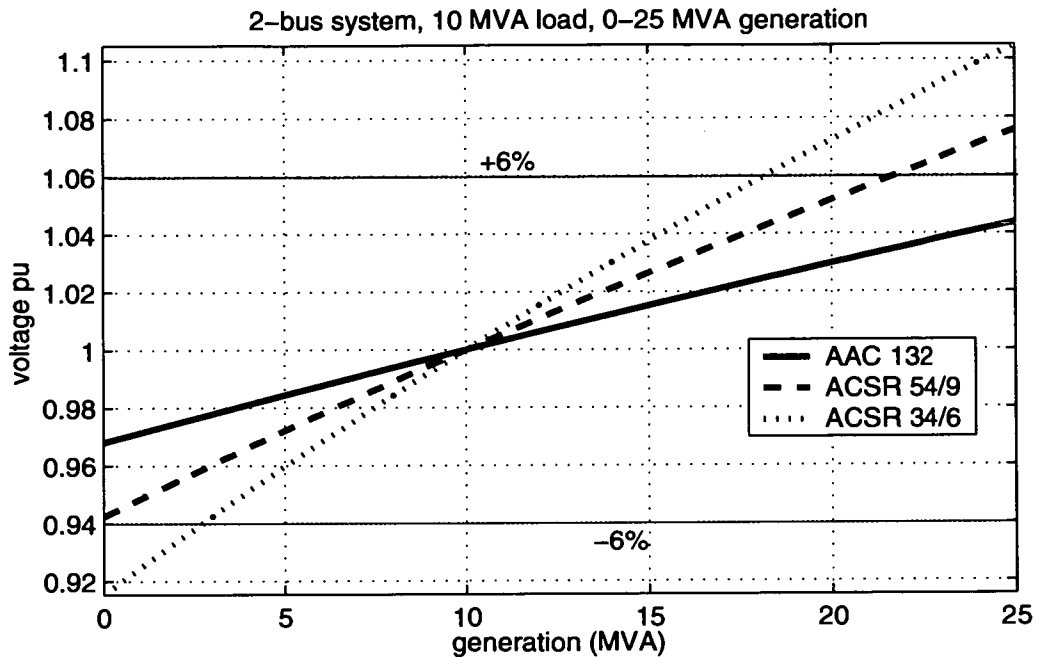

Figure 2.7: Voltage effect of increasing generation on the two-bus system

It should be noted here that this graph shows the power loss ( $P_{loss}$ ) for the simple case that generation power factor is equal to load's PF (*i.e.*  $P_G = P_L$  and  $Q_G = Q_L$ ). In most cases  $PF_G \neq PF_L$  and therefore the losses on the line cannot be zeroed.

Once again it is apparent that the effects of weak lines are more significant. Nevertheless, in all cases connection of a generator in the distribution network will improve system operation as the losses will generally be reduced, unless the generator output is higher than the local demand. Power losses are closely related to thermal loading, as the lost power on the line is dissipated as heat, and each conductor type has a limit on the power that can be dissipated without overheating. Consequently, line losses (together with transformer ratings) determine the maximum power transmission capacity of the feeder.

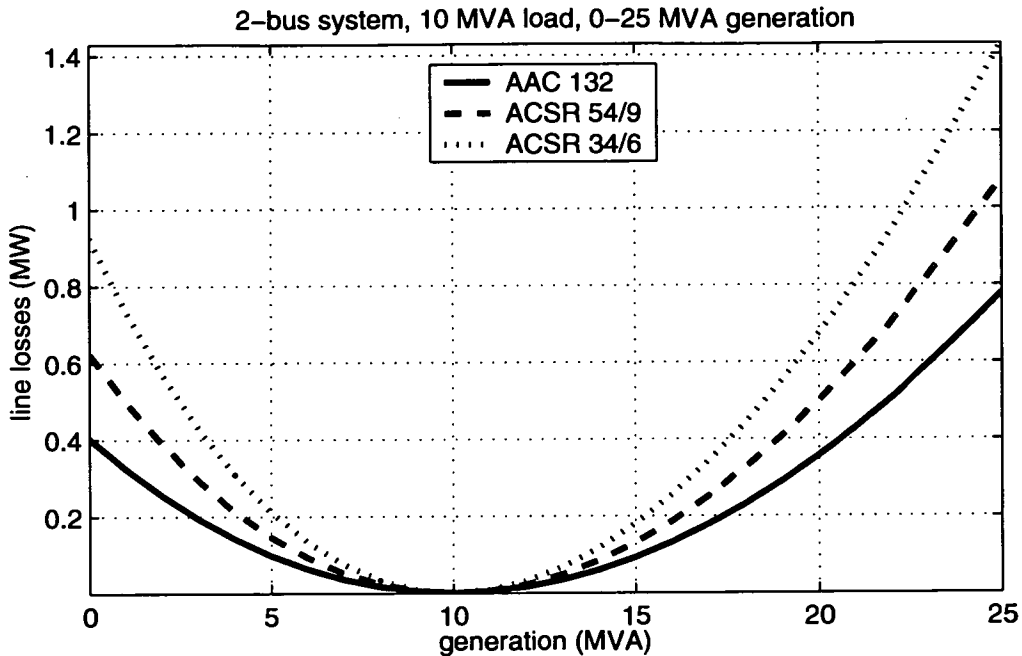

Figure 2.8: Power losses on the line for the two-bus system

## 2.4.2 Illustration of the Effects of Voltage Level

The operating voltage level of a distribution network has a significant effect on the power flows and the voltage variation. Equation 2.7 indicates that for the same power exchange from/to a bus, a higher bus voltage would result in proportionally lower line current. Since the voltage drop on the line is proportional to current (Equation 2.9), a high operating voltage is desired in order to reduce current and voltage fluctuations with varying power flows. This is depicted in Figure 2.9.

The excursion is significantly wider (and unacceptable as it crosses the  $\pm 6\%$  margins) for the 11kV system. It is shown that in the modelled system the highest power output that could be safely accommodated using an 11kV line would be 20MVA. In monetary terms this would mean a £2,400 reduction of revenue per day for the 25MW generator, assuming it can otherwise generate at capacity for 24 hours a day. Deviation decreases with operating voltage and the smallest is experienced for the 33kV system. The reduction of line current with increasing system voltage will also lead to lower losses as  $P_{loss} = \Re(\bar{I} \times Z_{line})$ . This is illustrated in Figure 2.10.

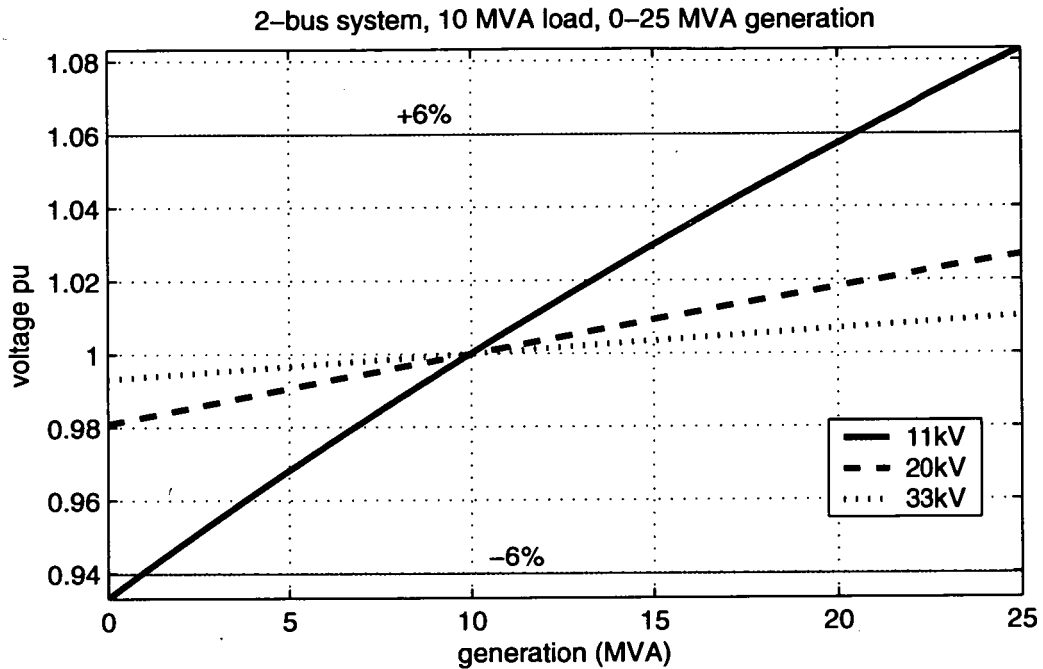

Figure 2.9: Voltage variation at the load bus of the two-bus system for type ACSR54/9 conductor and for three operating voltage levels

## 2.5 Voltage Variation in the Distribution Network

Typically, distribution systems consist of long, radially tapered feeders such as the one shown in Figure 2.1. Assuming that the transformers operate at a fixed tap, in such a system the bus voltages in per unit are derived from the equation:

$$\overline{V}_{n+1} = \overline{V}_1 - \sum_{k=1}^n \frac{(R_k + jX_k)(P_{k+1} - jQ_{k+1})}{V_{k+1}^*} \text{ pu} \quad (2.17)$$

As Equation 2.17 shows, the distributed loads (as well as the loading of each branch) affect the voltage profile across the feeder. A common way for network operators to tackle the voltage drop problem is to raise the voltage at the Bulk Supply Point (BSP) and therefore throughout the whole feeder. Table 2.3 shows the electrical data of an example network with the same topology as the one in Figure 2.1. The voltage profile across that network is presented in in Figure 2.11.

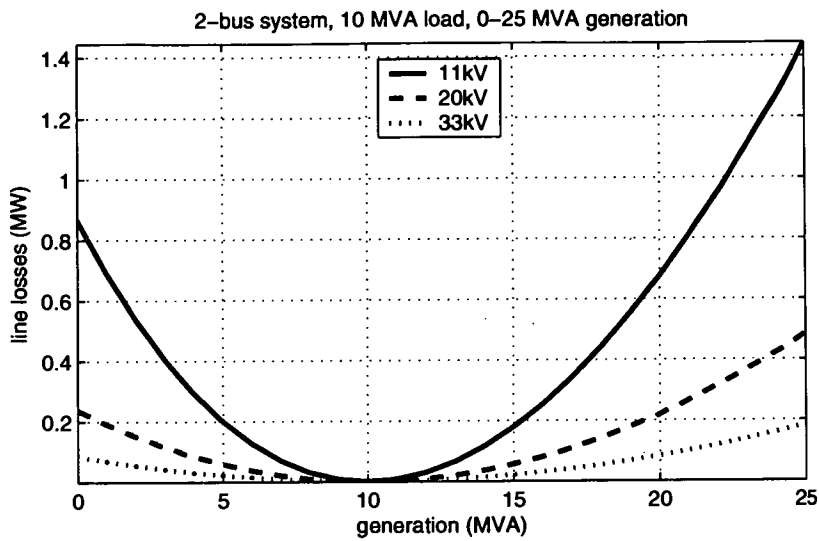

Figure 2.10: Power losses on the line for three operating voltage levels

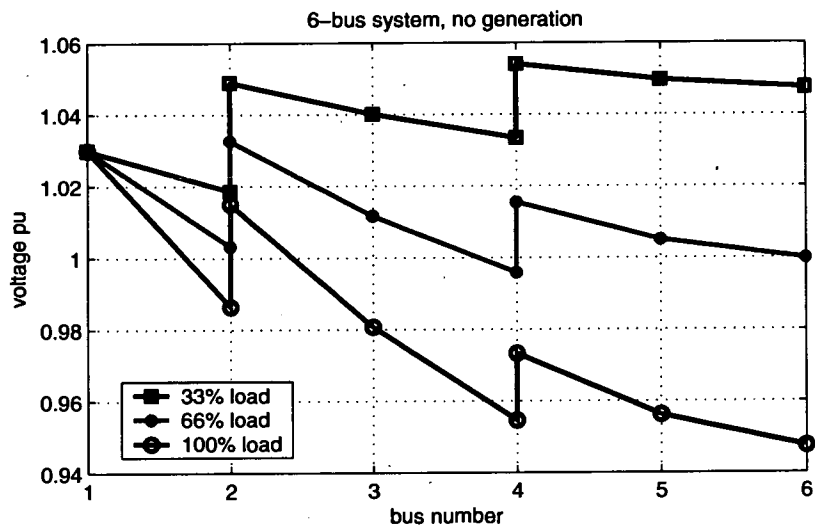

Figure 2.11: Voltage profile of the six-bus system of Figure 2.1 with no embedded generation

The voltage at the BSP was selected to be 3% above the nominal voltage of 11kV to compensate for the voltage drop along the long line. Two transformers were installed to serve the same purpose at positions further down the feeder. As shown in Figure 2.11 the voltage variation for three different load levels (100%, 66% and 33% of the maximum)

System voltage	11kV
Conductor type	ACSR 54/9
$R_{km}$	0.536 $\Omega/km$
$X_{km}$	0.4 $\Omega/km$
Branch length	1km
$T_1$ ratio	+3%
$X_{T1}$	0.0363 $\Omega$
$T_2$ ratio	+2%
$X_{T2}$	0.0363 $\Omega$
Loads	1.5MVA each
Embedded Generator	2MVA

Table 2.3: Electrical data of the network of Figure 2.1

is just within the statutory limits. Addition of an embedded generator at the farthest bus of the feeder would raise the voltage of all the buses above the +6% limit for the low load case as shown in Figure 2.12.

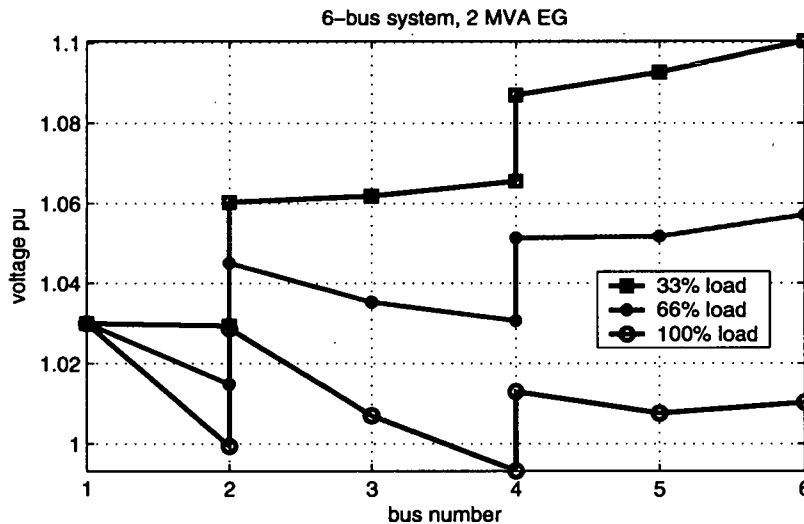
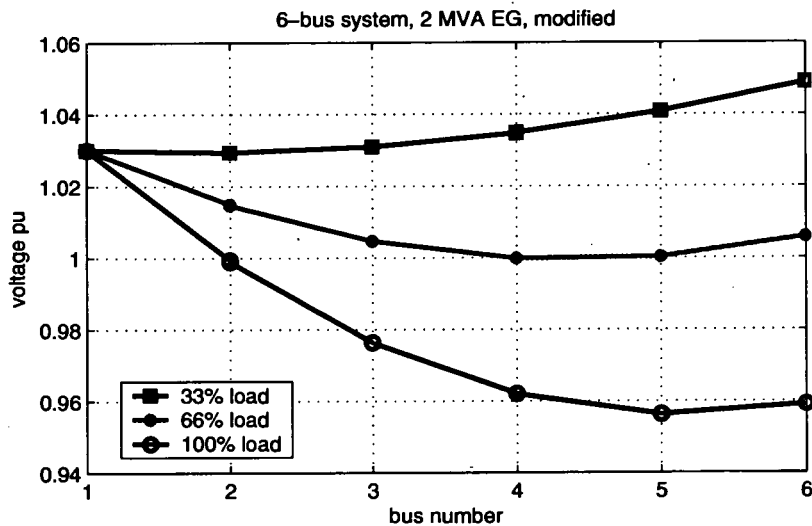

Figure 2.12: Voltage profile of the six-bus system of Figure 2.1 with 2 MVA of embedded generation on bus 6

The problem could be resolved by readjusting the tap positions on the transformers to 1.0 or less as shown in Figure 2.13. However, since an embedded or renewable generator is inherently intermittent, the risk of undervoltages in case of an output reduction (or

even complete disconnection) would be greatly increased.

It should be noted here that for the purpose of these simulations, the BSP was represented by the slack bus. In a real network, BSP is the point of connection of the local distribution system to the transmission grid. However, in the Scottish network, the BSP is often considered to be at 33kV, or (in some remote, low demand areas) even at 11kV.



**Figure 2.13:** *Voltage profile of the six-bus system of Figure 2.1 modified to accommodate 2 MVA of embedded generation on bus 6 (transformer 1:1)*

## 2.6 Voltage Control in the Distribution Network

Control of voltage in a power system is generally performed according to a three-level hierarchical structure. The reasons of using such a mode of control are the size, structure and complexity of the system, as well as the difficulty of collecting and managing the amount of information needed to control such a system from a central location. A system of the size of a distribution network may contain areas with conflicting objectives and in need of different methods of control. A hierarchical scheme can be divided into sections, each with its own control strategy, performed by a dedicated controller. This way the computational burden is also reduced.

The three levels of control of a power system are primary, secondary and tertiary. *Primary control* involves the second by second (instantaneous) control of a generating plant using its governor, Automatic Voltage Regulator (AVR), Power System Stabiliser (PSS) etc. to regulate voltage and power output in a safe and acceptable manner during steady-state and transient operation of the system. *Secondary control* ensures that the steady-state voltage profiles in the controlled area are within the statutory limits of quality of supply. Secondary control is performed by inductors, capacitors and more rarely synchronous and Static VAr Compensators (SVCs) installed throughout the network. All these devices regulate voltage by adjusting the amount of reactive power exchanged with the power system. OLTC transformers are also utilised for (direct) secondary voltage control. Finally *tertiary control* ensures an optimal voltage profile of the system and coordination of the tertiary control mechanisms according to safety and economic criteria. Tertiary control is generally performed centrally on large transmission networks in a time frame of tens of minutes, by sending commands to the generators to adjust their operating point according to system's estimated requirements.

In this work it is proved that the distributed generators themselves can be used for tertiary voltage control.

## **2.7 Further Effects of Increased Generating Capacity within the Distribution Network**

It is well understood that voltage rise is the number one issue concerning the increasing generating capacity within distribution networks. However, there is a series of other significant obstacles that are associated with distributed generation.

As already discussed, distribution networks were designed for unidirectional power flow from the heavily reinforced transmission system to the consumer, via radial-feed overhead lines. Connection of generators at the former receiving-ends will under certain circumstances cause severe situations such as undesirable function of automatic control voltage equipment, increment of fault levels, effects on system protection and reduction

of system stability [16, 20, 21].

Connection of a DG to a distribution network will increase the fault levels everywhere, but most in the neighbourhood of the connection point. If the fault levels before the connection of the DG are already close to the design limits, the fault contribution of the DG may increase them to unacceptable levels. Towards the remote ends of the distribution network, the fault levels are lower and the problem becomes more apparent [2, 22].

Distributed generation schemes based on synchronous generators can both export and absorb reactive power and can therefore cause a steady state voltage rise or fall. Consequently they will generally improve voltage and frequency stability. Induction generators will contribute real power to system thus increasing capacity and hence frequency stability. In case of induction generators, a three-phase fault would inhibit supply of reactive power to the generator, hence its excitation will be discontinued and therefore its contribution to fault currents will be constrained only in the subtransient period [23–25].

A great concern should be dedicated to the islanding issue. In case that the grid supply is interrupted for any reason, any EG connected to the "islanded" part of the network is required to be disconnected for safety reasons. The network voltage must be absolutely equal with that of the EG in terms of amplitude, frequency and phase upon reconnection, otherwise this would lead to asynchronous connection and possibly the destruction of the EG. It should be noted that an induction generator cannot maintain voltage amplitude and frequency. DGs should be reconnected only after synchronisation with the network voltage. Islanding may also cause security issues for the consumers and the repair personnel, or leave the DG without earth. Engineering Recommendation G.59/1 describes the way that an DG should behave in the event of loss-of-mains [2, 23, 26].

Flicker is an engineering expression for short-lived voltage variations in the electrical grid, which may cause connected light bulbs to flicker. A wind turbine connected to a weak grid may cause voltage flicker, as momentary wind variations will cause

fluctuations in power output. When the blades of the turbine pass in front of the tower, the reduction of the torque due to the wind shadowing causes a reduction of real power export and voltage variation with a frequency around 10Hz. Flicker effect is reduced when many wind turbines work in parallel. Moreover, the time-varying output of photovoltaic systems can cause flicker [23].

DGs that incorporate line commutated power electronic converters will introduce harmonics to the system that (depending on converter size and technology) may be outside the statutory limits set out by Engineering recommendation G.77. However, modern inverter-based DGs, such as photovoltaic systems and variable-speed wind turbines use power electronic converters based on Insulated Gate Bipolar Transistors (IGBTs) operating at frequencies that are well outside the bandwidth of the network (typically 10kHz) and thus are filtered out. Harmonics are considered as "voltage pollution" and are the reason for problems like machine and transformer overheating as well as the malfunction of line-commutated rectifiers. Excessive levels of harmonic distortion may require operation of the network at reduced ratings. Engineering recommendation G.77 has been issued by the Electricity Association in order to set the limitations regarding harmonics in the transmission/distribution network. Although large inverter-based plants do not exist at the moment, advances of converter design and power electronic devices may increase their utilisation [23, 27].

## **2.8 Summary**

Distributed renewable generation cannot be dispatched. It can be constrained 'off' (or be asked to reduce its output) by agreement with the DNO by using protection mechanisms that restrict network impacts such as overvoltage at times of low local demand. However, it cannot be constrained 'on', or be asked to increase its output, as it is always depended on the primary energy source. Where the energy source is time varying, power flows and voltage profiles in the network take on a time variation, which if unchecked can lead to violations in supply quality of the voltage. This can be of a high incidence and a highly varying nature where the energy source is extremely

variable such as in the case of wind. Longer term, more steady reversals in power flow can occur with biomass or Combined Heat & Power (CHP) plants that are crop- or heat-led.

The loss of possible generation in a distribution network due to its weakness can be quite significant. To accommodate the power flow characteristics of distributed generation in a weak rural system, where the renewable energy resources are mainly located, within acceptable limits on supply quality either will require the extensive and deep reinforcement of the network to mitigate voltage variation, or a very high level of active management. The investment in new plant could be drastically increased, and operating costs would rise by an order of magnitude. A better understanding of the nature, operation and control of distributed generation is therefore necessary if the set targets of DG penetrations are to be met. The next step would be to devise modes of operation and control strategies for the DGs such that they can contribute to tertiary control. The following chapters discuss the modelling and control of such generators and provide the basis for the proposed control algorithms.

# Modelling of Hydro Generation within the Distribution Network

---

## 3.1 Introduction

During the conversion of energy from its original state (e.g. wind, hydro, chemical) to electricity a number of distinct processes are taking place. In order to build a system model that is both functional and intuitive, the process has to be broken down to several subsystems according to their function, and each of them has to be modelled individually. This chapter discusses the dynamic model of a Small-Hydro Generation Plant that can be used for voltage variation studies. Further, it presents a Distribution Network model based on power flow analysis and its interfacing with the SHG model. A model for an On-line Tap Changing transformer is then presented and the chapter closes with a set of simulation results that illustrate the combined operation of the developed models.

## 3.2 Modelling of Distributed Generation

It is possible to build a system model where its top level block diagram is common for many different types of energy sources and conversion schemes. Use of a standardised top level model allows direct comparisons of the operation and performance of such systems, as well as easy transfer and evaluation of applicable control techniques between them [28]. Such a top level diagram for dispersed generation schemes is depicted in Figure 3.1.

In large scale, conventional power stations the energy source is completely controllable and can be considered constant (e.g. coal, large hydro, nuclear). Therefore, their

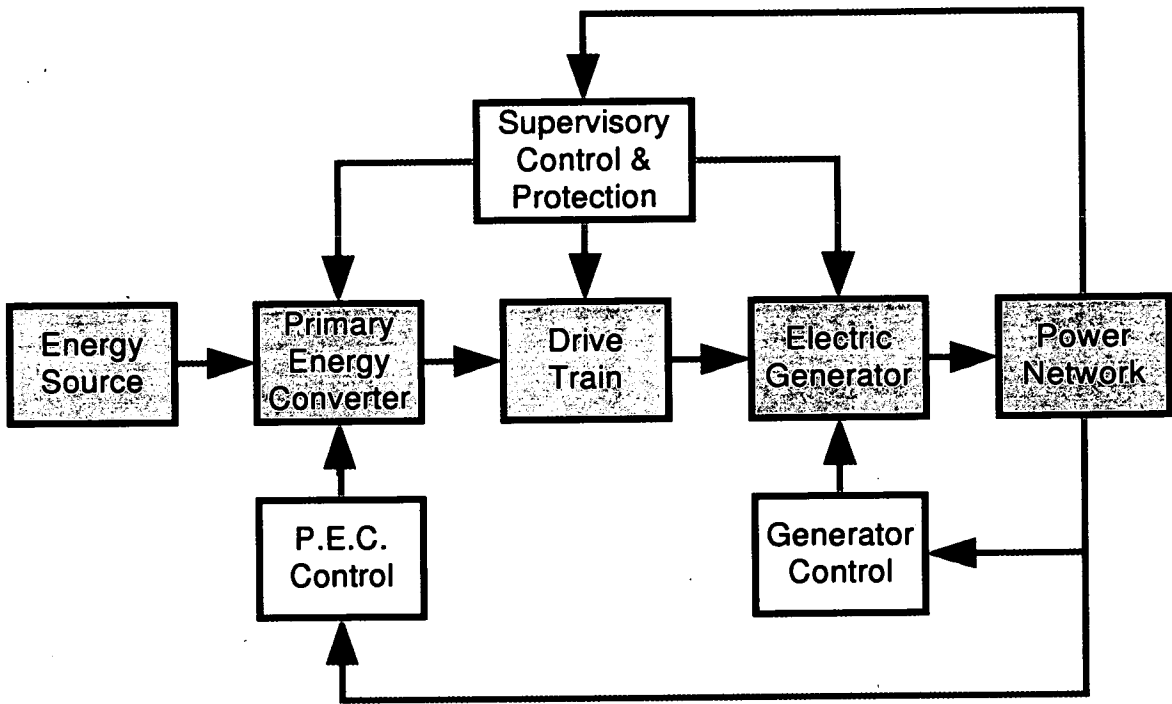

**Figure 3.1:** *Source-to-electricity block diagram of a power conversion scheme. Blue arrows represent energy flow and red arrows represent control signals.*

modelling can be omitted if the simulation focuses on the electrical aspects of the system. This is not the case with dispersed generation, where in most cases the primary energy resource is variable due to natural (wind, water flow, sunlight, sea state), or technical (varying demand on combined heat & power) reasons. Natural resources cannot be controlled and, additionally, in most cases are hard to predict, and the output of CHP plants is often governed by the heat load.

The prime mover translates the energy from its original form to rotational speed (torque) in order to drive the generator. This rotational speed can be variable, and well out of the operational range of the generator. Large wind turbines rotate at a speed of about 25 rev/min maximum and a gas or steam turbine can operate at up to several thousand rev/min. This speed has to be matched to the optimum value for the generator, which depending on its pole pairs number can be 3000 rev/min or less for a 50 Hz power network. This job is done by the drive train, which can be a constant ratio gearbox.

The electric generator in dispersed generation schemes is typically a Synchronous, Squirrel Cage Induction, or Doubly-Fed Induction Generator. The generator controller regulates one or more of the real and reactive power, the speed and the voltage. The primary energy converter is also used to regulate the mechanical power and/or the rotational speed of the generator. The supervisory control performs high-level control on the system in order to optimise the performance of the system as a whole and the protection systems are there to disconnect and lock the generator in case of emergency. Finally, the power network model includes all the components of the distribution system and can have varying levels of detail, depending on the type of simulation.

A model of a generator (and in general any component of the power system) can be categorised according to the time frame it is operating in. In that respect, there are three categories of models, namely steady-state, transient (dynamic) and sub-transient. Table 3.1 shows the possible applications for each type of DG model [29].

Model Type	Type of study
Steady-state (static)	Load and power flows
	Voltage variation
	Energy capture assessments
	Short-circuit studies
	Supervisory control design
Transient (dynamic)	Transient stability
	Small-signal stability
	Transient Response
	Low-level control
	Optimisation
Sub-transient	Start-up transients studies
	Load transients studies
	Fault operation
	Harmonics and sub-harmonics studies
	Control of power electronics
	Detailed optimisation

**Table 3.1:** *Possible applications of dispersed generator models in the three time frames*

Selection of the correct model for each type of study has a very high importance. Selecting a model of higher order than needed will increase simulation times without

offering more information, and a lower order model will generate suboptimal and/or erratic results [30, 31]. The static model of a dispersed generator is used in all steady and quasi-steady state analyses such as load and power flows (power delivery and voltage variation studies) as well as assessments of energy capture and calculation of fault levels. The static model is very basic and consists of a pure voltage source, a voltage and real power source, or a real and imaginary power source, depending on the type and mode of operation of the generator [32]. In each case the respective parameter(s) is (are) constant or adjusted according to the control strategy of the generator.

The transient model of a dispersed generator is one step more detailed and is used for studies that involve system dynamics such as small-signal stability and dynamic response to faults, as well as optimisation of controllers.

Finally the sub-transient model is of higher order and is needed for non-fundamental frequency analysis, short-lived transient effects such as the ones that occur during faults, generator start-up, power electronics simulation and control, and low-level controller design and optimisation. Study of such phenomena is not an object of this work and therefore sub-transient models will not be discussed.

### **3.3 Small Scale Hydro Power Generation**

Small-scale Hydro Generators (SHGs) convert the kinetic energy of flowing water to electricity. Obviously, SHGs can only be built at places where adequate water flow is available, but if the resource exists they can generate clean and reliable energy as the technology is more mature compared to other RES such as solar and wind. On the other side, land costs and infrastructure usually raise the initial expenditure [11]. Additionally, an SHG plant can have minimal environmental impact if carefully designed. It can provide an alternative source of energy to remote loads, and due to its simple construction can be a viable option for rural electrification in many developing countries [33]. There is not a clear threshold between 'small' and 'large' Hydro Generation, but for this work anything less than 10 MW will be classified as 'small'. Mini- (mHG) and micro- ( $\mu$ HG) Hydro Generation installations are defined

by unit capacities of above and below 100 kW respectively and are usually connected to the LV network. The total UK capacity of technically and financially feasible sites was estimated to be approximately 240 MW [34]. At the end of 2002, a total capacity of 194 MW was installed [14]. Figure 3.2 illustrates the basic diagram of an SHG installation.

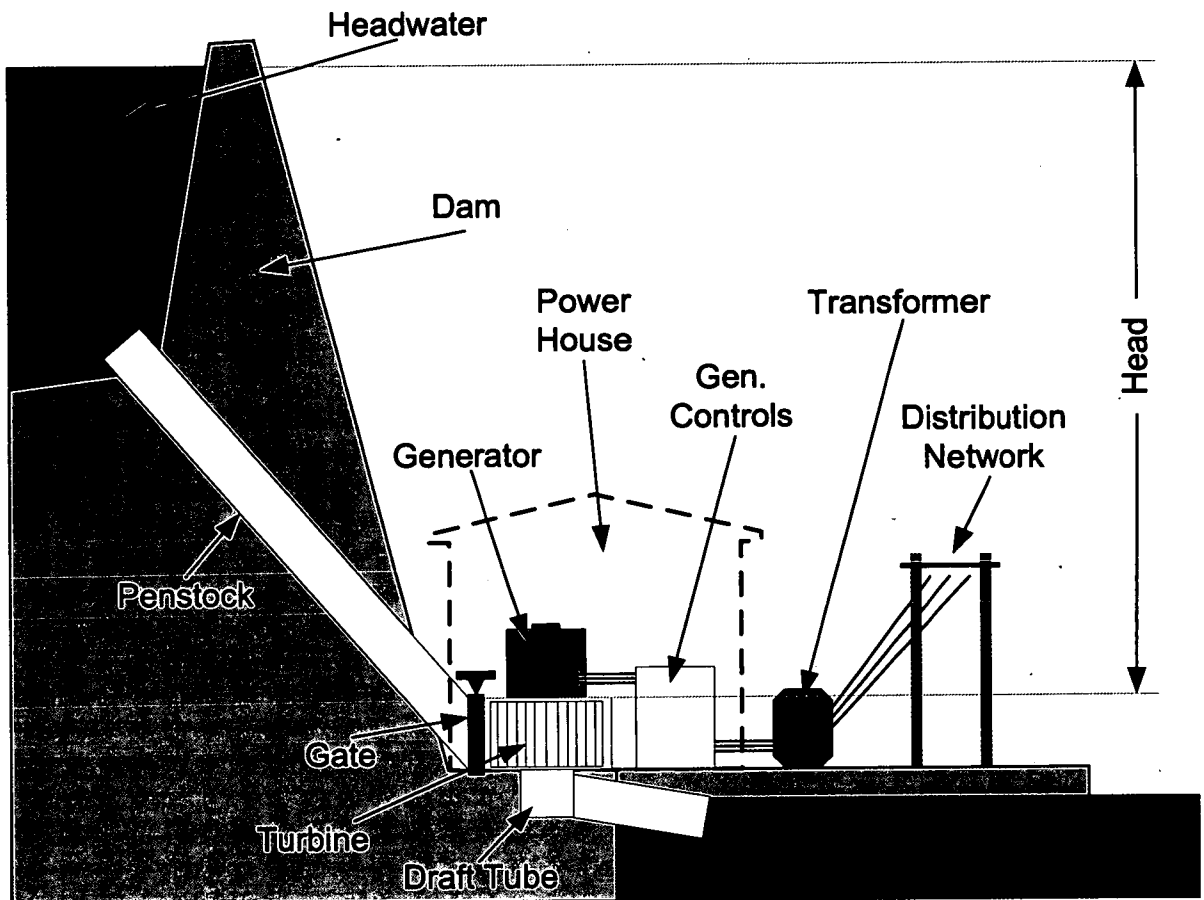

**Figure 3.2:** *Diagram of a Small Hydro Generator Installation.*

### **3.3.1 Hydro Turbine Selection and Modelling**

As water flows downstream in a river (or within a penstock), its potential energy is transformed to kinetic energy. The transitional kinetic energy of the water is then transferred as rotational kinetic energy to the hydraulic turbine, and the water exits with a lower energy content. In a Francis (reaction) turbine water enters the turbine

tangentially through guide vanes (or gates) and exits axially. The guide vanes regulate water flow (and therefore output power) by increasing or decreasing the cross-sectional area of the gate.

The shaft output power is given by Equation 3.1 [35].

$$P = \rho \times g \times H \times Q \times \eta \quad \text{Watts} \quad (3.1)$$

where:  $\rho$  is the density of water ( $1000\text{kg}/\text{m}^3$ );  
 $g$  is the acceleration due to gravity ( $9.81\text{m}/\text{s}^2$ );  
 $H$  is the hydraulic head in metres;  
 $Q$  is the volume flow rate ( $\text{m}^3/\text{s}$ ); and  
 $\eta$  is the turbine efficiency.

From the equation above, the two variables that affect output power are the hydraulic head  $H$  and the volume flow rate  $Q$ . There are a number of different turbine types and their efficiency (and therefore their appropriateness for a particular site) is defined by the available operating head. Because energy density in the water varies with head, for lower heads a larger volume of flow is needed. Therefore it is clear that the hydraulic head defines the turbine type, physical size and mechanical power output. The water flow, and hence the torque of the generator is controlled by the governor. The most common turbine types are the Pelton wheel (impulse category), the turgo-impulse and the crossflow type (part impulse, part reaction), the Francis and the Kaplan types (reaction category) and finally the tubular and the bulb types [34]. Table 3.2 shows the head range of each turbine type.

### **3.3.2 Electric Generators for SHGs**

The most common generator type in SHGs is the synchronous machine. Only in very small installations (mHGs and  $\mu$ HGs) are induction generators (IGs) utilised, and only when the generator is connected to the grid, which provides steady voltage and frequency, as when stand-alone, the induction generator's voltage and frequency vary

<b>Turbine Type</b>	<b>Head Range (m)</b>
Pelton	100 - 1400
Turgo	10 - 300
Crossflow	60 - 300
Francis	50 - 400
Kaplan	10 - 50
Tubular	4 - 20
Bulb	2 - 30

**Table 3.2:** *Types of hydro turbines and their head ranges*

with load and mechanical power input. Otherwise induction machines are an attractive option due to their robustness and cost-effectiveness. Another disadvantage of IGs is their inability to control power factor as the relationship between their real and reactive power output cannot be regulated. Although not widely used at the moment, recent developments on doubly fed induction generators (DFIGs) are expected to assist the utilisation of them in small hydro schemes.

When a synchronous generator is used standalone, the generated voltage is held constant by an Automatic Voltage Regulator (AVR), which directly or indirectly controls the magnetising (excitation) current for the rotor field. The operational frequency is determined by the rotational speed and the number of pole pairs. When connected to a network, a synchronous generator can independently regulate its real and reactive power by adjustment of its mechanical power input and excitation respectively.

### **3.3.3 Turbine - Generator Control**

There are three types of excitation systems and two types of governors. The Synchronous Generator in SHG installations can be shunt or separately excited, and there are also some (small) SGs that have a permanent magnet mounted on the shaft which provides the required EMF to the stator. Shunt excited generators do not need external supply for their excitation and therefore are ideal for off-grid plants. However, the excitation voltage is dependent on the stator voltage and therefore a sudden change of the load will induce a transient to the excitation, which may destabilise

the machine. Separately excited SGs can overcome this problem, but at the cost of requiring an external power supply.

A top-level block diagram of the developed model is shown in Figure 3.3. In the following sections its constituent blocks will be discussed.

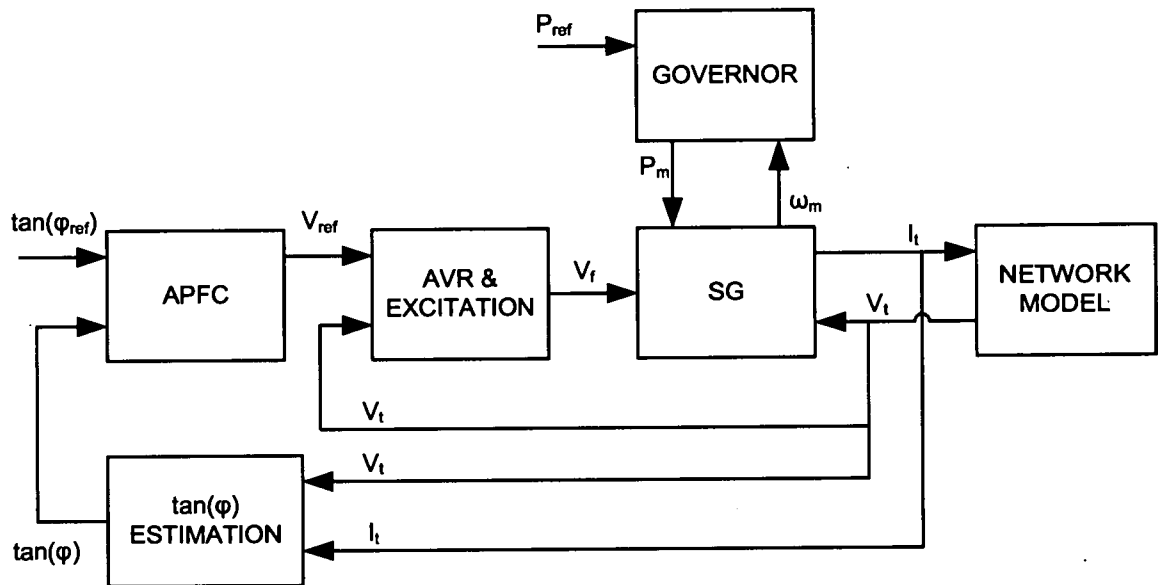

**Figure 3.3:** *Top-level block diagram of the developed model for the small-hydro plant*

### 3.4 Hydraulic Governor Model

The gate opening input of the hydraulic turbine has to be continuously controlled to react to load or turbine mechanical power (input) changes, otherwise the generator's output power would vary accordingly. This is performed by the speed governor, which measures the machine speed and adjusts the gate opening (and therefore the power input) to compensate the variability of the source or the load. Modern governors are electronically controlled, but due to the high associated forces there is a need for a combination of pneumatic, hydraulic and/or mechanical subsystems to assist gate control [36]. The block diagram of a Woodward-type governor [37] is shown in Figure 3.4 below.

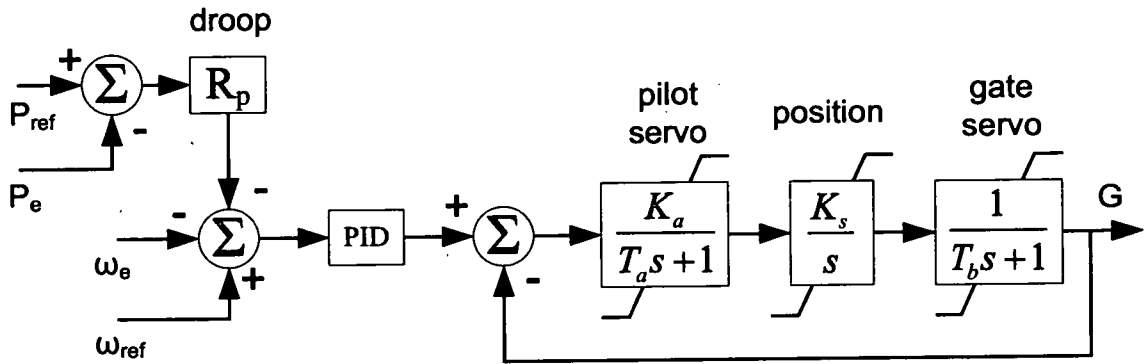

Figure 3.4: Block diagram of the hydraulic governor

In "island operation" (generator and local load not connected to a larger network), or during startup of the generator (pre-synchronisation), the governor is regulated by means of a feedback loop that provides a rotational speed error signal and a power error signal with a droop characteristic (if there are multiple generators running in parallel). When the generator is connected to the network, the speed error signal is disabled (since the generator is synchronised) [38,39]. These error signals are fed to a Proportional-Integral-Derivative (PID) controller. The proportional part of the PID controller amplifies that error signal, thus accelerating the correction. However the higher the proportional term, the worse the stability of the system is. It is impossible to eliminate steady state error by pure P-control, as an error signal is always needed for the controller to produce a non-zero output. The integral action of the PID can assist in eliminating the offset error by providing an output proportional to the accumulated error signal over time. The hydraulic turbine is a non-minimum phase system, which means that the initial response is opposite to that of the gate position. This can be physically reasoned by the fact that a sudden opening of the gate would cause a reduction of the pressure across the penstock. However, due to water inertia the flow will not change immediately. As power is the product of flow times pressure, the initial power would be reduced. Then the water flow would accelerate with a time constant  $T_w$  until the turbine power has reached the steady state level for that gate opening. The derivative action of the PID controller mitigates that effect by boosting the short-term response to sudden load changes. The overall transfer function of the PID controller is

given by Equation 3.2:

$$C(s) = K_P + \frac{K_I}{s} + \frac{K_D \times s}{T_D \times s + 1}, \quad (3.2)$$

where:  $K_P$  = proportional gain,

$K_I$  = integral gain,

$K_D$  = derivative gain,

and  $T_D$  = derivative filter time constant (s).

An additional error signal derived by the difference between reference and electrical power ( $P_{ref}$  and  $P_e$  respectively) is added to the input of the PID controller to provide correction of the power mismatch. In order to ensure stable operation and load sharing among several generating units, a droop characteristic is given to the governor. The (steady-state) power droop  $R_P$  is of the range of 0.05 pu. This means that a power deviation of 5% would bring about a 100% change in gate opening and therefore power output. Finally each servo can be efficiently modelled by a first order, limited output transfer function as shown in the block diagram of Figure 3.4. The rate of change of gate position is also limited.

### 3.5 Synchronous Generator Model

The Synchronous Machine (SM) has been used for over a century in industrial and power applications. Many large loads are driven by synchronous motors, and synchronous generators are the cornerstone for power generation. The synchronous machine is also used as a synchronous condenser, to control network voltage by reactive power compensation [38]. Low-speed, salient pole synchronous generators are the most usual option for small hydro schemes [40]. Research on SM modelling was carried out extensively during the 20's and 30's, but more work has been done recently [38]. This section presents the dynamic SG model that will be used in the simulations throughout this thesis. It assumes knowledge of the physical and electrical properties of the synchronous machine that can be found in [38, 39, 41–43].

### 3.5.1 Electrical Subsystem

The mechanical speed  $\omega_m$  of the SG in rad/s is given by:

$$\omega_m = \frac{\omega_e}{pp}, \quad (3.3)$$

where  $pp$  is the number of pole pairs,  $\omega_e = 2\pi f_e$  and  $f_e$  is the network's electrical frequency. Due to their low mechanical speed, small hydro schemes utilise SGs with a large number of pole pairs in order to achieve an  $\omega_m$  equal to  $2 \times \pi \times 50$  (or  $2 \times \pi \times 60$  for the US) rad/s.

The SG has three sets of windings, namely the armature (stator), the excitation or field (rotor) and (for salient pole machines) the damper windings. Power is transferred through the armature winding, while the excitation uses direct current to produce the required magnetic field to induce alternating voltage in the armature. Finally the damper windings provide electrical damping to the frequency oscillations. For the purpose of generator control, it is more convenient to use the  $0dq$  model derived by the 3-phase model using the Park transformation [38, 39]. The main advantage of the  $0dq$  model is that the fundamental frequency is eliminated and therefore all its components are constant and independent of time. In the  $0dq$  model, the three components are perpendicular to each other. The  $d$  axis is aligned with the magnetic flux, rotates with the rotor and axis  $q$  follows it with a  $90^\circ$  lag. In the  $dq$  plane all vector quantities are resultants of their respective  $d$  and  $q$  components according to:

$$\bar{U} = U_d + jU_q, \quad (3.4)$$

where  $U$  can be any vector quantity such as voltage, current, flux etc. The flux linkages of the synchronous generator in the per unit system are given by the following set of equations:

$$\Psi_0 = L_0 i_0 \quad (3.5)$$

$$\begin{bmatrix} \Psi_d \\ \Psi_f \\ \Psi_D \end{bmatrix} = \begin{bmatrix} L_d & kM_f & kM_D \\ kM_f & L_f & L_{fD} \\ kM_D & L_{fD} & L_D \end{bmatrix} \times \begin{bmatrix} i_d \\ i_f \\ i_D \end{bmatrix} \quad (3.6)$$

$$\begin{bmatrix} \Psi_q \\ \Psi_Q \end{bmatrix} = \begin{bmatrix} L_q & kM_Q \\ kM_Q & L_Q \end{bmatrix} \times \begin{bmatrix} i_q \\ i_Q \end{bmatrix} \quad (3.7)$$

In the above equations  $L$  and  $kM$  denote self and mutual inductance respectively, subscripts  $0, d, q$  denote the respective components of the armature,  $D, Q$  the respective components of the damper windings and finally  $f$  denotes the field winding. For balanced and symmetrical systems the zero sequence component of current  $i_0 = 0$ , and since the system is assumed such, Equation 3.5 can be omitted.

The voltage equations of the synchronous generator (also in the  $0dq$  reference frame) are the following:

For the stator:

$$\begin{aligned} v_0 &= -R_a i_0 - \dot{\Psi}_0 \\ v_d &= -R_a i_d - \dot{\Psi}_d - \omega_m \Psi_q \\ v_q &= -R_a i_q - \dot{\Psi}_q + \omega_m \Psi_d \end{aligned} \quad (3.8)$$

For the rotor:

$$\begin{aligned} v_f &= -R_f i_f - \dot{\Psi}_f \\ 0 &= -R_D i_D - \dot{\Psi}_D \\ 0 &= -R_Q i_Q - \dot{\Psi}_Q \end{aligned} \quad (3.9)$$

All quantities in the above equations are in the per unit system. As with the flux equations, the top equation of 3.8 can be omitted. The remaining can be rearranged and written in matrix format:

$$\begin{bmatrix} \dot{\Psi}_{dq} \\ \dot{\Psi}_{fDQ} \end{bmatrix} = - \begin{bmatrix} \mathbf{v}_{0dq} \\ \mathbf{v}_{fDQ} \end{bmatrix} - \begin{bmatrix} \mathbf{R}_a & & \\ & \mathbf{R}_{fDQ} & \end{bmatrix} \times \begin{bmatrix} \mathbf{i}_{0dq} \\ \mathbf{i}_{fDQ} \end{bmatrix} + \begin{bmatrix} \Omega & \\ & \mathbf{0} \end{bmatrix} \times \begin{bmatrix} \Psi_{dq} \\ \Psi_{fDQ} \end{bmatrix}, \quad (3.10)$$

where  $\Omega$  is the rotation matrix and is given by:

$$\Omega = \omega_m \times \begin{bmatrix} 0 & 0 & 0 \\ 0 & 0 & -1 \\ 0 & 1 & 0 \end{bmatrix} \quad (3.11)$$

The instantaneous electrical power  $P$  (under balanced operation) in the per unit system is equal to the air-gap torque  $T_e$  and is given by:

$$P = v_d \times i_d + v_q \times i_q = T_e \quad (3.12)$$

Similarly the reactive power in pu is given by:

$$Q = v_d \times i_q - v_q \times i_d \quad (3.13)$$

The steady state model of the synchronous generator emerges when the dynamic terms of the above equations are removed and the assumption  $\omega_m = 1.0$  pu is made. The resulting equivalent circuit is depicted in Figure 3.5 below.

In the terminal voltage/current vector diagram of Figure 3.5  $X_d$  is the synchronous reactance of the generator. In the per unit system and neglecting saliency,  $X_d = X_q = L_d = L_q$ . From that vector diagram, the basic equivalent circuit for the SG can be derived, and is shown in Figure 3.6. Voltage  $E_d$  in Figure 3.6 is the effective internal voltage of the machine which is equal to the excitation voltage due to the field current.

### 3.5.2 Mechanical Subsystem

The acceleration or deceleration of the machine is proportional to the difference between the mechanical torque  $T_m$  from the prime mover (or to the load, if motoring), which in this case is the hydraulic turbine, and the electrical torque  $T_e$  supplied to (or imported from) the grid. This is mathematically expressed by the following equation:

$$J \frac{d\omega_m}{dt} = T_m - T_e, \quad (3.14)$$

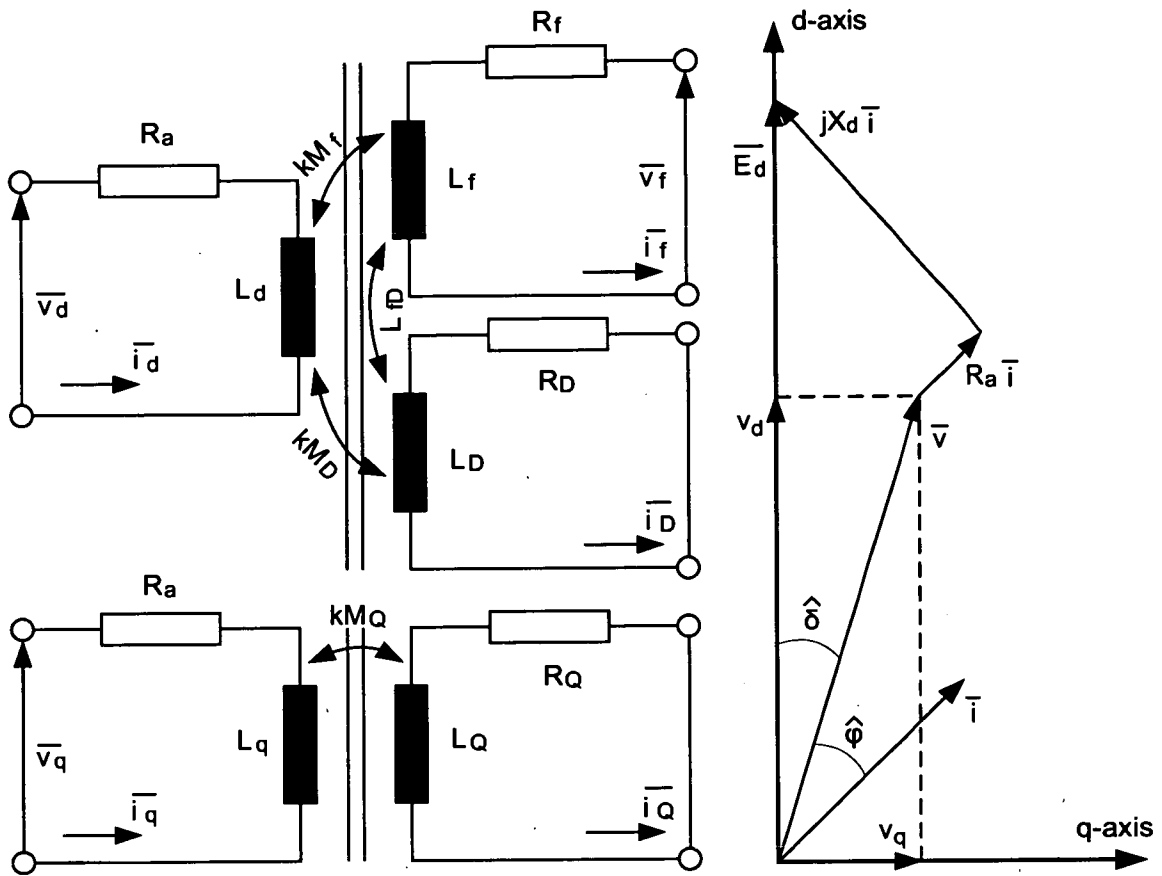
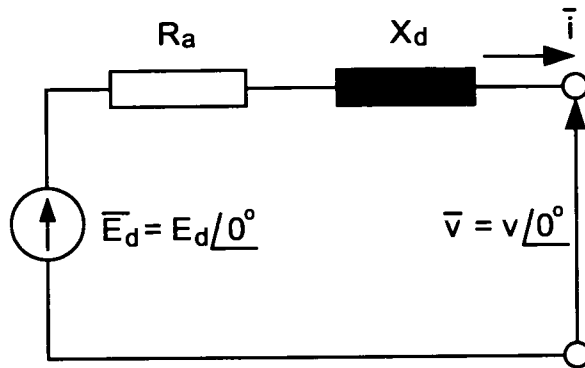

Figure 3.5: Steady state equivalent circuit of the synchronous generator (left) and terminal voltage/current vector diagram

where  $J$  is the sum of moments of inertia of the machine and the prime mover in  $kgm^2$  and  $\omega_m$  is the rotational speed of the rotor in rad/s. When a body rotates, its kinetic energy is equal to  $0.5J\omega_m^2$ . Kinetic energy divided by the base apparent power  $S_{base}$  in VA (equal to rated VA of the machine for simplicity) equals the per unit inertia constant  $H$ , measured in seconds. Thus, Equation 3.14 becomes:

$$\frac{2HS_{base}}{\omega_{m0}^2} \frac{d\omega_m}{dt} = T_m - T_e, \quad (3.15)$$

where  $\omega_{m0}^2$  is the rated rotational speed in rad/s. By setting base torque  $T_{base} = S_{base}/\omega_{m0}^2$  and then dividing Equation 3.15 by  $T_{base}$ , the swing equation for the machine



**Figure 3.6:** Basic steady state equivalent circuit of the synchronous generator with saliency neglected

is obtained:

$$2H \frac{d\omega_m}{dt} = T_m - T_e \quad (3.16)$$

Typical values for the per unit inertia constant  $H$  range from 2 to 4 seconds [38]. Equations 3.6, 3.7, 3.10, 3.12, 3.13 and 3.16 constitute the complete dynamic model of the synchronous generator that will be used throughout this thesis.

### 3.6 Operation and Control of the Synchronous Generator

The main advantage of the synchronous generator is that it has a well-understood, wide-range control over its basic quantities, i.e. terminal voltage, real and reactive power output. Additionally, real and reactive power controls can be individually controlled, allowing easy regulation of its output and power factor. While real power is governed by the prime mover, reactive power (and terminal voltage, when not connected on an infinite bus) is governed by the DC excitation. The Automatic Voltage Regulator (AVR) operates on the exciter according to a pre-defined control objective. This objective can be maintenance of constant terminal voltage, constant reactive power or constant power factor, depending on the level of connection (transmission or distribution) and the applicable regulations or agreements with the network operator.

### 3.6.1 Exciter & Excitation Control

A number of different technologies have been used for excitation of SGs, ranging from DC exciters utilising DC-generators to provide the excitation current, to modern digitally controlled solid state active rectifiers [38, 39, 41, 44]. A basic functional diagram of such a system is shown in Figure 3.7. The excitation control acts on the exciter, which provides the field current (and hence voltage) for the synchronous generator. The feedback loop is closed by the voltage transducer, which measures the terminal voltage that is then compared to the setpoint and therefore an error signal is generated. The excitation system operation has a great impact on the performance of the overall plant, therefore care must be taken to ensure that it is optimally set up and tuned. Bad tuning of the AVR may lead to reduced performance, unstable operation and possibly damaging of the plant [45]. Excitation systems are often complemented by other components such as load compensators, power system stabilisers etc. However, their functionality is beyond the scope of this work and therefore will not be discussed here. Additional information on them can be found in [38, 39, 41, 44, 46].

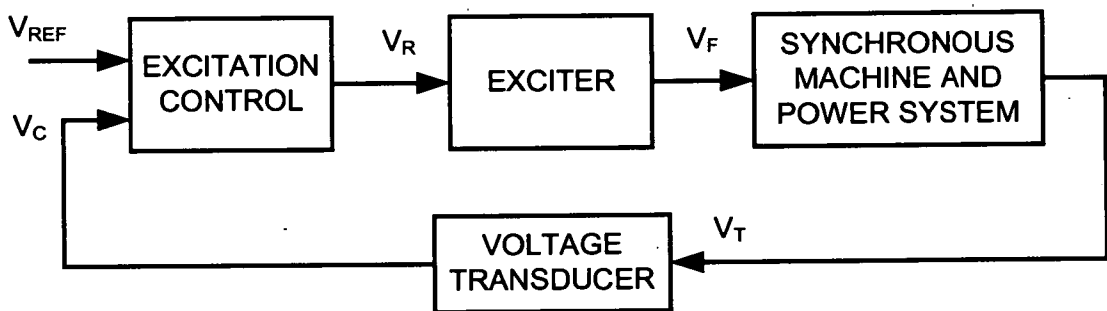

**Figure 3.7:** *Basic functional diagram of excitation system of a synchronous machine*

Additionally, the excitation system contains components such as current and voltage limiters in order to protect the generator and the exciter. IEEE in [44] has issued a recommendation for the modelling of excitation systems. A commonly used AVR / static exciter is type-ST1A. The complete ST1A model can be found in the above document. A simplified version of it (with load compensation and power system stabilisation omitted) will be used here. The block diagram of the simplified ST1A model is shown in Figure 3.8.

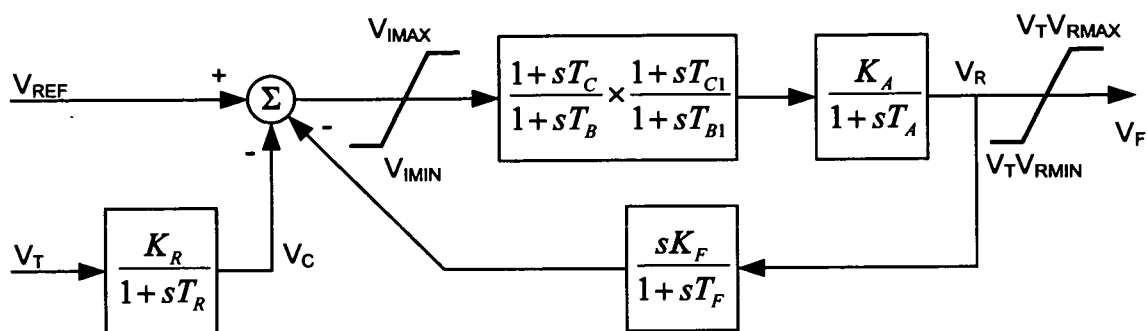

**Figure 3.8:** Block diagram of the simplified ST1A excitation system model

Since the dynamics of the (power electronics based) static exciter are significantly faster than the rest of the system, it can be assumed that exciter's action is instantaneous and hence an exciter block is not included in this model [41]. The main voltage regulator is modelled as a first order transfer function with gain  $K_A$  and time constant  $T_A$ . Its input is supplied by a Lead-Lag compensator with time constants  $T_B$  and  $T_C$ , which provides forward path transient gain reduction. Alternatively, rate feedback stabilisation may be included in the feedback path via the compensator ( $K_F$ ,  $T_F$ ). The feedback loop can be disabled (if transient gain reduction is performed in the forward path) by setting  $K_F = 0$ . Sometimes an extra component for transient gain increase is included in the forward path ( $T_{B1}$  and  $T_{C1}$ , with  $T_{C1} > T_{B1}$ ). This section can also be disabled if not needed, by setting  $T_{B1}$  and  $T_{C1}$  equal to zero.

The error signal that is used to regulate the generator's voltage emerges by subtracting terminal voltage  $V_T$  from the reference  $V_{REF}$ . Before this happens, the former is passed through the transducer/filter (modelled here with the 1st order transfer function ( $K_R$ ,  $T_R$ )) that removes noise and scales the signal to the controller's input range.

The model also makes provision for limitation of the input and output of the excitation system. The input limits are represented by  $[V_{IMIN}, V_{IMAX}]$  and in many cases can be neglected [41]. However, the same document proposes that the output limits  $[V_TV_{RMIN}, V_TV_{RMAX}]$  should always be included in the model. The output limits are proportional to the terminal voltage because ST1A is a voltage source, controlled rectifier bridge system with its excitation power supplied by a transformer connected

directly on the generator terminals. If the exciter employs a fully controlled bridge (as in most cases),  $V_{RMIN} < 0$ . Otherwise the minimum excitation voltage will be equal to zero ( $V_{RMIN} = 0$ ).

### **3.6.2 Automatic Power Factor Controller**

When the generator operates in Automatic Voltage Control (AVC) mode, the voltage reference  $V_{REF}$  is set by a potentiometer or is provided (in modern AVRs) as an output from a computerised supervisory system. This is the standard mode of operation of generators connected to the transmission network. Distributed generators are required by the network operators to operate in Automatic Power Factor Control (APFC) mode except for very few cases that the DNOs allow AVC operation in order to enable generators connected to weak grids to perform voltage support. However, this is expected to happen more often in the future when the capacity of DG will increase. This has to be evaluated carefully because larger capacity SGs can cause AVC equipment on DNO transformers to operate in response.

Automatic power factor control is most easily applied when network impedance is low and when machines can export full capacity without a measurable increase in terminal voltage. SGs are usually loaded immediately after synchronising by increasing the speed setting in the governor, while simultaneously transferring the AVR from voltage control (AVC) for synchronising to power factor control (APFC). Thereafter active and reactive power ramp in constant ratio, up to any load limits. One method of implementing APFC is to include in the excitation system a separate control module that operates on the voltage setpoint of the AVR to hold the phase angle between generator terminal voltage and current constant. A possible configuration for such a system is shown in Figure 3.9. Terminal voltage  $\bar{V}_T$  and current  $\bar{I}_T$  are measured and the instantaneous real and imaginary powers are calculated using Equations 3.12 and 3.13 respectively. From these values the tangent of the voltage-current angle is calculated ( $\tan(\phi) = Q/P$ ) and used as an indicator for the actual power factor. Use of tangent instead of cosine ensures that the input term is always single-valued over the range of control. This value is compared to a reference and the resulting error signal is fed to a PID compensator



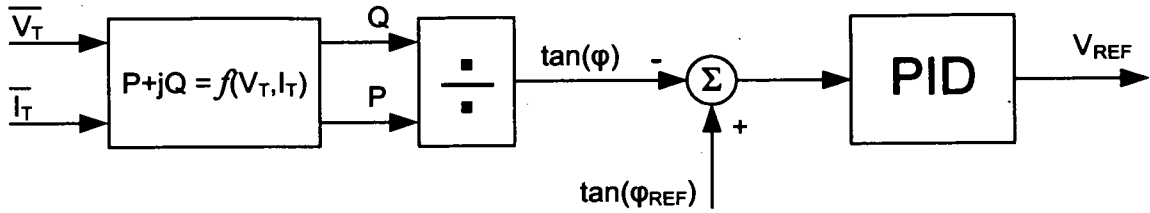

Figure 3.9: Automatic power factor controller block diagram

identical to the one discussed in Section 3.4, described by Equation 3.2. The PID compensator then provides the reference voltage for the AVR of Figure 3.8.

### 3.7 Voltage Regulation Using Transformers with On-Line Tap Changers

As already mentioned, distributed generation did not contribute to voltage regulation until recently. This was mainly performed by transformers with automated tap changing mechanisms installed at the bulk supply points. However, with the increase of distributed generation, transformers with On-Line Tap Changers (OLTCs) are increasingly being used at the points of DG connection in order to mitigate the increased voltage fluctuation due to the existence of the generator [47–52]. The OLTC mechanism acts on the taps on the primary winding of the transformer. The most common mode of operation is Automatic Voltage Control (AVC), where the OLTC regulates the voltage on the secondary winding through a voltage feedback signal. Therefore voltage at the DG busbar remains within the limits set in the OLTC control system. Figure 3.10 illustrates the working of such an OLTC mechanism.

A typical OLTC mechanism operates as follows [53]: First, the terminal voltage  $V_t$  on the secondary winding is measured. The measured voltage is then compared to the preset thresholds for tap action  $V_{min}$  and  $V_{max}$ . A command to raise (lower) the tap position is issued if  $V_t$  is higher (lower) than  $V_{max}$  ( $V_{min}$ ), and if a time longer than the delay setting  $t_d$  has passed since the last tap change, and the tap changer has not

already reached its highest position. The time delay is used as a means to avoid hunting and rapid tap changes that may destabilise the system and cause quick wear-out of the tap contacts.

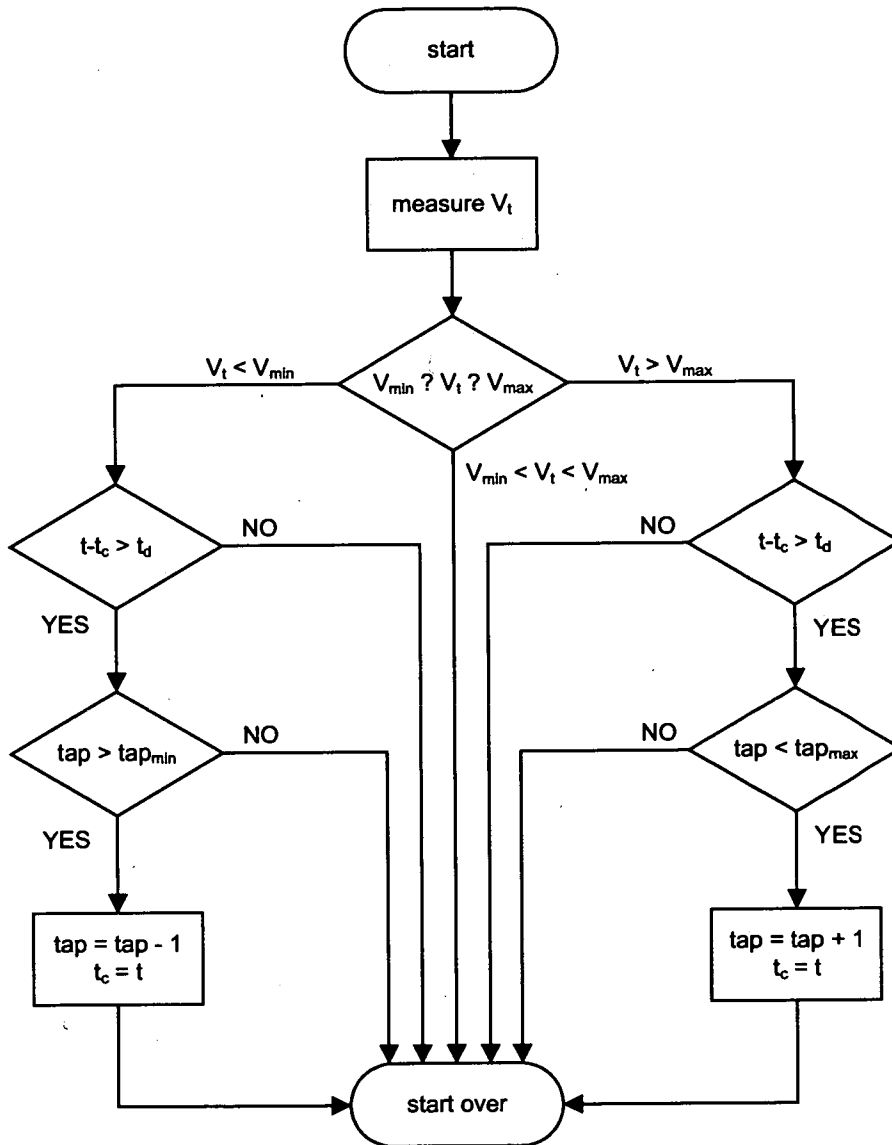

Figure 3.10: Flow chart of the operation of an On-Line Tap Changing mechanism

There are also cases where the transformer is located at another point in the network (usually upstream in the radial feeder) and controls the DG bus voltage by Line Drop/Rise Compensation (LDRC). This is achieved by including a circuit that emulates the impedance of the feeder, and by injecting samples of the measured voltage and

current, the voltage drop (or rise) across the feeder can be "virtually" measured. Then this voltage drop is used as a control signal to the OLTC [54]. The flow chart for the LDRC mode is the same with the one shown in Figure 3.10, with the only difference that measured  $V_t$  is the product of the emulating circuit. The operation of the OLTC mechanism is stepwise. At each tap change, a positive or negative voltage step  $V_{step}$  occurs. In addition, in order to avoid hunting and wear-out of the tap contacts, time delay circuits and voltage deadbands are included in the control system. However, these discontinuities degrade the quality of the controlled voltage by slowing down its response (time delay  $T_d$ ) and reducing its sensitivity (deadband  $V_{max} - V_{min}$ ). In addition, when operating in LDRC mode, the tolerance of the emulating circuit can also worsen the performance of the OLTC [54]. Table 3.3 shows a set of typical OLTC parameters [55].

The OLTC process described in Figure 3.10 was modelled in Matlab using the parameters of Table 3.3. The Simulink block diagram of the OLTC mechanism can be seen in Figure 3.11. In the developed model, the emulating circuit of the LDRC subsystem is assumed ideal. This simplifies the model as the voltage reading can be taken directly from the controlled bus, thus eliminating the need for inclusion of the emulating circuit in the model. However, in reality the emulating circuit is not 100% precise and therefore errors are introduced to the estimations of voltages at remote buses. Consequently, this decreases the accuracy of the control mechanism.

Parameter	Value	Description
$tap_{max}$	7	max. no. of taps above nominal position
$tap_{min}$	-7	max. no. of taps below nominal position
$V_{step}$	0.0125pu	voltage step per tap change
$V_{dmax}$	0.0125pu	high side of voltage deadband
$V_{dmin}$	0.0125pu	low side of voltage deadband
$t_d$	60 s	time delay between tap changes

**Table 3.3:** *A typical set of parameters for an OLTC mechanism*

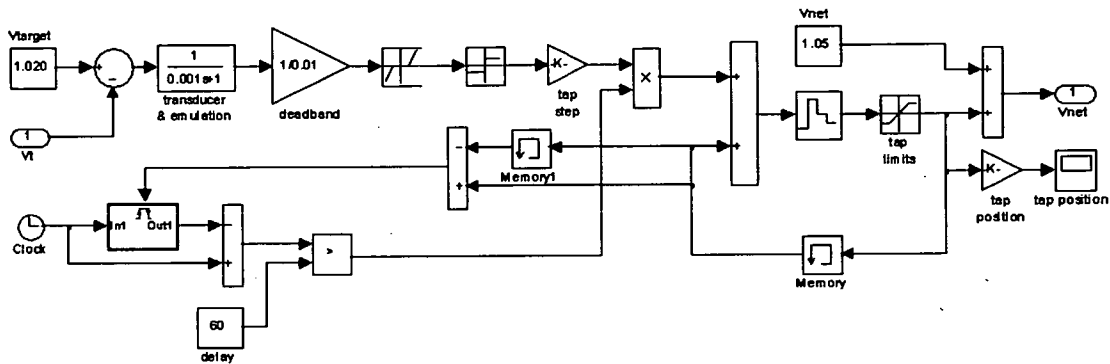

Figure 3.11: Simulink block diagram of the OLTC mechanism

### 3.8 The Synchronous Generator in a Distribution Network and its Operational Limitations

The limiting factors of the operation of a synchronous generator when connected to the distribution network can be divided in two categories: power plant protection and seamless operation of the distribution network. The former are related to the characteristics of the power plant itself, while the latter are imposed by the DNO in order to ensure security and quality of supply. The common way to display the power plant limitations, specifically the P, Q and V limits, is by using the capability diagram of the synchronous generator. A typical capability diagram is shown in Figure 3.12.

Detailed information on the construction of the capability diagram can be found in most power system analysis textbooks, such as [38, 39, 42]. The operational limits of the synchronous generator are drawn in the capability diagram as follows:

- **Stator heating limit:** Defines the maximum apparent power output (MVA) of the generator and is represented by the concentric circles with centre at O and radius  $S$ .
- **Prime mover limit:** Defines the maximum real power output of the generator and is represented by the horizontal lines.

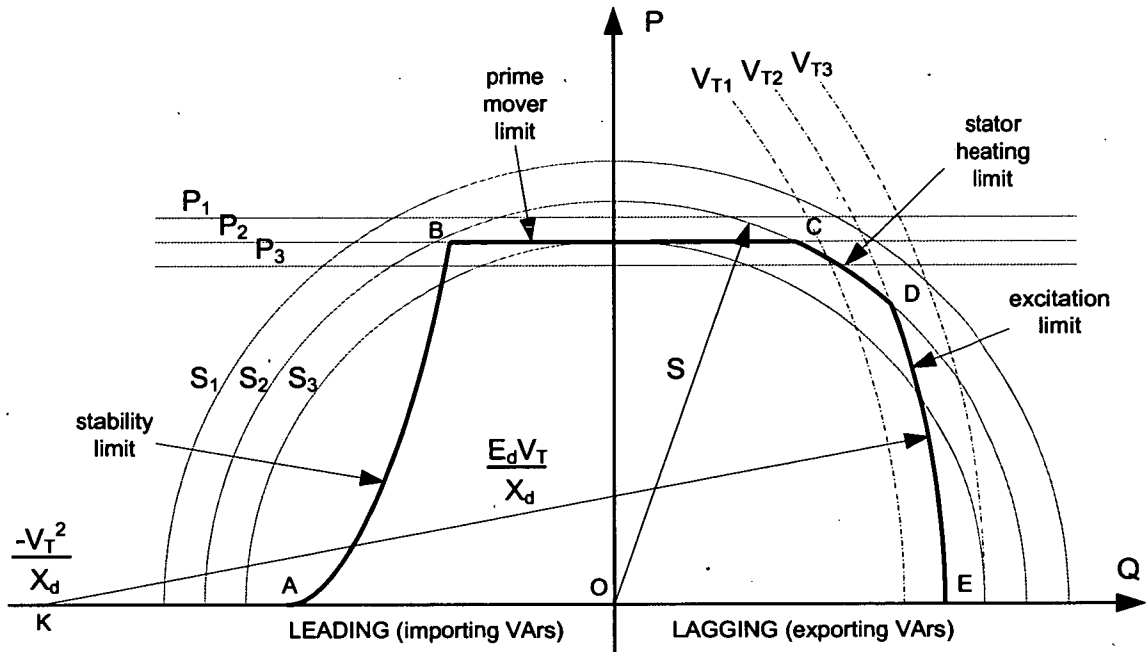
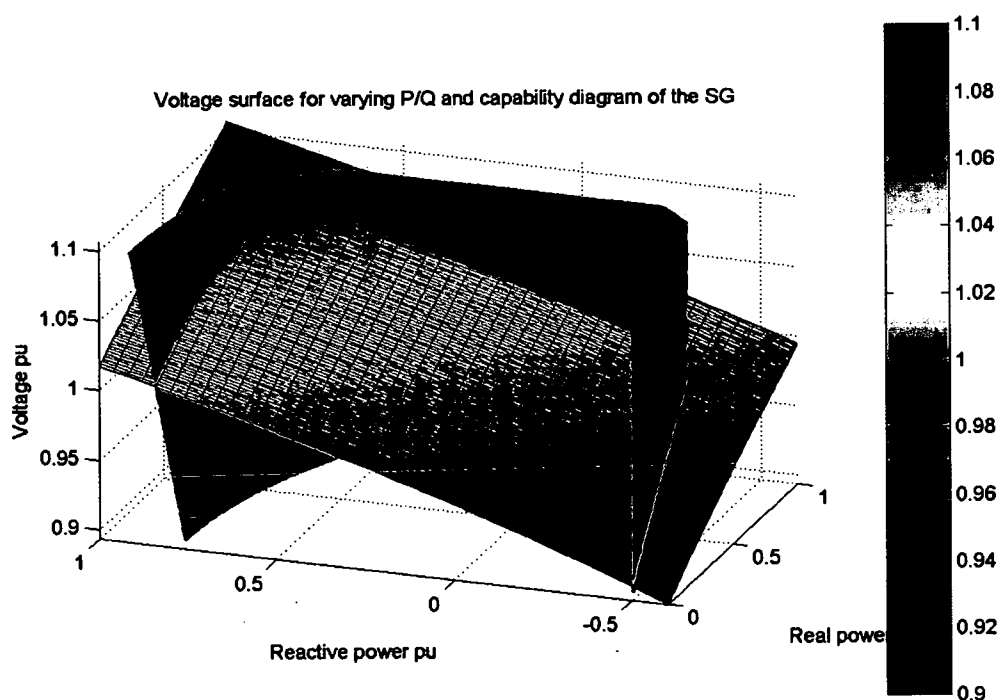

Figure 3.12: Capability diagram of the synchronous generator

- **Excitation limit:** Is defined by the maximum excitation voltage. Its locus is a circle with centre at  $-\frac{V_T^2}{X_d}$  and radius  $\frac{E_d V_T}{X_d}$ .
- **Stability limit:** Defines the minimum excitation, beyond which the generator is at risk of losing stability. It is a function of excitation current and its construction is discussed in [42].

For a given set of  $S$ ,  $V_T$  and  $P_{MAX}$ , the capability diagram of a generator with synchronous reactance  $X_d$  can be constructed, by connecting the pre-mentioned sections of the curve. The resulting curve ABCDE in Figure 3.12 is the capability diagram. It should be noted that for the construction of the capability diagram as discussed above, it is assumed that the generator is connected directly to the infinite grid and any change in real or imaginary power output is not reflected on the terminal voltage. Of course, as already discussed, this is not the case in the distribution network, where terminal voltage  $V_T$  may vary widely with power changes, depending on the network impedance at the point of connection [56]. The capability diagram as constructed above can not be used other than when  $V_{gen} = 1.0pu$ . The result of this fact is that the capability diagram

of a DG cannot be represented in the two-dimensional P-Q plane as in Figure 3.12, and a third dimension to accommodate voltage changes is needed. Figure 3.13 shows the resulting 3D capability diagram for a synchronous generator in the distribution system combined with the voltage surface for varying P and Q (note the change of direction of the Q axis compared to Figure 3.12). The generator convention is used, i.e. power is positive when exported.



**Figure 3.13:** *Combined voltage surface and 3-dimensional capability diagram for a synchronous generator*

In this figure, the radius of the excitation limit (left side of the diagram) is scaled in proportion to  $V_T$  and therefore the "static" capability curve at each voltage level is different. The actual operational area of the DG in this case is the (non-planar) section of the voltage surface that is encompassed by the 3D capability diagram. An important aspect of the capability diagram is that in a real system it is "dynamic", i.e. it changes in time according to demand fluctuations and network reconfiguration. For

of a DG cannot be represented in the two-dimensional P-Q plane as in Figure 3.12, and a third dimension to accommodate voltage changes is needed. Figure 3.13 shows the resulting 3D capability diagram for a synchronous generator in the distribution system combined with the voltage surface for varying P and Q (note the change of direction of the Q axis compared to Figure 3.12). The generator convention is used, i.e. power is positive when exported.

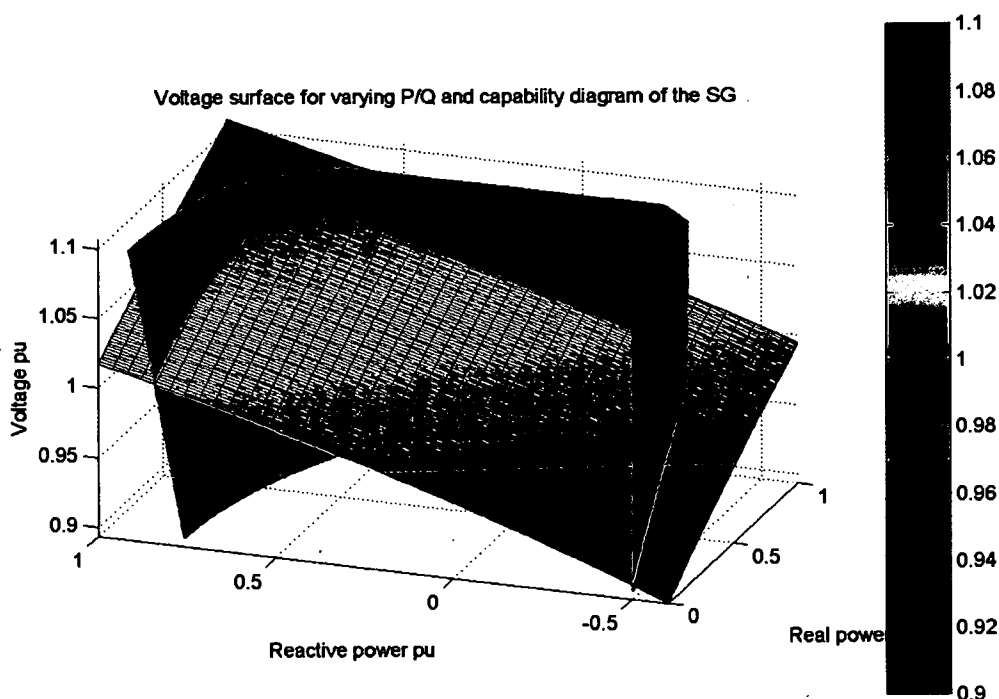

**Figure 3.13:** Combined voltage surface and 3-dimensional capability diagram for a synchronous generator

In this figure, the radius of the excitation limit (left side of the diagram) is scaled in proportion to  $V_T$  and therefore the "static" capability curve at each voltage level is different. The actual operational area of the DG in this case is the (non-planar) section of the voltage surface that is encompassed by the 3D capability diagram. An important aspect of the capability diagram is that in a real system it is "dynamic", i.e. it changes in time according to demand fluctuations and network reconfiguration. For

example, a decrease of demand would result in a voltage surface higher on the V-axis (and vice-versa), and disconnection of a feeder would bring about an increase of the voltage surface slope in both P and Q directions. Since the 3D capability diagram is machine-specific and therefore constant, a change of the voltage surface would alter the operational area of the generator. This change may move the operating point of the generator closer to (or farther from) its operational limits. This is further discussed in Chapter 5.

### 3.9 Power System Modelling

The task of the power network model is to calculate the power flows across the network as well as the associated voltage changes. Mathematically, the power network is described by a set of algebraic equations. For a network with  $p$  nodes, Equation 3.17 is the *nodal equation*:

$$\bar{\mathbf{I}} = \bar{\mathbf{Y}} \times \bar{\mathbf{V}} \quad (3.17)$$

where:  $\bar{\mathbf{I}} = [I_1 \ I_2 \ \dots \ I_p]^T$  current injections at nodes 1 to  $p$ ,  
 $\bar{\mathbf{V}} = [V_1 \ V_2 \ \dots \ V_p]^T$  voltages at nodes 1 to  $p$ ,  
 and  $\bar{\mathbf{Y}}$  nodal admittance matrix.

The nodal admittance matrix is equal to:

$$\bar{\mathbf{Y}} = \begin{bmatrix} \bar{Y}_{11} & \bar{Y}_{12} & \bar{Y}_{13} & \dots & \bar{Y}_{1p} \\ \bar{Y}_{21} & \bar{Y}_{22} & \bar{Y}_{23} & \dots & \bar{Y}_{2p} \\ \vdots & \vdots & \vdots & \ddots & \vdots \\ \bar{Y}_{p1} & \bar{Y}_{p2} & \bar{Y}_{p3} & \dots & \bar{Y}_{pp} \end{bmatrix}, \quad (3.18)$$

where  $\bar{Y}_{ii}$  is the self admittance of node  $i$ , equal to the sum of all admittances ending at node  $i$ , and  $\bar{Y}_{ij}$  is the mutual admittance between nodes  $i$  and  $j$  and is equal to the negative of the branch series admittance between  $i$  and  $j$ .

example, a decrease of demand would result in a voltage surface higher on the V-axis (and vice-versa), and disconnection of a feeder would bring about an increase of the voltage surface slope in both P and Q directions. Since the 3D capability diagram is machine-specific and therefore constant, a change of the voltage surface would alter the operational area of the generator. This change may move the operating point of the generator closer to (or farther from) its operational limits. This is further discussed in Chapter 5.

### 3.9 Power System Modelling

The task of the power network model is to calculate the power flows across the network as well as the associated voltage changes. Mathematically, the power network is described by a set of algebraic equations. For a network with  $p$  nodes, Equation 3.17 is the *nodal equation*:

$$\bar{\mathbf{I}} = \bar{\mathbf{Y}} \times \bar{\mathbf{V}} \quad (3.17)$$

where:  $\bar{\mathbf{I}} = [I_1 \ I_2 \ \dots \ I_p]^T$  current injections at nodes 1 to  $p$ ,  
 $\bar{\mathbf{V}} = [V_1 \ V_2 \ \dots \ V_p]^T$  voltages at nodes 1 to  $p$ ,  
 and  $\bar{\mathbf{Y}}$  nodal admittance matrix.

The nodal admittance matrix is equal to:

$$\bar{\mathbf{Y}} = \begin{bmatrix} \bar{Y}_{11} & \bar{Y}_{12} & \bar{Y}_{13} & \dots & \bar{Y}_{1p} \\ \bar{Y}_{21} & \bar{Y}_{22} & \bar{Y}_{23} & \dots & \bar{Y}_{2p} \\ \vdots & \vdots & \vdots & \ddots & \vdots \\ \bar{Y}_{p1} & \bar{Y}_{p2} & \bar{Y}_{p3} & \dots & \bar{Y}_{pp} \end{bmatrix}, \quad (3.18)$$

where  $\bar{Y}_{ii}$  is the self admittance of node  $i$ , equal to the sum of all admittances ending at node  $i$ , and  $\bar{Y}_{ij}$  is the mutual admittance between nodes  $i$  and  $j$  and is equal to the negative of the branch series admittance between  $i$  and  $j$ .

When power injections are given, they can be converted to currents by:

$$I_i = \frac{S_i^*}{\bar{V}_i^*} = \frac{P_i - jQ_i}{\bar{V}_i^*}; \quad (3.19)$$

where  $P_i$ ,  $Q_i$  are the real and imaginary power injections at node  $i$  respectively. Using powers instead of currents implies that the nodal equation cannot be solved algebraically, as, by substituting  $\bar{I}$  from Equation 3.19 into 3.17,  $\bar{V}$  appears on both sides of the equation in a non-linear fashion. Therefore an iterative algorithm has to be utilised for the solution, such as Newton-Raphson or Gauss-Seidel [19, 39].

Equations 3.17 and 3.19 are in the network reference frame (a,b) where the voltage of the infinite bus is assumed at an angle of zero degrees; however, the synchronous generator model described earlier is in the generator (d,q) reference frame. In order to be able to connect the generator model to any node of the network (where the voltage angle is arbitrary), the two systems must be aligned. This is performed by the transformation matrix as shown in Equation 3.20. The d-axis of the generator is shifted with respect to the network real axis a by the rotor angle  $\delta$ . The terminal voltage can be transformed by:

$$\begin{bmatrix} v_a \\ v_b \end{bmatrix} = \begin{bmatrix} -\sin \delta & \cos \delta \\ \cos \delta & \sin \delta \end{bmatrix} \times \begin{bmatrix} v_p \\ v_q \end{bmatrix} \quad (3.20)$$

The rotor angle  $\delta$  in radians is given by Equation 3.21:

$$\delta = \int (\omega_s - \omega_m) dt, \quad (3.21)$$

where  $\omega_s$  and  $\omega_m$  are the synchronous (network) angular speed and mechanical speed of rotation, both in radians, and  $\omega_s - \omega_m = 0$  for  $t = 0s$ . Since the transformation matrix is unitary, the inverse transformation (from  $ab$  to  $dq$ ) can be performed using the same matrix.

In the dynamic simulations throughout this work, energy sources are considered as current injections (as a function of generated power). Additionally, loads are assumed to be either constant or varying, but in both cases with no dynamic terms, and are modelled as power injections converted to currents by means of 3.19. A procedure for

When power injections are given, they can be converted to currents by:

$$I_i = \frac{S_i^*}{\bar{V}_i^*} = \frac{P_i - jQ_i}{\bar{V}_i^*}; \quad (3.19)$$

where  $P_i$ ,  $Q_i$  are the real and imaginary power injections at node  $i$  respectively. Using powers instead of currents implies that the nodal equation cannot be solved algebraically, as, by substituting  $\bar{I}$  from Equation 3.19 into 3.17,  $\bar{V}$  appears on both sides of the equation in a non-linear fashion. Therefore an iterative algorithm has to be utilised for the solution, such as Newton-Raphson or Gauss-Seidel [19, 39].

Equations 3.17 and 3.19 are in the network reference frame (a,b) where the voltage of the infinite bus is assumed at an angle of zero degrees; however, the synchronous generator model described earlier is in the generator (d,q) reference frame. In order to be able to connect the generator model to any node of the network (where the voltage angle is arbitrary), the two systems must be aligned. This is performed by the transformation matrix as shown in Equation 3.20. The d-axis of the generator is shifted with respect to the network real axis a by the rotor angle  $\delta$ . The terminal voltage can be transformed by:

$$\begin{bmatrix} v_a \\ v_b \end{bmatrix} = \begin{bmatrix} -\sin \delta & \cos \delta \\ \cos \delta & \sin \delta \end{bmatrix} \times \begin{bmatrix} v_p \\ v_q \end{bmatrix} \quad (3.20)$$

The rotor angle  $\delta$  in radians is given by Equation 3.21:

$$\delta = \int (\omega_s - \omega_m) dt, \quad (3.21)$$

where  $\omega_s$  and  $\omega_m$  are the synchronous (network) angular speed and mechanical speed of rotation, both in radians, and  $\omega_s - \omega_m = 0$  for  $t = 0s$ . Since the transformation matrix is unitary, the inverse transformation (from  $ab$  to  $dq$ ) can be performed using the same matrix.

In the dynamic simulations throughout this work, energy sources are considered as current injections (as a function of generated power). Additionally, loads are assumed to be either constant or varying, but in both cases with no dynamic terms, and are modelled as power injections converted to currents by means of 3.19. A procedure for

solving the power flow in a distribution network is presented in [29]. This procedure has been implemented in Matlab and is used in all the simulations. The program receives as inputs the voltage of the infinite bus and the current injections at all nodes, and produces the node voltages. The source code of the program can be found in Appendix B. For the steady state simulations, a standard Matlab power flow program from [19] has been used, modified to include variable loads and On-Line Tap Changers (OLTCs) on the transformers. The modified code can also be found in Appendix B.

### **3.10 Simulation of the Developed SHG Model**

A model of a small hydro scheme with a synchronous generator as described in this chapter has been built in Simulink. The block diagrams of the components of the model can be found in Appendix A. The model uses the Matlab code for the network solution that was presented in the previous section to solve the power flow. The top level diagram of the small hydro scheme block is shown in Figure 3.21. The modelled generator is a 12.5MVA, 10MW salient pole synchronous machine. The turbine is rated at 10.3MW output to account for the electrical losses. The generator and excitation system parameters of the plant were taken from [57]. The generator is connected to the infinite grid at 11kV through a feeder with  $R_L = 0.5pu$  and  $X_L = 0.4pu$  on a 100MVA base. Two tests of the developed model were performed; loading up the generator (post synchronisation) in APFC mode, and the response of the excitation system to a step change of the local load in AVC mode. Figure 3.14(a) below shows the process of loading up the generator.

On the generator bus, a 5MW, 0.9 lagging power factor load is connected. After synchronising, the power setpoint on the governor was increased linearly from zero to 1.0 per unit turbine output in 60 seconds, with the generator operating in automatic power factor control mode. The electrical power output of the generator shown in the top diagram of Figure 3.14(a) followed that increase. The increase stopped when the limit of the gate opening was reached. At that point the real power output of the generator was 0.8pu, or 10MW, which is the rating of the machine. At the same time

solving the power flow in a distribution network is presented in [29]. This procedure has been implemented in Matlab and is used in all the simulations. The program receives as inputs the voltage of the infinite bus and the current injections at all nodes, and produces the node voltages. The source code of the program can be found in Appendix B. For the steady state simulations, a standard Matlab power flow program from [19] has been used, modified to include variable loads and On-Line Tap Changers (OLTCs) on the transformers. The modified code can also be found in Appendix B.

### **3.10 Simulation of the Developed SHG Model**

A model of a small hydro scheme with a synchronous generator as described in this chapter has been built in Simulink. The block diagrams of the components of the model can be found in Appendix A. The model uses the Matlab code for the network solution that was presented in the previous section to solve the power flow. The top level diagram of the small hydro scheme block is shown in Figure 3.21. The modelled generator is a 12.5MVA, 10MW salient pole synchronous machine. The turbine is rated at 10.3MW output to account for the electrical losses. The generator and excitation system parameters of the plant were taken from [57]. The generator is connected to the infinite grid at 11kV through a feeder with  $R_L = 0.5pu$  and  $X_L = 0.4pu$  on a 100MVA base. Two tests of the developed model were performed; loading up the generator (post synchronisation) in APFC mode, and the response of the excitation system to a step change of the local load in AVC mode. Figure 3.14(a) below shows the process of loading up the generator.

On the generator bus, a 5MW, 0.9 lagging power factor load is connected. After synchronising, the power setpoint on the governor was increased linearly from zero to 1.0 per unit turbine output in 60 seconds, with the generator operating in automatic power factor control mode. The electrical power output of the generator shown in the top diagram of Figure 3.14(a) followed that increase. The increase stopped when the limit of the gate opening was reached. At that point the real power output of the generator was 0.8pu, or 10MW, which is the rating of the machine. At the same time

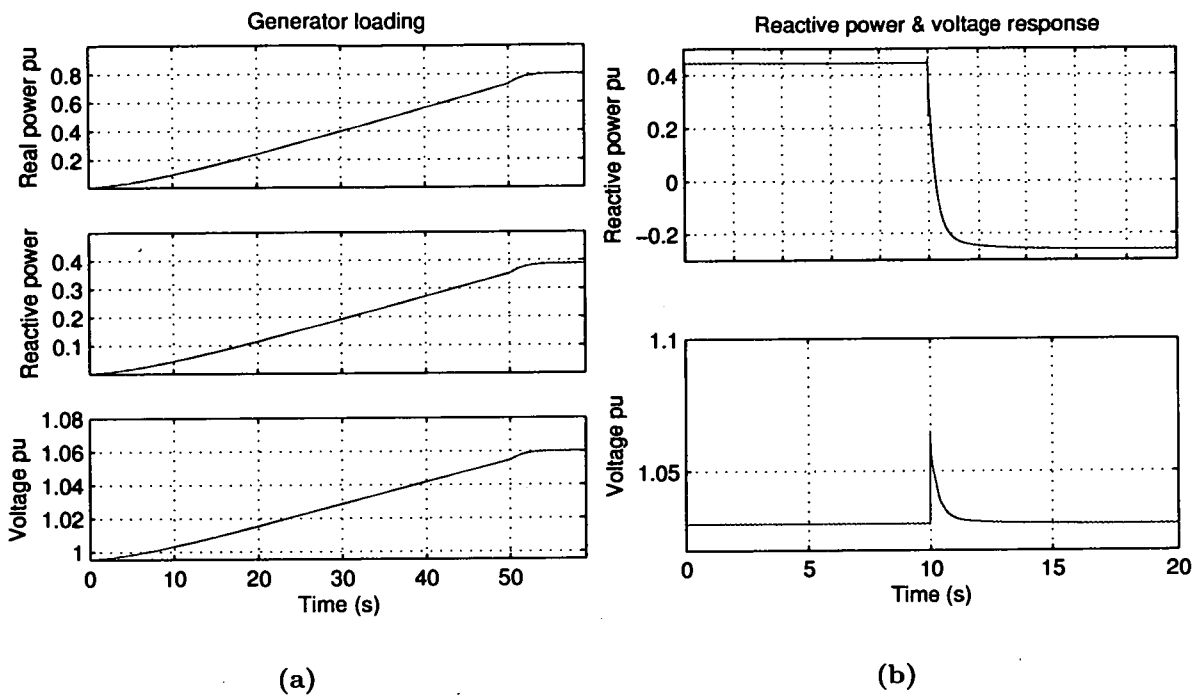

**Figure 3.14:** Synchronous generator loading up in APFC (a) and response to a load step change in AVC mode (b)

the reactive power generated by the machine also increased in proportion so that the power factor remained constant at 0.9 lagging. The result of the simultaneous increase of  $P_{GEN}$  and  $Q_{GEN}$  was an increase of the terminal voltage to just above 1.06 pu. In a real situation the generator would not be allowed to reach that voltage level and would either have to constrain its output, or disconnect.

Figure 3.14(b) shows the response of the generator to a step change of the local load, with the AVR operating in automatic voltage control mode. The voltage reference was set at 1.03pu. At  $t = 10$  seconds the local load was reduced stepwise from 10MW (0.9 PF) to 5MW. The top diagram of Figure 3.14(b) shows the reduction of reactive power from 0.45 pu (lagging) to -0.26pu (leading). By importing reactive power from the network, the bus voltage was maintained at 1.03pu. However the voltage spike once again violated the 1.06 pu statutory limit. Engineering Recommendation G59/1 [26] allows transient overvoltages with duration of less than 0.5s before the generator is disconnected.

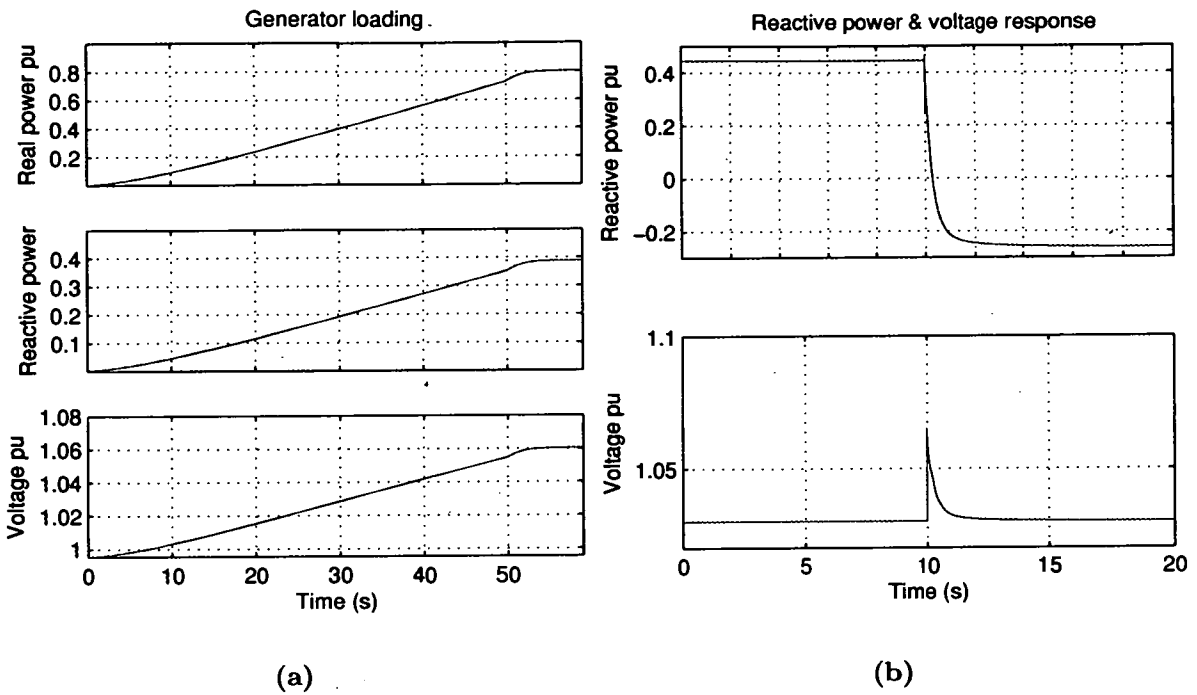

Figure 3.14: Synchronous generator loading up in APFC (a) and response to a load step change in AVC mode (b)

the reactive power generated by the machine also increased in proportion so that the power factor remained constant at 0.9 lagging. The result of the simultaneous increase of  $P_{GEN}$  and  $Q_{GEN}$  was an increase of the terminal voltage to just above 1.06 pu. In a real situation the generator would not be allowed to reach that voltage level and would either have to constrain its output, or disconnect.

Figure 3.14(b) shows the response of the generator to a step change of the local load, with the AVR operating in automatic voltage control mode. The voltage reference was set at 1.03pu. At  $t = 10$  seconds the local load was reduced stepwise from 10MW (0.9 PF) to 5MW. The top diagram of Figure 3.14(b) shows the reduction of reactive power from 0.45 pu (lagging) to -0.26pu (leading). By importing reactive power from the network, the bus voltage was maintained at 1.03pu. However the voltage spike once again violated the 1.06 pu statutory limit. Engineering Recommendation G59/1 [26] allows transient overvoltages with duration of less than 0.5s before the generator is disconnected.

### 3.11 Simulation of the OLTC in a Network with Varying Loads

The following simulations illustrates the operation of a transformer equipped with an On-Line Tap Changer in a radial system with a distributed generator and a varying load. The line diagram of the system is shown in Figure 3.15.

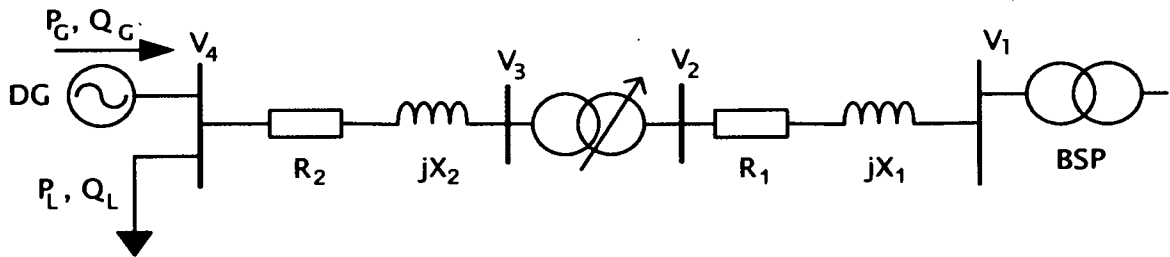

Figure 3.15: The simulated 4-bus system with the OLTC

In the first simulation the transformer was assumed to be directly connected on the DG bus and the OLTC operated in AVC mode. This was achieved by setting  $R_2$  and  $X_2$  equal to zero (so that  $\bar{V}_4 = \bar{V}_3$ ). In the second simulation  $R_2$  and  $X_2$  were given non-zero values and the OLTC operated in LDRC mode. In both simulations the OLTC settings were the ones presented in Table 3.3 with a target voltage of  $1.0pu$ . The profile of the load on the DG bus is shown in Figure 3.16 in per unit. It has been constructed using a 80% domestic and 20% industrial profile with data taken from [58]. Such a profile is typically found in rural areas. The system data for the simulation of the OLTC in AVC and in LDRC mode are shown collectively in Table 3.4.

#### 3.11.1 Simulating the OLTC in AVC Mode

The system data for the simulation of the OLTC in AVC mode are shown in Table 3.4. Figure 3.17 shows the tap changer action throughout the simulated period. It is shown that at low demand periods, the tap changer raises the tap position, thereby reducing the transformer ratio and hence lowering the secondary winding voltage. Inverse action

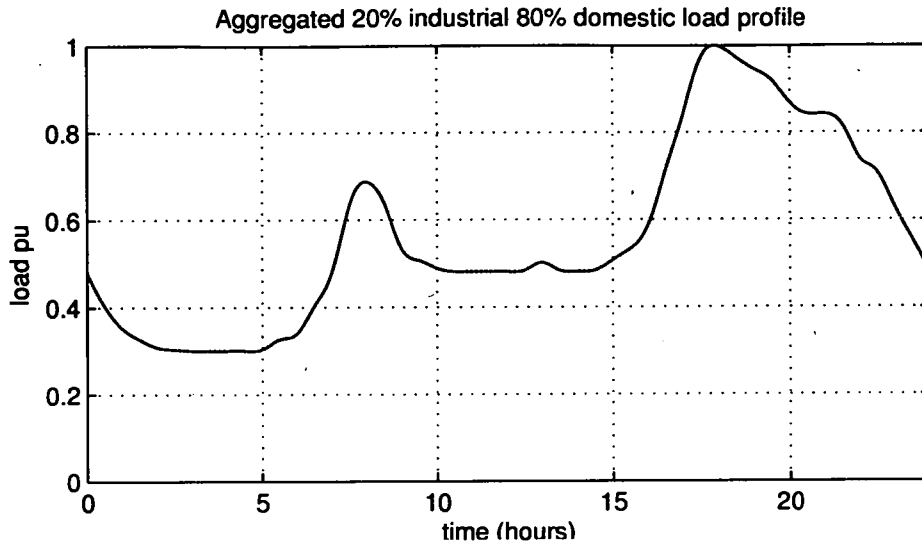

Figure 3.16: 24-hour varying load used in OLTC simulations

takes place during high demand. The resulting voltage profile is represented by the red trace in Figure 3.18.

### 3.11.2 Simulating the OLTC in LDRC Mode

For the second simulation the impedance of the lines has been altered as shown in the third column of Table 3.4. There is now an impedance between the transformer's secondary and the DG bus. However The OLTC is still set to regulate  $V_4$ , thus operating in LDRC mode. The tap changer position is shown in Figure 3.19 and the voltages at buses 2, 3 and 4 in Figure 3.20. It can be observed that  $V_4$  is still well regulated, however voltage  $V_3$  (at the transformer's secondary terminals) is fluctuating widely to account for the voltage drop or rise across  $R_2 + jX_2$ . Nevertheless this is not a problem, as node 3 is a "virtual bus", i.e. it does not have any loads or generators connected.

Parameter	Value (AVC test)	Value (LDRC test)
Network		
$S_{base}$	10MVA	
$V_{base}$	11kV	
$V_1$ (slack)	1.015pu	
$R_1$	0.125pu	0.030pu
$X_1$	0.100pu	0.020pu
$R_T$	0.003pu	
$X_T$	0.050pu	
$R_2$	0.000pu	0.060pu
$X_2$	0.000pu	0.040pu
Load		
$P_{Lmax}$	8MW	
PF	0.9 lagging	
Generator		
$P_G$	6MW	
PF	0.95 lagging	

Table 3.4: Parameters for the simulation of the OLTC operating in AVC and LDRC mode

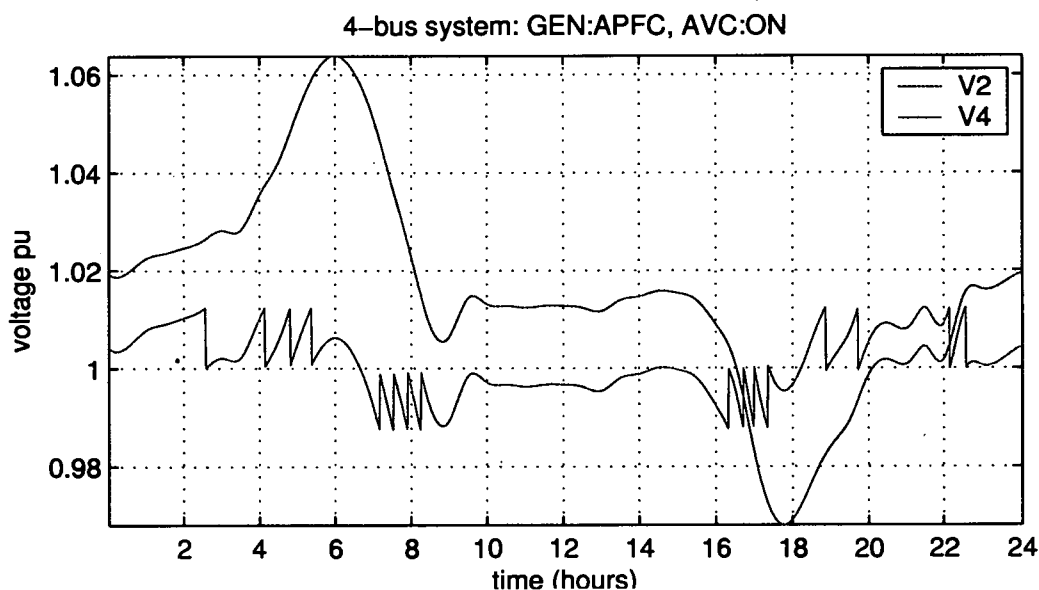

Figure 3.18: Transformer primary and load bus voltage for the 24-hour simulation (AVC)

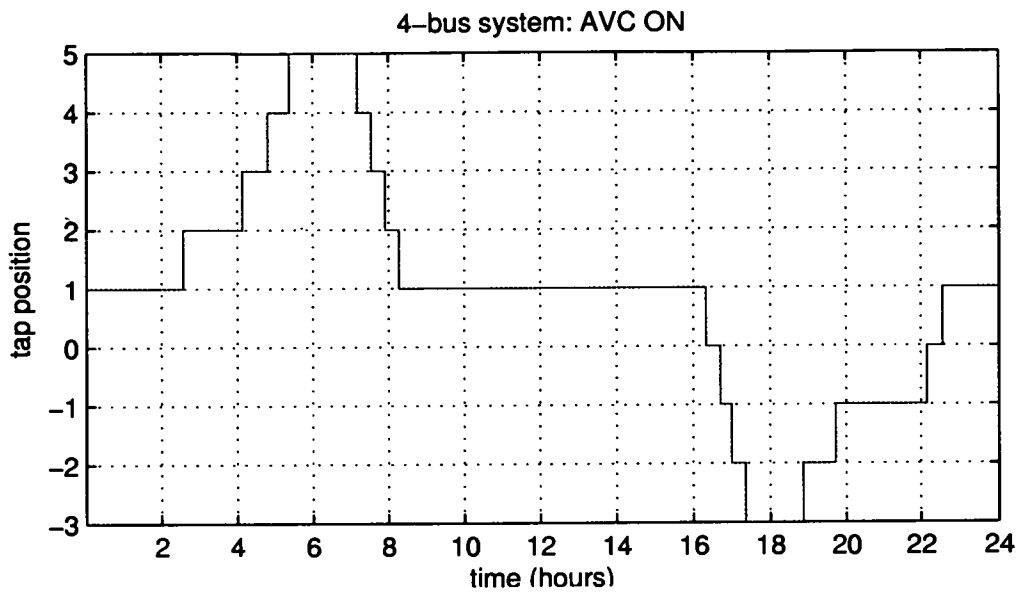

Figure 3.17: OLTC tap position for the 24-hour simulation (AVC)

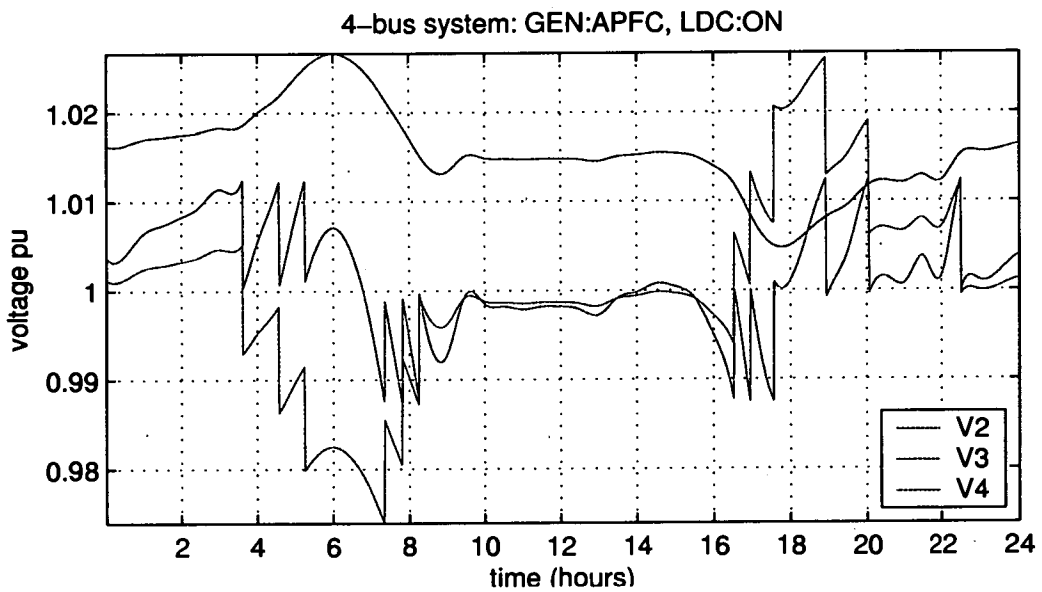

Figure 3.20: Transformer primary and load bus voltage for the 24-hour simulation (LDRC)

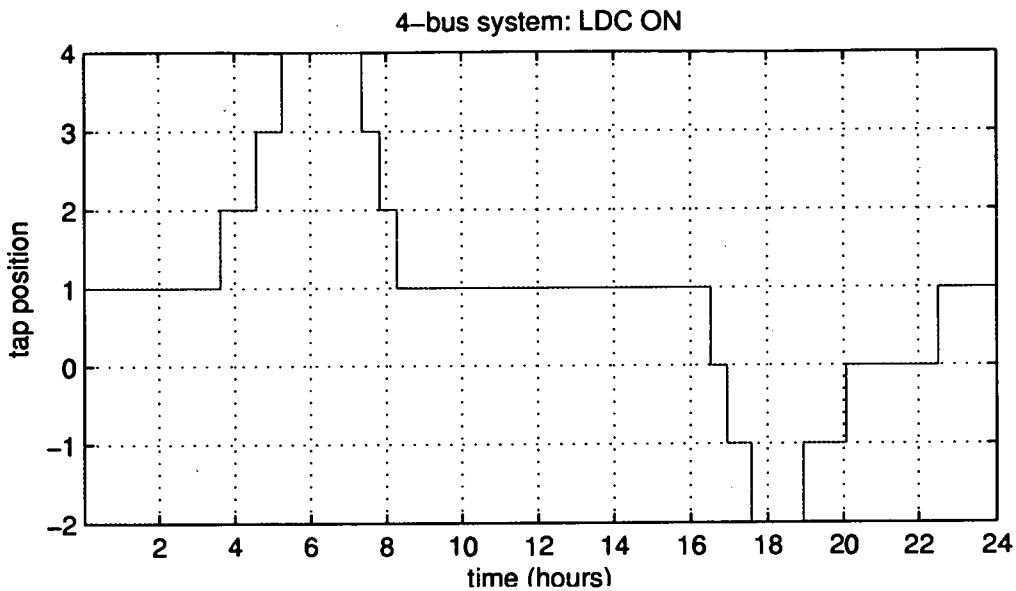

Figure 3.19: OLTC tap position for the 24-hour simulation (LDRC)

### 3.12 Summary

In this chapter the methodology for modelling a distributed generator within a distribution network was presented. A complete source-to-network model of a small hydro scheme has been constructed. The model is modular and therefore allows easy replacement of any of its components for further studies, e.g. control system development, or investigation of alternative means of power generation. The various components were represented using standard models found in the literature in order to allow comparison of the simulation results with related work. Automatic power factor mode and automatic voltage control mode, the two usual methods of operation of a synchronous generator were then presented. In addition, Automatic Voltage Control and Line Drop/Rise Compensation, two types of voltage control using transformers with On-Line Tap Changers were illustrated. The operation of the OLTC was assumed to be ideal. Further work could include consideration of the inaccuracies of the emulating circuit for the Line Drop Compensator. The operational aspects of utilisation of synchronous generators in distribution networks were also discussed, with particular interest on the determination of their range of allowed operation as defined by the machine characteristics and the DNO requirements. This was achieved

by representing the capability diagram of the synchronous generator as a 3D locus and combining it with the voltage surface on the  $P - Q$  plane. This is a very useful tool for visualising and understanding how a synchronous machine based power plant will behave in a weak network. Finally the working of the developed small hydro scheme model was shown by simulating two characteristic events, namely generator loading and sudden loss of load, as well as operation of the OLTC in a network with a varying load. In the following chapter a similar procedure is followed to model and investigate the operation of a variable speed wind turbine including a Doubly Fed Induction Generator.

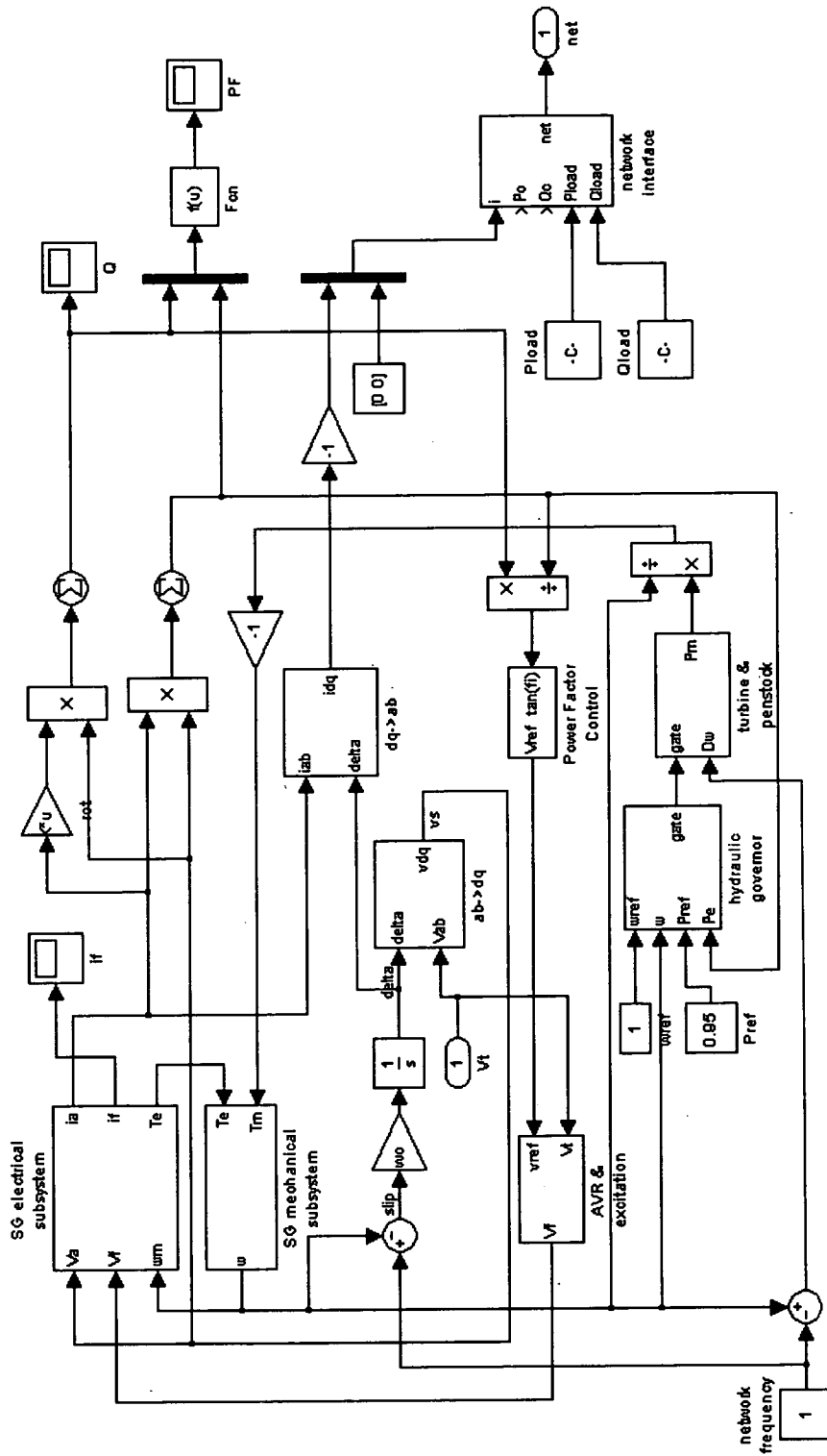

Figure 3.21: Top-level block diagram of the Simulink small hydro scheme model

---

# Chapter 4

## Modelling of Wind Energy Conversion Systems

---

### 4.1 Introduction

In this chapter the current technology and modelling of wind energy conversion systems is presented. In particular, a detailed model of wind speed is presented and then the model of a variable speed wind turbine with its drive train is shown. The various configurations available for a wind energy conversion system are then discussed, and the chapter ends with an analysis of the dynamic model of the doubly-fed induction generator.

### 4.2 Wind Energy Conversion System Modelling

There are a number of different designs of wind turbines (WTs) and selection is based upon their size and use. Hence wind turbines can be categorised as follows:

- large (MW range) or small (kW range);
- grid connected or isolated;
- onshore, nearshore or offshore.

The design of the mechanical part of the (grid connected) large onshore WECSs, which was studied in this work, follows invariably the 3-bladed, horizontal axis turbine model although some different old and experimental setups exist. A 3-D representation of the nacelle and rotor of a 3-bladed, horizontal axis wind turbine is depicted in

Figure 4.1. The most common design for the electrical part features a standard squirrel cage induction generator (SCIG) but due to its versatility, the doubly fed induction generator (DFIG) is nowadays being increasingly utilised. A third alternative is the Synchronous Generator (SG), either direct-drive or with a gearbox, and there are several implementations of WECS using SGs by various manufacturers.

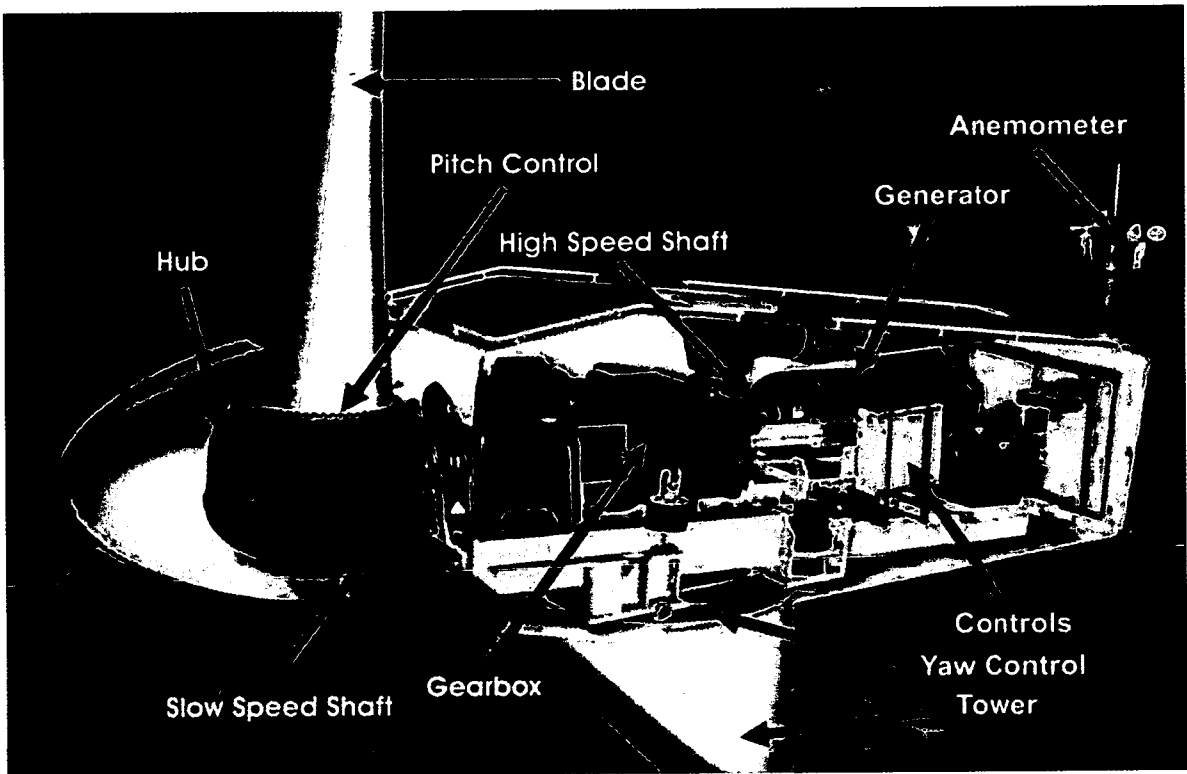

**Figure 4.1:** *Diagram of a 3-blade, horizontal axis wind turbine, image courtesy of Vestas*

Depending on the generator type the WT can be constant or variable speed. In a typical SCIG based WECS the slip, and hence the speed can vary typically only from 102% to 106% from nominal 104%; therefore the turbine operates nearly at constant speed. DFIG and SG based wind turbines can operate in a much wider range of speeds (typically up to  $\pm 30\%$  of nominal) by decoupling the rotor mechanical speed and the network frequency through use of power electronic converters. Full variable speed operation of an SCIG can also be achieved by installing a power electronic converter between the generator and the network. A WT benefits from operating over a wide

range of speeds by the reduction of mechanical stresses on the blades and the WT body during wind gusts, as the extra wind energy is converted to increased (rotational) kinetic energy. Furthermore, this momentary storage of energy increases the efficiency of the WT and improves the quality of the electricity supplied by smoothing out the fluctuations of generated power [59, 60]. A disadvantage of variable speed operation is the need for a Power Electronic Converter (PEC) that decouples the network electrical frequency from the varying rotational speed of the WT. Use of PECs increases the overall cost of the WECS and can introduce harmonics [61].

The most common method of control of power flow within a constant speed WT is stall control, which is passive, as it constrains the rotor's rotational speed to its rated value by proper aerodynamic design of the blades. The design of the blades in a stall-controlled WT intrinsically regulates the power production. The blades have fixed pitch and operate near or at the optimal tip speed ratio at low wind speeds. The aerodynamics of the blades are such that with the increase of wind speed, the stall effect occurs on an increasingly larger part of the blade, thus reducing blade efficiency and therefore limiting output power. A stall regulated WT coupled to an SCIG is the so-called 'Danish' model and is the most common WT type installed today.

Variable speed WTs mainly use pitch control to actively regulate the rotational speed by altering the pitch angle of the blades (or parts of them). Below rated power such WTs operate at a fixed (optimal) pitch with a variable rotational speed in order to maintain an optimal tip speed ratio and therefore maximise efficiency and output power. When rated power is reached, pitch control is used to keep rotor speed within safe operation limits. While wind speed fluctuates, power output can be maintained almost constant by allowing the rotor to accelerate (thus storing energy) or to decelerate (thus supplying energy) [62]. Despite the associated cost rise, pitch control is attractive as it increases significantly the turbine efficiency [63]. Petersen in his 2000 work for the Danish Energy Agency showed that a pitch-regulated WT will yield 2.5% more energy than a dual-speed stall-regulated WT operating under the same conditions [64], and the increase in production will be even higher when compared to single-speed WTs. Figure 4.1 shows the diagram of an active pitch regulated WT made by Vestas, where

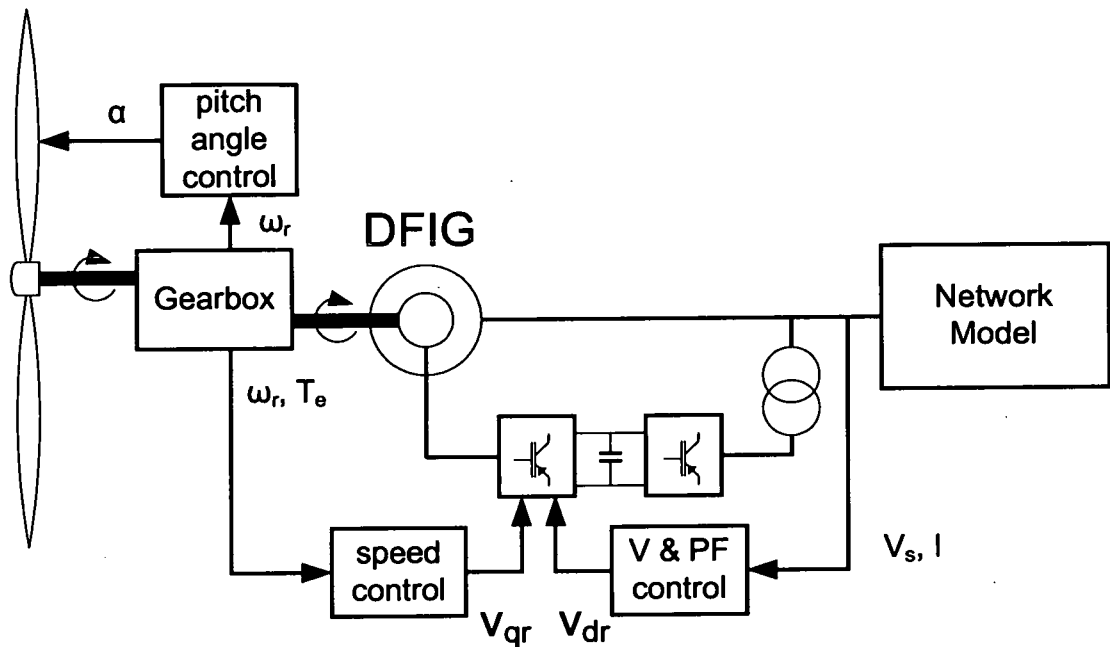

**Figure 4.2:** Functional diagram and power transfer in a Wind Energy Conversion System

the pitch control mechanism is located in the hub.

On the electrical side both real and reactive power may be controlled by appropriate action on a power electronic converter. Figure 4.2 shows the functional diagram of a WECS. Functionally, a WECS can be divided into four parts; rotor, drive train, generator and control system.

The wind turbine rotor consists of the blades and the hub, and is regarded as the most crucial element of the whole WECS because the overall efficiency of the WT is largely dependent on the aerodynamic design of the blades. Further, due to their size, their weight is an important factor from the design and cost standpoints [65]. The rotor diameter has increased from 12 m in late 1970's for a 50 kW turbine, to 120 m for the latest 4.5 MW turbines. Consequently, tower height has also increased from 25 m to 100 m [66].

### 4.2.1 Wind Modelling

The power in watts of a wind stream passing through an area  $A$  can be calculated from the following equation:

$$P_{wind} = \frac{1}{2} \times \rho \times A \times v_{wind}^3, \quad (4.1)$$

where  $\rho$  is the air density in  $kg/m^3$  and  $v_{wind}$  is the instantaneous wind speed in  $m/s$ . Air density varies with the location and with time and it is approximately  $1.26kg/m^3$  at  $20^\circ C$  in a standard atmosphere. For wind turbines,  $A$  is the swept area of the blades and equals  $\pi \times (\frac{D}{2})^2 m^2$ , where  $D$  is the diameter of the rotor in metres. It is therefore obvious that the wind power varies in proportion to the square of the WT diameter and the cube of the wind speed. However, Betz's law [67] proves that the theoretical maximum power that can be extracted from wind equals  $16/27 \times P_{wind}$ . Turbulent and non-homogeneous air flow, as well as friction losses typically reduce extracted power to about 0.5 of the power contained in the wind.

The variability of wind speed can be efficiently represented with a probability density function with a Weibull distribution according to the following equation [65]:

$$p(v_{wind}) = \left(\frac{k}{c}\right) \times \left(\frac{v_{wind}}{c}\right)^{k-1} \times e^{-\left(\frac{v_{wind}}{c}\right)^k}, \quad (4.2)$$

where  $k$  is the shape factor and  $c$  is the scale factor, both location-dependent parameters. These parameters can be calculated from the mean wind speed  $\bar{v}$  ( $m/s$ ) and the standard deviation  $\sigma_v$  using the following empirical equations [65]:

$$k = \left(\frac{\sigma_v}{\bar{v}}\right)^{-1.086}, \quad (4.3)$$

and

$$c = \bar{v} \times \left(0.568 + \frac{0.433}{k}\right)^{-\frac{1}{k}}. \quad (4.4)$$

For onshore sites, a typical pair of  $\sigma_v$  and  $\bar{v}$  is 3.715 and 8 m/s, which gives  $k = 2.3$  and  $c = 9.033$ . Figure 4.3 shows the probability density function for a wind speed time series with these characteristics.

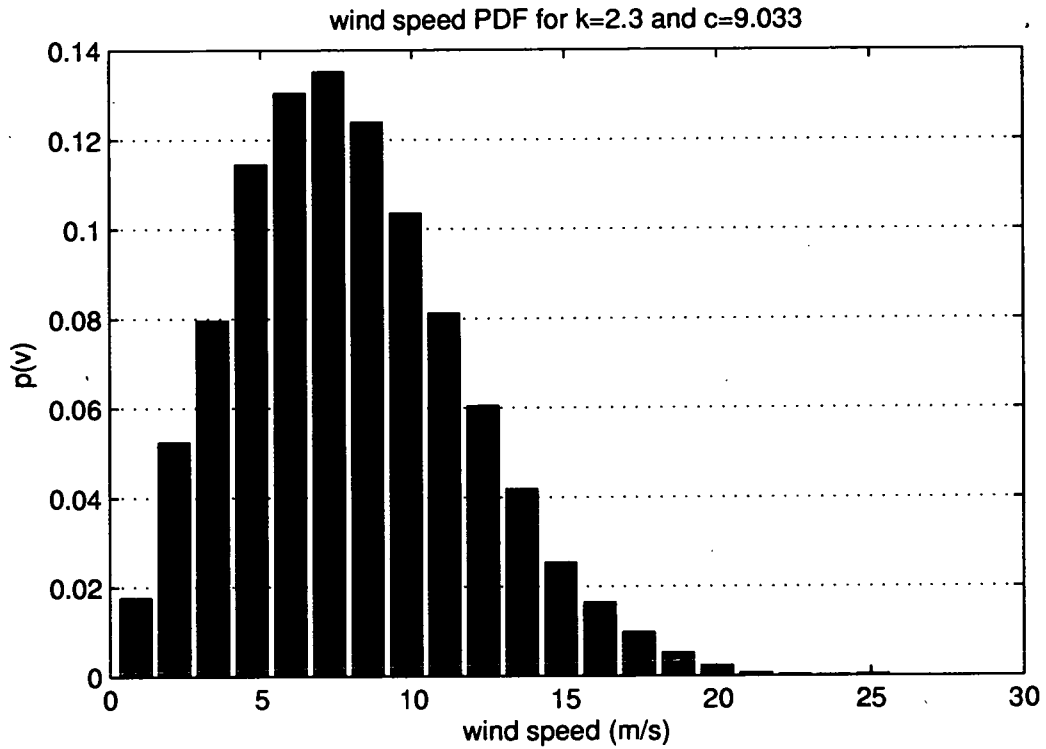

Figure 4.3: Probability density function for a wind speed time series with  $k=2.3$  and  $c=9.033$ .

Wind speed can also be modelled as the Fourier series of a periodic signal. In this case, wind speed is given by:

$$v_{wind}(t) = \alpha_0 + \sum_{m=1}^{\infty} \alpha_m \cos(2\pi m \Delta f t + \phi_m), \quad (4.5)$$

where:  $\alpha_0$  is the mean wind velocity in m/s,  
 $\Delta f$  is the frequency interval in Hz,  
 $m$  is the index of the frequency component, and  
 $\phi_m$  is the initial uniform random phase of the  $m_{th}$  frequency component,  
 which varies from 0 to  $2\pi$ .

Transitions between largely different wind speeds (i.e. wind gusts) are less likely to occur than smoother changes. For a given measured wind speed time series this tendency is described by the autocorrelation function:

$$R(r\Delta t) = \frac{1}{\sigma_v^2 (N_s - r)} \times \sum_{i=1}^{N_s-r} (u_i \times u_{i+r}), \quad (4.6)$$

where:  $r$  is the lag number,

$\Delta t$  is the sample period and

$N_s$  is the number of samples in the data series.

The autocorrelation function will start from 1.0 for  $r = 0$  and will eventually decay to zero for an  $r > 0$ . The integral of  $R(r\Delta t)$  over that period is called the integral time scale of turbulence and is a measure of the average time that the data are considered correlated over time. Typical values are below 10 seconds, but longer periods are possible too.

The frequency spectrum  $S(f)$  is taken from [65] and is given by:

$$S(f) = \frac{4\sigma_v^2 (L/\bar{u})}{[1 + 70.8 (fL/\bar{u})^2]^{5/6}}, \quad (4.7)$$

where  $L$  is the integral length scale, which can be found by multiplying the mean wind speed with the integral time scale that throughout this thesis is set to be equal to 10s [65].

From this, the Fourier parameter  $\alpha_m$  can be derived as:

$$\alpha_m = \sqrt{S(m\Delta f) \times \Delta f} \quad (4.8)$$

The wind speed time series used in this thesis was generated as follows. A 30 minute average of the wind speed over 24 hours is first generated. Then, for each half-hour

interval a time series is generated using equations 4.5 to 4.8. This results to a wind speed time series with a Weibull probability density function with the parameters shown in 4.3. This simulation represents a windy "day" at a location of a fairly flat grass field, a typical case of the Scottish landscape. In order to avoid periodicity of the generated signal the period interval  $\Delta T = 1/\Delta f$  has to be longer than the duration of the signal, which in this case is 1800s. Therefore it is set that  $\Delta T = 2000s$  and  $\Delta f = 5 \times 10^{-4}Hz$ . In order to include frequencies up to 1Hz, the frequency index  $m$  in Equation 4.5 is constrained to a maximum of 2000. The same procedure is repeated for all the 30 minute intervals of the 24 hours. Due to the large number of frequency components this can be a time consuming procedure if sufficient computing power is not available. For the purposes of this work, a wind speed time series for 24 hours, sampled at 1 Hz, was generated using the described method. Figure 4.4 shows a wind speed time series obtained by the this procedure (blue trace) together with the 30 minute average wind speed (red trace) for a period of 24 hours.

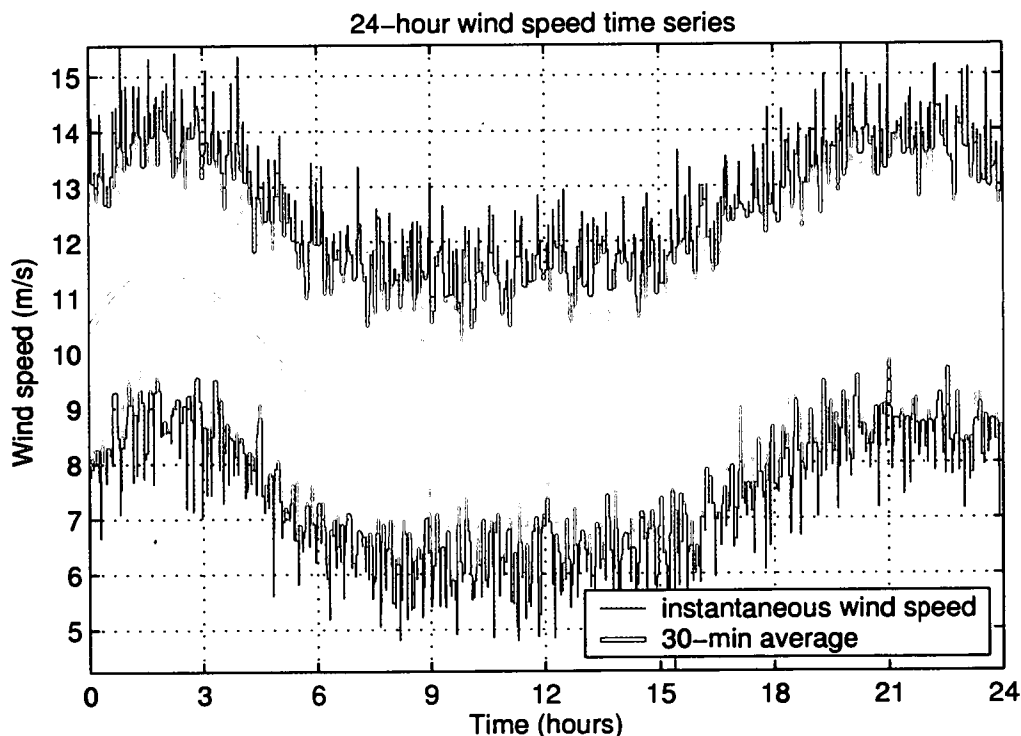

Figure 4.4: *Wind speed time series sampled at 1 Hz (blue) and 30 min. average (red)*

A 3-minute zoom (from 02:45 to 02:48) of the same time series is depicted in Figure 4.5. The mean wind speed of this period was  $10\text{m/s}$ . On this particular "day", the average wind speed is mostly flat at about  $9\text{m/s}$ , with two more "windy" periods at around 02.00 and 21.00 hours with maximum average speeds of about  $11.6\text{m/s}$ .

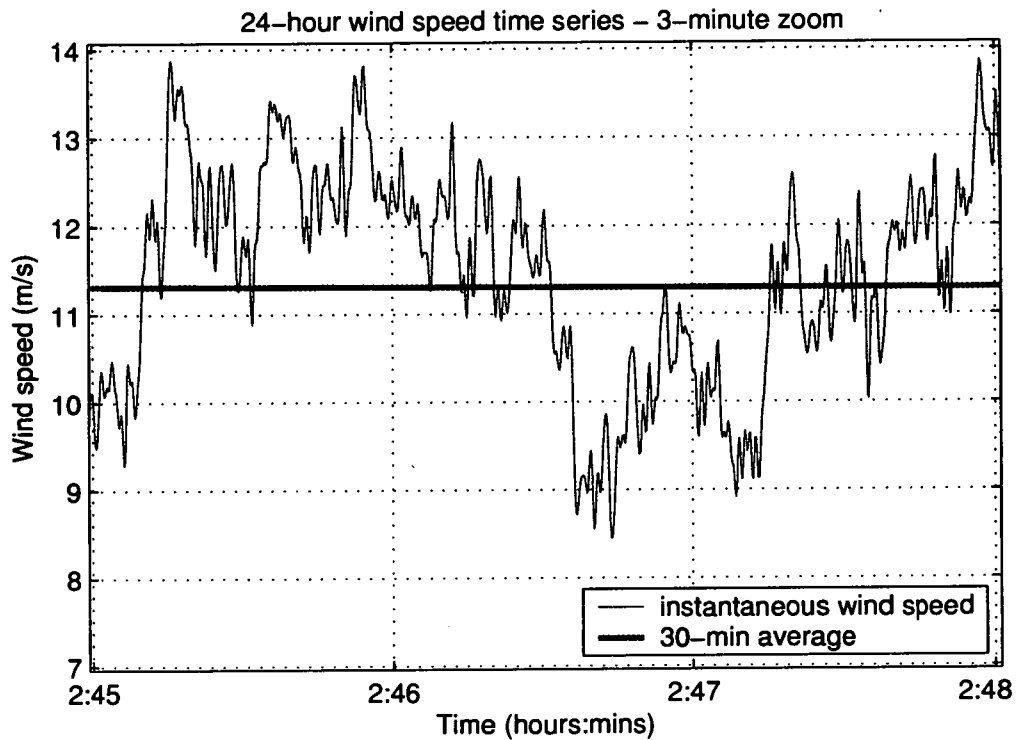

Figure 4.5: A 3-minute zoom of the wind speed time series

An alternative method to eliminate periodicity without the need for a high  $\Delta f$  is described in [68]. In this approach, a small, uniformly distributed random phase is added in Equation 4.5, in order to convert the stationary process to a quasi-stationary process.

Another wind speed model that takes into account the autocorrelation property of the wind speed can be obtained by using discrete Markov process theory [69]. The wind spectrum is divided into smaller regimes and the transition from one regime to another is governed by a Stochastic Transition Probability Matrix (STPM) which is constructed by processing measured wind speed time series or obtained by a Weibull PDF. Once again the STPM is site-specific and prone to periodic changes.

## 4.2.2 Dynamic Model of a Variable Pitch Wind Turbine

Complete aerodynamic modelling of a wind turbine leads to a set of high-order nonlinear equations. However, the scope of this thesis does not include the dynamics of the blades and therefore it allows significant simplifications of the wind turbine dynamics, as they do not impose a notable effect on the steady state operation of the WECS. Akhmatov *et al.* in [70, 71] propose that the wind turbine operation can be modelled as the Laplace transform of a 1st order differential equation. This is caused by a phenomenon known as spatial filtering. The total torque of the rotor is the sum of the torques of each blade element. However, wind speeds at all points of the rotor disk are not equal, therefore the applied torque to each blade element is not uniform. Hence the total torque variance is less than the variance of torque for each blade because turbulence factors of the blades partially cancel each other. The incident wind speeds of two points are correlated but this correlation is reduced with increasing distance from one another. Therefore on large wind turbines, the large swept area brings about an averaging of the wind speed, thus acting as a low pass filter of the form:

$$G(s) = K_w \times \frac{1 + sT_{w1}}{1 + sT_{w2}} \quad (4.9)$$

The gain  $K_w$  and the time constants  $T_{w1}$  and  $T_{w2}$  are depended on the wind turbine design. Their approximation is based on emperical data and is based on the fact that a larger turbine will filter more effectively the wind turbulence. A medium size WT with an induction generator will have  $K_w = 1$ ,  $T_{w1} = 3.3$  s and  $T_{w2} = 0.9$  s. A similar approximation is also discussed in [72].

As mentioned in the previous section, a wind turbine rarely achieves conversion of more than 50% of the available power in the wind. The power coefficient  $c_p$  of a variable speed WT varies with the blade pitch angle  $\alpha$  (degrees) and the tip speed ratio  $\lambda$ , i.e. the ratio of the tangential velocity of the blade tip and the wind speed component that is prependicular to the rotor disk. Therefore the converted mechanical power of the WT becomes:

$$P_m = c_p(\lambda, \alpha)P_w = \frac{1}{2}c_p(\lambda, \alpha)\rho Av_{wind}^3 \quad (4.10)$$

From Equation 4.10 the definition of the power coefficient  $c_p$  can be derived as the ratio of extracted over available power:

$$c_p = \frac{P_m}{P_w} \quad (4.11)$$

The power coefficient has a non-linear relationship with blade pitch angle  $\alpha$  and tip speed ratio  $\lambda$ . There are a number of methods followed to model this relationship, such as Look-Up Tables, splines, and linearisation using Taylor series. Another approach is to develop a numerical approximation of  $c_p(\lambda, \alpha)$  curves generated from measurements on real turbines [73, 74]. This is the method that was followed here, using the numerical example presented in [74]. According to this,  $c_p(\lambda, \alpha)$  can be calculated using the following two equations:

$$c_p(\lambda, \alpha) = c_1 (c_2 - c_3\alpha - c_4\alpha^x - c_5) e^{-c_6(\lambda,0)} \quad (4.12)$$

and

$$\frac{1}{\lambda_i} = \frac{1}{\lambda - 0.02\alpha} + \frac{0.003}{\alpha^3 + 1} \quad (4.13)$$

The values of  $c_x$  parameters are selected as below [73]:

$$\begin{aligned} c_1 &= 0.73 & c_2 &= 116/\lambda_i & c_3 &= 0.4 \\ c_4 &= 0.0 & c_5 &= 5/\lambda_i & c_6 &= 12.5/\lambda_i \end{aligned}$$

A series of  $c_p(\lambda, \alpha)$  curves versus  $\lambda$  for some values of  $\alpha$  is depicted in Figure 4.6 below. It is shown that power coefficient rises with decreasing pitch angle  $\alpha$ . It is also notable that the optimum tip speed ratio is different for every blade pitch angle  $\alpha$ .

The power output versus rotor speed of a 2 MW wind turbine with the above characteristics and a rotor diameter of 75 metres is shown in Figure 4.7 for various wind speeds. This graph was generated by combining Equations 4.10, 4.12 and 4.13.

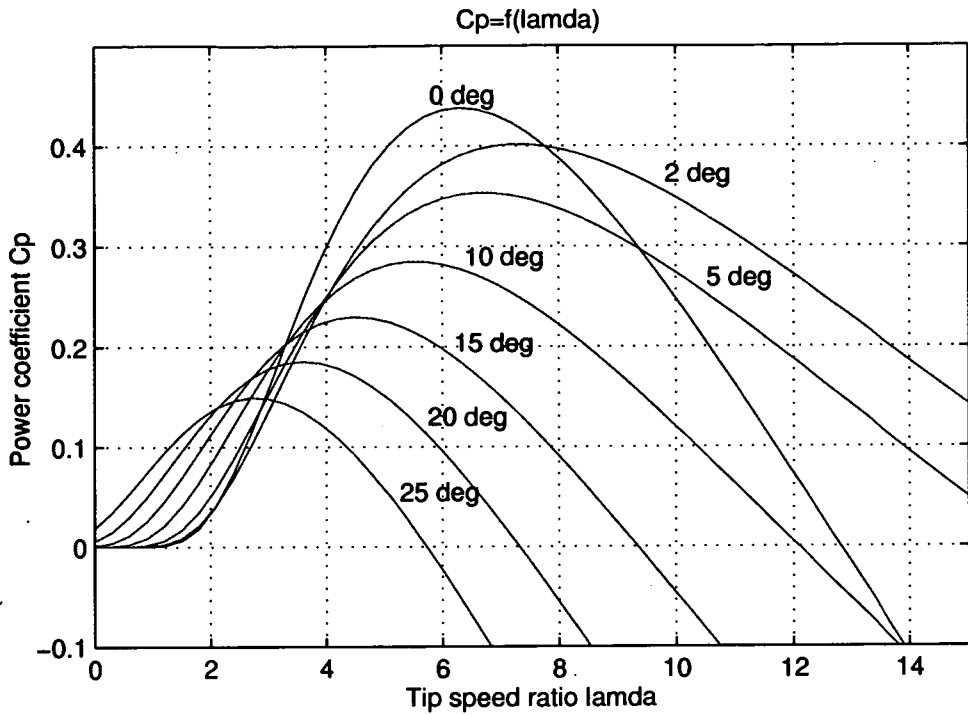

Figure 4.6: Power coefficient versus tip speed ratio for various values of blade pitch angle. Regenerated after Slotweg et al., 2001

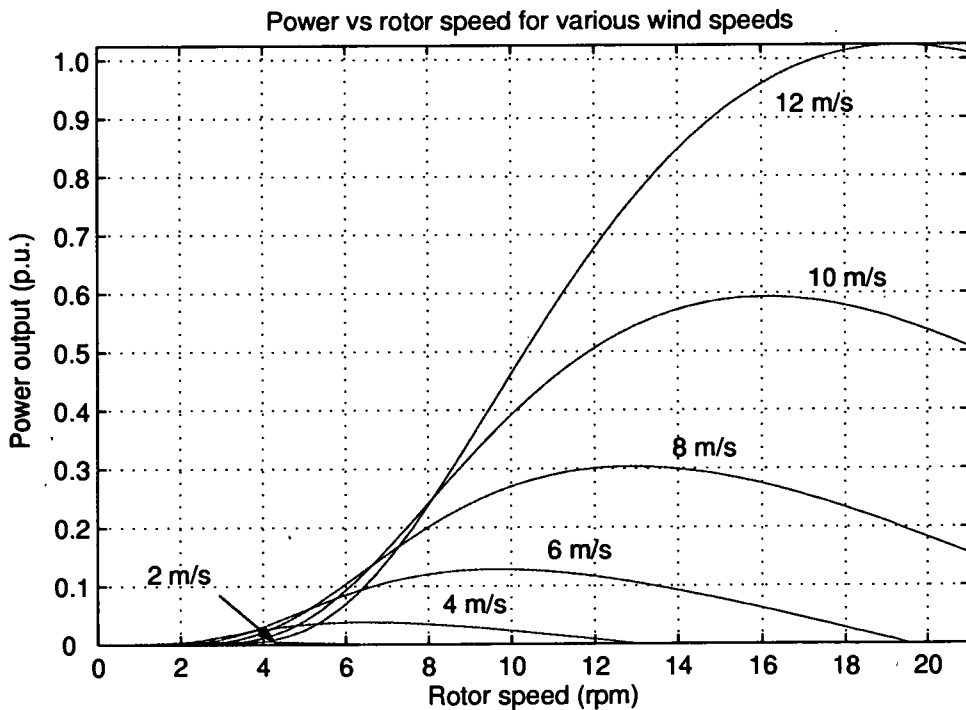

Figure 4.7: Power capture versus rotor speed for various wind speeds

The equation of motion of the wind turbine can be derived in the same manner as in the case of the small hydro generator that was presented in the previous chapter. In per unit terms it is given by:

$$2H \frac{d\omega_m}{dt} = T_m - T_e, \quad (4.14)$$

where  $H$  is the inertia constant in seconds,  $\omega_m$  is the per unit mechanical angular velocity,  $T_m$  and  $T_e$  are the mechanical and electrical torques, respectively, in per unit. This model assumes no interaction between the drive train and tower dynamics and no periodic phenomena such as gravitational forces on the blades or shadowing of the tower.

### 4.2.3 Electric Generators for WECSs

The most common turbine-generator configurations are shown in Figure 4.8. The first one (a) is the typical "Danish" concept, which consists of a constant speed, stall regulated induction generator directly connected to the network. This is the cheapest and most robust solution and the vast majority of the installed WECSs follow this scheme. Its major disadvantage is the complete lack of active control of the generator. Diagram (b) shows the variable speed version of the "Danish" concept.

In the variable speed configuration the induction generator is connected to the network through a power electronic converter, which decouples the rotor's speed from the network frequency, allowing the WT to vary its rotational speed. This way the energy yield is higher as the turbine can be controlled to operate always at its highest efficiency (tip speed ratio). Additionally, the power surge during wind gusts is less severe, as the rotor is allowed to accelerate (or decelerate) thus acting as a short-term buffer. The disadvantages of this configuration are (i) the added cost of the converter and (ii) the harmonics that the power electronics introduce to the system, as the converter that is connected in series to the generator has to cater for the whole power transfer between the generator and the network. A similar scheme is shown in (c), where the induction generator has been replaced by a high-speed synchronous generator.

Diagram (d) shows a direct driven (no gearbox) synchronous generator based WECS.

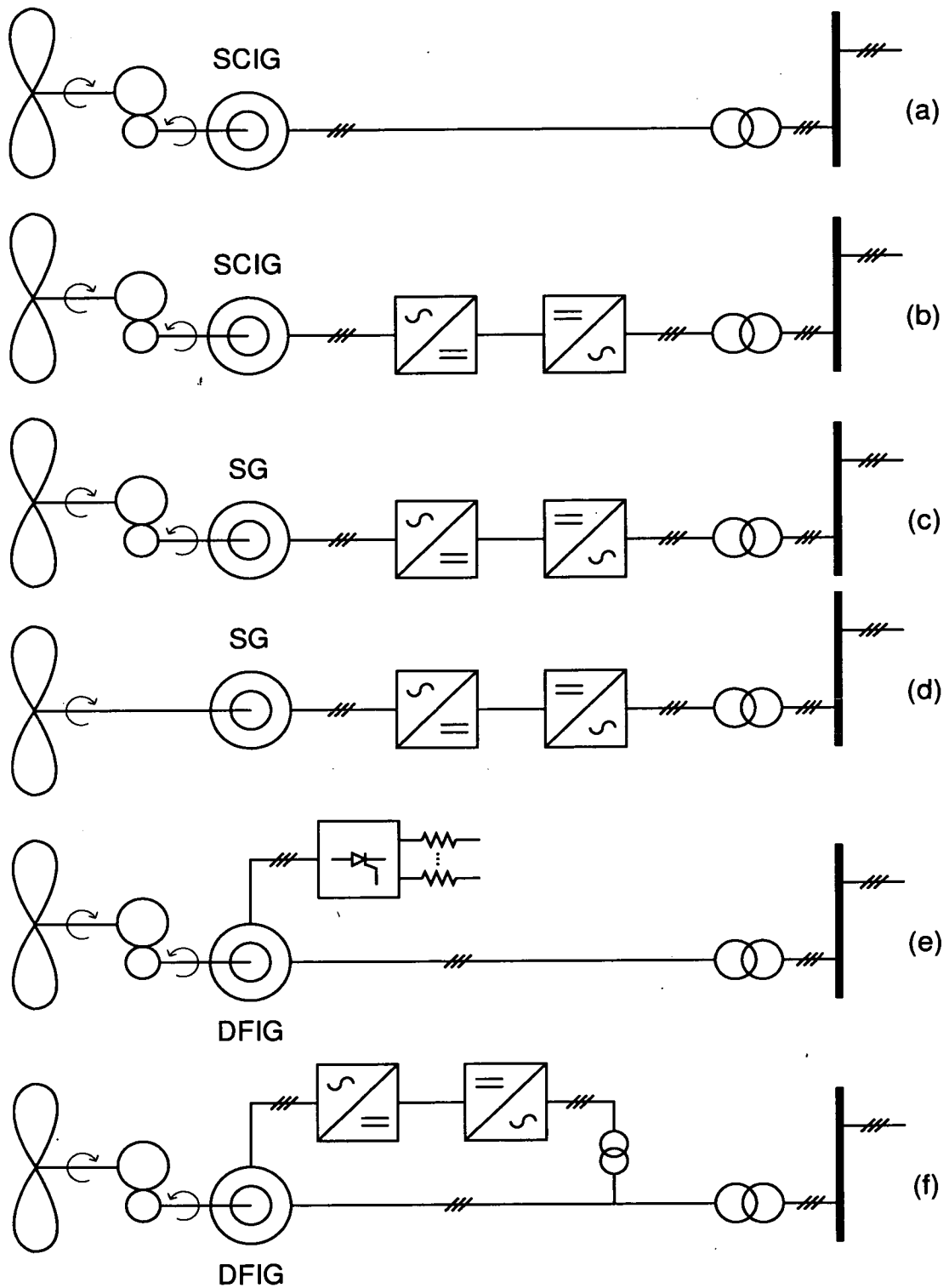

Figure 4.8: Most common generator topologies of wind energy conversion systems

The generator used in this case is a multi-pole, low-speed synchronous machine. This generator may be more expensive than the high-speed SG, but the extra cost is balanced by the savings due to the lack of a gearbox, which is the most expensive and sensitive part of a WECS.

The last two diagrams show WECSs that utilise the Doubly-Fed Induction Generator (DFIG). In (e) the speed of the generator can be increased by up to 20% over synchronous speed by altering the rotor circuit resistance by means of power electronic switches. Finally, diagram (f) shows a DFIG-based WT that is controlled by injecting a voltage to the rotor through a back-to-back power electronic converter. This configuration allows a  $\pm 30\%$  variation around synchronous speed. By feeding only the rotor circuit, the converter can be significantly smaller than in cases (b), (c) and (d) (typically 30% of rated generator power) which means that it is much cheaper and generates less harmonics [75]. This is the system that will be mainly considered in this thesis.

#### 4.2.4 Dynamic Model of the Doubly Fed Induction Generator

The dynamic model for the doubly fed induction generator will be constructed in the dq reference frame, as in the case of the synchronous generator in Chapter 3. The DFIG can be described in per unit by the following equations:

The generator convention is applied, which means that rotor and stator currents are positive when they are outputs.

$$v_{ds} = -R_s i_{ds} - \omega_s \psi_{qs} + \frac{d\psi_{ds}}{dt} \quad (4.15)$$

$$v_{qs} = -R_s i_{qs} + \omega_s \psi_{ds} + \frac{d\psi_{qs}}{dt} \quad (4.16)$$

$$v_{dr} = -R_r i_{dr} - s\omega_s \psi_{qr} + \frac{d\psi_{dr}}{dt} \quad (4.17)$$

$$v_{qr} = -R_r i_{qr} + s\omega_s \psi_{dr} + \frac{d\psi_{qr}}{dt} \quad (4.18)$$

where  $\omega_s$  is the stator electrical frequency,  $\psi$  the flux linkage,  $s$  the rotor slip, indices

$s$  and  $r$  are stator and rotor quantities, and finally  $d$  and  $q$  represent the direct and quadrature components. The rotor slip is given by:

$$s = \frac{\omega_s - pp \times \omega_m}{\omega_s}, \quad (4.19)$$

where  $pp$  is the number of pole pairs and  $\omega_m$  is the mechanical angular speed of the generator in *rad/s*.

The dq reference frame is oriented so that the d-axis coincides with the maximum of the stator flux and q-axis is preceding the d-axis by  $90^\circ$ . Therefore  $\psi_{ds} = \psi_s$  and  $\psi_{qs} = 0$ . Hence, from Equations 4.15 and 4.16 results that  $v_{ds} = 0$  and  $v_{qs} = v_s$ , which is equal to the terminal voltage.

The flux linkages in Equations 4.15 to 4.18 are given in per unit by:

$$\psi_{ds} = -(L_s + L_m)i_{ds} - L_m i_{dr} \quad (4.20)$$

$$\psi_{qs} = -(L_s + L_m)i_{qs} - L_m i_{qr} \quad (4.21)$$

$$\psi_{dr} = -(L_r + L_m)i_{dr} - L_m i_{ds} \quad (4.22)$$

$$\psi_{qr} = -(L_r + L_m)i_{qr} - L_m i_{qs} \quad (4.23)$$

where  $L_m$  represents mutual,  $L_s$  stator and  $L_r$  rotor leakage inductance respectively.

The real and reactive power generated (or consumed) by the doubly fed induction generator are given by:

$$P_g = v_{ds}i_{ds} + v_{qs}i_{qs} + v_{dr}i_{dr} + v_{qr}i_{qr} = P_s + P_r \quad (4.24)$$

$$Q_g = v_{qs}i_{ds} - v_{ds}i_{qs} + v_{qr}i_{dr} - v_{dr}i_{qr} = Q_s + Q_r \quad (4.25)$$

Assuming no losses within the turbine, the power given by Equation 4.10 equals the generated (and supplied to the network) electrical power of Equation 4.24. However, Equation 4.25 represents the reactive power of the machine, which is not necessarily equal to that exchanged with the network. Whereas the stator circuit is directly connected to the network (and therefore  $P_s$  and  $Q_s$  are directly exchanged with it), the

rotor circuit is connected through the power electronic converter. The network-side of the latter is able to generate or absorb reactive power independently and the rotor-side of it can provide the MVar requirements of the DFIG rotor. Therefore  $Q_r$  disappears from Equation 4.25, and at its place  $Q_c$  is added. However, in order to reduce the rating (and hence the cost) and losses of the network-side converter, in most cases the converter control strategy is to keep  $Q_c = 0$ , although other strategies can be applied as well (e.g.  $Q_{net} = Q_s + Q_c = 0$ ). It should be noted that the converter cannot store real power, therefore  $P_r = P_c$  and  $P_g = P_{net}$ . The following equation gives the electro-mechanical torque developed by a doubly fed induction generator:

$$T_e = \psi_{ds}i_{qs} - \psi_{qs}i_{ds} \quad (4.26)$$

Substituting the fluxes in Equation 4.26, it becomes:

$$T_e = L_m (i_{qr}i_{ds} - i_{dr}i_{qs}) \quad (4.27)$$

The changes in generator speed that result from a difference in electrical and mechanical torque can be calculated using the generator equation of motion (4.14). Equations 4.9 to 4.27 have been modelled to constitute a complete, wind-to-wire, dynamic model of a variable speed wind energy conversion system equipped with a doubly fed induction generator. In the next sections the required controllers for such a generation system will be discussed.

### 4.2.5 Blade Pitch Angle Controller

The blade pitch angle controller is one of the two components of a variable speed WT that controls the rotor speed. However in this implementation it has only a secondary role, as the main speed control function is performed by the speed controller described in the next section. The block diagram of the blade pitch angle controller is shown in Figure 4.9.

The pitch angle controller operates during high wind speeds when the maximum torque

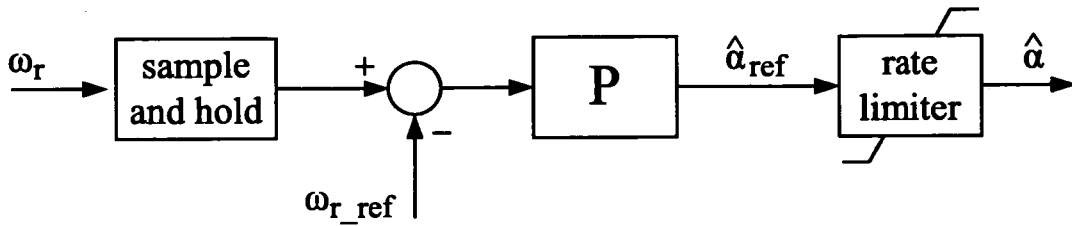

Figure 4.9: Blade pitch controller for the wind turbine

has been reached. Further increase of torque would overload the machine and the converter and therefore the pitch angle controller takes action by increasing the blade pitch, thus modifying the power coefficient curve  $c_p(\lambda, \alpha)$  of the turbine as shown in Figure 4.6 [76]. The rotor's rotational speed  $\omega_r$  (pu) is continuously sampled with a sample rate  $F_s$ , typically about  $2Hz$ . The speed error between  $\omega_r$  and reference (maximum) speed  $\omega_{r,ref}$  is then fed to a Proportional (P) compensator, which outputs the reference pitch angle  $\alpha_{ref}$  (deg). By using a simple P compensator the rotor speed may overshoot by a 15%-20% from its nominal value, depending on the gain of the compensator. However this is acceptable as the WT structure can sustain such overspeeds and since the system is never in steady-state (due to the variability of wind), use of a Proportional-Integral (PI) compensator to minimise the offset error is not justified. The rate limiter models the function of the pitch mechanism, which has a finite rate of change (typically  $3^\circ - 10^\circ$ ). It also constrains the pitch angle between the minimum and maximum values ( $0^\circ - 30^\circ$ ).

#### 4.2.6 Speed Controller

The speed controller is the main component used for rotor speed regulation. The controller objective described here is to optimise power extraction from wind. The blue trace Figure 4.10 shows graphically the relationship between rotor speed and power.

This curve, though, is sub-optimal for the reasons that will be discussed below. The optimal  $P_m - \omega_r$  curve is represented by the red dashed trace. It consists of three rotor speed regions, divided by speeds at points A' and D'. At A' is the cut-in speed, below

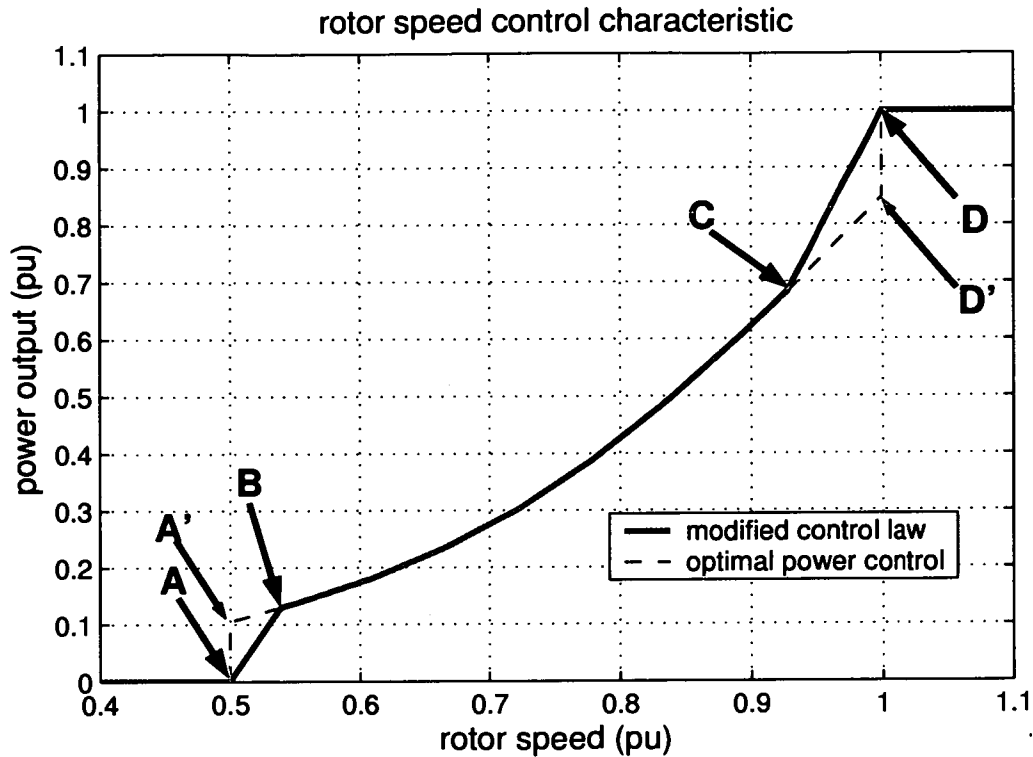
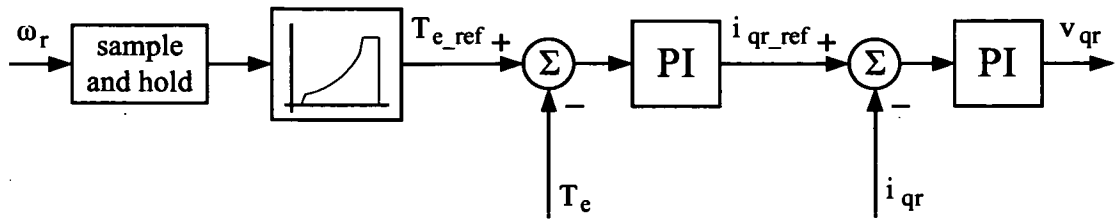

Figure 4.10: Speed control characteristic for the DFIG

which the wind turbine is turned off as the extracted power for these speeds will be very small and comparable to the losses. Between points A' and D', power rises in proportion to  $\omega_r^3$  and the objective of the speed controller is to track the maxima of the power coefficient curves for the particular wind speed (shown in Figure 4.6). When the rotor reaches its nominal speed, the speed controller objective changes to maintain power capture at rated value (1.0pu). That is the point that the blade pitch controller comes into play to constrain speed (and therefore power). However, the step changes at points A' and D' would bring about large power fluctuations when speed varies only a little around these values. Hence the step changes are replaced by the slopes A-B and C-D to allow a smoother change of power [77]. Obviously there is a trade-off between smooth operation and optimal power extraction as the farther the distance from A to B and C to D (smoother change of power), the greater the difference between optimal and actual power extraction will be [78]. Figure 4.11 shows the block diagram of the rotor speed controller.



**Figure 4.11:** Speed controller for the wind turbine

Rotor speed is measured and sampled with a sample rate of a few tens of Hertz (typically  $20\text{Hz}$ ). Using the sampled speed measurement and the control law depicted in Figure 4.10, a torque setpoint is generated by dividing the power derived from the graph with speed. It should be noticed that torque is used instead of power because it is proportional to  $i_{qr}$  and therefore makes control easier. Combining Equations 4.20 - 4.23, 4.31 - 4.34 and 4.26 and assuming that  $r_s = 0$  it emerges that:

$$T_e = -\frac{L_m v_{qs}}{L_m + L_s} \times i_{qr} \quad (4.28)$$

The error between the derived torque setpoint and measured electrical torque is fed to a PI compensator to define the  $i_{qr\_ref}$  reference value. Then the error between  $i_{qr\_ref}$  and actual  $i_{qr}$  is fed in turn to a second PI in order to generate the  $v_{dr}$  reference, which is then sent to the rotor side inverter.

### 4.2.7 Voltage / Reactive Power Controller

One of the most important advantages of doubly fed induction generators over standard squirrel cage machines is that their reactive power can be controlled and this makes them a very attractive option especially when the network that the turbine or farm is going to be connected is weak [79, 80]. The reactive power exchanged between the DFIG and the network is regulated by the controller shown in Figure 4.12.

Assuming that  $r_s = 0$ , by combining Equations 4.31 - 4.34 and 4.24 - 4.25, it can be

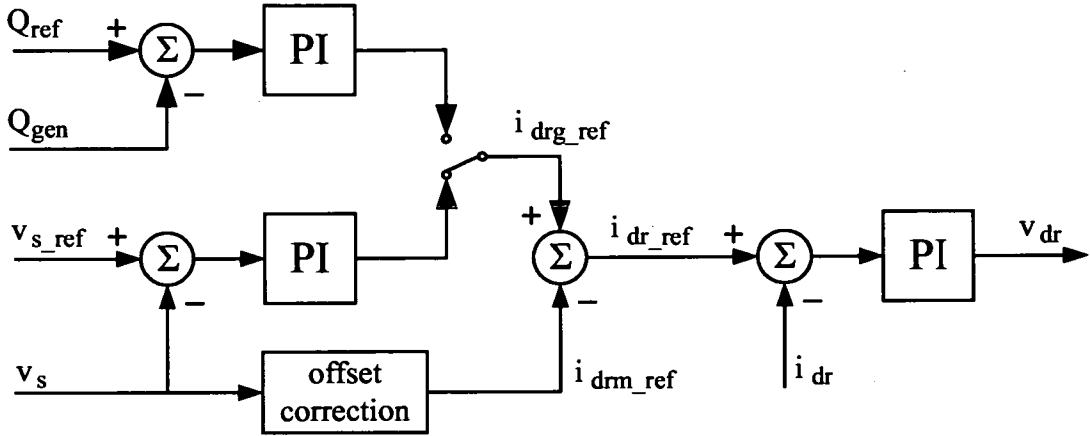

Figure 4.12: Voltage / reactive power controller for the DFIG

derived that the relationship between  $Q$  and  $i_{dr}$  is governed by the following equation:

$$Q_{gen} = -\frac{L_m i_{dr} v_{qs}}{L_m + L_s} - \frac{v_{qs}^2}{\omega_s (L_m + L_s)} \quad (4.29)$$

In the block diagram of Figure 4.12 the offset correction block calculates the current  $i_{drm}$  required for magnetising the rotor. This current can be found by the following equation:

$$i_{drm} = -\frac{v_{qs}^2}{\omega_s (L_m + L_s)} \quad (4.30)$$

If this value is used as a reference for  $i_{dr}$ , then the inverter will provide only the reactive power required for the magnetisation of the rotor and therefore no reactive power will be exchanged with the network and the DFIG will operate at unity power factor. In the block diagram of Figure 4.12, this would require the PI compensator responsible for voltage regulation (lower left) to be disabled. A reactive power setpoint could then be compared to generator's actual MVAR output, and with the assistance of the upper left PI compensator, the controller could perform Q or PF control. Alternatively the DFIG can operate in voltage control mode by selecting the lower left compensator.

### 4.3 Simulation of Wind Turbine Operation in a Distribution Network

The WECS model presented in this chapter has been constructed in Simulink. The top level diagram as well as the most important components of the WECS model are shown in Figure 4.14. In order for the model to be validated, it had to be comparable to that modelled and reported in the literature. Therefore the turbine and machine parameters presented in [74] have been used. These parameters are shown in Tables 4.1 and 4.2. Its main components are the wind turbine (as described by Equations 4.9 - 4.13), the DFIG (Equations 4.14 - 4.27), the real and reactive power controllers as shown in Figures 4.9 - 4.12 and finally the network model, which is implemented as a Matlab function. The 120 second wind speed time series shown in Figure 4.13 was used as an input to the model.

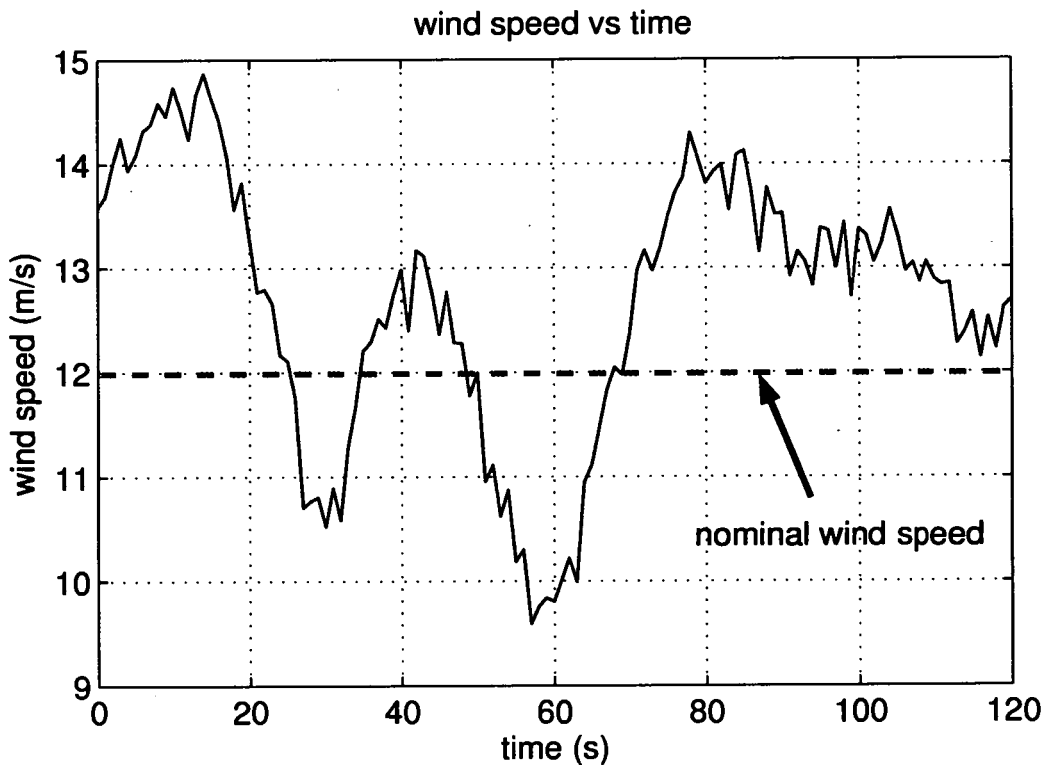

**Figure 4.13:** 120 second wind speed time series used for the simulations

In the following simulations the network consists of a simple two-bus system, one of

which hosts the WT and the other is the slack bus. The two buses operate at 11kV and are connected by a line with  $R_l + jX_l = 0.0443 + j0.0331$  pu on a 2MVA base. This is the equivalent of a 5km line made of a ACSR 54/9 type conductor.

rotor radius	37.5m
rotor speed range	9 - 21 rpm
rated power	2 MW
nominal wind speed	12 m/s
cut-in wind speed	3.5 m/s
gear box ratio	1:100
total moment of inertia	$5.9 \times 10^6 \text{kgm}^2$

**Table 4.1:** *Wind turbine characteristics*

pole pairs	2
generator speed range	900 - 2100 rpm
mutual inductance $L_m$	3.0pu
stator inductance $L_s$	0.1pu
rotor inductance $L_r$	0.08pu
stator resistance $R_s$	0.01pu
rotor resistance $R_r$	0.01pu
line resistance $R_l$	0.0443pu
line inductance $L_l$	0.331pu
network voltage	1.0pu
base voltage	11kV
base power $MVA_{base}$	2MVA

**Table 4.2:** *DFIG characteristics*

### 4.3.1 WT Operating at Constant Power Factor

The first simulation presents the conventional mode of operation of a wind turbine equipped with a doubly fed induction generator. At first, the voltage control component of the reactive power controller shown in Figure 4.12 is disabled and the power factor setpoint is set at 1.0 (no reactive power). Figure 4.15 shows the resulting real power export, rotor speed and blade pitch angle when the DFIG is operating at constant power factor mode.

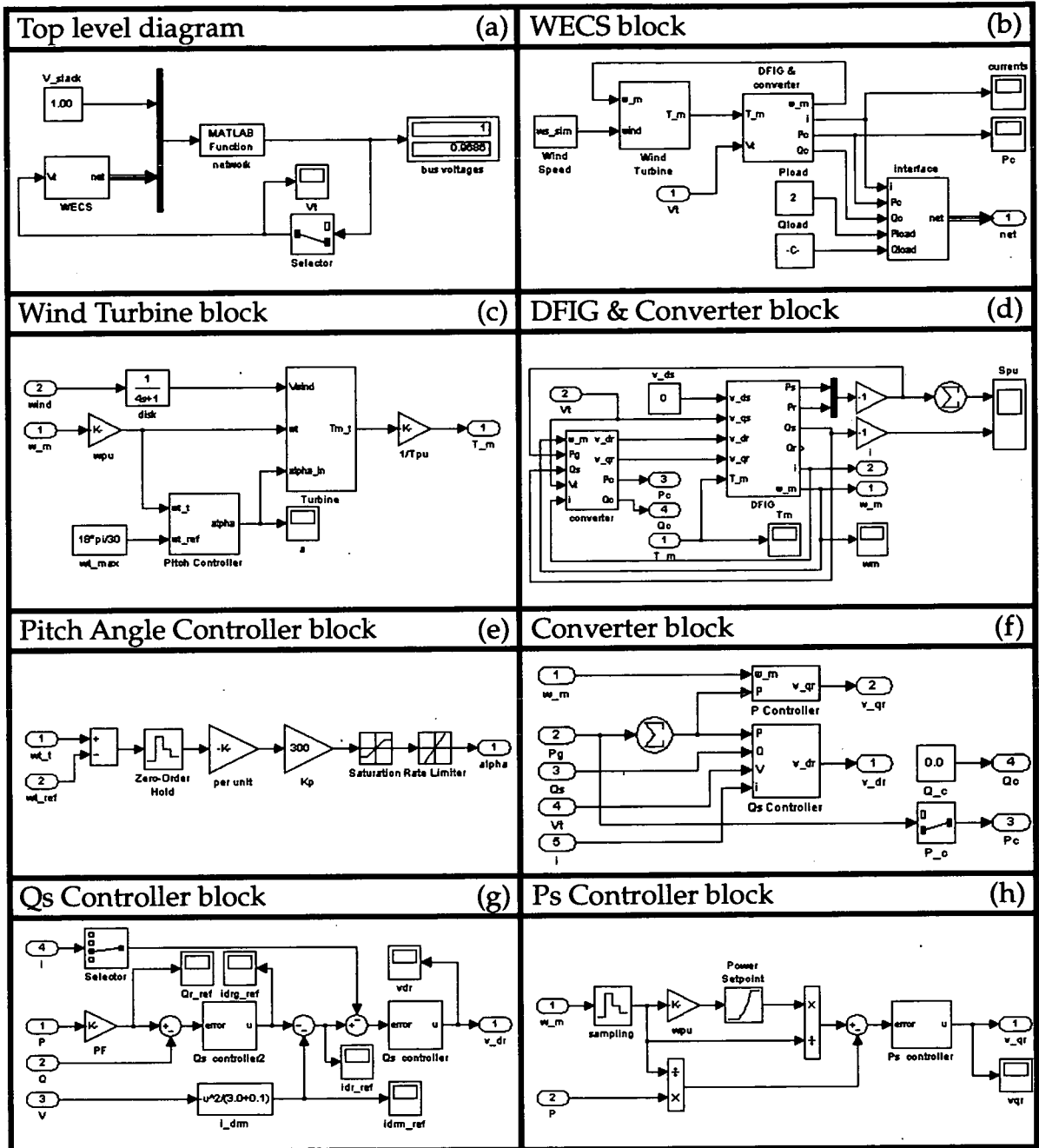

Figure 4.14: Diagrams of the most significant blocks of the dynamic WECS model in Simulink. From (a) to (h): Top level diagram, WECS, wind turbine, DFIG and converter, pitch angle controller, power electronic converter, reactive power controller and real power controller. In (g) the  $Q_s$  controller has been set up to perform power factor control.

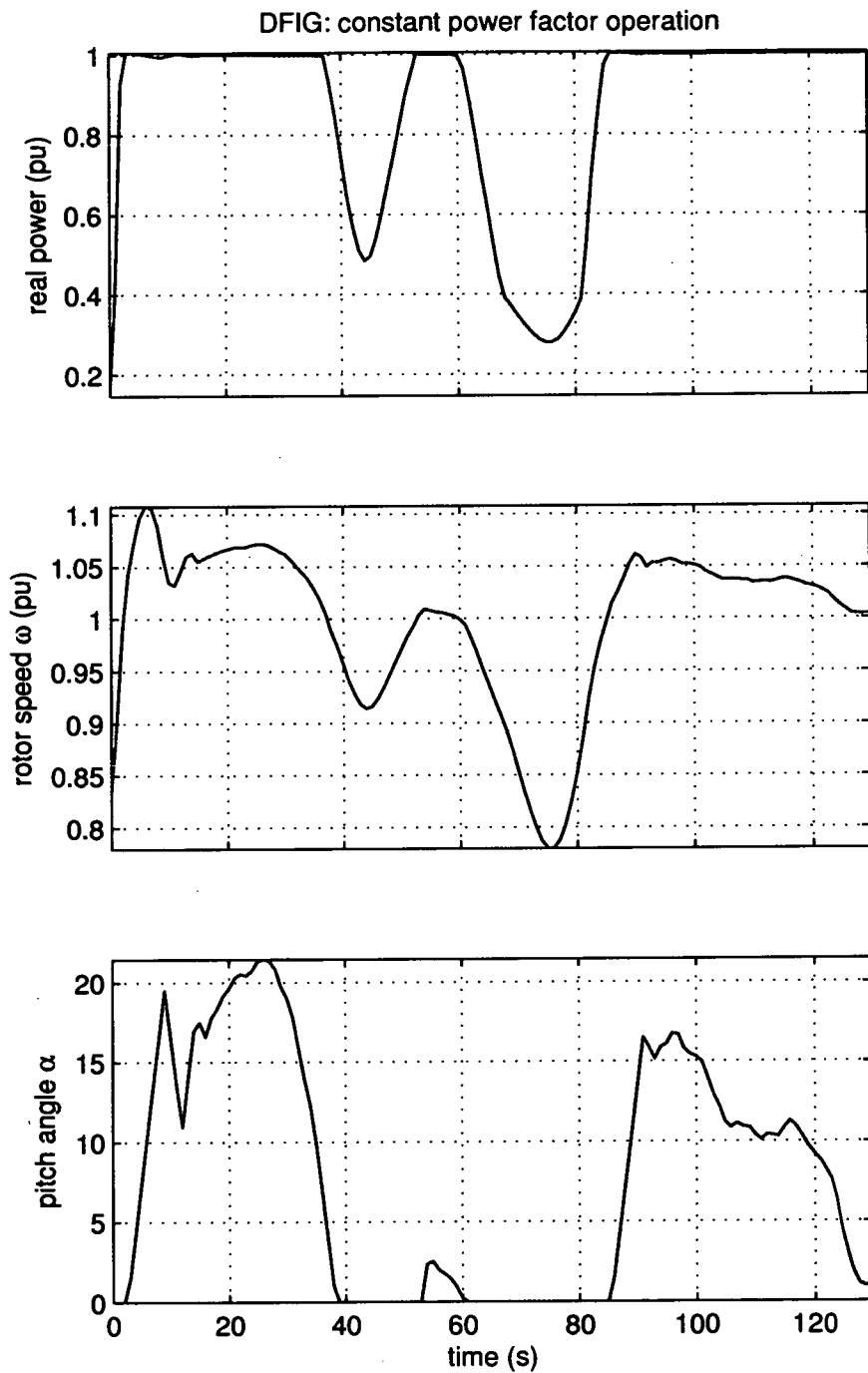
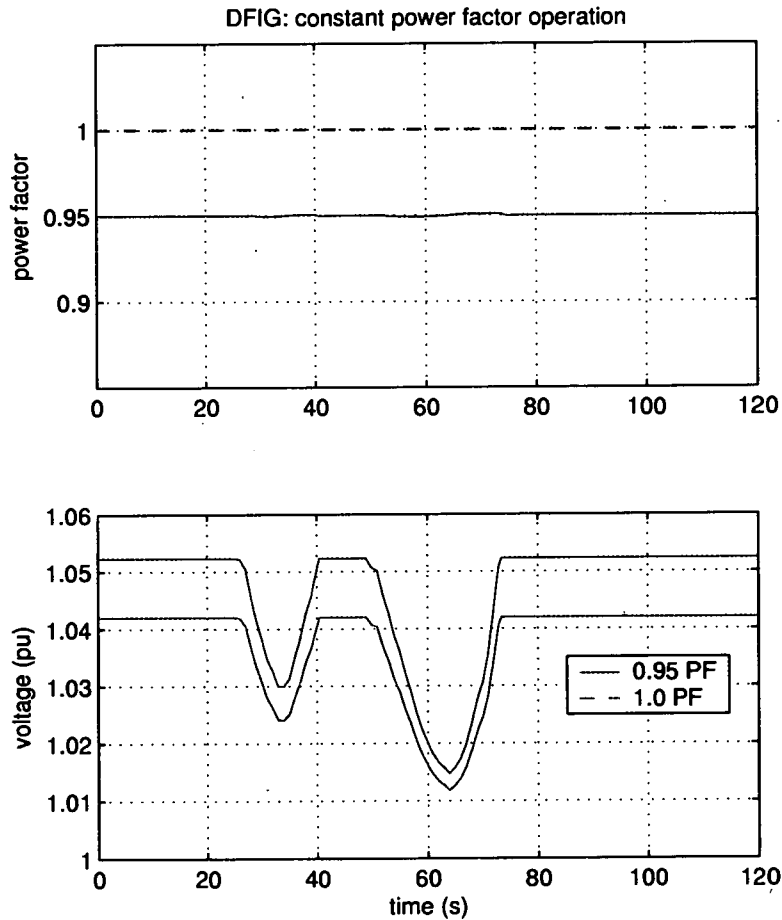

Figure 4.15: Real power export, rotor speed and blade pitch angle for the DFIG in constant power factor operation

The first observation is that the short-term transients of the wind speed have been smoothed away due to the averaging over the rotational area, the inertia of the system and the variable speed operation of the turbine, which acts as a short-term energy buffer. It is also shown that the speed varies between +10% and -20% even at rapid gusts, thus the turbine is operating safely, since the turbine can rotate with up to +30% deviation from nominal speed, depending on the converter ratings. Finally the operation of the pitch angle controller is depicted in the last graph of Figure 4.15. At times of high wind speed the controller increased the pitch angle up to 20 degrees for this particular time series in order to constrain the power output. Figure 4.16 shows the response of the power factor and the terminal voltage of the generator when it operates in constant power factor mode.



**Figure 4.16:** Power factor and terminal voltage for the DFIG in constant power factor mode

In this figure the blue trace represents a power factor setpoint of 1.0 and the red dashed trace shows the response for 0.95 PF lagging (exporting reactive power). It should be noted here that in both cases the responses of real power export, rotor speed and blade pitch angle were identical to the ones shown in Figure 4.15. The reactive power controller manages to fix power factor at the desired setpoints, but as a consequence the voltage varies with the changing power generation. It can be seen that the variation is wider in the case of lagging power factor than the one at unity, and this is explained by the fact that at unity the reactive power is zero, whereas at 0.95 lagging, the reactive power varies in proportion to the real power, thus increasing the effect of voltage fluctuation.

### **4.3.2 WT Operating at Constant Voltage**

Although not widely practiced yet, wind turbines equipped with doubly fed induction generators can perform voltage control in a distribution system, thus assisting the DNOs to regulate the voltage profile of the network. However, for this to happen a solid regulatory framework has first to be developed. The response of the power factor and the terminal voltage of the generator when it operates in constant voltage mode is shown in Figure 4.17.

The V/Q controller is now set to perform voltage control, and fix the terminal voltage at 1.03 per unit. In this case also the responses of real power export, rotor speed and blade pitch angle were identical to the ones shown in Figure 4.15. However the power factor and voltage responses are quite different. Power factor has now settled at 0.95 leading (absorbing VARs), as due to the high real power output the voltage tends to rise over the 1.03 pu set point. It can be observed that terminal voltage remains practically constant at the setpoint value, but the power factor is increased during the two sudden reductions of wind speed at  $t = 35s$  and  $t = 65s$ , as the voltage rise due to the real power export became smaller.

It should be noted that the results obtained in the last two sections agree with the results presented in [74], where the WECS data were taken from. Although the wind speed

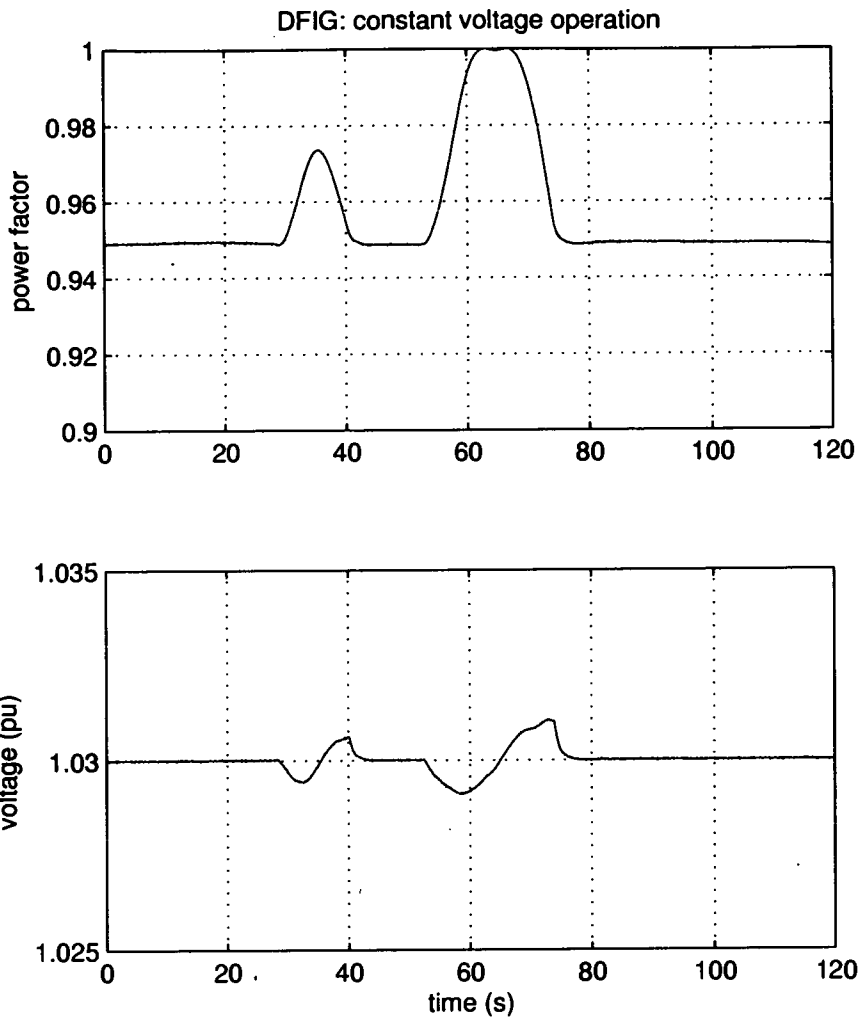

**Figure 4.17:** Power factor and terminal voltage for the DFIG in constant voltage mode of operation

input and the network characteristics are different in this case, the numerical values for power output, rotor speed and pitch angle are almost equal for the same wind speed. Some deviation is expected, as the systems are not at (but close to) steady-state. The voltage results agree with the results of a standard power flow for the same generated power and power factor (and in the same network). Therefore it is concluded that the model is accurate.

## 4.4 Steady State Model of the DFIG

Inclusion of the flux derivatives in Equations 4.15 to 4.18 would require a simulation step time well below 50ms that is a typical value for fundamental frequency dynamic simulations, hence drastically increasing the computational load. The full model is useful when studying the dynamic performance of the system (including the controllers), but does not provide more information for long term simulations than the steady state model. The above set of equations can be simplified to give the steady state model as follows. By allowing the generator to operate with variable speed, the torque does not experience rapid fluctuations. This has a smoothing effect on the generator currents as well (and hence the fluxes), and therefore the dynamic terms of Equations 4.15-4.18 have negligible effect and can be eliminated [65].

Taking into account the assumption discussed above and by substituting Equations 4.20-4.23 into Equations 4.15-4.18 the voltage equations for the DFIG become:

$$v_{ds} = 0 = -R_s i_{ds} + \omega_s [(L_s + L_m) i_{qs} + L_m i_{qr}] \quad (4.31)$$

$$v_{qs} = -R_s i_{qs} - \omega_s [(L_s + L_m) i_{ds} + L_m i_{dr}] \quad (4.32)$$

$$v_{dr} = -R_r i_{dr} + s\omega_s [(L_r + L_m) i_{qr} + L_m i_{qs}] \quad (4.33)$$

$$v_{qr} = -R_r i_{qr} - s\omega_s [(L_r + L_m) i_{dr} + L_m i_{ds}] \quad (4.34)$$

The above equations do not include a dynamic term and therefore can be used to draw the steady-state equivalent circuit of the DFIG. By considering Equations 4.31 - 4.34 the steady-state equivalent circuit of the DFIG as well as the corresponding phasor diagram can be derived as shown in Figure 4.18, where  $X = \omega_s L$  and index  $m$  denotes magnetising quantities.

The power electronic converter that injects voltage in the rotor circuit can now be modelled as an ideal current source. The current setpoints are assumed to be instantaneously reached. This is a safe assumption as today's power electronic switches have response times well below the time frame in consideration. The set of equations

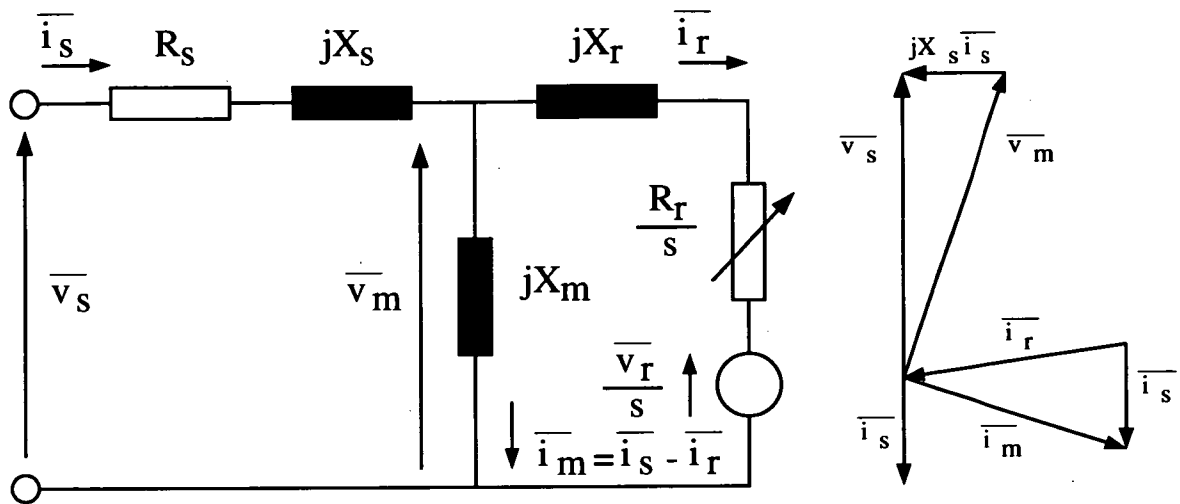

**Figure 4.18:** *Steady-state equivalent circuit for a DFIG and corresponding phasor diagram*

described in this section was utilised to construct the steady state model used in the following chapters for long term simulations.

## 4.5 Summary

In this chapter the modelling philosophy and the fundamental components for a wind-to-wire model of a wind energy conversion system were presented, namely the models of the wind speed, the wind turbine, the drive train and the doubly-fed induction generator. The advantages and disadvantages of the available configurations for WECS were discussed. Variable speed wind turbines are favoured by the industry due to their superior efficiency and controllability. From the available generators for variable speed WT schemes, the doubly-fed induction generator is most favoured and therefore this is the configuration that this work is based on. The dynamic model of a DFIG was presented in this chapter and two characteristic examples of its operation under constant power factor and constant voltage control were simulated. The results were in close match with other models in the published literature and therefore the constructed model can be relied upon. The next chapter uses the models developed here (and

in Chapter 3) to devise and validate intelligent control of distributed generators to overcome the voltage fluctuations brought about by the weakness (in electrical terms) of the distribution network.

---

# Chapter 5

## Intelligent Control of Distributed Generation

---

### 5.1 Introduction

This chapter proposes two methods of steady-state voltage control in remote parts of rural distribution networks that accommodate an increasing capacity of synchronous and doubly fed induction generators. The first of them is a deterministic system that uses a set of rules to switch intelligently between voltage and power factor control modes, while the second is based on a Fuzzy Inference System that adjusts the reference setting of the Automatic Power Factor Controller in response to the terminal voltage. Extensive simulations have verified that the proposed approaches increase the export of real power while maintaining voltage within the statutory limits.

### 5.2 The Need for Intelligent Control

The steady-state, slow and transient variations of voltage levels related to the connection of a DG can lead to undesired operation of voltage control equipment on transformers at the primary substations of the network. A net reversal of power flow in the distribution network line due to the presence of a DG can cause unacceptable voltage variations, and to protect quality of supply the Distribution Network Operator (DNO) may require that the DG be automatically disconnected by protection devices [4]. Operation of DGs in constant voltage or constant power factor (PF) mode, as required by most DNOs, may create a need for network reinforcement in order to reduce voltage variation and the cost of this work may be attributed to the connection costs of the DG. This may make potential schemes less attractive or even impossible to implement [3, 4].

The ability to export active and reactive power without voltage violation depends on network characteristics above the point of connection, and on the active and reactive power exported from the local busbar. Line power flow is reduced by local demand according to daily and seasonal patterns. The network impedance and X/R ratio can also vary due to automatic reconfiguration, but less frequently. Changes in local loading and network configuration causes local voltage excursions that can shut down the DG with loss of production and revenue. These effects are widely experienced by operators of DGs in rural areas. Depending on its capacity and the inherent voltage variation in the network, there may be merit in operating the DG with the excitation system in constant voltage mode as necessary. The ability to operate inside an acceptable voltage envelope and the opportunity to reduce network reinforcement costs could increase DG development.

Additionally, at times of high local load, or when changes in network impedance led to reduced voltage at the local busbar, the DG could be used to attempt to maintain voltage. While this could provide a measure of network support in the weak areas Distribution Network Operators need not accept this method of operation. An unconstrained machine in voltage control could attempt to define voltages that may conflict with their automatic voltage control equipment, and cause spurious operation of protection, particularly at times of light local load. If the DG tried to meet an excessive demand for reactive power, as voltage continued to fall, the AVR could attempt force excitation with potentially damaging results for the generator. While excitation overcurrent or busbar undervoltage protection should limit this they would shut the plant down, with loss of production and the need for a restart. There is a need to make best use of potential DG plants both from the developers' and the DNOs' point of view.

### 5.2.1 Universal Power Circle Diagram

Considering the simple two-bus system of Figure 5.1, if the DG produces  $P_G + jQ_G$  and the local demand is  $P_L + jQ_L$ , the complex power delivered to the line in VA is:

$$S_{line} = P_{line} + jQ_{line} = (P_G - P_L) + j(Q_G - Q_L) \quad (5.1)$$

In Chapter 2 it was shown that the voltage rise due to the exported power from the DG bus would be:

$$D\bar{V} = \bar{V}_2 - \bar{V}_1 = \frac{RP_{line} + XQ_{line}}{V_2} + j\frac{XP_{line} - RQ_{line}}{V_2} \quad (5.2)$$

Equations 5.1 and 5.2 show that, where line power flow is dominated by DG production,

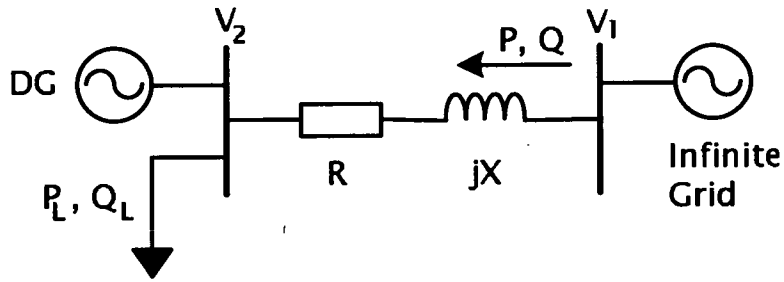
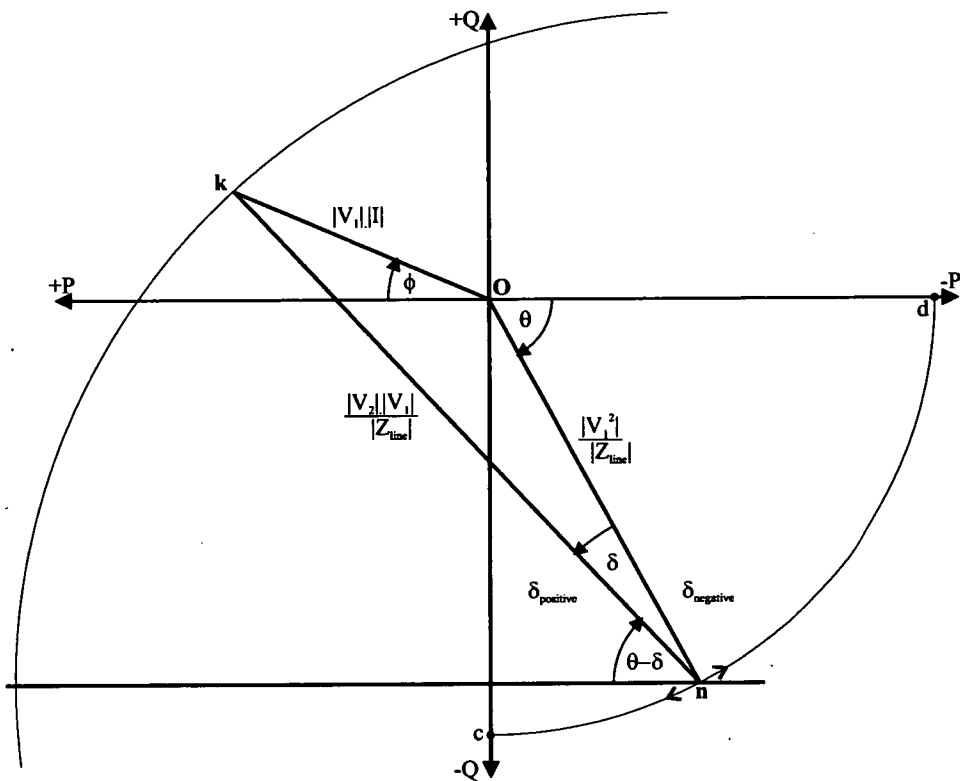

Figure 5.1: Basic 2 bus system

operating the generator at a constant power factor will result in voltage excursion as the plant tries to export reactive power in constant proportion to active power. Line impedance directly increases voltage rise. Line X/R ratio skews the effects of real and reactive power. A clearer appreciation of these may be obtained by considering the Universal Power Circle Diagram (UPCD) for a short distribution line shown in Figure 5.2. For  $X_{line} \gg R_{line}$  angle  $\theta$  approaches  $-90^\circ$  degrees and the diagram resembles that of a synchronous generator connected to the infinite grid. At the edges of the distribution network, where the X/R ratio tends to be lower,  $\theta$  is less than  $90^\circ$  and the voltage origin and centre of constant  $V_2$  circles rotates around a semicircle towards the  $-Q$  axis by less than  $90^\circ$ . The complex power line drawn out of the PQ origin may be used to prescribe constant MVA circles and power factor lines at the remote end of the line, as shown in Figure 5.3. If the voltage at that end of the line



**Figure 5.2:** Universal power circle diagram for a short distribution line

is constant (nominally 1.0 pu) semi-circles of constant busbar voltage may be drawn, including voltage limits. The effects of changing network impedance may be separated from changing line power flow. Only increased complex power flow moves point  $k$  further away from the PQ origin, towards voltage limits. Where  $X/R$  ratios are high, dispatch of reactive power will rapidly take the busbar voltage to the overvoltage limit. Where the  $X/R$  ratio is lower reactive power flow has less effect and eventually active power flow becomes limited by the anti-clockwise rotation of the voltage phasors and voltage circles. Increased network impedance rescales the constant voltage circles to bring the limits closer to or inside point  $k$  and therefore dispatch of complex power is limited. While these diagrams are based on complex power flow in the line, they are useful to enable computation and examination of loci of busbar voltage as the DG is loaded or as local demand varies, while the plant is in constant power factor or constant voltage control. They also visualise the effects of network changes on the limits of operation and dispatch of DGs connected to the local busbar, particularly where the capacity of

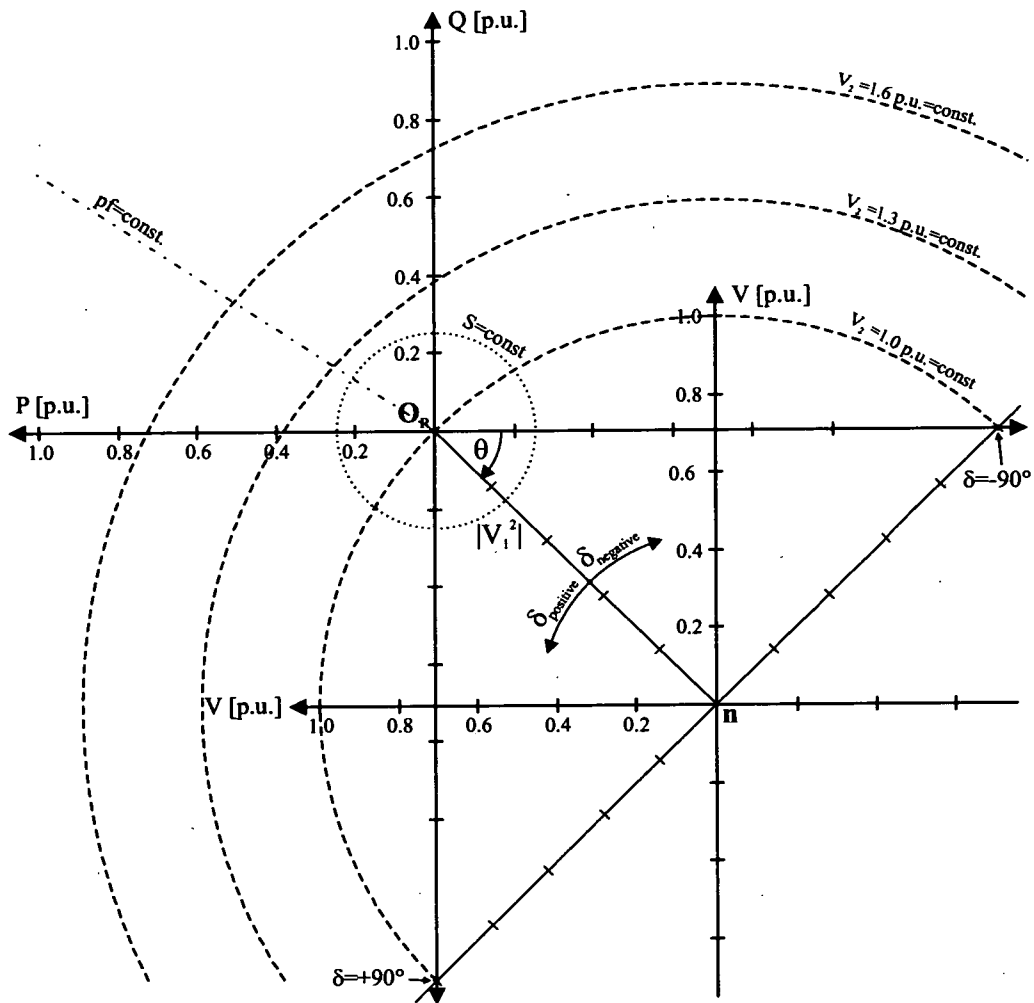

**Figure 5.3:** Composite universal power circle diagram

the generator is dominant. Finally they show that for an increasing MW export from the generator, the only way to maintain local voltage within limits is by reducing export and (should the generator be capable) even going further to import MVARs.

The universal power circle diagram focuses on the network impacts of varying power flows and line impedances. It would be useful to be able to combine the UPCD with the capability diagram of the generator in order to define the working limits of the whole system. However, the UPCD involves varying voltages for the generator bus, thus becoming incompatible with the capability diagram. In order to devise a control strategy for the generator, the network limitations should be reflected on the

machine's operational regime. This can be achieved by using 3D diagrams as shown in Figure 3.13. In this figure, the capability diagram of a synchronous machine connected to a distribution network scaled in the z-axis by terminal voltage, was superimposed to the voltage surface resulting from the real and reactive power loading of the generator. Figure 5.4 shows the same graph from the top. The black line is the intersection of the

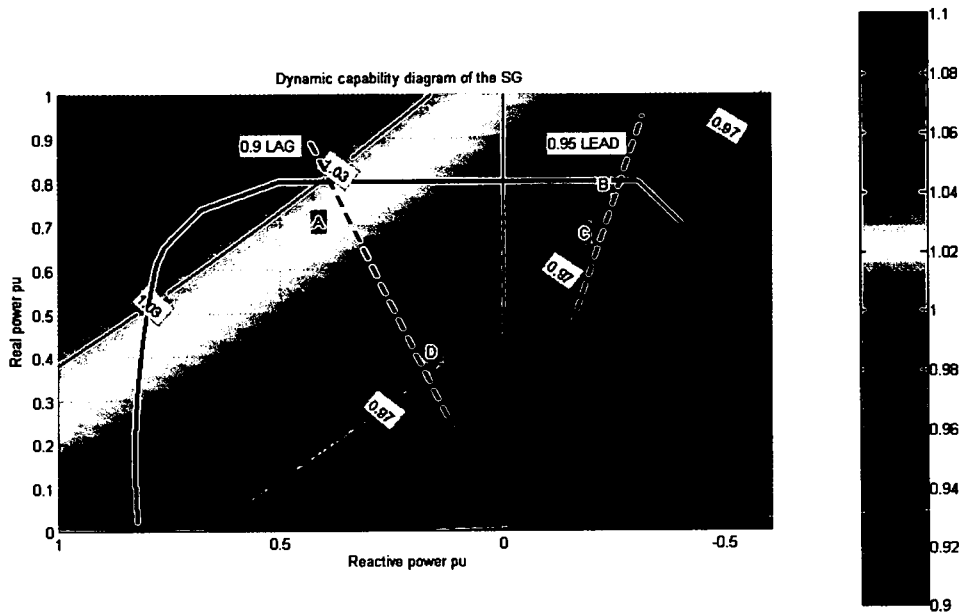

Figure 5.4: Dynamic capability diagram for  $P_{load} = 0.6 pu$ ,  $PF = 0.8$ .

3D capability diagram with the voltage surface; in effect it depicts the actual operating limits for this generator in that particular network and load conditions. In this case the local load was  $6MW/4.5MVAr$ . The rating of the generator was  $12MVA$ , its reactance was  $0.8pu$ , the feeder's impedance was  $0.8 + j0.6pu$  and the network's voltage was  $1.0pu$ . Base quantities were  $11kV / 10MVA$ . On the same graph, the voltage and power factor limitations imposed by the DNO are shown. The dashed lines represent the power factor limits (in this case assumed to be 0.9 lagging - 0.95 leading), the blue line is the overvoltage limit set at  $1.03pu$  and the red line is the undervoltage limit, at  $0.97pu$ . While the generator is able to operate safely anywhere within the capability diagram, should the DNO's demands be satisfied the operating area is constrained

to section ABCD, confined by the capability diagram and voltage and PF limits. It is shown that at rated output (0.8pu) the generator can use all the available power factor range, staying just below the overvoltage limit at 0.9 PF. In Figure 5.5 the local load was decreased to 4MW/3MVAr. At its rated real power, the reactive power of the

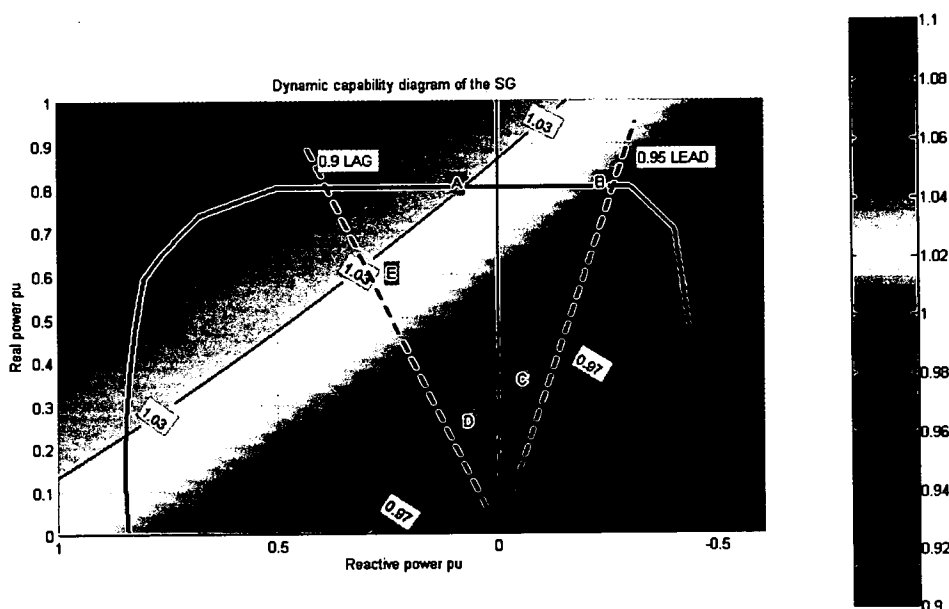

Figure 5.5: Dynamic capability diagram for  $P_{load} = 0.45 \text{ pu}$ ,  $PF = 0.8$ .

generator is now constrained by the overvoltage limit and the minimum (leading) power factor. The effective power factor limits are therefore 0.995 lagging - 0.95 leading. If the generator wanted to increase its reactive power output and yet remain within the voltage limits, it would have to reduce its real power output.

It is therefore apparent that due to the variability of the network conditions in a weak distribution system, operating at a fixed power factor assumes accepting the risk of hitting the over/undervoltage limits. Work done by the author for the purposes of this project, involving mixed voltage/PF control of DGs, have shown that by intelligently controlling the distributed generators, voltage variations can be mitigated and reinforcement may be avoided [4, 81, 82]. Utilisation of a Fuzzy Logic

(FL) Controller to control the DG may also prove to be a means of reducing voltage fluctuations [83]. In this chapter these control algorithms will be presented and it will be shown that the same method can be applied to both synchronous and doubly fed induction generators.

## 5.3 Artificially Intelligent Controllers

The term *Artificial Intelligence* (AI) is described as a

”computer process that attempts to emulate the human thought processes that are associated with activities that require the use of intelligence”

There are a number of algorithms that can be categorised as AI controllers, such as expert systems, knowledge based systems, fuzzy logic controllers, neural networks, genetic algorithms etc. In this work two of these types of algorithms have been utilised: expert systems and fuzzy logic controllers. Artificial intelligence concepts have been investigated by several research groups as a means of improving voltage quality in electricity systems [49, 55, 84–91]

### 5.3.1 AI Controllers Based on Expert Systems

Expert systems are one of the most basic types of AI. The core of an expert system is the knowledge base, which contains the encoded problem solving knowledge for the particular application. A well known mechanism for knowledge representation is rule-based knowledge that takes the form of *if condition(s) then action(s)* statements. The expert system gathers information which it then uses to make decisions based on a pre-loaded set of rules. Their advantages are their ability to permanently encapsulate knowledge provided by human experts, their flexibility and their ability to generate answers quickly and with consistency. On the other hand, their disadvantages are that they are not adaptive to changing environments and they have difficulty in handling large amounts of data or use of large rule bases.

### 5.3.2 Fuzzy Logic Controllers

Fuzzy set theory was first discussed in the mid-sixties. Fuzzy controllers are being used with noisy, nonlinear and time-variant systems, tuning problems and with complex multiple input multiple output systems. In conventional logic the number 1 indicates that an object belongs to a set, while 0 indicates that the object is not a member of the set. The distinctive feature of fuzzy systems is that there are degrees of membership that vary from 0 to 1. A fuzzy logic system consists of four stages: the fuzzyfication stage, where crisp input information is converted to fuzzy values, the decision-making stage where it is decided how the fuzzy logic operations are performed, the knowledge base, which contains the decision-making rules and the defuzzyfication stage which converts the fuzzy information back to crisp information.

## 5.4 Hybrid Voltage / Power Factor Controller

The disadvantage of Figure 5.4 and 5.5 is that they are generator-specific. A generic diagram that includes both the network and generator limitations is shown in Figure 5.6. This vector diagram shows the operational limitations and the constraints (i.e. power factor values and ranges of permissible voltage) that the network operator imposes on the DG in the basic case of a 2-bus system such as the one shown in Figure 5.1. In this diagram  $V_{min}$  and  $V_{max}$  are the minimum and maximum acceptable voltages and  $PF_{min}$  and  $PF_{max}$  are the lines of constant minimum and maximum power factor, respectively. The allowable area of operation for the generator is the shadowed region between these boundaries. Ideally, therefore, a control system should constrain the operation of the distributed generator within these boundaries. The block diagram of a system that restricts operation of a synchronous generator within the shadowed area is shown in Figure 5.7. The details of excitation systems and synchronous machine modelling have been presented in Chapter 3.

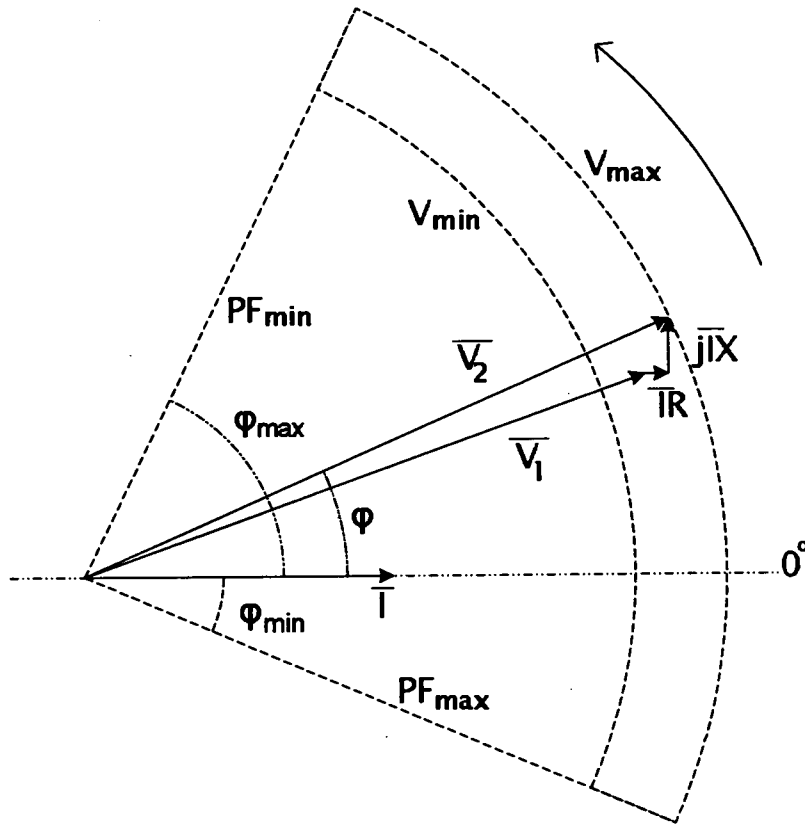

Figure 5.6: Voltage vector diagram for the two-bus system of Figure 5.1

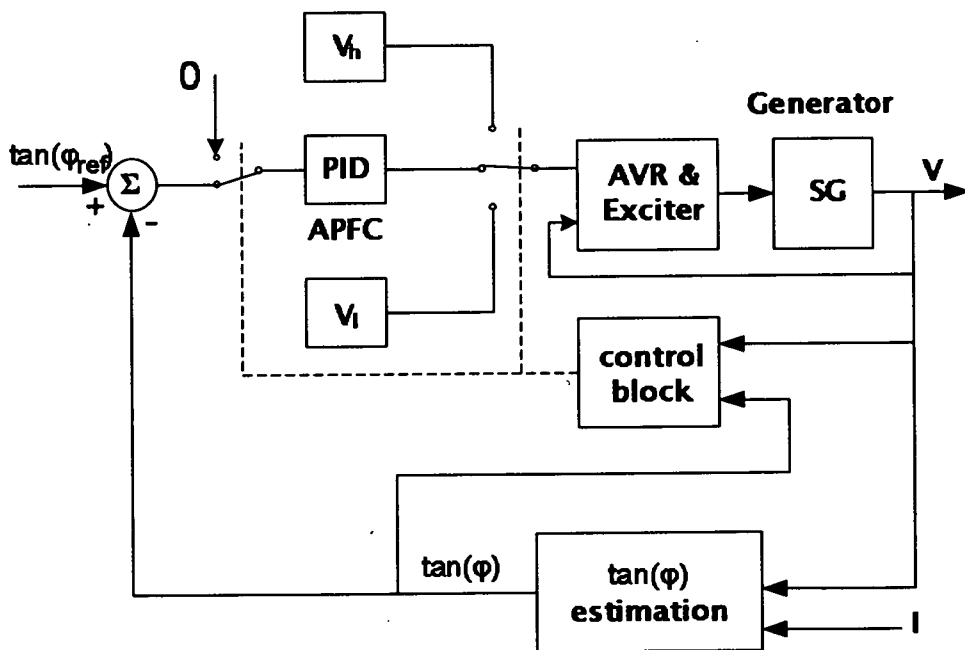

Figure 5.7: AVPFC controlled synchronous generator block diagram

There are two nested control loops in the block diagram of Figure 5.7. The inner loop performs voltage control and adjusts the terminal voltage of the generator according to the setpoint that is defined either from the output of the APFC, or the  $V_h$  and  $V_l$  setpoints. The external loop regulates the power factor of the generator according to the reference value given by  $\tan(\phi_{ref})$ . The control block contains the heuristics of the expert system that ensure continuous operation of the generation within the shadowed area of Figure 5.6. The operation of this block is depicted in the flow chart of Figure 5.8. This constitutes the core of the expert system. The actions of the controller depend on

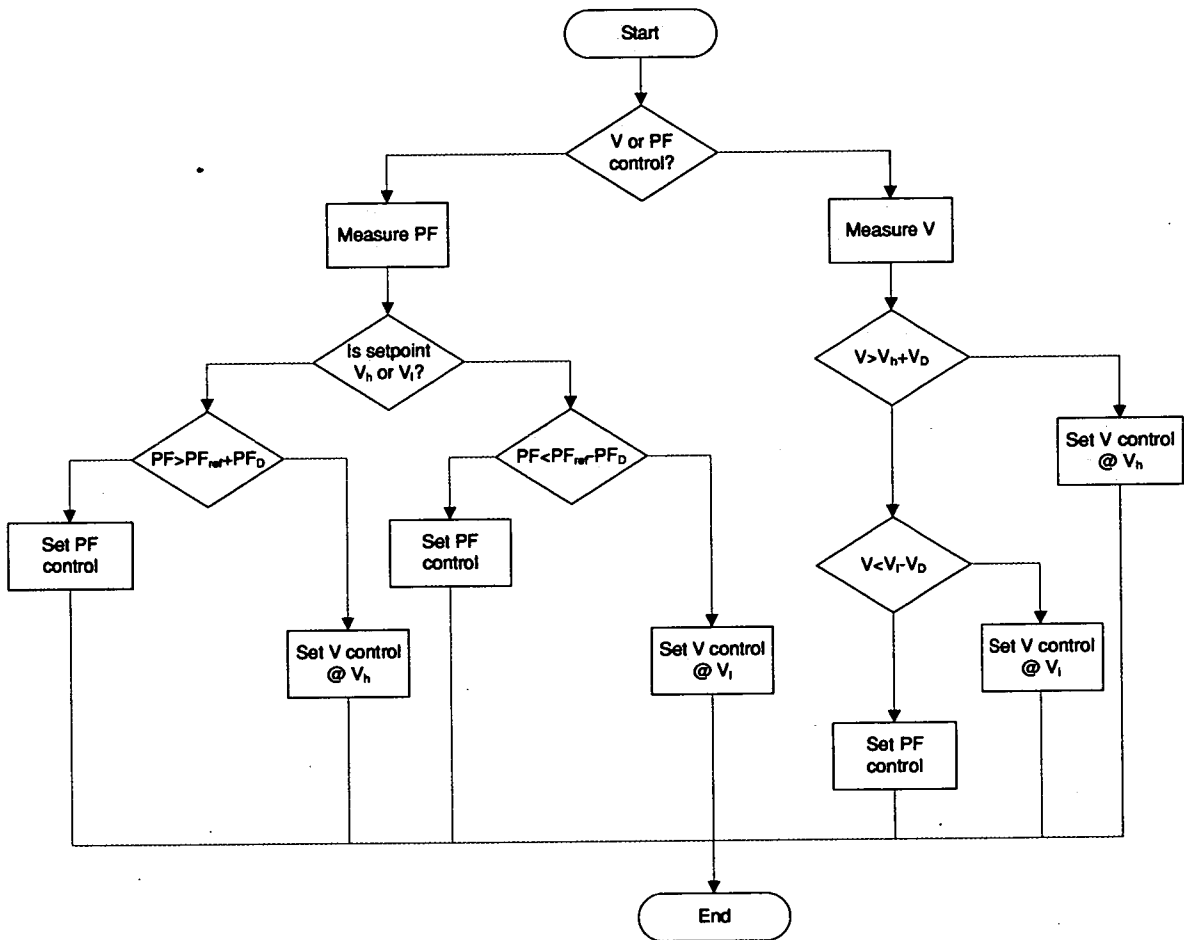

Figure 5.8: The flow chart of the automatic voltage/power factor control algorithm

its state, i.e. whether it is in voltage or power factor control mode:

- If the controller is in Automatic Power Factor Control (APFC) mode (right branch), terminal voltage is continuously measured and checked against two

values: the high voltage target  $V_h$  plus the deadband  $V_D$ , and the low voltage target  $V_l$  minus the deadband  $V_D$ . If the terminal voltage is higher than the first, or lower than the second, the controller switches to Automatic Voltage Control (AVC) with the reference voltage set at  $V_h$  or  $V_l$  respectively.

- If the controller is in AVC mode (left branch), the power factor (through  $\tan(\phi)$ ) is measured. Then, the measured PF value is compared to the PF target plus or minus the power factor deadband  $PF_D$ , depending on the current voltage setpoint ( $V_h$  or  $V_l$  respectively). As a result of this comparison, if the power factor is outside these limits, the controller switches to APFC.

After synchronisation, the DG could be brought towards capacity in constant power factor mode (travelling out on its constant power factor line) until the busbar voltage exceeds a pre-defined threshold voltage within the statutory limits. At that point APFC could be replaced with AVC to vary excitation and move the operating point around the constant voltage circle within the busbar overvoltage limit. Increased local load and reduction in terminal voltage could take the system back into APFC by sensing the increased demand for reactive power and therefore the reduction of power factor. Variations in network impedance would have a similar effect. This system, termed 'Automatic Voltage - Power Factor Controller' (AVPFC), would also enable voltage support at times of heavy local demand. On reaching a voltage just above the undervoltage limit the excitation system would be transferred to AVC to maintain local voltage. Excitation under- and over-voltage and over-current protection should protect the DG excitation and control system against prolonged forcing. When AVC is active the APFC module is disengaged, otherwise the non-zero power factor error signal would saturate the integrator of the internal PID compensator.

#### **5.4.1 Determination of AVPFC mode selection rule set**

The control block in Figure 5.7 is responsible for the control mode decision making. The system will attempt to regulate the DG operation around one of three possible setpoints: the power factor setting  $PF_{ref}$ , and the high or low voltage setting  $V_h$  and  $V_l$ ,

respectively. Table 5.1 shows the heuristics of the control algorithm, *i.e.* the reference value which is applied to the controller for every combination of voltage and power factor conditions. In order to prevent hunting, a deadband exists around the decision thresholds. Voltage deadband is annotated as  $V_D$  and power factor deadband is  $PF_D$ .

	$V_2 \leq V_B$	$V_B < V_2 < V_T$	$V_T \leq V_2$
$PF \leq PF_B$	$V_l$	$PF_{ref}$	$PF_{ref}$
$PF_B < PF < PF_T$	$V_l$	$PF_{ref}$	$V_h$
$PF_T \leq PF$	$PF_{ref}$	$PF_{ref}$	$V_h$

**Table 5.1:** *AVPFC mode selection rules set*

where:  $V_B = V_l - V_D$  ,  
 $V_T = V_h + V_D$  ,  
 $PF_B = PF_{ref} - PF_D$  ,  
and  $PF_T = PF_{ref} + PF_D$  .

### 5.4.2 Performance of a Synchronous Machine Based DG under AVPFC control

In order to test model validity, the process of generator load-up was simulated under AVPFC control and the results compared with those under AVC and APFC modes. The radial test network in Figure 5.1 was used with its characteristics shown in Table 5.2.

The results of the DG loading-up, post-synchronisation, are shown in Figure 5.9. In this (hypothetical) case, local power demand is sufficiently high to result in the voltage at bus 2 ( $V_2$ ) lying below the 0.94 pu limit. Normally, however, DNOs would ensure that voltage remained within statutory limits prior to connection. In the initial stages of load-up ( $t \leq 45s$ ), local power demand exceeds DG output and in the case of the APFC-controlled DG, is sufficiently high to result in voltage  $V_2$  being below 0.94 pu (a hypothetical situation as in general DNOs would ensure voltage remained within statutory limits prior to connection).

During the same period a fixed-voltage, AVC-controlled generator would try to hold

<i>Network Data</i>	
Machine size:	10 MW
Load size $P_L, Q_L$ :	4 MW, 3 MVA
Line resistance $R$ :	0.124 pu
Line reactance $X$ :	0.099 pu
Network Voltage $V_1$ :	1.0 pu
Base Voltage $V_{base}$ :	11 kV
Base Power $S_{base}$ :	10 MVA
<i>AVPFC Data</i>	
$V_h$ :	1.03 pu
$V_l$ :	0.97 pu
$V_B$ :	0.0025 pu
$PF_{ref}$ :	0.9 lagging
$PF_B$ :	0.0025
<i>APFC Data</i>	
$PF_{ref}$ :	0.9 lagging
<i>AVC Data</i>	
$V_{ref}$ :	1.03 pu

**Table 5.2:** *Test system data*

voltage at the 1.03 pu reference voltage leading to significant reactive power generation and a fall in the power factor wherein the DG excitation protection devices would shut the plant down. The AVPFC controller responded by fixing the terminal voltage at 0.97 pu. The low power factor would cause the protection devices to shut the generator down, albeit for a significantly shorter time than in the AVC case. Between  $t = 45s$  and  $t = 125s$  the AVPFC operated the generator in constant power factor mode as this would not result in voltage excursions outside the preset thresholds. For that period the response of the controller was identical to the response of APFC.

At  $t = 125s$ , the voltage of the APFC and AVPFC controlled generators reached 1.03 pu. Under AVPFC there was a switch to voltage control to maintain voltage, and from this point on its response is identical to that with AVC. The voltage under APFC continued to rise towards and through 1.06 pu - over-voltage protection would trip the DG at that point. This simulation showed that compared to APFC, hybrid voltage/PF control of a DG can improve the voltage profile in a weak network when the power transfer from or to the local bus is high, and at the same time will reduce import

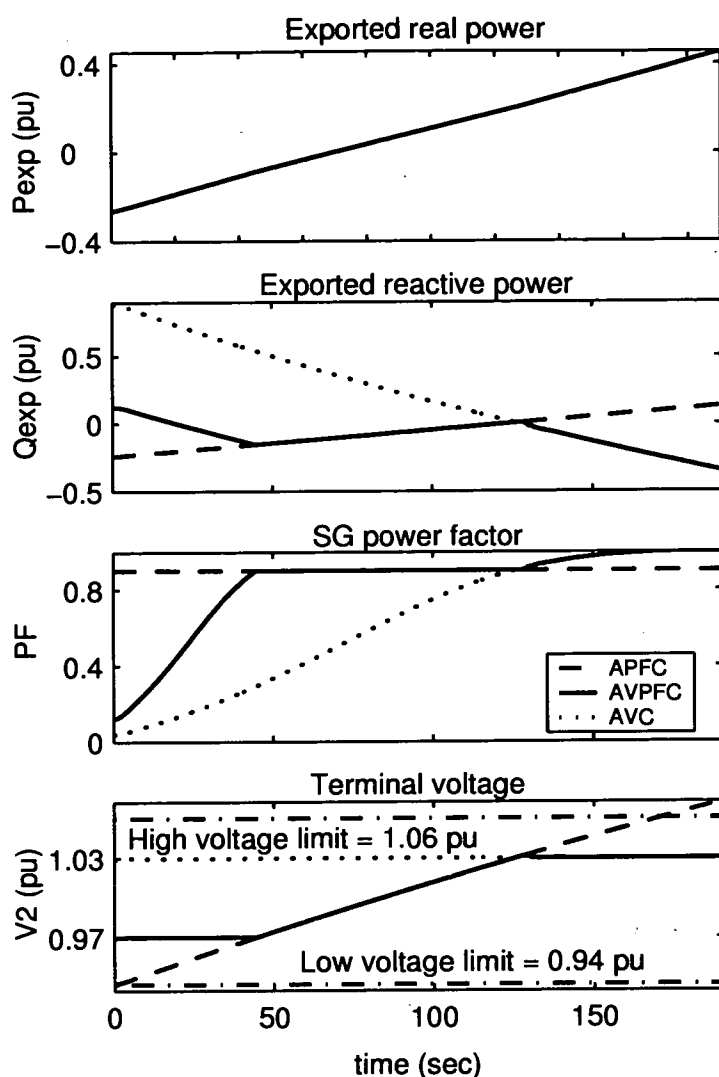

Figure 5.9: DG loading-up under AVC, APFC and AVPFC control. Legend applies to all subfigures.

or export of reactive power, compared to automatic voltage control. However, should another automatic voltage control device exist in the vicinity such as an On-Line Tap Changing (OLTC) transformer, the attempt of the AVPFC to hold voltage constant can potentially cause spurious operation of the OLTC mechanism, if the settings of the two control devices are not carefully selected.

## **5.5 Fuzzy Logic Power Factor Controller (FLPFC)**

Artificial Intelligence has been applied successfully to solve many power system problems [92]. Being highly nonlinear, power systems are very difficult to control with conventional methods and linearisation techniques very often fail to produce models that resemble the actual characteristics of the system. The resulting ambiguities impose constraints on power system controller design. In addition to this, the stochastic variation of load, generation and topology of a power system exaggerate uncertainty and imprecision [89]. The use of a fuzzy inference-based approach can be shown to overcome these difficulties.

### **5.5.1 Formulation of the problem**

As discussed in the previous section, hybrid voltage and power factor control of a DG can improve voltage quality in a weak network, but can only be applied when no other voltage control device exists in the vicinity, and at the same time will reduce the need to install such a device. On the other hand, with the rapid increase of distributed generation and the subsequent extension and improvement of the DN, it is expected that the DNOs will move toward more active control of the DN, and therefore the number of DN voltage control devices will increase. Hence, network operators in such areas may not allow generators to operate in any form of voltage control mode, including AVPFC. In that case, a method of reducing voltage fluctuations while in APFC mode is required. A conventional automatic power factor controller has a flat power factor characteristic over the permissible range of voltage. A human operator (or a specifically designed controller) of the DG plant would respond to voltage variation by altering the power factor setpoint in a way that the change in generated (or absorbed) reactive power regulated the terminal voltage. The DG should operate with constant power factor in a band spread about the middle of the permissible voltage range. When voltage falls the power factor should shift to a more lagging value so that the extra reactive power generated restores voltage. Conversely, increased voltage would require a move to a more leading power factor to compensate for the voltage increase. It is possible

to achieve such operation by adjusting the power factor reference rather than voltage reference in single AVC mode by means of a specifically designed fuzzy controller. The block diagram of a DG controlled in this manner is shown in Figure 5.10.

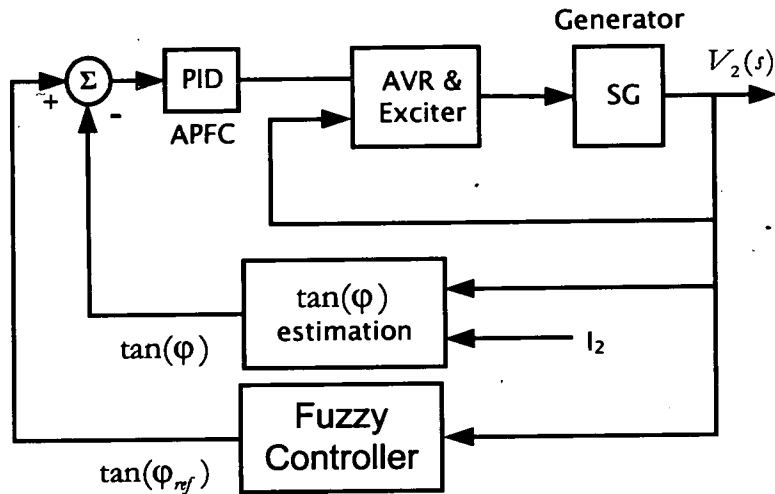

Figure 5.10: Block diagram of a DG with a Fuzzy Logic Power Factor Controller

Compared to the block diagram of the AVPFC controlled system, the block diagram shown in Figure 5.10 includes three nested loops. The inner is the same as previously; it is the voltage regulation loop. The middle one performs power factor control with the assistance of the PID controller, and the external loop provides the power factor reference (emerging from  $\tan(\phi)$ ) through the fuzzy controller. The latter behaves as a numerical input - numerical output, nonlinear element of a closed-loop control system [93]. It should be stressed that this nonlinear mapping is not unique and is heavily affected by the conversion procedure of the fuzzy control sets [93]. As it will be shown later, exploitation of this characteristic can lead to "tight" or "loose" voltage regulation, specifically designed to match the network characteristics and /or the DNO's requirements. Furthermore, extrapolation capabilities should be given to the fuzzy controller to enable it to produce an output even when the input is outside the design limits. In this case, the protection devices of the generator will ensure that it always operates within its design limits.

## 5.5.2 Design of the Fuzzy Logic Power Factor Controller

From the two available types of Fuzzy Logic (FL) controllers (Mandamani-type and Sugeno-type), the one proposed by Takagi and Sugeno [94] has superior control performance [95]. Once the desired controller response has been identified, there is a number of steps that have to be followed, namely the design of the input stage (fuzzification), determination of the fuzzy rules, and design of the output stage (defuzzification).

### 5.5.2.1 Design of the input stage

Since this is a Single Input - Single Output (SISO) controller, the input fuzzy set consists only of the measured terminal voltage  $V_T$ , varying over the range  $[V_{T_{min}}, V_{T_{max}}]$ . Three linguistic labels define voltage; LOW (L), NORMAL (N) and HIGH (H). The (Gaussian) input membership functions are shown in Figure 8(a) and are described by Equations 5.3 - 5.5:

**LOW:**

$$A_{L(V_T)} = \exp \left[ - \left( \frac{V_T - V_{T_{min}}}{V_{T_1} - V_{T_{min}}} \right)^2 \right] \quad (5.3)$$

$$\forall V_T \in [V_{T_{min}}, V_{T_{max}}]$$

**NORMAL:**

$$A_{N(V_T)} = \begin{cases} \exp \left[ - \left( \frac{V_T - V_{T_1}}{V_{T_1} - V_{T_{min}}} \right)^2 \right], & V_{T_{min}} \leq V_T < V_{T_1} \\ 1, & V_{T_1} \leq V_T \leq V_{T_2} \\ \exp \left[ - \left( \frac{V_T - V_{T_2}}{V_{T_h} - V_{T_2}} \right)^2 \right], & V_{T_2} < V_T \leq V_{T_{max}} \end{cases} \quad (5.4)$$

**HIGH:**

$$A_{H(V_T)} = \exp \left[ - \left( \frac{V_T - V_{T_{max}}}{V_{T_h} - V_{T_{max}}} \right)^2 \right] \quad (5.5)$$

$$\forall V_T \in [V_{T_{min}}, V_{T_{max}}]$$

### 5.5.2.2 Determination of the fuzzy rules

A typical rule in a Takagi-Sugeno - type fuzzy model has the form [94]:

*IF Input =  $x_i$ , THEN Output is  $y_i = a_i x_i + b_i$ , where  $i$  is the index of the fuzzy rule.*

For a zero - order Takagi-Sugeno model, the output level  $y$  is a constant ( $a = 0$ ). Therefore the fuzzy rule set becomes:

- i. IF ( $V_T = LOW$ ) THEN ( $u_1 = PF_{min}$ )
- ii. IF ( $V_T = NORMAL$ ) THEN ( $u_2 = PF_{nom}$ )
- iii. IF ( $V_T = HIGH$ ) THEN ( $u_3 = PF_{max}$ )

where  $u_1, u_2, u_3$  are the outputs of the respective fuzzy rules.

### 5.5.2.3 Design of the output stage

The output level  $u_i$  of each fuzzy rule is weighted by the level of activation  $\mu_i$  of the rule as shown in Figure 5.11. The final output of the system is the weighted average of all rule outputs, computed as:

$$PF_{ref} = \frac{\sum_{i=1}^3 \mu_i u_i}{\sum_{i=1}^3 \mu_i} \quad (5.6)$$

### 5.5.3 Performance of the DG under FLPFC control

To quantify the benefit of using the FLPFC, a simulation on a system identical to the one in Section 4.3.2 was performed, this time with the DG under FLPFC control. The details of the FLPFC are shown in Table 5.3. Application of these data on the FLPFC produced a Look Up Table (LUT) with the response shown in Figure 5.12.

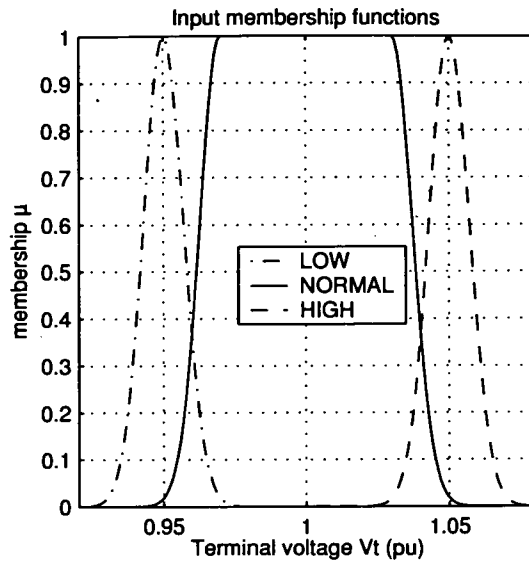

Figure 5.11: Input membership functions of the Fuzzy Power Factor Controller

FLPFC Data	
$V_{Tmax}$ :	1.05 pu
$V_{Tmin}$ :	0.95 pu
$V_{Th}$ :	1.04 pu
$V_{Tl}$ :	0.96 pu
$V_{T2}$ :	1.03 pu
$V_{T1}$ :	0.97 pu
$\tan(\phi_{max})$ :	0.750 ( $PF_{min} = 0.8$ lagging)
$\tan(\phi_{nom})$ :	0.484 ( $PF_{nom} = 0.9$ lagging)
$\tan(\phi_{min})$ :	-0.329 ( $PF_{max} = 0.95$ leading)

Table 5.3: Fuzzy Logic Power Factor Controller data

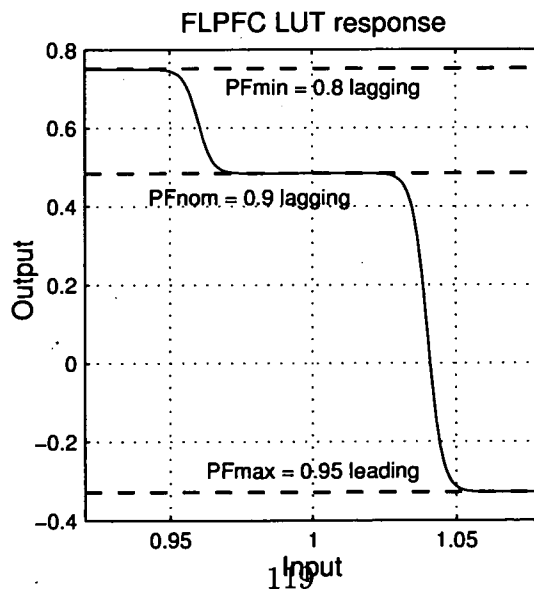

Figure 5.12: Overall response of the Fuzzy Power Factor Controller

Triangular membership functions could be used instead of the Gaussian ones shown in Figure 5.11. In that case, the input-output relationship of the fuzzy controller would consist of sections of straight lines. However, Gaussian functions were preferred as they result in a gradual increase of the slope, which has positive effects on voltage regulation, as it will be shown later. The results of the simulation are shown in Figure 5.13. The response of the AVC and APFC controlled DGs are shown in the same graph for comparison.

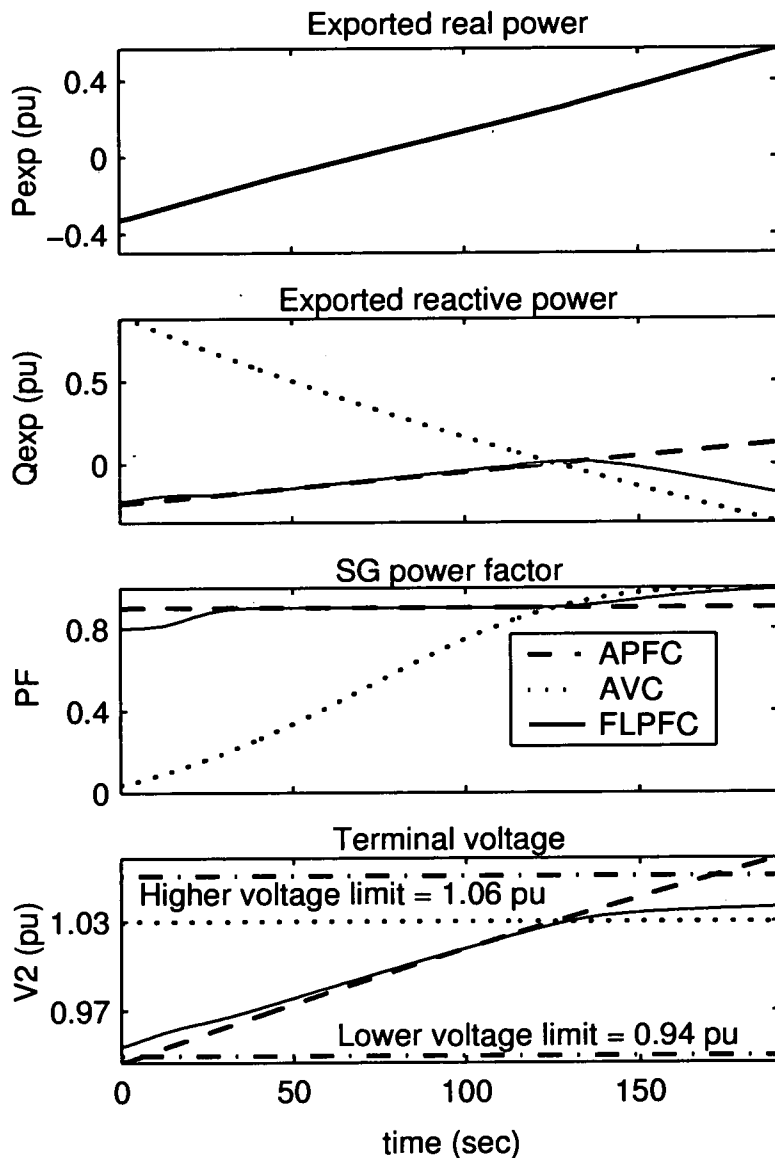

Figure 5.13: DG loading-up under AVC, APFC and FLPFC control

Early in the loading process the FLPFC controlled machine operates at a slightly higher voltage compared to the APFC controlled one. This is because the FLPFC allows the SG to operate at 0.8 power factor exporting extra reactive power. In the middle section of the loading process and while voltage lies between 0.97 pu and 1.03 pu the system operates at constant 0.9 PF, almost identical to the APFC and AVPFC cases. When voltage rises above 1.03 pu, the FLPFC starts decreasing the power factor setpoint - increasing  $\tan(\phi_{nom})$  - and by constraining  $Q_{exp}$ , the terminal voltage is held within acceptable levels. It should be noted that the the FLPFC (as well as the AVPFC) will maintain the voltage within the permissible range only as long as the reactive power limits have not been met. These three tests showed that for the same network conditions, utilisation of either AVPFC or FLPFC would be beneficial as their operational margins are wider compared to the traditional fixed power factor operation of a synchronous generator.

## **5.6 AVPFC and FLPFC controlled DG under real-time varying load conditions**

To test the response of the DG under the control of APFC, AVPFC and FLPFC to voltage variations brought about by changes in local load, the load of the 2-bus system in Figure 5.1 was given the time-varying profile shown in Figure 5.14, to simulate the time variation of actual aggregated load at a DN substation. The network characteristics are given in Table 5.4.

The varying demand profile was applied at constant 0.9 power factor over a 24-hour period. It resembles an aggregated 80% domestic - 20% industrial load. The simulation was performed three times; with the APFC, then with the AVPFC and lastly with the FLPFC. The settings of APFC and FLPFC were the same as the ones used for the generator loading tests (see Tables 5.2 and 5.3). Setpoints  $V_h$  and  $V_l$  of the AVPFC have been changed to 1.05 p.u and 0.95 p.u. respectively in order to match those of the FLPFC. Additionally, the power factor of the generator has been constrained between 0.8 lagging and 0.95 leading to resemble real-life operation in a DN, as a DNO would

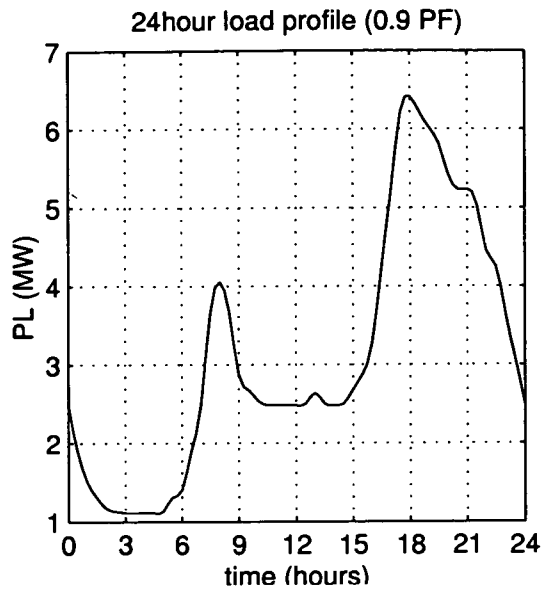

Figure 5.14: 24-hour, 80% domestic 20% industrial load profile

<i>Network Data</i>	
Machine size:	4.0 MW
Min. Load $P_L, Q_L$ :	1.11 MW, 0.538 MVA <sub>r</sub>
Max. Load $P_L, Q_L$ :	6.411 MW, 3.105 MVA <sub>r</sub>
Load power factor PF:	0.9
Line resistance $R$ :	0.1901 pu
Line reactance $X$ :	0.1521 pu
Network Voltage:	1.0 pu
Base Voltage $V_{base}$ :	11 kV
Base Power $S_{base}$ :	10 MVA

Table 5.4: Test system data

generally not allow a generator to operate with an unconstrained PF. The response of a typical APFC generator setup is shown in Figure 5.15.

The power factor of the generator remains constant throughout the whole period. However, for the period between 0:45-06:15 hours the generator would be disconnected as the large (constant) amount of generated power in combination with the low local demand would cause excessive power export and thus voltage violation. Additionally, during the 17:15-18:45 hours high local demand period, the bus voltage would be below the 0.94 p.u. statutory limit. Figure 5.16 shows the response of an AVPFC controlled SG under the same circumstances.

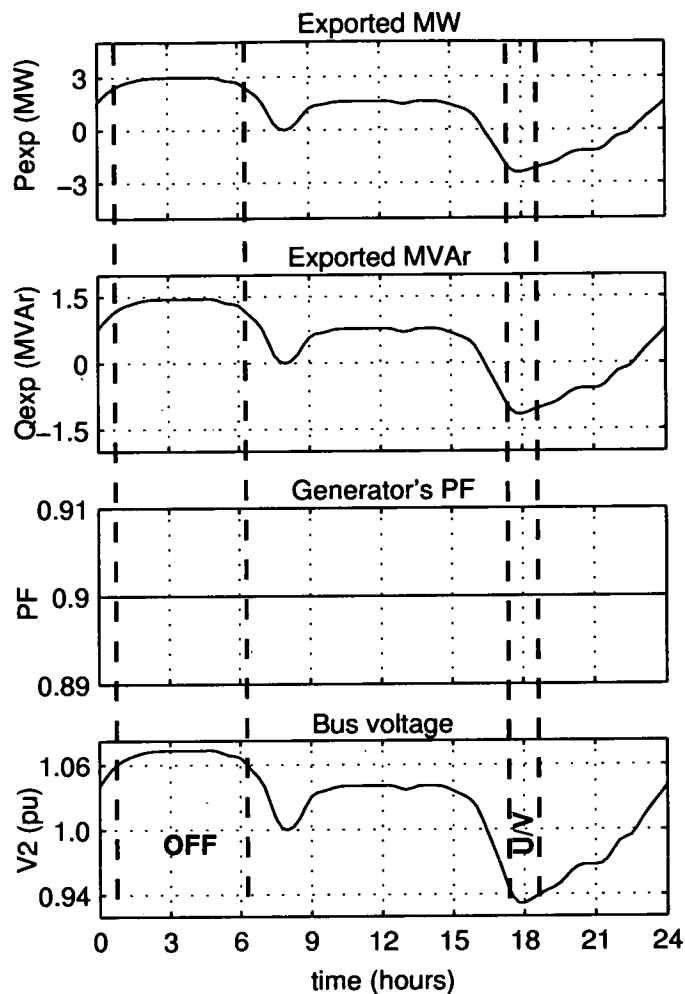

Figure 5.15: Response of APFC to a varying load

Compared to the APFC controlled SG response, it is apparent that for the periods while the bus voltage would be in the 0.97 pu - 1.03 pu region, the operation of the two systems is identical. However, during the periods of low (00:30-07:00 hours) and high (17:15-19:30 hours) demand, the AVPFC switches to constant voltage mode and holds voltage at 1.04 pu and 0.96 pu, respectively. This results in a longer period of operation, more energy shipped to the network and therefore increased revenue for the developer. It should be noted that for a short period just before 18:00 hours the voltage falls below the 0.95 p.u. setpoint, because the power factor limit has been met and the generator cannot support voltage any further. Figure 5.17 presents the results of simulations under FLPFC control.

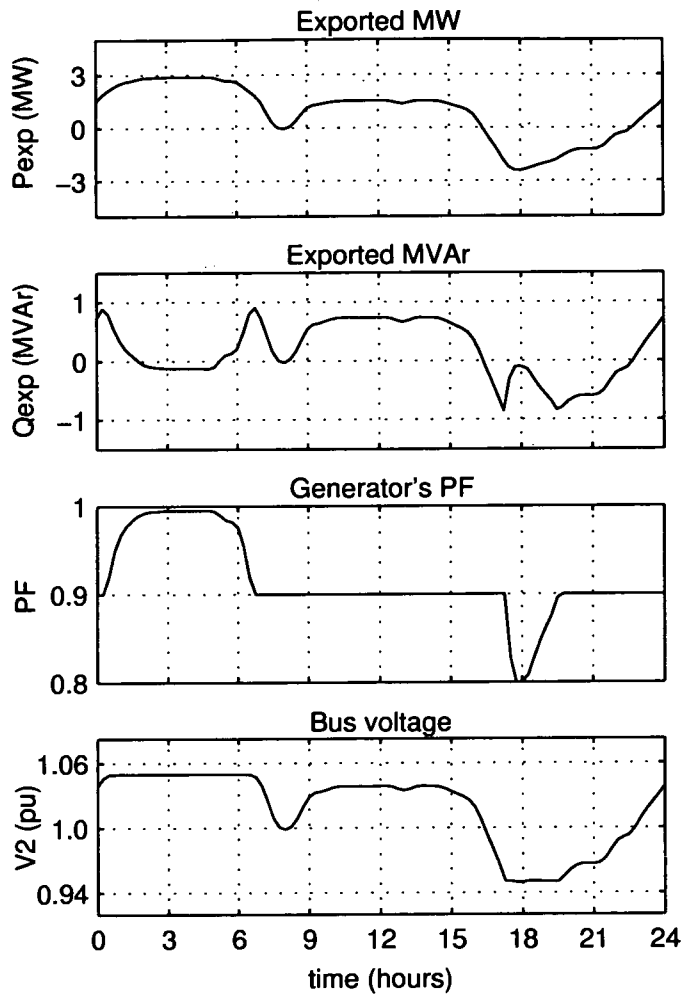

Figure 5.16: AVPFC response to 24-hour varying load

Compared to the AVPFC response shown in Figure 5.16, the FLPFC gives quite similar results. It is clear that neither voltage nor power factor exceed their operational range and therefore the generator will remain connected for the whole period of simulation, resulting in an extra 22 MW-hours exported energy compared to APFC operation. For a 4MW machine, this represents considerable increase in output with consequent financial benefits.

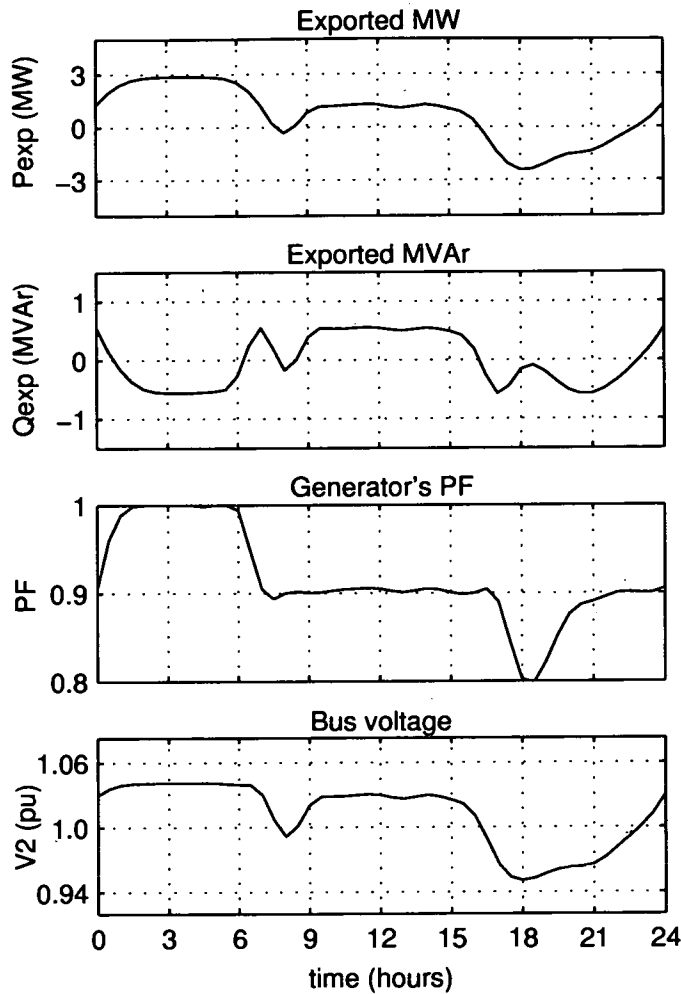

Figure 5.17: *FLPFC response to 24-hour varying load*

## 5.7 Application of the FLPFC to Wind Turbines with Doubly Fed Induction Generators

The increasing rating of modern wind turbines and in a greater extent the size of the new and proposed wind farms introduce a major concern regarding voltage control in the distribution network. In the case of wind energy, an additional factor of voltage variation to the one of load change is the wind intermittency. Therefore operating the DFIGs in pure power factor control mode is expected to cause wider voltage excursions than in the case of SG-based hydroelectric or CHP plants, and the need for intelligent control is more prominent. Decoupled real and reactive power regulation of the DFIG through

$d-q$  control makes possible the utilisation of the AVPFC and FLPFC controllers in the same manner with the synchronous generators as discussed in the previous sections.

One of the advantages of the fuzzy logic power factor controller is that although it does not fix the voltage at a constant value (an action that has the disadvantage of wide reactive power fluctuations when real power is varying), it can constrain its range, and at the same time it has a reduced variation of the reactive power exchange with the network compared to pure voltage control. This can be a very interesting feature in the case of wind generation, as its inherently intermittent energy source causes wide voltage fluctuations, one of the most important issues that restricts penetration of wind energy. To quantify the possible advantages and disadvantages of the utilisation of FLPFCs in wind energy, a set of simulations was done. FLPFC control was applied to a DFIG wind turbine that was connected to a two bus system like the one shown in Figure 5.1. The real and imaginary parts of the line impedance were  $R_l + jX_l = 0.05 + j0.05$  per unit on a 2 MVA base. The load is assumed to be zero and the network voltage 1.0 pu. A method to alter the operation of the FLPFC controller in order to study its characteristics is by changing the non-linear  $v - Q$  slope by altering the membership functions. For this example a set of three different  $V - Q$  characteristics were used. These relationships are shown in Figure 5.18. The efficiency in regulating voltage is defined by the slope of these curves. The steeper the slope, the easier becomes the reactive power exchange between the DFIG and the network, and the more the controller looks like a usual automatic voltage controller. Of course there lies a trade-off, as increased steepness also leads to increased reactive power fluctuations in case of disturbances. On the other hand, a less steep characteristic resembles more to an ordinary power factor controller (when slope is zero) which has less MVar fluctuations but a worse voltage regulation. Figure 5.19 shows the power factor and voltage response of the DFIG utilising an FLPFC with each of the three  $V - Q$  curves of Figure 5.18, for 120 seconds of operation under varying wind power input. The response of a PF-controlled DFIG is also shown for comparison. The setpoint of the power factor controller was set at 0.95 lagging.

It can be seen that in terms of voltage regulation, the best performance is by curve B, which achieved the lowest voltage and the least variation, then curve A and last curve B.

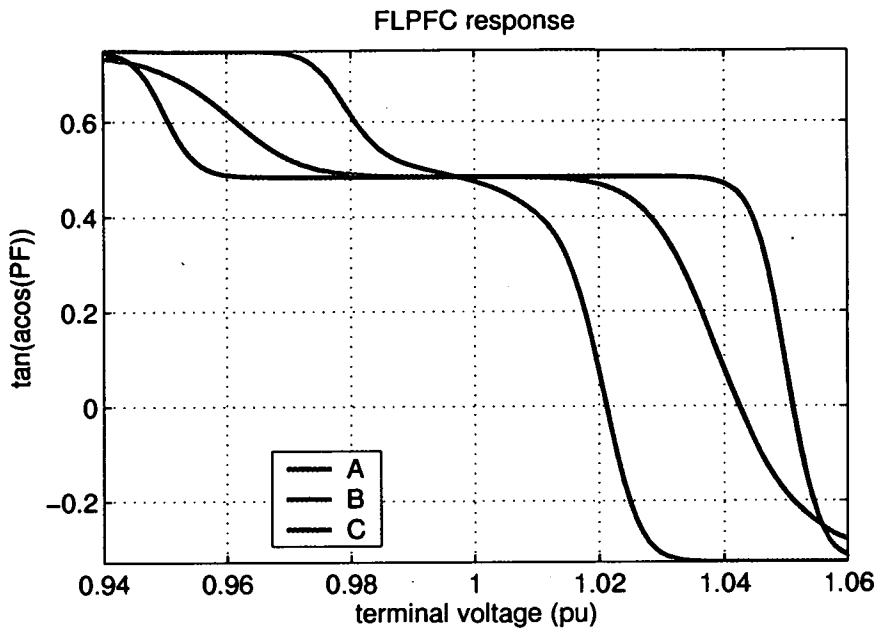
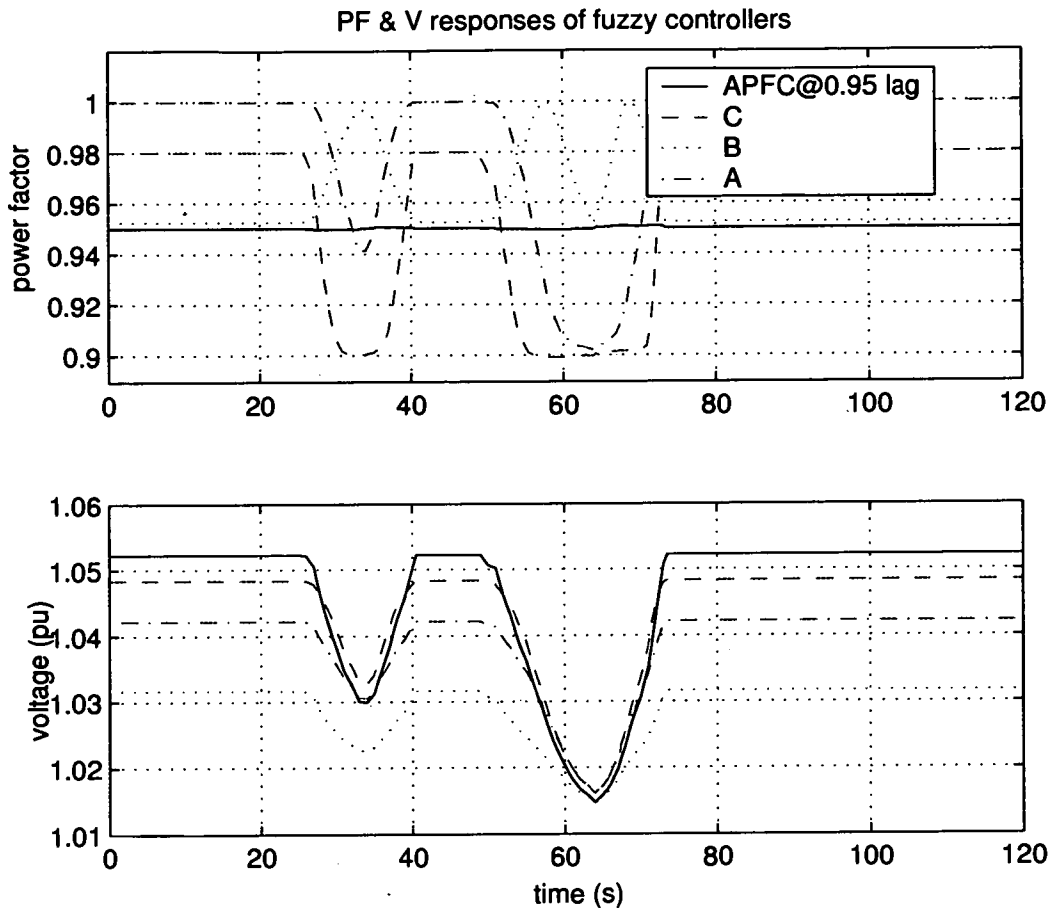

**Figure 5.18:** A set of three  $V - Q$  curves for the FLPFC

All three of them though have better voltage characteristics than the APFC controller as expected. It can also be seen that curve A has the widest variation in reactive power. In all cases though, the reactive power exchanged with the network would be less than in the case of pure voltage control. This would have the obvious advantage of lesser network and generator loading. The fuzzy controller gives the opportunity to select a set of rules that match with the network characteristics and the machine and converter reactive capability. Selection of the fuzzy rules could therefore be done in agreement with the DNO on an individual basis.

## 5.8 Combining Intelligent Voltage Control at Generators and OLTCs

One of the reasons for the DNOs for not allowing constant voltage operation of the distributed generators, is the possibility of conflict with their control equipment such as On-Line Tap Changing transformers. Although AVPFC is partially a voltage controller,



**Figure 5.19:** Responses of three different fuzzy controllers and the classic power factor control

it is possible to coordinate its operation with the network's OLTCs. This will be demonstrated through a simulation of a 4-node radial feeder such as the one depicted in Figure 5.20. The details of the system are shown in Table 5.5 below.

When combining OLTC operation and AVPFC, one of the two controllers has to be given priority for its action over the other in order to avoid hunting between them. Since the AVR of the synchronous generator (or the power electronics converter, in case of a DFIG) is much faster than the OLTC, it can provide more robust voltage regulation. In addition, its operation is smooth and does not cause step voltages as in the case of the OLTC transformer. On the other hand, its range of control is limited by the reactive power capability of the machine (and/or the converter). For these reasons, generator

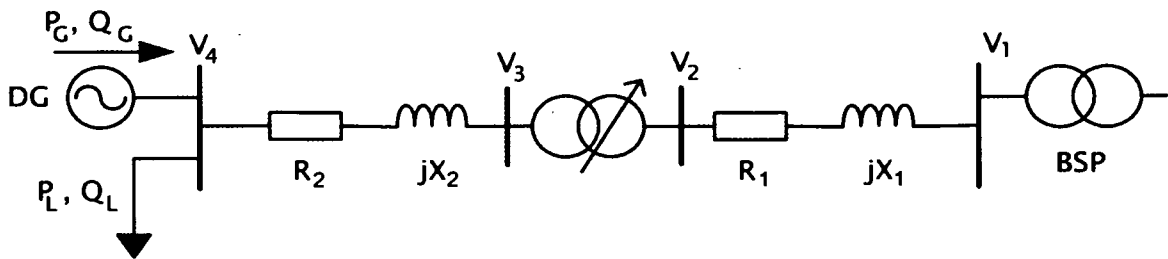

**Figure 5.20:** A radial feeder with an OLTC transformer and distributed generation

control could be used for fast, fine voltage regulation and OLTC control could be used for coarse, secondary control. This can be achieved by assigning the same target voltage to both controllers, and setting the OLTC deadband wider than the AVPFC one. Thus, should voltage rise from the nominal (target) value, it would first reach the AVPFC deadband, switching it to voltage control. The AVPFC would hold voltage steady up to its reactive power capability. Then voltage would start rising further up until it reached the OLTC limit. The OLTC would then act to reduce it, by switching one tap up on the transformer. Lowering voltage under the AVPFC limit would turn it back to automatic power factor control ('normal' mode) etc. The inverse sequence would be followed for undervoltages. Figures 5.21 - 5.28 illustrate the effects of individual and combined AVPFC/OLTC control for the system in Figure 5.20. In this simulation the distributed generation plant is a wind farm that comprises six 1MW DFIG wind turbines, and one day of operation with varying wind and demand conditions is shown. Figure 5.21 illustrates the 24-hour voltage profile at the wind farm and neighbouring buses when the turbines operate at constant power factor (0.98). It is shown that at the DG bus ( $V_4$ ), voltage fluctuates from 0.95 pu to 1.045 pu.

Utilisation of AVPFC reduced the voltage range on the DG bus to [0.955 1.03] pu. It should be noted here that due to the limited reactive power capabilities of the induction generator, its voltage regulation is by default worse than the synchronous machine. The voltage profile at the wind farm and neighbouring buses with the turbines operate under AVPFC control is shown in Figure 5.22.

Figure 5.23 shows the node voltages when the generators operate on constant power

Parameter	Value
<b>Network</b>	
$S_{base}$	10MVA
$V_{base}$	11kV
$V_1$ (slack)	1.03pu
$R_1$	0.03pu
$X_1$	0.02pu
$R_2$	0.060pu
$X_2$	0.040pu
<b>Transformer</b>	
$V_{nom}$	1.00pu
$V_{step}$	0.0125pu
$V_{deadband}$	0.0125pu
No. of taps on each side	5
$R_T$	0.003pu
$X_T$	0.050pu
<b>Load</b>	
$P_{Lmax}$	8MW
PF	0.9 lagging
<b>Generator</b>	
$P_G$	6 × 1MW DFIG WECS
$PF_{nom}$	0.98 lagging
$PF_{range}$	0.95 lagging - 0.99 leading
$V_{nom}$	1.00 pu
$V_{range}$	0.99 - 1.01 pu

**Table 5.5:** *Parameters of the system in Figure 5.20*

factor mode and the OLTC performs Line Drop/Rise Compensation (LDRC). As can be seen in the graph, the voltage on the DG bus is clearly constrained within the OLTC deadband another interesting observation is that the DG voltage is lowered at the expense of node  $V_3$  voltage, which was increased from about 1.01 pu to over 1.02 pu during the peak demand period (after 09:00). Thus the voltage drop across  $R_2 + jX_2$  was compensated.

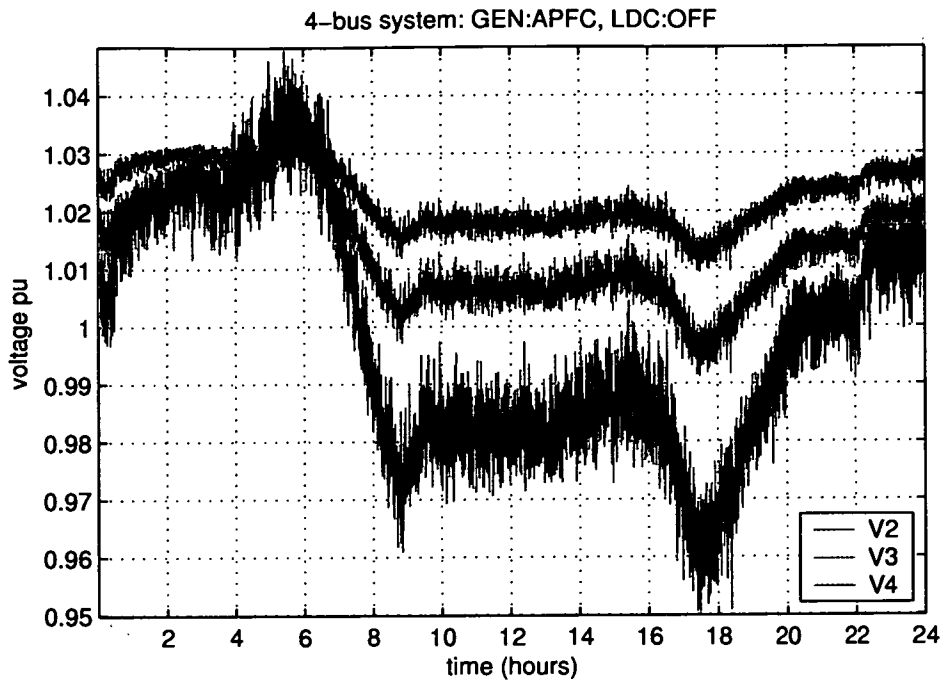

Figure 5.21: Voltage profile for the APFC controlled wind farm

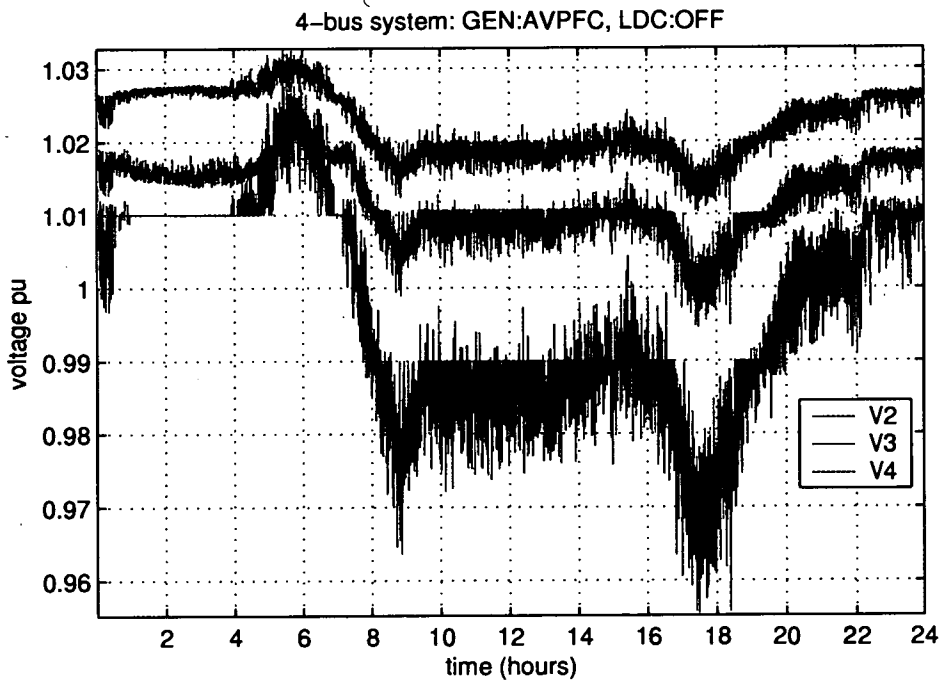

Figure 5.22: Voltage profile for the AVPFC controlled WECS

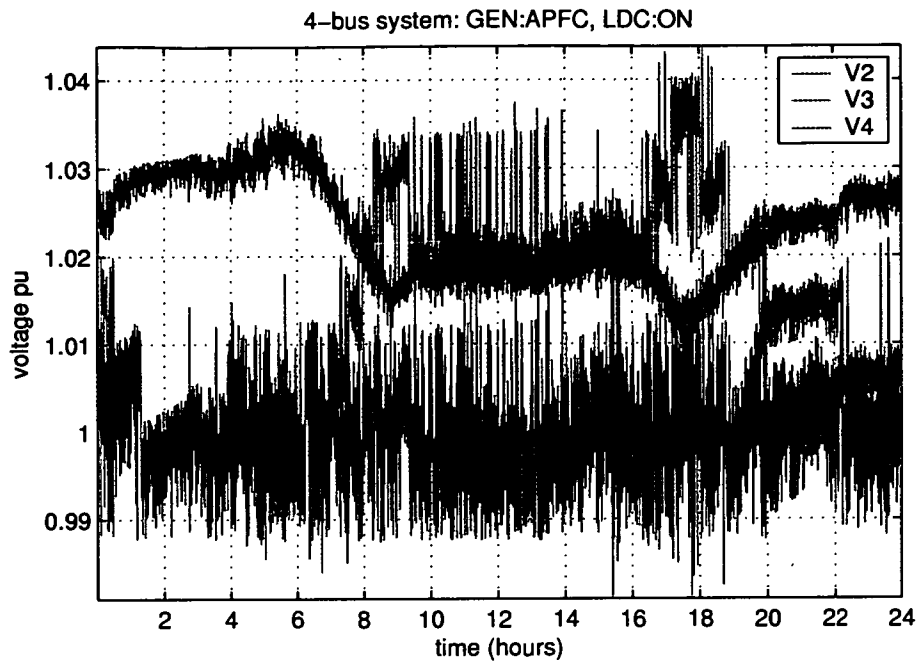

Figure 5.23: Voltage profile for the APFC controlled WECS with line drop / rise compensation

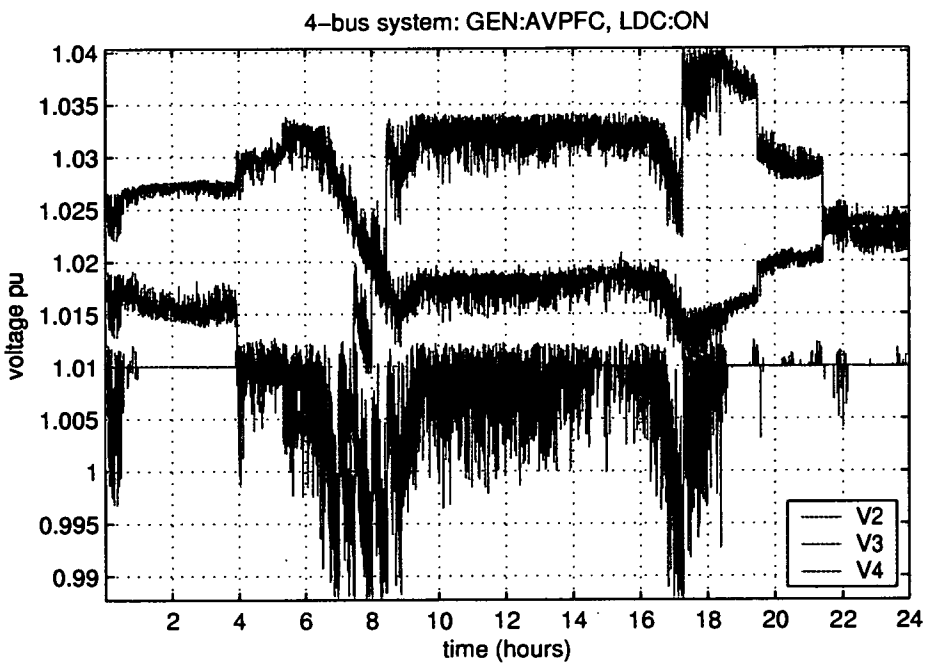

Figure 5.24: Voltage profile for the AVPFC controlled WECS with line drop / rise compensation

Combination of OLTC and AVPFC control is depicted in Figure 5.24. Compared to all previous three voltage profiles, the voltage profile for the combined control is further improved. With regard to the AVPFC-only case, combined operation produced better results as it 'centered' the average voltage value within the operating range of the AVPFC, thus allowing it to operate for more time without hitting its reactive power limits. This is illustrated in Figures 5.25 and 5.26, where the respective reactive power outputs (from a single generator out of six) are shown. With regard to the LDRC-only case, combined operation improved the voltage profile as for significant periods (00:30-04:00 and 16:20-24:00 approx.) the generator was able to operate at constant voltage as the reactive power requirement for that was within its capacity. A final but equally important observation that can be made with these simulations, is the drastic reduction of the tap changes at the combined operation, compared to LDRC-only. Figures 5.27 and 5.28 show the tap transitions throughout the simulated period. It is demonstrated that for the simulated wind, load and network conditions, the LDRC-only operation would bring about 197 actions of the tap changer. This is a large number of transitions and would cause quick wear-out of the tap contacts and therefore would increase maintenance costs. Combined AVPFC-LDRC operation reduced the tap changes to only 9 for the same simulated conditions. The reason for this reduction is that AVPFC is able to reduce voltage fluctuation due to wind variability below the OLTC action threshold, and therefore the OLTC needs only to follow the slow load variation. It should be mentioned that in the above simulations operation of the emulating circuit for the LDRC was assumed to be ideal. In reality, the (possible) inaccuracy in estimation of the receiving end voltage would require some extra margin between the LDRC and AVPFC deadbands to ensure that the AVPFC deadband is fully enclosed in the LDRC one.

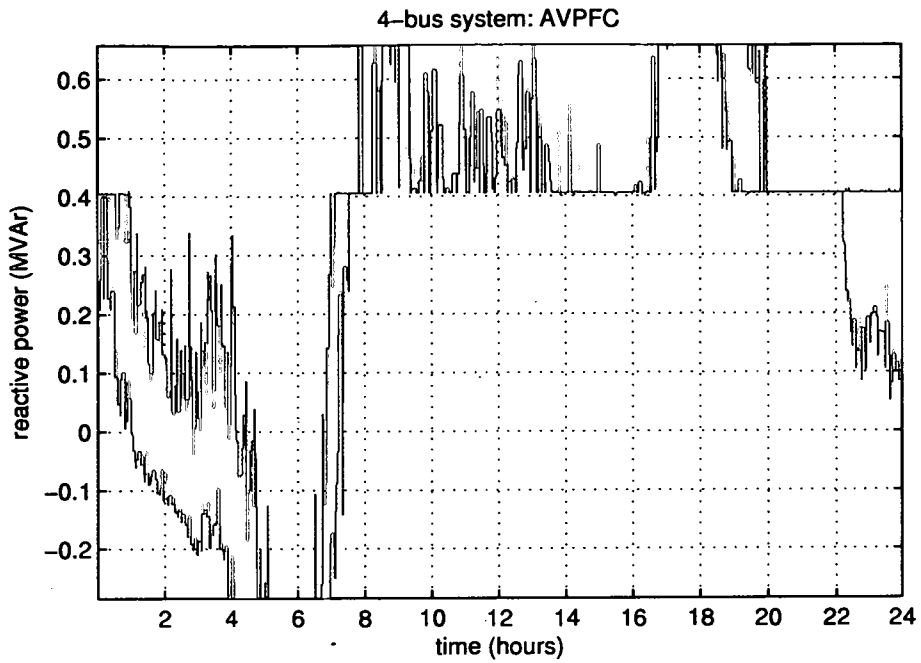

Figure 5.25: Reactive power exchange from one AVPFC controlled WECS

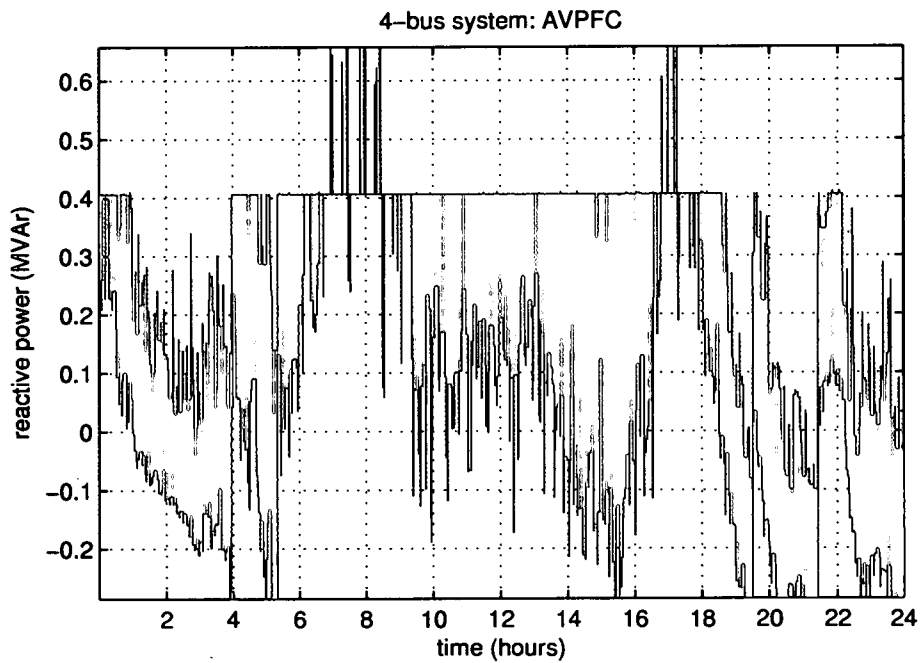

Figure 5.26: Reactive power exchange from one AVPFC controlled WECS with line drop / rise compensation

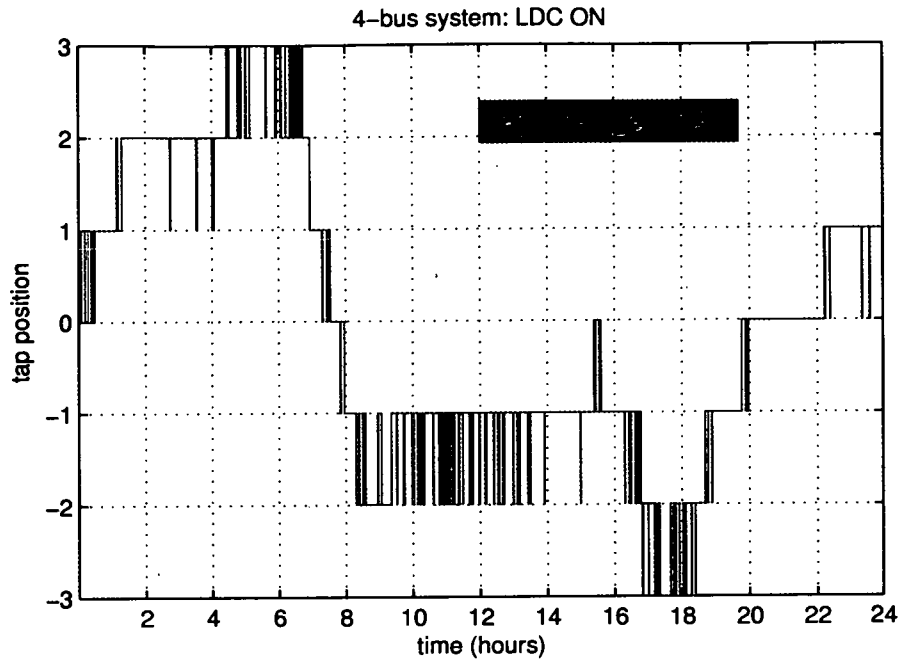

Figure 5.27: OLTC tap position during the 24-hour simulation with the APFC controlled WECS

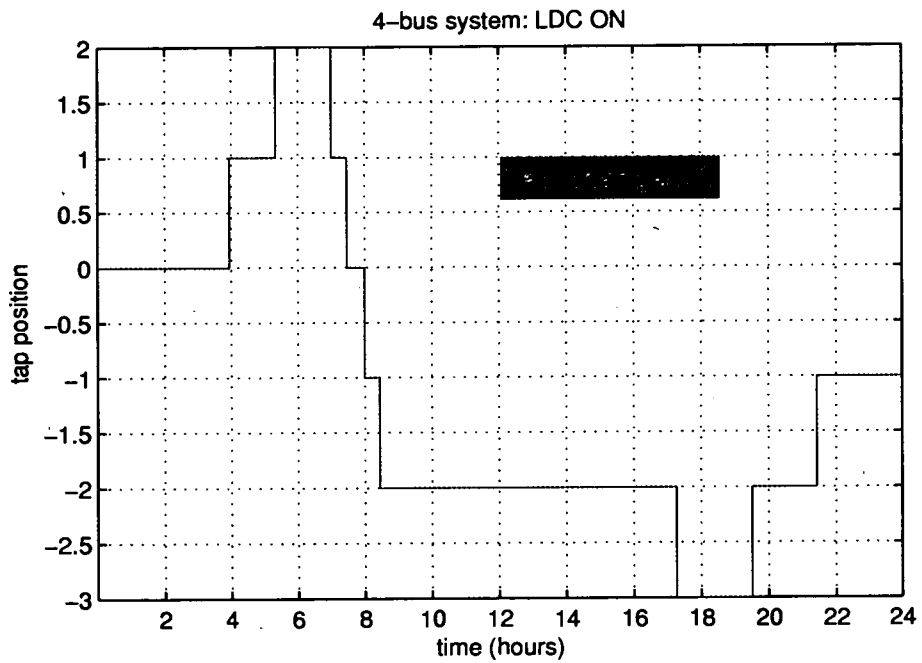

Figure 5.28: OLTC tap position during the 24-hour simulation with the AVPFC controlled WECS

## 5.9 Summary

In this chapter the need for an intelligent control strategy for distributed generators was discussed and two candidate solutions were proposed: a hybrid voltage / power factor controller and a fuzzy logic power factor controller. Both algorithms allowed extension of generator operating period in a weak network and therefore an increase of the revenue from energy export. This was illustrated by simulations of a DG in a radial network using a realistic local load pattern. It is possible to combine operation of OLTC transformers with the proposed intelligent generation controllers. The results of the combination appear to be improved when compared to individual generator or OLTC control. However, the developer should discuss with the DNO beforehand about the adoption of the AVPFC scheme because the generator's settings may conflict with those of the network equipment when in constant voltage mode. On the other hand, adoption of the Fuzzy Controller scheme can be straightforward, provided that the controller is set to operate within the voltage and power factor limits set by the machine specifications and the DNO. In the next chapter the two proposed algorithms will be tested in a real section of the Scottish distribution network in order to quantify the possible merit of their utilisation.

---

# Chapter 6

## Case Study: Integrating New Generation in the Scottish DN

---

### 6.1 Introduction

This chapter presents a series of simulations of a real section of the Scottish distribution system, which prove that the proposed control strategies can (a) improve voltage profiles in a weak network and (b) increase the capacity of Embedded Generation in the Distribution Network. A number of simulations has been performed using both synchronous generators with a constant or slow-varying source and doubly fed induction generators with a very intermittent source (wind). Firstly, the operation of the test system including synchronous generators with and without intelligent control is presented. The second set of simulations includes transformers with OLTCs performing Line Rise Compensation. The effects of combining OLTCs with intelligent generators are discussed. Finally, wind generation is introduced to the system and the effects of primary source intermittency on network voltage are presented.

### 6.2 Description of the Test System

This section presents the system under consideration (shown in Figure 6.1), describes the operating conditions and stating the assumptions and simplifications used in the following simulations. This system is a part of the Scottish distribution network. It made of overhead lines and the loads follow a typical rural demand profile. The line data as well as the maximum load values were obtained by the DNO. It is assumed that the demand (shown in Figure 6.2 consists of 80% domestic and 20% industrial loads with a minimum of 30% of the maximum value on each bus and that all loads have constant and equal power factor (0.9).

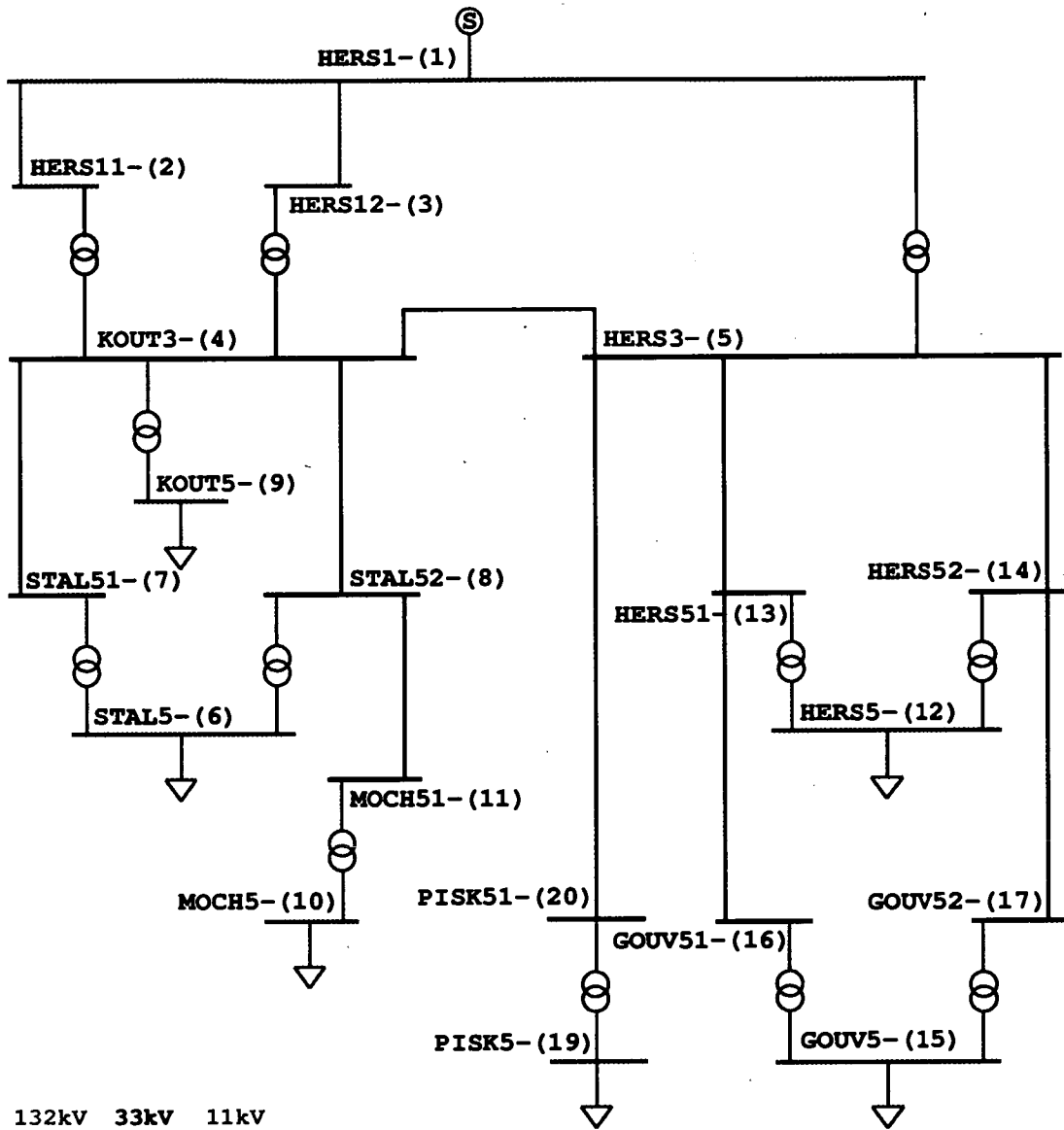

Figure 6.1: The section of the Scottish distribution network used as a test system. The names of the buses are concealed.

There are several transformers installed in the system under investigation, some of them serve as step-down transformers to reduce the voltage level from the 132kV of the bulk supply point down to 33kV and then further to 11kV, others re-adjust the bus voltages closer to the nominal values using fixed taps, and a few others are equipped with auto tap changers to provide a means of voltage regulation. By dynamically altering the voltage levels, the latter have the ability to assist power transfer from and to the far ends

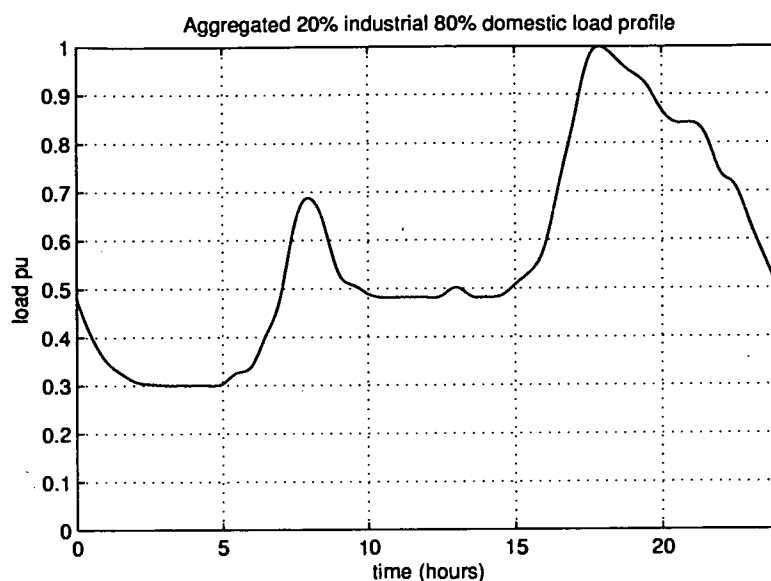

Figure 6.2: Demand profile in the simulated network

of the system, thus interfering with the action of the designed controllers. Therefore, in order to have a clear image of the controllers effects, automatic tap-changing on these transformers was disabled in some of the simulations. Unless otherwise stated, the results presented in this chapter are the outcomes of steady-state analysis, as the major concern here is energy capture and not the action of the controllers themselves, as this has been discussed in detail in the previous chapter.

### 6.3 Operation of the Test System Without Use of OLTCs

In order to have a clear image of the effects and the possible benefits of utilisation of intelligent control of distributed generators, the OLTCs of the test system have been disabled so that their operation will not affect the results of the simulations. In this section two sets of simulations are presented, one with the generators connected to 11kV buses and one to the 33kV ones. Thus the difference in the performance of the generators when connected both to weak and stiff feeders is shown.

### 6.3.1 Generators on the 11kV System

The 11kV network is more prone to voltage fluctuations and therefore has a lower capacity headroom. Simulations with the generators connected at 11kV show that voltage regulation can be assisted by utilisation of intelligent generator control, while the capacity that can be installed is increased. Figure 6.3 shows the voltage profile for 24 hours of operation of the simulated network with an embedded generation of 2MW connected to bus GOUV5.

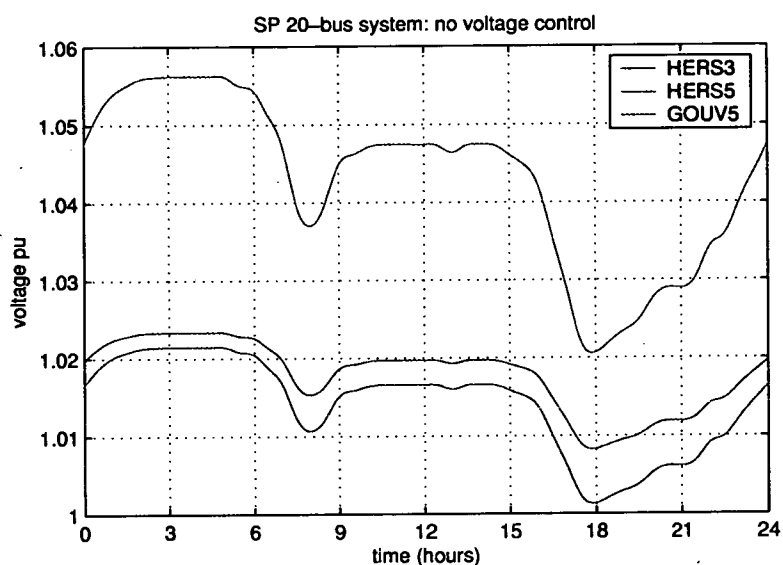

**Figure 6.3:** *Voltage profiles of buses HERS3, HERS5 and GOUV5 after the connection of a 2MW generator at GOUV5 operating in power factor control mode*

The generator is assumed to have constant power output and a power factor of 0.95 (required by the DNO). It is obvious that under the traditional power factor control, the generator would cause an overvoltage on its bus that partially propagates to its neighbouring buses too. Although it does not reach the 1.06 pu statutory limit, operating the generator at such high voltage is a risk, as any sudden change of the network parameters (loss of loads, feeder availability) would drive the voltage outside the 1.06 pu limit and would cause disconnection of the plant. Figure 6.4 shows the voltage profile for the same buses with the generator under AVPFC control. The controller settings are shown in Table 6.1.

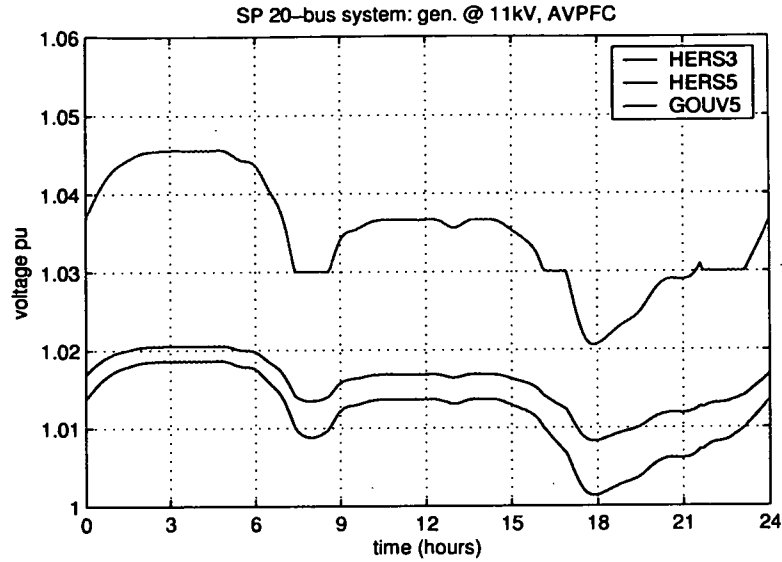

**Figure 6.4:** Effect of operating the generator at GOUV5 in AVPFC mode on the voltage profiles of buses HERS3, HERS5 and GOUV5

$V_{high}$ :	1.03 pu
$V_{low}$ :	0.97 pu
$V_{deadband}$ :	0.001 pu
$PF_{ref}$ :	0.95 lagging
$PF_{max}$ :	0.99 leading
$PF_{min}$ :	0.9 lagging
$PF_{deadband}$ :	0.0005

**Table 6.1:** AVPFC settings

The controller allowed operation of the generator at lower voltages although only for 8 hours below the 1.03 pu setpoint. This was because for the rest of the time the generator had reached its reactive power capability, as shown in Figure 6.5 and therefore could not import more MVARs to reduce voltage.

It should be noticed however that the voltage was reduced at the neighbouring buses too, which shows that intelligent generator control not only can have a positive effect at the generator bus, but may improve voltage quality throughout a larger area of the distribution network.

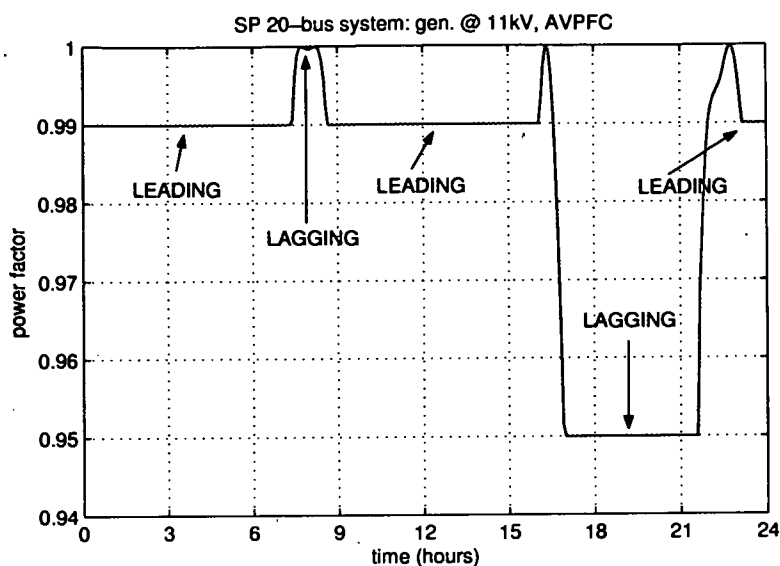

**Figure 6.5:** Power factor of generator at GOUV5 operating in AVPFC mode

Figure 6.6 shows the operating voltage ranges for all the buses in the simulated system. For this simulation a 2.4MW synchronous generator operating at a constant 0.95 power factor was connected to bus 15 (GOUV5). The dark blue part of the bars represents undervoltage, light blue and red are the headrooms for undervoltage and overvoltage respectively, and finally yellow is the operating area for each bus. It is shown that voltage at GOUV5 is marginally at the limit for overvoltage, meaning that any further increase of the generating capacity on that bus (or its neighbouring ones, in electrical terms) will lead to overvoltage. Application of the fuzzy logic power factor controller (FLPFC) to the generator led to a reduction of the level and constraint of the range of voltages for all the buses that are electrically close to GOUV5. Figure 6.7 shows the voltage response of the network to the same generator, this time under control of an FLPFC with the volt -  $\tan(\phi)$  characteristic of Figure 6.8. Therefore for the same load and network conditions, intelligent generation control improves voltage quality in the distribution system.

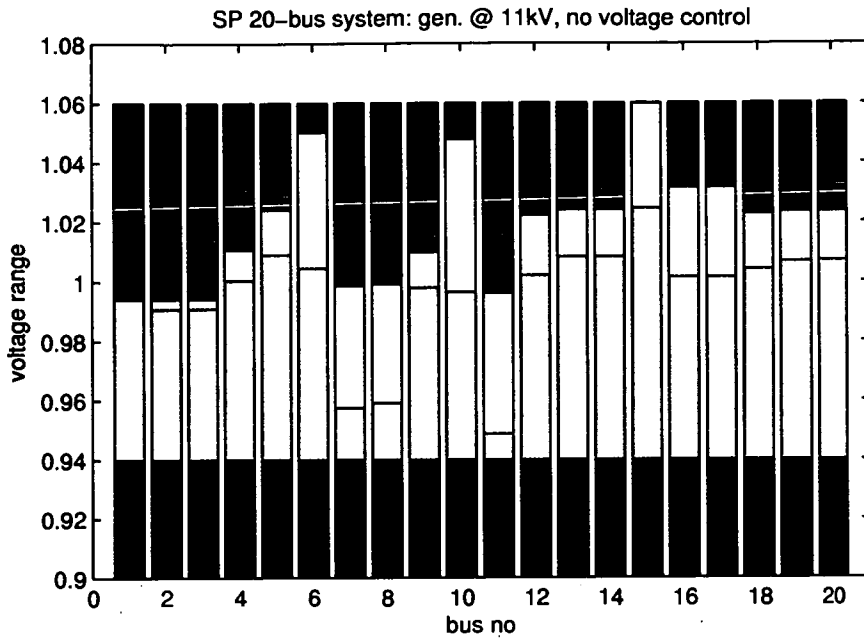

Figure 6.6: Voltage range on all 20 buses with a 2.4MW generator connected to bus GOUV5

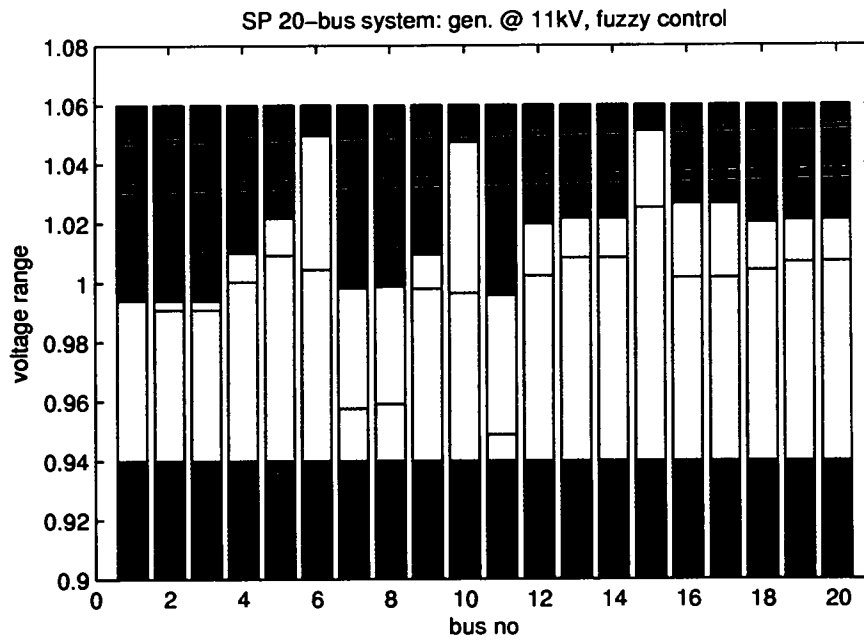

Figure 6.7: Voltage ranges with the generator controlled by the fuzzy controller

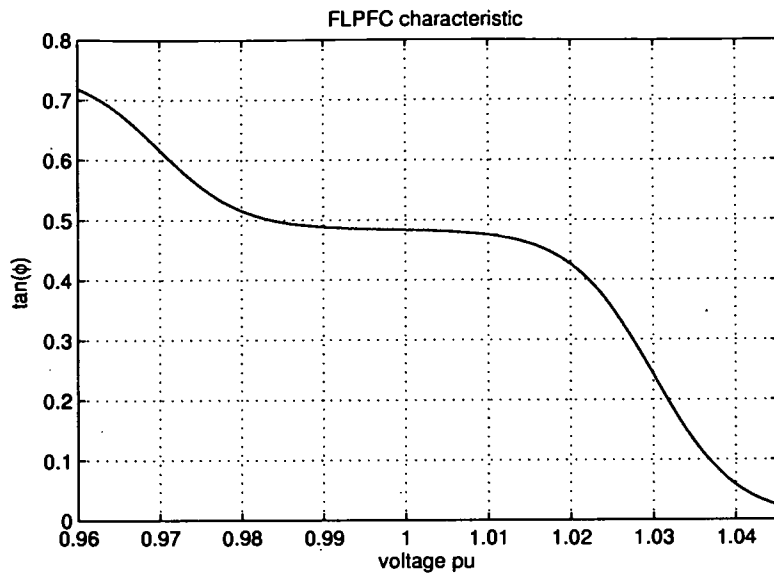
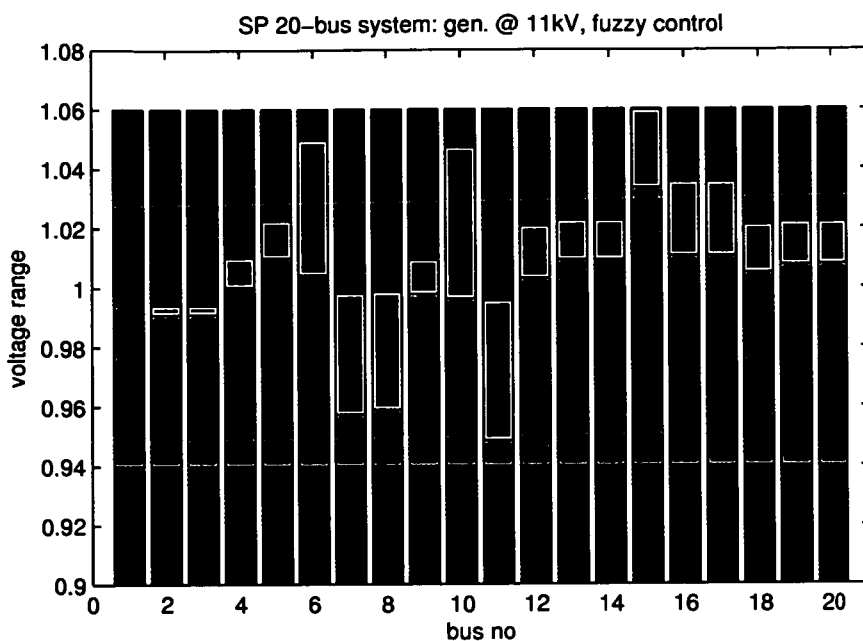

Figure 6.8: Volt- $\tan(\phi)$  characteristic of the FLPFC

An alternative way to quantify the merit of utilising intelligent generation control in a distribution system, is to derive the increase of generator capacity before the voltage levels occurred when traditional power factor control was used. The size of the generator at bus GOUV5 was gradually increased until voltage reached 1.06 pu, as in the case of power factor controlled 2.4MW, 0.95 PF machine. Under FLPFC control, the voltage at bus GOUV5 reached 1.06 pu for a capacity of 4.2MW, which represents an 1.8MW (or 75%) increase. This increase would not otherwise be possible to achieve, unless a network upgrade or installation of an OLTC transformer was performed. The resulting voltage ranges after the 1.8MW increase are shown in Figure 6.9.

### 6.3.2 Generators on the 33kV System

The 33kV network can accommodate larger capacity of distributed generation and the voltage fluctuation is less than in the 11kV grid. The simulations of the system with the generators connected at 33kV show that both in percentage and in absolute terms, the increase of capacity due to the use of intelligent generator control is greater than the 11kV case, while voltage regulation is also improved. Figure 6.10 shows the voltage at



**Figure 6.9:** Voltage ranges with a 4.2MW generator under fuzzy control on bus GOUV5

buses HERS3, HERS5 and STAL5 after the connection of an 8MW generator running at a constant 0.95 power factor, this time at bus HERS3.

The first noteworthy point is that compared to Figure 6.3, equivalent voltage levels are observed with a generator with four times larger capacity. Secondly, although the voltage of the generator bus is not high (max. 1.024 pu), the voltage at the bus at the far end of the feeder (GOUV5) exceeds 1.05 pu. This could be resolved by upgrading the feeder or stepping down the transformers that feed GOUV5. However the former is an expensive solution and the latter implies that the generator will be always need to be connected and generating its rated power, which may not be the case for an embedded generator. Enabling AVPFC control of the generator reduces voltage at the generator bus as well as all the way down the feeder. The controller's characteristics are the same as in the 11kV case and are shown in Table 6.1. Figure 6.11 shows the effect of using the AVPFC on the voltage along the feeder.

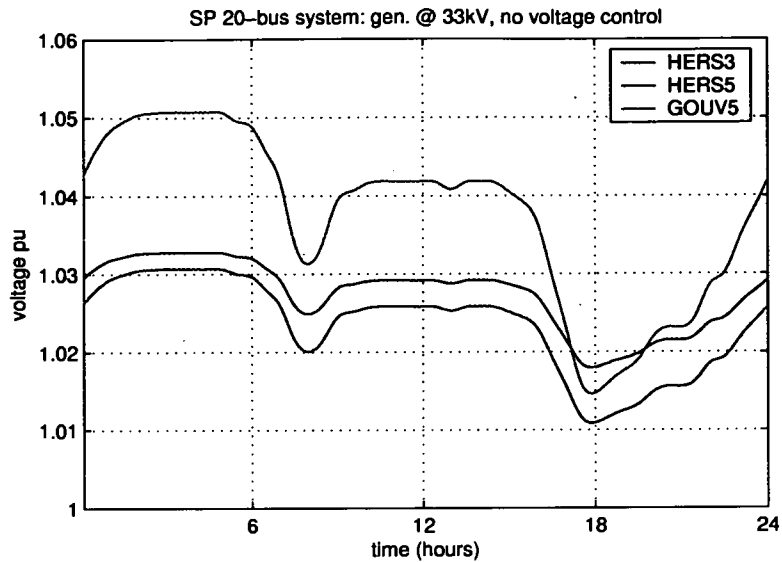

**Figure 6.10:** Voltage profiles of buses *HERS3*, *HERS5* and *GOUV5* after the connection of a 8MW generator at *HERS3* operating in APFC mode

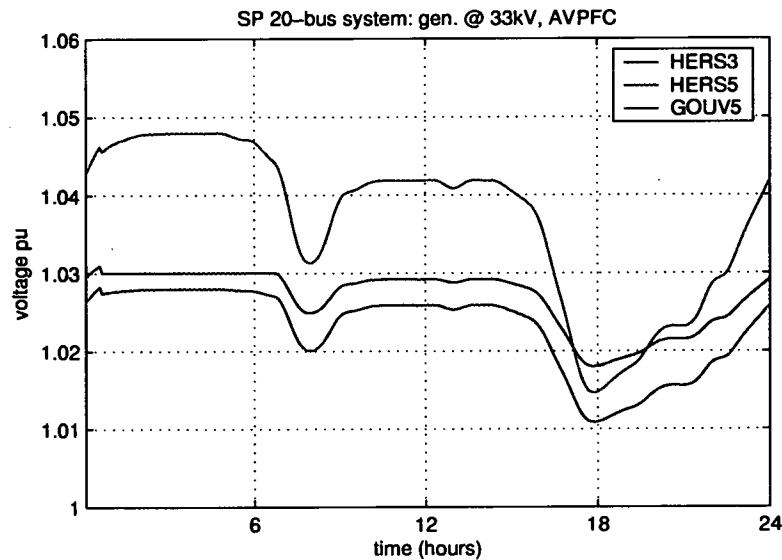

**Figure 6.11:** Effect of operating the generator at *HERS3* in AVPFC mode on the voltage profiles of buses *HERS3*, *HERS5* and *GOUV5*

This time the generator does not reach its excitation limit and is able to hold bus voltage at or below the 1.03 pu setpoint for the whole period of the simulation. Figure 6.12

shows the power factor of the machine and can be observed that it does not need to go into leading (importing MVARs) to hold voltage. Installing a 14MW generator at bus HERS3 will cause voltage at bus HERS5 to rise up to the statutory voltage limit of 1.06 pu thus restricting access for further generation in the network.

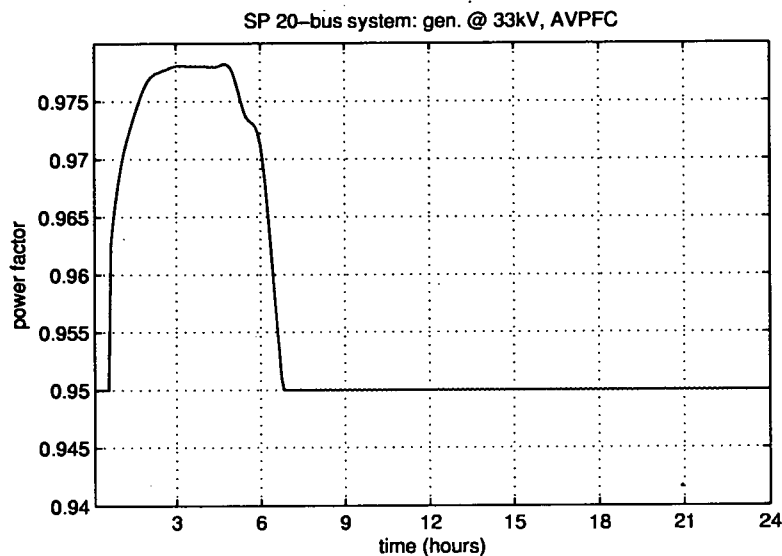

**Figure 6.12:** Power factor of generator at HERS3 operating in AVPFC mode

The operating voltage ranges of the whole system are depicted in Figure 6.13. Use of a fuzzy power factor controller on the generator led to a reduction of the voltage level and range, more noticeably at bus GOUV5 but also in a lesser degree at all buses below HERS3. Figure 6.14 shows the new voltage ranges and it can be observed that bus GOUV5 voltage does not exceed 1.05 pu when the generator is assisted by the FLPPFC. Being under FLPPFC control, the capacity of the generator at bus HERS3 can be further increased up to 36MW before a bus voltage in the simulated system (once again, GOUV5) hits the 1.06 pu limit. Compared to the 11kV case, the 22MW (or 157%) increase from the initial 14MW is more dramatic due to the fact that the generator bus is electrically closer to the bulk supply point and therefore the generated power can be easily exported to the slack bus.

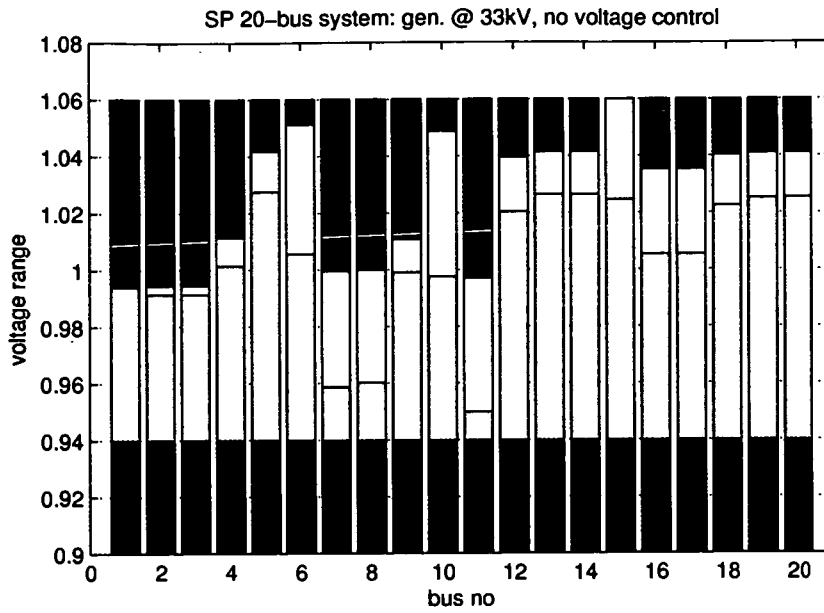

Figure 6.13: Voltage range on all 20 buses with a 14MW generator connected to bus HERS3

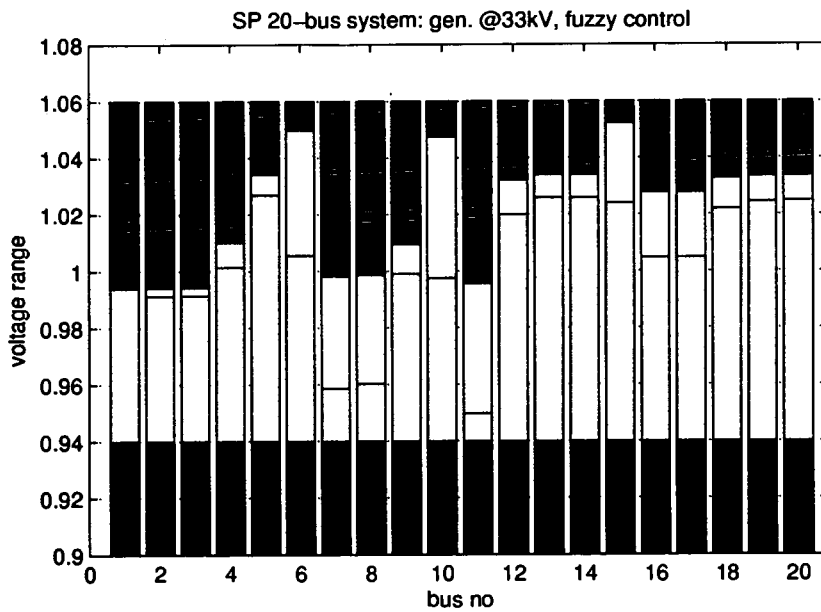
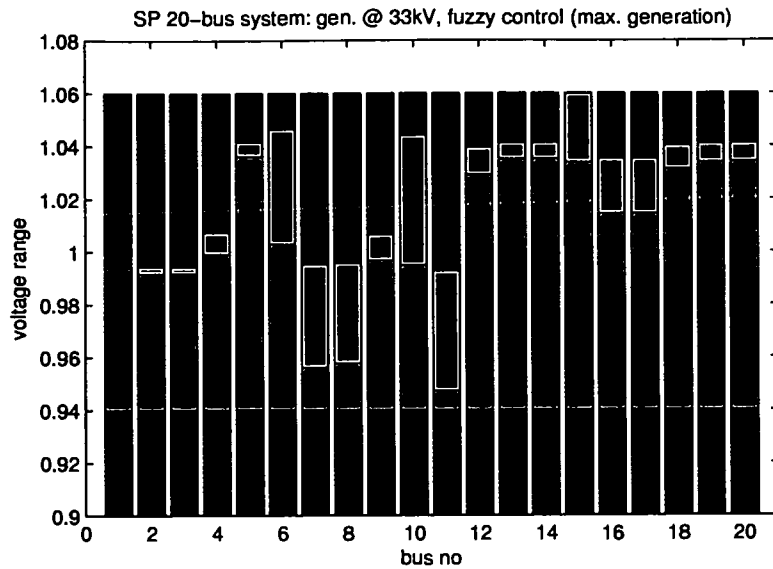

Figure 6.14: Voltage ranges with the generator controlled by the fuzzy controller

The resulting voltage ranges for the 20-bus system after the increase of the capacity of the generator at HERS3 are shown in Figure 6.15. One strange phenomenon is that the



**Figure 6.15:** Voltage ranges with a 36MW generator under fuzzy control on bus HERS3

voltage ranges in some buses (no. 12-14, 16-20) are reduced, although with the increase of local generation capacity the opposite effect was expected. This can be explained as follows: both the minimum and the maximum value of these bus voltages tend to rise due to the increasing generating capacity, but due to its nonlinear nature, the fuzzy controller tries more aggressively to reduce higher voltages, therefore contracting the voltage range at the generator bus and consequently to all its neighbouring buses as well.

## 6.4 Intelligent Generator Control and OLTCs in the Test System

This section presents a series of simulations that compare and then combine intelligent generation control with OLTC operation in line rise/drop compensation mode. In all cases a 24 hour period was simulated, with a resolution of 5 seconds. It is shown that there is an improvement in voltage regulation as well as a reduction in tap changes, which in turn reduces the maintenance costs and increases lifetime of the tap changers.

### 6.4.1 Connection of a Small-Hydro Scheme with Synchronous Generator

In this section the effects of connecting a Small-Hydro Generator (SHG) in the test system will be presented through simulation. The characteristic of SHG in power generation terms is that its output is relatively constant (assumed constant for the entire simulated period here) compared to wind generation. In that sense, this simulation could represent any SG-based power plant of that size. In the test system, the transformer that feeds bus HERS3 from the bulk supply point is equipped with an On-Line Tap Changer and it is set to perform line voltage drop/rise compensation across the feeder down to bus GOUV5. At that bus, a 2MW, 0.95 power factor SHG is connected. The OLTC settings are shown in Table 6.2 below.

$V_{target}$ :	1.03 pu
$V_{deadband}$ :	0.0125 pu
number of taps:	$\pm 5$
time delay:	60 seconds

**Table 6.2:** *OLTC settings*

Operation of the generator in APFC mode without OLTC operation is shown in Figure 6.3. As it was seen in Section 6.3.1, the voltage on GOUV5 was very close to the overvoltage limit during the period of low demand. After enabling the OLTC, voltage was reduced to  $V_{target} \pm V_{deadband}$  as shown in Figure 6.16. It should be noticed however, that the voltage at the upstream buses is not kept between limits, especially during the peak demand period. The voltage on GOUV5 is increased in order to remain within the operational band, but in order to compensate the voltage drop across the feeder, the voltage at the buses between the transformer and the controlled bus is increased even further. Figure 6.17 shows the tap changes, which add up to six.

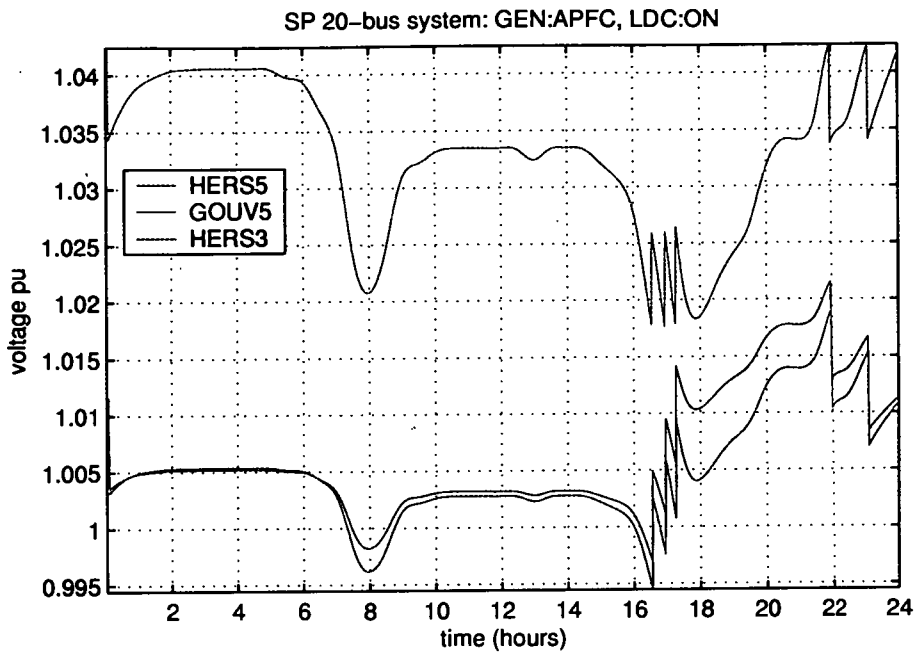

Figure 6.16: Voltage profile of buses GOUV5, HERS5 and HERS3 with a 2MW synchronous generator at GOUV5 and LDR operation

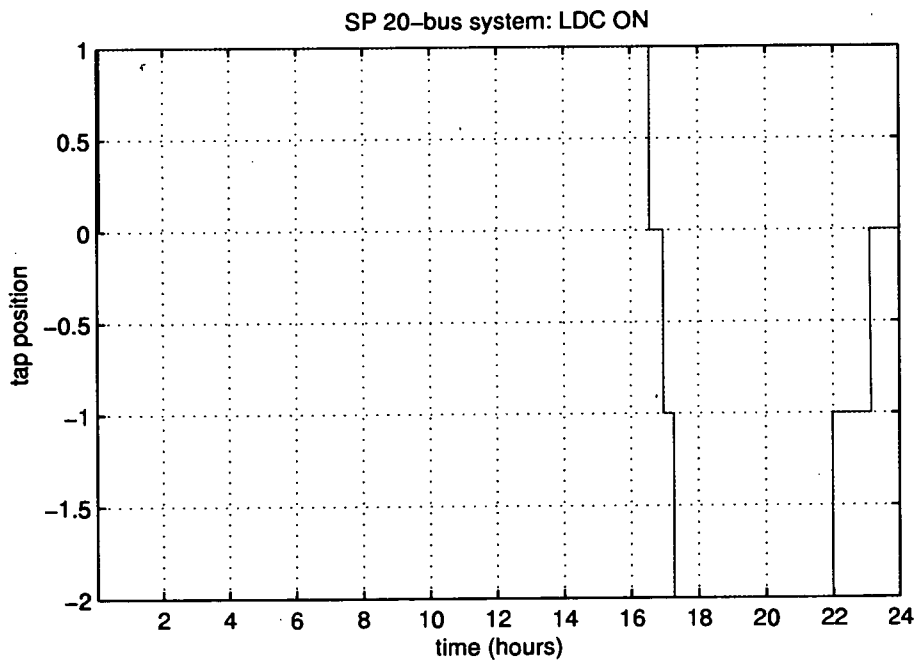

Figure 6.17: Tap transitions of the OLTC transformer

Figure 6.18 displays the resulting voltages on buses GOUV5, HERS5 and HERS3 from the combined use of AVPFC on the generator and LDRC on the transformer. The AVPFC settings for this simulation are shown in Table 6.3. The reactive power exchange of the generator (shown in Figure 6.19) was sufficient to keep voltage constant for most of the time that was needed. Only during the extreme states of demand (low at 00:30 and high at 17:00) the MVAR limits of the generator were met. At these instances voltage could not be further controlled by the generator, and appropriate action of the OLTC brought it back within the specified area. The assistance of the AVPFC in voltage regulation is reflected to the number of tap changes, which is reduced to four. The total tap excursion was also reduced, from +1/-2 tap positions to +1/-1. The result of this reduction is that the voltage of the upstream buses experienced a smaller increase.

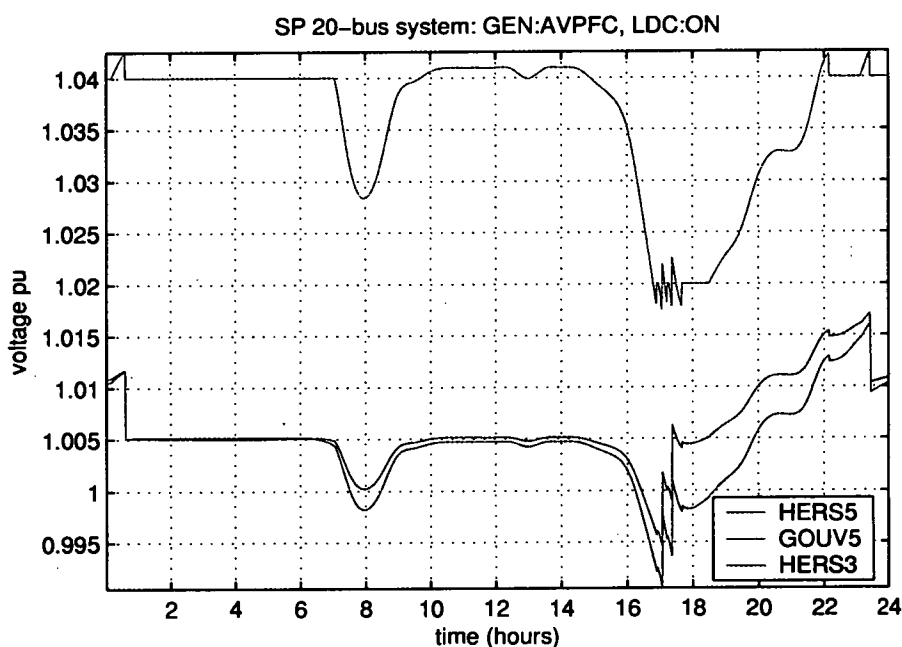

Figure 6.18: Voltage profiles for combined AVPFC and LDRC operation

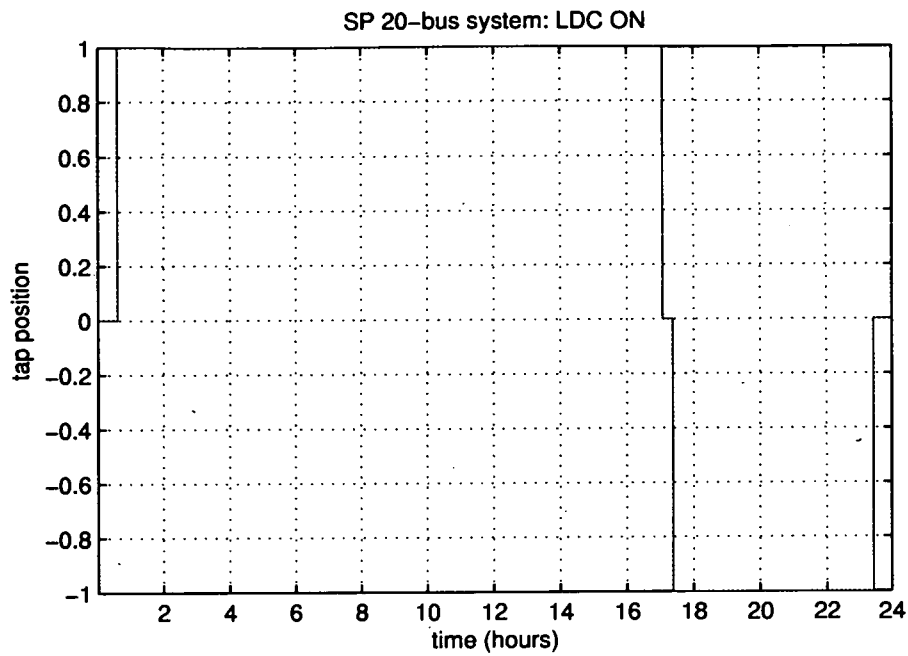

Figure 6.19: Tap transitions of the OLTC transformer with the generator under AVPFC control

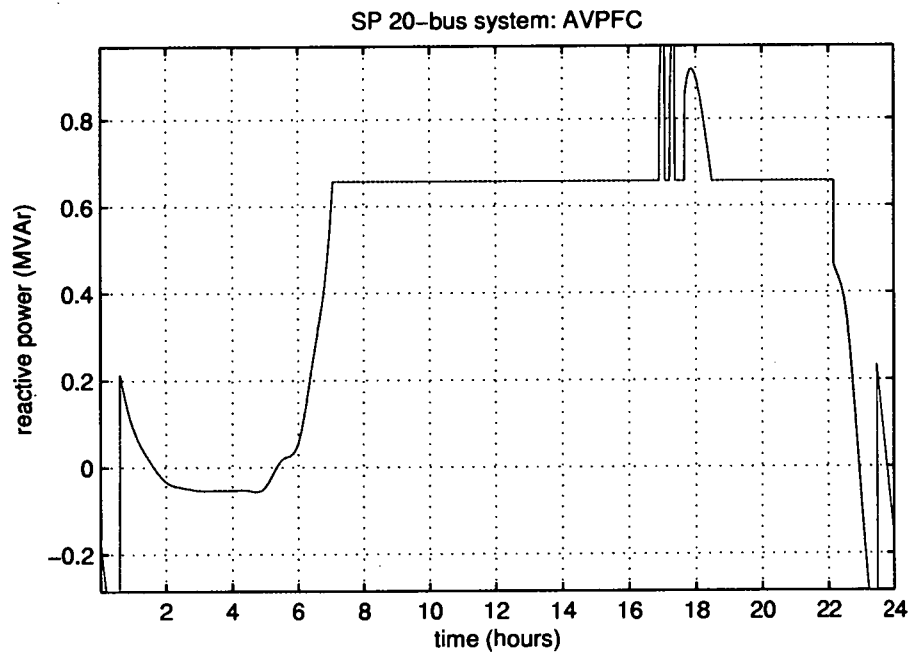

Figure 6.20: Reactive power exchange of the generator under AVPFC control

$V_{high}$ :	1.04 pu
$V_{low}$ :	1.02 pu
$V_{deadband}$ :	0.001 pu
$PF_{ref}$ :	0.95 lagging
$PF_{max}$ :	0.99 leading
$PF_{min}$ :	0.9 lagging
$PF_{deadband}$ :	0.0005

Table 6.3: AVPFC settings

### 6.4.2 Wind Generation in the Test System

Intelligent generation control has also been applied to wind turbines equipped with Doubly Fed Induction Generators (DFIGs). In this section a simulation of the test system including a wind turbine with a DFIG connected on a weak bus is presented. The operation of the generator under constant power factor and automatic voltage/reactive power control is compared. Then, an OLTC transformer is set to perform line drop/rise compensation in order to further assist voltage regulation. Figures 6.21 to 6.28 show the simulation results of the operation of a 2MW DFIG wind turbine at the same bus and under the same load conditions.

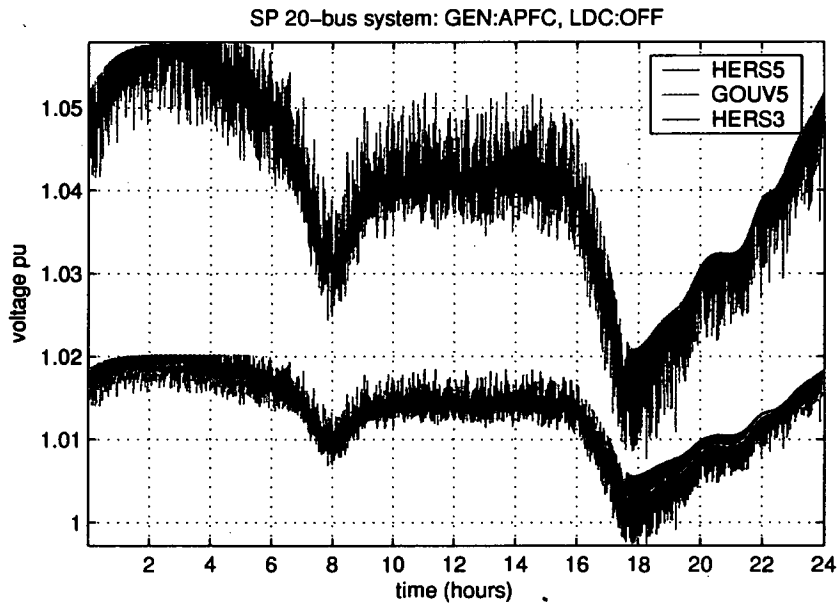

Figure 6.21: 24-hour voltage profile with the wind turbine operating in APFC

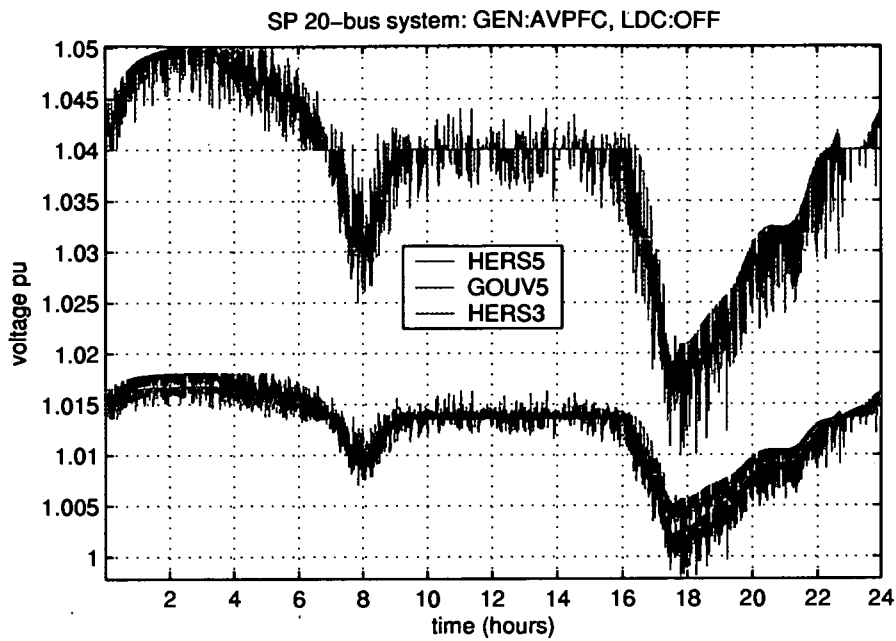

Figure 6.22: 24-hour voltage profile with the wind turbine operating under AVPFC control

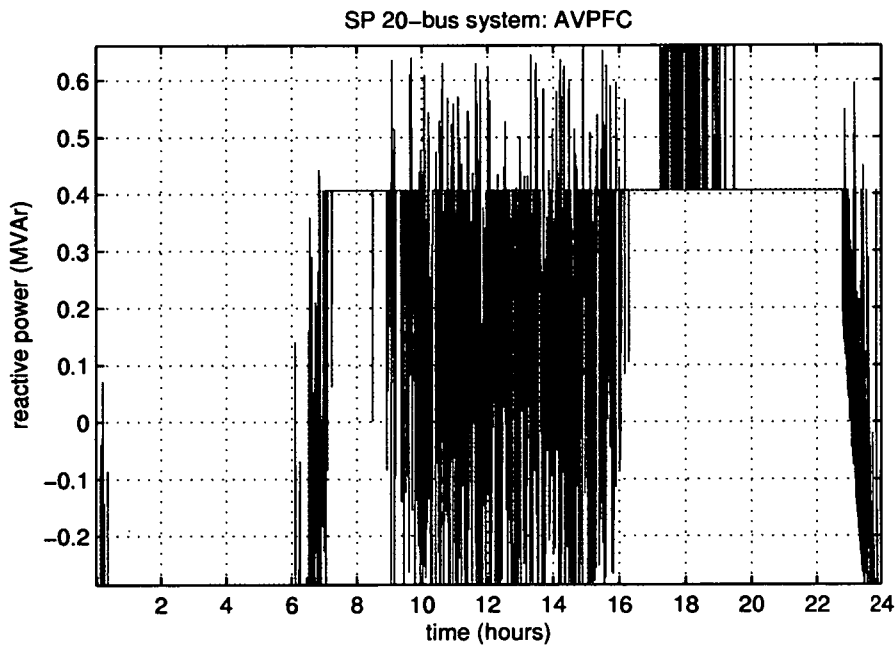

Figure 6.23: Reactive power exchange of the wind turbine operating under AVPFC control

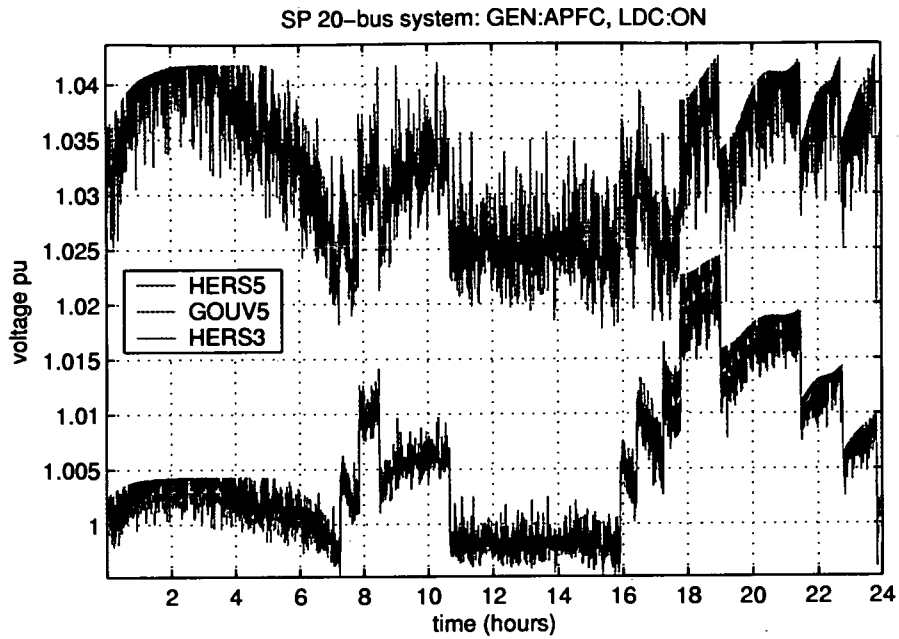

Figure 6.24: 24-hour voltage profile with the wind turbine in APFC mode assisted by line drop/rise compensation

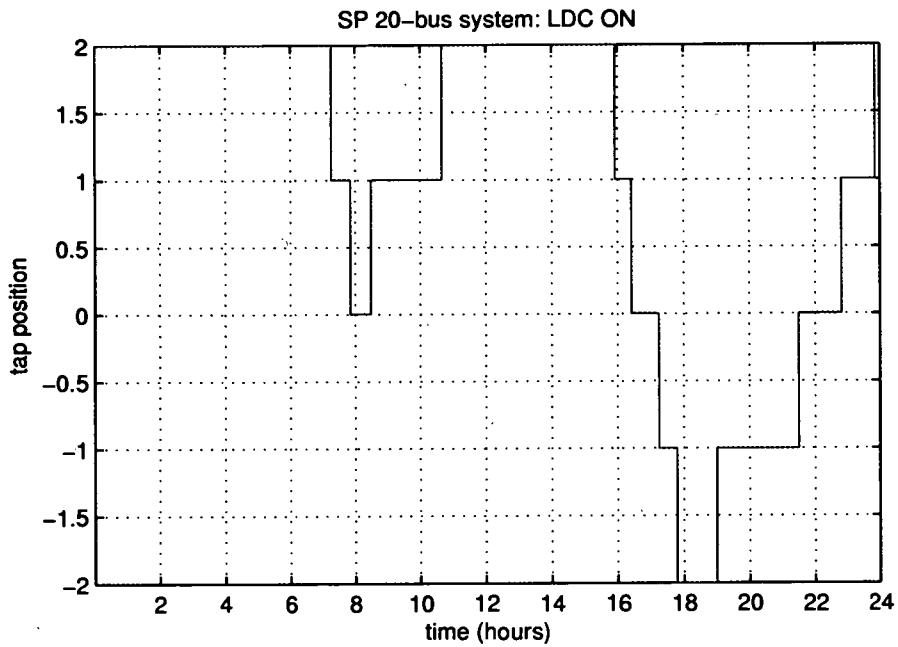

Figure 6.25: Tap changes throughout the 24-hour period with the generator in APFC mode

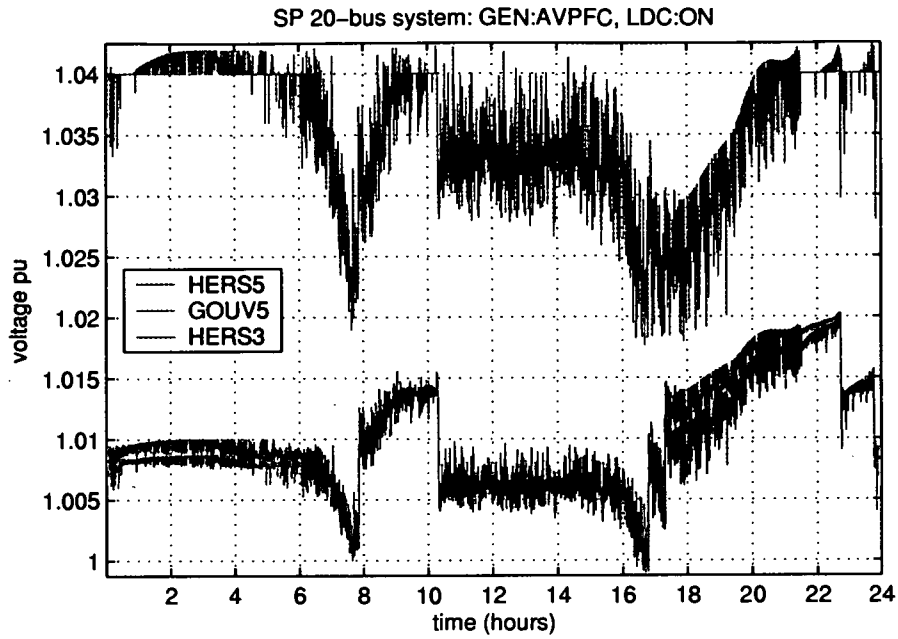

Figure 6.26: 24-hour voltage profile with the wind turbine operating under AVPFC control combined with LDRC

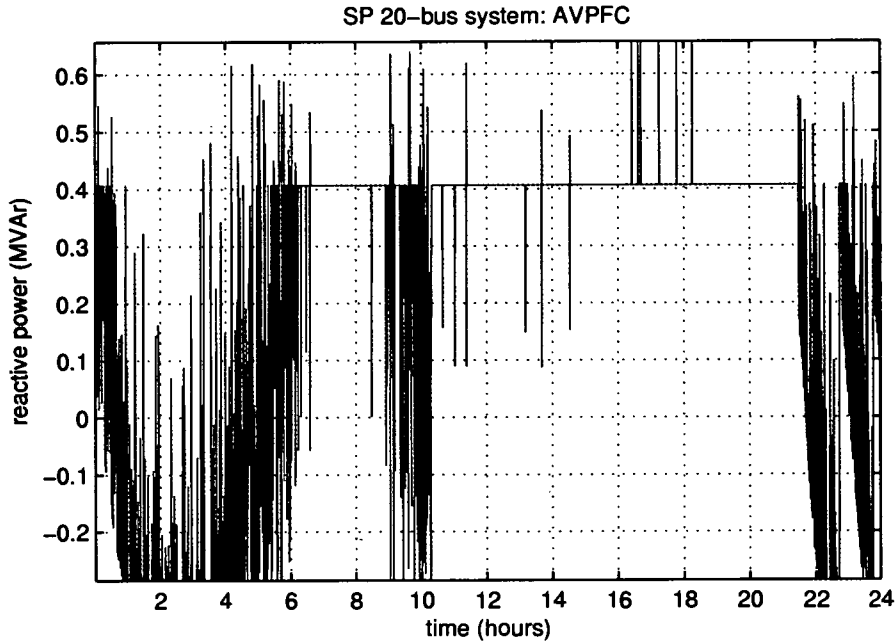
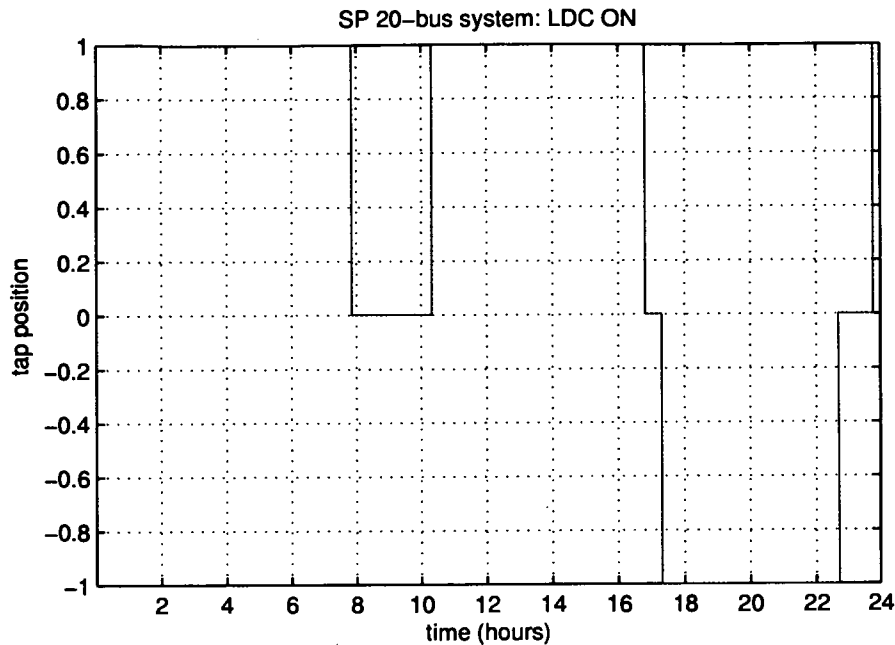

Figure 6.27: Reactive power exchange of the wind turbine operating under AVPFC control combined with LDRC



**Figure 6.28:** *Tap changes throughout the 24-hour period with the generator in AVPFC mode*

The wind speed time series developed in Section 4.2.1 (Figure 4.4) was used as power source input. Figure 6.21 shows the voltage profile with the generator operating at a constant 0.98 power factor (lagging) and Figure 6.22 depicts the voltage profile for AVPFC operation. A first observation reveals that during mid-day, when average voltage is at about 1.04 pu (which is the overvoltage setting in the AVPFC), voltage fluctuation is reduced as there are short periods that it switches to constant voltage mode, but is not eliminated completely as there are other periods that it either operates in constant power factor mode, or it reaches the reactive power limits (see Figure 6.23). This improvement of the voltage profile due to AVPFC operation is also apparent in the neighbouring buses.

Line voltage drop/rise compensation through the OLTC transformer reduced the overall range of voltage at bus GOUV5, but did no good to the short-term variability. In addition, there is a notable alteration of the voltage profile of the middle buses due to tap excursion, which was +2/-2 tap positions and is shown in Figure 6.25.

Combination of AVPFC and LDRC once again brought about an improved overall performance of the system than the individual control cases. Compared to AVPFC-only, the voltage at the controlled bus was always kept within the OLTC bandwidth of  $\pm 0.0125pu$ , and compared to LDRC-only, the combination resulted in a reduced number of tap changes (6 instead of 12, shown in Figure 6.28).

## 6.5 Comparison of Intelligent Generator Control with Central "Active" Network Management

*Credits: This section describes work done in cooperation with Mr Panagis Vovos and Mr Robert Barrie. As a part of his MEng project [96], Mr Barrie embedded the intelligent generation control algorithms into a capacity allocation program based on Optimal Power Flow (OPF), which was developed by Mr Vovos. Under the supervision of Dr Gareth Harrison and the guidance of Mr Vovos and the author, Mr Barrie set up the simulations and obtained the results presented here.*

Voltage control in the distribution system might be achieved by central control, in a similar way that is performed in the transmission system. Distributed generators could have their real and reactive power centrally dispatched, so that the voltage profile throughout the distribution network is flattened. Although traditionally the DN was passively managed, there is now a great interest in active DN management, primarily due to the expansion of distributed generation [97–100]. For obvious reasons, this only concerns generation types that have a predictable and controllable output such as small hydro, biomass etc. Active distribution network management is a promising technology, however its uptake is expected to be slow due to the telecommunications and automation infrastructure that is required, and the associated technical and economic difficulties involved.

In theory, under the assumption of perfect telecoms and infinite availability of information on the conditions throughout the network, the optimal operating regimes for all the connected generators could be estimated at a central point (the control

centre) and then transmitted to them. A capacity allocation program based on Optimal Power Flow, originally presented in [101] was used to simulate central control and dispatch of the DGs. A novelty of the particular program is that it has the additional functionality to consider constraints imposed by protection equipment. Inclusion of the intelligent DG control algorithms to the program, allowed comparison between central voltage control (CVC) of conventionally operating DGs, and DGs under AVPFC or FL PFC control (collectively termed "IntelliGens"). The methodology that allowed inclusion of the DG control algorithms into the capacity allocation program is described in [96, 102, 103].

An OPF algorithm estimates the values for system variables such that an operational criterion is minimised. Several constraints can be imposed mathematically to bound the solution within feasible technical and economic limits. A cost function is assigned to each generator, which represents a "preference factor" according to which a generator is favoured against the others. A series of simulations was carried out in order to compare the benefits of CVC and IntelliGens in terms of capacity increase compared to normal APFC operation of the distributed generators. The network depicted in Figure 6.29 was used as a test base for the simulations.

The bulk supply point (BSP) is considered as a slack bus and is located at bus 12. The network is fed by the BSP through a 90MVA OLTC transformer with 8 steps that holds voltage within  $\pm 2\%$  of the nominal value. The controlled generators are connected at buses 1, 10 and 11 through three 30MVA transformers with fixed taps. There is also a 15MW, 10MVA<sub>r</sub> (max.) generator connected at bus 5. The loads in the network are considered static and their values are shown in Figure 6.29. The network operates at 33kV, except for the BSP which is 132kV and the generator buses (11kV). The transformers and lines characteristics are given in Table 6.4.

It is assumed that the network can exchange 100MW/60MVA<sub>r</sub> with the transmission grid through the BSP without any effect on its operation and that line 2-5 and 4-9 are constrained by a thermal limit of 14MVA and 40 MVA respectively. The power factor setpoint of the generators is set at 0.9 lagging, and the range is 0.9 lagging to 0.9 leading. The IntelliGens operate in power factor control until voltage reaches the



Type	Buses	R (pu)	X (pu)	B (pu)	Therm. Limit (MVA)
trans.	1-2	0.00	0.3	0.00	30
line	2-3	0.48	0.3	0.0008	$\infty$
line	2-5	0.24	0.15	0.0004	$\infty$
line	2-6	0.72	0.45	0.001	$\infty$
line	3-4	0.64	0.4	0.001	$\infty$
line	3-6	0.64	0.4	0.001	$\infty$
line	4-6	0.48	0.3	0.0008	$\infty$
line	4-9	0.66	0.35	0.0009	40
trans.	4-10	0.00	0.25	0.00	30
line	5-7	0.688	0.43	0.0006	$\infty$
line	6-8	0.768	0.48	0.00	$\infty$
line	7-8	0.56	0.35	0.0008	$\infty$
trans.	7-11	0.00	0.3	0.00	30
line	8-9	0.768	0.48	0.00	$\infty$
trans.	9-12	0.00	0.1	0.00	90

Table 6.4: Line and transformer characteristics for the network in Figure 6.29

	APFC	IntelliGens	CVC
Gen @ bus 1	20.0MVA, 0.9 lag	36.6MVA, 0.98 lead	33.7MVA, 0.9 lead
Gen @ bus 10	3.7MVA, 0.9 lag	7MVA, 0.9 lag	20.8MVA, 0.95 lag
Gen @ bus 11	16.9MVA, 0.9 lag	35.2MVA, 0.97 lead	35.5MVA, 0.98 lead
BSP	-16.5MW	-29.7MW	-34.0MW
Total	40.6MVA	78.9MVA	90.0MVA
Losses	3.9MW	30.7MW	34.7MW

Table 6.5: Capacity allocation from the optimal power flow for APFC, IntelliGens and CVC with the fault level constraints considered

## 6.6 Summary

Distribution networks impose serious constraints in the development and operation of distributed and renewable generation. This chapter used a model of an actual section

of the Scottish distribution network to validate the proposed control strategies. The test network has the typical characteristics of a weak rural system. It has a radial topology and can accommodate a small capacity of generation, mainly due to voltage constraints. These characteristics make it an ideal test bed for the assessment of DG operation and the performance of DG control strategies. Through simulations it was demonstrated that adoption of the proposed intelligent generator control techniques may lead to an increase of the generating capacity that may be accommodated in a weak distribution network, and / or an improvement of voltage profiles. Further, it was shown that although OLTC control is an attractive method for voltage regulation, in distribution systems, combination with intelligent generator control may further improve its performance. This becomes more apparent in the case of wind generation, as the OLTC action is not fast enough to mitigate the voltage fluctuations due to wind variability. Finally, simulations using a capacity allocation program based on optimal power flow incorporating fault level constraints, showed that the increase in DG capacity by using intelligent generator control is comparable to the increase that can be achieved if active DN management is utilised. Given the technical and economical burden of the latter, it may well be a more attractive solution for the distribution network voltage control task.

---

# Chapter 7

## Discussion and Conclusions

---

### 7.1 Thesis Summary

This thesis was structured as following. After the introduction, the problem of voltage variation in the distribution network was discussed. Then, detailed modelling of the DN, small hydro and wind generators was presented. Two possible methods of mitigation were proposed, and finally these algorithms were evaluated in a simulation of a test network. Particularly:

In **Chapter 1** an introduction to this work was given. First, the background of the research was presented. Sustainable energy systems were discussed from a global perspective, and then the current state of renewable and distributed energy resources in the UK was described. An overview of the RNET project was given, and the chapter closed with the thesis statement, the contribution to knowledge and the project deliverables.

**Chapter 2** introduced the issues regarding embedded and renewable generation in the DN. This was achieved through a presentation of the current regulations that govern the connection of ERG in the UK, a description of the distribution network structure and the effect of various network parameters on voltage. Finally, the chapter ended with a discussion of the voltage control hierarchy in the distribution network.

In **Chapter 3** a model of a small hydro scheme within a distribution network was constructed. This started with an overview of the design considerations of a SHG and continued with the description of the mathematical model of each component of the SHG. The described model was based on a synchronous generator and two typical methods of SG control were discussed: automatic voltage control and automatic power factor control. The operational limits of the synchronous generator were shown by

means of the 3D "composite" capability diagram. Then, the model of the distribution system including on-line tap changing transformers was presented. The functionality of the full model was presented through a series of simulations.

The complete wind-to-wire dynamic model of a wind energy conversion system based on a doubly fed induction generator was presented in **Chapter 4**. The aspects of WECS modelling were discussed and then wind characteristics and modelling were presented. Then, an analysis of the mathematical model of the turbine, the generator and the controls was performed. The chapter closed with a series of simulation results with the WECS operating with varying wind speed and under automatic power factor, and automatic voltage control.

**Chapter 5** presented the developed intelligent generator control algorithms. The need for intelligent control was illustrated using the universal power circle diagram for the distribution network and the dynamic "composite" capability diagram of the synchronous generator. A brief introduction to artificially intelligent controllers was done, and then the automatic voltage/power factor controller, an expert system, was described. Operation of the AVPFC was illustrated through a simulation of a small hydro generator operating under AVPFC control. A second controller based on fuzzy logic, the fuzzy logic power factor controller, was then discussed. Its operation was also demonstrated using the same simulation as in the case of AVPFC. Both controllers' performance in voltage regulation was compared to the one of the traditional techniques. Their performance was then tested using a varying local load, and the final test was carried out with a WECS operating with varying wind conditions. It was then shown that coordination of intelligent generator control and OLTC operation is possible and reduces tap operations. The final part of Chapter 5 presented a further upgrade of the fuzzy controller, where real power generation of the WECS was also adjusted by means of a fuzzy controller, with the objective of voltage regulation.

In **Chapter 6** a section of the Scottish distribution network was used as a test bed for a real-life assessment of the performance and the advantages of intelligent controllers utilisation. Operation of the system with, and without OLTCs in use was investigated, and the developed algorithms were compared to normal DG operation. In each case,

the benefits of utilising intelligent generator control on voltage regulation and installed capacity increase were shown. The tests involved connection of generators to both 11kV and 33kV buses.

**Chapter 7** summarises the thesis, includes a discussion on the findings and draws the overall conclusions.

## **7.2 Areas of Activity**

This work included three main areas of activity:

- i. development of two source-to-wire dynamic models of forms of generation that classify as 'distributed'; namely small-hydro schemes and wind energy conversion systems;
- ii. development of strategies and algorithms for controlling synchronous and induction DG to maximise capacity and energy production, with minimum network impact;
- iii. validation of the proposed control systems on DG in a representative distribution network.

Experience and extensive simulations identify that DG capacity in rural networks is most frequently limited by voltage violation, where and when the generator usually operates in constant power factor mode. DGs must operate within voltage envelopes to gain access and, once connected, to avoid protection shutdown, loss of production and revenue. The operational envelope is constant and pre-defined by the power factor limits of the generator and the voltage limits set by the DNO and system conditions. The DG operating point is dynamic and varies with changing local power flows, network configuration (action of transformer on-load tap changers, network re-configuration etc.) and prime mover input. The relatively high impedance of radial feeders in the distribution network exaggerates the effects of these changes on voltage level. This work developed a control mode for continuous DG operation within the operational envelope.

## **7.3 Discussion of the Research Outcomes**

The outcomes of this research can be broken into two sections: distributed generation and network modelling, and intelligent generation control algorithm development. The following sections discuss the findings.

### **7.3.1 Distributed Generation and Network Modelling**

Steady-state and dynamic models of a small-hydro generating plant and an active pitch-controlled wind energy conversion system utilising a doubly fed induction generator were constructed in Matlab and Simulink. The developed models were built according to widely accepted bibliography and their results matched those of the originals. The original and novel modes of operation proposed (AVPFC and fuzzy logic PF control) were incorporated and their operation was tested in several weak networks, including a simple two-bus system, a radial network and a section of the test system. The variations of voltage under real load profiles and the response of the system to increasing capacities of DG were studied. The studies confirm that the new control modes developed in this work can effectively mitigate the impact of DG on the network.

### **7.3.2 Intelligent Generation Control Algorithm Development**

Extension of the synchronous machine capability diagram on the network to the three-dimensional space P-Q-V enabled projection of the network voltage response to varying P and Q and generated a 3D surface locus of acceptable operation of the machine for every possible network condition. Adding the DNO voltage constraints as horizontal surfaces identified the allowable operational regime for the DG. The initial approach to the problem was to use an extension of the traditional excitation control system to constrain the operation of the machine within voltage and power factor limits. The novel controller developed smooth transfers from power factor to voltage control (PFC to AVC) or back dependent on network conditions. It is implemented as an algorithm

operating on voltage and mechanical power set-points and is termed Auto-voltage Power Factor Control (AVPFC). The controller enables greater export during low demand periods and can also provide voltage support at times of high demand. Extensive simulations compared operation of a water-turbine driven synchronous generator using only a PFC system and with the new AVPFC scheme. Under PFC, the voltage rose above the upper statutory limit during periods of low demand and in consequence the generator was disconnected with significant loss of production. Secondly, excessive local demand drew voltage below the lower voltage limit, and under-voltage protection disconnected the DG when it might have provided voltage support. In AVPFC, however, the voltage was continuously maintained within statutory limits, allowing the DG to remain connected. While PFC used to be obligatory, some DNOs may now permit voltage controlled operation for DGs at weak parts of the network for voltage support. This has to be evaluated carefully as the behaviour larger DGs can cause network voltage control systems to operate in response. However, the combination of power factor control together with voltage control of DGs may offer significant benefit to developers if it enables acceptable access to weak areas of the network and allows continuous operation of the plant when co-ordinated with varying local demand.

Further development led to a fuzzy control system where the generator operates constantly in PFC mode, but the fuzzy controller alters the power factor set point in response to the terminal voltage of the generator. The whole control system has the effect of applying a non-linear voltage droop to the machine. Simulations of a synchronous generator and a variable speed, pitch-controlled Wind Energy Conversion System (WECS) with a Doubly Fed Induction Generator (DFIG), operating under the control of the fuzzy system has demonstrated that, in both cases, the voltage not only remained within the statutory limits for longer periods than with the conventional power factor control, but its distribution was more concentrated around the nominal value, thus improving the overall voltage quality.

## 7.4 Contribution to Knowledge, Novelty and Potential Impact of Study

This work made a contribution to knowledge through:

- i. introduction of a holistic approach for the determination of the generator's acceptable operating area, taking into account both network and plant induced constraints;
- ii. development of intelligent generator control techniques for synchronous and induction DG to enhance network integration and maximise capacity of new plant that can connect;
- iii. demonstration of a method to combine network and generator voltage control that overcomes the widely known problems due to their co-existence; and
- iv. validation of the proposed control systems on representative distribution networks.

While automatic voltage and automatic power factor control are well-established modes of operation, this combination of the two using an expert system to change from one to the other according to network conditions is a novel technique. Furthermore, the proposed use of fuzzy logic to adjust the power factor setpoint of an APFC (collectively termed "FLPFC") for the purpose of minimising voltage fluctuation and increasing capacity has not been discussed elsewhere.

The application and uptake of these outcomes has increased the available understanding, methodologies, software tools and techniques that quantify and mitigate the effects of DG on the distribution network. The major impact will be the wider development and network integration of distributed generation. An additional benefit is the opportunity for further research to extend and expand to three dimensions the applications of the proposed control algorithms:

- **Depth:** Perform further study of the intelligent generation control by building a prototype and evaluate its operation in an emulated distribution system. Several

generator manufacturers have shown interest in this prospect. A project proposal is planned and an application for a 'Proof of Concept' grant will be submitted for that purpose.

- **Width:** Use the same philosophy to mitigate other DG-related issues such as the effect of distributed generation to system stability. Work towards this direction is already under way within the 'SUPERGEN' research project, supported by the Engineering & Physical Sciences Research Council, which the Institute of Energy Systems is participating through work done by Prof. Janusz Bialek.
- **Extent:** Investigate the application of intelligent generation control to further kinds of distributed and/or renewable generation. This workpath is also being explored by IES mainly through the author's work within the 'SUPERGEN Marine' research project (led by Dr Robin Wallace), also supported by EPSRC. This study is the fourth out of thirteen work packages of the project and investigates how intelligent generation control can be applied to wave and tidal energy converters, as well as its potential effect as a means of assisting the development and uptake of marine energy.

Finally, this work generated 6 journal publications, 5 conference papers and a lecture in an IEE seminar. All these documents can be found in Appendix A.

## 7.5 Beneficiaries of this Work

There are many potential beneficiaries of this research, from society at large to specific sections of the industrial and academic community. The dissemination and transfer of the results of this work, and knowledge gained, may be applied within the UK and other countries committed to reducing carbon flows in the energy supply chain. Developing countries may use the developed strategies to supply electricity in areas where the distribution network is under-developed. Increased uptake of renewable energy generation will enable CO<sub>2</sub> reductions and environmental improvements that will increase the quality of life and preserve natural resources. The expanded markets

for new DG plant and their subsequent operation will lead to increased levels of business and employment, ideally indigenous to the areas under development. DNOs will be able to provide wider and greater network access for DG at lower associated cost. This will benefit economically the developers and DNOs and increase the sustainability of distributed renewable generation. Finally the industrial collaborators have had access and input to evolving methodologies and tools that they can apply to their benefit.

## **7.6 Suggestions and Further Improvements**

It is possible that the proposed control strategies may introduce some problems. As already mentioned, the amount of voltage regulation that a particular generator can achieve depends on the network characteristics above the point of connection, the rating and the type of the generator. It is therefore possible that the required reactive power to compensate over- or undervoltage is close to, or above the capability of the machine. In such cases excitation limiters should be carefully set as the generator may overheat if adequate counter measures are not taken. This will consequently increase the wear on the machine and hence the maintenance costs. Overheating is expected to be more prominent in DFIGs, as their reactive power capability is more constrained than with the synchronous machines. Typical design power factor limits of the latter are 0.8 lagging to 0.9 leading, which are well outside the DNOs requirements therefore are more difficult to be met. Additionally, overheating due to high reactive power exchange may appear at the power electronic converter that feeds the rotor circuit of the DFIG.

By (partially) solving the voltage rise issue the next problems that may arise from the network point of view are the increased losses (especially in weak networks) as an effect of the increased power transfer, as well as overloading of the system especially during high demand periods, when the generator will try to export high reactive power. The (imported) real and (exported) reactive power add up vectorially and may reach the feeders' and transformers' ratings.

Another potential problem is the poor coordination between intelligently controlled generators or between generators and network voltage control devices. This can be

more serious in the case of AVPFC when it operates in voltage control mode. Therefore care must be taken so that both network voltage controllers and generator adhere to the setpoints agreed between the DNO and the developer. This is less important with the FLPFC as an FLPFC controlled generator is essentially still under power factor control (therefore terminal voltage is allowed to vary in order to allow reactive power sharing).

There are also some potential improvements that can be made to the proposed control strategies. In extreme situations when voltage cannot be kept within the statutory limits by using solely power factor control, the output of the generator could be reduced. This may not be possible in schemes such as some heat-led CHP units, but it is possible in others, such as small hydro or wind turbines. In effect this implies decomposition of the generator to a decoupled pair of real and reactive power sources. The effect of reducing real power output on voltage regulation can be very significant in networks with high resistance. However, this comes at the expense of reduced revenue when compared to a generator of the same size with fixed output.

Additionally, in the case of wind generation (as well as other intermittent sources), further voltage regulation could be achieved by means of intermediate energy storage. Mechanical power could be stored temporarily before it is fed to the electric network, thus removing the transient effects of the primary source. A possible means of intermediate storage could be hydraulic accumulators connected via pump/motor pairs.

## **7.7 Overall Conclusions**

There is a global movement towards the reduction of fossil fueled generation of electricity and the increase of renewable energy resources uptake. The drivers of this trend are economical, political and environmental. Current oil prices are reaching \$60 per barrel and rising. Countries that are not major fossil fuel producers seek to reduce their dependency on oil. National and international regulations are also being set in order to promote reduction of greenhouse gases. Increased utilisation of RES (and replacement of fossil fuel fired power plants) is a step towards that direction. However this means

that central, conventional generation will give its place to distributed generation, often powered by intermittent, unpredictable (and therefore non-dispatchable) energy sources, such as wind, small hydro, marine etc.

Increased generation capacity in the distribution network is expected (and already experienced) to introduce several technical and operational problems to both the network operators and the potential developers. The most prominent of these problems is voltage fluctuation due to variation of the energy source and the local power demand. The fact that the distribution network is weak (high resistance and low X/R ratio), particularly close to its remote ends, augments the fluctuation of voltage, and this brings about the need for an alternative operation of both the network and the generator. Distributed generation plants with inherently varying output such as wind farms, small hydro schemes and others, should not be considered as firm (guaranteed) capacity since they cannot be centrally dispatched according to the demand, but rather as energy sources, which should be controlled with the objective to best accommodate their varying output and reduce their impact on the system.

The traditional control methods for the generators, such as automatic power factor and automatic voltage control may not suffice for optimal operation of distributed generation. This can be verified by the results of simulations of DG operation in weak networks. A set of distributed generation models (small hydro and wind) illustrated the effect of such plants on voltage profile. These models were used as a base for development of novel control techniques that would reduce voltage fluctuation. The developed algorithms allowed connection of larger generating capacity in the network before the statutory overvoltage limits were hit, and at the same time the overall quality of supply was improved, as voltage fluctuation was reduced, when compared to automatic power factor control. Additionally, the developed controllers were able to assist voltage regulation when the demand/generation ratio was high and the undervoltage limits would otherwise be hit. However, their ability is constrained by the reactive power generation capability of the plant. Therefore directly coupled synchronous generators (with no power electronic converter in the middle) will have better performance than doubly fed induction machines, as the latter have a smaller

reactive power capability. In terms of reactive power flow (and consequently loading of the generator and the network), the developed algorithms were shown to have superior performance than the automatic voltage control, as they featured lower MVA<sub>r</sub> import to / export from the generator, while they also allowed cooperation with network voltage control devices such as on line tap changing transformers. However, combination and coordination of the two should be discussed in advance between the developer and the network operator.

The proposed control strategies can be an alternative to centrally operated, active network management as they are able to exploit network resources without the need of dedicated communication links.

## 7.8 Thesis Statement

The original thesis statement as expressed in Section 1.7 was that: *"Intelligent voltage and reactive power control algorithms of small-scale generators, which are connected to weak distribution networks, can allow increase of their capacity before the statutory voltage limits for quality of supply are violated."*

This work showed that the above thesis statement is true by proposing two candidate control strategies and proving that they can assist network integration of distributed generation through a series of simulations of their operation in a test network. Application of these control algorithms to synchronous generator based small-hydro schemes as well as wind turbines and farms featuring doubly fed induction machines, was shown to have a positive impact on capacity and overall voltage quality within the distribution network.

---

## References

---

- [1] E. Lakervi and E. Holmes, *Electricity Distribution Network Design*. Power Series 21, London UK: IEE, 2nd (revised) ed., 2003.
- [2] A. R. Wallace, "Protection of embedded generation schemes," in *Colloq. Protection and Connection of Renewable Energy Systems*, pp. 1/1–5, IEE, 1999.
- [3] G. P. Harrison, A. E. Kiprakis, and A. R. Wallace, "A new era for mini-hydro," *International Water Power and Dam Construction*, vol. 54, pp. 20–24, November 2002.
- [4] A. R. Wallace and A. E. Kiprakis, "Reduction of voltage violations from embedded generators connected to the distribution network by intelligent reactive power control," in *Proc. 5th Int. Conf. on Power System Management and Control*, (London, UK), pp. 210–215, IEE, April 2001.
- [5] DTI, *Energy, its impact on the environment and society*. London, UK: The UK Department of Trade and Industry, 2002.
- [6] EIA, *International Energy Outlook 2003*. USA: Energy Information Administration (EIA), 2003.
- [7] S. Bull, "Renewable energy today and tomorrow," *Proceedings of the IEEE*, vol. 89, pp. 1216–1226, August 2001.
- [8] DTI, *Energy, its impact on the environment and society, 2003 Update*. London, UK: The UK Department of Trade and Industry, July 2003.
- [9] United Nations Framework Convention on Climate Change, "The Kyoto protocol," December 1997.
- [10] RCEP, *Energy - The Changing Climate*. London, UK: Royal Commission on Environmental Pollution, June 2000.
- [11] G. Boyle, B. Everett, and J. Ramage, *Energy Systems and Sustainability*. Oxford, UK: Oxford University Press, 2003.
- [12] H. Geller, "Energy revolution. policies for a sustainable future," *Renewable Energy World*, vol. 6, pp. 36–49, July-August 2003.
- [13] D. Helm, "The energy policy Britain needs," *IEE Maxwell Lecture*, April 2003.
- [14] DTI, *Digest of United Kingdom Energy Statistics*. London, UK: The UK Department of Trade and Industry, July 2003.

- 
- [15] G. P. Harrison, A. E. Kiprakis, and A. R. Wallace, "Distribution networks: Constraining renewable energy development," in *Re-Gen*, vol. 1, pp. 50–59, Wilmington Publishing, April/May 2003.
- [16] C. Masters, "Voltage rise: The big issue when connecting embedded generation to long 11 kv overhead lines," *IEE Power Engineering Journal*, vol. 16, pp. 5–12, February 2002.
- [17] C. Dai and Y. Baghzouz, "On the voltage profile of distribution feeders with distributed generation," in *Proc. IEEE Power Engineering Society General Meeting*, pp. 1136–1140, IEEE, 2003.
- [18] G. Harrison and A. Wallace, "Maximising renewable energy integration within electrical networks," in *Proc. World Renewable Energy Congress (WREC2005)*, World Renewable Energy Network, WREN, May 2005.
- [19] H. Saadat, *Power System Analysis*. Electrical Engineering Series, McGraw Hill, 1st ed., 1999.
- [20] N. Jenkins, "Embedded generation (part 1)," *Power Engineering Journal*, vol. 9, pp. 145–150, June 1995.
- [21] N. Jenkins, "Embedded generation (part 2)," *Power Engineering Journal*, vol. 10, pp. 233–239, October 1996.
- [22] Econnect Ltd. and ILEX Associates, *A Technical Guide for Connection of Embedded Generators to the Distribution Network*, November 1998.
- [23] N. Jenkins, R. Allan, P. Crossley, D. Kirschen, and G. Strbac, *Embedded Generation*. Power and Energy Series, London, UK: IEE, 2000.
- [24] M. J. Checksfield and M. A. Redfern, "Assessment of embedded generator stability when connected to a utility distribution system," in *Proc. 30th Universities Power Engineering Conference*, 1995.
- [25] N. Jenkins and G. Strbac, "Impact of embedded generation on distribution system voltage stability," in *Proc. IEE Colloquium on Voltage Collapse*, IEE, 1997.
- [26] Engineering Recommendation G 59/1, "Recommendations for the connection of embedded generating plant to the public electricity suppliers distribution systems," tech. rep., The Electricity Association, London, UK, 1991.
- [27] R. Barnes, "Harmonics in power systems," *IEE Power Engineering Journal*, January 1989.
- [28] B. Ozpineci and L.M.Tolbert, "Simulink implementation of induction machine model - a modular approach," in *IEEE Int. Conf. Electric Machines and Drives*, vol. 2, pp. 728–734, IEEE, June 2003.

- 
- [29] Z. Lubosny, *Wind Turbine Operation in Electric Power Systems*. Power Systems, Springer, 2003.
- [30] J. Sloopweg, "Representing distributed resources in power system dynamics simulations," in *Proc. IEEE Power Engineering Society Summer Meeting*, pp. 176–178, IEEE, 2002.
- [31] G. Berube and L. Hajagos, "Modelling based on field tests of turbine/governor systems," in *IEEE Power Engineering Society Winter Meeting*, vol. 1, (New York, USA), pp. 567–573, IEEE, February 1999.
- [32] A. Feijoo and J. Cidras, "Modelling of wind farms in the load flow analysis," *IEEE Trans. Pwr. Syst.*, vol. 15, pp. 110–115, February 2000.
- [33] H. Ramos and A. de Almeida, "Small hydropower schemes as an important renewable energy source," in *Proc. Hydroenergia 99*, (Vienna, Austria), October 1999.
- [34] A. R. Wallace, "A review of small scale hydro power in europe," in *Proc. 1st Portugese Mini-Hydro Seminar*, (Lisbon, Portugal), November 1988.
- [35] C. C. Warnick, *Hydropower Engineering*. New Jersey, USA: Prentice Hall Inc., 1984.
- [36] Working Group on Prime Mover and Energy Supply Models for System Dynamic Performance Studies, "Hydraulic turbine and turbine control models for system dynamic studies," *IEEE Trans. Power Systems*, vol. 7, pp. 167–179, February 1992.
- [37] I. Kamwa, D. Lefebvre, and L. Loud, "Small signal analysis of hydro-turbine governors in large interconnected power plants," in *Proc. IEEE Power Engineering Society Winter Meeting*, vol. 2, pp. 1178 – 1183, IEEE, January 2002.
- [38] P. Kundur, *Power system stability and control*. The EPRI Power System Engineering Series, New York, USA: McGraw-Hill, 1994.
- [39] J. Machowski, J. Bialek, and J. Bumby, *Power system dynamics and stability*. London, UK: John Wiley & Sons, 1998.
- [40] D. Clemen, *Hydro plant electrical systems*. Kansas, USA: HCI Publications, 1999.
- [41] The Brown Book Working Group, *IEEE Recommended Practice for Industrial and Commercial Power Systems Analysis*. New York, USA: IEEE, August 1998.
- [42] B. Weedy and B. Cory, *Electric Power Systems*. London, UK: John Wiley & Sons, 4th ed., 1998.

- [43] C. M. Ong, *Dynamic Simulation of Electric Machinery*. Prentice Hall, 1998.
- [44] IEEE Standards Committee, "IEEE recommended practice for excitation system models for power system stability studies," IEEE Standard IEEE Std 421.5-1992, IEEE, New York, USA, March 1992.
- [45] I. Elsedawi, A. Ellassal, and E. Azzuz, "Effects of avr systems on the performance of synchronous generators," in *IEEE Canadian Conf. on Electrical and Computer Engineering*, vol. 1, pp. 25–28, IEEE, May 1997.
- [46] I. D. E. Force, "Computer models for representation of digital based excitation systems," *IEEE Trans. Energy Conversion*, vol. 11, pp. 607–615, September 1996.
- [47] J. Fan and S. Salman, "The effect of integration of wind farms into utility network on voltage control due to the co-ordination of AVC relays," in *Proc. IEEE 4th Int. Conf. Advances in Power System Control, Operation and Management APSCOM-97*, pp. 260–265, IEEE, November 1997.
- [48] M. Larsson, *Coordinated Voltage Control in Electric Power Systems*. PhD Thesis, Department of Industrial Electrical Engineering and Automation, Lund University, Lund, Sweden, 2000.
- [49] S. Salman and I. Rida, "ANN-based AVC relay for voltage control of distributed network with and without embedded generation," in *IEEE Int. Conf. Electric Utility Deregulation, Restructuring and Power Technologies*, (London, UK), pp. 263–267, IEEE, April 2000.
- [50] S. Salman, F. Jiang, and W. Rogers, "The effect of private generators on the voltage control of 11 kV network and on the operation of certain protective relays," *IEEE Joint Int. Pwr. Conf. Athens PowerTech*, vol. 2, pp. 591–595, September 1993.
- [51] S. Salman, F. Jiang, and W. Rogers, "Investigation of the operating strategies of remotely connected embedded generators to help regulating local network voltage," in *Int. Conf. on Opportunities and Advances in International Electric Power Generation*, pp. 180–185, IEE, March 1996.
- [52] C. Taylor, "Line drop compensation, high side voltage control, secondary voltage control - why not control a generator like a static var compensator?," in *Proc. IEEE/PES Summer Meeting*, (Seattle, USA), IEEE, July 2000.
- [53] Beckwith Electric Co. Inc., "M-0067E tap changer control," instruction book, Florida, USA, 1999.
- [54] M. Thomson, "Automatic voltage control relays and embedded generation (part 1)," *IEE Power Engineering Journal*, pp. 71–76, April 2000.

- [55] J. Choi and J. Kim, "Advanced voltage regulation method at the power distribution systems interconnected with dispersed storage and generation systems," *IEEE Trans. Power Delivery*, vol. 15, pp. 691–696, April 2000.
- [56] M. Kashem and G. Ledwich, "DG impact on rural lines: Voltage control and line protection issues," in *Proc. 1st Int. Symposium on Distributed Generation: Power System and Market Aspects*, June 2001.
- [57] J. Chow, M. Glinkowski, R. Murphy, T. Cease, and N. Kosaka, "Generator and exciter parameter estimation of fort patrick henry hydro unit 1," *IEEE Trans. En. Conv.*, vol. 14, pp. 923–929, December 1999.
- [58] Scottish Power UK plc, Scotland, *Transmission Seven Year Statement*, April 2003.
- [59] L. S. T. Ackermann, "Wind energy technology and current status: A review," *Renewable and Sustainable Energy Reviews*, vol. 4, pp. 315–374, 2000.
- [60] M. Davidson, "Interaction of a wind farm with the distribution network and its effect on voltage quality," in *IEE Colloquium on the Impact of Embedded Generation on Distribution Networks*, pp. 9/1–9/5, IEE, October 1996.
- [61] K. G. T. Ackermann, "Embedded wind generation in weak grids - economic optimisation and power quality simulation," *Renewable Energy*, vol. 18, pp. 205–221, 1999.
- [62] Z. Chen and E. Spooner, "Grid power quality with variable speed wind turbines," *IEEE Trans. En. Conv.*, vol. 16, pp. 148–154, June 2001.
- [63] K. Burges, A. M. D. Broe, and A. Feijoo, "Advanced power control in a wind farm network," in *Proc. IEEE Bologna PowerTech Conf.*, (Bologna, Italy), IEEE, June 2003.
- [64] H. Petersen, "Evaluation of wind turbine performance," Tech. Rep. ENS-51171/00-0016, Danish Energy Agency, Denmark, 2000.
- [65] J. F. Manwell, J. G. McGowan, and A. L. Rogers, *Wind Energy Explained, Theory Design and Application*. UK: John Wiley & Sons, 2002.
- [66] J. G. Slootweg and W. L. Kling, "Is the answer blowing in the wind?," *IEEE Power & Energy Magazine*, vol. 1, pp. 26–33, November/December 2003.
- [67] A. Betz, *Wind-Energie und ihre Ausnutzung durch Windmuehlen*. Gottingen: Vandenhoeck et Ruprecht, 1926.
- [68] A. Leon-Garcia, *Probability and random processes for electrical engineering*. Reading: Addison-Wesley Publishing Company, 2nd ed., 1992.

- [69] C. Masters, J. Mutale, G. Strbac, S. Curcic, and N. Jenkins, "Statistical evaluation of voltages in distribution systems with embedded wind generation," *IEE Proc. Gen. Transm. Distrib.*, vol. 147, pp. 207–212, July 2000.
- [70] V. Akhmatov, H. Knudsen, and A. H. Nielsen, "Advanced simulation of windmills in the electric power supply," *Journal of Electrical Power and Energy Systems*, no. 22, pp. 421–434, 2000.
- [71] V. Akhmatov and H. Knudsen, "Modelling of windmill induction generators in dynamic simulation programs," in *Proc. IEEE PowerTech Budapest*, (Budapest), IEEE, August 1999.
- [72] W. E. Leithead, S. A. de la Salle, D. Reardon, and M. J. Grimble, "Wind turbine modelling and control," in *International Conference on Control*, vol. 1, pp. 1–6, 1991.
- [73] S. Heier, *Grid Integration of Wind Energy Conversion Systems*. Chicester, UK: John Wiley & Sons Ltd., 1998.
- [74] J. G. Sloopweg, H. Polinder, and W. L. Kling, "Dynamic modelling of a wind turbine with doubly fed induction generator," in *Power Engineering Society Summer Meeting*, vol. 1, pp. 644–649, IEEE, July 2001.
- [75] D. Henderson, "Synchronous or induction generators? The choice for small scale generation," in *Proc. Opportunities and Advances in Int. Power Generation Conf.*, IEE, March 1996.
- [76] E. N. Hinrichsen, "Controls for variable pitch wind turbine generators," *IEEE Trans. Pwr. Appar. & Syst.*, vol. PAS-103, pp. 886–892, April 1984.
- [77] J. Ekanayake, L. Holdsworth, X. Wu, and N. Jenkins, "Dynamic modeling of doubly fed induction generator wind turbines," *IEEE Trans. Power Systems*, vol. 18, pp. 803–807, May 2003.
- [78] W. Hofmann and F. Okafor, "Optimal power utilisation with doubly-fed full-controlled induction generator," in *Proc. IEEE 6th AFRICON*, vol. 2, pp. 693–698, October 2002.
- [79] G. Arnold and S. Heier, "Grid control with wind energy converters," in *Proc. 2nd Int. Workshop on Transmission Networks for Offshore Wind Farms*, March 2001.
- [80] H. B. (ed.), "Power control for wind turbines in weak grids," Project summary Risoe-R-1117(EN), Risoe National Laboratory, Roskilde, Denmark, March 1999.
- [81] A. R. Wallace and A. E. Kiprakis, "Intelligent voltage and reactive power control of mini-hydro power stations for maximisation of real power export," in *Proc. Waterpower XIII*, (Buffalo, USA), HCI Publications, July 2003.

- [82] A. E. Kiprakis and A. R. Wallace, "Hybrid control of distributed generators connected to weak rural networks to mitigate voltage variation," in *Proc. 17th Int. Conf. Electricity Distribution CIRED*, (Barcelona, Spain), CIRED, May 2003.
- [83] A. E. Kiprakis and A. R. Wallace, "Maximising energy capture from distributed generators in weak networks," *IEE Proc. Gener. Transm. & Distrib.*, vol. 151, pp. 611–618, September 2004.
- [84] R. Chedid, "Intelligent control for wind energy conversion systems," *Wind Engineering*, vol. 22, no. 1, pp. 1–16, 1998.
- [85] A. Ekwue, D. Cheng, and J. Macqueen, "Artificial intelligence techniques for voltage control," in *Artificial intelligence techniques in power systems* (K. Wardwick, A. Ekwue, and R. Aggarwal, eds.), 22, pp. 109–120, London, UK: IEE, 1997.
- [86] W. J. Laycock, "Intelligent networks," *IEE Power Engineering Journal*, pp. 25–29, February 2002.
- [87] M. Marei, E. El-Saadany, and M. Salama, "A novel control algorithm for the DG interface to mitigate power quality problems," *IEEE Trans. Power Delivery*, vol. 19, pp. 1384–1392, July 2004.
- [88] G. Ramakrishna and N. Rao, "Fuzzy inference system to assist the operator in reactive power control in distribution systems," *IEE Proc. Gener. Transm. Distr.*, vol. 145, pp. 133–138, March 1998.
- [89] Y. H. Song and A. T. Johns, "Applications of fuzzy logic in power systems, part 1," *IEE Power Engineering Journal*, vol. 11, pp. 219–222, October 1997.
- [90] C. Su and C. Lin, "A new fuzzy control approach to voltage profile enhancement for power systems," *IEEE Trans. Power Syst.*, vol. 11, pp. 1654–1659, August 1996.
- [91] H. Al-Duwaish, "Adaptive output feedback controller for wind turbine generators using neural networks," *Electric Machines and Power Systems*, vol. 27, pp. 465–479, 1999.
- [92] R. Bansal, "Bibliography on the fuzzy set theory applications in power systems (1994-2001)," *IEEE Trans. Pwr. Syst.*, vol. 18, pp. 1291–1299, November 2003.
- [93] W. Pedrycz, *Fuzzy Control And Fuzzy Systems*, pp. 106–116. Taunton, Somerset, England: Research Studies Press, 2nd ed., September 1993.
- [94] T. Takagi and M. Sugeno, "Fuzzy identification of systems and its application to modelling and control," *IEEE Trans. Syst., Man., Cybern.*, vol. 15, pp. 116–132, 1985.

- 
- [95] H. Ying, "Constructing nonlinear variable gain controllers via the takagi-sugeno fuzzy control," *IEEE Trans. on Fuzzy Systems*, vol. 6, no. 2, pp. 226–234, 1998.
- [96] J. Barrie, "Incorporating novel generator control into optimal power flow," meng individual project report, School of Engineering and Electronics, The University of Edinburgh, Edinburgh, UK, November 2004.
- [97] Embedded Generation Working Group, "Future network design, management and business environment," rapporteur contribution, DTI/OFGEM, London, UK, December 2000.
- [98] J. McDonald, G. Burt, S. McArthur, C. Booth, I. Elders, and S. Bell, "Power network management using intelligent systems," in *Proc. IEE Power System Control and Management Conf.*, pp. 240–245, IEE, April 1996.
- [99] G. Dudgeon, W. Leithead, J. O'Reily, and J. McDonald, "Prospects for the decentralised control of small-scale power networks with embedded generation," in *IEEE Power Engineering Society Winter Meeting*, vol. 2, pp. 1399–1404, IEEE, 2000.
- [100] Z. Saoud, M. Lisboa, J. Ekanayake, N. Jenkins, and G. Strbac, "Application of STATCOMs to wind farms," *IEE Proc. Gener. Transm. Distrib.*, vol. 145, pp. 511–516, September 1998.
- [101] P. Vovos, G. Harrison, A. Wallace, and J. Bialek, "Optimal power flow as a tool for fault level constrained network capacity analysis," *IEEE Trans. Power Systems*, vol. 20, pp. 731 – 741, May 2005.
- [102] P. N. Vovos, A. E. Kiprakis, G. P. Harrison, and J. R. Barrie, "Enhancement of network capacity by widespread intelligent generator control," in *Proc. 18th Int. Conf. Electricity Distribution CIRED*, (Torino, Italy), CIRED, June 2005.
- [103] P. N. Vovos, A. E. Kiprakis, G. P. Harrison, and A. R. Wallace, "Augmenting network capacity by widespread intelligent generator control," *Submitted to IEEE Trans. Power Systems*, 2005.

---

# Appendix A

## Publications

---

### A.1 Journal Papers

- i. **P. N. Vovos, G. P. Harrison, A. E. Kiprakis and A.R. Wallace,** '*Augmenting network capacity by widespread intelligent generator control*', submitted to IEEE Trans. Power Systems (*not included*)
- ii. **A. E. Kiprakis and A. R. Wallace,** '*Maximising Energy Capture from Distributed Generators in Weak Networks*', IEE Proc. Gener., Transm., Distrib., 151, 05, 611-618, September 2004
- iii. **A. E. Kiprakis, G. P. Harrison, D. S. Forrest and A. R. Wallace,** '*Increasing Distributed Generation Capacity: A Holistic Approach*', Renewable Energy 2004, WREN-UNESCO, 98-11, 2004
- iv. **G. P. Harrison, A. E. Kiprakis and A. R. Wallace,** '*Distribution Networks: Constraining Renewable Energy Development*', Re-Gen, Wilmington Publishing, 1, 1, 50-59, April/May 2003, ISSN 1479-0351
- v. **G. P. Harrison, A. E. Kiprakis and A. R. Wallace,** '*A new era for mini-hydro*', International Water Power and Dam Construction, Wilmington Publishing, 54 (11), November 2002, pp. 20-24
- vi. **A. E. Kiprakis and A. R. Wallace,** '*Novel Control Algorithms for Distributed Generators to Mitigate Voltage Fluctuation Phenomena*', PhDEE (Departmental Journal), School of Engineering & Electronics, The University of Edinburgh, November 2002 (*This is a reduced edition of item A.1(i) and is not included.*)

## A.2 Conference Publications

- i. **A.E. Kiprakis, A.R. Wallace**, '*Voltage Control in the Distribution Network: Traditional Techniques and New Developments*', World Renewable Energy Congress (WREC2005), 22-27 May 2005 (*Invited paper*)
- ii. **P. N. Vovos, A. E. Kiprakis, G. P. Harrison, J. R. Barrie**, '*Enhancement of Network Capacity by Widespread Intelligent Generator Control*', Proceedings 18th International Conference on Electricity Distribution CIRED 2005, June 2005, Torino, Italy
- iii. **A. R. Wallace and A. E. Kiprakis**, '*Intelligent Voltage and Reactive Power Control of Mini-Hydro Power Stations for Maximisation of Real Power Export*', Proceedings of the Waterpower XIII Conference, July 2003, Buffalo, USA
- iv. **A. E. Kiprakis and A. R. Wallace**, '*Hybrid Control of Distributed Generators Connected to Weak Rural Networks to Mitigate Voltage Variation*', Proceedings 17th International Conference on Electricity Distribution CIRED 2003, 12 - 15 May 2003, Barcelona, Spain.
- v. **A. R. Wallace and A. E. Kiprakis**, '*Reduction of Voltage Violations from Embedded Generators connected to the Distribution Network by Intelligent Reactive Power Control*', Proceedings IEE 5th International Conference on Power System Management and Control PSMC 2002, April 2002, London, UK

## A.3 Seminar Lectures

- i. **A.E. Kiprakis**, '*Doubly Fed Induction Generators for Offshore Wind Energy Systems*', IEE Seminar on Electrical Aspects of Offshore Renewable Energy Systems, 24-25 February 2004 (*Presentation only, not included*)

# Maximising energy capture from distributed generators in weak networks

A.E. Kiprakis and A.R. Wallace

**Abstract:** The paper discusses the implications of the increasing capacity of synchronous generators at the remote ends of rural distribution networks where the line resistances are high and the X/R ratios are low. Local voltage variation is specifically examined and two methods of compensation are proposed. The first of them is a deterministic system that uses a set of rules to switch intelligently between voltage and power factor control modes, while the second is based on a fuzzy inference system that adjusts the reference setting of the automatic power factor controller in response to the terminal voltage. Extensive simulations have verified that the proposed approaches may increase the export of real power while maintaining voltage within the statutory limits.

## 1 Introduction

Electricity generation from renewable energy sources is considered as a solution for environmental pollution, global warming and the rapid depletion of fossil fuels. Governments throughout the world have generated a number of incentives to motivate development of renewable energy (RE) resources including small-hydro and combined heat and power (CHP) plants. A typical example is the UK, where the Renewables Obligation sets a target that by 2010 10% of total electricity supplied should be from RE plant. In absolute terms this implies connection of around 2000 MW of new distributed generator (DG) plant every year [1]. In most countries, a great amount of this new generation (especially RE) is typically found in remote rural areas where the loads are low, the distribution network (DN) is medium or even low voltage and designed for a unidirectional, downstream flow of energy [2]. The steady-state, slow and transient variations of voltage levels related to the connection of a DG can lead to undesired operation of voltage control equipment on transformers at the primary substations of the network. A net reversal of power flow in line, due to the presence of a DG, can cause unacceptable voltage variations and the distribution network operator (DNO) will then require that the DG be disconnected [3].

Operation of DGs under constant voltage or constant power factor (PF) mode, as required by most DNOs, may create a need for network reinforcement, to reduce voltage variation, and the cost of this work may be attributed to the connection costs of the DG. This may make potential schemes less attractive or even impossible to implement [2, 3]. Recent developments involving mixed voltage/PF control have shown that by intelligently controlling synchronous generators (SGs), voltage variations can be mitigated and reinforcement may be avoided [3]. Utilisation of a fuzzy-logic (FL) controller to control the DG may also

prove to be a means of reducing or deferring network reinforcement.

## 2 Impact of increased dispersed generation in weak rural networks

At the moment, the distribution networks in all the industrialised countries are operated with minimal active control as a unidirectional energy path. The same applies for the UK, where the distribution network has been significantly extended during the last 50 years, but its structure and operation has remained largely unchanged [4]. Energy is conveyed from the bulk supply points (connections to the transmission grid) towards the far ends of the DN using overhead lines in a radial manner as Fig. 1 shows.

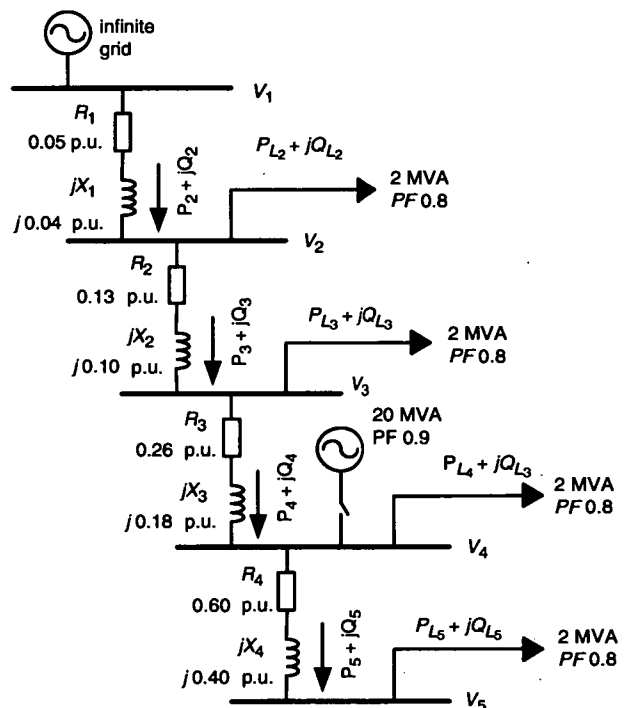

Fig. 1 Radially tapered network

© IEE, 2004

IEE Proceedings online no. 20040697

doi:10.1049/ip-gtd:20040697

Paper first received 11th August 2003 and in revised form 26th April 2004.

Originally published online: 2nd November 2004

The authors are with the Institute for Energy Systems, University of Edinburgh, King's Buildings, Mayfield Road, Edinburgh EH9 3JL, UK

Moving away from the primary substation the loads become smaller and this has allowed the DNOs to use conductors of decreasing cross-sectional area in order to reduce network development costs. However, this means that the network resistance  $R$  per kilometre increases. This has serious implications for the development of DG projects located close to the remote ends of the DN as the increased resistance will exaggerate the variation of voltage due to generated power export. In an 11 kV radially tapered network, such as the one shown in Fig. 1, the busbar voltages in per unit are derived from the equation:

$$\overline{V}_{n+1} = \overline{V}_1 - \sum_{k=1}^n \frac{(R_k + jX_k)(P_{k+1} - jQ_{k+1})}{\overline{V}_{k+1}^*} \text{ p.u.} \quad (1)$$

In order to ensure quality of supply, DNOs impose limits on the allowable voltage levels throughout the network. In the UK, the statutory limit on the 11 kV network is  $\pm 6\%$ . The voltage profile of the network of Fig. 1 when the generator on busbar 4 is disconnected is shown in Fig. 2a. It is obvious that, although the loads are equal, the voltage gradient increases towards the end of the line, due to the higher line impedance.

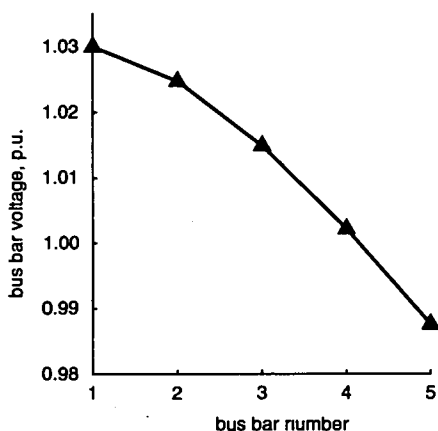

Fig. 2 Voltage profile of the radially tapered network

Connection of the 20 MW generator operating at 0.9 lagging constant power factor on busbar 4 would alter the voltage profile of the line as shown in Fig. 2b. The voltages on busbar 4, as well as the neighbouring busbars 3 and 5, are outside the allowable range. To remain connected, the generator should decrease its output to 0.5 p.u. in order to bring the voltage back within the statutory limits. Other than network reinforcement, alternative measures to accommodate the added DG capacity could include [5]:

### 2.1 Operating DG at leading power factor

Voltage rise may be mitigated, to some extent, by operating at or below unity power factor, but the need to import excessive reactive power would have to be discussed with the DNO.

### 2.2 Lowering primary substation voltage

The DNO can reduce the setpoint voltage at the primary substation reducing all voltages further down the feeder. However, owing to the variability of the RE sources and nondispatched nature of the DGs, the possibility of loss of generator cannot be neglected. Should this happen, the voltages would be further reduced, perhaps below the statutory limits.

### 2.3 Operating DG in constant voltage mode

Disallowed by most DNOs until recently, operating in voltage control mode may help to maintain voltages within acceptable levels, but the voltage dictated by the DG may lead to conflicts of control with the DNO's transformer auto tap-changer settings.

### 3 Automatic voltage/power factor controller

Considering a basic 2-busbar system such as the one shown in Fig. 3, the operating constraints that the network operator imposes on the DG (i.e. ranges of permissible

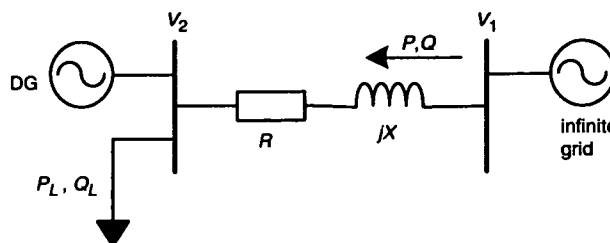
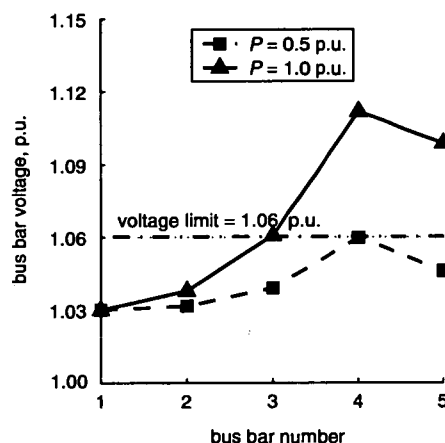

Fig. 3 Basic 2 busbar system



voltage and power factor values) are shown in the voltage vector diagram of Fig. 4.

In this diagram  $V_{min}$  and  $V_{max}$  are the minimum and maximum acceptable voltages and  $PF_{min}$  and  $PF_{max}$  are the lines of constant minimum and maximum power factor, respectively. The allowable area of operation is the shadowed region between these boundaries. The block diagram of a possible system that restricts operation of the synchronous generator within the shadowed area is shown in Fig. 5.

Details of excitation systems and synchronous machine modelling have been presented extensively in [6-8] and will not be discussed here.

After synchronisation, the DG could be brought towards capacity in constant power factor mode (travelling out on its constant power factor line) until the busbar voltage exceeded a predefined threshold voltage within the statutory limits. At that point APFC could be replaced with AVC to vary excitation and move the operating point around the constant voltage circle within the busbar overvoltage limit. Increased local load and reduction in terminal voltage could take the system back into APFC by sensing the increased demand for reactive power and, therefore, the reduction of power factor. Variations in network impedance would have a similar effect. This

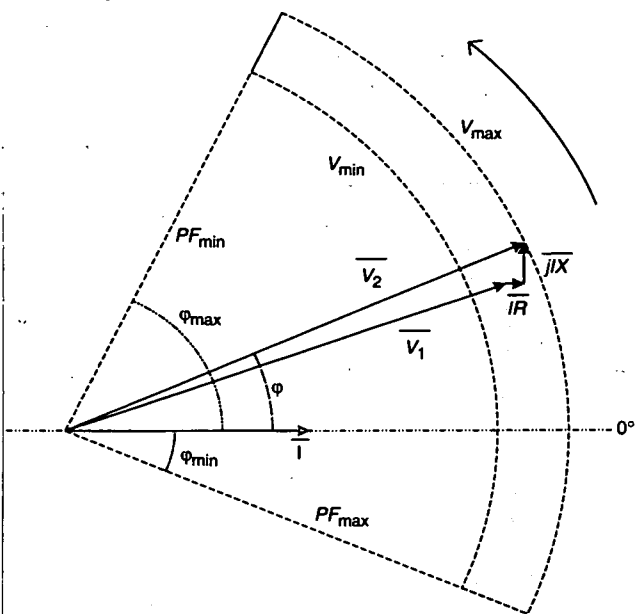

Fig. 4 Voltage vector diagram for the two-busbar system of Fig. 3

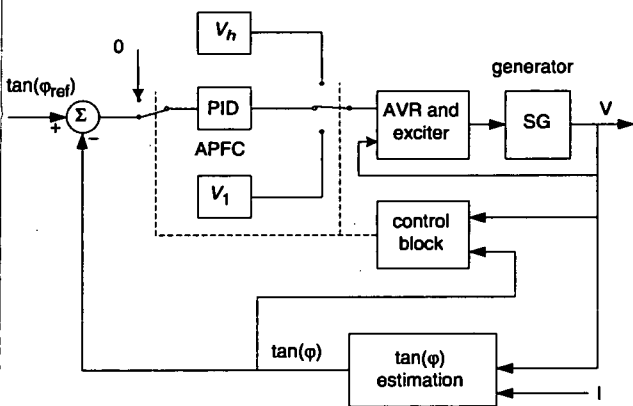

Fig. 5 AVPFC-controlled synchronous generator block diagram

system would also enable voltage support at times of heavy local demand. On reaching a voltage just above the undervoltage limit the excitation system would be transferred to AVC, to maintain local voltage. Excitation under- and overvoltage and overcurrent protection should protect the DG excitation and control system against prolonged forcing. When AVC is active the APFC module is disengaged, otherwise the nonzero power factor error signal would saturate the integrator of the internal PID compensator.

### 3.1 Determination of AVPFC mode selection rule set

The control block in Fig. 5 is responsible for the control mode decision making. The system will attempt to regulate the DG operation around one of three possible setpoints: the power factor setting  $PF_{ref}$  and the high- or low-voltage setting  $V_h$  and  $V_l$ , respectively. Table 1 shows the heuristics of the control algorithm, the reference value which is applied to the controller for every combination of voltage and power factor conditions. In order to prevent hunting, a deadband exists around the decision thresholds. Voltage deadband is annotated as  $V_D$  and power factor

Table 1: AVPFC mode selection rules set

	$V_2 \leq V_B$	$V_B < V_2 < V_T$	$V_T \leq V_2$
$PF \leq PF_B$	$V_l$	$PF_{ref}$	$PF_{ref}$
$PF_B < PF < PF_T$	$V_l$	$PF_{ref}$	$V_h$
$PF_T \leq PF$	$PF$	$PF_{ref}$	$V_h$

deadband is  $PF_D$ , where:

$$V_B = V_l - V_D$$

$$V_T = V_h + V_D$$

$$PF_B = PF_{ref} - PF_D$$

and

$$PF_T = PF_{ref} + PF_D$$

When voltage is within the statutory limits, the DG is in APFC mode and tries to set the power factor at  $PF_{ref}$ . When a voltage higher than  $V_T$  is detected and at the same time the power factor is equal to or higher than  $PF_B$ , the controller will switch to AVC and will try to adjust  $V_2$  to  $V_h$ . However, if the power factor is lower than  $PF_B$  the controller will operate in APFC, because its attempt to raise the power factor will result in lowering the terminal voltage (and thus the exported reactive power). This way it is ensured that the system will never lock into one of its states. The inverse procedure is followed when the terminal voltage is lower than  $V_B$ .

### 3.2 Performance of DG under AVPFC control

In order to test model validity, the process of generator load-up was simulated under AVPFC control and the results compared with those under AVC and APFC modes. The radial test network in Fig. 3 was used with its characteristics shown in Table 2.

The results of the DG loading-up, postsynchronisation, are shown in Fig. 6. In this (hypothetical) case, local power demand is sufficiently high to result in the voltage at busbar

Table 2: Test system data

Network data	
Machine size	10 MW
Load size $P_L, Q_L$	4 MW, 3 MVar
Line resistance $R$	0.123 p.u.
Line reactance $X$	0.099 p.u.
Network voltage $V_1$	1.0 p.u.
Base voltage $V$	11 kV
Base power $S_{base}$	10 MVA
AVPFC data	
$V_h$	1.03 p.u.
$V_l$	0.97 p.u.
$V_B$	0.0025 p.u.
$PF$	0.9 lagging
$PF_B$	0.0025
AVC data	
$PF$	0.9 lagging
AVC date	
$V_{ref}$	1.03 p.u.

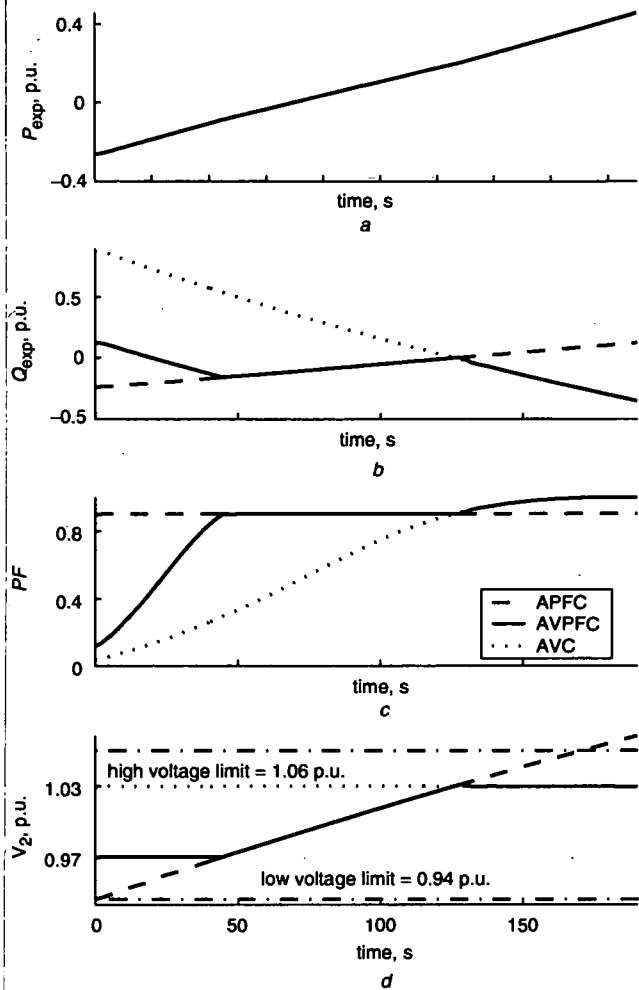

**Fig. 6** DG loading-up under AVC, APFC and AVPFC control  
 (a) Exported real power  
 (b) Exported reactive power  
 (c) SG power factor  
 (d) Terminal voltage

2 ( $V_2$ ) lying below the 0.94 p.u. limit. Normally, however, DNOs would ensure that voltage remained within statutory limits prior to connection. In the initial stages of load-up ( $t \leq 45$  s), local power demand exceeds DG output, and, in the case of the APFC-controlled DG, is sufficiently high to result in voltage  $V_2$  being below 0.94 p.u. (a hypothetical situation as, in general, DNOs would ensure voltage remained within statutory limits prior to connection).

During the same period, a fixed-voltage AVC-controlled generator would try to hold voltage at the 1.03 p.u. reference voltage leading to significant reactive power generation and a fall in the power factor, wherein the DG excitation protection devices would shut the plant down. The AVPFC controller responded by fixing the terminal voltage at 0.97 p.u. The low power factor would cause the protection devices to shut the generator down, albeit for a significantly shorter time than in the AVC case. Between  $t = 45$  s and  $t = 125$  s the AVPFC operated the generator in constant power factor mode as this would not result in voltage excursions outside the preset thresholds. For that period the response of the controller was identical to the response of APFC.

At  $t = 125$  s, the voltage of the APFC and AVPFC controlled generators reached 1.03 p.u. Under AVPFC there was a switch to voltage control to maintain voltage and, from this point on, its response is identical to that with AVC. The voltage under APFC continued to rise towards

and through 1.06 p.u., overvoltage protection would trip the DG at that point.

This simulation showed that compared to APFC, hybrid voltage/PF control of a DG can improve the voltage profile in a weak network, when the power transfer from or to the local busbar is high, and at the same time will reduce import or export of reactive power, compared to automatic voltage control. However, should another automatic voltage control device exist in the vicinity, such as an on-line tap changing (OLTC) transformer, the attempt of the AVPFC to hold voltage constant can potentially cause spurious operation of the OLTC mechanism, if the settings of the two control devices are not carefully selected.

#### 4 Fuzzy logic power factor controller (FLPFC)

Artificial Intelligence has been applied successfully to solve many power system problems. Being highly nonlinear, power systems are very difficult to control with conventional methods and linearisation techniques very often fail to produce models that resemble the actual characteristics of the system. The resulting ambiguities impose constraints on power-system controller design. In addition to this, the stochastic variation of load, generation and topology of a power system exaggerate uncertainty and imprecision [9]. The use of a fuzzy inference-based approach can overcome these difficulties.

##### 4.1 Formulation of the problem

As discussed in the preceding section, hybrid voltage and power factor control of a DG can improve voltage quality in a weak network, but can only be applied when no other voltage control device exists in the vicinity, and at the same time will reduce the need to install such a device. On the other hand, with the rapid increase of distributed generation and the subsequent extension and improvement of the DN, it is expected that the DNOs will move toward a more active control of the DN, and therefore the number of DN voltage control devices will increase. Hence, network operators in such areas may not allow generators to operate in any form of voltage control mode, including AVPFC. In that case, a method of reducing voltage fluctuations while in APFC mode is required. A conventional automatic power-factor controller has a flat power-factor characteristic over the permissible range of voltage. A human operator (or a specifically designed controller) of the DG plant would respond to voltage variation by altering the power-factor setpoint in a way that the change in generated (or absorbed) reactive power regulated the terminal voltage. The DG should operate with constant power-factor in a band in the middle of the permissible voltage range. When voltage falls, the power-factor should shift to a more lagging value, so that the extra reactive power generated restores voltage. Conversely, raised voltage would require to change to a more leading power-factor to compensate for the voltage increase. It is possible to achieve such operation by adjusting the power factor reference according to a signal generated from measurements of the terminal voltage via a look-up table (LUT). The block diagram of a DG controlled in this manner is shown in Fig. 7.

The LUT behaves as a standard numerical-input/numerical-output nonlinear element of a closed-loop control system [10], but even though the controller is a number - to - number mapping, as discussed in the following Section, it is designed with a procedure that relies

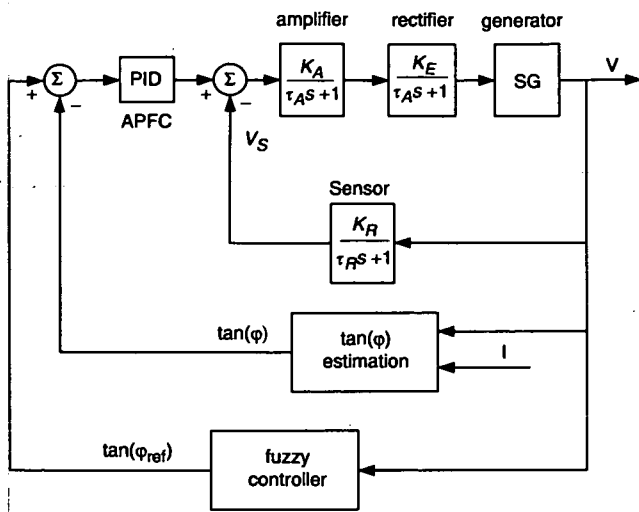

Fig. 7 Block diagram of a DG with a fuzzy logic power-factor controller

on fuzzy inference systems (FIS) theory. It should be stressed that this nonlinear mapping is not unique and is heavily affected by the conversion procedure of the fuzzy control sets [10]. Furthermore, extrapolation capabilities should be given to the LUT to enable it to produce an output, even when the input is outside the design limits.

#### 4.2 Design of fuzzy logic power-factor controller

From the two available types of fuzzy logic (FL) controllers (Madamani-type and Sugeno-type), the one proposed by Sugeno [11] has superior control performance [12]. Once the desired controller response has been identified, there are a number of steps that have to be followed, namely the design of the input stage (fuzzification), determination of the fuzzy rules, and design of the output stage (defuzzification).

**4.2.1 Design of the input stage:** As this is a single-input/single-output (SISO) controller, the input fuzzy set consists only of the measured terminal voltage  $V_T$ ,

varying over the range  $[V_{T_{min}}, V_{T_{max}}]$ . Three linguistic labels define voltage; LOW (L), NORMAL (N) and HIGH (H). The (Gaussian) input membership functions are shown in Fig. 8a and are described by (2)–(4):

LOW:

$$A_L(V_T) = \left[ -\left( \frac{V_T - V_{T_{min}}}{V_{T_1} - V_{T_{min}}} \right)^2 \right] \quad (2)$$

$\forall V_T \in [V_{T_{min}}, V_{T_{max}}]$

NORMAL:

$$A_N(V_T) = \begin{cases} \left[ -\left( \frac{V_T - V_{T_1}}{V_{T_1} - V_{T_2}} \right)^2 \right] & , V_{T_{min}} \leq V_T < V_{T_1} \\ 1 & , V_{T_1} \leq V_T \leq V_{T_2} \\ \left[ -\left( \frac{V_T - V_{T_2}}{V_{T_2} - V_{T_{max}}} \right)^2 \right] & , V_{T_2} < V_T \leq V_{T_{max}} \end{cases} \quad (3)$$

HIGH:

$$A_H(V_T) = \left[ -\left( \frac{V_T - V_{T_{max}}}{V_{T_2} - V_{T_{max}}} \right)^2 \right] \quad (4)$$

$\forall V_T \in [V_{T_{min}}, V_{T_{max}}]$

**4.2.2 Determination of the fuzzy rules:** A typical rule in a Sugeno - type fuzzy model has the form [11]:

**IF Input =  $x_i$ , THEN Output is  $y_i = a_i x_i + b_i$ ,** where  $i$  is the index of the fuzzy rule.

For a zero-order Sugeno model, the output level  $y$  is a constant ( $a = 0$ ), therefore the fuzzy rule set becomes:

1. IF ( $V_T = \text{LOW}$ ) THEN ( $u_1 = PF_{min}$ )
2. IF ( $V_T = \text{NORMAL}$ ) THEN ( $u_2 = PF_{nom}$ )
3. IF ( $V_T = \text{HIGH}$ ) THEN ( $u_3 = PF_{max}$ )

where  $u_1, u_2, u_3$  are the outputs of the respective fuzzy rules.

**4.2.3 Design of the output stage:** The output level  $u_i$  of each fuzzy rule is weighted by the level of

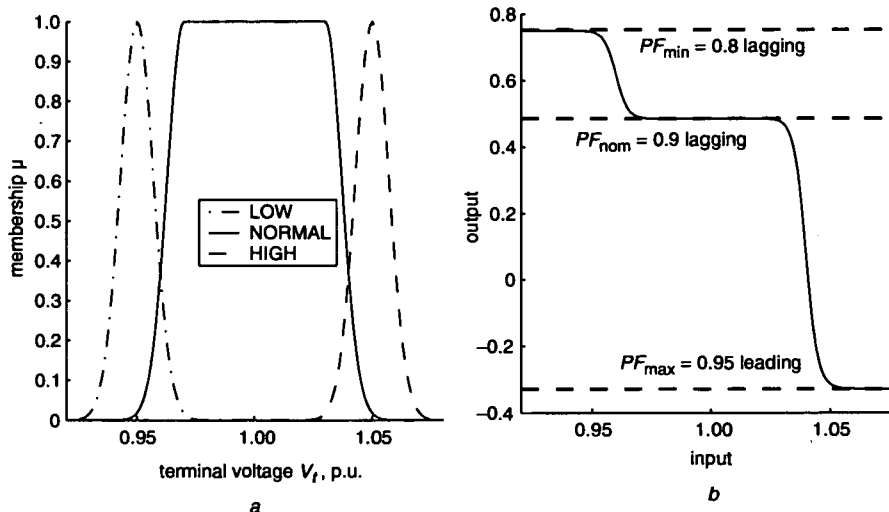

Fig. 8 Input membership functions

(a) and overall response

(b) of the Fuzzy Power Factor Controller

activation  $\mu_i$  of the rule (see Fig. 8a). The final output of the system is the weighted average of all rule outputs, computed as:

$$PF_{ref} = \frac{\sum_{i=1}^3 \mu_i u_i}{\sum_{i=1}^3 \mu_i} \quad (5)$$

### 4.3 Performance of the DG under FLPFC control

To quantify the benefit of using the FLPFC, a simulation on a system identical to the one in Section 3.2 was performed, this time with the DG under FLPFC control.

**Table 3: Fuzzy-logic power-factor controller data**

FLPFC Data	
$V_{T_{min}}$ :	1.05 p.u.
$V_{T_{min}}$ :	0.95 p.u.
$V_{T_0}$ :	1.04 p.u.
$V_{T_1}$ :	0.96 p.u.
$V_{T_2}$ :	1.03 p.u.
$V_{T_3}$ :	0.97 p.u.
$\tan(\phi_{max})$ :	0.750 ( $PF_{min} = 0.8$ lagging)
$\tan(\phi_{nom})$ :	0.484 ( $PF_{nom} = 0.9$ lagging)
$\tan(\phi_{min})$ :	-0.329 ( $PF_{max} = 0.95$ leading)

The details of the FLPFC are shown in Table 3.

Application of the data of Table 3 on the FLPFC produced a LUT with the response shown in Fig. 8(b) and the results of the simulation are shown in Fig. 9. The response of the AVC and APFC controlled DGs are shown in the same graph for comparison.

Early in the loading process, the FLPFC controlled machine operates at a slightly higher voltage compared to the APFC controlled one. This is because the FLPFC allows the SG to operate at 0.8 power-factor exporting extra reactive power. In the middle section of the loading process and while voltage lies between 0.97 p.u. and 1.03 p.u., the system operates at constant 0.9 PF, almost identical to the APFC and AVPFC cases. When voltage rises above 1.03 p.u. the FLPFC starts decreasing the power-factor setpoint (increasing  $\tan(\phi_{nom})$ ) - and by constraining  $Q_{exp}$ , the terminal voltage is held within acceptable levels. It should be noted that the the FLPFC (as well as the AVPFC) will maintain the voltage within the permissible range only as long as the reactive power limits have not been met. These three tests showed that, for the same network conditions, utilisation of either AVPFC or FLPFC would be beneficial, as their operational margins are wider compared to the traditional fixed power factor operation of a synchronous generator.

## 5 Simulation of operation of APFC, AVPFC and FLPFC controlled DG under real-time varying load conditions

To test the response of the DG to voltage variations brought about by changes in local load under the control of APFC, AVPFC and FLPFC, the load of the 2-busbar system in Fig. 3 was given the time-varying profile shown in Fig. 10, to simulate the time variation of actual aggregated

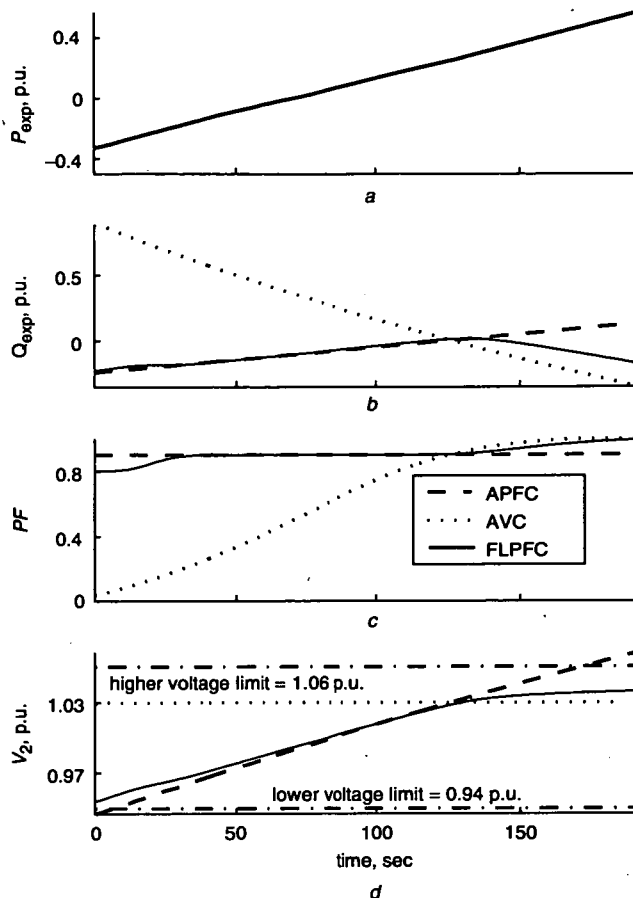

**Fig. 9** DG loading-up under AVC, APFC and FLPFC control

- (a) Exported real power
- (b) Exported reactive power
- (c) SG power factor
- (d) Terminal voltage

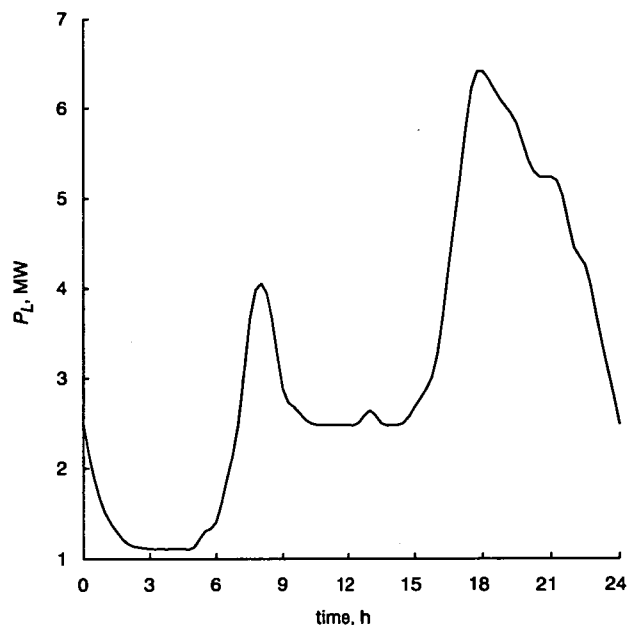

**Fig. 10** 24 h, 80% domestic 20% industrial load profile (0.9 PF)

load at a DN substation. The network characteristics are given in Table 4.

The varying demand profile was applied at constant 0.9 power factor over a 24-h period. It resembles an aggregated 80% domestic, 20% industrial load. The simulation was

**Table 4: Test system data**

Network data	
Machine size:	4.0 MW
Minimum load $P_L, Q_L$ :	1.11 MW, 0.538 MVA <sub>r</sub>
Maximum load $P_L, Q_L$ :	6.411 MW, 3.105 MVA <sub>r</sub>
Load power factor PF	0.9
Line resistance $R$ :	0.1901 p.u.
Line reactance $X$ :	0.1521 p.u.
Network voltage:	1.0 p.u.
Base voltage $V_{base}$ :	11 kV
Base power $S_{base}$ :	10 MVA

performed three times: with the APFC, then with the AVPFC and lastly with the FL PFC. The settings of APFC and FL PFC were the same as the ones used for the generator loading tests (see Tables 2 and 3. Setpoints  $V_t$  and  $V_l$  of the AVPFC have been changed to 1.04 p.u and 0.96 p.u., respectively, in order to match to the FL PFC ones. Additionally, the power factor of the generator has been constrained between 0.8 lagging and 0.95 leading to resemble real-life operation in a DN, as a DNO would generally not allow a generator to operate with an unconstrained PF. The response of a typical APFC generator setup is shown in Fig. 11.

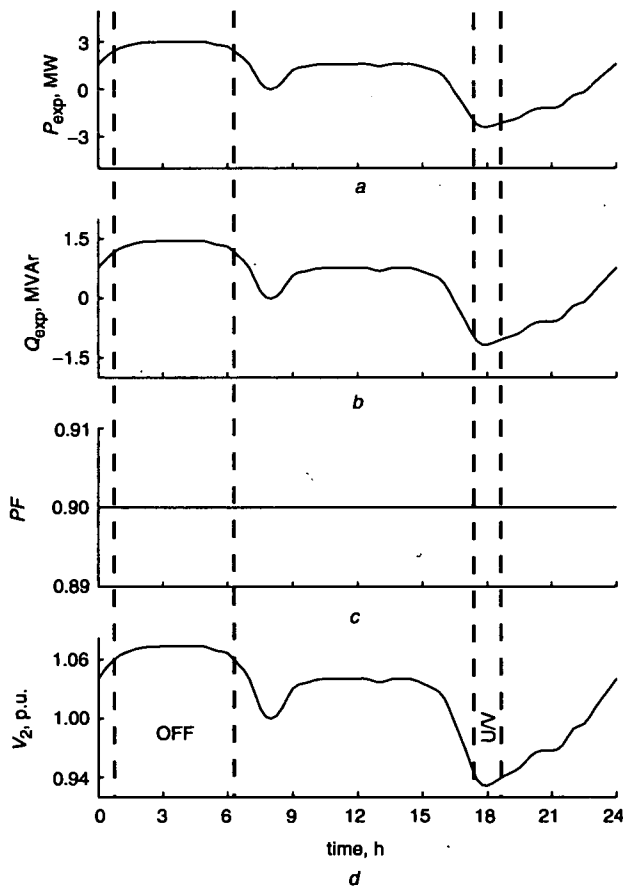

**Fig. 11** Response of APFC to varying load  
 (a) Exported MW  
 (b) Exported MVA<sub>r</sub>  
 (c) Generator's PF  
 (d) Busbar voltage

The power-factor of the generator remains constant throughout the whole period. However, for the period between 0:45-06:15 h the generator would be disconnected as the large (constant) amount of generated power in combination with the low local demand would cause excessive power export and thus voltage violation. Additionally, during the 17:15-18:45 hours high local demand period, the bus voltage would be below the 0.94 p.u. statutory limit.

Figure 12 shows the response of an AVPFC controlled SG under the same circumstances. Compared to the APFC controlled SG response, it is apparent that for the periods while the busbar voltage would be in the 0.97 p.u.- 1.03 p.u. region, the operation of the two systems is identical. However, during the periods of low (00:30-07:00 h) and high (17:15-19:30 h) demand, the AVPFC switches to constant voltage mode and holds voltage at 1.04 p.u., and 0.96 p.u., respectively. This results in a longer period of operation, more energy shipped to the network and therefore increased revenue for the developer. It should be noted that, for a short period just before 18:00 h the voltage falls below the 0.95 p.u. setpoint, because the power factor limit has been met and the generator cannot support voltage any further.

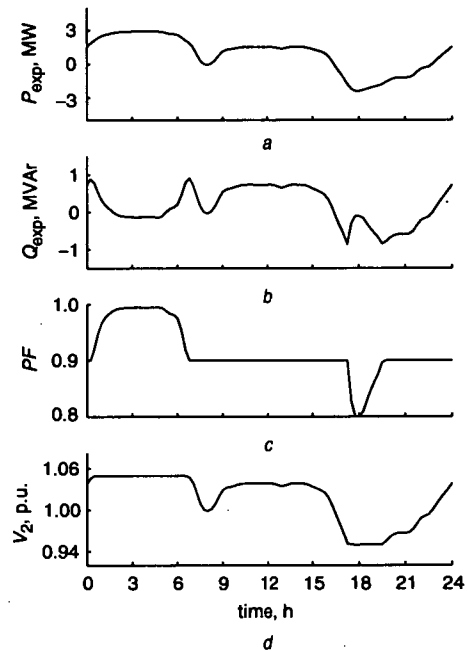
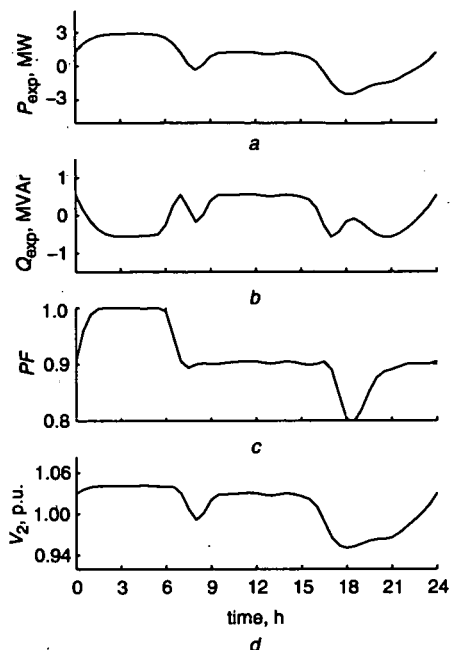

**Fig. 12** AVPFC response to 24 h varying load  
 (a) Exported MW  
 (b) Exported MVA<sub>r</sub>  
 (c) Generator's PF  
 (d) Busbar voltage

Figure 13 presents the results of simulations under FL PFC control. It is clear that neither voltage nor power factor exceed their operational range and therefore the generator will remain connected for the whole period of simulation, resulting in an extra 22 MWh exported energy compared to APFC operation. For a 4 MW machine, this represents considerable increase in output with consequent financial benefits, particularly if the DG qualifies for Renewable Obligation Credits.

**6 Discussion**

There is a need for DGs to be able to operate flexibly within a voltage envelope, to maximise dispatch of active power



**Fig. 13** FLPFC response to 24 h varying load

- (a) Exported MW
- (b) Exported MVAR
- (c) Generator's PF
- (d) Busbar voltage

and to support the voltage in cases of high demand. Some DNOs are now prepared to consider and integrate DGs that can operate to provide voltage control services. Network reinforcement costs may be deferred and loss of generation due to under- or overvoltage shutdown may be reduced. Network, generator and excitation system protection settings and timings will need to be applied carefully, within statutory and manufacturers limits, to ensure that the DG plant operates within accepted network voltages and machine ratings. While voltage and power factor control techniques are well established, their combination has never been co-ordinated, actively, to sustain production of real power in a weak network. Active transfer between voltage and power factor control modes and fuzzy logic DG control have been shown to allow extended operation when network or local demand conditions would otherwise cause excessive voltage variation and plant shutdown. The presented simulations show that in both AVPFC and FLPFC cases, the 24 h uninterrupted operation would cause an extra 22 MW h exported from a 4 MW generator, compared to the traditional APFC scheme. Possible solutions to maintain constant operation of an APFC controlled generator could be network reinforcement, or utilisation of an on-line tap changing (OLTC) transformer, but this would increase the capital and/or maintenance costs and could make a potential project infeasible. Utilisation of these new control algorithms could make potential DG projects more attractive, by allowing the generator capacity to increase further before it causes a voltage violation.

Overall generator and prime mover control is frequently incorporated in programmable logic controllers (PLCs) and this may make the implementation of the presented algorithms easier, due to their rule-based nature.

## 7 Conclusions

In this paper, the impact of an increased generation capacity in the distribution network has been discussed. This has made apparent the need for an intelligent control strategy for the distributed generation and two candidate solutions were proposed: a hybrid voltage / power factor controller and a fuzzy logic power factor controller. Both algorithms allowed extension of generator operating period in a weak network and, therefore, an increase of the revenue from energy export. This was illustrated by computer simulations of a DG in a rural network using a realistic local load pattern. However, the developer should discuss with the DNO in beforehand about the adoption of the AVPFC scheme, because the generator's settings may conflict with those of the network equipment when in constant voltage mode. On the other hand, adoption of the fuzzy controller scheme can be straightforward, provided that the controller is set to operate within the voltage and power factor limits set by the machine specifications and the DNO.

## 8 Acknowledgements

The authors acknowledge with gratitude support provided by EPSRC under grant RNET/GR/N04744, and Scottish Power plc. Dr Gareth Harisson's input to this paper through discussions and comments is also greatly appreciated.

## 9 References

- 1 Wallace, A.R.: 'Protection of embedded generation schemes'. IEE Colloq. on Protection and Connection of Renewable Energy Systems, 9th November 1999, pp. 1/1-1/5
- 2 Harrison, G.P., Kiprakis, A.E., and Wallace, A.R.: 'Network integration of mini-hydro generation in liberalised markets', *Int. Water Power Dam Constr.*, 2002, 54, (11), pp. 20-24
- 3 Wallace, A.R., and Kiprakis, A.E.: 'Reduction of voltage violations from embedded generators connected to the distribution network by intelligent reactive power control'. Proc. 5th Int. Conf. on Power System Management and Control, 2001, pp. 210-215
- 4 Scottish Executive. 'Impact of renewable generation on the electrical transmission network in Scotland' October 2001
- 5 Masters, C.L.: 'Voltage rise: the big issue when connecting embedded generation to long 11 kv overhead lines', *Power Eng. J.*, 2001, 16, (1), pp. 5-12
- 6 Recommended practice for excitation system models for power system stability studies, IEEE Standard 421.5-1992, August 1992
- 7 Grainger, J.J., and Stevenson, W.D. (Jr): 'Power system analysis', (McGraw-Hill, 1994), (Section 3.5)
- 8 Saadat, H.: 'Power system analysis', (WCB/McGraw-Hill, 1999)
- 9 Song, Y.-H., and Johns, A.T.: 'Applications of fuzzy logic in power systems, Part 1', *Power Eng. J.*, 1997, 11, (5), pp. 219-222
- 10 Pedrycz, W.: 'Fuzzy control and fuzzy systems', (Research Studies Press, 1993, 2nd Edn.), (Section 4.5)
- 11 Takagi, T., and Sugeno, M.: 'Fuzzy identification of systems and its application to modelling and control', *IEEE Trans. Syst. Man. Cybern.*, 1985, 15, pp. 116-132
- 12 Ying, H.: 'Constructing nonlinear variable gain controllers via the takagi-sugeno fuzzy control', *IEEE Trans. Fuzzy Sys.*, 1998, 6, (2), pp. 226-234

# Increasing Distributed Generation Capacity: A Holistic Approach

New approaches to integrating generation.  
 By Aristides Kiprakis, Dr Gareth Harrison,  
 Simon Forrest and Dr Robin Wallace,  
 University of Edinburgh, UK

New and renewable energy sources are being connected at all levels of the electricity network: from large wind farms at transmission level to single-phase domestic micro-generation at low-voltage. The location of resources and the consequent generator capacities means that new connections will be predominantly at distribution level. The connection of distributed generation has a range of impacts, the magnitude of which varies between voltage levels.

In considering impacts, it is useful to identify the purpose of each level of the electricity system. Transmission systems are designed to convey large volumes of electricity from large centralised power stations to distant bulk supply points. The energy is then carried by the distribution network down through the voltage levels to customers at low-voltage. At transmission level, the consequences of distributed generation will only be seen when aggregate capacity is high enough to influence power flow patterns or intermittent sources produce a significant

fraction of the total. However, it is at distribution level that the greatest impacts will be felt, given the proportion of connections and the characteristics of the system at this level. Examination of these effects and their consequences is a key research activity within the Institute for Energy Systems at the University of Edinburgh.

## NETWORK IMPACTS

Historically, distribution networks served loads that tended to reduce with distance from the transmission system. Rural areas are characterised by low population and load densities and the medium or low-voltage systems tend to consist of long, overhead radial feeders (Figure 1) supplying consumers. This results in distribution networks that have considerably more resistance than the transmission grid, creating significant voltage drops within the network. To compensate, Distribution Network Operators (DNOs) often set primary

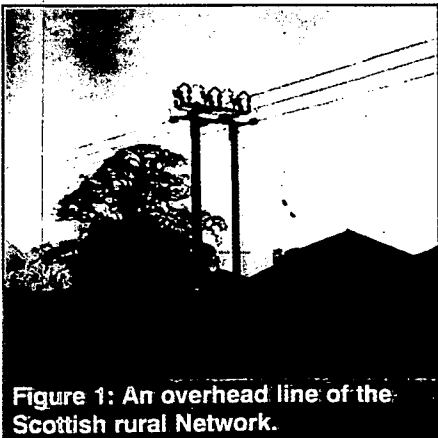

Figure 1: An overhead line of the Scottish rural Network.

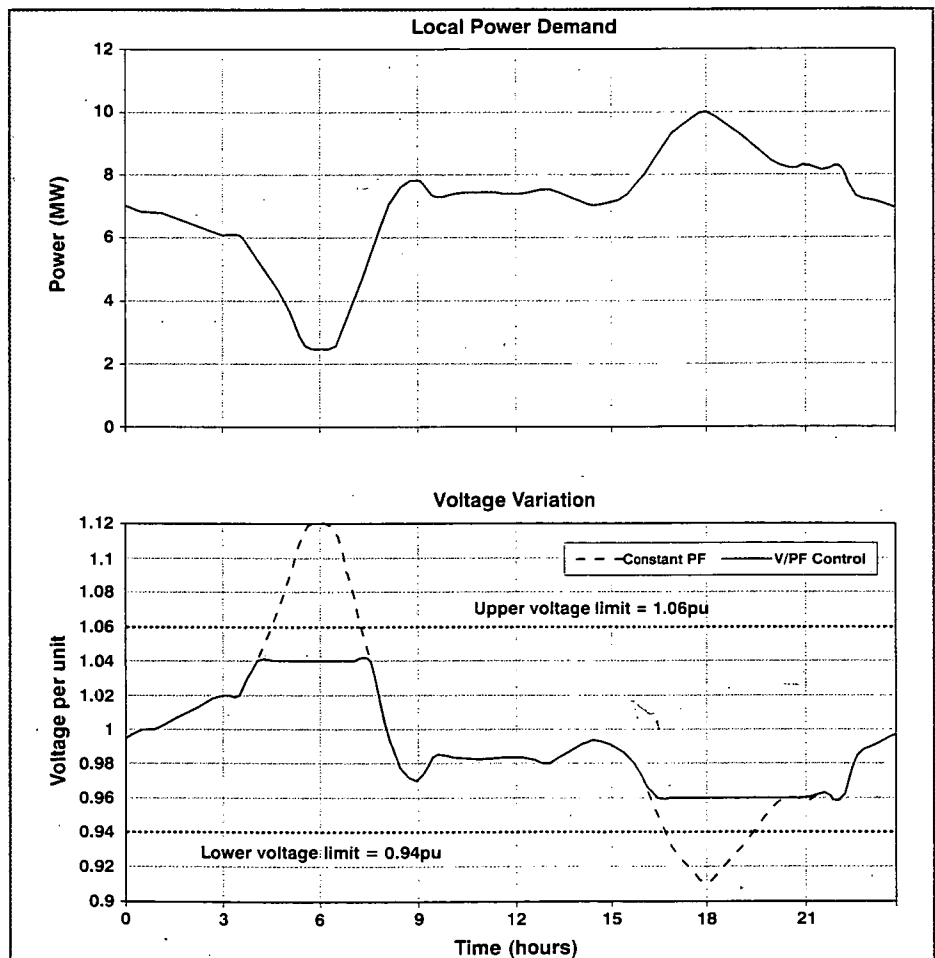

Figure 2: 24-h voltage profile due to load variations with and without hybrid control

substation voltages that are 3-4% above nominal, to ensure that all customers are supplied within statutory voltage limits ( $\pm 6\%$  for the UK 11 kV).

Connecting generation within the distribution network radically changes its operation. Power flows will become bi-directional, because when production exceeds local demand, the direction of flow will reverse. The major impact of this is that network voltages will rise – potentially outside allowable limits. Other impacts include raised fault levels and problems with the coordination and operation of network protection schemes. Network studies carried out following applications to connect generators have highlighted the impact at medium-voltage level and these have been widely reported given that the majority of connections have been at this level.

Much less is known about the network impacts of single-phase micro-generating units such as fuel cells, photo-voltaics and Domestic Combined Heat and Power, which are typically less than 5kW and may be located in domestic properties. Connections will be in an unplanned, relatively unrestricted, unconstrained manner. Where a large number of these units are installed in a specific area, there is potential for effects similar to that seen at medium-voltage. If the high levels of domestic generation predicted (1 -3 million units by 2010) are to be met, DNOs need to understand the impacts on their systems all the way to the extreme edges.

In collaboration with a UK DNO, such a study is being performed using a small town as a case study. A model of the actual network was constructed including recorded load and power flow data. While more involved and time consuming, this offers more realistic and verifiable results than might be possible with generic models that avoid problematic and abnormal events. The study is examining the impacts from a range of domestic generation penetration levels with a view to identifying the volume that could be accommodated before network performance is degraded. Initial findings show that high penetration levels create reverse power flows and raise voltage levels; the impact on network fault levels and protection schemes is currently being assessed.

## IMPACT MITIGATION AND ALLEVIATION

Although fault level rise is a significant issue in heavily inter-connected urban networks, voltage rise is generally cited as the most frequent and serious connection issue. Accordingly, the discussion concentrates on the strategies that DNOs may employ to mitigate this problem.

Lowering the set-point voltage at the primary substation allows a greater amount of voltage rise before violation; the downside is that when generator output decreases, customer voltages may fall below the lower statutory limit. Allowing generators to import reactive power will tend to decrease voltage rise and allow more real power to be exported, although the degree of success will depend very much on network characteristics. While effective, constraining generator active power export impacts on the revenue of the developer and is generally only acceptable where curtailment is likely to be infrequent and where alternatives are costly. Replacing the existing conductors of a network with larger ones is very effective in reducing resistance and limiting voltage

rise. However, this approach can be very expensive. The DNO may offer to connect the generator to a portion of the network at a higher voltage where the per-unit resistance is lower; the downside to this is that switchgear and transformers must be rated for the higher voltage and consequently are more costly. At the low-voltage level, there would appear to be fewer options for mitigating the negative effects of domestic generation. Approaches include transformer reconfiguration, installation of auto tap transformers, voltage limit relaxation of or limitations on domestic generation connections.

Under current commercial arrangements, the developer will largely bear the financial responsibility for mitigating adverse impacts. The economic implications can make potential schemes less attractive and restrict development of distributed generation. It has become apparent that traditional network design and operation is constraining the amount of capacity that can be connected. Where network development is not carried out carefully, connection of a generator can block network access for other, potentially larger plants. Furthermore, practices

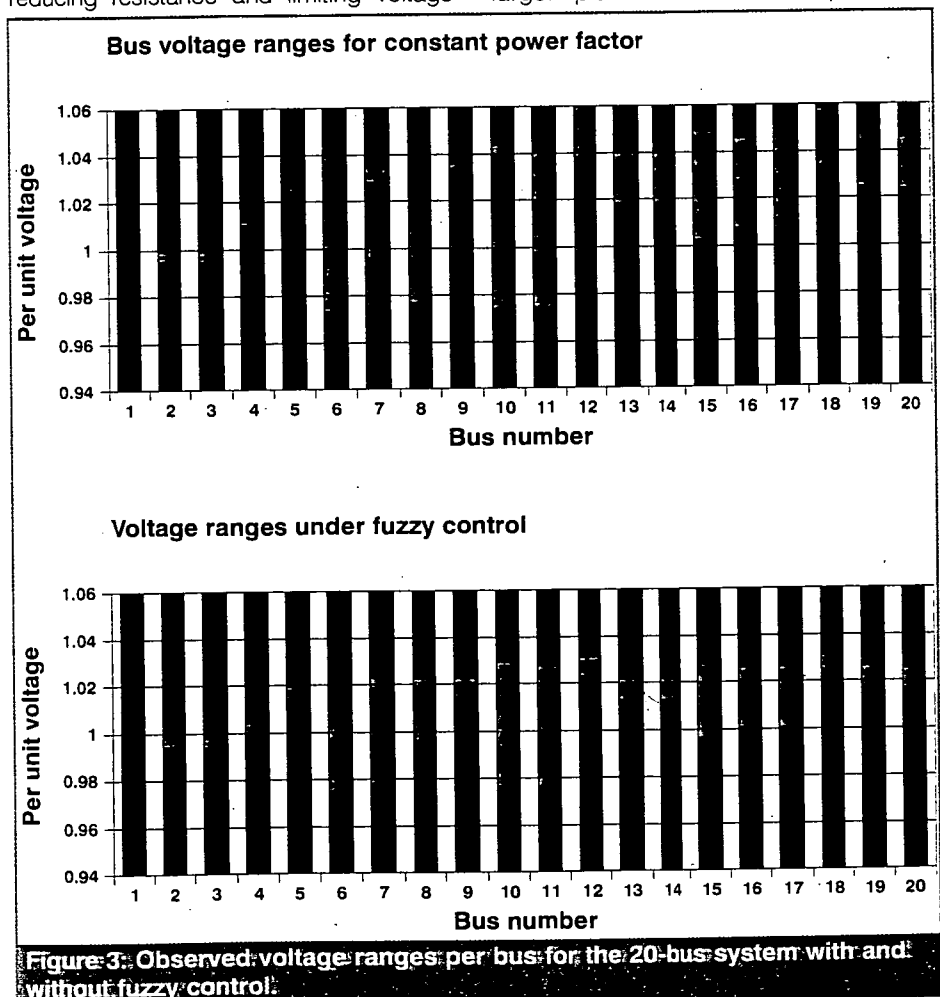

followed at transmission level are not yet generally applicable at distribution level. Generators are conventionally operated at constant power factor and this restriction contributes to the voltage rise effect and constrains generator capacity. Alternative methods of avoiding or mitigating the impact of distributed generator connections are highlighted below.

### INTELLIGENT CONTROL OF DISTRIBUTED GENERATORS

It used to be obligatory that synchronous generators in the distribution system were operated at constant power factor. Some network operators now permit voltage control operation at weak parts of the network to provide voltage support at times of high local demand, although this has to be evaluated carefully as larger generators can cause spurious operation of network voltage control systems. Two novel control techniques have been demonstrated to provide a means of voltage control without losing the benefits of the conventional constant power factor operation.

The first involves a hybrid voltage/power factor controller that combines the features of both control methods. Its normal mode of operation is to export power at a pre-defined and constant power factor. Once the local system voltage exceeds a threshold that lies within the statutory limits, the controller smoothly transfers to voltage control to maintain voltage within the limits. Once conditions change and allow the voltage to fall, power factor control resumes. The controller can also provide voltage support at times of high local demand. Figure 2 compares the operation of a small synchronous generator using a typical power factor control system with one

using the new hybrid scheme (for variations in local demand over the course of a day (top graph)). The bottom graph shows the resulting variations in local voltage under power factor and hybrid control schemes. It can be seen that power factor control allows voltage to exceed statutory limits at times of low and high demand. To reduce the voltage during the low demand period, the generator would have to disconnect from the network. However, with hybrid control, voltages remain within acceptable levels at all times. This has obvious implications for the revenue of the developer.

The second method uses a fuzzy logic controller to adapt the generator's power factor set-point according to the (varying) terminal voltage. This occurs in a similar manner to a human operator: reducing power factor (i.e. increasing import of reactive power) to constrain voltage and increasing power factor (vice versa) to support it. Figure 3 shows the voltage ranges on 20 buses in a section of a Scottish distribution network (Figure 4). The top graph of Figure 3 shows bus voltage ranges in the course of a day using typical power factor control on the local generators (annotated with "DG"), and the bottom graph of Figure 4 using the developed fuzzy controller. The fuzzy controller improves voltage quality as voltage ranges are narrower and more central. There is some potential to extend these approaches to domestic generation although remote on/off control by, e.g., SMS text, might also be effective.

### OPTIMAL CAPACITY OF DISTRIBUTED GENERATORS

Under current legislation, a developer's rights to network access are guaranteed once the connection agreement is signed. However, due to subsequent developments in the same area, there may be an increase in the likelihood of system constraint violation and a consequent need for network upgrades. It is the case that an inappropriate connection can prevent development of other sites in the vicinity, "sterilising" the network. This factor has led to developers rushing to guarantee network access. A second issue relates to the equity of network upgrades. Where the need for upgrading is identified, the DNO will only choose from a range of standard conductor sizes which may well be in excess of the actual requirement. Where the generator agrees

to finance this, a subsequent application will be able to "free-ride" and use the new capacity for free. Both these issues further complicate and constrain the development of distributed generation.

Consequently, there is a desire to indicate to developers the likely network capacity available at each location. Such a study on even a relatively small distribution network is difficult given number of connection points and the added complexity of voltage issues. The difficulties have been addressed through the development of a bespoke simulation manager to facilitate control of industry standard network software. This has avoided the need to carry out repetitive and time consuming manual studies and, instead, has enabled rapid, automated analyses. With the expected increase in the number of developments it is likely that there will be a multitude of developments rather than just one in progress at any one time. The interdependence of the network and, the range of possible generator sizes, means that the determination of available network capacity is a multi-dimensional problem. A solution has been developed with Optimal Power Flow techniques – normally used in transmission studies – that allows not only the determination of available capacity (subject to thermal, voltage and fault level constraints) but also investigation of network sterilisation and asset stranding. It is anticipated that these techniques will be used by DNOs and developers to reduce the need for network upgrades and to allow maximum development by avoiding network sterilisation.

### CONCLUSIONS

Connection of new and renewable distributed generation is impacting on all levels of the electricity network. Although the greatest impact is currently being seen at distribution level there is a need to identify adverse effects from the very edges of the system up to transmission level. Activity outlined here is examining the technical and economic issues influencing the development of distributed generation right across the network. Furthermore, through new techniques designed to enhance network planning and generator control, there is potential for easing some of the constraints that are hampering development. ■

Detailed information may be found at <http://www.see.ed.ac.uk/research/IES/>  
Contact: [Aristides.Kiprakis@ed.ac.uk](mailto:Aristides.Kiprakis@ed.ac.uk)

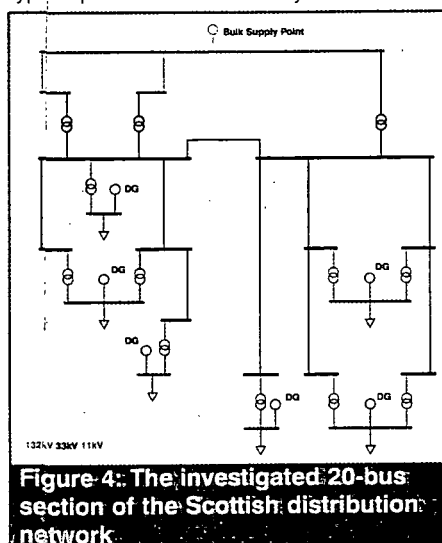

Distributed renewable energy systems, such as mini-hydro, can significantly affect the power distribution network. Liberalisation of power markets presents further complications

# Network integration of mini-hydro

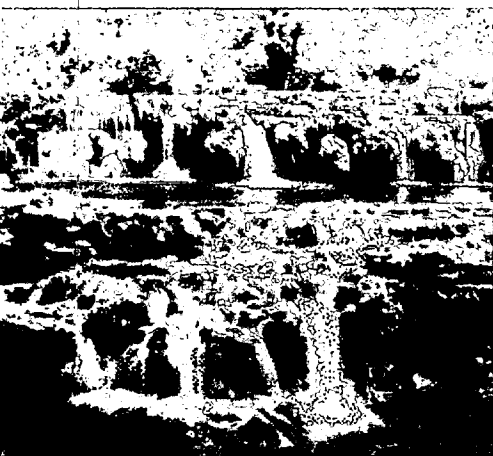

**Dr Gareth P. Harrison**

**Aristides E. Kiprakis**

**Dr A. Robin Wallace**

Institute for Energy Systems  
University of Edinburgh, UK

Privately-owned distributed generation (DG) is fast replacing state-owned centralised generation in many liberalised electricity markets. The EU Renewables Directive and national incentives such as the UK Renewables Obligation are encouraging the development of renewables, including mini-hydro. Mini-hydro resources are commonly found in areas with low population and load densities and the capacities of potential new plant means that they will connect to medium or low voltage distribution networks. Historically, the networks in these areas were designed to supply demand that tended to reduce with distance from the transmission system and were operated passively to ensure that the quality of electricity supplied to customers was within statutory limits.

Connection of DG can fundamentally alter the operation of distribution networks. Where DG capacity is comparable to, or larger than, local demand there are likely to be observable impacts on network power flows and voltage regulation. New DG connections must be evaluated to identify and quantify any impact on the security and quality of local electricity supplies. While a range of options exist to mitigate adverse impacts, under current commercial arrangements the developer will largely bear the financial responsibility. The economic implications can make potential schemes less attractive and have restricted the development of DG in liberalised markets.

There are two new techniques that could facilitate a greater capacity of mini-hydro generation. The first allows Distribution Network Operators (DNOs) to determine the capacity of plant that may be progressively connected to their existing system whilst avoiding stranding assets and/or sterilising access. The second describes a means of operating mini-hydro generators to allow more power to be exported to the network whilst maintaining local quality of supply. These techniques may assist the network integration of a greater capacity of mini-hydro both in liberalised markets and in rural areas of less-developed countries.

## **Distribution networks**

Historically, distribution networks were designed to convey electrical energy from the high voltage transmission grid to

consumers supplied at lower voltages. A common feature of distribution networks in rural areas is that they consist of medium to long overhead line circuits (known as radial feeders) extending out to consumers at the most rural edges. As population density and demand for electricity tended to reduce along the feeder, the capacity of the network to supply load could quite reasonably be reduced with increasing remoteness. Accordingly, transformer ratings and conductor cross sectional areas reduce towards the edges of the network and impedance increases. The system was designed and operated on the basis that power flows were uni-directional with active and reactive power moving from the sub-transmission network towards loads. They were also designed on the basis that load patterns, and hence network power flows, were fairly predictable, with daily and seasonal patterns that were well understood. The distribution networks generally operated passively with auto-tap changers on transformers maintaining secondary voltages at pre-set values as loads varied. To compensate for the line voltage drop and to ensure that consumers at the remote end of the network are supplied within statutory voltage limits the DNO will often set the substation voltage a few per cent above the nominal 11 kV. The statutory limits defined in the UK Electricity Supply Regulations, for example, specify that steady-state voltages should remain between  $\pm 6$  per cent of nominal for systems between 1 kV and 132 kV. To ensure this, DNO planners often designed networks to operate over a  $\pm 3$  per cent voltage range.

In the centrally-planned era, consumer demand, losses and contingencies were met by advance scheduling of generation supplying the distribution network via the transmission grid. In the liberalised market, distributed generation can be located geographically to convert renewable or other resources, delivering to the distribution network non-constrainable, intermittent supplies of energy. The connection of distributed generation to the edges of the distribution network results in an operating regime fundamentally different. Depending on the type and rating of the generator, active and reactive power flows can become bi-directional. Furthermore, the development and connection of renewable sources can lead to intermittent, less predictable flows.

## Impacts of DG on the network

The presence of distributed mini-hydro generation can have a number of significant impacts on the operation of the distribution network, including:

- 1 Bi-directional power flow and the potential to exceed equipment thermal ratings
- 2 Reduced voltage regulation and violation of statutory limits on supply quality
- 3 Increased short circuit contribution and fault levels
- 4 Altered transient stability
- 5 Degraded protection operation and co-ordination

### Power flow, thermal ratings, losses

Figure 1, below, shows four scenarios (a-d) for connecting distributed generators to a simple but representative network consisting of a 25 km long, 32 mm<sup>2</sup> copper radial feeder that supplies a local load from a bulk supply point in the sub-transmission network via a 1 MVA transformer. The peak value of the local (rural domestic) load is 400 kW at 0.98 power factor. A series of DG capacities ranging from (a) 0 to (d) 1 MVA (at 0.9 lagging power factor) are connected to the remote end of the feeder.

a When there is no DG production the local load is supplied entirely from the

transmission network. All equipment operates within thermal limits, and the losses in the overhead line are 19 kW.

- b Where DG production is 300 kW, the power delivered from the transmission network reduces, along with the losses in the feeder. A benefit is that unloading the feeder may allow the DNO to defer network upgrades brought about by future load growth.
- c Where DG production is 600 kW and production exceeds local demand, power will be exported back up the feeder towards the substation and losses increase again, although the line and transformer loadings are still within thermal ratings.
- d If DG production increased to 900 kW the net export back towards the transmission network increases losses beyond their original values. With a generator larger than this and under low demand conditions, the reverse flow may exceed the thermal rating of the transformer or overhead line.

Thermal limitations brought about by increasing DG capacity are usually encountered first in substation equipment such as transformers and switchgear, or at the edges of heavily tapered radial networks where plant capacity is several

Figure 1, below, shows four network scenarios

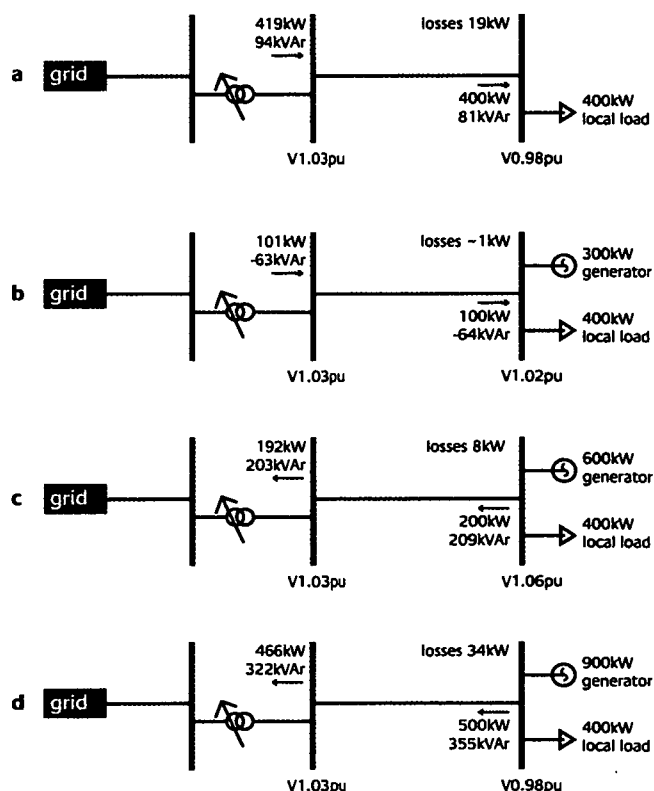

# Network integration

multiples of the local demand. However, it is more frequently the case that voltage violations at the extremities of the network are the first limiting effect.

## Voltage regulation

Power flows along the feeder towards the load will create a voltage drop between the substation and the local load. When the presence of a distributed generator causes the power flow to reverse there will be a local voltage rise at the location of the generator and load. At transmission level, reactive impedance (X) is much greater than resistive impedance (R), and the voltage excursion is brought about by reactive power flow. However, in the distribution network where R can be comparable with or exceed X, the voltage rise is influenced by both active and reactive power flows. Hence, the relatively high line resistance at the edges of distribution networks can restrict active power export from a DG. The network, load and DG capacities shown are once again used to demonstrate the impact of DG on voltage profiles. The local voltages in cases a-d are described below:

- a With no DG generation the voltage at the local load is 0.98 per unit with the transformer adjusted to establish 1.03 per unit voltage at the substation.
- b At 300 kW, DG reduces the local demand, the line voltage drop decreases and local voltage rises to 1.02 per unit.
- c A 600 kW DG reverses power flow and raises local voltage above that of the substation to 1.06 per unit.
- e A 900 kW DG further increases the voltage rise, leading to a local voltage of 1.10 per unit, well in excess of the statutory limit.

As these cases illustrate, reverse power flow along the feeder determines the voltage rise. When local demand is high and met by DG capacity the voltage rise is reduced. If local demand reduces, say overnight, more DG production is exported to the network and the voltage rise increases. This effect could cause transformer tap-changers (where provided) to operate or over-voltage protection to disconnect the DG. Voltage rise effects can significantly limit the capacity of DG that may be connected to the network in remote rural locations.

## Fault levels

In the event of a short circuit fault on the network all generators will contribute to the fault currents flowing. As such, the switchgear in the DNO network and that of the DG must be rated to withstand the effects of the combined network and DG fault currents. As the point of connection becomes more remote from the transmission network the intervening impedance increases, and the network fault contribution falls. Where connection of the DG would increase fault levels beyond the rating of existing DNO switchgear, it must be replaced.

## Transient stability

The ability of DG to remain connected to the network during transient conditions caused by load changes or network reconfiguration depends on the topography of the network, the nature of the perturbation and the characteristics of the DG. During the transient conditions network stability is reduced. Some DGs can assist in restoring stable conditions and hence it is mutually beneficial for the DNO and developer that such plant should remain connected. Those that cannot may

be disconnected. In terms of overall system stability, current levels of DG penetration are not a concern but this may alter if, as the capacity of renewable energy DG increases it displaces high energy thermal plant that currently ensures stability.

## Protection operation and co-ordination

Prior to the installation of a DG, operation of the distribution network is made safe and reliable by the provision and co-ordination of protection devices at energy sources, switching points or loads. This ensures the integrity and security of supply to consumers based on the traditional operation of the network. The protection schemes were designed and co-ordinated largely for uni-directional flow and their use with bi-directional power flows may lead to unstable or spurious operation. While settings may be adjusted so that protection remains effective during DG operation, it must also be effective when the DG is shut down. The achievement of such a balance may leave the network less closely protected than before, and this must be carefully evaluated.

## Connection studies

The impacts that arise from an individual DG scheme are assessed in detail when the developer makes an application for connection. DNOs appraise requests for connection under near-worst case operating conditions to ensure that the quality of supply to their customers will not be adversely affected under all normal DG and network operating scenarios. For instance, studies are carried out assuming that the DG is operating at maximum capacity, but that local load is at a minimum, typically 25 per cent of normal peak demand. These conditions are chosen as they represent the largest reverse power

# network integration

flows and consequently the greatest local voltage change which, particularly for rural areas, tends to be the most significant limitation to the DG capacity.

Where the presence of DG will adversely affect the operation of the DNO network, its impact must be mitigated in a way that encourages development and that is not needlessly punitive, financially, to the developer and the DNO.

## Impact mitigation

There are a number of options open to the DG developer and DNO to reduce adverse network effects arising from a potential mini-hydro generation project and these depend on the initial problem. Where there is the potential to exceed the thermal or fault level rating of equipment then there is generally little option but to replace affected equipment with new plant of higher rating. There is potential for DG and, in particular, mini-hydro plant to benefit the rural network by reducing losses and providing increased reliability, stability and security of supply. However, to extract these benefits, active management of the network would be required along with commercial benefit for the DNO. In any event, the barrier most frequently met and which offers most scope for innovation is maintenance of local voltages within statutory limits. Mitigation strategies include:

- Constraining generator export
- Reducing primary substation voltage
- Importing reactive power
- Conductor upgrading
- Connection at higher voltage

These mitigation measures are discussed with reference to the network illustrated in Figure 1 on page 57 and their effect is demonstrated in Figure 2, above. The analyses do not consider the effects of distance, or intermediate loads. The highest voltage rise shown is that resulting from a 600 kW DG operating at maximum output and at 0.9 power factor, exporting, whilst local load is 100 kW, 25 per cent of maximum. In this case, the voltage exceeds the limit by nearly four per cent.

### Constraining generator export

It is possible to apply load limitation in the turbine governor control system to alter production of active power to avoid network voltage violations. Whilst

Figure 2 illustrates the effects of the four mitigation measures on the distribution network

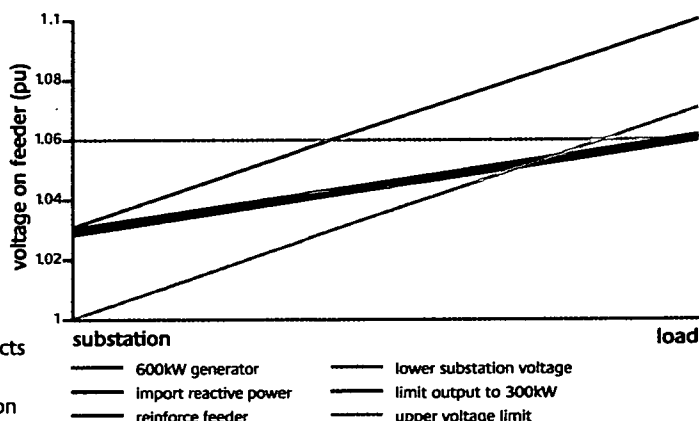

effective, this option affects generator revenue and is generally only acceptable where curtailment is likely to be infrequent and where alternatives are costly. Where active power output is limited to 300 kW the voltage remains within limits. This represents the maximum production in the absence of alternative mitigation means.

### Reducing primary substation voltage

Lowering the set-point voltage at the primary substation allows a greater voltage rise before violation. This strategy is shown to shift the voltage profile vertically downwards, but it still does not allow full generator capacity to be exported without voltage violation. Although this may be achieved by setting the voltage set-point to 0.99 per unit, this approach is likely to be prohibited because if generator output decreases (or the DG trips), customer voltages may fall close to or below the lower voltage limit. Intelligent control or active management of simple networks might be employed to restore the depressed voltages, but this may not be practical in large rural systems.

### Importing reactive power

DNOs normally require DGs to export active power at a defined and constant power factor, determined by the network capability to accept or provide reactive power. Synchronous generators may be operated to export or import reactive power and while normally operated to control power factor, they could usefully provide network support by operating in voltage control mode. Standard induction generators can only import reactive power and while this can mitigate the voltage rise, the network must provide the reactive

power. The financial benefits for the developer in exporting more active power could be partly offset by charges imposed by the DNO for the provision of reactive power from the network. In Figure 2 the generator is operated at full output whilst importing reactive power at 0.9 power factor. The voltage gradient and local voltage are reduced significantly.

All of these mitigation techniques are of an operational nature and have consequent implications for DG revenue or local quality of supply. The remaining measures can bring considerable capital costs to the DG development, but result in fewer operational restrictions.

### Conductor upgrading

Replacing existing overhead line conductors with those of greater cross sectional area reduces impedance and limits voltage rise. Unfortunately, the use of any larger and heavier conductors requires the replacement and re-spacing of the support poles or towers to correct the physical profile of the line. As such, this approach can be very expensive. Figure 2 shows the impact of replacing the existing 32 mm<sup>2</sup> conductor with 130 mm<sup>2</sup> copper conductor. It can be seen that voltage rise is significantly reduced and that voltage remains just within statutory limits.

### Connection at higher voltage

At higher voltages a given flow of active and reactive power has a lower current and, as such, the voltage rise is lower. Accordingly, for larger plants that simply cannot connect at lower voltages without violation, the DNO may offer only to connect the DG to the network at the next highest voltage. This may mean the

construction of a sub-transmission network switchyard and significant extension of the 33-132 kV sub-transmission system that, inevitably, will be expensive, and therefore may only be feasible for much larger DG schemes.

### Finance and management

Each of the mitigation strategies will have associated costs, either operating costs borne directly by the DG developer, for example production constraints or reactive imports, or capital costs borne by the developer and/or the DNO. As a condition of connection the DNO can insist that the developer finances the expenditure necessary to mitigate adverse impacts. This system is known as 'deep charging' and may add significantly to the capital cost of the project, particularly where line upgrades are involved. In many cases and particularly for smaller projects it may render them uneconomic and limit the penetration of mini-hydro and other renewables. An alternative 'shallow charging' system is being considered where the DNO finances the necessary network upgrading and collects Distribution Use of System (DuoS) charges from generators. However, in this case the DNO must consider carefully whether the volume of renewables and developer commitments could justify the investment.

A further risk to the holistic development of mini-hydro and renewable resources can emerge from the current strategy of developing sites on a first come-first served basis. Currently, a developer's rights to network access are guaranteed once the Connection Agreement is signed. With this guarantee instated, subsequent developments in the same area must not

impact adversely on the access afforded to previously connected DG. This means that an early and sometimes quite minor connection can prevent development of other larger sites in the same area of the network, effectively 'sterilising' areas of the network. If unchecked, this effect can lead to developers rushing to 'bag capacity' and guarantee access.

An opposite effect relates to the equity of investment to upgrade the network. Where a new connection is to be financed by the developer and/or the DNO it is unlikely that it will be designed, specified and installed at the exact capacity of the DG. Design prudence or the use of standard plant ratings may leave spare capacity on a new network modification. While the developer may have agreed to finance this, a subsequent application may be able to access and use the new capacity at a much lower connection charge because the network has already been upgraded. Both issues further complicate and restrict DG development and commend the need for planned and holistic development.

### New approaches to DG

It seems that if the developer or the DNO is prepared to finance, piece-wise, network reinforcement then many of the restrictions to individual network access are reduced or avoided. This is unlikely to lead to full development of the mini-hydro or other renewable resource in a DNO network area. There needs to be a more holistic strategy to develop the network in a way that provides the greatest access to DG within an area for a given level of investment in network infrastructure. Additionally, DG plant that connects to existing or newly reinforced areas of the network ought to be

controlled to make the maximum use of access that is available within the constraints of voltage violation.

### Maximising DG access to networks

Recent studies of the transmission network in Scotland have provided a number of locational signals for the development of renewables that are contingent on significant network investment. They have identified areas where renewable energy could be absorbed by the existing and up-graded transmission network. Not all of the new developments will be deep-connected and most will connect to the sub-transmission or distribution network. Carrying out a similar study on even a small section of the distribution network is more intense and time consuming due to the much greater number of busbars and the greater influence of voltage, thermal and fault level restrictions. To explore holistic expansion of DG access there is a need to determine possible capacity from three types of development within the network.

The notionally simplest approach is a single location-by-location appraisal of the possible DG capacity that could be connected in an area – but in even a small section of the distribution network there may be several hundred busbars. This required the development of a bespoke simulation manager to facilitate control of network power flow analysis software to automate repetitive and otherwise time consuming manual studies. The results of the survey were thereafter more readily obtained but may be optimistic because they do not recognise the effects of prior connections of new DG in the adjoining network.

The number of applications for connection of renewable DG plant and the volume of activity in the UK means that development is a parallel activity. There can many co-lateral applications for access to sometimes different, sometimes identical points within an area of the network. The interdependence of network behaviour and the range of capacities and locations for development means that the determination of overall access is a large multi-dimensional problem not amenable to repetitive simulation. Harrison and Wallace have applied Optimal Power Flow (OPF) techniques, normally used in transmission

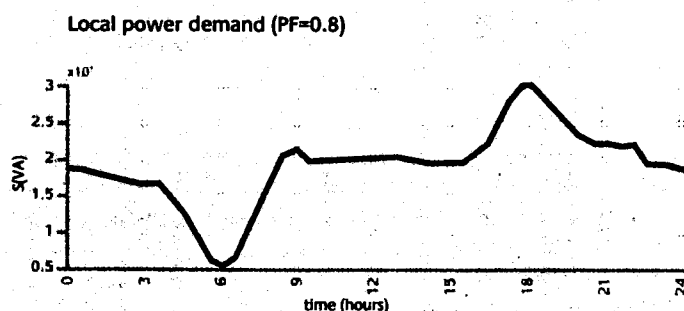
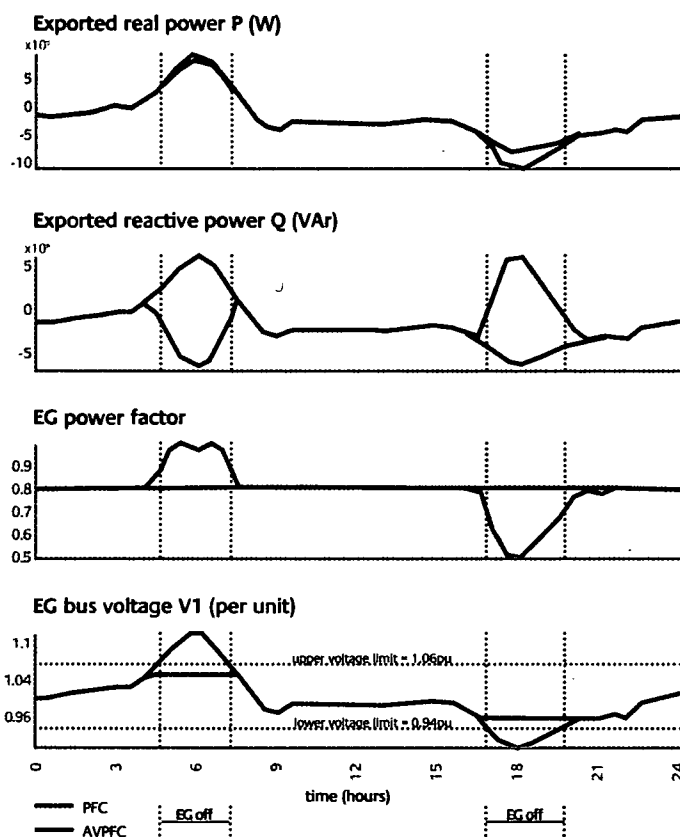

Figure 3 (right) illustrates a typical demand profile.

Figure 4: showing variations in network power flow and local voltage under power factor (APFC) and hybrid (AVPFC) control schemes.



studies, to determine the maximum simultaneous access for DG plant across some or all network locations selected using the simulation manager. This takes full account of all adjacent development but results in pessimistic totals since locations that may never be sought are maximised unnecessarily.

More realistic use of OPF techniques through the simulation manager enables scenario studies within a selected area of the distribution network. Access to the network and DG development can be modelled sequentially in time and with concurrent multiple developments. This allows not only the determination of maximum connectable capacity but also an investigation of network sterilisation and stranding of assets. These techniques may be used by DNOs, working with developers, to maximise access, clarify the need for network upgrades and avoid network sterilisation or asset stranding.

#### New generator control

Synchronous generators can be operated in either voltage control or power factor control modes. While power factor control used to be obligatory, some DNOs

have permitted voltage controlled operation for DGs at weak parts of the network to provide some voltage support. This has to be evaluated carefully as larger DGs can cause network voltage control systems to operate in response. However, the combination of power factor control together with voltage control of DGs may offer significant benefit to developers if it enables acceptable access to weak areas of the network and allows continuous operation of the plant when co-ordinated with varying local demand.

Wallace and Kiprakis have developed a hybrid voltage/power factor control algorithm that combines the features of both methods. Its normal mode of operation is to export power at a pre-defined and constant power factor. However, once the local voltage exceeds a threshold, that lies within the statutory limits, the controller smoothly transfers to voltage control to hold voltage within these limits. Once conditions change and allow the voltage to fall, power factor control resumes. The controller enables greater export during low demand periods and can also provide voltage

support at times of high demand.

Extensive simulations have compared operation of a water-turbine driven synchronous generator using a typical power factor control system and with the new hybrid scheme. Figure 4, left, shows the resulting variations in network power flow and local voltage under power factor (APFC) and hybrid (AVPFC) control schemes. There are a number of observations regarding operation in power factor control mode. Firstly, the voltage would rise above the upper statutory limit during the period of low demand, and in consequence the generator would be disconnected with significant loss of generation. Secondly, between 1630 and 1930 excessive local demand would draw voltage below the lower voltage limit. Under-voltage protection would disconnect the DG causing the voltage to fall further and in the absence of available voltage controls the DNO would draw more power from the sub-transmission system. Under hybrid control, however, the voltage is continuously maintained within limits, allowing the generator to stay connected.

#### Conclusions

The connection of mini-hydro and other renewable generation to the distribution network creates a range of impacts that must be limited to protect security and quality of supply. Mitigation techniques currently employed may add significant costs and deter investment in DG plants. The inappropriate siting of new generation, or poorly phased development can lead to the sterilisation of an entire area of network and lowers the opportunity for developing surrounding potential without network upgrades. Extensive development of renewables will require a more holistic approach to network infrastructure.

#### Biography

Dr Gareth Harrison, Aristides Kiprakis and Dr Robin Wallace are with the Institute for Energy Systems, School of Engineering & Electronics, University of Edinburgh, Edinburgh, U.K.

The authors acknowledge with gratitude support provided by EPSRC (research grant number GR/N04744). For more information and references please contact the authors on:

(+44) 131 650 5583 or email Gareth at: email: Gareth.Harrison@ee.ed.ac.uk

# A new era for mini hydro?

*The financial responsibility which developers have to bear for new connections of distributed generation can restrict the growth of mini hydro in liberalised markets. But now two new techniques could facilitate the connection of mini hydro projects*

**P**RIVATELY-OWNED distributed generation (DG) is replacing state-owned centralised generation in many liberalised electricity markets around the world. The EU Renewables Directive and national incentives such as the UK Renewables Obligation are encouraging the development of renewable energy resources including mini hydro. Such resources are commonly found in areas with low population and load densities and the capacities of potential new plant means that they will connect to medium or low voltage distribution networks. Historically, the distribution networks in these areas were designed to supply demand that tended to reduce with distance from the transmission system and were operated passively to ensure that the quality of electricity supplied to customers was within statutory limits.

Connection of DG can fundamentally alter the operation of distribution networks. Where DG capacity is comparable to, or larger than, local demand, there are likely to be observable impacts on network power flows and voltage regulation. New connections of DG must be evaluated to identify and quantify any adverse impact on the security and quality of local electricity supplies. While a range of options exist to mitigate adverse impacts, under current commercial arrangements the developer will largely bear the financial responsibility for their implementation. The economic implications can make potential schemes less attractive and have restricted the development of mini hydro generation in liberalised markets.

This article reviews the impacts of connecting distributed mini hydro generation to distribution networks and examines existing means of mitigation. Two new techniques that could facilitate the connection of a greater capacity of mini hydro generation are discussed. The first allows distribution network operators (DNOs) to determine the capacity of plant that may be progressively connected to their existing system whilst avoiding stranding assets and/or sterilising access. The second describes a means of operating mini hydro generators to allow more power to be exported to the network whilst maintaining local quality of supply. These techniques may assist the network integration of a greater capacity of mini hydro generation in liberalised markets in developed countries, or in rural areas of less-developed countries.

## DISTRIBUTION NETWORKS

Historically, distribution networks were designed to convey electrical energy from the high voltage transmission grid to consumers supplied at lower voltages. A common feature of distribution networks in rural areas is that they consist of medium to long overhead line circuits (known as radial feeders) extending out to consumers at the most rural edges. As population density and demand for electricity tends to reduce along the feeder towards the end, the capacity of the network to supply load could quite reasonably be reduced with

increasing remoteness. Accordingly, transformer ratings and conductor cross sectional areas decrease towards the edges of the network and circuit impedance increases. The system was designed and operated on the basis that power flows were uni-directional with active and reactive power moving from the sub-transmission network towards the loads. They were also designed on the basis that consumer load patterns and hence network power flows were fairly predictable, with daily and seasonal patterns that were well understood. The distribution networks generally operated passively with auto-tap changers on transformers maintaining secondary voltages at pre-set values as loads varied (see Figure 1 below). To compensate for line voltage drop and to ensure that consumers at the remote end of the network are supplied within statutory voltage limits, the DNO will often set the substation voltage a few percent above the nominal 11kV. In the UK the statutory limits defined in the Electricity Supply Regulations specify that steady-state voltages should remain between  $\pm 6\%$  of nominal for systems between 1kV and 132kV. To ensure this, DNO planners often designed networks to operate over a  $\pm 3\%$  voltage range.

In the centrally-planned era, consumer demand, losses and contin-

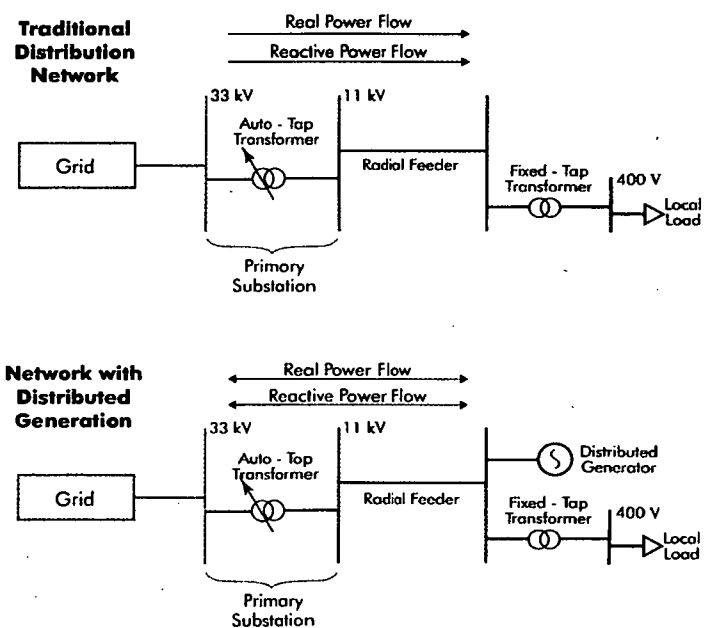
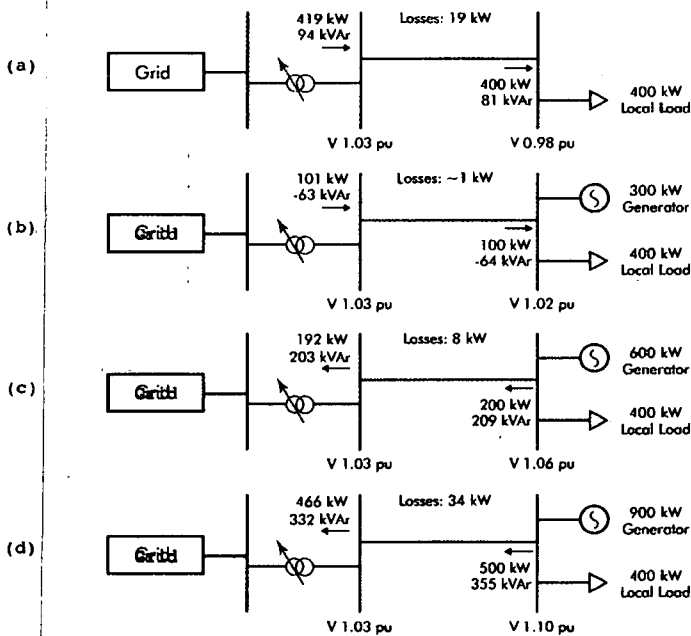

**Figure 1: Traditional passive distribution network and active network with distributed generation**

agencies were met by advance scheduling of generation supplying the distribution network via the transmission grid. In the liberalised market, distributed generation can be located geographically to convert renewable or other resources, delivering to the distribution network non-constrainable, intermittent supplies of energy. The connection of distributed generation to the edges of the distribution network results in an operating regime fundamentally different from that of uni-directional and predictable power flow. Depending on the type and rating of the generator, active and reactive power flows can become bi-directional (Figure 1). Furthermore the development and connection of non-firm renewable energy sources can lead to intermittent and less predictable network power flows.

The presence of distributed mini hydro generation can have a number of significant impacts on the operation of the distribution network, including:

- *Bi-directional power flow* and the potential to exceed equipment thermal ratings;
- *Reduced voltage regulation* and violation of statutory limits on supply quality.
- *Increased short circuit contribution and fault levels.*
- *Altered transient stability.*
- *Degraded protection operation and co-ordination.*



**Figure 2: Changes in power flows, losses and voltages with connection of distributed generators**

**Power flow, thermal ratings, losses**

Figure 2 shows four scenarios (a-d) for connecting distributed generators to a simple but representative network consisting of a 25km long, 32mm<sup>2</sup> copper radial feeder that supplies a local load from a bulk supply point in the sub-transmission network via a 1 MVA transformer. The peak value of the local (rural domestic) load is 400kW at 0.98 power factor. A series of DG capacities ranging from (a) 0 to (d) 1 MVA (at 0.9 lagging power factor) are connected to the remote end of the feeder.

a. *When there is no DG production* the local load is supplied entirely from the transmission network. All equipment operates within thermal limits, and the losses in the overhead line are 19kW.

b. *Where DG production is 300kW*, the power delivered from the transmission network reduces, along with the losses in the feeder. A benefit is that unloading the feeder may allow the DNO to defer network upgrades brought about by future load growth.

c. *Where DG production is 600kW* and production exceeds local demand, power will be exported back up the feeder towards the substation and losses increase again, although the line and transformer loadings are still within thermal ratings.

d. *If DG production increased to 900kW* the net export back towards the transmission network increases losses beyond their original values. With a generator larger than this and under low demand conditions, the reverse flow may exceed the thermal rating of the transformer or overhead line.

Thermal limitations brought about by increasing DG capacity are usually encountered first in substation equipment such as transformers and switchgear, or at the edges of heavily tapered radial networks where plant capacity is several multiples of the local demand. However, it is more frequently the case that voltage violations at the extremities of the network are the first limiting effect.

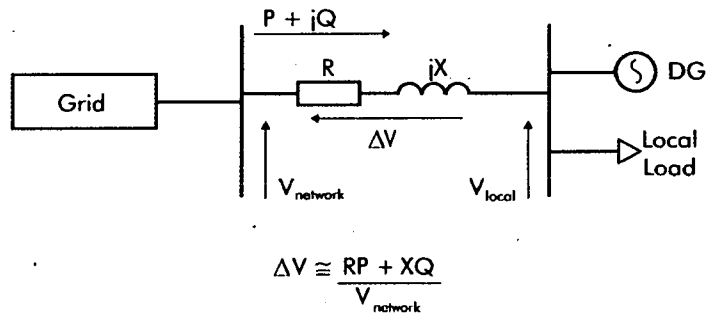

**Figure 3: Voltage drop in feeder**

**Voltage regulation**

Where a combination of active (P) and reactive power (Q) flows from the transmission network along a feeder with resistive (R) and reactive (X) impedance (as shown in Figure 3), the voltage drop along the line can be approximated by:

$$\Delta V \cong \frac{RP + XQ}{V_{network}}$$

where  $V_{network}$  is the primary substation voltage (all values in per-unit).

Power flows along the feeder towards the load will create a voltage drop between the substation and the local load. When the presence of a DG causes the power flow to reverse, there will be a local voltage rise at the location of the generator and load. At transmission level, X is much greater than R, and the voltage excursion is brought about by reactive power flow. However, in the distribution network where R can be comparable with (or exceed) X, the voltage rise is influenced by active and reactive power flows. Hence, the relatively high line resistance at the edges of distribution networks can restrict active power export from a DG. The network, load and DG capacities shown in Figure 2 are again used to demonstrate the impact of DG on voltage profiles. The local voltages in cases a-d are described below:

a. *With no DG production* the voltage at the local load is 0.98 pu with the transformer adjusted to establish 1.03 pu voltage at the substation.

b. *When a 300kW DG* reduces the local demand the line voltage drop decreases and the local voltage rises to 1.02 pu.

c. *A 600kW DG* causes a reversal of power flow and raises local

## SMALL HYDRO LIBERALISED MARKETS

voltage above that of the substation (to 1.06 pu).

d. A 900kW DG further increases the voltage rise, leading to a local voltage of 1.10 pu, well in excess of the statutory limit. This would cause over-voltage protection to disconnect the DG.

As these cases illustrate, reverse power flow along the feeder determines the voltage rise. When local demand is high and met by DG capacity the voltage rise is reduced. If local demand reduces, say overnight, more DG production is exported to the network and the voltage rise increases. This effect could cause transformer tap-changers (where provided) to operate or over-voltage protection to disconnect the DG. Voltage rise effects can significantly limit the capacity of DG that may be connected to the network in remote rural locations. Means of mitigating the problem are described later.

### Fault levels

In the event of a short-circuit fault on the network, all generators will contribute to the fault currents flowing. As such, the switchgear in the DNO network and that of the DG must be rated to withstand the effects of the combined network and DG fault currents. As the point of connection becomes more remote from the transmission network, the intervening impedance increases, and the network fault contribution falls. Where connection of the DG would increase fault levels beyond the rating of existing DNO switchgear, the switchgear must be replaced.

### Transient stability

The ability of DG to remain connected to the network during transient conditions caused by load changes or network reconfiguration depends on the topography of the network, the nature of the perturbation and the characteristics of the DG. During the transient conditions network stability is reduced. Some DGs can assist in restoring stable conditions and hence it is mutually beneficial for the DNO and developer that such plant should remain connected. Those that cannot may be disconnected. In terms of overall system stability, current levels of DG penetration are not a concern but this may alter if, as the capacity of renewable energy DG increases to meet 2010 or 2020 targets, it displaces high-stored-energy thermal plant that currently ensure overall network stability.

### Protection operation and co-ordination

Prior to the installation of a DG, operation of the distribution network is made safe and reliable by the provision and co-ordination of protection devices at energy sources, switching points or loads. This ensures the integrity and security of supply to consumers based on the traditional operation of the distribution network. The protection schemes were designed and co-ordinated largely for uni-directional flow and their use with bi-directional power flows may lead to unstable or spurious operation. While settings may be adjusted so that protection remains effective during DG operation, it must also be effective when the DG is shut down. The achievement of such a balance may leave the network less closely protected than before, and this must be carefully evaluated.

## CONNECTION STUDIES

The impacts that arise from an individual DG scheme are assessed in detail when the developer makes an application for connection. DNOs appraise requests for connection under near-worst case operating conditions to ensure that the quality of supply to their customers will not be adversely affected under all normal DG and network operating scenarios. For instance, network power flow studies are carried out assuming that the DG is operating at maximum capacity, but that local load is at a minimum (typically 25% of normal peak demand). These conditions are chosen as they represent the largest reverse power flows and consequently the greatest local voltage change which, particularly for rural areas, tends to be the most significant limitation to the capacity of DG that can be connected.

If the UK is to meet its 2010 and 2020 targets for supplying

demand with electricity generated from renewable resources, every technically and economically feasible mini hydro site that can become a network-connected DG should be considered for development. Where the presence of DG will adversely affect the operation of the DNO network, its impact must be mitigated in a way that encourages development and that is not unnecessarily punitive, financially, to the developer and the DNO.

## IMPACT MITIGATION

There are a number of options open to the DG developer and DNO to reduce adverse network effects arising from a potential mini hydro generation project and these depend on the initial problem. Where there is the potential to exceed the thermal or fault level rating of equipment, then there is generally little option but to replace affected equipment with new plant of higher rating. There is potential for DG and, in particular, mini hydro plant to benefit the rural network by reducing losses and providing increased reliability, stability and security of supply. However, to extract these benefits, active management of the network would be required along with commercial benefit for the DNO. In any event, the barrier most frequently met and that which offers most scope for innovative solution is the maintenance of local voltages within statutory limits. The mitigation strategies include:

- Constraining generator export.
- Reducing primary substation voltage.
- Importing reactive power.
- Conductor upgrading.
- Connection at higher voltage.

These mitigation measures are discussed with reference to the network illustrated in Figure 2 and their effect is demonstrated in Figure 4. The analyses do not consider the effects of distance, or intermediate loads, which are well described by Masters. The highest voltage rise shown in Figure 4 is that resulting from a 600kW DG operating at maximum output (and at 0.9 power factor, exporting) whilst local load is 100kW (25% of maximum). In this case, the voltage exceeds the 6% limit by nearly four percentage points.

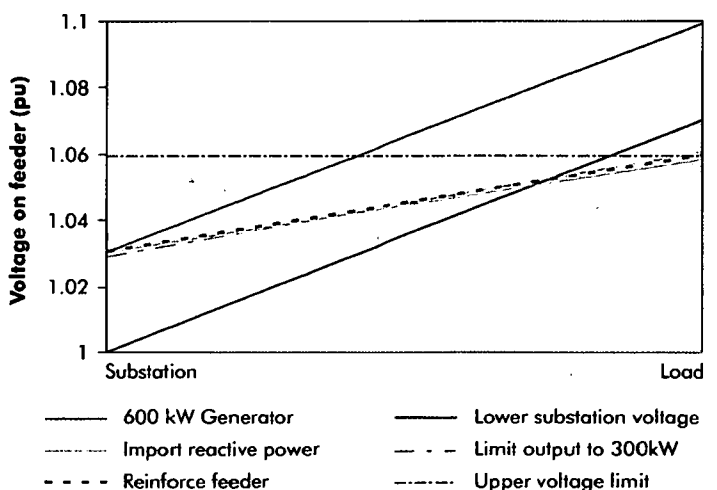

Figure 4: Feeder voltage profile and mitigation measures

### Constraining generator export

It is possible to apply load limitation in the turbine governor control system to alter production of active power to avoid network voltage violations. Whilst effective, this option impacts on the rev-

enue of the generator and is generally only acceptable where curtailment is likely to be infrequent and where alternatives are costly. Figure 4 shows that where active power output is limited to 300kW the voltage remains within limits. This output represents the maximum production in the absence of alternative mitigation means.

*Reducing primary substation voltage*

Lowering the set-point voltage at the primary substation allows a greater voltage rise before violation. This strategy is shown (Figure 4) to shift the voltage profile vertically downwards, but it still does not allow full generator capacity to be exported without voltage violation. Although this may be achieved by setting the voltage set-point to 0.99 pu, this approach is likely to be prohibited because if generator output decreases (or the DG trips), customer voltages may fall close to or below the lower voltage limit. Intelligent control or active management of simple networks might be employed to restore the depressed voltages but this may not be practical in large rural systems.

*Importing reactive power*

DNOs normally require DGs to export active power at a defined and constant power factor, determined by the network capability to accept or provide reactive power. Synchronous generators may be operated to export or import reactive power and while normally operated to control power factor, they could usefully provide network support by operating in voltage control mode. Standard induction generators can only import reactive power and while this can mitigate the voltage rise, the network must provide the reactive power. The financial benefits for the developer in exporting more active power could be partly offset by charges imposed by the DNO for the provision of reactive power from the network. In Figure 4 the generator is operated at full output whilst importing reactive power at 0.9 power factor. The voltage gradient and local voltage are reduced significantly and avoid violation.

All of the above mitigation techniques are of an operational nature and have consequent implications for DG revenue or local quality of supply. The remaining mitigating measures can bring considerable capital costs to the DG development, but result in fewer operational restrictions.

*Conductor upgrading*

Replacing existing overhead line conductors with those of greater cross sectional area reduces impedance and limits voltage rise. Unfortunately, the use of any larger and heavier conductors requires the replacement and re-spacing of the support poles or towers to correct the physical profile of the line. As such, this approach can be very expensive. Figure 4 shows the impact of replacing the existing 32mm<sup>2</sup> conductor with 130mm<sup>2</sup> copper conductor. It can be seen that voltage rise is significantly reduced and that voltage remains (just) within statutory limits.

*Connection at higher voltage*

At higher voltages, a given flow of active and reactive power has a lower current and, as such, the voltage rise is lower. Accordingly, for larger plants that simply cannot connect at lower voltages without violation, the DNO may offer only to connect the DG to the network at the next highest voltage. This may mean the construction of a sub-transmission network switchyard and significant extension of the 33-132kV sub-transmission system that, inevitably, will be expensive, and therefore may only be feasible for much larger DG schemes.

**MANAGEMENT OF CHANGE**

Each of the mitigation strategies will have associated costs, either operating costs borne directly by the DG developer (e.g. production constraint, reactive imports) or capital costs borne by the developer and/or the DNO. As a condition of connection, the DNO can insist that the developer pays all the costs necessary to mitigate adverse impacts. This system is known as 'deep charging' and may add significantly to the capital cost of the project, particularly where line upgrades are involved. In many cases, particularly for smaller

projects, it may render them uneconomic and limit the penetration of mini hydro and other renewable energy generation. An alternative 'shallow charging' system is being considered where the DNO finances the necessary network upgrading and collects Distribution Use of System (DuoS) charges from generators, but the DNO has to consider carefully whether the volume of renewable resource and commitment by developers could properly justify the investment.

A further risk to the holistic development of mini hydro and renewable resources can emerge from the current strategy of developing sites on a first-come first-served basis. Currently, a developer's rights to network access are guaranteed once the Connection Agreement is signed. With this guarantee instated, subsequent developments in the same area must not impact adversely on the access afforded to previously connected DG. This means that an early and sometimes quite minor connection can prevent development of other larger sites in the same area of the network, effectively 'sterilising' areas of the network. If unchecked, this effect can lead to developers rushing to 'bag capacity' and guarantee access.

An opposite effect relates to the equity of investment to upgrade the network. Where a new connection is to be financed by the developer and/or the DNO, it is unlikely that it will be designed, specified and installed at the exact capacity of the DG. Design prudence or the use of standard plant ratings may leave spare capacity on a new network modification. While the developer may have agreed to finance this, a subsequent application may be able to access and use the new capacity at a much lower connection charge because the network has already been upgraded. Both these issues further complicate and restrict the development of DG and commend the need for planned and holistic development.

**NEW APPROACHES**

From the foregoing it seems that if the developer or the DNO is prepared to finance, piece-wise, network reinforcement then many of the restrictions to individual network access are reduced or avoided. This is unlikely to lead to full development of the mini hydro or other renewable resource in a DNO network area. There needs to be a more holistic strategy to develop the network in a way that provides greatest access to DG within an area for a given level of investment in network infrastructure. Additionally, DG plant that connects to the existing or newly reinforced areas of the network ought to be controlled to make maximum use of the access that is available within the constraints imposed by limitation of voltage violation. The next section describes two inter-related research activities within the Institute for Energy Systems at the University of Edinburgh, UK, that address these challenges. The work complements collaborative activity at UMIST that is studying area management of voltage profiles within the distribution network.

*Maximising DG access to distribution networks*

Recent studies of the transmission network in Scotland have provided a number of locational signals for the development of renewable resources that are contingent on significant investment in the network. They have identified areas where renewable energy could be absorbed by the existing and upgraded transmission network. Not all of the new developments will be deep-connected and most will connect to the sub-transmission or distribution network. Carrying out a similar study on even a relatively small section of the distribution network is more intense and time consuming, due to the much greater number of busbars and the greater influence of voltage, thermal and fault-level restrictions. To explore holistic expansion of DG access there was a need to determine possible capacity from three types of development within the network.

The notionally simplest approach was a single location by location appraisal of the possible DG capacity that could be connected in an area subject to the above constraints – but in even a small section of the distribution network there may be several hundred busbars. This required the development of a bespoke simulation manager to facilitate control of network power flow analysis software to automate repetitive and otherwise time consuming manual

studies. The results of the survey were thereafter more readily obtained but may be optimistic because they do not recognise the effects of prior connections of new DG in the adjoining network.

The number of applications for connection of renewable DG plant and the volume of activity in the UK means that development is a parallel activity. There can be many co-lateral applications for access to sometimes different, sometimes identical points within an area of the network. The interdependence of network behaviour and the range of capacities and locations for development means that the determination of overall access is a large multi-dimensional problem not amenable to repetitive simulation. Harrison and Wallace have applied optimal power flow (OPF) techniques, normally used in transmission studies, to determine the maximum simultaneous access for DG plant across some or all network locations selected using the simulation manager. This takes full account of (all) adjacent development but results in pessimistic totals since locations that may never be sought are maximised unnecessarily.

More realistic use of OPF techniques through the simulation manager enables scenario studies within a selected area of the distribution network. Access to the network and DG development can be modelled sequentially in time and with concurrent multiple developments. This allows not only the determination of maximum connectable capacity but also an investigation of network sterilisation and stranding of assets. These techniques may be used by DNOs, working with mini hydro developers, to maximise access, clarify the need for network upgrades and avoid network sterilisation or asset stranding.

*New generator control to maximise network access and operation*

Synchronous generators can be operated in either voltage control or power factor control modes. While power factor control used to be obligatory, some DNOs have permitted voltage controlled operation for DGs at weak parts of the network to provide some voltage support. This has to be evaluated carefully as larger DGs can cause network voltage control systems to operate in response. However, the combination of power factor control together with voltage control of DGs may offer significant benefit to developers if it enables acceptable access to weak areas of the network and allows continuous operation of the plant when co-ordinated with varying local demand.

Wallace and Kiprakis have developed a hybrid voltage/power factor control algorithm that combines the features of both methods. Its normal mode of operation is to export power at a pre-defined and constant power factor. However, once the local voltage exceeds a threshold (that lies within the statutory limits) the controller smoothly transfers to voltage control to hold voltage within these limits. Once conditions change and allow the voltage to fall, power factor control resumes. The controller enables greater export during low demand periods and can also provide voltage support at times of high demand.

Extensive simulations have compared operation of a water-turbine driven synchronous generator using a typical power factor control system and with the new hybrid scheme. Figure 5 (below) shows the local demand variation over the course of a day for an 11kV network similar to Figure 1. Figure 6 shows the resulting variations in network power flow and local voltage under power factor (APFC - red trace) and hybrid (AVPFC - blue trace) control schemes. There are a number of observations regarding operation in power factor control mode. Firstly, the voltage would rise above the upper statutory

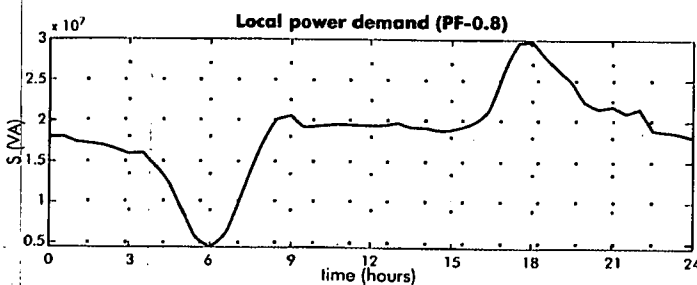

Figure 5: Local demand profile

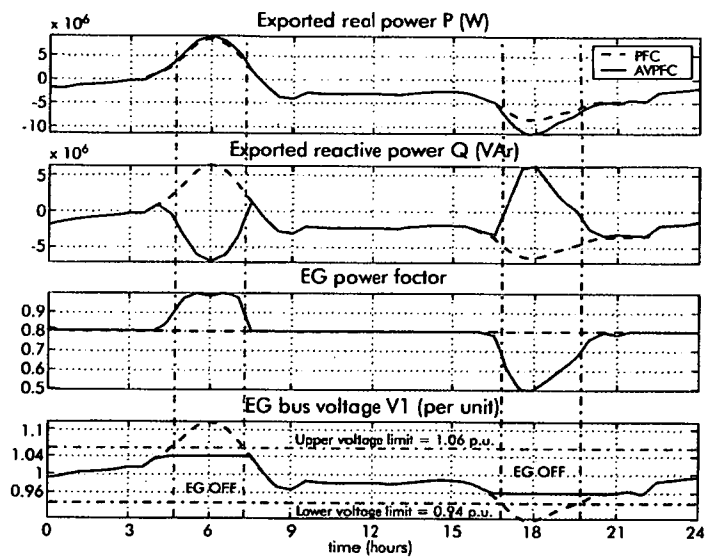

Figure 6: DG operation with power factor control and hybrid voltage/power factor control

limit during the period of low demand (04.30 to 07.30 hours), and in consequence the generator would be disconnected with significant loss of generation. Secondly, between the hours of 16.30 and 19.30, excessive local demand would draw voltage below the lower voltage limit. Under-voltage protection would disconnect the DG causing the voltage to fall further and, in the absence of available voltage controls, the DNO would draw more power from the sub-transmission system. Under hybrid control, however, the voltage was continuously maintained within statutory limits, allowing the generator to remain connected and export power.

**Bibliography**

- HARRISON G. P. and WALLACE, A. R., Novel techniques to maximise distributed generation capacity in distribution networks, Institute for Energy Systems Working Paper, University of Edinburgh, 2002.
- HMSO, The Electricity Supply Regulations (Amdt 2), 1994.
- MASTERS C. L., Voltage rise: the big issue when connecting embedded generation to long 11kV overhead lines, IEE Power Engineering Journal, Vol. 16, No. 1, February 2002, 5-12.
- SCOTTISH EXECUTIVE, Impact of Renewable Generation on the Electrical Transmission Network in Scotland, October 2001.
- WALLACE A. R., Protection of embedded generation schemes, IEE Colloquium on Protection and Connection of Renewable Energy Systems, 9th November 1999, 1/1-1/5.
- WALLACE A. R. and KIPRAKIS A. E., Reduction of voltage violations from embedded generators connected to the distribution network by intelligent reactive power control, Fifth International Conference on Power System Management and Control, 2002, 210-215.

*The authors are Dr Gareth P. Harrison, Aristides E. Kiprakis and Dr A. Robin Wallace, Institute for Energy Systems, School of Engineering & Electronics, University of Edinburgh, Kings Buildings, Mayfield Road, Edinburgh EH9 3JL, UK.*

*The authors acknowledge with gratitude support provided by EPSRC (research grant number GR/N04744).*

# Voltage Control in the Distribution Network: Traditional Techniques and New Developments

Aristides E. Kiprakis

A. Robin Wallace

Aristides.Kiprakis@ed.ac.uk

Robin.Wallace@ed.ac.uk

Institute for Energy Systems, School of Engineering & Electronics,  
University of Edinburgh, The King's Buildings, EH9 3JL, Scotland, UK

## Abstract

Distributed generators are normally operated in constant power factor control, although this can be more difficult in weak areas of the network. Operating the generator in constant voltage mode is not usually acceptable by distribution network operators, since an unconstrained machine may attempt to define voltages that conflict with the settings of their automatic voltage control equipment. Additionally, active control of the distribution network is only scarcely utilised. The most common means of voltage control in the DN is using transformers with automatic tap changers either for direct voltage control on the transformer bus or for line drop compensation. Novel voltage control techniques include intelligent real and reactive power control of the distributed generator.

This paper will present the traditional techniques and compare them with the novel DN voltage control proposals. Their relative advantages will be quantified through a comparison of the maximum seamless energy dispatch from the connected distributed generators in each case.

## 1 Introduction

The rise of environmental awareness as well as the recent oil crisis drives governments towards the development of new renewable plants for electricity generation. A great amount of this new generation is typically found in remote rural areas where the Distribution Network (DN) is weak and designed for a unidirectional, downstream flow of energy [1]. A net reversal or increase of power flow in line due to the presence or the loss respectively of a DG can cause unacceptable voltage variations and the Distribution Network Operator (DNO) will then require that the DG be disconnected. The resulted loss of profit can be a barrier for the development of DG towards the governmental targets. Any network reinforcement in order to eliminate voltage fluctuation effects and the cost of this work may be attributed to the connection costs of the DG. This may make potential schemes less attractive [1, 2]. Recent developments have shown that by intelligently controlling distributed generators (DGs) the voltage variation issue can be mitigated and reinforcement may be avoided [3]. Utilisation of the Fuzzy Logic (FL) Controller presented in this paper to control the DG may also prove to be a viable alternative to the costly network reinforcement.

## 2 Impact of Increased Dispersed Generation in Weak Rural Networks

In an 11 kV radially tapered network such as the one shown in Figure 1, the bus voltages in per unit are derived from Equation 1 and its voltage profile when the 20MW generator on bus 4 is offline is shown in Figure 2(a).

$$\overline{V}_{n+1} = \overline{V}_1 - \sum_{k=1}^n \frac{(R_k + jX_k)(P_{k+1} - jQ_{k+1})}{\overline{V}_{k+1}^*} \text{ pu} \quad (1)$$

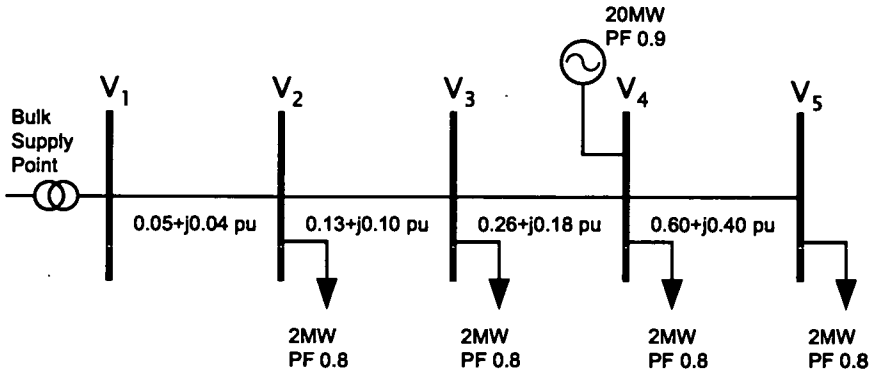

Figure 1: Radially tapered network

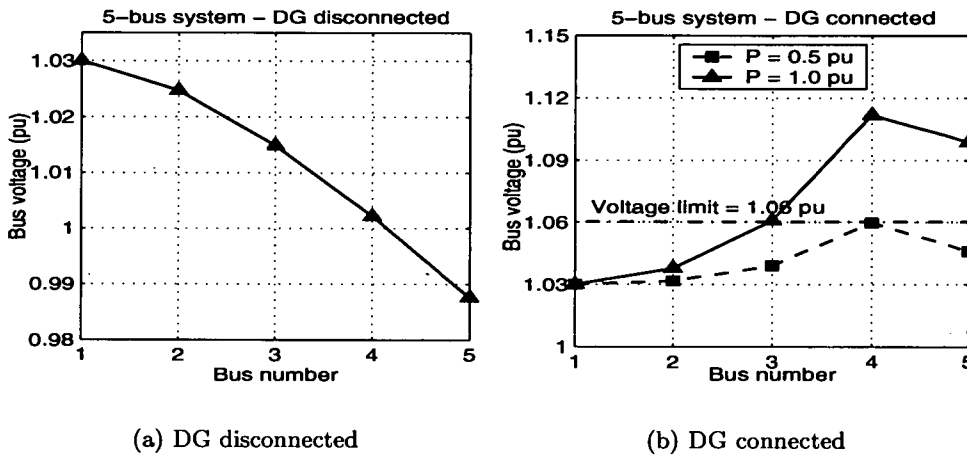

Figure 2: Voltage profile of the radially tapered network

Although the loads are equal, the gradient of the voltage becomes larger towards the end of the line due to the higher impedance of the line. With the generator connected (Figure 2(b)), the voltage on bus 4 as well as the neighbouring buses 3 and 5 is outside the statutory limits of  $\pm 6\%$ . The DG should either decrease its output to half its rated power (0.5 pu) in order to bring voltage back within the statutory limits, or disconnect.

Measures to accommodate the added DG capacity could include a combination of network reinforcement, setting the DG to import VARs, lowering the primary substation voltage or operating the DG in constant voltage mode. However these measures may be costly, or degrade other factors of the DN [4].

### 3 Intelligent Generator Control

For the two-bus system of Figure 3(a), assuming that  $RP + XQ \gg RQ - XP$ , Equation 1 is reduced to

$$V_2 = V_1 - \frac{RP + XQ}{V_2} \quad \text{pu} \quad (2)$$

It is apparent that a large  $R$  makes  $P$  an increasingly significant factor of the voltage fluctuation

issue, and its effects could be counterbalanced by appropriate regulation of  $Q$ . The operating constraints that the DNO poses to the DG (i.e. range of permissible voltages and power factor values) are visualised in the voltage phasor diagram of Figure 3(b).

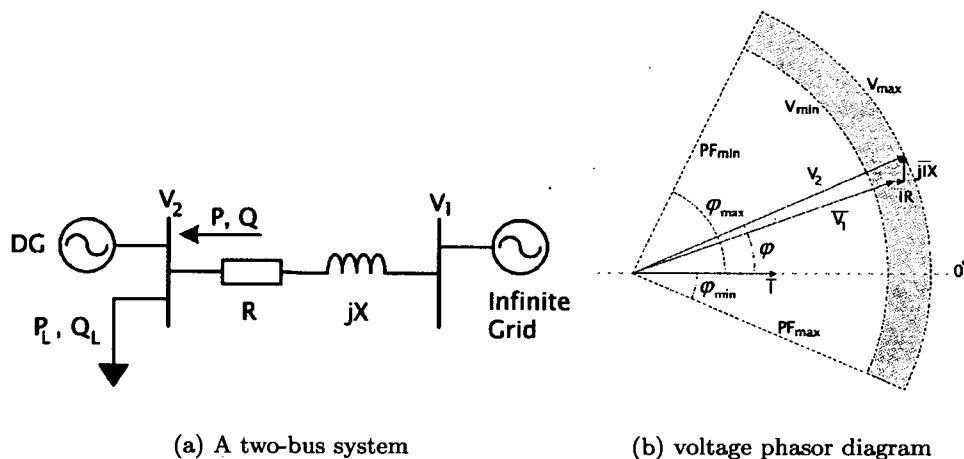

Figure 3: Basic power network

With large generators connected to the transmission network, a central control system is supervising and controlling each generator such that its terminal voltage phasor tip always lies within the shadowed area of the diagram in Figure 3(b). However this is not an option with distributed generation due to the lack of central control. Therefore each generator has to act individually to maintain safe operation within the statutory limits. The Fuzzy Logic Power Factor Control (FLPFC) has been developed for this purpose. Its block diagram is shown in Figure 4 below. FLPFC uses fuzzy logic to continuously regulate the power factor setpoint according to the terminal voltage. A conventional automatic power factor controller has a flat power factor characteristic over the permissible range of voltage. A human operator (or in this case an intelligent controller) of the DG plant though would respond to voltage fluctuation by altering the power factor setpoint in a way that the change in generated (or absorbed) reactive power would bring about a regulation of the terminal voltage as suggested by Equation 2. A typical voltage - reactive power (represented by  $\tan(\phi)$ ) characteristic for an FLPFC is shown in Figure 4(b).

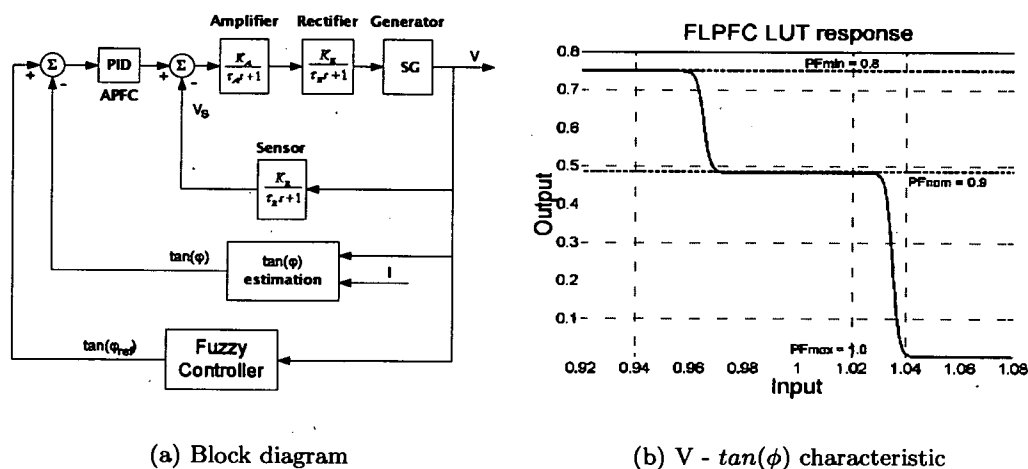

Figure 4: Block diagram of a DG with an FLPFC and its response to voltage changes

## 4 Simulations of DG operation under Intelligent Control

To test the response of the DG to voltage variations brought about by changes in local load under the control of typical Automatic Power Factor Control (APFC) and FLPFC, a time-varying load was connected to the DG busbar of a network similar to the one shown in Figure 3(a) to simulate the time variation of an actual rural load at a DN substation. The details of the network are shown in Table 1.

Network Data	
Machine size:	4.0 MW
Min. Load $P_L, Q_L$ :	1.11 MW, 0.538 MVA <sub>r</sub>
Max. Load $P_L, Q_L$ :	6.411 MW, 3.105 MVA <sub>r</sub>
Load power factor PF:	0.9
Line resistance $R$ :	0.1901 pu
Line reactance $X$ :	0.1521 pu
Network Voltage:	1.0 pu
Base Voltage $V_{base}$ :	11 kV
Base Power $S_{base}$ :	10 MVA

Table 1: Test system data

The response of a typical APFC generator setup is shown in Figure 5(a). The power factor of the generator remains constant throughout the whole period. However, for the period between 00:45-06:15 hours the DNO would disconnect the generator as the large amount of generated power in combination with the low local demand would cause excessive power export and thus voltage violation. This 5.5-hour disconnection would reduce the daily energy output of the DG by 22MWh. This loss represents 23% of the 96MWh maximum for a day by the 4MW generator. Additionally, for the period 17:15-18:45 hours due to the high local demand the DNO would have to shed a part or all the load in order to bring voltage back in the operational range.

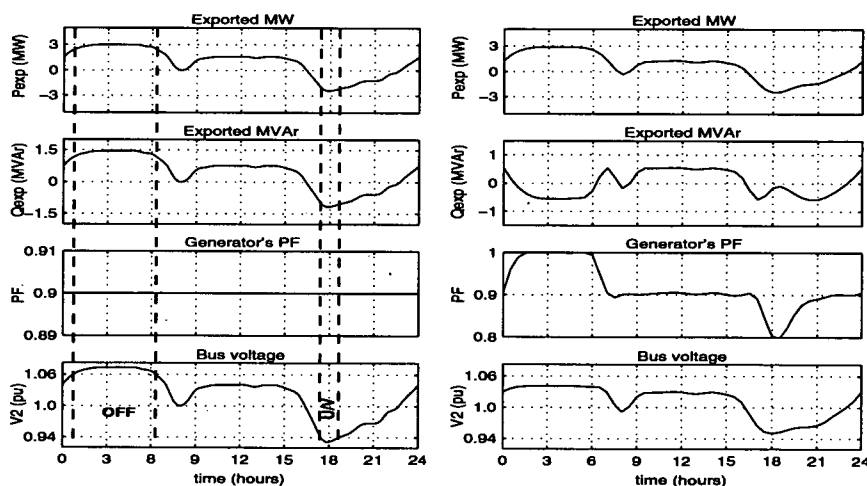

(a) APFC response

(b) FLPFC response

Figure 5: Operation of an APFC and FLPFC controlled generator under varying load

In the case of FLPFC control (Figure 5(b)) neither voltage nor power factor goes outside the operational ranges and therefore uninterrupted operation for the whole period in study is guaranteed. The exported power is thus maximised and the profit significantly increased.

### 5 Intelligent Generator Control in a Distribution Network

A series of simulations of a section of the Scottish distribution system have been performed in order to prove that the proposed control strategies can (a) improve voltage profiles in a weak network and (b) increase the capacity of Embedded Generation in the Distribution Network. The system under consideration is shown in Figure 6.

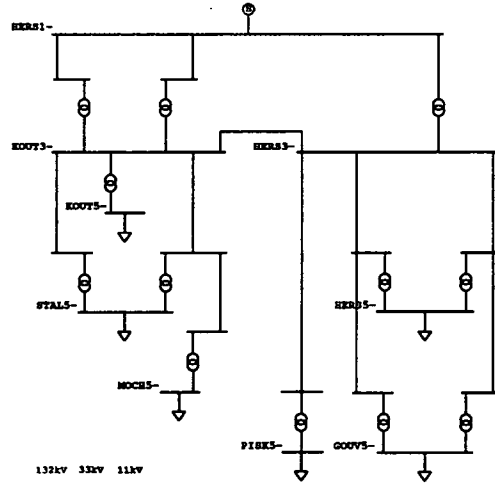

Figure 6: The section of the scottish distribution network used as a test system

Figure 7(a) shows the operating voltage ranges for varying load, for all the buses in the simulated system. For this simulation a 2.4MW generator operating at a constant 0.95 power factor was connected to bus 15 (GOUV5). The dark blue part of the bars represents undervoltage, light blue and red are the overheads for undervoltage and overvoltage respectively, and finally yellow is the operating area for each bus. It is shown that voltage at GOUV5 is marginally at the limit for overvoltage, meaning that any further increase of the generating capacity on that bus (or its neighbouring ones, in electrical terms) will lead to overvoltage.

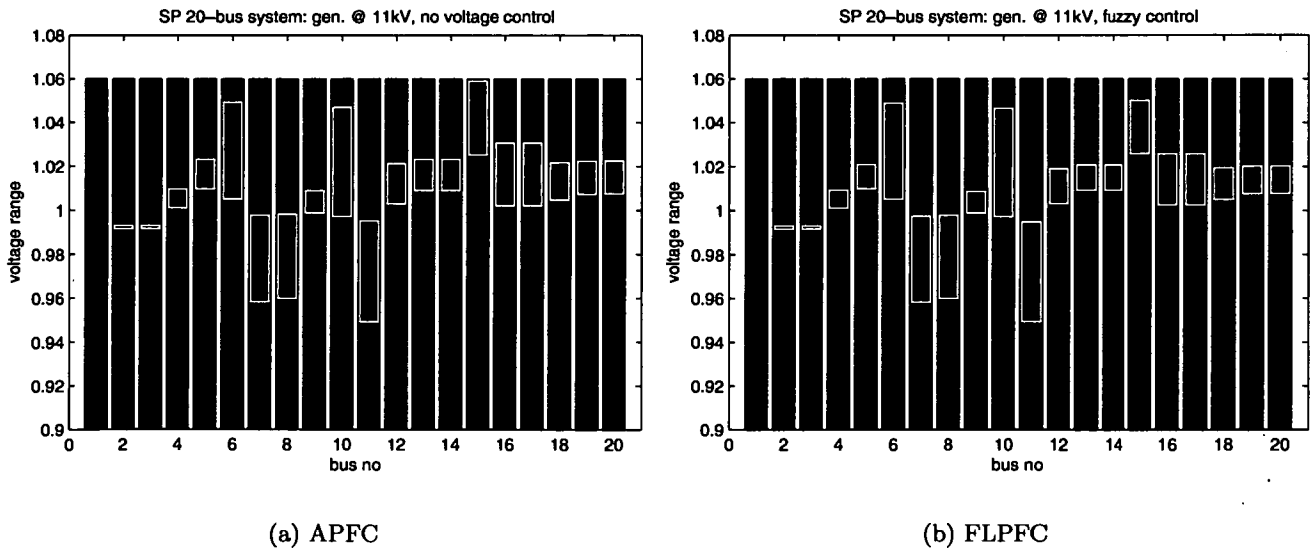

Figure 7: Network voltage ranges with APFC (a) and FLPFC (b) controlled generator on bus 15

Figure 7(b) shows the voltage response of the network to the same generator, this time under control of FLPFC. Application of the FLPFC to the generator led to a reduction of the level and constraint of the range of voltages for all the buses that are electrically close to GOUV5. Therefore for the same load, generation and network conditions, intelligent generation control improves voltage quality in the distribution system.

Further simulations showed that under FLPFC control voltage at bus GOUV5 reached 1.06 pu only when capacity was increased to 4.2MW, which represents an 1.8MW (or 75%) increase. This increase would otherwise not be possible to be achieved, unless a network upgrade or installation of an autotransformer was performed. The merit of utilising intelligent generator control in the DN is further emphasised when several generators within the same network operate under such control. Vovos *et al.* in [6] proved that application of FLPFC on multiple generators has the same effect as if they were centrally controlled.

## 6 Discussion

While voltage and power factor control techniques are well established their combination has never been used. Active transfer between the two modes and fuzzy logic DG control have been shown to allow extended operation when network or local demand conditions would otherwise cause excessive voltage fluctuations and plant shutdown. Similarly, utilisation of these algorithms is expected to make potential DG projects more attractive by allowing the generator capacity to further increase before it causes a voltage violation. By using an intelligent controller on a generator within a weak distribution network the voltage variation throughout the network is decreased thus improving quality of supply. Most modern AVR's are implemented in a Programmable Logic Controller (PLC) and the proposed method can be easily embedded as code in the PLC software. Utilisation of such a DG control strategy is therefore economic and may defer the need for immediate network reinforcement (or automation), which are expensive solutions. If governmental targets for distributed and renewable generation development are to be achieved, operation of distributed networks and generators within them has to be reassessed in order to overcome the technical obstacles, with most significant the one of voltage variation. The proposed control strategy may assist towards this direction.

## References

- [1] G. P. Harrison, A. E. Kiprakis, A. R. Wallace, "Network Integration of Mini-Hydro Generation in Liberalised Markets", *International Water Power and Dam Construction*, **54**, 11, Nov.2002.
- [2] A. R. Wallace, A. E. Kiprakis, "Reduction of Voltage Violations from Embedded Generators Connected to the Distribution Network by Intelligent Reactive Power Control", *Proc. 5th Int. Conf. on Power System Management and Control*, 210-215, Apr. 2001.
- [3] A. E. Kiprakis, A. R. Wallace, "Maximising energy capture from distributed generators in weak networks", *IEE Proc. on Gen. Trans. & Dist.*, **151**, 05, 611-618, Sept. 2004.
- [4] C. L. Masters, "Voltage Rise: the Big Issue When Connecting Embedded Generation to Long 11kV Overhead Lines", *IEE Power Engineering Journal*, **16**, 01, 5-12, Feb. 2001.
- [5] W. Pedrycz, "Fuzzy Control And Fuzzy Systems, 2nd ed." sec. 4.5, Research Studies Press, 1993.
- [6] P. N. Vovos, A. E. Kiprakis, G. P. Harrison, J. R. Barrie, "Enhancement of Network Capacity by Widespread Intelligent Generator Control", To appear in: *Proc. 18th Int. Conf. on Electricity Distribution CIRED 2005*.

## ENHANCEMENT OF NETWORK CAPACITY BY WIDESPREAD INTELLIGENT GENERATOR CONTROL

Panagis N. VOVOS, Aristides E. KIPRAKIS, Gareth P. HARRISON, James R. BARRIE

University of Edinburgh - United Kingdom

P.Vovos@ed.ac.uk

### INTRODUCTION

*Electricity networks are called on to accommodate more and more generation capacity in order to supply the increasing demand. Social, planning and environmental reasons hinder the expansion of the existing infrastructure, whereas lack of investment prohibits its reinforcement. Therefore, the efficient utilisation of the existing network is not only suggested for economy, but also imposed by need. Consequently, the realisation of government targets for renewable energy will depend, in part, on the ability of developers and Distribution Network Operators (DNOs) to maximise generator capacities connected to the network whilst minimising negative impacts.*

*One means of ensuring maximum capacity with minimal voltage impact is through the use of intelligent power factor and voltage control of generators and other network components. Previously published work demonstrated the benefits in terms of the minimisation of voltage variations and violations as well as the ability of larger generators to connect to the network. While the capacity benefit could be easily quantified for individual dispersed generators, it was more difficult to explore the benefit of widespread usage.*

*To achieve this it was necessary to draw on earlier work that used Optimal Power Flow (OPF) techniques to evaluate the network capacity available for connecting dispersed generators. The capacity evaluation technique was extended such that it could incorporate the intelligent generator control algorithms and in doing so could find optimal levels of connections. The results of a case study indicate that intelligent power factor and voltage control of generators increases significantly the connecting capacity of existing networks.*

### GENERATOR CONTROL: AVR VERSUS PFC

To date, Distribution Network Operators have generally been reluctant to allow any operation by independent generators which could potentially disrupt the passive role of the distribution network to supply demand. Specifically, Distributed Generators (DGs) are not permitted to perform Automatic Voltage Regulation (AVR), an inherent feature of synchronous generators to regulate the terminal bus voltage by adjusting their reactive power output, as it may destabilise the automatic Load Tap Changers (LTCs) of distribution transformers. A further issue is that where a small generator with AVR control is connected to a utility bus that suffers from voltage drops, it has to inject great amounts of reactive power in order to raise the bus voltage. This may result in high field currents and overheat the generator, triggering the protection and disconnecting the generator from the network. Accordingly, in most DG applications the generators do not have AVR control.

DGs usually operate in Power Factor Control (PFC) mode. They produce proportional amounts of active and reactive power in order to maintain constant Power Factor (PF) at all times. PFC is less disruptive for LTCs and results in much lower field currents than AVR under voltage drops, therefore reduces thermal stresses on the generator [1].

### TACKLING VOLTAGE RISE FROM NEW CAPACITY

Unfortunately, PFC has an adverse effect on the generator's terminal bus voltage. The voltage drop  $\Delta V$  along a radial feeder is approximated by the equation:

$$\Delta V = R \cdot P + X \cdot Q \quad (1)$$

where  $R+jX$  is the line impedance and  $P$ ,  $Q$  the active and reactive power produced by the DG. When  $P$  increases  $V$  rises. In PFC mode  $P/Q$  is maintained constant, so when  $P$  increases  $Q$  follows and  $V$  increases even further! Conversely, when  $P$  decreases,  $Q$  decreases as well, leading to further voltage drop. Masters [2] notes that voltage rise as one of the major impacts of, and constraints on, the connection of new DGs on the network.

In equation (1), if  $Q$  was allowed to compensate for the feeder voltage rise or drop created by  $P$  by adjusting in the opposite direction (with  $P$ ), then  $V$  could be maintained within limits allowing greater active power export. For voltage rise, this would be achieved by defining a leading power factor at which the generator is to be controlled. Power factor settings could be specified on a time-of-day basis, wherein DG operates at lagging power factor to export reactive power during high demand periods whilst importing during low demand. While this appears to be a relatively simple approach, it would require analysis to ensure that voltage is maintained appropriately under all normal operation cases and may require a degree of central coordination.

An alternative to these techniques would be that the generator itself controls reactive power in an 'intelligent' and 'network friendly' manner.

### INTELLIGENT GENERATOR CONTROL

Kiprakis and Wallace [3], [4] proposed a voltage control method for DGs which assumed a more flexible directive from DNOs in terms of the voltage control by DGs. The target was to develop a voltage control method capable of keeping DGs online during light and/or heavy loading conditions by combining the advantages of AVR and PFC. The method was termed Automatic Voltage / Power Factor Control (AVPFC) and it relaxes the PFC when voltage approaches limits defined

by statute or by the DNO (with reference to accepted engineering practice). In normal operation and within defined minimum ( $V_{min}^{PFC}$ ) and maximum ( $V_{max}^{PFC}$ ) threshold voltages, the DG operates in PFC mode at a defined power factor ( $PF_{PFC}$ ). When voltage reaches these limits, which lie within the defined voltage limits ( $V_{min}, V_{max}$ ) the PFC is deactivated and the DG operates in AVR mode, producing or absorbing reactive power to support voltage. The generator produces additional reactive power to maintain a low voltage during high demand periods and absorbs it to contain a high voltage during low demand periods. The DG must be restricted to its over and under-excitation limits as defined by the minimum and maximum operating power factors  $PF_{min}$  and  $PF_{max}$ , respectively. Once the generator reaches its excitation limits the voltage will no longer be controlled and may continue to move towards the statutory limits before the voltage protection equipment operates to disconnect the DG. Figure 1 presents the AVPFC operational scheme with the generator operating on the thick, dashed line.

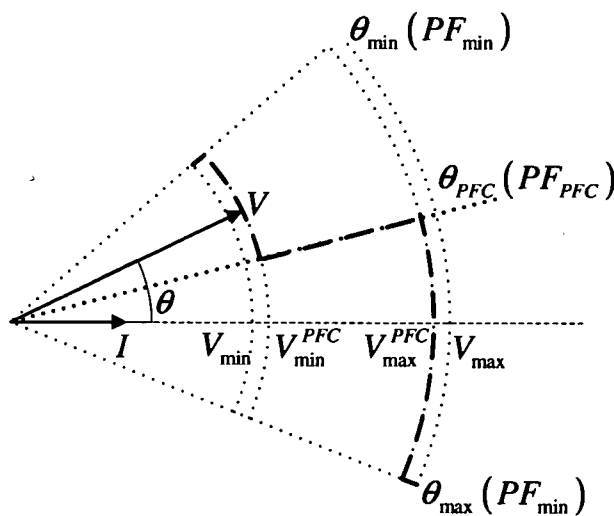

Figure 1 Hybrid AVPFC voltage control.

In extensive simulations, the AVPFC algorithm was found to extend the period of operation for an individual DG in a weak network and increased revenue from energy export. A further benefit was that the method allowed a larger generator to connect to the network without voltage violations during low demand periods [4]. Identifying the benefit in terms of enhancing DG connection was relatively straightforward for the single generator. In examining the benefit of applying the technique on a widespread basis with two or more generators it was found that the interdependency of voltage in the network made manual comparisons rather difficult and time consuming. A more sophisticated approach was sought.

**CAPACITY ALLOCATION**

It was recognised that attempts to determine the additional generator capacity added to the network through the use of intelligent control was similar in aim to other work published by Harrison and Wallace [5], [6]. Their aim was to develop a means of determining available network capacity for DG

connection. Using proprietary Optimal Power Flow (OPF) software and modelling DG as negative loads, the ‘reverse-loadability’ technique found the maximum capacity of DG that could be connected at any given set of locations in the network subject to network voltage and thermal constraints.

The approach was extended significantly by Vovos *et al.* [7] which incorporated fault level as a constraint in the OPF via a stepwise iterative approach. A bespoke implementation of an OPF was required for this and presented the opportunity to explicitly model power factor controlled DG. Reference [8] describes the formulation of OPF, but a brief outline of the method implemented in [7] is given below.

**New Generation Capacity**

New generators are simulated as generators with quadratic cost functions with negative coefficients. These generators are connected to predetermined locations in the network, the ‘Capacity Expansion Locations’ (CELs), with the output of generators simulating the allocated capacity at the CEL. Since in most DG applications the generators perform PFC we can simplify our analysis by assuming that CELs have constant lagging power factors set at 0.9. This assumption also holds for most DG installations that interface to the network through inverters [9].

**Cost Model**

The cost model assumes that the negative cost (benefit)  $C_g$  from new generation capacity is connected only to the size of new generators  $P_g$ :

$$C_g(P_g) = a \cdot P_g^2 + b \cdot P_g + c \tag{2}$$

w.r.t.  $a, b, c < 0$  and  $P_g > 0$ , where  $C_g$  is the operational cost of generator  $g$  at output level  $P_g$ . Different sets of coefficients between cost functions declare preferences for the allocation of new capacity between CELs. If the voltage control scheme enforced by the DNO affects the allocated size of DGs at the CELs, then its impact will be reflected in the OPF objective function. Therefore, the cost model is capable of encapsulating the effects of different voltage control schemes.

**Tie Lines**

Energy transfers from/to external networks are also simulated as generators with quadratic cost functions. We will refer to them as Export/Import Points (E/IPs). The coefficients of the cost functions are negative for exports and positive for imports. The outputs of the generators are negative when they represent exports and positive when they represent imports.

**Existing Capacity and Loads**

Existing generation capacity is simulated as generators with constant active power output, equal to their maximum capacity, and given reactive power injection capabilities. Loads are simulated as sinks of constant active and reactive power.

**INTELLIGENT VOLTAGE CONTROL IN OPF**

Generally, DG capacity is simulated with the real power output  $P^g$  of virtual generators placed at the CELs. In order to examine the impact an alternative voltage control scheme has

on network capacity using the OPF, we have to simulate the behavior of DGs implementing those schemes during steady-state operation.

The main difference in the OPF formulation between DGs operated under the current voltage control scheme ('PFC-Gens') and the hybrid scheme (hereafter termed 'Intelli-Gens') is that the otherwise constant PF is allowed to vary (within the DG operating limits) when voltage drops or rises beyond a critical value. Since we focus on capacity planning it is logical to expect that new capacity will only raise voltage levels. Thus, in order to simplify our analysis we will assume that the PF constraint is relaxed only when the generator's voltage  $V_G$  rises to a critical value  $V_{threshold}$ . In addition, in order to consider leading and lagging PFs we will constrain the angle  $\theta_G = sign(PF) \cdot \cos^{-1}(PF)$  instead of the PF directly, where  $sign(PF)$  is positive for lagging and negative for leading PF.

Finally, the minimum ( $PF_{min}$ ) and maximum ( $PF_{max}$ ) operating PFs are roughly the same for various sizes of DGs. Therefore, we can presume that  $PF_{min}$ ,  $\theta_{min}$ ,  $PF_{max}$ ,  $\theta_{max}$  are common for all new DGs. Furthermore,  $PF_{max}$  is usually the rated PF, so it is considered here as the target  $PF_{PFC}$  of PFC. Both these assumptions can be described in the OPF formulation by the following constraints for the virtual generators at the CELs:

$$PF_{min} < PF_G < PF_{max} \Rightarrow \theta_{min} < \theta_G < \theta_{max} \quad (3)$$

and  $PF_{max} = PF_{PFC} \Rightarrow \theta_{max} = \theta_{PFC}$

The voltage control strategy of Intelli-Gens is described by the curve in the power factor ( $\theta_G$ ) versus voltage ( $V_G$ ) graph as Figure 2 shows.

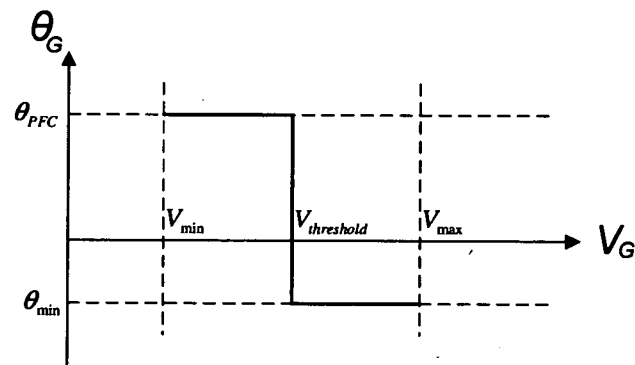

Figure 2. Voltage control strategy of Intelli-Gens.

Equation (4) describes this control strategy mathematically:

$$\theta_G = \theta_{PFC} \quad \text{when } V_{min} \leq V_G < V_{threshold} \quad (4)$$

$$\theta_{PFC} < \theta_G \leq \theta_{min} \quad \text{when } V_G = V_{threshold}$$

In order to avoid the optimisation burden that discrete transitions create we approximate (4) with the equality constraint below:

$$\theta_G = \theta_{eq} \Rightarrow \tan^{-1}(Q^G / P^G) = A + K \cdot \tan^{-1}(B \cdot V_G + C) \quad (5)$$

where  $K = K_{steep} \frac{\theta_{PFC} - \theta_{min}}{\pi}$ , and

$$A = \theta_{min} + K \frac{\tan^{-1}[S_1 + S_2]}{(V_{max} - V_{threshold}) \cdot \eta\mu_{threshold}^{min} \cdot \eta\mu_{max}^{min}}$$

where  $S_1 = (V_{max} - V_{min}) \cdot \eta\mu_{threshold}^{min} \cdot \sigma V_{max}^{min}$

where  $S_2 = (V_{min} - V_{threshold}) \cdot \eta\mu_{max}^{min} \cdot \sigma V_{threshold}^{min}$

where  $\eta\mu_y^x = \sin[(\theta_x - \theta_y)/K]$ ,  $\sigma V_y^x = \cos[(\theta_x - \theta_y)/K]$

$$B = \frac{\tan[(\theta_{threshold} - A)/K] - \tan[(\theta_{max} - A)/K]}{V_{threshold} - V_{max}}$$

and  $C = \tan[(\theta_{max} - A)/K] - B \cdot V_{max}$ .

$K_{steep}$  is a real number marginally over 1, which defines the steepness of  $\tan^{-1}$ . The higher the value, the smoother the transition from  $\theta_{PFC}$  to  $\theta_{min}$ . A value of 1.01 for  $K_{steep}$  produces a quite smooth function without significant loss in precision. This approximation creates a 'smooth' transition around  $V_{threshold}$  for  $\theta_G$  with respect to  $V_G$  (Figure 3).

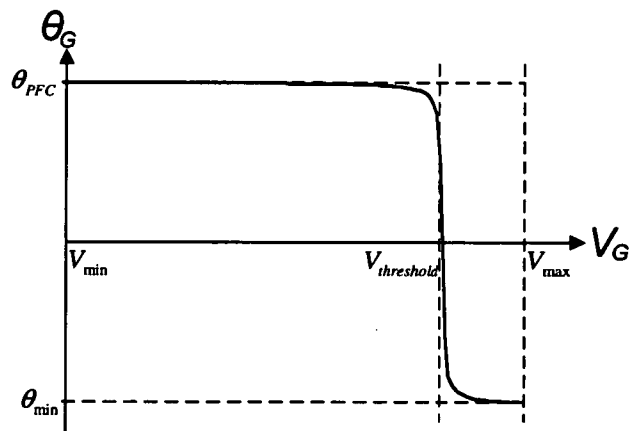

Figure 3. Smoothing of control strategy transition for Intelli-Gens.

## CASE STUDY

### Network Topology

The 12-bus 14-line network presented in Figure 4 has 3 CELs at buses 1, 10 and 11. It also has an E/IP to an external network at bus 12. A 15 MW generator is installed on bus 5, capable of providing up to 10 MVar of reactive power. The network has a common rated bus voltage level at 33 kV, except for the CEL buses which have a rated voltage of 11 kV and the E/IP bus at 132 kV. The CEL buses connect to the network through 30 MVA transformers with fixed taps. The E/IP bus connects through a 90 MVA transformer with automatic tap changer, which regulates the voltage within a  $\pm 2\%$  range of the rated voltage at the low voltage side with a  $\pm 10\%$  tap range around the nominal tap ratio. The electric characteristics of transformers and lines are presented in the table next to the network topology in Figure 4. We assume that loads consume

constant complex power on buses 1, 3, 5, 6, 8, 10 and 11. Their size is depicted on the same figure.

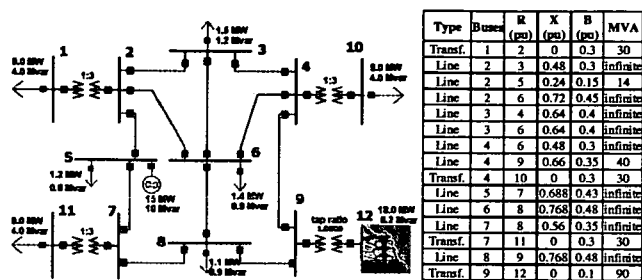

Figure 4. 12-bus 14-line test case and transformer/line characteristics

**Constraints**

Line 2-5 is constrained by a thermal limit of 14 MVA, 4-9 by a thermal limit of 40 MVA, while all other lines are considered to be unconstrained. We assume that the E/IP can exchange up to 100 MW with the external network without affecting its secure operation. The external network is also capable of providing/consuming up to 60 MVar of reactive power to the local network. Finally, statutory regulations limit bus voltage fluctuations to  $\pm 10\%$  around the nominal values. The CELs at buses 1, 10 and 11 will accommodate PFC-Gens and Intelli-Gens in turn.

**Voltage Control Properties**

We assume that the voltage control strategy of Intelli-Gens has  $V_{\text{threshold}} = 1.05$  p.u. for the relaxation of the PFC from a PF of 0.9 lagging. When the generator's voltage reaches  $V_{\text{threshold}}$  they are permitted to operate at any PF between 0.9 lagging and 0.9 leading. We will examine the impact of each control strategy on network capacity assuming that there is no preference for the allocation of new generation capacity at any specific CEL.

**RESULTS**

The initial capacity allocation from OPF is presented in Table 1. PFC results in the lowest total new capacity and exports.

TABLE 1 - OPF capacity allocation with PFC and Intelli-Gens

	PFC	Intelli-Gens	Change
CEL 1	9.2 MVA PF=+0.90	28.3 MVA PF=- 0.96	19.1 MVA
CEL 10	25.9 MVA PF=+0.90	24.8 MVA PF= +0.99	-1.1 MVA
CEL 11	15.3 MVA PF=+0.90	33.0 MVA PF= - 0.96	17.7 MVA
Total MVA	50.4 MVA	86.1 MVA	35.7 MVA
E/IP	-25.2 MW	-38.1 MW	12.9 MW
Losses	4.0 MW	29.2 MW	25.2 MW
Obj.Fun.	1411.5	2424.2	1012.7

Obviously, the broader the voltage operating region of the generators the broader the solution space for the OPF. Consequently, the OPF objective function has a value which increases in each case that we relax the PF control further: in turn PFC-Gens and Intelli-Gens. However, the impressive total

capacity achieved from the Intelli-Gens comes at a cost: high losses. This is due to the fact that most of the reactive power consumed by Intelli-Gens during their attempt to maintain low terminal voltage, is provided from the distant E/IP at bus 12. Reactive power traveling long distances through a network raises losses.

**CONCLUSION**

The main conclusion of this paper is that the relaxation of DNOs' strict PFC policies, specifically, through widespread application of intelligent automatic voltage/power factor control schemes allow the connecting capacity of the existing network to be better exploited. Further work is required to compare the potential benefits of intelligent local control with those that accrue from a more centralised, active approach to voltage control within the distribution network.

**REFERENCES**

- [1] T.W. Eberly, R.C. Schaefer, 2002, "Voltage versus VAR/power-factor regulation on synchronous generators", *IEEE Trans. Ind. Apps.*, vol. 38, 1682-1687.
- [2] C.L. Masters, 2002, "Voltage rise: the big issue when connecting embedded generation to long 11 kV overhead lines", *Power Eng. J.*, vol. 16 (1), 5-12.
- [3] A.E. Kiprakis, A.R. Wallace, 2003, "Hybrid control of distributed generators connected to weak rural networks to mitigate voltage variation", *Proc. CIRED 2003*, Barcelona, Spain, May 2003
- [4] A.E. Kiprakis, A.R. Wallace, 2004, "Maximising energy capture from distributed generation in weak networks", *IEE Proc. Gen. Transm. Distrib.*, vol. 151 (5), 611-618.
- [5] A.R. Wallace, G.P. Harrison, 2003, "Planning for optimal accommodation of dispersed generation in distribution networks", *Proc. CIRED 2003*, Barcelona, Spain, May 2003.
- [6] G.P. Harrison, A.R. Wallace, 2005, "OPF evaluation of distribution network capacity for the connection of distributed generation", *IEE Proc. Gen. Transm. Distrib.*, vol. 152 (1).
- [7] P.N. Vovos, G.P. Harrison, A.R. Wallace, J.W. Bialek, in press, "Optimal power flow as a tool for fault level constrained network capacity analysis", *IEEE Trans. Pwr. Sys.*
- [8] H. W. Dommel and W. F. Tinney, 1968, "Optimal power flow solutions," *IEEE Trans. Power Appar. Syst.*, vol. PAS-87, pp. 1866-1876.
- [9] S.R. Wall, 2001, "Performance of inverter interfaced distributed generation," presented at IEEE/PES Transmission & Distribution Conference.

# Intelligent Voltage and Reactive Power Control of Mini-Hydro Power Stations for Maximisation of Real Power Export

Aristides E. Kiprakis and A. Robin Wallace  
Institute for Energy Systems, University of Edinburgh, Scotland

## ABSTRACT

*Operating the automatic voltage regulator (AVR) of a small-scale water turbine-driven synchronous generator in constant power factor mode may lead to excessive voltage variations in a rural electricity network. Depending on the capacity of the hydro-generator and the inherent voltage variation in the network, operating in constant voltage mode may lead the machine and AVR into excess excitation and shut-down or failure. Furthermore, network operators need not accept this method of operation, since an unconstrained machine may attempt to define voltages that will conflict with their automatic voltage control equipment. In this paper a hybrid mode of control is proposed that combines Automatic Voltage Control (AVC) and Automatic Power Factor Control (APFC) modes. The ability to export active and reactive power from mini-hydro generators, which are connected to a weak rural network, is assessed under APFC mode of operation. This is contrasted in energy terms with the increase in dispatch available by operating more flexibly within the statutory voltage limits under the action of the proposed algorithm that automatically transfers between voltage and power factor control.*

## Introduction

In the UK and many other countries there is a significant drive towards electrical power generation from renewable resources. Additionally, the potential early retiral of central thermal power plants will increase the total and proportion of capacity of small-scale generators that are connected to Distribution Networks (DNs) in many countries. Mini-hydro power generation plants featuring on synchronous generators (SGs) are expected to be a significant contributor to the total DN generation capacity. The larger renewable energy resources including mini-hydro tend to be geographically and electrically remote from load centres [1,2]. Unlike large-hydro plants that are connected to dedicated extensions of the transmission network, mini-hydro schemes are often at the end of long open-ended radial feeders at the edge of the Distribution Network, where the network impedance can be relatively high, with high resistance and a low X:R ratio.

Truly dispersed mini-hydro generation is seldom centrally dispatched and the power produced can vary according to constraints imposed by run-of-river operation. Additionally, the hourly, daily and seasonal variation of local power demand can result in un-constrained bi-directional variation in network power flow and consequently a wide fluctuation of busbar voltages is expected in these parts of the network. If un-restricted, these voltage variations may violate the statutory limits for quality of supply [3,4].

Distribution Network Operators must maintain voltage levels within statutory limits while supplying customers. Active network management or control of the distributed mini-

hydro generators can achieve the limitation of these voltage variations. However, it has not been common practice to manage actively the DN and this limits the export of real power to the network, reduces revenue and inefficiently utilises the hydropower resource. Another common way to increase access for distributed mini-hydro generation has been to reinforce the network but this is usually an expensive modification and can jeopardise the economic viability of otherwise attractive schemes.

While voltage and power factor control techniques are individually well established, active transfer between the two modes is not widely practised as a means of increasing access for generation in the DN. Hybrid control has been shown to allow extended operation when generator production, network conditions or local demand would otherwise cause excessive voltage variation and plant shutdown.

### Impact of Connection of a Mini-Hydro Power Generator to the Rural Grid

The UK distribution network has been significantly extended during the last 50 years, but its structure and operation has remained largely unchanged [2]. Energy is transferred from the bulk supply points (substations connecting the DN to the transmission grid) towards the far ends of the DN using overhead lines. Moving away from the primary substation the loads tend to become smaller and therefore the Distribution Network Operators (DNOs) use lines with conductors of decreasing cross-sectional area. However, this means that the network resistance  $R$  per kilometre and line voltage rise increases. Therefore the amount of power that can be delivered within statutory voltage limits becomes smaller. Consequently, there are difficulties in shipping the amount of power generated at the far ends of the DN. This is expected to restrict the development of mini-hydro generation projects far from the Bulk Supply Points (BSPs).

To illustrate the effect, an 11 kV radially tapered network is shown in Figure 1, where the busbar voltages are derived from the equation:

$$\overline{V}_{n+1} = \overline{V}_1 - \sum_{k=1}^n \frac{(R_k + jX_k)(P_{k+1} - jQ_{k+1})}{V_{k+1}^*} \quad \text{per unit} \quad (1)$$

Each of the loads on the radial feeder is 2 MW operating at 0.8 power factor and all lines between buses have equal lengths. Moving towards the end of the feeder, the line impedance rises as the cross-sectional area of the feeder becomes smaller. In order to ensure quality of supply for all of its customers, the DNO will have to raise the voltage at the Bulk Supply Point (BSP) to around 1.03 pu so that it remains above the lowest acceptable level even at the far end of the line. With the generator on bus 4 disconnected, it is obvious from Figure 2(a) that although the loads are equal at all locations, the gradient of the voltage drop increases towards the end of the line because of the higher line impedance. For the same reason, it can be inferred that a generator connected close to the distant end of the feeder will cause a larger voltage rise than if it were at the bulk supply point.

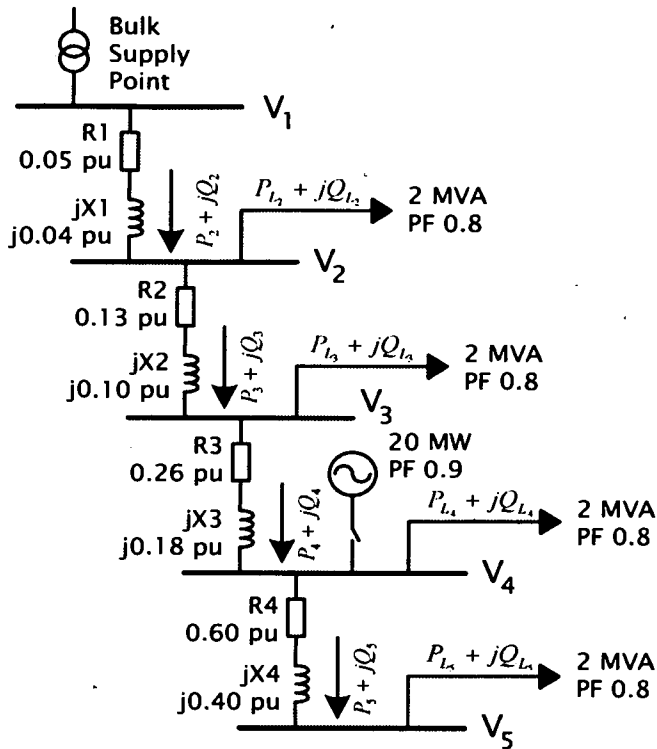

Figure 1: Radially tapered network

Connection of the 20 MW generator on bus 4 operating at constant 0.9 lagging power factor would alter the voltage profile of the line as Figure 2(b) shows.

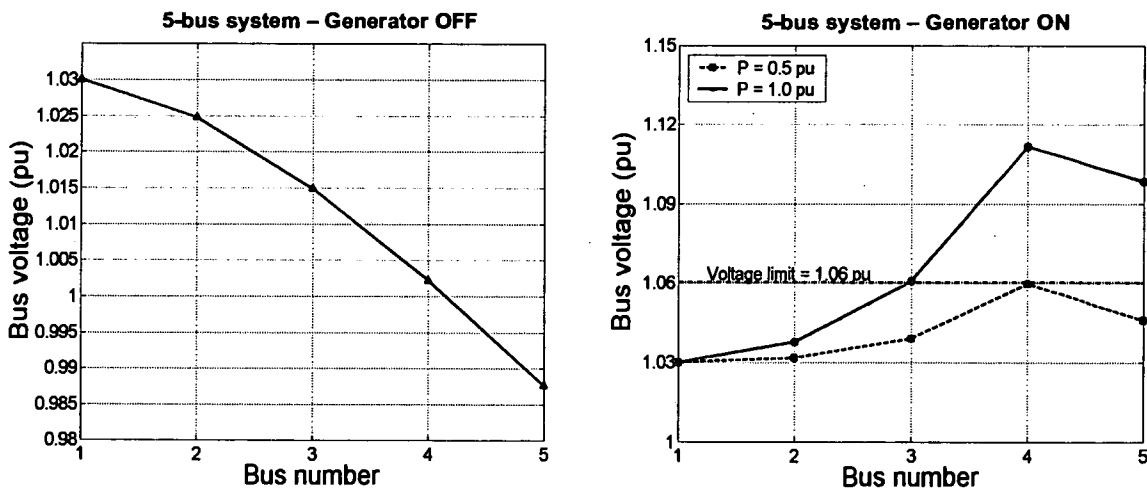

Figure 2: Voltage profile of the 5-bus system with the generator off (a) and on (b)

It is apparent that the network restricts the amount of power that can be accommodated, as at full output (1 pu), voltage levels at buses 3, 4 and 5 are outside the statutory limit of  $\pm 6\%$  and the DG would have to reduce output to less than 50% of its capacity (0.5 pu) to avoid disconnection. Reduction of local loads during the low demand periods will further reduce the amount of power that can be dispatched by the generator, as the power flow towards the BSP will be further increased, and therefore the voltage variation will be more severe.

In [6] is proposed that alternative solutions to this problem could be: reinforcing the feeder, operating the synchronous generator at a higher or leading power factor, lowering the voltage at the primary substation, or operating the generator in constant voltage mode. However, reinforcement of the feeder can be a very expensive process, operating the generator at leading power factor can cause instability problems due to under-excitation, the intermittent nature of renewable resources raises security issues regarding lowering the primary substation voltage as a sudden loss of a plant would suppress the voltage at the neighbouring buses below the permissible levels, and finally, operating the generator in constant voltage mode can cause unwanted action of the DNO's voltage control equipment.

### **Control of Small Synchronous Generators Connected to a Rural Grid**

Currently there are two methods of control of synchronous machine-based mini-hydro power plants that are connected to the DN, namely Automatic Power Factor Control (APFC) and Automatic Voltage Control (AVC), although the second method is rarely used.

#### ***Operation in Automatic Power Factor Control***

One method of implementing APFC would be to include in the excitation system a separate Proportional-Integral-Derivative (PID) compensator module that operates on the voltage setting of the Automatic Voltage Controller (AVR) to hold the generated power factor (PF) constant. The generator is usually loaded immediately after synchronising by increasing the speed setting in the governor, while simultaneously transferring the AVR from voltage control (AVC) for synchronising to power factor control (APFC). Thereafter active and reactive power ramp in constant ratio, up to any load limits set by the governor. However, the terminal voltage of the generator is not restricted and will vary with the changes in real and reactive power transferred through the line. This variation may become unacceptable in a weak DN and the generator will be required to limit power or shut down. Therefore APFC operation can limit dispatch in weak networks or else it demands upgrading of them in order to host increased amounts of generation. True APFC can only be applied when the network impedance is sufficiently low that machines can export full capacity without significant variation of their terminal voltage.

#### ***Operation in Automatic Voltage Control***

Automatic power factor control is most easily applied when network impedance is low and when machines can export full capacity without a measurable increase in terminal voltage. While PF control used to be obligatory, some DNOs have recently allowed mini-hydro power plants at weak parts of the network to operate in AVC to provide some system voltage support [3]. This has to be evaluated carefully because larger capacity of generation can cause automatic voltage control equipment on DNO's transformers in the vicinity to operate in response and cause spurious operation of protection, particularly at times of light local load [4,5].

## Proposed Control Algorithm for Small Synchronous Generators

Recent work has proven that a hybrid control system which combines the merits of both APFC and AVC can improve steady-state and slow transient voltage profile and is expected to increase net energy dispatch [3]. The block diagram of the combined Automatic Voltage / Power Factor Controller (AVPFC) is shown in Figure 3.

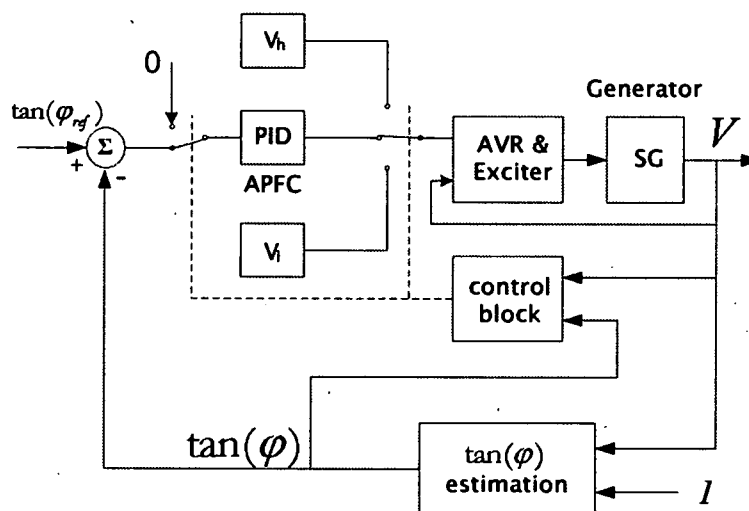

Figure 3: AVPFC block diagram

The control block will engage the PID compensator for the periods that the terminal voltage is within a preset permissible band. The PID compensator will maintain constant power factor by comparing the tangent of the angle of terminal voltage ( $V$ ) and current ( $I$ )  $\tan(\varphi)$  with a reference value  $\tan(\varphi_{ref})$  (normal APFC action). Should the voltage violate the preset high or low limit, the control block would override the PID compensator and operate the SG in pure AVC mode, fixing voltage at  $V_h$  or  $V_l$  respectively. The AVR will try to hold voltage constant by controlling the amount of reactive power generated (or consumed, for leading power factor). With the generator operating in AVC mode fixing voltage at  $V_h$  the control block will be monitoring the power factor (in the form of  $\tan(\varphi)$ ). A more lagging PF than a preset value will mean that the AVR overexcites the generator in order to hold voltage and this will flag the control block to return to APFC. Conversely, while the AVR fixes voltage at  $V_l$ , if the PF rises above a preset value (becomes more leading), the control block will again switch back to APFC. Hysteresis is provided for switching operations in order to prevent hunting.

Automatic power factor and voltage control have been applied together before now, but to achieve other objectives. Over- and under-current protection forcing margins were maintained during network voltage disturbances by composite power factor and voltage control [7].

## Simulation of Operation of APFC and AVPFC Controlled Mini-Hydro Power Plants Connected to the Distribution Network

In order to evaluate the merit of implementing the proposed control method against the traditional APFC mode of operation, the system of Figure 5 was modelled in Matlab.

This system is a part of the actual scottish distribution network and has been identified as an ideal test system, in that it has a high content of potential mini-hydro power plant locations and being at the extremities of the rural network it demonstrates wide voltage variations due to the varying power flows. A day's (24 hours) operation of the network was simulated. The demand at all load locations was given a typical 80% domestic, 20% industrial profile (Figure 4).

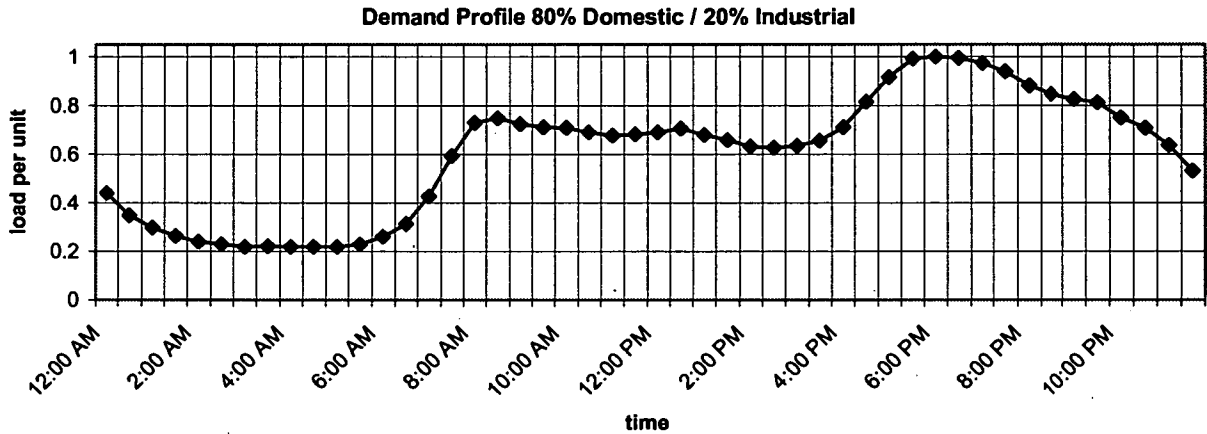

Figure 4: Load demand profile

The power factor of the load was set at constant 0.9 lagging. Two potential mini-hydro power plants have been identified in the area covered by the studied network, 7 MW at location L1 and a 5 MW at location L3.

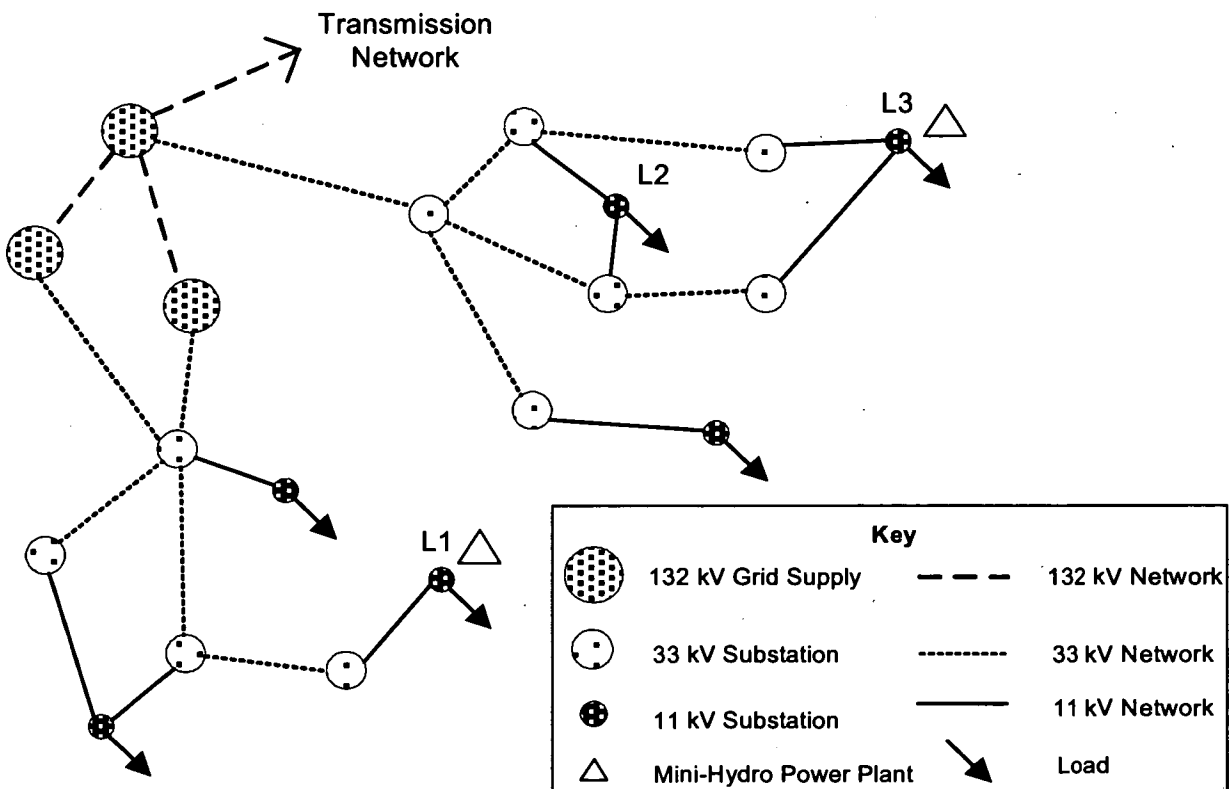

Figure 5: The test network

The simulation was performed twice; firstly with the generators operating in APFC mode with the power factor set at 0.95 and, secondly, using the AVPFC controller. The parameters of the AVPFC controllers of both generators are shown in Table 1.

Maximum Voltage	1.04 pu
Minimum Voltage	0.96 pu
Voltage Hysterisis	$\pm 0.002$ pu
Operating PF	0.95 lagging
PF Hysterisis	$\pm 0.0005$
Generator PF <sub>max</sub>	0.99 leading
Generator PF <sub>min</sub>	0.9 lagging

Table 1: AVPFC parameters

## Results of the Simulations

The results of the simulations of the two control modes for both generators are shown in the next sections.

### Potential site 1: Location L1

Connection of the 7 MW generator at location L1 and operating it in APFC mode caused voltage variations that exceeded the maximum statutory limit. Tapping down the transformer on the bus reduced the average voltage but as Figure 6 shows, the voltage variation was wider than 0.12 pu and therefore it was inevitable that in the best case (tapping down the transformer to center voltage at approximately 1.0 pu), both the maximum and minimum statutory limits would be violated.

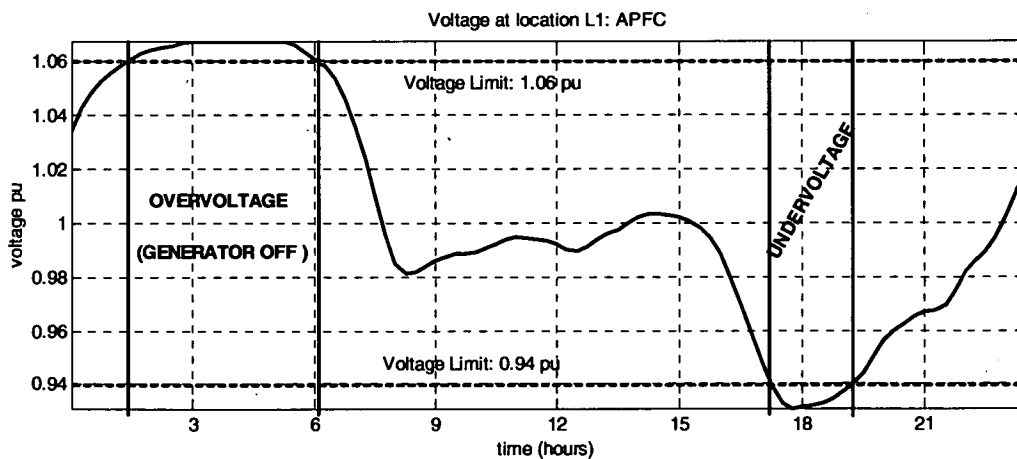

Figure 6: Voltage at location L1 (APFC mode)

Therefore the generator would have to shut down for 4.5 hours during the low-demand period (01:00-06:00). This downtime would cause a loss of 31.5 MWh of generated energy and therefore significant loss of revenue. Additionally, there is another period of 2 hours (17:15-19:15) during high demand that the voltage at this location would be below the 0.94 pu statutory limit.

Using the AVPF Controller, the generator did not cause any voltage violation and hence remained connected for the whole 24-hour period. Figure 7 shows the power factor of the generator and the voltage at the generator terminals. When voltage exceeded the (1.04 pu + hysteresis) setpoint, the controller switched from constant power factor to constant voltage mode, holding voltage at 1.04 pu. The power factor rose (generated reactive power dropped) to hold voltage, and when the PF dropped back to the (0.95 pu - hysteresis) setpoint it returned to APFC mode.

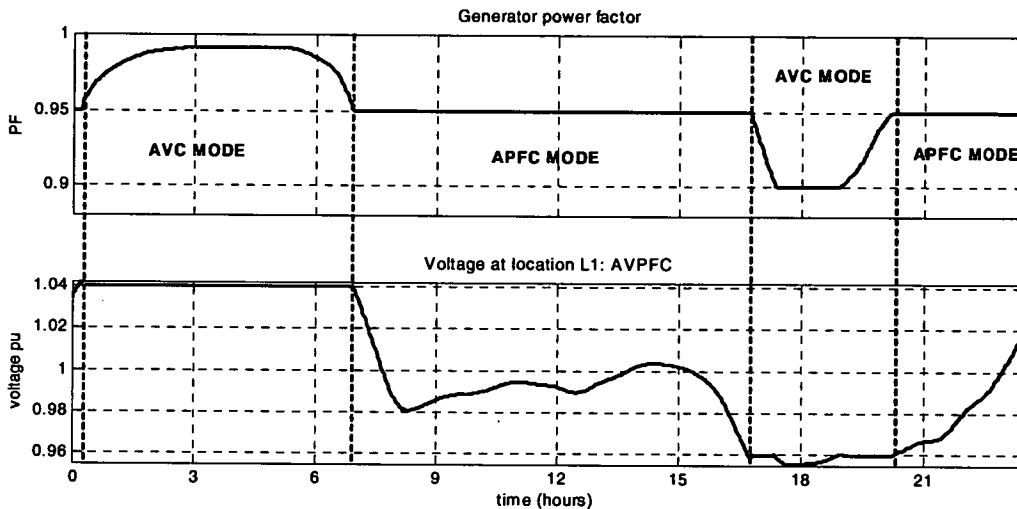

Figure 7: Generated power factor and voltage at location L1 (AVPFC mode)

The inverse procedure occurred during the 16:45 – 20:15 high demand period. Undervoltage was detected and the controller switched to AVC mode holding voltage at 0.96 pu. Increase of PF above the (0.95 pu + hysteresis) setpoint triggered the controller to switch back to APFC mode of operation. It is worth noticing that there is a 2-hour period during the high demand, in which the AVR cannot hold the voltage constant. It can be observed that during that period, the SG has reached its maximum reactive power capability (minimum PF) and the excitation overcurrent protection circuits disallow excitation to increase. Therefore no more reactive power can be generated and the voltage cannot be supported any further.

### Potential Site 2: Location L3

The voltage at L3 with the generator operating in APFC mode is shown in Figure 8.

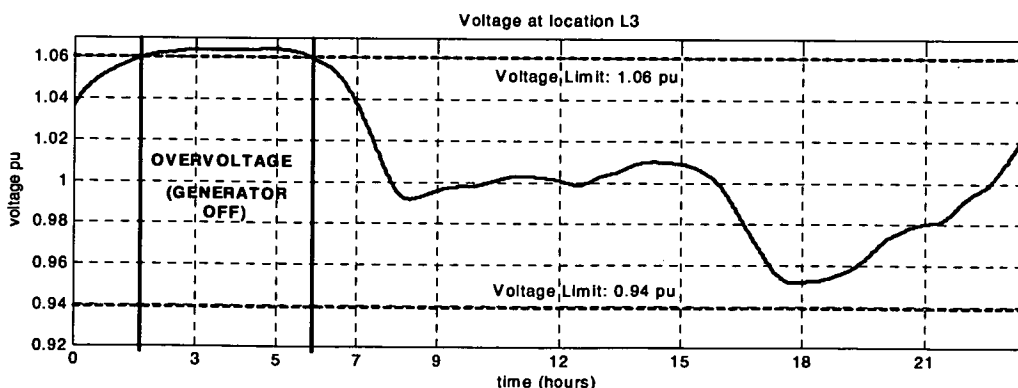

Figure 8: Voltage at location L3 (APFC mode)

The 5 MW generator causes unacceptable voltage rise above the maximum permissible value of 1.06 pu for 4 hours during the low demand period. In this case the local load is not big enough to cause a voltage drop below the 0.94 pu statutory limit. Utilising the AVPF controller the terminal is once again restricted within the permissible band as Figure 9 illustrates. This would allow the generator to export an additional 20 MWh therefore maximising revenue.

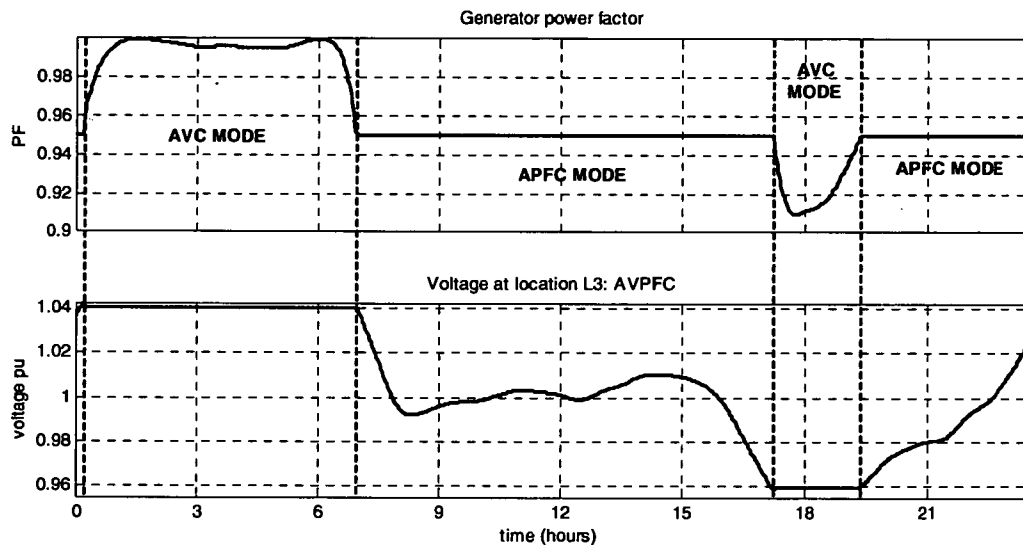

Figure 9: Generated power factor and voltage at location L2 (AVPFC mode)

In this case, the drop of PF that can be observed during the low demand period is because the SG is operating at leading power factor and, therefore, it imports reactive power in order to reduce its terminal voltage. Additionally, during the high demand period, the machine managed to maintain constant voltage at 0.96 pu without hitting the over-excitation limits.

## Conclusion

The number of mini-hydro generators in the distribution network and particularly at its weak corners is increasing. In this paper the impact of increased generation capacity by synchronous machines in the distribution network was discussed and the conventional methods of SG control, namely the Automatic Voltage Control and the Automatic Power Factor Control were reviewed. While voltage and power factor control techniques are well established, active transfer between the two modes has seldom, if ever, been utilised in order to allow extended operation when local demand conditions would otherwise cause excessive voltage rise or drop and plant shutdown. This made apparent the need for an intelligent control strategy of the mini-hydro generator and a possible solution was proposed, the Automatic Voltage / Power Factor Controller. Extensive simulations have shown that the proposed approach has great potential for adoption by mini-hydro generation plant developers and equipment manufacturers, as it is expected to significantly increase the capacity of the generator at a potential site, and / or increase developer's revenue by allowing increased connection time. The proposed method is easy to implement both in new and existing sites where generating plant is controlled by programmable logic controllers (PLCs), and the algorithm can be embedded as an extension to their existing code.

## References

- [1] Wallace A. R., "Protection of Embedded Generation Schemes", 1999, *Colloquium on Protection and Connection of Renewable Energy Systems*, IEE, 1/1-1/5.
- [2] Harrison G. P., Kiprakis A. E. and Wallace A. R., 2002, "A New Era for Mini Hydro", *International Water Power and Dam Construction*, vol. 54, no. 11.
- [3] Wallace A. R., Kiprakis A. E., 2002, "Reduction of Voltage Violations from Embedded Generators Connected to the Distribution Network by Intelligent Reactive Power Control", *Proc. 5th Int. Conf. on Power System Management and Control*, 210-215.
- [4] Salman S. K., Jiang F., Rodgers W. J., 1993, "The Effect of Private Generators on the Voltage Control of 11kV Networks and on the Operation of Certain Protective Relays", *Proc. IEEE/NTUA Int. Conf. on Modern Power Systems*, 591-595.
- [5] Eberly T. W., Schaefer R. C., 2002, "Voltage Versus VAR/Power Factor Regulation on Synchronous Generators", *Pulp and Paper Industry Technical Conf.*, Conference Record of the 2002 Annual, 2002.
- [6] Masters C. L., 2002, "Voltage Rise: the Big Issue When Connecting Embedded Generation to Long 11kV Overhead Lines", *Power Engineering Journal*, IEE, vol. 16, no. 1, 5-12.
- [7] Bobo P. O., 1972, "Regulator Apparatus Responsive to Generator Output Power Factor and Voltage", US Patent 3634750.

## Authors

*Aristides E. Kiprakis, BEng(Hons) is a Doctoral Researcher at the Institute for Energy Systems at the University of Edinburgh. He is currently on his final year of research towards his PhD. His research interests include modelling and intelligent control of distributed renewable generation. Aristides is a Member of the Institution of Electrical Engineers and the Institute of Electrical and Electronic Engineers.*

*A. Robin Wallace, PhD is Head of the Institute for Energy Systems at the University of Edinburgh. A former Assistant Chief Project Engineer with Parsons Peebles, and currently a consultant on small hydropower and distributed generation issues, Dr Wallace is a Chartered Engineer and a Member of the Institution of Electrical Engineers.*

## HYBRID CONTROL OF DISTRIBUTED GENERATORS CONNECTED TO WEAK RURAL NETWORKS TO MITIGATE VOLTAGE VARIATION

Aristides E. KIPRAKIS and A. Robin WALLACE  
The University of Edinburgh - United Kingdom  
kiprakis@iee.org; Robin.Wallace@ed.ac.uk

### ABSTRACT

Distributed generators are normally operated in automatic power factor control, although this can be more difficult in weak areas of the distribution network as they are frequently connected to long open-ended radial feeders, which have low  $X/R$  ratios and high resistance. The un-constrained bi-directional power flow may cause unacceptable voltage fluctuations that would cause generator or other system protection to operate. Operating the generator in constant voltage mode is only occasionally acceptable to distribution network operators, since an unconstrained machine may attempt to define voltages that conflict with setting of their automatic voltage control equipment. Line-Rise Compensation (LRC) is a network control technique that may lower steady-state overvoltages. This paper will discuss the implications, consequences and benefits of network LRC control compared to flexible control of power factor and voltage of the distributed generator.

### DISTRIBUTED GENERATION CONNECTED TO A RURAL NETWORK

Government initiatives to generate more electricity from renewable resources, and the potential early retiral of central thermal power plants will increase the total and proportion of capacity of Distributed Generation (DG) in many countries.

The larger renewable energy resources tend to be geographically and electrically remote from load centres [1,2]. Consequently many distributed renewable energy generators (e.g. wind; marine, mini-hydro power plants) will be connected to long open-ended radial feeders in the Distribution Network (DN), which have low  $X/R$  ratios and high resistance. The intermittent nature of most renewable energy generation and the hourly, daily and seasonal variation of local demand results in un-constrained bi-directional variation in network power flow. The presence of the distributed generation results in local voltage variations that can cause more frequent operation of network voltage control equipment. If un-restricted, these voltage variations may violate the statutory limits for quality of supply [3,4]. Limitation can be achieved by active network management or control of the distributed generators. It has not been common practice to manage actively the distribution network and, unless the network is upgraded at the developer's expense, the avoidance of network overvoltages may restrict the power that can be delivered by the DG, with associated loss of revenue.

### IMPACT OF CONNECTION OF SYNCHRONOUS GENERATORS IN THE DISTRIBUTION NETWORK

The distribution network has been significantly extended during the last 50 years, but its structure and operation has remained largely unchanged [2]. Energy is transferred from the bulk supply substations towards the far ends of the DN using overhead lines. Moving away from the primary substation the loads tend to become smaller and therefore the Distribution Network Operators (DNOs) use lines with conductors of decreasing cross-sectional area. However, this means that the network resistance  $R$  per kilometre increases and this restricts the development of DG projects far from the Bulk Supply Points (BSPs), as the increased  $R$  will amplify the voltage fluctuation due to generated power export, as Equation 1 below shows.

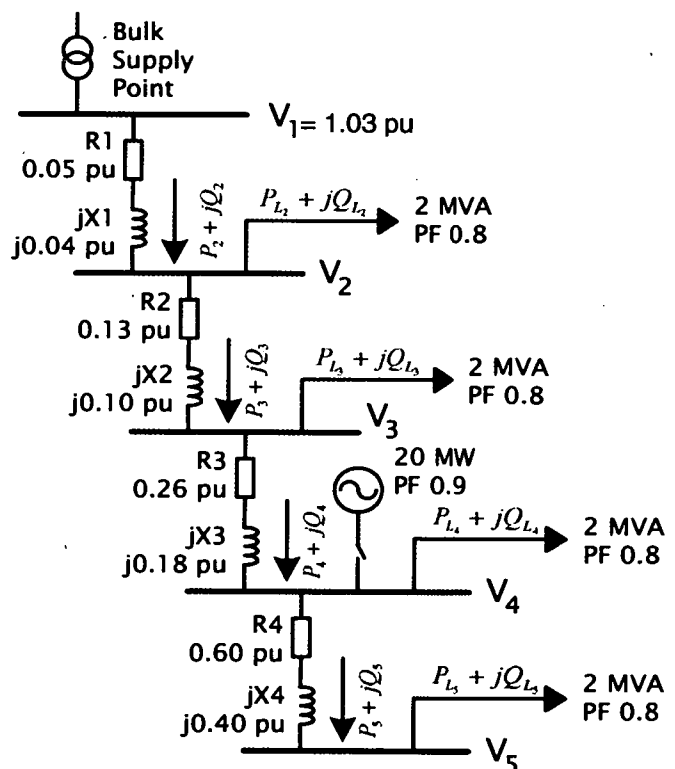

Figure 1 – Radially tapered network

In an 11 kV radially tapered network such as the one shown in Figure 1, the bus voltages are derived from the equation:

$$\overline{V_{n+1}} = \overline{V_1} - \sum_{k=1}^n \frac{(R_k + jX_k)(P_{k+1} - jQ_{k+1})}{V_{k+1}^*} \quad \text{pu} \quad (1)$$

With the DG on bus 3 disconnected, it is obvious from Figure 2 that although the loads are equal, the voltage drops increase towards the end of the line and that is because of the higher line impedance. For the same reason, a DG connected close to the distant end of the feeder is expected to cause a larger voltage rise than if it were closer to the bulk supply point.

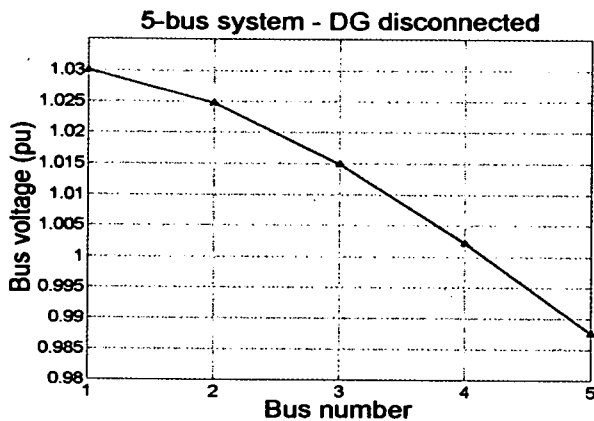

Figure 2 – Voltage profile with the DG disconnected

Connection of the 20 MW generator on busbar 4 operating at constant 0.9 lagging power factor would alter the voltage profile of the line as Figure 3 shows. It is apparent that the network restricts the amount of power that can be accommodated, as voltage levels at buses 3, 4 and 5 are outside the statutory limit of  $\pm 6\%$  and the DG would have to reduce its output to less than 0.5 pu to avoid disconnection.

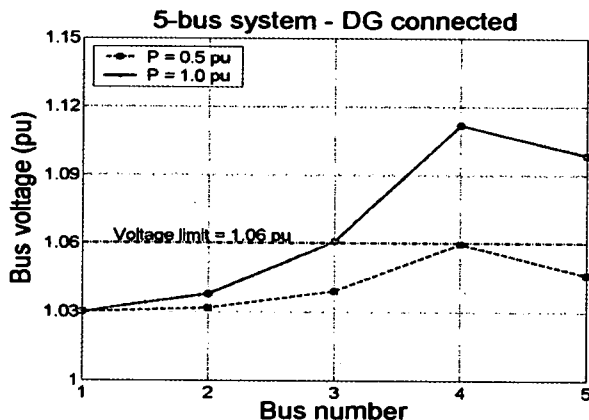

Figure 3 – Voltage profile with the DG connected

Other alternative solutions could be [6]:

- to operate at a higher or leading power factor,
- to lower the primary substation voltage,
- or to operate the DG in constant voltage mode.

### TRADITIONAL CONTROL OF DISTRIBUTED GENERATORS

Traditional control of synchronous machine-based DGs includes Automatic Power Factor Control (APFC) and Automatic Voltage Control (AVC), although the second method is rarely used.

One method of implementing APFC is to include in the excitation system a separate control module that operates on the voltage setting of the AVR to hold the phase angle between generator terminal voltage and current constant. DGs are usually loaded immediately after synchronising by increasing the speed setting in the governor, while simultaneously transferring the AVR from voltage control (AVC) for synchronising to power factor control (APFC). Thereafter active and reactive power ramp in constant ratio, up to any load limits imposed by the governor. However, the terminal voltage of the generator is not restricted and will vary with the changes in real and reactive power. This variation may become unacceptable in a weak DN and the DG will be required to limit power or shut down. Therefore APFC limits capacity in weak networks or demands upgrading of them in order to host increased amounts of generation. True APFC can only be applied when the network impedance is sufficiently low that machines can export full capacity without significant variation of their terminal voltage. While PF control used to be obligatory, some DNOs have recently allowed DGs to operate in AVC in order to provide some system voltage support [3]. Such a control strategy should be evaluated very carefully as larger capacity DGs can cause AVC equipment on DNO transformers to operate in response [4,5].

### HYBRID VOLTAGE / POWER FACTOR CONTROL OF DISTRIBUTED GENERATORS

There is a need to increase the capacity of existing networks by minimising / mitigating voltage violations. It has been shown that a hybrid control system that combines the merits of both APFC and AVC can improve steady-state and slow transient voltage profile and increase net energy dispatch [3]. The block diagram of such a system is shown in Figure 4.

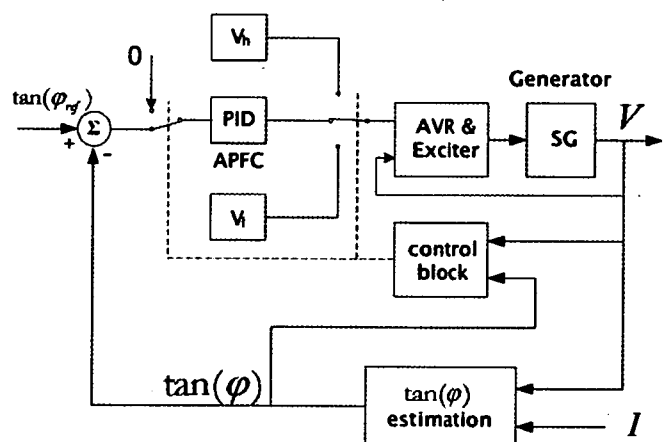

Figure 4 – AVPFC block diagram

After synchronising, the SG could be brought towards maximum power output in APFC until the busbar voltage exceeded a specified threshold voltage *within* statutory limits. At that point APFC could be replaced with AVC to vary excitation and move the SG's operating point within the voltage limit. Increasing local demand could take the system

back into APFC by sensing the increased demand for reactive power and therefore the reduction of power factor. Following the inverse route, this system would also enable voltage support at times of heavy local load. A small amount of hysteresis around the decision thresholds would prevent hunting between control modes. The AVR's over- and underexcitation limiters would restrict reactive power within the generator's operational region when in AVC mode.

## LINE DROP / RISE COMPENSATION

Autotransformers (ATs) with On-Line Tap Changers (OLTCs) and Automatic Voltage Control (AVC) equipment have long been used in the DN to hold terminal voltage within an acceptable band (Figure 5) [7,8]. The voltage on the secondary winding of the AT (bus 3) is measured and the tap-changing mechanism on the primary winding adjusts in order to hold voltage  $V_3$  within a predefined band. However, no information is provided on the voltage level at the other end of the feeder (bus 4) and in cases of high load/low generation or low load / high generation voltage  $V_4$  on the remote busbar may pass the lowest or highest permissible levels respectively, even with operation of AVC to hold  $V_3$ .

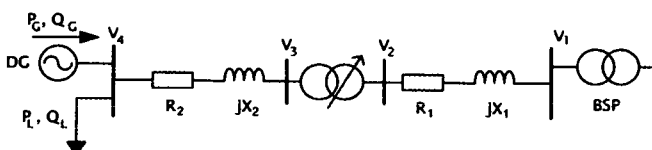

Figure 5 – AT with OLTC in the DN

Line Drop Compensation (LDC) is a technique that has been used in the past to mitigate large voltage drops on a bus in a weak DN when local load was high, by appropriate control of the voltage on a bus closer to the bulk supply point. The distribution line between them is simulated by a resistor and an inductor with values that match the ones of the line ( $R_2$ ,  $X_2$ ). The voltage on the secondary winding of the AT of Figure 5 is applied to this simulation circuit and by feeding it a fraction of the line current, a voltage drop proportional to the one of the line is created across the resistor and the inductor. This voltage is then used as a control signal for the OLTC and therefore voltage  $V_4$  on the remote bus is maintained within a permissible band [7-9]. An extension of this technique, Line Rise Compensation (LRC), that would accommodate line voltage *rise* as well as line voltage drop, would improve the voltage profile of DN buses with DGs connected to them and therefore it is expected to allow larger capacities of generation to be connected.

## SIMULATION OF THE PROPOSED METHODS

In order to evaluate the merit of implementing the proposed control methods against the traditional APFC mode of operation, the test system of Figure 5 was modelled in Matlab. The details of the system are shown in Table 1 below. A

varying load with a typical rural profile (Figure 6) was applied on bus 4 and a 24-hour simulation of 3 cases was performed:

1. APFC and AT's taps fixed at 1.0 pu
2. AVPFC and AT's taps fixed at 1.0 pu
3. APFC and the AT in LRC mode

TABLE 1 – Test network data

$V_{\text{network}}$	11 kV
Trans. tap setting at BSP	1.03 pu
$R_1$	0.11580 pu
$X_1$	0.09260 pu
$R_{\text{transformer}}$	0.00321 pu
$X_{\text{transformer}}$	0.04625 pu
$R_2$	0.21480 pu
$X_2$	0.17200 pu
$P_G$	3.0 MW
$P_L$	4.0 MW
$PF_{\text{load}}$	0.8

The (fixed) tap setting of the transformer at the BSP is set at 1.03 pu, as it would be in order to compensate the voltage drop that would ensue on the lines due to the load on bus 4 without the presence of the DG.

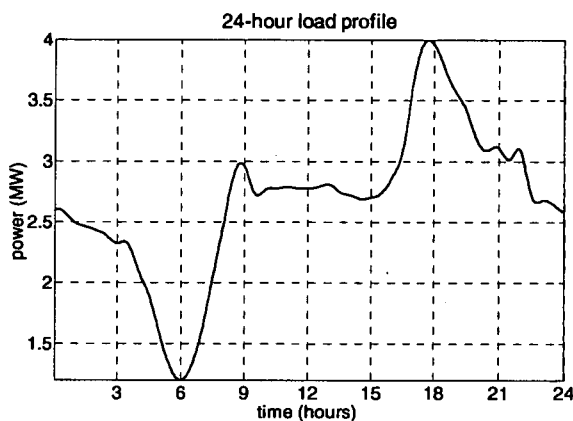

Figure 6 – Profile of load on bus 4

The results of these simulations are presented and discussed in the sections that follow.

### Simulation 1: Normal Operation (APFC, no LRC)

The response of a typical APFC generator setup without LRC operation of the AT is shown in Figure 7. The power factor of the generator remains constant and set at 0.95 lagging throughout the whole 24-hour period. However, during the low demand period between 04:30 and 07:30, voltage would rise above the 1.06 pu limit and the generator would be disconnected by the network interface protection of the machine. Alternatively, the generator could reduce its output but this would require continuous supervision of the DG, and either manual or automatic adjustment, by way of a control module on the governor. In both cases the revenue from

energy sales would be reduced due to the reduced real power export and/or the increased operational costs.

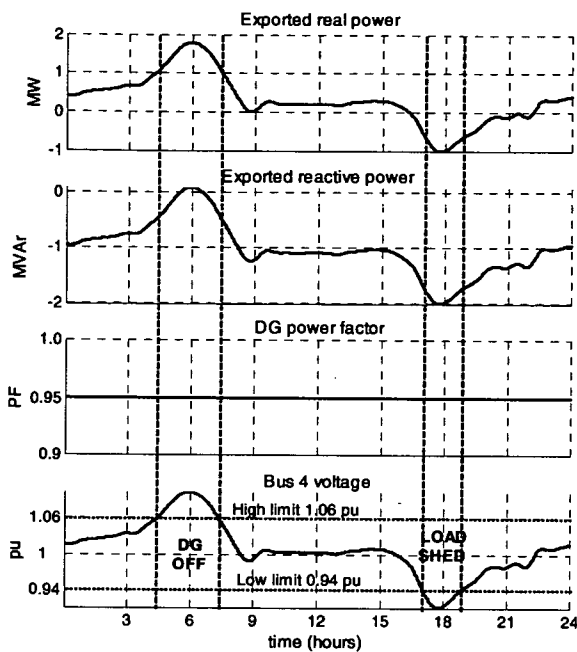

Figure 7 – APFC operation

Furthermore, during the peak demand period 17:00-19:00 the voltage was found to be below 0.94 pu and would remain low, unless there was a priority load disconnect scheme.

**Simulation 2: DG under AVPFC control**

The effects of utilising AVPFC under the same demand curve are shown in Figure 8 below. The controller was set to limit voltage between 0.97 – 1.03 pu.

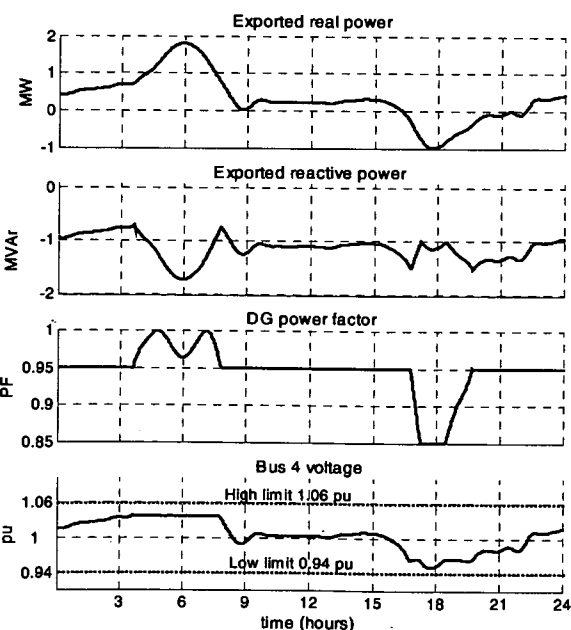

Figure 8 – AVPFC operation

When the reduction of the local demand pushed voltage above the 1.032 pu setpoint, the controller switched to constant voltage mode holding it at 1.03 pu (the 0.002 difference is deadband provided for hunting prevention). Power factor rose towards and past unity and when it was pulled back below 0.9495 (lagging) due to the increase of the local demand, the controller switched back to constant PF mode, holding it at 0.95 (the deadband is introduced for the same reason). In these 3 extra hours that the DG operated (compared to APFC), it exported another 9 MWh with the consequent increase of revenue. Additionally, during the high local demand period that voltage fell below the 0.968 setpoint the controller switched again to constant voltage holding it at 0.97 pu. Significantly, there was a 1-hour period during the peak demand that although in constant voltage mode, the controller could not hold the voltage at 0.97 pu, because the machine had reached its maximum reactive power capability. The voltage was still above the -6% limit although this might not always be the case.

**Simulation 3: AT in LRC mode**

Figure 9 shows the simulation results of the same system with the autotransformer OLTC mechanism operating in LRC mode and the DG in APFC holding PF at 0.95 lagging.

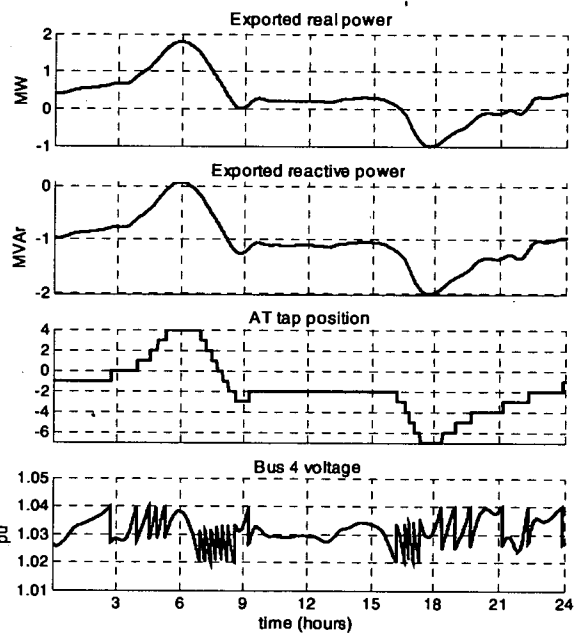

Figure 9 – LRC operation

The AT was set to hold voltage on bus 4 using line rise compensation at 1.03 pu ±1%. The OLTC mechanism on the primary of the AT has 17 taps, and each of them changes the transformer ratio by 1.25%. As Figure 9 shows, the AT manages to hold voltage within the requested limits but at the expense of a high number of tap operations (24). The frequency of tap changes may lead to rapid wear out of the AT's contacts and therefore increased maintenance costs for the DNO.

## DISCUSSION OF THE RESULTS

Automatic power factor control of a synchronous generator in the distribution network may cause unacceptable voltage variations if the generator is large enough and / or the network impedance is high. This is a very common case at the remote ends of the DN where renewable energy resources are more likely to be found. Line voltage rise compensation may be used to mitigate the wide voltage fluctuations due to the existence of the DG in the network in the same way that line voltage drop compensation is used to reduce voltage fluctuations due to varying loads. However, the autotransformer's tap changers are expected to operate frequently in order to hold the voltage within the prescribed limits and this will increase maintenance costs for the DNO.

A hybrid voltage / power factor control scheme of the DG may be a viable alternative since it was shown that can it maintain voltage within a predefined band with no extra equipment installation required by the DNO. An existing generator would then be allowed to stay connected for longer periods, resulting in increased power export, and would also allow larger capacities of new generation to be connected without the need for network upgrade. However, developers have to discuss such a possibility with the DNO beforehand.

A combination of AVPFC and LRC may be possible but further investigation should be carried out, as the two techniques may conflict during the periods that AVPFC will be trying to maintain constant voltage.

## CONCLUSIONS

Unlike central power stations where their placement can be planned, the sites of small-scale renewable energy generation plants are dictated by the availability of the resource. Large amounts of renewable energy are most likely to be found geographically and electrically remote from load centres.

With network reinforcement being an extremely expensive operation, renewable energy generators are expected to be connected to long open-ended radial feeders in the distribution network that will mainly consist of overhead lines, which have low  $X/R$  ratios and high resistance. The output of most renewable energy generation cannot be scheduled. This, in addition to the wide variation of local demand will result in un-constrained bi-directional variation in network power flow and consequently voltage fluctuation that may violate the statutory limits for quality of supply. In this paper a hybrid control algorithm that combines automatic voltage and power factor control has been presented and compared to line voltage rise / drop compensation. Simulations have shown that it can improve voltage profiles in the distribution network and at the same time avoid the extra capital and maintenance costs of utilisation of an LRC scheme. This can make potential renewable energy projects more attractive and increase the profit of existing ones.

## ACKNOWLEDGEMENT

The authors acknowledge with gratitude support provided by EPSRC under grant RNET/GR/N0474.

## REFERENCES

- [1] Wallace A. R., "Protection of Embedded Generation Schemes", 1999, *Colloquium on Protection and Connection of Renewable Energy Systems*, IEE, 1/1-1/5.
- [2] Harrison G. P., Kiprakis A. E. and Wallace A. R., 2002, "A New Era for Mini Hydro?", *International Water Power and Dam Construction*, vol. 54, no. 11.
- [3] Wallace A. R., Kiprakis A. E., 2002, "Reduction of Voltage Violations from Embedded Generators Connected to the Distribution Network by Intelligent Reactive Power Control", *Proc. 5th Int. Conf. on Power System Management and Control*, 210-215.
- [4] Salman S. K., Jiang F., Rodgers W. J., 1993, "The Effect of Private Generators on the Voltage Control of 11kV Networks and on the Operation of Certain Protective Relays", *Proc. IEEE/NTUA Int. Conf. on Modern Power Systems*, 591-595.
- [5] Eberly T. W., Schaefer R. C., 2002, "Voltage Versus VAR/Power Factor Regulation on Synchronous Generators", *Pulp and Paper Industry Technical Conf.*, Conference Record of the 2002 Annual, 2002
- [6] Masters C. L., 2002, "Voltage Rise: the Big Issue When Connecting Embedded Generation to Long 11kV Overhead Lines", *Power Engineering Journal*, IEE, vol. 16, no. 1, 5-12.
- [7] Tomson M., 2000, "Automatic-Voltage-Control Relays and Embedded Generation: Part 1", *Power Engineering Journal*, IEE, vol. 14, no. 2, 93-99.
- [8] Tomson M., 2000, "Automatic-Voltage-Control Relays and Embedded Generation: Part 2", *Power Engineering Journal*, IEE, vol. 14, no. 3, 71-76.
- [9] Choi J. H., Kim J. K., 2000, "Advanced Voltage Regulation Method at the Power Distribution Systems Interconnected with Dispersed Storage and Generation Systems", *IEEE Trans. on Power Delivery*, vol. 15, no. 2, 691-696.

# REDUCTION OF VOLTAGE VIOLATIONS FROM EMBEDDED GENERATORS CONNECTED TO THE DISTRIBUTION NETWORK BY INTELLIGENT REACTIVE POWER CONTROL

A.R. Wallace and A.E. Kiprakis

University of Edinburgh, UK

## INTRODUCTION

This paper describes the construction and test of a software model of a weak rural distribution network containing embedded water turbine driven synchronous generators (EGs). The characteristics of the network and its influence are related by development of the universal power circle diagram. The delivery of active and reactive power when the EG is operated purely in automatic power factor control (APFC) is compared with that when operated in automatic power factor control modified by voltage control (AVPFC). It is shown that this combined control enables increased EG dispatch within statutory network conditions.

## IMPACT OF SYNCHRONOUS GENERATORS

The effects of EGs connected to rural distribution networks include steady state, slow and transient variations of local voltage levels. The statutory limits on voltage levels of the rural supply are  $\pm 6\%$ . (1) Excursions lower than this can cause voltage control equipment on transformers at primary substations to operate as a result of the EG production, and this is not desirable. A net reversal of power flow in the line due to the presence of a new EG can lead to a voltage violation that is not acceptable. The Distribution Network Operator assesses the voltage change arising from the operation of a proposed EG. The DNO may attribute the cost of consequent network reinforcement to the connection costs of the new EG and this can impede development of otherwise attractive sites.

The ability to export active and reactive power without voltage violation depends on network characteristics above the point of connection, and on the active and reactive power exported from the local busbar. Line power flow is reduced by local demand according to daily and seasonal patterns. The network impedance and X:R ratio can also vary due to automatic reconfiguration, but less frequently. Changes in local loading and network configuration causes local voltage excursions that can shut down the EG with loss of production and revenue. These effects are widely experienced by operators of synchronous EGs in rural areas. Depending on its capacity and the inherent voltage variation in the network, there may be merit in operating the EG with the excitation system in constant voltage mode as necessary. The ability to operate inside an acceptable voltage envelope and the

opportunity to reduce network reinforcement costs could increase EG development.

Additionally, at times of high local load, or when network impedance led to reduced voltage at the local busbar the EG could be used to attempt to maintain voltage. Recent work has considered the use of embedded diesel generators to provide such voltage support. (2, 3) While this could provide a measure of network support in the weak areas Distribution Network Operators need not accept this method of operation. An unconstrained machine in voltage control could attempt to define voltages that may conflict with their automatic voltage control equipment, and cause spurious operation of protection, particularly at times of light local load. (4) If the EG tried to meet an excessive demand for reactive power, as voltage continued to fall, the AVR could force excitation with damaging results. While excitation overcurrent or busbar undervoltage protection should limit this they would shut the plant down, with loss of production and the need for a restart. (5) There is a need to make best use of potential EG plants both from the developers' and the DNOs' point of view.

Power factor and voltage control have been applied together before now, but to achieve other objectives. Overcurrent protection forcing margins were maintained during network voltage disturbances by composite power factor and voltage control. (6) Line voltage drop compensation is a long-established technique that has been used to assist the performance of synchronous motors at the end of long radial feeders. Torque was maintained by the action of a power factor/voltage regulator that sensed reduced voltage and increased excitation. (7) A converse process - line rise compensation is shown in this paper to improve the operation of synchronous EGs on weak networks. Power factor and voltage control are actively exchanged to maximise the dispatch of active power within voltage limits under varying network and load conditions.

## DISTRIBUTION LINE CIRCLE DIAGRAM

If the EG produces  $P_{gen} + jQ_{gen}$  and the local load is  $P_{load} + jQ_{load}$ , the complex power delivered to the line shown in figure 1 is

$$S_{line} = (P_{gen} - P_{load}) + j(Q_{gen} - Q_{load}) \quad VA \quad (1)$$

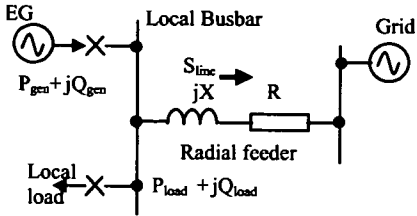

Figure 1 – Radial feeder with connected EG

From the phasor diagram in figure 2 the per-unit voltage rise at the local busbar may be estimated as

$$\Delta V = \frac{RP_{grid} + XQ_{grid}}{V_{grid}} + j \frac{XP_{grid} - RQ_{grid}}{V_{grid}} \quad V \quad (2)$$

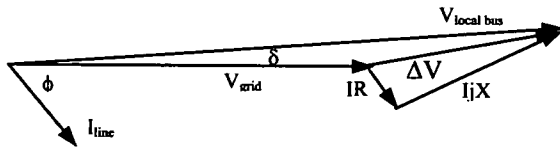

Figure 2 – Voltage Phasor Diagram

Equations 1 and 2 show that, where line power flow is dominated by EG production, operating synchronous EGs at a constant power factor will result in voltage excursion as the plant tries to export reactive power in constant proportion to active power. Line impedance directly increases voltage rise. Line X:R ratio skews the effects of real and reactive power. A clearer appreciation of these may be obtained by considering the Universal Power Circle Diagram (UPCD) for a short distribution line shown in figure 3. (8)

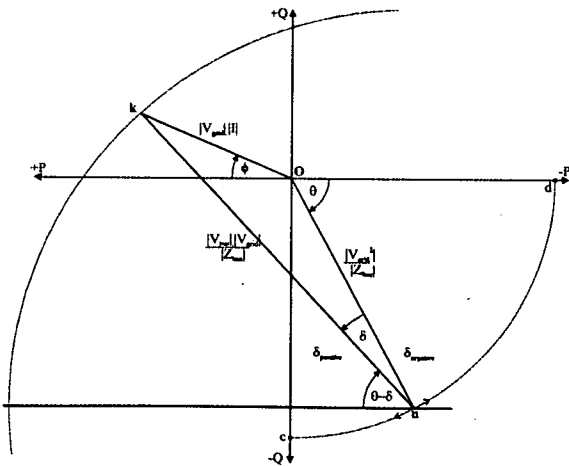

Figure 3 – UPCD for short distribution line

For  $X_{line} \gg R_{line}$  angle  $\theta$  approaches  $-90^\circ$  degrees and the diagram resembles that of a synchronous generator connected to the infinite grid. At the edges of the distribution network, where the X:R ratio tends to be lower,  $\theta$  is less than  $90^\circ$  and the voltage origin and centre of constant  $V_{bus}$  circles rotates around a

semicircle towards the  $-Q$  axis by less than  $90^\circ$ . The complex power line drawn out of the PQ origin may be used to prescribe constant MVA circles and power factor lines at the remote end of the line, as shown in figure 4. (9) If the voltage at that end of the line is constant (nominally 1.0 pu) semi-circles of constant busbar voltage may be drawn, including voltage limits.

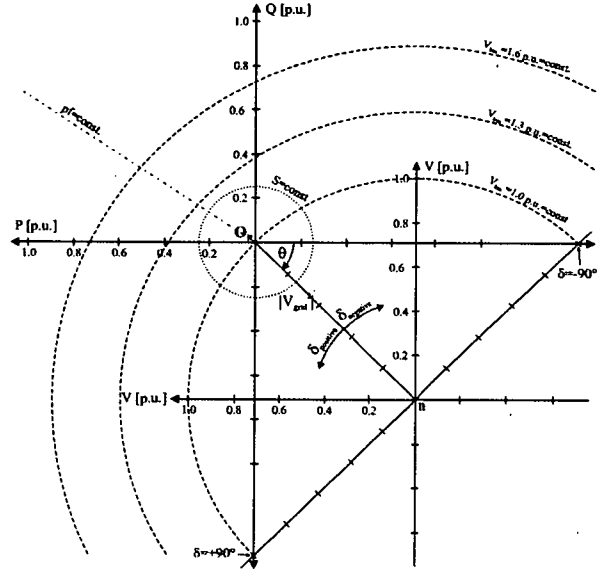

Figure 4 – Composite UPCD

The effects of changing network impedance may be separated from changing line power flow. Only increased complex power flow moves point k further away from the PQ origin, towards voltage limits. Where X:R ratios are high dispatch of reactive power will rapidly take the busbar voltage to the overvoltage limit. Where the X:R ratio is lower reactive power flow has less effect and eventually active power flow becomes limited by the anti-clockwise rotation of the voltage phasors and voltage circles. Increased network impedance re-scales the constant voltage circles to bring the limits closer to or inside point k. This limits dispatch of complex power. While these diagrams are based on complex power flow in the line, they are useful to visualise the effects of network changes on the limits of operation and dispatch of synchronous EGs connected to the local busbar, particularly where the capacity of the EG is dominant. They also enable computation and examination of loci of busbar voltage as the EG is loaded or as local demand varies, while the plant is in constant power factor or constant voltage control.

#### OPERATION IN AUTO PF CONTROL

One method of implementing automatic power factor control is to include in the excitation system a separate control module that operates on the (motorised) voltage setting potentiometer of the AVR to hold the phase angle between generator terminal voltage and current constant. EGs are usually loaded immediately after

synchronising by increasing the speed setting in the governor, while simultaneously transferring the AVR from voltage control (AVC) for synchronising to power factor control (APFC). Thereafter active and reactive power ramp in constant ratio, up to any load limits. Increasing EG dispatch at constant power factor moves the operating radially away from the PQ origin. If local demand is steady, or if EG capacity exceeds local demand, the operating point of the busbar will also move down a constant power factor line towards and through the voltage limit, resulting in the plant being shut down. The margin below the limiting voltage circle for development of maximum active (and then) reactive power can vary in real time, with variation of local load and network configuration.

## OPERATION IN AUTO VOLTAGE CONTROL

Automatic power factor control is most easily applied when network impedance is low and when machines can export full capacity without a measurable increase in terminal voltage. While PF control used to be obligatory, some DNOs have recently allowed EGs at weak parts of the network to operate in auto voltage control to provide some system voltage support. This has to be evaluated carefully because larger capacity EGs can cause AVC equipment on DNO transformers to operate in response. However, automatic power factor control combined with automatic voltage control of EGs will be an asset to developers if it allows continuous operation of the plant as local load and network parameters vary, or allows deferral of network reinforcement.

## AUTO VOLTAGE/PF CONTROL (AVPFC)

After synchronising the EG could be brought towards capacity in constant power factor mode (travelling out on its constant power factor line) until the busbar voltage exceeded a threshold *voltage within the statutory limits*. At that point APFC could be replaced (smoothly) with AVC to vary excitation and move the operating point around the constant voltage circle *within the busbar overvoltage limit*. Increased local load and reduction in terminal voltage could take the system back into APFC by sensing the increased demand for reactive power and therefore the reduction of power factor, as could variation in network impedance. This system would also enable voltage support at times of heavy local load. On reaching a voltage just above the undervoltage limit the excitation system would be transferred to AVC to maintain local voltage. Excitation under- and over-voltage and over-current protection should protect the EG excitation and control system against prolonged forcing.

## PROOF OF CONCEPT MODEL

A combined control system and algorithm for AVPFC was developed in MATLAB® & SIMULINK® running under Unix. This provided a simulation

environment that inherently combined network power flow analysis and control system design tools. The Power System Blockset® allowed the design and development of unique models and control algorithms not readily available elsewhere. Solving network power flow at each time step in the control response resulted in long computation times when modelling the real-time response of the controllers – even in simple networks. Using a discrete solver accelerated the process but a simulation time step of 50  $\mu$ s was necessary to simulate line-switching transients. (10) Even at this, to simulate 1 second of operation with a 1.7 GHz processor and 512 Mb of RAM required around 3.5 seconds in real time. To enable simulation of 30 minute variations of local load over 24 hours of operation each 30-minute step was reduced to 30 seconds. This allowed the system to reach steady state after each load change and reduced the overall simulation time to less than 90minutes.

The network constructed to test the concept of the AVPFC is shown schematically in figure 5. A 12.5 MVA water-turbine driven synchronous EG was connected to an 11 kV local busbar. A corner of a rural network with three phase symmetrical short circuit fault level of 164 MVA was represented (to 10MVA base) as a total impedance of  $0.048+j0.038$  pu and X:R ratio of 0.8. Two parallel lines of individual impedance 3/2 and 3 times this value gave a possible 3:1 ratio of impedance when the lower impedance line was tripped. Two loads, one of 7.5 MVA and one of 2.5 MVA, at 0.8 PF were connected to the local busbar, and with the option to trip and reconnect the larger one.

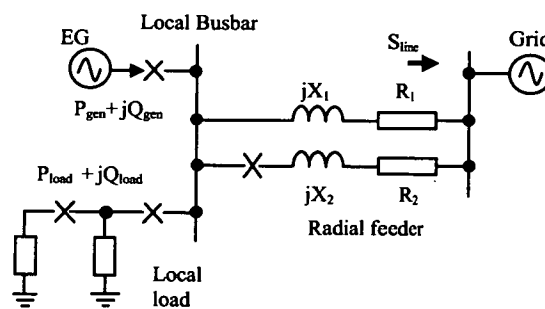

Figure 5 – Test Network

## CONTROLLER DESIGN

Two alternative systems were modelled and compared.

### Power Factor Controller

PFC was modelled to include a simple PID controller shown in block diagram form in figure 6. The error signal driving the PID was derived from the difference of tangents of phase angles  $\phi$  from measured and preset power factors. This ensured that the input term was always single-valued over the range of control.

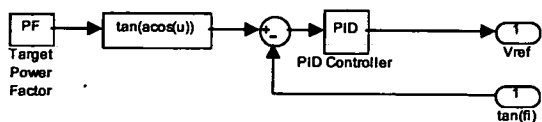

Figure 6 – Power Factor Controller block diagram

### Automatic Voltage Power Factor Controller

Figure 7 shows the block diagram of the AVPFC wherein separate auto-voltage and auto-PF controllers operate alternately dependent on the voltage at the generator terminals. The output of either the voltage or power factor controller is connected by V/PF switching logic to the raise/lower controls of the motorised voltage setting potentiometer and sets the reference voltage for the Automatic Voltage Regulator (AVR). This is an established practice. Alternatively in some applications the power factor controller adjusts  $V_{ref}$  by injecting a current through the whole potentiometer winding, which provides faster response.

The V/PF switching logic switches from APFC to AVC depending on the voltage  $V_{bus}$  at the generator terminals, which is measured continually. While  $V_{bus}$  is below the target voltage  $V_{ta}$  (set below the 1.06 pu limit), the output of the PFC adjusts the AVR reference voltage input  $V_{ref}$ . If  $V_{bus}$  rises to  $V_{ta}$ , the output of the PFC is disconnected and the reference voltage  $V_{ta}$  is connected to the setting potentiometer. The APVFC is now in voltage control and regulates  $V_{bus}$  to  $V_{ta}$  by decreasing excitation. To prevent a step change in  $V_{ref}$  and excitation at changeover the difference between the PFC output and the target voltage  $V_{ta}$  is minimised continually. A difference signal from the V/PF switching logic block is fed back to the PF controller. While the AVPFC operates in voltage control this feedback signal causes the output of the (disconnected) PFC to mirror the generator terminal voltage.

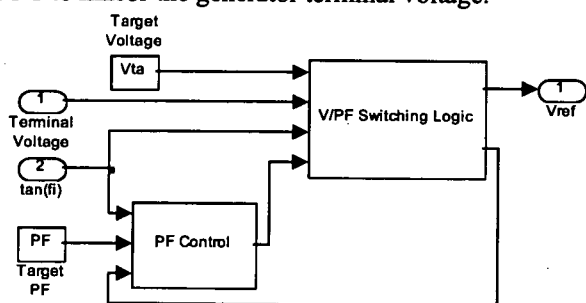

Figure 7 – Auto Voltage/Power Factor Controller

Changeover takes place smoothly in either direction. Release from voltage control cannot take place on falling voltage because, ideally, the AVR will hold  $V_{bus}$  at  $V_{ta}$ . A high demand for reactive power that would cause the voltage to fall also results in excitation overvoltage and current that has to be limited in the model. Falling power factor is used to re-establish APFC when the generator power factor falls below the preset value in the controller – typically 0.8 lagging.

## TEST RESULTS

Four tests were simulated: EG connection and loading, local load loss and reconnection, parallel feeder tripping and re-closure, and finally 24 hours of EG operation in conjunction with a local load varying to a typical rural/urban demand profile. To simulate fully the start and loading process an auto-synchroniser was incorporated acting on the governor and AVR set points to ensure synchronising within prescribed tolerances. (11, 12) The real-time variation of network complex power flow and voltage response was compared in simple auto power factor control (APFC) with that in composite auto voltage power factor control (AVPFC). The time variation of EG active and reactive power, power factor and terminal voltage are shown below.

### Test 1: EG Connection and loading

The EG was synchronised and pre-loaded to  $P=0.05$  pu by applying a momentary speed raise instruction to the governor set point. At  $t = 30$  s the load set point was raised to establish a ramp in the active power of gradient just less than 0.001 pu/s. Rated active power was reached after 1000s. The simulation was performed twice, once with the EG in APFC with a preset power factor of 0.8 lagging and again in AVPFC with the same preset power factor, but with a target voltage  $V_{ta}=1.054$  pu. The local load in this case was set close to zero to exaggerate the effects of the EG.

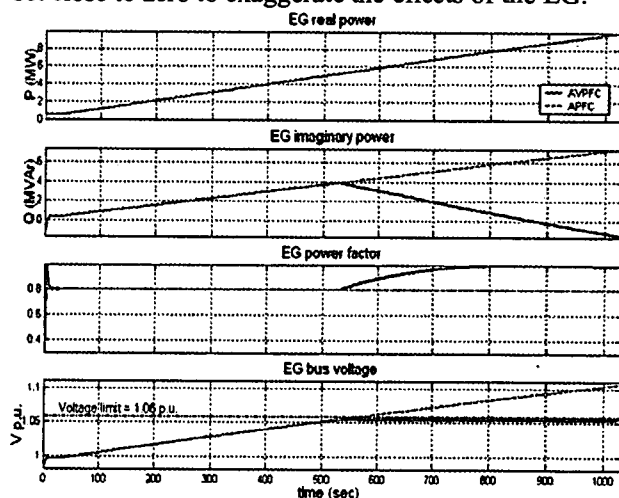

Figure 8 – Machine loading results

In figure 8 the dashed trace is the effect of the EG in APFC and the solid one is for AVPFC. In APFC the power factor was held at 0.8 lagging, and this brought about a voltage violation at  $t \approx 530$  s, when the machine was only part-loaded. In AVPFC the effects were identical until the bus voltage reached  $V_{ta}=1.054$  pu, when auto PF control was superceded by auto voltage control. To hold the busbar voltage constant the AVR reference setting and excitation voltage was reduced. Reactive power was seen to fall and at  $t \approx 870$  s the power factor passed through unity. Further increase of active power required the EG to operate at a leading power factor, when reactive power drawn from the

network would have held the busbar voltage at the target value. Operationally this would have to be incorporated in a connection agreement with a willing DNO, but the simulation has illustrated the possibility of transfer to voltage control.

### Test 2: Local load loss and reconnection

The EG was synchronised. At  $t = 25$  s the 7.5 MVA load was tripped and then re-connected 25 seconds later. The effects of the load changes are shown in figure 9 for the EG in both modes of control.

Operating simply in APFC the EG power factor remained substantially constant at 0.8 lagging through load loss and restoration, but for some transients after switching. Rapid field reduction can reduce these transients and this is being investigated at the time of writing. On loss of local load the initial surplus reactive power was exported into the network and caused a 0.07 pu voltage rise to 1.09 pu with resulting violation and requirement to shut down the EG. In AVPFC the response was different. On reaching the target voltage  $V_{ta} = 1.054$  pu the voltage control took over and attempted to hold the busbar voltage at this level. Generator excitation was reduced and reactive power fell to less than 2MVar, with the EG close to unity power factor. On reconnection of the additional local load, the power factor momentarily fell below 0.8 lagging at this excitation and the control system returned to APFC, to restore and hold power factor at the target value.

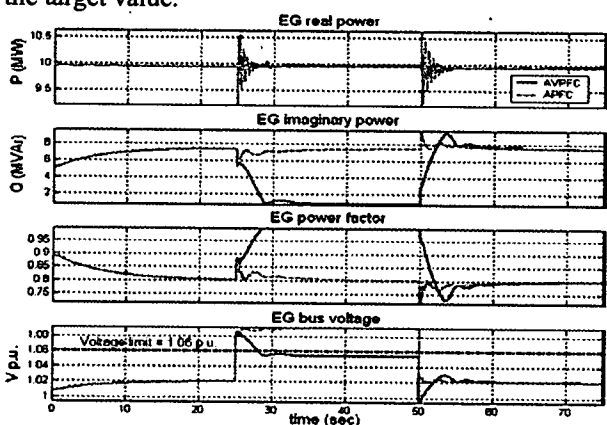

Figure 9 – Load switching results

The magnitude ( $>1.06$  pu) and the duration ( $>0.5$  s) of a small voltage transient demonstrated that the generator would be shut down. With careful selection of  $V_{th}$  and  $V_{ta}$ , and adjustment to time constants the duration of the overvoltage may be reduced below 0.5 seconds.

### Test 3: Feeder tripping and reclosure

Loss of (parallel) rural feeders is commonplace and results in vector shifts and voltage changes that cause spurious operation of Loss of Mains protection, or correct operation of overvoltage protection. To test the way the composite control would react to network reconfiguration a local load of 7.5 MVA was connected at 0.8 lagging power factor. The generator

was set to deliver 12.5 MVA at 0.8 lagging power factor, and the lower impedance line was tripped and re-connected with the results shown in figure 10.

When both lines were connected and the EG was in APFC the busbar voltage was 1.042 pu. At  $t = 25$  s one line was tripped and the network impedance trebled. Since the EG operated at constant power factor the resulting busbar voltage was 1.11 pu.

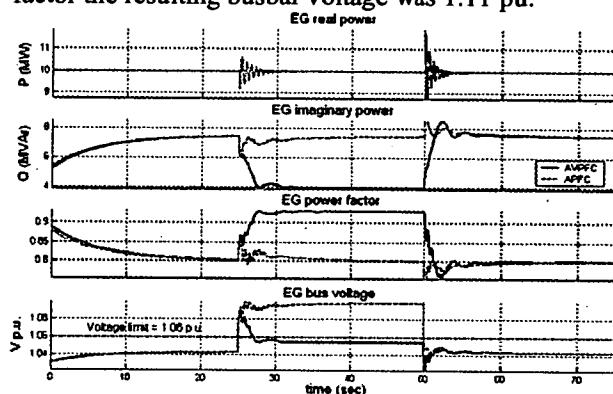

Figure 10 – Line switching results

This would cause a violation and shut down. With AVPFC selected the effects were identical until the busbar voltage exceeded the target voltage. Sensing the overvoltage, excitation and reactive power were reduced to hold the voltage at 1.054 pu. Reconnection of the second feeder reduced the busbar voltage below the target level and the additional export of reactive power brought the power factor below the preset for APFC. This transferred the EG back into power factor control, held at 0.8 lagging.

### Test 4: Operation with time-varying local load

To test the response of the EG to voltage variations brought about by changes in local load, a variable load was connected to the local busbar to simulate the time variation of actual load at a primary substation.

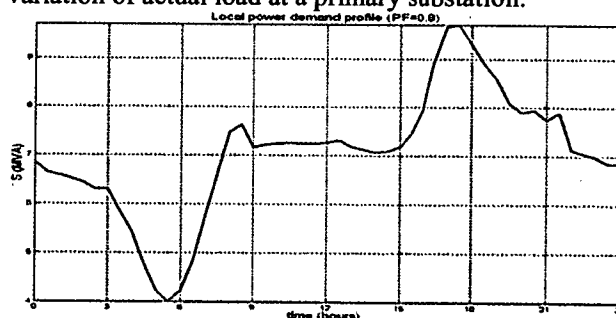

Figure 11 – Local load profile

Figure 11 shows the actual demand profile that was applied at constant 0.8 power factor. The software contains 9 fixed loads of which 8 were switched in binary logic to simulate a 256 level variation over constant minimum demand. Alternative simulations were carried out with the EG in APFC and AVPFC. The smoothed variation of network power flow and busbar voltage is shown in figure 12. At times of low

load demand the excess generated power is exported to the network.

In APFC, fixing the EG power factor at 0.8 lagging exported reactive power to the network led to busbar voltage rise. Between 04:00 and 07:30 the voltage rise was found to exceed 1.06 pu and the EG would have been tripped and locked out at 04:00.

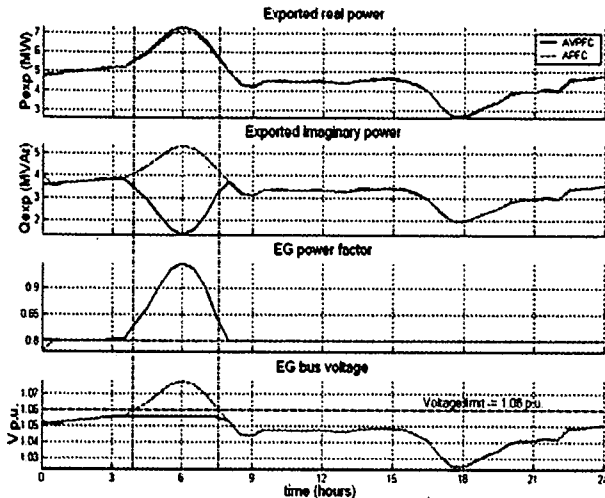

Figure 12 – Variable load results

The next opportunity to generate in APFC would be at 07:30, illustrating significant loss of generating time. Over the same demand curve, the effects in AVPFC are quite different. While the busbar voltage was below the threshold voltage  $V_{th}$  the controller operated the EG at constant 0.8 power factor. When the voltage rose above that the controller switched to voltage control and decreased excitation to hold bus voltage at 1.054 pu. Generated and line reactive power dropped and the generator power factor moved towards unity. Increased demand caused the busbar voltage to fall and the generator power factor to drop below 0.8 lagging. This returned the AVPFC system back to PF control and thereafter the power factor was held at 0.8 lagging.

## DISCUSSION AND CONCLUSIONS

There is a need for EGs to be able to operate within a voltage envelope to maximise dispatch of active power. Additionally, at times when network voltage is depressed the same system could export controlled reactive power for system voltage support. Some DNOs are now prepared to consider and integrate EGs that can operate to provide voltage support. Network reinforcement costs may be deferred and loss of generation due to over-voltage shutdown may be reduced. Busbar, generator and excitation system protection settings and timings will require to be applied carefully, within statutory and manufacturers' limits to ensure that EG plant operates within accepted network voltages and machine ratings.

While voltage and power factor control techniques are well established, active transfer between the two modes

and intelligent control have been shown to allow extended operation when network or local demand conditions would otherwise cause excessive voltage rise and plant shutdown. The smooth transfer and reliable operation of the EG requires a combined AVPFC control system whose settings are optimised for best response. Depending on network X:R ratio, and prime mover characteristics, governor settings might also need to be controlled in a similar strategy to maximise dispatch. Work is underway to investigate this combined control.

## ACKNOWLEDGEMENTS

The authors acknowledge with gratitude support provided by EPSRC and Scottish Power plc. MATLAB, SIMULINK and Power System Blockset are registered trademarks of The Mathworks Inc.

## REFERENCES

1. HMSO, 1994, "The Electricity Supply Regulations (Amdt 2)"
2. Pandiaraj, K and Fox, B, 2000, "Novel voltage control for embedded generators in rural distribution networks", *Proc. of Int. Conf. of Power System Technology PowerCon 2000*, 457-462
3. Pandiaraj, K, Hodgkinson G, and Fox B, 2000, "Use of embedded generators for voltage support in rural distribution networks", *Proc. 35<sup>th</sup> UPEC*.
4. Salman, S K, Jiang, F, Rodgers W J, 1993, "The Effect of Private Generators on the Voltage Control of 11kV Networks and on the Opn. of Certain Protective Relays", *Proc. IEEE/NTUA Intl. Conf. on Modern Power Systems*, 591-595
5. Wallace, A R, 1999, "Protection of Embedded Generation Schemes", *Proc of IEE Coll. on Protection and Connection of Renewable Energy Systems*, 1-5
6. Bobo, P O, 1972, "Regulator Apparatus Responsive to Generator Output Power Factor and Voltage", US Patent 3634750.
7. Parsons Peebles Motors & Generators, 1974, "Project Engineering Group Procedures"
8. Stevenson, W D, 1962, "Elements of Power Systems Analysis", McGraw Hill.
9. Schmaranz, R, 2000, "Modelling the Absorbance of Rural Distribution Networks for the Connection of Embedded Generators", Diploma Thesis, TU Graz.
10. The Mathworks, 2000, "Power System Blockset: User's Guide", Version 2, 1, 22-24
11. Electricity Association, 1991, "ER G59/1 Recommendations for the Connection of EGs to the REC Distribution Systems"
12. Electricity Association, 1995, "ER G75 Recommendations for the Connection of EG Plant to the PES Distribution Systems above 5 MW or 20kV"