

SOME ASPECTS OF THE TAFSİR OF MUJÄHID

BY

'Abd El-Gädır Muḥammad Aḥmad

THESIS PRESENTED TO
THE UNIVERSITY OF EDINBURGH
FOR THE DEGREE OF DOCTOR OF PHILOSOPHY
1993



بِسْمِ اللّٰهِ الرَّحْمٰنِ الرَّحِیْمِ

TO THE SOUL OF MY FATHER

Declaration

I hereby declare that this thesis has been written by me (undersigned) and does not represent the work of any other person.

Acknowledgement

Thanks are indeed to God Almighty worthy of all praise. "The one who does not thank people, does not thank God". Thus, first of all I would like to give my sincere gratefulness to my supervisor Dr. I. K. A. Howard for his continuous help, support and for lending me some of his own books. I really benefited from his experience, constructive suggestions and invaluable comments, all of which have helped in the presentation of this work.

I also record my gratitude to the staff of the department of Islamic and Middle Eastern Studies, University of Edinburgh for their cooperation and friendship. I owe special thanks to Dr. C. Hillenbrand for the careful reading of part of this thesis. Miss I. Crawford, the secretary of the department of Islamic and Middle Eastern Studies, always surrounded us with her help and kindness. She deserves a special thanks.

The staff of Edinburgh University library and in particular the staff of the interlibrary loan department spared no efforts in tracing the references I need from other places and making them readily available. I also extend my thanks to Mr. Peter Scott and Mr. Abdul. Majothi of the Computing Services, University of Edinburgh for their assistance and help.

My thanks also due to a number of my colleagues and friends who helped me in one way or another. I mention Ibrāhim M. Ibrāhim and Dr. W. J. Donaldson for the proof-reading of the work, and Hikmat Allāh B. Ṣāhib for typing the diagrams attached at the end of this thesis.

I am also indebted to my University of Khartoum for offering me this opportunity to study in Edinburgh and for the financial support.

I should record my indebtedness and gratefulness to my wife Rajā' who was a major source of support and encouragement throughout the period of our stay in Edinburgh, and also to my children Muḥammad and Ḥusām El-Dīn who brought happiness and fresh spirit in my life which enabled me to accomplish this work. Finally, I owe a special tribute to my beloved mother for her patience to hear the good news of my return to Sudan.

ABSTRACT

The thesis starts with an introduction which contains Mujāhid's life, sources for his Tafsīr and background to the writing of tafsīr. It also examines the authorities for Mujāhid's interpretations and gives the background of their lives and an estimate of their reliability. Chapter One highlights Mujāhid's view on the role of the exegete, with special reference to the notion of whether those who are rooted in knowledge (rāsikhūn fī al-'ilm) are able to understand the mutashābihāt of the Qur'ān or not. Mujāhid is shown to have held the view that they are. The Disconnected Letters (al-hurūf al-muqatta'ah) are given as an example of the mutashābihāt which is treated in Chapter Two. Chapter Three examines the theological issue of whether God can or cannot be seen in the Hereafter. Here Mujāhid is shown to have held the view that God could^{not} be seen in the Hereafter. Chapter Four deals with the interpretation of the expression maqāman maḥmūdā mentioned in verse 17 : 79. It shows the rationalism of Mujāhid's interpretation. Chapter Five discusses the way into which the Sabbatarians were transformed and Mujāhid's unique view that this must be interpreted metaphorically. Chapters Six and Seven are devoted to juristic problems. The former investigates the interpretation of fāhishah mentioned in verses 4 : 15-16, in addition to the interpretation of verse 24 : 2. In one opinion widely attributed to Mujāhid as regards the interpretation of fāhishah, he held that this referred to lesbianism and sodomy. The

latter chapter (Seven) fully examines the different kinds of 'iddah and in particular Mujahid's view of the widow's 'iddah. The Last Chapter (Eight) treats linguistic aspects where the interpretations of different Qur'ānic verses are discussed and Mujāhid puts forward some original interpretations. The conclusion estimates Mujāhid as an exegete .

Preface

A. Transliteration :

The present study follows the system of transliteration of the United States library of Congress as outlined in the cataloguing service Bulletin No. 49, November 1958. With the exception that the tā' marbūtah when not in idāfah is written as an h.

B. Translation of the Qur'ān :

In translating Qur'ānic verses, the study relies generally on two widely circulated translation, namely 'Abd Allāh Yūsuf 'Alī and Marmaduke Pickthall. However, slight modification had to be made.

C. References :

It should be noted that two versions of the Tafsīr of al-Ṭabarī have been used in the thesis. Volumes 1-16 (until Sūrat Ibrāhim, verse 27) is the version which is edited by Muḥammad and Aḥmad M. Shākir and printed in Dār al-Ma'ārif, Egypt, 1374 A.H. This covers volume 1 - to almost the end of volume 13 in the version of the third edition, 1388 / 1968, Egypt. All other citations from al-Ṭabarī refer to the latter edition.

D. Appendix :

The numbering in the diagrams appended to the thesis indicates the number of narrations transmitted through that particular scholar.

List of Abbreviations

Ahkām	al-Shāfi'ī, <u>Ahkām al-Qur'ān</u> . Ibn al-'Arabī, <u>Ahkām al-Qur'ān</u> . al-Jassās, <u>Ahkām al-Qur'ān</u> .
Anwār	al-Bayḍāwī, <u>Anwār al-Tanzīl</u> .
Burhān	al-Zarkashī, <u>al-Burhān fī 'Ulūm al-Qur'ān</u> .
Durr	al-Suyūṭī, <u>al-Durr al-Manthūr fī al-Tafsīr bi- al-Ma'thūr</u> .
Fatāwā	Ibn Taymiyyah, <u>Majmū' Fatāwā Ibn Taymiyyah</u> .
Fiṣal	Ibn Ḥazm, <u>al-Fiṣal fī al-Milal wa-al-Ahwā' wa-al-Nihal</u>
Gharā'ib	al-Nīsābūrī, <u>Gharā'ib al-Qur'ān wa-Raghā'ib al-Furqān</u> .
Ghāyat al-Nihāyah	Ibn al-Jazarī, <u>Ghāyat al-Nihāyah fī Ṭabaqāt al-Qurrā'</u> .
Ibānah	al-Ash'arī, <u>al-Ibānah 'an Uṣūl al-Diyānah</u> .
'Ibar	al-Dhahabī, <u>al-'Ibar fī Khabar man Ghabar</u>
Al-'Iqd al-Thamīn	al-Fāsī, <u>al-'Iqd al-Thamīn fī Ma'rifat al-Balad al-Amīn</u>
Ihyā'	al-Ghazālī, <u>Ihyā' 'Ulūm al-Dīn</u> .
Ikmāl	Ibn Mākūlā, <u>al-Ikmāl fī raf' al-Irtiyāb 'an al-Mu'talif wa- al-Mukhtalif fī al-Asmā' wa-Kunā wa-al-Ansāb</u> .
Iṣābah	Ibn Ḥajar, <u>al-Iṣābah fī Tamīyiz al-Ṣaḥābah</u> .
Istī'āb	Ibn 'Abd al-Barr, <u>al-Istī'āb fī Ma'rifat al-Ashāb</u> .

Itqān	al-Suyūṭī, <u>al-Itqān fī 'Ulūm al-Qur'ān</u> .
Jawāhir	al-Tha'ālibī, <u>Jawāhir al-Hisān fī Tafsīr al-Qur'ān</u> .
Kashshāf	al-Zamakhsharī, <u>al-Kashshāf 'an Haqā'iq Ghawāmid al-Tanzīl wa-'Uyūn al-Aqāwīl fī Wujūh al-Ta'wīl</u> .
Kāmil	Ibn al-Athīr, <u>al-Kāmil fī al-Tārīkh</u> .
Kitāb al-Arba'in	al-Rāzī, <u>Kitāb al-Arba'in fī Uṣūl al-Dīn</u> .
Lisān	Ibn Manẓūr, <u>Lisān al-'Arab al-Muḥīt</u> .
Ma'ālim	al-Baghawī, <u>Ma'ālim al-Tanzīl</u> .
Ma'ānī	al-Farrā', <u>Ma'ānī al-Qur'ān</u> .
Mafātīḥ	al-Rāzī, <u>Mafātīḥ al-Ghayb</u> .
Majāz	Abū 'Ubaydah, <u>Majāz al-Qur'ān</u> .
Mīzān al-I'tidāl	al-Dhahabī, <u>Mīzān al-I'tidāl fī Naqd al-Rijāl</u> .
Rūḥ	al-Alūsī, <u>Rūḥ al-Ma'ānī fī Tafsīr al-Qur'ān</u> .
Sīrah	Ibn Hishām, <u>al-Sīrah al-Nabawīyyah</u> .
Tafsīr	- al-Ṭabarī, <u>Tafsīr al-Ṭabarī (Jāmi' al-Bayān 'an Ta'wīl Ay al-Qur'ān</u> . - al-Ṭūsī, <u>Tafsīr al-Tibyān</u> . - al-Ṭabarsī, <u>Majma' al-Bayān</u> . - al-Qurṭubī, <u>al-Jāmi' li-Aḥkām al-Qur'ān</u> . - Ibn Kathīr, <u>Tafsīr al-Qur'ān al-'Azīm</u>
Al-Tafsīr al-Bayānī	Bint al-Shāṭ'ī, <u>al-Tafsīr al-Bayānī Li-al-Qur'ān al-Karīm</u> .
Tārīkh	al-Ṭabarī, <u>Tārīkh al-Ṭabarī (Tārīkh al-Rusul wa-al-Mulūk)</u> .
Uṣūl	al-Baghdādī, <u>Uṣūl al-Dīn</u> .

TABLE OF CONTENTS

Acknowledgement	i - ii
Abstract	iii - iv
Preface	v - vi
List of Abbreviations	vii - ix
Table of Contents	x - xii
Introduction :	1 - 40
1 - Mujāhid	
i - His Life.	1 - 19
ii. Mujāhid's Character.	19 - 20
iii- Mujāhid's reputation in Qur'ānic studies	20 - 23
2- The sources for the <u>Tafsīr</u> of Mujāhid.	24 - 34
3- The background to the writing of the <u>tafsīr</u> .	34 - 40
Chapter One: Mujāhid's View on the Role of the Exegete	41 - 63
- The <u>Muhkam</u> of the Qur'ān.	42 - 46
- The <u>Mutashābihāt</u> of the Qur'ān.	46 - 51
- The punctuation of verse 3 : 7.	51 - 63
Chapter Two: The Disconnected Letters as an example of the <u>Mutashābihāt</u> .	64 - 79

Chapter Three: The Doctrine of the Visibility	80 - 109
of God in the Hereafter :	
- Verses 75 : 22-23.	83 - 92
- Verse 6 : 103.	93 - 97
- Verse 10 : 26.	98 - 102
- Verse 50 : 35.	102 - 103
- Verse 83 : 15.	104 - 109
Chapter Four: The Honourable Status	110 - 127
(<u>al-Maqām al-Mahmūd</u>)	
- The Hand of God.	125 - 127
Chapter Five: The Metamorphosis (<u>maskh</u>)	128 - 145
of the Sabbatarians	
- The interpretation of <u>khatama</u> in verse 2 : 7.	140 - 145
Chapter Six: <u>Zinā</u> (Adultery or fornication)	146 - 180
- The Interpretation of Qur'ān 4 : 15-16.	146 - 168
- Mujāhid's interpretation of <u>fāhishah</u> as meaning <u>zinā</u> and the dispute concerning that.	
-Mujāhid's interpretation of <u>allātī</u> and <u>alladhāni</u> as indicating lesbianism and sodomy respectively.	
- The interpretation of Qur'ān 24 : 2.	169 - 180
(A) The interpretation of the phrase <u>wa-lā ta'khudhukum bi-hi-mā ra'fatun fī dīn Allāh.</u>	
(B) The interpretation of <u>tā'ifah</u> .	

Chapter Seven: The <u>'Iddah</u> :	181 - 211
- The <u>'iddah</u> of the Divorcee .	181 - 194
- The <u>'iddah</u> of the Widow.	194 - 206
- The <u>'iddah</u> of the <u>Umm Walad</u> .	206 - 211
Chapter Eight: Linguistic Aspects :	212 - 262
1- The difference in readings in <u>Sūrah</u> 12 : 110.	212 - 225
2- The difference in readings in <u>Sūrah</u> 5 : 6.	225 - 237
3- The interpretations of verses 2 : 104 and 4 : 46.	237 - 249
i- <u>rā'inā</u> or <u>rā'inan</u> or <u>rā'ūnā</u> .	
ii- <u>unzurnā</u> or <u>anzurnā</u> or <u>anzirnā</u> .	
4- The Interpretation of <u>hūr</u> as mentioned in the Qur'ān.	249 - 256
5- Rhetorical Aspects :	256 - 262
(A) To whom does the pronoun in the word <u>kānat</u> in verse 2 : 143 refer ?	
(B) The Significance of the preposition <u>min</u> in the phrase <u>wa-aj'al af'idatan min</u> <u>al-nās tahwī ilayhim</u> in verse 14 : 37.	
Conclusion	263 - 277
Appendices	278 - 296
Bibliography	297- 309

INTRODUCTION

The purpose of this thesis is to examine some of the principal facets of Mujāhid's Tafsīr in the context of the history of tafsīr writing. The importance of this is that because of a surviving manuscript in Cairo and through reconstructions from the Tafsīr of al-Ṭabarī, we are able to examine one of the earliest Qur'ānic commentaries to have been handed down. In the course of this introduction we will examine Mujāhid's life, the sources of his Tafsīr and the background of tafsīr writing in which he worked.

1. MUJĀHID :

(i) His life :

His full name was Abū al-Ḥajjāj Mujāhid b. Jabr al-Makkī al-Makhzūmī.¹ Some biographers give other names for his father. Al-Dūlābī holds that it is Khayr.² Ibn al-Qaysarānī (d. 507/ 1113),³

¹- Ibn Qutaybah, al-Ma'ārif, p.444.
- Iṣbahānī, Hilyat al-Awliyā', vol.3, p.279.
- Nawawī, Tahdhīb al-Asmā' wa-al-Lughāt, vol.1, p.83.
- Dhahabī, Siyar A'lām al-Nubalā', vol.4, p.449; and Tārikh al-Islam, vol.4, p.190; and Mizān al-I'tidāl, vol.3, p.439; and Tadhkirat al-Huffāz, vol.1, p.92.
- Ibn Kathīr, al-Bidāyah wa-al-Nihāyah, vol.9, p.224.
- Suyūṭī, Ṭabaqāt al-Huffāz, p.34.
- Dāwūdī, Ṭabaqāt al-Mufasssīrīn, vol.1, p.305.
- Ibn Sa'd, al-Ṭabaqāt al-Kubrā, vol.5, p.466.
- Yāqūt al-Ḥamawī, Mu'jam al-Udabā', vol.17, p.77.
- Ibn Mākūlā, al-Ikmāl, vol.2, p.17.
- Zirīklī, al-A'lām, vol.5, p.278.

²- Dūlābī, Kunā, vol.1, p.144.

³- see Sūrtī's Introduction in Tafsīr Mujāhid, vol.1, p.39.

Yāqūt al-Ḥamawī (d. 626 / 1229)⁴ and al-Nawawī (d. 676 / 1277)⁵ maintain that the name of Mujāhid's father is Jubayr, a diminutive form of Jabr. However, it seems that most of the biographical references name Mujāhid's father as being Jabr.⁶ Abū al-Ḥajjāj was the kunya by which Mujāhid is known, despite the fact that the references do not mention that he has a son who is called al-Ḥajjāj.⁷ Al-Makkī is, of course, derived from Mecca, the place where he spent a great deal of time. Al-Makhzūmī refers to his kin which is traced back to the Makhzūm tribe. Although Abū Dāwūd (d. 316 / 928) in his book Kitāb al-Masāhif confirms that Mujāhid is ascribed to Banū Makhzūm, he states that he (Mujāhid) was originally a Kufan, who used to live in Mecca.⁸ However, the sources are quite clear that Mujāhid was born in Mecca during the Caliphate of 'Umar b. al-Khaṭṭāb (d.23 / 643). Two views are put forward as regards his date of birth. According to Shams al-Dīn al-Dhahabī (d.748 / 1348)⁹ and Ibn Ḥajar al-'Asqalānī (852 A.H)¹⁰ he was born in the year 21 / 641. The other view is held by Taqy al-Dīn al-Ḥasanī al-Fāsī (d. 832 / 1428) who, in al-'Iqd al-Thamīn, takes the year 20 / 640 as the date for Mujāhid's birth.¹¹ We are thus presented with the problem of how Mujāhid can be described as a Kufan in origin if he was born in Mecca and spent a

4- Yāqūt al-Ḥamawī, Mu'jam al-Udabā', vol.17, p.77.

5- Nawawī, Tahdhīb al-Asmā' wa-al-Lughāt, vol.1, p.83.

6- See the references mentioned in the footnotes 1.

7- However, a mention has been made to two of his sons : 'Abd al-Wahhāb [see, Ibn Ḥibbān, al-Majrūhīn, vol.1, p.146. And Ibn Kathīr, al-Bidāyah wa-al-Nihāyah, vol.9, p.228.] and Ya'qūb [see, Dhahabī, Siyar A'lām al-Nubalā', vol.4, p.455.

8- Abū Dāwūd, Kitāb al-Masāhif, p.89.

9- Dhahabī, Tārīkh al-Islam, vol.4, p.195.

10- Ibn Ḥajar, Tahdhīb al-Tahdhīb, vol.10, p.43.

11- Fāsī, al-'Iqd al-Thamīn, vol.7, p.134.

considerable number of years in Mecca. It seems most likely that what this actually means is that Mujāhid's family probably came from the Kufa area before he was born and they became clients (mawālī) of the Banū Makhzūm in Mecca. He may have later spent some years also in Kufa, thus emphasising to some scholars the Kufan origin of his own family.

Although all the sources agree that Mujāhid was a client (mawlā) of Banū Makhzūm, they differ as regards the exact name of his master (sayyid). Four views have been suggested in this respect. It seems that the most widely accepted view maintains that his master was al-Sā'ib b. Abī al-Sā'ib al-Makhzūmī,¹² who was the father of 'Abd Allāh b. al-Sā'ib, the qāri' of the people of Mecca.¹³ It is said that al-Sā'ib used to share trading with the Prophet Muḥammad in the pre-Islamic period (jāhiliyyah).¹⁴ In this respect, Ibn Hishām quotes the tradition of the Prophet in which he praises the nobleness and generosity of al-Sā'ib in their trade together.¹⁵ However, Ibn Ḥajar further quotes Abū 'Amr who states that the report which speaks about the one who used to trade in partnership with the Prophet, is ambiguous.¹⁶ While some scholars confirm that it was al-Sā'ib b. Abī al-Sā'ib, others say it was his

12- Ibn Ḥajar, Tahdhīb al-Tahdhīb, vol.10, p.42; and Iṣābah, vol. 2, p.10.

- Dhahabī, Tārīkh al-Islam, vol.4, 190; and Siyar A'lām al-Nubalā', vol.4, p.449, and; Tadhkirat al-Huffāz, vol.1, p.92.

- Suyūṭī, Tabaqāt al-Huffāz, p.35.

- Ibn Kathīr, al-Bidāyah wa-al-Nihāyah, vol.9, p.224.

13- Ibn Ḥajar, Tahdhīb al-Tahdhīb, vol.3, p.449.

14- Dhahabī, Siyar A'lām al-Nubalā', vol.4, p.454.

- Ibn Ḥajar, Tahdhīb al-Tahdhīb, vol.3, pp.448-9.

- Ibn 'Abd al-Barr, al-Istī'āb, vol.1, p.101.

- Ibn Hishām, Sīrah, vol.2, p.29.

15- Ibn Hishām, Sīrah, vol.2, p.29.

16- Ibn Ḥajar, Tahdhīb al-Tahdhīb, vol.3, p.449.

father.¹⁷ Other suggestions are that it was Qays b. al-Sā'ib,¹⁸ or 'Abd Allāh b. al-Sā'ib.¹⁹

Ibn 'Abd al-Barr maintains that there is a disagreement whether al-Sā'ib, who is suggested to have been Mujāhid's master, embraced Islam or not.²⁰ Ibn Ishāq mentions him among the infidels who were killed in the battle of Badr.²¹ On the contrary, Ibn Hishām holds that he did embrace Islam and became a good Muslim.²² Confirming al-Sā'ib's belief in Islam, Ibn Hishām further quotes Ibn Shihāb al-Zuhri who maintains that al-Sā'ib was one of the Quraysh tribe who accepted Islam, and that the Prophet gave him part of the spoils of the battle of Ḥunayn.²³ Also, the fact that al-Sā'ib embraced Islam can be understood from the following account which is narrated by Mujāhid himself. In this respect Mujāhid is reported to have said: "I used to guide my master al-Sā'ib when he was blind. He used to ask me whether the sun had started to decline (hal dalakat al-shams ?) When I replied positively, he used to stand up and perform zuhr prayer".²⁴

17- Ibid, p.449.

18- Ibid, 449.

19- Ibid, p.449.

20- Ibn Ḥajar, Tahdhīb al-Tahdhīb, vol.3, p.449.

21- Ibn Hishām, Sīrah, vol.2, 29.

22- Ibid, p.29.

23- Ibid, p.29.

24- Ibn Sa'd, al-Ṭabaqāt al-Kubrā, vol.5, p.466.

- Ibn Ḥajar, Isābah, vol.2, p.10.

The second view says that Mujāhid was a mawlā of al-Sā'ib's son, Qays b. al-Sā'ib b. Abī al-Sā'ib al-Makhzūmī.²⁵ Qays was regarded as one of those whose hearts were to be reconciled (al-mu'allafatu qulūbuhum). Later, his belief in Islam became strong. He is reported to have transmitted traditions from the Prophet.²⁶ Here, Mujāhid is also quoted as saying that the verse "... for those who can do it (the fasting of Ramadān) [but] with hardship is a ransom, the feeding of one that is indigent (wa-'alā alladhīna yuṭīqūnahu fidyatun ta'ām miskīn) ..." (2:184), was revealed concerning his master Qays b. al-Sā'ib who, therefore, broke his fasting and fed a destitute for each day of Ramadān.²⁷ The third view suggests that Mujāhid was a mawlā of another of al-Sā'ib's sons, 'Abd Allāh b. al-Sā'ib b. Abī al-Sā'ib al-Makhzūmī.²⁸ Ibn Sa'ad states that 'Abd Allāh embraced Islam on the day of the conquest of Mecca, and he remained in Mecca until he died there in the time of 'Abd Allāh b. al-Zubayr.²⁹ According to al-Dāwūdī, in addition to Mujāhid himself, this view is held by al-Bukhārī.³⁰ The fourth and final view says that the master of Mujāhid was Qays b. al-Ḥārith.³¹

25. Ibn Qutaybah, al-Ma'ārif, p.444.

- Ibn Sa'd, al-Ṭabaqāt al-Kubrā, vol.5, 466.

- Dāwūdī, Ṭabaqāt al-Mufassirīn, vol.1, p.305.

- Yāqūt al-Ḥamawī, Mu'jam al-Udabā', vol.17, p.78.

26. Ibn Ḥajar, Tahdhīb al-Tahdhīb, vol.8, p.402.

27. Ibn Qutaybah, al-Ma'ārif, p.444.

- Ibn Sa'd, al-Ṭabaqāt al-Kubrā, vol.5, p.466.

- Dāwūdī, Ṭabaqāt al-Mufassirīn, vol.1, p.305.

28. Yāqūt al-Ḥamawī, Mu'jam al-Udabā', vol.17, p.77.

29. Ibn Sa'd, al-Ṭabaqāt al-Kubrā, vol.5, p.445.

30. Dāwūdī, Ṭabaqāt al-Mufassirīn, vol.1, p.305.

31. Nawawī, Tahdhīb al-Asmā' wa- al-Lughāt, vol.1, p.83.

- Dhahabī, Siyar A'lām al-Nubalā', vol.4, p.450.

The only anomalous view is the fourth one, which attributes Mujāhid's walā' to Qays b. al-Ḥārith. The other three are clearly reconcilable, for if Mujāhid's walā' was held by al-Sā'ib b. Abī al-Sā'ib, both his sons Qays and 'Abd Allāh would have been regarded as inheriting the walā' relationship with Mujāhid.

The sources do not indicate how and where Mujāhid spent his early years. He is said to have studied under a number of Companions (Ṣaḥābah). The sources list the following scholars : Ibn 'Abbās (d.68 / 687), 'Abd Allāh b. al-Zubayr ((d.73 / 692), 'Abd Allāh b. 'Umar (d.73 / 692), 'Abd Allāh b. Mas'ūd (d.32 / 653), Jābir b. 'Abd Allāh (d.78 / 697), Abū Hurayrah (d. 59 / 679), Abū Sa'īd al-Khudrī (d.74 / 693), Abū Rayḥānah, Sa'ad b. Abī Waqqāṣ (d. 55 / 675), 'Ā'ishah (d. 58 / 678). As regards his having directly heard (samā') from 'Ā'ishah, Abū Ḥātim says that Mujāhid did not learn directly from 'Ā'ishah, and his narration on her authority is mursal.³² Mujāhid is also reported as having learnt from Umm Hāni' bint Abī Ṭālib (d. after 40 A. H), Juwayriyyah bint al-Ḥārith (d.56 / 676), Rāfi' b. Khudayj (d. 74 / 693), 'Abd Allāh b. 'Amr b. al-'Āṣ (d.65 / 684),³³ and from Maslamah b. Mukhlid in Egypt.³⁴

32- Ibn Ḥajar, Tahdhīb al-Tahdhīb, vol.10, p.42.

33- Dhahabī, Siyar A'lām al-Nubalā', vol.4, p.450 ; and Tārīkh al-Islām, vol.4, p.190.

- Yāqūt al-Ḥamawī, Mu'jam al-Udabā', vol.17, p.78.

- Dāwūdī, Ṭabaqāt al-Mufasssīrīn, vol.1, p.306.

- Ibn Ḥajar, Tahdhīb al-Tahdhīb, vol.10, p.42.

- Nawawī, Tahdhīb al-Asmā' wa-al-Lughāt, vol.1, p.83.

34- Dāwūdī, Ṭabaqāt al-Mufasssīrīn, vol.1, p.306.

If we look at this list we see that the vast majority of those Companions were residents in Mecca or Medina. The presence of Ibn Mas'ūd in this list is clearly anomalous for Mujāhid could have only been eleven or twelve when Ibn Mas'ūd died. If he did study in Kufa, he would have heard Ibn Mas'ūd's teaching through one of the latter's disciples. 'Abd Allāh b. 'Amr b. al-'Āṣ is particularly associated with Egypt.³⁵ This would seem to indicate that at some date prior to 65 A.H, Mujāhid visited Egypt. In this respect, 'Abd al-Ghanī b. Sa'īd al-Azdī (d.409 / 1018) maintains that Mujāhid, the intimate of Ibn 'Abbās, went to Egypt and settled there for a considerable period of time, to the extent that he was regarded as an Egyptian.³⁶ Yāqūt al-Ḥamawī also under the biography of Mujāhid b. Jabr (or Jubayr) al-Qāri', reports on the authority of Ibn 'Ufayr that 'Amr b. al-'Āṣ (d., according to Ibn Sa'ad, either in 42, 43 or 51 A.H), after the conquest of Egypt, came twice to see the Caliph 'Umar b. al-Khattāb in Medina. In one of those visits, he appointed Zakariyyah b. al-Jahm al-'Abdarī to be in charge of the army, and he appointed Mujāhid b. Jabr mawlā Banū Nawfal to be in charge of the kharāj.³⁷ 'Umar asked 'Amr b. al-'Āṣ about whom he left as his deputy in Egypt. When 'Amr b. al-'Āṣ mentioned Mujāhid b. Jabr, 'Umar asked: "The mawlā of bint Ghazwān ? " 'Amr answered affirmatively and added that he (Mujāhid) was a scribe (kātib). Then 'Umar commented that indeed the knowledge ('ilm) would raise the one who gains it to a higher

35- Ibn Ḥajar, Tahdhīb al-Tahdhīb, vol.5, p.338.

36- see Sūrtī's Introduction in Tafsīr Mujāhid, vol. 1, p.43.

37- Yāqūt al-Ḥamawī, Mu'jam al-'Udabā', vol.17, pp.79-80.

position.³⁸ However, it seems that this account mentioned by Yāqūt al-Ḥamawī concerns Mujāhid b. Jabr, the mawlā of Banū Nawfal, and not our exegete Mujāhid b. Jabr al-Makkī al-Makhzūmī. Because Mujāhid b. Jabr al-Makhzūmī was just a child during the reign of 'Umar b. al-Khaṭṭāb since, as has been mentioned, he was born in the year 20 or 21 A. H. Besides, all the sources we have been able to consult, including Yāqūt al-Ḥamawī himself,³⁹ attribute our Mujāhid to Banū Makhzūm, and that he has nothing to do with Banū Nawfal. Notwithstanding, it still seems highly likely that Mujāhid b. Jabr al-Makhzūmī visited Egypt and stayed there for a certain period of time as 'Abd al-Ghanī al-Azdī and al-Sūrī suggest.⁴⁰

Mujāhid's late teens were spent during the traumatic period that included the murder of 'Uthmān (d. 35 / 655) and the caliphate of 'Alī (d. 40 / 660). During this time, Ibn 'Abbās was heavily involved in administrative duties in Iraq and would have had little time to teach. Presumably, therefore, during these years Mujāhid studied under those Companions who were not so involved in public affairs.

Al-Balādhurī reports in Futūḥ al-Buldān that in one of the expeditions, the Caliph Mu'āwiyah b. Abī Sufyān (d. 60 / 679) sent Junādah b. Abī Umayyah al-Azdī to Rhodes which he conquered in

³⁸- Ibid, pp. 79-80. Yāqūt al-Ḥamawī says that bint Ghazwān was the sister of 'Utbah b. Ghazwān who participated in the battle of Badr. 'Utbah used to be an ally (ḥalīf) of Banū Nawfal b. 'Abd Manāf. [see Yāqūt al-Ḥamawī, Mu'jam al-Udabā', vol.17, p.80].

³⁹- Yāqūt al-Ḥamawī, Mu'jam al-Udabā', vol.17, p.78.

⁴⁰- see Sūrī's Introduction in Tafsīr Mujāhid, vo.1, pp.43-4.

the year 52 A.H,⁴¹ and he was appointed by Mu'āwiyah as a ruler there. Mu'āwiyah settled a number of Muslims in Rhodes for seven years until his death. Mujāhid also settled there where he used to teach the Qur'ān to the people.⁴² Al-Balādhurī goes on to say that in 54 A.H, Junādah conquered Arwād, where Mu'āwiyah also settled Muslims. Among those who participated in the conquest of Arwād was Mujāhid Ibn Jabr and Tubay' b. Imra'at Ka'b al-Aḥbār.⁴³ In Arwād, Mujāhid is reported to have taught Tubay' the Qur'ān. Another view suggests that Mujāhid taught Tubay' the Qur'ān in Rhodes.⁴⁴ It has been reported by al-Fāsī in al-'Iqd al-Thamīn that Mujāhid was a qādī,⁴⁵ though he does not say where or when. It is possible that Mujāhid may have functioned as a qādī for the Muslim settlers in either Rhodes or Arwād. Since he is the only significant religious figure to have been reported as present there, and it is clearly stated that he had an important role in teaching the Qur'ān in those places. The report of Mujāhid taking part in the conquest of Rhodes and Arwād is the only evidence we have of Mujāhid, whose name means one who takes part in jihād, actually taking part in jihād until towards the end of his life we come across him alongside the Muslim fighters in a siege of Constantinople. It is possible that Mujāhid was in Mecca when he decided to go to Egypt to learn from the scholars there and to take part in jihād. In this connection, al-Ṭabarī (d.310 / 923) with

41- Ṭabarī dates for the conquest of Rhodes by Janādah as being in year 53 A.H. [See Ṭabarī, Tārīkh, vol.5, p.288].

42- Balādhurī, Futūḥ al-Buldān, p.330.

43- According to Ṭabarī in his Tārīkh, Arwād was an island off the sea and near Constantinople. [see Ṭabarī, Tārīkh, vol.5, p.293.]. But this is incorrect since Arwād is near Tortosa, off the Syrian coast.

44- Balādhurī, Futūḥ al-Buldān, p.330.

45- Fāsī, al-'Iqd al-Thamīn, vol. 7, p.34.

regard to Qur'ānic verse 8 : 60 " Make ready for them all you can of force (wa-a'iddū la-hum mā istata'tum min quwwah) ...", maintains that a man met Mujāhid in Mecca when Mujāhid was carrying baggage (jawāliq).⁴⁶ Mujāhid explained to the man that this was his quwwah as mentioned in the above verse. The account adds that he was preparing to go on a military expedition.⁴⁷

Although Syria had a small naval fleet, the bulk of the Arab navy came from Egypt.⁴⁸ Thus, it seems likely that Mujāhid was in Egypt prior to his stay in Rhodes. This would seem to indicate that Mujāhid studied under 'Abd Allāh b. 'Amr and Maslamah during the caliphate of Mu'āwiyah sometime before 52 -3 A.H. However, as Mujāhid is already recognised as an expert on the Qur'ān, it would seem probable that his studies under Ibn 'Abbās took place when the latter came back from 'Iraq to Mecca after the death of 'Alī. Thus, it seems likely that most of the period 40 - 52 /3 A. H was spent in Mecca studying under Ibn 'Abbās.

It is Ibn 'Abbās who is always mentioned as the prominent figure from whom Mujāhid took abundant knowledge. He was regarded as the closest teacher of Mujāhid,⁴⁹ whom he accompanied for a lengthy period of time.⁵⁰ Ibn 'Abbās is well known among the Companions for his talent and profound knowledge in Qur'ānic

46- Ṭabarī, Tafsīr, vol. 14, pp.31-3.

47- Ibid, pp.31-3.

48- Sha'bān, Islamic History, p.123.

49- Ibn Kathīr, al-Bidāyah wa-al-Nihāyah, vol. 9, p.224.

50- Dhahabī, Tārīkh al-Islam, vol.4, p.190.

exegesis.⁵¹ Hence, he was given a number of titles, e.g., Turjumān al-Qur'ān (the Interpreter of the Qur'ān), Habr al-Ummah (the Well-Versed of the Nation) and al-Bahr (the Sea).⁵² Ibn Ḥajar quotes Mujāhid himself as saying that Ibn 'Abbās is called al-Bahr due to his abundant knowledge.⁵³ Thus Mujāhid benefited from these high abilities of Ibn 'Abbās especially in the field of tafsīr. Al-Ṭabarī reports on the authority of Ibn Abī Mulaykah who says : "I saw Mujāhid asking Ibn 'Abbās about the Tafsīr of the Qur'ān , carrying with him his shoulder-blades (alwāh). Ibn 'Abbās dictated the interpretation of the Qur'ān and asked Mujāhid to write down what he said, until Mujāhid asked him about the interpretation of the entire Qur'ān." ⁵⁴ Mujāhid is reported to have said that he read the whole Qur'ān before Ibn 'Abbās twice,⁵⁵ thrice,⁵⁶ nineteen times ⁵⁷ or thirty times ⁵⁸ and stopped him at each verse, asking him about its

⁵¹ For further details of the virtues and matchless knowledge of Ibn 'Abbās, see :

- Dhahabī, Tārīkh al-Islam, vol.3, pp.30-7.
 - Nawawī, Tahdhīb al-Asmā' wa-al-Lughāt, vol.1, pp.275-6.
 - Ibn Khallikān, Wafīyyāt, vol.3, pp.62-3.
 - Ibn Kathīr, al-Bidāyah wa-al-Nihāyah, vol.8, pp.295-307.
 - Dūlābī, Kunā, pp.82-3.
- ⁵²- Dhahabī, Tārīkh al-Islam, vol.3. p.30 and p.34.
- ⁵³- Ibn Ḥajar, Iṣābah, vol.2, p.333.
- ⁵⁴-Ṭabarī, Tafsīr, vol.1, p.90.
- ⁵⁵-Ibn Kathīr, al-Bidāyah wa-al-Nihāyah, vol.9, p.224.
- ⁵⁶- Iṣbahānī, Hilyat al-Awliyā', vol.3, pp.279-80.
- Dhahabī, Siyar A'lām al-Nubalā', vol.4, p.450; and Tārīkh al-Islam, vol.4, p.191.
- ⁵⁷- Ibn al-Jazarī, Ghāyat al-Nihāyah, vol.2, p.42.
- ⁵⁸- Ibn Sa'd, al-Ṭabaqāt al-Kubrā, vol.5, p.466.
- Dāwūdī, Ṭabaqāt al-Mufasssīrīn, vol.1, p.306.
 - Iṣbahānī, Hilyat al-Awliyā', vol.3, p.280.
 - Dhahabī, Siyar A'lām al-Nubalā', vol.4, p.450. & Tārīkh al-Islam, vol.4, p.191.
- & Mizān al-Itidāl, vol.3, p.439.
- Ibn Kathīr, al-Bidāyah wa- al-Nihāyah, vol.9, p.224.
 - Ibn Hajar, Tahdhīb al-Tahdhīb, vol.10, p.43.
 - Nawawī, Tahdhīb al-Asmā' wa al-lughāt, vol.1, p.83.
 - Ibn al-'Imād, Shadharāt al-Dhahab, vol.3, p.125.
 - Yāqūt al-Ḥamawī, Mu'jam al-Udabā', vol.17, p.78.
 - Suyūṭī, Ṭabaqāt al-Huffāz, p.35.
 - Dāwūdī, Ṭabaqāt al-Mufasssīrīn, vol.1, p.306.

implication and cause of revelation.⁵⁹ Some scholars attempt to reconcile these different views concerning the number of times in which Mujāhid read the whole Qur'ān before Ibn 'Abbās. Ibn al-Jazarī understands that as meaning that Mujāhid read the entire Qur'ān before Ibn 'Abbās either twenty something or thirty times, among which three where he asked him about the cause of the revelation of each verse.⁶⁰ Muḥammad Ḥusayn al-Dhahabī in al-Tafsīr wa- al-Mufasssirūn reports two narrations in which the readings of the Qur'ān done by Mujāhid before Ibn 'Abbās are either three or thirty times. Muḥammad Ḥusayn al-Dhahabī argues that there is no discrepancy between those two narrations, because, as he further adds, Mujāhid might have read the whole Qur'ān before Ibn 'Abbās thirty times for the purpose of the precise correct reading, then he read it three times in order to attain its interpretation.⁶¹

We do not know when Mujāhid left the Greek islands. However, al-Ṭabarī states that the Muslims only settled in Arwād for seven years and then they left after severe storms destroyed the islands.⁶² It is therefore possible that it was around 61 A.H. that Mujāhid returned to the mainland. It is possible that some of the period up to 73 / 692 (when our sources positively identify Mujāhid

- Dāwūdī, Ṭabaqāt al-Mufasssirīn, vol.1, p.306.

⁵⁹- Iṣbahānī, Hilyat al-Awliyā', vol.3, pp.279-80.

- Dhahabī, Siyar A'lām al-Nubalā', vol.4, p.450. And Tārīkh al-Islam, vol.4, p.190.

- Ibn Kathīr, al-Bidāyah wa- al-Nihāyah, vol.9, p.224.

⁶⁰- Ibn al-Jazarī, Ghāyat al-Nihāyah, vol.2, p.41.

⁶¹- Muḥammad Ḥusayn al-Dhahabī, al-Tafsīr wa- al-Mufasssirūn, vol.1, p.107.

⁶²-Ṭabarī, Tārītkh, vol.5, p.293.

in a specific place) was spent in Kufa. This would have been a possible time which, if Mujāhid was present there, would have helped to identify him with Kufa as some of the sources have done. It seems that at the time of the death of 'Abd Allāh b. al-Zubayr in 73 / 692 Mujāhid came back to Mecca. This can be deduced from the account of Ibn Kathīr who in al-Bidāyah wa-al-Nihāyah reports that Mujāhid was accompanying Ibn 'Umar when the latter came and prayed for the body of Ibn al-Zubayr after he was killed.⁶³ The conquest of Mecca by al-Ḥajjāj b. Yūsuf al-Thaqafī (d. 95 / 714) may have had a profound effect on Mujāhid. Although the sources we have been able to consult do not say whether Mujāhid participated in the movement of Ibn al-Zubayr or not, it is clear that Mujāhid hated al-Ḥajjāj. In this connection, Ibn Ḥajar al-'Asqalānī in Tahdhīb al-Tahdhīb, maintains that some scholars like Mujāhid, Sa'īd b. Jubayr, al-Nakh'ī, 'Āṣim b. Abī al-Nujūd, al-Sha'bī and others regard al-Ḥajjāj as an infidel (kāfir).⁶⁴ Perhaps because of his holding this belief, the Kharijites claim that Mujāhid was one of them. The Kharijites, according to al-Ash'arī in Maqālāt al-Islāmiyyīn, claim that those who belong to them among the early scholars (salaf) were Mujāhid, Jābir b. Zayd, 'Ikrimah and 'Amr b. Dīnār.⁶⁵ The Kharijites' doctrine of regarding the grave sinner as a kāfir provides a legitimization for revolt if the grave sinner is in opposition. However, this is not the only justification for revolt and Mujāhid may have been claimed as a Kharijite by the Kharijites simply because he took part in a revolt against al-Ḥajjāj. It has also been

63- Ibn Kathīr, al-Bidāyah wa-al-Nihāyah, vol. 8, p.369.

64- Ibn Ḥajar, Tahdhīb al-Tahdhīb, vol.1, p.211.

65- Ash'arī, Maqālāt, p.109.

suggested that Mujāhid was a Murji'ite.⁶⁶ Perhaps, this suggestion has been made because his name has been associated with people like Sa'īd b. Jubayr, who are also claimed by some Islamic authorities to be Murji'ites. However, if he held this view of al-Ḥajjāj and was prepared, as we shall see in the next paragraph, to take part in a rebellion, his associations with the Murji'ah were somewhat tenuous.

It has been reported that Mujāhid participated in the revolt of 'Abd al-Raḥmān b. al-Ash'ath, which took place in the year 82 / 701, against al-Ḥajjāj b. Yūsuf al-Thaqafī, the representative of al-Walīd b. 'Abd al-Malik (d. 96 / 715), the Umayyad Caliph in Irāq. Ibn al-Ash'ath renounced his allegiance to al-Ḥajjāj and fought against him in the battles of al-Zāwiyah and Dīr al-Jamājim.⁶⁷ When Ibn al-Ash'ath was defeated, some of his supporters among the Tābi'ūn including Mujāhid fled to Mecca. Al-Ḥajjāj informed al-Walīd b. 'Abd al-Malik, asking for those scholars to be arrested. Al-Walīd, in turn, asked his representative at Mecca at that time, Khālīd b. 'Abd Allāh al-Qasrī (d. 126 / 743), to arrest those scholars and send them to al-Ḥajjāj. Khālīd al-Qasrī arrested Mujāhid b. Jabr, 'Aṭā', Sa'īd b. Jubayr, Ṭalq b. Ḥabīb (d. 94 / 713) and 'Amr b. Dīnār (d. 126 / 743). As for 'Amr b. Dīnār and 'Aṭā' they were set free because they were originally Meccans. However, the other three were sent to al-Ḥajjāj. Ṭalq died on the way before reaching Irāq.

66. Staath, Die Überlieferung Des Korankommentars Muḡāhid b. Ḡabrs, pp.12-22.
- F. Leemhuis, "Origins and Early Development of the Tafsīr Tradition" in Rippin, Approaches to the History of the Interpretation of the Qur'ān, p.24

67- for full details of the revolution of Ibn al-Ash'ath against al-Ḥajjāj and the battles between them, see: Ṭabarī, Tārīkh, vol.6, pp.334-50. Also: Ibn al-Aṭhīr, Kāmil, vol.4, pp.374-9.

Sa'īd b. Jubayr was executed by al-Ḥajjāj.⁶⁸ Mujāhid was imprisoned until the death of al-Ḥajjāj.⁶⁹ Thus, Mujāhid was in prison for about thirteen years. He must have left prison in 95 / 714. He was now an old man. However, Mujāhid may still have been regarded as someone who may have been troublesome for the Umayyads, for he is reported to have been present at the siege of Constantinople in 98 / 717. Al-Ṭabarī in his Tārīkh, when referring to the siege of Constantinople by Maslamah b. 'Abd al-Malik (d. 120 / 738), maintains that Maslamah settled in Constantinople subjugating the Byzantines, and he was accompanied by the renowned Syrian scholars (wujūh ahl al-shām): Mujāhid b. Jabr, Khālid b. Ma'dān (d. 104 / 722), and 'Abd Allāh b. Abī Zakariyyā al-Khuzā'ī (d. 117 / 735).⁷⁰ According to this report of al-Ṭabarī, Mujāhid came to Constantinople from Syria. Perhaps, after he was released from prison in 95 / 714, Mujāhid was taken to Damascus, the capital of the Umayyad-Caliphs, since he was regarded as an influential religious figure who had to be removed from his sphere of influence in Iraq and Ḥijāz. Thus, when Maslamah conquered Constantinople, he might have brought Mujāhid with him in order to keep him under his control. However, when Ibn al-Athīr (d. 630 / 1232) in al-Kāmil reports the same event of the siege of Constantinople in 98 A.H., he does not consider Mujāhid and the

68- For the full story of the execution of Sa'īd b. Jubayr at the hands of al-Ḥajjāj, see :

- Ṭabarī, Tārīkh, vol.6, pp.487-91.

- Ibn al-Athīr, Kāmil, vol.4, pp.358-60.

- Ibn Kathīr, al-Bidāyah wa- al-Nihāyah, vol.9, pp.96-7.

69- Ṭabarī, Tārīkh, vol.6, p.488.

70- Ibid, p.530.

two other colleagues who accompanied Maslamah as Syrians, but he just describes them as eminent people (a'yān al-nās).⁷¹

During the reign of the Umayyad Caliph 'Umar b. 'Abd al-'Azīz (99 - 101 A.H), it seems that Mujāhid was again back to Syria . This can be inferred from the report of Ibn Sa'ad who quotes Mujāhid himself as saying that he visited 'Umar b. 'Abd al-'Azīz when he was a Caliph and the latter gave him thirty dirhams.⁷² It also seems that Mujāhid remained in Syria until the death of 'Umar b. 'Abd al-'Azīz. This can be understood from the report of al-Suyūṭī in Tārīkh al-Khulafā' who quotes Mujāhid himself as saying that when 'Umar b. 'Abd al-'Azīz was on his deathbed, he asked him about the opinion of the people as regards the cause of his illness.⁷³ Mujāhid told him that the people were saying that he was put under an evil spell (mashūr). 'Umar then said that he had not been but he had been given poison and he drank it.⁷⁴ Probably after that Mujāhid returned from Syria to Mecca where he spent his last years until his death which, according to both Ibn Sa'd⁷⁵ and Ibn Qutayba,⁷⁶ was in Mecca.

Thus, it can be said that Mujāhid spent his life between Mecca, Egypt, the islands of Rhodes and Arwād, Kufa, Constantinople and Syria. There is also a report that at some time in his life Mujāhid

71. Ibn al-Athīr, Kāmil, vol.5, p.18.

72. Ibn Sa'd, al-Tabaqāt al-Kubrā, vol.5, p.399.

73. Suyūṭī, Tārīkh al-Khulafā', p.246.

74. Ibid, p.246.

75. Ibn Sa'd, al-Tabaqāt al-Kubrā, vol.5, p.467.

76. Ibn Qutaybah, al-Ma'ārif, p.444.

went to Ḥaḍramawt.⁷⁷ Al-A‘mash relates that whenever Mujāhid heard of a miraculous thing, he became eager to see it. He is said to have had a special interest in the supernatural.⁷⁸ It was for this reason that he went to Hadramawt to see Bi‘r Barhūt.⁷⁹ He is also said to have travelled to Babylon to observe the evils of Hārūt and Mārūt.⁸⁰ He ended his life in Mecca where he started it.

Muslim scholars and historians differ as regards the exact year in which Mujāhid died. Some scholars hold that he died in the year 100 / 718.⁸¹ However, although, al-Dhahabī ascribes this view to Abū ‘Umar al-Ḍarīr, he describes it as anomalous.⁸² Al-Dhahabī bases his rejection on the ground that Mujāhid did see ‘Umar b. ‘Abd al-‘Azīz (d. 101 / 719) while he was dying.⁸³ The second view

77- Dhahabī, Tadhkirat al-Huffāz, vol.1, p.92.

78- See J. Cooper's Introduction to the Commentary on the Qur‘ān by al-Ṭabarī, vol.1, p. xvi.

79- Dhahabī, Tadhkirat al-Huffāz , vol.1, p.92.

80- The story of his visit to Babylon runs as follows : It has been narrated that Mujāhid went to Babylon at the time when its ruler was fortunately his friend. Mujāhid asked him if he could see Hārūt and Mārūt. The ruler called one of the magicians, who was a Jewish, to show Mujāhid the two evils; Hārūt and Mārūt. The Jew agreed on condition that his visitor (Mujāhid) must not mention God when seeing them. The guide took Mujāhid to a castle, from which he cut a stone. Making Mujāhid hold his leg, the magician descended with him into a deep cavity. There, Hārūt and Mārūt were hanging down like two great mountains. Having seen them, Mujāhid praised God, their creator. At that moment they both trembled. The two men lost consciousness. The Jew recovered first and told Mujāhid that they were about to die.

[for this story, see : Dhahabī, Tadhkirat al-Huffāz, vol.1, p.93. And Siyar A‘lām al-Nubalā‘, vol.4, p.456. See also: Dāwūdī, Ṭabaqāt al-Mufasssīrīn, vol.1, p.308.

81- Ibn Kathir, al-Bidāyah wa-al-Nihāyah, vol.9, p.224.

- Dhahabī, Mīzān al-I‘tidāl, vol.4, p.455.

- Ibn Hajar, Tahdhīb al-Tahdhīb, vol.10, p.43.

- Sūyūtī, Ṭabaqāt al-Huffāz , p.36.

82- Dhahabī, Siyar A‘lām al-Nubalā‘ , vol.4, p.455.

83- Ibid, p.455.

suggests that Mujāhid's death took place in the year 101 / 719.⁸⁴ Ibn al-Athīr mentions Mujāhid's death as one of the historical events which took place in the year 101 A.H.⁸⁵ However, Ibn al-Athīr further adds by referring to other views which suggest that Mujāhid died in the years 103 / 721, 104 / 722 or 107 / 725, and his age was eighty three years.⁸⁶ The third view proposes that Mujāhid died in 102 / 720,⁸⁷ while he was prostrating.⁸⁸ The fourth view opts for 103 / 721 as the year of Mujāhid's death.⁸⁹ Al-Mas'ūdī mentions Mujāhid among those scholars who died in the year 103 A. H, and his age was eighty four years.⁹⁰ Al-Dhahabī reports on the authority of Aḥmad b. Ḥanbal on the authority of Ḥammād b. Khālid who says that he heard his teachers saying that Mujāhid died in the year 103 A.H.⁹¹ The fifth view suggests that Mujāhid died in the year 104 / 722.⁹²

84- Ibn Hajar, Tahdhīb al-Tahdhīb, vol.10, p.43.

- Ibn Kathīr, al-Bidāyah wa-al-Nihāyah, vol.9, p.224.

- Suyūṭī, Ṭabaqāt al-Huffāz, p.36.

- Dāwūdī, Ṭabaqāt al-Mufasssīrīn, vol.1, p.308.

85- Ibn al-Athīr, Kāmil, vol.5, p.58.

86- Ibid, p.58.

87- Ibn Sa'd, al-Ṭabaqāt al-Kubrā, vol.5, p.445.

- Dhahabī, Siyar A'lām al-Nubalā', vol.4, p.455.

- Ibn Hajar, al-'Asqalānī, Tahdhīb al-Tahdhīb, vol.10, p.43.

- Ibn Kathīr, al-Bidāyah wa-al-Nihāyah, vol.9, p.224.

- Suyūṭī, Ṭabaqāt al-Huffāz, p.36.

- Ibn al-Jazarī, Ghāyat al-Nihāyah, vol.2, p.42.

88- Ibn Sa'd, al-Ṭabaqāt al-Kubrā, vol.5, p.467.

89- Ibid, p.467.

- Ibn Qutaybah, al-Ma'ārif, p.445.

- Yāqūt al-Hamawī, Mu'jam al-Udabā', vol.17, p.78.

- Dhahabī, Siyar A'lām al-Nubalā', vol.4, p.455. & al-'Ibar, vol.1, p.125.

- Ibn Hajar, Tahdhīb al-Tahdhīb, vol.10, p.43.

- Ibn Kathīr, al-Bidāyah wa- al-Nihāyah, vol.9, p.224.

- Suyūṭī, Ṭabaqāt al-Huffāz, p.36.

- Dāwūdī, Ṭabaqāt al-Mufasssīrīn, vol.1, p.308.

- Ibn al-Jazarī, Ghāyat al-Nihāyah, vol.2, p.42.

90- Mas'ūdī, Murūj al-Dhahab, vol.3, pp.202-3.

91- Dhahabī, Tārīkh al-Islam, vol.4, p.192.

92- Ibn Sa'd, al-Ṭabaqāt al-Kubrā, vol.5, p.467.

At any rate, it seems that one of the years 103 / 721 or 104 / 722, is the most correct date of Mujāhid's death, because, since most of the sources agree that at the time of his death Mujāhid's age was eighty three and since his birth was either in 20 / 640 or 21 / 641, then his death most likely took place either in the end of 103 A.H or in the beginning of 104 A. H.

(ii) Mujāhid's Character :

Mujāhid had a reputation for humbleness. In this respect it is claimed that he says : "Whoever cherishes himself would subdue his religion and whoever humbles himself would cherish his religion (man a'azza nafsahu adhalla dīnahu wa-man adhalla nafsahu a'azza dīnahu) ".⁹³ Al-A'mash states that if one saw Mujāhid's features, one would scorn him. He was like a sad shepherd who had lost his donkey.⁹⁴ But, when he spoke, pearls came out of his mouth.⁹⁵ Al-A'mash further adds that Mujāhid was always seen grieved (maghmūm). When he was asked about this he said that 'Abd Allāh b. 'Abbās held his hand (Mujāhid's hand) and told him that the Prophet had held his hand (Ibn 'Abbās's hand) and advised

-
- Yāqūt al-Ḥamawī, Mu'jam al-Udabā', vol.17, p.78.
 - Ibn Kathīr, al-Bidāyah wa- al-Nihāyah, vol.9, p.224.
 - Suyūṭī, Tabaqāt al-Huffāz, p.36.
 - Dāwūdī, Tabaqāt al-Mufasssīrīn, vol.1, p.308.
 - Ibn al-Jazarī, Ghāyat al-Nihāyah, vol.2, p.42.

⁹³- Iṣbahānī, Hilyat al-Awliyā', vol.3, p.279.

⁹⁴- Ibn Sa'd, al-Tabaqāt al-Kubrā', vol.5, pp.466-7.

- Dhahabī, Siyar A'lām al-Nubalā', vol.4, p.452.

- Dāwūdī, Tabaqāt al-Mufasssīrīn, vol.1, p.307.

⁹⁵- Dhahabī, Mizān al-I'tidāl, vol.3, p.440.

- Ibn 'Imād al-Ḥanbalī, Shadharāt al-Dhahab, vol.3, p.125.

him to be as a stranger or a traveller (wayfarer) in this life.⁹⁶ Mujāhid is also cited as having said: "Do not speak highly of me".⁹⁷ He is also quoted as saying: "I accompanied Ibn 'Umar and I intended to serve him, but instead he served me".⁹⁸ He is also reported to have said: "We came to 'Umar Ibn 'Abd al-'Azīz in order to teach him religious knowledge, but when we went out from him we discovered that it was we who learnt from him".⁹⁹

Mujāhid is reported to have paid every respect to the Qur'ān. He says: "If one yawns while reciting the Qur'ān, one should abstain from the recitation until the yawning goes away".¹⁰⁰ He is also reported to have permitted that the verses of the Qur'ān can be used as a benediction (barakah) to bring about the healing of sick persons.¹⁰¹

(iii) Mujāhid's reputation in Qur'ānic studies :

Mujāhid devotes special effort to studying the different readings (qirā'āt) of the Qur'ān. It has been reported that he learnt qirā'āt from 'Abd Allāh b. 'Abbās. In this respect, al-Qurṭubī maintains that Mujāhid learnt the reading (qirā'āh) of the Qur'ān from Ibn 'Abbās, who took it from Ubayy b. Ka'b (d.21 / 641), who took it from the Prophet.¹⁰² He is also reported to have taken

96- Ibn Qutaybah, al-Ma'ārif, p.445.

97- Dhahabī, Ṣiyar A'lām al-Nubalā', vol.4, p.452.

98- Ibid, p.452.

99- Ibn al-Athīr, Kāmil, vol.5, p.35.

100- Qurṭubī, Tafsīr, vol.1, p.27.

101- Ibid, p.31.

102- Qurṭubī, Tafsīr, vol.1, p.83.

qirā'ah from 'Abd al-Raḥmān b. Abī Laylā (d.82 -3 A.H).¹⁰³ Despite the fact that Mujāhid learnt the qirā'āt from the aforementioned Companions, he was always humble and regarded himself as having not yet attained satisfactory knowledge. In this respect, al-A'mash cites Mujāhid as saying : " If I had read the Qur'ān according to the reading of Ibn Mas'ūd, I would not have needed to ask Ibn 'Abbās about the parts which I asked him about".¹⁰⁴ Al-Ṭabarī maintains that Mujāhid used to read the Qur'ān according to five ways.¹⁰⁵ Mujāhid becomes a well known figure in the field of qirā'āt. Shams al-Dīn al-Dhahabī¹⁰⁶ gives him the title of the leader (shaykh) of the qurrā' . In turn, it has been reported that Mujāhid taught the qirā'āt to a number of disciples.¹⁰⁷

As already mentioned, Mujāhid's principal teacher was Ibn 'Abbās. He is very much associated with the other scholars who were disciples of Ibn 'Abbās and who are generally referred to as the Meccan school. Although some of these scholars have already been mentioned, it would seem appropriate to list them here in full as there was a great interchange of scholarship between all of them. They are: Ṭāwūs (d.106 / 723), Sa'id b. Jubayr (d.95 / 714),¹⁰⁸ Surāqah b. Mālik b. Ju'shum (d.24 / 645), 'Ikrimah (d.150 / 676), 'Atā' (d.114 / 732),¹⁰⁹ 'Amr b. Dīnār(d.126 / 743), Sulaymān b. Mihrān

103. Yāqūt al-Ḥamawī, Mu'jam al-Udabā', vol.17, p.78.

104. Dhahabī, Siyar A'lām al-Nubalā', vol.4, p.454.

105. Ṭabarī, Tafsīr, vol.1, p.53.

106. Dhahabī, Siyar A'lām al-Nubalā', vol.4, p.449.

107. Ibn al-Jazarī, Ghāyat al-Nihāyah, pp.41-2.

108. Dāwūdī, Tabaqāt al-Mufasssīrīn, vol.1, p.306.

109. Dhahabī, Siyar A'lām al-Nubalā', vol.4, p.450.

al-A'mash (d.148 / 765), 'Abd Allāh b. Abī Najīh (d.131 -132 / 748 - 749),¹¹⁰ 'Abd Allāh b. Kathīr (d. 120 / 737) and many others.¹¹¹

Mujāhid's profound knowledge has been admired and praised by many Muslim scholars. Ibn Sa'ad (230 / 844) describes Mujāhid as authoritative, knowledgeable, jurist and traditionist.¹¹² Al-Ṭabarī reports on the authority of Abū Bakr al-Ḥanafī who said that he heard Sufyān al-Thawrī saying: " If you learn the tafsīr of the Qur'ān from Mujāhid, then that is sufficient for you."¹¹³ Al-Ṭūsī (d.406 A.H) maintains that among the early mufassirūn there were some whose methods were appreciated and their schools of thought were praised, e.g., Ibn 'Abbās, al-Ḥasan al-Baṣrī, Mujāhid and others.¹¹⁴ They rank in the first class of the mufassirūn.¹¹⁵ Al-Qurṭubī (d.671 A.H) quotes Mujāhid himself as saying: "The most beloved to God among his creation is the one who is most knowledgeable with the Divine revelation".¹¹⁶ Ibn Khallikān (d.681 A.H.) quotes Khuṣayf as saying that the most knowledgeable one amongst the Tābi'ūn as regards the rules of divorce, was Sa'īd b. al-Musayyab (d. 94 / 713), and as regards the rules of pilgrimage it was 'Aṭā', and as regards the lawful and unlawful it was Ṭāwūs, and as regards tafsīr , it was Abū al-Ḥajjāj Mujāhid b. Jabr, and the best one who combines all these knowledges it was Sa'īd b. Jubayr.¹¹⁷

110. Nawawī, Tahdhīb al-Asmā' wa-al-Lughāt, p.83.

111. see, Ibn Ḥajar, Tahdhīb al-Tahdhīb, vol.10, p.42.

112. Ibn Sa'd, al-Ṭabaqāt al-Kubrā, vol.5, p.91.

113. Ṭabarī, Tafsīr, vol. 1, p.91.

114. Ṭūsī, Tafsīr, vol.1, p.6.

115. Ibid, p.6.

116. Qurṭubī, Tafsīr, vol.1, p.26.

117. Ibn Khallikān, Wafayāt al-A'yān, vol.2, p.372.

Ibn Taymiyyah (d.728 / 1327) states that if one can find the tafsīr of a certain Qur'ānic verse or verses neither in the Qur'ān nor in the hadīth nor in the interpretation of the Ṣahābah, then many scholars turn to the interpretation by the Tābi'ūn, like Mujāhid b. Jabr who was eminent in the field of tafsīr.¹¹⁸ Emphasising Mujāhid's reliability in this respect, Ibn Taymiyyah further adds that due to his eminence in tafsīr, al-Bukhārī (d.256 / 869), Aḥmad b. Ḥanbal (d.241 / 855) and other scholars depend on and quote his views.¹¹⁹

Al-Dhahabī in Tadhkirat al-Huffāz' quotes Ibn Jurayj as saying that hearing Qur'ānic exegesis from Mujāhid, was more precious to him than his family and wealth.¹²⁰ In Mizān al-I'tidāl, al-Dhahabī states that the ummah unanimously agreed upon the leadership (imāmah) of Mujāhid and considers him as an authoritative source to rely on.¹²¹ Ibn Kathīr (d 774 A.H) holds that Mujāhid was one of the closest disciples of Ibn 'Abbās, and he was regarded as the most knowledgeable exegete in his time, to the extent that it has been said that no one learnt or taught religious knowledge for the sake of God except Mujāhid and Ṭāwūs.¹²² Ibn Kathīr further adds by quoting Mujāhid himself as saying: "Ibn 'Umar said to me: I wished that my son Sālim and my client Nāfi' committed the Qur'ān to memory as you did".¹²³

118. Ibn Taymiyyah, Fatāwā, vol.13, p.368.

119. Ibid, vol.17, 408.

120. Dhahabī, Tadhkirat al-Huffāz, vol. 1, p.92.

121. Dhahabī, Mizān al-I'tidāl, vol. 3, p.440.

122. Ibn Kathīr, al-Bidāyah wa-al-Nihāyah, vol.9, p.224.

123. Ibid, p.224.

2. SOURCES FOR THE TAFSİR OF MUJĀHID :

According to F. Leemhuis, there were probably at least eight different recensions of Mujāhid's Tafsīr in circulation in the fourth century A.H.¹²⁴ The main evidence for Mujāhid's Tafsīr is presented to us in a unique manuscript in Dār al-Kutub in Cairo and the transmissions of Mujāhid's work in the Tafsīr of al-Ṭabarī. It would seem appropriate first to examine the contents of the manuscript. This examination is helped by the fact that the manuscript has been edited by 'Abd al-Raḥmān b. Muḥammad al-Sūrtī and published in Islamabad (n. d.). Fortunately, F. Leemhuis¹²⁵ has also compared this edition with the manuscript and has been able to clarify some points which al-Sūrtī should have included in his edition.

The text opens with the following isnād :

Abū Maṣṣūr Muḥammad b. 'Abd al-Malik b. al-Ḥasan
b. Khayrūn (Rajab , 538 A.H).

Abū al-Faḍl Aḥmad b. al-Ḥasan b. Khayrūn (Shawwāl ,
482 A.H).

Abū 'Alī Al- Ḥasan b. Aḥmad b. Ibrāhīm b. al-Ḥasan
b. Muḥammad b. Shādhān.

Abū al-Qāsim 'Abd al-Raḥmān b. al-Ḥasan b. Aḥmad
b. Muḥammad b. 'Ubayd b. 'Abd al-Malik al-Hamadhānī
(Dhū al-Qa'idah 349 A.H).

¹²⁴- F. Leemhuis " Ms. 1075 Tafsīr of The Cairene Dār al-Kutub and Mujāhid's Tafsīr ", in R. Peters, ed., Proceedings of the Ninth Congress of the Union Europeenne des Arabisants et Islamisants, p.169

¹²⁵- Ibid, p.169.

Ibrāhīm b. al-Ḥusayn b. 'Alī al-Hamadhānī.

Ādam b. Abī Iyyās.

Warqā' b. 'Umar and Muḥammad b. al-Faḍl.

'Aṭā' b. al-Sā'ib.

Abū 'Abd al-Raḥmān al-Sulamī.

The Companions of the Prophet (aṣḥāb rasūl Allāh).¹²⁶

The text of the following tradition then reads: "The Companions of the Messenger of God used to learn the Qur'ān from the Messenger of God and they did not go beyond ten verses until they had understood the meaning and the practice which were in them. They reported that therefore they learned the Qur'ān, understanding and practice together".¹²⁷ This is clearly a dedicatory tradition for a work on tafsīr. What is particularly noticeable about it is the fact that in a work purporting to be the Tafsīr of Mujāhid, the latter's name is not in the isnād. On examining al-Sūrṭī's edition it soon becomes clear that the bulk of the traditions in the text are reported by Warqā' on the authority of Ibn Abī Najīḥ on the authority of Mujāhid. The nature of the bulk of the text would have been clearer if al-Sūrṭī had included in his edition the colophons of the eight fascicles that make up the 95 folios of the manuscript together with the title pages of fascicles 2 - 8. Each of these title pages indicates that what follows is the second (third etc ...) part of the book of tafsīr on the authority of Warqā' b. 'Umar on the authority of Ibn Abī Najīḥ on the authority

126- see Sūrṭī's Introduction in Tafsīr Mujāhid, vol.1, p.67.

127- Ibid, pp.67-8.

of Mujāhid.¹²⁸ Thus, the bulk of the book is Ādam b. Abī Iyyās's book which he collected from Warqā'. However, a close examination of the text reveals that not all of it is from Mujāhid as indeed the first tradition in the work was not from Mujāhid. Twelve traditions are added by Ibrāhīm to Ādam b. Abī Iyyās's text. Perhaps he did this to embellish the text. Otherwise Ādam b. Iyyās is responsible for the rest of the text. In total there are 2159 traditions in the text. If we reduce these by 12, we see that Ādam has presented us with 2147 traditions. Of these, in 323 cases Ādam does not cite Warqā' as his authority. Thus the bulk of the text, 1824 traditions, form Ādam b. Abī Iyyās's recension of Warqā''s transmission. The bulk of Warqā''s transmission is from Ibn Abī Najīh (1738). Of 86 traditions in which Warqā' does not cite Ibn Abī Najīh as his authority, 11 of them refer to Mujāhid through another transmitter. In another Mujāhid is quoted without an intermediary. The remaining 74 traditions refer neither to Mujāhid nor to Ibn Abī Najīh. Of the 1738 traditions on the authority of Ibn Abī Najīh, Mujāhid is not cited in 27 cases; in 20 of these another authority is cited and in 7 the isnād stops with Ibn Abī Najīh. Thus, in 1711 traditions Ibn Abī Najīh cites Mujāhid.

Both Stauth and Leemhuis have drawn attention to a rather large lacuna in Ādam's Ibn Abī Iyyās's transmission from Warqā'. Al-Sūrtī does not even mention this lacuna, let alone draw attention to it. It occurs from the beginning of Sūrah 68 until Sūrah 77,

¹²⁸. F. Leemhuis "Ms. 1075 Tafsīr of the Cairene Dār al-Kutub and Mujāhid's Tafsīr", in R. Peters, ed., Proceedings of the Ninth Congress of the Union Europeenne des Arabisants et Islamisants, p.169.

verse 20. In this lacuna Ādam has given us 42 traditions and Ibrāhīm has added another which goes back to Mujāhid but not through Warqā'. Of Ādam's 42 traditions, only four go back to Mujāhid, and only one of these is transmitted on the authority of Warqā' and Ibn Abī Najīh. The other three have Maṣṣūr as the authority for Mujāhid's views. In three other traditions Ādam quotes Warqā' referring to a different authority. Leemhuis has suggested that Ādam had received a defective copy of Warqā''s recension with this section, which he suggests would be about 950 words missing and that he has tried to replace it with traditions he believes will be in accord with Mujāhid's views. This suggestion sounds plausible.

The editor of the manuscript of Tafsīr Mujāhid, al-Sūrtī, has attempted to give the alternative versions to Tafsīr Mujāhid which he has been able to garner from other sources. However, his work is far from complete and he never quotes the isnād. It is clear nevertheless from any examination of al-Ṭabarī's Tafsīr that he has available to him several versions of Mujāhid's Tafsīr, probably eight.¹²⁹ According to Leemhuis, at least five of these recensions were based on the transmission of Ibn Abī Najīh.¹³⁰ None of these are exactly comparable to the Tafsīr of Mujāhid which has just been discussed. Leemhuis has made a comparison of the independently transmitted text with three of the versions from al-Ṭabarī. He maintains that the versions of Tafsīr Warqā', Tafsīr 'Īsā and Tafsīr

¹²⁹- A list of the principal isnāds given by al-Ṭabarī is contained in an appendix to this thesis.

¹³⁰- Ibid, p.169.

Shibl which give Ibn Abī Najīh's transmission from Mujāhid, must have been works of about the same length as the Tafsīr Warqā' which we have in the manuscript. However, he says that these three works show a difference in distribution of individual tafsīrāt and where there are tafsīrāt in them which refer to the same passages, as in the majority of cases, there is often a difference in wording, although mostly not in content.¹³¹ It should be noted that these three versions of the Ibn Abī Najīh transmission from Mujāhid, including the Warqā's version, differ from the Ādam's version of Warqā's recension in the same way. Leemhuis claims: "The kind of the exegetical activity that found its fixation in the works of Shibl, Warqā', and 'Īsā may easily be characterised. By far its most conspicuous characteristic is what may be called paraphrastic exegesis. The paraphrasis is mostly of a lexical nature".¹³² He concludes: "Theologically, the three major versions of tafsīr in the Ibn Abī Najīh / Mujāhid tradition may be considered as rather neutral. They do not seem to belong to an identifiable school of thought. There is, however, in accordance with the tendency to objectivism in the use of narrative, a slant to rationalism."¹³³

However, before accepting Leemhuis's conclusion, it will be necessary to look at these three scholars' reputations with greater scrutiny and examine their contribution in the various aspects of Mujāhid's Tafsīr which will be studied in the course of this thesis.

131. F. Leemhuis "Origins and Early Development of the Tafsīr Tradition", in Rippin's Approaches to the History of the Interpretation of the Qur'ān, p.20.

132. Ibid, p.20.

133. Ibid, p.24.

Warqā' was from Merv and is regarded as a Kufan scholar.¹³⁴ He may have been in contact with Ibn Abī Najīh towards the end of the latter's life, for he is widely criticised for not having heard the full tafsīr from Ibn Abī Najīh.¹³⁵ He is also accused of not having a sound grasp of the Arabic of the Qur'ān. In addition, it is claimed that he belonged to the Murji'ah.¹³⁶ In view of this and of his residence in Kufa we might expect him to reflect some of the ideas associated with the Murji'ah and the Ḥanafis.

Both 'Īsā¹³⁷ and Shibl¹³⁸ are scholars from Mecca. Both are regarded as preferable to Warqā' in terms of Tafsīr. Both, too, are accused of professing qadar. Shibl died either in 148 A.H or some time after 150 A.H.

The remaining versions of Ibn Abī Najīh's transmission of Mujāhid are reported by al-Ṭabarī from the Tafsīr of Sufyān al-Thawrī (d. 161 / 777) and the Tafsīr of Ma'mar b. Rāshid al-Azdī (d.152-3 / 769-70). Sufyān reports from Ibn Abī Najīh on 61 occasions between Sūrahs 67- 114. Ma'mar reports from Ibn Abī Najīh only four times between the same Sūrahs.

134. Ibn Ḥajar, Tahdhīb al-Tahdhīb, vol.11, p.113.

135. Ibid, p.114.

136. Ibid, pp.114-5.

137. Ibn Ḥajar, Tahdhīb al-Tahdhīb, vol.7, pp.235-6.

138. Ibn Ḥajar, Tahdhīb al-Tahdhīb, vol.3, pp.305-6.

Other principal transmitters of Mujāhid's Tafsīr are: Manṣūr b. al-Mu'tamar (d.132 / 749),¹³⁹ Ibn Jurayj (d. 150 / 767),¹⁴⁰ Sulaymān b. Mihrān al-A'mash (d. 145 / 762), Khuṣayf b. 'Abd al-Raḥmān (d. 137 / 754), al-Qāsim b. Abī Bazzah (d. 124 / 741), al-Ḥajjāj b. Arṭa'ah (d. 145 / 762), 'Abd Allāh b. Kathīr (d.120 / 737), 'Amr b. Dīnār (d. 125- 6 / 742-3) al-Ḥakam b. 'Uṭaybah (d. 113-14-15 / 731- 32-33), Qays b. Sa'ad al-Makkī (d. 117 or 119 / 735 or 737), Ḥamīd b. Qays al-A'raj (d.130 / 747), Ayyūb al-Sikhtiyānī (d.131 / 748), Sālīm al-Aftas (d. 132 / 749), Salamah b. Kuhayl and others.

The role of Ibn Abī Najīḥ in the transmission of Mujāhid's Tafsīr is so important that it is necessary to examine him in further detail. Ibn Ḥajar quotes Yaḥyā b. Sa'īd al-Qaṭṭān as saying that Ibn Abī Najīḥ did not hear the tafsīr directly from Mujāhid.¹⁴¹ However, al-Dhahabī in both Mīzān al-I'tidāl¹⁴² and Siyar A'lām al-Nubalā¹⁴³ states that Ibn Abī Najīḥ did not hear 'all' the tafsīr from Mujāhid, but he heard all of it from al-Qāsim b. Abī Bazzah.¹⁴⁴ Ibn Ḥibbān maintains that Ibn Abī Najīḥ is equal to Ibn Jurayj, as they both narrate the Tafsīr of Mujāhid without hearing directly from him.¹⁴⁵ However, Ibn Mu'in implies that Ibn Abī Najīḥ did hear the tafsīr directly from Mujāhid.¹⁴⁶

139- Manṣūr reports from Mujāhid on 103 occasions between Sūrahs 67-114.

140- Ibn Jurayj reports from Mujāhid only six times between Sūrahs 67-114.

141- Ibn Ḥajar, Tahdhīb al-Tahdhīb, vol.5, p.54.

142- Dhahabī, Mīzān al-I'tidāl, vol.2, p.515.

143- Dhahabī, Siyar A'lām al-Nubalā, vol.4, p.449.

144- Dhahabī, Mīzān al-I'tidāl, vol.2, p.515.

145- Ibn Ḥajar, Tahdhīb al-Tahdhīb, vol.5, p.54.

- Ibn Abī Ḥātim, al-Jarḥ wa- al-Ta'dīl, vol.2, p.203.

146- Ibn Ḥajar, Tahdhīb al-Tahdhīb, vol.11, p.114.

Other scholars accuse the beliefs and teachings of Ibn Abī Najīh, without referring to the tafsīr which he narrates on the authority of Mujāhid. Ibn Sa'ad¹⁴⁷ and Ibn Abī Hātim¹⁴⁸ claim that Ibn Abī Najīh believes in qadar, but Ibn Abī Hātim adds that his reports are reliable.¹⁴⁹ Al-Bukhārī is reported to have said that Ibn Abī Najīh was accused of being a Mu'tazilite and of believing in qadar (i.e., predestination).¹⁵⁰

On the other hand, the trustworthiness and reliability of Ibn Abī Najīh have been approved by many great scholars, e.g., Ibn Ḥanbal, al-'Ijlī, Ibn Mu'in, Ibn Sa'ad, Abū Zar'ah and al-Nisā'ī, and also by the late scholars Ibn Ḥajar and al-Sadāwdī.¹⁵¹ Al-Shīrāzī describes Ibn Abī Najīh as the muftī of Mecca after 'Atā'.¹⁵² Praising the morals of Ibn Abī Najīh, al-Bukhārī in al-Tārīkh al-Ṣaghīr states that he spent thirty years without insulting any one.¹⁵³ Ibn Ḥanbal says that there is no one who is more authoritative in narrating Mujāhid's views than Manṣūr, except Ibn Abī Najīh.¹⁵⁴ Ibn Taymiyyah maintains that most of the views which al-Shāfi'ī reports in his books are related on the authority of Ibn 'Uyaynah on the authority of Ibn Abī Najīh on the authority of Mujāhid, and that al-Bukhārī also in his Sahīh depends

147. Ibn Sa'ad, al-Ṭabaqāt al-Kubrā, vol.5, p.483.

148. Ibn Abī Hātim, al-Jarh wa-al-Ta'dīl, vol.2, p.203.

149. Ibid, p. 203.

150. Dhahabī, Mizān al-I'tidāl, vol.2, p.515. Also: Siyar A'lām al-Nubalā', vol.6, p.127.

151. Nawfal, Mujāhid Mufasssiran, unpublished Ph.D thesis, Cairo, 1978, p.288.

152. Ibid, p.289.

153. Ibid, p.289.

154. Ibid, p.289.

on the Tafsīr of Mujāhid narrated by Ibn Abī Najīh.¹⁵⁵ Ibn Taymiyyah further answers the claim which undermines the authoritativeness of Ibn Abī Najīh as a transmitter of Mujāhid's Tafsīr. He says that the Tafsīr of Mujāhid which is narrated by Ibn Abī Najīh is the most correct tafsīr, to the extent that there is no other book in the hands of the commentators which is more correct than it, except a book which is just analogous to it.¹⁵⁶ Thus if we take into account that Ibn Abī Najīh was contemporary with Mujāhid for a long time, we can imagine how much he benefited from him. As regards the claim that he did not hear the tafsīr from Mujāhid, the meaning is probably that he did not hear 'all' of it, and not that the absolute hearing (samā') is negated. Leemhuis holds that both Mujāhid and his disciple Ibn Abī Najīh are not associated with any school of thought. As already mentioned, Leemhuis has suggested that Ibn Abī Najīh / Mujāhid tradition may be considered as rather neutral. They do not seem to belong to an identifiable school of thought. There is, however, in accordance with the tendency to objectivism in the use of narrative, a slant towards rationalism.¹⁵⁷

Probably the second most important transmitter of the Tafsīr of Mujāhid was Mansūr b. al-Mu'tamar. He was a Kufan who died in 132 A.H. He has a reputation as a sound reporter of traditions, and he seems to have been a disciple of Mujāhid at some point in

155. Ibn Taymiyyah, Fatāwā, vol.17, p.408.

156. Ibid, p.409.

157. F. Leemhuis, "Origins and Early Development of the Tafsīr Tradition" in Rippin, Approaches to the History of the Interpretation of the Qur'ān, p.24.

his career. Perhaps this was around the time that Mujāhid was in prison in Kufa.

Another important transmitter of Mujāhid's Tafsīr was 'Abd al-Malik b. 'Abd al-'Azīz, who is known as Ibn Jurayj. He was born in 80 A.H. and died in 150 A.H. Ibn Ḥanbal praises him as being one of the sources of knowledge.¹⁵⁸ He was regarded as the faqīh of Mecca in his time.¹⁵⁹ On the other hand, Ibn Ḥanbal accuses Ibn Jurayj of narrating spurious traditions (aḥādīth mawḍū'ah) and that he does not care from whom he take them.¹⁶⁰ Ibn Jurayj was also accused of believing in mut'ah (i.e., temporary) marriage, thus he is reported to have married seventy women.¹⁶¹ The transmission of the isnād of his narration comes as follows: Al-Qāsim b. al-Ḥusayn relates on the authority of al-Ḥusayn on the authority of al-Ḥajjāj on the authority of Ibn Jurayj on the authority of Mujāhid.¹⁶² This succession of transmission is the most regular and most circulated one on the authority of Ibn Jurayj. However, sometimes there is another transmitter who enters between Mujāhid and Ibn Jurayj. This other transmitter is either al-Qāsim or Ibn Kathīr.¹⁶³ Ibn Jurayj is accused in general of not hearing the tafsīr directly from Mujāhid.¹⁶⁴

158. Dhahabī, al-'Ibar, p.213.

159. Dhahabī, Mīzān al-I'tidāl, vol.2, p.659.

160. Ibid, p.659.

161. Ibn Ḥajar, Tahdhīb al-Tahdhīb, vol.5, p.406.

- Dhahabī, Mīzān al-I'tidāl, vol.2, p.659.

162. Nawfal, Mujāhid Mufassiran, unpublished Ph.D thesis, Cairo, 1978, p.304.

163. Ibid, p.304.

164. Ibn Ḥajar, Tahdhīb al-Tahdhīb, vol.11, p.114.

Reports of Mujāhid's interpretations of the Qur'ān are also occasionally found in Tafsīr al-Qurtubī, Tafsīr Ibn Kathīr, al-Durr al-Manthūr of al-Suyūṭī (d.911 A.H), al-Kashshāf of al-Zamakhsharī (d.538 A.H) and al-Bahr al-Muḥīt of Abū Ḥayyān (d.745 A.H). These commentators are not as helpful as they rarely give the isnād and when they do, it is usually incomplete. However, they will help either to establish the interpretations of Mujāhid or else to present us with possible interpretations not found elsewhere.

3. THE BACKGROUND TO THE WRITING OF TAFSİR :

It is a tradition of Muslim students of tafsīr that three schools of Tafsīr emerged in the first century of Islam. They are :

(i) The school of tafsīr in Mecca. As previously mentioned, its foremost authority was claimed to be 'Abd Allāh b. 'Abbās.¹⁶⁵ Ibn Taymiyyah writes concerning this school: "The most knowledgeable scholars in the field of tafsīr were the people of Mecca, because they were the disciples of Ibn 'Abbās. They include Mujāhid b. Jabr, 'Atā' b. Abī Rabāḥ (d. 114 / 732), 'Ikrimah (d.150 / 676), Ṭāwūs (d.106 / 724), Abū al-Sha'thā' (d. 93, 103 or 104 / 711, 21 or 22), Qatādah b. Du'āmah (d. 117 / 735), Sa'id b. Jubayr (d.94 / 712) and others ".¹⁶⁶

165- Muḥammad Ḥusayn al-Dhahabī, al-Tafsīr wa-al-Mufasssīrūn, vol.1, p.102.

166- Ibn Taymiyyah, Fatāwā, vol.13, p.347.

- Muḥammad Ḥusayn al-Dhahabī, al-Tafsīr wa-al-Mufasssīrūn, vol.1, p. 102.

- Ṣābūnī, al-Tibyān fī 'Ulūm al-Qur'ān, p.73.

(ii) The school of tafsīr in Medina whose teacher was claimed to be Ubayy b. Ka'b (d. 21 / 641). The disciples of this school includes Abū al-'Aliyah al-Rayāhī (d. 93 / 711), Muḥammad b. Ka'b al-Qurazī (d.117 / 735), Zayd b. Aslam (d.136 / 753) and others.¹⁶⁷

(iii) The school of tafsīr in Irāq. The teacher of this school was claimed to be 'Abd Allāh b. Mas'ūd. His disciples include Murrah al-Hamadhānī (d. 76 / 695), 'Aṭā al-Khurāsānī (d.135 / 752), Masrūq al-Ajda' (d.63 / 682) and others.¹⁶⁸

Muslim Scholars maintain that tafsīr of the Qur'ān is carried out by exegetes in various ways. The first of these is known as tafsīr bi- al-riwāyah . According to these Muslim scholars, the first type of this tafsīr is to use the Qur'ān to explain itself, i.e to take one passage in the Qur'ān as an explanation for another passage. This kind of tafsīr has only a limited number of occasions on which it can be used. The remaining three types in this category rely on the transmission of the tafsīr through an isnād. Ideally, this isnād should go back to the Prophet, in which case it would be a full tradition. A cursory glance through the Tafsīr of al-Ṭabarī will make it clear that the occasions on which an isnād goes back to the Prophet for explanation are infrequent. The next type is where the tafsīr is reported by an isnād which goes back to a Companion of the Prophet. This type of tafsīr is regarded by Muslim scholars as very reliable because it is felt that the Companions of the Prophet were the men closest to the Prophet

¹⁶⁷- See the references in the previous footnote.

¹⁶⁸- See the references in footnote 166.

and therefore more able to understand how the Prophet would have interpreted the Qur'ānic verses. In some cases the Companions' interpretations may have actually been the Prophet's, but because they were being asked to explain something they merely gave the explanation which they knew from the Prophet. However, we can see from the existence of divergent schools of Tafsīr which were founded by Companions of the Prophet that these Companions could sometimes differ in their interpretations. In the case of Mujāhid we have already mentioned that he belongs to the Meccan school of Ibn 'Abbās who was his teacher. Some, but by no means the majority of his tafsīrāt, go back to Ibn 'Abbās. The fourth type of tafsīr which is regarded as tafsīr bi-al-riwāyah are the reports from the Tābi'ūn or the generation after the Companions. Mujāhid was one of this class. It is possible that reports which go back only to Mujāhid and his fellow Tābi'ūn were in many cases actually the opinion of a Companion or even the Prophet himself. However, the lack of an isnād going further than the actual Tābi'ī means that this is only a matter of speculation. By far the majority of tafsīrāt given by Mujāhid have an isnād which stops at him. As regards the status of tafsīr by Tābi'ūn, we quote Ibn Taymiyyah who says : " If one does not find the interpretation of certain Qur'ānic verses in the Qur'ān itself, nor in the hadīth of the Prophet, nor in the exegesis by the Sahābah, then many scholars turn to the tafsīr of the Tābi'ūn, like Mujāhid b. Jabr who is regarded as a reliable authority in this respect ".¹⁶⁹

¹⁶⁹. Ibn Taymiyyah, Fatāwā, vol. 13, p. 368.

Traditional Islamic scholarship regards the second category of tafsīr as tafsīr bi-al-ra'y which literally means the interpretation of the Qur'ān according to the sound opinion or reasoning ijtihād, and it does not mean mere opinion or one's own desire.¹⁷⁰ It is clear that within this category must also be included all the tafsīrāt given by Companions and Tābi'ūn when neither the evidence of the Qur'ān or the Prophet is cited. As regards the attitude of the Ṣahābah and Tābi'ūn towards tafsīr bi-al-ra'y, it has been reported that some of them are reluctant to use ijtihād in tafsīr, while others see that as permissible. As for the first group, Ibn Kathīr states that when Abū Bakr al-Ṣiddiq was asked about the interpretation of the verse: "And fruits and herbage (wa-fākihatan wa-abbā)" (80 : 31), he is reported to have said: "Which heaven shall shelter me, and which earth shall carry me, if I say concerning the Qur'ān things of which I have no knowledge".¹⁷¹ A similar attitude of abstention from indulging in rational interpretation is also attributed to 'Umar when he was asked about the meaning of the word abb mentioned in the same verse (80 : 31).¹⁷² It has also been reported that when Sa'īd b. Jubayr was asked about the lawful and the unlawful he used to reply, but when he was asked about the interpretation of the Qur'ān he used to keep silent as if he did not hear anything.¹⁷³ On the other hand, a group of exegetes among the Ṣahābah and Tābi'ūn are reported to have seen no harm in exercising reasoning ijtihād in tafsīr. In this respect, 'Alī and Ibn Mas'ūd, are reported to have challenged the people to ask them about

170. Ṣābūnī, al-Tibyān fī 'Ulūm al-Qur'ān, p.153.

171. Ibn Kathīr, Tafsīr, vol.1, p.5.

172. Ibid, p.5.

173. Ṭabarī, Tafsīr, vol.1, p.86.

anything concerning the Qur'ān.¹⁷⁴ Al-Ṭabarī quotes Ibn Mas'ūd as saying : " By God there is no verse in the Qur'ān, but I know its causes and place of revelation. And were I to know about any one with greater knowledge than me, who could be reached on horseback, I would go to him".¹⁷⁵ As regards our exegete, Mujāhid, it is also reported that his son said : "A man came to my father (Mujāhid) and said to him : 'Are you the one who interprets the Qur'ān according to your opinion ?' Mujāhid wept. Then he answered the man : 'Indeed if I had done that, I would have been bold as regards the Divine revelation. I took the Qur'ānic knowledge from more than ten of the Companions of the Prophet '".¹⁷⁶ However, the absence of these authorities in Mujāhid's own Tafsīr must make this statement suspect.

Despite the fact that Mujāhid learnt the Qur'ānic exegesis from Ibn 'Abbās and from other Companions, it is clear that he sometimes practises ijtihād in tafsīr. In this connection, Ibn Qutaybah (d. 276/ 889) cites Mujāhid himself as saying that the most preferable worship of God was the sound opinion (afḍal al-'ibādah al-ra'y al-ḥasan).¹⁷⁷ Ibn Qutaybah also maintains that the most strict and rigorous in exercising rational opinion (ra'y) and analogy (qiyās) was al-Sha'bī, whereas the most flexible in this respect was Mujāhid.¹⁷⁸ Shams al-Dīn al-Dhahabī takes the matter even further by stating that Mujāhid has some anomalous views in

174-.Ayyūb, The Qur'ān and its Interpreters , p.22.

175-.Ṭabarī, Tafsīr, vol.1, p.80.

176. Muḥammad Ḥusayn al-Dhahabī, al-Tafsīr wa-al-Mufasssīrūn, vol.1, p.250.

177. Ibn Qutaybah, Ta'wīl Mushkil al-Qur'ān, p.63.

178. Ibid, p.63.

religious knowledge as well as in tafsīr, which are unacceptable.¹⁷⁹

It should also be noted that when reporting the sciences which the mufassir requires in order to be capable of interpreting the Qur'ān, al-Suyūṭī mentions competence in the Arabic language. In this respect, he quotes Mujāhid as saying that it is not permissible for the one who believes in God and the Last Day to interpret the Qur'ān, if he is not well-qualified in the understanding of the Arabic language.¹⁸⁰ This statement of Mujāhid implies that he regarded himself a competent scholar in the Arabic language.

Thus in the light of this background to tafsīr, some Qur'ānic aspects will be examined in future chapters to see to what extent Mujāhid agrees or disagrees with the early exegetes. In addition, some crucial verses will also be investigated in which Mujāhid is accused of using a rational opinion and how his approach in those particular places is justified. Furthermore, his view of considering the Arabic language as one of the tools of interpreting the Qur'ān needs also to be examined to see whether and how he employs that means in his Tafsīr.

* * *

179-Dhahabī, Siyar A'lām al-Nubalā', vol.4, p.455.

180- Suyūṭī, Itqān, vol.4, p.185.

The first and perhaps the most important issue to start with is Mujāhid's view on the role of the exegete and whether those who are regarded as rāsikhūn fī al-'ilm (well-grounded in knowledge) are able to understand the mutashābihāt of the Qur'ān or not.

CHAPTER ONE

MUJĀHID'S VIEW ON THE ROLE OF THE EXEGETE

The role of the Qur'ānic exegete and his approach to his task are crucially determined by that exegete's interpretation of Qur'ān 3 : 7: "He it is who has sent down to you the Book : in it are muḥkamāt verses, which are the foundation of the Book (umm al-kitāb). Other verses are mutashābihāt. Those in whose hearts is perversity follow that which is mutashābih (literally mā tashābaha) out of desire for discord through them and out of desire for their interpretation (ta'wīl). No one knows the interpretation (ta'wīl) except God [;]¹ and those who are firmly rooted in knowledge [who] say: 'We believe in it ; all of it is from our Lord'. No one will grasp its meaning except men of understanding (ūlū al-albāb)".

Two problems arise in trying to understand this verse. Both of these are linguistic problems, but the answers given by exegetes involve the very essence of interpretation of the Qur'ān. The first problem concerns the meaning of muḥkam and mutashābih. The second concerns the manner of punctuation and whether "those who are firmly rooted in knowledge" know the interpretation of the mutashābihāt.

1- The translation read without the square brackets represents the more orthodox interpretation of the verse, whereas when read with the square brackets, the interpretation is open to those who claim special knowledge of the Qur'ān. The discussion following hinges on this dispute.

In addition to Qur'ān 3 : 7, two other verses in the Qur'ān use words related to the root form of muḥkamāt; h - k - m , to describe the Qur'ān. They are :

(i) "Alif-lām-rā' , this is a Book whose verses are uḥkimat, then elaborated (fussilat). It is from One who is Hakīm and All-Knowing (Khabīr)". (11 : 1).

(ii) "Alif-lām-rā', these are the verses of the hakīm Book". (10 : 1).

On the other hand, the whole Qur'ān is portrayed as mutashābih. That is in the verse : "God has revealed the most beautiful message in the form of a Book mutashābihan mathāniya .." (39 : 23).

THE MUḤKAM OF THE QUR'ĀN :

In interpreting the meaning of 11: 1, "... a Book whose verses are uḥkimat and then fussilat...", al-Ṭabarī² and Ibn Kathīr³ maintain that Mujāhid interprets that the verses are muḥkamāt in their expression and explained (fussilat) in their meanings, and thus the whole Qur'ān is complete in form and meaning. Al-Ṭabarī reports this view of Mujāhid from 'Īsā's version on the authority of Ibn Abī Najīh.⁴ He also has two reports from Warqā's version on the authority of Ibn Abī Najīh,⁵ and one from Shibl's version on the same authority.⁶ In addition, he also gives a further two reports from Ibn Jurayj reporting Mujāhid.⁷ Surprisingly, there is

2- Ṭabarī, Tafsīr, vol.15, p.227.

3- Ibn Kathīr, Tafsīr, vol.2, p.435.

4- Ṭabarī, Tafsīr, vol. 11, p. 180.

5- Ibid, p. 180.

6- Ibid, p.180.

7- Ibid, p. 180.

no mention of this in Ādam b. Abī Iyyās's version of Warqā's recension. The consensus of the other exegetes reported concurs with this interpretation.⁸ It appears that they and Mujāhid understand the muḥkamāt verses to be clear and concise and refer to legal injunctions, which would be close to the usual understanding of the root ḥ-k-m. These verses are fussilat, that is 'explained', which appears to mean that they give a full explanation of their meaning. This view of Mujāhid is given a slightly different emphasis by al-Qurṭubī,⁹ who suggests that Mujāhid interprets uḥkimat as jumlah, i.e., the Qur'ān is precise in its totality, but the individual verses explain the evidence for all that man needs in terms of the Unity of God, Prophethood, Resurrection and the like.

As far as Qur'ān 10 :1 "...these are the verses of the ḥakīm Book" is concerned, Mujāhid is not attributed with any interpretation by later exegetes. However, he is reported as suggesting that the verses referred to (in verse 10 :1) are from the Gospel and the Torah, and not the Qur'ān.¹⁰ This report is given on the authority of Sufyān who is reporting directly from Mujāhid,¹¹ and al-Qurṭubī also mentions it on the authority of Muāhid.¹² It is not given in Ādam's version of Warqā's recension. In terms of the meaning of ḥakīm, al-Ṭabarī reports that it is generally accepted as equivalent to muḥkam, as interpreted in the Qur'ān 11 : 1. In this case, Mujāhid's treatment of the meaning of ḥakīm can be

8- Ṭabarī, Tafsīr, vol.15, pp.225-8.

9- Qurṭubī, Tafsīr, vl.9, p.3.

10- Ṭabarī, Tafsīr, vol.15, p.11.

11- Ibid, vol.11, p 80.

12- Qurṭubī, Tafsīr, vol. 9, p.3.

understood to be similar to his treatment of uḥkimat as already discussed.

As regards the meaning of the term muḥkamāt in verse 3:7, al-Ṭabarī has reported that Mujāhid maintains that it refers to the verses of the Qur'ān in which God explains the lawful (ḥalāl) and the forbidden (ḥarām).¹³ Al-Ṭabarī gives this view of Mujāhid in two reports. The transmitter of both is Ibn Abī Najīh, who is cited by 'Isā in one and by Shibl in the other.¹⁴ Thus its meaning is very conspicuous and far from confusion and ambiguity.¹⁵ In explaining Mujāhid's view, al-Ṭabarsī maintains that muḥkam is (that part of) the Qur'ān whose meaning is straightaway very obvious from the ostensible wording of the text. It does not need any context (qarīnah) to be connected with it in order to clarify its purport. Al-Ṭabarsī further proceeds to give two examples for Mujāhid's definition of the term muḥkam. They are :

(i) "Verily God will not deal unjustly with man in aught (inna Allāha lā yazlimu al-nāsa shay'an)...". (10 : 44).

(ii) "God is never unjust in the least degree (inna Allāha lā yazlimu mithqāla dharratin) ...". (4: 40).

The statements in both verses are very clear in that they disapprove injustice as far as God is concerned.¹⁶

13- Ṭabarī, Tafsīr, vol.6, p.177.

- Alūsī, Tafsīr, vol.3, p.118.

14- Ṭabarī, Tafsīr, vol.6, p.177.

15- Ṭūsī, Tafsīr, vol.2, p.395.

- Abū Ḥayyān, al-Baḥr al-Muḥīt, vol.2, p.381.

16- Ṭabarsī, Tafsīr, vol.3, p.409.

Al-Qurṭubī suggests that the muḥkamāt are the verses which contain the proof for the existence of God, the means of people being protected (from evil) and means to prevent disputes and falsehood (bātil); these cannot be changed from what they are.¹⁷ Al-Qurṭubī also reports al-Naḥḥās's approval of this definition in which he explains that muḥkamāt are the fundamental and independent verses which are sufficient by themselves without needing other verses to explain them.¹⁸ It seems possible to assume that Mujāhid considered the muḥkamāt are verses concerned with the guidance of mankind in terms of beliefs and law.

In all, al-Ṭabarī lists five different interpretations of the muḥkamāt including Mujāhid's view which has been mentioned. The second view held by some exegetes suggests that muḥkamāt in verse 3 : 7 are the verses which laid down fixed rules which are in force for ever. In other words, those are the abrogating verses.¹⁹ This view is attributed to Ibn 'Abbās, Ibn Mas'ūd, al-Suddī, Qatādah, al-Rabī' and al-Ḍaḥḥāk.²⁰ The third view is held by Ibn Zayd, who defines muḥkamāt as the verses which deal with the narratives of the by-gone nations and their Prophets employing clear and fixed words throughout the whole text.²¹ The fourth opinion was adopted by Muḥammad b. Ja'far b. al-Zubayr and propounds that muḥkamāt are the verses which have only one interpretation.²² The fifth and last opinion which is attributed to the Companion Jābir b. 'Abd Allāh and

17 - Qurṭubī, Tafsīr, vol.4, pp.10- 1.

18- Ibid, p. 11.

19- Ṭabarī, Tafsīr, vol.6, p.174.

20- Ibid, 174- 6.

21- Ibid, p.178.

22- Ibid, p.177.

is preferred by al-Ṭabarī, maintains that muḥkamāt are the verses which it is possible for the scholars to know their elucidation and understand their meanings.²³

There is some similarity between the extended version of al-Qurṭubī and the fifth view given by al-Ṭabarī. However, that fifth view as put forward by al-Ṭabarī, wants to limit the role of the exegetes to explaining those verses which are muḥkamāt. This is something which, as we will see shortly, Mujāhid does not want to do.

THE MUTASHĀBIHĀT OF THE QUR'ĀN :

In discussing Qur'ān 39 : 23: "God has revealed to you a Book which is mutashābihan mathāniya ...", Mujāhid is not attributed with any definition of the term mutashābih by later exegetes. However, he does explain mathāniya as the repetition of the reports, destiny, rules and proofs which occur throughout the Qur'ānic text.²⁴ Al-Ṭabarī gives this report from Warqā's recension on the authority of Ibn Abī Najīḥ,²⁵ but this particular explanation is not in Ādam b. Abī Iyyās's version of Warqā's recension. It would seem that given the context of this report that Mujāhid must have agreed with the general exegesis of mutashābih as being "similar" in the sense of "consistent". The above meaning is the general

23- Ibid, p.179.

24- Ṭabarī, Tafsīr, vol.23, p.210.

25- Ibid, p.210.

meaning of mutashābih. However, in the critical verse 3 : 7, most of the exegetes maintain that its meaning is equivalent to "obscure".

Ibn Manẓūr (d. 711/1311) maintains that mutashābihāt basically means that the verses are similar to each other. However, with regard to this verse, he cites Ibn 'Abbās as indicating that the verses referred to are similar in their obscurity (i.e., there are several verses at the beginning of certain Sūrahs giving similar mysterious letters). Whether this is the true derivation or whether the word is being used in this verse as equivalent to mutashābihāt, which would mean "obscure" is difficult to decide. Nonetheless, it is clear that mutashābihāt cannot be understood as similar in the ordinary sense of the word and seems to mean something equivalent to "obscure".²⁶

With regard to the meaning of mutashābihāt in verse 3 : 7, five different views have been suggested by al-Ṭabarī. One of those views has been attributed to Mujāhid, who is reported to have treated mutashābihāt here as opposite to muḥkamāt, which was explained earlier. Al-Ṭabarī attributes this report to Mujāhid from the recensions of 'Īsā' and Shibl on the authority of Ibn Abī Najīh.²⁷ It is also in Ādam b. Abī Iyyās's version of Warqā's recension..²⁸ Mujāhid says that everything other than the muḥkamāt is mutashābih, that is, verses or words whose meaning other verses or words in the Qur'ān confirm.²⁹ This view of Mujāhid is confirmed by the

26- Ibn Manẓūr, Lisān, vol.2, p.266.

27- Ṭabarī, Tafsīr, vol.6, p.177.

28- Mujāhid, Tafsīr, vol. 1, p. 121.

29- Ṭabarī, Tafsīr, vol.6, pp.176-7.

commentators al-Ṭūsī,³⁰ al-Ṭabarsī,³¹ Abū Ḥayyān,³² al-Alūsī³³ and al-Suyūṭī.³⁴ Mujāhid, according to al-Ṭabarī, goes on to give illustrations. They are :

i. " ... and only the wicked will be led astray by (Him) it (wa-mā yudillu bi-hi illā al-fāsiqīna). (2 : 26).

ii. " ... thus God makes abomination for those who do not believe (kadhālika yaj'alu Allāhu al-rijsa 'alā alladhīna lā yu'minūna). (6 : 125).

iii. "Those who are guided He increases in guidance and makes them pious (wa-alladhīna ihtadaw zādahum hudan wa-ātāhum taqwāhum) ". (47 : 17).

Al-Ṭabarsī (d.548 A.H) explains Mujāhid's opinion as meaning that the mutashābihāt of the Qur'ān cannot be understood unless they are looked at within the whole context in which they fall.³⁵ Al-Ṭabarsī further explains Mujāhid's definition with the illustration of the meaning of idlāl (leading someone astray) in the following two verses:

(i) "Then seest thou such a one as takes as his god his own vain desire ? God has left him astray (a-fa-ra'ayta man ittakhadha ilāhahu hawāhu wa-adallahu Allāhu 'alā 'ilmin)..." (45 : 23).

30- Ṭūsī, Tafsīr, vol.2, p.395.

31- Ṭabarsī, Tafsīr, vol.2, p.409.

32- Abū Ḥayyān, al-Baḥr al-Muḥīt, vol.2, p.381.

33- Alūsī, Rūḥ, vol3, p.118.

34- Suyūṭī, Durr, vol.2, p4.

35- Ṭabarsī, Tafsīr, vol.2, p.409.

(ii) "God said: ' we have tested thy people in thy absence : the Sāmīrī ³⁶ has led them astray (qāla fa-innā qad fatannā qawmaka rin ba'dika wa- adallahumu al-Sāmīrī)". (20 : 85).

The first verse (45 : 23) speaks about the infidel, or about everyone who takes his own desire as his god³⁷ and does not worship the real God. Therefore God led him astray (adallahu Allāh), because God has already known in His knowledge of eternity ('ilm al-azal) that he would not follow the right path. The other verse (20 : 85) speaks about the people of Moses whom he had left behind when he went to Mount Sinai in order to listen to His Lord. Those people have been tested by God during the absence of their Prophet Moses. However, most of them have failed the test by following the Sāmīrī who led them astray (wa-adallahum al-Sāmīrī). From the above two verses, it becomes clear that there is an obvious distinction between the idlāl of God (as mentioned in verse 45: 23) which is fair because it comes as a result of disobedience, and the idlāl of the Sāmīrī (as mentioned in verse 20 : 65) which is bad, because it diverted the people from the right path.³⁸ In general, as al-Ṭabarsī states, the ishtibāh (confusion) occurs as regards theological

36- According to al-Qurtubī, four views have been set forth as regards "who is meant by the Sāmīrī ?". Ibn 'Abbās maintains that he was a man from among the Hindus, who used to worship the calfs (baqar). Then he came to Egypt, and embraced Islam, but his inner heart was still worshipping the calfs. The second view suggests that the Sāmīrī was a man from the Qibt, who used to be a neighbour to Moses. When Moses became a Prophet, he believed in him and went out with him. The third view presumes that he was one of the nobles of the sons of Isrā'īl, who belongs to a tribe called al-Sāmīrah, who were well known in Shām. The fourth view is attributed to Sa'īd b. Jubayr, who suggests that the Sāmīrī was one of the people of Karmān. [see, Qurtubī, Tafsīr , vol. 11, pp.223-4.]

37- For further detail of that one who "ittakhadha ilāhahu hawāhu", see Qurtubī, Tafsīr, vol. 16, pp. 166-7.

38- Ṭabarsī, Tafsīr, vol. 2, p. 409.

issues, i.e., in understanding monotheism (tawhīd), the negation of anthropomorphism to God (nafy al-tashbīh 'an Allāh) and the negation of injustice (jawr) as far as God is concerned.³⁹

The second of the five views reported by al-Ṭabarī proposes that mutashābihāt are the abrogated verses (mansūkhāt) whose rules are no longer in existence.⁴⁰ The third view suggests that the mutashābihāt are the verses which treat stories of the by-gone nations, but use different terminologies in different places of the Qur'ānic text for the same story.⁴¹ The fourth opinion propounds the mutashābihāt as the verses which are capable of more than one interpretation.⁴² The fifth view suggests that the mutashābih is (that part of) the Qur'ān whose interpretation is exclusively restricted to God, and no mortal can attain its meaning.⁴³ This includes the date of the return of Jesus, the date of the Day of Resurrection and so forth.⁴⁴ The partisans of this view regard also the disconnected letters (al-hurūf al-muqatta'ah) as related to the mutashābih.⁴⁵ Al-Ṭabarī shows some inclination towards this view but leaves the matter unreconciled.⁴⁶

Any of the views reported by al-Ṭabarī, including Mujāhid's, would give a scope for the well qualified mufassir to engage in elucidating the Qur'ān except for the fifth view. This (fifth) view

39- Ibid, p. 409.

40- Ṭabarī, Tafsīr, vol. 6, p. 174.

41- Ibid, p. 178.

42- Ibid, p. 177.

43- Ibid, p.179.

44- Ibid, p.179.

45- Ibid, p.179.

46- Ibid, p.180.

clearly indicates that the interpretation of the mutashābihāt is impossible for man and will, as we will see, require that the verse is read in a particular way which restricts any exegete from interpreting the mutashābihāt. Mujāhid's understanding of the meaning of mutashābihāt sees a distinct role for the well qualified exegete in interpreting mutashābihāt.

THE PUNCTUATION OF VERSE 3 : 7 :

We have already discussed the various meanings given of the key words muḥkamāt and mutashābihāt in the above verse. The verse as punctuated by Mujāhid reads: "He it is who sent down to you the Book: in it are verses muḥkamāt, they are the foundation of the Book and others are mutashābihāt. But those in whose hearts is perversity follow the part thereof that is mutashābih (literally mā tashābah min-hu), seeking discord and searching for its interpretation, but no one knows its interpretation except God and those who are firmly grounded in knowledge (who) say: 'We believe in the Book; the whole of it is from our Lord, and none will grasp the message except men of understanding.'" (3 : 7).

In the above verse we are concerned with the part: "... but no one knows its interpretation (ta'wīl) except God [;] and those who are firmly grounded in knowledge [who] say: 'We believe in the Book, the whole of it is from our Lord (wa- mā ya'lamu ta'wīlahu illā Allāhu [;] wa- al-rāsikhūna fī al-'ilmi yagūlūna āmannā bi-hi) ...".



Muslim exegetes and scholars have differed as to whether there is a waqf (pause) i.e., the equivalent of a semi-colon or a full stop after the word Allāh in the above Qur'ānic verse or whether there should be a wasl (continuation of reading) between the word Allāh and the following phrase wa-al-rāsikhūn, i.e., those who are rooted in knowledge are coupled with God as exceptions.

Many of Muslim scholars, and according to al-Qurṭubī the majority,⁴⁷ maintain that there is an obligatory and complete pause (waqf tāmm) after the word Allāh. In other words, they consider that there are two separate clauses. The first clause is: "Wa- mā ya'lam ta'wīlahu illā Allāh" (no one knows its interpretation except God.). The second clause starts: "Wa- al-rāsikhūn fī al-'ilm yaqūlūna āmannā bi-hi kullun min 'ind rabbīnā" "Those who are firmly grounded in knowledge say: we believe in it, all of it is from God."⁴⁸

On the other hand, the other group including Mujāhid who treat the Qur'ānic phrase as one sentence, maintain that wa- al-rāsikhūn fī al-'ilm is joined to the preceding word Allāh.⁴⁹ Thus the Qur'ānic phrase "wa- mā ya'lam ta'wīlahu illā Allāh wa-al-rāsikhūn fī al-'ilm" is regarded as one sentence in which there is no break (waqf) between the word Allāh and the following phrase wa-al-rāsikhūn fī al-'ilm.⁵⁰ In other words, they regard the wāw as a conjunction (ḥarf 'atf) which joins the word al-rāsikhūn, with the preceding word Allāh. According to this opinion, the reason for the word al-rāsikhūn

47- Qurṭubī, Tafsīr, vol.4, p.16.

48- Ibid, p.16.

49- Ṭabarī, Tafsīr, vol.6, p.203.

50- Ibid, p.203.

being in the nominative case (hālat raf') is because it is joined (ma'tūfah) to the preceding word Allāh, which comes in the nominative case, because it is the subject for the verb ya'lam. They explain the rest of the sentence "... yaqūlūna āmannā bi-hi kullun min 'ind rabbinā ..." as being a hāl, a clause indicating the circumstances in which the action of the main verb takes place. Therefore, those who adopt the above reading understand the verse at issue as meaning that no one knows the elucidation (ta'wīl) of the obscure Qur'ān save God and those who are rooted in knowledge (al-rāsikhūn fī al-'ilm). In addition to their understanding of the mutashābih and their firmness in knowledge, they (al-rāsikhūn fī al-'ilm) say: "We believe therein; the whole is from our Lord."⁵¹ This is the view of Mujāhid as reported by al-Ṭabarī from the recensions of 'Īsā and Shibl.⁵² It is also quoted in Ādam b. Abī Iyyās's version of Warqā's recension, all of which report Mujāhid on the authority of Ibn Abī Najīh.⁵³ Mujāhid maintains that al-rāsikhūn fī al-'ilm know the elucidation of the mutashābih, saying that they believe in it.⁵⁴ Perhaps, when adopting the above reading and consequently the interpretation, Mujāhid was influenced by the view attributed to his teacher Ibn 'Abbās.⁵⁵ In this respect, Mujāhid reports on the authority of Ibn 'Abbās, that he (Ibn 'Abbās) declares that he is one of al-rāsikhūn,⁵⁶ i.e., those who are firmly grounded

51- Ibid, p.203.

52- Ibid, p.203.

53- Mujāhid, Tafsīr, vol.1, p.122.

54- Ibid, p.122.

- Ṭabarī, Tafsīr, vol.6, p.203.

55- Ibn 'Abbās is also attributed with the opposite view. See Ṭabarī, Tafsīr, vol. 6, p.202.

56- It is reported that the Prophet has been asked about who is al-rāsikh fī al-'ilm, and he replied that it is he who fulfils his oath; he is a truthful, pious and he who seeks lawfulness in his eating and drinking. [see Ṭabarī, Tafsīr, vol.6, p.206].

in knowledge, and as such is well qualified to understand the meaning of the obscure Qur'ān.⁵⁷ In confirming the ability of al-rāsikhūn to understand the mutashābih, Ibn 'Abbās is reported to have said that tafsīr has four aspects: Firstly, an aspect which no one is excused from understanding; secondly, tafsīr which depends on the understanding of the Arabic language; thirdly, tafsīr which is known by al-rāsikhūn; and fourthly, tafsīr which is exclusively known to God.⁵⁸ Like his master, Mujāhid also declares that he is one of al-rāsikhūn who are able to discern the elucidation of the mutashābih.⁵⁹

Ibn Taymiyyah plainly maintains that Ibn 'Abbās's influence is undoubtedly behind Mujāhid's adoption that the waqf should be at wa- al-rāsikhūn fī al-'ilm. Ibn Taymiyyah further adds that because Mujāhid learned from the mouth of Ibn 'Abbās the interpretation of the whole Qur'ān, he assumes that he became one of al-rāsikhūn who can therefore comprehend ta'wīl of the mutashābih of the Qur'ān.⁶⁰

Muḥammad b. Ja'far b. al-Zubayr, who is one of the partisans of Mujāhid's opinion, asserts that no one can apprehend the intention of God in the obscure verses of the Qur'ān except God Himself and al-rāsikhūn. In explaining how al-rāsikhūn comprehend the mutashābih, Muḥammad b. Ja'far b. al-Zubayr maintains that they use the muḥkam (parts of the Qur'ān) on which there is an agreement to help them to explain the mutashābih. This therefore results in the fact that the

57- Ṭabarī, Tafsīr, vol.6, p.203.

58- Ibn Kathīr, Tafsīr, vol.1, p.346.

59- Qurṭubī, Tafsīr, vol.4, p.18.

60- Ibn Taymiyyah, Fatāwā, vol.13,p.284.

whole Qur'ān is in complete accord and each part of it confirms the other parts.⁶¹

Mujāhid's interpretation is held by some of the early exegetes as well as by a group of Muslim scholars. In addition to Ibn 'Abbās and Muḥammad b. Ja'far b. al-Zubayr, it is also held by al-Rabī' b. Anas.⁶² Later, Ibn Qutaybah (d.276/889) is regarded as an ardent supporter of Mujāhid's interpretation.⁶³ Arguing in favour of Mujāhid's view that al-rāsikhūn fī al-'ilm perceive the mutashābih, Ibn Qutaybah states that Ibn 'Abbās once claimed that he knew all the meaning of the Qur'ān except for four words: ghislīn,⁶⁴ ḥanānan,⁶⁵ awwāh⁶⁶ and al-raqīm.⁶⁷ However later, as Ibn Qutaybah adds, Ibn 'Abbās is reported to have learnt the meaning of those four words.⁶⁸ The Shi'ite commentators al-Qummī (d.310/ 922)⁶⁹ and al-Ṭabarsī⁷⁰ and the commentator al-Alūsī (d.1270 / 1853)⁷¹ also prefer the reading of al-waṣl between the word Allāh and the

61-Ṭabarī, Tafsīr, vol.6, pp.203-4.

- Qurtubī, Tafsīr, vol.4, pp.17-8.

- Ibn Kathīr, Tafsīr, vol.1, p.317.

62- Ṭabarī, Tafsīr, vol.6, p.203.

- Qurtubī, Tafsīr, vol.4, pp.16-7.

- Ibn Kathīr, Tafsīr, vol.1, p.347.

63- Ibn Qutaybah, Ta'wīl Mushkil al-Qur'ān, p.100.

64- This word occurs in the verses : " So nor friend hath he here this day. Nor hath he any food except from ghislīn. (69 : 35-6).

65- This word occurs in the verse : " wa-ḥanānan as from us, and purity : He was devout ". (19 : 13).

66- This word occurs in the verse : " ...for Abraham was awwāh, forbearing ". (9 : 114).

67- This word occurs in the verse : " Or dost thou reflect that the Companions of the Cave and of al-raqīm were wonders among our signs ? ". (18 : 9).

68- Ibn Qutaybah, Ta'wīl Mushkil al-Qur'ān, p.99.

69- Qummī, Tafsīr, vol.1, pp.96-7.

70- Ṭabarsī, Tafsīr, vol.1, p.410.

71- Alūsī, Rūḥ, vol.3, pp.119-20.

expression wa-al-rāsikhūn fī al-'ilm (Mujāhid's reading), which results in the understanding of al-rāsikhūn to the mutashābih as the sole way of reading that verse. The Mu'tazilite scholar al-Zamakhsharī,⁷² as would be expected, supports Mujāhid's interpretation, asserting that only God and those who are firmly rooted in knowledge have the ability to discern the exact elucidation of the mutashābih.⁷³ Al-Zarkashī (d.794 / 1391) also gives his preference to the view of Mujāhid.⁷⁴ According to al-Suyūṭī, al-Nawawī maintains that Mujāhid's interpretation is the most accurate one, while Ibn al-Ḥājjib says that the apparent sense of the verse conforms with Mujāhid's opinion.⁷⁵

The grammatical argument in favour of Mujāhid's interpretation put forward by the philologists is that yaqūlūna in the phrase wa-al-rāsikhūna fī al-'ilm yaqūlūna āmannā bi-hi is in the place of ḥāl clause meaning qā'ilīn (saying). So the verse denotes that al-rāsikhūn comprehend the mutashābih saying that they believe in it. In order to assert the occurrence of such a literary device in the Arabic language, which might be intended by Mujāhid, those philologians further quote the following verse of poetry:

الريح تبكي شجوها والبرق يلمع في الغمامة

Here, the Arab poet likens the wind when it blows as if it weeps from sadness, while the lightning is glittering in the sky.

72- Zamakhsharī, Kashshāf, vol.1, p.338.

73- According to al-Rāzī and Abū Ḥayyān most of the theologians (mutakallimūn) adopt this view. (see Rāzī, Mafātiḥ, vol.2, p.400, and Abū Ḥayyān, al-Bāhr al-Muḥīṭ, vol.2, p.384).

74- Zarkashī, Burhān, vol.2, pp.72-4.

75- Suyūṭī, Itqān, vol.2,p.5.

Thus it has been argued in favour of Mujāhid's view that there is a correspondence between the aforementioned verse of poetry and the interpretation of Mujāhid for the Qur'ānic phrase at issue. This is because Mujāhid states that the term al-rāsikhūn is joined (ma'tūf) to the word Allāh,⁷⁶ and yaqūlūna is in the place of hāl meaning qā'ilīn. As in the poetical verse the word al-barq is joined to the preceding word al-rīh, and the word yalma' is in the place of hāl meaning lāmi'an.⁷⁷ It is further argued that the use of the phrase al-rāsikhūn fī al-'ilm implies of its nature people with special qualities and abilities to understand the Qur'ān. Therefore it should be natural to assume that those rāsikhūn fī al-'ilm are exempted from not understanding the mutashābihāt.⁷⁸ In addition, it has been reported that the Prophet prayed for Ibn 'Abbās saying: "O God grant Ibn 'Abbās the religious knowledge and teach him the elucidation (ta'wīl) of the Qur'ān." Therefore, it is argued that if ta'wīl were not allowed for Muslims, the Prophet's prayer for Ibn 'Abbās would have become meaningless.⁷⁹ Another argument put forward, which also gives support to Mujāhid's view is attributed to Abū al-'Abbās Aḥmad b. 'Umar who says that since this category of people are called al-rāsikhūn, that description entails that they should know more than the muḥkam of the Qur'ān which all the Arabs are equal in understanding. He further questions how their firmness could exist, if

76- Ash'arī, Maqālāt al-Islāmiyyīn, p.224.

- Jaṣṣāṣ, Aḥkām, vol.2, p.284.

77- Ibn Qutaybah, Mushkil, pp.100- 1.

- Qurtubī, Tafsīr, vol.4, pp.16-7.

- Tūṣī, Tafsīr, vol.2, p.400.

- Ṭabarsī, Tafsīr, vol.2, p.410.

- Zarkashī, Burhān, vol.2, pp.72-3.

78- Rāzī, Mafātīh, vol.3, pp.17-8.

79- Ibid, p.18.

their knowledge is limited to that of the mass of the people.⁸⁰ Finally, al-Qurṭubī reports a view which also advocates Mujāhid's opinion. Al-Qurṭubī observes that in the Qur'ānic phrase wa- mā ya'lam ta'wīlahu illā Allāh wa-al-rāsikhūn fī al-'ilm, the Qur'ān does not necessarily mean all (kull) the rāsikhūn must perceive the elucidation of the mutashābih of the Qur'ān. So if it is not known by some scholars, it might well be comprehended by others.⁸¹

As mentioned earlier, contrary to Mujāhid's opinion, the majority of Muslim exegetes and scholars (al-jumhūr) maintain that there is a complete break (waqf tāmm) after the word Allāh in the verse at issue.⁸² In other words, in the opinion of al-jumhūr, there are two separate clauses, each of them aims at an independent meaning from the other. So this group read the verse as follows: "... No one knows the elucidation of the obscure Qur'ān save God. And al-rāsikhūn fī al-'ilm say: 'We believe in it ...' ". Building on this reading, this group understands the first clause as meaning that the elucidation of the obscure verses in the Qur'ān is exclusively restricted to God alone, and no human being is able to achieve the knowledge of the mutashābih. However, in putting this view forward they restrict the mutashābihāt to such matters as the time of the final Hour, the duration of Muḥammad's ummah, what will happen in the future and so forth.⁸³ All these matters are known only to God and it is impossible even for al-rāsikhūn to know such matters.

80- Ibid, p.18.

81- Ibid, p.18.

82- Ṭabarī, Tafsīr, vol.6, pp.201-3.

83- Reference to fifth view of mutashābihāt reported by al-Ṭabarī, see p. 49 of this thesis.

The privilege (fadl) of al-rāsikhūn over other believers is their acknowledgement that it is only God who knows the unseen (ghayb).⁸⁴

In support of this view, a reading (qirā'ah) is attributed to Ibn 'Abbās and Ubayy b. Ka'b is used. Ibn 'Abbās and Ubayy are said to have read the verse at issue as follows: "Wa-mā ya'lamu ta'wīlahu illā Allāhu. Wa-yaqūlu al-rāsikhūna fī al-'ilmi āmannā bi-hi".⁸⁵ By making yaqūl singular and putting it in front of al-rāsikhūn fī al-'ilm, only al-rāsikhūn fī al-'ilm can be the subject of yaqūl and it (al-rāsikhūn) is not joined to Allāh in understanding the interpretation of the mutashābihāt. Mujāhid's opponents also use a reading ascribed to Ibn Mas'ūd who is said to have read the verse as follows: "... In ta'wīluhu illā 'inda Allāhi. Wa-al-rāsikhūn fī al-'ilm yaqūlūna āmannā bi-hi ...".⁸⁶ The interpretation of the mutashābihāt belong to God, and those who are rooted in knowledge say: "We believe in it, all is from our Lord...". This reading also makes it impossible for al-rāsikhūn to have knowledge of the ta'wīl of the mutashābihāt. These two alternative readings of the Qur'ān may represent early interpretations of the verse.

Secondly, it has been argued that if the wāw in the expression wa-al-rāsikhūn were taken as a wāw of conjunction (wāw 'atf), then the phrase kullun min 'ind rabbinā (all of it is from our Lord) would have become meaningless. This is because when this phrase is

84- Ṭabarī, Tafsīr, vol.6, pp.201-3.

85- Ibid, pp.202-4.

86- Ibid, p.204.

- Abū Ḥayyān, al-Baḥr al-Muḥīṭ, vol.2, p.384.

uttered by al-rāsikhūn, it indicates that they believe in all the Qur'ān; the part that they understand and the part which they do not. So, if they know the whole Qur'ān, they need not to mention the word kullun.⁸⁷

Another argument is propounded to criticize the main point on which Mujāhid's builds his view that the expression al-rāsikhūn fī al-'ilm is joined to the prior word Allāh. The opponents of Mujāhid's view argue that had the former expression (Allāh) been joined to the latter (al-rāsikhūn), then the phrase yaqūlūna āmannā bi-hi would have been in the place of mubtada', and that, of course, contradicts the idea of eloquence. If the sentence yaqūlūna āmannā bi-hi is to be regarded as mubtada', then it should either be wa-hum yaqūlūna āmannā bi-hi or wa-yaqūlūna āmannā bi-hi.⁸⁸

The opponents of Mujāhid's view further argue that the Qur'ānic phrase prior to the phrase at issue regards the demand for the elucidation of the mutashābih as detestable. The preceding phrase runs as follows: "... but those in whose hearts is perversity follow the part thereof that is allegorical, seeking discord, and searching for its hidden meanings (fa-ammā alladhīna fī qulūbihim zayghun fa-yattabi'ūna mā tashābah minhu ibtighā' al-fitnati wa-ibtighā' ta'wīlihi...)". So, this part indicates that the demand for the elucidation (ta'wīl) of the mutashābih is detestable. Thus, as Mujāhid's opponents argue, if the enquiry into the elucidation of the mutashābih were permissible, then God would not have made that sort of knowledge

87- Rāzī, Mafātīh, vol.2, p.401.

- Qurṭubī, Tafsīr, vol.4, p.17.

88- Rāzī, Mafātīh, vol.2, p.401.

detestable. It may be in turn argued, however, in favour of Mujāhid's opinion that the mutashābih, whose interpretation is forbidden is that which relates to unknown matters, e.g., the Day of Resurrection. However, Mujāhid's opponents answer that God divides his Book into muḥkam and mutashābih, and the intellect approves that division. When a Qur'ānic expression is interpreted according to its preponderant meaning, it is considered as muḥkam, but when it is interpreted according to the meaning which is not preponderant, it is regarded as mutashābih. And since God censures the enquiry into the mutashābih in general, so it is incorrect to take that censure as applying to some of the mutashābih and not applying to the others.⁸⁹

Finally, Mujāhid's opponents argue that it is impossible that God disapproves of something from his creatures and approves it for Himself, while at the same time mentioning partners who share with him that thing.⁹⁰ As examples of that they quote the following verses :

(i) "Say: none in the heavens or in the earth, except God, knows what is hidden (qul lā ya'lamu man fī- al-samāwāti wa-al-ardī al-ghayba illā Allāhu...)". (27: 65).

(ii) "... everything (that exists) will perish, except His Own Face (kullu shay'in hālikun illā wajhuhu)..."

So in those two verses and in others similar, the exemption (istithnā') applies to God alone that the knowledge of the unseen, the date of the final Hour and such matters are exclusively known to God,

⁸⁹-Ibid, p.400.

⁹⁰- Qurtubī, Tafsīr, vol.4, p.17.

and no one else shares with Him that knowledge. Therefore, the verse under discussion (3 : 7) should also be treated in the same way as the aforementioned examples, that when it is read an obligatory break should be made on the word Allāh.⁹¹

In an attempt to reconcile the two views, some scholars argue that God divides his Book, according to its understanding, into two kinds; muḥkam and mutashābih. The muḥkam is the part of the Qur'ān whose meaning is clear for every one who understands the Arabic language; in that al-rāsikh fī al-'ilm and the one who is not rāsikh are equal. The other kind is the part of the Qur'ān which is the mutashābih , but this has two branches. The first branch is that which is exclusively known by God, and no one else whosoever can perceive it. This includes the issue of the soul (rūḥ) and all the unseen (ghayb) e.g., the date of death of each of the human beings, the date of the Day of Judgment and so forth. The other branch of the mutashābih is that which needs high skills of understanding of the Arabic language and its eloquence and styles. No one can attain the description of rāsikh unless he possesses a great deal of this kind of skill.

Therefore, as those scholars argue, according to the above definition, those who maintain that al-rāsikhūn know the elucidation of the mutashābih (i.e., Mujāhid's group) refer to the second branch of the mutashābih (the branch which its understanding needs high abilities in the Arabic language). On the other hand, those who deny that

⁹¹- Ibid, p.17.

al-rāsikhūn can attain the elucidation of the mutashābih , refer to the first kind of the mutashābih, i.e., that which concerns the knowledge of the unseen and so on.⁹²

In conclusion it can be said that Mujāhid does not mean that the knowledge of al-rāsikhūn is equal to the that of Almighty God, nor does he mean that they are able to discern the unseen. Most likely, what Mujāhid actually wants to say is that al-rāsikhūn are well versed savants, who can discern that kind of the mutashābih whose interpretation is permissible. Perhaps they can achieve that through a special talent which is granted to them by God, besides their higher skills in the Arabic language. However, it is impossible for them to know the mutashābih which is related to the unseen matters.

Mujāhid's position as regards the punctuation of verse 3 :7, and consequently his declaration that he is one of al-rāsikhūn fī al-'ilm, might be the firmest basis on which he builds his interpretation of the Qur'ān. According to that declaration, Mujāhid attributes to himself the ability of understanding the mutashābihāt verses of the Qur'ān, whose interpretations are impossible for ordinary people. Perhaps Mujāhid has taken that privilege even further to the extent that in certain verses, as will be seen in the following chapters, he sets forth interpretations which have been solely ascribed to him, or at least in those interpretations he disagrees with the majority of the early exegetes amongst the Sahābah and the Tābi'ūn.

⁹²- Qurtubī, Tafsīr, vol.4, p.18.
- Abū Hayyān, al-Bahr al-Muhīt, vol.2, p.385.
- Tha'ālibī, Jawāhir, vol.1, p.245.

CHAPTER TWO

THE DISCONNECTED LETTERS AS AN EXAMPLE OF THE MUTASHĀBIHĀT

It has already been mentioned that a group of exegetes, including al-Ṭabarī, regard the abbreviated letters in the Qur'ān as mutashābihāt and that they can only be understood by God. These disconnected letters (al-ḥurūf al-muqatta'ah) appear in 29 Sūrahs of the Qur'ān which begin with a letter, two letters or a group of letters of the Arabic alphabet.¹

1- Here some observations have been deduced from the number and the combination of these letters.

- Firstly, it is argued that there are 29 letters in the Arabic alphabet (when counting hamzah and alif as two letters). So this number (29) is equal to the number of the Sūrahs (29) in which these letters occurred.

- Secondly, it has been argued that if one takes half of the alphabet omitting the fraction, one gets the number 14, and this is the actual number of the letters which occur in the beginning of the Sūrahs.

- Thirdly, if we grouped the disconnected letters which occur in the beginning of the 29 Sūrahs, according to their combination, they can be put as follows :

(a) One letter :

ص in Sūrat Sād (chapter 38).
ق in Sūrat Qāf (chapter 50).
ن in Sūrat al-Qalam (chapter 68).

(b) Two letters :

طه in Sūrat Tāha (chapter 20).
طس in Sūrat al-Naml (chapter 27).
يس in Sūrat Yāsīn (chapter 36).
خم in the following Sūrahs :

al-Mu'min (chapter 40).
Fuṣṣilat (chapter 41).
al-Shūrā (chapter 42).
al-Zukhruf (chapter 43).
al-Dukhān (chapter 44).
al-Jāthiyah (chapter 45).
al-Aḥqāf (chapter 46).

(c) Three letters :

الم in the following Sūrahs:

al-Baqarah (chapter 2).
Al 'Imrān (chapter 3).
al-'Ankabūt (chapter 29).
al-Rūm (chapter 30).

Al-Samarqandī (d.373 / 983) in his Tafsīr (Bahr al-'Ulūm) reports on the authority of the great Companions 'Umar, 'Uthmān and Ibn Mas'ūd that the disconnected letters belong to the Qur'ān which cannot be interpreted by the human beings (maktūm).² Also, Al-Qurtubī³ attributes to Abū Bakr, 'Alī, 'Āmir al-Sha'bī and Sufyān al-Thawrī the view that the disconnected letters are the secret of God in the Qur'ān, for in every Divine Scripture God has a secret.⁴ So according to these people, al-ḥurūf al-muqatta'ah belong to the mutashābihāt whose meaning is exclusively known to God.

الر in the following Sūrahs :

Luqmān (chapter 31).
al-Sajdah (chapter 32).

Yūnus (chapter 10).
Hūd (chapter 11).
Yūsuf (chapter 12).
Ibrāhīm (chapter 14).
al-Hijr (chapter 15).

طسم in the following Sūrahs:

al-Shu'arā' (chapter 26).
al-Qaṣaṣ (chapter 28).

(d) Four letters :

القص in Sūrat al-A'rāf (chapter 7).

المر in Sūrat al-Ra'd (chapter 13).

(e) Five letters :

كهيعص in Sūrat Maryam (chapter 19).

حدم عشق in Sūrat al-Shūrā (chapter 42).

For further discussion on the above observation, see :

- Zamakhsharī, Kashshāf, vol.1, pp.29-31.
- Rāzī, Mafātiḥ, vol.1, p.156.
- 'Alī, The Holy Qur'ān, pp.118-20.

2- Samarqandī, Bahr al-'Ulūm, pp.249-50.

3- Qurtubī, Tafsīr, vol.1, p.154.

4- Ṭabarī also states that some exegetes adopt this view, but he does not name them.
[see Ṭabarī, Tafsīr, vol.1, p.88.]

Therefore, we should not be allowed to indulge in their interpretation, but rather we must assent and recite them as they were revealed.⁵

Another view, which may be associated with Mujāhid, is that the disconnected letters are mutashābihāt and capable of being interpreted by scholars who are rāsikhūn fī al-‘ilm. However, if we are to judge from the many different interpretations of this verse, several of them attributed to Mujāhid himself, it would appear that to some of these Qur’ānic mutashābihāt and in particular to the disconnected letters no definitive interpretation could be given. This is understood from the report that Fakhr al-Dīn al-Rāzī (d.606 A.H) attributes to Ibn ‘Abbās, who is claimed to have stated that the scholars are unable to discern the exact meanings of these letters.⁶ Also, al-Qurṭubī attributes to Abū Ḥātim b. Ḥibbān the view that the scholars do not know the exact intention of God in these letters.⁷ In this connection, it should be added that al-Ṭabarī, who earlier seemed to regard the disconnected letters as mutashābihāt,⁸ seems also to treat them as muḥkamāt in his special discussion.⁹ This is probably due to his understanding that the muḥkamāt may sometimes have more than one interpretation.¹⁰ The majority of Muslim exegetes and scholars (al-jumhūr) adopt a similar approach maintaining that since these

5- Qurṭubī, Tafsīr, vol.1, p.154.

6- Rāzī, Mafātīḥ, vol.1, p.150.

7- Qurṭubī, Tafsīr, vol.1, p.154.

8- Ṭabarī, Tafsīr, vol.6, p.180.

9- Ibid, p.181.

10- Ibid, pp.181-2.

letters are part of the Qur'ān, the scholars should discuss, interpret and scrutinize their meanings. ¹¹

It would seem then that the division between the scholars was whether they were allowed to try to interpret the meanings of these letters or not. The fact that a variety of different meanings were given, indicates that those scholars who attempted to disclose their interpretations were not at all sure of their exact meanings. In fact, Mujāhid is attributed with three slightly different interpretations. It should be noted that all these reports come from al-Ṭabarī, ¹² al-Baghawī, ¹³ al-Ṭūsī, ¹⁴ Ibn Kathīr ¹⁵ and Abū Ḥayyān. ¹⁶

Firstly, Mujāhid is reported to have maintained that Alif-lām-mīm is one of the names of the Qur'ānic Scripture. ¹⁷ Al-Ṭabarī gives this report on the authority of Ibn Abī Najīh from the recension of Shibl. ¹⁸ The statement of Mujāhid could mean that Alif-lām-mīm is a name by which the whole Qur'anic text is known, like the name al-Furqān. In his explanation of this, al-Ṭabarī suggests that Alif-lām-mīm. Dhālika al-kitāb... (2:1-2) would represent a kind

-
- 11- Qurtubī, Tafsīr, vol. I, p. 155.
- Abū Ḥayyān, al-Baḥr al-Muḥīt, vol. I. p. 35.
- Tha'ālibī, Jawāhir, vol. 1, p. 30.
- 12- Ṭabarī, Tafsīr, vol. 1, pp. 87-8.
- 13- Baghawī, Ma'ālim, vol. 1, p.44.
- 14- Ṭūsī, Tafsīr, vol. 1, pp.47-8.
- 15- Ibn Kathīr, Tafsīr, vol. 1, pp.36-7.
- 16- Abū Ḥayyān, al-Baḥr al-Muḥīt, vol. 1, p. 34.
- 17 Tabarī, Tafsīr, vol. 1, p. 87.
- Ibn Kathīr, Tafsīr, vol. 1, p. 36.
- Ṭūsī, Tafsīr, vol. 1, p. 47.
- Suyuṭī, Durr, vol. 1, p. 22.
- 18- Ṭabarī, Tafsīr, vol.1, p.87.

of an oath, that God swears by the Qur'ān whereof there is no doubt.¹⁹

Alternatively, according to al-Ṭabarī, the second possible elucidation for Mujāhid's opinion that Alif-lām-mīm is one of the names of the Qur'ān, is that it refers to the name of the Sūrah by which it is known, as the common things are known by their names which work as signs for them.²⁰ For instance, if one says: "Today I read Alif-lām-mīm-ṣād and Nūn", he meant that he read two complete Sūrahs: Alif-lām-mīm-ṣād (Sūrah 7) and Nūn (Sūrah 68). This is similar to when one says: "Today I met Zayd and 'Amr", when both the speaker and the listener are well acquainted with the persons spoken about. Carrying on his analysis of Mujāhid's view, al-Ṭabarī questions how can a Sūrah be called by its prefixed disconnected letters, i.e., the Sūrah of Alif-lām-mīm, or the Sūrah of Alif-lām-ra, at a time when there is more than one Sūrah which starts with Alif-lām-mīm, and similarly a group of Sūrahs begin with Alif-lām-ra. The answer which he gives supporting Mujāhid's view, is that if more than one Sūrah share the same disconnected letter in their openings, then a further description or distinction should be added to the disconnected letters in order to avoid confusion. For instance, when one reads the second Sūrah, he would say: "qara'tu Alif-lām-mīm al-Baqarah", or "qara'tu Alif-lām-mīm dhālika al-kitābu". The same method would apply also to the third Sūrah which also starts with Alif-lām-mīm. So when one reads Sūrah three, he can say: "qara'tu Alif-lām-mīm, Allāhu lā ilāha

¹⁹ - Ibid, p. 90.

²⁰ - Ibid, p. 90.

illā huwā al-Hayyu al-Qayyūmu". This method is exactly similar to the case when one wants to refer to two persons, each of them is called 'Amr though they are from two different tribes; one is from Tamīm, and the other is from Azd. So in order to differentiate between them one would follow the name of each of them with the attribution of his own tribe by saying: "Laqitu 'Amr al-Tamīmī wa-'Amr al-Azdī".²¹

Ibn Kathīr confirms the above suggestion of al-Ṭabarī, that when Mujāhid refers to Alif-lām-mīm as one of the names of the Qur'ān, he means that it is one of the names of the Sūrahs of the Qur'ān,²² as does 'Abd al-Raḥmān b. Zayd who is also attributed with this interpretation of the disconnected letters.²³ Ibn Kathīr argues that it is highly unlikely to take Alif-lām-mīm-ṣād as a name for the whole Qur'ān. If one says: "qara'tu Alif-lām-mīm-ṣād", the listener would straightaway understand that statement as referring to Sūrat al-A'rāf, and not to the whole Qur'ān.²⁴

Furthermore, according to al-Baghawī, Mujāhid directly states that the disconnected letters connote the names of the Sūrahs.²⁵ That when one says: "qara'tu Alif-lām-mīm-ṣād", it is understood that he has read the Sūrah which starts with Alif-lām-mīm-ṣād.²⁶

21 - Ibid, p. 90.

22 - Ibn Kathīr, Tafsīr, vol. 1, p. 36.

23 - Ibid, p. 36.

- Ṭabarī, Tafsīr, vol. 1, p. 87.

- Baghawī, Ma'ālim, vol. 1, p. 44.

24 - Ibn Kathīr, Tafsīr, vol. 1, p. 87.

25 - Baghawī, Ma'ālim, vol. 1, p. 44.

26 - Ibid, p. 44.

Fakhr al-Dīn al-Rāzī tries to justify this interpretation by stating that it has been adopted by the majority of the theologians (mutakallimūn), and it is also favoured by the linguists al-Khalīl and Sībawayh.²⁷ In support of this view, he cites the statement of al-Qaffāl that the Arabs use letters as names for things. For instance they use the letter lām as a name for the father of Ḥārithah when they called him Ḥārithah b. Lām al-Ṭā'ī. They also call the clouds (siḥāb) ghayn, and the mountain (jabal) qāf.²⁸ Al-Ṭabarsī also supports this interpretation.²⁹ However, this argument could be extended to numerology and mystical meanings for the letters, an interpretation which al-Ṭabarī reports but firmly rejects. It does not appear that Mujāhid was in any way involved in such interpretations.

It seems clear that Mujāhid's view indicates that the disconnected letters are signs for the name of the Qur'ān, and later exegetes and scholars have inferred that Mujāhid probably meant that they are signs for the names of the Sūrahs of the Qur'ān. According to al-Baghawī, Mujāhid does say that. Hence if Mujāhid actually means that the disconnected letters are names of the Sūrahs of the Qur'ān, his view can be strengthened by two arguments. Firstly, the majority of the exegetes adopt this view. Secondly, perhaps since these letters are placed in the very beginning of those certain chapters (Sūrahs), logically they can be taken as names for

27- Rāzī, Mafātīḥ, vol.1, p.152.

28- Ibid, p.152.

29- Ṭabarsī, Tafsīr, vol.1, p.33.

those chapters. In addition, western scholarship has also suggested that these letters may possibly refer to group names for certain Sūrahs.³⁰

The second possible interpretation suggested by Mujāhid for the disconnected letters, is that they are openings (fawātiḥ) with which God initiates the Qur'ān.³¹ Al-Ṭabarī gives this report in four traditions. Two versions come from Sufyān's Tafsīr, in one of which he directly quotes from Mujāhid while in the other Ibn Abī Najīḥ is the intermediary.³² The other two are from Ibn Jurayj quoting directly from Mujāhid.³³ Mujāhid further gives examples of these letters by saying that Alif-lām-mīm, Hā'-mīm, Alif-lām-mīm-ṣād and Ṣād are beginnings of God's Speech.³⁴

Some philologists, whom al-Ṭabarī does not name, try to justify this view of Mujāhid by arguing that these letters are put by God in the beginning of the Sūrahs for a specific reason, that is each letter or a group of letters signify the ending of the previous chapter and simultaneously the starting of the following one. In other words, these letters serve as signs of division between the Sūrahs, and they have nothing to do with the meaning of the Qur'ānic text in which they appear.³⁵ However, Ibn Kathīr rejects

30- Watt, Bell's Introduction to the Qur'ān, pp.61-2.

31- Ṭabarī, Tafsīr, vol.1, p.87.

- Ṭūsī, Tafsīr, vol.1, p.47.

- Ibn Kathīr, Tafsīr, vol.1, p.36.

- Abū hayyān, al-Baḥr al-Muḥīṭ, vol.1, p.34.

- Suyūṭī, Durr, vol.1, p.23.

32- Ṭabarī, Tafsīr, vol.1, p. 87.

33- Ibid, p. 87.

34- Ibid, p.87.

35- Ṭabarī, Tafsīr, vol.1, p.89.

- Ṭūsī, Tafsīr, vol.1, p.47.

this report which is stated by al-Ṭabarī on behalf of some of the philologists who take the function of these letters as being separative elements. Describing that report as weak, Ibn Kathīr further argues that the division between the Qur'ānic Sūrahs takes place even without the existence of these letters. This is because these letters occur in the beginning of only 29 Sūrahs whereas the bulk of the other Sūrahs (85) do not start with these disconnected letters. Besides, al-basmalah whether in writing or recitation serves as a clear and more suitable sign of separation between the Sūrahs , though it does not occur at the beginning of Sūrah 9.³⁶

When the linguists explain this second view of Mujāhid that the benefit of the disconnected letters is just to separate between the Sūrahs , this implies that these letters have nothing to do with the meaning of the text in which they occur. According to Abū Ḥayyān,³⁷ Mujāhid states that the disconnected letters come in the beginning of some Qur'ānic Sūrahs , as the Arabs start some of their poems with the particles bal or lā bal.³⁸ Mujāhid's opinion is

- Abū Ḥayyān, al-Baḥr al-Muḥīṭ, vol.1, p.34.

- Rāzī, Mafātīḥ, vol.1, p.153.

36- Ibn Kathīr, Tafsīr , vol.1, p.37.

37- Abū Ḥayyān, al-Baḥr al-Muḥīṭ, vol.1, p.34.

38- For example the Arab poets use the particle bal before the beginning of the poetical verse :

بل ... وبلدة ما الإنس من أعالها

Also, for the usage of bal , see Lane, Madd al-Qāmūs , vol.1, pp.243-4.

adopted by the philologists Abū 'Ubaydah and al-Akhfash,³⁹ and also by al-Balkhī.⁴⁰

It seems from the above treatment that Mujāhid is putting forward a purely linguistic perspective. He tends to say that although sometimes certain particles appear in the beginning of the Arabic speech, they do not have any meaning whatsoever which affects the following text. In other words, in the opinion of Mujāhid and those linguists who support his view the particles bal and lā bal are otiose their sole purpose being to signify division between a preceding and a succeeding speech.⁴¹

However, al-Ṭabarī fiercely opposes the above justification which is cited by Mujāhid and the linguists. He further gives three arguments to prove its inaccuracy. Firstly, al-Ṭabarī argues that although it is acceptable that the Arabs sometimes initiate certain verses of poetry with bal or lā bal, it is well known that they never started their speech with Alif-lām-mīm or Alif-lām-ra or Alif-lām-mīm-ṣād. Thus since the Qur'ān in all its verses addresses the Arabs with a language which is familiar and understandable to them, then the same argument applies to the disconnected letters simply because they are part of the Qur'ān. Had the Qur'ān as regards the disconnected letters diverted from the language which is familiar to the Arabs, it would not have deserved the clarity (ibānah)

39- Abū Ḥayyān, al-Baḥr al-Muḥīṭ, vol. 1, p. 34.

40- Ṭūsī, Tafsīr, vol. 1, p. 47.

41- Ṭabarī, Tafsīr, vol. 1, p. 89.

with which God describes His whole Book.⁴² As God says: " With it came down the spirit of faith and truth to your heart and mind, that you may set admonish in the prespicuous Arabic tongue (nazala bi-hi al-rūḥu al-Amīnu 'alā qalbika li-takūna min al-mundhirīna bi-lisānin 'Arabiyyīn mubīnin)". (26 :193-5). The phrase bi-lisānin 'Arabiyyīn mubīnin plainly states that the entire Qur'ān was revealed in a clear Arabic tongue which is known to the Arabs.

The second argument of al-Ṭabarī is directed to the view of the linguists who argue on behalf of Mujāhid that these fawātiḥ are meaningless. Al-Ṭabarī strongly denounces this idea arguing that it is impossible that God addresses his servants with something which has no meaning or has no benefit for them.⁴³

In his third argument regarding the criticism of Mujāhid's opinion, al-Ṭabarī adopts a linguistic approach. Contrary to what has been held by Mujāhid and his group, al-Ṭabarī maintains that bal has an understandable meaning in the Arabic language that the Arabs use it as a contrast to a speech which took place in the past (rujū' 'an kalām). As they say:

مَا جَاءَنِي أَخُوكَ بَلْ أَبُوكَ

Your brother did not come to me, but (bal) it is your father who came.⁴⁴ According to al-Ṭabarī's argument, when the particle bal is used by the Arabs, as in the above example, it does not have indispensable meaning. In other words, it is linguistically incorrect

42- Ibid, p.95.

43- Ibid, p.95.

44- Ibid, p.95.

to assume that bal is without a real significance, that if it is omitted it leaves no effect on the meaning of the text in which it appears. The same argument should therefore be applied to the disconnected letters, that when they came in the beginning of certain Sūrahs they do have a specific meaning and they have not been put in vain, as Mujāhid and his supporters among the philologists seem to allege in this interpretation.⁴⁵

The third possible interpretation suggested by Mujāhid for the disconnected letters, is that all the openings of the Qur'ānic Sūrahs such as Qāf , Ṣād , Hā'-mīm, Tā'-sīn-mīm , Alif-lām-ra and others are Arabic alphabetical letters which have been put down (hurūf hijā' mawdū') in the beginning of certain Qur'ānic Sūrahs.⁴⁶ Al-Ṭabarī gives this report through the transmission of Khuṣayf from Mujāhid.⁴⁷ Mujāhid is content with the above statement and does not go any further to clarify the wisdom behind the placing of these letters of the Arabic alphabet in this position. This is no interpretation beyond the explanation that the disconnected letters are letters. In fact this statement is only the first step towards a fuller interpretation because only when it is admitted that the letters are separate letters and not mysterious unknown words, can an attempt be made to interpret why they are there and what they mean. However, it should be noted that none of the aforementioned

45- Ibid, p.95. For further discussion on the possible linguistic meaning of bal, see Ibn Manẓūr, Lisān, vol.1, pp.262-3.

46- Ṭabarī, Tafsīr, vol.1, p.88.

- Ibn Kathīr, Tafsīr, vol.1, p.37.

47- Ṭabarī, Tafsīr, vol. 1, p. 88.

three views attributed to Mujāhid is found in Ādam b. Abī Iyyās's version of Warqā's recension.

In addition to the aforementioned three views of Mujāhid, several other interpretations have been suggested for the disconnected letters. Fakhr al-Dīn al-Rāzī gives twenty-one different interpretations,⁴⁸ but al-Ṭabarī gives only eleven.⁴⁹ Here we will briefly mention those given by al-Ṭabarī. Ibn 'Abbās and Sa'īd b. Jubayr propound that the disconnected letters are letters which have been taken from complete nouns and verbs where each letter has a different meaning from the other letter. They say that Alif-lām-mīm means "I am God, more knowing (anā Allāhu a'lamu)".⁵⁰ In another view of Ibn 'Abbās, al-Suddī and al-Sha'bī say that these letters are the greatest Names of Almighty God.⁵¹ Some exegetes are of the opinion that the disconnected letters are some of the Names of God by which He swears.⁵² Another group of scholars and philologists treat these letters as signs of the miracle and inimitability of the Qur'ān with which it challenges the Meccan polytheists.⁵³ Some linguists suggest that the mentioning of some of

48- Rāzī, Mafātīh, vol. 1, pp. 152-4.

49- Ṭabarī, Tafsīr, vol. 1, pp. 86-9.

50- Ibid, p. 88.

- For further meanings of Alif-lām-mīm, see:

- Qurṭubī, Tafsīr, vol. 1, p. 155.

- Ṭabarsī, Tafsīr, vol. 1, p. 32.

- Abū Ḥayyān, al-Baḥr al-Muḥīṭ, vol. 1, p. 34.

51- Ṭabarī, Tafsīr, vol. 1, p. 87.

- Ṭūsī, Tafsīr, vol. 1, p. 47.

52- Ṭabarī, Tafsīr, vol. 1, p. 87.

- Ṭūsī, Tafsīr, vol. 1, pp. 47-8.

53- For further details of this view, see :

- Ṭabarī, Tafsīr, vol. 1, p. 89.

- Zamakhsharī, Kashshāf, vol. 1, pp. 27-31.

- Qurṭubī, Tafsīr, vol. 1, p. 155.

the alphabet (14 letters) in the beginning of certain chapters dispenses with the mentioning of the remaining letters of the Arabic alphabet which have not been mentioned.⁵⁴ Some other exegetes suggest that each of these letters comprises various meanings. In this respect, it has been ascribed to al-Rabī' b. Anas that he says the three letters Alif-lām-mīm are the most common ones. Each one of them is a key of one of God's Names, or each of them might represent one of the Names of His blessings and trial (balā'), or each one of them might indicate a duration of certain people.⁵⁵ This interpretation goes on to elaborate a system of numerology. Finally there is the view already discussed that the disconnected letters are the secret of the Qur'ān.⁵⁶

The western scholars have also found the explanation of the of the disconnected letters difficult and have attempted several conjectures. As for Watt's view, he seems unwilling to accept even the notion that these letters have any meaning whatsoever,

- Bint al-Shāṭ'i , al-Tafsīr al-Bayānī li-al-Qur'ān al-Karīm , vol.2, p.43.

54- Ṭabarī, Tafsīr, vol.1, p.89.

- Ibn Kathīr, Tafsīr, vol.1, p.37.

55- Ṭabarī, Tafsīr, vol.1, p.88.

- For further discussion on various opinions being suggested regarding the meanings of these letters, see :

-Ṭabarī, Tafsīr, vol.1, pp.86-96.

- Zamakhsharī, Kashshāf, vol.1, pp.19-31.

- Ṭabarsī, Tafsīr, vol.1, pp.32-4.

- Ṭūsī, Tafsīr, vol.1, pp.47-51.

- Rāzī, Mafātīh, vol.1, pp.150-6.

- Abū Ḥayyān, al-Baḥr al-Muhīt, vol.1, pp.34-6.

- Zarkashī, Burhān, vol.1, pp.165-78.

- Qurṭūbī, Tafsīr, vol.1, pp.154-7.

-Suyūṭī, al-Durr, vol.1, pp.32-3.

56-Ṭabarī, Tafsīr , vol.1, p.88.

since he calls these letters "The mysterious letters". In this respect, we quote him: "These letters are a mystery. No satisfactory explanation of their meaning, if they have one, has been given, nor has any convincing reason been found for their occurrence in this position".⁵⁷ Sale although reporting some of the interpretations suggested by Muslim scholars, sees that the exact purport of these letters is unknown for people, except the Prophet Muḥammad. In this connection Sale writes: "These letters the Moḥammedans believe to be the peculiar marks of the Qur'ān, and to conceal several profound mysteries, the certain understanding of which, the more intelligent confess, has not been communicated to any mortal, their Prophet only excepted".⁵⁸

The fact that Mujāhid gives three somewhat differing views indicates that he was unsure himself as to the correct meaning of the disconnected letters. Similarly such great scholars as his teacher, Ibn 'Abbās, seem to be unsure in view of the different interpretations of the letters. From Mujāhid's definition, it seems clear that he was seeking to interpret the letters in a very literal way. As we have already noted, his third definition that the letters are separate letters is the starting point for his two other definitions. The disconnected letters are letters which stand at the beginning of the Sūrahs designating either the marks of the beginning of the Sūrahs or the names of new Sūrahs.

* * *

57- Watt, Bell's introduction to the Qur'ān, pp.61-2.

58- Sale, The Qur'ān with preliminary Discourse, pp.63-4.

Building on Mujāhid's understanding of the role of the Qur'ānic exegete, three issues in which Mujāhid is said to have exercised rational interpretation will then be studied. The first of these is the concept of the visibility of God in the Hereafter.

CHAPTER THREE

THE DOCTRINE OF THE VISIBILITY OF GOD IN THE HEREAFTER

One of the theological problems about which there was much discussion, is the question of whether God can or cannot be seen in the Hereafter. In this discussion the arguments in favour or against God being seen in the Hereafter involve the interpretation of two Qur'ānic verses. They are :

1. " That day will the believers' faces be resplendent, looking towards their Lord [or waiting for God's reward]¹ (wujūhun yawmai'dhin nādiratun. ilā rabbihā nāziratun)". (75 : 22-3).
2. "Visions comprehendeth Him not, but He comprehendeth all, He is the Subtle the Aware (lā tudrikuhu al-abṣāru wa-huwa yudriku al-abṣāra wa- huwa al-laṭīfu al-khabīru)". (6 : 103).

Before the development of systematic theology in Islam, Mujāhid propounded an interpretation of these two verses which later theologians, in particular the Mu'tazilites and the Shi'ites were to adopt.² He is reported to have held that God cannot be seen in the Hereafter.³

1- The second interpretation is the one which is adopted by Mujāhid.

2- For further debate on this theological problem, see :

- Ṭabarī, Tafsīr, vol.12, pp.13-23.

- Ash'arī, Maqālāt al-Islāmiyyīn, pp.153-7 and pp.213- 7, where nineteen points of view are put forward. Also, Ibānah, pp.13-9.

Al-Ṭabarī gives eight reports of this view of Mujāhid. Four of these are from Sufyān's Tafsīr and in three of these Sufyān's authority is Maṣū' while in the fourth Thuwayr is the transmitter of Mujāhid's view.⁴ Thuwayr has a very unsound reputation according to Ibn Ḥajar.⁵ He is regarded by many authorities as a liar and one of the weak transmitters. He is even accused of being a Shi'ite.⁶ In the remaining four reports, one is transmitted by al-A'mash directly from Mujāhid, two are transmitted by Jarīr on the authority of Maṣū' and the last one interestingly is transmitted by 'Amr b. 'Ubayd,⁷ one of the alleged founders of the Mu'tazilah, on the authority of Maṣū'. Thus Maṣū' is the authority for Mujāhid's view in six out of the eight reports. The claim that this was Mujāhid's view certainly was accepted by many later scholars including al-Qurṭubī⁸ and Ibn Kathīr.⁹

- Baghdādī, Uṣūl, pp.97-102.

- Rāzī, Mafātīḥ, vol.4, pp.114-8 and pp.560-1 and vol. 8, pp.266-9. Also, Kitāb al-Arba'in, pp.198-218.

- Watt, Free Will, p.135 and pp.138-9. Also, The Formative Period, pp.247-8. Also, Islamic Philosophy, pp. 84-5.

- Wensinck, The Muslim Creed, pp.88-90.

3-Ṭabarī, Tafsīr, vol.29, pp.192-3.

4- Ibid, pp.192-3.

5- Ibn Ḥajar, Tahdhīb al-Tahdhīb, vol. 2, pp.36-7.

6- Ibid, p.36.

7- wrongly given in the text of al-Ṭabarī 'Umar b. 'Ubayd. see Ṭabarī, Tafsīr, vol. 29, pp.192-3.

8- Qurṭubī, Tafsīr, vol. 19, p.108.

9- Ibn Kathīr, Tafsīr, vol.4, p.450.

10- Ṭabarī, Tafsīr, vol.29, pp.192-3.

However, it is noticeable that Ibn Abī Najīh's authority who is after all the most well-known transmitter of Mujāhid's views, is absent from all these reports. Nor it is quoted on the authority of Ibn Jurayj. It is not given in Ādam b. Abī Iyyās's version of Warqā's recension but as it occurs in the lacuna, discussed earlier, we cannot be absolutely certain that Warqā' did not report it. Yet the absence of Ibn Abī Najīh's name from al-Ṭabarī's reports makes this seem likely. Mujāhid's view on the issue at hand is always mentioned whenever his rational approach in tafsīr is discussed. In fact, the position of Mujāhid in this respect raises many questions. For instance, why does Mujāhid who is regarded as one of the greatest Ṭabi'ūn, disagree with the general consensus of the Sunnī Muslims? For many of early Sahābah and Tābi'ūn are reported to have held the view that God can be seen in the Hereafter.¹⁰ In addition, did Mujāhid's interpretation have any influence on the Mu'tazilite or the Shi'ite teachings since they adopt an opinion similar to his as regards this issue?

The nature of the thesis however requires that we have to restrict ourselves to the Qur'ānic verses which directly deal with this specific issue. In other words, we will not address those verses which speak about the probability or improbability of seeing God Almighty in this life. For instance, the verses in which Moses beseeches his Lord to show Himself to him and whether this may or may not imply the possibility of ever seeing God. Also it is not

part of our concern to deal with the accounts of whether the other Prophets including Muḥammad did or did not see God in this life.

Thus, the discussion will be presented as follows :

Firstly, the verses "That Day will the believers' faces be resplendent. looking towards their Lord [or waiting for God's reward] (ilā rabbihā nāziratun)" (75: 22-3) :

Constant reference is usually made by the majority of Muslim scholars to the above two verses because they regard them as the cornerstone of their contention, that God will be seen by the believers in the Hereafter. Al-Ṭabarī gives two ways of interpretations for the word nāzīrah mentioned in the above verse (75 : 23). Ibn 'Umar, al-Ḥasan al-Baṣrī and 'Ikrimah elucidate the word nāzīrah in the literal sense (zāhir) that it means the actual seeing of God.¹¹ The second interpretation is that it denotes waiting for the rewards and bounties of God. As already noted, this is the view maintained by Mujāhid.¹²

According to Mujāhid, the two verses together (75: 22-3) connote that the radiant faces of the believers will be nāzīrah that is muntazīrah (i.e., waiting for the rewards of God). Mujāhid further adds that the actual meaning of verse 75 :23 has nothing to do with

11- Ibid, pp. 192-3.

12- Ibid, pp.192-3.

the sensory seeing of God. In this connection, it has been reported that Manṣūr who was one of Mujāhid's disciples, as mentioned earlier, asked Mujāhid about the claim of some people that God can be seen. Mujāhid replied that God Himself sees but He cannot be seen by others.¹³

It seems that Mujāhid in interpreting the Qur'ānic word nāzīrah in the above verse by muntazīrah is adopting a purely linguistic approach, presuming that his linguistic explanation does exist in the Arabic language. As nāzīrah is a derivative of nazara yanzuru which means to wait.¹⁴

Nonetheless, even if Mujāhid tackles the word nāzīrah from a genuinely linguistic perspective, his explanation would still be opposed by many philologists as well as by many Sunni scholars. As far as language is concerned, for instance al-Azharī (d.370 / 980) sees that Mujāhid is mistaken in interpreting the word nāzīrah in the above verse (75:23) as muntazīrah, i.e., waiting for God's rewards. In justifying his argument, al-Azharī argues that in the Arabic lexicon it is incorrect to connect the verb nazara with the preposition ilā when intending intizār (waiting).¹⁵ Also, al-Tha'labī (d.427 / 1036) rejects the interpretation of Mujāhid for the word nāzīrah and describes it as spurious (madkhūl) because, as

13- Ibid, p.193.

14- Ibn Manzūr, Lisān, vol.7, p.74.

15- Qurtubī, Tafsīr, vol.19, p.107.

al-Tha'labī argues, since in the Qur'ānic verse under discussion nāzirah is connected with the preposition ilā, it does not mean anything else but the sensory ocular vision.¹⁶ Similarly Ibn Manẓūr puts it plainly that whoever explains the word nāzirah in the Qur'ānic verse (75: 23) as muntazirah, i.e., waiting for God's reward is mistaken. This is because, as Ibn Manẓūr argues, in the Arabic language it is incorrect to say nazartu ilā al-shay', (I looked at that thing) when you intend to say you expected it. But you can say nazartu fulānan when you mean that you expected him. In other words, Ibn Manẓūr wants to explain that the preposition ilā cannot be used with the verb nazara when it refers to expectation.¹⁷

In addition to the linguists, the theological opponents of the Mu'tazilites also use all the weapons at their disposal to attack the contention of Mujāhid and its proponents. Like Mujāhid, they resort to the Arabic language. For instance, al-Ash'arī¹⁸ (d.324 / 936) and al-Baghdādī¹⁹ (d.429 / 1037) maintain that when the verb nazara is meant to indicate intizār (waiting), it should be used without the preposition ilā. Al-Baghdādī further adds another stipulation in this respect, that the verb nazara when meaning intizār should also not be connected with the face (wajh) i.e., the face of the listener.²⁰

16- Ibid, p.107.

17- Ibn Manẓūr, Lisān, vol.3, p.665.

18- Ash'arī, Ibānah, p.13.

19- Baghdādī, Usūl, p.100.

20- Ibid, p.100.

The proponents of the view held by Mujāhid have put forward two arguments against this linguistic interpretation. Firstly, al-Nīsābūrī (d.550 / 1155) maintains that the argument that the preposition ilā cannot be used with the verb nazara when it means expected is sound when one deals with persons (i.e., waiting for somebody to come), but not when deals with abstract notions such as reward, ... etc.²¹

Secondly, both the Mu'tazilite scholar al-Zamakhsharī²² and the Shi'ite scholar al-Ṭabarsī²³ quote the Arabic verse poetry of Jamīl b. Ma'mar to illustrate that nazara ilā can mean expected. Jamīl says:

وَإِذَا نَظَرْتُ إِلَيْكَ مِنْ مَلِكٍ وَالْبَحْرُ دُونَكَ زِدْتَنِي نِعَمًا

i.e., when I hoped for your grace, you generously lavished upon me bounties and gifts. The phrase wa-al-bahru dūnaka is a parenthesis which denotes that even al-bahr (the sea) is less generous than the praised of the poet (mamdūh al-shā'ir). So the word nazartu which is used with the preposition ilā, (nazartu ilayka) in the above verse of poetry refers to the expectation and hope for the gifts of the praised. Therefore, since in the Arabic poetry the verb nazara meaning intizār (waiting and expectations) is used connected with the preposition ilā, this usage confirms the correctness of Mujāhid's interpretation of the Qur'ānic verse at issue (ilā rabbihā nāzirah)

21- Nīsābūrī, Gharā'ib, vol.29, p.103 f.

22- Zamakhsharī, Kashshāf, vol.2, p.662.

23- Ṭabarsī, Tafsīr, vol.1, p.398.

(75:23), that the believers are waiting and expecting the rewards of their Lord in the Hereafter.

Another reason is given by the Mu'tazilite Abū 'Alī al-Jubbā'i (d.303 / 915) in support of the interpretation of nāzīrah as waiting for. He argues that the word ilā in the verse ilā rabbiḥā nāzīrah is not a preposition (ḥarf jarr), but it is rather a single noun whose plural is ālā' (bounties). Thus, the meaning of the verse is that the believers are looking forward to be granted their Lord's bounties and rewards.²⁴ This view is opposed by Abū Naṣr al-Qushayrī (d. 514 / 1120) who firstly argues that the singular form of the word ālā' which is ilā, is usually written with the final alif (إِلا) and not with the final alif maqṣūrah (إِلي). Secondly, he says that if, according to al-Jubbā'i, the preposition ilā is regarded as a noun whose plural is ālā', then the meaning of the verse would be that the believers in the Paradise are waiting for God's bounties. Of course, the one who is waiting for something would be assumed to be uncomfortable. But the inhabitants of the Paradise who are immune from any calamity, are far secure from any discomfort.²⁵

However, the partisans of Mujāhid's opinion continue seeking more evidence to support their view and to repudiate their opponents'. They say that the word nāzīrah in the verse under discussion cannot mean the actual looking because, according to the

24- Ibn Ḥazm, Fiṣal, vol.3, p.3.

25- Qurtubī, Tafsīr, vol.19, p.108.

26- Ibid, p.108.

verse, the vision (baṣar) is ascribed to the face (wajh) instead of the eyes.²⁶ But Qushayrī objects saying that this structure is a literary device which is used in other Qur'ānic verses. For instance, in the verse: "God has prepared for them gardens under which rivers flow (tajrī min taḥtihā al-anhāru)" (9 : 89). Here in actual fact it is the water (mā') which flows in the rivers and not the rivers themselves which flow. Therefore since this sort of literary device is acceptable in the Arabic language, then there need be no restriction in ascribing the vision to the face and not to the eyes.²⁷ Besides, as al-Qushayrī adds, wajh might be used metaphorically to mean the eye ('ayn) as it is the case in the story of Joseph and his brothers. Joseph asked his brothers to take his shirt and cast it over their father's (Jacob's) face, as the Qur'ān says: "Go with my shirt and cast it over the face of my father, he will come to see clearly (idhhabū bi-qamīṣī hādhā fa-alqūhu 'alā wajhi abī ya'ti baṣīrān ..." (12:93). So what Joseph really meant is that he asked them to cast the shirt over Jacob's eyes, as blindness inflicts only the eyes and not the face.²⁸ Al-Qushayrī further remarks that it is not impossible that the normal convention of things can be reversed by the Almighty God in the Hereafter or at any time, that God is able to create the vision in the face instead of the eyes. This is similar to the verse: "Is there one who walks headlong with his face grovelling better guided, or one who walks evenly on a straight way ?" (67:22). With regard to the interpretation of this verse, it has been reported that when the

27- Ibid, P.108.

28 - Ibid, 108.

Prophet had been asked about how the unbelievers can walk on their faces in the Hell-fire, he answered that God who created for them the feet to walk with is able to change that and make them walk on their faces.²⁹

These are the main arguments put forward by al-Qushayrī to support the view that the usage of the Qur'ānic phrase ilā rabbihā nāzīrah denotes that the believers will see their Lord with their eyes in the Hereafter. They support the view of the majority of the exegetes and consequently reject Mujāhid's and the Mu'tazilites' opposing interpretation mentioned above.

The Qāḍī 'Abd al-Jabbār (d 415 / 1024), the celebrated Mu'tazilite commentator and the author of Tanzīh al-Qur'ān 'an al-Maṭā'in also agrees with Mujāhid's opinion. He maintains that the seeing of God in the life to come is not rationally possible. Thus the word nāzīrah in the verse should not be understood to mean that God will be seen by the physical eyes. But it is the reward of God that the eyes of the believers are looking for. He adds that the verse under discussion is similar to another Qur'ānic verse which says: "... and ask the town (qaryah)..." . Qaryah here, of course, metaphorically stands for the inhabitants of the town and not the town itself.³⁰ Similarly al-Zamakhsharī in his renowned book al-Kashshāf fully

29- Ibid, p.108.

30- Jullanari, I. Q. 12, p.92.

31- Zamakhsharī, Kashshāf, vol. 2, p.661. Also for the view of al-Zamakhsharī, see Catje, The Qur'ān and its Exegesis, pp.162-3.

accepts Mujāhid's interpretation.³¹ He likens the verse ilā rabbihā nāzīrah with some one saying: "anā nāzīrun ilā fulānin mā yaṣna'u bī". The meaning of nāzīr in both statements indicates expectation and hope. Al-Zamakhsharī further adds another rhetorical remark which has not been mentioned by Mujāhid as regards the interpretation of the Qur'ānic verse at issue. He says that the placing of the phrase ilā rabbihā before the word nāzīrah is an emphatic indication that the believers will not anticipate the bounties and grace from any one but God.³²

In his treatment of the rational approach in tafsir, the western scholar Goldziher discusses Māhid's interpretation of the verse under discussion. He remarks that although Mujāhid is regarded as one of the authoritative exegetes and one of the closest disciples of Ibn 'Abbās, he rejects the common and obvious interpretation of the above verse.³³ Instead, he adopts a daring opinion that the verse refers to the eagerness of the believers for God's reward. Goldziher concludes by stating that although Mujāhid's contention corresponds with that of the Mu'tazilites with regard to this particular issue, he does not have any inclinations towards Mu'tazilite teachings.³⁴ However, the full elaboration of Mu'tazilite theology had not yet

32- See the previous footnote.

33- Goldziher, Die Richtungen der Islamischen Koranauslegung, translated into Arabic by 'Abd al-Ḥalīm al-Najjār, p.129.

34- Ibid, p.129.

been realised in Mujāhid's life time and this interpretation by Mujāhid does show his rationalistic tendencies.

Like the Mu'tazilites, the Shi'ites also advocate Mujāhid's contention with regard to the doctrine of the visibility of God on the Day of Judgement.³⁵ With reference to the elucidation of the verse at issue, the Shi'ite commentator al-Qummī states that the word nāzirah in the above verse connotes that the believers are looking for the reward of God in the Hereafter.³⁶ In addition to Mujāhid, al-Qummī attributes this interpretation to a group of the Tabi'ūn. They are : Abū Ṣāliḥ , al-Ḥasan al-Baṣrī, Sa'īd b. Jubayr and al-Ḍaḥḥāk.³⁷

Similarly the Shi'ite commentator al-Ṭūsī (d.406/1015) supports Mujāhid's contention by construing the verse as meaning that the believers are waiting for the reward of God to reach them.³⁸ Al-Ṭūsī further adds that there is no discomfort in that waiting (intizār) for God's reward because, as he argues, the waiting would cause discomfort when there is no guarantee or assurance that the one who waits for the reward would get it or the discomfort may occur if the one who waits for that reward is in a great need for it forthwith. However, as al-Ṭūsī argues, the condition of the believers on that Day is otherwise, because while they are waiting for God's

35- Ash'arī, Maqālāt al-Islāmiyyīn , p.216.

36- Qummī, Tafsīr , vol.10, p.199.

37- Ibid, p.199.

38- Ṭūsī, Tafsīr, vol.10, pp.197-9.

on that Day is otherwise, because while they are waiting for God's grace, they are comfortable, happy and in unimaginable luxury. Besides, they are sure and confident that they will obtain God's reward.³⁹ Al-Ṭūsī ascribes this view to Mujāhid, as well as to that group of Tābi'ūn mentioned earlier by al-Qummī. However, al-Ṭūsī further adds the name of 'Ali b. Abī Ṭālib as also being one of the adherents of this opinion.⁴⁰

Like his predecessors, the Shi'ite commentator al-Ṭabarsī opts for the standpoint of Mujāhid that nāzirah in the verse at issue connotes that the believers are waiting for God's grace. In other words, he rejects the interpretation of the opponents of Mujāhid when they take nāzirah here as referring to the actual seeing of God, arguing that God is too great to be seen by the human eye.⁴¹

Furthermore, al-Ṭabarsī puts a linguistic argument to support Mujāhid's contention. He says that nazar in the Arabic language does not mean merely ru'yah (seeing) because, as he argues, when nazar pertains to the eye, it implies the demand to see. For instance, one says: nazartu ilā al-hilāli fa-lam arahu (I looked for the moon but I did not see it). So if nazar had meant ru'yah, then the above phrase would have been invalid and contradictory.⁴²

39- Ibid, pp.197-9.

40- Ibid, pp.197-9.

41- Ṭabarsī, Tafsīr, vol.10, p.398.

42- Ibid, p.398.

Secondly, the verse: "Visions comprehendeth Him not, but He comprehendeth all visions (lā tudrikuhu al-absāru wa-huwa yudriku al-absāra ...)". (6:103) :

The above verse is the strongest evidence which could be used by Mujāhid and those who deny the seeing of God in the Hereafter. In fact no actual report on this verse is given from Mujāhid either by al-Ṭabarī or in Ādam b. Abī Iyyās's version of Warqā's recension. The proponents of the idea of the possibility of seeing God in the Hereafter just take the literal sense of the verse (zāhir) and therefore interpret the term ru'yah (vision) in the above verse as exactly equal to the term idrāk (comprehension).⁴³ So the phrase lā tudrikuhu al-absāru explicitly means lā tarāhu al-absāru (the material eyes cannot see God), while God is able to see his creatures (wa-huwa yudriku al-absāra). So the main emphasis of this group lies in the fact that the terms ru'yah and idrāk are synonymous.

On the other hand, the opponents of this view consider the term ru'yah as something quite different from idrāk and that the two terms are not synonymous, as is claimed. They contend that idrāk

⁴³. Tabari, Tafsir, vol. 12, pp.16-7.

- Razi, Mafatih, vol. 4, p.115.

connotes catching (luḥūq) and reaching (wuṣūl). This meaning of idrāk , according to their view, does occur in the Qur'ān. For instance, in the verse : "... when drowning overtook him (hattā idhā adrakahu al-gharaghu)". (10 : 90). So according to this Qur'ānic verse, the drowning reached Pharaoh. This group further argues that if idrāk means ru'yah , as is alleged, then the meaning of the aforesaid verse (10:90) would be that the drowning saw Pharaoh which is, of course, an absurd idea, that is to consider drowning (gharaq) as a living object which can see other things.⁴⁴ Hence in their view, the argument of their opponents apparently crumbles and does not stand the test.

So the majority of Muslim scholars who object to this opinion, interpret the verse under discussion (6:103) according to the above understanding, that the visions of the human beings will see God but will not be able to conceive nor discern fully the Glory and Majesty of Almighty God, because it is beyond the limit. They further add that the statement that God will be seen but not utterly perceived by the human faculty of vision, is similar to the statement that He is known but at the same time He is the Absolute and the Infinite.⁴⁵

44- Ṭabarī, Tafsīr , vol.12, p.15

45- Ibid, p.15.

The partisans of the view that God cannot be seen seek every possible support for their aforementioned opinion. They set forth another rational argument that if the visions (absār) will see God in the same manner as they see human beings, then this indicates that God is limited (maḥdūd). So if God can be described by the characteristics of corporeality, then He would be like the other tangible bodies.⁴⁶ But, since that is an untrue conclusion, as far as God is concerned, then logically the premise that the human eyes cannot see Him is a true proposition.⁴⁷ Furthermore, this group in their rejection of the seeing of God presents another logical argument which is closely related to the above one. They say that it is known that the function of the eyes is to distinguish the colours. If God is visible by the ordinary eyes, therefore then that means He has colours. However since it is absurd to describe God as possessing colours, then it is impossible that He can be seen.⁴⁸

Ibn Ḥazm (d. 456 / 1063) however answers the above argument of those who deny the seeing of God of whom Mujāhid seems to be a precursor. Ibn Ḥazm says that he accepts that ordinary human eyes are unable to see God on the Last Day. But he adds that God will be seen by an extra power other than that originally made for

46- Ibid, p.18.

47- Ibid, p.18.

48- Ibid, p.18.

the human eyes⁴⁹ Some scholars like Dirār b. 'Amr and Ḥafṣ al-Fard name that extra power as the sixth sense.⁵⁰

In addition, the partisans of the view that God cannot be seen in the Hereafter infer another argument concerning the verse at issue (6:103) to support their view. They say that the Qur'ānic verse prior to the verse at hand (i.e., 6:102) concludes by mentioning praises to God. That verse says: "Such is God your Lord. There is no God save Him the Creator of all things, so worship Him. And He taketh care of all things". Similarly the second part of verse 6 : 103 (... wa-huwa yudriku al-absāra) indicates also a praise to God. Therefore, as this group argues, the first part of verse 6:103 lā tudrikuhu al-absāru should also be considered as an exclusive Praise to God, because that part falls between two statements, each of which is a particular praise to God. So if it has been understood from the first part of the second verse (i.e., lā tudrikuhu al-absāru) that God will be seen, as their opponents argue, then this indicates disharmony between those two Qur'ānic verses (6:102 and 6:103). Of course, disharmony is believed to be impossible as regards the Qur'ān which is the speech of God.⁵¹ The contention and arguments that deny the concept of seeing God in the Hereafter would therefore be proved to be correct as this group believes.

49- Ibn Ḥazm, Fīṣal , vol.3, p.2.

50- Ash'arī, Maqālāt al-Islāmiyyīn , p.216.

- Ash'arī al-Qummī, al-Maqālāt wa- al-Firaq, p.143.

51- Rāzī, Mafātiḥ, vol.4, p.115.

If we look at the two Qur'ānic verses previously discussed (75 : 23 and 6 : 103) together, it appears that each of the two groups (i.e., the group to whom Mujāhid seems to be a precursor and their opponents) understands both verses as being in complete conformity with each other. The proponents of the view that God cannot be seen in the Hereafter maintain that this is the clear meaning of verse 6 : 103 and is thus reconciled with verse 75 :23 by understanding nāzirah to refer to expecting and not seeing. On the other hand, their opponents mainly argue that since God speaks plainly in the verse 75: 23 that the believers will see Him, then verse 6:103 should be understood to confirm this meaning. Verse 6:103 must thus not be taken in its esoteric sense because, as they argue, if that verse is discerned in its obvious and ostensible sense (zāhir), then a state of contradiction will occur between the two verses, which is an impossible event. Because essentially the Qur'ānic texts confirm and explain each other as held by the consensus of Muslim exegetes and scholars.⁵²

Three other verses are used in the argument of whether God can be seen in the Hereafter. None of these three verses actually refer to words which could be literally interpreted as the believers either seeing or not seeing God in the Hereafter. However, all Muslims exegetes deal with them in terms of this argument. The first of these verses is :

⁵²- Ṭabarī, Tafsīr , vol. 12, pp.15-6.

"Those who do good shall receive a most excellent reward and a superabundant addition neither dust nor ignominy cometh near their faces (li-alladhīna aḥsanū al-husnā wa-ziyādatun wa-lā yarhaqu wujūhahumu qatarun wa-lā dhillatun ...)" (10:26) :

The exegetes differ concerning the meaning of the word ziyādah (literally addition) in the above verse. Two main interpretations are propounded. (i) The term ziyādah may denote looking at the Face of God. (ii) It might indicate the abundant reward and bounties given by God to those who did good deeds in their lives.⁵³ As would be expected from his interpretation of verse 75 : 23, Mujāhid adopts the second elucidation. Accordingly, he interprets ziyādah as referring to the pleasure and forgiveness bestowed by God on the believers.⁵⁴ This report is given in Ādam b. Abī Iyyās's version of Warqā's recension⁵⁵ and it is also reported by al-Ṭabarī from Shibl's version.⁵⁶ In both cases the authority for Mujāhid's view is Ibn Abī Najīh.⁵⁷

Al-Zamakhsharī, who represents the Mu'tazilite view, prefers Mujāhid's interpretation as he holds that ziyādah means more than the reward deserved, which is the grace of God.⁵⁸ Al-Zamakhsharī

53- Ibid, vol.15, pp.62-71.

54- Mujāhid, Tafsīr, vol.1, p.293.

55- Ibid, p.293.

56- Ṭabarī, Tafsīr, vol. 15, p. 70.

57- Ibid, p. 70.

58- Zamakhsharī, Kashshāf, vol.2, p.342.

goes further to argue that the explanation of Mujāhid can be strengthened by both the Qur'ānic text and the statements of the authoritative exegetes. Regarding the Qur'ān, al-Zamakhsharī cites the verse: "Then as for those who believed and did good works unto them will He pay the wages in full adding unto them of His bounty (wa-yazīduhum min fadlihi ...)". (4: 173). So in the opinion of al-Zamakhsharī, the statement wa-yazīduhum min fadlihi stands for the additional grace bestowed by God on those who believe in Him. There are also statements by some of the early exegetes regarding the explanation of the word ziyādah in the verse at issue (10: 26) which support Mujāhid's view that the term ziyādah does not mean the sensory seeing of God but it rather means more grace offered by God. For instance, 'Alī b. Abī Ṭālib maintains that ziyadah is a room made of a single pearl which has four doors.⁵⁹ Ibn 'Abbās, 'Alqamah and Qatādah construe ḥusnā, mentioned in the same verse, as one single reward for each single good deed and ziyādah as the doubling of the reward tenfold.⁶⁰ Ibn Zayd understands ziyādah as referring to the bounties which God gives to the believers in their worldly life and that He will not call them to account for those bounties in the Day of Resurrection.⁶¹

Furthermore, according to Fakhr al-Dīn al-Razī's analysis, the contention of Mujāhid that ziyādah stands for the grace and forgiveness of God, can be supported by a rational argument. It is

59- Ṭabarī, Tafsīr, vol. 15, p. 69.

60- Ibid, p. 70.

61- Ibid, p. 71.

argued that ziyādah should be from the same kind of object (i.e., bounties) to which it has been added (al-mazīd 'alayhi). The seeing of God nonetheless is not a part of the bounties of Paradise.⁶² Al-Rāzī does not actually accept this argument but supports the view that ziyādah signifies the seeing of God in the Hereafter. He suggests that if al-mazīd 'alayhi (the augmented) can be measured by a specific amount, then the augmentation (ziyādah) should be from the same kind. But if al-mazīd 'alayhi cannot be measured by a certain gauge, then the additional must be something different. Al-Rāzī continues his logical argument by applying the above premises to the verse at hand (10:26). He says that the term ḥusnā which refers to Paradise is infinite (mutlaq) so that additional (ziyādah) must also be something different which is the sensory seeing of God.⁶³ According to him, the argument of Mujāhid therefore is invalid.

By and large, the majority of the exegetes object to Mujāhid's contention as regards the interpretation of the above Qur'ānic verse (10: 26). They interpret ḥusnā as Paradise and ziyādah as the sensory seeing of the Face of the Almighty God. Al-Ṭabarī mentions Abū Bakr, 'Āmir b. Sa'd, Ḥudhayfah, Abū Ishāq, Abū Mūsā al-Ash'arī, 'Abd al-Raḥmān b. Abī Laylā, al-Ḥasan al-Baṣrī, Ṣuhayb, Qatādah, Ka'b b. 'Ujrah, 'Abd al-Raḥmān b. Thābit and Abū

62- Rāzī, Mafātih, vol.4, p.561.

63- Ibid, p.561.

al-‘Āliyah as some of the staunch adherents of the aforesaid exegetical opinion.⁶⁴ However, surprisingly, Ibn Kathīr in his treatment of the verse at issue mentions the name of Mujāhid among the exegetes who understand ziyādah as referring to the actual seeing of God.⁶⁵ As there is no earlier report to this effect, we must presume that Ibn Kathīr is incorrect in making this attribution to Mujāhid.

In supporting their contention that ziyādah in verse 10 : 26 means the actual seeing of God, the majority of the exegetes quote a tradition reported by Muslim in his Ṣaḥīḥ. "Ṣuhayb narrates that the Apostle says: 'When those deserving Paradise enter it, the Blessed and the Exalted would ask them: 'Do you wish Me to give you anything more?' They would say: "Have you not brightened our faces? Have you not made us enter Paradise and saved us from Hell-Fire?" The narrator says: 'God would then lift the veil and of things given to them nothing would be dearer and more magnanimous to them than the seeing of their Lord the Mighty and the Glorious'".⁶⁶ Ḥammād b. Salamah narrates this tradition on the same authority but he adds: "The Prophet then recited the Qur'ānic verse: 'Those who do good shall receive a most excellent reward and a superabundant addition ...' (the verse under discussion).⁶⁷ So that is

64- Ṭabarī, Tafsīr, vol.15, pp.63-9.

65- Ibn Kathīr, Tafsīr, vol.2, p.414.

66- Muslim, Ṣaḥīḥ, vol.1, p.75.

67- Ibid, p.75.

a clear indication that the Prophet understands ziyādah in this verse as referring to the seeing of God.

The above verse (10: 26) according to al-Rāghib al-Iṣfahānī (d. 502 / 1108) indicates that the seeing of God is the highest propitious reward ever received by a Muslim. It is a special favour from God.⁶⁸ Al-Ghazālī (d. 505 / 1111) also in Iḥyā', like the majority of the exegetes, interprets the word ziyādah to mean the seeing of the Face of God. For him that is the greatest pleasure and the utmost favour to be granted to the believers.⁶⁹ In other words, al-Ghazālī rejects Mujāhid's opinion.

It is not surprising for Mujāhid to ignore this interpretation and to adhere to the idea of additional reward since otherwise he would seem inconsistent in his position.

The second of these subsidiary verses is :

"There they have all that they desire, and there is more with us (la-hum mā yashā'ūna fī-hā wa-ladaynā mazīdun)"
(50:35) :

In their efforts to seek more support for their view, the opponents of Mujāhid usually quote the above verse (50:35) as one

68- 'Abd al-Raḥmān Ṣidqī, see Ṣaḥīḥ Muslim, vol.1, p.75, English edition, the comments of the translator.

69- Ghazālī, Iḥyā', vol.4, pp.674-5.

In their efforts to seek more support for their view, the opponents of Mujāhid usually quote the above verse (50:35) as one of their textual evidence that God will be seen in the Hereafter. They construe the word mazīd (augmentation) mentioned in the above verse as meaning that it is possible to see the Face of God in the Hereafter without asking how.⁷⁰ Al-Qurṭubī ascribes the above contention to Anas b. Mālik and Jābir b. ‘Abd Allāh, the two prominent Sahābah.⁷¹ Confirming the possibility of seeing God, Ibn Kathīr adds that the appearance of God for the believers in the Hereafter will take place every Friday.⁷²

As for Mujāhid himself, no specific elucidation as regards the above Qur’ānic verse has been ascribed to him either in the Ādam b. Abī Iyyās’s version of Warqā’s recension or in the other known tafāsīr we have been able to consult. However, those who deny the doctrine of seeing God interpret the word mazīd here as referring specifically to the luxuries in Paradise. Al-Zamakhsharī, who endorsed Mujāhid’s previous interpretation, interprets mazīd as the greatest bounties which no eye has ever seen and no ear has ever heard of. It is perfect life and perpetual delight.⁷³ Other exegetes maintain that the term mazīd stands for the houris being offered to the believers as an honour from God.⁷⁴

70- Qurṭubī, Tafsīr, vol.17, p.21.

71- Ibid, p.21.

72- Ibn Kathīr, Tafsīr, vol.4, p.228.

73- Zamakhsharī, Kashshāf, vol.4, p.39.

74- Abū Ḥayyān, al-Baḥr al-Muḥīṭ, vol.8, p.390.

Finally, there is the verse:

"Nay, but surely on that Day they (the disbelievers) will be covered from their Lord (kallā inna-hum 'an rabbihim yawma'idhin la-mahjubuna)" (83:15) :

The majority of the exegetes see hijāb (veil), which is derived from the word mahjūbūn mentioned in the above verse, as a real barrier which prevents the disbelievers from seeing God.⁷⁵ With regard to this, al-Shāfi'ī (d. 204 / 819) infers an interesting remark as he argues that since some people who are the unbelievers will be debarred from their Lord, others should see him. Of course, the latter are supposed to be the believers.⁷⁶

There is no specific mention of the opinion of Mujāhid in al-Ṭabarī's Tafsīr or in Ādam b. Abī Iyyās's version of Warqā's recension. However, Ādam b. Abī Iyyās does include a tradition which is reported from al-Ḥasan al-Baṣrī which maintains that the believers will see God and the unbelievers will be prevented from seeing him.⁷⁷ The same tradition with the same isnād is given by al-Ṭabarī.⁷⁸ Despite the absence of a report from Mujāhid in

⁷⁵- Qurṭubī, Tafsīr, vol.20, p.259.
- Baghawī, Ma'ālim, vol.4, p.460.

⁷⁶- Ibn Kathīr, Tafsīr, vol.4, p.486.

⁷⁷- Mujāhid, Tafsīr, vol.1, p. 738.

⁷⁸- Ṭabarī, Tafsīr, vol.30, p. 100.

both al-Ṭabarī's work and Ādam b. Abī Iyyās's version of Warqā's recension, al-Qurṭubī claimed that Mujāhid interprets the verse under discussion as indicating that the unbelievers are debarred from the favour and mercy of God.⁷⁹ Of course, the believers' recompense will be the opposite of that that they will receive the favour and mercy of God. Qatādah is said to have supported Mujāhid's view in this respect.⁸⁰

Although al-Zamakhsharī concurs with Mujāhid's opinion in principle, that God will not be seen in the Hereafter, he adopts a different standpoint from him as far as the above verse is concerned. He says that the veil (hijāb) is not real and tangible but it is rather used here metaphorically. The purpose of the metaphor, according to al-Zamakhsharī, is to mock and humiliate the unbelievers. He further explains this opinion by comparing God to a king whom only the high ranking people are allowed to see, whereas ignoble people are not.⁸¹ Like Mujāhid, al-Zamakhsharī's main emphasis is to deny the concept of seeing God in the Hereafter.

Despite being a commentator who advocates the idea that God will be seen, it seems that concerning the elucidation of the above verse (83:15), al-Ṭabarī takes an intermediary position between the two conflicting views. He construes the present verse as indicating

79- Qurṭubī, Tafsīr, vol.20, p.259.

80- Ibid, p.259.

81- -Zamakhsharī, Kashshāf, vol.4,p.722.

that the unbelievers will be veiled from both the seeing of God and from His favour and mercy.⁸² Al-Ṭabarī argues that since the statement in the verse at hand (kallā inna-hum 'an rabbihim yawma'idhin la-mahjūbūna) comes in general and there is no indication for any specifications, we should take it as it is. In other words, al-Ṭabarī combines the explanation of Mujāhid (i.e., the verse indicates that the believers will get the favour and mercy of God) and the view of those who take the verse as referring to the actual seeing of God.⁸³

The aforementioned Qur'ānic verses form the basic textual evidence usually propounded as regards the question whether God will or will not be seen in the Hereafter. However, in addition to those above named verses, the antagonists of Mujāhid's view understand also every Qur'ānic verse which deals with the meeting of God (liqā' Allāh) with His creatures as further textual evidence of the possibility of seeing God on the Day of Resurrection.⁸⁴

In addition to the Qur'ān, the partisans of the concept of seeing God in the Hereafter resort also to the Sunnah to supply them with further necessary proofs. Numerous traditions are reported in the Books of hadīth, all of which convey the idea that God will reveal Himself before the believers on the Day of Resurrection.⁸⁵ However,

82- Ṭabarī, Tafsīr, vol.30, p.100.

83- Ibid, p.100.

84-Rāzī, Mafātīh, vol.1, pp.328-9.

85- We will suffice with only two traditions in this respect. (i) " Jābir b. 'Abd Allāh narrates that they were sitting with the Prophet and he looked at the moon on the night

what is the position of Mujāhid as regards those traditions? The answer to this question is given by Ibn Ḥazm who maintains that an excuse such as the ignorance of the Prophetic traditions which give rise to the concept of seeing God in the Hereafter, should be sought for Mujāhid.⁸⁶

In conclusion, it can be said that even if we accept the justification suggested by Ibn Ḥazm, that Mujāhid did not hear the Prophetic traditions which convey the idea of the possibility of seeing God in the Hereafter, the question is still raised that why does Mujāhid interpret the Qur'ānic verses at issue in a way which deny the seeing of God. It appears from the report of Maṣūūr that

of the full moon, and said: 'You people will see your Lord as you see this full moon and you will have no trouble in seeing Him, if you can avoid (through sleep) a prayer before sunrise (fajr) and a prayer before sunset ('asr) you must do so.'" [Bukhārī, Sahīh, vol.9, pp.389- 90]. According to this tradition, the Prophet emphatically states that the believers will see their Lord in an indubitable way on the Day of judgement. Therefore, this tradition confirms the interpretation of Mujāhid's opponents that the seeing of God by the believers on the Last Day is beyond doubt.

(ii) "Abū Hurayrah narrates that the Prophet said : 'There are three types of persons God neither speaks to them on the Day of Resurrection, nor look at them (wa-lā yanzur ilayhim). They are : (A) A man who takes a false oath that he has been offered for a commodity a price greater than what he has actually been offered. (B) A man who takes a false oath after 'asr prayer in order to grasp the property of a Muslim through it. (c) A man who forbids others to use the remaining superfluous water. To such a man God will say on the Day of Resurrection: "Today I withhold my blessings from you as you withheld the superfluous part of the water which your hands did not create""'. [Bukhārī, Sahīh, vol.9, p.405]. So what concerns us in this tradition is one of the two bad things which the three wicked persons, mentioned in the above hadīth, found as a punishment from God, is that God will never look at them. In other words, they will be debarred from seeing God. Hence other people who are supposed to be the righteous believers, will be on the opposite scale, i. e. , they will be honoured the privilege of seeing God. Therefore, this tradition also gives support to the opinion of Mujāhid's opponents as regards their interpretation of the five Qur'ānic verses discussed .

86- Ibn Ḥazm, Fiṣal, vol.3, p.2.

Mujāhid in principle rejects the notion of seeing God in the Hereafter. As regards his treatment of the Qur'ānic verses at issue, it seems that Mujāhid adopts a rational approach where he disagrees with most of the reports from the Ṣahābah and Tābi'ūn on this subject. Perhaps Mujāhid also uses his linguistic abilities in interpreting the verses here in a way not to refer to the actual seeing of God. Both the Mu'tazilites and the Shi'ites also adopt the idea that it is impossible to see God in the Hereafter. However, there is no evidence at all which shows that there is any relationship between the teaching of those two groups and that of Mujāhid.

In fact, this is one of the main issues on which Mujāhid has been criticized by the orthodox scholars of exercising a rational tendency in tafsīr.

As a result of his interpretation of being one of the those who are rāsikhūn fī al-'ilm, Mujāhid is claiming to have the necessary scholarship to decide what the various verses of the Qur'ān mean. In this case, he has chosen a meaning which is in conflict with the orthodox theological interpretation of these verses whenever that was elaborated.

This interpretation of Mujāhid is surprisingly advanced theologically when one considers that theologians of that time and later were concerned with a far more material description of God.

* * *

The second of those issues in which Mujāhid is said to have used a rational approach concerns the interpretation of the phrase maqāman mahmūdā in verse 17:79. This will be the subject of the following chapter.

CHAPTER FOUR

THE HONOURABLE STATUS (AL-MAQĀM AL-MAHMŪD)

The Qur'ān states : "And some part of the night awake for it as a largess for thee it may be that thy lord will raise thee to an honourable stature ('asā an yab'athaka rabbuka maqāman maḥmūdān)." (17: 79).

In the above Qur'ānic verse God speaks to the Prophet Muḥammad encouraging him to perform the voluntary midnight prayer,¹ because the practice of this particular prayer will lead to the Prophet being raised to an honourable stature (maqāman maḥmūdān). So the question which arises here is: what is meant by maqām maḥmūd?

Two major interpretations have been put forward as regards the meaning of this expression. Firstly, the majority of Muslim scholars (al-jumhūr) hold that it denotes the privilege of the intercession being given to the Prophet Muḥammad on the Last Day. This interpretation, for instance, has been attributed to Mujāhid,² Ḥudhayfah, al-Ḥasan al-Baṣrī, Qatādah and Sulaymān.³ Al-Ṭabarī

1- This prayer is the -so-called ṣalāt al-tahajjud , i.e., the prayer after midnight in the small watches of the morning.

2- Mujāhid, Tafsīr, vol. 1, p.369.

- Ṭabarī, Tafsīr, vol. 15, pp.144-5.

3- Ṭabarī, Tafsīr, vol. 15, pp.144-5.

gives this report on the authority of Ibn Abī Najīh according to the recensions of 'Īsā and Warqā'.⁴ It is also reported in Ādam b. Abī Iyyās's version of Warqā's recension on the authority of Ibn Abī Najīh.⁵ In addition, al-Ṭabarī also gives this report on the authority of Ibn Jurayj who reports directly from Mujāhid.⁶ The second interpretation is that maqām mahmūd connotes that God will raise His Prophet to the highest position of honour, that God will seat the Prophet with Him on the Throne (yujlisuhu ma'a-hu 'alā al-'arsh) in the Hereafter. According to al-Ṭabarī, this interpretation is also attributed to Mujāhid.⁷ He gives it on the authority of Layth.⁸ Al-Qurṭubī⁹ and al-Suyūṭī¹⁰ both confirm the attribution of this interpretation to Mujāhid. However as they are both quoting al-Ṭabarī, this cannot be regarded as independent evidence for the attribution of this view to Mujāhid. Al-Baghawī¹¹ also gives this report on the authority of Mujāhid but does not give his source for this. Fakhr al-Dīn al-Rāzī also quotes this attribution of this view to Mujāhid from al-Wāḥidī (d.468 / 1075).¹² However as al-Wāḥidī died over a century after al-Ṭabarī, we cannot be sure that he is not quoting al-Ṭabarī. Al-Qurṭubī suggests a further interpretation of this verse by Mujāhid which is a modification of the second interpretation. This simply involves God making the Prophet sit on the Throne without mentioning

4- Ibid, p.144.

5- Mujāhid, Tafsīr, vol. 2, p. 369.

6- Ṭabarī, Tafsīr, vol. 15, p. 144.

7-Ibid, p.145.

8- Ibid, p. 145.

9- Qurṭubī, Tafsīr, vol.10, p.311.

10- Suyūṭī, Durr, vol.4, p.198.

11- Baghawī, Ma'ālim, vol.3, p. 132.

12- Rāzī, Mafātīh, vol. 5, p. 431.

that the Prophet sat with God.¹³ While al-Ṭabarī does not attribute this interpretation to Mujāhid, he does mention that it was the view of 'Abd Allāh b. Sallām.¹⁴

In fact both the first and the second interpretations of the Qur'ānic phrase 'asā an yab'athaka rabbuka maqāman mahmūdan have aroused dispute concerning two important issues; namely shafā'ah (i.e., the intercession of the Prophet on the Day of Judgment) and the seating of the Prophet with his Lord on the Throne in the Hereafter. Interestingly, as has been mentioned, Mujāhid is attributed with both opinions. If the first one is really his, then he is in an agreement with the orthodox approach of the majority of the scholars (jumhūr), whereas the second view is regarded as unusual.¹⁵ However, it seems to have been held by a group of Ḥanbalis, immediately prior to al-Ṭabarī, including Aḥmad b. Ḥanbal himself. Al-Ṭabarī has already been involved in rather vitriolic disputes with these Ḥanbalis on this subject. It may be that he includes this second interpretation from Mujāhid as an attempt to pacify his Ḥanbalī critics. He certainly goes out of his way to affirm that he thought it could be a possible interpretation of the verse, even though he had previously denied such a possibility.¹⁶

13- Qurṭubī, Tafsīr, vol. 10, p. 311.

14- Ṭabarī, Tafsīr, vol. 15, p. 148.

15- The second view is also attributed to the following Companions: Ibn 'Abbās. [see, Suyūṭī, Durr, vol. 4, p. 198], 'Abd Allāh b. Mas'ūd [see Rāzī, Mafātīh, vol. 5, p. 431], 'Abd Allāh b. Sallām [see Baghawī, Ma'ālim, vol. 3, p. 132].

16- See Gilliot, Exégèse, langue, et théologie en Islam: L'exégèse coranique de Ṭabarī, pp. 249-54.

THE INTERPRETATION OF MAQĀM MAĤMŪD AS
REFERRING TO THE INTERCESSION OF THE PROPHET
IN THE HEREAFTER:

As has been mentioned, Mujāhid in the first opinion attributed to him agrees with the general consensus that maqām maĥmūd, which is mentioned in the Qur'ānic verse under discussion (17: 79), means the honour of intercession being granted to the Prophet Muĥammad on Doomsday.¹⁷ It should be noted that this report of Mujāhid's view is given both by Ibn Abī Najīĥ and Ibn Jurayj who, as already discussed, are regularly cited as authorities for Mujāhid's interpretations in al-Tabarī's Tafsīr.¹⁸ Perhaps in adopting this opinion Mujāhid has been influenced by the numerous traditions which convey this meaning. For instance, al-Bukhārī (d.256 / 869) reported in his Ṣaĥīĥ that Ibn 'Umar related that : " On the Day of Resurrection the people will fall on their knees and every nation will follow its respective Prophet saying : 'O So-and-So ! intercede for us with God', till the right of the intercession (shafā'ah) is finally given to the Prophet Muĥammad and that will be the day when God will raise him to the stature of high praise and glory (maqām maĥmūd)".¹⁹ Likewise, al-Tirmidhī reports a tradition which gives support to the above opinion of Mujāhid, that Abū Hurayrah narrates that when the Prophet has been asked about the interpretation of the Qur'ānic verse 'asā an yab'athaka rabbuka

17-Mujāhid, Tafsīr, vol.1, p.369.

18- The full isnād is that 'Abbād b. ya'qūb al-Asdī on the authority of Ibn Fuḍayl on the authority of Layth on the authority of Mujāhid.

- For Ibn Abī Najīĥ reporting from Mujāhid, see Stauth, Die Überlieferung des Korankommentars Muĥāhid B. Ġabrs, pp. 68-80.

19-Bukhārī, Ṣaĥīĥ, vol.1, p.205.

maqāman mahmūdān , he replies that it refers to the intercession.²⁰

Al-Baghdādī in Uṣūl al-Dīn confirms the exegetical contention of Mujāhid that maqām mahmūd refers to the intercession of the Prophet on the Day of Resurrection.²¹ Al-Baghdādī further tries to assert the significant effect of the Prophet's intercession . He states that the Prophet has been given the choice of either half of his community entering Paradise or to be granted the power to intercede on the Day of Judgment. The Prophet chose intercession declaring that seventy thousand of the believers will enter Paradise without being liable to any reckoning (kashf ḥisāb). Each of those favourite believers will, in turn, intercede for seventy Muslims.²² Al-Rāzī maintains that it has been unanimously agreed that the Prophet Muḥammad will be offered the privilege of the intercession on the Day of Judgment.²³ Al-Baghawī (d.516 / 1122) reports that the first man who denied the principle of the intercession was 'Amr b. 'Ubayd.²⁴

Nonetheless, al-Ash'arī states that although the general consensus of Muslims scholars agree on the existence of the Prophet's intercession on Doomsday, they differ on the question as whether that intercession embraces the grave sinners (aṣḥāb al-kabā'ir) or not. The Sunnis are of the opinion that the intercession includes the grave sinners.²⁵ On the other hand, the Mu'tazilites strongly

20-Tirmidhī, Sunan, vol. 11, p.296.

21-Baghdādī, Uṣūl , p.244.

22- Ibid, p.224.

23- Rāzī, Mafātīḥ, vol.1, p.332.

24- Baghawī, Ma'ālim , vol.3, p.132.

25-Ash'arī, Maqālāt al-Islāmiyyīn, p.447.

reject this belief and some of them contend that it is only the true believers who deserve the intercession of the Prophet. They argue that the function of that intercession for the believers is to increase the propitious rewards bestowed on them by God.²⁶ However, as far as Mujāhid is concerned, he has not been attributed with any view as far as the tafāsīr we have been able to consult are concerned regarding the question of to whom does the Prophet's intercession apply. Therefore, we will not go into details as regards the arguments which support each view.²⁷

THE INTERPRETATION OF MAQĀM MAHMŪD AS INDICATING THE SEATING OF THE PROPHET WITH HIS LORD IN THE HEREAFTER :

As has already been mentioned, in addition to the first interpretation, Mujāhid has been attributed with another interpretation with regard to the term maqām mahmūd mentioned in the verse 17: 79. It is claimed that Mujāhid maintained that it connotes that God will seat his Prophet Muḥammad with Him on the Throne (yujlisuhu ma'ahu 'alā al-'arsh) in the Hereafter.²⁸

26.-Ibid, p.447.

27- For further details regarding the issue to whom does the intercession go, see :
 - Rāzī, Mafātīh, vol.1, p.332.
 - Qurṭubī, Tafsīr, vol.1, p.379.
 - Baghawī, Ma'ālim, vol.3, p.132.
 - Wensinck, The Muslim Creed, p.61.
 - Watt, The formative Period of Islamic Thought, p.138.

28-Tabarī, Tafsīr, vol.15, p.147.
 -Ṣuyutī, Durr, vol.4, p.198.

Although al-Ṭabarī gives preference to the first interpretation of maqām maḥmūd adopted by Mujāhid and al-jumhūr, he does not reject this second interpretation attributed to Mujāhid.²⁹ Al-Ṭabarī argues that no objection to Mujāhid's second opinion has been made either from a reliable authority or from a rational point of view. As regards the reliable authority there is no report from the Prophet nor from his Companions nor from their Successors which renders the second interpretation attributed to Mujāhid as impossible. As far as the rational point of view is concerned, al-Ṭabarī states that all Muslim scholars who interpret the phrase at issue as referring to the seating of the Prophet beside his Lord on the Throne can be divided into three groups whom he does not name. According to al-Ṭabarī, Mujāhid's contention could fit in with each of these three groups, who philosophically proved that this merit (i.e., the seating of the Prophet with His Lord on the Throne in the Hereafter) does not contradict the concept of the intercession which constitutes the first opinion.³⁰

According to al-Suyūṭī, Ibn 'Abbās propounds an interpretation for maqām maḥmūd which can accommodate both opinions of Mujāhid. Ibn 'Abbas maintains that maqām maḥmūd means that God will seat his Prophet Muḥammad between Himself and Gabriel, and thereat the Prophet intercedes for his community.³¹ Also it has been reported that Ibn 'Umar relates that the Prophet construes maqām maḥmūd as meaning that God will seat him with Himself on

29-Ṭabarī, Tafsīr, vol.15, p.147- 8.

30- Ibid, pp. 147- 8.

31- Suyūṭī, Durr, vol.4, p.198.

the Throne.³² So again this is a very strong support for Mujāhid's view, if the authenticity of this narration is proved. It is therefore possible that Mujāhid could have taken the second interpretation of maqām mahmūd (i.e., when he says that it refers to the seating of the Prophet with His Lord on the Throne in the Hereafter) either from Ibn 'Abbas or from Ibn 'Umar who ascribes that interpretation directly to the Prophet himself. Furthermore, two other Companions are reported as concurring partially with Mujāhid's second interpretation. They are 'Abd Allāh b. Mas'ūd³³ and 'Abd Allah b. Sallām.³⁴ According to al-Rāzī, Ibn Mas'ūd says that maqām mahmūd connotes that God will seat His Prophet Muḥammad on the Throne in the life to come.³⁵ So the interpretation of Ibn Mas'ūd partly coincides with that of Mujāhid on the point that as a matter of honour and respect, the Prophet will be seated on the Throne. Ibn Mas'ūd however just contents himself with this statement and does not go any further. On the other hand, this interpretation attributed to Mujāhid carries the additional meaning that the Prophet would accompany God as far as sitting on the Throne is concerned.³⁶ Similarly according to al-Ṭabarī³⁷ and al-Baghawī,³⁸ 'Abd Allāh b. Sallām interprets the phrase under discussion as meaning that God will seat his Prophet on the Throne in a way which is known only to God. However, Ibn Sallām further denies that the Prophet will accompany God on the Throne.

32- Ibid, p.198.

33-Rāzī, Mafātih, vol.5, p.431.

34- Ṭabarī, Tafsīr, vol.15, p.148, and Baghawī, Ma'ālim, vol.3, p.132.

35-Rāzī, Mafātih, vol.5, p.431.

36- Ibid, p.431.

37- Ṭabarī, Tafsīr, vol.15, p.148.

38- Baghawī, Ma'ālim, vol.3, p.132.

In other words, Ibn Sallām rejects the interpretation attributed to Mujāhid as far as the Prophet accompanying God is concerned.³⁹

Nonetheless, al-Ṭabarī who supports the possibility of this idea, answers the objection of Ibn Sallām. He argues that if Ibn Sallām admits that God will seat His Prophet on the Throne, one of two things must be meant: either God will actually seat His Prophet with Himself on the Throne, or else He will seat him on the Throne on his own. So to whichever of these two ideas Ibn Sallām refers, it would lead to the acceptance of what he denies. Because, God is either separate from the Throne, or He is neither separate from nor adjacent to the Throne. Nevertheless, as al-Ṭabarī continues his argument, if Ibn Sallām says that his interpretation does not refer to the idea that the Prophet is seated on the Throne, then he disagrees with all Muslims. Since there is no view in this respect other than the three views of the aforementioned groups, al-Ṭabarī concludes by stating that it is not impossible then that the opinion of Mujāhid can be included under one of the opinions of those three groups.⁴⁰

However, in opposition to al-Ṭabarī's position, al-Wāḥidī, as cited by al-Rāzī, puts forward an acrimonious criticism against Mujāhid's standpoint of the Prophet accompanying God as far as the sitting on the Throne is concerned. He describes the contention of Mujāhid in this respect as utterly unlikely.⁴¹ Al-Wāḥidī argues that

39- Ṭabarī, Tafsīr, vol.15, p.148.

40- Ibid, p.148.

41-Rāzī, Mafātīḥ, vol.5, p.431.

the obvious sense of the Qur'ānic phrase under discussion 'asā an yab'athaka rabbuka maqāman maḥmūdan (17 : 79), implies the invalidity of this view.⁴² In justifying his judgment and weakening this interpretation, al-Wāḥidī, according to al-Rāzī, gives the following arguments :

Firstly, he tries to explain linguistically the meaning of the verb ba'atha in the verse at issue 'asā an yab'athaka rabbuka maqāman maḥmūdan (17 : 79). He says that when one says: ba'atha Allāhu al-mayyita that means God raised up the dead person from his grave. So linguistically ba'th is the state of making someone stand. But Mujāhid, as al-Wāḥidī argues, takes the opposite meaning when he interprets ba'th as signifying the state of being seated (ijlās).⁴³ Al-Wāḥidī further presents another linguistic meaning of the term ba'th which again weakens Mujāhid's interpretation. He says that if it is said: ba'atha al-ḥākimu fulānan , one usually understands the verb ba'atha here as meaning sent, i.e., the ruler sent his messenger to certain people to do so and so. It will not come to one's mind that the ruler seated the messenger with himself.⁴⁴ Ibn Manzūr confirms the correctness of the above two linguistic meanings of the word ba'atha mentioned by al-Wāḥidī.⁴⁵

Secondly, as al-Wāḥidī argues, in the verse under discussion 'asā an yab'athaka rabbuka maqāman maḥmūdan , the Qur'ān refers to the maqām and not to the maq'ad. Of course, maqām linguistically

42-Ibid, p.431.

43-Ibid, p.431.

44-Ibid, p.432.

45. Ibn Manzūr, Lisān, vol.1, p.230.

refers to the place of standing and not the place of sitting. Hence again, in al-Wāḥidī's view, this is a convincing response to Mujāhid's opinion.⁴⁶

Thirdly, al-Wāḥidī puts a rational argument by saying that if God sits on the Throne, as Mujāhid claims, then this is an indication that God is limited (maḥdūd) and the one who is limited is supposed to be created (muḥdath). Of course, such corporeal descriptions are utterly impossible as regards God.⁴⁷

Fourthly, al-Wāḥidī argues by saying that even if we accept that the Prophet will be seated beside His Lord, as Mujāhid alleges, then there is no honour or respect for the Prophet in that state. Because it has also been alleged that all the inhabitants of Paradise visit and sit with their Lord in the Hereafter. Therefore since all the believers will also gain that status, there is no point in specifying the Prophet with that privilege.⁴⁸ Al-Wāḥidī thus endeavours by resorting to linguistic and rational arguments to confront this view which has been attributed to Mujāhid.

On the other hand, it seems that al-Qurṭubī takes a different perspective from both al-Ṭabarī and al-Wāḥidī as far as the second interpretation attributed to Mujāhid is concerned. As mentioned earlier, al-Qurṭubī attributes two views to Mujāhid concerning this interpretation. In the first he agrees with al-Ṭabarī that Mujāhid

46-Rāzī, Mafātīḥ, vol.5, p.431.

47-Ibid, p.431.

48-Ibid, pp.431-2.

maintained that God will seat his Prophet with him on the Throne in the Hereafter.⁴⁹ In the second he maintains that Mujāhid interpreted the words as meaning that God will seat his Prophet on the Throne in the Hereafter without any reference to Him sitting with the Prophet.⁵⁰ Al-Qurṭubī objects to the first explanation attributed to Mujāhid, when he takes maqām mahmūd as meaning that God will seat His Prophet together with Him (yujlisuhu ma'a-hu) on the Throne in the Hereafter. His main objection is based on the meaning of the preposition ma'a in the statement of Mujāhid yujlisuhu ma'a-hu 'alā al-'arsh. In other words, al-Qurṭubī denies the accompaniment between the Exalted God and His Prophet who is a human being. He argues that if we have to accept the aforementioned statement of Mujāhid which includes the word ma'a-hu, i.e., "with him", then that word (ma'a-hu) must be understood metaphorically.⁵¹ In justifying his objection to Mujāhid's opinion, al-Qurṭubī further argues that the meaning of the preposition ma'a-hu in the statement of Mujāhid is similar to the meanings of ma'a and 'inda in the following Qur'ānic verses :

(i) "... and lo! God is with the good (wa-inna Allāha la-ma'a al-muḥsinīna)." (29 : 69).

(ii) "... still those who are with thy lord (fa-alladhīna 'inda rabbika) ... " (41: 38).

(iii) "...My Lord build for me a home with thee in Garden (rabbī ibni lī 'indaka baytan fī al-jannati)..." (66 : 11).

⁴⁹- Qurṭubī, Tafsīr, vol.10, p.311.

⁵⁰- Ibid, p.311.

⁵¹- Ibid, p.312.

So in the opinion of al-Qurṭubī, the adverbs (zurūf makān): ma'a and 'inda in the above verses do not refer actually to the tangible accompaniment of God by the Prophet. But they rather indicate the preferable status and high position being granted by God to the believers.⁵² Al-Qurṭubī then proceeds to criticize al-Ṭabarī who does not only favour the standpoint attributed to Mujāhid but also tries to seek support for it. Al-Qurṭubī maintains that the arguments which are stated by al-Ṭabarī in support of the notion of the real ma'iyah, i.e., accompaniment between God and His Prophet, are somewhat farfetched.⁵³

Al-Qurṭubī further quotes Abū 'Umar who also opposes Mujāhid's aforementioned elucidation. Abū 'Umar states that although Mujāhid is regarded as one of the greatest exegetes, he has two anomalous views. One of them is this very interpretation when he says that maqām mahmūd means that the Prophet will be seated beside His Lord on the Throne in the Hereafter. The other anomalous view of Mujāhid concerns the already heavily debated Qur'ānic verses wujūhun yawma'idhin nādiratun. ilā rabbihā nāziratun (75 : 22-3).⁵⁴ As we have discussed in the previous chapter, Mujāhid construes the word nāzirah as meaning that the believers are waiting for God's reward. In other words, Mujāhid denies the the doctrine of seeing God on Doomsday which is accepted by the majority of the Muslims.⁵⁵

⁵²-Ibid, p.312.

⁵³-Ibid, p.311.

⁵⁴-Ibid, p.311.

⁵⁵-See the thesis, pp. 81-90.

As for the second interpretation attributed to Mujāhid, i.e., the seating of the Prophet on the Throne without mentioning him sitting alongside God, al-Qurṭubī declares that it is not impossible. In justifying his judgment he sticks to rational discussion. He says that God existed before the creation of all things. Then He created the things including the Throne. He sat on it (istawā 'alay-hi),⁵⁶ as He wished without being adjacent to that Throne and without rendering that Throne as a place for Himself.⁵⁷ So, as al-Qurṭubī carries on supporting the second interpretation attributed to Mujāhid, it is said that God now is in the same state before He created time and place. Therefore, according to this argument, it is equal by possible to God to seat Muḥammad on the Throne or on Earth. This is because, the istiwā' of God on the Throne does not mean the transition or the changing of the circumstances, e.g., the states of standing and sitting which occupy the Throne. But God sits on the Throne as He told about Himself without how.⁵⁸ The seating of the Prophet signifies honour, respect and attainment of high rank over

⁵⁶-The Istiwā' of God on the Throne is one of the important issues which preoccupies Muslims and non-Muslims theologians. It has been mentioned in seven Qur'ānic verses. They are: 7 : 54, 10 : 103, 13 : 2, 20 : 5, 25 : 59, 32 : 4 and 57 : 4.

- For further discussion on this subject, see the following references:

-Ash'arī, Ibānah, p.34.

-Baghdādī, Uṣūl, p.112.

-Ibn Ḥazm, Fiṣal, p.123.

-Zamakhsharī, Kashshāf, vol.1, p.51.

-Rāzī, Mafātiḥ, vol. 4, pp. 218-27.

-Qurṭubī, Tafsīr, vol.1, p.254; and vol.3, p.278; and vol.7, p. 219.

⁵⁷-Qurṭubī, Tafsīr, vol.10, pp.311-2.

⁵⁸-It has been reported that Anas b. Mālik says that the meaning of istiwā' in the Arabic language is well known, but the how of it as regards God is beyond people's comprehension. Nevertheless, the belief and assent to that fact is obligatory. And the inquiry into it is an innovation (bid'ah). [see : Qurṭubī, Tafsīr, vol.1, p.254; and vol.7, p.219.]

his people.⁵⁹

The perspective of al-Qurṭubī is therefore that he accepts the second interpretation attributed to Mujāhid, i.e., when he is alleged to have understood maqām maḥmūd in the verse under discussion (17 : 79) as referring to the seating of the Prophet on the Throne in the Hereafter. While he fiercely rejects the first interpretation attributed to Mujāhid, when it is claimed that he goes too far by adding that the Prophet will be seated on the Throne beside His Lord.

Shams al-Dīn al-Dhahabī describes the view of Mujāhid when he interprets the Qur'ānic phrase 'asā an yab'athaka rabbuka maqāman maḥmūdan' as meaning that God will seat His Prophet with Him on the Throne as the most anomalous (ankar) exegetical view ever held by Mujāhid.⁶⁰

It might be noted that Ibn al-Athīr connects the second interpretation of Mujāhid of the Qur'ānic verse under discussion 'asā an yab'athaka rabbuka maqāman maḥmūdan' (17 : 79) with important historical events. He reveals that a great trial (fitnah) took place in the year 317 A.H between the followers of Abū Bakr al-Marwazī al-Ḥanbalī and the commonalty of the people ('āmmah) concerning the interpretation of that verse. Because the followers of Abū Bakr al-Ḥanbalī adopt the second interpretation attributed to Mujāhid, that they take maqām maḥmūd in the verse at issue as meaning that God

⁵⁹- Qurṭubī, Tafsīr, vol.10, p.311-2.

⁶⁰- Dhahabī, Mizān al-I'tidāl, vol.3, p.439.

will seat his Prophet with Him on the Throne. Whereas in the opinion of the commonalty maqām maḥmūd simply refers to the intercession of the Prophet on Doomsday.⁶¹

To conclude this chapter, we can say that the first opinion ascribed to Mujāhid that maqām maḥmūd means the intercession of the Prophet on the Day of Judgment is in complete conformity with the interpretation held by the majority of the exegetes and scholars. On the other hand, it seems that doubts are thrown on the second opinion attributed to Mujāhid that maqām maḥmūd refers to the seating of the Prophet on the Throne beside His Lord. If Mujāhid does hold this interpretation, then he would be contradicting himself because, as we have seen in the previous chapter, his view is that God cannot be seen in the Hereafter. So by saying that the Prophet will be seated on the Throne beside his Lord that simply means he can see God. It is highly unlikely that Mujāhid himself could not have observed this obvious contradiction. It is therefore most probable that Mujāhid held only the first interpretation, whereas the second is not actually his.

The Hand (s) of God :

If the earlier suggestion regarding Mujāhid's interpretation of maqām maḥmūd is correct, it would be expected that Mujāhid would interpret physical descriptions of God in the Qur'ān metaphorically. However, the only verse in which an interpretation of Mujāhid is reported concerning the interpretation

⁶¹-Ibn al-Athīr, Kāmil, vol.7, pp.157-8.

of the Hand(s) of God, is: "The Jews say : God's Hand is tied up, be their hands tied up and be they accursed for their blasphemy they utter. Nay both His Hands are widely outstretched : He gives and spends (of His bounty) as He pleases (wa-qālati al-yahūdu yadu Allāhi maghlūlatun ghullat aydihim wa-lu'inū bi-mā qālū bal yadāhu mabsūtātāni yunfiqū kayfa yashā')..." (5 : 64).

In this interpretation, as would be expected, Mujāhid maintains that the allegation of the Jews: "yad Allāh maghlūlah" means that God is miserly and avaricious towards them that He forbids His bounties from them. They liken Him with one whose hand is tied up (al-maghlūlah yadahu) so that he is unable to expand it in order to give things to others.⁶² Al-Ṭabarī gives Mujāhid's view in two reports. The transmitter of both is Ibn Abī Najīh who is quoted by 'Īsā in one and by Shibl in the other.⁶³ It is also found in Ādam b. Abī Iyyās's version of Warqā''s recension.⁶⁴ Mujāhid's interpretation of this part of the verse is also held by his teacher Ibn 'Abbās, in addition to the Successors Qatādah, al-Suddī,⁶⁵ 'Ikrimah and al-Ḍaḥḥāk.⁶⁶

However, this particular verse cannot be regarded as a decisive verse in which Mujāhid's general view of the Hand(s) of God and whether he always regards it as metaphorical, can be deduced. Because the bulk of the commentators, except for a small

62- Ṭabarī, Tafsīr, vol.10, pp.452-3.

- Ibn Kathīr, Tafsīr, vol.2, p.75.

63- Ṭabarī, Tafsīr, vol.10, pp.452-3.

64- Mujāhid, Tafsīr, vol.1, pp.199-200.

65- Ṭabarī, Tafsīr, vol.10, pp.452-3.

66- Ibn Kathīr, Tafsīr, vol.2, p.75.

minority of the literalists, choose to interpret this verse metaphorically.⁶⁷ Unfortunately, Mujāhid's interpretation of other verses where the Hand(s) of God is referred to,⁶⁸ have not been reported to us. Nonetheless, it seems probable to conclude that in the light of his interpretation of this verse and his other metaphorical and rationalistic interpretations, already discussed, that Mujāhid probably interprets the Hand of God metaphorically wherever it occurs in the Qur'ān.

* * *

The third rational issue is the metamorphosis (maskh) of the Sabbatarians. This will be the subject of the next chapter.

67- As for the following phrase bal yadāhu mabsūtātān, some of the scholars, according to al-Ṭabarī, hold that the term yadāhu here means his two bounties (ni'matāhu). Another group takes this term as referring to the power of God (quwwah). A third group understands this word as indicating God's dominion (mulk). However, the fourth group opposes the metaphorical interpretation altogether maintaining that yad here is an Attribute which pertains to the Essence of God. However, as they further add, it is a Special Attribute which is entirely different from the parts of the body of the human being. [see Ṭabarī, Tafsīr, vol.11, pp.454-5].

68- The other Qur'ānic verses in which mention has been made to the term yad or its derivatives are: 3 : 26 and 73, 7 : 57, 23 : 88, 25 : 48, 27 : 63, 36 : 71 and 83, 38 : 75, 48 : 10, 49 : 1, 57 : 29 and 67 : 1.

CHAPTER FIVE

THE METAMORPHOSIS (MASKH) OF THE SABBATARIANS

Another issue on which Mujāhid is reported to have expressed a rational interpretation, which diverges from that of the rest of the Companions and their Successors, concerns the way by which the disobedient people of Moses were transformed.

Three main Qur'ānic verses are usually cited in this matter. They are:

(1) "And indeed you know those among you who violated the Sabbath, so we said to them: 'Be as apes despised and hated' (wa-la-qad 'alimtumu alladhīna i'tadaw min-kum fī al-sabti fa-qulnā la-hum kūnū qiradatan khāsi'īna) " (2 : 65).

(2) " When in their insolence they transgressed all prohibitions, we said to them be you apes, despised and rejected (fa-lammā 'ataw 'ammā nuhū 'anhu qulnā la-hum kūnū qiradatan khāsi'īna) " (7 : 166).

(3) " Say: 'Shall I point out to you something much worse than this, (as judged) by the treatment it received from God? Those who incurred the curse of God and His wrath, those of whom some He transformed into apes and swine, those who worshipped evil; these are many times worse in rank and far more astray from the even path!' (qul hal unabbi'ukum bi-sharrin min dhālika mathūbatan 'inda Allāhi man la'anahu Allāhu wa-ghadība 'alayhi wa-ja'ala minhumu

al-qiradata wa-al-khanāzīra wa-'abada al-ṭāghūṭa ūlā'ika sharrun makānan wa-aḍallu 'an sawā'i al-sabīli)" (5:60).¹

In the above Qur'ānic verses, the Qur'ān directs the message to the Jews who lived with the Prophet Muḥammad in Medina warning them about what had happened to their predecessors, namely the people of Moses (sons of Isrā'īl). When the latter transgressed, they exposed themselves to the punishment of God and were metamorphosed into apes.²

The story of those people who were transformed by God can be summed up as Ibn 'Abbās and Mujāhid narrate : Those Jews (the people of Moses) were firstly asked by God to observe Friday as a sacred day for worship. But they refused and insisted on Saturday instead. Moses agreed on their choice on condition that on Saturday they should cease from any sort of activity including fishing. However, as a great temptation to those people, the fish began to appear openly on the surface of the water on Saturdays, while they completely

1- Also, the transgression of the Sabbatarians has been dealt with in the following Qur'ānic verses: 4 : 47, 4 : 154, 5 : 78 and 16 : 124.

2- Respecting the town in which those people lived, the Qur'ān says: "ask them concerning the town standing close by the sea..." (7 : 163). Mujāhid names the town as 'Aylah. Ibn 'Abbās (in a narration by 'Ikrimah) locates that town between 'Aylah and Mount Sinai which is called Midyan. Although Qatādah agrees that qaryah here refers to 'Aylah, he sees that it is situated on the shore of Midyan. Al-Zuhrī maintains that it is called Ṭabariyyah. The fifth and last view is attributed to Ibn Zayd who holds that it is Maqnā, which is situated between Midyan and 'Aynūnā. (for all these different views, see : Ṭabari, Tafsīr, vol.13, pp.179-82. Also: Qurtubī, Tafsīr, vol.7, p.305). In commenting on these variant opinions, Ṭabari states that what is certain is that the town stands close to the sea. However, it might be 'Aylah, Midyan or Maqnā, because all these towns are situated on the sea. Besides, there is no direct tradition from the Prophet which determines the exact situation of that town (see: Ṭabari, Tafsīr, vol.13, p.182).

With regard to the time in which those metamorphosed people lived, Qurtubī states that they lived in the time of the Prophet David. (see: Qurtubī, Tafsīr, vol.7, p.306).

disappeared during the other six days of the week. As the Qur'ān says: "For on the day of their Sabbath, their fish did come to them openly holding their heads, but on the day they had no Sabbath, they do not come ..." (7 : 163). Of course, this was a great temptation for the Sabbatharians which some of them could not resist. They engaged themselves in fishing on Saturdays therefore in one way or another. For instance, they used to dig pools for the fish and filled them from large canals which were also dug for the same purpose. They gathered the fish trapped in the pools on Sunday. In other words, they made all sorts of pretences that they were not catching fish on Saturday, whereas they actually did. The sons followed in the footsteps of their fathers and grandfathers in this respect. Having done so, those people had actually transgressed and violated the Divine Command openly. As a result, they incurred God's wrath and punishment as the above verses state.³

In fact there are many points related to these verses. Our discussion here will however chiefly concern how those people were transformed into apes ; that is to say, in what manner the transformation happened . Mujāhid in his interpretation of the verse: "So, we said to them: 'Be as apes...'"(2 : 65) maintains that those people were not physically changed into apes, but it is only their hearts which were transformed. He further adds that it is only a proverb which God sets forth for them. He likens them to the asses which are mentioned in another Qur'ānic verse which says: "The

³-For further details of this story, see :

- Ṭabarī, Tafsīr; vol.2, pp.166-81, and vol.10, pp.435-9, and vol.13, pp.179-201.
- Qurtubī, Tafsīr, vol.1, pp.439-44, and vol.7, pp.304-9.
- Ibn Kathīr, Tafsīr, vol.2, pp.105-7, and pp.256-9.

similitude of those who were charged with the obligations of Mosaic law but who subsequently failed in those obligations, is that of a donkey which carries huge tomes (but does not understand them) ..." (62 :5).⁴ Al-Ṭabarī gives this view of Mujāhid in two reports and Ibn Abī Najīḥ is his transmitter in both. In one of the reports Ibn Abī Najīḥ is quoted by 'Īsā,⁵ while in the other he is quoted by Shibl.⁶ Mujāhid's view is also found in Ādam b. Abī Iyyās's version of Warqā's recension on the authority of Ibn Abī Najīḥ.⁷ In support of Mujāhid's view, Muḥammad 'Alī, the translator of the Qur'ān, writes: "The verse that follows: ' So we made it an example to their time ... ' (2: 66), lends support to Mujāhid's explanation as a monkey could not afford a lesson to the generations that came after the metamorphosis had taken place ".⁸

According to Fakhr al-Dīn al-Rāzī, Mujāhid understands the transformation which happened to those people as affecting their hearts, that God has set a seal on their hearts so that they cannot discern the right path.⁹ Al-Qurṭubī cites Mujāhid as ascribing the metamorphosis to the hearts of those disobedient people while their intellects were made like the intellects of the apes.¹⁰ According to

4- Ṭabarī, Tafsīr, vol.2, pp.172-3.
 - Ibn Kathīr, Tafsīr, vol.2, p.105.
 - Bayḍāwī, Anwār , vol.1, p.159.
 - Abū Ḥayyān, al-Baḥr al-Muḥīṭ, vol.1,p.346.
 - Qurṭubī,Tafsīr, vol.1, p.443.
 5- Ṭabarī, Tafsīr, vol.2, p. 172.
 6- Ibid, p 172-3.
 7- Mujāhid, Tafsīr, vol.1, pp.77-8.
 8- Muḥammad 'Alī, The Holy Qur'ān, p.32.
 9- Rāzī, Mafāṭīḥ, vol.1, p.373.
 10- Qurṭubī, Tafsīr, vol.1, p.443.

the Shi'ite commentators al-Ṭūsī¹¹ and al-Ṭabarsī,¹² in addition to the commentator Abū Ḥayyān,¹³ Mujāhid is attributed with two interpretations both of which deny that the actual bodies of those people were physically metamorphosed. Mujāhid's first view is similar to the report previously mentioned by al-Ṭabarī that he strongly denies the transformation of those people into apes. Mujāhid further adds that this is just a proverb which God sets forth for them as He likens them to the donkey which carries huge tomes but does not understand them (62 : 5).¹⁴ The second opinion of Mujāhid, according to al-Ṭūsī, al-Ṭabarsī and Abū Ḥayyān, is that it is their hearts which have been metamorphosed, to the extent that they became like the hearts of the apes which neither accept preaching nor understand rebuke.¹⁵ However, this second view could be considered as a gloss on his original interpretation.

Contrary to Mujāhid's view, the majority of the exegetes among the Ṣaḥābah and Tābi'ūn interpret the Qur'ānic phrase at issue fa-qulnā la-hum kūnū qiradatan khāsi'īna in the very literal sense of the text.¹⁶ In other words, they hold that the metamorphosis (maskh) of the disobedient sons of Isrā'il has occurred materially, that those people were actually changed into apes.¹⁷

11- Ṭūsī, Tafsīr, vol.1, pp.290-1.

12- Ṭabarsī, Tafsīr, vol.1, p.129.

13- Abū Ḥayyān, al-Baḥr al-Muḥīt, vol.1, p.246.

14- Ibid, p.246.

15- Ibid, p.246.

16- Ṭabarī, Tafsīr, vol.2, pp.167-72.

- Qurṭubī, Tafsīr, vol.1, pp.440-1.

- Ibn Kathīr, Tafsīr, vol.2, p.105.

17- As whether the metamorphosed (mamsūkh) breeds or not, the scholars differ into two groups. Al-Zajjāj maintains that some people say that the apes of today might be offspring of those metamorphosed people. Ibn al-'Arabī prefers this

In asserting the physical transformation of those people Ibn 'Abbās, for instance, states that the transgressors who were changed into apes were their younger members whereas the elderly were changed into swine.¹⁸ Qatādah reveals that those people were transfigured into howling apes which possess tails after they used to be ordinary men and women.¹⁹ Al-Suddī also affirms the transformation of those people into apes which were jumping over each other.²⁰ Ibn Rūmān holds that when those who obeyed Moses met their colleagues who were transformed into apes, the apes recognized their relatives among Moses' folk, while the latter could not know their relatives among the apes.²¹

Al-Jāhiz (d.255 / 868), in his voluminous Kitāb al-Hayawān , speaks of the ugliness of swine and apes, with reference to the above three Qur'ānic verses. He observes that two of these verses, namely 2 : 65 and 7:166, state that the Sabbatarians were transformed into apes only, and there is no mention of swine. According to the third verse (5 : 60) however those people were changed into both apes and swine.²² He further maintains that some scholars therefore infer that since a mention of apes comes in all three verses while swine

opinion. The second group, who are the majority of the Muslim scholars, are of the opinion that the metamorphosed human being (mamsūkh) does not generate and the apes, swine and other animals were found before that. They add that those people whom God has metamorphosed were perished and therefore left no progeny. (see: Ibn al-'Arabī, Aḥkām, vol. 4, pp.798-9. Also Qurtubī, Tafsīr, vol.1, p.440-1).

18- Ṭabarī, Tafsīr, vol.13, p.203.

- Ibn Kathīr, Tafsīr, vol.2, p.105.

- Abū Ḥayyān, al-Baḥr al-Muḥīṭ, vol.3, p.518.

19- Ṭabarī, Tafsīr, vol.2, p.171; and vol.13, p.203.

- Ibn Kathīr, Tafsīr, vol.2, p.105.

20- Ṭabarī, Tafsīr, vol.2, p.172.

21- Qurtubī, Tafsīr, vol.7, p.306.

22- Jāhiz, Hayawān, vol.4, p.105.

are mentioned only once, the metamorphosis of a human being into apes is more horrid.²³

In discussing Mujāhid's view that it is impossible that human beings could be physically changed into apes, the philosophical commentator al-Rāzī puts forward two philosophical arguments which he suggests might be used by those who support that interpretation. However, al-Rāzī then proceeds to refute those arguments and goes on to assert that Mujāhid's interpretation must also be rejected as it is not sustainable, and therefore the correct interpretation must be that those Jews were actually changed into apes. Like al-Rāzī's own position on this issue, most of the other commentators oppose Mujāhid's elucidation in this respect. For instance, al-Ṭabarī puts forward two arguments to refute Mujāhid's opinion. Firstly, he states that the opinion of Mujāhid which denies the occurrence of maskh, contradicts the very obvious meaning of the Qur'ānic texts of the verses at issue. In justifying his judgment, al-Ṭabarī enumerates a number of incidents which were mentioned in the Qur'ān as punishments inflicted by God on the sons of Isrā'īl. For instance, they were transformed into apes and swine and people who serveth idols...(Q.5 : 60). Also when they said to Moses: "Show us God manifestly ..." (4 :153), God dazed them by thunder and lightning. Likewise, it is reported that when they worshipped the calf instead of God, God commanded them to slay themselves in

23- Jāhiz just says that this is the view of some scholars, but he does not tell who they are.

- For further discussion on what has been said generally about apes and swine, the cause of the metamorphosis, the description of the metamorphosed and the contempt of the apes and swine, see Jāhiz, Hayawān, vol.4, pp.36-42; and pp.49-52; and pp.54-77; and pp.93-9; and pp.105-7.

order to accept their repentance, as the Qur'ān says: "So turn in repentance to your Maker and slay yourselves ...". (2 : 54). Similarly they have been afflicted by wandering through the land (yaṭihūna) for forty years as a punishment for their refusal to enter the holy land, as the Qur'ān states: "Their Lord said: 'For this the land will surely be forbidden to them for forty years that they will wander in earth bewildered ...'" (5 : 26).

Having quoted all the above punishments, al-Ṭabarī questions how Mujāhid can deny the punishment of the metamorphosis of the Sabbatarians into apes and swine at the time as accepting the other punishments, mentioned above, which were inflicted on the same disobedient people. ²⁴ In other words, there is no strong ground for Mujāhid's denial of the punishment of the metamorphosis, because this punishment had been stated in the same way as the other punishments. The second argument which al-Ṭabarī puts forward as further evidence that Mujāhid's elucidation is incorrect is the unanimity of Muslim scholars who approve the occurrence of the physical metamorphosis and therefore contest Mujāhid's standpoint.

The Shi'ites commentators al-Ṭūsī ²⁵ and al-Ṭabarsī ²⁶ argue that Mujāhid's two interpretations, mentioned earlier, contradicts the obvious (zāhir) meaning of the text which is adopted by most of the exegetes. The Mu'tazilite commentator al-Zamakhsharī also treats the verses at hand in their very literal sense and thus disagrees

24- Ṭabarī, Tafsīr, vol.2, p.173.

25- Ṭūsī, Tafsīr, vol.1, pp.290-1.

26- Ṭabarsī, Tafsīr, vol.1, p.129.

with Mujāhid's interpretation.²⁷ Similarly al-Qurṭubī affirms the actual mutation of those people into apes.²⁸ In opposing Mujāhid's elucidation, al-Qurṭubī further adds that Mujāhid is the only exegete among the Sahābah and Tābi'ūn to adopt the view that the metamorphosis did not occur materially.²⁹ Nonetheless, according to al-Suyūṭī, Ibn al-Mundhir and Abū Ḥātim adopt a view similar to that of Mujāhid. They say that the metamorphosis affects the hearts of the people and not their bodies and that maskh here is just a proverb set by God.³⁰ Thus Mujāhid is not alone in holding this interpretation, though it may be that it is his explanation which has influenced these two later scholars. Likewise, Ibn Kathīr emphasises that the transformation of the Sabbatarians into apes and swine took place in both ways: i.e., physically and morally and not morally only as Mujāhid claims.³¹ Al-Alūsī also asserts that the ostensible sense of the Qur'ān shows that those Jews were actually transformed into apes. This view, which is the correct one according to him, is favoured by the majority of Muslim exegetes.³²

The only two commentators who seem to reach a somewhat similar conclusion to Mujāhid's regarding the interpretation of the Qur'ānic phrases under discussion are the Ṣūfī commentator Ibn 'Arabī (d.638 /1240), and the modern commentator Sayyid Quṭb (d.1386 / 1966). As for Ibn 'Arabī, he construes the verses under discussion allegorically and therefore he considers the change of a

27- Zamakhsharī, Kashshāf, vol.1, p.147; and pp.651-3.

28- Qurṭubī, Tafsīr, vol.1, pp.440-3; and vol.7, p.309.

29- Ibid, p.443.

30- Suyūṭī, Tafsīr, vol.1, p.75.

31- Ibn Kathīr, Tafsīr, vol.2, p.106.

32- Alūsī, Tafsīr, vol.1, p. 283.

human being into animal form as symbolic. He sees the act of worship as a way of purifying the soul and keeping it above the animal level of existence.³³ In this respect Ibn 'Arabī writes: "Whoever does not heed these situations and acts of vigilance, the light of his potentiality would be extinguished. He would be metamorphosed as the people of the Sabbath".³⁴ Nonetheless Ibn 'Arabī adds that the actual transformation (maskh) is real and cannot be denied in this world or in the world to come.³⁵ In supporting this point, he cites the tradition: "some people shall be gathered on the Day of Resurrection in such ugly forms, that apes and swine would look better." ³⁶ Like Ibn 'Arabī, Sayyid Quṭb explains the verses at issue figuratively. He states that the Sabbatarians deserve the punishment of God since they broke their promise with Him. By doing so, they are degraded from the state of the human being and fall into the state of the animal and beast; the animal which has no will and the beast which cannot rise above the demand of the stomach.³⁷ Quṭb concludes that it is not necessary therefore for those people to have been transformed into apes in their bodies, but rather only in their spirits and minds. This is because the inner feelings and thoughts are signs which leave their mark and are reflected in faces and complexions. ³⁸

Hence it can be said that both Ibn 'Arabī and Sayyid Quṭb share the main conclusion of Mujāhid, that the metamorphosis of the

33- Ibn 'Arabī, Tafsīr , vol.1, pp.55-7.

34- Ibid, pp.56-7.

35- Ibid, p.57.

36- Ibid, p.57.

37 Quṭb, Zilāl, vol.1, pp.97-8.

38- Ibid, pp.97-8.

Sabbatarians does not affect their bodies, despite the fact that both commentators (Ibn 'Arabī and Quṭb) have entirely different approaches in tackling the verses at issue. Ibn 'Arabī, as has been shown, treats the verses metaphorically concentrating on the inner meanings. Quṭb also rejects the apparent meaning, looking at the verses from a metaphorical angle and giving the metamorphosis further dimensions.

Muḥammad 'Alī, the translator of the Holy Qur'ān, deduces a logical standpoint which gives support to Mujāhid's contention in this respect. Muḥammad 'Alī compares the Qur'ānic phrase (fa-) qulnā la-hum kūnū qiradatan khāsi'īna mentioned in the two verses 2 : 65 and 7 : 166 with the verse "... and of whom He made apes and swine and those who serve the devil ..." (5 : 60). He then infers that the description of the same people clearly shows that it is men who imitate apes and swine that are meant. Muḥammad 'Alī in his comment on the verse "...or we shall curse them as we cursed the violators of the Sabbath" (4 : 47) writes : "Now in the case of the holy Prophet's opponents from among the Jews who are referred to in the phrase 'We shall curse them' there was no metamorphosis, but here it is stated that the same curse must overtake them as overtook the violators of the Sabbath. A reference to Deuteronomy 28 will show that the curse which Moses prophesied for them meant their being scattered among the nations of the earth, and this was the fate which overtook the Prophet's enemies from among the Jews. Qiradah is the plural of qird meaning an ape, and among the Arabs

the ape is proverbially an incontinent animal, they say 'more incontinent than an ape.'³⁹

So having rejected the ostensible meaning of the phrase at issue and disagreed with the view of the majority of the Companions and their Successors, it seems that Mujāhid exercises a purely rational opinion. In this respect, Jullanārī writes: "The seeds of free thought and personal opinion were sown in the early days of Islam."⁴⁰ As an example for this, he refers to the interpretation of Mujāhid for the phrase "fa-qulnā la-hum kūnū qiradatan khāsi'īna" when he denies the literal sense of the verse which refers to the transformation of the Sabbatarians into monkeys. Instead, he understands it as meaning that their status was lowered to that of the animals.⁴¹ In addition, in pursuing Mujāhid's rational approach in tafsīr, Goldziher refers to Mujāhid's interpretation of verse 2:65 when he holds that the metamorphosis did not affect the bodies of the Sabbatarians but it affected their hearts. Goldziher further comments by saying that in this interpretation Mujāhid goes even further than the Mu'tazilites who came later, because the Mu'tazilites have no doubt about the occurrence of the material metamorphosis.⁴²

From the above discussion some main points can be drawn as a conclusion for this chapter. Firstly, Mujāhid's treatment of the phrase at issue qulnā la-hum kūnū qiradatan khāsi'īna is similar to

39- Muḥammad 'Alī, The Holy Qur'ān, p.32.

40- Jullanārī, Islamic Quarterly, vol.12, p.87.

41- Ibid, pp.87-8.

42- Goldziher, Die Richtungen Der Islamischen Koranauslegung, translated into Arabic by 'Abd al-Ḥalīm al-Najjār, pp..129-30.

his treatment of the Qur'ānic verse ilā rabbihā nāziratun, as mentioned earlier in chapter three, for in both places Mujāhid rejects the exoteric sense of the Qur'ānic text and resorts to a metaphorical elucidation. Secondly, both rationalists: the Mu'tazilites and the Shi'ites, as has been shown, surprisingly take the literal sense of the text, agreeing with the interpretation held by the majority of the exegetes and scholars and therefore disagree with Mujāhid's elucidation. This, of course, is strong evidence that Mujāhid has not influenced the teachings of the Mu'tazilites and the Shi'ites in this particular aspect of his rational interpretation. Thirdly and perhaps most significantly, Mujāhid is the only exegete among the Ṣaḥābah and Tābi'ūn to adopt this interpretation. There is no doubt that Mujāhid here is exercising a rational approach which makes his interpretation extremely interesting. Perhaps in this particular respect, he wants to affirm that he is one of al-rāsikhūn fī al-'ilm who have the higher abilities to tackle Qur'ānic exegesis.

THE INTERPRETATION OF KHATMA IN VERSE 2 : 7 :

Having found Mujāhid interpreting the Qur'ān metaphorically with regard to the metamorphosis of the Sabbatarians, it is rather surprising to find him giving a much more literalist interpretation to the Qur'ānic verse about God sealing the hearts of the unbelievers. That verse says :

"God hath set a seal on their hearts and on their hearing, and on their eyes is a veil; Great is the penalty they incur (khatama Allāhu 'alā qulūbihim wa-'alā sam'ihim wa-'alā absārihim ghishāwatun wa-la-hum 'adhābun 'azīmun)". (2 : 7).

This verse describes the condition of the unbelievers whom God has khatama 'alā qulūbihim wa-'alā sam'ihim wa-'alā absārihim ghashāwah. Two interpretations have been put forward for the verb khatma mentioned in this verse, one of which is attributed to Mujāhid. Al-Ṭabarī gives Mujāhid's view in four reports.⁴³ Two of these reports are transmitted by al-A'mash who in both directly quotes Mujāhid.⁴⁴ The other two reports are transmitted by Ibn Jurayj who directly quotes Mujāhid in one while 'Abd Allāh b. Kathīr is an intermediary in the other.⁴⁵ In this interpretation Mujāhid treats khatma as referring to to an actual event. In this context, al-A'mash relates that Mujāhid uses his hand to explain the meaning of khatma. Drawing a comparison between the heart of a person and his hand (kaff), Mujāhid says that when that person commits a sin part of his heart will be clenched like a fist.⁴⁶ Mujāhid clenched his little finger (khunṣur) to show that condition with which the heart could be afflicted. He goes on to say that if that person commits another sin, another part of his heart will be made smaller. Again Mujāhid symbolizes this by clenching another finger of his hand. He carries on symbolizing an extra condition of the heart by clenching more fingers until he reaches the point where all his fingers are clenched.⁴⁷ Then as Mujāhid further adds, a seal will be stamped on it (ṭubi'a 'alayhi bi-ṭābi') and that is the so-called rān or rayn.⁴⁸

43- Ṭabarī, Tafsīr, vol.1, p.112.

44- Ibid, p.112.

45- Ibid, p.112.

46- Ibid, p.112.

47- Ibid, p.112.

48- Ibid, p.112.

In one of the reports by Ibn Jurayj, Mujāhid portrays the effect of the sins on the heart and how they surround it from all directions until they gather on it. This gathering of the sins on the heart is known as tab' or khatm.⁴⁹ In his other report, Ibn Jurayj said that 'Abd Allāh b. Kathīr told him that he had heard Mujāhid saying that rān is easier than tab' and tab' is easier than iqfāl (closing) and iqfāl is the strongest of all.⁵⁰ Here it is quite clear that Mujāhid is referring to another verse which contains the same meaning that is verse 83 : 14. In this latter verse which says : "Nay but that which they have earned is rust upon their hearts (kallā bal rāna 'alā qulūbihim mā kānū yaksibūn)", Mujāhid interprets the verb rāna as referring to the accumulation of the sins on the heart.⁵¹ In explaining this latter verse (83 :14), Mujāhid also invokes another verse, that is verse 2 : 81 which again gives a similar meaning. This verse says : " Nay those who seek gain in evil and are girt round by their sins, they are companions of Fire : Therein shall they abide [forever] (balā man kasaba sayyi'atan wa-aḥāṭat bi-hi khaṭī'atuhu fa-ulā'ika aṣḥābu al-nāri hum fī-hā khālidūna)". In this verse, al-Ṭabarī gives two similar reports from Mujāhid, one on the authority of Ibn Abī Najīḥ in 'Īsā's recension and the other on the authority of Manṣūr as reported by Sufyān.⁵² This same view is

49- Ibid, p.112.

- Ibn Kathīr, Tafsīr, vol.1 p.45.

50- Ṭabarī, Tafsīr, vol.1, p.112. According to Sūrtī, the interpretation of this verse (2 : 7) is not found in the manuscript of Tafsīr Mujāhid and the editor quotes Mujāhid's views from Ṭabarī.

- Ibn Kathīr, Tafsīr, vol.1, p.45.

51- Ṭabarī, Tafsīr, vol.30, pp.98-9.

52- Ibid, vol. 2, pp. 284-5.

given in Ādam b. Abī Iyyās's version of Warqā's recension on the authority of Ibn Abī Najīh.⁵³ Mujāhid construes the phrase ahātat bi-hi khatī'atuhu as referring to the countless sins committed by the unbeliever until they surrounded all his heart and thereby caused God to punish them.⁵⁴

It can also be noted that the interpretation of Mujāhid of the verse under discussion (2 : 7) is also held by Ibn 'Abbās, Abū Hurayrah, al-Ḥasan al-Basrī, 'Aṭā' and Qatādah.⁵⁵ Al-Qurṭubī maintains that it can be inferred from the interpretation of Mujāhid of the verse under discussion and from the hadīth of the Prophet in which he says : "In the body there is a morsel of flesh (mudghah) ; if it is good then the whole body will be good but if it is spoiled the whole body will be spoiled", that khatm takes place materially.⁵⁶

According to Mujāhid's opinion, the general meaning of the phrase khatama 'alā qulūbihim is that because the believers insist on disobeying God, He causes their sins to seal their hearts so that they finally refuse to accept the truth. And khatama 'alā sam'ihim means that they are unable to understand the Qur'ān when it is read to them or when they are called to believe in God. Similarly as a result of their numerous sins, a veil was set on their eyes so that they cannot contemplate creation which can lead them to perceive

⁵³- Mujāhid, Tafsīr, vol.1, p. 83.

⁵⁴- Ibn Kathīr, Tafsīr, vol.1, p.119.

⁵⁵- Ṭabarī, Tafsīr, vol.30, pp.98-100.

⁵⁶- Qurṭubī, Tafsīr, vol.1, p.86.

the power of God.⁵⁷ However, there is no mention to this interpretation in Ādam b. Abī Iyyās's version of Warqā's recension.

The other interpretation suggested for the verse under discussion (2: 7) which al-Ṭabarī attributes to an unnamed group differs from the former interpretation held by Mujāhid. This second view takes khatma as referring to a metaphor and not to a matter which takes place actually.⁵⁸ This view says that the phrase khatam Allāhu 'alā qulūbihim wa-'alā sam'ihim wa-'alā absārihim ghishāwatun refers to the arrogance of the unbelievers and their aversion to listening to the truth they were summoned by. This is similar to when one says: A person is deaf to what somebody says to him and arrogantly refuses to listen to it.⁵⁹ This, of course, is an advanced theological interpretation of the verse which is strongly defended by the Mu'tazilite commentator al-Zamakhsharī.⁶⁰

It should be noted that however Mujāhid's interpretation does not require the Ash'arite doctrine of God creating all human actions, for Mujāhid maintains that it is the sins of men which causes God to seal their hearts without discussing the origin of the acts which were sins.

* * *

57- Ibid, p.186.

58- Ṭabarī, Tafsīr, vol.1, p.112.

59- Ibid, p.112.

60- Zamakhsharī, Kashshāf, vol.1, pp.48-53.

After these rationalistic aspects, the discussion moves to investigate Mujāhid's contribution in the field of fiqh. The first issue in that respect will be zinā (adultery or fornication).

CHAPTER SIX

ZINĀ (ADULTERY OR FORNICATION)

THE INTERPRETATION OF QUR'ĀN 4 : 15 and 16:

The interpretation of Sūrat al-Nisā' (chapter 4), verses 15 and 16 provide us with an interesting problem as to what Mujāhid's actual interpretation means. The verses deal with the punishment of the crime of fāhishah which is understood by most commentators to mean zinā. The word zinā presents serious problems of translation, because it is applied to both adultery and fornication. Only the context of a revelation or its exegetical explanation can tell us which of the two forms of illicit sexual relations between men and women is involved. Therefore, in this chapter the term zinā will be used without translation until its nature in the particular discussion either as adultery or as fornication is identified.

The two verses read as follow :

- i. " And as for those of your women who are guilty of an indecency (fāhishah) call to witness against them four witnesses from among you; so, if they bear witness, confine them to houses until death takes them away or God opens a way for them (Wa-allātī ya'tīna al-fāhishata min nisā'ikum fa-istashhidū 'alay-hinna arba'atan min-kum fa-in shahidū fa-amsikūhunna fī al-buyūti ḥattā yatawaffāhunna al-mawtu aw yaj'alu Allāhu la-hunna sabīlan)."
- (4: 15).

ii. "And as for the two of you who are guilty of it if they repent and amend, turn aside from them. Surely, God is ever relenting, the Merciful (Wa- alladhāni ya'tiyānihā min-kum fa-adhūhumā¹ fa-in tābā wa-aṣlahā fa-a'riḍū 'anhumā inna Allāha kāna tawwāban raḥīman)". (4: 16).

Although the exegetes differ on some important points, only those aspects on which important opinions have been attributed to Mujāhid will be discussed here. The first point upon which the exegetes vary concerning the interpretation of the above verses is to whom do the relatives (ismā al-mawṣūl): allātī and alladhāni in verses 4 : 15 and 16 respectively refer. As far as Mujāhid is concerned, two different interpretations have been attributed to him for the term allātī in the first verse (4:15). Similarly two interpretations have also been attributed to him in respect of the meaning of the term alladhāni in the following Qur'ānic verse (4 :16). In other words, each of the two opinions attributed to Mujāhid on each of the two Qur'ānic verses has its complementary interpretation in the other verse with regard to the meaning of fāhishah and whether it is zinā or not.

¹-The exegetes give two meanings for the term īdhā' or adhā. (A) Ibn 'Abbās holds that it denotes rebuke and punishment by shoes. (B) Mujāhid and Qatādah maintain that it refers to the rebuke by tongue only. [see Alūsī, Rūḥ , vol.4, p.359].

Mujāhid's interpretation of fāḥishah as meaning zinā and the dispute concerning that :

Al-Ṭabarī gives four reports as regards the first interpretation attributed to Mujāhid. Two of these reports come on the authority of Ibn Abī Najīḥ. In one of these he is quoted by Warqā' ² and in the other he is quoted by Abū 'Āṣim.³ The third report is given on the authority of Ibn Jurayj. ⁴ Khuṣayf is the transmitter of the fourth report.⁵ The same view attributed to Mujāhid is also found in Ādam b. Abī Iyyās's version of Warqā''s recension.⁶ It is also reported by al-Qurṭubī.⁷ This interpretation is the standard of the exegetes and there is generally little or no dispute among the vast majority of the exegetes concerning fāḥishah meaning zinā.⁸ This view of Mujāhid can be propounded as follows : allātī in verse 4: 15 refers to both married and unmarried women (muḥṣanāt wa-ghayr muḥṣanāt) who perpetrate zinā,⁹ while the term alladhāni in verse 4 : 16 indicates married and unmarried men (man uḥṣin min al-rijāl wa-man lam yuḥṣan) who perpetrate zinā.¹⁰ Thus in this interpretation fāḥishah is equivalent to zinā.

2- Ṭabarī, Tafsīr, vol.8, p. 76.

3- Ibid, p.74.

4- Ibid, p.74.

5- Ibid, p.76.

6- Mujāhid, Tafsīr, vol.1, 148.

7- Qurṭubī, Tafsīr, vol.5, p.86.

8- Ṭūsī, Tafsīr, vol.3, p.143.

- Ṭabarsī, Tafsīr, vol.3, p.21.

- Rāzī, Mafāṭih, vol.3, p.167.

- Nisābūrī, Tafsīr, vol.4, p.203.

- Abū Ḥayyān, al-Bahr al-Muḥīt, vol.3, p.194.

9 -Qurṭubī, Tafsīr, vol.5, p.86.

10-Ibid, p.86.

-Ṭabarī, Tafsīr, vol.8, p.82.

However, despite the fact that the occurrence of the crime of zinā entails the involvement of both a male and a female, Mujāhid restricts the purport of verse 4 : 15 to women only, as far as the juristic rules of zinā are concerned. In Mujāhid's opinion, verse 4 :15 deals only with the punishment of women in general: married and unmarried (al-nisā' 'āmmah: muḥsanāt wa- ghayr muḥsanāt) when they commit zinā.¹¹ On the other hand, Mujāhid equally holds that the succeeding verse: wa-alladhāni ya'tiyānihā ... (4 : 16) treats only the punishment of married and unmarried men who commit the same crime.¹² In other words, Mujāhid admits that the term fāḥishah which has been plainly stated in the text of the first verse (4 : 15) and which has been referred to by the pronoun hā in the word ya'tiyānihā in the following verse (4 : 16) does mean zinā.

Although the majority of the exegetes concur with Mujāhid's opinion that fāḥishah denotes zinā, they disagree with him as far as the specific aim of each verse is concerned. Two main groups can be distinguished as forming Mujāhid's opponents in this respect. The first group, which is represented by al-Suddī, Ibn Zayd,¹³ Qatādah, and others,¹⁴ hold that the term allātī in verse 4 : 15 refers to married men and women who commit adultery (al-muḥsanūn min

11-Qurtubī, Tafsīr , vol.5, p.86.

12-Ibid, p.86.

-Tha'ālibī, Jawāhir , vol.1, p.356.

13- Ṭabarī, Tafsīr, vol.8, pp.81-2.

- Qurtubī, Tafsīr, vol.5, p.87.

14- Qurtubī, Tafsīr, vol.5, p.87.

al-rijāl wa-al-nisā'). Having excluded unmarried men and women from this verse, they interpret it as being exclusively about adultery. According to the view of this group, the reference of allātī to adulterous women is directly understood from the obvious sense (zāhir) of the text of the verse under discussion (4 : 15). However, the inclusion of adulterous men together with adulterous women is a matter of deduction, because the crime of adultery in the view of this group cannot take place unless there is a male and a female. The meaning of the verse should therefore be extended to cover adulterous men as well as adulterous women.¹⁵ As for the dual term alladhāni in the second verse, this group interprets it as referring to unmarried men and women (al-bikrayn ghayr al-muḥsanayn).¹⁶ Thus it is clear that this group opposes Mujāhid's view as regards the purport of the terms allātī and alladhāni. The other group maintains that the dual term alladhāni in verse 4 : 16 refers to men and women who commit zinā regardless of their matrimonial status.¹⁷ As for the interpretation of the term allātī in the first verse (4 : 15), it seems that this group are of the opinion that it indicates only women who commit zinā. However, those exegetes keep silent and give no further details whether those women who are referred to by the term allātī are married or not.¹⁸ Similarly this group, which is represented by 'Aṭā, 'Ikrimah, al-Ḥasan al-Baṣrī and 'Abd Allāh b. Kathīr, disagree with Mujāhid's contention.¹⁹

15-Ibid, p.87

16-Ṭabarī, Tafsīr, vol.8, p.81.

17- Ibid, p.82.

18-Ibid, pp.82-3.

19-Ibid, pp.82-3.

It should be noted that the western scholar Burton maintains that the aforementioned interpretation of Mujāhid for the term alladhāni in the second verse (4 : 16) is possible. In this connection, Burton writes: "Although verse 4 : 16 is phrased in the masculine dual and thus possibly a reference to two males, it has traditionally been read by most scholars as a reference to the male and the female partners in the act of gross moral turpitude".²⁰

When Mujāhid takes verse 4 : 15 as referring only to women who commit zinā and verse 4 : 16 as indicating men only, there are strong arguments in support of his view which have been put forward by later scholars. These arguments are :

1: The first supporting point is reported by Abū Bakr Muḥammad b. 'Abd Allāh, Ibn al-'Arabī, (d.543 /1148) who strongly maintains that this interpretation of Mujāhid of both verses is absolutely correct.²¹ Ibn al-'Arabī says that the text of the first verse (4 : 15) definitely refers to women. This can be inferred from two things in the verse. (i) The femininity (ta'nīth) of the expressions in the text of the verse at issue, e.g., ya'tīna, 'alayhinna, fa-amsikūhunna....etc. (ii) The clear statement (taṣrīḥ) "those of your women" (min nisā'ikum) must refer to women in particular. Thus there is no possibility of the inclusion of men in this verse.²² Ibn al-'Arabī further supports Mujāhid's elucidation by maintaining that the wording (lafz) of the following verse (4 : 16)

20-Burton, The Collection of the Qur'ān, p.73.

21-Ibn al-'Arabī, Aḥkām , vol. 1, p. 360.

22-Ibid, p.360.

could possibly be understood as referring to both men and women who are engaged in the perpetration of zinā. However, as he further argues, had the juristic rulings concerning women not been mentioned in the preceding verse, then they would have been included in the next verse.²³

2: The second supporting point for Mujāhid's view is also reported by Ibn al-'Arabī. He argues that if the second verse had been taken as a verse independent from the antecedent verse, then it (i.e., verse 4 : 16) would have been dealing with another ruling which contradicts the ruling laid down in the preceding verse (4 : 15). However, since the second verse (4 : 16) immediately follows the first verse (4 : 15) in the order of the Qur'anic text and since verse 4 : 16 is connected with the foregoing verse by the pronoun hā in the phrase ya'tiyānihā min-kum, which refers to fāhishah (indecentcy) in the preceding verse, then it is understood that the next verse (4 :16) would inevitably refer to men.²⁴

3: In addition, according to the above elucidation of Mujāhid, the text in the two Qur'anic verses 4 : 15 -16 covers all kinds of persons who might be involved in committing adultery and fornication (men and women whether married or not).²⁵

4: The fourth argument which also advocates Mujāhid's interpretations is of a linguistic nature. It is suggested that when the Qur'ān speaks about the persons who commit adultery and fornication in the first verse 4 : 15, it says: min nisā'ikum, and of course that expression points to women, whereas in the following

23-Ibid, p.360.

24-Ibid, p. 360.

25-Ibid, p. 86.

verse the Qur'ān uses the expression min-kum which semantically refers to men.²⁶

It might further be cited that the view of Mujāhid regarding the interpretation of the terms allātī and alladhāni in the verses 4 : 15-16 has also been adopted by al-Naḥḥās (d.338 /949) who relates that view on the authority of Ibn 'Abbās.²⁷ This interpretation is also supported by the four further arguments mentioned above. It can therefore be said that within the terms of the definition of fāḥishah as zinā three different standpoints have been put forward concerning the meanings of allātī and alladhāni in verses 4 : 15 -16 respectively. As has been discussed, one of those standpoints is held by Mujāhid in which he entirely disagrees with the other two opinions.

Al-Ṭabarī, after weighing the three aforementioned interpretations which have been mentioned, rejects the interpretation of Mujāhid and opts for that of the first group of Mujāhid's opponents. The explanation of that group, as has been discussed earlier, says that the term allātī in verse 4 : 15 refers to the married adulteresses and adulterers (muḥṣanūn), and the dual term alladhāni in the following verse 4 : 16 points to those who are unmarried, i.e., one of them is a man and the other is a woman.²⁸ In justifying his judgment, al-Ṭabarī resorts to a linguistic argument mainly to criticise the elucidation of Mujāhid of the term

26- Qurtubī, Tafsīr, vol.5, p. 87.

-Tha'ālibī, Jawāhir, vol.1, p. 356.

27- Qurtubī, Tafsīr, vol.5, p.87.

28-Ṭabarī, Tafsīr, vol.8, p.33.

alladhāni in the second verse (4 : 16). Al-Ṭabarī argues that if the dual term alladhāni in verse 4 : 16 had been perceived as referring to the juristic ruling concerning the two kinds of men who commit zinā: married and unmarried (al-zunāh min al-rijāl), and if the term allātī in the first verse (4 : 15) had pointed to the juristic ruling concerning the two kinds of women: married and unmarried (al-zawānī min al-nisā'), as Mujāhid claims, then the relative (ism al-mawṣūl) alladhāni in the second verse (4 : 16) would have come either in the plural or in the singular form. The second verse would then have run either : wa-alladhīna ya'tūnahā min-kum fa-adhūhum, as it is the case in the preceding verse (4 : 15) which says: wa-allātī ya'tīna al-fāḥishah ...; or else: wa-alladhī ya'tihā min-kum fa-adhūhu. In other words, in the previous verse (4 : 15), the Qur'ān refers to the adulteresses (al-nisā' al-zawānī) by the plural form allātī and not by the dual form allatāni, i.e., it does not say : wa-allatāni ta'tiyāni al-fāḥishah ... ²⁹.

In order to strengthen his argument and to defeat Mujāhid's contention, al-Ṭabarī invokes the usage of those terms in the Arabic language. He says that when the Arabs want to express the promise (wa'd) for an action and the threat (wa'id) against it, they use either the plural or the singular for the persons to whom wa'd or wa'id is directed. This is because both the plural and the singular forms symbolize the kind (jins). In other words, the Arabs do not use the dual form in this respect and say either alladhīna yaf'alūna kadhā fa-la-hum kadhā, i.e., those who do such and such

²⁹-Ibid, p.83.

will be rewarded or punished such and such; or else alladhī yaf'alu kadhā fa-la-hu kadhā, i.e the one who does such and such will be granted or punished by such and such. They would never say however: alladhāni yaf'alāni kadhā fa-la-humā kadhā, i.e., the two who do such and such will be rewarded or punished by such and such, unless that particular action cannot be done save by two different persons. For instance, the actual crime of zinā cannot take place except between a male and a female. so, in that particular case, the dual form alladhāni can be used as referring to the doer (fā'il) and the one with whom that crime is committed (maf'ūl bi-hi). Al-Ṭabarī continues his argument against Mujāhid's view by saying that if the dual form alladhāni is used to indicate the involvement of two persons in an action, each of whom might do it alone, or in an action in which they do not participate together, then this latter usage and meaning does not exist in the Arabic language.³⁰ Therefore al-Ṭabarī concludes that the interpretation of Mujāhid when he says that the term alladhāni in verse 4:16 refers to two kinds of men who commit zinā: married and unmarried, is erroneous.³¹ The correct elucidation of the term alladhāni in that particular respect is that it refers to an unmarried man and unmarried woman when they commit fornication.³²

Building on the above premises and results, al-Ṭabarī proceeds to draw further conclusions, which support his argument to the detriment of Mujāhid's view. He states that since it has

30- Ṭabarī, Tafsīr, vol.8, p.83.

31-Ibid, p. 83.

32-Ibid, p.83.

previously been proved that the dual term alladhāni refers to the adulterous man and woman, it is understood that it is a kind of variant for allātī whose ruling has been stated in the preceding verse (4 : 15). This is simply because the term alladhāni stands for two persons, while allātī indicates a group of persons. Hence, as al-Ṭabarī adds in opposing Mujāhid's opinion, since that is the case, it is conceived that ḥabs, that is, confinement in houses until death used to be the penalty for the adulterous married women before a sabīl (way) has been found for them. This is because the punishment of ḥabs is harsher than that of adhā which used to be the legal punishment for the adulterous unmarried women. The sabīl (way) of stoning to death which is enacted later as a punishment for the married adulteresses, is more rigorous than the sabīl that was made for the unmarried adulteresses which is flogging (jald) and banishment for one year (taghrīb 'āmm).³³

³³-Ibid, p.83. In the case of the married adulterer and adulteress whether the legal punishment should be rajm only or both jald and rajm, two views have been set forth. (i) The first opinion is that both penalties should be executed. In this connection, it is reported that 'Alī b. Abī Ṭālib lashed al-Hamadhāniyyah, then on the following day he stoned her to death. It is reported that the above opinion is also adopted by Ibn 'Abbās, Ubayy b. Ka'b, Abū Dharr and others. (ii) The second view is that only the punishment of the stoning to death should be imposed on the married adulterer and adulteress. This is the opinion of 'Umar, 'Uthmān, Ibn Mas'ūd and others. It is also preferred by the Jurists Mālik and al-Shāfi'ī.

Similarly in the case of the unmarried adulterer and adulteress and whether the legal punishment should be only jald or jald together with taghrīb, two opinions have been put forward. (i) The majority of Muslim scholars hold that both jald and taghrīb should be imposed on the unmarried perpetrators of adultery. (ii) Abū Ḥanīfah maintains that the punishment in this case should be jald only without taghrīb. Mālik says that taghrīb should be imposed on the unmarried adulterer (i.e., the man) and not on the unmarried adulteress (i.e., the woman). Ibn Ḥanbal states that unmarried adulteress should be exiled to a distance less than the distance in which the prayer should be shortened (masāfat al-qaṣr). [For further details on these points, see Ibn Qudāmah, Mughnī, vol.8, pp.160-1; and pp.167-70].

Mujāhid's interpretation of allātī and alladhāni as indicating lesbians and sodomites respectively :

In addition to the above view, another interpretation is also attributed to Mujāhid with regard to the meaning of the term alladhāni in verse 4 : 16. Al-Ṭabarī gives two reports for this second view attributed to Mujāhid. In one the transmitter is Ibn Abī Najīh in 'Īsā's recension³⁴ and in the other it is Ibn Jurayj.³⁵ Mujāhid maintains that alladhāni in the verse 4 :16 refers to two sodomites.³⁶ This second view on verse 4 : 16 attributed to Mujāhid is however not mentioned in Ādam b. Abī Iyyās's version of Warqā's recension. The same view as regards verse 4 : 16 is also attributed to Mujāhid by the commentators Fakhr al-Dīn al-Rāzī³⁷ and Ibn Kathīr.³⁸ Nonetheless, the aforementioned three commentators do not attribute any interpretation to Mujāhid as regards the meaning of allātī in the first verse (4 :15). It is only Abū Ḥayyān who plainly states that Mujāhid conceives allātī in verse 4 : 15 as indicating lesbianism and alladhāni in verse 4 : 16 as indicating sodomy.³⁹ Al-Sūrtī in his introduction to the Tafsīr of Mujāhid confirms that it is only Abū Ḥayyān who attributes the above elucidation of the term allātī to Mujāhid.⁴⁰ However, although no statement can be found other than that reported by Abū Ḥayyān to attribute allātī as referring to lesbians, it seems

34- Ṭabarī, Tafsīr, vol.8, p.82.

35- Ibid, p.82.

36- Ibid, p.82.

37- Rāzī, Mafātīh, vol.3, p.168.

38- Ibn Kathīr, Tafsīr, vol.1, p.462.

39- Abū Ḥayyān, al-Baḥr al-Muḥīt, vol.3, p.194.

40- see Sūrtī's Introduction to the Tafsīr of Mujāhid, vol.1, p.32.

possible that the interpretation of alladhāni as sodomites implies that allātī refers to lesbians. So according to the interpretation given by Abū Ḥayyān for the two verses and which is supported by the interpretation stated by the above commentators for the second verse, Mujāhid sees that the first hadd inflicted on lesbians was ḥabs, i.e., imprisonment in houses until death or God enacts a way (sabīl) for them which is the legal marriage bond.⁴¹ Similarly according to this interpretation, the first punishment imposed on sodomites used to be adhā.⁴² However, later on, Mujāhid observes that adhā as a punishment for the sodomites might be superseded by a heavier penalty which is the stoning to death (rajm).⁴³ This is because, according to Abū Dāwūd⁴⁴ (d.275/888) and al-Bayhaqī⁴⁵ (d.458/1065), Mujāhid narrates a tradition on the authority of Ibn ‘Abbās in which he states that the punishment for the unmarried sodomite is stoning to death (rajm). Hence, since it is known that the punishment for the unmarried sodomite is stoning to death, then by the same token the married sodomite is more deserving of the punishment of rajm.⁴⁶ Thus in this interpretation attributed to

41- Ibid, p.194.

42- Ibid, p.194.

43-Ṭabarī, Tafsīr, vol.8, p.82.

44-Abū Dāwūd, al-Sunan, vol.4, p.159.

45- Bayhaqī, al-Sunan al-Kubrā, vol.8, p.232.

46-Muslim scholars differ greatly regarding the legal punishment of the crime of sodomy. Three main standpoints have been put forward.

1. The first view says that the legal punishment of the crime of Sodomy is death (qatl). However, the upholders of this view vary among themselves concerning the way in which qatl should be executed. The following suggestions have been stated :

a: Some scholars, including Mujāhid, adopt the view that the death of a sodomite should be stoning to death, i.e., rajm.

b: Some other scholars propound that the sodomite should be thrown down to the ground from the highest building in his town.

c: Another group of scholars propose that he should be burnt by fire.

Mujāhid, fāhishah which is mentioned in the first verse (4 : 15) stands for the crime of lesbianism where the offenders are exclusively women. Fāhishah which is referred to by the pronoun hā in the word ya'tiyānihā in verse 4 : 16 indicates the crime of sodomy where the perpetrators are purely men. In other words, according to above opinion attributed to Mujāhid, neither of the verses 4 : 15-16 touches the crimes of adultery and fornication. The crimes of adultery and fornication, according to this view attributed to Mujāhid, have been dealt with by an entirely different Qur'ānic verse which is verse 2 of Sūrat al-Nūr.⁴⁷ That verse says : " The man and the woman who commit zinā flog each of them with a hundred stripes (al-zāniyatu wa-al-zānī fa-ajlidū kulla wāhidin min-humā mi'ata jaldatin...)(24 : 2).

It can be noted that the above explanation assigned to Mujāhid regarding the terms allātī and alladhānī in the verses 4 :15-16 was never held by any of the Companions nor by any of their other Successors according to all the tafāsīr consulted by

d: The fourth group of the scholars suggest that the sodomite should be killed by the sword then burnt by fire.

e: The fifth group say that the sodomite should be buried by a wall. For these views see Shawkānī, Nayl al-Awtār, vol.7, pp.286-8.

2. The second opinion states that the legal punishment of the crime of sodomy is the same as that of adultery.

3. The third opinion says that the legal punishment of sodomy is just ta'zīr.

[For more details of the punishment of sodomy, see Bayhaqī, al-Sunan al-Kubrā, vol.8, pp. 232-3. Also: Ibn Qudāmah, Mughnī, vol.8, pp.187-9. Also: Shawkānī, Nayl al-Awtār, vol.7, pp. 287-8].

47- Abū Hayyān, al-Baḥr al-Muḥīṭ, vol.3, p.194.

the present author.⁴⁸ It has been reported that the later Mu'tazilite scholar Abū Muslim al-Isfahānī (d.322 /933) adopted the above interpretation attributed to Mujāhid, i.e., verse 4 : 15 as referring to lesbians and verse 4 : 16 as indicating sodomites.⁴⁹ However, it should be noted that this opinion of Abū Muslim does not seem to reflect the position of the Mu'tazilite school on this matter, since for instance, the Mu'tazilite commentator al-Zamakhsharī interprets the verses at issue (4 : 15-16) in a different way from that of Abū Muslim. Al-Zamakhsharī maintains that fāhishah which is mentioned in both verses refers to the crime of zinā.⁵⁰ By saying that both verses 4 : 15 and 16 deal directly with zinā, al-Zamakhsharī, more likely, wants to explain that one of the verses concerns married adulterers and adulteresses, whereas the other verse pertains to unmarried adulterers and adulteresses, though he does not specify which verse refers to which meaning. At any rate, al-Zamakhsharī's opinion varies from that of Abū Muslim and consequently from the interpretation ascribed to Mujāhid.

48-According to the following Tafāsīr, none of the Sahābah nor of their Tābi'ūn, except Mujāhid, adopts this interpretation. Those Tafāsīr consulted on this issue are:

- Ṭabarī, Tafsīr, vol.3, pp.73-88.
- Baghawī, Ma'ālim, vol.1, pp.405-7.
- Zamakhsharī, Kashshāf, vol.1, p.197.
- Rāzī, Mafātīh, vol.3, pp. 166-70.
- Qurtubī, Tafsīr, vol.5, pp.83-90.
- Abū Ḥayyān, al-Baḥr al-Muḥīṭ, vol.3, p.194.
- Ibn Kathīr, Tafsīr, vol.1, pp.462-3.
- Suyūṭī, Durr, vol.2, pp.129-30.
- Bayḍāwī, Anwār, vol.2, pp.72-3.
- Tha'ālibī, Jawāhir, vol.1, pp.355-6.

49- Rāzī, Mafātīh, vol.3, p.167.

-Abū Ḥayyān, al-Baḥr al-Muḥīṭ, vol.3, p.194.

50- Zamakhsharī, kashshāf, vol.1, p.197.

It is noticeable that some arguments have been set forth in support of the above interpretation attributed to Mujāhid :

1: It may be argued in favour of Mujāhid that the statement wa-allātī ya'tūna al-fāḥishata min nisā'ikum in verse 4 : 15 hints exclusively at lesbians, while the structure of the phrase wa-alladhāni ya'tiyānihā min-kum in verse 4 : 16 exclusively refers to two sodomites . This is simply because the term allātī is a feminine plural, but alladhāni is a dual masculine. However, some people might oppose this argument by asking why the term alladhāni cannot be understood as referring to both male and female. The answer which is cited in support of Mujāhid would be as follows : if alladhāni refers to both men and women, then there is no point in particularizing women by the preceding verse (4 : 15). Hence since the Qur'ān specifies the first verse (4 : 15) to refer to women only and immediately follows that by the sentence wa-alladhāni ya'tiyānihā min-kum , then that possibility falls.⁵¹

2: Secondly, according to the view of the opponents of Mujāhid in this respect, both verses 4 : 15 and 16 are regarded as treating the issue of zinā. This leads therefore to the repetition of the same thing in the same place twice, while according to the explanation attributed to Mujāhid, i.e., to take the first verse (4 : 15) as referring to lesbianism and the next verse (4 : 16) to signify sodomy, no repetition occurs.

3: Thirdly, the opponents of Mujāhid who hold that verse 4 : 15 concerns zinā conceive sabīl in the Qur'ānic phrase aw yaj'ala

⁵¹- Rāzī, Mafātīḥ, vol.3, p.167.

Allāhu la-hunna sabīlan as referring to the punishments of stoning to death (rajm), flogging (jalid) and banishment (taghrīb). So it might be linguistically argued on behalf of Mujāhid that if the above punishments were meant here, then the verse would have read: aw yaj'ala Allāhu 'alay-hinna sabīlan, i.e., to use 'alay-hinna instead of la-hunna. This is because if those punishments virtually take place, they should be regarded as being carried out against the perpetrators ('alay-hinna) and not for them (la-hunna). This argument can be strengthened by another Qur'ānic verse which says: "... it shall have what it has earned (la-hā mā-kasabat) and it suffers that (evil) which it has earned (wa 'alay-hā mā iktasabat)" (2 : 286). So the purpose of the above argument is to assert that the meaning of the statement aw yaj'al Allāh la-hunna sabīlan is that God will facilitate for the lesbians a way to satisfy their sexual desires through a legal means which is the valid marriage bond. In other words, Mujāhid may reject the elucidation of his adversaries when they take sabīl in the above statement to refer to the punishments of stoning to death, flogging and banishment, which should be imposed on adulterous women.⁵²

4 : Fourthly, in this connection, it is argued that the Prophet says: "When a man practises sodomy with another man, they are regarded as adulterers (zāniyān), and when a woman practises lesbianism with another woman, they are considered as adulteresses (zāniyatān)."⁵³

⁵²-Ibid, p.167.

⁵³- Bayhaqī, al-Sunan al-Kubrā, vol.8, p.233.

-Rāzī, Mafātiḥ, vol.3, p.167.

-Nisābūrī, Raghā'ib, vol.18, p.38.

Nonetheless, the preceding arguments cited in support of the above interpretation attributed to Mujāhid are challenged by his rivals. Firstly, they argue that Mujāhid is the only exegete among the Companions and Successors to adopt that interpretation. So if that interpretation were sound, it would have been held by at least one or more of those early exegetes.⁵⁴ Secondly, in this respect, it has been reported that the Prophet says in a tradition narrated by 'Ubādah b. al-Ṣāmit : "Receive teaching from me, receive teaching from me (khudhū 'annī , khudhū 'annī) God has ordained a way for the adulterous women (qad ja'ala Allāhu la-hunna sabīlan). When an unmarried male commits fornication with unmarried female, they should each receive one hundred lashes (jald mi'ah) and banishment for one year (taghrīb 'āmm). As for the case of a married male committing adultery with a married female, they should each receive one hundred lashes and be stoned to death (rajm)"⁵⁵ Therefore, the Prophetic statement (qad ja'ala Allāhu la-hunna sabīlan) indicates that the Prophet refers to the Qur'ānic phrase (aw yaj'al Allāh la-hunna sabīlan) (4 : 15) which he understands as referring to the adulteress and adulterer.⁵⁶

In turn, however it has been argued in favour of Mujāhid that the above argument of his opponents necessitates the abrogation of the Qur'ān by the isolated reports (akhbār āhād) and that is, of course, unacceptable because as is held by some specialists of uṣūl al-fiqh, the Qur'ānic verses cannot be abrogated except by the same

54- Rāzī, Mafātīh, vol.3, p.167.

55- Muslim, Ṣaḥīḥ, vol.2, p.911.

56- Rāzī, Mafātīh, vol.3, p.167.

Qur'ān or by a mutawātir ḥadīth (a tradition which is narrated by an uncountable multitude of transmitters). Even though other uṣūlis do not accept that any kind of ḥadīth can abrogate the Qur'ān.⁵⁷

The opponents of Mujāhid further put forward a third argument to refute the explanation attributed to him on this matter. They argue that the Companions differ as regards the juristic rules of sodomy, but none of them invokes verse 4 : 16. The fact that the Companions did not resort to this verse though they were in a great need for a Qur'anic text to clarify the rule they were looking for, is the strongest proof that verse 4 : 16 has nothing to do with the crime of sodomy, as Mujāhid alleges.⁵⁸ However, again, those who support the interpretation attributed to Mujāhid answer this argument. They say that what the Companions were looking for is whether the ḥadd should be inflicted on the sodomite or not. In other words, they wanted to know whether the sodomite is to be considered as an adulterer or not. But, as they argue, the verse at issue (4 : 16) does not give either a positive or a negative answer to the exact question raised by the Companions. This is the reason why the Companions did not refer to this verse.⁵⁹

The fact that the Mu'tazilite scholar Abū Muslim is entirely in accord with Mujāhid's elucidation on this matter raises the

57- See Shāfi'ī, Risālah , pp.16-9; and pp.21-2. Also: Qurṭubī, Tafsīr, vol.2, pp.61-9.

58- Rāzī, Mafāṭih, vol.3, p.167.

59- Ibid, p. 167.

question of whether the agreement between Mujāhid and Abū Muslim is due to a common theological approach or not. To answer this question, we must examine the methodology which each of the two scholars follows in reaching that opinion. As for Abū Muslim, he is not ready to accept the elucidation which says that the fāhishah mentioned in the verses at issue 4 : 15-16 stands for zinā, which is the opinion of the majority of the exegetes including Mujāhid in the first opinion attributed to him.⁶⁰ This is because, according to the view of the majority of the exegetes, the legal punishments of zinā stated by those two verses, are later abrogated.⁶¹ This conclusion based on the concept of abrogation, is

⁶⁰-Ṭabarī, Tafsīr, vol.8, p.82-3.

-Qurtubī, Tafsīr, vol.5, p.86.

⁶¹-According to Qurtubī and Tha'ālibī, both verses 4 : 15-16 have been abrogated. (see Qurtubī, Tafsīr, vol.12, p.159; and Tha'ālibī, Jawāhir, vol.1, p.356.

-As regards the abrogation of verse 4 : 15, Two main views can be distinguished.

1: Firstly, the majority of Muslim scholars unanimously agree that verse 4 : 15 has been abrogated, but they divide into three camps with regard to the cause of the abrogation.

a: Some of them, including Mujāhid, maintain that verse 4 : 15 has been abrogated by verse 24 : 2. (see Ṭabarī, Tafsīr, vol.8, pp.74-6. Also: Rāzī, Mafātīh, vol.3, p.168. Also: Qurtubī, Tafsīr, vol.5, p.84.)

b: The second group of al-jumhūr hold that the abrogation occurs twice. Firstly, verse 4 : 15 is abrogated by the ḥadīth of 'Ubādah which is mentioned in the text of the previous pages, then in turn the ḥadīth of 'Ubādah is abrogated by the Qur'ānic verse 24 : 2. (see Rāzī, Mafātīh, vol.3, p.168.)

c: The third group of al-jumhūr, who are the followers of Abū Ḥanīfah, develop the matter of abrogation in this respect by saying that the abrogation occurs thrice. In their opinion verse 4 : 15 is firstly abrogated by the tradition of 'Ubādah, then, in turn, the tradition of 'Ubādah is abrogated by the verse of flogging (āyat al-jald) i.e., 24 : 2, then, in turn, the verse of flogging is abrogated by the verse of stoning (āyat al-rajm). The stoning verse says: "The shaikh and the shaikhah when they fornicate stone them outright, as an exemplary punishment from God. God is Mighty, wise. Several reports have been cited which maintain that this verse used to be a part of the Qur'ānic text, but later it has been abrogated in terms of recitation (naskh al-tilāwah ma'a baqā' al-ḥukm). One account may suffice in this respect. "Al-Bayḥaqī relates that Ubayy asked Zirr b. Ḥubaysh saying: 'How many verses do you recite in Sūrat al-Aḥzāb?' Zirr replied: 'seventy three verses'. Ubayy then asked if that is all. 'I have seen it' he said 'when it was equal in length to Sūrat al-Baqarah. [For this account and others see, Bayḥaqī, al-Sunan al-Kubrā, vol.8, p.211

unacceptable as far as Abū Muslim is concerned, because, in principle, he rejects the concept of abrogation in the Qur'ān altogether.⁶² In other words, Abū Muslim is already bound by his own views not to admit any interpretation which is based on the principle of abrogation. For this reason he takes verse 4 : 15 as referring to lesbianism, and verse 4 :16 as indicating sodomy, and he also takes verse 24 :2 to refer to fornication and not to adultery. By adopting this elucidation, he denies the occurrence of abrogation in the aforementioned two verses 4 : 15-16 and in the verse 24 : 2. This is because, according to Abū Muslim's interpretation, each of the above three named verses treats an entirely different subject. However, as for the position of Mujāhid with respect to the second explanation attributed to him of the verses at hand (4 : 15-16), it is a different story. Unlike Abū Muslim, Mujāhid in principle accepts the occurrence of abrogation

2: The second main view is held by Abū Muslim al-Iṣfahānī who enthusiastically denies the occurrence of the abrogation in that verse and in the Qur'ān as a whole.

62- As regards the acceptance or the rejection of the doctrine of abrogation, three main approaches can be distinguished. They are:

a: The first group rejects the doctrine of abrogation altogether. The father of this group is Ubayy b. Ka'b. Later, this view is also held by Abū Muslim al-Iṣfahānī.

b: The second group, who are the majority of Muslim scholars, accept the existence of abrogation in the Qur'ān, but they restrict it to the realm of law only. Our exegete, Mujāhid, is regarded as one of the partisans of this group.

c: The third group although they accept the existence of the abrogation, widen its scope to cover the field of law, i.e., enjoinders and prohibitions as well as the informative statements (*akhbār*). The upholders of this view are the Shi'ites.

- For further discussion on the issue of abrogation, see the following references :

-Ṭabarī, *Tafsīr*, vol.1, p.475.

- Ash'arī, *Maqālāt al-Islāmiyyīn*, p. 53; and p.478.

- Rāzī, *Mafātīḥ*, vol.1, p. 433-4.

- Qurtubī, *Tafsīr*, vol.2, p.56.

-Ibn Kathīr, *Tafsīr*, vol.1, p. 150.

in the Qur'ān.⁶³ According to the interpretation attributed to him that verse 4 : 15 refers to lesbianism and verse 4 : 16 refers to sodomy, he is not therefore bound by any pre-conceived teachings. He just sees this view as a possible interpretation for the verses under discussion.

Ultimately, it can be concluded that two interpretations have been attributed to Mujāhid as regards the meanings of verses 4 : 15- 16. As has been mentioned, the first interpretation attributed to him that fāhishah in both verses refer to zinā is given by al-Ṭabarī on the authority of Ibn Abī Najīh who is regarded as a regular transmitter of Mujāhid's views. Al-Qurṭubī also attributes this view to Mujāhid. In addition, this is Mujāhid's sole interpretation according to Ādam b. Abī Iyyās's version of Warqā's recension.⁶⁴ Furthermore, this is the view widely accepted by the majority of Muslim exegetes and scholars. Al-Ṭabarī also attributes to Mujāhid on the authority of two reliable transmitters namely Ibn Abī Najīh and Ibn Jurayj that the second verse (4 :16) concerns sodomy. Fakhr al-Dīn al-Rāzī and Ibn Kathīr also ascribe this interpretation to Mujāhid. Despite the fact that these three commentators keep silent and do not attribute to Mujāhid any interpretation as regards the first verse 4 :15, as has been mentioned, one might deduce that Mujāhid construed verse 4 :15 as referring to lesbianism. This deduction is confirmed by Abū Ḥayyān who puts it plainly that Mujāhid understands verse 4 :15 as referring to lesbianism and verse 4 : 16 as referring to sodomy.

⁶³- see the references in the previous footnote.

⁶⁴- Mujāhid, Tafsīr , vol.1, p.148.

Since the two interpretations attributed to Mujāhid are narrated by reliable transmitters, as has been shown in the reports of al-Ṭabarī, it seems possible that both are Mujāhid's own views. The fact is that both interpretations restrict allātī to women and alladhāni to men. As a result the main dispute between them becomes a matter of the nature of fāhishah. If that term refers to sexual relations between the opposite sexes outside marriage (i.e., zinā), then Mujāhid's first reported opinion would be his most valid interpretation. It is a matter of deciding what was Mujāhid's final interpretation of the word fāhishah in order to establish his view. However, the two interpretations, working as they do on a similar understanding of the relative pronouns, are not totally contradictory. It is possible that he had adopted one of the interpretations at an early date then later changed his mind and adopted the other one. If the suggestion in the introduction that Warqā' studied under Ibn Abī Najīḥ late in the latter's life is correct, then it would be most likely that the meaning of fāhishah as zinā was Mujāhid's final view. Whatever the case, in respect of the second interpretation attributed to him, Mujāhid is regarded as the sole exegete among the Ṣahābah and Tābi'ūn to suggest that interpretation. He is therefore the first exegete to suggest that the crimes of lesbianism and sodomy are treated by the Qur'ānic text.

THE INTERPRETATION OF QUR'ĀN 24 : 2 :

Verse 2 of Sūrat al-Nūr says : "Al-zāniyatu wa-al-zānī flog each of them with a hundred stripes. wa-lā ta'khudhukum bi-himā ra'fatun fī dīni Allāhī if you believe in God and the Last Day and let tā'ifatun of the believers witness their punishment." (24 : 2).

As it has been mentioned earlier, this verse establishes that the ḥadd punishment of the unmarried male and female when committing zinā that each of them should be flogged with a hundred stripes. In this verse, we will restrict ourselves to two points upon which Mujāhid sets forth juristic rules.⁶⁵ The first point concerns the meaning of the phrase wa-lā ta'khudhukum bi-himā ra'fatun fī dīn Allāh. The second concerns the interpretation of the term tā'ifah and who should witness the execution of the penalty.

(A) The interpretation of the phrase: wa- lā ta'khudhukum bi-himā ra'fatun fī dīn Allāh :

Three interpretations have been put forward as regards the above Qur'ānic phrase :

i-This phrase refers to the prohibition of any reluctance to execute the ḥadd punishment prescribed by God in this respect.⁶⁶

65. On this Qur'ānic verse alone, Qurtubī discusses twenty two issues among which many that concern fiqh. [see Qurtubī, Tafsīr, vol.12, pp.159-67].

66. Ṭabarī, Tafsīr, vol.18, p.66.

ii- It refers to the nature of the flogging that it should be severe and painful to some extent.⁶⁷

iii- Others suggest that the meaning of this phrase comprises both the above interpretations.⁶⁸

Mujāhid adopts the first interpretation when he maintains that the phrase at issue refers to the need to carry out the hadd of flogging on the perpetrators of zinā.⁶⁹ This view of Mujāhid is given by al-Ṭabarī in three reports.⁷⁰ In two of these reports Mujāhid's transmitter is Ibn Abī Najīh who is quoted by Sufyān in one and by al-Thawrī in the other.⁷¹ The third report is transmitted by Ibn Jurayj who directly quotes Mujāhid.⁷² However, this view of Mujāhid is not mentioned in Ādam b. Abī Iyyās's version of Warqā's recension. The phrase, according to Mujāhid's understanding, warns the judicial authorities against manifesting any sympathy or compassion towards the offenders of zinā that may totally preclude or reduce the due hadd.⁷³ In other words, as

67- Ibid, p.68. Nonetheless, all the authoritative jurists agree that the enforcement of the penalty of jalḍ (lashing) on the perpetrators of zinā should be carried out as humanly as possible without any undue suffering on the part of the culprit, especially pregnant women. Moreover, the stripes, the weather, the choice of the person who would carry out this penalty (jallād) must all be reasonable, i.e., neither too harsh nor too tolerant. ['Awdah, al-Tashrī' al-Janā'ī fī al-Islam , vol.2, pp. 448-53].

68- Ibn al-'Arabī, Ahkām, vol.3, p.1326.

69- Ṭabarī, Tafsīr, vol.18, p.67.

- Ṭabarsī, Tafsīr, vol.7, p.124.

70- Ṭabarī, Tafsīr, vol.18, p.67.

71- Ibid, p.67. Although Ṭabarī's isnāds give Sufyān and al-Thawrī, it is to be assumed that they both refer to Sufyān al-Thawrī, as Sufyān b. 'Uyaynah did not transmit from Ibn Abī Najīh. It should also be noted that Ṭabarī in including the second report (i.e., from al-Thawrī) as evidence for this view makes it look as if the actual words were that the hudūd were not to be carried out (lā tuqām). This is a view held by no one else and clearly the lā should not have been included.

72- Ibid, p.67.

73- Ṭabarī, Tafsīr, vol.18, p.67-8.

al-Zamakhsharī puts it, the judicial authorities should be very firm in implementing Sharī'ah law in this respect.⁷⁴ Ibn Kathīr further confirms this view of Mujāhid when he quotes Mujāhid's statement that when the crime is proved before the judicial authorities the ḥadd should be executed immediately and not be abandoned at all.⁷⁵ The above statement of Mujāhid implies that as long as the crime has not been brought to the attention of the authorities, there is a possibility of the ḥadd not being executed. In this statement, Mujāhid might perhaps have invoked the Sunnah, as it is reported that the Prophet says: "You can forgive each other in ḥudūd. When the ḥadd is brought before me however, then its execution becomes an obligatory matter."⁷⁶ This ḥadīth makes it quite clear that when the crime of zinā is reported and proved⁷⁷ before the judicial authorities, then the ḥadd must be implemented. On the other hand, this ḥadīth also gives the Muslims a chance of forgiving each other in matters involving ḥudūd as long as the ḥadd has not yet been submitted to the judicial authorities. Similarly this interpretation of Mujāhid shows that the intercession (shafā'ah) in the ḥadd of zinā, if the crime is reported and proved, is entirely prohibited.⁷⁸

- Rāzī, Mafātīh, vol.6, p.224.

74- Zamakhsharī, Kashshāf, vol.3, p.209.

75- Ibn Kathīr, Tafsīr, vol.3, p.261.

76- Abū Dāwūd, Sunan, vol.4, p.133.

77- According to the jurist Mālik, the establishment of the proof of zinā can be obtained either by testimony of four credible men or by the manifestation of pregnancy or by voluntary confession. [see Mālik, Muwatta', p.592]. However, the majority of the jurists restrict the means of proof in such a case to only: valid confession which is made four times, and testimony of four witnesses, with the apparent exclusion of pregnancy. [see Ibn Qudāmah, Mughnī, vol.8, pp.191-213]. Thus pregnancy alone is not sufficient for issuing a ḥadd penalty in zinā trials.

So in short, in Mujāhid's opinion, the phrase at issue wa-lā ta'khudhukum bi-himā ra'fatun fī dīn Allāh emphasises the obligation of carrying out of the ḥadd of flogging on the unmarried male and female when zinā has been committed.⁷⁹ It may be relevant to mention that this interpretation of Mujāhid was also held by 'Ubayd Allāh b. 'Abd Allāh b. 'Umar, Ibn Jurayj, 'Atā' b. Abī Rabāh, Sa'īd b. Jubayr, Abū Mujlazz, Ibn Zayd, 'Āmir and Sulayman b. Yasār.⁸⁰ It is also favoured by the linguists al-Zajjāj (d. 311/ 924) and Farrā' (d. 457/ 1064).⁸¹

A different interpretation from that of Mujāhid was propounded by another group who understand the Qur'ānic phrase at issue wa-lā ta'khudhukum bi-himā ra'fatun fī dīn Allāh as inhibiting the mitigation of the penalty as a sign of pity (ra'fah) on the felons of zinā. They say that pity which is forbidden occurs when Muslim rulers or the authorities lighten the lashing on the perpetrators of zinā so that they are not beaten severely.⁸² So,

78- The doctrine of the necessity of implementing ḥudūd is also confirmed by the following traditions :

(i) "Abū Hurayrah narrates that the Prophet says : 'Whoever intercedes in the due waiver of a ḥadd penalty, would be considered as opposing the commandment of God". [See Ibn Ḥanbal, Musnad , vol.7, pp.234-5; and pp. 291-6. Also: Abū Dāwūd, Sunan, vol. 4, pp.132-3.].

(ii) "Abū Hurayrah relates that the Prophet says: 'the execution of a ḥadd on earth is better for its inhabitants than rain falling for forty days. [see Ibn Mājah, Sunan, vol.2, p.848].

79- For further discussion on this interpretation, see :

- Rāzī, Mafātīh, vol.6, p.221.

- Baghawī, Ma'ālim, vol.3, p.321.

- Abū Hayyān, al-Baḥr al-Muḥīt, vol.6, p.429.

- Suyūṭī, Durr, vol.5, p.518.

80- Ṭabarī, Tafsīr, vol.18, pp.66-8.

81- Rāzī, Mafātīh, vol.6, p.221.

82-Ṭabarī, Tafsīr, vol.18, p.68.

unlike Mujāhid, this group believes that the legality of the implementation of the ḥadd itself is beyond doubt, but what is actually meant here is the way in which the ḥadd is executed. This second interpretation is adopted by some famous exegetes namely al-Ḥasan al-Baṣrī, Sa'īd b. al-Musayyab, Ḥammād, al-Zuhri and Qatādah.⁸³

Al-Ṭabarī favours Mujāhid's interpretation which limits the meaning to simply carrying out the ḥadd without there being any leniency in it.⁸⁴ As a basis for his conclusion, he puts forwards two arguments. Firstly, he remarks that in the phrase under discussion, the Qur'ān connects the prohibition of showing ra'fah (pity) towards the offenders with the phrase fī dīn Allāh which means as regards obedience to God. And since dīn Allāh (Commandment of God) in this context refers to the enforcement of flogging as the legal ḥadd, there would be no ra'fah (abandonment of the punishment) towards the felons. Mujāhid's interpretation mentioned above, as al-Ṭabarī argues, is therefore a tenable and a reasonable one.⁸⁵ In his second argument to support Mujāhid's interpretation, al-Ṭabarī argues that it is impossible that God should ordain the Muslims with any injunction unknown to them.⁸⁶ Al-Ṭabarī concludes that the most proper and just criterion which Muslim authorities can easily be acquainted

83- Ibid, p.68.

84- Ibid, p.68.

85- Ibid, p.68.

86- Ibid, p. 68.

with is therefore the number of lashes (100 stripes) i.e., the mere execution of the hadd and this is the view held by Mujāhid.⁸⁷

The third interpretation is reported by Ibn al-‘Arabī who contends that the meaning of the statement under discussion wa-lā ta’kudhukum bi-himā ra’fatun fī dīn Allāh covers both the interpretation of Mujāhid and that of his opponents. According to him, the verse prohibits the Muslim from being too tolerant towards the offenders of zinā either by relinquishing the hadd or by mitigating it.⁸⁸ Fakhr al-Dīn al-Rāzī confirms the possibility of this third interpretation mentioned by Ibn al-‘Arabī.⁸⁹ It seems that this third interpretation tries to reconcile the interpretation of Mujāhid and that of the second group.

(B) The Interpretation of tā’ifah in verse 24 : 2 :

The other part pertaining to zinā penalty mentioned in verse 24 : 2 concerns the meaning of the term tā’ifah in the phrase wa-li-yashhad ‘adhābahumā tā’ifatun min al-mu’minīn. The following suggestions have been put forward . Mujāhid, according to al-Ṭabarī, holds that the minimum number of the tā’ifah (party) recommended to witness (yashhad) the enforcement of the punishment of flogging on the perpetrators of zinā is one believer.⁹⁰ Al-Ṭabarī gives this view of Mujāhid in four reports,

87- Ibid, p. 68.

88- Ibn al-‘Arabī, Aḥkām, vol.3, p.1326.

89- Rāzī, Mafāṭīḥ, vol.6, p.224.

90- Ṭabarī, Tafsīr, vol.18, p.69.

- Nisābūrī, Raghā’ib, vol.18, p.46.

all of which are transmitted by Ibn Abī Najīh.⁹¹ Sufyān is quoting Ibn Abī Najīh in three of these reports.⁹² In the fourth report Ibn Abī Najīh is quoted by Ibn 'Alyah.⁹³ Al-Ṭabarī also cites further traditions which express this view in a slightly different way. In them Mujāhid maintains that tā'ifah means one to a thousand.⁹⁴ This is in fact no more than saying one or more believers, i.e., the minimum number is one. Al-Ṭabarī also gives this expression of Mujāhid's view in four reports.⁹⁵ Abū Bishr is Mujāhid's transmitter in three of these reports.⁹⁶ The authority for the fourth report is Ibn Abī Najīh who is quoted by al-Thawrī.⁹⁷ None of the two expressions of Mujāhid's views is mentioned in Ādam b. Abī Iyyās's version of Warqā's recension. In supporting his view that the minimum of tā'ifah can be only one believer, Mujāhid invokes two other Qur'ānic verses. The first verse says: "If two parties (tā'ifatān) among the believers fall into a quarrel, you make peace between them (wa-in tā'ifatāni min al-mu'minīna iqtatalū fa-aṣlihū bayna-humā ...)". (49: 9).⁹⁸ According to asbāb al-nuzūl (causes and occasions of revelation), this latter Qur'ānic verse was revealed

- Baghawī, Ma'ālim, vol.3, p.321.

91- Ṭabarī, Tafsīr, vol.18, p.69.

92- Ibid, p.69.

93- Ibid, p.6.

94- Ṭabarī, Tafsīr, vol.18, p.69.

- Zamakhsharī, Kashshāf, vol.3, p.210.

Qurṭubī, Tafsīr, vol.12, p.166.

- Ibn Kathīr, Tafsīr, vol.3, p.262.

95 - Ṭabarī, Tafsīr, vol.18, p.69.

96- Ibid, p.69.

97- Ibid, p. 69.

98- Ibid, p.69.

concerning the fight that erupted between two of the men of Anṣār community. In this verse the Qur'ān uses tā'ifah as referring to a single person, which can also be used to refer to a group of persons.⁹⁹ This usage therefore confirms Mujāhid's view. The second verse cited by Mujāhid to support his interpretation was: "And the believers should not go forth all together. Why, then, does not a company from every party from among them go forth (wa- mā kāna al-mu'minūna li-yanfirū kāffatan fa-lawlā nafara min kulli firqatin minhum tā'ifatun) ...". (9:122).¹⁰⁰ Although the term tā'ifah in this verse refers to a group of believers (jamā'ah), it can also be used to indicate the minimum of one single person.¹⁰¹ This verse thus also supports Mujāhid's view.

Mujāhid's second expression of this interpretation of tā'ifah, i.e., one to a thousand was also endorsed by some famous exegetes among the Sahābah and Tābi'ūn. They are: Ibn 'Abbas,¹⁰² Ibrāhīm al-Nakh'ī,¹⁰³ Hammād,¹⁰⁴ 'Ikrimah¹⁰⁵ and al-Ḥasan al-Baṣrī.¹⁰⁶ The jurist Aḥmad b. Ḥanbal also prefers Mujāhid's opinion that tā'ifah

- Rāzī, Mafātīh, vol.6, p.221.

- Qurṭubī, Tafsīr, vol.12, p.166.

99- Ibid, vol.16, pp.315-6.

100- Ibid, vol.12, p.166.

101- Ibid, vol.8, p.294.

102- Ibid, vol.12, p.166.

Suyūṭī, Durr, vol.5, p.518.

103- Ṭabarī, Tafsīr, vol.18, p.69.

- Qurṭubī, Tafsīr, vol.12, p.166.

- Baghawī, Ma'ālim, vol.3, p.321.

- Nisābūrī, Raghā'ib, vol.18, p.46.

104- Ṭabarī, Tafsīr, vol.18, p.69.

105- Ibn Kathīr, Tafsīr, vol.3, p.262.

106- Qurṭubī, Tafsīr, vol.12, p.166.

denotes one believer,¹⁰⁷ although the Ḥanbalī school did not adopt this as their view. They maintain that a group of people should attend.

The second opinion as regards the interpretation of the word tā'ifah, which is attributed to 'Aṭā' b. Abī Rabāḥ and 'Ikrimah,¹⁰⁸ proposes that the minimum of tā'ifah is two believers. Mālik b. Anas also adopted this opinion, arguing that the witness of the punishment of zinā is similar to the general testimony which necessitates two witnesses.¹⁰⁹ However, this view was not adopted by the later Malikites as they maintained that the minimum number was four. The third opinion, which is adopted by al-Zuhri, Qatādah and Abū Barazah al-Aslamī, suggests that tā'ifah means three believers, because the minimum number of jamā'ah is three.¹¹⁰ The fourth opinion, which is attributed to Ibn Zayd, says that the minimum number of tā'ifah is four witnesses.¹¹¹ This opinion considers the presence of the punishment of zinā as equal to witnessing the commission of the crime of zinā itself, where four witnesses are essential. Accordingly, the same number would be required to attend the implementation of the penalty.¹¹² This view is later attributed to the jurists: al-Layth

107- Ibn Kathīr, Tafsīr, vol.3, p.262.

108- Ṭabarī, Tafsīr, vol.18, p.69.

- Qurṭubī, Tafsīr, vol.12, p.166.

- Ibn Kathīr, Tafsīr, vol.3, p.166.

109- Qurṭubī, Tafsīr, vol.12, p.166.

110- Ṭabarī, Tafsīr, vol.18, p.70.

- Qurṭubī, Tafsīr, vol.12, p.166.

- Ibn Kathīr, Tafsīr, vol.3, p.262.

111- Ṭabarī, Tafsīr, vol. 18, p.70.

112- Qurṭubī, Tafsīr, vol.12, p.166.

and al-Shāfi'ī.¹¹³ Mālik is also attributed with this view and the Mālikī school came to hold this position. The Shāfi'ī school adopted the doctrine of the need for four witnesses at the punishment. Abū Ḥanīfah goes as far as asserting that the four witnesses should begin the stoning with the imām.¹¹⁴ So clearly he believes that at least five should be present as a minimum but he also wishes the people to be present. This is the same as the view held by Rabī'ah who suggests that tā'ifah denotes five believers.¹¹⁵ Later Ḥanafis demanded that a group of people (mala') be present at the punishment.¹¹⁶ The fifth view, which is ascribed to al-Ḥasan al-Baṣrī¹¹⁷ and Abū Baradah¹¹⁸ takes tā'ifah as denoting ten believers.

Al-Ṭabarī gives preference to Mujāhid's view that the minimum of tā'ifah who should attend the punishment of the felons of zinā is one believer though it can be more. He supports Mujāhid's interpretation by a linguistic argument that in the Arabic lexicons tā'ifah means one person or more. Hence if that is the case, and since the Qur'ān does not specify a certain number, then the minimum tā'ifah suffices in this context. Nevertheless, al-Ṭabarī further adds that he recommends the number of the attendants for the punishment of zinā to be not less than

113- Ibid, p.166.

114- Nisābūrī, Gharā'ib, vol.18, p.46.

115- Ibn Kathīr, Tafsīr, vol.3, p.262.

116- Zuḥaylī, al-Fiqh al-Islāmī wa-Adillatuhu, vol.6, p.64.

117- Rāzī, Mafātīḥ, vol.6, p.225.

- Qurṭubī, Tafsīr, vol.12, p.167.

- Ibn Kathīr, Tafsīr, vol.3, p.262.

118- Jaṣṣās, Aḥkām, vol.5, p.106.

- Zamakhsharī, Kashshāf, vol.3, p.210.

four believers which also complies with the linguistic meaning of tā'ifah. The number of four witnesses is equal to the number of witnesses who testify to the occurrence of the crime of zinā. So obviously, al-Ṭabarī combines Mujāhid's opinion with the fourth opinion.¹¹⁹

It is surprising that there is no report from the recension of Shibl, 'Īsā and Warqā' with regard to the meaning of tā'ifah, especially as Sufyān has reported Mujāhid's interpretation on the authority of Ibn Abī Najīh. However, it may be that as a result of later jurists advocating at least four people, this interpretation may have been omitted by the three important recensions or by transmitters of them.

Al-Zamakhsharī prefers the latter statement of al-Ṭabarī that the number of tā'ifah should be at least four witnesses. Al-Zamakhsharī further refers to the importance of the presence of tā'ifah in this context so that the delivery of the ḥadd should be well-known and so that this would deter potential perpetrators of zinā. According to him, the number is intended for publicity, so the bigger it is, the better. One or two persons would not therefore suffice, so tā'ifah should be understood in the fullest possible interpretation.¹²⁰

On these two points connected with verse 24: 2, Mujāhid's views show him be advocating interpretations which later

119- Ṭabarī, Tafsīr, vol.18, p. 70.

120- Zamakhsharī, Kashshāf, vol.3, pp.210-1.

mufassirūn particularly al-Ṭabarī, felt to be the most appropriate. It is interesting to note that here in his interpretation of tā'ifah, Mujāhid uses the occurrences of the word elsewhere in the Qur'ān as evidence for its meaning in this verse.

* * *

The other juristic problem concerns the different kinds of 'iddah. This will be the subject of the next chapter.

CHAPTER SEVEN

THE 'IDDAH

The term 'iddah refers to the prescribed period that the divorcee or the widow should wait before contracting a new marriage.

1. THE 'IDDAH OF THE DIVORCEE :

The exegetes and jurists differ in their interpretation of qur' in the Qur'ān 2 : 228. The verse states: "And the divorced women should keep themselves in waiting for three qurū' (wa-al-muṭallaqātu yatarabbaṣna bi-anfusihinna thalāthata qurū'in) ...". Before discussing Mujāhid's interpretation of this word and the arguments involved in its interpretation, it would be appropriate to outline to whom the verse refers. Al-Qurṭubī observes that although the term al-muṭallaqāt in the above verse is generalized, that is to say, it comprises all divorced women, it is nevertheless understood to refer to a certain kind of divorced woman. It is the free divorced woman who menstruates and has been approached by her husband.¹ He adds that the other divorced women have been excluded from the above verse because they have been dealt with in other Qur'ānic verses.² The other kinds of the divorced women whose 'iddah does

1- Qurṭubī, Tafsīr, vol.3, p.112.

2- Some people argue that the generalization in the term al-muṭallaqāt in verse 2 : 228 is used to cover even those divorced women whom al-Qurṭubī maintains are excepted from this verse. Later, according to those people, the other kinds of the divorced women have been excluded from this term. However, commenting on

not fall under the juristic rule mentioned in the above verse (2 : 228), are the following:

(i) The divorced woman who menstruates but her marriage has not been consummated. The 'iddah of such woman is determined by the Qur'ānic verse: " O ye who believe! When ye marry believing women, and then divorce them before ye have touched them, no period of 'iddah have ye to count in respect to them (yā ayyuhā alladhīna āmanū idhā nakaḥtum al-mu'mināti thumma tallaqtumūhunna min qabli an tamassūhunna fa-mā la-kum 'alay-hinna min 'iddatin ta'taddūnahā)". (33 : 49). This verse puts it quite plainly that if a woman marries but her husband divorces her before they have sexual intercourse, then no 'iddah at all is incumbent on her.

(ii) The pregnant divorced woman. The 'iddah of the pregnant divorced woman is laid down by the verse: "... for those who carry life within their wombs, their period is until they deliver their burdens (wa- ūlāti al-aḥmāli ajaluhunna an yaḍ'ana ḥamlahunna) ...". (65 :4). This verse determines the 'iddah of the pregnant woman, whether a divorcee or a widow, with the delivery of the baby. As regards the 'iddah of the pregnant widow there is however another view, which is attributed to 'Alī and Ibn 'Abbās who take her 'iddah to be the furthest duration of the four months and ten days and the delivery of the baby. It seems that there is only one view with regard to the 'iddah of the pregnant widow, which is that her 'iddah ends with the delivery of the baby.³ This indicates that

this suggestion, al-Qurṭubī describes it as weak (da'if). (see Qurṭubī, Tafsir, vol.3, p.112.

³- Sarakhsī, Mabsūṭ, vol.6, pp.10-5.

- Ibn Ḥazm, Muḥallā, vol.11, p.635.

- Ibn Qudāmāh, Mughnī, vol.7, p.449.

the principal purpose of the 'iddah' in the case of the divorced women is to determine whether they are pregnant or not.

(iii) The divorced woman who no longer menstruates, and the divorced girl who has not yet menstruated. The 'iddah' of both kinds of divorcees is three months, as stated by the verse: "Such of your women as have passed the age of monthly courses, for them the prescribed period, if ye have any doubts, is three months, and for those who have no courses, it is the same (wa-allā'ī ya'isna min al-mahīdi min nisā'ikum in irtabtum fa-'iddatuhunna thalāthatu ashhurin) ...".(65 :4).

Nonetheless, although the 'iddah' of the free divorced woman who menstruates is explicitly determined by three qur' according to verse 2 : 228, Muslim scholars and exegetes differ as regards the exact meaning of the term qur'. Two major explanations have been put forward. The first group maintain that qur' indicates menstruation (hayd). Our exegete Mujāhid is one of the adherents of this opinion.⁴ The second group hold the view that qur' refers to the period of purity (tuhr) of the woman.⁵

However, before the arguments of each group is discussed, it is relevant to mention the singular and the plural forms of the word qur'. Ibn Manzūr says that the singular form of the word is either qur' or qar'. The plural form can be qurū', aqrā' or aqrū'.⁶ The latter form is used by al-Liḥyānī as a plural of

4-Ṭabarī, Tafsīr, vol.4, pp.500- 6.

5-Ibid, p. 506-13.

6- Ibn Manzūr, Lisān, vol.3, p.43.

paucity (jam' qillah).⁷ As regards the linguistic meaning, Ibn Manzūr says: "qara'atu al-shay'a qurānan" means I collected the thing and put its parts together (jama'tuhu wa-damamtu ba'dahu ilā ba'din).⁸ He adds that qur' or qar' connotes waqt, i.e., the time which applies to both hayd (menstruation) and tuhr (purity), because, as Ibn Manzūr argues, each of the two conditions hayd and tuhr occupies a certain period of time. Ibn Manzūr thus regards qur' as a word with contrary meaning.⁹ As we shall see, this view of Ibn Manzūr will be confirmed by the different pre-Islamic poetry which each side in the argument cites.

As has been mentioned, Mujāhid interprets qur' as referring to menstruation (hayd). Al-Ṭabarī gives this view of Mujāhid in only one report on the authority of 'Īsā on the authority of Ibn Abī Najīh.¹⁰ Mujāhid's view is also mentioned in Ādam b. Abī Iyyās's version of Warqā's recension on the authority of Ibn Abī Najīh.¹¹ By stating that the term qur' connotes the monthly courses (hayd), Mujāhid sees that the divorced woman whose marriage has been consummated should wait for three periods of menstruation before contracting a new marriage.¹² These three menstruations are regarded by exegetes and jurists who hold this interpretation of qur' as being as follows:

7- Ibid, p.43.

8- Ibid, p.42.

9- Ibid, p.43. For further linguistic discussion on this matter, see Ibn Manzūr, Lisān, vol.3, pp.42-4.

10- Ṭabarī, Tafsīr, vol.4, p. 500.

11- Mujāhid, Tafsīr, vol.1, p.108.

12-Ṭabarī, Tafsīr, vol. 4, p.500.

i. The first menstruation which comes after the purity in which the woman is divorced.

ii. Then the second menstruation which follows a full period of purity.

iii. Lastly, the third menstruation which succeeds the second full period of purity.

Therefore if a husband divorces his wife once or twice he can revoke that divorce, but on condition that his wife has not started her obligatory ritual bathing after the third menstruation. In this connection, it has been reported that 'Umar b. al-Khaṭṭāb divorced his wife. She wished to have her ritual bath after the third menstruation. But before she started doing so, 'Umar declared that she was his wife and withdrew the divorce.¹³ However, if the wife already started her ritual bath of the third monthly courses, that would mean that she completed her waiting period and would be considered as separated from her former husband and would be free to remarry whom she wishes, except her former husband, if it was the third declaration of divorce.¹⁴

There are many exegetes among the Companions and the Successors who interpret the term qur' as meaning hayḍ, and therefore their opinion tallies with that of Mujāhid. We can mention 'Umar b. al-Khaṭṭāb, Ibn Mas'ūd, 'Alī b. Abī Ṭālib, Abū Mūsā al-Ash'arī, Ibn 'Abbās, 'Amr b. Dīnār, al-Ḍaḥḥāk, 'Ikrimah, Sa'īd b. Jubayr and Ma'bad al-Juhanī.¹⁵

¹³-Ibid, p.500.

¹⁴-Ibid, pp.504-6.

¹⁵- Ibid, pp.500-6.

This interpretation of Mujāhid and of those who take the term qur' in the verse under discussion wa-al-mutallaqātu yatarabbaṣna bi-anfusihinna thalāthata qurū'in ..." (2 : 228) as referring to menstruation (hayḍ), can be supported by a number of points and arguments. Firstly, two textual arguments have been put forward in favour of this view :

(i) In this very same verse (2 : 228) when the Qur'ān says "...thalāthata qurū' ...", what is meant is that the 'iddah of the wife whose marriage has been consummated has been determined by a specific number which is three. It is therefore argued that if the word qur' is interpreted as meaning period of purity, as those who hold the other view claim, then there will be only two complete qurū' and a part of the third one. This is because the legal divorce of a woman should take place in a period of purity which becomes an incomplete qur' as far as the 'iddah is concerned. Qur' thus must be taken to refer to menstruation (hayḍ).¹⁶

(ii) This group also resorts to the verse: "And such of your women who despair of menstruation, if you have any doubt, their period of waiting shall be three months and for those who have no courses it is the same... ". (65 : 4). As has been mentioned, this Qur'ānic phrase deals with the 'iddah of the divorced woman who has passed the age of the monthly courses, in addition to the 'iddah of the girl who has not yet had the courses, where it determines the 'iddah of both of them as three months. It is argued in favour of the view held by Mujāhid and others that the 'iddah of

16. Jaṣṣāṣ, Aḥkām, vol.2, p.59.

these two kinds of women is reckoned by months because they both share the non-existence of the menses (ḥayd). This is a clear indication that the origin (asl) is the menses and not the period of purity.¹⁷ In order to strengthen this argument which has been cited in favour of Mujāhid's view, al-Jaṣṣāṣ likens the relationship between menstruation and purity with that of water and clean dust (turāb) when one prepares oneself for the prayer or needs to have an obligatory ritual bath. As the Qur'ān says: "...but if you are ill or on a journey or one of you comes from the offices of nature or you have been in contact with your wives and you find no water, then take for yourselves clean sand or earth (fa-lam tajidū mā'an fa-tayammamū ṣa'idan ṭayyiban)...". (5 : 6). It is understood from this verse that the water is the origin and not the clean sand as far as the ablution or the obligatory ritual bath are concerned.¹⁸ Thus similarly in the case of menstruation and purity, the origin is the former and not the latter.

Secondly, the Sunnah also might give support for the elucidation of Mujāhid and his group that qur' refers to menstruation. On this matter, the following traditions are often cited :

(i) The Prophet says to Fāṭimah bint Abī Ḥubaysh : "When your qur' comes, abandon the prayer and when it goes away take the ritual bath and perform the prayer".¹⁹ The words of the Prophet

17- Ibid, p.59.

18- Ibid, p.59.

19- Ibn Mājah, Sunan , vol.1, pp.203-4.

thus indicate that he understands the term qur' as referring to menstruation.

(ii) 'Ā'ishah relates that the Prophet says: "The legal number of declarations of divorce of the slave-wife are two and her qur' is two menstruations (talāq al-amah tatliqatān wa-qur'uhā haydatān)".²⁰ This hadīth comes in another version on the authority of both 'Ā'ishah and Ibn 'Umar who relate that the Prophet says: "The number of declarations of divorce for the slave-girl are two and her 'iddah is two menstruations."²¹ The first version of the above hadīth thus puts it quite plainly that qur' stands for menstruation. As for the second version of that hadīth, since the Prophet states that the 'iddah of the slave-girl is two menstruations, it is understood that the 'iddah of the free woman is three menstruations. Commenting on those two traditions, al-Jaṣṣāṣ says that although the narrations of those two hadīths are isolated (āḥād), the scholars agree to take them as evidence that the 'iddah of the slave-girl is half of the 'iddah of the free woman. This indicates therefore the authenticity of those two traditions.²²

(iii) The third hadīth which might also give support for the view of Mujāhid and others about the meaning of qur' concerns the captives of Awṭās. Abū Sa'īd al-Khudrī relates on the authority of the Prophet who says: "No pregnant woman is allowed to be touched until she delivers her baby and no woman who is not menstruating at the time (hā'il) is allowed to be touched until she is relieved

20- Ibid, 672.

- Dārimī, Sunan, vol.2, pp.170-1.

21- Ibn Mājah, Sunan, vol.1, p.672.

22 -Jaṣṣāṣ, Aḥkām, vol.2, p.58.

(tastabri) by a single menstruation.²³ Hence since the Prophet stipulates the releasing of the menstruation (istibrā) of the slave-girl on the menstruation and not on the purity, then the waiting period ('iddah) also should be looked at according to the menstruation and not according to the purity.

Thirdly, the opinion of Mujāhid and others who hold the same view is supported by the Arabic language itself:

(i) The word qur' is used in the Arabic poetry to mean menstruation (hayd) as the poet recites :

يا رب ذي ضغن على فارض له قروء كقروء الحائض

The above verse of poetry means the that brave man stabs his enemy deeply to the extent that the blood flows from him , as the blood flows from the menstruated woman.

(ii) al-Jaṣṣāṣ argues in favour of the same view by maintaining that if we take the term qur' as linguistically referring to the time (waqt) which applies to both menstruation and purity, we find that the closest condition to that meaning is menstruation (hayd), since the waqt can be none other than the time of the event which takes place therein and that event which actually occurs is the menstruation (hayd), whereas the period of purity (tuhr) is merely non-menstruation and it is not an independent event which occurs by itself. It would seem therefore that menstruation is the more appropriate interpretation of qur'.²⁴ In asserting the above conclusion, al-Jaṣṣāṣ further argues that if we

²³- Ibid, p.58.

²⁴- Ibid, pp.56-7.

take the term qur' as linguistically referring to the collection and composition (damm wa-ta'lif), again the state of the menstruation is more appropriate to that meaning since the blood of the menstruation gathers from all parts of the body.²⁵

On the other hand, the group who oppose the view held by Mujāhid and those who support the same interpretation take qur' as indicating the period of purity (tuhr), maintaining that it is obligatory for the divorcee to wait for three periods of purity (athār) before getting married again.²⁶ So if a man divorces his wife when she is in a period of purity, then the rest of that period of purity is reckoned as a full purity as far as the waiting period ('iddah) is concerned. So that woman should wait for the second period of purity which follows a menstruation, and then wait for the third period of purity which follows her menstruation. When the woman sees the first blood of the third menstruation, then her 'iddah is over and she is allowed to remarry.²⁷

The group which support this position is represented also by a considerable number of exegetes among the Companions and their Successors. We mention 'Abd Allāh b. 'Umar, Zayd b. Thābit, Sālim b. 'Abd Allāh, Abbān b. 'Uthmān and Abū Bakr b. 'Abd al-Raḥmān b. al-Ḥārith b. Hishām. Despite the fact that 'Ā'ishah is named as the authority for one of the ḥadīths quoted in support of the first view, she is widely reported as being a proponent of this view also.

25- Ibid, pp.56-7.

26- Ṭabarī, Tafsīr, vol.4, p.506-13.

27-Ibid, pp.506-13.

This second group who construe qur' as meaning period of purity also have their arguments to sustain their interpretation and therefore challenge Mujāhid's. Firstly, they quote the Qur'ānic verse: "O Prophet, when you divorce women, divorce them at their prescribed periods and count accurately their prescribed periods (yā ayyuhā al-nabiyyu idhā ṭallaqtumu al-nisā' fa-ṭalliḳūhunna li-'iddatihinna wa-aḥṣū al-'iddata) ..." (65 : 1). The argument which the exegetes deduce from this verse concerns the phrase fa-ṭalliḳūhunna li-'iddatihinna, that it is unanimously agreed that the divorce should take place when the woman is in the condition of purity (ṭuhr). They thus argue that since consideration is given to ṭuhr regarding the matter of the correct legal divorce, then it is the ṭuhr, too which should be considered in the matter of 'iddah.²⁸

Secondly, this group also turn to the ḥadīth to find support for their view and a repudiation against Mujāhid's. They cite the following tradition: "Mālik b. Anas reports on the authority of Nāf'i that in the time of the Prophet Ibn 'Umar divorced his wife whilst she was in her monthly courses. 'Umar asked the Prophet concerning this matter. The Prophet replied by asking 'Umar to tell his son 'Abd Allāh to retract the divorce of his wife and to keep her until she achieves purity, then to have her menstruation, and then achieve purity again. After that he can decide either to keep his wife, or to divorce her before touching her. Thus that is the

28- Qurṭubī, Tafsīr, vol.3, p.115.

waiting period ('iddah) which God commands that the woman is to be divorced at."²⁹

Thirdly, this group also find support for their opinion from the statement of one of the closest Companions of the Prophet, his wife 'Ā'ishah who says that: "Do you know what al-aqrā' are? Al-aqrā' means al-athār (the periods of purity)".³⁰

Fourthly, this group also resort to a linguistic viewpoint to advocate their interpretation. They quote the verses of poetry of al-A'shā :

أفي كل عام أنت جاشم غزوة

تشد لأقصاها عزم عزائك

مورثة عزا وفي المحي رفعة

لما ضاع فيها من قروء نساك

In these two verses, al-A'shā praises Hawdhah b. 'Alī, admiring his battles in which he spent considerable time aiming at achieving honour and high rank. However, due to his continuous travelling and fighting, Hawdhah did not have much time to stay with his wives and thus missed their qurū' (li-mā dā'a fī-hā min qurū' i nisā'ikā) in which they can be approached. Therefore, according to the meaning of al-A'shā, qur' denotes period of purity since the periods of purity (athār) are the legal and most suitable times in which women can be approached.

²⁹- Muslim, Ṣaḥīḥ, vol.2, p.669.

³⁰- Ṣābūnī, Tafsīr Āyyāt al-Aḥkām, vol.1, p.328.

It might further be cited that although Ibn Shihāb al-Zuhri adopts the view of the second group who take qur' as referring to purity, he disagrees with that group regarding the number of periods of purity which are required for the 'iddah. This is because all the partisans of that group count the period of purity in which the wife could be divorced as one of the three prescribed periods of purity for the 'iddah, whereas al-Zuhri did not.³¹ In the opinion of al-Zuhri, the period of purity in which the woman is divorced is to be disregarded and in calculating full period of tuhr, and that she should therefore wait for another three complete periods of purity. In other words, according to al-Zuhri's view, the waiting period ('iddah) of the divorced wife is not complete and she is not allowed to remarry until she enters into the fourth period of menses.³² Commenting on the standpoint of al-Zuhri, Abū 'Amr states that none of the exegetes who explain qur' as referring to purity adopts the view of al-Zuhri.³³

In conclusion, it can be said that as far as the Arabic language is concerned, both interpretations suggested for qur' are correct, and the arguments cited in favour of both interpretations have reasons to commend them. However, in terms of time the difference between the two interpretations might affect the 'iddah of the divorcee by a few additional days when qur' is explained to denote ḥayd. It is only according to the view of al-Zuhri that there would be a major difference, when the divorcee is asked to wait

31- Qurṭubī, Tafsīr, vol.3, p.116.

32-Ibid, p.116.

33-Ibid, p.116.

for a longer period. As regards the position of the commentators, the schools of law and Muslim scholars on this matter, we find that they are divided between these two interpretations. Abū Ḥanīfah (d.150 / 767)³⁴ and Aḥmad b. Ḥanbal (d. 241/ 855)³⁵ in his most accepted interpretation, according to Ibn Kathīr, adopt the view held by Mujāhid that qur' indicates ḥayd. The Mu'tazilite commentator al-Zamakhsharī also prefers this interpretation.³⁶ Denying the usage of the term qur' as a reference to tuhr, Ibn al-Qayyim stresses that qur' has not been used in the Divine Word save for the meaning of ḥayd.³⁷ Ibn al-Humām also favours this view.³⁸ On the other hand, the interpretation of qur' as meaning tuhr is supported by the jurists Mālik, al-Shāfi'ī, Aḥmad b. Ḥanbal (in the less acceptable view attributed to him) and the scholars Dāwūd b. 'Alī, Abū Thawr and Ibn Ḥazm.³⁹ This explanation is also held by the commentators al-Ṭabarī⁴⁰ and al-Qurṭubī.⁴¹

2. THE 'IDDAH OF THE WIDOW :

The question of what happens to a widow on the death of her husband aroused some problems both for the exegetes and jurists. According to the ḥadīth of al-Furay'ah bint Mālik b. Sinān,⁴² in pre-Islamic times a widow was supposed to spend a

34- Ibn Kathīr, Tafsīr, vol.1, p.270.

35- Ibid, p.270.

36- Zamakhsharī, Kashshāf, vol.1, p.271.

37- Ibn al-Humām, Sharḥ Faḥ al-Qadīr, vol.4, p.308.

38- Ibid, p.308.

39- Ibn Ḥazm, Muḥallā, vol.10, p.257.

40- Ṭabarī, Tafsīr, vol.4, pp.511-5.

41- Qurṭubī, Tafsīr, vol. 3, pp.115-7.

42- For the full text of this ḥadīth, see Mālik, Muwatta', pp.405-6.

year in mourning for her dead husband. During this time she would live in a wretched small room, put on the worst clothes she had and could not touch any perfume. At the end of the year, an animal (e.g., a donkey, a sheep or a bird) was brought to her and she would rub her body against it. It was only then that she would be able to leave the room. She was given a piece of dung which she threw away. From that moment her mourning ceased and she could use perfume and put on jewelry and fine clothes. It is not clear from this account whether the mourning period was spent in her dead husband's house or with her own family. However, as will be seen in the later discussion, it seems more likely that this period of mourning was spent with her own family.

Three verses in the Qur'ān which concern the period of mourning of the widow were the subject of dispute among the exegetes. They are :

i : 2 : 234 " Such of you who die and leave widows behind, they shall wait, keeping themselves apart four months and ten days (wa-alladhīna yutawaffawna min-kum wa-yadharūna azwājan yatarabbaṣna bi-anfusihinna araba'ata ashhurin wa-'ashran) ".

ii : 2 : 240 " Those of you who die and leave wives (i.e., widows) should make a bequest (waṣiyyah) for their wives of a year's maintenance and lodging without turning them out. But if they leave their residence there is no blame on you for what they do with themselves provided that it is honourable (wa-alladhīna yutawaffawna min-kum wa-yadharūna azwājan waṣiyyatan)

li-azwājihim matā'an ilā al-ḥawli ghayra ikhrājin fa-in kharajna fa-lā junāḥa 'alay-kum fī mā fa'alna fī anfusihinna min ma'rūfin wa-Allāhu 'azīzun ḥakīmun).

iii : 4 : 12 "... their (the widows') share is a quarter if you leave no child, but if you leave a child they get an eighth after payment of legacies and debt (wa-la-hunna al-rub'u mimmā taraktum in lam yakun la-kum waladun fa-in kāna la-kum waladun fa-la-hunna al-thumnu mimmā taraktum min ba'di waṣiyyatin tūṣuna bi-hā aw-daynin) ...".

Most exegetes and Muslim scholars held that verse 2 : 234, although occurring earlier in the Qur'ān than verse 2 : 240, was in fact a later revelation, and therefore abrogated what was interpreted as an optional year's mourning to the fixed requirement of spending an 'iddah period of four months and ten days.⁴³ Thus the requirement of the waṣiyyah in 2 : 240 was not abrogated but merely limited to four months and ten days. Later this waṣiyyah was abrogated by the verse of inheritance, i.e., 4 : 12 which entitles the widow to a quarter of her husband wealth if there were no children and an eighth if there were children. However, there was a dispute among the jurists as to whether the option of spending the 'iddah period wherever the widow wished as indicated in 2 : 240 still held. Some jurists maintain that the 'iddah can be spent wherever she wishes, while others require it to be spent in the dead husband's house.⁴⁴

43- Qurṭubī, Tafsīr, vol.3, p.227.

- Ibn Kathīr, Tafsīr, vol.1, p.296.

44- Shāfi'ī, al-Umm , vol.5, pp.209-12.

Al-Ṭabarī gives the view of Mujāhid as regards the interpretation of verses 2 : 234 and 2 : 240 in two reports, both of which are transmitted by Ibn Abī Najīh who is quoted by 'Isā in one and by Shibl in the other.⁴⁵ In addition to al-Ṭabarī, this view of Mujāhid is also reported by the commentators al-Rāzī,⁴⁶ al-Qurṭubī⁴⁷ and Ibn Kathīr.⁴⁸ However, it is not mentioned in Ādam b. Abī Iyyās's version of Warqā's recension. Mujāhid together with Ibn 'Abbās, as quoted by 'Aṭā', regard the two verses as occurring in the order in which they are given in the Sūrah: that is to say, that 2 : 240 has been revealed later than 2 : 234.⁴⁹ Although 2 : 234 has nothing to say about where the widow should spend her 'iddah of four months and ten days, all three exegetes interpret it as requiring her to spend it in her dead husband's house.⁵⁰

This interpretation is supported by a tradition quoted by al-Bukhārī. This tradition from Mujāhid is transmitted by Shibl on the authority of Ibn Abī Najīh. It seems appropriate to quote this tradition in full. " Mujāhid relates as regards verse 2 : 234 as follows: 'Those of you who die and leave wives behind, they (their wives) shall wait with regard to their marriage for four months and ten days ...'. The widow, according to this verse, was to spend the

- Zuḥaylī, al-Fiqh al-Islāmī wa-Adillatuhu , vol.7, p.659.

45- Ṭabarī, Tafsīr , vol.5, p.258.

46- Rāzī, Mafātīh, vol.2, p.284.

47- Qurṭubī, Tafsīr , vol.3, p.227.

48- Ibn Kathīr, Tafsīr, vol.3, p.296.

49- Ṭabarī, Tafsīr , vol.5, p.258.

50- Ibid, p.258.

period of waiting ('iddah) in her husband's home, so God revealed: "Those of you who die and leave wives (i.e., widows) should bequeath for their wives a year's maintenance and residence without turning them out. But if they leave their residence there is no blame on you for what they do with themselves provided that it is honourable. (2 : 240)". So God entitled the widow to be bequeathed extra maintenance for seven months and twenty days, and that is the completion of one year. If she wished, she can stay in her husband's home, according to the bequest, or she could leave it if she wished, as God says : '... without turning them out, but if they leave the residence, there is no blame on you ...'. So the 'iddah (i.e., four months and ten days is obligatory for her). 'Aṭā' said: "Ibn 'Abbās said: "This verse, i.e., the statement of God "without turning them out...", cancelled the obligation of staying the waiting period in her dead husband home . And she can complete this period wherever she liked". 'Aṭā' said: "If she wished, she can complete her 'iddah by staying in her dead husband's residence, according to the bequest, or leave it , according to God's statement: "There is no blame on you for what they do with themselves". 'Aṭā' added: "Later, the regulation of the inheritance came and abrogated the order (allowing her the option) of dwelling in her dead husband's home, so she could complete the 'iddah wherever she liked. And it is no longer necessary to provide her with a residence". Ibn 'Abbās said: "This verse abrogated her dwelling in her dead husband's house, and she can complete the 'iddah (which presumably is one year if verse 2 : 240 is abrogating 2 : 234) wherever she liked, as the Qur'ānic statement says : "without turning

them out ...".⁵¹ Although this report confirms al-Ṭabarī's attribution of this interpretation to Mujāhid, the text of the hadīth does contain za'ama Mujāhid, indicating perhaps some doubt.

In his interpretation of 2 : 240, Mujāhid maintains that the wasiyyah referred to is in fact the additional seven months and twenty days. However, he asserts that the 'iddah of four months and ten days at the home of the dead husband was still obligatory. Thus the widow had the right only to leave it or to take up the additional period at the end of four months and ten days. According to Mujāhid, as transmitted on the authority of Ibn Jurayj,⁵² this wasiyyah (in verse 2 : 240) was abrogated by the verse of inheritance which removed the wasiyyah by making the widow one of the heirs with a fixed amount of the inheritance.⁵³ 'Aṭā' shares the same opinion with Mujāhid.⁵⁴ The jurist al-Shāfi'ī also agrees with Mujāhid's view that verse 4 : 12 was a later revelation which abrogates verse 2 : 240.⁵⁵

Although 'Aṭā' agrees with Mujāhid in interpreting 2 : 240 as being revealed later than 2 : 234, he gives a somewhat different interpretation. He seems to think that 2 : 240 gives the woman the right to leave her dead husband's house wherever she wishes. Thus she could even spend the required 'iddah of four months and ten days with her family if she

51- Bukhārī, Ṣaḥīḥ, vol. 6, pp. 41-2.

52- Ṭabarī, Tafsīr, vol. 5, p. 256.

53- Ibid, vol. 4, pp. 275-6.

54- Ibid, pp. 255-6.

55- Shāfi'ī, al-Umm, vol. 1, p. 252.

wished. However, he does confirm that the verse of inheritance abrogates the wasiyyah in 2 : 240 but he also thinks that it abrogates her right and duty to spend her 'iddah in the dead husband's house. The Tafsīr of Mujāhid in the Ādam b. Abī Iyyās's version of Warqā's recension quotes a tradition from 'Aṭā' citing Ibn 'Abbās which confirms that 4 : 12 abrogates the widow's wasiyyah,⁵⁶ but surprisingly does not include the tradition from Mujāhid cited by al-Ṭabarī through 'Īsā's and Shibl's recensions on the authority of Ibn Abī Najīḥ and through Ḥajjāj's recension on the authority of Ibn Jurayj, which uses more or less the same words.⁵⁷

On the matter of verse 2 : 240 being a later revelation than 2 : 234, Ibn Kathīr is not convinced with the attribution of this view to Mujāhid, as he ends the discussion in this respect by the following words: "It has been alleged that Mujāhid adopts that view (zu'ima dhālika 'an Mujāhid)".⁵⁸ It seems also that al-Bayhaqī (d.458 / 1065) disagrees with the above view of Mujāhid. After quoting Mujāhid's aforementioned opinion reported by al-Ṭabarī (d.310 / 922), al-Bayhaqī comments with the following: "Mujāhid claimed that opinion (za'ama dhālika Mujāhid)".⁵⁹ So both al-Bayhaqī and Ibn Kathīr question the above contention attributed to Mujāhid, despite the fact that each of them put the question in a different way. The words of al-Bayhaqī indicate that Mujāhid claims this opinion which, according to the judgment of al-Bayhaqī,

56- Mujāhid, Tafsīr, vol.1, pp.147-8.

57- Ṭabarī, Tafsīr, vol.4, pp.275-6.

58- Ibid, p.297.

59- Bayhaqī, al-Sunan al-Kubrā, vol.7, p.435

is incorrect. While the statement of Ibn Kathīr (zu'ima dhālika 'an Mujāhid) implies that Mujāhid himself might not have been of that view, it may have been assigned to him by others.

Likewise, Ibn 'Aṭīyah (d.546 /1151) is not convinced by the report of al-Ṭabarī in which he attributes the aforementioned opinion to Mujāhid. Ibn 'Aṭīyah directly accuses al-Ṭabarī of attributing this opinion to Mujāhid erroneously.⁶⁰ However, al-Qurṭubī rejects the statement of Ibn 'Aṭīyah asserting that what al-Ṭabarī reports on the authority of Mujāhid is correct and reliable.⁶¹ Although al-Qurṭubī endeavours to prove that the opinion which has been ascribed to Mujāhid is definitely his, he himself (i.e., al-Qurṭubī) disagrees with it. Al-Qurṭubī maintains that the majority of Muslim scholars agree that verse 2 : 240 has been abrogated by verse 2 : 234. He adds that the only exception in this respect is an anomalous and abandoned narration which is related by Ibn Abī Najīh on the authority of Mujāhid.⁶² Al-Qurṭubī further remarks that none of the Ṣaḥābah nor the Tābi'ūn follows the above view attributed to Mujāhid.⁶³ However, he appears to be ignoring the view attributed to Ibn 'Abbās and 'Aṭā'. In addition, it seems also that al-Qurṭubī assumes that Mujāhid has two different views as regards the 'iddah of the widow. The earlier view, according to al-Qurṭubī, is the aforementioned one which he describes as anomalous. Mujāhid's later view, according to al-Qurṭubī, is the one transmitted by Ibn Jurayj in which

⁶⁰-Qurṭubī, Tafsīr, vol.3, p.226.

⁶¹-Ibid, p.227.

⁶²-Ibid, p.227.

⁶³-Ibid, p.227.

Mujāhid entirely agrees with the opinion of al-jumhūr that verse 2 : 234 abrogates 2 : 240. When Mujāhid adopted this second view he simultaneously dismissed the earlier one, as al-Qurṭubī concludes, the general consensus has been reached and the disagreement on this issue no longer exists.⁶⁴ Although al-Qurṭubī reaches the correct conclusion, i.e., that Mujāhid eventually agrees with the rest of the exegetes in his view that the 'iddah of the widow is only four months and ten days, he however completely misses the process by which this view was reached. Ibn Jurayj is not saying that 2 : 234 abrogates 2 : 240. He is actually saying that the waṣiyyah for the extra seven months and twenty days is abrogated by verse 4 : 12.

Fakhr al-Dīn al-Rāzī seems to understand the above view attributed to Mujāhid in a different way from that of the scholars and exegetes mentioned above. In Mujāhid's opinion, according to al-Rāzī, God reveals two Qur'ānic verses as regards the 'iddah of the widow. They are : 2 : 234 and 2 : 240. Therefore, as he argues, we should apply those two verses to two different states of the widow. That is to say, if the widow chooses not to live in her dead husband's home during the period of 'iddah and she does not want to be maintained from his estate, then her 'iddah would be four months and ten days, as verse 2 : 234 rules. However, if the widow chooses to inhabit her dead husband's home during the period of 'iddah and to be maintained from his estate, then her 'iddah would be one year, as verse 2 : 240 states. Al-Rāzī concludes by remarking that the understanding of these two verses in this

⁶⁴. Ibid, p.227.

way is more appropriate, so that both of them are in force.⁶⁵ Here again, al-Rāzī too is failing to understand the abrogating force of verse 4 : 12 on the wasiyyah of verse 2 : 240.

In all the tafāsīr we have been able to consult, only Mujāhid, Ibn ‘Abbās and ‘Atā’ amongst the Ṣahābah and Tābi‘ūn are alleged to hold the view that verse 2 : 240 just extends the period previously mentioned in verse 2 : 234, and that there is no abrogation between the verses 2 : 234 and 2 : 240. Later the Mu‘tazilite scholar Abū Muslim al-Ṣfahānī adopts the opinion of Mujāhid.⁶⁶ Abū Muslim says that the verse means that when Muslims die and leave wives for whom they make a bequest of maintenance and residence for one year if these widows prefer to go out before completing the period of the bequest of their deceased husbands after they have waited the prescribed period (four months and ten days), they are blameless, because the residence of one year in their deceased husband's home is not obligatory.⁶⁷ Hence Abū Muslim agrees with the above view attributed to Mujāhid on the point that no abrogation whatsoever has occurred between the two verses at issue, i.e., 2: 234 and 2: 240, despite the fact that he uses different arguments to justify this interpretation. However, his approach is entirely different from that of Mujāhid. As has been mentioned in the previous chapter, Abū Muslim primarily has a preconception that the Qur’ān is free from any sort of abrogation whatsoever. Therefore on this assumption, he builds up his

⁶⁵- Rāzī, Mafātīh, vol.2, pp.285-6.

⁶⁶-Ibid, p.286.

⁶⁷-Ibid, p.286.

arguments and explanations. In this analysis, Abū Muslim also fails to see the abrogating effect of verse 4 : 12 on the wasiyyah of verse 2 : 240.

To conclude, it should be noted that Ādam b. Abī Iyyās's version of Warqā''s recension of the Tafsīr of Mujāhid contains no report about Mujāhid holding the view that verse 2 : 240 was a later revelation than verse 2 : 234. Our evidence for this comes from al-Bukhārī and al-Ṭabarī. Later exegetes almost certainly depended on al-Ṭabarī for their evidence of Mujāhid holding this view. The fact that in their discussions of Mujāhid's view they ignore the abrogating effect of verse 4 : 12 on verse 2 : 240 leads them to assume that Mujāhid held two views about the 'iddah of the widow. This does not seem really to be the case. He arrives at the same view as everybody else, namely that the 'iddah of the widow is four months and ten days. It is the process of interpretation by which he arrives at this view which differs from the majority of the scholars.

* * *

It is clear that originally the 'iddah of four months and ten days was regarded as a period of mourning from the ḥadīth of Zaynab bint Abī Salamah which comes in the following three narrations.

(1) Humayd b. Nāfi' said that Zaynab bint Abī Salamah narrated the following to him: "I went to Umm Ḥabībah, one of the Prophet's wives, when her father, Abū Sufyān b. Ḥarb, had died.

Umm Ḥabībah asked for a perfume which contained yellow scent and she first perfumed one of the girls with it and then rubbed her cheeks with it and said: 'It is not lawful for a woman who believes in God and the Last Day to mourn for a dead person for more than three days, unless he is her husband for whom she should mourn for four months and ten days' ".

(2) Zaynab said: "I went to Zaynab bint Jaḥsh when her brother died. She asked for perfume and used some of it and said: 'By God, I am not in need of perfume, but I have heard God's Apostle saying on the pulpit: "It is not lawful for a woman who believes in God and the Last Day to mourn for more than three days except for a husband for whom she should mourn for four months and ten days" ' " .

(3) Zaynab said : "I heard Umm Salamah saying that a woman came to God's Apostle and said: 'O, God's Apostle ! The husband of my daughter died, and she [the daughter] was suffering from an eye disease. Can she apply kohl to her eye ?' God's Apostle replied 'No' twice or thrice and each time she asked her question he said: 'No' ".⁶⁸

At the end of this third Ḥadīth the Prophet then gives the account of mourning rites already mentioned at the beginning of this section.

Despite the fact that there is no mention of ḥayḍ or tuhr in the Qur'ānic verse: " wa-alladhina yutawaffawna min-kum

⁶⁸. Bukhārī, Ṣaḥīḥ, vol.7, pp.190-2.
- Baghawī, Ma'ālim, vol.1, p.215.
- Jaṣṣāṣ, Aḥkām, vol.2, p.119.
- Qurtubī, Tafsīr, vol.3, p.27.

wa-yadharūna azwājan yatarabbaṣna bi-anfusihinna arba'ata ashhurin wa-'ashran" (2 : 234) where the Arabic word for months is a word concerning time only and the additional ten days indicate that the whole period has nothing to do with menstruation, the interpretation of verse 65 : 4 "...wa-ūlāti al-aḥmāli ajaluhunna an yaḍa'na ḥamlahunna ..." is however interpreted by all exegetes as applying to both divorcees and widows.⁶⁹ Thus if the widow was pregnant and delivered her child before the elapse of four months and ten days, her 'iddah would be over. Only Ibn 'Abbās and 'Alī are attributed with the view that her 'iddah should be the longer of the two periods.⁷⁰ However, we do not have an interpretation attributed to Mujāhid on this subject.

3.THE 'IDDAH OF THE UMM WALAD :

With regard to the Qur'ānic verse 2 : 234, there is also some discussion among the exegetes and the jurists about the 'iddah of the umm walad. There are five views concerning this matter. Before discussing these views, it is necessary to describe her legal position. Umm walad is a slave who is the mother of a child whom her owner has recognized as his own offspring. Al-Sarakhsī maintains that according to the view of the majority

⁶⁹- Jaṣṣāṣ, Aḥkām, vol.2, pp.119-20; and vol.5, p.354.

⁷⁰- Ibid, vol.2, pp.119-20 ; and vol.5, p.354. For further discussion on this view, see :

- Ṭabarī, Tafsīr, vol.22, p.144.
- Qurtubī, Tafsīr, vol.3, p.174.
- Ibn Kathīr, Tafsīr, vol.1, p.284.
- Abū Ḥayyān, al-Baḥr al-Muḥīt, vol.2, p.223.

(jumhūr) of the fuqahā', the sale of the umm walad is invalid (bātil), and she becomes free on the death of her owner.⁷¹

The five views concerning the 'iddah of the umm walad are :
(i) Firstly, Mujāhid maintains that the 'iddah of the umm walad is four months and ten days.⁷² In other words, he treats the umm walad as a free widow. Mujāhid's view is reported by Ibn Kathīr only.⁷³ We do not have any reference to this view in either al-Ṭabarī's Tafsīr or the Ādam b. Abī Iyyās's version of Warqā's recension. Qubayṣah b. Dhu'ayb reported on the authority of 'Amr b. al-'Āṣ who said: " Do not confound (tulbisū) the Sunnah of the Prophet. The 'iddah of the umm walad when her husband dies is four months and ten days".⁷⁴ It has however been said that Ibn Ḥanbal and other scholars deny this hadīth on the ground that Qubayṣah did not hear directly from 'Amr b. al-'Āṣ.⁷⁵ Nevertheless, Mālik b. Anas has a tradition in which a similar view is held by al-Qāsim b. Muḥammad.⁷⁶ It also seems to have been held by many of the early jurists including Sa'īd b. al-Musayyab, Sa'īd b. Jubayr, al-Ḥasan al-Baṣrī, Ibn Sīrīn, Abū 'Ayyād, al-Zuhrī and 'Umar b. 'Abd al-'Azīz.⁷⁷ It is also favoured by al-Awzā'ī, Ishāq b.

71- Sarakhsī, Mabsūt, vol.7, p.149. For further details on the position of the umm walad, see the following pages 149- 78, in the same reference.

72- Ibn Ḥazm, Muḥallā, vol.11, p.708.
- Ibn Qudāmah, Mughnī, vol.7, p.500.
- Ibn Kathīr, Tafsīr, vol.1, p.285.

73- Ibn Kathīr, Tafsīr, vol.1, p.285.

74- Ibn Ḥazm, Muḥallā, vol.11, p.707.

75- Ibn Kathīr, Tafsīr, vol.1, p.285.

76- Mālik, Muwatta', p. 407.

77- Ibn Qudāmah, Mughnī, vol.7, p.500.
- Qurṭubī, Tafsīr, vol.3, p.184.
- Ibn Kathīr, Tafsīr, vol.1, p.285.

Rāhawayh and Aḥmad b. Ḥanbal (in one view attributed to him).⁷⁸ Similarly it has been reported that the Caliph Yazīd b. 'Abd al-Malik b. Marwān enjoined the same ruling mentioned above.⁷⁹

(ii) This view, which is adopted by Qatādah, Ṭāwūs⁸⁰ and Abū al-Khaṭṭāb,⁸¹ suggests that the 'iddah of the umm walad is half of the 'iddah of the free widow, i.e., two months and five days.

(iii) The third view, which is attributed to 'Alī, Ibn Mas'ūd, 'Aṭā', Ibrāhīm al-Nakh'ī, 'Amr b. Dīnār, Sufyān al-Thawrī and aṣḥāb al-ra'y,⁸² says that the 'iddah of the umm walad is three menstruations. This view is also preferred by the jurist Abū Ḥanīfah.⁸³ As it appears, this group treats the slave after giving birth as equal to a free divorced woman, i.e., they impose the 'iddah of ṭalāq on her.

(iv) The fourth view, which is ascribed to Ibn 'Umar, 'Uthmān, 'Ā'ishah, al-Ḥasan al-Baṣrī, al-Sha'bī, al-Qāsim b. Muḥammad, Abū Qulābah and Makhūl, determines the 'iddah of umm walad to be a single menstruation.⁸⁴ This view is held by the jurists: Mālik, al-Shāfi'ī, Abū 'Ubayd, Abū Thawr and Ibn Ḥanbal in the most accepted view attributed to him.⁸⁵ This is presumably on the basis

78- Ibn Kathīr, Tafsīr, vol.1, p.285.

79- Ibn Qudāmah, Mughnī, vol.7, p.500.

- Ibn Kathīr, Tafsīr, vol.1, p.285.

80- Qurṭubī, Tafsīr, vol.3, p.184.

81- Ibn Qudāmah, Mughnī, vol.7, p. 500-1.

82- Ibn Ḥazm, Muḥallā, vo.11, pp.707-8.

- Ibn Qudāmah, Mughnī, vol.7, p.501.

- Qurṭubī, Tafsīr, vol.3, p.184.

- Ibn Kathīr, Tafsīr, vol.1, p.285.

83- Ibn Kathīr, Tafsīr, vol.1, p.285.

84- Ibn Ḥazm, Muḥallā, vol.11, p.709.

- Ibn Qudāmah, Mughnī, vol.7, p.500.

- Qurṭubī, Tafsīr, vol.3, p.184.

- Ibn Kathīr, Tafsīr, vol.1, p.285.

85- See the references in the previous footnote.

that the death of her master brings about a transference in ownership, i.e., she moves from being owned by her master to owning herself.

(v) The fifth and last view, which is in contrast with the previous views, is held by Ibn Ḥazm al-Zāhirī. He maintains that there is no 'iddah on the umm walad if she is emancipated by her master, or if her master dies. In both cases she can get married whenever she likes.⁸⁶

Al-Qurṭubī prefers the view which says that the 'iddah of the umm walad is only one menstruation. In justifying his choice, he argues that the Qur'ānic phrase wa- al-muṭallāqātu yatarabbaṣna bi-anfusihinna thalāthata qurū' stipulates that the waiting (tarabbus) of qurū' should be exclusively due to a divorce. By this argument, al-Qurṭubī rejects the view which takes the 'iddah of the umm walad as three menstruations. Al- Qurṭubī adds that the verse wa-alladhīna yutawaffawna min-kum wa-yadharūna azwājan yatarabbaṣna bi-anfusihinna arba'ata ashhurin wa-'ashran ... also determines the waiting (tarabbus) to be four months and ten days on condition that the woman who is going to observe this waiting period (mutarabbiṣah) should be a wife. This indicates that the slave (i.e., amah who is not a wife) is excluded. Similarly the umm walad is regarded as a slave who is possessed by one's right hand and not a wife, then her istibrā' can be obtained through a single menstruation. In his second argument al-Qurṭubī thus wants to refute the view held by Mujāhid and those who say that the 'iddah of the umm walad is four months and ten days.

⁸⁶- Ibn Ḥazm, Muḥallā, vol.7, p.706 ; and p.710.

Mujāhid is clearly laying emphasis on the fact that the umm walad gains her freedom with the death of her master. In this way, he requires her to observe the same 'iddah' as would be observed by a free widow.

In their analysis of the situation, the majority of Islamic exegetes and jurists take the view that the umm walad had the status of slave, albeit a specially privileged slave. Therefore they only require of her the 'iddah' of a slave girl who is transferred from one master to another.

The Ḥanafis, on the other hand, require the umm walad to observe a three months waiting period, the same as a free divorced woman. The reasoning behind this is not altogether clear, but seems to indicate that as a result of her newly-acquired free status the umm walad should have the same 'iddah' as the divorced woman.

The other group of Qatādah, Ṭāwūs and Abū al-Khattāb also seem along with Mujāhid to regard the death of the owner as producing an 'iddah' for the umm walad as analogous to that of the widow. Because of her slave-status up until the death of the master however, they cut the four months and ten days to half, i.e., to two months and five days, presumably on analogy with the slave receiving half of the ḥadd penalty of a free person.

Although Mujāhid's view is not followed by any of the schools of law, it does show consistent thinking.

* * *

Having finished these juristic issues, the discussion moves to examine Mujāhid's contribution in the field of language. This will be the subject of the following and last chapter

CHAPTER EIGHT

LINGUISTIC ASPECTS

This chapter examines Mujāhid's views on some linguistic aspects of various Qur'ānic verses. Each verse will be dealt with under a separate sub-title.

1. THE DIFFERENCE IN READING IN SŪRAH 12 : 110 :

The exegetes have three different readings for the word with the three radicals kāf , dhāl and bā' which occurs in verse 12 : 110. These lead to different interpretations of the meaning of the verse. The verse read as follows: "(Respite will be granted) until, when the Messengers despaired (of their people) and thought that they (Messengers or people) kudhibū or kudhhdhibū or kadhabū , then our help came to them, and those whom we wanted were saved. But our punishment will never be warded off by those who are in sin". (12 : 110).

In this verse we are concerned with the reading of the Qur'ānic word which falls after the phrase wa-zannū annahum qad. The three readings put forward for that word are kudhibū , kudhhdhibū and kadhabū. Not only does each reading result in a different meaning, but also for the very same reading different interpretations have been suggested. Two of these readings kudhibū

and kadhabū have been attributed to Mujāhid.¹ The first reading attributed to Mujāhid is :

i. kudhibū :

Kudhibū with dammah on the kāf and with kasrah on the dhāl is the reading attributed to Mujāhid by al-Ṭabarī in two reports. Both of these reports are transmitted by Ibn Abī Najīḥ who is quoted by Warqā' in one and by 'Īsā in the other.² It is also found in Ādam b. Abī Iyyās's version of Warqā''s recension.³ It is also the one which is adopted by a considerable number of the exegetes among the Ṣaḥābah and Tābi'ūn.⁴ However, for the very same reading (kudhibū) the exegetes among the Ṣaḥābah and Tābi'ūn offer two divergent interpretations, one of which is attributed to Mujāhid.

According to this reading, Mujāhid is reported to have construed the phrase hattā idhā istay'asa al-rusulu wa-zannū annahum qad kudhibū jā'ahum naṣrunā ..." as meaning that until when the Messengers despaired (of their people believing in them) and the people (to whom the Messengers have been sent) assumed that they had been lied to [by the Messengers] (in what they have told them regarding the help which God promised them), then

1- Ṭabarī, Tafsīr, vol.16, p. 302 ; and p.310.

2- Ibid, p. 302.

3- Mujāhid, Tafsīr , vol.1, p.322.

4- Ṭabarī, Tafsīr, vol.16, pp. 296-305.

- Qurṭubī, Tafsīr, vol.9, p.275.

- Ṭabarsī, Tafsīr, vol.5, p.271.

God's help came.⁵ So according to this interpretation, there are two different subjects (fā'il) in the phrase wa-zannū annahum qad kudhibū. As for the first verb zannū the subject is the people who are referred to by the third person plural ending "ū". For the second verb kudhibū, which is passive, the subject (nā'ib fā'il) referred to by both the hum of annahum and by the third person plural ending "ū" is al-rusul. It should be noted that this reading is attributed to Mujāhid's teacher Ibn 'Abbās as well as to Ibn Mas'ūd among the Sahābah.⁶ It is also attributed to a group of Tābi'ūn such as Sa'id b. Jubayr, al-Ḍaḥḥāk b. Muzāḥim, Ibn Zayd and 'Abd Allāh b. al-Ḥārith.⁷

It is reported however that Ibn 'Abbās has another interpretation for the verse at issue. In this interpretation, Ibn 'Abbās maintains that the phrase ḥattā idhā istay'asa al-rusulu wa-zannū annahum qad kudhibū means that having seen their message being rejected by their people, the Messengers, as human beings, became frustrated and despaired of the help promised to them by God.⁸ Thus the subject of both zannū and annahum kudhibū is al-rusul. In support of his opinion Ibn 'Abbās argues that the same meaning is contained in another Qur'ānic verse 2 : 214 which says: "So that the Prophet and those who believed with him said: 'When (will come) the help of God?' Ah! Verily the help of God is always near! (ḥattā yaqūla al-rasūlu wa-alladhīna āmanū ma'ahu

5- Mujāhid, Tafsīr, vol.1, p.322.
- Ṭabari, Tafsīr, vol.16, p. 302.

6- Ibid, pp.296-306.

7- Ibid, pp. 297-306.

8- Ibid, P.305-6.

matā naşru Allāhi alā inna naşra Allāhi qarībun)" (2 : 214).⁹ In addition to Ibn 'Abbās, this interpretation has also been attributed to Ibn Mas'ūd and Sa'īd b. Jubayr.¹⁰ However, it has been argued that if the above interpretation cited on the authority of Ibn 'Abbās is correct, then zannū in the verse must mean that they are influenced by things that occur to the mind by way of the Devil's insinuation.¹¹

In weighing up the two interpretations, al-Ṭabarī prefers the first one.¹² As a basis for his preference, al-Ṭabarī argues that the verse at issue is directly preceded by the verse: "Nor did we send before thee (as Messengers) any but men, whom we did inspire, men living in human habitations. Do they not travel through the earth and see what was the end of the those before them? (wa-mā arsalnā min qablika illā rijālan nūhī ilayhim min ahli al-qurā a-fa-lam yasīrū fī al-ardī fa-yanzurū kayfa kāna 'āqibatu alladhīna min qablihim ...)". (12 : 109). This verse thus implies that the Messengers despaired of their people accepting their message. The consequence for those people would be that they would perish.¹³

The interpretation attributed to Mujāhid and the other scholars mentioned is supported by the fact that in the verse under discussion (12 :110) the Qur'ān followed what had happened to the Messengers concerning their people with the statement fa-nujjī

9- Ibid, p.305.

10- Ibid, p. 305.

11- Zamakhsharī, Kashshāf, vol.2, p.510.

- Bayḍāwī, Anwār, vol.3, p.144.

12- Ṭabarī, Tafsīr, vol.16, p. 306-8.

13- Ibid, p. 306.

man nashā'u , i.e., those whom we wanted were saved. This implies that the section of the people who were destroyed were those who mistakenly thought that the Messengers had told them lies and therefore had rejected the message of the Messengers.¹⁴

Al-Ṭabarī criticizes Ibn 'Abbās's second interpretation by arguing that it is impossible that the Messengers would have doubt about the promise of their Lord.¹⁵

ii. The reading kudhhibū :

It has been reported that when 'Ā'ishah heard the second interpretation of Ibn 'Abbās she reacted by vehemently denying it. She put forward another reading to find a way out from both the reading kudhibū itself and from Ibn 'Abbās's second interpretation. Thus 'Ā'ishah suggests kudhhibū (with shaddah and kasrah on the dhāl and with dammah on the kāf).¹⁶ She interprets the subject of both zannū and annahum kudhhibū accordingly as being the Messengers, and the people who claimed that the Messengers were liars were not the unbelievers , but the Messengers' own followers.¹⁷

14- Ibid, p.306.

15- Ibid, p. 306.

16- Ibid, pp.307-8.

17- Ibid, pp.307-8.

- For the full account of 'Ā'ishah's opinion, see Bukhārī, Ṣaḥīḥ, vol.6, pp. 179-80.

This reading of kudhddhibū by 'Ā'ishah is followed by Qatādah and al-Ḥasan al-Baṣrī.¹⁸ However, they modify her interpretation slightly. They still understand that it is the people who claimed that the Messengers were liars; but while 'Ā'ishah has interpreted "those people" to be the followers of the Messengers, they regard them as people in general.¹⁹ The other difference is that they maintain that al-rusul zannū means not "the Messengers thought" but "the Messengers knew". Thus in this verse they understand zannū to be equivalent to 'alimū.²⁰

Al-Ṭabarī in commenting on this interpretation of zannū as implying certain knowledge rather than more general supposition argues that zannū is not used in this sense by the Arabs. It is worth pointing out that al-Ṭabarī informs us as that the reading kudhddhibū was the one adopted by the majority of the qurrā' of Medina, Baṣrah and Shām.²¹

iii. The reading kadhabū :

The reading kadhabū (with fathah on both kāf and dhāl and with no doubling sign 'shaddah' on the dhāl) in the active of the first form, according to al-Ṭabarī,²² al-Zamakhsharī²³ and Ibn Kathīr²⁴ has never been attributed to any qārī' except Mujāhid.

18- Ṭabarī, Tafsīr, vol.16, p.309.

19- Ibid, p.309.

20- Ibid, p. 309.

21- Ibid, p.309.

22- Ibid, pp. 309-10.

23- Zamakhsharī, Kashshāf, vol.2, p.510.

24- Ibn Kathīr, Tafsīr, vol.2, pp.497-8.

Al-Ṭabarī gives this reading attributed to Mujāhid in two reports. The transmitter of both reports is Ibn Jurayj who is quoted by Ḥajjāj.²⁵ However, this reading has not been mentioned in Ādam b. Abī Iyyās's version of Warqā's recension. In addition to Mujāhid, al-Qurṭubī²⁶ ascribes this reading to Ḥamīd. Al-Ṭabarsī states that the reading kadhabū has been attributed problematically (*bi-khilāf*) to Ibn 'Abbās and Mujāhid.²⁷ Al-Bayḍāwī also mentions kadhabū as being one of the readings suggested for the word at issue, though he does not say to whom it has been attributed.²⁸

According to al-Ṭabarī, when Mujāhid reads the word as kadhabū he interprets the phrase "... ḥattā idhā istay'as al-rusulu wa- zannū annahum qad kadhabū jā'ahum naṣrunā ..." as meaning that when the Messengers gave up hope of their people (who rejected their message) being punished and that the people thought that the Messengers told lies (kadhabū), there reached them our help.²⁹ So in the phrase "...wa-zannū annahum qad kadhabū...", Mujāhid sees that there are two different subjects. The first subject is the people who are referred to by the third person plural ending (ū) in the word zannū, and the second subject is al-rusul who are referred to by the third person plural ending (ū) in the word kadhabū.

In support of this interpretation, Mujāhid invokes another Qur'ānic verse which, as he presumes, contains a similar meaning

25- Ṭabarī, Tafsīr, vol.16, p. 310.

26- Qurṭubī, Tafsīr, vol.9, p.276.

27- Ṭabarsī, Tafsīr, vol.5, p.269.

28- Bayḍāwī, Anwār, vol.3, p.145.

29- Ṭabarī, Tafsīr, vol.16, p. 310.

as the phrase under discussion. The first part of that verse says: "For when their Messengers came to them with clear signs they exulted in such knowledge and skill as they had (fa-lammā jā'athum rusuluhum bi-al-bayyināti fariḥū bi-mā 'indahum min al-'ilmi) ...". (40 : 83). In interpreting this part of the latter verse, Mujāhid says that when the Messengers brought their message before their people, the people claimed that they are more knowledgeable than their Messengers and therefore they will neither be punished nor be resurrected.³⁰ As for the second part of the verse "... but that very (wrath) at which they were wont to mock encompassed them (wa-ḥāqa bi-him mā kānū bi-hi yastahzi'ūn)". (40 : 83), Mujāhid takes it as meaning that what befell those unbelievers as a punishment from God is the very same Truth which their Messengers had brought to them, but they used to mock at it.³¹

Al-Qurṭubī suggests another possible interpretation for the reading kadhabū. He maintains that the meaning of the verse might also be that when the Messengers are sure (ayqanū) that their people betrayed God (kadhabū 'alā Allāh) by insisting on their infidelity (kufrihim), there God's help came to the Messengers.³²

According to al-Zamakhsharī, when Mujāhid reads the word under discussion as kadhabū, he understands the phrase "...wa-zannū

30- Ibid, vol.24, p.89.

31- Ibid, p.89.

- Qurṭubī, Tafsīr, vol.15, p.336.

32- Qurṭubī, Tafsīr, vol.9, p.276.

annahum qad kadhabū ..." as meaning that the Messengers thought that they had lied in what they related to their people concerning their imminent help (the help of the Messengers).³³ Al-Zamakhsharī suggests one of two justifications for Mujāhid in holding this interpretation. Perhaps, as al-Zamakhsharī says, Mujāhid follows the second interpretation of Ibn 'Abbās who, as has been mentioned, understands the verse as meaning that the Messengers thought that they had been deceived as regards God's promise.³⁴ Or, as al-Zamakhsharī adds, Mujāhid might have meant that having not seen any effect of the fulfilment of the help promised by their Messengers, the people treated those Messengers as liars.³⁵ Al-Zamakhsharī further puts forward his own view, as a third possible interpretation for the verse under discussion. He maintains that the phrase wa-zannū annahum qad kadhabū might also denote that the people thought that the Messengers had lied. Indeed, this interpretation differs from the ones which al-Zamakhsharī attributed to Mujāhid. This is because, according to al-Zamakhsharī's own interpretation, there are two subjects in the phrase at issue. The people (al-mursal ilayhim) is the subject for the first verb zannū, and al-rusul is the subject for the second verb kadhabū. This contrast with Mujāhid's two interpretations suggested by al-Zamakhsharī where there is only one subject for both verbs zannū and kadhabū which is al-rusul. At all events, it seems that in principle al-Zamakhsharī accepts the reading kadhabū, as one of the readings suggested for that word under discussion, since

33- Zamakhsharī, Kashshāf, vol.2, p.510.

34- Ibid, p.510.

35- Ibid, p.510.

he does not only mention this reading but also goes further in elaborating its possible interpretations.

Goldziher, on the other hand, takes an entirely different viewpoint by stating that kadhabū is the original reading for the word under discussion.³⁶ According to his suggested reading, the meaning of the phrase wa-zannū annahum qad kadhabū would be that the Messengers themselves thought that they had lied in what they told their people.³⁷ However, as Goldziher observes, this meaning that the Messengers suspect themselves to be liars cannot be accepted by Muslims. As he says, it thus becomes important to find a way out of this reading kadhabū.³⁸ According to Goldziher, different solutions have been offered. He maintains that some exegetes introduce the readings kudhibū and kudhhibū (that is, the passive form) as alternatives for the original reading kadhabū (the active form).³⁹ Another group of exegetes, according to Goldziher, preserve the reading kadhabū as it is, but trying to solve the problem from a grammatical perspective. Some of this latter group argue that the subject of the verb zannū in the phrase wa-zannū annahum qad kadhabū is al-mushrikūn who thought that the Messengers had lied.⁴⁰ This is exactly the second possible interpretation assigned to Mujāhid by al-Zamakhsharī. The rest of the second group hold the opposite view by rendering al-rusul as the subject for the first verb zannū and al-mushrikūn (some of the

36- Goldziher, Die Richtungen der Islamischen Koranauslegung, translated by 'Abd al-Ḥalīm al-Najjār, p.41.

37- Ibid, p.41.

38- Ibid, p.41.

39- Ibid, pp.41-2.

40- Ibid, p.42.

people) as the subject for the second verb kadhabū.⁴¹ Goldziher therefore deduces that these great exegetical efforts exerted by the exegetes to solve the problem of the reading kadhabū imply that it is the original reading.⁴²

The importance and emphasis which Goldziher lays on the reading kadhabū indicate that this reading, which is mainly attributed to Mujāhid, is at least one of the readings for the word under discussion. Nonetheless, it seems that Goldziher goes too far by claiming that kadhabū is the original reading. 'Abd al-Ḥalīm al-Najjār, the translator of Goldziher's Die Richtungen Der Islamischen Koranauslegung strongly objects to such a claim, accusing Goldziher of having no evidence in alleging that one reading is an original (asliyyah) and the other is a secondary (far'iyyah).⁴³ Similarly the claim of Goldziher is rejected by Ḥamūdah, the author of Al-Qirā'āt wa-al-Lahjāt who states that the original readings for the word under discussion are kudhibū and kudhhibū which are the common ones, and that the anomalous reading kadhabū which is attributed solely to Mujāhid, is derived from the two authentic readings.⁴⁴

Al-Ṭabarī also strongly rejects the reading kadhabū which, according to him, is held solely by Mujāhid.⁴⁵ He bases his rejection on the ground that it contradicts the general consensus

41- Ibid, p.42.

42- Ibid, p.42.

43- Ibid, p.41.

44- Ḥamūdah, al-Qirā'āt wa- al-Lahjāt , p.209.

45- Ṭabarī, Tafsīr, vol.16, p. 310.

of the qurrā' of the amsār.⁴⁶ Al-Ṭabarī further argues that if it is permissible to read the word as kadhabū, then it should be interpreted in a better way than that of Mujāhid.⁴⁷ The best interpretation for Mujāhid's reading, al-Ṭabarī suggests, is that "... hattā idhā istay'as al-rusulu wa-zannū annahun qad kadhabū ..." means that until when the Messengers gave up hope of their people (who regarded them as liars) being punished by God, the Messengers knew that their people lied.⁴⁸ So by considering zannū here as meaning 'alimū', al-Ṭabarī utilizes the view of al-Ḥasan al-Baṣrī and Qatādah mentioned earlier. In short, both Mujāhid's reading and interpretation, al-Ṭabarī concludes, are completely inconsistent with the majority of the qurrā' and mufassirūn.⁴⁹ Ibn Khālawayh also places the reading of Mujāhid kadhabū among the anomalous readings.⁵⁰ Ibn al-Jazarī maintains that Abū al-Qāsim al-Hudhalī in his al-Kāmil ascribes to Mujāhid certain readings with a non-authentic isnād,⁵¹ and elsewhere mentions that al-Hudhalī's work is full of errors regarding the asānīd of the qirā'āt, and that it contains unaccepted readings which have no authentic transmission.⁵² However, al-Ṭabarī has different isnāds in which Ibn Jurayj quotes Mujāhid. He gives two narrations which go

46- Ibid, p. 310.

47- Ibid, p. 310.

48- Ibid, p. 310.

49- Ibid, p.310.

50- Ibn Khālawayh, Mukhtasar, p.65.

51- Ibn al-Jazarī, Ghāyat al-Nihāyah, vol.2, p.42.

52- Ibid, vol.1, p.349. For further discussion on different readings of the word at issue, see also A. A. 'Abd Allāh, The Variant Readings of the Qur'an: A Critical Study of their Historical and Linguistic Origins, unpublished Ph.D thesis, Edinburgh, 1984, pp.239-4.

back to Ḥajjāj on the authority of Ibn Jurayj who cites Mujāhid.⁵³

From the earlier discussion, some important points can be drawn in conclusion. Firstly, no Muslim scholar questions the authenticity of the readings kudhibū and kudhḥibū, since both are regarded as the most highly esteemed readings widely accepted by the Sahābah and Tābi'ūn. Mujāhid, as has been seen, is credited with the reading kudhibū. However, controversy arises from the third reading kadhabū which is also associated with Mujāhid. Although this reading is rigorously opposed by al-Ṭabarī, it seems that some commentators like al-Zamakhsharī, al-Qurṭubī and Ibn Kathīr, have no objection to it as one of the possible readings for the word under discussion. Goldziher's claim that it is the original reading seems to be somewhat tenuous in the face of the evidence of early exegetes putting forward the other readings and the fact that kadhabū is attributed only to Mujāhid.

Which then of the two readings attributed to Mujāhid is the one that he held? The authorities for the two readings, Ibn Abī Najīḥ and Ibn Jurayj, are both regular transmitters of Mujāhid's views. It may well be that in the discussions taking place about the correct reading, Mujāhid put forward both readings. However, the presence of kudhibū in al-Ṭabarī's Tafsīr from the recensions of 'Īsā and Warqā' on the authority of Ibn Abī Najīḥ and its presence also in Ādam b. Abī Iyyās's version of Warqā's

⁵³- Ṭabarī, Tafsīr, vol. 16, p. 310.

recension would tend to suggest that Mujāhid's reading was ultimately in accord with the majority of exegetes.

2. THE DIFFERENCE IN READING IN SŪRAH 5 : 6 :

The Qur'ān says: "O you who believe! When ye prepare for prayer, wash your faces and your hands (and arms) to the elbows; rub your heads (with water), and wash (or rub) your feet to the ankles (yā ayyuhā alladhīna āmanū idhā qumtum ilā al-ṣalāti fa-aghsilū wujūhakum wa-aydiyakum ilā al-marāfiqi wa-amsahū bi-ru'ūsikum wa-arjulakum (or arjulikum, or arjulukum) ilā al-ka'bayn) ...". (5 : 6).

This Qur'ānic verse deals with the ablution when one needs to prepare oneself for prayer. There is much controversy over the Arabic reading of the phrase 'your feet', which result in major juristic differences as far as ablution is concerned. In this connection, it has been suggested: "However, although this dispute became polarised, with the development of sectarian conflict, there is plenty of evidence that its subject was controversial among Muslim fuqahā' before the sectarian barriers became firmly established in fiqh".⁵⁴ Since we are treating this issue as a part of "Mujāhid's linguistic approach", then our concern will be devoted primarily to the linguistic nature of the verse under discussion.

⁵⁴- I.K.A.Howard, Imāmī -Shī'ī Ritual in the Context of Early Islamic Jurisprudence, unpublished Ph.D thesis, Cambridge, 1975, p.231.

Three readings can be distinguished in this respect. They are : arjulakum , arjulikum and arjulukum.⁵⁵ The last reading (arjulukum) with dammah on the lām is attributed to al-Ḥasan al-Baṣrī and al-A'mash.⁵⁶ It is also adopted by Nāfi' from whom al-Walīd b. 'Abd al-Malik took it.⁵⁷ The other two readings namely arjulakum and arjulikum will be the core of the following discussion, since the former is adopted by the Sunnites,⁵⁸ while the latter is associated with the Shi'ites.⁵⁹ In addition, most importantly and interestingly, Mujāhid is attributed with both readings.⁶⁰

The reading arjulakum :

Arjulakum with fathah on the letter lām is the reading of the majority of the exegetes and Muslim scholars.⁶¹ According to al-Ṭabarī, this reading has been attributed to Mujāhid on the authority of Qays b. Sa'd.⁶² There is no mention however of this reading from the recensions of 'Isā, Shibl and Warqā' in al-Ṭabarī's Tafsīr. Nor is it mentioned in Ādam b. Abī Iyyās's version of Warqā's recension. This reading is also held by a considerable number of the Companions and their Successors, e.g., Ibn 'Abbās, Ibn Mas'ūd, 'Umar b. al-Khattāb, 'Alī, Ibn 'Umar, al-Qāsim b. Muḥammad, 'Umar b. 'Abd al-'Azīz, al-Suddī, 'Ikrimah and al-

55- Qurtubī, Tafsīr, vol.6, p.91.

56- Ibid, p.91.

57- Ibid, p.91.

58- Ṭabarī, Tafsīr, vol.6, p.91.

59- Ṭūsī, Tafsīr, vol.3, pp.452-7.

- Ṭabarsī, Tafsīr, vol.6, p.164-7.

60- Ṭabarī, Tafsīr, vol.10, p. 57; and p.61.

61- Qurtubī, Tafsīr, vol.6, p.91.

62- Ṭabarī, Tafsīr, vol.10, p.57.

- Bayhaqī, al-Sunan al-Kubrā, vol.1, pp.70-1.

Dahḥāk.⁶³ Since Mujāhid agrees with the general consensus therefore, his view will be included here in the discussion of that of the majority (al-jumhūr).

In justifying the correctness of this reading, al-jumhūr looks at the grammatical structure of the verse at hand. They argue that although the expression "your feet" comes later in the verse, its position is meant to be earlier than it should come immediately after the words "wash your faces and your hands up to the elbows". In other words, the verse must be read as follows: "... fa-aghsilū wujūhakum wa-aydiyakum ilā al-marāfiqi wa-arjulakum ilā al-ka'bayn wa-amsahū bi-ru'ūsikum ...". But according to the order of the Qur'ānic text, the wiping of the heads (wa-amsahū bi-ru'ūsikum) enters among the parts of the body which are to be washed (namely the face, the hands and the feet) because the ra's is usually dealt with before the arjul as far as their order in the ablution is concerned.⁶⁴ In this connection, Abū 'Abd al-Raḥmān al-Sulamī relates that al-Ḥasan and al-Ḥusayn read in his presence the word under discussion as arjulikum, i.e., with kasrah instead of fathah. 'Alī heard the reading of his sons while he was judging between the people, and he therefore told them that the correct reading is arjulakum. He further explains that this sort of device where a word comes later although its position is supposed to be earlier, is found in the Arabic language.⁶⁵ So according to the above reading of al-jumhūr, the word arjulakum in this verse is

63- Ṭabarī, Tafsīr, vol.10, pp.52-7.

64- Qurṭubī, Tafsīr, vol.6, p.93.

65- Ibid, pp.92-3.

joined (ma'tūfah) to the preceding word aydiyakum. Since the word aydiyakum was in an accusative case because it is an object (maf'ūl bi-hi), then the word arjulakum also must be read in the accusative, because they are both governed by the verb aghsilū. Thus according to this reading, the face, the hands and the feet should be washed with water in the ablution.

The reading arjulakum is also supported by the tradition of the Prophet in which he warns against the rubbing of the feet. He says: "Beware of the Hell-Fire as a result of not washing the heels (waylun li-al-a'qābi min al-nāri)".⁶⁶ Similarly many traditions have been cited in favour of the necessity of washing the feet.⁶⁷ Al-Jāṣṣāṣ argues that it has been agreed by the Sunnites that when a Muslim washes his feet in the ablution he performs the obligation and he is not blamed for not rubbing the feet.⁶⁸ He further adds that the washing of the feet involves rubbing, whereas rubbing does not necessarily involve washing.⁶⁹

The reading arjulikum :

Arjulikum with the kasrah on the lām is the reading strongly supported by the Shi'ites.⁷⁰ Mujāhid, according to al-Ṭabarī, is also attributed with this reading on the authority of Ḥamīd.⁷¹ However,

66- Bukhārī, Ṣaḥīḥ, vol.1, p.115.

67- See Ibn Kathīr, Tafsīr, vol.2, pp.26-30.

68- Jaṣṣāṣ, Aḥkām, vol.3, p.350.

69- Ibid, p.351.

70- Ṭūsī, Tafsīr, vol.3, pp.452-7.

- Ṭabarsī, Tafsīr, vol.6, p.164-7.

71- Ṭabarī, Tafsīr, vol.10, p.61.

there is no mention of this reading from the recensions of Isā, Shibl and Warqā' in al-Ṭabarī's Tafsīr. Nor is it mentioned in Ādam b. Abī Iyyās's version of Warqā's recension of Tafsīr Mujāhid. Similarly some Companions and their Successors adopt this reading. They are Ibn 'Abbās (in one of his two opinions), Anas b. Mālik, 'Ikrimah, al-Sha'bī, Qatādah, 'Alqamah, al-Ḍaḥḥāk,⁷² al-Ḥasan al-Baṣrī and Abū 'Alī al-Jubbā'ī.⁷³ According to this reading, the verse is read as follows: wa-amsahū bi-ru'ūsikum wa-arjulikum ilā al-ka'bayn, the word arjulikum being dependent on the preposition bi and thus governed by the verb amsahū. So the meaning is: "and rub your heads and rub your feet to the ankles".

The point here is that Mujāhid is attributed with both readings arjulakum and arjulikum and each of them results in a different meaning and consequently different juristic ruling as far as ablution is concerned. The former reading (arjulakum) makes it necessary (wājib) that in the ablution the feet should be washed, while according to the latter the wiping of the feet is sufficient. Some scholars and linguists nonetheless try to reconcile these two readings; a resolution which would, of course, solve the problem for Mujāhid, if he actually did hold both readings at the same time.

Firstly, it has been argued that the word arjulikum has the kasrah due to its position of next to the preceding word ru'ūs which receives the kasrah because it is governed by the preposition

72- Ibid, pp.58-61.

73- Ṭūsī, Tafsīr, vol.3, p.452.

bi before it.⁷⁴ Al-Akhfash and Abū 'Ubaydah maintain that this sort of device (i.e., a word is ending with kasrah for the reason of proximity) is common in the Arabic language. The phrase usually cited in this respect is: hādhā juhrū ḍabbin kharibin, i.e., this is a destroyed hole of a lizard. As far as the grammatical structure is concerned therefore, the word kharib should end with dammah because it is an adjective (ṣifah) for the word juhr (mawṣūf) which ends with dammah. The fact that the word kharib in the above example ends with kasrah is justified by proximity.⁷⁵ Asserting the correctness of the accusative (naṣb) because of proximity, Abū 'Ubaydah b. al-Muthannā maintains that such rhetorical devices exist in the Qur'ānic text itself. He quotes the verse: "He will admit to His mercy whom He will, but for the wrongdoers (al-zālimīn) He has prepared a grievous penalty". (76 : 31). The Arabic text of this verse comes as follows: Yudkhillu man yashā'u fī raḥmatihi wa-al-zālimīna a'adda la-hum 'adhāban alīman. In this verse, the Arabic word for the wrongdoers is read as al-zālimīn, i.e., in the accusative case because the object (maf'ūl bi-hi) man mentioned earlier in the verse is mansūb. It is well known that however al-zālimīn will not be among those whom God's mercy includes.⁷⁶ Although the word al-zālimīn is thus read with naṣb, its grammatical position and meaning must be with raf' that is to say, wa-al-zālimūna a'adda la-hum 'adhāban alīman.

74- Abū 'Ubaydah, Majāz, vol.1, p.155.

75- Rāzī, Mafātīḥ, vol.3, p.370.

76- Abū 'Ubaydah, Majāz, vol.1, p.155.

Secondly, when Mujāhid reads the word as arjulikum, it has been suggested that he may have understood the above verse as referring to the wiping of the sandals (al-mash 'alā al-khuffayn) and not the bare feet. Hence the phrase wa-amsahū bi-ru'ūsikum wa-arjulikum means that when one makes ablution one is told to rub one's head as well as one's covered feet. In this case the feet are supposed to be covered with sandals or shoes. Al-Shāfi'ī adopts this justification.⁷⁷ The matter of al-mash 'alā al-khuffayn has been approved by a considerable number of the Companions. In this connection, al-Ḥasan al-Baṣrī is reported to have said that seventy of the Prophet's Companions told him that they did rub their sandals.⁷⁸

The third possibility in reconciling the two readings is that although ostensibly the word arjulikum indicates the rubbing of the feet, it would involve a slight washing (al-ghasl al-khafī).⁷⁹ In

77- Ibn Kathīr, Tafsīr, vol.2, p.26.

78- Qurṭubī, Tafsīr, vol.6, p.93. It is relevant here to refer to the views of the schools of law on this issue. For Abū Ḥanīfah and al-Shāfi'ī the rubbing of the sandals is permissible for those who are at home during a day or night. As for the traveller, he is allowed to do so up to three days and nights. [see Jāṣṣāṣ, Aḥkām, vol.3, p.353]. In the opinion of Mālik, there is no question about the legality of al-mash 'alā al-khuffayn. However, Mālik in the most acceptable view by his followers rejects the limit of time in practising this matter. He argues that there is no difference between the one who is at home or the traveller, that both are regarded as equal as far as al-mash 'alā al-khuffayn is concerned. [see Jāṣṣāṣ, Aḥkām, vol.3, p.353]. Aḥmad b. Ḥanbal reports many traditions in his Musnad which convey that the wiping of the sandals is permissible [see Ibn Ḥanbal, Musnad, vol.3, pp.1452-3; and p.1458; and p.1618; and vol.5, p.3461].

Ibn al-'Arabī holds that the issue of al-mash 'alā al-khuffayn is an origin (asl) in the Islamic law (sharī'ah). He further adds that it is one of the issues which differentiates between the Sunnites and the heterodox sects. [see Ibn al-'Arabī, Aḥkām, vol.2, p.579]. As regards the position of the Shi'ites and the Kharijites on this issue, we quote Wensink: "The Shi'ites and the Kharijites reject the wiping of the sandals as a substitute for the washing of the feet. The Qur'ān 5 : 6 orders that the feet should be washed (Sic! Does he mean rubbed ?), no mention being made of the sandals". [see Wensinck, The Muslim Creed, p.158].

79- Ibn Kathīr, Tafsīr, vol.2, p.26.

supporting this justification, Ibn 'Atiyyah maintains that some scholars who advocate the reading with kasrah (arjulikum) understand the wiping of the feet (mash) as referring to the washing (ghasl).⁸⁰ Arguing from a linguistic perspective in favour of this argument, al-Qurtubī says that the term mash is a mutual expression which refers to both rubbing and washing.⁸¹ In this respect, it is also relevant to refer to the report of al-Farrā' on the authority of 'Alī b. Abī Ṭālib in which he says that the Qur'ān has been revealed with mash, whereas the Sunnah is al-ghasl (nazala al-kitābu bi-al-mash wa-al-Sunnah al-ghasl).⁸²

Fourthly, it has been argued that even the reading of the accusative case (arjulakum) necessitates also the the rubbing (mash) of the feet.⁸³ This is because in the phrase wa-amsahū bi-ru'ūsikum wa-arjulikum the preposition bi is regarded as an additional, that is to say, otiose particle which can be omitted. After the omission of the preposition bi the phrase would be read as follows: wa-amsahū ru'ūsikum wa-arjulakum meaning rub your heads and your feet.⁸⁴ According to this argument, the reading arjulakum thus also results in the necessity (wājib) of mash, a conclusion which concurs with that of the reading arjulikum which beyond doubt entails mash. Another linguistic argument is also cited in support of the idea that even in the reading with a kasrah (arjulikum), the feet should be washed. It is argued that in the phrase fa-aghsilū wujūhakum

80- Qurtubī, Tafsīr, vol.6, p.92.

81- Ibid, p.92.

82- Farrā', Ma'ānī, vol.1, p.302.

83- Rāzī, Mafāṭih, vol.3, p.370.

84- Ibid, p.370.

wa-aydiyakum ilā al-marāfiqi wa-amsahū bi-ru'ūsikum wa-arjulikum ilā al-ka'bayn although the word arjulikum has a kasrah on the lām, it is governed by the verb aghsilū as far as the meaning is concerned, which is that the feet must be washed. The adherents of this argument argue that this sort of device, that is to say, to join something with another thing by means of a verb which applies to only one of them, does exist in the Arabic language. In this way one says: "akaltu al-khubza wa-al-labana", i.e., I ate the bread and the milk, which actually means I ate the bread and drank the milk. Similarly in the phrase at issue, the actual meaning is wa-amsahū bi-ru'ūsikum wa-aghsilū arjulakum.⁸⁵

The first argument cited in favour of Mujāhid's position as a compromise between the two readings, that arjulikum has the ending kasrah because of its position of proximity to the word ru'ūsikum, has been opposed by three arguments :

i. It is argued that the occurrence of the kasrah at the end of a word by reason of proximity is regarded as linguistically incorrect (lahn) and if it is sometimes accepted as a necessity in the poetry, such a usage would be out of place in the Qur'ān which must be free from such imperfections.⁸⁶

ii. It is also argued that the use of the kasrah through proximity takes place without the need for the conjunction (ḥarf 'atf), as in the above phrase hādhā juḥru ḍabbin kharibin. When however there

85- Qurtubī, Tafsīr, vol.6, pp.95-6.

86- Rāzī, Mafātīḥ, vol.3, p.370.

is harf 'atf as in the Qur'ānic phrase at issue wa-arjulikum , it is unacceptable in the Arabic language.⁸⁷

iii. It is argued that the occurrence of the kasrah due to proximity is only resorted to when there is a guarantee that no confusion (iltibās) would occur, as in the example hādhā juhru dabbin kharibin. However, in the Qur'ānic phrase under discussion, if the word (arjulikum) receives the kasrah by reason of proximity to the preceding word ru'ūsikum, confusion and ambiguity would occur.⁸⁸

Although the Shi'ites read the word under discussion as arjulikum , they argue that even if it is read with naṣb (i.e., arjulakum) both readings must result in the obligatory mash (rubbing) of the feet.⁸⁹

As we have seen, Mujāhid, according to al-Ṭabarī, is attributed with both readings: arjulakum on the authority of Qays b. Sa'd and arjulikum on the authority of Ḥamīd. Despite the fact that neither of the two readings is reported by the regular transmitters of Mujāhid's views such as Ibn Abī Najīḥ or Ibn Jurayj, it might still be highly likely that Mujāhid actually did adopt both readings. This can be inferred from the fact that some early scholars including al-Ṭabarī also hold both readings.⁹⁰ Al-Ṭabarī maintains that both readings arjulakum and arjulikum are satisfactory ways of reading the Qur'ānic word under discussion . He further adds that

87- Ibid, p.370.

88- Ibid, p.370.

89- Ṭūsī, Tafsīr, vol.3, p.452.

90- Ṭabarī, Tafsīr, vol.10, p. 61-80.

he prefers however the reading arjulikum (with kasrah) that is to say, the feet should be rubbed in the ablution rather than washed.⁹¹ He bases his view on two arguments: Firstly, he argues that when one rubs one's bare feet with water, one deserves the description of māsiḥ ghāsil. In other words, al-Ṭabarī considers mash as covering both meanings: the rubbing (mash) and the washing (ghasl).⁹² The second argument which is stated by al-Ṭabarī in support of his preference of the reading arjulikum is that the word arjulikum comes immediately after the phrase wa-amsahū bi-ru'ūsikum. To join (ta'tif) the word arjulikum to the preceding word ru'ūsikum, is thus more appropriate than to join it to the word aydiyakum which is separated from it by the phrase wa-amsahū ru'ūsikum.⁹³

It follows from this that if the reports of Mujāhid's views are correct, then he and al-Ṭabarī agree on the main point that both arjulakum and arjulikum are acceptable readings for the word under discussion. Although there is no direct justification from Mujāhid himself for supposing that he held both readings, he might have resorted to arguments similar to those of al-Ṭabarī or to the other arguments mentioned earlier which try to reconcile the two readings.

Nonetheless, there is still some difference between the position of al-Ṭabarī and that of Mujāhid. In Mujāhid's view, it

91- Ibid, p.64.

92- Ibid, p.62.

93- Ibid, p.64.

seems that both readings are equally correct and acceptable since Mujāhid is not reported to have preferred one reading to the other as al-Ṭabarī did. In the first reading arjulakum both Mujāhid and al-Ṭabarī follow directly the view of the majority of the exegetes. The second reading (arjulikum) is one of the aspects for which al-Ṭabarī is accused of having some inclinations towards Shi'ism. Dr. E. Y. Nūr al-Dā'im in his thesis The Charge of Shi'ism Against Ṭabarī discusses al-Ṭabarī's position on this particular verse (5 : 6). In the conclusion he writes: "In holding the view that it is permissible to rub the bare feet, al-Ṭabarī was not following the Shi'ites blindly. He was relying on the obvious sense of the verse at hand (5 : 6)".⁹⁴

It is clear that both readings have considerable support among the earliest exegetes and that there was some dispute before the consensus was reached. If the list of supporters of the two different views is studied, it is seen that Ibn 'Abbās is cited as holding both readings as are 'Ikrimah and al-Ḍaḥḥāk. It is not surprising therefore to find that both readings have been attributed to Mujāhid.

Ibn al-Jazarī maintains that the reading arjulakum is adopted by the qurrā' Nāfi', Ibn 'Āmir, al-Kisā'i and Ya'qūb, whereas the rest of the qurrā' read the word as arjulikum. This report of Ibn al-Jazarī implies that he accepts both readings.

⁹⁴- E. Y. Nūr al-Dā'im, The Charge of Shi'ism against Ṭabarī, with special reference to his Tafsīr, unpublished Ph.D thesis, Edinburgh, 1969, p.175.

The fact that the Shi'ites follow the reading arjulikum is of little significance, since as has been already stated, the discussion was taking place before a consensus was reached and several early scholars like al-Ḥasan al-Baṣrī are reported to have allowed the feet to be either washed or rubbed. If he had accepted both readings, Mujāhid may well have found himself in a similar situation.

3. THE INTERPRETATIONS OF VERSES 2 :104 AND 4 :46:

The Qur'ān states : " O you who believe! Do not say (to the Prophet) rā'inā or rā'inan or rā'ūnā , but say unzurnā or anzurnā or anzirnā and hearken (to him): To those without faith is a grievous punishment (yā ayyuhā alladhīna āmanū lā-taqūlū rā'inā [or rā'inan or rā'ūnā] wa-qūlū unzurnā [or anzurnā or anzirnā] wa-asma'ū wa-li-al-kāfirīna 'adhābun alīmun)". (2 : 104).

In another verse, the Qur'ān says : " Of the Jews there are those who displace words from their right places, and say: 'We hear and we disobey', and 'Hear what is not heard', and rā'inā (or rā'inan or rā'ūnā), with a twist of their tongues and a slander of faith. If only they had said: 'We hear and we obey' and 'Do hear', and unzurnā (or anzurnā or anzirnā), it would have been better for them, and more proper; but God hath cursed them for their unbelief; and but few of them will believe (min alladhīna hādū yuḥarrifūna al-kalīma 'an mawāḍi'ihī wa-yaqūlūna sami'nā wa-'aṣaynā wa-asma' ghayra musma'in wa-rā'inā (or rā'inan or rā'ūnā) layyan bi-alsinatihim wa-ta'nan fī al-dīni wa-law annahum qālū sami'nā

wa-ata'nā wa-asma' wa-unzurnā (or anzurnā or anzirnā) la-kāna khayran la-hum wa-aqwama wa-lākin la'anahumu Allāhu bi-kufrihim fa-lā yu'minūna illā qalīlan)". (4 : 46).

In these two verses two expressions will be dealt with each of which is given different readings and consequently different interpretations. The first expression is :

1. rā'inā or rā'inan or rā'ūnā :

Mujāhid is reported to have had only one reading as regards this first expression, where he reads it as rā'inā.⁹⁵ This is the reading of the majority of the exgetes and Muslim scholars (al-jumhūr).⁹⁶ With regard to the meaning of this word (rā'inā), Mujāhid, according to al-Ṭabarī⁹⁷ and Ibn Kathīr⁹⁸ is attributed with two interpretations. Al-Ṭabarī reports the first interpretation attributed to Mujāhid on the authority of Ibn Abī Najīḥ who is quoted by 'Īsā.⁹⁹ In this interpretation Mujāhid maintains that the word rā'inā is derived from the expression when one says to another ar'inī sam'aka , that is to say, give me your ears or listen to me. The believers used to say to the Prophet rā'inā meaning listen to us and we will listen to you (asma' min-nā wa-nasma' min-ka).¹⁰⁰ In other words, Mujāhid regards rā'inā as a word which has a mutual purport, that it represents a kind of mufā'alah which cannot

95- Mujāhid, Tafsīr, vol.1, p.85.

96- Abū Hayyān, al-Baḥr al-Muḥīṭ, vol.1, p.338.

97- Ṭabarī, Tafsīr, vol.2, pp.459-60.

98- Ibn Kathīr, Tafsīr, vol.1, p.149.

99- Ṭabarī, Tafsīr, vol. 2, p.460.

100- Ibid, p.460.

occur except between two things. In the verse under discussion, according to Mujāhid's view, the Qur'ān strongly forbids the believers from using the word rā'inā when talking to the Prophet, because this indicates that there is an equality between their status and that of the Prophet. This verse condemns such attitude of rudeness and teaches the believers to choose the most polite and respectful language when addressing the Prophet. This view is also attributed to Mujāhid by the Shi'ite commentator al-Ṭūsī.¹⁰¹ This view of Mujāhid is held by his teacher Ibn 'Abbās, al-Ḍaḥḥāk and Qatādah.¹⁰² It should be noted however that this interpretation attributed to Mujāhid is not mentioned in Ādam b. Abī Iyyās's version of Warqā's recension.

Some other exegetes suggest another interpretation for the word rā'inā in the above verse. They take it as being derived from the expression when someone says to someone else: "Ra'āka Allāh", that is to say, may God take care of you and look after you. So in the verse at issue, according to this understanding, the believers used to say to the Prophet: "Look after us and we will look after you (aḥfaznā wa-naḥfazuka wa-arqubnā wa-narqubuka)."¹⁰³

Although the second interpretation suggested for the word rā'inā is different from the earlier one attributed to Mujāhid, both of them share the idea that they convey mutual meaning (mufā'alah) between two sides. This is because when the believers address the

101. Ṭūsī, Tafsīr, vol. 1, p.388.

102- Ṭabarī, Tafsīr, vol.2, p.460.

103- Ibid, p.464.

- Qurtubī, Tafsīr, vol.2, p.57.

Prophet with the expression asma' min-nā wa-nasma' min-ka or ahfaznā wa-nahfazuka this implies rudeness and cruelty which is unacceptable as regards the status of the Prophet. Ibn Kathīr observes that the particle lā in the phrase lā taqūlū rā'inā indicates a nahy, which entails tahrīm (prohibition),¹⁰⁴ that the believers are vehemently forbidden to use such insulting words with the Prophet.¹⁰⁵ It is also suggested that when the Jews say to the Prophet : rā'inā , they understand it as meaning: "You are the shepherd of our flocks" (rā'ī ghanaminā).¹⁰⁶

Al-Ṭabarī comments that God dislikes the word rā'inā to be said to the Prophet, and therefore he substitutes for it another word unzurnā (or anzurnā or anzirnā)¹⁰⁷ In justifying the preference of the usage of a word over another word, though synonymous in meaning, the commentators al-Ṭabarī¹⁰⁸ and Ibn Kathīr¹⁰⁹ refer to the tradition of the Prophet in which he asks the

104- Ibn Kathīr, Tafsīr, vol.1, p.149.

105- Three justifications have been put forward as regards the reason for which the believers are forbidden to use the word rā'inā. Some exegetes believe that it is of a Jewish origin. [Ṭabarī, Tafsīr, vol.2, p.460]. The Jews had a word in Hebrew or Syriac, that is rā'inā with which they used to curse each other. Having heard the Muslims say rā'inā, they seized the opportunity and address the Prophet with that word. They pretend to use the word in the same way as Muslims do, though they actually intend the insulting meaning of the word. [Zamakhsharī, Kashshāf, vol.1, p.174. Also: Rāzī, Mafāṭīḥ , vol.1, p.440. Also: Abū Ḥayyān, al-Baḥr al-Muḥīt, vol.1, p.339. Nisābūrī, Tafsīr, vol.1, p.351]. Thus due to this insulting meaning, God instructs the believers not to say it to the Prophet. The second group hold that a certain Jews used to talk to the Prophet in a way that insults him, so the believers were ordered not to use such expression with the Prophet. [Ṭabarī, Tafsīr, vol.2, pp. 462-3]. The third group suggests that rā'inā is a word which the helpers of the Prophet (anṣār) used to say in the pre-Islamic era (jāhiliyyah). So in Islam God forbids the believers to say it to the Prophet. [Ṭabarī, Tafsīr, vol.2, pp.461-2].

106- Abū Ḥayyān , al-Baḥr al-Muḥīt, vol.1, p.339.

- Nisābūrī, Tafsīr, vol.1, p.351.

107- Ṭabarī, Tafsīr, vol.2, p.460

108- Ibid, pp.463-4.

109- Ibn Kathīr, Tafsīr, vol.1, p.149.

believers not to call the grape ('inab) karm , but rather to call it halabah,¹¹⁰ and also not to call your client 'abdī, but to say fatāya.¹¹¹ The same method applies to the word rā'inā, that whether it denotes ar'inā sam'aka, according to Mujāhid's interpretation or whether it means ahfaznā wa-nahfazuka , according to the other view, it results in rudeness, and therefore it is substituted by another word. In fact the believers are enjoined by God to revere and respect the Prophet to the extent that they are forbidden even to raise their voices in his presence as the Qur'ān says: "O ye who believe ! Raise not your voices above the voice of the Prophet, nor speak loudly to him in talk, as ye may speak aloud to one another, lest your deeds become vain and ye perceive not (yā ayyuhā alladhīna āmanū lā tarfa'ū aṣwātakum fawqa ṣawti al-nabii wa-lā tajharū la-hu bi-al-qawli ka-jahri ba'dikum li-ba'din an taḥḥata a'mālukum wa-antum lā tash'urūna)".¹¹² (49 : 2). Here Mujāhid interprets the phrase lā tajharū la-hu bi-al-qawli ka-jahri ba'dikum li-ba'din as meaning that the believers should not call the Prophet merely by his name Muḥammad as they call each other, and that they should respect the status of Prophethood, and therefore call him by his title the Messenger of God.¹¹³ So like the verses under discussion 2 : 104 and 4 : 46 , this verse also negates the equality between the Prophet and the believers. Likewise, there is another verse which also teaches the believers the proper behaviour with the

110- The wisdom behind calling the grapes halabah and not karm is lest to confuse with the word karam (generosity), although the former gets a sukūn on the rā'.

111- Also, when one says 'abdī that means he ascribes 'ubūdiyyah (slavery) to other than God. Therefore, he is asked to say fatāya in order to avoid unacceptable usage.

112- Ṭabarī, Tafsīr, vol.2, pp.463-5.

113- Ibid, vol.26, pp.117-8.

Prophet. This verse says: "Deem not the summons of the Apostle among yourselves like the summons of one of you to another (lā taj'alū du'ā'a al-rasūli baynakum ka-du'ā'i ba'dikum ba'dan) ..." (24 : 63). Mujāhid interprets this phrase as meaning that God orders the believers to call the Prophet by his title observing gentleness and humility and not to call him rudely merely by his name Muḥammad.¹¹⁴

The second interpretation attributed to Mujāhid as regards the word rā'inā is given by al-Ṭabarī in four reports. Two of these reports are transmitted by Ibn Abī Najīḥ who is quoted by 'Isā in one and by Shibl in the other.¹¹⁵ The third report is transmitted by an unnamed man (rajul) who is quoted by Sufyān.¹¹⁶ The fourth report is transmitted by Sufyān directly from Mujāhid.¹¹⁷ In this interpretation Mujāhid maintains that rā'inā means disagreement (khiḷāf).¹¹⁸ 'Aṭā' is also attributed with this interpretation on the authority of Ibn Jurayj.¹¹⁹ Thus the meaning of the verse is that as a matter of respect to the Prophet, God commands the believers to follow what the Prophet says and not to say something different. This interpretation is also mentioned in Ādam b. Abī Iyyās's

114. Ibid, vol.18, p.177.

- Qurtubī, Tafsīr, vol.12, p.322.

115. Ṭabarī, Tafsīr, vol.2, p.459.

116. Ibid, p.459.

117. Ibid, p.459.

118. Mujāhid, Tafsīr, vol.1, p.85.

- Ṭabarī, Tafsīr, vol.2, p.459.

- Ibn Kathīr, Tafsīr, vol.1, p.149.

119. Ṭabarī, Tafsīr, vol.2, p.459.

version of Warqā's recension.¹²⁰ It is also attributed to Mujāhid by the commentators al-Ṭūsī,¹²¹ and Ibn Kathīr.¹²²

Criticizing the second interpretation attributed to Mujāhid, al-Ṭabarī maintains that rā'inā as denoting khilāf is unacceptable as far as the Arabic language is concerned. In justifying his judgment, al-Ṭabarī argues that the term rā'aytu can give one of two meanings. Either it might mean I gave ear to (ar'aytuhu sam'ī) which is the first interpretation attributed to Mujāhid. Or else rā'aytu may be derived from the ri'yah meaning I took care of or I looked after something or somebody. However, as al-Ṭabarī further adds, rā'aytu as meaning I disagreed (khālaftu) has no understandable purport. In attempting to find a solution for the second explanation attributed to Mujāhid, al-Ṭabarī suggests that the only way to make this explanation acceptable is to assume that the word under discussion might be read as rā'inan, i.e., with nunation (tanwīn) and refer to thoughtlessness (ru'ūnah), ignorance (jahīl) and error (khata').¹²³ Hence al-Ṭabarī suggests that with this reading the verse means that the believers were commanded by God not to describe the Prophet as being rash (rā'inan). This reading (rā'inan with tanwīn), is attributed to 'Abd al-Raḥmān b. Zayd,¹²⁴ al-Ḥasan al-Baṣrī,¹²⁵ Ibn Abī Laylā, Abū Ḥayawah and Ibn Muḥayṣin.¹²⁶

120. Mujāhid, Tafsīr, vol. 1, p. 85.

121. Ṭūsī, Tafsīr, vol. 1, p. 388.

122. Ibn Kathīr, Tafsīr, vol. 1, p. 149.

123. Ṭabarī, Tafsīr, vol. 2, p. 465.

124. *Ibid*, p. 465.

125. Ṭabarī, Tafsīr, vol. 2, p. 466.

- Zamakhsharī, Kashshāf, vol. 1, p. 174.

- Qurtubī, Tafsīr, vol. 2, p. 60.

- Nisābūrī, Tafsīr, vol. 1, p. 351.

- Abū Ḥayyān, al-Baḥr al-Muḥīṭ, vol. 1, p. 338.

Al-Ṭabarī concludes by saying that although this reading (rā'inan) disagrees with the reading adopted by the majority of the qurrā', it still has an understandable meaning.¹²⁷ However, as al-Ṭabarī argues, as far as the qirā'āt are concerned, rā'inan is regarded as an anomalous reading for the word under discussion, because it contradicts the reading of the general consensus of the exegetes and Muslim scholars.¹²⁸

Another group of exegetes give a variant reading for the word under discussion by reading it as rā'ūnā, that is to say, in the plural form.¹²⁹ This reading is ascribed to Ibn Mas'ūd,¹³⁰ Ubayy b. Ka'b,¹³¹ Zirr b. Ḥubaysh¹³² and al-A'mash.¹³³ According to this reading, the verse means that the believers were forbidden to use rā'ūnā whether they speak to the Prophet or to somebody else.¹³⁴ However, al-Ṭabarī throws doubts on the correctness of this reading.¹³⁵

Thus it can be said that for the word under discussion although Mujāhid read it as rā'inā, he is attributed with two different interpretations. The first interpretation seems to be in conformity

126- Abū Ḥayyān, al-Baḥr al-Muḥīt, vol.1, p.338.

127- Ibid, p.465.

128- Ṭabarī, Tafsīr, vol.2, p.466.

129- Ibid, p.467.

- Qurtūbī, Tafsīr, vol.2, p. 53.

130- Ṭabarī, Tafsīr, vol.2, p.467.

- Zamakhsharī, Kashshāf, vol.1, p.174.

- Abū Ḥayyān, al-Baḥr al-Muḥīt, vol.1, p.338.

131- Abū Ḥayyān, al-Baḥr al-Muḥīt, vol.1, p.338.

132- Qurtūbī, Tafsīr, vol.2, p.60.

133- Ibid, p.60.

134- Ṭabarī, Tafsīr, vol.2, p.467.

135- Ibid, p.467.

with that of the majority of Muslim scholars and exegetes. The second interpretation attributed to him is rejected by al-Ṭabarī from a linguistic point of view. However, although this second interpretation is not generally accepted as the correct one as it has not been attributed to any other of the mufassirūn except 'Aṭā', we should bear in mind that this is the sole interpretation to be found in Ādam b. Abī Iyyās's version of Warqā's recension of the Tafsīr of Mujāhid. It has also been transmitted as Mujāhid's interpretation, according to al-Ṭabarī, by two further reports on the authority of Ibn Abī Najīḥ from the recensions of 'Īsā and Shibl and two from Sufyān.

The second expression in the verses under discussion which the exegetes differ upon its reading and meaning is :

ii. unzurnā or anzurnā or anzirnā :

Mujāhid is reported to have read the second word in the two Qur'ānic verses under discussion (2 : 104 and 4 : 46) as unzurnā , that is to say, with a conjunctive hamzah (hamzat wasl) and with ḍammah on the letter zā'.¹³⁶ This word, according to this reading, has been interpreted in four different ways, two of which are attributed to Mujāhid.¹³⁷ Al-Ṭabarī gives five reports for the first interpretation attributed to Mujāhid.¹³⁸ Three of these reports are

136- Ṭabarī, Tafsīr, vol. 2, p.467.

137- Ibid, pp.467-9; and Ibid, vol. 8, pp.436-8.

138- Ibid, vol. 2, p.467; and Ibid, vol.8, p.437.

transmitted by Ibn Abī Najīḥ who is quoted by 'Īsā¹³⁹ in two and by Shibl in the third one.¹⁴⁰ The remaining two reports of al-Ṭabarī are transmitted by Ibn Jurayj¹⁴¹ who in both directly quotes Mujāhid. In this first interpretation, Mujāhid maintains that unzurnā denotes afhimnā¹⁴² or fahhimnā wa-bayyin la-nā,¹⁴³ i.e., teach us and explain to us.¹⁴⁴ Thus the meaning of the phrase wa-unzurnā is that the Qur'ān instructs the believers to ask the Prophet politely about what they want to know. This interpretation is also mentioned in Ādam b. Abī Iyyās's version of Warqā's recension on the authority of Ibn Abī Najīḥ citing Mujāhid¹⁴⁵ This interpretation is also attributed to Mujāhid by the commentators al-Ṭūsī,¹⁴⁶ Abū Ḥayyān¹⁴⁷ and al-Qurṭubī¹⁴⁸ The second interpretation which is attributed to both Mujāhid and 'Ikrimah is transmitted on the authority of Jābir.¹⁴⁹ In this second interpretation, Mujāhid maintains that unzurnā connotes hearken to what we say (asma' minnā).¹⁵⁰ However, this interpretation is not

139. One of 'Īsā's narration is in Ṭabarī's Tafsīr, vol. 2, p.467 and the other is in vol.8, p.437.

140. Ṭabarī, Tafsīr, vol.2, p.467.

141. One of Ibn Jurayj's narrations is in Ṭabarī's Tafsīr, vol.2, p.467 and the other is in vol.8, p.437.

142. Mujāhid, Tafsīr, vol.1, p.85.

- Ṭabarī, Tafsīr, vol.8, p.437.

143. Ṭabarī, Tafsīr, vol.2, p.437.

- Qurṭubī, Tafsīr, vol. 2, p.60.

144. Ṭabarī, Tafsīr, vol. 2, p.467; and vol.8, p.437.

- Qurṭubī, Tafsīr, vol.2, p.60.

145. Mujāhid, Tafsīr, vol.1, p.85, where Mujāhid maintains that anzurnā means afhimnā.

146. Ṭūsī, Tafsīr, vol.1, p.389.

147. Abū Ḥayyān, al-Baḥr al-Muḥīṭ, vol.1, p.339.

148. Qurṭubī, Tafsīr, vol.2, p.60.

149. Ṭabarī, Tafsīr, vol.8, p.437.

150. Ṭabarī, Tafsīr, vol.8, p.437.

- Abū Ḥayyān, al-Baḥr al-Muḥīṭ, vol.3, p.264.

mentioned in Ādam b. Abī Iyyās's version of Warqā's recension. The third interpretation suggested for the word unzurnā is that it might also mean come to us and look at us (aqbil 'alaynā wa-unzur la-nā).¹⁵¹ The fourth possible interpretation suggested for the word unzurnā is that it means wait for us (intazirnā wa-ta'anna bi-nā).¹⁵²

Commenting on these different views, al-Ṭabarī rejects both interpretations attributed to Mujāhid for the word unzurnā. Al-Ṭabarī says that the interpretation which is attributed to both Mujāhid and 'Ikrimah (unzurnā denotes asma' min-nā) and the other interpretation attributed to Mujāhid (with the meaning afhimnā or fahhimnā) are both unacceptable in the Arabic language. However, al-Ṭabarī further adds that the interpretation attributed to Mujāhid (unzurnā means afhimnā or fahhimnā) can be accepted if Mujāhid actually intends by afhimnā : "Give us a chance so we can understand what you say (intazirnā nafham mā taqūl)",¹⁵³ or "Await for us to say what we want so that you can listen to us (intazirnā naqul ḥattā tasma' min-nā)".¹⁵⁴ Thus if that is the case, as al-Ṭabarī further argues, then we can get an understandable purport, despite the fact that this is not a direct interpretation of the word under discussion.¹⁵⁵

151- Qurtubī, Tafsīr, vol.2, p.60.

152- Ibid, p.60.

153- Ṭabarī, Tafsīr , vol.8, p.437.

154- Ibid, p.437.

155- Ibid, p.437.

It may be mentioned that, unlike Mujāhid, another group of exegetes read the word under discussion with a disjunctive hamzah (hamzat qat'). Some of the adherents of this group such as Ubayy,¹⁵⁶ al-A'mash and others¹⁵⁷ read the word as anzirnā i.e., with kasrah on the letter zā', while others whom al-Ṭabarī does not name read it as anzirūnā, in the plural form.¹⁵⁸ Both readings with hamzat qat' (anzirnā and anzirūnā) mean give us a respite and more time in order to understand what you say to us (akhkhirnā wa-amhilmā ḥattā nafham min-ka).¹⁵⁹ As the Qur'ān says on behalf of Iblīs in verse 38 : 79: "O my lord ! Give me respite till the Day the dead are raised (qāla rabbi fa-anzirni ilā yawmi yub'athūna)".¹⁶⁰ Anzirnā is also used in Arabic poetry as 'Amr b. Kalthūm recites¹⁶¹ :

أبا هندٍ فلا تجلِّ علينا وأنظرنا نبرك اليقينا

Al-Ṭabarī comments by saying that if anzirnā is taken to mean amhilmā, then whether the word is read with hamzat qat' or wasl, the meaning will be similar.¹⁶² Al-Ṭabarī concludes by saying that he however prefers the reading of unzurnā with the hamzat wasl meaning intazirnā, because it is the reading approved by the general consensus of the exegetes and Muslim scholars.¹⁶³ In other words, al-Ṭabarī prefers the reading which is adopted by Mujāhid. As

156- Zamakhsharī, Kashshāf, vol.1, p.518.

157- Qurṭubī, Tafsīr, vol.2, p.60.

158- Ṭabarī, Tafsīr, vol.2, p.468.

159- Ibid, p.468.

- Qurṭubī, Tafsīr, vol.2, p.60.

160- Ṭabarī, Tafsīr, vol.2, 468.

161- Ibid, p.468

162- Ibid, pp.468-9.

163- Ibid, p.469.

far as the meaning is concerned nonetheless, he rejects both interpretations attributed to Mujāhid. Of these two interpretations of Mujāhid, the second has the the least authority since it is quoted in only one place with an isnād which is very unusual for Mujāhid's work. On the other hand, the first interpretation is reported by al-Ṭabarī on the authority of Ibn Abī Najīḥ from the recensions of 'Īsā and Shibl as well as being transmitted by Ibn Jurayj and being reported in Ādam b. Abī Iyyās's version of Warqā's recension.

4. THE INTERPRETATION OF HŪR AS MENTIONED IN THE QUR'ĀN :

One of the great rewards which God stores for the true believers in Paradise is that they will be in the company of heavenly beautiful women. These women are given various descriptions in several Qur'ānic verses. However, they are mentioned by the name hūr in four places in the Qur'ānic text. These places are :

(i) "And also We shall join them to companions with beautiful, big and lustrous eyes (kadhālika wa-zawwajnāhum bi-hūrīn 'īnīn)". (44 : 54).

(ii) " They shall recline (with ease) on Thrones (of dignity) arranged in ranks; and We shall join them to companions with beautiful, big and lustrous eyes (muttaki'īna 'alā sururīn maṣfūfātīn wa-zawwajnāhum bi-hūrīn 'īnīn)". (52 : 20).

(iii) "Companions restrained (as to their glances) in (goodly) pavilion (hūrūn maqṣūrātun fī al-khiyāmi)". (55 : 72).

(iv) " And (there will be) companions with beautiful, big and lustrous eyes (wa-hūrun 'īnun) ". (56 : 22).

It can be mentioned that in the first two verses, mention has been made to tazwīj, that is to say, i.e., to making marriage. However, according to Muḥammad 'Alī, tazwīj between the believers and those houris in the Hereafter does not refer to the marriage known among the human beings. Rather it indicates being in couples or in pairs.¹⁶⁴

Four interpretations have been put forward as regards the term hūr, three of which are attributed to Mujāhid. Al-Ṭabarī reports the first interpretation attributed to Mujāhid on the authority of Maṣṣūr who is quoted by Sufyān.¹⁶⁵ In this interpretation Mujāhid briefly construes hūr as referring to women (nisā').¹⁶⁶ Ibn Maṣṣūr elaborates this meaning further by saying that they are the women who are clean and live a comfortable life.¹⁶⁷ However, this interpretation attributed to Mujāhid is not mentioned in Ādam b. Abī Iyyās's version of Warqā's recension.

Al-Ṭabarī gives the second interpretation attributed to Mujāhid in two reports. The transmitters of these reports are Muslim¹⁶⁸ and Abū Yaḥyā al-Qattāt.¹⁶⁹ In this interpretation

164. Muḥammad 'Alī, The Holy Qur'ān, p.955.

165. Ṭabarī, Tafsīr, vol.27, p.159.

166. Ibid, p.159.

167. Ibn Maṣṣūr, Lisān, vol.1, p.751.

168. Ṭabarī, Tafsīr, vol.27, p.159.

169. Ibid, p.158.

Mujāhid takes hūr as meaning white ones (bīd).¹⁷⁰ In another report narrated by Manṣūr, Mujāhid is said to have elaborated this interpretation by saying that hūr are those ones whose hearts, souls and eyes are white.¹⁷¹ Again, this interpretation is not mentioned in Ādam b. Abī Iyyās's version of Warqā's recension. Al-Ṭabarī tries to support this second interpretation of Mujāhid from a linguistic angle. He says that the Arabs use the infinitive form hawar to signify the intense whiteness (shiddat al-bayād). Thus the man whose eye-balls are extremely white can be described as aḥwar and similarly the woman is described as hawrā'.¹⁷² In support of this meaning, al-Ṭabarī further argues that the followers of Jesus might acquire the name hawāriyyūn¹⁷³ because their clothes were white,¹⁷⁴ or because they used to be washermen (qassārūn) who whiten clothes.¹⁷⁵ It is also argued that this second interpretation of Mujāhid that hūr means bīd, might be supported by the reading of Ibn Mas'ūd of verse 44 : 54. Ibn Mas'ūd is reported to have read the last part of this verse as follows: "bi-'īsin 'īnin", that is to say he uses 'īs instead of hūr.¹⁷⁶ Linguistically, the word 'īs means white (bīd).¹⁷⁷ Stressing this interpretation, Ibn Mas'ūd,

170- Ibid, p.159.

- Bayḍāwī, Anwār, vol.5, p.68.

171- Ṭabarī, Tafsīr, vol.27, p.159.

172- Ibid, vol.6, p.450.

173- The word hawāriyyūn and hawāriyyīn have been mentioned in the following Qur'ānic verses: 3 : 52, 5 : 111-2 and 61 : 14.

174- Ṭabarī, Tafsīr, vol. 6, p.450.

175- Ibid, p.450. For further details of the meanings of hawāriyyūn, see Ṭabarī, Tafsīr, vol.6, pp.449-52.

176- Ṭabarī, Tafsīr, vol.25, p.136.

- Zamakhsharī, Kashshāf, vol.4, p.283.

- Qurtubī, Tafsīr, vol.16, p.153.

177- See the references in the previous footnote. The word 'īs is usually used for camels. 'īs is a plural form whose singular is either a'yas, which applies to masculine, so that one says: ba'ir a'yas; Or else the singular of 'īs can be 'aysā' which applies to feminine, that one says: nāqah 'aysā'. [See Qurtubī, Tafsīr,

according to al-Qurṭubī, describes that the bones and flesh of the legs of the woman of al-ḥūr al-ʿīn can be seen even through seventy garments, as a red drink can be seen in a white bottle.¹⁷⁸

Al-Qurṭubī also attributes this interpretation to Qatādah and the majority of the exegetes.¹⁷⁹

Al-Ṭabarī reports the third interpretation attributed to Mujāhid on the authority of an unnamed man (rajuḷ) who is quoted by Sufyān.¹⁸⁰ In this interpretation, Mujāhid explains ḥūr as referring to those women who cause the eye-sight to be amazed (yahāru fī-hinna al-ṭarfu).¹⁸¹ This interpretation, according to al-Ṭabarī, is further elaborated on the authority of Ibn Abī Najīh who is quoted by Warqā'.¹⁸² Mujāhid, according to this version of Ibn Abī Najīh, maintains that ḥūr are those women who cause the eyesight to be amazed (yahāru fī-hinna al-ṭarfu) as a result of the outline of their legs which can be seen through their garments. Their colour is so pure and their skin so delicate that the viewer can almost see his own reflection in their bodies.¹⁸³ This last version of Mujāhid's interpretation is also found in Ādam b. Abī Iyyās's version of Warqā''s recension of on the authority of Ibn Abī Najīh.¹⁸⁴ Both al-Qurṭubī¹⁸⁵ and al-Baghawī¹⁸⁶ ascribe to Mujāhid

vol.16, p.153.]. As for the term ʿīn, it is the plural of a'yan (applied to the masculine), and aynā (applied to the feminine) which refers to the largeness of the eyes. [see Bayḍāwī, Anwār, vol.5, p.68.].

178- Qurṭubī, Tafsīr, vol.16, p.153.

179- Ibid, p.152.

180- Ṭabarī, Tafsīr, vol.27, p.178.

181- Ibid, p.178.

182- Ibid, vol.25, p.136.

183- Ibid, p.136.

184- Mujāhid, Tafsīr, vol.2, p.590.

185- Qurṭubī, Tafsīr, vol.16, p.153.

a somewhat similar interpretation of the one above, but without isnād. According to them, Mujāhid maintains that hūr are given this name because they make the eyesight amazed (yahāru al-ṭarfu) as a result of their beauty, whiteness and purity of their colour.

Although Mujāhid seems to be deriving hūr from the verb hāra, yahāru, he also by the elaboration of the meaning understands these women to be of a pure colour and thus is adding the sense of the second interpretation attributed to him to the overall interpretation. This is particularly so as in this third interpretation he seems to be following Ibn Mas'ūd's elaboration of the second interpretation. In addition, there is no real rejection in his third interpretation of the first, namely that hūr refers to women (nisā'). It is possible therefore that the first two interpretations attributed to Mujāhid are merely separate aspects of his full interpretation as given by the third interpretation.

The fourth view which is not attributed to Mujāhid, takes the infinitive hawar as referring to the beauty of the eye in which the exquisite whiteness of the eye-ball stands against the ardent blackness of the pupil.¹⁸⁷ This interpretation is held by Sufyān.¹⁸⁸

Al-Ṭabarī strongly opposes the third interpretation attributed to Mujāhid, particularly the statement of Mujāhid that hūr are those

186. Baghawī, Ma'ālim, vol.4, p.155.

187. Ṭabarī, Tafsīr, vol.27, p.159.

- Rāzī, Mafātiḥ, vol.7, p.458.

- Qurṭubī, Tafsīr, vol.16, p.153.

- Baghawī, Ma'ālim, vol.4, p.155.

188. Ṭabarī, Tafsīr, vol.27, p.159.

who cause the eyesight to be amazed (yahāru fi-hinna al-ṭarf).¹⁸⁹ Arguing from a linguistic perspective, al-Ṭabarī puts it plainly that Mujāhid's understanding that hūr are those who cause the eyesight to be amazed is unacceptable in the Arabic language.¹⁹⁰ Al-Ṭabarī adds that the term hūr is derived from the infinitive hawar which means the pure whiteness (naqā' al-bayād).¹⁹¹ He further tries to support the interpretation that hūr denote the white (bīd) by quoting the reading of Ibn Mas'ūd ('īsin 'īnin) mentioned earlier.¹⁹²

As far as the Arabic language is concerned, Ibn Manzūr differentiates between two different forms of infinitives: (i) hawar¹⁹³ and (ii) hayrah (or hayran or hayarānan),¹⁹⁴ and thus he discusses each of them separately. According to him, it is only the first form (hawar) and its noun-derivations which pertains to women's beauty. This usage is the one contained in the verses under discussion where Ibn Manzūr gives several meanings for the term hūr which comprise the first two interpretations attributed to Mujāhid, in addition to the fourth interpretation suggested for the word hūr.¹⁹⁵

Contrary to Ibn Manzūr, it seems that Mujāhid in the third interpretation attributed to him, considers the two roots mentioned earlier by Ibn Manzūr as referring to one thing. Thus he interprets

189. Ibid, vol.25, p.136.

190. Ibid, p.136.

191. Ibid, p.136.

192. Ibid, p.136.

193. Ibn Manzūr, Lisān, vol.1, pp.751-2.

194. Ibid, p.767-8.

195. Ibid, pp.751-2.

hūr as referring to those women who are extremely beautiful to the extent that they cause the viewer to be perplexed (yahāru fī-hinna al-tarfu). In other words, Mujāhid here sees that the verb yahāru which he uses in his interpretation, as being derived from the same root of the word hūr. According to Ibn Manzūr, in contrast, there is no verb which can be derived from the word hūr, and therefore the Qur'ānic word hūr has nothing to do with the amazement (hayrah) which Mujāhid takes it to be.

Although the third interpretation attributed to Mujāhid therefore seems to be linguistically incorrect, Mujāhid's view still looks interesting. This is because it is generally understood that the inimitable beauty of any thing might cause the eyesight to be amazed. It seems highly likely that this third interpretation was actually held by Mujāhid as it is attributed to him on the authority of Ibn Abī Najīh, the regular transmitter of Mujāhid's views. Furthermore, this is the sole interpretation found in Ādam b. Abī Iyyās's version of Warqā's recension as regards the term hūr. Another remark which needs to be mentioned is that this interpretation is attributed only to Mujāhid among the Sahābah and Tābi'ūn, as far as the Tafāsīr which have been consulted are concerned. This thus presents Mujāhid as independent thinker. As already pointed out, the first two interpretations attributed to Mujāhid seem also to be actually held by him, because both are in basic accord with his understanding of hūr in the third interpretation, even though the basic linguistic analysis may be faulty. According to al-Qurṭubī, the second of them is the one adopted by the majority of the exegetes. It can be said that

Mujāhid nevertheless sees the word as accessible to all three meanings, because they all point to the highest beauty of those heavenly women.

5. RHETORICAL ASPECTS :

A. To whom does the pronoun in the word kānat in verse 2 : 143 refer ?

It is well known that the Prophet and his Companions used to pray towards Jerusalem for several months after the hijrah.¹⁹⁶ Afterwards the Qur'ān gives the instructions that the direction of prayer must be changed to the Ka'bah. This matter is elaborated in many Qur'ānic verses. One of these verses is: "...and we appointed the qiblah to which thou was used, only to test those who follow the Apostle from those who would turn on their heels (from faith). Indeed it was momentous, except to those guided by God (wa-mā ja'alnā al-qiblata allatī kunta 'alayhā illā li-na'lama man yattabi'u al-rasūla mimman yanqalibu 'alā 'aqibayhi wa-in kānat la-kabīratan illā 'alā alladhīna hadā Allāhu) ...". (2 : 143).

In this verse we are concerned with the phrase wa-in kānat la-kabīratan illā 'alā alladhīna hadā Allāh. In this phrase the commentators differ as to what the implied pronoun in the word kānat refers ? According to al-Ṭabarī,¹⁹⁷ three opinions have been suggested, one of which is attributed to Mujāhid. Al-Ṭabarī gives

196. It is said that it was variously for nine, ten, thirteen, sixteen or seventeen months after the hijrah. For the different views as regards the period which the Prophet and his Companions spent praying towards Jerusalem before changing to Mecca, see: Ṭabarī, Tafsīr, vol.3, pp. 132-7.

197. Ṭabarī, Tafsīr, vol.3, pp.163-5.

Mujāhid's view in two reports.¹⁹⁸ Both reports are transmitted by Ibn Abī Najīh who is quoted by 'Isā in one and by Shibl in the other.¹⁹⁹ Mujāhid takes the pronoun in the word kānat as referring to the matter of changing (taḥwīlah or tawliyah) of the qiblah from Jerusalem to Mecca.²⁰⁰ This interpretation is found in Ādam b. Abī Iyyās's version of Warqā's recension on the authority of Ibn Abī Najīh in a further elaborated version. In that version Mujāhid maintains that when the direction of the prayer had been altered from Jerusalem to the Ka'bah, the men have been given the place of women and the women the place of men as far as the position of each sex in the prayer in the Mosque is concerned.²⁰¹ As it is well known that the feminine form taḥwīlah must refer to a specific example, whereas the ordinary form taḥwīl refers to the general idea of changing or turning. So Mujāhid interprets the part of the verse wa-mā ja'alnā al-qiblata allatī kunta 'alayhā illā li-na'lama man yattabi'u al-rasūla mimman yanqalibu 'alā 'aqibayh wa-in kānat la-kabīratan illā 'alā alladhīna hadā Allāh as meaning that God addresses His Messenger telling him that the turning of the qiblah from Jerusalem to Mecca is due to a certain reason, namely to distinguish between the true believers who accept all commands of God and those who turn back upon their heels. Indeed, having spent that length of time praying towards Jerusalem, Muslims, except those whom God guided, found it difficult to turn to a new direction.²⁰² It might be further cited that this interpretation of Mujāhid is

198. Ibid, p. 163.

199. Ibid, p. 163.

200. Mujāhid, Tafsīr, vol.1, p.91.

-Ṭabarī, Tafsīr, vol.3, p.164.

201. Mujāhid, Tafsīr, vol.1, p.91.

202. Ṭabarī, Tafsīr, vol.3, p.165.

also adopted by his teacher Ibn 'Abbās as well as by Qatādah.²⁰³ It is also supported by the Kufan grammarians.²⁰⁴

The second view, which is held by Abū al-'Āliyah al-Rayāhī, suggests that the pronoun in the word kānat in the verse under discussion refers to the direction of the prayer towards Jerusalem itself (qiblat bayt al-maqdis) before the Prophet is ordered to change from it.²⁰⁵ The third view, which is adhered to by Ibn Zayd, maintains that the pronoun in the word kānat refers to the prayer (ṣalāh) which the believers used to perform towards the first qiblah (of Jerusalem).²⁰⁶ Perhaps in this respect Ibn Zayd supports his view by verse 2 : 45. This verse says: "Nay, seek (God's) help with patient perseverance and prayer: it is indeed hard, except to those who bring a lowly spirit (wa-ista'inū bi-al-ṣabri wa-al-ṣalāti wa-inna-hā la-kabīratun illā 'alā alladhīna hadā Allāhu)". In this latter verse it is clear that the pronoun hā in the word inna-hā refers to the prayer (ṣalāh).²⁰⁷

Commenting on the three aforementioned views, al-Ṭabarī prefers the view of Mujāhid that the pronoun in the word kānat refers to the changing of the qiblah.²⁰⁸ As a basis for his preference, al-Ṭabarī says that the matter which becomes hard for some of the believers is the changing of the qiblah from Jerusalem to Mecca.²⁰⁹

203. Ibid, p.164.

204. Ibid, p.165.

205. Ibid, p.164.

206. Ibid, p.165.

207. Ibid, vol.2, p.15.

208. Ibid, vol.3, p.165.

209. Ibid, p.165.

In rejecting the other two views, al-Ṭabarī argues that the matter which burdens those believers is not the qiblah itself, nor the prayer, because they used to perform their prayers facing the first qiblah (Jerusalem) without any complaint.²¹⁰ Al-Ṭabarī further adds that the only way to accept that the pronoun in the word kānat as referring to the qiblah is to assume that mention of the qiblah actually indicates the changing of the qiblah because the context of the verse indicates that meaning.²¹¹

However, according to the commentators al-Zamakhsharī,²¹² Fakhr al-Dīn al-Rāzī,²¹³ al-Qurṭubī²¹⁴ and al-Bayḍāwī,²¹⁵ the pronoun in the word kānat in the verse under discussion refers to one of two things. Either it indicates the changing of the qiblah or it might point to the qiblah itself. Like al-Ṭabarī, al-Rāzī favours the view which takes the pronoun as referring to the changing of the qiblah.²¹⁶

The evidence presented by al-Ṭabarī shows Mujāhid's interpretation, which is also in Ādam b. Abī Iyyās's version of Warqā's recension, is the one held by the Meccan school since it is also attributed to both Ibn 'Abbās and Qatādah.

210- Ibid, p.165.

211- Ibid, p.165.

212- Zamakhsharī, Kashshāf, vol.1, p.200.

213- Rāzī, Mafātīḥ, vol.1, pp.11-2.

214- Qurṭubī, Tafsīr, vol.2, p.157.

215- Bayḍāwī, Anwār, vol.1, p.196.

216- Rāzī, Mafātīḥ, vol.1, p.12.

B. The significance of the preposition min in the phrase: wa-aj'al afi'datan min al-nāsi tahwī ilayhim in verse 14:37 :

The Qur'ān says: "O our Lord ! I have made some of my offspring to dwell in a valley without cultivation, by thy Sacred House, in order O our Lord that they may establish regular prayer: so fill the hearts of some among men with love towards them and feed them with fruits, so that they may give thanks (rabbanā innanī askantu min dhurriyyatī bi-wādin ḡhayri dhī zar'in 'inda baytika al-muḥarram rabbanā li-yuqīmū al-ṣalāta wa-aj'al afi'datan min al-nāsi tahwī ilayhim)". (14 : 37).

This verse is actually the prayer (du'ā') said by the Prophet Abraham when he left his child Ishmael with his mother Hagar alone in an infertile valley near the Sacred House in Mecca. In this verse we are concerned with the phrase fa-aj'al afi'datan min al-nās tahwī ilayhim . Two interpretations have been put forward for this phrase, one of which is attributed to Mujāhid. Al-Ṭabarī gives Mujāhid's view in three reports.²¹⁷ The transmitter of all these reports is Manṣūr who is quoted by Jarīr in two of them and by Sufyān in the third one.²¹⁸ However, this view of Mujāhid is not mentioned in Ādam b. Abī Iyyās's version of Warqā's recension. Nor is it reported by al-Ṭabarī from the recensions of Shibl, 'Īsā and Warqā'. According to Manṣūr, Mujāhid interprets the Qur'ānic phrase under discussion (fa-aj'al afi'datan min al-nās tahwī

217. Ṭabarī, Tafsīr, vol.13, pp.233-4.

218. Ibid, pp.233-4.

ilayhim) as meaning that Abraham asked God to make the hearts of some people of his creatures yearn to go to this place and join his offspring there. The prayer of Abraham, as Mujāhid understands it, indicates a supplication that God may grant some people the chance to perform pilgrimage to the Holy House in Mecca, and therefore accompany his family there.²¹⁹

In his detailed treatment of this Qur'ānic verse, Mujāhid observes a rhetorical remark that the verse says: "fa-aj'al afi'datan min al-nās" and it does not say "afi'dat al-nās". This is because, as Mujāhid argues, had the Qur'ān here used "afi'dat al-nās", then the Persians, the Romans,²²⁰ the Turks, the Hindus, the Jews, the Christians and the Magians²²¹ would have crowded into the Sacred House. In other words, Mujāhid emphasises the importance of the occurrence of the preposition min here as a partitive (tab'īd) that it is only the Muslims who hoped to come to Mecca.²²² The view of Mujāhid is the one adopted by Ibn 'Abbās (as one of his two opinions), Sa'īd b. Jubayr, 'Ikrimah, 'Atā' b. Abī Rabāh, Tāwūs and Qatādah.²²³

The other interpretation suggested for the phrase under discussion, which is also attributed to Ibn 'Abbās, says that Abraham

219. Ṭabarī, Tafsīr, vol.13, p.233.

220. Ibid, pp.233-4.

221. Qurṭubī, Tafsīr, vol.9, p.373.

- Ibn Kathīr, Tafsīr, vol.2, p.541.

- Rāzī, Mafātīh, vol.5, p.246.

222. Rāzī, Mafātīh, vol.5, p.246. Al-Zamakhsharī further adds that the preposition min in the Arabic language might also refer to the ibtidā'. As an example he says: al-qalb minnī salīm meaning qalbī salīm. Applying this method to the phrase under discussion, he maintains that the Qur'ān means afi'datu nās. The word nās is rendered indefinite (nakirah), because in the verse the prior word (afi'idah) is indefinite in order to refer to some hearts. [Zamakhsharī, Kashshāf, vol.2, p.559].

223. Ṭabarī, Tafsīr, vol.13, pp.233-4.

asked God to render some people to become eager to inhabit Mecca, i.e., just for the purpose of habitation and nothing else.²²⁴

It is noticeable that the interpretation attributed to Mujāhid is also held by his colleagues in the Meccan school. Thus the alternative view attributed to Ibn 'Abbās seems anomalous. The interpretation of the Meccan school including Ibn 'Abbās, is the one which prevailed among the majority of the exegetes. The significance of the mentioning of the preposition min in the verse under discussion which is observed by Mujāhid, is a very interesting rhetorical remark.

224. Ibid, p.234.

CONCLUSION

In reviewing the subjects discussed in the course of this thesis, it is necessary to take a detailed look at the isnāds in order to be able, if possible, to examine whether any of these may be anomalous. A cursory glance at the isnāds which have been discussed indicates that Ibn Abī Najīḥ is by far the most important authority for Mujāhid's views. Al-Ṭabarī reports these from the recensions of Shibl, 'Īsā and Warqā'. Occasionally, Ibn Abī Najīḥ is cited by other authorities. In Ādam b. Abī Iyyās's recension of Mujāhid's Tafsīr, Ibn Abī Najīḥ is the principal transmitter and Warqā's recension is the basis of the transmission of the whole.

In Chapter One where the definition of muḥkamāt in verse 11 : 1 was discussed, al-Ṭabarī cites similar definitions from Ibn Abī Najīḥ from the recensions of 'Īsā, Shibl and Warqā'. A similar report is also cited from Mujāhid on the authority of Ibn Jurayj. The fact that this is missing from Ādam b. Abī Iyyās's version of Warqā's transmission must raise question marks against the completeness of that version. In the definition ḥakīm in verse 10 : 1 there is no transmission from Warqā, 'Īsā, Shibl or Ibn Jurayj. Only Sufyān quotes Mujāhid. Clearly, this definition was not in the Tafsīr of Mujāhid as reported by Ibn Abī Najīḥ. There is unanimity between the recension of 'Īsā, Shibl and Warqā' (from Ādam b. Abī Iyyās's transmission) on the meaning of muḥkamāt in verse 3 : 7; all of them reporting from Ibn Abī Najīḥ. In the case of the meaning of mutashābihāt, we have another indication

of the probable incompleteness of Ādam b. Abī Iyyās's version when al-Ṭabarī quotes from Warqā's recension from Ibn Abī Najīḥ on verse 39 : 23 but it is missing from Ādam b. Abī Iyyās's recension. However, when giving the meaning of mutashābihāt in verse 3 : 7, the recensions of 'Īsā, Shibl and Warqā' from Ibn Abī Najīḥ are in agreement as given by al-Ṭabarī and Ādam b. Abī Iyyās. There is similar agreement in the two texts using the same authorities on the critical matter of the punctuation of verse 3 : 7.

Thus it is safe to conclude that Mujāhid's understanding of the role of the mufassir and therefore of himself was that those who are " rooted in knowledge " were able to interpret the mutashābihāt. This is a view which was also attributed to his teacher, Ibn 'Abbās. However, in Mujāhid's case, he may have extended it to giving more rationalistic interpretations of certain matters in the Qur'ān.

In our study of the disconnected letters in Chapter Two, it was surprising to find absolutely no evidence in Ādam b. Abī Iyyās's recension of any attempt by Mujāhid to explain these letters. Whereas in al-Ṭabarī, there are three slightly different interpretations attributed to Mujāhid. Only one of these is reported from one of the three key recensions of Ibn Abī Najīḥ transmission, i.e., Shibl, 'Īsā and Warqā'. In this case, it is from Shibl's recension. The other authorities are Sufyān, Ibn Jurayj and Khuṣayf. In one case, Sufyān is quoting Ibn Abī Najīḥ. If Mujāhid did genuinely present these different

interpretations, we are left to wonder why they are not more numerous quoted by al-Ṭabarī from Shibl, Warqā' and 'Isā. Clearly, Ibn Abī Najīḥ is not an important source for these or they have been deliberately omitted by the three narrators. Alternatively later transmitters of the three recensions may be responsible for the omission.

On the critical theological issue discussed in Chapter Three, on whether God can be seen in the Hereafter, there is no report from the recensions of Shibl, 'Isā and Warqā' in either al-Ṭabarī or Ādam b. Abī Iyyās's recension on verse 75 : 23. However, al-Ṭabarī does quote eight reports from Mujāhid which clearly indicate that he thought that God could not be seen in the Hereafter. These reports are transmitted by Sufyān, al-A'mash, Jarīr and 'Amr b. 'Ubayd. The principal transmitter of this view attributed to Mujāhid is Manṣūr, but there is also one from Thuwayr. Ibn Abī Najīḥ is not once cited as a transmitter. The fact that Ibn Abī Najīḥ was claimed to be a Mu'tazilite makes this omission curious. Clearly, either Ibn Abī Najīḥ never knew this interpretation of Mujāhid or Shibl, 'Isā and Warqā' so disliked it, that they deliberately omitted it. However, on what seems at first sight a less controversial interpretation, that the interpretation of 10 : 26, where the word ziyādah is interpreted by most orthodox commentators as referring to seeing of God in the Hereafter, we have an interpretation in Shibl's recension from Ibn Abī Najīḥ in al-Ṭabarī and also in Ādam b. Abī Iyyās's version of Warqā's recension from Ibn Abī Najīḥ that ziyādah means the pleasure and forgiveness bestowed by God on the

believers on the Day of Judgment. Thus if there has been any deliberate omission, this verse escaped their notice.

As pointed out earlier, if Mujāhid did not believe in the possibility of seeing God in the Hereafter, he could not have believed that maqām mahmūd, mentioned in verse 17 : 79 in Chapter Four, meant that the Prophet will be seated beside God in the Hereafter. This is confirmed by reports both in al-Ṭabarī and Ādam b. Abī Iyyās's version where both cite Warqā's recension on the authority of Ibn Abī Najīḥ that maqām mahmūd meant the intercession of the Prophet in the Hereafter. This is also confirmed by Ibn Jurayj's report from Mujāhid in al-Ṭabarī. Therefore, it seems necessary to regard Layth's report that the words meant that the Prophet would sit beside God in the Hereafter as highly suspicious.

If the apparent rationalistic tendency in Mujāhid's Tafsīr is correct, it would have been expected that Mujāhid would have interpreted the physical descriptions of God metaphorically. It has only been possible to find one reference on verse 5 : 64 to such a metaphorical interpretation. This is reported by al-Ṭabarī from the recensions of Shibl and 'Īsā on the authority of Ibn Abī Najīḥ. It is also reported in Ādam's version of Warqā's recension. However, this cannot be regarded as conclusive because most exegetes interpret this verse metaphorically.

The recensions of 'Īsā and Shibl both citing Ibn Abī Najīḥ and the version of Ādam b. Abī Iyyās of Warqā's recension on

the authority of Ibn Abī Najīh in Chapter Five all confirm that Mujāhid held the unique interpretation that the metamorphosis of the Sabbatarians was metaphorical and not physical. This interpretation fits in well with the rationalistic tendency that may be discernible in Mujāhid's Tafsīr, even though it was not taken up by the rationalist Mu'tazilites.

However, it is to be noted that when discussing God sealing the hearts of the unbelievers, Mujāhid adopts a more literalist approach. This view of Mujāhid is substantiated by a wide range of authorities including al-A'mash, Ibn Jurayj, 'Īsā's recension on the authority of Ibn Abī Najīh, and Sufyān on the authority of Manṣūr. Nonetheless Mujāhid's interpretation does seem to allow the possibility of rationalistic understanding of men having free-will.

In the fiqh issue of the meaning of fāhishah in verses 4:15-16, in Chapter Six, we are faced with a real problem of testing the isnāds. On the one hand, al-Ṭabarī quotes the recension of Warqā' on the authority of Ibn Abī Najīh together with Abū 'Āṣim's transmission from Ibn Abī Najīh and Ibn Jurayj's and Khuṣayf's transmissions from Mujāhid that the latter maintained the normal view that fāhishah meant zinā. This is also confirmed in Ādam b. Abī Iyyās's version of Warqā's recension. On the other hand, al-Ṭabarī also gives 'Īsā's recension on the authority of Ibn Abī Najīh and a transmission of Ibn Jurayj that fāhishah meant lesbianism and sodomy. It is impossible to conclude which of these narrations are correct. The most likely explanation is that

Mujāhid held first one view and then changed his mind. However, it is difficult to decide which was his final view.

There is no mention of Shibl, 'Īsā or Warqā's recensions reporting from Ibn Abī Najīḥ either in al-Ṭabarī or in Ādam b. Abī Iyyās's version that Mujāhid believed that the phrase wa-lā ta'khudhukum bi-himā ra'fatun fī dīn Allāh, in verse 24 : 2 discussed also in chapter six, meant that the ḥadd punishment should be carried out. However, Sufyān al-Thawrī reports on the authority of Ibn Abī Najīḥ, and Ibn Jurayj also cites Mujāhid as saying that this was the case. Despite this somewhat surprising omission in the three important recensions, there seems no reason to doubt that Mujāhid held this view since Ibn Jurayj seems to be a fairly reliable transmitter of Mujāhid's views and Sufyān al-Thawrī cites Ibn Abī Najīḥ as his authority for Mujāhid's view.

The other point of discussion in this verse 24 : 2, concerning the minimum number that constitutes a tā'ifah is again not reported in the three important recensions of Shibl, 'Īsā and Warqā' either by al-Ṭabarī or in Ādam b. Abī Iyyās's recension. However, we do have reports of Mujāhid on the authority of Ibn Abī Najīḥ from Sufyān al-Thawrī and Ibn 'Aliyyah maintaining that tā'ifah meant a minimum of one. Also there is another authority for Mujāhid's view.

In Chapter Seven on the problem of the interpretation of the meaning of qur', we find that Mujāhid's view is that it means

menstruation is reported in al-Ṭabarī from 'Īsā's recension and in Ādam b. Abī Iyyās's version of Warqā's recension, both citing Ibn Abī Najīh. Mujāhid's view here accords with Ibn 'Abbās and also is the one adopted by Abū Ḥanīfah.

On the matter of the 'iddah of the widow and the view which only seems to be held by the Meccan scholars, Ibn 'Abbās, 'Aṭā' and Mujāhid that verse 2 : 240 extends the period of the four months and ten days to an optional year as the result of her husband's waṣiyyah which is later abrogated by the verse of inheritance, 4 : 12, there is clear evidence in al-Ṭabarī from the recensions of Shibl and 'Īsā on the authority of Ibn Abī Najīh. Surprisingly, Ādam b. Abī Iyyās's version of Warqā's recension is silent about the extension of the 'iddah and only comments on the verse of inheritance abrogating the waṣiyyah. In this way, this version of Warqā's recension makes it appear as if Mujāhid interpreted the verse in exactly the same way as most of the other commentators although no actual interpretations are given for 2 : 234 and 2 : 240. We have no evidence apart from Ibn Kathīr as to Mujāhid's view of the 'iddah of the umm walad being the same as a free widow. Despite the absence of any reports on this subject, it is not inconceivable that Mujāhid could have held this view.

In Chapter Eight, although there is fairly late evidence in support of Mujāhid's reading kadhabū instead of kudhibū in verse 12 : 110, al-Ṭabarī only provides two tradition from Ibn Jurayj on this matter. Whereas he provides traditions from the recensions

of Warqā' and 'Īsā on the authority of Ibn Abī Najīh for the reading kudhibū. This is also supported by Ādam b. Abī Iyyās's version of Warqā's recension. The evidence would therefore tend to question Ibn Jurayj's report of Mujāhid's reading.

On the question whether the phrase "and wash your feet" in verse 5 : 6 should be read arjulakum or arjulikum, al-Ṭabarī presents no evidence from the recensions of 'Īsā, Shibl and Warqā'. Nor is there any mention of this in Ādam b. Abī Iyyās's version of Warqā's recension. We are left therefore with single traditions from Mujāhid for each reading on the authority of transmitters who are not closely associated with Mujāhid's Tafsīr. However, it seems certain that Mujāhid must have had a view on this subject. Perhaps, he changed his mind several times as the matter seems to have been fairly open for discussion in the early period. It may be for this reason that it has been omitted from the three important recensions.

As for the meaning of rā'inā in verse 2 : 104 and verse 4 : 46 although there is one report of Mujāhid interpreting it in the orthodox manner from the recension of 'Īsā, there is far more evidence for him holding a unique interpretation that rā'inā means disagreement. This is reported not only from the recension of 'Īsā but also from Shibl's and it is included in Ādam b. Abī Iyyās's version of Warqā's recension as well as being reported by Sufyān. It seems appropriate to conclude that the balance of

evidence favours this latter interpretation even though it came to be rejected by all the other exegetes.

In the same Qur'ānic verses, Mujāhid is again attributed with two interpretations of the reading unzurnā, a reading which is regarded as the most acceptable by the vast majority of Qur'ānic scholars. Although both Mujāhid's interpretations of the meaning of this word are rejected by al-Ṭabarī, it is clear from the evidence of the isnāds that Mujāhid's first interpretation was his, while the second is anomalous. The first is reported by al-Ṭabarī from the recensions of 'Īsā and Shibl on the authority of Ibn Abī Najīḥ and it is also reported on the authority of Ibn Jurayj. It is also reported in Ādam b. Abī Iyyās's version of Warqā's recension on the authority of Ibn Abī Najīḥ. Whereas the second interpretation is only reported by Jābir, a very infrequent transmitter of Mujāhid's views.

Although Mujāhid seems to have attributed with three different interpretations on the word hūr in the Qur'ān, it has been demonstrated that the first two may well be only parts of the third interpretation. In this interpretation which is reported by al-Ṭabarī from Warqā's recension on the authority of Ibn Abī Najīḥ and also from Sufyān in addition to being in Ādam b. Abī Iyyās's version of Warqā's recension. In this Mujāhid maintains that hūr are those women who cause the eyesight to be amazed as a result of the outline of their legs which can be seen through their garments, and whose colour is so pure and whose skin is so delicate that the one viewing them can almost

see his own reflection in their bodies. Although this is an unusual and probably incorrect derivation of the word hūr from hāra, it nevertheless incorporates the meanings adopted by other exegetes.

In his interpretation of verse 2 : 143 on the changing of the qiblah, Mujāhid's view is reported by al-Ṭabarī from the recension of Shibl and 'Īsā on the authority of Ibn Abī Najīḥ. It is also reported in Ādam b. Abī Iyyās's version of Warqā's recension on the authority of Ibn Abī Najīḥ. By making the pronoun of kānat refers to tawliyah, Mujāhid is adopting the preferred interpretation of the Meccan school and of al-Ṭabarī.

Although Mujāhid's interpretation of min in verse 14 : 37 as referring to only a part of the people is not reported from the recensions of 'Īsā, Shibl and Warqā', and only has Manṣūr as its authority, it conforms with the standard view of the Meccan school. Again Sufyān is one of the authorities for Manṣūr's report and it seems reasonable to accept this view as Mujāhid's despite it not being reported from the three important recensions.

* * *

some major points can be drawn as a general conclusion to this study. It seems clear that in the recensions of 'Īsā, Shibl and Warqā', we have important sources for one of the earliest commentators of the Qur'ān. It also seems reasonable to assume that Sufyān al-Thawrī reports from Manṣūr also give a version of

Mujāhid's Tafsīr even though it is difficult to give a satisfactory explanation of their omission, if they were really omitted from the recensions of Shibl, 'Īsā and Warqā'.

As has been discussed, Mujāhid used ijtihād in tafsīr when tackling certain Qur'ānic verses. Perhaps his statement that the best worship of God is the exercising of a sound opinion together with his declaration that he was one of al-rāsikhūn fī al-'ilm form the first and foremost basis upon which Mujāhid builds his exegetical views in which he disagrees with the other exegetes. Mujāhid's teacher, Ibn 'Abbās, is also attributed with the same declaration that he is one of al-rāsikhīn fī al-'ilm. However, as the previous chapters show, when Mujāhid is sometimes attributed with an unusual interpretation, Ibn 'Abbās does not always share that interpretation with his disciple. In addition, Mujāhid's high linguistic abilities and his knowledge of the different readings (qirā'āt) are factors whose effect, especially in the linguistic interpretations, cannot be denied. Furthermore, as has been mentioned earlier, Mujāhid settled in Kufa for a considerable period of time to the extent that he was regarded as one of its inhabitants. Kūfa came to be associated with the use of reason both in law and in tafsīr. This may have had some influence on Mujāhid's approach to Qur'ānic exegesis.

Sometimes, Mujāhid puts forward rational interpretations which are adopted by later theologians, namely the Mu'tazilites and the Shi'ites. As we have seen in the dogma of whether God can or cannot be seen in the Hereafter, both the Mu'tazilites and the Shi'ites hold a view similar to that of Mujāhid. Also, as regards

the issue of whether the feet are to be washed or rubbed in the ablution, as discussed in the linguistic chapter, the Shi'ites view conforms with one of the readings attributed to Mujāhid. However, as has been fully discussed, there is no proof that Mujāhid's views affects the teachings of those groups. It seems that those later theologians seized the golden opportunity and tried to support their views by referring to early famous exegetes, like Mujāhid, as holding similar interpretations as theirs'. The fact that there is no linkage between the views of Mujāhid and those of the Mu'tazilites and the Shi'ites can be seen in the position of each side as regards the issue of the metamorphosis of the Sabbatarians. As has been discussed earlier, the Mu'tazilites, the Shi'ites and the majority of the exegetes and Muslim scholars take the literal sense of the verses when treating that issue, while Mujāhid alone rules out the literal sense and opts for a metaphorical interpretation. This particular issue reflects quite clearly that Mujāhid has his own way of thinking which differs even from the Sunnites. There is also no evidence for the claim of the Kharijites that Mujāhid belongs to them other than his declaration that al-Ḥajjāj was a kāfir.

On some Qur'ānic verses, Mujāhid is attributed with more than one interpretation. On some of these occasions, especially when the transmitter of Mujāhid's views is a regular one, there is a high possibility that Mujāhid actually holds all the views attributed to him. As examples of that we can refer to his two interpretations of faḥishah in verses 4 : 15-16, and to his three interpretations as regards al-ḥurūf al-muqatta'ah . In these two

examples, the closest justification for him in holding more than one interpretation is that he perhaps sees that the verses are accessible to all interpretations. The other justification for Mujāhid in holding more than one interpretation, which is less possible in these two cases and which might apply to others, is that he may have adopted one of the views earlier and then later he abandoned it and held another one. In fact this phenomena of holding two different views, prevails among both the Ṣahābah and Tābi'ūn.¹

On other occasion, when Mujāhid is attributed with more than one view, one or more might have been associated with him without any evidence that it or they are actually his. An example of this can be his interpretation of maqām mahmūd, which is dealt with in verse 17 : 79. On this verse, as has been explained, Mujāhid is attributed with two interpretations. One of them conforms with the view of the majority of the exegetes that when he takes maqām mahmūd as referring to the intercession of the Prophet on the Last Day. In the second it is claimed that he construes it as referring to the seating of the Prophet with His Lord in the Hereafter. We demonstrated that it is highly unlikely that this interpretation is Mujāhid's. This is because, if it is actually his, it would contradict his well known interpretation of verses 75 : 22-23 in which he maintains that God cannot be seen in the Hereafter. Perhaps, this attitude of attributing some views to Mujāhid when he actually has not said them, is due to the fact since Mujāhid is well known as having sometimes exercised rational

¹- See, Muḥammed Ḥusayn al-Dhahabī, al-Tafsīr wa-al-Mufasssīrūn, vol. 1, p.250 f.

interpretation, therefore some scholars assume that every unusual view might have been held by Mujāhid.

It should also be noted that although Mujāhid's second interpretation of verses 4 : 15-16, when he maintains that the former verse (4 : 15) indicates lesbianism and the latter (4 : 16) refers to sodomy, has not been held by any of the Sahābah or Tābi'ūn , it looks sound and reasonable. In fact in this particular respect, Mujāhid is regarded as a pioneer because he is the first ever exegete to suggest that the crimes of lesbianism and sodomy have been dealt with in the Qur'ānic text. Despite the fact that al-Sūrtī, the editor of Tafsīr Mujāhid, refers to the uniqueness of this view of Mujāhid, he makes a general statement that it is rarely that Mujāhid speaks concerning juristic problems. It seems that al-Sūrtī's statement is inaccurate, because in addition to Mujāhid's distinguished contribution as regards verses 4 : 15-16 and his involvement in the interpretation of the few verses discussed in respect of different kinds of 'iddah , he also puts forward juristic rulings as regards other Qur'ānic verses which have not been dealt with in this thesis as they are now interpretations which are generally accepted by all Muslims.

The statement of Mujāhid that whoever is unskillful in the Arabic language must not be allowed to interpret the Qur'ān implies that he masters the Arabic language. To prove this fact, we investigated his treatment of some linguistic aspects. In the field of qirā'āt , for instance, in verse 12 : 110, we found that in addition to the reading kudhibū in which he agrees with the majority of the exegetes, he is alone, according to most of the commentators,

attributed with the reading kadhabū for which he offers a reasonable interpretation. He is also attributed with two readings as regards verse 5 : 6. Another feature which can be deduced from the linguistic approach of Mujāhid, is that he is able to suggest more than one interpretation for a single Qur'ānic word. However, sometimes some of his interpretations are opposed by the commentators on linguistic grounds, as we have seen in one of his interpretations regarding the word rā'inā and his both interpretations concerning the word unzurnā, mentioned in verses 2 : 104 and 4 : 46. His third interpretation of the word hūr is also rejected as it is contradicting the Arabic language.

From the examination that has been made of the Tafsīr of Mujāhid, a picture has emerged of an early commentator who has made a considerable contribution to Qur'ānic exegesis. His views reflect his association with Ibn 'Abbās and the Meccan school as well as his own rationalistic tendency, perhaps influenced by his stay in Kufa. He is an important exegete among the Tābi'ūn.

THE ASĀNĪD USED IN
ĀDAM IBN ABĪ IYYĀS'S
VERSION OF WARQĀ'S
RECENSION
OF THE TAFSĪR OF
MUJĀHĪD

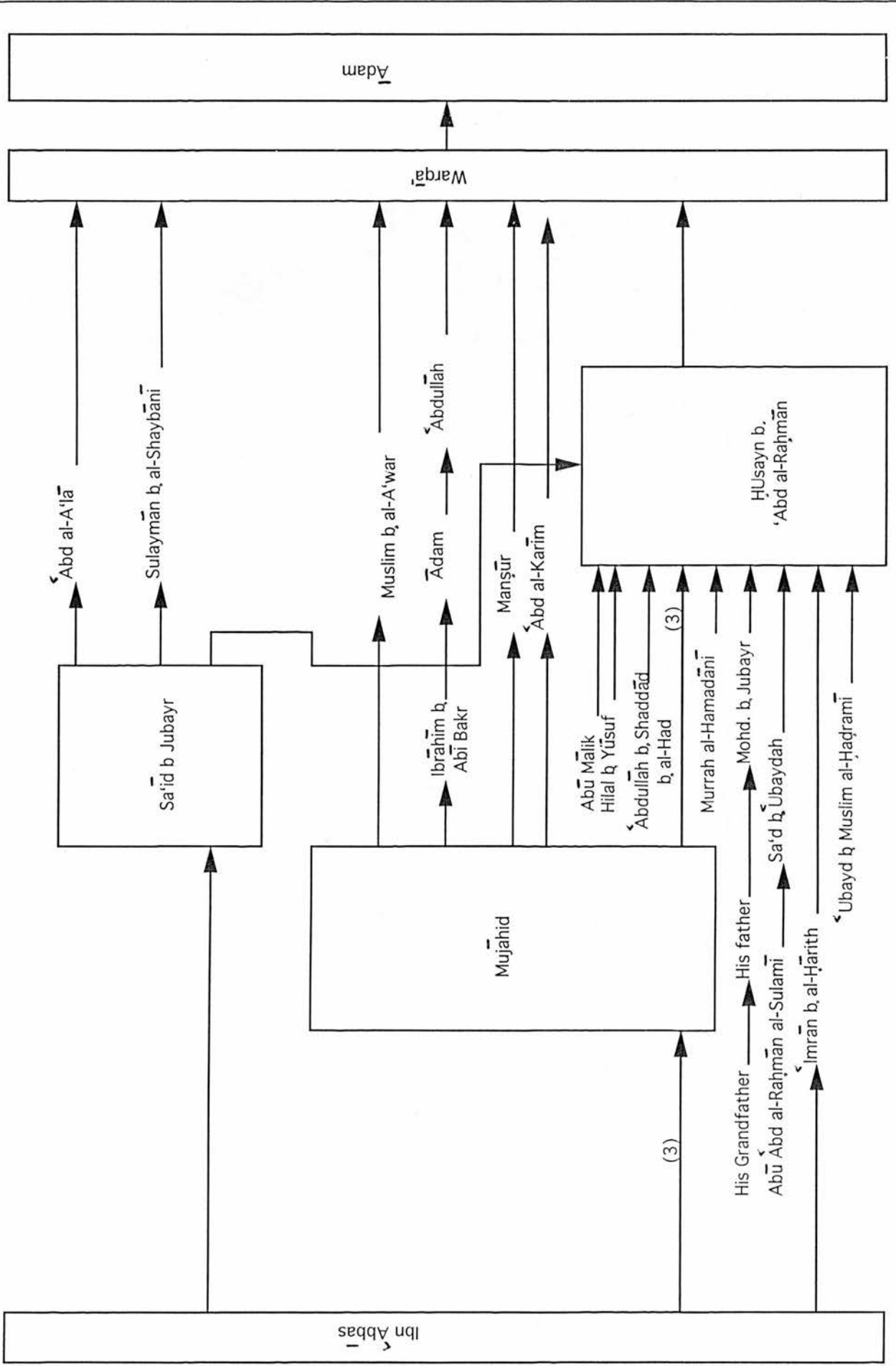

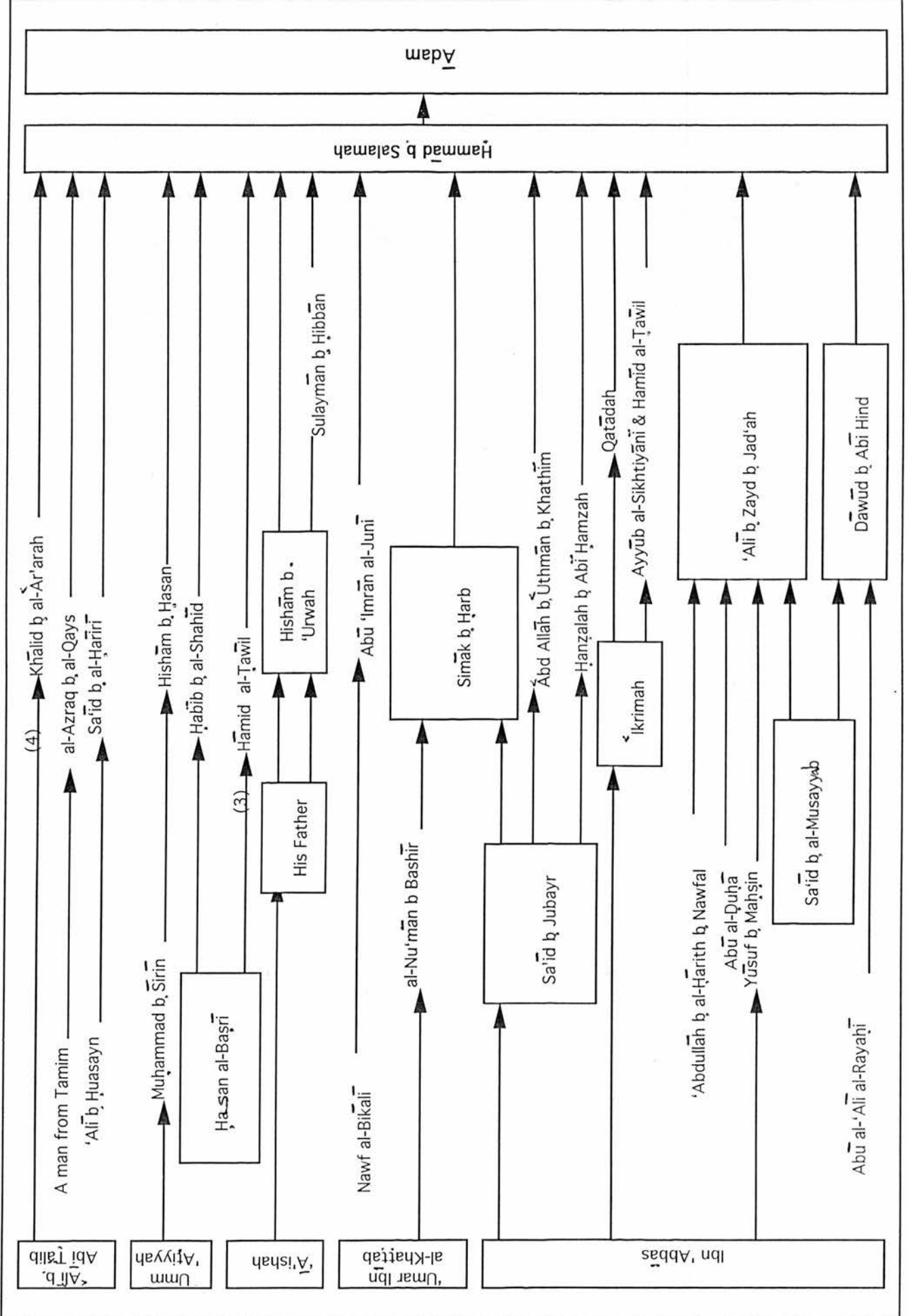

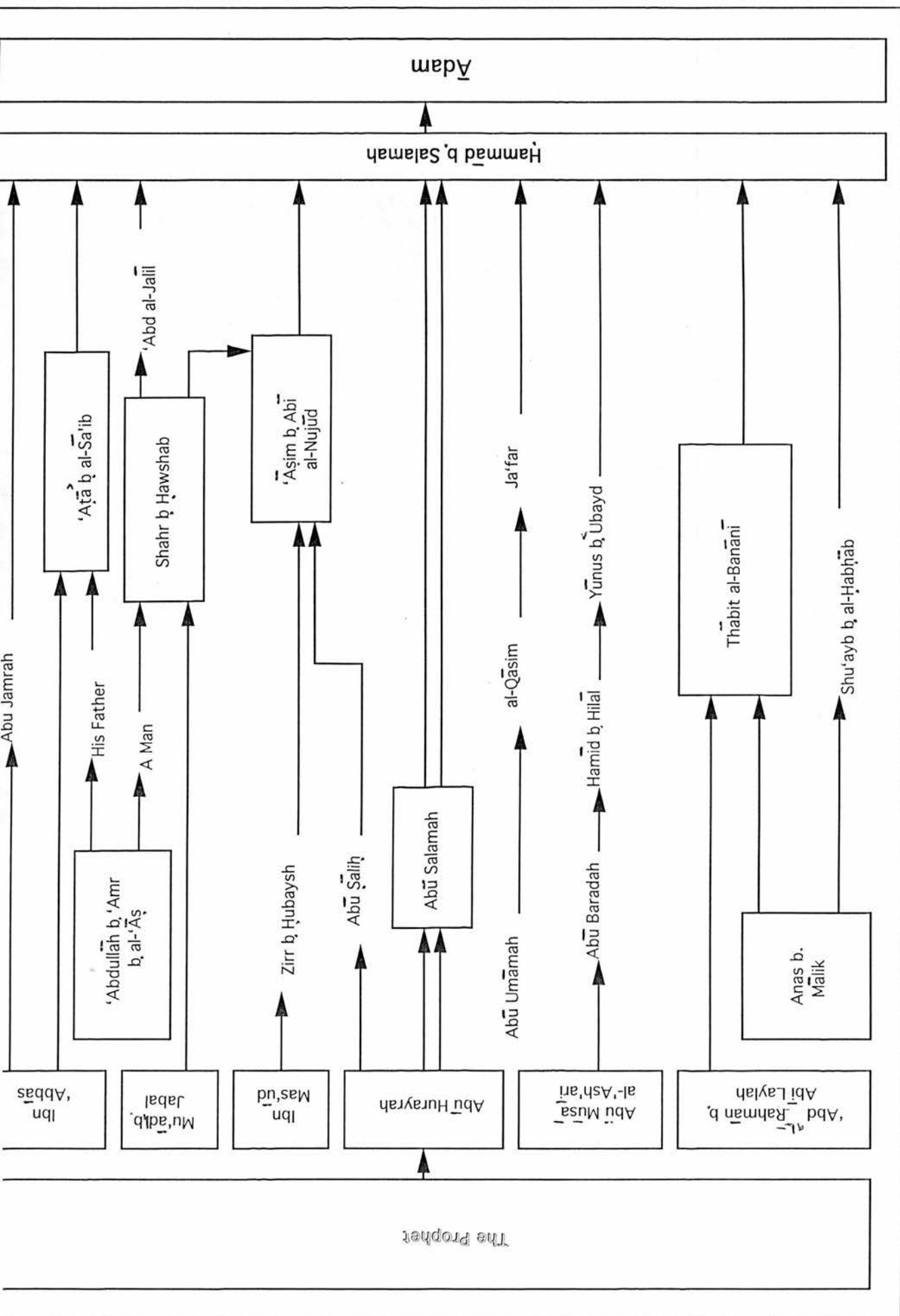

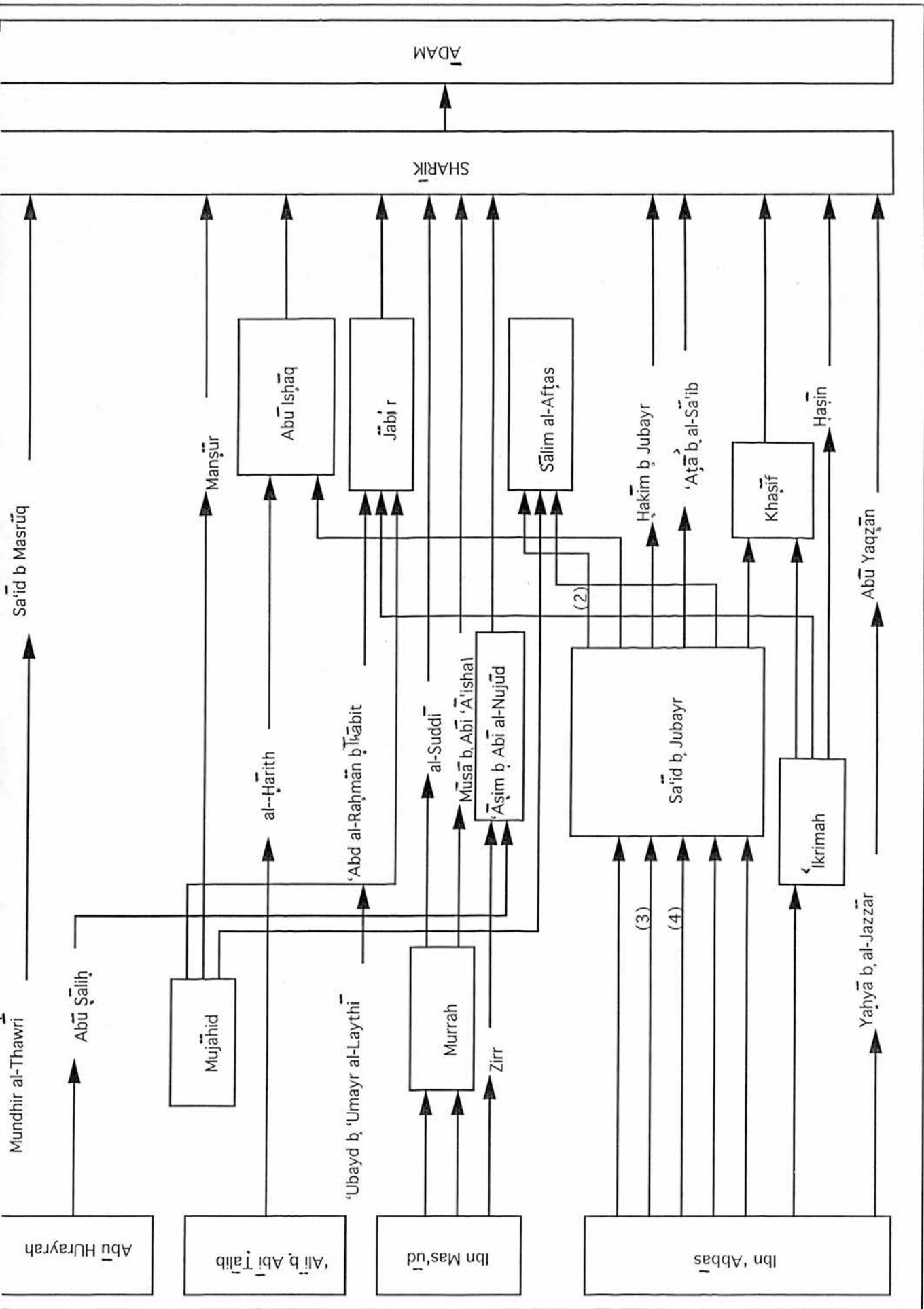

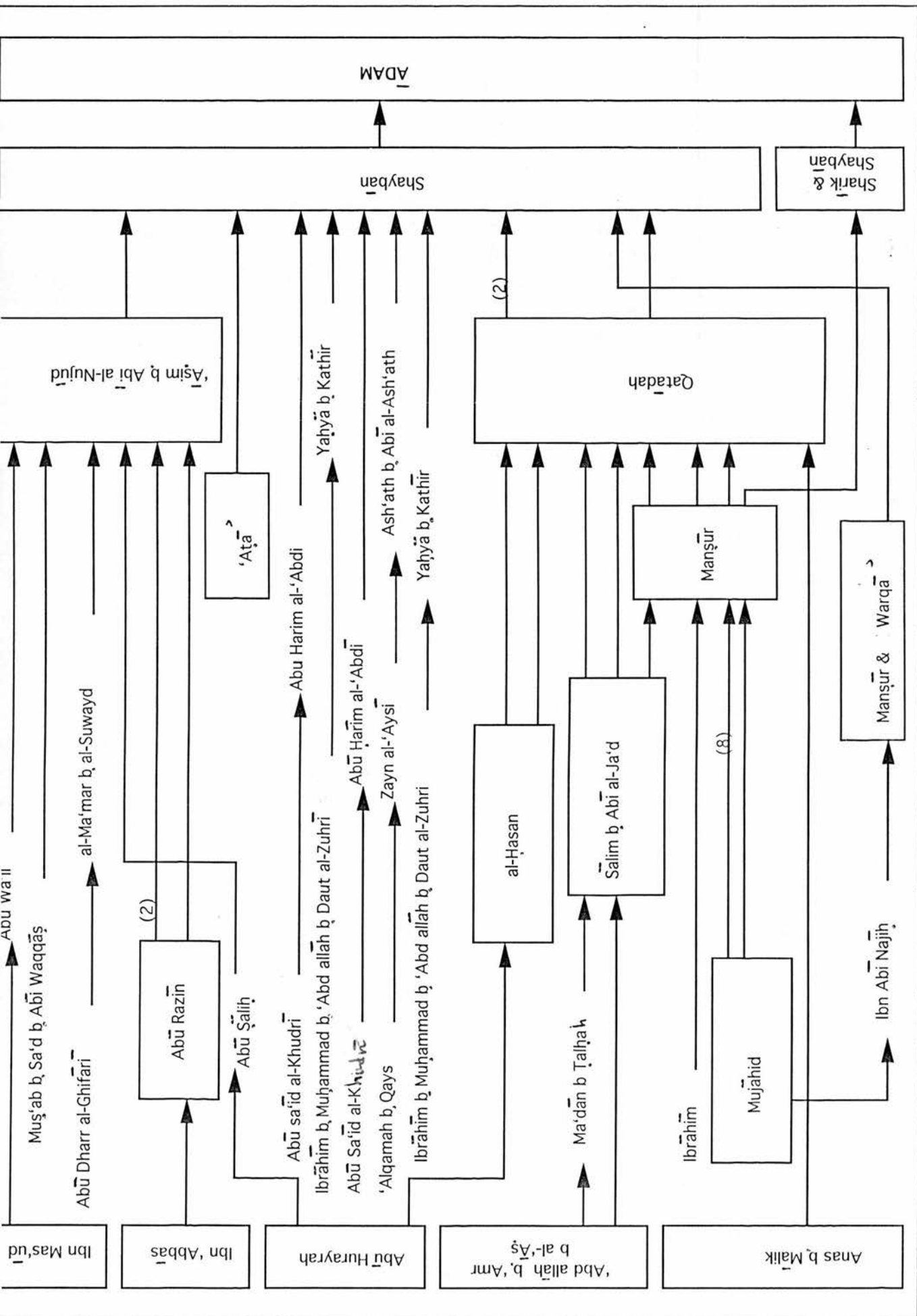

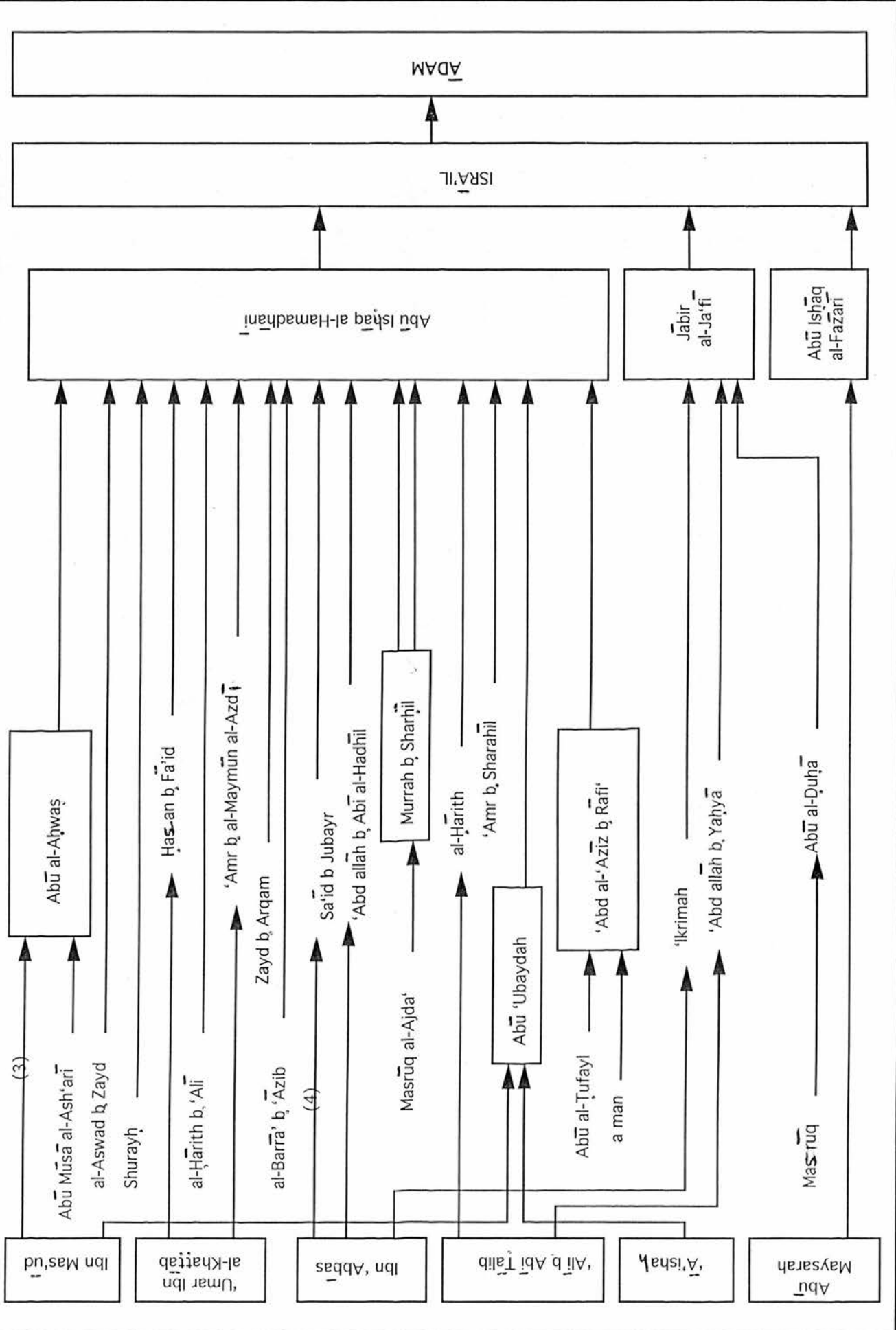

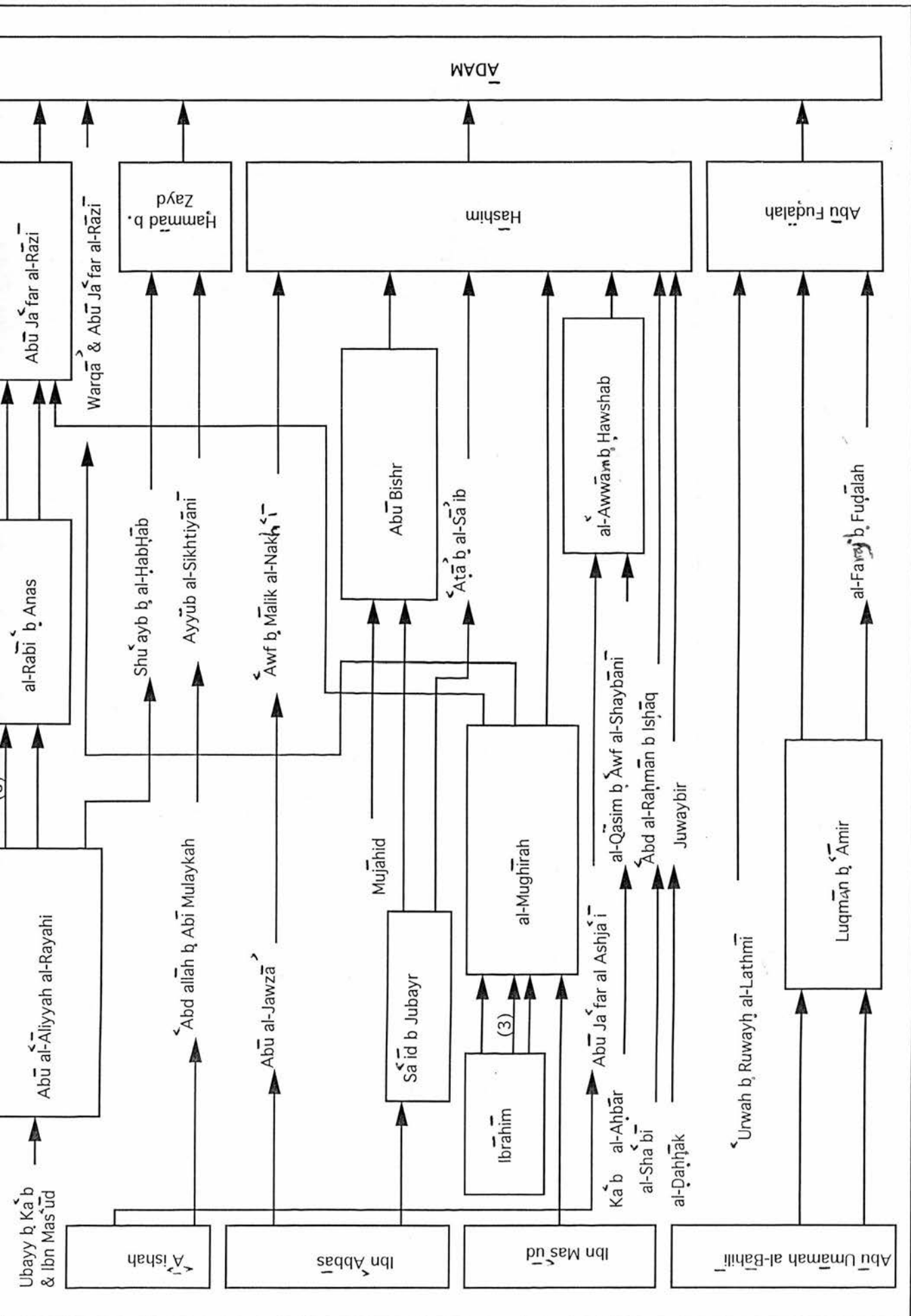

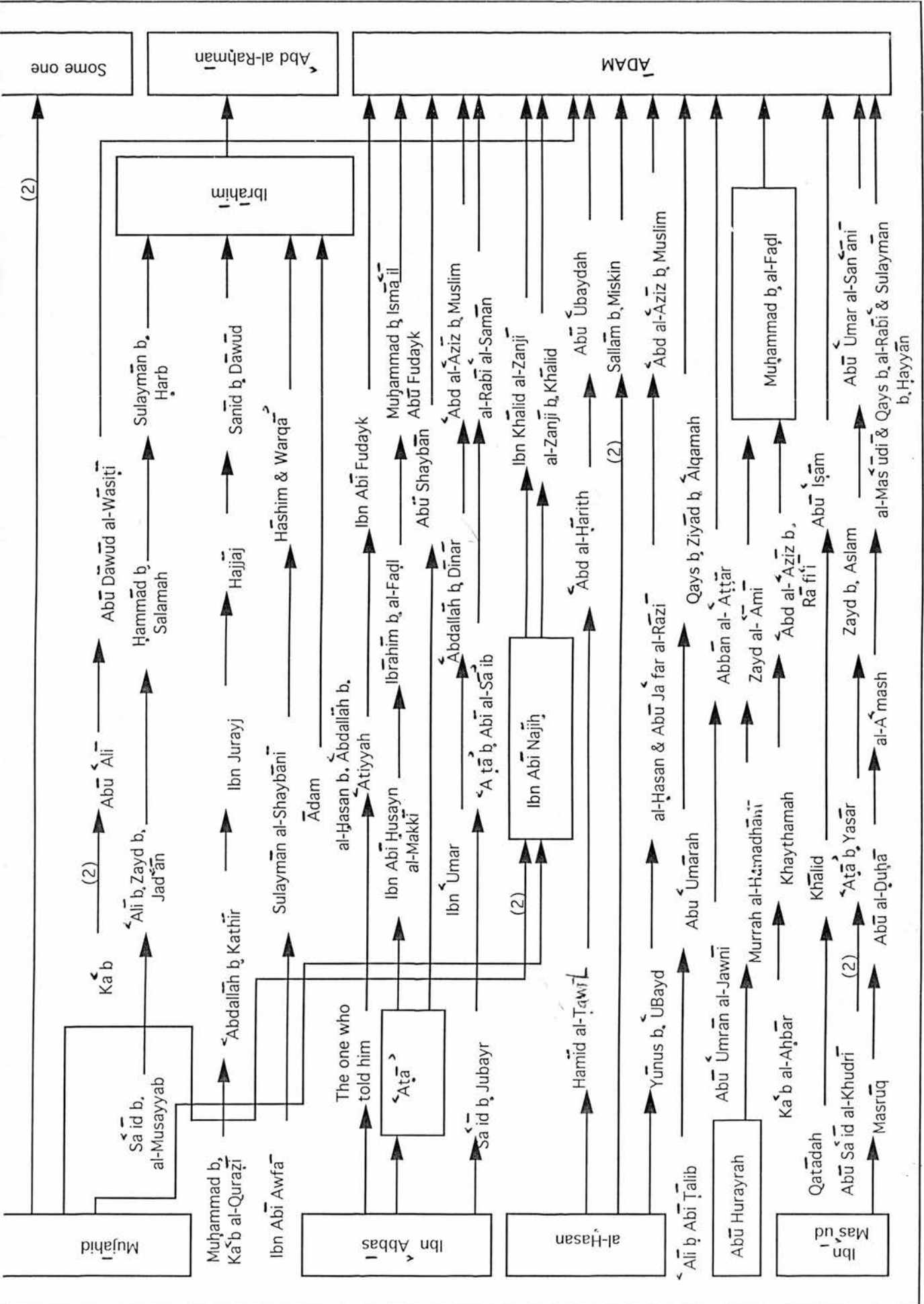

The Main Isnāds quoting Mujāhid :

The sources that Stauth suggests as the principal ones in Tabarī's Tafsīr from Mujāhid, are the followings :

1. The Isnāds in which Warqā' quotes Ibn Abī Najīḥ and Mujāhid :
 - i al-Ḥārith b. Muḥammad
al-Ḥasan al-Ashyab
Warqā'
Ibn Abī Najīḥ
Mujāhid
 - ii Al-Muthannā
Ishāq b. al-Ḥajjāj
Ibn Abī Ja'far al-Rāzī
Warqā'
Ibn Abī Najīḥ
Mujāhid
 - iii. Al-Ḥasan b. Muḥammad (d. 259-60 / 873-4)
Shabāba^h (d. 254-6 / 868-9)
Warqā'
Ibn Abī Najīḥ
Mujāhid
 - iv Sufyān b. Wakī' (d. 247 / 861)
Ibn Numayr (d. 199 / 814)
Warqā'
Ibn Abī Najīḥ
Mujāhid¹

1- Stauth, Die Überlieferung des Korankommentars Muḡāhid b. Ḡabrs , p. 116.

2. The Isnād of Warqā' through ' Ubayd Allāh b. Abī Ja'far and Mujāhid :

Al-Muthannā
Ishāq b. al-Ḥajjāj
Ibn Abī Ja'far al-Rāzī
Warqā'
Ubayd Allāh b. Abī Ja'far(d. 132-6 / 749-53)
Mujāhid ²

3. The Isnād of Ibn Jurayj 'an Mujāhid :

- i Al-Qāsim b. al-Ḥasan (d. 272 / 885)
Al-Ḥusayn b. Dā'ūd (226 / 840)
Al-Ḥajjāj b. Muḥammad (206 / 821)
Ibn Jurayj
Mujāhid b. Jabr ³
- ii Hārūn b. Idrīs
Al-Muḥāribī
Ibn Jurayj
Mujāhid ⁴
- iii. Suwayd b. Naṣr (d. 240 - 41 / 854 - 5)
Ibn al-Mubārak
Ibn Jurayj
Mujāhid ⁵

2- Ibid, p.116.

3- Ibid, p.110.

4- Ibid, p.114.

5- Ibid, p.128.

4. (A) The Isnād of Sufyān 'an Mujāhid :

i. Ibn Ḥumayd al-Rāzī

Mihrān

Sufyān

Mujāhid ⁶

ii Abū Guṣūn

Abū Zāhir

Sufyān

Mujāhid ⁷

(B) The Isnād of Sufyān 'an Manṣūr :

Ibn Ḥumayd al-Rāzī

Mihrān

Sufyān

Manṣūr ⁸

(d.132 / 749)

(C) The Isnād of Sufyān 'an Manṣūr 'an Mujāhid :

Ibn Ḥumayd al-Rāzī

Mihrān

Sufyān

Manṣūr

Mujāhid ⁹

⁶- Ibid, p.120.

⁷- Ibid, p.128.

⁸- Ibid, p. 120.

⁹- Ibid, p.120.

5. The Isnād of Sufyān 'an Ibn Abī Najīh 'an Mujāhid :

i. Al-Ḥasan

'Abd al-Razzāq b. al-Ṣan'ānī (d. 211 / 827)

Sufyān

Ibn Abī Najīh

Mujāhid

ii Ibn Bashshār (d. 252 / 866)

Yaḥyā b. Sa'īd (d. 198 / 814)

Sufyān

Ibn Abī Najīh

Mujāhid

iii. Sufyān b. Wakī'

Wakī' b. al-Jarrāh (d. 197 / 813)

Sufyān

Ibn Abī Najīh

Mujāhid

iv Yaḥyā b. Ṭalḥa

Yaḥyā b. Sa'īd

Sufyān

Ibn Abī Najīh

Mujāhid

v. Ibn Bashshār

'Abd al-Raḥmān b. al-Mahdī (d. 198 / 814)

Sufyān ¹⁰

Ibn Abī Najīh

¹⁰- Ibid, p. 120.

Mujāhid

vi. Ibn Ḥumayd al-Rāzī

Mihrān

Sufyān

Ibn Abī Najīḥ

Mujāhid ¹¹

6. The Isnād of Sufyān quoting Mujāhid through another authority :

i. Ibn Ḥumayd al-Rāzī

Mihrān

Sufyān

Layth

(d. 148 / 765)

Mujāhid

ii. Ibn Bashshār

Yaḥyā b. Sa'īd

Sufyān

'Atā'

Mujāhid

iii Abū Kurayb

(247 / 861)

Wakī' b. al-Jarrāḥ

Sufyān

A man (rajul)

Mujāhid

¹¹- Ibid, p.120.

- iv Yahyā b. Ṭalḥah
'Abd al-Raḥmān b. Maḥdī
Sufyān
'Uthmān b. al-Aswad (d. 149 / 766)
Mujāhid ¹²

7. The Isnād of Abū Ḥudhayfah 'an Shibl 'an Mujāhid :

- i Abū Ḥudhayfah
Shibl
Khālīd b. Yazīd
Mujāhid
- ii. Abū Ḥudhayfah
Shibl
Ibn Abī Najīh
Mujāhid
- iii Abū Ḥudhayfah
Shibl
Ibn Kathīr
Mujāhid ¹³

12- Ibid, p.120.

13- Ibid, p.127.

8. The Isnād of Mansūr 'an Ibn Abī Najīh 'an Mujāhid :

- i Al-Ḥasan b. Yaḥyā (d. 263 / 876)
'Abd al-Razzāq al-Ṣan'ānī
Ma'mar b. Rashīd
Ibn Abī Najīh
Mujāhid

- ii. Muḥammad b. 'Abd al-A'lā (245 / 859)
Muḥammad b. Ṭawr al-Ṣan'ānī (190 / 805)
Ma'mar b. Rashīd
Ibn Abī Najīh
Mujāhid ¹⁴

14- Ibid, p.123.

BIBLIOGRAPHY

- Abū Dāwūd, Sulaymān Ibn al-Ash'ath, Sunan Abī Dāwūd, 4 vols., ed. by Muḥammad Maḥy al-Dīn 'Abd al-Ḥamīd, 2nd. edn., Egypt, 1369 / 1950.
- Abū Ḥayyān, Muḥammad Ibn Yūsuf Ibn 'Alī Ibn Yūsuf Ibn Ḥayyān, al-Tafsīr al-Kabīr (al-Baḥr al-Muḥīt), 8 vols., Riyadh, 1969.
- Abū 'Ubaydah, Ma'mar Ibn al-Muthannā al-Taymī, Majāz al-Qur'ān, 2 vols., ed. by Muḥammad Fu'ād Sirkīn, 2nd edn., Beirut, 1401 / 1981.
- Al-Alūsī, Abū al-Faḍl, Shihāb al-Dīn al-Sayyid Muḥammad al-Alūsī Rūḥ al-Ma'anī fī Tafsīr al-Qur'ān al-'Azīm wa-al-Sab' al-Mathānī, Egypt, 1964.
- Al-Ash'arī, Abū al-Ḥasan, 'Alī Ibn Ismā'il,
- Al-Ibānah 'an Uṣūl al-Diyānah, Egypt, 1348 A.H.
- Maqālāt al-Islāmiyyīn wa-Ikhtilāf al-Muṣallīn, 2nd. edn., Wiesbaden, 1382 / 1963.
- Kitāb al-Luma' fī al-Radd 'alā Ahl al-Zayagh wa-al-Bida', Beirut, 1952.
- Al-Ash'arī al-Qummī, Abū Khalaf, Sa'ad Ibn 'Abd Allāh,
Al-Maqālāt wa-al-Firaq ed. by Muḥammad Jawād Mashkūr, Teheran, 1963.
- Al-Baghawī, Abū Muḥammad, al-Ḥusayn Ibn Mas'ūd,
Tafsīr al-Baghawī (Ma'ālim al-Tanzīl), 4 vols., Beirut, 1986.

- Al-Baghdādī, Abū Mansūr, 'Abd al-Qāhir Ibn Ṭāhir al-Tamīmī,
Uṣūl al-Dīn, Istanbul, 1346 / 1928.
- Al-Balādhurī, Abū al-'Abbās Aḥmad Ibn Yaḥyā Ibn Jābir,
Futūḥ al-Buldān, ed. by 'Abd Allāh Anīs
al-Ṭabbā' and 'Umar Anīs al-Ṭabbā', Beirut,
1377 / 1957.
- Al-Bayḍāwī, Abū Sa'īd, 'Abd Allāh Ibn 'Umar Ibn Muḥammad,
Tafsīr al-Bayḍāwī (Anwār al-Tanzīl wa-Asrār
al-Ta'wīl, 5 vols., Egypt, 1330 A. H.
- Al-Bayhaqī, Abū Bakr, Aḥmad Ibn al-Ḥusayn Ibn 'Alī,
al-Sunan al-Kubrā, 10 vols., India, 1353 A. H.
- Al-Bukhārī, Abū 'Abd Allāh, Muḥammad Ibn Ismā'īl,
Ṣaḥīḥ al-Bukhārī (al-Jāmi' al-Ṣaḥīḥ), 9 vols., With
English translation by Muḥammad Muḥsin khān,
2nd. edn., Ankara, n. d.
- Al-Dāwūdī, Shams al-dīn Muḥammad Ibn 'Alī Ibn Aḥmad,
Ṭabaqāt al-Mufasssīrīn, Egypt, 1972.
- Al-Dhahabī, Abū 'Abd Allāh, Muḥammad Ibn Aḥmad Ibn 'Uthmān,
- Mizān al-I'tidāl fī Naqd al-Rijāl, 5 vols.,
Egypt, 1963.
- Siyar A'lām al-Nubalā', 8 vols.
- Tārīkh al-Islām wa-Ṭabaqāt al-Mashāhīr
wa-al-A'lām, Egypt, 1369 A. H.
- Al-'Ibar fī Khabar man Ghabar, Kuwait, 1960.
- Kitāb Tadhkirat al-ḤUFFāz, 5 vols., Beirut, n. d.
- Al-Dūlābī, Abū Bishr, Muḥammad Ibn Aḥmad Ibn Ḥammād,
Kitāb al-Asmā' wa-al-Kunā, India, 1322 A. H.

- Al-Farrā', Abū Zakariyyā, Yaḥyā Ibn Ziyād, Ma'ānī al-Qur'ān,
2 vols., Cairo, 1374/ 1955.
- Al-Fāsī, Taqiyy Al-Dīn Muḥammad Ibn Aḥmad Al-Hasanī, Al-'Iqd
Al-Thamīn Fī Tārīkh Al-Balad Al-Amīn, 8 vols.,
ed. by Fuā'd Sayyid and Maḥmūd Muḥammad
Al-Tanāqī, Cairo, (1962- 69).
- Al-Ghazālī, Abū Ḥāmid, Muḥammad Ibn Muḥammad,
Iḥyā' 'Ulūm al-Dīn, 5 vols., Cairo, 1967.
- Ibn 'Abd al-Barr, al-Namrī al-Qurṭubī, Al-Istī'āb fī Ma'rifat
al-Ashāb, 4 vols., Printed on the margin of Ibn
Ḥajar's Isābah, 4 vols., New edn., Baghdad,
1328 A.H.
- Ibn Abī Dāwūd, Abū Bakr, 'Abd Allāh Ibn Abī Dāwūd Sulaymān
Ibn al-Ash'ath al-Sijistānī, Kitāb al-Maṣāḥif,
Egypt, 1936.
- Ibn al-'Arabī, Abū Bakr Muḥammad Ibn 'Abd Allāh, Aḥkām
al-Qur'ān, 4 vols., Beirut, n. d.
- Ibn 'Arabī, Maḥy al-Dīn, Tafsīr al-Qur'ān al-'Azīm, ed. by
Muṣṭafā Ghālib, 2nd. edn., Beirut, 1978.
- Ibn al-Athīr, 'Izz al-dīn, Abū al-Ḥusayn, 'Alī Ibn Abī al-Karam
Muḥammad Al-Kāmil fī al-Tārīkh, 12 vols.,
Leiden, 1899.
- Ibn Ḥajar, Aḥmad Ibn 'Alī Ibn Ḥajar al-'Asqalānī,
- Tahdhīb al-Tahdhīb, 12 vols., India, 1325 A.H.
- Al-Isābah fī Tamīyīz al-Ṣaḥābah, 4 vols.,
New edn., Baghdad, 1328 A. H.

- Ibn Ḥanbal, Abū 'Abd Allāh, Aḥmad Ibn Muḥammad, Al-Musnad, 15 vols., ed. by Aḥmad Muḥammad Shākir, 4th. edn., Egypt, 1373 / 1954.
- Ibn Ḥazm, Abū Muḥammad 'Alī Ibn Aḥmad,
 - Al-Fiṣal fī al-Milal wa-al-Ahwā' wa-al-Nihal, 5 vols., Egypt, 1317 A. H.
 - Al-Muḥallā, 12 vols., revised edn., ed. by Zaydān Abū al-Makārim Ḥasan, Egypt, 1387 / 1967.
- Ibn Ḥibbān, Muḥammad Ibn Ḥibbān Ibn Aḥmad Abī Ḥātīm al-Tamīmī
Kitāb al-Majrūḥīn wa-al-Du'afā' wa-al-Matrūkīn, Aleppo (Syria), n. d.
- Ibn Hishām, Abū Muḥammad 'Abd al-Mālik, Sīrat al-Nabī, 2 vols., Egypt, 1346 A. H.
- Ibn al-Humām, Kamāl al-Dīn, Muḥammad Ibn 'Abd al-Wāḥid al-Saywasī al-Sakandrī, Sharḥ Faṭḥ al-Qadīr, 10 vols., Egypt, 1970.
- Ibn al-'Imād al-Ḥanbalī, Abū al-Falāh, 'Abd al-Ḥayy Ibn Aḥmad Ibn Muḥammad, Shadharāt al-Dhahab fī Akhbār man Dhahab, 10 vols., Cairo, 1350 A. H.
- Ibn al-Jazarī, Shams al-Dīn, Abū al-Khayr, Muḥammad Ibn Muḥammad, Ghāyat al-Nihāyah fī Ṭabaqāt al-Qurrā', 2 vols., Cairo, 1933.
 - Al-Nashr fī al-Qirā'āt al-'Ashr, 2 vols., Beirut, n. d.

- Ibn Kathīr, Abū al-Fidā', Ismā'īl Ibn Kathīr al-Qurashī al-Dimashqī,
 - Tafsīr al-Qur'ān al-'Azīm, 4 vols., Beirut,
 759 A.H.
 - Al-Bidāyah wa-al-Nihāyah, 14 vols., Beirut and
 Riyadh, 1966.
- Ibn Khālawayh, Abū 'Abd Allāh Al-Ḥusayn Ibn Aḥmad,
Al-Mukhtaṣar fī Shawādh al-Qirā'āt, ed. by
 Bergstraesser, Cairo, 1934.
- Ibn Khallikān, Abū al-'Abbās, Shams al-Dīn Aḥmad Ibn Muḥammad
Wafayat al-A'yān wa-Anbā' Abnā' al-Zamān,
 ed. by Iḥsān 'Abbās, 8 vols., Beirut, 1397/ 1977.
- Ibn Mājah, Abū 'Abd Allāh Muḥammad Ibn Yazīd, Sunan Ibn Mājah
 2 vols., ed. by Fu'ād 'Abd al-Bāqī, Egypt, n.d.
- Ibn Mākūlā, Abū Naṣr Sa'ad al-Malik, 'Alī Ibn Hibat Allāh Ibn
 'Alī, Al-Ikmāl fī Raf' al-Irtiyāb 'an al-Mu'talif
 wa-al-Mukhtalif fī al-Asmā' wa-al-Kunā
 wa-al-Ansāb, 7 vols., ed. by 'Abd al-Raḥmān
 Ibn Yaḥyā al-Ma'lamī, Mecca, n.d.
- Ibn Manzūr, Muḥammad Ibn Mukrim, Lisān al-'Arab al-Muḥīṭ,
 3 vols., ed. by Yūsuf Khayyāt, Beirut, n.d.
- Ibn Qudāmah, Abū Muḥammad, 'Abd Allāh Ibn Aḥmad Ibn
 Muḥammad, Al-Mughnī, 9 vols., ed. by Muḥammad
 Sālim Muḥaysin and Sha'bān Muḥammad Ismā'īl,
 Egypt and Riyadh, n.d.
- Ibn Qutaybah, Abū Muḥammad, 'Abd Allāh Ibn Muslim,
 - Ta'wīl Mushkil al-Qur'ān, 2nd. edn., Cairo, 1973.
 - Ta'wīl Mukhtalif al-Ḥadīth, Beirut, 1989.
 - Al-Ma'ārif, Cairo, 1960.

- Ibn Saʿd, Muḥammad Ibn Saʿd Ibn Manīʿ al-Baṣrī,
Al-Tabaqāt al-Kubrā, 8 vols., Beirut, 1978.
- Ibn Taymiyyah, Aḥmad Ibn ʿAbd al-Ḥalīm b ʿAbd al-Salām,
Majmūʿ Fatāwā Shīkh al-Islam Aḥmad Ibn
Taymiyyah, 30 vols., Saudi Arabia, n. d.
- Al-Iṣbahānī, Abū Naʿīm Aḥmad Ibn ʿAbd Allāh, Hilyat al-Awliyāʾ
wa-Tabaqāt al-Aṣfiyāʾ, 10 vols., Egypt, 1933.
- Al-Jāhiz, Abū ʿUthmān ʿAmr Ibn Baḥr, Al-Ḥayawān, 5 vols., ed. by
ʿAbd al-Salām Muḥammad Hārūn, 2nd. edn.,
Egypt, 1357 A.H.
- Al-Jaṣṣāṣ, Abū Bakr, Aḥmad Ibn ʿAlī al-Rāzī,
Aḥkām al-Qurʾān, 5 vols., Beirut, 1985.
- Mālik, Abū ʿAbd Allāh, Mālik Ibn Anas Ibn Mālik Ibn Anas,
Al-Muwattāʾ, 4th. edn., Beirut, 1400 / 1980.
- Al-Masʿūdī, Abū al-Ḥasan, ʿAlī Ibn al-Ḥusayn Ibn ʿAlī,
Murūj al-Dhahab wa-Maʿādin al-Jawhar,
4 vols., ed. by Yūsuf Asʿad Dāghir,
3rd. edn., 1978.
- Mujāhid, Abū al-Ḥajjāj, Mujāhid Ibn Jabr al-Makkī al-Makhzūmī,
Tafsīr Mujāhid, 2 vols., ed. by ʿAbd al-Raḥmān
bn Muḥammad al-Sūrtī, Pakistan, n. d. (This work
has also been published in Doha [Qatar] 1396/ 1976).
- Muslim, Abū al-Ḥusayn Muslim Ibn al-Ḥajjāj Ibn Muslim,
Ṣaḥīḥ Muslim , 4 vols., Egypt, 1377 A.H.
- Al-Nasāʾī, Abū ʿAbd al-Raḥmān Aḥmad Ibn Shuʿayb,
Sunan al-Nasāʾī , 6 vols., 1383 / 1964.

- Nawawī, Abū Zakariyā, Maḥy al-Dīn Ibn Sharaf,
Tahdhīb al-Asmā' wa-al-Lughāt, 2 vols.,
 Egypt, n.d.
- Al-Nisābūrī, Nizām al-Dīn, al-Ḥasan Ibn Muḥammad,
Gharā'ib al-Qur'ān wa-Raghā'ib al-Furqān, printed
 on the margin of Tabarī's Tafsīr, Maymaniyyah
 press, Cairo, 1321 A.H.
- Al-Qummī, Abū al-Ḥasan 'Alī Ibn Ibrāhīm,
Tafsīr al-Qummī, 2 vols., 2 nd. edn, Beirut, 1968.
- Al-Qurtubī, Abū 'Abd Allāh, Muḥammad Ibn Aḥmad al-Anṣārī,
Tafsīr al-Qurtubī (al-Jāmi' li-Aḥkām al-Qur'ān),
 20 vols., Cairo, 1936.
- Al-Rāzī, Fakhr al-Dīn Ibn Diyā' al-Dīn 'Umar,
 - Mafātīḥ al-Ghayb (al-Tafsīr al-Kabīr), 8 vols.,
 Egypt, n.d.
 - Kitāb al-Arb'īn fī Uṣūl al-Dīn, Hyderabad,
 1353 A.H.
- Al-Samarqandī, Abū al-Layth, Naṣr Ibn Muḥammad Ibn Ibrāhīm,
Tafsīr al-Qur'ān al-Karīm (Baḥr al-'Ulūm)
 Baghdad, 1985.
- Al-Sarakhsī, Abū Bakr, Muḥammad Ibn Abī Sahl,
Kitāb al-Mabsūṭ, 30 vols., Beirut, 1986.
- Al-Shāfi'ī, Abū 'Abd Allāh, Muḥammad Ibn Idrīs,
 - Aḥkām al-Qur'ān, 2 vols., Beirut, 1980.
 - Al-Umm, 8 vols., Egypt, 1321 A. H.
 - Risālat al-Shāfi'ī, printed at the beginning
 of al-Umm, Egypt, 1321 A.H.

Al-Shawkānī, Muḥammad Ibn 'Alī Ibn Muḥammad,

Nayl al-Awtār, 9 vols., Beirut, 1973.

Al-Suyūṭī, Jalāl al-Dīn 'Abd al-Raḥmān Ibn Abī Bakr,

- Al-Durr al-Manthūr fī al-Tafsīr bi-al-Ma'thūr,
Tehran, 1377 A.H.

- Al-Itqān fī 'Ulūm al-Qur'ān, 4 vols., Cairo, n. d.

- Tabaqāt al-Ḥuffāz, Cairo, 1973.

- Tārīkh al-Khulafā', 4th. edn., Egypt, 1969.

Al-Ṭabarī, Abū Ja'far, Muḥammad Ibn Jarīr,

- Tafsīr al-Ṭabarī (Jāmi' al-Bayān 'an Ta'wīl āy al-Qur'ān), 30 vols., two versions consulted:

vols., 1- 16, Egypt, n.d. , vols., 17-30,

3rd., Egypt, 1986.

- Tārīkh al-Ṭabarī (Tārīkh al-Rusul wa-al-Mulūk),
10 vols., 1960.

Al-Ṭabarsī, Abū 'Alī al-Faḍl Ibn al-Ḥasan,

Tafsīr al-Ṭabarsī (Majma' al-Bayān fī Tafsīr al-Qur'ān), 10 vols., 5th.edn., Tehran, 1395 A.H.

Al-Tha'ālibī, 'Abd al-Raḥmān Ibn Muḥammad Ibn Makhlūf,

Tafsīr al-Tha'ālibī (Jawāhir al-Ḥisān fī Tafsīr al-Qur'ān), Beirut, n.d.

Al-Tirmidhī, Abū 'Isā Muḥammad Ibn 'Isā, Sunan al-Tirmidhī

(al-Jāmi' al-Ṣaḥīḥ), 5 vols., ed. by Aḥmad Muḥammad Shākir, Cairo, 1356 / 1937.

Al-Ṭūsī, Abū Ja'far, Muḥammad Ibn al-Ḥasan,

Tafsīr al-Tibyān , 10 vols., Iran, n.d.

- Yāqūt , Ibn 'Abd Allāh al-Rūmī al-Ḥamawī ,
Mu'jam al-Udabā', 20 vols., Beirut.
- Al-Zajjāj, Abū Ishāq Ibrāhīm Ibn al-Sārī,
Ma'ānī al-Qur'ān wa-'Irābuhu, 5 vols. ,
 Beirut, 1988.
- Al-Zamakhsharī, Jār Allāh, Muḥammad Ibn 'Umar,
Al-Kashshāf 'an Haqā'iq Ghawāmiḍ al-Tanzīl
Wa- 'Uyūn al-Aqāwīl fī Wujūh al-Ta'wīl,
 4 vols. , Beirut, n.d.
- Al-Zarkashī, Badr al-Dīn Muḥammad b. 'Abd Allāh, Al-Burhān fī
'Ulūm al-Qur'ān, 4 vols., ed. by Muḥammad Abū
 al-Faḍl Ibrāhīm, 2 nd. edn. (revised), Egypt,
 1391 /1972.
- Al-Ziriklī, Khayr al-Dīn, Al-A'lām, 8 vols. , 6th. edn. , Beirut, 1984.

2. Modern Works (Arabic and English) :

- 'Abd Allāh, Aḥmad 'Alī, The Variant Readings of the Qur'ān :
A critical Study of their Historical and
Linguistic Origins , unpublished Ph.D thesis,
Edinburgh, 1984.
- 'Abd al-Bāqī, Muḥammad Fu'ād, Al-Mu'jam al-Mufahras li-Alfāz
al-Qur'ān al-Karīm, Beirut, 1406 /1986.
- 'Alī, 'Abd Allāh Yūsuf, The Holy Qur'ān, Riyadh, 1403.
- 'Alī, Muḥammad, The Holy Qur'ān, 4 th. edn., Pakistan, 1951.
- 'Awdah, 'Abd al-qādir, al-Tashrī' al-Janā'ī fi al-Islam , 2 vols.,
Beirut, n.d.
- Ayyūb, Muḥmūd, The Qur'ān and its Interpreters, vol.1,
New York, 1984.
- Bint al-Shāṭ'ī, 'Ā'ishah 'Abd al-Raḥmān, Al-Tafsīr al-Bayānī
li-al-Qur'ān al-Karīm, 2 vols., 5 th. edn.,
Cairo, 1397 / 1977.
- Brockelmann, Carl, The History of The Islamic Peoples,
London, n.d.
- Burton, John, The Collection of The Qur'ān, Cambridge, 1977.
- Cooper, J , An Abridged Translation of al-Ṭabarī's Jāmi' al-Bayān
'an Ta'wīl āy al-Qur'ān, vol.1, Oxford, 1987.
- Denffer, Aḥmad Von, Ulūm al-Qur'ān, Bradford, 1403 / 1983.
- Gatje, Helmut, The Qur'ān and its Exegesis, London, 1976.
- Gilliot, Claude, Exégèse, Langue, et Théologie en Islam , L'exegese
Coranique de Ṭabarī (m. 311/ 923) , Paris, 1990.

- GoldZiher, Ignaz, Die Richtungen der Islamischen Koranauslegung , translated into Arabic as Madhāhib al-Tafsīr al-Islāmī , by 'Abd al-Ḥalīm al-Najjār, 2 nd. edn. , Beirut, 1403 / 1983.
- Ḥamūdah, 'Abd al-Wahhāb, Al-Qirā'āt wa- al-Lahjāt, Cairo, 1368 / 1948.
- Howard, I. K. A. Imāmī- Shī'ī Ritual in the Context of Early Islamic Jurisprudence, unpublished Ph.D thesis, Cambridge, 1975.
- Jullandrī, Rāshid Aḥmad, Qur'ānic Exegesis and Classical Tafsīr, I.Q., 12, London, 1968.
- Lane, Edward William, Madd al-Qāmūs , an Arabic - English Lexicon, 8 vols. , London, 1863 - 1893.
- Leemhuis, F. , - " Origins and Early Development of the tafsīr tradition" in Andrew Rippin's Approaches to the History of the Interpretation of the Qur'an , Oxford, 1988.
- " Ms. 1075 tafsīr of the Cairene Dār al-Kutub and Mugāhid's Tafsīr " in R. Peters, ed. , Proceedings of the Ninth Congress of the Union Européenne des Arabisants et Islamisants
- Muḥammad Ḥusayn al-Dhahabī, Al-Tafsīr wa-al-Mufasssīrūn, 2 vols. , 3rd. edn. , Egypt, 1405/ 1985.
- Nawfal, Aḥmad Muḥammad, Mujāhid Mufasssiran, unpublished Ph. D thesis, Azhar University (Cairo), 1978.

- Nūr al-Dā'im, Al-Ḥibr Yūsuf, The Charge of Shi'ism Against Al-Ṭabarī with Special Reference to His Tafsīr, unpublished Ph.D thesis, Edinburgh, 1969.
- Pickthall, Muḥammad Marmaduke, The meaning of the Glorious Qur'ān, New Delhī, 1983.
- Qutb, Sayyid, Fī Zilāl al-Qur'ān, 8 vols., Beirut, 7th. edn., Beirut, 1391/ 1971.
- Al-Ṣābūnī, Muḥammad 'Alī,
 - Tafsīr āyāt al-Aḥkām min al-Qur'ān,
 2 nd. edn., Damascus, 1397 / 1977.
 - Al-Tibyān fī 'Ulūm al-Qur'ān, 2nd., edn.,
 Beirut, 1401 / 1981.
- Sale, George, The Qur'ān, London and
 New York, n.d.
- Sha'bān, M. A., Islamic History, Cambridge, 1971.
- Stauth, George , Die Überlieferung Des Korankommentars Mugāhid b. Gabrs , aus Otterberg bei
 Kaiserslautern, 1969.
- Watt, William Montgomery,
 - Free Will and Predestination in Early Islam, Bristol, 1948.
 - Islamic Philosophy and Theology,
 Edinburgh, 1962. - Bell's Introduction to The Qur'ān, Edinburgh, 1970.
 - The Formative Period of Islamic Thought, Edinburgh, 1973.

Wensinck, A. J. The Muslim Creed, London, 1932, (2 nd.impression
1965).

Al-Zuḥaylī, Wahbah, Al-Fiqh al-Islāmī wa- Adillatuhu , 8 vols. , 3rd.
edn., 1409 / 1989, Syria.