

AN INVESTIGATION INTO THE DESIGN AND USE
OF THE CAPACITANCE PROXIMITY TRANSDUCER
AS A DETECTOR OF CARDIOVASCULAR SOUNDS

by

Denis N. Smith, B.Sc.

A thesis presented for the Degree of Doctor of Philosophy

of the

University of Edinburgh in the Faculty of Science,

September, 1967.



CONTENTS

SUMMARY

<u>Chapter</u>	<u>Page</u>
1 INTRODUCTION	
1.1 History of Phonocardiography	1
1.2 Nature of Cardiovascular Sounds	6
1.3 Standardization of Phonocardiography	9
1.4 Aims of the Investigation	13
2 TRANSDUCERS	
2.1 Mechanical Properties of Tissue in Relation to Transducer Performance	17
2.2 The Ideal Displacement Transducer	
(i) Requirements for an Ideal Transducer	21
(ii) The Eddy Current Proximity Transducer	22
(iii) The Capacitance Proximity Transducer	23
(iv) Advantages and Limitations of the Capacitance Method	23
2.3 Design of a Practical Capacitance Proximity Transducer	
(i) Reactance of a Parallel Plate Capacitor	26
(ii) Edge Effects	27
(iii) Use of a Guard Ring to Reduce the Edge Effects	28
(iv) Other Stray Capacitances	29
(v) Errors due to the Shape of the body surface	30
(vi) Errors due to variations in other parameters	32
3 SIGNAL PROCESSING METHODS	
3.1 Reactance Measuring Techniques	
(i) Requirement for a continuous method of reactance measurement	35
(ii) Modulation	36
(iii)/	

<u>Chapter</u>	<u>Page</u>
(iii) Amplitude Modulation Methods	37
(iv) Improvement of Amplitude Modulation Methods by tuning	39
(v) Frequency Modulation Methods	42
(vi) Demodulation	44
3.2 Bridge Methods	
(i) Impedance measurement by comparison with a known standard	47
(ii) Transformer Ratio-Arm Bridges	48
(iii) Impedance Bridges	50
(iv) Admittance Bridges	51
(v) Analysis of the Equivalent Circuit of the Thompson Bridge	53
(vi) Conditions for Optimum Linearity	56
3.3 Bridge Networks with Feedback	
(i) Modulation of Source Voltage to Improve Linearity	59
(ii) Analysis of the Modulation Method	60
(iii) An Alternative Method	61
(iv) The Effects of Cable Capacitance	62
3.4 Operational Amplifier Method	
(i) Impedance Comparison Using an Operational Amplifier	64
(ii) Analysis of the Method	65
(iii) Limits of Accuracy	66
4 DEVELOPMENT OF A PRACTICAL BRIDGE CIRCUIT	
4.1 Basic Requirements	68
4.2 Source Oscillators	
(i) Single Sided Oscillator	71
(ii) Push-Pull Oscillator	72
(iii) Oscillator Output Impedance	74
4.3 Detector	76
4.4 Linearity Correction	
(i) Non-Linearity at Large Amplitudes	79
(ii) Correction by Non-Linear Amplifier	79
(iii) Correction by Feedback	80
4.5 Final Form of the Bridge Network	82

<u>Chapter</u>	<u>Page</u>
5	CONSTRUCTION AND TESTING OF A PRACTICAL CAPACITANCE PROXIMITY TRANSDUCER
5.1	Construction of the Transducer 87
5.2	Calibration of the Transducer
	(i) Static Calibration 89
	(ii) Dynamic Testing 90
	(iii) Testing under Simulated Conditions of actual use 92
	(iv) Modifications to the Transducer 92
6	PRACTICAL INVESTIGATION OF THE OPERATIONAL AMPLIFIER METHOD
6.1	Use of an Integrated Circuit Amplifier 94
6.2	Use of the Wayne Kerr Distance and Vibration Meter Type B 731 B
	(i) Description of the Instrument 97
	(ii) Modifications to Give Backing-Off Facility 98
	(iii) Use of Wayne Kerr Probes 99
7	RESULTS AND CONCLUSIONS
7.1	Detection of Cardiovascular Sounds Using the Bridge Method 101
7.2	Qualitative Examination of Foetal Heart Sounds 105
7.3	Observation and Recording Using the Wayne Kerr Distance and Vibration Meter 107
7.4	Conclusions 109
	APPENDIX A 111
	APPENDIX B 124
	ACKNOWLEDGEMENTS 134
	REFERENCES 135

SUMMARY

In recent years the knowledge of cardiovascular sounds has been increased by the use of electronic techniques for their detection and analysis. A variety of methods are now available for the detection of these sounds but there is no standard method by which the results of different workers can be compared.

The properties of a phonocardiographic system depend to a large extent on the nature of the transducer used to pick-up the sounds. If this transducer makes contact with the body surface then the mechanical parameters of the underlying tissue must be taken into account when its performance is measured. In order to avoid this it is necessary to use a transducer which does not make contact with the body surface and which therefore has a performance independent of the tissue parameters.

The capacitance proximity transducer provides an almost ideal method for the detection of vibrations of the body surface without contact. It can be constructed in such a way that the electrical reactance of the transducer is proportional to the spacing between it and the body surface. It is therefore necessary to measure the changes in this reactance by some suitable circuit in order to obtain an electrical output which is a function of the vibration. It is essential that the signal processing method chosen produces an output which is proportional to the reactance variations, otherwise the output waveform will not be linearly related to the input displacement. This has apparently been overlooked by other workers/

workers with consequent loss of accuracy, sensitivity and signal to noise ratio.

A new bridge method with feedback is described by which an output can be obtained which is closely proportional to the changes in transducer reactance, even when the change approaches 100% of the nominal reactance. The development of a suitable oscillator and detector for this circuit is also described.

A second linear method using an operational amplifier was also examined and modifications are described by which some of the advantages of the bridge technique can be retained. This method is expected to have an error $\sim 1-2\%$ for 100% deviations from the nominal transducer reactance.

The use of the capacitance proximity transducer for the detection and recording of a variety of cardiovascular sounds is described and some records obtained by both bridge and operational amplifier techniques are presented.

CHAPTER 1

INTRODUCTION.

1.1. History of Phonocardiography

It has been known since ancient times that the heart produces sounds which occur at more or less regular intervals and that associated with these sounds there is a pressure pulse which can be felt in various parts of the body. The full significance of these phenomena was not explained until the year 1628 when Harvey published his 'De Motu Cordis' in which he showed that heart sounds were related to the mechanical activity of the heart and the circulation of the blood. Since that time auscultation of the heart sounds and palpation of the pulse have formed an essential part of clinical examination.

At first, observation of the heart sounds was made by placing the ear in direct contact with the patient so that the physician could both hear and feel the beating heart. This meant that the lower frequency components of the vibrations produced by the heart (which could not be heard but were felt because of their greater intensity) were not excluded from the examination. The first significant change in this method of observation came in 1816 when Laënnec (1819) introduced the use of the stethoscope. The original purpose of this invention was more out of consideration for feminine modesty than as an aid to auscultatory perception although it did facilitate observation of more obese patients. However although/

although the practice of auscultation was made more acceptable to patient and physician, the loss of direct contact meant that only the audible vibrations were detected. It is probable that some of the low frequencies could be transmitted along the rigid monaural stethoscopes but the flexible tubing used in the modern binaural stethoscope prevents the transmission of palpable vibrations. In addition the character of the audible sounds is altered by their passage through the stethoscope since this consists of rigid structures and air passages of specific dimensions. The character of the observed sound may also be modified by the pressure of application, the size of the end piece, the use of a diaphragm and the fit of the stethoscope to the ear. Some of these factors can be used to good purpose since they may enable emphasis of sounds in a particular frequency band which are of special interest. The resulting situation is very unsatisfactory since the performance of different makes of stethoscope may vary widely and there is no standardization.

Notwithstanding these difficulties the stethoscope has proved a very convenient instrument and almost all the major types of heart sounds were recognised in the century or so following Laënnec's discovery. Explanations for these sounds were obtained by correlation with autopsy findings. Some of these explanations were later found to be incorrect due to lack of accurate physiological knowledge but most are still acceptable today.

The great disadvantage of this type of subjective observation is that no permanent and continuous record of the heart sounds could be made; the advantage of such a record being that it can/

can be used to establish the time relationship which exists between the various sounds and events of the cardiac cycle. First attempts at recording of time sequences were very crude, Chauveau and Faivre in 1856 used a method in which the observer marked the Kymograph manually as he listened to the heart. In 1867 Potain attempted to make direct recordings without a human intermediary using purely mechanical methods but was unsuccessful due to the very small amplitude of the signals. The first successful continuous recordings were made by Huerthle in 1893 using a microphone, inductorium and frog nerve-muscle preparation. In the following year Einthoven and Geluk (1894) made the first true phonocardiographic recordings using the Lippman capillary electrometer. Direct mechanical recording was first achieved by Frank in 1904 using a mirror system to obtain optical magnification of the deflections of a membrane produced by the heart sounds. This method was so successful that the Frank segment capsule became the standard recording technique for almost forty years. The overall frequency response of the method was not good and it was found necessary to use low frequency acoustical filtration to avoid overloading the system. A further improvement in purely electrical methods came in 1907 when Einthoven described the use of the string galvanometer for heart sound recording.

The next major advance in the history of phonocardiography came as a result of the invention of the thermionic triode valve by De Forrest in 1906. By about 1920 suitable amplifiers of electrical signals/

signals had been developed in connection with radio. These enabled the amplification of faint murmurs so that they could be reproduced by means of d'Arsonval type galvanometers. Later the use of the cathode ray tube in place of the galvanometer made possible direct observation and recording of the full spectral range of heart sounds. Further improvements in electronic technique have meant that over the last twenty five years the mechanical methods of recording have been entirely superceded.

At the present time electronic amplifiers and recording instruments are available which are capable of handling the full range of frequencies and amplitudes which are encountered in heart sound recording. The noise level of the amplifiers is such that it is no longer necessary to exclude the low frequency component of the heart sounds in order to reproduce the weaker high frequency components. This means that selective filtering of the sounds in order to identify particular components can take place after initial amplification. The only part of the phonocardiograph which is still unsatisfactory is the microphone or transducer which is used to detect the heart sounds.

The first attempts at electrical phonocardiography were made with the carbon granule type of microphone commonly used in telephones. This was superceded by the crystal microphone which has a higher sensitivity and a more reliable performance. A variety of other types of microphone have also been used for the detection of heart sounds but the majority of those used up to the present time/

time have not been developed specifically for the purpose. For this reason it is necessary to consider very carefully the method of application of the microphone to the body surface and the resulting performance of the microphone. In particular the frequency response of a microphone intended for free-field work may change radically when applied to the precordium so that calibration under actual conditions is necessary. Unless this is done the frequency characteristics of the phonocardiograph will depend largely on the type of microphone used and it is no longer possible to compare the results obtained by different workers. In spite of the difficulties of calibration and standardization a considerable amount of information is now available on the nature of adult heart sounds.

The electrical methods of phonocardiography have also been applied to the study of cardiovascular sounds other than those detected in the precordial area. Of particular interest in clinical diagnosis are the Foetal Heart Sounds and the Korotkoff Sounds. Foetal heart sounds, which were first observed by auscultation in 1650, provide one of the few available indications of foetal life and well being. The Korotkoff sounds occur as the result of partial occlusion of an artery by applying external pressure and are an essential part of the established method of external blood pressure measurement described by Korotkoff in 1905.

1.2. Nature of Cardiovascular Sounds

Cardiovascular sounds arise from the beating action of the heart and the resultant pulsatile flow of blood through the arterio-venous system. Since the heart and blood vessels are entirely surrounded by body tissues and bony structures any vibrations originating from them are transmitted to the body surface. The resultant periodic complex wave of displacement of the surface represents a summation of the mechanical action occurring within the body near the point of observation.

The heart itself is an elastic walled container which is periodically filled with fluid and each successive contraction of the walls sets it and its contents into vibration. The frequencies contained within the spectrum of these vibrations are a function of the mass of fluid and of the elasticity of the walls, both of which are known to vary during the heart cycle. Analysis of the spectral distribution of heart sounds by Williams and Dodge (1926), Mannheimer (1940), McKusick, Webb, Humphries and Reid (1955), Yoshimura (1960) and many others has shown that the intensity of the component frequencies detected at the chest wall falls off rapidly as the frequency rises. This can be explained in part by the fact that for a given sound pressure the amplitude of a sinusoidal wave falls off at a rate proportional to the square of the frequency. The observed rate of fall of intensity with frequency at the body surface is greater than this so that some further attenuation of the higher frequencies must occur during transmission through the body tissue. Intracardiac and Esophageal phonocardiography have shown that/

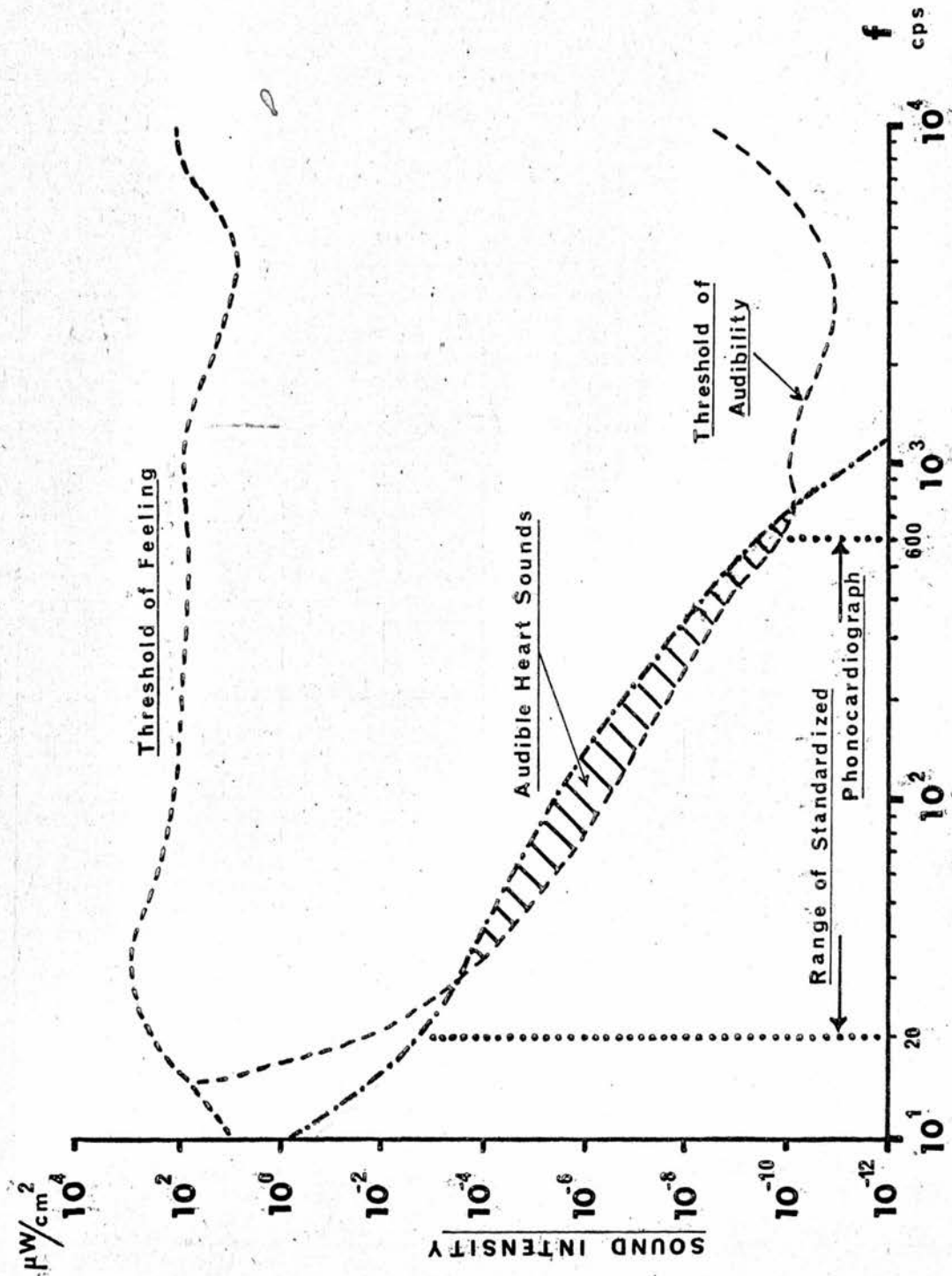

FIG.1.1 SPECTRAL DISTRIBUTION OF AUDIBLE HEART SOUNDS

that heart sounds detected near their origin do in fact have components with a larger amplitude at higher frequencies.

The total spectrum of adult heart sounds has been found to extend from below 1 Hz to at least 2,000 Hz. It can be seen from Fig. 1.1. that, due to the characteristics of the ear and the fall-off of intensity of the heart sounds, only a part of this spectrum is normally audible. Consequently the division of these sounds into audible and non-audible bands is imposed by the limitations of human hearing rather than by any characteristics of the vibrations themselves. There is no reason however why all the clinically useful information should be confined to the audible band. Nevertheless it has often been the case that phonocardiographic systems have been designed to represent the sounds as heard by the ear and the quality of record produced has been judged on the same basis. Since the ear can select only part of the spectrum it seems undesirable that the phonocardiograph should be restricted to this particular response characteristic.

A more satisfactory detection system would be one having a level frequency response throughout the whole spectrum. This could then be linked to a suitable processing system in order to produce any required emphasis or de-emphasis of parts of the spectrum. This method would have obvious advantages for recording cardiovascular sounds other than those from the precordium since these will not necessarily have the same distribution of intensity with frequency.

In/

In particular the non-linear transmission properties of body tissue will have a much greater effect on the nature of foetal heart sounds, which originate at a considerable distance from the point of observation, than on Korotkoff sounds, which can be observed very close to their origin.

1.3. Standardization of Phonocardiography

An international committee was formed in 1950 at the First World Congress of Cardiology to consider the question of standardization in phonocardiography. A second meeting was held in 1953 at a meeting of La Société Française de Cardiologie and a series of recommendations were drawn up, which were published by Kleyn, Leatham, Maasz, Lian and Minot in 1955. The most significant of these recommendations from the instrumental point of view was that the basic phonocardiographic tracing was required to follow the sensitivity curve of the human ear and that vibrations outside the range 15-800 Hz were to be excluded from the recordings. It was also recommended that if selective tracings of high, and low parts of the audible spectrum were included in the recording not more than two of these should be presented simultaneously for clarity.

A third meeting of this committee took place in Stockholm in 1956 at the time of the Second European Congress of Cardiology. Seven main proposals were made at this meeting and these were reported by Mannheimer in 1957. Since these proposals provide a basis for the standardization of instrumentation it is necessary to consider them in detail.

1. "A phonocardiograph is an apparatus for recording mechanical vibrations originating from the heart and adjacent vessels.
2. In order to get a record of the auscultative findings in accordance with the sensitivity of the human ear, means should be provided for recording according to the/
the/

the Fletcher O-isophon, i.e. the sensitivity of the apparatus should increase 14 db per octave, by increasing frequency, from 15 to 600 cps (Hz). Maximum allowed error is ± 6 db. In the range 600 - 800 cps (Hz), the sensitivity may fall 6 db. This characteristic is called auditory.

3. In order to obtain further information from the frequency spectrum of the phonocardiogram, means may be provided for one or several additional frequency channels.

The channels employed should be named with the frequency at which the slope of the increase of sensitivity, by increasing frequency, is 15 db per octave. The frequency which approximately is that at which the oscillations are recorded with the largest amplitude is called the nominal frequency of the channel.

The slope of the sensitivity curve should be outlined clearly in the description of the apparatus.

4. For further analysis it may be of value if more frequency channels are provided, whereupon an interval of about 1 octave between standard frequencies is suitable.
5. The sensitivity should bear reference to the displacement of the unloaded chest wall, and the/

the transmission from the thorax wall to the microphone should be taken into account.

6. Because of the transient nature of the heart sounds, it is important that transients originating from the filters be kept as small as possible. If a square electric potential is applied between the input terminals of the phonocardiograph, the developed transient should be decreased to 10 per cent of the initial deflection within 2 cycles.
7. The phonocardiograph may be provided with a device for determination of the constancy of sensitivity from microphone to graph."

(from Mannheimer, 1957).

The committee were not unanimously in favour of all these points as it is on record that one of the participants was "not of the opinion that means should be made to get a record of the auscultative findings in accordance with the sensitivity of the human ear."

A further meeting dealing with the technical problems of phonocardiography was held during the Third World Congress of Cardiology in Brussels in 1958. At this meeting it was agreed that it would be premature to define the frequency characteristics to be used in the construction of phonocardiographs. Some points were made which clarify and extend the definitions agreed at the Stockholm meeting. These are quoted in full in view of their importance for instrumental/

instrumental development.

1. "It is necessary to use some type of filter to obtain relevant and clinically significant phonocardiographic tracing.
2. If the frequency response given by microphone, amplifiers and recording units is linear (a highly desirable feature of any apparatus) the most important variable is represented by the filter or set of filters. The frequency response of all these parts, including filters, should be such as to give the desired response for each frequency.
3. It would be desirable for each researcher to indicate in his publications the frequency characteristics of his filters in a uniform manner."

(from Kleyn et al. 1959).

A method of specifying the characteristics of both high pass and band pass filters was recommended but this was later modified as it was found that the original description was not adequate. The selection of the frequencies used was left to the individual researcher.

Further meetings dealing with nomenclature and standardization were held in Mexico City in 1962 at the Fourth World Congress of Cardiology, at Kyoto in 1964 during the III Asian-Pacific Congress of Cardiology and in Prague in 1964 at the Fourth European Congress of Cardiology. No further recommendations were made at these meetings as regards the standardization of instrumentation.

1.4. Aims of the Investigation

In spite of the recommendations of the various committees on standardization a review of recent literature shows that little progress has been made towards the design and production of satisfactory phonocardiographic equipment.

A method for detecting the unloaded displacement of the body surface by means of a capacitance proximity transducer has been described by Groom and Sihvonen (1957). The system as originally described was unsatisfactory as the sensitivity varied with the amplitude. Yoshitoshi, Machii, Sekiguchi, Mishina, Ohta, Watanabe, Shinohara, Hanaoka, Kohashi, Shimizu, Ohno and Shimizu (1965) have described a servo-method by which the capacitance proximity transducer can be maintained at a constant distance from the body surface and thus obtain constant sensitivity. However the frequency response of their apparatus was only linear over the range 30 - 1,000 Hz so that it is not suitable for wide band phonocardiography. They also made a comparison between the performance of the proximity microphone and a variety of other types of microphone which showed considerable differences in response at low frequencies. Other workers have concentrated largely on the calibration of existing types of microphone and the description of different filter systems for cardiographic analysis.

In almost every case the properties of the resulting phonocardiograph have depended to a large extent on the properties of the transducer and the requirement that the overall response should match/

match that of the human ear. This means that the transducer must be calibrated under the normal conditions of operation and the response of the signal processing circuit adjusted by means of suitable filters. The resulting amplitude/frequency distribution is such that no single calibrating signal is adequate. It is clear that there is still a need for some form of instrumentation which can detect cardiovascular sounds in a known manner without the need for elaborate calibration procedures. Such an equipment could then serve as a standard for all other types of phonocardiograph currently in use and as a means of obtaining additional information on heart sounds which could be used in the design of future phonocardiographs.

A basic specification of such an equipment can be drawn up from the standardization recommendations.

- (a) The transducer must detect the displacement of the body surface without loading it in any way.
- (b) The signal processing method used to convert displacement at the transducer into an electrical signal must be independent of the frequency and amplitude of the displacement.
- (c) Any amplifiers used to increase the magnitude of the electrical signal must also be independent of the frequency and amplitude of the signal.
- (d) The system must be designed so that it can be calibrated independently of the conditions of use.
- (e) The final output must be available in a form suitable for display, recording or immediate further analysis.

The/

The question of suitable filters for use in phonocardiographic studies has not been included in the above specification. This is because standardization may only be possible once a better understanding of heart sounds has been obtained. It is better therefore not to prejudice the issue by specifying filter characteristics at too early a stage in the development. In any case filters can always be added after the basic detection system to suit the needs of the individual worker.

One fact must however be considered in connection with the form of the final output from the detection circuit. The amplitude of component frequencies of the vibrations of the body surface generated by the heart varies by a factor of a million over the frequency range 1 - 1,000 Hz. The dynamic range of the electrical signal which can be displayed or recorded is generally limited to less than 100 : 1 due to the lack of resolution of the trace or the noise level of the equipment. Linear methods of display or recording cannot therefore retain the high frequency components in any detail. If these components are to be indicated in a display or recovered from a recording some form of pre-emphasis is necessary to ensure that the signal amplitude at the required frequency is adequately above the noise level of the apparatus.

It has therefore been the aim of this investigation to study further the properties of the capacitance proximity transducer as a means of detecting cardiovascular sounds without loading the body surface; to devise a method of detecting the variations which occur
in/

in the transducer so that an output can be obtained which is proportional to the amplitude of the displacement irrespective of the rate of change of displacement; and to produce an output which has a sufficiently low noise level for selective amplification of any frequency in the cardiovascular sound spectrum to be possible.

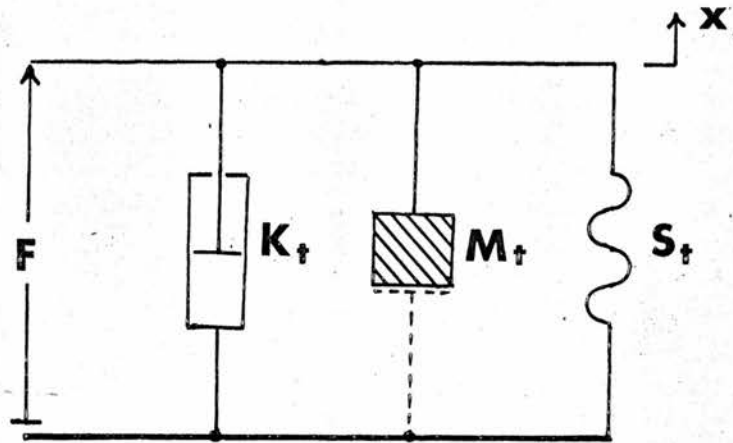

FIG. 2.1. A MECHANICAL CIRCUIT FOR HUMAN TISSUE

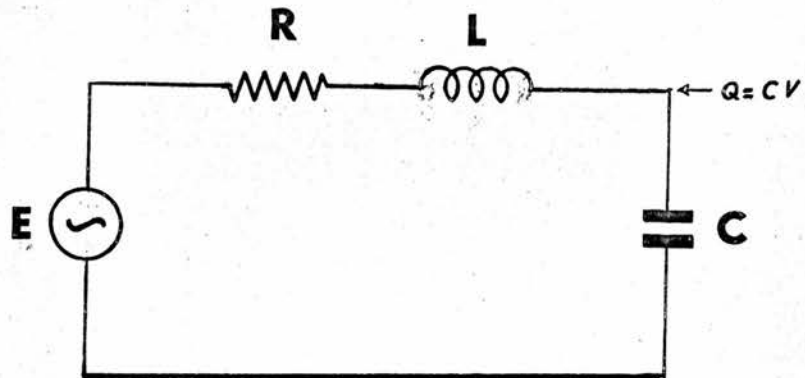

FIG. 2.2 ELECTRICAL ANALOGUE OF MECHANICAL CIRCUIT

CHAPTER 2

TRANSDUCERS

2.1 Mechanical Properties of Tissue in Relation to Transducer Performance.

The motion of the body surface arising due to vibrations within the cardiovascular system is a complex function of the mass, stiffness and viscous damping of the tissues between the vibration source and the point of observation. Since the vibration source cannot be replaced by a standard source there is no means of measuring the transmission characteristics of the tissue. It is necessary therefore to regard the body surface motion as the physiological variable which is to be measured. Since this measurement is made by a transducer which is applied to the body surface it is necessary to know the mechanical impedance of the surface at the point of application. This enables the performance of a given type of transducer to be predicted.

Determinations of the mechanical impedance of the body surface have been made by Bárány (1942), Franke (1951 a,b), Von Gierke et al (1952), Takagi et al. (1963) and others. Their results give values for the mass, stiffness and viscous damping components of the complex driving point impedance observed at various points on the body surface. The frequency at which this impedance appears real (i.e. mechanical resonance) was also determined.

The measured body surface impedance can be represented diagrammatically as shown in Fig. 2.1. where

$M_t/$

M_t is the effective mass of tissue in motion
 S_t is the stiffness of the tissue
 K_t is the viscous damping of the tissue.

The equation of motion of this system is given by

$$M_t \ddot{x} + K_t \dot{x}^2 + S_t \dot{x} x = F\dot{x}$$

where F is the applied force
 x is the resultant surface displacement.

This can be reduced to a simple differential equation by dividing through by \dot{x} .

i.e.
$$M_t \ddot{x} + K_t \dot{x} + S_t x = F.$$

In order to study the properties of the mechanical system more fully it is convenient to use an electrical analogue (Olson 1958). This has the advantage that it can be set up on an analogue computer and the individual parameters can be varied at will. Using the method of 'direct' analogy the mechanical system described appears in the form of a series resonant electrical circuit as shown in Fig. 2.2. Where

L is an inductance proportional to the tissue mass M_t
 C is a capacitance inversely proportional to the stiffness S_t
 R is a resistance proportional to the viscous damping K_t .

The energy equation of this equivalent circuit is given by

$$L \dot{q} \ddot{q} + R \dot{q}^2 + \frac{\dot{q}q}{C} = E\dot{q}$$

where E is the applied voltage
 q is the displaced charge.

Dividing through by \dot{q} gives a similar differential equation to that of/

of the mechanical system

$$\text{i.e. } L\ddot{q} + R\dot{q} + \frac{q}{C} = E.$$

In these two equations a one-to-one correspondence exists between charge and displacement, and force and voltage. The detection of motion of the body surface is thus equivalent to the detection of the charge on the capacitor in the electrical analogue.

Since $Q = CV$

the charge on the capacitor can be determined by measuring the potential difference set up between its plates. In order to do this a voltmeter with a high input impedance is required so that the charge is not disturbed by the observation. For the measurement of mechanical displacement this implies that the mass, stiffness and resistance of the detector must be very low.

The resonant frequency of the electrical circuit is given by

$$F = \frac{1}{2\pi\sqrt{LC}}$$

and so the resonant frequency of the mechanical system will be given by

$$F_t = \frac{1}{2\pi\sqrt{\frac{S_t}{M_t}}}$$

It can be seen from this that changes in the effective mass or stiffness of the vibrating tissue will produce a change in the natural resonance of the system. There is no means by which the mass or stiffness of the tissue can be reduced so that the mass and stiffness of the system will both be increased by the presence of a/

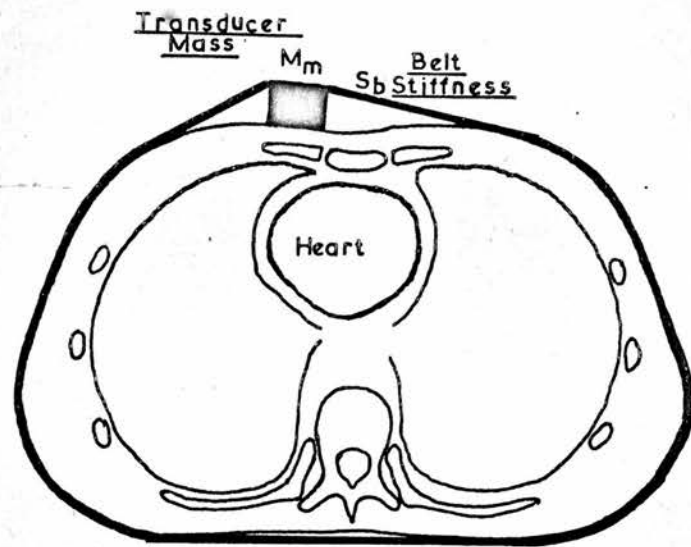

FIG. 2.3. TRANSDUCER HELD ON PRECORDIUM
BY MEANS OF A BELT

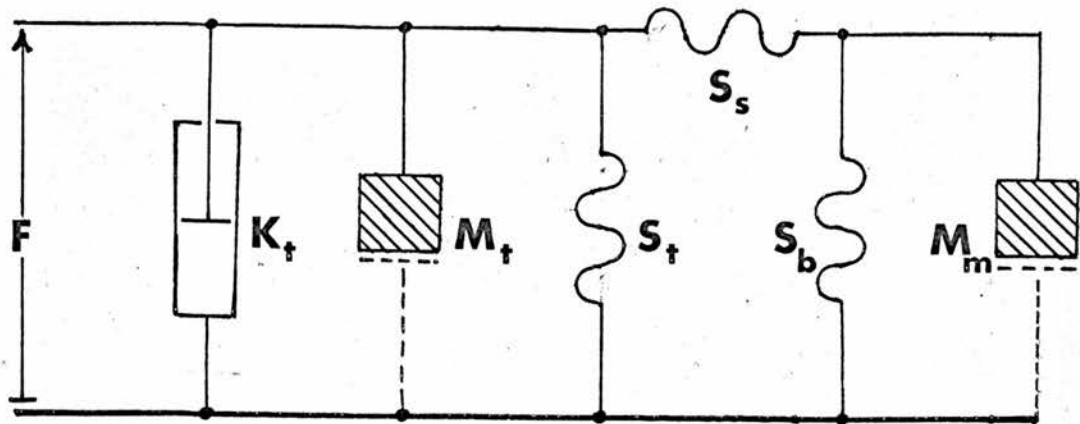

FIG.24. MECHANICAL CIRCUIT USING BELT

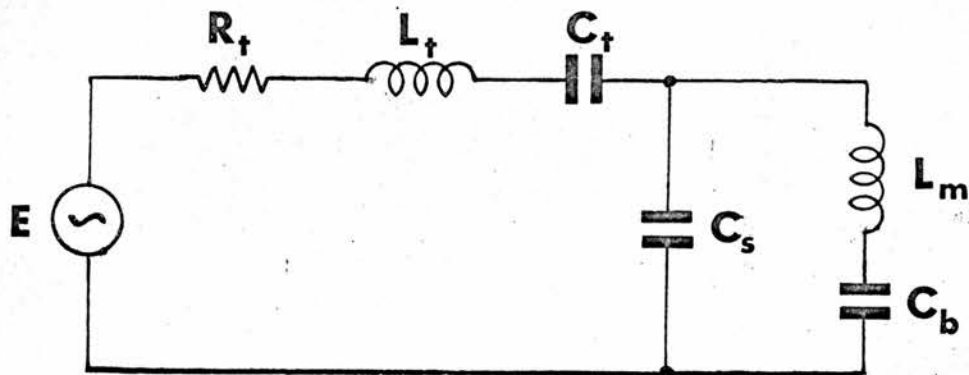
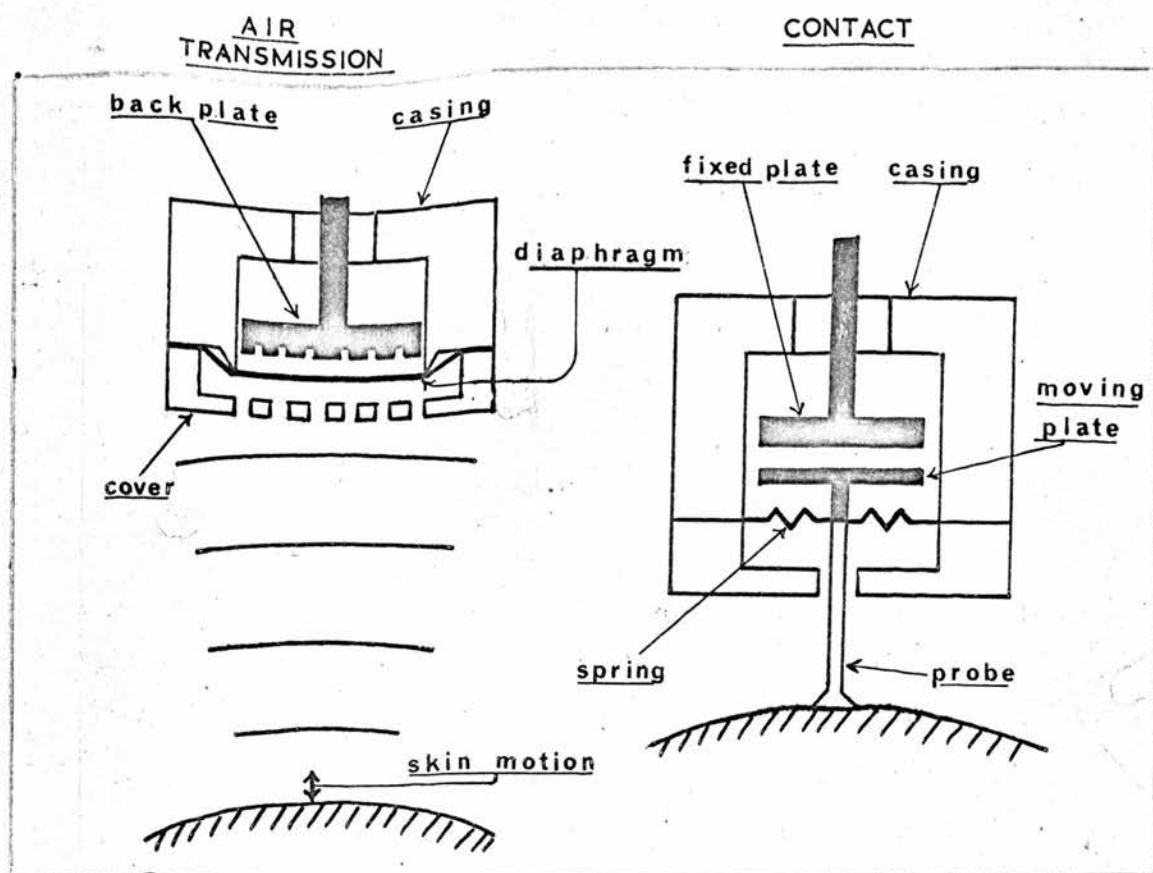

FIG.25. ELECTRICAL ANALOGUE USING BELT

a transducer. Unless the impedance of the transducer is matched to the impedance of the body surface at the point of observation then the frequency response of the system will be altered. However it is known that the impedance measured at different points on the body of a given subject and at the same points on different subjects can vary over a wide range. It is thus impossible to construct a transducer which would give an unaltered response for all parts of the body and for all subjects, unless it does not add any mass, stiffness or viscous damping to the system.

It can also be seen from this discussion that the normal method for holding phonocardiographic microphones in contact with the body by means of a rubber belt (see Fig. 2.3) will alter the frequency characteristics of the detected vibrations. Since the belt cannot be applied with a consistent tension the resonant frequency of the system may vary over a wide range. This may well be the explanation of the inconsistent results which are sometimes obtained by this method. The arrangement is complicated further because the body does not have a rigid boundary so that the stiffness of the tissue between the microphone and the effective tissue mass must be taken into account. This situation is shown diagrammatically in Fig. 2.4 and the analogous electrical circuit in Fig. 2.5. When the microphone rests on the surface of the body, without the use of a belt, the mechanical and electrical circuits can be simplified since the stiffness of the belt becomes zero.



ABSOLUTE MOTION TRANSDUCERS

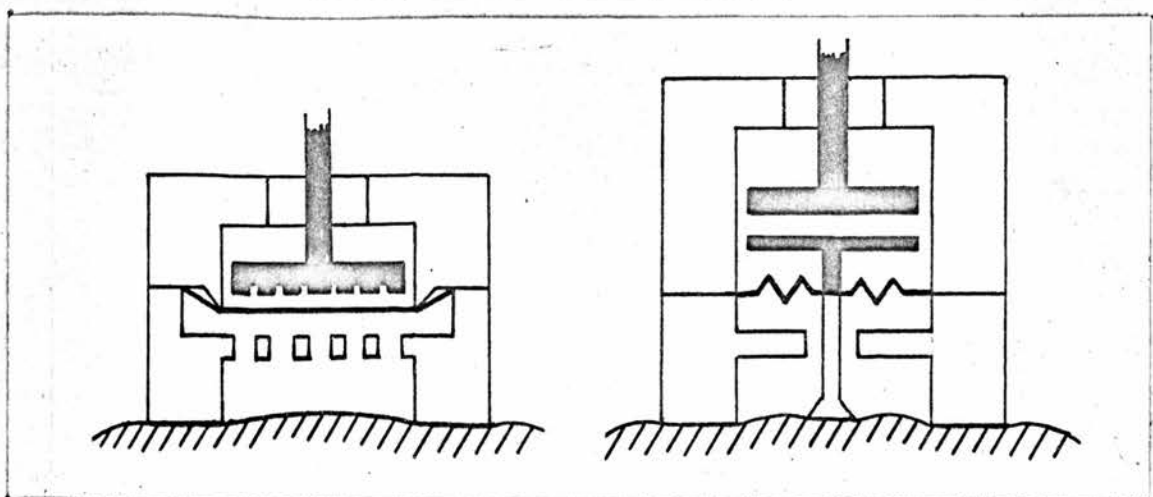

RELATIVE MOTION TRANSDUCERS

FIG. 2.6. SOME COMMON TYPES OF HEART SOUND TRANSDUCER

2.2. The Ideal Displacement Transducer

(1) Requirements for an Ideal Transducer

The basic requirement for an ideal transducer is that its electrical output should be a faithful representation of the physiological variable over the full range of amplitudes and frequencies to be observed. This implies that;-

- (a) The vibrations are not modified in any way by the presence of the transducer.
- (b) The transducer and signal processing system are not overloaded by large amplitude vibrations.
- (c) The output amplitude and phase are independent of the frequency of the vibration.
- (d) The total internal noise level of the transducer and signal processing system is adequately below the smallest signal to be detected.

None of the transducers which are currently in common use meet any of these conditions satisfactorily so that a compromise is often necessary. Typical examples of these transducers are shown in Fig. 2.6. (a - d).

In the previous section it has been shown that any transducer which makes contact with the body will modify the vibration in some way. It can also be shown that any transducer which has moving parts must have a natural mechanical resonant frequency of its own. Consequently, even if contact with the body is reduced to a minimum, (e.g. the air transmission microphone in Fig. 2.6(a)) the internal resonance may well modify the properties of the/

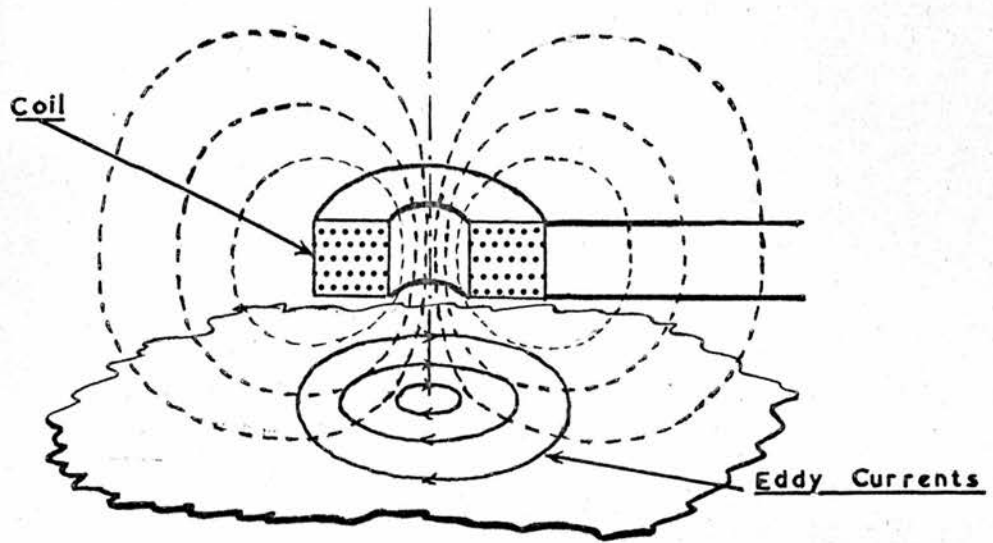

FIG.2.7, EDDY CURRENT TRANSDUCER

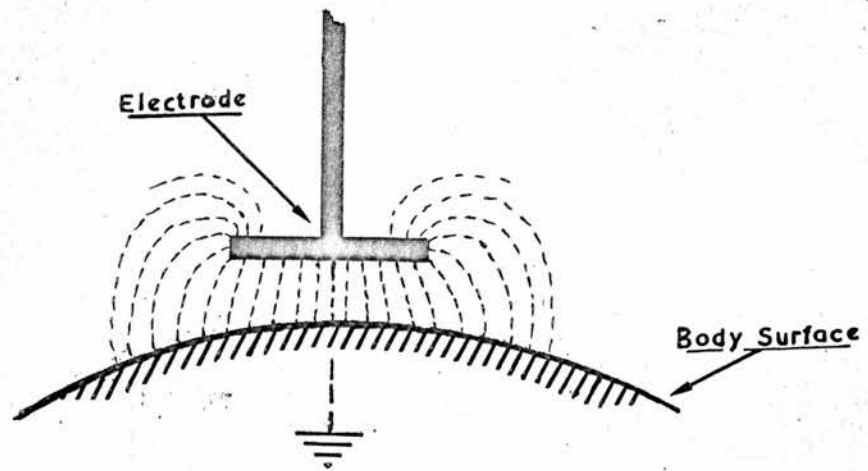

FIG.2.8, CAPACITANCE PROXIMITY TRANSDUCER

the transducer. It becomes clear that the only satisfactory method of detecting the motion of a moving surface without moving parts or contact with the surface is to use a 'proximity transducer'. This type of device is well known in industrial applications but most of the types used are unsuitable since they depend on properties not possessed by human tissue e.g. use of ferromagnetic materials. However two types exist which could make use of the fact that body tissue is conducting. These are the Eddy Current and Capacitance Proximity Transducers.

(ii) The Eddy Current Proximity Transducer

The basic form of this transducer is shown in Fig. 2.7.

A radio frequency current flowing in the coil sets up circular and coaxial eddy currents in the conducting medium. The magnetic field produced by the eddy currents opposes that of the coil, reducing its effective inductance. The change of inductance is a function of the spacing between the coil and the surface of the conductor but the method is not suitable because this is not a linear relationship. In order to achieve satisfactory operation of the device it is necessary to use a low carrier frequency since the stray capacitance between coil and conductor may otherwise alter the effective inductance of the coil. The choice of a low carrier frequency may affect the response of the system at the high frequency end of the vibration spectrum which is another disadvantage of the method. (Further details of the method and its applications are given by Lion (1959)).

(iii)/

(iii) The Capacitance Proximity Transducer

The basic form of this transducer is shown in Fig. 2.8.

The operation of this device depends on the fact that an electrical capacitance exists between two conducting objects. The magnitude of this capacitance is a function of the distance between the objects so that if a suitable electrode is placed near a vibrating surface its vibrations can be detected. The use of such an arrangement for the measurement of small displacements was first described by Whiddington (1920). The method is well understood both electrically and mechanically, and industrial instruments operating on this principle are manufactured by Fielden Electronics Ltd. (c 1947) and Wayne Kerr Laboratories Ltd. (1958). The principle has also been applied to the study of cardiovascular sounds and other biological movements by Cembala (1949), Groom et al (1957), Chlebus (1962) Mäkelä et al (1959),/Fischler et al (1964) and Yoshitoshi et al (1965). None of the methods described by these workers is capable of giving an output which is linear with displacement of the body surface over the range of amplitudes and frequencies required. However it will be shown in Section 2.3 that, under suitable conditions, the reactance of a capacitor which consists of a plane electrode parallel to a plane conducting surface is proportional to the spacing between the electrode and the surface.

(iv) Advantages and Limitations of the Capacitance Method

The advantages which have been claimed for the capacitance method may be summarized as follows.

- (a) The detecting electrode does not make contact with the body surface so that it does not

- not modify the vibrations in any way.
- (b) There are no moving parts so that the frequency response is not limited by the mechanical resonance of the transducer.
 - (c) The detecting electrode is totally insensitive to airborne ambient noise: (a major source of interference in heart sound recording.)
 - (d) The device is only sensitive to motion of the area of the surface directly beneath the electrode. It is therefore ideally suited to the study of the origin and transmission of cardiovascular sounds.
 - (e) With a suitable signal processing circuit the transducer can have a very high sensitivity.
 - (f) Since there are no moving parts within the transducer it can have a wide amplitude tolerance.
 - (g) The mechanical construction required is simple so that a very rugged device can be made.

The form of transducer so far described has some limitations although the effects of these can be minimized by suitable observational techniques.

- (a) The motion detected by the transducer is the total motion relative to its position. Consequently, if a fixed mounting is used for the detection of heart sounds, respiration and other body movements may/

may be detected. The effects of these movements can be reduced by the use of alternative types of mounting although these may affect the response to low frequency components of the heart sounds.

- (b) Although airborne noise does not affect the transducer directly it may set up vibrations in the tissue which will be detected by the transducer. This can be avoided by making observations in a soundproof or quiet room.
- (c) The output obtained will be distorted at large amplitudes due to the signal processing methods used. This distortion is usually avoided by ensuring that the amplitude of vibration is always small compared with the spacing between the electrode and the body surface. It can however be eliminated completely by the use of a suitable signal processing method.
- (d) The transducer is susceptible to electrostatic hum pick-up at very large spacings. The choice of a linear detecting method means that spacings which are large compared with the vibration amplitude are no longer required so that hum pick-up becomes much less significant.

2.3. Design of a Practical Capacitance Proximity Transducer

(1) Reactance of a Parallel Plate Capacitor

The transducer described in Section 2.2 is in the form of a capacitor consisting of two parallel plates one of which is the body surface. Provided the spacing between the other electrode and the body surface is very small compared with the dimensions of the electrode then the effective capacitance of the transducer is given by

$$C_t = \epsilon_0 \epsilon_r \cdot \frac{r^2}{d} \quad \text{Farads}$$

where r is the radius of the detecting electrode in metres.

d is the spacing between the electrode and body surface in metres

and ϵ_r is the dielectric constant of the air.

If the electrode area and dielectric are not changed then the capacitance is inversely proportional to the spacing.

The reactance of a capacitor is given by

$$X = \frac{1}{\omega C}$$

where ω is the angular frequency applied to the capacitor.

It can be seen that if the reactance of the transducer capacitance is measured at a constant frequency it is proportional to the spacing.

$$\text{i.e. } X_t = \frac{1}{\omega \cdot \epsilon_0 \epsilon_r} \cdot \frac{d}{r^2}$$

(11)/

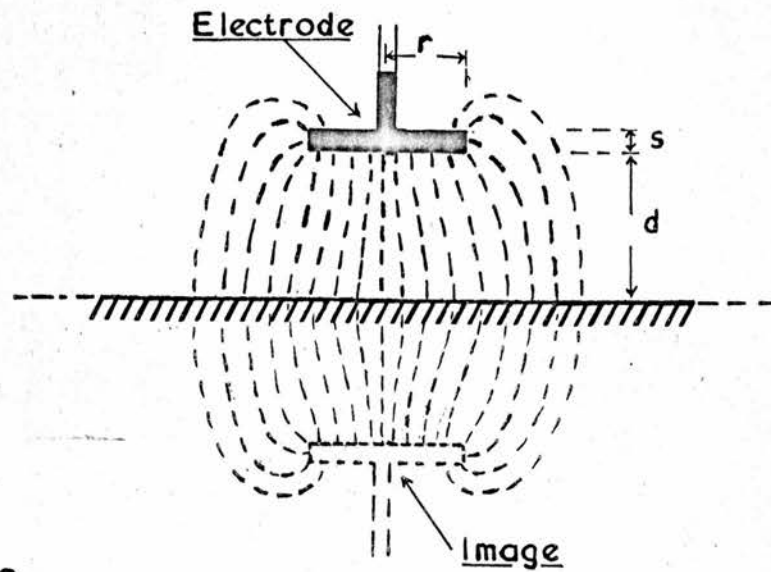

FIG.2.9. CALCULATION OF ELECTRODE CAPACITANCE

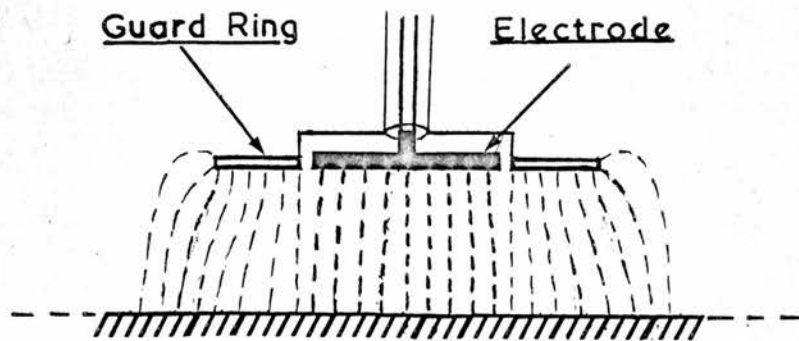

FIG.2.10. USE OF GUARD RING

(ii) Edge Effects

The expression derived above does not take into account the distortion of the electrical field which occurs at the edge of detecting electrode. The error this produces under the conditions specified is very small but it may be necessary to operate the transducer under conditions in which it is not negligible. A formula for the total capacitance of a circular-plate capacitor including the edge effect is given by Lion (1959). This must be modified since the transducer has only one circular plate and the other which is the body surface can be regarded as infinite (see Fig. 2.9). The resulting equation is of the form

$$C_t = \epsilon_0 \epsilon_r \left\{ \frac{\pi r^2}{d} + 2r \left[\ln 8\pi r + 1 + f\left(\frac{s}{2d}\right) \right] \right\}$$

where s is the thickness of the detecting electrode.

A table of the correction factors $f\left(\frac{s}{2d}\right)$ for various values of $\left(\frac{s}{2d}\right)$ is given in the book by Lion (1959) and also in a paper by Foldvari and Lion (1964).

It can be shown that if the radius of the detecting electrode is more than 400 times the distance of the electrode from the body surface, the increased capacitance of the transducer due to the edge effect will be less than 1%. If the ratio between the electrode and the distance is ~ 100 , the thickness of the electrode being equal to the spacing, then the error rises to $\sim 6\%$.

(iii) Use of a Guard Ring to Reduce the Edge Effects

The effects of the fringing capacitance at the edge of the transducer electrode can be reduced considerably by the use of a guard ring (see Fig. 2.10). The guard ring surrounds the detecting electrode but is separated from it by a very small gap. If this ring is energized at the same potential as the detecting electrode then the disturbance of the field lines at the gap will be very small. The fringing effects now appear at the edge of the guard ring and if this is wide enough the field lines will be normal to the detecting electrode. The source of potential for the guard ring must be arranged so that the capacitance of the ring does not affect the measuring circuit. It is found that such an arrangement is not possible with some types of measuring circuit. One condition which is necessary for the guard ring method is that the total surface presented to the transducer must be at least as large as the combined area of electrode and guard ring.

Details are given by Wayne Kerr (c 1959) for the construction of transducers other than those supplied with their instruments. The formulae given for these transducers are claimed to give an accuracy of 2% for a separation between the transducer and the body surface less than a specified value.

If the gap between the detecting electrode and the guard ring is very small then the radius of the electrode is given by

$$r = \sqrt{(d_m \cdot b)}$$

where d_m is the maximum spacing between transducer
and body surface

and/

and b is a constant having the dimensions of length.

($b = \frac{1}{2}$ when d_m and r are measured in inches).

The minimum outside radius of the guard ring is then given by

$$r_g = r + 3d_m$$

so that the guard ring is at least three times wider than the maximum spacing between the electrode and the body surface.

Values are also given for the thickness of insulation between the electrode and guard ring, which vary from 4% to 10% of the electrode radius. It is also recommended that the guard ring has a depth which is some five times this insulation thickness i.e. 20% to 50% of the electrode radius.

(iv) Other Stray Capacitances

Stray capacitances may also exist between the detecting electrode and its connecting lead, and objects other than the vibrating surface. These will affect the detecting circuit accuracy because the total capacitance which is present is greater than that of the transducer alone. Thus the measured reactance is no longer proportional to the transducer spacing.

The effects of such stray capacitances can be eliminated by screening the electrode and connecting lead. If this screen is connected to a suitable point in the measuring circuit then the capacitances between lead and screen, and between screen and vibrating surface will not affect the measurement. Only the face of/

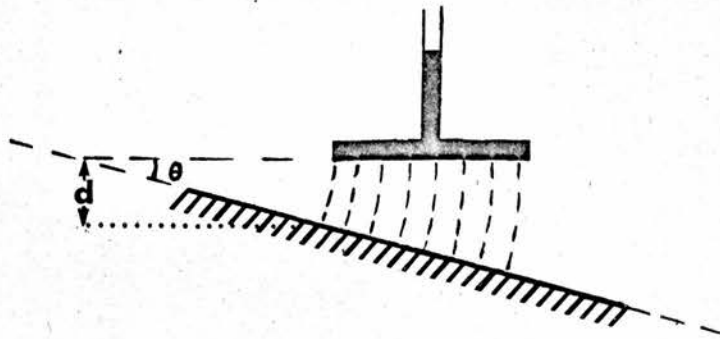

FIG.2.11, SURFACE NOT PARALLEL WITH ELECTRODE

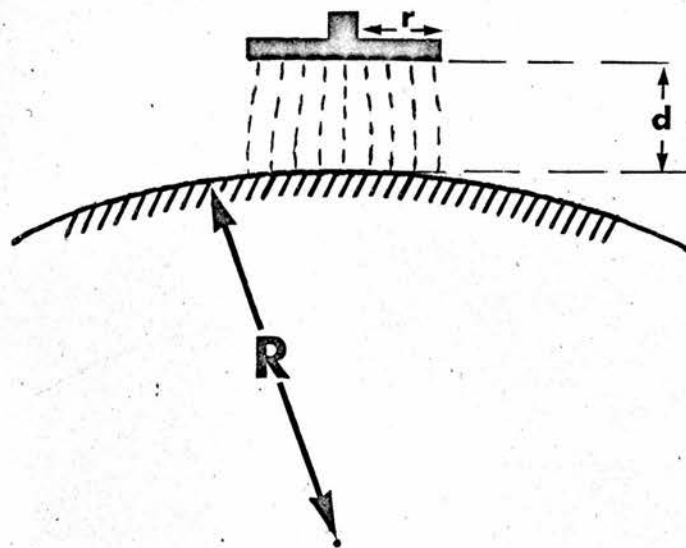

FIG.2.12. CURVED SURFACE

of the electrode opposite the vibrating surface is left unscreened. This can be achieved very conveniently if the connection to the guard ring is made by means of the screen of a coaxial cable the centre lead of which is connected to the electrode. With some types of bridge network a cable screen at neutral potential can be used but since this is not identical with the electrode potential the guard ring would be ineffective.

(v) Errors due to the shape of the body surface

The body does not have a plane rigid surface so that when it is in motion it is not possible to ensure that it remains parallel to the electrode. As a result it may not be possible to interpret the measured reactance of the transducer in terms of a perpendicular spacing between the electrode and the body.

Three possible sources of error must be considered.

- (a) the electrode is not parallel with the body surface. (see Fig. 2.11)
- (b) the body surface is curved in the region of the electrode. (see Fig. 2.12)
- (c) the curvature of the body surface changes as it vibrates.

Wayne Kerr (c 1959) states that if the angle between the two surfaces is less than 5° then the measurement error will be less than 0.4%. The error rises to $\sim 1\%$ at 8° . Since zero output must correspond to zero spacing it is clear that the distance measured must be the minimum spacing measured perpendicular to the electrode./

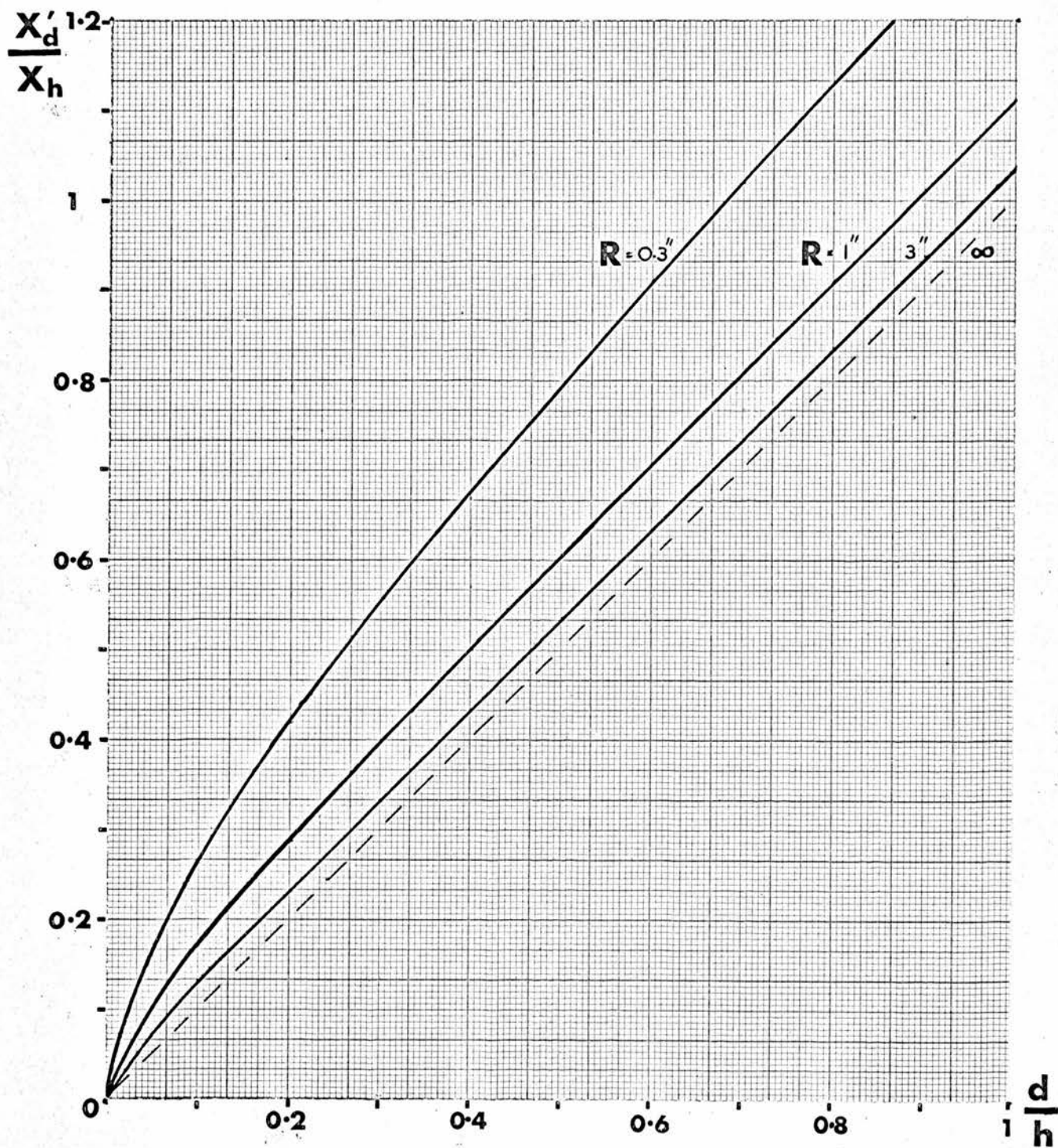

FIG.2.13. VARIATION OF TRANSDUCER REACTANCE WITH DISTANCE FROM A CYLINDRICAL SURFACE

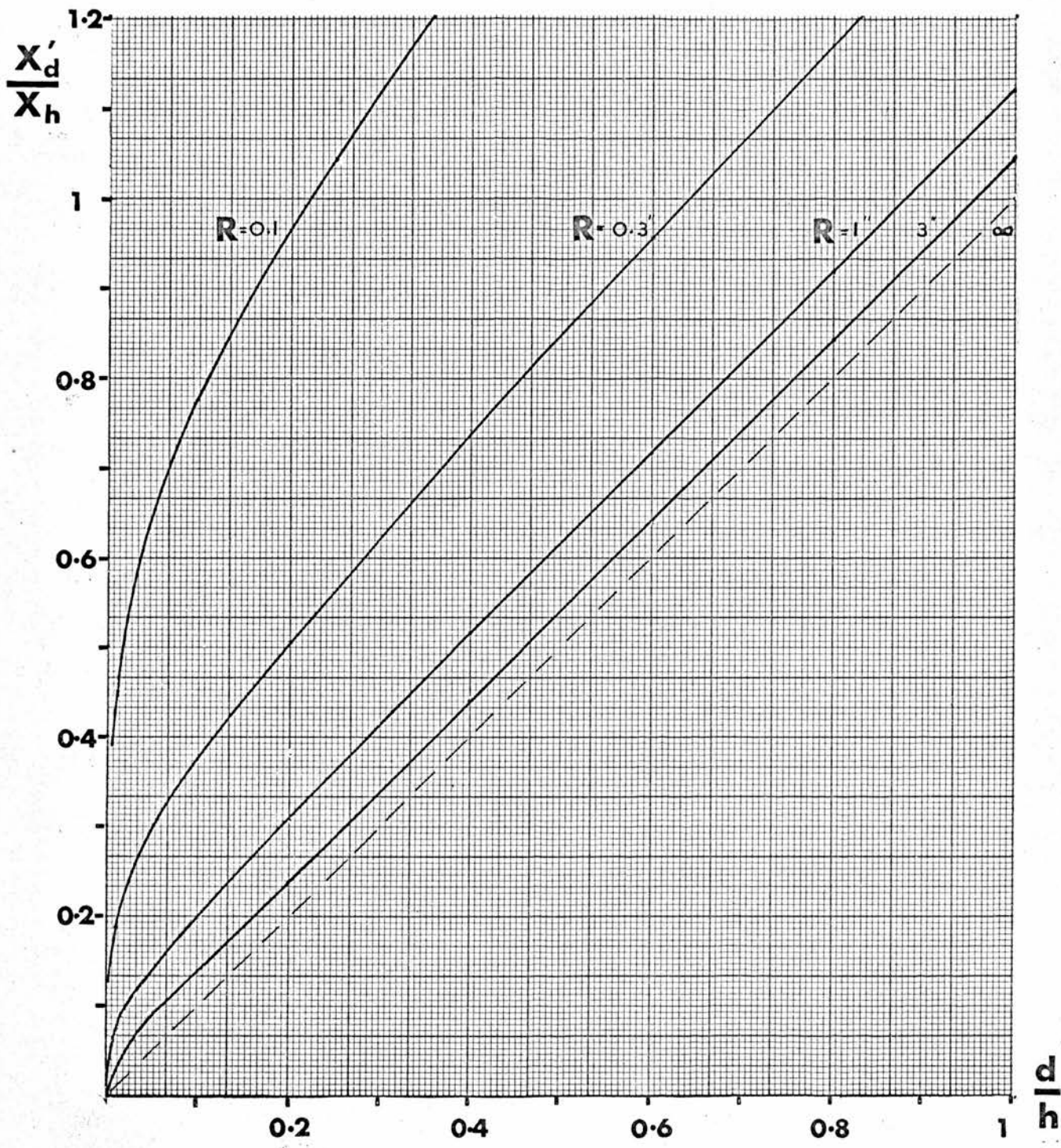

FIG.2.14. VARIATION OF TRANSDUCER REACTANCE WITH SPACING FROM A SPHERICAL SURFACE.

electrode. They have found that it is not difficult to ensure that the angle between the electrode and vibrating surface is less than 8° by visual inspection.

It is more likely in the study of cardiovascular sounds that the vibrating surface will be curved in some way and that the curvature will not correspond to any regular geometrical form. An estimate of the error which arises due to surface curvature can however be made by consideration of the special cases of cylindrical and spherical curvature.

It can be shown (see Wayne Kerr (c 1959)) that if a probe of radius r is placed at a minimum axial distance d from a cylindrical surface of radius R the measured reactance is given by

$$X'_d = \frac{d}{\omega \epsilon_0 \epsilon_r \pi r^2} \cdot \frac{1}{\frac{4}{\pi} \int_0^{\pi/2} \frac{\cos^2 \theta \cdot d\theta}{1 + \frac{R}{d} \left[1 - \sqrt{\left(1 - \frac{r^2}{R^2} \sin^2 \theta\right)} \right]}}$$

Fig 2.13 shows a series of correction curves suitable for two of the Wayne Kerr probes which may be used with cylindrical surfaces having radii of curvature between $0.1''$ and ∞ .

A similar result can be obtained for a probe of radius r at a minimum axial distance d from a spherical surface of radius R . (see Appendix B). In this case

$$X'_d = \frac{d}{\omega \epsilon_0 \epsilon_r \pi r^2} \cdot \frac{1}{\frac{1}{r^2} \int_0^r \frac{2x \cdot dx}{1 + \frac{R}{d} \left[1 - \sqrt{\left(1 - \frac{x^2}{R^2}\right)} \right]}}$$

Fig. 2.14 shows a similar series of correction curves for the Wayne Kerr/

Kerr probes which may be used when the curved surface is spherical.

It can be seen in both cases that the measured reactance is greater than that obtained with a plane surface at the same axial distance. The resultant error in distance measurement is however small for surfaces having a radius of curvature greater than 1" and this only becomes significant at very small spacings. In the present application an absolute measurement of distance is not required so that the non-linearity as the spacing becomes small will be the only major cause of error. This source of error can be eliminated however, if the curvature of the detecting electrode can be made to match that of the vibrating surface.

If the curvature of the body surface changes during the course of the vibration then the problem becomes more complex. (An analysis of some particular cases is given in Appendix B). However, provided the curvature of the surface stays within the above limits and the spacing between surface and electrode does not approach zero then the additional error will be small. If the curvature of the electrode matches the mean curvature of the surface then the error can be reduced still further.

(vi) Errors due to variations in other parameters

(a) Dielectric Constant of Air

The dielectric constant of a gas is given by

$$\epsilon_r = (1 + \eta)$$

where η is the electric susceptibility.

The electric susceptibility of air is a function of temperature, /

TEMP, °C	RELATIVE HUMIDITY			
	0%	25%	60%	100%
0	0.0006	0.0006	0.0006	0.0006
20	0.0005	0.0006	0.0007	0.0007
40	0.0005	0.0007	0.0008	0.0011
60	0.0005	0.0008	0.0013	0.0018

Variation of η with Temperature and Relative Humidity at Atmospheric Pressure.
(from Kaye and Laby, 1957)

1	40	80
0.0005	0.0218	0.0439

Variation of η with Pressure at 20°C.

FIG. 2.15. VARIATION OF η WITH TEMPERATURE, PRESSURE, AND HUMIDITY

temperature, pressure, humidity and the frequency of the measuring speed. Typical values of γ under a variety of conditions are tabulated in Fig. 2.15.

In the present application the measuring frequency may lie between 10kHz and 2MHz. If the region between the electrode and body surface is enclosed the relative humidity may approach 100%. The pressure will be very close to atmospheric at all times since normal sound waves cause a variation of less than 10%. The temperature will normally lie between 15° and 35° C.

Under these conditions it can be seen that the maximum change in dielectric constant will be less than 0.2% and the change occurring during any period of observation will be much smaller.

(b) Expansion of Detecting Electrode

Since the detecting electrode is in close proximity to the body surface its temperature will be slightly above the ambient air temperature. Changes in the area of the electrode due to expansion will alter the sensitivity of the instrument. This could be avoided by using a material with a low coefficient of expansion, This is not however necessary in the present application since the effect is so small.

The linear coefficient of expansion of Brass has a maximum value of 23×10^{-6} (Kaye and Laby (1957)) so that for the whole temperature rise from 15° to 35° C the electrode area will only change by about 0.1%.

(c) Variation of Carrier Frequency

Since the reactance of a capacitor is given by

$$X_t = \frac{1}{\omega C_t}$$

any variation in carrier frequency will result in a change in the measured reactance. The magnitude of the error depends on the stability of the source oscillator and the type of measuring circuit. An oscillator stability of $\sim 0.1\%$ can be obtained easily and if a balanced circuit is used the resultant change of sensitivity will be very small.

It can be seen that the three possible sources of error covered in this section will have very little effect on the accuracy of the instrument as a vibration detector.

CHAPTER 3

SIGNAL PROCESSING METHODS

3.1 Reactance Measuring Techniques

- (i) Requirements for a continuous method of reactance measurement.

It has been shown in Section 2.3 that the reactance of the capacitance proximity transducer can be made proportional to the spacing between its detecting electrode and the body surface. In order to display or record the motion of the body surface it is therefore necessary to convert the variations of the transducer reactance into a voltage or current. It is necessary that the conversion process from spacing to voltage (or current) should have a good linearity otherwise the final signal will be distorted.

Reactance can be measured in a variety of ways but if a continuous output is required rather than a single measurement a carrier signal must be used. The instantaneous value of the reactance modulates this carrier in some way and subsequent demodulation gives a signal which varies continuously with changes in spacing. It is essential that the combined process of modulation and demodulation is linear. This can be achieved if both sub-processes are themselves linear or if the law obeyed by one is exactly reciprocal to that of the other. A satisfactory solution cannot be obtained if either law is non-linear and some reciprocal analogue non-linearity must be incorporated to correct the output.

Other/

Other requirements for the signal processing method are

- (a) good stability
- (b) high sensitivity
- (c) fast response
- (d) wide dynamic range
- (e) high signal to noise ratio
- (f) independent controls for sensitivity and zero
- (g) simple operating procedure.

(ii) Modulation

The instantaneous amplitude of a carrier wave can be expressed in the form

$$E = A \sin (\omega t + \theta)$$

where A is the maximum amplitude
 ω is the angular frequency of the carrier
and θ is the relative phase.

Variations in the maximum amplitude A or in the angle $(\omega t + \theta)$ will produce changes in the instantaneous amplitude of the carrier. Variations produced by changes in the maximum amplitude of the carrier are known as "Amplitude Modulation", those produced by changes in angle are known as "Angle Modulation". Amplitude modulation includes various forms of pulse modulation and angle modulation includes both frequency and phase modulation.

If the modulation of the carrier is to be linear then the displacements occurring at the transducer must produce proportional changes/

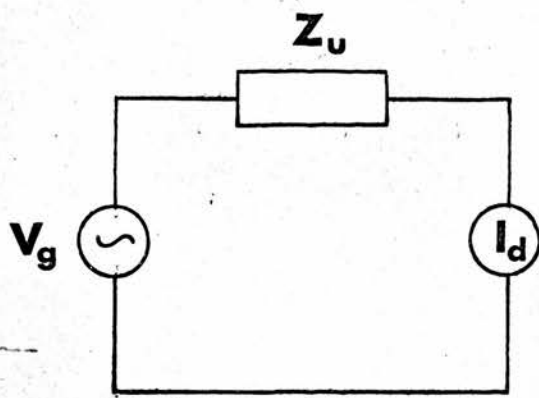

(a) Series Method

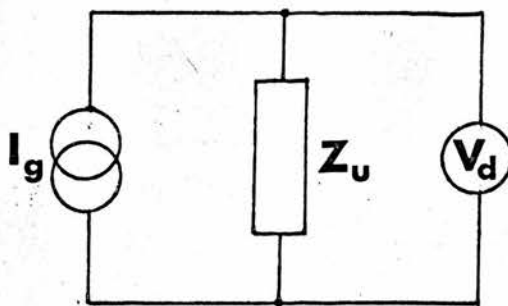

(b) Shunt Method

FIG. 3.1. BASIC METHODS OF IMPEDANCE MEASUREMENT

changes in amplitude or angle. These changes of amplitude or angle must in turn be converted to proportional changes in output voltage or current. Finally this output voltage or current is used to produce a deflection of the electron beam in a cathode ray oscillograph or the pen of a chart recorder and this deflection must be a linear representation of the original displacement at the transducer.

The most convenient methods for use with the capacitance proximity transducer are

- (a) simple amplitude modulation
- (b) frequency modulation.

(iii) Amplitude Modulation Methods

If the complex voltage and current between two points of an a.c. network are known then the impedance between those points is defined by

$$Z = \frac{V}{I}$$

(The generalized form of Ohm's Law)

It can be seen that the most convenient way of measuring a continuously varying impedance is to keep either the voltage or the current constant and detect the variations of the other. The impedance variations in fact produce amplitude modulation of the current or the voltage. Fig. 3.1(a,b) illustrates the two possible methods of measuring the transducer impedance. The impedance/

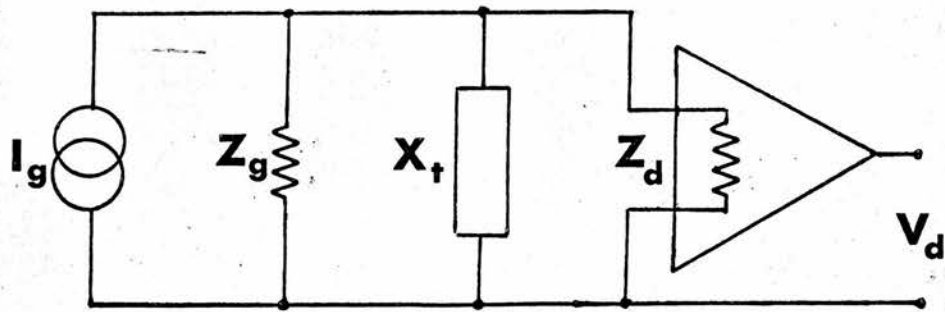

FIG. 3.2. PRACTICAL CIRCUIT FOR SHUNT METHOD

impedance can be attached to a source of constant voltage, as shown in Fig. 3.1a, the current which passes through it being measured by a suitable detector. In this case

$$I_d = \frac{V_g}{Z}$$

Alternatively, the impedance can be attached to a source of constant current, as shown in Fig. 3.1b, the potential difference which is developed across it being measured by a suitable detector, and in this case

$$V_d = Z I_g$$

The first method produces an output current which is inversely proportional to impedance so that changes of spacing at the transducer will not produce proportional changes in the output current. The second method thus provides the simplest means of making a continuous linear measurement of the transducer impedance.

The practical circuit (see Fig. 3.2) consists of an oscillator having a high internal impedance which supplies a current at constant amplitude and frequency to the transducer. The voltage appearing across the transducer is proportional to its impedance and since this impedance is the reactance of the electrode capacitance it will be proportional to the spacing between electrode and body surface. The voltage is detected by means of an amplifier with a very high input impedance. In order that the measured voltage is not affected to a significant degree by the impedance of the/

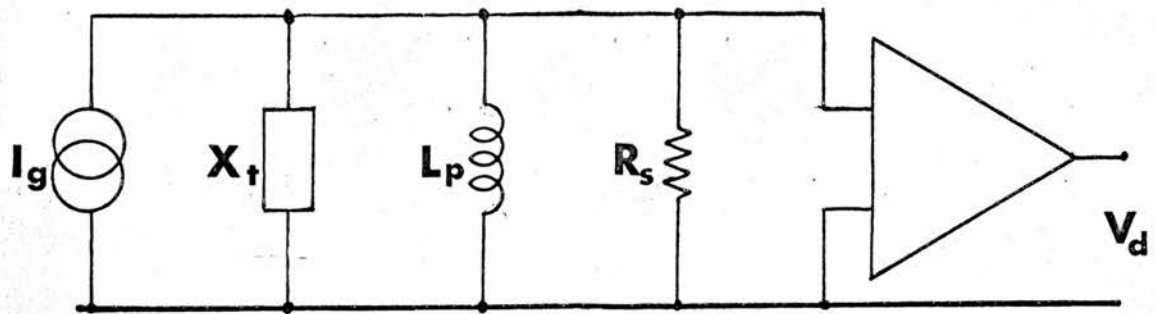

FIG. 3.3. SHUNT METHOD WITH PARALLEL TUNING

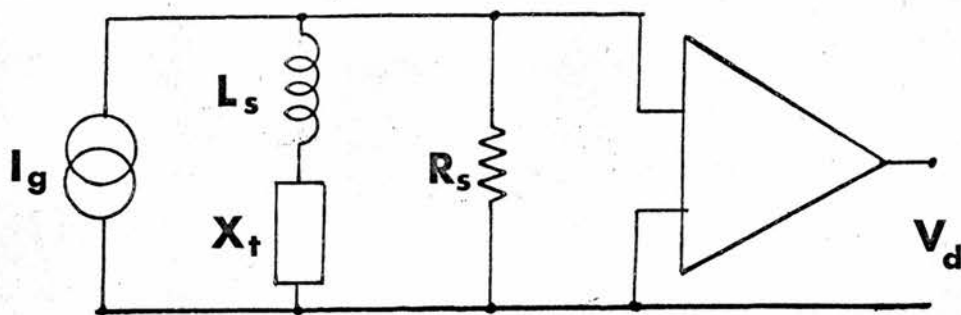

FIG. 3.4. SHUNT METHOD WITH SERIES TUNING

the source or detector it is necessary that these impedances shall be at least 200 times greater than that of the transducer. For a transducer having a capacitance $\sim 1\text{pF}$ this means that the source and detector impedances must be greater than $\frac{2 \cdot 10^{14}}{\omega} \text{M}\Omega$, which is greater than $20\text{M}\Omega$ for all carrier frequencies up to 3MHz . It is found in practice that stray capacitance and leakage resistance throughout the circuit do not permit this level of source and detector impedance to be obtained.

(iv) Improvement of Amplitude Modulation method by tuning

(a) Parallel tuning of transducer and stray capacitances

If other capacitances appear in parallel with the transducer, e.g. cable capacitance, these can be eliminated from the measurement by parallel tuning with a suitable inductance as shown in Fig. 3.3. The inductance is adjusted so that the tuned circuit impedance is a maximum when the transducer capacitance is nominally zero i.e. the electrode is a very large distance from any earthed object. The effective reactance is then given by

$$X = \frac{1}{\frac{1}{\omega L_0} - \omega(C_0 + C_t)} = \frac{1}{\omega C_t}$$

When the cable capacitance is very large it is convenient to construct this inductor in the form of an auto-transformer situated within the transducer housing. This can be used to make the effective transducer capacitance appear much larger than the cable capacitance/

capacitance. The method is not perfect, however, since the Q-factor of the inductor cannot be made large enough. Consequently the loss resistance which appears in parallel with the reactance will be smaller than the required level of source and detector impedance.

This arrangement was used by Groom and Sihvonen (1957) with their capacitance heart sound pick-up but the output obtained was not linear with displacement because they used a constant voltage source.

(b) Series tuning of transducer capacitance

It has been shown by Zaalberg van Zelst (1947) and Hickling (1952) that the effective impedance of the transducer can be made very small by series tuning with a suitable inductor. If the series tuning inductor is situated within the transducer housing then stray impedances in parallel with the cable and measuring circuit will have little effect on the output. This arrangement will also have a good thermal noise performance because the resistance in the measuring circuit will be very low.

The impedance of the series tuned circuit, as shown in Fig. 3.4, is given by

$$Z = r + j\omega L + \frac{1}{j\omega C}$$

where r is the series loss resistance of the inductor and connecting cable.

The voltage amplitude which appears across the tuned circuit is proportional to the modulus of this impedance.

i.e. /

i.e.
$$|Z| = \left\{ r^2 + \left(\omega L - \frac{1}{\omega C} \right)^2 \right\}$$

If the inductor is chosen so that the transducer is series tuned at its minimum capacitance then the voltage will increase as the transducer capacitance increases. A maximum value of output voltage is reached when the transducer electrode makes contact with the body surface. The modulus of the impedance is then given by

$$|Z| = \left\{ r^2 + (\omega L)^2 \right\}$$

Alternatively, the inductor can be chosen to tune the maximum capacitance and then any increase in spacing appears as a linear increase in the measured reactance. This relationship is positive and the electrode can in theory be displaced to infinity. If the transducer electrode is uninsulated then contact between the plates becomes possible so that a maximum capacitance cannot be defined and no impedance advantage is obtained by series tuning.

The inductor could also be chosen to tune any convenient intermediate value of the transducer capacitance, however a phase sensitive detector is then required to avoid ambiguity. The effective sensitivity can be improved in this way since the changes in transducer impedance appear larger in relation to the total measuring circuit impedance. If the intermediate value of capacitance chosen corresponds to the mean value of the transducer spacing then the optimum thermal noise output is obtained.

It can be seen that the advantages of this approach will be lost for large displacements at the transducer because the effective impedance/

impedance becomes as large as that obtained without series tuning.

(v) Frequency Modulation Methods

The method of measuring very small displacements described by Whiddington (1920) used a frequency modulation circuit. This type of circuit has been used frequently in industrial applications and also with the cardiovascular sound transducers described by Cembala (1949); Mäkelä, Österlund and Wallgren (1959); Groom, Medina and Sihvonen (1963), and Aronow, Currens and Cosman (1963).

The basic principle of the method is that the capacitance of the transducer forms part of the tuned circuit which defines the frequency of an oscillator. As the capacitance of the transducer varies so the frequency of oscillation varies according to the relationship

$$f = \frac{1}{2\pi\sqrt{L.C}}$$

where C is the total capacitance tuning the oscillator.

If the transducer capacitance forms the whole of the tuning capacitance C then

$$f \propto \sqrt{d}$$

where d is the spacing between the transducer electrode and the body surface.

Since the frequency of oscillation is not proportional to the spacing the frequency modulation produced will not be linearly related to the changes in spacing at the transducer electrode. The method/

method is also unsatisfactory since the carrier frequency might fall below 10kHz at very small spacings and oscillations would cease altogether if the electrode made contact to earth. If the spacing is not allowed to fall to zero then sensitivity is lost because this is equivalent to connecting a small capacitor in series with the transducer.

In most practical circuits the transducer forms only part of the tuning capacitance of the oscillator. This reduces the effective sensitivity although the linearity is improved near resonance since changes in spacing now produce much smaller changes in frequency. However, the non-linearity is increased when the spacing becomes very small compared with the value at resonance.

The resonant frequency in such cases is given by

$$f = \frac{1}{2\pi\sqrt{L(C \pm \frac{a}{\Delta d})}}$$

where

a is a constant for the transducer
 Δd is the change of spacing which occurs at the transducer.

The change of frequency Δf produced by a change in transducer spacing Δd is given by

$$\Delta f \propto \frac{b}{2\Delta d} - \frac{3b^2}{8\Delta d^2} + \dots$$

(an infinite series)

The significance of these terms depends on the construction of the transducer and the magnitude of the parallel capacitance. The factor b is equal to the spacing of the transducer which would be/

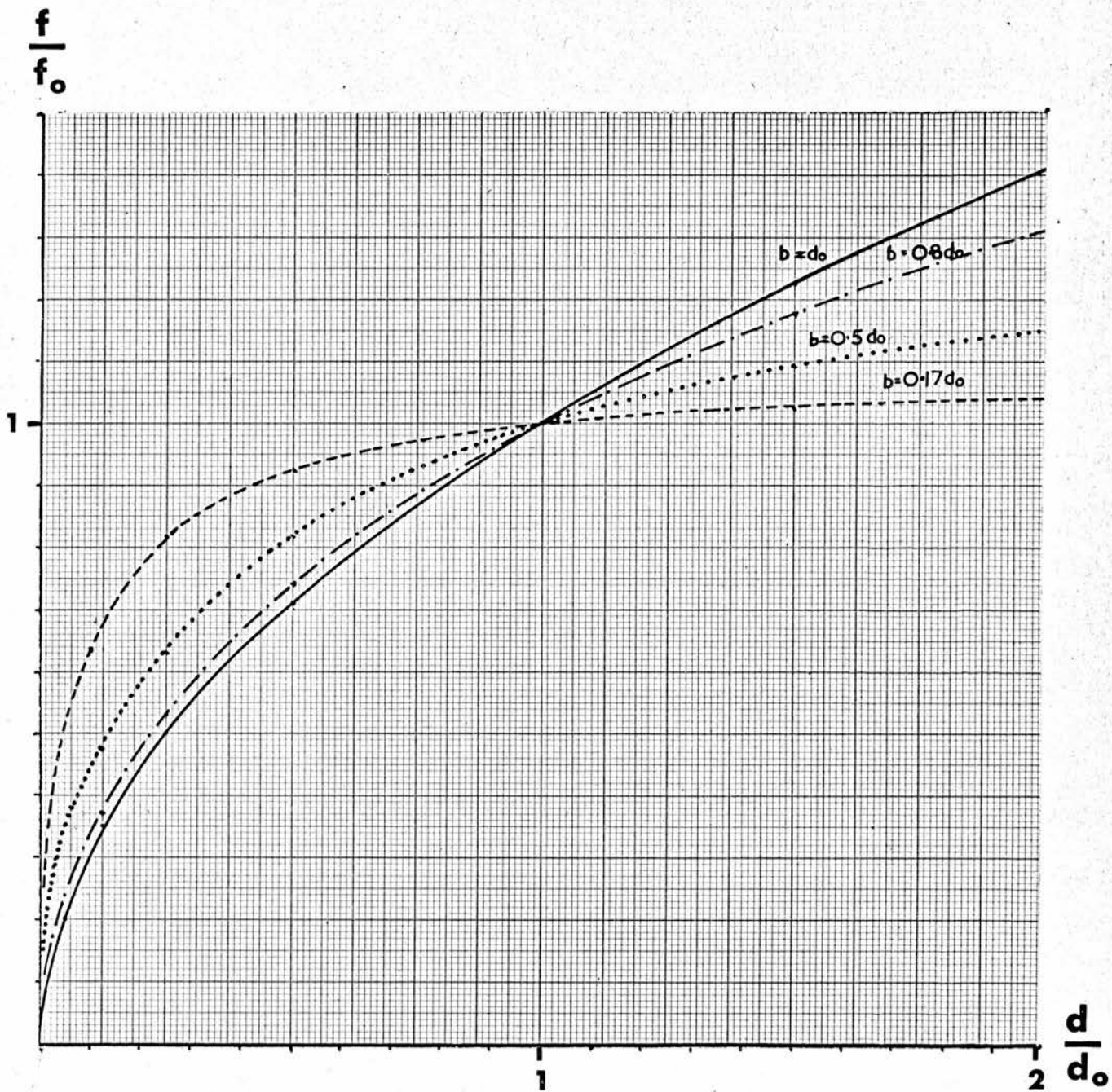

FIG. 3.5 VARIATION OF FREQUENCY WITH DISTANCE FOR DIFFERENT CAPACITANCES IN PARALLEL WITH THE TRANSDUCER

be necessary to produce a capacitance equal to the total capacitance in the tuned circuit. It is thus much smaller than the actual mean spacing of the transducer. It can be seen that Δf is not proportional to Δd even to a first approximation. Fig. 3.5 shows a series of normalized curves for displacement to frequency conversion for different values of b .

(vi) Demodulation

(a) Amplitude Modulated Signals

An amplitude modulated signal can be demodulated by a simple rectifier. At low signal levels this may not be satisfactory due to the characteristics of the rectifier elements. This may not be a disadvantage with the measuring circuits described in this section since a small signal implies a large deviation from the mean position. Improved rectification characteristics can be achieved by an operational amplifier method as described by Widlar (1964). If the output voltage passes through zero amplitude with a phase change of 180° during an oscillation cycle a phase sensitive demodulator is required to avoid ambiguity in the output. Since the elements of this type of detector operate as controlled switches the linearity is better than that of a simple rectifier. The phase sensitive demodulator using transistors as switches is discussed more fully in Appendix A .

(b) Frequency Modulated Signals

A common method of frequency demodulation uses a tuned circuit/

circuit to convert the frequency variations into amplitude variations which are then detected by the same means as an amplitude modulated signal. The efficiency and linearity of this method are poor. Improved efficiency can be obtained by the use of two tuned circuits as a discriminator. However this configuration is only approximately linear over a limited range and the law is not such that it corrects for the non-linearity of the modulation process. A linear conversion from frequency to amplitude can be obtained over a much wider range of frequencies by the use of a beat frequency or a pulse rate method.

It can be seen that however linear the method of frequency demodulation may be, ~~but~~ it is not possible to correct for the non-linearity of the modulation process within the demodulation circuit. In addition the circuits used for frequency modulation are such that guard rings or screens cannot be used to eliminate strays and give a linear field at the electrode. For these reasons it was decided to make a more detailed investigation of amplitude modulated methods to see if there were any capable of giving a better linearity than those so far described.

A disadvantage of the amplitude modulated methods described in this section is that they give an output which is proportional to the transducer spacing. Since the transducer is being used to detect a vibration it is not necessary to determine the absolute value of spacing and it would be more appropriate if the detector output was proportional to the changes in spacing. This could be achieved/

achieved by the use of an A.C. coupling between the detector and output which would remove the constant component of signal due to the mean spacing. However, the resultant output would have a poor signal to noise ratio because the source noise component reaching the output would be proportional to the transducer spacing, rather than to the change of spacing. In addition the use of an A.C. coupling means that the transducer response cannot extend down to zero frequency. A more satisfactory arrangement would be to use a circuit with some kind of balance mechanism or zero offset to compensate for the mean signal level of the transducer.

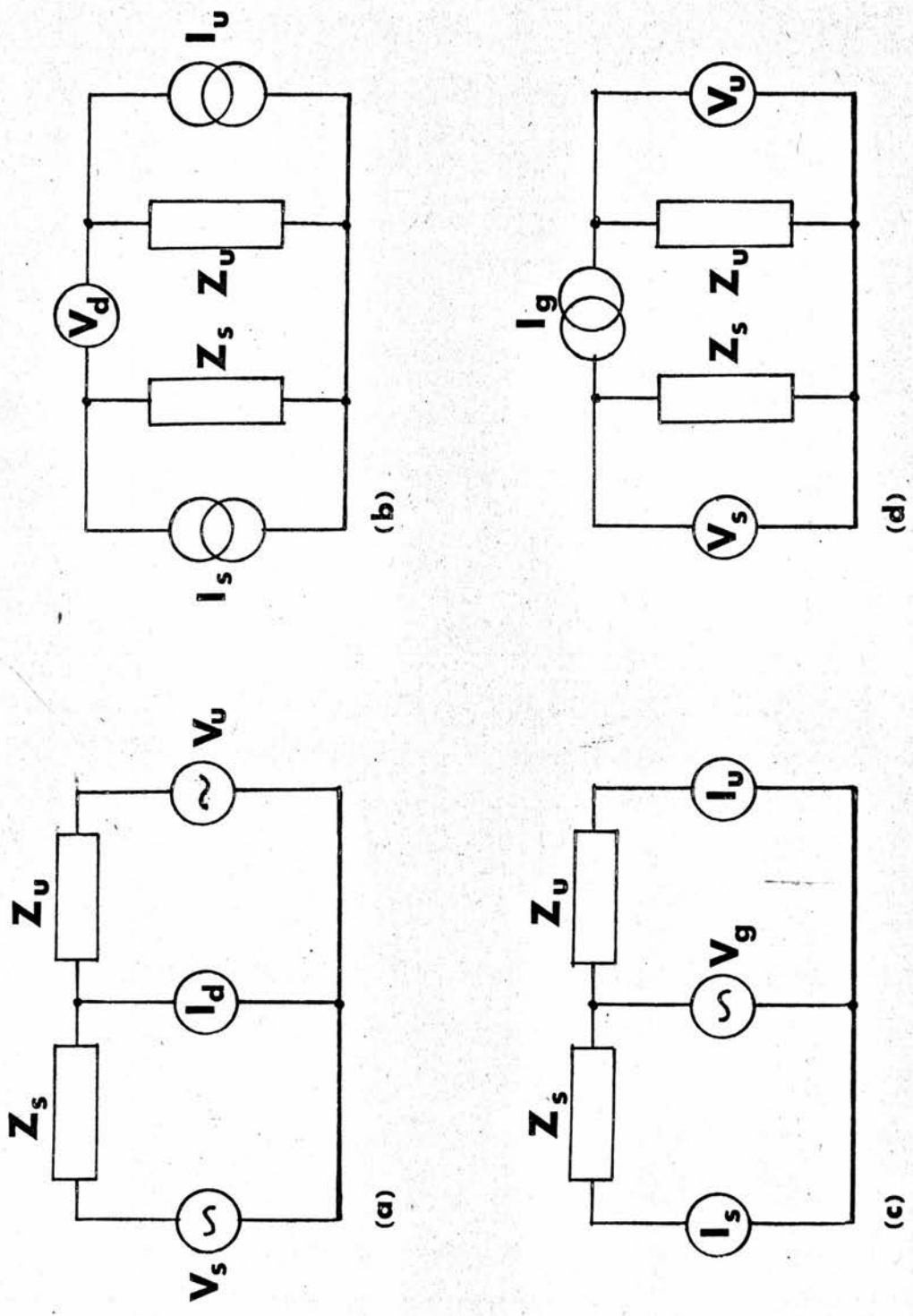

FIG. 3.6. IMPEDANCE MEASUREMENT BY COMPARISON METHODS

3.2. Bridge Methods

(i) Impedance measurement by comparison with a known standard

It is well known that one of the most accurate methods of measuring an impedance is to compare it with a known impedance under similar conditions. When a single measurement is required this can be done by substitution of the known impedance in place of the unknown in circuits of the type described in Section 3.1(iii). In the present application a signal is required which is proportional to variations in the unknown impedance of the transducer. This can be obtained by making a continuous comparison between the transducer impedance and an impedance which is adjusted so that it is equal to the mean value of the transducer impedance.

A continuous comparison between the standard and the unknown impedances can only be made if two separate measuring circuits exist. The need to measure both current and voltage in each circuit can be avoided by arranging that the voltages across the two impedances are identical, as in Figs. 3.6(b,c) or the currents flowing through both impedances are identical as in Figs. 3.6(a,d). This is achieved by having either the source or the detector common to both measuring circuits.

The circuits shown in Figs. 3.6(a,b) are described as null methods since the impedance comparison is made by adjusting the detector output to zero.

It can be seen that the output current in Fig. 3.6a becomes/

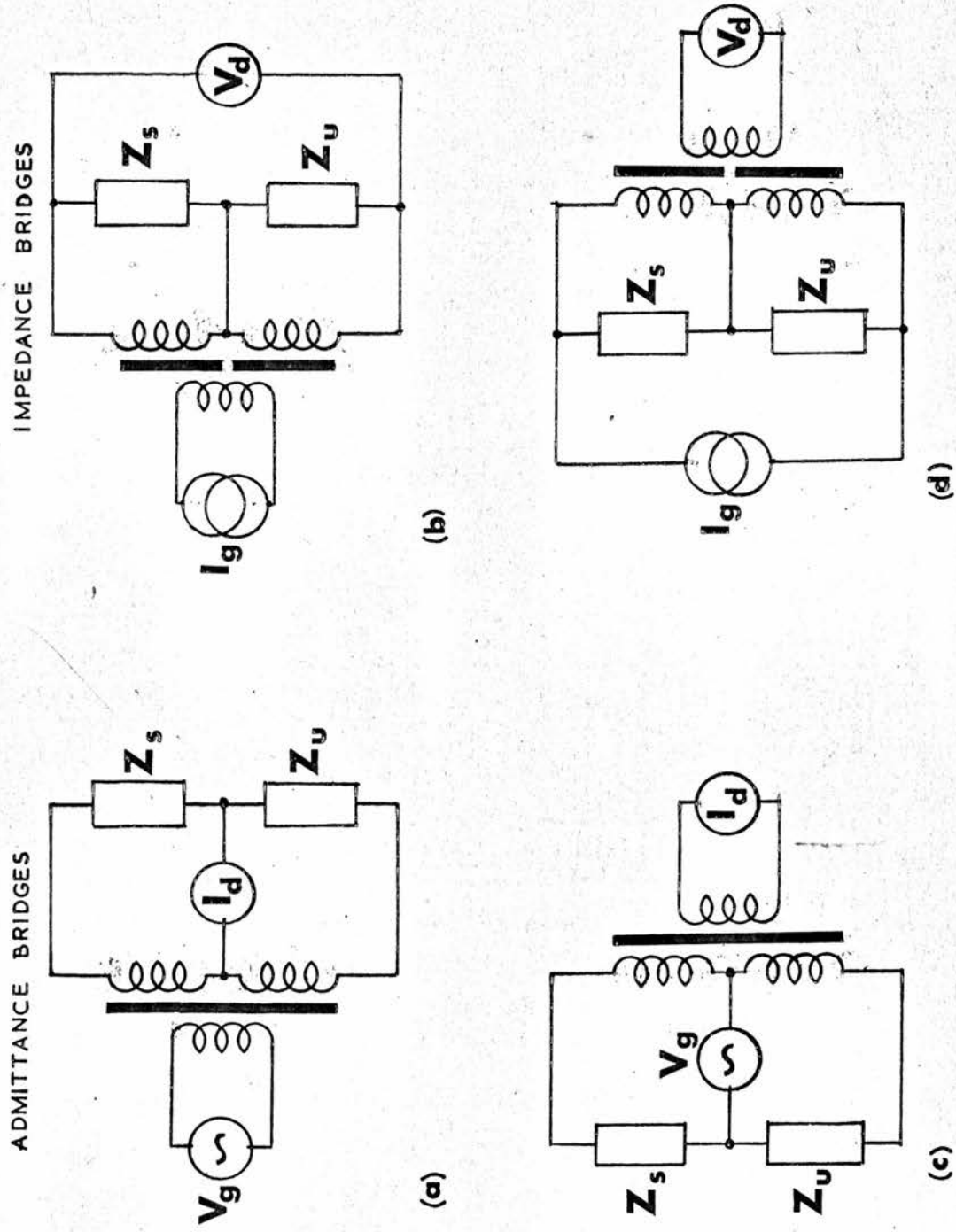

FIG. 3.7. TRANSFORMER RATIO-ARM BRIDGES

becomes zero when

$$\frac{V_s}{Z_s} = \frac{V_u}{Z_u}$$

i.e. when $Z_u = Z_s \cdot \frac{V_u}{V_s}$

This relationship can be further simplified if the two source voltages are equal in amplitude.

i.e. $Z_u = Z_s$ when $|V_u| = |V_s|$

The most convenient method of producing two equal voltages from a low impedance source is by means of a centre tapped transformer.

A similar method can be used to supply the two current sources required in the circuit of Fig. 3.6(b) except that the transformer windings must have a high output impedance.

It can also be seen that suitable transformers may be used in the circuits in Figs. 3.6(c,d) to obtain the difference signal between the two detectors.

(ii) Transformer Ratio-Arm Bridges

The corresponding circuits using transformers which are derived from those in Fig. 3.6(a-d) are shown in Fig. 3.7 (a-d). These are known as Transformer Ratio-Arm Bridges. The use of this type of circuit was first proposed by Blumlein in 1928 and has been described in detail by Calvert (1948), Clark and Vanderlyn (1949), Karo (1958), Butler (1960), Rogal (1961), Leslie (1961), Golding (1961) and others. The Transformer Ratio Bridge has formed the basis/

basis of a variety of circuits using capacitative transducers including an aircraft altimeter described by Watton and Pemberton (1959), a proximity meter by Fielden (c 1947), an electronic micrometer by Wayne Kerr (1959) and carrier operated electrostatic microphones by Arends (1961) and Baxandall (1963). The method has not however been applied to the study of cardiovascular sounds although another type of bridge was used by Yoshitoshi, Machii, Sekiguchi, Mishina, Ohta, Watanabe, Shinohara, Hanaoka, Kohashi, Shimizu, Ohno and Shimizu (1965).

The method has a number of advantages not possessed by other methods of measuring impedances. These may be summarized as follows

- (a) The output signal depends on the change of impedance from the balance value rather than on the absolute impedance.
- (b) The noise output at balance is a minimum since noise generated within the source is cancelled at the detector terminals.
- (c) Separate source and detector circuits exist so that both can be connected to earth.
- (d) The transducer cable can be screened in such a way that it does not affect the accuracy or sensitivity of the measurements.
- (e) At balance the source and detector impedances do not affect the accuracy of the impedance comparison.

(f)/

- (f) The transformer ratio arm has a high stability.
- (g) Since differences in impedances are being measured the method has a high sensitivity.
- (h) If the transducer impedance is a simple reactance then the balancing impedance need only consist of a similar variable reactance. The operation of the circuit is therefore simple.
- (i) One terminal of the transducer capacitance can always be at earth. This is necessary since it is desirable that the patient is at earth potential for his own safety and because the large capacitance which would otherwise exist between him and earth might affect the measuring circuit.

The major disadvantage of the null method is that the output voltage changes phase by 180° as the bridge passes through balance. In order to avoid ambiguity a phase sensitive detector must be used. This detector must work efficiently at very small signal levels otherwise errors will arise when the bridge is close to balance.

(iii) Impedance Bridges

In Fig. 3.7 it can be seen that the bridges b and d give output voltages which are proportional to the difference between the two impedances. Either of these arrangements would therefore seem suitable for the measurement of variations in the impedance of the cardiovascular sound transducer. At balance this circuit gives/

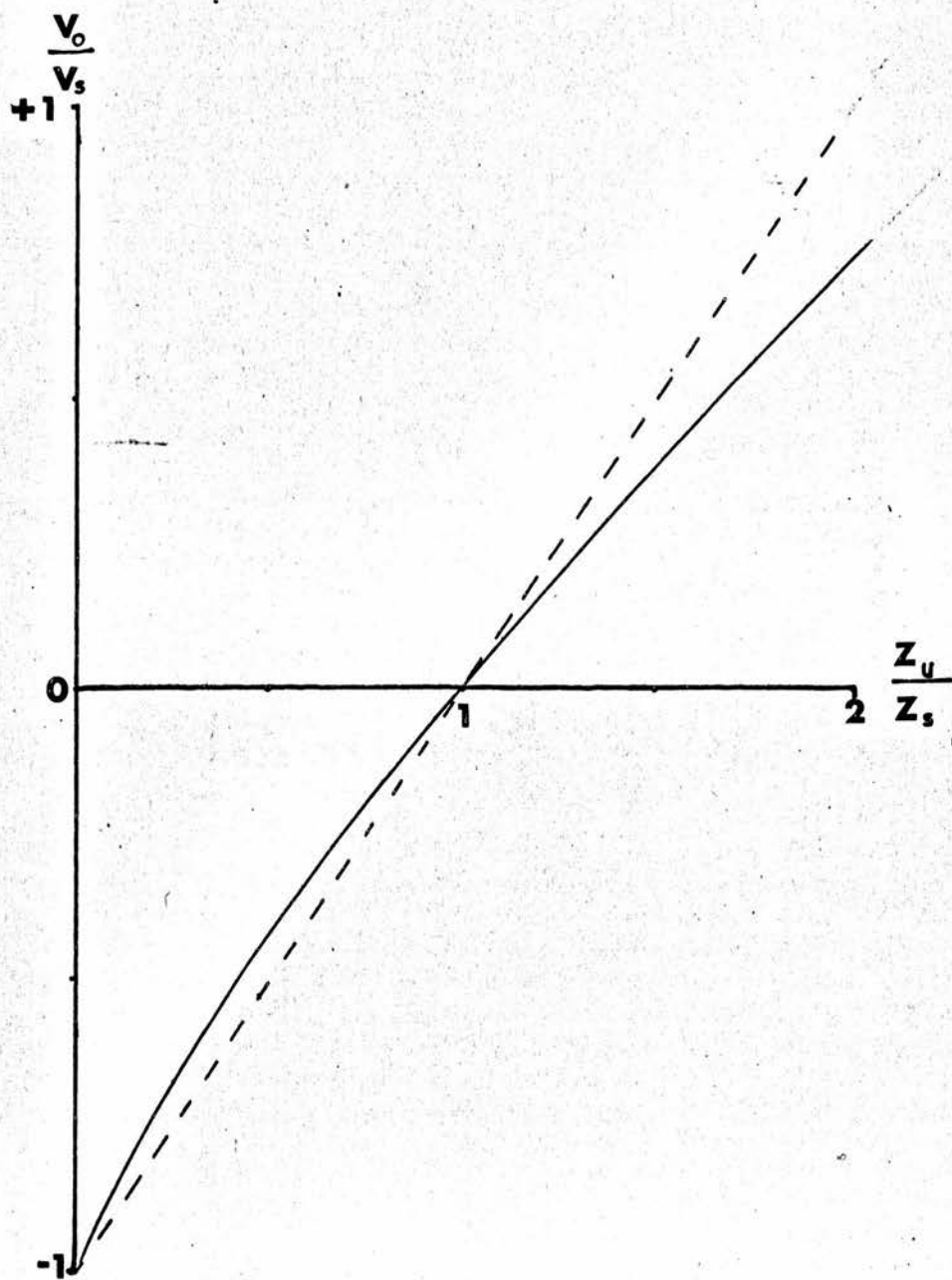

FIG. 38. EFFECT OF PARALLEL IMPEDANCE ON THE LINEARITY OF THE IMPEDANCE BRIDGE

gives an accurate measure of the transducer impedance but off balance it is found that impedances in parallel with the transducer affect the linearity of the output. The distortion which is produced in the output characteristic is sketched in Fig. 3.8. Since the source and detector appear in parallel with the unknown it is not possible to arrange a neutral screen to reduce the effects of stray capacitance from the transducer lead.

The effects of the stray capacitance can be reduced by series tuning the transducer with a suitable inductor so that its impedance is low. If the same arrangement is used for the balancing impedance the effective output impedance of the bridge is very low at the resonance of the two circuits. The source and detector impedances can then be ignored. However for wide departures from balance the impedance of the transducer will appear high and these parallel impedances can no longer be neglected.

(iv) Admittance Bridges

The bridges shown in Fig. 3.7 a,c give output currents which are proportional to the difference between the admittances of transducer and standard. Since the admittance is defined as the reciprocal of the impedance the output is not proportional to the difference of the impedances. These two bridges are however particularly suitable for the measurement of the impedance of a small capacitance at a remote point. This is because the source and detector impedances are very small compared with the impedance of the/



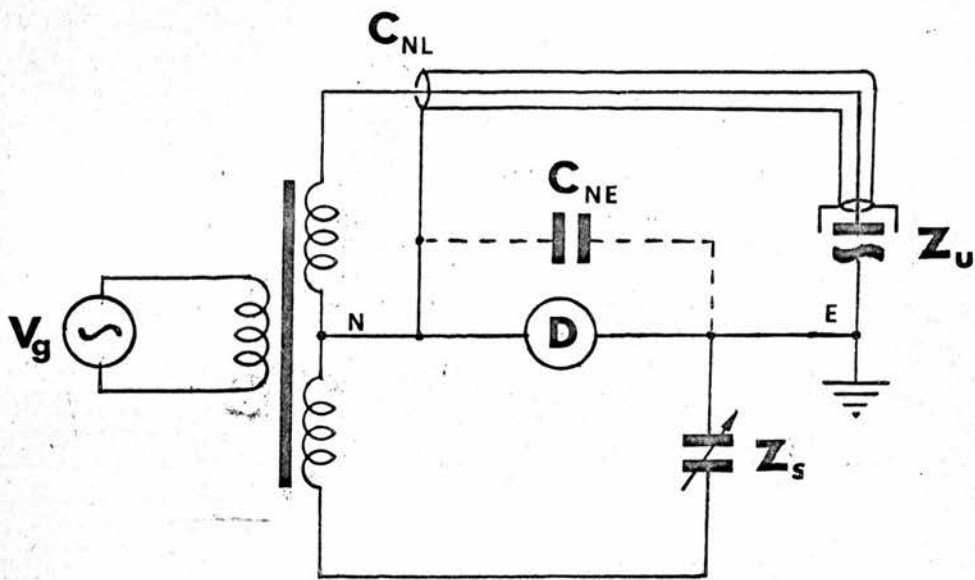

FIG. 3.9. THOMPSON BRIDGE FOR SMALL CAPACITANCES

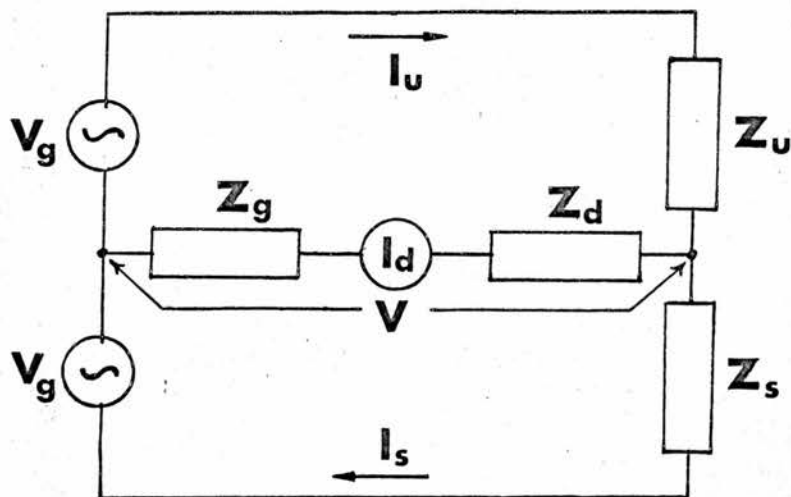

FIG. 3.10. SIMPLIFIED EQUIVALENT CIRCUIT

the capacitor and the cables to the capacitor can be screened in such a way that the strays are eliminated from the measuring circuit.

One possible form of screening arrangement is shown in Fig. 3.9. This circuit is commonly known as the Thompson Bridge, and detailed analyses of its operation are given by Leslie (1961) and Binnie and Foord (1964). It is the arrangement preferred by Fielden (c 1947), Arends (1961) and Baxandall (1963) for use with their respective types of transducer.

It can be shown that provided the leakage inductance and resistance losses of the transformer windings are small the presence of stray impedances in parallel with one or both windings will have no significant effect on the output ratio. The bridge can then be represented by the equivalent circuit shown in Fig. 3.10. This contains two equal but antiphased voltage sources having a common impedance which appears in series with the detector. The internal impedance of the balance detector is also included for completeness of analysis.

Since the source impedance is very small the thermal noise component associated with the two source voltages will be small and will cancel at balance. The magnitude of the thermal noise which appears at the detector input at balance will therefore depend on the parallel combination of the impedances in the bridge network. Baxandall (1963) has shown that if these impedances are reactive then the effective output impedance of the bridge network can be reduced by series tuning. The resultant output impedance of the balanced bridge is then equal to the common source impedance Z_g plus/

plus any loss resistance in the tuning reactances and an optimum noise performance is obtained if the detector is matched to this impedance.

(v) Analysis of the Equivalent Circuit of the Thompson Bridge

Since the impedance in the detector arm of the equivalent bridge circuit is not zero the output current off balance is not simply related to the difference between the unknown and standard impedances. The actual value of detector current for all states of unbalance can be determined by nodal analysis of the bridge network.

$$V = V_g - I_u Z_u \dots\dots\dots (1)$$

$$-V = V_g - I_s Z_s \dots\dots\dots (2)$$

$$V = (I_u - I_s) (Z_d + Z_g) \dots\dots\dots (3).$$

Substituting in equation (3) for I_u and I_s from equations (1) and (2) gives

$$V = \left\{ \frac{(V_g - V)}{Z_u} - \frac{(V_g + V)}{Z_s} \right\} \cdot (Z_d + Z_g) \dots\dots\dots (4)$$

Collecting up all terms in V this gives

$$V = \frac{\left(\frac{1}{Z_u} - \frac{1}{Z_s} \right)}{\left[\frac{1}{(Z_d + Z_g)} + \frac{1}{Z_u} + \frac{1}{Z_s} \right]} \cdot V_g \dots\dots\dots (5)$$

which/

which can be rearranged to give

$$V = \frac{(Z_s - Z_u)}{\left[Z_s + Z_u \left\{ 1 + \frac{Z_s}{(Z_d + Z_g)} \right\} \right]} \cdot V_g \dots\dots\dots (6)$$

Since Z_d and Z_g are constant I_d is proportional to V . Z_s is also constant so that variations in the voltage V are produced solely by variations in the unknown impedance Z_u . It can be seen that since a term in Z_u appears in the denominator of the fraction on the right hand side of equation (6) this equation is not linear with respect to Z_u . The magnitude of the non-linearity is clearly dependent on the value of the term

$$\left\{ 1 + \frac{Z_s}{(Z_d + Z_g)} \right\}$$

It is found that four particular values of this function are of interest.

(a) Ideal Voltage Source and Ideal Current Detector

As $(Z_d + Z_g) \rightarrow 0$, $\left\{ 1 + \frac{Z_s}{(Z_d + Z_g)} \right\} \rightarrow \infty$ so that

the non-linearity increases. Such an arrangement is clearly undesirable.

(b) Ideal Voltage Detector or High Impedance Source

$(Z_d + Z_g) \rightarrow \infty$ so that $\left\{ 1 + \frac{Z_s}{(Z_d + Z_g)} \right\} \rightarrow 1$

giving $V = \frac{(Z_s - Z_u)}{(Z_s + Z_u)} \cdot V_g$

It can be seen that this condition removes the source and detector impedances from the bridge output function. The output function obtained is still non-linear with respect to Z_s but to a lesser degree than that predicted for the Frequency Modulated circuit in Section 3.1.

(c) Baxandall's Low Noise Condition

Ideally this requires $(Z_d + Z_g) = \frac{-Z_s}{2}$ which gives

$$V = \frac{(Z_s - Z_u)}{(Z_s + Z_u/2)} \cdot V_g$$

It can be seen that this gives a better linearity than the previous case as well as having a better noise performance.

(d) Linear Condition

If $(Z_d + Z_g) = -Z_s$ it can be seen that the term in Z_u is eliminated from the equation giving

$$V = \frac{(Z_s - Z_u)}{Z_s} V_g$$

which is a linear equation in terms of Z_u .

Although this result is possible in theory it cannot be achieved in practice since the conditions require that Z_d and Z_g are pure reactances. A close approximation is however possible by making the resistive parts of Z_d and Z_g very small compared with the circuit reactances.

(vi) Conditions for Optimum Linearity

Since Z_s and Z_d are both complex they can be expressed in the forms

$$Z_s = \frac{1}{\left(\frac{1}{R_s} + j\omega C_s\right)}$$

and

$$Z_d = j\omega L + r$$

The source impedance Z_g may be assumed to be a pure resistance R_g . The condition for optimum linearity is that $(Z_g + Z_d + Z_s) \rightarrow 0$, which can now be expressed in the form

$$\frac{1}{\left(\frac{1}{R_s} + j\omega C_s\right)} + j\omega L + r + R_g \rightarrow 0$$

i.e. $1 + \left(\frac{1}{R_s} + j\omega C_s\right)(j\omega L + R_g + r) \rightarrow 0$

In order that this expression does become small it is necessary that its real and imaginary parts are both small so these can be treated separately.

$$\mathcal{R} = \left(1 + \frac{R'}{R_s} - \omega^2 L C_s\right) \quad \text{where } R' = R_g + r$$

It can be seen that by a suitable choice of the inductance this term can be made to equal to zero.

$$\mathcal{I} = \left(\frac{\omega L}{R_s} + \omega C_s R'\right)$$

Both/

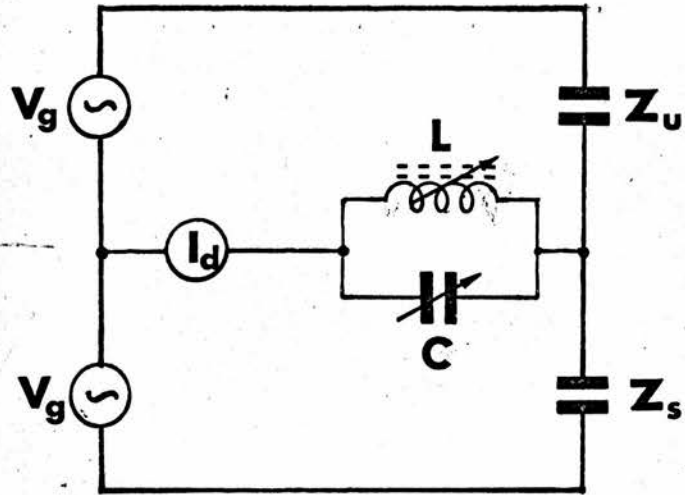

FIG. 3.11. METHOD FOR VARYING SERIES INDUCTANCE

Both terms in this expression are positive so that the imaginary part of the equation is not zero. The individual terms can be made small when

$$R' \ll \omega L$$

and $R_s \gg \frac{1}{\omega C_s}$

This implies that, provided the internal resistance of the generator is very small compared with the reactance of the linearizing inductance and the leakage resistance of the transducer is large compared with its reactance, an operating frequency can be chosen which will give a very small error.

A practical difficulty encountered with this arrangement is that since a wide range of balancing adjustment is required the linearizing inductor must be changed for each new setting of the balance capacitor. It is therefore necessary to incorporate some means of varying the effective inductance in the circuit or the frequency of the generator. One possible arrangement is shown in Fig. 3.11 where the capacitor in parallel with the inductance is used to control the effective reactance in the detector path of the bridge. Further difficulties arise when the stray impedances in the network are considered since the method of screening used in The Thompson Bridge increases the capacitance which appears in parallel with the detector path. The effective reactance can be made positive by increasing the value of inductance. This results in an increased series resistance so that the linearity of the arrangement/

arrangement is lower than predicted.

Since the linearity which would be obtained by this method is not as good as might be expected from the simple theory, and since a continuous adjustment is required for the linearizing inductor, it was decided to investigate other methods capable of giving a better performance.

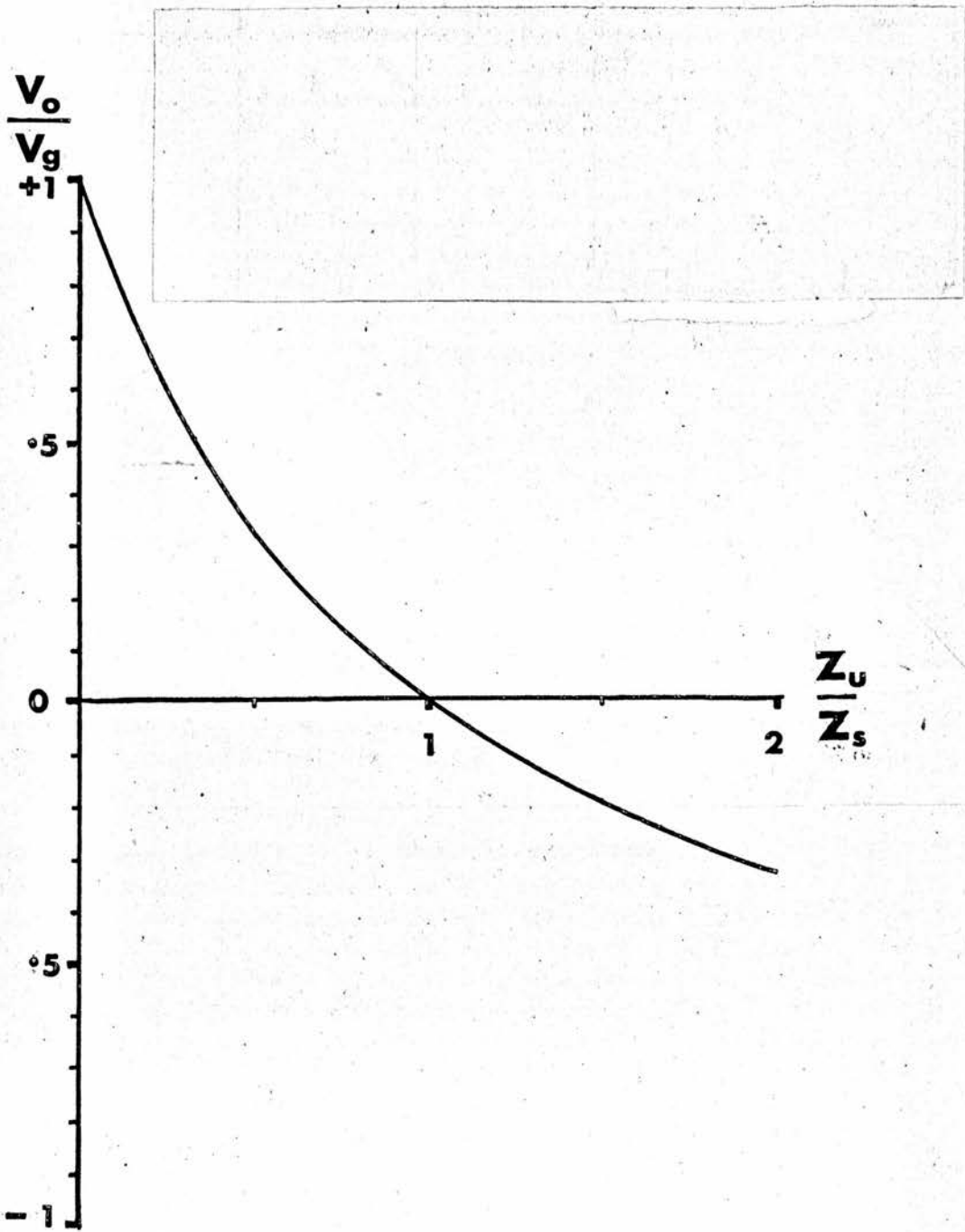

FIG. 3.12. OUTPUT CHARACTERISTIC OF CAPACITANCE BRIDGE

3.3 Bridge Networks with Feedback

(i) Modulation of Source Voltage to Improve Linearity

It has been shown in Section 3.2 that the output voltage of the Thompson Bridge becomes linear with respect to changes in the unknown impedance when certain conditions are fulfilled. In practice it is found that the stray capacitances and the loss resistances which exist within the bridge circuit reduce the accuracy with which a linear characteristic can be obtained. An investigation was therefore made into the possible use of feedback within the bridge network to produce a linear conversion between input displacement and output voltage.

In order to avoid the difficulties associated with the use of series inductors in the detector circuit it is desirable to use a detector with a high input impedance. The output voltage of the bridge is then given by

$$V = \frac{(Z_s - Z_u)}{(Z_s + Z_u)} \cdot V_g$$

A normalized graph of this function is shown in Fig. 3.12. It can be seen that if the source voltage amplitude could be reduced when Z_u is less than Z_s and increased when Z_u is greater than Z_s the resultant output of the bridge would be more linear with respect to changes in Z_u . This modulation can be obtained by using the detected output of the bridge to control the oscillator amplitude or by adding a proportion of the carrier frequency output in a suitable phase/

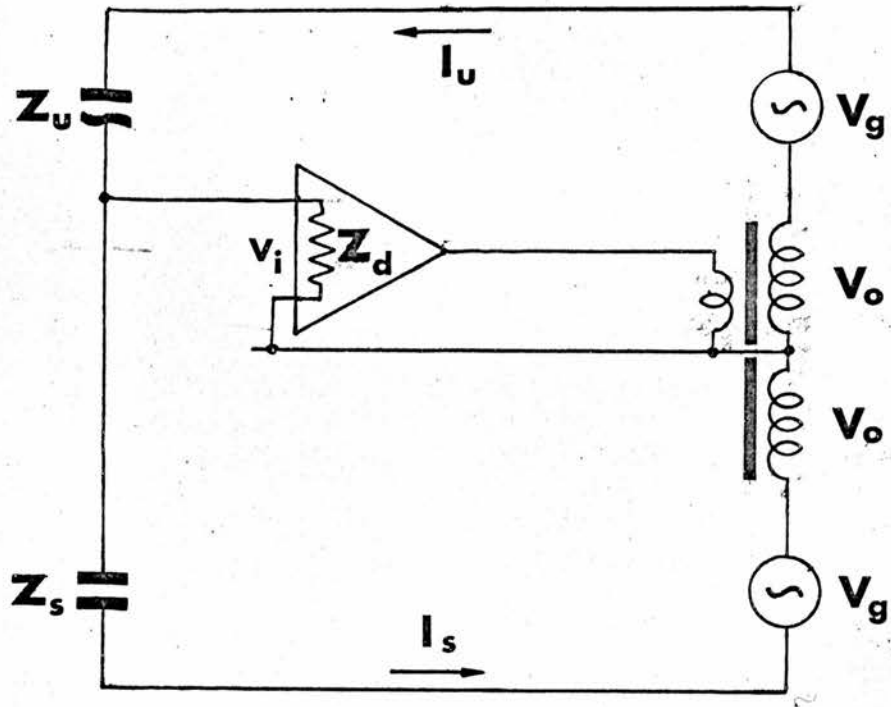

FIG. 3.13. BRIDGE NETWORK WITH FEEDBACK MODULATION

phase to each half of the source transformer. A simplified circuit of the method is shown in Fig. 3.13.

(11) Analysis of the Modulation Method

The output function of the circuit shown in Fig. 3.13 may be derived as follows.

$$v_i = V_g + V_o - I_s Z_s \dots\dots\dots (1)$$

$$-v_i = V_g + V_o - I_u Z_u \dots\dots\dots (2)$$

$$v_i = (I_u - I_s) Z_d \dots\dots\dots (3)$$

$$V_o = \beta v_i$$

From (1)
$$I_s = \frac{V_g + V_o - v_i}{Z_s}$$

and from (2)
$$I_u = \frac{V_g + V_o + v_i}{Z_u}$$

Substitution for I_s , I_u and V_o in equation (3) gives

$$v_i \left\{ \frac{1}{Z_d} - \frac{(1+\beta)}{Z_u} + \frac{(1-\beta)}{Z_s} \right\} = V_g \cdot \left(\frac{1}{Z_u} - \frac{1}{Z_s} \right)$$

and after multiplying through by $(-Z_u \cdot Z_s)$ this becomes

$$v_i \left\{ (1+\beta)Z_s - \left(1 + \frac{Z_s}{Z_d} - \beta\right)Z_u \right\} = V_g (Z_u - Z_s)$$

It can be seen that if $\beta = \left(1 + \frac{Z_s}{Z_d}\right)$ the term in Z_u is eliminated

from/

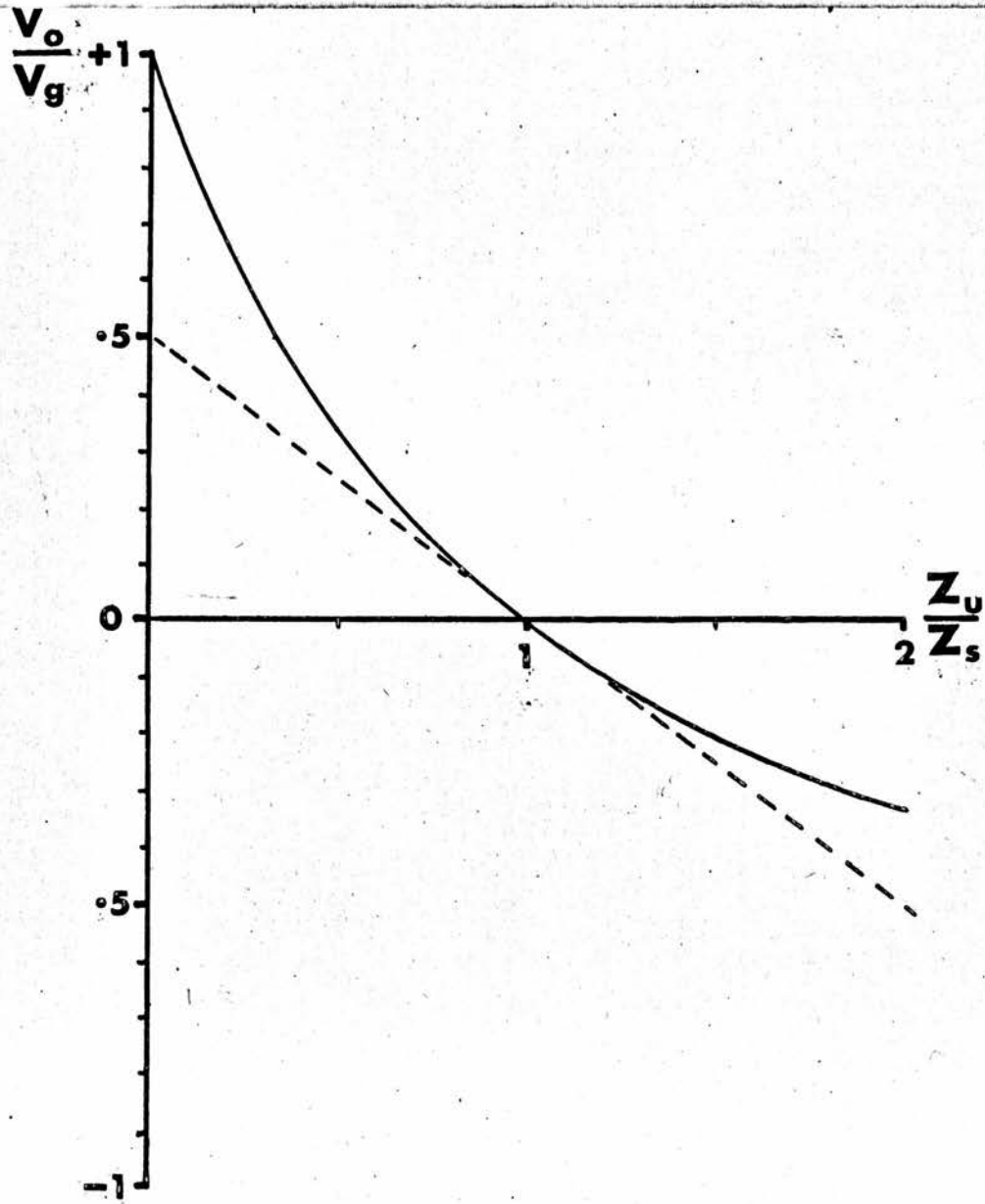

FIG. 3.14. MODIFICATION OF OUTPUT CHARACTERISTIC BY USE OF FEEDBACK

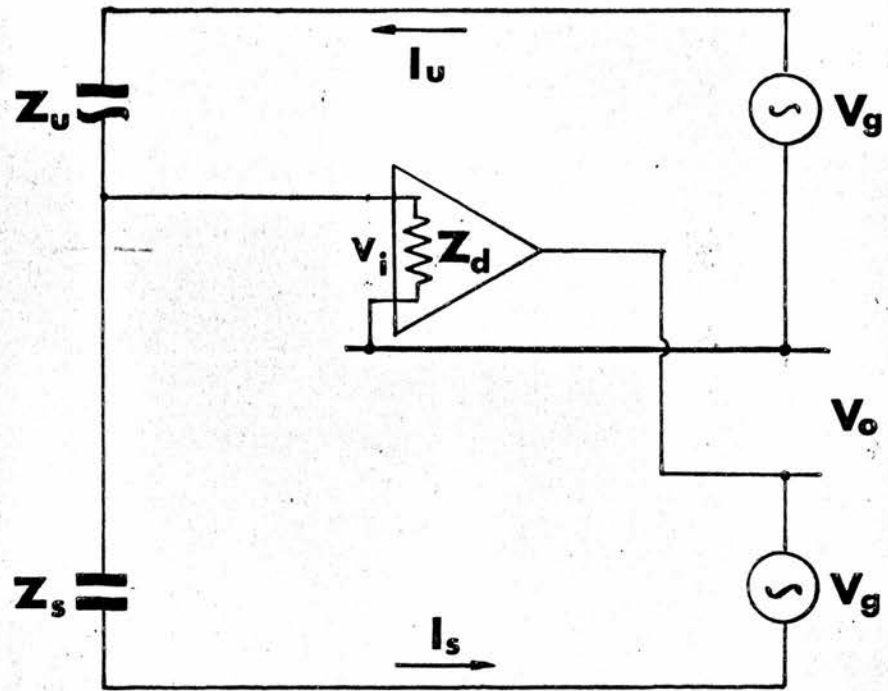

FIG. 3.15. ALTERNATIVE BRIDGE NETWORK USING FEEDBACK

from the left hand side of the equation. The output voltage v_1 is then proportional to changes in the unknown impedance Z_u .

$$\text{i.e. } v_1 = \frac{(Z_u - Z_s)}{\left(2 + \frac{Z_s}{Z_d}\right) Z_s} \cdot V_g$$

Provided $Z_d \gg Z_s$ this may be written as

$$v_1 = \frac{(Z_u - Z_s)}{2 Z_s} \cdot V_g$$

This condition corresponds to a 50% modulation of the carrier amplitude and produces an output characteristic represented by the dotted line in Fig. 3.14. It can be seen that this line is tangential to the uncorrected characteristic at the balance point.

(iii) An Alternative Method

Examination of the equations for the modulation method show that it is not necessary to modulate both sources in the bridge network in order to produce a linear output. The circuit shown in Fig. 3.15 also gives a linear output and has a higher sensitivity than the method described above.

The output function of this circuit is derived as follows.

$$\begin{aligned} v_1 &= V_g + V_o - I_s Z_s && \dots\dots\dots (1) \\ -v_1 &= V_g - I_u Z_u && \dots\dots\dots (2) \\ v_1 &= (I_u - I_s) Z_d && \dots\dots\dots (3) \\ V_o &= \beta v_1 && \dots\dots\dots (4) \end{aligned}$$

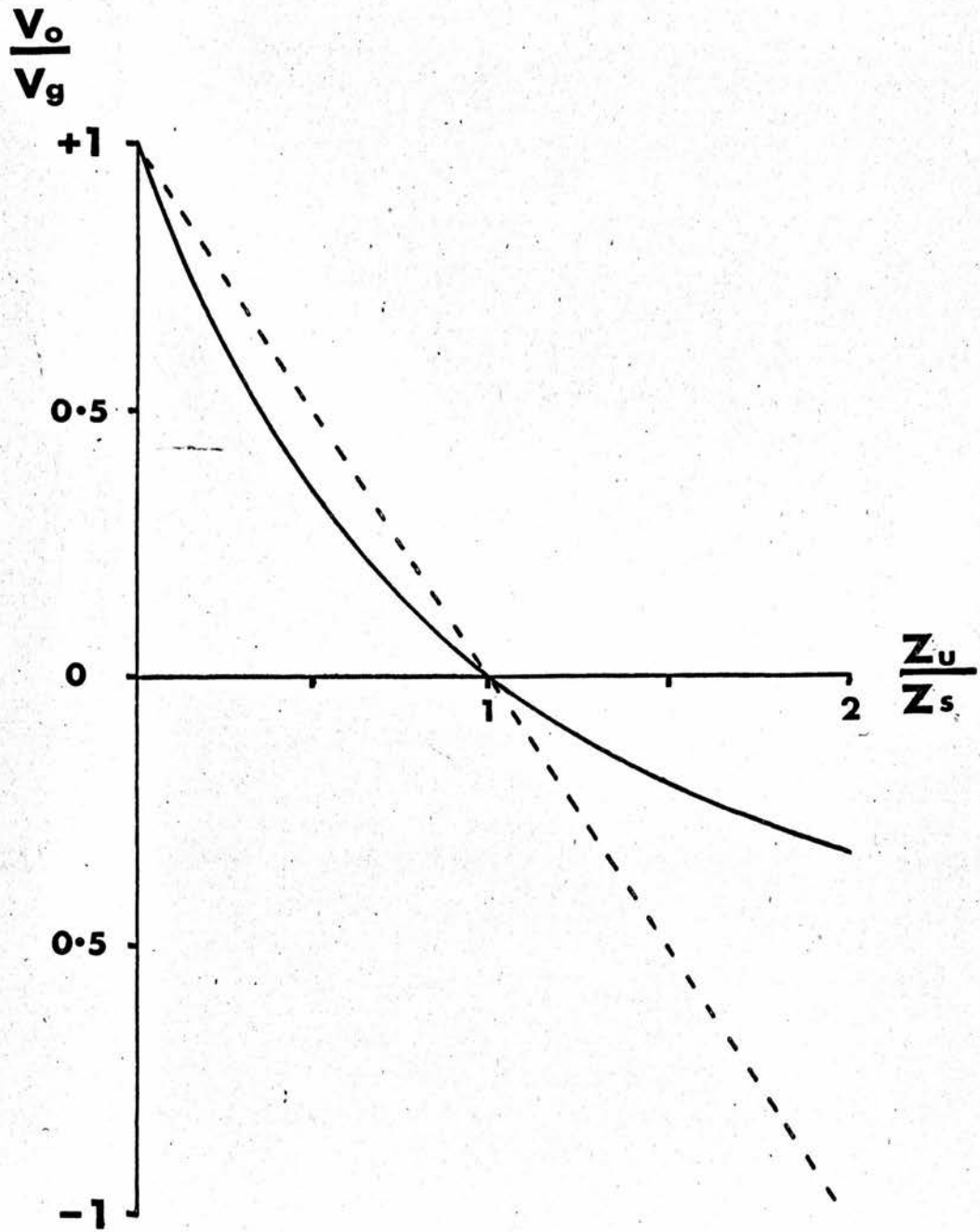

FIG. 3.16. LINEAR CHARACTERISTIC GIVEN BY ALTERNATIVE METHOD

Substitution for I_s , I_u and V_o from equations (1), (2), and (4) in equation (3) give

$$v_i = \left\{ \frac{[V_g - (1-\beta)v_i]}{Z_s} - \frac{[V_g + v_i]}{Z_u} \right\} \cdot Z_d$$

Collecting up terms in v_i and v_g this gives

$$v_i \left\{ Z_s + \left(1 + \frac{Z_s}{Z_d} - \beta \right) \cdot Z_u \right\} = V_g (Z_u - Z_s)$$

It can be seen that if $\beta = \left(1 + \frac{Z_s}{Z_d} \right)$ the terms in

Z_u on the left hand side can be eliminated. The output voltage is then proportional to changes in the unknown impedance Z_u .

$$\text{i.e. } v_i = \frac{(Z_u - Z_s)}{Z_s} V_g$$

It can be seen that the sensitivity in this case is at least twice that of the method described in the previous section. The resultant linear characteristic is shown in Fig. 3.16.

(iv) The Effects of Cable Capacitance

It has been shown in sections (ii) and (iii) above that a linear output is obtained when the gain of the detector amplifier is given by

$$\beta = \left(1 + \frac{Z_s}{Z_d} \right)$$

where/

where Z_s is the standard impedance used to balance the bridge

Z_d is the input impedance of the detector.

Provided $Z_d \gg Z_s$, β can be considered constant irrespective of the value of Z_s . However the use of a neutral screen to reduce the stray capacitance to the transducer lead increases the capacitance across the detector input. The effective input impedance of the detector is reduced so that at very large spacings of the transducer Z_s is not negligible. As a result different values of β are $\frac{Z_s}{Z_d}$

required at different balance settings in order to obtain optimum linearity. This cannot be obtained unless some form of gain control is coupled to the balancing impedance. The effective input impedance of the amplifier can be increased by parallel tuning the cable capacitance but if the 'Q' - factor of the tuned circuit is too high the bandwidth for vibration frequencies will be reduced.

The use of parallel tuning at this point in the circuit produces an arrangement in which the requirements for a linear solution of the equations are no longer unambiguous. This is because the parallel tuned circuit can itself be adjusted to produce an approximately linear characteristic without modulation of the source. The same parallel combination of inductance and capacitance can be adjusted to produce any of the solutions given in Section 3.2. It can then be shown that in each case a suitable choice of the feedback gain will produce a linear solution.

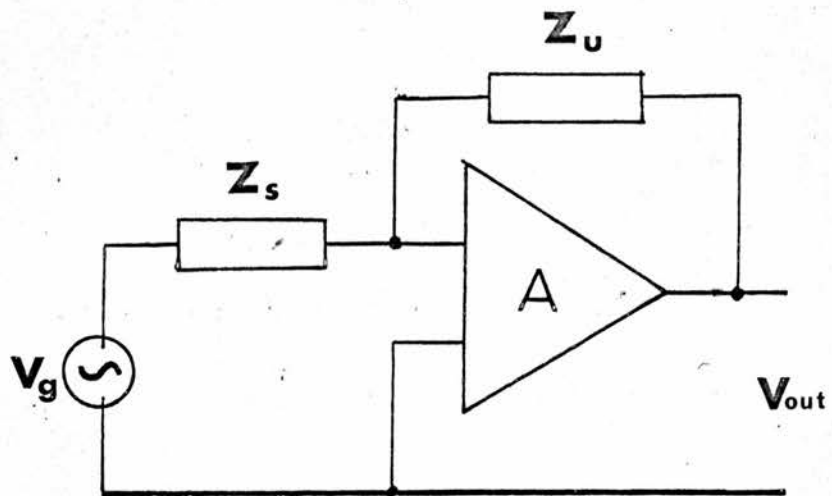

FIG. 3.17. OPERATIONAL AMPLIFIER METHOD

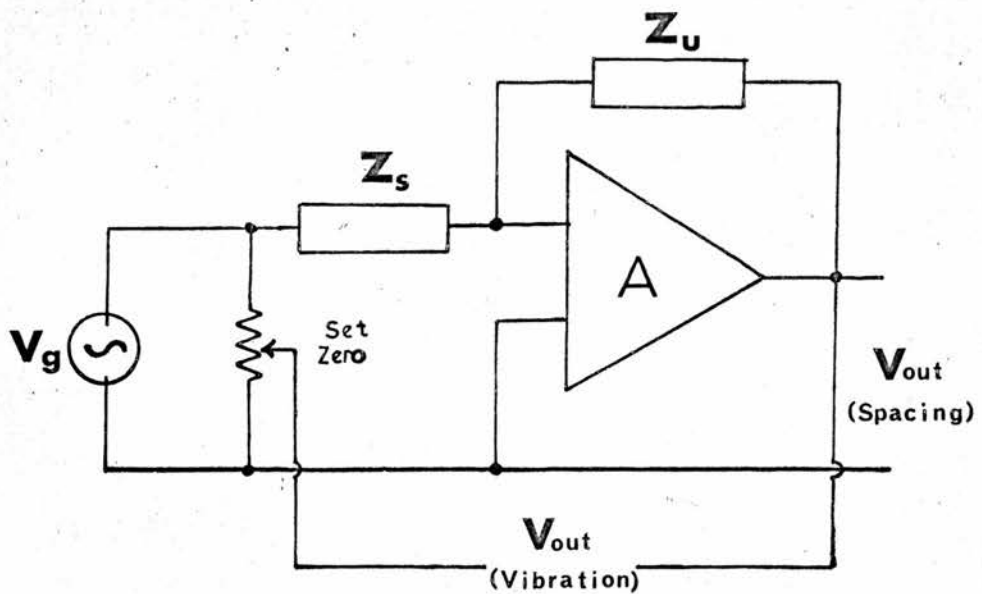

FIG. 3.18. OPERATIONAL AMPLIFIER WITH 'BACKING-OFF' FACILITY

3.4. Operational Amplifier Method

(1) Impedance Comparison Using an Operational Amplifier

Another method of comparing two impedances is to use them to define the gain of a circuit containing an operational amplifier as shown in Fig. 3.17. (See Gilbert (1964)). If the gain of the amplifier is very large then it can be shown that

$$V_{out} = \frac{Z_u}{Z_s} \cdot V_g$$

It can be seen that changes in output voltage are proportional to changes in the unknown impedance but these are associated with a constant output proportional to the mean value of the unknown impedance. The disadvantages of using A.C. coupling in such circumstances have been discussed already in Section 3.1. The need for A.C. coupling can be avoided if the mean signal at the output is "backed off" with an equal but opposite signal derived from the source. This method has the advantage that noise arising in the source is also cancelled so that some of the advantages of the bridge network are retained.

A simple form of "backing-off" arrangement is shown in Fig. 3.18. This type of circuit would however require the use of a phase sensitive detector. It is often more convenient and reliable if the output and reference signals are both detected at high level before the constant component is cancelled out. This avoids/

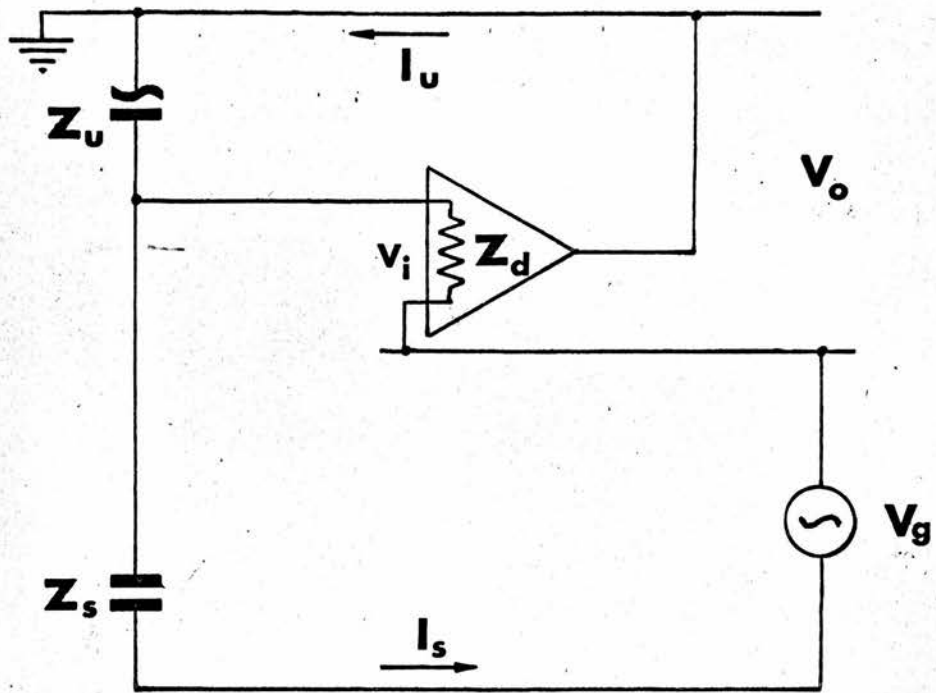

FIG. 3.19. OPERATIONAL METHOD SHOWN IN BRIDGE FORM

avoids the difficulties which would otherwise arise if a phase difference existed between the two signals.

(ii) Analysis of the Method

The circuit of the operational amplifier method is redrawn in Fig. 3.19 so that an easy comparison can be made with the two bridge methods described in Section 3.3. Analysis by the nodal method gives

$$v_i = V_g - I_s Z_s \quad \dots\dots\dots (1)$$

$$v_i = V_o - I_u Z_u \quad \dots\dots\dots (2)$$

$$v_i = (I_u + I_s) Z_d \quad \dots\dots\dots (3)$$

$$V_o = \beta v_i \quad \dots\dots\dots (4)$$

From (1)
$$I_s = \frac{V_g - v_i}{Z_s}$$

From (2)
$$I_u = \frac{V_o - v_i}{Z_u}$$

which give by substitution in equation (3)

$$v_i = \left\{ \left(\frac{V_o - v_i}{Z_u} \right) + \left(\frac{V_g - v_i}{Z_s} \right) \right\} \cdot Z_d$$

Collecting up terms and substituting for v_i from equation (4) this becomes

$$V_o = -V_g \cdot \frac{Z_u}{Z_s} \cdot \frac{1}{\left\{ \left(1 - \frac{1}{\beta} \right) - \frac{1}{\beta} \left(\frac{1}{Z_s} + \frac{1}{Z_d} \right) Z_u \right\}}$$

In/

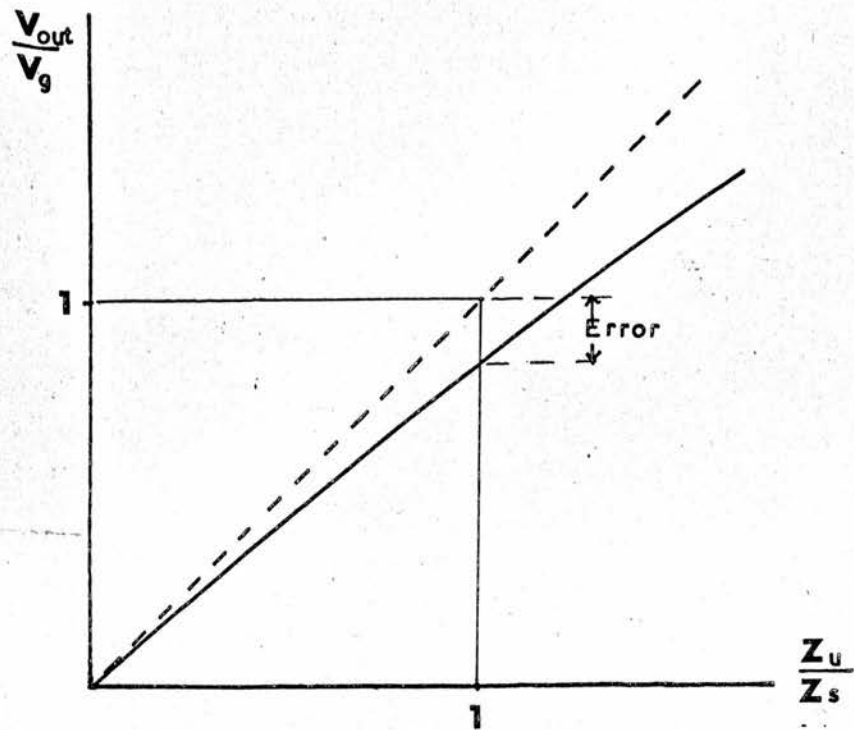

FIG. 3.20. EFFECT OF ERROR TERMS ON OUTPUT OF OPERATIONAL METHOD

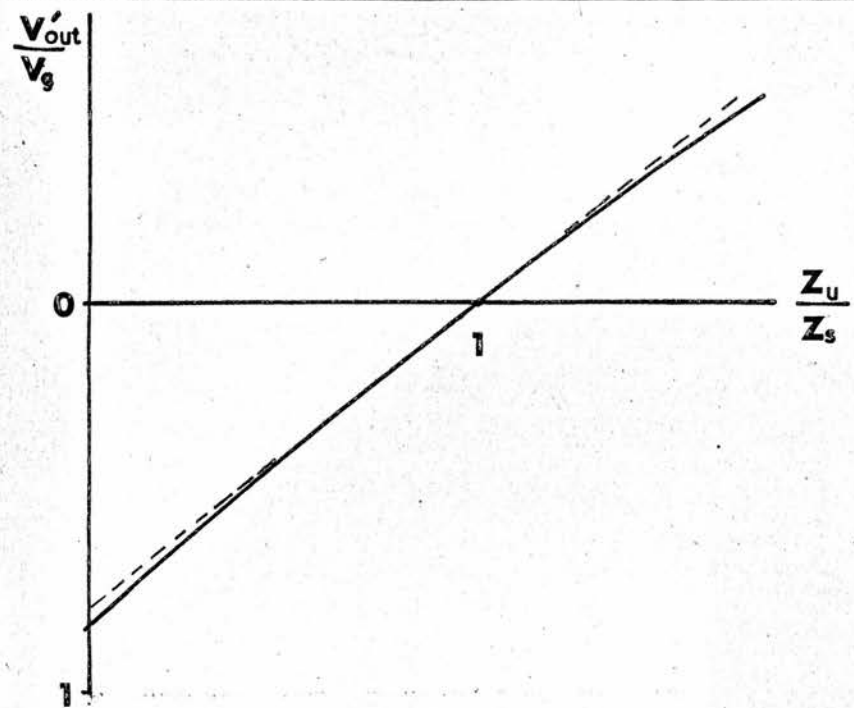

FIG. 3.21. 'BACKING-OFF' ELIMINATES CONSTANT ERROR

In order that the output voltage is proportional to Z_u it is necessary to eliminate the term in Z_u from the denominator in this equation. If $Z_d = -Z_s$ then this term is zero but even if this is not so the error will be small provided β is very large and the unknown impedance is not large compared with either the standard or the detector input impedance.

(iii) Limits of Accuracy

It can be seen from the above equation that, provided the gain and input impedance of the operational amplifier are known and the normal range of variation of the unknown impedance is specified, the minimum accuracy of the system can be determined. Fig. 3.20 shows how the output characteristic of the amplifier is affected by the error term.

This error can be expressed in the form

$$e = -\frac{1}{\beta} \left\{ 1 + \left(\frac{1}{Z_s} + \frac{1}{Z_d} \right) Z_m + \left(\frac{1}{Z_s} + \frac{1}{Z_d} \right) (Z_u - Z_m) \right\}$$

The constant error terms associated with the mean value of the unknown impedance Z_m are eliminated by the "backing-off" procedure since the output voltage is brought to zero at the mean value.

The remaining error terms then produce a non-linear characteristic as shown in Fig. 3.21. Since it is usually arranged that the mean value of the unknown impedance is of the same order of magnitude as the standard impedance the linearity of the characteristic will depend on the term

$$\frac{(Z_m - Z_u)}{Z_d}$$

Provided/

Provided $(Z_m - Z_u)$ is not greater than Z_d the error due to this term will be of the same order as the other error terms. The magnitude of Z_d is however limited by the capacitance which shunts the amplifier input terminals when a guard screen is used. The reactance of this capacitance may be more than an order of magnitude smaller than the impedance variations in the unknown so that unless β is very large the resultant characteristic will be very non-linear.

CHAPTER 4

DEVELOPMENT OF A PRACTICAL BRIDGE CIRCUIT

4.1. Basic Requirements

A variety of methods for the measurement of impedance have been discussed in theory in Chapter 3. It was decided at an early stage in the project that a bridge system would be the most satisfactory of these methods for the present application. This chapter describes the development of a suitable linear bridge circuit together with its associated oscillator and detector. The practical form of the Capacitance Proximity Transducer will be described in a later chapter.

The most convenient form of bridge network for the comparison of two capacitative impedances is the Thompson Bridge discussed in Section 3.2. The voltage sources of the network are provided by a high frequency oscillator which has a centre tapped output winding. This winding forms the ratio-arm of the network, and the transducer and a variable capacitor are connected across the full winding to complete the bridge. The output signal of the bridge is detected between the centre tap of the transformer and the junction of the two capacitances. The amplitude and phase of the voltage which appears at this point is a function of the value of the variable capacitor and the spacing between the transducer electrode and the body surface. The detected voltage is zero when the capacitance of the variable is adjusted so that it equals the capacitance of the transducer. Any changes in spacing which occur at/

at the transducer will then produce an output voltage. If the amplitude of this voltage is detected by a suitable phase sensitive method a low frequency signal related to the motion of the body surface can be obtained.

It is known that the spectrum of adult heart sounds has component frequencies extending from ~ 1 Hz to at least 2kHz (see Luisada 1965) so that the signal bandwidth of the instrument must extend from 0 to > 2 kHz. In order to achieve this bandwidth the carrier frequency used must be greater than 10kHz. In practice it is found desirable to make this frequency as high as possible so that the transducer impedance is small compared with that of the detector. The upper limit of carrier frequency is at about 1 MHz, since the transistors required in the detector circuit will not operate at higher frequencies.

It is intended that the output obtained from the instrument is suitable for recording on magnetic tape since this is the most convenient form of record for further analysis. Direct recording of the signal is not possible since the spectral distribution extends below the limit of normal direct recording bandwidths. Direct recording of the modulated carrier was considered but this is not possible at a realistic speed for carrier frequencies above 10kHz. For this reason frequency modulation recording is necessary and even with this method a speed of 15"/sec. is necessary to give a signal bandwidth from 0 to 2.5kHz. Equipment suitable for F.M. recording at 15"/sec. was not available although recordings/

recordings at $7\frac{1}{2}$ " / sec. were made in the later stages of the project.

This gives an effective signal bandwidth from 0 to 1.25kHz.

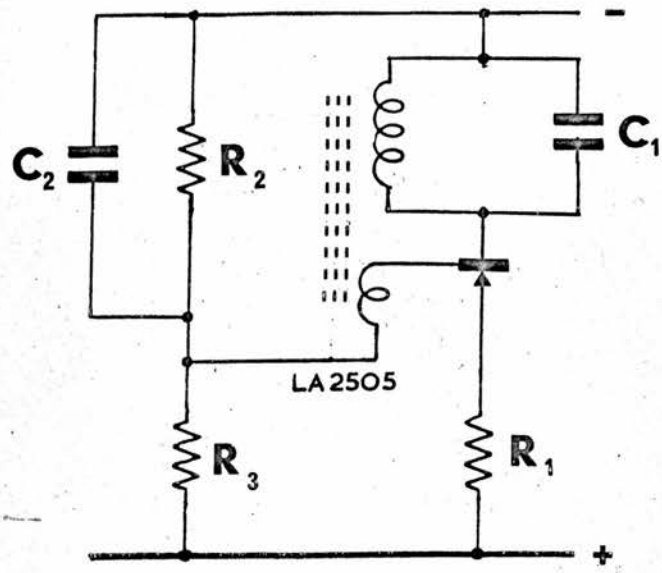

FIG. 4.1. CLASS 'B' OSCILLATOR

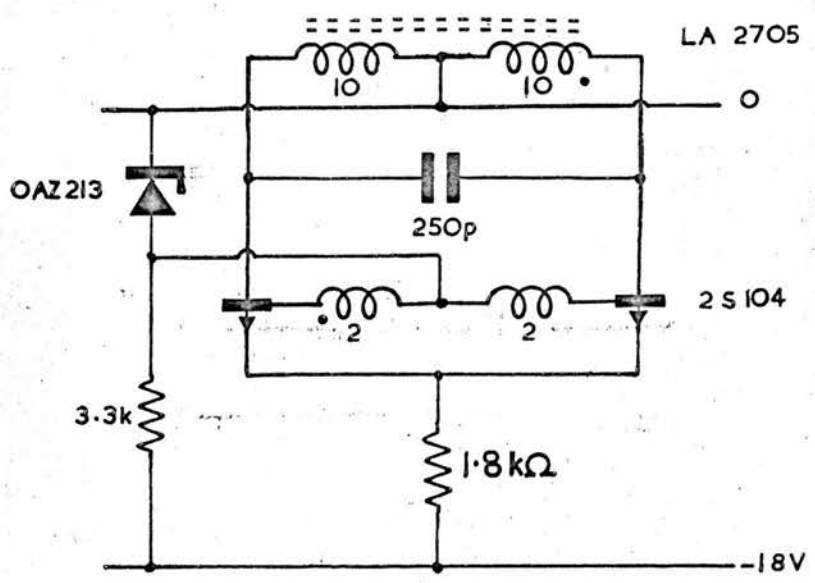

FIG. 4.2. LONG-TAILED-PAIR CURRENT-SWITCHING OSCILLATOR

4.2. Source Oscillators

(i) Single Sided Oscillator

Some preliminary experiments were made using a single transistor class B oscillator of the same type as that used by Baxandall (1963) in his circuit for an electrostatic microphone (shown in Fig. 4.1). In order to produce two output voltages which are exactly equal it is necessary to use bifilar secondary windings. This ensures close magnetic coupling between the two windings. However the capacitance between the two sections of the winding is high so that when these are connected in series the winding capacitance forms part of the tuning capacitance of the oscillator. In the particular circuit used it was found that the self resonant frequency of the oscillator transformer was less than 100kHz.

Another difficulty which occurs with this type of winding is the uneven distribution of stray capacitances between its sections and other windings on the same core. This affects the measuring circuit because certain of these capacitances appear in parallel with the elements of the bridge. The effect of these capacitances can be reduced by the use of a suitable interwinding screen but this was not possible with the miniature ferrite pot-core which was used for the transformer. Some improvement was obtained by rearranging the connections to the primary and feedback windings of the oscillator so that the 'earthy' ends of these were adjacent to the secondary winding.

In/

In order to test this arrangement before the transducer was completed two miniature air dielectric trimmers were used to complete the bridge network. Examination of the output amplitude with an oscilloscope showed that the arrangement was highly sensitive to the proximity of earthed objects. The oscillator waveform was also examined and found to have a high harmonic content. This was due to the low 'Q'-factor of the oscillator tuned circuit and was particularly noticeable at low frequencies of oscillation.

(ii) Push-Pull Oscillator

After it was found that the output of the Class B oscillator had a high harmonic content it was decided to use a push-pull oscillator for later versions of the bridge circuit. This type of oscillator is symmetrical throughout so that even-order harmonics are not present in the output and also the interwinding capacitances of the output transformer are more symmetrical with respect to earth.

A very simple and satisfactory push-pull oscillator is the long-tailed-pair current switching circuit described by Foss and Sizmuir (1962). This is shown in Fig. 4.2. The great advantage of this type of circuit is that its performance is much less dependent on transistor parameters than the class B circuit which may operate in class A or class C depending on the current gain of the transistor. In order to avoid the production of even harmonics due to asymmetry the stray capacitances between the ends of the primary/

primary winding and earth must be equal. A bifilar primary winding is therefore undesirable although equality between the two halves of the winding is essential. Baxandall (1964) recommends a method in which the two halves of the winding are wound on separate halves of the transformer core. These windings are arranged so that the 'starting turns' are adjacent at the centre of the former. The windings are built up in opposite directions and the 'finishing turns' are linked externally to produce a centre tapped winding. In this way the stray capacitances to the two halves of the winding are almost identical and the 'finishing turns' of the winding act as a partial screen between the primary and secondary windings. Any residual unbalance can be corrected by the use of external trimmer capacitors.

On the secondary side of the transformer exact equality of the two halves is still essential but it is necessary to reduce the capacitance associated with a bifilar winding. This can be achieved by splitting the secondary winding into four equal sections which are wound bifilarly on the two halves of the former. These coils are then connected externally to complete the secondary winding in such a way that each half-winding consists of two of the four sections, one from each half of the former. The self capacitance of the resulting secondary winding is less than that associated with a simple bifilar winding and the stray capacitances associated with the winding are more symmetrically distributed. A schematic arrangement of the primary and secondary transformer windings is shown/

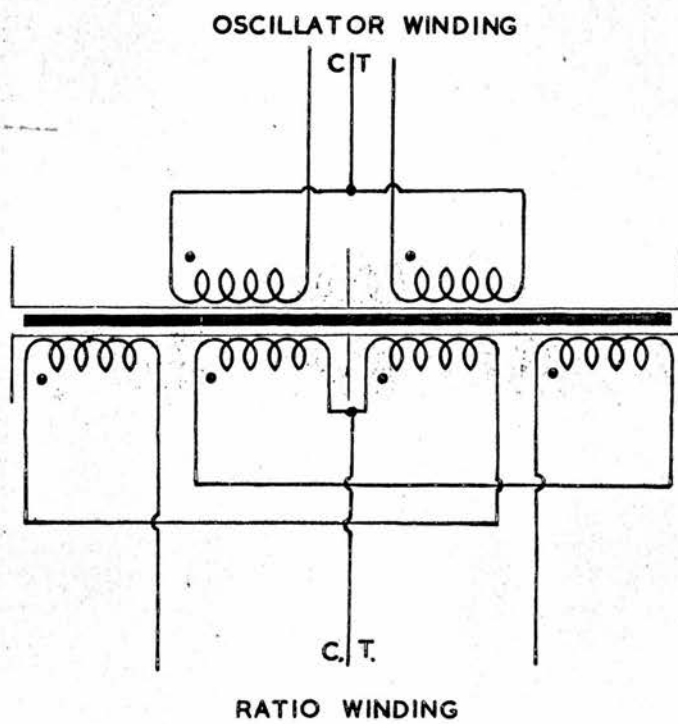

FIG.4.3. SCHEMATIC ARRANGEMENT OF BRIDGE TRANSFORMER WINDINGS

shown in Fig. 4.3.

Examination of the output of an oscillator constructed with this type of transformer showed that the most significant harmonic remaining in the output was the seventh. The amplitude of this harmonic was such that any error it produced would certainly be less than other errors present in the system. Litz wire was later used to improve the 'Q' factor of the transformer windings and this resulted in a further reduction in the harmonic content of the oscillator output.

(iii) Oscillator Output Impedance

In the long-tailed-pair circuit the voltage which appears across the secondary winding is proportional to the dynamic resistance of the tuned circuit. A low harmonic content is obtained when the circuit has a high Q-factor i.e. the dynamic resistance is large compared with the tuned circuit reactance. The resulting source impedance for the bridge energizing voltage is therefore high. For optimum performance of the bridge network it is necessary that the two voltages appear to come from very low impedance sources. Baxandall (1963) has not included this in his calculation of the output impedance of the bridge network although it will obviously increase the noise output of the series-tuned bridge.

Alternatives to the long-tailed-pair oscillator, described by Baxandall (1960) and Roddam (1963) were considered but it was found that none of these had suitable output arrangements for the bridge circuit. It was necessary, therefore, to include a buffer amplifier/

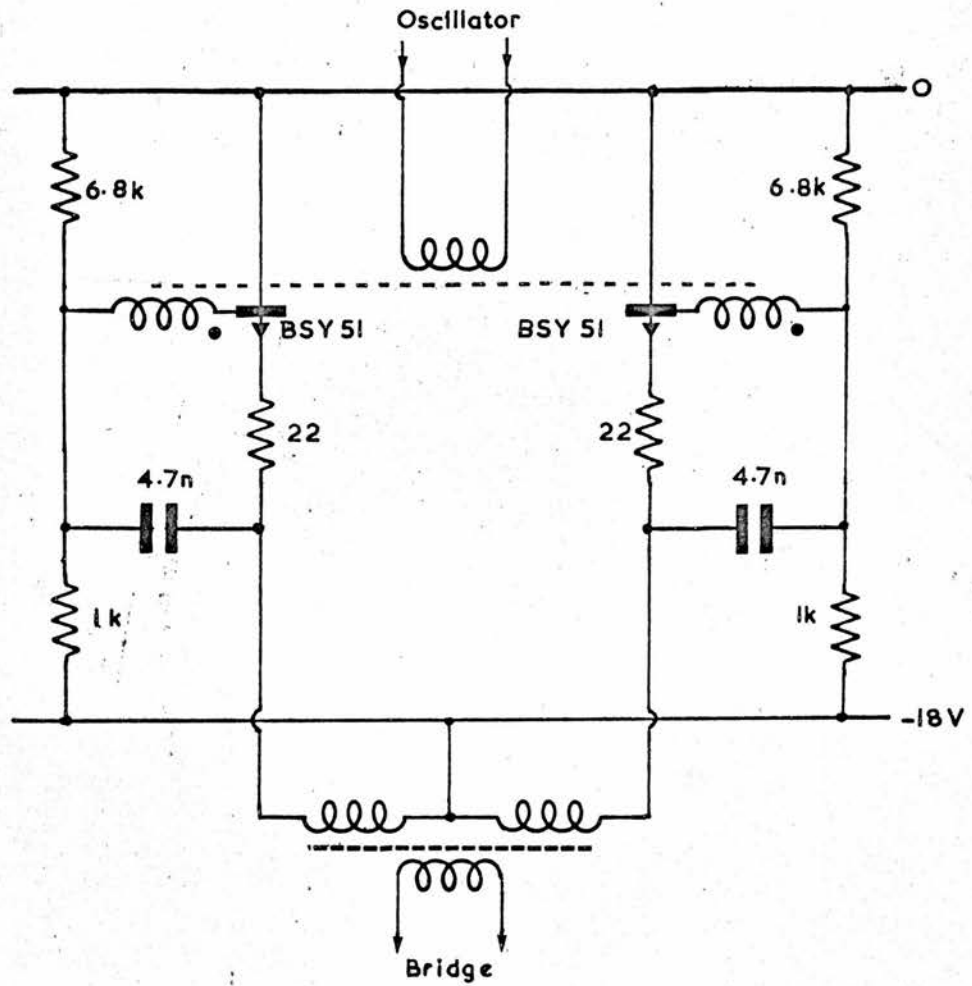

FIG. 4.4. CARRIER FREQUENCY BUFFER AMPLIFIER

amplifier between the oscillator and the bridge ratio transformer in order to reduce the effective source impedance presented to the bridge network. The circuit of this amplifier, which is of the Earthed Collector Common-Emitter type described by Hilling (1963) and Bond (1964), is shown in Fig. 4.4. The use of a buffer amplifier in this way isolates the tuned circuit of the oscillator from the bridge network so that changes in bridge reactance do not affect the oscillator frequency. It is arranged that the output transformer of the amplifier has a very low 'Q' factor so its response is independent of oscillator frequency and variations of components in the bridge network. Since the transistors in the amplifier operate in Class B Push-Pull careful matching is required to avoid cross-over distortion. Using Mullard type BSY51 transistors an output impedance of $\sim 240 \Omega$ was obtained. This is limited by the maximum amplitude of drive signal, the supply voltage of the amplifier and the maximum permissible power dissipation in the transistors. The effective source impedance to be added to the bridge impedance at balance is thus about 60Ω . This source impedance could be further reduced if transistors with a higher dissipation rating were used.

4.3. Detector

Since the output of the bridge passes through zero at balance and the signals on either side of balance differ in phase by 180° it is necessary to use a phase sensitive detector to avoid ambiguity of output. This consists essentially of two electronic switches which are driven on and off alternately by a signal in phase with the oscillator. A full wave rectified output is therefore obtained which changes sign as the bridge passes through balance and changes phase. Quadrature components of the fundamental and even-order harmonics average to zero each half cycle and so do not contribute to the output amplitude. The high frequency ripple which appears as part of the full wave rectified signal is removed by a suitable filter with a high frequency cut-off at 10 K Hz.

An experimental detector was constructed using two transistors as shown in Fig. 4.5. The detector circuit is of the same form as the well known 'Ring Modulator' using transistors as the switching elements (Hakim and Barrett, 1964). A similar circuit has also been used by Baxandall (1963) as a detector for the bridge output. In his paper he observes that the waveforms obtained from the detector transistors depends on their high frequency characteristics. A variety of transistor types were therefore examined to find which would give the most satisfactory performance in the detector circuit. Some difficulty was encountered in carrying out these investigations due to the inadequate frequency response of the oscilloscopes available. The Fairchild C 111 E transistor/

transistor was found to give the best results of the types which were tested although this was not completely satisfactory. From the papers by Semiconductors Ltd. (1961), Standard Telephones and Cables Ltd. (1961) and Evans ^{et al} (1961) it appears that the bidirectional type of switching transistor would give a more satisfactory performance. This type of transistor has been used in a bridge detector by Calvert and Mildwater (1963). The C 111 E is not a bidirectional device and it was found that it would not operate in the inverted mode which is a common practice in this type of switching circuit (Lydén, 1965).

In use it was found that the phase sensitive detector action was affected by the state of balance of the bridge. At wide departures from balance the signal being rectified was in fact larger than the reference signal with the result that the 'switch' was not remaining on. The detector output was therefore limited at large amplitudes. In addition it was found that since the transistors would not work in the inverted mode only half wave rectification of the bridge output was occurring. As a result the detected output was less than predicted and a high level of carrier ripple was presented to the filter. Modifications to the oscillator output transformer would enable an improved drive to be supplied.

A four transistor detector was also tested since this type of circuit is designed to handle signals of either polarity (Decker, 1955, Milnes, 1957, Lydén 1965). However it was found to be unsatisfactory because the 'on' resistance of the transistor pairs was/

was comparable with the filter impedance.

A further difficulty was encountered with both types of detector circuit since the drive waveform used was sinusoidal. The transistor switches cannot come on until the drive exceeds the base saturation voltage. The sinusoidal drive must therefore be large enough to ensure this for as much as possible of the cycle without exceeding the break-down ratings of the transistor at maximum drive amplitude. A square waveform could be derived from the oscillator output by the use of additional amplifiers and limiting stages but this would increase the complexity of the apparatus and might produce a phase lag in the reference path.

An attempt was made to devise a 'floating' circuit which would allow a high current to flow into the base of the switching transistor when the applied voltage was small but limit it once saturation was achieved. However it was found that such an arrangement would only function for one polarity of signal.

A reasonably acceptable detector performance was ultimately obtained by using the type OC141 Symmetrical Germanium transistors, although their frequency response was hardly adequate for switching at 1M Hz. (Appendix A discusses in more detail the characteristics of transistors in relation to their switching performance).

4.4. Linearity Correction

(i) Non-Linearity at Large Amplitudes

Most workers who have used bridge methods for dynamic measurements make the assumption that the variation to be observed in the unknown element is very small compared with the bridge standard. In such cases the output may be considered linear within the specified accuracy of the instrument and if it is operated near balance the sensitivity will be approximately constant. However such a specification does not make full use of the available sensitivity and signal to noise ratio of the bridge method.

In the present application it cannot be assumed that the bridge will always remain close to balance so that, unless the output function is linear, distortion will result. Since distortion implies harmonic generation and the detected signals are required for frequency analysis it is necessary to correct for any non-linearities in the output. Once a linear output function is achieved then the sensitivity will be constant irrespective of the state of balance of the bridge and optimum signal to noise ratio can be obtained by allowing very large changes (i.e. fluctuations of the same order of magnitude as the standard).

The linearity and sensitivity of the transducer and bridge network were tested under both static and dynamic conditions. The results of these tests are discussed in detail in Chapter 5, Section 2.

(ii) Correction by Non-Linear Amplifier.

In order to reduce the distortion observed a special non-linear/

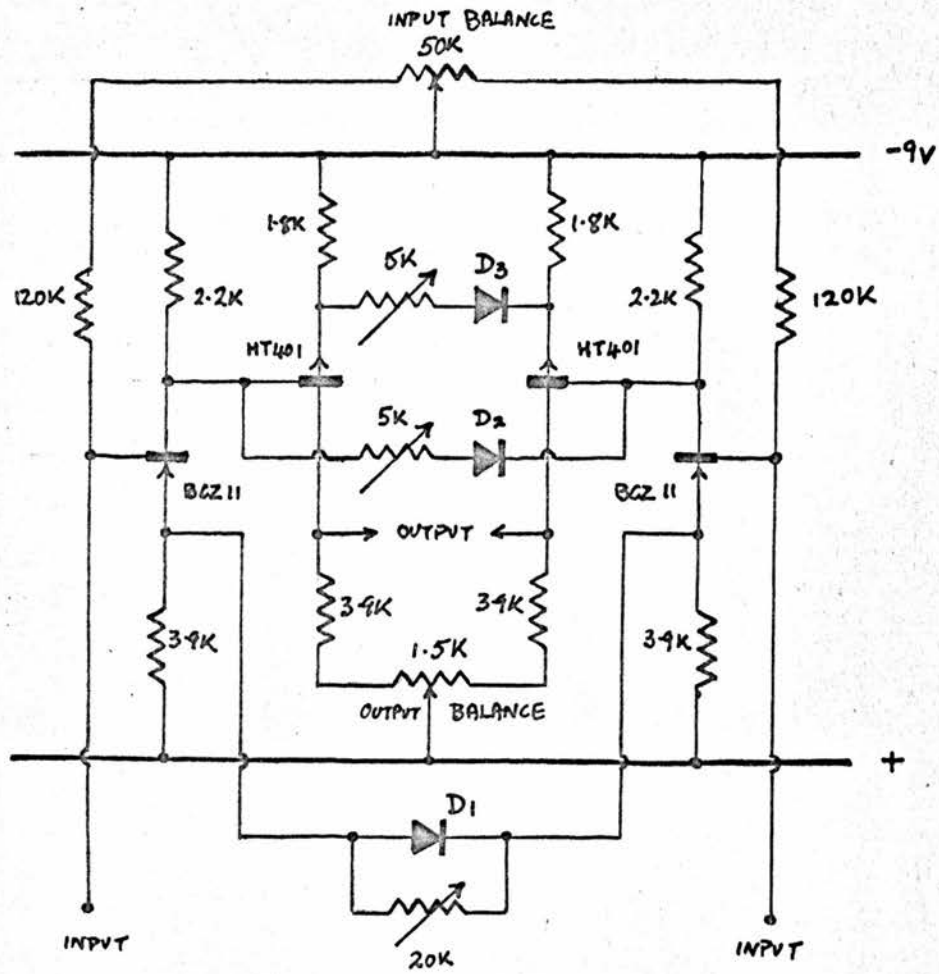

FIG. 4. 6. A DIFFERENTIAL INPUT NON-LINEAR AMPLIFIER USING DIODES

non-linear amplifier was constructed using semiconductor diodes to give an approximate correction curve. Since the bridge output can be assumed linear at small amplitudes any correction, if only approximate, can be used to limit the distortion to a known level at large amplitudes. Under suitable bias and gain conditions in the non-linear amplifier its transmission characteristic can be made a good approximation to the inverse of the output characteristic of the bridge network. A difficulty in the present situation is that the correction system must be able to function irrespective of balance conditions of the bridge and very low frequencies. Diode shaping network and multiplication elements are recognised analogue computing techniques (Berry 1959, 1963) but in such cases the signal is at least of audio frequency and can be A.C. coupled. This means that the biasing arrangements of the shaping network are independent of the signal input. As a result it was found that although the circuit could be made to function satisfactorily under fixed balance conditions it could not be made to work for all possible conditions. The final circuit shown in Fig. 4.6. was also difficult to set up since three diodes were required to produce the necessary characteristic.

(iii) Correction by Feedback

In general, feedback may be used to reduce the distortion of a non-linear amplifier but the combination of oscillator, bridge and detector do not form an amplifier in the conventional sense. However if the detected output of the bridge could be feedback in some way to control/

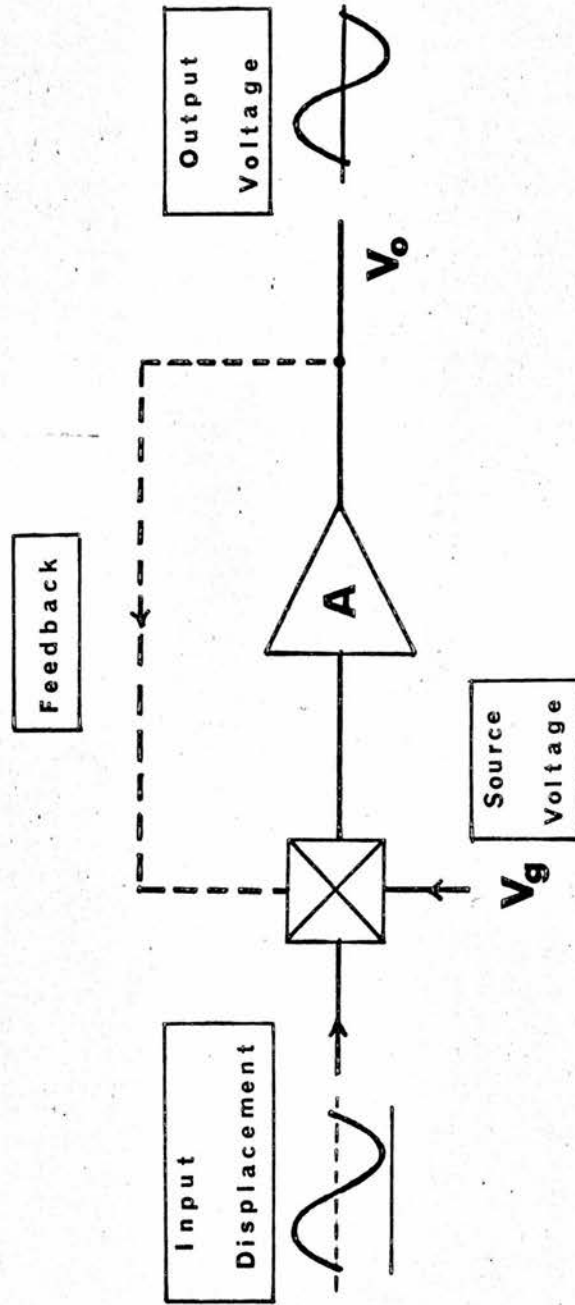

FIG.4.7. FEEDBACK CONTROLS OUTPUT OF DISPLACEMENT TO VOLTAGE CONVERTOR

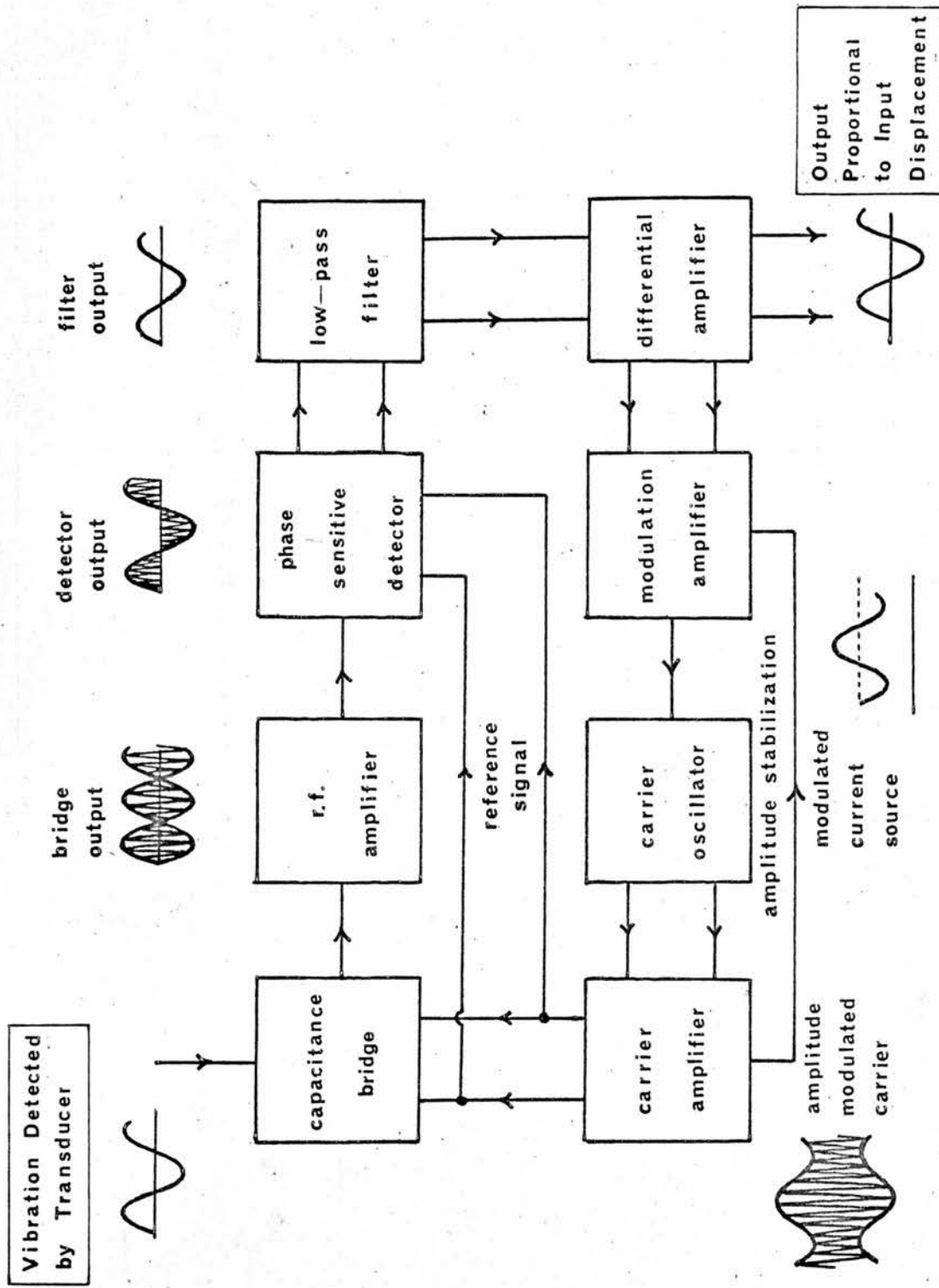

FIG. 4.8. A METHOD OF FEEDBACK CORRECTION GIVING A LINEAR OUTPUT

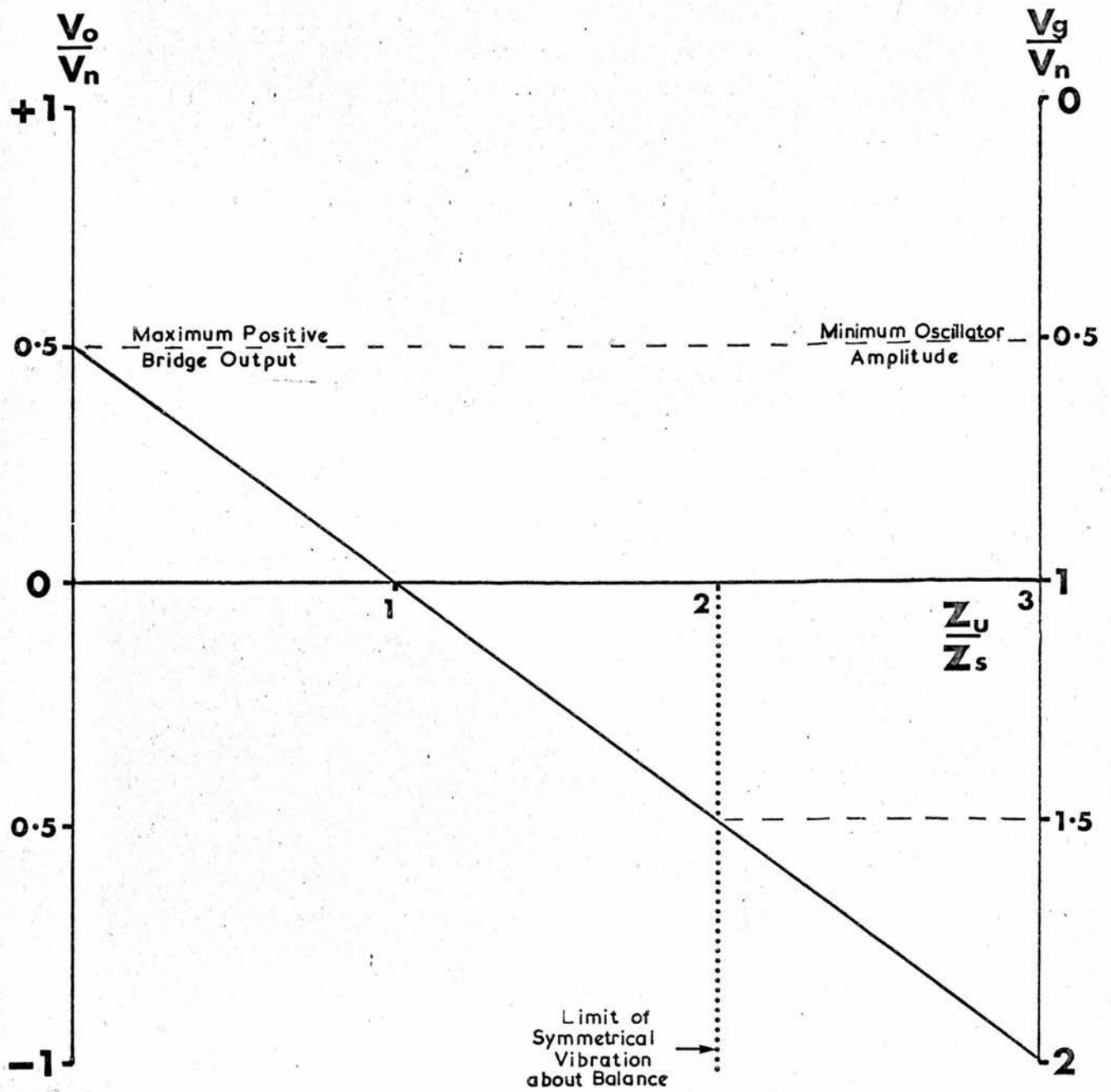

FIG.4.9. OUTPUT AND MODULATION CHARACTERISTIC OF CORRECTED BRIDGE

control the amplitude applied to the bridge as indicated in Fig. 4.7. then improved linearity might be obtained. It would be necessary to arrange the connections so that the oscillator amplitude was reduced as the transducer spacing was reduced and vice versa. This modulation of the oscillator amplitude can be obtained fairly readily in the long-tailed pair oscillator by controlling the tail current (Foss & Sizmuir, 1962). An experimental circuit was constructed using the detected output to control the tail current. This is shown in block form in Fig. 4. 8.

Correct adjustment of the mean level of the bridge operating voltage was essential otherwise the range of correction was limited by over modulation in the oscillator. For perfect correction of the non-linearity at the maximum amplitude of vibration a modulation depth of 50% was required. Fig. 4.9. shows the resulting bridge characteristic. This must be achieved without bottoming the transistors. In addition the minimum amplitude of reference signal provided for the detector must remain greater than the transistor saturation voltage if the detector is to function at all.

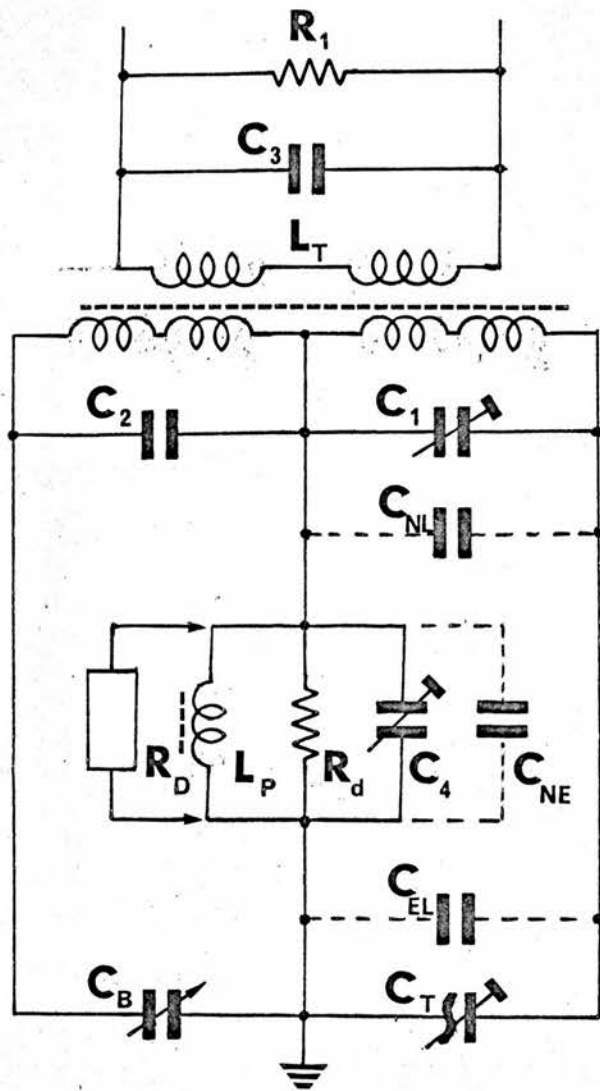

FIG. 4.10. COMPLETE BRIDGE NETWORK INCLUDING STRAYS

4.5. Final Form of the Bridge Network

In the final arrangement of the bridge network it is necessary to take into account the effects of the screened cable used to eliminate stray capacitance in parallel with the transducer. The screen of this cable is connected to the neutral point of the bridge network so that the capacitance of the cable is in parallel with one half of the secondary winding. (C_{NL}). The capacitance (C_{NE}) between the neutral point and the junction of the two bridge capacitors, which is at earth potential, will also be increased by the presence of this cable. These capacitances are shown in Fig. 4.10.

Since it is desirable to keep these capacitances as small as possible a low capacitance cable is required and its length must be limited. For convenience a maximum length of 10 ft. was chosen as being adequate for most purposes. It is also important that the cable should be light and flexible. The 'Transradio' type J 00230 which has a capacitance of 15 pF/ft. was found to be the most satisfactory type of cable available. The total capacitance of 10 ft. of this cable connected to the transducer was found to be 165 pF.

This capacitance appears in parallel with one half of the winding and it is desirable to balance it with a similar capacitor across the other half winding. This is because the leakage impedance of the transformer winding will not be zero, with the result that the two outputs obtained from the winding will not be accurately equal and/

and antiphase unless the shunt impedances are also equal. It is convenient to keep the total capacitance across the transformer windings constant irrespective of the actual length of cable used. This can be arranged by means of a preset capacitor (C_1) in parallel with the cable capacitance, which is set to its minimum value when a 10 ft. cable is used, and a fixed capacitor (C_2) across the other half winding. The minimum value of a suitable preset capacitor is 20pF so that the nominal capacitance across half the winding is 185pF. Since the next larger value of fixed capacitor is 200pF, the working value of capacitance in parallel with both halves of the winding was adjusted to 200pF.

These capacitances will also affect the tuning of the bridge transformer which forms part of the load of the buffer amplifier. In order to minimize the harmonic content in the buffer amplifier output it is necessary to make the 'Q'-factor of the transformer as high as possible. The load resistance of the amplifier (R) is $\sim 240 \Omega$ so the inductance (L_t) of the transformer must be very low in order to give a high working 'Q'-factor. A large value capacitor will therefore be required to tune the transformer inductance to the oscillator frequency. This has the advantage that changes in the bridge balance capacitor and the transducer, which also appear in parallel with the transformer, will have little effect on the resonant frequency of the transformer.

In order to obtain a reasonable accuracy for the turns-ratio of the transformer the number of turns in each winding cannot be reduced indefinitely. The optimum was found to be about 8 turns per half winding/

winding which gives an effective primary inductance L_t of 16 μ H and a working 'Q' of 2.4 at 1 M Hz. The capacitance necessary to tune this inductance at 1 M Hz is 1.5 nF of which 100 pF is provided by the capacitances C_{NL} , C_1 and C_2 . The transformer is tuned to parallel resonance by means of preset C_3 when the transducer and balance capacitor are disconnected, in order that these do not affect the resonant frequency.

The capacitance between neutral and earth C_{NE} must also be considered in relation to the bridge characteristics since it appears in parallel with the detector input terminals. This consists largely of the capacitance of the screen of the transducer cable to the earth lead which connects with the transducer housing. This was measured and found to be 160 pF for the 10 ft. cable. This capacitance would make no difference to a detector with a low input impedance but for proper operation of the feedback correction a very high input impedance is necessary. This impedance can be increased if it is parallel-tuned by a suitable inductor and the greater the 'Q'-factor of the inductor the greater the effective impedance across the detector. The 'Q'-factor cannot be increased indefinitely since a maximum value is set by the bandwidth required.

This is given by

$$Q_{\max} = \frac{f_0}{2f}$$

where f_0 is the carrier frequency

f is the maximum signal frequency.

For a 1 M Hz carrier frequency and a 2 k Hz maximum signal frequency/

frequency this gives a maximum permissible 'Q'-factor of 250. This value will increase as the carrier frequency is increased. However the 'Q'-factor of the type LA 2704 and LA 2705 ferrite pot-cores, which are the most suitable for the construction of inductors at around 1 M Hz, decreases as the frequency rises. This means that an optimum operating frequency can always be found at which the 'Q'-factor of the inductance will equal the 'Q'-factor giving the necessary bandwidth at that frequency. It is found that an optimum 'Q'-factor of 225 is obtained at a frequency of 0.9 M Hz. using an LA 2704 vinkor. This means that the maximum possible detector impedance which can be obtained is no more than seven times greater than the maximum output impedance of the bridge network and this will be further reduced by the input impedance of the actual detector. It can be seen that a reduction in cable length would increase the effective impedance in parallel with the detector. Since a cable of less than 5 ft. would be unsatisfactory for clinical use, a twofold increase in impedance is the maximum obtainable by this means.

The use of a negative impedance convertor as an alternative to parallel tuning was also considered but it was found that such circuits do not function satisfactorily at large amplitudes and high frequencies. Other methods of screening the transducer lead were investigated but no satisfactory arrangement was found which did not produce a capacitance across the detector terminals.

Since/

Since the detector impedance is not very large compared with the transducer impedance the feedback arrangement is not entirely satisfactory. This is because, although the correction can be set up to give a linear output at any particular balance capacitor setting, a different adjustment is required for every other balance setting. In spite of this difficulty the overall linearity of the bridge network with feedback can be adjusted so that it is always significantly better than that of an uncorrected bridge network.

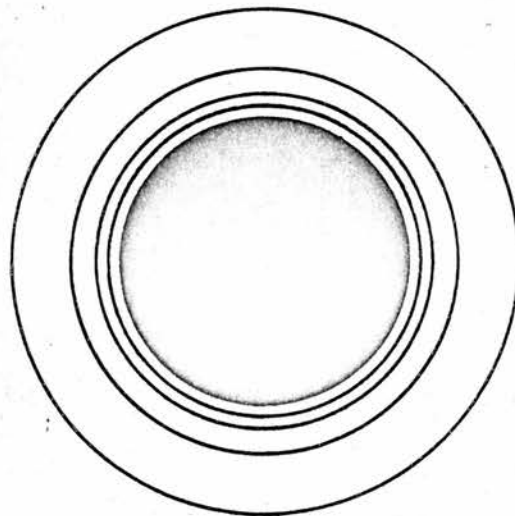
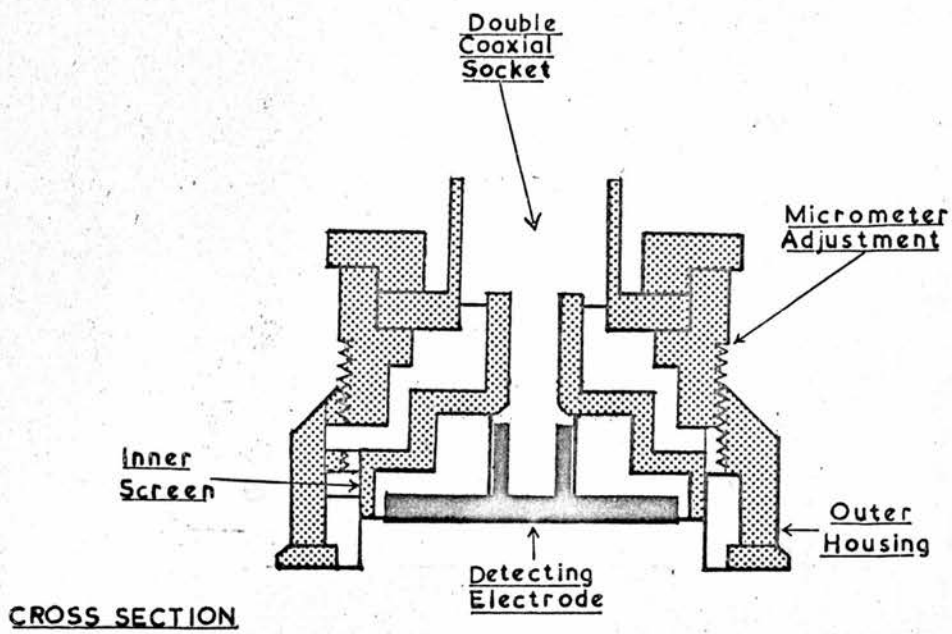

PLAN VIEW

TWICE
ACTUAL
SIZE

FIG. 5.1. CONSTRUCTION OF CAPACITANCE PROXIMITY TRANSDUCER

CHAPTER 5

CONSTRUCTION AND TESTING OF A PRACTICAL

CAPACITANCE PROXIMITY TRANSDUCER

5.1. Construction of the Transducer

The basic design factors for the Capacitance Proximity Transducer have been discussed in Chapter 2. It is intended in this chapter to describe in more detail the form of transducer which was constructed and used during the course of these investigations.

The initial form of transducer construction was based on the transducer described by Groom and Sihvonen (1957a). This design was modified so that the lead to the detecting electrode and the electrode itself are screened within the earthed outer housing of the transducer. The transducer thus consists of an outer shell at earth potential which can be in contact with the patient or mounted at some 'remote' point. An inner shell which is maintained at the neutral potential of the bridge, and the detecting electrode. A cross section of the transducer and a view of its front face are shown in Fig. 5.1. The three sections are connected to a double coaxial socket on the top of the transducer so that double screened cable could be used if necessary. However it was found later that this type of cable is too heavy and rigid. In practice it is not necessary to make any earth connection to the patient and a single screened cable was therefore used. This enabled the stray capacitance from the electrode lead to earth to be eliminated from the bridge balance conditions. The effective/



Fig. 5.2 Heart Sound Transducer, Vacuum Ring and Connecting Plug.



Fig. 5.3 Close-Up of Complete Transducer Assembly.



Fig. 5.4 Transducer Assembly resting on a Smooth Surface.

effective sensitivity of the transducer is thus increased and the need for building a transformer within the housing is avoided. A micrometer adjustment was incorporated so that the spacing between the electrode and any surface on which the housing rested could be adjusted.

The overall dimensions of the transducer were chosen to be of the same order as those used by Groom, the diameter of the detecting electrode being made as large as possible in order to cut down edge effects. The neutral screen does not function as a guard ring since it is not at the same potential as the detecting electrode when used with the bridge network. The width of the screen presented at the front face is thus dictated by mechanical construction rather than electrical requirements.

For convenience the Detecting Electrode was made $\frac{3}{4}$ " in diameter, this gives a capacitance in picofarads which is equal to the reciprocal of the spacing measured in tenths of an inch. From the simple theory it can be shown that this equality is in error by less than 0.3% and this will be less than the errors in manufacture of the electrode. Graduations were marked on the Rotating Barrel at 18° intervals round its circumference to enable the transducer spacing to be set in increments of one thousandths of an inch.

Fig. 5.2. shows the transducer together with its connecting plug and an aluminium vacuum^{ring} which can be used to hold it in position. Figs. 5.3. and 5.4. show the complete assembly in more detail.

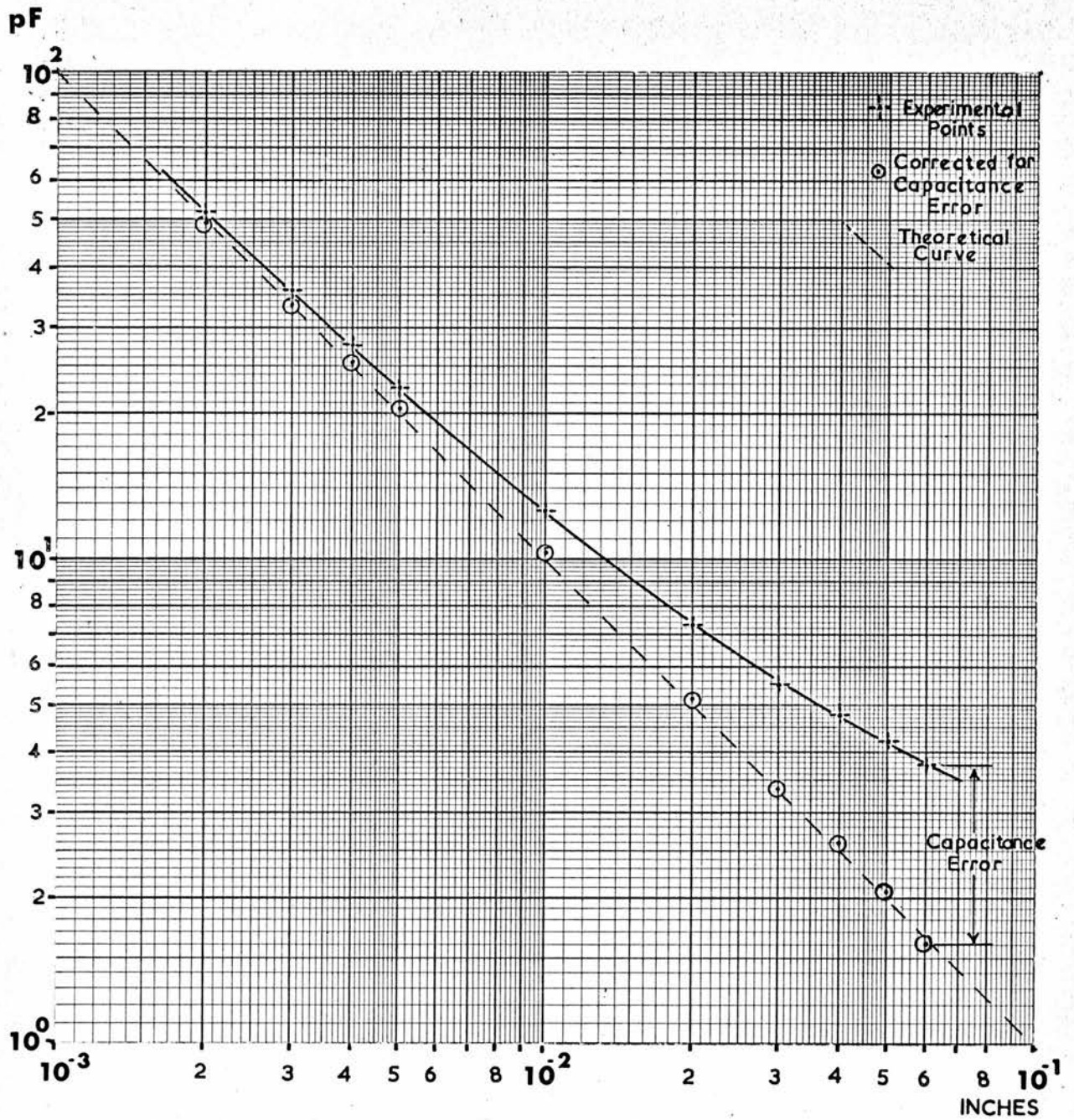

FIG. 5.5. VARIATION OF TRANSDUCER CAPACITANCE WITH SPACING

5.2. Calibration of the Transducer.

(1) Static Calibration

The first test made on the completed transducer was a static calibration curve to enable the correct mechanical zero to be marked on the device and an estimate of the capacitance error to be determined. The measurements were made using a Wayne Kerr Universal Bridge Type B 221, the transducer being stood on a flat metal plate and connected to the bridge through its own cable.

The zero was set at the point at which the electrode and plate just came into contact. The spacing was then increased from zero to maximum, the capacitance being measured at suitable intervals. If the capacitance is inversely proportional to spacing a straight line plot would be obtained on log-log paper. However the capacitance error becomes significant at large spacings so that the inverse relationship is not strictly observed. The magnitude of the zero error can be deduced from the graph shown in Fig. 5.5. It was not possible to determine the cause of this capacitance error as the trimming control on the Wayne Kerr Bridge did not have a sufficient range of adjustment. This prevented the bridge from being balanced when the transducer was not connected to the cable.

Calibration of the balancing capacitor was also carried out using the Wayne Kerr Bridge. Since the Wayne Kerr Bridge operates at an angular frequency of 10^4 radians per second the extrapolation of this calibration to frequencies ~ 1 M Hz may not be justified. However the results which were later obtained with

a/

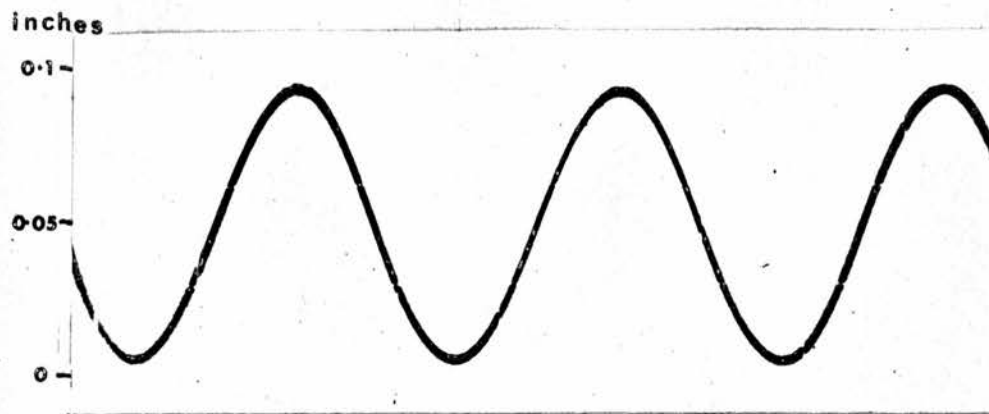

(a) Vibrator Displacement Waveform

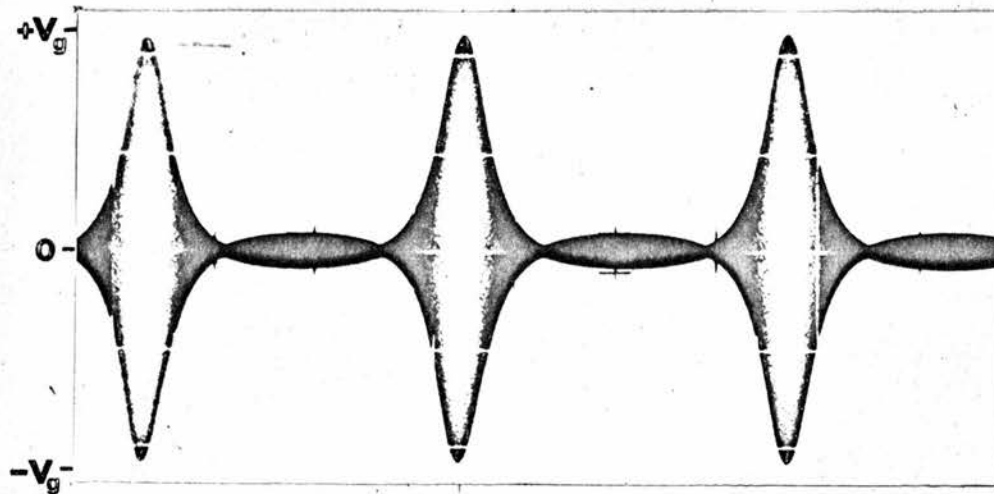

(b) Bridge Output (Modulated Carrier)

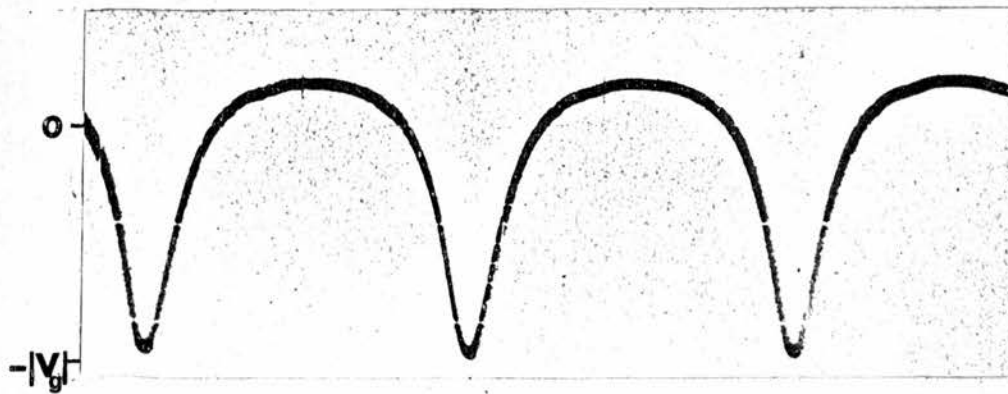

(c) Demodulated Output

FIG. 5.6. DYNAMIC TEST OF BRIDGE LINEARITY

a 1 M Hz bridge using the transducer and balance capacitor remained consistent with the above calibration.

(ii) Dynamic Testing

A dynamic test of the transducer was made using a Pye-Ling Type 47/3 vibration generator with a suitable disc attached to the driving spindle. In order to produce a large change in the transducer impedance during each vibration cycle the vibrator was driven at an amplitude close to the maximum and the transducer was placed at a distance such that any increase in amplitude would result in contact between the disc and the electrode. The driving frequency was adjusted to the mechanical resonance of the vibrator so that a sinusoidal displacement was obtained. Under these conditions it was possible to examine the distortions produced by a large amplitude piston-like motion at the transducer. Fig. 5.6 shows oscilloscope tracings of the bridge output obtained during these tests.

(iii) Testing under simulated conditions of actual use

The vibrator was also modified so that the drive could be applied to an artificial body or to a convenient part of a suitable subject. (i.e. The Arm Method of Takagi et al 1963). This was to enable the transducer to be tested with a known signal under conditions similar to those encountered when observing actual heart sounds.

Some experiments of this type were made with a water filled polythene bag but the results obtained were not very satisfactory although vibrations in the bag could be detected. This was probably due to the insulating nature of the polythene surface/

surface. An Aluminized Melinex cover was attached to the bag to provide a conducting surface but was found to be very unsatisfactory. Better results were achieved by painting the bag with colloidal graphite although this tended to flake off after a time. It was also considered that a water filled bag was a very poor approximation to living tissue and so the observations were later made with a gelatine filled bag.

Using these dummies it was found that the maximum capacitance which could be obtained before contact occurred between electrode and surface was smaller than expected and the effective sensitivity was reduced. This was apparently because of the curvature of the surface which was presented to the transducer electrode. It became clear that although the vibrator can impart a piston like motion of a known frequency and amplitude to the test object the motion detected at the transducer will not necessarily have the same wave form.

In particular when the housing of the transducer is in contact with the body surface the detected motion is restricted to the curved skin surface presented to the electrode. The changes of spacing which are observed will in this case be due to variations in the curvature of the surface beneath the detecting plate. Since the properties of the skin vary between different individuals and on different parts of the body it is not possible to say exactly what form this curvature will take. It can be shown that the transducer produces some initial curvature of the body surface when resting under its own mass or applied with the vacuum ring. Under these/

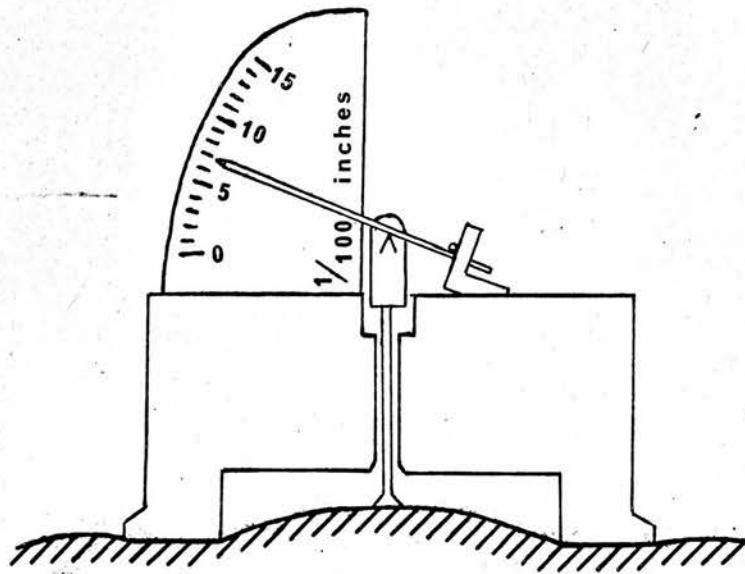

FIG.5.7. DEVICE FOR MEASURING SKIN CURVATURE

these conditions better linearity and a higher sensitivity can be obtained by matching the curvature of the electrode face to this curvature.

It is convenient to regard the surface beneath the electrode as a portion of a sphere. This is probably a reasonable approximation provided the area of the detecting electrode is somewhat smaller than the area of the body surface which is free to vibrate beneath the transducer. An estimate of the required radius of curvature was made by means of a dummy transducer of identical mass to the real transducer. This incorporated a direct reading probe which made contact with the body surface immediately beneath the centre of the device. A sketch of this device is shown in Fig. 5.7.

(iv) Modifications to the Transducer

As a result of these observations a new detecting electrode was made with a suitably curved surface. In order to repeat the static and dynamic calibrations described earlier in this section a curved surface and a curved piston were then necessary. The effect this has on the bridge characteristics is discussed in Appendix B .

The first version of the transducer was constructed with a plain housing over which a rubber belt or vacuum ring could be fitted to hold the transducer in place on a patient. In use the rubber belt was found to be unworkable and a separate vacuum ring greatly increased the transducer diameter. In the final version of/



Fig. 5.8 Modified Transducer with an Integral Vacuum Ring.



Fig. 5.9 Close-Up of Housing of Modified Transducer.

of the transducer shown in Fig. 5.8 the housing has been modified to include the vacuum ring as a permanent feature. This means that the overall diameter of the device is not increased when the vacuum ring is used to hold it in position. Fig. 5.9 shows another view of the final version of the transducer.

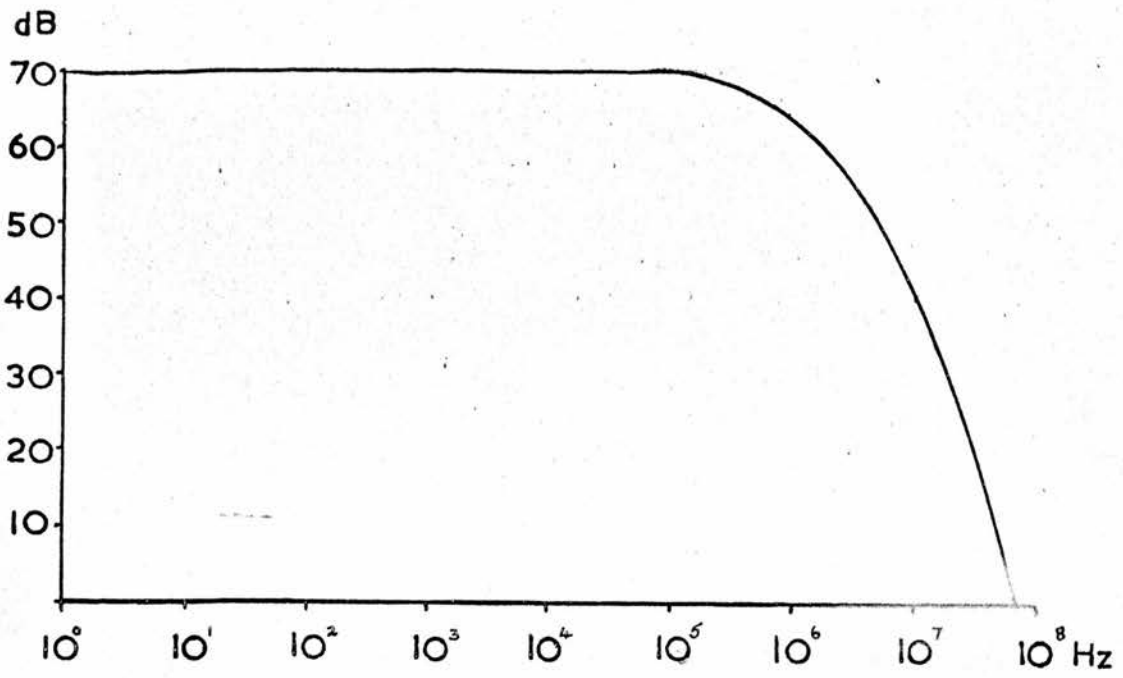

FIG. 6.1. OPEN LOOP FREQUENCY RESPONSE OF $\mu A 702$

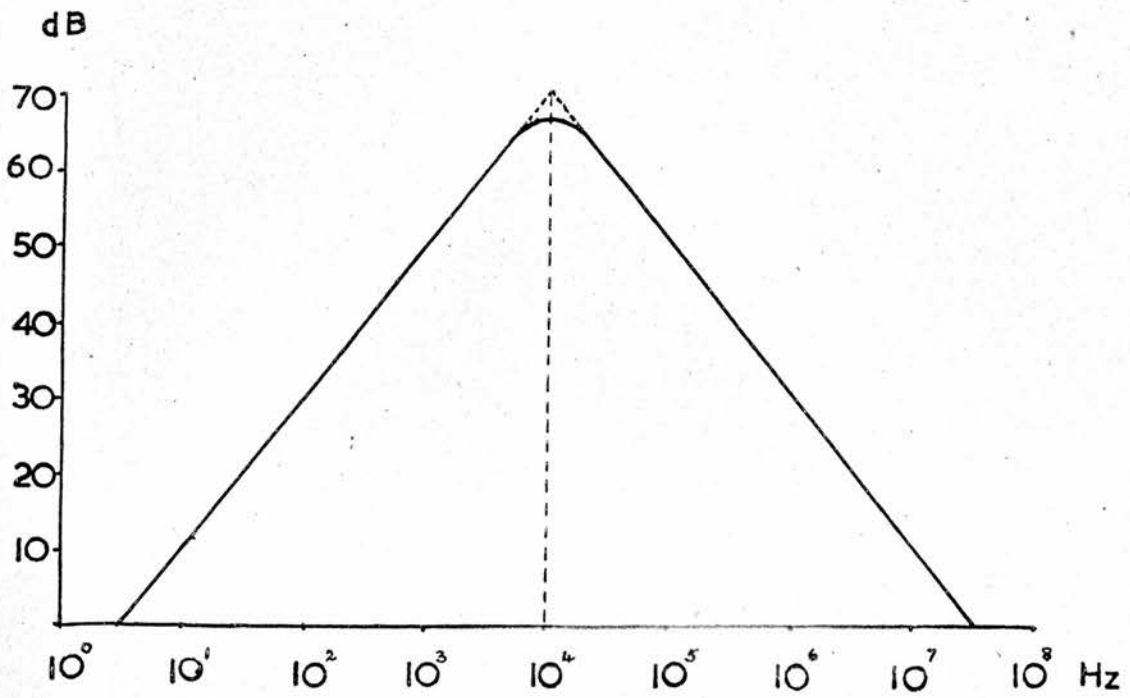

FIG. 6.2. UNCONDITIONALLY STABLE RESPONSE

CHAPTER 6

PRACTICAL INVESTIGATION OF THE

OPERATIONAL AMPLIFIER METHOD

6.1. Use of an Integrated Circuit Amplifier

In view of the difficulties encountered with the practical bridge circuit described in Chapter 4 it was decided to investigate further the method of impedance measurement using an operational amplifier. A large number of integrated circuit operational amplifiers are now on the market so that it should be possible to construct a pocket sized instrument for clinical use. The performance which could be obtained from such an instrument would then depend on the characteristics of the amplifier. In particular it is necessary to ensure that the resulting feedback circuit remains stable irrespective of the value of the transducer impedance. This can be achieved by tailoring the response of the amplifier within the feedback loop so that the circuit becomes unconditionally stable.

The S.G.S. - Fairchild μ A 702 C described by Widlar(1964, 1965), is a typical example of the integrated circuit operational amplifiers currently available. The low frequency open loop gain of this device is typically 70 db with roll-off points at 0.8, 4 and 40 M Hz. The gain reaches 0 db at approximately 100 M Hz. The open loop response curve of the amplifier is shown in Fig. 6.1.

In order to achieve an unconditionally stable response it is necessary to ensure that the gain does not fall-off at a rate greater than 30 db/decade on either side of the carrier frequency until/

until the 0 db line is reached. If both lag and lead compensation are used to obtain a 20 db/decade fall-off the maximum upper frequency at which the gain curve can reach the 0 db line is 40 M Hz (see Giles 1965). This means that the maximum carrier frequency at which the full 70 db gain can be obtained is ~ 10 k Hz. This gives a maximum usable bandwidth for the vibration signal of 0 - 2 k Hz which is just adequate provided a satisfactory noise level can be obtained. The overall gain characteristic of the amplifier with an unconditionally stable response is shown in Fig. 6.2.

The accuracy of the impedance measurement is limited since the input impedance Z_d has a typical value of 20 k Ω . The resultant transfer impedance of the amplifier (βZ_d) is thus 60 M Ω . For a 1% measurement accuracy this implies that the transducer impedance must not be greater than 600 k Ω , which is equivalent to a transducer capacitance of 20 pF at 10 k Hz. This is inconvenient since it means that the transducer must either have a very large detecting electrode or be used at very small spacings. An increase by at least a factor of ten in the transfer impedance of the amplifier is necessary to produce a transducer of acceptable dimensions and working range. A greater transfer impedance can be obtained by increasing either the gain and bandwidth of the amplifier, or its input impedance. Since the gain-bandwidth product of an integrated circuit amplifier is defined by its internal construction there is no method by which either the gain or the bandwidth of a given type of amplifier can be increased without reducing the other.

An/

An increased input impedance can be obtained by means of a suitable unity gain stage in front of the main amplifier.

The input impedance of the amplifier combination is then limited by the capacitance of the cable to the transducer since this appears in parallel with the input. For a standard coaxial cable 10 ft. in length this capacitance is ~ 200 pF which means that the transducer capacitance must not be less than 6 pF for 1% accuracy. The working range of the transducer used with the operational amplifier circuit would thus be similar to that obtained with the bridge circuit.

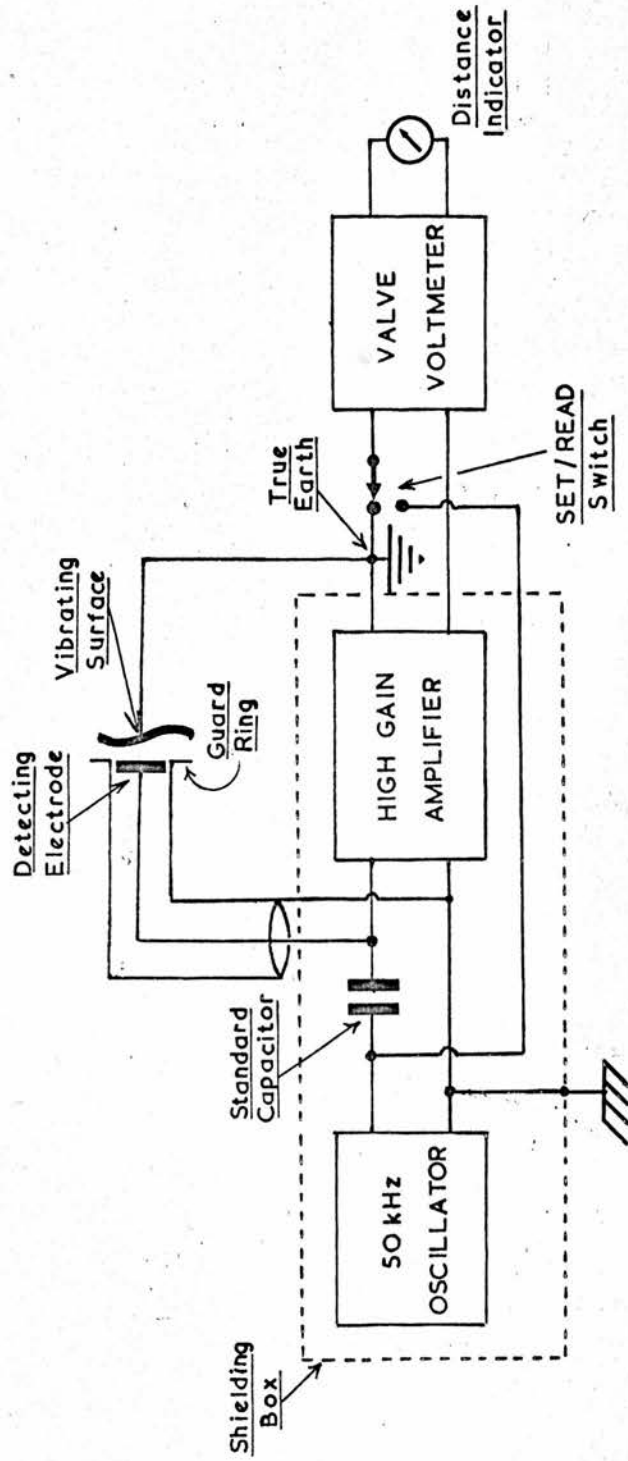

FIG. 6.3. BLOCK DIAGRAM OF THE WAYNE KERR DISTANCE METER

6.2. Use of the Wayne Kerr Distance and
Vibration Meter Type B731B

(i) Description of the Instrument

The Wayne Kerr Distance and Vibration Meter Type B731B is a commercially available instrument for the linear measurement of distance and peak-to-peak vibration using a capacitative probe. The distance measurement is made by means of the operational amplifier technique and is shown in block form in Fig. 6.3. The 50 k Hz oscillator provides a signal of constant amplitude so that the output of the amplifier is proportional to the spacing between the probe and a suitable earthed conducting surface. The detected output from a vibrating surface can therefore be resolved into a constant component due to the mean probe spacing and a varying component due to the vibration. There is no means provided within the instrument for backing-off the constant component of the output signal so that only the vibration output is obtained. The peak-to-peak vibration channel is A.C. coupled immediately after the demodulator circuit and no output is provided at this point so that it is not possible to obtain the vibration signal except through the A.C. coupling.

Some modification is therefore necessary in order to make the instrument suitable for the detection of cardiovascular sounds. In addition the instrument is a mains operated device using thermionic valves which means that it is not ideally suited for clinical use. It was thought that one of these instruments could be used as a test of the operational amplifier method and an arrangement/

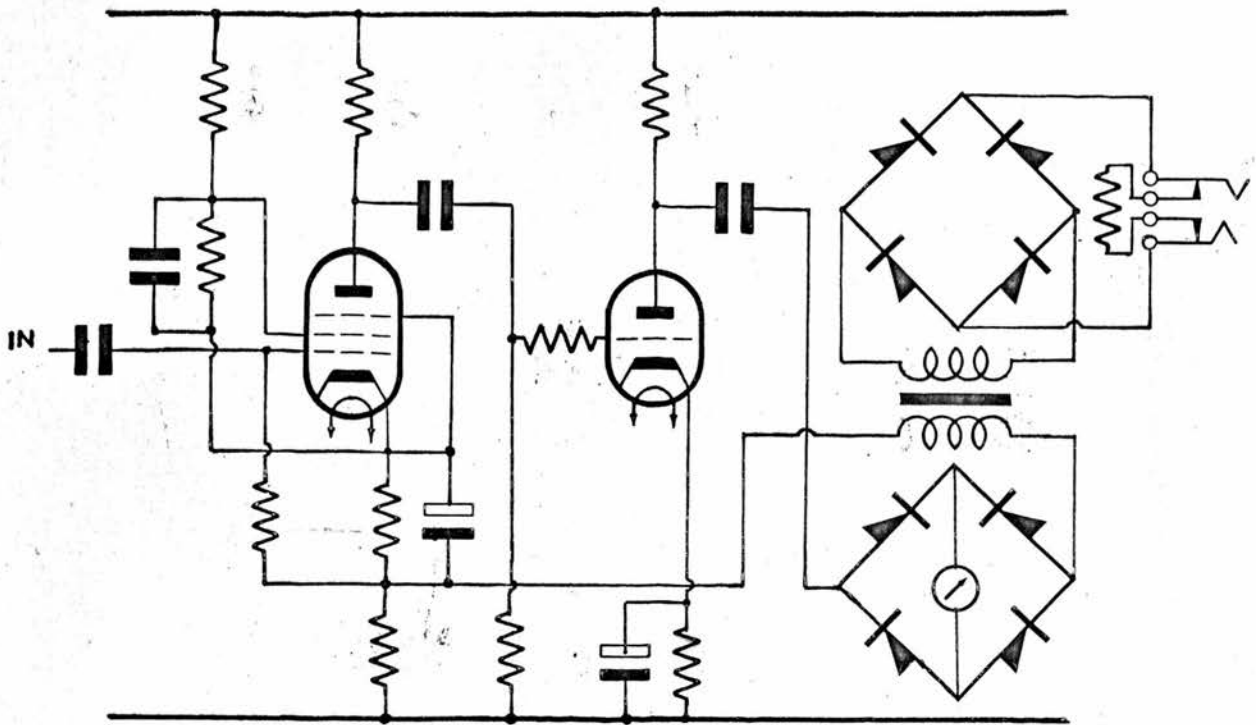

FIG. 6.4. VOLTMETER SECTION OF WAYNE KERR DISTANCE METER

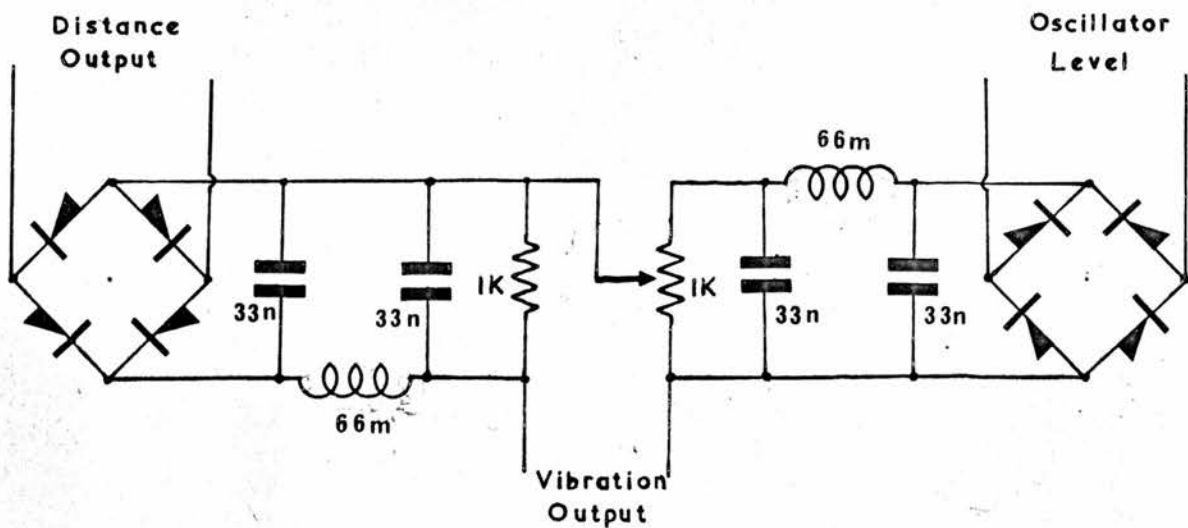

FIG. 6.5. FILTERS AND 'BACKING-OFF' ARRANGEMENT

arrangement was made to borrow one for this purpose. External modifications were made to the instrument so that the required backing-off facility could be obtained and some heart sound recordings were made.

(ii) Modifications to Give Backing-Off Facility

It can be seen from the block diagram (Fig. 6.3) that a switch is provided within the instrument so that the oscillator output can be set to a known value. If the valve voltmeter circuit shown in Fig. 6.4. is duplicated then the oscillator amplitude can be monitored continuously. The output of the valve voltmeter is displayed on a meter but it can also be used to drive a chart recorder of $1\text{ K } \Omega$ input impedance through a jack socket provided. If a suitable connection is then made between the two voltmeter circuits the constant component of the vibration channel signal can be backed-off using part of the oscillator amplitude signal. Unfortunately the available terminals on the instrument do not enable the oscillator amplitude to be monitored externally, so it is not possible to provide a variable input to the oscillator amplitude detector.

In order to achieve the required result it is necessary to operate the instrument with the switch in the 'Set' position. The Distance Indicator then reads full scale continuously, corresponding to the output of the oscillator. A variable backing-off voltage is obtained by means of a potential divider across the detector output. The duplicate valve voltmeter circuit is connected externally/

externally across the amplifier output between the earth and chassis terminals provided so that a signal is obtained proportional to the amplifier output. Since this is run from an external battery power supply it is convenient to connect the zero volts line to the earth point and the input to the chassis terminal of the Wayne Kerr Meter.

The output obtained from each of the voltmeters is a full wave rectified version of the carrier signal so that a filter is required to remove the ripple. A filter is supplied with the instrument so that the detected output of the distance channel can be displayed on an oscilloscope. This filter is not suitable because although it contains a "twin-T" circuit which can be tuned over the range 50 - 100 k Hz the output has component signals at both 50 and 100 k Hz. It is found that the filter cannot be adjusted to cancel both these frequencies. New filters were therefore constructed for both voltmeter channels.

Fig. 6.5 shows the connections required to produce a single sided output suitable for connection to an F.M. tape recording system. This arrangement is not as satisfactory as a differential system since each of the filters can then be connected to the earth line, thus resulting in a lower noise level. With the set zero control in this position it is not possible to back-off mean levels larger than full scale deflection but the present instrument does not allow any alternative.

(iii) Use of Wayne Kerr Probes

The Wayne Kerr Distance and Vibration Meter is designed to work/

work with a probe having a capacitance of 0.35 pF at its nominal range. The transducer constructed for the bridge network is not suitable therefore for use with this instrument because it has a much larger effective capacitance.

A set of five probes are normally supplied with the Wayne Kerr instrument for working at different ranges from 0.001" to 0.1". These are each provided with a guard ring of suitable area to ensure linearity of field at the probe face. Only two of these probes with ranges of 0.05" and 0.1" are suitable for the detection of cardiovascular sounds, as the ranges of the others are too small to ensure that limiting does not occur.

Both these probes have been used successfully for recordings of the total motion of the body surface. It was also found possible to make a small modification of the housing of the transducer described in Chapter 5 so that it would accept either of these probes. This enabled them to be used for relative motion studies with the housing held in place on the body surface by means of the vacuum ring.

CHAPTER 7

RESULTS AND CONCLUSIONS

7.1 Detection of Cardiovascular Sounds Using the Bridge Method.

As soon as the prototype of the transducer was completed it became possible to carry out observations on real subjects. In order to do this a bridge circuit without feedback was first constructed using a series tuned circuit of the type described by Baxandall (1963). This arrangement had the disadvantage that additional tuning controls were required and these could not be ganged to the bridge balancing capacitor. As a result, it was not possible to rebalance the bridge when the transducer was in position on a subject. Instead it was necessary to set up the bridge, using the Pye-Ling Vibrator, so that it was correctly tuned at some particular balance setting and then adjust the transducer on the subject to give the same balance setting.

Using this procedure an attempt was made to detect heart sounds from the precordium. At first, results were not very satisfactory as the transducer was held in place by hand. This resulted in a continual variation of contact pressure with respiration and other movements which affected the bridge balance. The addition of a vacuum ring enabled the transducer to be held in place on the chest wall and more consistent results were then obtained. The waveforms were observed by means of an oscilloscope.

More success was obtained when an attempt was made to pick-up the carotid pulse by 'hand application' of the transducer to the neck. The detected output of the bridge was again observed by means/

means of an oscilloscope. Some distortion was apparent but the dichrotic notch, a typical feature of the waveform, was easily recognised. On another occasion the radial pulse was detected by 'hand application' of the transducer to the wrist.

In addition to observing the waveforms by means of an oscilloscope the output of the bridge was A.C. coupled to an amplifier and loudspeaker. This enabled the sounds to be heard even when the bridge was not balanced and the trace did not appear on the oscilloscope screen. With a conventional air transmission microphone this arrangement would have resulted in acoustical feedback due to the sensitivity of such microphones to air borne noise. This did not occur with the capacitance proximity transducer as it has no moving parts and a large amount of energy would be required to set the body surface in motion.

Tape recordings were made of the output of the Proximity Transducer and a number of other microphones available in the laboratory. These were reproduced over a loudspeaker and a subjective judgement made of the quality of the sounds detected by each. It was considered that the Proximity Transducer was not as good as the other microphones but the poor quality of this signal was later found to be due in part to external radio frequency interference.

A number of successful recordings were later made of foetal heart sounds. These were first attempted using a rubber belt to hold the transducer in position. However this gave rise to considerable difficulties due to variations in contact pressure and made/

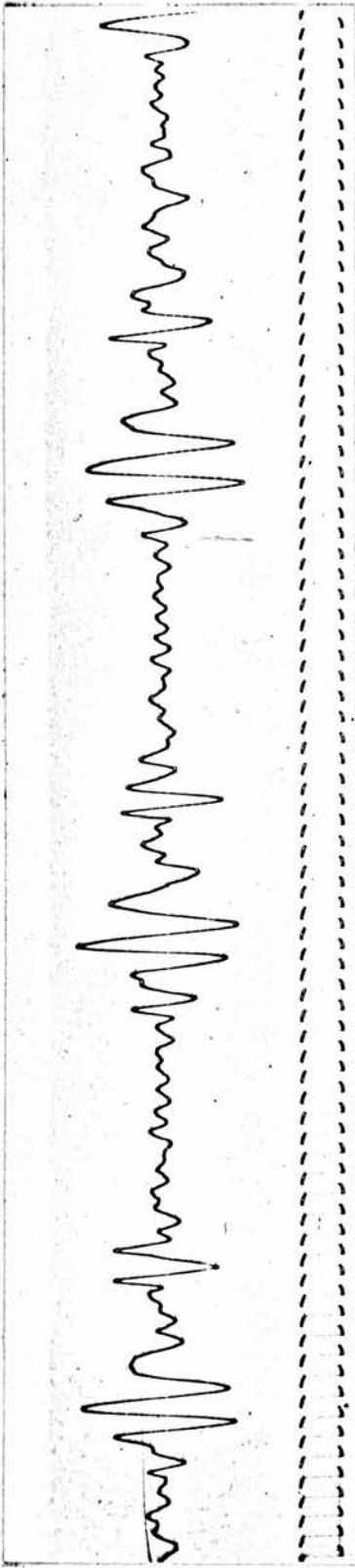

FIG.7.1. FOETAL HEART SOUNDS RECORDED DURING A CONTRACTION

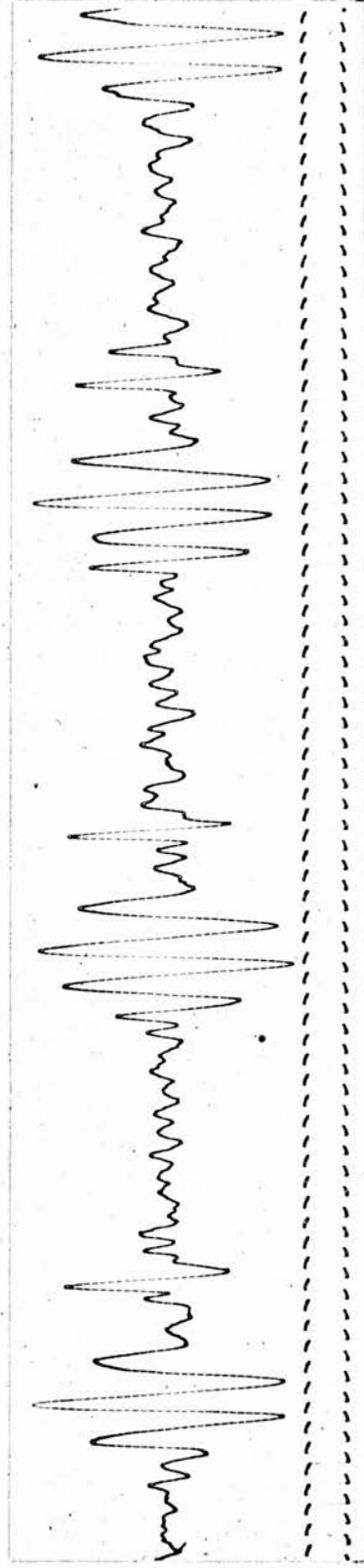

FIG.7.2. FOETAL HEART SOUNDS RECORDED BETWEEN CONTRACTIONS

made it inconvenient to change the transducer location on the maternal abdomen. In these circumstances it was found that "hand application" was the ideal method for locating the source of the sound since the position and pressure could be changed more easily. This method is not suitable for recording as there is a continual variation in balance conditions due to changes in contact pressure. The vacuum ring can however be used to hold the transducer in position once the source of sound has been located by hand. Continuous observation and recording for periods up to

20 minutes is possible using the vacuum ring but this leads to bruising of the skin due to the reduced pressure. For extended recordings it might therefore be necessary to attach the transducer by means of adhesive tape.

The final phase of this series of observations was a semicontinuous recording of foetal heart sounds during the first stage of labour. The vacuum ring was again used in preference to the rubber belt and was found to give the minimum of inconvenience to the mother-to-be. The recordings were made continuously during contractions with only a slight variation in observed signal level. Fig. 7.1 shows three heart sound complexes recorded during a contraction and Fig. 7.2 three complexes recorded between contractions. (The time-scale is given by the 50 Hz square wave).

These recordings were made using a bridge method with A.C. coupled feedback. D.C. coupled feedback could not be used because the/

the D.C. level at the output of the detector amplifier was different from the level required to set the tail current of the oscillator to its nominal value. With A.C. feedback it was necessary to ensure that the bridge was balanced in order that the linearity correction was properly applied.

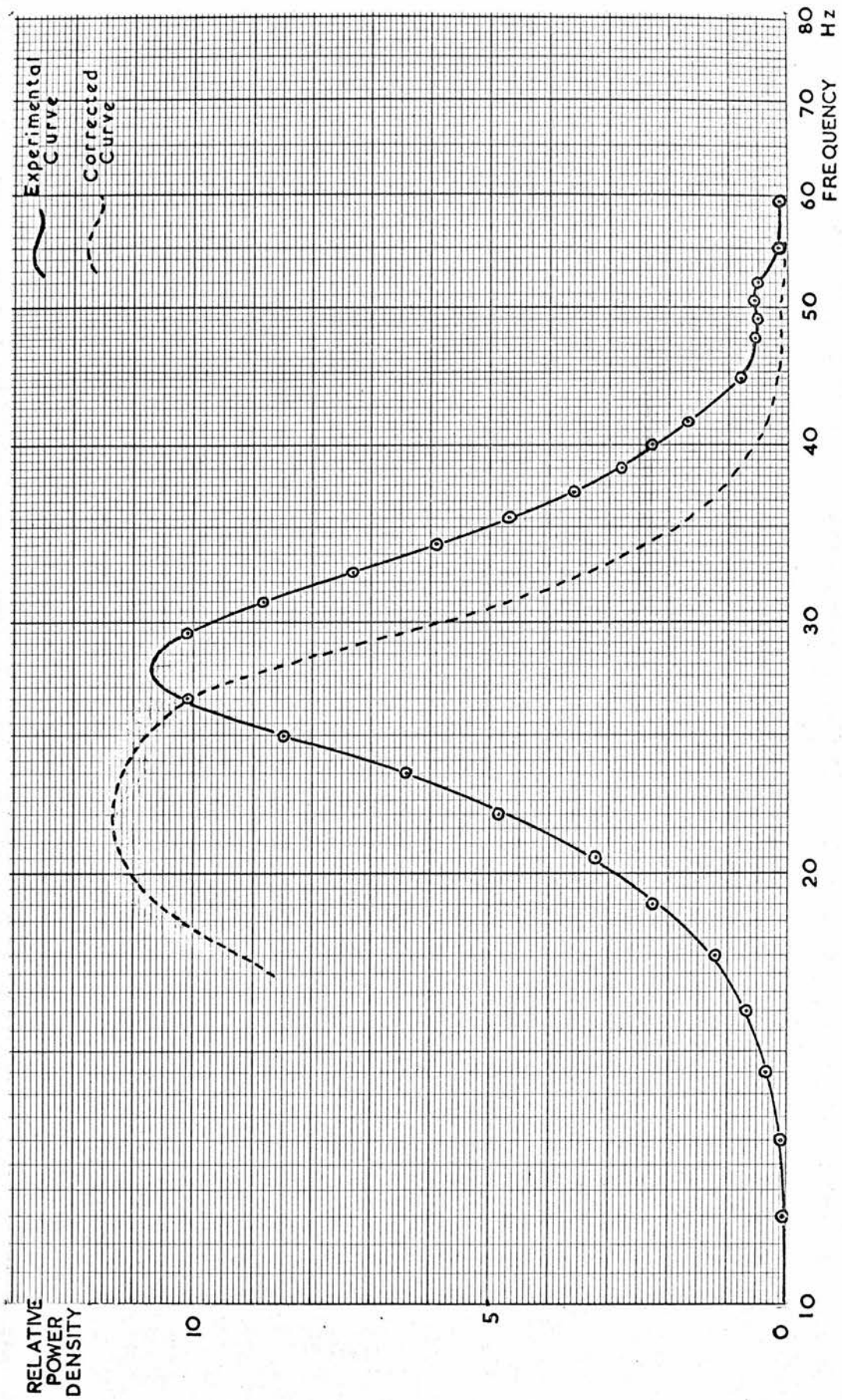

FIG. 7.3. A SPECTRAL POWER DISTRIBUTION FOR FOETAL HEART SOUNDS

7.2. Qualitative Examination of Foetal Heart Sounds

Arrangements were made to borrow a "Fenlow Low Frequency Spectrum Analyser Type SA2" and some associated apparatus normally used for the analysis of electroencephalograph signals. This enabled a series of analyses of the spectral power distribution to be carried out on selected passages of the foetal heart sound recordings of up to 90 seconds in duration. Some preliminary examinations were made over a wide range of frequencies using a bandwidth of 7.5 Hz. Some more detailed analyses were then made for the range from 10 - 80 Hz using a bandwidth of 1.5 Hz. It was found that all sections of the record contained an energy peak which was situated in the band between 25 and 30 Hz. The graph shown in Fig. 7.3 is a typical example.

In spite of the fact that a direct recording method with a response falling off below 40 Hz was used for these observations the peak appears at least an order of magnitude greater than any other possible peak in the spectrum. A correction curve was prepared for the record-replay system for frequencies below 100 Hz. After applying this correction to the results the peak appears some two orders of magnitude greater than any peak above 30 Hz. Owing to the poor signal to noise ratio of the tape system it was not possible to obtain a satisfactory correction factor for the tape system below 20 Hz.

In view of the findings of Smith (1957), Simpson & Leask (1959), Leonard & Farrer (1963), Cornwall & Tattam (1964) and other workers/

workers regarding the existence of favoured frequencies for the detection of foetal heart sounds at 50 - 60 Hz or 75 - 90 Hz, it is interesting to note that the peak between 25 and 30 Hz is the only one of significance in the spectrum. In some cases a small peak was obtained at 50 Hz but it was found that this was due to mains hum in the recorder on replay. Since the normal bandwidth of the recorder extends from 40 Hz upwards it would be expected that had other energy peaks existed at higher frequencies these would have been apparent in the uncorrected analysis. It is obvious that a harmonic relationship could exist between the observed peak at 25 - 30 Hz and the other preferred frequencies at 50 - 60 Hz and 75 - 90 Hz. Further investigation has shown that the observed peak may be due to the mechanical modes of vibration of the transducer and of the maternal abdomen rather than to properties of the foetal heart sounds.

It has not been possible to repeat this analysis with other records as the Fenlow equipment is no longer available in Edinburgh.

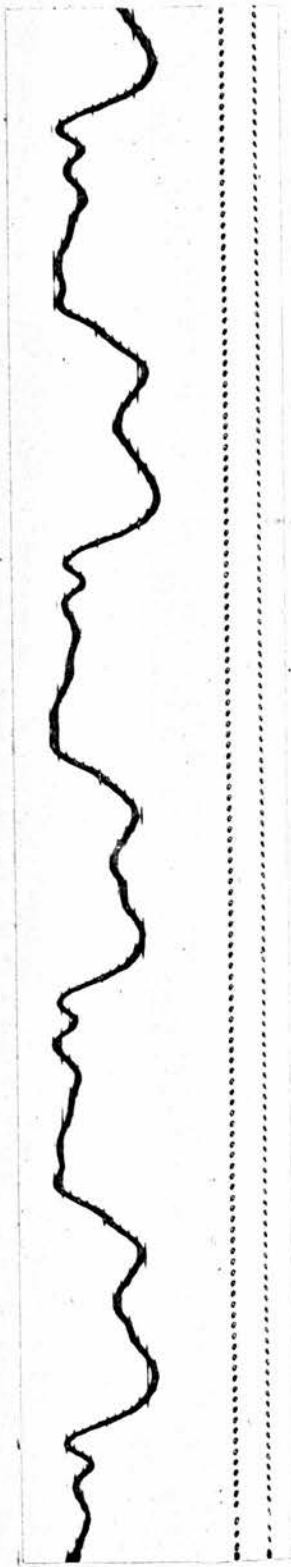

FIG. 7.4. PRECARDIAL VIBRATIONS (APEX BEAT)

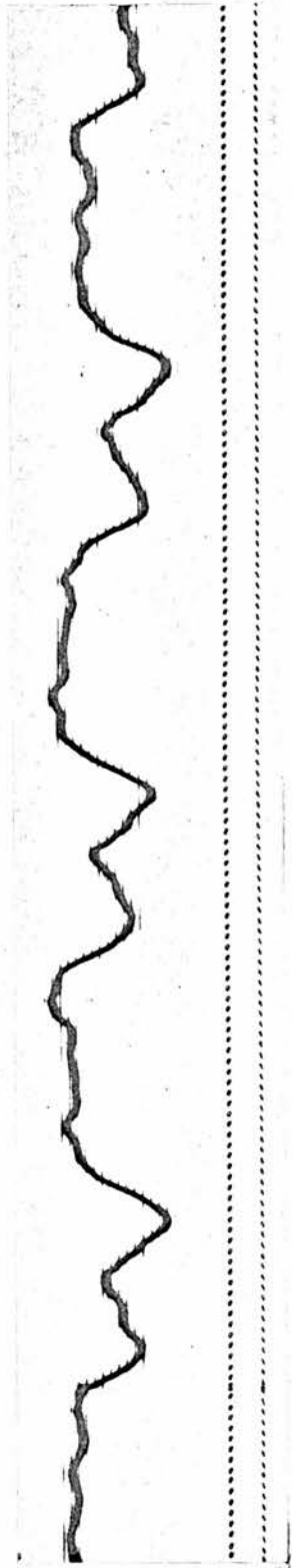

FIG. 7.5. PRECARDIAL VIBRATIONS FROM PULMONARY AREA (MALE SUBJECT)

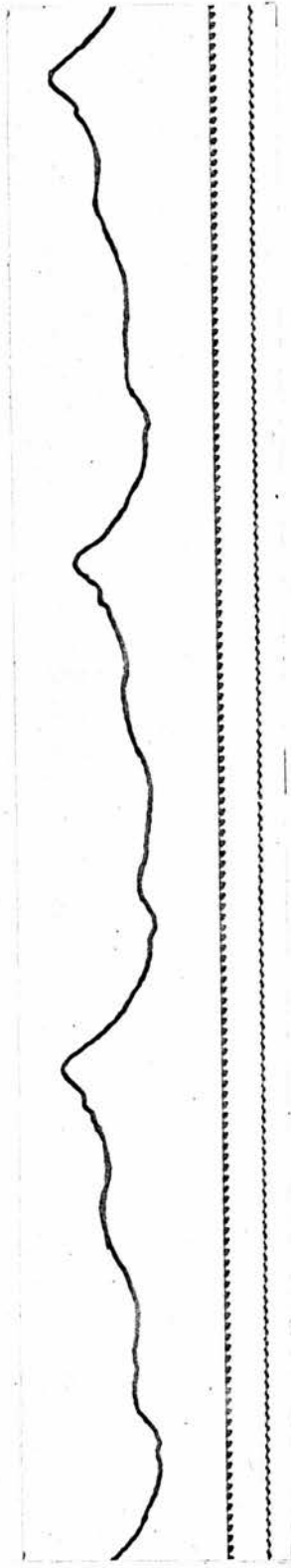

FIG. 7.6. PRECARDIAL VIBRATIONS FROM PULMONARY AREA (FEMALE SUBJECT)

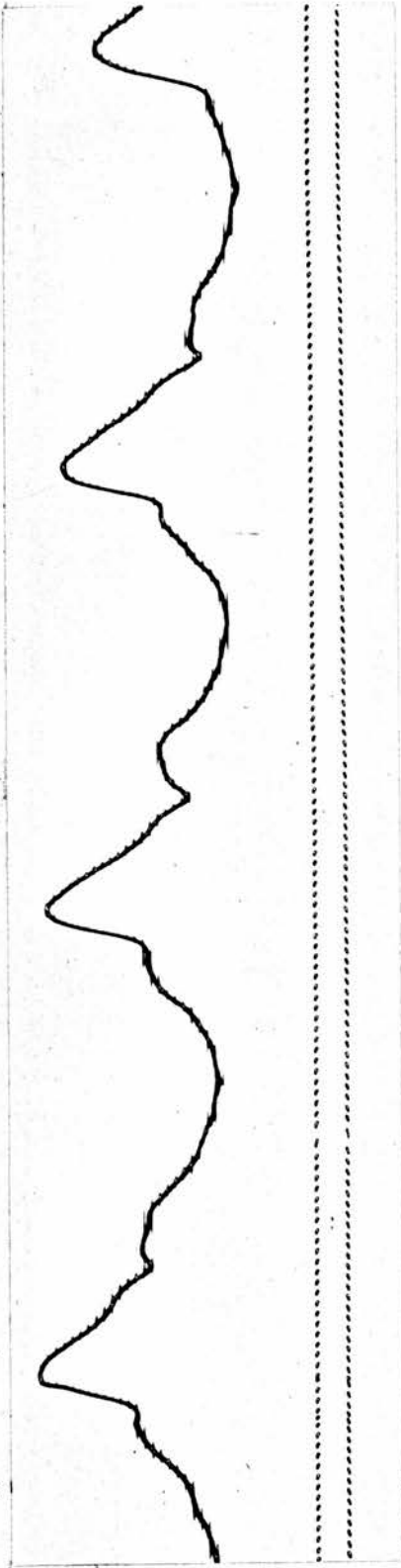

FIG.7.7. CAROTID PULSE (ARTERIAL)

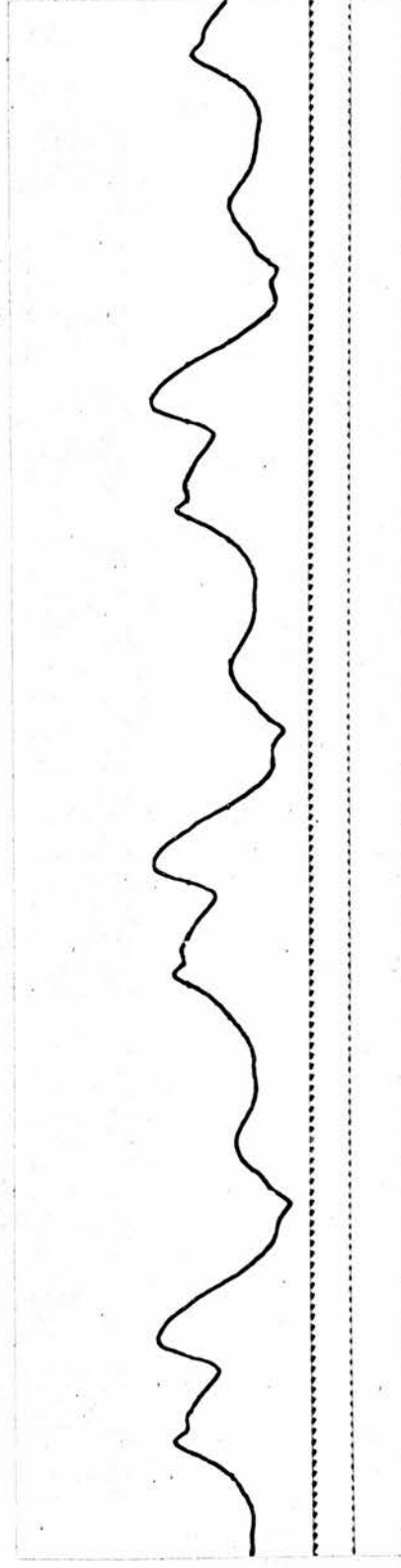

FIG.7.8. JUGULAR PULSE (VENOUS)

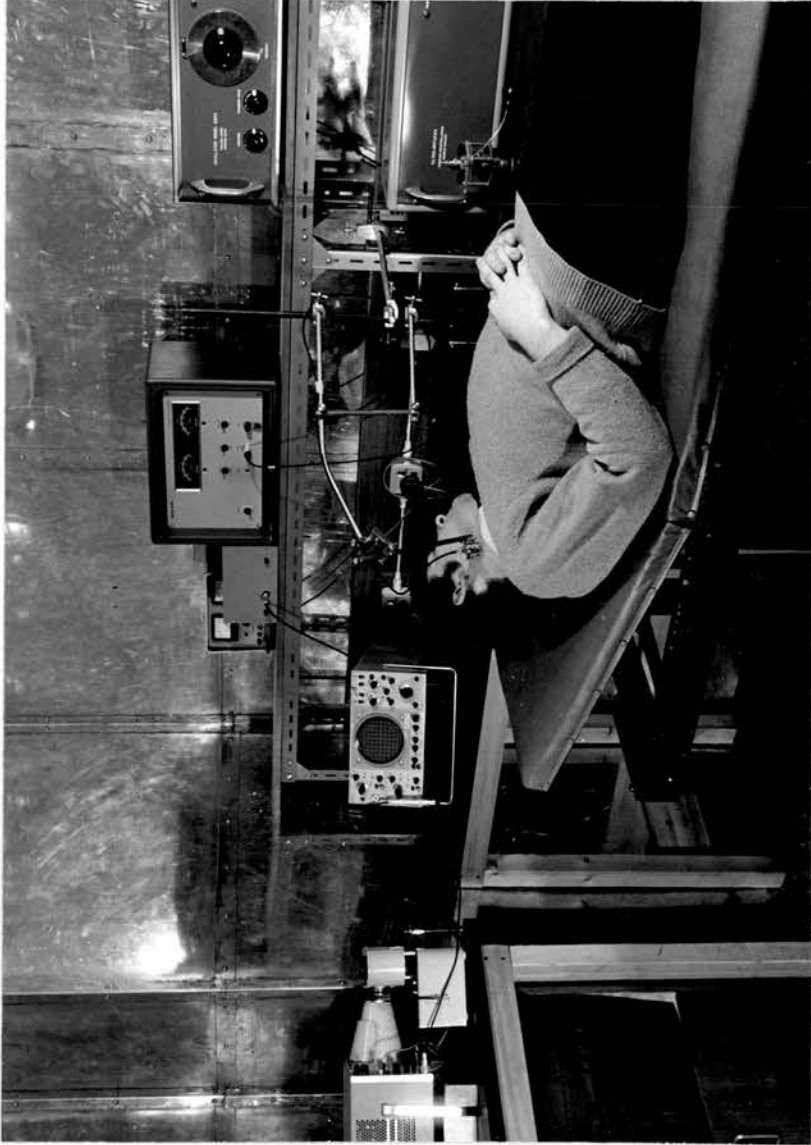

FIG.7.9. CAROTID PULSE RECORDING USING THE WAYNE KERR METER.

7.3 Observation and Recording using the Wayne Kerr Distance and Vibration Meter

The observations described in Sections 7.1 and 7.2 were made using forms of the bridge network without complete linearity ^{the} correction. Although/overall linearity of the uncorrected bridge method is better than that obtained by other workers it is not considered to be sufficient for/^{the}present application. Further investigation of the feedback method showed that it was not possible to design a working instrument which would have satisfactory linearity at all settings of the balance capacitor. For this reason the operational amplifier method of impedance measurement was examined and modifications were made to a commercial instrument of this type so that it could be used for the detection of cardiovascular sounds.

Figs. 7.4 - 7.8 show oscilloscope tracings of a number of different cardiovascular sounds recorded using this instrument. These were made with the subject lying on a couch, and the transducer supported on a stand above the point of observation so that there was no physical contact with the body surface. The transducer used for the recordings was the Wayne Kerr Probe E which has a range of 0.1". This was brought as close as possible to the skin without contact occurring during any part of the vibration cycle. During the recordings from the precordium it was necessary for the subject to hold h_{is} breath in order to eliminate the large excursion due to respiration. Unless this was done it was not possible to obtain a steady trace on the oscilloscope with adequate sensitivity for observation of the heart sounds. This was not necessary for detection of the carotid and jugular pulsations in the neck. (As shown in Fig. 7.9)

Recordings/

Recordings of the foetal heart sound were also attempted using the Wayne Kerr probe. This was supported in the modified housing of the bridge transducer so that it could rest on the maternal abdomen. Due to the large amplitude of signal detected from the maternal heart it was not possible to distinguish the foetal heart sounds in the waveforms observed on the oscilloscope.

7.4 Conclusions

The historical development of auscultation and phonocardiography has resulted in the use of observing techniques which only provide information from a part of the spectrum of cardiovascular sounds. However there is still a need to observe the whole of the spectrum even though much of it lies outside the range of human hearing. Valuable clinical information can be deduced from the low frequency wave shapes and from low-intensity components at high frequencies which are not normally audible.

In order to detect these vibrations satisfactorily over such a wide range of frequency and intensity without distortion a special transducer is required. The capacitance proximity transducer is ideally suited to this use since it makes no contact with the body surface. Its use for the detection of a variety of cardiovascular sounds has been described by other workers. In particular Chlebus (1962) has shown that it gives superior results in the diagnosis of athero sclerosis when compared with the normal type of contact transducer.

The errors inherent in the use of this type of transducer have been considered theoretically. It has been shown that with a suitable construction the effective reactance is proportional to the spacing between the transducer and the body surface.

The methods of detecting the changes in this reactance have also been considered and the importance of the linearity of the method has been stressed. Sufficient consideration of the linearity of the detecting method has not been made by other workers although this will affect the wave shapes and component frequencies observed.

Details/

Details are given of a new bridge method giving a linear output under specified conditions. This method is not suitable for use with variable settings of the transducer. An operational amplifier method was therefore investigated. This type of circuit is available as an industrial distance measuring equipment but is not immediately suitable for the detection of ultra-low frequency vibration waveforms. Suitable modifications have been described whereby it can be used for this purpose. Some results have been presented to illustrate the possible modes of operation of this type of transducer with a linear measuring system.

In their present forms neither the bridge method nor the operational amplifier method are suitable for clinical use. However the use of integrated circuits are discussed in connection with the operational amplifier method and it seems that these would make possible the construction of a more portable instrument. Further experience of making measurements in the laboratory may make possible the construction of a simpler type of transducer which because of its robustness might well be suitable for use as a routine clinical instrument.

APPENDIX A - TRANSISTORS IN CHOPPER CIRCUITS

1. Physical Construction of the Transistor and its Equivalent Circuit

All transistors of the conventional type, regardless of the process by which they were manufactured, contain two p-n junctions. One semiconductor material is common to both junctions and forms the base region of the transistor, so that in an npn transistor the base is of p-type material and in a pnp transistor it is of n-type material. Each of the junctions can function as a rectifier and so the nature of the base material will define the polarity which must be applied to enable current to flow between the base and either of the other terminals of the device. Owing to the close proximity of the two junctions current flowing in the forward biased diode will allow a controlled current to flow between the two similar terminals of the device. The ratio of this controlled current to the base current is defined as the current gain of the transistor. It is clear that either junction may function in this way, the terminal of the forward biased junction being called the emitter, and that of the reverse biased junction, the collector.

In practice these devices are not constructed symmetrically so that there will be considerable differences between the characteristics of the two junctions (Standard Telephones and Cables, 1961). In particular, differences in the areas of the two junctions will give rise to different current gains depending on the terminal which functions as emitter. The devices are usually supplied by/

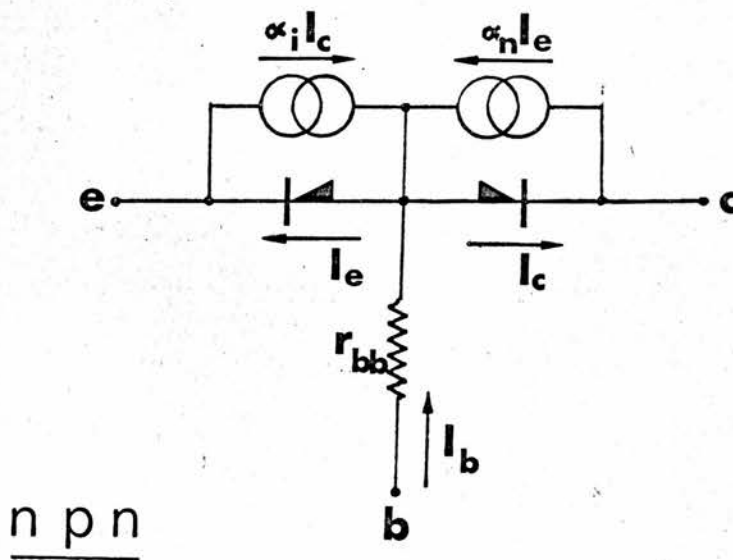
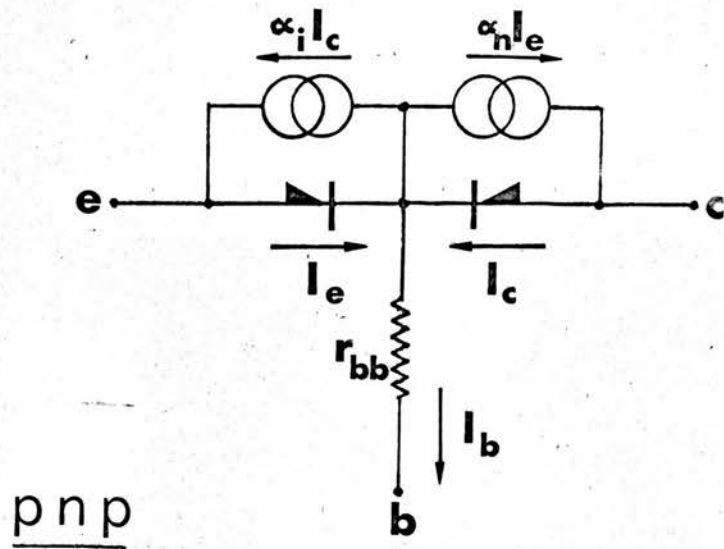

FIG. A.1. LARGE SIGNAL D.C. EQUIVALENT CIRCUITS

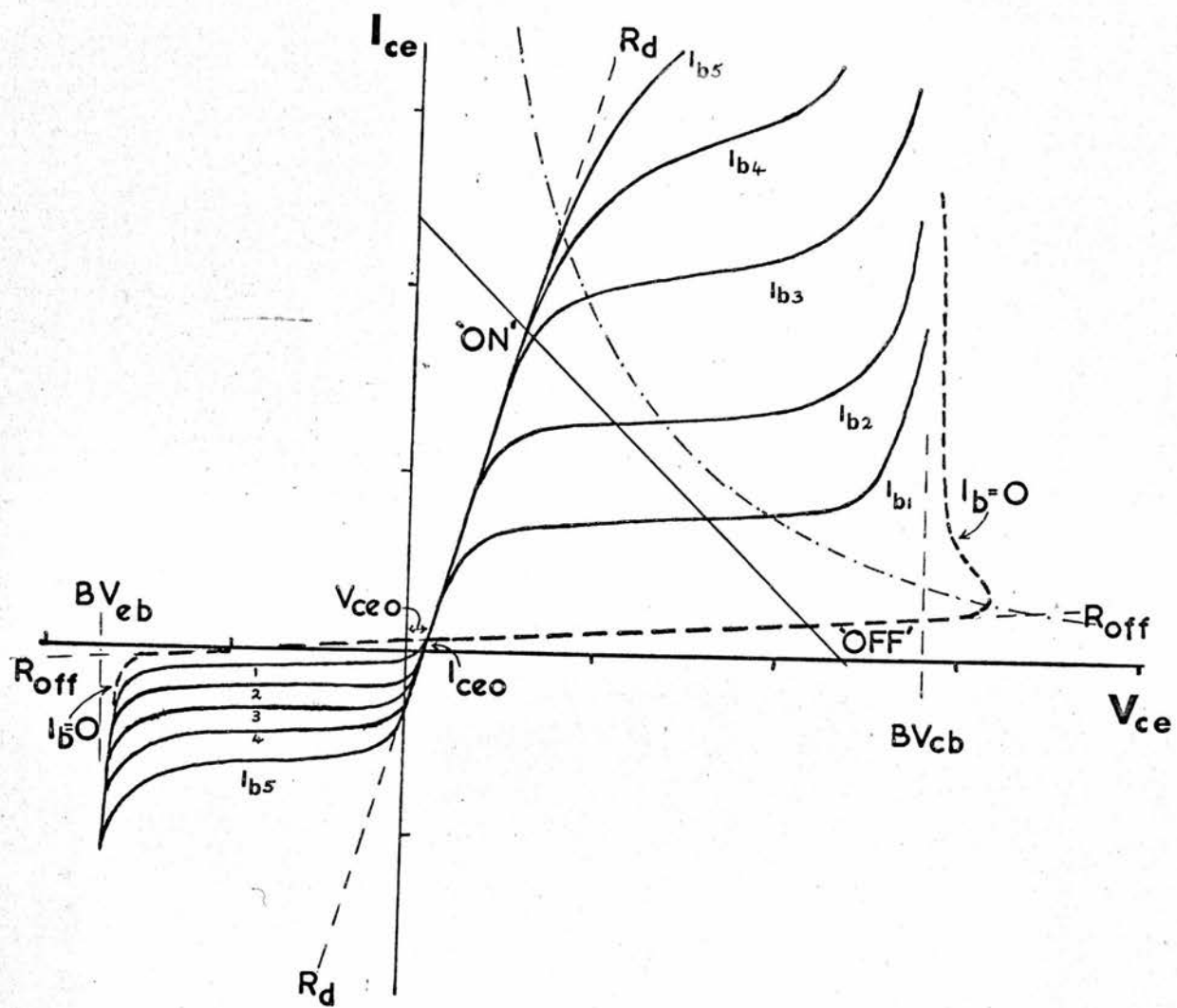

FIG. A.2. OUTPUT CHARACTERISTICS OF AN ASYMMETRIC TRANSISTOR

by the manufacturer with a marking which identifies the mode of connection which will give rise to the greater of the two current gains. This is commonly called the 'normal current gain'.

It is thus possible to construct a very simplified equivalent circuit for large signal d.c. operation which consists of two current generators and two ideal diodes arranged back to back, as shown in Fig. A. 1. (cf. Lydén, 1963). It can be seen that $I_b = I_c (1 - \alpha_i) + I_e (1 - \alpha_n)$ in both cases.

If both junctions are reverse biased then I_e and I_c are very small and the effective impedance between emitter and collector terminals is very high. This is the cut-off state.

With only one junction forward biased the device operates in the normal or inverse active regions of its characteristics allowing a controlled current between emitter and collector.

When both junctions are forward biased the device is said to be bottomed and there is a very low effective impedance between collector and emitter terminals. Owing to the inherent asymmetry of the device the saturation base current required will depend on the direction of current flow between emitter and collector.

2. Transistor Output Characteristics.

Output characteristics are shown in Fig. A.2. for an asymmetrical transistor connected in the normal mode. Certain features have been exaggerated to emphasise the parameters which must be considered when selecting a transistor for bidirectional current switching/

switching applications. In particular it is desirable that R_d , V_{ce0} and I_{ce0} should be as small as possible, and R_{off} , BV_{eb} and BV_{cb} as large as possible.

Output characteristics can also be drawn for the inverse mode and are apparently similar to those for normal mode but rotated through 180° . One useful effect is that the 'Offset Voltage' (V_{ce0}), which always has the same polarity as the forward bias applied to the base, is reduced by a factor equal to the ratio of normal and inverse current gains.

Germanium transistors have lower offset voltages than Silicon Transistors but the leakage currents are higher (i.e. R_{off} is lower) and all parameters are more dependent on temperature.

It can be seen that irrespective of the mode of operation an asymmetric transistor will require a high level of base current in order that the transistor is saturated for both directions of current flow. The inverse mode is most frequently used in low level circuits where a minimal offset voltage is required.

For high level work the ultimate limits to the usefulness of the transistor as a switch are set by the reverse breakdown voltages of the two junctions and the "punch-through" voltage between emitter and collector. Whichever of these is the lowest will set the maximum peak-peak alternating voltage which the device is capable of withstanding in the cut-off condition.

Some symmetrical transistor types are available with similar forward and reverse current gains and more equal breakdown ratings for/

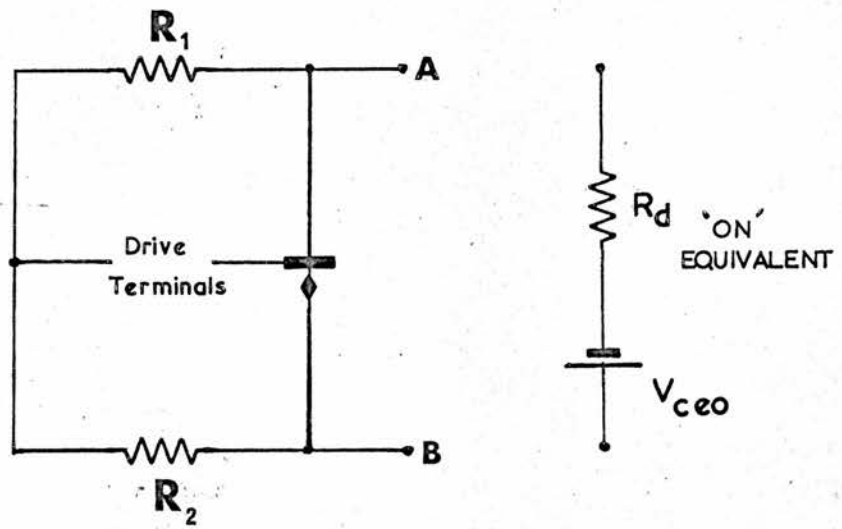

FIG.A.3. GENERALIZED DRIVE CIRCUIT

for the two junctions. These types also have the advantage of much lower offset voltages. Unfortunately the most satisfactory of these devices are Germanium Transistors and as a result of the method of fabrication their high frequency performance is limited to a maximum of 20 M Hz. which may not be adequate for the present application. Improved performance may however be possible by tuning the switch capacitances.

3. Generalized Drive Circuit

The circuit shown in Fig. A.3 can be regarded as a generalized form of all possible drive arrangements for a transistor switching circuit (Evans, Gill and Moffitt (1961)).

In the limit as $R_1 \rightarrow \infty$ it represents the normal mode of operation, and as $R_2 \rightarrow \infty$ the inverse mode. With symmetrical transistors it is convenient if $R_1 = R_2$ but the series combination $R_1 + R_2$ shunts the 'OFF' resistance of the switch. This can, however, be avoided if diodes are added in series with each resistor so that they conduct in the desired direction of base drive current. The ratio of currents flowing in R_1 and R_2 when the device is bottomed will depend on the potential applied across the terminals AB and the normal and inverse current gains of the device. In order that the switch turns on and off satisfactorily the drive amplitude must be at least as great as the maximum potential which is applied when the switch is to remain open circuit.

Using this drive circuit it is possible to derive an approximate/

approximate expression for the offset voltage and dynamic resistance of the transistor switch.

$$V_{ce0} = \frac{V_0}{2} \left\{ \frac{1+\delta}{\beta_n} - \frac{1-\delta}{\beta_i} \right\}$$

where $V_0 = \frac{kT}{q}$; $\frac{1+\delta}{1-\delta} = \frac{R_1}{R_2}$; and, β_n and β_i are the normal

and inverse current gains of the transistor.

$$R_d = \frac{2V_0}{|I_b|} \left\{ \frac{1}{(1+\delta) + 2\beta_i} + \frac{1}{(1-\delta) + 2\beta_n} \right\}$$

where the collector and emitter lead resistances have been neglected.

For normal mode operation $R_1 = \infty \therefore \delta = +1$ and $V_{ce0} = \frac{V_0}{\beta_i}$

For inverse mode operation $R_2 = \infty \therefore \delta = -1$ and $V_{ce0} = \frac{-V_0}{\beta_n}$

For a symmetrical device with $R_1 = R_2 \therefore \delta = 0$ and $\beta_n = \beta_i$, $V_{ce0} = 0$

A useful asymmetrical arrangement giving $V_{ce0} = 0$ can be obtained if $\frac{1+\delta}{1-\delta} = \frac{\beta_i}{\beta_n} = \frac{R_1}{R_2}$ but in this case the load on the drive circuit will depend on the direction of current between the switch terminals.

From the equation given for the 'ON' resistance it can be seen that in the case of asymmetrical transistors with $\beta_n \gg \beta_i$ operated in the normal mode ($\delta = +1$) there is a limiting value given by

$$\text{The/ } (R_d)_n = \frac{V_0}{|I_b|} \cdot \frac{1}{(1+\beta_i)}$$

The corresponding limit for the inverse mode is slightly greater.

For symmetrical transistors this limiting value will be much smaller since β_s is generally of the same order as β_n of an asymmetrical device.

$$\text{i.e. } (R_d)_s \cong \frac{2V_o}{|I_b|} \cdot \frac{2}{(1+2\beta_s)} \therefore (R_d)_s < (R_d)_a \text{ provided } \beta_s > \left(2\beta_i + \frac{3}{2}\right)$$

The 'ON' state of the transistor switch is thus equivalent to a battery of E.M.F. V_{ce0} in series with a resistance R_d . The magnitudes of these components are dependent on the type of device and the drive circuit and are lowest for the completely symmetrical system.

When alternating voltages of large amplitude appear across the switch in the open circuit condition the breakdown voltages of the two junctions must be greater than the peak amplitude otherwise conduction will occur. The breakdown voltages on asymmetrical devices can differ widely, so that the lower (usually BV_{be}) will be the limiting factor, for high frequency transistors this may be as little as 3V compared with a BV_{cb} of $\sim 50V$. Symmetrical transistors, whilst having equal or similar breakdown ratings for the two junctions, cannot be obtained with values $> 25V$ so that the alternating voltage applied must not exceed 25V pk-pk. If higher potentials are to be withstood combinations of transistors/

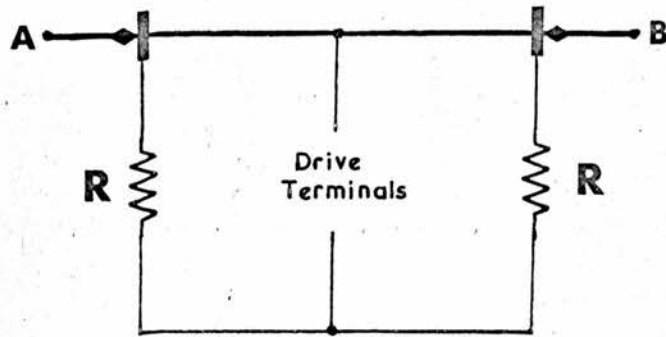
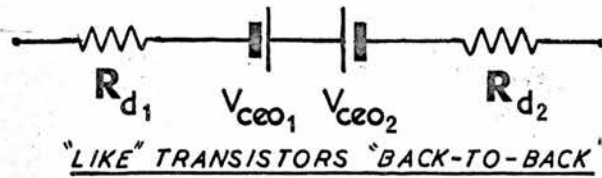

FIG.A.4.



"LIKE" TRANSISTORS "BACK-TO-BACK"

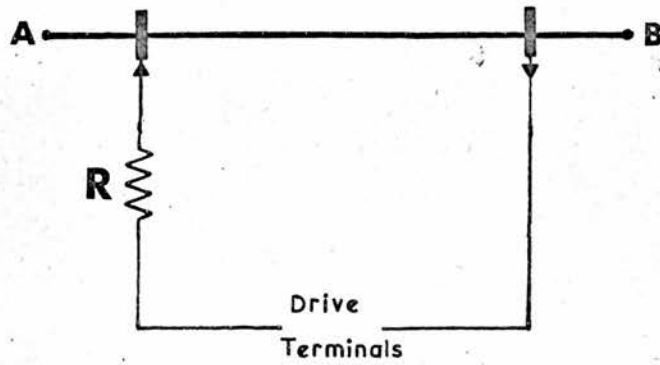
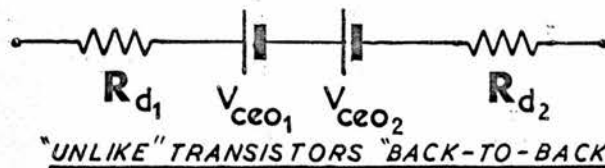

FIG.A.5.



"UNLIKE" TRANSISTORS "BACK-TO-BACK"

transistors may be effective but the low level performance is degraded.

4. Transistor Pairs for the Reduction of Offset Voltage and the Increase of Breakdown Ratings

Two cases have been mentioned above in which the Offset Voltage of a single transistor acting as a switch can be made equal to zero. When these particular circuits are unsuitable, pairs of asymmetrical devices may be used to obtain zero offset voltage but careful matching is required if cancellation is to be obtained for wide ranges of base current and ambient temperature. For the present application cut-off frequency and breakdown ratings are the limiting factors on the usefulness of the symmetrical transistor switch, and it is possible that some combination of asymmetric devices might give better performance.

4.1. Series Combinations

(1) 'Like' Transistors 'Back-to-Back'

The circuit shown in Fig. A.4, which was first described by Bright (1955), is most frequently used for the cancellation of offset voltage. It can be seen from the equivalent circuit that if

$(V_{ce0})_1 = (V_{ce0})_2$ the offset voltage is zero, however the dynamic resistance is increased to twice the value for a single transistor.

The transistors are normally driven in parallel in the inverted configuration, as shown, since inverted drive produces a lower offset voltage and hence reduced variation with ambient temperature.

The circuit will also function satisfactorily if the transistors are/

are driven in the normal mode.

A disadvantage of the circuit is that the switch current flows in opposite senses in relation to the collector and emitter terminals of the two devices so that for a given current one transistor will require a greater drive than the other in order to hold on satisfactorily. (i.e. In practice an excess of the base current must always be supplied to one of the transistors in order that there is sufficient current to saturate the other.) As a result this circuit requires about ten times as much current in the 'ON' state as the single symmetrical transistor circuit.

However the circuit has the advantage that the reverse voltage which must be applied to switch off can be less than the signal voltage across the terminals AB provided it is sufficient to reverse bias both junctions of one transistor. The other transistor can still conduct, so that the off resistance is only that of a single transistor, hence the ratio of 'ON' to 'OFF' resistances is twice that for a single device. Further, the breakdown ratings of the switch will depend on the breakdown characteristics of the 'OFF' transistor so that for the connection shown BV_{ebo} will limit the maximum voltage which can be applied in the 'OFF' condition. Clearly, the breakdown rating can be improved by using the normal connection since

$$BV_{cbo} > BV_{ebo}.$$

(ii) 'Unlike' Transistors 'Back-to-Back'

It can be seen from the equivalent circuit in Fig. A.5 that this particular arrangement will not give cancellation of offset voltage/

voltage since the control current flows through the devices in series. The current flowing between AB will be either in the forward direction for both transistors or in the reverse direction for both, hence the base drive current for one direction of flow will be greater than that for the other. This is true irrespective of whether the emitters or the collectors of the two transistors are coupled together. Considering the voltage necessary to keep the switch in the 'OFF' condition it is found that when the polarity across the switch is such that A is negative with respect to B the potential at the drive terminals must be greater than that between AB. So that breakdown in the drive circuit will limit the amplitude in this polarity. For the opposite potential between AB very little drive is required to reverse-bias both transistors so that the breakdown rating of the switch depends on the sum of the other two breakdown ratings of the transistors. Consequently the best rating which can be given for bidirectional operation is $2V_{cbo}$.

This arrangement is clearly unsatisfactory for most applications due to the inequality of drive requirements for true bidirectional operation and the additive nature of the offset voltages.

(iii) Other Series Combinations

It is clear that a wide range of circuits involving different drive arrangements and combinations of transistors can be derived from these two circuits.

For example the 'Like' Transistors discussed in Section 4.1.(1) can be arranged front to back and if they are driven as shown/

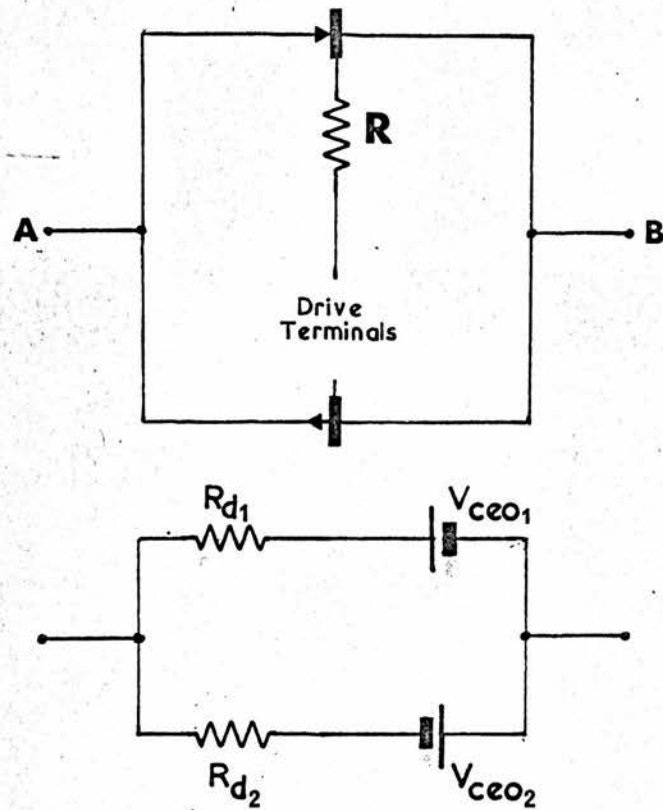

FIG.A.6. "UNLIKE" TRANSISTORS "SIDE-BY-SIDE"

shown in Fig. A.4. one will be in the normal and one in the inverse connection. As a result only partial cancellation of offset voltage can be obtained but both transistors will conduct in the same direction. A further modification would be to separate the drives and then no cancellation of V_{ce0} would be possible.

The 'Unlike' Transistors discussed in Section 4.1.(ii) can also be connected front to back but if the drive is separated so that they are driven in antiphase cancellation of V_{ce0} can be obtained. Of course this means that the transistors do not conduct in the same direction and hence their drive requirements are a function of current direction between A.B. Further examination shows that they cannot give an increase in Breakdown Voltage for bidirectional operation above that obtained with the circuit shown in Fig. A.4 and at the same time have an improvement in one of the other relevant factors.

4.2. Parallel Combinations

(1) 'Unlike' Transistors - 'Side by Side'

In the configuration shown in Fig. A.6., which has been discussed by Lydén (1965), both transistors are being driven in the same mode so that irrespective of the direction of current flow between A and B there will be one transistor conducting in its most favourable direction. As a result base current requirements are reduced. The equivalent circuit shows that under suitably matched conditions the Offset voltage can be reduced to zero and the 'ON' resistance can be as low as half that for a single transistor.

In/

In order to keep the switch open circuit the reverse drive voltage must always be greater than the signal appearing across the terminals A.B. since one transistor of the pair is always biased in the forward direction. The breakdown rating of the switch is always set by The Reverse Base-Emitter Breakdown Voltage of the inverse conducting transistor.

(ii) 'Like' Transistors - 'Side by Side'

This must be regarded as a trivial case since the drive requirements are the same as for a single transistor except that twice the current must be supplied. The 'ON' and 'OFF' resistances are both halved but the offset voltage is not reduced. The breakdown ratings correspond to those of a single transistor.

(iii) Other Parallel Combinations

It is clear that many other parallel combinations of two transistors are possible.

For example one of the transistors in circuit shown in Fig. A.6. can be inverted. This has the advantage of increasing the Breakdown Voltage for one polarity applied to AB but not the other. On the other hand conduction in one direction will not be so easily brought about so a higher level of drive current will be necessary and also the offset voltages will not cancel completely. Some of these disadvantages can be removed by separating the two drives but then there is no cancellation of V_{ce0} and the circuit has similar properties to that discussed in Section 4.2.(ii).

'Like' Transistors can however be used effectively in this arrangement/

arrangement since cancellation of Offset voltage can be obtained when they are driven in the same mode but in antiphase. The breakdown ratings of such a combination are always restricted to BV_{ebo} in both directions since the two paths are in parallel. The equivalent circuit is the same as that shown in Fig. A.6.

4.3. Conclusions

Although all possible combinations of transistors have not been discussed in the preceding paragraphs certain relationships between the relevant parameters become apparent. These may be summarized as follows:-

1. The drive power required to obtain effective ON/OFF action for all currents and voltages is approximately constant irrespective of the combination in use. This is so because a circuit requiring a small current to switch on requires a large voltage to switch off and vice versa.
2. As a result of manufacturing processes the normal current gain of the transistor is always associated with the junction having the lower of the two breakdown voltages. Hence it is found that a high breakdown voltage prevents equal conduction in both directions and vice versa.
3. When using minimum drive current to hold the switch on and minimum reverse voltage to keep the switch off the ratio of 'ON' to 'OFF' resistances is twice that for a single transistor switch.

5. More Complex Combinations

The requirements for a switch element of any degree of complexity are as follows:-

1. At least one transistor in each path of the switch shall have both junctions reverse biased when the switch is driven 'OFF'.
2. In the 'OFF' condition the junction receiving the maximum reverse bias in any path shall have the greater of the two specified breakdown voltages for the device.
3. In order that the dynamic resistance shall be a minimum all transistors in one path of the switch must conduct in the forward (high gain) direction when the switch is 'ON'.

Examination of possible series-parallel combinations of four transistors shows that there is no possible arrangement which can meet these three requirements so well as a symmetrical transistor with high breakdown ratings.

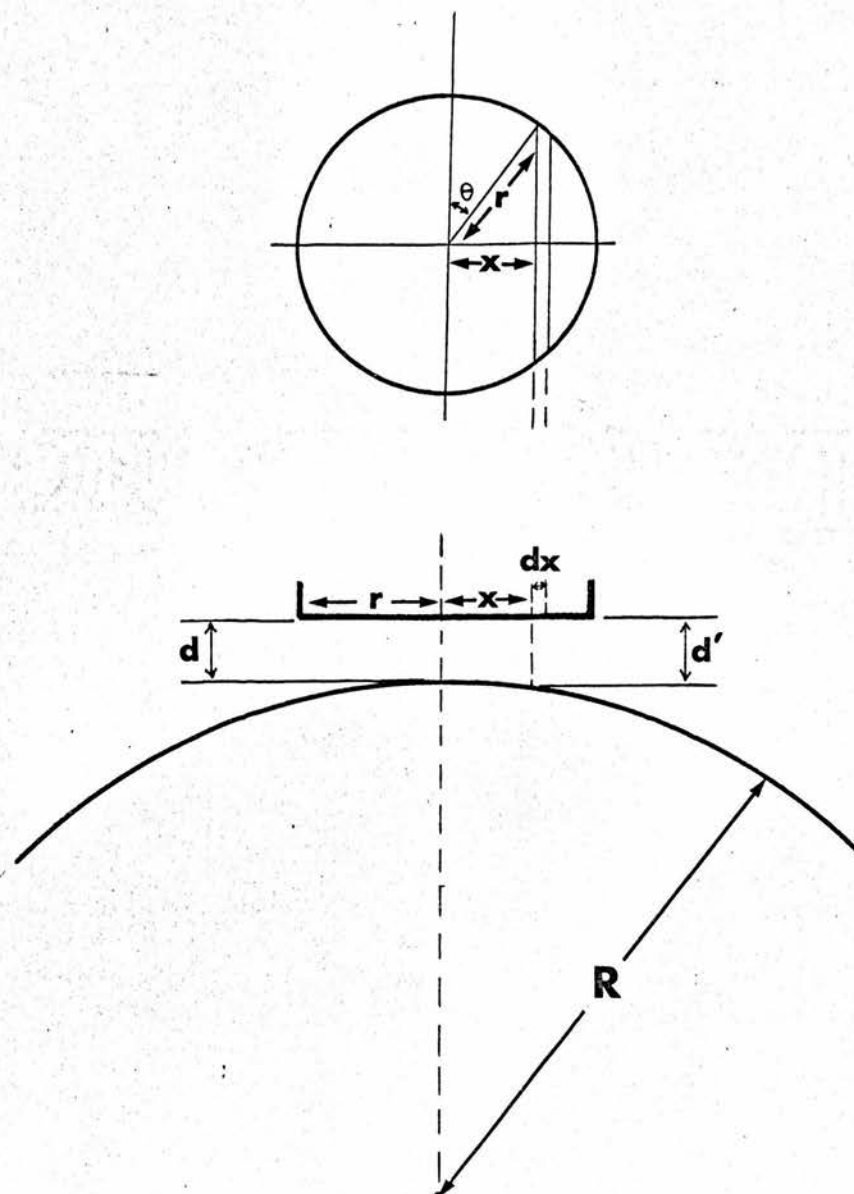

FIG. B.1. TRANSDUCER USED WITH A CYLINDRICAL SURFACE

APPENDIX B - USE OF THE CAPACITANCE TRANSDUCER WITH CURVED SURFACES

1. Flat Detecting Electrode

If the radius of curvature of the surface is large then the field between the electrode and surface can be regarded as uniform and parallel. The capacitance of an elemental area of the transducer δA at an effective distance d' from the surface is given by

$$\delta C = \epsilon_0 \epsilon_r \frac{\delta A}{d'}$$

The total capacitance of the transducer can then be obtained by integration over the area of the detecting electrode. The form of the integral depends on the shape of the body surface, since this defines the way in which d' varies over the area of the transducer face.

(1) Cylindrical Surface

(This calculation follows the method given by Wayne Kerr (c 1959)). (See Fig. B.1.)

If the detecting electrode of radius r is placed at a true minimum axial distance d from a cylinder of radius R then the capacitance of an elemental strip parallel to the axis of the cylinder is given by

$$\delta C = \epsilon_0 \epsilon_r \frac{2\sqrt{r^2 - x^2} \cdot dx}{d'}$$

The distance d' remains constant along the length of this strip and is/

is given by

$$d' = d + R \left(1 - \sqrt{1 - \frac{x^2}{R^2}} \right)$$

Hence the total capacitance of the electrode to the cylindrical surface is given by

$$C = \epsilon_0 \epsilon_r \cdot \frac{1}{d} \int_{-r}^{+r} \frac{2 \sqrt{r^2 - x^2} \cdot dx}{1 + \frac{R}{d} \left(1 - \sqrt{1 - \frac{x^2}{R^2}} \right)}$$

It is convenient to change the variable of integration from x to θ such that

$$x = r \sin \theta$$
$$dx = r \cos \theta \cdot d\theta$$

This gives

$$C = \epsilon_0 \epsilon_r \frac{\pi r^2}{d} \cdot \frac{1}{\pi} \int_{-\frac{\pi}{2}}^{+\frac{\pi}{2}} \frac{2 \cos^2 \theta d\theta}{1 + \frac{R}{d} \left[1 - \sqrt{\left(1 - \frac{r^2}{R^2} \cdot \sin^2 \theta \right)} \right]}$$

It can be seen that as $R \rightarrow \infty$ this expression gives the capacitance of the parallel plate capacitor

i.e.
$$C = \epsilon_0 \epsilon_r \cdot \frac{\pi r^2}{d}$$

Since $R \gg r$ under the usual conditions of operation, $\sqrt{\left(1 - \frac{r^2}{R^2} \cdot \sin^2 \theta \right)}$ can be expanded by means of the binomial theorem and a reasonable/

reasonable approximation obtained by using only the first two terms of the expansion.

i.e.

$$\sqrt{\left(1 - \frac{r^2}{R^2} \cdot \sin^2 \theta\right)} \approx 1 - \frac{1}{2} \cdot \frac{r^2}{R^2} \cdot \sin^2 \theta$$

The integral then becomes

$$C = \epsilon_0 \epsilon_r \cdot \frac{\pi r^2}{d} \cdot \frac{1}{\pi} \int_{-\frac{\pi}{2}}^{+\frac{\pi}{2}} \frac{2 \cos^2 \theta \cdot d\theta}{\left[1 + \frac{r^2}{2Rd} \cdot \sin^2 \theta\right]}$$

A simple general solution of the integral is not possible so that it is necessary to tabulate values of capacitance for specific values of the function $\frac{r^2}{2Rd}$.

It can be seen from this expression that the measurement error produced by a cylindrical surface of radius R will be the same for all sizes of probe when the minimum axial distance is the same fraction of the probe range. Normalized curves can therefore be drawn showing the measured reactance X_d' as a fraction of the reactance X_h measured to a plane surface at maximum range as a function of the minimum axial distance d expressed as a fraction of the probe range h.

i.e.

$$\frac{X_d'}{X_h} = f\left(\frac{d}{h}\right)$$

Fig. 2.13 shows a set of curves of this function for different values of R compiled from data given by Wayne Kerr (c.1959).

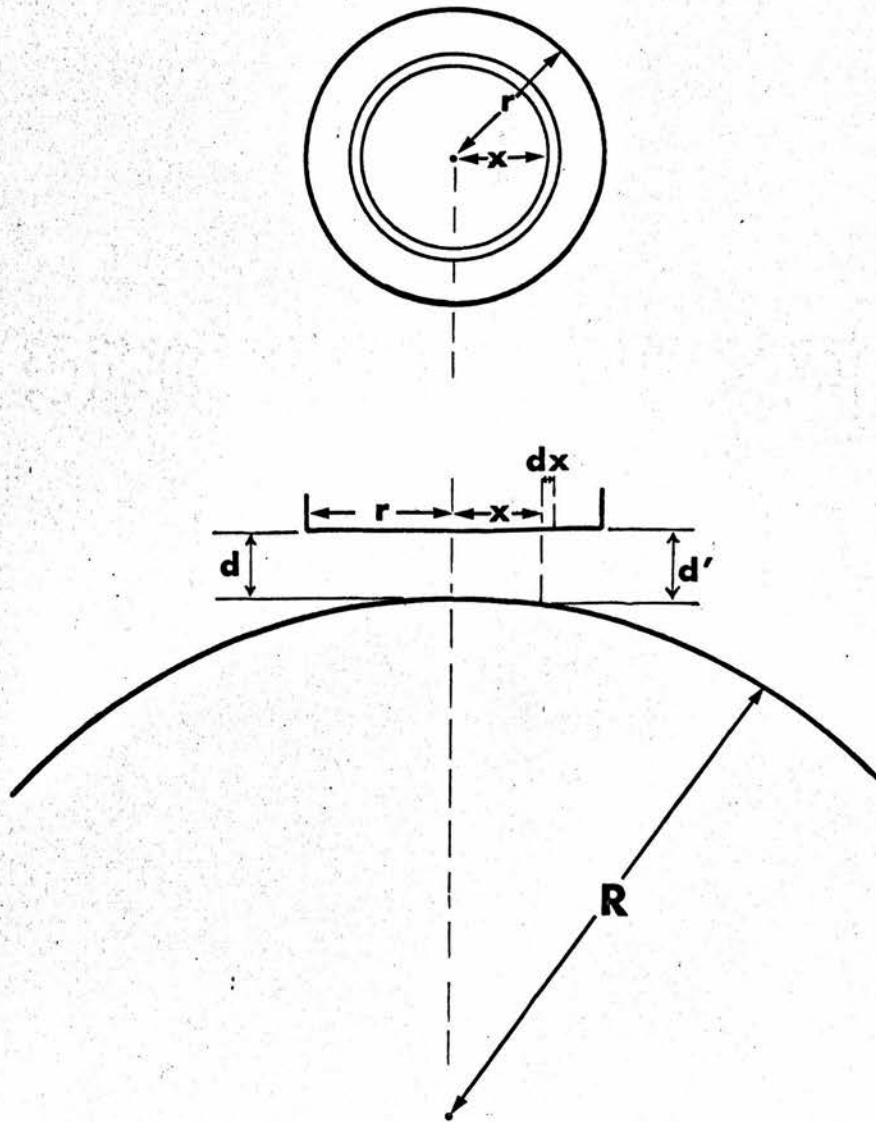

FIG. B.2. TRANSDUCER USED WITH A SPHERICAL SURFACE

(ii) Spherical Surface

A similar set of curves can be derived for spherical surfaces with different radii of curvature. (See Fig. B.2)

The capacitance of an elemental ring of radius x of the electrode is given by

$$\delta C = \epsilon_0 \epsilon_r \cdot \frac{2\pi x \cdot dx}{d'}$$

The distance d' is constant along the perimeter of this strip and is given by

$$d' = d + R \left(1 - \sqrt{1 - \frac{x^2}{R^2}} \right)$$

The total capacitance of the electrode to the spherical surface is then given by

$$C = \epsilon_0 \epsilon_r \cdot \frac{1}{d} \int_0^r \frac{2\pi x \cdot dx}{1 + \frac{R}{d} \left(1 - \sqrt{1 - \frac{x^2}{R^2}} \right)}$$

In all practical cases $R \gg r$ and $x \leq r$ so that $\sqrt{1 - \frac{x^2}{R^2}}$ can be expanded by the binomial theorem and the first two terms give a good approximation.

The integral then becomes

$$C = \epsilon_0 \epsilon_r \cdot \frac{1}{d} \int_0^r \frac{2\pi x \cdot dx}{\left(1 + \frac{x^2}{2Rd} \right)}$$

This/

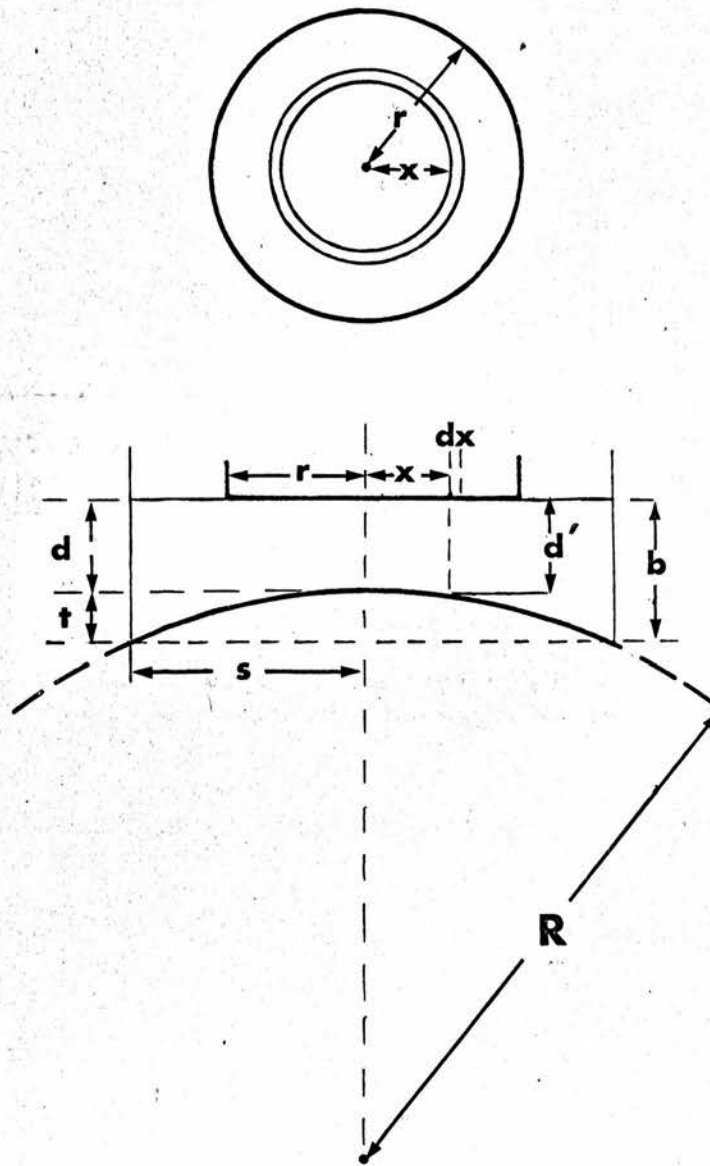

FIG.B.3. TRANSDUCER RESTING ON A CURVED SURFACE

This integral can be evaluated easily and gives

$$C = \epsilon_0 \epsilon_r \cdot \frac{\pi r^2}{d} \cdot \frac{2Rd}{r^2} \cdot \ln\left(1 + \frac{r^2}{2Rd}\right)$$

It can be seen that this expression is also a function of $\frac{r^2}{2Rd}$ and so the same error considerations will apply for different probes as in the cylindrical case. Fig. 2.14 shows a set of curves for different radii of curvature plotted from this formula.

(iii) Changes of Curvature

It is not possible to analyse the form of the capacitance variations at the transducer when the surface undergoes a change of curvature unless the form of motion of the curved surface can be specified. If the curvature remains large throughout the vibration then any additional error due to changes in curvature will be small.

However when the transducer is allowed to rest on the body surface the vibrating area beneath the electrode will be curved and in this case the vibrations can only appear as changes in curvature. A similar situation exists in the electrostatic microphone and pressure transducer where the second electrode of the capacitor takes the form of a diaphragm or membrane having negligible stiffness in bending.

The arrangement is shown in Fig B. 3 . The radius S of the sidewalls of the transducer is larger than the radius of the detecting/

detecting electrode. The height of the sidewalls b remains constant during the observation. t is the height of the 'bulge' above the plane defined by the ring of contact of the sidewalls on the body surface.

$$\text{Hence } d + t = b$$

and from the Geometry of the circle

$$t(2R - t) = s^2$$

$$\begin{aligned} \therefore R &= \frac{1}{2} \cdot \left(\frac{s^2 + t^2}{t} \right) \\ &= \frac{1}{2} \cdot \left[\frac{s^2 + (b-d)^2}{(b-d)} \right] \end{aligned}$$

This value of R can be substituted in the solution of the integral obtained in Section (ii) above.

$$C = \epsilon_0 \epsilon_r \frac{\pi r^2}{d} \left[\frac{s^2 + (b-d)^2}{(b-d)} \right] \frac{d}{r^2} \cdot \ln \left[1 + \frac{r^2}{d} \cdot \frac{(b-d)}{s^2 + (b-d)^2} \right]$$

Since b and d will both be small compared with S this expression can be simplified without much loss of accuracy.

$$\text{i.e. } C = \epsilon_0 \epsilon_r \cdot \frac{\pi r^2}{d} \cdot \frac{s^2}{(b-d)} \cdot \frac{d}{r^2} \cdot \ln \left[1 + \frac{r^2}{d} \cdot \frac{(b-d)}{s^2} \right]$$

This formula can be used to prepare a set of error curves for different ratios of r and s , and different values of the sidewall height b .

In/

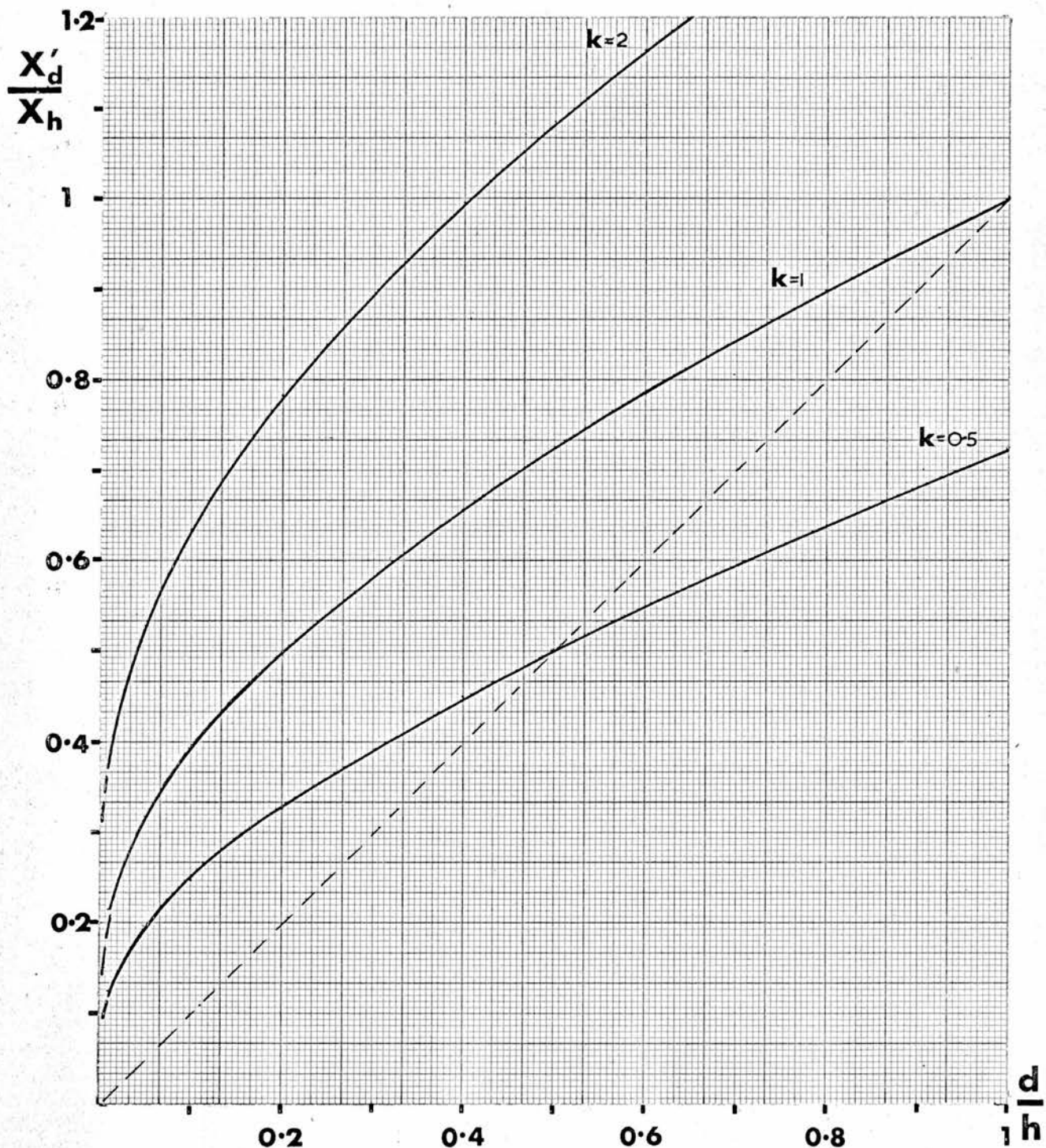

FIG. B4. REACTANCE MEASURED TO A SPHERICAL SURFACE WITH VARYING CURVATURE ($r=s$)

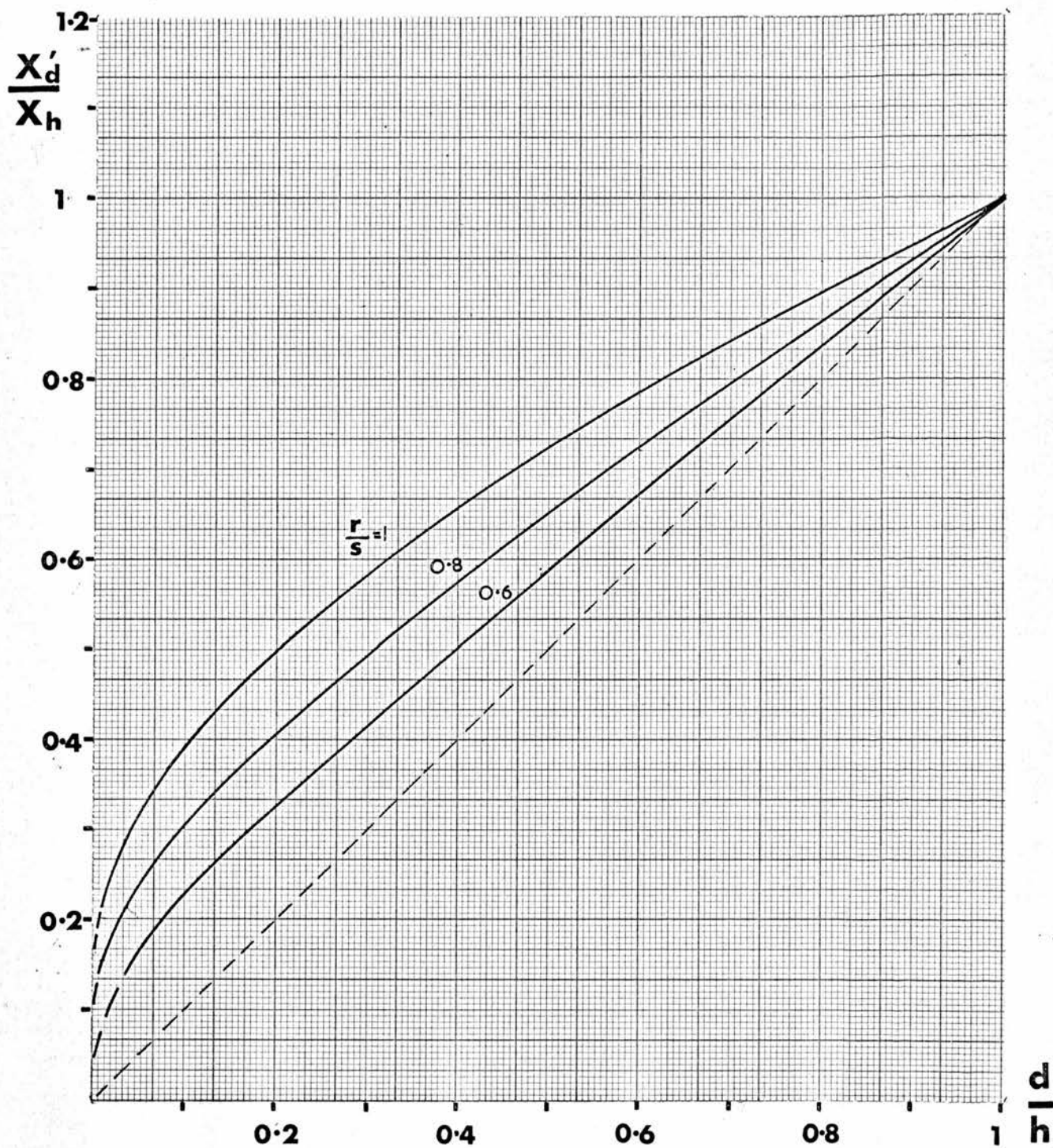

FIG.B.5. REACTANCE MEASURED TO A SPHERICAL SURFACE WITH VARYING CURVATURE ($b=h$)

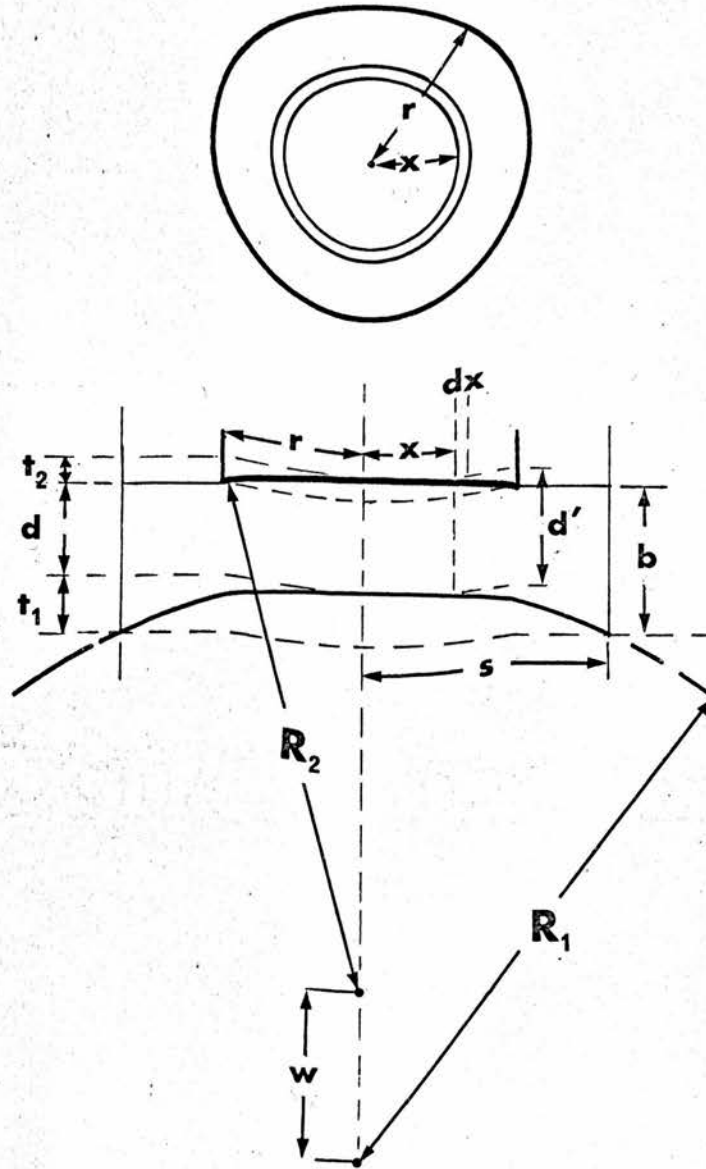

FIG.B.6. TRANSDUCER WITH CURVED ELECTRODE

In this case

$$\frac{X_d'}{X_h} = \frac{d}{h} \cdot \frac{(b-d)}{d} \cdot \frac{r^2}{s^2} \cdot \frac{1}{\ln\left[1 + \frac{r^2}{s^2} \cdot \frac{(b-d)}{d}\right]}$$

Since b is a constant it is convenient to represent it as a function of h

i.e. $b = kh$

then
$$\frac{X_d'}{X_h} = \frac{d}{h} \cdot \left(\frac{kh}{d} - 1\right) \frac{r^2}{s^2} \cdot \frac{1}{\ln\left[1 + \frac{r^2}{s^2} \left(\frac{kh}{d} - 1\right)\right]}$$

Fig. B. 4 . gives a series of normalized curves for different values of k with $r = s$ and Fig. B. 5 . for different values of $\frac{r}{s}$ with $k = 1$.

2. CURVED ELECTRODE

When the transducer housing rests on the body surface it is known that the surface will have some initial curvature. If this curvature can be measured then improved linearity can be obtained by matching the curvature of the detecting electrode to the curvature of the surface.

Fig. B. 6 shows the general arrangement of the transducer with a curved electrode with radius of curvature R_2 and a curved surface of radius of curvature R_1 . b defines the distance between these two surfaces at the boundary of the transducer and is constant.

W is the distance between the two centres of curvature.

In this case the spacing between the two surfaces at radius/

radius x from the axis is given by

$$d' = \left\{ \left(\sqrt{R_2^2 - x^2} \right) - \left(W + \sqrt{R_1^2 - x^2} \right) \right\}$$

the total capacitance is therefore

$$\begin{aligned} C &= \epsilon_0 \epsilon_r \int_0^r \frac{2\pi x dx}{\left(\sqrt{R_2^2 - x^2} \right) - \left(W + \sqrt{R_1^2 - x^2} \right)} \\ &= \epsilon_0 \epsilon_r \int_0^r \frac{2\pi x dx}{\left\{ R_2 \sqrt{\left(1 - \frac{x^2}{R_2^2} \right)} - R_1 \sqrt{\left(1 - \frac{x^2}{R_1^2} \right)} - W \right\}} \end{aligned}$$

Since $\frac{x}{R_1} < 1$ and $\frac{x}{R_2} < 1$ in all practical cases both

$$\sqrt{1 - \frac{x^2}{R_1^2}} \quad \text{and} \quad \sqrt{1 - \frac{x^2}{R_2^2}} \quad \text{can be}$$

expanded using the binomial theorem. Subtracting the two expansions

gives

$$\begin{aligned} R_2 \sqrt{1 - \frac{x^2}{R_2^2}} - R_1 \sqrt{1 - \frac{x^2}{R_1^2}} &= (R_2 - R_1) + \frac{1}{2} x^2 \left(\frac{1}{R_1} - \frac{1}{R_2} \right) + \left(\frac{1}{2} \right)^2 \frac{x^4}{2!} \left(\frac{1}{R_1^3} - \frac{1}{R_2^3} \right) + \dots \\ &\approx (R_2 - R_1) \left(1 + \frac{1}{2} \frac{x^2}{R_1 R_2} \right) \end{aligned}$$

The other terms in the expression are small and can be neglected.

The integral then becomes

$$C = \epsilon_0 \epsilon_r \int_0^r \frac{2\pi x dx}{(R_2 - R_1) \left(1 + \frac{1}{2} \frac{x^2}{R_1 R_2} \right) - W}$$

From/

From the diagram it is clear that $R_2 = d + W + R_1$

$$\therefore W = (R_2 - R_1) - d$$

so further simplification of the integral is possible

i.e.
$$C = \epsilon_0 \epsilon_r \int_0^r \frac{2\pi x \cdot dx}{d + \frac{(R_2 - R_1)}{2R_1 R_2} \cdot x^2}$$

Putting $g = \frac{2R_1 R_2 d}{(R_2 - R_1)}$ the integral becomes

$$\begin{aligned} C &= \epsilon_0 \epsilon_r \frac{2\pi R_1 R_2}{(R_2 - R_1)} \int_0^r \frac{2\pi x \cdot dx}{(g + x^2)} \\ &= \epsilon_0 \epsilon_r \frac{2\pi R_1 R_2}{(R_2 - R_1)} \cdot \ln\left(1 + \frac{r^2}{g}\right) \end{aligned}$$

From the geometry of the transducer shown in the diagram

$$R_1 = \frac{1}{2} \left\{ \frac{s^2 + t_1^2}{t_1} \right\} \quad \text{and} \quad R_2 = \frac{1}{2} \left\{ \frac{s^2 + t_2^2}{t_2} \right\}$$

so that

$$\begin{aligned} \frac{2R_1 R_2}{(R_2 - R_1)} &= \frac{s^2}{(t_1 - t_2)} \\ &= \frac{1}{2} \cdot \frac{s^2}{(b-d)} \end{aligned}$$

Substituting/

Substituting this in the expression for the capacitance gives

$$\begin{aligned} C &= \epsilon_0 \epsilon_r \frac{\pi s^2}{(b-d)} \cdot \ln \left\{ 1 + \frac{r^2}{d} \cdot \frac{(b-d)}{s^2} \right\} \\ &= \epsilon_0 \epsilon_r \frac{\pi r^2}{d} \cdot \frac{s^2}{r^2} \cdot \frac{d}{(b-d)} \cdot \ln \left\{ 1 + \frac{r^2}{s^2} \cdot \frac{(b-d)}{d} \right\} \end{aligned}$$

The resulting expression is clearly the same as that obtained with a flat detecting electrode used with a curved surface and the curves given in Figs. B. 4 and B. 5 . can be used. In this case however zero error would be obtained for piston-like motion of two surfaces with equal radii of curvature.

ACKNOWLEDGEMENTS

I should like to thank Professor Greening of the Department of Medical Physics who made it possible for me to carry out this work whilst employed as a member of his staff.

I am very grateful to Dr. D.C. Simpson for his helpful supervision throughout the project, and also to Dr. A.R. Dinnis, of the Department of Electrical Engineering, who has assisted him.

My thanks also go to all those other members of the staff of the Department of Medical Physics without whose advice and assistance the work described would not have been possible.

I am indebted to Wayne Kerr Laboratories Ltd. for the loan of a Distance and Vibration Meter during the final stages of the project.

Finally, I should like to thank my wife for the assistance she has given me, in particular with the making of some of the recordings discussed in the thesis.

REFERENCES

- ARENDS, G.F.J. (1961) 49,52.
'De Condensatormicrofoon met Halfgeleiders-ov 442'
Omroep-technische Mededelingen, Feb. 15th, 1961, 5-10.
- ARONOW, S., CURRENS, J.H., AND COSMAN, B.J. (1963) 42
'A Capacitance Method for Recording Vascular Pulsations'
Proc. Vth Int. Conf. on Med. Electron. (ed. Bostem, F.H.)
pp 213-220, Liege.
- BÁRÁNY, E., (1942). 17
'On the Mechanical Impedance of the Human Thorax'
Acta med. scand. CXI, No. 3, 252-260.
- BAXANDALL, P.J. (1959). 74
'Transistor Sine-Wave LC Oscillators'
Proc. Instn. Elect. Engrs. 106B, Suppl. No. 16, 748-758.
- BAXANDALL, P.J. (1963). 49, 52, 74, 76
'New Low Noise Transistor Circuit for Electrostatic
Microphones'
Wireless Wld. 69, 538-542; 593-597.
- BAXANDALL, P.J. (1964) 73
'The Elimination of Residual Even-Harmonic Distortion
in Transistor Oscillators'.
Electron. Engng. 36, 97-99.
- BERRY, S.D. (1959) 80
'Transistor Amplifiers for Sound Broadcasting'
B.B.C. Engng. Monogr. No. 26.
- BERRY, S.D. (1963) 80
'The Application of Transistors to Sound Broadcasting'
B.B.C. Engng. Monogr. No. 46.
- BINNIE, A.J., and FOORD, T.R. (1964) 52
'Toroidal Ratio Transformers their Equivalent Circuits
and the Measurement of their Parameters'
Electron. Engng. 36, 740-745.
- BLUMLEIN, A.D. (1928) 48
'Closely coupled inductor ratio-arm bridge'
Brit. Patent 323,037 Sept. 1928. (Cited by Clark
and Vanderlyn, 1949).
- BRIGHT, R.L. (1955) 117
'Junction Transistors Used as Switches'
A.I.E.E. Trans 74, Pt. I, 111-121.

- BOND, M.V. (1964) 75
'Transistor R.F. Power Amplifiers'.
Wireless Wld. 70, 594-600.
- BUTLER, F. (1960) 48
'A.C. Bridges with Inductive Ratio Arms'
Electron. Technol. 37, 303-309.
- CALVERT, R. (1948) 48
'A New Technique in Bridge Measurements'
Electron. Engng. 20, 28-29.
- CALVERT, R. and MILDWATER, J. (1963) 77
'Self-Balancing Transformer Ratio Arm Bridges'
Electron. Engng. 35, 782-787.
- CEMBALA, D. (1949). 23,42
'The Resonance Method of Electrosphygmography'
Bull. Int. de l'acad. pol. des sci. et des lett.
Classe de méd., 1949. 269-274.
- CHAUVEAU, A. and FAIVRE, J. (1856) 3
'Nouvelles recherches expérimentales sur les
mouvements et les bruits du coeur.
'Gaz. méd. de Paris,' 1856 (Cited by McKusick, 1958).
- CHLEBUS, H. (1962)
'Value of examination of carotid pulse by means of
resonance electrophygmographs in relation to intra-
arterial pressure tracings'.
Amer. Heart J. 64, 22-32.
- CLARK, H.A.M. and VANDERLYN, P.B. (1949) 48
'Double-Ratio A.C. Bridges with Inductively-Coupled
Ratio Arms'.
J. Inst. Elect. Engrs. 96, Pt. III, 189-202.
- CORNWALL, J.B. and TATTAM, F.G. (1964)
'An Instrument for Recording the Fetal Pulse Rate'
Inst. elect. electron. Engrs. Trans. on Bio-Med. Engng.
BME-11, 24-28.
- DECKER, R.O. (1955) 77
'Transistor Demodulator for High-Performance
Magnetic Amplifiers in A.C. Servo Applications'
A.I.E.E. Trans. 74, Pt. I., 121-123.
- EINTHOVEN, W. (1907) 3
'Die Registrierung der menschlichen Herztöne mittels
des Sartengalvanometers'.
Pflügers Arch. ges. Physiol. 117, 461 (Cited by
McKusick, 1958).

- EINTHOVEN, W. and GELUK, M.A.J. (1894) 3
'Die Registrierung der Herztöne
Pflügers Arch. ges. Physiol. 57, 617 (Cited by McKusick 1958).
- EVANS, J.F.O., GILL, D.A., and MOFFITT, ^{B.R.}(1961) 77
'Symmetrical Transistors as A.C. or D.C. Switches and
their Applications in Modulator and Demodulator Circuits'
Jour. Brit. Inst. Rad. Engrs. 21, No. 2, 143-149.
- FIELDEN ELECTRONICS LTD. (c 1947) 23, 49, 52.
"Proximity Meters Types PM2 and PM4"
(An Introduction to the Use of Capacitance Measurement
in Research and Industry)
Publication No. 225 FE/38.
- FISCHLER, H., FREI, E.H., RUBINSTEIN, M., and SPIRA, D., (1964). 23
'Measurement of Sound Transmission in the Middle Ear'
Med. Electron. Biol. Engng. 2, 289-298.
- FOLDVARI, T.L., and LION, K.S. (1964) 27
'Capacitive Transducers'
Instrums. Control Syst. 37, 77-85.
- FOSS, R.C., and SIZMUIR, M.F. (1962) 72,81
'LC Oscillator Design'
Wireless Wld. 68, 535-539, 595-597.
- FRANK, O. (1904) 3
"Die unmittelbare Registrierung der Herztöne".
München med. Wchnschr 51, 593.
(Cited by Luisada, 1965 and McKusick, 1958)
- FRANKE, E.K. (1951a) 17
'Mechanical Impedance of the Surface of the Human Body'
J. appl. Physiol. 3, 582-590.
- FRANKE, E.K. (1951b) 17
'Mechanical Impedance Measurements of the Human
Body Surface'.
U.S.A.F. Technical Report No. 6469.
- Von GIERKE, H.E. OESTREICHER, H.L., FRANKE, E.K., PARRACK, H.O.,
and von WITTERN, W.W. (1952) 17
'Physics of Vibrations in Living Tissues'
J.appl. Physiol. 4, 886-900.
- GILBERT, C.P. (1964) 64
'The Design and Use of Electronic Analogue Computers',
Chapman and Hall, London.

- GILES, J.N. (1965) 95
'Frequency Compensation Techniques for an Integrated Operational Amplifier'.
S.G.S.-Fairchild Application Report 141.
- GOLDING, J.F. (1961) 48
'Transformer-Ratio-Arm Bridges'
Wireless Wld. 67 No. 6, 329-335.
- GROOM, D., and SIHVONEN, Y.T. (1957a) 13, 23, 87
'High-Sensitivity Capacitance Pickup for Heart Sounds and Murmurs'
I.R.E. Trans. on Med. Electron. PGME-9, 35-40.
- GROOM, D., and SIHVONEN, Y.T. (1957b) 13, 23
'A High Sensitivity Pickup for Cardiovascular Sounds'
Amer. Heart J. 54, 592-601.
- GROOM, D., MEDINA, L.H. and SIHVONEN, Y.T. (1963) 42
'The Proximity Transducer'
Proc. Vth Int. Conf. on Med. Electron. (ed. Bostem, F.H.)
221-228, Liege.
- HAKIM, S.S. and BARRETT, R. (1964) 76
'Transistor Circuits in Electronics'
Chapter 9 - 'Modulator and Demodulator Circuits'
Iliffe, London.
- HARVEY, W., (1628) 1
'Exercitatio Anatomica de Motu Cordis et Sanguinis in Animalibus', Frankfurt.
(English Translation in Willius and Keys, (1941), pp 19-79).
- HICKLING, G.H., (1952) 40
'The Activities and Equipment of an Industrial Electronics Laboratory' (Part 4).
Electron. Engng. 24, 148-151.
- HILLING, A.E. (1963) 75
'Transistorised 4W Transmitter for 8.315 M^c/s'
Mullard Tech. Comm. 7, No. 62, 56-63.
- HUERTHLE, K. (1893) 3
'Ueber eine Methode zur mechanischen Registrierung der Töne'
Deutsche med. Wchnschr 19, 17 (Cited by McKusick, 1958).
- KARO, D. (1958) 48
'A Novel, High-Accuracy Circuit for the Measurement of Impedance in the A.F., R.F., and V.H.F. Ranges'
Proc. Inst. Elect. Engrs. 105 Pt. B, 505-510.

- KAYE, G.W.C. and LABY, T.H. (1957) 33
'Tables of Physical and Chemical Constants'
Longmans, Green and Co., London.
- KLEYN, J.B., LEATHAM, A., MAASZ, H., LIAN, C., and MINOT, G.L. (1955) 9
'Standardization of Phonocardiography'
Amer. Heart J. 50, 82.
- KLEYN, J.B., HOLLDAK, K., and LUISADA, A.A. (1959) 12
'Further International Efforts for Standardization of
Phonocardiography'
Amer. J. Cardiol. 4, 675 (Cited by LUISADA, 1965)
- KOROTKOFF, N.S. (1905) 5
'A Contribution to the problem of methods for the
determination of the blood pressure'
Rep. Imper. Milit-Med. Acad., St. Petersburg 11, 365
(Cited by McKusick, 1958).
- LAËNNEC, R.T.H. (1819) 1
'Traité de l'auscultation médiate, Paris.
(American Edition of 1823 reprinted in Willius and Keys,
1941. pp 328-382).
- LEONARD, J.L., and FARRER, W., (1963) 105
A Foetal Heart Monitor
Electron. Engng. 35, 83-85.
- LESLIE, W.H.P. (1961) 48, 52.
'Choosing Transformer Ratio-Arm Bridges'
Proc. Inst. Elect. Engrs. 108 Pt B, 539-545.
- LION, K.S. (1959) 22,27
'Instrumentation in Scientific Research(Electrical
Input Transducers')
McGraw-Hill, New York.
- LUISADA, A.A. (1965)
'From Auscultation to Phonocardiography'
The C.V. Mosby Company, Saint Louis.
- LYDÉN, A. (1963) 112
'Theory of Low Level Transistor Chopper'
Elteknik 6, 157-165.
- LYDÉN, A. (1965) 77
'Single and Matched Pair Transistor Choppers'
Electron. Engng. 37, No. 445, 186-189.

- MÄKELÄ, P., ÖSTERLUND, K., and WALLGREN, E.I., (1959) 23, 42
"A Method for Continuous Recording of Movement".
Acta physiol. Scand. 45, 43-47.
- MANNHEIMER, E. (1940) 6
"Calibrated Phonocardiography and Electrocardiography"
Acta Paediat. (Uppsala) 28, (Suppl. II) 1-287.
(Cited by McKusick, 1958, and Luisada, 1965).
- MANNHEIMER, E. (1957) 9,11
'Standardization of Phonocardiography'
Amer. Heart J. 54, 314-315.
(Reprinted in I.R.E. Trans. on Medical Electronics
PGME-9, 54, December 1957).
- McKUSICK, V.A. (1958)
'Cardiovascular Sound in Health and Disease'
The Williams & Wilkins Company, Baltimore.
- McKUSICK, V.A., WEBB, G.N., HUMPHRIES, J.O., and REID, J.A. (1955) 6
'On Cardiovascular Sound. Further Observations by
means of spectral phonocardiography'.
Circulation 11, 849.
- MILNES, A.G. (1957) 77
'Transistor Circuits and Applications'
Proc. Inst. Elect. Engrs. 104, Pt. B, No. 18, 565-580.
- OLSON, H.F. (1958) 18
'Dynamical Analogies' (2nd Edition)
D. Van Nostrand Company Inc., Princeton.
- POTAIN, P.C.E. (1867) 3
'On the Movements and Sounds that take place in the
Jugular Veins'
Bull. et Mem. de la Soc. med. des Hôp. de Paris 4, 3-27.
(Translation in Williams & Keys (1941) pp 533-556).
- RODDAM, T. (1963) 74
'Transistor Inverters and Converters'
(Chap. 10 - Sine-Wave Inverters pp 173-194)
Iliffe, London.
- ROGAL, B. (1961) 48
'Recent Advances in Three-Terminal Bridge Techniques'
Proc. Instn. Electron. 4, No. 2. (Reprint)
- SEMICONDUCTORS LTD. (1961) 77
'Chopper Transistors and their application'
Semiconductors Ltd., Application Note 103.

- SIMPSON, D.C., and LEASK, E., (1959) 105
A Foetal Pulse-Rate Monitor. The Lancet, May 23, 1959, 1077
- SMITH, D.H. (1957) 105
A Foetal Pulse-Rate Recorder
Electron. Engng. 29, 132.
- STANDARD TELEPHONES & CABLES LTD. (1961) 77
'Bidirectional Transistors'
S.T.C. Application Report MK/139.
- TAKAGI, S., YOSHIMURA, S. and OKAMURA, T., (1963) 17,90
'Trial and Success in the Technical Realization of
Requirements for Phonocardiographic Microphones'.
Proc. Vth Int. Conf. on Med. Electron. (ed. Bostem, F.H.).
268-283, Liege.
- WATTON, W.L., and PEMBERTON, M.E., (1959). 49
'A Direct-Capacitance Aircraft Altimeter'.
J. Instn. Elect. Engrs. 96, Pt. III, 203-213.
- WAYNE KERR LABORATORIES LTD. (1958) 23
'Electronic Measurement'
Aircraft Production, 20, 410-411.
- WAYNE KERR LABORATORIES LTD. (c 1959) 28, 30, 31
'Instruction Manual for Vibration Meter B731A
and Distance Meter DM100.
Publication TP4.
- WAYNE KERR LABORATORIES LTD. (1959) 49
'Electronic Micrometer'
(Reprint from 'Aircraft and Missiles Manufacturing', August
1959).
- WAYNE KERR LABORATORIES LTD. (1962)
'Linear Capacitance Transducer Provides
Precision Distance Measurement'
Reprint from Design and Components in Engineering December,
1962.
- WHIDDINGTON, R. (1920) 23,42.
'The Ultra-Micrometer'
Phil. Mag.(Ser. 6)40, 634-639.
- WIDLAR, R.J. (1964) 94
'A Monolithic Operational Amplifier'
S.G.S.-Fairchild Application Report AR129.

- WIDLAR, R.J. (1965) 94
'The Improved μ A-702 Wideband D.C. Amplifier'
S.G.S.-Fairchild Application Report AR131.
- WILLIAMS, H.B., and DODGE, H.F. (1926) 6
'Analysis of Heart Sounds'
Arch. intern. Med. 38, 685.
- WILLIUS, F.A. and KEYS, T.E. (1941)
"Cardiac Classics" Henry Kimpton, London.
- YOSHIMURA, S. (1960) 6
'Principle and Practice of Phonocardiography'
Jap. Circulat. J. 24, 921-931.
- YOSHITOSHI, Y., MACHII, K., SEKIGUCHI, H., MISHINA, Y.,
OHTA, S., WATANABE, S., SHINOHARA, Y., HANAKA, W., KOHASHI, Y.,
SHIMIZU, S., OHNO, T., and SHIMIZU, S., (1965). 13, 23,49
'Fundamental Studies on P.C.G. Microphone - Effect of a
Load on the Chest Wall upon the Performance Characteristics
of the Contact Microphones'.
Digest of the Vith Int. Conf. on Med. Electron. and
Biol. Engng., Tokyo, 30-31.
- ZAALBERG van ZELST, J.J. (1947) 40
'Circuit for Condenser Microphones with Low Noise
Level'.
Philips Techn. Rev. 9 No. 12, 357-363.