

649
2

AN EXAMINATION AND POSSIBLE EXPLOITATION OF CERTAIN
UNEXPLORED FEATURES IN THE OPERATION OF
HIGH PRESSURE CLOUD CHAMBERS.

Thesis
submitted by

Alan A. Watson,
B.Sc. (Edin.)

For the degree of
Doctor of Philosophy.

University of Edinburgh.

May, 1964.



PREFACE

The research described in this thesis has been carried out in the Department of Natural Philosophy of the University of Edinburgh, under the joint direction of Professor N. Feather, F.R.S., and Dr. G. R. Evans. A note containing preliminary results pertinent to the work discussed in Chapters 4, 5 and 6 has been published in *Nature*, Vol. 196, 1962, in collaboration with Dr. G. R. Evans.

INDEX

| Chapter | | Page |
|---------|---|------|
| 1. | <u>Introduction</u> | 1 |
| 2. | <u>The Cloud Chambers and Ancillary Equipment</u> | |
| | 2: 1: 1. The High Pressure Cloud Chamber | 6 |
| | 2: 1: 2. The Cloud Chamber Control Circuits | 8 |
| | 2: 1: 3. Recording of Observations | 10 |
| | 2: 2: 1. The 3-atmosphere Cloud Chamber | 11 |
| | 2: 2: 2. Operation and Performance of the 3-atmosphere Chamber | 13 |
| 3. | <u>Some Remarks on Theories of Condensation with Special Reference to Techniques of Cloud Chamber Operation</u> | |
| | 3: 1. Theories of Condensation Processes | 16 |
| | 3: 2. The Principles of Cloud Chamber Operation | 19 |
| | 3: 3. Cleaning Expansion. | 22 |
| | 3: 4. Some Peculiarities of High Pressure Cloud Chambers | 28 |
| | 3: 5. Summary | 30 |
| 4. | <u>A Study of Condensation Nuclei produced in a Supersaturated Vapour by an Electric Field</u> | |
| | <u>I. The Experimental Observations.</u> | |
| | 4: 1. Introduction | 31 |
| | 4: 2. The Experimental Arrangement | 32 |
| | 4: 3. The Production Conditions | 33 |
| | 4: 4. Description of the Phenomenon | 36 |
| | 4: 5. Properties of the Nuclei | 38 |
| | 4: 6. Experiments with a 'Dry Chamber' | 42 |
| | 4: 7. Changes in the Chemical Constituents of the System | 44 |
| | (1) Addition of Argon | 44 |
| | (2) Oxygen-free nitrogen as the carrier gas | 45 |
| | (3) Addition of Oxygen and Hydrogen | 46 |
| | (4) Addition of Carbon Dioxide | 46 |
| | (5) Addition of Ammonia | 46 |

| Chapter | | Page |
|---------|---|------|
| | 4: 8. The Nitrite Test | 47 |
| | 4: 9. The Effect of Altering the Gas Pressure | 49 |
| | 4:10. Summary | 50 |
| 5. | <u>A Study of Condensation Nuclei Produced in a Supersaturated Vapour by an Electric Field</u> | |
| | II. <u>A Possible Explanation</u> | |
| | 5: 1. Are the c-nuclei Charged Water Droplets? | 51 |
| | 5: 2. A Physical-Chemical Explanation | 54 |
| | 5: 3. A Re-examination of Methods of Cleaning the Chamber | 60 |
| | 5: 4. A Re-examination of the Production Process | 63 |
| | 5: 5. Evaporation of Drops Formed on c-nuclei | 65 |
| | 5: 6. Another Possible Explanation | 67 |
| | 5: 7. Conclusion and Summary | 68 |
| 6. | <u>Other Condensation Phenomena Observed in the High Pressure Cloud Chamber</u> | |
| | 6: 1 Nuclei Produced by an Electrostatic Field from a Damp Electrode in a Vapour which is not Supersaturated. | |
| | 6: 2. Nuclei Produced from a Damp Electrode in Equilibrium with a Saturated Vapour, by an Electrostatic Field | 74 |
| | 6: 3. Determination of a Diffusion Coefficient for the s-nuclei | 76 |
| | 6: 4. Nuclei Produced by an Electrostatic Field from a Damp, Flat Surface | 79 |
| | 6: 5. Unusual Drops Observed in the High Pressure Chamber | 81 |
| 7. | <u>Other Condensation Studies: I. Nuclei Produced by Irradiating Nitrogen, Saturated with Water Vapour, with Ultra Violet Light</u> | |
| | 7: 1. Introduction | 85 |
| | 7: 2. The Experimental Observations | 87 |
| | (1) The Production Conditions | 87 |
| | (2) The Disappearance of Nuclei from the Gas | 88 |
| | 7: 3. The Proposed Condensation Mechanism | 89 |

| Chapter | | Page |
|---------|--|------|
| 8. | <u>Other Condensation Studies. II. The Addition of Unusual Liquids, and Large Expansion Experiments</u> | |
| | 8: 1: 1. The Addition of Unusual Liquids | 93 |
| | 8: 1: 2. Breaking Water Tubes | 94 |
| | 8: 1: 3. Breaking Nitric Acid Tubes | 95 |
| | 8: 1: 4. Breaking Hydrogen Peroxide Tubes | 96 |
| | 8: 1: 5. Other Liquids | 97 |
| | 8: 2: 1. Some Condensation Studies at Large Expansion Ratios | 98 |
| 9. | <u>Speculations on Some Aspects of Cloud Physics</u> | |
| | 9: 1. Introduction | 103 |
| | 9: 2. The Occurrence of c-nuclei in Nature | 103 |
| | 9: 3. Nucleation Mechanisms | 106 |
| | 9: 4. Ice Crystals | 107 |
| 10. | <u>An Assessment of the Value of High Pressure Cloud Chambers</u> | |
| | 10: 1. Introduction | 109 |
| | 10: 2. Further Condensation Studies | 110 |
| | 10: 3. A Nuclear Physics Experiment | 111 |
| | 10: 4. Possible Radiation Chemistry Studies | 114 |
| | <u>Appendices</u> | |
| A. | The Density of the Cloud Seen in Cleaning Expansions | 115 |
| B. | Supersaturation Required for Drop Growth on Multi-Charged Nuclei | 117 |
| C. | Rate of Collision of Impurity Vapour Molecules with Nuclei of Different Radii | 118 |
| D. | An Estimate of the Maximum Radii of the c-nuclei using the Barometer Formula | 121 |
| E. | Diffusion Coefficient and Mobility of the c-nuclei | 122 |
| F. | The Temperature of an Evaporating Drop | 124 |
| G. | The Possibility of Studying Direct Pair Production by μ -mesons, using a High Pressure Cloud Chamber | 126 |
| | Acknowledgements | 130 |
| | References | 131 |

Chapter I

INTRODUCTION

Following the pioneer experiments of Coulier (1875) and Aitken (1880-1) on the condensation of water vapour, C. T. R. Wilson (1895) constructed a device called a cloud chamber, in which gaseous samples, saturated with water vapour, could be made supersaturated by subjecting them to controlled, measurable expansions of high speed. In an early paper, (1897), it was reported that the rain-like condensation seen when clean moist air was sufficiently cooled was enhanced by irradiating the gas with the newly discovered X-rays. Concluding that he was observing condensation promoted by gaseous ions, this work was extended, and 1899 Wilson was able to show that water vapour condenses on negatively charged ions when the expansion ratio, defined as the ratio of the final to the initial gas volume, is more than 1.25, and on positively charged ions if it exceeds 1.31. In 1911 he observed and photographed the lines of drops formed on ions produced by individual particles, reducing the equilibrium ion concentration in the gas with an electrostatic sweeping field. Physics was thus provided with an invaluable tool for the study of atomic and nuclear interactions.

This elegant technique was extended and improved by many workers. The early instruments were operated with gas pressures close to one atmosphere so that to observe rare particle interactions large cloud chambers were required, the operation of which presented considerable technical difficulties. Chambers of several cubic metres were, however, successfully constructed. Blackett and Occhialini (1932) used counter systems in conjunction with cloud chambers so that an

expansion was made only if it were probable that a charged particle had passed through the chamber.

With small atmospheric pressure chambers it is possible to make expansions every few minutes without track distortion arising. In this enforced waiting period, called the recycling time, small expansions are made to remove unwanted condensation nuclei, and the gas is allowed to resaturate and return to a steady temperature. Particles passing through the chamber shortly before and just after the start of the expansion will be recorded. This recording time is only about 0.3 sec., after which the gas has heated up so that the supersaturation is insufficient to enable visible drops to form around gaseous ions. The ratio of the recording time to the recycling time is thus rather low.

In 1934 Mott-Smith constructed a cloud chamber which could be operated with gas at pressures up to 30 atmospheres, thus enabling rare cosmic ray interactions to be observed with a higher frequency per unit volume of interacting gas than had been hitherto possible. Several other high pressure cloud chambers were built, notably those of Williams and Evans (1940) and Johnson, Bendetti and Shutt (1943) which could be used at 100 atmospheres pressure. Apart from the advantage of the increased gas density a high pressure chamber, at 80 atmospheres, will continue to record particles for about 2 sec. after the expansion. Unfortunately the recycling time of about 20 minutes restricts its possible fields of application.

About 1950 beams of high energy particles of considerable intensity became available from machines and visual recording techniques with shorter recycling times than the high pressure cloud chamber

were sought. The nuclear emulsion was, of course, available for many experiments but its density (about 4 gm/cm^3) is too high for some fields of investigation. The diffusion chamber, a continuously sensitive cloud chamber first described by Langsdorf in 1939, was redeveloped. This instrument, which operates over a more restricted pressure range than the cloud chamber, is very suitable for machine work (e.g. Fowler et al, 1953) but not for cosmic ray studies as its sensitive region, in which the particle tracks are seen, extends horizontally. The bubble chamber, invented by Glaser in 1952, employs a superheated liquid as the detecting medium and has proved immensely powerful when used with high energy machines. It cannot however be employed for cosmic ray work as the high diffusion rate of ions in a liquid makes it impossible to operate using counter control. The density of liquid hydrogen is 70 gm/litre , whereas the density of hydrogen gas at 25 atmospheres and 0°C is 2.6 gm/litre , so that recording devices using different media are required depending on the energies of the secondary particles from the reaction which is being studied. Other visual techniques such as the spark chamber, which has a very short recycling time but rather poor spatial resolution, have been developed more recently.

A considerable reduction in the recycling time of cloud chambers was achieved by the fast recompression method first discussed by Emigh (1954) and developed for use with high pressure chambers by the University College, London, and University of Edinburgh cloud chamber groups [Evans(1955), Donald (1956), Tait (1960) and Cairns et al, (1961)]. In this technique the gas is recompressed very quickly after the start of the expansion, so re-evaporating the drops and

thus apparently reducing the need for small intermediate expansions. By this means the recycling time could be reduced to 2 minutes with argon at 80 atmospheres and to about 1 minute with hydrogen at a similar pressure, thus giving the high pressure cloud chamber some advantages over the diffusion chamber which is restricted to using hydrogen at less than 30 atmospheres, and heavier gases at only 5 atmospheres, because of the rate of vapour diffusion. However Tait (*loc. cit.*), using one of the Edinburgh high pressure chambers in an experiment with the Liverpool synchro-cyclotron, found it necessary to make small expansions after 10 consecutive expansions because of the build up of background condensation. The recycling time of his chamber was thus considerably increased.

Following Tait's observations the author was given the task of assessing the value of high pressure cloud chambers in nuclear physics experiments with the opportunity to exploit their peculiar properties in any other kinds of investigation. The following pages contain results which indicate that the high pressure chamber is a useful instrument in several fields. Since background cloud was a major limitation to the successful operation of such chambers, the work was started by investigating its origin and properties. It was thus discovered that the high pressure chamber is a powerful tool for the study of condensation phenomena, results having been obtained which are thought to have important applications in the science of cloud physics. A much clearer understanding of cloud chamber operation was also gained and consequently it has been possible to make some remarks about optimum operating conditions. A projected experiment to study the electron pairs produced by high energy mu-mesons is

briefly discussed. In addition conclusions are drawn from certain experiments which indicate that some interesting radiation chemistry studies might be made using the high pressure cloud chamber technique.

Chapter 2

THE CLOUD CHAMBERS AND ANCILLARY EQUIPMENT

The apparatus used in these investigations will be briefly described in this chapter. The majority of the observations were made using a high pressure cloud chamber but for some subsidiary and supplementary work another chamber, operating at lower pressures and with easy access to its working section, was designed and constructed.

2: 1: 1. The High Pressure Cloud Chamber.

The high pressure cloud chamber originally described by Williams and Evans (1940), and more recently by Evans (1955), was used in this work. Figure 1 illustrates the principal features of the working section of the chamber which is made of "Weldana" non-magnetic stainless steel. The working volume is a cylinder, 8" in diameter and 8" deep, mounted with its axis horizontally. It may be illuminated through two armour plate glass windows, $1\frac{1}{2}$ " in diameter and 1" thick, (only one of which is shown in the diagram), and can be viewed, either by an observer or with a camera, through a larger porthole of similar glass, $5\frac{1}{2}$ " in diameter and 1" thick. For some experiments the glass of one illumination window was replaced by a piece of synthetic quartz, "Spectrosil", supplied by Thermal Syndicate Ltd. The cloud chamber is positioned so that the illumination windows are at opposite ends of its vertical diameter. The observation window is held in place by a heavy steel ring bolted to the main body of the chamber, the seal being made of neoprene. The rigid brass plates, P_1 and P_2 , are drilled with a large number of evenly spaced $1/16$ " diameter holes to assist uniform gas motion. Electrical connections, E, to the inside can be made via wires inserted through two rubber or neoprene

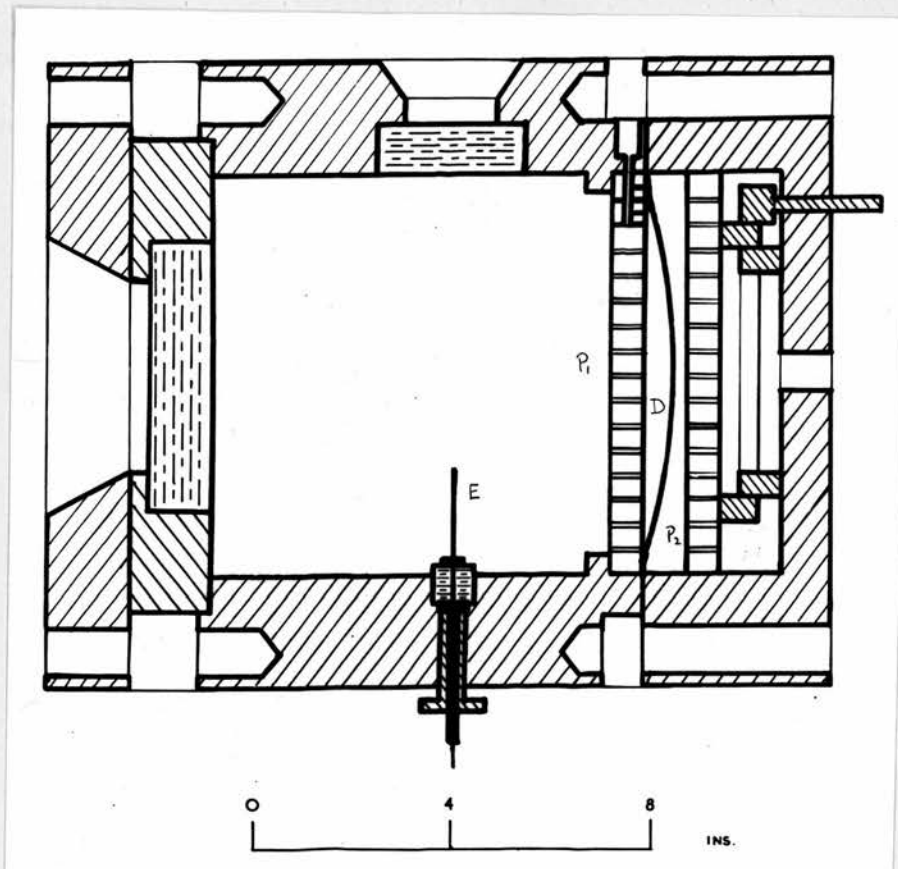

Figure 1. Working Section of High Pressure Cloud Chamber.

E - high voltage electrode
D - rubber diaphragm
 P_1, P_2 - perforated brass plates.

plugs in the steel wall of the chamber. The inside is painted with black, alcohol resistant paint to reduce light reflection; the plate, P, being covered with black velvet which provides a suitable photographic background and is an additional aid to uniform gas flow.

An expansion is achieved by releasing pressure behind the rubber diaphragm, D, which is constrained to move between P_1 and P_2 . The position of the latter is variable so that the extent of the backward excursion of the diaphragm, and thus the expansion ratio, can be controlled. An expansion valve, not shown in Figure 1, connects the back of the chamber to a cylinder attached to an oil pump. The valve, which was designed by Dr. G. R. Evans, and is similar to those described by him in 1955, is opened by a large solenoid. The sequence of operations for any expansion is as follows:-

- (1) Pump the diaphragm forward to the required position (usually hard against the front plate, P_1 , with a pressure difference of about 2 atmospheres across it).

- (2) Close the expansion valve.

- (3) Reduce the gas pressure in the expansion cylinder by letting oil from it flow into the pump reservoir.

- (4) Allow the temperature of the gas in the chamber to come to room temperature.

- (5) Open the expansion valve, either automatically or manually.

- (6) Make visual or photographic observations.

- (7) Reset the gas pressures.

The expansion ratio is calculated, using Boyle's Law, from the pressures in the front of the chamber before and after an expansion. Pressure measurements are made on a Budenburg gauge connected to the working volume via a needle valve. The gauge can be read easily to

1/10th atmosphere so that at 30 atmospheres the expansion ratio can be determined with a precision of about 0.3%. Any particular expansion ratio is highly reproducible since the diaphragm moves between rigid metal plates. A second gauge is used to monitor the pressure in the region between the diaphragm and the expansion valve. In this chamber the maximum value of the expansion ratio is $1.120 \pm .003$, and it can be efficiently operated over a pressure range of 10 to 80 atmospheres with a variety of gas fillings, nitrogen and argon being most frequently used in the present work.

2: 1: 2 The Cloud Chamber Control Circuits.

Apart from the opening of the expansion valve and the operation of the flash tubes at a pre-set time, which are controlled electronically, the sequence of operations described in the previous section is carried out manually by the operator. This has been advantageous since it would have been impossible to design an automatic control system with the required flexibility. The basic control circuit was built by Dr. R. M. Hudson and Mr. M. J. Landels, who used this cloud chamber for another purpose, and is similar in design to that described previously by Hudson (1958). The author has added some simple switching circuits for various specific operations connected with the electrostatic field.

In normal cloud chamber work an electrostatic field is applied to an electrode system inside the chamber to remove newly created ions from the gas. It had been arranged that this clearing field was automatically switched off just prior to an expansion of the chamber. However for some of the experiments it was found necessary to leave the field on throughout the expansion or to apply it at pre-set times after the start. A small thyatron timing circuit, shown

in Figure 2, was built to do this. Power supplies for it were obtained from the main control circuit from which it was isolated except when in use.

Pressing the spring-loaded switch, S, starts the chamber cycle and simultaneously the EN91 thyratrons, V_1 and V_4 , strike. Relay R is energised, thus bringing the voltage on the electrode system, supplied either from a home-made E.H.T. unit or an Isotope Developments 592/D power pack, to zero. The current through V_4 is broken via R1, and the relay holds itself on via R2. It can be de-energised by opening the manual switch S1 or the relay contacts B4. When contacts A1 are closed the $1\mu\text{F}$ condenser in the grid circuit of V_2 is charged up through a high, variable resistance X, until the voltage becomes approximately 0 volts, when V_2 will strike, thus energising relay B. Contacts of this relay are arranged to break the anode current through V_1 (B1), to discharge the $1\mu\text{F}$ condenser to its bias potential (B2), to initiate the charging of the $1\mu\text{F}$ condenser in the grid circuit of V_3 (B3) and to de-energise relay R (B4). When V_3 strikes relay C is energised, the current through V_2 is cut off and the $1\mu\text{F}$ condenser is discharged. When contact C3 closes relay R is again energised if the manual switch S2 is closed. The discharge through V_3 is extinguished using the oscillations set up in the LC circuit formed by the $4\mu\text{F}$ condenser, the 5mH inductance and the conducting thyatron. The frequency of oscillation is low enough so that the anode potential is driven negative for a period longer than the de-ionization time of the thyatron.

This circuit, together with the manual switches, makes available a number of different field switching arrangements.

(1) If V_4 is removed and S2 is opened the field remains on

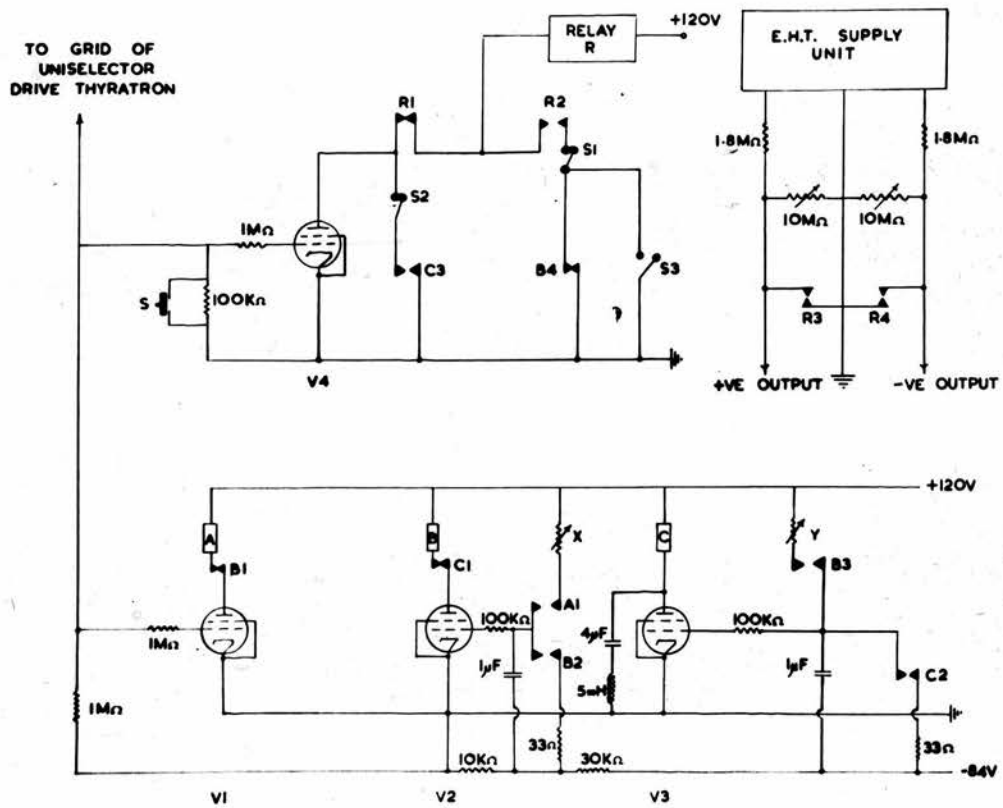

FIG.2. HIGH PRESSURE CLOUD CHAMBER FIELD SWITCHING CIRCUIT

throughout the expansion.

(2) With V_4 present, switch S2 open, and switch S3 closed, the field is switched off at the expansion and stays off.

(3) If the field is put off at, or long before the expansion, it can be switched on after a pre-set time, and left on indefinitely provided S2 and S3 are open. (To switch the field off without an expansion being made, relay R is energised by operating the uni-selector cycle with the expansion valve disconnected.)

(4) If S2 is closed and S3 open, the field may be switched on during the expansion for a short period, set by resistance Y, using relay contact C3.

(5) If the field is left on throughout the expansion (see (1) above), it may be switched off after a pre-set time by means of relay C, provided switch S1 is closed. Switch S1 is normally used to switch on the field if relay R has been left energised after any series of operations.

The time delays, for various values of the resistance X, were measured using the standard pulse generator-scalar technique.

The electrostatic field is variable from 0 to 3kV and is of either polarity. The time delays depend on resistances X and Y, and on the $1\mu F$ condensers in the grid circuits of V_2 and V_3 . The valves V_1 to V_4 are Mullard EN91 thyratrons. Relays A, B and C are post office relays, while relay R is an alternating current relay with silver/platinum contacts. The 5mH inductance is basket-wound on a $\frac{3}{4}$ " cylindrical paxolin former using Litz (7/44SWG) wire. The assembled circuit is mounted on an aluminium chassis.

2: 1: 3

Recording of Observations

The work to be described is mainly concerned with an investigation

of the properties of condensation nuclei produced in a variety of ways. The majority of the observations were made visually although photographs of different production processes were frequently taken. Visual estimates of the density and rate of growth of the uniform clouds sometimes formed in the expansions must have been subject to almost daily variations since they depend on such variables as the angle of view, and the strength and position of the source of illumination.

It should perhaps be emphasised that conclusions were only drawn from sets of observations which had been repeated many times. For visual observations the chamber was illuminated with a 24 watt, 12 volt Osram car headlamp placed close to the lower illumination port-hole. Stereoscopic photographs were taken on Ilford HPS plates using a camera fitted with a pair of Carl Zeiss f/4.5, 5 cm. lenses, the necessary illumination being obtained by discharging 200 joules from a bank of condensers through each of two Mazda LSD7 Xenon-filled flash tubes.

2: 2: 1 The 3-atmosphere Cloud Chamber.

The 3-atmosphere cloud chamber to be described below was built so that certain results obtained with the high pressure chamber could be supplemented and extended. It was planned to study the effect of some chemically reactive substances such as hydrogen peroxide and nitric acid on condensation phenomena so that a chamber which could be readily cleaned and dismantled was required. Also certain results suggested that it would be instructive to examine the cloud formed in a region similar to that between the plate, P, and the diaphragm, D, of Figure 1. This region is not normally visible in cloud chambers. Further, it was a limitation of the high pressure chamber

that condensation on ions could not be observed using pure water vapour as the condensant even with argon as the carrier gas. With these considerations in mind the chamber shown in Figure 3 was designed and constructed.

It consists essentially of two pyrex glass cylinders $\frac{3}{8}$ " thick, 13" in diameter and 4" deep, sandwiched between three 16" x 16" x $\frac{1}{2}$ " the brass plates. The brass plate at the front of the working section is fitted with an armour plate glass window, of 7" diameter and $\frac{1}{2}$ " thick, held in position by a brass ring bolted to the plate. The centre plate is drilled with 359 equally spaced $\frac{3}{16}$ " diameter holes and is covered on its front surface with black velvet. The rubber diaphragm is clamped between the second glass cylinder and the back brass plate which has a 2" diameter expansion port cut in it. Apart from this interface, soft rubber gaskets are inserted between all other glass-brass surfaces, the whole assembly being held together with a number of $\frac{5}{16}$ " bolts. The necessary fittings for connections to gauges and pumps are provided in a conventional manner.

The expansion valve is shown in Figure 4(a). It consists of a loose coupling joint which forces an aluminium disc, fitted with an O-ring, over the 2" expansion port. The disc is constrained on three $\frac{1}{4}$ " brass rods which support the loose coupling joint and are screwed to the back of the chamber. A slight upward displacement of the joint opens the valve which is then thrown back by the pressure excess in the chamber. A fairly rapid expansion is thus achieved. The valve is opened and closed manually.

The inside of the expansion port is covered with a hemispherical dome, drilled with 45 $\frac{1}{4}$ " diameter holes, which prevents the centre

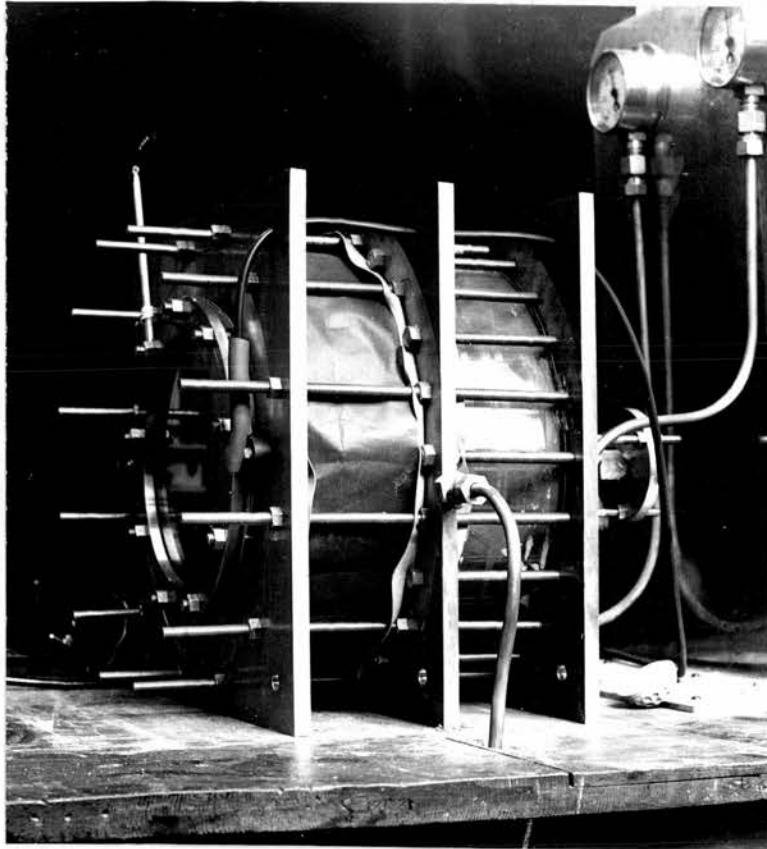

Figure 3. The 3-Atmosphere Cloud Chamber.

One of the clearing field electrode plugs can be seen, together with part of the loose-coupling expansion valve. A filling tube and the two pressure gauges are also visible.

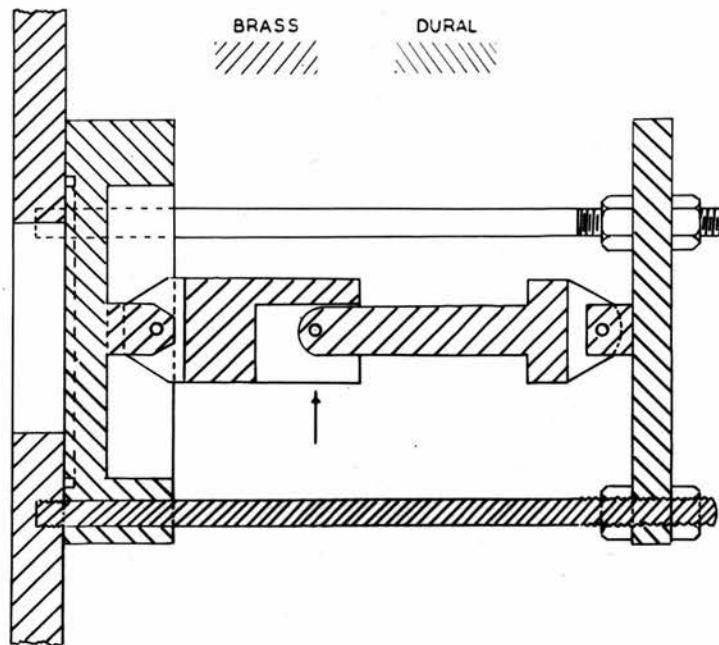

FIG4a LOOSE COUPLING EXPANSION VALVE [FULL SCALE]

0 1 2 3 4 INS.

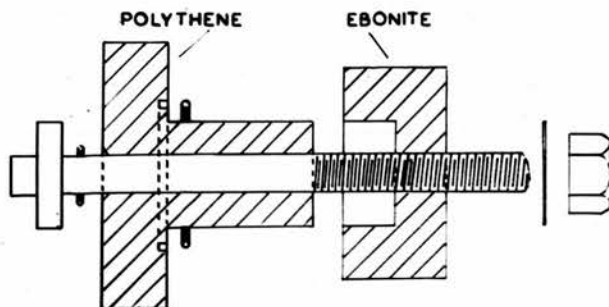

FIG4b ELECTRODE PLUG [FULL SCALE X 2]

of the diaphragm from sealing the expansion port and from being forced out of the chamber. Various baffles can be fitted behind this honeycomb to alter the expansion speeds. A large aperture tap in the back plate enables fine pressure adjustments and controlled slow expansions to be made.

Electrical connections to the working volume might have been made using metal-to-glass seals but a more robust system was designed as shown in Figure 4(b). The action of these plugs is clear from the diagram, the seal being achieved by drawing the 2BA bolt tight, thus forcing the rubber O-rings against the chamber wall. Two such connections are presently fitted. The ion sweeping field electrode is a ring of 26 SWG wire, 11" in diameter, mounted on ebonite supports, with its axis along that of the cloud chamber. The field, which is normally 600v positive with respect to the chamber walls, can be switched off at the start of any expansion by a microswitch actuated by the expansion valve. Additional microswitches are available to control other operations such as the photographic flash tubes which are similar to those used with the high pressure chamber. For visual illumination a 60 watt, 240 volt strip-light is mounted at the side of the chamber.

2: 2: 2

Operation and Performance of the 3-Atmosphere Chamber.

The pressure range of the chamber is from $\frac{1}{2}$ to 3 atmospheres above atmospheric pressure. The expansion ratio, which has been varied from 1.01 to more than 1.40, is altered by pumping air behind the diaphragm with a compressor. The theoretical maximum expansion ratio, for the present chamber, is almost 2.0 with the diaphragm fully stretched, and would be about 1.5 for an 8" deep working section. With water vapour and nitrogen, excellent particle tracks

are seen with an expansion ratio of about 1.28, at 2 atmospheres total pressure. With water vapour and argon the equivalent expansion ratio is 1.16. These values correspond to an equal fall in temperature in the two cases, and hence to an equal supersaturation, as might be expected. The expansion ratio cannot be found accurately as the pressure gauge is rather coarse.

The speed of the expansion has been roughly measured by fixing a metal contact to the centre point of the diaphragm, the contact acting as a switch in a pulse generator-scalar circuit so that the time of excursion between the front and back plates during an expansion can be obtained. For reasons set out in the next chapter full use could not be made of the 2" expansion port which had to be stopped down with a baffle containing only 5 $\frac{1}{4}$ " holes. Under these conditions the expansion time was 0.18 sec. This could be greatly reduced, possibly by a factor of 10, if many larger holes were drilled in the central plate so that full use could be made of the very large expansion aperture. A lighter diaphragm might also be employed if really high expansion speeds were sought. However, for the present work, no further improvement was considered necessary.

All the benefits which this chamber was designed to supply were obtained, although the possibility of measuring and varying expansion speeds had not been considered initially. Expansions tend to lack reproducibility because the diaphragm does not move between two fixed plates. These variations are caused by slight temperature changes and also by the coarseness of the pressure gauge which is used to set and measure the expansion ratio. These difficulties could be overcome fairly readily with more elaborate control equipment. A more fundamental drawback is the short sensitive time of

a chamber operating at this pressure, caused by rapid warming up of the gas by heat conducted from the walls. Indeed while attempts to study condensation processes with this apparatus were fairly successful, they served also to stress the advantages of the high pressure cloud chamber in this field.

Chapter 3

SOME REMARKS ON THEORIES OF CONDENSATIONWITH SPECIAL REFERENCE TO TECHNIQUES OF CLOUD CHAMBER OPERATION

Although originally invented by C. T. R. Wilson as a device for studying cloud formation, the extensive use of the cloud chamber as a visual detector for charged particles has overshadowed this aim, and has tended to cause the study of many of its basic principles to be scantily treated and often ignored. Since the experiments to be described are mainly concerned with condensation processes observed in an expansion cloud chamber it will be useful to collect together and to examine critically the principles behind cloud chamber operation, precisely defining the meaning of many terms used later in the discussion. It is in fact believed that some of the observations have enabled a few imperfectly understood aspects of cloud chamber technique to be elucidated. Indeed a minor success of the present work is that many individual and scattered comments throughout the massive literature on cloud chambers can be interpreted and correlated using a theory deduced from it.

3: 1 Theories of Condensation Processes.

In 1870, before the experimental studies of Coulier, Aitken and Wilson on the condensation of water vapour, a theoretical discussion of the unstable equilibrium existing between liquid droplets and a supersaturated vapour had been given by Sir William Thomson, later Lord Kelvin. He showed that the radius, r , which a droplet must attain to be in equilibrium with a superstaturated vapour of pressure, p_r , could be expressed by the relation:-

$$r = \frac{2M\sigma}{RTp \log_e p_r/p_\infty} \quad (3: 1)$$

where p_∞ is the saturated vapour pressure at a temperature, $T^\circ\text{K}$; R is

the Universal gas constant, and M , ρ and σ are the molecular weight, density and surface tension respectively, of the liquid. The variation of σ with r , which would add an additional term to equation (3: 1) will be ignored at this stage. It will be convenient to refer to the ratio p_r/p_∞ as the supersaturation, and to denote it by the symbol, S .

Kelvin's relation implies that if a supersaturation, S , is established, a nucleus of radius greater than r must be present before droplets of the liquid phase will separate out and start to grow. The necessary nuclei can arise in numerous ways. Microscopic drops of liquid formed artificially, wettable solid particles, hydrophobic particles, and small molecular aggregates arising from chance clusterings of vapour molecules will all, if present when supersaturation is established, act as condensation centres. It is possible to calculate theoretically the expected rate of appearance of visible drops for any particular supersaturation when the only available nuclei are the randomly formed molecular aggregates. A number of attempts have been made to measure this rate of homogeneous nucleation in water and other vapours, for different values of S , but because of many experimental and interpretative difficulties the agreement found between theory and experiment has been regarded as largely fortuitous (Mason, 1960).

J. J. Thomson (1888) extended Kelvin's result to the case of nuclei carrying an electric charge. The relation which he derived may be written as:-

$$\log_e \frac{p_r}{p_\infty} = \frac{M}{RT\rho} \left[\frac{2\sigma}{r} + \frac{d\sigma}{dr} - \frac{q^2}{8\pi\epsilon r^4} \right] \quad (3: 2)$$

where q is the charge on the drop and ϵ the dielectric constant of

the surrounding medium. The variation of surface tension with radius has this time been included. Charged nuclei act as efficient condensation centres because, whereas the potential energy due to surface tension decreases with decreasing radius, that due to the presence of charge decreases with increasing radius. Surface tension therefore tends to decrease the radius of the drop while the charge tends to increase it.

Several important differences between the behaviour of charged and uncharged drops are revealed by a study of Thomson's equation. A singly charged ion in a gas will always be surrounded by a cluster of vapour molecules even if the gas is fairly dry. In a gas saturated with water vapour such clusters will contain about 10 water molecules and have radii of approximately 4×10^{-8} cm. Hence embryonic condensation nuclei are always present which are able to grow to visible drops provided the supersaturation is increased above a certain maximum value. Again taking water as an example, it is found that S , the supersaturation, must be greater than 4.2 for drops to form on singly charged ions, though statistical fluctuations in the size of the embryo make this an average value.

As with homogeneous nucleation comparison can be made between the theoretical and experimental values of S necessary to form visible drops about ions. It is found that with certain liquids condensation occurs more readily on ions of a particular sign, water condensing preferentially on negatively charged ions. Such behaviour is not predicted by the theory. A detailed experimental study of this problem has been carried out by Loeb, Kipp and Einarsson (1938) who consider that the newly created ion is captured by a vapour molecule cluster whose surface force field is then altered so that capture of

further molecules is enhanced or impeded depending on the sign of the ion. Although apparently qualitatively correct, a mathematical treatment of this theory has not yet been given. The values of S predicted from equation (3: 2), for onset of ionic condensation in various liquids, are in rather poor agreement with experiment.

While some of the discrepancy may be caused by impurities present in the liquids studied, the dubious validity of the concept of surface tension at small drop sizes, coupled with the inability to predict preferential condensation, show that the equation should be regarded only as a simplified representation of the detailed mechanism.

The behaviour of a drop formed about a soluble nucleus has been examined by several authors, but most recently by Mason (1957). The relation derived, which is similar in form to Thomson's equation, appears to give good agreement with experiment for salt crystals dissolved in water, possibly because the concept of surface tension is now valid as the droplet radii are usually greater than 10^{-6} cm., so that a classical thermodynamical calculation is applicable. Mason's conclusions may be summarized briefly for completeness. In the presence of insoluble wettable particles drop growth will take place slightly more readily than on pure water droplets of the same size. Hydrophobic particles are slightly less efficient as condensation nuclei, but if the droplet is formed on a wholly or partially soluble nucleus the equilibrium vapour pressure at its surface is reduced by an amount depending on the concentration and nature of the solute, which means that condensation occurs at a lower supersaturation than that required for an insoluble nucleus of the same size.

3: 2 The Principles of Cloud Chamber Operation.

In the expansion cloud chamber a fixed mass of gas saturated with

the vapour of a liquid is expanded very rapidly to produce supersaturation. If the gas is free from the aerosols normally found in room air, or other artificially produced nuclei, then the molecular clusters containing gaseous ions formed by the passage of a charged particle through the gas will be the most efficient available condensation centres. Provided the degree of supersaturation is as great as the maximum value predicted by equation (3: 2), visible drops will be formed. The maximum degree of supersaturation which can be produced in any expansion is normally calculated from the initial and final volumes of the gas assuming that the expansion has been adiabatic. This theoretical maximum will not be reached when appreciable condensation occurs since vapour molecules condensing and heat liberated by the growing drops will reduce the supersaturation (Mason, 1951). Typical gases used in cloud chambers are nitrogen or argon, with ethyl alcohol, water or ethyl alcohol and water mixtures acting as the condensant. The ion background in the chamber is normally reduced by application of an electrostatic sweeping field (about 60 volt/cm at 3 atmospheres) for a short period before the expansion, the magnitude of the field required depending on the pressure of the gas.

The supersaturation established by an expansion will be sufficient to promote ionic condensation only for a short time. This sensitive period is curtailed by the compression of the central mass of gas which occurs when the gaseous layer close to the chamber wall is warmed and expanded by heat conduction. The duration of the sensitive period may readily be measured, and for chambers operating at about 1 atmosphere it can be accurately predicted from a relation derived by Williams (1939). In the high pressure cloud chamber,

however, turbulence near the walls enhances heat conduction and the sensitive time is much shorter than calculated. Although freshly formed ions will not promote condensation after this time, the drops already formed remain visible for several more seconds before evaporating. Some drops, of course, will be removed from the gas by falling to the floor of the chamber.

As mentioned in Chapter I, a limitation to the use of any cloud chamber is its long recovery time. In the case of the high pressure chamber this is a particularly serious restriction. During the waiting period a number of small expansions have to be made to remove unwanted condensation nuclei from the gas. The pressures are then reset and vapour and thermal equilibrium re-established. This recovery time, which at 80 atmospheres is about 20 minutes, may be reduced by the technique of fast recompression, first discussed by Emigh (1954), in which the gas is returned rapidly to its initial pressure as soon as the necessary observations have been made. By this means the droplets formed are evaporated in situ. This reduces the time necessary for re-establishing vapour and thermal equilibrium and apparently eliminates the necessity for cleaning expansions in most chambers, although the mechanism by which this is achieved is not clear. A similar technique, known as overcompression, was developed earlier by Gaerttner and Yeater (1949), in which, following an expansion, the gas is compressed beyond its normal equilibrium position and is then slowly re-expanded to its operating pressure. The condensation nuclei normally precipitated in cleaning expansions are reduced in size during the compression and can be removed from the gas by an electrostatic clearing field or else by growing and falling out during the small expansion. Although partially success-

ful in enabling cloud chambers to be operated with short recovery times these techniques have sometimes failed because of the production of unwanted condensation nuclei, the origin of which is often obscure. In the course of the present investigations a study has been made of several types of condensation nuclei which can be produced in expansion chambers. It is believed that consequently a better understanding of the cleaning process has been gained.

3: 3 Cleaning Expansions.

Unless high gas purity is required it is normal practice to leave 1 atmosphere of air in a cloud chamber before the main carrier gas is added. Then, before it can be used as a charged particle detector, any nuclei which can cause condensation at a supersaturation smaller than that required for drop growth on ions must be removed. Such nuclei are commonly the Aitken nuclei found in room air. They may be swept from the gas by a series of small expansions in which they are deposited, in visible drops, at the walls of the chamber. Alternatively the gas can be cleaned by replacing the room air with filtered air or by leaving the chamber for several days while the nuclei settle out. Once the gas has been cleaned it will sustain a supersaturation up to the ion limit without any visible drops being formed.

Assuming that Thomson's equation, (3: 2) gives even a qualitative picture of the ionic condensation mechanism, an obvious deduction from it is that evaporation of a drop formed round an ion should produce a nucleus very similar to the initial one, thus requiring a similar large expansion before a visible drop is again formed. That this subsequent expansion often need only be a small one is well known to all cloud chamber workers. Thomson (1928) suggested,

on the basis of some experimental evidence of Reinold and Rücker (1886) and Johannot (1906) on the variation of the surface tension of soap films, that the surface tension of water falls to a minimum value, rises to a maximum and then goes to zero as the radius of curvature of the droplet varies from infinity to zero. Including this hypothetical variation in his theory Thomson predicted that droplets of quite large but sub-visible sizes would be stable, even in unsaturated conditions, and would require only a slight expansion to make them visible. Tolman (1949), by classical methods, and Kirkwood and Buff (1949), using a statistical mechanical approach, have found no theoretical evidence for this behaviour, and have questioned the validity of extrapolating the results of Reinold and Rücker to water vapour, but the above explanation for the formation of the sensitive re-evaporation nuclei has been accepted rather uncritically in the most recent reviews of cloud chamber technique (Das Gupta and Gosh, 1946, and J. G. Wilson, 1951). A major drawback to achieving short recovery times in cloud chamber operation is the necessity for making several cleaning expansions after ionic condensation has been observed. If, in fact, there is no Thomson variation in surface tension, why should cleaning expansions be required?

The agreement between cleaning expansion theory and the experimental evidence is not as good as might be expected. It has already been noted that the techniques of overcompression and fast recompression, which certainly reduce the waiting period required for thermal and vapour equilibrium to be re-established, are not uniformly successful in eliminating cleaning expansions. While the action of the overcompression might be to re-evaporate sub-visible

droplets to a very small size, the fast recompression technique could certainly not achieve this. Further Hazen (1954) has found that a 50% overcompression is not sufficient to destroy the re-evaporation nuclei. It might appear, therefore, that the need for cleaning expansions is dependent on the mode of operation of the chamber and is not a direct consequence of ionic condensation. Further experimental evidence supports this view. Dr. G. R. Evans (private communication) has operated a cloud chamber successfully for very long periods without cleaning expansions, provided the rubber diaphragm which controlled the expansion did not contact the front brass plate (compare diaphragm D and plate P_1 of Figure I). This observation has been confirmed by several workers in this laboratory, including the author. In addition it has been commonly found that the number of drops seen in the first cleaning expansion, following that in which particle tracks have been observed, is much larger than can be accounted for by the re-evaporation nucleus theory. These results suggest that cleaning expansions are only necessary if extra nuclei, of high condensation efficiency, are produced in the primary expansion.

In chambers such as those described in the previous chapter, where the expansion is controlled by a rubber diaphragm moving between 2 plates, it is believed that nuclei are produced by an electric field generated as the rubber separates from the front plate. Subsequently, on recompression, these nuclei appear in the front of the chamber, acting as efficient condensation centres until they are removed from the gas by repeated small expansions. Hazen (1942) and other authors have commented on this problem. Donald (1956) and Hudson (1958) investigated the process in some detail, using different rubbers, and found that fewer nuclei were produced if the rubber was fairly stiff.

This conclusion agrees qualitatively with the observation of Hodson (1955) that neoprene diaphragms are useful in low background chambers. Neoprene is much less flexible than the stiffest rubber used by Donald and Hudson.

As remarked above, cloud chambers with rubber diaphragms can be operated without cleaning expansions provided the diaphragm does not touch the front plate. It was found, however, that if the holes in this plate were restricted slightly (two layers of velveteen over the surface were sufficient) that nuclei were produced in the plate-diaphragm region, even without plate-diaphragm separation, unless the expansion speed was greatly reduced. Further, Tait (1960) has found, with the other Edinburgh high pressure chamber, that the increased expansion speed achieved with his redesigned, large aperture valves was accompanied by the production of unwanted condensation nuclei.

In observing homogeneous condensation most workers from C. T. R. Wilson (1897) to Courtney (1963) report that several small expansions are required to remove from the gas nuclei formed in the larger primary expansion. No explanation for the occurrence of these nuclei has been offered. In Wilson's and Courtney's experiments 'rubber diaphragm nuclei' could not have been formed as their chambers were piston operated.

It was therefore proposed that unwanted background nuclei might originate in large expansions occurring momentarily in the plate-diaphragm region, when the expansion speed is too great for the restrictions presented to the gas flow by the plate and its accessories. A test of this hypothesis was made as described below.

The 3-atmosphere cloud chamber had been designed with the plate-

diaphragm volume visible so that any condensation occurring there might be studied. In an early run with a nitrogen-water mixture in the chamber, the area of the holes in the centre plate was $1\frac{1}{2}$ times the area of the holes in the expansion port. After the natural aerosol component had been removed from the gas by a number of small expansions, a series of similar expansions could be made without any condensation occurring in the front or back volumes of the chamber. However, increasing the expansion ratio produced conditions under which no condensation could be seen in the front of the chamber although dense cloud was formed in the plate-diaphragm region. This cloud appeared to be uniform except for dense streams formed close to the holes in the plate. A further small expansion, made after recompression of the gas, produced a dense cloud in both volumes although the drops in the plate-diaphragm region took much longer to evaporate than those in the front, possibly because a greater temperature fall had occurred there. Under these conditions condensation on particle tracks could only be observed if the chamber was cleaned, with numerous small expansions, after each large expansion. An electrostatic field was ineffective in removing the nuclei responsible for the cloud.

By reducing the area of the expansion port to $1/9$ th that of the holes in the centre plate the chamber was successfully operated with nitrogen-water and argon-water mixtures over a range of pre-expansion total pressures from $1\frac{1}{2}$ to 4 atmospheres. Long series of expansions, in which tracks of cosmic radiation particles were always seen, were made without the necessity for interposing cleaning expansions between primary expansions. During these runs the diaphragm never made contact with the brass plate and only light condensation, presumably also on gaseous ions, was observed in the plate-diaphragm volume.

These results are consistent with the hypothesis that high expansion speeds can cause homogeneous condensation, and subsequently background cloud, to occur without the diaphragm touching the front plate. In a chamber where the diaphragm does separate from this plate, a fast expansion will cause a very small volume of gas to be expanded considerably, unless the area of the holes is extremely large. Diaphragms which tend to stick to the metal will be more troublesome since the speed of the expansion, when it does commence, will be enhanced. The reason for the success of the stiff diaphragms used by Hodson, Donald, and Hudson is now clear, although it appears that if the area of the holes in the plate is much greater than the area of the expansion port no trouble will occur. Indeed in the chamber of Emigh and Fisher (1955) there were "thousands of $\frac{1}{8}$ " holes" in this plate though the expansion port was only $\frac{1}{8}$ " diameter. Peyrou (1955) has shown that background cloud in large piston-controlled chambers can be caused by very fast expansions. In addition, Davies and Evans (private communication) found that a small heater placed in the plate diaphragm volume reduced background cloud, probably because the region was then, initially, unsaturated although a large expansion still occurred. Apparently, therefore, if no expansion greater than that necessary for ionic condensation is allowed to take place, no cleaning expansions are required. Although the occurrence of such expansions might be eliminated by correct design procedure the nature of the re-evaporation nuclei formed in them remains obscure. Discussion of this point is deferred till Chapter 8, where an explanation based on a theory of condensation processes, deduced from the experiments shortly to be described, is outlined.

3: 4 Some Peculiarities of High Pressure Cloud Chambers.

The major advantage of the high pressure cloud chamber over atmospheric chambers for condensation studies is the long time for which supersaturation is maintained after an expansion. It has, however, at least two limitations. Duff and Morris (1955) have shown that following an expansion which causes a temperature drop of about 12°C , the gas remains at least 5°C below the wall temperature 30 secs. after the expansion. They also demonstrated that the decay of the temperature gradient which is established across the chamber after an expansion, and subsequent compression, takes about 20 mins., unless fast recompression techniques are used, thus limiting the rate at which expansions can be made for condensation studies as for charged particle experiments. A further serious limitation is the possible occurrence of vapour depletion when heavy condensation causes a large quantity of the condensant to be carried in drops to the floor of the chamber. The diffusion coefficient of the vapour varies inversely as the gas pressure so that it may take a long time for vapour equilibrium to be re-established. This was demonstrated by Banford et al (1955) who observed vapour depletion in the course of some high pressure cloud chamber experiments with a proton beam from the Harwell 150 MeV cyclotron.

An observation of some interest is that the expansion ratio required to produce condensation on ions is reduced as the pressure is increased. This is believed to be caused by the enhanced absorption, at high pressures, of gas molecules on the surface of liquid drops causing the surface tension of the liquid to be lowered. Johnson (1947) has derived a useful relation for comparing the observed value of expansion ratio for ionic condensation with theory. He found that

to explain his own observations at pressures of 1.5 and 110 atmospheres, the surface tension of iso-propyl alcohol in argon would have to be reduced by about 20% at the higher pressure. Laughlin (1948), using Johnson's relation, compared values of threshold expansion ratio with theory over a range of 5 to 45 atmospheres using an iso-propyl alcohol and water mixture with argon as the carrier gas. He claimed that the reduction in surface tension with pressure was insufficient to explain his results but like other workers he was hampered by a lack of experimental data for the mixture and pressures used. Apart from the early observations of Kundt (1881) few results have been published on the variation of surface tension with pressure until quite recently when Masterton, Bianchi and Slowinski (1963) reported measurements of the surface tension of bulk liquids as the surrounding gas pressure was varied. Amongst the systems studied, using essentially the capillary rise method to determine σ , the surface tension, were argon-water and nitrogen-water. They represented their results by an empirical relation of the form

$$\sigma = \sigma_0 - A(p - p_0) + B(p - p_0)^2 \quad (3: 3)$$

where σ_0 is the surface tension at atmospheric pressure, p_0 and p is the pressure of the mixture; A and B are constants which depend on the gas and liquid system.

Since it was hoped to extend the conclusions from the present work to conditions prevalent in the atmosphere, knowledge of the surface tension variation was important. Using Johnson's formula, the expansion ratio necessary to cause ionic condensation in an argon-water mixture at 80 atmospheres was calculated taking the appropriate value of σ from the data of Masterton and his co-workers. This

rough calculation indicated that condensation on ions should start at an expansion ratio of 1.125 which is slightly larger than that available in the high pressure chamber already described. An unsuccessful attempt to observe this threshold was made with argon and water at 80 atmospheres. This indicates that the smaller expansion ratios required at high pressures are due largely to surface tension variations and not to other, unknown, factors as Laughlin's results might suggest. Results at 30 atmospheres, where the surface tension of water in nitrogen is reduced by about 2.9%, may thus be extrapolated to atmospheric pressure with some confidence, although clearly the question of expansion ratio threshold at high pressures merits further investigation.

3: 5. Summary.

In this chapter theories of condensation for various specific cases have been reviewed. The operation of a cloud chamber has been discussed, particular attention being paid to the necessity for making cleaning expansions. These were shown to be required only if efficient condensation nuclei were produced in large expansions occurring in the plate-diaphragm region. The peculiar properties of high pressure cloud chambers were outlined.

Chapter 4

A STUDY OF CONDENSATION NUCLEI PRODUCED IN A SUPERSATURATED VAPOUR
BY AN ELECTRIC FIELDI. The Experimental Observations4: 1 Introduction.

Following a suggestion by Dr. G. R. Evans that some of the background cloud seen in cloud chambers might be caused by condensation on nuclei produced when an electrostatic field is applied to the clearing field electrodes during the period for which the vapour in the chamber is supersaturated, a preliminary search for such an effect was undertaken using the high pressure cloud chamber described in Chapter 2. The first experiments were carried out using nitrogen as the carrier gas and ethyl alcohol as the condensant. If the field was applied during the post expansion period it was found that cloud billowed out from any points or pieces of fluff or hair on the electrode surfaces. An example of this phenomenon is shown in Figure 5. The tracks of cosmic ray particles can also be seen although these are beginning to fall out because of the rather long delay in taking the photograph.

It was quickly found that this billowing cloud could be produced from such points or fluff even when the supersaturation produced initially in the chamber was quite small and application of the field was delayed for many seconds. Although these initial observations were made using ethyl alcohol as the vapour, the major part of the work has been carried out using water vapour, partly because of its simpler chemistry and partly because of the possibility of similar processes occurring in the atmosphere.

Normally, when the chamber is used as a charged particle detector, the electrostatic field is switched off shortly before the expansion.

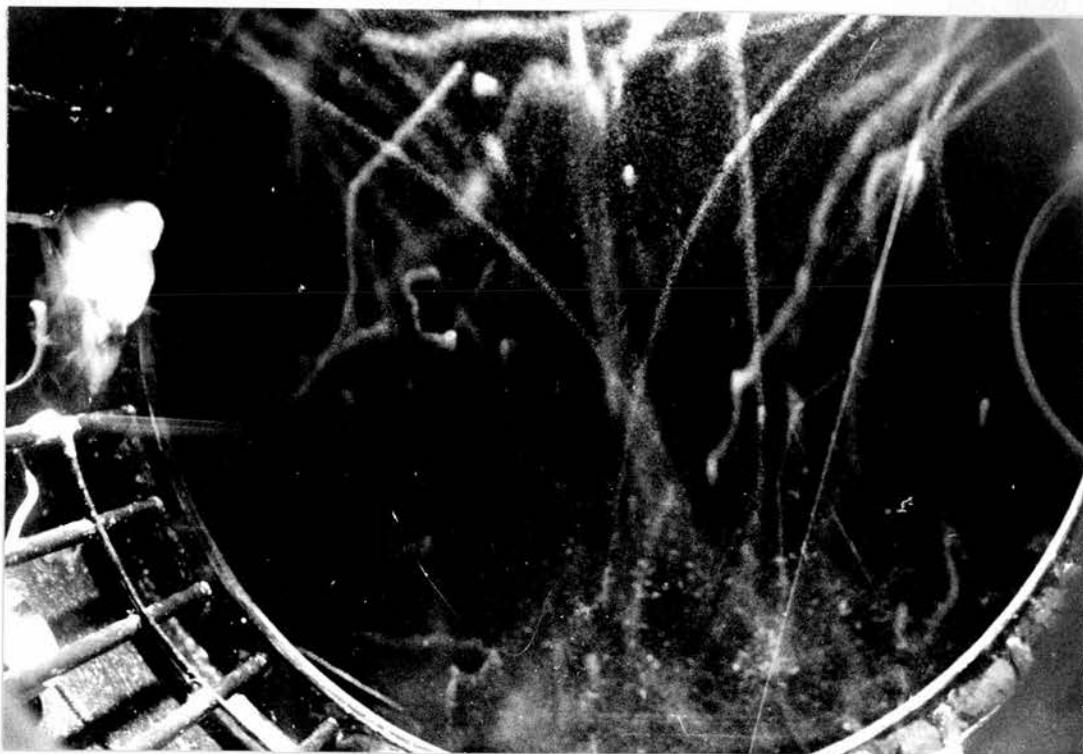

Figure 5. Cloud Produced from a Fibre Point by the Electrostatic Field.

S 1. Nitrogen + ethyl alcohol at 50 atmospheres.
Expansion ratio = 1.08
Field = + 820V. (on before and after the expansion).
Flash delay = 1 sec.

The cloud produced on the left is from a fibre point; particle tracks are visible in the centre and condensation on multi-charged ions can be seen at the right.

The dense, curved lines of drops, seen in Figure 5, between the edges of the electrodes are familiar to cloud chamber workers (see, for example, Valley and Vitale, 1949). They are believed to be caused by condensation on multi-charged ions produced at sharp points by the field in the pre-expansion period, drops forming on these nuclei at expansion ratios only slightly less than the ion threshold. Tait (1960) briefly investigated their properties as they appeared to be a possible source of background cloud though, from the argument put forward in the previous chapter, this must now be considered as unlikely.

4: 2. The Experimental Arrangement.

To study the production and properties of the nuclei responsible for this unusual cloud a simple experimental arrangement and procedure were devised. Various points attached to a copper electrode were used as sources of nuclei. This electrode was connected, via the neoprene or rubber plug in the wall of the chamber, to a variable high voltage source of either polarity. Nitrogen at 30 atmospheres with 6 c.c. distilled water spread round the walls of the chamber formed the usual filling mixture, with which, using velveteen as the photographic background, it was found possible to operate with the diaphragm initially against the forward plate, without any unwanted condensation nuclei being produced. It was thought that this was achieved because even the largest expansions were well below the ion or homogeneous condensation limits for water. In addition, the velveteen (which has a fine mesh) may act as a filter, preventing any nuclei formed in the plate-diaphragm region from reaching the working volume. This operating condition enabled exactly reproducible expansions to be made which was particularly advantageous in the early exploratory experiments.

The chamber was usually operated at 30 atmospheres above atmospheric pressure which provided a compromise between the increased sensitive time gained by increasing the working pressure and the longer waiting time required between expansions to obtain consistent results. An advantage of working at high pressures is that all processes which occur so rapidly at low pressures are slowed down and are thus particularly amenable to visual observation. The carrier gas filling normally contained 1 atmosphere of room air unless a fairly pure system was required when it was removed by repeatedly flushing the chamber. Observations were also made over a wide range of pressures without any significant differences being observed.

As already stated, expansions from which conclusions have been drawn were repeated numerous times, and were often studied by two observers. Many important deductions have been made from the cleaning expansions which follow the primary expansions in which the nuclei are formed. Because other possible sources of background nuclei might have been present blank runs were always made with identical expansion and waiting sequences, but without production processes. A typical example of the clouds of drops seen during a production expansion is shown in Figure 6 where a piece of silk acts as the electrode in an atmosphere of nitrogen and water vapour.

4: 3 The Production Conditions.

As it will be shown later that the presence of nitrogen is necessary before these hypersensitive nuclei can be produced, the conditions necessary for production will be discussed assuming a filling of nitrogen and water vapour in the chamber. The voltage threshold required to produce the nuclei depends upon the shape and nature of the material attached to the permanent copper electrode in



Figure 6. Jets of drops produced from silk electrode.
Field left on during the expansion.

X22. Nitrogen + distilled water at 30 atmospheres.
Silk electrode.
Expansion ratio = 1.061. Field = -1340V.
Flash delay = 2 sec.

the chamber. For silk or cotton strands, which were most frequently employed, the voltage threshold was found to be approximately 500V. and was independent of the polarity. A more accurate threshold potential cannot be quoted since it varies within $\pm 100V$. from sample to sample probably, depending on the number, length and orientation of the individual fibres of each strand. Other variations are introduced dependent on the history of the electrode material. Bundles of glass fibres, a human hair, various metal points and a Japonica leaf were also used. The threshold voltages, which varied considerably from material to material, are tabulated for comparison in Table I. These results suggest that the production of this type of condensation nucleus is independent of the electrode material, the voltage threshold varying with the sharpness of the electrode point. Nuclei were also produced, at a similar voltage, when an alternating field was applied to a cotton electrode, but for most observations a D.C. field was used. The voltage threshold for production was found to be independent of the position of the electrode in the chamber indicating that the voltage gradient close to the point is an important factor.

If the electrostatic field is applied at the start of an expansion then, provided that the expansion is greater than 1.0%, visible drops will be seen in the gas around the electrode. If a smaller expansion is made no visible drops are observed although, as will be shown below, nuclei are produced but do not grow to a visible size. Assuming that the expansion process is adiabatic the supersaturation existing immediately after the expansion may be calculated by well known methods and is shown graphically for nitrogen-water mixtures in Figure 7. The calculated supersaturation, if it is ever realized,

TABLE I

Threshold voltages for hypersensitive condensation nuclei production
in nitrogen supersaturated with water vapour.

Gas pressures = 30 ± 3 atm.

Gas temperatures = $20 \pm 2^\circ\text{C}$.

Voltage thresholds determined at the maximum
 expansion ratio, 1.120

| Material | Voltage Threshold. | Remarks. |
|---------------------------|-------------------------|---|
| Cotton waste. | $500 \pm 100\text{V}$. | |
| Cotton thread | $500 \pm 100\text{V}$. | |
| Silk thread | $500 \pm 100\text{V}$. | |
| Japonica leaf | 800V. | Nuclei are produced from fibres on the leaf surface. |
| Artificial silk thread | 1000V. | Strands are thicker than those of real silk. |
| Glass wool fibres | 1200V. | Absorbs little moisture. |
| Human hair | 1200V. | Absorbs little moisture. |
| Brass points | $\geq 1700\text{V}$. | Threshold depends on sharpness of point. |
| Tungsten points | $\geq 1800\text{V}$. | Threshold depends on sharpness of point. |
| Sharp solder points | $\leq 2000\text{V}$. | * Probably insufficient voltage applied. |

* When these electrodes were tried the E.H.T.
 unit available had a voltage output limited
 to the range 0 to $\pm 2000\text{V}$.

Figure 7.

Degree of Supersaturation produced by Adiabatic Expansions.

The curve opposite shows the calculated supersaturation which is produced when nitrogen, saturated with water vapour, is adiabatically expanded.

The initial temperature, before the expansion, was taken as 20°C and the ratio of the principal specific heats of nitrogen, as 1.41.

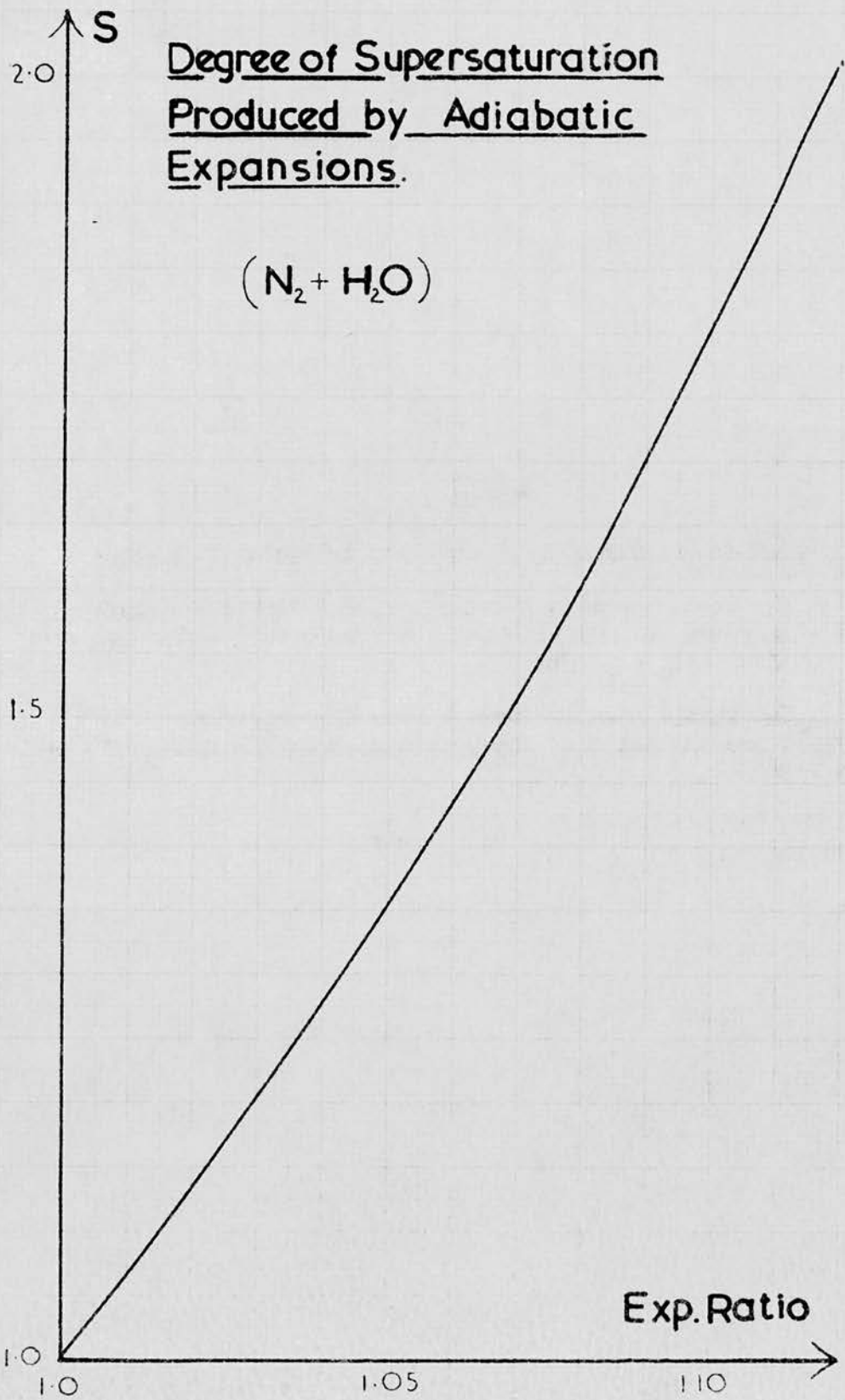

will be destroyed because of heat conduction from the chamber walls enhanced by turbulence, and because of local heating due to the release of heat of condensation. Now, although visible drops are not produced in expansions of 1.008 the production of drops in any expansion near threshold continues for several seconds, after which the supersaturation must have fallen to a value very much less than that initially produced in the smaller expansion. Interpretation of this apparently paradoxical result provides important evidence for the theory advanced in the next chapter. The expansion of 1.0% will be termed the visible production threshold.

With metal points such as brass or tungsten, the normal visible threshold is slightly higher than 1.010, but if the point is artificially cooled by holding a block of dry ice to the external end of the supporting copper electrode the threshold is reduced to the normal value. The metal point, even in a saturated chamber, will normally have only a very thin layer of water on its surface so that artificial cooling will increase its thickness by causing condensation. Silk, or cotton, on the other hand, if they have been in a saturated chamber for several days will contain a considerable quantity of water (most natural fibres absorb about 10% of their own weight of water at 78% relative humidity). It appears therefore that part of the purpose of the expansion is to provide the excess water necessary on the electrode surface for production of the nuclei to take place. This is more necessary with metal than fibrous points. With both types of electrode, however, it is found that nuclei are produced in expansions below the visible production threshold but do not form visible drops on that expansion. It is further observed that the voltage threshold tends to rise slightly with decreasing expansion ratio, a typical set of observations for argon and water being dis-

played in Table 2. These results suggest that the production of the nuclei takes place, or is associated with the water layer on the silk or other electrode surface, an increased voltage possibly being required at low expansion ratios because the water film condensed on to the electrode is rather thin. The high pressure cloud chamber is not an ideal technique for studying the physical production requirements of the nuclei because of its rather inaccessible working volume and the difficulty of controlling and altering various parameters at high pressures. Most effort has been expended in trying to elucidate the chemical production process, the physical and chemical properties of the nuclei, and the mechanism by which they grow to visible drops. However some further studies of the production requirements are presently being made in this laboratory using a diffusion cloud chamber.

4:4 Description of the Phenomenon.

Some of the properties of the condensation nuclei produced by an electrostatic field have been deduced from a study of the visible phenomena which are associated with their production. Provided sufficient supersaturation has been established by the expansion, jets of drops are shot into the gas from the electrode as soon as the field is applied. Except when the expansions were close to the visible threshold, or when application of the field was deferred for a long time (e.g. about 60 secs. after an expansion of 1.10), no delay has been observed in the appearance of the drops.

In the initial stages the jets appear as hollow cones of large drops surrounded by a more diffuse cloud of smaller drops, their respective radii being estimated visually as about 5×10^{-4} cm. and 10^{-4} cm. respectively. These figures are arrived at by comparison

TABLE 2

Variation of threshold voltage, required for hypersensitive nuclei
production, with expansion ratio.

Data from Run 23.

The electrode was a piece of human hair which does not absorb much water naturally on to its surface.

Argon gas in the chamber at 33 atm., with distilled water.

| Expansion Ratio. | Voltage Threshold (for visible production). |
|------------------|---|
| 1.12 | -1000V. |
| 1.063 | -1000V. |
| 1.048 | -1000V. |
| 1.036 | -1060V. |
| 1.026 | -1120V. |
| 1.015 | -1300V. |

The argon in the chamber for this run contained a considerable amount (about 0.3%) of nitrogen so that jets of drops were produced readily. (See section 4: 7(1)).

with drops seen in cloud chambers at low pressures which are approximately 10^{-3} cm. in radius (J. G. Wilson, 1951). The main jet of large drops moves away from the production point with a mean speed, over the first few centimetres, of about 2 cm/sec., depending, of course, on the applied voltage and the shape of the electrode. The diffuse cloud moves more slowly than the central core. The speed may be readily estimated from photographs of identical production processes taken at different times after the expansion. Vibrations of strands in the fibrous electrode are probably responsible for the striations seen in some of the jets shown in Figure 8 which is another example of their appearance. The associated diffuse cloud of drops cannot be seen in the photographs. A short gap is usually evident between the end of the electrode and the first drops in any particular jet. In this region the potential gradient will be extremely high, so that nuclei will have little time available to grow to a visible size.

After the voltage has been applied for several seconds the gas becomes full of a diffuse cloud of drops caused by the break up of the individual jets and by their reflection at the chamber walls. This cloud tends to obscure the electrode but growth of new drops and creation of new jets can be seen to continue for many seconds. Although initially the jets are well directed, latterly they leave the points very slowly and in random directions which are probably determined by gas currents set up in the chamber by heating and turbulence. All points on a fibrous strand are not effective centres, possibly due to their unfavourable position or orientation relative to other sources. The similarity between jets produced at the same source in different, but identical, expansions is quite



Figure 8. Jets of drops showing striations due to vibration of silk strands.

W28. Nitrogen + distilled water at 30 atmospheres.
Artificial silk electrode.
Expansion ratio = 1.12. Field = + 1200V. (on at
(expansion)).
Flash delay = 2 sec.

The striations are particularly prominent on the left hand, lower jet of drops.

striking. This is illustrated in Figure 9 which shows a double exposure in which jets of drops were photographed 3 and $3\frac{1}{2}$ secs. after the start of the respective expansions. The density of drops in the jets increases considerably as the voltage is raised above the threshold. This is illustrated in Figures 10 and 11.

The manner of appearance of the drops associated with nuclei produced in expansions near the visible threshold is rather remarkable. If the field is applied simultaneously with the start of the expansion drops form, after a delay of about 5 to 10 secs., close to the chamber wall (about 10 cm. from the electrode) in a diffuse cloud rather than in the normal, well collimated, jet which starts near the production point. The jet then appears, 'growing back' slowly from near the wall of the chamber, until after a further few seconds a stream of drops can be seen leaving the electrode in the usual manner. This behaviour is quite unexpected since nuclei produced late in the expansion would appear to have less favourable conditions for growth. Similarly, jets forming initially close to the chamber wall are seen if a larger expansion is made to take place slowly over a period of 15 to 30 secs., when the supersaturation established is never very large. This slow expansion is achieved by manual operation of the expansion valve. Also, if a very slow expansion, with the field switched on, is followed immediately by a fast adiabatic expansion without the field (that is, the expansion is made in two stages) then the jets of nuclei produced, but not seen, during the initial stage grow rapidly. They are, however, rather more diffuse than the jets normally observed.

4: 5 Properties of the Nuclei.

After a primary expansion in which the hypersensitive or c-nuclei have been produced, many of the drops formed around them evaporate in

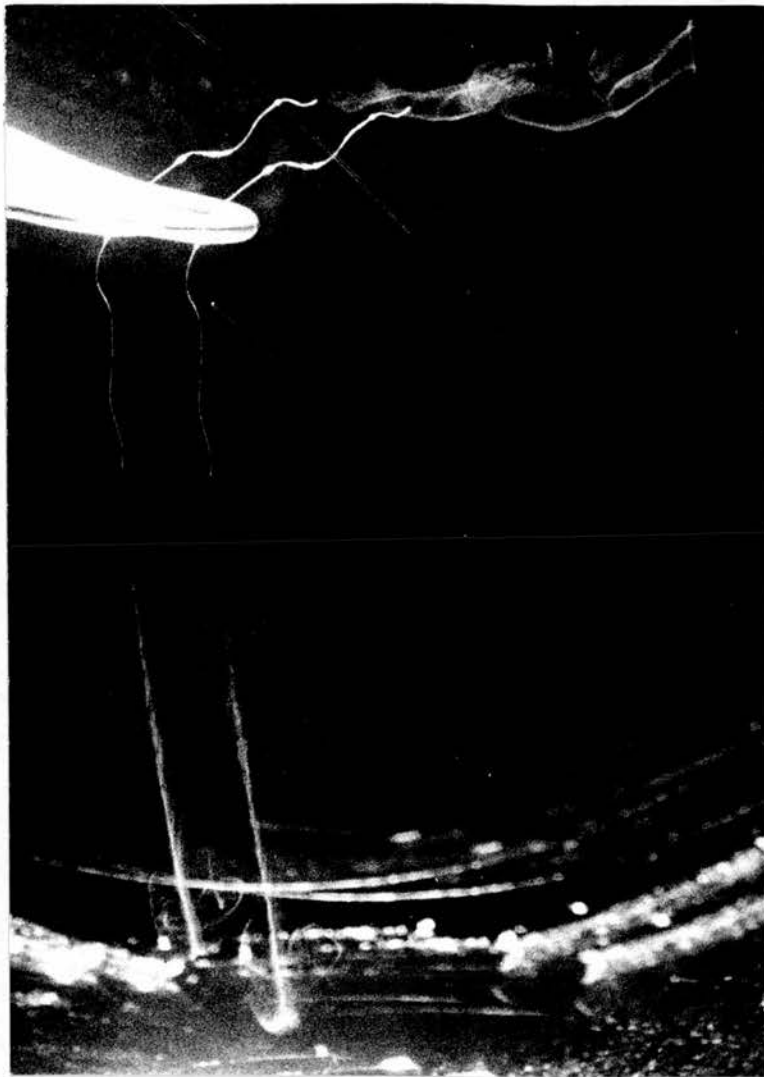

Figure 9. Similarity between jets of drops produced
on different expansions.

W39 and W40. Nitrogen + distilled water at 30 atmospheres.
Artificial Silk electrode.
Expansion ratio = 1.068. Field = -1300V. (on at
expansion).

Flash delay = 3 and $3\frac{1}{2}$ sec.

The movement of the droplet jets through the gas is also
clearly seen.

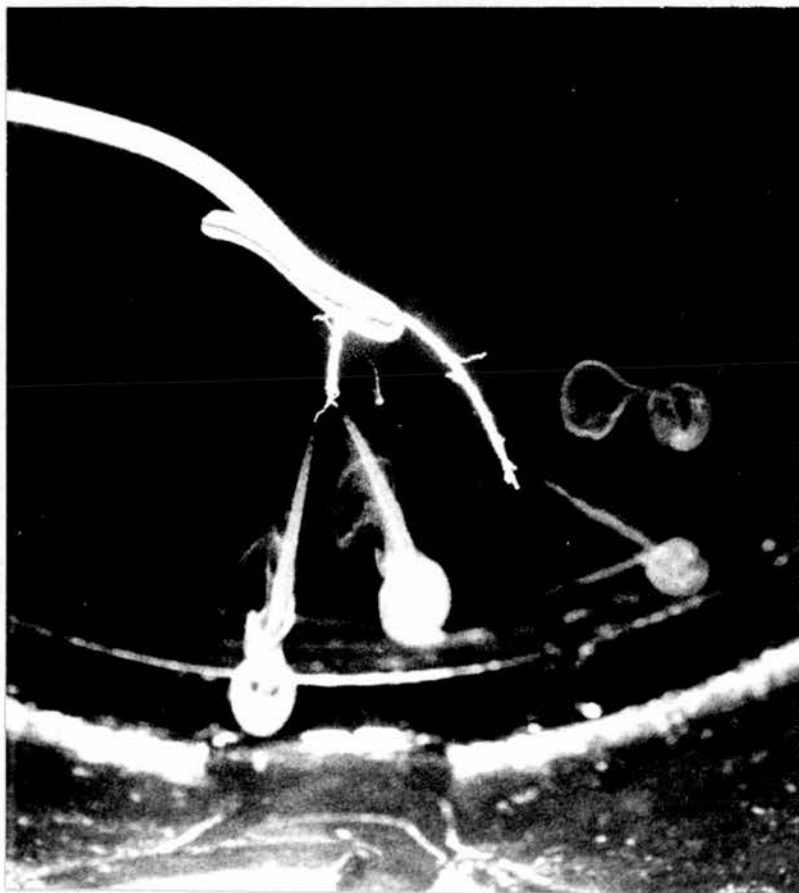

Figure 10. Jets of drops produced by a low voltage, at a low expansion ratio. (Compare Figure 11.)

W19 Nitrogen + distilled water at 30 atmospheres.
Cotton electrode.
Expansion ratio = 1.02. Field = -400V. (on at expansion).
Flash delay = 2 sec.

One jet of drops has become completely detached from the electrode.



Figure 11. Jets of drops produced by a high voltage,
at a low expansion ratio. (Compare
Figure 10.)

W7 Nitrogen + distilled water at 30 atmospheres.
Cotton electrode.
Expansion ratio = 1.030. Field = -1200V. (on at
Flash delay = 2 sec. expansion).

situ in the gas without falling out. Subsequent secondary expansions produce dense uniform clouds showing that nuclei are still present, and a detailed study of these has yielded a great deal of information. Successive cleaning expansions cause the nuclei to be removed from the gas in drops which fall to the walls of the chamber.

Although the visible production expansion ratio threshold is 1.10, visible drops form in expansions of 1.008 on nuclei left after the evaporation of the primary expansion cloud. Also, nuclei produced by applying the field during an expansion less than 1.010 promote visible drops on any subsequent expansion greater than or equal to 1.008. This result confirms the conclusion reached in 4: 3 that some condensation on the electrode is normally necessary before nuclei production can take place. A delay in the appearance of drops close to the visible production threshold has already been noted and this may partly be caused by slow condensation on to the electrode retarding the production process, whereas in a smaller cleaning expansion full advantage of the initial supersaturation can be taken as all the requisites for drop formation are initially present.

No expansion ratio threshold for the production of the nuclei has been found. The smallest measurable expansion ratio is 1.002 in which the theoretical maximum supersaturation would be less than 1%. Here the calculated temperature drop of 1°C will not be achieved as the temperature gradient across the chamber, even after a long waiting period, may be as much as $\frac{1}{2}$ °C, (Duff and Morris, 1955), and the expansion will be rather slow. It is suggested, therefore, that if any supersaturation is produced around the electrode then nuclei will be created when an electrostatic field is applied.

In Chapter 6, it will be shown that under rather more stringent conditions, similar nuclei are formed if the chamber is only saturated. Since at low degrees of supersaturation the density of the nuclei will cause considerable competition for the available vapour the observed slow rate of growth in these small expansions can be at least partially explained.

The number of secondary expansions necessary to reduce the concentration of nuclei in the gas to less than 1 per 10 cm^3 (estimated visually) varies with the total number created in the primary expansion. Typically, after an expansion of 1.08 when $\pm 1000\text{V}$. has been applied to the silk electrode for about 15 sec., about 4 secondary expansions are required to clean the chamber. The number of such secondary expansions depends on their size since the drops formed in small expansions are not very large and may not fall out before the gas warms up and causes them to evaporate.

Provided the chamber is fully saturated and there is surplus water available all nuclei will disappear from the gas in about 10 hours. It is important to notice that cloud seen on any secondary expansion made during this period is uniform throughout the chamber indicating that the nuclei do not fall out under gravity. Disappearance by coagulation is probably an unimportant process since the secondary expansion threshold does not fall after an extended waiting period. The larger nuclei so formed would be expected to have a lower condensation threshold. The total number of drops seen on any cleaning expansion is independent of its size; larger expansions produce larger, but not more drops. If the density of drops in the chamber is reduced by successive expansions of intermediate size, say 1.04, some interesting observations are made. The drops seen in the first two or three expansions are small,

about 10^{-4} cm in radius, and grow fairly rapidly, a number falling from the gas to the walls. On subsequent expansions the density of the nuclei being now much reduced and more water vapour consequently being available, the size of the drops in the cloud is larger but their rate of growth is much decreased. The cloud takes about 5 secs. to appear. After 6 or 7 expansions, when the chamber is nearly clean, no drops are seen for about 15 secs. when a light shower of small drops appears uniformly in the gas. This last stage is independent of the size of the expansion. These three distinctive regions, except for the appearance of delayed showers of drops, are not observed in very large cleaning expansions where a substantial number of nuclei are removed from the gas each time.

The c-nuclei may also be cleaned from the chamber using an electrostatic field. The time required to remove them depends on the geometry of the electrode system used and on the voltage applied. While gaseous ions can be cleared from the gas in a few seconds with a moderate field, the time required to sweep the c-nuclei from the chamber is of the order of 5 min. with 800V. applied to the production electrode, and about 15 min. with 600V. applied to a semi-cylindrical electrode, without sharp points, placed close to the chamber wall. The nuclei do not therefore appear to carry a charge after they have been in the gas for even a short time. They may be produced with a charge, presumably positive if the production point is positive, or even several charges, but their properties as condensation centres cannot be greatly modified by this. It is well known that water condenses preferentially on negatively charged ions, and no such preferential condensation has in fact been observed in these experiments. That is, no difference has been

detected between the properties of the nuclei produced from identical electrodes by fields of different polarity.

4: 6 Experiments with a 'Dry Chamber'

In some of the early experiments made to study the production requirements of the nuclei it was found that the visible threshold decreased steadily with time until it reached a final value close to 1.010. It was first supposed that the silk required this period of several days to reach equilibrium with the vapour but it was later found that the time was dependent on the way in which the water was introduced into the chamber. If the water was contained in a dish with a small surface area then the final visual threshold was not obtained for about 6 days. If, however, an equal volume of water, normally 6 cc., was spread well round the chamber so that its surface area was very large the final visual threshold was attained in about 2 days. Further, if the gas pressure was not raised to 30 atmospheres until about 12 hours after adding the water, the final visible threshold was reached almost at once. Obviously the saturation of the chamber is a very slow process. It is important, therefore, when determining a threshold to make sure that the gas is properly saturated. This steady decrease of the threshold is illustrated in Figure 12 where the relative humidity in the chamber is plotted as a function of time. To determine each point the visible production threshold was measured assuming, as a first approximation, that this corresponded to saturation having been produced in the chamber. Hence the relative humidity before the expansion was found. The presence of velvet or velveteen appreciable retards the saturation process.

Having thus shown that it was possible to produce hypersensitive

Figure 12.

Increase of Relative Humidity with Time.

Each point on the curve opposite was obtained as described in the text. The gas used in each case was nitrogen at a pressure of 30 atmospheres. The water was added as indicated below.

- Run 27. 6 cm³ water in pool on chamber floor.
- Run 31. 6 cm³ water spread around chamber walls.
(Large surface area.)
- Run 43. 6 cm³ water in glass dish with surface area of 20 cm².
- Run 53. (Dry chamber) 0.1 cm³ of water on chamber wall.
Initial (room) humidity, 33%. Velvet in the chamber.

The chamber was assembled and filled as quickly as possible before each run.

Increase of Relative Humidity with Time.

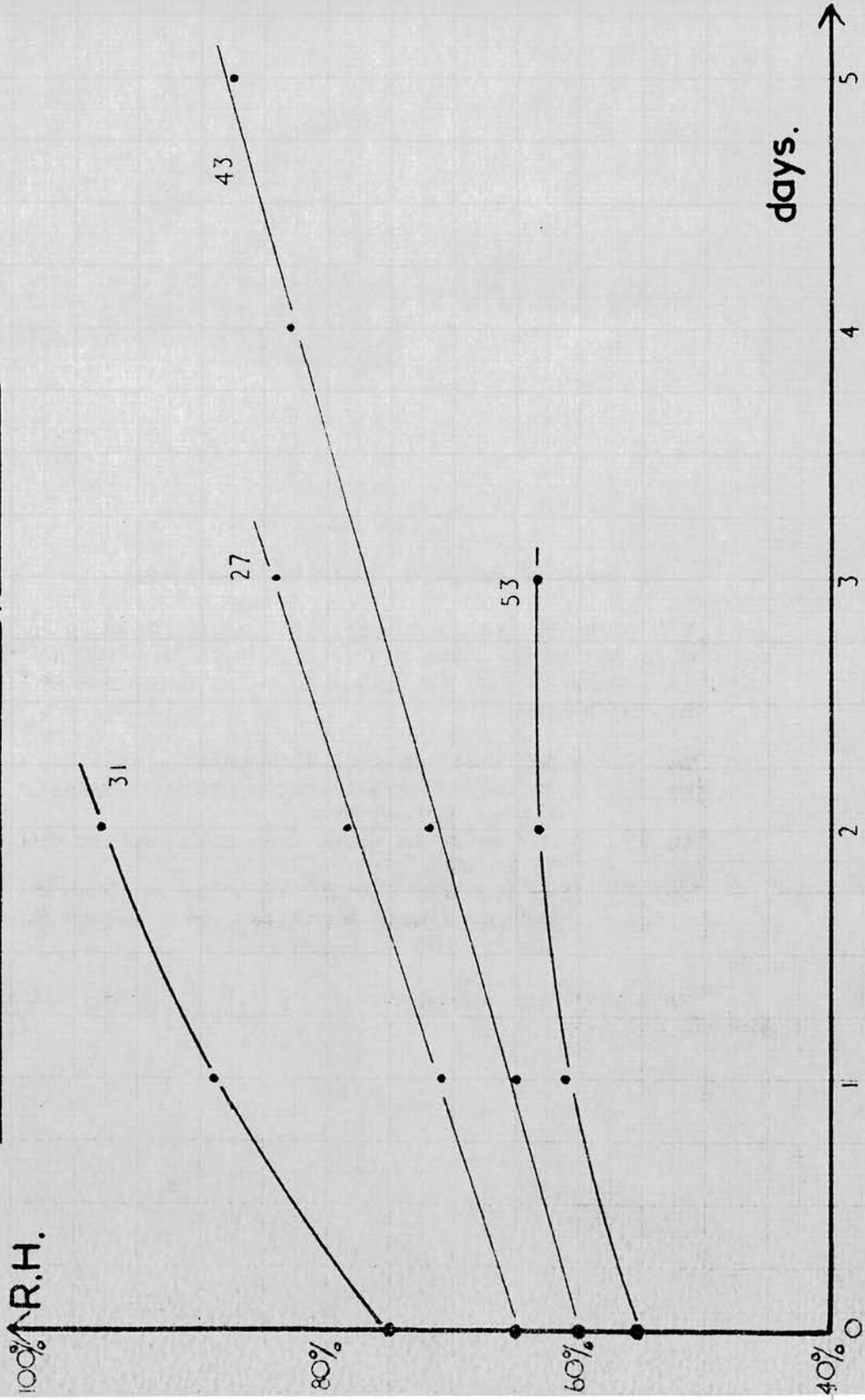

condensation nuclei when the chamber was unsaturated prior to the expansion several runs were made in which insufficient water vapour was present for complete saturation ever to occur. About 0.1 cc. of water is required to saturate the gas at 20°C, so that if the relative humidity is determined in the room (using an Assmann psychrometer) just before the chamber is assembled, water can be added so that saturation, without expansion, cannot be achieved even when the surplus water initially present has evaporated. For these experiments the velvet, which absorbs water, was removed from the chamber and an ebonite back plate, drilled with holes to enable uniform gas flow to be maintained, was added as the photographic background. Ebonite does not absorb water. With this arrangement several interesting results were obtained.

It had been supposed that the c-nuclei would be unstable in a dry chamber but this was not confirmed. The chamber could be operated with an initial relative humidity of about 60% and, under these conditions, even after waiting periods of 17 hours following a production expansion, dense clouds of very small drops were still produced when a sufficiently large expansion was made. However, if the gas temperature fell sufficiently during this time, saturation of the chamber could occur (with a resultant fall of threshold expansion ratio), and the nuclei then disappeared much more quickly. This suggests that the nuclei are removed most easily when there is surplus water lying on the walls of the chamber. During the period of these experiments a fall in temperature of more than 5°C regularly occurred at night so that the results obtained while the room heating was on gave unsaturated initial conditions, and those when it was off, saturated conditions.

Except under the special circumstances discussed in Chapter 6, applying the electrostatic field for a short time up to the expansion normally produces no c-nuclei. In the dry chamber runs it was however found that when the field was switched off just before the expansion minute jets were produced. These were caused by charge still residing on the silk, which was relatively dry because of the unsaturated condition of the chamber. The voltage on the electrode was initially -1300V. and there is a delay of 1/10th sec. between switching off the field and making the expansion. As the voltage threshold for this dry silk was only slightly less than -1300V. the charge must leak away very slowly. These jets are produced for a time depending on the voltage applied, but even for 2000V. it is less than 5 secs.

As might have been expected cleaning the chamber of the room air aerosol component, under these conditions, is very difficult, about 30 expansions usually being required.

4: 7 Changes in the Chemical Constituents of the System.

The effect of changing the chemical constituents of the system was investigated by adding relatively large quantities of different gases to the chamber. Strong evidence was found that it was necessary to have nitrogen in the chamber before c-nuclei could be produced. Apart from the early investigations with ethyl alcohol as the condensant, distilled water was always used as the vapour in the system. The observations made under different chemical conditions will be considered separately.

(1) Addition of Argon.

The addition of small quantities of argon to the nitrogen-water system did not appear to alter the production of c-nuclei. The

expansion ratio threshold for visible drops was slightly lowered by an amount depending on the argon concentration. This was expected since the resultant cooling and supersaturation is greater for argon than for nitrogen as the former is a monatomic gas. The argon available was not of high purity, containing 500 v.p.m. of nitrogen, but if the nitrogen content of the chamber was made as low as possible by repeated flushing, an interesting difference was observed. Initially the production of α -nuclei was fairly similar to that found in nitrogen-water systems but after a small number of production expansions (about twenty) the efficiency fell off most markedly. The number of nuclei created per expansion was greatly reduced, although production never stopped completely. This was verified photographically as illustrated in Figures 13 and 14, which show the products of identical expansions between which 15 nuclei-producing expansions were made. The field, expansion ratio, flash delay and time for plate development were the same for both photographs. A later addition of a small quantity of nitrogen to the system appeared to restore production to its normal efficiency.

From these experiments it was concluded that nitrogen was necessary for the production of α -nuclei, that a chemical process was involved and that a certain amount of nitrogen, however it was bound up chemically, was always available for further α -nuclei production, or available to enhance drop growth.

(2) Oxygen-free Nitrogen as the Carrier Gas.

In most of the experiments with water-nitrogen systems, 1 atmosphere of air remained in the chamber thus ensuring that about 1% of O_2 was present at 30 atmospheres. The nitrogen normally used contained 0.05% oxygen. Although it can be concluded from the argon-water

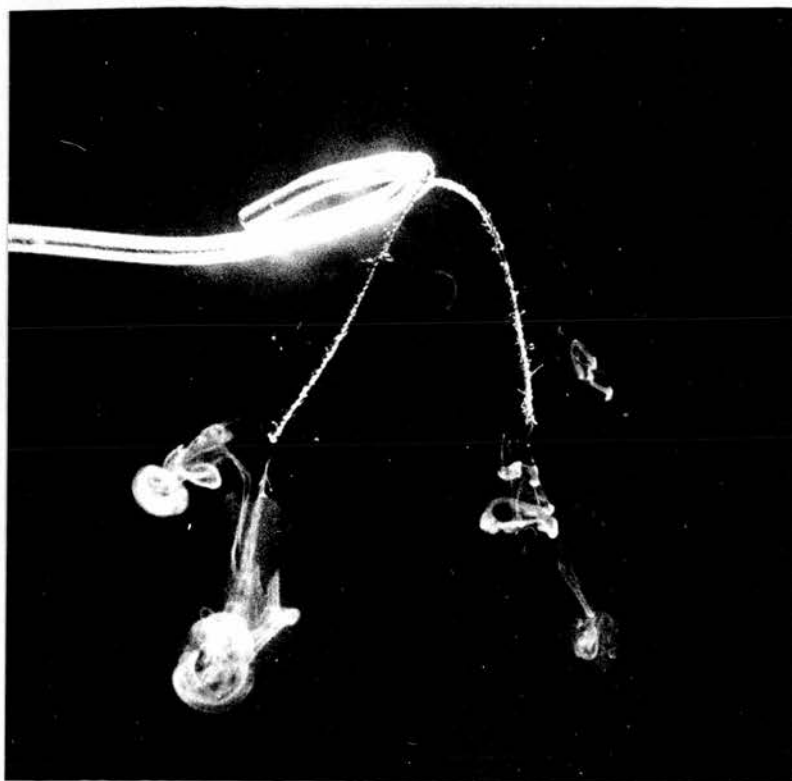

Figure 13. Jets of drops in pure argon at start of a run.
(Compare Figure 14.)

X34 Pure argon + distilled water at 30 atmospheres.
Silk electrode.
Expansion ratio = 1.051. Field = -1300V. (on at
expansion).
Flash delay = 1.5 sec. Temperature = 20°C.

Conditions of exposure and development of plates and
prints were identical for Figures
13 and 14.

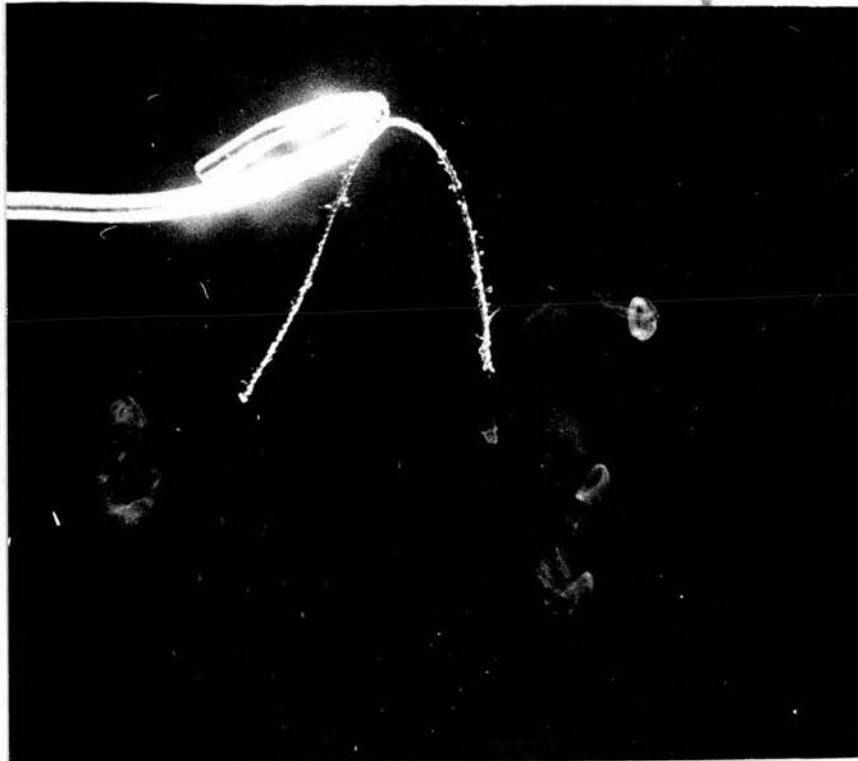

Figure 14. Jets of drops in pure argon late in a run.
(Compare Figure 13.)

X35. Pure argon + distilled water at 30 atmospheres.
Silk electrode.
Expansion ratio = 1.051. Field = -1300V. (on at
expansion).
Flash delay = 1.5 sec. Temperature = 20°C.

There were 15 production expansions between Figure 13
and Figure 14.

Conditions of exposure and development of plates and
prints were identical for Figures
13 and 14.

experiments that molecular oxygen, O_2 , is not required in the c-nuclei production process, a further test was made with an oxygen-free nitrogen-water system. Oxygen-free nitrogen (supplied by British Oxygen Co. Ltd.) contains less than 10 v.p.m. of O_2 . No variations in the properties or production of the c-nuclei was observed. It must be recorded, however, that molecular oxygen, and possibly atomic oxygen, will always be present in trace quantities in the chamber because of the rubber diaphragm, which will also introduce contaminations of carbon and sulphur.

(3) Addition of Oxygen and Hydrogen.

The addition of excess oxygen and hydrogen separately to the chamber did not appear to alter the production requirements or properties of the c-nuclei. One important new feature was observed with oxygen present which will be discussed in section 4: 8, below.

(4) Addition of Carbon Dioxide.

Carbon dioxide was added to the chamber by allowing solid CO_2 to sublime while the chamber was being reassembled. The c-nuclei were produced with normal efficiency but it was found that the drops formed round them in the primary and secondary expansions were very much smaller than usual. The largest drops normally seen in the high pressure cloud chamber are probably nearly 10^{-3} cm. radius, but these did not grow much above the smallest visible size, about 1 micron. Sechrist (1963) has observed that carbon dioxide enhances the rate of evaporation of water from a bulk liquid surface, so that the inhibition of drop growth observed here is explicable.

(5) Addition of Ammonia.

Ammonia was added to the chamber by using a 10% solution of ammonium hydroxide as the condensant. A smaller quantity of NH_3 was

thus introduced compared with the other gases discussed above. Again the c-nuclei were formed with normal efficiency. It was found, however, to be impossible to clean the chamber completely, a slight background of small drops always being present. This result was not unexpected since the presence of ammonia in a cloud chamber has always been regarded as undesirable by cloud chamber workers, although McHenry and Twomey (1952) found ammonia ineffective in promoting condensation in an Aitken dust counter. It was further found that, if $\pm 250V.$ was applied to the electrode system for a few seconds before supersaturation was established, a dense cloud of small drops was formed on subsequent expansions which could be of the order of 1.02. The positive field did not produce as much cloud as the negative field although the sensitivity of the nuclei was apparently the same. With these voltages the production of c-nuclei was not observed, although clearly, the field, in the presence of ammonia, was producing sensitive condensation centres, although no localized source for them could be identified.

It was thought desirable to study the effect of adding other chemicals but cleaning the high pressure chamber of traces of substances such as hydrogen peroxide or nitric acid is not easy, so that further investigations along these lines were carried out in the 3 atmosphere chamber, which can be readily cleaned and is also suitable for the addition of controlled quantities of impurity at the desired time.

4: 8 The Nitrite Test.

It was pointed out by Dr. W. A. Seddon, formerly of this department, that the presence of nitrite ions, NO_2^- , could be detected in the liquid phase provided their concentration was greater than

5×10^{-8} moles/litre. The method used was based on that suggested by Shinn (1941) in which a pink dye, p-hydroxy azo benzene, is formed. The concentration of NO_2^- can be determined quantitatively by measuring the light extinction achieved by solutions of this dye. Tests for the nitrite ion were frequently made on the surplus water lying on the floor of the chamber at the end of a run.

No quantitative estimate was attempted of the nitrite ion concentration in the solution, but comparisons between tests made after different experimental runs were possible in a rough way since the same quantity of sample and reagents were used each time. Provided about 10 expansions, during which the electrostatic field had been applied for 10 seconds per expansion, had been made in nitrogen-water systems the nitrite test on the surplus water in the chamber always indicated that nitrite ions were present, in a concentration estimated visually, by comparison with solutions of known strength, to be of the order of 10^{-6} moles/litre. Tests made after argon-water runs were invariably negative. Following runs in which ammonia or excess oxygen had been present the nitrite test was very much stronger than normal indicating that the presence of these chemicals somehow enhances nitrite production. The presence of carbon dioxide or hydrogen did not alter the strength of the test.

A number of checks were made to ensure that nitrite ions were only produced directly in or as a result of the c-nuclei production process. Samples of the distilled water used in the chamber were repeatedly tested for nitrite without success. Samples of paint, velvet, neoprene, rubber and silk were soaked for long periods with water but no evidence for nitrite in these materials was found. In addition ammonium hydroxide was tested but a negative result was obtained.

The electric field was applied to the silk in a saturated chamber for 48 hours without producing any detectable concentration of nitrite ion. Although these results strongly suggest that NO_2^- is formed as a consequence of applying an electric field to a damp electrode in a supersaturated vapour they do not indicate that the chemical responsible for the presence of NO_2^- , which might be, for example, nitrous acid, is actually the cause of the hypersensitivity of the c-nuclei. There are, however, strong arguments which suggest that it is. Since oxygen and carbon dioxide did not enhance the creation of c-nuclei it may be concluded that the oxygen required for the formation of NO_2^- comes from the water in the chamber. The enhancement of the nitrite test by oxygen may be caused by a secondary chemical reaction.

4: 9 The Effect of Altering the Gas Pressure.

No differences in the properties or production efficiency of the c-nuclei were observed when the gas pressure was varied from 10 to 80 atmospheres in the high pressure chamber, or from 1.5 to 4 atmospheres in the low pressure chamber. It is in fact believed that c-nuclei are formed in the pressure range 0.8 to 80 atmospheres (G. R. Evans, private communication). The visible production threshold is slightly reduced as the gas pressure is increased. Whereas at 30 atmospheres this is about 1.010, at 50 atmospheres it falls to 1.008. The cleaning expansion threshold also falls from 1.008 to 1.003 in the same pressure range. Although part of this reduction is undoubtedly due to the fall of surface tension with increasing pressure, the relatively large drop in the cleaning expansion threshold suggests that the visible threshold is also dependent on the size of the chamber at constant pressure, or on the sensitive time and hence on the pressure for a chamber of constant size. At

elevated pressures the supersaturation will be destroyed rather slowly by conduction of heat into the gas.

4: 10 Summary.

In this chapter the observation of the production of hypersensitive condensation nuclei when an electrostatic field is applied to a damp electrode in a supersaturated vapour has been described. Various experiments carried out in an attempt to study the nature and properties of the nuclei have been discussed. In the following chapter an explanation of the production and properties of the c-nuclei is suggested which will be used to explain, in addition, other condensation nuclei produced by different methods. Certain features of the experimental results already set down will be amplified in this discussion as required. For reference a summary of the most important properties of the c-nuclei has been attempted in Table 3. It should be re-emphasised that condensation nuclei can, under certain circumstances, be produced when the electrostatic field is applied to the electrode before the expansion.

TABLE 3

Summary of the properties of the c-nuclei.

| Property. | Characteristics. | Reference. |
|--|---|------------------------|
| 1. <u>Production requirements in a nitrogen-water system.</u> | Voltage above a certain threshold must be applied to a damp electrode in a super-saturated vapour. | Section 4: 3 |
| 2. <u>Efficiency as nucleation centres (after production).</u> | Visible drops produced if production expansion is larger than 1.010, at 30 atmospheres. | Section 4: 4 |
| 3. <u>Efficiency as nucleation centres (after re-evaporation).</u> | Visible drops formed in expansions larger than 1.008 at 30 atmospheres, but this is pressure dependent indicating that threshold is a function of chamber size. | Section 4: 5 and 4: 9. |
| 4. <u>Stability.</u> | Remain in the chamber for several hours depending on the relative humidity and surplus water available. | Section 4: 5 and 4: 6. |
| 5. <u>Effect of electrostatic sweeping field.</u> | Nuclei can be removed from the chamber very slowly. | Section 4: 5 |
| 6. <u>Effect of chemicals on production.</u> | | |
| (1) Argon-water system. | Production diminished. N ₂ must be present. | Section 4: 7 |
| (2) Oxygen-nitrogen-water system. | No change. | |
| (3) Carbon dioxide-nitrogen-water system. | No change, but drops very small. | |
| (4) Hydrogen-nitrogen-water system. | No change. | |
| (5) Ammonia-nitrogen-water system. | No change, but other nuclei are also created by the electrostatic field. | |
| 7. <u>Evidence for chemical change when nuclei are produced.</u> | NO ₂ ⁻ detected in surplus water except after argon-water runs. Presence of NH ₃ or O ₂ enhances strength of test. | Section 4: 8 |
| 8. <u>Effect of increased pressure.</u> | No change in production efficiency, although thresholds are altered (see above). | Section 4: 9. |



Chapter 5

A STUDY OF CONDENSATION NUCLEI PRODUCED IN A SUPERSATURATED VAPOUR
BY AN ELECTRIC FIELD

II. A Possible Explanation

In this chapter an explanation of the experimental observations just described will be proposed, and other possible theories outlined and discussed. Numerical calculations which support the arguments are presented in some detail in Appendices A to E.

5: 1 Are the c-nuclei Charged Water Droplets?

In the initial report of the observation of the hypersensitive condensation nuclei, (Evans and Watson, 1962), it was tentatively suggested that nitric acid was being produced by the action of the electric field on the water layer on the silk, and on the nitrogen gas, nitric acid being known, from the work of Crane and Halpern (1939), to promote condensation of water vapour most readily. The chemical analysis of the surplus water for nitrite ions had not then been undertaken, nor had many later experiments been carried out. At this stage, Professor B. Vonnegut (private communication, 1963) drew attention to his work on electrical atomisation, (Vonnegut and Neubauer, 1952, 1953), in which the ejection of water from a capillary tube, by means of an electric field, was studied. He suggested that highly charged drops of water might be ejected from the end of a damp electrode and act as condensation nuclei in the gas. The process examined in some detail by Vonnegut and Neubauer is identical to that observed by Zeleny (1914) and English (1948), during their investigations of corona from water points.

At first sight Vonnegut's experiments offer an attractive and simple physical explanation of the phenomena. He observed two sizes

of drops to be formed. With positive and negative voltages of between 5 and 10kV, (A.C. or D.C.), drops of about 0.1 mm. diameter were ejected from the end of the capillary tube in a long stream. Also with positive D.C. potentials only, a monodisperse aerosol of much smaller drops was sometimes produced under rather ill-defined conditions, both sizes ^{of} drops occasionally appearing at the same time. Although the potentials necessary in these experiments are higher by nearly an order of magnitude than those used in the present work, an extrapolation of the results of Druett and May (1954) on electrostatic firing suggests that small, sub-visible drops might be produced by such a method, using lower voltages. It is not to be expected that there should be a one-to-one correspondence between Vonnegut's observations and the present work, and certainly none exists, but it is most important to consider whether the formation of highly charged drops of sub-visible size could explain the present phenomena.

Assuming for the moment that the nuclei produced are charged, two possible cases must be considered. Either the nucleus is a highly charged drop, which grows to a visible size because of its charge, or else it is a large drop, probably charged, which grows to a visible size because of its initial radius. The current drawn from the E.H.T. supply was frequently monitored during runs, and was never found to be greater than $1\mu\text{A}$. Hence a maximum of 6×10^{12} elementary units of charge leave the end of an electrode and pass through the gas per second. From visual observations of the density of the cloud seen in expansions during which the field has been on for 10 secs., it is found that 10^9 nuclei ($1.7 \times 10^5/\text{cm}^3$) are produced in this time. This estimate is considered in some detail in

Appendix A. Each nucleus must therefore have been created carrying more than 10^4 charges. Using Thomson's equation (3: 2), already discussed, it is shown in Appendix B that, for water at 273°K , the minimum supersaturation which must be produced to give growth to visible size on nuclei carrying n charges, is given by:-

$$\log_e S_{\min} = \log_e p^*/p_\infty = 1.54 n^{-2/3}. \quad (5: 1)$$

If n is about 10^4 , the degree of supersaturation must be very small before nuclei, which grow very rapidly, will fail to act as condensation centres. If $n = 10^3$ visible drops will form quickly if the supersaturation produced is greater than 1.5%. In fact drops form only rather slowly on the nuclei observed in these experiments at supersaturations of 5%, a threshold which would correspond to drops with $n = 400$ and a very much denser cloud than is observed. The experimental observation that preferential condensation with respect to sign does not occur, also indicates that multi-charged drops are not formed.

The measurement of $1\mu\text{A}$ for the current flowing through the surface layer of water is an upper limit since there may be a relatively large leakage current across the insulating plug in the chamber wall. If the 10^9 nuclei produced in 10 secs. were singly charged, the current through the gas would be only 10^{-11}A , and the droplet radius at formation would have to be about $5 \times 10^{-6}\text{cm}$. An estimate of the size of the nuclei, made in the following section, shows this to be unreasonably large. The assumption that a large percentage of the measured value of the current is required for the creation process is further supported by estimates of the number of NO_2^- ions created per expansion, (Appendix C).

However many charges a nucleus might have initially, it will soon

become either neutral or singly charged so that a visible drop formed in this way must be similar to the visible drop formed by condensation on a gaseous ion. Hence these drops must evaporate to singly charged clusters of water molecules, just as do drops around gaseous ions. The possibility that they should evaporate only to a size which is just sub-visible, in the manner suggested by J. J. Thomson, has been shown in Chapter 2 to be inconsistent with experiment. Apart from the evidence presented there, the results of the experiments in which the chamber was unsaturated by almost 40%, except during the expansions, shows that the variation of surface tension with radius would require to be unreasonably large to explain the extreme stability of the nuclei in these dry conditions. It appears, therefore, that any theory of charged water droplets does not explain the properties observed for the nuclei.

5: 2 A Physical-Chemical Explanation.

The detection of nitrite ions in the surplus water on the floor of the chamber indicates that a chemical reaction is taking place when a high voltage is applied across a damp surface. Many chemicals are known to enhance the condensation of water vapour, although a detailed understanding of their action is still sought. In particular, Crane and Halpern (1939), having observed that neutral condensation centres were produced by the recoil nucleus of a β -disintegration in a cloud chamber, investigated the effect on water vapour condensation of HNO_3 , NO_2 , CO_2 , NO and NH_3 , finding that HNO_3 and NO_2 were extremely efficient in promoting the phase change. They introduced minute traces of these substances into their chamber, and concluded from their observations that each molecule of the

impurity acted as a condensation centre, in a manner similar to a gaseous ion. While this deduction could explain the neutral condensation nuclei observed in their experiments as being due to the dissociation of molecules in the air, with subsequent recombination of the atoms formed into new, reactive complexes, it does not seem reasonable to suppose that the presence of a single neutral impurity molecule, amidst many uncharged water molecules, could alter the condensation properties of a cluster by the appreciable amount required to explain the present results. The dipole moment of HNO_3 or NO_2 is not very different from that measured for water in the liquid state, and is less than the value attributed to the water molecule from infra red studies, which is perhaps more appropriate here. Certainly, however, the presence of a large number of impurity molecules will lower the equilibrium vapour pressure over the surface of the droplet and so make it easier for condensation to occur on the cluster. This idea has been examined in considerable detail by Mason (1957), with particular attention to aqueous solutions of sodium chloride, as already mentioned.

As a preliminary tentative explanation, the nuclei under discussion might be regarded as clusters of water and NO_2 molecules. However, water and nitrogen dioxide react in the following way:-

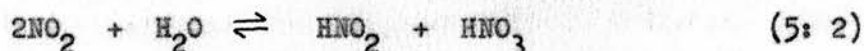

so that the droplet will actually contain HNO_2 , HNO_3 , NO_2 and water. The origin of the nitrogen dioxide will be considered below. Such an aggregate can exist in stable equilibrium with the surroundings, having a size determined by the prevalent vapour pressure of the water in the gas and the amount of nitrogen dioxide in the cluster. Because of the reaction (5: 2) calculation of the size is complicated

since it would be necessary to know the reaction rates inside such a droplet. However, according to accepted theories, any cluster of this type would require a definite critical supersaturation to exist before drop growth to a visible size could occur. Hence certain clearly defined qualitative properties can be suggested for the nuclei, as for gaseous ions.

Neglecting for the moment consideration of the production expansions, the behaviour of the nuclei on subsequent cleaning expansions should be accurately predicted, if the above picture is correct. After the production process the chamber is filled with a dense cloud of drops which slowly evaporates as the gas in the chamber warms up, and any remaining supersaturation is destroyed. A subsequent cleaning expansion exhibits dense, uniform cloud. If the re-evaporation nuclei, or r-nuclei, are all of the same size and chemical composition, the density of drops in the cloud should be independent of the size of the expansion, provided it is greater than a certain minimum value. A certain number of drops will fall to the walls of the chamber, their nuclei becoming lost from the gas. The remainder must evaporate back to exactly the same nucleus as was initially present. The number of nuclei removed in this way, by each subsequent cleaning expansion, will depend only on the size of the expansion, which determines the final drop size, and hence the drop's chance of falling out. Thus the only difference between successive expansions would be that fewer drops would be seen on each one. Moreover these drops would always take approximately the same time to grow, reaching eventually the same final size (if each expansion is of the same magnitude), except, perhaps, in the initial expansions where a high density of nuclei will cause competition for water

vapour, so that the rate of growth, and the final size, will both be reduced. These are the properties predicted for nuclei consisting of impurity molecules and water molecules in equilibrium with water vapour. The properties of the c-nuclei are rather different, as was indicated in section 4: 5.

If a series of cleaning expansions of equal size is made, to remove the c-nuclei, following a normal production expansion, the following observations are noted. The process of cleaning the chamber can be roughly divided into three distinct sequences.

(1) During the first two or three expansions, a dense cloud of very tiny drops is formed. The drops grow rapidly requiring only about 0.2 sec. to reach a final size of about 1 micron, which depends slightly on the magnitude of the expansion.

(2) The above type of expansion eventually gives way to others in which the final drops are quite large, about 10^{-3} cm. radius, but in which the drops take a short time, perhaps 2 to 3 seconds, to appear. Their final size and their rate of growth is now largely independent of the expansion. At this time the density of the nuclei has fallen from about $1.7 \times 10^5/\text{cm}^3$ at the start of sequence (1) to about $100/\text{cm}^3$. The appearance of the cloud is very like a shower of rain.

(3) On subsequent expansions the drops are greatly reduced in number. They are very much smaller and take about 15 to 20 secs. to appear. This behaviour is also independent of the expansion, provided it is larger than 1.008.

These observations are completely contrary to those expected with the type of nucleus postulated above. They can however be explained if it is assumed that c-nuclei consist of aggregates of impurity and

water molecules, in equilibrium with water vapour and impurity vapour. In this case the main impurity is probably nitrogen dioxide. Nuclei thus grow to visible drops, of a size, and at a rate, determined by the ambient water and impurity vapour pressures together. In the early stages of the cleaning expansion, (sequence 1), the high density of drops will cause considerable competition amongst the nuclei, for the water and impurity vapour, so that few will grow to a large size. As some of the drops fall out, carrying impurity with them, the overall mass of impurity in the gas will be reduced, so that when the remaining droplets re-evaporate, the vapour pressure will be lower than before and the radius of the nuclei will be slightly decreased. Now, for these remaining nuclei to grow, they must gather impurity vapour and water vapour. The water vapour is readily available, but the impurity vapour has a low density which thus impedes their growth. In the final stage, (sequence 3), the search for sufficient impurity lasts so long that the quantity of water vapour available for condensation has fallen considerably before the drops become visible. Hence it is found that the few visible drops formed are of very small size and appear after a very long delay.

It is assumed in this theory that the impurity vapour molecules are produced from the electrode simultaneously with the ejection of the initial condensation nuclei into the gas. These initial nuclei may in fact require to collect some of the individual vapour molecules to grow at all. This possibility is illustrated in the experiments previously discussed where production near the threshold was found to take place in an unusual and paradoxical way. Here drops were first observed to form close to the wall of the chamber, and then, later in the post-expansion period, although the gas was warming up, drops

were found to grow right back to the production point. This observation is explicable in terms of the impurity vapour. Nuclei, formed late in the expansion, will immediately find themselves in a region rich in impurity molecules, and hence will grow more rapidly than those nuclei produced early in the production period. It will also be recalled that the jets of drops leaving the point are surrounded, in large expansions, by a diffuse slow moving cloud of smaller droplets. These are thought to be formed on relatively uncontaminated nuclei ejected into regions with a low vapour density, or on single impurity molecules which have been produced at the point. It is probable that the nuclei capture impurity molecules and water molecules simultaneously, since often an impurity molecule will be surrounded by a few water molecules, in a manner similar to a gaseous ion. Individual impurity molecule capture will also be important. The exact details of the process will depend to some extent on the nature of the impurity being collected by the nucleus, and on the water and impurity vapour pressure in the chamber.

Estimates of the rate of capture of impurity molecules in a uniform system, such as found in the cleaning expansions, can be made if the density of the impurity vapour and the size of the nucleus is known. Rates of capture are calculated in Appendix C for various sizes of nucleus. It is found that the nuclei are probably larger than 10^{-7} cm., since at this radius the drops contain few impurity molecules, have a small surface area and hence a poor chance of capturing extra molecules. In Appendix D, another calculation, based on the observation that the cloud in cleaning expansions is always uniform, shows that the nuclear size cannot be greater than 7×10^{-7} cm. A nucleus of 5×10^{-7} cm. will be struck by more than 10^3 impurity vapour molecules

per second at maximum vapour density. The actual size of the nucleus is relatively unimportant since it undoubtedly varies as impurity is removed from the chamber.

The fundamental idea of considering the nucleus as being in equilibrium with both water and impurity vapours, which has been propounded in this section, was derived by considering the behaviour of the nuclei in cleaning expansions made subsequent to nucleus production. Absorption of impurity molecules by droplets of aqueous solutions is normally ignored in calculations of the equilibrium saturated vapour pressure. However Tsuji (1950), in a little known paper, has considered this effect for drops containing sodium chloride and has calculated that it will be rather important for condensation nuclei with radii less than 10^{-6} cm. This theory will now be shown to be consistent with other properties of the c-nuclei, and in subsequent chapters a diverse range of condensation phenomena will be examined in the same way.

5: 3 A Re-examination of Methods of Cleaning the Chamber.

In addition to estimating an upper limit to the nuclear size from the observation that cleaning expansions contain uniform cloud, evidence supporting the new theory of drop growth can be deduced from it. One consequence of a fast expansion in a cloud chamber is that a temperature gradient is established vertically across the gas, which takes about 10 min. to disappear at 30 atmospheres. If the chamber was used as a charged particle detector, an expansion made before this waiting period had elapsed would produce particle tracks only in the lower regions of the gas. An expansion large enough to cause drop growth on ions in the top of the chamber would inevitably produce dense cloud, due to homogeneous nucleation, near the floor.

Hence if condensation on c-nuclei was solely dependent on the availability of water vapour, cleaning expansions made without this intervening waiting period would contain non-uniform cloud. This has not been observed, although the presence of windows at the top and bottom of the high pressure chamber must have increased the stability of the temperature gradient, and cleaning expansions have often been made on a 2 minute cycle. A drop growth mechanism, which relies largely on the capture of impurity molecules, enables these observations to be understood, since the number of collisions with the embryonic droplets depends on the vapour density more strongly than on the temperature. This is brought out in the calculations in Appendix C.

The c-nuclei can be cleaned from the gas in three ways, (a) by successive cleaning expansions, (b) by allowing the system to stand for a long time and (c) by application of an electrostatic sweeping field. The first method has already been considered in detail, (section 5: 2). The natural cleaning process, (b) is envisaged as taking place in the following way. Single impurity molecules will become dissolved in any surplus water lying on the walls of the chamber, at a rate determined by the water's surface area, and in a quantity determined by the total mass of water and impurity present. This absorption will upset the equilibrium existing in the gas between the water and impurity vapours, and the c-nuclei. The nuclei will be reduced in size so that more impurity is released into the gas. This process will take place continuously until no nuclei remain, except, perhaps, for some water molecules clustered round single impurity molecules. These small clusters, however, are unlikely to promote condensation at low degrees of supersaturation,

but may grow to drops in larger expansions, near the ion limit, as suggested by Crane and Halpern. At the end of the cleaning process, therefore, the carrier gas contains only water molecules and impurity molecules with perhaps a few small, stable clusters. No hypersensitive nuclei remain.

Direct absorption of the c-nuclei at the chamber walls cannot be an important process, since it would cause the size of the remaining nuclei to increase. This, in turn, would be detected as an increase in the rate of growth of drops in the cleaning expansions, and possibly as a reduction in the visible expansion ratio threshold. Neither has been observed. A cleaning expansion made during this natural cleaning period is similar to one of those seen in a normal series, the type depending on the time for which the chamber has been standing. Cleaning of the chamber by absorption of c-nuclei and vapour molecules together is excluded by the same argument. In a dry chamber the process is much slowed down because the impurity molecules can only disappear if they become attached to the chamber walls which are dry. Absorption will now be very difficult.

The action of the electrostatic field in clearing the nuclei from the chamber is not fully understood. It seems unlikely that the nuclei themselves are charged as no preferential condensation is observed in production or cleaning expansions, and their mobility, if they are charged, cannot be as low as is necessary to explain the measured clearing times. (A rough estimate of the minimum mobility has been attempted in Appendix E) The chamber will always contain a large number of ions of both signs, each surrounded by a few water molecules. It is possible that these clusters will capture some impurity molecules, which will then be removed from the gas along with the ions when the field is switched on. Successive degradation of

the nuclei will then occur, as in the other cleaning processes. It may also happen that vapour molecules, and even the nuclei, will acquire a charge from the capture of a gaseous ion, or by direct ionization. The latter occurrence must, however, be rather rare, because of the low concentration of vapour molecules and nuclei relative to the nitrogen in the chamber. It is possible that charging occurs when nuclei or vapour molecules pass close to the high voltage point, with the result that they are swept to the chamber walls.

5: 4 A Re-examination of the Production Process.

It has already been suggested that nitrogen dioxide is produced in the water layer formed on the electrode by condensation. A possible reaction mechanism is:-

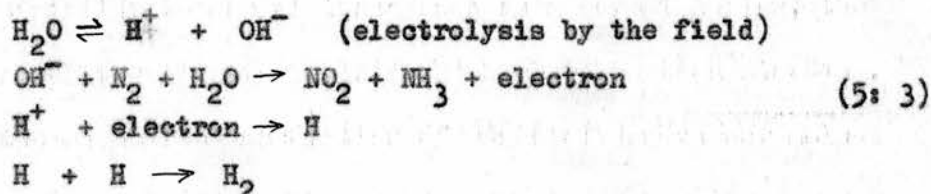

the nitrogen required being dissolved in, and in contact with, the water layer. Most of the ammonia so formed will remain on the silk because of its very high solubility in water. The nitrogen dioxide can escape into the gas by two different routes. Single molecules will be evolved from the water surface, and will, in the initial stages, be largely responsible for the vapour of nitrogen dioxide present in the chamber. During the condensation which occurs at the start of every expansion, microscopic drops of water may form on the electrode. These will become contaminated with the new chemical complexes created on the silk, and will be ejected into the gas in a manner similar to that proposed by Vonnegut. The impurities will lower the surface tension of the water and thus enhance the process. The postulate of drops being originally present is unnecessary, since

they can always be formed in this way if sufficient water is available. The observation that the voltage threshold rises either under very dry conditions, or at low expansion ratios, gives further support to these ideas.

The ejection of NO_2 (and other species) into the gas provides a satisfactory explanation of the argon-water results. It will be recalled that with argon only slightly contaminated with nitrogen, c-nuclei were initially produced copiously, but after a few expansions the production efficiency seemed to fall to a low but constant value. In the early expansions, most of the nitrogen present would have been converted to nitrogen dioxide and ammonia. In a clean chamber these will exist partly in the surplus water on the walls, and partly in the gas, no condensation nuclei being present. Sensitive condensation nuclei will then be formed when almost pure water droplets, ejected from the electrode in the normal way, capture some of the impurity molecules, and are transformed into c-nuclei. Unfortunately with argon in the chamber it is not possible to detect changes in thresholds, because low supersaturations cannot be produced.

Although nitrogen dioxide has been considered as the only condensation catalyst throughout this discussion, it should not be thought that other complexes are ineffective. It would appear that ammonia and hydrogen can be produced in the nitrogen dioxide reaction, so that these are likely to be present in some of the original nuclei, and in the gas. It is also reasonable to imagine hydrogen peroxide being formed on the silk. These compounds, together with others, cannot be detected in such low concentrations as the nitrite ion, but are undoubtedly present, playing a greater or lesser part in the condensation mechanism.

Most of the phenomenological features of c-nucleus production have already been discussed, and attempts have been made to explain them. It is believed that the initial jets move so quickly because they are carried on a stream of ions and gas molecules. This electric wind will cause rapid movement of the gas over the end of the electrode, and in addition to removing the nuclei in a spectacular stream from this region, it will provide a useful method of furnishing fresh vapour for condensation on the electrode surface. Later in the expansion most of the ions will have disappeared from the gas, so that the jets of drops will leave the point in the slower, and less directed, manner actually observed.

The increased production of nitrite ion found when oxygen is in the chamber is not fully understood. It may be that, although oxygen from the water molecules is sufficient for nitrogen peroxide formation, and hence for the presence of NO_2^- ions in water, the yield is increased in the presence of surplus oxygen because of a second reaction in which atomic nitrogen is formed which combines directly with the oxygen. The enhancement seen when ammonia is in the chamber is considered in a later section.

5: 5 Evaporation of the Drops Formed on c-nuclei.

A further striking difference between the drops formed on c-nuclei and those formed on gaseous ions lies in their manner of evaporation. Even at high pressures (about 50 atmospheres), drops on ions evaporate to less than visible size in under 60 secs., because the gas has heated up to such an extent that the supersaturation is becoming very small. After an expansion of 1.008 the drops on c-nuclei have been observed to remain visible in the chamber for longer than 150 secs., evaporating only slowly during this period. Since it is unreasonable to suppose that the chamber remains supersaturated for this length of

time, when the maximum supersaturation immediately after the expansion could not have been more than 4%, these observations require further explanation. In addition, a temperature gradient may exist across the chamber before an expansion, and one will certainly be established soon after, so that the supersaturation may never be very large. Indeed, if any drops fall out during this $2\frac{1}{2}$ min. period, slightly unsaturated conditions may exist.

Several workers have studied the enhancement and inhibition of water evaporation from plane surfaces. Sechrist (1963) has shown that CO_2 dissolved in water increases evaporation, while Eisner and his co-workers, (1958, 1961), have demonstrated the enhanced stability of water mists when the drops are coated with a monolayer of an insoluble fatty alcohol, such as cetyl-stearyl alcohol. The effect of CO_2 on drop size in these experiments has already been discussed, but it is considered extremely unlikely that an insoluble monolayer coats the drops. An explanation of the long evaporation time might lie along the following lines.

It has been shown that nitrogen dioxide is produced with c-nuclei, and is probably responsible for their properties. NO_2 is hydrolysed in the gas phase to nitric acid by the following reaction:-

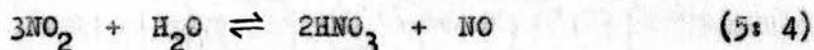

but because of the low ratio of nitrogen dioxide to water concentrations, very little nitric acid will be formed. However in the liquid phase, or in the c-nucleus, a large proportion of the nitrogen dioxide will become nitric acid. Nitric acid has a stronger affinity for water than has nitrogen dioxide, and consequently it will tend to keep the drop stable in conditions of saturation which would normally require that it evaporated. A detailed study of this point would

require an experimental arrangement in which drops of known composition could be produced and their evaporation studied.

5: 6 Another Possible Explanation.

In the theory outlined in sections 5:2, 5:3, 5:4 and 5:5, it has been assumed that the chemically reactive vapour assisting the condensation is produced on the electrode surface. It is well known that the irradiation of nitrogen and water vapour, by charged particles and neutrons, produces measurable quantities of nitric acid, (Lind, 1961), and probably of other chemicals as well. Ammonia can be oxidized in this way, in the presence of water, to nitric acid, which perhaps explains the strong concentration of nitrite found when ammonia is in the chamber, since nitrous acid was probably also being formed. If the action of the field was only to produce microscopic drops of water, as in the later stages of the argon experiments, these could pick up molecules of impurity during the time for which the chamber is saturated and hence give rise to c-nuclei on re-evaporation. A test of this explanation might consist of producing small water droplets which are definitely nitric acid or nitrogen dioxide free, allowing them to grow in supersaturated conditions, collecting them and testing the liquid obtained for nitrite ions.

Such a test was carried out in the following way. If a sufficiently large expansion is made, so that the supersaturation produced is 700 to 800%, homogeneous nucleation will occur in which drops of water are formed by condensation of water molecules on water molecules. If these drops are formed in a gas containing a vapour impurity, then they will capture some of it which can, in theory at least, be detected if the drops or nuclei reach the floor of the chamber. It was not possible to make sufficiently large expansions in the high

pressure chamber so that this experiment was performed in the 3-atmosphere chamber. It was found, although sensitive re-evaporation nuclei were formed in great quantity, requiring many cleaning expansions to remove them all from the chamber, that no nitrite ions were detectable in the water. The idea, therefore, that the nitrite ions always found after α -nuclei have been produced, have been formed in the water layer on the electrode appears to be correct. Clearly, however, the re-evaporation nuclei formed after homogeneous nucleation expansions must be caused by the drops picking up a chemically reactive vapour which is not nitrogen dioxide. The identity and origin of the impurities responsible is considered in a later chapter.

5: 7 Conclusion and Summary.

It has still not been proved that nitrogen dioxide or nitric acid is responsible for the α -nuclei, but it does seem most unlikely that a reactive vapour, known to be an effective condensation catalyst, could be produced in a supersaturated vapour without having some influence on the phenomena observed to take place there. Assuming, as before, that the electrolytic current is 10^{-6} A, this would produce about 10^{13} molecules of nitrogen dioxide in 10 secs., which agrees well with the figure arrived at in Appendix C, working back from the strength of the nitrite test. The idea of a chemically reactive vapour encouraging condensation is not confined to nitric acid or nitrogen dioxide, and might even be extended to the vapour associated with a solid, such as sodium chloride dissolved in a water droplet, as Tsuji (loc. cit.) suggested. It must be stressed, however, that the presence of the vapour does not necessarily give rise to sensitive condensation nuclei. These must be formed in some creation process, becoming stable because of the contamination

they contain, and because of the impurity in the gas phase. This conclusion may require modification if the quantity of impurity molecules is so great that collisions on embryonic clusters, such as the 10 molecule groups round ions, are very frequent.

Chapter 6

OTHER CONDENSATION PHENOMENA OBSERVED INTHE HIGH PRESSURE CLOUD CHAMBER.

During the experiments carried out to study the properties of the c-nuclei, three other interesting condensation phenomena were observed in the high pressure cloud chamber, interpretation of which is greatly simplified if a theory similar to that proposed in Chapter 5 is invoked. They thus furnish additional experimental verification of the ideas set forth there.

6: 1. Nuclei Produced by an Electrostatic Field from a Damp Electrode in a Vapour which is not Supersaturated.

An obvious extension of the c-nuclei experiments was to explore the possibility that condensation nuclei might be formed when an electrostatic field is applied to the electrode prior to an expansion. This investigation was in fact made early in the work, when it was found, under rather ill-defined conditions, that nuclei could be created. When an expansion was made, the voltage being applied previously for a few seconds, streams of drops were seen in the chamber, as shown in Figures 15 and 16. The field was short circuited about 0.1 sec. before these expansions, otherwise additional drops, formed on c-nuclei, would have been observed. The actual position of the silk strands in the photographs is not that which they occupied while the nuclei were produced, as the presence of the field modifies their orientation. For brevity these nuclei will be referred to as s-nuclei.

Whereas c-nuclei appear whenever a sufficiently large voltage is applied to a sharp electrode in a supersaturated vapour, s-nuclei were only formed with electrodes which retain a certain mass of

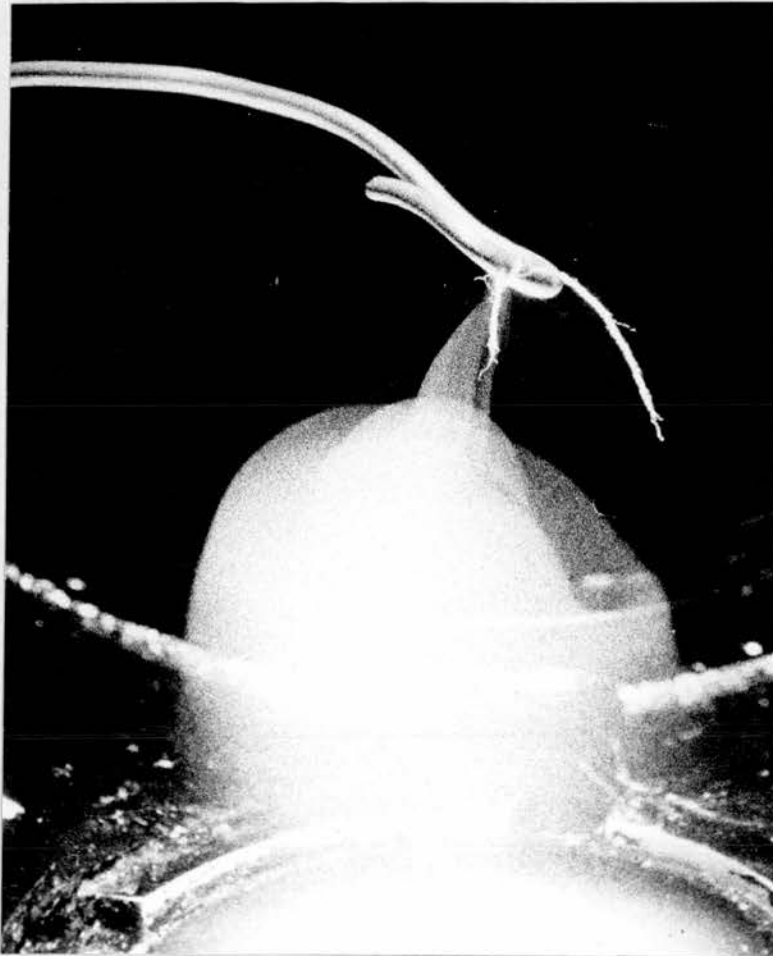

Figure 15. Diffuse Streamers.
W14. Nitrogen + distilled water at 30 atmospheres.
Cotton electrode.
Expansion ratio = 1.08. Field = -1200V. (on
10 sec. till expansion).
Flash delay = 2 sec.

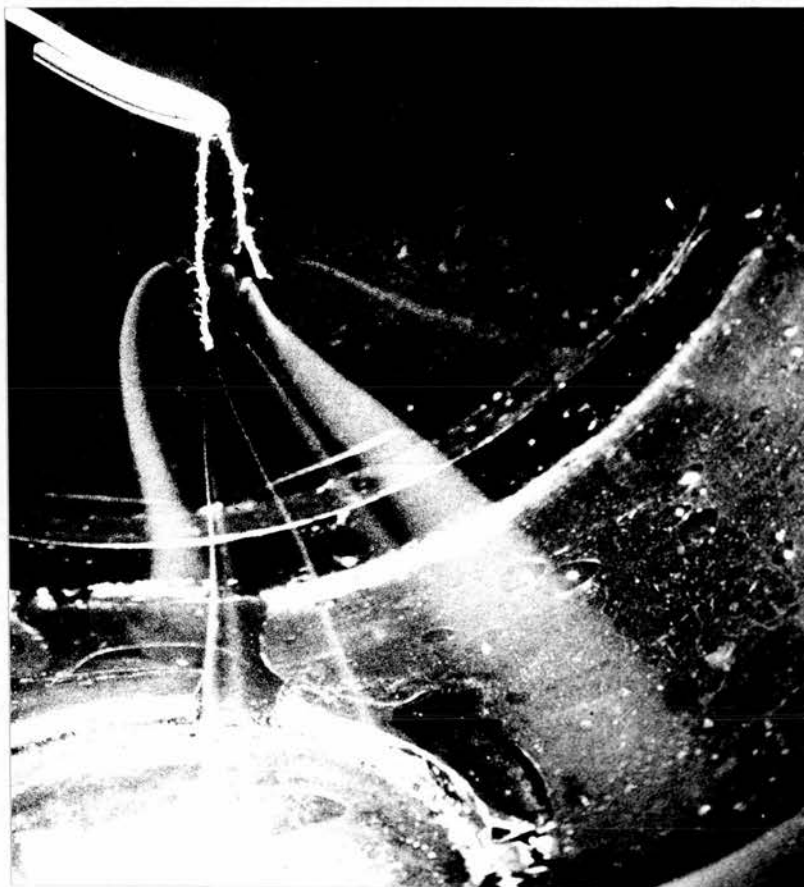

Figure 16. Thin, tight streamers.

W66. Nitrogen + argon + distilled water at
30 atmospheres. Cotton electrode.
Expansion ratio = 1.06. Field = -1300V. (on 5 min.
till expansion).
Flash delay = 1 sec.

water when they are in a moist gas. Silk, cotton and glass wool fibres all acted as efficient sources, whereas nuclei were never produced from single electrodes such as a metal point, or a human hair. Soaking the silk in water for several hours increased its efficiency which further indicated that a water layer was necessary for the process. Also, s-nuclei could not be produced, even from fibrous materials, in a 'dry chamber'. The apparent similarity between the production requirements for s- and c-nuclei make the great differences which were observed in their properties all the more remarkable. A detailed study was hampered by their irregular appearance, even in experimental runs which were made, as far as possible, the same. Although it was eventually shown that s- and c-nuclei were nearly identical, provided one production condition was fulfilled, it is useful to record the properties first assigned to them as this helps to give a clearer insight into the problem of nuclei formed by damp electrodes.

The expansion ratio required to see s-nuclei, if they were produced, exhibited threshold values which varied considerably from run to run, and even within runs. The voltage threshold behaved in a similar erratic manner, being equal to, or greater than, the corresponding c-nuclei threshold. Preferential condensation on the negatively charged nuclei also occurred, as for gaseous ions. Typical values for the threshold expansion ratios in nitrogen were 1.03 for negatively charged s-nuclei, and 1.04 for those positively charged, with a production voltage threshold of 1.2 kV. The threshold expansion ratio for the nuclei was very dependent on the production voltage used, being reduced if the voltage was increased to 2.0 kV,

with a reduction of the positive-negative differential.

The production of the nuclei in pure argon was similar to that noted for the c-nuclei: initial copious production rapidly gave way to low efficiency. The addition of oxygen, hydrogen or carbon dioxide to the nitrogen had no noticeable effect. As previously remarked, when ammonia was present sensitive nuclei were produced with $\pm 250V.$, although no characteristic streamers were observed.

In general the streamers appeared as one or other of the distinct types illustrated in Figures 15 and 16. In the diffuse streamers, (Figure 15), the drops were generally dense and quite small, and beautiful diffraction colours were often seen in the cloud, indicating that the drop size was of the order of 1 micron. The drops in the thin, tight streamers (Figure 16) were generally very much larger. From a study of about 80 suitable photographs, it was concluded that diffuse streamers always started from round the point, whereas sharp streamers had their first drops away from the electrode. Because the presence or absence of the field alters the position of the silk, comparisons were made with contemporary photographs of c-nuclei production whenever possible. A particular source always produced the same shape of streamer, and both types frequently appeared in the same expansion (Figure 17). No consistent difference in the expansion ratio threshold was established for the nuclei in the two forms of streamers.

After condensation had taken place, the re-evaporation nuclei so formed appeared to behave identically to the c-nuclei. They could be made visible with very small expansions of 1.008; they showed no preferential condensation with respect to sign: they could be cleared from the chamber either naturally, or with a field, in



Figure 17. Diffuse and thin streamers.

WS1. Nitrogen + argon + distilled water at 30
atmospheres. Cotton electrode.
Expansion ratio = 1.06. Field = -1300V. (on 5 sec.
till expansion).
Flash delay = 2 sec.

similar times to those required for c-nuclei. The broad features of this phenomenon are then explicable if the s-nuclei are regarded as weakly contaminated, moderately charged water droplets, ejected from damp, fibrous electrodes by electrostatic fields. The transformation to c-nuclei takes place when impurity molecules, present in the gas, are captured by drops formed during the expansion. This conclusion was supported by some weak indications that s-nuclei production was enhanced if c-nuclei had been created just prior to attempts at their formation.

While the observations had been thus roughly interpreted, it was regarded as unsatisfactory that a direct relationship between s- and c-nuclei could not be established. Streamers often failed to be formed even when it was certain that the chamber was properly saturated, and the c-nucleus production threshold was at its minimum value. The observation that production efficiency was higher when the room temperature, and hence the gas temperature, was falling, and that repeated cleaning expansions, in quick succession, increased production especially near threshold, directed attention once more to the water content of the silk. It was eventually discovered that if the chamber was allowed to stand, fully assembled, for about 10 days, before filling to 30 atmospheres, that s-nuclei could be produced with complete regularity. Furthermore they appeared to have identical properties to the c-nuclei, so that advantage was taken of the easily controlled, pre-expansion conditions to make some preliminary measurements of a diffusion coefficient which is perhaps applicable to the c-nuclei.

6: 2 Nuclei Produced from a Damp Electrode in Equilibrium with a Saturated Vapour, by an Electrostatic Field.

Although s-nuclei could be produced efficiently and regularly when the chamber was filled in the manner just described, a rise in voltage thresholds for the c- and s-nuclei was observed. This can be explained in the following way. In his work on the moisture content of natural and man-made fibres, Ashpole (1952) drew attention to the difficulty of attaining equilibrium between a fibre and water vapour, especially close to saturation, even when the temperature of the whole system was constant to within 0.02°C . The erratic results found under the original, less rigorous conditions can now be understood. The moisture content of any silk electrode is dependent on its previous history in storage, and on the stability of the conditions in the chamber. Surplus water will only be readily available on its surface for s-nuclei production when the silk is in equilibrium with the water vapour in the chamber. The details of absorption of water by fibres is not well understood, but it is a reasonable assumption that the fibres will swell so that the ends of their strands will become less sharp. This means that a higher voltage will be necessary to produce the electric field strength required to eject the nuclei into the gas. The observed threshold for c-nucleus production now rose to about $\pm 1000\text{V}$., while the s-nucleus threshold was initially about $\pm 1500\text{V}$.

The reason for the consistency of c-nucleus formation, under conditions which are now seen to have been far from stable, is apparent. Any water which condenses on to the silk during an expansion will be available for nucleus production, independently of the existing moisture content. For s-nuclei, however, surplus water will only

be available if the silk is in equilibrium with a saturated vapour. The difference in voltage thresholds for the two nuclei may thus be interpreted as an extension of the rise in voltage threshold with decreasing expansion ratio, discussed in section 4: 3, and illustrated in Table 2. When little water is available, nuclei cannot be formed unless the voltage is increased, possibly because it is then easier to form sufficient nitrogen dioxide for production to take place, or easier to draw water off the silk. The high voltage threshold already noted for the dry chamber agrees with this trend.

In one run no c-nuclei were created, that is, the field was never applied during the expansion. Initially the s-nuclei voltage threshold was -1500V., but after a number of such expansions it fell to -1200V. The nitrite test made on the water from the chamber was strongly positive, indicating that nitrogen dioxide had been produced along with the s-nuclei. These two observations suggest the following explanation, which indicates that they are another manifestation of the c-nuclei phenomenon.

At the start of an experimental run, when the chamber is reasonably free from impurities, s-nuclei will be produced at voltages below the measured threshold, but they will not be stable in an atmosphere free from NO_2 . Disintegration will take place, increasing the nitrogen dioxide content of the system. At higher voltages the nuclei are more contaminated, and probably larger, so that they will survive, even in a clean chamber, until the expansion, when they can grow to visible drops. In addition, of course, to nuclei being formed, nitrogen dioxide molecules will be evolved into the gas, as with the c-nuclei, so that the mass of nitrogen dioxide in the system will increase. Hence nuclei formed at the lower voltages will have a

better chance of survival until the expansion, the voltage threshold thus appearing to fall. The weak indication noted in the previous section, that s-nuclei were formed more regularly if some c-nuclei had been produced, is now seen to be explicable. This conclusion is further borne out by the observation that nuclei produced, but not condensed on at once, are more stable late in an experimental run than earlier on.

The s- and c-nuclei, at production, thus appear to have a range of sizes depending on the exact conditions. Whereas s-nuclei may change in size before they actually act as condensation centres, the c-nuclei cannot, as they are growing almost as they are formed. Both types of nuclei will evaporate to a size depending on the quantity of impurity present in the surplus water, in the nuclei and in the gas, the total amount of nitrogen dioxide gradually increasing as the run continues.

6: 3 Determination of a Diffusion Coefficient for the s-nuclei.

It was found possible, using the streams of drops formed on the s-nuclei, to obtain preliminary measurements of their diffusion coefficients. The problem was treated in a manner similar to that used by Farley (1951), to measure the diffusion coefficient of the nuclei which he produced by irradiating nitrogen-water systems with ultra violet light. Assuming that the s-nuclei are originally formed within a cylinder of negligible radius, it can be shown, as for ions along the track of a charged particle, (Blackett, 1934), that the width of the projection of the cylinder, after a time t , on a plane parallel to it, which contains 90% of the nuclei formed, is:-

$$X = 4.68 \sqrt{Dt} \quad (6: 1)$$

where X is the cylinder width, and D is the diffusion coefficient of

the nuclei.

Certainly the s-nuclei, in many cases, will not be produced in a negligibly thin cylinder, (for example, the streamers shown in Figure 16), but for certain thin streamers, where measurements are made within about 2 cm. of the production point, the error in this assumption will not be large. It will reveal itself, in a plot of X^2 vs t , by the fact that the resulting straight line will not pass through the origin. The constant, 4.68, will be slightly modified, but it is uncertain anyway because of the experimental difficulty in defining the width containing 90% of the nuclei.

By photographing streams of s-nuclei produced in a 10 sec. period, the end of the production being at different times before the expansion, it was possible to measure a diffusion coefficient in the way just outlined above. A streamer used in such a measurement is shown in Figure 18, where the delay between the end of production and drop growth, that is, the diffusion time, was nominally zero. The widths of the streamers were measured in space at a point 1.5 cm. away from the production point, using the reprojection device designed for cloud chamber track analysis by Dr. G. R. Evans, and described by Williams (1955). The results of one series of measurements are shown graphically in Figure 19. Using equation (6: 1) above to give the gradient of the straight line, a value for the diffusion coefficient of the s-nuclei at 31.6 atmospheres, (the working pressure), of 5.4×10^{-5} cm²/sec., which is equivalent to 0.0017 cm²/sec. at atmospheric pressure, was derived. The accuracy of each point is not high, partly because each streamer had rather ill-defined edges. The zero time error appears artificially large for several reasons. There is a delay of 0.1 sec. between the end of production and the

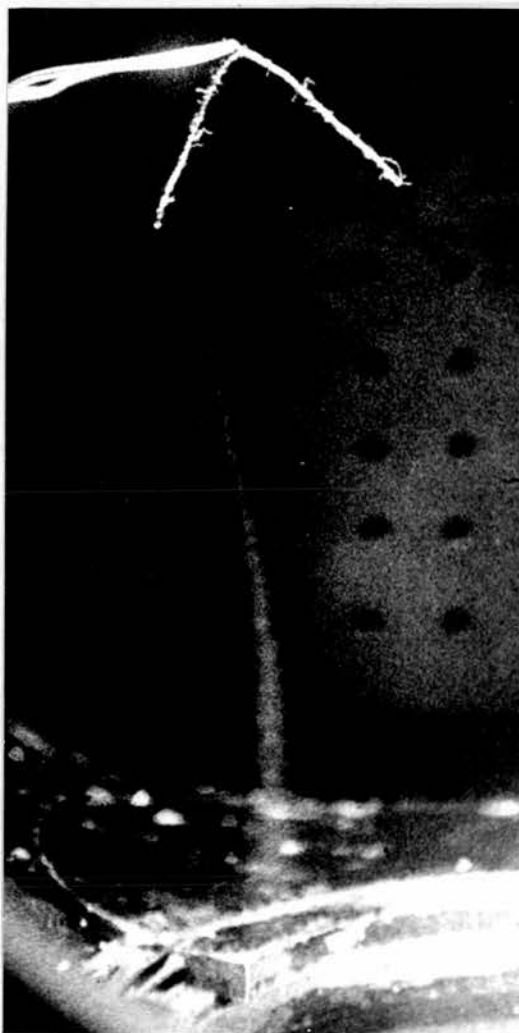

Figure 18. Streamer used in diffusion coefficient measurement.

X84. Nitrogen + distilled water at 31.6 atmospheres.
Silk electrode.
Expansion ratio = 1.10. Field = -2000V. (on 10
sec. till expansion).
Flash delay \approx 1.0 sec.

The diffusion time is nominally zero in this photograph.

The ebonite back-plate used in the chamber at this time can be seen.

Figure 19.

Graph of X^2 vs t
(X = streamer width, after a diffusion time, t)

Data from Run 93. (see, also, Figure 18)

The gradient of the graph was found, using a 'least squares' calculation, to be 0.00117 ± 0.00004 cm²/sec. This gives for the diffusion coefficient, $5.4 \pm 0.2 \times 10^{-5}$ cm²/sec at 31.6 atm., or 0.00171 ± 0.00006 cm²/sec at 1 atm.

GRAPH OF X^2 vs t

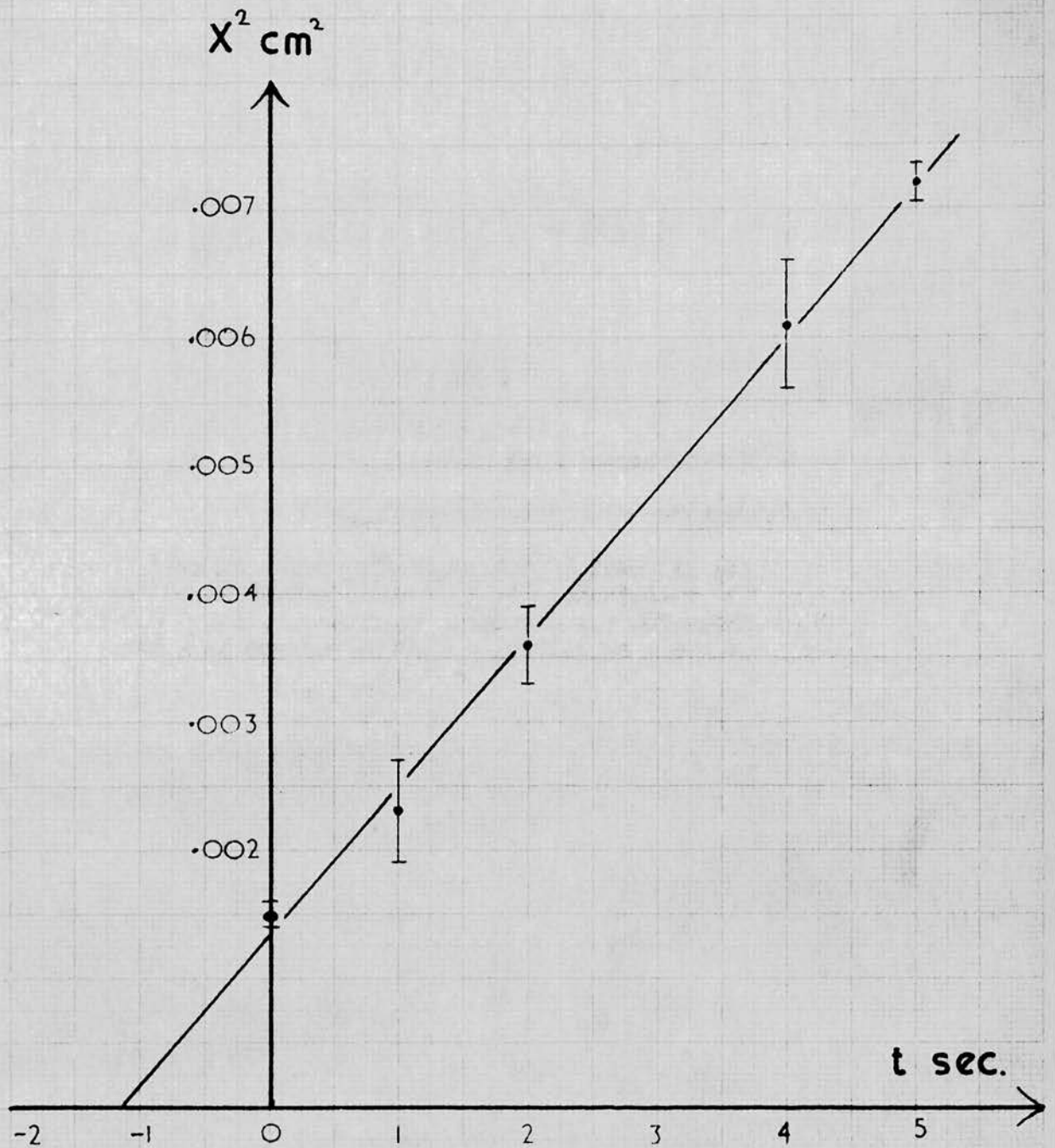

start of the expansion; the drops take about 0.2 sec. to grow, and there is an additional delay of 0.5 sec. before photography. Further, the nuclei, 1.5 cm from the production point, have been in the chamber perhaps $\frac{1}{2}$ sec. Notwithstanding these and other limitations already mentioned, it is considered that the value of \bar{D} obtained is not in error by more than a factor of 2, either way.

At the present time only two diffusion coefficient determinations have been undertaken. These were made using streamers produced in different runs at the same nitrogen pressure, and with the same production voltage (-2000V.). The results obtained, corrected to 1 atmosphere pressure, are:-

$$(1) D = 0.0017 \pm .0002 \text{ cm}^2/\text{sec.} \quad (\text{Run 89})$$

$$(2) D = 0.00171 \pm .00006 \text{ cm}^2/\text{sec.} \quad (\text{Run 93})$$

The agreement is good but must be regarded with caution, considering the paucity of the observations. It is planned to extend these measurements, paying particular attention to the variation of D with voltage used. Unfortunately, although streamers can be produced readily, it is not easy to obtain suitable ones in good illumination, good focus, and parallel to the plane of the photographic plate, so that accurate measurements can be made.

The hypothesis that s- or c- nuclei are carried through the gas by an ion wind, receives support from this result. The diffusion coefficient leads to a mobility estimate which does not explain the rapid motion of the streams of nuclei through the gas, unless they are highly charged. This has already been shown to be unlikely, largely using arguments based on the density of the cloud observed, (section 5: 1), but also because of the non-occurrence of preferential condensation.

The diffusion coefficients for ions in moist gases are not well known, but at N.T.P. the values lie in the range 0.02 to 0.043 cm²/sec., so that the present measurements demonstrate conclusively that neither the s-nuclei nor, by the arguments of section 6: 2, the c-nuclei, are singly charged ions. Further, application of the Stokes-Millikan-Cunningham relation already used, (Appendix E), gives a value for the radius of the nucleus of about 4×10^{-7} cm., which is below the upper limit predicted for the c-nuclei by considerations of fall-out under gravity.

It has been shown, therefore, that the nuclei produced, when the electrostatic field is applied before the expansion, can be explained in a manner consistent with the theory outlined previously. Further, under certain well controlled conditions, the nuclei, even just after the expansion, are very similar in character to those already discussed. The purpose of the electrode is thus seen to be to create a range of nuclei, of differing size and constitution, which will be changed to some well defined entity, depending on the vapour pressure of the impurity in the atmosphere in which they find themselves. Nuclei ejected into a region not rich enough to support them will tend to evaporate, but under more favourable conditions they will be stable, or even tend to grow slightly until equilibrium has been established.

6: 4 Nuclei Produced by an Electrostatic Field from a Damp, Flat Surface.

On a number of occasions the chamber has been assembled prior to a run with an excess quantity of water spread over the surface of the rubber plug, which insulates the high voltage electrode from the chamber wall. If the field is applied at this stage, a leakage current passes through the water layer, which is sometimes as large

as $500\ \mu\text{A}$. This current drops the voltage supplied by the E.H.T. power unit to a nominal value of a few volts. It appears, however, that nuclei are evolved in the water layer. If an expansion is made while the current is flowing, or shortly after, dense cloud erupts from around the plug, rapidly filling the chamber. The nuclei causing the cloud appear to have the same properties as those produced at the pointed electrode.

In addition, on two occasions when the field was applied across the water layer, without the chamber being expanded, cloud was formed in considerable quantity. When this occurred the chamber had only just been assembled and filled, so that as well as being unsaturated, the temperature throughout the gas would be far from uniform. The most probable explanation is that water was evaporating naturally from the wet plug, but the slow diffusion of vapour at 30 atmospheres, and the unstable temperature conditions, had caused a supersaturated region to be formed in the neighbouring gas. These nuclei, apart from their mode of production, were in all respects similar to those observed under more stable conditions. The significance of these phenomena is that they indicate that the pointed electrode serves merely to provide a mechanism for ejecting nuclei into the gas, and that the field close to the point has nothing to do with the production of the chemicals causing condensation. The mechanism which ejects nuclei into the gas from a flat surface is probably one of enhanced evaporation. On one of the occasions when cloud was formed without the necessity for an expansion, it was noticed that a frothing action did occur on the plug. The chemicals in the rubber may be important in forming these nuclei, although replacing the rubber plug with one of neoprene, which is chemically more inert, did not seem to inhibit the effect.

Other workers have found cloud to be formed under similar conditions. Street and Stevenson (1936), working with a wooden cloud chamber, observed that nuclei were produced by a leakage current across a flat surface wetted with ethyl alcohol. The resulting cloud caused a troublesome background of drops, but they did not investigate the phenomenon further. Valley and Vitale (1949), in their high pressure cloud chamber, applied 4000V. to a propyl alcohol soaked rubber diaphragm, which acted as a clearing field electrode. They did not switch off their field at the expansion, and, not surprisingly, found that dense cloud was formed in this region. Several authors, for example Alston, Crewe and Evans (1954) have found that, when methyl alcohol is heated in a diffusion chamber to increase the rate of evaporation, nuclei are evolved which, acting as effective condensation centres, make the chamber unusable. Bevan (1954) observed that if a "fairly large current" was passed through a wire wet with methyl alcohol, or carrying drops of that liquid, a curtain or stream of cloud was formed in his diffusion chamber. The common explanation suggested by these authors is that aggregates of alcohol molecules are formed in the evaporation process, but from the work discussed above it seems possible that an actual chemical change is effected by the action of the electric field, and that condensation centres are created around any new complexes thus produced.

6: 5 Unusual Drops Observed in the High Pressure Cloud Chamber.

Normally liquid drops formed in a cloud chamber are seen by light scattered from them, which has its maximum intensity in the forward direction. Webb (1935) has shown that this intensity is many times the minimum value, observed at about 90° to the incident direction.

Although in most of the several thousand cleaning expansions made during the course of these experiments, the drops have been viewed at an angle close to this unfavourable one, the author is most familiar with the appearance and brightness of drops of different sizes, when viewed from a wide range of angles. It has been found under certain conditions that a small number of drops are formed with rather peculiar properties as regards their visibility. They differ in two major respects from those normally seen in cloud chambers. They appear to twinkle as if light from them was being reflected by regular surfaces, and their brightness is invariant over a range of angles from 10° to 135° . Unfortunately attempts to photograph these "twinkling drops" have been unsuccessful.

These unusual drops have only been observed during the initial cleaning expansions, made to remove the aerosol component present in the room air frequently left in the chamber. A further requirement is that the gas must be fully saturated. This is normally achieved by deferring filling the chamber for about two days after assembly. The "twinkling drops" are not normally seen in the first or second cleaning expansion, but, if they are to be present at all, they appear during the third, fourth, fifth and perhaps sixth expansions. At this stage the cloud is still quite dense, containing possibly 10^4 drops / cm^3 , the water drops themselves being fairly large. Amidst this cloud about 20 or 30 of these remarkable drops may appear, uniformly over the chamber, about 3 to 5 secs. after the start of the expansion. It is very easy to follow their movement, even from the top to the bottom of the chamber, a distance of about 20 cm. They are very much brighter than the other drops, and, in addition, they twinkle continuously. In appearance they resemble

the descriptions of ice crystals observed by many authors in cloud chambers at low temperatures. They are found over a range of expansions from 1.06 to 1.12, but persist for longer at the larger values. Although the minimum final temperature, even in the largest expansion, is, with nitrogen, only $+8^{\circ}\text{C}$, it is believed that ice crystals have actually been formed and observed in the gas. No other explanation presents itself.

It is well known that if ether is caused to evaporate sufficiently rapidly, it will freeze, and Cwilong (1945) has reported that supercooled drops of water can be made to freeze in a similar manner, if dry air is suddenly introduced round about them. Although a water drop will cool on evaporation, the difference between the ambient vapour pressure and the equilibrium vapour pressure, required to exist over its surface, must be very large before any forced freezing could occur. Certainly in the present experiment such an explanation is untenable, as a simple calculation shows, (Appendix F), that even at atmospheric pressure the temperature fall at the surface of the drop could not be more than about 0.3°C . However if the drop was very dependent on the presence of some impurity vapour in the gas for its stability, it is quite possible that removal of this vapour, say by chance capture in other drops, or by the drop falling into a depleted region, would cause forced freezing to occur. If these observations and their interpretation are correct, it is of the greatest importance in the field of cloud physics where ice crystals are believed to be formed, only at slightly sub-zero temperatures, by the nucleating properties of various solid materials in supercooled water droplets.

As far as can be discovered, such twinkling drops have not been

previously reported by other cloud chamber workers, except for the similar examples at low temperatures which are undoubtedly ice crystals. Although the temperature fall for water drops evaporating at atmospheric pressure is greater than at 30 atmospheres, the reduced diffusion coefficient at high pressures will enhance the stability of the impurity depleted regions once they are formed. Also at lower pressures the rapid warming of the whole gas volume will tend to inhibit such a process. No suggestion is made as to the nature of the impurity which might be involved. The phenomenon is, however, apparently explicable in terms of the new theory, that impurities in the gas phase play an important part in drop growth.

Chapter 7.

OTHER CONDENSATION STUDIES: I. NUCLEI PRODUCED BY IRRADIATING
NITROGEN, SATURATED WITH WATER VAPOUR, WITH ULTRA VIOLET LIGHT7: 1 Introduction.

The origin and nature of the nuclei produced when a moist gas is irradiated with ultra violet light have received considerable attention since the classical experiments of C. T. R. Wilson (1899a). Wilson found that the effectiveness of the nuclei as condensation centres increased with the integrated flux of light irradiating the gas. Indeed he observed one phenomenon which no one since has succeeded in reproducing, namely, that if the exposure was continued for sufficient time, cloud was formed in the chamber without the necessity for an expansion. Wilson suggested that hydrogen peroxide was being produced by the interaction of the ultra violet radiation with oxygen and water vapour.

Crane and Halpern (1939) and Farley (1951) believed that the formation of atomic oxygen was an important preliminary step towards the creation of condensation nuclei, although they were not certain of its exact role. Mulcahy and Kuffel (1962) concluded that hydrogen peroxide was the substance involved, and suggested that it was produced by the action of mercury atoms, excited by the ultra violet light, on water vapour. There appears to be no direct evidence to show that hydrogen peroxide does enhance condensation, and indeed McHenry and Twomey (1952), using a modified Aitken nucleus counter, found little effect after irradiating moist oxygen, concluding that if hydrogen peroxide, atomic oxygen or ozone were produced they might even inhibit nucleus formation.

Several authors have attributed the formation of nuclei to the

presence of a variety of impurities, in trace quantities. Locher (1936) observed photonuclei to be formed, after ultra violet irradiation, when his chamber contained trace quantities of ethyl chloride, chloroform, acetylene and hydrogen sulphide. McHenry and Twomey (loc. cit.) showed that ammonia was a possible impurity, suggesting also that nitrogen dioxide might act in a similar manner. Atkinson (1955) concluded that the presence of rubber in any gaseous system was sufficient to cause nucleus production, and this would certainly explain the results of Wilson, Crane and Halpern, and Farley. Barnard and Mouton (1958) repeated many of the early experiments in carefully purified air-water and argon-water systems, finding no effect unless they added traces of carbon tetrachloride, or ammonia, to their apparatus.

The experimental evidence seems to indicate that a wide variety of substances form condensation nuclei, of varying efficiency, after interaction with ultra violet light. The real interest of the problem lies in understanding the mechanism by which the nuclei are formed from the traces of impurity so activated. Because of the success of the theory deduced from a study of the c-nuclei, it was decided to investigate ultra violet irradiation of moist nitrogen systems with the high pressure chamber. It was realized from the outset that no conclusions as to the nature of the impurity responsible could be drawn because of the rubber diaphragm in the chamber, but it was found that the observations on the properties of the nuclei were readily explicable using the new theory. It is believed that this is the first study of the problem made at gas pressures above atmospheric.

7: 2 The Experimental Observations.

The source of ultra violet light for the present experiments was a high pressure mercury lamp. There is some disagreement in the literature as to the range of wavelengths which is effective in producing nuclei, probably because this is dependent on the impurity being activated. However the spectrum emitted by the source was examined with a quartz spectrograph, and it was found that the lines were quite strong below 2300\AA , which is a shorter wavelength than commonly found to be necessary. Because the heat from the lamp disturbed the gas temperature, the light was reflected into the chamber with an aluminized mirror. The top window of the chamber was replaced with a piece of 'Spectrosil' which transmits with 98% efficiency down to 2000\AA . A manually operated shutter could be used to turn off the beam. The light intensity was not measured, but for all experiments the source was 30 cm. from the chamber window. The chamber was generally filled to about 30 atmospheres with nitrogen, and was saturated with water vapour, as for the majority of the c-nuclei experiments.

It was found that to obtain consistent results the chamber had to be fully saturated before irradiation was started. To make sure that this was so, the chamber was always left for 30 min. after the last compression. The observations were concerned mainly with the production conditions, and with the way in which the chamber cleaned up after an irradiation. From these, details of the condensation mechanism are deduced.

1. The Production Conditions.

The normal procedure was to set the chamber for a certain expansion, wait 30 min., and then irradiate for some measured time before the

expansion was made. It was discovered that, for any particular expansion ratio, there was a threshold time for which irradiation had to continue before cloud was seen in the subsequent expansion. This effect is shown graphically in Figure 20, where the supersaturation produced in any expansion is plotted against the irradiation time. It can be seen that as the expansion ratio is reduced towards 1.010, the irradiation time necessary for cloud had to be increased.

The density of the cloud seen in the initial expansion depended on the irradiation time. If the chamber had been exposed to light for just the threshold period then the cloud seen was very faint and patchy, taking 2 or 3 secs. to grow. After a longer exposure time the cloud grew quickly, being concentrated initially in the part of the gas directly in the ultra violet light beam. The drops remained in the chamber for a very long time after they had been formed, sometimes for longer than 3 min., depending on the size of the expansion. If no cloud was seen on the initial expansion, i.e. if the irradiation time was less than threshold, then cloud was formed on a subsequent expansion, without any additional exposure, provided the second expansion was as large as corresponded to the initial irradiation time. After drops had been formed on these nuclei once, they were always sensitive in very small expansions of about 1.005. In this respect they resemble the nuclei discussed in section 6: 1, which gave rise to sensitive re-evaporation nuclei after condensation. The re-evaporation nuclei produced in this case are apparently more sensitive than the c-nuclei.

2. The Disappearance of Nuclei from the Gas.

After drops have been formed in an expansion following irradiation, the nuclei may be removed from the gas by a series of cleaning ex-

Figure 20.

Graph of Supersaturation vs. Irradiation Time.

The threshold expansion ratio (and hence supersaturation) was found for different ultra violet light irradiation times of saturated nitrogen. The interpretation of this curve is discussed in the text.

(Data from Run 94. Nitrogen + distilled water at 30 atmospheres.)

Supersaturation vs Irradiation Time.

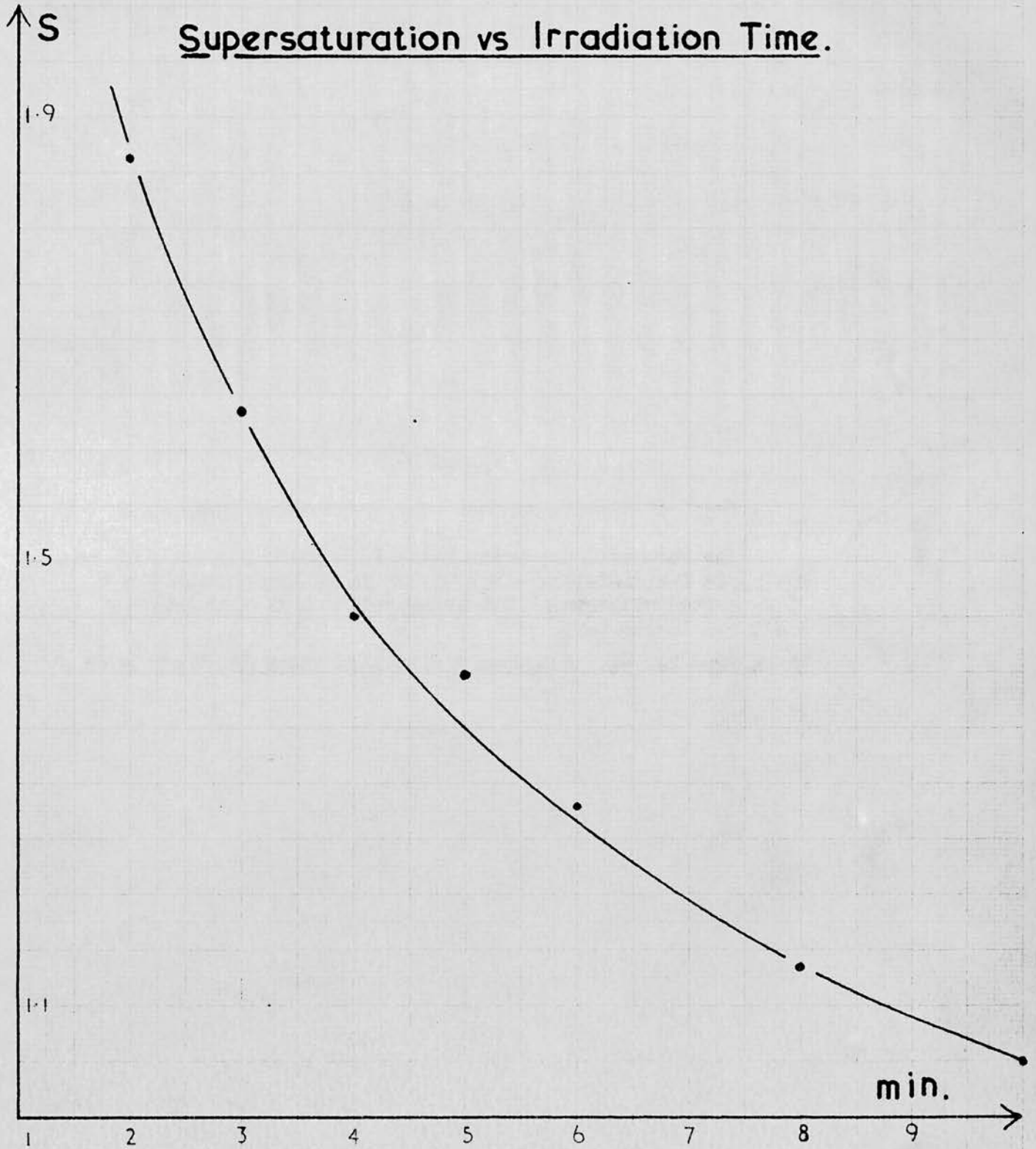

pansions. As with other condensation nuclei, the number of cleaning expansions required depends on the density of the initial cloud and also on their sensitivity. The chamber can of course be cleaned by leaving the gas for a long time. In the case of these nuclei it is necessary to wait about 30 hours after the primary expansion (following a 3 min. irradiation at 1.10) before subsequent expansions produce no cloud. The density of the cloud decreases continuously throughout this period, the same distinctive stages being observed as were found with the c-nuclei.

A typical clearing time following a 3 min. irradiation and expansion is thus rather long, but if (after the light is shuttered) no expansion is made, the nuclei disappear much more rapidly. In fact, unless the first expansion is made within 8 hours of the exposure, no cloud is seen, even if the irradiation time was well above the threshold value. The difference in the clearing times, depending on whether or not an expansion has been made is thus rather striking. An electrostatic field appears to have little or no effect when used to remove the nuclei from the chamber.

It was found, when the surplus water left after a run was tested, that a considerable quantity of nitrite ions had been formed by the action of the ultra violet light.

7: 3 The Proposed Condensation Mechanism.

Considering the fairly detailed study of the problem made over a number of years, there have been remarkably few attempts to suggest a condensation mechanism. McHenry and Twomey (1952) supposed that a neutral cluster of water molecules could be formed around an excited NH_3 or NH_2 molecule. Coalescence of several such clusters would then take place, the clusters remaining stable, and thus acting

as condensation centres after de-excitation, because of the solubility of the ammonia. If the ammonia was not irradiated then the initial clusters could not form because the dipole moment of an unexcited ammonia molecule was supposed to be less than that of one in an excited state. A similar mechanism cannot explain the present observations. For nuclei to be formed at all it seems that an expansion must take place, otherwise, leaving the gas for several hours after irradiation should produce nuclei which are more stable than those normally imagined to develop in the short, pre-expansion period. Diffusion of the initial products of irradiation from the central gas region cannot be very rapid because, even after 5 min. exposures, the cloud is very concentrated. In the experiments of Mulcahy and Kuffel (1962) nuclei are formed in unsaturated conditions, the size of the nuclei increasing with saturation and irradiation. However, the impurity activated in their experiments was probably mercury vapour, which is unlikely to have been present in any other recent work.

As each impurity molecule interacts with the ultra violet light, it may, or may not, cluster some water molecules around it. However when the expansion takes place clustering will occur, and visible drops will be formed, provided sufficient impurity vapour is present to enhance the capture of water vapour. The growth of the cloud will be a statistical process since any particular impurity molecule may be captured by a large cluster, or remain surrounded by relatively few water molecules. Such a mechanism explains both production and cleaning expansions. With short irradiation times, high supersaturation is required to compensate for the lack of impurity vapour produced by the ultra violet light. Once condensation has occurred

the nuclei then disappear from the gas rather slowly. Since the cleaning expansions show the same distinctive stages as with the c-nuclei, it appears that not all the impurity is trapped in the drops; some must remain in the vapour phase. If condensation does not occur immediately after irradiation, then most of the impurity will be in the vapour phase, and will disappear from the gas quite readily. The drops on these nuclei are more stable against evaporation than the c-nuclei, suggesting perhaps that the presence of the vapour is less important for their stability. Also the rather long cleaning time of 30 hours indicates that the successive degradation is a slow process, since this impurity vapour might be expected to disappear at approximately the same rate as the c-nucleus vapour. The ineffectiveness of the electrostatic field further supports these conclusions, as it is supposed that it removes vapour molecules rather than nuclei.

An attempt was made to see if producing c-nuclei before the irradiation would enhance the density of the cloud, since McHenry and Twomey have suggested that nitrogen dioxide might interact with ultra violet light to produce condensation nuclei. No effect was found but this may be because slight increases in the cloud density cannot be readily detected visually. It is hoped that this point will be further investigated if future plans to make quantitative measurements of cloud density (see Chapter 10) are carried out. However it does seem that the broad features of the phenomena are explicable in terms of the new theory, whatever the impurity vapour responsible for the reactive vapour may be.

Since the nitrite test was positive, it is tempting to speculate that atomic oxygen may be created by the ultra violet light, giving

rise to nitrogen dioxide by a series of chemical reactions. Such reactions are known to be important sources of NO_2 in the atmosphere (Cadle, 1963, and section 9: 2). This conclusion would agree with the suggestion of Farley (1951), but, as was stated in the introduction above, many other sources of condensation nuclei may be present. The results of Barnard and Mouton (1958) are rather conclusive in showing that pure systems of air and water are inert under irradiation. However the sensitive time of their small, low pressure expansion chamber would certainly be rather short, so that formation of nuclei may not have occurred unless the necessary chemicals were present in considerable density.

Chapter 8.

OTHER CONDENSATION STUDIES. II. THE ADDITION OF UNUSUAL LIQUIDS,
and LARGE EXPANSION EXPERIMENTS.8: 1: 1 The Addition of Unusual Liquids.

Because of the basic assumption that was made in the proposed explanation of the c-nuclei, that nitric acid, formed from nitrogen dioxide, was efficient in promoting condensation, it was thought appropriate to study the effect of adding traces of it, and other chemical impurities, to water-nitrogen systems. There does not appear to have been a systematic study of the addition of trace impurities, probably because quantities of material much less than may conveniently be handled have a very great effect. Aitken (1880-1), for example, demonstrated that touching a clean wire, just prior to heating it, was sufficient to cause many condensation nuclei to be produced.

The high pressure cloud chamber, used in most of the work discussed so far, is not suitable for this kind of study since cleaning it is a long and difficult process. The 3-atmosphere chamber, already described, is more useful, however, as it can be readily taken down, thoroughly cleaned, and reassembled, in a few hours. The liquid to be studied was contained in a small capillary tube, about 0.1 mm in radius and 5 cm. in length, although the quantity introduced could be made much less than this volume, normally a maximum of 10^{-4} cm.³ being ejected into the gas. The capillary tube was held with sellotape across the hollow core of a solenoid fitted with a heavy armature. The armature smashed the capillary tube when a microswitch, actuated by the expansion valve, connected the solenoid to the 240V. A.C. line. The resultant condensation could be observed

visually or photographically. A number of liquids were studied using this technique, tubes being broken at the start of any expansion, or without any expansion being made. For all experiments the chamber was filled with nitrogen and water vapour at a pressure of 20 p.s.i. above atmospheric.

8: 1: 2 Breaking Water Tubes.

When any liquid is introduced into a gas in the manner just described, it is to be expected that a large number of small, charged and neutral droplets will be formed. 10^{-4}cm^3 of liquid is sufficient to create more than 10^7 drops of 10^{-4}cm radius, each of which will act as a condensation centre and give rise to visible drops even at low degrees of supersaturation. However, if the liquid is not one which enhances condensation, these droplets will evaporate rapidly and not give much cloud on subsequent cleaning expansions.

A typical example of a water tube being broken in a cloud chamber, at the expansion, is shown in Figure 21, in which the solenoid and armature can also be seen. As expected with distilled water, the drops evaporated rapidly, in less than 15 secs. On the cleaning expansion made immediately after only about 10 drops/cm^3 were formed. A second expansion was sufficient to remove them all from the chamber. The fact that any drops at all are seen in the cleaning expansion is perhaps surprising. There are, however, at least two reasons why this was expected. It is always probable that there will be traces of impurities in the chamber because of the presence of the rubber diaphragm and gaskets, but even if this contamination can be discounted, there remains the possibility of chemical reactions, induced by the cosmic radiation causing impurity molecules to be available for capture by the large drops. The cloud

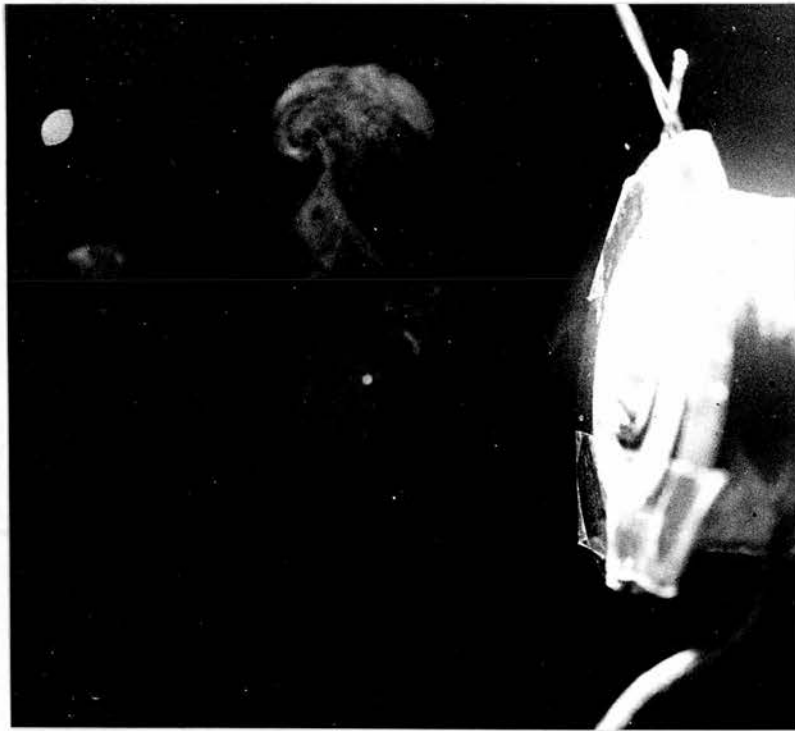

Figure 21. Water-tube breaking.
(Compare Figure 22.)

B 5. Nitrogen + distilled water at 20 p.s.i. above
atmospheric pressure.
Expansion ratio = 1.25.
Flash delay = 1.2 sec.

The water-tube was broken at the start of the
expansion.

seen when a water tube is broken was regarded as a standard for comparison with other liquids.

8: 1: 3 Breaking Nitric Acid Tubes.

Of the liquids and gases investigated by Crane and Halpern (1939), nitric acid was found to form the densest clouds. The dramatic cloud seen when a tube containing concentrated nitric acid is broken during an expansion in the 3-atmosphere chamber is illustrated in Figure 22. Apart from the greatly increased density of the cloud, the most marked difference between this photograph and Figure 21 is the numerous straight lines of drops, almost as sharp as particle tracks, but much denser, seen in the chamber. It is thought that these are caused by flying pieces of glass, each carrying traces of nitric acid, leaving a trail of condensation nuclei, consisting of nitric acid and water, behind them in the gas. The cloud formed in such an expansion takes about 90 sec. to evaporate, much longer than the water cloud. Between 20 and 25 expansions were necessary to remove the nuclei from the chamber. Some molecules however were still present and contributed to background cloud on expansions in which condensation on particle tracks was observed. The nuclei present in the cleaning expansions were found to produce visible drops at expansions less than 1.02. These drops were very small but remained visible for nearly a minute. Not surprisingly the nitrite test made on the surplus water on the floor of the chamber was very strong, NO_2^- presumably being formed by a secondary reaction.

On a number of occasions after a nitric acid tube had been broken, a small quantity of the liquid still remained in the tube. When the chamber had been cleaned it was found that diffusion of nitric acid from the tube could be studied if an expansion was made. Cloud was seen in the region of the tube even at expansions of about



Figure 22. Nitric acid tube breaking.
(Compare Figure 21.)

B 6. Nitrogen + distilled water at 20 p.s.i.
above atmospheric pressure.
Expansion ratio = 1.21.
Flash delay = 1.2 sec.

The solenoid device used to break the capillary
can be seen.

The most striking difference between this photograph
and Figure 21 is the sharp lines of drops.

1.10, much below the ion limit at this pressure. The condensation must have been initiated by single molecules which grew to nuclei and hence to drops because of the vapour of HNO_3 in the chamber. The cloud was denser near to the tube showing that drop growth is enhanced if there is a high impurity vapour density.

When a similar quantity of liquid was introduced into the gas without any expansion being made, even if the chamber was slightly unsaturated, a very dense cloud of small drops was observed which took about 75 secs. to evaporate. This again demonstrates the stability of water drops containing a quantity of nitric acid, which has already been discussed in section 5: 5. The chamber was found to be much harder to clean under these conditions possibly because less nitric acid was contained in the drops and more was in the vapour, being thus able to attack the rubber and other materials in the chamber so producing a variety of chemicals.

Crane and Halpern (loc. cit.) found it impossible to clean their chamber completely after the introduction of nitric acid, and normally scrubbed it after each experiment. This was not found to be necessary in this case, unless it was desired to study the effects of another liquid, or ionic and spontaneous condensation phenomena, for which the brass and glass walls were carefully cleaned, and the rubber gaskets and the diaphragm replaced.

8: 1: 4 Breaking Hydrogen Peroxide Tubes.

Although hydrogen peroxide has been suggested as a potent condensation catalyst by many authors, no one seems to have studied its properties directly. A preliminary investigation with dilute solutions of hydrogen peroxide in water had indicated that, in fact, little cloud was caused by the presence of the liquid and vapour alone. Some further tests were made in the 3-atmosphere chamber by introducing small quantities of strong (100 volumes) hydrogen peroxide into

the gas.

When a hydrogen peroxide tube was broken without an expansion very little cloud was seen, in contrast to the nitric acid tubes. The drops were fairly stable taking about 20 secs. to evaporate. The chamber cleaned up readily after about 8 expansions and moreover, after the gas had been cleaned, tracks were observed at normal thresholds without any unusually high background of drops.

When a tube was broken during an expansion a dense cloud of quite large drops was produced. Usually there were signs of lines of drops but these were not nearly so dense or sharp as with the nitric acid. The number of cleaning expansions required to clean the chamber was again about 8.

From these experiments it was concluded that hydrogen peroxide is not a very efficient condensation substance. The fact that lines of drops were seen, similar to the nitric acid cases does however suggest that it will enhance condensation if the vapour is sufficiently concentrated. It seems unlikely, therefore, that it is the substance responsible for the cloud seen after ultra violet light irradiations (section 7: 1).

8: 1: 5 Other Liquids.

A number of other liquids were introduced into the gas in small quantities by the method used above. An attempt has been made to list their properties and introduction conditions in Table 4. The behaviour of liquids already discussed in detail are listed for comparison.

The liquids which caused lines of drops similar to nitric acid are regarded, from this brief survey, as being fairly effective in initiating condensation since probably only a small number of im-

TABLE 4

Summary of Effect of Introducing Trace Quantities of Liquids into Nitrogen-Water Systems.

| Liquid. | Method of Introduction. | Comments on the Cloud First Seen. | Cleaning Expansions. | Effect on Small Expansions. | Effect on Particle Tracks. | Other Comments: |
|---|----------------------------------|---|--|---|--|---|
| H ₂ O | During expansions of about 1.23 | Not much cloud seen. (see Figure 21). Drops evaporated in less than 15 secs. | Only about 2 required to clean chamber. | Little cloud seen in expansions of 1.02. | None. | |
| HNO ₃ (cont.) | During expansions of about 1.20. | Very dense cloud with lines of drops. (see Figure 22). Took about 90 sec. to disappear. | About 25 expansions required to clean the chamber. | Dense cloud of high stability seen on small expansions, ≤ 1.02 . | Heavy background found at track limit. | After chamber had been cleaned with cleaning expansions, cloud only found at track limit. |
| HNO ₃ (cont.) | Without an expansion | Dense cloud of small drops, with lines of drops seen. Took about 75 secs. to disappear. | Chamber could not be got clean with cleaning expansions. | Dense cloud on small expansions. | Heavy background at track limit. | Other chemical complexes probably produced via action on rubber. |
| H ₂ O ₂ (100 vols.) | During an expansion of 1.17 | Dense cloud with lines of drops. Drops evaporated in about 20 secs. | About 8 expansions required to clean the chamber. | Dense cloud on small expansions, ≤ 1.02 | Very little, if any. | |
| H ₂ O ₂ (100 vols.) | Without an expansion. | Very little cloud which disappeared in about 5 secs. | About 9 expansions required to clean the chamber. | Dense cloud on small expansions, ≤ 1.02 | Very little, if any. | |

TABLE 4 (Contd.)

| Liquid. | Method of Introduction. | Comments on the Cloud First Seen. | Cleaning Expansions. | Effect on Small Expansions. | Effect on Particle Tracks. | Other Comments. |
|--|-----------------------------|---|--|---|--|---|
| NH ₄ OH (conc.) | During an expansion of 1.17 | Not much cloud. Drops, which were quite small, evaporated in about 25 secs. | About 4 cleaning expansions required to clean chamber. | Not much cloud seen on small expansions. | Very little, if any. | |
| NaCl/H ₂ O Solution (Strong) | During an expansion of 1.17 | Quite large drops which evaporated in about 15 secs. | About 4 cleaning expansions required to clean chamber. | Dense cloud of very small drops on small expansion. | No effect. | |
| CCl ₄ | During an expansion of 1.17 | A lot of cloud produced. Large drops evaporated in 25 sec. | About 6 cleaning expansions required to clean chamber. | Dense cloud on small expansion. | Some background cloud but tracks seemed to be very bright, and stood out against background. | Presence of Iodine slightly modified properties of CCl ₄ . |
| Solution of I ₂ in CCl ₄ (strong) | During an expansion of 1.17 | A lot of dense cloud. Quite large drops, which evaporated in 30 sec. | Chamber clean after about 5 expansions, but slow growing drops seen in later expansions. | Dense cloud in small expansions. | Background around track limit. | |

TABLE 4 (Contd.)

| Liquid | Method of Introduction | Comments on the Cloud First Seen. | Cleaning Expansions. | Effect on Small Expansions. | Effect on Particle Tracks. | Other Comments. |
|-------------------|-----------------------------|---|--|--------------------------------------|-------------------------------|--|
| HCl (conc.) | During an expansion of 1.17 | Cloud comparable to HNO ₃ . Lines of drops seen. Drops became small rapidly but took about 70 sec. to evaporate. | 7 cleaning expansions required to clean the chamber. | Very dense cloud on small expansion. | Background at track limit. | Effect very comparable to HNO ₃ except chamber cleaned up much more easily. |
| CH ₃ I | During an expansion of 1.17 | Dense cloud which lasted about 30 secs. | 5 cleaning expansions required to clean the chamber. | Very dense cloud on small expansion. | Little effect on track limit. | |

purity molecules were available to start drop growth. It is interesting to note that ammonia was not very effective in this respect, which agrees with the findings of other workers (Crane and Halpern, 1939, and McHenry and Twomey, 1952), but disagrees with the earlier conclusions of this work (section 4: 7(5)), to some extent. Hydrogen peroxide, although giving dense cloud just after introduction, appears to have little effect on background condensation near the ion limit. The fact that all liquids required more cleaning expansions than water alone to remove the nuclei from the chamber further emphasises that the presence of a vapour as well as nuclei increases the cloud. The different stabilities of the drops, under similar production conditions, is interesting but it requires further well controlled investigations before any conclusions can be drawn from the results. Nitric acid, hydrochloric acid and carbon tetrachloride would appear to be the most undesirable substances to have in a cloud chamber from the point of view of low background cloud near the particle track limit.

8: 2: 1 Some Condensation Studies at Large Expansion Ratios.

The work described so far has concentrated on the nature of the nuclei and the mechanism involved in condensation processes which take place at low degrees of supersaturation. As was discussed in Chapter 3, much of the cloud causing unwanted background in cloud chambers arises from large expansions in which homogeneous nucleation takes place in the volume between the diaphragm and the brass plate, at the back of the working volume of the chamber. Interest lies in elucidating the nature of the nuclei which remain, following evaporation of the drops so formed. Many authors have studied the limit for onset of homogeneous condensation and have uniformly reported the

observation that nuclei are formed which cause cloud on small subsequent expansions. No attempt has been made here to calculate the nucleation rate for homogeneous condensation as this has been attempted by many workers using chambers specifically designed for the purpose. Several series of experiments were however carried out to study the re-evaporation nuclei, using the 3-atmosphere chamber, in which sufficiently large expansions could be made. It should be emphasised that these experiments were completed before those just described (in section 8: 1: 1 et seq.) were begun, so that there is no question of any unremoved contamination invalidating the results.

A typical set of observations is presented in Table 5 for a nitrogen-water system. The gas in the chamber, at a pressure of 18.4 p.s.i. above atmospheric pressure, was allowed to saturate with water vapour by being left undisturbed for several days. The expansion ratio for good particle tracks, that is, for equal positive and negative ion condensation and low background, was then found. Observations on the cloud under various settings of the electrostatic clearing field were then made for different expansion ratios on either side of this value, and subsequent cleaning expansions were studied. Each observation recorded in Table 5 was repeated several times, the whole experiment running for several days. If the field was not required to be on, until, or during the expansion it was normally applied for 30 secs., before being switched off for 2 minutes prior to the expansion, so that the ion level in the chamber was approximately constant.

A few rather general conclusions can be drawn from these results:-

(a) At low expansion ratios, ions must be left in the chamber to give visible drops. The subsequent cleaning expansions have to be

TABLE 5

Summary of Observations on Condensation Processes
in Large Expansions.

Run B 12. Oxygen-free Nitrogen at 18.4 p.s.i. above atmospheric pressure, saturated with distilled water.

Clearing Field Voltage = + 600V.

| Primary Expansions. | Secondary (cleaning) Expansions. |
|--|--|
| 1.25 No field. Fairly dense cloud seen. | 1.21 Hardly any drops. |
| 1.26 No field. Dense cloud. | 1.21 Quite a few drops seen. |
| 1.27 No field. Dense cloud | 1.07 Some drops. |
| | 1.11 Light cloud, slow to grow. |
| | 1.17 Uniform light cloud. |
| 1.27 Field on till expansion. Tracks seen as they fell out. | 1.21 Hardly any drops seen. |
| 1.28 Field on till expansion. Good tracks seen. No background. | 1.21 Hardly any drops. |
| 1.29 No field. Dense cloud seen. | 1.20 Heavy cloud formed. |
| | 1.03 Tiny drops which grew very slowly. |
| 1.30 No field. Dense cloud of large drops. | 1.03 Not very dense cloud, appearing slowly. |
| 1.31 Field on till expansion. Dense cloud but good tracks. | 1.03 Light cloud after a long delay. |
| 1.31 No field. Dense cloud. | 1.03 Drops seen after a long delay. |
| 1.325 No field. Dense cloud. | 1.03 Dense cloud of small drops. |
| 1.35 Irrespective of the field a dense cloud was seen. | 1.03 Dense cloud of small drops. Nuclei stable for more than 20 hours. |

large to detect any cloud at all.

(b) At large expansion ratios the presence or absence of ions appears to have little effect on the initial density of cloud, and on the cleaning expansions.

(c) In the intermediate range between efficient ionic condensation and efficient homogeneous condensation, the presence of ions does appear to have a noticeable effect on the cleaning expansions.

Two further observations may be noted. The field does not affect subsequent cleaning expansions if it is applied after the expansion has been started. Also, an identical set of observations were obtained with argon as the carrier gas, the absolute expansion ratios being different, although the corresponding supersaturations were similar. The number, size and lifetime of the visible drops appears to determine their behaviour on subsequent cleaning expansions. At low expansion ratios only a small number of drops are seen, and these exist only for a short time after the expansion. Correspondingly the cleaning expansions are not dirty unless they are made quite large. On the other hand, at very large expansions many drops are formed, and these remain visible for a relatively long time giving rise subsequently to dense cloud even on small expansions. The number of drops at this stage is so great that the small contribution of perhaps 2×10^3 drops/cm³ made by the ions in the gas is not detectable as an increase in density. If, in the chamber, there was an impurity of constant density continually present, then it could be picked up by the drops only in significant quantities when their surface area was large and when the supersaturation conditions were favourable. Until the expansion no nuclei, apart from ion clusters, are present, and little or no coagulation of the

vapour molecules is thought to occur. After evaporation an equilibrium state, as found with the α -nuclei, will be established.

Postulating the existence of such an impurity appears to explain the experimental observations, but the nature and origin of it remain to be considered. Certainly it is well known that irradiation of a nitrogen-water vapour system can produce nitric acid (Lind, 1961). It is possible, indeed certain that this will occur here although the quantities produced must be minute. Removing ions from the gas will not necessarily remove any chemical which has been newly formed so that an equilibrium concentration of it will be established in the two phase system. It seems reasonable to suppose that nitric acid will be produced in nitrogen-water systems, but it cannot be formed in an argon-water mixture. Tests for nitrite ions made on the water in the chamber have been negative although they were always positive when nitric acid had been introduced artificially. Ozone could possibly be produced from the water alone, and hydrogen peroxide might be present. Although H_2O_2 appears to be ineffective in promoting condensation while in the vapour phase, if captured in drops it may stabilize the resultant re-evaporation nuclei. There is no experimental evidence for, or against, this hypothesis. These substances can be formed in any gas-water system, the chemicals which are finally produced depending very much on the reaction rates, and the occurrence of any other competing process.

Unfortunately little is known about radiation-induced chemical reactions on such a very small scale. From Crane and Halpern's results (1939), and from the experiments discussed in the preceding sections, it is improbable that nitric acid or any other molecules which singly can act as a condensation centre, with a visible

threshold less than or equal to the ion limit, could be present. If such an impurity was formed in any quantity, a cloud chamber would be impossible to operate as it could never be cleaned. Apart from these incidental observations, Farley (1951) appears to be the only author to have attacked this problem directly. He succeeded in observing dense cloud formed on neutral particles produced by 600 keV deuterons passing through an air-water cloud chamber. The nuclei persisted in the gas for at least 2 minutes after irradiation by the deuterons had ceased. He suggested that these nuclei, created directly or indirectly by the deuterons, were similar to those observed by him when his chamber was irradiated with ultra violet light, although this is inconsistent with his conclusion that the lifetime of the ultra violet produced nuclei was much less than 2 minutes.

While the nature of the chemical complexes formed by ionizing radiation is still obscure, it seems possible that their production could give rise to the sensitive re-evaporation nuclei found in so many experiments. If this conclusion is correct it must appear doubtful whether homogeneous condensation has, in fact, ever been observed, since the complete absence of such chemicals cannot be obtained under normal experimental conditions. Madonna et al (1961) have reached a similar conclusion, though they consider that it is the presence of ions which initiates condensation even at high expansion ratios, an observation which is supported by a remark of Blumenfeld, Booth and Lederman (1954) to the effect that if an electrostatic field is maintained in the plate-diaphragm region of a cloud chamber, then the background cloud is reduced.

Chapter 9

SPECULATIONS ON SOME ASPECTS OF CLOUD PHYSICS.9: 1 Introduction.

Although Aitken was well aware of the cloud forming properties of hygroscopic substances such as sodium chloride and nitric acid, he apparently considered sulphur as being the most important, naturally occurring, condensation substance. Coste and Wright (1935) regarded nitrous acid, produced as a by-product of human activity, together with sodium chloride, as the main atmospheric condensation nuclei, both being much more important than sulphur compounds such as sulphuric acid. More recent views (Mason, 1957, 1960, and Fletcher, 1962) accept these and other compounds as important in promoting condensation, much effort being expended in attempts to find the origin of the chemicals in the nuclei and also, in certain cases, to understand the mechanism whereby the nuclei are formed. An important source of the ubiquitous Aitken nuclei, which are between 5×10^{-7} cm. and 2×10^{-5} cm. in radius, is thought to be the reactions between trace gases through the action of heat, radiation and humidity. The origin of one trace gas, namely nitrogen dioxide, and some speculations on drop growth mechanisms are considered below.

9: 2 The Occurrence of c-nuclei in Nature.

Nitrogen dioxide plays an important role in atmospheric physics (Cadle, 1963). It can readily be oxidized to N_2O_5 by ozone, which is present in abundance, especially in the region of the atmosphere above the troposphere. N_2O_5 reacts with water to form nitric acid:-

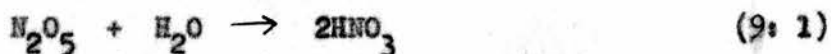

while NO_2 itself reacts with water in the gas phase (equation 5: 5) to give nitric acid which, as has been amply demonstrated in this,

and other, work is an excellent condensation substance. Nitrogen dioxide is responsible for the conversion of NaCl to gaseous chlorine compounds such as Cl_2 or HCl, both of which are important in atmospheric chemistry.

Georgii (1963) has reviewed the possible sources of NO_2 in the earth's atmosphere, reaching the conclusion that human activity and oxidation of ammonia are the predominant sources, and that no significant amount of the total atmospheric NO_2 is produced by thunderstorm activity. Aitken (1911) realized that condensation nuclei could be readily produced at a discharging point, particularly if the air was moist. He was of the opinion, however, that "in nature the point discharge is very feeble under all but exceptional conditions, and is probably too feeble to produce any effect". In their original report on the observation of c-nuclei, Evans and Watson (1962) speculated that such nuclei might occur in nature, particularly in heavily afforested areas. It is appropriate at this stage to re-examine this situation in more detail, and in the light of later work.

It is well known that even under fair weather conditions the currents flowing through living trees may be of the order of $\frac{1}{2} \mu\text{A}$, while the potential difference between the top of a tree and earth may be about 12kV (Milner and Chalmers, 1961). It has been shown, in the experiments described above, that when a current of this order flows through a water layer under unsaturated, saturated or super-saturated gas conditions, molecules of nitrogen dioxide are produced which combine rapidly with water to form nitrons and nitric acids. It has been shown further that it is not necessary to have a point, with a large voltage applied to it, to eject these molecules from

the liquid surface into the surrounding gas. The experiments in which cloud was observed when a current passed through an evaporating liquid surface have demonstrated another mechanism for getting the molecules into the gas. Some c-nuclei may be produced directly under favourable conditions, but their formation in the atmosphere, from individual nitrogen dioxide molecules, seems more likely. This is considered below.

It is not being here suggested that the only sources of nitrogen dioxide in the atmosphere are trees. It is possible, however, that some of the world's budget of nitrogen dioxide is made up of c-nuclei and NO_2 molecules produced in the manner outlined above. If all the trees on the earth's surface passed $\frac{1}{2} \mu\text{A}$ of current continuously, then, assuming efficient release and conversion of nitrogen dioxide, an order of magnitude calculation shows that 7000 tons of nitrogen dioxide would be produced annually, in this way. This represents perhaps one hundredth of the total quantity of NO_2 present in the world's atmosphere. The average density of NO_2 in the troposphere is probably not more than 10^{-13} gm/cm^3 (Fletcher, 1962), which is slightly less than the mean density of NO_2 molecules in the high pressure chamber after a typical production expansion.

Indirect evidence on the production of nitrogen dioxide by trees comes from the observations of Went (1960) on the blue hazes which exist all year over such areas as the Amazon basin and the jungles of northern Columbia. He attributes the haze to the presence of small particles formed by the condensation of partially oxidized volatile organic compounds (such as terpenes), which are released from plants, to form macromolecules. This partial oxidation is supposed to take place when sunlight is absorbed, with oxides of

nitrogen present to act as catalysts in the process. It is tentatively suggested that the nitrogen dioxide participating in these reactions may also come from the trees.

9: 3 Nucleation Mechanisms.

One of the unsolved problems of condensation phenomena is the question of the formation of nuclei from the products of reactions between trace gases. It has been shown, both in the experiments with the s-nuclei, and in those with the nuclei formed after ultra violet light irradiation, that condensation nuclei are much more stable after slight supersaturation has been produced, although under certain circumstances they may exist, for limited periods, even in unsaturated conditions. The existence of supersaturation, however slight, enables condensation nuclei to be formed, of a size dependent on the vapour pressures of the trace impurity and the water. Once the nuclei are formed their stability is very high even if the water vapour pressure is reduced much below its value at production, the impurity vapour exerting the major controlling influence upon them.

This mechanism may well be responsible for the production of some of the smaller Aitken nuclei in the atmosphere, from the molecules of trace gases, while larger ones might be created by coagulation, a process which so far has not been observed with the nuclei of these experiments, probably because the size of the chamber restricts the lifetime of the small aggregates in the gaseous state. No such restriction is present in the atmosphere. The purpose of the expansion in the cloud chamber experiments is now seen to be twofold. If no nuclei are present initially, it provides the slight supersaturation necessary to initiate nucleation, and, if sufficient supersaturation has been established, it will give rise to drop growth.

The rate of formation of the nuclei will be very dependent on the impurity vapour density (as has been shown many times in the c-nuclei experiments) so that the major advantage of the long sensitive time in the high pressure cloud chamber is that it allows observation of nucleus and drop formation in the same expansion.

Certainly a puzzling observation of Aitken's is explicable in this manner. He discovered (1917) that nuclei effective only in 4% expansions were formed if an electric discharge occurred in a flask containing a weak solution of sulphurous acid, whereas in the presence of a stronger solution, nuclei producing drops in 2% expansions were found. As with other results discussed in the same paper he apparently thought that nuclei of different sizes were being created in the discharge. It seems more likely, however, that more of some impurity was being formed in the second case, so that the very short sensitive time of his expansion chamber was sufficient for observing both the nucleation and drop formation periods in a 2% expansion.

It is probable that these ideas might be extended to the formation of nuclei which are really aqueous solutions of solids, such as sodium chloride. However, there are perhaps not many mechanisms which could produce single salt molecules, and nuclei of this kind are more likely to arise by absorption of water vapour on to hygroscopic particles formed by mechanical disruption and dispersal of matter at the earth's surface (Mason, 1960). The importance of the impurity vapour during the early stages of drop growth still remains.

9: 4 Ice Crystals.

The observation of what were called twinkling drops has been described in a previous chapter, where it was also suggested that they

might be ice crystals formed in a novel way. At this stage the remarks which follow are pure conjecture since a great deal of work remains to be done before the origin, properties and freezing mechanism of the crystals can be fully understood. It does, however, seem fairly certain that the impurity causing their formation is present in the air taken from the room. There is also some slight correlation between their observation or, at least, their time of collection in the chamber, and the weather. They have been rarely observed except on occasions when rain fell some short time after the room air was enclosed in the chamber.

If the impurity can produce ice crystals because of rapid evaporation when the surrounding gas has less than its equilibrium amount present, then this would be an important process for ice formation in clouds. It is well known that supercooled water droplets will not freeze unless ice-forming nuclei, or other ice crystals, are present, and these are only effective at temperatures below 0°C . Here, however, is a possible mechanism for producing ice crystals at temperatures above 0°C which might then inoculate supercooled water droplets present at a lower temperature, if it passed through them. The importance of such a process in cloud physics, if it does occur, will be easily realized.

CHAPTER 10

AN ASSESSMENT OF THE VALUE OF HIGH PRESSURE CLOUD CHAMBERS10: 1 Introduction.

It will be recalled that the inspiration for this work arose out of a desire to re-evaluate the position of the high pressure cloud chamber as a tool for physics research. The experiments, and the conclusions which have been derived from them, are thought to show that certainly in the field of condensation research the high pressure chamber is most useful, probably more so than the atmospheric cloud chamber. Mason (1957) has shown that the diffusion cloud chamber is of great value for studying the growth of ice crystals, but it has a number of disadvantages for condensation work. It is not possible, as was discussed in Chapter 1, to operate the diffusion chamber with air at any very high pressure, so that the rapid rate of fall of the drops, with consequent alteration in the condition of supersaturation, is a disadvantage. Further, information cannot be obtained in any way corresponding to the cleaning expansions which were studied extensively in the present work with cloud chambers. Once drops are formed in the diffusion chamber they fall out without evaporating, so that only a very limited study of their properties can be made. However one advantage of the diffusion chamber is that it would be relatively easy to construct a chemically pure apparatus for investigating the effect of adding trace impurities to gas-water systems.

The potential of the high pressure cloud chamber is not however restricted to condensation work. It is thought that there are some important nuclear physics experiments which could be carried out most adequately using this detection technique rather than any other.

Also, as was indicated in an earlier discussion, it may be possible to study some radiation-induced chemical reactions in unusual conditions and at uncommonly low concentrations of final products.

These possibilities will be further amplified below.

10: 2 Further Condensation Studies.

A major improvement in the condensation investigations possible with the high pressure chamber would be made if it were adapted for more quantitative work. In particular the facility for making relative measurements of cloud density would be advantageous in understanding more clearly the way in which drops grow and evaporate. In this respect it should be possible to use the chamber as a modified Nolan-Pollak counter (Nolan and Pollak, 1946), so that the density of any cloud formed could be determined photo-electrically.

Facilities for measuring the gas temperature and saturation in different regions of the chamber are also desirable. Courtney (1962) has described in detail a suitable system which he used in some spontaneous condensation studies at atmospheric pressure.

In the two chambers used in the present work the necessary presence of the rubber diaphragm has been unfortunate from the point of view of chemical purity. Contamination might be avoided if the rubber was coated with a substance having a low vapour pressure, such as araldite, or else the possibility of using a pliable polythene material might be investigated. At some expense an armour plated glass chamber, readily demountable for efficient cleaning, which could be operated at about 30 atmospheres pressure, might be designed and constructed.

There are many interesting lines of investigation which could be pursued with such apparatus. Some of the outstanding problems

may be mentioned. An investigation of the spontaneous condensation and ionic condensation limits at high pressures has never been made, and although it is known that the bulk value of the surface tension varies with pressure, no results have been reported which can seriously claim to compare theory with experiment. Because of the long sensitive time of the high pressure chamber it is possible to simulate natural cloud conditions much more closely than at low pressures, so that if a sufficiently large chamber could be built studies of drop growth on condensation nuclei might be facilitated. An investigation of the properties of the twinkling drops already discussed is also a problem of great interest, particularly because of its relevance to cloud physics. Finally, examination of problems such as the interaction of ultra violet light with water vapour and different gases would undoubtedly prove useful for understanding fundamental nucleation processes.

10: 3 A Nuclear Physics Experiment.

An important test of the theory of quantum electrodynamics lies in comparing the theoretical cross section for direct electron pair production by a charged particle, such as an electron or μ -meson, with the observed value, particularly in regions of high energy transfer. The cross section has an appreciable value only if the energy of the primary particle is very great. Unfortunately the probability that an electron will undergo a bremsstrahlung transition in which the resultant photon produces a pair of electrons close to the primary electron track is comparable to the probability of true direct electron pair production, so that comparison of theory with experiment is difficult with electron primaries. With μ -mesons this problem is absent, but higher primary energies are required for a comparable cross section.

Theories of the process have been worked out by a number of authors (Bhabha, 1935, Block, King and Wada, 1954, and Murota, Ueda and Tanaka, 1956) and are now believed to be in fair agreement (Roe and Osaki, 1959). There is, however, in each theory at least one undetermined parameter, known to be equal to unity in order of magnitude only. Experiment is normally compared with the calculations of Murota et al. where this parameter, α , arises as a cut-off factor in the momentum transferred from the primary particle to the electron pair. The predicted values of the cross sections can be changed by 30%, and in some regions by a factor of 2, by merely making reasonable changes in these parameters, (Stoker et al, 1963).

Two attempts have been made to determine the cross section for μ -meson primaries, directly, using nuclear emulsions to detect the events. Avan and Avan (1957), working at two different depths underground, found agreement with theory for the 30 events observed at each depth. Gailloud and Piron (1963) using the 8.2 GeV μ -meson beam from the C.E.R.N. proton-synchrotron claim agreement with theory on the basis of 14 events. Neither experiment is able to assign a definite value to α . The more common technique (Roe and Osaki, 1959, Gaebler, Hagen and Hendel, 1961, and Stoker et al, 1961, 1962, 1963) has been to observe the showers produced by the secondaries associated with cosmic ray μ -mesons in series of lead plates in multiplate cloud chambers, deducing the value of the cross section from a study of the energy transfer and the structure of the showers. This method is unsatisfactory for a number of reasons but principally because shower theory has not been confirmed for the energy transfers being investigated.

The cross sections differ, for different values of α , most

markedly in the region of low energy transfers, and, so that an accurate theory may be available to compare with experiment at high energy transfers, it seems most convenient to determine α from results in this region. Only Stoker et al (1962, 1963) have been able to attempt this, but their result is by no means conclusive. On the basis of 24 events they found that the most probable value was $\alpha = 2$. This, however, is very dependent on 13 events corresponding to energy transfers in the range 25 to 60 MeV. The authors themselves express uncertainty about the lower energy limit for electron absorption in this range, and in view of this, and the rather large discrepancy (about 30%) between the observed and expected numbers of knock-on electrons of 15 to 60 MeV, this conclusion should be treated with caution.

It should be possible, using a high pressure cloud chamber, to make a direct measurement of the pair production cross section for μ -mesons, particularly in regions of energy transfer from 2 to 200 MeV. The theory of Murota et al. is accurate for transfers as low as 10 MeV, so that an estimate of α could be made with some confidence. It is shown in Appendix G that such an experiment is possible (with reasonable running times) using a cloud chamber filled with argon at 100 atmospheres. Cosmic ray muons of energy above about 2 GeV could readily be picked out by a simple counter system. The only competing process which might make identification of electron pairs difficult is that in which two knock-on electrons are produced within 0.1 mm. of each other so that their origins cannot be resolved, but, as shown in the appendix, this probability is small. It seems feasible, therefore, to use a high pressure chamber for this experiment, for which no other technique is really suited.

10: 4 Possible Radiation Chemistry Studies.

The possibility of using the high pressure cloud chamber as a detector of radiation-produced chemical species has been hinted at briefly in the discussion of the origin of the re-evaporation nuclei produced after a large expansion. Before it was possible to use the chamber for such work it would be necessary to calibrate its behaviour with known reaction products. A chamber which could be efficiently cleaned is essential, and it must also be fitted with devices for recording cloud densities and supersaturations. Apart from the pioneer investigations of Crane and Halpern (1939) and Farley (1951) in this field, no other experiments have been made, so that initially, any work would be exploratory. Variable dose rates of particles, such as are obtainable from a strong radioactive source, an accelerator or nuclear reactor, would be very useful. The study of reactions produced at high degrees of supersaturation in gas-liquid systems could be investigated by this method, in addition to similar investigations at very low concentrations, a field which at present is excluded from the radiation chemist.

The high pressure cloud chamber, therefore, has a number of uses: it is a valuable tool in condensation research, some nuclear physics experiments are best performed using it, and a practically unexplored field may exist for its exploitation in radiation chemistry.

APPENDIX A (Chapter 5)

THE DENSITY OF THE CLOUD SEEN IN CLEANING EXPANSIONS.

An estimate of the droplet density of a cloud formed in the first cleaning expansion after a production expansion, in which a large voltage has been applied to the silk for 10 secs., may be made in the following way. Mason (1957) has calculated that the maximum density of drops formed by homogeneous condensation in an expansion of 1.45 is $3.8 \times 10^6/\text{cm}^3$, for an expansion time of 0.01 sec., and has found this estimate to be in fair agreement with experiment. Very dense clouds have been seen in the 3-atmosphere chamber in expansions of 1.40, but they cannot be as dense as Mason's estimate because a much slower expansion was used. The clouds are, however, as dense as those formed in the cleaning expansions in the high pressure chamber, under the conditions mentioned.

Since condensation nuclei are available in these cleaning expansions, an upper limit to the droplet density in the high pressure chamber can be estimated from the water which is available for condensation just following an expansion. If 5% of the total mass of water vapour is released then a total of 1.2×10^9 nuclei could grow to a size of 1 micron, neglecting the rise in temperature of the chamber during the condensation process. This corresponds to a density of 2×10^5 drops/ cm^3 . Further the cloud seen in the cleaning expansions when the natural aerosol component is present is normally denser than the cloud being considered. The density of the aerosol component may be estimated from figures given for the nuclei concentration in city air by various authors, and may be as great as $4 \times 10^6/\text{cm}^3$. From these considerations it seems reasonable to estimate the total number of nuclei produced in 10 secs. as being

10^9 (or $1.7 \times 10^5 \text{ cm}^3$), this figure being regarded as reliable to an order of magnitude.

APPENDIX B (Chapter 5)

SUPERSATURATION REQUIRED FOR DROP GROWTH ON MULTI-CHARGED NUCLEI.

Thomson's equation (3: 2) was given in the form:-

$$\log_e S = \frac{M}{RT\rho} \left[\frac{2\sigma}{r} + \frac{d\sigma}{dr} - \frac{e^2}{8\pi\epsilon r^4} \right]$$

Assuming that the variation of surface tension with radius is negligible, this equation may be written as:-

$$\frac{RT\rho}{M} \log_e S = \frac{2\sigma}{r} - \frac{n^2 e^2}{8\pi\epsilon r^4}$$

if q , the total charge on the drop, is ne , where e is the electronic charge, and n is the number of units of charge. The maximum value of S , that is, that which must be exceeded to give visible drops, is found from $\frac{dS}{dr} = 0$

$$\text{Thus } \frac{RT\rho}{M} \cdot \frac{1}{S} \cdot \frac{dS}{dr} = -\frac{2\sigma}{r^2} + \frac{4n^2 e^2}{8\pi\epsilon r^5} = 0$$

$$\text{Hence } \frac{RT\rho}{M} \log_e S_{\max} = \frac{3}{8} \cdot \frac{n^2 e^2}{\pi\epsilon r^4}$$

$$\text{and } \log_e S_{\max} = \frac{3}{8} \cdot \frac{M}{RT\rho} \cdot \frac{1}{\pi\epsilon} \cdot n^2 e^2 \cdot \left(\frac{n^2 e^2}{4\pi\epsilon\sigma} \right)^{-4/3}$$

Taking water as an example, with $e = 4.8 \times 10^{-10}$ e.s.u.,
 $R = 8.3 \times 10^7$ ergs/gm. mol/°K, $\rho = 1$ gm/cm³, $\epsilon = 1$, $M = 18$,
 $T = 273^\circ\text{K}$ and $\sigma = 75$ ergs/cm², this may be expressed as:-

$$\log_e S_{\max} = 1.54 n^{-3} = \log_e S_{\min} \quad (\text{p 53})$$

Some values are tabulated below:-

| n | $\log S_{\max}$ | S_{\max} |
|-------|-----------------|---------------|
| 1 | 1.540 | 4.66 or 366% |
| 10 | 0.331 | 1.40 or 40% |
| 100 | 0.0715 | 1.074 or 7.4% |
| 500 | 0.0244 | 1.033 or 3.3% |
| 1000 | 0.0154 | 1.016 or 1.6% |
| 10000 | 0.0003 | 1.003 or 0.3% |

APPENDIX C (Chapter 5)

RATE OF COLLISION OF IMPURITY VAPOUR MOLECULES WITH NUCLEI
OF DIFFERENT RADII.

It is possible to estimate very roughly the quantity of NO_2^- produced in an expansion during which the electric field is applied for about 10 secs., in the following way. After 10 such expansions it is found by visual comparison with solutions of known strength that about 10^{-6} moles of nitrite ion/litre of water have been produced. Hence for the 6 cc. of distilled water normally added to the chamber 3.6×10^{14} nitrite ions are formed during each expansion.

Immediately following a production expansion, the nitrogen dioxide, assumed to be responsible for the nitrite detected, will be mainly in the gas phase with a certain quantity solvated in the c-nuclei, equilibrium existing between the two phases. If equilibrium exists in this manner then even when a nitrogen dioxide molecule does collide with a nucleus it will not be captured, otherwise the expansion ratio threshold would be found to decrease with time. However when supersaturation is produced in the gas the equilibrium will be upset and any nitrogen dioxide molecules which the nucleus encounters can be absorbed. The collision rate for various sizes and compositions of nuclei may be estimated.

The mass of a nitrogen dioxide molecule is approximately 8×10^{-23} gm., and the root mean square velocity of these molecules is given by:-

$$\sqrt{\bar{c}^2} = \sqrt{\frac{3kT}{M}}$$

where M is the molecular mass, T the absolute temperature and k Boltzmann's constant.

Therefore $\sqrt{\bar{c}_{\text{NO}_2}^2} = 3.8 \times 10^4$ cm/sec. for $T = 293^\circ\text{K}$. The

number of NO_2 molecule collisions experienced by a nucleus

$$\approx \rho \sqrt{c^2} A = n/\text{sec.}, \text{ where } \rho \text{ is the vapour density of } \text{NO}_2 \text{ and}$$

A is the surface area of the nucleus.

The maximum number of nuclei estimated to be in the gas immediately after the primary production expansion is 10^9 , (see Appendix A), so that for different nuclei the collision frequency can be calculated as tabulated below, where it has been assumed that 10^{14} nitrogen dioxide molecules are produced in each expansion.

| Radius of nucleus. | % of nucleus which is NO_2 . | Collisions/sec/nucleus. |
|------------------------|--|-------------------------|
| 10^{-7} cm. | 50% | 70/sec. |
| 5×10^{-7} cm. | 50% | 2×10^3 /sec. |
| 10^{-6} cm. | 0.1% | 7×10^3 /sec. |
| 10^{-6} cm. | 1% | 7×10^3 /sec. |
| 10^{-6} cm. | 10% | 6.3×10^3 /sec. |
| 10^{-5} cm. | 0.01% | 6.3×10^5 /sec. |
| 10^{-5} cm. | 0.1% | not possible. |

Also for a nucleus the size of an ion cluster, about 4×10^{-8} cm., the collision frequency per cluster in a vapour of this density is about 10^{-2} /sec.

It should be recalled that the estimate of nitrite found in the surplus water is only a lower limit since some will have been converted to undetected by-products by several reactions. For example, in the liquid phase,

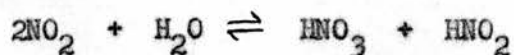

may occur, while in the gas phase the following reaction can take place, the equilibrium of which lies far to the left:-

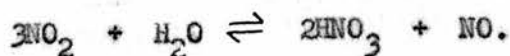

It may also be remarked that for a leakage current of 10^{-6} A, about

6×10^{13} nitrogen dioxide molecules would be created in 10 sec. if reaction (5: 3) takes place with high efficiency. This is lower by a factor of 6 than the estimate made from the nitrite test, but is nevertheless regarded as being in good agreement with the former value.

APPENDIX D (Chapter 5)

AN ESTIMATE OF THE MAXIMUM RADII OF THE c-NUCLEIUSING THE BAROMETER FORMULA

It was found experimentally that the cloud seen in any cleaning expansion made following a production expansion was uniform even after the gas had been left undisturbed for several hours. The equation which represents the expected distribution of particle density with height after equilibrium has been established is the well known Barometer Formula used by Perrin in his classical determination of N , Avogadro's number (see, for example, Saha and Srivastava, 1931).

The equation may be written:

$$\log_e \frac{n_0}{n} = \frac{4\pi r^3 \cdot (\rho - \rho') \cdot g \cdot (h - h_0) \cdot N}{3RT}$$

where n_0 , n are the particle concentrations at heights h_0 and h , g is the acceleration due to gravity, R the gas constant, T the absolute temperature, r the radius of the particles of density, ρ , suspended in a fluid of density, ρ' .

$$\text{Hence } r^3 = \frac{3RT}{4\pi N g \cdot (h - h_0) \cdot (\rho - \rho')} \cdot \log_e \frac{n_0}{n}$$

For the case of c-nuclei suspended in nitrogen, $\rho \gg \rho'$ and $\rho \approx 1 \text{ gm/cm}^3$,

$R = 8.3 \times 10^7 \text{ ergs/gm. mol/}^\circ\text{K}$; $T = 293^\circ\text{K}$ and $g = 981 \text{ cm/sec./sec.}$

Over a visible range of 15 cm., no density distribution is found and a factor of 2 or greater would have been noticed.

$$\text{Hence } r > \underline{7.7 \times 10^{-7} \text{ cm.}}$$

If in fact a density difference of 4 was the lowest detectable variation,

$$r > \underline{9.7 \times 10^{-7} \text{ cm.}}$$

Hence these calculations set a rough upper limit to the size of the c-nuclei.

APPENDIX E (Chapters 5 and 6)

DIFFUSION COEFFICIENT AND MOBILITY OF THE c-NUCLEI

Using the Stokes-Millikan-Cunningham relationship (see, for example, Nolan and Guerrini, 1935) it is possible to calculate a diffusion coefficient for nuclei of various radii. The diffusion coefficient is given by

$$D = \frac{RT}{N} \cdot \frac{1 + \frac{\ell}{r} \left[0.898 + 0.312 \exp(-2.73 \frac{r}{\ell}) \right]}{6 \pi \eta r}$$

where ℓ is the mean free path in the gas of viscosity, η ; r is the radius of the nucleus, R the gas constant, T the absolute temperature and N is Avogadro's number. The term $\left[1 + \frac{\ell}{r} (A + B \exp(-\frac{C}{\ell})) \right]$ may be regarded as a factor correcting Stokes' Law, where A , B and C are constants determined experimentally. The values used here are those given by Nolan and Guerrini (loc. cit.) and are valid for ℓ/r from 0.1 to 5.

The mean free path in nitrogen at 30 atmospheres is estimated from a kinetic theory calculation to be 2.5×10^{-7} so that the formula is valid for $5 \times 10^{-8} \text{ cm} \leq r \leq 25 \times 10^{-7} \text{ cm}$, while Appendix D indicates that for c-nuclei, $r > 7.7 \times 10^{-7} \text{ cm}$. The gas viscosity varies only slowly with pressure, a recent investigation (Flynn et al, 1963) giving $\eta = 182 \mu \text{ P}$ for nitrogen at 30 atmospheres and 25°C .

Using these figures the following values of diffusion coefficient for various radii were calculated.

| r cm. | $\frac{\ell}{r}$ | $D + \text{cm}^3/\text{sec.}$ ($D =$ diffusion coefficient at 30 atmospheres) | cm^2/sec | μ , mobility cm/sec/volt/cm. |
|----------------------|------------------|--|--------------------------|-------------------------------------|
| 5×10^{-8} | 5 | 7.58×10^{-11} | 1.5×10^{-3} | 6.0×10^{-2} |
| 10^{-7} | 2.5 | 4.17×10^{-11} | 4.2×10^{-4} | 1.7×10^{-2} |
| 2.5×10^{-7} | 1 | 2.27×10^{-11} | 9×10^{-5} | 3.6×10^{-3} |
| 5×10^{-7} | .5 | 1.71×10^{-11} | 3.4×10^{-5} | 1.4×10^{-3} |
| 10^{-6} | .25 | 1.43×10^{-11} | 1.4×10^{-5} | 5.6×10^{-4} |
| 2.5×10^{-6} | .1 | 1.28×10^{-11} | 5×10^{-6} | 2.1×10^{-4} |

The mobility and diffusion coefficient, assuming the nuclei to be charged, are related by the following equation:-

$$\text{Mobility, } \mu = \frac{DN}{RT} \cdot \frac{e}{300}$$

where e is the charge in electrostatic units.

At 293°K, $\mu = 40.3 D \text{ cm/sec/volt/cm.}$

The mobility of nuclei of various radii (at 30 atmospheres pressure) is also tabulated above. Hence for a nucleus of $5 \times 10^{-7} \text{ cm.}$, a field of about 1.5 kV/cm. would be required to explain the observed speed of the nuclei in the chamber. Such a high field is not possible, but one of 30 v/cm. which would move nuclei of $5 \times 10^{-8} \text{ cm.}$ in this fashion is easily available. The assumption that the nuclei are carried through the gas by an ion wind thus appears quantitatively correct. The ions, of course, would be in clusters of water molecules about $4 \times 10^{-8} \text{ cm.}$ in radius.

APPENDIX F. (Chapter 6)

THE TEMPERATURE OF AN EVAPORATING DROP

In the mixed aerosol present in the room air in the chamber there will be some particles, causing visible drops, which are insoluble or even hydrophobic. These drops will obey an equilibrium equation for the vapour pressure at their surface not very different from Kelvin's equation (3: 1). When a dense cloud of drops has formed the temperature in the chamber will be greater than the final temperature produced by the adiabatic expansion, and the vapour density in the chamber will be nearly the saturated vapour density at this temperature. For a water droplet which is just visible, the equilibrium vapour density at its surface cannot be much greater than 0.1% of this value, whereas for a drop formed around an insoluble nucleus it will be slightly less. For a droplet formed on a hydrophobic particle the equilibrium vapour density will certainly not be more than 1% above the ambient value.

Following Hazen (1942) the temperature fall of an evaporating drop can be calculated. The temperature of the drop is dependent on the thermal conductivity of the surrounding medium while the vapour pressure difference determines the rate of evaporation. The two pertinent equations may be written

$$\frac{dr}{dt} = \frac{2D}{\rho} \Delta \rho_v \quad \text{and} \quad \frac{dr}{dt} = \frac{2K}{\rho L} (T_d - T_v)$$

where r = drop radius, ρ = vapour density, D = diffusion coefficient for the vapour and $\Delta \rho_v$, the difference between the equilibrium and ambient vapour densities, K is the thermal conductivity of the gas, L the latent heat of vaporization of the liquid, T_d and T_v are the drop and vapour temperatures.

Suppose the ambient temperature in the chamber is the average of

the initial temperature and the temperature at the end of the expansion, that is, about 14°C for a 12% expansion in the high pressure chamber filled with nitrogen.

Then

$$\rho_v = \text{density of saturated vapour} = 14 \times 10^{-6} \text{ gm/cm}^3.$$

$$\text{For a 1\% difference} \quad \Delta \rho_v = - 14 \times 10^{-8} \text{ gm/cm}^3.$$

At atmospheric pressure,

$$D = 0.24 \text{ cm}^2/\text{sec.}, \quad K = 6 \times 10^{-5} \text{ cal/cm}^2/\text{unit temp. gradient/sec.}$$

and $L = 590 \text{ cal/gm.}$

$$\text{Hence} \quad T_d - T_v = \frac{DL}{K} \Delta \rho_v = 0.33^{\circ}\text{C}.$$

This temperature fall, which is insufficient to freeze the water droplets, would be even smaller at 30 atmospheres because of the decreased diffusion coefficient for the vapour. It is clear, therefore, that the twinkling drops sometimes observed in cleaning expansions cannot be caused by rapid evaporation of pure water droplets.

APPENDIX G. (Chapter 10)

THE POSSIBILITY OF STUDYING DIRECT PAIR PRODUCTION BY μ -MESONS,
USING A HIGH PRESSURE CLOUD CHAMBER.

Stoker and Haarhoff (1960) have simplified the formula of Murota et al (1956) to a form suitable for numerical integration with the aid of a computer. By this means they obtained the cross section for direct pair production as a function of μ -meson energy, and the calculation was extended (Stoker et al, 1961, 1962, 1963), in order to compare the observed number of electron pairs produced by cosmic ray muons above 1.7 GeV with the theory. From their experimental values a cross section for pair production in lead, and hence in argon, can be estimated so that the possibility of studying direct pair formation in a high pressure cloud chamber can be considered.

The cross section for lead is $\sigma = 1.05 \times 10^{-25} \text{ cm}^2/\text{lead nucleus}$, for the cosmic ray muons found at sea-level, with energy above 1.7 GeV. The range of energy transfer detected in this experiment was 25 MeV to 10 GeV, although nearly half the events corresponded to transfers in the interval 25 to 60 MeV. Pair production cross sections are proportional to Z^2 , where Z is the atomic number of the nucleus with which the μ -meson interacts. Hence for argon, the cross section (for energy transfers above 25 MeV) is $4.8 \times 10^{-27} \text{ cm}^2/\text{argon nucleus}$. Using the relation

$$l = \frac{1}{\sigma n}$$

where l is the mean interaction path and n is the number of nuclei/ cm^3 , it is found, for argon at 100 atmospheres, that $l = 7.8 \times 10^4 \text{ cm}$.

Now the predicted numbers of pairs found for cosmic ray muons above 1.7 GeV differ by a factor of 20% for $\alpha = 1, 2$ or 3 . Hence to decide between these values about 100 examples of direct pair

production are required, so that 7.8×10^6 cm. of cosmic ray muon track must be examined. In the larger high pressure chamber available in Edinburgh, about 20 cm. of muon track can be studied for each photograph containing a muon traversal, so that it is necessary to take nearly 4×10^5 photographs to obtain sufficient track length. This seems a formidable task but a few considerations improve the position.

The low energy cut off in the experiments of Stoker and his co-workers corresponded to an energy transfer of 25 MeV, with some uncertainty about the validity of the results in the lower region from 25 to 60 MeV. The formula of Stoker and Haarhoff has a similar cut off at 10 MeV, but in the energy transfer range from 10 to 25 MeV an increased number of pairs are expected. The actual numbers may be estimated from the calculations of Stoker et al (1963), for cosmic ray muons at sea level above 1.7 GeV., to be larger by a factor of at least 4 and possibly by a factor of more than 10. This is supported by a cross section calculation using the Weisacker-Williams model thought to be valid in this region (Heitler, 1954). Thus in 4×10^4 photographs it is estimated that approximately 100 examples of direct pair production would be observed. Perhaps only half of these would be suitable for comparison with the different theoretical predictions, but considering the detailed information on angular distribution and energy sharing between the pairs which could be obtained, the investigation would prove most fruitful.

Selecting muons of energy above about 1.7 GeV is not too difficult. If a large mass of lead is placed below the chamber, μ -mesons of lower energy can be absorbed, and a coincidence counting rate which would keep the cloud chamber continuously operating could

easily be obtained. Even if the recycling time was as long as 6 min. the necessary photographs could be taken in 150 days, so that, allowing for 50% efficiency during the experiment, the running time would be less than a year. It is interesting, too, to consider the possibility of using xenon in the chamber. Since its atomic number is 3 times that of argon, the time to collect 100 events would be reduced by a factor of 9. 6 litres of xenon at 100 atmospheres would cost approximately £4000, though even if 10% of the gas in the chamber was xenon the time factor would be reduced by a factor of nearly 2.

Identification of direct pair events would not be difficult since the only process which might resemble it is double knock-on production, where two knock-on electrons might be produced within the spatial resolving limit of the cloud chamber. The expected contribution from this effect can be calculated. Provided the energy transferred to the electron is very small compared with the maximum transferable energy, the cross-section for knock-on production is given by, (Rossi, 1952):-

$$\sigma(E', dE') = 2\pi r_e^2 \cdot \frac{mc^2}{\beta^2} \cdot \frac{dE'}{(E')^2} \quad \text{cm}^2/\text{atomic electron}$$

where the knock-on electron of mass, m , has energy in the range E' to $E' + dE'$, $r_e =$ classical radius of the electron and $\beta = \frac{v}{c}$ where $v =$ particle velocity and $c =$ velocity of light. Hence the cross section for producing an electron of energy greater than some arbitrary lower limit, E_0 , and less than some value E_{\max} such that the above equation applies, is:-

$$\begin{aligned} \sigma(E_0) &\approx 2\pi r_e^2 \cdot \frac{mc^2}{\beta^2} \int_{E_0}^{E_{\max}} \frac{dE'}{(E')^2} \quad \text{cm}^2/\text{atomic electron} \\ &\approx 2\pi r_e^2 \cdot Z \cdot \frac{mc^2}{\beta^2} \cdot \frac{1}{E_0} \quad \text{cm}^2/\text{nucleus} \end{aligned}$$

if $E_{\max} \gg E_0$.

Hence the probability that a knock-on electron will be produced in a distance x , followed by a second electron in a short distance, is $n^2 \cdot \sigma^{\gamma}(E_0) \cdot x \cdot \Delta t$, where, as before, n is the number of atoms/cm³. To a good approximation $\beta = 1$, and for a cloud chamber at 100 atmospheres $E_0 = mc^2$ and $\Delta t = 0.1$ cm. Hence for argon at 100 atmospheres, the distance which a muon of high energy must travel for such an event to occur is 1.7×10^6 cm., or more than 20 times further than for direct pair formation.

This experiment could, of course, make use of a beam of high energy muons from an accelerator. This has been done in the emulsion study by Gailloud and Piron (1963) but the statistics of their experiment are poor, possibly because of scanning difficulties. So that the experiment could be completed in a reasonable time it would be necessary, in this case, to fill the chamber with xenon. A hydrogen bubble chamber is definitely not a suitable instrument as liquid hydrogen is less dense than argon at 100 atmospheres, and the cross section would be reduced by a factor of nearly 400 anyway because of the atomic number difference. The muon track length required is thus increased to approximately 6×10^6 cm. A bubble chamber containing a heavy liquid such as propane would be a suitable detector but is not particularly useful for studying low energy transfers.

ACKNOWLEDGEMENTS

I should like to thank Professor N. Feather, F.R.S., for extending to me the facilities of his laboratory, and for the interest which he has taken in the work.

It is a great pleasure to acknowledge with sincere gratitude the enthusiastic help, guidance and encouragement given to me at all times by Dr. G. R. Evans, who suggested most of the problems studied in this thesis.

I have had stimulating discussions with many members of the Department but I should like to express my thanks particularly to the members of the radiation chemistry group and to my colleagues in the cloud chamber group, Mr. N. E. Fancey and Mr. J. R. Norbury.

Mr. A. Headridge and his workshop staff have been most helpful, particularly during the early stages of testing the 3-atmosphere cloud chamber. Mr. W. Wilson and Mr. C. McAnna, in their different ways, have been very obliging at all times.

Lastly, I am indebted to the University of Edinburgh for a Vans Dunlop Scholarship which was held during the first two years of this work.

REFERENCES

- Aitken, J. (1880-1), *Trans. Roy. Soc. Edin.* 30, 327, 1880-1.
- Aitken, J. (1911), *Proc. Roy. Soc. Edin.* 31, 478, 1911.
- Aitken, J. (1917), *Proc. Roy. Soc. Edin.* 37, 215, 1917.
- Alston, M.H., A.V. Crewe and W.H. Evans, *Rev. Sci. Inst.* 25, 547, 1954.
- Ashpole, D.K., *Proc. Roy. Soc. A.* 212, 112, 1952.
- Atkinson, J.R., *Geophys. Pura. Appl.* 31, 54, 1955.
- Avan, M., and L. Avan, *Nuovo Cimento* 6, 1590, 1957.
- Banford, A.P., W.E. Duncanson, T.C. Griffith and W.S.C. Williams, Conference on Recent Developments in Cloud Chamber and Associated Techniques. University College, London. 1955, p.104.
- Barnard, A.J., and W.L. Mouton, *Nature* 182, 1001, 1958.
- Bevan, A.R., *J. Sci. Inst.* 31, 45, 1954.
- Bhabha, H.J., *Proc. Roy. Soc. A.* 152, 559, 1935.
- Blackett, P.M.S., *Proc. Roy. Soc. A.* 146, 281, 1934.
- Blackett, P.M.S., and G.P.S. Occhialini, *Nature* 130, 363, 1932.
- Block, M.M., D.T. King and W.W. Wada, *Phys. Rev.* 96, 1627, 1954.
- Blumenfeld, H., E.T. Booth and L.M. Lederman, *Rev. Sci. Inst.* 25, 1220, 1954.
- Cadle, R.D., *J. Geophys. Res.* 68, 3977, 1963.
- Cairns, D.J., T.C. Griffith, G.J. Lush, A.J. Metherington and R.H. Thomas, *Nuclear Instrum. Methods* 10, 272, 1961.
- Coste, J.H., and H.L. Wright, *Phil. Mag.* 20, 209, 1935.
- Coulier, M., *J. Pharmacie et Chimie* 22, 165, 1875.
- Courtney, W.G. (1962), Kinetics of Condensation from the Vapor Phase. Report to U.S. Office of Naval Research, TM-1340, 1962.
- Courtney, W.G. (1963), *J. Chem. Phys.* 38, 1448, 1963, and private communication, 1963.
- Crane, H.R., and J. Halpern, *Phys. Rev.* 56, 233, 1939.
- Cwilong, B.M., *Proc. Roy. Soc. A.* 190, 137, 1947.

- Das Gupta, N.N., and S.K. Gosh, *Rev. Mod. Phys.* 18, 228, 1946.
- Donald, R.A., Ph.D. Thesis, University of Edinburgh, 1956.
- Druett, H.A., and K.R. May, *Nature* 174, 467, 1954.
- Duff, M.J.B., and N. Morris, Conference on Recent Developments in Cloud Chamber and Associated Techniques. University College, London. 1955, p.78.
- Eisner, H.S., F.R. Brookes and B.W. Quince, (1958), *Nature* 182, 724, 1958.
- Eisner, H.S., B.W. Quince and C. Slack, (1960), *Disc. Faraday Soc.* 30, 86, 1960.
- Emigh, C.R., *Rev. Sci. Inst.* 25, 221, 1954.
- Emigh, C.R., and P.C. Fisher, Conference on Recent Developments in Cloud Chamber and Associated Techniques. University College, London. 1955, p.155.
- English, W.N., *Phys. Rev.* 74, 179, 1948.
- Evans, G.R., Conference on Recent Developments in Cloud Chamber and Associated Techniques. University College, London. 1955, p.67.
- Evans, G.R., and A.A. Watson, *Nature* 196, 729, 1962.
- Farley, F.J.M., *Proc. Roy. Soc. A.* 207, 527, 1951.
- Fletcher, N.H., *Physics of Rainclouds.* Cambridge, 1962.
- Flynn, G.P., R.V. Hanks, N.A. Lemaire and J. Roos, *J. chem. Phys.* 38, 154, 1963.
- Fowler, E.C., W.B. Fowler, R.P. Shutt, A.M. Thorndike and W.L. Whittemore, *Phys. Rev.* 91, 135, 1953.
- Gaebler, J.F., W.E. Hazen and A.Z. Handel, *Nuovo Cimento* 19, 265, 1961.
- Gaerttner, E.R., and M.L. Yeater, *Rev. Sci. Inst.* 20, 588, 1949.
- Gailloud, M., and C. Piron, *Helv. Phys. Acta* 36, 164, 1963.
- Georgii, H.W., *J. Geophys. Res.* 68, 3963, 1963.
- Glaser, D.A., *Phys. Rev.* 87, 665, 1952.
- Hazen, W.E. (1942), *Rev. Sci. Inst.* 13, 247, 1942.
- Hazen, W.E. (1954), Private Communication to N.C. Barford, quoted in Conference on Recent Developments in Cloud Chamber and Associated Techniques. University College, London. 1955, p.137.

- Heitler, W., *The Quantum Theory of Radiation*. Oxford, 1954.
- Hodson, A.L., *Conference on Recent Developments in Cloud Chamber and Associated Techniques*. University College, London. 1955, p.189.
- Hudson, R.M., Ph.D. Thesis, University of Edinburgh, 1958.
- Johannot, E.S., *Phil. Mag.* 11, 746, 1906.
- Johnson, T.H., *Phys. Rev.* 72, 86, 1947.
- Johnson, T.H., S. Bendetti and R.P. Shutt, *Rev. Sci. Inst.* 14, 265, 1943.
- Kelvin, Lord, *Proc. Roy. Soc. Edin.* 7, 63, 1870.
- Kirkwood, J.G., and F.P. Buff, *J. chem. Phys.* 17, 338, 1949.
- Kundt, A., *Ann. physik Chem.*, 12, 538, 1881.
- Langsdorf, A., jr., *Rev. Sci. Inst.* 10, 91, 1939.
- Laughlin, J.S., *Rev. Sci. Inst.* 19, 918, 1948.
- Lind, S.C., *Radiation Chemistry of Gases*. Reinhold, 1961.
- Locher, G.L., *Rev. Sci. Inst.* 7, 471, 1936.
- Loeb, L.B., A.F. Kipp and A.W. Einarsson, *J. chem. Phys.* 6, 264, 1938.
- McHenry, J.J., and S. Twomey, *Proc. Roy. Irish Acad.* 55A, 51, 1952.
- Madonna, L.A., C.M. Sciulli, L.N. Ganjar and G.M. Pound, *Proc. Phys. Soc.* 78, 1218, 1961.
- Mason, B.J. (1951), *Proc. Phys. Soc. B.* 64, 773, 1951.
- Mason, B.J. (1957), *Physics of Clouds*. Oxford, 1957.
- Mason, B.J. (1960), *Disc. Faraday Soc.* 30, 20 and 62, 1960.
- Masterton, W.L., J. Bianchi and E.J. Slowinski, jr., *J. Phys. Chem.* 67, 615, 1963.
- Milner, J.W., and J.A. Chalmers, *Quart. J.R. Met. Soc.* 87, 592, 1961.
- Mott-Smith, L.M., *Rev. Sci. Inst.* 5, 346, 1934.
- Mulcahy, M.J., and E. Kuffel, *Proc. Phys. Soc.* 80, 1333, 1962.
- Murota, T., A. Ueda and H. Tanaka, *Prog. Theor. Phys.* 16, 482, 1956.
- Nolan, J.J., and V.H. Guerrini, *Proc. Roy. Irish Acad.* 43A, 5, 1935.

- Nolan, P.J., and L.W. Pollak, Proc. Roy. Irish Acad. 51A, 9, 1946.
- Peyrou, G., Conference on Recent Developments on Cloud Chamber and Associated Techniques. University College, London, 1955, p.38.
- Reinold, A.W., and A.W. Rücker, Phil. Trans. Roy. Soc. A, 177, 627, 1886.
- Roe, B.P., and S. Ozaki, Phys. Rev. 116, 1022, 1959.
- Rossi, B., High Energy Particles. Constable, 1952.
- Saha, M.N., and B.N. Srivastava, Text Book of Heat. Indian Press, 1931.
- Sechrist, F., Nature 199, 899, 1963.
- Shinn, M.B., Ind. and Eng. Chem. Anal. Edn. 13, 33, 1941.
- Stoker, P.H., and P.C. Haarhoff (1960), Nuclear Physics 14, 512, 1960.
- Stoker, P.H., C. Hofmeyer and C.H. Bornmann, Proc. Phys. Soc. 78, 650, 1961.
- Stoker, P.H., C.H. Bornmann and J.P. Van der Merwe, J. Phys. Soc. Japan 17, Supplement A-III, 348, 1962.
- Stoker, P.H., C.H. Bornmann and J.P. Van der Merwe, Nuclear Physics 45, 505, 1963.
- Street, J.C., and E.C. Stevenson, Rev. Sci. Inst. 7, 347, 1936.
- Tait, N.R.S., Ph.D. Thesis, University of Edinburgh, 1960.
- Thomson, J.J., Applications of Dynamics to Physics and Chemistry. Macmillan, 1888.
- Thomson, J.J., (with G.P. Thomson), Conduction of Electricity Through Gases. Third Edition, Vol. 1, Cambridge, 1928.
- Tolman, R.C., J. chem. Phys. 17, 71, 1949.
- Tsuji, M., Geophys. Mag. (Tokyo) 22, 15, 1950.
- Valley, G.E., and J.A. Vitale, Rev. Sci. Inst. 20, 411, 1949.
- Vonnegut, B., private communication, 1963.
- Vonnegut, B., and R.L. Neubauer, J. Colloid. Sci. 7, 616, 1952.
- Vonnegut, B., and R.L. Neubauer, J. Colloid. Sci. 8, 551, 1953.
- Webb, C.G., Phil. Mag. 19, 927, 1935.
- Went, F.W., Nature 187, 641, 1960.

- Williams, Elwyn J., Conference on Recent Developments in Cloud Chamber and Associated Techniques. University College, London. 1955, p.95.
- Williams, E.J., Proc. Camb. Phil. Soc. 35, 512, 1939.
- Williams, E.J., and Evans, G.R., Nature 145, 818, 1940.
- Wilson, C.T.R. (1895), Proc. Camb. Phil. Soc. 8, 306, 1895.
- Wilson, C.T.R. (1897), Phil. Trans. Roy. Soc. A. 189, 265, 1897.
- Wilson, C.T.R. (1899), Phil. Trans. Roy. Soc. A. 193, 289, 1899.
- Wilson, C.T.R. (1899a), Phil. Trans. Roy. Soc. A. 192, 403, 1899.
- Wilson, C.T.R. (1911), Proc. Roy. Soc. A. 85, 285, 1911.
- Wilson, J.G., The Principles of Cloud Chamber Technique. Cambridge, 1951.
- Zeleny, J., Phys. Rev. 3, 69, 1914.