

"INHABITED SCROLLS"  
FROM THE IVth TO THE VIth CENTURY A.D.  
IN ASIA MINOR AND THE EASTERN PROVINCES  
OF THE BYZANTINE EMPIRE

VOL. III

Code - Types

Figs. 1 - 169

CLAUDINE M. DAUPHIN

1974



ORIGIN OF ILLUSTRATIONS

<u>Fig. No.</u>	<u>Origin</u>
1	Photo A. Pralong.
2	Photo A. Pralong.
3	Drawing C. Dauphin.
4	Photo M. Thurlby.
5	Photo M. Thurlby.
6	Drawing C. Dauphin.
7	Drawing C. Dauphin.
8	Photo M. Thurlby.
9	Photo M. Thurlby.
10	Photo M. Thurlby.
11	Photo M. Thurlby.
12	Drawing C. Dauphin.
13	Drawing C. Dauphin.
14	Photo M. Thurlby.
15	Drawing C. Dauphin.
16	Drawing C. Dauphin.
17	Photo C. Dauphin.
18	Photo M. Thurlby
19	Drawing C. Dauphin
20	Photo C. Dauphin.
21	Photo C. Dauphin.
22	Drawing C. Dauphin.
23	Drawing C. Dauphin.
24	Photo C. Dauphin.
25	Photo C. Dauphin.
26	Harrison, 1963, 125, Fig. 3.
27	Harrison, 1963, 1933, Fig. 11.
28	Photo R.M. Harrison.
29	Drawing R.M. Harrison.
30	Drawing C. Dauphin.
31	Photo M. Thurlby.
32	Photo M. Thurlby.
33	Gough, 1952, 116, Fig. 7.
34	Photo M. Thurlby.
35	By courtesy of the Department of Antiquities of Cyprus.

<u>Fig. No.</u>	<u>Origin</u>
36	By courtesy of the Department of Antiquities of Cyprus.
37	By courtesy of the Department of Antiquities of Cyprus.
38	By courtesy of the Department of Antiquities of Cyprus.
39	By courtesy of the Department of Antiquities of Cyprus.
40	By courtesy of the Department of Antiquities of Cyprus.
41	Drawing from Soteriou, 1935, 137, Pl. 137.
42	Drawing from Soteriou, 1935, 137, Pl. 137.
43	Drawing C. Dauphin.
44	Photo M. Thurlby.
45	Drawing C. Dauphin.
46	Photo M. Thurlby.
47-52	Drawing C. Dauphin.
53	Headlam, 1892, Pl. 1, Fig. 2.
54	Gough, 1972a, 204, Fig. 4.
55	Photo M. Thurlby.
56	Photo M. Thurlby.
57	Photo M. Thurlby.
58	Lafontaine-Dosogne, 1967, Pl. XIII.
59	Nasrallah, 1972, Fig. 7.
60	Drawing from Bell, 1908, 247.
61	Drawing from Lassus, 1936, 112.
62	Drawing from Lassus, 1936, 39-40.
63	Drawing from Preusser, 1911, 52, Abb. 16.
64	Drawing C. Dauphin.
65	Photo M. Thurlby.
66	Photo M. Thurlby.
67	Drawing from Khatchatrian, 1957, 408, Fig. 1.
68	Drawing C. Dauphin.
69	Drawing C. Dauphin.
70	Photo M. Thurlby.
71	Drawing C. Dauphin.
72	Photo C. Dauphin
73	Avi-Yonah, 1961, Pl. XI, 2.
74	Drawing C. Dauphin.

<u>Fig. No.</u>	<u>Origin</u>
75	Ovadia, 1970, No. 148, Pl. 58.
76	By courtesy of the Israel Department of Antiquities and Museums.
77	Drawing C. Dauphin.
78	By courtesy of the Istanbul Arkeoloji Müzesi.
79	By courtesy of the Istanbul Arkeoloji Müzesi.
80	By courtesy of the Istanbul Arkeoloji Müzesi.
81	By courtesy of the Istanbul Arkeoloji Müzesi.
82	<u>Great Palace, First Report</u> , Plan 60.
83	<u>Great Palace, First Report</u> , Index Plan No. 64a.
84	Photo C. Dauphin.
85	<u>Great Palace, Second Report</u> , Pl. 50.
86	<u>Great Palace, Second Report</u> , Pl. 48b.
87	Photo C. Dauphin.
88	<u>Great Palace, Second Report</u> , Pl. 48a.
89	<u>Great Palace, Second Report</u> , Pl. 49a.
90	Budde, 1969, 37.
91	Photo M. Thurlby.
92	Photo L. Budde.
93	Photo M. Thurlby.
94	Budde, 1969, 50-51, Fig. 24.
95	Budde, 1972, 184, Abb. 184.
96	Budde, 1972, 214, Abb. 262.
97-101	Drawings from Gough, 1958a.
102	Levi, 1947, I, 227, Fig. 85.
103	Levi, 1947, II, Pl. LIIB.
104	Levi, 1947, II, Pl. LV.
105	A.II, Pl. 66, No. 87, Panel T.
106	A.II, Pl. 66, No. 87, Panel P.
107	Photo C. Dauphin.
108	A.II, Pl. 69, No. 88, Sections 1 and 3.
109	A.II, Pl. 69, No. 88, Sections 2, 4 and 6.
110	A.II, 200, No. 88.
111	A.II, 200, No. 90.
112	A.II, Pl. 70, No. 90, Sections 1 and 2.
113	A.II, Pl. 70, No. 90, Sections 2 and 3.
114	A.II, Pl. 45, No. 60, Section 2.

<u>Fig. No.</u>	<u>Origin</u>
115	Levi, 1947, II, Pl. XCI.
116	A.II, Pl. 41, Section 1.
117	A.II, Pl. 41, Section 2.
118	A.II, Pl. 41, Section 3.
119	A.II, Pl. 41, Section 4.
120	A.II, Pl. 41, Section 5.
121	A.II, Pl. 41, Section 6.
122	Levi, 1947, II, Pl. CLXXXId.
123	Photo C. Dauphin.
124	A.II, 37.
125	Levi, 1947, II, Pl. LXXXIXb.
126	Levi, 1947, II, Pl. CLXXXIc.
127	Photo C. Dauphin.
128	<del>AAES</del> PAES II, 120, Ill. 134.
129	AAES II, 290.
130	AAES II, Fig. 31.
131	Photo Nicoghos, Aleppo.
132	Photo Nicoghos, Aleppo.
133	Photo Nicoghos, Aleppo.
134	Photo C. Dauphin.
135	Photo C. Dauphin.
136	Mattern, Mouterde and Beaulieu, 1939, Pl. I.
137	Mattern, Mouterde and Beaulieu, 1939, Pl. XIV.
138	Drawing C. Dauphin.
139	Photo C. Dauphin.
140	Photo M. Thurlby.
141	Photo M. Thurlby.
142	DACL, T. VIII, Ière partie, 1928, Fig. 6439.
143	By courtesy of the Département des Antiquités Grecques et Romaines, Musée du Louvre, Paris.
144	Plan by Edelstein with scroll numbering additions by C. Dauphin.
145	Edelstein, 1973, 172.
146	Foerster, 1972, 41.
147	Chehab, 1959, Plan No. 7.
148	Photo C. Dauphin.
149	Chehab, 1959, Pl. L.
150	Photo C. Dauphin.

<u>Fig. No.</u>	<u>Origin</u>
151	Chehab, 1959, Pl. LI.
152	Photo C. Dauphin.
153	Photo C. Dauphin.
154	Drawing C. Dauphin.
155	Photo C. Dauphin.
156	Photo C. Dauphin.
157	Photo C. Dauphin.
158	Chehab, 1959, Plan No. 12.
159	Photo C. Dauphin.
160	Chehab, 1959, Plan No. 4.
161	Chehab 1959, Pl. XXIX.
162	Photo C. Dauphin.
163	Chehab, 1959, Pl. XXX, 1-3.
164	Drawing C. Dauphin.
165	Photo C. Dauphin.
166	Chehab, 1959, Plan No. 8.
167	Drawing C. Dauphin.
168	Photo C. Dauphin.
169	Photo C. Dauphin.
170	By courtesy of the Israel Department of Antiquities and Museums.
171	By courtesy of the Israel Department of Antiquities and Museums.
172	By courtesy of the Israel Department of Antiquities and Museums.
173	Photo C. Dauphin.
174	Ovadia, 1970, No. 54, Pl. 26.
175	Photo C. Dauphin.
176	By courtesy of the Israel Department of Antiquities and Museums.
177	Photo C. Dauphin.
178	Photo C. Dauphin.
179	Drawing C. Dauphin.
180	Photo C. Dauphin.
181	By courtesy of the Istanbul Arkeoloji Müzesi.
182	Photo C. Dauphin.
183	Trendall, 1964, 22, Fig. 5(a).
184	Photo C. Dauphin.
185	Photo C. Dauphin.

<u>Fig. No.</u>	<u>Origin</u>
186	Photo C. Dauphin.
187	Petrozzi, 1971, Fig. 45.
188	Photo C. Dauphin.
189	Lassus, 1947, 105, Fig. 44.
190	By courtesy of the Israel Department of Antiquities and Museums.
191	Photo C. Dauphin.
192	Baramki, 1933, Pl. XXXVI.
193	By courtesy of the Israel Department of Antiquities and Museums.
194	Ovadia, 1969, 194, Fig. 1.
195	By courtesy of the Israel Department of Antiquities and Museums.
196	By courtesy of the Israel Department of Antiquities and Museums.
197	By courtesy of the Israel Department of Antiquities and Museums.
198	Photo Palphot, Jerusalem.
199	Photo C. Dauphin.
200	Trendall, 1964, Pl. II.
201	Avi-Yonah, ed. 1960, Fig. 13.
202	Avi-Yonah, 1965, Fig. 5.
203	Photo C. Dauphin.
204	By courtesy of the Israel Department of Antiquities and Museums.
205	Fitzgerald, 1939, Pl. II.
206	Peirce and Tyler, 1934, II, Pl. 195.
207	Photo Palphot, Jerusalem.
208	Photo Palphot, Jerusalem.
209	Drawing C. Dauphin.
210	Kitzinger, 1965a, Fig. 15.
211	Photo C. Dauphin.
212	Bahat, 1972, 56.
213	Photo C. Dauphin.
214	Sukenik, 1934, 33, Fig. 8.
215	Photo C. Dauphin.
216	Photo C. Dauphin.
217	Photo C. Dauphin.
218	Photo C. Dauphin.

<u>Fig. No.</u>	<u>Origin</u>
219	Drawing C. Dauphin.
220	Photo C. Dauphin.
221	By courtesy of A. Negev.
222	By courtesy of A. Negev.
223	By courtesy of A. Negev.
224	By courtesy of R. Cohen.
225-230	Drawings C. Dauphin
231	Photo C. Dauphin.
232	Avi-Yonah, 1954, 14, Fig. 3.
233	Drawings from Pavlovski and Kluge, 1902, Pl. VI, I.
234	Drawings from Pavlovski and Kluge, 1902, Pl. VII.
235	By courtesy of the Department of Antiquities of Jordan.
236	Lux, 1968.
237	Drawing C. Dauphin.
238	Photo C. Dauphin.
239	Lux, 1967.
240	Lux, 1967, Taf. 30c.
241	By courtesy of the Department of Antiquities of Jordan.
242	By courtesy of the Department of Antiquities of Jordan.
243	Photo C. Dauphin.
244-249	Drawings C. Dauphin.
250-251	Photos C. Dauphin.
252	By courtesy of the Department of Antiquities of Jordan.
253	Saller and Bagatti, 1949, <u>TN</u> , Fig. 10.
254	Photo C. Dauphin.
255	Saller and Bagatti, 1949, <u>TN</u> , Fig. 4.
256	Saller and Bagatti, 1949, <u>TN</u> , Pl. 12, 1.
257	Saller and Bagatti, 1949, <u>TN</u> , Fig. 7.
258	Photo C. Dauphin.
259	Photo Palphot, Jerusalem.
260	Saller and Bagatti, 1949, <u>TN</u> , Fig. 8.
261	Saller and Bagatti, 1949, <u>TN</u> , Pl. 25, 3.
262	De Vaux, 1938a, Pl. X.
263	Crowfoot, 1941, <u>ECP</u> , Pl. XXVI.
264	From the Jarash Brochure, Jordanian Tourism Authority.

<u>Fig. No.</u>	<u>Origin</u>
265	Crowfoot, 1931b, 45, Diagram 2.
266	Kraeling, 1938, Plan XXXII.
267	Kraeling, 1938, Pl. LVIIIc.
268	Crowfoot, 1941, <u>ECP</u> , 40, Fig. 8.
269	Kraeling, 1938, Plan XLIII.
270	Kraeling, 1938, Pl. LXXIXb.
271	Kraeling, 1938, Pl. LXXIXc.
272	Crowfoot, 1941, <u>ECP</u> , 97, Fig. 19.
273	Kraeling, 1938, Pl. LXXIID.
274	Kraeling, 1938, Plan XXXVI.
275	Kraeling, 1938, Pl. LXVIIa.
276	By courtesy of the Department of Antiquities of Jordan.
277	By courtesy of the Department of Antiquities of Jordan.
278	Photo C. Dauphin.
279	Crowfoot, 1941, <u>ECP</u> , 69, Fig. 14.
280	Kraeling, 1938, Pl. LXXVa.
281	Kraeling, 1938, Plan XL.
282	Crowfoot, 1941, <u>ECP</u> , 60, Fig. 12.
283	Kraeling, 1938, Pl. LXXXIVb.
284	By courtesy of the Department of Antiquities of Jordan.
285	Photo C. Dauphin.
286	Saller and Bagatti, 1949, <u>TN</u> , Pl. 48.
287	Drawing C. Dauphin.
288	Photo C. Dauphin.
289	Drawing C. Dauphin.
290	Drawing C. Dauphin.
291	Drawing C. Dauphin.
292	By courtesy of the Department of Antiquities of Jordan.
293	By courtesy of the Department of Antiquities of Jordan.
294	Photo C. Dauphin.
295	By courtesy of the Département des Antiquités Grecques et Romaines, Musée du Louvre.
296	Photo M. Thurlby.
297	<u>Repertoire</u> AIEMA, Nos. 121-131, p. 33.
298	De Vogüé, 1865-1877, I, Pl. 1.

<u>Fig. No.</u>	<u>Origin</u>
299	Photo C. Dauphin.
300	Bagatti, 1936, Fig. 14a.
301	Bagatti, 1936, Fig. 14b.
302	Bagatti, 1936, 47, Figs. 86, 8.
303	Drawing C. Dauphin.
304	Drawing C. Dauphin.
305	Drawing C. Dauphin.
306	Drawing C. Dauphin.
307	Photo C. Dauphin.
308	De Vogüé, 1865-1877, I, Pl. 24.
309	Photo C. Dauphin.
310	Photo C. Dauphin.
311	Photo C. Dauphin.
312	Photo C. Dauphin.
313	Photo M. Thurlby.
314	Photo C. Dauphin.
315	Photo C. Dauphin.
316	By courtesy of the Syrian Department of Antiquities.
317	Photo C. Dauphin.
318	By courtesy of the Syrian Department of Antiquities.
319	Photo C. Dauphin.
320	Photo M. Thurlby.
321	Photo M. Thurlby.
322	Photo C. Dauphin.
323	Sukenik, 1951, Fig. 5.
324	Photo C. Dauphin.
325	A.II, Pl. 74, No. 92, section 1.
326	Photo C. Dauphin.
327	Photo M. Thurlby.
328	Photo M. Thurlby.
329	Drawing C. Dauphin.
330	Drawing C. Dauphin.
331	Drawing C. Dauphin.
332	Drawing C. Dauphin.
333	Photo M. Thurlby.
334	Photo C. Dauphin.

<u>Fig. No.</u>	<u>Origin</u>
335	Drawing C. Dauphin.
336	Drawing C. Dauphin.
337	Gsell, 1952, 102.
338	Photo M. Blanchard-Lemée.
339	Photo M. Blanchard-Lemée.
340	Photo C. Dauphin.
341	Foucher, 1960, Pl. XXXVIII.
342	Ward-Perkins, 1958, 185, Fig. 2.
343	Ward-Perkins, 1958, 186, Fig. 3.
344	Photo C. Dauphin.



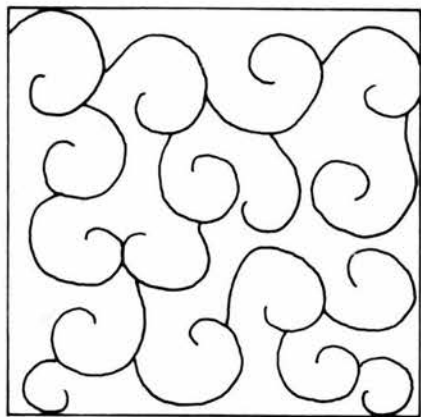
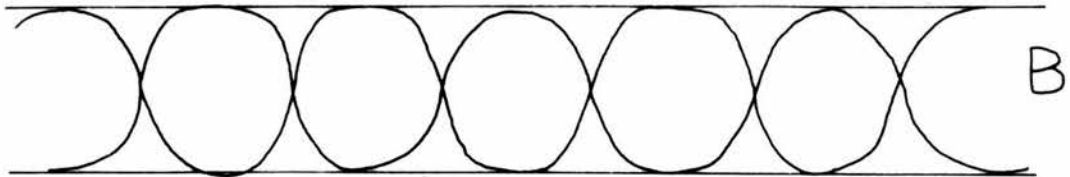
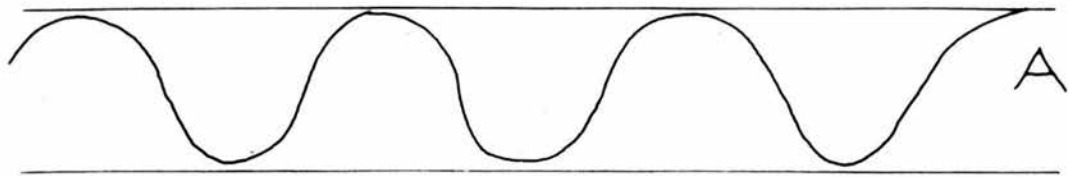

C<sub>1</sub>

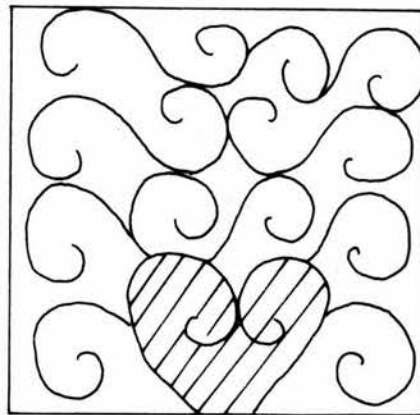

C<sub>2</sub>

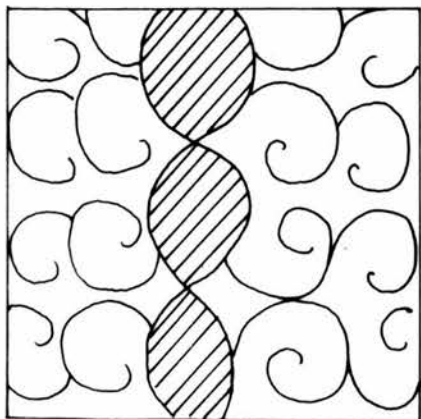

C<sub>3</sub>

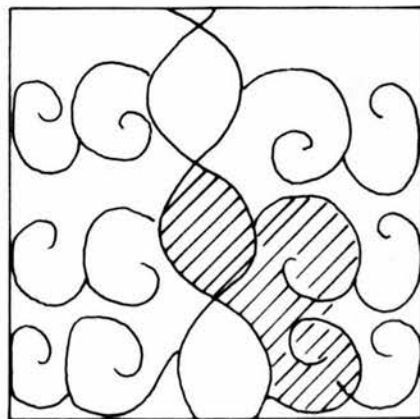

C<sub>4</sub>

I<sub>1</sub>



I<sub>1a</sub>



I<sub>1b</sub>



I<sub>1c</sub>



I<sub>1d</sub>

I<sub>2</sub>

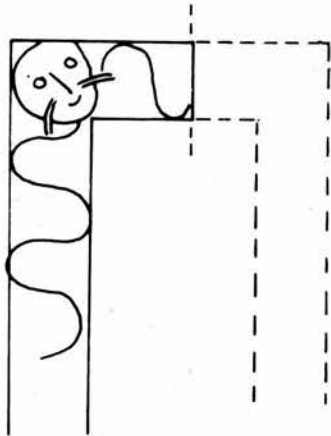

I<sub>2a</sub>

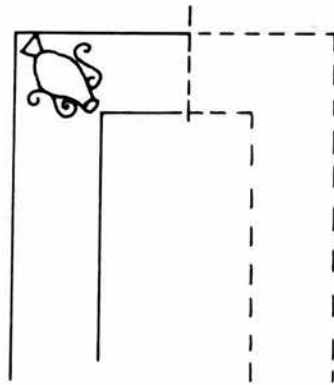

I<sub>2b</sub>

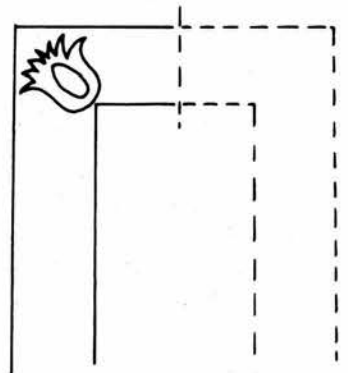

I<sub>2c</sub>

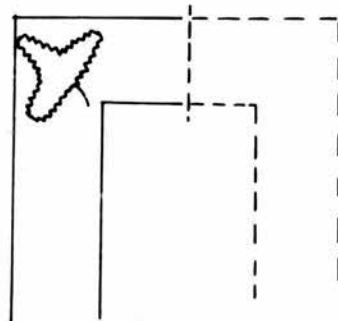

I<sub>2d</sub>

II<sub>1</sub>

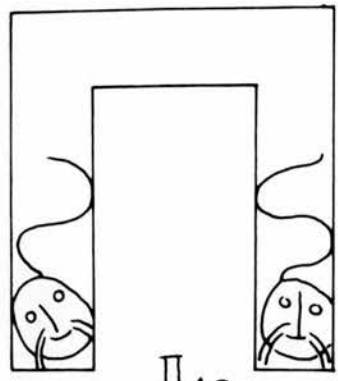

II<sub>1a</sub>

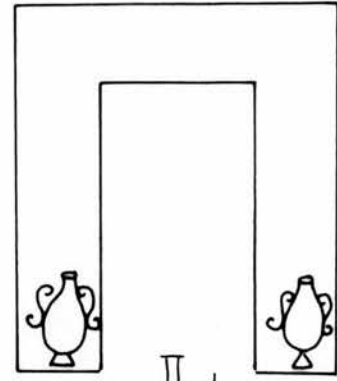

II<sub>1b</sub>

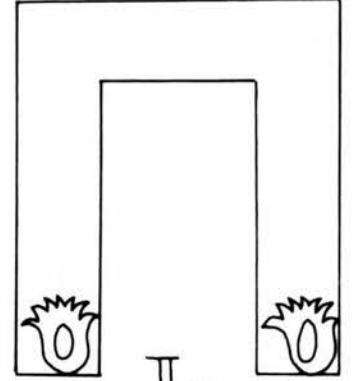

II<sub>1c</sub>

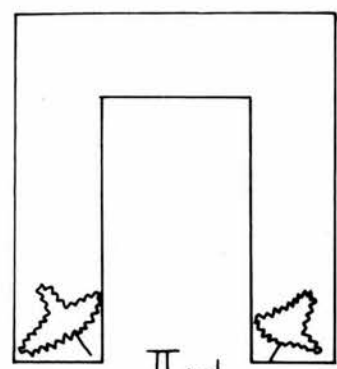

II<sub>1d</sub>

II<sub>2</sub>

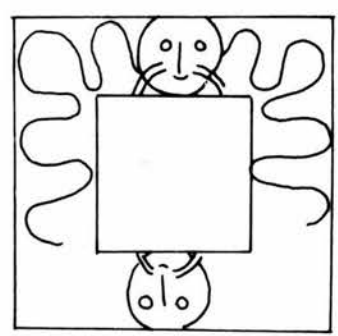

II<sub>2a</sub>

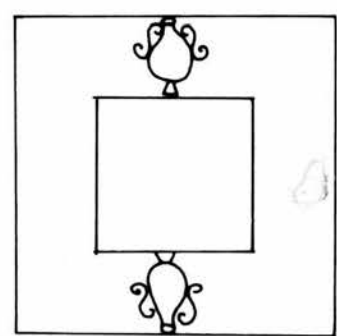

II<sub>2b</sub>

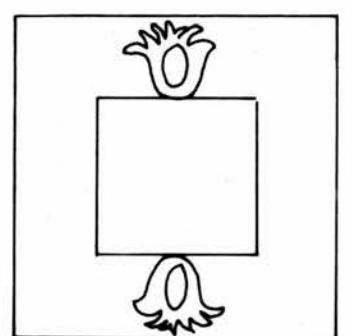

II<sub>2c</sub>

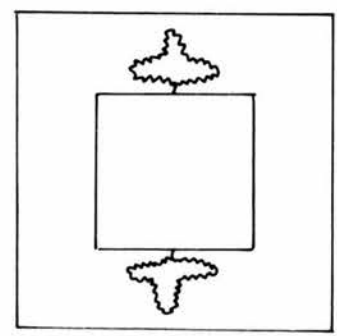

II<sub>2d</sub>

III<sub>1</sub>

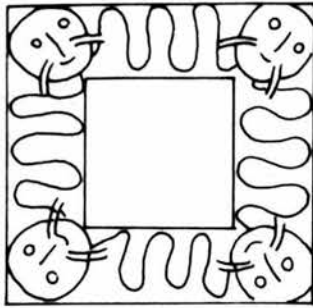

III<sub>1a</sub>

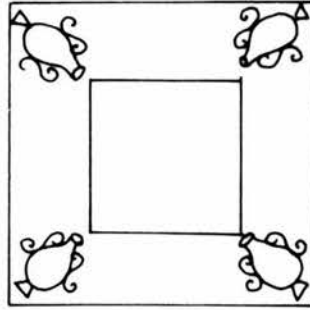

III<sub>1b</sub>

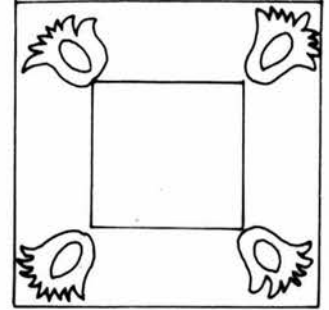

III<sub>1c</sub>

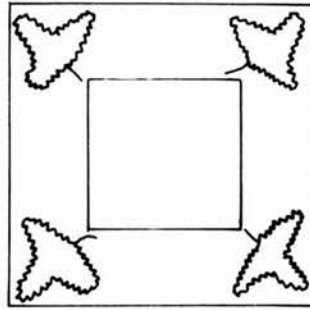

III<sub>1d</sub>

III<sub>2</sub>

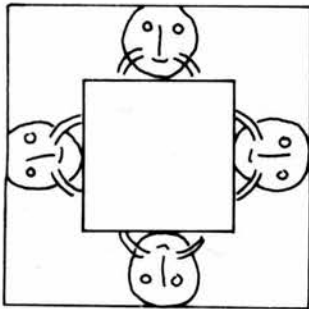

III<sub>2a</sub>

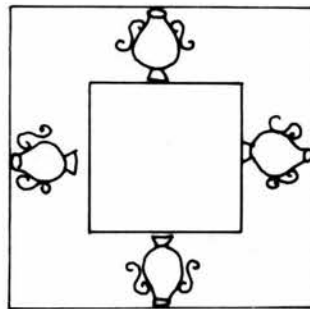

III<sub>2b</sub>

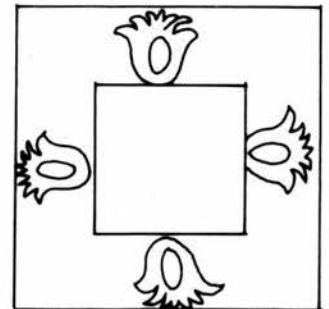

III<sub>2c</sub>

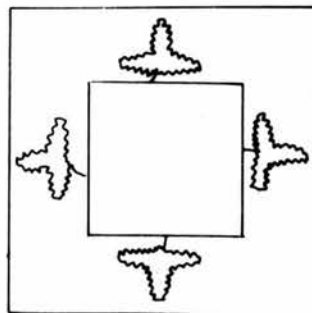

III<sub>2d</sub>

IV

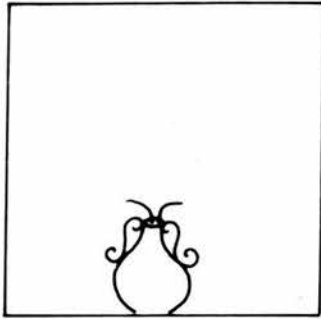

IVb

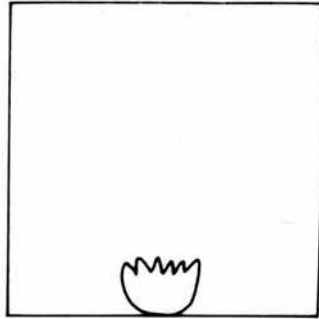

IVc

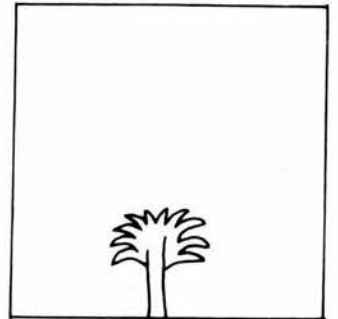

IVe

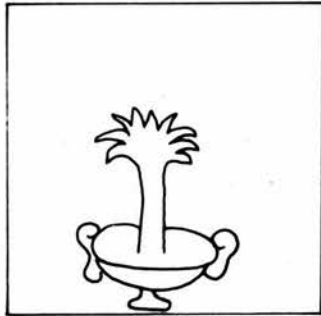

IV<sub>e</sub>  
b

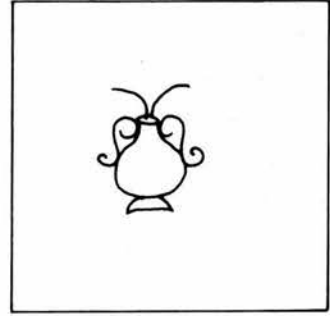

IVb

V

VI

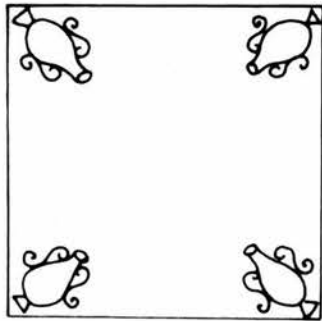

VIb

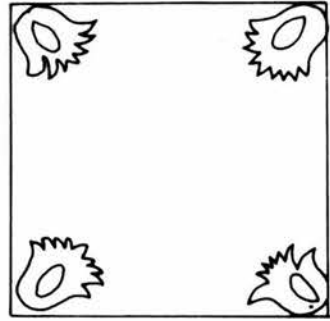

VIc

VII: "Inhabitants" dispersed over surface.

Fig. 1

Fig. 2

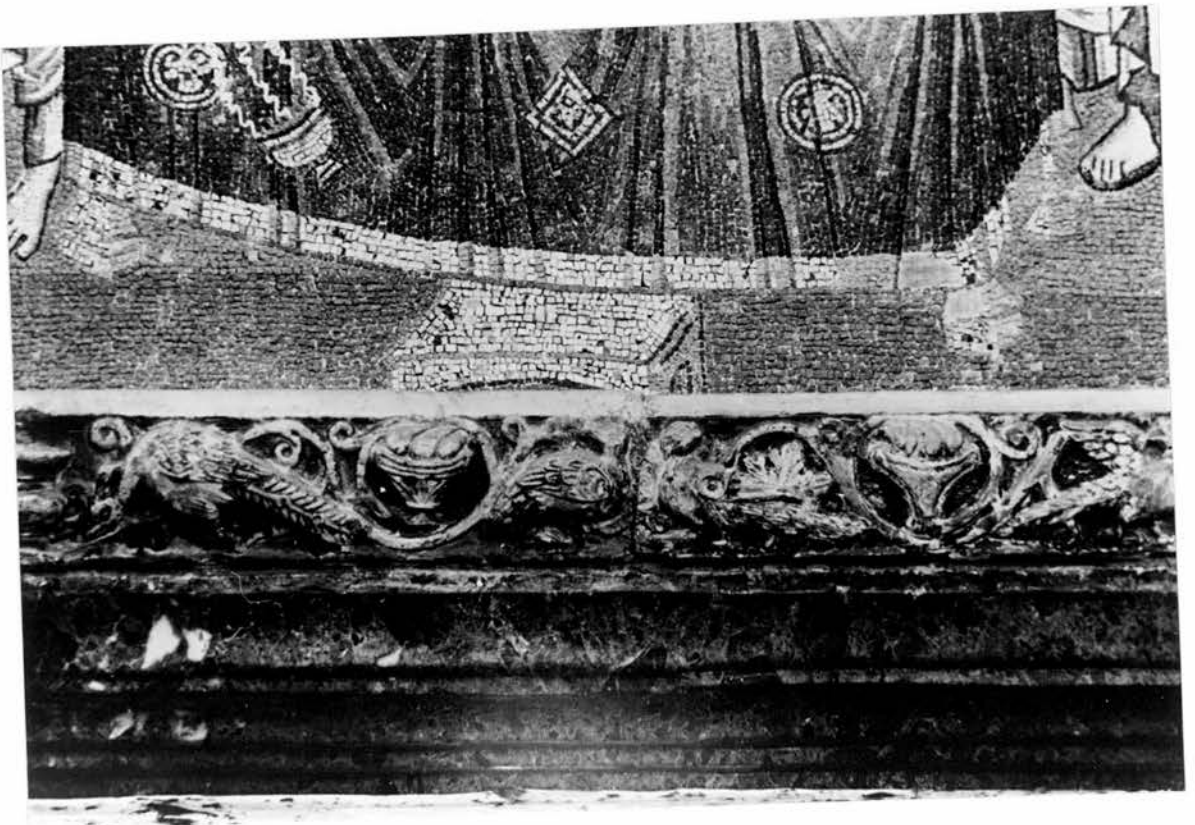

Fig. 3

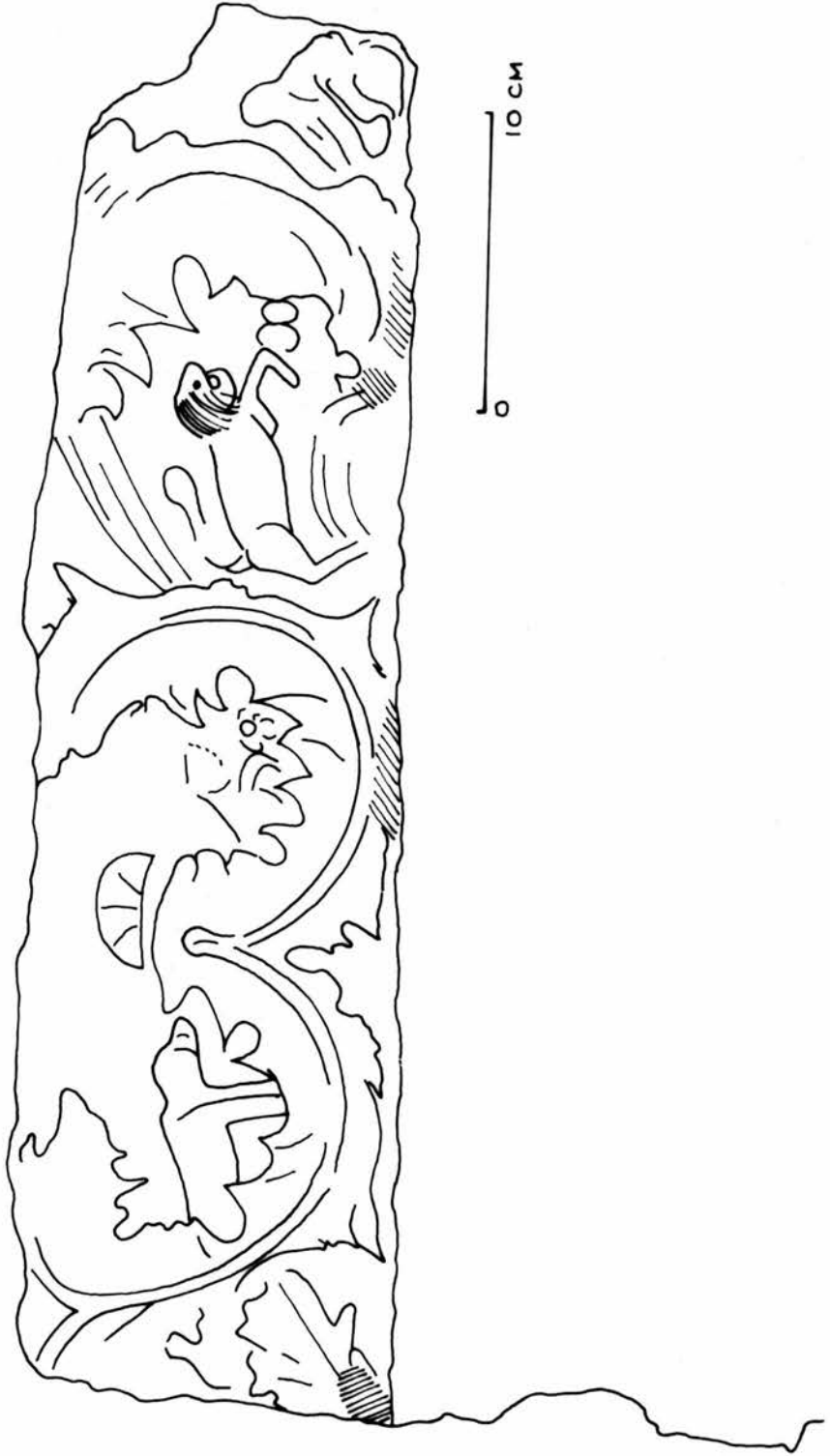
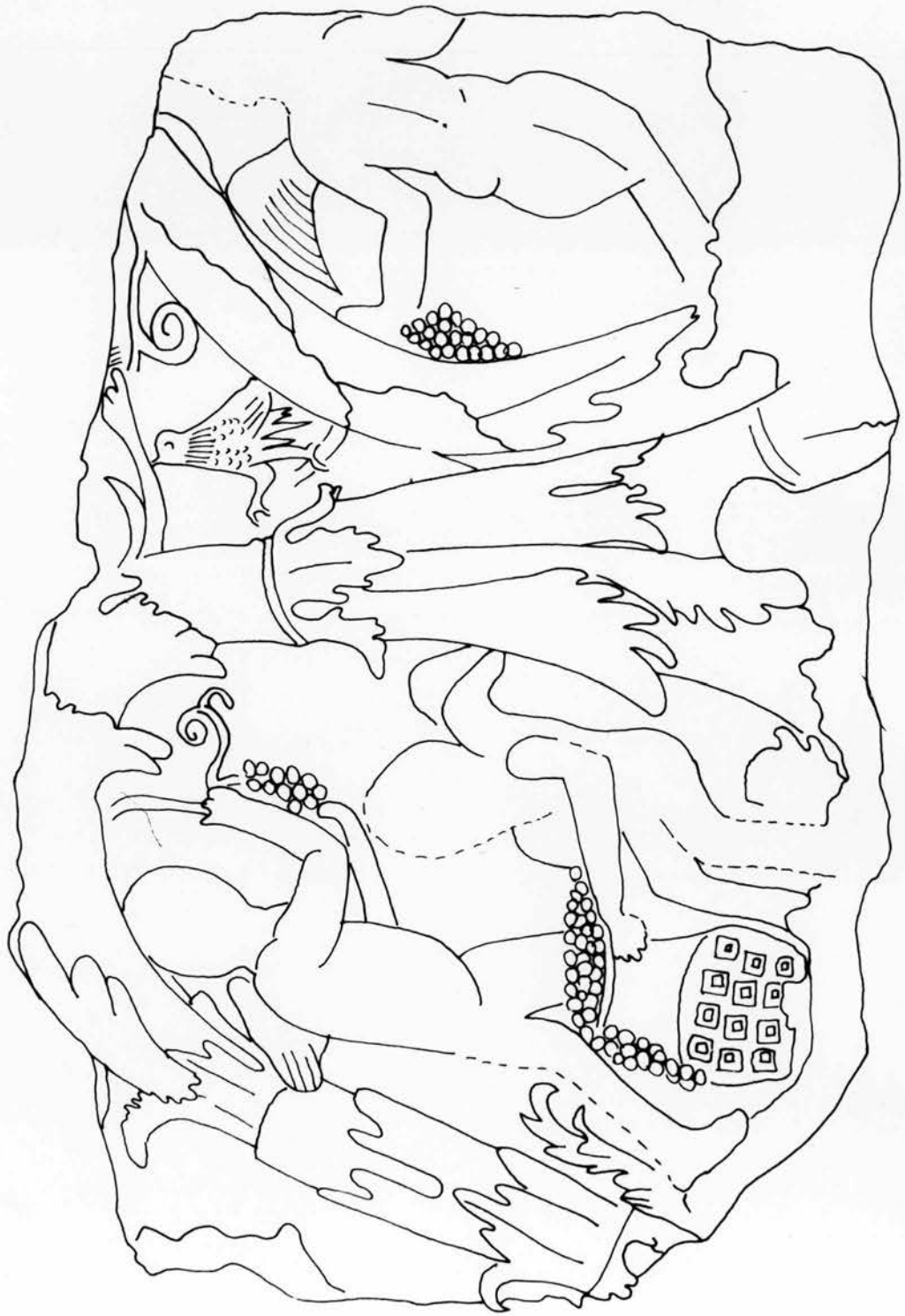

Fig. 4

Fig. 5



Fig. 6



0 10 CM

Fig. 7

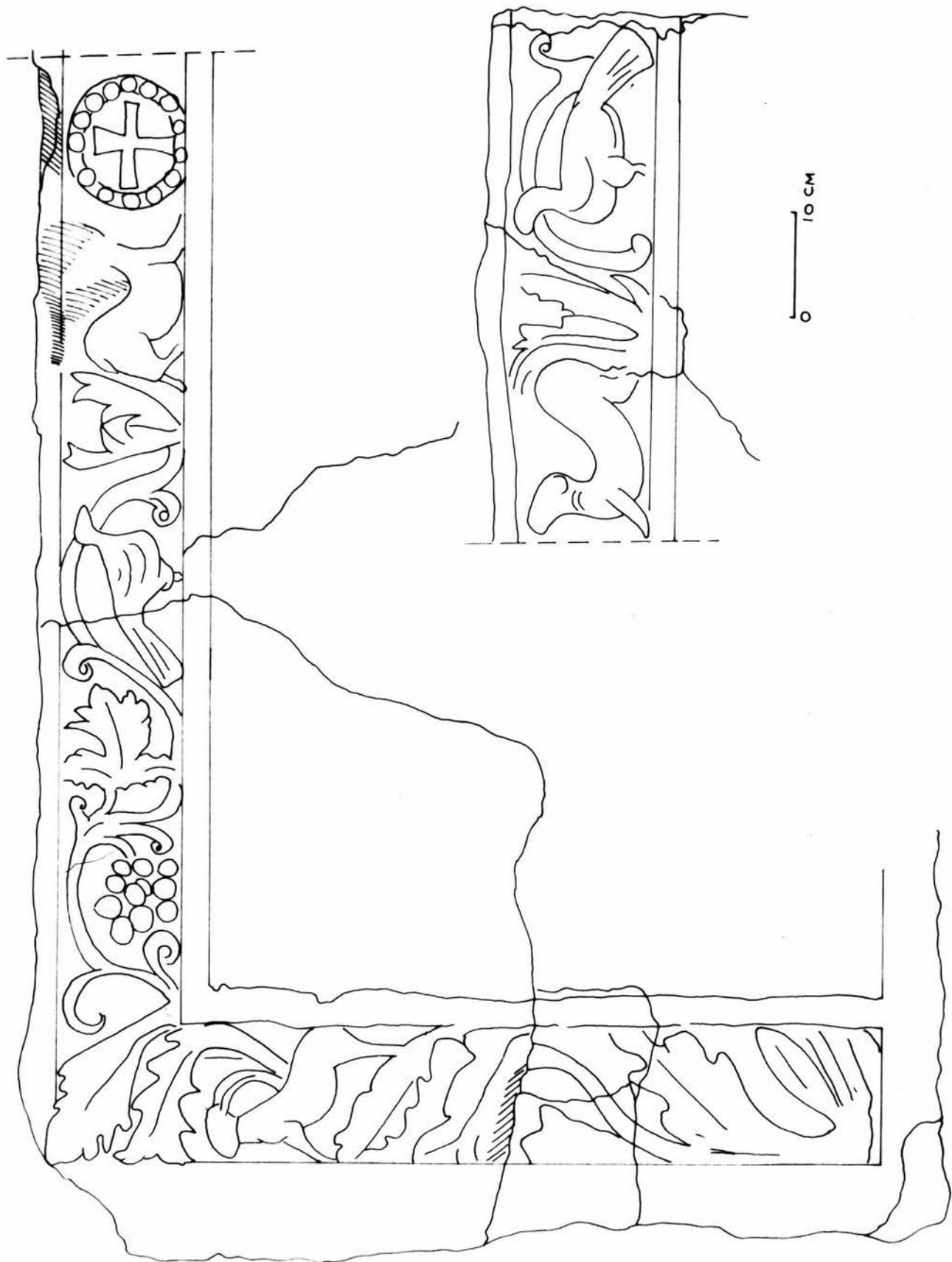

Fig. 8

Fig. 9



Fig. 10



Fig. 11

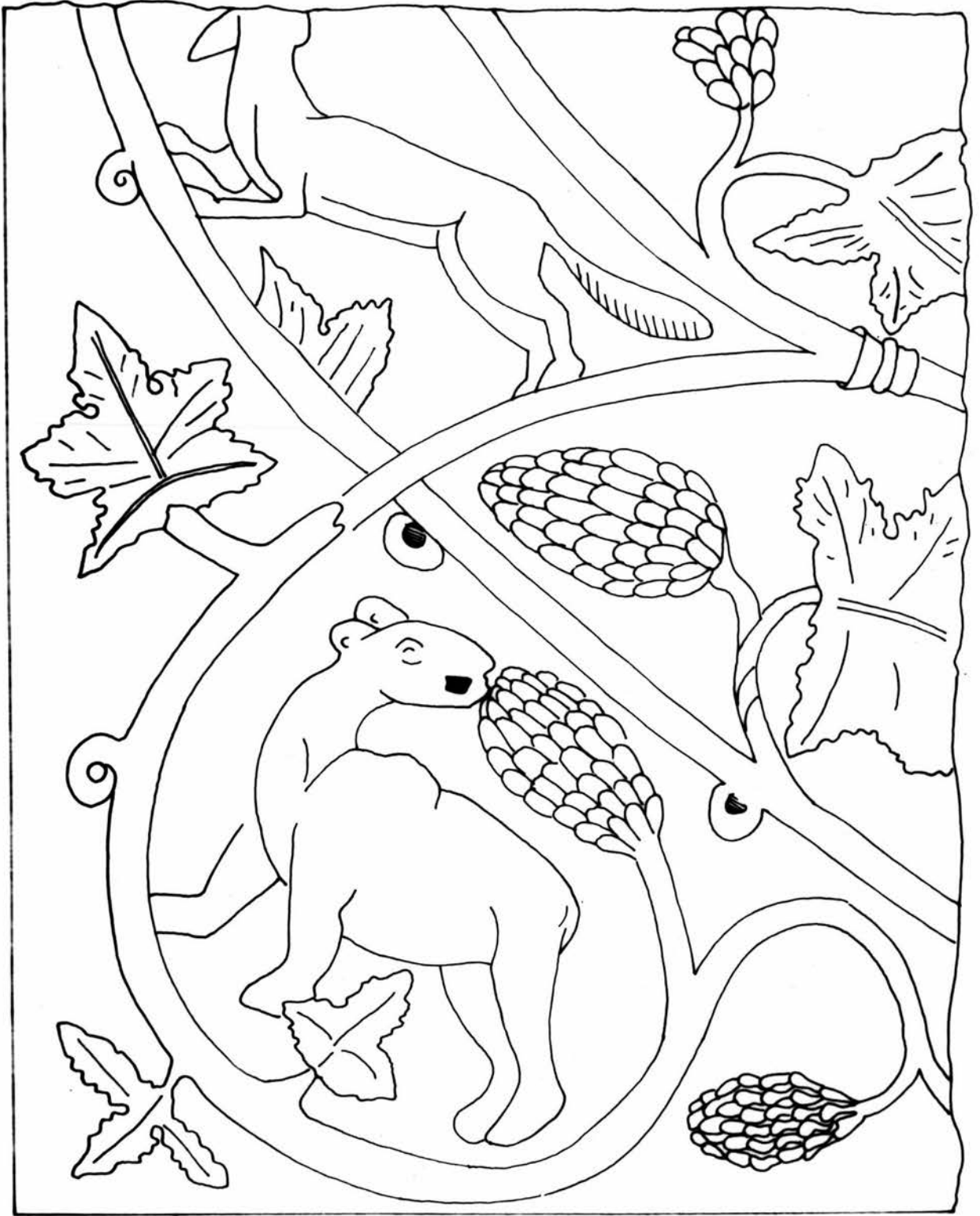

Fig. 12



0 5 cm

Fig.13



0 17CM

Fig. 14

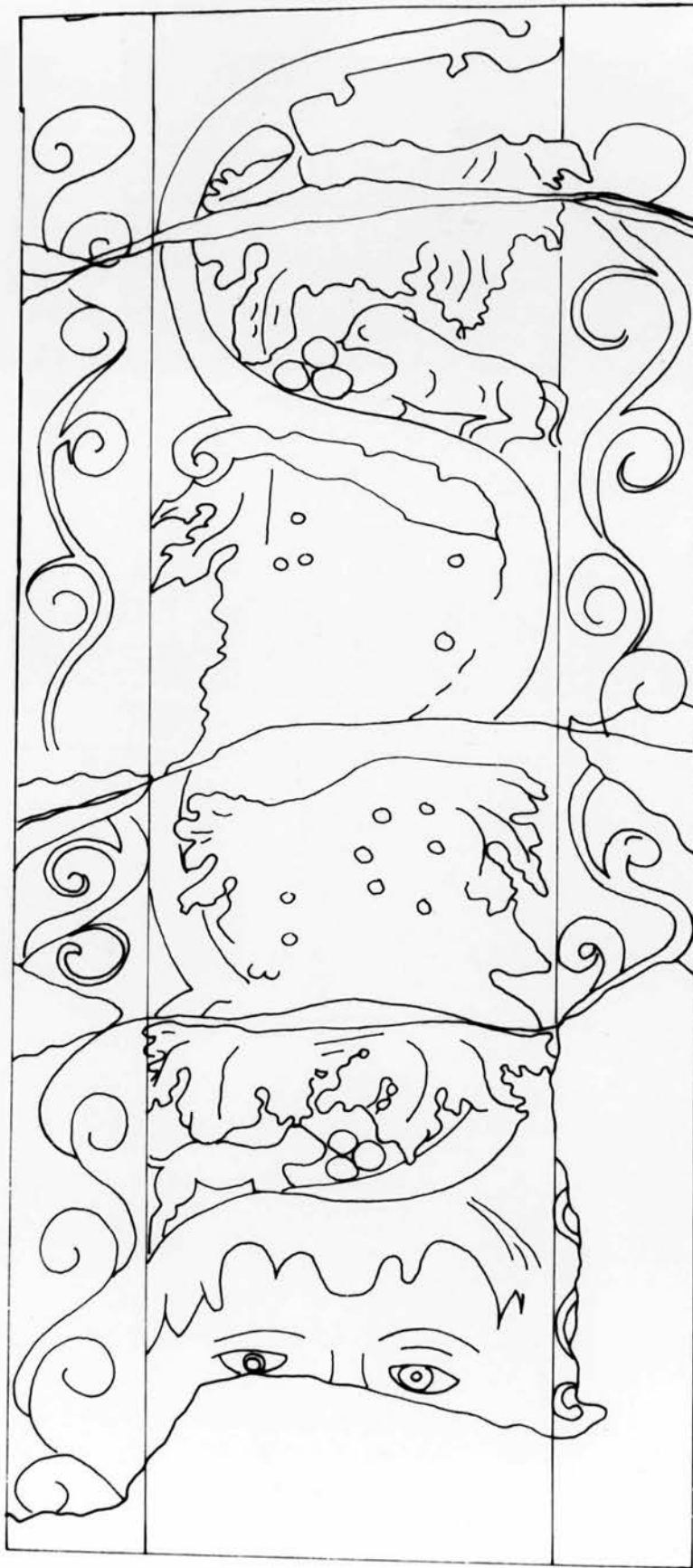

Fig. 15



0 10 CM

Fig. 16



0 10 CM





Fig. 19

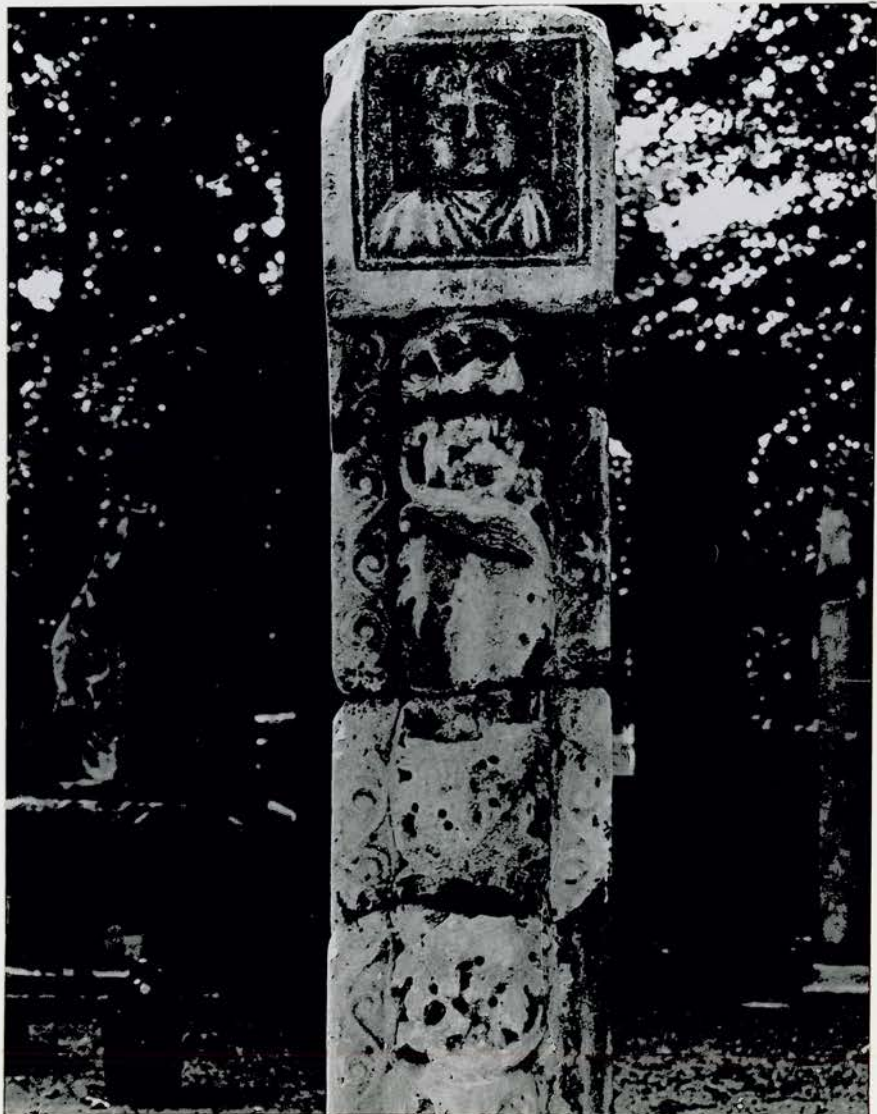
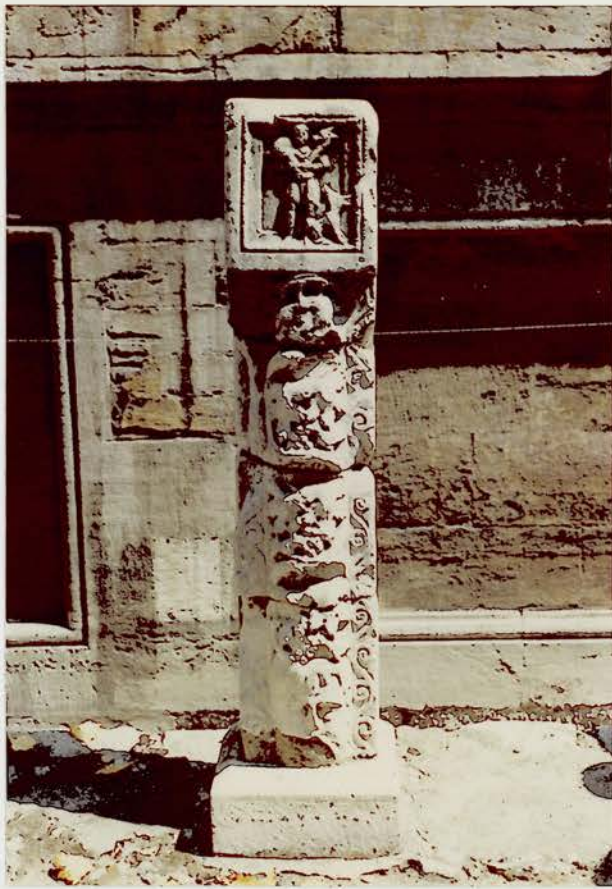

10 cm

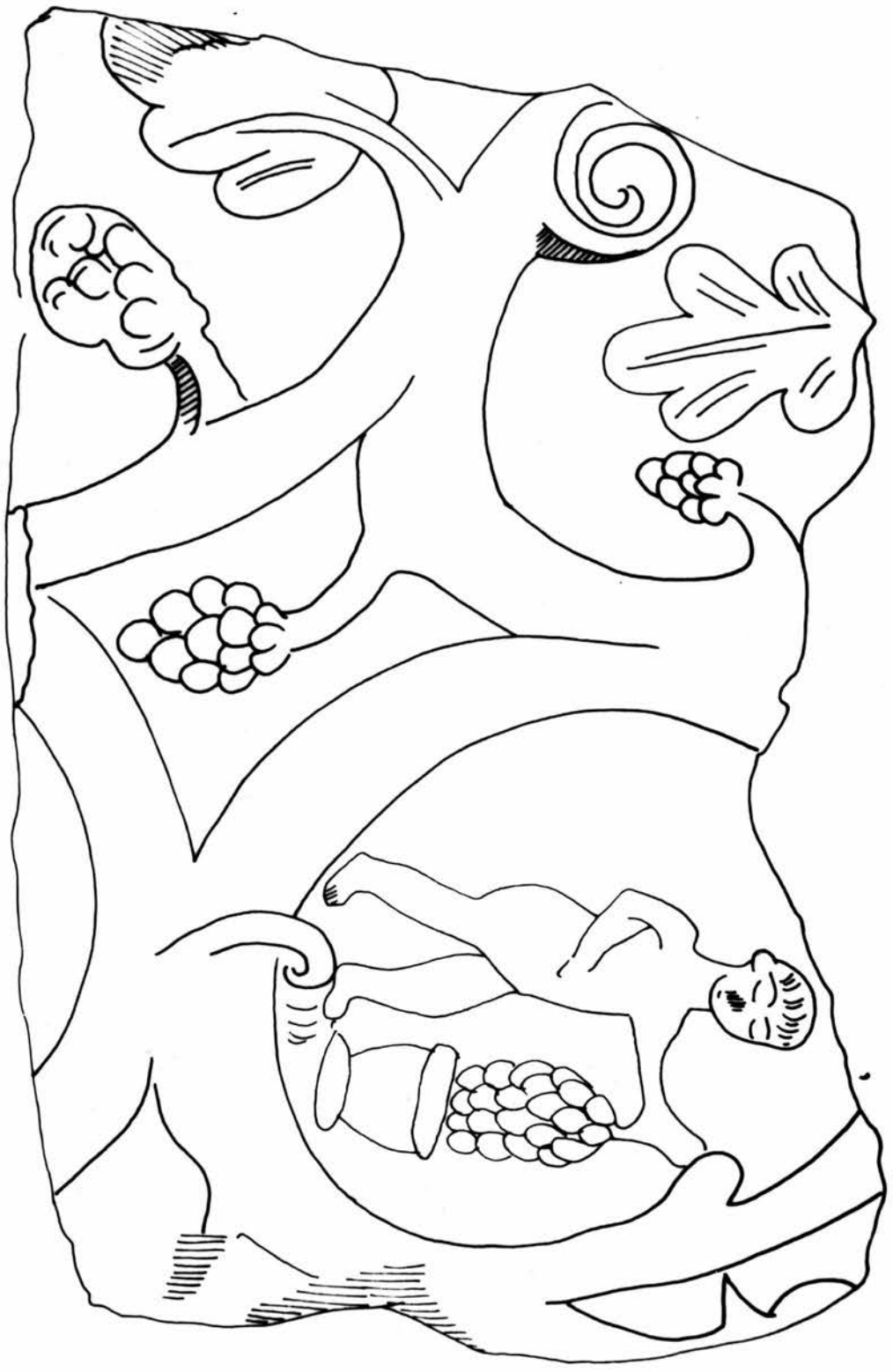
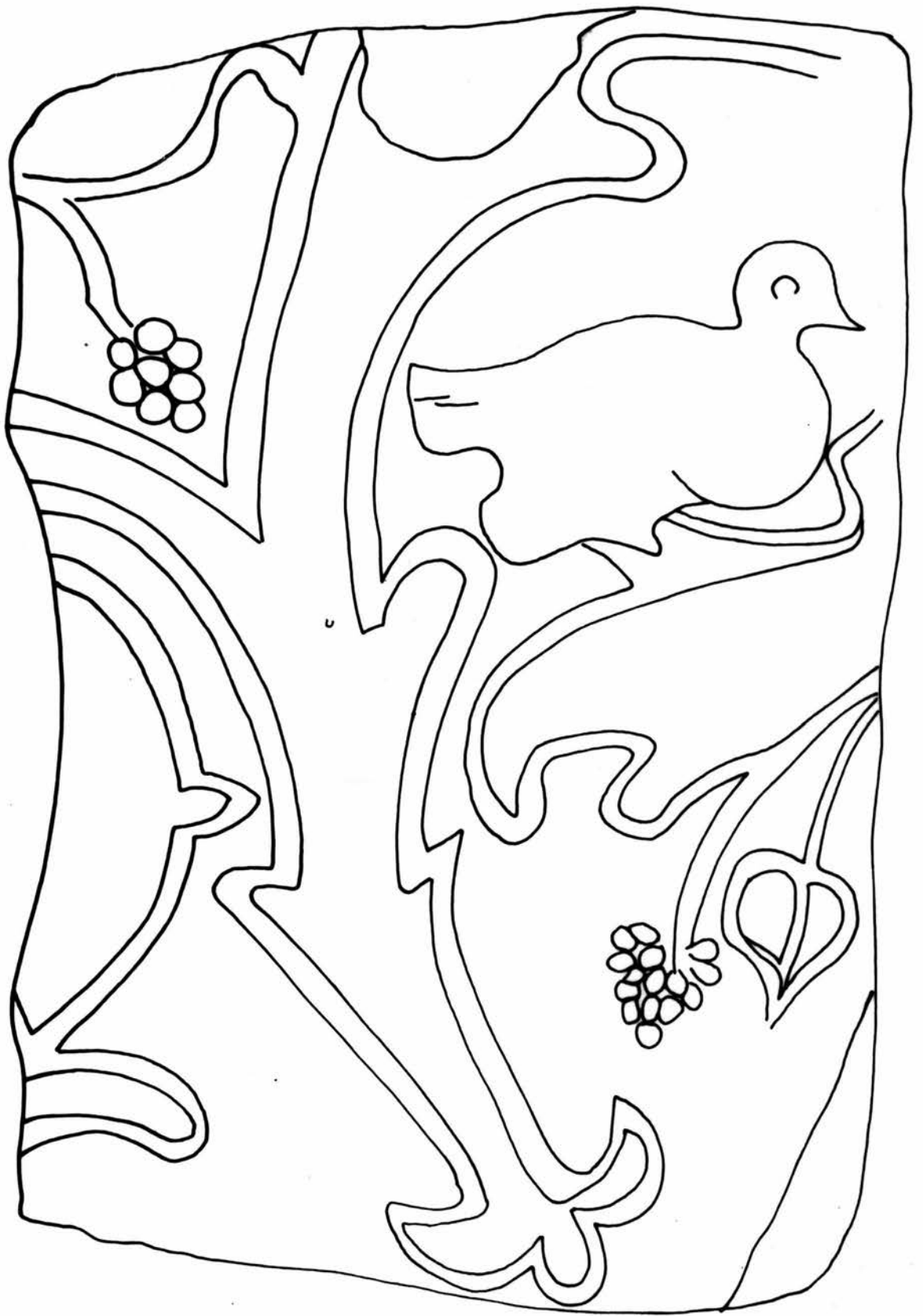

Fig. 20

Fig. 21

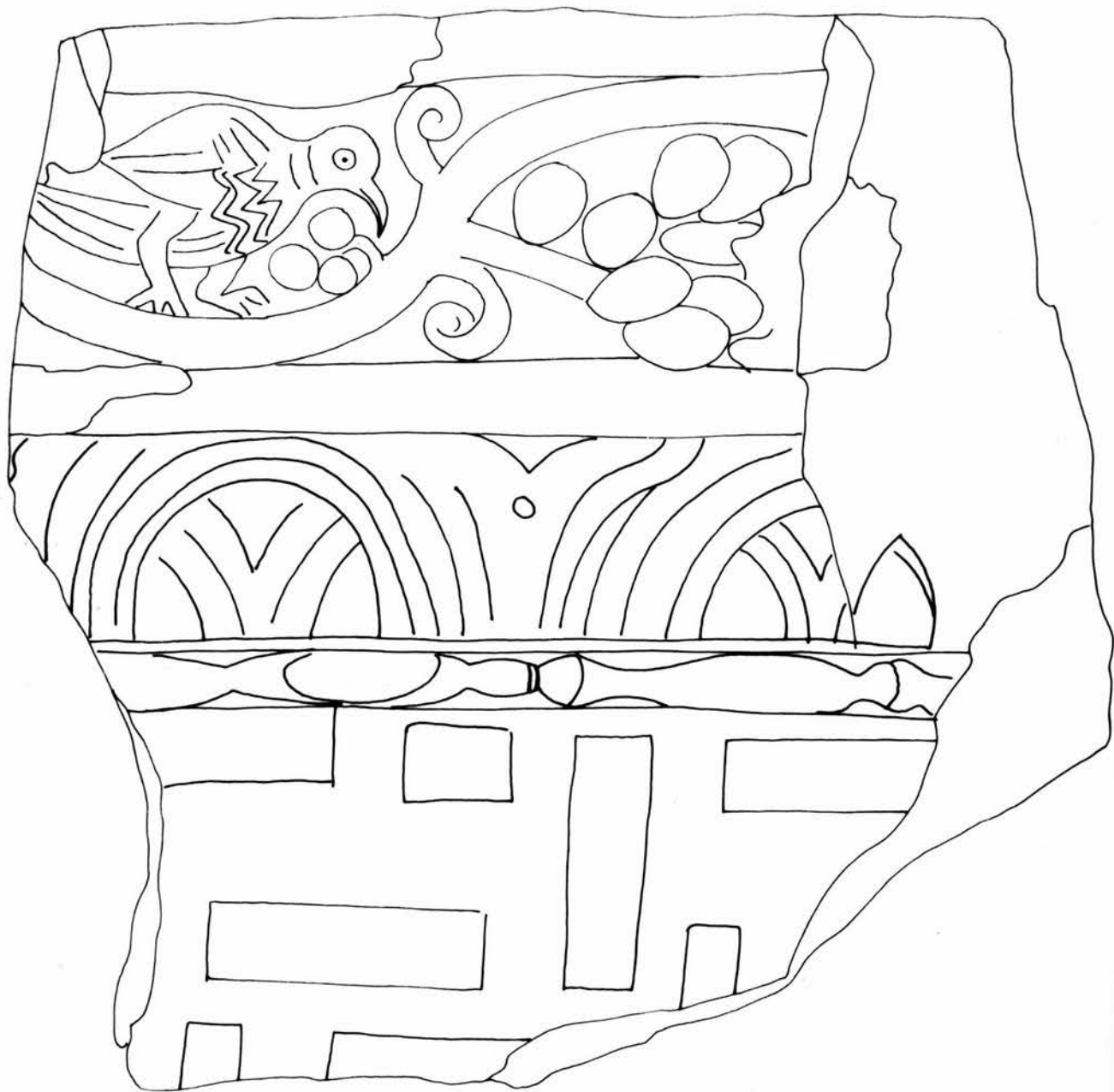

Fig. 22



0 10 CM

Fig. 23



0 10 CM

Fig. 24

Fig. 25



Fig. 26

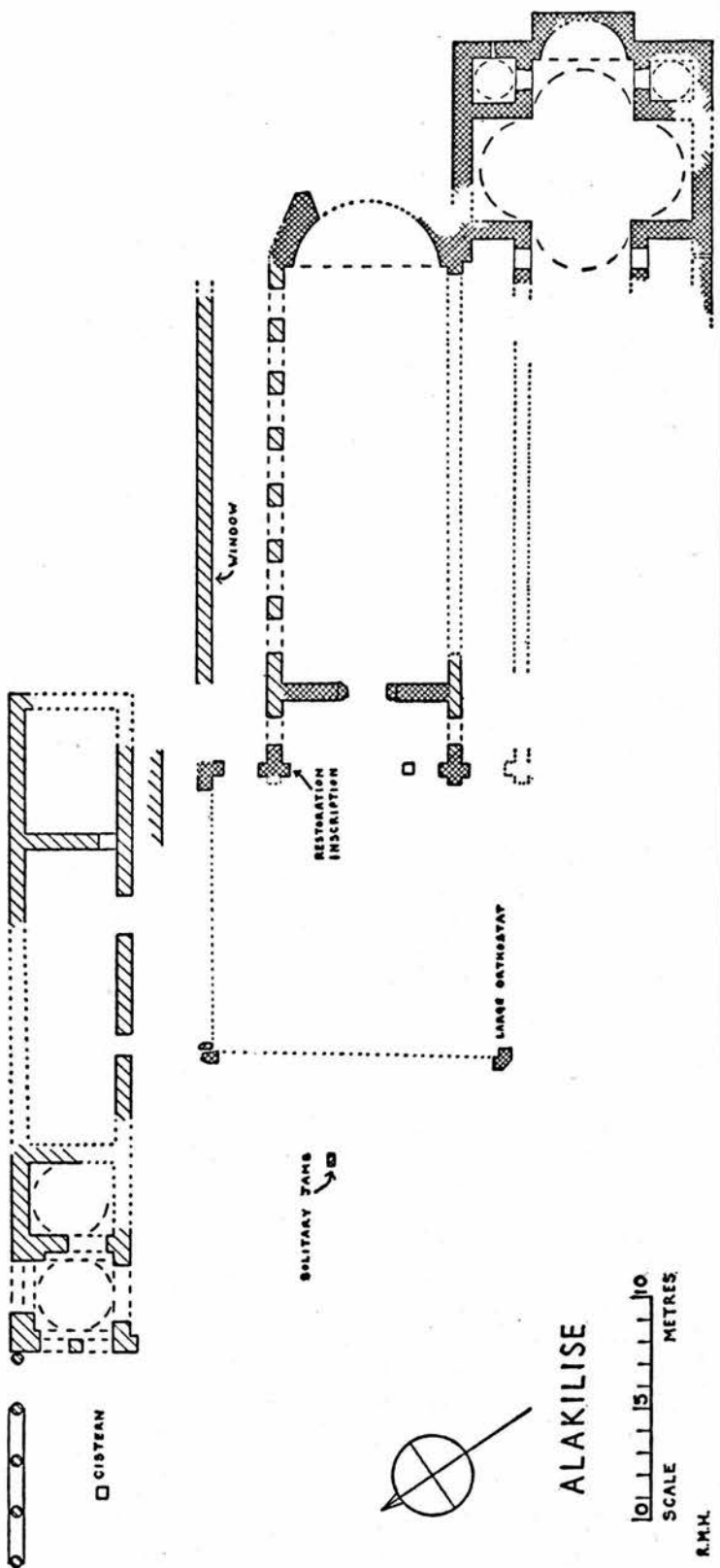

ALAKILISE

Fig. 27

MONASTERY CHURCH  
NEAR KARABEL

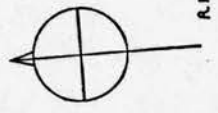
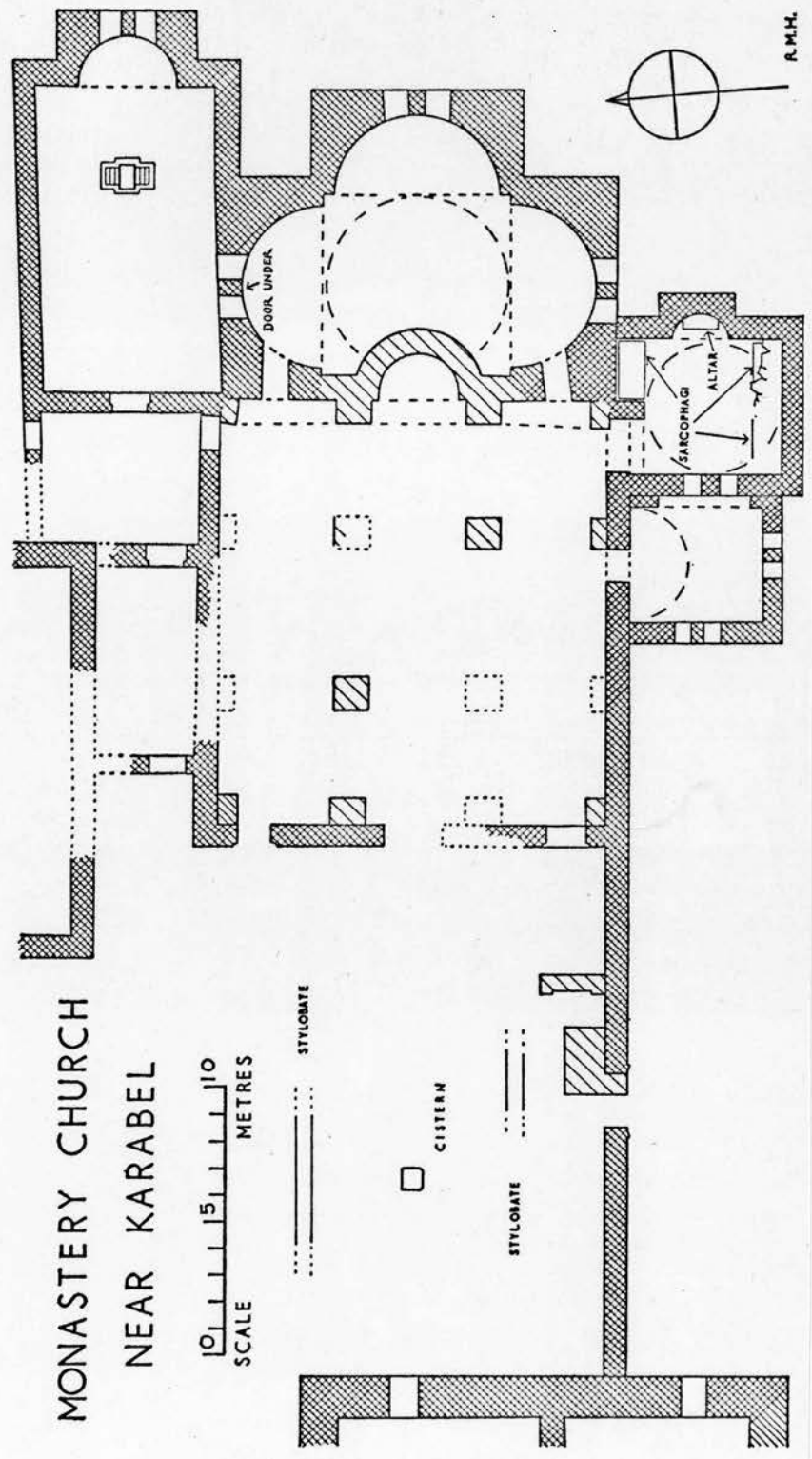
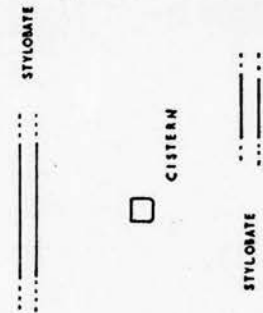
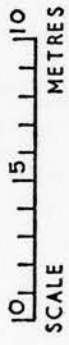

R.M.H.

Fig. 28

Fig. 29



1:2

Fig. 30

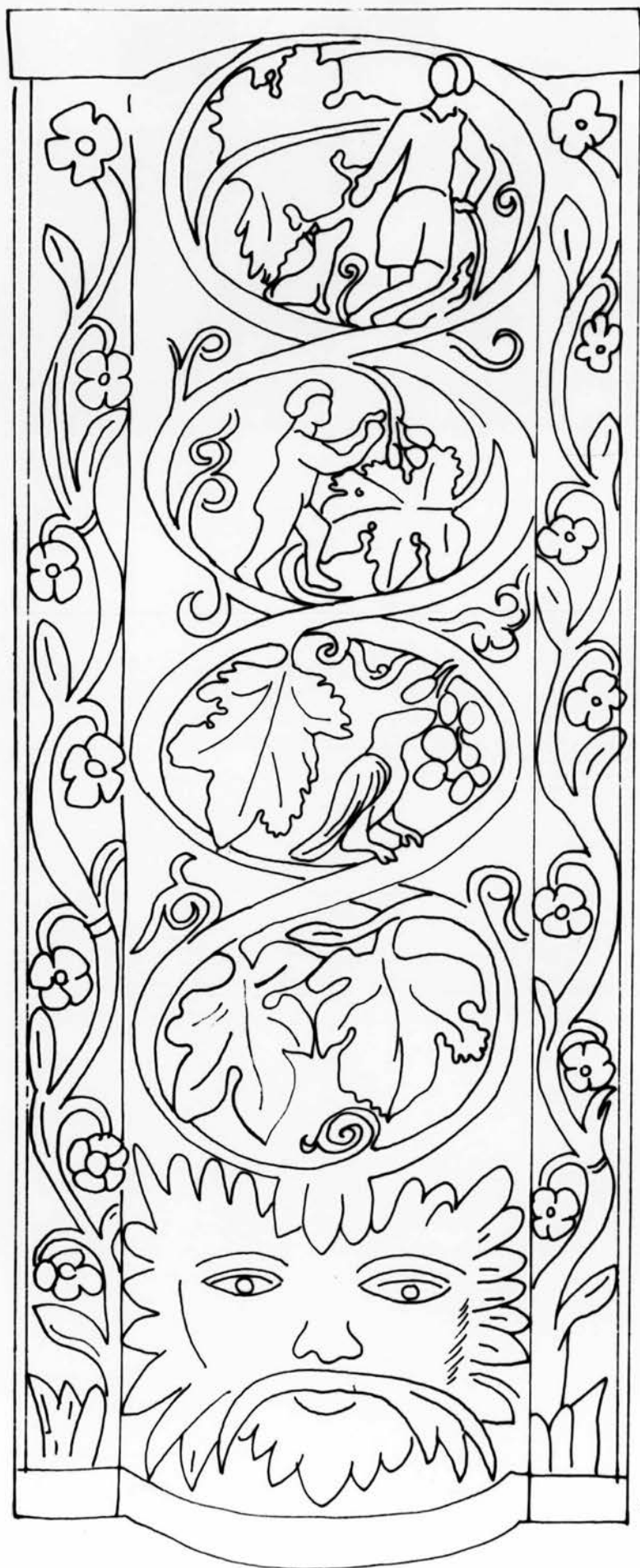

0 6 cm

Fig. 31

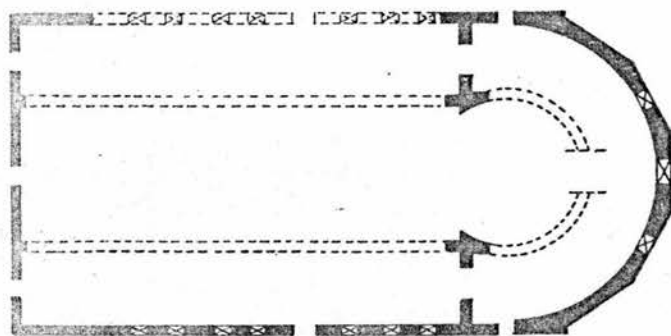

Fig. 32



Fig. 33

Fig. 34



CHURCH OF THE APOSTLES

0 5 10 15 20 M.



Fig. 35

Fig. 36

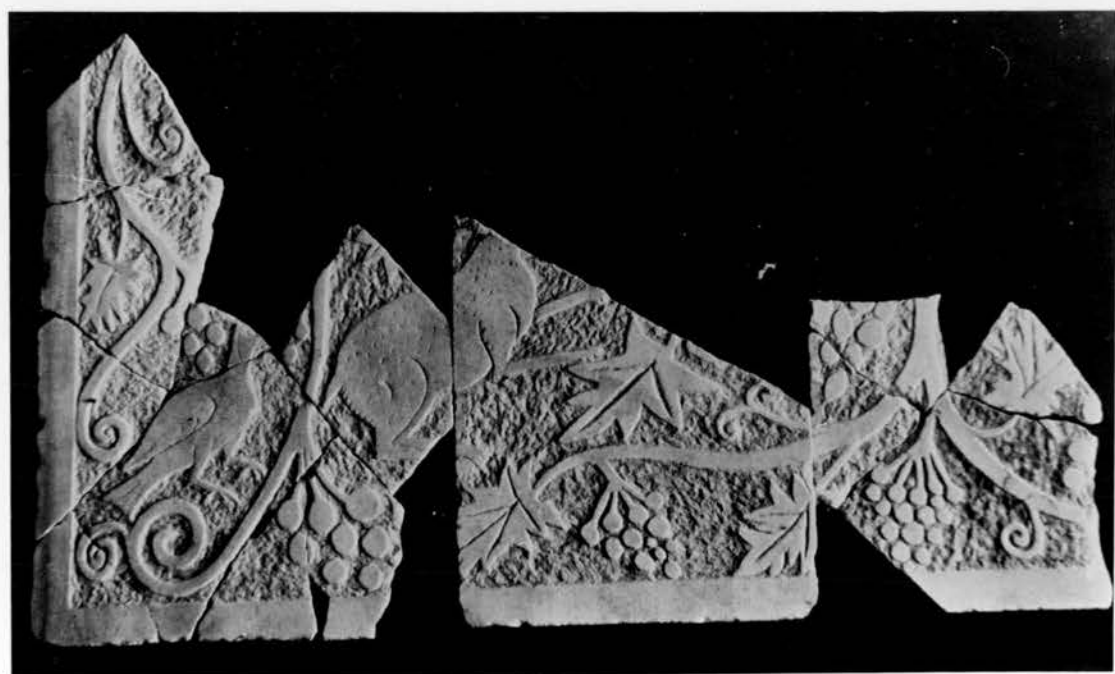
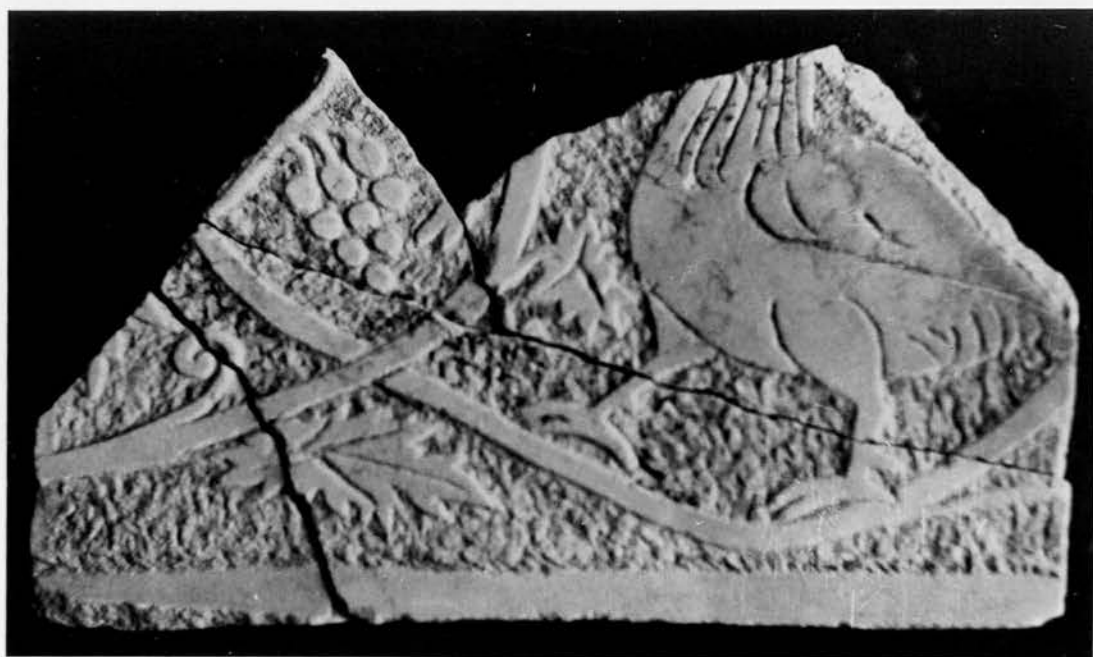

Fig. 37

Fig. 38

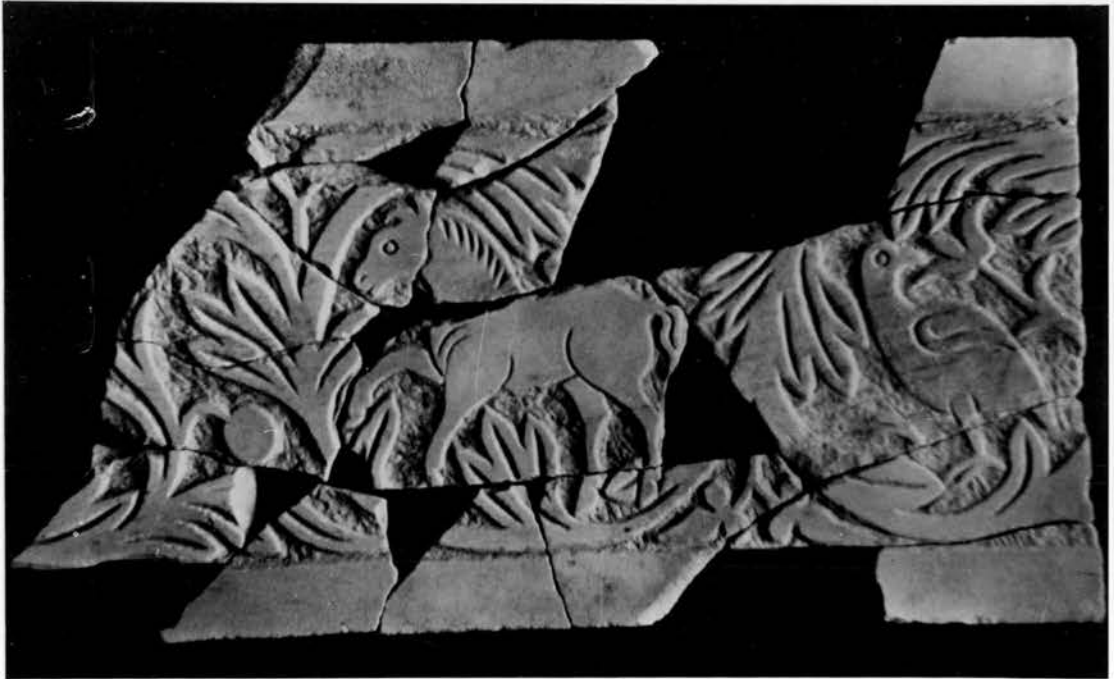

Fig. 39

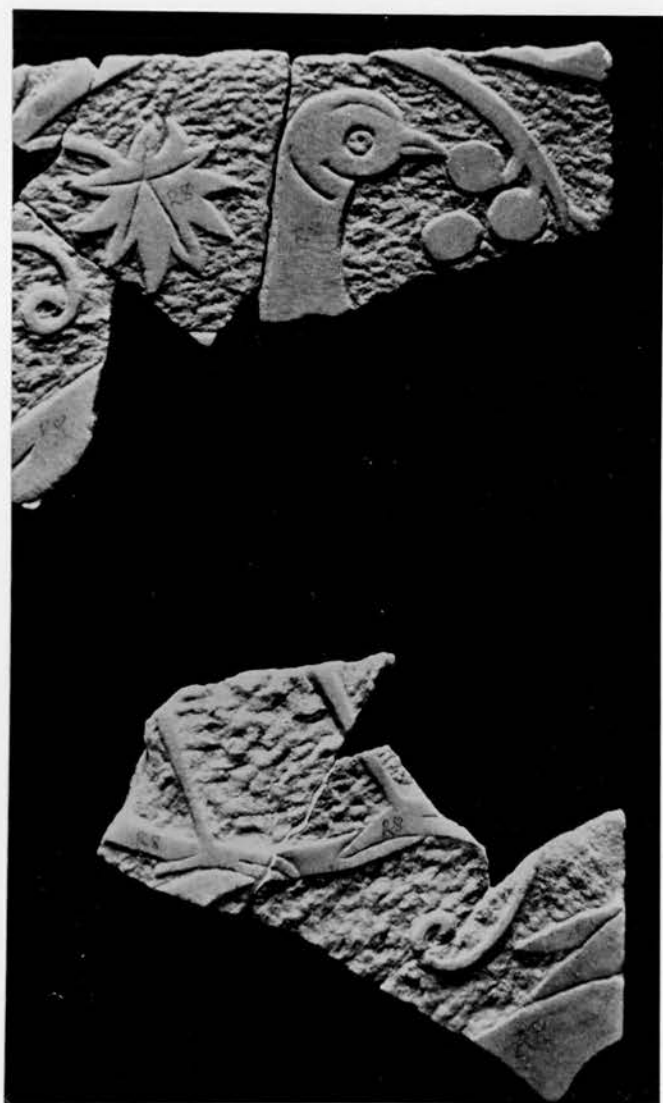

Fig. 40

Fig. 41

Fig. 42



Fig. 43

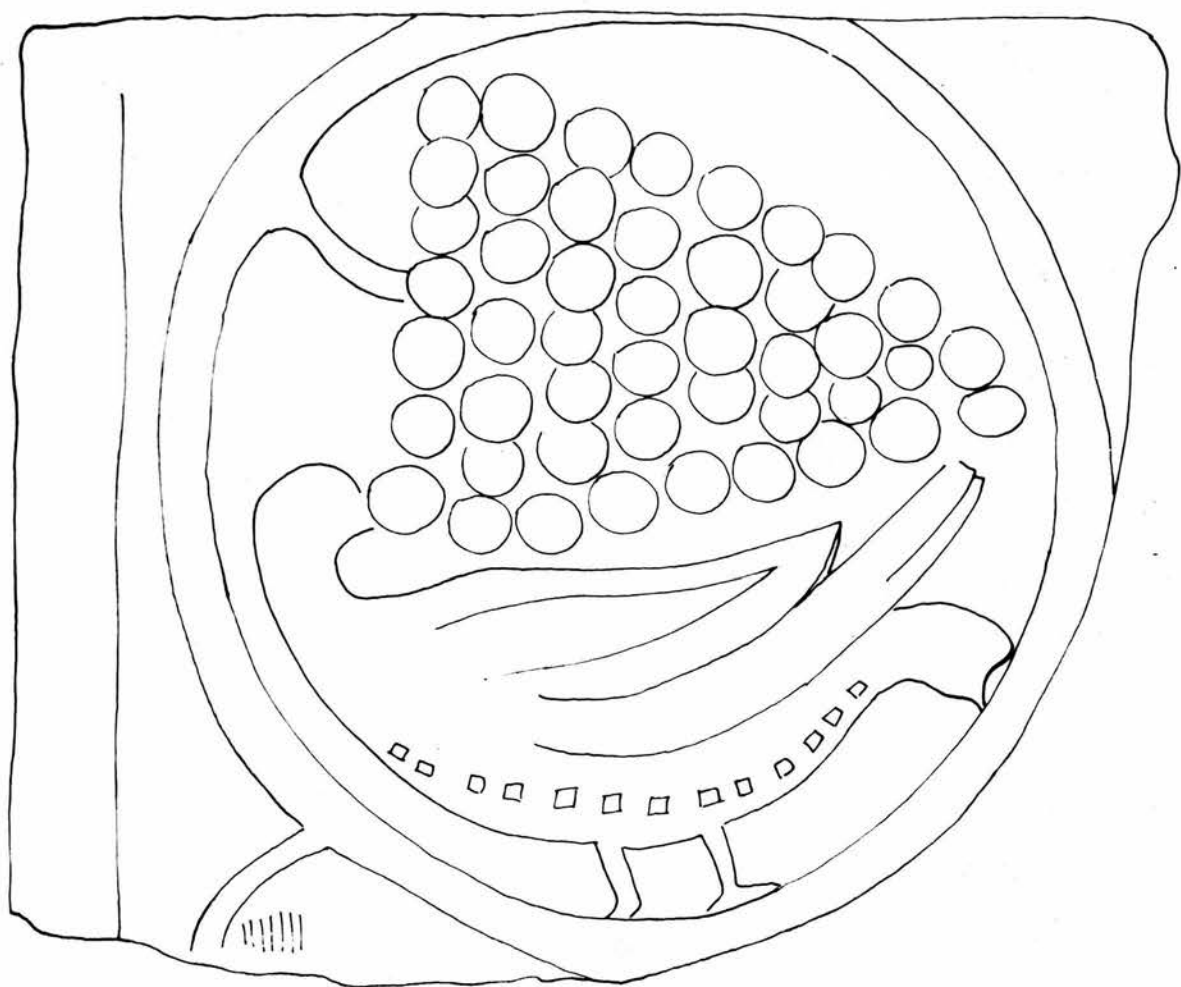

0 ————— 10 CM

Fig. 44





THE UNIVERSITY *of* EDINBURGH

PAGE ORDER INACCURATE IN ORIGINAL

Fig. 46

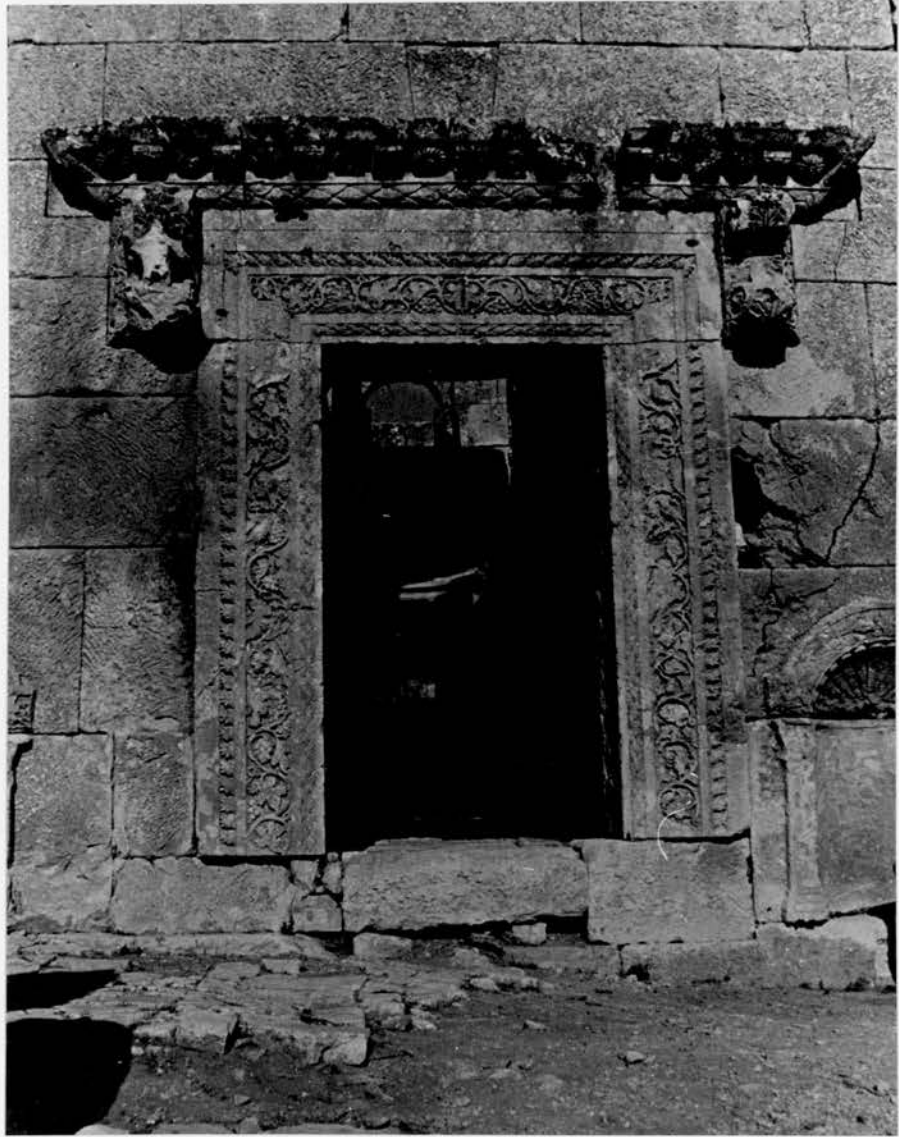
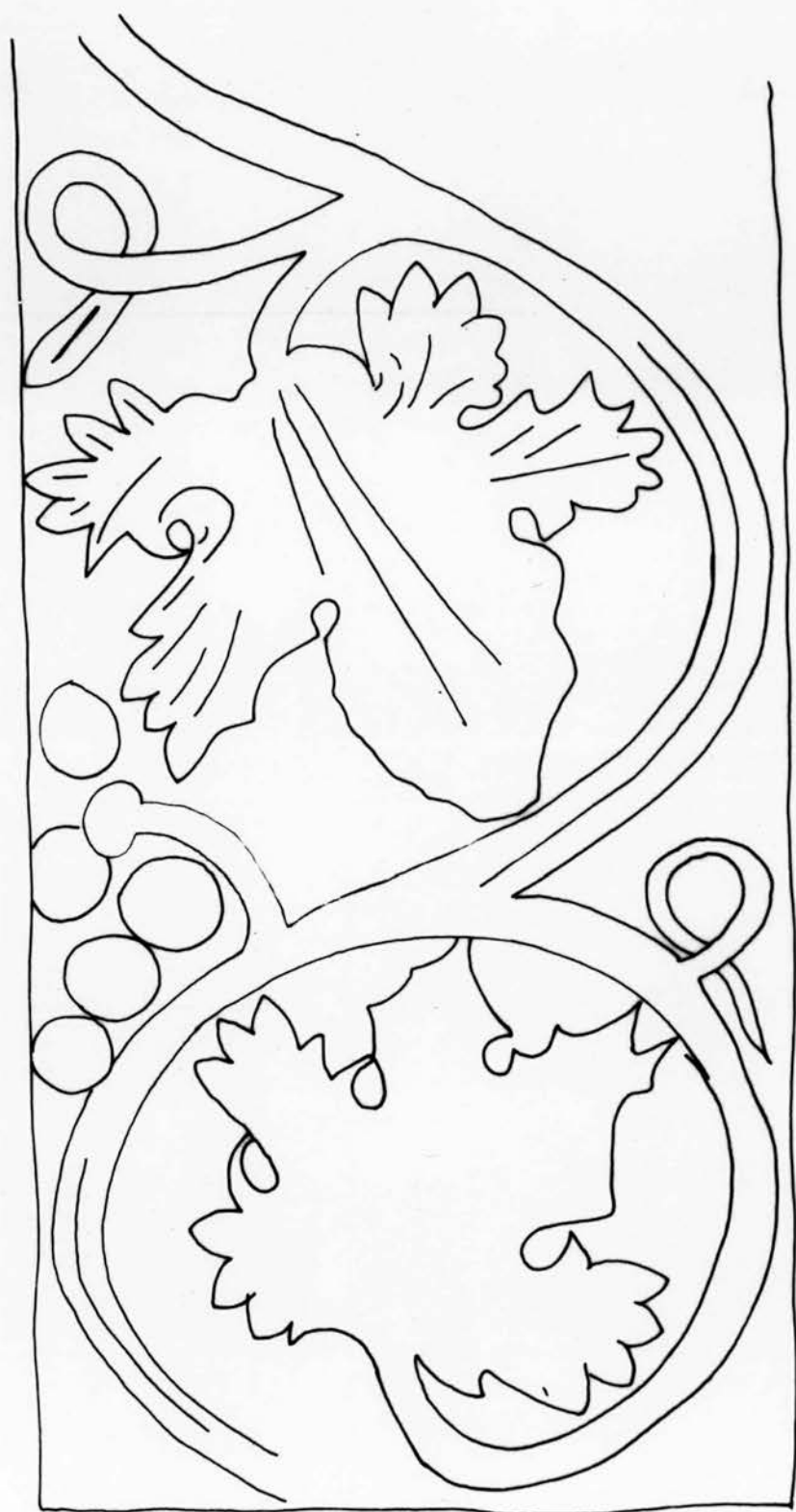
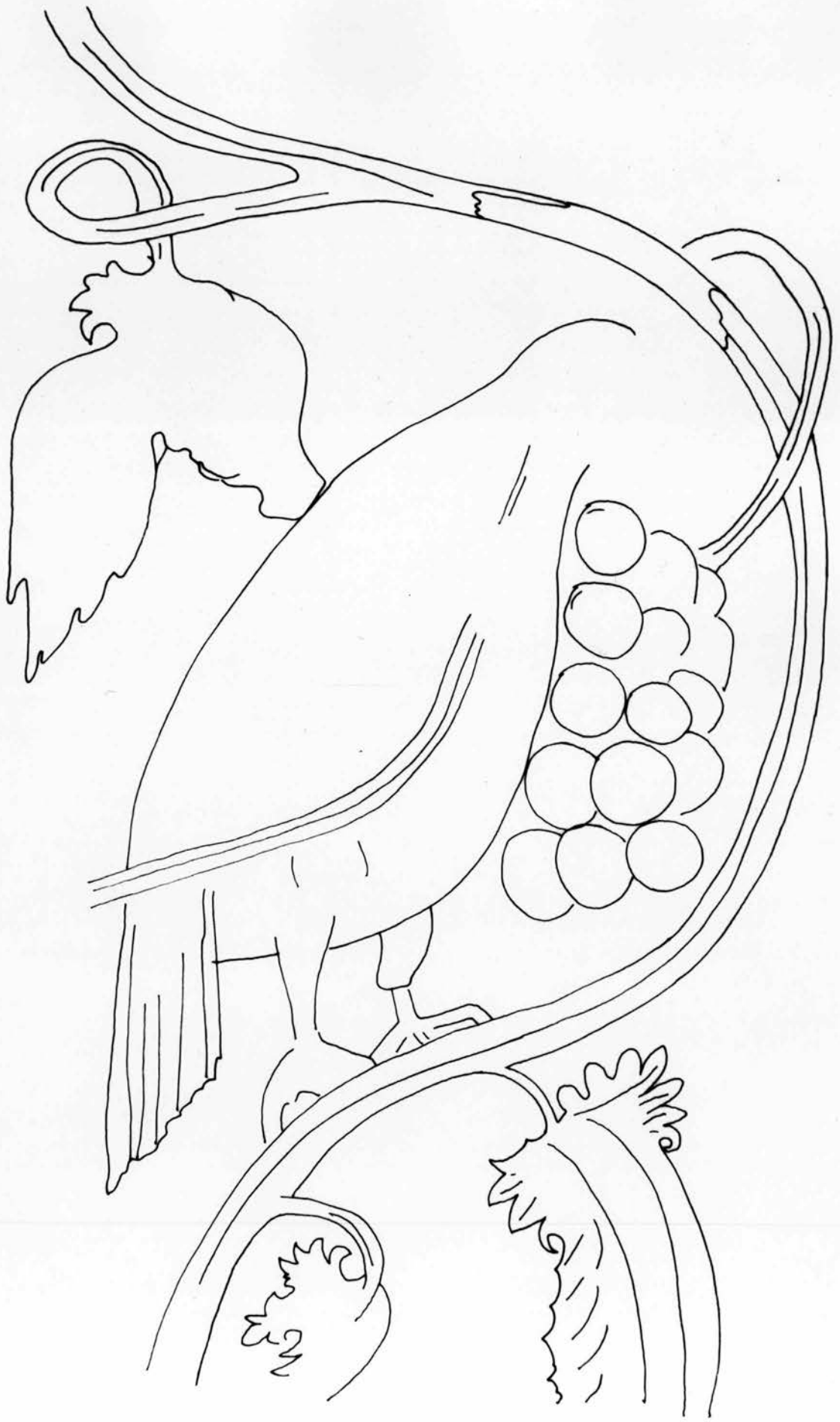

Fig. 47



0 10 CM

Fig. 48



0 5cm

Fig. 49

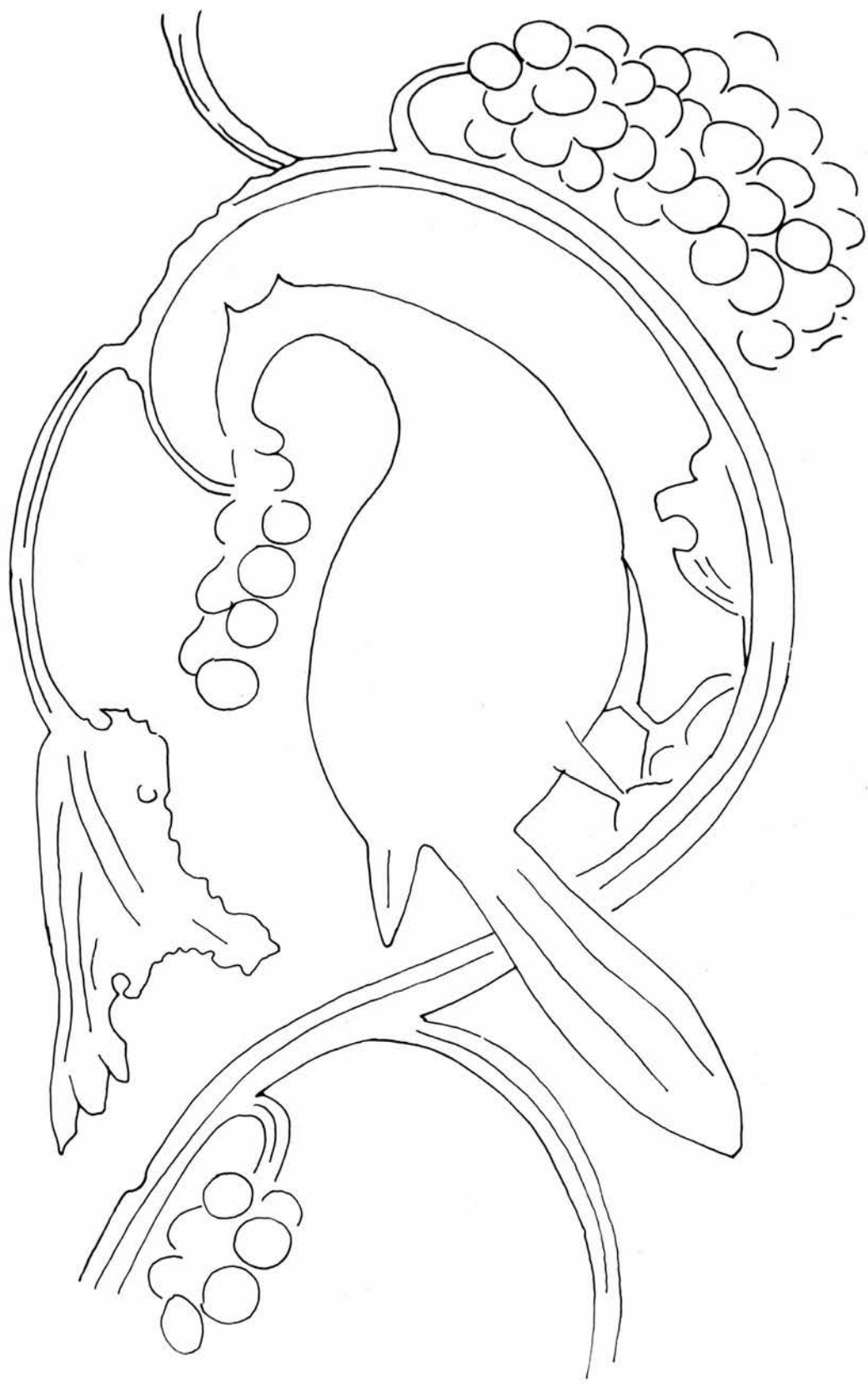

0 5 CM

Fig. 50

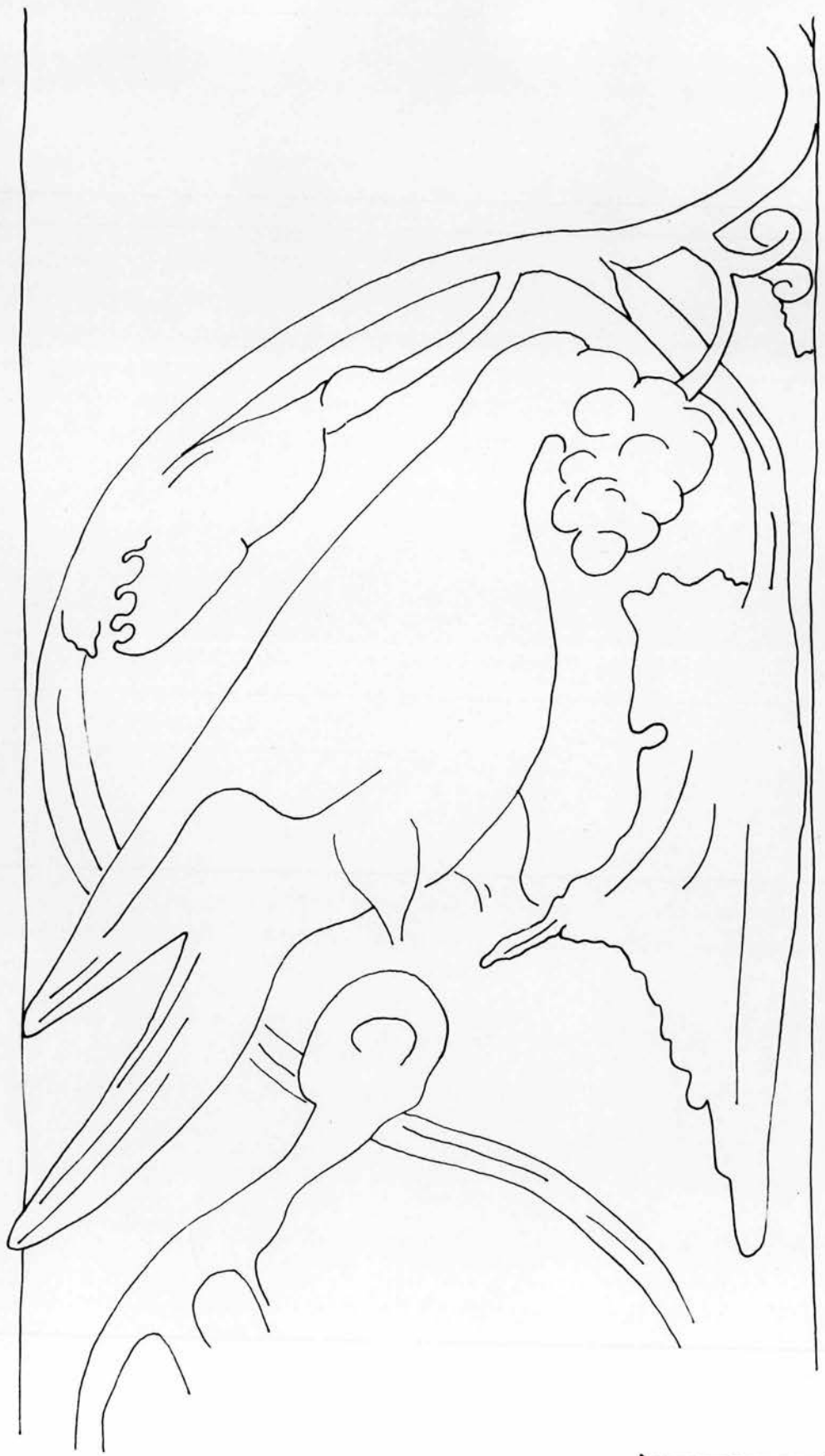

0 ————— 5cm

Fig. 51





0 5 CM

Fig. 52

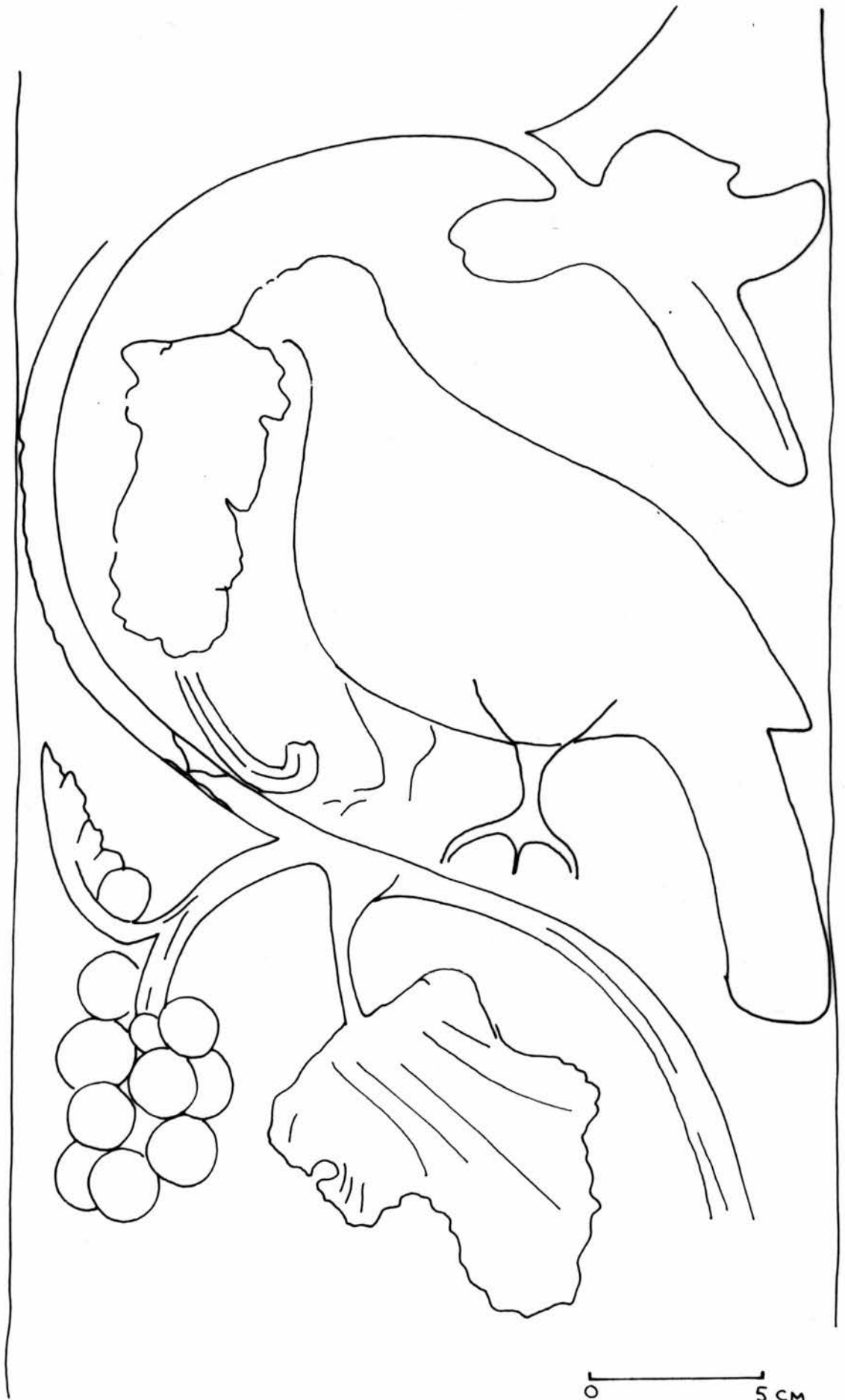

Fig. 53

Fig. 54

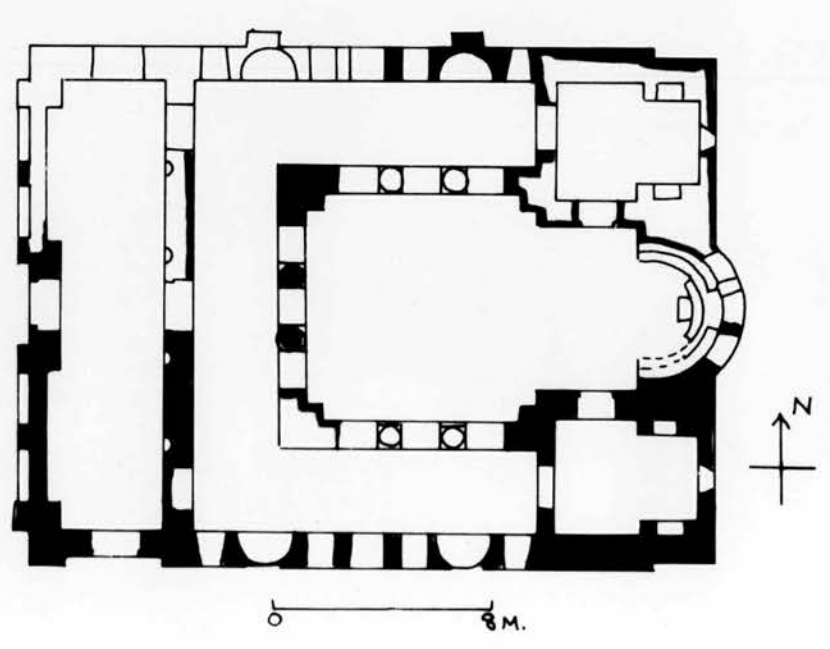
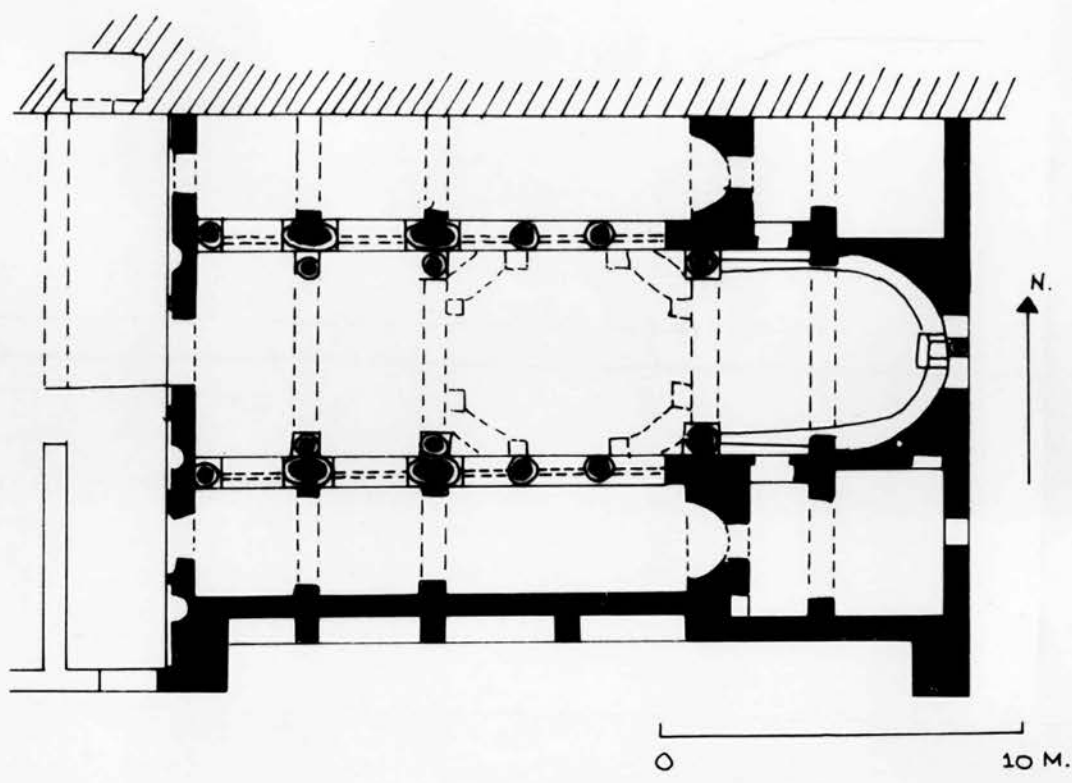

Fig. 55

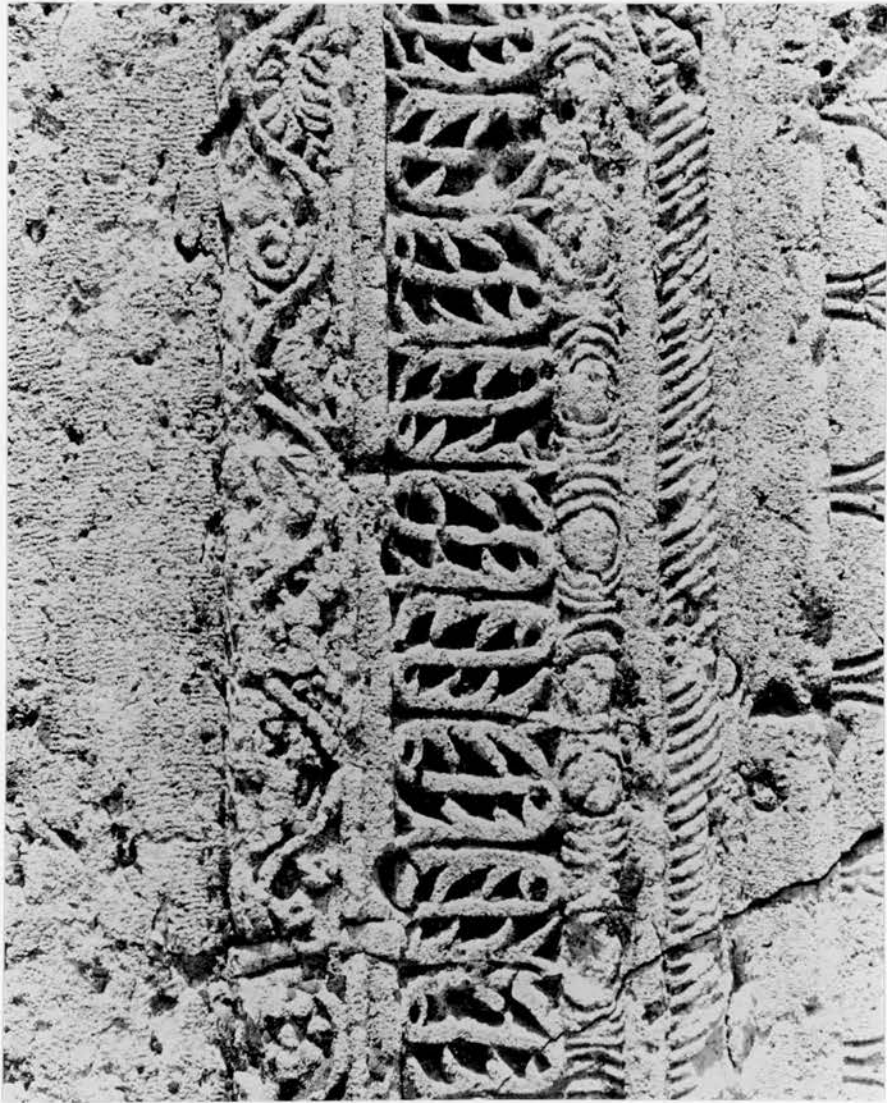

Fig. 56

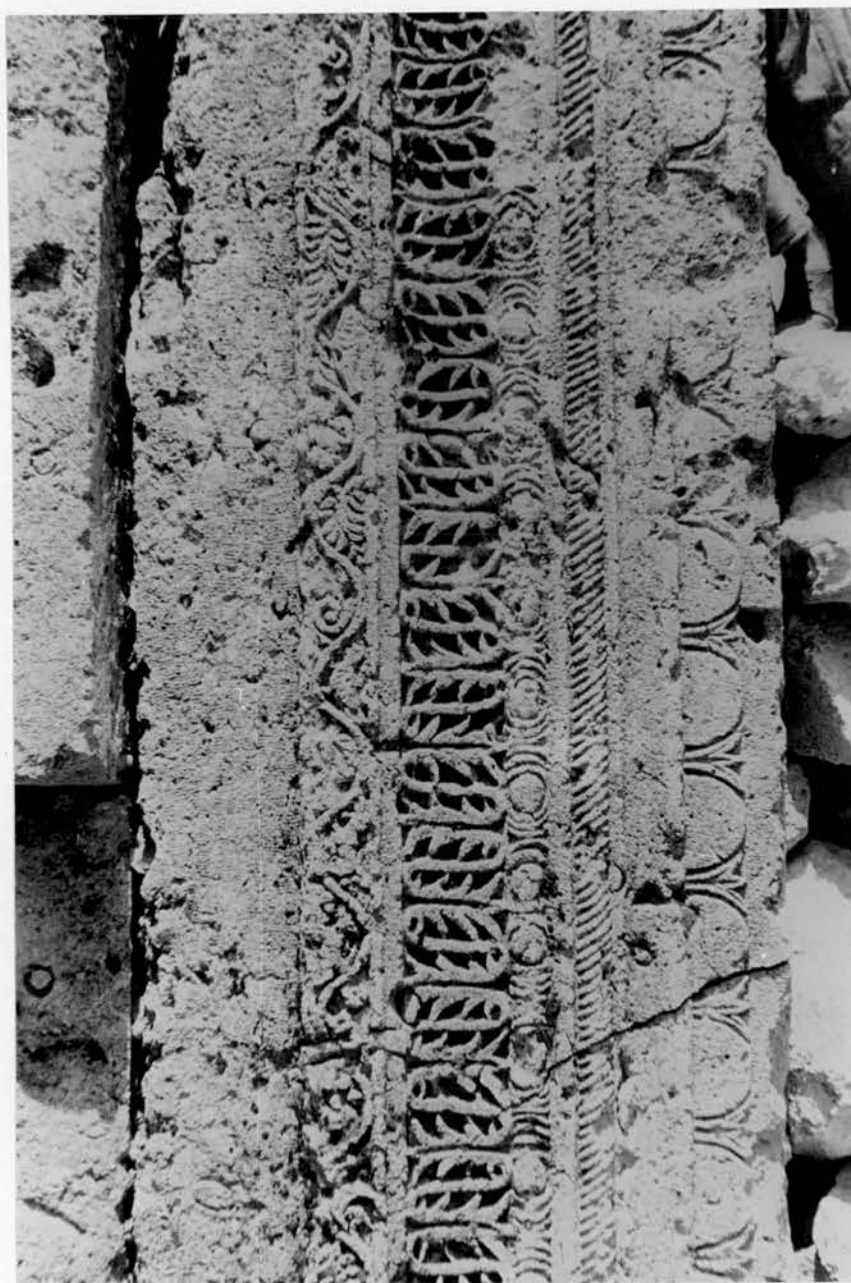
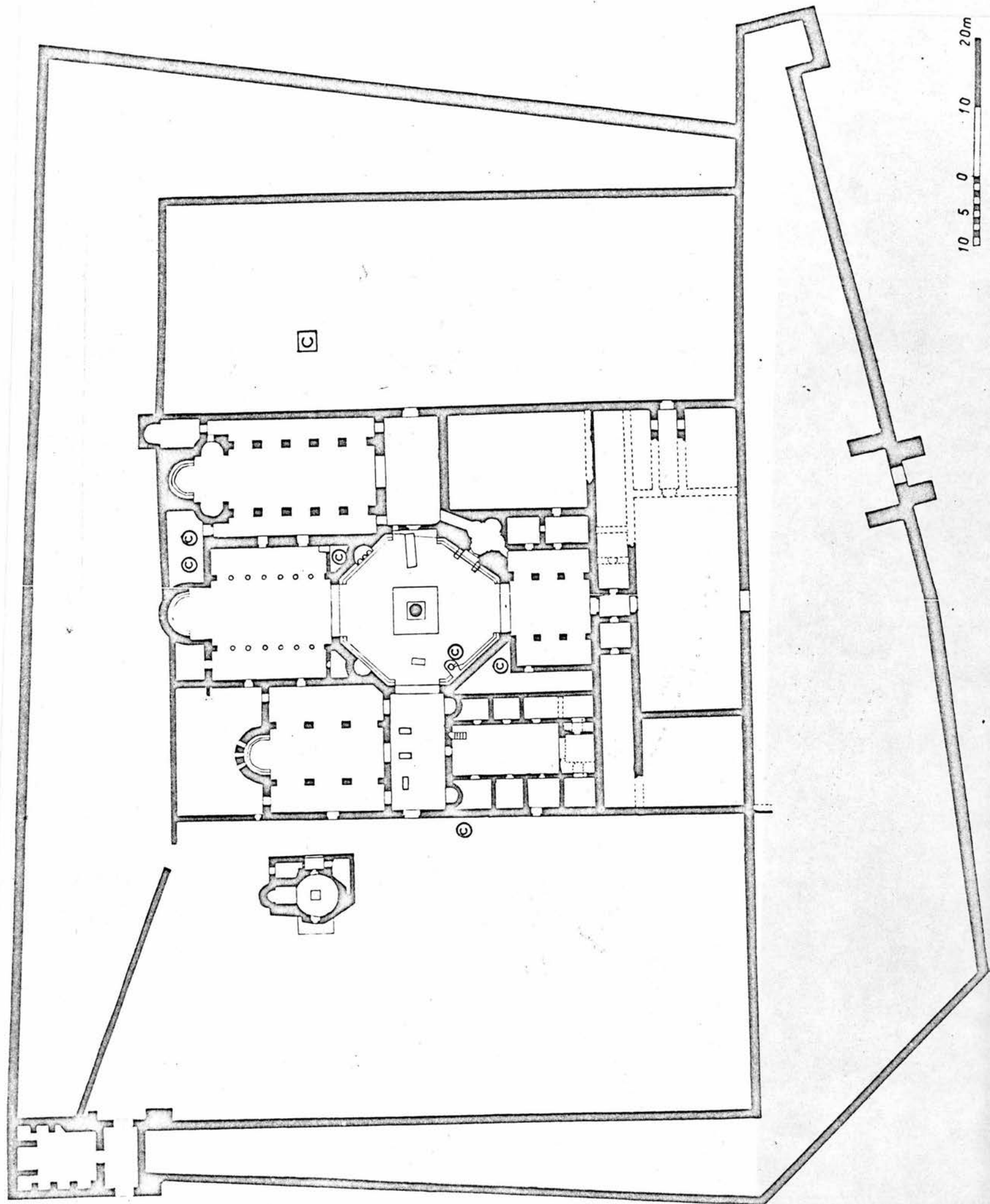

Fig. 57



Fig. 58



10 5 0 10 20m

Fig. 59

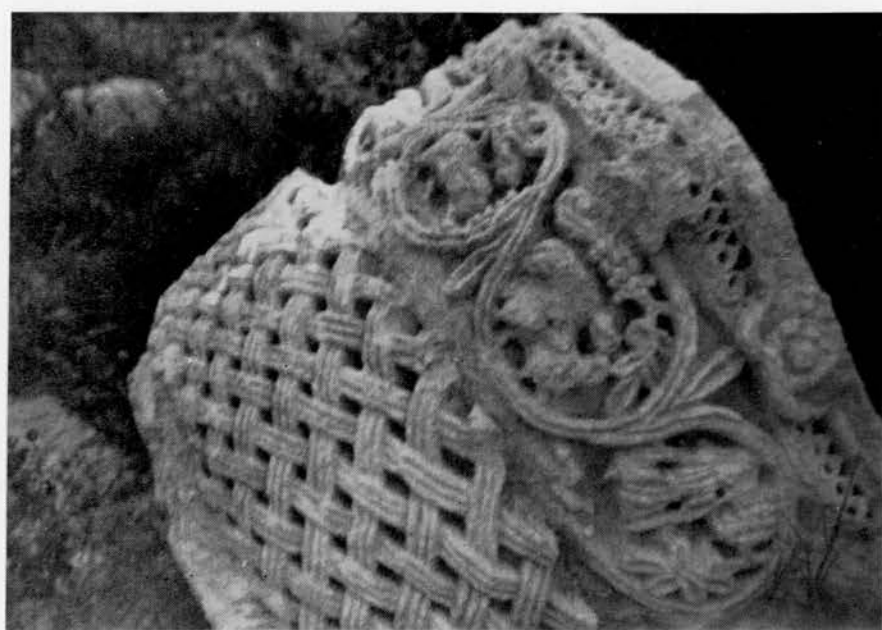
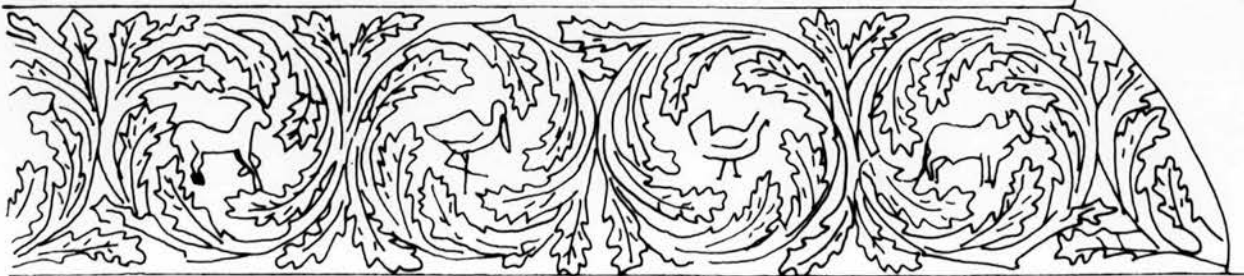
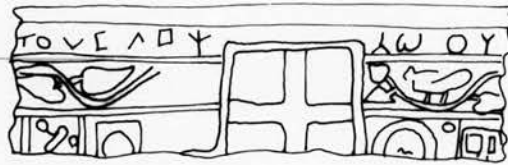
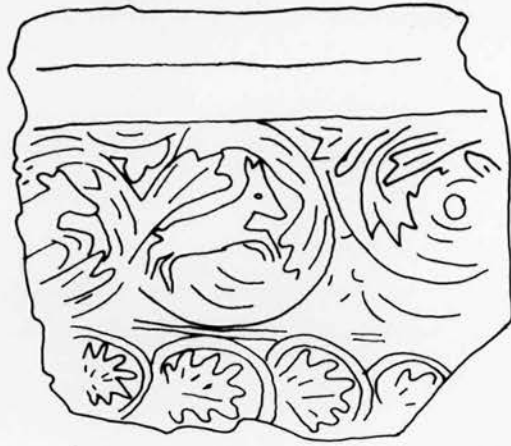

Fig. 60

Fig. 61

Fig. 62

Fig. 63



0 100 CM

Fig. 64

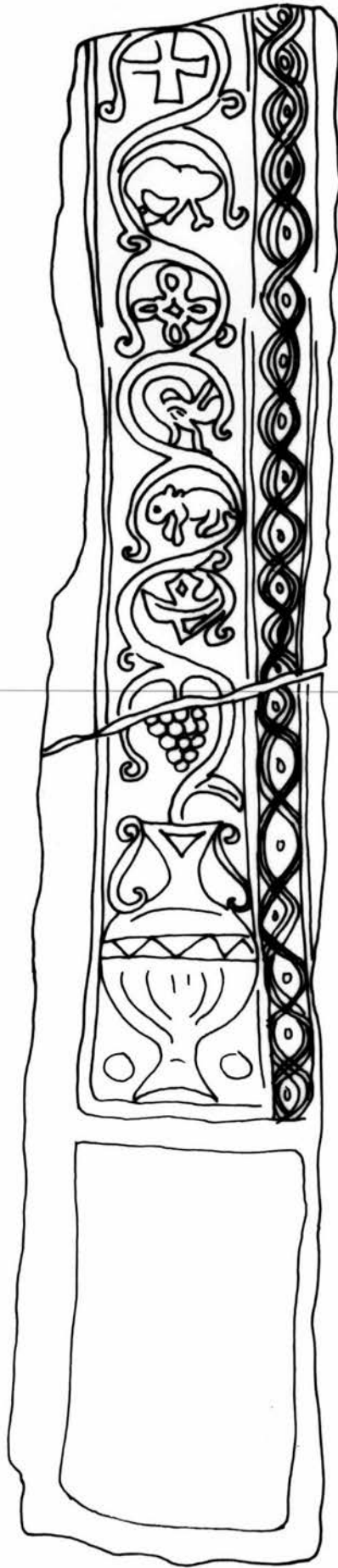

0 — 10 cm

Fig. 65

Fig. 66

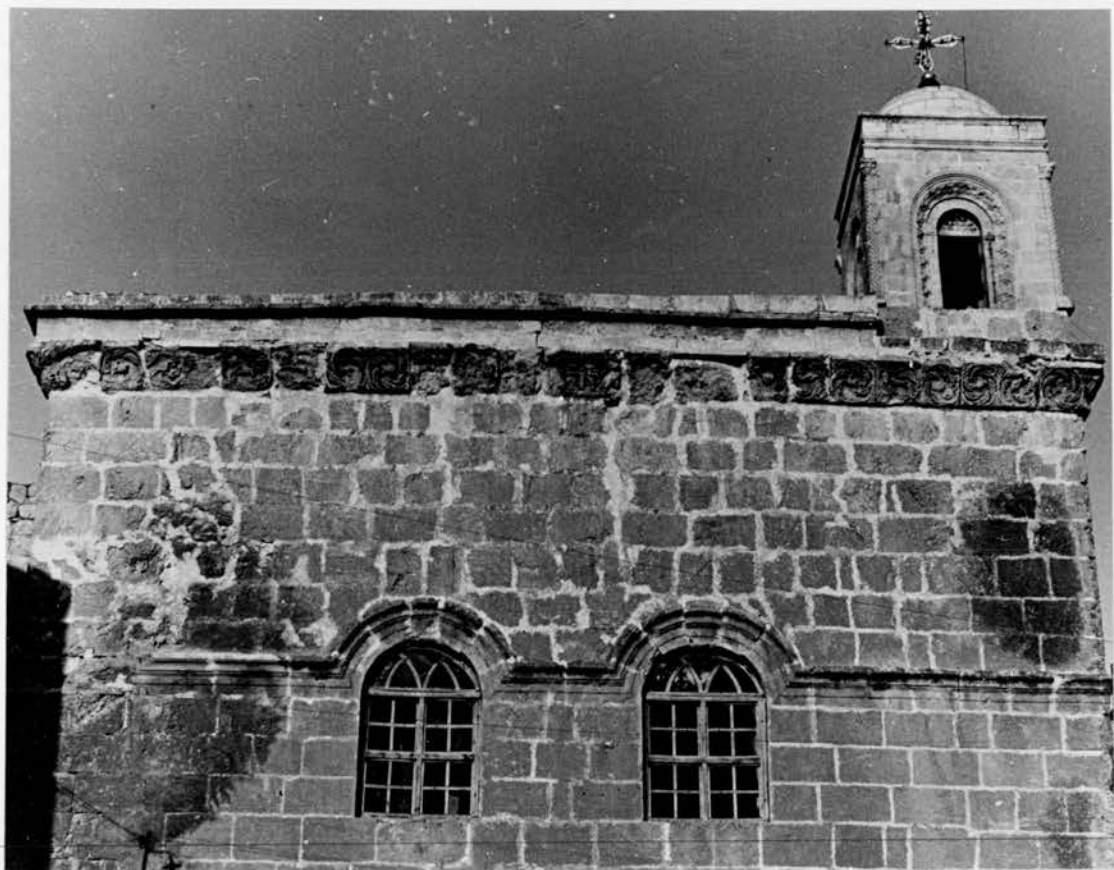
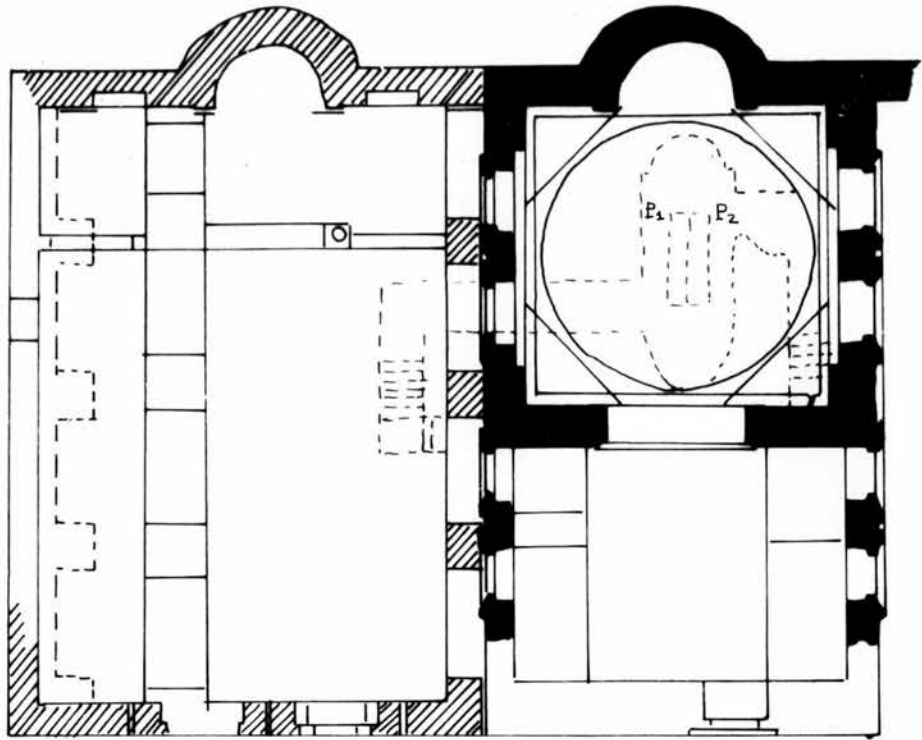

Fig. 67

---

Fig. 68

Fig. 69



0 ——— 5M.

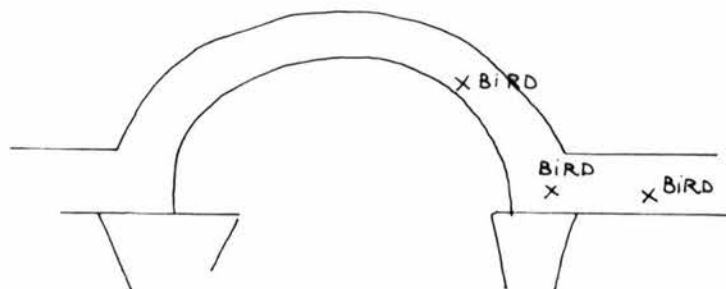
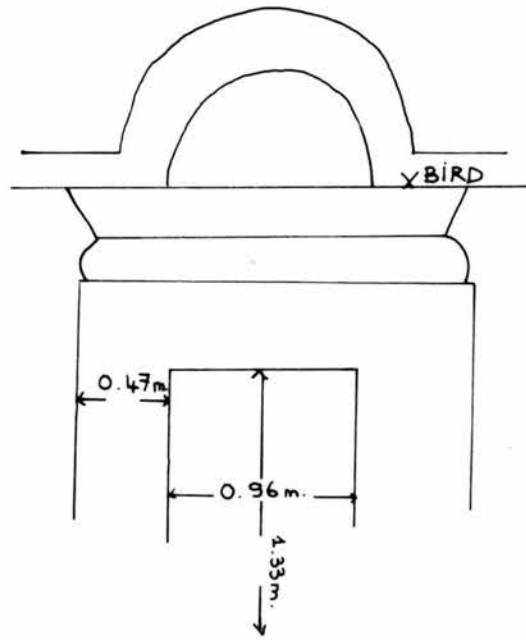

Fig. 70

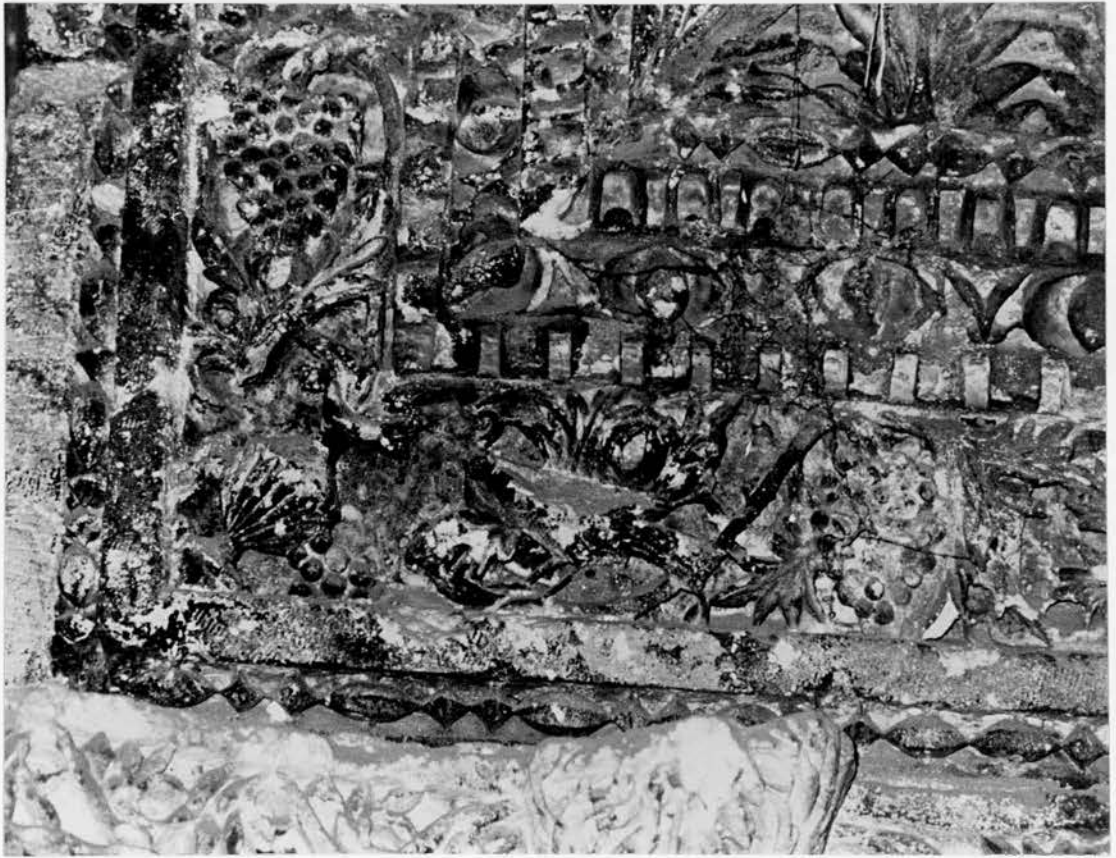
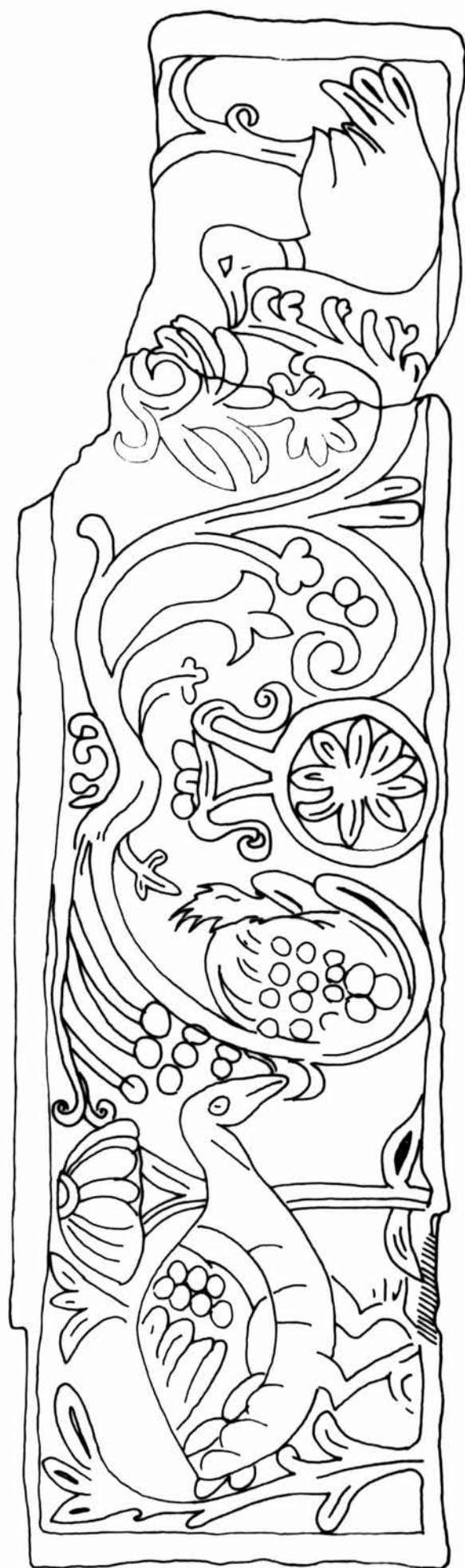

Fig. 71



0 — 10 cm

Fig. 72

Fig. 73



Fig. 74

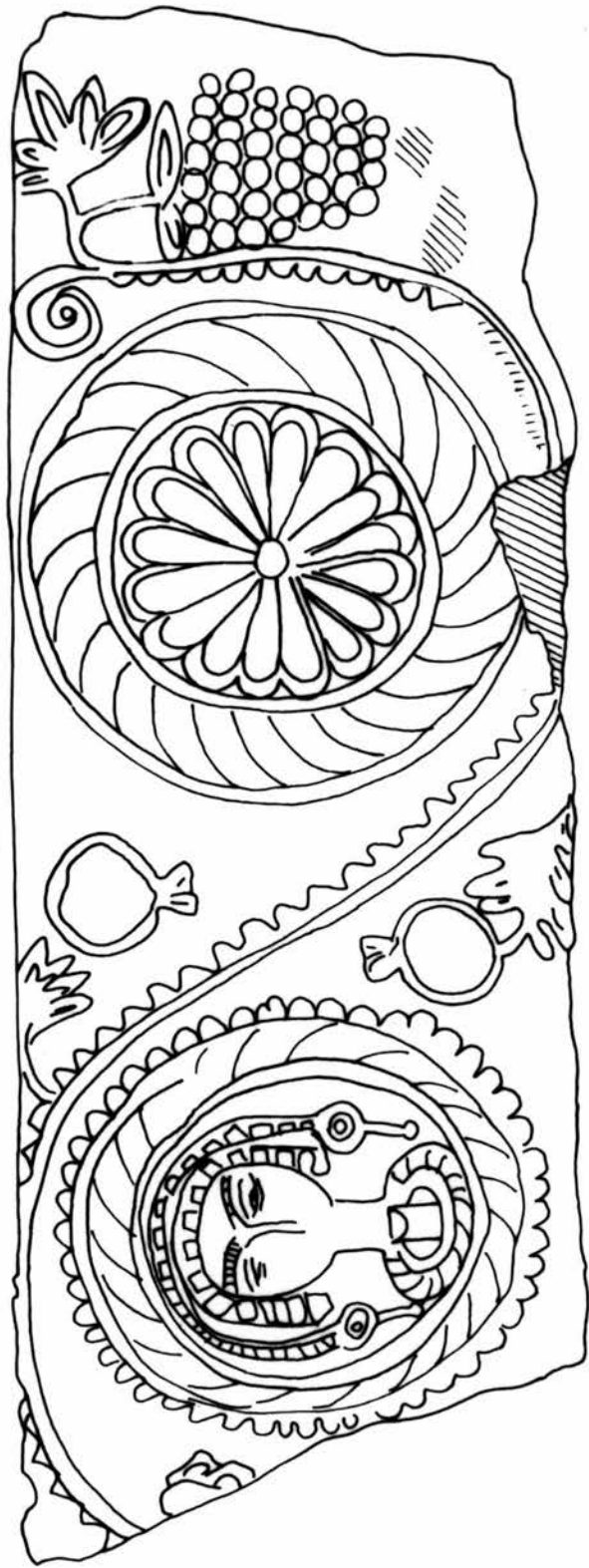

10 cm

Fig. 75

Fig. 76

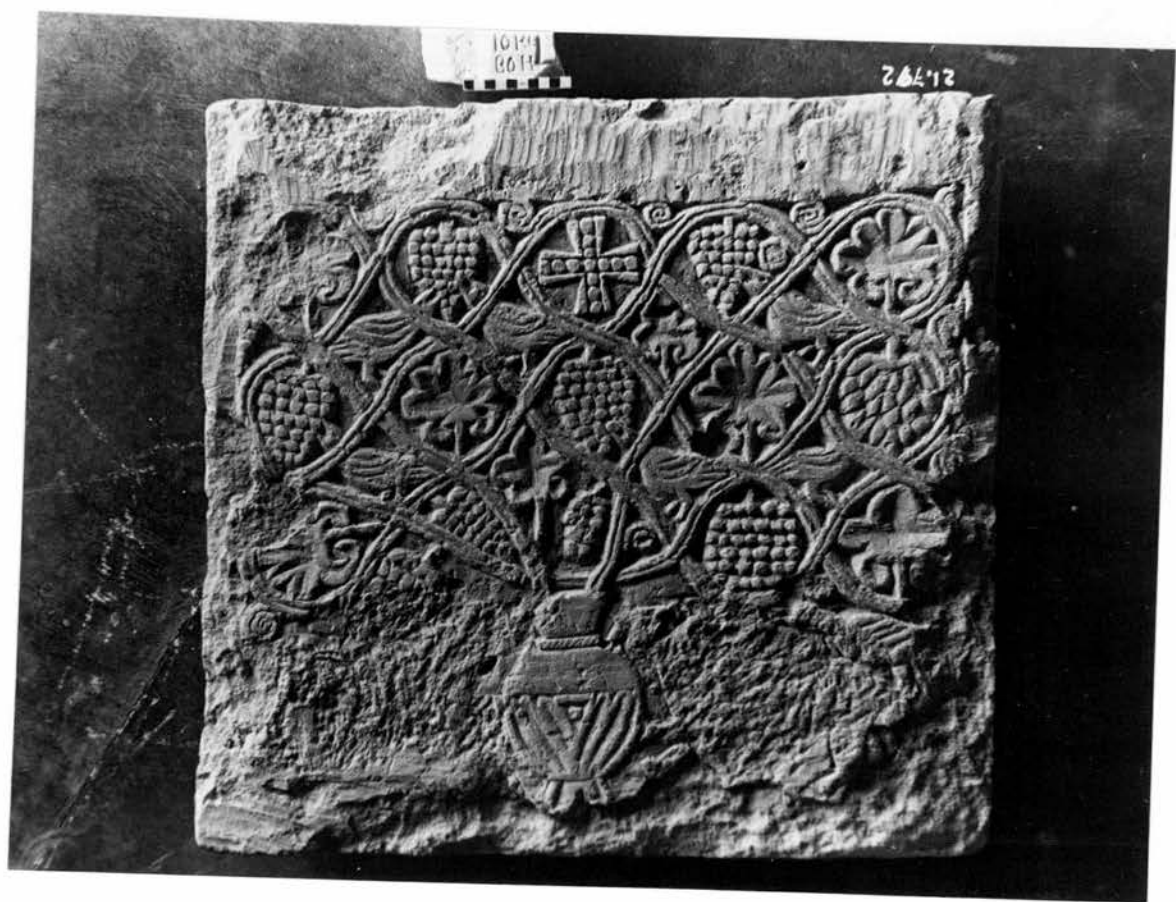
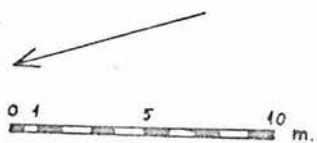
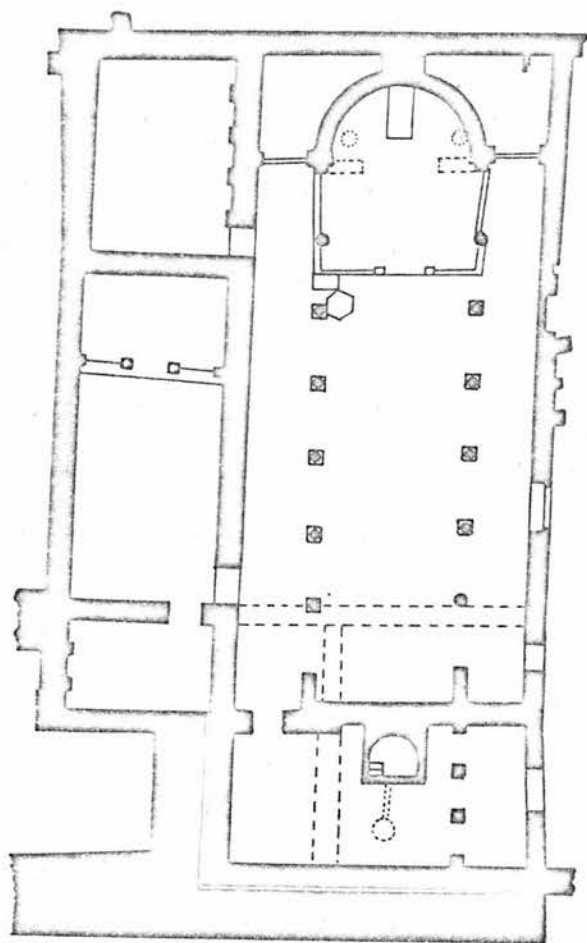
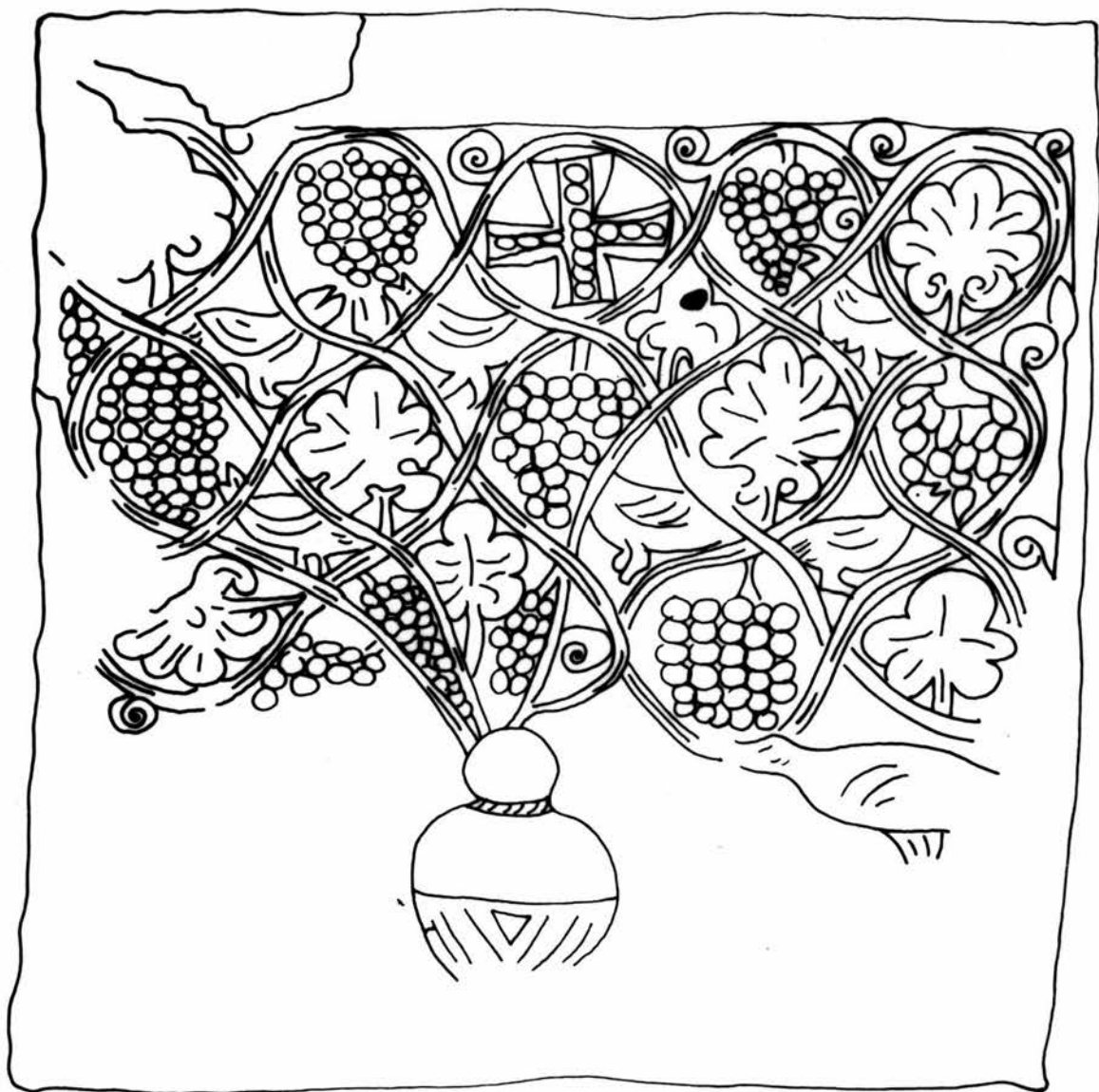

Fig. 77



0 ——— 10 CM

Fig. 78

Fig. 79



Fig.80

Fig. 81



Fig. 82

# THE GREAT PALACE

The Peristyle and its dependencies, showing the sites excavated and the extent of the Mosaic Pavement.

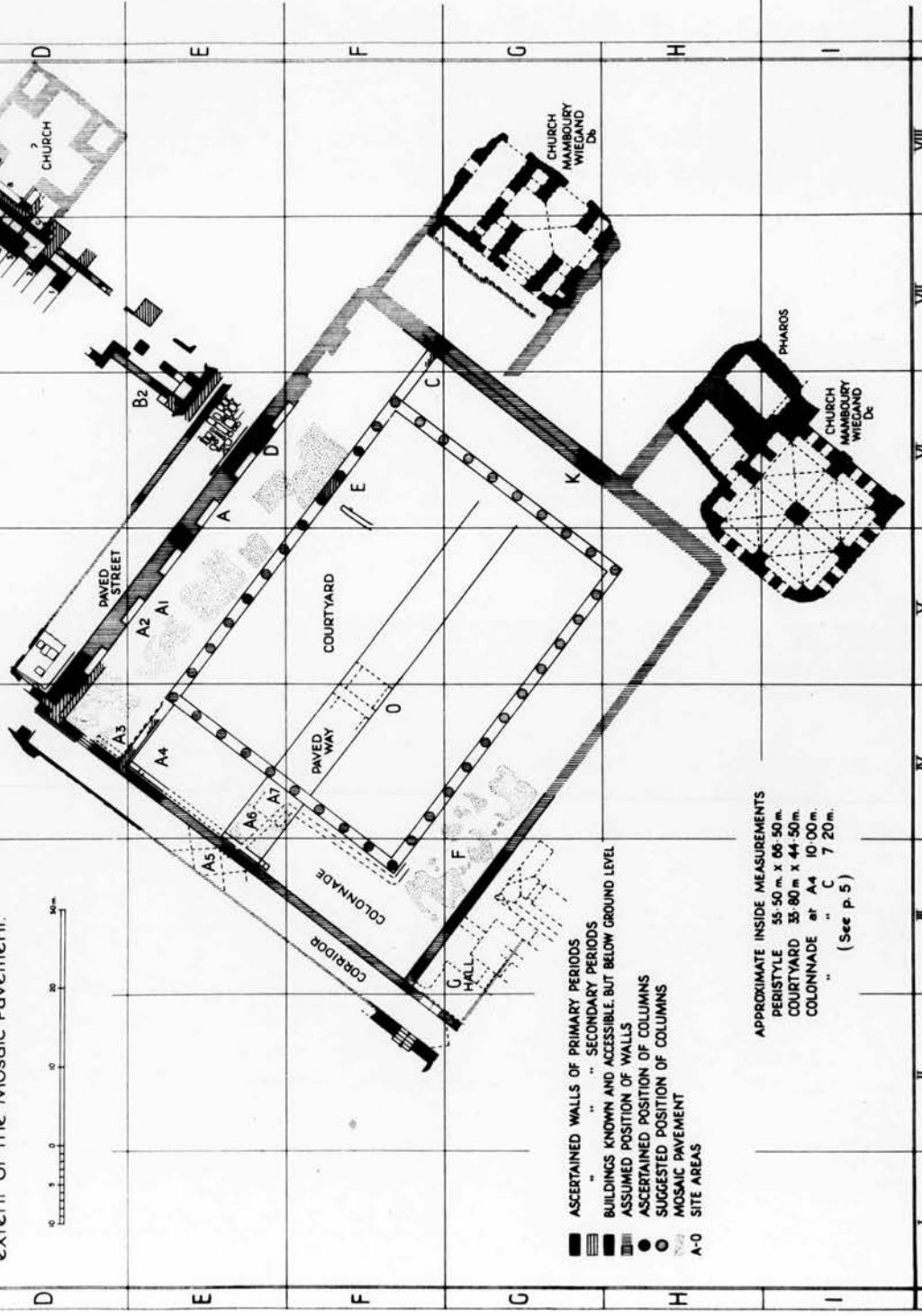

- ASCERTAINED WALLS OF PRIMARY PERIODS
- ▨ " " SECONDARY PERIODS
- ▩ BUILDINGS KNOWN AND ACCESSIBLE, BUT BELOW GROUND LEVEL
- ▧ ASSUMED POSITION OF WALLS
- ASCERTAINED POSITION OF COLUMNS
- SUGGESTED POSITION OF COLUMNS
- ▨ MOSAIC PAVEMENT
- A-O SITE AREAS

APPROXIMATE INSIDE MEASUREMENTS  
 PERISTYLE 55.50 m. x 66.50 m.  
 COURTYARD 35.80 m. x 44.50 m.  
 COLONNADE at A4 10.00 m.  
 " " C 7.20 m.  
 (See p. 5)



Fig. 83

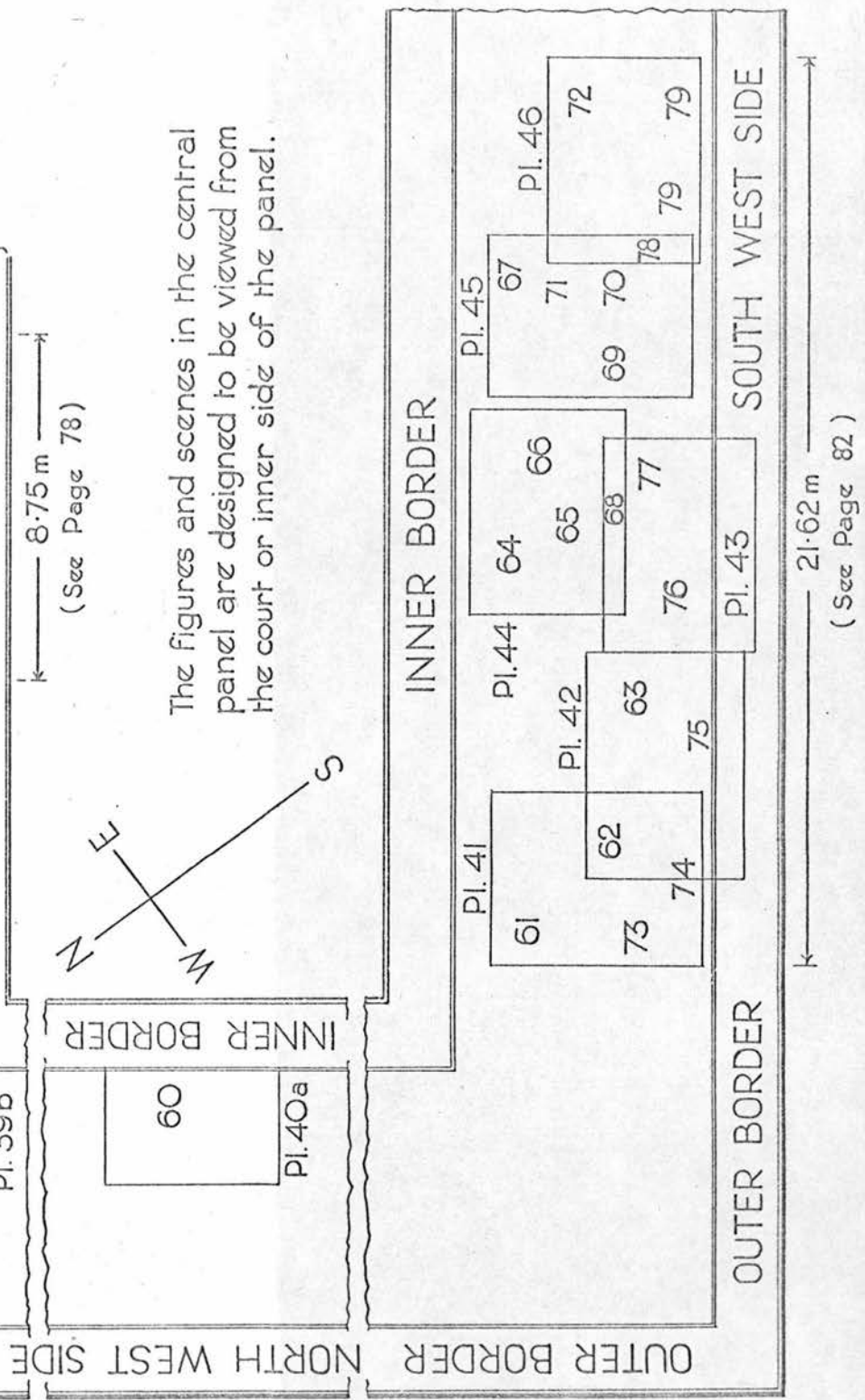
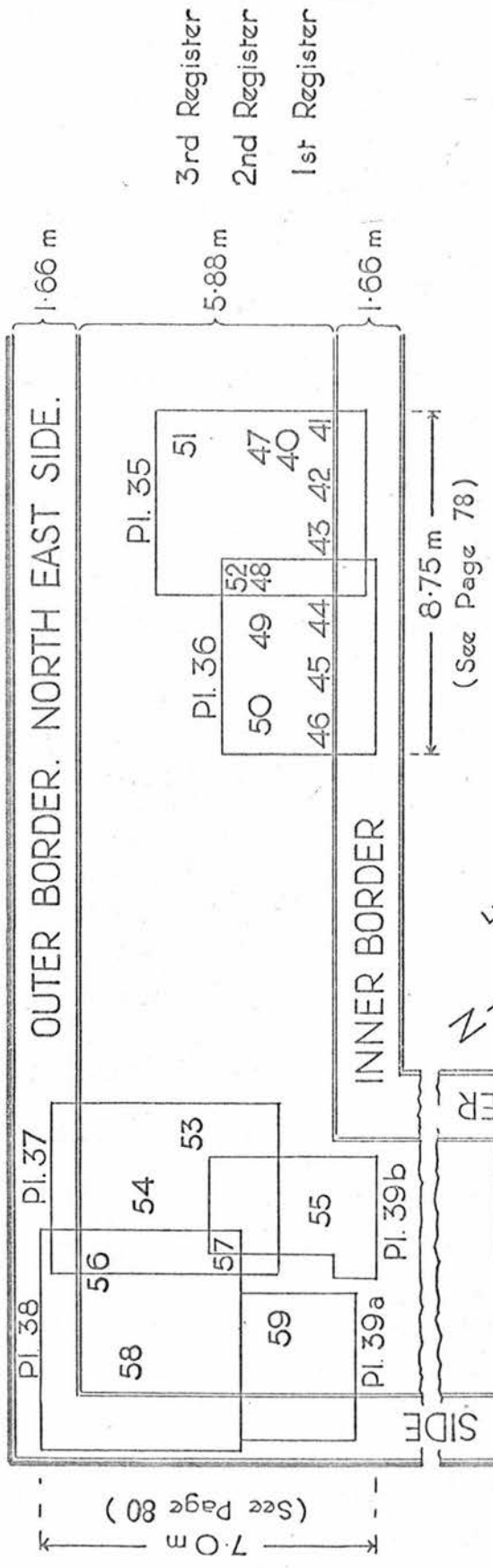
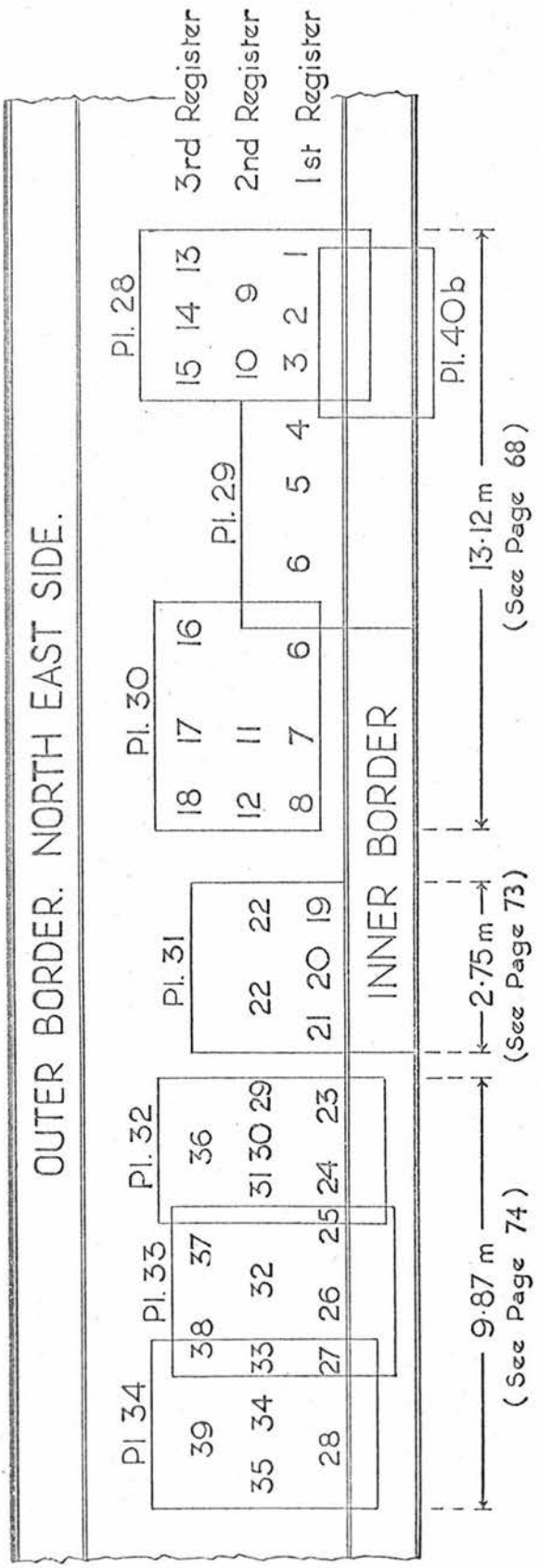

The figures and scenes in the central panel are designed to be viewed from the court or inner side of the panel.

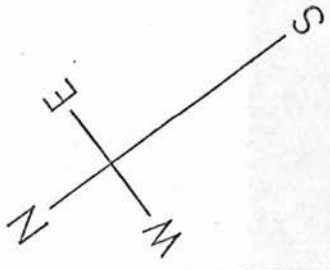

Fig. 84

Fig. 85

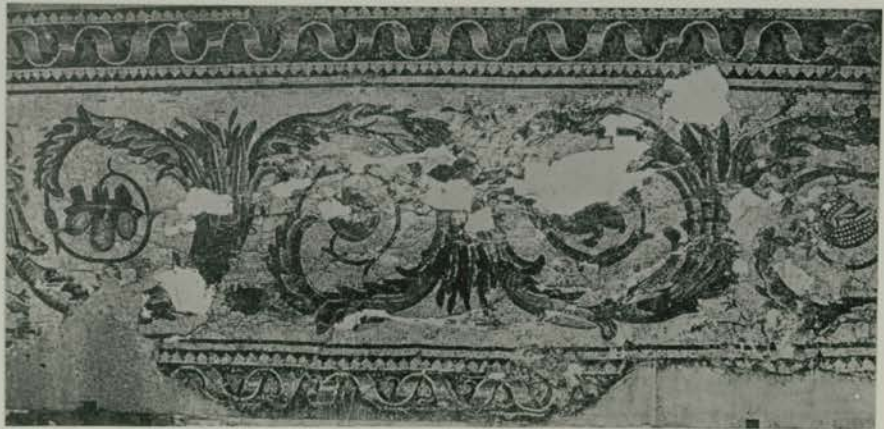

Fig. 86

Fig. 87

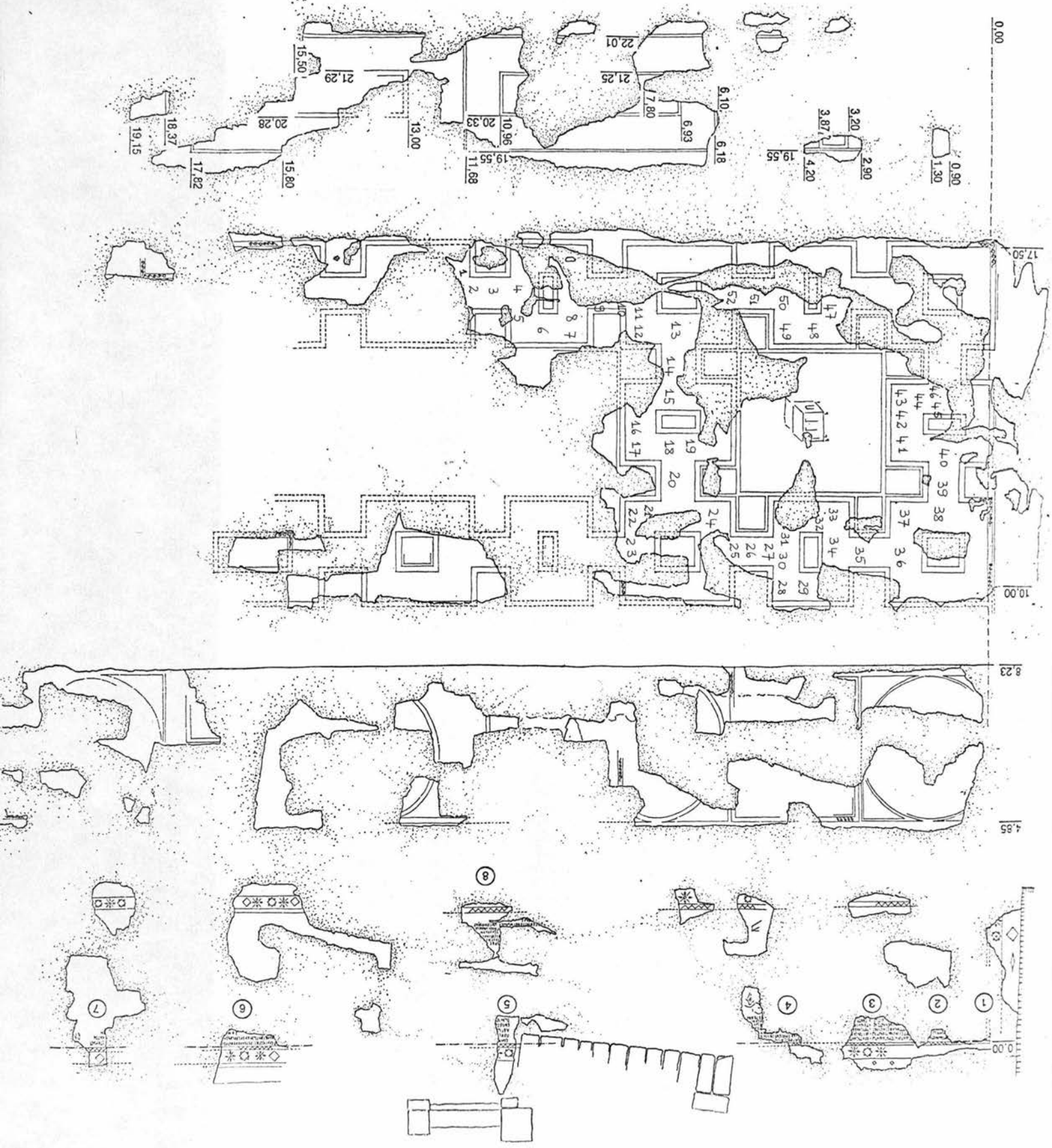

Fig. 88

Fig. 89



Fig. 90



0.00

17.50

10.00

8.23

4.85

0.00

0.90  
1.30

3.20  
2.90

3.87  
4.20  
19.55

6.10  
6.18

22.01  
21.25  
17.80

6.93  
10.96  
20.33  
19.55  
11.68

13.00

15.50  
21.29  
20.28  
15.80

18.37  
19.15

17.82

17.50

10.00

8.23

4.85

0.00

0.90  
1.30

3.20  
2.90

3.87  
4.20  
19.55

6.10  
6.18

22.01  
21.25  
17.80

6.93  
10.96  
20.33  
19.55  
11.68

13.00

15.50  
21.29  
20.28  
15.80

18.37  
19.15

17.82

17.50

10.00

8.23

4.85

0.00

0.90  
1.30

3.20  
2.90

3.87  
4.20  
19.55

6.10  
6.18

22.01  
21.25  
17.80

6.93  
10.96  
20.33  
19.55  
11.68

13.00

15.50  
21.29  
20.28  
15.80

18.37  
19.15

17.82

17.50

10.00

8.23

4.85

0.00

0.90  
1.30

3.20  
2.90

3.87  
4.20  
19.55

6.10  
6.18

22.01  
21.25  
17.80

6.93  
10.96  
20.33  
19.55  
11.68

13.00

15.50  
21.29  
20.28  
15.80

18.37  
19.15

17.82

17.50

10.00

8.23

4.85

0.00

0.90  
1.30

3.20  
2.90

3.87  
4.20  
19.55

6.10  
6.18

22.01  
21.25  
17.80

6.93  
10.96  
20.33  
19.55  
11.68

13.00

15.50  
21.29  
20.28  
15.80

18.37  
19.15

17.82

17.50

10.00

8.23

4.85

0.00

0.90  
1.30

3.20  
2.90

3.87  
4.20  
19.55

6.10  
6.18

22.01  
21.25  
17.80

6.93  
10.96  
20.33  
19.55  
11.68

13.00

15.50  
21.29  
20.28  
15.80

18.37  
19.15

17.82

17.50

10.00

8.23

4.85

0.00

0.90  
1.30

3.20  
2.90

3.87  
4.20  
19.55

6.10  
6.18

22.01  
21.25  
17.80

6.93  
10.96  
20.33  
19.55  
11.68

13.00

15.50  
21.29  
20.28  
15.80

18.37  
19.15

17.82

17.50

10.00

8.23

4.85

0.00

0.90  
1.30

3.20  
2.90

3.87  
4.20  
19.55

6.10  
6.18

22.01  
21.25  
17.80

6.93  
10.96  
20.33  
19.55  
11.68

13.00

15.50  
21.29  
20.28  
15.80

18.37  
19.15

17.82

17.50

10.00

8.23

4.85

0.00

0.90  
1.30

3.20  
2.90

3.87  
4.20  
19.55

6.10  
6.18

22.01  
21.25  
17.80

6.93  
10.96  
20.33  
19.55  
11.68

13.00

15.50  
21.29  
20.28  
15.80

18.37  
19.15

17.82

17.50

10.00

8.23

4.85

0.00

0.90  
1.30

3.20  
2.90

3.87  
4.20  
19.55

6.10  
6.18

22.01  
21.25  
17.80

6.93  
10.96  
20.33  
19.55  
11.68

13.00

15.50  
21.29  
20.28  
15.80

18.37  
19.15

17.82

17.50

10.00

8.23

4.85

0.00

0.90  
1.30

3.20  
2.90

3.87  
4.20  
19.55

6.10  
6.18

22.01  
21.25  
17.80

6.93  
10.96  
20.33  
19.55  
11.68

13.00

15.50  
21.29  
20.28  
15.80

18.37  
19.15

17.82

17.50

10.00

8.23

4.85

0.00

0.90  
1.30

3.20  
2.90

3.87  
4.20  
19.55

6.10  
6.18

22.01  
21.25  
17.80

6.93  
10.96  
20.33  
19.55  
11.68

13.00

15.50  
21.29  
20.28  
15.80

18.37  
19.15

17.82

17.50

10.00

8.23

4.85

0.00

0.90  
1.30

3.20  
2.90

3.87  
4.20  
19.55

6.10  
6.18

22.01  
21.25  
17.80

6.93  
10.96  
20.33  
19.55  
11.68

13.00

15.50  
21.29  
20.28  
15.80

18.37  
19.15

17.82

17.50

10.00

8.23

4.85

0.00

0.90  
1.30

3.20  
2.90

3.87  
4.20  
19.55

6.10  
6.18

22.01  
21.25  
17.80

6.93  
10.96  
20.33  
19.55  
11.68

13.00

15.50  
21.29  
20.28  
15.80

18.37  
19.15

17.82

17.50

10.00

8.23

4.85

0.00

0.90  
1.30

3.20  
2.90

3.87  
4.20  
19.55

6.10  
6.18

22.01  
21.25  
17.80

6.93  
10.96  
20.33  
19.55  
11.68

13.00

15.50  
21.29  
20.28  
15.80

18.37  
19.15

17.82

17.50

10.00

8.23

4.85

0.00

0.90  
1.30

3.20  
2.90

3.87  
4.20  
19.55

6.10  
6.18

22.01  
21.25  
17.80

6.93  
10.96  
20.33  
19.55  
11.68

13.00

15.50  
21.29  
20.28  
15.80

18.37  
19.15

17.82

17.50

10.00

8.23

4.85

0.00

0.90  
1.30

3.20  
2.90

3.87  
4.20  
19.55

6.10  
6.18

22.01  
21.25  
17.80

6.93  
10.96  
20.33  
19.55  
1

Fig. 91

Fig. 92

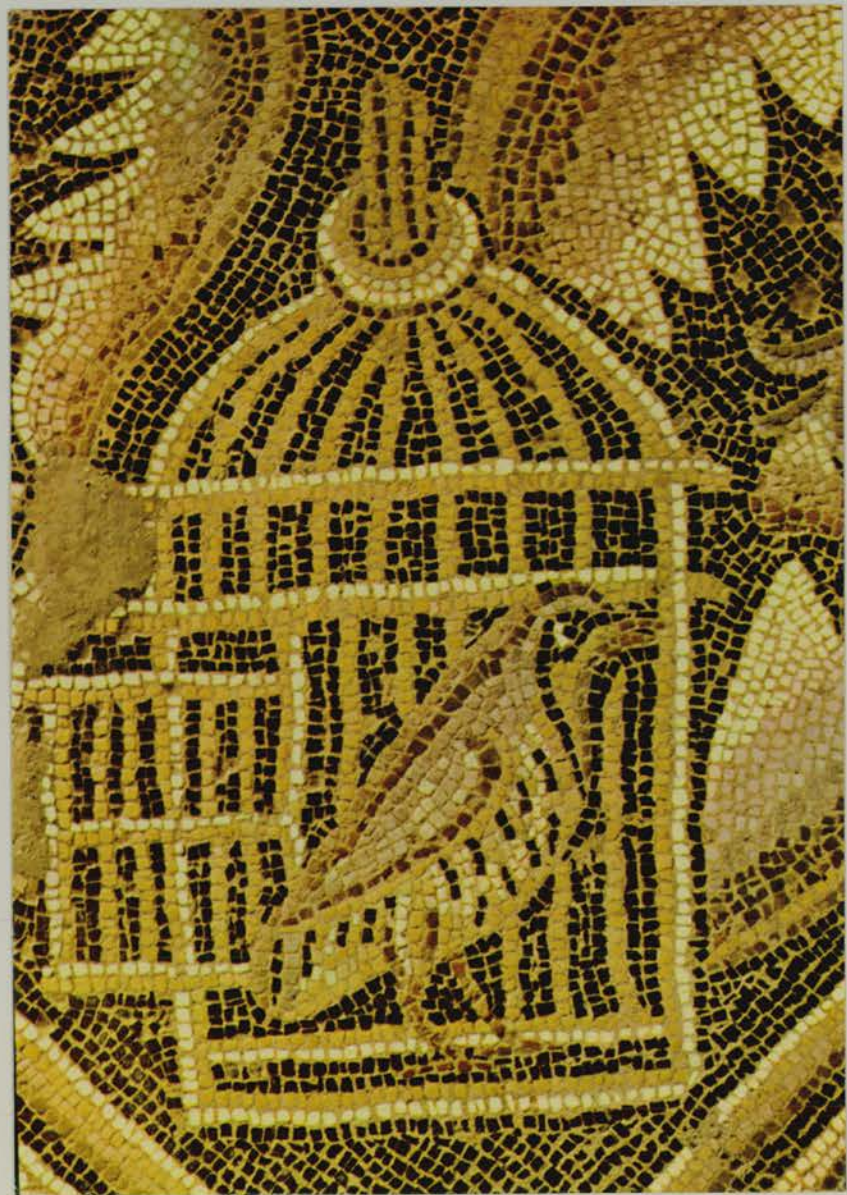
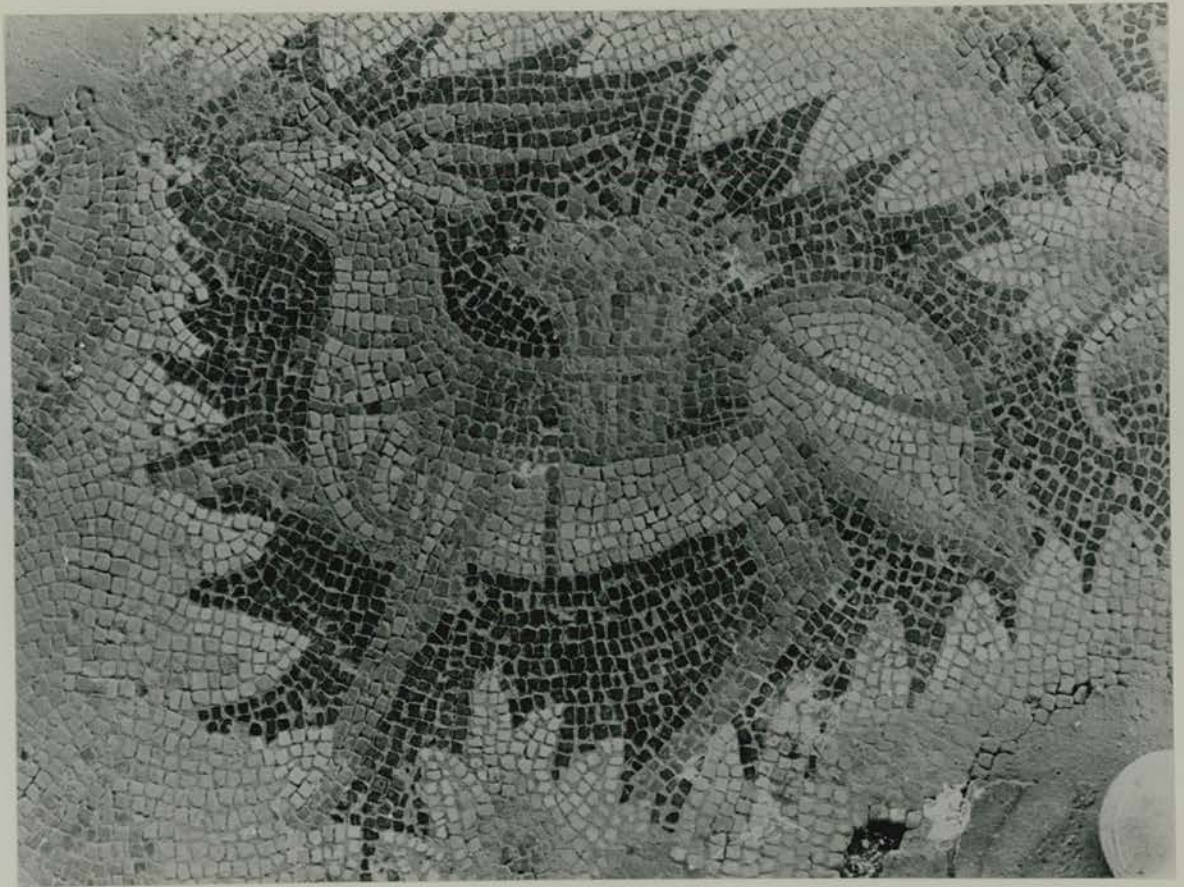

Fig. 93



Fig. 94

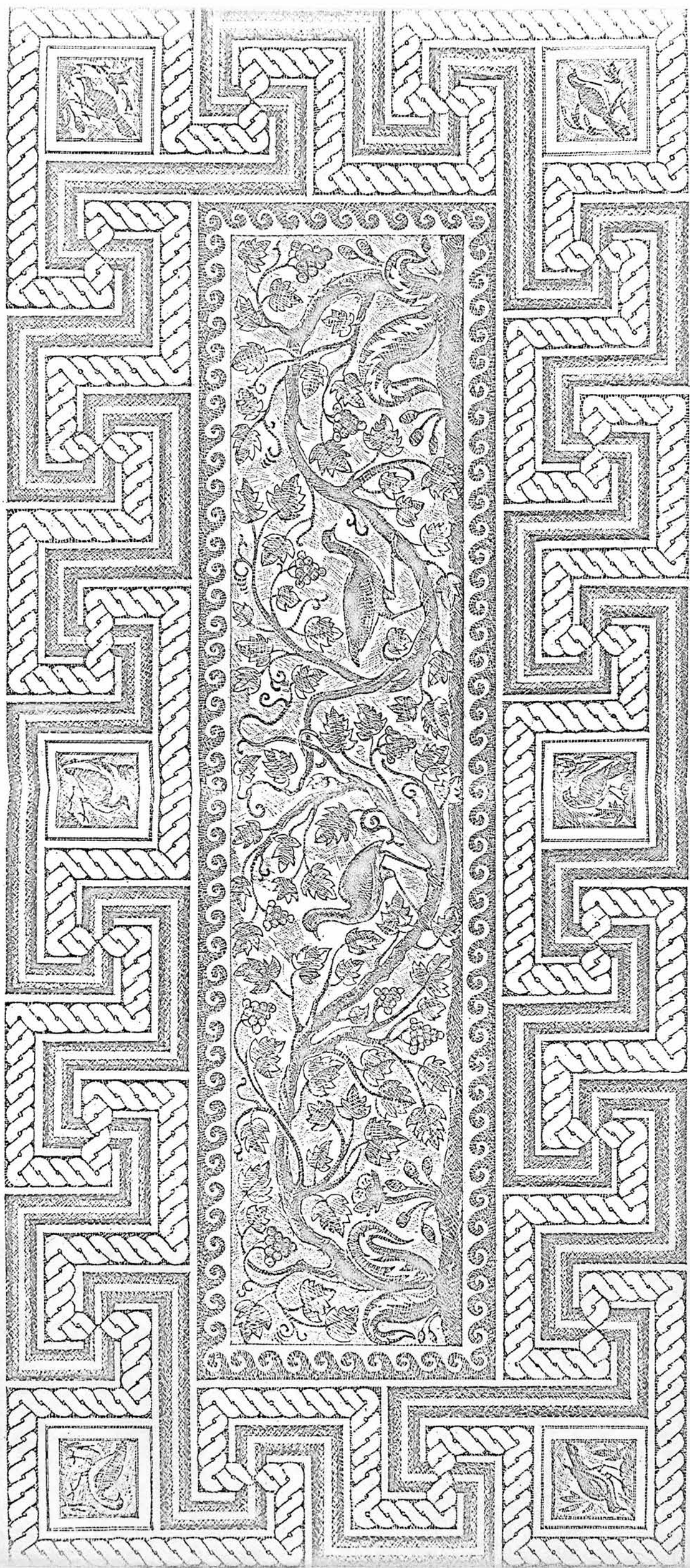

Fig. 95

Fig. 96



Fig. 97

Fig. 98

Fig. 99

Fig. 100

Fig. 101

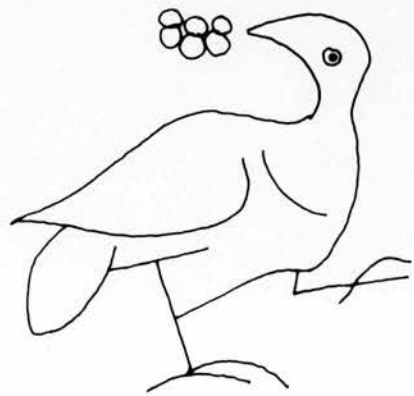
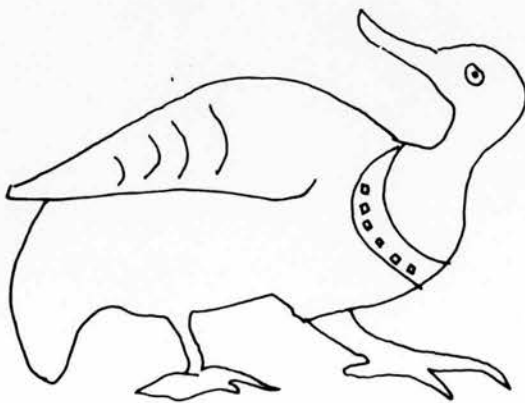
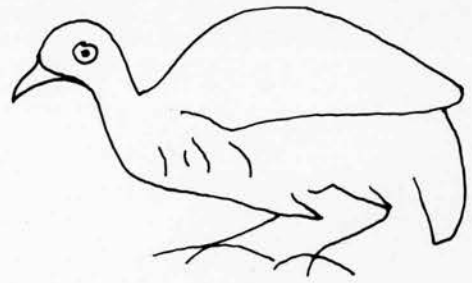
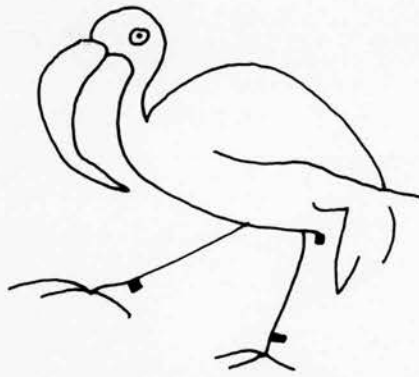
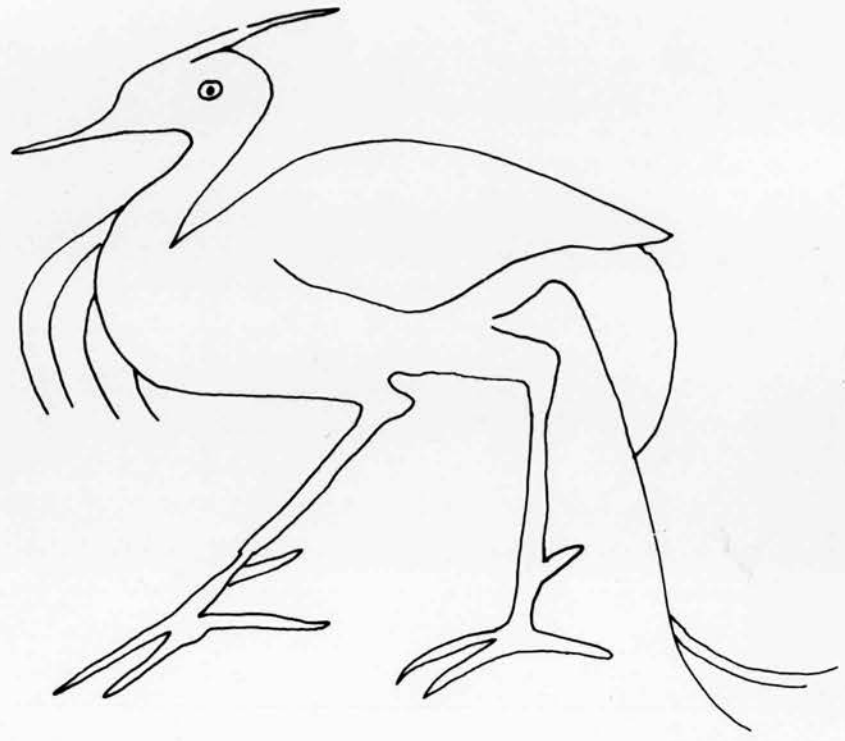

Fig. 102

25-K

25-L

26-K

26-L

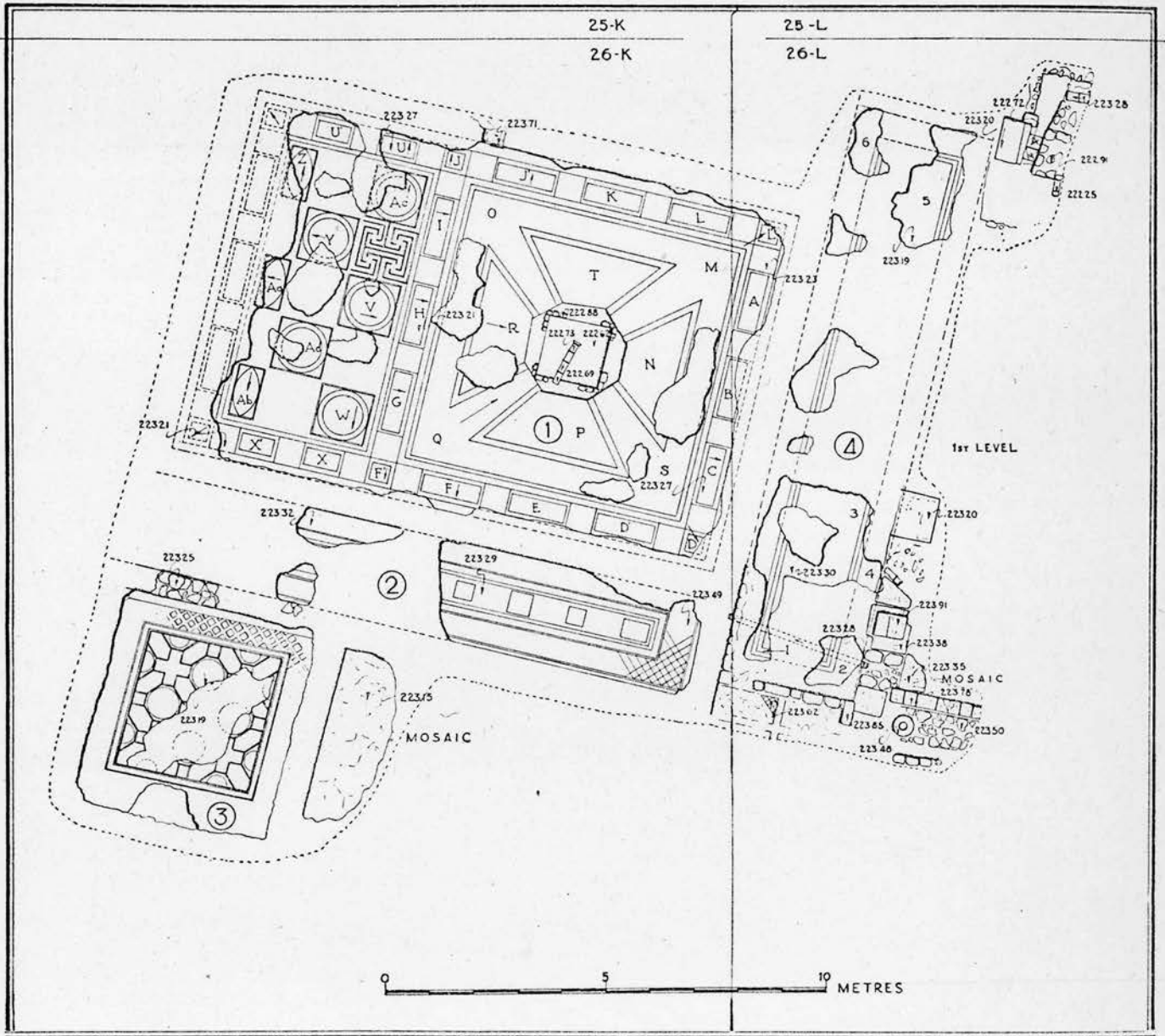

Fig. 103

Fig. 104

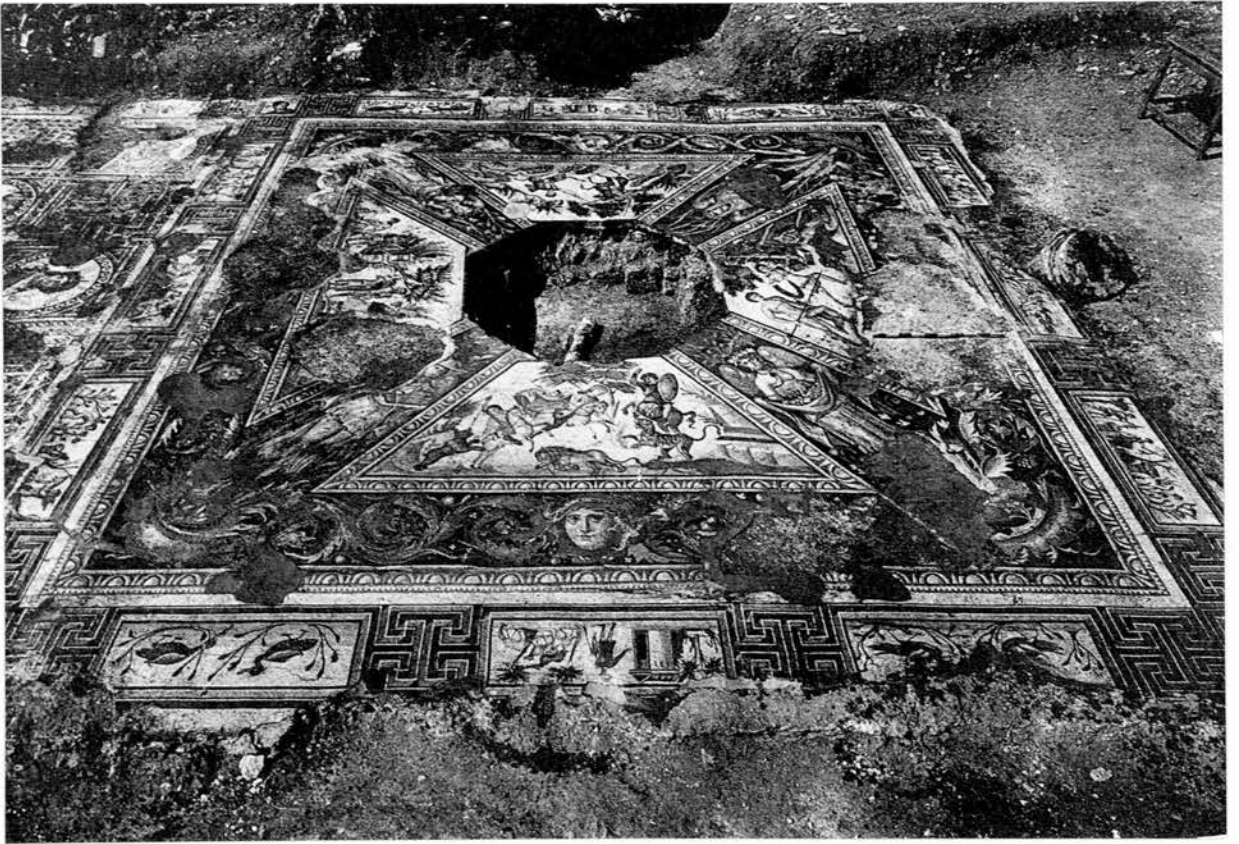

Fig. 105

Fig. 106



Fig. 107

Fig. 108



88. Section 1



Fig. 109



88. Section 6



88. Section 2



Fig. 110

Fig. 111

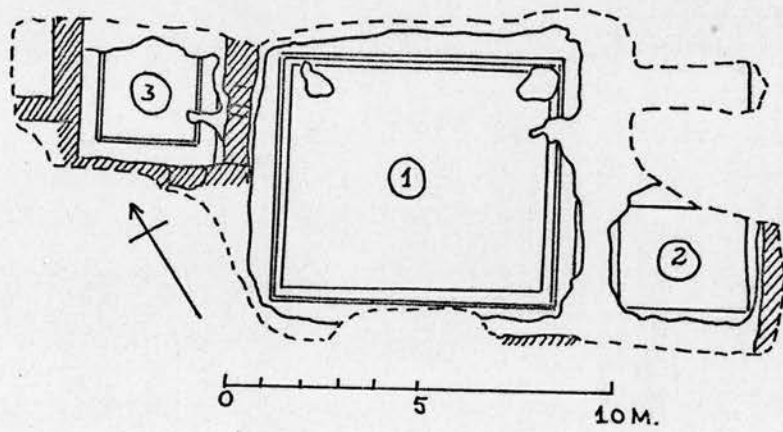
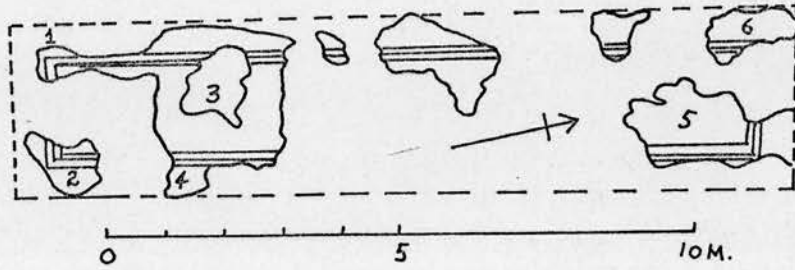

Fig. 112

Fig. 113



90. Section 1 (Border)



90. Section 2 (Border)



90. Section 2 (Border)



90. Section 3 (Border)

Fig. 114

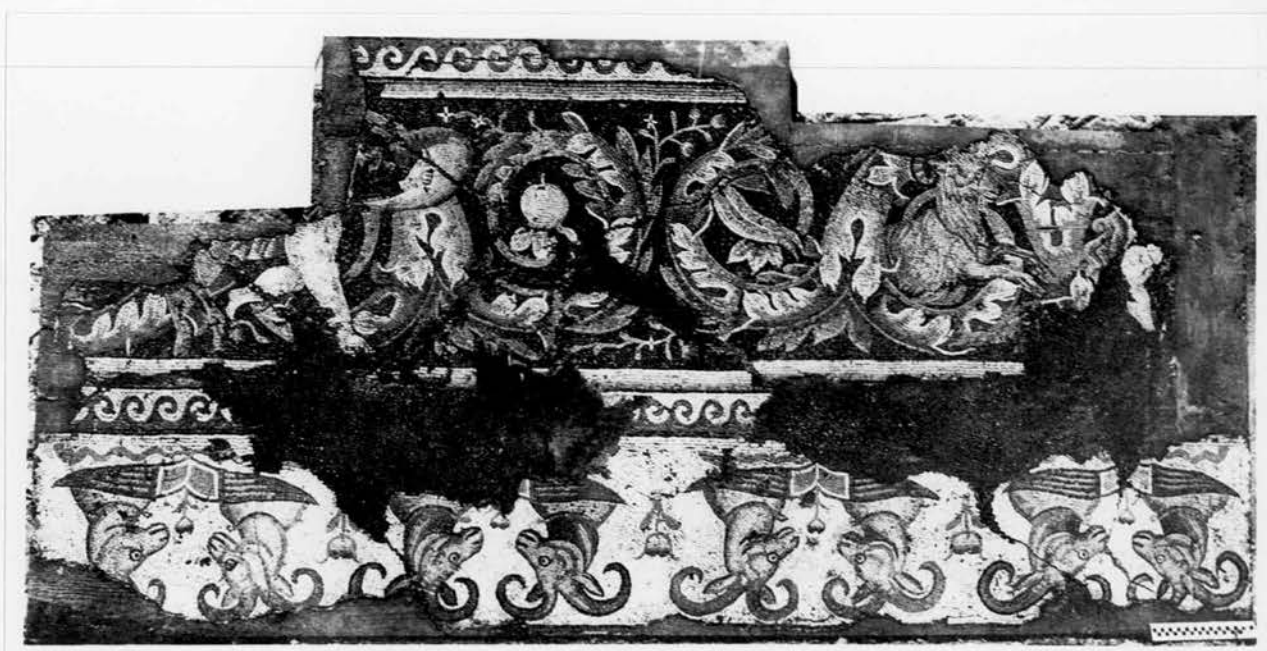
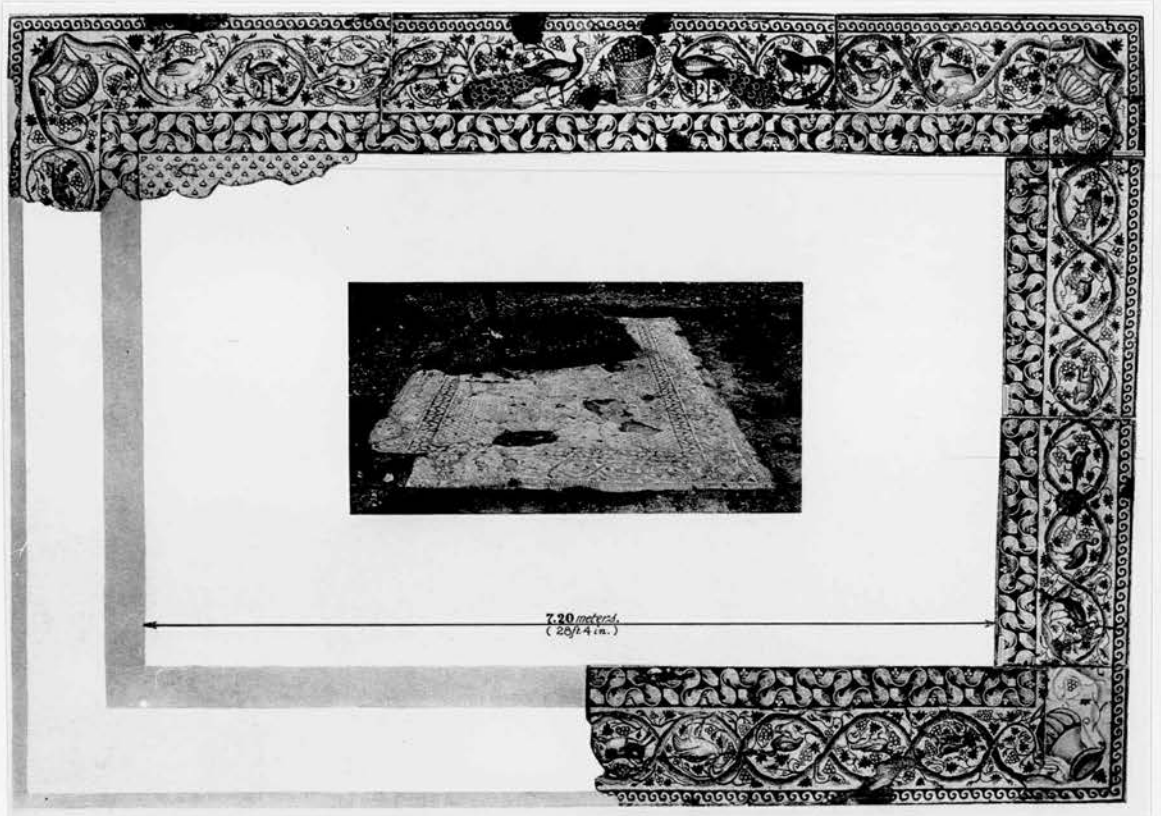

Fig. 115



7.20 meters  
(23/4 in.)

Fig. 116

Fig. 117



Fig. 118

Fig. 119

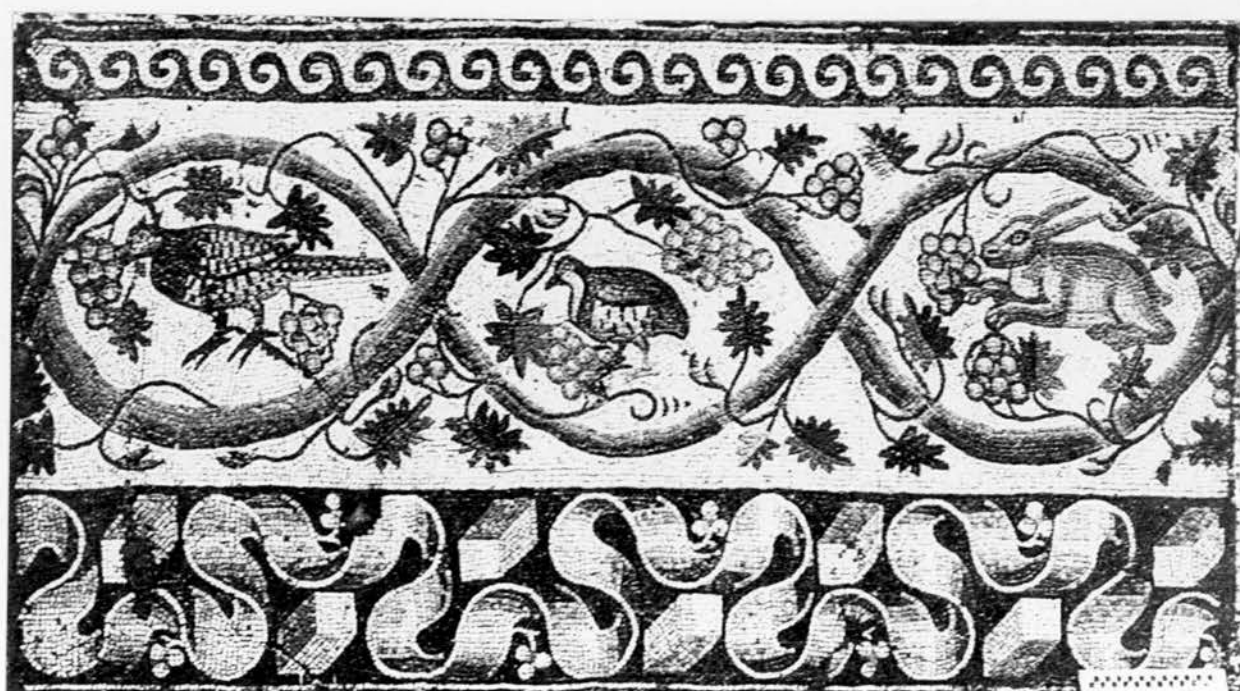

Fig. 120

Fig. 121

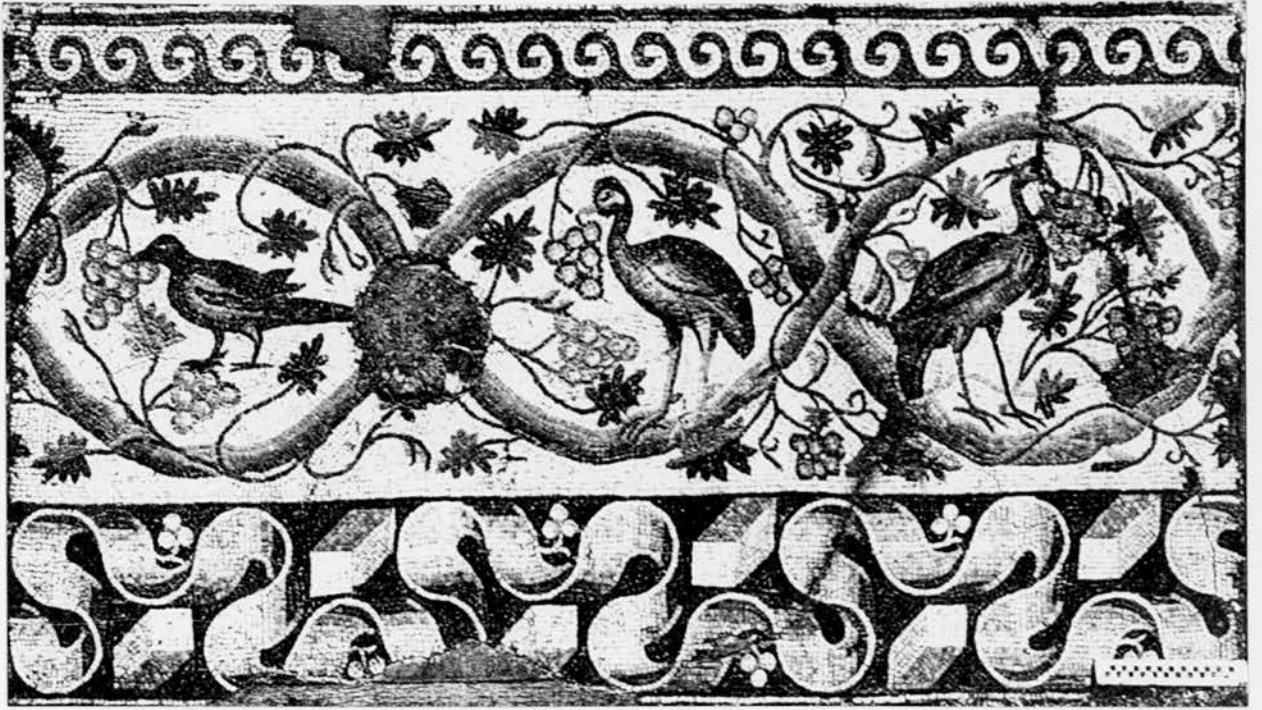

Fig. 122

Fig. 123



Fig. 124

Fig. 125

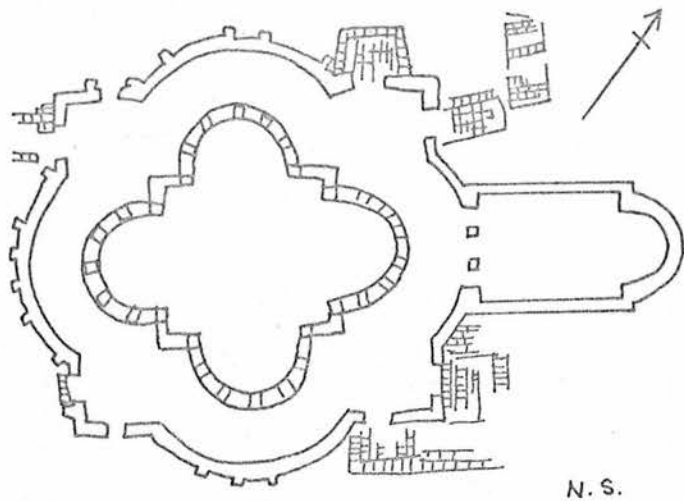

N. S.

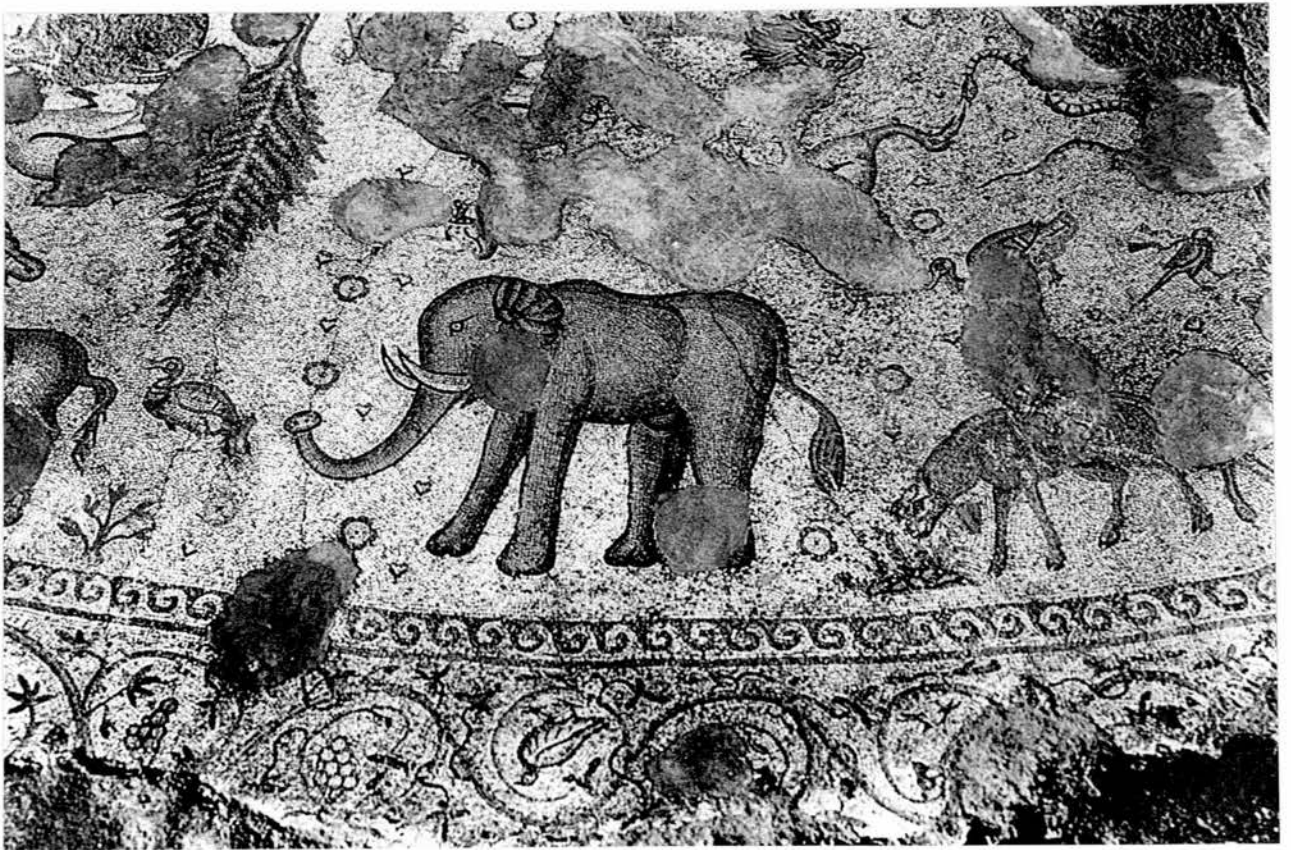

Fig. 126

Fig. 127



Fig. 128

Fig. 129

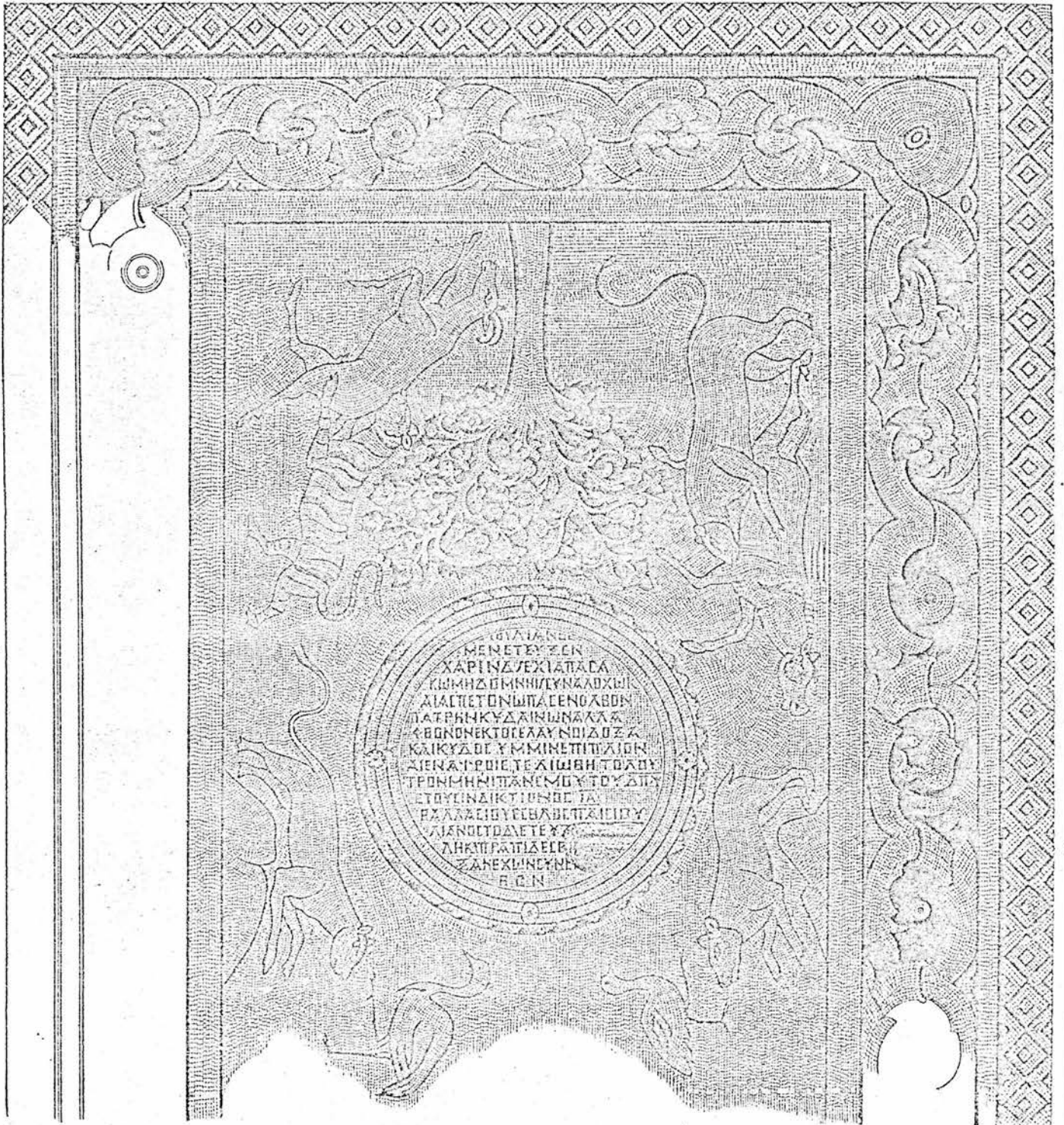
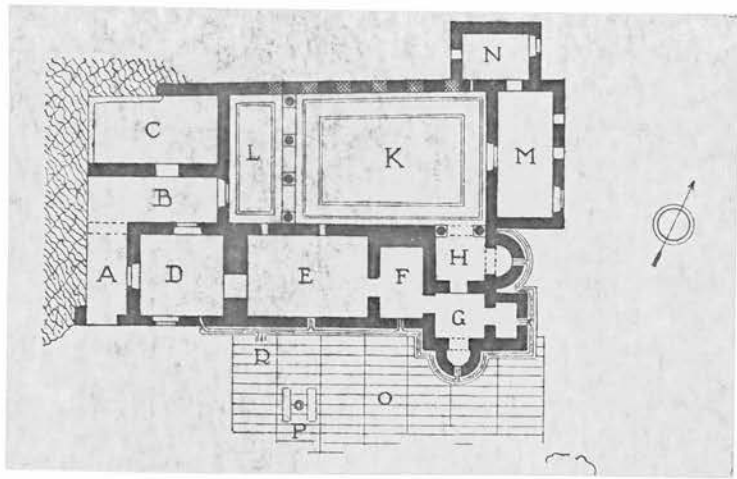

Fig. 130

Fig. 131

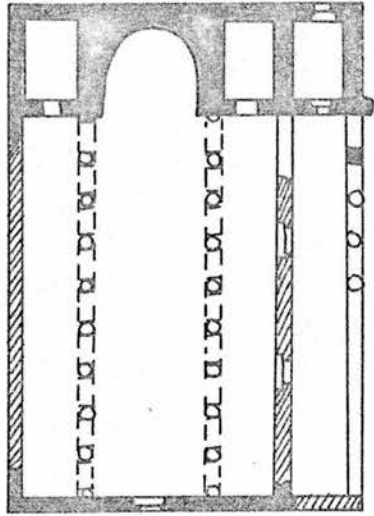

Fig. 132

Fig. 133



Fig. 134

Fig. 135



Fig. 136

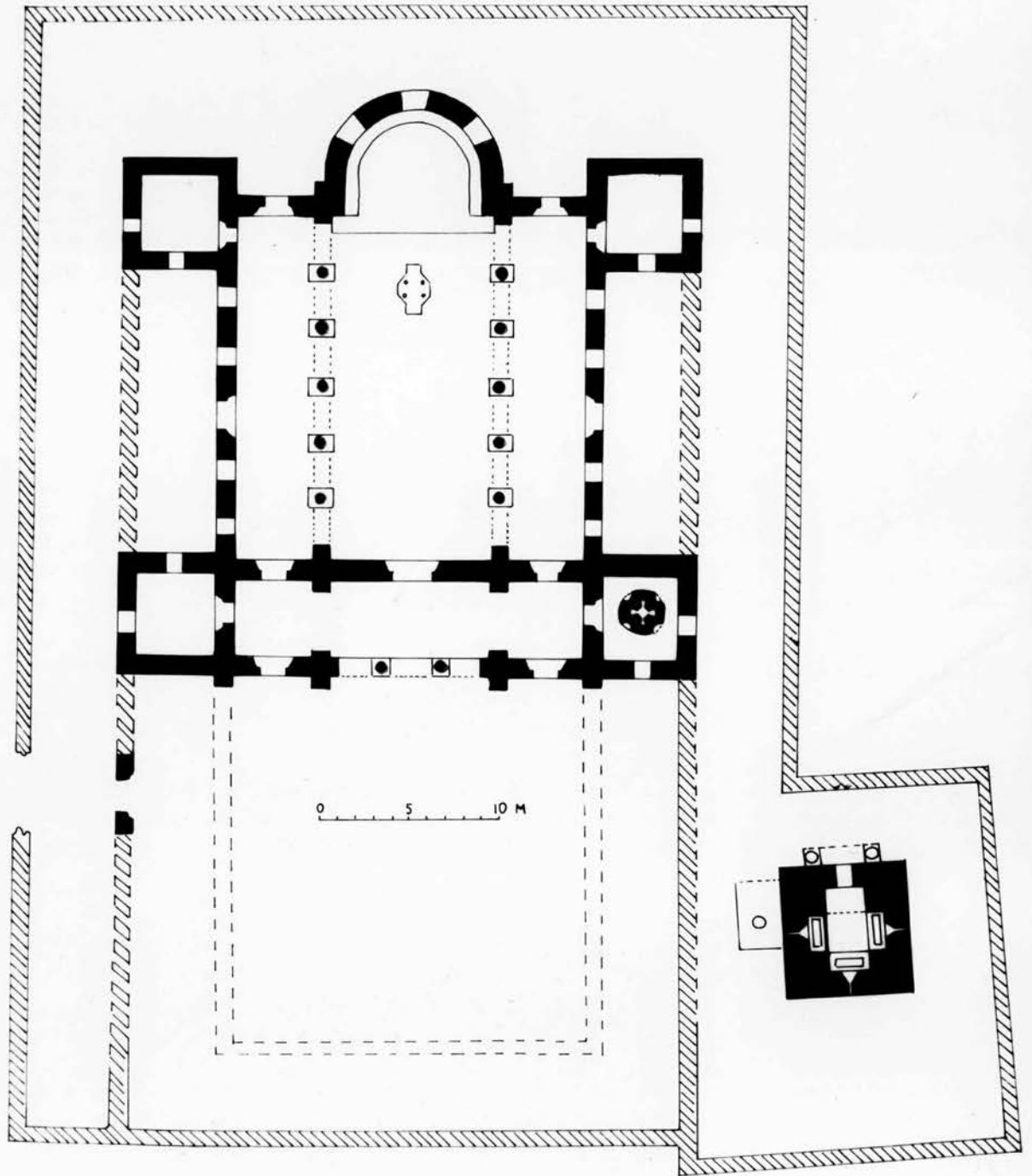

Fig. 137

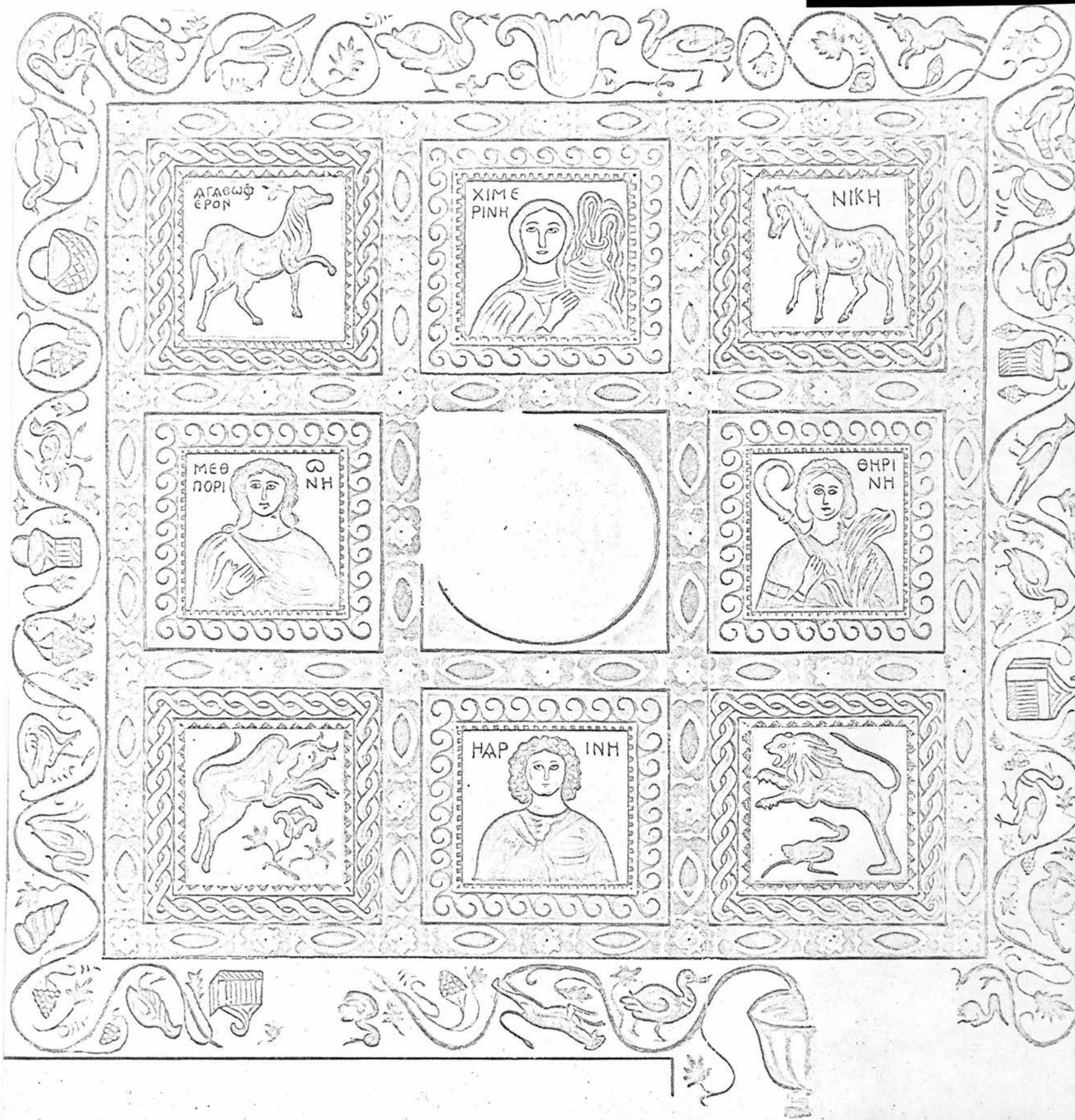
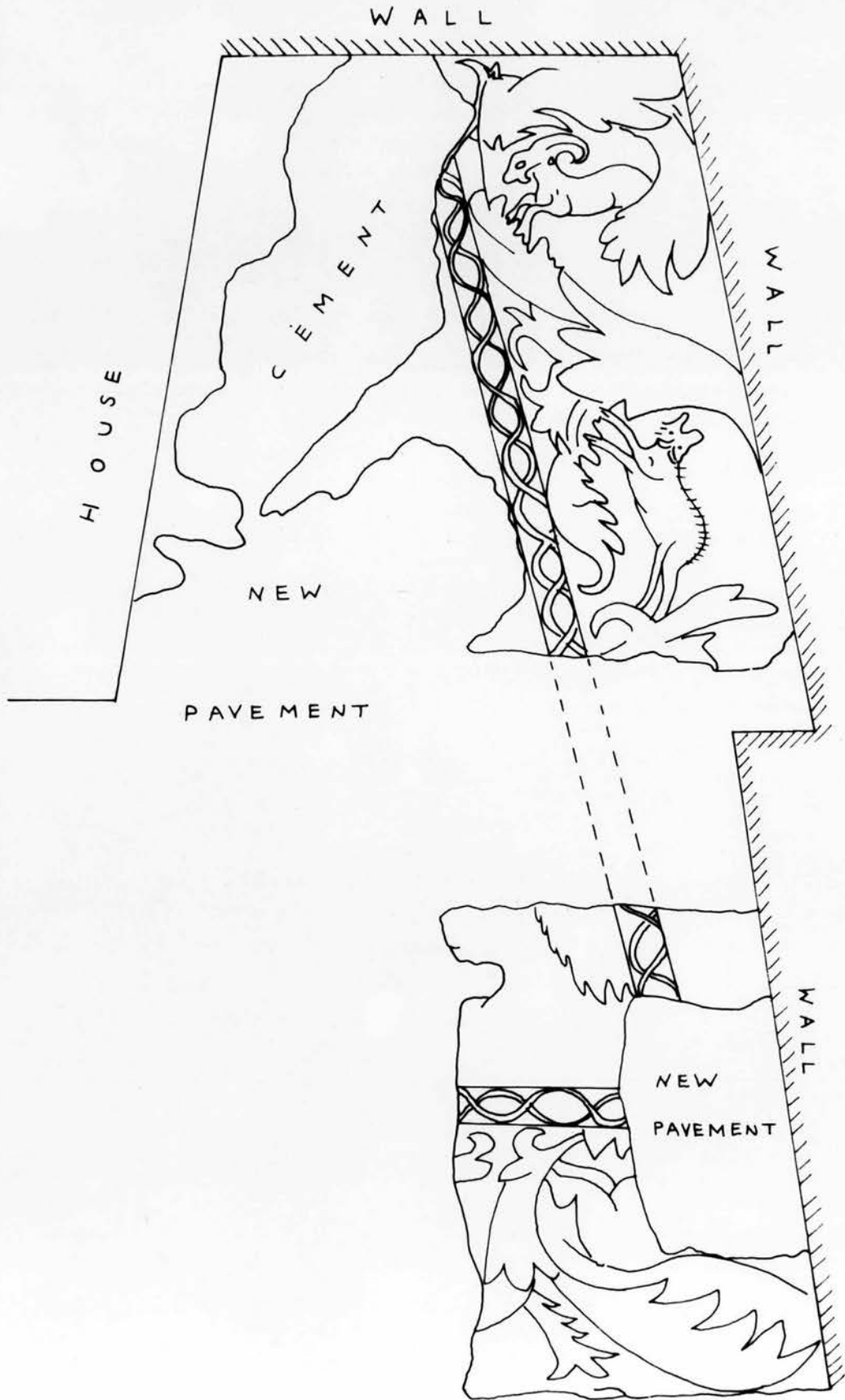

Fig. 138



0 ————— 1M

Fig. 139



Fig. 140

Fig. 141

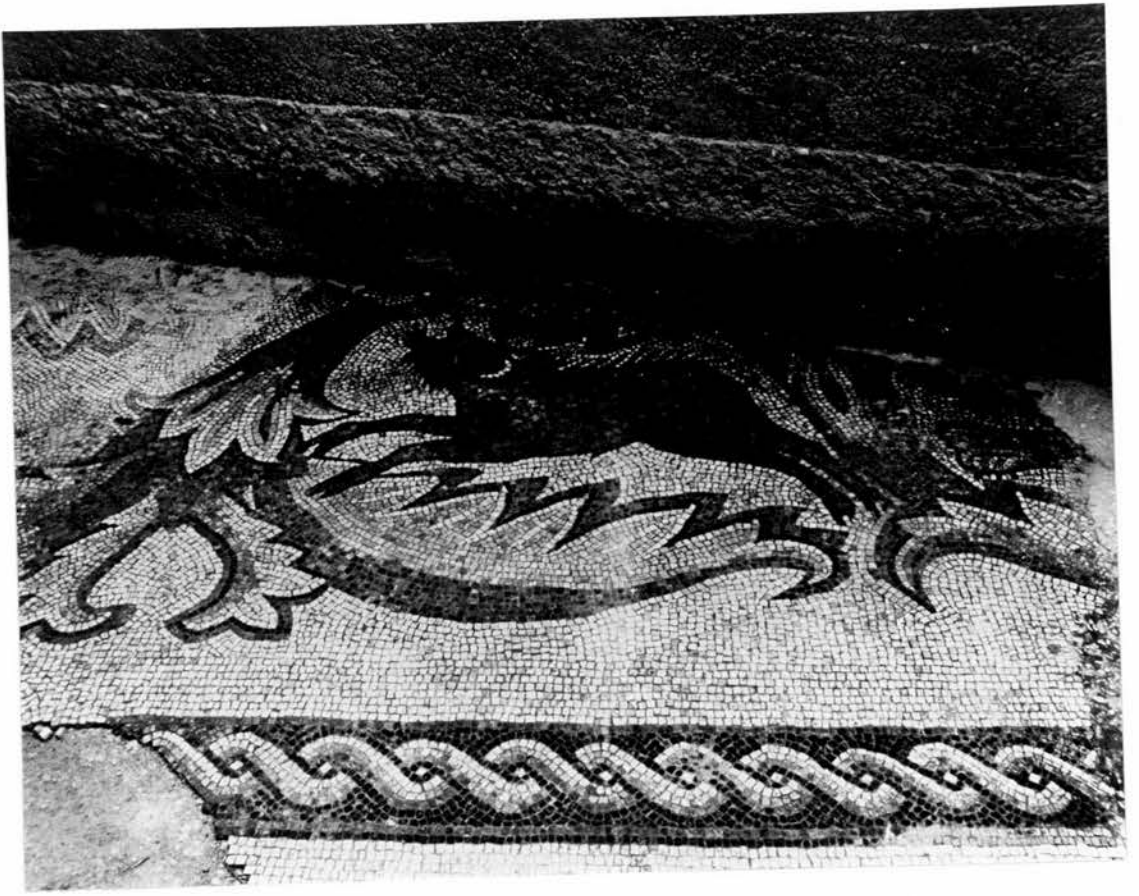
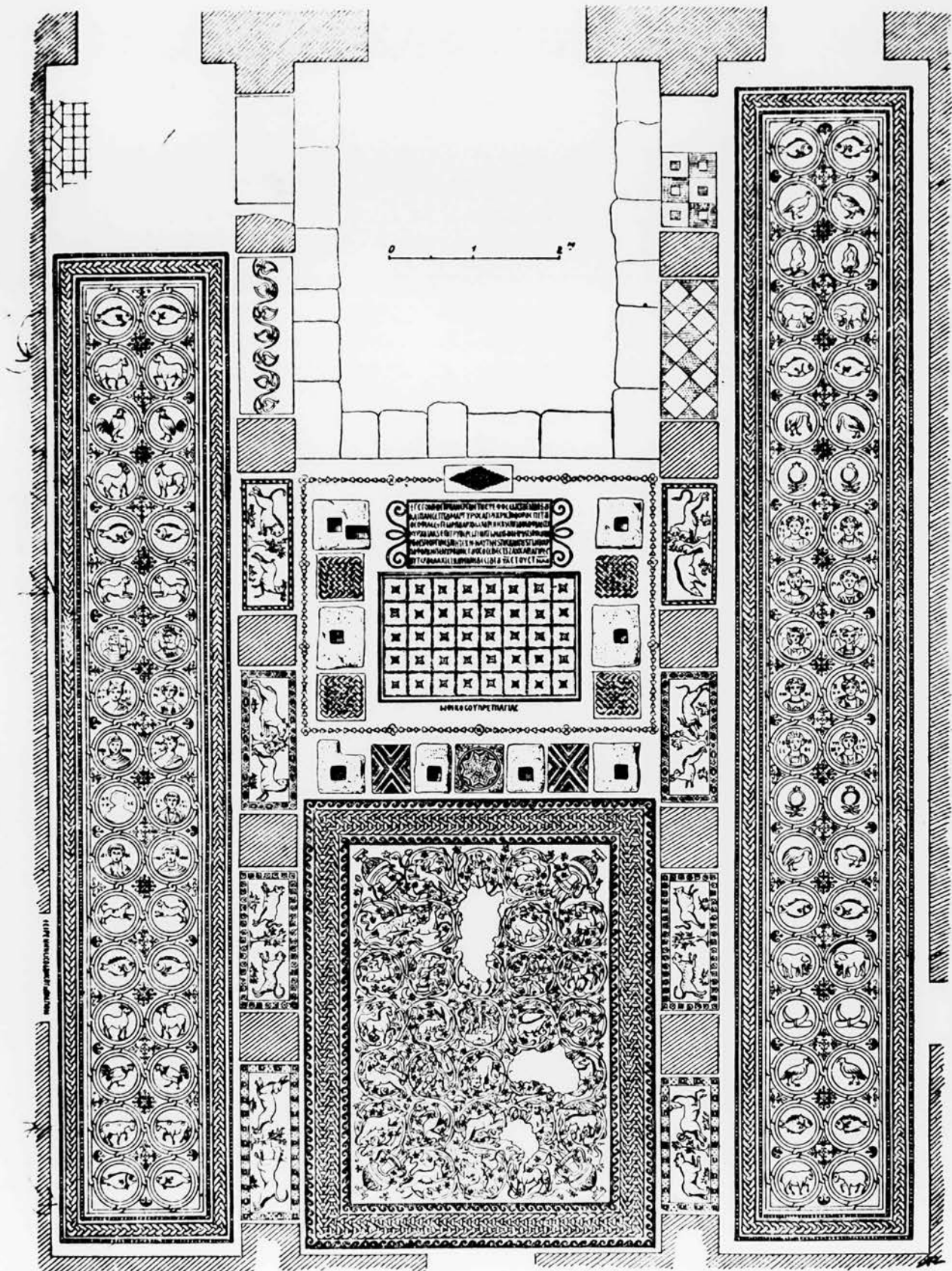

Fig. 142



0 1 2

THESE CHIFFRES SONT LES MEMES QUE CEUX QUI SE TRUVENT DANS LE MANUSCRIT DE LA BIBLIOTHEQUE DE LA VILLE DE GENÈVE. ILS SONT ARRIVÉS EN FRANCE EN 1793, PENDANT LA RÉVOLUTION, ET ONT ÉTÉ DÉCOUVERTS PAR M. DE LAUNAY, ALORS DIRECTEUR DES BUREAUX DE LA BIBLIOTHEQUE DE LA VILLE DE GENÈVE. ILS SONT ENCORE EN POSSESSION DE LA BIBLIOTHEQUE DE LA VILLE DE GENÈVE.

ANCIENNE GROTTE DE LA VILLE DE GENÈVE

ANCIENNE GROTTE DE LA VILLE DE GENÈVE

Fig. 143



Fig. 145

Fig. 146

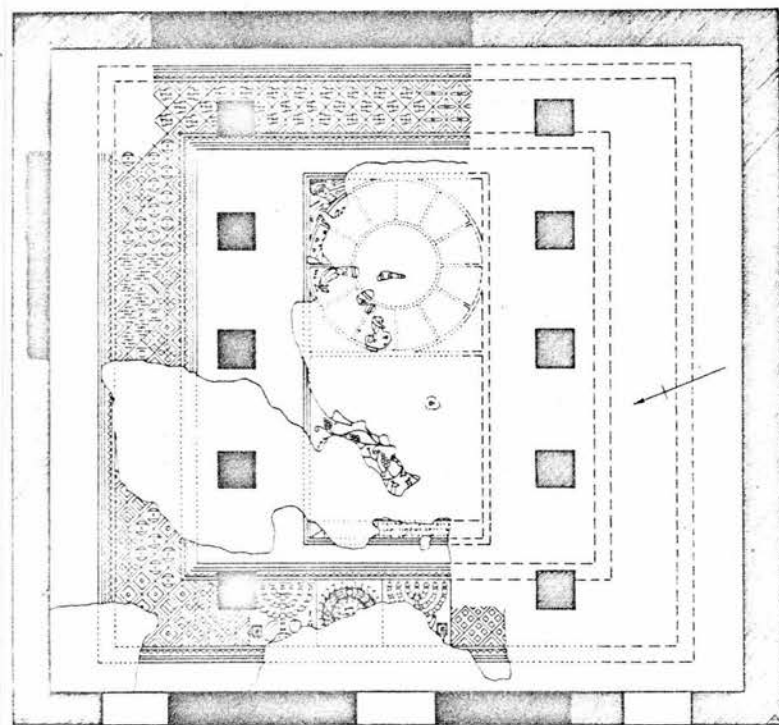

שוחזר נחשף

0 1 2 3 4 5 מ

Fig. 147

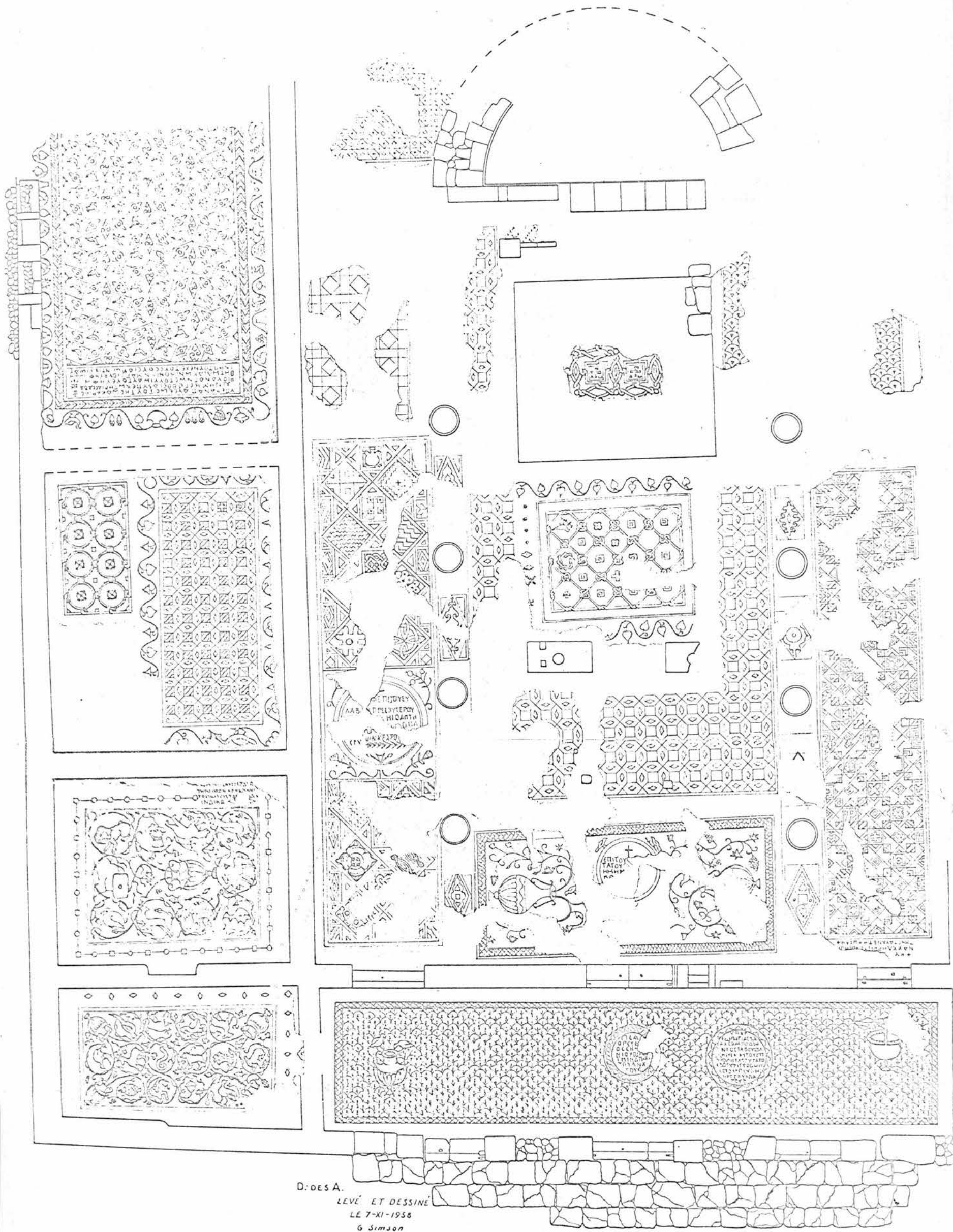

D: des A.  
 LEVÉ ET DESSINÉ  
 LE 7-XI-1958  
 G. SIMON

5M

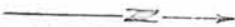

Fig. 148



Fig. 149

Fig. 150

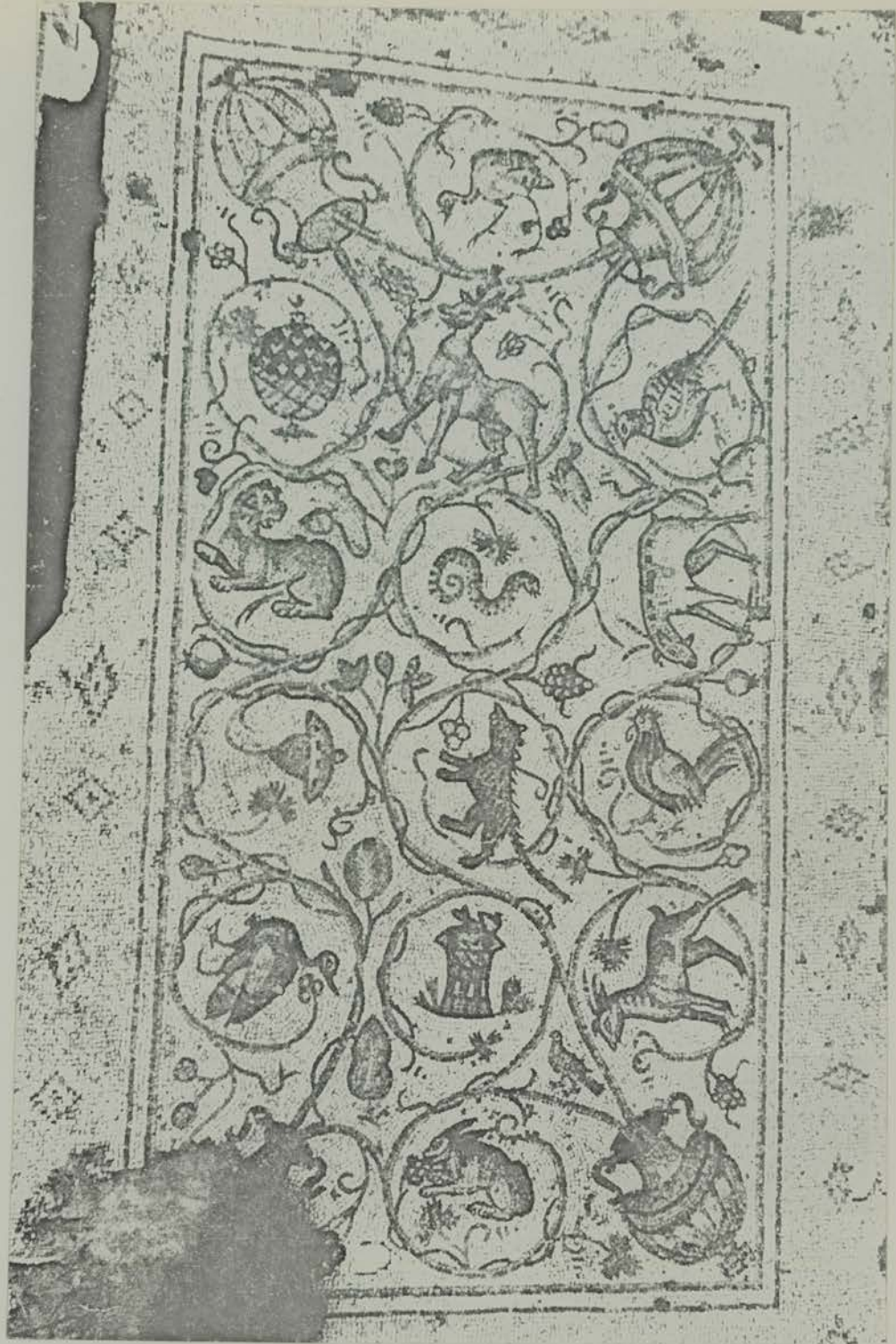

Fig. 151



Fig. 152

Fig. 153





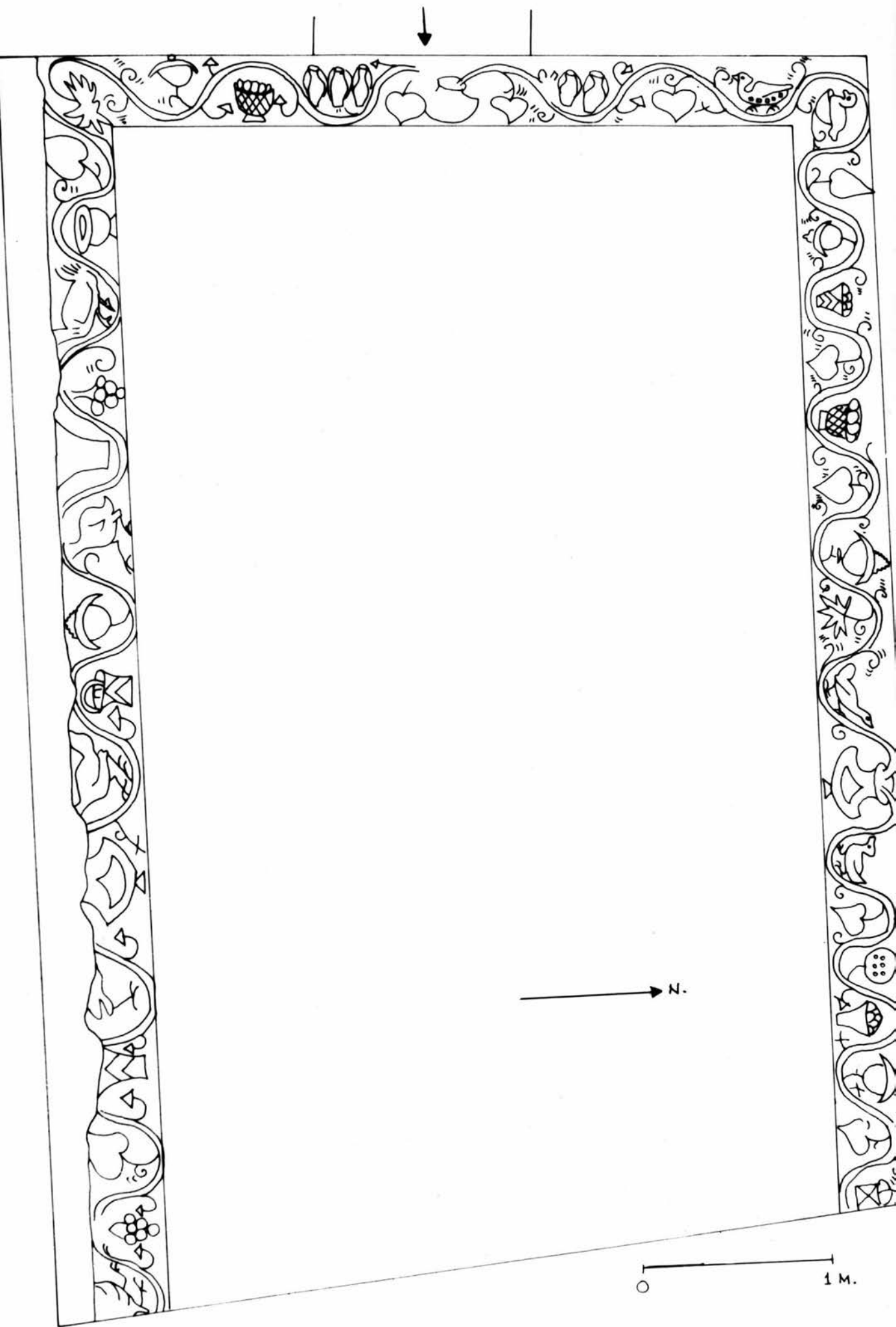

Fig.155

Fig. 156



Fig. 157



Fig. 158

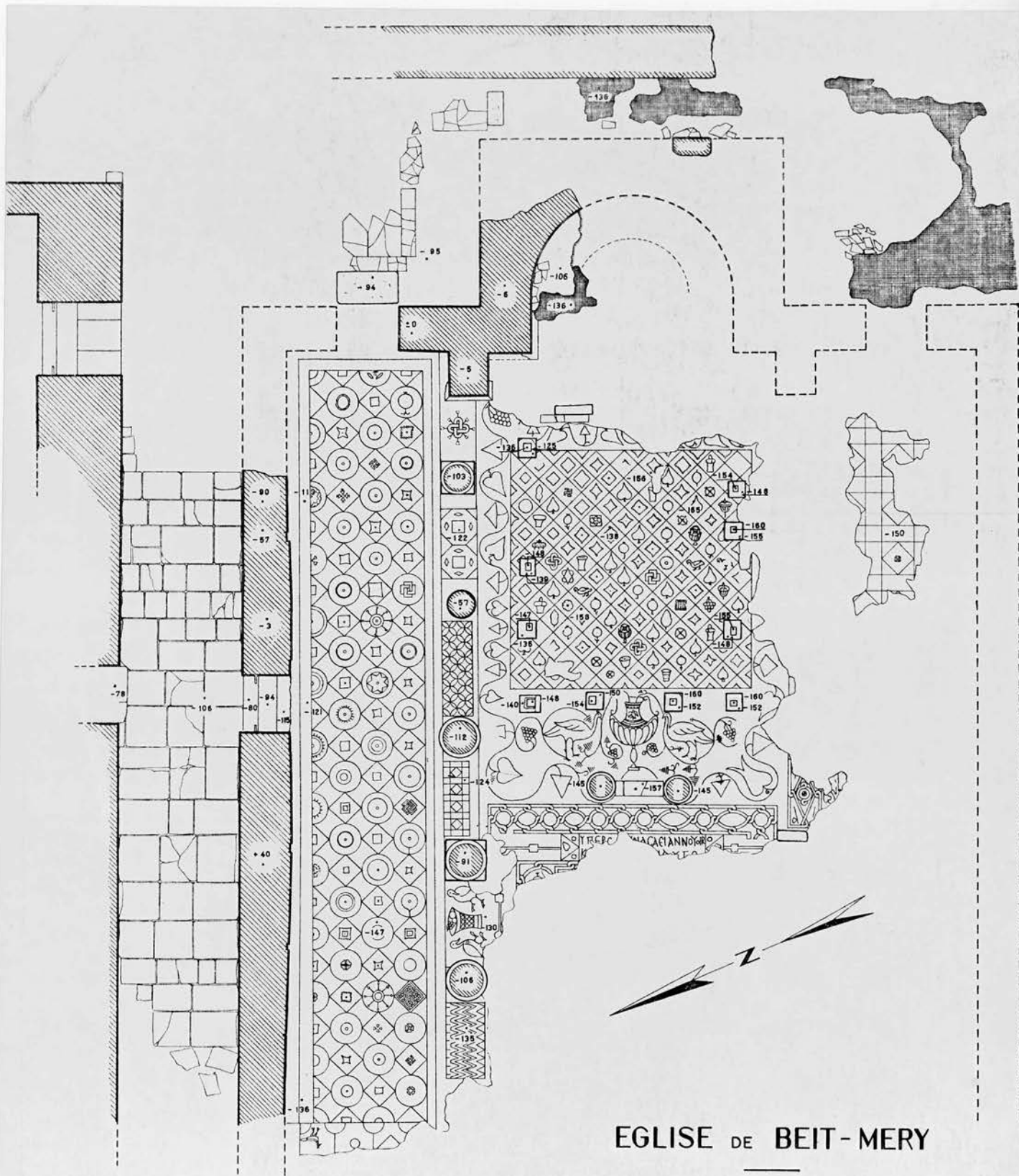

EGLISE DE BEIT-MERY

0 5 M.

Fig. 159



Fig. 160

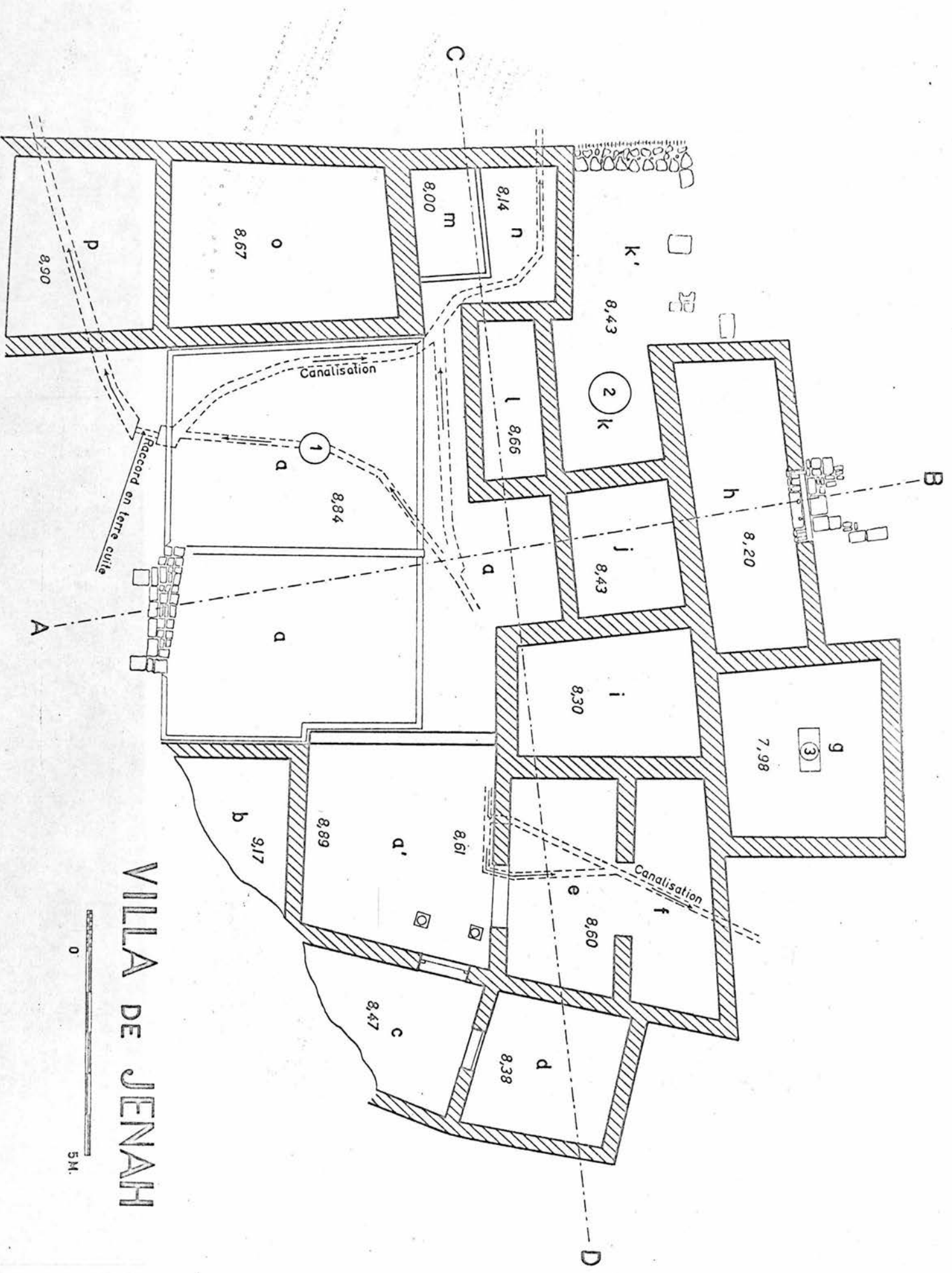

# VILLA DE JENAH



Fig. 161

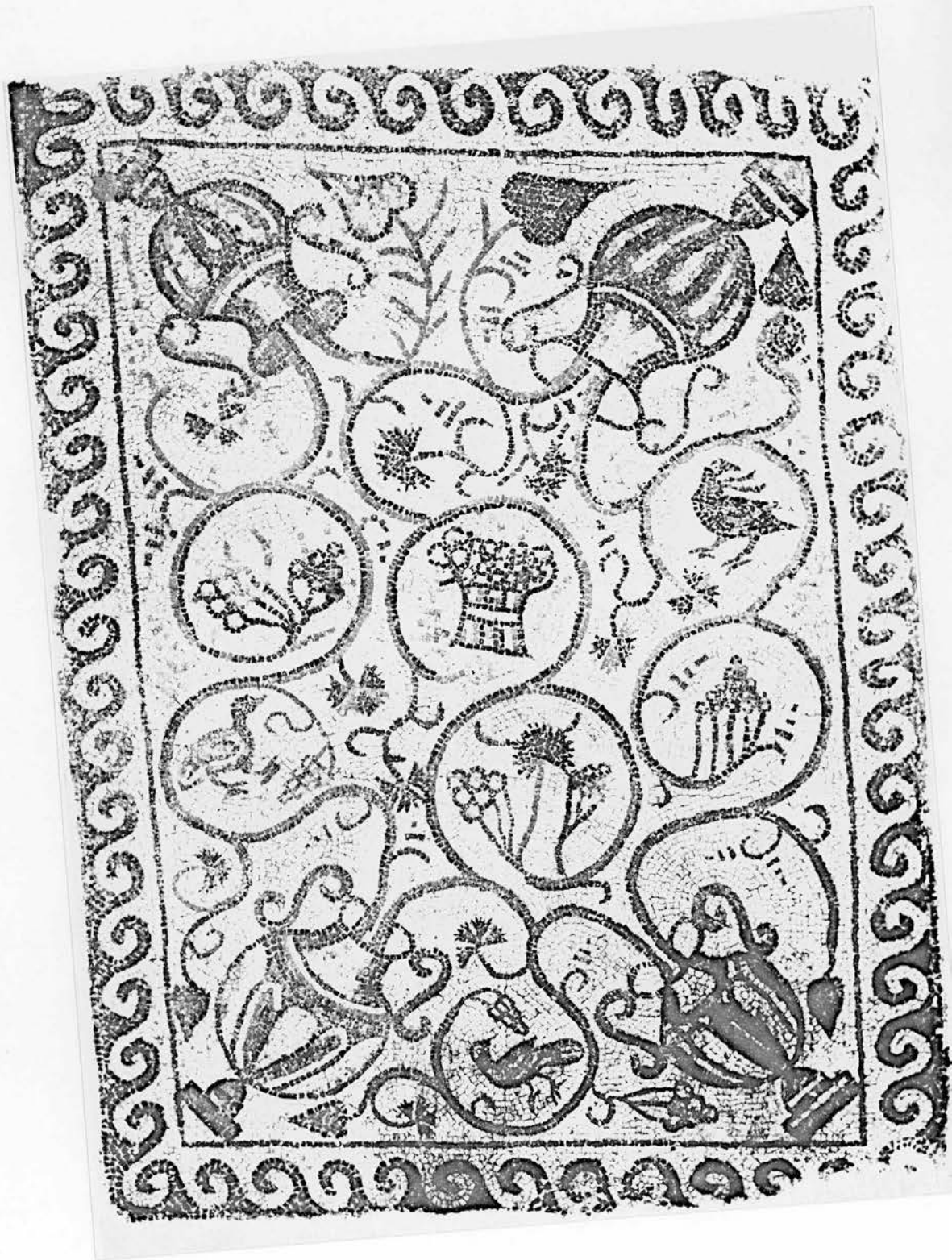

Fig. 162

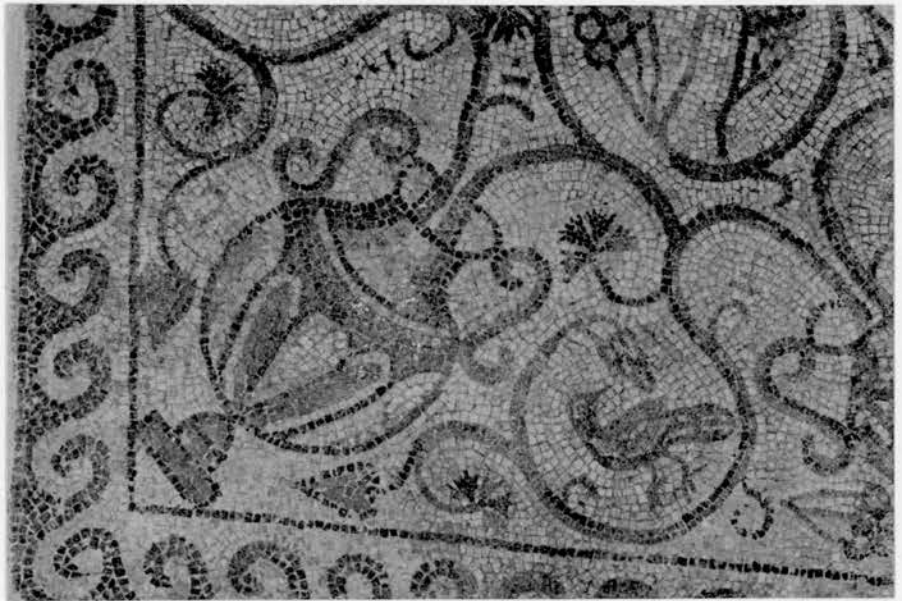
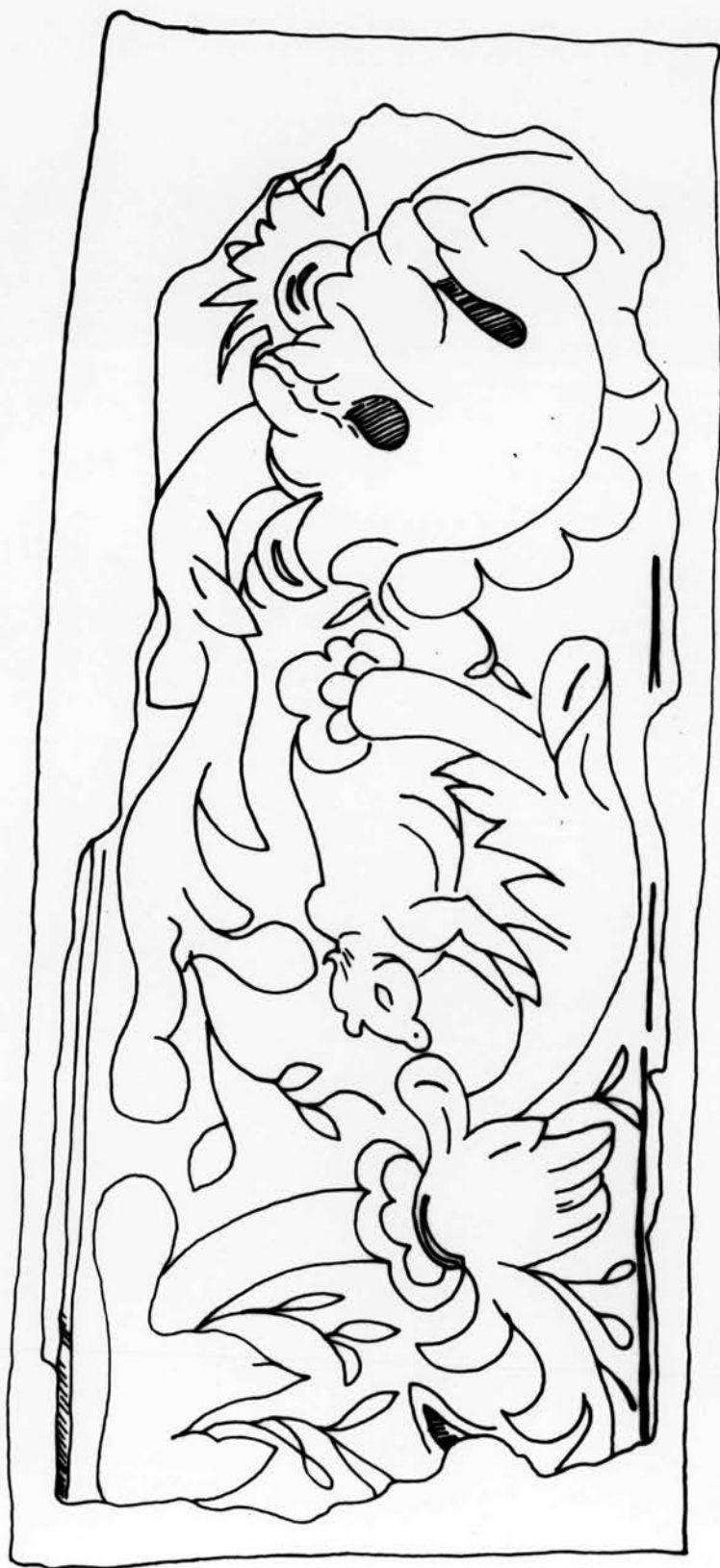

Fig. 163



Fig. 164



0 12 CM

Fig. 165

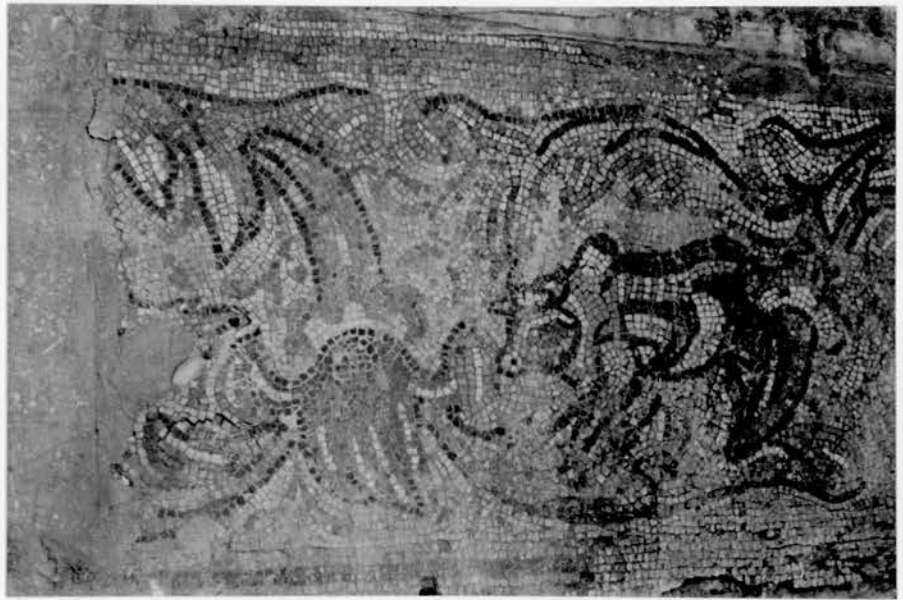
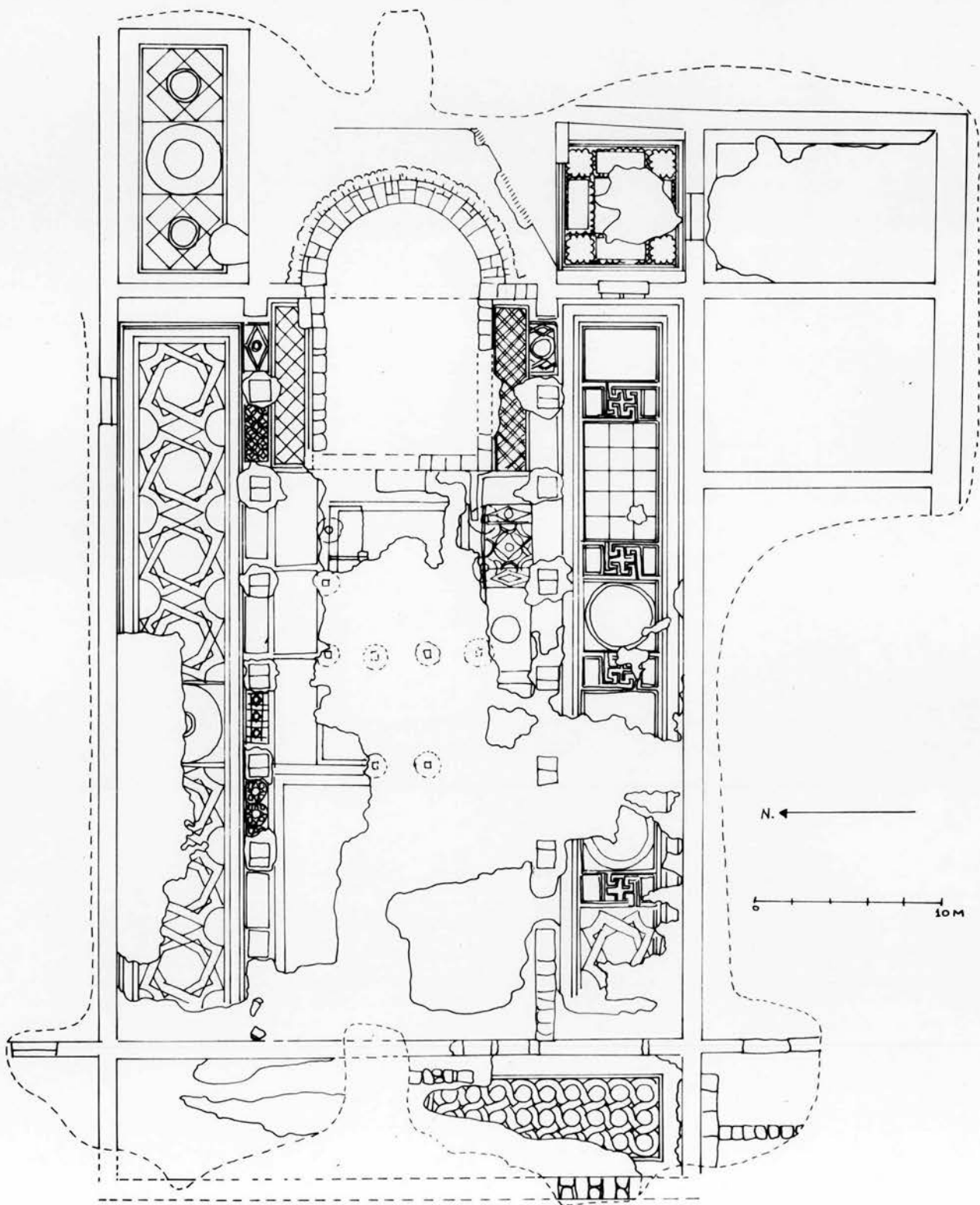
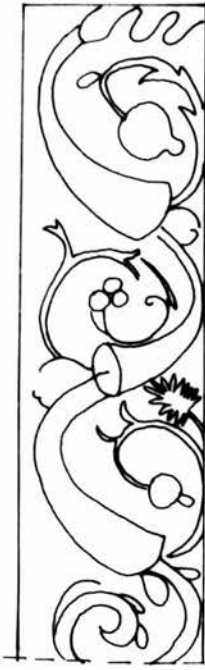
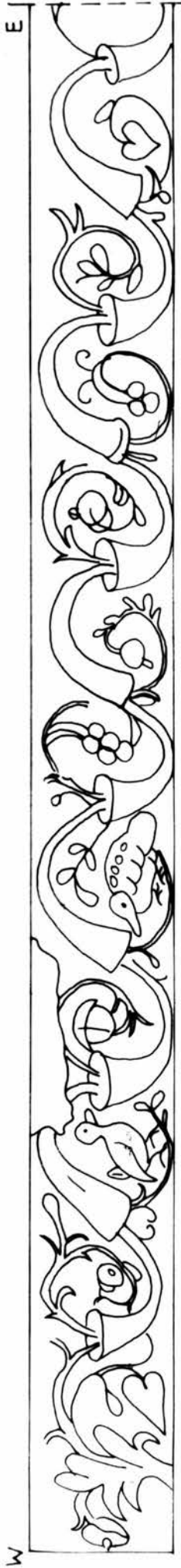

Fig. 166







NORTH SIDE

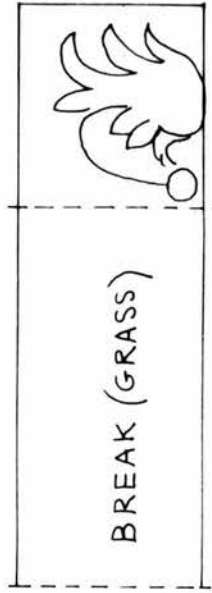
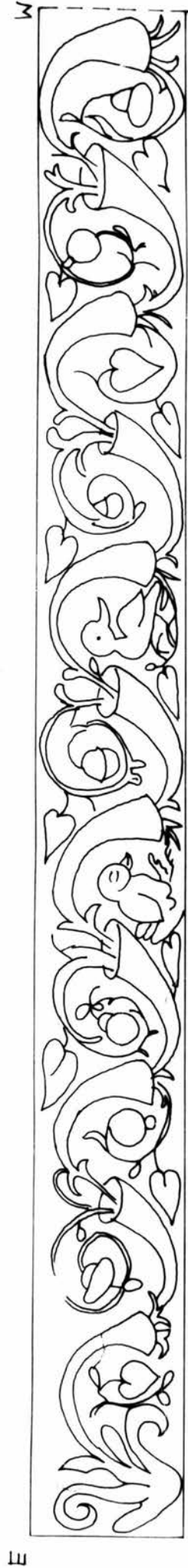

SOUTH SIDE



Fig. 168

Fig. 169

