

W.E.S.C.

CONSULTANTS PRELIMINARY REPORT

1977

WAVE ENERGY STEERING COMMITTEE

UNITED KINGDOM WAVE ENERGY PROGRAMME

CONSULTANTS PRELIMINARY REPORT

1977

RENDEL PALMER & TRITTON,
Consulting Engineers,
Southwark Bridge House,
61, Southwark Street
London SE1 1SA

In Association with
KENNEDY & DONKIN,
Consulting Engineers,
Premier House,
Woking, Surrey.

EXECUTIVE SUMMARY AND CONCLUSIONS

A. SUMMARY

This Report on the Wave Power programme is preliminary in two senses. The Consultants have been able to make only an interim appraisal of current proposals and the development of the Devices is still in a formative stage. No assessment, however thorough, can be considered to be definitive under these circumstances. Much useful ground has been covered, but the Consultants have deliberately avoided drawing firm conclusions except where facts are clear even at this early stage. The Report will assist the Wave Energy Steering Committee in detail planning for the next twelve months, and in forward thinking towards 1985. It does not give a basis for rejecting any of the Devices at this stage, but does show clearly the problems that have to be solved in the fairly near future for particular Devices to remain technically or economically credible. The main Report is concerned primarily with the review of Device proposals and consideration of the means of achieving practical feasibility. The results of a preliminary costing exercise are summarised in a separate document.

The four Devices which currently comprise the WESC programme were studied in detail, and a fifth Device under development at Queen's University, Belfast has been reported on in less detail. The five Devices comprise:-

- The Salter Duck (Sea Energy Associates)
- The Cockerell Rafts (Wavepower Limited)
- The N.E.L. Oscillating Water Column
- The Russell Rectifier (H.R.S.)
- The Wells Oscillating Column (Queen's University Belfast) (outside present WESC funding).

None of the Devices studied was found to have reached the stage at which a feasibility and costing exercise could be carried out entirely on the basis of information supplied by the Device Team. Only one engineering drawing and no valid cost estimates were available to the Consultants. Meetings with the Device Teams, and reports provided by them, revealed that data was available from which preliminary designs could be prepared. With this information the Consultants then undertook the production and costing of Reference Designs for the first four of the Devices listed. The Reference Designs vary greatly from one another in respect of the firmness and reliability of the input data (see Table 2.1 Chapter 2) and in all cases are classed as very preliminary. Insofar as the Consultants have made their own judgement on practical engineering solutions or proven technology, the Reference Designs do not on all points correspond with the proposals of the Device Teams.

The report and conclusions on the costing are covered in a separate Costing Annexe to this Report.

Each Reference Design has been developed to meet an installed capacity, mean continuous rating, of 200 MW, at a site just west of the Outer Hebrides (Uist). For the purpose of costing, the tabulated data given in Table 1.1 Chapter 1 of the Report, has been assumed.

Fixed Devices

HRS Device

This is the only Device which is mounted on the sea bed. The selected economic water depth of 20 m and the restriction to sites where this contour conveniently faces the high energy waves means that there is about 4000 MW (rated) of site available off Scotland where conditions appear favourable. The Device consists essentially of two large reservoirs, a high level one which is filled by inflowing water on the wave crest, and a lower level one which is drawn down on the trough. Power is taken off using a large low head Kaplan turbine driven alternator. The concept is simple and presents fewer technical problems than most other Devices. The simplicity of the concept means that although the Device was late in the field of terms of testing work and research, it will be the easiest to bring to a decision point. A modest programme of testing and design development, which could be encompassed in the period up to June 1978, would allow the Device to be comprehensively assessed on a cost effectiveness basis by that date. The Device is massive and the construction and placing of the caissons will dominate the cost. The structural mass compares favourably with several other Devices. There are some promising avenues to be explored to reduce this size, but it is not yet clear how far these will lead.

Floating Devices

The remaining Devices float in about 60 m of water, and extract energy by applying pressure on a surface which is either within or on the surface of the waves. It is not difficult to identify sites off the West Coast of Scotland corresponding to a potential 30,000 MW installed capacity. All these Devices present problems in mooring and in providing for electrical power offtake, but there appears a reasonable chance that such problems will be solved without incurring prohibitive expense. The floating Devices all seem to have reasonably high efficiencies over a useable band of wave periods.

(1) Salter Ducks

The essentials of this Device are a very long floating cylindrical spine, and a series of cams or ducks which are located on, and rotate around the spine. Power is generated from the relative rotation between the duck and the spine. The primary power offtake is to hydraulic pumps which deliver oil through a main in the spine to an oil-hydraulic turbine driving a generator.

The concept is ingenious and leads to a very compact Device. Testing is well advanced in two dimensions, but this Device in particular requires three-dimensional testing. The latter testing is still at an early stage.

The Device is feasible in principle but involves many untried ideas and components as yet undeveloped. The main structure is complex and the primary power offtake presents severe problems, particularly in connection with maintenance, which are not yet resolved. Work on the theoretical side is significantly ahead of design development, and effort is now urgently needed on this latter side.

This Device will probably require the greatest development effort to reach a stage where a final assessment will be possible.

(2) Cockerell Rafts

In this Device a string of three rafts, hinged together, are moored parallel to the prevailing wave direction. Power is taken from the relative rotation at the raft hinges; in the Reference Design by means of a link arm connected to a rack and pinion driving oil pumps. The oil is used to drive a hydraulic turbine linked to a generator.

The concept is simple and practicable. Testing and theoretical works are progressing well and the Device Team are investigating promising ideas to overcome the disadvantages of having many independently moored units of small capacity.

The structures are entirely conventional in the field of civil engineering and could easily be constructed on any site adjacent to water. Survival in extreme seas remains an undefined risk, particularly if this is combined with a loss of damping from the power take-off. The primary power take-off would require design development and testing for several components, but appears completely credible. Access for maintenance is good. Work on this, and on the hinge design, needs to be done and taken to a stage where a reliable overall assessment can be made. This work could be well advanced during the next 12 months.

(3) NEL Oscillating Water Column

The concept of an oscillating water column forcing air through a turbine to extract power from waves is well established. The NEL device incorporates a series of such water columns on one of the long sides of a massive floating structure. The system employs a minimum of mechanical components and these are located in fairly readily accessible positions. The Device therefore has a high technical credibility. Being a single rigid structure its ability to survive extreme sea conditions should be good.

Small-scale model testing has reached a fairly advanced stage for the currently favoured structure, but the Team are still investigating alternative configurations. Little work has been done on the air turbines which are outside current manufacturing experience.

The cost effectiveness of the Device seems likely to depend largely on the cost of the massive structure itself.

(4) Wells Oscillating Water Column

Generically similar to the NEL Device, but radically different in appearance, the Wells Device consists of a hollow dome floating high in the water, connected to a deeply submerged toroidal structure which provides passive inertia. An air turbine venting to the atmosphere is located on the top of the dome.

Little model testing has taken place for this Device but a large-scale model is planned for sea trials this Autumn. The Device Team are relying heavily on the theoretical analysis of their Device.

This Device is the only one of the five which was conceived as a point absorber of energy. It is claimed that this will give it a very high capacity rating for a given size of Device, and is one reason why large-scale models can be built at little cost.

A novel air turbine has been developed for this Device which is claimed to have several significant advantages, including being self-rectifying and operating at fairly high speed. Testing of this component is under way.

In summary, if the theoretical predictions of the Device Team are validated, then the prospects for this Device are exceptionally good, although very little testing has been carried out to date. The Autumn sea trials should provide enough information for an authoritative technical and cost appraisal to be based on a preliminary prototype design.

B. CONCLUSIONS RELATING TO THE IMMEDIATE PROGRAMME

1. The programme for the immediate future should remain flexible enough to accommodate the assessment of any promising new Devices or variants of existing Devices.
2. The Wells Oscillator seems to hold sufficient promise at this early stage to warrant consideration of financial support to allow its development to be brought to a point where a proper appraisal of this Device can be made.
3. The separate Costing Annexe to this Report gives the approximate order of the capital costs for each Device based on 200 MW rated output. These costs relate to the Reference Designs and, as explained in the Annexe, are necessarily limited in their accuracy at this stage. They indicate, however, that for each Device the main cost centre lies in the structure. Since the overall dimensions of wave energy devices are related to the wave length of the waves from which energy is drawn (see Chapter 2 Table 2.1) then there are physical limitations to the cost reductions that might be achieved for the structures themselves.
4. It is possible that one or more components of any particular Device may possess technical problems to which no reasonable economic solution can be found even within generous cost boundaries.

In this context the critical areas for each Device are seen as follows:-

HRS

Water turbine with acceptable efficiencies in moderate seas.

Flap gates of reasonable life

Siltation of Device

Salter Duck

Power take-off system

Beak location system

Peripheral seals (if used)

Spine and hinge system

Maintenance facilities

Damage stability

Duck survival

Cockerell Raft

Survival of front raft
Hinges with an adequate life
Power take-off system

NEL

Air turbines
Prevention of slugs of water passing through turbines.

Most of these problems could be proved to be surmountable as a result of work over the next one or two years.

5. In respect of the work of TAG 3, anchors and moorings are identified as an area where work is urgently required.

6. The mechanical and electrical plant equipment required is in many cases outside present manufacturing experience. The development work required is generally common to two or more of the Devices.

7. Costs of the Reference Designs, as reported on in the Annexe, are high but, in view of the very early stage of the whole project, are not too high to discourage continuation of the work. Four avenues are seen to be available for reducing the estimated costs:

- (a) Re-organising basic device layouts on a more cost effective basis.
- (b) More accurate stressing and proportioning of the present Reference Designs.
- (c) Radical changes of components within the existing design formats
- (d) More searching approach to costing of components when designs are firmed up.

8. Generalising on the WESC programme as a whole, present testing and theoretical understanding are ahead of design development. There is now an urgent need to put effort in this direction so that there is a balanced understanding of both sides of the cost/output equation. If this is not done there is a danger that expensive testing may be done on schemes that could never be cost effective.

Effort at the present time might be better directed towards reducing Device costs than in seeking marginal improvements in overall efficiencies.

C. CONCLUSIONS RELATING TO THE OVERALL WAVE POWER PROGRAMME

1. Wave energy as a source of power generation appears to be a sound prospect viewed from a technical standpoint. Each of the five Devices reviewed at this stage possess unproven features, but the Consultants feel that few of the problems should prove to be technically insuperable. Even if one or two of the present Devices are finally rejected on technical grounds, then the remaining contenders ensure that a wave power programme could be implemented.

2. Unlike some other new power sources, wave power is not dependent on a fundamental new development of high technology. Different Devices do however incorporate a number of components which are novel and as yet undesigned. In addition conventional components will be required to function in new ways.

3. A preliminary study of the available sites around the west and north-west coasts of Scotland indicate that there is a potential for installing the following generating capacity.

For schemes based on floating devices - 30,000 MW
For schemes based on HRS fixed device - 4,000 MW

These figures are a broad estimate based on a study of contours, energy density, and sea bed conditions.

4. Since at present no National study has been undertaken to determine the value of electrical power produced from a non-firm and seasonally variable source, an evaluation needs to be available when making key investment decisions.

5. No work has been done by the Consultants on uses of the primary power other than for direct generation of electricity for the C.E.G.B. A little work has been done by TAG 6 on Hydrogen production.

6. Environmental problems have not been studied in depth for this Report. Wave power devices will be sited typically between five and eighteen kilometres off-shore and will be very low in the water. Calm, semi-enclosed, water inshore of the devices may be beneficial but at the proposed locations, this may not be of any direct significance. The environmental impact of the associated construction and supply facilities and power transmission lines may be of greater importance.

7. A 200 MW station commissioned in the 1980's has been mentioned as one possible scenario.

It seems likely that the preparatory work leading up to a 200 MW station would include in sequence, the testing of a Device which is full scale in cross-section but short in length to test power offtake, followed by a Device up to 1 Km long to check out all features which are length dependent. It is a convenient feature of wave power that it can be thoroughly tried out on what is, relatively speaking, a small scale.

8. A preliminary estimate of the time required for the construction and installation of a 200 MW station might be five years if the construction facilities listed in Table A.9 of the Costing Annexe to this Report are available and the extended facilities have been built.

Production of any of the deep-draft Devices would be limited by the available capacity in the deep construction basins which, in the mid 1980's could still have oil platforms in them. The Cockerell Raft scheme would not be so restricted since it will be possible to construct these units on existing slipways, dry docks and a variety of ad-hoc coastal situations.

Power take-off equipment for a 200 MW station might also prove a bottleneck for specialist manufacturers in the U.K. unless special production lines were set up to provide the equipment in the quantities required.

9. If Wave Power is implemented, the call on the resources of the construction industry would be massive. For the deep draught devices the five existing offshore construction yards in the U.K. might between them turn out only 60 MW of capacity per annum operating full time. It is interesting to note that, at the present time, four out of five of these yards are completely empty.

For the shallow draught devices, the employment of dry docks and ad-hoc casting yards would improve the annual output but would still constitute a major civil engineering programme.

Depending on the particular Device adopted, new or extended facilities would be required to manufacture the components of the primary offtake in the necessary volume.

UNITED KINGDOM WAVE ENERGY PROGRAMME

CONSULTANTS PRELIMINARY REPORT

CONTENTS

PAGE

CONSULTANTS BRIEF

1

SECTION A - REVIEW OF DEVICES AND
BASIS OF CONSULTANTS STUDY

CHAPTER 1 INTRODUCTION AND COMPARATIVE REVIEW OF SHORT-LISTED
WAVE ENERGY CONVERTERS

3

1.1. Introduction

3

1.2. Moving Surface Modulators

5

1.3. H.R.S. Wave Rectifier

7

1.4. Other Devices

8

CHAPTER 2 STATE OF DEVELOPMENT AT APRIL 1977

9

CHAPTER 3 BASIS OF THE PRELIMINARY CONSULTANTS STUDY

11

3.1. Consultation

11

3.2. Design of Devices

11

3.3. Performance Specifications

11

3.4. Power Generation and Transmission

14

3.5. Procedure for Costing

15

SECTION B - ASSESSMENT OF INDIVIDUAL DEVICES

CHAPTER 4 SALTER DUCKS (DEVICE TEAM - SEA ENERGY ASSOCIATES)

4.1. General Description of Concept

18

4.2. The Reference Design Adopted for the Study

21

4.3. Possible Alternative Designs

27

4.4. Construction and Installation

31

4.5. Critical Assessment of Technical Feasibility

33

4.6. Future Research Requirements

CHAPTER 5 COCKERELL RAFTS (DEVICE TEAM - WAVEPOWER LTD)

38

5.1. General Description of Concept

38

5.2. The Reference Design Adopted for the Study

39

5.3. Possible Alternative Designs

43

5.4. Construction and Installation

44

5.5. Critical Assessment of Technical Feasibility

45

5.6. Future Research and Development

47

CHAPTER 6 N.E.L. OSCILLATING WATER COLUMN (DEVICE TEAM - NATIONAL ENGINEERING LABORATORY)

6.1.	General Description of Concept	49
6.2.	The Reference Design Adopted for the Study	51
6.4.	Construction Installation and Siting	55
6.5.	Possible Alternative Designs	57
6.6.	Critical Assessment of Technical Feasibility	57
6.7.	Future Research Requirements	58

CHAPTER 7 H.R.S. RECTIFIER (DEVICE TEAM - HYDRAULICS RESEARCH STATION)

7.1.	General Description of Concept	60
7.2.	State of Development at April, 1977	62
7.3.	The Reference Design Adopted for the Study	63
7.4.	Siting of the Devices	69
7.5.	Critical Assessment of Technical Feasibility and Potential	69
7.6.	Future Activity	72

CHAPTER 8 WELLS OSCILLATOR

8.1.	Description	73
8.2.	Status	74
8.4.	Assessment of Feasibility and Potential	75

SECTION C - GENERIC STUDIES

CHAPTER 9 WAVE DATA

9.1.	Data Available at present	78
9.2.	Wave Data required in the immediate future	78

CHAPTER 10 DESIGN DATA

10.1.	Mathematical Modelling	80
10.2.	Efficiencies	81
10.3.	Wave loading	83
10.4.	Structural Design	84

CHAPTER 11 MOORINGS AND ANCHORS FOR FLOATING DEVICES

11.1.	Device Team proposals	85
11.2.	The Mooring Problem	85
11.3.	Derivation of a specification for the Reference Design Moorings	86
11.4.	General Summary	95

CHAPTER 12 CONSTRUCTION MATERIALS

12.1.	The use of concrete in wave power structures	97
12.2.	The use of steel in wave power structures	100
12.3.	Rubber	101
12.4.	Other Materials	101
12.5.	Conclusion	101

CHAPTER 13 SPECIAL MARINE PROBLEMS

13.1.	Corrosion	102
13.2.	Fouling	102
13.3.	Siltation	102

CHAPTER 14 POWER GENERATION

14.1.	General Observations on Design	103
14.2.	Russell Rectifier - H.R.S. Power Plant	106
14.3.	Salter - SEA Oil hydraulic power plant	109
14.4.	N.E.L. - Air turbine generators	113
14.5.	Cockerell Raft - W.P. Limited Oil-hydraulic turbine generators	115
14.6.	Manufacturing Resources	117

CHAPTER 15 POWER COLLECTION AND TRANSMISSION

15.1.	General	119
15.2.	Power Collection	125
15.3.	Main Transmission	126
15.4.	Efficiency	133

CHAPTER 16 MAINTENANCE AND MANNING

16.1.	General	134
-------	---------	-----

CHAPTER 17 ENVIRONMENTAL CONSIDERATIONS

17.1.	General	135
-------	---------	-----

SECTION D - ECONOMICS

CHAPTER 18 BROAD ECONOMIC AND RESOURCE STUDY

18.1.	General	137
18.2.	Resource Study	137
18.3.	Economics of power generation for the National Grid	138
18.4.	Other routes and applications for wave energy	138
18.5.	Energy accounting	139
18.6.	Economic study for West Scotland (TAG 7)	139

SECTION E - IMPLEMENTATIONS

CHAPTER 19 IMPLEMENTATION OF A WAVE ENERGY PROGRAMME

19.1.	Considerations	140
-------	----------------	-----

SECTION F - ACKNOWLEDGEMENTS AND REFERENCES

SECTION G - DRAWINGS

<u>INDEX OF DRAWINGS</u>		144
<u>General Data</u>		
WP/GEN 1	Wave Energy Devices under construction scale comparison drawing	145
WP/GEN 2	Location plan showing existing on-shore construction yard facilities - potential device sitings and mean annual energy contours KW/metre	146
WP/GEN 3	Wave energy device sitings in relation to sea bed geology	147
<u>H.R.S. Russell Rectifier</u>		
WP/RECT 1	200 MW scheme	148
WP/RECT 2	Reference Design - General Arrangement of working unit	149
WP/RECT 3	Reference Design - Construction and flotation	150
WP/RECT 4	Wave Energy device sitings off the outer Hebrides	151
<u>N.E.L. Oscillating Water Column</u>		
WP/OWC 1	200 MW scheme	152
WP/OWC 2	Model to full size development of OWC device	153
WP/OWC 3	Reference Design - General arrangement of practical working unit	154
WP/OWC 4	Reference Design - Construction and flotation	155
<u>Salter Duck</u>		
WP/SALT 1	200 MW scheme	156
WP/SALT 2	Reference Design - General arrangement of working unit	157
WP/SALT 3	Reference Design - Details and power take off	158
WP/SALT 4	Construction sequence	159
<u>Cockerell Raft</u>		
WP/RAFT 1	200 MW Scheme	160
WP/RAFT 2	Reference Design - General arrangement of working unit	161
WP/RAFT 3	Reference Design - Details and Power take off	162
WP/RAFT 4	Construction sequence and flotation	163

Figures

4.1.	The Interaction between Spine Characteristics and Duck Behaviour	22
4.2.	Non-integrated Collars	25
4.3.	Alternative Configurations of Duck Device Spines	28
5.1.	Possible Alternative Raft Configurations	44
6.1.	N.E.L. Model dimensions to be scaled up for Reference Design	53
6.2.	Working cell into a wave Energy Device - Development of N.E.L. oscillating water column	54
7.1.	H.R.S. Dimension Parameters to be considered in Reference Design	65
7.2.	H.R.S. Russell Rectifier - Principle of Operation	66
8.1.	Wells Oscillator - sketch of the proposed full scale device	77
11.1.	The average wave force acting on an N.E.L. OWC Device as a function of wave height and period for monochromatic waves	87
11.2.	Mooring schemes investigated.	90
14.1.	H.R.S. - Russell Rectifier - Proposed Kaplan turbine & generator installation	107
14.2.	Salter Duck Hydraulics - Proposed arrangement of hydraulic circuits for pumps and flow control valves	110
14.3.	Salter Duck Hydraulics - Hydraulic system diagram	112
15.1.	Wave Energy preliminary proposal for 2000 MW H.V. DC transmission over Hebrides to central Scotland AC system	120
15.2.	Outline of typical ⁺ 250 kV DC double circuit suspension tower	122
15.3.	Power plant module and 400 MW converter station	124
15.4.	Outline design for 2000 MW transmission scheme	122
15.5.	Preliminary design of seaward converter station 400 MW ⁺ 250 kV DC	128
15.6.	D.C. power transmission scheme - proposed indoor cable switching station	129

Tables

1.1.	Summary of Data Relating to Study Reference Designs for 200 MW schemes	4
1.2.	The Limitations on the Size of Devices as Determined by Efficiency Requirements	6
2.1.	State of Progress on Specific Devices at April 1977	10
3.1.	Installed Capacities in Reference Designs	13
4.1.	Components requiring Significant Technological Development	33
10.1.	Data available on device efficiencies	82
11,1.	Components of Mooring Forces	86

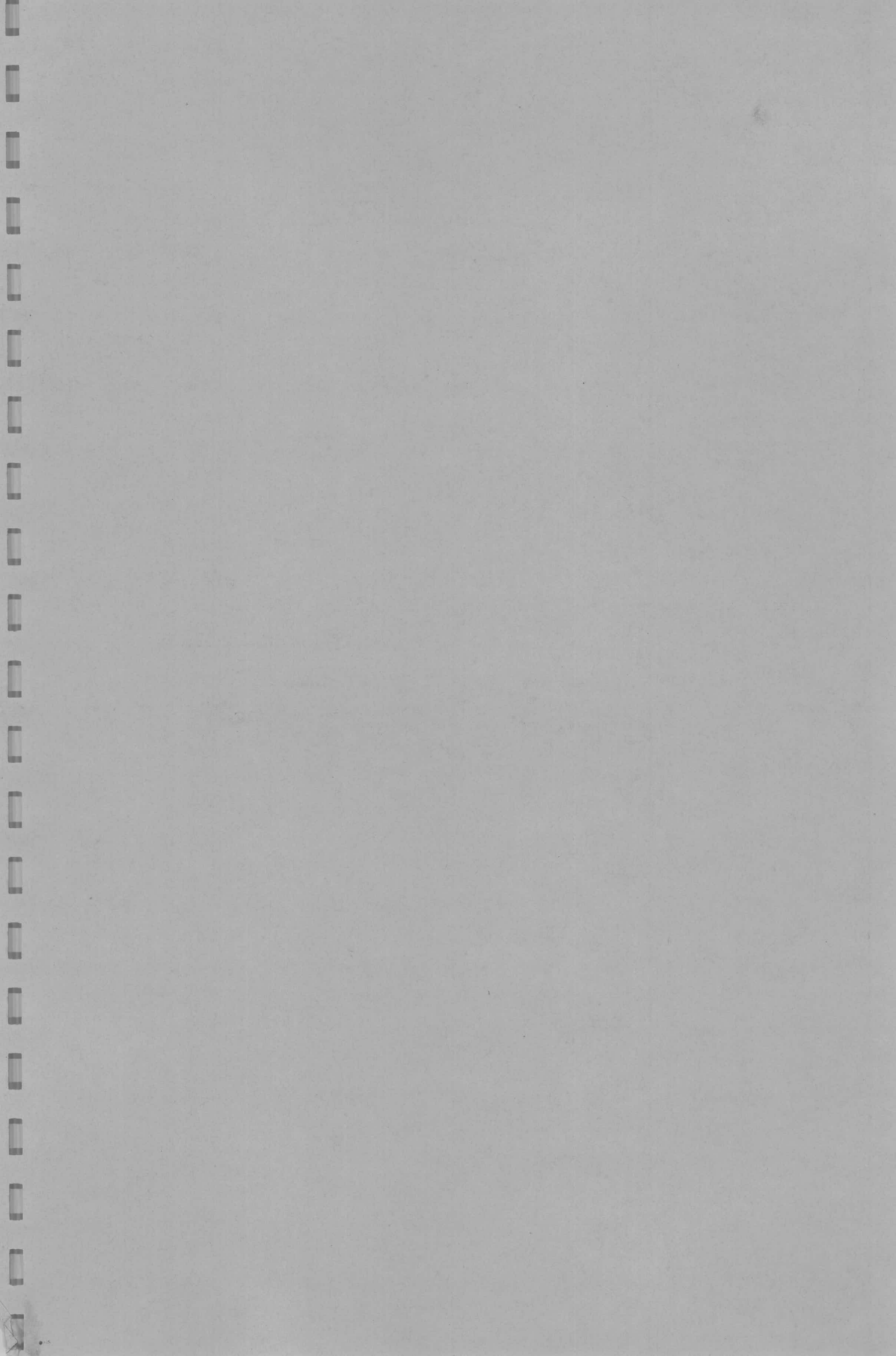

CONSULTANTS BRIEF

The following brief formed part of the contract placed with the Consultants on 18th April 1977.

"The Consultants' Remit

It is recognised that Device designs are not yet sufficiently firmed-up to allow detailed planning and accurate costing; expert advice on problems of large-scale production of wave-energy devices is nevertheless desirable at an early stage, both as an aid to Device Teams and as a guide to the Steering Committee and Technical Advisory Groups in assessing Device Team proposals and cost estimates. It is envisaged that during Phase I of the Department of Energy's Wave Energy Programme this advice will be based on studies carried out by Consultants in two distinct stages defined as follows:

Stage I: Preliminary Study, Duration 4 months (April - August 1977)

- (i) Carry out a preliminary assessment of the feasibility and cost of large scale implementation of contending wave energy devices.
- (ii) Consulting as necessary with Device Teams, establish a provisional "Implementation Plan" for each Device, identifying problems associated with planning, construction, installation and maintenance.
- (iii) Carry out a critical assessment of the plans and cost estimates prepared by the Device Teams having regard to the following:-
 - (a) Practicality of structural, mechanical and electrical aspects of device designs.
 - (b) Selection of construction sites.
 - (c) Procurement of materials and labour.
 - (d) Transport arrangements.
 - (e) Certification, inspection and insurance requirements.
 - (f) Logistics of installation and maintenance.

Aspects of the Programme to be Considered

1. The members of the Device Teams each have their particular areas of expertise. The Consultants will be expected to advise the Steering Committee of any aspects of design or implementation which may have been overlooked, and to suggest improvements where appropriate.

2. The Consultants will be required to make an evaluation of the cost estimates prepared by the Device Teams and to make such an evaluation possible some common standards and methods of cost estimating must be set out.

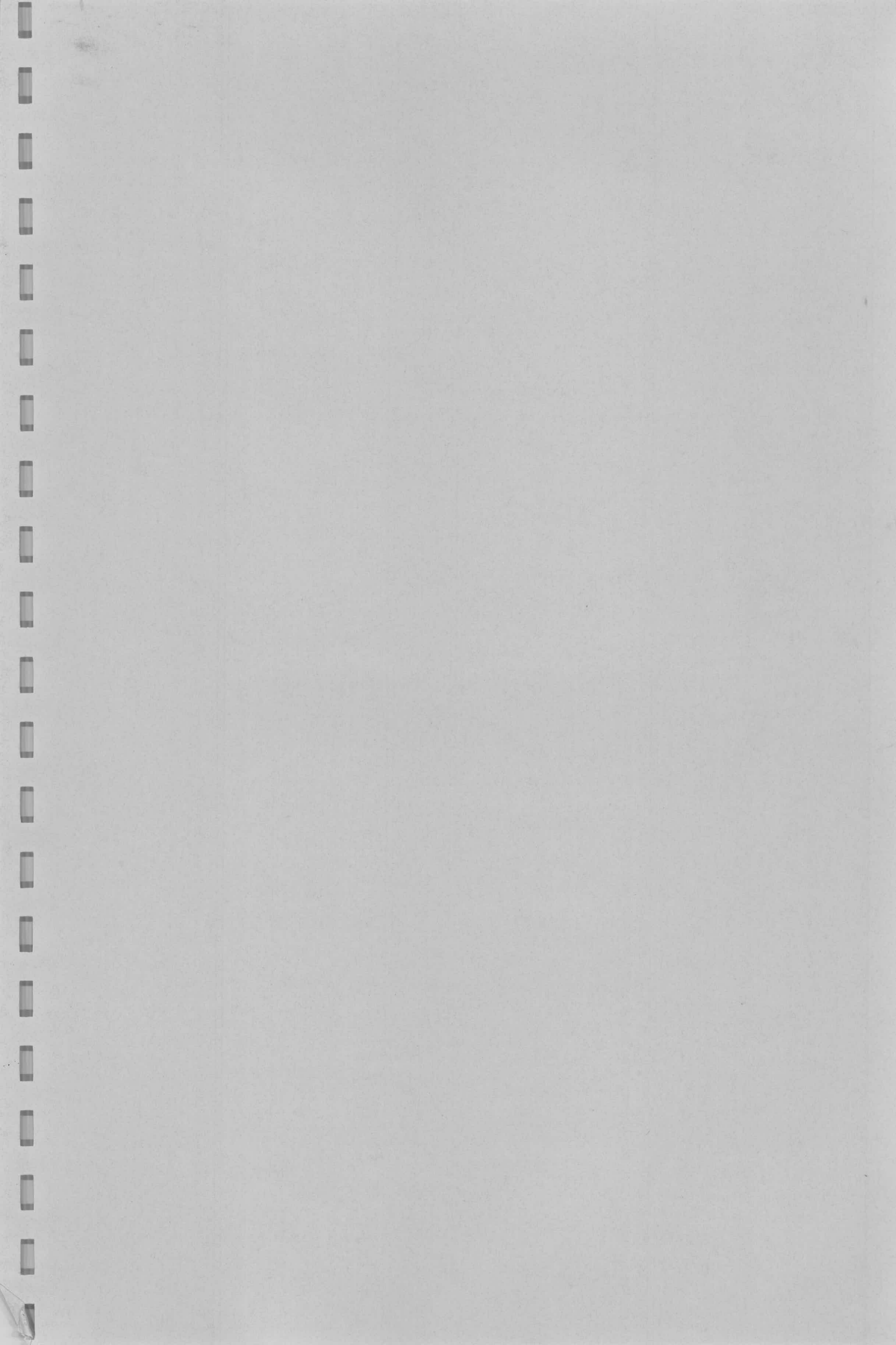

3. The seakeeping, maintenance and survival requirements of the Devices will be very different and the Consultants will make an evaluation of these aspects of each device and in this evaluation will interact with the Structural Response Group (TAG 3) as well as with the Device Teams.

4. The methods of transferring the energy ashore may be different for each device and the Consultants will evaluate the effect which these different methods are likely to have on costs, reliability etc. In forming the criteria to make this evaluation the Consultants will interact with the Generation and Transmission Group (TAG 6).

5. Finally the Consultants must keep in mind the need to remain independent and take an overview of the programme as a whole".

This brief recognised the fluid state of development of the Devices and it was made clear to the Consultants through the Secretary of the WESC that the Consultants would be expected to exercise their own judgement in their detailed interpretation.

Early in the course of the study it became clear that it would be necessary for the Consultants to carry out quite extensive design work to produce engineering plans on which to base feasibility and cost assessments.

This has had the effect of reducing the time available for the consideration of several important aspects, which should be dealt with in a Stage 2 study.

The following items in this Stage 1 brief have not been specifically covered by the Consultants.

Procurement of materials and labour.
Transport arrangements
Certification, inspection and insurance requirements.

SECTION A - REVIEW OF DEVICES AND BASIS OF CONSULTANTS STUDY

CHAPTER 1.0 - INTRODUCTION AND COMPARATIVE REVIEW OF SHORT-LISTED WAVE ENERGY CONVERTERS

1.1 Introduction

The scope of the brief to the Consultants was very wide, both in respect of the number of Devices to be examined and in the number of aspects to be considered for each Device. The work required was broadly divided into technical engineering, and costing and economics with the work necessarily having to be carried out in this sequence.

Section A of this Report introduces the broad principles that govern the Devices, and sets out the way in which the work was carried out and the way in which the balance of the effort was determined.

A significant part of the four months allotted for the study was taken up in meeting Device Teams and building up a first understanding of the principles of their Devices, and of the various structural and mechanical configurations being employed. It became clear early in the course of these meetings that the efforts of Device Teams had been primarily directed towards conceptual thinking, experimentation and the solution of fundamental problems. Useable plans were not available and had to be produced by the Consultants as a prior requirement before any assessment or costing could be carried out.

Section B of this Report presents, for the first time, a collection of Reference Designs for Wave Power Devices which have been costed in a very preliminary way, and which should now provide the start point for an exercise in design development directed towards improvement and major cost reduction. These Reference Designs derive from the Consultants understanding of the work of the Device Teams and the TAG groups, to whom the better features of the designs are readily ascribed. The Consultants have noted in their own Reference Designs many areas where closer design work should afford significant cost savings. Time has not thus far allowed such refinements, but attention is drawn in the Report to some areas where major improvements can be expected. Table 1.1 summarises the data upon which the Reference Designs have been based.

Section C of this Report deals with generic work. The Consultants have had to limit their interaction with TAG groups to areas absolutely vital for the production of the Reference Designs, and even then the Consultants had too little time to talk in detail with TAG 3. This omission must be corrected in Stage 2 and the Consultants apologise in advance for omissions in this Section of the Report.

Finally the programme did not allow the crucial areas of costing and economics to be looked at as thoroughly as had been hoped. The Costing Report on the Devices is submitted as a separate Annexe to the main Report and the Sections on economics, manning, maintenance and environmental considerations simply points the way to work that needs to be carried out.

TEAM DEVICE	S.E.A. DUCKS	W.P.L. RAFTS	N.E.L. O.W.C.	H.R.S. RECTIFIER
Report Chapter	4	5	6	7
Length of station	5.70 km	6.20 km	5.55 km	5.60 km
No. of Devices in station	5 (spines)	80	28	40
Length of individual Device	1040 m	50 m	143 m	140 m
Width of individual Device	24 m	100 m	39 m	63 m
Height of individual Device	20 m	7 m	52.5 m	28 m
All-up dry weight/metre* (including ballast)	(overall) 250 T/M	290 T/M	670 T/M	1245 T/M
Construction material	Concrete	Concrete	Concrete + steel	Concrete
Operating condition	Floating	Floating	Floating	Fixed
Draught	20 m	3 m	25.5 m	-
Depth of water	60 m(+)	60 m(+)	60 m(+)	20 m
Distance from shore	18 km(+)	18 km(+)	18 km(+)	5 km
Extreme wave height	33 m	33 m	33 m	16 m
Average incident wave power*	70 kW/m	70 kW/m	70 kW/m	65 kW/m
Primary power take-off	Mechanical/ Hydraulic	Mechanical/ Hydraulic	Air Turbine	Water Turbine
Nominal installed capacity of primary power take-off*	101 kW/m	101 kW/m	63 kW/m	57 kW/m
Installed capacity of trans- mission (max. continuous rating)*	50 kW/m	50 kW/m	50 kW/m	36 kW/m
Estimated average annual output*	33 kW/m	33 kW/m	33 kW/m	23 kW/m

* Note - figures quoted per metre are calculated per metre of working face of Device.

Table 1.1 Summary of Data Relating to Study
Reference Designs for 200 M.W. Schemes

The Report indicates the work that needs to be done rather than reporting on completed work. For this reason alone it cannot be emphasised too strongly that both the data and the conclusions of this Report must be treated as no more than an interim stage.

In assembling this Report, the Consultants were aware of the very large number of WESC reports already circulated. These reports varied from broad reviews through to extremely detailed treatment of individual topics and within them many of the areas touched on in this Report are dealt with in greater depth. This Report has therefore been written to present in broad perspective the present state of the wave energy programme, both technical and economic, seen from the viewpoint of practising engineers experienced over the wide fields of power generation and offshore and marine construction.

1.2 Moving Surface Modulators

1.2.1 Similarities in Primary Behaviour and Design

In the first examination of the diverse assortment of machines presented as potential wave energy converters, it is very easy to miss the fact that most of them are attempting to perform essentially similar operations on the incoming waves. Of the Devices covered by this study, and listed under Section 2 of the Report, all except the HRS Device operate by reacting on the wave with a modulating force which effectively damps out part of the wave movement, and transfers energy from the wave, through a reacting interface, to the primer mover in the Device. The Salter Duck is included in this group, although in its case the interface surface operates in the wave rather than on the wave surface. Given this basic similarity of function there are very many parameters which can be played on the choice of reacting surface, the type of movement of the surface, the means of reacting the local forces applied to the Device by the impinging waves, and the power offtake. Many of these parameters have been the subject of patents. The promising ones are those which offer some favourable combination of economy of material, efficiency in performance, and simplicity in manufacture and maintenance. Three devices of this type are at present funded by WESC and are covered by this study. They are the NEL oscillating air column, the Cockerell Rafts (WPL) and the Salter Duck (SEA). A fourth device, also an oscillating water column, is under development at Queen's University and is also covered by this Report. Descriptions of the modes of action of the individual devices are given in Section B, particularly with regard to the way in which this affects the engineering design of the device.

For any device designed to extract energy from an oscillating source, it is essential that the device is tuned to respond to the frequency of the energy source. This means that the working elements of these devices are in some way related, by size, stiffness, and inertia to a selected wave frequency and therefore to the wave length. It is likewise important that the reference body against which the working elements react is detuned to that same frequency. In practice the response is not to a single frequency but to a band of frequencies, which is selected according to the energy distribution in the sea. Table 1.2 has been drawn up to show the way in which the sizes of the different devices relate to the "tuning" wave length, which is about 150 m for the Reference Design. (120 m for the shallow water HRS Device).

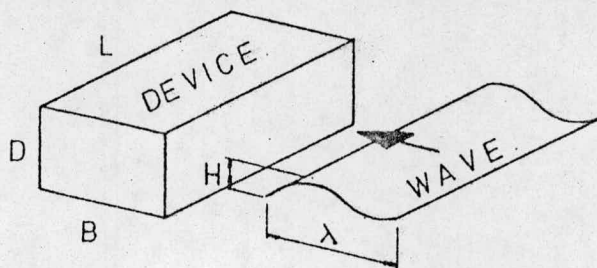

λ = wave length

H = wave height

	L	B	D	MASS AND INERTIA
HRS	Overall L not critical L of flap array $< \frac{\lambda}{10}$ to reduce reflection	$\frac{\lambda}{2}$ to prevent reflection	Water depth+ H/2 (Note- min. water depth to avoid breaking waves $\doteq \frac{\lambda}{7}$)	- (Function of structural stability only)
NEL	Overall - not critical Column L $\ll \lambda$	Overall B - see RHS Column B - $\frac{\lambda}{8}$ to tune column to wave period	Overall D - see RHS Column D - $\frac{\lambda}{4}$ to minimise transmitted energy	Overall mass - $B \times D = \frac{\lambda^2}{20}$ for min. inertia to give stability. (Immersed dimensions)
SALTER	Several crest lengths for stability from self cancellations (approx. $> 3 \times \lambda$).	B = D (circular)	$\frac{\lambda}{10}$ to collect energy and minimise transmitted energy	Overall mass governed by neutral buoyancy requirements. Also rotational inertia of duck to be minimised
COCKERELL	Not critical \ll crest length ($\ll 1.7 \lambda$) to avoid cancellation of energies	0.7λ overall to minimise transmitted energy.	Preferred as small as possible.	Min. weight needed to overcome power off-take torque on return.
BELFAST	Circular point absorber L = B	$\doteq 0.25 \lambda$	Working cell-immersed depth $\doteq \frac{H}{2}$ (Height of dome - H depends on survival conditions)	Working cell - small as possible. Inertia sphere - neutral buoyancy and diameter $\doteq B$.

Table 1.2 The limitations on the size of devices as determined by efficiency requirements

(ratios quoted are approximate and relate to 'typical' waves of perhaps 8-10 second period).

1.2.2 Efficiencies

It is interesting to note that in spite of their many diverse features, all the devices in the group show peak efficiencies which are similar, in the region 70 to 80%. Refinements in shape and power offtake are important in maximising efficiency and broadening the wave band over which efficiencies are high.

1.2.3 Size

As indicated in Table 1.2, there is a direct relationship between governing dimensions of the device and the wave lengths for which the device is optimised.

1.2.4 Inertia, Stiffness and Length

For all floating devices of this type, wave forces transmitted through the reacting surface are resisted either by the mass inertia of the device and its associated water, or by making the structure long in relation to effective crest length so that the forces on the structure as a whole tend to be self compensating. Achieving one or both of these requirements with absolute economy of materials is a prior aim in the design of any Device. It is important to note that each of the Devices reported on in this study has a different approach to this problem. In this vital area all Devices have room for improvement.

1.2.5 Differences in Power Take-off

Any device which uses a solid structure surface to modulate the waves requires a power take-off which deals with the very high torques and slow movements. Such mechanical systems tend to be inherently expensive and not suitable for direct coupling to generators. Devices which modulate using a fluid surface are in principle at a significant advantage, since the resulting moving volume of fluid can be used to drive a turbine linked directly to a generator.

1.2.6 Future Devices

Underlying the diversity of solutions which are the subject of this Report there is seen to lie a common set of problems. At present, there is no one Device which is clearly identified as the best solution and eventually the best wave energy converter could be one that draws from all the current solutions.

1.3 H.R.S. Wave Rectifier

This Device is seen to have a somewhat different mode of action from any of the other Devices reported on. Energy is extracted from the waves and stored as the potential energy between high and low level reservoirs. It does however, share with the other devices a key feature, in that its size is wave length dependent, and in this particular device this feature leads to a structure which is inherently larger than the other Wave Energy Converters. A description of the mode of action of this Device is given in Chapter 7 of this Report.

Other Devices

The Consultants brief called for an appraisal of contending devices. Five devices have been examined in this study but there are several other schemes being researched, principally in University Departments.

From this report it can be seen that the ideas of the five Device Teams are in a state of flux, and it is not at all inconceivable that ideas from other teams may eventually be incorporated, in part or in whole, in a wave power scheme. Technical Advisory Group Seven has been briefed to review at intervals the results of research into such new ideas.

A single meeting was arranged by the Consultants with Dr. G. Potter of the Science Research Council. The broad questions of University involvement and SRC funding of projects were discussed. Outline details of the Lancaster University Device of Professor French were tabled.

CHAPTER 2.0 STATE OF DEVELOPMENT AT APRIL 1977

The stages which the Device Teams had reached in the various aspects of their work, at the time when the Consultants began their assessment, is described in the texts of Chapters 4 to 8. For convenience, a very much simplified tabular summary of this information has been prepared (Table 2.1). This is intended only to give a broad picture of the state of the programme as a whole at that time and for a precise appreciation of any particular activity the reader is referred to the reports prepared by the Device Teams.

Aspects of the Project	HRS	NEL	SEA	WPL	Belfast
Theoretical Study and appreciation*	Preliminary only	Preliminary only	Significant	Significant	Significant for present early stage
Lab or tank testing of prime mover 2D - Monochromatic Waves	early stages	Well advanced	Well Advanced	Well Advanced	early stages
2D - Random Waves	none	No	Yes	Yes	No
- 3D Wide Tank Models	No	No	No	Yes (unidirectional only)	No
Larger scale (Lake or sea tests) Prime Mover	None	None	Lake Tests	Sea Model part designed	Sea Model designed
Structure Design of a prototype Prime Mover	General Arrangement Conceived	Idealized Cross section almost decided	Many ideas but no firm proposed design	Preliminary Plan available	General Arrangement conceived in outline
Structure Design for costing	None	None	None available to R.P.T.	Preliminary Plan available, concrete only.	None
Prototype Power Take Off	Conceived, Not designed	Conceived, but not designed	Conceived, but design subject to disagreement with TAG 6.	Ideas, but no firm proposal.	Conceived, preliminary design ready for wind tunnel testing.
Prototype Power take off, design for costing	None	None	None	None	None
Main current activity	Lab testing	Lab testing & Theoretical Work	Lab testing Preparing for Loch Ness trials Theoretical Work Prototype design Work. Building wide tank	Tank testing. Preparing for Solent trials. Theoretical Work	Lab Testing Design for sea trials Theoretical Work

TABLE 2.1 Stage of Progress on specific devices at April, 1977

See also table 11.3

3.1 Consultation

3.1.1 Consultation with Device Teams

The main interaction and passing over of information took place in a single day-long visit by the Consultants to each of the Device Teams. These visits were preceded by an introductory visit by the director of the Consultants project team. Further visits were made by members of the project team during the course of the study; to N.E.L. twice, to Edinburgh twice, and to N.E.L. in connection with the HRS turbine, once. Towards the end of the study, Device Teams were invited to visit the Consultants' offices for general discussion, and particularly to discuss the Reference Designs.

3.1.2 Consultation with Technical Advisory Groups

For this preliminary study consultation was confined to individual chairmen and members of particular groups. No attempt was made to report on all the T.A.G. work, and contact was limited mainly to the T.A.G's involved in providing basis design support - TAG's 3, 4 and 6. Meetings were held with the C.E.G.B members of TAG 6 (power generation transmission), with Mr. Hancock (moorings), Dr. Smith (TAG3, structures and loading) and Dr. Potter (SRC, university work).

3.2 Design of Devices

It became clear at an early stage that although a great deal of testing and conceptual thinking had been carried out by the Device Teams, no engineering drawings or cost estimates were available for any of the Devices. The Consultants considered it would not be possible to assess or cost anything which had not been clearly defined and communicated through the medium of engineering drawings, and it was therefore decided that Reference Designs would be a pre-requirement of any assessment. It was agreed with the Wave Energy Steering Committee secretariat and with the Device Teams that these Reference Designs would be prepared by the Consultants. Except where the Consultants had strong reasons for making a change, the Reference Designs would follow the latest proposals of the Device Teams. A performance specification was drawn up for each device. This was then interpreted, first into basic design parameters, and then into the Reference Designs which form a part of this Report. Paragraphs 3.3 and 3.4 following relate to this specification.

The Reference Designs are preliminary in every sense of the word. Their function has been to permit the writing of this Report. The preparation of them has crystallised thought and brought problems into sharp focus in many areas.

3.3 Performance specifications

3.3.1 Electrical output and sizes of devices

The choice of the economic optimum device is a complex problem depending on the characteristics of devices of various sizes with various amounts of plant installed, and upon the method of evaluating the worth of the output.

No attempt was made to find this optimum in the study. The principal device parameters were chosen on the advice of the Device Teams and TAG 6. The Consultants had two main objectives; to provide a common basis for fair comparison of the various devices, and to obtain a reasonable estimate of the scale of schemes rated at a capacity of 200 MW (maximum continuous rating supplied to shore). It is not claimed that these objectives have been achieved with any degree of precision.

The following assumptions were made.

(i) The wave power devices are expected to extract a reasonable proportion of the annual mean incident wave power. Teams are all looking at large devices covering most of the available wave frontage at a given site. The effects of scale are such that it is unlikely that a small device extracting just a little power will ever be economic, since power tends to decrease faster than size.

(ii) The three floating devices share common efficiency characteristics. The size of the cross section for each floating device was chosen with the object of having them all operating in broadly the same efficiency band. These sizes are the basis of the Reference Designs, and referring to the most significant dimensions, are as follows; a 100m long string of rafts, a 15 metre diameter duck, and an oscillating water column 15 metres wide. The debate concerning relative efficiencies will continue after this study, but the Consultants judgement was influenced by both measured results, and the degree to which the test models simulate the behaviour of a complete three dimensional scheme.

(iii) The fixed bottom device of HRS was assumed to have a lower overall efficiency due to wave energy losses in shallow water and inherent inefficiencies in the Device. The principal dimensions of the Device Reference Design are as recommended by the Device Team.

(iv) It was assumed that a wave power scheme would be built in 200 MW modules, this being a reasonable amount of power for connection into a collection system. In the event later studies showed that it would be more economic to collect 400 MW (maximum continuous rating) of power before transmitting to shore in a one cable system. The Reference Designs now illustrated are for a 200 MW module, with two modules sharing a common link to shore.

(v) For the floating devices, the preliminary optimisations of the Teams and TAG6 were taken for guidance. The length of the schemes was fixed by assuming that 50 kw per metre (maximum continuous rating) would be the optimum amount of transmission equipment to install. In this, the length is that of the useful working face of the Device.

(vi) For the HRS device the figure of 50 kw/m, was reduced to 36 kw/m to reflect the lower output of the device.

(vii) The capacities of the various electrical and mechanical components were derived by working back from the maximum continuous rating of the transmission. In this, allowance was made for inefficiencies and the fact that individual components are producing variable output, so that the sum of their individual capacities must exceed the required mean rating by an amount which depends on the degree of smoothing of the input wave power. For example, a Salter duck takes power from a 30 m wave front and the duck angular velocity has zero value twice in each wave cycle, on the other hand, an HRS Device turbine takes power from a 150 M wave front, and the head and flow through the turbine varies far less during each wave cycle (never crossing zero). Clearly the ratio of peak power to mean power is the more favourable in the latter case.

(viii) The Consultants did not have available sufficient data to assign accurate ratings to all components in the power chain particularly in the case of the mechanical devices (Cockerell raft and Salter Duck). Furthermore, a single rating for a component is far from a complete design specification. The following data is required for more reliable design.

(a) For mechanical devices - required efficiencies and lifetime statistics of angular velocity and torque.

(b) For turbine devices - required efficiencies and lifetime statistics for head (or pressure) and flow.

(ix) The nominal installed capacities for the Reference Designs are given in Table 3.1.

TEAM DEVICE	S.E.A DUCKS	W.P.L. RAFTS	N.E.L O.W.C.	H.R.S. RECTIFIER
Report Chapter	4	5	6	7
Nominal installed capacity of primary power takeoff*	101kW/m	101kW/m	63kW/m	57kW/m
Installed capacity of transmission (max. continuous rating)*	50kW/m	50kW/m	50kW/m	36kW/m
Estimated average annual output*	33kW/m	33kW/m	33kW/m	23kW/m

Table 3.1 Installed capacities in Reference Designs

* figures quoted in kilowatts per metre of working face.

(xi) It is assumed that the annual load factor will be of the order of 0.65. This factor is defined as the ratio between the output supplied to shore averaged throughout a year divided by the rated capacity of 200 MW. Thus each scheme is assumed to generate a mean annual output of 130 MW (the differing efficiencies of various devices have, been taken care of in the different lengths chosen for the various schemes).

3.3.2 Siting of devices

The geographical location assumed for the Reference Designs is the west coast of the Outer Hebrides. This area is favoured by many of the Device Teams because of the wave climate and low density of shipping. The principle disadvantage of this location is its remoteness from major areas of power consumption.

The transmission link will also involve at least one sea crossing to reach the mainland from the Outer Hebrides. Cornwall has been proposed as an alternative site as the Southwest is a net importer of electricity. A comparison of the economics of different locations has not been attempted in this preliminary study. However, this Report applies to any location with a similar wave climate and bathymetry to that of the Hebrides except for the transmission costs. (The state of development of mooring schemes is such that the mooring systems used in the Reference Designs do not reflect any particular characteristics of the seabed material.)

The distance offshore of the devices was determined by the required water depth and a typical bed profile for the Hebridean Coast.

The floating devices are shown in the Reference Designs to be in 60 metres of water. This depth was chosen for the following reasons.

(a) The useful energy of the sea is associated with moderate seas, not extreme seas. The attenuation of this useful energy as the waves approach the coast from deep water should be negligible in depths of 60 m.

(b) In 60 m of water there are unlikely to be major breaking waves, except for crest spillage. For shallower depths the frequency and violence of breaking waves will increase rapidly.

(c) For greater water depths the distance to shore will be greater, increasing transmission costs.

(d) For greater depths it was assumed that mooring costs would be greater (In fact this assumption has been called into question by the preliminary mooring study - see Chapter 12).

The bottom sitting HRS device is located in only 20 m of water as recommended by the Device Team (see Chapter 7).

3.4 Power Generation and Transmission

Discussions with the Device Teams were naturally concerned primarily with the wave energy conversion device itself. Information on the intentions of the Device Teams on the secondary power conversion process was generally limited to an indication of the types of mechanical and electrical equipment proposed with very little idea of how to go about the major problem of power collection and transmission from devices some distance out to sea to an inland bulk power delivery point. In the case of the Salter device and

the work of S.E.A. in Coventry, preliminary design of the power generation and transmission arrangements was more advanced, nevertheless there were no detailed design submissions but only investigations in depth of means of primary power take-off and of electrical generation compatible with a variable speed prime mover. Work was being done by other Device Teams but this was in the very preliminary stages, and of little use in the present review.

It should be explained that the Consultants have given consideration only to electrical means of energy conversion and transmission. Others have considered alternative methods which have thus far turned out to be both technically and economically unattractive as methods of augmenting national energy resources by conversion of the wave energy potential. The preliminary study by the Consultants is therefore concerned only with mechanically driven electrical generators and practicable means of collecting the energy produced and transmitting it from a marine environment to a possible delivery point associated with a major high voltage transmission network which would be capable of receiving up to 2000 MW of power input possibly towards the end of the 1980's.

The Consultants' terms of reference call for a preliminary assessment not only of the practical feasibility of the devices under development but also an assessment of the present cost of large-scale implementation of each type. In view of the preliminary nature of the information gathered by the team it has been necessary to do some original work on both secondary power conversion and particularly on transmission aspects of proposed installations. It was decided to compare alternatives on a 200 MW installation basis and to include appropriate proportions of the succeeding stages of power collection and transmission. On the evidence of wave energy intensities available around the coasts of Britain it was decided to design the transmission system for a 2000 MW wave energy installation off the outer Hebrides.

A preliminary study of the short-listed wave energy devices - and other possible contenders - was required. However, on investigation it was found that generation and transmission designs were in a preliminary state and subject to change. In order to have sufficient data to produce budgetary cost estimates it was necessary to develop the designs for at least one of the devices and others if time permitted. In the event it has only been possible to consider the mechanical and electrical plant aspects of the Salter-S.E.A. type of device in any depth, others have been considered in basic design only. Nevertheless power collection and transmission, assuming a location off the west coast of Scotland, would be similar for all devices. There would be appropriate design adjustments at the power collection level but at this stage they have not been considered in detail.

3.5 Procedure for Costing

3.5.1 Civil Works

Since the construction of each of the contending wave power devices represented a major civil engineering project, it was considered imperative to obtain the views of a number of experienced major contractors in the off-shore field in order to assess the likely order of cost of constructing the civil works of the devices.

In view of the need to respect the confidentiality of the Device Teams' current proposals, particularly with regard to the proposals of Sea Energy Associates and Wavepower Ltd., it was felt that the drawings relating to these two schemes should not be issued to contractors for pricing. Permission was granted by N.E.L. and H.R.S. to forward details of the Reference Designs of their devices to the various contractors who had expressed willingness to carry out a preliminary pricing exercise.

Bills of Quantities for the N.E.L. and H.R.S. caissons were prepared and forwarded together with the relevant drawings to the following contractors.

Sir Robert McAlpine & Sons Ltd.
George Wimpey Ltd.
Anglo Dutch Offshore Concrete (Tarmac Construction) Ltd.

In assessing the order of cost for the civil works of these devices, each contractor was told that his prices should reflect normal civil engineering construction rather than oil industry conditions. Meetings were held with these contractors prior to pricing to ensure that the information passed to them was fully understood and that their prices would take into account the large number of units that would have to be constructed for a 2000 MW station.

In discussion with Messrs. McAlpine, the Consultants determined that this contractor had already carried out a pricing exercise for Wavepower Ltd. The Device Team's permission was obtained for releasing a breakdown of this price, adjusted to allow for building 100 units over a five year period.

3.5.2 Mechanical Components (excluding mechanical plant)

In estimating the order of cost of many of the mechanical components indicated on the Reference Designs, the Consultants drew upon their own in-house experience and knowledge of present-day prices. Since in the limited time available many of these components had been sized by judgement, rather than by full design procedures, the pricing of these components was estimated on the basis of the Consultants knowledge of current levels for various types of steel fabrications and castings.

For the more specialised components, such as the cast steel racks and pinion drives and various rubber laminated bearings, advice was sought from Davey-Loewy Ltd. and the Andre Rubber Company on the basis of isolated sketches illustrating the individual component and not the Reference Design of the Device itself.

Although accurate costing of the mechanical components is not possible until further design work has been carried out, it was felt that by assessing the individual components separately the overall cost obtained for the mechanical components for any one Device would indicate the right order of cost sufficient to compare with the other cost areas of each Device.

As explained in 3.4, it has only been possible, in the time available, to produce outline designs for the mechanical and electrical plant for one wave energy device (Salter-SEA). Draft performance specifications were prepared for the mechanical drives, the generation and associated electrical equipment and for the submarine power cables and DC transmission equipment including a purpose designed transmission line.

Individual designs were prepared in sufficient detail to enable budgetary costs to be obtained for the principal items and rational estimates made for the remainder.

Considering the hydro-mechanical drive the design and availability of high pressure oil pumps was discussed with Chamberlain Industries Limited. The oil pressure turbines were specially designed by Boving and Company, London, who have long experience of hydraulic turbines and pump turbines for the hydro-electric industry. Other items of mechanical plant were estimated from 'in-house' data on current contract prices of equivalent plant. Advice from Shell Technical Sales was given in connection with the special hydraulic fluid required for the pump/turbine circuits.

The major items of electrical plant including transmission, were estimated from data made available by A.S.E.A. Limited in the case of converter stations and Pirelli Construction Company for the DC cables and the submarine laying.

The costs of the alternators and their control equipment, the main switchgear and the transformers, the switching stations and electrical auxiliaries generally were derived from current cost data available to the Consultants.

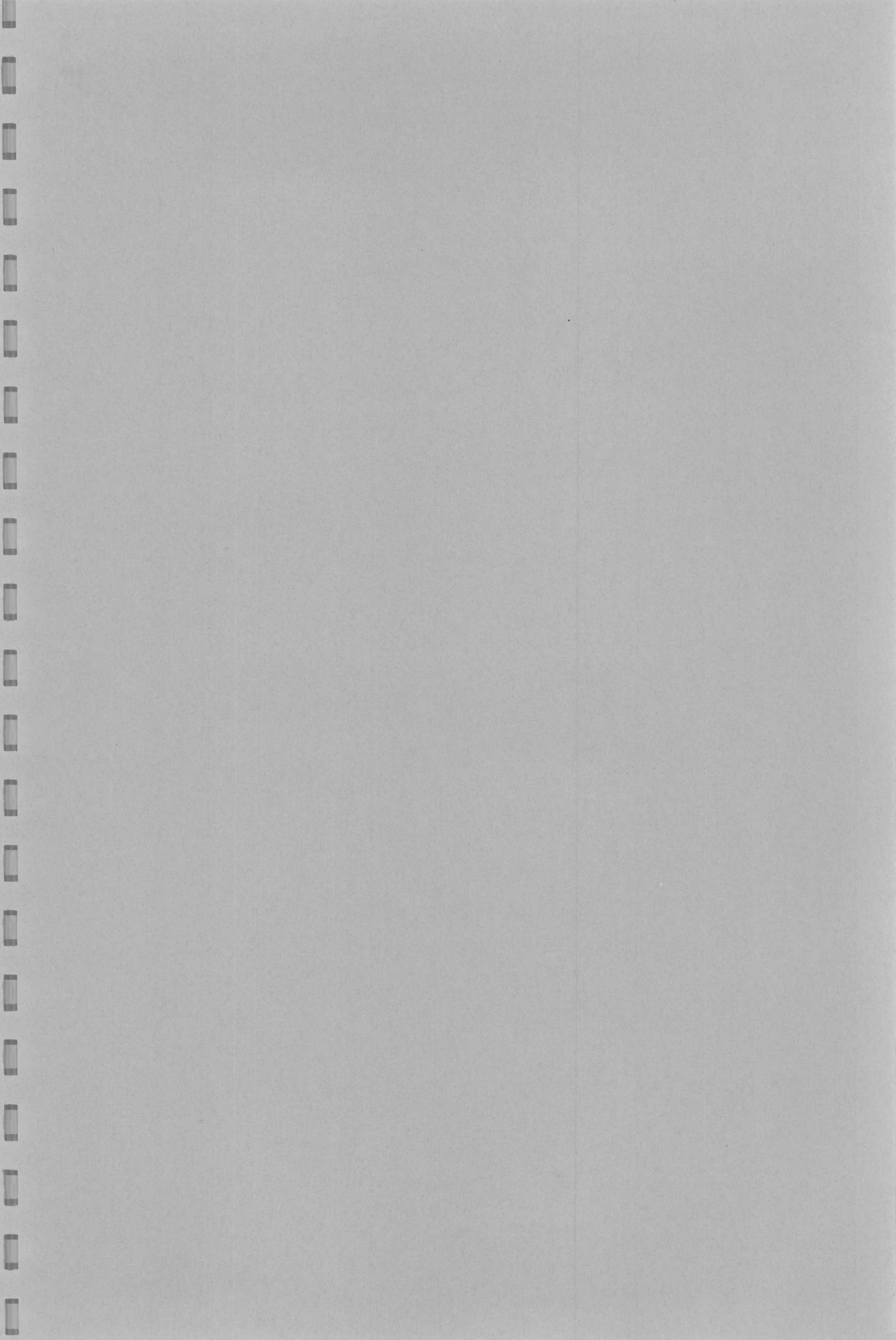

SECTION B - ASSESSMENT OF INDIVIDUAL DEVICES

CHAPTER 4.0 SALTER DUCKS (DEVICE TEAM - SEA ENERGY ASSOCIATES)

4.1 General Description of the Concept

4.1.1 Description of the Device

The bare essentials of the Device are a very long floating cylindrical spine and a cam or duck which is located on, and rotates around the spine. Power is generated from the relative movement of the duck and spine.

4.1.2 Principles of Operation

4.1.2.2 The Original Concept

The original concept of the Device was simple, and closely approached an ideal hydrodynamic solution. The front face of the Device was carefully chosen such that for small rotations of the Device the displacements exactly matched the water particle displacements in a given wave. The back face was circular and therefore did not displace any water behind the duck. The spine was to be a fixed datum. If the restraining torques applied to the ducks could be made exactly equal to the wave pressures integrated over the face of the duck, the incident wave would be unable to distinguish between duck and adjacent water, and would transfer all of its energy to the duck. No energy would be transmitted from the circular back face and in this case the duck would be a perfect absorber.

4.1.2.3 The Behaviour of a Real System

A real duck will achieve less than perfect efficiency for the following reasons:-

I. Duck Size

Clearly, even in ideal circumstances the cam can only match wave particle motion within its own depth. If a significant proportion of wave power is associated with water particle motion below the duck, the duck will only absorb a proportion of the incident energy. Water particle motion decays exponentially with depth, the exponent being a function of wave length, and hence wave period. Long period, long wave length waves decay less rapidly with depth. Hence the duck size imposes an upper limit on the wave period for which the Device can be efficiently designed.

II. Cam Profile

As the rate of decay of wave motion with depth is a function of wave period the cam shape can only be a perfect fit for one wave period. This imposes both upper and lower limits on wave periods in which the Device operates efficiently.

III. Small and Large Deflection Behaviour

The geometry of a cam is such that the displacements seen by the water are only linearly related to duck rotation for small displacements. It is not possible therefore, to match displacement fields perfectly for all wave heights. In extreme cases the cam rotates sufficiently for the beak to start displacing water behind the duck. This imposes limits on efficiency as a function of wave height rather than period.

The dynamics of waves also varies with wave height. Small waves conform to linear wave theory, larger waves requiring higher order theories. However, these effects are small for all except the very highest of waves.

IV. Drag and Viscous Effects

The wave theory on which wave power devices are designed ignores drag and viscous effects adjacent to the Device. These effects necessarily imply loss of energy but again are likely to be small except in extreme conditions.

V. Duck Torques

The duck torque, as seen by the waves, is a function of the inertia of the duck, the buoyancy of the duck, losses due to friction between duck and spine, and the characteristics of the power offtake system. In a real duck this torque will never completely match the ideal torque (as defined above) and a loss of efficiency will result.

VI. Spine Deflection

It is not possible to attain a truly fixed spine. A moving spine will, except in very special circumstances, cause waves to be generated behind the duck.

VII. Random Seas

A duck designed for ideal performance in a monochromatic (regular) wave will in practice be employed in a random sea. This in itself is not necessarily additional to the above list of sources of inefficiency but highlights the need for a Device to work simultaneously with many types of wave.

4.1.2.4 Benefits and Disadvantages of Real System Behaviour

The above factors which distinguish the behaviour of a real system from that of the simple ideal duck are by no means all disadvantages. A most important feature of any practical system is that it should be capable of shedding power in extreme conditions. The duck size (I) (and to a lesser extent cam profile (II) ensure that for the long period waves associated with the most extreme conditions the duck efficiency will be low and most of the unwanted energy will be transmitted through the system. Furthermore, the large deflection behaviour (III) peculiar to the duck Device, can increase the proportion of transmitted energy, waves being generated behind the duck for wave heights above a certain threshold.

This is similar in effect to waves breaking over other devices, but is probably relatively more effective in transmitting rather than dissipating the energy in turbulence. The importance of transmitting excess energy rather than reflecting, dissipating or absorbing lies in the reduction to the mean mooring forces. Any of the means of shedding excess energy will tend to reduce the extreme speeds and loads seen by the primary power take-off. Drag effects (IV) are not very significant but again probably play some part in reducing extreme responses (losses being non-linearly related to response). The technical and economic constraints on the construction and ballasting of the duck, and on the installation and control of the power take-off mechanism will determine how closely the overall duck torque (V) can be matched to the ideal. Experiments indicate that the mass distribution and primary power take-off characteristics can radically affect the peak efficiencies, and even more critically the range of wave periods over which a useable efficiency is maintained. Also it is possible to conceive of power take-off systems which are able to simulate any required level of duck buoyancy, inertia and damping force. This concept is termed 'smart' power take-off by the Edinburgh team and has been used to optimise duck performance, particularly by the reduction of apparent inertia of a duck. The importance of the latter work is that it opens up the possibility of reducing the optimum economic size of duck by increasing the ability of a small duck to extract power from longer period waves. The possibility of reducing, for example, inertia, artificially, needs to be compared with achieving the same result physically. The Edinburgh team now hope to be able to achieve the improved performance by very careful choice of duck inertia.

The effects of spine deflection (VI) are further discussed below.

4.1.2.5 The Concept of a Spine

The original concept of a spine was of a continuous backbone which would obtain its stability from the self-cancelling of wave effects over several wave crest lengths. For torsional stability, to resist the torques from power take-off, this simple concept has remained the basis of the Device Team's design. However, the longitudinal bending in the vertical and horizontal planes, the Device Team are now working towards a much more sophisticated approach incorporating a degree of compliance in the spine by means of discrete rotational joints. This has been necessary as elementary checks on the forces in a rigid spine indicate unacceptable stress levels in the lengths of spine needed for stability. The applied cyclic wave loadings can always be reduced on offshore structures by introducing flexibility (or compliance) and allowing the structure to move with the waves (i.e., following the water particle motions). However, elementary checks then show that the required strains are far too great to be accommodated in any structural material. Hence it was decided to provide the compliance by introducing discrete flexibility at hinges.

By definition any flexible spine moves considerably, and this in turn must affect device efficiency and wave loadings. Commonsense suggests that increasing the freedom of a device to move with the water particles motion must reduce its capacity to absorb energy. For this reason the Device Team initially proposed non-linear hinges which only gave way above a pre-set level of moment. Hence for calm and moderate seas the spine was to be rigid, for rough seas the hinges would yield and excess power shed. Recent investigations by the Device Team have suggested that the adverse effects of compliance on efficiency may not in some

cases be as severe as at first thought. Furthermore, problems have been found with the design of breaking points, principally concerning the impact load which occurs on reclosure. Hence the Device Team are now developing ideas with hinges having spring characteristics which are continuous functions. The spine is now seen as an active rather than passive component in the duck scheme, its functions including the storage of energy and the redistributing of input energy between ducks.

The problem of designing a suitable spine has therefore become extremely complex. For a truly rigid long spine, individual ducks can be considered in isolation, forces and power levels derived, and loadings on the spine calculated. For a spine with hinges, firstly there are many parameters introduced which need to be chosen, (e.g. number of hinges, type of hinge, spring characteristics etc., etc.) and secondly the spine characteristics radically affect local duck behaviour. Thirdly both static and dynamic responses of the spine need to be considered. The interaction between spine characteristics and duck behaviour is shown in simplified form in Figure 4.1. To design a spine it will be necessary to iterate many times around this interaction diagram, and each iteration requires a knowledge of the behaviour of a particular spine configuration. The only information on this subject at present is that which can be inferred from the single duck tests on the pitch, heave and surge rig at Edinburgh.

Clearly there are problems of extrapolating test data from a single duck to a string of perhaps 28 ducks on a spine with 4 hinges of a particular stiffness. It must therefore be said that at present all spine designs are speculative. The Device Team are keeping an open mind on the subject, and their present thinking includes the following possibilities.

1. Choosing the geometry of a universal joint such that when prestressed the effective rotational stiffness decreases with rotation.
2. Knuckle joints with variable prestress to allow stiffness to be varied with sea state.
3. Varying the orientation of the spine in long-crested seas to shorten the 'apparent' crest length.

4.2 The Reference Design Adopted for the Study

4.2.1 Civil and Structural (refer to drawings WP/DUCK/1, 2, 3 & 4)

General The overall plan of the scheme follows the general recommendations of S.E.A. A string consists of 4 rigid spines connected by 3 universal joints. Each spine supports seven working ducks, each 30 m long with nominal diameters of 15 m (2 x radius of backface). In addition each spine has a 15 m long section with a landing platform plus hatchways on the top for access into the spine. Contrary to the SEA recommendations the universal joints contain no major plant, the power houses having been transferred to either end of the string. This has been done to ease access problems and to reduce the forces which have to be taken by the bearings in the universal joint. Ideally the universal joint would have all bearings in one plane. It would be possible on the Reference Design to detach and replace the power houses, if required, without affecting the spine string proper.

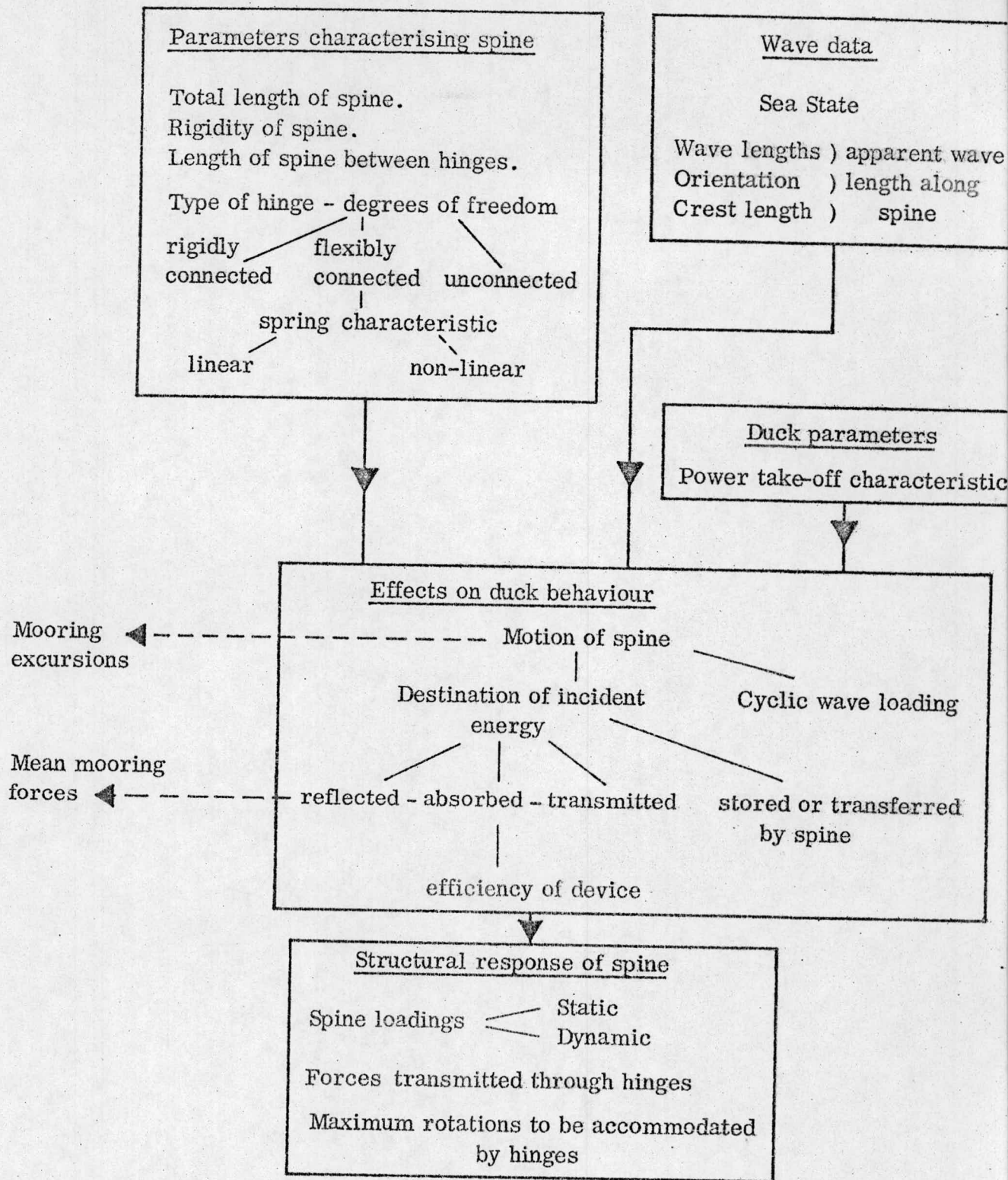

Figure 4.1 The interaction between spine characteristics and duck behaviour

Note: This diagram is included to indicate the complexity of the design process for a long spine device.

It was not possible in the course of this study to undertake a rigorous design of the concrete structures shown on the drawings. This was due to time restrictions and lack of basic design data. The problems of quantifying spine stresses have been outlined in Chapter 4.1.2. In all probability the spine will be constructed with prestressed concrete, this being the ideal approach for long components of regular cross-section subject mainly to overall loading and torque. The thickness of spine shown '500 mm', reflects the large moments to which the spine is subjected, and the need to provide sufficient thickness to allow the inclusion of prestressing ducts (for post tensioning). Each duck is composed of several precast units which are post tensioned together longitudinally. However, due to the complex geometry and the nature of the applied loading the precast units themselves will be of reinforced construction.

Damage Stability

It is customary in the design of ships and floating structures to consider the consequences of local failure or leakage of the hull (or outer skin).

It is normally required that the structure will be stable even if part of it is flooded. A very high level of structural reliability will certainly be required of these devices (a 1 km string of ducks cannot be regarded as expendable, even if unmanned) and it is probable that damage stability will be a design criteria.

The reference design would be vulnerable to these conditions because :-

1. There is little excess buoyancy - the ducks need to be almost totally submerged to function efficiently. Hence a high degree of compartmentalisation will be required to be effective.
2. It would be very difficult to compartmentalise the spine without severely impeding access and significantly increasing costs.
3. The peripheral seals and large number of spine penetrations will reduce the reliability level of the watertightness of the Device.

4.2.2 Duck Location and Primary Power Take-off

The choice of a power take-off and location system for the Reference Design of the Duck Device was one of the most difficult decisions which had to be taken by the Consultants. No proposals made available to the Consultants were sufficiently detailed for direct adoption for this study. SEA is known to favour a system based on wheels with rubber tyres, which would serve in the dual role of locating the duck, and providing the power offtake through friction drive. A hydraulic pump would be built into the body of each wheel. This solution is not favoured by TAG 6, who have suggested a number of mechanical systems which do not rely on friction. Salter is continuing to investigate a wide range of options.

In choosing a system for incorporation in their Reference Design the Consultants were constrained by the need to produce a design which could be costed by reasonable extrapolation of existing experience. Also, the Consultants did not wish to incorporate features which were well outside engineering practice unless they had been the subject of a reasonable programme of research and development.

It was decided therefore to investigate a system which operated in an air environment, was accessible for maintenance, and incorporated a circumferential rack and pinion for power take-off. The resulting design is not elegant, and in avoiding some problems others have been introduced. The study team do not necessarily consider the chosen system to be the most promising yet proposed. All that can be said is that no proposal has been put forward which shows a clear balance of advantages; and for this system a first attempt at costing can be made.

In making the above choice the Consultants have not rejected the concept of friction drive. Indeed it is quite possible that a simple substitution of rubber tyres for pinion could be made in the study Reference Design. However, it was felt that there was as yet insufficient information available on the rubber tyre option for it to be included in this first 'state-of-the-art' cost estimate. The Consultants were particularly concerned with the expected life of friction drive components and the effect this would have on maintenance requirements.

Provision for maintaining equipment

Looking at the Reference Design in more detail, the first notable feature is the access area provided as collar extensions to the standard duck shape. These were provided for maintenance as it was felt that an SEA proposal for maintenance by splitting of ducks at biennial or triennial intervals would be difficult and very costly.

In the study Reference Design, three levels of accessibility are provided.

Firstly it was felt that low speed hydraulic pumps could not be made with very long lives. Occasional replacement would be essential and regular attention desirable. Hence the pumps have been placed inside the spine and are readily disconnected and replaced. All of the hydraulic system is totally accessible, including the valves and pipework.

Secondly, the components in the compartment between the ducks and the spine are all long-life components, capable of lasting the life of the duck. These comprise the rack, pinion, bearings/mountings and carriage for the pinion, the main bearings and suspension and brake unit, the overload rubbing strip and the two sets of translational seals. The seals are perhaps the most questionable feature of the system. They are, however, essential to the concept as the required long life of the components and accessibility would not be achieved if the compartment were flooded. Access to the compartment would be limited to replacement of component and lubrication.

Thirdly, consideration has been given to the need for a major re-furbishing of either a damaged duck, or a string of ducks at the end of their first life of say thirty years. If this need arises it will be necessary to dry dock and split the duck. However, on the Reference Design it is likely that only the collars would need to be split. This would most easily be accomplished if the collars were not integrated into the duck profile (see Figure 4.2). This task would be further eased if the collar were fabricated in steel rather than concrete.

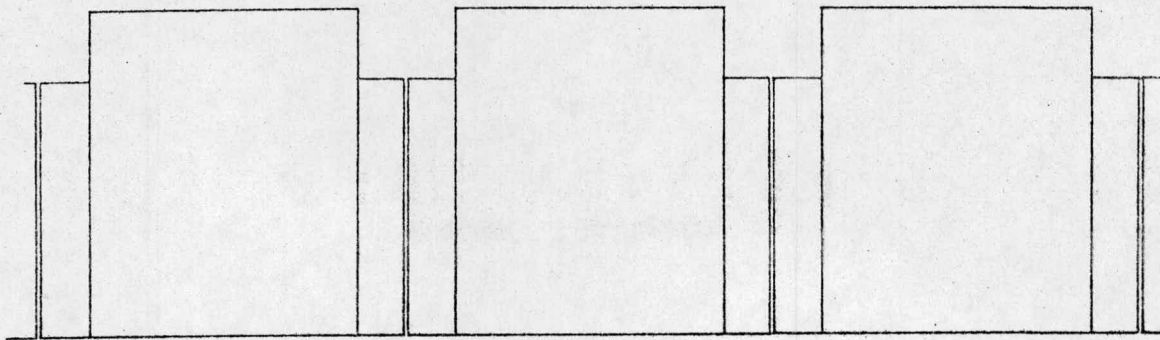

Figure 4.2 Non-Integrated Collars

4.2.2.2 The Study Reference Design - Component by Component

Bearings in the Universal Joint (refer to WP/DUCK/2

The bearings have all been placed on axis at 45 degrees to the horizontal to ensure that they will all be subject to equal loadings and to improve access to the submerged bearings during the operation of joining the spine modules. Only very simple provision for guidance of the two halves of the universal joint during stab-in have been shown as it is assumed that connection will occur at a calm water site. The two ends of the bearing shaft seat casting are shown joined by a tubular member to ensure accurate relative location during construction, and to distribute bearing loads. The bearings themselves are composed of a cylindrical laminated rubber bearing plus a laminated rubber circular bearing to take thrust. The thickness of the bearings were determined from the required rotation of 15° , the other dimensions from the estimated loading of 2000 tonnes thrust and 1000 tonnes shear. In fact these loadings do not take into account the prestress in the universal joint cables and are probably underestimates. The size of bearing used in the Reference Design is quite feasible although at least twice the dimensions of currently available bearings. Any requirement to increase the load capacity would probably lead to the adoption of more compact mechanical bearings in place of rubber. Laminated cylindrical bearings as shown on the Reference Design are not manufactured at present but could probably be developed. Provision for replacement of the bearings is included in the design but in fact the rubber bearings could be expected to have an extremely long life.

Cable Straps to the Universal Joint

No details for this component are given on the Reference Design drawings as the Device Team have not yet tested the idea on their models. The cables are required to provide a degree of stiffness to the joint in the horizontal plane. It is thought that without this stiffness the efficiency of the device would be reduced. Because of fatigue it is unlikely that the cables will have a long life and provision for replacement of the cables will be required (an area to be investigated in future mooring studies - see Chapter 12). The Device Team have suggested that a cable prestress of perhaps 2000 tonnes per side will be required to avoid the cables going slack during operation.

Rack and Pinion (refer to WP/DUCK/3)

The rack and pinion are not greatly outside normal engineering practice, the principle novelties being the segmental construction of the 15 m rack and the method of locating the pinion. The arrangement is a low velocity - high torque configuration (normal pinion speeds are less than 100 rpm). Segmental construction of the rack is necessary due to the large diameter and it should be possible to allow the pinion to run over joints. The concrete duck collar will not be true and the rack will need to have tolerance to imperfections. The rack would be placed on an epoxy mortar bed and should easily be within ± 5 mm overall in position, with very small changes in slope at joints. The rack and pinion form a set of slightly bevelled gears rather than a simple circumferential rack plus cylindrical pinion. This will only slightly increase manufacturing problems.

The restraint of the pinion carriage is unconventional and it is possible that the rates of wear of the gears will differ from that normally assumed. The pinion is restrained against movement in 5 of the 6 degrees of freedom - the sixth being the drive shaft. Taking the x axis through the drive shaft and the y axis around the rack, the restraints are as follows:-

- translation x - groove in roller
- translation y - thrust bearing reaction
- translation z - preloaded thrust bearing (also taking axial duck forces)
- rotation about x - drive shaft
- rotation about y - rollers on each side prevent rotation
- rotation about z - connecting arms between adjacent pinion carriages

It is generally accepted that rack and pinions can only operate successfully in an air environment and with occasional greasing. The rack is shown bolted to a foundation plate and could in theory be replaced in short segments. However, this would be difficult because of the restricted access. It should be possible to design a rack with a life exceeding that required for the overall scheme and replacement will only be required in exceptional circumstances. The pinion, pinion carriage and thrust bearings could also be designed with a very long life but in the event of isolated failures could be dismantled and replacement piecemeal, either through the man-access or through the drive shaft opening. Two universal joints and couplings (perhaps of the disc type) are incorporated in the drive shaft to allow the pinion to move relative to the pump and to allow the pump to be disconnected.

Thrust Bearings for the Pinion Carriage.

These components have not been designed but it is envisaged that they will be rubber bearings. The bearing thrust in the axial direction must be capable of keeping the pinion rollers in contact with the rail at all times. Hence they will need to be preloaded sufficiently to accommodate level tolerances of the rack/rail and axial duck loads without lifting off. Their maximum capacity will be determined similarly. No data is available on axial duck loading and hence the required capacity of the bearing can only be very roughly estimated. It is possible that the capacity of the rollers may be exceeded in practice, this would necessitate separate axial thrust bearings. There is little space in which to place such bearings in the Reference Design access chambers.

Main Bearings

Again no detailed design of these units was undertaken. Certainly the wheels and suspension unit will be large and hence not replaceable as a whole.

The Rubbing Seals

These seals are quite outside present engineering practice. Perhaps the closest approach to the required seals are the 4 m diameter peripheral seals incorporated in Straflo water turbine generators. It is not clear whether a flexible rubber 'music-note' seal or a spring loaded compression seal would be most suitable. Seals are inherently unreliable and each unit would need at least 2 sealing stages. In the Reference Design a notional 2 layer music-note seal is shown with space for duplication if the seal fails. The seals would also need to be segmental, firstly to limit leakage in the event of a local failure, and secondly to allow replacement in situ. The design of a suitable joint detail has not been attempted.

The seals are surrounded by drainage channels as no seal, even if functioning normally, will be watertight. In this context it is important to remember that the seals will be required to resist water heads of up to 20 m (static) plus any dynamic wave pressures. Water leaking through will drain to a sump and be pumped out of the duck.

The Inflateable Seals

These seals serve two functions, firstly to brake the duck during calm weather maintenance, preventing relative movement of the duck and spine, and secondly to seal the duck to allow replacement or inspection of the rubbing seals. The inflateable seals would probably need to be segmental to mitigate the consequences of a local failure, but they are essentially irreplaceable components.

Overload Rubbing Strip

This component is included as means of limiting the extreme peak loads taken by the main bearings, and hence also the peak deflections of the duck relative to the spine as seen by the power take-off and the main seals. However, it is not certain if the concept is feasible because of the possibilities of shock loading because of the limitations on wear rates of the strip materials, and because of the possibility of overheating by friction. It may be that it is more satisfactory to design the main bearing units to take all extreme loadings even though the extreme loads are rare occurrences.

4.3 Possible Alternative Designs

The significances of the spine characteristics have been discussed in 4.2 above. In Fig. 4.3 the alternative configurations of spine are listed. At this stage of development none of the alternatives shown can be completely discounted but the following points can be made.

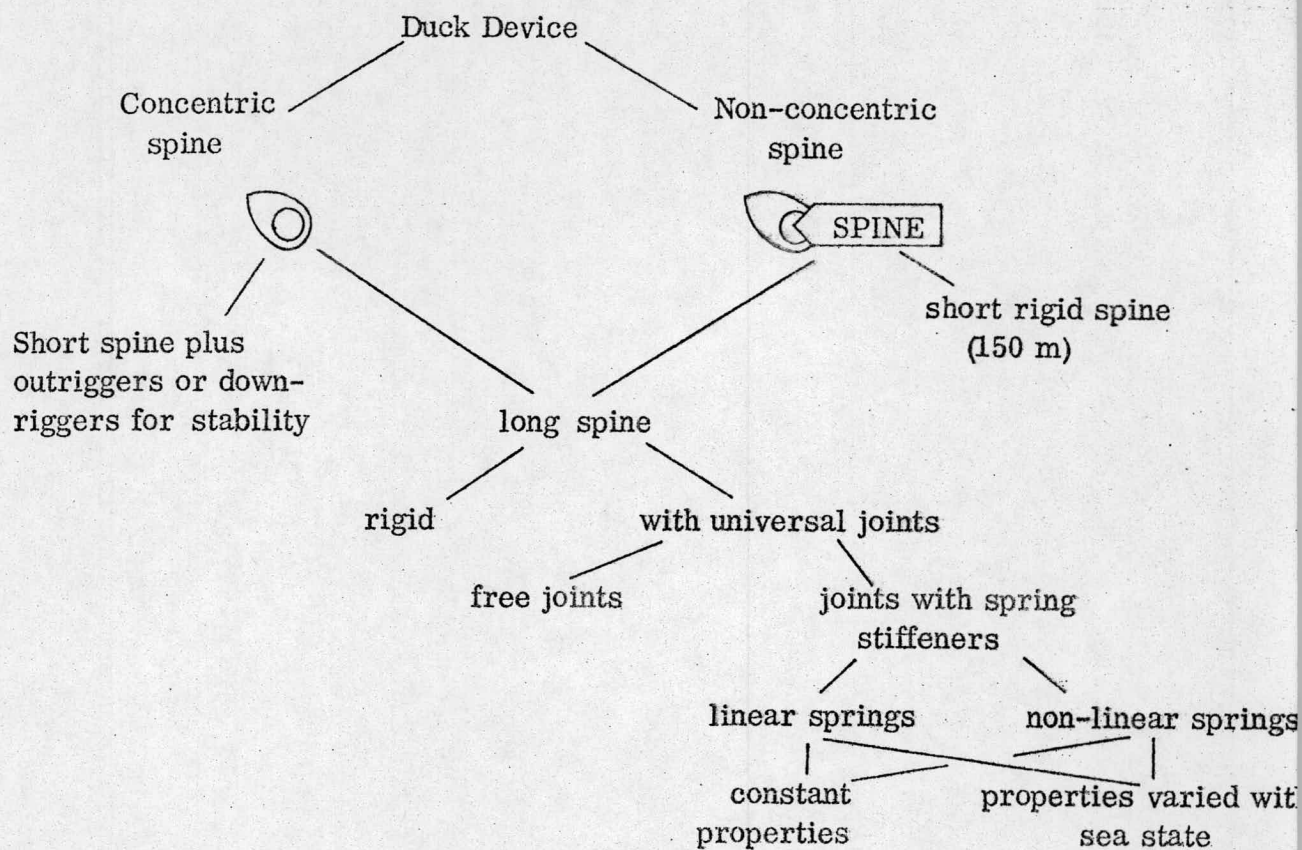

Figure 4.3 Alternative Configurations of Duck Device Spines

4.3.1 Concentric Versus Non-Concentric Spines

The overriding advantage of a concentric spine is that it minimises the volume of structural material used. A further advantage lies in the ability of this type of device to shed unwanted power by the suitable design of the back of the duck, an option not open for the non-concentric spine. The principle disadvantages are the problems of constructing two extremely large concentric shells, with a considerable amount of machinery to install in the space between shells, and the problems of access to the machinery after construction for inspection, repair or replacement.

For a non-concentric spine the advantages and disadvantages are reversed. Problems of construction, maintenance and repair would be considerably eased at the cost of a considerable increase in volume of structural material.

4.3.2 Alternative Power Take-Off and Location Systems

In the course of this study a wide range of alternative systems have been suggested by the Device Team and TAG 6. The following brief comments are included for completeness.

4.3.2.1 Operating Environments for Machinery in the Space Between Duck and Spine - Sea water, Fresh water, Air and Bentonite

Only the most rudimentary of mechanical equipment will have a long life (say 20 years or more) when immersed in sea water. There are many examples of hydraulic motors and pumps etc, which are used in sea water but all are subject to regular maintenances and replacement. Gears and tracks do not have a significant life in sea water due to corrosion problems and the difficulty of maintaining a suitable lubricant. On the other hand bearings and hinges are frequently designed to have lives in excess of 30 years for immersed marine structures, (e.g. dock gates). Fresh water, or even bentonite have been suggested as alternative environments, to sea water but both imply seals. Fresh water delays but does not prevent corrosion.

Apart from the physical effects of the environment on corrosion and lubrication, the environment also influences the accessibility of components. Diver operations would be far too hazardous, costly and ineffective to be considered for tasks in the space between the duck and the spine.

Finally, the influence of water or air in the space between duck and spine on the relative buoyancy of the duck and spine is very significant. In the Reference Design only the duck collars are filled with air, the majority of the space being filled with water to reduce the main bearing loads.

4.3.2.2 Maintenance by Splitting of Ducks

The Device Team have proposed that maintenance will probably involve splitting ducks. The problems of splitting ducks are very closely linked with scale. Maintenance would involve the following procedures:

1. Disconnection of services and hydraulic mains.
2. Uncoupling of a length of a spine.
3. Uncoupling the moorings.
4. Tow into dry dock.
5. Dewater dry dock.
6. Breaking the ducks.
7. Pulling ducks clear.
8. Replacing all equipment.
9. Replacement of ducks.
10. Post tensioning of ducks.
11. Flooding of dock.
12. Tow out to site.
13. Reconnection of spine unit to rest of spine.
14. Reconnection of moorings.
15. Hook-up.

Steps 1 to 4 - To get a length of spine into protected waters is technically feasible but is not to be underestimated. The hire of the required tug boats would be expensive, and careful planning would be required to control the critical operations of disconnection to avoid damage during separation. Presumably the work would be undertaken only during summer months when wave power is least needed and suitable weather most frequent.

Step 6 - The requirement to break ducks imposes serious constraints on the structural designer. Very large concrete components joined together to form structure are very common, but once made the joints are permanent. Joints capable of being broken and remade are certainly feasible, but will involve a cost penalty during construction. This is due not only to the joint itself, which must develop the full strength of the adjacent shell, but also because of the additional limitations on the prestressing and/or reinforcement adjacent to the joints. Corrosion of the post-tensioning anchorages would have to be prevented.

It is assumed that the breaking of the ducks will be accomplished in dry dock. This is because firstly the duck halves will by themselves either not be buoyant or will float at an incorrect attitude, and the replacement of mechanical components could not be economically achieved by divers. As the broken halves will be weak in comparison to the duck when whole, purpose built support and lifting equipment will be required for handling the ducks. Each duck weighs 5000^T which is a very large unit for handling. It is not beyond the capability of some purpose built machine, but it should be noted that the very largest lifts currently being undertaken by the Offshore Industry are of the order of 1000T to 2000T.

To summarise, maintenance by splitting ducks is thought by the Consultants to be feasible, but involves a programme of work amounting to a major offshore engineering exercise.

The Consultants considered that it was desirable to avoid the costs of such an exercise, particularly at intervals of as little as two years, if at all possible. A further disadvantage is the inflexibility of the maintenance method. There would be no way of effecting any repairs on isolated ducks with known faults. Finally, and perhaps most importantly there would be no possibility of a programme of routine inspection and maintenance (e.g. lubrication).

4.3.2.3 Combined Duck Location and Power Take-off

The duck Device Team prefer a combined system for duck location and power take-off. The principle attraction of this approach is its elegance and the reduction of the number of components required in the space between duck and spine. However, it could be that the requirements for location and power take-off may conflict, for example, rubber tyres may be desirable for power take-off because of the high coefficient of friction but steel would be more appropriate for location to take the high applied loading. In the Reference Design the axial location has been combined with the power take-off system, on the assumption that the axial loads will be much smaller than the main surge and heave loadings on the duck.

4.3.2.4 Friction Drive or Gears

The balance of merits between friction drive and gears on tracks has yet to be resolved. Friction drive is attractive in its tolerance to constructional imperfections and probably in terms of low capital first cost. Gears are attractive for their high torque capacity with very small transverse load. However, friction drive necessarily implies some form of wear and all the friction systems proposed so far have required replacement at intervals of not more than 3 years. For the low speed duty required of the gears an almost indefinite life should be obtainable.

4.3.2.5 Hydraulic Power Take-off Versus Electrical

There now appears to be a concensus between the Device Teams and TAG 6 that hydraulic power take-off is likely to be superior to direct electrical generation. This is primarily because of the technical problems and economics of having many hundreds of electrical generators, of small rated output running at very low speeds, and all interconnected into a common electrical collection system.

4.3.2.6 Hydraulic Pumps and Rams

Two types of pumps have been proposed by the Device Team, the low speed hydraulic pump used in the study Reference Design, and a swashplate pump. Neither type of pump is in fact manufactured at present but there is no reason to believe that with suitable modifications existing motors cannot be used in this role. The principle problems associated with the use of these pumps concern their reliability, particularly in view of the wide range of angular velocities to be accommodated between normal operation and extreme peak velocities. It seems most unlikely that such pumps could have a life of say 30 years and replacement must be possible.

TAG 6 suggested rams acting on a cam formed duck. This solution was not adopted for the Reference Design because it was felt that the problems of the very high side thrusts on the piston, and the design of the roller had not been adequately resolved.

4.3.2.7 Hydraulic Bearings

The Device Team is investigating the possibility of floating the ducks on hydraulic bearings round the spine. These would resist the cyclic heave and surge forces by the resistance to the flow of water around an annulus. This resistance might be increased by the incorporation of nylon 'brushes' to restrict the flow. The idea is certainly attractive in concept but has not been developed sufficiently for appraisal by the Consultants. This type of action will in fact be present even in the Reference Design as there is a comparatively narrow space between duck and spine (apart from the duck collar) filled with water. The action may be beneficial in resisting short-term peak loads but alternatively may be harmful because of possible high velocity flow of water in the annulus. In the Reference Design the gap between duck and spine was chosen fairly arbitrarily and relates to constructional requirements and stiffness of the main bearings. If necessary the gap could be changed to benefit from, or avoid the disadvantages of, the water filled space.

4.4. Construction and Installation (refer to WP/DUCK/4)

Construction

By present day concrete construction standards this Device will be difficult to build.

The factors determining this include:-

1. Size.
2. Construction of concentric shells.
3. Irregular shell construction.
4. Joining of large concrete shells.
5. Maximum accuracy required to minimise required tolerance of power take-off and duck location equipment.

The most economical method for constructing long cylinders and prismatic shells is by slipforming. The process minimises the size of shutters required and converts the construction into a continuous process. The Consultants investigated the possibility of slipforming each duck on end (together with the associated length of spine), turning the ducks over in a flooded dock, dewatering the dock and joining the spine lengths together. The required draft (22 m) was found to be well outside the limits of any available dry dock facility available at present (14 m maximum) and also required substantial temporary bulkheads for each duck.

The tentative scheme shown on the drawing employs horizontal construction totally in the dry. The draft required is about the maximum currently available in the U.K. The deepest dock, Portavadie, would in fact suit the Device well, being long enough for construction of two 210 m lengths of Device simultaneously. The construction activities illustrated, use precast components. It is anticipated that all shells will be constructed with the duck axis vertical, and will then be righted by a purpose built device. (Curved shell construction with both top and bottom shuttering is difficult and technically inferior). The maximum weight of a precast unit to be handled is about 1300 tonnes for the beak of the duck. Although large, this weight is not unusual in the field of heavy civil engineering.

The collars housing the machinery are shown precast in complete rings. This is to enable them to be constructed with maximum accuracy, and to be fitted out with machinery before being righted and threaded onto the projecting spine. The ducks are shown constructed in two halves. This was determined by the problem of threading such large limits onto a spine and the problem of supporting the spine and ducks separately during each construction stage. Large cradles are shown supporting the duck halves, the back half in particular will have little strength or rigidity before being joined to the beak.

Tow-out and Installation

For the reference design it was assumed that the connection of the seven-duck modules at the universal joints to make a complete spine will take place in a calm water site. The alternative of completing this operation in the open sea at site is thought to be very difficult and would at best involve considerable re-design of the universal joint to include provision for temporary connections and stab-in details. Tow-out of the complete structure, an articulated string just over 1 km long, is thought to be feasible but would be a major operation involving at least four tugs. The location of the calm water site for connection (and hook-up of hydraulic mains and services) would have to be chosen to give easy access to the open sea.

On site the connection of the spine to the permanent moorings would involve two steps, firstly, temporary mooring of the Device sufficiently clear of the adjacent spines to avoid the danger of collision, and secondly, movement of the spine to its final location under the control of winches and the temporary moorings.

4.5 Critical Assessment of Technical Feasibility

The Duck Device has evolved into a relatively compact but complex system. The Device Team have not yet presented a complete scheme in sufficient detail for the technical feasibility of the Device to be demonstrated beyond doubt. A very large number of options are being kept open by the Device Team in all of the areas of investigation and in particular for spine configuration and power take-off.

It is not clear at this stage which combination of options is most likely to lead to a feasible duck design. On the one hand the larger the range of options the greater should be the possibility that a solution can be found. In some cases however, it must be said that a choice will have to be made between the lesser of two evils. For example, splitting ducks for maintenance is the alternative to providing access chambers, machinery operating for long periods in a marine environment is the alternative to long life peripheral water seals.

Judging the components required for the scheme in terms of existing technology (an ill-defined concept) it is true that no new developments are required for exotic materials, or extreme temperature or pressure resistance. The developments required are rather connected with the low cost manufacture of large scale components, and the operation of components in new environments with totally unprecedented duty cycles or modes of operation - (see Table 4.1 and Chapter 4.6.3 for details of possible research requirements.)

	<u>Study Reference Design</u>	<u>Device Team Proposals</u>
<u>Spine</u>	Universal joint bearings Cables used to provide spring stiffness in universal joint Inflatable seals and brakes Peripheral seals Main bearing units	Universal joint bearings Cables used to provide spring stiffness in universal joint. Rubber tyres Tyre track Low speed hydraulic pumps
<u>Primary Power Take-off</u>	Overload strips Segmental bevel gears (replaceable) Gear carriage Low speed hydraulic pumps.	Wheel bearings for under water Multiple use post-tensioning system for split ducks

Table 4.1 Components Requiring Significant Technological Development

It should be emphasised that the following two tasks are crucial to the proving of the feasibility of the Duck Device.

1. Proving of the various spine concepts in a random wave wide tank with a spine realistically modelling achievable structural rigidities and hinge characteristics.

2. Preparation of a detailed design for primary power take-off which meets a minimum agreed performance specification. This will include requirements for normal operating and extreme survival cases, and life and maintenance.

The duck on spine concept has unfavourable damage stability characteristics due to lack of excess buoyancy and problems of adequate compartmentalisation.

In conclusion, it is an unavoidable consequence of the spine concept that for any system of primary power take-off the installation, inspection, maintenance, repair and replacement of the machinery necessarily included between duck and spine will present considerable problems. If these problems can be overcome and the predictions of the Device Team are confirmed the Device promises to be a compact wave energy generator, with low mooring forces, and a high efficiency over a wide range of sea conditions.

4.6 Future Research Requirements

The following comments relate specifically to the need for information for engineering appraisal of the Device, as set out in the Consultants brief. Research with, for example, more fundamental or long term objectives is not considered here.

Much information has already been obtained from the programme of testing undertaken by the Device Team. In some areas this has been extremely detailed and accurate. To further the proving of the technical feasibility of the Device tests are needed which relate to specific proposals for Device designs.

The testing for this purpose should aim to provide comprehensive information on all aspects relevant to design rather than very precise information on one aspect.

4.6.1 Basic Research on the Spine Concept

It is clear that the overriding need for research in this area is in connection with the behaviour of real spines in random seas. The only way of obtaining detailed information on this aspect will be with the proposed wide tank tests. The Consultants will not attempt to comment on how the tests should be conducted but the final objective of the experiments should be to understand and quantify the behaviour of a real duck string. This can only be achieved if the following phenomena are correctly modelled.

1. Spine characteristics -

Structural flexibility of spine (unless shown to be effectively rigid).
Hinge kinematics.
Hinge springs (if any).

2. Mooring characteristics (load-excursion curves)

3. Primary power take-off characteristics for both power, and no-power cases (the latter particularly concerns duck survival if power cannot be transmitted to shore).

4. Sea conditions -

Orientation of spine to prevailing sea.
Random multi-directional sea spectra.

5. Normal operating and extreme sea conditions.

4.6.2

Basic Research on Desirable Characteristics of Duck Structures

The objective of this research, which is a continuation of the Edinburgh studies, is to provide interactive feedback for a study of achievable duck mass distributions using several different structural materials. The Device Team believe this distribution could be critical for duck efficiencies. The existing narrow tank facilities are probably adequate for this work.

4.6.3

Basic Research on Primary Take-off

This research can be split into two sections.

1. Research to establish lifetime duty cycles for the mechanical/hydraulic equipment.
2. Research to prove the performance of components designed to comply with 1.

Results for 1 above will come from the laboratory tests on overall device performance, coupled with a study of the short term statistics (individual sea state) and long term statistics (lifetime distribution of sea states).

The research for 2 above cannot be initiated before preliminary designs for components have been completed. Component testing will have the following general features.

1. The primary problems are likely to concern tolerances to imperfections, wear rates and durability.
2. It is likely that testing of full size components will be required in many cases.
3. Testing will need to simulate life-time duty cycles in realistic environments. The duty cycles are likely to be 'random'.
4. Accelerated testing of components to establish corrosion resistance is notoriously unreliable.

The following is a tentative list of some components which, if included in the design, will need testing (see 4.5 Table 4.1).

<u>Component</u>	<u>Nature of Testing Required</u>
Universal joint bearings	Method of manufacture (if rubber). Wear rates of bearing and seals - if any.
Cables used to provide spring stiffness at universal joints	Long term 'random' cyclic loading - strain rate effects, creep, effective modulus, internal fatigue fatigue at end connections. Durability.
Inflateable seals used as brakes.	Durability, coefficient of friction, leak resistance, wear resistance.
Peripheral seals of segmental construction	Leak resistance and tolerance to imperfections. Wear resistance. Durability.
Main bearing units	Strength and durability of very high loaded steel wheels. Durability and creep effects for the suspension unit.
Overload strips	Wear resistance. Temperature effects. Friction resistance. Impact effects.
Segmental bevel gears	Effects of joints in 'rack' on wear rates.
Gear Carriage	Tolerances, movements seen by pinion and their effects on gear wear rates and strength.
Low speed hydraulic pumps	Varied - the pump will be of novel design. Of particular concern will be the randomness of the duty, i.e. ability to operate efficiently in normal conditions but survive overspeed extremes.
Rubber tyres and track	Materials and composition. Wear rates. Temperature effects. Friction coefficients. Tolerance to track imperfections. Survival of extreme conditions.

4.6.4 Design Development

Methods of Construction

Various constructional techniques need to be investigated so that their influence on the feasibility of various design concepts and costs can be established.

For example - Vertical slip forming of spine lengths.
 Horizontal casting of spines
 Large precast segments
 Floating construction

Splitting of Ducks

A high priority should be given to a study of the implications of splitting ducks. This would consist of the following:-

1. Design of joints in ducks capable of being broken and remade.

2. Construction methods for taking ducks apart and recombining.
3. A construction programme covering the 15 activities described in Chapter 4.3.2.2.
4. Costing of 3.

Beak Construction

This design activity would be intended to discover how far real beaks can approach the ideal in terms of mass distribution as determined by the laboratory tests above (4.6.2). Concrete steel and fibre composite materials should be investigated. The effects of marine growth should also be considered.

Spine Design

It is likely that the Device Team will wish to maximise the length of spine between universal joints. Hence a fairly detailed design of the spine structure will be required as soon as results become available from laboratory testing. This will require very careful consideration of the conditions under which the worst design loadings are likely to occur.

Design of Universal Joints

Several types of bearings need to be investigated including both rubber and mechanical joints. The implications of splitting and remaking these bearings need to be considered. Finally the overall design of the universal joint complete with cable springs will need some preliminary study.

Power Take-off

As mentioned above component testing cannot be undertaken before a considerable amount of design work has been completed.

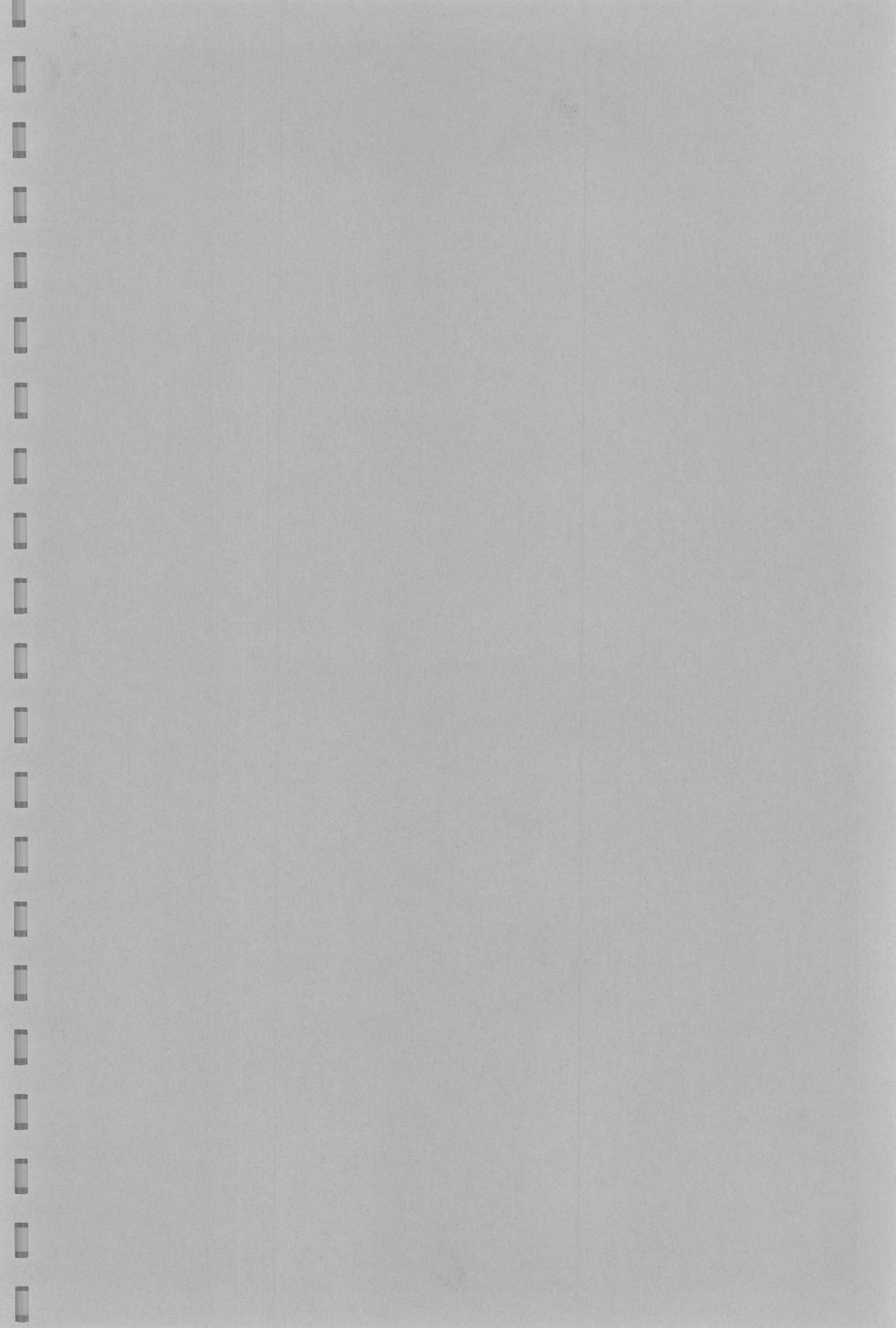

5.1 General Description of the Concept

5.1.1 Description of the Device

The Device consists of a string of shallow rafts connected by hinges, moored in line with the prevailing wave direction. Power is extracted from the relative angular movements of adjacent rafts.

5.1.2 Principles of Operation

The string of rafts extracts energy from the waves by the application of pressures to the water surface. As the wave travels under the rafts the water surface displacements are damped out. (It is of interest to note that this is the reverse of the mechanism by which waves are generated from wind pressures). In an ideal device the back of the last raft would not move and the sea behind the raft would be calm.

In a wave crest the rafts are lifted by buoyancy against the resistance of the power take-off. During the passage of the trough the weight of the rafts must be adequate to overcome the resistance of the power take-off or the water will leave the raft suspended in air. This imposes a minimum weight limitation on the raft, but in practice this is easily accomplished with a raft of quite small draft.

Unfortunately it is not possible to present a simple picture of the pattern of water particle motions under a raft string, although the concept is fairly readily amenable to mathematical analysis. The Device Team originally assumed that many rafts would be required to give a reasonable efficiency (presumably to allow a smooth matching of water surface profiles) and the first experiments were conducted with up to five rafts. It was soon discovered that the hinges towards the rear of the string contributed little to the total power output. Clearly, however, the length of the string required must be related to wave length and dispensing with the back rafts would increase the transparency of the Device to long wavelength waves. It was therefore decided to rigidly join the back rafts. The present configuration consists of only three rafts; two rafts of equal length and a back raft twice as long. This configuration gives approximately equal sharing of power between the two lines of hinges.

All wave power devices act to a degree as tuned oscillators extracting power at peak efficiency when the wave period approaches their resonant frequency. One of the main objectives of the design of wave power devices is to extract as much power as possible from the long period waves with a device which is as compact as possible. This implies that the resonant frequency of the Device should be made as low as possible. All floating and immersed bodies undergoing cyclic motion have an associated added mass of water which increases the apparent inertia of the body. A significant advantage of a raft system is the very favourable ratio of added mass to actual mass (due to the large area covered by the shallow rafts). This in turn decreases the resonant frequency and improves the long period response for a given size of device.

To summarise, many of the principles of operation of the raft are common to all floating wave power devices. For example:

1. Very short period waves are reflected with little power absorption.
2. Very long period waves pass under the raft. The raft floats freely on the surface and extracts power at very low efficiencies.
3. Efficiency is a function of the primary power take-off characteristics.
4. Overall size (in this case length of raft string) is a function of wavelength.

Of the characteristics listed above the second helps to limit the response of the Device to extreme waves which are associated with longer wave lengths. However, in contrast to the Duck Device, the raft string has no favourable mechanism for selectively shedding power from fairly high, steep waves. For the Duck Device this is achieved either by wave generation at the rear of the device as for a hunched back duck or by waves sweeping over the Device. For the raft system, waves sweeping over the Device will cause severe loadings on the power offtake superstructure, and at the same time by virtue of the length of the string, would be associated with energy dissipation, as opposed to wave transmission. This latter factor probably implies that mooring forces will be somewhat higher than would be the case if such waves could be transmitted through the system.

Finally, any shallow draft floating body will in certain circumstances be subject to wave slam. Tests have shown that for the present raft system this effect tends to be particularly severe if the power take-off system is inoperative.

5.2 The Reference Design Adopted for the Study

5.2.1 Civil and Structural (refer to drawings WP/RAFT/1,2,4)

General

The overall plan of the Device follows the scheme shown on a Drawing No. 2177.201 submitted by Wavepower Ltd. The location of the hinges and the shape of the rafts adjacent to the hinges were determined by the power take-off requirements and the rotational excursions of the raft in extreme conditions.

The Device Team have not prepared a stressed design for their Device and it was not possible for the Consultants in the course of this study to properly design the concrete structures shown on the drawing. This was because of time restrictions and lack of data on the local pressure distributions which will be the most critical loading on the rafts. A general concrete wall thickness of 300 mm is shown, as recommended by the Device Team. This is compatible with minimum thickness requirements, and typical concrete ship construction. A feature of the raft structure is its simplicity and the freedom it allows the structural designer to choose an optimum spacing of bulkheads and stiffening beams within the raft structure. Hence the chosen concrete dimensions are considered to be reasonable.

The hinges shown in the Reference Design were chosen for their rugged simplicity. The design forces were based on tank measurements of hinge forces, which suggest that the horizontal forces are similar to the mooring line tension, and the vertical forces are about half of this value. The hinge forces are also dependent on the power take-off arrangement. For link arm or piston mechanisms the hinge will be required to react the link arm or piston forces. The Reference Design uses a long stroke low force arrangement which reduces the required hinge force. In fact the hinge forces from this source are much less than those from the mooring forces. There is little doubt that the hinges shown would have adequate capacity, and frictional torques too small to reduce device efficiency. The life of this type of hinge is unlikely to be limited by corrosion provided pressure greasing and neoprene seals are included in the design. However, it has not been possible to check the rates of wear of the hinges and their expected life. It appears that the total relative displacement of the wearing surfaces during the life of the structure may be many times that normally associated with this type of bearing. In the Reference Design provision has been shown for the removal of the hinges, and for the replacement of the wearing bushes and discs. However, if later studies show that the expected life of the bearings is unacceptably short, either dry self lubricating or a more sophisticated form of hinge based on roller bearings may be required.

Survival

As with all ship-like structures two special cases need to be considered, wave slam and damage stability.

Wave Slam

Wave slam is the impact phenomena which occurs when the raft re-enters the water having been thrown clear of the sea by a wave. The loading incurred is localised and very short lived but can be very severe in intensity. It is normal to design structures to have a degree of resistance to this phenomenon but in laboratory tests the rafts have shown an unusual susceptibility to slam if the power take-off is not operative. Only a small level of damping from the power take-off is required to minimise this effect. The effects of wave slam on the front rafts have not yet been quantified but it is possible that the final design will require the power take-off to be at least partly operative at all times. The undersea cables will not have a very high degree of reliability in this context, and some alternative means of shedding power may be required. This may take the form of a bypass throttle in the hydraulic system of each carpet sweeper plus an oil cooling system. The hydraulics of each carpet sweeper would be kept independent to reduce the probability of failure still further.

Damage Stability

It is customary in the design of ships and floating offshore structures to consider the implications of failure of part of the hull. Although the loss of one raft would not be catastrophic in itself (being unmanned) the raft on sinking would probably break the mooring system which could cause sequential failure by collision of adjacent rafts. A very high degree of structural reliability will almost certainly be required. However, the raft is split into many compartments, and has considerable excess buoyancy. It is likely, therefore, to survive any reasonable postulated damage condition.

5.2.2. Primary Power Take-off

The more likely forms of power take-off for the Raft Device include:

1. Long stroke pistons.
2. Direct gear drive coupled to generators.
3. Rack and pinion coupled to low-speed hydraulic motors.

The Device Team are undecided on the most promising system and have not prepared any detailed design of power take-off.

For the purpose of this study, the Consultants favoured adopting the last mentioned system. This preference resulted from their experience of the problems and costs of very large pistons. This application in particular would present problems of designing a piston with a very wide range of displacement between the normal working and extreme excursion cases. The direct gear system employs complex gear trains of unprecedented size and can only be regarded as a system for the future. It is unlikely that such machinery would be used in the initial stages of a wave power programme.

For the Reference Design, the Consultants, with the agreement of the Device Team, decided to adopt the rack and pinion plus low speed hydraulic pump system. A variant using friction drive rather than a rack was also investigated but the first indications were that the saving on the cost of the rack was unlikely to offset the additional complexity of a preloaded spring clamp system and the extra space needed. The choice between these options will require further investigation.

A notable feature of the Reference Design is the choice of fixed rack and moveable pinion arrangement (the carpet sweeper solution) rather than a moving rack. The arguments leading to this arrangement are as follows:-

1. It is desirable to maximise the relative travel of rack and pinion during normal operating conditions to give a reasonable pinion size capable of transmitting power at a speed corresponding to the preferred operating range of a low speed hydraulic pump.
2. The extreme survival excursion is much larger than the normal operating limits -
3. hence a very large travel is needed - preferably as close as possible to the limiting distance - i.e. the length of the middle raft.
4. Racks are long and thin and need considerable support throughout their length. The limiting travel for a moving rack would be only half of the middle rack length, supports for the moving rack being provided for the whole of the raft length.
5. For a fixed rack/moving pinion the limiting rack length is equal to the middle raft length.
6. The required travel for a moving pinion solution suits well the predicted extreme travel ($\pm 45^\circ$) and the kinematics of the Device with a link-arm connection.

7. The design with a moving power take-off will be ideal for replacement maintenance. All moving parts, except the link arms, can be removed in one operation by lifting off the power take-off module.

8. The moving power take-off unit arrangement will require hydraulic take-off mains passing along the link arms and through the raft hinges. This indirect path is a disadvantage, but the seals required will be slow-speed rotary seals of very modest dimensions. An advantage of the arrangement is that the hydraulic motors driving the generators can, at no extra cost, be located in any of the 3 rafts. In the Reference Design the back raft has been chosen - this being the most stable and accessible position.

5.2.2.1 The Components of the Power Take-off System

Link-arms

The location of the pin ends of the link arms were determined from a brief study of the kinematics of raft motion, for both maximum operating and extreme excursion cases. There is considerable freedom in the positioning of the pin ends and these can be moved to suit more accurate data on the likely operating and extreme raft movements as this becomes available.

The kink in the link arm (as seen in elevation) is required to ensure clearance of the power take-off housing. The link arm forces are moderate and the kink does not present any structural problem.

The triangulation of the link arm (as seen in plan) is necessary to provide stiffness and strength, the first to prevent buckling instability, the second to resist the severe transverse environmental forces acting on the arm in storm conditions (wind and spray impact).

Link-arm Pin Bearings

These bearings have not been detailed but may be of the same type as the main raft bearings (refer to drawing WP/RAFT/2) with the hydraulic mains running through the pin.

The Power Take-off Housing

It was assumed for the Reference Design that the middle raft would not be totally submerged by the waves in any condition. However, in storms this raft will be subject to extremely severe conditions, the decks being awash and the superstructure well within the range of very heavy spray. Hence the criteria for design of the power take-off housing are:-

1. To provide a dry environment for the rack and machinery.
2. To allow connection of the power take-off with the moving link arm.
3. Easy access for maintenance and replacement.

In the Reference Design a fully-clad housing on a concrete plinth has been adopted. The concrete plinth increases the height of the base of the steel superstructure above mean sea level but is not an essential feature, its primary function being to support the power take-off side rails. The housing is a fully-clad steel structure consisting of two short cantilever arms which can be pivoted back from their base to

allow access for maintenance and replacement. The sealing flap on top of the housing has not been fully detailed but would probably be a pair of hinged steel flaps, perhaps with rubber/neoprene seals at the tips to improve sealing. The flap would open and close as the 'power take-off bracket upstand' passes. The latter would be specially shaped to smooth the lifting of the flaps, either with a tapered plough shape or more elaborate detail. The steel flaps would be made in short lengths. Any residual water passing through the flap seal adjacent to the power take-off module would be caught by the small roof and drainage channels located on the moving module.

Power Take-off Frame Guidance Wheels and Rails

The guidance wheels have to be designed to take the weight of the power take-off module, the vertical component of the link arm force, and the moment created by the difference in level between the applied and resisting horizontal link-arm forces. This moment is likely to cause the largest wheel reaction and is governed by the vertical distance from the link arm pin to the rack (not the guidance rail). This distance is in turn governed by design details; that is the flap depth, drainage channels, frame roof and structure of the frame. Increasing the distance between front and rear guidance wheels would adversely affect the maximum allowable travel of the frame. The guidance wheels are also required to give the correct location of the pinion relative to the rack, both horizontally and vertically. Plain cylindrical steel wheels are shown running on a smooth steel track but their diameters and widths have not been checked. This track will have to be set out accurately relative to the rack.

Rack and Pinion

The pinion size has been chosen to give a reasonable range of operating speeds for the hydraulic pumps. Rudimentary calculations indicate that it would probably be possible to design suitable components with an adequate life in cast steel. The rack would need to be made in short lengths, both for manufacture and fitting.

Lowspeed Hydraulic Pumps

These are discussed in Chapter 15.

5.3

Possible Alternative Designs

The Device Team is actively considering three possible amendments to the current Device configuration. These are:-

1. Reducing the number of rafts to 2, a short front raft and a long back raft.
2. Joining together several back rafts to make a short spine. The front rafts would remain of the order of 50 m wide.
3. Replacing the rafts by submerged hydrofoil sections supported from an upper frame.

Modification 1 was first suggested as a result of mathematical analysis on several raft configurations. These indicate that it may be possible to obtain efficiencies from a two raft system which are at least equal to those of a three raft system over the range of useful wave periods (7-13 seconds). The main advantage of a two raft system is that it reduces the number of components, although it is not yet clear whether the overall size of the raft chain would be significantly affected.

Modification 2 was first investigated to reduce the problems of close mooring a line of independent rafts, to reduce the number of flexible cables needed, and to allow the use of fewer, but larger, electrical generators driven by a common hydraulic system. It is likely that the back raft will remain less than about 200 m wide to avoid the loading and dynamic problems of a long spine. How the hydrodynamic efficiency of the Device is affected by joining several back rafts has yet to be established, but there is no reason to believe that it will be a significantly adverse influence. The arguments for this configuration are primarily engineering expediency. A further variant on the configuration is to deliberately space out the front rafts. There is theoretical evidence to suggest that this gives only a small loss in efficiency (per unit of total length) but increases the power accepted by each front raft.

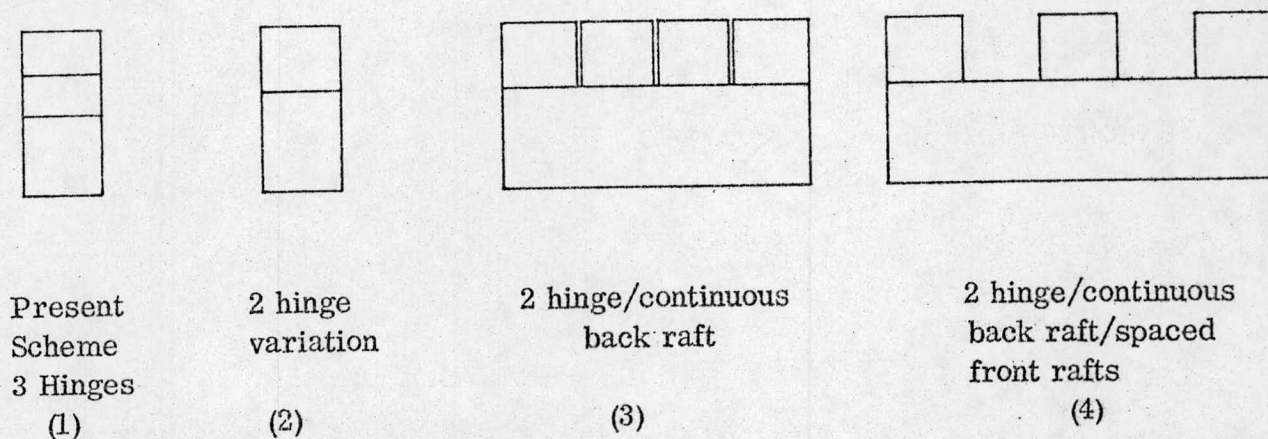

Figure 5 - Possible Alternative Raft Configurations

The third alternative using submerged hydrofoils is a much more radical change in concept which has not been tested in a tank. A model has been constructed but test results are not yet available. The added mass of such a structure is even more favourable than for a raft and the hydrofoils could be made as light as possible without affecting performance. However, the concept will be very much more difficult to put into practice. In contrast to the rafts, thin hydrofoils of the dimensions required are not inherently strong structures. Perhaps the most promising outlet for the idea would be in a marriage with the raft concept. Hydrofoils slung underneath or as submerged outriggers on a narrow raft, could improve efficiency and help to control the raft in steep waves and reduce slamming.

5.4 Construction and Installation (refer to WP/RAFT/4)

Construction

The construction methods for the rafts are entirely within current practice and need little comment. A method of construction is shown on the drawing, but there are a number of alternative methods of construction which would vary in detail. An important advantage of the raft system is that a dry dock is not needed, the rafts could be constructed on land and launched down a slipway. Hence there are an almost unlimited number of possible construction sites. If the space is available it would probably be simpler for the three rafts to be linked by hinges on land rather than in the water.

Fitting out with mechanical equipment could be complete in the construction yard, or the rafts could be towed to an alternative location. The latter would give important programme flexibility by removing mechanical fitting from the critical path in the construction yard.

Tow out

The rafts are ideal for the tow out condition.

Installation

The mooring system shown on drawing WP/RAFT/1 is complex and no programme for installation has been developed. It is intended that the main longitudinal cables will be installed prior to the rafts, these being hooked on (or taken off) individually without upsetting the overall stability of the chain of rafts. Investigation of this mooring system is urgently required as the method of installation is crucial to the cost.

5.5. Critical Assessment of Technical Feasibility

5.5.1 Concrete Raft Structures

The concrete rafts employed in the Device are very straightforward and will present few, if any, novel problems to the designer or constructor. The rafts can be constructed by a number of conventional methods and do not require a large dry dock construction yard. The box shape of the rafts is ideal to resist overall bending movements and torques. There are no penetrations sufficiently large to weaken the rafts, even if access is provided to install the power generation equipment in a single module.

The shallow draft of the structures ensures that the local water pressures are generally low. Wave slam will control the design of the bottom of the front raft but there are several ways in which this problem can be overcome (e.g. fail-safe damping provided by the power take-off, local strengthening, submerged hydrofoils under the raft).

The rafts are ideal for tow out (and, if necessary, for return to port for refurbishing) and have excellent capacity to survive local failure of the hull. The structures also have a great deal of readily accessible space which could be used, if required, for storage or secondary services.

5.5.2 Main Hinge Bearings

The duty of the bearings can be summarised as follows:-

1. Very heavy loads.
2. Submerged marine environment.
3. Very large, but slow movements repeated almost continuously.
4. Long life required.
5. Accessibility for maintenance.

On their own, none of the above factors is an insuperable problem, and indeed many examples can be found of bearings designed for such duties (e.g. dock gate bearings designed for 1, 2 and 4). All four factors combined represent a very exacting specification, but the range of possible bearing types available should ensure that at least one type of bearing can be found with suitable properties. This task will be considerably eased if provision is made for replacement of the bearings.

The inclusion of a hydraulic main passing through the hinge bearings is not likely to be a major problem, but will increase the minimum size of the hinge bearings. If this increase in size, or the increase in complexity, is found to be unacceptable the path of the mains through the hinge point could be diverted from the bearings.

5.5.3 Primary Power Take-off System

There are many examples of very long rack and pinion systems and there is no fundamental problem in manufacturing the rack shown in the reference design. If necessary the accuracy of location of the pinion provided by the guidance rail could be improved by making the rack support and guidance rail in one piece of fabricated steelwork.

The hydraulic system and electrical generation are discussed in Chapter 14.

5.5.4 Moorings

The close mooring of many individual groups of rafts must be considered at present as more of an unresolved problem than for the mooring of other devices, but if it is found that the mooring system required is barely feasible, or uneconomic, then the Device Team have the option of adopting the common back raft concept described previously. This would greatly reduce the mooring problem.

Conclusion

A primary objective of the Device Team in devising this system was to minimise engineering problems. In this the Team has achieved considerable success. The Device has an excellent structural form, is very easy to construct, has excellent damaged stability, and is ideal for tow out. The problem of wave slam can almost certainly be overcome. Maximum freedom has been given to the designer of a power take-off system, in terms of the space available, accessibility for installation and maintenance, and ability to provide dry environments.

Much work remains to be done before the technical feasibility of the power take-off system can be properly demonstrated. In particular it will be necessary to establish a comprehensive description of the lifetime history of loading on the system before the individual components can be appraised in detail. The principle advantage of the system shown on the Reference Design is the ease of installation and replacement of the modular power take-off system. However, this is just one system of several proposed which may well be feasible.

The mooring system requires considerable further investigation.

The need for additional information on the following topics has been highlighted by this study.

1. Overall Raft Configuration

The search for the optimum configuration (i.e. in terms of the size and number of rafts and the use of common back rafts etc.) is a necessary part of the research programme but is unlikely to have a major influence on an assessment of technical feasibility. This is because the various configurations proposed all imply the same type of components. This work will, however, be critical in detailed economic assessment. In fact the search for the optimum configuration will be a cost effectiveness study based on a cost/performance model.

2. Raft Hinges

The research and development required here is in three parts.

1. Model testing to establish a realistic loading and displacement history for the hinges. The end product should include statistical distributions of loadings and rotations for both the short term (for a given sea state) and for the long term (distribution of sea state, plus extreme value prediction).

Existing work by the Device Team indicates that hinge forces are closely dependent on the mooring system, hence this will need to be accurately modelled in any laboratory tests.

2. Preparation of designs of bearings for testing. This will be a desk study based on available published data for a range of bearing types.
3. Component testing for selected designs. As described previously the total requirements for the bearings are probably more onerous than for any existing bearings of similar load capacity. Hence it is most likely that testing will be required to study the following:-

1. Tolerance of bearings to manufacturing imperfections.
2. Wear rates.
3. Lubrication systems and efficiency.
4. Corrosion resistance.
5. Effect of random loading - recovery after extreme loadings, etc.
6. Fatigue life.

3. Loading Applied to Concrete Rafts

To allow a more detailed assessment of the concrete structure, future laboratory testing should include an attempt to measure local water pressures for slamming and non-slamming conditions, particularly for the front raft. The peak pressures are likely to be difficult to measure because of their very short duration.

4. Primary Power Take-off System

As for the hinges, the most urgent current need is for a statistical definition of the short and long term loadings and excursions seen by the power take-off system. Two cases need to be considered; with the rafts producing power, and for the case of a raft system where the power transmission system is not functioning.

Once the loading history has been established the components can be designed. Many of the components in, for example, the study Reference Design are in fact conventional but undoubtedly the need for some component testing will be established during the preliminary design stage. (For discussion of the hydraulic and generation systems see Chapter 15).

5. Moorings

One problem peculiar to the present raft scheme is that of close mooring many narrow devices. Additional design effort is required to complement the fundamental research which will be common to all wave power devices. A further problem concerns the problem of attaching moorings to the front raft. This raft will rotate by up to 90° in extreme conditions. The positioning of the attachment point has been found in tank tests to affect performance and the peak mooring forces. The main moorings cannot easily be attached to the back raft as they would then be fouled by the front raft at its lowest point. This topic appears to require further study and tank testing.

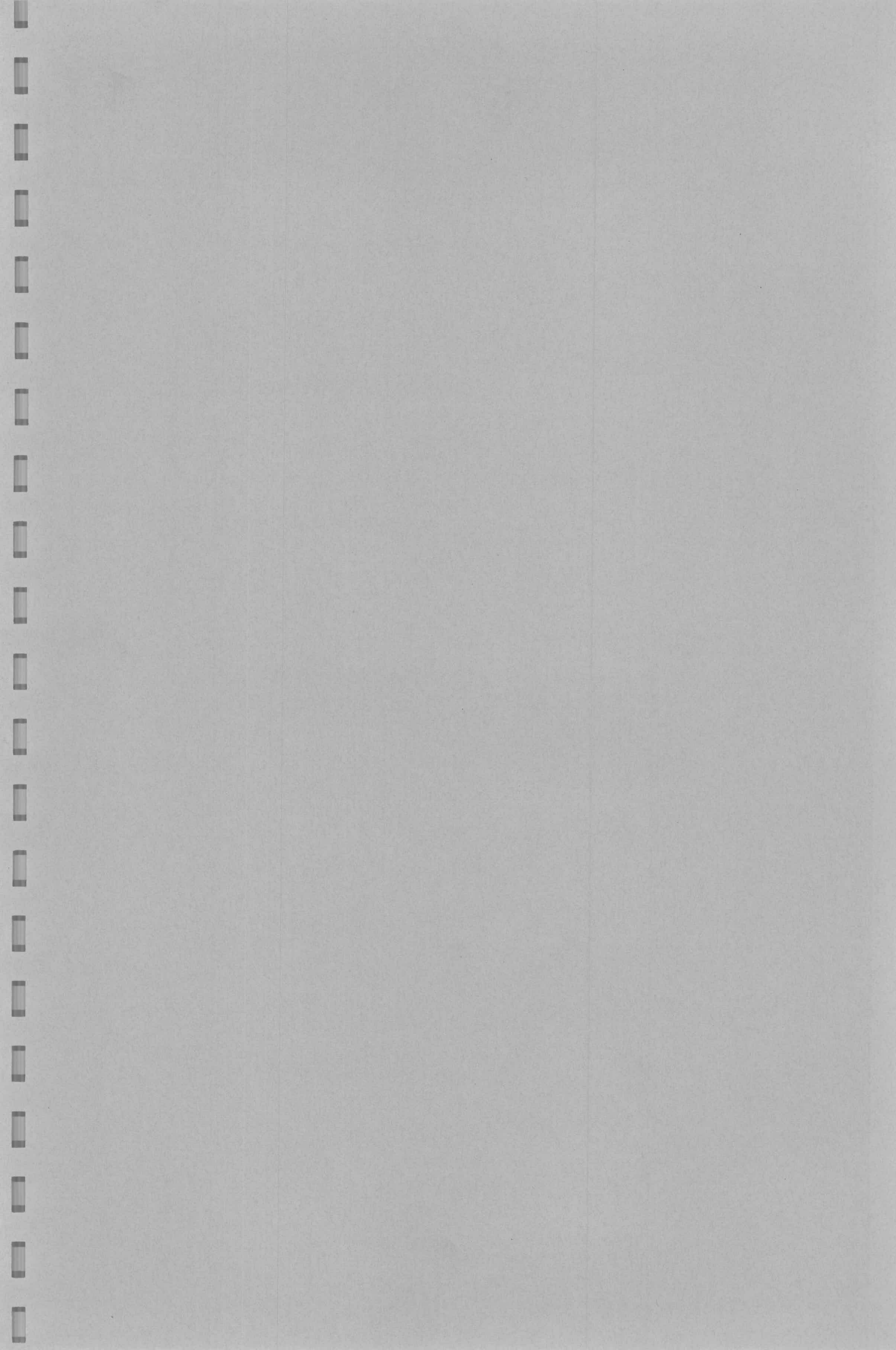

CHAPTER 6.0 N.E.L. OSCILLATING WATER COLUMN (DEVICE TEAM - NATIONAL ENGINEERING LABORATORY)

6.1 General Description of the Concept

6.1.1 Description of the Device

The oscillating water column has for many years been thought of as a promising means of extracting wave energy, and several small scale devices have been constructed, notably by Japanese engineer, Yoshio Masuda. Common to all devices is a partially submerged vessel open to the sea at the bottom or side, and at the top of which is trapped a volume of air. The air space has outlet ducts which lead to and from an air turbine. (Water turbines within the column are possible, but generally less favoured, alternative).

The NEL Device is a massive floating structure approximately equal in depth and width, and about three times as long as wide. The majority of the cross-section is taken up by ballast and buoyancy compartments. One of the long sides of the Device is made up of a series of oscillating water columns. These columns drive air through large ducts to turbines driving electrical generators. This power take-off equipment is located on the top of the device. A large two way rectifier system is included in the ducts to the turbine to provide continuous unidirectional air flow.

6.1.2 Principles of Operation

6.1.2.1 General - Oscillating Water Columns

The action of the water column can be compared to that of a classical mass/spring/damping system, where the parameters of the system are as follows:-

1. Mass - the resistance of the water column to acceleration due to its own inertia and that of the associated mass of water at the mouth of the column.
2. Spring - the resistance of the column to displacement upwards or downwards. This depends on the weight of the water lifted for a given displacement, and hence the area of the water column at its top surface. The air normally acts almost incompressibly and contributes little to the system stiffness for practical damping values.
3. Damping - the velocity proportional component of resistance to motion, supplied by the air turbines, and to a lesser extent by hydrodynamic losses in the water column.

The Water Column is therefore to be expected to exhibit many of the response characteristics of a simple dynamic system, but the analogy with a one degree of freedom system is only approximate. In particular the column is not subject to a definable set of simple forcing functions by the waves. However, the column does exhibit a form of resonance, and must be tuned to an appropriate wave period for maximum efficiency in typical conditions.

The characteristics of the floating device overall is even more closely parallel to a mass/spring/damping system, but with three degrees of freedom; pitch, heave and surge. Hence the parameters are :

1. Mass - the mass and rotational inertia of the body plus the associated added mass of water which tends to move with the Device. This added mass is not the same for the three degrees of freedom.
2. Stiffness - buoyancy stiffness (note that this is zero for surge).
3. Damping - largely caused by radiated waves. For large bodies losses due to drag tend to be very small.

To minimise movement it is necessary to detune the floating characteristics.

The NEL Oscillating Water Column

The layout adopted by the Device Team contains two novel features.

1. Asymetry - the back face of each column has been made deeper than the front face.
2. Stability through inertia - resistance to movement of the body of the Device is provided purely by inertia. This refers to the total inertia of the Device, plus an effective added mass of water, rather than that of the oscillating water column itself.

6.1.2.2 Parameters Affecting Device Efficiency

These parameters can be divided into two groups, those affecting the efficiency of the water column directly, and those which affect the movement of the Device (stability). Optimum efficiency is achieved if the Device is held rigidly and movement is in general an adverse influence. In some particular cases a degree of movement can improve the band width of the Device, that is increase its performance over a range of wave periods.

6.1.2.2.1 Parameters Directly Affecting the Efficiency of the Water Column

Width of Column

This is a critical parameter governing the tuning of the Device to wave period. For peak acceptance of wave energy the width should be about one-eighth of the wave length in monochromatic seas.

Depth of the Back Face of the Column

The functions of this face is to minimise the percentage of energy able to escape under the Device and lost by transmission. Little gain in efficiency is achieved if this is made greater than $\frac{\lambda}{4}$.

Depth of the Front Face

The function of this face is purely to keep the air cell trapped even at the trough of the wave. Hence this dimension is a function of the minimum wave height for which the Device is required to function efficiently. Increasing the depth tends to increase the wave energy lost by reflection from face of the Device, so this depth is kept to a minimum compatible with the previous requirement.

Horizontal Appendages

Experiments have shown that these give a general improvement in Device response, perhaps by increasing the volume of water constrained to move with the column.

Height of the Air Column

It has been stated that the air acts approximately incompressibly, hence the height of the air column is determined largely by the clearance to prevent water reaching the top of the column in extreme conditions.

Damping - the Power Take-off

The size and characteristics of the turbine must be chosen to give the optimum energy conversion efficiency. Too little or too much damping increases the reflected and transmitted energy at the expense of absorbed energy.

6.1.2.2.2 Parameters Affecting the Stability of the Device

Mass and Mass Distribution

For the movement of a floating body to be much less than the water particle motion (i.e. the wave height), it is necessary for the resonant period of the body to be much greater than the wave period. This implies that a large mass inertia is required. The exact value of this mass, and its distribution, depends on the tolerance of the Device to movement.

6.1.2.2.3 Water Column and Floating Body Interaction

The oscillation of the water column, and the heave, pitch and surge response of the overall Device interact in a complex way. Hence the above parameters have to be investigated using a model of the complete system. The Device Team have investigated a range of devices with various values for the above parameters. For the shapes investigated they have discovered that if the submerged cross-sectional area of the Device is about $\frac{\lambda^2}{20}$ (λ = wavelength) then the response in pitch, heave and surge is such that a favourable water column efficiency can be maintained.

Recent tests have indicated that some degree of movement may be desirable in giving a favourable variation of efficiency over the range of wave periods experienced in practice. For example the extreme waves are associated with long wave periods. For these periods the Device will tend to move with the waves and the water column will not be required to deal with an unacceptable energy level. The free floating Device is also thought to have a wider high efficiency band width.

6.2 The Reference Design Adopted for the Study (Ref. Dwg. No. WP/OWC 2 and 3)

On the recommendation of the Device Team the Reference Design is based on the latest floating model. The scale of the full size Device was agreed with the Team on the basis of the criteria described in Chapter 3. Constructional considerations have been introduced into the design.

6.2.1 Specification

Location - see Section 3.

Rating of power take-off - see Section 3.

Moorings - compliant moorings and fixed orientation to suit the predominant sea direction - see Section 11.

Cross-section of Device - to match, as closely as practicable, the shape, mass and distribution of mass of the model - see Figure 3.1.

Size of Device - the cross-section is fixed by the adoption of a 15 m wide water column. Nine water column chambers 15 m x 15 m are combined into a unit of overall length 143 m.

Materials - reinforced concrete designed to CP110 "The structural use of concrete" .

Material characteristic strengths -

Concrete 40 N/mm²

Steel reinforcement 410 N/mm²

Cover to reinforcement 75 mm.

Sea states - extreme sea state significant wave height 15 m, average zero crossing period 14 secs. Extreme wave height 30 m, period 14 secs.

Design loading - little information is available on the water pressures acting on the Device. A heave response of 50% of the wave height was assumed, and this was taken to act in phase with the wave. The pressures were then estimated hydrostatically for the extreme wave.

Construction restrictions - a first stage dry dock draught of 13 m maximum is allowable. Structure was checked for buoyancy and trim at all stages of construction in the floating mode.

6.2.2 Development of the Reference Design (Ref. Figures 6.1 and 6.2)

Cross Section of the Device

The cross-section of the NEL model has evolved from careful consideration of inertia, buoyancy and hydrodynamic streamlining. In scaling up to a full scale Device it was not possible to match precisely the mass distribution, buoyancy and shape of the model due to the following constraints.

1. The use of structural forms suitable for resisting the loads on the Device.
2. The practical constraints on construction in concrete and steel.
3. The need for correct buoyancy and trim to be maintained throughout the construction, bearing in mind that the largest part of the construction will be undertaken with the Device floating.

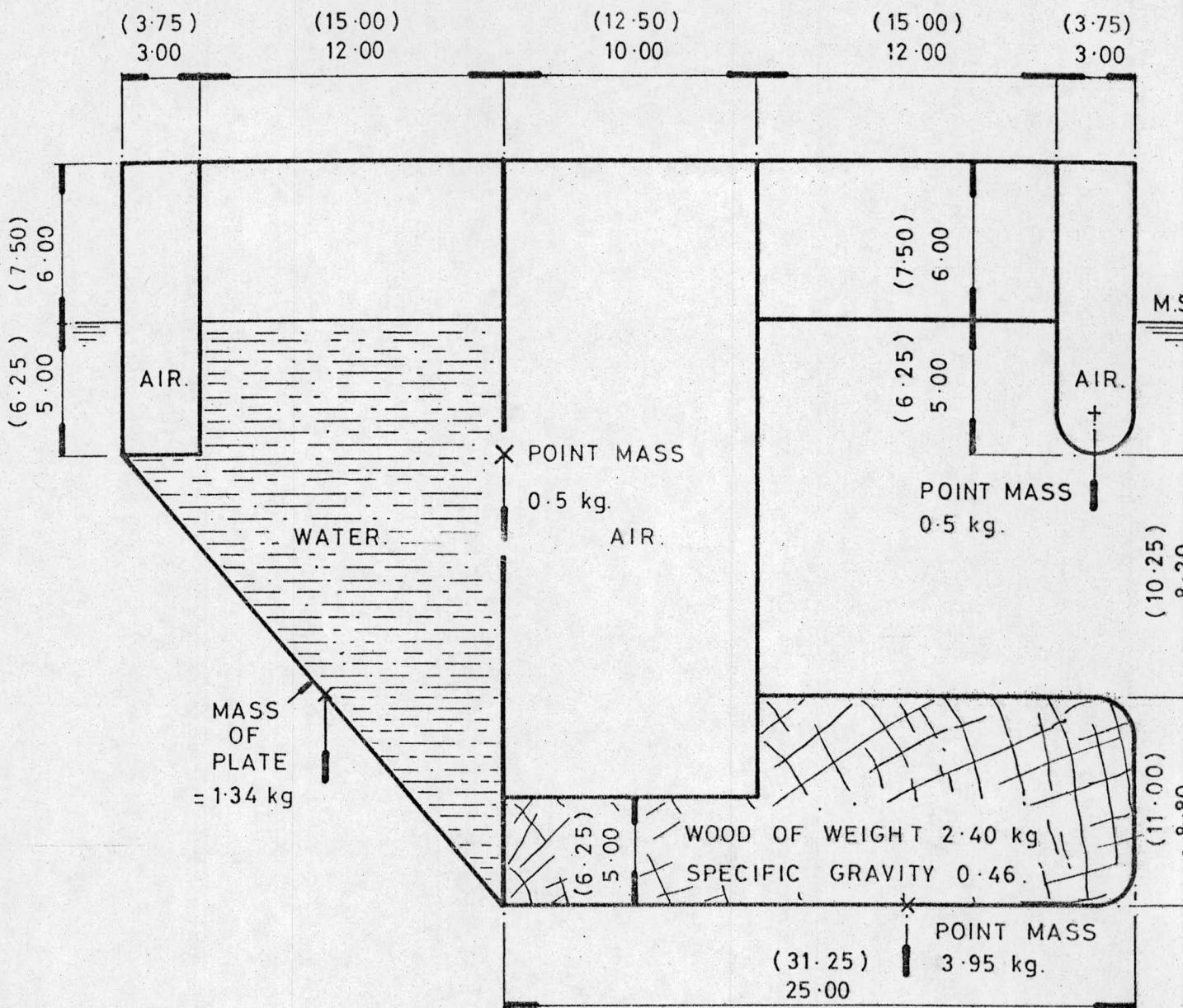

WEIGHT OF WATER DISPLACED = 17.0 kg.
 TOTAL WEIGHT SHOWN IN SKETCH = 14.3 kg.
 THE REMAINDER (2.7kg.) IS ACCOUNTED FOR BY CONSTRUCTIONAL MATERIAL AND ACCESSORIES.

WIDTH OF MODEL = 30 cms.
 TEST MODEL DIMENSIONS IN cms
 SCALED UP DIMENSIONS (BRACKETED.) IN METRES.

$$\frac{\text{MODEL}}{\text{FULL SIZE}} = \frac{1}{125}$$

INFORMATION SUPPLIED BY NATIONAL ENGINEERING LABORATORIES.

MODEL DIMENSIONS TO BE SCALED UP FOR REFERENCE DESIGN.

Fig. 6.1

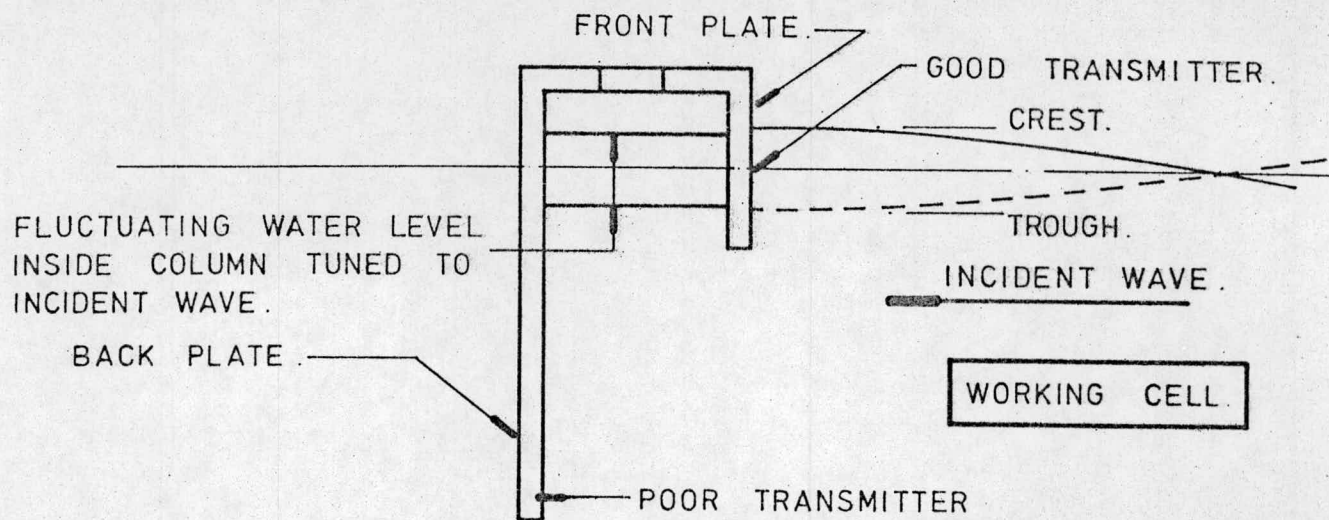

STAGE 1. BASIC CONCEPT. - WORKING CELL.

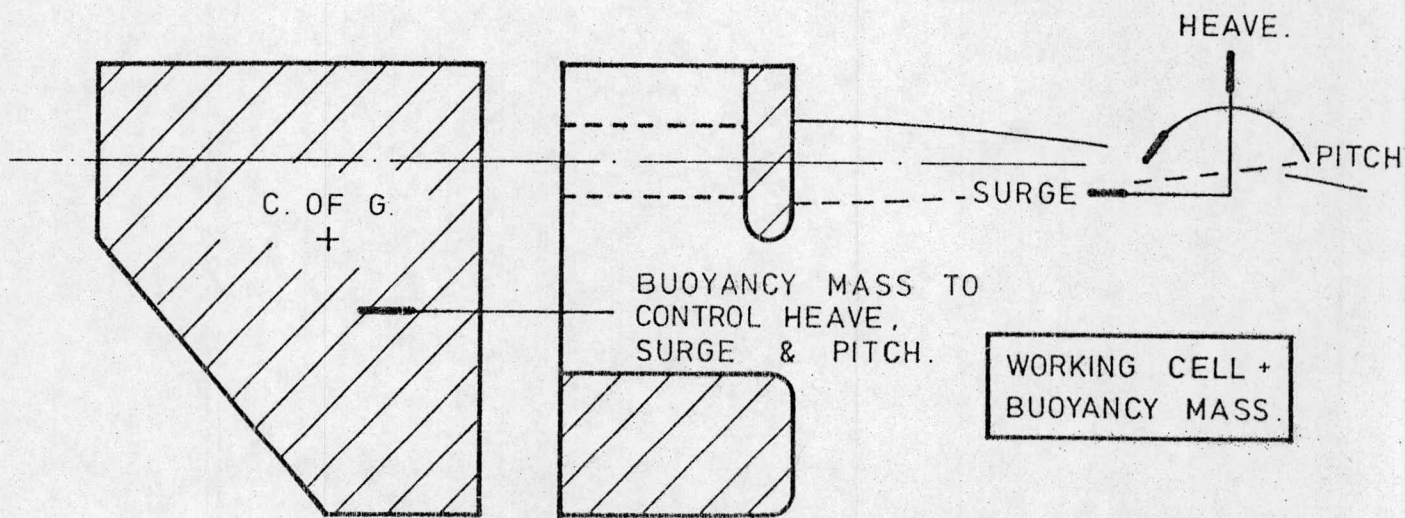

STAGE 2. WORKING CELL INTO A FLOATING DEVICE.

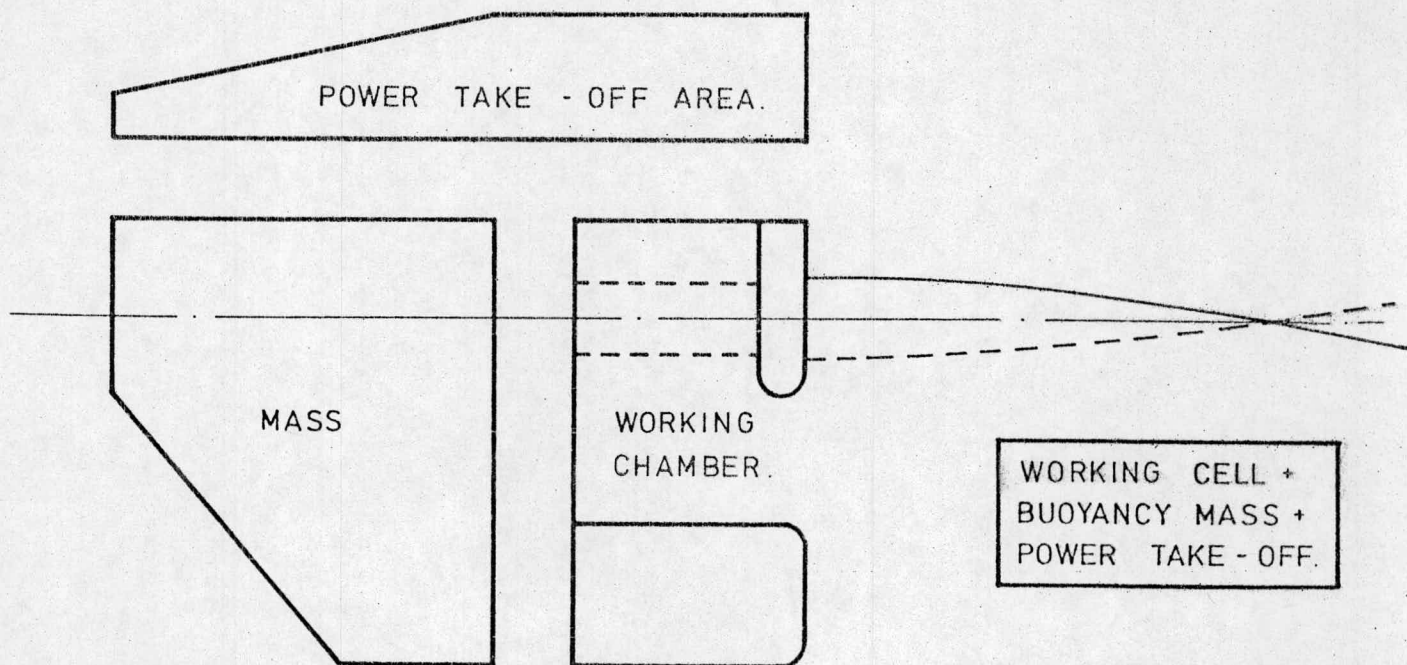

STAGE 3. WORKING CELL INTO A WAVE ENERGY DEVICE.

DEVELOPMENT OF N.E.L. OSCILLATING WATER COLUMN.

Two attempts to achieve a working compromise are given Ref. Drawings WP/OWC/2 and 3. The first all-concrete construction matches the model fairly closely, but is unstable at some intermediate stages of construction. In addition the raking of the back wall would preclude slipform techniques and would be difficult to construct by other methods. A modified cross-section has therefore been adopted for the Reference Design. The body of the Device is shown rectangular in section which gives a firm base for construction. The back streamlining is shown as a steel/concrete addition. As an appendage, its size and shape could be varied considerably to give optimum balance between Device efficiency and cost.

Superstructure - Power take-off module - to simplify the air ducting arrangements the power take-off module is shown located above the oscillating water chamber. This however may not be the optimum location for this module as the protective housing increases the freeboard exposure to the incident wave. If suitable ducting can be devised the obvious location for the power take-off is in the body of the structure just behind the working chamber. In the Reference Design the power take-off housing is shown as a steel superstructure which from weight considerations is more attractive than the alternative heavy concrete shell housing. The maintenance problems of interconnected steel and concrete in the marine environment are however obvious disadvantages for using steel.

Structural Considerations - The manner in which the Reference Device will respond hydrodynamically to the extreme environmental loading is not known. It is, at least, necessary to establish the heave response of the Device under these conditions. The water level differentials can then be established which will lead to approximate estimates of the structural loading to be accommodated in the design. This can be most readily undertaken with a three dimensional model in the wave tank. The water column chamber is likely to be subjected to the most extreme loading. The back wall of the chamber will be subjected to the greatest hydrostatic pressures while the roof and the front wall will be subjected to the effects of dynamic slam and local air pressure build ups. In the Reference Design the front wall is shown as a steel member for ease of fabrication. To assist in dispersing the hydrostatic heads on the back wall the structure behind is divided internally into cells which transmit the loading back into a number of walls. The body of the Device consequently takes the form of a cellular caisson which can be readily constructed using slipform techniques. In the absence of precise loading information the Reference Designer has used a postulated head increase of 7.5 m which have enabled the spacing and the wall thicknesses of the cells to be determined.

Float Out Condition - the Reference Design shows the structure when completed floating in some 29 metres of water. As the majority of the existing construction facilities have a draught limitation of between 13 and 14 metres this will entail two stages of construction, the second stage being in deep calm water. This is compatible with the vertical cellular caisson shape which is inherently stable and can be readily trimmed during the second stage construction.

6.4 Construction Installation and Siting

Reference Design Construction Sequence - the proposed construction sequence for the Phase 1 Reference Design is outlined on drawing No. WP/OWC/4. The existing offshore dry dock construction facilities all impose a draught limit at

float out of between 13 and 14 metres. This has dictated the two stage construction; Stage one to form a floating working platform in the dry dock to be floated out to deep water for Stage two where the body of the Device will be completed.

Construction Period

The Anglo Dutch offshore concrete construction company based at Hunterston have submitted a programme for the construction of the Reference Design to take 12 calendar months for two number working Devices.

Wimpey Construction based at Nigg Bay have outlined a 2½ year programme for three number working Devices.

McAlpine Construction based at Ardyne Point where there are three basin facilities, have outlined a 5 year programme for fifteen number working Devices.

Construction Points

1. It is envisaged that at peak production between 750 and 1000 construction personnel would be employed on each Device to meet the construction periods outlined above.

2. The following construction yards are considered capable with some modifications to handle the O.W.C. Reference Design construction.

Andoc - Hunterston

Ardyne Point - Sir Robert MacAlpine.

Loch Kishorn - Howard Doris

Portavadie - Sea Platform Constructors (Scotland) Ltd.

Nigg Bay - Wimpey Construction.

3. Lifting plant will have to be capable of handling loads of up to 100 tons for both Stage 1 and 2 construction. This will entail the provision of heavy floating cranes for the offshore construction.

4. Upwards of 1000 m³ of concrete/day would be poured during Stage 1 construction halving to 500 m³ of concrete/day during Stage 2.

5. The Reference Design is standardised for slipform construction in Stage 1 combined with precast fabrication in Stage 2.

6. Material considerations - Reference Section 13 for generic material studies.

The ordering of the power take-off equipment (air turbines and valves) will need to be made well in advance of construction due to the very long lead times for such plant.

Device Siting - Ref. Drawing No. WP/GEN/2

The floating O.W.C. Device requires to be sited in a minimum of 60 metres of water (see Section 3). For the purpose of this Report the deepwater siting is shown along the 60 metre contour just off the West Coast of the Hebrides. Along this front the available annual power is thought to be approximately 75 KW/M.

6.5 Possible Alternative Designs

6.5.1 Structure Fixed on the Sea Bed

The floating Device relies on its size for stability. The Device Team have considered a variant of their Device fixed to the bottom in shallower water. The overall mass then becomes a function of its ability to survive in extreme conditions. For water depths of the order of 20 m it is likely that the volume of structural material could be considerably reduced, particularly if it was possible to use piled (on sand or clay) or rock bolted (on bedrock) foundations. The disadvantages are the restrictions on sites available (see drawing WP/GEN/1) and somewhat lower wave energy levels available.

6.5.2 Floating Structures with Greater Added Mass

The effective inertia of all floating bodies is increased by an added mass of water. For the shape of the Reference Design (between square and circular in cross-section) only a modest added mass acts with the structure. It is possible this could be advantageously increased with other cross-sectional shapes.

6.5.3 Spine Designs

The Reference Design is dominated by local water pressures. Little use is made of the excellent overall stiffness and strength of the rear portion of the Device. The use of a more compact rear portion as a spine in a long Device relying on the self cancellation of the forces from several wave crests would eliminate the requirements for inertia. The governing criteria then become those of strength and stiffness. The Device Team have studied the implications of this in some detail and do not favour the spine alternative.

6.6. Critical Assessment of Technical Feasibility

The very clear advantages of this Device are the minimum number of mechanical components required, and the undeniable feasibility of a structural form where the cyclic loadings are balanced on each cross-section. Being a single rigid structure the ability of the Device to survive extreme sea conditions should be good.

Civil

There is no doubt that the NEL oscillating water column Device structure could be built, the only major construction problem being the scale of the structure. The size is such that a two stage construction is required. The base would be constructed in dry dock. The main structure would be completed while floating at a calm water site. The various contractors consulted have expressed confidence in being able to construct the Reference Design. The following points are noted:-

1. The structure has a depth to width ratio of 1:1 compared with that of a super tanker of 1:3. It is a very large structure to support a relatively small working cell. The general consensus of opinion was that slipforming techniques would be viable provided 30 metre uninterrupted lift could be achieved.

2. The design incorporates precast diaphragm walls for Stage 2 construction to reduce the amount of deep water concrete work. The penalty will be costly floating cranes which will have to be on hand for lifting these walls (up to 100 tonnes in weight) into position.
3. The forces on the various structural members during the extreme environmental sea state still have to be determined. Until the forces are better understood the Reference Design number sections and spacing of member sections should be considered only as indicative. No structural assessment on the design is made at this stage.
4. The mooring problems associated with the NEL floating Device are common to all the floating devices. Reference should be made to Section 11 - Moorings.
5. The possibility of the water level hitting the roof in the working chamber not only provides structural design problems but also threatens to flood the power take-off housing unless shut off valves can be developed for the roof of the working chamber. The valves would have to allow unrestricted flow of air during normal operation, but seal off before the water level reaches the roof, leaving a cushion of air. Several possible types of valves have been discussed with the Device Team but no valves were included in the Reference Design.
6. The O.W.C. Device may be technically more attractive if it is designed as a prestressed structure. The reference scheme has been designed in reinforced concrete. It is the Consultants experience that contractors given the choice favour ordinary reinforced concrete construction which is reflected in the cost. However, it must be stressed that this is a very broad generalisation and may not be typical for all organisations. The choice between prestressed and reinforced concrete should be based on their technical and cost merits for the individual device taking all factors into consideration.

6.6.2 Power Take-off

The valves to prevent water entering the air ducts have been discussed above.

The two way rectifier valves are novel, in terms of the volume of low speed air they need to pass when open, and the small back pressure that should be required for the valves to seal. A very large valve is indicated, and the Reference Design employs pneumatic rubber spheres within steel cages. These components have not been designed in detail and although appear entirely plausible they would require development and testing for proof of their efficiency and durability.

The mechanical and electrical plant is discussed in Section 14.

6.7 Future Research Requirements

It is clear that the fundamental investigations of the Device Team concerning the alternative two and three dimensional forms of the device should continue. The need for information to aid engineering assessment has been indicated in the following areas:

1. Loadings

The present structural design is dominated by considerations of local water pressure during extreme sea conditions. Model tests for such conditions would help to improve the estimates made for these pressures in the study Reference Designs. A visual examination of response in extreme seas would be adequate for a first stage refinement of the design, more detailed direct monitoring of local pressures would be required at a later stage. Mathematical models are potentially capable of providing the required pressures for normal conditions, but would need to be interpreted in conjunction with model test results for extreme waves.

2. Power Take-off

For detailed assessment of the shut-off air valves and the rectifying valves (Section 6.6.2) laboratory testing is required to establish a life history of operating pressures and flows. A programme of tests on proposed component designs at a representative scale will then be required.

For mechanical and electrical plant - see Section 14 and 15.

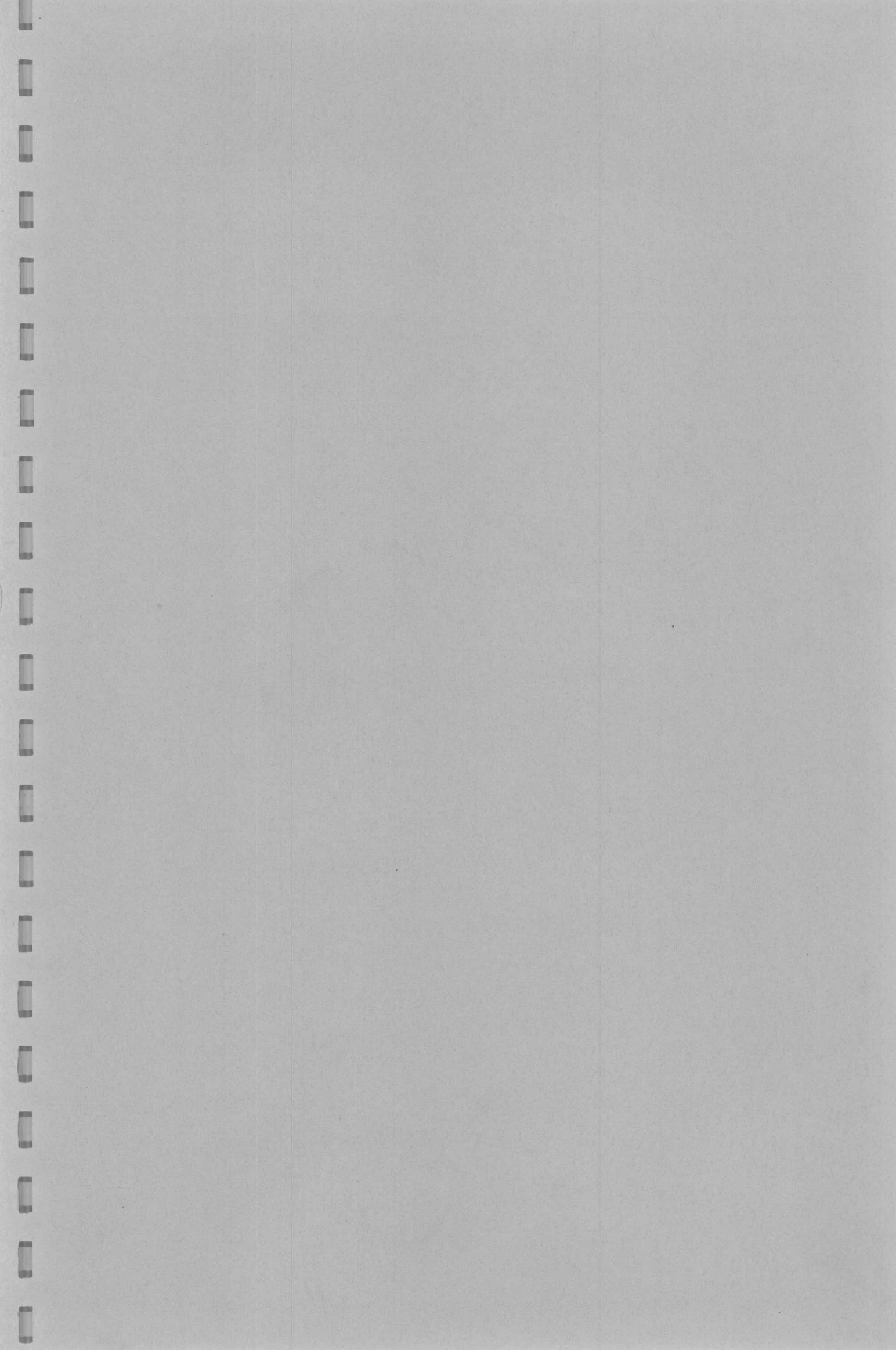

7.1 General Description of the Concept7.1.1 Description of the Device

The Device consists essentially of a series of very large linked caisson structures placed normal to the incident wave front in about 20 m of water. The front face of each caisson is provided with a continuous array of inlet and outlet flap gates, arranged alternately along the face. Internally the caisson is divided into high and low level reservoirs linked by a large low head turbine. The separation of the caisson into reservoirs is effected by a series of diaphragm walls which channel all the inflowing water into a common collecting flume at the back of the Device and similarly direct the discharging water to the outlet gates.

7.1.2 Principles of Operation7.1.2.1 Normal Operation

During the half cycle of the wave when the water level at the face of the device is above mean sea level, the non-return flaps open and water enters the upper reservoir. This then flows through a low head water turbine to the lower reservoir. Water leaves the lower reservoir through outlet flaps during the half wave cycle and when the sea level is below the mean.

Relation between Head and Flow for an ideal Device

With no flow through the turbine, the separation of the reservoir levels approaches that of the standing wave which forms in front of the Device ($2 \times H$, where H is the height of the incident wave). In this case all of the incident energy is reflected off the front face.

At the other extreme with no resistance to flow through the turbine, the head difference between the reservoirs at the location of the turbine inlet and outlet disappear. The level of the two reservoirs is not constant throughout their breadth, ideally the wave travel in and out of the Device without impedance. In this case all of the wave energy is reflected from the back wall of the Device.

For the Device to extract power from the waves a case intermediate between the above extremes is required. It is thought that for a perfect device the optimum reservoir level separation would be the height of the incident wave.

Behaviour of a Real System

A real system will not achieve perfect efficiency for the following reasons:

1. Geometric Limitations

A basic feature of the Device is that at any time only half of the face of the Device is able to accept energy. The remaining half presents a closed face to the wave. Allowing for the fact that the 'open' part of the face is also partly

blocked by the flap support structure, it is clear that there could potentially be a significant loss of energy. This loss is reduced as far as possible by maximising the defraction of energy round the solid obstructions and into the device through the open flaps. To achieve the greatest reduction, closely alternating inlet and outlet ports are required. This is not possible to achieve in practice and the final layout is a compromise between hydraulic and structural requirements.

2. Flap Limitations

Three losses can be identified.

1. Resistance to flow when open, due to drag on the flaps and flap support structure.
2. Leakage of the flap when closed.
3. Step-function control of flow (open and closed).

The third effect implies that the rectifier will always disturb the regular nature of the incident wave. The front face cannot be ideally transparent to an incident wave. Some energy must be reflected at wave frequencies higher than the incident wave.

3. Breadth of the Devices

Part of the incoming wave passing through the flaps is reflected from the back face of the reservoir, and the path of this wave inside the Device must be long enough to prevent interference with the incoming flow. This establishes a minimum breadth for the Device which is the order of 0.4 times the wave length.

4. Hydraulic Storage

The Device has a natural capacity to even out, to some extent, the flow of water through the turbine, so that the output of the turbine is significantly less variable than the input energy of a random sea. This smoothing takes place within each wave cycle, between consecutive waves of dissimilar heights, and along the crest length of a short crested or inclined sea. Theoretically this loss of responsiveness reduces the capacity of the Device to accept the whole range of energies incident upon the front face. In practice this disadvantage tends to be far outweighed by the practical advantages to the turbine, the generator and the electrical connection system. The smoothing effects along the Device in particular are under the control of the designer. These are a function of the distance between turbines (i.e. the extent of each reservoir along the Device) and also depend on whether adjacent reservoirs are interconnected by channels.

5. Hydraulic Losses in Channels

The passage of water through the Device is somewhat tortuous, and head losses will depend to a degree on the sizes of the channels (particularly for the parts of the Device remote from the turbines), details at the changes of direction, whether there are structural members intruding into the channels, and perhaps most importantly the details of the turbine draft tubes.

6. Turbine Characteristics

The turbines required will be of unusually low head, large flow design. Broadly speaking, this implies that the turbines will be very large and slow running. As the turbines will be required to operate within a range of heads, which depend on sea conditions, it will be difficult to ensure that the turbines are effective in the more moderate seas. (It is possible that the economic optimum design may employ flows which are slightly less than the theoretical optimum for the Device, this helping to increase the differential head. The freedom for such juggling is, however, very limited).

Floating or Bottom Mounted

There is nothing in the principle of operation which dictates whether the Device should float or be bottom mounted. The Device Team have proposed a bottom mounted solution in a depth of water which will attenuate the largest waves. The Consultants agree with the Device Team that this is the correct solution. There are three good reasons for this.

- (a) Any structure which has one face consisting largely of a big hole to let water in is inherently a bad floating device, lacking both the bending and the torsion strength needed to survive extreme seas.
- (b) Even could the structural problems of a floating device be solved economically, there remain problems in stabilising the device.
- (c) The Device has no significant capability to reject energy from extreme long wave length seas, so that mooring forces would be excessive.

7.1.2.2 Survival in Extreme Seas

Partial Transparency to Large Waves

There is no theoretical requirement for the outlet waves in the lower reservoir to extend higher than some level below high tide. Above this level, the whole face can in theory be furnished with inlet flap valves so that the upper part of the face becomes transparent to the waves. This could be a useful way to reduce wave forces on the whole device, but to obtain this advantage the structure behind would have to be designed not to reflect the waves passing through the front face. This would involve spilling the wave through the back face through more flaps or over the top of the back face by means of a sloping ramp.

7.2 State of Development at April 1977

At the time when the Consultants met with the Device Team, development was at an early stage. The basic thinking and appreciation of behaviour had been completed and some of the most important design parameters were established. A simple model was being tested in monochromatic waves, but problems in modelling the flap valves were obscuring direct measurements of efficiency. Some mathematical work was underway and there were indications that efficiency in a random sea might not be a long way short of the performance that would be measured in the monochromatic waves. Research had thus not progressed very far, but the

basic simplicity of the Device, and the fact that it was to be bottom mounted seemed to indicate that much less work would be needed to reach optimum design than would be required for some other devices. It seems likely that the early dimensions and data supplied by the Device Team for the Consultants Reference Design might not change markedly as a result of continuing hydraulic testing.

7.3 The Reference Design Adopted for the Study (refer WP/RECT/1-4) Civil and Structural

The layout adopted for the Reference Design is very close to the layout proposed by the Device Team. The changes that have been made to meet practical requirements should not significantly affect performance. The design is dominated in some areas by requirements that have nothing to do with the principles of operation. These requirements form part of a construction and performance specification which was established by the Consultants at an early stage to control the Reference Design. Key features of this specification are set down below.

7.3.1 Specification

7.3.1.1 Performance

- (a) The layout of the hydraulic chambers and the arrangement of flap valves should as far as possible match that specified by the Device Team.
- (b) If possible, hydraulic linking of caissons should be achieved.

7.3.1.2 Construction

- (a) The Device should be capable of being floated into position and ballasted onto the sea bed.
- (b) The method of founding and fixing the Device should be tolerant of variable bed conditions, including rock or sand.
- (c) The body of the Device should be capable of being constructed in a typical offshore dry dock. From a broad investigation of the sizes of the existing facilities in the U.K. the float out condition should be limited to a draught of 13 metres.
- (d) Construction which would increase the draught above 13 metres would have to be carried out in deeper water in the floating mode.

7.3.1.3 Construction Material

Reinforced concrete (40 N/mm^2) selected for the first Reference Design, but not in any sense a prerequisite of the design for future study.

7.3.1.4 Maintenance

- Rubber flaps to be mounted for simple replacement.
- Facility to be provided for sealing off and dewatering parts of the Device, including the turbine, for occasional major maintenance.
- Permanent craneage to be provided for replacement of flap units and turbines.

7.3.2 Development and Description of the Reference Design

Dimensions supplied by the Hydraulic Research Station in April 1977 for the reference costing design are reproduced on Figure No. 7.1. The following paragraphs set down some of the other requirements which have controlled the design.

7.3.2.1 Float-out Constraint

The Device is essentially two dimensional in its performance (performance is not significantly a function of length) and the length of each caisson was fixed at 140 m to meet the requirements of float out, and the availability of dry docks for construction. Unfortunately the Device makes an extremely bad "ship" for float out. The open face, which is temporarily sealed off, contributes nothing to the strength of the caisson. The structure is left inherently weak in torsion, and unsymmetrical in bending resistance, with the shear centre of the bending section well displaced from the centre of gravity. The solution of this problem has been to provide torsional strength by building the caisson with a double bottom and to reduce bending stresses by reducing the length of the caisson. The cellular bottom structure varies in depth from 4 metres on the leading face to 6 metres on the back. It is effectively the spine of the structure and is designed to cater for loadings imposed during the flotation and setting down condition. This construction results in the leading edge of the floor of the Device being 4 metres proud of the sea bed. Rather than leaving a step, a stone rubble run up is provided to assist in directing the flow of the incident wave into the inlet chambers and also to protect the base of the Device from scour and undermining. The double bottom is filled with sand ballast after founding to increase the overall mass of the structure.

7.3.2.2 Resistance to Extreme Seas

As with all Wave Energy Devices, the structure strength is largely determined by the extreme environmental loading conditions. Unlike floating devices which can be de-tuned to the high energy waves, and restrained by compliant mooring systems, a bottom mounted structure tends to meet the sea head on. The only practical method of reducing wave forces is to make the structure low enough for the very largest waves to pass over it. There are various ways of providing resistance to the overall horizontal forces, including piling and skirts penetrating the sea bottom, but the simplest way is to mobilise friction with the sea bed. This is an obvious solution where the structure is naturally heavy or the bed possibly unsuitable for piles, and is the one adopted here.

From this decision it follows that the design must incorporate room for ballast. All things being equal, heavy construction in a cheaper material will be preferable to a lighter form of construction in a more expensive material. This requirement of course could conflict with the need to meet a particular draft limit at some stage during the construction.

7.3.2.3 Chamber Design

Within the 140 metres there are 6 inlet and 6 outlet chambers which together feed through a single 6 MW water turbine. The chamber walls constitute a large part of the structure weight, and during the life of the Device they will be

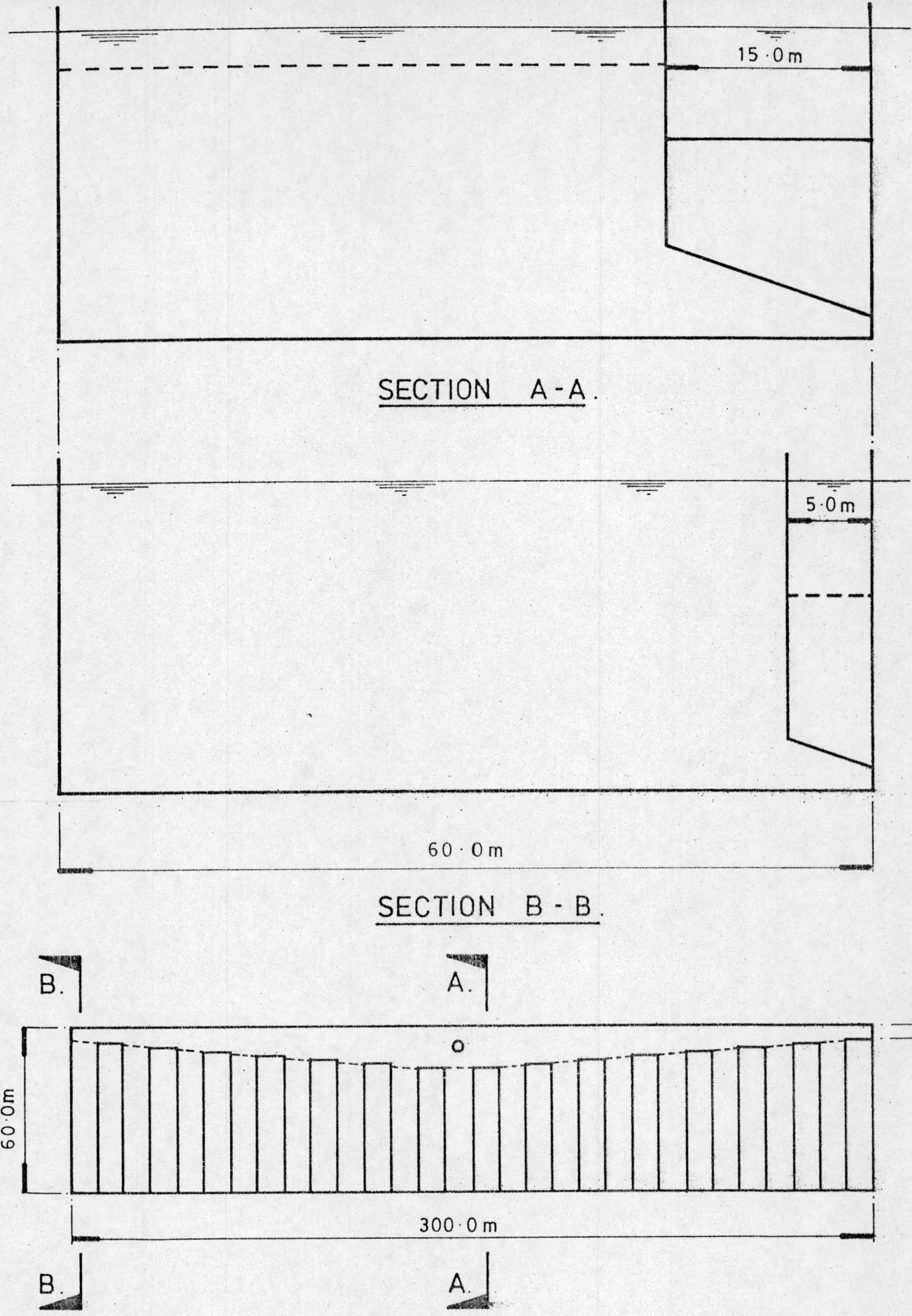

INFORMATION SUPPLIED BY HYDRAULICS RESEARCH STATION, WALLINGFORD.

DIMENSION PARAMETERS TO BE
CONSIDERED IN REFERENCE DESIGN.

Fig. 7.1

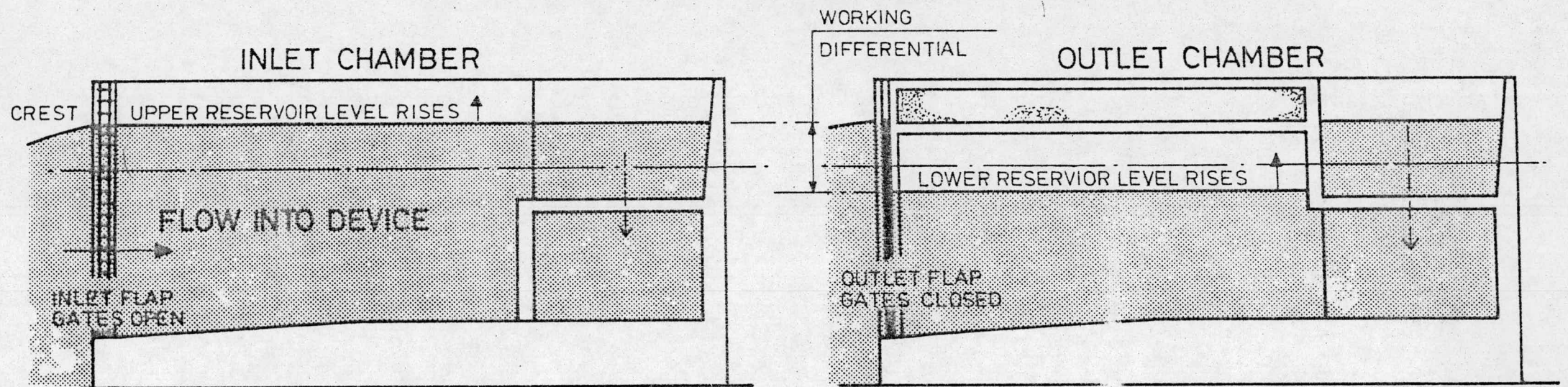

CREST CYCLE

NOTE: ↓ FLOW THROUGH TURBINE IS CONTINUOUS.

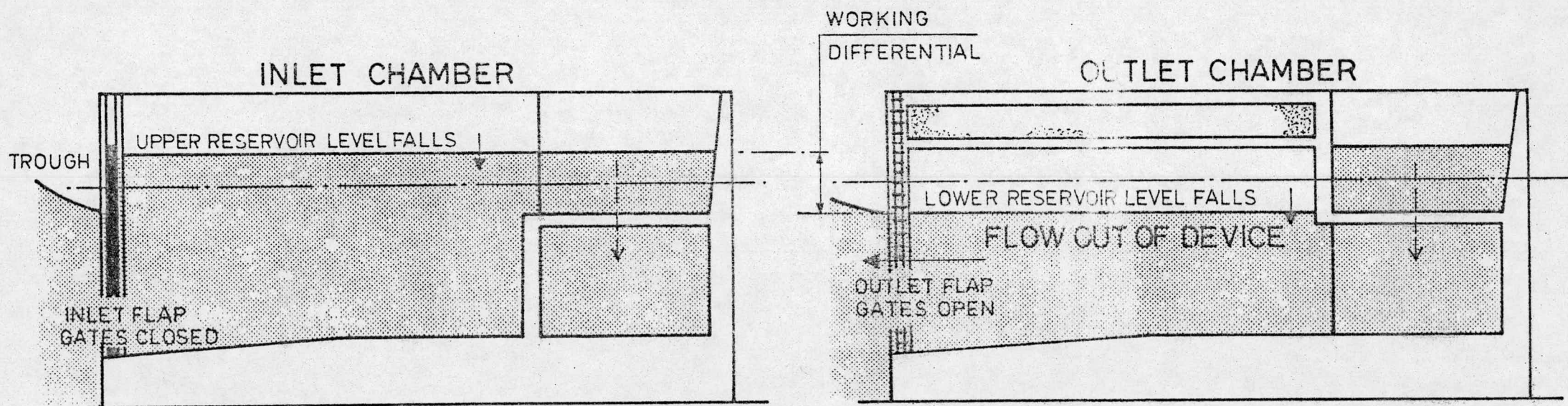

TROUGH CYCLE

continuously subjected to a variable differential water head, which under the extreme environmental loading could be up to 12 metres. (Various methods could be used to reduce this extreme head, and hence the weight of the whole Device, but these ideas have not been incorporated into this first Reference Design). Stress calculations based on the 12 m head and the fatigue regime have led to the design of diaphragm and other walls in the region of 0.8 to 1.0 m thick in 40 N/mm² concrete. Prestressed concrete construction should be considered as an alternative Mark II design incorporating a number of ideas which have not yet been worked on.

7.3.2.4 Linking of Caissons

Each caisson is designed to be placed separately onto a prepared screeded gravel rock bed. Placement should be not more than about 150 mm out from the specified position. Adjacent caissons are then connected for horizontal shear forces only, by a cast insitu concrete key 'plug'. A joint of this type provides freedom for caissons to settle independently without introducing additional torsion and bending forces. At the same time the caissons are able to share resistance to local peak wave loads.

7.3.2.5 Hydraulic Linking

By linking caissons in shear, it becomes possible for the main flume to be made continuous over a long length of caissons. All that is required is a cast insitu concrete seal to join up flumes, with some built in flexibility to allow for any possible movement. The open ends of the channel are blanked off during construction.

7.3.2.6 Face with Flap Valves

During float out the front face of the Device has to be blanked off. In operation the front face has to present an array of inlet and outlet flap gates which if required can be removed for servicing. To meet these double requirements the entrance quoins of the inlet and outlet chambers are provided with slots onto which concrete or steel blanks of convenient size are fixed for the temporary floatation condition. Once in position these blanks are removed and replaced with the inlet and outlet flap gates. Each gate consists of a steel frame carrying a series of balanced rubber flaps reinforced to resist water pressure. Provision is made for an overhead crane to travel the full length of the Device to undertake the lifting in and out of blanks and gates.

7.3.2.7 Ballasting

Mention has already been made of the ballast which is pumped into the double bottom. Further ballast is required to achieve the necessary resistance to sliding, and this has been placed on the roof of the lower reservoir chambers. This ballast area thus presents a 'face' to incident waves which might otherwise have been passed through a special set of inlet valves. In an alternative Mark II design some streamlining on the Device should be sought to minimise the force on the ballast face.

7.3.2.8 Draft Tube

The relatively low total height of the Device has meant that even using all the depth available in the double bottom, the draft tube is still short. There has as yet been no time for interaction between the civil and mechanical designers to explore the layout in this area.

7.3.2.9 Maintenance Facility

Provision is made in the Reference Design for a cantilever roadway at the back of the Device. In addition an overhead service gantry is installed to run the length of the whole power station. Both link to a service caisson, which is positioned mid-way along and to the shore side of a 5.6 Km length of connected devices. The service caisson is the storage area for flap gates.

7.3.2.10 Mechanical and Electrical

The Phase 1 Reference Design incorporates a 6 Mw Kaplan turbine to operate at 60 r/minute in each 140 metre working unit. This utilises a normal maximum net head of about 3.9 metre between upper and lower reservoirs with water discharging through the orifice at 140 cu m/sec.

Electricity cables will run from the 40 Kaplan turbine generators to a central service caisson where the D.C. electrical power will be collected and linked to a shore base inverter by single H.V. cells. A complete MW installation is shown on drawing No. WP/RECT/1. Full details of electrical installation are given in Chapter 15.

7.3.3 Construction and Installation of Reference Design

7.3.3.1 Construction Sequence

The proposed construction sequence for the Phase 1 Reference Design is outlined on Drawing No. WP/RECT/3.

The sequence reflects the need to segregate labour intensive operations, such as the construction of the turbine housing module from the main construction, to achieve the most efficient use of the expensive dry dock facilities. The construction sequence is planned around the most efficient use of a typical dry dock facility.

7.3.3.2 Construction Period

Discussions have been held with three major offshore contractors to establish possible construction schedules. Estimates vary widely, and a much closer joint exercise between the Consultants and the contractors will be required to get firmer estimates. It was concluded that the construction period would range between 3 years and 5 years for a 5.6 Km/200 Mw string of 40 linking devices using three construction basins. For only three device units, the construction period estimated, using only one basin was between 1½ years and 2½ years.

7.3.3.3 Onshore Construction Yards

The Consultants have a full set of details of major offshore construction yards. Five of them have been visited. The following yards are considered capable with some modifications to handle this size and category of construction. Ref. Drawing WP/GEN/2.

Hunterston	-	ANDOC
Ardyne Point	-	Sir Robert McAlpine
Lock Kishorn	-	Howard Doris
Portavadie	-	Sea Platform Constructors (Scotland)
Nigg Bay	-	Wimpey Construction
Greythorpe	-	Laing

Some of the yards have more than one basin, but most would have to invest in large caisson gates. Apart from Nigg Bay on the East Coast of Scotland, all the above mentioned dry docks are located on the West Coast. Collectively, they represent a large National Capital investment which is currently heavily under-employed.

7.3.3.4 Installation (DR6 WP/RECT/1)

In the Reference Design 40 number individual working units are shown linked together to produce a 200 Mw station. The individual units will be floated out separately and under controlled conditions ballasted down onto the prepared sea bed. Once in position the Devices will be structurally and hydraulically linked.

7.4 Siting of the Devices (Refer to Drg. No. WP/RECT/4 and WP/GEN/3)

The Device requires to be sited in about 20 metres depth of water in an area where the mean annual power density of the waves is 65 to 70 kw/metre. A preliminary study of sea bed contours and energy fronts around the coast line of the U.K. shows that there is approximately 100 Km of suitable sitings available to meet these requirements, 95 Km of which are some 5 Km off the West coast of the outer Hebrides. This indicates a total U.K. power capability rating on a 65 Kw/m front for this type of device of about 4000 Mw. This is only a preliminary study, and a less rigid specification of water depth and energy levels could extend this significantly. The relative economics of designing smaller devices for lower energies have not yet been examined. The Device would probably be sited over irregular rock. Consequently provision is made in the cost build-up for materials to be laid on a prepared bed to produce a uniform foundation for the device. It is anticipated that most of this material will have to be imported, as suitable deposits in the required quantities are unlikely to be found locally. This represents a high cost element in the Reference Design which will have to be quantified by further investigation in Phase 2 when Reference Design sitings have been agreed with WESC.

7.5 Critical Assessment of Technical Feasibility and Potential

7.5.1 Limitations to Assessment

The 'HRS Russell Rectifier' is still at an early two dimensional model study stage. Testing has thus far been restricted to monochromatic waves. The following is probably a minimum estimate of the work which will have to be undertaken before it will be possible to assess the likely output from a Device with any certainty.

- (a) Testing in random waves (superposition is not valid).
- (b) Testing of a three dimensional model to prove the water flow through the system.

- (c) Development and proving the efficiency of practical flap valves.
- (d) Proving by modelling (hydraulic or mathematical) the behaviour in a random three dimensional sea. This is necessary to investigate the degree of hydraulic smoothing which can be achieved.
- (e) Development of a turbine generator design matched to the predicted variation in heads and flows.

The other side of the assessment equation, the cost of the Device should be calculable on the basis of existing experience without too much trouble.

7.5.2 Assessment

1. The concept is simple. The realisation of it depends on two unproven components, the flap valves and the turbine, which must operate in a quite novel variable head regime. There are grounds for believing that the valves can be designed to work, but their cost and life cannot be estimated yet. The problem for the turbine will be to achieve satisfactory efficiency and to solve corrosion and fatigue reservations. The Consultants have some confidence that an effective full scale Device could be designed and built in the relatively near future.

7.5.2.2 2.. The Device is inherently large, locked in, as the design is, to a height greater than the water depth and a breadth of the order of $\frac{\lambda}{2}$. A bypass system to reduce the differential head between chambers in storm conditions could significantly reduce wall thicknesses but the major problem to be overcome in the Device will certainly remain the large cost of the caisson structures.

7.5.2.3 3. Although there is a lot of research work to be done, and some of this is listed in 7.4.1., it is interesting to note that as listed, most of this will be directed to measuring the performance of a Device which is already designed in all its essentials. This is in marked contrast to the floating devices for which the optimisation of the key design parameters of mass, stiffness, size, and buoyancy has to be accomplished in a highly complex dynamic response situation. For this reason it could be said that this Device is closest to being brought to a point where a firm cost assessment will be possible.

7.5.2.4 4. The Consultants identify a number of changes which can be made to the design and the structural interpretation of it without greatly affecting efficiency. Effort in this area will probably show most rapid results in improving the estimated cost/output balance.

7.5.2.5 5. The present concept of alternating narrow 'upper' and 'lower' reservoirs at 12 m intervals means that each 140 m Device has water retaining frontage equivalent to a dam of the order of perhaps 1000 m in length. No amount of ingenious structural design can avoid this basic fact. At this early stage it would be wrong to rule out the possibility of a breakthrough in the layout which might get around this.

7.5.2.6 6. It is difficult to make a quantitative assessment of the prospects of the Device until some firm figures on output become available. It is clear that there is an inherent loss of efficiency because the Device cannot extract any energy

from the smaller waves in a random sea. On the other hand because the Device is not detuned to the larger waves, there could be some useful bonus power from storms. It seems likely however that it will not be economic to provide turbine and generating capacity to use this potential power and the Consultants have already indicated that this 'bonus' head is an embarrassment to the structure.

7.5.2.7 7. Assessment of this Device as a civil engineering structure is not difficult. The contracting organisations consulted have expressed confidence that they can construct the civil content of the Device in accordance with the Phase 1 Reference Design drawings. The standardisation of detail and repetition of work are attractive features.

Several contractors commented on the fact that the lower torsion box would be difficult to construct due to the height of the diaphragm walls precluding slip form techniques.

If the structure is redesigned in prestressed concrete, and full advantage is taken for reducing differential head, it should then prove possible with the lighter structure to complete the whole of the work in the dry dock. This could possibly offer a cheaper solution.

The structure has a stress hot spot at the recess in the leading edge of the inlet and outlet chambers into which the temporary blanks and the permanent flap gates fit. In this area of high cyclic stress it might be desirable to incorporate a changeable/serviceable component so as not to downgrade the life of the structure to this particular point.

7.5.2.8 8. Assessment of the flap gates is less easy. A working design has still to be proved. The 'gates' must be light, durable and pressure sensitive to small head differentials without losing significant amounts of the incident wave energy in work to open and close the flaps. The structural members in the gate module must be slender to present the minimum frontage to the incident wave while remaining strong in bending and shear to sustain pressures of up to 12 tons/m² on 6 m spans. The design of the gates offers scope for the researcher to investigate new materials and develop new technological ideas - but there is no reason to think that the work will not be successful.

7.5.2.9 9. Assessment of the turbine, etc. Ref. Chapter 14.

7.5.2.10 10. Siltation - No work has yet been done to confirm that the Device will not suffer from silting, but HRS, who are experts in this field are confident that it will not.

7.5.2.11 Economic Assessment and Overall Conclusion

An assessment based on the Reference Design and very preliminary performance data is given in a separate annexe to this Report. Although much ground has still to be covered before any reliable figures can be produced, it is very clear that a very large reduction will be needed in the basic civil engineering costs to make the Device competitive on a straight cost effectiveness basis. As already indicated, there are a number of areas where large cost savings can probably be achieved by redesign. It is likely that a much closer cost picture on this Device could be obtained over the next six months without going beyond the present scale of testing.

7.6. Future Activity

In general terms, certain things seem clear.

7.6.1 Although an in-depth programme of experimentation would be required before any decision could be taken to construct a prototype device, a relatively simple extension of the existing work could fairly quickly provide enough performance data for input for a fuller economic assessment of the Device. This assessment could then be the basis for deciding whether to proceed to a fuller experimental study.

7.6.2 A Mark II Reference Design should be prepared.

This design would explore the various cost saving ideas discussed in this Report, including by-pass to reduce extreme differential heads, use of prestressed concrete, use of curved and ribbed sections to resist pressure and adoption of a lower minimum thickness for concrete sections.

7.6.3 Explore modifications to the geometric layout, on the model to determine effects on performance, and in the design and costing to find out the influence on final costing. In this way there should be a first optimisation on a cost effectiveness basis. The simplest examples of such a study would be to determine the optimum spacing of the chamber walls, and the optimum maximum differential head.

7.6.4 If preliminary designs show that a fairly radical rethink of the layout could be attractive, this should be explored through as a Reference Design

7.6.5 When it has been established by laboratory testing combined with design costing that the Device is economically attractive, a further programme of activity should be drawn up to investigate various problems (e.g. flaps) that require larger scale testing.

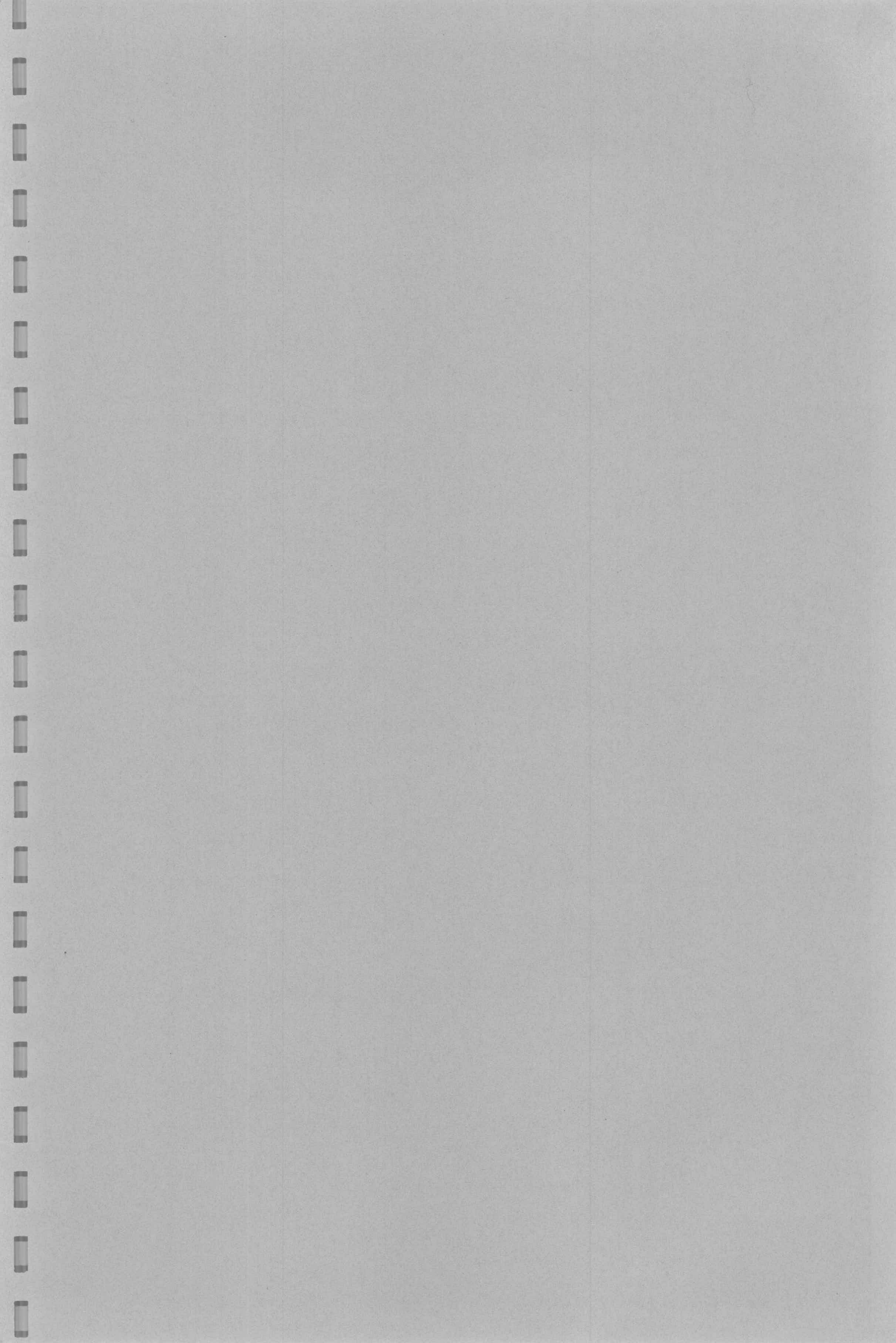

CHAPTER 8.0. WELLS OSCILLATOR

8.1 Description (See Fig. 8.1)

Mode of Operation

The prototype design has a working chamber which is a hollow dome, with an open bottom immersed in the sea and a duct in the top venting to the atmosphere through an air turbine. The working chamber is attached by an open tubular framework to a deeply immersed toroidal vessel ballasted so that it has almost neutral buoyancy. This in turn is moored to the sea bed through flexible moorings. Buoyancy for the Device is provided by air chambers around the periphery of the upper chamber. An electrical generator is linked directly to the air turbine.

8.2 As with the NEL Device, air is alternately drawn in and expelled as the water surface oscillates inside the upper chamber in response to the incident waves. The size of the upper chamber, the damping of the system, and the total effective inertia are the key parameters determining the response of the system, and have been optimised by theoretical calculation to give the best predicted response in the 8 to 10 sec. period sea. Theory shows that the best results come from minimising buoyancy of the working chamber structure (the cut surface area) and increasing the total effective vertical inertia to a value of $\frac{\rho g d T^2}{4 \pi}$ where d is the diameter.

Although generically similar to the NEL Device there are two important differences. The first difference is that this is conceived as a point generator designed to collect energy from any direction, and over a wave front several times its own diameter. The second difference is that it utilises a large volume of contained water or ballast located below the main energy level of the waves to provide the inertia force to restrain the working chamber vertically. Horizontal restraint is detrimental.

Air Turbine

A key feature of the Device is the design of the air turbine. This is an axial flow machine designed to accept flow in either direction while rotating at fairly high and substantially constant speed (about 700 rpm full scale). The advantages of this are:-

1. No rectification of the air flow is needed.
2. Direct drive to compact electrical generators is possible.
3. The speed fluctuations are comparatively small and could perhaps be further reduced by including flywheels.

Two further characteristics of the turbine are -

4. The damping characteristic is very nearly linear, which corresponds to the theoretical optimum for the Device.
5. The turbine has a self limiting response in that above the design air velocity the turbine stalls, and the efficiency drops sharply to zero, thus avoiding possible overspeeding of the generators in extreme sea conditions.

Structure

The axisymmetrical shape of the Device has obvious hydrodynamic attractions, but it seems likely that the most important advantage of this feature will be in reducing structure costs. By working entirely with elements of spheres, and other surfaces of revolution, pressures are resisted in the most efficient way and the structural shells can be relatively thin.

No design work has been carried out on the prototype structure, but the Device Team is thinking in terms of relatively flexible structure that is able to absorb shock loading by deformation, and in the case of the lower chamber, by direct transmission through the vessel and the contained water. For the latest proposed layout the Team favour steel construction for the dome (to minimise weight) and concrete for the submerged torus. Glass fibre composite construction is still a possible option, particularly for near full scale devices. Whatever material is finally chosen, the shell form of the structure, probably combined with lower wave loading may well make the structure cost of this Device relatively low.

Mooring

The method of mooring of a full scale Device has not been studied in detail but the Device Team favour kedge chain moorings.

Transmission

The Team has given some theoretical attention to the question of transmission of the power. Their first proposal is for the following power chain:- Variable speed alternator - Solid state rectification - D.C. transmission to shore - Direct industrial use as raw D.C. or inversion and transmission to the grid.

8.2 Status

8.2.1 Background - Unlike the other devices this project is not funded by WESC. A grant originally awarded by the Wolfson Foundation for work on plastic composites was re-allocated for wave energy work following the oil crisis, when it became clear that energy work was a more relevant line of research. This modest grant, which runs out next year, has been stretched by the enterprise of a multi-disciplinary team to fund a significant range of experimental and theoretical work. The Device was conceived by Professor Alan Wells, Head of the Civil Engineering Department and it is he who has been primarily responsible for the work thus far.

8.2.2 Current State of Development

8.2.2.1 Team - Project Director - Prof. Alan Wells.

The Team is made up of staff members from the Departments of Civil, Mechanical, Electrical and Aeronautical Engineering, with one or two research students working full time on aspects of the Device, with some help from research assistants. The department of Marine Biology has made available a sea-going boat and back up facilities in support of projected sea trials.

8.2.2.2 Theoretical Work

The form of the Device has been derived from a three-dimensional analytical study of the motion of a water surface subjected to an applied damping or exciting pressure, and the oscillating motion of an inverted, floating, closed cylinder. This analytical work remains the foundation of the work, since at this stage there is no significant volume of test data available. The need for a fuller mathematical treatment is appreciated, and it is likely that the CEGB will be undertaking a numerical analysis in the near future.

8.2.3 Experimental Work

Laboratory

A 1.5 metre diameter working chamber in glass fibre resin is currently under test in a 2 m wide x 1 m deep flume. The flume is relatively shallow and it is therefore not possible to properly model the lower part of the Device, which has had to be 'flattened'. The model incorporates a simple demonstration turbine in the neck, but this is not designed to measure the real power take-off. Pressures inside the chamber are being measured, but efficiency curves for the Device will not be available until the end of the year. The shape of the Device in relation to the depth of flume available will tend to limit laboratory work at Belfast.

Air Turbine

A model of the axial flow turbine of 0.6 m diameter and speed up to 6000 rpm is about to be tested in the wind tunnel at the University. This model with a theoretical power output of 30 KW (45 KW overload peak) will be tested in an unidirectional airflow, and calibrated for power output. The air flow tests at this scale have already demonstrated that the turbine is consistently self-starting.

Sea Trials

A ($\frac{1}{9}$ scale) 45 m diameter glass fibre resin model is now under construction and is due to be tested in the North Channel this Autumn. The calibrated air turbine referred to above will be installed in the model and will be used with a generator feeding through a fixed resistance to give a direct measurement of power. A four channel telemeter link will be used to monitor this information directly at the University laboratory. The remaining three channels will be used to monitor sea state, the vertical movement of the Device, and the vertical movement of the oscillating water surface inside the Device. The results are expected to provide good data for a prototype design early in 1978.

That it has proved possible to mount such a meaningful scale sea trial on a small budget and early in the project is probably a demonstration of the simplicity of the Device, and of the relative cheapness of developing point generators compared with long connected units.

8.4 Assessment of Feasibility and Potential

Falling as it does outside the scope of WESC the Consultants have not attempted to put any cost figures to the Device at this stage, so that any present assessment is made without benefit of either cost input or value output data.

However, by comparing it with other devices and knowing the general trends of WEC efficiency curves some comment is valid.

(a) The inherent simplicity of both the device and its power offtake give grounds for optimism that this could develop into an attractive device.

(b) No measurements are available for primary efficiency. It is possible that the very simple turbine might prove to have a lower efficiency than a traditional one, although a recent theoretical check at CEGB has confirmed an expectation of 80% or more over the useful part of the operating range. If in both of these cases reductions in efficiency are found to occur favourable basic cost of the Device could still lead to a competitive price per kilowatt.

(c) The Device is at present a point generator drawing power from a wave front of perhaps 7 times its own width. The designers say that it is very important that it is allowed freedom for horizontal travel. Although adjacent moored units will tend to move as a group, there will be limits on how close together they can be located, but the latest information from the Team indicates that close mooring is not required.

(d) The mooring and gathering of power from point generators which are essentially non directional is at present an unexplored area. The experiments of W.P.L. on their rafts will be helpful, but these rafts are essentially directional. It may be that the horizontal travel permitted to the oscillator might have to be limited for economic reasons.

Potential

At this early stage the Device appears to be attractive and some of its features look very promising indeed. It incorporates some ideas which could be valuable to other wave energy devices.

Theoretical work just reported (22nd July) suggests that a point generator ought to be 38 m diameter. It is claimed that such a device would generate 10 m watts, drawing energy from a wave front of 7 x diameter. This represents a very much more compact structure for the given output than for any of the other contending devices, although extracting rather less power per metre of wave front (263 kw/m of device but only 38 kw/m of wave front). On this evidence it seems likely that this device is always likely to be a point generator, but the figures given here should be used with extreme caution until laboratory work has confirmed the device efficiency. Any attempt to join units would at once lose the benefits of energy gathering by diffraction, and probably present a whole range of structural problems which are not present in the point generator.

NOTE : DEVICE IS AXISYMMETRIC.

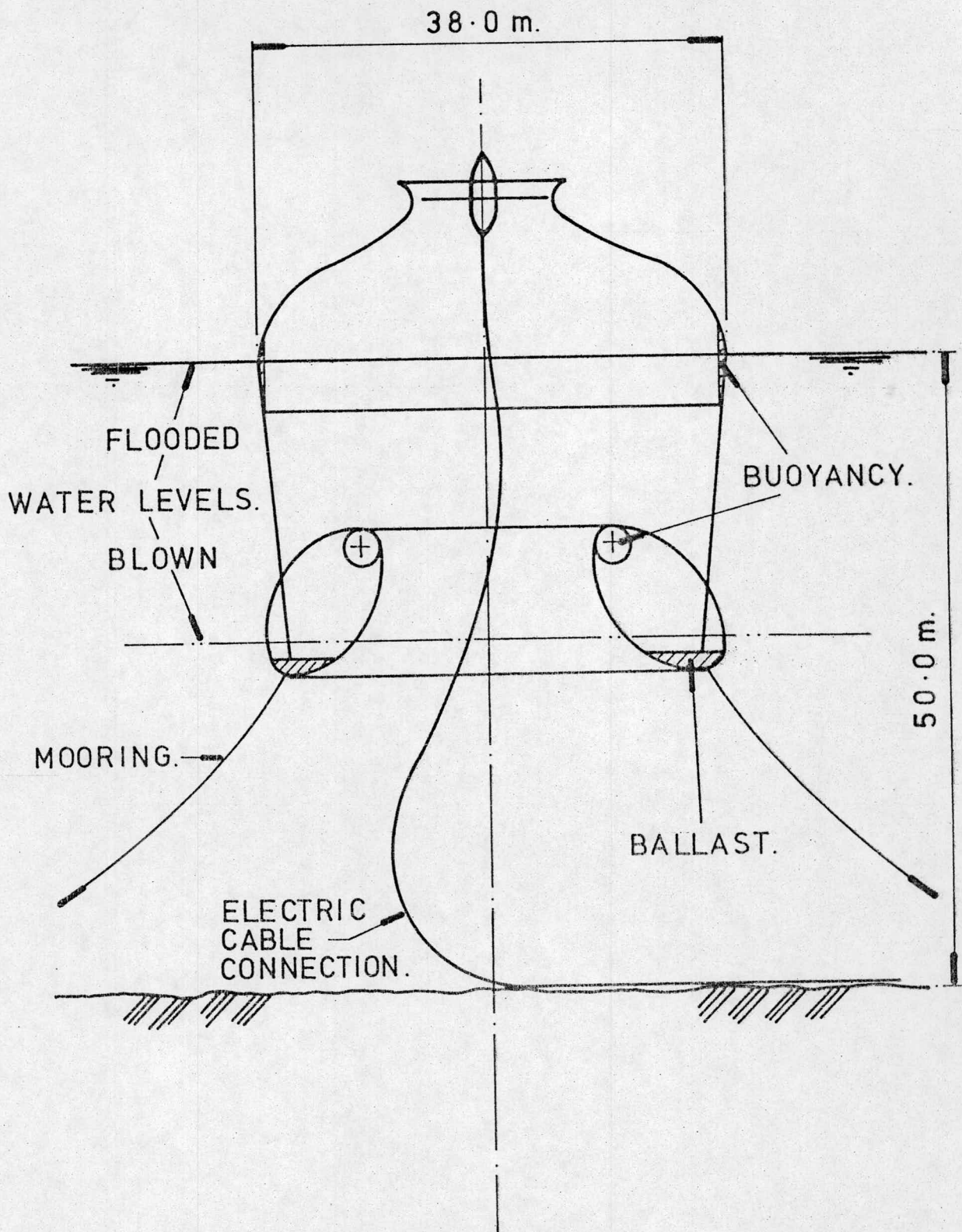

WELLS OSCILLATOR - SKETCH OF THE PROPOSED FULL SCALE DEVICE.

PROPOSED 10 MW. UNIT.

SCALE . 1 : 500.

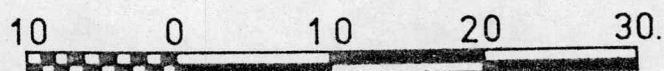
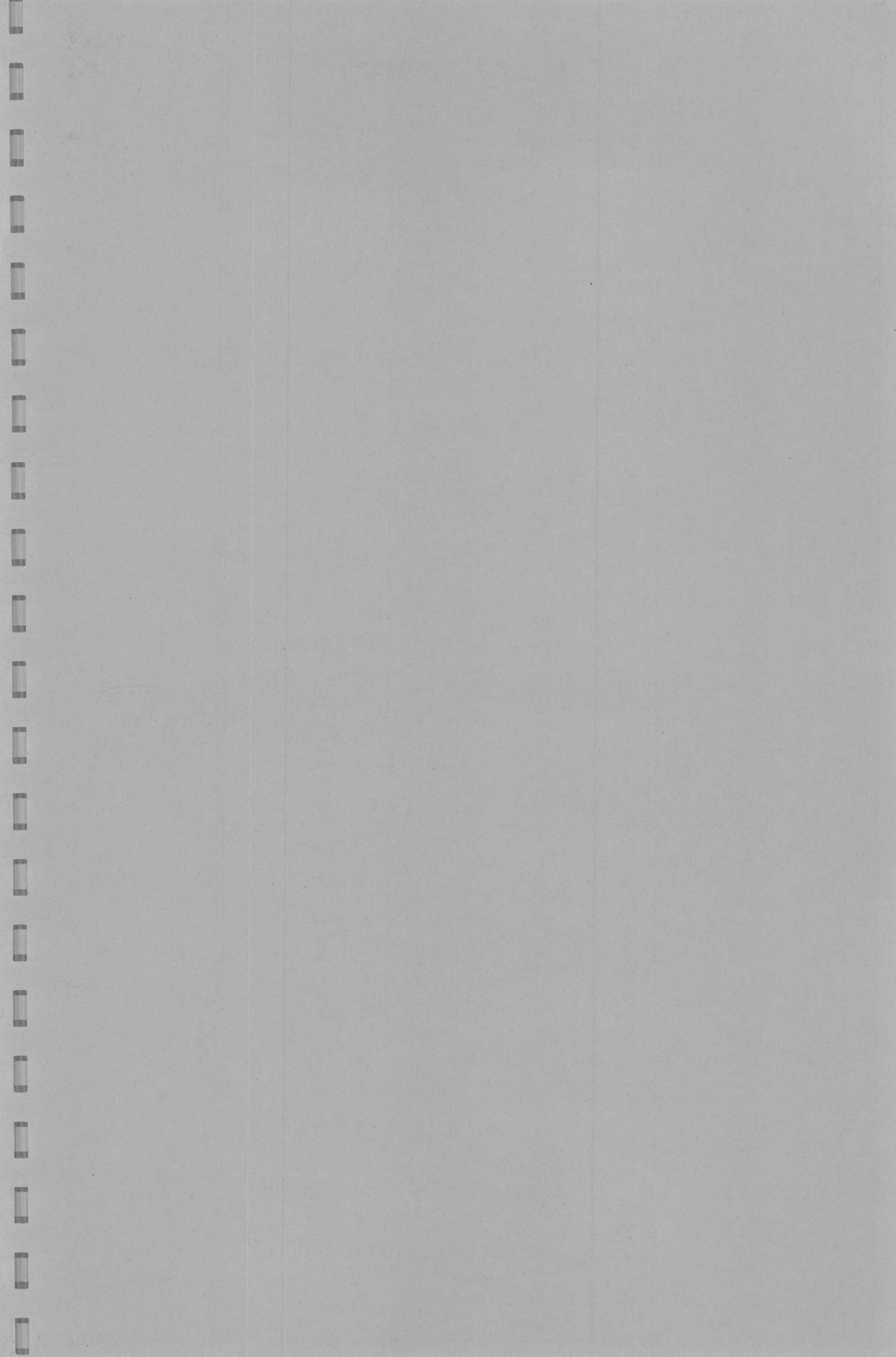

Fig. 8.1



CHAPTER 9.0 WAVE DATA

The collection and interpretation of wave data has not formed part of the preliminary study. The following comments relate to the significance of wave data and the adequacy of data available at present.

9.1 Data Available at Present

There are no comprehensive wave measurements for sites immediately adjacent to the likely location of wave power schemes (e.g. West of the Hebrides, Cornwall). For example, the best measured data available for the Hebridean coast is that recorded at Station India, 700 km offshore. However, this lack of measured wave data may not be as significant as at first appears. The general pattern of wave climate changes little over large distances in deep water, and much missing data can be filled in by wave forecasting techniques. Two major differences between Station India and the possible Hebridean sites are the very short fetch afforded to Easterly winds, and the influence of shallow water effects, particularly for the bottom siting devices.

9.2 Wave Data Required in the Immediate Future

Four principal types of data are required -

- (1) Scatter diagrams, for likely sites, of significant wave heights (H_S) and average zero crossing periods (T_Z). (Annual and seasonal sea state distribution).
- (2) The annual and seasonal distribution of average wave direction for given sea states.
- (3) Data on crest lengths in various seas, preferably in the form of defined multi-directional sea spectra, (the latter refers to the distribution of wave energy around the compass at a given time, i.e. for a given sea state).
- (4) A general description of the way in which sea states are modified in gently shelving waters, for example the incident of breaking waves, energy losses due to bed friction and the residual level of useful energy at various water depths.

Of the above list probably only item (3) cannot be obtained with any degree of reliability from present data. This is because very few long-term measurements of directional spectra have been attempted, this data being of only marginal interest to many marine installations. (It is of interest to note, however, that the influence of multi-directional seas, as opposed to unidirectional random seas, have been recently identified as a key factor in the response of several fixed North Sea platforms, and interest in this area may well promote the publication of relevant information). Perhaps the most important application for this information is in providing data for the wide tank tests of the spine concept to establish the efficiency of spines which rely on self cancellation between out of phase waves for stability and to predict the extreme loadings on the spine.

The scatter diagrams (1) are the basis of all attempts to predict the useful output of a given wave power scheme. Hence any improvement in the current information will improve the chances of optimum device sizes being chosen for preliminary appraisal, although very accurate refinement of this data is unlikely to change the course of the wave power programme at this stage. It is assumed that, for present purposes, one of the standard wave spectra formulae can be applied to each H_S/T_z combination with negligible effects on calculated annual device output. However, TAG 6 have recently raised the question of treating the swell component of wave climate as a special case, arguing that it is likely that the useful incident wave power is otherwise underestimated. (Swell tends to be monochromatic, the useful energy being concentrated close to the average zero crossing period part of the spectrum, unlike that in the standard Pierson-Moskowitz Spectra). Data on predominant wave direction (2) is also essential for an assessment of the total annual wave energy output of a long string of wave power devices. This data will also be needed in the investigation of suitable sites.

The information on the influence of water depth (4) is also crucial to the choice of the optimum distance offshore for both floating and fixed devices.

CHAPTER 10.0 DESIGN DATA

Because of lack of time the Consultants have not been able to prepare a general overview of the design data needed by each Device Team, and the present sources of information. The investigations of the Consultants were largely concerned with their immediate needs to complete the designs proposed by the Device Teams. The following tentative comments are included for completeness.

10.1 Mathematical modelling

Hydrodynamic solution of wave power device

The restrictions of currently available mathematical theories are as follows : -

1. Linear wave theory
2. Small deflection response of devices
3. No turbulence
4. Velocity proportional damping (power take-off)
5. Linear mooring springs
6. Linear structural stiffnesses

There is little prospect of any of the above restrictions being removed within the foreseeable future, but the approximations involved are probably quite acceptable for a great many cases.

To illustrate the power of the mathematical techniques the following is a list of problems for which, within the above list of restrictions, and the limits of accuracy of the numerical techniques used, an exact solution can be found.

1. Fixed devices
2. Free floating devices
3. Two dimensional solutions for individual devices
4. Three dimensional solutions for assemblies of devices
5. Multi degree of freedom systems (e.g. Cockerell rafts, ducks on spines with hinges)
6. Monochromatic (regular wave) seas
7. Random seas
8. Unidirectional sea spectra
9. Multidirectional sea spectra
10. Solutions for water particle motion, device motion, output power, local water pressures, forces in the structure.

All solutions at present are restricted to two dimensional solutions and cover 1, 2, 3, 5, 6, 7, 8, and 10 above. The generalisation to three dimensions is a very major step but is being actively pursued by several groups. Both analytical (e.g. explicit solutions and transformations using infinite series) and fully numerical (e.g. source distribution, finite difference) techniques are being used.

For some problems mathematical solutions are direct competitors to small-scale laboratory tests. The areas in which the mathematical solution can show advantages are :-

1. Rapid repetition of solutions for a range of device parameters once a solution has been set up. This type of work is very relevant to choosing optimum sizes and shapes, and even, in many cases, for different device configurations.
2. Cost effectiveness - particularly for the two dimensional cases.
3. If required solutions are available for the full list of parameters in 10 above at little or no extra cost. This facility tends to be very limited by practical restrictions on monitoring (e.g. the number of strain gauges that can be accommodated).
4. The task of formulating a mathematical solution can greatly aid the fundamental understanding of the problem.

The advantages of laboratory testing are in the relaxation of most of the restrictions listed previously, in particular relating to large waves, extreme responses and non-linear effects in general. Also it will be some time before mathematical solutions, even for linear theory, become available for the full range of three dimensional options.

10.2

Efficiencies

Available data

The Device Teams have rightly placed great emphasis on the measurement of device efficiencies as a function of wave period in laboratory experiments. A summary of the available data is given in Table 11.1.

The distinction between monochromatic and sea efficiency should be emphasised. Monochromatic efficiencies are measured in regular wave trains of constant period. Sea efficiencies are defined as the percentage of total power available extracted by a device in given random sea state. Sea states are normally characterised by the average zero crossing period T_z , but for most wave spectra the majority of power is associated with component waves of period considerably greater than the T_z period. Hence, firstly sea efficiencies tend to have a lower peak efficiency but a broader band width, and secondly the peak efficiencies occur at values of T_z which are approximately 0.7 times the period for peak efficiency in monochromatic wave trains. For example, a device which had an efficiency curve which reached a maximum value at a period of 11 secs would probably achieve peak efficiencies in random seas of 8 second average zero crossing period.

	HRS Rectifier	NEL O. W. C.	Salter Duck	Cockerell Raft	Wells Oscillator
Laboratory Tests	1/30 Scale monochromatic but results are unreliable due to leaking flaps on model	1/120 Scale monochromatic fixed and free floating	1/150 Scale monochromatic and random for fixed spine and approx simulations of non-rigid spines. Several power take-off Character- istics simulated	1/40 Scale monochromatic free floating	1/30 Scale Very approx estim- ates only
Mathematical Models	None of overall device	Fixed device only	Fixed and free floating (short spine) effici- encies (CEGB model)	Free floating results for several different configura- tions(CEGB model)	Both 2 and 3 dimension solutions but with approx modelling effects of inertia torus.

Table 10.1 Data available on device efficiencies

Monochromatic efficiency curves can be measured accurately in laboratory tests, and are essential for understanding the behaviour of a Device. (ref. EWPP 2nd Year Report Sept '76 P5.7 para 1). The initial efficiency curves from mathematical models are also for monochromatic seas.

Sea efficiencies are to an extent a function of the assumed wave spectrum properties. They can be measured directly in random sea wave tanks, but with less accuracy than for monochromatic waves. For most devices with velocity proportional damping/power take off, sea efficiencies can also be rigorously calculated by superposition using monochromatic efficiencies derived either from laboratory or mathematical models. This approach is particularly approximate for the Russel Rectifier due to the discontinuities in the inlet and outlet flows. For other types of power take off this latter approach is only approximate, but is as accurate as random sea tank measurements in some cases.

In summary, although much data has been collected on efficiencies, there is still much additional data required, particularly in the following areas :

1. Efficiency curves for specific full scale proposals.
2. Efficiency curves for realistic power offtake characteristics.
3. The integration of data on sea efficiencies with annual wave statistics.

The limitations on efficiency data

It should be emphasised that data on sea efficiency for a device does not provide sufficient information for design of a power take-off system. From the efficiencies and the annual sea state statistics the distribution of hourly mean power produced by the devices can be estimated. As the power input is a random process the output is similarly random in character. Hence, for design a complete history of response needs to be estimated. The minimum requirements for mechanical devices (ducks and rafts) are the short term and long term statistics of velocities and torques, and for turbine devices, the statistics for pressure and flow.

10.3 Wave Loading

The designer requires data on the following :-

1. Local pressure loadings applied to the device.
2. Resultant cyclic forces and moments applied to a cross-section of the device (the second order mean drift forces are discussed separately in section 12 - Moorings and Anchors).

No measurements have been made of 1 above, although these are likely to be the more important loadings for the design of most devices. Furthermore none of the teams has plans to include these measurements in their immediate test programmes. Hence design information in the near future will have to be derived from approximate theoretical considerations, and mathematical solutions. The latter should soon become available for all devices except the HRS rectifier but the solutions are limited to linear theory and hence exclude the extreme loading cases and phenomena such as wave slam. Loadings on the HRS rectifier can probably be estimated with sufficient accuracy by inference from the wave action observed on the models and experience with conventional breakwaters.

Resultant section forces (2) are not used on the structural design of free-floating devices such as the NEL, O.W.C. or the Cockerell raft (except insofar as they determine raft hinge forces). These forces are of particular concern where the movement of the Device is restrained, e.g. by a long spine, or by the sea bed for a bottom sitting device. For the latter the overall forces can, at the present, probably best be found by integration of the water pressures estimated as described above. For example, the total forces on the HRS device were estimated in this study by Sainflou theory. Such simple methods are not applicable to a long floating spine. The Edinburgh team have made an extensive set of force measurements for rigid spines and not surprisingly have shown that the simple version of Morrison's equation (the mainstay of conventional offshore structure design) is not applicable. It is not clear whether a correction, (similarly to the Mcamy-Fuchs equation for large vertical cylinders) could be used to improve the predictions of this equation by giving a better approximation to the diffraction loading on a large diameter horizontal cylinder, but no formulation will give accurate answers unless it is capable of taking into account the duck motion, the power take off and the compliance (or partial compliance) of the spine. For such a complex problem only wide tank tests are likely to yield any useful information. Numerical mathematical solutions may also become available in the future but will not be capable of predicting extreme conditions accurately.

Structural DesignDevice Team Designs

No substantial structural design work has been attempted by any of the Device Teams.

The Duck Device Team have restricted their attentions to estimates of limiting static loading and strains for various spine configurations.

NEL have studied the dynamic response behaviour of long structurally continuous spines and have proposed an approximate limiting stiffness criteria. This work influenced their decision to pursue a short inertia dominant system.

The Raft Device Team have made no design calculations but are able to cite the many conventional concrete ships and barges to which the rafts bear a close resemblance.

The appropriate level of design effort

The preparation of fully detailed structural designs will not be relevant to wave power development for some time. For the near future effort should be restricted to that required to demonstrate the technical feasibility of various proposals and to allow rudimentary economic optimisations. The structures are likely to be the most costly items in several of the proposed schemes, and improved estimates of total structural mass would be of immediate interest. Also, in several cases, local structural details could significantly affect the feasibility of proposals, for example, the stresses adjacent to the duck collars and universal joint bearings in the duck device. In such cases more detailed local analysis would be justified.

CHAPTER 11.0 MOORINGS AND ANCHORS FOR FLOATING DEVICES

11.1 Device Team Proposals

None of the Device Teams has prepared a preliminary design for a full scale mooring system. The Duck Device Team and Raft Device Team have both prepared mooring systems for their large models (approx. 1/10 scale) in Loch Ness and the Solent. However, at this scale the mooring systems bear little relation to economic full scale moorings. NEL have also examined the characteristics and costs of conventional moorings, and have concluded that such moorings with adequate compliances will be very costly. NEL are, of course, also developing new types of anchors and assessing their costs relative to conventional anchors.

The Consultants considered that at least a preliminary attempt should be made to outline a mooring system for the reference designs, and the following is a description of this work.

11.2 The Mooring Problem

The requirements for a wave power device mooring are quite outside the range of conventional mooring systems, in terms of performance, degree of compliance, resistance to extreme conditions and sheer scale.

To understand the forces imposed on the mooring system it is necessary to consider two limiting cases.

1. A rigid mooring system - If the device is constrained not to move, it will be subject to both cyclic and non-cyclic forces which will be directly transferred to the mooring system.

The cyclic mooring force would be many times the steady mean force (perhaps typically 20 times).

2. A mooring system with very little stiffness (tending to zero) - In this case the steady forces will impose a large mean displacement on the system, but the mooring system will not sustain any cyclic forces. However, the device will be essentially free to oscillate with the waves and if of small dimensions will undergo a cyclic displacement equal to the surface water particle motion (i.e. a circle of radius $H/2$ where H is the wave height).

In practice all mooring systems fall between the above extremes. Even the most elementary calculations show that it will be uneconomic to provide mooring systems sufficiently strong to resist the full cyclic loading on the devices, and in fact no device team is proposing to rely on the mooring system to restrain the device rigidly, even if this would result in increased efficiency. The problem is seen rather as providing a mooring system adequate to resist the small steady force component, but with sufficient flexibility to avoid the large cyclic forces. The above system 2 is regarded as being close to the ideal.

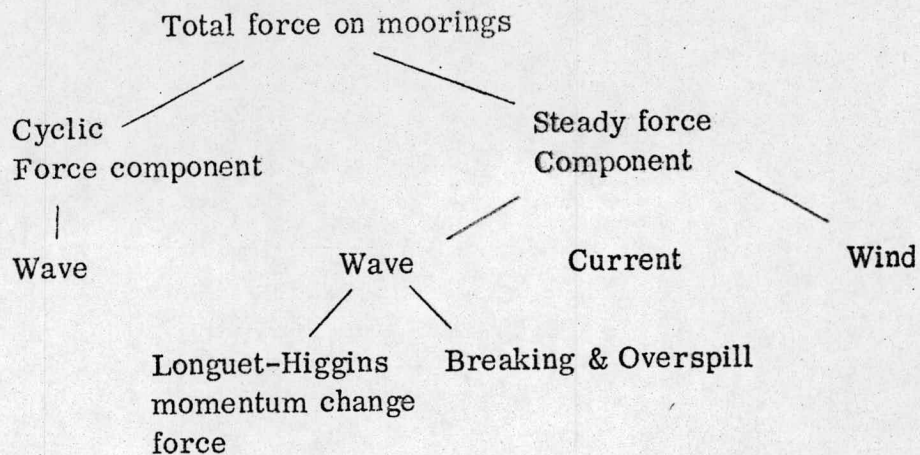

Fig. 11.1 Components of Mooring Forces

Mooring Forces

The force components are illustrated in Fig 11.1. For the locations considered in this study, wave induced forces are probably much larger than current and wind forces for most devices. The Longuet-Higgins force is a second order force which is related to the change in total momentum of the water in front of, and behind, the device and is a function of the proportions of wave energies reflected, absorbed and transmitted. The breaking and overspill components are more difficult to quantify and are very dependent on the detailing of the device. In some cases this latter force can be negative, causing the device to move towards an oncoming wave train.

11.3 Derivation of a Specification for the Reference Design Moorings

11.3.1 The Steady Force

In deriving the characteristic steady force on devices it was generally assumed that for the governing design case the Longuet Higgins equation would give a reasonable estimate of the steady force due to wave action. Wind and currents were checked very approximately. They were found to be small and have therefore been ignored.

For a given monochromatic wave the equation derived by Longuet-Higgins (L-H) can be expressed as follows :

$$F = \frac{\rho g H^2}{16} \quad (1 + (\text{proportion of power reflected}) - (\text{proportion of power transmitted}))$$

Where H = the incident wave height

That such a convenient formulation is possible is due to the force being proportional to the square of the wave heights.

The L-H equation was derived for a device with no losses (e.g. turbulence) but the Consultants have assumed that the above equation is accurate for real devices if the losses are equated with power absorbed in the consideration of mooring forces. The equation is at first sight independent of the wave period T, however in fact the proportioning of power (the terms in the bracket) is strongly period dependent for a given device. Similar trends are likely to occur in this proportioning for all devices designed to operate in similar conditions. As an example the Consultants took the /...

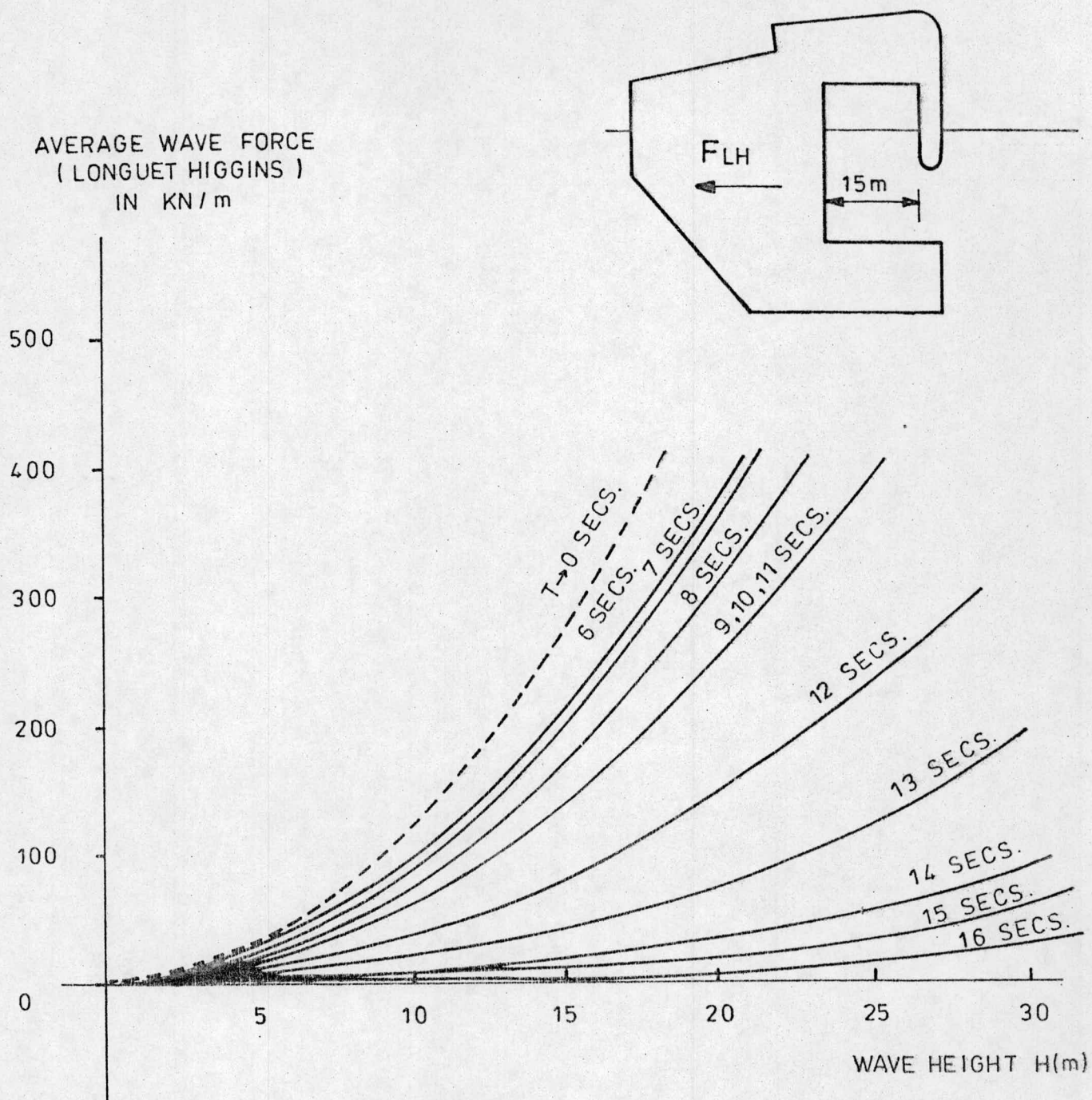

THE AVERAGE WAVE FORCE ACTING ON AN
N.E.L. O.W.C. DEVICE (15m COLUMN WIDTH)
AS A FUNCTION OF WAVE HEIGHT AND PERIOD
— FOR MONOCHROMATIC WAVES.

(FOR RELATIONS BETWEEN INCIDENT, REFLECTED, TRANSMITTED
AND OBSORBED WAVES — SEE NEL LETTER 10/6/77)

Fig. 11.1

data supplied by NEL for their latest model and calculated the L-H force for a range of wave heights and periods. The results are plotted in Fig 11.1.

Although the results are derived for regular waves they give a general picture of the wave forces in various conditions. Most importantly it can be seen that the largest wave forces are not associated with the largest waves. For example the force from a 30 M high wave which might typically have a 16 second period is only one third of that for a 15 m wave which might have a period as low as 12 seconds. The above refers to single waves and it does not imply that the rougher seas will cause lower mean mooring forces. In fact as the spectra for the roughest seas tend in most cases to be envelopes of all lesser seas for all wave frequencies it is still likely that peak mooring forces will occur in the roughest seas.

NEL Oscillating Water Column

By inspection of Fig.11.1, and bearing in mind the likely worst combinations of wave height (H) and period (T), and the fact that mean mooring forces are not determined by single extreme waves, a figure of 150 kN/M of mooring force was thought to be the maximum possible L-H force which could occur. However, for extreme conditions the L-H equation breaks down, particularly if the waves overtop the device. Hence for the reference design it was finally decided to adopt a figure of 100 kN/M. (In shallow waters this figure may be low, as a correction factor for the L-H equation tends to increase horizontal forces, perhaps a 25% increase in 60 m of water).

W. P. L. - Cockerell rafts

In the absence of better information it was decided to adopt the same figure per metre for the Cockerell rafts, on the basis that the reference designs for both the OWC and the raft are intended to have efficiency curve at the same period peaks, and the percentages of energy reflected, absorbed and transmitted are closely related to the value of this peak.

S.E.A. - Salter ducks

This device has virtually no freeboard and hence over-topping is likely to occur earlier than for the OWC or raft devices. Furthermore curved-back ducks are capable of generating transmitted waves behind the duck in just the type of conditions likely to cause peak mooring forces. Both these effects will tend to reduce mooring forces. Salter has measured mean forces on a fixed spine duck in random seas and estimates a maximum steady force of only 50 kN/M for a 15 m duck. This figure was adopted for the reference design. For a compliant spine the team hope to significantly reduce this figure, but the evidence for this is indirect. The tank measurements were also for the less onerous deep water case. On balance the Consultants did not feel justified in taking a figure less than 50kN/M.

11.3.2 Deflection criteria

As stated previously it was decided to adopt a compliant mooring system. However, the load-extension curve for a mooring system will not be ideal, and some consideration has to be given to the relations between steady forces, cyclic excursions, peak mooring forces and mooring stiffness. For the purpose of the Reference Design it was decided to adopt the following simplified approach.

1. The device was assumed to adopt a mean position determined by the deflection corresponding to the steady force on the load/extension diagram.

2. The potential cyclic forces are virtually irresistible and the device will undergo a cyclic excursion of 10 metres either side of the mean position.

The 50 year return extreme wave height is about 32 metres. For this wave the surface water particle motion is 16 metres. The reduced figure of 10 metres reflects the size of the devices, and also allows for a small reduction due to finite mooring stiffness.

11.3.3 Final design criteria and safety factors

There is no standard way of evaluating the correct safety margin for structural systems which have an ultimate condition which is partially deflection/strain controlled and partially load/stress controlled. This is particularly true for systems with non-linear characteristics. For the reference design the following criteria were adopted.

1. Design steady mooring force = characteristic steady mooring force x 1.2.
2. Maximum peak mooring load is determined by the characteristic cyclic deflection of $\pm 10\text{m}$ x 1.0.
3. The maximum peak cable tensions is to be not more than 70% ultimate breaking load of ropes for long life systems or 60% for synthetic twisted ropes.

11.3.4. Dynamic criteria

Dynamic criteria were not considered in the reference design. For cyclic excursions greater than the wave particle motions the wave forces will be strongly restorative, and hence resonance should not be a problem for a compliant mooring system.

11.3.5 Mooring systems investigated (see Fig.12.3)

The conventional solution for a compliant mooring is a very long chain cable. Although on a much smaller scale, the moorings of lightships for long periods in areas of severe climate probably bear greater resemblance to wave power device moorings than any other systems. These lightships are in fact moored with very long chains. For example the Seven Stones Lightship probably has the longest moorings in the U.K. at 330 metres. The vessel is moored in about 60 m of water (as for the reference designs), is 150 feet long and about 500T displacement. The chain is 42 mm diameter stud link chain cable with a breaking load of 90 tonnes. Overseas it is not unknown for the flexibility of chain moorings to be increased by the addition of lengths of coir rope for hurricane conditions, or by means of deck mounted spring systems. However calculations have shown that mooring systems are likely to be a significant component of total scheme costs, and it appeared to the Consultants that catenary chain systems would be prohibitively expensive. It was decided to investigate in more detail systems which would be more cost effective.

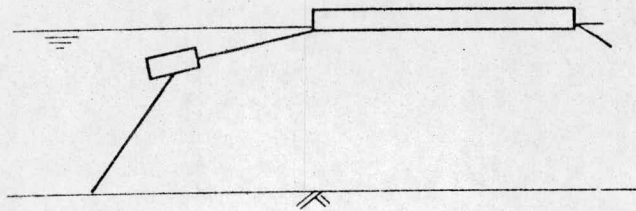

② SINKING BUOY.

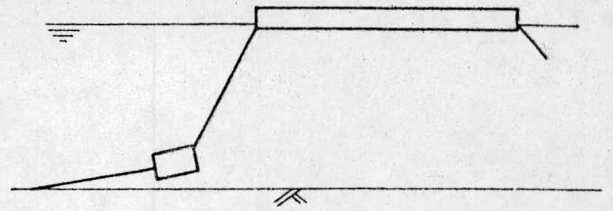
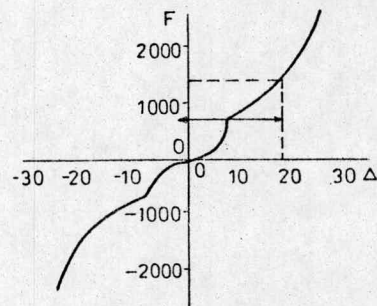

① WEIGHT.

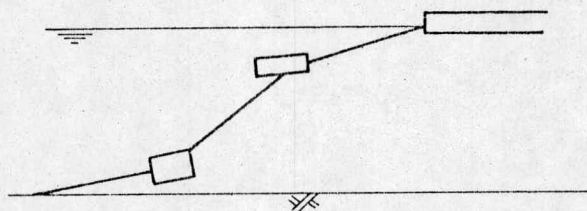
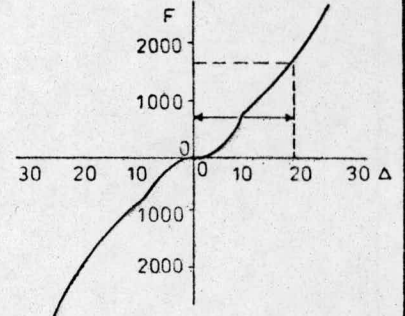

③ WEIGHT AND SINKING BUOY.

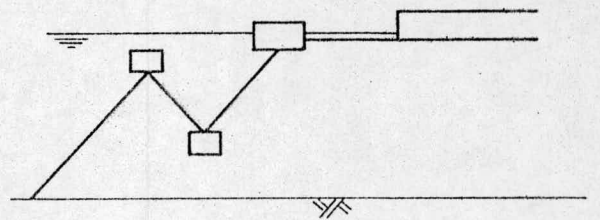
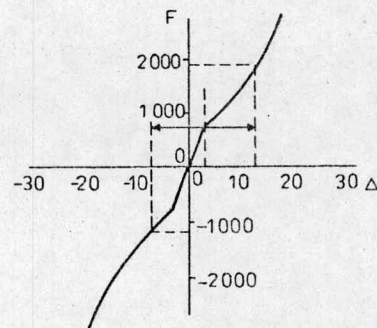

④ SINKING BUOY WEIGHT AND FLOATING BUOY.

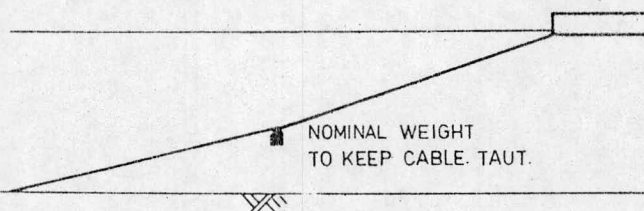
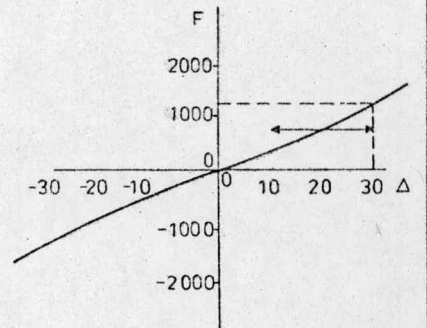

⑥ ELASTIC CABLE

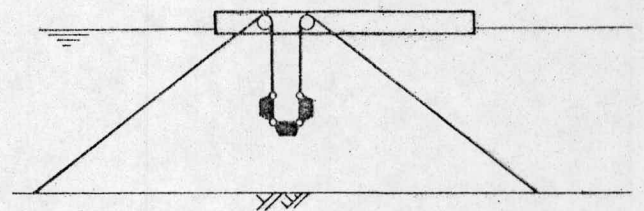
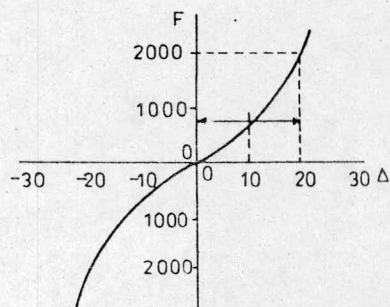

⑤ COMMON WEIGHTS SYSTEM SUPPORTED OVER PULLEYS ON DEVICE.

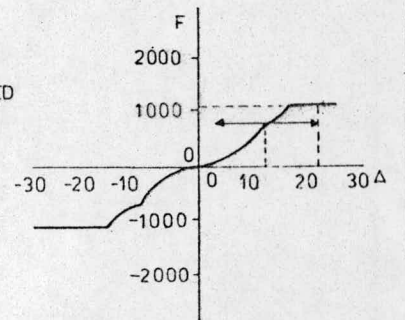

UNLESS SHOWN OTHERWISE, ALL MOORING SCHEMES ARE GEOMETRICALLY SYMMETRICAL ABOUT THE DEVICE CENTRE LINE. FIGURES GIVEN ARE NOMINAL AND ARE NOT DIRECTLY COMPARABLE BETWEEN SCHEMES

FIG.11.2 MOORING SCHEMES INVESTIGATED.

Lifting weights System 1

As the mooring systems must sustain the steady mooring force, and also suffer a large excursion it is unavoidable that some form of energy transfer must be included in the system. This energy transfer must be conservative (storage, not dissipation) to ensure that the device will return to its mean position. Chains store energy by the lifting of the links. This appears to be inefficient, since in a catenary much of the chain weight is only lifted over a very small distance, and the weight/strength ratio may not be the optimum. For these reasons systems based on discrete weights and light cables or ropes were investigated as an alternative. By this means more cost effective materials might be used for both weight (concrete and sand) and strength (synthetic ropes, steel cables or bars).

In designing a lifting weight system it was found that it was necessary to allow the weight to sit on the bottom in the at-rest position. This reduces the mean excursion and hence the peak cable tension. The disadvantage is that the weight will suffer repeated impacts as it returns to the sea bed. The large vertical mooring force component acting on the device may also be a disadvantage.

Sinking buoys System 2

These store energy by overcoming buoyancy force. The response characteristics are similar to the sinking weight but buoys avoid the bottom impact and vertical force problem. The anchorage force is no longer predominately horizontal which would be a disadvantage for conventional anchors, but an advantage for buried anchors.

Hybrid weight/buoy Systems 3 & 4

Several hybrid systems were investigated and some gave improved mooring characteristics but at the cost of an increase in complexity and materials.

Weights plus pulley System 5

The idea behind this system was to minimise the material used in the cables and weights. This is achieved by maximising the lift of the weights per unit horizontal displacement, using the same weights for energy storage for excursions in either direction and minimising peak cable tensions. The system was indeed found to use significantly less material than for any other system investigated. The disadvantages are :

1. The need for mechanical components - pulleys and links between weights.
2. Problems with marine growth on the mechanical components.
3. The possibility that the ropes would have a very short life due to wear over the pulleys - (even if the pulleys were very large diameter and with very little bearing friction).

Purely elastic mooring System 6

This is the simplest possible mooring, and stores energy in a nearly straight rope by elastic extension. For such systems the very large cable extensions normally

quoted in manufacturers catalogues for synthetic ropes are totally misleading. These are only relevant for a single slow loading, and much of the extension is non-recoverable. For cyclic extension at periods of, say, 10 secs, the effective modulus of the ropes is many times greater than the normally quoted value and the allowable extensions correspondingly less. Furthermore, repeated loading (perhaps 3×10^6 cycles per year) may cause major fatigue problems. The fatigue life of synthetic ropes is almost totally unknown for this type of duty.

Materials for ropes and chains

Chain, steel wire rope, steel bar, twisted ropes in polypropelene, nylon and polyster and parallel filament ropes in terylene were briefly considered in the study.

Very simply, chain is expensive and its life varies from very many years (20 years or more) to a few months depending on the degree of movement suffered by the chain. A notable advantage is that short sections worn by fretting corrosion can easily be replaced, worn links probably being adequate for use at the still end of the chain.

Steel wire rope is cost effective in terms of cost per ton capacity per metre length of rope, but is very susceptible to corrosion. Galvanised wire rope has a maximum life of about 3 years. Plastic coatings are not thought by several authorities to be reliable.

Rolled steel bars with either rigid threaded or link connection could well be cost effective and have a long life but have not been used extensively elsewhere.

Twisted ropes are normally used where only a limited life is required. The twisted construction of the rope and the materials used give these ropes an extremely high initial extensibility, but the flexibility under repeated loadings is very much less. The fatigue life of such ropes is not known but it is thought that it could be poor. The cost effectiveness as defined above is very good.

Parallel filament ropes in terylene or kevler offer extremely compact high strength ropes (up to or exceeding that of steel wire rope of the same circumference) with a high stiffness (about one quarter of that of steel). These ropes are 3 to 4 times as expensive as twisted ropes of the same capacity but are believed to have a very long life. These ropes also require special end connections.

Mixed mooring lines

The requirements for a mooring line in several of the schemes is very different in different regions i.e.

1. Close to the water surface.
2. The middle section.
3. Close to the anchor.
4. Sections of rope travelling over pulleys.

It is likely that in some cases a mixture of materials would be economic, using costly but replaceable sections in areas of severe duty, and long life components for other areas. Theoretical advantages would have to be weighed against the costs of end connections and increased complexity of laying and maintenance.

Prospects for the development of new ropes

Although ideal ropes are not available for some systems, there is good reason to believe that the performance of existing ropes could be improved if the novel requirements for wave power moorings were considered in detail. Conventional mooring ropes have been designed to meet specifications which are not wholly appropriate to wave power schemes. Of the many possible combinations of rope construction and materials, only a fraction have to date been tested.

Anchors

Four types of anchors are possible.

1. Dragging anchors or sinkers relying solely on mass and friction to counter both uplift and horizontal forces.
2. Burying anchors (e.g. plough anchors) which dig in to the sea bed to increase horizontal resistance. This type of anchor only acts efficiently for shallow angle mooring lines.
3. Combinations of 1 and 2 where the mass resists the uplift, and the buried anchor resists the horizontal force.
4. Embedded anchors with positive provision for burial by explosives or hydraulic jets. Piled and rock bolted anchors also belong to this family.

Compared with anchors normally used for ships and floating offshore structures, the anchors required for wave power must be capable of resisting unusually large forces, but there is no requirement for retrieval of the anchors.

Preliminary estimates showed that dragging anchors will probably be prohibitively expensive. Burying anchors show only a marginal cost improvement, particularly for those schemes with a significant uplift component. Embedded anchors are very small but their cost bears little relationship to the size of the anchor itself. The Consultants are convinced that for wave power devices some form of embedded anchor will be adopted.

Summary of the systems and preliminary costings.

1. For all the systems involving catenaries, weights and floating buoys it was found that the large cyclic excursion needed on top of the mean excursion was such that in 60 m of water the moorings were approaching the limits of their travel. The force deflection curves were therefore climbing steeply and peak cable tensions tended to be much higher than mean values (factors of 3 to 6 times). Preliminary estimates suggest that mooring costs may be less for these systems in 100 m than in 60 m of water. (Longer cables of smaller cross-section could be used with smaller anchors).

2. The system involving pulleys makes more efficient use of materials (cables, weights and anchors) than any of the other weight or buoy systems. The total cost of the system is, however, difficult to assess as it depends on mechanical components and may need frequent and difficult maintenance.

3. The pulley system is severely restricted by space limitations under the devices and would not be feasible for some devices in depths of water less than 80 m.

4. With the exception of the system incorporating pulleys and the elastic system, the cost of the weights and sinking buoys would seem to dominate the costs of the mooring systems, even assuming the crudest form of construction (concrete boxes filled with sand or air). In general weights are more cost effective than sinking buoys, but weights suffer the disadvantages of imposing large vertical loads on the device and are subjected to impact loads on the sea-bed.

11.3.6 The elastic system chosen for the reference design

The reasons for choosing the simple elastic system for the reference design were as follows :

1. Simplicity - this will aid installation and maintenance.
2. Cost effectiveness - if an elastic system can be made to work it is unlikely that any of the alternative systems will be competitive.
3. It is most likely that no rope presently produced has all of the properties required, but on the advice of NEL it seems that the chances of developing a suitable rope in the future are probably better than those for overcoming the disadvantages of the pulley/weight system. This rope may be synthetic, or possibly a steel wire rope (the latter probably needing to be considerably longer).

Polyester rope was chosen as being, of ropes presently available, the one with properties most closely approaching the ideal. The cyclic elastic properties were estimated approximately from manufacturers test data, but there is no data available on the fatigue life of the rope. It seems that as far as can be judged these ropes will require replacement at regular intervals. For this study a notional life of 4 years was assumed.

Self-embedding uplift-resistant anchors were chosen. For sites with insufficient depth of sand (or other suitable material) overlying bedrock it is probable that rock anchors will be used in preference to mass anchors.

Details of the reference design moorings requiring further study.

The following features of the mooring systems shown on the reference designs have not been investigated by the Consultants.

1. Position of mooring line attachment. These are shown on the underside of devices. Particularly in view of the need for replacement of moorings at intervals, this may not be possible. One solution frequently adopted elsewhere is to include tubes from /...

the required position of anchorage up to a convenient location on deck, with abrasion resistant cable or chain for the length of mooring in the tube.

2. Methods for installation and replacement.
3. The anchors shown resist largely horizontal forces. It is not certain if embedded anchors are generally suitable for this duty.
4. Some anchors are shown connected to two mooring lines, and are required to resist pull in different directions at different times.

Finally all mooring systems shown are for fixed orientation moorings. If only due to geometrical restrictions, the Consultants see little hope of developing systems allowing a significant degree of freedom for the alignment of devices to be varied to suit the direction of the waves.

11.4 General Summary

11.4.1 The present position

The rudimentary estimates prepared suggest that conventional mooring systems will be prohibitively expensive for wave power devices. It is almost certain that the final mooring scheme will employ a novel configuration, and will use specially designed ropes and anchors. Designs will need to take full advantage of the large number of similar components used in a complete wave power scheme, and of the fact that the mooring system is a permanent installation. However conventional moorings should continue to be included in future investigations to provide a benchmark, until a fully proven novel system is devised.

The reference design includes elastic rope moorings but it is not certain that this type of mooring is feasible. If not, of the other systems the Consultants tentatively favour the pulley based system for its efficiency in the use of materials, hoping that with the large number of systems required the problems inherent in this system can be overcome. These problems include wear of ropes passing over the free pulleys, the life of underwater pulley bearings, and the weight link hinges.

11.4.3 Future activity

A major programme of work is still required on the following aspects of the mooring problem.

1. Establishment of a mooring specification

Realistic modelling of mooring line characteristics should present few problems to the Device Teams. No team has yet attempted this, and no designs of mooring have yet been available to model. It is clear that this is a problem needing iterative solution.

At this early stage two dimensional modelling (narrow tank) will probably be adequate, but the articulated spine of the SEA team will need wide tank tests to establish the interaction between compliant spine and mooring system.

2. Desk studies - preparation of proposed designs

This task has been attempted in a very preliminary way during this study. It is clear that there are many possible solutions which should be considered by Device Teams.

3. Component testing

Ropes This work can be summarised as testing of ropes of novel construction, both cores and sheaths, and new materials. The testing should investigate long and short term load extension characteristics, fatigue and durability for both ropes and end connections.

Anchors A fundamental re-appraisal of anchor types and cost effectiveness is required. NEL are already engaged on such a study for the offshore industry and are intending to extend this work to cover the requirements of the wave power programme. The possibility of devising an economical embedded anchor to take mainly horizontal forces, together with forms of anchor suitable for mixed ground conditions (e.g. bedrock overlain with a shallow sand layer), will require special attention.

Mechanical components Wear rates and corrosion of mechanical components such as pulleys, links, etc., should be investigated.

4. Installation, maintenance and replacement

These items will form a major proportion of the mooring system costs and cannot be properly assessed until a schedule for maintenance and replacement is produced. Figures simply based on current experience are likely to be very inaccurate and possibly misleading.

CHAPTER 12.0 CONSTRUCTION MATERIALS

There are several materials which could be used in the construction of Wave Power Devices. Time has prevented the Consultants from reporting on their relative merits, criteria for adoption of the alternatives, information on design procedures to be used, and areas where further research is needed.

The following notes are the Consultants first thoughts on the above topics for the more common materials.

12.1 The Use of Concrete in Wave Power Structures

General Comments on Concrete as a Structural Material

Concrete has the capability of being readily placeable in complicated sections and of maintaining consistent quality in the process. On the debit side it is relatively weak in compression and has negligible resistance in tension. These deficiencies are overcome by the use of relatively heavy sections and, in respect of tensile stress, by providing reinforcement to sustain the tension, or prestress to obviate it.

Over recent years engineers have sought continuously to use concrete in new situations, and to increase its durability and economy in more familiar applications. Considerable funds have been made available to support research activities on the broadest front, and there is now a formidable volume of information available to the designer. Of particular relevance to this Report, it should be noted that concrete is being successfully exploited in a range of structures which subject it, collectively to most or all of the conditions that will apply to Wave Energy Devices. A sample list of structures would include dams, shell structures, medium span bridges, nuclear containment, tall chimneys, concrete ships, and offshore gravity platforms.

The research that has been undertaken and is continuing to be undertaken in support of the above applications has provided comprehensive information on the properties of different concretes related to the type of loading (cyclic or static) to which they are subjected, to the environmental conditions that they must meet and to the endurance required. Activities in the North Sea in particular have stimulated specific research which has gone a long way towards overcoming or at least identifying possible difficulties associated with the use of mass, reinforced and prestressed concrete in a marine environment. The stressing and environmental exposure to which a wave energy device might be subjected will in all likelihood be not worse than that currently experienced by an offshore gravity platform. Thus, it could be said that wave energy devices do not in principle require any extension of structural design into uncharted waters. However, concrete in offshore structures, heavily prestressed and subjected to intensive inspection, has proved to be a notoriously expensive material. Wave energy devices can almost certainly not economically sustain the costs that have been incurred in meeting oil company specifications, and in executing the Reference Designs the Consultants have assumed cheaper reinforced concrete in situations where the Oil Industry would currently not accept its use.

A major new departure in wave power will therefore be in the area of applying 'cheaper' concrete design solutions in offshore, dynamic loading situations. Fortunately there is a history of dynamically loaded inshore concrete structures which is now being investigated to provide vital information on durability.

In addition there are a number of other problem areas which are not specific to wave power but which will be particularly evident. They include -

- (a) Problems associated with extensive fixing of steel to concrete in exposed corrosion situations. This will occur in all Devices at the power take-off interface.
- (b) Possible problems related to stray electric currents.
- (c) Marine growth, which may not be tolerable in some locations.
- (d) Requirement for very long structure life.
- (e) On the construction side, some of the required sections will call for special expertise in casting and particularly in slip forming if porosity and honeycombing is to be avoided at locations of rapidly changing geometry.

Alternatives of Reinforced and Prestressed Concrete Construction

Mention has already been made of the crucial importance of minimising the capital cost of the concrete structure of the Devices. A major offshore contractor specifically identified the high cost of prestressing as the major factor elevating costs of concrete in gravity platforms. On the other hand there is a considerable body of experience in the area of concrete ships and of fixed marine structures which suggests that ordinary reinforced concrete should be able to meet most of the requirements of the Device designer. The Consultants are convinced that both forms of concrete will have their places in the final designs, and a key feature of a Stage 2 study should involve cost optimisation between the two in the areas where both are valid solutions.

Mix Design

A careful balance of conflicting criteria will have to be resolved particularly technical versus economic considerations. In the case of the wave energy devices long term durable concrete is required with a design life of at least 50 years in a marine environment. The temptation to aim for strong mixes (in excess of 40 N/mm²) should be resisted if thermal and shrinkage effects are to be minimised, since both phenomena contribute to the long term breakdown of concrete.

Quality concrete requires proper site control. Correct mix design and rigid quality control are essential in the production of the concrete to be used in the wave energy devices. Slip forming techniques are likely to be used for forming some of the device sections particularly where long continuous pours can be undertaken. Fortunately the circumstances of the large offshore construction sites have been ideal for establishing just that high level of quality control that is required, and no unsurmountable problems would be expected in this area. It should be noted however that these ideal conditions will not necessarily apply to any smaller Devices or Device components which might be made locally on a 'cottage industry' basis.

Research Activity

Apart from possible work in the area of high duty low cost marine concrete, it is likely that WESC will find that current work will meet present requirements. A brief note on current research is given below.

Much of the work referred to is of a commercially restricted nature. It is assumed that the WESC will obtain access to such studies. In this context, attention is drawn to the paper "U.K. Committees and Working Groups concerned with Offshore Work" published by the CIRIA Underwater Engineering Group (U.E.G.) dated 7th March, 1977.

In particular, the "Concrete in the Oceans" study groups of the U.E.G. have provided valuable contributions including ad hoc research.

Attention is also directed to the non-restricted document "Directory of Current U.K. Research and Development relating to Offshore Structures and Pipelines - 1977" published for the Institute of Offshore Engineering by the U.E.G.

(i) Cracking and Corrosion

Concrete, whether mass, reinforced or prestressed is vulnerable to surface or deeper cracking which although itself may be structurally insignificant could readily initiate corrosion of reinforcement metal fittings or, in the extreme, of prestressing steel.

In "Concrete in the Oceans": Cracking and Corrosion, Report Number 2/11", Dr. Beeby has produced a comprehensive study of crack widths in relation to corrosion control.

Space does not allow comment on this beyond the observation that it would appear that crack width has less significance than previously believed in corrosion initiation.

Other Papers have supported this view and in particular it is considered that severe galvanic action can more readily be initiated by an area of porous concrete than by an equivalent cracked area in well-consolidated concrete.

(ii) Long Term Performance of Marine Concrete Structures

Although much useful information can be gained from exposing mock-ups of structures, either to scale or in part to accelerated tests, the results can be misleading. Detail surveys of marine structures that have experienced over 20 years exposure are essential in confirming or otherwise short term tests.

The Report "Survey of Existing Reinforced Concrete Marine Structure: General Report for Phase I" Report Number P4/11, U.E.G. forms a progress statement on an examination being undertaken by Taylor Woodrow Construction Limited of the naval fort at Tongue Sands.

(iii) Fatigue

(a) Concrete - Little is known on fatigue of concrete per se. A useful and apparently successful rule of thumb which has been applied in the Reference Design is to limit stresses to less than one half of the characteristic strength of the concrete. This level of stress appears to be below the threshold of onset of fatigue.

(b) Steel - Much work has been undertaken as regards corrosion fatigue of reinforced concrete. For example, the U.E.G. Paper "Corrosion Fatigue of Reinforcing Steel in Offshore Structures - A Review of Existing Information P6/II" by B.S. Hockenull provides a useful background. It is pertinent to note that corrosion fatigue is more harmful at frequencies corresponding to those of sea waves than the higher ranges. Thus accelerated tests are not representative.

(iv) Water Penetration

Numerous papers dealing with other relevant aspects of the subject are available. It is perhaps worth mentioning work by Browne and Domone on the penetration of sea water into structures at varying depths. In the case of wave power devices, which are either floating or grounded in comparatively shallow water, the degree of penetration is not of major concern provided a consistent dense durable mix is achieved. Porosity and honeycombing are of far greater concern in this connection.

(v) Special Coatings

A problem that will require further examination is that of protective surface coatings to the structures. Clearly an impermeable membrane would prolong operational life since spalling, corrosion, etc. would be reduced. However, the application of such coatings to extensive areas and their ability to bond permanently without change of properties is presently open to some doubt. This is a possible area for a long term research project.

12.2

The Use of Steel in Wave Power Structures

Little need be said about technical capabilities of steel plated structures in a marine environment, since this material has been in use for sea-going vessels for just on a century. It possesses a high strength/weight ratio which is often advantageous to the designer and it can be fabricated in sub-assembled sections suitable for transport to a convenient assembly site.

In the context of wave power devices, however, the use of steel fabrication in quantity has two major disadvantages:

- (i) the maintenance problem in a corrosive environment,
- (ii) the present-day high cost of welded steel structures.

In the former case, steel can be protected by modern paint systems designed specifically for a marine environment and, below the water line, further protected by a cathodic protection system. Such schemes, however, have an initial high cost and a continuing high cost for the subsequent maintenance of the chosen system which would require dry docking facilities to implement.

The very high cost of welded steel fabrication today is an inescapable fact that can only be marginally reduced by cost effective design.

12.3 Rubber

The Reference Designs for most of the Devices employs rubber in some form or another, either as a sealing material against the ingress of water or as a spring material where use is made of its capability to recover from large deformations.

The technology of vulcanised rubber has advanced a great deal in the last twenty years since the first "Rubber in Engineering" conference was organised in 1956. Not only have design techniques advanced but the volume and range of uses of rubber in industry have expanded dramatically to the extent that the high performance and durability of natural rubber compounds is now relied upon on the basis of established proof.

The material has been used extensively for a variety of applications in a marine environment and providing the components are correctly designed in accordance with the criteria established through years of scientific research and practical experience, the use of rubber in a wave power device should not present any major problem.

12.4 Other Materials

Materials for moorings are briefly discussed in Chapter 11. The SEA Device Team are also proposing the use of synthetic rope to provide spring stiffness for their spine hinge design. This is a totally novel application for a rope and would require research similar in intent to that required for elastic moorings.

Composite construction in glass fibre resin has also been suggested by one Team. The suitability of this material for marine construction is already well proven in its application in small ships. The principle problems would be concerned with cost and structural design (particularly deflections, stability and details at joints) rather than with material properties.

Materials used in mechanical components in the primary power take-off for the mechanical devices have been mentioned where relevant, in the Device chapters

12.5 Conclusion

The Device Teams are almost unanimous in their choice of concrete as the primary structural material. This is certainly the correct choice for the majority of these structures. The choice between simple reinforcement and pre-stressing of the concrete is less obvious and can only be decided after fairly detailed costing, and examination of possible technical objections to reinforced concrete on the question of durability. It is most likely that both forms of reinforcement will be used in the final structures in different areas. The advantages and limitations of steel are well known and the possible use of this material should not be excluded, particularly where weight or compactness are primary considerations.

Materials for moorings are discussed in Chapter 11. Other materials can only be judged in the context of their particular application.

CHAPTER 13.0 SPECIAL MARINE PROBLEMS

A brief summary of special marine problems is given in the Wavepower Ltd. Report Number ETSU CR/9, and the Consultants are in general agreement with the comments made. The following points are intended to indicate how these problems will influence development of wave power devices in the near future.

13.1 Corrosion

For the purposes of preliminary design, adequate information on the corrosion protection of the main structural materials is available. The protection of mechanical components will need to be studied for each Device and must be considered at the earliest stages of component design. Measures will have to be taken to minimise exposure to the elements by housing, and maintaining the components in a greased environment wherever possible.

13.2 Fouling

Extensive marine fouling of the Devices will be unavoidable. The functioning and durability of mechanical components can be seriously affected without proper attention to design details.

For Wave Power Devices fouling can also significantly affect performance, due to increased mass and increased surface roughness. The susceptibility of the several devices will vary, and will need to be investigated at an early stage.

The areas which may be vulnerable for each device are -

HRS	- Flap valves, roughness of channels and draft tubes.
NEL	- Roughness of water column only.
Rafts	- Hinges, roughness of rafts.
Salter	- Increased mass and roughness on beak, fouling of peripheral seal units if used, (or fouling of immersed power off-take equipment,) fouling of spine hinge bearings and straps.

13.3 Siltation

The general problem of sediment transport has been given preliminary consideration in the HRS interim report on environmental effects (unreferenced dated April 1977). For the Russell Rectifier Devices, the seabed at locations west of the Hebrides is thought to be rocky, but there is evidence of sandy areas both in adjacent deeper water, and in shallower water, (for example, the sandy beaches of South Uist). The possibility of transported sand cannot be ruled out until more details are known of the actual site conditions

CHAPTER 14.0 POWER GENERATION

14.1. General Observations on Design

Subsidiary to the main discussions on devices per se were others on the proposals of the four recognised Device Teams on possible methods of converting primary motion, air compression or water collection, into some form of electrical power output. Generation proposals were more advanced in the case of the Salter-SEA device than with others, nevertheless outline ideas were given by each team, and these have been tentatively developed in this study to the stage of design feasibility and approximate cost.

Two devices give mechanical outputs characterized by low speed relative angular motion at high torque. A third by resonant oscillation produces a large supply of low pressure air, whilst the fourth, by a system of valves, abstracts energy from water flowing from wave peak to wave trough. A fifth device, being separately developed, also makes use of mass air flows derived from water column oscillation.

It is characteristic of wave trains that large oscillations of, for example, 10 second period, are followed by lesser movements which together occupy a total period of up to 50 or 60 seconds. The mechanical power input not only pulsates at twice the wave frequency but also varies in magnitude in keeping with the pattern of wave amplitudes. For power generation it is necessary to smooth out these constant changes of power level, and it is desirable to introduce an appropriate means of energy regulation. This can be achieved by short term energy storage in the manner of large volume air chambers or water inlet channels, or again by short term storage of high pressure hydraulic fluid.

A prime requirement of a wave energy system is that it shall have the highest economically attainable energy output per annum. This entails a high operational availability. In order to achieve both requirements, it is essential to consider power plant designs approximating to those of conventional power station practice. Designs should be conservative as regards stress levels, speeds and pressures. Superior plant design would be essential, as also high quality manufacture. In the interests of long term availability, construction materials should be chosen with care, having due regard to the unusual environment, the influence of fatigue on stress levels acceptable, and the ability to withstand wear under conditions of constant use.

Design of plant installations should also maintain ready accessibility in spite of the difficult plant locations involved.

The electrical generators should operate at the governed speed of the particular prime mover. Direct current alternators are not considered suitable. Normal three phase alternating current generators should, wherever possible, operate at or close to the standard industrial frequency of 50 Hz. This is important in allowing the use of standard design and manufacturing procedures for the electrical equipment including generators, switchgear and transformers.

Brushless or fully static excitation would be preferable and also the static control equipment necessary for synchronous operation.

It has been pointed out elsewhere that the four device types considered involve large numbers of relatively small generators. Even with the proposed 200 MW prototype Salter-SEA scheme there would be twenty 14 MW sets. Their parallel operation will involve carefully designed automatic control equipment, probably with computer supervision. Design of the power plant installation would require extensive investigation of dynamic performance. Consideration should also be given to fault levels and means of protection.

Wave energy systems of the power outputs considered necessarily involve a large amount of repetition of power plant installations. In the case of the Salter-SEA and Cockerell-WPL wave responsive systems, it would be practicable to construct the power turbines and generators and their associated transformers, switchgear and control equipment in standardised modular form. This would speed construction, reduce cost, and facilitate unit replacement in service.

Whilst HRS devices would involve repetition of the same power plant, they would be individual to the particular unit and would, by their nature and physical dimensions, involve in situ construction.

The NEL air operated device also requires the use of very large components, and whilst these would be repeated from one device to another, they would require installation on an individual basis.

It is appreciated that the sea-worthiness of some of the devices considered relies on some measure of mechanical stiffness in reaction to the wave movement. Raft devices in particular need rotational restraint from the mechanical plant to maintain stability.

With any electrical system there is always the risk of total loss of output. This would result in immediate reduction of mechanical torque reaction, and in producing more advanced designs thought should be given to suitable means of emergency loading until an electrical output can be re-established. In the first phase study, allowance has been made for the continued circulation of pressure oil, but a more adequate means of loading will be required. Electrolytic loading of the generators might be one possible solution.

Mentioned has been made of the relatively small size of the power units. These are based on the preliminary study of the wave energy intensities and the resulting annual load factors - all in the context of a proposed location off the Outer Hebrides, for which oceanographic data similar to that provided by the weather station "India" might apply.

The devices themselves are subject to the whole range of incident wave power levels, but it would be uneconomic to design the mechanical and electrical plant to make use of peak inputs. The question of the economic limit of plant rating is still a matter for investigation.

The economic value of wave energy conversion is very largely dependent on the mean annual productivity of an installation. This, however, must be related to the annual cost of the necessary capital investment.

Whilst economic considerations will dictate the ratings of power plant to be installed, all systems must be safeguarded against excessive wave power inputs. With some devices this can be achieved by virtue of the performance characteristics of the prime mover. In others, surplus power may have to be dumped by safety by-pass systems. In all cases the speed of rotating plant should be controlled by governor operated device. A spear type throttle valve would be appropriate to the oil pressure turbines, and guide vanes to both hydraulic and pneumatic turbines.

Preliminary ideas on the power plant of the four principal devices are given in the following subsections 14.2 to 14.5, whilst manufacturing prospects are discussed in the final section 14.6.

General

Construction of the large concrete caissons has led to the adoption of an overall length of 140 m. For the purpose of comparing alternatives it has been assumed that the devices would be established in line abreast some 5 to 8 km off-shore and suitably founded on a stable sea-bed, giving a tidal range of mean water depths of 20 to 24 m. The tidal range of ± 2 m is a preliminary assumption and would have to be related to the particular site adopted.

In association with this tidal range, there is a super-imposed wave amplitude condition of ± 2.5 m, this being regarded as a maximum for the design.

A section of the device taken through the centrally located vertical turbine generator unit is shown in Fig. 14.1. The waterway system is not shown in this diagram but it should be understood that the device is divided into a number of transverse compartments which are alternately associated with water intake at high level and subsequent discharge into the troughs of the waves. The turbine spiral casing is supplied from a longitudinal high level water collecting channel which would be of sufficient capacity to regulate the flow to the turbines from the random inputs of wave peaks entering through the inlet flap valves.

The discharge from the turbine is taken into a corresponding low level discharge chamber which distributes the out flowing water to the low level compartments, and again through the outlet flap valves which can only open whilst the sea level is near its minimum height.

Water Turbine

After allowing for head losses through the two sets of valves and the complicated waterways, it has been assumed for preliminary design purposes that the net head available at the turbine would not exceed about 3.9 m.

The water gathering capability of the HRS device has been stated as approximately $1 \text{ m}^3/\text{s}$. per metre of Device length. This being so, the maximum output to be expected from a single 140 m. long device might be about 6 MW. As a preliminary approach, this has been accepted, but it may not be the optimum size economically. However, it has enabled a preliminary design to be prepared for a conventional Kaplan turbine driven waterwheel alternator. The turbine is provided with inlet guide vanes and runner blade combinator equipment. It will be noted from Fig. 14.1. that the machine is of considerable size and runs at low speed. This might be 60 r/m, or possibly 75 r/m if greater submergence can be achieved. There is, however, considerable difficulty in producing a satisfactory design within the limited vertical dimensions dictated by low tidal levels.

The turbine runner would have to be about 6 m diameter, using suitable stainless alloy runner blades and guide vanes, appropriate for use in

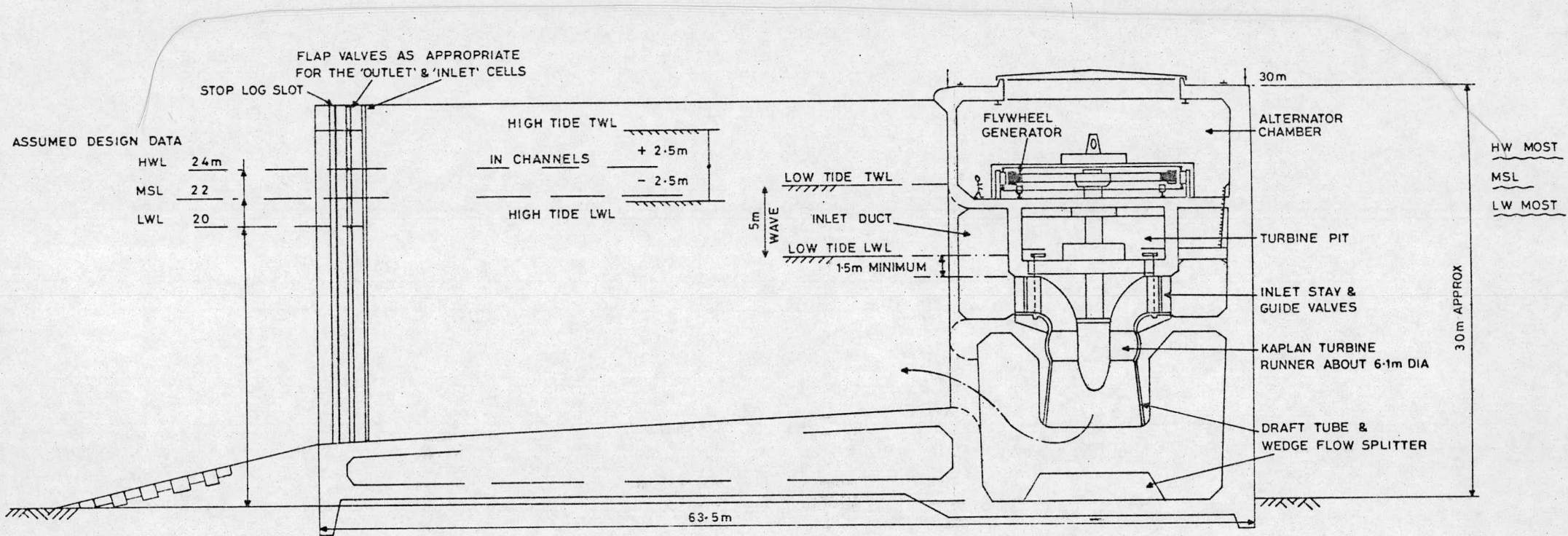

DESCRIPTION

DEVICE LENGTH 140.0m
 DEVICE WIDTH 63.5m
 DIVIDE INTO A NUMBER OF TRANSVERSE CELLS
 ALTERNATELY 'INLET' & 'OUTLET'

BOTH CONNECT INTO LONGITUDINAL CHANNELS
 AT THE BACK OF THE RECTIFIER.
 AN UPPER HEADRACE SUPPLYING A CENTRALLY
 LOCATED TURBINE (VERTICAL KAPLAN) & A
 LOWER WAVE TROUGH DISCHARGE CHAMBER
 RECEIVING & DISTRIBUTING WATER FROM THE
 TURBINE DRAFT TUBE

HYDRAULICS RESEARCH STATION RUSSELL RECTIFIER
 PROPOSED KAPLAN TURBINE & GENERATOR INSTALLATION
 6 MW PER 140m UNIT

Fig. 14.1

sea water. Other components of the turbine structure would require protection against corrosion and erosion in order to have a long operational life.

The draft tube shown in the diagram is a preliminary and somewhat inefficient arrangement dictated by the necessity to discharge water through an angle of 180° and for distances of 75 m in either direction. Draft tube design would need very careful investigation and model testing in order to produce a reasonably efficient arrangement. This is particularly important under the exceptionally low head of the design.

Alternator

The alternator would be of the conventional waterwheel type with the thrust bearing beneath the rotor and incorporating pressure oil injection to reduce the starting torque required under minimum head conditions. The 8000 h.p. turbines would operate under governor control at normal system frequency. It would be necessary to devise a means of automatic control so that the rate at which water is used by the turbine is directly related to the rate at which it is being gathered into the upper channel.

Electrically it would be appropriate to group the devices into sets of four, interconnected by 11 kV cable and having a single 27 MVA 11/33 kV generator transformer output. Forty separate caissons, each with a single power unit, would be required for the nominal 200 MW installation which has been adopted in all cases for comparative purposes.

A large scale installation would have eighty caissons with twenty groups of four alternators connected by 33 kV submarine cables, to a platform mounted converter station having a DC transmission rating of some 400 MW.

The very large Kaplan alternator units would have to be installed at appropriate stages in the construction of the concrete caisson. They would not lend themselves to pre-fabrication and unit installation.

Alternative Plant

It is important to comment that the very simple but rather unwieldy solution of the power plant problem given in Fig. 14.1. might be improved by a much more detailed investigation of the use of a larger number of smaller machines, probably of the bulb type, but such refinement of design is more appropriate to a second phase study of wave energy systems.

Salter-SEA Oil Hydraulic Power Plant

General

The primary conversion of wave energy results in a slow speed high torque angular reciprocation between duck and spine units. Typically the rotation follows an approximately harmonic motion with an angular velocity of about $8^\circ/\text{sec}$. but reversing every half wave period. The design allows for the fact that the peak instantaneous velocity would be about $12.5^\circ/\text{sec}$.

Primary mechanical power take-off

The two device teams in Edinburgh and Coventry have investigated friction drives for an arrangement of small hydraulic pumps taking power from each end of a duck unit. There are known to be problems with rubber tyres, not only due to the high torque loadings but also in a sea water application. Following a preliminary review it is thought better to transfer all the principal loads between duck and core through extra heavy duty low speed bearings which would also be arranged to maintain reasonable concentricity. The mechanical power abstraction then relies solely on rotary movements of the duck. The arrangement shown in Fig. 14.2. indicates a rack and pinion drive within external water seals.

Water seals and Rack and pinion

Much work would have to be done on the design of satisfactory water seals. The problem may be partly solved by work which has been done in recent years in connection with a special design of straight flow water turbine and generator. As regards the rack and pinion gears, a preliminary suggestion would be to consider the application of the Swiss rack rail section used by the Abt system for very many years. These could be made in curved sections incorporating a roller track and possibly in manganese steel to withstand constant use.

Hydraulic pumps

Fig. 14.2. gives an indication of the disposal of pumps around the inside of the concrete core in dry and accessible conditions. It is proposed that there be fifteen pumps arranged radially at each end of a duck with drive shafts passing through holes in the core exterior. The design includes hydro-mechanically operated clutch couplings between pinion and pump. These would be arranged for engagement at zero speed.

The pumps at the present stage of design could be adaptations of presently available hydraulic motors of about 100 kW rating. Delivery pressure would be reduced to a more conservative figure of 1500 p.s.i. (10.34 MN/m^2) but the return oil would be delivered at 150 p.s.i. (1.03 MN/m^2) to suit the characteristics of the pump design and reduce the risk of cavitation.

Hydraulic Mains

Reversal of rotation means that oil is delivered alternately into two

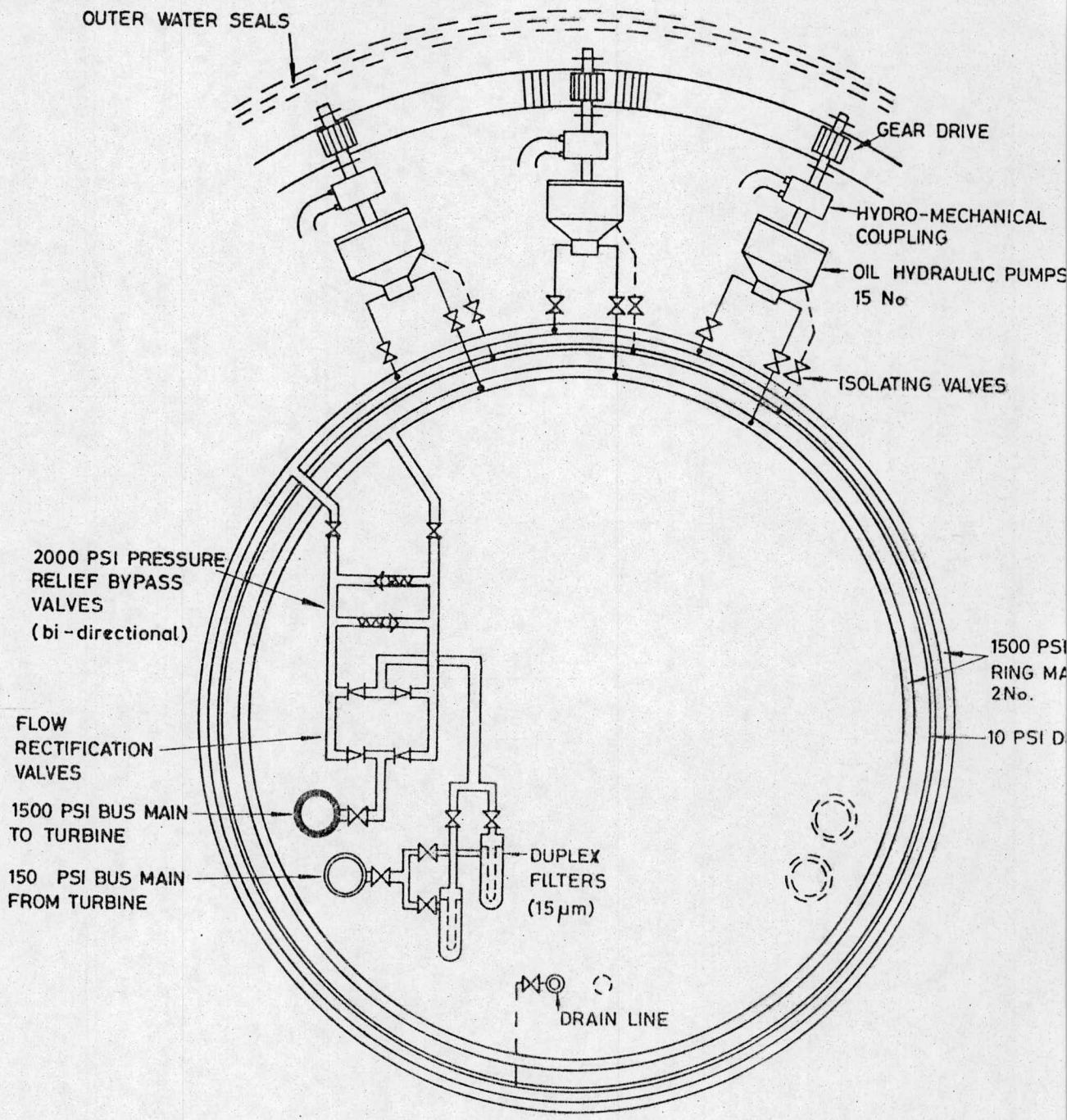

SALTER DUCK HYDRAULICS
 PROPOSED ARRANGEMENT OF HYDRAULIC CIRCUITS
 FOR PUMPS AND FLOW CONTROL VALVES
 (Repeated at each end of a duck.)

high pressure ring mains - in pairs at each end of a duck. In Fig. 14.1. an arrangement of valves is shown. These provide a uni-directional output into a longitudinal pressure main. The return oil would be taken through a number of filters so that only clean oil is returned to the pumps.

For lubrication purposes each pump discharges a small quantity of oil. This is collected in a low pressure drain system and eventually re-injected into the return oil bus main and subsequent filters.

A further diagram Fig. 14.3. gives an indication of the complex pressure oil system for a typical half duck string assembly of fourteen 30 m ducks on a hinged and jointed core structure. This terminates in a power module containing the main power plant and all necessary auxiliaries.

Power Module

The power module would be in the nature of a floating power station physically attached to the central core but with flexible flow and return oil mains and two 22 kV submarine power cables passing over the stern and providing interconnection with switchgear on the converter platform about 0.5 km to the rear of the array of duck strings.

The principle followed in this design is to coalesce the outputs of sets of seven ducks and their pumping equipment, and to deliver the pressure oil flow to a specially designed multi-stage oil driven turbine and conventional generator unit. There would thus be two 14 MW turbine generator units at each end of a 28 duck string, giving a peak capability of about 56 MW.

} ~50 kW/m
-53.8 kW/m

With a total of 210 pumps, each with its own number of reciprocating pistons and cylinders, and allowing a measure of diversity in the angular motions of the seven ducks, there is expected to be a steady regulated flow of pressure oil to the power turbine. Allowance has, however, been made for some additional regulation by providing gas cushion storage vessels in each power plant module.

The generators and electrical equipment would follow conventional marine practice. All the generators associated with a single platform would operate in synchronism. Load control would be by an automatically controlled inlet valve to each turbine, the setting of which would depend on the rate at which oil is being delivered by the pumps. The electrical output thus reflects the mean wave energy input over periods of perhaps one minute. There would thus be frequent adjustments of output which would be equalised to some extent by the very large number of device strings in the 50 km long coastal installation.

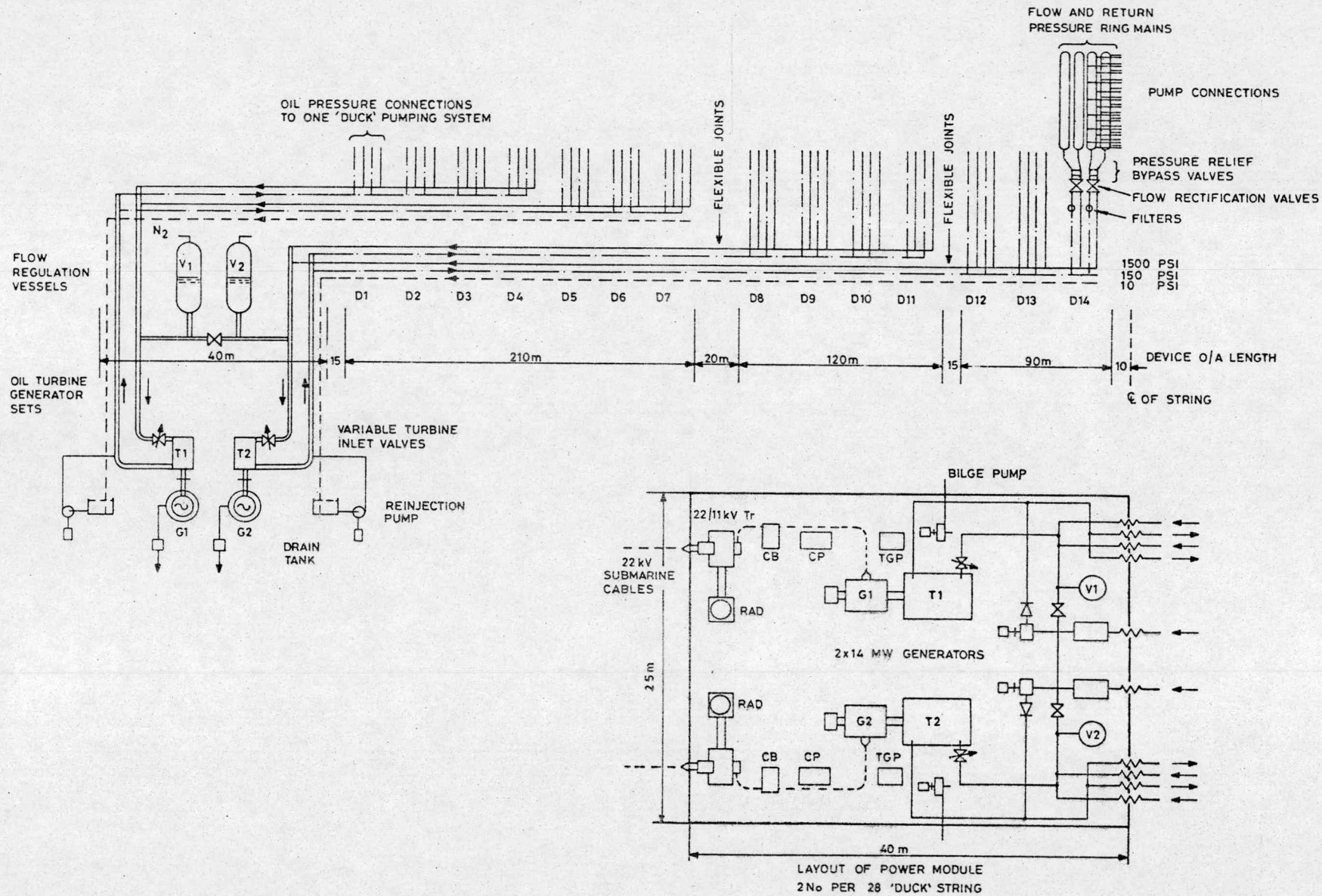

HYDRAULIC SYSTEM DIAGRAM
(HALF STRING LENGTH)
Relevant to Salter 'Duck' type of device

Fig. 14.3

General

The oscillating water column device has assumed the preliminary form of a large floating concrete box structure, 140 m overall length, and containing nine 15 m² water/air cells. The water level in the individual cells pulsates with the wave motion relative to the device's own rolling movements, and this results in air compression during upward movements and suction during downward. Large air volumes are displaced cyclically but at very low pressures, and the air will be water saturated.

Power production from these air flows is based on the principle of collecting the outputs of three adjacent cells through inlet and outlet plenum chambers. It is safe to assume that over the 45 m length of three cells the wave conditions and cell behaviour will be similar. There are thus three power abstraction units to each device and arranged at 50 m centres. Power abstraction is by large low pressure air turbine driven alternators.

Rectification of air flow

Uni-directional rotation of the turbines is required. It is necessary to rectify the air flow direction. This could be achieved by a rudimentary arrangement of large diameter ball and cage type air valves, as indicated on Drg. WP/OW3. These would be large to suit 1.8 m diameter air ports, arranged in two sets of six along the forward and rear edges of the cell roof. The valves would be of the inlet and discharge types and duplicated by similar valves connecting the "in" and "out" plenum chambers to atmosphere.

Whilst such an arrangement of valves would rectify the air flow to the power turbine, special care would be necessary in their design in order to ensure reliable operation in the long term and in difficult environmental conditions. It would be necessary to pressurise the rubber balls to counteract distortion under compression, and also to provide means of balancing their weight so as to ensure correct seating under low differential pressures. The seatings themselves might be of stainless steel.

Prevention of the ingress of water

Design of the air system must include precautions against ingress of sea water into the two air chambers leading to the air turbines and their vulnerable blading.

Air Turbines

Preliminary design of the air turbines is based on a mean cyclic pressure difference of only about 1.15 to 1.20 p.s.i. (8 kN/m^2). Assuming a 4 m water level oscillation in the cells at a time period of 8 seconds, it is estimated that there should be a free air displacement of some 1.4 million ft³/min - with an efficient system of rectifying valves. This should be sufficient

to drive an air turbine of up to 5000 h.p. and a directly driven alternator of 3.5 MW. These, however, are very preliminary figures, and at this stage used only to establish the main parameters of the generating plant and an approximate cost.

On this basis it is proposed that there be three nominal 5000 h.p. air turbine generator units arranged symmetrically on each 140 m floating device. To handle the large air volumes at low water gauge pressure - about 32 in. w.g. - it would seem appropriate to provide a large (about 8.8 m diameter) multi-stage axial fan type turbine with inlet guide vanes and running at low speed (about 200 r/m).

Alternator

The air turbine would just fit between the two air plenum chambers, and it is proposed that the drive shaft should be taken through the inlet duct to a generator located over the rear half of the floating device. The alternator would be a conventional low speed unit provided with static or brushless excitation, automatic control and synchronisation.

It is appreciated that the proposed adoption of large low speed air turbine generators is not in accord with the power plant arrangement briefly outlined by the NEL. This involved the use of two or more high speed air turbine driven generators per cell unit. It is, however, felt that for a large scale installation of the NEL type there should be a minimum practicable number of power units. Furthermore, the large low speed turbines are more appropriate to continuous operation with infrequent opportunities for maintenance.

In considering a nominal 200 MW installation, there would be a total of 28 devices, probably moored in line abreast facing the incoming seas. Each would have three 3.5 MW power units. The collection of these outputs is based on use of a 3.3 kV generator busbar common to three machines in a device unit. The output would be stepped up to a power collection voltage of 22 kV, and it is proposed that pairs of devices be connected together by flexible 22 kV cable, with a common submarine cable to the nearby 400 MW platform mounted converter station

General

The wave contouring raft system as described elsewhere in the report, comprises three units which are hinged together, the forward and centre rafts each being 25 m long, and the rear or stable unit, 50 m long. All rafts are 50 m wide, facing the incoming seas. As with other devices, an installation has been designed giving a net output of 200 MW. With the Raft Device it would be necessary to provide an interconnected string of 80 raft assemblies, flexibly moored and with suitable restraining connections between raft units.

The net output level attainable is again the same as that with other devices, and an approximately correct figure of 50 kW/m has been used. Diversity again plays an essential part in deciding the plant installation, and the effective output is taken to be 3.5 MW per raft assembly.

However, it is a feature of the hinged design that the rates of power abstraction from the first and second hinge can be in the proportion 60:40, with either hinge providing the greater power output. This has dictated two oil pump installations, each of 2.1 MW operated by the relative angular movements at the two hinges.

Primary mechanical power take-off

In the course of discussions with the Device Team, alternative power conversion systems were mentioned. Neither had been investigated closely, and for the purposes of this Report, an entirely different mechanical drive, but similar to that used for the Salter/SEA device, has been proposed.

Hydraulic pumps

The oil hydraulic pumps would be in two sets of twelve, each rated 175 kW, and the two groups operated by linkages from the forward and rear rafts. At first sight, the method seems cumbersome, but it does have the virtue of simplicity and accessibility. As in the earlier example, the pumps would be driven in pairs by rack and pinion arranged horizontally on the deck of the second raft. The dynamics of motion of the lever arms, and the gear ratio for the rack and pinion drive, would be designed so as to keep the rotational speed of the pumps well within design limits, not only so as to reduce wear and tear but also to have some margin for faster rotation with more violent raft movements.

Hydraulic mains

As the groups of oil pumps are mounted on carriages reciprocated by the forward and rearward driving arms it will be necessary to arrange the pressure oil flow and return pipes by attachment to the same moving arms. This is not an attractive arrangement, but it should be possible to borrow from the oil industry and their North Sea experience, suitable designs of universal pipe joint.

The oil feed from the twelve pumps driven by the forward raft would require four such joints, being routed via the over-arm to the forward and centre rafts and thence to the larger rear raft in which the main power plant would be installed.

Correspondingly, oil delivered by the second group of pumps would pass via the rear over-arm and swivel joints directly to the rear raft, where the two supplies would be combined and the pressure regulated by means of a gas cushion storage vessel.

The flow and return oil pressures would have nominal values of 1500 p.s.i. (10.34 MN/m^2) and 150 p.s.i. (1.03 MN/m^2), whilst the effective pressure available at the oil turbine might be about 1230 p.s.i. (8.5 MN/m^2).

Turbine

The turbine could be a smaller version of the one proposed for the SEA device, producing about 4900 h.p. at 1500 r/m. Speed would be maintained by governor control, with a suitable design of modulating inlet valve, which again adjusts the power output to the rate at which oil is supplied.

Generator

The single generator would be a 3.5 MW three phase unit. A 4 MVA generator transformer would also be mounted in the rear raft, together with switchgear and control equipment. All generators would operate at industrial frequency. It is appreciated that there would be problems in ensuring stable operation of so many small machines in parallel. It would be necessary to undertake comprehensive dynamic system studies to ensure that the multiple generator system would perform satisfactorily in practice.

The method of interconnecting the rafts electrically, and of assembling the outputs at a common point, is based on linking together five raft units with flexible 22 kV cables, and taking the summated output of about 17.5 MW through a rather longer 22 kV three core submarine cable to the 400 MW converter platform established about 0.5 km to the rear. The arrangements from this point onwards would be the same for all devices.

Power plant of the types described under the preceding device sections could be designed and built either by application of existing practice or by practicable extensions of present design and manufacturing techniques. A matter of importance, however, concerns the large number of mechanisms required for any major wave energy installation. Discussions with potential manufacturers would therefore form part of any detailed development programme.

The conventional water turbines required for the HRS rectifier device would involve physically large turbines of the Kaplan design, with due consideration of the metallurgy in view of the sea water application. The turbine runner blades and the inlet guide vanes would be stainless steel castings. If required in very large numbers, it might be necessary to import castings from the Continent.

Resources for the manufacture of water turbines and large water-wheel alternators are presently limited to two firms in the U.K. Production in the numbers required would involve long term arrangements with a number of main and sub-contractors.

The high pressure oil turbines would be entirely new developments in the ratings required. The basic design of the turbine could be an adaptation of mult-stage pump turbine experience in the hydro-electric field or of large feed pumps associated with thermal power generation. Here again the field of manufacture is limited, but design discussions with potential manufacturers well in advance of requirements would facilitate subsequent arrangements for main and subcontract manufacture.

The Salter duck and Cockerell raft devices both require large numbers of high pressure oil pumps. These must accept low speed reversible rotation. A pump of this type is not normally produced but the hydraulic motor industry makes readily adaptable units. One particular manufacturer has confirmed that his motors could be used as pumps in the manner intended, with the sole proviso that they are given a positive suction pressure. This has been allowed for in the two designs.

The oil motors are intended for intermittent use and a recommended design modification would include the provision of larger shaft bearings so as to prolong the intervals between maintenance.

As regards production prospects, it would be necessary to make arrangements with the manufacturer to set up a special production line so as to provide the pumps in the quantities required. Pumps for the raft design are larger than presently available, so that these would involve a new design and development testing.

The two systems employing hydraulic pumps and turbines will need large quantities of hydraulic oils of appropriate quality. These are readily

available in the U.K., and the following four types would be suitable:-

1. Shell Tellus 27
2. Esso Nuto H40
3. Energol HLP80
4. Castrol AWS30

The oils should have a viscosity of about 20 centistokes in the temperature range 0°C - 20°C , and should be suitable for use at pressures up to 3000 p.s.i. (20.7 MN/m^2).

The air turbines and flow rectification valves required for the NEL type of device are not available at the present time. Both should be subject to development contracts, the proposed design of flow valve by the industrial rubber industry, and the very large low speed air turbines possibly as an extension of heavy industrial fan design.

Manufacturing capacity will be inadequate, but once approved designs have been reached, mass production could be organised through the heavy engineering industry aided by sub-contracting.

All four devices use conventional industrial frequency three phase alternators. Design would be straight forward. Manufacturing capacity should be available for the higher speed units through a number of firms in the U.K. Large waterwheel alternators for the HRS design would normally be sought from only one or two firms.

On the electrical side, large quantities of transformers, switchgear, cabling, and control and protection equipment would be required. They could all be standard production items and, with due notice, produced by several manufacturers in the numbers required.

The high voltage submarine cables and the high power converter equipment both invoke special design and manufacturing techniques.

Submarine cable technology is already available. Manufacturing capacity should also be adequate. The converter equipment, on the other hand, will require large numbers of power thyristors. Whilst at the present time these may have to be imported from the Continent or Scandinavia, they could be available in sufficient numbers from British manufacturers if required in the 1980s.

CHAPTER 15.0 POWER COLLECTION AND TRANSMISSION

15.1. General

It has been explained in earlier sections of the report that whilst there may be differences between the conversion efficiencies of one device compared with another they all give rise to an average mechanical power input of about 100 kw/m. This would apply to the normal run of winter sea conditions.

The conversion of this power to an electrical output is subject to a series of efficiency factors. These result in a net output in the region of 60-70 kw/m. This is the basis of design used for power collection.

The relatively low power intensity means that the generation of power from waves is spread out uniformly over considerable distances parallel to the coastline. This requires the grouping together of numbers of small generator units. With the spread of devices and the random nature of sea waves a factor of diversity is introduced which further reduces the maximum amount of power which has to be transmitted, to an effective average of 50 kW/m.

A prototype scheme for power collection and transmission was developed on the above basis. A design was primarily based on a wave energy scheme of the Salter-SEA type but was readily adaptable to other installations of the same power output.

After considering the longer term trend of power demand for the interconnected C.E.G.B. and Scottish systems and bearing in mind that power derived from wave energy is non-firm, it was decided to limit the prototype installation to 2 GW assuming completion in the late 1980s. Compared with the length of suitable coastline available this scheme would be a relatively small one extending only about 50 kilometres. Nevertheless it could provide an acceptable amount of power and energy in keeping with system operating requirements.

A further matter of importance to transmission design is that the devices would be installed or anchored at distances off shore from 5 kilometres to 20 kilometres depending on the water depth required for the particular device.

Furthermore all but one of the devices examined are subject to wave and tidal motions. Whilst submarine cables are essential for the collection of numerous small electrical outputs they must also be able to withstand repeated flexure, being attached to floating equipment.

Having adopted a nominal 2000 MW (2 GW) scheme it was decided to locate this off the Outer Hebrides where wave energy levels are greater than at other points around the coast. See Fig. 15.1.

As the total power produced has to be transmitted to a point on the mainland system which could accept this amount of power, it was appropriate to think in terms of the heavily loaded industrial areas of central Scotland, the existing and future extension of the main transmission networks and the inter-system ties between the Glasgow area and North-West England via Carlisle and

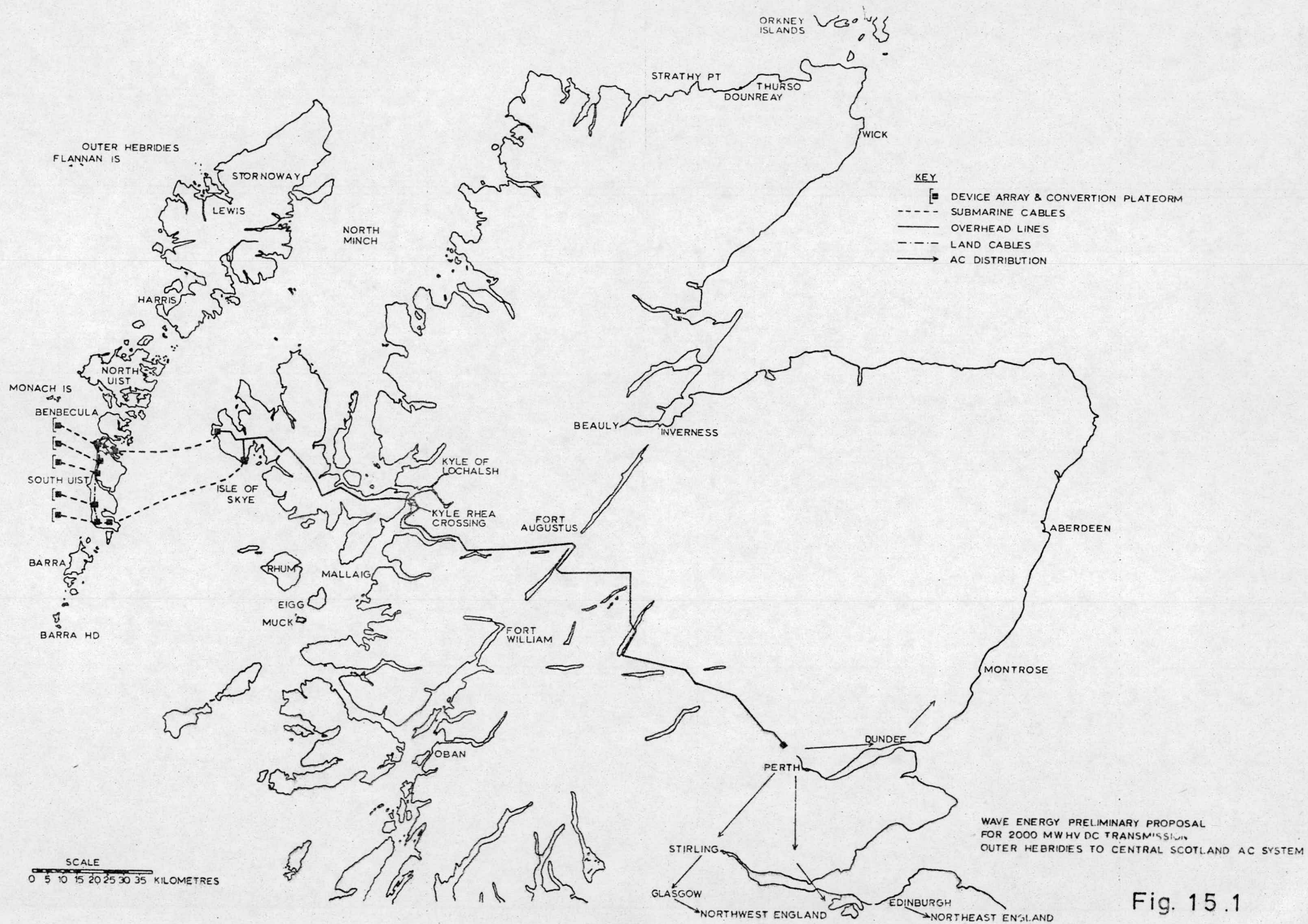

Fig. 15.1

also the circuits between Edinburgh and Newcastle in the industrial North-East of England.

This led to the choice of a wave energy delivery point in the region of Perth in the Scottish Midlands where it is reasonable to assume that new interconnections could readily be made to existing 275 kV and possible future 400 kV transmission circuits.

The requirement to transmit up to 2000 MW by under-sea cable meant that an AC system would not be practicable very high voltage cables would be required and also relatively large conductor sections. Three core cables would be far too large to manufacture and handle; single core AC cables could not be protected by steel wire armouring nor could they be laid in trefoil groups; there would therefore be unacceptably large variations in the inter-phase reactances. For practical reasons, including the subsequent recovery of cables from the sea bed, it is necessary to lay individual cables some distance apart - possibly 50-100 m - this again is unacceptable for AC circuits but normal for a DC installation.

For the initial power collection stage of a prototype 2000 MW scheme it was decided to use a 22 kV AC power collection network with flexible three core cables - about the largest that can at present be made. For the next stage of bulk power transmission a high voltage (+ 250 kV) direct current system has been chosen. The converter station would employ bi-polar rectification of the 12 pulse type using water-cooled power thyristors. Apart from their locations, the converter equipments would be well within present design and manufacturing experience. A possibly unique feature would be the parallel operation of five converter stations delivering their DC outputs to two long distance transmission circuits, involving submarine cable crossings and an overhead line route to the projected 2000 MW inverter station in the Perth area.

The site proposed for the 2000 MW installation lies some 16 kilometres off the west coast of the island of South Uist. The cable crossings to the west coast of Skye would be as direct as practicable, thereafter the power would be transmitted by double circuit DC overhead steel tower line on a carefully selected route through the Highlands. Each circuit would have a 1000 MW continuous rating.

A suitable design of tower is shown in Fig. 15.2. There are two fully insulated positive and negative conductors. As an initial approach, fully insulated mid-point conductors have also been provided. Whilst the conductors will be essential, it may be possible to reduce the insulation level and also the height of the tower itself.

It has also been considered prudent to provide a metallic inter-connection of all DC mid-points so as to eliminate earth return currents and so avoid objections by communications authorities and others who might be concerned were there to be large earth return currents.

The 2 GW wave energy installation described in previous paragraphs and the transmission arrangements required to deliver the power to the proposed

OUTLINE OF TYPICAL ± 250KV D C DOUBLE CIRCUIT
SUSPENSION TOWER (WITH MID POINT CONDUCTORS)

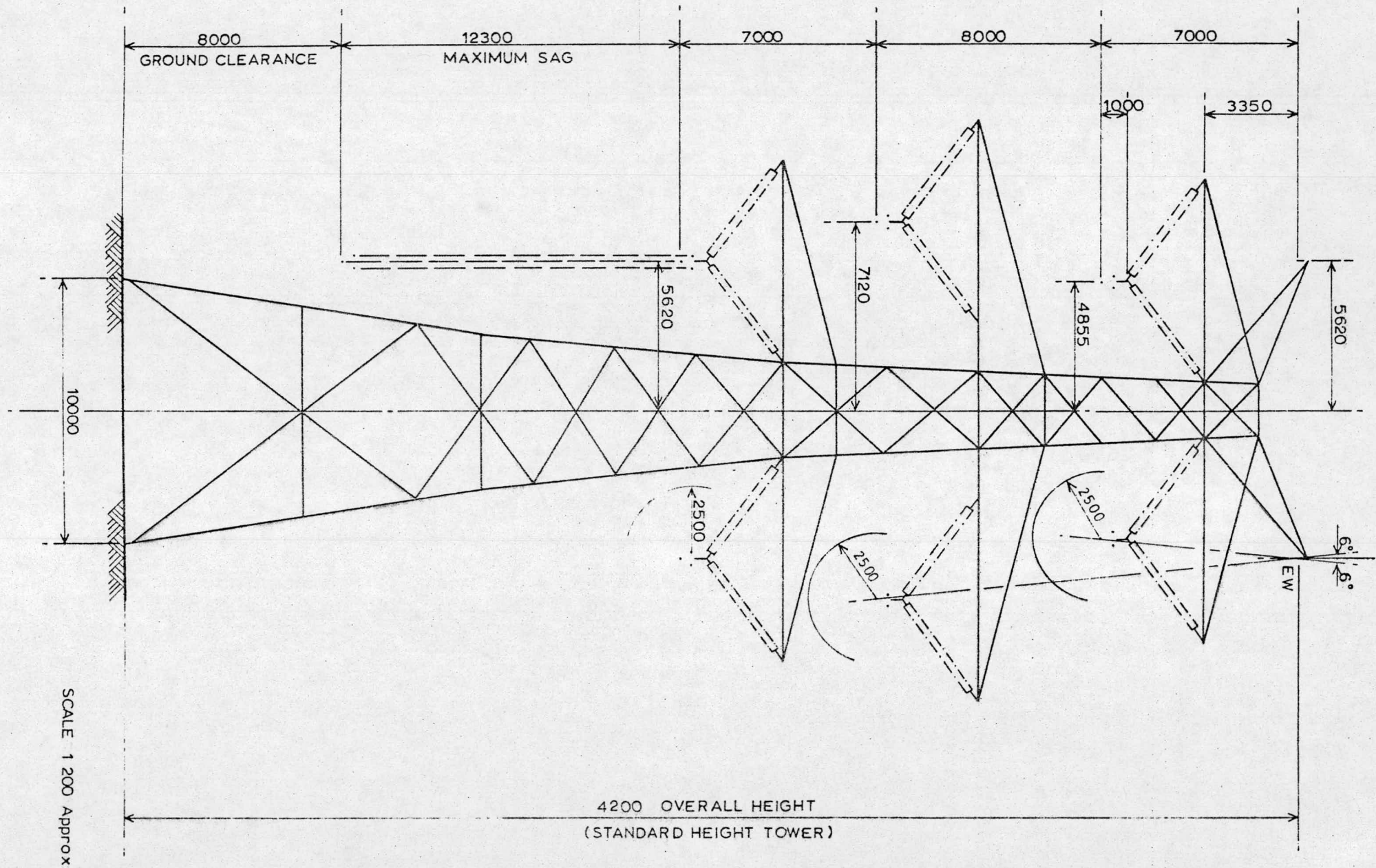

Fig. 15.2

mainland inverter station near Perth is illustrated in Fig. 15.1. This is interesting in that it shows the coastwise extent assuming devices of the Salter-SEA type giving a maximum output of 2000 MW.

The drawing also shows the location of the platform mounted converter stations and the submarine cable routes from the off shore platforms across South Uist to a pair of twin circuit terminal sub-stations on the west coast of Skye.

The schematic arrangement of one of the converter stations and of a floating power generator unit is shown in Fig. 15.3.

Considerable reactive currents are required at each converter station. These would be provided by the installation of static reactive equipment and by arranging for the generators to operate at an appropriate power factor.

In Fig. 15.1. an attempt has been made to show a possible route for the double circuit HV DC overhead line from the submarine cable terminations on the coast of the Duirinish peninsula, across the Isle of Skye to the narrows at Kyle Rhea and thence in a south-easterly direction through the Highlands towards the DC termination in the neighbourhood of Perth. Low level routes would be followed wherever possible. Onward distribution of the wave energy from the inverter station into the networks of the present North and South Scottish Boards has not been considered.

It is appreciated that the main transmission circuit availability may not comply with accepted standards, but the single double circuit line is considered realistic in the context of a non-firm source of energy. It should be borne in mind that transmission requirements during the summer months will be less than 1000 MW, so that there is ample time each year for line maintenance.

Main transmission of the high voltage direct current type is considered appropriate at the present time. It should be remembered, however, that development work is proceeding on the design and manufacture of super-conducting cables. When development work has proceeded further and such cables become practicable and economic, then consideration should be given to the advantages of high voltage alternating current transmission. At the present time it is not known when cables of the super-conducting type will be commercially available.

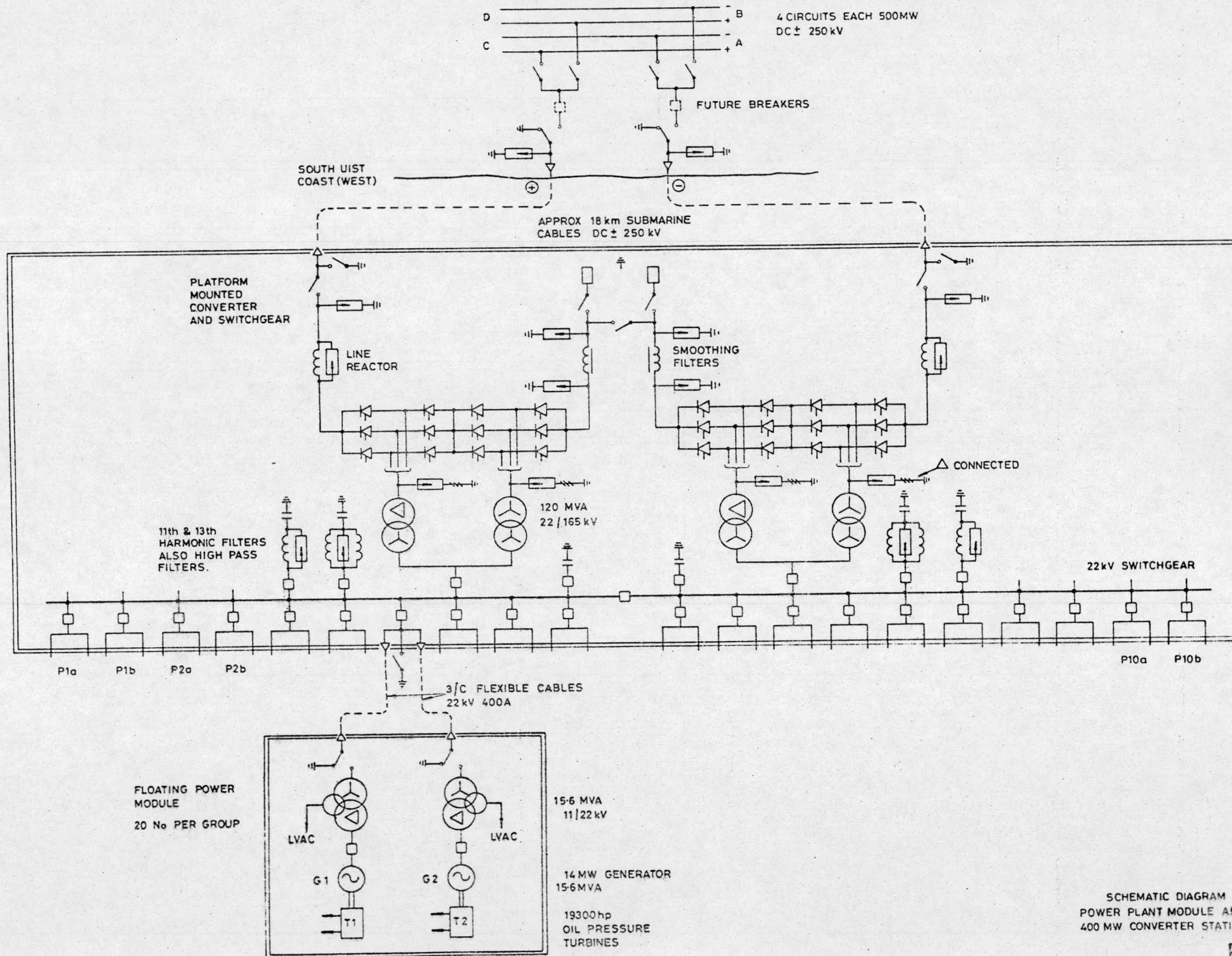

Fig. 15.3

A characteristic of wave power is that energy is produced in large numbers of relatively small generators spaced out at intervals over many kilometres along the coastline and some distance off-shore. System operation and economic considerations require that these small outputs be coalesced as rapidly as possible so as to reap the advantage of diversity of output leading to a smaller power transmission requirement.

The preliminary review of energy conversion methods tend to indicate that power will be produced in machines having ratings of between 1 MW and 14 MW. the larger the unit rating the simpler the scheme. For this initial review design has been based on a Salter Device installation with conventional 14 MW alternators operating as close as possible to the industrial 50 Hz frequency.

Design of the duck string includes a floating power plant module attached one at each end of the string and containing two 14 MW alternators operating at a normal voltage of 11 kV. To keep cable numbers and sections to a minimum the collection voltage is increased to 22 kV by individual generator transformers. These also help to limit fault levels at the main platform switchboard and are also arranged to provide supplies for auxiliary loads in the duck string and power compartments.

The arrangement is illustrated in Fig. 15.3. where it will be noted that the 22 kV 3 core flexible cables from a pair of generators are connected to a single switch at the platform receiving end.

It is intended that power modules should be detachable and capable of being towed away to a dry dock for major overhauls. To facilitate this the 22 kV cables would be disconnected and the ends supported by temporary mooring buoys.

For the 2 GW scheme envisaged, there would be a total of fifty 28 duck strings. Each string would require four 22 kV cables - two from each end. The Device assembly is far too long to collect the whole of the output at one point. The scheme therefore includes 5 nominal 400 MW platform mounted converter stations each of which would receive the outputs of 10 strings involving 20 generator circuits.

Fig. 15.3. is purely schematic. A preliminary review of the current ratings required and of the fault levels involved suggests that the main 22 kV switchgear should be of the double busbar type split into three sections; power transformers probably on the two outer sections and harmonic filter and reactive compensation equipment in the centre.

15.3. Main Transmission

Fig. 15.4. shows the power transmission proposed for inter-connecting the five platform converter stations some 16 kilometres to the West of South Uist via both submarine and island cable systems to the two cable terminal substations on the Duirinish peninsula in the Western part of Skye. Thereafter, the 2000 MW output would be transmitted to central Scotland by double circuit overhead line.

The converter stations are illustrated in Figs. 15.3. and 15.5.; they are each of 400 MW rating with bi-polar rectification of the 12 pulse type.

In Fig. 15.3. the mid-point is shown earthed. This would normally be the only such connection, since long distance earth return currents are undesirable. The cost estimates have therefore included a third cable on each route as a mid-point conductor - or emergency main conductor. The operating voltage could be - 250 kV.

Fig. 15.5. indicates the type of marine converter station proposed. It is supported on legs in a very similar manner to a North Sea oil rig and stands in 25 to 30 fathoms water depth. The electrical plant is totally enclosed.

The platforms are arranged in a North-South alignment about 0.5 kilometres to the East of the wave energy devices. This is to allow for some translation of the device strings and for the movement of vessels immediately in the lee of the Devices. This position close to the power modules also helps to reduce the considerable length of 22 kV cable radiating from each platform. An indication of the extent of the 22 kV submarine cables is that there would be 40 to each platform, the total length per platform being in excess of 130 kilometres.

The converter equipment including the 4 main transformers might weigh about 800 tonnes. The rectification process gives rise to radio frequency interference. The design therefore includes a metal clad building together with effective screening resulting in a reduction of as much as 40 db in radiated noise.

The platforms have also to be accessible by sea and by helicopter. Landing facilities, craneage and a helicopter landing platform have been incorporated.

A further essential is that there must be reliable means of communication between all converter equipment and the landward inverter station, intermediate sub-stations and the control centre. Microwave links are envisaged with main and standby facilities.

In the present preliminary phase little detailed thought has been given to the control and protection of the generation and transmission equipment, nor to special features of its design. These would all need careful investigation bearing in mind the special environmental problems, but would in general follow the rigorous standards already established for similar equipment on North Sea platforms.

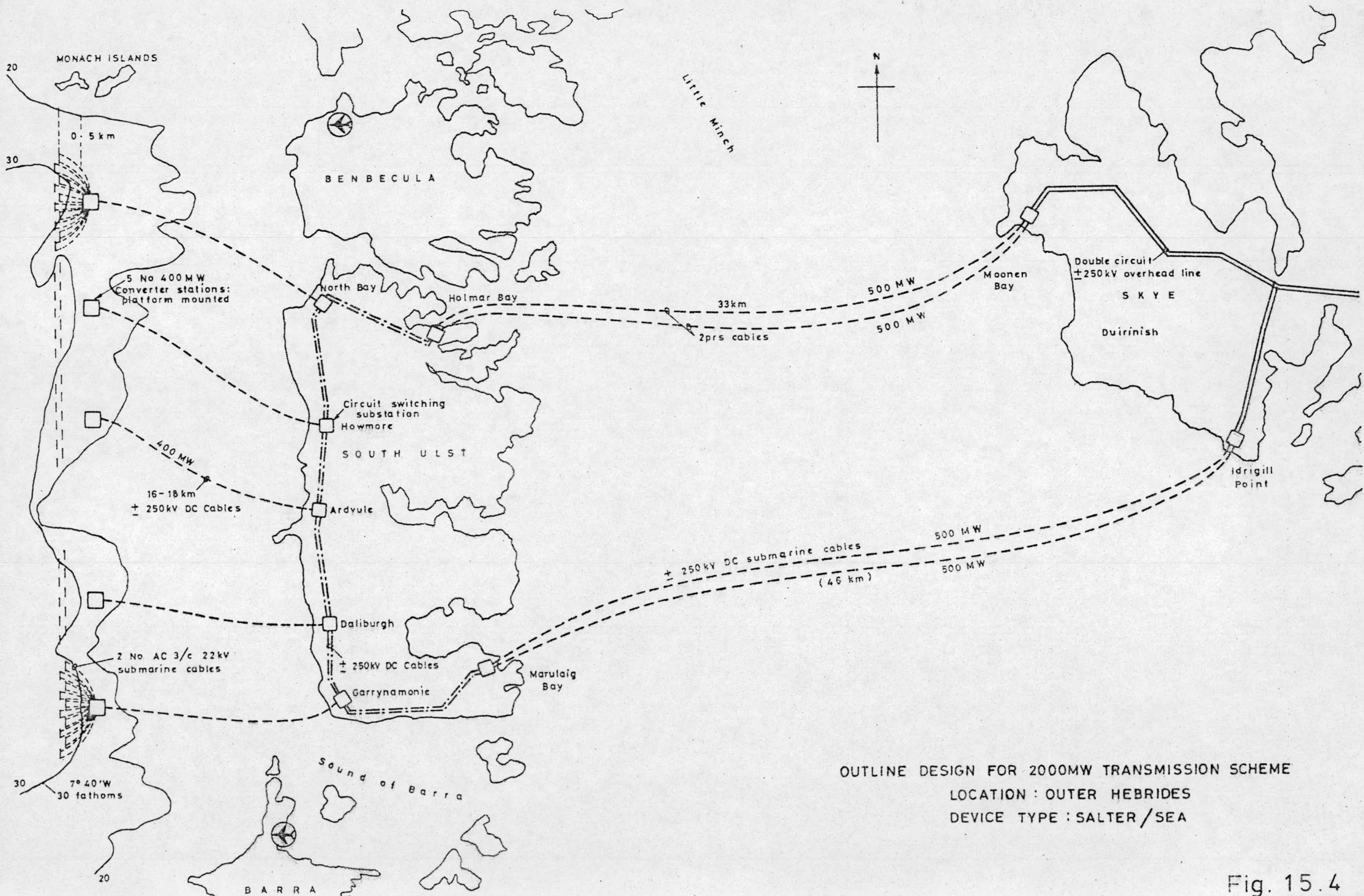

OUTLINE DESIGN FOR 2000MW TRANSMISSION SCHEME
 LOCATION : OUTER HEBRIDES
 DEVICE TYPE : SALTER / SEA

Fig. 15.4

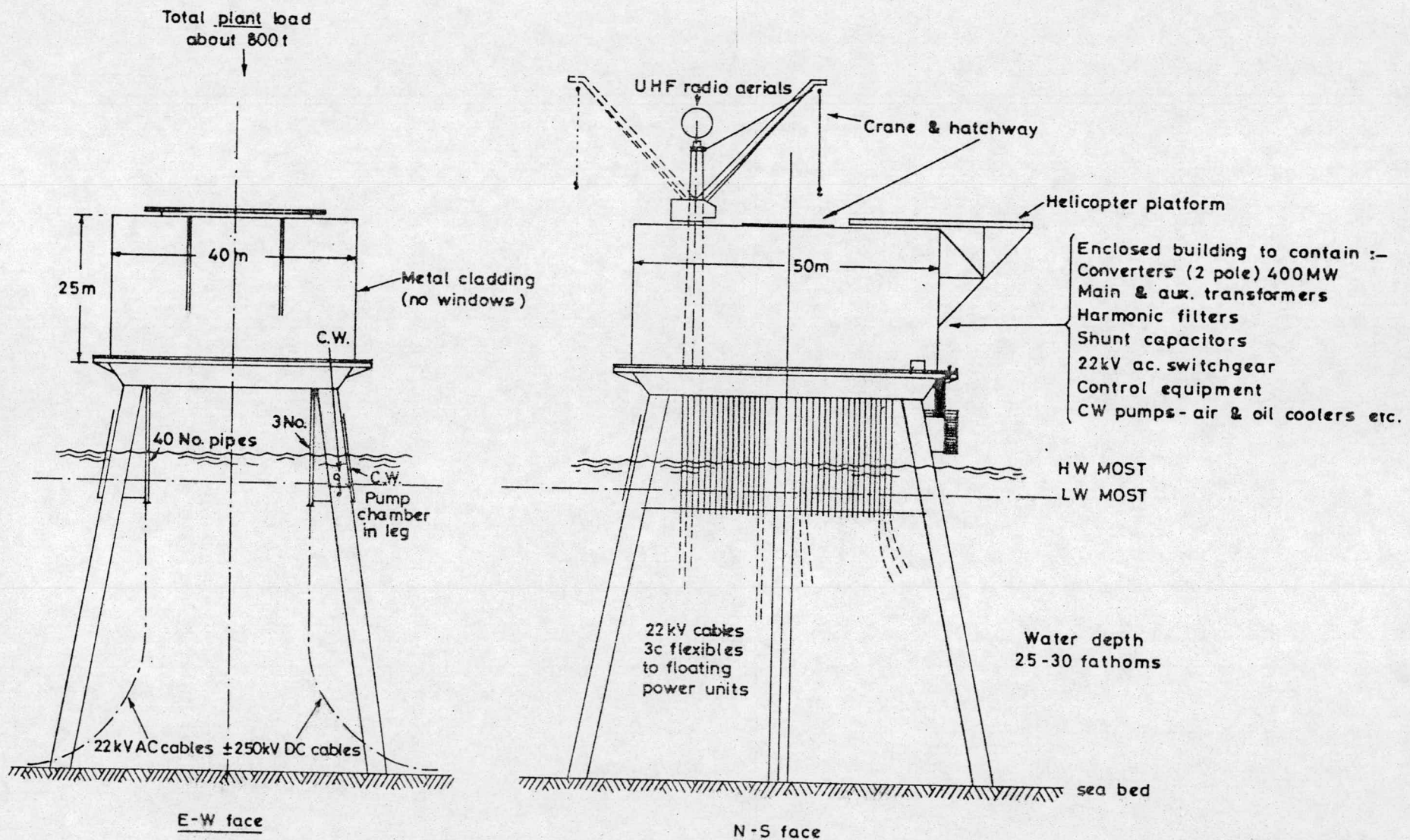

Scale 1:1000

PRELIMINARY DESIGN OF SEAWARD
CONVERTER STATION
400MW ± 250kV d.c.

Fig. 15.5

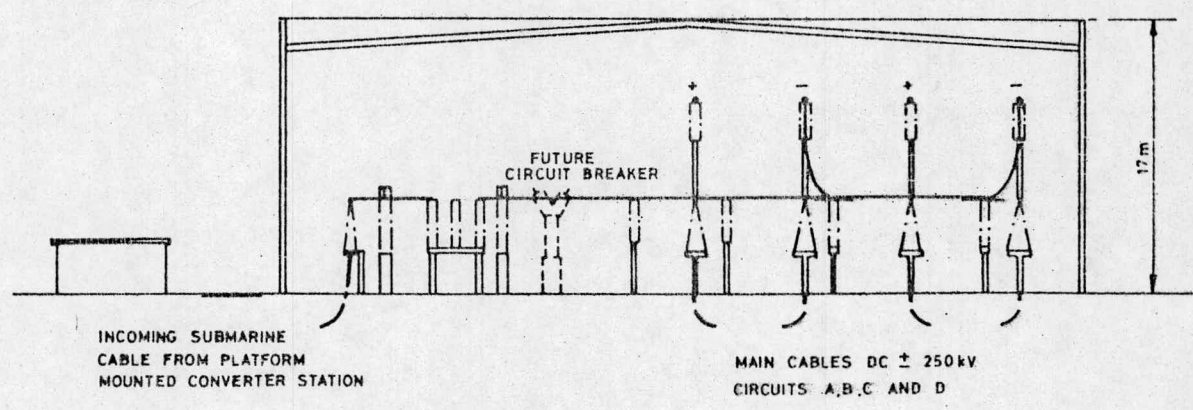
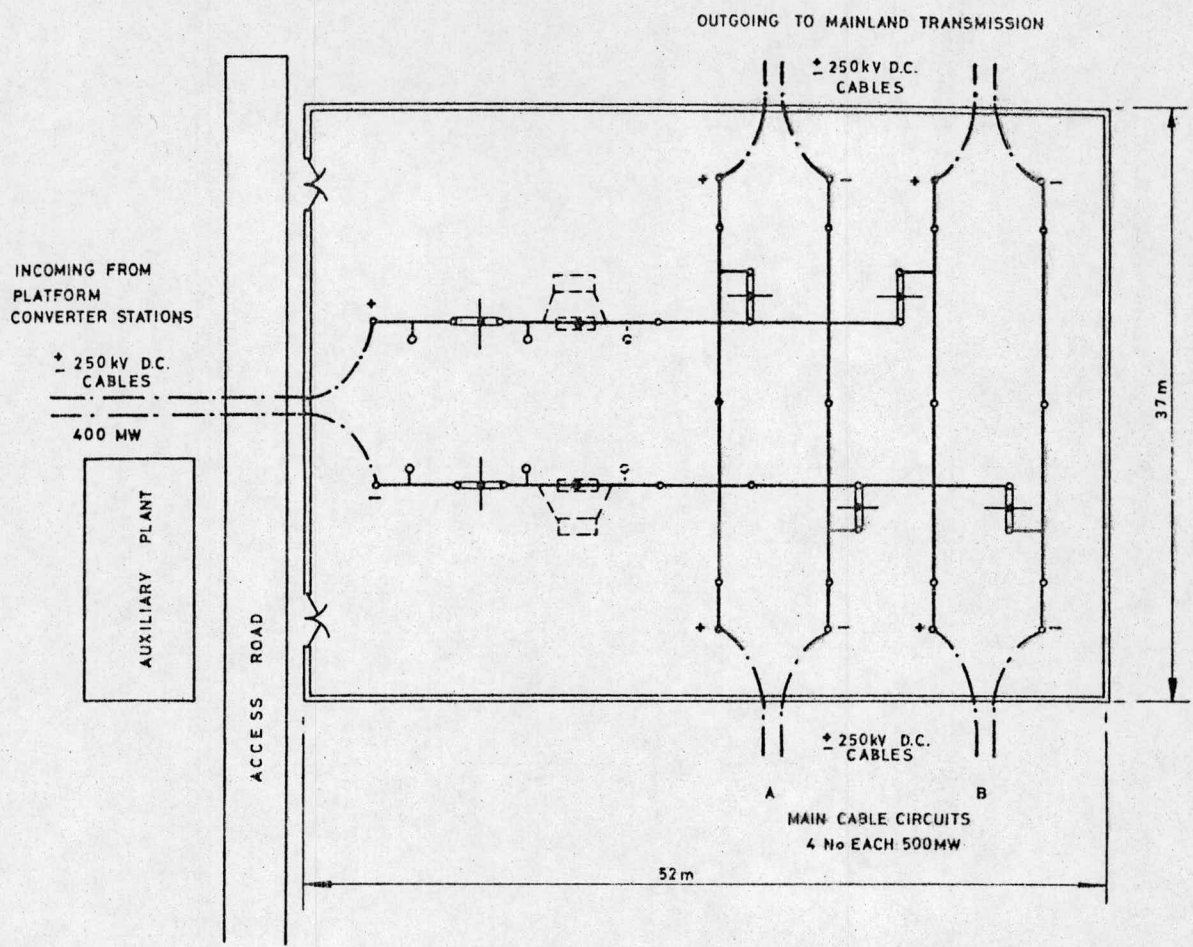

DC. POWER TRANSMISSION SCHEME
PROPOSED INDOOR CABLE SWITCHING STATION

Fig. 15.6

A matter of design which should be mentioned here is that whilst there will be a factor of diversity in determining the simultaneous output of a small number of duck strings, there may be no further diversity between groups of 10 strings - as shown in Fig. 15.4. - and for this reason bulk power transmission design has been based on a total of 2000 MW from five converter stations each associated with 10 duck strings.

For the prototype installation considered, a series of ten duck strings would be associated with each converter platform. A string of 28 individual ducks, each 30 m wide, could produce a peak output of 90 - 95 MW, but diversity of angular movement along the string would reduce the power level to only about 80 MW.

The conversion to a Device electrical output through mechanical and electrical systems of limited efficiency, would lead to a normal maximum output per string of about 56 MW, using four nominal 14 MW generators. This defines the power collection design.

For bulk power transmission, allowance should be made for further diversity of output along the 10 km or so of the wave energy installation, so that the net output to be expected from each converter platform would be about 400 MW. This figure decides the main transmission design.

The 400 MW output of a converter platform is transmitted by submarine DC cables to small switching stations along the Western Coast of South Uist. The locations shown in Fig. D are first suggestions but generally corresponding with suitable beach conditions for the cable landings.

The cables themselves would be of the paper insulated pressure oil impregnated type, steel wire armoured over a reinforced lead sheath. Polyethylene would be used for the outer sheath. Insulation would be designed for a BIL voltage of 700 kV.

The single core conductor section could be about 400 mm^2 for an 800A rating.

On reaching the island the incoming circuit would be protected in an enclosed switching station generally as shown in Fig. 15.6. Off-load switching arrangements would be provided so that the incoming power can be fed into the appropriate main circuit, i.e. arranging the load flow to suit the main transmission capacity available.

Larger $\pm 250 \text{ kV}$ DC cables are required on South Uist since each is to carry 500 MW. A copper section of 500 mm^2 is proposed.

Here again a mid-point cable has been included. The small substations at the two submarine cable terminations on the East coast of South Uist would be provided with cable isolation and earthing switches and probably also means of surge suppression.

The next stage involves two major submarine crossings of the Little Minch to convenient landing points on the neighbouring West coast of Skye. See Fig. 15.4. Examination of maps of the area suggest that the two Northern 500 MW circuits might follow a 33 kilometre route starting from Holmar Bay on Uist and terminating at Moonen Bay in Skye.

The two similarly rated DC circuits might be laid from the small switching station at Marulaig Bay on Uist to somewhere near Idrigill Point on the coast of the Duirinish Peninsula. The route length in this case would be about 46 kilometres. One might ask why not take all circuits along the shorter route? The reason for the Southerly route is to provide greater security and to facilitate relocation of the cables should it be necessary to recover them for repair.

Fig. 15.4. indicates the general layout proposed but the diagram is only approximately to scale.

The four 500 MW cable circuits include mid-point interconnection cables as allowed for throughout the main transmission design.

Both terminal sub-stations on Skye would have circuit isolation and earthing facilities in addition to surge suppression equipment and possibly also reactive compensation equipment.

From these two points onwards the 2000 MW wave energy output would be transmitted by double circuit overhead steel tower line across Skye to the mainland, through the Highlands to a termination somewhere in the neighbourhood of Perth.

The line would have to be routed as unobtrusively as possible in view of major environmental considerations. A practicable route is indicated broadly in Fig. 15.1. The route would have to be checked by very careful site investigation. For this preliminary review it would appear that a route length of about 300 kilometres would be realistic.

An outline design for a steel transmission tower is given in Fig. 15.2. It will be noted that this carried two circuits of positive and negative conductors and one mid-point interconnector for each circuit. The latter by suitable end switching could temporarily replace a damaged circuit conductor.

The conductor proposed would be a triple "Zebra" s.c.a. bundle supported by the double insulator configuration shown.

The steel towers would be rather shorter and lighter in weight - about 18.2 tonnes - than the standard 400 kV double circuit towers of the C.E.G.B. L6 design. Further reduction of height would be possible if reduced insulation were acceptable for the mid-point conductors.

It will be noted that a double earth wire design has been proposed giving particularly good shielding of the conductors. It should also be mentioned that the proposed insulators would have extra long leakage paths to withstand pollution, particularly in coastal areas, aggravated by direct current polarization.

An overhead line crossing of the straits at Kyle Rhea has been allowed for. This would involve a span of about 1000 m. High crossing towers and twin anchor towers have been allowed for in the design and costs.

It is appreciated that both circuits would be required to transmit the 2000 MW. There is no spare capacity for routine or unscheduled maintenance outages but it should be remembered that for a large part of the year - six months or more - the output of the notional 50 kilometre long wave energy installation would probably be less than 1000 MW. This means that normal maintenance should not affect circuit availability. The economics of providing a third circuit would have to be considered if it were decided to implement the prototype installation proposed. The same principle would apply equally to the submarine cable circuits but the additional cost would be considerable.

The HV DC transmission line would terminate at a major inverter station with a 2000 MW rating located appropriately in the Perth area of central Scotland from which there would have to be several 275 kV three phase AC transmission links to distribute the wave power into the primary networks of the N.S.H.E.B. and the nearby S.S.E.B.

A preliminary design for this large inverter station has not been prepared but apart from the rating required, the design would not involve any extrapolation of present electrical design. The budgetary estimates do, however, include an appropriate overall sum for the inverter installation but not for the onward AC transmission nor for the site required.

15.4. Efficiency (and Cost)

The collection of multiple generator outputs at 11 kV and their conversion, in five groups each of 400 MW, to a final bulk HV DC transmission of 2000 MW involves the following five main stages:-

- (i) 11/22 kV transformers and flexible 22 kV AC cables (power module to platform).
- (ii) The main transformers and AC/DC conversion equipment (on platform).
- (iii) ⁺ - 250 kV DC submarine cables from the seaward platforms across South Uist and the Little Minch to the West coast of Skye.
- (iv) A 300 kilometre ⁺ - 250 kV DC transmission line from Skye to Perth.
- (v) The 2000 MW main inverter station to the AC busbars.

A review of the relative efficiencies of each of the about five stages leads to a net transmission efficiency from the device generators right through to the delivery point of the 2000 MW as alternating current of about 85% under fully loaded conditions.

If the economics of wave energy are to depend on power and energy actually delivered into the National Grid network, then the annual productivity of the prototype wave generator installation should be reduced by this efficiency factor if delivering energy at the full 2000 MW power level.

CHAPTER 16.0 MAINTENANCE AND MANNING

16.1 General

Maintenance of Wave Power Devices is a very important consideration, which has been taken into account continuously by the Consultants in preparing the Reference Designs. In many instances it has been the ruling criterion in key design decisions. The selection of the power take-off arrangement for the Cockerell Rafts, the provision of accessible machinery chamber for the Salter Ducks, and the removable flap gates of the HRS design are just three design features which derive preliminary from the maintenance requirement. Maintenance is a continuous thread running through the Report and the maintenance requirements for each device are not repeated in this Chapter.

It is clear that the manning of Wave Power Devices is closely associated with the level of maintenance required, and the two subjects will need to be studied together as an input into the cost effective study of each Device. The total manpower requirements will clearly be different for each Device.

It will not be possible to make reliable assessments of maintenance costs until the Devices have been defined in some detail, and preliminary maintenance programmes established.

Two meetings were held with an offshore maintenance company (OMISCO) to discuss maintenance, but time has not permitted significant specialist input during the Stage I study. This input is identified as a requirement for a Stage II study, with a particular emphasis on cost.

The Consultants have also had contact with the Highlands and Islands Development Board who have an interest in the employment aspect of maintenance activity.

CHAPTER 17.0 ENVIRONMENTAL CONSIDERATIONS

17.1 General

TAG 7 and a number of the Device Teams have already given thought to this area of activity and their preliminary assessments appear in the following reports.

- (i) National Engineering Laboratory - Techno Economic Study.
- (ii) Hydraulics Research Station - Interim Report April 1977, on the Environmental Effects of Wave Energy Systems.
- (iii) S.H. Salter - Paper presented at "Energy from Oceans" Conference, January 1976.

The reports do not reach firm conclusions but identify several areas for consideration. In this it is necessary to consider the effect on the environment of not just the Devices themselves, but rather that of the scheme as a whole. For this purpose a wave power scheme may be sub-divided as follows:

- (i) the Devices,
- (ii) the transmission including offshore power collection platforms, subsea cables, overland cables and electricity sub-stations,
- (iii) support facilities for an operational scheme, bases for supply and maintenance, and the associated marine traffic,
- (iv) construction facilities, yards, dry docks and quarries.

The areas for investigation are as follows, and the corresponding parts of a scheme which may have a significant impact are indicated in brackets.

- (a) Navigation, and hazards to shipping ((i), (ii) and (iii)).
- (b) Coastal erosion, littoral drift and beach accretion ((i))
- (c) Tides and river outlets ((ii))
- (d) Scenic beauty and tourism ((i), (ii), (iii), (iv))
- (e) The sea fishing industry and fish farming ((i), (ii))
- (f) Salmon/sea trout river fishing ((i), (iii), (iv))
- (g) Bird life ((iii), (iv))
- (h) Marine plant life and the kelp/alginate industry ((i), (ii))
- (i) Pollution ((i), (iv))
- (j) Existing infrastructure of local industry ((iii), (iv)).
(including road and rail transport)
- (k) Existing establishments - Firing ranges, designated waste disposal areas ((i), (ii))
- (l) Existing installations - telephone cables, etc. ((ii))

In conclusion, much of the impetus for the wave power programme has been on a belief in its environmental acceptability.

In fact little is known about the actual effects of a wave power scheme, but no overriding objections have yet been identified.

All that can be said on the relative merits of the contending Devices is that Devices fixed to the seabed in shallow water are likely to have a greater impact than the deep water floating devices in several of the above areas, but in practice this may not be significant.

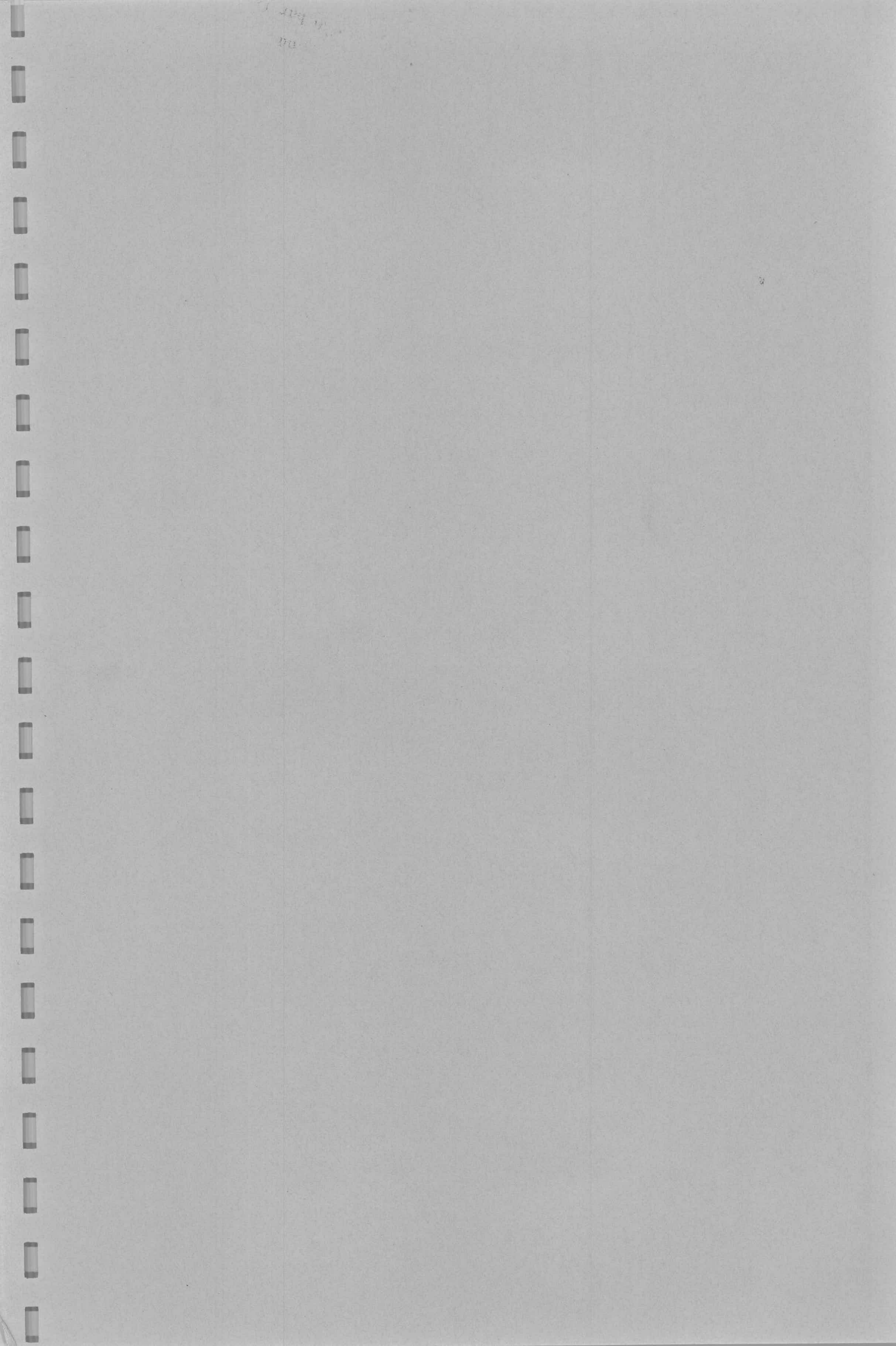

CHAPTER 18.0 BROAD ECONOMIC AND RESOURCE STUDY

18.1 General

At the start of the preliminary study, internal meetings were held with the Consultants' own Economic Studies Group (ESG) and a preliminary brief was prepared for their input. It soon became apparent that there would be insufficient data available to support even outline studies during Stage I. An outline of some of the work that needs to be done in the future is set down in the paragraphs following. Overall it will be necessary to build up a picture of the implications for the UK economy of a succession of key decisions which could be taken on wave power.

An important economic consideration to be included in a second stage study, will be the alternative Scales of Investment which might be implemented in the form of wave power generation capacity. From this input will flow all other implications, such as impact on the construction industry; appropriate level of tariffs for wave power; and the effect on the Nation's energy resources.

18.2 Resource Study

Obtaining power from wave energy will be unusually capital intensive. The construction of devices will draw very heavily on the resources of the heavy construction industry, the generator manufacturers, cable manufacturers, and a number of other industries (such as turbine and pump manufacturers), depending on which type of Wave Energy Device is selected. In addition other support industries could suddenly find themselves with long term heavy demand for particular components.

It can be anticipated that in some areas, parallel activity, such as the nuclear power programme, or the continuous development of new oil fields offshore, could create direct competition for these resources. In this respect the availability of capacity in the offshore construction yards will be very relevant in terms of the provision of construction sites for some of the Devices, although not for the Cockerell Rafts.

The capacity to produce basic materials, particularly cement, aggregates, and reinforcement bar could also provide restraints on a National development programme. Similarly the demand for turbines or oil pumps would in some cases exceed existing production capacity so that new manufacturing plants would have to be provided. The availability of manpower will also be a factor for consideration.

To assess the ability of the relevant industrial sectors to meet the demand which would be placed on them by any decision to proceed with wave energy converting systems, the economic study should be designed to establish the following data:

- (i) the existing and prospective capacity of the principal industrial bases which would be involved in the construction programme, in terms of both capital and manpower;
- (ii) a brief appraisal of the likely level of alternative commitments for these industries;

- (iii) the increase in capital investment and/or manpower which would be required of each industry if the programme were to be instituted, taking into account the possible alternative commitments already referred to;
- (iv) a broad outline of the financial costs involved in achieving the successful implementation of the plan over the defined period;
- (v) a brief appraisal of the overall social and economic implications of the plan.

18.3 Economics of Power Generation for the National Grid

A most important application of wave energy converters is as generators of electric power to be fed directly into the National Grid. The power input would be variable on a seasonal, daily and hourly basis, but within an overall pattern which will be predictable on the basis of sea state statistics and device performance data. The CEGB have already quoted values which might be used by them in evaluating the attractiveness of this sort of power supply. These values are derived from the Board's own very detailed economic analysis, which will presumably have been carried out in terms of the financial duties and obligations placed on the Board by its operating Charter. It seems at least possible that a valuation of wave power to the U.K. based on a set of premises and requirements other than those imposed on the Board, would produce a different valuation. It is understood that the Department of Energy has already done some work in this area. Obviously co-operation from CEGB in this exercise would be essential.

The study should entail an examination of the following:

- (i) the theory underlying present pricing policies for energy;
- (ii) the existing tariff systems related to energy from different sources and their interactions;
- (iii) alternative theoretical basis for energy pricing which might be more applicable to wave energy, and
- (iv) how these might be applied in practice to the pricing of energy from this source.

Although a major emphasis of the economic review to be carried out should be placed on the estimation of the resource costs and logistics which would be required by the programme, the importance of evaluating and pricing the energy product should not be overlooked and this fundamental issue should be given due attention.

18.4 Other Routes and Applications for Wave Energy

TAG 6 has already devoted some effort to considering alternative modes for using the energy of wave energy devices, and it seems that this is a whole area for study. In some ways direct power to the grid is one of the less attractive options for using wave energy devices, since from the primary power take-off the electricity produced tends to be of variable power, variable frequency, and in the wrong place geographically. Correcting for these snags is part of the cost of

generating for the grid, but already any industry or process which can use the raw power at source is potentially a customer for wave power. The Consultants believe that a technical and economic assessment of the possible use of wave power for fuel synthesis or for some electricity intensive industry, should be included in future studies.

A first study should be carried out as part of Stage 2. Again, the resources to be made available need to be carefully considered in relation to the whole Stage 2 study. If the future for wave energy looks promising, it is probable that studies of alternative uses would be funded by industry on a contributory basis.

18.5 Energy Accounting

This technique has already thrown some interesting light on some other projects in the power field, and it will be right to apply the approach to these wave power devices which are leading the field towards the end of the study. A primary use of energy accounting has been to show the viability or non-viability of schemes from the point of view of the total energy input and output through to the end of the life of a scheme.

With a number of contending devices it may be that a device which is relatively low on materials but high in workmanship might be attractive from an energy balance viewpoint, although not the cheapest according to normal economic assessment. The same could apply between two versions of the same basic device. For example, extensive post tensioning of relatively thin, complicated shapes may produce the lightest, and probably the 'lowest' energy' solution to many structural problems, but this might also be the dearest solution, with labour costs dominating.

Energy accounting is thus a possible measure for use in the design development of individual devices, as well as to guide major policy decisions relating to wave energy in general.

18.6 Economic Study for West Scotland (TAG 7)

The implications for the small communities on the West coast of Scotland of a major wave energy programme would be immense. Early in a Stage II study, the various threads of activity in this area should be pulled together and a co-ordinated study made of the local economic impact of a wave energy programme. Topics for consideration should include -

- Local construction of Wave Energy Devices.
- Installation of Wave Energy Devices.
- Continuing maintenance, operation, and support activity.
- Establishment of energy intensive industry.
- Effect on the fishing industry, fish farming.
- Effect on the tourist industry.
- Aggregate resources.

This study would be closely linked with any environmental studies (see Chapter 17).

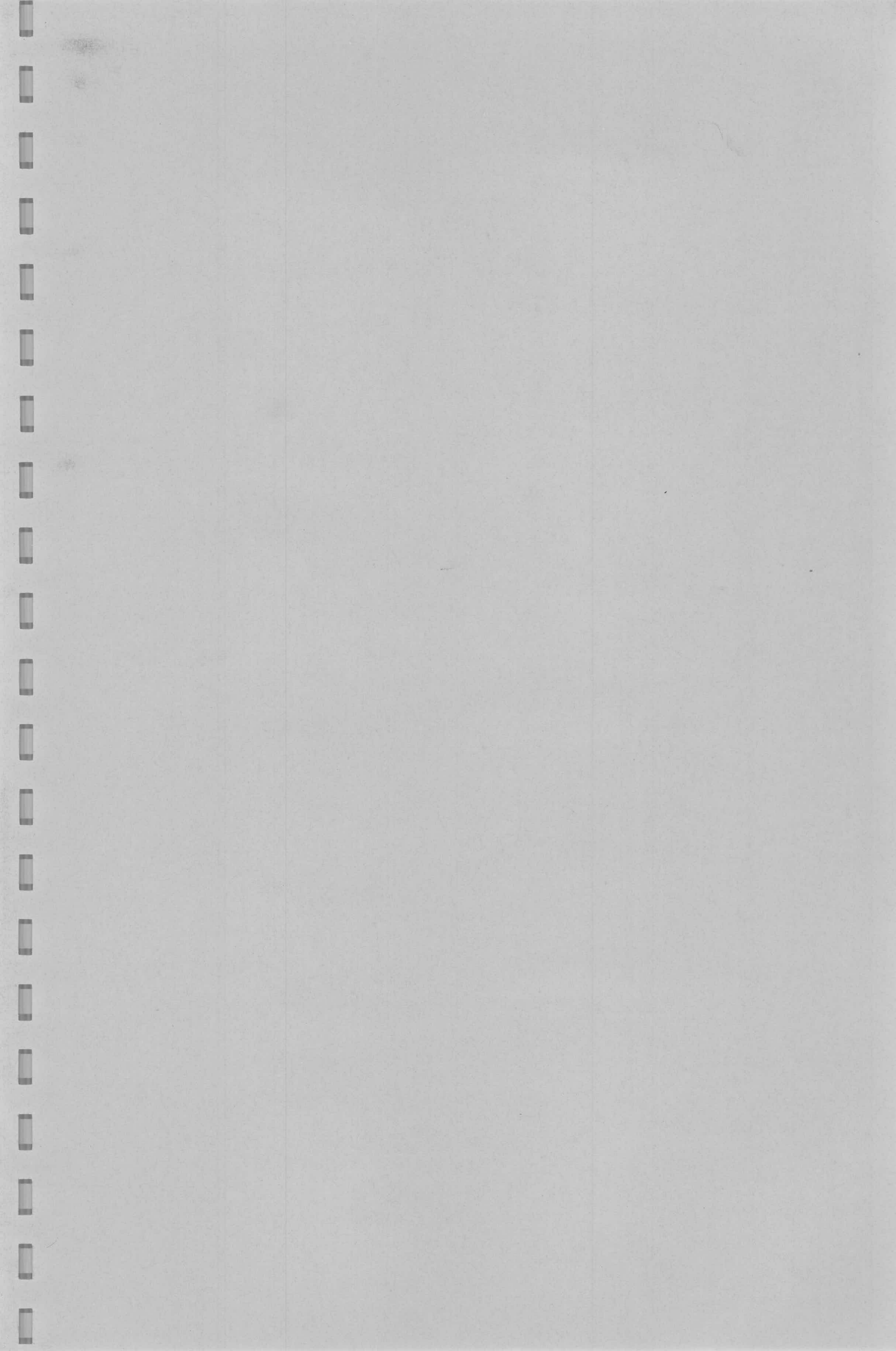

SECTION E - IMPLEMENTATION

CHAPTER 19.0 IMPLEMENTATION OF A WAVE ENERGY PROGRAMME

19.0 Considerations

The brief to prepare an implementation plan was common to both Stage I and Stage II studies. The Consultants came to the view that the preparation of complete implementation plans for each of the five Devices would be premature on the Stage I study, and would be appropriate for a second stage. The following lists are intended to highlight the areas which will require the attention of WESC over the coming six to twelve months. The activities are identified as device orientated, generic, or reporting. Work already identified by WESC for a Stage II study is not included.

1. Device Orientated Studies

- (i) Small scale laboratory testing (including moorings).
- (ii) Application of mathematical methods to each device.
- (iii) Larger scale models (e.g. 1/10 scale).

The first question to be considered by WESC is the scale at which testing should be taking place. Even with unlimited funds the case for the intermediate scale models is in many cases doubtful. A principle reason for larger scale outdoor testing has been the need to test arrays of devices in multi-directional random seas. Extension of laboratory facilities to enable such testing to be carried out under controlled conditions at small scale will reduce the need for outdoor tests. Only when the scale is such that details such as power take-off can be realistically modelled (with representative machines) does the superiority of the large-scale testing become self evident.

Secondly it will be necessary to decide what resources should go into design development and costing. Theoretical appreciation and design costing and testing need to be interlocked activities to achieve cost-effective solutions economically and in the shortest time.

Finally, a significant level of quite fundamental experimentation with novel concepts and variations continues to be essential at this stage of the programme. Such concepts might equally derive from improved theoretical understanding or from a careful analysis of the high cost centres in an existing device.

2. Generic Studies

The present areas of generic study are -

- (i) Wave data.
- (ii) Fluid loading.
- (iii) Structural response.
- (iv) Mooring
- (v) Generation and transmission.
- (vi) Environmental.

The need for continued study in all of the above areas is clear. Comments on these topics have been given in this Report, but the Consultants would in particular, emphasize the need for urgent research on moorings. (Section 11).

In addition to the above, this Stage I study has highlighted the need for work in certain cost intensive areas where the possible gains in terms of reduced costs (or lower cost estimates) could be extremely valuable. The following will particularly repay study.

- (a) Construction methods suited to the needs of wave power devices - particularly economic methods of constructing many similar thin shell (or plate) structures in concrete, the criteria for adopting reinforced or prestressed concrete, a study of techniques that have been adopted for concrete ship construction in this country and abroad. (TAG 3 are already working in this area).
- (b) Production techniques for mass production of mechanical components which are currently made by relatively expensive small batch methods.

3. Stage II Reporting

Certain information, including test data, will be required to enable a proper appraisal report to be prepared for WESC in mid-1978. Where this will not be forthcoming as a result of current or planned activity, additional work may have to be commissioned.

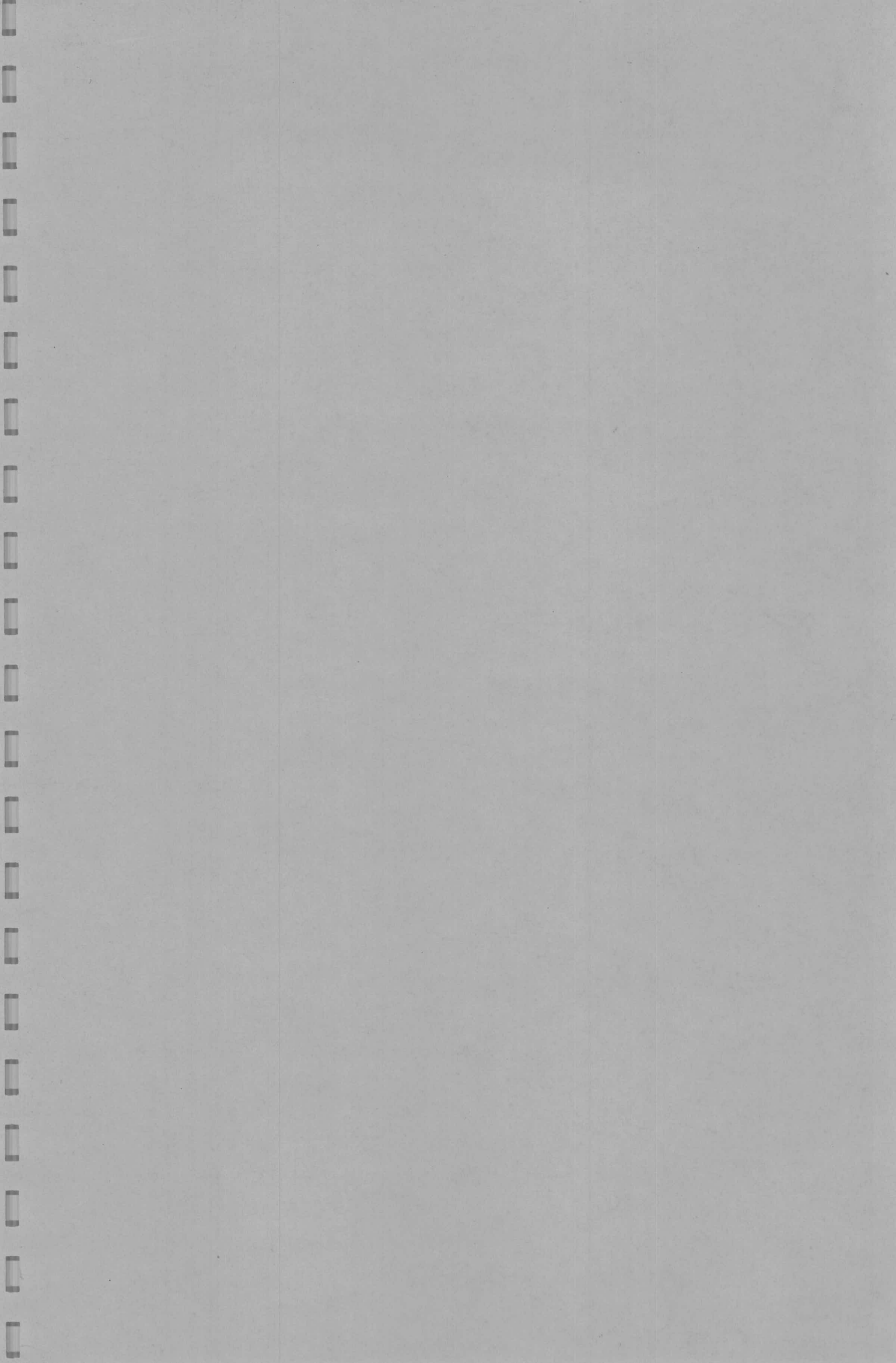

ACKNOWLEDGEMENTS

The Consultants wish to thank the very many organisations and individuals whose help and co-operation have made this study possible. In particular they would like to thank -

The Device Teams.
The Secretariat and TAG Group of WESC.
The Central Electricity Generating Board.

The Consultants would also like to thank the following Contractors and Manufacturers for their specialist assistance -

Sir Robert McAlpine Ltd.
ANDOC (Tarmac Construction Ltd.)
George Wimpey Ltd.
British Petroleum Ltd.
David Loewy Ltd.
Pirelli Ltd.
Boving Ltd.
Sea Platform Constructors (Scotland) Ltd.
Shell Industrial Oils Ltd.
Chamberlain Industries Ltd.
Staffa Pumps Ltd.
Andre Rubber Company Ltd.

REFERENCES

The Reports of the Wave Energy Steering Committee and the Device Teams.

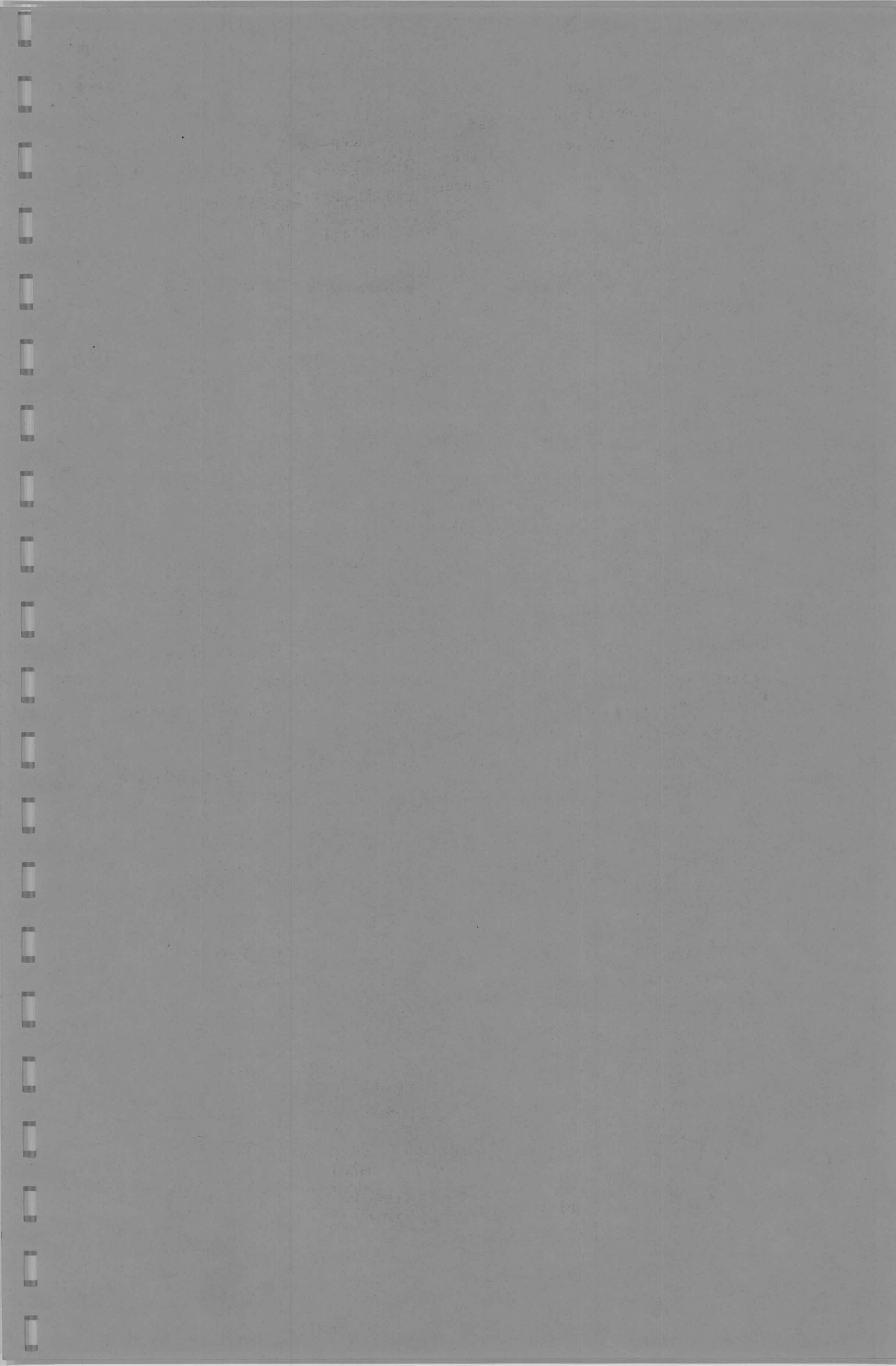

INDEX OF DRAWINGS

GENERAL DATA

- WP/GEN 1. WAVE ENERGY DEVICES UNDER CONSTRUCTION SCALE COMPARISON DRAWING.
- WP/GEN 2. LOCATION PLAN SHOWING EXISTING ON SHORE CONSTRUCTION YARD FACILITIES, POTENTIAL DEVICE SITINGS AND MEAN ANNUAL ENERGY CONTOURS KW/METRE.
- WP/GEN 3. WAVE ENERGY DEVICE SITINGS IN RELATION TO SEA BED GEOLOGY.

HRS. RUSSEL RECTIFIER

- WP/RECT 1. 200 MW SCHEME.
- WP/RECT 2. REFERENCE DESIGN - GENERAL ARRANGEMENT OF WORKING UNIT.
- WP/RECT 3. REFERENCE DESIGN - CONSTRUCTION AND FLOTATION.
- WP/RECT 4. WAVE ENERGY DEVICE SITINGS OFF THE OUTER HEBRIDES.

N.E.L. OSCILLATING WATER COLUMN

- WP/OWC 1. 200 MW SCHEME.
- WP/OWC 2. MODEL TO FULL SIZE DEVELOPMENT OF O.W.C. DEVICE.
- WP/OWC 3. REFERENCE DESIGN - GENERAL ARRANGMENT OF PRACTICAL WORKING UNIT.
- WP/OWC 4. REFERENCE DESIGN - CONSTRUCTION AND FLOTATION.

SALTER DUCK

- WP/SALT 1. 200 MW SCHEME.
- WP/SALT 2. REFERENCE DESIGN - GENERAL ARRANGEMENT OF WORKING UNIT.
- WP/SALT 3. REFERENCE DESIGN - DETAILS AND POWER TAKE OFF.
- WP/SALT 4. CONSTRUCTION SEQUENCE.

COCKERELL RAFT

- WP/RAFT 1. 200 MW SCHEME.
- WP/RAFT 2. REFERENCE DESIGN - GENERAL ARRANGEMENT OF WORKING UNIT.
- WP/RAFT 3. REFERENCE DESIGN - DETAILS AND POWER TAKE OFF.
- WP/RAFT 4. CONSTRUCTION SEQUENCE AND FLOTATION.

H.R.S. RUSSELL RECTIFIER - FIXED STRUCTURE. - 5.0 MW/140 m.

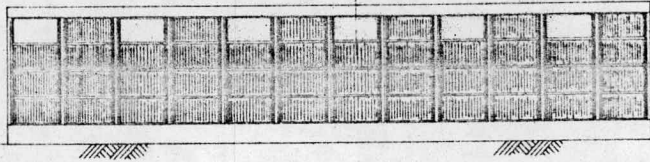

ELEVATION TO INCIDENT WAVE.

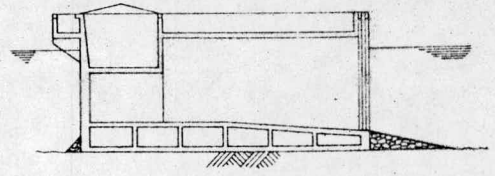

SECTION.

N.E.L. OSCILLATING WATER COLUMN - FLOATING. - 7.2 MW/143 m.

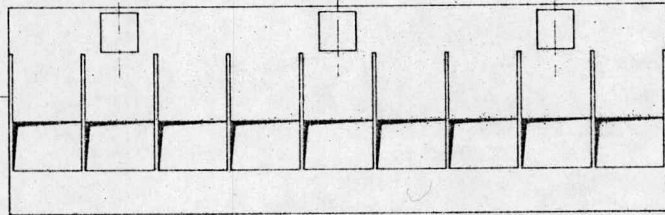

ELEVATION TO INCIDENT WAVE.

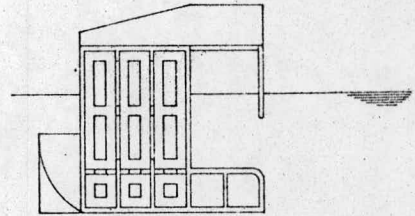

SECTION.

W.P.L. COCKERELL RAFT - 2.5 MW / 50m

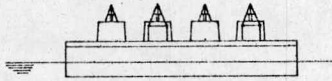

ELEVATION TO INCIDENT WAVE.

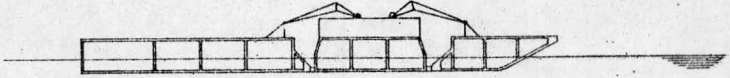

SECTION.

S.E.A. SALTER DUCK - 10.5 MW / 210m

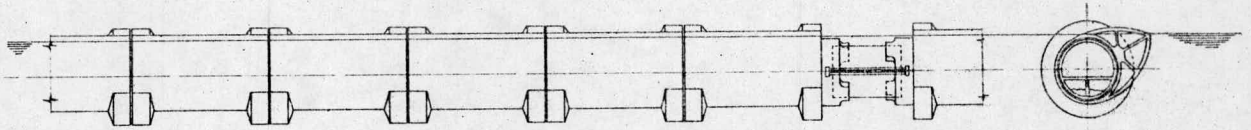

ELEVATION TO INCIDENT WAVE.

SECTION.

TOWER BRIDGE - LONDON.

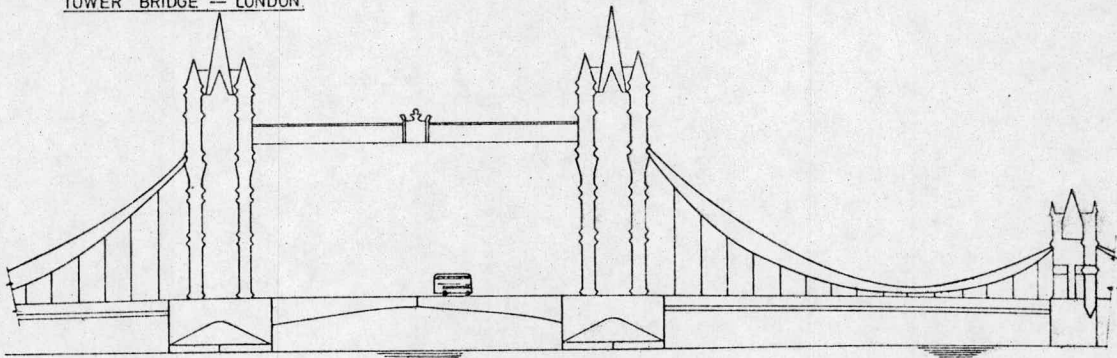

NOTE RATINGS ARE APPROXIMATE MAXIMUM CONTINUOUS RATINGS OF OUTPUT AVERAGED OVER WHOLE SCHEME

10 0 50 100m SCALE 1:500

GMR M.R. B.A. PRH 7.77

WAVE ENERGY STUDY

GENERAL DATA

WAVE ENERGY DEVICES
UNDER CONSIDERATION
SCALE COMPARISON
DRAWING

WP/GEN 1.

RENDEL, PALMER & TRITTON
CONSULTING ENGINEERS

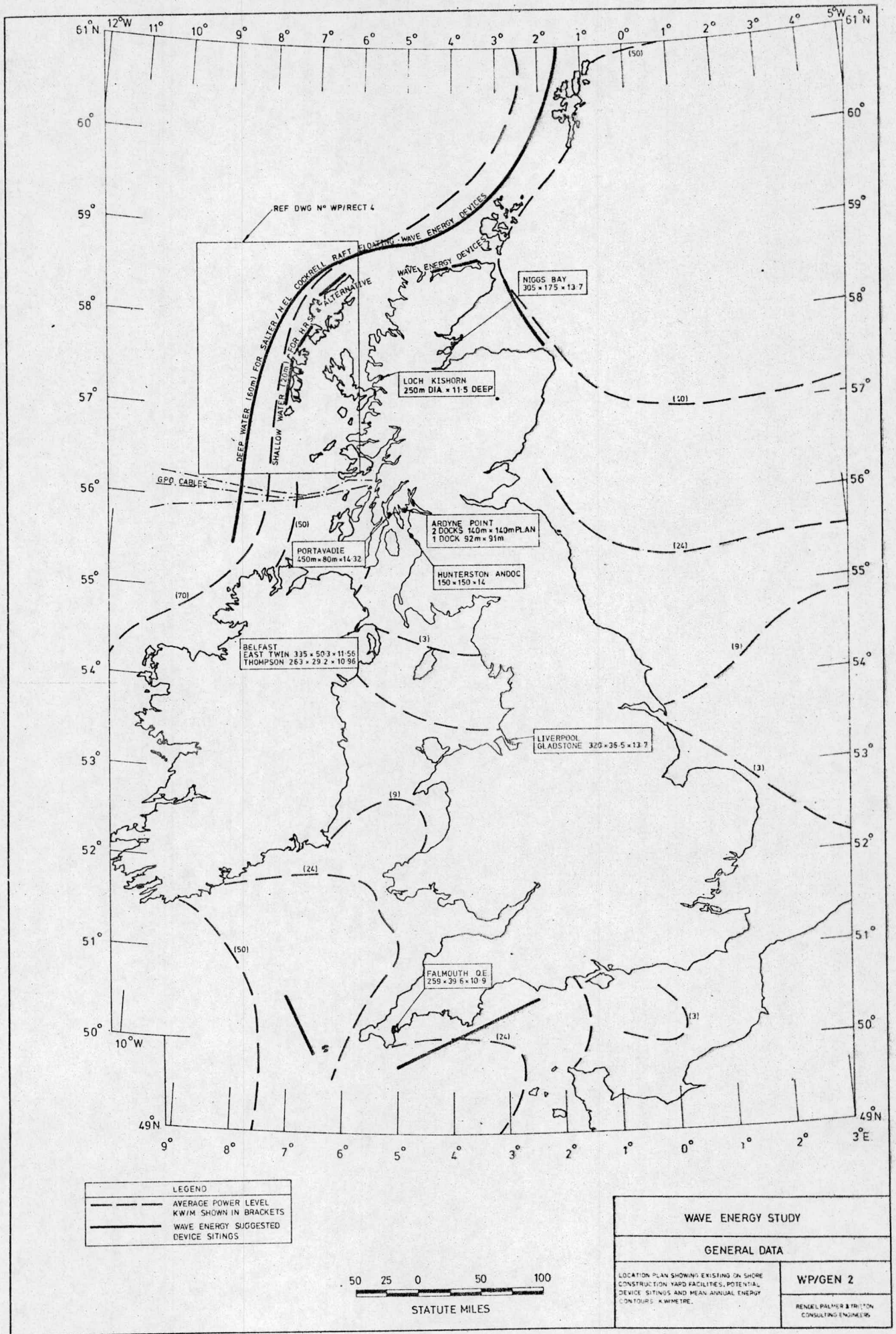

LEGEND
 - - - - - AVERAGE POWER LEVEL
 KW/M SHOWN IN BRACKETS
 ————— WAVE ENERGY SUGGESTED
 DEVICE SITINGS

50 25 0 50 100
 STATUTE MILES

WAVE ENERGY STUDY	
GENERAL DATA	
LOCATION PLAN SHOWING EXISTING ON SHORE CONSTRUCTION YARD FACILITIES, POTENTIAL DEVICE SITINGS AND MEAN ANNUAL ENERGY CONTOURS K.W/METRE.	WP/GEN 2
RENDEL PALMER & TRITTON CONSULTING ENGINEERS	

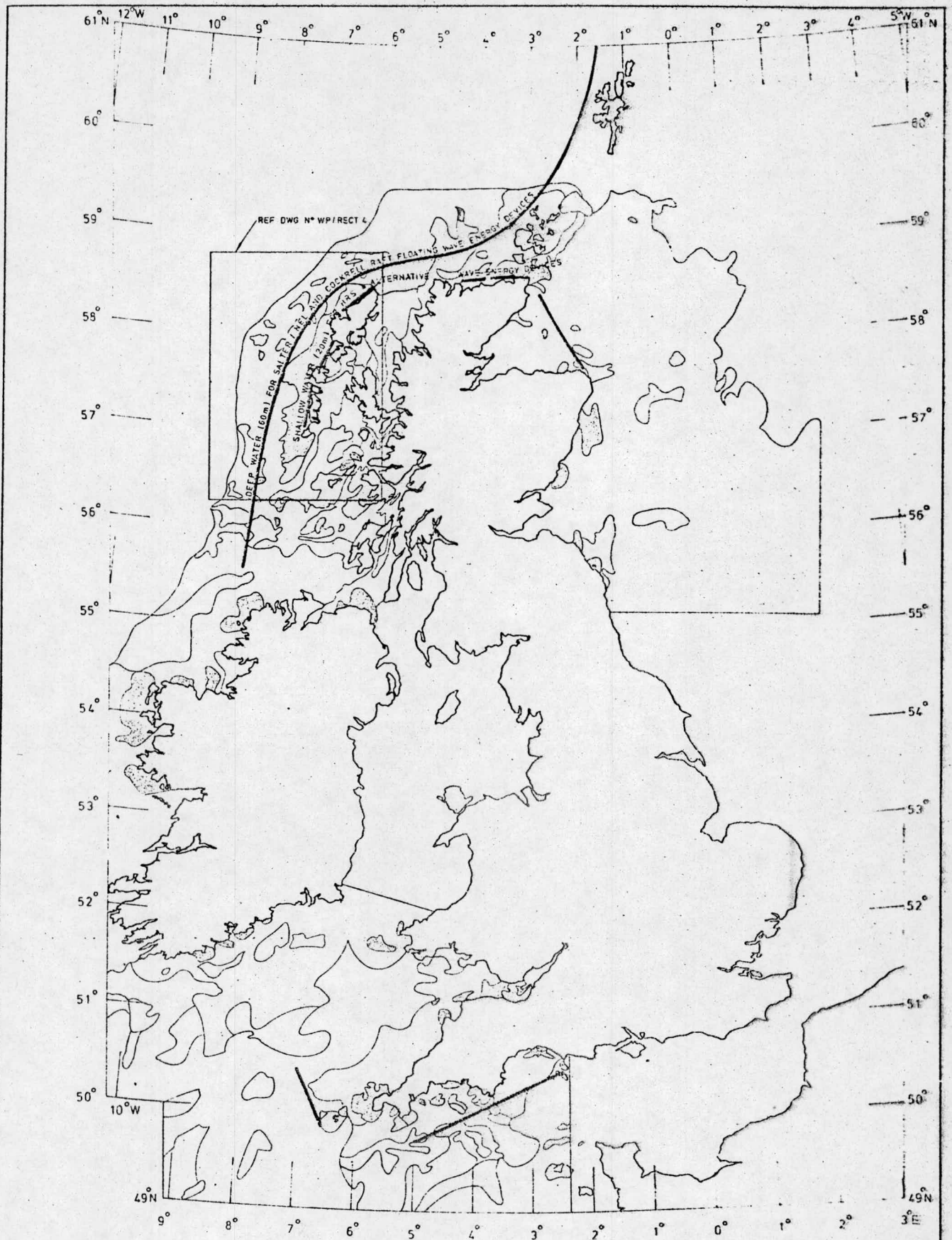

	WAVE ENERGY SUGGESTED DEVICE SITINGS
	ROCK
	GRAVEL & COARSE SAND
	SAND
	FINE SAND SILT & MUD

NOTE THE INFORMATION SHOWN ON THIS DRAWING IS TO BE TAKEN AS INDICATIVE ONLY



WAVE ENERGY STUDY	
GENERAL DATA	
WAVE ENERGY DEVICE SITINGS IN RELATION TO SEA BED GEOLOGY	WP/GEN 3
	RENDEL PALMER & TAYLOR CONSULTING ENGINEERS

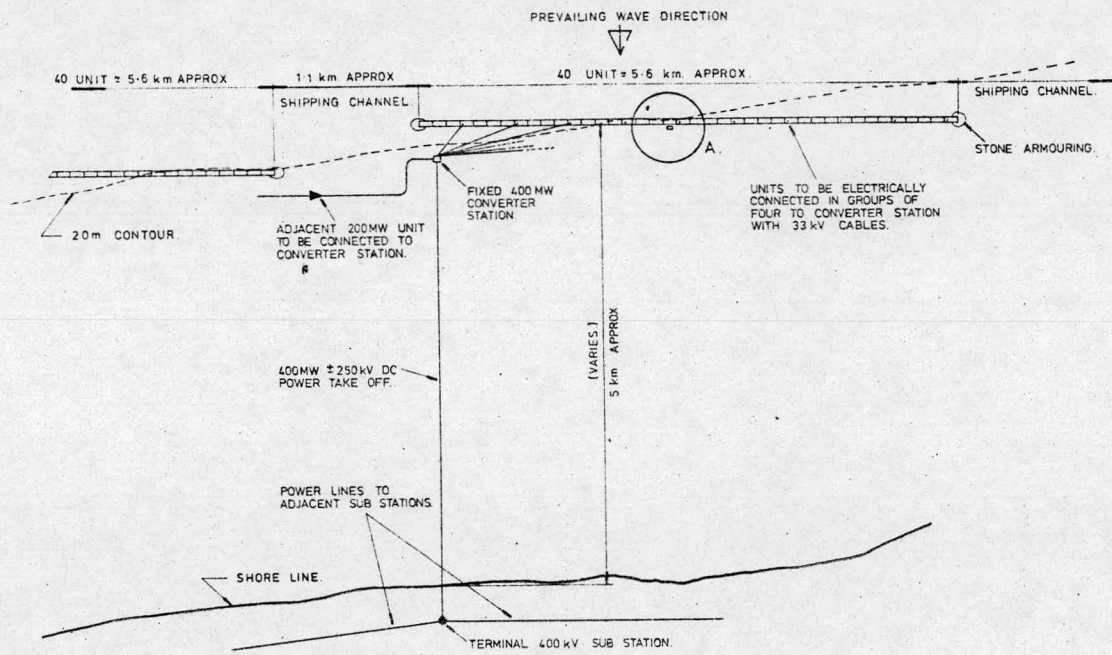

PLAN OF H.R.S. 200 MW SCHEME (SCALE 1:2500)

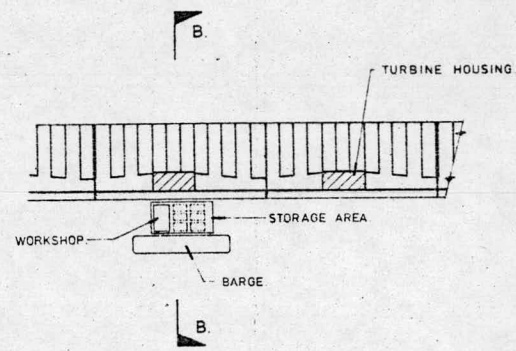

ENLARGED VIEW ON A (SCALE 1:500)

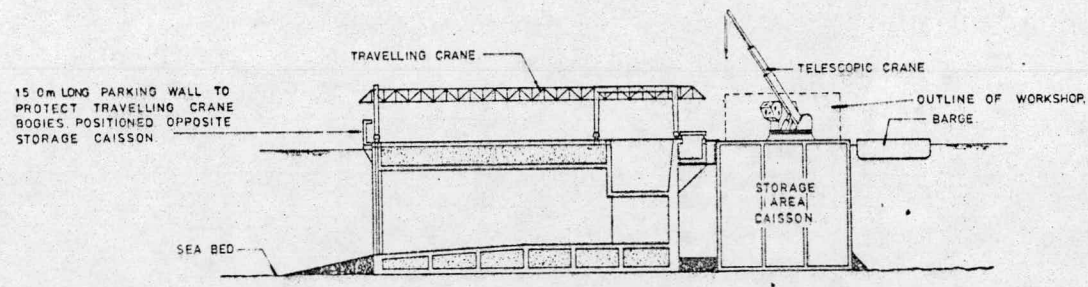

CROSS SECTION AT B-B (SCALE 1:200)



WAVE ENERGY STUDY	
H.R.S. RUSSELL RECTIFIER	
200 M.W. SCHEME	WP/RECT. 1.
HENSHEL PALMER & TRITTON CONSULTING ENGINEERS	

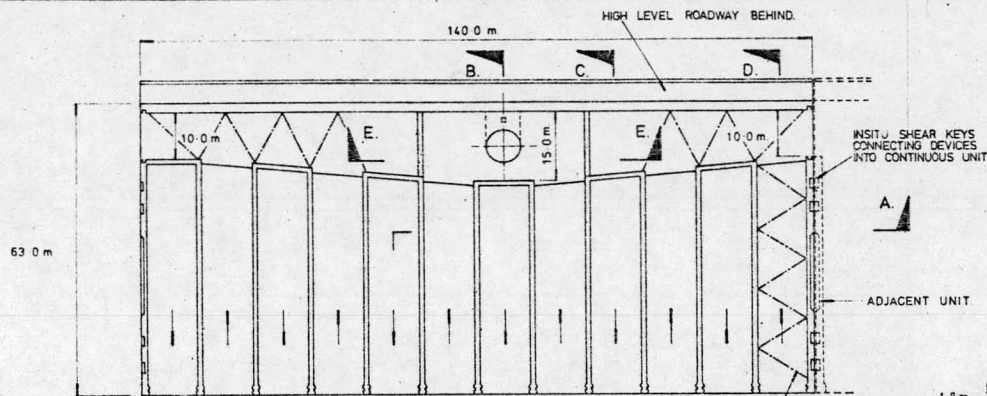

UPPER RESERVOIR.

TEMPORARY BRACING TO BE PROVIDED AT +3.4m LEVEL FOR FLOTATION PURPOSES ONLY.

A

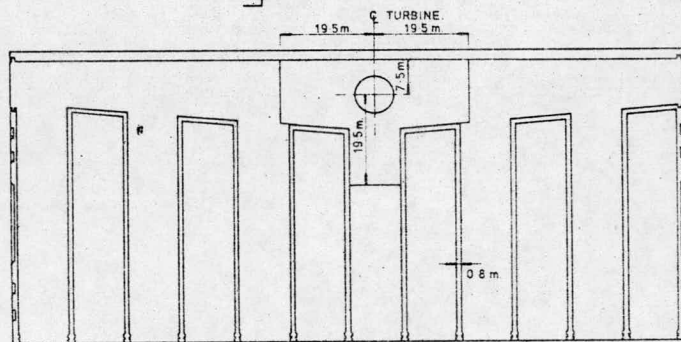

LOWER RESERVOIR.

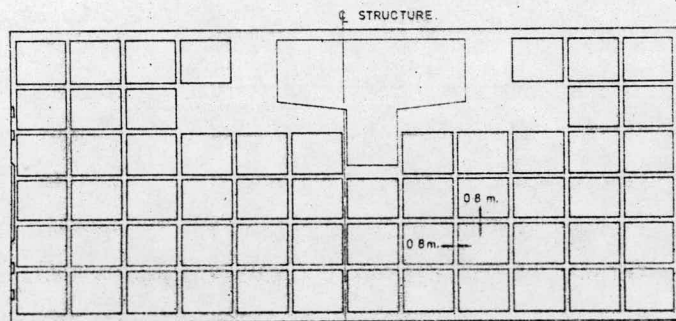

PLAN ON BASE

B C D

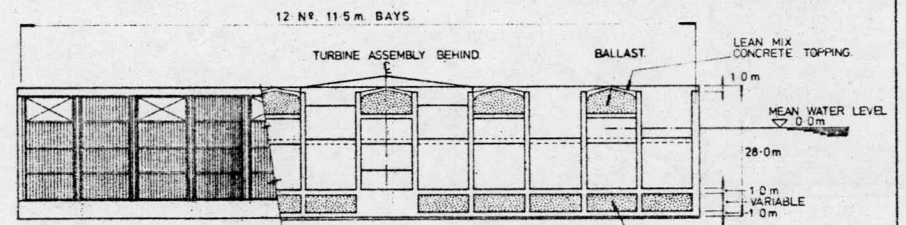

SECTIONAL ELEVATION ON A-A.

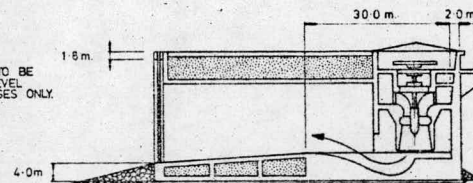

SECTION B-B.

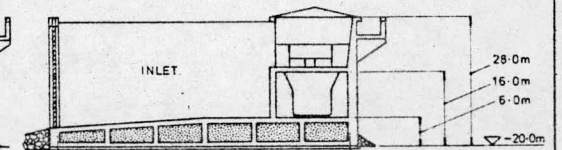

SECTION D-D

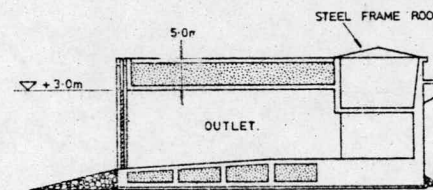

SECTION C-C.

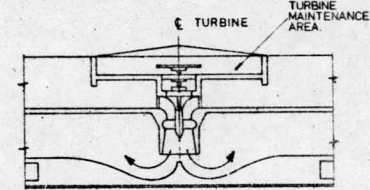

PART SECTION E-E.

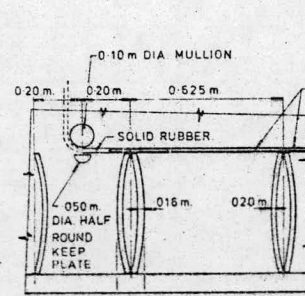

DETAIL OF GATE FLAPS (SCALE 1:10)

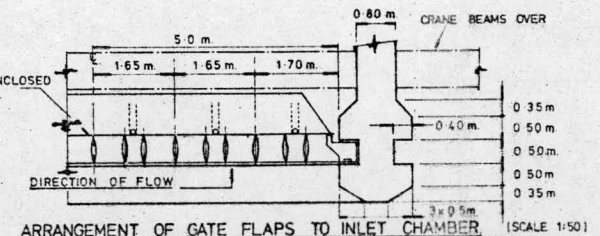

ARRANGEMENT OF GATE FLAPS TO INLET CHAMBER (SCALE 1:50)

NOTE GATE FLAPS TO OUTLET CHAMBER TO BE REVERSED.

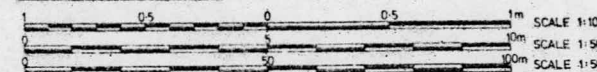

WAVE ENERGY STUDY

H. R. S. RUSSELL RECTIFIER

REFERENCE DESIGN.
GENERAL ARRANGEMENT
OF WORKING UNIT.

WP/RECT 2.

REGUL PALMER & TRITTON
CONSULTING ENGINEERS.

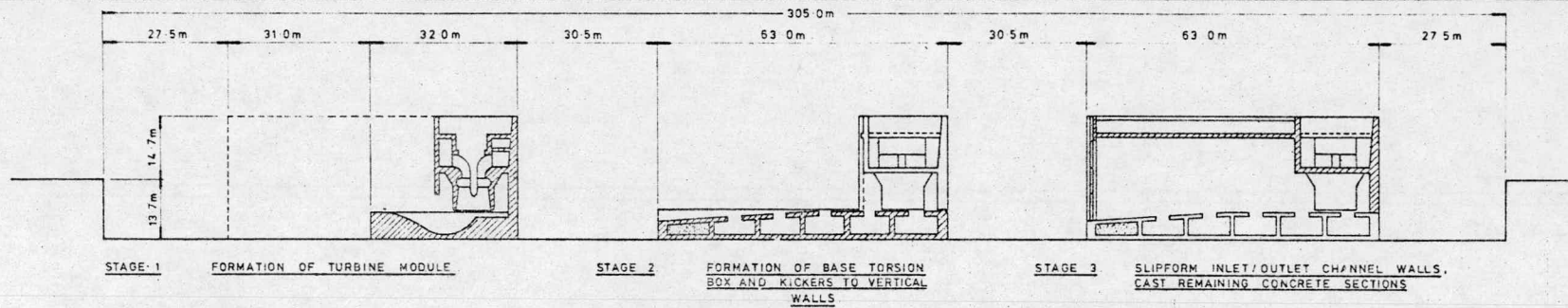

DRY DOCK SHOWING THREE MODULES UNDER CONSTRUCTION.

CONSTRUCTION NOTES:

- STAGE 1 FORMATION OF TURBINE MODULE HYDRODYNAMICALLY SHAPED BASE AREA FOR TURBINE OUTLET CHANNEL BACK WALLS AND BACK WALL TO DEVICE TO WIDTH OF TURBINE MAINTENANCE AREA WATERWAYS, SUPPORT STRUCTURE AND MAINTENANCE PLATFORM FOR TURBINE INSTALLATION OF COMPLETE TURBINE
- STAGE 2 FORMATION OF BASE TORSION BOX FRONT ROW OF CELLS TO BE SAND FILLED, REMAINING CELLS TO BE LEFT VOID WITH 3.0m x 2.0m ACCESS HOLE FORM KICKERS TO ALL VERTICAL WALLS.
- STAGE 3 SLIPFORM WALLS OF INLET/OUTLET CHANNELS TO FULL HEIGHT CAST REMAINING PARTS OF PERMANENT CONCRETE STRUCTURE EXCEPT FOR COMPLETION AT ACCESS HOLES TO VOIDS MANUFACTURE OF TEMPORARY BLANKS TO SEAL GATE POSITIONS AND ENDS OF BACK CHANNEL, HYDRAULIC CONNECTION BETWEEN UNITS AND PERMANENT GATES INSTALL EQUIPMENT FOR FLOODING DEVICE
- STAGE 4 INSTALL AND SEAL PRECAST BLANKS FLOOD DRY DOCK, ADD WATER BALLAST TO BASE VOIDS FOR LEVEL FLOATATION WITH 1m GROUND CLEARANCE TOW OUT OF DRY DOCK TO CALM WATER MOORING WITH MINIMUM DEPTH OF 20m
- STAGE 5 FILL REMAINING BASE VOIDS WITH SAND, AND CONCRETE INFILL TOP FLANGE OF TORSION BOX ADD WATER BALLAST TO ACHIEVE LEVEL FLOATATION
- STAGE 6 PREPARE SEA BED WITH ROCK FILL LAYER (MINIMUM THICKNESS 0.5m), FINISHED LEVEL 20m BELOW MEAN SEA LEVEL TOW OUT TO SITE AND, USING FLOODING EQUIPMENT, SINK ONTO PREPARED BED AND FULLY FLOOD DEVICE
- STAGE 7 PLACE SAND IN OUTLET CHANNEL ROOF CAVITIES AND ROUGH CAST CONCRETE OVER PLACE ROCK FILL SLOPES TO FRONT AND REAR OF DEVICE REMOVE PRECAST BLANKS INSTALL GATES AND HYDRAULIC CONNECTION TO ADJACENT UNIT. CAST SHEAR KEYS TO ADJACENT UNIT

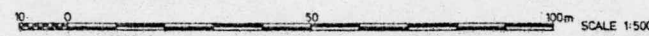
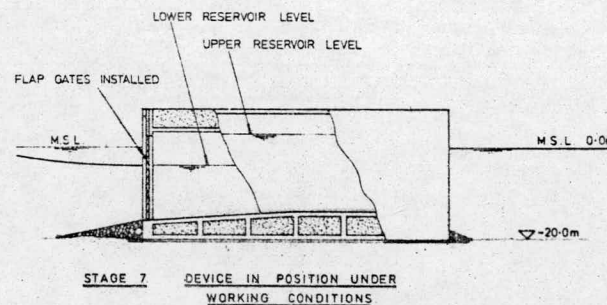
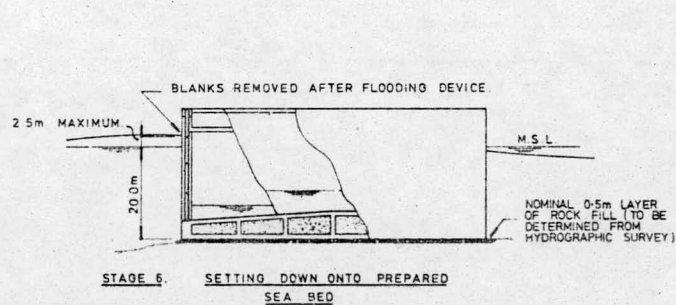
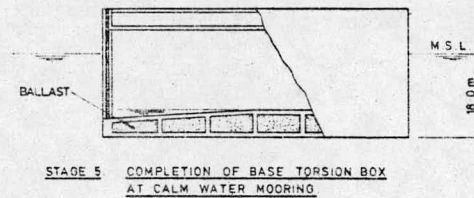
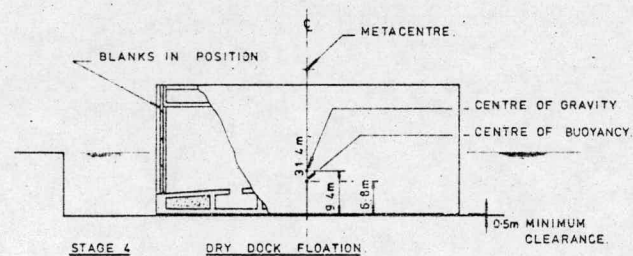

WAVE ENERGY STUDY

H. R. S. RUSSELL RECTIFIER

REFERENCE DESIGN.

CONSTRUCTION & FLOTATION.

WP/RECT 3.

RENDEL PALMER & TRITTON CONSULTING ENGINEERS.

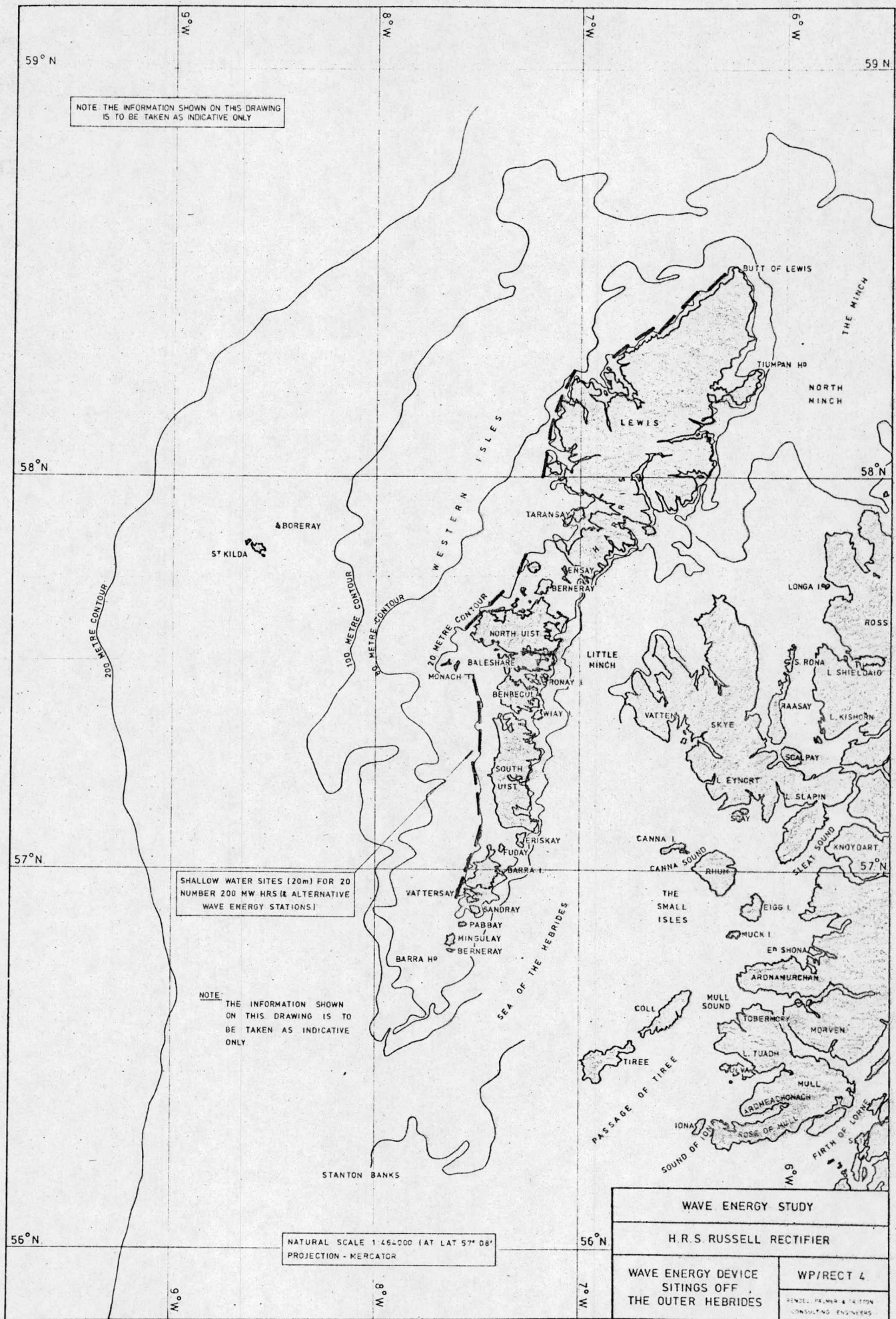

NOTE: THE INFORMATION SHOWN ON THIS DRAWING IS TO BE TAKEN AS INDICATIVE ONLY

SHALLOW WATER SITES (20m) FOR 20 NUMBER 200 MW HRS (& ALTERNATIVE WAVE ENERGY STATIONS)

NOTE: THE INFORMATION SHOWN ON THIS DRAWING IS TO BE TAKEN AS INDICATIVE ONLY

NATURAL SCALE 1:46,000 (AT LAT 57° 08')
PROJECTION - MERCATOR

WAVE ENERGY STUDY	
H.R.S. RUSSELL RECTIFIER	
WAVE ENERGY DEVICE SITINGS OFF THE OUTER HEBRIDES	WP/RECT 4
	PENEL PERMA & PARTON CONSULTING ENGINEERS

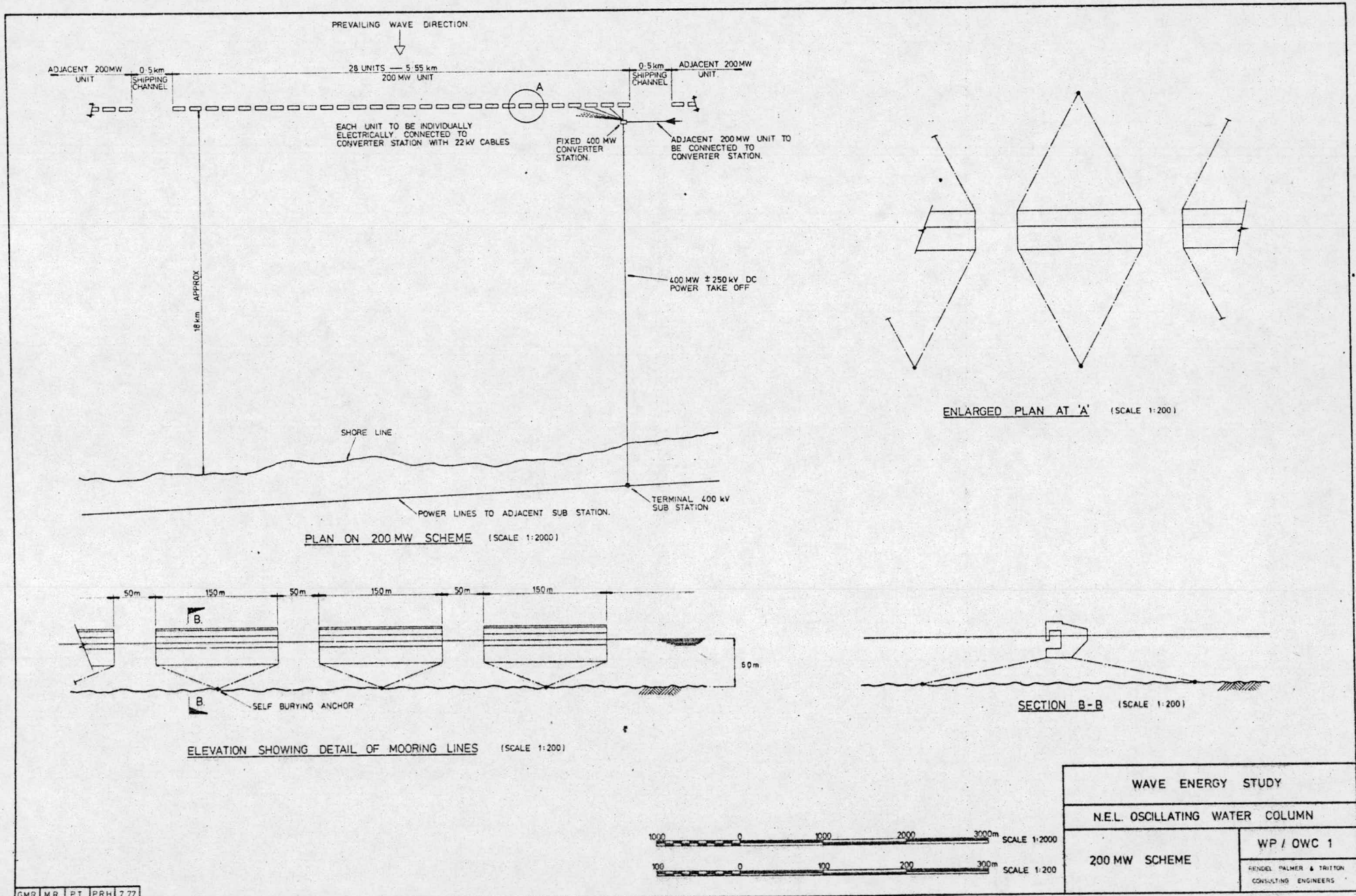

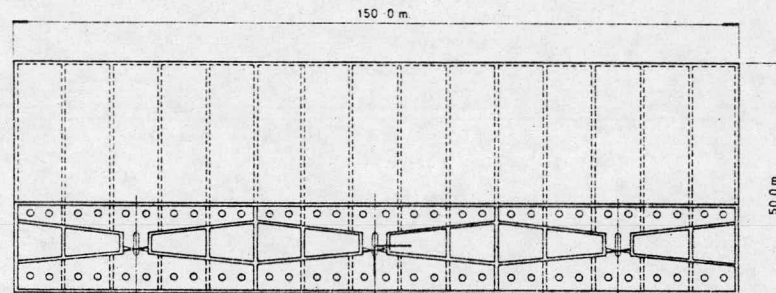

PLAN AT POWER TAKE OFF LEVEL

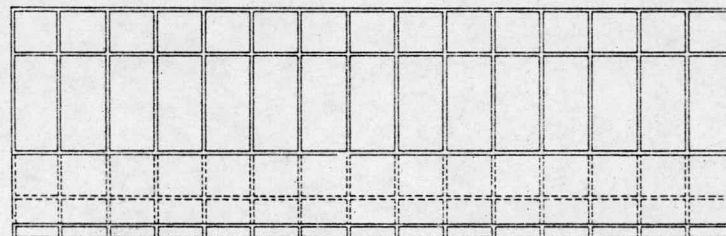

PLAN ON RESERVOIR

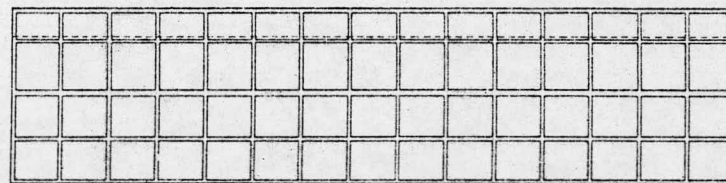

PLAN ON BASE

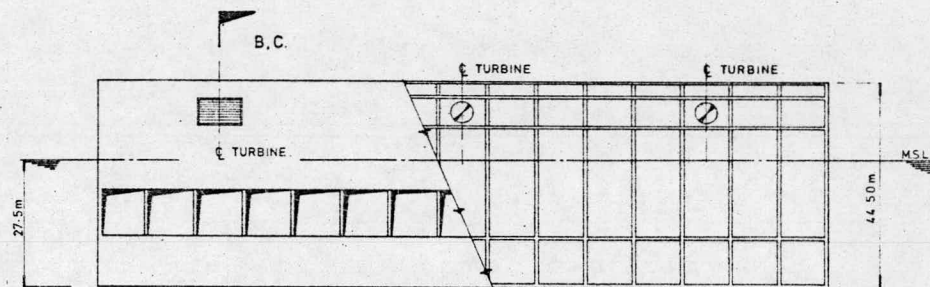

SECTIONAL ELEVATION ON A-A

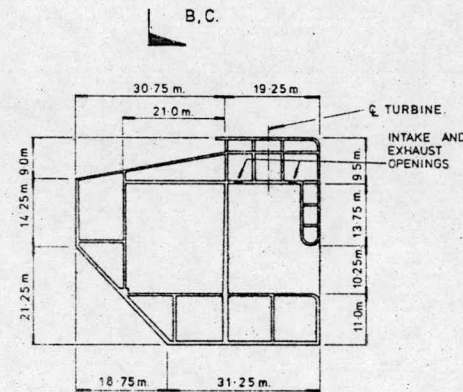

SECTION B - B

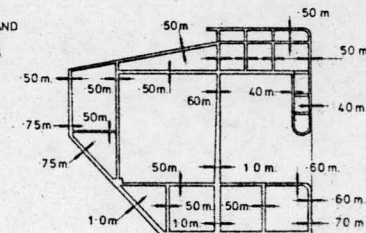

SECTION C - C

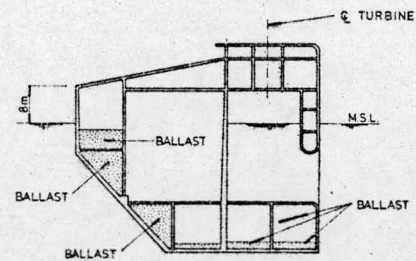

BALLAST ARRANGEMENT

NOTE
THE N.E.L. MODEL TO FULL SIZE DEVELOPMENT SHOWN IS IDEALISED AND IS CONSIDERED IMPRACTICAL TO CONSTRUCT FOR A MORE PRACTICAL STRUCTURE REFER TO REFERENCE DESIGN DRAWING WP/OWC 3

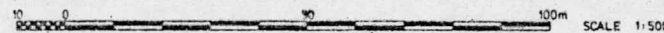

WAVE ENERGY STUDY	
N.E.L. OSCILLATING WATER COLUMN	
MODEL TO FULL SIZE DEVELOPMENT OF OWC DEVICE.	WP/OWC 2. RENDEL PALMER STRATTON CONSULTING ENGINEERS

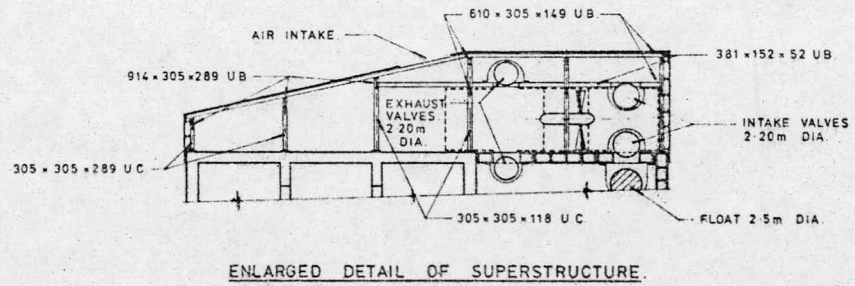
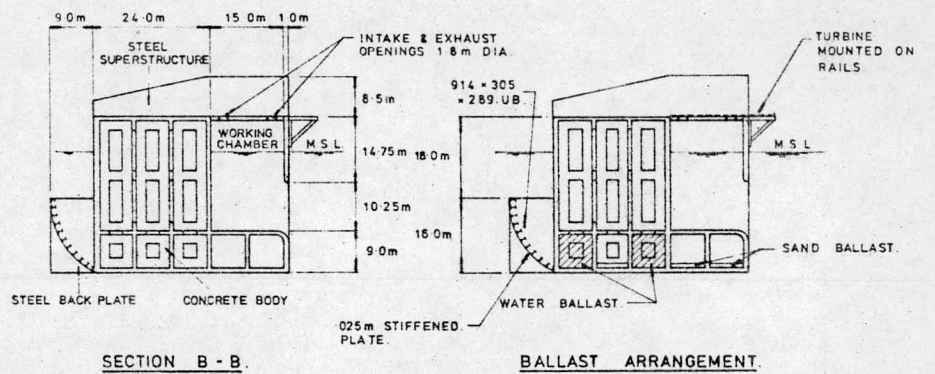
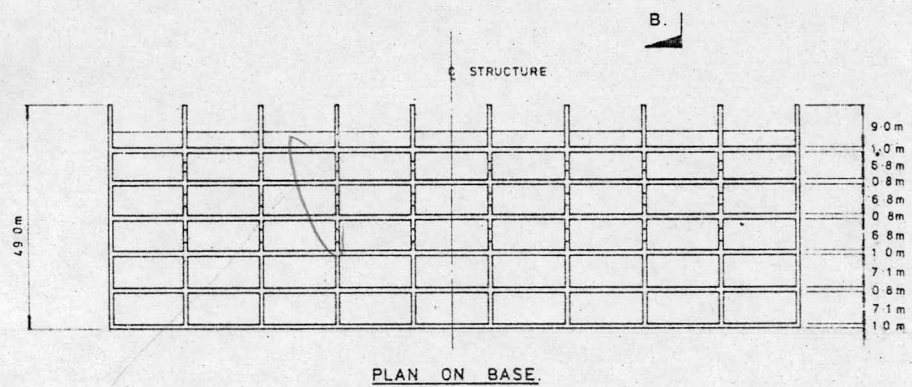
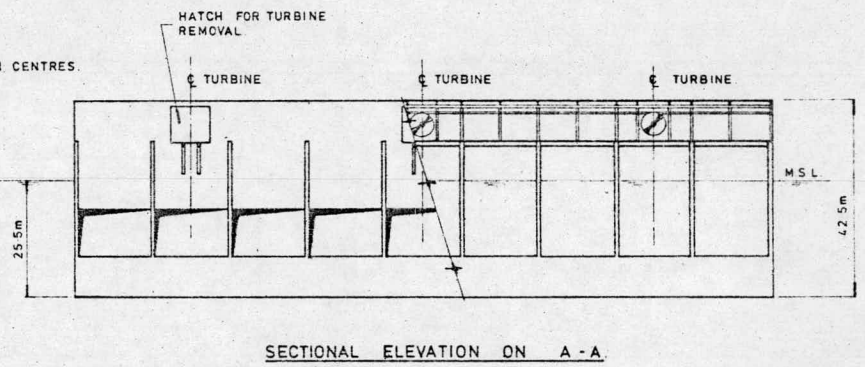
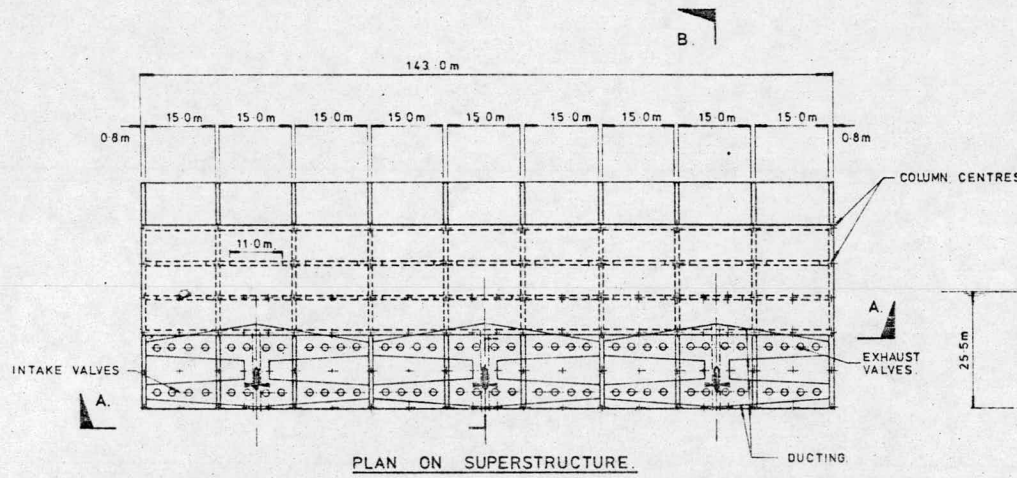

WAVE ENERGY STUDY	
NEL OSCILLATING WATER COLUMN	
REFERENCE DESIGN. GENERAL ARRANGEMENT OF PRACTICAL WORKING UNIT.	WP/OWC. 3. RENDEL PALMER & TRITTON CONSULTING ENGINEERS.

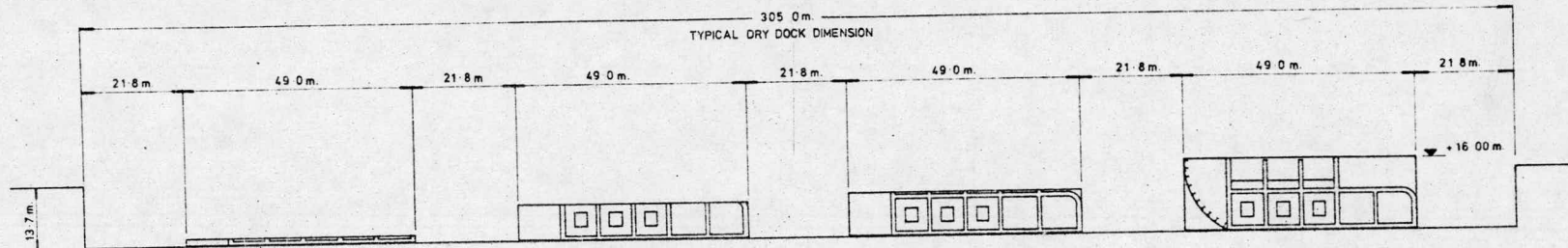

STAGE 1. FORMATION OF BASE SLAB
(PLAN DIMS 49.0 x 14.3'0m.)

STAGE 2. SLIPFORM WALLS AND DIAPHRAGMS.

STAGE 3. FORM INTERMEDIATE SLAB

STAGE 4. SLIPFORM EXTERNAL WALLS TO LONGITUDINAL DIAPHRAGM UPTO +16.0m

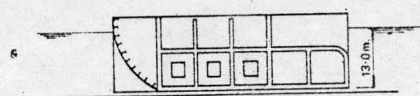

STAGE 5. DRY DOCK FLOTATION

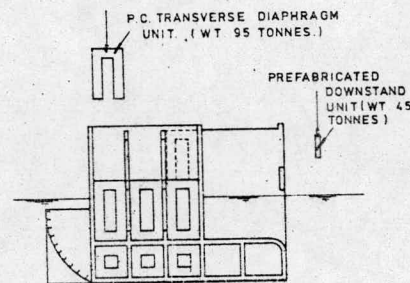

STAGE 6. SLIPFORM EXTERNAL WALLS AND LONGITUDINAL DIAPHRAGMS PLACE PREFABRICATED P.C. UNITS ADJUST TRIM THROUGHOUT

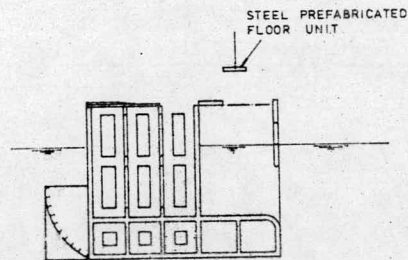

STAGE 7. FORM ROOF SLAB AND PLACE STEELWORK TO TOP OF AIR CELL

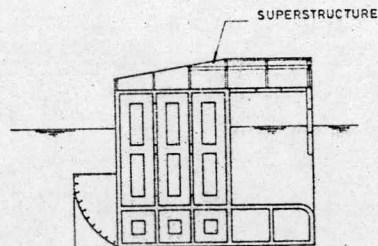

STAGE 8. FIX STEELWORK SUPERSTRUCTURE INSTALL PLANT AND BALLAST TO REQUIRED TRIM FOR TOWING TO WORKING LOCATION AND ADJUST BALLAST ATTACH MOORING LINES.

CONSTRUCTION SEQUENCE:

- STAGE 1. PREPARE CONSTRUCTION BED, FORM BASE SLAB AND KICKERS FOR LOWER DIAPHRAGM
- STAGE 2. SLIPFORM EXTERNAL WALLS AND LONGITUDINAL AND TRANSVERSE DIAPHRAGMS TO SOFFIT LEVEL OF INTERMEDIATE SLAB
- STAGE 3. FORM INTERMEDIATE SLAB AND KICKERS FOR UPPER WALLS AND DIAPHRAGMS
- STAGE 4. SLIPFORM EXTERNAL WALLS AND LONGITUDINAL DIAPHRAGMS TO A HEIGHT OF 16.0 METRES ABOVE THE BASE. POSITION AND FIX STEELWORK TO THE STERN OF THE STRUCTURE
- STAGE 5. PLACE SAND BALLAST TO LOWER CELLS TO ACHIEVE THE REQUIRED TRIM DURING TOW-OUT FLOOD THE DRY DOCK AND TOW UNIT OUT TO CALM WATER CONSTRUCTION SITE HAVING A MINIMUM DEPTH OF 30.0 METRES
- STAGE 6. AT DEEP WATER CONSTRUCTION SITE, REOR THE UNIT AND ADJUST BALLAST AND TRIM FOR CONTINUING CONSTRUCTION OPERATIONS CONTINUE SLIPFORM CONSTRUCTION OF EXTERNAL WALLS AND LONGITUDINAL DIAPHRAGMS POSITION PRECAST TRANSVERSE DIAPHRAGMS AND POST TENSION TO INSITU CONSTRUCTION (WEIGHT OF ONE PRECAST UNIT IS APPROX 95.0 TONNES) POSITION AND FIX STEEL BOX GIRDER SECTIONS TO DOWNSTAND (DOWNSTAND TO ONE CELL COMPRISES 3 No PREFABRICATED UNITS EACH WEIGHING APPROX 45.0 TONNES)
- STAGE 7. PLACE PRECAST CONCRETE PANELS AS PERMANENT FORMWORK TO ROOF SLAB AND FORM INSITU CONCRETE TOPPING POSITION AND FIX STEEL BOX GIRDER SECTIONS TO THE ROOF OF THE AIR CELL (ROOF TO EACH AIR CELL COMPRISES 3 No PREFABRICATED UNITS EACH WEIGHING APPROX 54.0 TONNES)
- STAGE 8. POSITION AND FIX STRUCTURAL STEELWORK SUPERSTRUCTURE AND CLADDING INSTALL PLANT BALLAST FOR REQUIRED TRIM DURING TOW OUT TO THE FINAL WORKING LOCATION TOW TO THE FINAL WORKING LOCATION

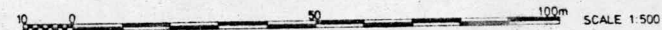

WAVE ENERGY STUDY	
NEL OSCILLATING WATER COLUMN	
REFERENCE DESIGN	WP/OWC. 4.
CONSTRUCTION & FLOTATION	RENEAL PALMER & PARTNERS CONSULTING ENGINEERS

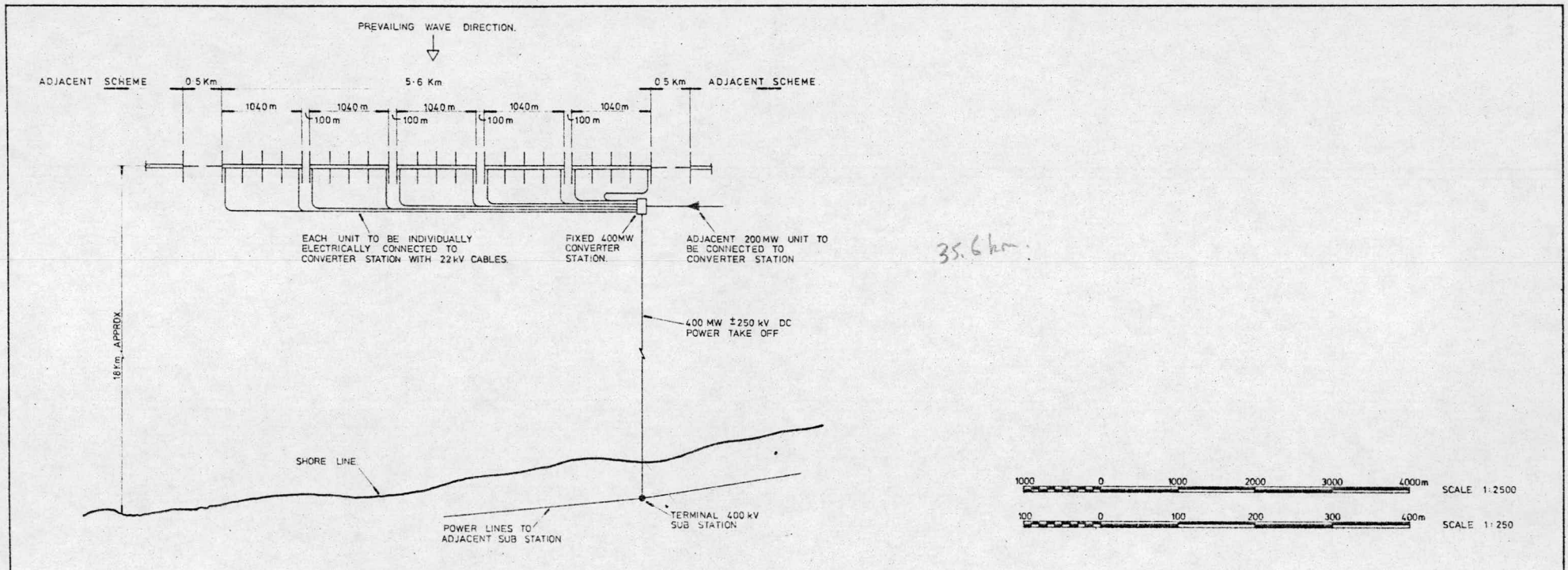

PLAN ON 200 MW. SCHEME. (SCALE 1:2500)

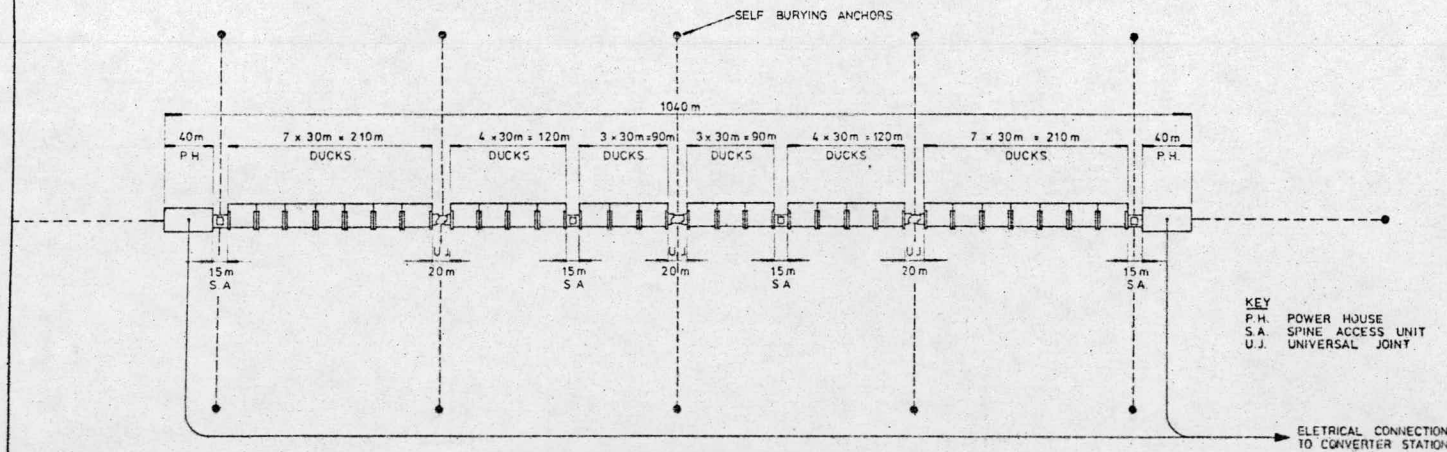

PLAN ON ONE SPINE (SCALE 1:250)

GMR M.R. J.D. PRH 7.77

WAVE ENERGY STUDY	
SALTER DUCK	
200 MW SCHEME.	WP/SALT. 1.
RUSSEL PALMER & TRITTON CONSULTING ENGINEERS.	

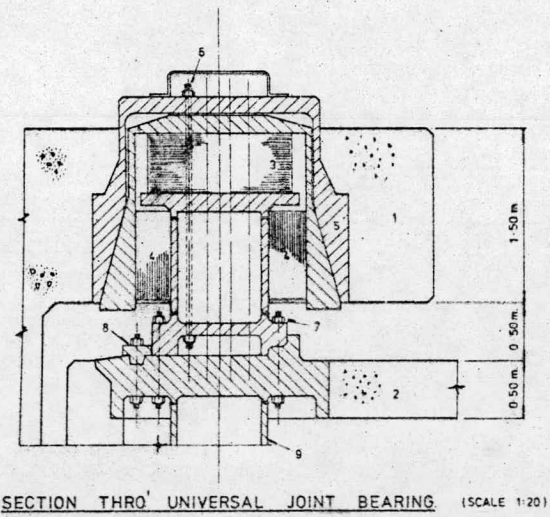
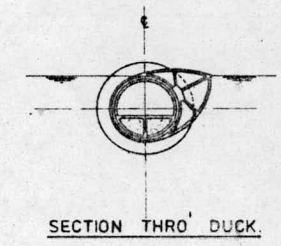
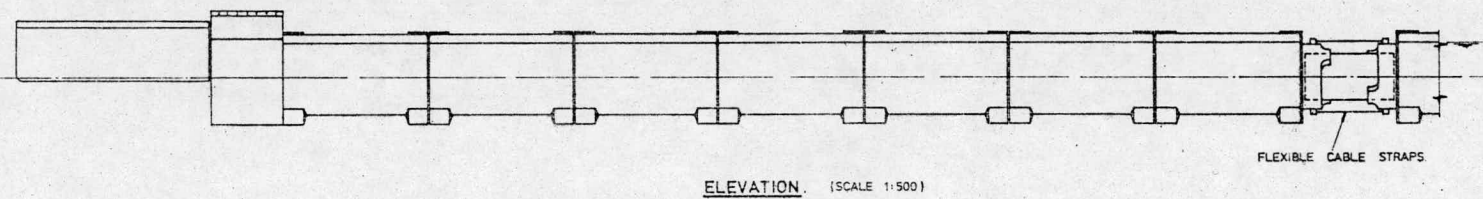
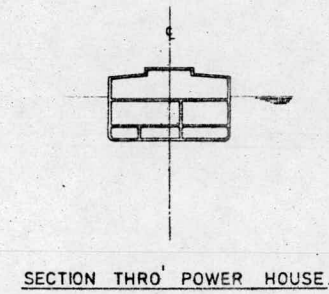
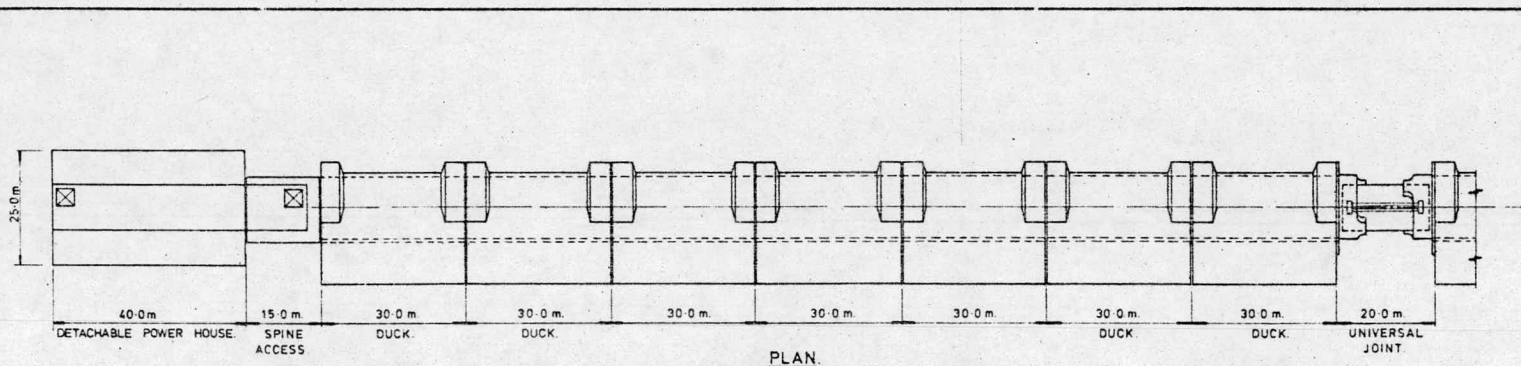

KEY TO PARTS.

1. EXTENSION TO SPINE.
2. UNIVERSAL JOINT SECTION.
3. CIRCULAR LAMINATED RUBBER BEARING.
4. CYLINDRICAL LAMINATED RUBBER BEARING.
5. CONICAL SEAT FOR BEARING CASTING ANGLE OF SEAT TO BE 4° (SELF RELEASING).
6. 12 No. 40mm 4 MACALLOY BARS TO PRESTRESS BEARING ONTO CONICAL SEAT MAY BE RELEASED FOR REPLACEMENT OF BEARING.
7. MAIN BOLTS FOR CONNECTION OF SPINE SECTION TO UNIVERSAL JOINT SECTION MAY BE RELEASED ON SITE FOR DISCONNECTION OF SPINE.
8. SHEAR KEY BOLTED ON AFTER CONNECTION OF 1 & 2.
9. TUBULAR SECTION CONNECTED TO BOTH BEARINGS TO ENSURE ACCURATE LOCATION DURING CONSTRUCTION.

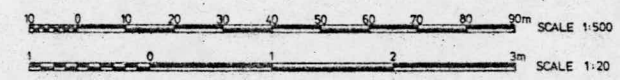
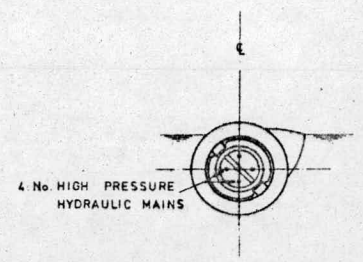

WAVE ENERGY STUDY	
SALTER DUCK	
REFERENCE DESIGN GENERAL ARRANGEMENT OF WORKING UNIT.	WP/SALT. 2. RENDEL PALMER & TRITTON CONSULTING ENGINEERS.

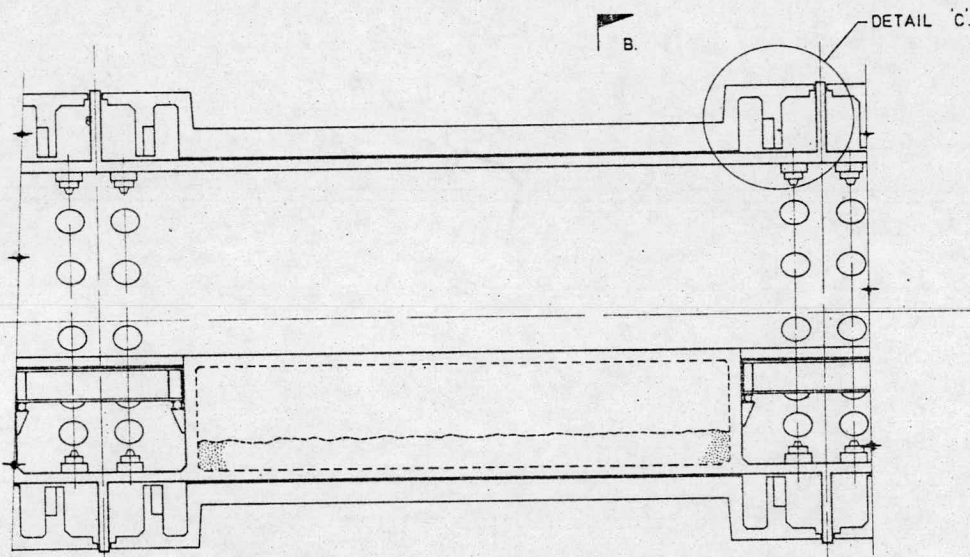

LONGITUDINAL SECTION A-A (SCALE 1:100)

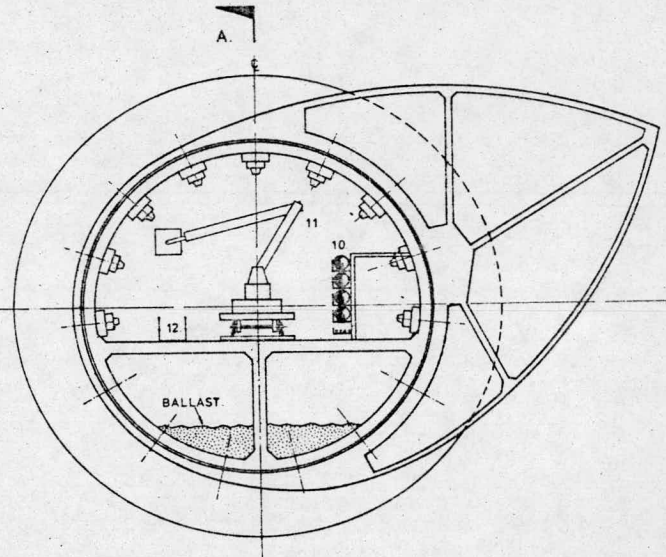

SECTION B-B (SCALE 1:100)

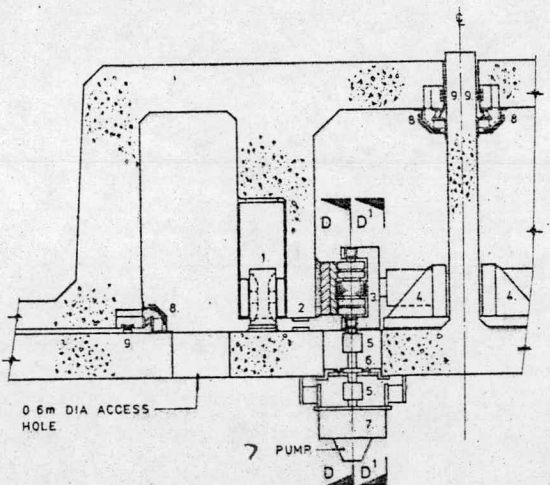

DETAIL 'C' OF POWER TAKE-OFF AND BEARINGS (SCALE 1:25)

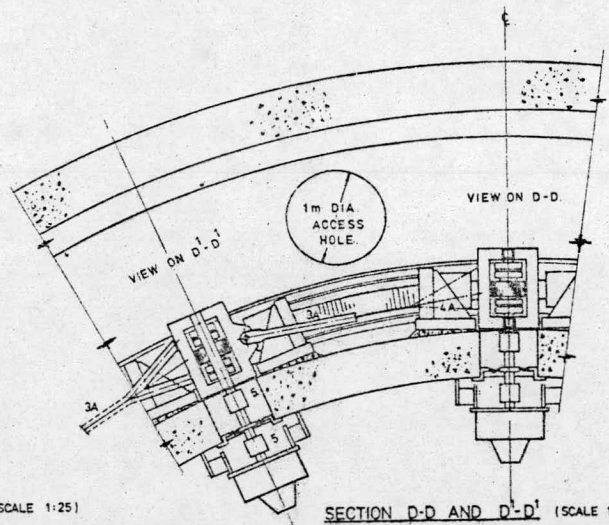

SECTION D-D AND D-D' (SCALE 1:25)

- DETAILS OF MECHANICAL EQUIPMENT:**
- BEARINGS FOR HORIZONTAL & VERTICAL FORCES
15 No UNITS PER END EACH UNIT 2 No 600mm Ø
STEEL ROLLERS CAST STEEL WITH
SPRING SUSPENSION SYSTEM PLUS BRAKING ADEQUATE
TO CLAMP DUCK TO SPINE FOR MAINTENANCE WORK
IN CALM WEATHER
 - RUBBING STRIP: P.T.F.E SURFACES ON STEEL STRIPS
TO CATER FOR OCCASIONAL EXTREME OVERLOAD OF
BEARINGS
 - POWER TAKE-OFF: CONICAL PINION RUNNING ON
TOOTHED TRACK (CAST STEEL 0.35-0.45 % C)
LONGITUDINAL ALIGNMENT FIXED BY SMOOTH ROLLERS
RADIAL ALIGNMENT FIXED GROOVE IN ROLLERS
ROTATION OF THE PINION AXIS ABOUT A LONGITUDINAL
AXIS IS PREVENTED BY BEAM CONNECTION 3A OF
ADJACENT PINION CARRIAGES
 - THRUST BEARING TO KEEP ROLLERS ON TRACK AND
TO RESIST LONGITUDINAL FORCES
 - THRUST BEARING TO RESIST TRACTION FROM
PINIONS (OVERALL DUCK TORQUE)
 - UNIVERSAL JOINTS TO BE DISCONNECTED FOR
PUMP REPLACEMENT
 - ROTARY SEAL
 - PUMPS ON RUBBER MOUNTINGS
 - TRANSLATION SEALS WITH SPACE FOR DUPLICATION
- PLUS DRAINAGE CHANNEL COVERS
 - EXPANDABLE RUBBER SEAL FOR REPAIR AND OR
REPLACEMENT OF 8
 - HIGH PRESSURE MAINS AND SERVICES
 - HYDRAULIC SERVICING PLATFORM FOR INSPECTION
AND REPLACEMENT OF PUMPS ETC
 - WALKWAY
- NOT TO SCALE - PINIONS, P.C.D. AND
ROLLERS TO BE 500mm Ø
(SHOWN AT 350mm Ø)

WAVE ENERGY STUDY	
SALTER DUCK	
REFERENCE DESIGN. DETAILS AND POWER TAKE OFF.	WP/SALT 3. RENDEL PALMER & TRITTON CONSULTING ENGINEERS.

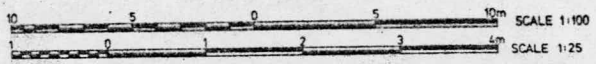

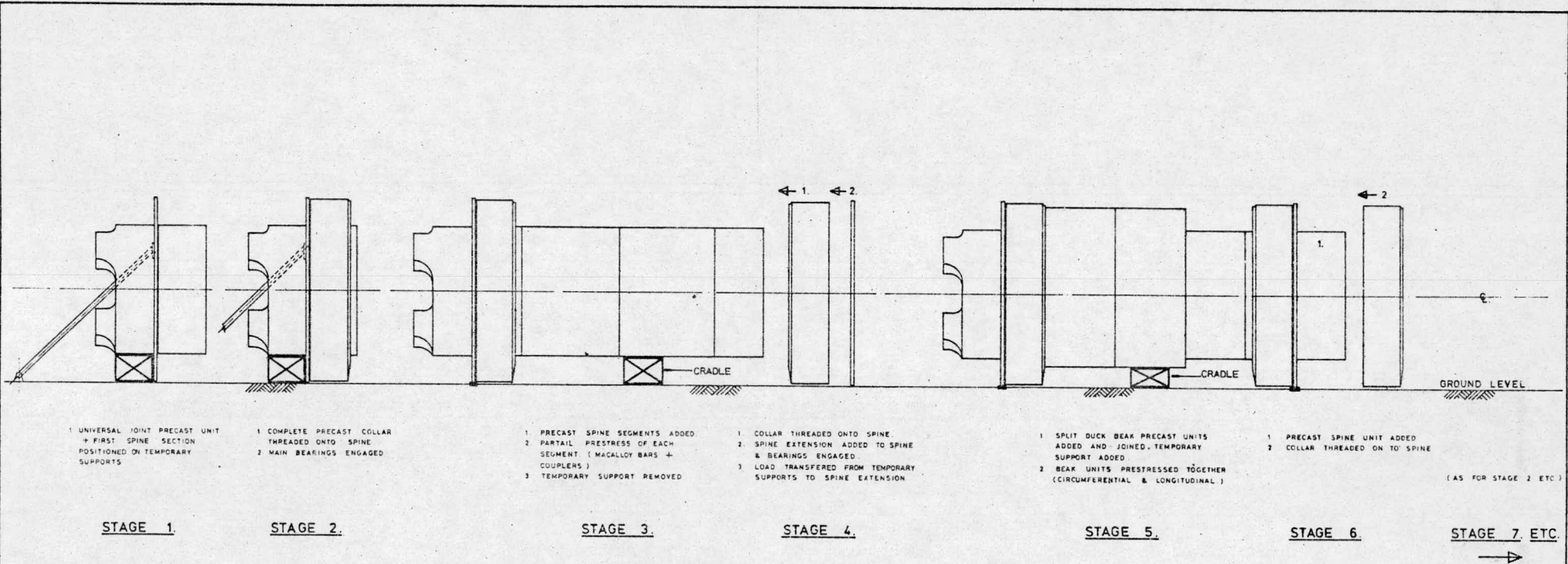

1 UNIVERSAL JOINT PRECAST UNIT + FIRST SPINE SECTION POSITIONED ON TEMPORARY SUPPORTS

1 COMPLETE PRECAST COLLAR THREADED ONTO SPINE
2 MAIN BEARINGS ENGAGED

1 PRECAST SPINE SEGMENTS ADDED
2 PARTIAL PRESTRESS OF EACH SEGMENT (MACALLOY BARS + COUPLERS)
3 TEMPORARY SUPPORT REMOVED

1 COLLAR THREADED ONTO SPINE
2 SPINE EXTENSION ADDED TO SPINE & BEARINGS ENGAGED
3 LOAD TRANSFERRED FROM TEMPORARY SUPPORTS TO SPINE EXTENSION

1 SPLIT DUCK BEAK PRECAST UNITS ADDED AND JOINED, TEMPORARY SUPPORT ADDED
2 BEAK UNITS PRESTRESSED TOGETHER (CIRCUMFERENTIAL & LONGITUDINAL)

1 PRECAST SPINE UNIT ADDED
2 COLLAR THREADED ON TO SPINE

(AS FOR STAGE 2 ETC.)

STAGE 1.

STAGE 2.

STAGE 3.

STAGE 4.

STAGE 5.

STAGE 6.

STAGE 7. ETC.

CONSTRUCTION SEQUENCE FOR ONE SEVEN DUCK UNIT - VIEW ON BACK OF SPINE.

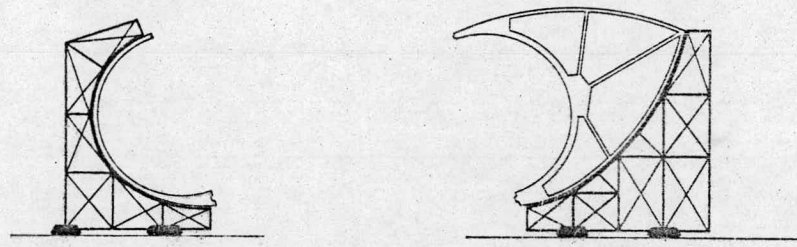

SECTION THROUGH DUCK BEAK SHOWING 2 COMPONENT PRECAST UNITS PLUS SUPPORT CRADLES. (SCHEMATIC ONLY.)

NOTES

- 1 FINAL PRESTRESSING NOT SHOWN
- 2 7 DUCK UNIT FLOATED OUT TO FINAL LOCATION AND JOINED TO OTHER UNITS BY MEANS OF THE UNIVERSAL JOINT SECTIONS.

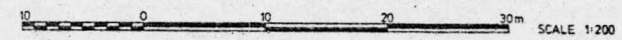

WAVE ENERGY STUDY	
SALTER DUCK	
CONSTRUCTION SEQUENCE	WP/SALT 4.
RENDEL PALMER & TRITTON CONSULTING ENGINEERS	

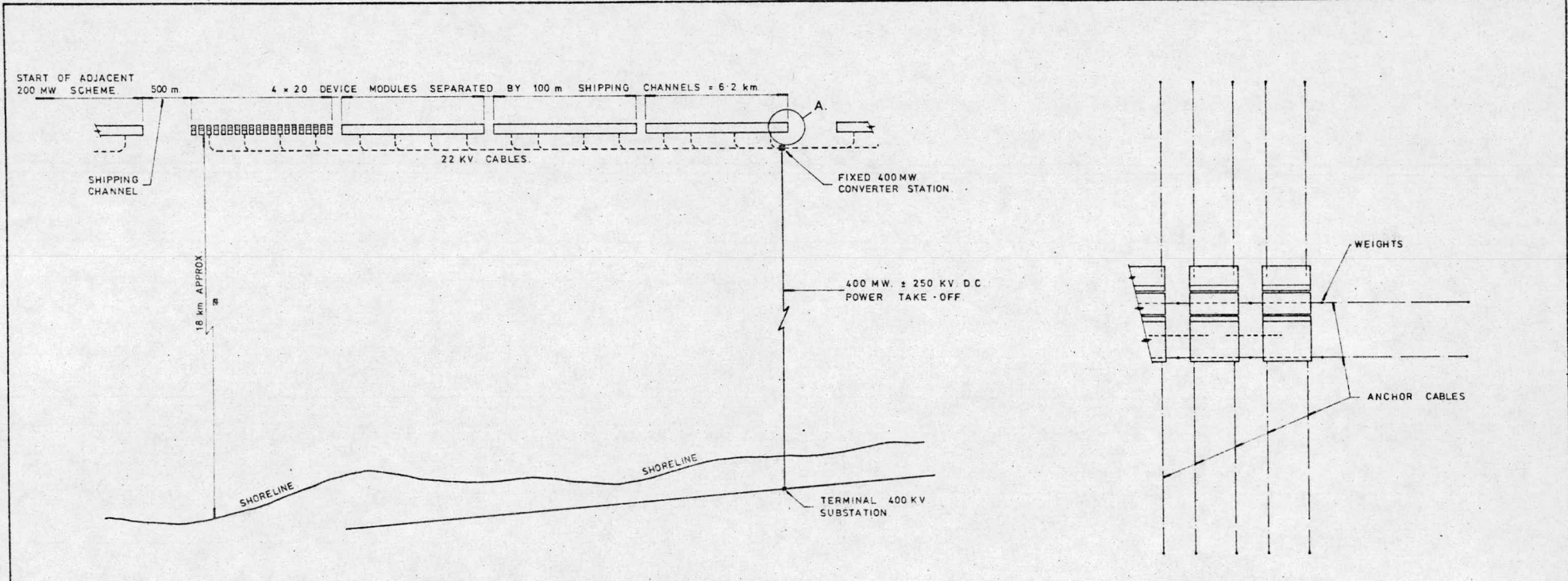

PLAN OF COCKERELL RAFT 200 M.W. SCHEME

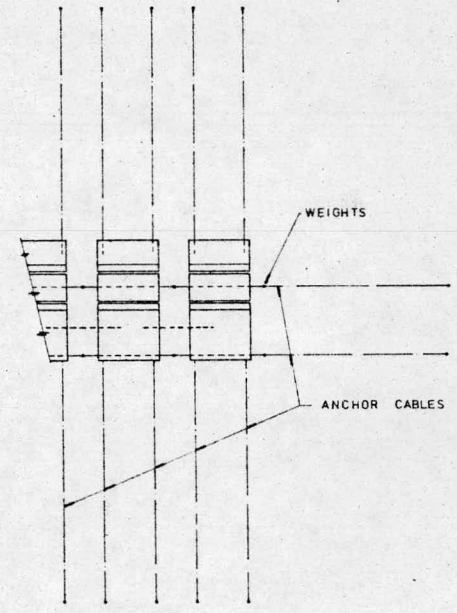

ENLARGED VIEW ON A.

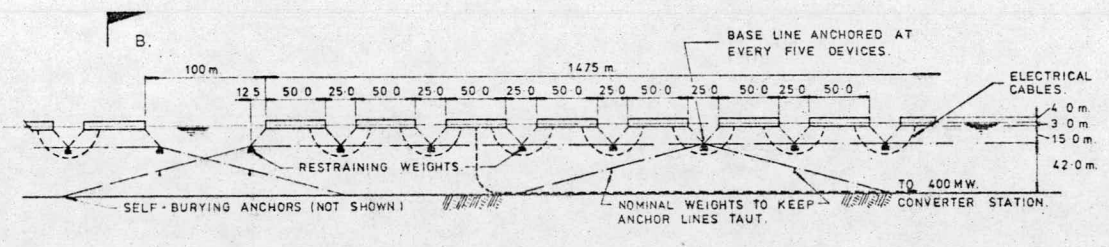

PART ELEVATION OF 20 DEVICE MODULE

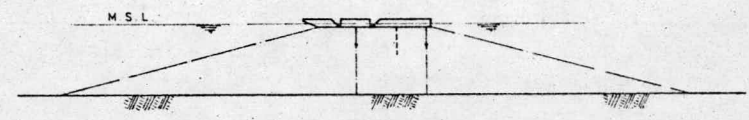

SECTION B-B.

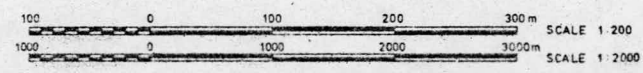

WAVE ENERGY STUDY	
COCKERELL RAFT	
200 M.W. SCHEME.	WP/RAFT 1.
HENCEL PALMER & TRITTON CONSULTING ENGINEERS	

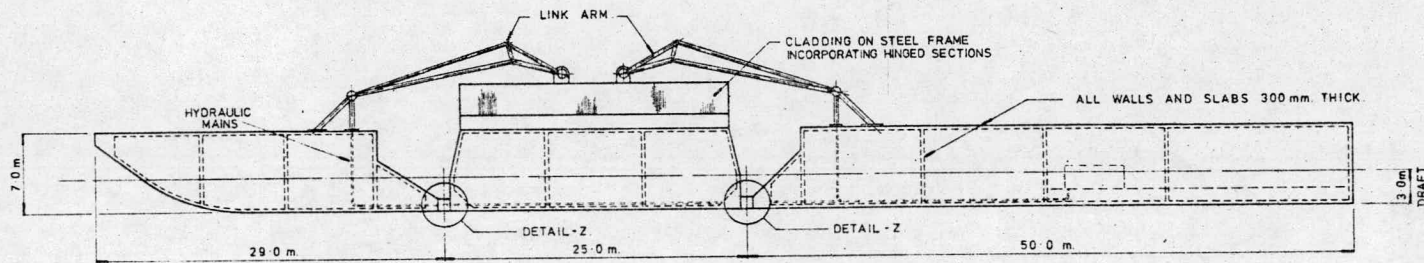

CROSS SECTION THROUGH RAFT

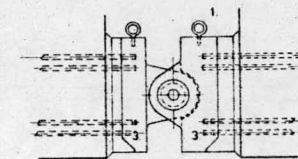

DETAIL - Z (SCALE 1:20)

REPLACEABLE HINGE UNIT
WITHOUT HYDRAULIC CONNECTION
(6 No.)

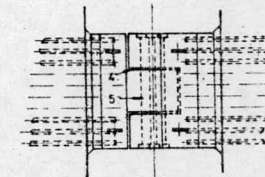

PLAN ON DETAIL - Z

NOTES ON DETAIL - Z

1. LIFTING EYES.
2. BARS PRETENSIONED FROM INSIDE OF RAFT.
3. CAST STEEL UNITS.
4. REPLACEABLE BEARING DISC
5. CAST STEEL PINS
6. (NOT SHOWN) REPLACEABLE WEARING BUSHES
7. (NOT SHOWN) NEOPRENE SEALS

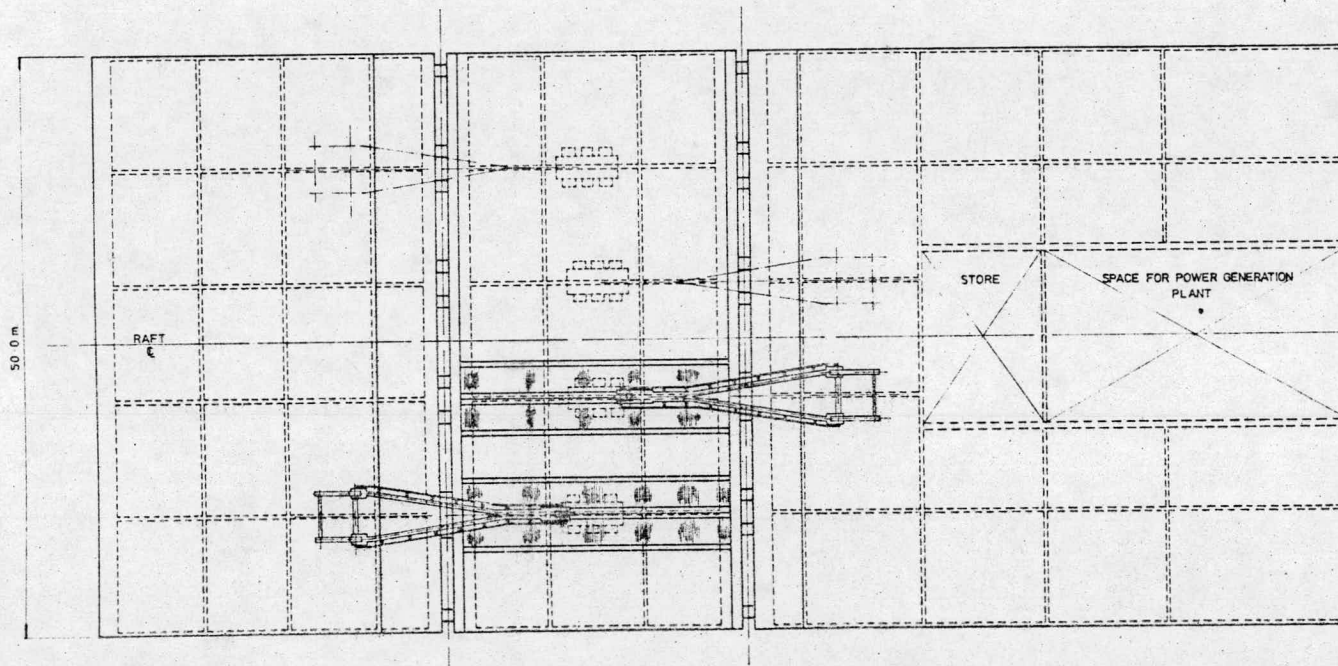

PLAN ON RAFT (SCALE 1:200)

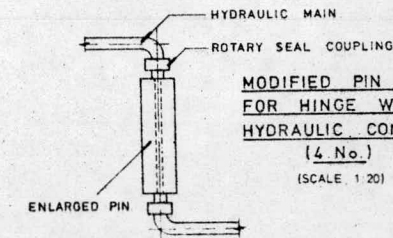

MODIFIED PIN DETAIL
FOR HINGE WITH
HYDRAULIC CONNECTION
(4 No.)
(SCALE 1:20)

WAVE ENERGY STUDY.

COCKERELL RAFT

REFERENCE DESIGN.
GENERAL ARRANGEMENT
OF WORKING UNIT.

WP/RAFT. 2.

HENDEL PALMER'S TRITON
CONSULTING ENGINEERS

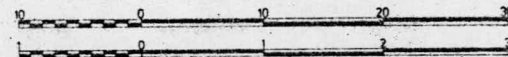

SCALE 1:200

SCALE 1:20

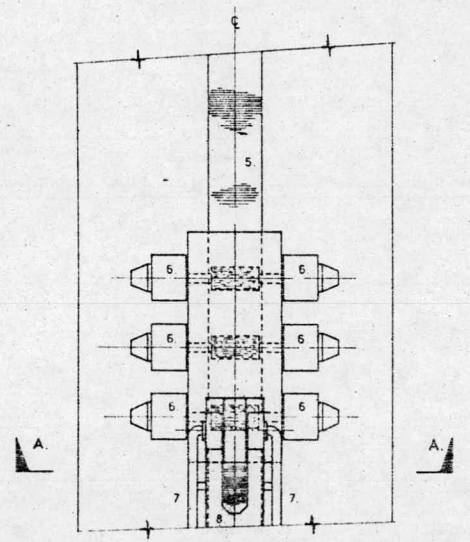

PLAN
COVERS OMITTED FOR CLARITY

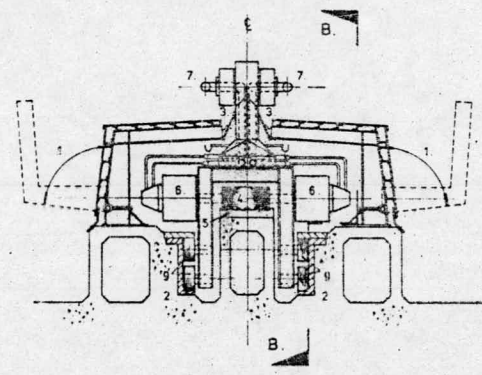

SECTION A - A

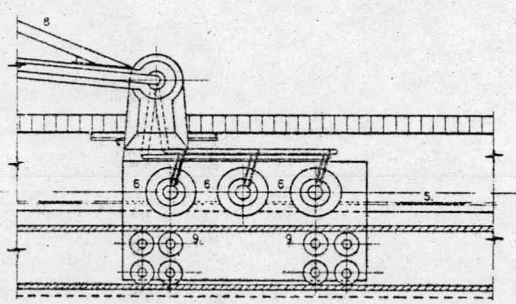

SECTIONAL ELEVATION B - B
COVERS (1) AND RAIL PLINTH (2) OMITTED

- NOTES
1. RETRACTABLE COVERS - (HINGED BACK FOR MAINTENANCE)
 2. RAIL PLINTH
 3. HINGED FLAPS FOR WEATHER SEALING
 4. 500mm ϕ PINION 1000mm WIDE CAST STEEL 3.5-4.5% C 20 TEETH
 5. RACK IN SECTIONS 5m LONG CAST STEEL 3.5-4.5% C
 6. HYDRAULIC PUMP
 7. HYDRAULIC PRESSURE MAINS - ROTATIONAL JOINT
 8. MAIN RAFT LINKAGE ARM
 9. STEEL WHEELS RUNNING IN STEEL TRACK

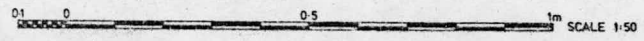

WAVE ENERGY STUDY	
COCKERELL RAFT	
REFERENCE DESIGN DETAILS AND POWER TAKE OFF.	WP/RAFT 3 RENDEL PALMER & TRITTON CONSULTING ENGINEERS

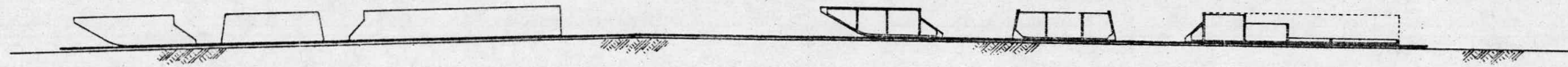

STAGE 2. TRANSFER OF RAFTS TO SLIPWAY.
INSTALLATION OF HINGES.

STAGE 1. CONSTRUCTION OF RAFTS.

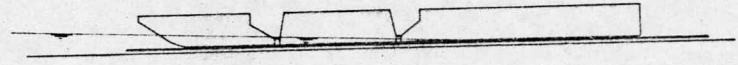

STAGE 3. LAUNCH AND TOW TO FITTING OUT BERTH.

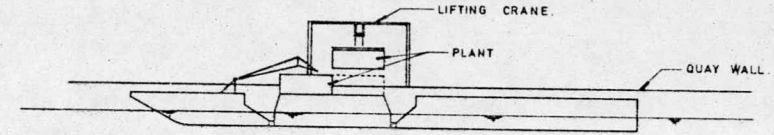

STAGE 4. FINAL FITTING - OUT WITH MECHANICAL AND ELECTRICAL PLANT.

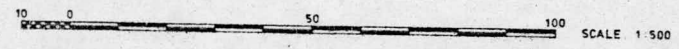

GMR MR. J.D. PRH 7 77

WAVE ENERGY STUDY	
COCKERELL RAFT	
CONSTRUCTION SEQUENCE	WP/RAFT 4
	RENDEL PALMER & TRITTON CONSULTING ENGINEERS